

Durham E-Theses

Optimisation and Operation of Residential Micro Combined Heat and Power (CHP) Systems

OMAR ALI SHANEB

How to cite:

SHANEB, OMAR ALI (2012) Optimisation and Operation of Residential Micro Combined Heat and Power (CHP) Systems. Doctoral thesis, Durham University.

Use policy

The full-text may be used and/or reproduced, and given to third parties in any format or medium, without prior permission or charge, for personal research or study, educational, or not-for-profit purposes provided that:

- a full bibliographic reference is made to the original source
- a <https://etheses.durham.ac.uk/id/eprint/4432/> is made to the metadata record in Durham E-Theses
- the full-text is not changed in any way

The full-text must not be sold in any format or medium without the formal permission of the copyright holders.

Please consult the [full Durham E-Theses policy](#) for further details.

Optimisation and Operation of Residential Micro Combined Heat and Power (μ CHP) Systems

Omar Ali Ali Shaneb



School of Engineering and Computing Sciences

Durham University

A thesis submitted in partial fulfilment of the requirements of the Council of
the University of Durham for the Degree of Doctor of Philosophy (PhD)

2012

Optimisation and Operation of Residential Micro combined Heat and Power (μ CHP) Systems

Omar Ali Shaneb

2012

Abstract

In response to growing concerns regarding global warming and climate change, reduction of CO₂ emissions becomes a priority for many countries, especially the developed ones such as the UK. Residential applications are considered among the most important areas for substantial reduction of CO₂ emissions because they represent a major part of the total consumed energy in those countries. For instance, in the UK, residential applications are currently accountable for about 150 Mt CO₂ emissions, which represents approximately 25% of the whole CO₂ emissions [1-2]. In order to achieve a significant CO₂ reduction, many strategies must be adopted in the policy of these countries. One of these strategies is to introduce micro combined heat and power (μ CHP) systems into residential energy systems, since they offer several advantages over traditional systems. A significant amount of research has been carried out in this field; however, in terms of integrating such systems into residential energy systems, significant work is yet to be conducted. This is because of the complexity of these systems and their interdependency on many uncertain variables, energy demand of a house is a case in point.

In order to achieve such integration, this research focuses on the optimisation and operation of μ CHP systems in residential energy systems as essential steps

towards integration of these systems, so it deals with the optimisation and operation of a μ CHP system within a building taking into account that the system is grid-connected in order to export or import electricity in certain cases. A comprehensive review that summarises key points that outline the trend of previous research in this field has been carried out. The reviewed areas include: technologies used as residential μ CHP units, modelling of the μ CHP systems, sizing of μ CHP systems and operation strategies used for such systems.

To further this, a generic model for sizing of μ CHP system's components to meet different residential application has been developed by the author. Two different online operation strategies of residential μ CHP systems, namely: an online linear programming optimiser (LPO) and a real time fuzzy logic operation strategy (FLOS) have been developed. The performance of the novel online operation strategies, in terms of their ability to reduce operation costs, has been evaluated. Both the LPO and the FLOS were found to have their advantages when compared with the traditional operation strategies of μ CHP systems in terms of operation costs and CO₂ emissions. This research should therefore be useful in informing design and operation decisions during developing and implementing μ CHP technologies in residential applications, especially single dwellings.

Acknowledgements

I would like to express my deep and sincere gratitude to my supervisor, **Professor Philip Taylor**. It has been a great opportunity to work under his supervision; his wide knowledge, his patience and advice have been of great value for motivating me. Furthermore, his understanding, encouraging and personal guidance have guided me to accomplish this thesis. In addition, his comments were always constructive, important, supportive and at the right time throughout this work. I also warmly thank my co-supervisor, **Dr. Graham Coates** for his encouragement and support, especially during writing for publications. Special thanks go to my family for their endless support and patience during my study.

The financial support of my country, through the Faculty of Engineering, Misrata University, is gratefully acknowledged.

Finally, I would like to thank my parents, my relatives and my special friends for their support and encouragement.

Declaration

I hereby declare that this thesis is a record of work undertaken by myself, that it has not been the subject of any previous application for a degree, and that all sources of information have been duly acknowledged.

© Copyright 2012, Omar Ali Shaneb.

Copyright of this thesis rests with the author. No quotation from it should be published without prior written consent and information derived from it should be acknowledged.

Contents

1	INTRODUCTION.....	1
1.1	AIMS AND RESEARCH OBJECTIVES.....	5
1.2	SCOPE OF THESIS.....	7
2	LITERATURE REVIEW.....	8
2.1	INTRODUCTION.....	8
2.2	RESIDENTIAL ENERGY DEMAND.....	8
2.3	RESIDENTIAL MICRO COMBINED HEAT AND POWER.....	13
2.4	TECHNOLOGIES USED IN RESIDENTIAL μ CHP SYSTEMS.....	17
2.4.1	<i>Internal combustion engines</i>	18
2.4.2	<i>Stirling engines</i>	19
2.4.3	<i>Fuel Cells</i>	20
2.5	AUXILIARY COMPONENTS OF μ CHP SYSTEMS.....	20
2.5.1	<i>Thermal storage device</i>	21
2.5.2	<i>Backup heater</i>	21
2.5.3	<i>Electrical storage device</i>	22
2.6	SIZING OF μ CHP SYSTEMS.....	23
2.6.1	<i>Aim of sizing</i>	23
2.6.2	<i>Sizing techniques</i>	23
2.6.3	<i>Sizing of residential μCHP systems</i>	24
2.7	OPERATION STRATEGIES FOR μ CHP SYSTEMS.....	25
2.7.1	<i>Conventional operation strategies</i>	26
2.7.2	<i>Non-conventional operation strategies</i>	28
2.8	CONCLUSION.....	34
3	TIME DOMAIN MODELLING OF μCHP SYSTEMS:.....	36
3.1	INTRODUCTION.....	36
3.2	REASONS FOR CHOOSING A PEMFC BASED μ CHP UNIT:.....	37

3.3	TIME DOMAIN MODELLING OF μ CHP SYSTEM:.....	40
3.3.1	<i>μCHP model:</i>	44
3.3.2	<i>Operation strategy model:</i>	47
3.3.3	<i>Electricity supply system model:</i>	48
3.3.4	<i>Thermal storage and heat supply system model:</i>	51
3.3.5	<i>Operation costs and CO₂ emissions model:</i>	58
3.4	CONCLUSIONS:.....	59
4	SIZING OF RESIDENTIAL μCHP SYSTEMS.....	61
4.1	INTRODUCTION.....	61
4.2	SIZING OF μ CHP SYSTEMS USING MAXIMUM RECTANGULAR METHOD.....	62
4.2.1	<i>The principle of the maximum rectangle method</i>	62
4.2.2	<i>Illustrative examples of residential demand</i>	63
4.3	SIZING OF μ CHP SYSTEMS USING LINEAR PROGRAMMING.....	69
4.3.1	<i>Overview</i>	69
4.3.2	<i>Model assumptions</i>	69
4.3.3	<i>Mathematical formulation</i>	71
4.4	ILLUSTRATIVE EXAMPLES.....	75
4.5	RESULTS OBTAINED BY LP MODEL.....	77
4.6	SENSITIVITY ANALYSIS OF THE LP MODEL'S RESULTS.....	78
4.6.1	<i>Sensitivity analysis of capital cost</i>	78
4.6.2	<i>Sensitivity analysis of feed-in tariff</i>	79
4.6.3	<i>Sensitivity analysis of gas price</i>	80
4.6.4	<i>Sensitivity analysis of electricity price</i>	81
4.6.5	<i>Sensitivity analysis of electricity demand</i>	82
4.6.6	<i>Sensitivity analysis of electrical efficiency</i>	83
4.6.7	<i>Sensitivity analysis of demand representation</i>	84
4.7	DISCUSSION.....	88
4.8	CONCLUSIONS.....	90

5	OPTIMAL ONLINE OPERATION OF RESIDENTIAL μCHP SYSTEMS USING LINEAR PROGRAMMING:	92
5.1	INTRODUCTION.....	92
5.2	ONLINE OPERATION OF μ CHP SYSTEMS USING LINEAR PROGRAMMING.....	93
5.2.1	<i>Overview</i>	93
5.2.2	<i>Model assumptions</i>	94
5.2.3	<i>Mathematical formulation</i>	96
5.3	RESULTS AND DISCUSSION	100
5.3.1	<i>Feed-in tariff (FIT) scenario</i>	101
5.3.2	<i>Electricity trading scenario</i>	106
5.3.3	<i>Carbon tax scenario</i>	110
5.4	CONCLUSIONS	116
6	REAL TIME OPERATION OF μCHP SYSTEMS USING FUZZY LOGIC	119
6.1	INTRODUCTION.....	119
6.2	A COMPARISON BETWEEN LPO AND FLOS	120
6.3	NON-CONVENTIONAL OPERATION STRATEGIES	123
6.4	REAL TIME FUZZY RULE-BASED OPERATION OF μ CHP SYSTEMS.....	125
6.4.1	<i>Overview</i>	125
6.4.2	<i>Model assumptions</i>	127
6.4.3	<i>Design of the real time fuzzy rule-based operation strategy</i>	128
6.5	RESULTS AND DISCUSSION	133
6.5.1	<i>Feed-in tariff (FIT) scenario</i>	134
6.5.2	<i>Electricity trading scenario</i>	138
6.5.3	<i>Carbon tax scenario</i>	142
6.6	CONCLUSIONS	144
7	DISCUSSION AND CONCLUSIONS	148
7.1	DISCUSSION.....	148
7.1.1	<i>Financial viability of μCHP systems for single dwellings</i>	148
7.1.2	<i>Non-conventional operation of a μCHP system</i>	151

7.2	CONCLUSIONS	156
7.3	FUTURE WORK.....	158

List of Abbreviations

AI	Artificial Intelligence
ANNs	Artificial Neural Networks
CCHP	Combined Cooling Heat and Power
CHP	Combine Heat and Power
DH	Detached House
DHW	Domestic hot water
DP	Dynamic Programming
ELOS	Electricity Led Operation Strategy
ETH	End terrace House
FC	Fuel Cell
FIT	Feed-in Tariff
FL	Fuzzy Logic
FLC	Fuzzy Logic Control
FLOS	Fuzzy Logic Operation Strategy
GA	Genetic Algorithm
H ₂	Hydrogen
HHV	Higher Heating Value
HLOS	Heat Led Operation Strategy
H:P	Heat to Power ratio
HVAC	Heating Ventilation And Cooling
ICE	Internal Combustion Engine
LF	Load Factor

LHV	Lower Heating Value
LP	Linear Programming
LPO	Linear Programming Optimiser
LVDN	Low Voltage Distribution Networks
MAS	Multi agent System
MINLP	Mixed-Integer Nonlinear Programming
MR	Maximum Rectangle
NLP	Non-linear Programming
PEMFC	Proton Exchange Membrane Fuel Cell
PID	Proportional Integral Derivative
SDH	Semi Detached House
SE	Stirling Engine
SOFC	Solid Oxide Fuel Cell
μ CHP	Micro Combined Heat and Power
μ G	Micro Grid

Nomenclature

Symbol	Description	units
c_{AC}	annualised capital cost	£
c_C	Capital cost	£
$c_{C, B}$	specific capital cost of back-up heater	£/kW _{th}
$c_{C, \mu CHP}$	specific capital cost of μ CHP	£/kWe
c_{DO}	daily operation cost	£
c_{EA}	equivalent annual cost	£
C_{exp}	price of exporting kWh of electricity to the grid	£/kWh
C_{imp}	price of importing kWh of electricity from the grid	£/kWh
C_{NG}	cost of a kWh of natural gas	£/kWh
C_O	operation cost including maintenance	£
C_{p_w}	specific heat of water at constant pressure	kJ/kg.K
e_{Grid}	CO ₂ emission factor of electricity from the grid	Kg/kWh
e_{NG}	CO ₂ emission factor of kWh of natural gas	Kg/kWh
FIT_{ex}	feed-in tariff for exported electricity	£/kWh
FIT_G	feed-in tariff for generated electricity	£/kWh
HHV	higher heating value of natural gas	kWh/kg
H_j	thermal demand in time period j	kWh
$H_{j,f}$	forecasted heat demand in time period j	kWh
LHV	lower heating value of natural gas	kWh/kg
L_j	electricity demand in time period j	kWh
$L_{j,f}$	forecasted electricity demand in time period j	kWh
LT	Life time	years
LT_B	expected life time of back-up heater	Years
$LT_{\mu CHP}$	expected life time of μ CHP	years
m_B	maintenance cost per kWh of backup thermal output	£/kWh

Symbol	Description	units
$m_{\mu\text{CHP}}$	maintenance cost per kWh of μCHP electrical output	£/kWh
n_d	number of representative days per month or per week according to type of demand representation	
n_m	number of months in a year	
n_h	number of hours in a day	
$O_{el,i}$	electrical output of μCHP unit during the i^{th} hour	kWh
$O_{el,i,j,k}$	electrical output of μCHP unit during the k^{th} hour of the week j and the month i	kWh
$O_{ex,i}$	exported electricity to the grid during the i^{th} hour	kWh
$O_{ex,i,j,k}$	exported electricity to the grid during the k^{th} hour of the week j and the month i	kWh
$O_{im,i}$	imported electricity from the μG during the i^{th} hour	kWh
$O_{im,i,j,k}$	imported electricity from the μG during the k^{th} hour of the week j and the month i	kWh
$O_{st_in,i}$	thermal input to the storage device during the i^{th} hour	kWh
$O_{st_out,i}$	thermal output from the storage device during the i^{th} hour	kWh
$O_{th,i,j,k}$	thermal output of back-up heater during the k^{th} hour of the week j and the month i	kWh
$O_{th,i}$	thermal output of backup heater during the i^{th} hour	kWh
P_+	electrical power surplus	W
P_-	electrical power shortfall	W
P_{AC}	AC power generated by FC	W
P_D	electrical power demand	W
P_{exp}	electrical power exported to grid	W
P^{max}	the maximum limit of generating power	kW

Symbol	Description	units
P^{\min}	the minimum limit of generating power	kW
R_B	size (rating) of backup heater	kWth
R_{CHP}	size (rating) of μ CHP unit	kW _e
R_d	maximum ramping down rate of μ CHP unit	kWe/hr
R_s	size (rating) of thermal storage device	kWh
R_u	maximum ramping up rate of μ CHP unit	kWe/hr
Q	heat to power ratio of μ CHP unit (only in equations)	
\dot{Q}_+	thermal power surplus	W
\dot{Q}_-	thermal power shortfall	W
Q_B	thermal energy produced by backup heater during Δt	kJ
\dot{Q}_B	thermal power produced by backup heater	W
Q_{C_o}	available thermal energy for charging to the thermal storage device	kJ
\dot{Q}_D	total thermal power demand	W
Q_{D_o}	available thermal energy for discharging from the thermal storage device	kJ
Q_{Dump}	dumped thermal energy during Δt	kJ
\dot{Q}_{Dump}	dumped thermal power	W
\dot{Q}_{FC}	thermal power produced by fuel cell	W
$\dot{Q}_{in,CH}$	thermal power demand of central heating system	W
$\dot{Q}_{in,DHW}$	thermal power demand of domestic hot water	W
t_C	carbon tax per tonne of CO ₂ emissions	£/tonne

Symbol	Description	units
T_{st}	instantaneous temperature of the water inside the storage device	$^{\circ}\text{C}$
$T_{st, max}$	maximum allowable temperature inside the storage device	$^{\circ}\text{C}$
$T_{st, min}$	minimum allowable temperature inside the storage device	$^{\circ}\text{C}$
U_{+}	increase in internal energy of the water inside the storage device during a period Δt	kJ
U_{-}	decrease in internal energy of the water inside the thermal storage device during a period Δt	kJ
U_{max}	maximum value of internal energy of the water inside the thermal storage device	kJ
U_{min}	minimum value of internal energy of the water inside the thermal storage device	kJ
U_{st}	internal energy of the water inside the storage device	kJ
V_{st}	volume of the thermal storage device	m^3
w_m	a weight factor for the number of weeks or days in the month m	
x_1	size (rating) of μCHP unit	kW_e
x_2	size (rating) of back-up heater	kW_{th}
α	cost of a kWh electricity produced by μCHP unit	$\text{£}/\text{kW}_e$
β	cost of a kWh heat produced by backup heater	$\text{£}/\text{kW}_{th}$
γ	cost of an imported kWh of electricity	$\text{£}/\text{kWh}$
Δt	time resolution of the model	h

Symbol	Description	units
δ	cost of an exported kWh of electricity	£/kWh
ε	total cost of a kWh of heat entering the storage device	£/kWh
ε_I	efficiency of DC/AC inverter	
η_B	efficiency of backup heater	
η_e	electrical efficiency of μ CHP unit	
η_s	round trip efficiency of the thermal storage device	
η_{th}	thermal efficiency of μ CHP unit	
ξ	total cost of a kWh of heat used from the storage device	£/kWh
v	salvage value	£
$v_{\mu CHP}$	salvage value of μ CHP	£/kWe
ρ_w	density of water	Kg/ m ³
ϕ_B	input energy of natural gas burned by the backup heater	kJ
$\dot{\phi}_B$	input natural gas power at any time	W
ϕ_{FC}	input energy of the natural gas burned by the FC.	kJ

List of Figures

Figure 1.1 A conceptual arrangement of a residential μ CHP system with a thermal storage device.....	4
Figure 1.2 Photos of a μ CHP unit (Fuel cell) and a thermal storage device from five different manufacturers [15]	5
Figure 2.1 Seasonal average daily electricity demands for a single house [23]	10
Figure 2.2 Daily electrical demand profile of a single dwelling based on a 1-min resolution [24].....	11
Figure 3.1 A conceptual arrangement of residential μ CHP system.....	36
Figure 3.2 Simulink time domain model of the residential μ CHP system	43
Figure 3.3 electrical efficiency and H:P ratio of PEM FC against load factor [142].....	44
Figure 3.4 Heat and electrical power produced against fuel flow rate of 1kWe PEMFC...	45
Figure 3.5 Schematic diagram of the electricity supply model.....	49
Figure 3.6 Inverter efficiency versus output power (curve fitted to SunnyBoy SB2500) [89].....	49
Figure 4.1 The maximum rectangle (MR) method [85].....	63
Figure 4.2 Heat demand of a representative day from each season.....	66
Figure 4.3 Electricity demand of a representative day from each season.....	66
Figure 4.4 Operation costs and CO ₂ emissions for different strategies and sizes of PEMFC system for the demand SDH	67
Figure 4.5 an overview of the sizing model.....	72
Figure 4.6 Sensitivity analysis of capital cost.....	79
Figure 4.7 Sensitivity analysis of gas price.....	81
Figure 4.8 Sensitivity analysis of electricity price.....	82
Figure 4.9 Sensitivity analysis of electricity demand	83
Figure 4.10 Sensitivity analysis of electrical efficiency	84

4.11 Change in μ HP rating when a representative day is used instead of a representative week per month.....	85
4.12 Change in backup heater rating when a representative day is used instead of a representative week per month	85
Figure 4.13 Change in the value of c_{EA} when a representative day is used instead of a representative week per month	86
Figure 4.14 ordered values of DH heat demand for different representation of demand ...	87
Figure 5.1 A conceptual arrangement of residential μ CHP system [35]	94
Figure 5.2 Overview of the LPO.....	96
Figure 5.3 Operation costs (£) for different strategies when FIT scenario is applied and no carbon tax is considered.....	102
Figure 5.4 Operation costs for different strategies when FIT scenario is applied and a 1kWe PEM is used.....	103
Figure 5.5 Operation costs for different strategies when FIT scenario is applied and a 2kWe PEM is used.....	103
Figure 5.6 Operation costs for different strategies when FIT scheme is applied, and a £20/tonne carbon tax is considered.....	105
5.7 Operation costs for different strategies when FIT scheme is applied, and a £20/tonne carbon tax is considered.....	107
Figure 5.8 Operation costs for different strategies when electricity trading scenario is applied, 100% exporting price is considered and a 1kWe PEMFC is used	109
Figure 5.9 Operation costs for different strategies when electricity trading scenario is applied, 100% exporting price is considered and a 2kWe PEMFC is used	109
Figure 5.10 Operation costs for different strategies when a £20/tonne carbon tax is applied, 100% exporting price is considered and a 1kWe PEMFC is used.....	113
Figure 5.11 Operation costs for different strategies when a £120/tonne carbon tax is applied, 100% exporting price is considered and a 1kWe PEMFC is used	114

Figure 5.12 Operation costs for different strategies when a £200/ tonne carbon tax is applied, 100% exporting price is considered and a 1kWe PEMFC is used	114
Figure 5.13 Operation costs for different strategies when a £500/tonne carbon tax is applied, 100% exporting price is considered and a 1kWe PEMFC is used	115
Figure 6.1 Overview of the real time fuzzy rule-based operation strategy	127
Figure 6.2 an overview of the real time fuzzy rule-based operation strategy in Simulink	129
Figure 6.3 membership functions of the instantaneous temperature of the water inside the thermal storage device	131
Figure 6.4 membership functions of the electrical output power required by the μ CHP unit	131
Figure 6.5 Operation costs for different strategies when FIT scenario is applied	135
Figure 6.6 Annual CO ₂ emissions for different strategies when FIT scheme is applied ..	138

List of tables

Table 2.1 Comparison between candidate μ CHP technologies for single dwellings	18
Table 3.1 The states of operation of the thermal storage device [153]	55
Table 4.1 Specification of the houses, occupancy and demand	65
Table 4.2 Results of sizing using MR method for different μ CHP units and for three types of demand	68
Table 4.3 Specifications of equipments used in the model.....	76
Table 5.2 Annual operation costs and savings (£) for different strategies when electricity trading scenario is applied and 1kWe PEMFC and 2kWe PEMFC are used.....	108
Table 5.3 Annual CO ₂ emissions (kg) for different strategies when electricity trading scenario is applied and 1kWe PEMFC and 2kWe PEMFC are used.....	111
Table 5.4 Annual operation costs (£) for different strategies when different values of carbon tax is applied and 1kWe PEMFC is used.....	112
Table 5.5 Annual operation costs and CO ₂ emissions for different strategies when different values of carbon tax are applied and 1kWe PEMFC is used	116
Table 6.1 Rules of the real time FLOS	133
Table 6.2 Operators of the real time FLOS.....	133
Table 6.3 Annual operation costs and CO ₂ emissions for different strategies when electricity trading scenario is applied and 1kWe PEMFC and 2kWe PEMFC are used...	139
Table 6.4 Annual operation costs and CO ₂ emissions for different strategies when different values of carbon tax are applied and 1kWe PEMFC is used	143
Table 7.1 Recommended sizes of different μ CHP units by using MR method and LP model	149

List of Publications

Journal Articles

O. Shaneb, P. Taylor and G. Coates, “Real Time Operation of μ CHP Systems Using Fuzzy Logic”, *Energy and Buildings Journal*, accepted for publication.

O. Shaneb, P. Taylor and G. Coates, “Optimal Online Operation of Residential μ CHP Systems Using Linear Programming”, *Energy and Buildings Journal*, Vol. 44, Issue (1), pp. 17-25, 2012.

O. Shaneb, P. Taylor and G. Coates “Sizing of Residential μ CHP Systems”, *Energy and Buildings Journal*, Vol. 43, pp. 1991-2001, 2011.

O. Shaneb, G. Coates, and P. Taylor, “Micro combined heat and power technologies and control for residential applications” *International Journal of Renewable Energy Technology (IJRET)*, Vol.1, issue (3), pp. 325-347, 2010.

Conference Proceedings

O. Shaneb and P. Taylor, “Evaluation of Alternative Operating Strategies for Residential Micro Combined Heat and Power”, IEEE International Energy Conference, Manama-Bahrain, 18-21 December 2010

O. Shaneb and P. Taylor, “An evaluation of integrated fuel cell and energy storage systems for residential applications”, UPEC 2009 conference, 1st-4th Sept 2009, Glasgow-UK.

1 INTRODUCTION

Combined heat and power (CHP) technology, which is also known as cogeneration, is defined as a concept of generating heat and electricity simultaneously on site from a single fuel source [3-4]. This technology is based on utilizing waste heat in order to significantly increase the total efficiency of the CHP system to over 80% compared to an efficiency of 30-35% in conventional electricity generation systems [5]. This results in significant reduction of operation costs and carbon dioxide (CO₂) emissions [6]. The small scale of such a technology is called micro combined heat and power (μ CHP) technology. μ CHP technology, which ranges in size from 1 kW-10 kW electricity and 1-20 kW recovered heat [7], is a fast growing technology in Europe, especially in the UK, since this technology leads to many advantages: increased efficiency; reduced overall emissions; lower transmission losses; and increased energy security from natural disasters and even terrorist acts since it can be operated independently with no need to be grid connected. There are three main technologies used in this field: internal combustion engine (ICE), Stirling engine (SE) and fuel cell (FC). μ CHP technology is being developed rapidly resulting in availability of Stirling engines (SEs) and internal combustion engines (ICEs) commercially [4, 8]. In addition, FC technology is also being developed, particularly, the types: solid oxide fuel cell (SOFC) and proton exchange membrane fuel cell (PEMFC) [8]. Each type of μ CHP offers advantages as well as disadvantages. For example, FC produces less noise (<60 dB) [9] and has relatively lower emissions than others but its capital cost is still relatively high (>£2400/kWe for PEMFC) [5].

There are some issues regarding μ CHP systems that must be resolved to encourage their penetration in the market; these issues include: integration of the system within the residential energy system; interconnection of its components; reliability and safety of the system [10]. Integrating such systems within residential energy systems is the most difficult task because it requires to optimally size the components of the system and to optimally operate it. Optimisation and operation of μ CHP systems depend on some dynamic variables, such as variation in heat to power (H:P) ratio. These dynamic variables must be taken into consideration to reach optimum design and operation strategy. So this research focuses on this issue trying to optimise the benefits of μ CHP systems through optimising the size of μ CHP units and optimising the heat and power flow of such systems during operation in order to minimise installation and operation costs.

Optimisation and operation of a μ CHP unit in a single dwelling, face significant challenges since thermal demand does not always coincide with electrical demand. For instance, in a review paper by Peacock and Newborough, it has been stated that the annual H:P ratio in a UK single house, which depends on the age of that house, its size, and occupancy, varies from 2:1 up to 8:1 approximately. This H:P ratio is not always constant along the operation time of the μ CHP unit [11]. As a result, a μ CHP unit must be connected to the low voltage distribution network (LVDN)/micro-grid (μ G). Alternatively, an electrical storage device or a thermal storage device might be integrated into the system to compensate any difference that might occur [5]. Instead, the μ CHP unit, thermal and electrical storages devices could be integrated in a single system connected to a LVDN/ μ G. On the

other hand, larger residential applications such as multifamily, commercial, or institutional applications can benefit from the demand diversity which occurs due to the multiple demands served; this reduces the need for storage devices [5, 12]. Therefore, a μ CHP system for a single dwelling, which has been considered in this research, consists of: a μ CHP unit, a thermal storage device, a backup heater, and the system is also connected to a LVDN/ μ G in order to export/import power, as illustrated in Figure 1.1 . It should be noted that a μ CHP unit is the μ CHP technology, which could be a SE, ICE or FC unit while a μ CHP system is a whole system connected to a LVDN/ μ G and includes: a μ CHP unit, a thermal storage device, a backup heater, as the one illustrated in Figure 1.1. Figure 1.2 shows photos of a micro CHP unit (fuel cell) and a thermal storage device from different manufacturers.

Each, μ CHP technology has some advantages as well as some disadvantages. For example, at partial loads, the electrical efficiency of a μ CHP unit drops significantly for an ICE unit although it does not considerably vary for a SE unit and a FC unit, where these two systems can be operated at low loads with a reasonable electrical efficiency [5]. As a result, each technology may satisfy the demands of a certain end-use, based on the potential carbon and financial savings which depend on the intensity of carbon and the cost of alternative choices [13], and other factors such as level of noise and H:P ratio. Accordingly, all these factors must be taken into consideration during the selection of a technology and its operating strategy to be used for a certain application. For instance, an ICE unit is not always suitable for a single dwelling application because it has a high level

of noise although it offers some advantages such as robustness, whereas FC is a promising technology to be applied for such application for many reasons such as low level of noise rate and high performance at partial load [14].

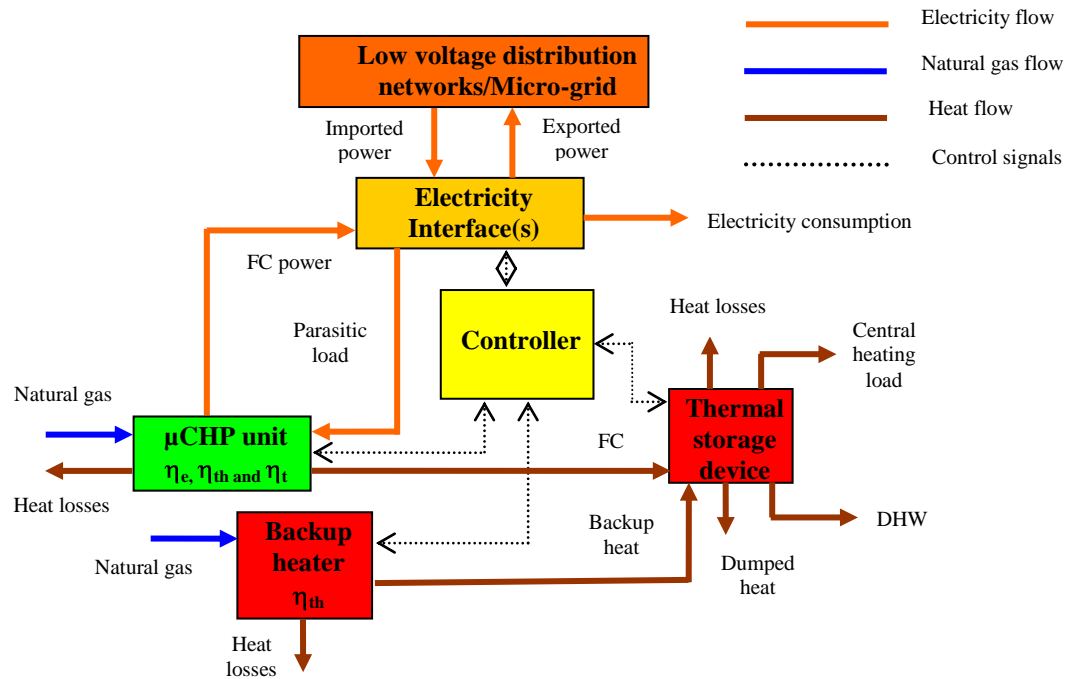

Figure 1.1 A conceptual arrangement of a residential μ CHP system with a thermal storage device

Although, the previous research in this field, gives very useful results and suggestions regarding the aspects of feasibility, overall emissions, detailed μ CHP modelling and field trial experiments, more research is still required to effectively integrate these technologies inside the energy system of the building and within a LVDN/ μ G and to improve their performance by developing an optimal sizing model and developing online operating strategies.



Figure 1.2 Photos of a μ CHP unit (Fuel cell) and a thermal storage device from five different manufacturers [15]

In this research, a generic optimal linear programming (LP) sizing model has been developed. Furthermore, two conventional operating strategies have been investigated. Two online operation strategies, which can efficiently manage the performance of μ CHP system online, have been developed. The first one is called an online LP optimiser (LPO) and it uses a LP technique while the other one is called a fuzzy logic operation strategy (FLOS) and it uses fuzzy rule-base technique.

1.1 Aims and Research Objectives

The main aim of this research is to integrate the μ CHP unit into a building within a LVDN/ μ G. As a result, this aim can be achieved by identifying three broad

objectives for potential contributions to academic and industrial knowledge as follows:

- ✓ The first objective is to develop a generic model for sizing μ CHP system components to meet the needs of different residential applications. The model is capable of determining the optimal size of each component through minimizing the installation and operation costs by considering all technologies and different demand patterns.
- ✓ The second objective is to develop an online linear programming operation strategy for residential μ CHP systems that can optimise heat and power flow between the components of the μ CHP system and the LVDN/ μ G informed by all technical and financial constraints. Thus, the performance of a μ CHP system can be optimised online through minimising operation costs and CO₂ emissions.
- ✓ The third is to develop a real time fuzzy logic operation strategy (FLOS) for residential μ CHP systems that can effectively manage heat and power flow between the components of the μ CHP system and the LVDN/ μ G informed by all technical and financial constraints.

There are also secondary objectives for this research as follows:

- ✓ This research would encourage the penetration of μ CHP technology, especially FCs, in the residential sector as it has the potential to increase their economic and environmental value.
- ✓ This research could lead to mass production of μ CHP units, particularly FCs, which would considerably reduce their costs.

1.2 Scope of Thesis

This thesis is structured in the following way.

- The second chapter of this research summarises the background research that has been reviewed. Key points for this research have been investigated through a comprehensive study of relevant previous literature in order to assess and distinguish the value of the proposed research in relation to the current state of the art.
- The third chapter is concerned with developing a model which can simulate the performance of a μ CHP system.
- The fourth chapter of this thesis presents the generic sizing models, where a linear programming model for sizing μ CHP systems has been developed in a generic form in order to be used for any type of μ CHP technology and any demand pattern.
- The fifth chapter presents an optimal online operation strategy using linear programming.
- The sixth chapter investigates the real time operation strategy using a FL approach.
- In the last chapter, the results have been further discussed and conclusions have drawn from the thesis and the steps identified for the required further studies in the field are described.

2 LITERATURE REVIEW

2.1 Introduction

This chapter summarises the background research that has been conducted to elicit the key points that outline the trends of current research carried out in the field of μ CHP units in residential energy systems. This chapter has been divided into eight sections as below.

2.2 Residential Energy Demand

Energy demand in houses can be divided into two main categories: electricity demand and heat demand. Both electricity demand and heat demand vary significantly from one household to another [16]. For instance, Peacock and Newborough has found that the annual heat demand of a sample of nine dwellings, for a full calendar year, ranged from 9.3 to 27.2 MWh, the annual electricity demand varied from 3.5 to 7.5 MWh; and the annual H:P ratio was in the range 1.5 to 5.7 [17]. This section explains the nature of residential energy demand and methods used to model such a demand. It also identifies the characteristics of a residential μ CHP system that should be considering for choosing a μ CHP unit according to the nature of single dwellings' electrical and thermal demand and economical and environmental concerns.

2.2.1 The nature of residential energy demand

Residential heat demand is more flexible than electricity demand because it does not contain rapid fluctuations during the same day, especially when a thermal storage device is used [18]. This is because residential heat demand has only two

common significant periods of demand in cold seasons occurring in the morning and evening.

Electricity demand in a house has transient behaviour since it considerably depends on daily variations. For instance, when the house is empty, operating an individual appliance, such as a fridge, consumes approximately 1kW but the usage of different appliances at the same time, generally leads to peaks of several kilowatts at peak times [19]. Electricity demand in a single dwelling is highly dependent on the activities of the occupants and their use of electrical appliances such as a toaster and an iron [20]. However, any residential electricity demand may be divided into three main categories: “predictable”, “moderately predictable” and “unpredictable” [21]. Predictable demand, which invokes small cyclic loads such as refrigeration appliances and steady loads from security lighting and standby items, occurs during un-occupancy and sleeping periods only [22]. The rest of the demand is affected by both occupancy and external influences such as the seasonal/weather variations. Moderately predictable demand is subject to occupants’ habitual behaviour patterns. For instance, many people operate television and switch lights on/off regularly. Finally, unpredictable demand, which represents the greatest part of the whole demand, has an irregular nature according the occupants’ wishes such as cooking and washing dishes/clothes. Figure 2.1 shows an example of an average daily electricity demand for a single house in the different seasons [23]. However, the actual daily electricity demand is different since it contains rapid variations and a higher peak value, as shown in figure 2.2. The peak value is approximately 7 kW for the actual demand while it is only 2.5 kW for the averaged one [24]. Consequently, the nature of such demand represents

a significant challenge for any operation strategy required to deliver economic, efficient and environmentally benign operation. Furthermore, if the μ CHP is sized using an average demand profile, which is always the case; the μ CHP unit would not be able to meet demand during the peak period. As a result, a sophisticated operation strategy able to deal with uncertainties of electrical and thermal demands is required to efficiently manage the flow of energy in such systems in order to reduce operation costs and CO₂ emissions.

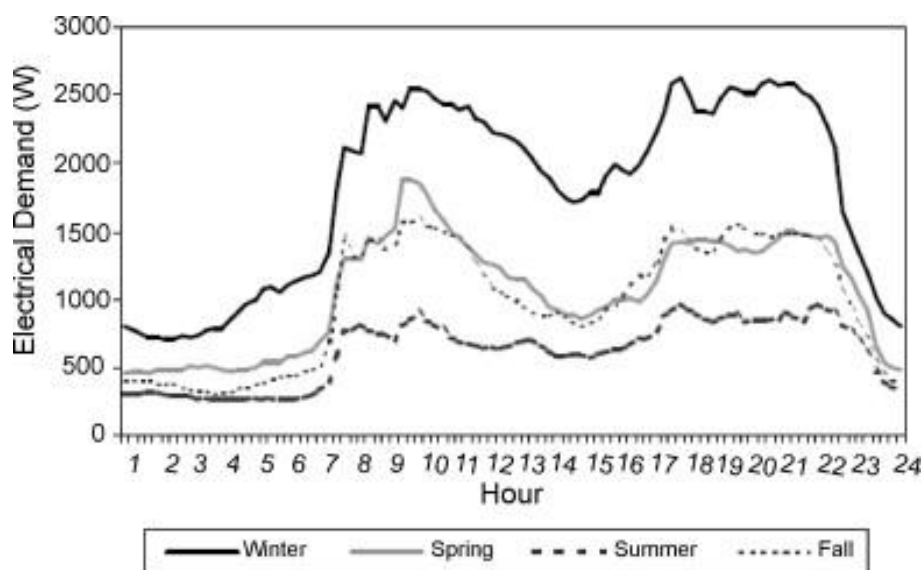

Figure 2.1 Seasonal average daily electricity demands for a single house [23]

2.2.2 Modelling of residential energy demand

Although there are many different methods for estimating residential thermal and electrical demand in both the long-term and short-term, these methods can be generally divided into three main groups [25]. Firstly, statistical approaches or regression analyses, such as the energy-signature method, are highly dependent on measured demand data, long-term weather characteristics and technical and

constructional specifications of the building [22, 26-27]. Secondly, energy simulation programs, such as EnergyPlus and ESP-r software, are mainly based on detailed specifications for the building and sociological factors such as consumers, behaviour and culture, and weather data [28]. Thirdly, intelligent computer systems, especially neural networks which has the ability to learn online, require measured data of demand, weather parameters and building information [29-30].

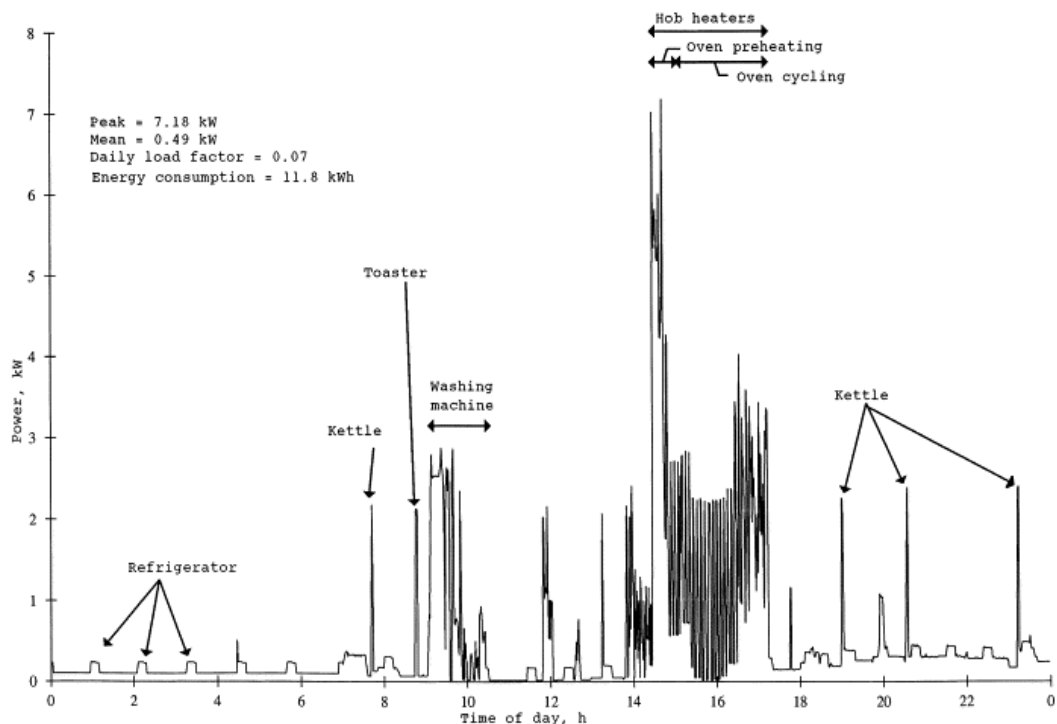

Figure 2.2 Daily electrical demand profile of a single dwelling based on a 1-min resolution [24]

2.2.3 Characteristics of residential μ CHP systems

According to the nature of single dwellings' electrical and thermal demand and economical and environmental concerns, it has been identified by the author that a μ CHP technology suitable for such dwellings should consider the following characteristics:

1. Market availability: necessary for any technology to be adopted.

2. Noise level: low since the μ CHP unit would be installed near or inside the house.
3. CO₂ emissions: low since the aim of using this technology are to be greener and to get benefits from any loans or exemptions.
4. Other pollutants: low CO and NO_x emissions.
5. Overall efficiency: high to be competitive relative to traditional technologies.
6. Heat to power ratio: low because of the advances in insulations, which means less heat is required and savings in bills can be achieved, thus motivating adoption.
7. Investment cost: low to motivate householders' adoption of technologies.
8. Maintenance requirements: low to motivate householders' adoption of technologies.
9. Life time: long to avoid replacement and its associated cost.
10. Fuel type: natural gas is preferred at this stage due to already being supplied to the house, especially in developed countries.
11. Electrical efficiency at partial load: high because of the changeable nature of residential demand for single houses, which means that the system is required to operate at partial load for significant amount of time.
12. Load following capability: rapid because residential demand for single houses changes rapidly.
13. Start-up capability: rapid to meet the demand once the system is operated.

2.3 Residential micro combined heat and power

Residential μ CHP, or cogeneration, involves the generation of both electricity and heat simultaneously from a single energy source [4, 31]. As a result, primary energy consumption, CO₂ emissions and other pollutants can be reduced. Furthermore, using this technology would reduce losses due to transmission and distribution, and overcome the problems of peak demand such as the stability of the grid. μ CHP technologies based upon FCs, SEs or ICEs are being developed worldwide by a number of manufacturers [4, 32]. Adoption of these technologies is being encouraged by many countries through different financial incentives such as loans and introducing feed-in tariff schemes [33-34]. This technology would be more beneficial in terms of savings and emission reduction by using renewable energy resources such as biomass fuels or hydrogen [35].

This section explores the existing literature regarding residential μ CHP systems and modelling of such systems. It also investigates the possibility of use of renewable energy

2.3.1 Residential μ CHP systems in literature

Some existing prototypes of μ CHP units have low electrical efficiencies, for example as low as 5% [10], while others have a high electrical efficiency as high as 45% but they have not yet been practically proven [36]. These efficiencies are relatively low compared to combined-cycle central power plants of 55% efficiency [37-38]. As such, it is essential to utilize the thermal output of μ CHP units to meet the heat demand of the dwelling. Otherwise using μ CHP units would not be more favourable than the existing central power generation technologies [33], where

efficiencies of over 50% is possible [39]. However, a perfect exploitation of the energy produced from this technology is not an easy task because of the mismatch between the building's thermal and electrical demands, especially for single dwellings. For example, when a μ CHP is operated according to HLOS during summer in a single dwelling, lighting and appliance demands may not be met because there is a low demand for heat during summer. Conversely, using this strategy in winter would probably lead to excess electricity during the period of peak heat demand. Consequently, it is advantageous to the system to be integrated with a thermal storage device to store thermal energy once it is not required in order to use it when less heat is produced.

The effect of adding a thermal storage device or an electrical storage device to these technologies, have also been investigated. For example, adding a thermal buffering to a μ CHP unit has a dramatic effect on its performance, where overall efficiency of the system is improved and the on/off cycling is significantly reduced [40]. Prototypes of different μ CHP units have been demonstrated: a SE unit [10, 41-42], an ICE unit [43], a PEMFC unit [44] and a SOFC unit [45]. For example, a PEMFC prototype has been demonstrated experimentally and it has been proved that the primary energy savings of this system compared to the conventional system could reach about 24% [44]. Furthermore, it has been shown that the amount of savings was considerably better when the system was tested in a cold region.

2.3.2 Modelling of residential μ CHP systems

Many models based on simple performance-map methods have been previously applied to assess different technologies of μ CHP, especially in terms of costs and emissions. For example, assessment of FCs [8, 46-48], assessment of ICEs [43], assessment of SEs [49-50], and comparative assessments between different technologies [3, 8, 51-54] have been conducted. The effects of uncertainties of objectives such as operation cost and constraints such as CO concentration in PEMFC on the energy system synthesis/design and operation/control optimisation have been also studied [55]. Sensitivities to economic and environmental parameters of μ CHP technologies have been widely investigated [47, 56-57].

More detailed models for μ CHP units have been developed in Annex 42 of the International Energy Agency's Energy Conservation in Buildings and Community Systems Programme [58], where simulation models that advance the design, operation, and analysis of μ CHP systems have been developed [33]. These models, which have been incorporated within the available whole-building simulation softwares such as ESP-r, EnergyPlus, and TRNSYS, can be used to assess the performance of these systems technically, environmentally, and economically. In addition, these models, which are system-level models, consider the thermodynamic performance of all components that consume energy and produce the μ CHP unit's heat and electricity.

2.3.3 Renewable energy and residential μ CHP systems

Sustainable energy vision has become a global issue due to the need for: reducing global carbon dioxide (CO_2) emissions and improving local (urban) air quality; ensuring security of energy supply and creating a new industrial and technological energy base [59]. As a result, using renewable energy sources such as wind or biomass has become an essential factor to be considered for any technology to be applied. Hydrogen (H_2) is an attractive alternative to fossil fuels. H_2 is not like fossil fuels since it is not a primary energy source rather than an ‘energy carrier’ similar to electricity. It can be produced using energy from other sources and then transported for future use. H_2 can be considered as a sustainable or renewable fuel as long as it is produced from non-fossil-fuel. It can be produced from three innovation renewable systems: from renewable electricity produced by hydro, wind, solar and geothermal; from biomass; and through direct production from solar. Although, direct solar production is still at an earlier stage of development [60-61], it is a promising source and can be predicted to be the main source of energy capable of producing the amount of H_2 required to supply a hydrogen economy [62]. The use of nuclear energy (both fission and fusion) to supply future needs for H_2 energy is also under consideration [59, 63].

μ CHP presently is predominantly based on natural gas combustion. However, the application of biomass is at the supported commercial stage, where residential μ CHP is moving from the early demonstration to the pre-commercial stage [60]. In addition, H_2 can be easily used for μ CHP once it becomes available. For instance, SEs, are external combustion engines and can burn renewable fuels such as biomass and H_2 [64-65]. μ CHP can utilise H_2 , especially FCs, where using H_2 is

preferable since it makes the technology simpler and more cost effective by excluding the costly reformer. Furthermore, SOFCs can be operated by different fuels such as biomass, because it has a high operation temperature [56]. However, though biomass-fuelled μ CHP systems are capable of playing a significant role in addressing a series of vital issues, the research and development on such a technology is still in its early stages [66-67]. So, adoption of such technologies has the potential to play a significant role in the transition to a future sustainable energy system with low CO₂ emissions. However, there are some challenges facing the adoption of μ CHP technologies such as the high capital cost and the integration within the LVDN/ μ G [39].

2.4 Technologies used in residential μ CHP systems

Although many types of technologies are used in μ CHP systems, only three types are suitable for use in single dwellings, namely ICEs, SEs and FCs [51]. A detailed review of different technologies can be found in [5]. Table 2.1 presents a comparison between these technologies relative to the characteristics identified in Section 2.2. Sections 2.4.1, 2.4.2 and 2.4.3 give more information regarding these technologies.

Table 2.1 Comparison between candidate μ CHP technologies for single dwellings

No.	Characteristic	ICEs	SEs	FCs
1	Market availability	Available [5]	Available	Not commercially yet [14]
2	Noise level	Relatively high [68-69]	Low [12, 69]	The lowest [5]
3	CO ₂ emissions	Low but it depends heavily on age of the engine [68]	Low [5, 70]	Low [5, 71]
4	Other pollutants	High [68]	Low [70]	The lowest [72]
5	Overall efficiency	85-90% [43, 73]	70–90% [74]	85-90% [5]
6	H:P ratio	3:1 [3]	12:1[1]	About 1 [75]
7	Investment cost	Low [5]	High [3]	Relatively high but it is expected to be reduced [74]
8	Maintenance requirements	Frequent [69]	Low [3, 13]	The lowest [5]
9	Life time	Long [5]	Long [5]	Relatively short [76]
10	Fuel type	Natural gas [3]	Natural gas or renewable fuels [69-70]	Hydrogen or natural gas [5, 70]
11	Electrical efficiency at partial load	Very low [3]	Good [5]	Very good [77]
12	Load following capability	Good [77]	Good [70]	Rapid [77]
13	Start-up capability	Rapid [5]	Rapid [70, 77]	Relatively low [70]

2.4.1 Internal combustion engines

The internal combustion engine (ICE) is a well-known technology that has been applied in many fields such as automobiles and small and medium power generation. In an ICE, the combustion of fuel happens inside cylinders, generating

high pressure, which in turn pushes a piston down resulting in mechanical work that is used for generating electricity via a generator, and heat energy is gained as a by-product of this process. They are suitable for medium and large applications such as schools, hotels, hospitals and industrial buildings [78]. This technology has been recently down-scaled, with the same principle, to be used in residential applications [3]. For this type of application, the engine is usually operated by natural gas to benefit from the infrastructure that already exists in most developed countries. ICEs used as μ CHP units vary in size from 1-4 kW of output electricity. Characteristics of this technology are summarised in table 2.1.

2.4.2 Stirling engines

The Stirling engine (SE) is a reciprocating engine but it differs from the ICE in the location where the combustion process occurs outside the cylinder. The internal piston of a SE moves up and down inside the cylinder due to compression/expansion of the working gas, which can be helium, hydrogen or nitrogen [69-70]. SE based μ CHP can be divided into two types: crank-driven and free piston; the second one can produce AC electricity directly which is compatible with the LV/DN/ μ G [79]. SE based μ CHP has a very large heat to power ratio of approximately 12:1 [1]; its electric efficiency varies between 7-15% [77] or 10% and 33% and its total efficiency varies between 70–90% [74]. Characteristics of this technology are summarised in Table 2.1.

2.4.3 Fuel Cells

The fuel cell (FC) is based, in its operation, on a chemical reaction, in the presence of an electrolyte, between oxygen and hydrogen to produce electricity, and as a result heat and water will be by-products [69-70, 80-82]. The hydrogen can be produced from hydrocarbon fuels such as natural gas [60, 82] or from renewable sources such as wind farms [83]. Although many types of FCs do exist, SOFC and PEMFC are the dominant types used for μ CHP systems [71, 81, 84]. PEMFCs can be considered the preferred technology since it has a low operating temperature of 90 °C, which makes using any material possible such as using the electrolyte from a plastic foil [74, 81]. Moreover, the cost of this technology is expected to be reduced significantly due to development of automotive applications; especially the complicated and expensive reformer technology. PEMFC has electric efficiencies ranging from 35–40% and a total efficiency in the region of 90%. Characteristics of FC technology are summarised in table 2.1.

2.5 Auxiliary components of μ CHP systems

A μ CHP unit should be integrated with other components to improve its performance in terms of energy savings and reduction of CO₂ emissions, and it should also be connected to a LV/DN/ μ G enabling it to export/import electricity whenever it is required [35]. The main components that might be integrated with a μ CHP unit are a thermal storage device, a backup heater and an electrical storage device, where each of them has a particular role in improving the performance of the μ CHP system and overcoming a certain problem. Figure 1.1 shown earlier

presents a conceptual arrangement of a residential μ CHP unit integrated with all possible auxiliary components within a LVDN/ μ G.

2.5.1 Thermal storage device

Adding an appropriately sized thermal storage device to a μ CHP system allows the μ CHP unit to operate continuously, so switching on/off and ramping up/down at partial load will no longer be required. Furthermore, operational time of the μ CHP unit will be extended resulting in more energy savings and larger CO₂ reductions [85]. For instance, it has been proved by demonstrating a natural gas fuelled SE based μ CHP system integrated with a thermal storage device that this system is able to meet all the heat demand, a considerable amount of the electrical demand, and exporting electricity in a few periods [10]. The size of thermal storage device is an important to be considered during the design stage of a μ CHP system since it affects the economics. Although a larger thermal storage device makes the storage process more flexible, it has higher heat loss and as a result it is less cost effective. On the other hand, a smaller thermal storage device makes the storage process less flexible but it has less heat loss and as a result it is more cost effective [86].

2.5.2 Backup heater

Adding an appropriately sized backup heater is useful because it can fulfil peak demands as well as low level demand that cannot be met by the μ CHP unit, since each μ CHP unit has an upper operating limit and a lower operating limit that the unit cannot work efficiently beyond [87]. As a result, heat dump can be avoided because there is no need to design the system according to the peak heat demand.

Moreover, many feasible operating strategies, such as HLOS and ELOS can be applied with the presence of a backup heater. This is due to such integrated systems allowing electricity production to be partially de-coupled in time phase from the thermal demand of individual dwellings, thus providing flexibility in choosing an operating strategy [88].

2.5.3 Electrical storage device

The effective usage of an electrical storage device can increase the usefulness of a μ CHP system since fluctuating electrical loads can be mostly satisfied, and consequently less effect on the LVDN/ μ G [89]. In addition, assuming an ideal response from the LVDN/ μ G may no longer be applicable if LVDN/ μ G becomes congested due to the proliferation of micro-generation technologies. This is due to the fact that both timing and firmness of μ CHP generation will be the essential factors governing the response of the LVDN/ μ G [17]. Therefore, an optimum capacity of an electrical storage device is valuable because it has a high impact on the import/export of energy to and from the LVDN/ μ G. For example, integrating an optimal electrical storage device in a μ CHP system can decrease exporting electricity significantly to 90% or even more [89]. As a result, reducing exporting electricity to the LVDN/ μ G has two advantages: electricity will not be sold cheaply and fluctuation of exported power generation will be avoided. Lead-acid batteries are considered good electrical storage device in μ CHP system, since it has the ability to capture the generated electricity [90]. However, the use of electrical storage device has been excluded from the investigated system because of its high capital cost and because the investigated μ CHP system is grid connected.

2.6 Sizing of μ CHP systems

2.6.1 Aim of sizing

The aim of sizing is to design a system where the main parameters such as the size (electrical rating) of the μ CHP unit and the size (thermal rating) of the backup heater are optimally defined. In addition, the optimum operation strategy can also be considered at this stage resulting in more realistic results because this gives an indication of what size μ CHP unit is the most appropriate for certain electricity and heat demand profiles and energy tariff combinations, rather than estimating the size independently [91].

2.6.2 Sizing techniques

There are several techniques that can be used for sizing energy systems such as: the maximum 'rectangle method' (MR) [85, 92], linear programming (LP) [93-94], non-linear programming (NLP) [95], mixed-integer non-linear programming (MINLP) [96], fuzzy logic (FL) [97], and genetic algorithms (GA) [14].

LP techniques are widely used in decision making, especially in economic studies. This technique is principally concerned with the determination of the best allocation of limited resources either by maximizing the profits or minimizing the total costs. LP optimization has the advantage of rapid calculation even with large problems. In contrast, NLP optimization tends to restrict the size of the optimization problem. In NLP, as the number of variables becomes large, solving the problem becomes time consuming [98-99]. LP has been used in optimization of energy systems with different purposes and applications. It has been recently used

for high level system design and unit commitment of a micro grid (μ G) [91]. It was also used in the scheduling of district energy systems including CHP for determining optimal operating costs [100]. Sundberg and Henning [101] have applied this technique for studying the effect of fuel price on cost minimized operation of CHP plants. [93-94] used LP to optimize the CHP system for industrial sites. It has also been used for evaluating the influence of uncertainties in energy demand on the optimal size of a FC based CHP system [102]. In μ CHP technology, a decision is needed to optimally size the equipment for a certain application. LP techniques are capable of solving such a problem and guide the user to select the most beneficial μ CHP size. Although LP technique is less accurate compared to NLP it is simpler and faster than NLP and it can also give reliable results.

The NLP technique has also been used in the optimization of energy systems. It has been used for finding the optimal size of CHP plants in consideration of operational strategy [95]. A MINLP technique has also been used for minimizing the annual cost of a given μ CHP system. However, the model focussed on an ICE based μ CHP system only [103].

2.6.3 Sizing of residential μ CHP systems

A generic LP model of the residential μ CHP system, which considers simultaneously the operation of a backup heater and its operation strategy, has not been previously developed. In addition, the influence of some emerging energy policies, such as the feed-in tariff, has not been considered to date. Furthermore, a

more accurate and detailed representation of heat and electricity demands should be considered. For example, a representative week of heat and electricity demands for each month could be used instead of using a representative day per season as is common in the literature. This results in a higher resolution representation of demand data, since it takes into consideration the variation between the days of the week, especially the difference between working days and the weekend. As a result, developing a generic deterministic LP model for sizing a μ CHP system would be useful.

2.7 Operation strategies for μ CHP systems

An operation strategy can be defined in general as a strategy for activating, deactivating or turning down a unit of the μ CHP system [11]. In other terms, an operation strategy is the way of operating the μ CHP system and controlling the flow of thermal and electrical energy within and to/from the system. The purpose of controlling the μ CHP system through an operation strategy is to achieve specific beneficial targets of the householder, the supplier or the LVDN/ μ G such as reducing the operation costs [17]. Consequently, an operation strategy aims to answer the following questions taking into consideration achieving certain goals:

- When should the μ CHP unit be activated/deactivated/ turned down/ ramped up or ramped down?
- When should the thermal storage device be charged/discharged and at what rate?
- When should the backup heater be switched on/off?

- When should the electrical storage device be charged/discharged and at what rate?
- When should electricity be exported/imported and how much? [35]

These questions are difficult to answer since controlling the system is complex due to: different μ CHP units and different sizes for each type with different thermal and electrical outputs; energy losses from both electrical and thermal storage devices to be considered; seasonal and in-seasonal variation in thermal and electrical demands according to climate, occupants and type of building; variation in prices of, gas, imported and exported electricity; the availability of the LVDN/ μ G to export and import electricity at any particular time; technical constraints of operating the μ CHP unit and other components of the system such as ramp-up and ramp-down rates [35].

Operation strategies of hybrid/multiple energy sources can be divided in general into two main categories: conventional operation strategies and non-conventional operation strategies.

2.7.1 Conventional operation strategies

Conventional operation strategies of energy systems are relatively simple straightforward strategies and can easily be implemented and controlled through a conventional control technique. Conventional control techniques or proportional integral derivative (PID) control techniques are widely used in industrial applications since it is simple and robust [104]. For instance, a typical paper mill could have approximately 200 PID controllers [105]. PID control is simply based

on measuring the actual signal and comparing it to a reference signal; and according to the difference between them control actions are taken. There are several conventional operation strategies used and described in existing literature [35]. However, HLOS and ELOS are the only two operating strategies applied for μ CHP systems available in the market.

A. *Heat led operation strategy*

Heat led operation strategy (HLOS) is based on meeting thermal demand by operating the μ CHP unit and then meeting any deficiency with a backup heater [106-107]. Technical constraints should be considered during operation of the system. For instance, the output power of the μ CHP unit is constrained by the unit's ability for modulation to meet low heat demands [75]. This operation strategy is the most prominent for operating the μ CHP units available in the market, especially SEs because it has a high heat to power ratio [14]. However, when a HLOS is used, a substantial amount of electricity will be exported during periods of high heat demand and low electrical demand [108]. As a result, it cannot be guaranteed that the cumulative amount of exporting electricity be absorbed by the grid once the mass deployment of μ CHP units are controlled according to this strategy.

B. *Electricity led operation strategy*

Electricity led operation strategy (ELOS) is based on operating the μ CHP unit, within the operating limits, to meet the maximum possible amount of the electrical demand while any deficiency can be imported from the LVDN/ μ G [87]. The same strategy may also be implemented to meet the needs of the electricity supplier [11]

by operating the μ CHP unit via a smart meter for certain periods. The system in this strategy should be integrated with a thermal storage device to store heat when there is no thermal demand or when thermal demand is less than the produced heat. In addition, it should also be integrated with a backup heater to compensate any deficiency in meeting the thermal demand [106].

2.7.2 Non-conventional operation strategies

Non-conventional operational strategies are the strategies which their main aim is to search for the optimal or near-optimal working condition of the system at each time step [109]. Non-conventional Operation strategies used for hybrid/multiple energy systems can be classified into two main categories: optimization-based and rules-based operation strategies [110].

A. Optimisation-based operation strategies

Operation strategies based on optimization techniques are performed over a fixed demand profile and hence a global optimal solution can be determined [111]. These operation strategies are based on searching, according to a certain objective function, for optimal parameters that lead to optimal performance of a system such as LP, NLP and dynamic programming (DP). DP is one of the most popular and effective methods in an offline operation strategy when the entire profile is known a priori [112-113], since it is a time consuming technique [114]. LP, which will be used in chapter 5, is relatively faster and less time consuming. Furthermore, LP is based on linearization of relationships, which simplify the complicated mathematical relationships. As a result, it can be said that LP technique has several

advantages to be applied in the field of online operation of μ CHP systems as will be described later in chapter 5.

B. Rules-based operation strategies

Rules-based operation strategies are those operation strategies which generally use artificial intelligent techniques. In order to improve operation strategies it is essential that several parameters of the systems should be taken into consideration during operation instead of priori decisions.

It is viewed as a complicated task to design such a model for operation of μ CHP systems, especially for single dwellings, by means of conventional techniques due to: non linear behaviour of the system, multiple objectives, uncertainties and multiple inputs. Firstly, the system comprises non-linearity such as the values of electrical efficiency and heat to power ratio under partial load. Secondly, the operation of such a system is based on uncertain variables such as conflicting heat and electrical demands. For example, at early morning in winter, there is a high demand for heat while there is little demand for electricity. Conversely, in summer heat demand could be negligible in some periods compared to electricity demand. Thirdly, the operation strategy of such a system would take decisions of operation according to multiple measured inputs such as heat and electricity demands and amount of stored heat in the thermal storage device. Furthermore, a μ CHP system consists of subsystems such as thermal storage device and backup-heater, which are highly interconnected. As a result, operation of the μ CHP systems requires an intelligent technique to deal with such complexities inherent in these systems [35].

AI techniques can be considered as useful alternatives to conventional techniques since they can solve complicated practical problems in various areas. They offer some advantages over the conventional PID controller [115-116]. AI techniques have the ability to: learn from examples, handle noisy and incomplete data, and manipulate non-linear problems [117]. In addition, these techniques can be trained, and once they are trained can further perform prediction and generalization at high speed [118]. This feature is of significant importance since it enables the operation strategy of μ CHP system to learn particular consumption patterns of a specific house. AI techniques have been developed and deployed in many applications such as engineering, economics, medicine, military, and marine because of their symbolic reasoning, flexibility and explanation capabilities [117]. They have also been applied in control of complex systems, modelling, identification, signal processing, optimization, prediction and forecasting [118].

AI systems comprise areas such as artificial neural networks (ANNs), fuzzy logic (FL), multi agent system (MAS) and various hybrid systems, which combine two or more techniques together.

I. Fuzzy logic technique

Fuzzy logic (FL) technique has gained considerable popularity in recent years [119]. This approach leads to a fuzzy system which is more likely a decision system (supervisor) based on fuzzy rules than a fuzzy controller [120]. Fuzzy rule-based strategies cannot assure the global optimal performance of a system like the optimization-based solution but it is capable of effectively providing a near optimal performance of a system. FL provides a significantly simple way to draw specific

conclusions from unclear, ambiguous or imprecise information. FL depends on a different way of thinking, which is based on modelling complex systems using a higher level of abstraction originating just from our knowledge and experience while classical logic entails exact equations and precise numeric values.

The idea of FL is based on relating the output variable/variables to input variables according to 'IF.THEN' statements, called rules. Unlike Boolean logic, which describes that a given input is either a member of a given set (logic 1) or not (logic 0), FL solves problems that tend to change anywhere in the range of 0-1 [121]. Therefore, the FL offers smooth relocation of the output signal instead of sharp switching when one rule dominates the other. As a result, FL is quite suitable to the systems composed of nonlinear behaviours where an overall mathematical model is difficult to obtain since the rules can be designed based on heuristics, intuition and human expertise [122].

FL is also very effective in the application of real-time operation strategies of power flow in a hybrid or multiple energy system [123], which is the case for the μ CHP system since it consists of more than one energy source. Moreover, there is no need for historical data of heat and electricity demands, which is an important advantage over other types of intelligent techniques such as neural networks ANNs and GAs and over the mathematical techniques such as LP. Finally, fuzzy rule-based operation strategy has a quite suitable structure for use in experimental studies due to its merit of fast decision capability and it can be easily embedded in an online control unit such as a microprocessor, etc [124]. On the other hand, a FL

system usually relies on domain experts to provide the necessary knowledge for a specific problem [125].

II. Artificial neural networks (ANNs) technique

ANNs have been significantly used during the last two decades [114, 126] to tackle tasks involving incomplete-data sets, fuzzy or incomplete information, and for highly complex and ill-defined problems, where humans usually decide on an intuitional basis [127]. They offer advantages such as the ability to learn from examples [128] and the ability to manipulate non-linear problems [129-130], which is the case for μ CHP system. This enables it to learn the behaviour of the μ CHP system in response to a particular demand pattern. In addition, they exhibit robustness and fault-tolerance. On the other hand, ANNs cannot deal effectively with tasks that require high accuracy and precision, as in logic and arithmetic [118]. ANNs have been applied successfully to a number of applications: classification such as pattern recognition and sound and speech recognition; forecasting such as weather and market trends; predicting mineral-exploration sites; electrical and thermal load predictions [16]; control systems such as adaptive control and robotic control [131]; and optimisation and decision making as in the case of engineering systems and management [132]. ANNs are also based in their performance on black-boxes, without clear explanations [125].

III. Multi agent system (MAS) technique

MAS offer four main attributes: autonomy, social ability, reactivity and pro-activity [129]. Autonomy is the ability to be self-starting and control over their

actions and internal state, whilst social ability is the ability to communicate with other agents such as negotiation with each other or with users to achieve targets. Reactivity is the capability to interact with the environment and respond at the right time to any changes that occur, while pro-activity is the ability to exhibit goal-directed behaviour by taking the initiative. In addition, MAS are flexible, modular and they allow model components to be easily reused [133]. All these features give MAS controllers the ability to be implemented as a plug and play system, which can then be implemented for any additional subsystem. A MAS controller is also scalable, which means that it can be applied to different size systems without a significant change.

MAS control, which is goal-driven, is more suitable for operating and controlling electricity infrastructure systems than the conventional control technique since it makes performance more flexible, robust, and configurable [134]. Furthermore, MAS techniques can be applied to any domain in which physical process is controlled by discrete decisions. Moreover, MAS can be used as a framework for a control system that can employ an appropriate AI technique. A MAS technique has been widely investigated, in the field of operation and control of μ G and distributed generations [129-130, 135-137].

IV. *Hybrid system technique*

A hybrid system uses more than one AI technique or to use one AI technique and one optimisation technique in order to perform a particular task. There are many types of hybrid systems such as neural-fuzzy control system, genetic algorithms (GAs) and FL system or ANNs and GAs [118]. Such a system is sometimes a part

of an integrated system or an independent system intended to perform specific tasks within the main system. The most prominent hybrid system used in control engineering is the neural-fuzzy control system, which integrates both ANNs and FL in a single control system to perform a certain task because the techniques offer complementary features [138].

2.8 Conclusion

Optimisation and operation of μ CHP technologies (such as ICEs, SEs and FCs) into residential energy systems face significant challenges due to the need to simultaneously satisfy two independently variable demand profiles, namely thermal and electrical. Therefore, selection of appropriate μ CHP technologies is a key factor in the pursuit of efficient residential energy provision. A review of literature has established thirteen characteristics that should inform the selection of μ CHP technologies: market availability; noise level, CO₂ emissions; other pollutants; heat to power ratio; overall efficiency; investment cost; maintenance requirements; life time; fuel type; electrical efficiency at partial load; load following capability and start-up capability.

Developing a generic sizing model of the residential μ CHP system, which considers simultaneously the operation of a backup heater and its operation strategy, would be useful and could be used for further investigation regarding key parameters such as capital cost and energy prices. In addition, the influence of some emerging energy policies on the optimal sizing should be investigated.

Furthermore, the effect of the detailed representation of heat and electricity demands can also be investigated.

Regardless of which μ CHP technology is selected for use within a residential energy system, a number of operation strategies may be considered, especially HLOS and ELOS. Furthermore, different techniques that can be applied for non-conventional operation strategies of hybrid/multiple energy systems have been investigated, which includes optimisation-based techniques and rules-base techniques.

The use of existing and emerging μ CHP technologies along with thermal and electrical storage devices, coupled with contemporary operation strategies and techniques, hold considerable promise for residential applications. More specifically, the effective operation of μ CHP systems could offer potential savings in operation costs and CO₂ emissions, especially when the use of renewable fuels becomes commonplace. As a result, an online operation strategy, which minimises operation costs and CO₂ emissions, is required to be developed.

3 TIME DOMAIN MODELLING OF μ CHP SYSTEMS:

3.1 Introduction

In order to develop and test the online and real time operation strategies a time domain model to simulate the performance of a μ CHP system is required. There are four candidate technologies that can be used as a μ CHP unit for a single dwelling: SE, ICE, SOFC and PEMFC. A PEMFC has been chosen as an example in this research for several reasons as it is explained in the next section. However, the time domain modelling of the μ CHP system has been generalised in order to be easily adopted for other μ CHP technologies.

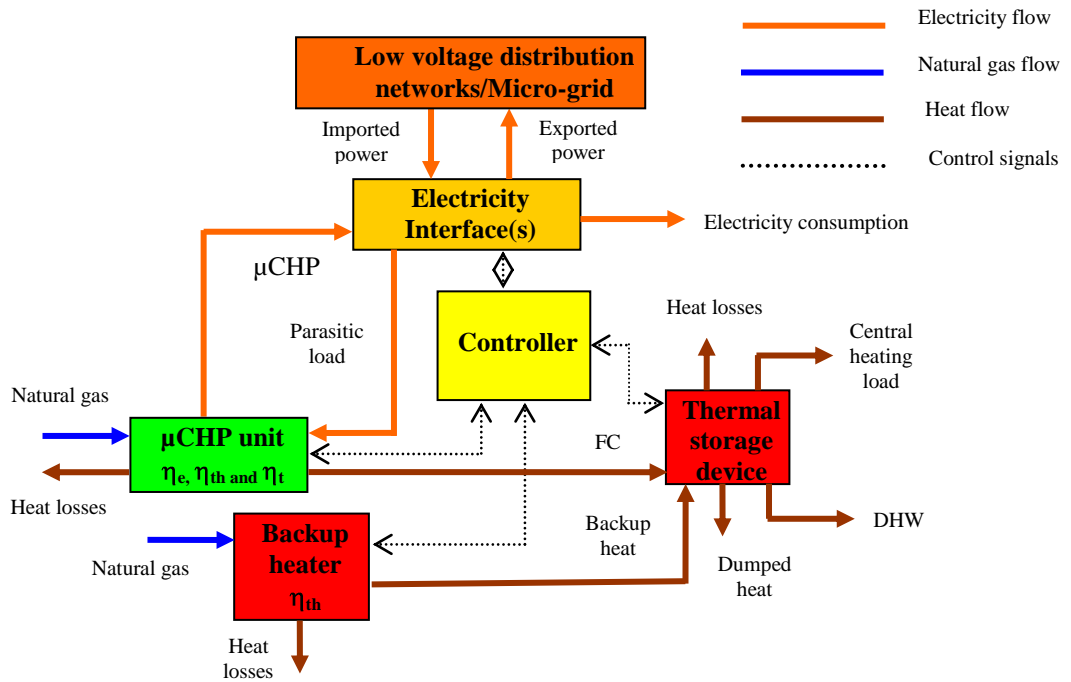

Figure 3.1 A conceptual arrangement of residential μ CHP system

The remainder of this chapter is organised as follows. Section 3.2 describes the reasons for choosing PEMFC as a μ CHP unit. Section 3.3 gives detailed

information about the time domain modelling of the μ CHP system. In section 3.4, conclusions have been drawn.

3.2 Reasons for Choosing a PEMFC based μ CHP unit:

There are several types of FCs but they can be generally classified into groups according to electrolyte, operational temperature or source of hydrogen [69]. Although several types of FCs exist, a SOFC and a PEMFC are the dominant types being considered for μ CHP systems [3, 48, 71, 81, 84, 139].

Fuel cells in general have three main disadvantages: a high capital cost [5, 70, 76, 81]; a relatively short life time [5, 76, 81]; and a long start-up time [70, 77], especially those with high operation temperatures such as SOFC [77]. These disadvantages can be eliminated once the technology is widely spread. For example, the US Department of Energy estimates the current price of the stationary fuel cell to be approximately \$2000/kW. However, the US Department of Energy indicates a target price of \$750/kW, which would make this technology relatively competitive to other μ CHP technologies [140].

Although FCs technology is an expensive technology in terms of capital cost compared to SEs and ICEs, they offer several advantages making them a promising technology to be utilised as a μ CHP unit, especially for single house application.

These advantages can be summarised as follows:

1. It has the lowest level of noise among all candidate technologies such as ICEs and SEs. [5, 70].

2. It has low CO₂ emissions [5].
3. It has low emissions of other pollutants such as NO_x, CO, SO₂ compared to other technologies, especially compared to ICEs which have the highest level of these pollutants.
4. It has a high overall efficiency even on small-scale basis, which is about 85-90% [5, 71].
5. It has the lowest H:P ratio (i.e. high electrical efficiency), which makes it the best technology to be operated in summer periods and when heat saving measures (improving energy efficiency and climate change) are applied [48].
6. It requires low maintenance because it has fewer moving parts compared to others [5], which means higher reliability and availability [5, 70].
7. It can be operated by different types of fuel such as hydrogen and natural gas.
8. It has a rapid adaptability to change in load while keeping a very high performance at partial load [5, 70, 77].
9. It is the only technology in which reduction in CO₂ emissions always coincides with minimum operation cost [8].

Research papers [74, 115, 141-143] claim that PEMFCs can be considered the most preferred FC technology for single dwellings since they offer several advantages as follows:

1. It leads other types of FCs in terms of market commercialization [116], and the cost of this technology is expected to be reduced

significantly due to development of automotive applications; especially the reformer which is very complicated and expensive [74].

2. It has longer cell life since it has less corrosion because its electrolyte is solid and has no corrosive liquids except water [116].
3. It has the lowest heat to power ratio, which makes it the best to be operated in summer periods and when heat saving measures (improving energy efficiency and climate change) are applied [7].
4. It has a relatively high electrical efficiency at a wide operating range [144].
5. It has faster response to power demand fluctuations [116].
6. Its start-up time is noticeably less compared to other types of FCs because its low operating temperature can be reached quicker than any other types of FCs [115-116, 145].
7. The water rejected is in the form of liquid sufficiently hot to be used as hot water directly or for space heating [116, 145].

There is also another type of PEMFCs called a high temperature proton exchange membrane (HTPEM) (or intermediate temperature PEM), operates at a slightly higher temperature (120–200 °C) than the conventional low-temperature PEMFC, and hence, its efficiency increases significantly [71]. However, this technology is still in an early stage of development.

On the other hand, PEMFC technology has three main disadvantages as follows [116]. The Platinum Pt catalyst used is costly; it represents close to 300 \$/kW for the precious metal alone [146]. Moreover, the input air should be devoid of carbon

monoxide CO since, CO binds to Pt and minimises the hydrogen chemisorption [116]. In addition, in order to increase the overall efficiency of the PEMFC, it is very important that care should be taken to manage water inside it [116, 147]. In FC, water is produced as a by-product and because of the low PEMFC operating temperature this water exists mainly as a liquid. The proton conductivity of the membrane is highly dependent on the water content of the membrane, so water production and removal must be balanced by the cell to insure that the polymer electrolyte membrane is highly saturated without flooding the electrodes, since if there is a deficiency of water in the flow channels, the membrane can be potentially dried out causing conductivity and efficiency reduction, and if channels are flooded with water, gas flow will be impeded and efficiency will drop [148].

SOFC has a relatively high operating temperature of about 800 °C, so an expensive material such as ceramic is required for its electrolyte [74]. SOFC has a slightly better electric efficiency than PEMFC, but starting-up and cooling phases are longer than those for PEMFC affecting maintenance, installation time and costs [74].

3.3 Time domain modelling of μ CHP system:

The proposed μ CHP system, which has been previously illustrated in figure 3.1 consists: of a μ CHP unit (PEMFC in this case), an electrical storage device, a thermal storage device, and a backup heater, a sink and electricity interface(s) system, which are electronic devices for inverting DC into AC. The system is also

integrated within a LVDN/ μ G in order to export/import electricity when it is required.

The general operation strategy employed for this system is based on compromising between the occupant comfort criteria whilst satisfying technological constraints of the devices. It is also based on mediating between optimisation of operation costs while meeting the householder needs. Furthermore, the general operation strategy considers the interconnection between the sub-models in order to allow the exploitation of all the different resources such as the thermal storage device. The operation strategies used for operating the PEMFC are a HLOS or an ELOS; these strategies have been previously explained in chapter 2. Once the FC is being operated according to a particular strategy, the system will follow the following rules:

1. The AC power from the μ CHP unit (PEMFC) is first used to meet the electricity demand of the house.
2. If an excess power is available after meeting the electricity demand, this power is exported to the LVDN/ μ G. On the other hand, if there is a deficit in power and the PEMFC can not meet the residential electricity demand, then the demand is met by importing power from the LVDN/ μ G.
3. The heat energy from the μ CHP unit (PEMFC) is first used to meet the residential thermal demand by passing it through the thermal storage device.
4. If an excess heat is available after meeting the thermal demand of the house, this heat energy will be stored in the thermal storage device. However, the maximum & minimum temperatures of the water inside the

thermal storage device are considered.

5. If the heat produced by the μ CHP unit (PEMFC) cannot meet the residential thermal demand, then the stored heat is used to meet the rest of this demand. However, the temperature limits are considered.
6. If there is an excess heat and the thermal storage device can not absorb it, the extra heat is dumped through the sink. On the other hand, if there is a deficit in heat and the thermal storage device can not meet the demand, then the thermal demand is met by operating the backup heater.

Different programming softwares can be used to model the μ CHP system such as FORTRAN and C⁺⁺. However, Matlab/Simulink has been chosen because it is very powerful software and is integrated with several toolboxes such as optimisation and FL toolboxes, which will be used over the next chapters.

The simulation uses time-series input data of electricity and thermal demand profiles. In order to simplify modelling, the μ CHP system has been divided into five sub-models as it appears in figure 3.2. These sub-models are:

1. μ CHP model: This model simulates the behaviour of the μ CHP unit, which in this case is a PEMFC. The function of this model is to estimate the amount of thermal power, electrical power and natural gas flow rate of the PEMFC at any time according to the signal received from the operation strategy model.
2. Operation strategy model: The function of this model is to decide how much power or heat should the PEMFC produce at any time depending on the type of operation strategy. The operation strategy can be either a HLOS

or ELOS. Notice that the operation strategy shown in figure 3.2 is an ELOS.

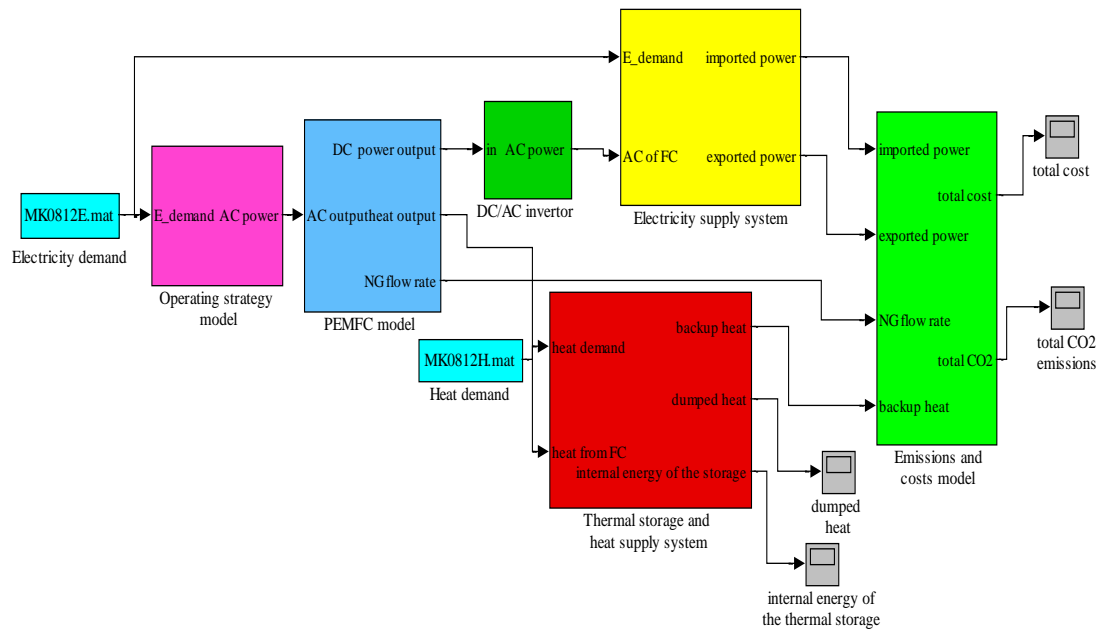

Figure 3.2 Simulink time domain model of the residential μ CHP system

3. Electricity supply system model: This model simulates the interaction between the μ CHP unit and the LVDN/ μ G through the electricity interface(s). In this model, all the calculations of electricity flow, such as exporting and importing of electricity, are executed as explained below. It should be noted that the inverter is a part of this system although it appears separate in figure 3.2 in order to clarify its function.
4. Thermal storage device and heat supply system model: This model simulates the performance of the thermal storage device, the backup heater and the sink. In this model, all calculations of heat flow are estimated.

5. Emission and costs model: This model estimates the CO₂ emissions that the system produces for any period of time and also estimates the operation costs of the whole system for any period of time.

3.3.1 μ CHP model:

This model simulates the performance of the μ CHP unit (PEMFC in this case). It is a sub-model of the whole system as shown in figure 3.2. Parametric relationships between electrical efficiency and heat to power ratio of the PEMFC as functions in the DC output of the PEMFC have been applied in this model. These relationships, which are based on empirical data, are illustrated in figure 3.3 [141-142, 149-150]. This data was manipulated and converted into the appropriate units based on the equations below; and it has been implemented in Simulink to represent the empirical model of PEMFC [14, 151].

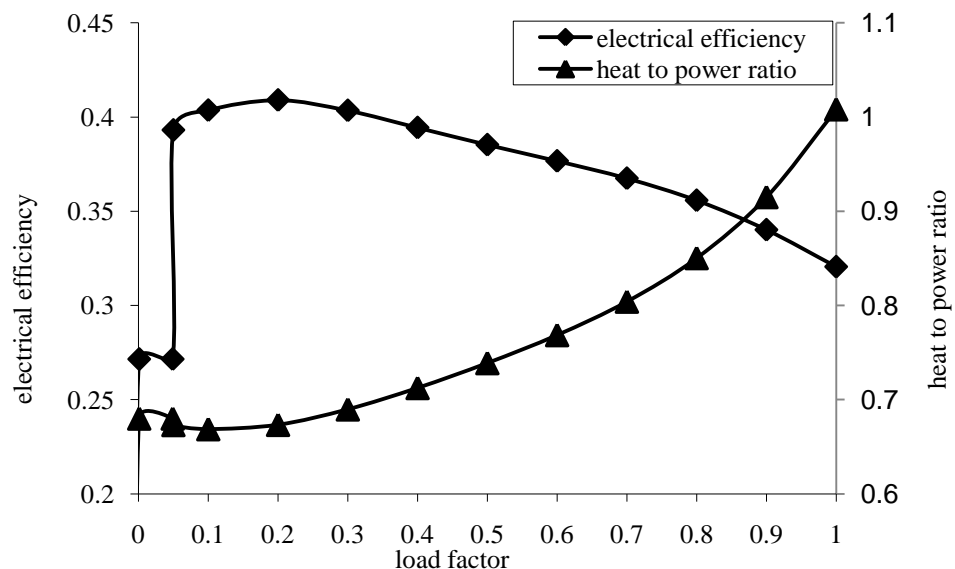

Figure 3.3 electrical efficiency and H:P ratio of PEM FC against load factor [142].

The model estimates the performance of the μ CHP unit (PEMFC) under partial loads. This model estimates the values of the electrical efficiency, the thermal efficiency and gas consumption at any level of operation. For instance, figure 3.4 illustrates the change of DC power and thermal power generated by the PEMFC against the change of the natural gas flow rate for a 1kWe AC PEMFC. A similar model for a 2kWe PEMFC unit has been developed. It is assumed that the minimum limit of generating power (P^{\min}) is zero and the maximum limit of generating power (P^{\max}) equals the maximum rating power for each size. The model can estimate all the following variables at any time:

1. DC power produced by the FC at any time (P_{DC}) can be estimated once the AC power required from FC (P_{AC}) is known using the following equation:

$$P_{DC} = \frac{P_{AC}}{\varepsilon_I} \quad (3.1)$$

Where ε_I is the efficiency of DC/AC inverter A ($0 < \varepsilon_I < 1$) and is estimated by a lookup table since it varies with change in load factor (LF) defined below.

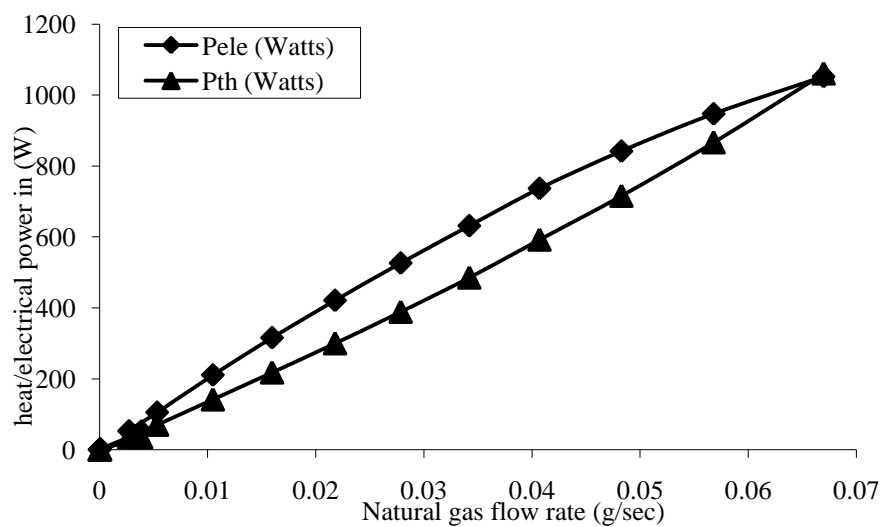

Figure 3.4 Heat and electrical power produced against fuel flow rate of 1kWe PEMFC

2. Load factor, which is the ratio of the DC power produced by the PEMFC at any time (P_{DC}) to the maximum power that the PEMFC can produce (P^{max}), can be calculated from this equation:

$$LF = \frac{P_{DC}}{P^{max}} \quad (3.2)$$

3. Electrical efficiency of the Fuel cell ($\eta_{e,FC}$) is estimated based on the value of load factor according the relationship shown in figure 3.3.
4. The mass flow rate of natural gas to the PEMFC at any time ($\dot{m}_{g,FC}$) in g/sec is calculated by the following equation:

$$\dot{m}_{g,FC} = \frac{P_{DC}}{\eta_{e,FC} \times LHV} \times 1000 \quad (3.3)$$

Where: LHV is the lower heating value of natural gas in J/kg.

6. Thermal power produced by the PEMFC (\dot{Q}_{FC}) at any time can be estimated through a lookup table. This relationship for a 1 kWe PEMFC unit is illustrated, as an example, in figure 3.4.
7. Thermal efficiency of the FC ($\eta_{th,FC}$) is the ratio of the thermal power produced by FC (\dot{Q}_{FC}) to the input power of the natural gas, and can be estimated as follow:

$$\eta_{th,FC} = \frac{\dot{Q}_{FC}}{\dot{m}_{g,FC} \times LHV} \times 1000 \quad (3.4)$$

8. Total efficiency of the FC ($\eta_{t,FC}$) is the ratio of total utilized power, which is the sum of thermal power (\dot{Q}_{FC}) and electrical DC power (P_{DC}) generated by FC, to the input power of the natural gas, and can be estimated as follow:

$$\eta_{t,FC} = \frac{P_{DC} + \dot{Q}_{FC}}{\dot{m}_{g,FC} \times LHV} \times 1000 \quad (3.5)$$

3.3.2 Operation strategy model:

According to the chosen operation strategy, either a HLOS or an ELOS, this model controls the output of the μ CHP unit (PEMFC) to the allowable levels. If the system is driven according to the HLOS, the input to this model will be the thermal demand profile, so the model reads the thermal demand (\dot{Q}_D) from the heat demand file, which is the sum of the thermal demand for central heating and the thermal demand of DHW. Then the model compares this demand to the maximum heat that the PEMFC can produce. When the demand (\dot{Q}_D) is less than the maximum thermal capacity of the fuel cell (\dot{Q}^{\max}) the operation strategy model sets the output thermal power of FC (\dot{Q}_{FC}) similar to this demand (i.e. $\dot{Q}_{FC} = \dot{Q}_D$). Otherwise, the operation strategy model sets the output thermal power of the PEMFC to its maximum value (i.e. $\dot{Q}_{FC} = \dot{Q}^{\max}$).

According to the value of the thermal output power at any time (\dot{Q}_{FC}), this sub-model estimates the corresponding value of output DC power (P_{DC}) that must be generated by the PEMFC to enable it producing this value of the thermal power using a lookup table. On the other hand, if the system is driven according to the ELOS, the input to this model will be the electricity demand profile, so the model reads the electricity demand (P_D) from a file. After that the model compares this demand to the maximum allowable AC power that the FC can produce (P^{\max}).

When the demand is less than the maximum allowable AC power of the PEMFC, the electricity operation strategy model sets the output AC power at that level (i.e. $P_{AC}=P_D$). However, when the demand is greater than the maximum allowable AC power of the PEMFC unit, the operation strategy model sets the output AC power to its maximum value (i.e. $P_{AC}=P^{max}$). Next, this sub-model estimates the corresponding value of output DC power that must be generated to meet this value of AC power using a lookup table.

The μ CHP model has also been improved by adding realistic constraints to the ability of the PEMFC unit to ramp up and ramp down. Experimental data has shown that a 1 kWe PEMFC cannot ramp up more than 41.67 Watts of electricity per minute and cannot ramp down more than 50 Watts per minute [152]. So, these values have been included in the model to make it more realistic.

3.3.3 Electricity supply system model:

The electricity supply model shown in figure 3.5 has been adopted [89], since it is relatively simple and satisfies the main purpose of the research, which is the online operation of μ CHP systems. The model simulates the electricity flow to/from the μ CHP system and power losses in the DC/AC inverter. It should be noted that the electrical storage device has been excluded from the system since the system is connected to a μ G.

The efficiency of DC/AC inverter is based on observed data from the Sunny Boy SB2500 as it appears in Figure 3.6 [89]. This efficiency varies according to the ratio between the instantaneous output power of the inverter to its rating. At any

time, the instantaneous power that flows through the inverter will be calculated by the model. It should be noticed that the DC/AC inverter, which is integrated within the PEMFC unit, is usually sized based on the maximum DC power generated by the PEMFC [89].

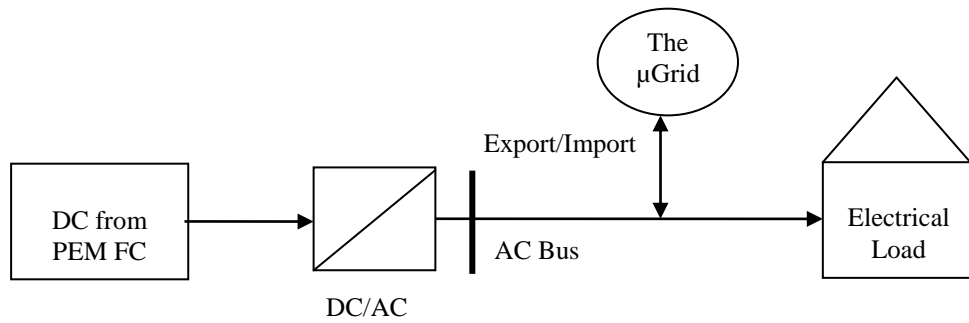

Figure 3.5 Schematic diagram of the electricity supply model

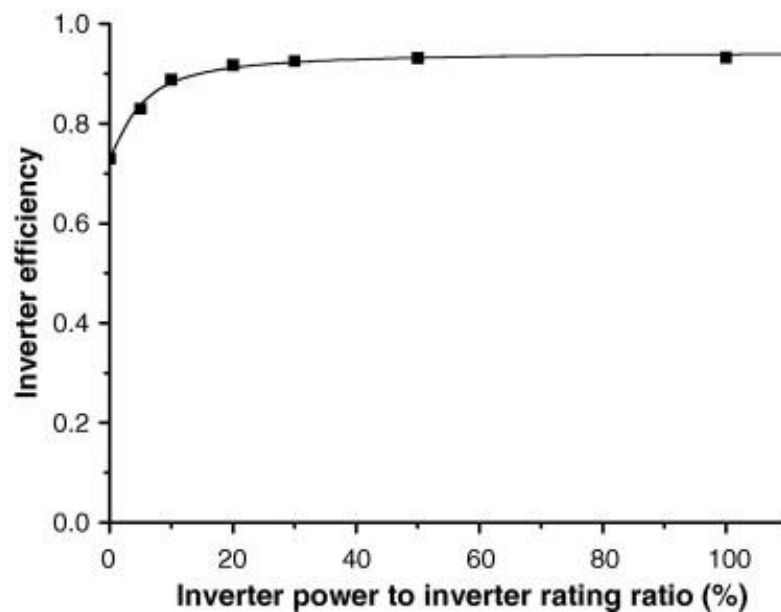

Figure 3.6 Inverter efficiency versus output power (curve fitted to SunnyBoy SB2500) [89].

According to electricity demand of the building and the AC power produced by the μ CHP (PEMFC) on a minute basis, the model can simulate the performance of the system throughout any time period specified by the user.

A. Calculation of AC power at the bus:

DC power generated by the μ CHP (PEMFC) is converted into AC, so the AC power from the PEMFC at the AC bus, P_{AC} , can be calculated as follows:

$$P_{AC} = \varepsilon_I \cdot P_{DC} \quad (3.6)$$

Where:

P_{AC} and P_{DC} are the AC and DC power generated by the μ CHP (PEMFC) in watts. ε_I is the efficiency of the DC/AC inverter and is based on the previous relationship shown in Figure 3.6 [89].

The surplus power (P_+) at any time is the difference between AC power of the PEMFC (P_{AC}) and the electricity demand of the dwelling P_D at the same time:

$$P_+ = P_{AC} - P_D, P_{AC} > P_D \quad (3.7)$$

Where: P_D is the electricity demand of the building at any time.

On the other hand, when the AC power produced by the PEMFC P_{AC} is less than the demand, then a shortfall in power P_- can be calculated as follow:

$$P_- = P_D - P_{AC}, P_D > P_{AC} \quad (3.8)$$

B. Exporting and importing power:

The electricity demand of the dwelling will be firstly met by the AC power available from the μ CHP prime mover (PEMFC). If there is still any shortfall, it will be met by the LVDN/ μ G. It is supposed that the LVDN/ μ G is available at any

time to meet any shortfall and to ensure satisfaction of the householder. The imported power from the LVDN/ μ G at any time P_{import} is determined by:

$$P_{import} = P_D - P_{AC}, \quad (\text{for } P_D > P_{AC}) \quad (3.9)$$

It is already known that $P_{-} = P_D - P_{AC}$, so equation (3.8) will be replaced by:

$$P_{import} = P_{-}. \quad (3.10)$$

Obviously, the imported power from the LVDN/ μ G equals the shortfall power P_{-} ; and if the PEMFC unit can meet the shortfall in power demand, there will be no power required from the LVDN/ μ G.

On the other hand, if there is surplus power P_{+} , the exported power P_{exp} will be determined by:

$$P_{exp} = P_{+} \quad (3.11)$$

3.3.4 Thermal storage and heat supply system model:

The thermal storage and heat supply system model shown in figure 4.2 has been developed based on the idea of [89] and the equations in [153] in order to make it relatively simple and satisfying the main purpose of the research, which is optimisation and online operating of μ CHP units in residential energy systems. The model estimates the amount of backup heat and dumped heat at any time; it also simulates the process of storing heat in the thermal storage device and utilizing it when there is no enough heat generated by the PEMFC. The model is a generic model and can simulate different storage sizes just by changing the volume of the thermal storage device (V_{st}).

A. Components of the thermal storage device and heat supply system

The thermal storage and heat supply system includes the following components:

1. A PEMFC, which produces amount of heat as a by-product during the process of electricity generation as mentioned in the part of PEMFC model.
2. A thermal storage device, which stores any excess heat might the PEMFC produce and supplies heat to meet the thermal demand when the heat delivered by the PEMFC system is insufficient. It is assumed that all the generated heat is passing via the thermal storage device before being transferred to the central heating system or to the domestic hot water system.
3. A backup heater, which is used as a backup heat source, can compensate any heat deficit.
4. A heat sink, which is usually a heat exchanger that can dissipate heat to the atmosphere. It is used when the PEMFC unit produces an amount of heat greater than the total amount of the demand heat plus the heat that can be stored inside the storage device at any time [153].

B. Calculation algorithm:

1. Calculations of internal energy and temperature:

It is assumed that the amount of water in the thermal storage stays constant all the time of the operation. So, the amount of energy stored in the water will simply depend on the temperature of the water inside the thermal storage device and can be expressed as follows [153]:

$$\Delta U_{st} = \rho_{st} V_{st} CP_{st} (T_{st} - T_{min}) \quad (3.12)$$

Where: ΔU_{st} is the difference between the current value of the internal energy of the water inside the thermal storage device at instantaneous temperature T_{st} and the internal energy of the water at the minimum allowable temperature of the water (T_{min}).

The operational range of storage temperatures, dictated by factors such as the boiling temperature of the water in the thermal storage device, is assumed to vary between T_{min} (where the internal energy is $U_{st} = U_{min}=0$) and T_{max} (where the internal energy is $U_{st} = U_{max}$). The values of T_{min} and T_{max} are assumed to be 50 °C and 75 °C, respectively [87]. It is also assumed that the density of water and its specific heat at constant pressure equal 1000kg/m³ and 4.2kJ/kg.K, respectively [153]. Furthermore, it is assumed that the thermal storage device has a volume of 200 liters because PEMFC has got a low H:P ratio of about only one, and most PEMFC units are already integrated with a thermal storage device of such size [69]. Therefore, from equation (4.12), the value of U_{max} can be estimated as follow [153]:

$$U_{max} = \rho_{st} V_{st} CP_{st} (T_{max} - T_{min}) \quad (3.13)$$

From equation (4.13), U_{max} will equal 21000 kJ, and then U_{st} at any time can be estimated by:

$$U_{ts} = U_{ts}(t - \Delta t) + \Delta U \quad (3.14)$$

Where: ΔU is the change of internal energy of the water inside the thermal storage device in kJ during a period of Δt .

When internal energy of the water U_{st} varies between U_{min} and U_{max} , the states of operation of the thermal storage device can be stated as in table 3.1, as will be explained in the next paragraph.

Heat losses from the thermal storage Q_{loss} can be estimated by equation 4.15 as follows:

$$Q_{loss}(t) = K_{st}A_{st} [T_{st}(t-\Delta t) - T_{amb}] \Delta t \quad (3.15)$$

Where:

$Q_{loss}(t)$ = heat losses from the thermal storage device for a period of Δt at the time t .

K_{st} = the specific loss coefficient that takes into account the heat transfer by convection, conduction and radiation from the water inside the thermal storage in $W/m^2.K$.

A_{st} = Heat transfer area of the thermal storage in m^2 .

$T_{st}(t-\Delta t)$ = the temperature of the water in the storage in degrees at time $(t-\Delta t)$.

T_{amb} = the ambient temperature of the surrounding.

Δt = the time step in seconds.

Internal energy of the water inside the thermal storage at any time can be estimated by equation (3.16):

$$U_{st}(t) = \rho_{st} V_{st} CP_{st} (T_{st} - T_{min}) \quad (3.16)$$

Where: U_{st} is the internal energy of the water inside the storage at instantaneous temperature (T_{st}) and T_{min} is the minimum allowable temperature of the water in degrees.

The change of the internal energy of the water inside the storage device in time can be calculated by equation (4.17) as follows:

$$\rho_{st} V_{st} CP_{st} \frac{dT_{st}}{dt} = \frac{dU_{st}}{dt} \quad (3.17)$$

By integration equation (4.17) and substitute with U

$U_{st}=0$ when $T_{st}=T_{min}$ equation (3.18) is obtained as follows:

$$T_{st}(t) = \frac{U_{st}}{\rho_{st} V_{st} CP_{st}} + T_{min} \quad (3.18)$$

Table 3.1 The states of operation of the thermal storage device [153]

State of operation	U_{st}	$\Delta U_{sto} = (U_{max} - U_{min})$	Backup heat	Dumped heat
Using backup heater	U_{min}	zero	>0	zero
Charging the thermal storage device	$U_{min} \leq U_{st} \leq U_{max}$	$0 \leq \Delta U_{sto} \leq \Delta U_{max}$	Zero	zero
Dumping heat by the sink	U_{max}	ΔU_{max}	Zero	>0
Discharging heat from the thermal storage device	$U_{min} \leq U_{st} \leq U_{max}$	$0 \leq \Delta U_{sto} \leq \Delta U_{max}$	Zero	zero

II. Calculation of heat power:

First of all, the model reads the thermal power produced by the PEMFC (\dot{Q}_{FC}) at any time, which is an output from the PEMFC model. Meanwhile the model reads the total thermal power demand (\dot{Q}_D) at the same time from a heat demand profile. After that, the model compares these two values to decide whether to store energy in the thermal storage device or to use the stored one. If there is an excess

thermal power more than the ability of the storage device, it will be dumped. On the other hand, if there is a shortfall in thermal power, this shortfall will be met by the backup heater.

In case of excess heat:

If ($\dot{Q}_{FC} \geq \dot{Q}_D$), the heat power surplus (\dot{Q}_+) will equal [5, 77]:

$$\dot{Q}_+ = \dot{Q}_{FC} - \dot{Q}_D \quad (3.19)$$

The available amount of thermal energy for storing Q_{C_0} in the step time Δt equals:

$$Q_{C_0} = \dot{Q}_+ \times \Delta t \quad (3.20)$$

The model checks the current value of the internal energy of the water inside the thermal storage device U_{st} . If it equals the maximum value of internal energy U_{max} , the excess heat will be dumped through the sink. As a result, dumped heat Q_{Dump} during this time step will be estimated as follows:

$$Q_{Dump} = Q_{C_0} = \dot{Q}_+ \times \Delta t \quad (3.21)$$

On the other hand, if U_{st} does not equal U_{max} (i.e. $U_{max} \geq U_{ts} \geq U_{min}$), then the model compares the value of Q_{C_0} to the maximum allowable energy that the thermal storage device can absorb, which equals $(U_{max} - U_{st})$. If

$Q_{C_0} \geq (U_{max} - U_{ts})$, then:

$$U_+ = (U_{max} - U_{ts}) \text{ and } Q_{Dump} = Q_{C_0} - (U_{max} - U_{ts}) \quad (3.22)$$

Where: U_+ is the increase in the internal energy of the water inside thermal storage device, kJ .

If $Q_{C_0} < (U_{max} - U_{ts})$, then:

$$U_+ = Q_{C_0} \quad \text{and} \quad Q_{Dump} = zero \quad (3.23)$$

In case of deficit heat:

If $\dot{Q}_{FC} \leq \dot{Q}_D$, the deficit heat power (\dot{Q}_-) will equal:

$$\dot{Q}_- = \dot{Q}_D - \dot{Q}_{FC} \quad (3.24)$$

The available amount of thermal energy for discharging from the storage device (Q_{D_0}) in any step time Δt equals:

$$Q_{D_0} = \dot{Q}_- \times \Delta t \quad (3.25)$$

The model compares the current value of the internal energy of the water inside the thermal storage device U_{st} to the minimum value of internal energy U_{min} , as previously illustrated in table 3.1. If ($U_{st} = U_{min}$), it means that no heat is available in the thermal storage device to compensate the deficit. As a result, the thermal energy required by the backup heater Q_B during this time step will be estimated by:

$$Q_B = Q_{D_0} = \dot{Q}_- \times \Delta t \quad (3.26)$$

On the other hand, if U_{st} does not equal U_{min} (i.e. $U_{max} \geq U_{ts} \geq U_{min}$), then the model compare the value of Q_{D_0} to the maximum allowable energy that the thermal storage device can deliver ($U_{st} - U_{min}$). If $Q_{D_0} > (U_{ts} - U_{min})$, then:

$$U_- = (U_{ts} - U_{min}) \quad \text{and} \quad Q_B = Q_{D_0} - (U_{ts} - U_{min}) \quad (3.27)$$

Where: U_- is the decrease in the internal energy of the water inside the thermal storage device in kJ.

If $Q_{D_0} \leq (U_{ts} - U_{min})$, then:

$$U_- = Q_{D_0}, \quad \text{and} \quad Q_B = 0 \quad (3.28)$$

III. Calculation of input heat to the backup heater:

The performance of the backup heater is based on its total efficiency (η_B), which is the ratio of the output heat from the backup heater to the total input energy of the natural gas (based on LHV or HHV) including the input energy consumption of the backup heater and the electrical energy required for the auxiliaries. This efficiency is assumed to be constant during operation and have a value of 85% based on *HHV* of natural gas [153]. It is also assumed that the output thermal energy from the backup heater equals to the thermal shortage at any time, so the input natural gas power at any time ($\dot{\phi}_B$) in kWh can be approximated by:

$$\dot{\phi}_B = \frac{\dot{Q}_B}{\eta_B} \quad (3.29)$$

To calculate the input energy of the burned natural gas (ϕ_B) by the backup heater at any period of time Δt , simply multiply the value of $\dot{\phi}_B$ by this period of time as follow:

$$\phi_B = \dot{\phi}_B \times \Delta t \quad (3.30)$$

3.3.5 Operation costs and CO₂ emissions model:

The model estimates the operation cost and CO₂ emissions for the μ CHP system. It simply estimates these values by multiplying the prices and emission rates by the corresponding energy consumed at any period of time. The amount of money gained from exported electricity is considered as a profit, so it is subtracted from the total operation costs. The model has the ability to estimate operation costs

and CO₂ emissions on hourly, daily, monthly, seasonally and annually basis for different sizes of PEMFC unit. This model should have the following inputs:

1. Maintenance costs of both μ CHP unit and backup heater, $m_{\mu\text{CHP}}$, m_B , respectively (£/kWh)
2. Prices of natural gas and imported electricity, C_{NG} , γ respectively, (£/kWh)
3. FIT for both generated and exported electricity, FIT_G , FIT_{ex} respectively, (£/kWh)
4. Carbon tax, t_C (£/tonne of CO₂)
5. CO₂ emission factor per kWh of natural gas and kWh of electricity from the grid, e_{NG} , e_{Grid} respectively, (Kg/kWh).
6. Lower heating value and higher heating value of natural gas, LHV, HHV respectively, kJ/kg.

3.4 Conclusions:

Fuel cells in general can be considered the most appropriate candidate for single house application since it offers several advantages among the other types of μ CHP technologies such as the low level of noises. However, PEMFC and SOFC are most the promising types of fuel cells that are suitable for residential application since they can meet the householders' needs. PEMFC has been chosen as an example since it offers several advantages over SOFC.

A model of a μ CHP system for residential application has been built; this model has the following capabilities:

1. Predict the amount of thermal and electrical power produced by μ CHP unit at any time.

2. Estimate the amount of electricity exported and imported to/from the LVDN at any time.
3. Estimate the required backup heat and the dumped heat at any time.
4. Operate the μ CHP unit according to either HLOS or ELOS.
5. Estimate the operation costs of the system for any period of time.
6. Estimate CO₂ emissions due to using the system for any period of time.

4 SIZING OF RESIDENTIAL μ CHP SYSTEMS

4.1 Introduction

A generic LP model of the residential μ CHP system, which considers simultaneously the operation of a backup heater and its operation strategy, has not been previously developed. In addition, the influence of some emerging energy policies, such as the feed-in tariff, has not been considered to date. In this chapter, a generic deterministic LP model for sizing a μ CHP system has been developed, using the Matlab optimization toolbox. This model is based on a similar concept as used in [91], however it imposes modified constraints and objectives on the problem to reflect the chosen definition of a μ CHP system. Furthermore, a more accurate and detailed representation of heat and electricity demands has been considered in this study. That is, a representative week for each month has been used instead of using a representative day per season as is common in the literature. This results in a higher resolution representation of demand data, since it takes into consideration the variation between the days of the week, especially the difference between working days and the weekend.

Given the dwelling's energy demands, utility tariff structure, as well as both technical and financial specifications of a residential μ CHP system, the new model minimizes the overall cost of such a system for a test year by selecting the appropriate size of the μ CHP unit, the appropriate size of the backup heater, and determining the hourly operating schedule of the system.

The remainder of this chapter is organised as follows. Section 3.2 describes an illustrative application of a MR method for sizing μ CHP systems for three different types of single dwellings. In section 3.3, a LP model is developed for sizing μ CHP systems, which is then applied to the same types of dwellings as in Section 3.2. Further, sensitivity analyses have been conducted to understand the influence of key parameters on decision making regarding the deployment of residential μ CHP systems. Section 3.4 presents a discussion of the results obtained through the application of the MR method and LP method. Finally, section 3.5 draws conclusions regarding the methods and the implications of the results obtained.

4.2 Sizing of μ CHP Systems Using Maximum Rectangular Method

4.2.1 The principle of the maximum rectangle method

The idea of maximum rectangle (MR) method is based on sizing the μ CHP unit to cover an ‘average’ heat or electricity demand instead of covering the maximal heat or electricity demand while the backup heater can meet the peak demand and the very low thermal demand levels when it is uneconomically to operate the μ CHP unit. It can be simply based on finding the ‘maximum rectangle’, where the 8760 hourly heat-demand values are sorted in descending order and placed in a load-duration diagram, as in Figure 4.1. Afterwards, the ‘maximum rectangle’ that can be drawn inside the demand-duration curve is determined (dashed line shown in Figure 4.1). The intersection of this rectangle with the Y-axis represents the suggested optimal value for the rated thermal power of the μ CHP unit to be used to fulfil this specific heat demand. As a result, the size (electrical rating) of the μ CHP

unit can be calculated by dividing the thermal rating by the value of H:P ratio [85]. The same procedure of sizing can be carried out by using the electricity demand curve instead of the heat demand curve. However, using the heat demand curve is preferred since the system is grid connected and the excess electricity can be sold back to the grid.

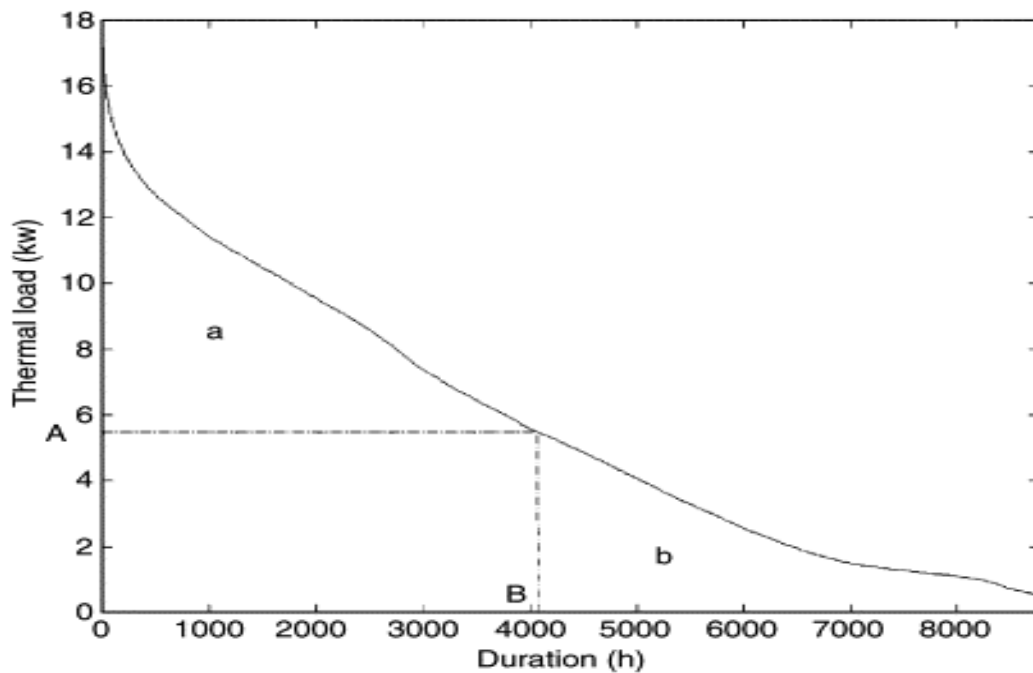

Figure 4.1 The maximum rectangle (MR) method [85]

4.2.2 Illustrative examples of residential demand

Three types of residential demand have been considered in this study, as summarized in Tables 3.1. This demand data, which is the hourly energy consumption for a whole year, was collected for low energy dwellings in an area northwest of London. It was accessed through the UK Energy Research Centre Energy Data Centre [154].

Both electricity and heat demands vary significantly during the day and they also vary significantly from one season to another. Figures 4.2 and 4.3 show these variations for the demand coded semi-detached house (SDH), which has been described in Table 4.1.

According to the MR method, the 8760 heat-demand values have been sorted in descending order and placed in a load-duration diagram, as previously shown in figure 4.1, for the three types of demand considered in this chapter. Then, the maximum rectangle that can be drawn inside the demand-duration curve has been specified for all the demand types described in Tables 4.1. Results show the MR based on heat demand for the demand of an SDH, where the suggested size (thermal rating) of the PEMFC is the one that corresponds to the maximum annual utilized heat. So, it can be concluded that, according to this estimation technique, the near-optimum size of PEMFC for this demand is just 3 kWth, which corresponds to size (electrical rating) of approximately 2.7 kWe. Alternately, a similar procedure was repeated by using electricity demand for the same demand. The results show that the suggested size (electrical rating) according to this method is now approximately 0.25 kWe.

Table 4.1 Specification of the houses, occupancy and demand

Demand code Item	SDH	ETH	DH
House type	Semi-detached house (SDH)	End-terrace house (ETH)	Detached house (DH)
U-value of floor	0.45 W/m ² K	not known	0.28 W/m ² K
Construction Type	timber frame (TF)	not known	timber frame (TF)
Floor area	64.8 m ²	64.8 m ²	139.1 m ²
Depth of floor insulation	50 mm	50 mm	100 mm
U-value of roof	0.26 W/m ² K	not known	0.2 W/m ² K
Number of bedrooms	2	2	4
Maximum occupancy	4	4	6
Min. electricity demand (kW)	zero	0.029	0.176
Max. electricity demand (kW)	2.96	3.069	2.818
Average electricity demand (kW)	0.2126	0.229	0.495
Annual electricity demand (kWh)	1862.4	2010.3	4335.2
Min. heat demand (kW)	zero	zero	zero
Max. heat demand (kW)	9.156	10.682	15.566
Average heat demand (kW)	1.1241	1.560	1.931
Annual heat demand (kWh)	9848.5	13660.1	16919.9
Average H:P ratio	5.3	6.8	3.9

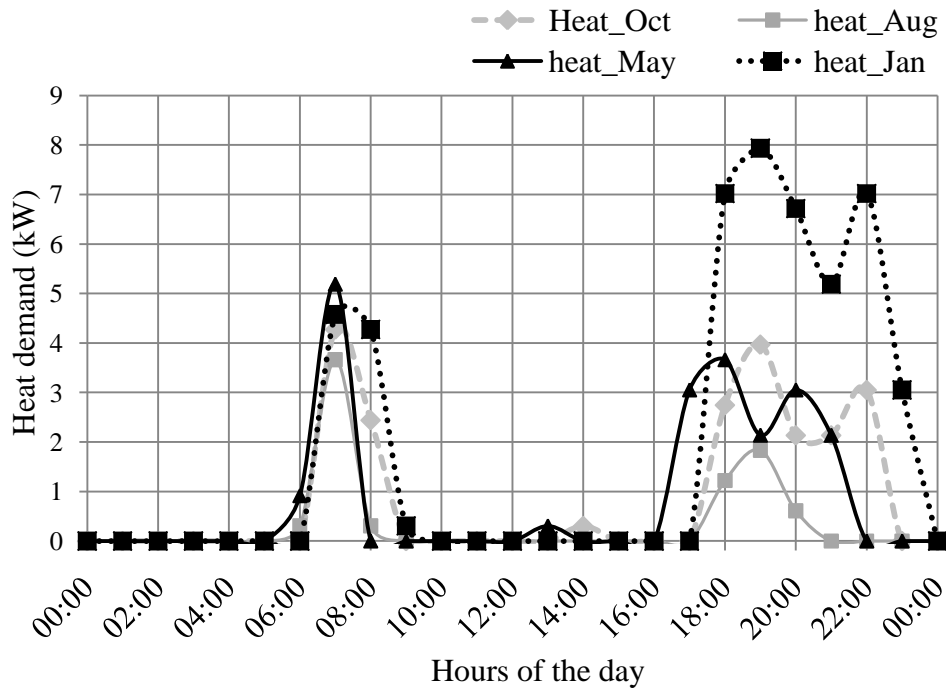

Figure 4.2 Heat demand of a representative day from each season

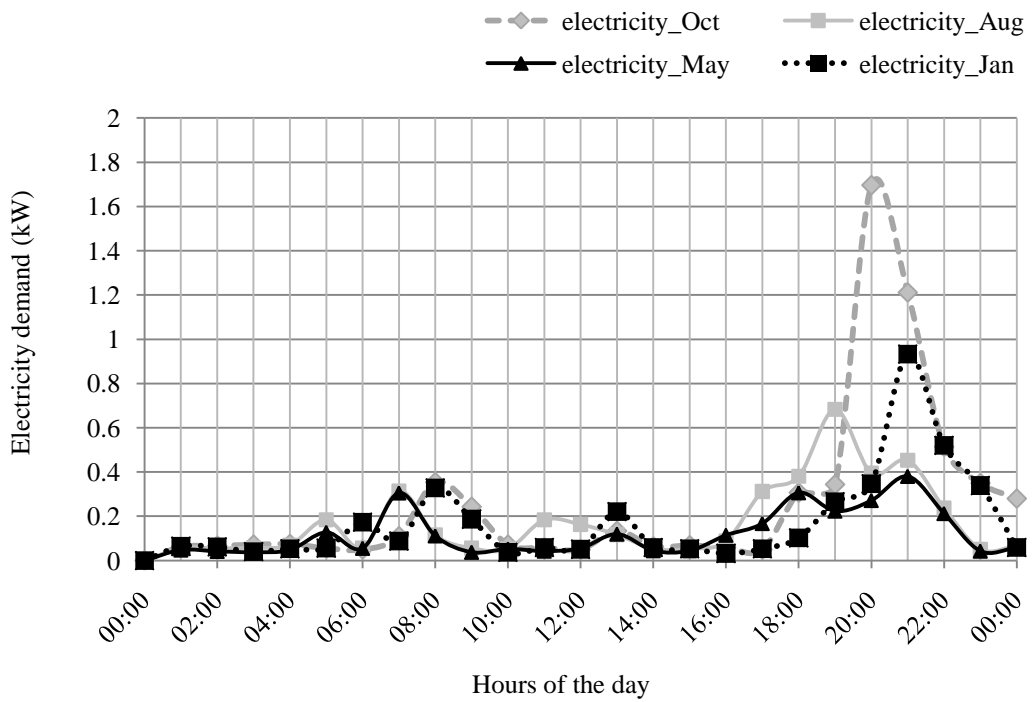

Figure 4.3 Electricity demand of a representative day from each season

In order to evaluate the results above, simulations were run for different sizes of PEMFC: 0.5 kWe, 1 kWe, 2 kWe, 3 kWe and 4 kWe with two different operation strategies: HLOS and ELOS using the models developed in chapter 3. The results for the demand SDH are shown in Figure 4.4. When these results are compared with the results of the MR method, it can be concluded that each method (based on heat demand or on electricity demand) has an advantage and a disadvantage. For example, the sizing estimation based on the MR of heat demand reduces emissions but pays for this with operation costs. The high operation costs are because of the low price for electricity sold to the μ G since when the system is operated according to a HLOS a significant amount of electricity is sold back to the μ G. This means that this type of sizing can be used once a considerable value of feed-in tariff is introduced. On the other hand, the MR with electricity demand has recommended a small size of PEMFC, as appears in Figure 4.4, which has the advantage of low operation cost but CO₂ emissions have not been significantly reduced.

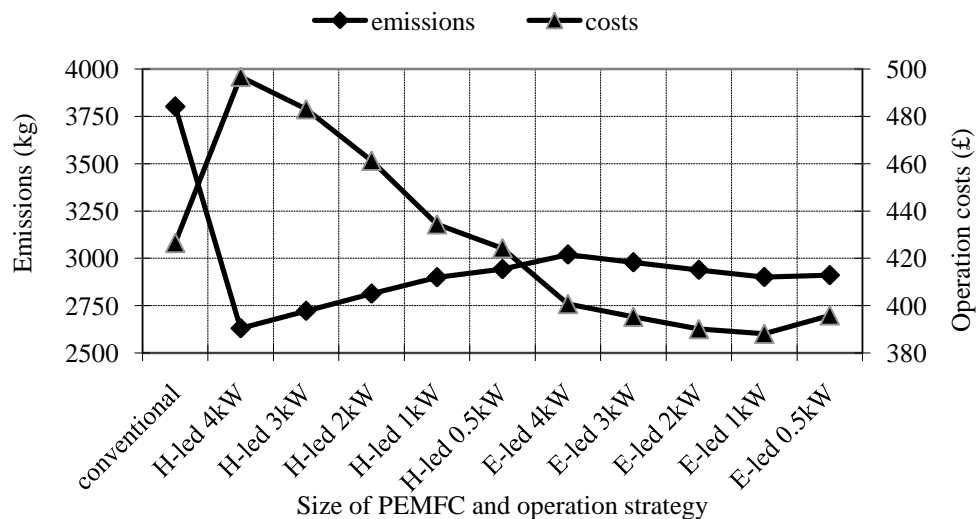

Figure 4.4 Operation costs and CO₂ emissions for different strategies and sizes of PEMFC system for the demand SDH

The same procedure of MR method has been carried out for end-terrace house (ETH) and detached house (DH) demands, where the optimum sizes based on heat demand are estimated to be 3.6 kWe and 4.1 kWe, respectively. On the other hand, the optimum sizes based on the electricity demand are 0.7 kWe and 0.3 kWe for ETH and DH demands, respectively. Furthermore, the MR method has been applied to the three types of demand by considering three other types of technology: SE, ICE and SOFC; the results are shown in Table 3.2. It can be noticed that using electricity demand in MR sizing has given the same results since it does not consider the value of H:P ratio. However, using heat demand curves has given different sizes depending on the value of H:P ratio. Table 4.2 shows the results of sizing using the MR method for different μ CHP units and for three types of demand.

Table 4.2 Results of sizing using MR method for different μ CHP units and for three types of demand

Demand type		μ CHP technology			
		SE	ICE	PEMFC	SOFC
SDH	μ CHP size using heat demand (kWe)	1.071	2.400	2.700	3.333
	μ CHP size using electricity demand (kWe)	0.25	0.25	0.25	0.25
ETH	μ CHP size using heat demand (kWe)	1.429	3.200	3.600	4.444
	μ CHP size using electricity demand (kWe)	0.7	0.7	0.7	0.7
DH	μ CHP size using heat demand (kWe)	1.643	3.680	4.140	5.111
	μ CHP size using electricity demand (kWe)	0.3	0.3	0.3	0.3

4.3 Sizing of μ CHP Systems using Linear programming

4.3.1 Overview

The residential μ CHP system which has been investigated in this chapter consists of a μ CHP unit and a backup heater. The μ CHP unit, which is driven by natural gas, is used to meet the electrical and heat demands. However, if the thermal output does not satisfy the demand, a backup heater is used. Similarly, when the amount of electrical output from the μ CHP unit is greater than the demand, the surplus electricity can be exported to the μ G. Conversely, the μ G can supply the dwelling with any deficit in electricity. In this study, the sizing of a residential μ CHP system is formulated as a generic deterministic LP model.

4.3.2 Model assumptions

The main purpose of the model is to optimally size a residential μ CHP system, where the size (electrical rating) of a μ CHP unit and the size (thermal rating) of a backup heater are determined. As such, the model involves determining optimum values for two decision variables: the size (electrical rating) of the μ CHP unit (kWe) and the thermal rating of the backup heater (kWth). However, the thermal rating of the μ CHP unit will be estimated indirectly since its value depends on the electrical rating and H:P ratio of the μ CHP unit. The two decision variables will be determined according to an objective function to minimize the equivalent annual cost (c_{EA}).

It is assumed that the μ CHP unit can operate anywhere between 0% and 100% of its rating and that it can ramp up and down at any rate to follow changes in

demands. In addition, the μ CHP system, i.e. the μ CHP unit and a backup heater, is assumed to be reliable in that shutdowns are not considered in the model.

The required constant values for the model are:

- specific capital cost of the μ CHP unit, $c_{C, \mu CHP}$, (£/kW_e),
- specific capital cost of the backup heater, $c_{C, B}$, (£/kW_h),
- salvage value of the μ CHP unit, $v_{\mu CHP}$, (£),
- operation and maintenance costs of both μ CHP unit and backup heater, $m_{\mu CHP}$ and m_B respectively, (£/kWh),
- prices of natural gas, imported and exported electricity (feed-in tariff), c_{NG} , γ and δ , respectively, (£/kWh),
- hourly end-use electricity and heat demands, L_j and H_j , respectively, (kWh),
- electrical and thermal efficiencies of the μ CHP unit, η_e and η_{th} , respectively,
- efficiency of the backup heater, η_B ,

The model determines the following outputs:

- optimal design size (electrical rating) of the μ CHP unit (kW_e),
- optimal design rating of the backup heater (kW_{th}),
- minimum equivalent annual cost of meeting electricity and heat demands, c_{EA} , (£),

The model uses the following operation variables, which inform the operation strategy of the μ CHP system:

- electrical output of μ CHP unit during the k^{th} hour of the week j and the month i , $O_{el, i, j, k}$ (kWh),

- thermal output of backup heater during the k^{th} hour of the week j and the month i, $o_{th, i, j, k}$ (kWh),
- imported electricity from the μ G during the k^{th} hour of the week j and the month i, $o_{im, i, j, k}$ (kWh),
- exported electricity to the grid during the k^{th} hour of the week j and the month i, $o_{ex, i, j, k}$ (kWh).

The value of $o_{el, k}$ can vary from zero kWh to the maximum possible electrical output of the μ CHP unit while the value of $o_{th, k}$ can vary from zero to the maximum possible output of the backup heater. The value of $o_{ex, k}$ can vary from zero when no exporting occurs to the maximum possible electrical output of the μ CHP unit when there is no demand at all. The value of $o_{im, k}$ can vary from zero when its more desirable to cover all the demand from the μ CHP unit to the highest possible value of demand, which vary from one dwelling to another.

4.3.3 Mathematical formulation

Sizing of a residential μ CHP system has been formulated as a generic deterministic LP minimization model. Figure 4.5 shows an overview of this model. In order to follow the notations used hereafter, the reader is directed to the nomenclature part.

A. *Decision variables*

To formulate the mathematical model, the decision variables are defined as:

- x_1 = size (electrical rating) of the μ CHP unit (kWe),
- x_2 = size (thermal rating) of the backup heater (kWth).

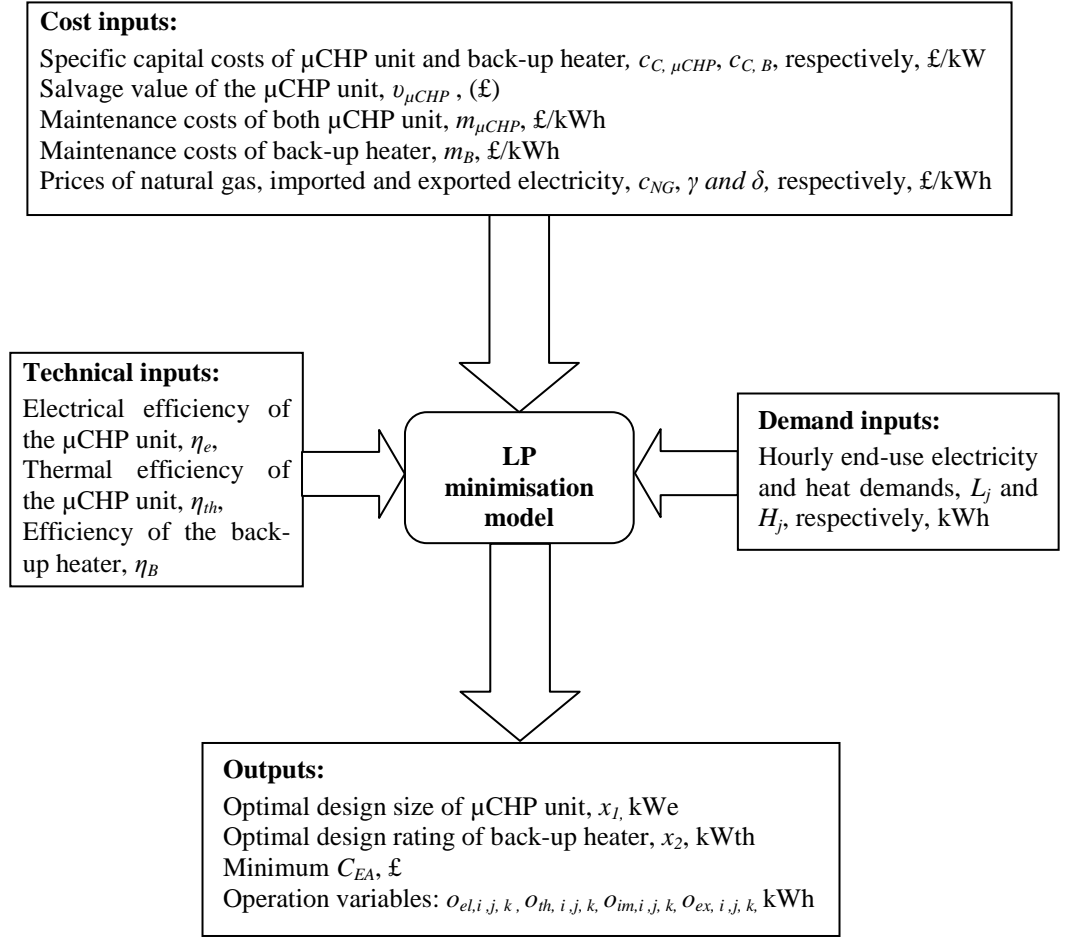

Figure 4.5 an overview of the sizing model

B. Objective function

The objective of the model is to minimize the equivalent annual cost (C_{EA}) of meeting electricity and heat demands, while meeting given electricity and heat demand profiles:

$$\bullet \min C_{EA} \quad (4.1)$$

The equivalent annual cost is the sum of the annualized capital cost (C_{AC}) of the μ CHP system and the operation cost (C_O). Thus, C_{EA} can be expressed as follows:

$$C_{EA} = C_{AC} + C_O \quad (4.2)$$

where C_{AC} can be calculated using:

$$c_{AC} = \frac{c_C^{-v}}{LT} \quad (4.3)$$

The operation cost includes the annual cost of exported and imported electricity, fuel and maintenance cost.

In general notation, the objective function can be expressed as follows:

$$\begin{aligned} \min c_{EA} = & C_{AC, \mu CHP} x_1 + C_{AC, B} x_2 + \\ & \sum_{i=1}^{n_m} \sum_{j=1}^{n_d} \sum_{k=1}^{n_h} w_i (\alpha o_{el,i,j,k} + \beta o_{th,i,j,k} \gamma o_{im,i,j,k} - \delta o_{ex,i,j,k}) \end{aligned} \quad (4.4)$$

In equation (3.4), the coefficients $C_{AC, \mu CHP}$, $C_{AC, B}$, α and β can be calculated as follows:

$$C_{AC, \mu CHP} = \frac{C_{C, \mu C}^{-v_{\mu CHP}}}{LT_{\mu CHP}} \quad (4.5)$$

$$C_{AC, B} = \frac{C_{C, B}}{LT_B} \quad (4.6)$$

$$\alpha = \frac{C_{NG}}{\eta_e} + m_{\mu CHP} \quad (4.7)$$

$$\beta = \frac{C_{NG}}{\eta_B} + m_B \quad (4.8)$$

Also, the coefficient γ is the cost of imported electricity (£/kWh), and δ is the cost of exported electricity (£/kWh).

When considering a representative day from each month in a year, n_m is 12, n_h is the number of hours per day and n_d is the number of representative days considered per month, i.e. 1. Thus, the number of hours modelled is the product of n_m , n_h and n_d , i.e. the number of hours using a representative day from each month, which is

288 (12×24×1). Since there are four types of operation variables each hour, the number of operation variables used in the model is 1152 (288×4). When a representative day is used, a weighting factor (w_i) is applied in order to account for the number of days in each month under consideration.

Similarly, when considering a representative week, the number of the representative days per month becomes 7. As such, the number of hours modelled is 2016 (12×24×7) and the number of operation variables used in the model is 8066 (2016×4). Furthermore, when a representative week is used, the weighting factor accounts for the number of weeks in each month under consideration.

C. Constraints

The constraints imposed on the LP problem are as follows:

- The inability of a μ CHP unit and a backup boiler to exceed their maximum ratings,

$$O_{el, i, j, k} - x_1 \leq 0 \text{ for all values of } i, j \text{ and } k \quad (4.9)$$

$$O_{th, i, j, k} - x_2 \leq 0 \text{ for all values of } i, j \text{ and } k \quad (4.10)$$

where i, j and k represent the month, day and hour, respectively.

- Electricity demand of the house must be met exactly. However, importing and exporting electricity from/to the μ G is possible.

$$O_{el, i, j, k} + O_{im, i, j, k} - O_{ex, i, j, k} = L_{i, j, k} \text{ for all values of } i, j \text{ and } k \quad (4.11)$$

- Heat demand must be met exactly and no heat dumping is allowed.

$$O_{el, i, j, k} \times Q + O_{th, i, j, k} = H_{i, j, k} \text{ for all values of } i, j \text{ and } k \quad (4.12)$$

The number of inequality constraints generated from the four expressions (4.9), (4.10), (4.11) and (4.12) when considering a daily representation of demand, is the product of the number of expressions, the number of hours per day and the number of months per year, i.e. 1152 ($4 \times 24 \times 12$). Similarly, the number of inequality constraints when considering a weekly representation of demand is 8064 ($4 \times 168 \times 12$).

4.4 Illustrative examples

In order to test the LP model, this model has been applied to the same demands described in Section 3.2 in order to investigate the sizing of a μ CHP system for specific demands in the UK. This analysis represents a final and complete picture of the μ CHP system's economics, design and operation for certain residential applications. Physically, the μ CHP system considered in this study consists of the following components: one μ CHP unit; one backup heater, and a μ G connection to allow importing and exporting of electricity. Load shifting or load reduction has not been considered in this study because fixed tariffs are used but once variable tariffs are available this issue can be considered since it is a valuable tool for reducing costs [91].

Four different μ CHP technologies have been considered, namely: SE, ICE, SOFC and PEMFC. The basic technical characteristics, specific capital, maintenance and operation costs of each of these candidate technologies are described in Table 4.3. These values are extracted as the best figures available in the literature [5, 70, 102,

154-163] (the use of μ CHP is expected to be in the near future when all prices are going to drop).

The central prices of gas and electricity used in this model are based on Department of Trade and Industry (DTI) quarterly energy prices in March 2007. The prices of electricity met by the μ G, natural gas and exported electricity are considered at fixed rate of 0.082 £/kWh, 0.0228 £/kWh based on based on higher heating value (HHV) of natural gas) and 00.041 £/kWh, respectively [75]. In reality, the energy tariff assigned to the μ G would differ from these estimates, and would almost certainly be in a half-hourly time-of-use format rather than single average values [103]. However, for the purposes of simplicity and to provide a non-supplier-specific picture of μ G economics, an average single rate tariff is considered to be acceptable. Maintenance is also an operating cost, and is presented in Table 4.3.

Table 4.3 Specifications of equipments used in the model

Equipment	capital cost (£/kWe)	η_e (%)	H:P	M cost (£/kWh)	Life time (Years)
SE	1650	25	2.8	0.004	15
PEM	2484	45	1.11	0.015	25 yrs and 5 yrs for stack
SOFC	4600	50	0.9	0.015	25 yrs and 5 yrs for stack
ICE	722	40	1.25	0.0074	15
Backup heater	100	80	-	0.004	10

4.5 Results obtained by LP model

According to the specifications in Table 3.3, sizing has been carried out for the three different types of demand described in Section 2.2. Each demand has been considered for SE, PEMFC, SOFC and ICE based μ CHP. Table 4.4 shows the results of sizing for the three types of demand: SDH, ETH and DH, by considering the four μ CHP technologies.

Table 4.4 Results of sizing for different μ CHP units and three different types of demand.

Technology \ Demand		SDH	ETH	DH
SE	X ₁ (kWe)	0.869	0.995	1.226
	X ₂ (kWth)	5.351	5.835	7.172
	c _{EA} (£)	473.1	562.4	802.4
PEM	X ₁ (kWe)	0.259	0.353	0.656
	X ₂ (kWth)	7.495	8.230	9.978
	c _{EA} (£)	523.4	636.9	904.3
SOFC	X ₁ (kWe)	0.00	0.135	0.358
	X ₂ (kWth)	7.783	8.500	10.283
	c _{EA} (£)	533.1	662.6	964.3
ICE	X ₁ (kWe)	1.709	2.198	2.869
	X ₂ (kWth)	5.646	5.875	7.020
	c _{EA} (£)	462.9	544.6	776.8

From Table 4.4, it can be seen that the size of ICE is the largest among the others since it has the lowest capital cost while the size of SOFC is the lowest one because its capital cost is the highest. It can also be noticed from the table that the

demand DH requires a larger size of μ CHP unit compared to the other two types of demand since it is the highest demand.

4.6 Sensitivity analysis of the LP model's results

Sensitivity analysis is a means to understand how variation of the main key parameters would affect the decision of μ CHP adoption. In this study, sensitivity analysis has been performed on: capital cost of μ CHP unit, electrical efficiency, natural gas price, imported electricity price, and feed-in tariff. The analysis has been performed for PEMFC based on the results obtained from the most optimistic technical and economic projections since it is an emerging technology for residential applications and thus its capital cost is expected to decrease in the near future [14]. Figures 4.6-4.12 show the impact of change in the main parameters on the size of μ CHP unit and the value of c_{EA} . All the results below are for the demand DH. However, the other two demands show similar trends when sensitivity analysis has been applied.

4.6.1 Sensitivity analysis of capital cost

First of all, sensitivity analysis to capital cost has been considered since this technology is still under development and its capital cost is expected to drop once it is widely adopted [14]. For instance, Lipman et al. [164] expects that the capital cost of the whole PEMFC system, including reformer, will dramatically drop during the time-frame 2010–2015 to reach 312 £/kWe by the end of this period. Therefore, sensitivity analysis based on capital cost will enable evaluation of a parameter that is likely to change rapidly in the near future. Graphs show that the

drop in capital cost has a significant impact in reducing the c_{EA} and a remarkable impact in increasing the size of μ CHP unit, where the c_{EA} has dropped by an amount of approximately £200 while the size of μ CHP unit has noticeably increased to exceed 6 kWe. Figure 4.6 shows the impact of capital cost on c_{EA} value and the rating of the μ CHP unit.

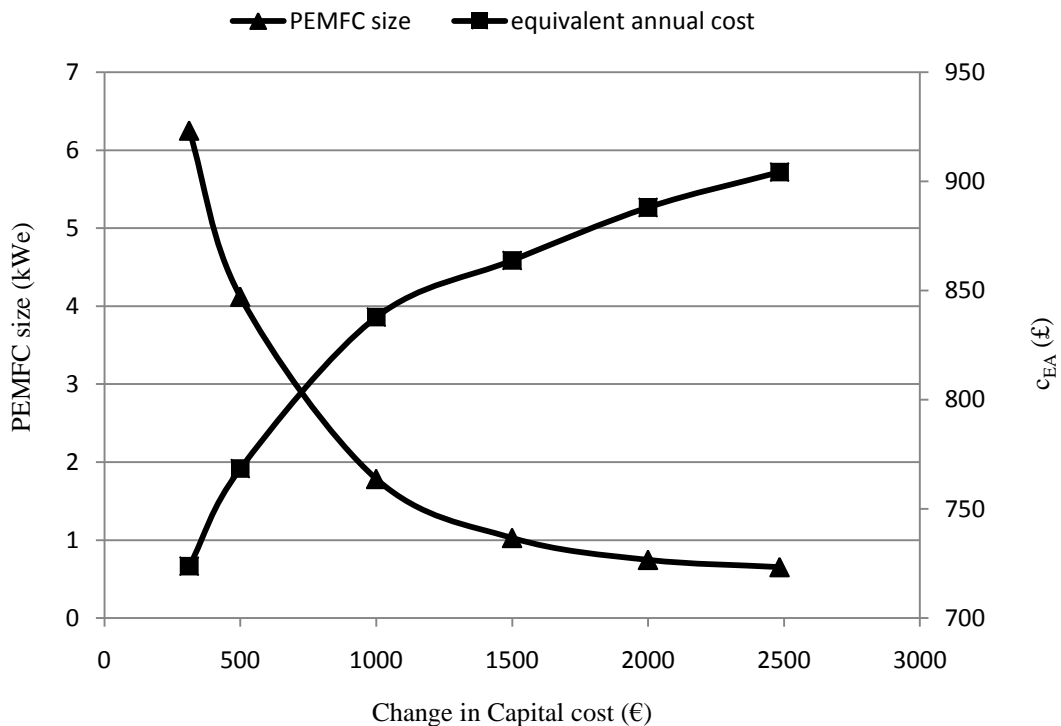

Figure 4.6 Sensitivity analysis of capital cost

4.6.2 Sensitivity analysis of feed-in tariff

Feed-in tariff has also been considered, since governments have recently increased this value in order to encourage the proliferation of renewable energy technologies such as wind turbines and efficient technologies such as μ CHP. It has been assumed that feed-in tariff could be equivalent to the retail price of electricity. So

the sensitivity analysis has been executed on this base. Figure 4.7 shows that using a high feed-in tariff has the potential to significantly decrease the value of c_{EA} and to increase the size of μ CHP unit because using a higher feed-in tariff makes using the μ CHP unit for producing heat more profitable. As a result, the size of μ CHP unit can be increased and the value of c_{EA} can be reduced. Figure 3.7 shows the impact of feed-in tariff on c_{EA} value and the size of μ CHP unit.

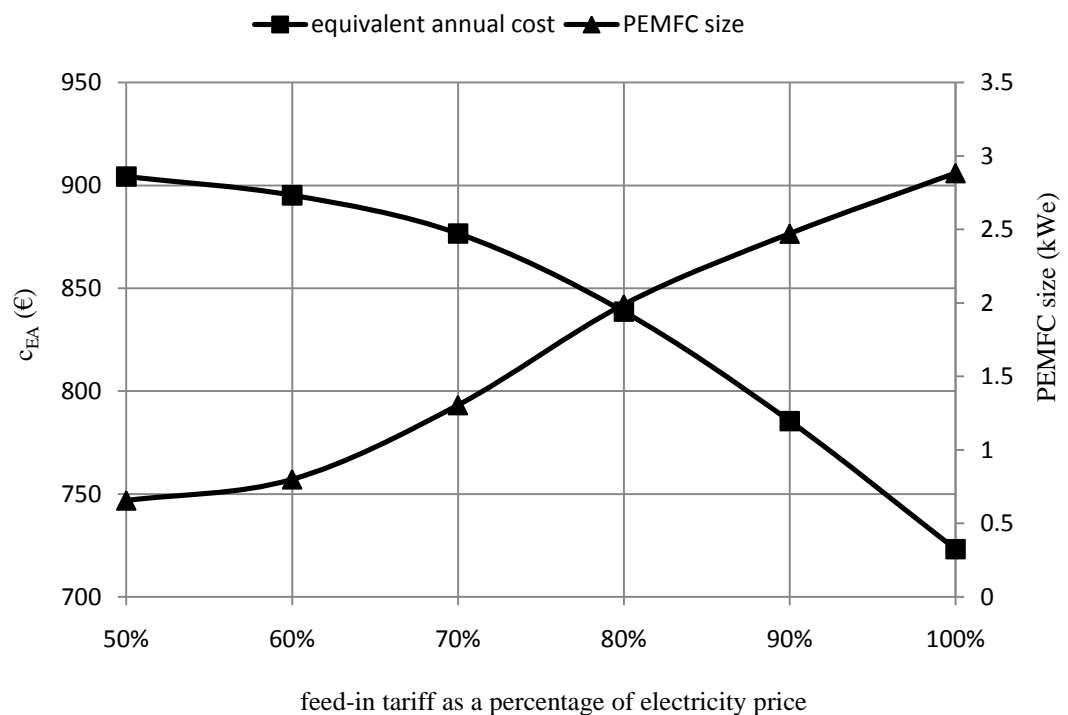

Figure 4.7 Sensitivity analysis of feed-in tariff

4.6.3 Sensitivity analysis of gas price

Gas price has also been considered in the sensitivity analysis since the international demand for energy is increasing while the sources of energy are limited and not secure, which can lead to fluctuation in the price of gas. The prices have been investigated in both regions: increasing and decreasing, where an increase and a

decrease of up to 20% have been investigated. However, the impact of variations in gas price on the calculated size of μ CHP unit was almost negligible. On the other hand, these variations have a significant impact on the value of c_{EA} since natural gas is one of the main operation costs. Figure 4.8 shows the impact of gas price on c_{EA} value and the size of μ CHP unit.

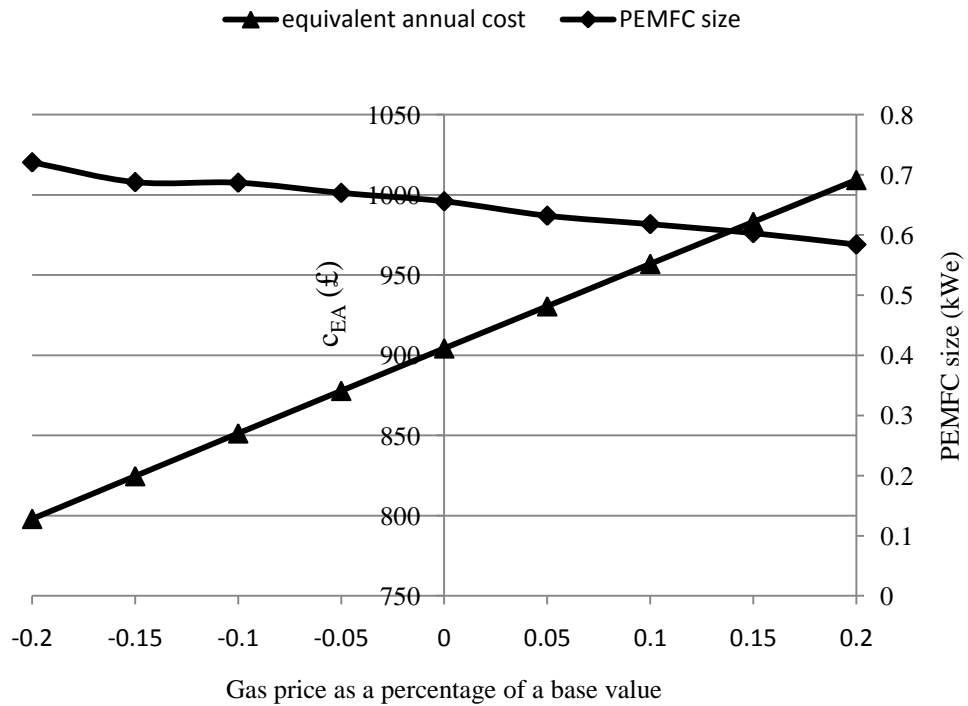

Figure 4.7 Sensitivity analysis of gas price

4.6.4 Sensitivity analysis of electricity price

Due to an increase in electricity demand, the electricity price can increase. As a result, the effect of increase in electricity price has been investigated as well. However, a very small change in the size of μ CHP unit can be seen. Figure 4.9 show the impact of electricity price on c_{EA} value and the size of μ CHP unit.

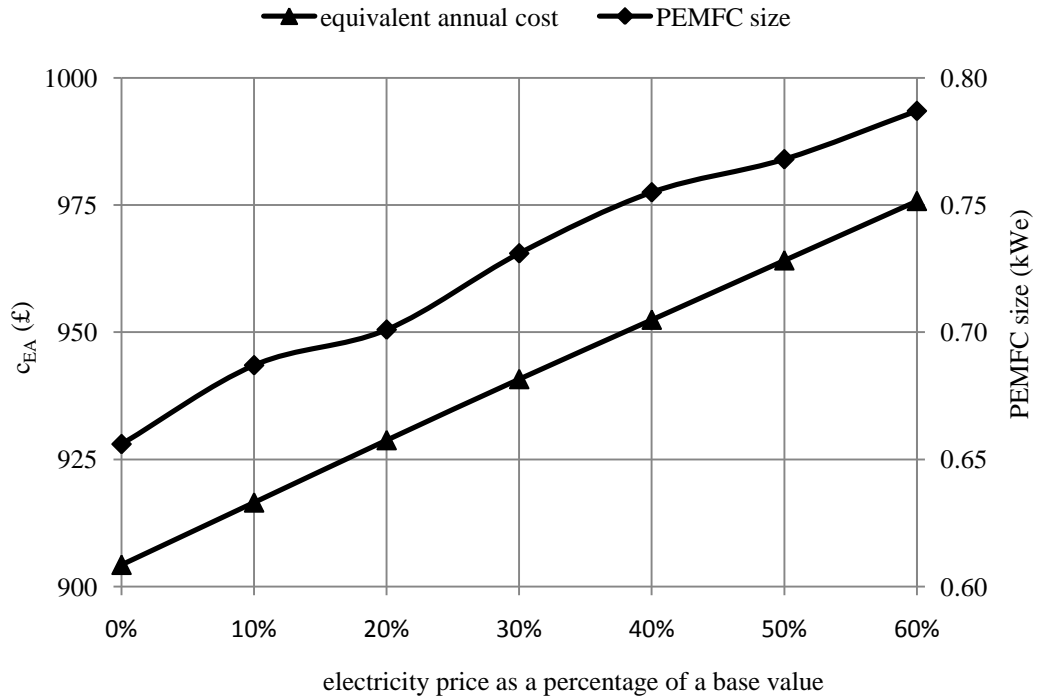

Figure 4.8 Sensitivity analysis of electricity price

4.6.5 Sensitivity analysis of electricity demand

Electricity demand can increase due to the demand for heat pumps and electric vehicles. Moreover, using measured data from certain houses does not guarantee that these values are a perfect representative of such a demand. As a result, the effect of change in electricity demand on the size of the μ CHP unit has been investigated. The analysis has shown that an increase in electricity demand of 10% can increase the optimal size of μ CHP unit by just 50 W and the same for decreasing the demand by 10% where a decrease in size of μ CHP unit by just 59 W has been noticed. Figure 4.10 shows the impact of electricity demand on c_{EA} value and the size of μ CHP unit.

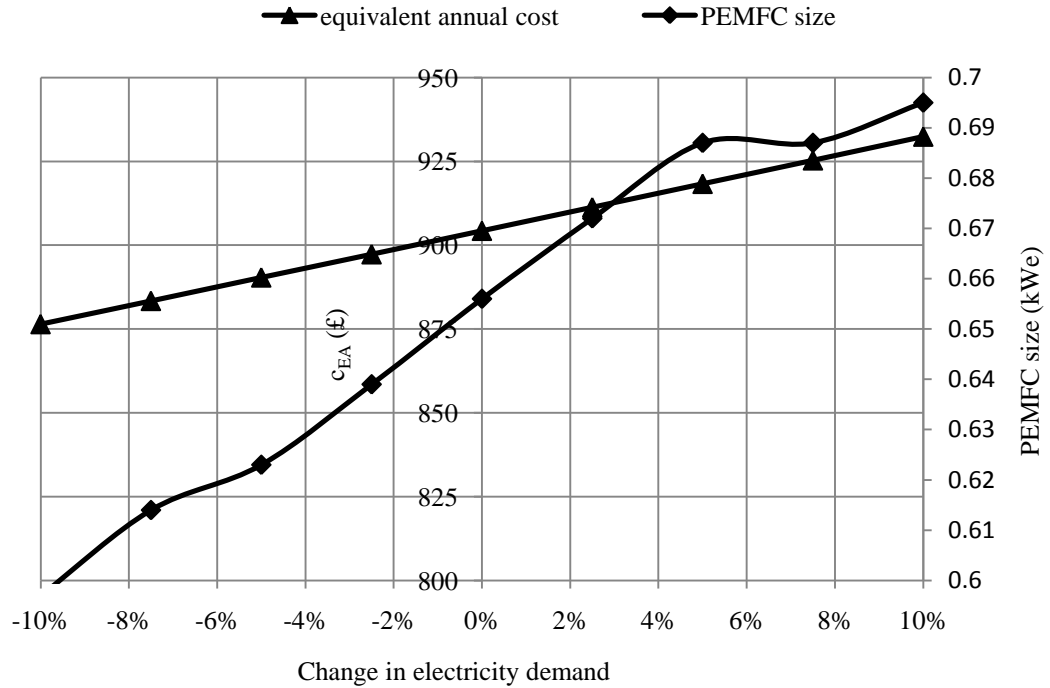

Figure 4.9 Sensitivity analysis of electricity demand

4.6.6 Sensitivity analysis of electrical efficiency

Since electrical efficiency is the main technical specification of a μ CHP unit which can affect the impact of the system, a variation in this value has been considered since there is uncertainty regarding this value in the literature. However, it has been concluded that an increase or decrease up to 6% of electrical efficiency has a negligible effect on both c_{EA} and the size of μ CHP unit. Figure 4.11 show the impact of electrical efficiency on c_{EA} value and the rating of μ CHP unit.

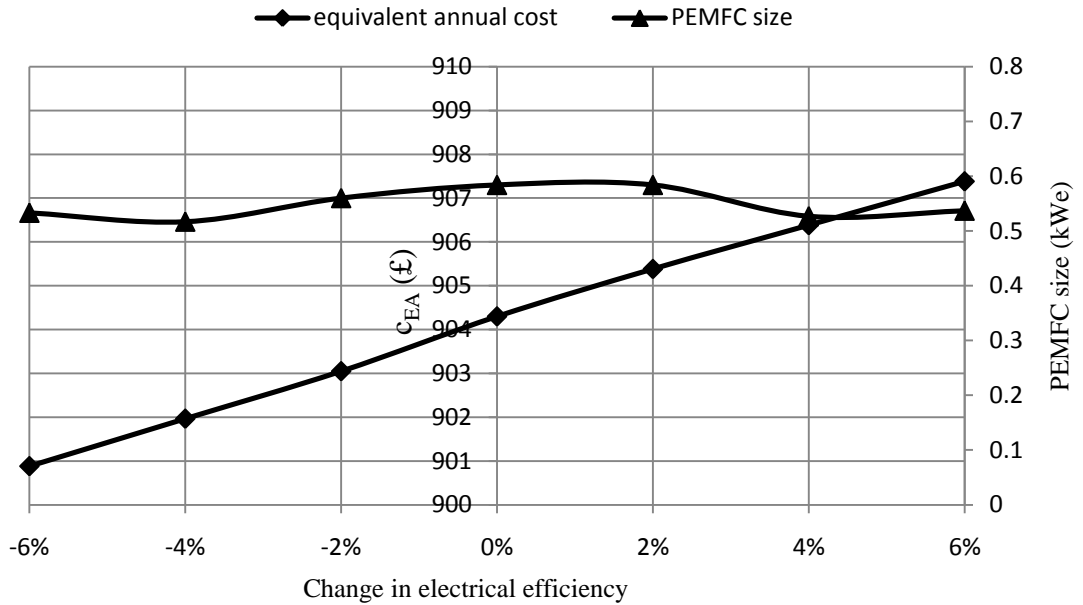
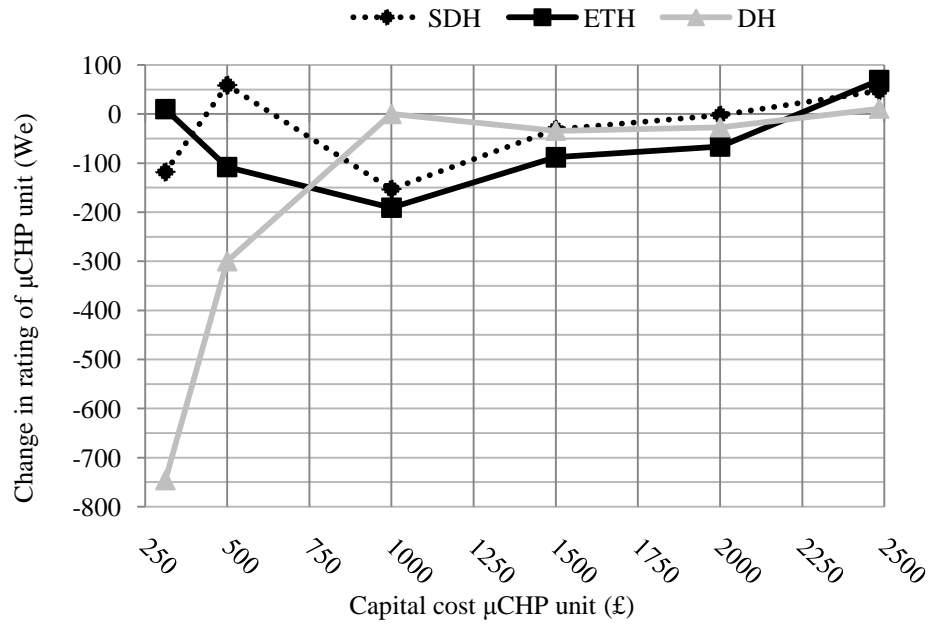

Figure 4.10 Sensitivity analysis of electrical efficiency

4.6.7 Sensitivity analysis of demand representation

The representation of heat and electricity demand has been investigated by comparing the results when a representative week is used with the results when a representative day is used. This comparison has been carried out for the three different types of demand and over a range of capital costs. The comparison has been made for sizing of PEMFC and backup heater for the three different demands previously described. Figures 4.11-4.13 illustrates this comparison. Results show that the c_{EA} value is not very sensitive to the representation of demand as it appears in Figure 4.13 because the total demand for both of the representations was the same. However, it can be seen that the optimum size of backup heater can be underestimated by approximately 2 kW in some cases, as shown in Figure 4.12. This is because averaging the weekly data to a daily data set reduces the peak value of heat demand.



4.11 Change in μ HP rating when a representative day is used instead of a representative week per month

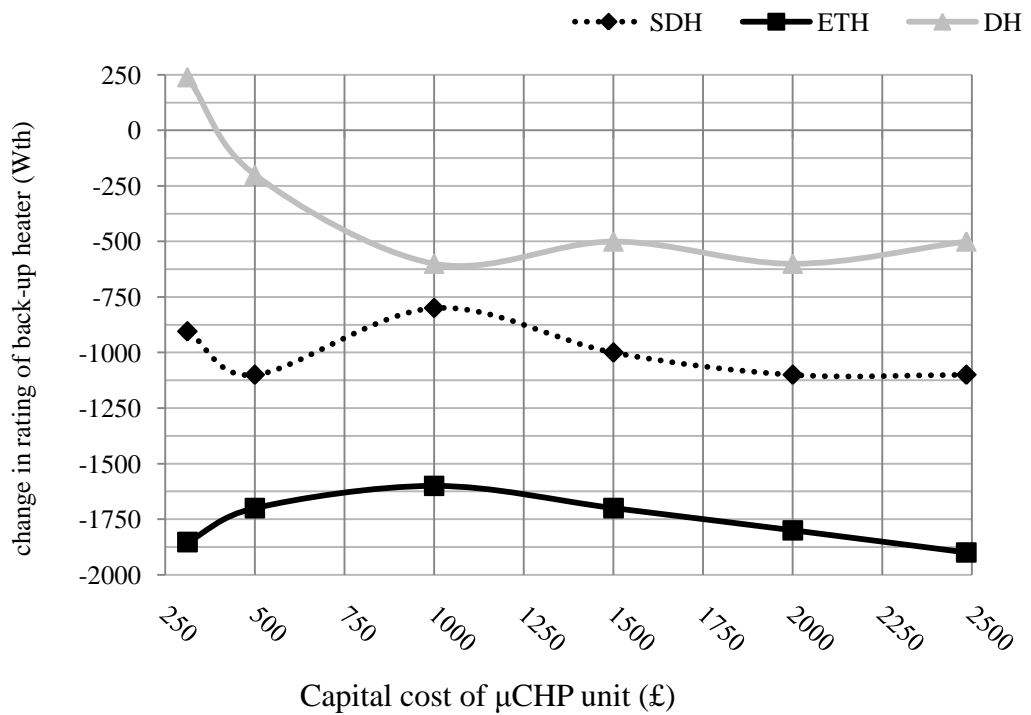

4.12 Change in backup heater rating when a representative day is used instead of a representative week per month

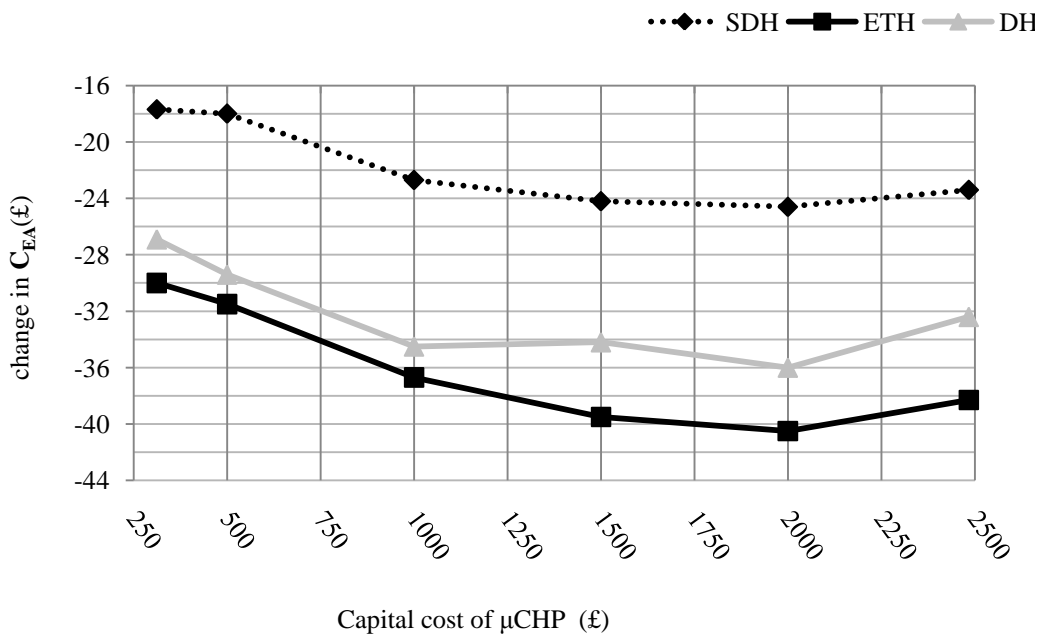

Figure 4.13 Change in the value of c_{EA} when a representative day is used instead of a representative week per month

Although the size of μ CHP unit is less sensitive to the representation of demand in general, it can be sensitive in some cases where an underestimation of the optimum size by approximately 0.75 kWe has been seen in Figure 4.11. The reason for this variation is due to the random nature of averaging data as appears in Figure 4.14, which shows the ordering of heat demand for both types of representation against the hours of the year as a percentage. At each capital cost value the optimal size of μ CHP unit is that size which can cover a certain percentage of heat demand which makes using a μ CHP unit instead of a backup heater more cost effective, so the value corresponding to this percentage can be different as appears in Figure 4.14. For instance, when the μ CHP unit can cover a percentage of heat demand of 30%–35% of the annual heat demand the corresponding sizes of the μ CHP unit are almost the same whether either a representative day or a representative week is used, as shown in Figure 4.14. On the other hand, when the μ CHP unit can cover a

percentage of heat demand lower than 30% of the annual heat demand, using a representative day leads to a larger size of the μ CHP being recommended compared to using a representative week. However, when the μ CHP unit can cover a percentage of heat demand greater than 35% of the annual heat demand, using a representative day results in a smaller size of the μ CHP being recommended compared to using a representative week, as shown in Figure 4.14. As a result, the difference in calculated sizes between a daily or weekly representation can be positive or negative depending on the randomness of heat demand data.

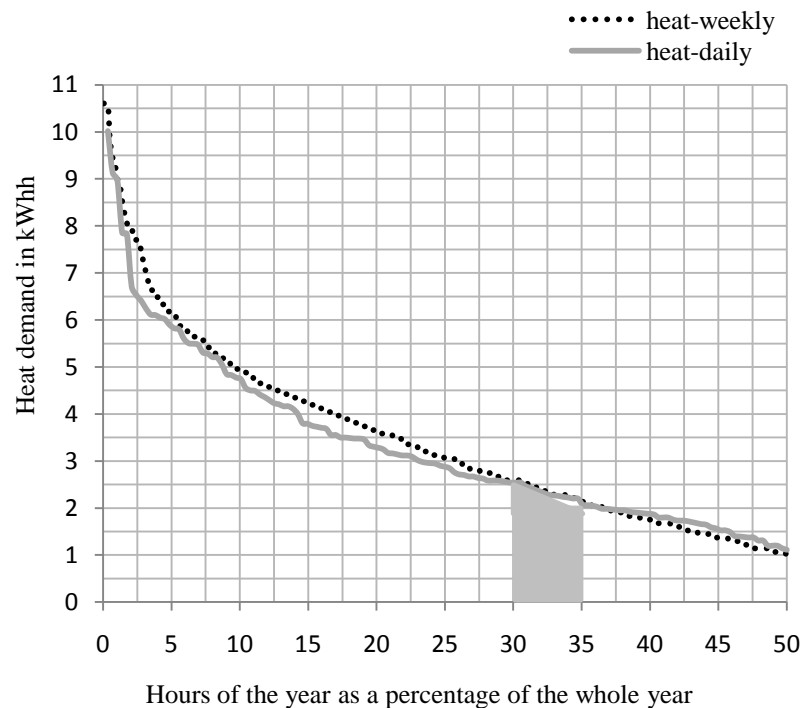

Figure 4.14 ordered values of DH heat demand for different representation of demand

Finally, it should be noticed that sensitivity analysis has been carried out based on a certain value of capital cost and specifications of μ CHP unit, which can inform us that some of the key parameters have no significant impact on the sizing when this

value of capital cost is used in combination with this value of feed-in tariff. However, using different combination of lower values of capital cost and higher feed-in tariff could result in a different optimal size of the μ CHP unit.

4.7 Discussion

Sizing of SE based μ CHP using the MR method was in the range of 1.00–1.650 kWe depending on the type of demand. However, when the LP model is applied to the same demands the size of SE based μ CHP was 0.850–1.250 kWe. Similarly, sizing of ICE based μ CHP using the MR method was 2.400–3.700 kWe depending on the type of demand but when the LP model is applied to the same demands the size of ICE based μ CHP was 1.7–2.9 kWe. Sizing of PEMFC and SOFC based μ CHP using the MR method were 2.700–4.150 kWe and 3.300–5.100 kWe, respectively, depending on the type of demand. Conversely, when the LP model is applied to the same demand the size of PEMFC and SOFC based μ CHP were 0.600–0.700 kWe and 0–0.400 kWe. These differences between the methods are because LP model considers the capital and operation cost while the MR method does not consider them. Furthermore, the MR method suggests the size that leads to the maximum possible energy that can be covered by the μ CHP regardless of its profitability. On the other hand, the LP model does not suggest a larger size unless it is more profitable.

Since fuel cells are still under development and are expected to see a drop in their capital cost in future, PEMFC has been investigated under a range of expected capital costs to find the optimal size at that cost. This analysis has been executed by

the LP model only because the MR method does not have the ability to find such results. This analysis, as shown in figure 6, shows that a drop in capital cost from £2884 to £312 can lead to a recommended size of 6.250 kWe instead of 0.656 kWe for the PEMFC. However, it seems that the £312 capital cost is very optimistic while a £1000 capital cost is more realistic and is widely expected in the literature. The value of £1000 capital cost has shown that the recommended size of PEMFC is in the range of 0.900–1.800 kWe depending on the type of demand. Similar results would be expected for SOFC when similar values of capital cost is used since it has similar characteristics to PEMFC. The results of sizing PEMFC based on a £1000 capital cost have been compared to the optimistic current SE and ICE. It has been noticed that PEMFC has the highest value of c_{EA} among the investigated technologies. This is because the analysis has been carried out by considering a feed-in tariff at 50% of retail price. As a result, exporting electricity at a low rate will result in a low value of c_{EA} for PEMFC. This is attributed to PEMFC having the potential to export more electricity than SE and ICE due to the fact that this technology has the highest electrical efficiency and the lowest heat to power ratio.

Sensitivity analysis has also shown that introducing an encouraging value of feed-in tariff has a significant impact on the calculated size of PEMFC. For instance, increasing the feed-in tariff from 50% to 100% of the electricity price has changed the optimal size of PEMFC from 0.656 kWe to 2.884 kWe. Further, this has reduced the value of c_{EA} from £904.3 to £723.2 as illustrated in Section 3.6. On the other hand, sensitivity analysis has shown that the other variables, electricity demand, electrical efficiency, electricity price, and gas price, have only a slight impact on the optimal size of PEMFC.

4.8 Conclusions

In this chapter, the introduction of μ CHP units combined with a backup heater, for typical residential dwellings, has been evaluated. A generic LP model aiming to determine the most economical residential μ CHP system, for given electricity and thermal demands, has been developed. This model is capable of determining the optimal size (electrical rating) of the μ CHP unit and the optimal size (thermal rating) of the backup heater required for any given residential demand regardless of the type of μ CHP technology. It can also indirectly determine the thermal rating of the μ CHP unit as it depends on the electrical rating and the heat to power ratio of the μ CHP technology type. It should also be noted that the model can be used for sizing large scale CHP systems, combine cooling heat and power (CCHP) systems and it can be easily modified to size other energy systems such as wind energy systems or Photovoltaic energy systems.

Different analysis and investigations, which takes into consideration the future scenario and uncertainty of several parameters, have been carried out. According to these analysis and investigations, the following conclusions can be drawn:

- Different μ CHP technologies can lead to different sizes of μ CHP unit and backup heater because each one has different specifications from the others such as heat to power ratio and electrical efficiency.
- A different type of demand entails a different size of μ CHP unit and a different size of backup heater. As a result, introducing different sizes of μ CHP unit is recommended as explained below.
- The capital cost of the μ CHP unit is an essential parameter and can significantly change the size of the optimal μ CHP unit.

- Introducing an encouraging value of feed-in tariff has the potential to significantly reduce the c_{EA} value of using μ CHP systems and to increase the optimal size of μ CHP units since exporting electricity to the grid will reduce the net cost.
- Electricity and heat demands are essential inputs for any sizing model, so using an averaged representative week each month is more reliable than using a representative day, especially for sizing of the backup heater where an underestimation of approximately 2 kWe can occur when a representative day is used instead of a representative week.

Results have shown that both the SE and ICE μ CHP are feasible at optimistic current costs and specification. The recommended sizes according to the LP model for an SE based μ CHP are in the range of 0.850–1.250 kWe while the recommended rating for ICE based μ CHP is in the range of 1.7–2.9 kWe depending on the type of demand. On the other hand, the current costs and specifications of fuel cell have shown that a very small size is recommended, especially when SOFC is used for a low demand type. However, the expectation for the future of PEMFC is that capital costs will drop to 1000 £/kWe. If this were to happen, the recommended sizes would be in the range of 0.900–1.800 kWe depending on the type of demand. Similar results are expected for SOFC but PEMFC is preferred for residential applications for many reasons such as the ability to follow variations in the electrical demand and the ability to start up rapidly [1].

5 OPTIMAL ONLINE OPERATION OF RESIDENTIAL μ CHP SYSTEMS USING LINEAR PROGRAMMING:

5.1 Introduction

Previous research has not developed a generic online LP optimiser (LPO) for residential μ CHP systems that accounts for a backup heater and a thermal storage device. In addition, the influence of some emerging energy policies, such as FIT and carbon tax, has not yet been considered. In this chapter, a generic optimal online LP model for operation of a μ CHP system, which is named ‘optimiser’, is presented and has been developed, using the Matlab. It has been formulated in a generic form to allow its use for any μ CHP system and any demand profile. Importantly, in contrast to earlier work in chapter 3 related to single run optimisation to determine the size of μ CHP systems [165], this optimiser operates continuously online with the aim of optimising the efficient operation of the μ CHP system. Further, the online optimiser minimises the daily operation costs (c_{DO}) of such a system. Uncertainties in electrical and thermal demands have been considered by generating random errors for each individual value. Three simulation scenarios with different incentive mechanisms for installing μ CHP technologies have been investigated: the feed-in tariff (FIT) scheme recently adopted in the UK [166]; the trade of electricity and the introduction of a carbon tax. Sensitivity analyses have been performed to gain an understanding of the influence of key parameters on decision making regarding the operation of residential μ CHP systems.

The remainder of this chapter is organised as follows. Section 5.2 describes the conventional pre-determined operation strategies for μ CHP systems. In Section 5.3, an online LPO is presented and developed for online operation of μ CHP systems. Section 5.4 presents results and a discussion based on the savings achieved through the application of the online LPO in three different simulation scenarios. Finally, Section 5.5 draws conclusions regarding the strategies and the implications of the results obtained.

5.2 Online operation of μ CHP systems using linear programming

5.2.1 Overview

The investigated residential μ CHP system consists of a μ CHP unit, a thermal storage device and a backup heater. The μ CHP unit, which is driven by natural gas, is used to meet the electrical and heat demands. However, when the amount of electrical output from the μ CHP unit is greater than the demand, the surplus electricity can be exported to the micro grid (μ G). Conversely, the μ G can supply the dwelling with any deficit in electricity. Any excess heat will be diverted to the thermal storage device and used when it is needed. However, if the thermal output does not satisfy the demand and there is not enough stored heat, a backup heater is used. Figure 5.1 shows the conceptual arrangement of the residential μ CHP system, which includes: a μ CHP unit, a thermal storage device and a backup heater and is integrated within a μ G.

In this chapter, the operation of a residential μ CHP system is formulated as an online optimisation LP model (LP optimiser (LPO)) as described in the following sections. The optimiser is formulated in a generic form to allow its use for any μ CHP system and any demand pattern.

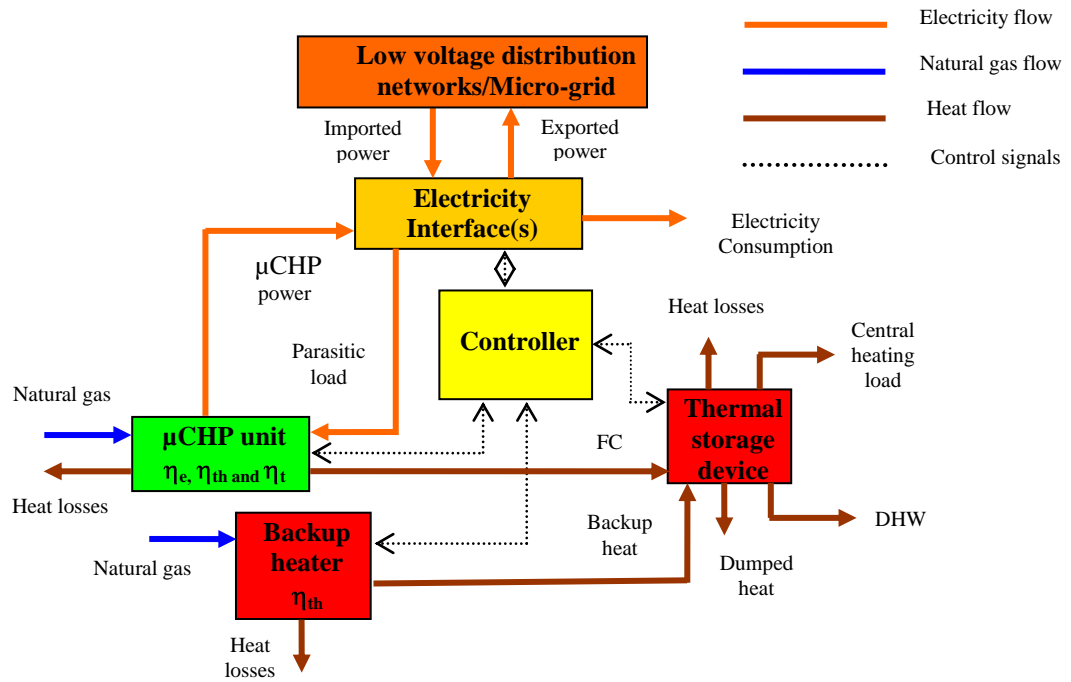

Figure 5.1 A conceptual arrangement of residential μ CHP system [35]

5.2.2 Model assumptions

The main purpose of the model is to optimally operate a residential μ CHP system, where the electrical output of the μ CHP unit is daily determined on an hourly basis. As such, the model involves determining optimal values for 24 decision variables: the hourly electrical output of the μ CHP unit (kWe) for a whole day. These decision variables will be determined according to an objective function to minimise C_{DO} .

It is assumed that the μ CHP unit can operate anywhere between 0% and 100% of its capacity. In addition, the μ CHP system is assumed to be perfectly reliable, i.e. shutdowns are not considered in the model.

The required input values for the model are:

1. Maintenance costs of both μ CHP unit and backup heater, $m_{\mu\text{CHP}}, m_B$, respectively (£/kWh)
2. Prices of natural gas and imported electricity, c_{NG}, γ respectively, (£/kWh)
3. FIT for both generated and exported electricity, FIT_G, FIT_{ex} respectively, (£/kWh)
4. Forecasted hourly end-use electricity and heat demands, $L_{j,f}, H_{j,f}$ respectively, (kWh)
5. Electrical and thermal efficiencies of the μ CHP unit, η_e, η_{th} respectively.
6. Efficiency of the backup heater, η_B
7. Round-trip efficiency of the thermal storage device, η_s
8. Carbon tax, t_C (£/tonne of CO_2)

All the above input values have been considered constants in the online operation model. However, the values of forecasted hourly end-use electricity demand ($L_{j,f}$) and heat demand ($H_{j,f}$) have been estimated to randomly vary within 10% of actual values [167]. Consequently, each single value of heat or electricity demand can randomly vary from 90% to 110% of the actual demand.

The model determines the following two outputs:

1. Electrical output of μ CHP unit for 24 hours, $o_{el,i}$ (kWe)
2. Minimum c_{DO} for meeting electricity and heat demands (£)

5.2.3 Mathematical formulation

Online operation of a residential μ CHP system has been formulated as an LP minimisation model. The model is named optimiser; Figure 5.2 shows an overview of this optimiser. In order to follow the notation used hereafter, the reader is directed to the nomenclature.

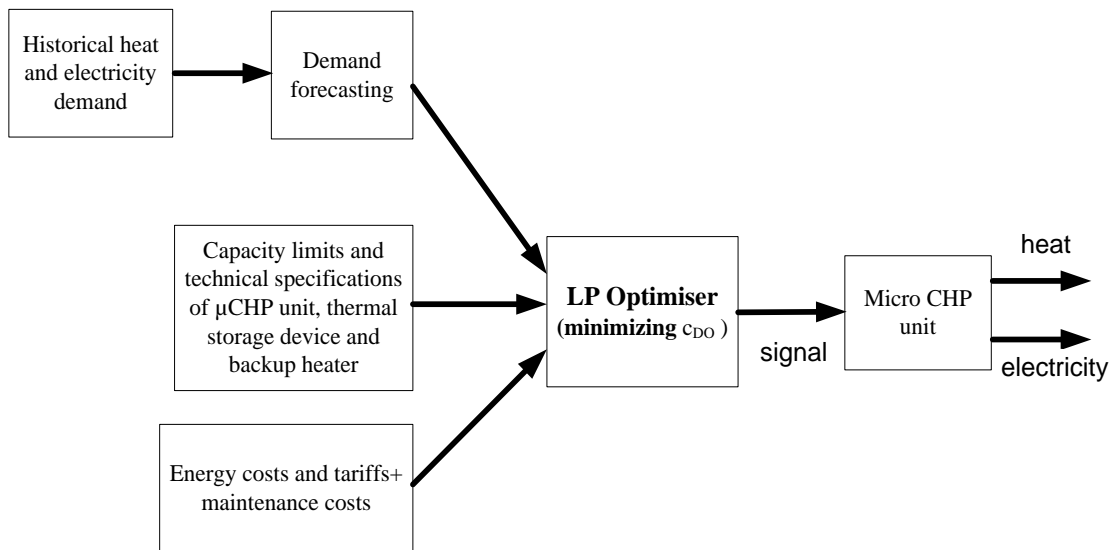

Figure 5.2 Overview of the LPO

A. Decision variables

The model contains six types of operation variables:

- the electrical output of the μ CHP unit during the i th hour, $(o_{el,i})$, (kWh),

- the thermal output of the backup heater during the i th hour, $(o_{th,i})$, (kWh),
- the exported electricity during the i th hour, $(o_{ex,i})$, (kWh),
- the imported electricity during the i th hour, $(o_{im,i})$, (kWh),
- the thermal input to the storage device during the i th hour, $(o_{st_in,i})$, (kWh),
- the thermal output from the storage device during the i th hour, $(o_{st_out,i})$ (kWh).

The number of variables is the product of the number of operation variables and the number of hours per day, i.e. 144 (6×24).

The value of $o_{el,i}$ can vary from zero kWh to the maximum possible electrical output of the μ CHP unit while the value of $o_{th,i}$ can vary from zero to the maximum possible output of the backup heater. The value of $o_{ex,i}$ can vary from zero when no exporting occurs to the maximum possible electrical output of the μ CHP unit when there is no demand at all. The value of $o_{im,i}$ can vary from zero when its more desirable to cover all the electrical demand from the μ CHP unit to the highest possible value of demand, which vary from one dwelling to another. The value of $o_{st_in,i}$ can vary from zero kWh to the value of thermal output of the μ CHP unit when there is no heat demand while the value of $o_{st_out,i}$ vary from zero when the μ CHP unit is able to cover heat demand to the maximum value that the storage device can deliver when there is no heat output from the μ CHP unit.

B. Objective function

There are several criteria that can be adopted to optimize the operation of energy systems [168]. However, reducing the operation cost is usually the most applied

one. As a result, the objective of this optimiser is stated to minimise c_{DO} , which is the sum of daily operation costs for operating the μ CHP system, while meeting both electricity and heat demands, taking technical and operational constraints into consideration. It includes the daily costs of imported electricity, fuel and maintenance, minus the revenue from the FIT for generation and exporting of electricity. As a result, the objective function can be expressed as follows:

$$\min c_{DO} = \sum_{i=1}^{n_h} (\alpha o_{el,i}) + (\beta o_{th,i}) + (\gamma o_{im,i}) - (\delta o_{ex,i}) + (\varepsilon o_{st_in,i}) - (\xi o_{st_out,i}) \quad (5.1)$$

The coefficients α , β , γ , δ , ε and ξ can be calculated as follows:

$$\alpha = \left(\frac{c_{NG} + e_{NG} \times t_C}{\eta_e} \right) \times \left(\frac{HHV}{LHV} \right) + m_{\mu CHP} \quad (5.2)$$

$$\beta = \left(\frac{c_{NG} + e_{NG} \times t_C}{\eta_B} \right) \times \left(\frac{HHV}{LHV} \right) + m_B \quad (5.3)$$

$$\gamma = c_{Eimp} + (e_{Grid} \times t_C) \quad (5.4)$$

$$\delta = c_{Exp} + (e_{Grid} \times t_C) \quad (5.5)$$

$$\varepsilon = \alpha \times Q \times \eta_e \quad (5.6)$$

$$\xi = \frac{\alpha \times Q \times \eta_e}{\eta_s} \quad (5.7)$$

C. Constraints

The constraints imposed on the LPO are as follows:

- The inability of a μ CHP unit, a thermal storage and a backup heater to exceed their maximum ratings:

$$o_{el,i} - R_{CHP} \leq 0 \text{ for } i= 1 \text{ to } 24 \quad (5.8)$$

$$o_{th,i} - R_B \leq 0 \text{ for } i= 1 \text{ to } 24 \quad (5.9)$$

$$o_{st,in,i} - R_S \leq 0 \text{ for } i= 1 \text{ to } 24 \quad (5.10)$$

$$o_{st,out,i} - R_S \leq 0 \text{ for } i= 1 \text{ to } 24 \quad (6.11)$$

- The output from the thermal storage device cannot exceed the amount of thermal energy stored plus the thermal energy absorbed by the thermal storage device each hour.

$$o_{st,out,i} \leq o_{st,in,i} + \sum_{i=1}^{24} (o_{st,in,i} - o_{st,out,i}) \quad (5.12)$$

- The input to the storage device cannot exceed the difference between the capacity of the thermal storage device and the amount of energy stored plus the energy exported from the storage device each hour.

$$o_{st,in,i} \leq R_S - \left(\sum_{i=1}^{24} o_{st,in,i} - o_{st,out,i} \right) + o_{st,out,i} \quad (5.13)$$

- Ramp limits for the μ CHP unit cannot be exceeded. Ramp limits are the ability of the PEMFC to ramp up and ramp down once it is steadily operated. Experimental data has shown that a 1 kWe PEMFC cannot ramp up more than 41.67 Watts of electricity per minute and cannot ramp down more than 50 Watts per minute [152]. Same percentage of the kWe rating is used for the 2kWe PEMFC, which means that a 2 kWe PEMFC cannot ramp up more than 83.34 Watts of electricity per minute and cannot ramp down more than 100 Watts per minute. So, these values have been included in the model as follows:

$$o_{el,i} - o_{el,i+1} \leq R_d \text{ for } i= 1 \text{ to } 24 \quad (5.14)$$

$$o_{el,i+1} - o_{el,i} \leq R_u \text{ for } i= 1 \text{ to } 24 \quad (5.15)$$

- Forecasted electricity demand of the house each hour (L_i) must be met exactly.

However, importing and exporting electricity from/to the μ G is possible.

$$o_{el,i} + o_{im,i} - o_{ex,i} = L_{i,f} \text{ for } i= 1 \text{ to } 24 \quad (5.16)$$

- Forecasted heat demand (H_i) must be met exactly and no heat dumping is allowed.

$$o_{el,i} \times Q + o_{th,i} - o_{st_in,i} + o_{st_out,i} = H_{i,f} \text{ for } i= 1 \text{ to } 24 \quad (5.17)$$

Where Q is the heat to power ratio of the μ CHP unit

The number of inequality constraints generated from the eight expressions (5.8)-(5.15), is the product of the number of expressions and the number of hours per day, i.e. 168 (8×24). Similarly, the number of inequality constraints generated from the two expressions: (5.16) and (5.17) is 48 (2×24).

5.3 Results and discussion

In order to test the online LPO, three simulation scenarios have been investigated to establish how the μ CHP unit operates and quantify its associated operating costs. The investigations represent a comparison between the optimiser and the conventional pre-determined operation strategies (HLOS and ELOS) for all three scenarios. The results obtained by the online LPO are used as input signals to a model of μ CHP system, which was previously developed and presented in chapter 4. That model is capable of simulating the performance of a μ CHP system for any period of time. This μ CHP system consists of the following components: one μ CHP unit, one backup heater, one thermal storage device and a μ G connection to allow importing and exporting of electricity, as previously illustrated in Figure 5.1.

5.3.1 Feed-in tariff (FIT) scenario

The FIT scheme, which has been introduced recently in the UK, has been considered. According to this scheme, μ CHP units of capacity less than or equal to 2 kWe will be eligible. The householder will be awarded 10 pence per each kWh of generated electricity and further 3 pence per each kWh of exported electricity [166]. Electricity and gas prices are based on typical prices for bulk purchase of fuels at domestic scale, issued by Biomass Energy Centre in January 2010 [169]. The price of natural gas is considered on a fixed rate of £0.041/kWh based on HHV, and the price of imported electricity is considered at a fixed rate of £0.133 /kWh.

According to the estimate published by the UK's Department for Environment, Food and Rural Affairs (DEFRA), CO₂ emission factors for the UK grid electricity and natural gas equal 0.54418 kg/kWh and 0.18396 kg/kWh, respectively [170]. Maintenance costs are considered to be £0.015/kWh for both sizes of the μ CHP unit and £0.004/kWh for the backup heater [165].

A 1kWe proton exchange membrane fuel cell (PEMFC) has been considered for a semi-detached house (SDH) since it is the optimal size for a PEMFC to be used for this type of demand, according to our sizing model [165]. This demand data, which is the hourly energy consumption of a SDH for a whole year, was collected for low energy dwellings in an area northwest of London. It was accessed through the UK Energy Research Centre Energy Data Centre [154]. Both electricity and heat

demands vary significantly during the day and they also vary significantly from one season to another. Figure 3 and Figure 4 show these variations for this demand profile. However, a 2kWe PEMFC has also been considered, to investigate the impact of using the LPO on a larger size. The 2 kWe size was chosen because it is the largest size eligible for the new FIT scheme as mentioned previously. The two conventional pre-determined operation strategies, as well as the LPO, have been applied for both sizes of PEMFC. Results are summarised in Figure 5.3. The monthly differences between these strategies, in terms of operation costs, are illustrated in Figure 5.4 and Figure 5.5.

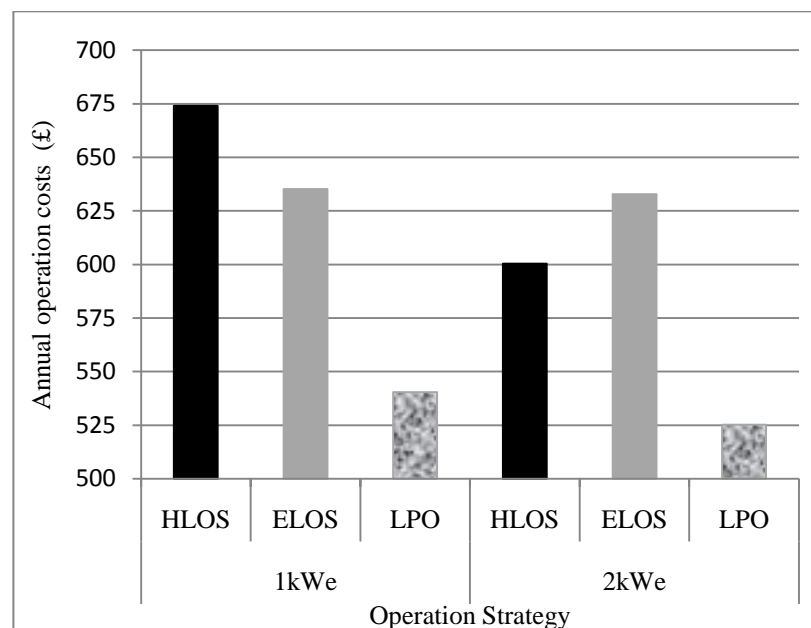

Figure 5.3 Operation costs (£) for different strategies when FIT scenario is applied and no carbon tax is considered

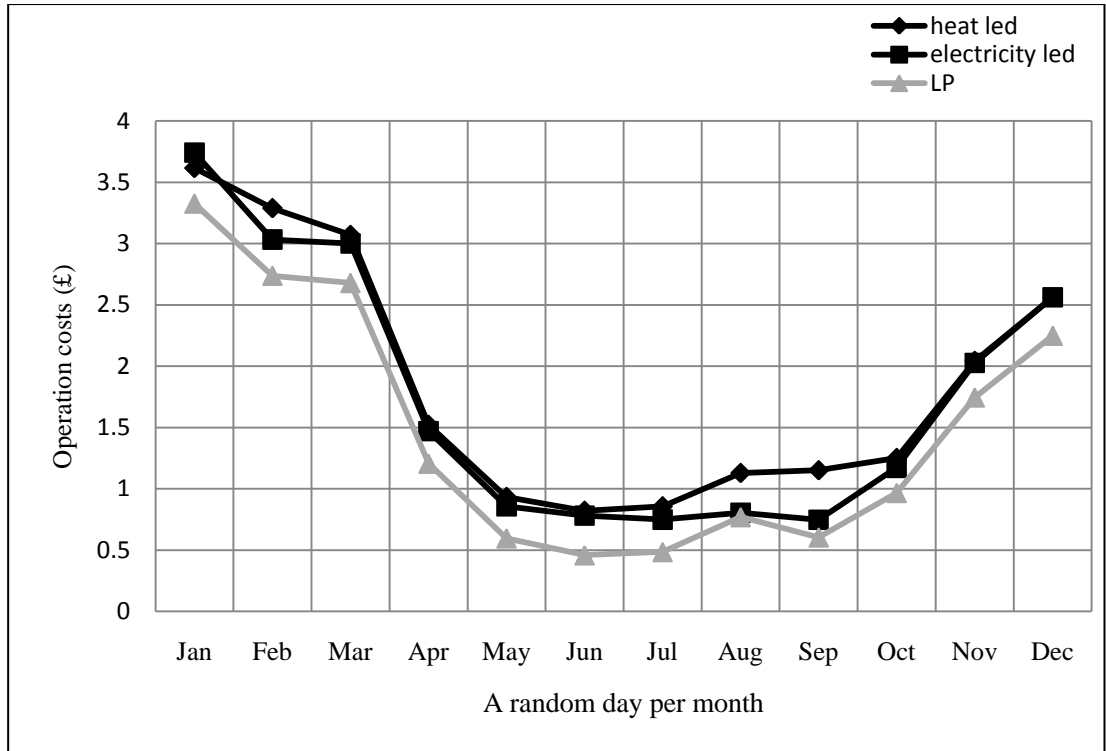

Figure 5.4 Operation costs for different strategies when FIT scenario is applied and a 1kWe PEM is used

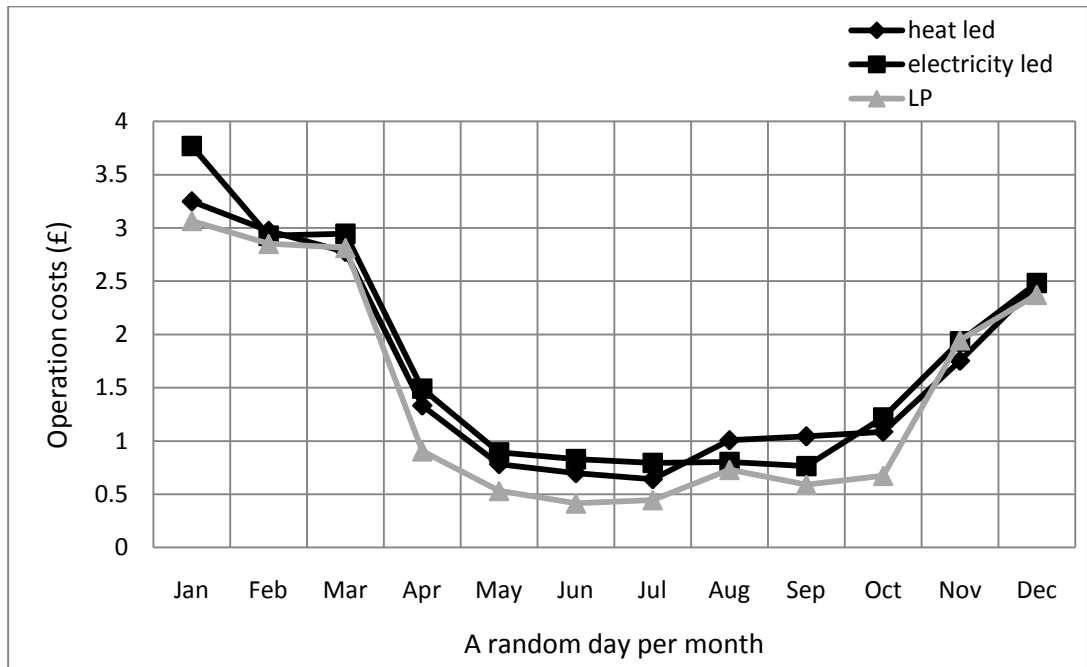

Figure 5.5 Operation costs for different strategies when FIT scenario is applied and a 2kWe PEM is used

When a 1kWe PEMFC is used, the results show that the online LPO has reduced the annual operation costs by approximately £153 and £108 when compared with the HLOS and ELOS respectively. Similar savings are achieved when a 2 kWe PEMFC is used, where approximately £86 and £123 of annual operation cost have been saved in comparison with the HLOS and ELOS respectively. However, it could be noted from figure 5.3 and figure 5.6 that a 2 kWe PEMFC has the potential to reduce operation costs when compared with the 1 kWe PEMFC for the HLOS and the online LPO optimiser because of the revenue from exporting electricity while when an ELOS is used almost no reduction in operation costs has been achieved. It can also be noted from Figures 5.4 and 5.5 that LPO reduces the daily operation cost when compared with both HLOS and ELOS in all but one month. Furthermore, it can be noted from figure 5.3 and figure 5.6 that when a 2 kWe PEMFC is used instead of a 1 kWe PEMFC, HLOS reduces the operation costs when compared with the ELOS because of the revenue gained from exporting electricity.

Typical weekdays and weekend days across January-December have also been investigated. No significant differences have been observed for all strategies. For example, the operation costs for a typical weekend day in January, was less than 6% higher than the operation costs for a typical weekday when HLOS and a 2 kWe PEMFC are used. Similar results have been observed for the online LPO and the ELOS. In addition, the online LPO reduces the operation costs with almost the same percentage when compared with the other two conventional strategies for both a typical weekday and a typical weekend day across January-December.

The same FIT scheme simulation scenario was investigated with the addition of a £20/tonne carbon tax of since it is expected that this tax may be adopted in the future to encourage the implementation of clean energy technologies. When a 1kWe PEMFC is used, as shown in Figure 5.6, the results show that the online LPO reduces the annual operation costs by approximately £165 and £125 when compared with the HLOS and ELOS respectively. Similar savings are gained when a 2 kWe PEMFC is used. These results indicate that the online LPO reduces annual operation costs when compared with the conventional pre-determined operation strategies.

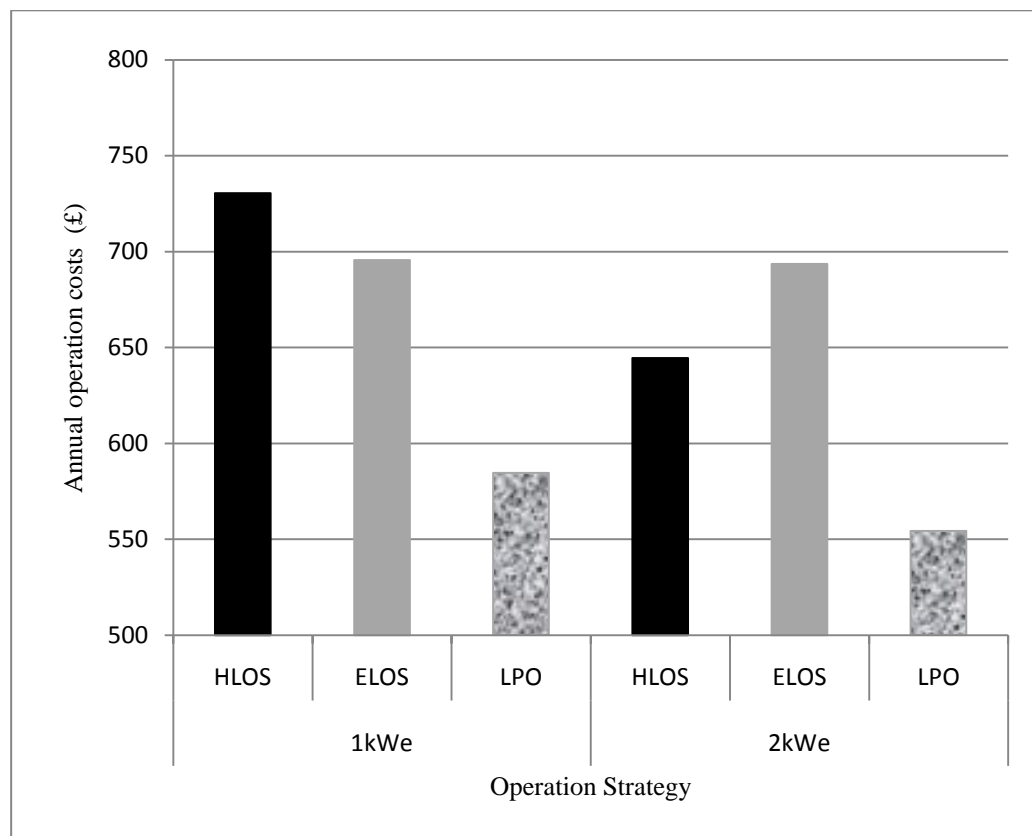
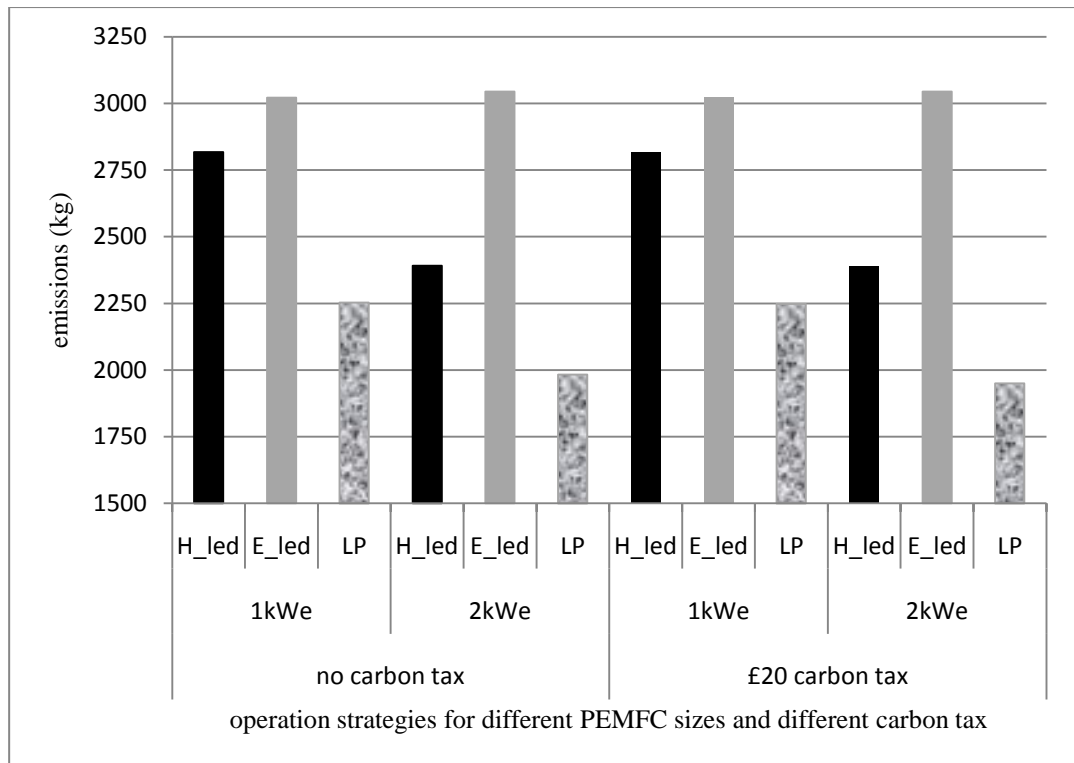

Figure 5.6 Operation costs for different strategies when FIT scheme is applied, and a £20/tonne carbon tax is considered

Figure 5.7 shows the annual CO₂ emissions for different strategies when FIT scenario is applied and two different sizes of PEMFC are considered. It can be noted that when a 1kWe PEMFC is used, the online LPO can significantly reduce the annual CO₂ emissions in comparison with HLOS and ELOS, regardless the value of carbon tax. The online LPO can reduce approximately 565 kg and 770 kg when compared with HLOS and ELOS, respectively. The LPO can further reduce the annual CO₂ emissions by approximately 300 kg against ELOS when a 2 kWe PEMFC is used regardless the value of carbon tax. However, when a 2 kWe PEMFC is used, the LPO reduces the annual CO₂ emissions by approximately 408 kg and 441 kg when compared with HLOS when no carbon tax and £20 carbon tax are considered respectively, because greater amount of heat can be produced by the 2kWe PEMFC. These results indicate that the online LPO reduces annual CO₂ emissions when compared with the conventional pre-determined operation strategies regardless the value of carbon tax.

5.3.2 Electricity trading scenario

Since the FIT scenario is only applicable to the first 3000 units installed [166], an electricity trading scenario has been considered. In this scenario any surplus electricity generated by μ CHP units can be sold and exported to the grid and any deficit in electricity can be purchased and imported from the grid.



5.7 Operation costs for different strategies when FIT scheme is applied, and a £20/tonne carbon tax is considered

The assumed values for maintenance cost and CO₂ emission factors are the same as used in the FIT scenario. However, the price of electricity met by the μ G is considered at a fixed rate of £0.082/kWh; the price of natural gas is considered on a fixed rate of £0.0228/kWh based on HHV [75]. Also, the price of exported electricity is considered at a fixed rate at three different percentage values of retail price: 50%, 75% and 100%.

As in the previous scenario, 1kWe and 2kWe PEMFCs have been considered for the same demand profiles. The two conventional pre-determined operation strategies and the online LPO have been applied for each size of PEMFC. Results of using 1 kWe and 2kWe PEMFCs are summarised in Table 5.2. The monthly

differences between these strategies, in terms of operation costs, when 1 kW_e PEMFC is used, are illustrated in Figure 5.7.

Results have shown that, when the electricity price of exporting is the same as the retail price (i.e. 100%), using the LPO with a 1kW_e PEMFC reduces the annual operation cost by approximately £156 and £112 when compared with the ELOS and HLOS respectively. Similarly, when the electricity price of exporting is the same as the retail price, using the LPO with a 2kW_e PEMFC reduces the annual operation cost by approximately £227 and £93 when compared with the ELOS and HLOS respectively. The monthly differences between strategies in terms of operation costs for a 2kW_e PEMFC are illustrated in Figure 5.8.

Table 5.1 Annual operation costs and savings (£) for different strategies when electricity trading scenario is applied and 1kW_e PEMFC and 2kW_e PEMFC are used

Size of PEMFC unit	Operation costs (£)	exported price 50%			exported price 75%			exported price 100%		
		HLOS	ELOS	LPO	HLOS	ELOS	LPO	HLOS	ELOS	LPO
1kW_e	Total	456	413	415	416	413	387	375	413	276
	Savings	0	44	41	0	3	29	38	0	137
2kW_e	Total	477	415	418	387	415	385	297	415	216
	Savings	0	62	59	28	0	31	118	0	199

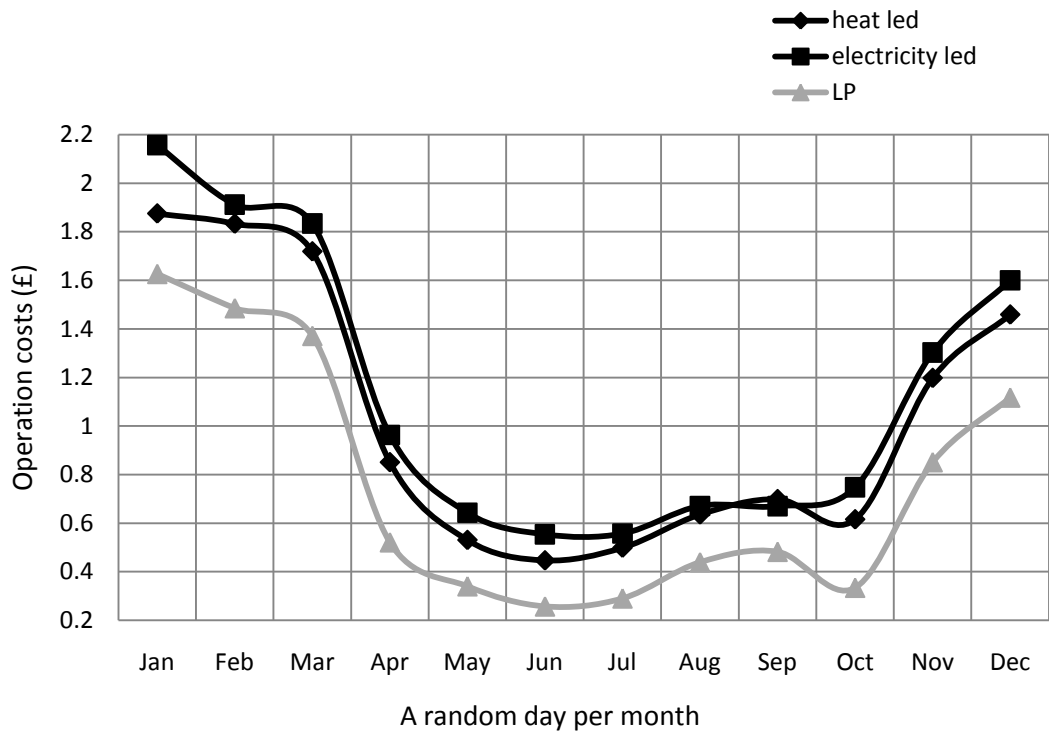

Figure 5.8 Operation costs for different strategies when electricity trading scenario is applied, 100% exporting price is considered and a 1kW PEMFC is used

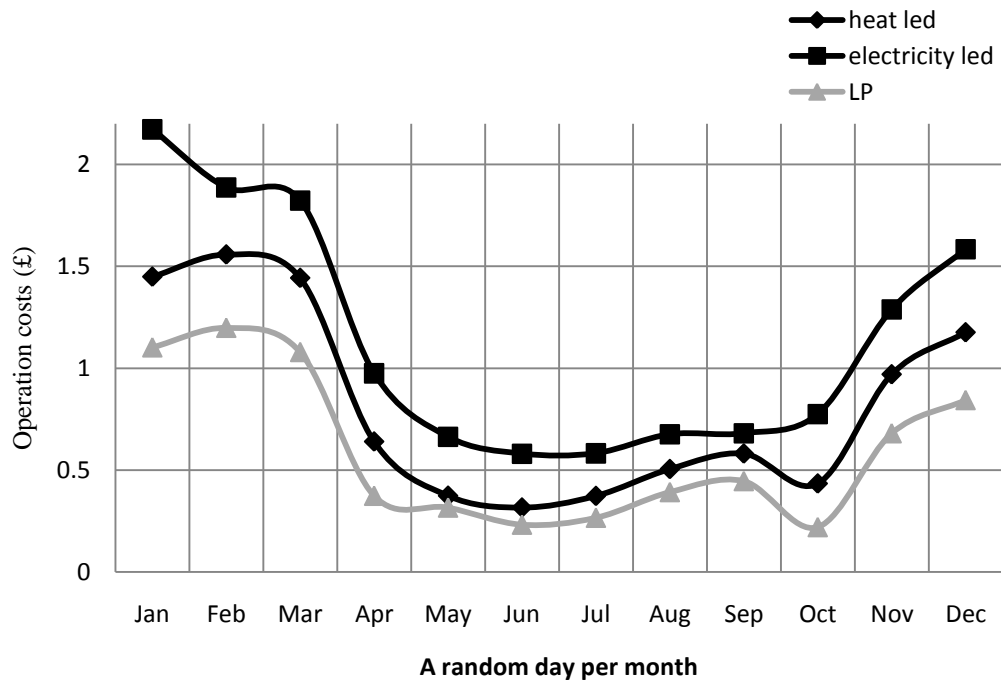

Figure 5.9 Operation costs for different strategies when electricity trading scenario is applied, 100% exporting price is considered and a 2kW PEMFC is used

It can be seen in Table 5.2 that when the exporting price is less than the retail price (i.e. 50% and 75%), the LPO achieve savings, albeit less significant, when compared with the conventional pre-determined operation strategies.

It can be noted from table 5.3 that the online LPO can reduce the annual CO₂ emissions when compared with the conventional predetermined operation strategies once 75% or 100% exporting price is considered. For example, when exporting price is 100% of retail price, the LPO reduces the annual CO₂ emissions by 609 kg and 859 kg when compared with ELOS once a 1kWe PEMFC and 2kWe PEMFC are used respectively. However, it reduces the annual CO₂ emissions by 405 kg and 206 kg against ELOS when a 1kWe PEMFC and 2kWe PEMFC are used respectively. However, when the exporting price is 50% of retail price, the LPO can even increase the annual CO₂ emissions, especially when compared with HLOS. For instance, the online LPO can increase the annual CO₂ emissions by 656 kg in comparison with HLOS when a 2kW PEMFC is used.

5.3.3 Carbon tax scenario

For this scenario, the impact of introducing a carbon tax coupled with an electricity trading scenario has been investigated. It is expected that a global CO₂ emission trading system will be a key element in the policies required for ensuring compliance with climate protection targets [171]. The rise in carbon reduction targets over the next decades is expected to lead to corresponding rises in carbon taxes. However, there is uncertainty regarding the extent of these rises ranging

from tens of Euros per tonne of CO₂ if technologies of carbon capture and storage are successfully developed [172] to several hundreds of pounds per tonne of CO₂ under more pessimistic assumptions [173-174]. One of the lowest current estimates in the UK assumes that the implied cost of carbon dioxide is £20/tonne of CO₂ [171]. Further, the carbon price support policy has recently been announced by the UK Treasury, which will start at £16/tonne CO₂ on the first of April 2013 and it is expected to rise to approximately £70/ tonne CO₂ by 2030 [65]. In order to investigate the effects of current and possible future carbon tax values, encapsulating those set out in the UK's current carbon process policy, a range from £0/tonne CO₂ (non carbon tax scenario) to £500/tonne CO₂ were used in the simulations. Within this range, intermediate values of £20/tonne, £120/tonne, and £200/tonne are also considered.

Table 5.2 Annual CO₂ emissions (kg) for different strategies when electricity trading scenario is applied and 1kWe PEMFC and 2kWe PEMFC are used

Export price as a percentage of retail price	Size of PEMFC	1 kWe			2 kWe		
	Operation strategy	HLOS	ELOS	LPO	HLOS	ELOS	LPO
50%	Total CO ₂ emissions (kg)	2817	3021	3017	2391	3044	3047
75%	Total CO ₂ emissions (kg)	2817	3021	2274	2391	3044	1913
100%	Total CO ₂ emissions (kg)	2817	3021	2412	2391	3044	2185

The same assumptions in Section 5.4.1 for electricity prices, maintenance costs and CO₂ emission factors have been applied. A 1kWe PEMFC was considered for the

same demand profile used in the previous scenarios. The two conventional pre-determined operation strategies and the LPO have been applied for different values of carbon tax: £20/tonne, £120/tonne, £200/tonne and £500/tonne in combination with three different values for exporting electricity: 50%, 75% and 100% of retail price. Table 5.4 shows the resulting annual operation costs when considering carbon tax at the four values stated. The monthly differences between these strategies, in terms of operation costs, when 1 kWe PEMFC is used are illustrated in Figures 5.9-5.12.

Table 5.3 Annual operation costs (£) for different strategies when different values of carbon tax is applied and 1kWe PEMFC is used

Carbon tax (£/tonne of CO ₂)	Operation strategy	HLOS			ELOS			LPO		
	Electricity export price (% of retail price)	50%	75%	100%	50%	75%	100%	50%	75%	100%
20	Annual operation costs (£)	588	549	510	538	538	538	546	542	440
	Annual Savings (£)	0	0	28	50	11	0	42	7	98
120	Annual operation costs (£)	873	831	790	840	840	840	846	769	658
	Annual Savings (£)	0	9.0	50	33	0	0	27	71	182
200	Annual operation costs (£)	1098	1057	1016	1082	1082	1082	1095	957	837
	Annual Savings (£)	0	25	66	16	0	0	3	125	245
500	Annual operation costs (£)	1943	1902	1861	1988	1988	1988	1726	1621	1504
	Annual Savings (£)	45.0	86	127	0	0	0	262	367	484

From Table 5.4, it can be seen that increasing the carbon tax significantly increases the savings in operation costs when the price of exporting electricity is the same as retail price. However, introducing a carbon tax when the export price is only 50% of the retail price, leads to significant reductions in the operation costs only when the carbon tax is at its highest level. That is, the LPO can reduce the annual operation costs by £247 against the HLOS and by £299 in comparison with ELOS when a carbon tax of £500/tonne is used.

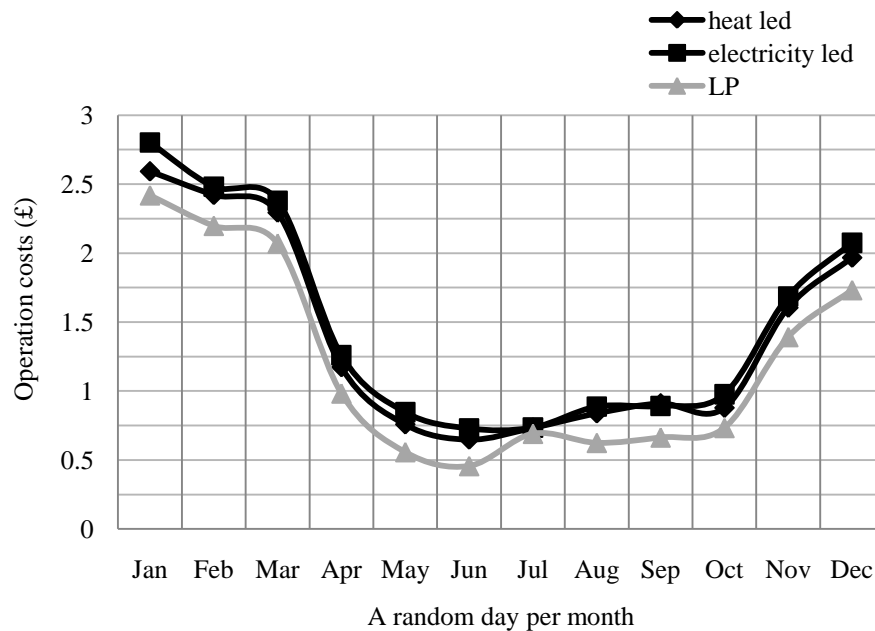

Figure 5.10 Operation costs for different strategies when a £20/tonne carbon tax is applied, 100% exporting price is considered and a 1kWe PEMFC is used

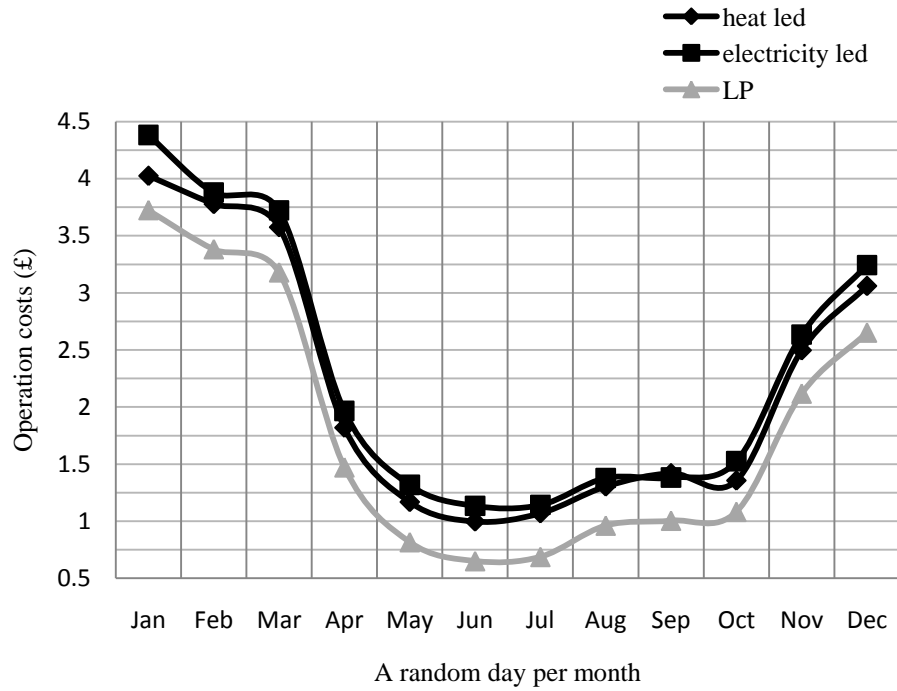

Figure 5.11 Operation costs for different strategies when a £120/tonne carbon tax is applied, 100% exporting price is considered and a 1kWe PEMFC is used

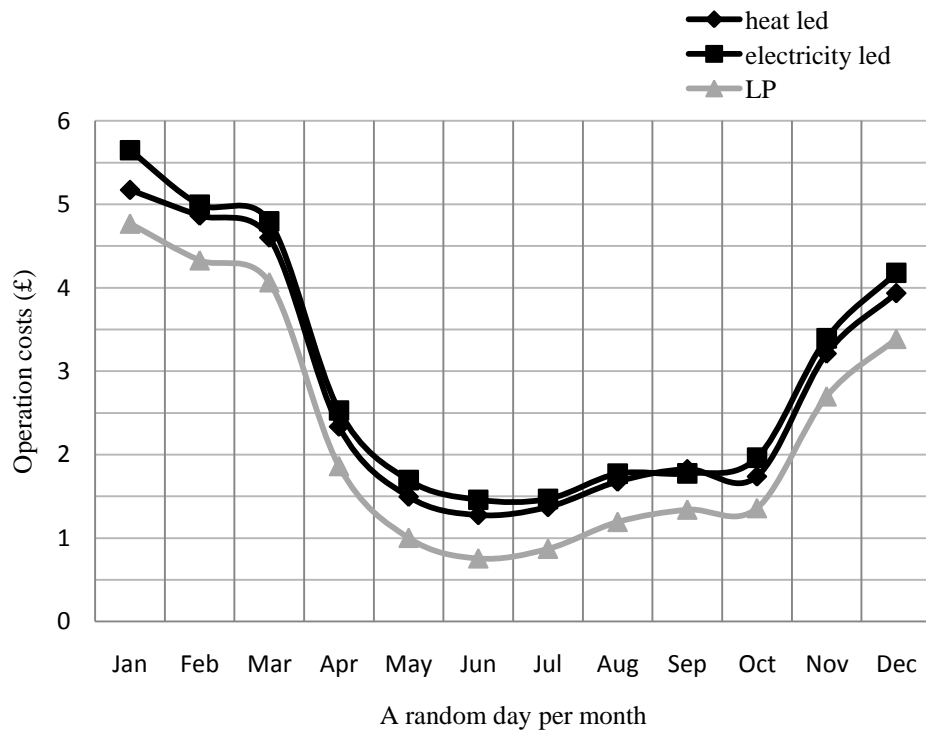

Figure 5.12 Operation costs for different strategies when a £200/ tonne carbon tax is applied, 100% exporting price is considered and a 1kWe PEMFC is used

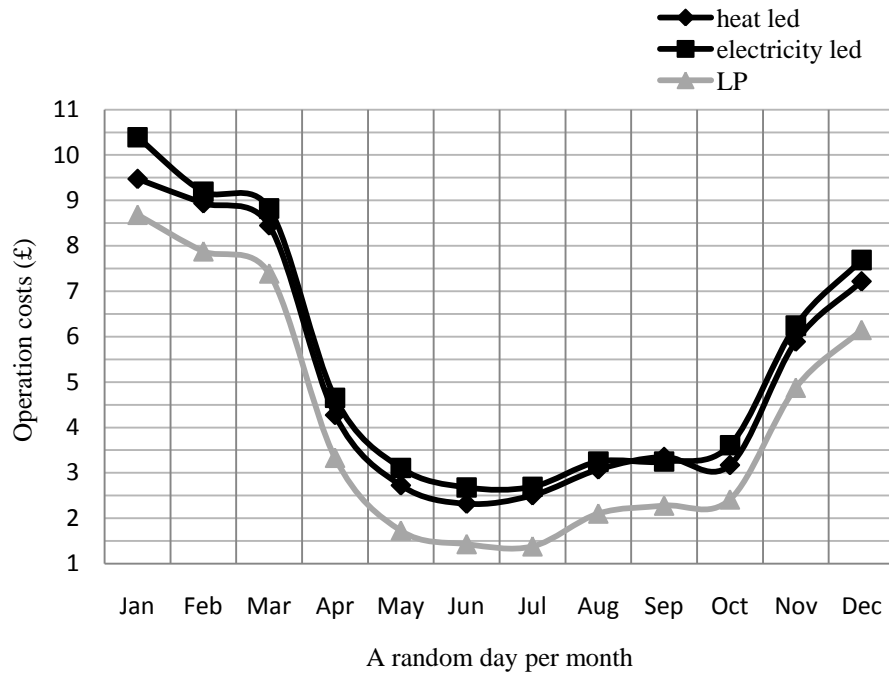

Figure 5.13 Operation costs for different strategies when a £500/tonne carbon tax is applied, 100% exporting price is considered and a 1kWe PEMFC is used

Table 5.5 shows the annual CO₂ emissions for the investigated strategies when different values of carbon tax are applied and a 1kWe PEMFC is used. It can be noted from this table that the LPO cannot reduce the annual CO₂ emissions when compared with the conventional predetermined operation strategies unless the value of carbon tax is incredibly high or the exporting price at 100% of retail price. Otherwise, the LP can even increase the emissions when compared with the conventional predetermined strategies. For instance, the LPO increases the annual CO₂ emissions by 228 kg and 24 kg when compared with HLOS and ELOS respectively when carbon tax is £20/tonne and the exporting price is 50% of retail price. On the other hand, when exporting price at 100% of retail price a significant amount of CO₂ can be reduced by using the online LPO instead of the conventional

operation strategies. For example, when carbon tax is £20/tonne the LPO reduces the annual CO₂ emission by 773 kg and 569 when compared with ELOS and HLOS respectively.

Table 5.4 Annual operation costs and CO₂ emissions for different strategies when different values of carbon tax are applied and 1kWe PEMFC is used

Carbon tax (£/tonne of CO ₂)	Electricity export price (% of retail price)	50%			75%			100%		
	Operation strategy	HLOS	ELOS	LPO	HLOS	ELOS	LPO	HLOS	ELOS	LPO
20	Annual emissions (kg)	2817	3021	3045	2817	3021	3040	2817	3021	2248
120	Annual emissions (kg)	2817	3021	3033	2817	3021	2249	2817	3021	2244
200	Annual emissions (kg)	2817	3021	3045	2817	3021	2255	2817	3021	2234
500	Annual emissions (kg)	2817	3021	2230	2817	3021	2244	2817	3021	2233

5.4 Conclusions

In the study presented in this chapter, the operation of a μ CHP unit, combined with a backup heater and a thermal storage device for typical residential dwellings, has been evaluated. A generic online LPO to determine the optimal operation of a μ CHP system has been developed and evaluated. The optimiser has been formulated in a generic form to allow its use for any demand profile and for any μ CHP technologies such as ICEs and SEs. This optimiser is capable of minimising the operation costs of such systems. Three different simulation scenarios have been investigated to evaluate the performance of the online optimiser: the FIT scheme, electricity trading and the introduction of a carbon tax.

The results have shown that the optimal online LPO reduces operation costs in comparison with the conventional pre-determined operation strategies in all the scenarios investigated. This optimiser provides a significant reduction in the annual operation costs when a FIT scheme is applied, which can reach approximately £153 when no carbon tax is considered and approximately £165 when a carbon tax is considered. The annual savings, due to using the LPO, increase significantly when the price of exporting electricity is the same as the retail price, which for example was approximately £227 when 1kWe PEMFC was used. Introducing a carbon tax maximises the benefits from using the online LPO, where the annual savings can reach £553 when a carbon tax of £500 per tonne of CO₂ is considered. It is emphasised that the LPO achieves the greatest savings when the export price is the same as retail price and the carbon tax is at the highest level.

Results have shown that when FIT scenario is applied the online LPO can significantly reduce the annual CO₂ emissions when compared with HLOS and ELOS, regardless the value of carbon tax. The online LPO can also reduce the annual CO₂ emissions when compared with the conventional predetermined operation strategies, especially when compared with ELOS, once 75% or 100% exporting price is considered. For example, when exporting price is 100% of retail price, the optimiser reduces the annual CO₂ emissions by 609 kg and 859 kg against ELOS once a 1kWe PEMFC and 2kWe PEMFC are used respectively. However, when the exporting price is 50% of retail price, the LPO can even increase the annual CO₂ emissions, especially in comparison with HLOS. For instance, the online LPO can increase the annual CO₂ emissions by 656 kg in

comparison with HLOS when a 2kW PEMFC is used. In addition, the LPO cannot reduce the annual CO₂ emissions when compared with the conventional predetermined operation strategies unless the value of carbon tax is incredibly high or the exporting price at 100% of retail price. Otherwise, the LP can even increase the emissions when compared with the conventional predetermined strategies. For instance, the LPO increases the annual CO₂ emissions by 228 kg and 24 kg when compared with HLOS and ELOS respectively when carbon tax is £20/tonne and the exporting price is 50% of retail price. On the other hand, when exporting price at 100% of retail price a significant amount of CO₂ can be reduced by using the online LPO instead of the conventional operation strategies. For example, when carbon tax is £20/tonne the LPO reduces the annual CO₂ emission by 773 kg and 569 when compared with ELOS and HLOS respectively.

In summary, it is suggested that the online LPO has the potential to deliver significant energy savings and operation cost savings in practice. It has also the ability to significantly reduce the annual CO₂ emissions when FIT scenario or a 100% exporting price is considered. That is, it is suggested that the continuously operating LPO could be embedded within the control systems of μ CHP technologies. Indeed, the adoption of the online LPO presented in this paper has the potential to make a significant contribution to the widespread proliferation of μ CHP technologies.

6 REAL TIME OPERATION OF μ CHP SYSTEMS USING FUZZY LOGIC

6.1 Introduction

This chapter is concerned with developing an effective tool for optimal real time operation of residential μ CHP systems without relying on historical data of heat and electricity demands. In this chapter, a real time FLOS of a μ CHP system is presented and has been developed, using the Matlab Fuzzy toolbox. This real time operation strategy allows for the μ CHP system to operate continuously online with the aim of achieving an efficient operation of the μ CHP system. Further, the real time FLOS minimises the operation costs and CO₂ emissions of such a system based on managing the thermal and electrical energy flow within the μ CHP system and exporting/importing electricity to/from the LVDN. The FLOS does not require any energy demand forecasting but it depends on the real thermal and electrical demands only. The same three simulation scenarios used in chapter 5, which have different incentive mechanisms for installing μ CHP technologies, have been investigated for the real time FLOS: the FIT scheme recently adopted in the UK [166]; the trade of electricity and the introduction of a carbon tax. Sensitivity analyses have been performed to gain an understanding of the influence of key parameters on decision making regarding the operation of residential μ CHP systems using the FLOS.

The remainder of this chapter is organised as follows. Section 6.2 describes the non-conventional operation strategies. In section 6.3, a real time FLOS is presented and for online operation of μ CHP systems. Section 6.4 presents results and a discussion based on the costs and emissions savings achieved through the

application of the real time operation strategy in three different simulation scenarios. Finally, Section 6.5 draws conclusions regarding the real time FLOS.

6.2 A comparison between LPO and FLOS

It has been stated in chapter 5 that μ CHP technologies are usually operated according to a predetermined conventional operation strategy, either according to a HLOS or an ELOS [14, 151]. An online LPO for operating a μ CHP system has been developed and evaluated in chapter 5. Results have shown that the LPO has the ability to reduce both operation costs and CO₂ emissions when compared with the two conventional operation strategies. However, this online optimiser significantly depends on the values of both electrical and thermal demands as inputs, which are stochastic and require a sophisticated forecasting model. There are several forecasting models available in the literature[175] but they require several measured meteorological input data such as outdoor temperature, global insolation, humidity and others, or alternatively, a data set of at least one year is necessary in order to generate satisfactory forecasted energy demand values for a residential building[176]. Furthermore, the accuracy of forecasting electricity and heat demands for a single dwelling is comparatively lower compared to a multiple single dwellings [175]. In addition, changing the occupancy of the house changes the demand pattern, which would further decrease the accuracy of the forecasting. As a result, obtaining another online operation strategy which is able to react with uncertainties of electricity and heat demand profiles, keeping as closed as possible to the optimal operation, is still to be investigated.

The efficient operation of μ CHP systems, especially for single dwellings, has the following attributes: nonlinear behaviour of the μ CHP unit, uncertainties, multiple inputs and vagueness. First of all, the system comprises non-linearity such as the values of electrical efficiency and heat to power ratio of the μ CHP unit under partial load. In addition, the operation of such a system is based on uncertain electrical and thermal demand variables. Furthermore, the operation of such a system would take decisions of operation according to multiple measured inputs: heat demand, electricity demand and amount of stored heat in the thermal storage device. Moreover, the performance of the μ CHP system is vague because it consists of subsystems: a μ CHP unit, a thermal storage device and a backup-heater, which are highly interconnected.

Due to the complexities inherent in the operation of the μ CHP systems, an intelligent technique that can deal with such complexities is required [35]. A FL approach, which aims to imitate the aspect of human cognition and sometimes called approximate reasoning [177], can deal with such complexities. Although FL is not able to provide the optimal decisions it has the ability to be executed in a relatively short time and has no convergence problem like LP. FL can also be easily implemented, flexible to change and it does not require any offline work. FL can efficiently deal with multiple inputs, which is the case for the μ CHP system, since it is based on if-then statements [178]. It is a transparent and qualitative technique, which gives this technique the capability to simplify the explanation of an operation strategy. In addition, these features makes the application of a 'human language' allowable for problems description and their fuzzy solutions [177]. FL can be applied in many applications, especially when the

systems have unknown models or when the input parameters are unstable and highly variable [117]. This feature is required for the operation of μ CHP systems since residential heat and electricity demands have such characteristics. In addition, FL is flexible where its rules can be easily modified because they do not use human operator's strategy only but they are also expressed in ordinary linguistic terms. Furthermore, FL can be applied successfully in modelling of vague systems which are complex and imprecise systems since it is a simple approach [179]. Due to the complexity of the μ CHP unit itself and the synergetic operation of different devices, it is complex to build a perfect mathematical model of such a system and FL appears to be suitable for such a system. Moreover, FL systems have a clear and understandable behaviour since they are based on a logical structure that possesses straightforward inference statements. On the other hand, a FL system usually relies on domain experts to provide the necessary knowledge for a specific problem[125] and it does not give an optimal solution. As a result, aimed at an efficient operation of such a complicated system, fuzzy rule-based technique appears to be a good candidate for operation of a μ CHP system.

Fuzzy rule-based technique has been widely investigated for hybrid electric vehicles [110, 119, 123, 180]. μ CHP system is extremely similar to a hybrid vehicle system, where both have a generation unit and a storage device unit and both systems have to respond to a changeable and uncertain energy demand. A μ CHP system is a complex electro-thermal system and consists of more than one energy source: μ CHP unit, a thermal storage device and a LVDN. A major challenge for the development of μ CHP system is the coordination of these multiple energy sources in order to efficiently manage the thermal and electrical

power flow aiming to maximize the benefits of such systems. This necessitates the utilization of an appropriate real time operation strategy, which is an algorithm to realize an efficient operation of a μ CHP system.

Previous research has not yet developed a real time FL operation strategy (FLOS) for residential μ CHP systems that accounts for a backup heater and a thermal storage device. Consequently, it would be developed and investigated in this chapter.

6.3 Non-conventional operation Strategies

Non-conventional operational strategies are the strategies which their main aim is to search for the optimal or near-optimal working condition of the system at each time step [109]. Non-conventional Operation strategies used for hybrid energy systems can be classified into two main categories: optimization-based and rules-based operation strategies [110].

Operation strategies based on optimization techniques are performed over a fixed demand profile and hence a global optimal solution can be determined [111]. These operation strategies are based on searching, according to a certain objective function, for optimal parameters that lead to optimal performance of a system such as LP, NLP and DP is one of the most popular and effective methods in optimisation when the entire profile is known a priori [112], which makes it suitable for offline optimisation only since it is a time consuming technique. LP, which has been used in chapter 5, is relatively faster and less time consuming but it still relies

on historical data of electricity and heat demands which are not always available. Furthermore, LP is based on linearization of relationships, which slightly reduces its accuracy. As a result, it can be said that LP technique has several advantages to be applied in the field of the operation of μ CHP systems as described in chapter 5 but it has some limitations to be applied for a direct real-time online operation of a system such as relying on historical demand data.

Rules-based operation strategies are those operation strategies which generally use deterministic, fuzzy logic or artificial intelligence. Fuzzy logic control (FLC) technique has gained considerable popularity in recent years [119]. This approach leads to a fuzzy system which is more likely a decision system (supervisor) based on fuzzy rules than a fuzzy controller [120]. Fuzzy rule-based strategies cannot assure the global optimal performance of a system like the optimization-based solution but it is capable of effectively providing a near optimal performance of a system. FL provides a significantly simple way to draw specific conclusions from unclear, ambiguous or imprecise information. FL depends on a different way of thinking, which is based on modelling complex systems using a higher level of abstraction originating just from our knowledge and experience while classical logic entails exact equations and precise numeric values.

The idea of FL is based on relating the output variable/variables to input variables according to 'IF.THEN' statements, called rules. Unlike Boolean logic, which describes that a given input is either a member of a given set (logic 1) or not (logic 0), FL solves problems that tend to change anywhere in the range of 0-1 [121]. Therefore, the FL offers smooth relocation of the output signal instead of sharp

switching when one rule dominates the other. As a result, FL is quite suitable to the systems composed of nonlinear behaviours where an overall mathematical model is difficult to obtain since the rules can be designed based on heuristics, intuition and human expertise [122].

FL is also very effective in the application of real-time operation strategies of power flow in a hybrid or multiple energy system [123], which is the case for the μ CHP system since it consists of more than one energy source. Moreover, there is no need for historical data of heat and electricity demands, which is an important advantage over other types of intelligent techniques such as neural networks and genetic algorithms and over the mathematical techniques such as linear programming. Finally, fuzzy rule-based operation strategy has a quite suitable structure for use in experimental studies due to its merit of fast decision capability and it can be easily embedded in an online control unit such as a microprocessor, etc [124].

6.4 Real time fuzzy rule-based operation of μ CHP systems

6.4.1 Overview

As it has been described in section 5.31., the residential μ CHP system consists of a μ CHP unit, a thermal storage device and a backup heater. The operation of a residential μ CHP system is designed as a real time fuzzy rule-based operation strategy based on fuzzy logic and named “*FL operation strategy*” (FLOS) as described in the following sections. The objective of the real time FLOS is to

decide the electrical output power of the μ CHP which would minimise the operation costs and CO₂ emissions. The main idea of the FL is to maximise the energy utilisation by delivering the maximum possible energy from the fuel cell while insuring that no heat is dumped. This principle can guarantee minimising the total amount of primary energy used and CO₂ emissions because of the inherent efficiency of the μ CHP unit. As a result, minimisation of the total amount of primary energy used will necessarily result in minimisation of operation costs once an encouraging exporting price or FIT is considered. The real time FLOS is formulated in a generic form to allow its use for any μ CHP system and any demand pattern. Moreover, this generic form enables the FLOS to work effectively with all different incentive mechanisms that could be applied for installing μ CHP technologies.

The real time FLOS has been designed to regulate the output power of the μ CHP unit using three input variables: heat demand, electricity demand and the instantaneous temperature of the water inside the thermal storage device. These three input variables have been stated the most influent input variables through studying and understanding the fundamental behaviour of the main devices of the μ CHP system. Figure 6.1 shows an overview of the real time FLOS.

The local controls of the μ CHP unit and the thermal storage device are considered effective. For instance, the μ CHP unit will not exceed the ramping upper limit even if it is decided by the FLOS to exceed that limit [124]. Once the μ CHP unit is operated according to the output of the real time FLOS the flow of thermal and electrical power (i.e. storing heat, backup heating, exporting and importing

electricity) is decided according to the similar rules stated in section 5.31. Simulation results obtained using MATLAB& Simulink are presented to verify the effectiveness of the proposed real time FLOS.

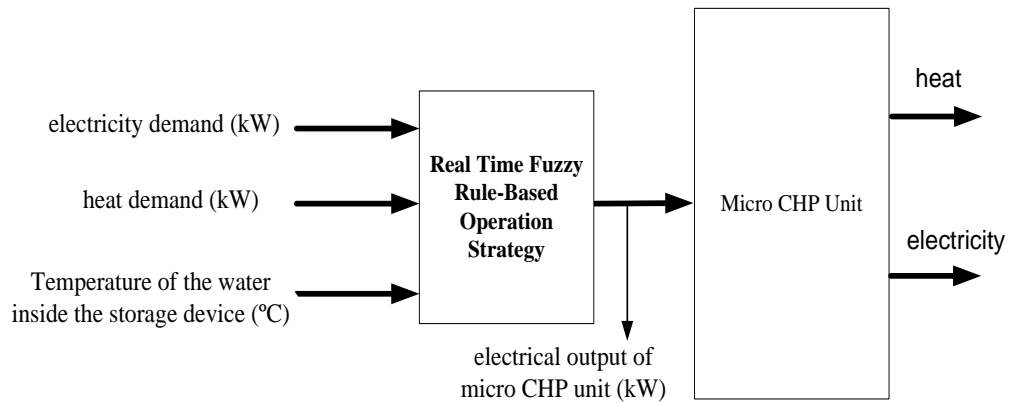

Figure 6.1 Overview of the real time fuzzy rule-based operation strategy

6.4.2 Model assumptions

The main purpose of the model is to develop a real time FLOS capable to operate a residential μ CHP system, where the electrical output of the μ CHP unit is instantaneously determined. As such, the model involves determining the instantaneous values of the electrical output power of the μ CHP unit (kWe) that would minimise operation costs and CO₂ emissions. The instantaneous value of electrical output power of the μ CHP unit (kWe), which is an output of the real time FLOS, will be determined according the value of three inputs: electrical demand, heat demand and the instantaneous temperature of the water inside the thermal storage device.

It is assumed that the μ CHP unit can operate anywhere between 0% and 100% of its capacity. In addition, the μ CHP system is assumed to be perfectly reliable, i.e. shutdowns are not considered in the model. Furthermore, the local controls of the μ CHP unit and the thermal storage device are assumed to be effective.

6.4.3 Design of the real time fuzzy rule-based operation strategy

Online operation of a residential μ CHP system has been formulated as a real time fuzzy rule-based model named “*FL operation strategy*” (FLOS). This section describes the main stages of the real time FLOS, which include: input fuzzification, fuzzy inference system and defuzzification. Particular attention has been paid to the rule base because it plays the main and significant role in the process of the operation strategy. The real time FLOS has been designed to have three inputs and one output. The inputs are the electrical demand (kW), the heat demand (kW) and the instantaneous temperature of the water inside the thermal storage device ($^{\circ}$ C) while the output is the instantaneous value of electrical output power required by the μ CHP unit (kWe). The model has been built in Matlab& Simulink by using the FL toolbox. Figure 6.2 shows an overview of this operation strategy in Matlab.

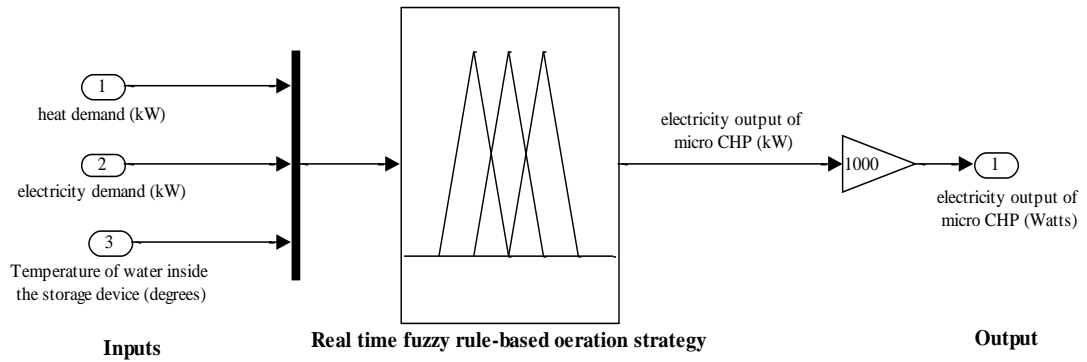

Figure 6.2 an overview of the real time fuzzy rule-based operation strategy in Simulink

A. Membership functions

A membership function is a curve which defines how to map each point in the input value to a membership value between 0 and 1 [181]. This process is called input fuzzification.

The universe of discourse for the both heat and electricity demands is 0 kW to 1 kW, when a 1 kWe PEMFC is used, while it is 0 kW to 2 kW when a 2 kWe PEMFC is used. The two inputs have the same universe discourse because the PEMFC has almost one heat to power ratio. It should be noted that when the value of heat or electricity demand is higher than the upper value of the universe of discourse it is simply consider it as the upper value because the fuel cell cannot produce heat or electricity greater than that value. The universe of discourse for the instantaneous temperature of the water inside the thermal storage device is 50 °C to 75 °C, which is the assumed as an operating range for the thermal storage device in the model of the μ CHP presented in chapter 4. The value of the temperature will be read instantaneously from the thermal storage device model presented in chapter 4 while the heat and electricity demand will be read instantaneously from the

electricity and heat demand profiles. The universe of discourse for the electrical output power required by the μ CHP unit is 0 kW to 1 kW when a 1 kWe PEMFC is used, while it is 0 kW to 2 kW when a 2 kWe PEMFC is used.

The selection of the membership function shapes and break points within the input and output universes slightly affects the way the FLOS works because the developed fuzzy system is aiming for an optimisation not for a control. Trapezoidal membership functions have been chosen for the low, the medium and the high of the real time fuzzy optimiser inputs and output due to its simplicity. Figure 6.3 shows the membership functions of the instantaneous temperature of the water inside the thermal storage device while figure 6.4 shows the membership functions of the electrical output power required by the μ CHP unit. It can be noted from examining the temperature membership functions in figure 6.3 that at temperature ranges from 61.25 °C to 63.75 °C the set medium was 100%. As the temperature makes excursion above or below this range the degree of membership of the sets high or low increases. The other two inputs and the output work in a similar way. It should be noted that membership functions can overlap which makes the possibility for a certain temperature for example to be a member of two sets at the same time. For instance, the temperature 65 °C has a membership value of the medium and high membership functions. This shows one of the ways in which the fuzzy logic deals with uncertainty.

Different types of membership functions have been investigated but trapezoid membership function has been found to perform more effectively than the others. Moreover, an asymmetric set of membership functions has been also investigated

but a symmetric set of membership functions has performed slightly more effectively. As a result, the symmetric trapezoid membership functions like those shown in figures 6.3 and 6.4 have been adopted for all the three inputs and the single output.

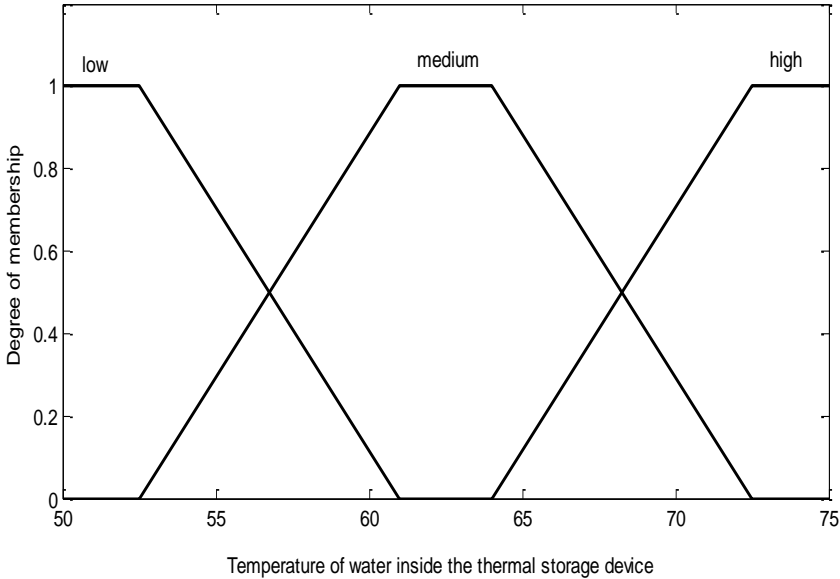

Figure 6.3 membership functions of the instantaneous temperature of the water (°C) inside the thermal storage device

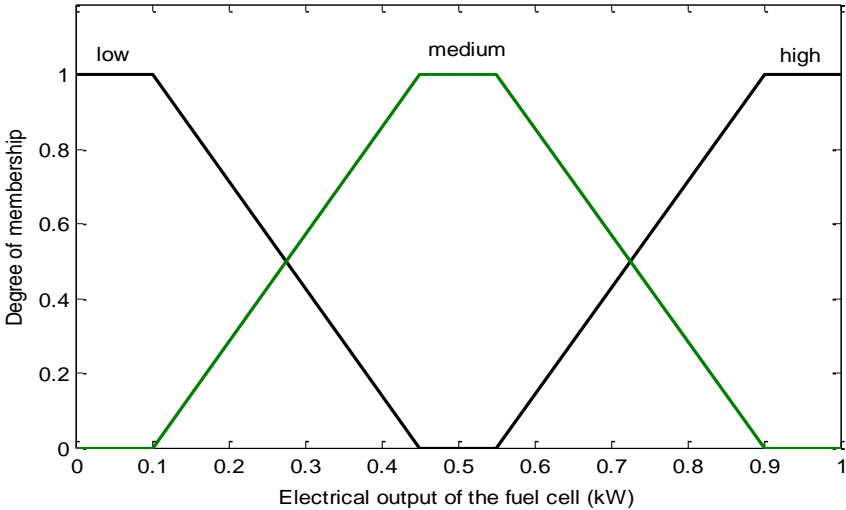

Figure 6.4 membership functions of the electrical output power required by the μCHP unit

B. Rule Base

The real time FLOS operates according to certain rules aiming to maximize the benefits of the μ CHP system in terms of operation costs and CO₂ emissions. The process state is evaluated and the output of the real time FLOS is determined at time t as a function of the inputs and the rules. The rules are in the following form:

IF (process state1) **AND** (process state2) **AND** (process state 3) **THEN** (FLOS output)

IF and AND part of the rule is known as the antecedent while THEN part is known as the consequent.

The selection of the rules is based on the idea of utilising the electrical and thermal energy produced by the μ CHP unit and considering the capacity of the thermal storage device. The real time FLOS has three membership functions or linguistic variables for each input of the three inputs and this has resulted in 14 rules as presented in table 6.1. The values in the un-highlighted boxes indicate the output produced for each combination of inputs, where H, M and L denote to high, medium and low respectively.

C. Fuzzy Inference System (FIS)

The process of formulating the mapping from a given input to an output value using fuzzy logic is called fuzzy inference process. This process includes the membership functions, FL operators and the fuzzy rules.

Table 6.1 Rules of the real time FLOS

		High electricity demand			Medium electricity demand			Low electricity demand		
		Heat demand			Heat demand			Heat demand		
		L	M	H	L	M	H	L	M	H
Storage Temperature	L	H	H	H	M	L	H	M	M	H
	M	M	H	H	M	M	H	M	M	H
	H	L	M	H	L	M	H	L	M	H

The fuzzy inference process that the real time FLOS uses to translate inputs values into an output value is show in table 6.2. Different other operators have also been investigated but theses operators have been selected due to their acceptable results.

Table 6.2 Operators of the real time FLOS

Stage	Operator Selected
AND method	MIN
Implication	MAX
Aggregation	MAX
De-fuzzification	MOM

6.5 Results and discussion

The real time FLOS has been integrated within a model of a μ CHP system, which was previously developed and presented in chapter 4. That model is capable of simulating the performance of a μ CHP system for any period of time. This μ CHP

system consists of the following components: one μ CHP unit, one backup heater, one thermal storage device, and a μ G connection to allow importing/exporting of electricity, as previously illustrated in Figure 5.1.

In order to test the real time FLOS, the three different simulation scenarios used in chapter 5 have been investigated to establish how the μ CHP unit operates and quantify its associated operating costs and CO₂ emissions. The investigations represent a comparison between the real time FLOS, the online LPO and the conventional pre-determined operation strategies (HLOS and ELOS) for all three scenarios.

6.5.1 Feed-in tariff (FIT) scenario

The FIT scheme, which has been investigated in chapter 5, has been considered in this chapter. The same electricity and gas prices, CO₂ emission factors for the UK grid electricity and natural gas, maintenance costs for the μ CHP unit and for the backup heater used in section 5.4.5 have been adopted in this section. Furthermore, two sizes of PEMFC: 1kWe and 2kWe have been considered for a semi-detached house (SDH). The impact of carbon tax in combination with the FIT scheme on the performance of the FLOS and the LPO as well as the predetermined conventional operation strategies has also been investigated. The results have been compared with the results obtained in section 5.4.5 for the two conventional pre-determined operation strategies, as well as the LPO for both sizes of PEMFC: 1kWe and 2kWe. Figure 6.3 shows the annual operation costs for different strategies when FIT scenario is applied and two different sizes of PEMFC are considered.

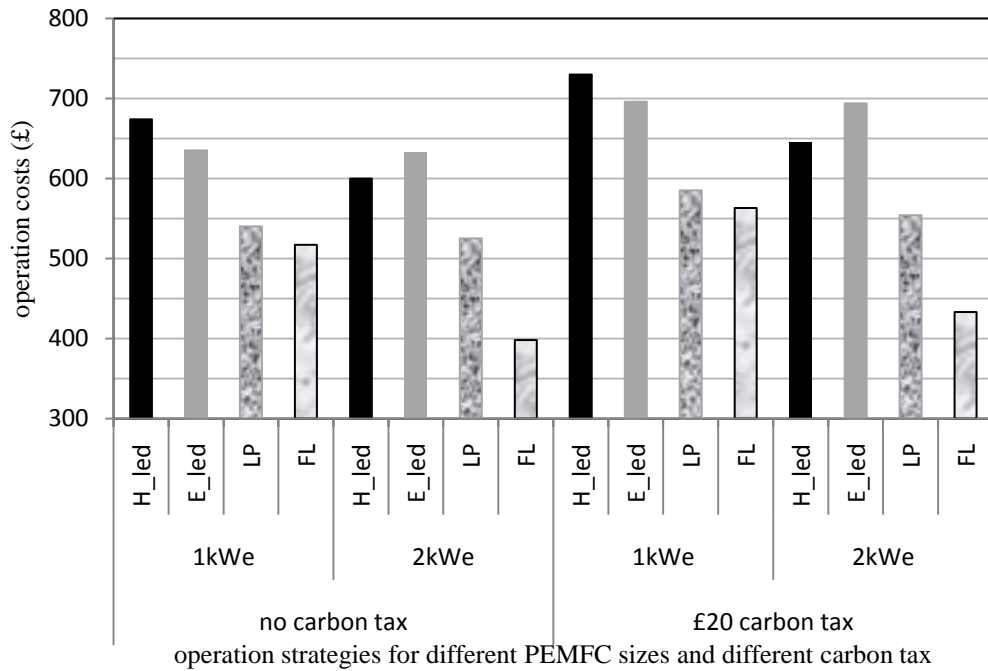

Figure 6.5 Operation costs for different strategies when FIT scenario is applied

When a 1kWe PEMFC is used, the results show that the online LPO has reduced the annual operation costs by approximately £134 and £95 in comparison with the HLOS and ELOS respectively, as it is shown in figure 6.5. When the real time FLOS is used further £23 has been saved when compared with the LPO optimiser, which means that the real time FLOS has reduced the annual operation costs by approximately £157 and £118 when compared with the HLOS and ELOS respectively. When a 2kWe PEMFC is used, the savings due to using of the online LPO were approximately £83 and £116 of annual operation costs when compared with the HLOS and ELOS, respectively. However, the FLOS has achieved savings approximately £202 and £235 of annual operation costs when compared with the HLOS and ELOS, respectively. These savings are higher than the savings achieved by the LPO by £119.

The same FIT scheme simulation scenario was investigated with the addition of £20/tonne carbon tax in order to compare with the results obtained in section 5.3.5, as it appears in figure 6.3. When a 1kWe PEMFC is used the results show that the LPO reduces the annual operation costs by approximately £145 and £111 when compared with the HLOS and ELOS respectively. The real time FLOS has achieved similar reduction in operation costs when compared with the predetermined operation strategies; where this operation strategy reduces the annual operation costs by approximately £167 and £133 when compared with the HLOS and ELOS respectively. This means that the real time FLOS reduces the annual operation costs slightly higher than the LPO. When a 2 kWe PEMFC is used, the LPO reduces the annual operation costs by approximately £91 and £140 when compared with the HLOS and ELOS respectively. The real time FLOS reduces the annual operation costs by £121 when compared with the LPO.

These results indicate that the real time FLOS significantly reduces annual operation costs when compared with the conventional pre-determined operation strategies. It also can considerably reduce the annual operation costs when compared with the LPO when 2kWe PEMFC is used. However, it slightly reduces the annual operation costs against the LPO when 1 kWe PEMFC is used. This is because the FIT is relatively high and more revenue can be gained due to exporting electricity when 2kWe PEMFC is used.

Figure 6.4 shows the annual CO₂ emissions for different strategies when FIT scenario is applied and two different sizes of PEMFC are considered. It can be

noted that when a 1kWe PEMFC is used, the FLOS can reduce the annual CO₂ emissions by 535 kg and 737 against HLOS and ELOS respectively, regardless the value of carbon tax. However, the LPO can slightly reduce the annual CO₂ emissions even against the FLOS where it reduces the annual CO₂ emissions when compared with the FLOS by approximately 29 kg when no carbon tax is applied and 34 kg when £20 carbon tax is applied.

When a 2 kWe PEMFC is used the FLOS can achieve significantly higher reductions in the annual CO₂ emissions against conventional predetermined operation strategies regardless the value of carbon tax, where it has reduced the annual emissions by 833 kg and 1486 kg when compared with HLOS and ELOS respectively. It can also be noted that when a 2kWe PEMFC is used, the FLOS can also reduce the annual emissions against the LPO by 425 kg and 392 kg when no carbon tax and a £20 carbon tax are applied, respectively.

It can be noted that the FLOS performed better than the LPO when a 2 kWe PEMFC is used while the LPO performed slightly better than the FLOS when a 1 kWe PEMFC is used. This is because same thermal storage capacity has been used with both sizes of PEMFC, which means that when 1 kWe PEMFC is used small amount of heat will be produced and can be absorbed by the thermal storage device while a 2 kWe PEMFC has the ability to produce higher amount of heat. So, if the LPO results in producing any extra heat because of any error due forecasting or linearization the thermal storage device can store this amount of heat once it is a small amount while it could not once it is higher than the storage capacity and the extra heat will be dumped resulting in higher CO₂ emissions. On the other hand,

when the FLOS is applied there is no chance for dumping heat even when a 2 kWe PEMFC is used because one of the inputs to the FLOS is the temperature of the thermal storage device.

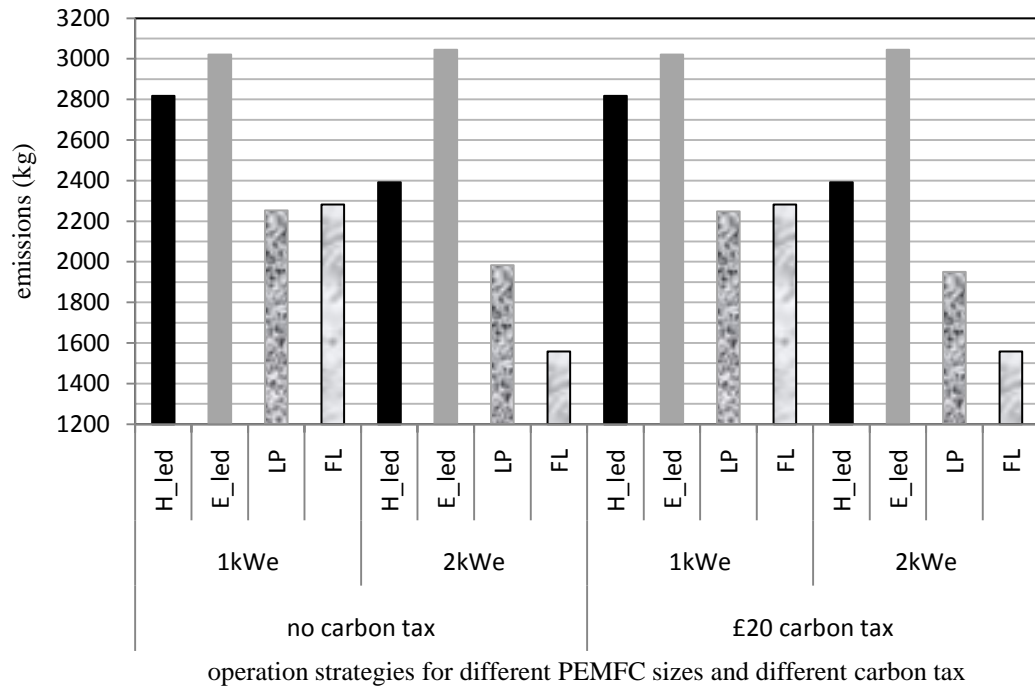

Figure 6.6 Annual CO₂ emissions for different strategies when FIT scheme is applied

6.5.2 Electricity trading scenario

An electricity trading scenario has been considered in order to compare with results obtained in 5.3.6. In this scenario, any surplus electricity generated by μ CHP units can be sold and exported to the grid and any deficit in electricity can be purchased and imported from the grid. The assumed values for maintenance cost, CO₂ emission factors, the price of electricity met by the μ G and the price of natural gas have the same values used in section 5.3.6. Also, the price of exported electricity is

considered at a fixed rate at three different percentage values of retail price: 50%, 75% and 100%.

As in the previous scenario, 1kWe and 2kWe PEMFCs have been considered for the same electricity and heat demand profiles. The two conventional pre-determined operation strategies, the online LPO and the FLOS have been applied for each size of PEMFC. Results of using 1 kWe and 2kWe PEMFCs are summarised in Table 6.3.

Table 6.3 Annual operation costs and CO₂ emissions for different strategies when electricity trading scenario is applied and 1kWe PEMFC and 2kWe PEMFC are used

Export price as a percentage of retail price	Size of PEMFC Operation strategy	1 kWe				2 kWe			
		HLOS	ELOS	LPO	FLOS	HLOS	ELOS	LPO	FLOS
50%	Operation costs (£)	456	413	415	446	477	415	418	479
	CO ₂ emissions (kg)	2817	3021	3017	2282	2391	3044	3047	1558
75%	Operation costs (£)	416	413	387	363	387	415	385	316
	CO ₂ emissions (kg)	2817	3021	2274	2282	2391	3044	1913	1558
100%	Operation costs (£)	375	413	276	281	297	415	216	153
	CO ₂ emissions (kg)	2817	3021	2412	2282	2391	3044	2185	1558

Results presented in table 6.3 have shown that, when the electricity price of exporting is the same as the retail price (i.e. 100%), using the real time FLOS strategy with a 1kWe PEMFC reduces the annual operation cost by approximately £94 and £137 when compared with the ELOS and HLOS respectively but the LPO can only reduce the annual operation cost by approximately £5 against the FLOS.

Similarly, when the electricity price of exporting is the same as the retail price, using the FLOS with a 2kWe PEMFC reduces the annual operation cost by approximately £144 and £362 and £63 when compared with the ELOS, HLOS and the LPO, respectively.

It can be seen in Table 6.3 that when the exporting price is less than the retail price (i.e. 50% and 75%), both the FLOS and the LPO achieve savings, albeit less significant, when compared with the conventional pre-determined operation strategies and even can slightly increase the annual operation costs against the conventional predetermined operation strategies. When the electricity price of exporting is 50% of the retail price, using the real time FLOS with a 1kWe PEMFC reduces the annual operation cost by only approximately £10 when compared with the HLOS but increases the annual operation costs by £33 and £31 when compared with the ELOS and the LPO respectively. When the electricity price of exporting is 75% of the retail price, using the real time FLOS can considerably reduce the annual operation costs against the predetermined operation strategies as well as when compared with the LPO for both sizes of PEMFC. For instance, when a 1kWe PEMFC is used, the FLOS reduces the annual operation cost by approximately £53 and £50 when compared with HLOS and ELOS respectively but it reduces the annual operation costs by only approximately £24 when compared with the LPO.

So, it can be concluded that FLOS can reduce the operation cost against the LPO when the exporting price is high and the PEMFC is larger while the LPO has the ability to reduce the operation costs slightly more than the FLOS when the

exporting price is low or the fuel cell is small. This because the FLOS is based on maximizing the utilization of energy and not based on minimizing the operation cost, which means some electricity will be sold with a low price.

It can be noted from table 6.3 that the real time FLOS in general reduces the annual CO₂ emissions when compared with the conventional predetermined operation strategies and the LPO for almost all the investigated cases because of the inherent efficiency of the PEMFC. When a 1kWe PEMFC is used, the FLOS reduces the annual CO₂ emissions by 535 kg and 737kg when compared with HLOS and ELOS respectively, regardless the price of exporting electricity. When a 2kWe PEMFC is used, the FLOS can further significantly reduce the annual CO₂ emissions, where this optimiser reduces the annual emissions by 833 kg and 1486 kg when compared with HLOS and ELOS for all levels of exporting electricity price. However, the FLOS reduces the annual CO₂ emissions when compared with the LPO with different values according to the exporting electricity price. When a 2 kWe PEMFC is used, the FLOS can reduce the annual CO₂ emissions when compared with the LPO by 1489 kg, 355 kg and 1627 kg when 50%, 75% and 100% exporting electricity prices as a percentage of the retail price are applied respectively. When a 1 kWe PEMFC is used, the FLOS reduces the annual CO₂ emissions in comparison with the LPO by only 130 kg once 100% exporting price is considered but it can reduce the annual emissions by 735 kg when the exporting price at 50% of the retail price. However, when the exporting price is 75% of retail price the LP reduces the annual CO₂ emissions by 8 kg when compared with the FLOS.

6.5.3 Carbon tax scenario

For this scenario, the impact of introducing a carbon tax coupled with an electricity trading scenario has been investigated. The same values of carbon tax used in section 5.37 which ranges from £20/tonne CO₂ to £500/tonne CO₂ have been considered in this analysis.

The same assumptions in Section 5.4.1 for electricity prices, maintenance costs and CO₂ emission factors have been applied. A 1kWe PEMFC was considered for the same demand profile used in the previous scenarios. The two conventional pre-determined operation strategies, the LPO and the real time FLOS have been applied for different values of carbon tax: £20/tonne, £120/tonne, £200/tonne and £500/tonne in combination with three different values for exporting electricity: 50%, 75% and 100% of retail price. Table 6.4 shows the resulting annual operation costs and CO₂ emissions considering carbon tax at the four values stated.

From Table 6.4, it can be seen that increasing the carbon tax significantly increases the savings in operation costs when the price of exporting electricity is the same as retail price for both the LPO and the FLOS. For example, when £20/tonne carbon tax is considered FLOS has saved £70 and £99 when compared with HLOS and ELOS respectively while the LPO has saved £75 and £104 when compared with HLOS and ELOS. However, introducing a carbon tax when the export price is only 50% of the retail price, leads to significant reductions in the operation costs for both the LPO and the FLOS only when the carbon tax is at its highest level. That is, when a carbon tax of £500/tonne is used the LPO can reduce the annual operation costs by £217 and £262 against the HLOS and the ELOS respectively

while the real time FLOS can reduce the annual operation costs by £223 and £268 when compared with the HLOS and the ELO respectively.

Table 6.4 Annual operation costs and CO₂ emissions for different strategies when different values of carbon tax are applied and 1kWe PEMFC is used

Carbon tax (£/tonne of CO ₂)	Electricity export price (% of retail price) Operation strategy	50%				75%				100%			
		HLOS	ELOS	LPO	FLOS	HLOS	ELOS	LPO	FLOS	HLOS	ELOS	LPO	FLOS
20	operation costs (£)	591	538	543	603	549	538	541	521	509	538	434	439
	emissions (kg)	2817	3021	3045	2282	2817	3021	3040	2282	2817	3021	2247	2282
120	operation costs (£)	873	840	846	836	831	840	769	754	790	840	658	672
	emissions (kg)	2817	3021	3033	2282	2817	3021	2249	2282	2817	3021	2244	2282
200	operation costs (£)	1098	1082	1092	1022	1057	1082	958	940	1016	1082	835	858
	emissions (kg)	2817	3021	3045	2282	2817	3021	2255	2282	2817	3021	2234	2282
500	operation costs (£)	1943	1988	1726	1720	1057	1082	958	940	1861	1988	1504	1556
	emissions (kg)	2817	3021	2230	2282	2817	3021	2244	2282	2817	3021	2233	2282

In general, the FLOS has the ability to reduce the annual operation costs almost at the same amount that the LPO does. However, the LPO reduces the annual operation costs slightly higher as the retail price and the value of carbon tax increases. For instance, the LPO can reduce the annual operation costs by £52 when compared with the real time FLOS when the carbon tax is £500/tonne of CO₂ and the exporting price at 100% of retail price. This is because the LPO can simply inform the PEMFC to operate at full load most of the time while the thermal energy storage can store any excess heat since a 1 kWe PEMFC cannot deliver a considerable amount of heat. On the other hand, when the exporting price is lower than 100% of the retail price the LPO will inform the PEMFC to deliver low

amount of electricity and this will entail the PEMFC to operate in the low efficiency region resulting (see Figure 4.3) in higher emissions.

The FLOS can reduce the annual CO₂ emissions by 535 kg and 739 kg in comparison with the ELOS and the HLOS respectively whatever the values of carbon tax and the price of exporting electricity. However, the LPO cannot reduce the annual CO₂ emissions when compared with the conventional predetermined operation strategies unless the value of carbon tax is incredibly high or the exporting price at 100% of retail price. Otherwise, the LPO can even increase the emissions when compared with the conventional predetermined strategies. For instance, the LPO increases the annual CO₂ emissions by 228 kg and 24 kg when compared with HLOS and ELOS respectively when carbon tax is £20/tonne and the exporting price is 50% of retail price. On the other hand, when exporting price at 100% of retail price the LPO can reduce the annual CO₂ emission even slightly better than the FLOS. For example, the LPO can reduce CO₂ emissions by 35 kg when compared with the FLOS when exporting price at 100% of retail price and the value of carbon tax is £20/tonne.

6.6 Conclusions

In this chapter, the use of fuzzy rule base technique has been applied for the real time operation of μ CHP systems used for typical residential dwellings. The investigated μ CHP system consists of a μ CHP unit, combined with a backup heater and a thermal storage. A generic real time FLOS to determine an efficient operation of a μ CHP system has been developed and evaluated. This operation

strategy has been formulated in a generic form in order to allow its use for any demand profile, and for any μ CHP technologies such as ICEs and SEs. The FLOS is capable of minimising the annual operation costs and CO₂ emissions of such systems. Three different simulation scenarios have been investigated to evaluate the performance of this real time operation strategy: the FIT scheme, electricity trading and the introduction of a carbon tax.

The results have shown that the real time FLOS reduces operation costs and CO₂ emissions in comparison with the conventional pre-determined operation strategies in all the scenarios investigated. It can also sometimes reduce the annual operation costs and CO₂ emissions when compared with the online LPO.

The real time FLOS strategy provides a significant reduction in the annual operation costs when a FIT scheme is applied when compared with the predetermined conventional strategies and the LPO, which can for example, reach approximately £235 when no carbon tax is considered and approximately £261 when a carbon tax is considered when compared with ELOS. The annual savings in operation costs when compared with the predetermined conventional strategies, due to using the real time FLOS, increase significantly when the price of exporting electricity is the same as the retail price, which for example was approximately £137 when a 1kWe PEMFC was used and £362 when a 2kWe PEMFC is used when compared with the ELOS. However, it has a comparable savings in operation costs when the price of exporting electricity is lower than 100% of retail price. Introducing a carbon tax maximises the benefits from using the real time FLOS when compared with the predetermined conventional operation strategies, where

the annual savings in operation costs can reach £432 when compared with ELOS when a carbon tax of £500 per tonne of CO₂ is considered and exporting price at 100% of retail price. It is emphasised that the real time FLOS as well as the LPO achieves the greatest savings when the export price is the same as retail price and the carbon tax is at the highest level.

The annual savings in CO₂ emissions when compared with the predetermined conventional strategies, due to using the real time FLOS, increase significantly when a 2kWe PEMFC used instead of a 1kWe PEMFC regardless the price of exporting electricity, which for example was approximately 737 kg when a 1kWe PEMFC was used and 1486 kg when a 2kWe PEMFC is used when compared with the ELOS, regardless the adopted incentive mechanism. However, the real time FLOS reduces the annual CO₂ emissions when compared with the LPO with different values according to the adopted incentive mechanism and the size of PEMFC. When FIT scheme is applied, the FLOS can significantly reduce the annual CO₂ emissions only when a 2kWe PEMFC is used while it can slightly increase the annual CO₂ emissions when compared with the LPO when a 1kWe PEMFC is used. The FLOS can also have significant reductions in CO₂emissions in comparison with the LPO, especially when a 2kWe PEMFC is used and the exporting price is at 50% of retail price, which for example this reduction was approximately 1489 kg when a 2kWe PEMFC was used and 789 kg when a 1kWe PEMFC is used. On the other hand, when carbon tax is introduced the real time FLOS has achieved comparable results to the LPO in terms of CO₂ emissions. As a result, it is emphasised that the real time FLOS as well as the LPO achieves the

greatest savings in CO₂ emissions when the export price is the same as retail price and the carbon tax is at the highest level.

In summary, it is suggested that the real time FLOS has the potential to deliver significant CO₂ emissions and operation cost savings in practice. That is, it is suggested that the real time FLOS could be embedded within the control systems of μ CHP technologies. Indeed, the adoption of the FLOS presented in this chapter has the potential to make a significant contribution to the widespread proliferation of μ CHP technologies.

7 DISCUSSION AND CONCLUSIONS

In section 7.1, results have been further discussed in order to highlight the importance of the developed models especially the LP sizing model and the developed non-conventional operation strategies. Conclusions that have been drawn as a result of this research have also been presented in section 7.2. In addition, section 7.3 proposes future work that could augment the value of this research.

7.1 Discussion

The results obtained in chapters 4, 5 and 6, which are related to optimal sizing and the developed non-conventional operation strategies using the linear programming optimiser (LPO) and the fuzzy logic operation strategy (FLOS), are further discussed in the following two sections. The first one discusses the financial viability of μ CHP systems for single dwellings while the second one discusses the performance of the non-conventional operation of a μ CHP system.

7.1.1 Financial viability of μ CHP systems for single dwellings

In chapter 4, two sizing techniques have been used to investigate the optimal size of a μ CHP system which could be used for a single dwelling. The techniques are the MR method and the LP technique. Table 16 shows the recommended sizes of different units by using the MR method and the LP model. The sizing is based on optimistic values of capital costs and technical specifications of the main candidate types of μ CHP units.

The results show that there are significant differences between results obtained by the two methods. This is because the LP model considers the capital and operation cost while the MR method does not. Furthermore, the MR method suggests a size that leads to the maximum possible energy that can be covered by the μ CHP regardless of its profitability. On the other hand, the LP model does not suggest a larger size unless it is more cost effective.

Table 7.1 Recommended sizes of different μ CHP units by using MR method and LP model

μ CHP technology	Recommended size by MR method (kWe)	Recommended size by LP model (kWe)
SE	1.00–1.650	0.850–1.250
ICE	2.400–3.700	1.7–2.9
SOFC	3.300–5.100	0–0.400
PEMFC	2.700–4.150	0.600–0.700

It can be concluded from the results that ICE and SE based μ CHP units are currently the most cost effective technologies because they have lower capital costs when compared with PEMFC and SOFC based μ CHP units. This is due the high capital cost of the FC. However, introducing a non-conventional operation strategy could increase the benefits of μ CHP system. Furthermore, in the future there may be no need for a fuel processor to convert the gas into hydrogen if the hydrogen becomes available in the market. As a result, the capital cost of the FC would be significantly reduced because the fuel processor represents one third of the capital cost.

Since FCs are still under development and are expected to see a drop in their capital cost in future, PEMFC has been investigated, as an example, under a range of expected capital costs to find the optimal size at those costs. This analysis has been executed by the developed LP sizing model. The analysis shows that a drop in capital cost from £2884 to £312 can lead to a recommended size of 6.250 kWe instead of 0.656 kWe for the PEMFC. However, it seems that the £312/kWe capital cost is very optimistic while a £1000/kWe capital cost is more realistic and is widely expected in the literature. The value of £1000/kWe capital cost has shown that the recommended size of PEMFC is in the range of 0.900–1.800 kWe depending on the type of residential energy demand.

The results of sizing PEMFC based on a £1000/kWe capital cost have been compared to the current SE and ICE based μ CHP. It has been noticed that PEMFC has the highest value of the equivalent annual cost (c_{EA}) among the investigated technologies. This is because the analysis has been carried out by considering a FIT at 50% of retail price. As a result, exporting electricity at a low rate will result in a low value of c_{EA} for PEMFC. This is attributed to PEMFC having the potential to export more electricity than SE and ICE due to the fact that this technology has the highest electrical efficiency and the lowest H:P ratio.

Sensitivity analysis has also shown that introducing an encouraging value of FIT has a significant impact on the feasibility of PEMFC and its estimated size. For instance, increasing the FIT from 50% to 100% of the import electricity price changed the optimal size of PEMFC from 0.656 kWe to 2.884 kWe. Further, this reduced the value of c_{EA} from £904.3 to £723.2.

In general, it can be concluded that using ICE and SE based μ CHP systems is financially viable even with their current capital costs, technical specification and even with introducing a low feed-in tariff. However, FCs are still relatively expensive and they are not financially viable according to the current prices unless a high feed-in tariff scheme is introduced. For this reason, adopting non-conventional operation strategies and introducing incentives such as feed-in tariff scheme would make using FCs in single dwellings viable. As a result, developing a non-conventional operation strategy has been considered and investigated in this research.

According to the literature, the capital costs of FCs will drop in the future and if this happened FCs would be one of the most attractive candidates for using in single dwellings because they have several advantages over other types of μ CHP technologies such as low emissions and low noise.

7.1.2 Non-conventional operation of a μ CHP system

μ CHP systems are usually operated by conventional operation strategies such as heat led operation strategy (HLOS) and electricity led operation strategy (ELOS). However, these strategies are predetermined strategies and they do not have the capability to manage the energy flow online. As a result two different non-conventional operation strategies have been developed: the LPO and the FLOS. The developed strategies aim to reduce operation costs and CO₂ emissions. As a result, adopting such strategies has the potential to increase the financial viability

of μ CHP systems in single dwellings. The operation of a μ CHP unit (PEMFC unit as an example) combined with a backup heater and a thermal storage device for typical residential dwellings has been evaluated by the two strategies.

A generic online LPO and a real time FLOS to efficiently operate a μ CHP system have been developed and evaluated. They have been formulated in a generic form to allow its use for any demand profile and for any μ CHP technologies such as ICEs and SEs. They are capable of minimising the operation costs of such systems. They also have been integrated in the model of the μ CHP system, which has been presented in chapter 3. Three different simulation scenarios have been investigated to evaluate the performance of the developed strategies: the FIT scheme, electricity trading and the introduction of a carbon tax. Furthermore, two different sizes of PEMFC units have been considered: 1 kWe PEMFC and 2 kWe PEMFC in order to cover the recommended range of sizes obtained by the LP sizing model.

The following sections discuss the performance of the developed non-conventional strategies for the three different scenarios.

A. *The Feed-in tariff scheme*

The LPO provides a significant reduction in the annual operation costs when a FIT scheme is applied, which can reach approximately £153 when no carbon tax is considered and approximately £165 when a carbon tax is considered. However, the real time FLOS still provides a significant reduction in the annual operation costs when a FIT scheme is applied when compared with the LPO, which can for example, reach approximately £121 when carbon tax is considered and 2kWe PEMFC is used.

Results have shown that when FIT scenario is applied the online LPO and the real time FLOS can significantly reduce the annual CO₂ emissions in comparison with HLOS and ELOS, regardless of the value of carbon tax. However, the real time FLOS reduces the annual CO₂ emissions when compared to the LPO with different values according to the adopted incentive mechanism and the size of PEMFC. When FIT scheme is applied, the FLOS can significantly reduce the annual CO₂ emissions only when a 2kWe PEMFC is used while it can slightly increase the annual CO₂ emissions when compared with the LPO when a 1kWe PEMFC is used.

B. Electricity trading scenario

The annual savings, due to using the LPO or the FLOS, increase significantly when the price of exporting electricity is the same as the retail price. For example, using the LPO in this case can reduce the annual operation costs by approximately £227 when a 1kWe PEMFC was used.

The online LPO can also reduce the annual CO₂ emissions when compared with the conventional predetermined operation strategies, especially when compared with ELOS, once 75% or 100% exporting price is considered. For example, when exporting price is 100% of retail price, the LPO reduces the annual CO₂ emissions by 609 kg and 859 kg against ELOS once a 1kWe PEMFC and 2kWe PEMFC are used respectively. However, when the exporting price is 50% of retail price, the LPO can even increase the annual CO₂ emissions, especially when compared with

HLOS. For instance, the online LPO can increase the annual CO₂ emissions by 656 kg against HLOS when a 2kW PEMFC is used.

The annual savings in CO₂ emissions when compared with the predetermined conventional strategies, due to using the real time FLOS, increase significantly when a 2kWe PEMFC used instead of a 1kWe PEMFC regardless the price of exporting electricity, which for example was approximately 737 kg when a 1kWe PEMFC was used and 1486 kg when a 2kWe PEMFC is used when compared with the ELOS, regardless the adopted incentive mechanism.

The FLOS can also have significant reductions in CO₂emissions when compared with the LPO, especially when a 2kWe PEMFC is used and the exporting price is at 50% of retail price, which for example this reduction was approximately 1489 kg when a 2kWe PEMFC is used and 789 kg when a 1kWe PEMFC is used.

C. Introducing of carbon tax scenario

Introducing a carbon tax maximises the benefits from using the online LPO and the real time FLOS. For example, the annual savings in operation costs due to using the FLOS can reach £432 when compared with ELOS when a carbon tax of £500 per tonne of CO₂ is considered and exporting price at 100% of retail price. It is emphasised that the real time operation strategy as well as the LPO achieves the greatest savings when the export price is the same as retail price and the carbon tax is at the highest level.

The LPO cannot reduce the annual CO₂ emissions when compared with the conventional predetermined operation strategies unless the value of carbon tax is

extremely high or the exporting price is at 100% of retail price. Otherwise, the LP can even increase the emissions when compared with the conventional predetermined strategies. For instance, the LPO increases the annual CO₂ emissions by 228 kg and 24 kg when compared with HLOS and ELOS respectively when carbon tax is £20/tonne and the exporting price is 50% of retail price. On the other hand, when exporting price at 100% of retail price a significant amount of CO₂ can be reduced by using the online LPO instead of the conventional operation strategies. For example, when carbon tax is £20/tonne the LPO reduces the annual CO₂ emission by 773 kg and 569 when compared with ELOS and HLOS respectively. When carbon tax is introduced the real time FLOS has achieved comparable results to the LPO in terms of CO₂ emissions. As a result, it is emphasised that the real time FLOS as well as the LPO achieves the greatest savings in CO₂ emissions when the export price is the same as retail price and the carbon tax is at the highest level.

In summary, it is suggested that the online LPO and the real time FLOS have the potential to deliver significant energy savings and operation cost savings in practice. They also have the ability to significantly reduce the annual CO₂ emissions when FIT scenario or a 100% exporting price is considered. That is, it is suggested that the continuously operating LPO or the real time FLOS could be embedded within the control systems of μ CHP technologies. Indeed, the adoption of the online LPO and the real time FLOS presented in this thesis has the potential to make a significant contribution to the widespread proliferation of μ CHP technologies.

7.2 Conclusions

This thesis has explored the optimisation and operation of μ CHP systems in the residential sector, especially in single dwellings. Three broad areas have been identified for potential contributions to academic and industrial knowledge:

- Development of a generic LP model for sizing μ CHP system components
- Development of an online LPO for operation of a residential μ CHP system
- Development of a real time FLOS for operating a residential μ CHP system

This research also has the potential to encourage the penetration of μ CHP technology, especially FCs, in the residential sector as μ CHP technology is capable of improving the economic and environmental value of this sector. Furthermore, the application of such operation strategies could encourage mass production of μ CHP units, particularly FCs, because these strategies would significantly reduce their costs.

The main conclusions of this research have been identified as follows.

1. A generic LP sizing model aiming to determine the most economical size of a residential μ CHP system has been developed and presented. The model is capable of determining the optimal size (electrical rating) of the μ CHP unit and the optimal size (thermal rating) of the backup heater required for any given residential demand regardless of the type of μ CHP technology.
2. An online operation strategy, which aims to determine the optimal operation of a μ CHP system by minimising operation costs, has been developed and formulated in a generic form using LP and it is called “online LPO”. The LPO has been formulated in a generic form to allow

its use for any demand profile and for other μ CHP technologies: SOFC, ICEs and SEs. Results obtained by the LPO have shown the following:

- The optimal online LPO reduces operation costs in comparison with the conventional pre-determined operation strategies in all the scenarios investigated, especially when a FIT scheme is applied or a relatively high price for exporting electricity (i.e. exporting price equals retail price) is considered.
 - The LPO achieves the greatest savings when the export price is the same as retail price and the carbon tax is at the highest level.
 - When FIT scenario is applied the online LPO can significantly reduce the annual CO₂ emissions in comparison with HLOS and ELOS, regardless the value of carbon tax. The online LPO can also reduce the annual CO₂ emissions in comparison with the conventional predetermined operation strategies, especially when compared with ELOS, once 75% or 100% exporting price is considered.
3. A real time FLOS, which is capable of minimising the annual operation costs and CO₂ emissions of a μ CHP system, has been developed and evaluated. This operation strategy has been formulated in a generic manner to allow its use for any demand profile, and a range of μ CHP technologies other than PEMFCs, namely SOFCs, ICEs and SEs. The results have shown the following:
- The real time FLOS reduces operation costs and CO₂ emissions in comparison with the conventional pre-determined operation strategies in all the scenarios investigated. Furthermore, in many

cases it can reduce the annual operation costs and CO₂ emissions compared with the online LPO.

- When considering the practical implementation of real time μ CHP operation strategies, the FLOS has a number of attractive features: namely FLOS:
 - has no requirement for a forecasting system or historical data,
 - can be easily embedded in a real time control unit such as a microprocessor, and,
 - has a fast execution time as it is not computationally expensive.
- 4. The LPO could be used for single dwellings which have a relatively predictable demand because it depends on forecasting. However, the FLOS could be used for dwellings which have non predictable demand such as renting houses because this model does not rely on demand forecasting.
- 5. The developed models could be slightly modified in order to be used for any hybrid or multiple energy system such as a tri-generation system or any renewable energy system.

7.3 Future Work

Although the current research has investigated the optimisation and operation of μ CHP systems in residential sector, especially in single dwellings, further research and investigation are still to be carried out in order to develop and implement this

research. Several areas which would improve the current research have been identified as follows.

1. Although the models have been designed in generic forms investigating the performance of other μ CHP technologies, namely: SOFCs, SEs and ICEs based μ CHP systems and investigating different types of current and future energy demand patterns would be beneficial.
2. Testing the performance of the LPO and the real time FLOS experimentally will support the current results.
3. The developed LPO and the real time FLOS have been designed to maximise the benefits of the householder. So, it would be useful to investigate a different scenario, where the benefits of the LVDN are considered instead of considering the benefits of the householder.

References

- [1] Committee on Climate Change, 2005, <http://www.theccc.org.uk>, last accessed 18/08/2009.
- [2] R. Kannan and N. Strachan, "Modelling the UK residential energy sector under long-term decarbonisation scenarios: Comparison between energy systems and sectoral modelling approaches," *Applied energy*, vol. 86, pp. 416-428, 2009.
- [3] J. Cockroft and N. Kelly, "A comparative assessment of future heat and power sources for the UK domestic sector," *Energy Conversion and Management*, vol. 47, pp. 2349-2360, 2006.
- [4] S. Abu-Sharkh, *et al.*, "Can microgrids make a major contribution to UK energy supply?," *Renewable and Sustainable Energy Reviews*, vol. 10, pp. 78-127, 2006.
- [5] H. Onovwiona and V. Ugursal, "Residential cogeneration systems: review of the current technology," *Renewable and Sustainable Energy Reviews*, vol. 10, pp. 389-431, 2006.
- [6] Y. Ruan, *et al.*, "Optimal option of distributed generation technologies for various commercial buildings," *Applied energy*, vol. 86, pp. 1641-1653, 2009.
- [7] A. DeBruyn, "Integration of Combined Heat and Power Generators into Small Buildings- A Transient Analysis Approach," Master, Waterloo university, 2006.
- [8] A. Hawkes and M. Leach, "Cost-effective operating strategy for residential micro-combined heat and power," *Energy*, vol. 32, pp. 711-723, 2007.
- [9] A. U. Dufour, "Fuel cells—a new contributor to stationary power," *Journal of power sources*, vol. 71, pp. 19-25, 1998.
- [10] E. Entchev, *et al.*, "Micro-generation technology assessment for housing technology," *Energy and Buildings*, vol. 36, pp. 925-931, 2004.
- [11] A. Peacock and M. Newborough, "Impact of micro-CHP systems on domestic sector CO2 emissions," *Applied thermal engineering*, vol. 25, pp. 2653-2676, 2005.
- [12] M. Newborough, "Assessing the benefits of implementing micro-CHP systems in the UK," *Proceedings of the Institution of Mechanical Engineers, Part A: Journal of Power and Energy*, vol. 218, pp. 203-218, 2004.
- [13] S. Allen, *et al.*, "Prospects for and barriers to domestic micro-generation: A United Kingdom perspective," *Applied energy*, vol. 85, pp. 528-544, 2008.
- [14] O. A. Shaneb and P. Taylor, "An evaluation of integrated fuel cell and energy storage systems for residential applications," in *The 44th UPEC conference*, Glasgow-UK, 2009, pp. 1-5.
- [15] I. Staffell, "Fuel cells for domestic heat and power: are they worth it?," PhD Thesis, University of Birmingham, 2010.
- [16] M. Beccali, *et al.*, "Energy, economic and environmental analysis on RET-hydrogen systems in residential buildings," *Renewable energy*, vol. 33, pp. 366-382, 2008.

- [17] A. Peacock and M. Newborough, "Effect of heat-saving measures on the CO₂ savings attributable to micro-combined heat and power ([mu] CHP) systems in UK dwellings," *Energy*, vol. 33, pp. 601-612, 2008.
- [18] A. Hawkes and M. Leach, "Impacts of temporal precision in optimisation modelling of micro-combined heat and power," *Energy*, vol. 30, pp. 1759-1779, 2005.
- [19] M. Aydinalp, *et al.*, "Modeling of the appliance, lighting, and space-cooling energy consumptions in the residential sector using neural networks," *Applied energy*, vol. 71, pp. 87-110, 2002.
- [20] I. Richardson, *et al.*, "Domestic electricity use: A high-resolution energy demand model," *Energy and Buildings*, vol. 42, pp. 1878-1887, 2010.
- [21] G. Wood and M. Newborough, "Dynamic energy-consumption indicators for domestic appliances: environment, behaviour and design," *Energy and Buildings*, vol. 35, pp. 821-841, 2003.
- [22] J. Widén and E. Wackelgard, "A high-resolution stochastic model of domestic activity patterns and electricity demand," *Applied energy*, vol. 87, pp. 1880-1892, 2010.
- [23] C. D. Aussant, *et al.*, "Residential application of internal combustion engine based cogeneration in cold climate--Canada," *Energy and Buildings*, vol. 41, pp. 1288-1298, 2009.
- [24] M. Newborough and P. Augood, "Demand-side management opportunities for the UK domestic sector," 1999, pp. 283-293.
- [25] L. Pedersen, "Use of different methodologies for thermal load and energy estimations in buildings including meteorological and sociological input parameters," *Renewable and Sustainable Energy Reviews*, vol. 11, pp. 998-1007, 2007.
- [26] G. Hondroyiannis, "Estimating residential demand for electricity in Greece," *Energy Economics*, vol. 26, pp. 319-334, 2004.
- [27] M. Caldera, *et al.*, "Energy demand for space heating through a statistical approach: application to residential buildings," *Energy and Buildings*, vol. 40, pp. 1972-1983, 2008.
- [28] F. Karlsson, *et al.*, "Measured and predicted energy demand of a low energy building: important aspects when using Building Energy Simulation," *Building Services Engineering Research and Technology*, vol. 28, p. 223, 2007.
- [29] M. Aydinalp-Koksal and V. I. Ugursal, "Comparison of neural network, conditional demand analysis, and engineering approaches for modeling end-use energy consumption in the residential sector," *Applied energy*, vol. 85, pp. 271-296, 2008.
- [30] Y. B. Xu, *et al.*, "Demand and Price Forecasting by Artificial Neural Networks (ANNs) in a Deregulated Power Market," *International Journal of Electrical and Power Engineering*, vol. 3, pp. 268-275, 2009.
- [31] J. E. Brown, *et al.*, "An emerging market in fuel cells? Residential combined heat and power in four countries," *Energy Policy*, vol. 35, pp. 2173-2186, 2007.
- [32] I. K. a. V. Ugursal, "Residential Cogeneration Systems: A Review of the Current Technologies," 2005.
- [33] I. Beausoleil-Morrison and K. Lombardi, "The calibration of a model for simulating the thermal and electrical performance of a 2.8 kWAC solid-

- oxide fuel cell micro-cogeneration device," *Journal of power sources*, vol. 186, pp. 67-79, 2009.
- [34] S. T. Schroeder, *et al.*, "Support Schemes and Ownership Structures-The Policy Context for Fuel Cell Based Micro-Combined Heat and Power," *Journal of power sources*, 2011.
- [35] O. A. Shaneb, *et al.*, "Micro combined heat and power technologies and control for residential applications," *International Journal of Renewable Energy Technology*, vol. 1, pp. 325-347, 2010.
- [36] R. Braun, *et al.*, "Evaluation of system configurations for solid oxide fuel cell-based micro-combined heat and power generators in residential applications," *Journal of power sources*, vol. 158, pp. 1290-1305, 2006.
- [37] U. C. Colpier and D. Cornland, "The economics of the combined cycle gas turbine--an experience curve analysis," *Energy Policy*, vol. 30, pp. 309-316, 2002.
- [38] T. DeMoss, "They're he-e-re (almost): the 60% efficient combined cycle," *Power Engineering*, vol. 100, pp. 17-21, 1996.
- [39] P. Taylor, "Active Network Management as an enabler for the proliferation of domestic combined heat and power," in *12th International Stirling Engine Conference*, Durham, UK, 2005.
- [40] D. B. a. N. Kelly, "Modelling the behaviour of domestic micro-cogeneration under different operating regimes and with variable thermal buffering," presented at the 1st International Conference on Micro-Cogeneration Technologies and Applications, Ottawa- Canada, 2008.
- [41] B. Thomas, "Benchmark testing of Micro-CHP units," *Applied thermal engineering*, vol. 28, pp. 2049-2054, 2008.
- [42] D. Veitch and K. Mahkamov, "Assessment of economical and ecological benefits from deployment of a domestic combined heat and power unit based on its experimental performance," *Proceedings of the Institution of Mechanical Engineers, Part A: Journal of Power and Energy*, vol. 223, pp. 783-798, 2009.
- [43] R. Possidente, *et al.*, "Experimental analysis of micro-cogeneration units based on reciprocating internal combustion engine," *Energy and Buildings*, vol. 38, pp. 1417-1422, 2006.
- [44] Y. Hamada, *et al.*, "Operating results and simulations on a fuel cell for residential energy systems," *Energy Conversion and Management*, vol. 47, pp. 3562-3571, 2006.
- [45] P. E. Santangelo and P. Tartarini, "Fuel cell systems and traditional technologies. Part I: Experimental CHP approach," *Applied thermal engineering*, vol. 27, pp. 1278-1284, 2007.
- [46] V. Dorer, *et al.*, "Performance assessment of fuel cell micro-cogeneration systems for residential buildings," *Energy and Buildings*, vol. 37, pp. 1132-1146, 2005.
- [47] K. Alanne, *et al.*, "The financial viability of an SOFC cogeneration system in single-family dwellings," *Journal of power sources*, vol. 158, pp. 403-416, 2006.
- [48] A. Hawkes, *et al.*, "Role of fuel cell based micro-cogeneration in low carbon heating," *Proceedings of the Institution of Mechanical Engineers, Part A: Journal of Power and Energy*, vol. 225, pp. 198-207, 2011.

- [49] P. Boait, *et al.*, "Optimisation of consumer benefits from microCombined Heat and Power," *Energy and Buildings*, vol. 38, pp. 981-987, 2006.
- [50] K. Alanne, *et al.*, "Techno-economic assessment and optimization of Stirling engine micro-cogeneration systems in residential buildings," *Energy Conversion and Management*, vol. 51, pp. 2635-2646, 2010.
- [51] A. Peacock and M. Newborough, "Impact of micro-combined heat-and-power systems on energy flows in the UK electricity supply industry," *Energy*, vol. 31, pp. 1804-1818, 2006.
- [52] M. De Paepe and D. Mertens, "Combined heat and power in a liberalised energy market," *Energy Conversion and Management*, vol. 48, pp. 2542-2555, 2007.
- [53] A. A. Aliabadi, *et al.*, "Efficiency Analysis of Natural Gas Residential Micro-cogeneration Systems," *Energy & Fuels*, vol. 24, pp. 1704-1710, 2010.
- [54] K. Uzunescu and D. Scarpete, "Energetic and environmental analysis of a micro CCHP system for domestic use," 2011, pp. 322-327.
- [55] K. Kim, "Dynamic proton exchange membrane fuel cell system synthesis/design and operation/control optimisation under uncertainty," PhD, Virginia Polytechnic Institute and State University, Blacksburg, Virginia, 2008.
- [56] M. Houwing, *et al.*, "Uncertainties in the design and operation of distributed energy resources: the case of micro-CHP systems," *Energy*, vol. 33, pp. 1518-1536, 2008.
- [57] F. TeymouriHamzehkolaei and S. Sattari, "Technical and economic feasibility study of using Micro CHP in the different climate zones of Iran," *Energy*, 2011.
- [58] "IEA/ECBCS Annex 42: The Simulation of Building-Integrated Fuel Cell and other cogeneration Systems", 2007, <http://cogen-sim.net/>, last accessed 18/08/2009.
- [59] P. P. Edwards, *et al.*, "Hydrogen and fuel cells: Towards a sustainable energy future," *Energy Policy*, vol. 36, pp. 4356-4362, 2008.
- [60] T. J. Foxon, *et al.*, "UK innovation systems for new and renewable energy technologies: drivers, barriers and systems failures," *Energy Policy*, vol. 33, pp. 2123-2137, 2005.
- [61] A. S. Joshi, *et al.*, "Exergetic assessment of solar hydrogen production methods," *International Journal of Hydrogen Energy*, vol. 35, pp. 4901-4908, 2010.
- [62] "Hydrogen Posture Plan: An Integrated Research, Development and Demonstration Plan", Produced by United States Department of Energy, 2006, <http://www.hydrogen.energy.gov/>, last accessed 16/09/2011.
- [63] G. Naterer, *et al.*, "Canada's program on nuclear hydrogen production and the thermochemical Cu-Cl cycle," *International Journal of Hydrogen Energy*, 2010.
- [64] S. Thiers, *et al.*, "Experimental characterization, modeling and simulation of a wood pellet micro-combined heat and power unit used as a heat source for a residential building," *Energy and Buildings*, vol. 42, pp. 896-903, 2010.
- [65] T. Li, *et al.*, "Development and Test of a Stirling Engine Driven by Waste gases for the Micro-CHP System," *Applied thermal engineering*, 2011.

- [66] L. Dong, *et al.*, "Development of small-scale and micro-scale biomass-fuelled CHP systems-A literature review," *Applied thermal engineering*, vol. 29, pp. 2119-2126, 2009.
- [67] S. Wood and P. Rowley, "A techno-economic analysis of small-scale, biomass-fuelled combined heat and power for community housing," *Biomass and Bioenergy*, 2011.
- [68] M. Pehnt, "Environmental impacts of distributed energy systems--The case of micro cogeneration," *Environmental science & policy*, vol. 11, pp. 25-37, 2008.
- [69] K. Alanne and A. Saari, "Sustainable small-scale CHP technologies for buildings: the basis for multi-perspective decision-making," *Renewable and Sustainable Energy Reviews*, vol. 8, pp. 401-431, 2004.
- [70] V. Kuhn, *et al.*, "MicroCHP: Overview of selected technologies, products and field test results," *Applied thermal engineering*, vol. 28, pp. 2039-2048, 2008.
- [71] A. R. Korsgaard, *et al.*, "Part one: A novel model of HTPEM-based micro-combined heat and power fuel cell system," *International Journal of Hydrogen Energy*, vol. 33, pp. 1909-1920, 2008.
- [72] A. Bauen, *et al.*, "Fuel cells for distributed generation in developing countries--an analysis," *International Journal of Hydrogen Energy*, vol. 28, pp. 695-701, 2003.
- [73] M. Smith and P. Few, "Domestic-scale combined heat-and-power system incorporating a heat pump: analysis of a prototype plant," *Applied energy*, vol. 70, pp. 215-232, 2001.
- [74] D. A. Dentice, "Micro-combined heat and power in residential and light commercial applications," *Applied thermal engineering*, vol. 23, pp. 1247-1259, 2003.
- [75] A. Hawkes and M. Leach, "On policy instruments for support of micro combined heat and power," *Energy Policy*, vol. 36, pp. 2973-2982, 2008.
- [76] A. Lokurlu, *et al.*, "Fuel cells for mobile and stationary applications--cost analysis for combined heat and power stations on the basis of fuel cells," *International Journal of Hydrogen Energy*, vol. 28, pp. 703-711, 2003.
- [77] A. Hawkes and M. Leach, "The capacity credit of micro-combined heat and power," *Energy Policy*, vol. 36, pp. 1457-1469, 2008.
- [78] D. Wu and R. Wang, "Combined cooling, heating and power: a review," *Progress in Energy and Combustion Science*, vol. 32, pp. 459-495, 2006.
- [79] A. Gomez, *et al.*, "From jet fuel to electric power using a mesoscale, efficient Stirling cycle," *Proceedings of the Combustion Institute*, vol. 31, pp. 3251-3259, 2007.
- [80] M. T. Gencoglu and Z. Ural, "Design of a PEM fuel cell system for residential application," *International Journal of Hydrogen Energy*, vol. 34, pp. 5242-5248, 2009.
- [81] M. H. Nehrir and C. Wang, *Modeling and control of fuel cells: distributed generation applications* vol. 41: Wiley-IEEE Press, 2009.
- [82] L. Barelli, *et al.*, "Dynamic analysis of PEMFC-based CHP systems for domestic application," *Applied energy*, vol. 91, pp. 13-28, 2012.
- [83] H. Miland, *et al.*, "Load control of a wind-hydrogen stand-alone power system," *International Journal of Hydrogen Energy*, vol. 31, pp. 1215-1235, 2006.

- [84] G. Gigliucci, *et al.*, "Demonstration of a residential CHP system based on PEM fuel cells," *Journal of power sources*, vol. 131, pp. 62-68, 2004.
- [85] D. Haeseldonckx, *et al.*, "The impact of thermal storage on the operational behaviour of residential CHP facilities and the overall CO₂ emissions," *Renewable and Sustainable Energy Reviews*, vol. 11, pp. 1227-1243, 2007.
- [86] K. Khan, *et al.*, "Energy conservation in buildings: cogeneration and cogeneration coupled with thermal energy storage," *Applied energy*, vol. 77, pp. 15-34, 2004.
- [87] H. I. Onovwiona, *et al.*, "Modeling of internal combustion engine based cogeneration systems for residential applications," *Applied thermal engineering*, vol. 27, pp. 848-861, 2007.
- [88] A. Peacock and M. Newborough, "Controlling micro-CHP systems to modulate electrical load profiles," *Energy*, vol. 32, pp. 1093-1103, 2007.
- [89] D. Jenkins, *et al.*, "Model for evaluating impact of battery storage on microgeneration systems in dwellings," *Energy Conversion and Management*, vol. 49, pp. 2413-2424, 2008.
- [90] M. Durr, *et al.*, "Dynamic model of a lead acid battery for use in a domestic fuel cell system," *Journal of power sources*, vol. 161, pp. 1400-1411, 2006.
- [91] A. Hawkes and M. Leach, "Modelling high level system design and unit commitment for a microgrid," *Applied energy*, vol. 86, pp. 1253-1265, 2009.
- [92] E. Cardona and A. Piacentino, "A methodology for sizing a trigeneration plant in mediterranean areas," *Applied thermal engineering*, vol. 23, pp. 1665-1680, 2003.
- [93] X. Kong, *et al.*, "Energy optimization model for a CCHP system with available gas turbines," *Applied thermal engineering*, vol. 25, pp. 377-391, 2005.
- [94] H. J. Ehmke, "Size optimization for cogeneration plants," *Energy*, vol. 15, pp. 35-44, 1990.
- [95] R. Yokoyama, *et al.*, "Optimal sizing of a gas turbine cogeneration plant in consideration of its operational strategy," *Journal of engineering for gas turbines and power*, vol. 116, p. 32, 1994.
- [96] Z. Beihong and L. Weiding, "An optimal sizing method for cogeneration plants," *Energy and Buildings*, vol. 38, pp. 189-195, 2006.
- [97] M. Kim, *et al.*, "Fuzzy control based engine sizing optimization for a fuel cell/battery hybrid mini-bus," *Journal of power sources*, vol. 178, pp. 706-710, 2008.
- [98] L. Wenyuan, "A successive linear programming model for real-time economic power dispatch with security," *Electric power systems research*, vol. 13, pp. 225-233, 1987.
- [99] E. Sandgren, "Structural design optimization for latitude by nonlinear goal programming," *Computers & structures*, vol. 33, pp. 1395-1402, 1989.
- [100] N. A. Tibi and H. Arman, "A linear programming model to optimize the decision-making to managing cogeneration system," *Clean Technologies and Environmental Policy*, vol. 9, pp. 235-240, 2007.
- [101] G. Sundberg and D. Henning, "Investments in combined heat and power plants: influence of fuel price on cost minimised operation," *Energy Conversion and Management*, vol. 43, pp. 639-650, 2002.

- [102] S. Gamou, *et al.*, "Optimal unit sizing of cogeneration systems in consideration of uncertain energy demands as continuous random variables," *Energy Conversion and Management*, vol. 43, pp. 1349-1361, 2002.
- [103] H. Ren, *et al.*, "Optimal sizing for residential CHP system," *Applied thermal engineering*, vol. 28, pp. 514-523, 2008.
- [104] T. Thanh and K. K. Ahn, "Nonlinear PID control to improve the control performance of 2 axes pneumatic artificial muscle manipulator using neural network," *Mechatronics*, vol. 16, pp. 577-587, 2006.
- [105] J. Wilki, Johnson, M. and Katebi, R., *Control Engineering: an introductory course*. Newyork: PALGRAVE, 2002.
- [106] R. V. d. Veen, "Balancing market performance in a decentralized electricity system in the Netherlands," Master report master SEPAM, Technology University Delft, 2007.
- [107] H. Aki, *et al.*, "Operational strategies of networked fuel cells in residential homes," *Power Systems, IEEE Transactions on*, vol. 21, pp. 1405-1414, 2006.
- [108] J. Harrison, *et al.*, "MICRO CHP implications for energy companies," *Cogeneration and on-Site Power Production*, vol. 1, 2000.
- [109] M. Geidl, "Integrated modelling and optimization of multi-carrier energy systems," PhD Thesis, Swiss Federal Institute of Technology (ETH), 2007.
- [110] S. Caux, *et al.*, "On-line fuzzy energy management for hybrid fuel cell systems," *International Journal of Hydrogen Energy*, vol. 35, pp. 2134-2143, 2010.
- [111] C. C. Lin, *et al.*, "Power management strategy for a parallel hybrid electric truck," *Control Systems Technology, IEEE Transactions on*, vol. 11, pp. 839-849, 2003.
- [112] S. Delprat, *et al.*, "Control of a parallel hybrid powertrain: optimal control," *Vehicular Technology, IEEE Transactions on*, vol. 53, pp. 872-881, 2004.
- [113] S. Kutter and B. Baker, "An iterative algorithm for the global optimal predictive control of hybrid electric vehicles," 2011, pp. 1-6.
- [114] Z. Ouyang and S. Shahidehpour, "A hybrid artificial neural network-dynamic programming approach to unit commitment," *Power Systems, IEEE Transactions on*, vol. 7, pp. 236-242, 1992.
- [115] M. Tanrioven and M. Alam, "Impact of load management on reliability assessment of grid independent PEM fuel cell power plants," *Journal of power sources*, vol. 157, pp. 401-410, 2006.
- [116] P. Srinivasan, "Dynamic Modelling and Control of a Proton Exchange Membrane Fuel Cell as a Distributed generator," Master Thesis, Ohio State University, USA, 2003.
- [117] A. Mellit, *et al.*, "Artificial intelligence techniques for sizing photovoltaic systems: A review," *Renewable and Sustainable Energy Reviews*, vol. 13, pp. 406-419, 2009.
- [118] S. A. Kalogirou, "Artificial intelligence for the modeling and control of combustion processes: a review," *Progress in Energy and Combustion Science*, vol. 29, pp. 515-566, 2003.
- [119] F. R. Salmasi, "Control strategies for hybrid electric vehicles: Evolution, classification, comparison, and future trends," *Vehicular Technology, IEEE Transactions on*, vol. 56, pp. 2393-2404, 2007.

- [120] Q. Zeng and J. Huang, "The design and simulation of fuzzy logic controller for parallel hybrid electric vehicles," 2007, pp. 908-912.
- [121] G. Chen, *et al.*, "Introduction to fuzzy sets, fuzzy logic, and fuzzy control systems," *Applied Mechanics Reviews*, vol. 54, p. B102, 2001.
- [122] M. Tekin, *et al.*, "Energy-management strategy for embedded fuel-cell systems using fuzzy logic," *Industrial Electronics, IEEE Transactions on*, vol. 54, pp. 595-603, 2007.
- [123] B. Xu, *et al.*, "Design and Simulation of Fuzzy Control Strategy for Parallel Hybrid Electric Vehicle," in *Intelligent System Design and Engineering Application (ISDEA)*, Changsha, 2010, pp. 539-543.
- [124] Y. Eren, *et al.*, "A fuzzy logic based supervisory controller for an FC/UC hybrid vehicular power system," *International Journal of Hydrogen Energy*, vol. 34, pp. 8681-8694, 2009.
- [125] A. Azadeh, *et al.*, "A hybrid simulation-adaptive network based fuzzy inference system for improvement of electricity consumption estimation," *Expert Systems with Applications*, vol. 36, pp. 11108-11117, 2009.
- [126] S. A. Kalogirou, "Applications of artificial neural-networks for energy systems," *Applied energy*, vol. 67, pp. 17-35, 2000.
- [127] C. Sayin, *et al.*, "Performance and exhaust emissions of a gasoline engine using artificial neural network," *Applied thermal engineering*, vol. 27, pp. 46-54, 2007.
- [128] M. S. S. Ashhab, "Fuel economy and torque tracking in camless engines through optimization of neural networks," *Energy Conversion and Management*, vol. 49, pp. 365-372, 2008.
- [129] P. Trichakis, *et al.*, "Distributed control approach for small-scale energy zones," *Proceedings of the Institution of Mechanical Engineers, Part A: Journal of Power and Energy*, vol. 222, pp. 137-147, 2008.
- [130] A. L. Dimeas and N. D. Hatziargyriou, "Operation of a multiagent system for microgrid control," *Power Systems, IEEE Transactions on*, vol. 20, pp. 1447-1455, 2005.
- [131] K. Nouri, *et al.*, "Adaptive control of a nonlinear dc motor drive using recurrent neural networks," *Applied Soft Computing*, vol. 8, pp. 371-382, 2008.
- [132] M. Sun, *et al.*, "Interactive multiple objective programming using Tchebycheff programs and artificial neural networks* 1," *Computers & Operations Research*, vol. 27, pp. 601-620, 2000.
- [133] a. N. D. H. A.L. Dimeas, "Agent based control of Virtual Power Plants," presented at the The 14th International Conference on Intelligent System Applications to Power Systems (ISAP), Kaohsiung, Taiwan, 2007.
- [134] M. H. K.M. Van Dam, Z. Lukszo and I. Bouwmans, "Modelling an Electricity Infrastructure as a Multi-Agent System-Lessons Learnt from Manufacturing Control," presented at the The 16th European Symposium on Computer Aided Process Engineering, Garmisch-Partenkirchen Germany, 2006.
- [135] K. H. Van Dam, *et al.*, "Agent-based control of distributed electricity generation with micro combined heat and power--cross-sectoral learning for process and infrastructure engineers," *Computers & Chemical Engineering*, vol. 32, pp. 205-217, 2008.

- [136] M. M. Nordman and M. Lehtonen, "Distributed agent-based State estimation for electrical distribution networks," *Power Systems, IEEE Transactions on*, vol. 20, pp. 652-658, 2005.
- [137] M. Pipattanasomporn, *et al.*, "Multi-agent systems in a distributed smart grid: Design and implementation," 2009, pp. 1-8.
- [138] M. Khashei, *et al.*, "A new hybrid artificial neural networks and fuzzy regression model for time series forecasting," *Fuzzy Sets and Systems*, vol. 159, pp. 769-786, 2008.
- [139] A. Arsalis, *et al.*, "Modeling and parametric study of a 1 kW_e HT-PEMFC-based residential micro-CHP system," *International Journal of Hydrogen Energy*, 2011.
- [140] "Fuel Cell Technologies Program Multi-Year Research, Development and Demonstration Plan", U.S. Department of Energy, 2007, <http://www1.eere.energy.gov/hydrogenandfuelcells/mypp/>, last accessed 18/09/2011.
- [141] A. R. a. M. S. A. M.Y. El-Sharkh, "Evolutionary programming-based methodology for economical output power from PEM fuel cell for micro-grid application," *Power Sources* vol. 139, pp. 165-169, 2005.
- [142] M. T. M.Y. El-Sharkh, A. Rahman, M.S. Alam', "Impact of hydrogen production on optimal economic operation of a grid-parallel PEM fuel cell power plant," *Power Sources* vol. 153, pp. 136-144, 2006.
- [143] L. Roses, *et al.*, "Comparison between fixed bed and fluidized bed membrane reactor configurations for PEM based micro-cogeneration systems," *Chemical Engineering Journal*, 2011.
- [144] F. Barbir, *PEM Fuel Cells: Theory and Practice*: Academic Press 2005.
- [145] N. Briguglio, *et al.*, "Evaluation of a low temperature fuel cell system for residential CHP," *International Journal of Hydrogen Energy*, 2011.
- [146] T. Ralph, *et al.*, "Low cost electrodes for proton exchange membrane fuel cells," *JOURNAL-ELECTROCHEMICAL SOCIETY*, vol. 144, pp. 3845-3857, 1997.
- [147] R. Cozzolino, *et al.*, "Theoretical and experimental investigations on thermal management of a PEMFC stack," *International Journal of Hydrogen Energy*, 2011.
- [148] R. Satija, *et al.*, "In situ neutron imaging technique for evaluation of water management systems in operating PEM fuel cells," *Journal of power sources*, vol. 129, pp. 238-245, 2004.
- [149] M. El-Sharkh, *et al.*, "Impact of recovered thermal energy management on the economics of operation of a grid-parallel PEM fuel cell power plant," *Electric power systems research*, vol. 77, pp. 1056-1064, 2007.
- [150] M. El-Sharkh, *et al.*, "Cost related sensitivity analysis for optimal operation of a grid-parallel PEM fuel cell power plant," *Journal of power sources*, vol. 161, pp. 1198-1207, 2006.
- [151] O. A. Shaneb and P. C. Taylor, "Evaluation of alternative operating strategies for residential micro combined heat and power," in *IEEE Energy Conference*, Manama-Bahrain, 2010, pp. 143-148.
- [152] A. M. Azmy, "Simulation and management of distributed generating units using intelligent techniques," PhD Dissertation, University of Duisburg-Essen, 2005.

- [153] K. Alanne, "Application of decision analysis in the assessment of Energy technology for buildings," PhD, Helsinki university of technology, Helsinki, 2007.
- [154] "Domestic (low energy) buildings - hourly gas and electricity consumption Dataset", UK Energy Research Centre website, 2008, http://data.ukedc.rl.ac.uk/cgi-bin/dataset_catalogue/view.cgi.py?id=9, last accessed 01/10/2009.
- [155] H. Ren, *et al.*, "Multi-criteria evaluation for the optimal adoption of distributed residential energy systems in Japan," *Energy Policy*, vol. 37, pp. 5484-5493, 2009.
- [156] R. Hashemi, "A developed offline model for optimal operation of combined heating and cooling and power systems," *Energy Conversion, IEEE Transactions on*, vol. 24, pp. 222-229, 2009.
- [157] A. Bernard, "Micro combined heat and power operating on renewable energy for residential building," PhD, CEP- Centre Energétique et Procédés, 2008.
- [158] K. Alanne, *et al.*, "Multi-criteria evaluation of residential energy supply systems," *Energy and Buildings*, vol. 39, pp. 1218-1226, 2007.
- [159] E. M. Ben Maalla and P. L. Kunsch, "Simulation of micro-CHP diffusion by means of System Dynamics," *Energy Policy*, vol. 36, pp. 2308-2319, 2008.
- [160] M. E. Corria, *et al.*, "Perspectives of Stirling engines use for distributed generation in Brazil," *Energy Policy*, vol. 34, pp. 3402-3408, 2006.
- [161] M. G. C. Gähler, R. Lamon, J. Tödtli, "Optimal control of cogeneration building energy systems," presented at the Clima 2007 -WellBeing Indoors, Helsinki-Finland, 2007.
- [162] M. V. A. Faber, P. Janssen, K. Frenken, "Domestic micro-cogeneration in the Netherlands: an agent-based demand model for technology diffusion," presented at the DIME International Conference on "Innovation, sustainability and policy", Bordeaux, 2008.
- [163] I. Staffell and R. Green, "Estimating future prices for stationary fuel cells with empirically derived experience curves," *International Journal of Hydrogen Energy*, vol. 34, pp. 5617-5628, 2009.
- [164] T. E. Lipman, *et al.*, "Fuel cell system economics: comparing the costs of generating power with stationary and motor vehicle PEM fuel cell systems," *Energy Policy*, vol. 32, pp. 101-125, 2004.
- [165] O. Shaneb, *et al.*, "Sizing of Residential micro CHP Systems," *Energy and Buildings*, vol. 43, pp. 1991-2001, 2011.
- [166] "Feed-in Tariff (FIT): Annual report 2010 - 2011", Produced by Ofgem, 2011, <http://www.ofgem.gov.uk/Sustainability/Environment/fits/Documents1/FITs%20Annual%20Report%202010%202011.pdf>, last accessed 03/03/2012.
- [167] M. Stokes, *et al.*, "A simple model of domestic lighting demand," *Energy and Buildings*, vol. 36, pp. 103-116, 2004.
- [168] E. Fabrizio, *et al.*, "Trade-off between environmental and economic objectives in the optimization of multi-energy systems," 2009, pp. 29-40.
- [169] *Statistics about energy costs and prices produced by Biomass Energy Centre*,

http://www.biomassenergycentre.org.uk/portal/page?_pageid=75,59188&dad=portal&schema=PORTAL, last accessed 11/08/2010.

- [170] "2009 Guidelines to Defra / DECC's GHG Conversion Factors for Company Reporting", Produced by Department of Energy and Climate Change ((DECC) and the Department for Environment, Food and Rural Affairs (Defra), 2009, <http://www.defra.gov.uk/environment/business/reporting/pdf/20090928-guidelines-ghg-conversion-factors.pdf>, last accessed 18/08/2009.
- [171] N. Bergman, *et al.*, "UK microgeneration. Part I: policy and behavioural aspects," *Proceedings of the ICE-Energy*, vol. 162, pp. 32-36, 2009.
- [172] R. S. Haszeldine, "Carbon capture and storage: how green can black be?," *Science*, vol. 325, p. 1647, 2009.
- [173] G. Anandarajah, *et al.*, "Pathways to a Low Carbon Economy: Energy Systems Modelling," *UK Energy Research Centre*, 2009.
- [174] R. Kannan, "Uncertainties in key low carbon power generation technologies-Implication for UK decarbonisation targets," *Applied energy*, vol. 86, pp. 1873-1886, 2009.
- [175] J. Matics and G. Krost, "Micro combined heat and power home supply: Prospective and adaptive management achieved by computational intelligence techniques," *Applied thermal engineering*, vol. 28, pp. 2055-2061, 2008.
- [176] H. Mori and M. Ohmi, "Probabilistic short-term load forecasting with Gaussian processes," in *13th Intelligent Systems Application to Power Systems (ISAP)*, Arlington, VA, USA, 2005.
- [177] J. Clarke, *et al.*, "Simulation-assisted control in building energy management systems," *Energy and Buildings*, vol. 34, pp. 933-940, 2002.
- [178] C. Sagüés, *et al.*, "Automatic control of biomass gasifiers using fuzzy inference systems," *Bioresource technology*, vol. 98, pp. 845-855, 2007.
- [179] C. Wu, *et al.*, "Development of control method and dynamic model for multi-evaporator air conditioners (MEAC)," *Energy Conversion and Management*, vol. 46, pp. 451-465, 2005.
- [180] X. Liu, *et al.*, "Power split control strategy for a series hybrid electric vehicle using fuzzy logic," in *Automation and Logistics, 2008. ICAL 2008. IEEE International Conference*, Qingdao-China, 2008, pp. 481-486.
- [181] D. Driankov, *et al.*, *An introduction to fuzzy control*: Springer Verlag, 1996.