

Durham E-Theses

New π -electron donor systems based on multi-tetrathiafulvalene derivatives

Derek Edward John

How to cite:

John, Derek Edward (1999) New π -electron donor systems based on multi-tetrathiafulvalene derivatives. Doctoral thesis, Durham University.

Use policy

The full-text may be used and/or reproduced, and given to third parties in any format or medium, without prior permission or charge, for personal research or study, educational, or not-for-profit purposes provided that:

- a full bibliographic reference is made to the original source
- a <https://etheses.durham.ac.uk/id/eprint/4390/> is made to the metadata record in Durham E-Theses
- the full-text is not changed in any way

The full-text must not be sold in any format or medium without the formal permission of the copyright holders.

Please consult the [full Durham E-Theses policy](#) for further details.

NEW π -ELECTRON DONOR SYSTEMS

BASED ON

MULTI-TETRATHIAFULVALENE DERIVATIVES

The copyright of this thesis rests with the author. No quotation from it should be published without the written consent of the author and information derived from it should be acknowledged.

19 JUL 2000

Derek Edward John B.A.

Graduate Society

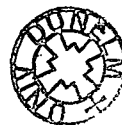

Department of Chemistry

University of Durham

A Thesis submitted for the degree of Doctor of Philosophy
at the University of Durham

September 1999

STATEMENT OF COPYRIGHT

The copyright of this thesis rests with the author. No quotation from it should be published without their written consent and information derived from it should be acknowledged.

DECLARATION

The work described in this thesis was carried out in the Department of Chemistry at the University of Durham, and at the Department of Chemistry, Odense University, in Denmark between October 1995 and September 1998. All the work was carried out by the author unless otherwise stated, and has not previously been submitted for a degree at this or any other university.

ABSTRACT**NEW π -ELECTRON DONOR SYSTEMS
BASED ON
MULTI-TETRATHIAFULVALENE DERIVATIVES**

Derek Edward John B.A.
University of Durham (September 1999)

A review of organic π -electron donor molecules is given. The focus is on tetrathiafulvalene (TTF) systems with particular emphasis on dimeric and oligomeric systems incorporating more than one TTF subunit. Such systems are reviewed based on the number and mode of linkage of the TTF subunits. A short discussion is given of the basic chemistry of the TTF system with emphasis on those areas which are utilised in the synthetic work undertaken.

Various iodine substituted TTF systems have been synthesised, in some cases requiring the synthesis of previously unknown TTF precursors. The properties of these compounds as π -electron donors have been investigated and complexation studies yielded several salts. The structure of an insulating salt with tetracyano-*p*-quinodimethane (TCNQ) was elucidated by X-ray analysis. Homocoupling of these iodine substituted TTFs via an Ullman-type methodology yielded new *bis*(tetrathiafulvalenyl) derivatives, two of which have been studied by X-ray diffraction. Salts of these derivatives have been prepared and the structure of a perchlorate salt has been studied by X-ray diffraction. The possible effects of the conformation of these systems on their physical properties is also discussed.

New *bis*TTF cyclophanes possessing a rare "Edge to Face" double linkage of the two TTF units have been prepared. The potential for isomerism is discussed and the X-ray structures of an isomerically pure cyclophane and a model compound have been obtained. Insulating and semiconducting salts were obtained of these systems with the structures of a perchlorate and polyiodide salt being elucidated by X-ray.

New macrocyclic derivatives incorporating three TTF units have been synthesised with the aim of preparing molecular cavities capable of binding suitable guest molecules. New functionalised TTF derivatives have been synthesised as suitable precursors to these systems.

*"O Speculator on Things, boast not of knowing the things
that nature ordinarily brings about; but rejoice if you know
the end of those things which you yourself devise."*

Leonardo da Vinci

For my parents

CONTENTS

	Page
CHAPTER ONE - INTRODUCTION AND BACKGROUND	
1.1 GENERAL INTRODUCTION	2
1.2 ORGANIC METALS; AN HISTORICAL OVERVIEW	2
1.3 THEORY OF ORGANIC METALS	4
1.3.1 BAND THEORY	4
1.3.2 TTF-TCNQ; THE FIRST ORGANIC METAL	7
1.3.4 THE PEIERLS DISTORTION	8
1.3.5 THE FEATURES OF AN IDEAL ORGANIC METAL	9
1.4 REMOVING THE PEIERLS DISTORTION: ORGANIC SUPERCONDUCTORS	10
1.5 CRYSTAL ENGINEERING	13
1.6 CRYSTAL ENGINEERING IN TTF DERIVATIVES	13
1.6.1 FUNCTIONALISED TTFS DISPLAYING <i>INTER</i> -MOLECULAR INTERACTIONS	13
1.6.2 DONOR SYSTEMS WITH EXTENDED π -CONJUGATION	15
1.7 OLIGOMERIC TETRATHIAFULVALENES	16
1.7.1 THE "MULTI-TTF" PRINCIPLE	16
1.7.2 CATEGORIES OF OLIGOMERIC TTFS	16
1.7.3 MULTI-TTFS OF TYPES 1 AND 2	17
1.7.3.1 Systems of Type 1 with non-conjugated linkages	17
1.7.3.2 Systems of Type 2 with non-conjugated linkages	20
1.7.3.3 Heteroatomic linkages	21
1.7.4 CONJUGATED MULTI-TTF SYSTEMS	23
1.7.4.1 Systems of Type 1 with conjugated linkages	23
1.7.4.2 Systems of Type 2 with conjugated linkages	25

1.7.5	DOUBLE BRIDGED TETRATHIAFULVALENEOPHANES	26
1.7.5.1	Systems of Type 3 with non-conjugated linkages	26
1.7.6	QUADRUPLE BRIDGED TETRATHIAFULVALENOPHANES	28
1.7.6.2	Systems of Type 4 with non-conjugated linkages	28
1.8	THE CHEMISTRY OF TTF	30
1.8.1	DIRECT FUNCTIONALISATION OF THE TTF RING SYSTEM	30
1.8.2	TTFS FROM FUNCTIONALISED 1,3-DITHIOLES	32
 CHAPTER TWO - IODOTTFS AS SYNTHETIC PRECURSORS TO <i>BISTTF</i> SYSTEMS		
2.1	INTRODUCTION: HALOGENATED TTFS	38
2.2	HALOGENATED TTFS AS SYNTHETIC INTERMEDIATES	41
2.3	IODOTTFS AS SYNTHETIC PRECURSORS TO <i>BISTTF</i> SYSTEMS	43
2.3.1	THE MYSTERY OF <i>BISTTF</i>	43
2.3.2	OTHER <i>BISTTF</i> SYSTEMS	45
2.4	SYNTHESIS OF <i>BISTTF</i> SYSTEMS	49
2.4.1	AIMS AND OBJECTIVES	49
2.4.2	SYNTHESIS AND HOMOCOUPLING OF IODOTTFS	50
2.4.3	ROOM-TEMPERATURE ULLMAN COUPLING	53
2.5	SINGLE CRYSTAL X-RAY ANALYSIS OF 120 AND 136	55
2.6	ELECTROCHEMISTRY OF <i>BISTTF</i> SYSTEMS	57
2.8	SALTS OF NEW <i>BISTTF</i> S	60
2.9	PROPERTIES OF NEW IODOTTFS	62
2.10	CONCLUSIONS	65

CHAPTER THREE - NOVEL *BIS*(TETRATHIAFULVALENE) CYCLOPHANES

3.1	INTRODUCTION: TTF CYCLOPHANES	67
3.2	TETRATHIAFULVALENOPHANES AND PARACYCLOPHANES	68
3.3	NEW TTF CYCLOPHANES	71
	3.3.1 SYNTHESIS	72
3.4	X-RAY CRYSTAL STRUCTURES OF 156 AND 183	78
3.5	SALTS OF 156	81
3.6	SOLID AND SOLUTION STATE STRUCTURES OF TTF-PHANES	83
3.7	ELECTROCHEMISTRY OF NEW <i>BISTTF</i> S	85
3.8	SPECTRAL CHARACTERISATION OF DISTORTED TTF SYSTEMS	88
	3.8.1 <i>TRISTTF</i> -PHANES AND BEYOND	88
3.9	CONCLUSIONS	89

CHAPTER FOUR - MOLECULAR CAVITIES INCORPORATING TTF

4.1	INTRODUCTION: THE USE OF TTF IN HOST-GUEST CHEMISTRY	92
4.2	HOST SYSTEMS INCORPORATING TTF	93
	4.2.1 GUEST MOLECULES	96
4.3	SYNTHESIS OF <i>TRISTTF</i> MACROCYCLES	97
4.4	TRIPLE-BRIDGED CAGE MOLECULES CONTAINING TTF	101
	4.4.1 SYNTHESIS	103
4.5	ATTEMPTED CAPPING REACTIONS	108
4.6	ELECTROCHEMISTRY	109

4.5	CONCLUSIONS	110
CHAPTER FIVE - EXPERIMENTAL PROCEDURES		
5.1	GENERAL METHODS	112
5.2	EXPERIMENTAL TO CHAPTER TWO	113
5.3	EXPERIMENTAL TO CHAPTER THREE	121
5.4	EXPERIMENTAL TO CHAPTER FOUR	134
REFERENCES		145
APPENDIX ONE - X-RAY CRYSTALLOGRAPHIC DATA		161
APPENDIX TWO - RESEARCH COLLOQUIA		170
APPENDIX THREE - PUBLICATIONS		176

ACKNOWLEDGEMENTS

I would like to express my gratitude to the following people who have been involved, either directly or indirectly, in the completion of this work.

My supervisor Prof. Martin Bryce for his insight, wisdom and infinite patience and for giving me the opportunity to come and work in Durham.

Dr. Adrian Moore and Dr. Antony "Chez" Chesney for advice on practical matters, taking time out to discuss ideas and results with me, and for applications of the "bony toe" when it was required.

The rest of the Bryce group over the years, both long term inmates and visitors, for being good co-workers and more importantly, good mates, (In no particular order): Alex, Ade, Chez, Brian, Andy, Richard, Terry, Claire, Pilar, Emma, Tatiana, Chang-Sheng, Shimon, Christian, Igor, Dima, Nicolas, Nathalie, Thierry, Hugh, and Naveed.

Prof. Jan Becher for letting me spend a very useful and enlightening time in his laboratories in Odense, and for giving me a different perspective on TTF chemistry. The rest of his group who made me welcome and taught me many "Tricks of the Trade", Niels, Jesper, Klaus, Kia, Ane, Dorte, Jan O., Martin, Jimmi, Christian (x 2), Takimiya and Christophe.

Dr. Andei Batsanov for many hours work solving difficult crystal structures. Dr. Alan Kenwright, Julia Say, Ian McKeague, and Catherine Heffernan for 400 MHz NMR, and for advice on spectroscopic matters. Dr. Mike Jones, and Lara Turner for a speedy and efficient mass-spec service, and Jarrka Dostal for elemental analyses. Jimmy Lincoln, Joe Peel, and Elizabeth Wood for running stores and dealing with all the paperwork. Dr. Ross for keeping everything running smoothly. Ray Hart and Gordon Haswell for glass blowing and all the people in the various workshops and the other technical staff for keeping Lab 29 in shape.

Dr. John Charters and Dr. Geoffrey Welsh of the S.H.S. and Dr. Mike Richardson of the Graduate Society, and also all the residents past and present of number 32, The Avenue, Hugh, Scott, Amanda, Liz, John, David, and Ernie. And finally, of course, my parents for their support over the years.

Chapter One

Introduction and Background

1.1 INTRODUCTION

The majority of organic solids are insulators with room temperature conductivities (σ_{rt}) in the range 10^{-9} to 10^{-20} S cm $^{-1}$. In the last twenty-five years there has been an explosion of interest in so-called "organic metals"; systems such as charge-transfer complexes,¹ polymeric systems,² and organometallic³ complexes, which exhibit unusual physical properties including: metallic conductivity, superconductivity and interesting optical and magnetic properties.⁴ The versatility of organic chemistry which enables subtle changes to be made to the molecular structure, introduces the possibility of "fine tuning" the properties of these materials to suit a specific task.

The sulfur heterocycle tetrathiafulvalene (TTF) **1** has been one of the main materials of interest both in organic metals research and in the wider field of materials science where TTF has found use as a component in Langmuir-Blodgett films,⁵ as a redox active transducer for cation sensors,⁶ as a π -electron donor for non-linear optical systems,⁷ it has been incorporated into polymeric⁸ and dendritic⁹ systems, and exploited as a component for molecular electronic devices.¹⁰

This thesis concerns the synthesis of novel donors for charge-transfer complexes based on tetrathiafulvalene **1**, with particular emphasis on new functionalised derivatives and oligomeric structures.

1.2 ORGANIC METALS; AN HISTORICAL OVERVIEW

Theoretical calculations published in 1911 by McCoy and Moore,¹¹ postulated that certain materials of non-metallic origin may display metallic behaviour, including high electrical conductivity. In 1954 these predictions were vindicated by the synthesis of a bromine complex of the polycyclic arene perylene **2**, by Akamatu *et al.*,¹² which was found to have a room temperature conductivity of ($\sigma_{rt} = ca. 1$ Scm $^{-1}$). However, this complex proved to be unstable and lost its conductivity gradually over a number of days. Several other complexes of perylene and other polycyclic arenes, such as pyrene, were synthesised by Kommandeur and Hall¹³ and were shown to be semiconductors.

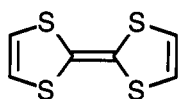
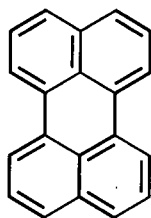
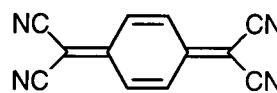
**1****2****3**

The discovery of the powerful organic electron acceptor 7,7,8,8-tetracyano-*p*-quinodimethane (TCNQ) **3** in the early 1960's led to the synthesis of a large number of stable ion-radical salts which displayed predominantly semiconductive behaviour.¹⁴

In 1970 Wudl *et al.*¹⁵ published the synthesis of the organosulfur electron donor tetrathiafulvalene (TTF) **1** which immediately yielded a series of promising cation-radical salts. They observed that TTF could be oxidised in two, one-electron steps to yield the radical cation and dication (Figure 1.1).

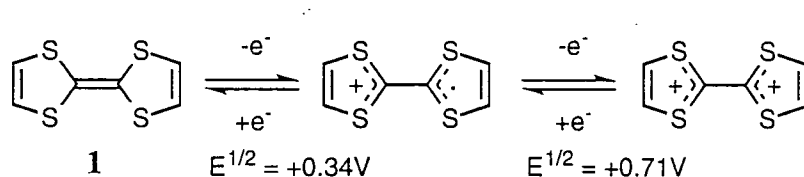

Figure 1.1 The redox chemistry of TTF.

This was elegantly shown by the action of chlorine gas on a carbon tetrachloride solution of TTF.¹⁵ When treated with one equivalent of chlorine an unusually stable purple radical cation was formed. Addition of excess chlorine yielded the stable yellow dication. The radical cation chloride salt was found to be a semiconductor with a room temperature conductivity of ($\sigma_{\text{TTF}} = ca. 0.27 \text{ Scm}^{-1}$). The radical cation and dication were both stable compounds compared to the salts of the polycyclic arenes. This is easily rationalised by the formation of first one, and then two, six- π aromatic systems on the dithiolenyl rings with each successive one-electron oxidation.

These two, successive, one-electron oxidations are clearly observed in the cyclic voltammogram (CV) at $E^{1/2} = +0.34$ and $E^{1/2} = +0.71\text{V}$ (vs. Ag/AgCl in MeCN) and are completely reversible (Figure 1.2).

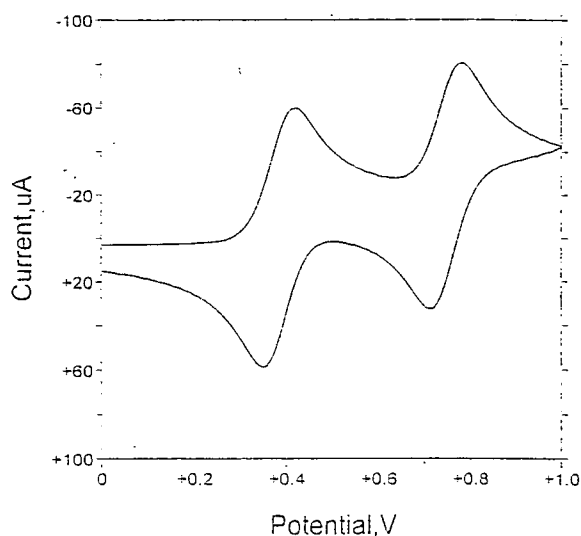
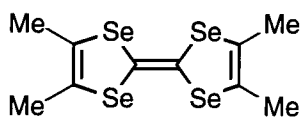
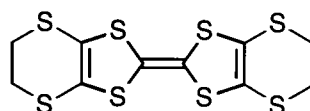

Figure 1.2 The CV of TTF.

The first report of metallic conductivity in a purely organic compound was in the 1:1 charge-transfer complex of TCNQ and TTF, which was reported to have a room temperature conductivity of 500 Scm^{-1} and to display metallic conductivity down to 59K.^{16,17} Over the next twenty-five years many advances have been made in the field of conducting charge-transfer and radical-ion salts, the majority of which are based on modifications to the basic TTF framework. In 1980, the first organic superconductor was reported based on the electron donor tetramethyltetraselenafulvalene (TMTSeF)¹⁸ **4** with a T_c of 0.9K at 12 Kbar. Currently the highest T_c for an organic superconductor belongs to a series of salts of the donor *bis*(ethylenedithio)TTF (BEDT-TTF) **5** of the general formula $k\text{-(BEDT-TTF)}_2\text{Cu}[\text{N}(\text{CN})_2]\text{X}$, where $\text{X} = \text{Br}, \text{Cl}$; ($T_c = 11.6\text{K}$ at ambient pressure for $\text{X} = \text{Br}$,¹⁹ $T_c = 12.5\text{K}$ at 0.3 kbar for $\text{X} = \text{Cl}$.)²⁰

**4****5**

1.3 THEORY OF ORGANIC METALS

1.3.1 Band Theory

In organic metals the theoretical model for the processes involved in the conductive properties is known as band theory.^{1,21} In a crystalline solid where a large number of molecules or atoms are brought close together, the atomic and molecular orbitals can combine to form bands (a continuum of energy states). In a simple example, if two atomic p -orbitals on two separate atoms are brought together, a π -bonding and a π^* antibonding set of orbitals are created. If two of these molecules are brought together a further splitting will occur. When an infinite number of molecules are brought together a quasi continuum of energy states is formed. These are called bands (Figure 1.3).

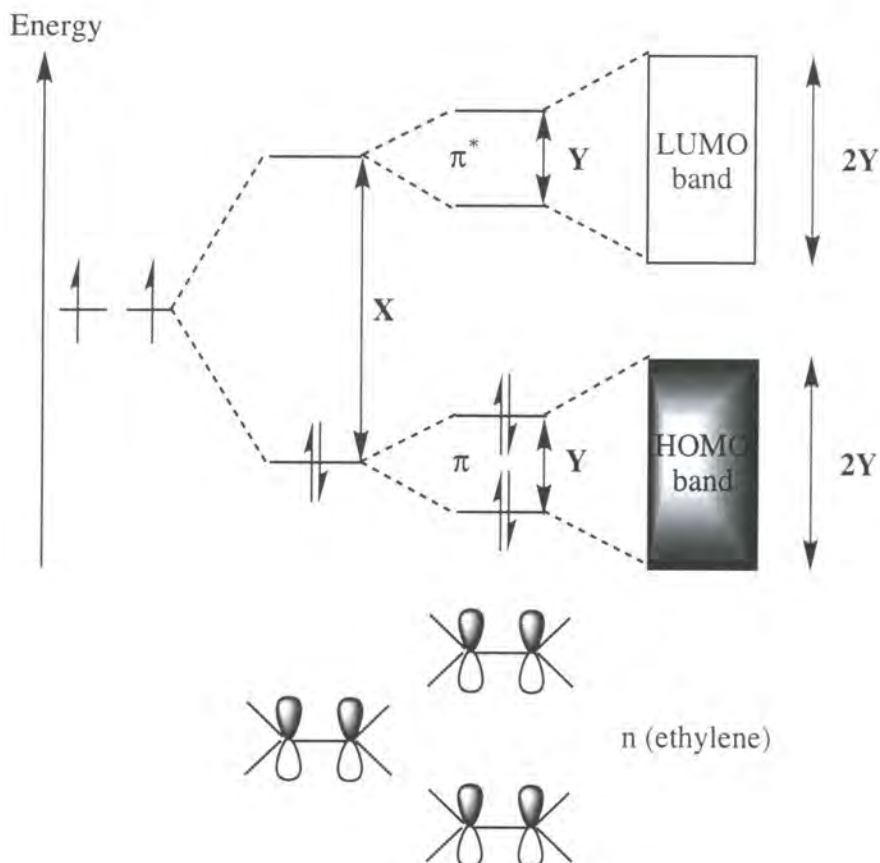

Figure 1.3 - Formation of electronic bands from a stack of ethylene molecules. X = initial splitting energy between bonding and anti-bonding orbitals in monomer. Band width ($2Y$) is approximately twice the value of the dimer splitting energy (Y).

If each of the original p -orbitals contained one electron, then the two bands created will consist of a lower filled band (called the Highest Occupied Molecular Orbital or HOMO) and a higher empty band (called the Lowest Unoccupied Molecular Orbital or LUMO). Quite often only this part of the band structure is represented, as the energy gap E_g between the HOMO and the LUMO determines the conductive processes which are permitted to occur within the material. The occupancy of these energy bands by electrons has a profound influence on their physical characteristics. The valence electrons derive from the HOMO orbital and it is the ease with which these move through the solid that determines how effective the conduction will be. The energy states which are closest to the highest occupied states within the band, known as the Fermi Level, are the most easily accessible. It is electrons in these energy states very near the Fermi Level which are involved in conduction. If conduction is to occur it is necessary to have free electrons in the LUMO or conductance band or "holes" in the HOMO or valence band. In an insulator, the bandgap, E_g , is too large for electrons to be thermally excited from the HOMO to the LUMO band and flow under the influence of an electric field. In a semiconductor the bandgap is smaller and conduction can occur.

but will be limited by the number of thermally excited cage carriers. Hence their conductivity decreases as the temperature is lowered. In a metal the valence band is only partially filled, so the electrons can move unhindered because a number of empty states will be available infinitesimally close to the filled states (Figure 1.4). Conductivity will, in such cases be limited by the scattering of electrons due to lattice vibrations. Hence in metals, as temperature decreases lattice vibrations are reduced and conductivity is increased, in direct contrast to semiconductors. In special cases at ultralow temperatures the conducting electrons associate into species called Cooper pairs²² which move through the lattice with zero resistance and the material becomes superconducting.

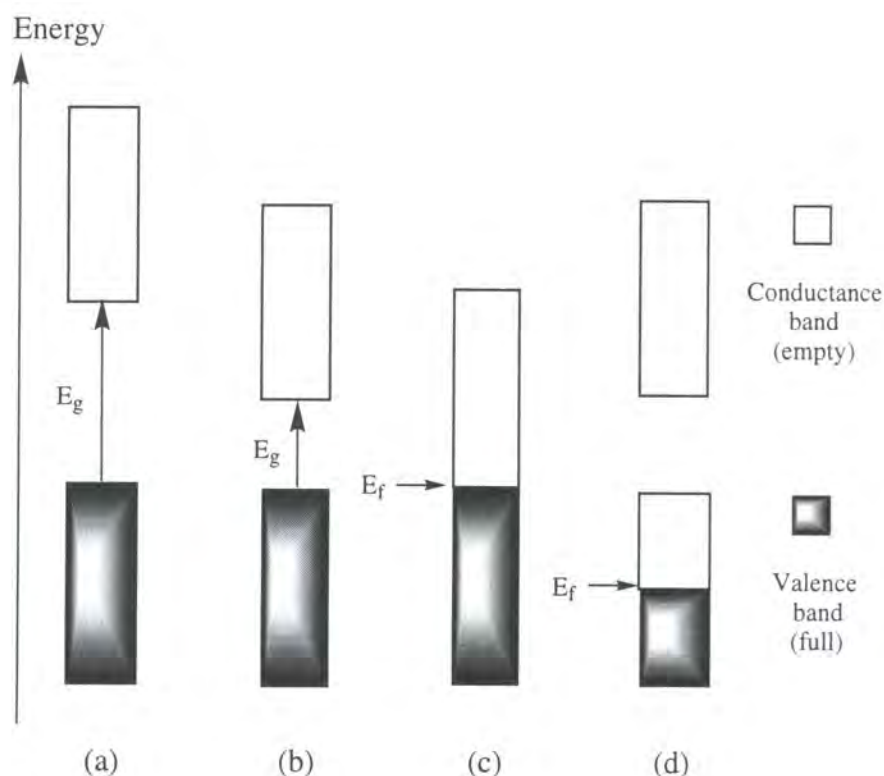

Figure 1.4 - Band structures of (a) an insulator, (b) a semiconductor, (c) a semimetal, (d) a metal. (E_g is the band gap, E_f is the fermi level).

A charge-transfer salt is a complex resulting from the transfer of an electron from a donor to an acceptor molecule. The most common case is that of an ionic crystal where complete charge transfer precludes a high conductivity. In special cases such as TTF-TCNQ, ordered arrays of donor and acceptor components form segregated stacks with transfer of electrons between the stacks. If the complex has a 1:1 stoichiometry of donor and acceptor components and there is partial charge transfer, or the complex is

non stoichiometric, a partially filled HOMO is formed and conduction may occur. In TTF-TCNQ the partially filled bands result from incomplete charge transfer (statistically 0.59 electrons per molecule).²³

1.3.2 TTF-TCNQ; The First Organic Metal.

In 1973, Ferraris¹⁶ *et al.* mixed TTF and TCNQ to obtain a black crystalline 1:1 charge transfer complex. This proved to be a remarkable compound with a room temperature conductivity of ($\sigma_{RT} = ca. 500 \text{ Scm}^{-1}$) and displaying metallic conductivity which rose to a maximum of $1 \times 10^4 \text{ Scm}^{-1}$ at 59K when a metal to insulator transition was observed. The conductivity was found to be highly anisotropic varying in the ratio of 500:5:1 along the three principal axes of the crystal.

The solution of the crystal structure revealed some of the factors behind its unusual properties. Segregated stacks of donor and acceptor with a characteristic "herringbone" pattern were observed. Within the acceptor and donor columns the molecules are laterally displaced, with the exocyclic carbon-carbon double bond lying over the ring of the molecule adjacent to it in the stack (Figure 1.5). The segregation of molecules into separate stacks leads to strong intrastack interactions giving rise to delocalised energy bands along a stack arising from regular interaction of the π -orbitals of the molecules. Both TTF and TCNQ are planar and of comparable size with extensive π -delocalisation along the stacks.

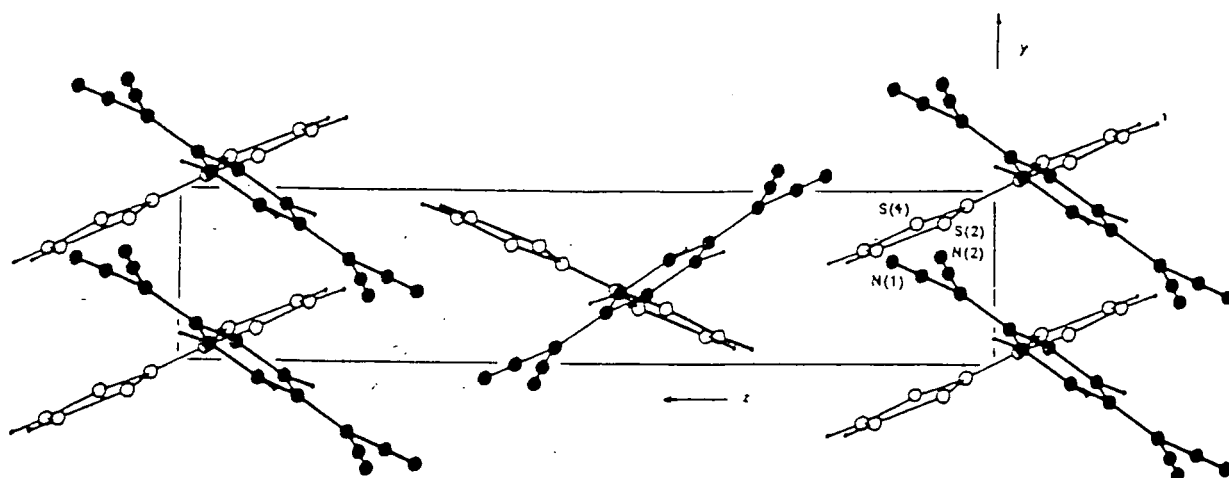

Figure 1.5 X-ray crystal structure of TTF-TCNQ.

The degree of charge transfer was found to be 0.59 electrons per molecule based upon diffuse X-ray scattering techniques and infrared spectroscopy.²³ This gives rise to partially filled electron bands which facilitate metallic conductivity within both stacks. Because charge delocalisation is only possible along a stack, this is the reason conduction in the TTF-TCNQ salt is highly anisotropic giving rise to the term "one dimensional metal".

1.3.4 The Peierls Distortion

The behaviour of anisotropic or one-dimensional organic metals was given a mathematical foundation by the work of Frölich²⁴ and Peierls.²⁵ They predicted that at low temperatures a quasi-one-dimensional metal could not support long range order and would be unstable with respect to lattice distortions. Although TTF-TCNQ does display metallic conductivity, cooling the complex to liquid helium temperatures revealed three phase transitions at 53, 47 and 38 K, leading to an insulating state (Figure 1.6).

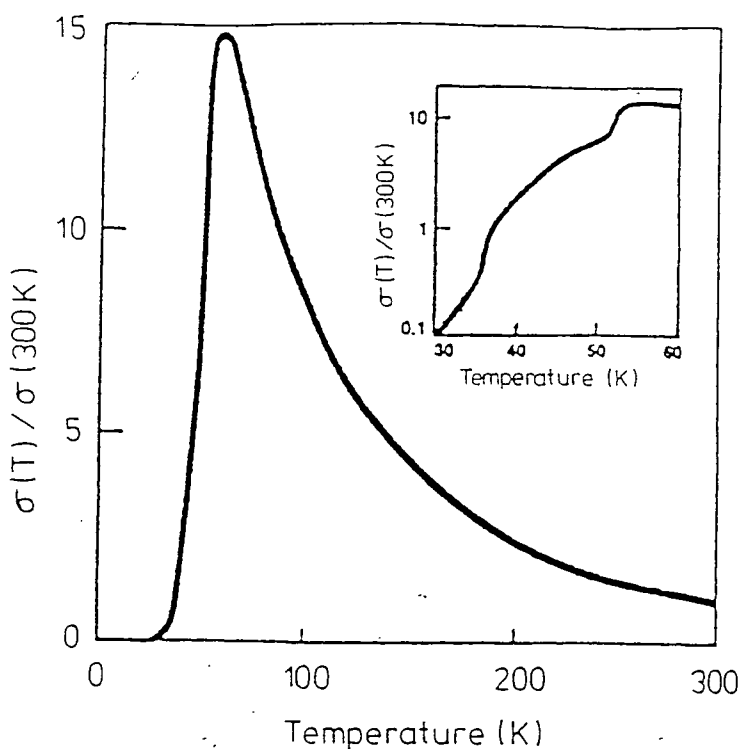

Figure 1.6 Temperature conductivity profile of TTF-TCNQ

Conducting one-dimensional charge-transfer complexes can be either single chain conductors (where the anion is a closed shell species, *e.g.* Cl^- , PF_6^-) or two chain conductors (*e.g.* TTF-TCNQ). In each case, the complex contains stacks of open shell radical moieties capable of one-dimensional conductivity. For radical species, however, there is always some electronic driving force for dimerization, and at a critical temperature spin pairing may occur. In consequence, a band gap will emerge separating

the HOMO and the LUMO energy levels, thus destroying metallic conduction. In parallel to this process the conducting chain becomes distorted, contracting at the points where the two radical entities come together and stretching in the regions they have vacated with the formation of a charge density wave. This distortion of the crystal lattice of one-dimensional metals is called the Peierls distortion (Figure 1.7).

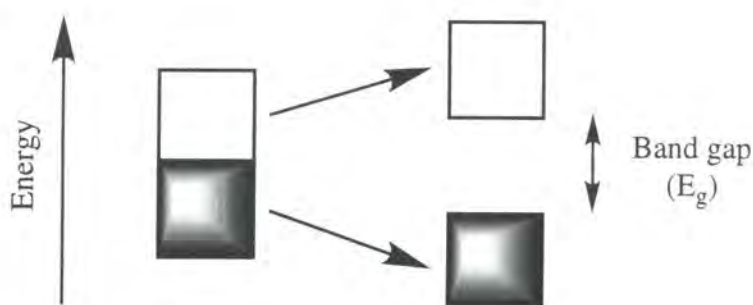

Figure 1.7 Band splitting caused by Peierls distortion

1.3.5 The Features Of An Ideal Organic Metal.

A detailed assessment of the design constraints for organic metals and superconductors has been provided by Cowan²⁶ and others.²⁷ In summary, the main guidelines for obtaining conducting CT salts are as follows:

- 1) Stable open-shell free radical components which form partially filled bands.
- 2) Segregated stacks of radical species, since alternating mixed donor-acceptor stacks will contain filled HOMO and empty LUMO bands with large energy gaps.
- 3) Inhomogenous charge and spin distribution, to reduce the repulsion when like charged species are stacked.
- 4) Planar molecules with delocalised π -molecular orbitals to aid effective overlap, and hence band formation.
- 5) An aversion to the Peierls distortion by strong interchain coupling which can suppress the formation of a charge density wave.

1.4 REMOVING THE PEIERLS DISTORTION: ORGANIC SUPERCONDUCTORS

In view of the above guidelines researchers have pursued several modifications to the basic TTF core unit in order to achieve structures which would resist the formation of a Peierls distortion at low temperatures.

Extending the σ -framework of TTF by attaching methyl groups to the TTF system to furnish the donor tetramethylTTF **8**,²⁸ gave the first CT salts with acceptors other than TCNQ (*viz.* tetrahalo-*p*-benzoquinones) to show metallic behaviour.²⁹

The first major breakthrough in achieving enhanced conductivities from TTF based systems came with the substitution of sulfur by other chalcogens.

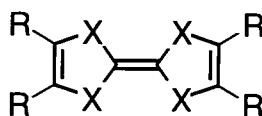

- 4** TMTSeF, X = Se, R = Me
6 TSeF, X = Se, R = H
7 TTeF, X = Te, R = H
8 TMTTF, X = S, R = Me

Tetramethyltetraselenafulvalene (TMTSeF) **4**, when oxidised in the presence of closed shell inorganic counterions formed salts of the general formula $(\text{TMTSeF})_2\text{X}$ (where $\text{X} = \text{PF}_6^-$, FSO_3^- , ReO_4^- , BrO_4^- and ClO_4^-) which are known as the Bechgaard salts.¹⁸ It was found that under a hydrostatic pressure of 12 kbar, $(\text{TMTSeF})_2\text{PF}_6$ underwent a transition to a superconducting state at $T_c = 0.9$ K thus becoming the first superconducting organic material. The other salts were found to undergo superconducting transitions under similar conditions with the exception of the ClO_4^- salt which is an ambient pressure superconductor at $T_c = 1.4$ K.³⁰

The effect of enhanced conductivity by substituting the heavier chalcogens into the TTF framework appears to be a general one. Both tetraselenafulvalene (TSeF) **6**,³¹ and tetratellurafulvalene (TTeF) **7**,³² exhibit higher conductivity values in their TCNQ complexes (*ca.* 800 Scm^{-1} for TSeF-TCNQ; 2200 S cm^{-1} for TTeF-TCNQ) when compared with TTF-TCNQ ($\sigma_{\pi} = 500 \text{ S cm}^{-1}$). The higher conductivities have been attributed primarily to an enhancement in intrastack π -interactions due to the more diffuse *p* and *d* orbitals of the selenium and tellurium atoms.

The X-ray crystal structure of $(\text{TMTSeF})_2\text{BrO}_4^{33}$ illustrates the significant structural features which lead to a suppression of the Peierls distortion and hence the onset of superconductivity at low temperatures (Figure 1.8). The donor molecules are essentially planar and are stacked in a ring-over-bond fashion into donor columns where both *inter*- and *intrastack* interactions are based on $\text{Se}\cdots\text{Se}$ close contacts. These *interstack* interactions give rise to an increase in the dimensionality of electrical conductivity, charge is now effectively delocalised over two dimensions in the crystal as opposed to the one dimensionality of TTF-TCNQ, with the advantage that the Peierls distortion is more likely to be suppressed.

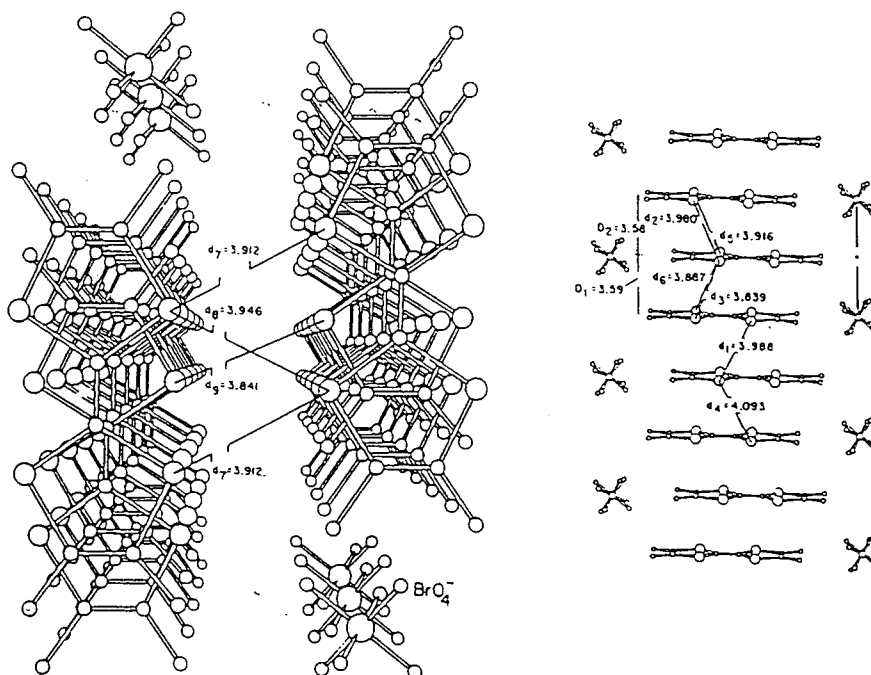
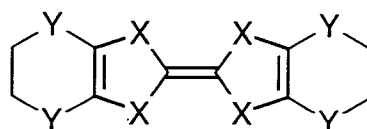

Figure 1.8 X-Ray crystal structure of $(\text{TMTSeF})_2\text{BrO}_4$.



- 5** BEDT-TTF, X = S, Y = S
9 BEDSe-TTSeF, X = Se, Y = Se
10 BEDSe-TTF, X = S, Y = Se

The next breakthrough in the field of superconducting organic metals came with the synthesis of the first superconducting salts of a sulfur containing donor, bis(ethylenedithio)tetrathiafulvalene (BEDT-TTF) **5**.³⁴ Currently, the organic salts with the highest critical temperatures all contain this donor unit.

The X-ray structures of the superconducting salts of BEDT-TTF exhibit several structural differences from the Bechgaard salts.³⁵ The non-planarity of BEDT-TTF

together with the large thermal vibration of the peripheral ethylenedithio groups hinders the formation of good face-to-face π -overlap. Instead, a quasi three-dimensional network of close S...S contacts is observed which leads to extensive charge delocalisation in the salts and suppression of the Peierls distortion.

This new type of assembly is seen in the single crystal X-ray structure of the salt k -(BEDT-TTF)₂Cu[N(CN)₂]Br.³⁶ This structure shows the formation of orthogonal BEDT-TTF dimers (called κ -packing), with an ordered, conducting network of S...S close contacts less than the sum of their Van der Waals radii (3.60 Å) (Figure 1.9).

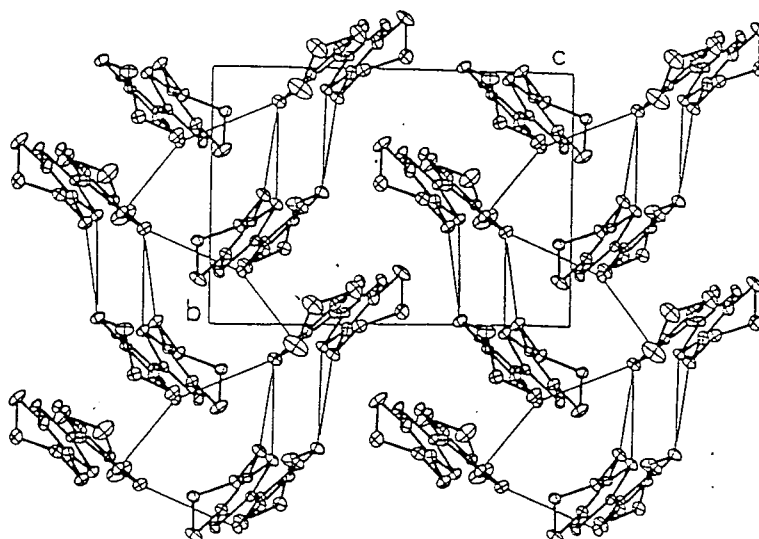
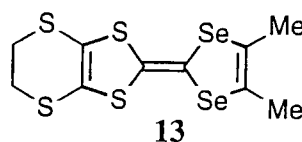
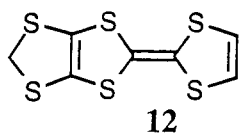
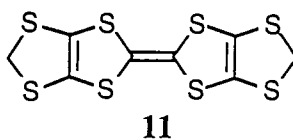

FIGURE 1.9 X-Ray crystal structure of k -(BEDT-TTF)₂Cu[N(CN)₂]Br.

Other packing motifs are also amenable to superconducting transitions, *e.g.* the salt (BEDT-TTF)₂I₃ forms four different stoichiometric phases,³⁷ termed α , β , θ , and κ , of which the last three are superconductors.

Other structures which combine κ -type structures with superconductivity include (BMDT-TTF)Au(CN)₂,³⁸ (MDT-TTF)₂AuI₂,³⁹ and (DMET)₂AuBr₂,⁴⁰ derived from the donors **11**, **12** and **13**, illustrating that superconductivity does not require symmetrical donors.



Surprisingly, no salts of the donors BEDSe-TTSeF **9** and BEDSe-TTF **10** exhibit superconducting properties. Based on the known correlation between high conductivities and the crystal packing motifs, current emphasis in organic metals research has been towards the rational design of α , β , θ , and κ -phase charge-transfer salts.

1.5 CRYSTAL ENGINEERING

It has been shown that donor molecules which pack in highly ordered two-, or three-dimensional arrays can display conductivities in more than one dimension and at low temperatures can display superconductivity. The suppression of the metal to insulator transition is ascribed to the more tightly packed and ordered structures of these salts. Early efforts based on the success of TMTSeF focused on modifying existing donors by substituting chalcogen atoms such as selenium and tellurium into the structures.⁴¹ Such syntheses were invariably time-consuming and involved the use of noxious and hazardous reagents such as CSe₂ or H₂Se.

The emphasis in rational design of organic conductors, therefore, is now concerned less with modifications to the basic donor unit but with a supramolecular approach to enhancing *interdonor* interaction. By such modifications it is hoped that molecules will pack within a crystal lattice in a prescribed manner; a strategy called molecular or crystal engineering.⁴² Three main areas of research have now opened up based on such approaches: 1) Functionalised TTFs capable of intermolecular interactions; 2) systems with extended π -electron conjugation; 3) Multi-TTF systems. A short overview of the first two areas will be given, with a more comprehensive treatment of the third, as a background to the experimental work undertaken in this thesis.

1.6 CRYSTAL ENGINEERING IN TTF DERIVATIVES

1.6.1 Functionalised TTFs Displaying *Intermolecular* Interactions

The rational design of TTF-based donor molecules with appended substituents capable of effective intermolecular donor...donor and donor...anion interactions is a new and burgeoning topic.⁴³ Interactions of this type should exert an orientating effect on the constituent molecules thereby encouraging intermolecular interactions and the formation of crystal phases of higher dimensionality.

4-(Hydroxymethyl)ethylenedithio-TTF **14** has been synthesised by Gorgues *et al.*⁴⁴ The isostructural ClO_4^- and ReO_4^- salts⁴⁵ (general formula 2:1 donor:anion), exhibit weak donor...anion hydrogen bonding and the donor molecules pack in a κ fashion similar to that observed in the superconducting salts of BEDT-TTF (Figure 1.10). Both the ClO_4^- and ReO_4^- salts display semiconductive behaviour ($\sigma_{\text{rt}} = 3.0$ and 0.27 S cm^{-1} , respectively).

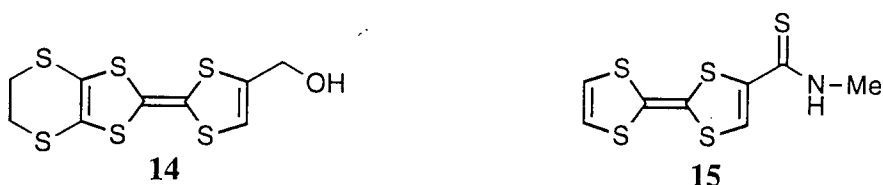

TTF derivative **15**⁴⁶ bearing a thioamide substituent has been shown to pack in a κ -fashion in the neutral crystal although no highly conducting salts have yet been obtained.

Recently, the strong and directional halogen...halogen interaction has been used to synthesise a series of highly conducting systems based on halogenated TTF systems; these are discussed in more detail in Chapter 3.

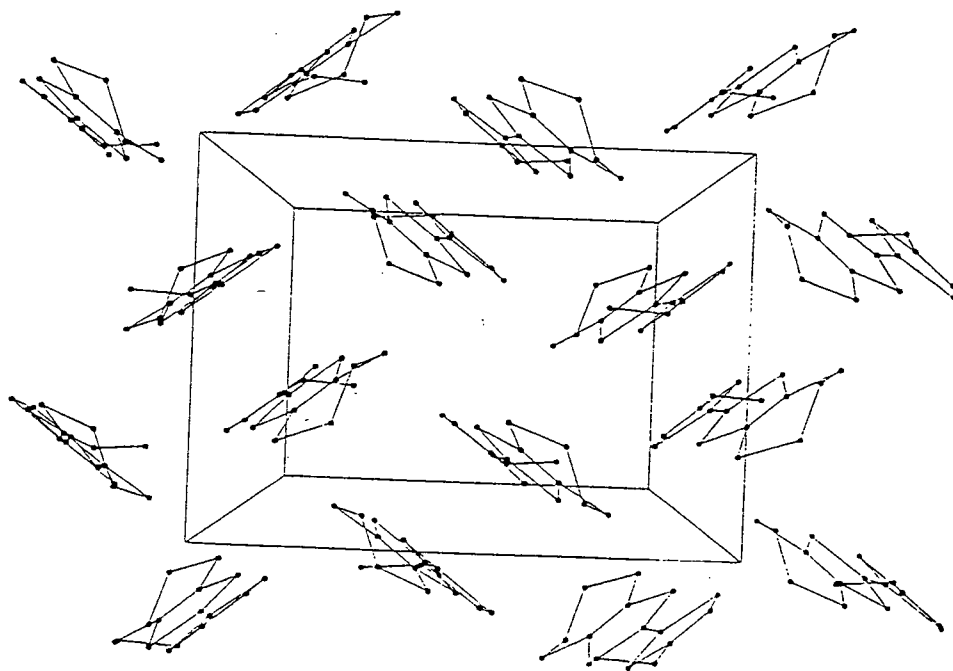
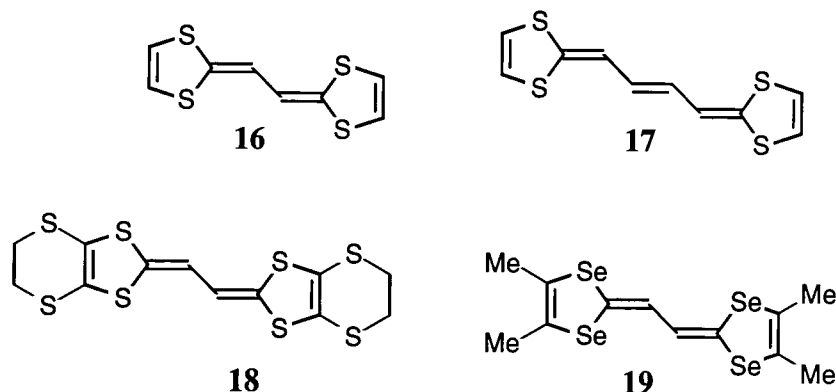

Figure 1.10 κ -phase network of donor molecules in the salt $(\mathbf{14})_2\text{ClO}_4$

1.6.2 Donor Systems With Extended π -Conjugation

The concept behind π -extended TTF systems is that a conjugated linker placed between the two dithiole rings of the TTF systems will lead to delocalisation of charge and stabilisation of the cation-radical and hence lower the oxidation potential by reducing the intramolecular coulombic repulsion in the oxidised dication state. The larger π -electron system should in theory lead to more polarizable systems which should favour strong *intermolecular* interactions.

Yoshida *et al.*⁴⁷ have synthesised **16** and **17** which are TTFs with extended vinylogous systems inserted between the two 1,3-dithiole rings. Donor **16** displays a considerable lowering of the first oxidation potentials with respect to TTF (at $E^{1/2} = 0.20$ and $E^{1/2} = 0.36$ V, respectively). With further π -extension as in **17** there is no further reduction in the redox values and the two 1,3-dithiole rings now act independently of each other and a single, two-electron, wave is observed at $E^{1/2} = 0.22$ V.



Several π -extended systems such as **18** and **19** have been synthesised as analogues of the successful donors, BEDT-TTF⁴⁸ and TMTSeF.⁴⁹ However, crystallisation of salts of these extended donors is considerably harder than for TTF or BEDT-TTF. So far, no superconducting complexes have been isolated for these systems.

An alternative approach to extending π -conjugation has involved the incorporation of cyclic spacer groups between the two 1,3-dithiafulvenyl rings. Anthracenediylidene derivatives such as **20** have been widely studied.⁵⁰ In its cyclic voltammogram **20** displays a quasi-reversible, two-electron transfer to yield the dicationic species at $E^{ox} = 0.28$ V. The driving force for complete oxidation is the formation of the planar aromatic anthracene moiety. Upon complexation with TCNQ, **20** yields a 1:4 charge-transfer complex. The presence of the donor moiety in the dicationic state means that the room temperature conductivity of 60 S cm^{-1} is due

entirely to charge percolation through the stacks of partially reduced TCNQ molecules.⁵¹

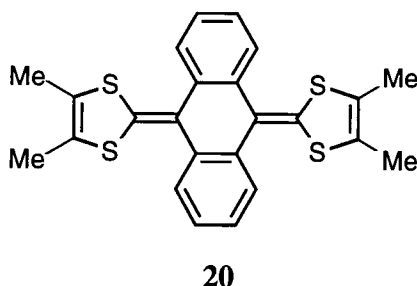

1.7 OLIGOMERIC TETRATHIAFULVALENES

1.7.1 The "Multi-TTF" Principle

The formation of partially filled conduction bands in 1:1 donor-acceptor complexes requires incomplete charge transfer which is achieved in practice by a careful balancing of the ionization potential of the donor and the electron affinity of the acceptor. In complexes such as the Bechgaard salts the partly filled bands arise from the formation of complexes of stoichiometry other than 1:1. While our understanding of the effects of various substituents on the oxidation potential of TTF is now at a stage where "fine tuning" of the redox chemistry is possible, the control of stoichiometry is still serendipitous.

The multi-TTF approach⁵² involves the synthesis of dimeric TTF molecules and higher oligomers, in which the TTF units are linked by one or more spacer units. Such an approach may lead to intramolecular through-bond or through-space interactions which in turn may allow an opportunity to control the band filling and stoichiometry in desired complexes.⁵³ As well as the formation of incompletely filled conduction bands, high conductivity is generally enhanced by the formation of networks of chalcogen-chalcogen interactions in more than one dimension. By physically linking the donor moieties it may be possible to encourage the formation of such networks by the spatial proximity of the redox centres.

1.7.2 Categories of Oligomeric TTFs

Dimeric TTFs and higher oligomers may be formally divided into the following generic types: i) a single linkage of type 1; ii) a double-linkage, macrocycle of type 2; iii) a double-linkage, cyclophane of type 3; and iv) a quadruple-linkage, cyclophane of type 4 (Figure 1.11).

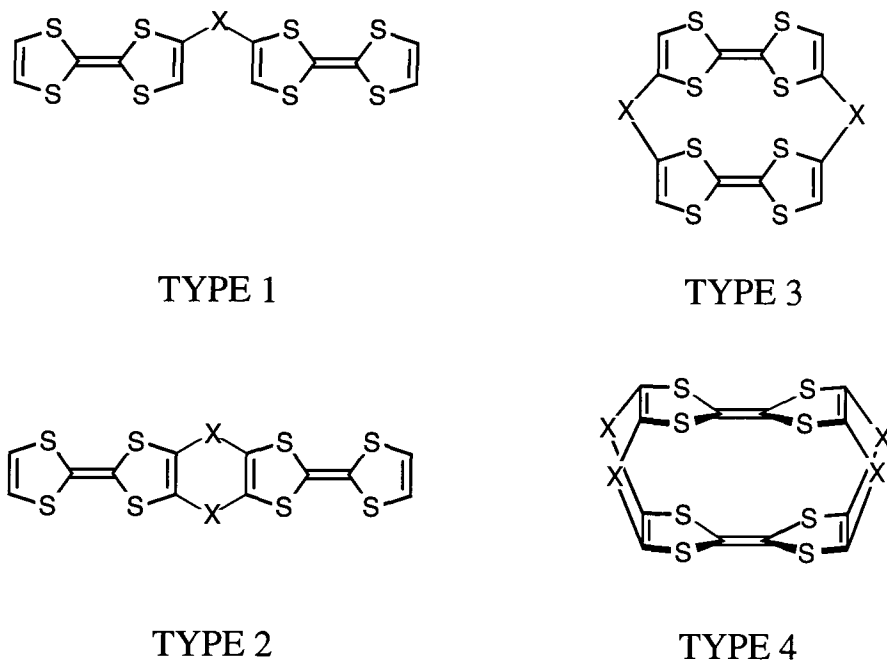

Figure 1.11 The four main categories of linkage for multi-TTF systems.

These represent the main geometrical orientations possible for multi-TTF systems: the mutual juxtaposition of the TTF units and hence the scope for *intramolecular* interactions depends greatly on the nature of the spacer groups. The spacer groups can be divided into two main subcategories: those with a conjugated linkage and those with a non-conjugated linkage.

1.7.3 Multi-TTFs of Types 1 and 2

1.7.3.1 Systems of Type 1 with non-conjugated linkages

Such systems may in theory favour various conformations; for example, a folded U-shape (Figure 1.12a), or a more open linear shape (Figure 1.12b), depending on the conformational flexibility of the linkages.

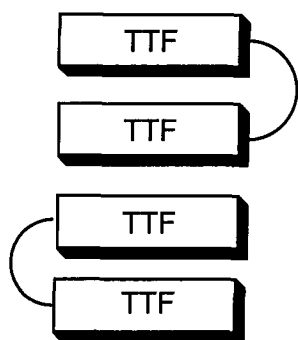

Figure 1.12 (a)

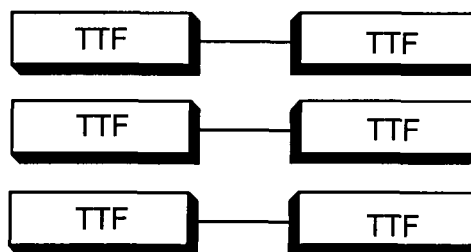
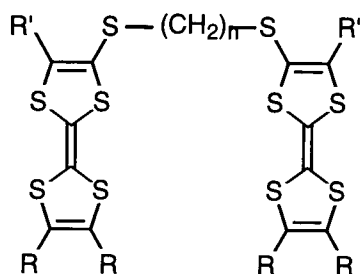

Figure 1.12 (b)

Such flexibility may lead to the formation of low energy conformers in complexation reactions, but such flexibility also reduces the control over the geometrical orientation of the TTF moieties. The flexibility of such non-conjugated linkages was postulated by Bechgaard *et al.*⁵⁴ to be partly responsible for the complex electrochemistry of the series of TTF dimers **21** - **23**.^{54,55,56}



21 R=R'=Me, (a) n=1, (b) n=2, (c) n=3, (d) n=10

22 R=R'=H, (a) n=3, (b) n=4

23 R=Me, R'=H, (a) n=2, (b) n=3, (c) n=4

Compounds **21a** and **21b** with short, flexible, alkylenedithio bridges, do not display the expected two, two-electron redox waves of TTF; instead, a three-stage redox wave was observed with two, one-electron, transfers followed by one, two-electron transfer, although this was not observed for **23a**. The first oxidation potential is also considerably lower when compared to the parent monomeric TTF. When longer linkages are used as in **21c-21d**, **22a-22b** and **23a-23c** the molecules behave as two separate TTF moieties and no interaction is observed. The lowering of the first oxidation potential was explained by postulating a sandwich structure for the stabilisation of the monocationic species. Removal of the second electron from the positively charged sandwich species is more difficult because of the resulting coulombic repulsion between the two charged TTF moieties, hence the first redox wave is split (Figure 1.13).

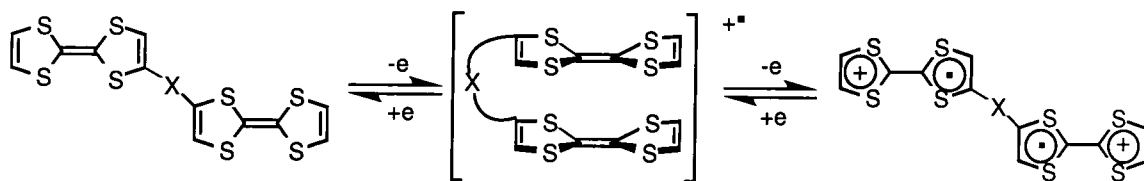
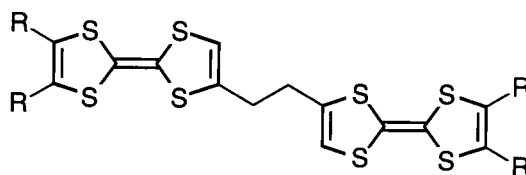

Figure 1.13 The stabilisation of the monocationic state in a TTF-dimer.

The crystal structures of several salts of non-conjugated TTF dimers have been published which illustrate the variety of solid state conformations possible due to the flexible nature of the linking group.



24a R = Me

24b R - R = SCH₂CH₂S

Compounds **24a-b** synthesised by Bechgaard *et al.*⁵⁷ have given several crystalline salts. **24a** displays a similar three-stage redox behaviour to that of **21a** and **21b**. Complexation with TCNQ and DMTCNQ,⁵⁸ gives salts with a donor...acceptor ratio of 1:1, (*i.e.* two TTF moieties to one acceptor). Upon oxidation in the presence of PF₆⁻, a semiconducting 1:1 complex is formed. Conducting complexes of **24a** have also been obtained with inorganic cluster anions such as Re₆S₆Cl₈,⁵⁹ which exhibited one-dimensional stacks of dimeric molecules in their crystal structures. **24b** displays two, reversible oxidation waves, and the salt **24b**[Au(CN)₂] is a semiconductor exhibiting a high room temperature conductivity ($\sigma_{rt} = 12 \text{ S cm}^{-1}$).

The conformational flexibility of TTF systems with non-conjugated linkers in salt formation is illustrated by the *bis*TTF **25** synthesised by Sugawara *et al.*,⁶⁰ which gave two different crystalline polymorphs of its ion radical salts with ClO₄⁻.

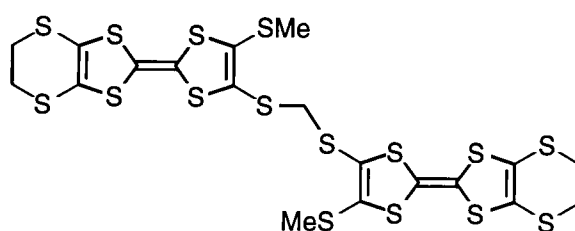

25

One polymorph has a 2:1 stoichiometry of donor to acceptor and displayed semiconductive properties, and an X-ray study revealed that the donor molecules exist in a twisted U-shaped conformation (Figure 1.14a). The other polymorph is insulating with the donor molecules existing in an eclipsed U-shaped conformation with the two TTF moieties interacting closely with an intramolecular separation of 3.09 Å (Figure 1.14b).

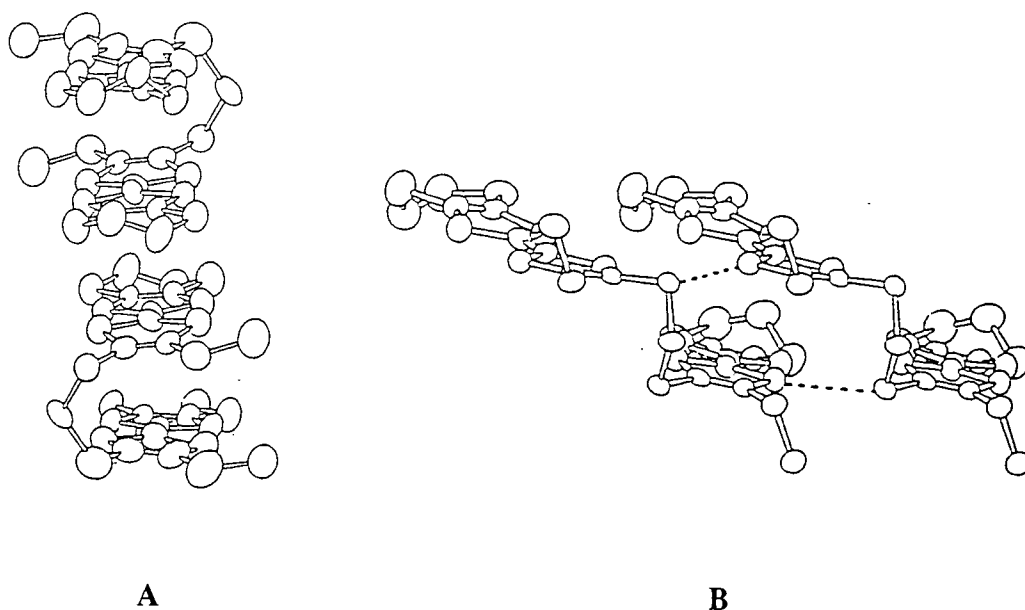
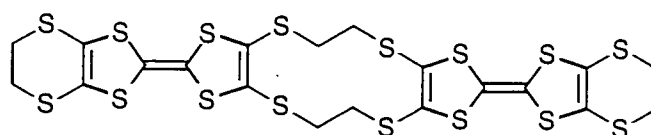

Figure 1.14 X-ray crystal structure of a) **(25)**(ClO₄); b) **(25)**(ClO₄)_{0.5}

1.7.3.2 Systems of Type 2 with non-conjugated linkages

The first report of a TTF dimer of type 2 was a low yielding synthesis of a polyglycol linked derivative by Otsubo⁶¹: no CV data or salt formation was reported.

Sugawara *et al.*⁶² synthesised a double-bridged TTF dimer **26** possessing a flexible cavity between the two TTF moieties which can complex molecules as diverse as the planar DDQ and the spherical C₆₀. This is discussed in more detail in Chapter 4. **26** forms a cation radical salt with ClO₄⁻, which has a conductivity of 5 S cm⁻¹, showing metallic behaviour down to 130 K⁶³ with the donor molecule displaying a V-shaped conformation.



26

Becher *et al.*⁶⁴ have synthesised an analogue of **26** with larger flexible polyglycol spacers. No inclusion complexes have been reported, but an insulating salt with linear polyiodide has been characterised. The synthesis of higher cyclic oligomers of compounds of this type by Becher *et al.* will be discussed in more detail in Chapter 4.

A series of *bis*TTFs with rigid benzylic **27**, and biphenylbenzylic **28**, spacer groups was synthesised by Becher *et al.*⁶⁵ The cyclic voltammograms displayed two,

two-electron oxidations with the first oxidation wave coming at a slightly lower potential than the acyclic parent compounds indicating a stabilizing effect on the first oxidation by the neighboring TTF.

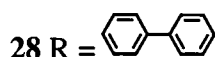
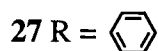
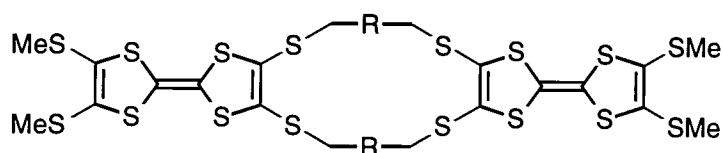

An isolated example of a non-conjugated linkage which nonetheless displays a rigid conformation is *bis*TTF **29a-b**⁶⁶ in which the linkage is a spirocyclic system which fixes the TTF units rigidly orthogonal to each other. **29a** displayed a four stage reversible redox wave where each stage corresponded to a one-electron transfer.

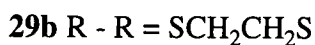
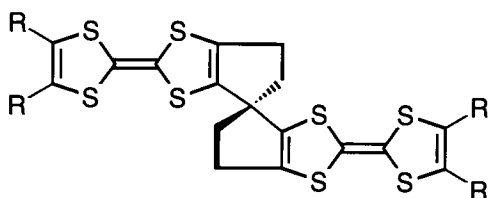

1.7.3.3 Heteroatomic linkages

A special class of multi-TTF systems are those in which the TTFs are linked via a heteroatom. The linkage of multi TTFs of type 1 and 2 by main group elements offers an alternative to rigid systems such as **29**.

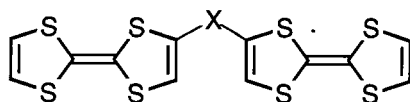

30 (a) X = S, (b) X = Se

31 (a) X = Te, (b) X = Te₂

32 (a) X = SiMe₂, (b) X = PPh₃, (c) X = Hg

A number of heteroatoms such as sulfur **30a**,⁶⁷ selenium **30b**,⁶⁷ tellurium **31a-b**,⁶⁸ silicon **32a**,⁶⁹ phosphorus **32b**,^{69,70} and mercury **32c**,⁶⁹ have been used to link dimeric and trimeric TTFs. In the case of the chalcogen linked derivatives, the possibility of intermolecular chalcogen-chalcogen interactions may lead to higher dimensionality of conduction in their ion-radical salts. Such molecules display a non-planar "butterfly" structure. In the case of **31b** the TTF units are nearly perpendicular as in **29**. A few conductive complexes have been reported: **31b** gave TCNQ salts of 1:1 and 1:2 stoichiometry, with room temperature conductivities of $\sigma_{rt} = 0.3 \text{ S cm}^{-1}$ and $\sigma_{rt} = 8.4 \text{ S cm}^{-1}$, respectively.

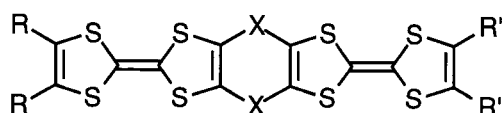

33 (a) X = S; R = R' = H,
(b) X = S; R = R' = SMe

34 (a) X = Te; R = R' = Me,
(b) X = Te; R = R' = SMe

More rigid systems linked with two heteroatom bridges⁷¹ (X = S and Te) analogous to type 2 are known. Compounds **34a** and **34b** have been shown to display networks of close chalcogen-chalcogen interactions in their crystal structures. Compounds **33a** and **33b** also display three-stage redox waves in their cyclic voltammograms similar to those of **21a** and **21b**. In this case, rigidity precludes the formation of the sandwich structure postulated by Bechgaard, and theoretical calculations have shown that through-bond interactions are negligible,⁶⁹ therefore, the dominant interaction is postulated to be coulombic in character. Conductivities of salts of these systems have tended to be low with the exception of **33b** and **34a** which formed complexes with TCNQ ($\sigma_{rt} = 6 \text{ S cm}^{-1}$) or DMTCNQ ($\sigma_{rt} = 6 \text{ S cm}^{-1}$).

A novel system **35** linked with double trisulfide linkers in which the TTF units are in a parallel orientation has been synthesised by Kobayashi *et al.*⁷² This gave an insulating salt with ClO_4^- .

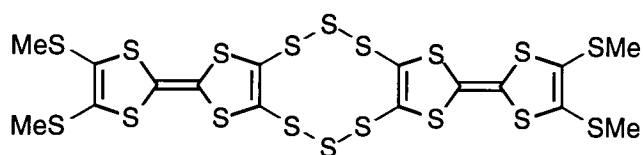
**35**

1.7.4 Conjugated TTF systems.

1.7.4.1 Systems of Type 1 with conjugated linkages

Multi-TTF assemblies in which the TTF units are linked by conjugated systems offer the same possibilities for charge delocalisation and reduced on site coulombic repulsion as the extended TTF derivatives discussed above. Compounds such as **36** and **37** are red shifted in their electronic spectra indicative of an extensively conjugated π -system.⁷³

For systems such as **36** and **37** the two TTF units do not seem to behave independently in complexation reactions, with 1:1 complexes with TCNQF_4 and DMTCNQ being formed.

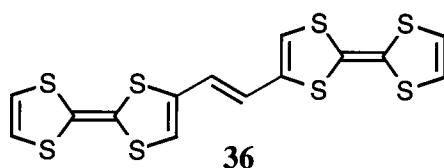
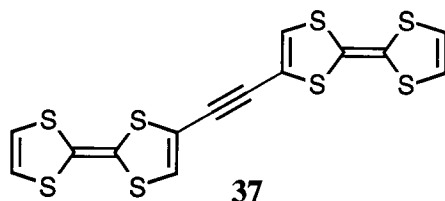
**36****37**

Multi-TTF systems linked via an aromatic system were among the first to be synthesised. The first example of a *bis*TTF derivative **38** was synthesised by Wudl *et al.*⁷⁴ in 1977.

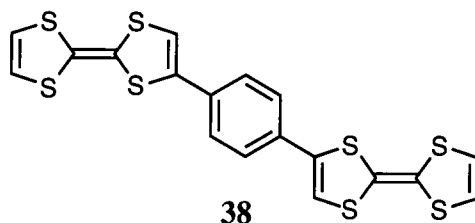

38 formed a 1:1 complex with TCNQ with a conductivity roughly an order of magnitude less than that of TTF-TCNQ. The group of Iyoda *et al.*⁷⁵ has synthesised a series of such compounds with different aryl linkers. For example, **39a-c** and **40** have been synthesised from 4-trimethylstannylTTF or 4-tributylstannylTTF and the corresponding iodoaromatics via a Stille coupling.

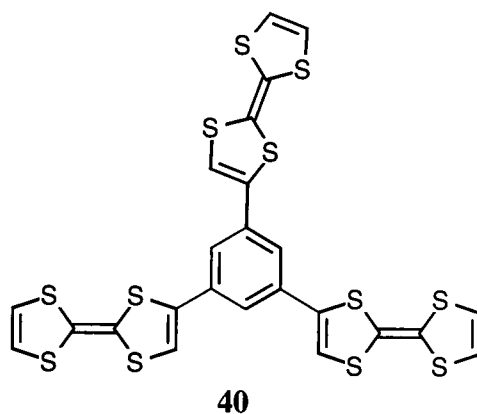
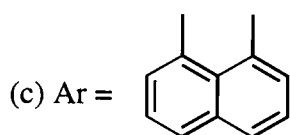
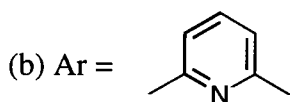
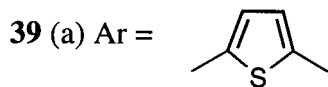
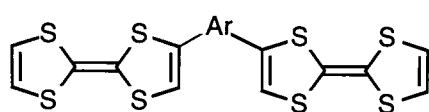

CV measurements indicated that the donors possessed similar oxidation chemistry to TTF. The conductivities of the TCNQ salts were of the order of $\sigma_{\text{rt}} = 1 \text{ Scm}^{-1}$ with **(40)(TCNQ)₂** giving a conductivity of $\sigma_{\text{rt}} = 30 \text{ S cm}^{-1}$.

The directly-linked TTF dimer *bis*(tetrathiafulvalenyl) **41** was first claimed to have been synthesised in 1982,⁷⁶ with a detailed synthesis and X-ray structure being published by Becker *et al.*⁷⁷ in 1995. The contradictory reports on this interesting class of multi-TTF compounds are discussed in more detail in Chapter 2.

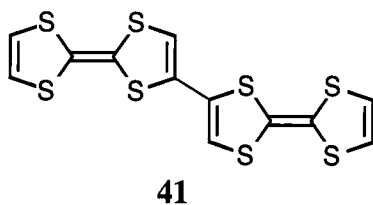

1.7.4.2 Systems of Type 2 with conjugated linkages

A series of benzo-fused *bis*TTFs of type 2 have been synthesised by Müllen *et al.*⁷⁸ Such *bis*- and *tris*TTF systems provide rigid, planar donors whose solubility in common organic solvents is low unless suitable lipophilic sidechains are appended, but large substituents tended to hamper close packing in the solid state and resulted in low conductivity values in salt formation. **42a** can be oxidised in four sequential one-electron steps to the tetracation. On complexation with DDQ **42b** gives a charge-transfer salt of stoichiometry 1:2, (i.e. each TTF subunit interacts with one molecule of DDQ) with a room temperature conductivity of $\sigma_{rt} = 1 \times 10^{-2} \text{ S cm}^{-1}$. **43** gave a complex with DDQ with a conductivity of $\sigma_{rt} = 10^{-1} \text{ S cm}^{-1}$.

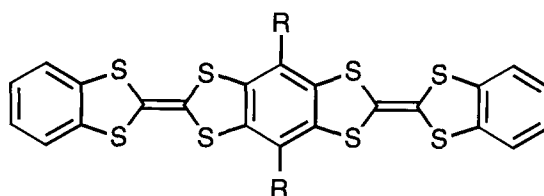

42 (a) R = OC₆H₁₃
(b) R = OC₂H₅

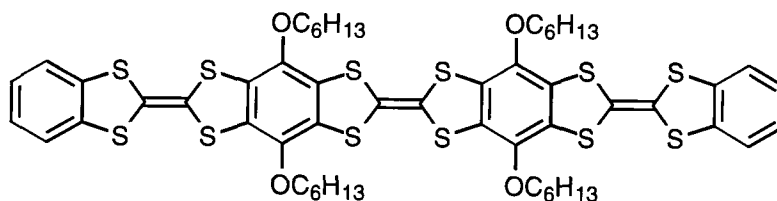

43

The TTF donor **44** fused to a selenophene ring has been synthesised by Becker *et al.*⁷⁹ in a one-pot procedure from 4,5-dimethylTTF. This molecule displayed four, successive, one-electron oxidations, similar to **42a** and gave a complex with TCNQ which displayed a room temperature conductivity of $\sigma_{rt} = 32 \text{ S cm}^{-1}$.

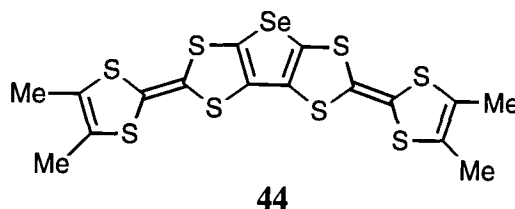

44

Derivatives of *bis*fused TTF **45**⁸⁰ have been synthesised but characterisation and salt formation have been hindered by their limited solubility in organic media. Substituted derivatives have yielded more soluble materials which have yielded several

salts which remained metallic down to low temperatures and displayed a β -type, two-dimensional network of interactions. The cyclic voltammograms of these *bisfused* donors display four sequential, one-electron oxidations. Recently, a hybrid of *bisfused* TTF **45** with extended conjugation, **46** synthesised by Misaki *et al.*⁸¹ has yielded superconducting salts.

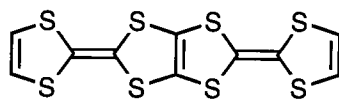
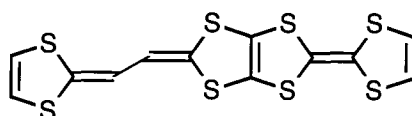
**45****46**

1.7.5 Double bridged tetrathiafulvaleneophanes

1.7.5.1 Systems of Type 3 with non-conjugated linkages

No such systems with rigid aromatic spacers have been reported.

Staab *et al.*⁸² reported the synthesis of the first tetrathiafulvaleneophanes in 1980. The synthesis of [2.2]tetrathiafulvaleneophanes **47** was accomplished as shown (Scheme 1.1).

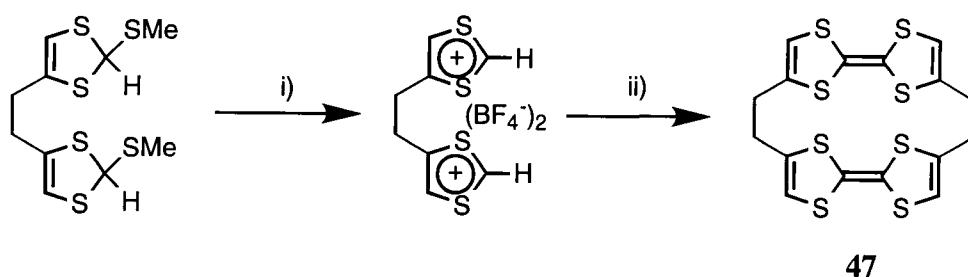

Scheme 1.1 The first synthesis of a [2.2]tetrathiafulvaleneophane.

Reagents and conditions: i) HBF_4 , $(\text{CH}_3\text{CO})_2$; ii) NEt_3 , MeCN .

Such compounds represent a considerable synthetic problem due to the ability of unsymmetrically substituted TTFs to undergo *cis/trans* isomerisation⁸³ catalysed by trace acid in solution. Therefore, for structures such as **47** several isomers are possible.

The group of Otsubo *et al.*⁸⁴ have investigated such systems in great detail. For example **48** was synthesised as a mixture of all four possible stereoisomers of which three of these could be isolated pure after repeated fractional crystallisation (Scheme 1.2).

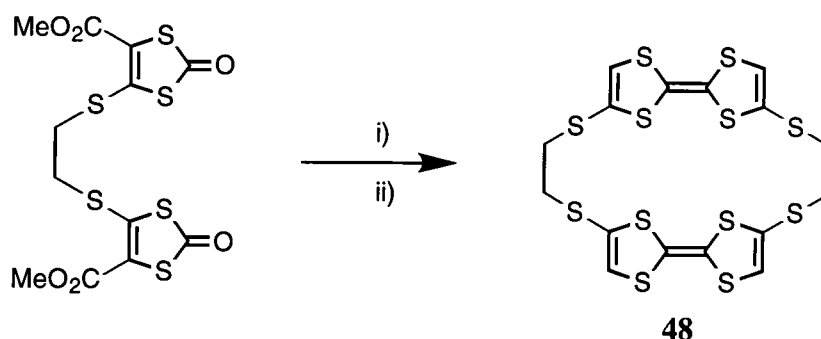

Scheme 1.2 Reagents and conditions : i) P(OMe)₃; ii) LiBr, HMPA.

Compound **48** exhibited a similar cyclic voltammogram to the non-conjugated dimeric TTFs **21a-b** indicating the formation of a similar sandwich structure in the monocationic state with transannular charge delocalisation. A salt with ClO₄⁻ gave a room temperature conductivity of $\sigma_{rt} = 0.16 \text{ S cm}^{-1}$. The analogous tetraselenafulvaleneophanes⁸⁵ have also been synthesised. The cyclophanes linked by a two-carbon thioalkyl chain displayed multi-stage redox processes indicative of a strong interaction between the TSeF moieties while the three-carbon analogue displayed only two broad, two-electron waves. The perchlorate salt of the TSeF analogue of **48** gave a room temperature conductivity of $\sigma_{rt} = 3.5 \text{ S cm}^{-1}$, which is an order of magnitude greater than its sulfur counterpart.

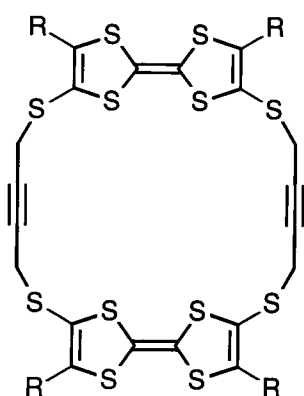

49 (a) R = SMe

(b) R = CO₂Me

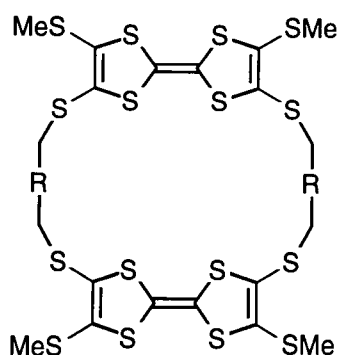

50 R = $\equiv\equiv\equiv$

51 R =

*Bis*TTFs **49a-b** and **50-51** were synthesised by Becher *et al.*⁶⁵ For **49a** and **49b** three oxidation steps were reported, consistent with the close interaction of the TTF moieties. With longer linkers as in **50** and **51**, no such interaction was observed.

An example of a higher oligomer of this type is the *tris*TTF **52** synthesised by Otsubo *et al.*⁸⁶ No salts were reported, but upon recrystallisation the *cis* isomer was obtained exclusively. The CV showed three redox waves, [$E_1^{1/2}$ (2e) = 0.50, $E_2^{1/2}$ (1e) = 0.63, and $E_3^{1/2}$ (3e) = 0.80 V]. The first, two-electron wave was assigned to the oxidation of the two outer TTF units, the second, one-electron wave to the oxidation of the inner TTF, and the third three-electron wave from the simultaneous second oxidations of all the TTFs.

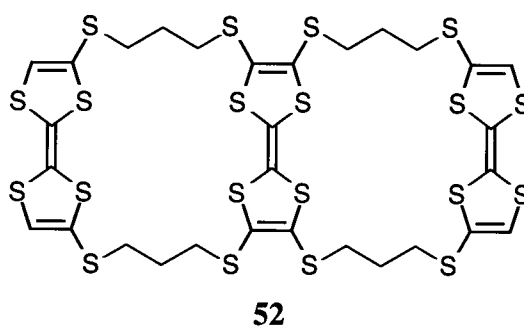

1.7.6 Quadruple bridged tetrathiafulvaleneophanes

1.7.6.2 Systems of Type 4 with non-conjugated linkages

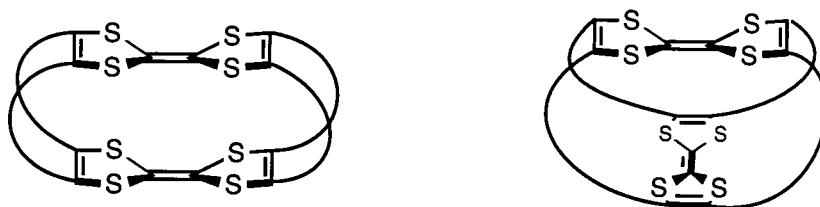
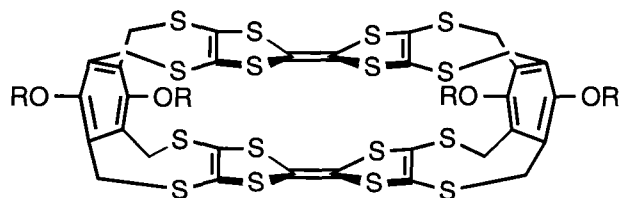

Figure 1.16 Parallel and criss-cross TTF-dimers

By using a quadruple linkage as opposed to a double linkage a much more rigid TTF 'sandwich' system could be envisaged with the TTF units either parallel or perpendicular to each other. One of the first such systems to be isolated was **53** by Müllen *et al.*,⁸⁷ which was isolated as the product of an electrochemical dimerization of the strained parent cyclophane.



53 R = hexyl

An X-ray structure showed that the sandwich structure was indeed replicated in the solid state and due to the rigid nature of the linkers no *cis/trans* isomerisation to give a möbius type structure was possible. This compound gave complexes with I_3^- and PF_6^- which had low conductivities of $\sigma_{rt} = 10^{-3}$ and $\sigma_{rt} = 10^{-4} \text{ S cm}^{-1}$ respectively.

Otsubo *et al.*⁸⁸ have synthesised a similar system with flexible thioalkyl linkages which formed semiconductive complexes with TCNQF₄, DDQ and iodine.

A series of criss-cross tetrathiafulvaleneophanes have been synthesised by Otsubo⁸⁹ **54a-d**, Sugawara⁹⁰ **54b** and Becher⁹¹ **55**, *via intramolecular coupling* reactions. Such a criss-cross overlap has been reported for the trimeric structures of the TTF units in the semiconductive salts (TTF)₃W₆O₁₉ and (TTF)₃Mo₆O₁₉.⁹²

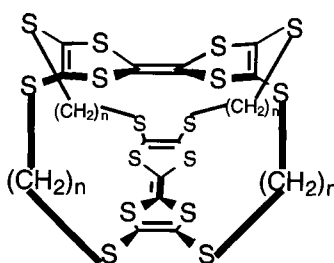

54

(a) n = 2; (b) n = 3
(c) n = 4; (d) n = 5

The cyclic voltammograms of such compounds are complex, indicating significant coulombic effects. It was suggested that the most flexible homologues could twist to adopt the sandwich conformation postulated by Bechgaard⁵⁴ for stabilisation of the monocationic state.

The salts of such compounds exhibited low conductivities, with the exception of **54d**·Br, which had a room temperature conductivity of $\sigma_{rt} = 1 \times 10^{-2} \text{ S cm}^{-1}$ and exhibited semiconducting behaviour. These results indicated that the criss-cross motif was not generally suitable for electrical conduction. It was suggested that the cavities formed within the macrocycles may show some inclusion ability for suitable guest molecules; this topic is dealt with in more detail in Chapter four.

The polyglycol linked analogue **55** synthesised by Becher *et al.*⁹¹ was flexible enough to adopt a Möbius type conformation due to *cis/trans* isomerism in solution.

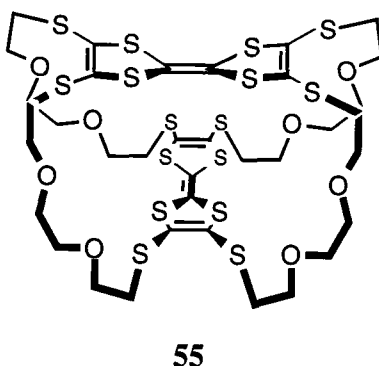

Although no conducting salts were reported, an inclusion complex with the redox active tetracationic cyclophane, cyclobis(paraquat-*p*-phenylene) was obtained.

1.8 THE CHEMISTRY OF TTF⁹³

The two main strategies towards functionalised TTF systems involve either a) direct functionalisation of the TTF ring system or b) formation of the TTF system by a coupling reaction of suitably functionalised 1,3-dithiole precursors.

1.8.1 Direct Functionalisation of the TTF Ring System.

TTF is now readily available in multigram quantities from several published syntheses.⁹⁴ The ring protons have a theoretical pK_a value of ~ 48 ⁹⁵ and can be lithiated by the addition of 1-4 equivalents of a suitable alkyl lithium reagent to give mono, di, tri and tetralithiated species. *N*-butyllithium (BuLi) and lithium diisopropylamide (LDA) have emerged as the reagents of choice for this reaction.

The first monofunctionalised TTF derivatives prepared directly from 4-lithiotetrathiafulvalene **56** were reported by Green⁹⁶, who showed that formation of the TTF anion could be accomplished via the action of butyllithium or LDA in ether at -78°C and trapped with a range of electrophiles to give monofunctionalised derivatives in a one-pot procedure (Scheme 1.3).

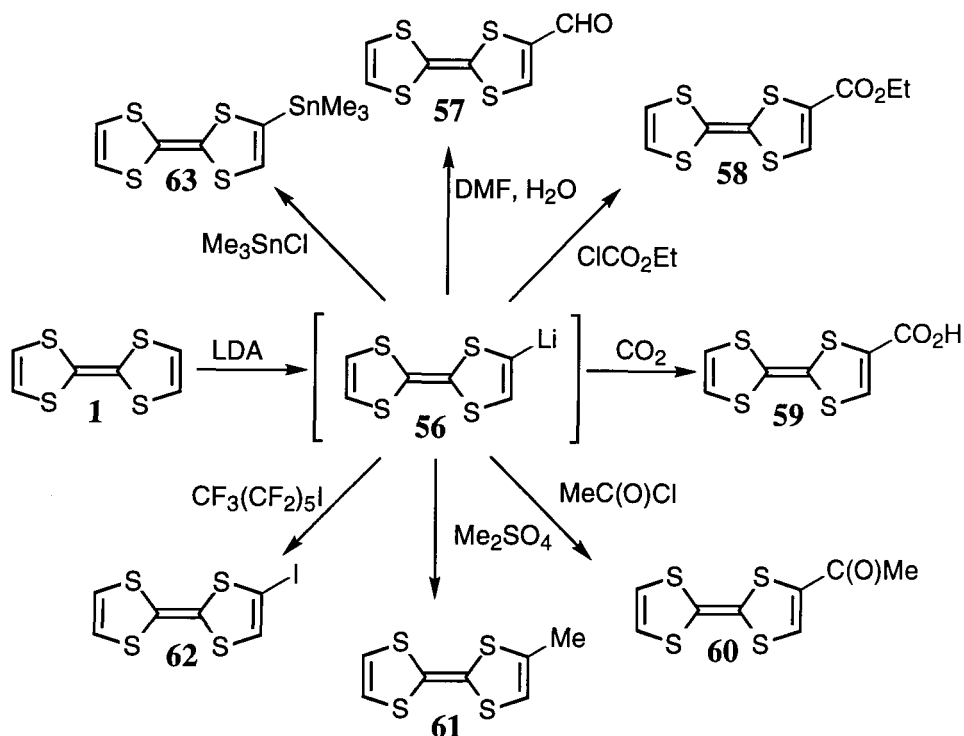

Scheme 1.3 Selected reactions of 4-lithioTTF.

Disproportionation of the monolithiated species occurs readily at temperatures above -78°C to give multilithiated and hence multisubstituted products, so strict temperature control is necessary at all times. If other substituents are present it has been found that electron-donating substituents direct a second lithiation and therefore substitution onto the other ring, while electron-withdrawing substituents increase the acidity of the adjacent proton, hence favouring lithiation on the same ring (Scheme 1.4).

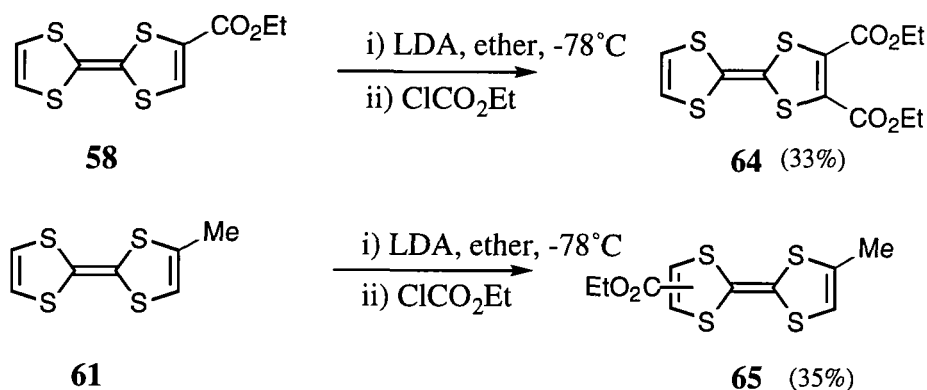

Scheme 1.4 Effect of substituents on lithiation reactions of TTF.

Such substituted TTFs, especially the aldehyde **57**, ester **58**, and carboxylic acid **59** derivatives are capable of undergoing further functional group transformations to build up more complex systems.⁹⁷

Chalcogenated TTF systems such as BEDT-TTF **5** are of great interest. The introduction of chalcogen atoms such as sulfur, selenium or tellurium onto the TTF backbone can be achieved by reaction of lithiated species with the elemental chalcogen^{55,98}; the resulting TTF chalcogenate anion **66** can then be alkylated with a suitable electrophile. Thioester derivative **69** is a useful shelf stable reagent in this respect; a deprotection with base regenerates the thiolate **66** (Scheme 1.5).

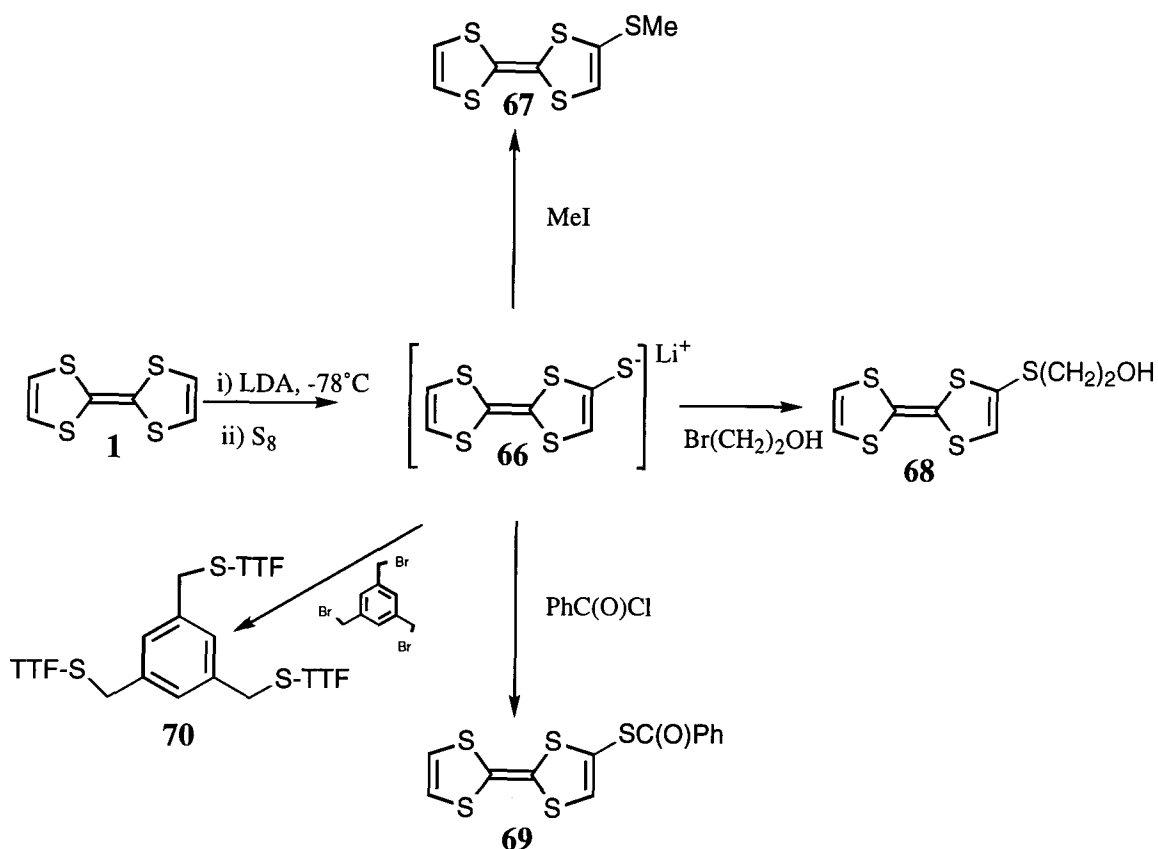

Scheme 1.5 Selected reactions of TTF thiolate.

1.8.2 TTFs from Functionalised 1,3-Dithioles

The other main synthetic route to functionalised TTFs involves formation of the TTF system by the self- or cross-coupling of suitable 1,3-dithiole derivatives. The chemistry of the 1,3-dithiole system has been extensively studied this century and several routes to substituted derivatives have been developed.^{94a,99}

A key reaction is the chemical reduction of carbon disulfide by sodium metal,¹⁰⁰ to generate in high yield the sodium dithiolate **71** (the exact reaction mechanism remains open to speculation). By chelation to zinc and precipitation as its tetraethylammonium salt it is possible to isolate **72** in a pure form (Scheme 1.6).

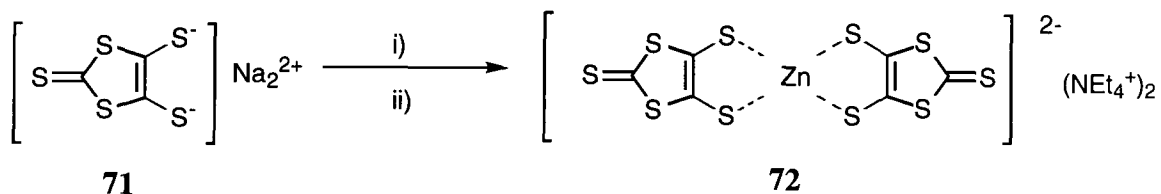

Scheme 1.6 Synthesis of zincate salt **72**. *Reagents and Conditions:* i) ZnCl_2 ; ii) $(\text{NEt}_4)\text{Br}$.

Zincate salt **72** is a shelf stable source of dithiolate **71** and may be alkylated or acylated in good yields. The group of Becher have developed the chemistry of the biscyanoethyl derivative **73**¹⁰¹ (Scheme 1.7), which can be deprotected with two equivalents of base to give the dithiolate **71**, usually as its more reactive sodium derivative. **73** can also be selectively and sequentially mono-deprotected by the addition of one equivalent of cesium hydroxide to give the mono-thiolate which can be alkylated to give species such as **74**.^{101b} Conversion of **73** to the oxo derivative **76** is achieved by the action of mercuric acetate¹⁰² in chloroform/acetic acid.

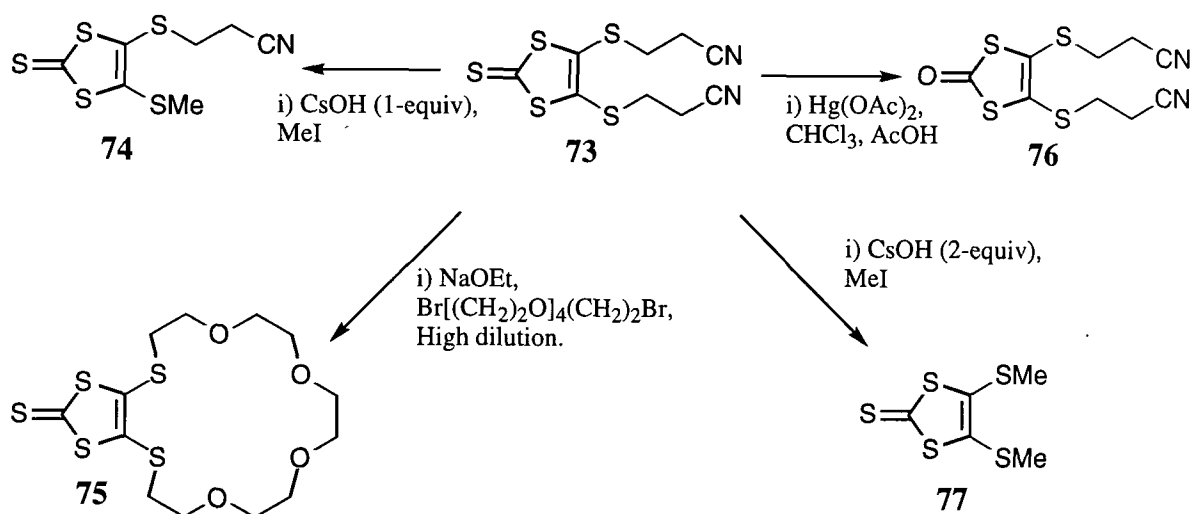

Scheme 1.7 Reactions of protected 1,3-dithiole dithiolate **73**

A common method for the synthesis of symmetrical TTF systems from 1,3-dithiole-2-thione or 1,3-dithiole-2-iminium salts is shown below (Schemes 1.8, 1.9).^{94a,103} The common intermediate is the 1,3-dithiolium cation **82** which is deprotonated by the action of a weak base such as triethylamine to generate the carbene which spontaneously self-couples to form the TTF.

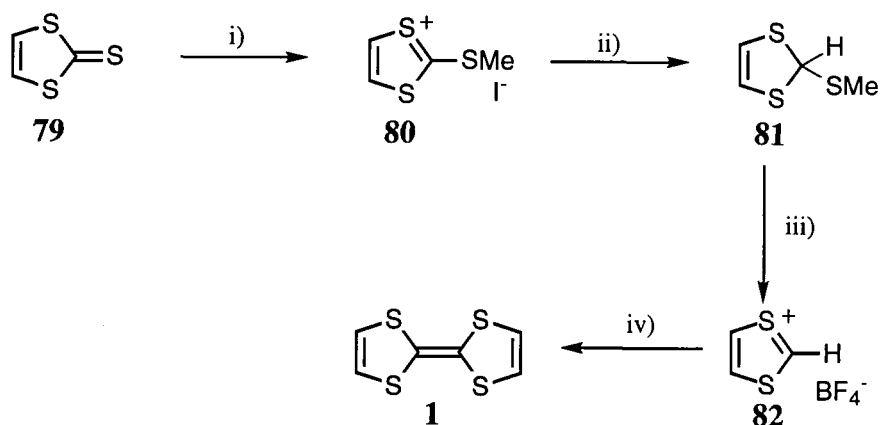

Scheme 1.8 Reagents and conditions: i) MeI; ii) NaBH₄; iii) HBF₄; iv) NEt₃.

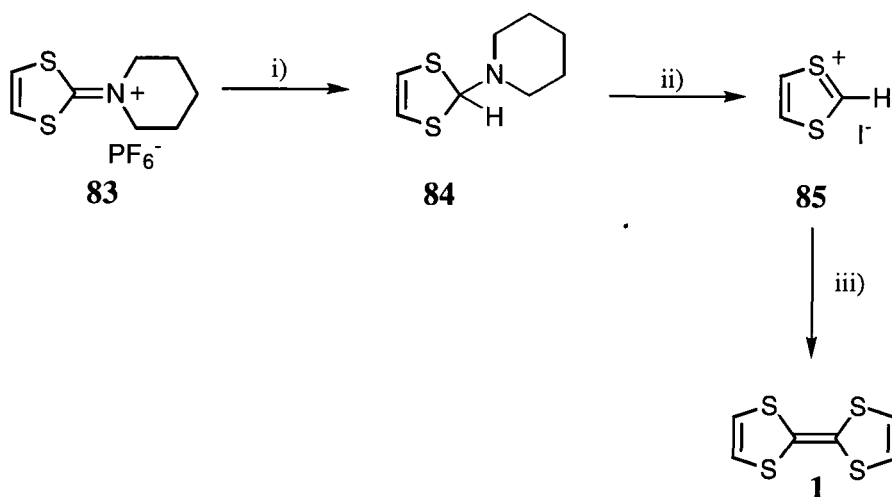

Scheme 1.9 Reagents and conditions : i) NaBH₄; ii) HPF₆, NaI; iii) NEt₃.

It is possible to react a mixture of two different dithiolium salts to afford an unsymmetrically substituted TTF,¹⁰⁴ but the mixture of self- and cross-coupled products is often difficult to purify unless the substituents differ greatly in polarity, this method was used by Wudl *et al.*⁷⁴ to synthesise the first known *bis*TTF derivative **38** (Scheme 1.10).

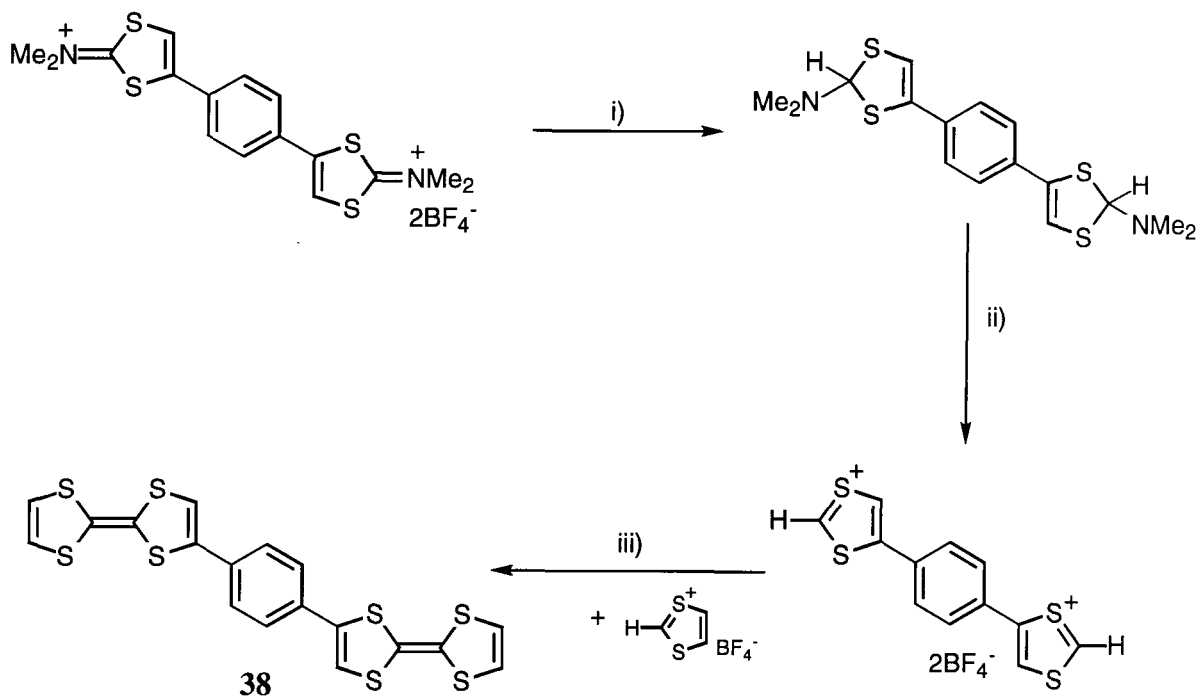

Scheme 1.10 Reagents and Conditions: i) $\text{NaBH}_4/\text{MeOH}$; ii) HBF_4/AcOH ; iii) $\text{NEt}_3/\text{sulpholane}$.

Unsymmetrical TTF systems may also be prepared by a pseudo-Wittig reaction of the ylide generated from phosphinate derivatives of 1,3-dithiole with 1,3-dithiolium cations^{46b,105} but the reaction is limited to substituents which are inert with respect to the generated ylide (Scheme 1.11).

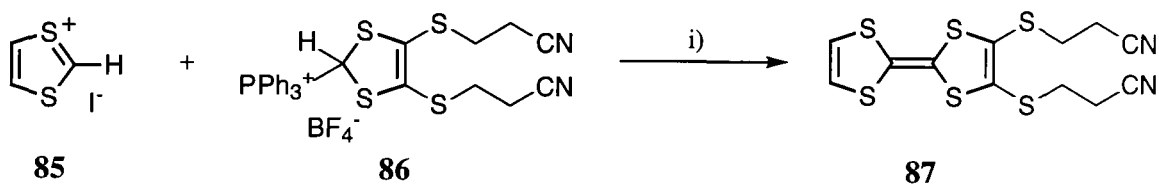

Scheme 1.11 Reagents and Conditions: i) NEt_3 , MeCN .

A variation of this reaction involving the reaction of phosphonate derivatives of 1,3-dithioles with 1,3-dithiole-2-iminium salts,¹⁰⁶ has proved a reliable method for the synthesis of unsymmetrical TTFs with the same restriction on substituents as above. (Scheme 1.12).

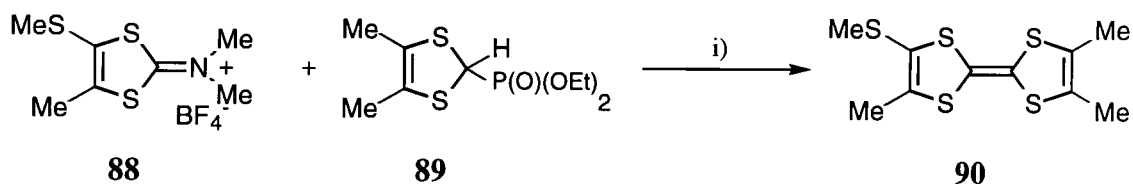

Scheme 1.12 Reagents and conditions : i) t-BuOK, -78°C; ii) AcOH.

The most commonly used method for the synthesis of both symmetrical and unsymmetrical TTF derivatives is the reaction of 1,3-dithiole-2-thiones, 1,3-dithiole-2-ones and 1,3-dithiole-2-selones with trialkyl phosphines and phosphites.¹⁰⁷ The postulated mechanism for the phosphite induced coupling involves two successive dechalcogenation reactions to give the central fulvalenic double bond.

In general, it is found when applying this reaction that 1,3-dithiole-2-ones couple in greater yields than their thione analogues. It has been noted that for unsymmetrical coupling reactions, the greatest yields of the required cross-coupled product are obtained if the dithiole with the most electron withdrawing substituents is used as its oxo analogue and the other as its thione derivative.¹⁰⁸ These phosphite mediated couplings are tolerant of a variety of functional groups and in conjunction with the protecting group strategy developed by Becher, can be used to build up TTF systems of increasing complexity (Schemes 1.13, 1.14). For example, self-coupling of oxone **76** gives **91** which is a protected form of TTFtetrathiolate **92**;¹⁰⁹ similarly, **76** can be cross-coupled to give species such as **94** which can be further functionalised by electrophilic reactions at the thiolate anion.¹¹⁰

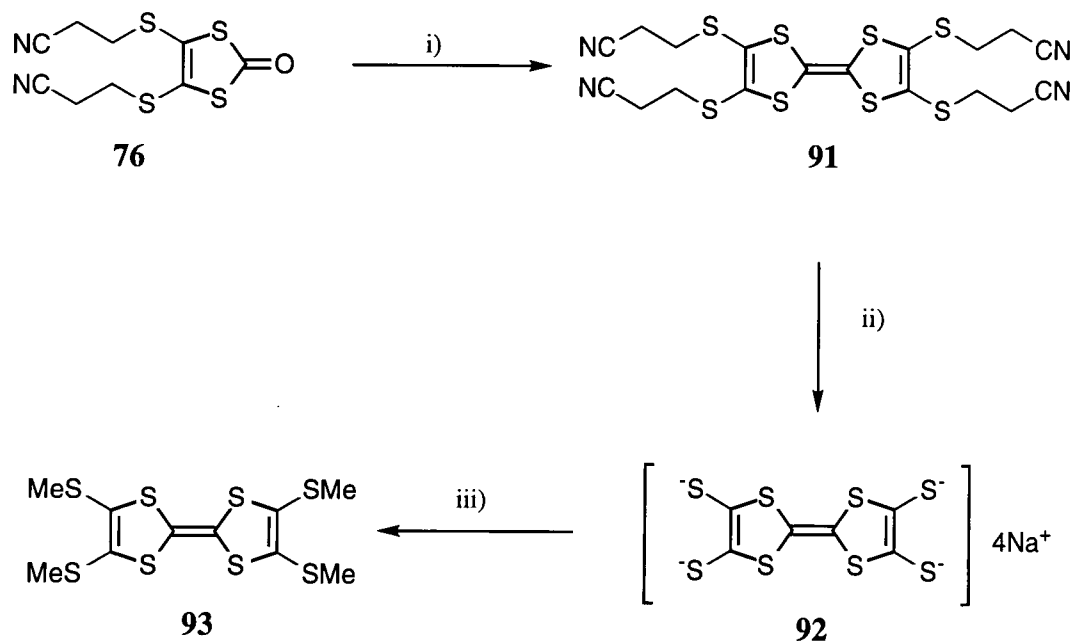

Scheme 1.13 Reagents and Conditions: i) P(OEt)₃, toluene, reflux; ii) Na, EtOH; iii) MeI.

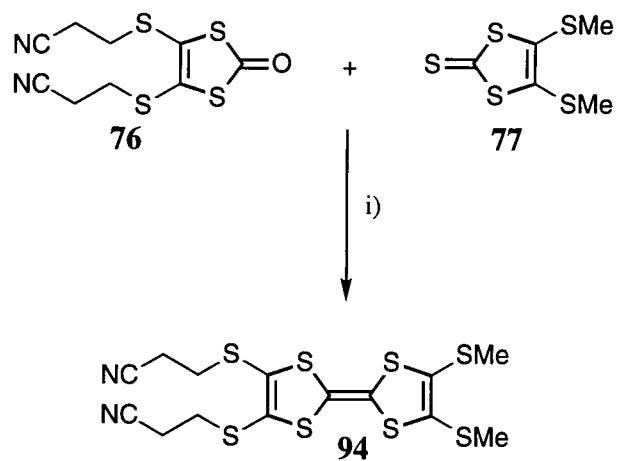

Scheme 1.14 *Reagents and Conditions:* i) $\text{P}(\text{OEt})_3$, 100°C .

Coupling and dechalcogenation can also be achieved by the use of certain transition metal complexes. Thus, treatment of 1,3-dithiole-2-thiones with dicobalt octacarbonyl in refluxing benzene or toluene solutions affords tetrathiafulvalenes directly in modest yields.¹¹¹

Chapter Two

IodoTTFs as Synthetic Precursors to BisTTF Systems

2.1 INTRODUCTION: HALOGENATED TTFS

In Chapter one it was established that the physical properties of molecular conductors are closely related to their crystal structures; variations of which can have profound effects upon the dimensionality of the conductive process. Designing and achieving new crystal architectures suitable for this purpose is an important goal of the materials chemist.

Several approaches to this problem have already been outlined; these may be broken down into two main classifications: one approach being modifications to the intrinsic properties of the donor molecule itself; the second being a supramolecular approach in which intermolecular interactions based on classical supramolecular synthons, such as the hydrogen bond, have been used to induce novel variations in the crystal structures of both neutral and oxidised donor species. The establishment of networks of intermolecular close contacts of both donor-donor and donor-anion types has been recognised as a prerequisite for increasing the dimensionality of conduction.⁴³

Of the many supramolecular synthons available¹¹² comparatively few have been applied to the field of molecular conductors. Intermolecular hydrogen bonded networks have been applied with some success⁴⁶ but due to the flexibility of this interaction it is not always possible to predict the direction of the interaction with any certainty.

Strong and directional halogen-halogen interactions which have been observed in several organic crystal structures,¹¹³ were first postulated as a potential tool for the crystal engineering of molecular conductors by Bechgaard in 1989.¹¹⁴ The synthesis of tetrachloro- **98**, and tetrabromoTTF **99** was undertaken as a rational extension of the series of superconducting donors based on TMTSeF **4**. The rationale behind this approach being the similarity between the Van der Waals radii of a methyl group (2.0Å), chlorine (1.80Å), and bromine atoms (1.95Å), which should exhibit similar spacefilling and crystal packing properties as TMTTF **8** and TMTSeF **4**, but with enhanced intermolecular interactions. However, the electronegativities of both chlorine and bromine significantly raise the oxidation potential of the TTF core and reduce its donor ability (Table 2.1). No salts of either tetrachloro- or tetrabromoTTFs were reported but crystal structures of semiconducting salts of a 4,5-dichloroTTF¹¹⁵ and a 4,5-dibromoTTF¹¹⁶ have been published. Iodine, with a similar electronegativity to carbon was a more attractive candidate, but the synthesis of tetraiodoTTF **99** proved elusive until finally achieved by Gompper *et al.*¹¹⁷ in 1995; an insulating salt with I⁻ was obtained. Syntheses of 4-iodoTTF, 4,5- and 4,5'-diiodoTTF were achieved independently by several groups,^{118,73} who found that substituting with iodine also raised the oxidation potential, but not excessively so as to preclude formation of salts (Table 2.1).

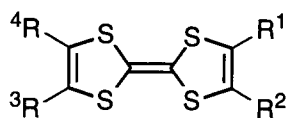

Compounds	R ¹	R ²	R ³	R ⁴	E ₁ ^{1/2}	E ₂ ^{1/2}
1	H	H	H	H	0.34	0.78
94	Cl	H	H	H	0.56	0.78
95	Br	H	H	H	0.55	0.76
96	I	H	H	H	0.55	0.80
97	Br	Br	Br	Br	0.79	1.13
98	Cl	Cl	Cl	Cl	0.83	1.12
99	I	I	I	I	0.71	1.03

Table 2.1 Half-wave potentials of halogenated TTF derivatives,^{117,118b}platinum electrode, vs Ag/AgCl, electrolyte: n-Bu₄NClO₄, (0.01 M), CH₂Cl₂, 20°C.

In 1995 Kato *et al.*¹¹⁹ explored alternatives based on the strong and directional I...X (X= CN, halogen or S) nonbonded interactions. The classical example of this supramolecular synthon is the crystal structure of *p*-iodobenzonitrile¹²⁰ which exhibits a one-dimensional chain structure along the axis of the strong intramolecular I...CN interactions. This interaction is associated with an unoccupied *p*-orbital on the iodine and the lone pair on the cyano group (Figure 2.1).

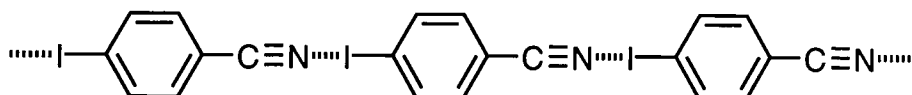
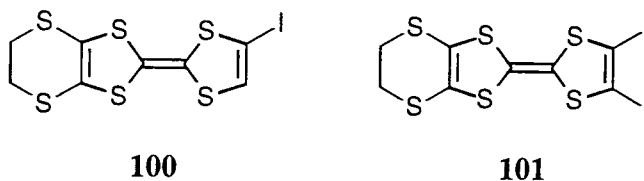

Figure 2.1 One-dimensional chain structure of *p*-iodobenzonitrile

The iodine substituted BEDT-TTF derivatives **100** and **101** were electrocrystallised with several counterions and X-ray structures were obtained of the salts (**100**)₂Ag(CN)₂ and (**100**)₂Br.



These structures illustrated the powerful effect these nonbonded interactions could bring to bear on the crystal packing. In the crystal structure of $(100)_2\text{Ag}(\text{CN})_2$ the I---N distance between the donor molecule and the $\text{Ag}(\text{CN})_2$ anion (2.88 Å) is almost 20% shorter than the sum of their Van der Waals radii. In the case of the bromide salt, a similar close interaction (3.21 Å) is seen between the two halogen atoms; this distance is again almost 20% shorter than the sum of their Van der Waals radii (3.83 Å) (Figure 2.2).

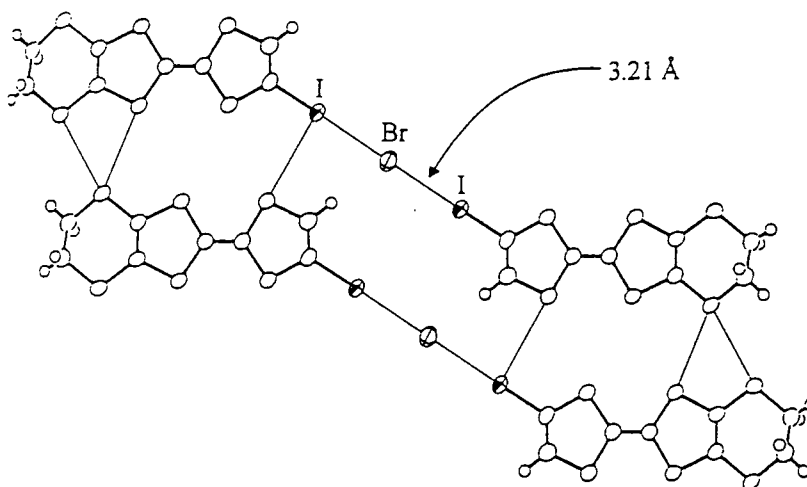
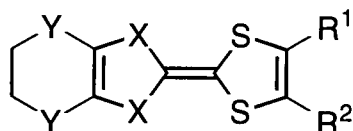

Figure 2.2 Crystal structure of $(100)_2\cdot\text{Br}$

Both these complexes are room temperature semiconductors, but these results provided the impetus for further research in this area. Several iodinated TTF derivatives are now known which exhibit high room temperature conductivities and which remain metallic down to liquid helium temperatures (Table 2.2). In 1997 Bryce *et al.*¹²¹ obtained the first structures of salts of the parent system 4-iodoTTF **96** which proved to be insulating.



102 X= S, Y= O, R¹= R²= I

103 X= S, Y=S, R¹=I, R²=H

104 X= Se, Y=S, R¹= R²= I

Donor	Acceptor	D:A	$\sigma_{rt}/\text{Scm}^{-1}$
102 ¹²²	TCNQ	1:1	152
102	ClO ₄	2:1	68
102	PF ₆	3:1	200
103 ¹²³	Pd(dmit) ₂	1:1	metallic to 4.2K
104 ¹²⁴	Pt(CN ₄)	4:1	metallic to 80K
104 ¹²⁵	FeBr ₄	2:1	metallic to 4.2K

Table 2.2 Some examples of salts of halogenated TTF's displaying high conductivities.

2.2 HALOGENATED TTF'S AS SYNTHETIC INTERMEDIATES

The only reliable method for direct introduction of functional groups onto the TTF core is its metallation at -78°C with alkyllithium reagents.⁹⁶ Various alternatives have been proposed including silyl,¹²⁶ and organomagnesium^{118a} derivatives of TTF but none has found favour mostly due to the low yields reported.

The use of halogenated TTFs as synthetic intermediates was first investigated in 1986 by Nakayama *et al.*¹²⁷ They synthesised the first halogenated TTF derivatives *via* lithiation and quenching with a source of electrophilic halogen. A series of mono-, di- and tri- substituted, chloro- and bromoTTFs were obtained in low yield. The basic chemistry of these species was explored: addition of strong base such as LDA or potassium *t*-butoxide to 4-bromoTTF **95**, lead to a deprotonation-transbromination scrambling reaction and a mixture of isomeric di- and tribromoTTFs were formed. More importantly, it was shown that by treating 4-bromoTTF with butyllithium the bromine-lithium exchange reaction was obtained exclusively thus giving a means to ensure selective lithiation of the TTF ring. An attempt was also made to obtain the alkyne species 4,5-dehydrotetrathiafulvalene from 4-bromoTTF by treatment with strong base and elimination of HBr but this was unsuccessful.

In 1992 Iyoda *et al.*⁷⁵ applied catalytic coupling reactions such as those developed by Stille,^{128,129} Negishi,¹³⁰ and Suzuki¹³¹ to TTF chemistry. Stannylated

TTF derivative **105** was found to undergo palladium(0) catalysed coupling reactions with various aryl halides to give TTF derivatives which were previously unavailable or required lengthy and low yielding synthetic routes. For example, compare Iyoda's synthesis of **38** with that of Wudl⁷⁴ in 1977 (Chapter 1, Scheme 1.10). The use of this reaction to synthesise previously unknown multi-TTF derivatives was explored and led to the synthesis of several complex systems. (Scheme 2.1).

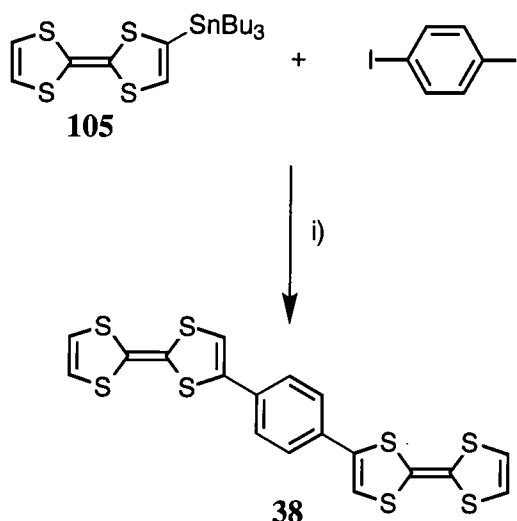

Scheme 2.1 Reagents and conditions: i) Pd(PPh₃)₄ (0.2 equiv), toluene, reflux, 61% yield.

Otsubo⁷³ and Yamamoto^{8d} were the first to show that halogenated TTFs could participate as the aryl halide component in many of these coupling reactions. For instance, 4-iodoTTF **62** can participate in a Sonogashira reaction with trimethylsilylacetylene to give **106**. Bryce *et al.*¹³² have also shown that 4-iodoTTF participates in the Suzuki coupling of aryl boronic acids to give **107** (Scheme 2.2).

The group of Becker showed that classical reactions of aryl halides could also be applied to halogenated TTFs.⁷⁷ The reaction of 4-iodoTTF **62** with copper powder in refluxing chlorobenzene gave 4-*bis*(tetrathiafulvalenyl) **41** (TTF-TTF) as the product of a postulated Ullmann-type reaction.

Becker *et al.*^{118c} have shown that 4-iodoTTF **62** may be deiodinated in high yield by reduction with sodium borohydride. It was found by Bechgaard *et al.*¹¹⁴ that tetrabromoTTF **97** could be sequentially dehalogenated by the addition of 1-4 equivalents of sodium borohydride, raising the possibility of using halogens as potential masking or protecting groups for various positions on the TTF ring.

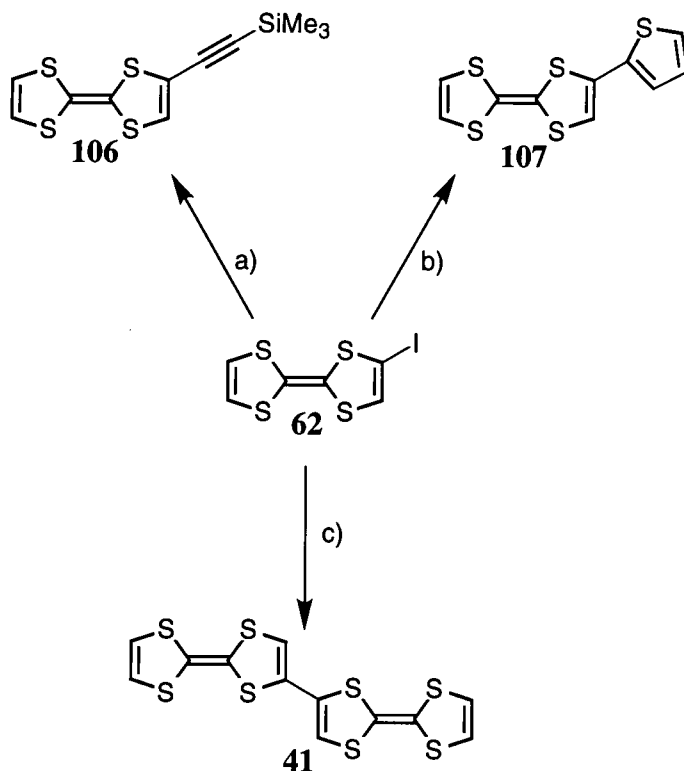

Scheme 2.2 *Reagents and conditions:* a) CuI, Ph₃P, Pd(PhCN)₂Cl₂, Et₃N, trimethylsilylacetylene, 60-90°C, 2-3h; b) Pd(PPh₃)₄, Ba(OH)₂, monoglyme-H₂O, 1:1, thiophene-3-boronic acid, 80°C, 24h; c) Cu, PhCl, reflux, 3h.

2.3 IODO TTFS AS SYNTHETIC PRECURSORS TO *BISTTF* SYSTEMS

2.3.1 THE MYSTERY OF *BISTTF*

The use of 4-iodoTTF by Becker *et al.*⁷⁷ to synthesise TTF-TTF **41** opened up a pathway to a previously ignored series of multi-TTF compounds. Previous reports of TTF-TTF date back to 1982 where its synthesis was reported in a perfunctory conference abstract⁷⁶ with no physical or experimental data. TTF-TTF was later claimed to have been synthesised by Neilands *et al.*^{118a} in 1989 via a complicated multistep sequence from di(butoxycarbonylTTF).

A melting point of 158-160°C (with decomposition) and three reversible redox waves at 0.45, 0.65 and 0.97V (*vs.* Ag/AgCl, in benzonitrile on a Pt electrode) corresponding to two, one-electron, and one, two-electron oxidations were reported by Neilands. Full characterisation was given including IR, UV, melting point, ¹H nmr and an unsatisfactory elemental analysis. Surprisingly, TTF-TTF appeared to be soluble in common organic solvents such as benzene and acetone. Iyoda *et al.*^{75a} reported in a communication the synthesis of TTF-TTF via the homocoupling of tributylstannyl- **63**

and trimethylstannylTTF **105**, catalysed by $\text{PdCl}_2(\text{CH}_3\text{CN})_2$, in 25 and 62% yields, respectively. However, these authors reported a much higher melting point of 225–226°C and observed only two redox waves at 0.43 and 0.84V (*vs.* Ag/AgCl, in benzonitrile on a Pt electrode).

Becker *et al.*⁷⁷ showed that refluxing 4-iodoTTF **62** with copper powder in chlorobenzene followed by column chromatography with CS_2 yielded several products including TTF-TTF **41**, which was isolated in 22% yield. A TTF trimer was isolated in 3% yield as a by-product but was not further investigated. A ^1H nmr and mass spectrum were obtained which were consistent with the formation of TTF-TTF. The solubility and melting point (202–203°C) of Becker's TTF-TTF was significantly different from that reported by Iyoda and Neilands. The structure of TTF-TTF was confirmed by a single crystal X-ray study⁷⁷ (Figure 2.3a) which showed that the entire molecule is nearly planar and the crystal structure comprises face-to-face dimers arranged in a similar manner to *kappa* packing. Becker found TTF-TTF to be insoluble in most common solvents except CS_2 and was able to obtain a CV only at elevated temperatures in acetonitrile (*vs.* Ag/AgCl, on a Pt electrode). This CV supported that of Neilands in that the first electron wave was split, but in Becker's case this splitting was also observed for the second oxidation wave. In all, four reversible sequential redox waves were claimed. (Figure 2.3b).

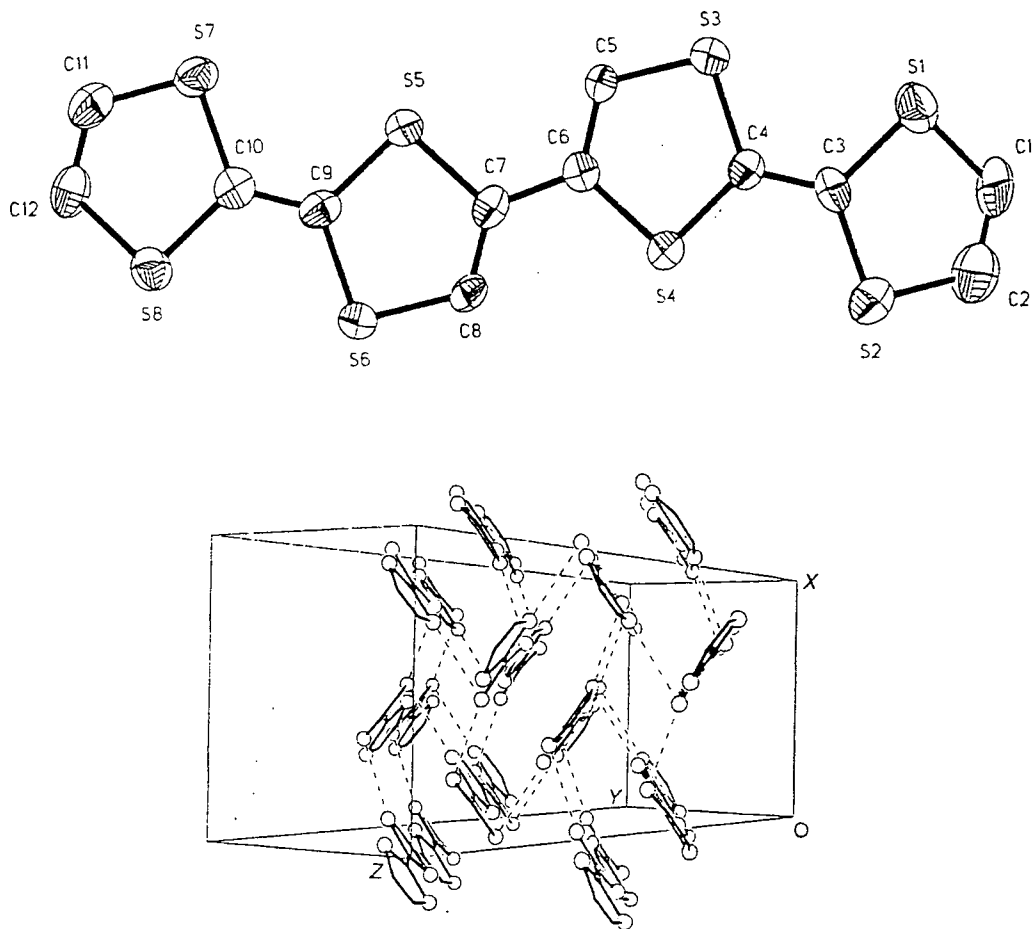

Figure 2.3a X-ray crystal structure of TTF-TTF.

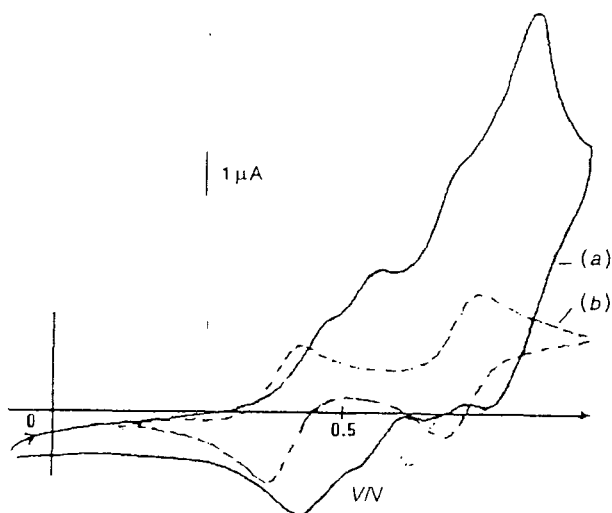
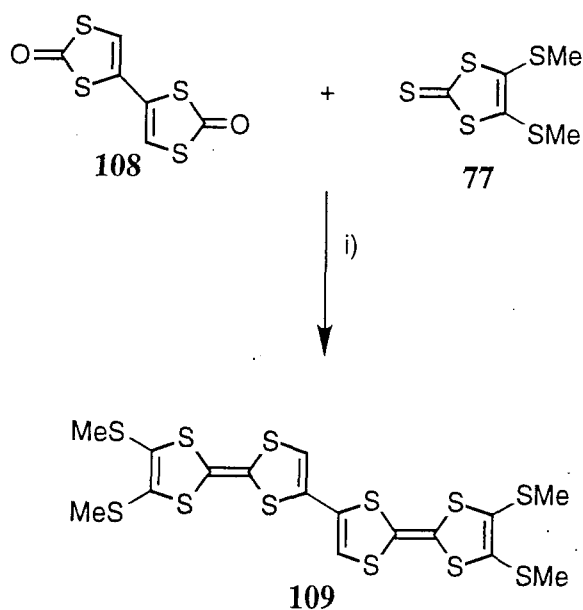

Figure 2.3b The CVs of TTF-TTF **41** (—) and TTF **1** (-----) reproduced from reference 77 (vs. Ag/AgCl, MeCN, 70°C, Pt electrode, 0.1 M Bu₄NClO₄, 100 mVs⁻¹).

2.3.2 OTHER BISTTF SYSTEMS

Besides the contradictory reports in the literature over the synthesis and properties of TTF-TTF, there are several examples of substituted derivatives of the parent system which rely on more traditional TTF chemistry. Tatemitsu *et al.*¹³³ synthesised *bis*TTF **109** by the synthetic route shown (Scheme 2.3) in 15% yield, amongst other products.



Scheme 2.3 Reagents and conditions: i) P(OEt)₃, 15% yield.

A melting point of 172-173°C and three reversible redox waves at 0.50, 0.59 and 0.85 V (*vs.* SCE, in DCM on a glassy carbon electrode) were reported for **109**. The compound did not form any complexes with TCNQ but did form a complex with DDQ which showed a room temperature conductivity of $5.78 \times 10^{-3} \text{ S cm}^{-1}$. By a similar methodology were synthesised the hexyl **111** and butyl **112** analogues¹³⁴ which also showed three reversible redox waves (Table 2.3) and gave semiconductive complexes with DDQ and I_3^- .

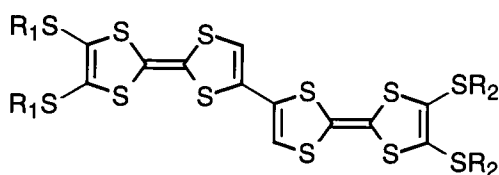

110 $R_1 = R_2 = \text{Me}$

111 $R_1 = R_2 = \text{hexyl}$

112 $R_1 = R_2 = \text{butyl}$

113 $R_1 = \text{hexyl}, R_2 = \text{butyl}$

Compound	$E_1^{1/2}/\text{V}$	$E_2^{1/2}/\text{V}$	$E_3^{1/2}/\text{V}$
110 ^a	0.50	0.59	0.85
111 ^b	0.30	0.47	0.76
112 ^b	0.28	0.45	0.74
113 ^b	0.28	0.44	0.72

Table 2.3 Half-wave potentials of *bis*TTF derivatives^{133,134}, (a) glassy carbon electrode, *vs.* SCE, electrolyte: $n\text{-Bu}_4\text{NClO}_4$, (0.1 M), CH_2Cl_2 , 20°C; (b) platinum electrode, *vs.* Ag/AgCl, electrolyte: $n\text{-Bu}_4\text{NClO}_4$, (0.1 M), CH_2Cl_2 , 20°C.

The *bis*TTF **114** synthesised by Bechgaard *et al.*⁵⁷ exhibited two, close-lying one-electron waves followed by a two-electron oxidation wave: no other synthetic data were reported.

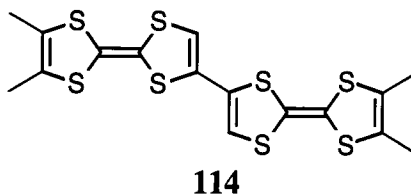

After completion of the work in this thesis, a further series of *bis*TTF donors and their salts were published by Iyoda *et al.*¹³⁵ Based on the homo-coupling of trimethylstannylTTF derivatives, *bis*TTF **109**, was resynthesised as well as two new

derivatives: **115**, and **116**. CV studies of these compound revealed a similar redox chemistry to that observed by Tatemitsu for his series, namely, two, one-electron waves followed by one, two-electron wave (Table 2.4).

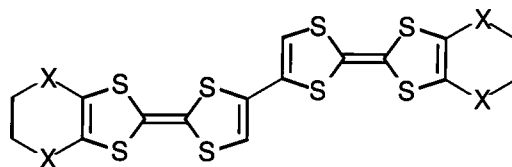

115 X = S

116 X = O

Compound	$E_1^{1/2}/V$	$E_2^{1/2}/V$	$E_3^{1/2}/V$
109	0.48	0.59	0.87
115	0.48	0.58	0.86
116	0.42	0.52	0.87

Table 2.4 Half-wave potentials of *bis*TTF derivatives,¹³⁵ (no conditions given).

Only **116** formed a complex with TCNQ, **109** and **115** both formed complexes with DDQ; all of which were semiconductors. Electrocrystallisation with a number of counterions proved successful, the I_3^- , AuI_2^- , and BrI_2^- salts of **115** exhibited high conductivities (125, 778, and 80 $S\text{ cm}^{-1}$) with metallic behaviour down to 20, 285 and 240 K respectively, below which a metal/semiconductor transition occurred, the I_3^- salt of **116** displayed a conductivity of 8.0 $S\text{ cm}^{-1}$ which remained metallic down to 135 K. The rest of the salts displayed semiconductive behaviour (Table 2.5), of these the structure of the 1:1 salt, **116**· ClO_4 was determined by X-ray crystallography.

The cation radical of **116** forms a conducting sheet, in the *ac* plane to make a segregated column. The *bis*TTF molecules are stacked face-to-face to form a dimeric structure and the dimers are arranged in a so-called β -type structure to form a conducting sheet. The interdimer interactions which form this two-dimensional system are labelled I-IV on the figure (Figure 2.4).

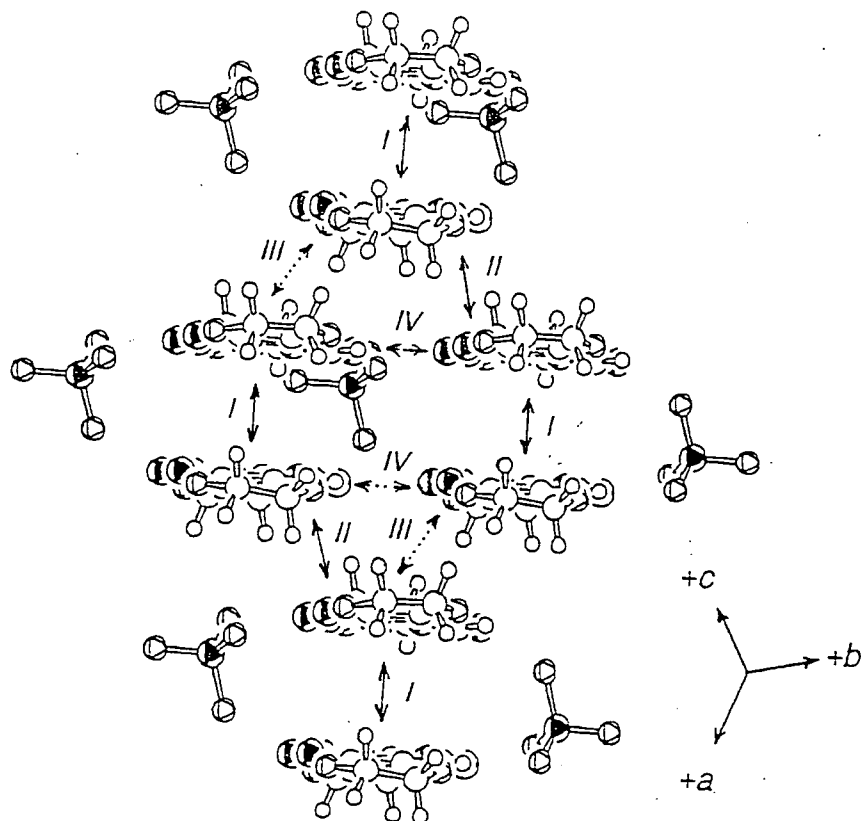

Figure 2.4 X-ray crystal structure of 116·ClO₄

Donor	Acceptor	D:A	$\sigma_{rt}/S \text{ cm}^{-1}$
109	ClO ₄	1:1	9.4×10^{-2}
115	DDQ	2:1	8.4×10^{-1}
115	I ₃	2:1	125(metallic)
115	AuI ₂	1:1	778(metallic)
115	BrI ₂	1:1	80(metallic)
116	TCNQ	3:1	3.6
116	ClO ₄	1:1	6.9
116	I ₃	3:1	8.0(metallic)

Table 2.5 Electrical conductivities of CT-complexes and radical ion salts of *bis*TTFs.

The attraction of *bis*TTF compounds as donors for organic metals is obvious. If the planar structure of the TTF-TTF molecule can be reproduced in the structures of its salts and the molecules associate in the traditional segregated stacks of conducting TTF compounds, then, we have, in effect, two TTF arrays physically linked by a covalent bond instead of the weak chalcogen-chalcogen interaction which is

responsible for extended conjugation in multidimensional conductors. This close linkage will hopefully encourage an increase in the dimensionality of conduction. The possibility of other structures mirroring the pseudo-*kappa* phase of neutral TTF-TTF offer alternatives for increased dimensionality. The complexes so far obtained have been non-stoichiometric which is a prerequisite for highly conducting species, the control of stoichiometry in charge-transfer complexes is one of the main goals of organic metals research. The main theoretical point of interest of *bis*TTF systems with regard to salt formation is, whether they behave as two independent TTF moieties or whether in effect a new donor system has been created with delocalisation occurring across the two TTF moieties upon oxidation.

2.4 SYNTHESIS OF *BISTTFS*

2.4.1 AIMS AND OBJECTIVES

The work of Becker identified iodo-TTFs as suitable precursors for *bis*TTF systems *via* a classical Ullmann coupling reaction with activated copper. By synthesising a range of novel iodoTTFs we hoped not only to synthesise a new family of *bis*TTF compounds with enhanced solubility over the parent compound but also to explore the possibility of using these precursor iodoTTFs as donors for organic metals in their own right.

Initial attempts to isolate the literature compounds **109** and **114** by coupling the iodoTTFs **117** and **118**¹³⁶ in either refluxing chlorobenzene or DMF with activated copper powder proved unsuccessful; with only small amounts of the desired products being isolated from complex reaction mixtures after tedious chromatography.

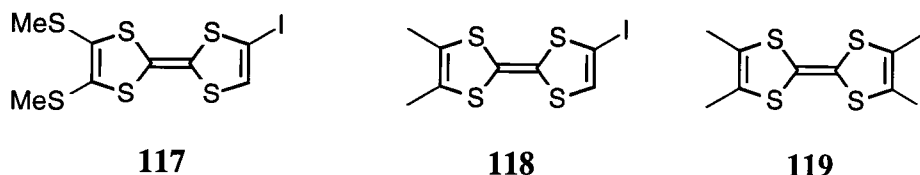

However, reaction of iodotrimethylTTF (TRIM-I)¹³⁷ **119** with copper powder in refluxing DMF yielded the *bis*TTF **120** cleanly in 60% yield without chromatography.

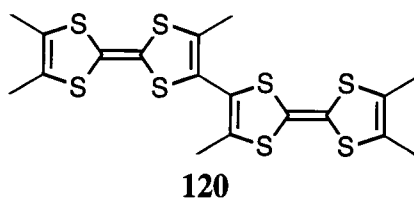

We note that in the synthetic route of Becker *et al.*,⁷⁷ as well as the self-coupled product, higher oligomers were also obtained, so some scrambling was occurring at the elevated temperatures needed to sustain the reaction. By removing all possible reaction sites by using trisubstituted iodoTTFs such as TRIM-I **119** these side reactions were suppressed.

Our synthetic efforts were, therefore, directed towards novel trisubstituted iodo-TTFs which in some cases necessitated the synthesis of new TTF precursors.

2.4.2 SYNTHESIS AND HOMOCOUPLING OF IODOTTFs

Literature precedents for the iodination of lithiated TTF include the use of ICl^{119} , tosyl iodide^{118b}, diiodoethane⁷³ and perfluorohexyliodide^{118c} as the source of electrophilic iodine. Perfluorohexyliodide has now emerged as the reagent of choice due to the high yields obtained and ease of work up. The main synthetic problem is the propensity of lithiated TTFs to disproportionate to give multilithiated species, and in these cases a mixture of iodinated products is obtained which are often difficult to separate chromatographically. Another approach which avoids this problem is to use halogenated 1,3-dithiole-2-thione prepared by the lithiation of vinylene trithiocarbonate. Both the mono- and di-halogenated half units have been cross coupled with a variety of other 1,3-dithiole-2-thiones to give iodinated TTF systems.^{122,138} The first preparation of tetraiodo-TTF¹¹⁷ **99** was *via* the self coupling of 4,5-diiodo-1,3-dithiole-2-one **123**; a route involving the tetralithiation of TTF had proved to be capricious (Scheme 2.4).

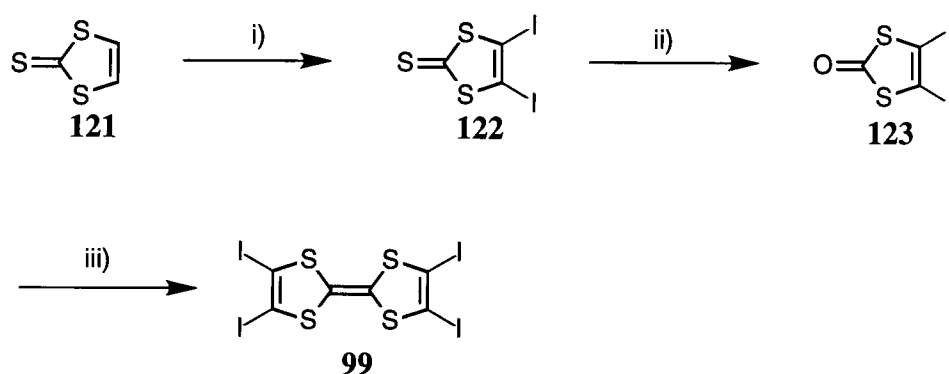

Scheme 2.4 Reagents and conditions: i) LDA, THF, -78°C , 3h, tosyl iodide, -78°C ; ii) $\text{Hg}(\text{OAc})_2$, CHCl_3 -AcOH; iii) $\text{P}(\text{OEt})_3$, toluene, 110°C , 16h.

TTF systems **124** and **125** were synthesised according to the route shown¹³⁹ (Scheme 2.5). Lithiation with LDA and quenching with perfluorohexyliodide yielded derivatives **126** and **127** in 65 and 45% yields respectively. While iodoTTF **126** was soluble in a wide range of organic solvents, **127** was sparingly soluble in most common

organic solvents and was finally purified by recrystallisation from boiling benzonitrile. Self coupling under the standard Ullmann conditions proceeded cleanly to give *bis*TTF systems **128** and **129** in 62 and 60 % yield respectively. Compound **128** was isolated as a red oil but precipitated as yellow crystals from a DCM/hexane mixture after several days in the freezer. Compound **129** was isolated as orange plates after recrystallisation from boiling toluene but displayed a low solubility in most common organic solvents.

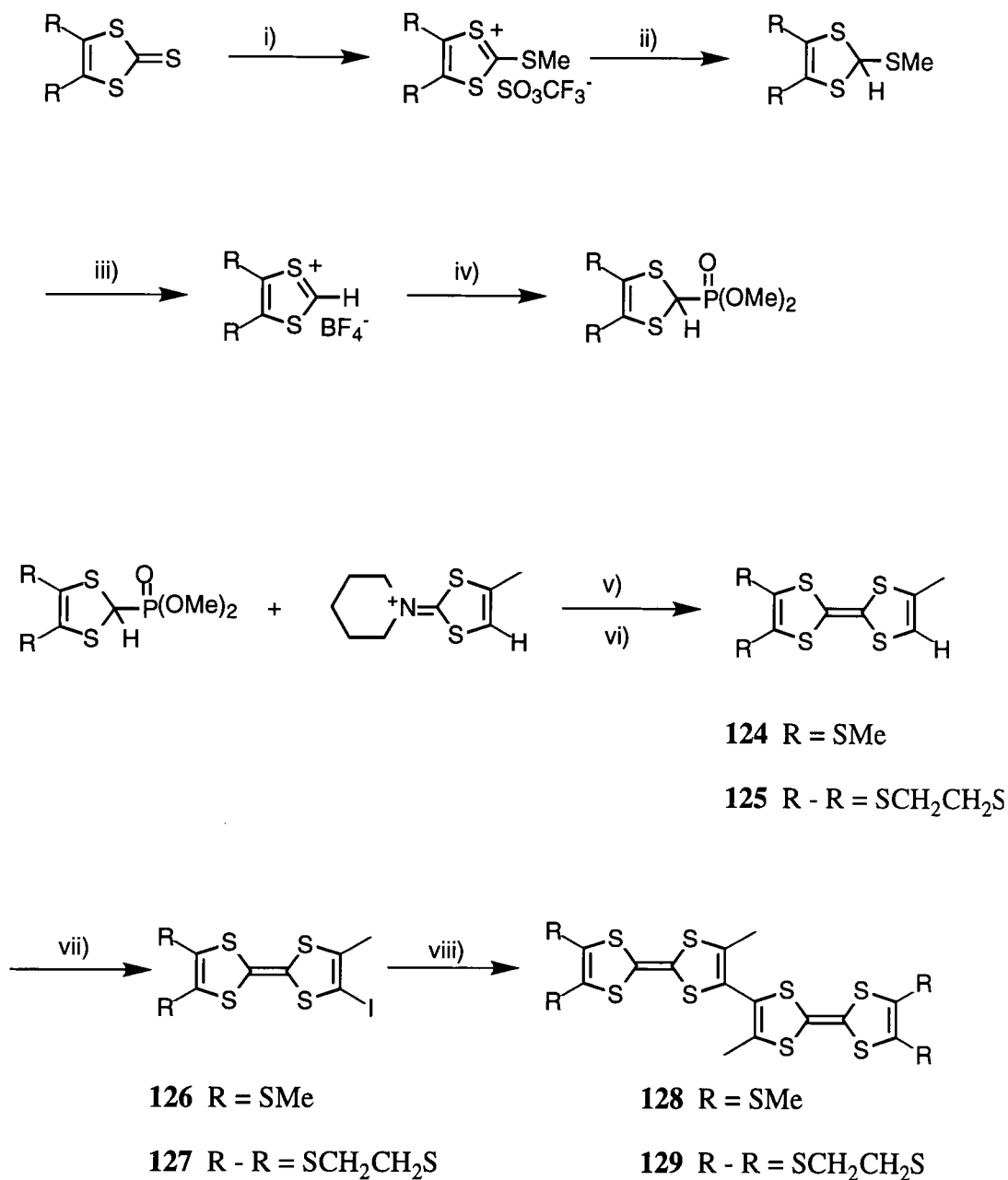

Scheme 2.5 Reagents and conditions. i) Et₂O, MeSO₂CF₃; ii) IPA, NaBH₄; iii) Ac₂O, Et₂O, HBF₄; iv) NaI, P(OMe)₃; v) *t*-BuOK, -78°C to rt.; vi) AcOH; vii) LDA, -78°C, CF₃(CF₂)₅I; viii) Cu, DMF, reflux.

Replacing the methyl group of **128** and **129** with an alkylthio group was a logical modification of our *bis*TTF series, which required the synthesis of the hitherto uncharacterised TTF derivative **134**.¹⁴⁰ The key synthetic component is the remarkably stable thiol **130**^{56,141} which may be isolated as a red solid from the cyclisation reaction shown (Scheme 2.6).

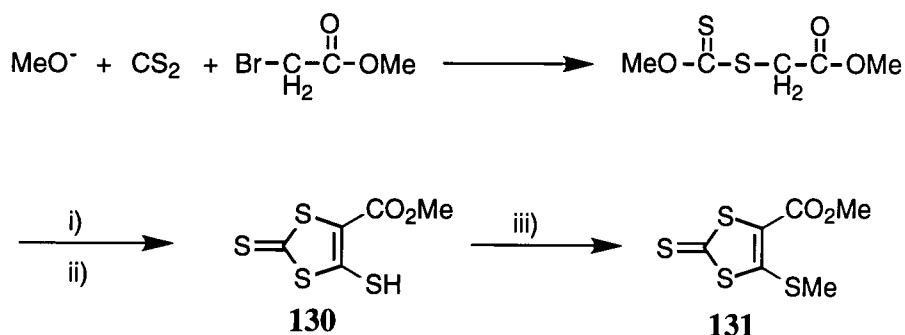

Scheme 2.6 Reagents and conditions. i) CS₂, t-BuONa, DMF; ii) HCl; iii) MeONa/MeOH, MeI.

Becher has generated the caesium salt of the thiol **130** as a stable solid which was alkylated with 3-bromopropionitrile to serve as a protected thiolate.^{110a} Cava *et al.*⁵⁶ have also shown that the sodium salt of **130** may be alkylated in good yields.

The methylthio analogue **131** was synthesised in a one-pot procedure by direct alkylation of the cyclisation mixture with methyl iodide. Cross-coupling of this with 4,5-bis(2'-cyanoethylthio)-1,3-dithiole-2-one **76** gave TTF **132** in 59% yield after chromatography. Deprotection of **132** with sodium methoxide in methanol/THF mixture (1:1, v/v) and subsequent alkylation with methyl iodide gave TTFester **133** in 81% yield.

De-esterification was accomplished by heating **133** with LiBr in DMF.¹⁴² The use of DMF for these de-esterification reactions is preferable to the highly toxic HMPA which is ubiquitous throughout the TTF literature. No decrease in yield or unwanted side products was observed by using DMF. Compound **134** was isolated as a red oil which resisted all attempts at crystallisation. Lithiation and iodination proceeded smoothly to give **135** as an orange powder in 91% yield.

Instead of using elemental copper to self-couple **135**, a variation involving copper(I)thiophene-2-carboxylate in N-methylpyrrolidinone was used to achieve this coupling in 72% yield to give **136** as an orange powder (Scheme 2.7). This reaction is described in more detail in the following section.

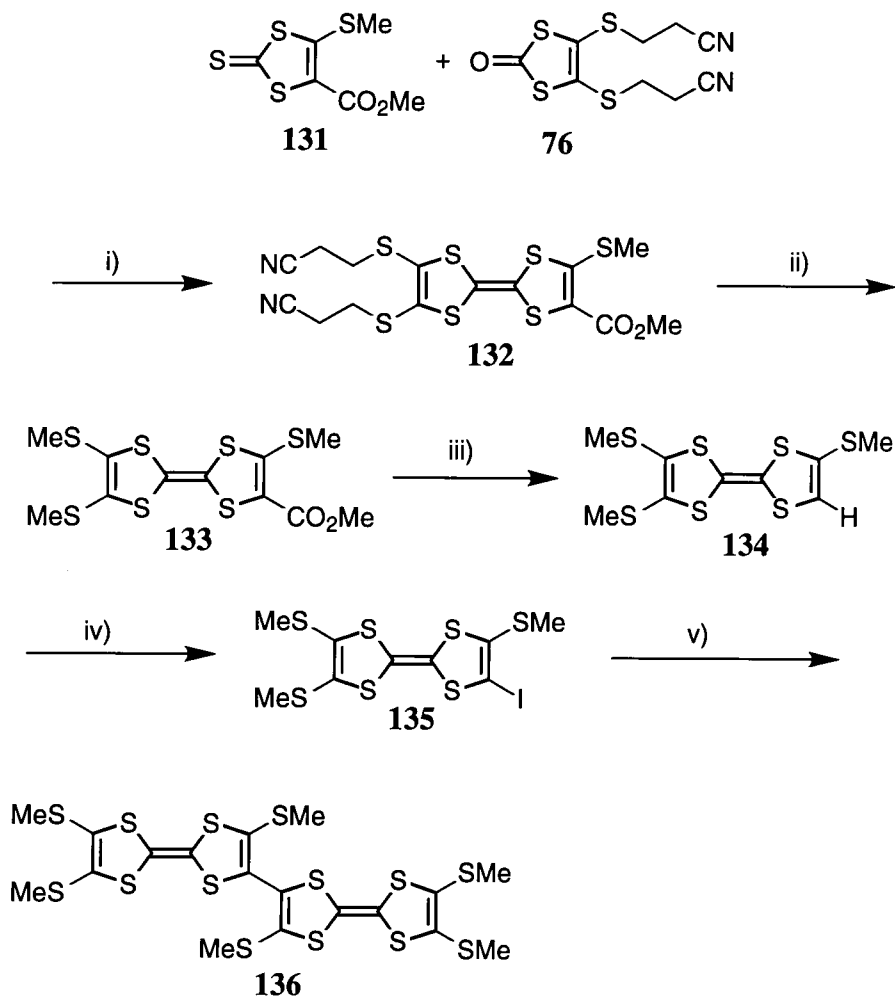

Scheme 2.7 Reagents and conditions. i) $\text{P}(\text{OEt})_3$, toluene reflux; ii) MeOH/THF , MeONa , MeI ; iii) LiBr , DMF ; iv) LDA , -78°C , $\text{CF}_3(\text{CF}_2)_5\text{I}$; v) CuTC , NMP .

2.4.3 ROOM TEMPERATURE ULLMANN COUPLING

During the course of this work a new modification of the Ullmann reaction was published by Liebeskind *et al.*,¹⁴³ who observed that copper(I)thiophene-2-carboxylate (CuTC) induced the reductive coupling of substituted aromatic iodides and bromides, 2-iodoheteroaromatics, and the stereospecific reductive coupling of alkenyl iodides effectively and in many cases rapidly at room temperature. The coupling reaction proved to be mild and tolerant of a variety of functional groups. The use of a polar coordinating solvent such as *N*-methylpyrrolidinone (NMP) was required in order for the reaction to proceed. Iodo-TTFs seemed to be ideal substrates for this reagent.

Thus, treatment of TRIM-I **119** with CuTC gave *bis*TTF **120** in 75% yield. Similarly, both **126** and **127** coupled to give *bis*TTFs **128** and **129** in 80% and 72% yields respectively. These are the highest reported yields for a homocoupling of two TTF's, and the mildness and relative rapidity of reaction should tolerate a number of

substituents which would otherwise perish under the harsher conditions of the classical Ullmann reaction.

We returned to **117** and **118** in the hope that these milder coupling conditions would avoid the formation of numerous side products observed at the elevated temperatures used previously. However, these iodoTTFs still gave complicated reaction mixtures even using this protocol. The difference in reactivity in the Ullmann reaction between trisubstituted TTF **119** and disubstituted TTF **118** was remarkable, the only point of difference being the presence of a proton α to the iodine which may be involved in some as yet undetermined side reactions. It appeared therefore, that the site adjacent to the iodine substituent needed to be blocked with a group which could be removed after the coupling had taken place. The methyl ester group is easily cleaved from the TTF ring using LiBr in DMF or HMPA, and it was decided to use **140** as the intermediate for this synthesis. The use of the intermediate in the synthesis of the compound **109** previously synthesised by Tatemitsu *et al.*²⁶ is outlined below (Scheme 2.8).

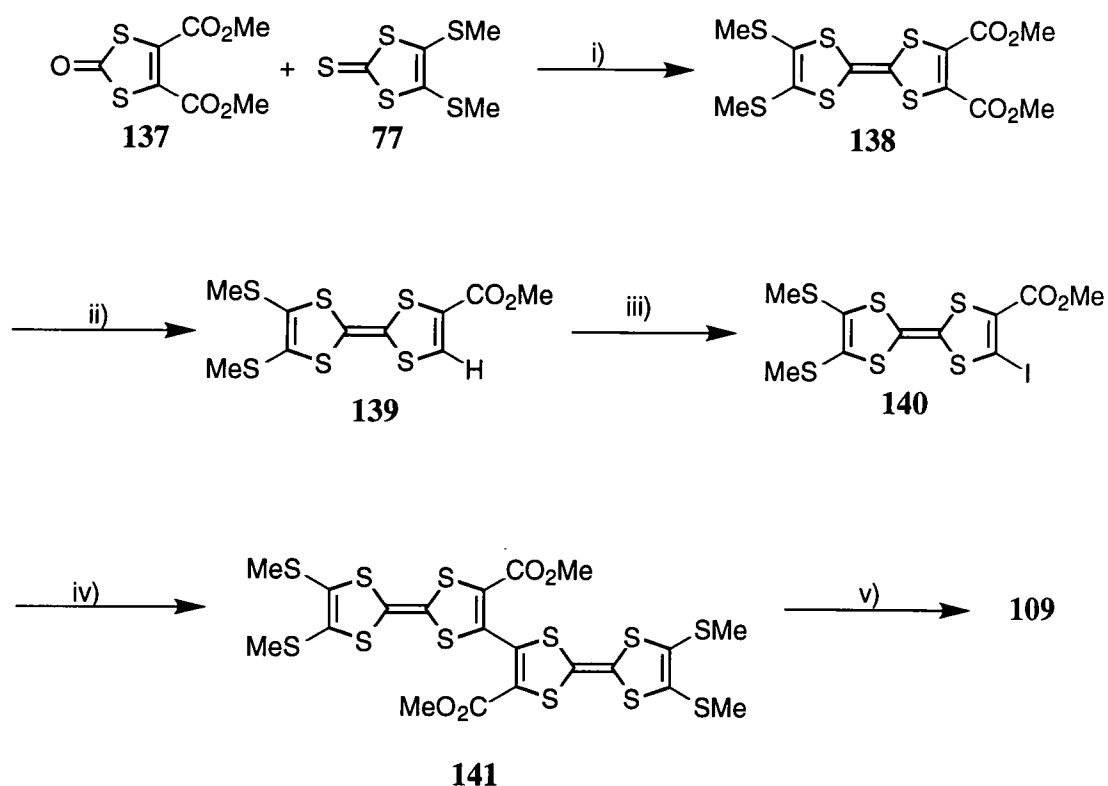

Scheme 2.8 Reagents and conditions: i) $P(OMe)_3$, toluene, reflux; ii) LiBr, DMF, 110°C ; iii) LDA, THF, -78°C , $\text{CF}_3(\text{CF}_2)_5\text{I}$; iv) CuTC, NMP; v) LiBr, DMF, 140°C .

Cross coupling of **137** and **77** proceeded to give **138**^{144a-b} in 55% yield from readily available starting materials. Mono de-esterification to yield **139**^{144c} in 91% yield was achieved by heating **138** at 110°C in DMF for 20 minutes. The formation of

iodoTTF **140** via the lithiation and iodination of TTFester **139** proved to be capricious with **140** being obtained in a maximum yield of 24%. The presence of the ester group next to the proton seemed to be affecting the usually straightforward lithiation/iodination sequence.

IodoTTF **140** couples in good yield (65%) using CuTC to give *bis*TTF **141**. De-esterification using LiBr in DMF gave *bis*TTF **109** in 59% yield which had an identical melting point and ^1H NMR to that reported by Tatemitsu.¹³³

In conclusion, a range of novel *bis*TTF compounds have been synthesised with various substituents by both the classical Ullmann coupling and the new Liebeskind variation thereof, from a series of novel iodoTTFs. The versatility of these halogenated TTFs and the growing number of reactions in which they may be utilised shows that their potential as building blocks for complex TTF systems has yet to be fully explored.

2.5 SINGLE CRYSTAL X-RAY ANALYSIS OF **120** AND **136**

Single crystals of **120** and **136** were grown by slow diffusion of hexane into a CS_2 solution of the donor. Molecule **120** is situated on a crystallographic twofold axis, passing through the midpoint of the C(2)-C(2') bond (Figure 2.5). The TTF moiety in **120** as in TTF-TTF **41** shows insignificant puckering, its atoms deviating from the mean plane by ≤ 0.07 Å. However, steric hindrance from the methyl groups induces a large (54°) twist around the C(2)-C(2') bond, which makes effective molecular stacking impossible, whereas in TTF-TTF the entire molecule is nearly planar and the crystal structure comprises face-to-face dimers arranged in a similar manner to *kappa* packing. The C(2)-C(2') distance of 1.471 Å is the same as in TTF; the only intermolecular S...S contact shorter than 3.8 Å is the S(1)...S(3) distance of 3.68 Å (*cf.* the Van der Waals radius of sulfur, 1.81 - 1.84 Å).

The X-ray crystal structure of **136** shows that the molecule possesses no crystallographic symmetry. The thiomethyl substituent S(5)C(8)H₃ is disordered over **A** and **B**, with occupancies of 62 and 38%, respectively. The conformations of the two TTF moieties are significantly different. One adopts a boat conformation, folding along the S(11)...S(12) and S(13)...S(14) vectors by 21° and 25° , respectively. The other is folded along the S(3)...S(4) vector by 9° . The torsion angle around the central C(2)-C(12) bond is increased to 89° , due to the bulky thiomethyl substituents, all of which adopt out of plane orientations, with torsion angles in the range 100 - 164° .

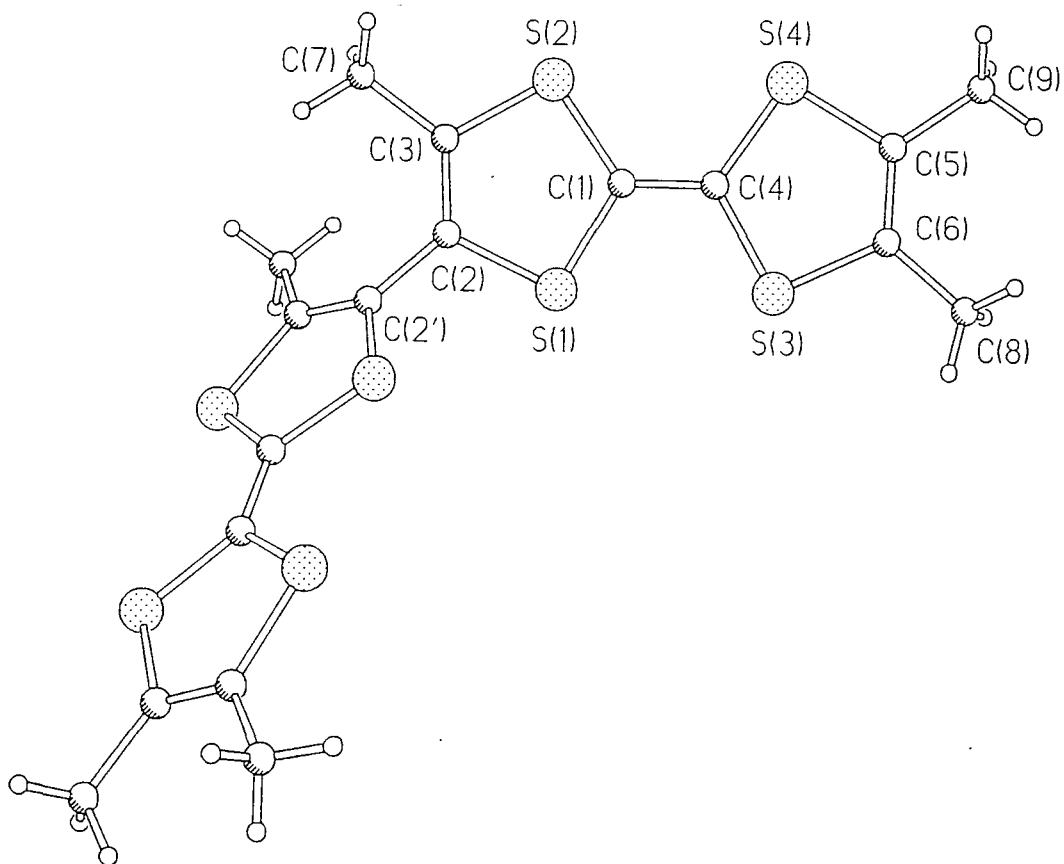

Figure 2.5 X-ray structure of **120** (axis 2 passes through the midpoint of the C(2)-C(2') bond).

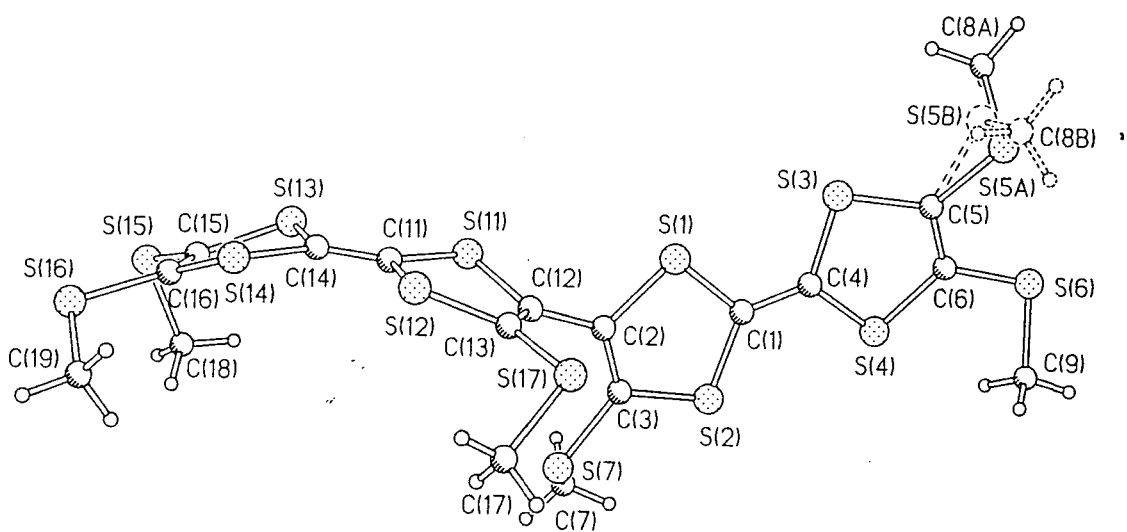

Figure 2.6 X-ray structure of **136**.

2.6 ELECTROCHEMISTRY OF *BISTTF* SYSTEMS

The electrochemistry of *bis*TTF systems **120**, **128**, **129**, and **136** was investigated by cyclic voltammetry (CV) and differential pulse voltammetry (DPV). The data obtained were consistent with that reported by previous workers in that the first oxidation wave is split into two, single-electron redox waves with a clear peak separation ranging from 67 to 87 mV, and the first oxidation is slightly anodically shifted when compared with monomeric TTFs such as **142**¹⁴⁵ (Figure 2.7).

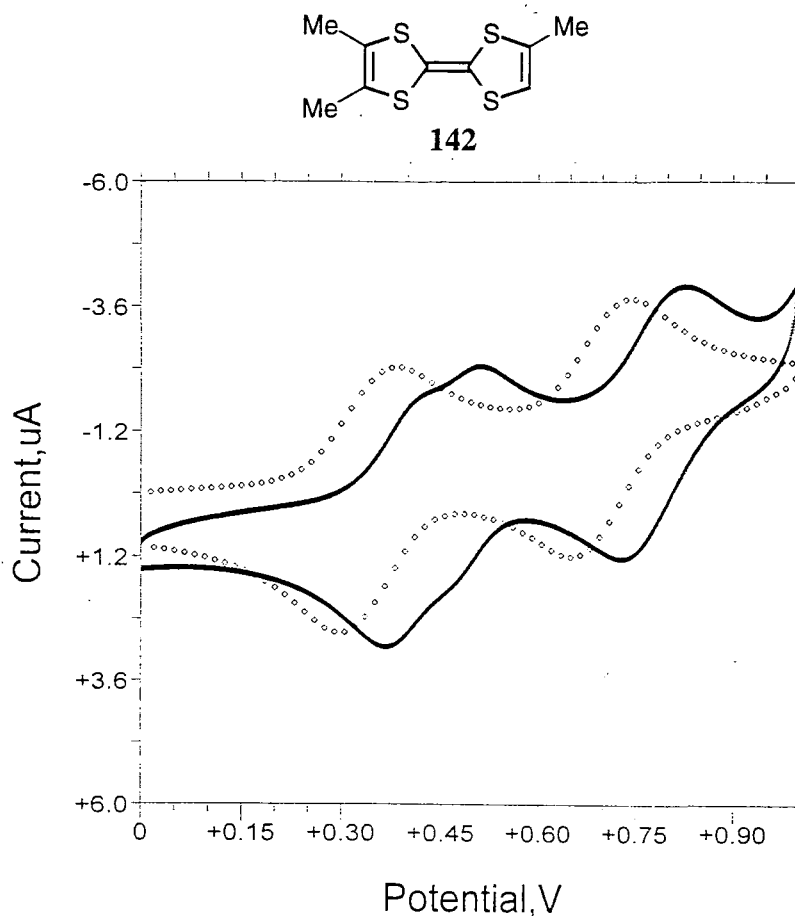

Figure 2.7 Cyclic voltammograms of **120** (—) and **142** (◇◇◇◇)

The third oxidation process for compounds **120**, **128**, **129**, and **136** gives rise to a broadened two-electron wave in the CV. In the case of TTF-TTF **41**, a clear splitting into two separate one-electron redox couples was observed for this process. For compounds **120** and **129** this second wave can be resolved into two, closely overlapping waves in the DPV with $E_1^{\text{ox}}-E_2^{\text{ox}}$ values of 39 mV and 30 mV respectively, which is a smaller splitting than the first electron wave. The values of the oxidation potentials of compounds **120**, **128**, **129**, and **136** as measured by DPV are collated in Table 2.6.

compound	E_1^{OX}	E_2^{OX}	E_3^{OX}	E_4^{OX}	$E_2^{\text{OX}} - E_1^{\text{OX}}$	$E_4^{\text{OX}} - E_3^{\text{OX}}$
120	380	456	750	780	76	30
128	466	540	770(2e ⁻)	-	74	-
129	446	549	770(2e ⁻)	-	87	-
136	529	596	770(2e ⁻)	-	67	-

Table 2.6 DPV of *bis*TTF donors, platinum electrode, electrolyte: n-Bu₄NClO₄, (0.01 M), CH₂Cl₂, 20°C, values measured in volts relative to Ag/AgCl, and corrected to Me₁₀Fc.

The similarity of the electrochemistry of compounds such as TRIM-TRIM **120** with TTF-TTF **41** is surprising. Consideration of the CV and DPV measurements demonstrates that coplanarity of the two TTF rings in solution which would be likely for TTF-TTF and analogues such as **109**^{133,134}, but sterically demanding for **120**, **128** and **129**, is not the main factor in determining the splitting of the redox waves. The most reasonable process for electrochemical oxidation is shown below, with sequential formation of the cation radical, the dication diradical, the trication radical, and the tetracation (Figure 2.8).

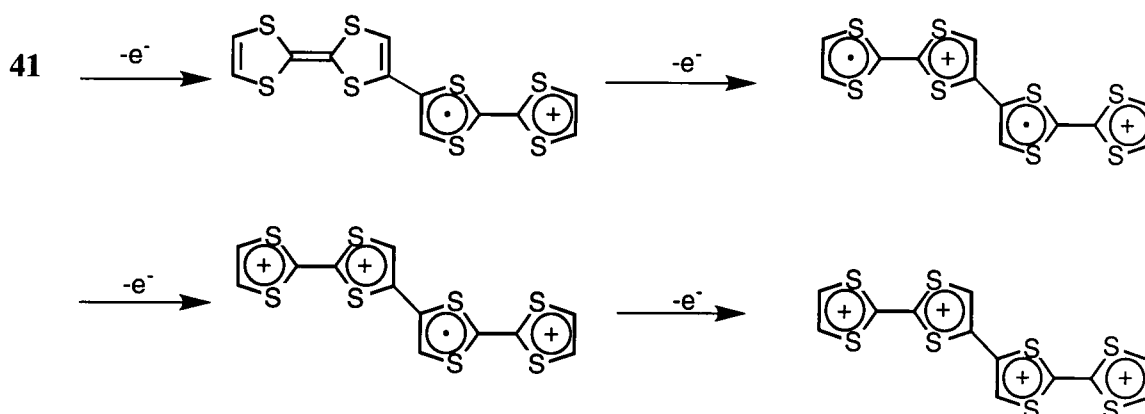

Figure 2.8 Oxidation of *bis*TTF systems.

Both Becker⁷⁷ and Tatemitsu^{133,134} assume coplanarity of the donors in solution and the formation of stable cation radicals which are delocalised over the whole molecule. However, we would expect the first wave to split regardless of any *through bond* interactions because of a *through space* coulombic interaction which would disfavour the formation of the dication diradical due to a mutual repulsion of the two positive centres. The assumption of planarity in solution by extrapolation from the solid state structure of TTF-TTF by Becker cannot be justified. Whether the splitting we see

is due to either of these factors alone or a combination of both is unclear. The smaller splitting of the second oxidation wave is also difficult to rationalise if the same criteria which were applied to the splitting of the first oxidation wave are used.

If the two TTFs are interacting through the π -orbitals as postulated by Becker and Tatemitsu the UV spectra should display a considerable bathochromic shift indicating the formation of an extended chromophore (Table 2.7). Upon comparison with similarly substituted monomeric TTFs such as **93**, **124**, **125**, **142** and TTF itself **1**, the UV spectra of the dimers **120**, **128**, **129**, **109**, **111**, and TTF-TTF **41** do display a slight red shift of one or more of their absorptions with the greatest shifts being in the longer wavelength absorption (typically of the order of 20-30 nm). Such results would suggest that the dimers possess a more delocalised π -system but this would lead us to expect them to display a *lower* first oxidation potential than the monomeric TTFs due to charge delocalisation, whereas we have seen they are in fact *harder* to oxidise.

Compound	λ /nm log(ϵ)	λ /nm log(ϵ)	λ /nm log(ϵ)	λ /nm log(ϵ)	λ /nm log(ϵ)
125 ^b	-	312 (5.14)	334 (5.04)	368 (4.47)	-
129 ^a	-	316 (4.99)	340 (4.90)	386 (4.30)	-
124 ^b	272 (5.14)	302 (5.21)	324 (5.21)	378 (4.60)	450 (3.90)
128 ^b	250 (5.14)	314 (5.24)	336 (5.26)	392 (4.70)	494 (3.47)
109 ^b	264 (4.26)	312 (4.29)	328 (4.28)	412 (3.99)	-
136 ^b	264 (5.34)	312 (5.35)	334 (5.32)	412 (4.71)	-
93 ^b	260 (5.36)	312 (5.33)	334 (5.33)	380 (4.75)	-
111 ^{d, 134}	-	316 (4.45)	330 (4.47)	415 (4.00)	-
120 ^c	230 (4.41)	326 (4.80)	334 (4.65)	390 (4.08)	473 (3.38)
142 ^{c, 145}	222 (3.88)	297 (4.25)	307 (4.23)	322 (4.20)	467 (3.25)
41 ^{e, 77}	-	320 [‡]	-	412	-
1c , ^{23c-d}	308 (4.08)	316 (4.09)	357 (sh)	446 (2.42)	-

Table 2.7 UV data for *bis*TTFs, and selected monomeric TTFs for comparison.

a) In 1,1,2-trichloroethane, b) in DCM, c) in MeCN, d) in chloroform, e) in toluene.

[‡]no value for ϵ given.

To achieve such extended π -systems across the two TTF moieties would, of course, require a coplanar arrangement to maximise orbital overlap as seen in the crystal structure of TTF-TTF **41**. Such *bis*TTFs as **109** and **111** which are also unsubstituted in the positions α to the junction should have similar conformational preferences. Any orbital delocalisation would be expected to occur through the ring junction and should be disrupted if the two TTFs cannot achieve coplanarity as we would expect for **120**,

128, **129**, and **136** due to the bulky substituents α to the junction. A representative comparison may be made between compound **109** which similar to TTF-TTF, may achieve coplanarity, and compound **136** which, due to the bulky thiomethyl substituents is in a twisted conformation. The UV spectra display virtually identical absorption maxima which suggests that any interaction through the ring junction is negligible and hence any charge delocalisation as postulated by Becker and Tatemitsu in this manner is unlikely.

A full theoretical MO calculation is needed in order to further probe the possible effects of planarity or non-planarity on these systems and whether the complex redox chemistry is the result of conformational changes upon oxidation in solution, or subtle *inter* or *intra* molecular coulombic interactions.

2.8 SALTS OF NEW BISTTFs

A solution of **129** in 1,1,2-trichloroethane was electrolysed at a constant current of $2.5\mu\text{A}$ using tetrabutylammonium perchlorate as the supporting electrolyte. Black crystals were seen to form on the anode after 3-7 days. X-ray studies proved these to be the 1:1 perchlorate salt of **129**. The cation (Figure 2.9a) is located on a twofold axis, passing through the midpoint of the C(2)-C(2') bond. The twist around this bond is 77° , compared to 54° in **120** and virtually nil in the unsubstituted TTF-TTF. Each TTF moiety in **129** adopts a slight boat-like folding, by *ca.* 9° along the S(1)⋯S(2) and S(3)⋯S(4) vectors. The ethylenedithio bridges adopt an envelope conformation, folding by 57° along the S(5)⋯C(9) vector. In the anion (Figure 2.7b), the O(1) atom lies on a twofold axis, while every other atom is disordered over two positions, related by this axis. The precision of the structure is insufficient to discuss bond distances. Atomic displacement parameters and large residual electron density may be indicative of some disorder in the cation as well.

Crystal packing of **129**.ClO₄⁻ (Figure 2.9c) is characterised by puckered layers, parallel to the (001) plane, of cations contacting via their sulfur atoms; these S⋯S contacts (3.57-3.66Å) are close to twice the Van der Waals radius of sulfur (3.62-3.68Å). The anions occupy infinite channels, parallel to the z-axis and running through the cation motif. The conductivity was measured by a two-probe compressed pellet method and was shown to be *ca.* $1.6 \times 10^{-3} \text{ S cm}^{-1}$.

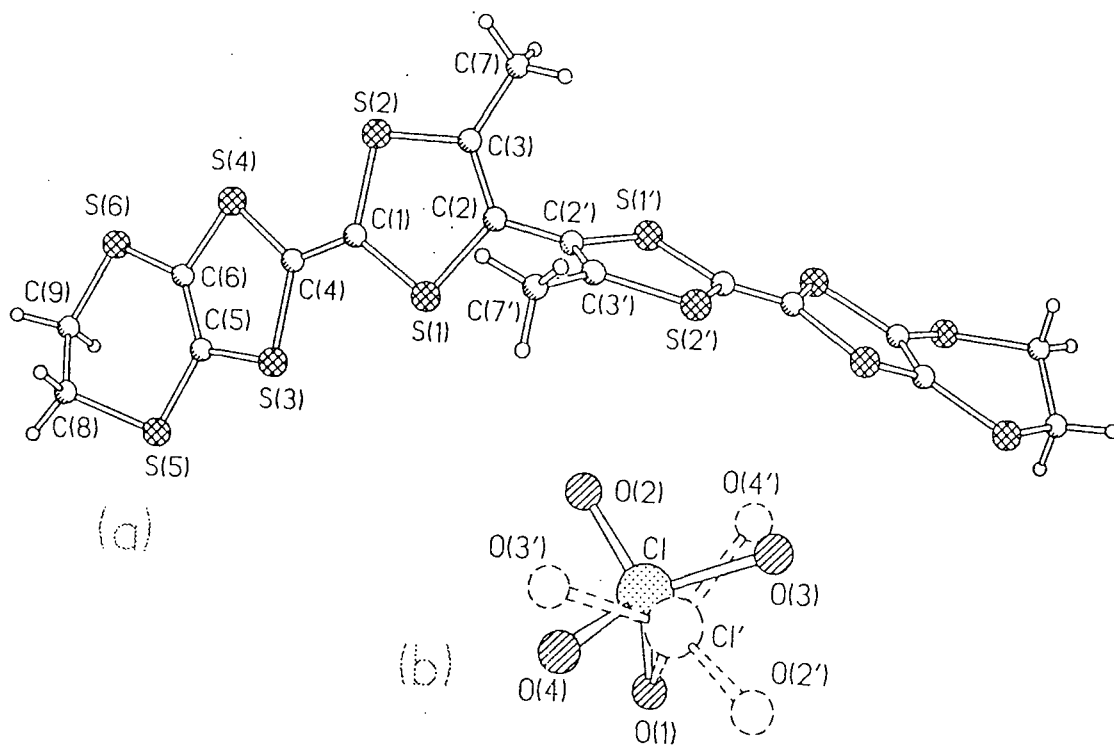

Figure 2.9a Cation (a) and anion (b) in the structure of $129.ClO_4^-$. Primed atoms are symmetry related via axis 2.

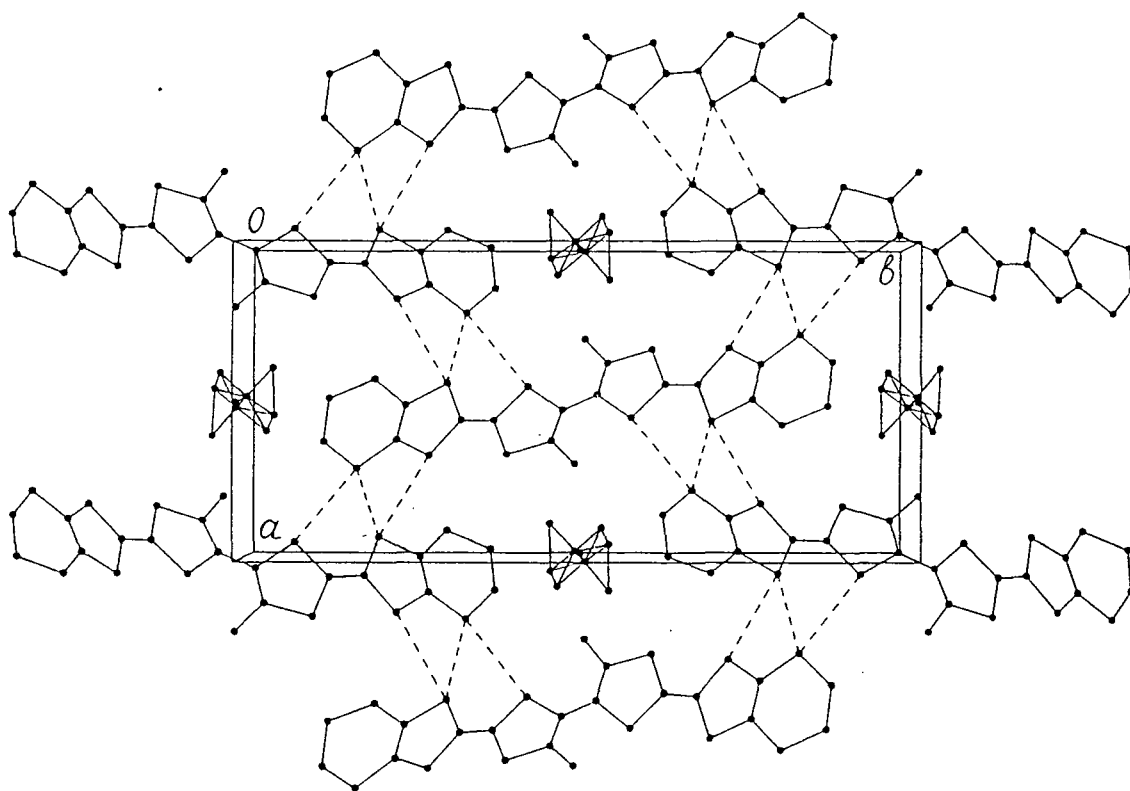

Figure 2.9b Crystal packing of $129.ClO_4^-$, perspective view on the (001) plane showing the S...S contacts of $<3.7 \text{ \AA}$.

The new *bis*TTF donors formed complexes with organic acceptors such as TCNQ, Br₂TCNQ and F₄TCNQ, whose conductivities as measured by the two-probe compressed pellet method, are tabulated below. None of these complexes formed crystals which were suitable for X-ray analysis (Table 2.8).

Donor	Acceptor	D:A	$\sigma_{rt}/\text{Scm}^{-1}$
120	TCNQ	1:1	1.2×10^{-2}
120	Br ₂ TCNQ	1:1	9×10^{-3}
120	F ₄ TCNQ	1:1	1.4×10^{-3}
120	ClO ₄ ⁻	uncertain	3.2×10^{-6}
129	ClO ₄ ⁻	1:1	1.6×10^{-3}
129	Br ₂ TCNQ	1:1	8.7×10^{-4}
128	Br ₂ TCNQ	uncertain	8.5×10^{-4}

Table 2.8 Salts of *bis*TTF systems.

Most of the new *bis*TTFs do not form complexes with TCNQ with the exception of **120**, which possibly reflects the increase in oxidation potential observed over the monomeric precursors, hence a more powerful electron acceptor such as Br₂TCNQ is required. The relatively high conductivity values are notable considering that the opportunities for effective molecular stacking of the donor are greatly reduced by the twisted conformation adopted in the solid state. An interesting result is the apparent preference of these *bis*TTF systems for a 1:1 donor- acceptor/counterion stoichiometry, this is, in effect, a 2:1 ratio if we consider the two TTF moieties to be independent. In the introduction it was observed that the stoichiometry most favoured for highly conducting complexes such as the Bechgaard salts was in the ratio 2:1 donor/anion. If, as in the case of **129**·ClO₄⁻, this is a general principle, then we may have achieved some rudimentary form of stoichiometry control in the formation of salts of these systems.

2.9 PROPERTIES OF NEW IODOTTFS

The new iodoTTFs synthesised as precursors to our *bis* TTF systems were fully characterised and their electrochemistry investigated by cyclic voltammetry. The results are tabulated below (Table 2.9). As expected, the presence of the iodine substituent raises the oxidation potential in comparison with their parent TTF, but this did not preclude a number of them forming charge transfer salts.

compound	$E_1^{1/2}/V$	$E_2^{1/2}/V$
119	0.34	0.68
126	0.46	0.72
127	0.44	0.78
135	0.50	0.73
140	0.57	0.82

Table 2.9 Cyclic voltammetry of iodoTTFs, platinum electrode, electrolyte: $n\text{-Bu}_4\text{NClO}_4$, (0.01 M), CH_2Cl_2 , 20°C, values measured in volts relative to Ag/AgCl, and corrected to Me_{10}Fc .

IodoTTF **126** when mixed with TCNQ in hot acetonitrile gives long black needles of the 1:1 charge transfer complex on cooling, the structure of which was elucidated by X-ray analysis (Figure 2.10).

The complex **126**·TCNQ has one donor and one TCNQ molecule in the asymmetric unit. The donor molecule **126** is disordered over two orientations, differing by a 180° rotation around the axis through the midpoints of the C(12)-C(13) and C(15)-C(16) bonds. Thus the iodine atom and the C(9) methyl group are distributed between positions I at C(12) and I' at C(13) with the probabilities of 53.7% and 46.3% respectively. The TCNQ molecule is planar, but for a small twist around the C(1)-C(7) and C(2)-C(8) bonds of 2.4 and 4.7°, respectively. In the TTF moiety the dithiole ring carrying the SMe substituents is folded along the S(3)···S(4) vector by 9°, while the folding of the other dithiole ring and the twist around the central C(11)-C(14) bond is insignificant (3°). The two SMe substituents adopt different conformations: one of them lies close to the TTF plane, while the other is nearly normal to this plane. The torsion angles S(3)C(15)S(5)C(17) and S(4)C(16)S(6)C(18) are 16.8 and 95.3° respectively. The donor and acceptor molecules form mixed stacks, parallel to the crystallographic axis with mean interplanar separations of *ca.* 3.4 and 3.5 Å. The degree of charge-transfer can be estimated from bond lengths in the TCNQ moiety¹⁴⁶ which differ slightly from those in the neutral molecule,¹⁴⁷ indicating a negative charge of -0.2 ± 0.1 . The structure displays interstack S···S contacts of 3.66 and 3.73 Å. The structure also contains interstack N···I contacts of 3.14 Å (for the iodine position I) and 3.18 Å (for I'), well below the sum of the van der Waals radii (3.67 in the spherical model,¹⁴⁸ 3.36 Å in the anisotropic model).¹⁴⁹ Such distances are more characteristic for weak donation of the N atom lone pairs into the vacant orbitals of the iodine atom, and the nearly linear N···I-C disposition is typical for such donation.¹⁵⁰ The conductivity of this complex (two-probe compressed pellet technique) was $\sigma_{\text{IT}} = 1.9 \times 10^{-8} \text{ Scm}^{-1}$. This low value is expected from the mixed stacking motif of the crystal structure.

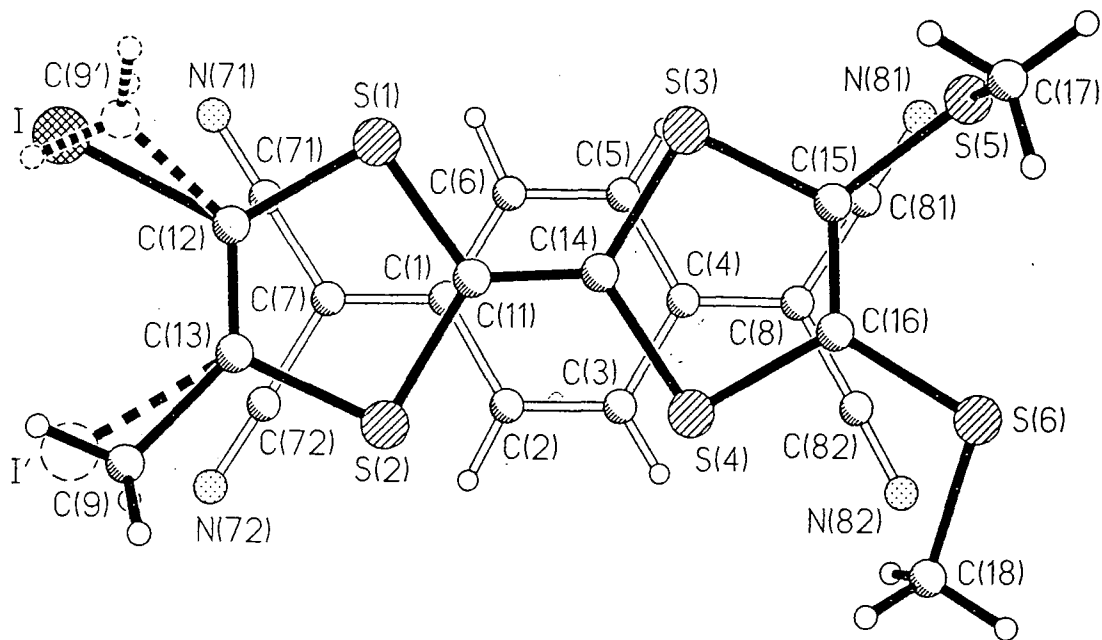

Figure 2.10 Crystal structure of 126·TCNQ.

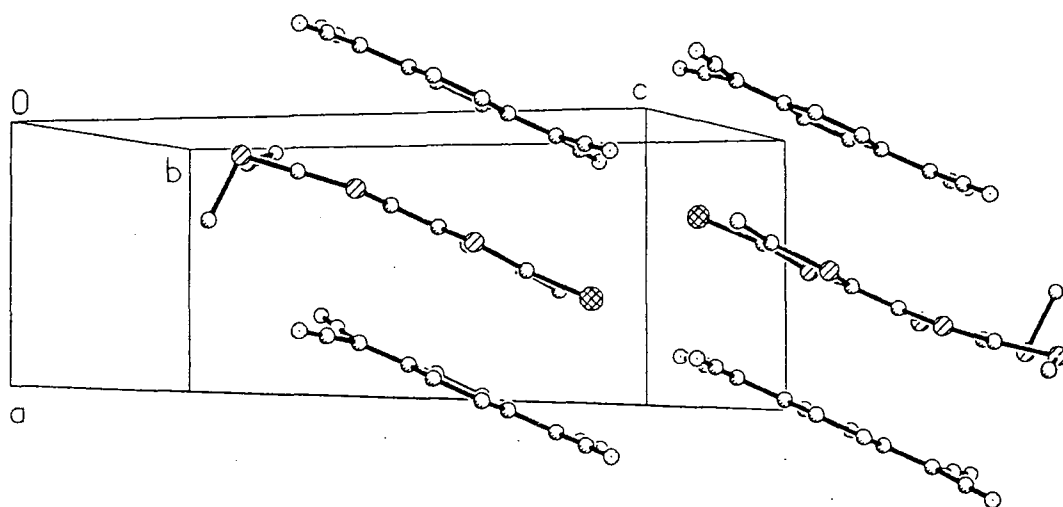

Figure 2.11 Crystal packing of 126·TCNQ.

2.10 CONCLUSIONS

A series of novel iodoTTFs has been synthesised and these have been shown to be suitable for use as precursors to new *bis*TTF systems. Such directly linked multi-TTF systems have given salts with reproducible and predictable stoichiometries similar to those of the highly conducting and superconducting derivatives of TTF. No such highly conducting salts have yet been obtained for these systems, but further electrocrystallisation experiments should prove fruitful.

Chapter Three

Novel Bis(Tetrathiafulvalene) Cyclophanes

3.1 INTRODUCTION: TTF CYCLOPHANES

The multi-TTF principle is based on the supposition that physically linking the TTF moieties may enforce a closer interaction in the solid state and hence an increase in dimensionality of conduction in any charge-transfer salts formed. We have discussed the three main types of linkage which may be envisaged: heteroatomic, conjugated and non-conjugated linkages, and their relative advantages and disadvantages. The use of flexible non-conjugated linkages, especially in the light of the advances in TTF thiolate chemistry achieved by Becher *et al.*^{101,110} is a most promising area of research. However, a potential disadvantage of this approach is the relative conformational flexibility of the TTF units; this is illustrated by the *bis*TTF **25** synthesised by Sugawara *et al.*⁶⁰ which displayed two polymorphic crystal structures in its radical cation salt with ClO_4^- due to its ability to adopt different conformations in the oxidised state. (Chapter 1; figure 1.14a-b).

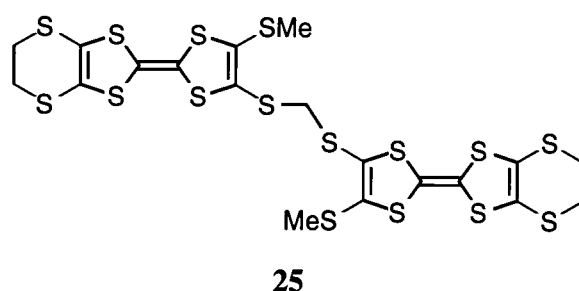

While such flexibility may indeed lead to the serendipitous formation of unpredicted novel structures, in order to achieve more control over the geometrical orientation of the TTF moieties yet still retaining enough flexibility to adopt low energy conformations in the solid state, a new class of compounds were proposed by Staab in 1978 which he termed tetrathiafulvaleneophanes⁸² (Scheme 3.1).

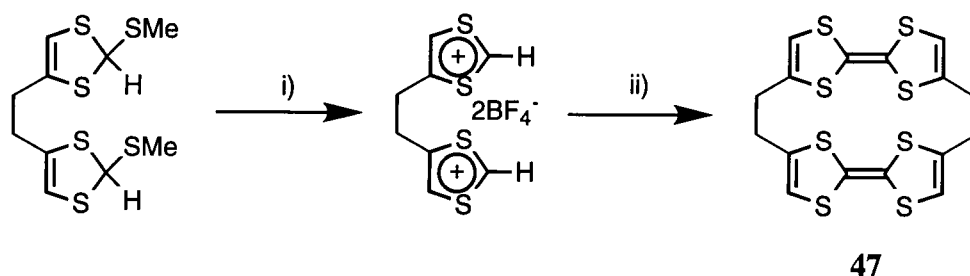

Scheme 3.1 The first synthesis of a [2.2]tetrathiafulvaleneophane by Staab.

Reagents and conditions: i) HBF_4 , $(\text{MeCO})_2$; ii) NEt_3 , MeCN .

In such compounds as **47** we can see that by utilising a cyclophane type structure, the TTF units are conformationally flexible but have limited geometrical freedom, thus allowing some control over the mutual orientation of the TTF moieties in the neutral and oxidised states.

3.2 TETRATHIAFULVALENOPHANES AND PARACYCLOPHANES

Cyclophanes are fundamentally important compounds in many aspects of macrocyclic and supramolecular chemistry.¹⁵¹ The incorporation of TTF into cyclophane structures was proposed by Staab to be a possible route to interesting electroactive macrocycles either incorporating simple aromatic spacers such as **144**, or another TTF unit such as **47**. A recent development has been the incorporation of acceptor species such as TCNQ and bipyridinium¹⁵² into TTF cyclophanes giving rise to networks of *inter* and *intramolecular* donor-acceptor interactions, but such systems are outside the scope of this chapter.

Most tetrathiafulvaleneophanes and tetrathiafulvaleneparacyclophanes described in the literature were prepared by a coupling reaction in which the central TTF moiety was formed in the final cyclisation step. For example, from *bis*1,3-dithiolium salt **143**, Staab *et al.*¹⁵³ prepared the [3]tetrathiafulvalene[3]paracyclophane **144** in 29% yield as a mixture of *cis* and *trans* isomers (Scheme 3.2).

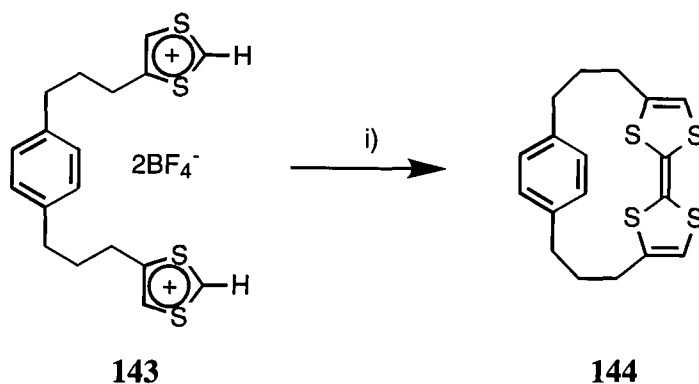

Scheme 3.2 Reagents and conditions. i) NEt_3 , MeCN.

An alternative route is via a trialkylphosphite mediated coupling of 1,3-dithiole-2-ones, for example in the synthesis of **48** by Otsubo.⁸⁴

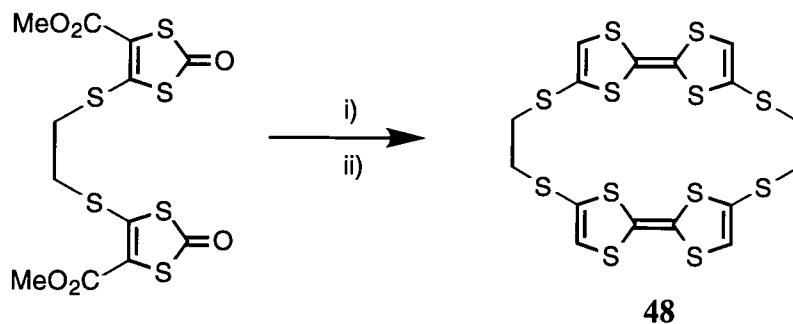

Scheme 3.3 Reagents and conditions : i) $\text{P}(\text{OMe})_3$; ii) LiBr , HMPA

Such cyclisations can in theory proceed *inter* or *intra* molecularly to give either the tetrathiafulvalenophanes or a cyclophane type bridged TTF. A general rule is that very short linkers such as ethyl (as in **47** or **48**), or propyl (as in **148**)¹⁵⁴ lead to *intermolecular* coupling as opposed to the formation of the highly strained *intramolecular* coupling product, although it has been shown that *intramolecular* coupling can be favoured by using longer chain lengths such as C_{12} , C_{10} , and C_6 in **145**, **146** and **147**, or by performing the reaction under dilute conditions, as in the synthesis of **150**.¹⁵⁵

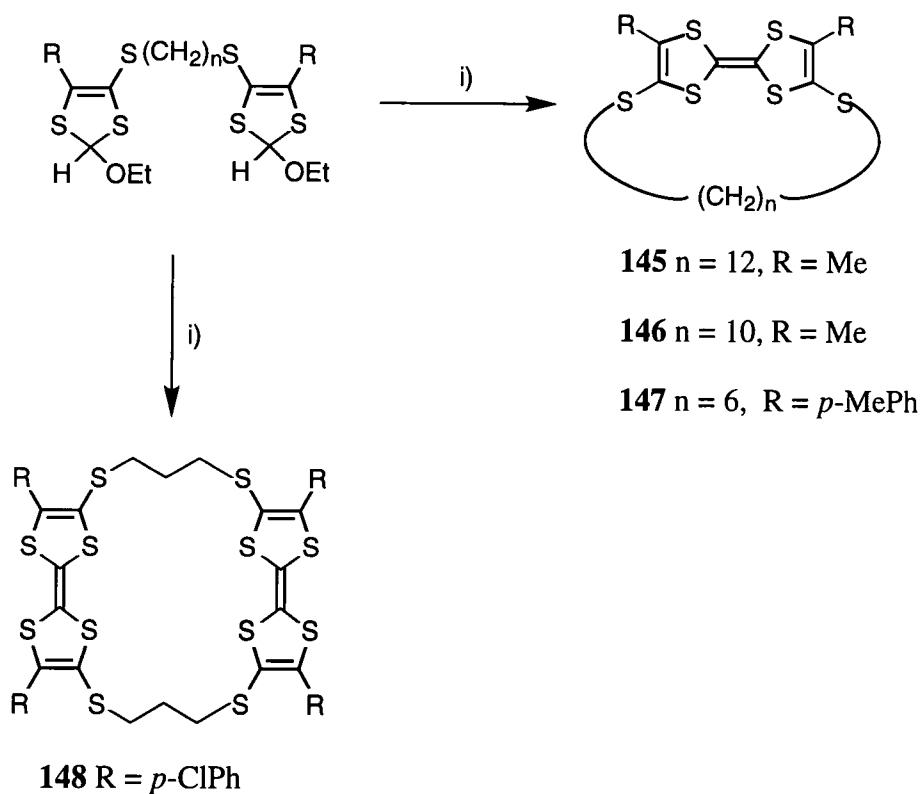

Scheme 3.4 Intra vs. inter molecular coupling. Reagents and Conditions: i) $\text{Cl}_3\text{CCO}_2\text{H}$, PhMe , Al_2O_3 .

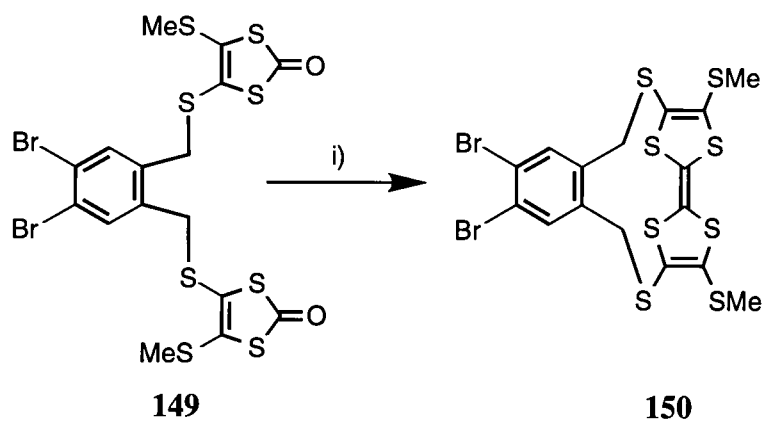

Scheme 3.5 Reagents and conditions: i) P(OEt)₃, toluene, reflux.

Recent advances in TTF thiolate chemistry and the use of high dilution conditions have made it possible to prepare a series of TTF cyclophane structures such as **152** and **155**¹⁵⁶ via the nucleophilic displacement of a suitable leaving group by a TTF-thiolate. These compounds were made with the primary aim of being incorporated into self-assembled structures such as rotaxanes and catenanes (Schemes 3.6 and 3.7). Such large macrocyclic structures as **155** are always obtained as mixtures of *cis/trans* isomers due to the acid catalysed isomerisation of TTF in solution.

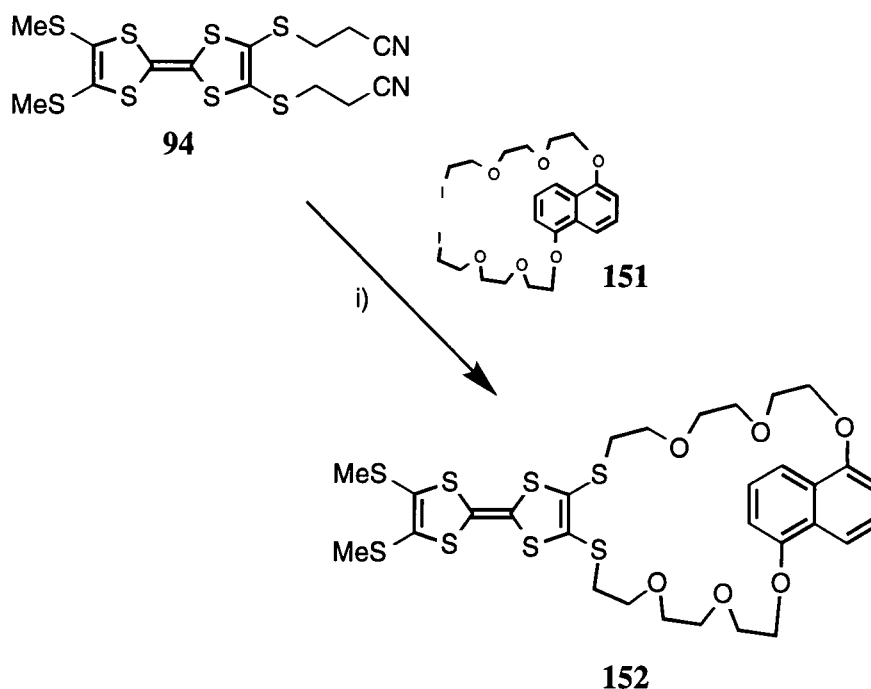

Scheme 3.6 Reagents and conditions: i) CsOH, **151**, High dilution.

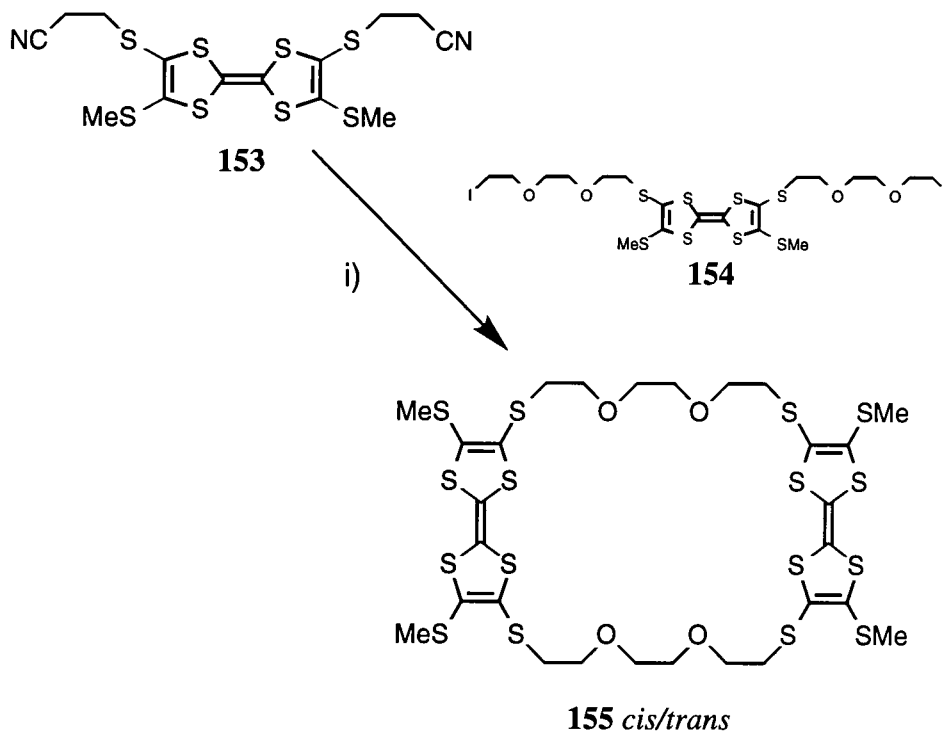

Scheme 3.7 Reagents and conditions: i) CsOH, **154**, High dilution.

3.3 NEW TTF CYCLOPHANES

We proposed the synthesis of macrocyclic TTF-phanes of the generic types **156-160** (Figure 3.1).

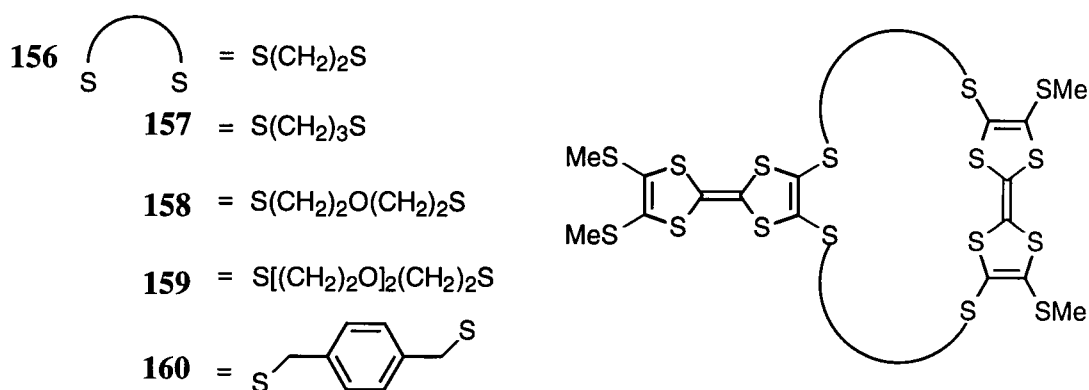

Figure 3.1 Proposed novel TTF cyclophanes.

This series was attractive for the same reasons as the crisscross TTFs of Otsubo and Sugawara, in that they mimic certain motifs observed in the crystal structures of conducting salts of TTF. In this case the dimeric and orthogonal TTFs mimic certain facets of the highly conducting *kappa* phases in which the TTF units associate in

orthogonal dimer pairs. These molecules should be incapable of forming the segregated stacks of one-dimensional conductors by the virtue of the inherent orientation of the TTF moieties and their close *intramolecular* association. Therefore, other novel structures are predicted if both TTF units are able to interact both *intra* and *intermolecularly* when oxidised and possibly give rise to conducting states of higher dimensionality.

3.3.1 SYNTHESIS

Two disconnections for our novel tetrathiafulvalenophanes were proposed based on the literature precedents (Figure 3.2). The first disconnection **A** involves the more traditional route of forming the central double bond of the bridging TTF in the final step from the precursor 1,3-dithiole-2-one via an *intramolecular* trialkylphosphite mediated coupling. The participating dithiols do not need to be closely oriented in the precursor molecule, this has been demonstrated in the synthesis of molecules such as **55**⁹¹ where the dithiols are widely separated through space.

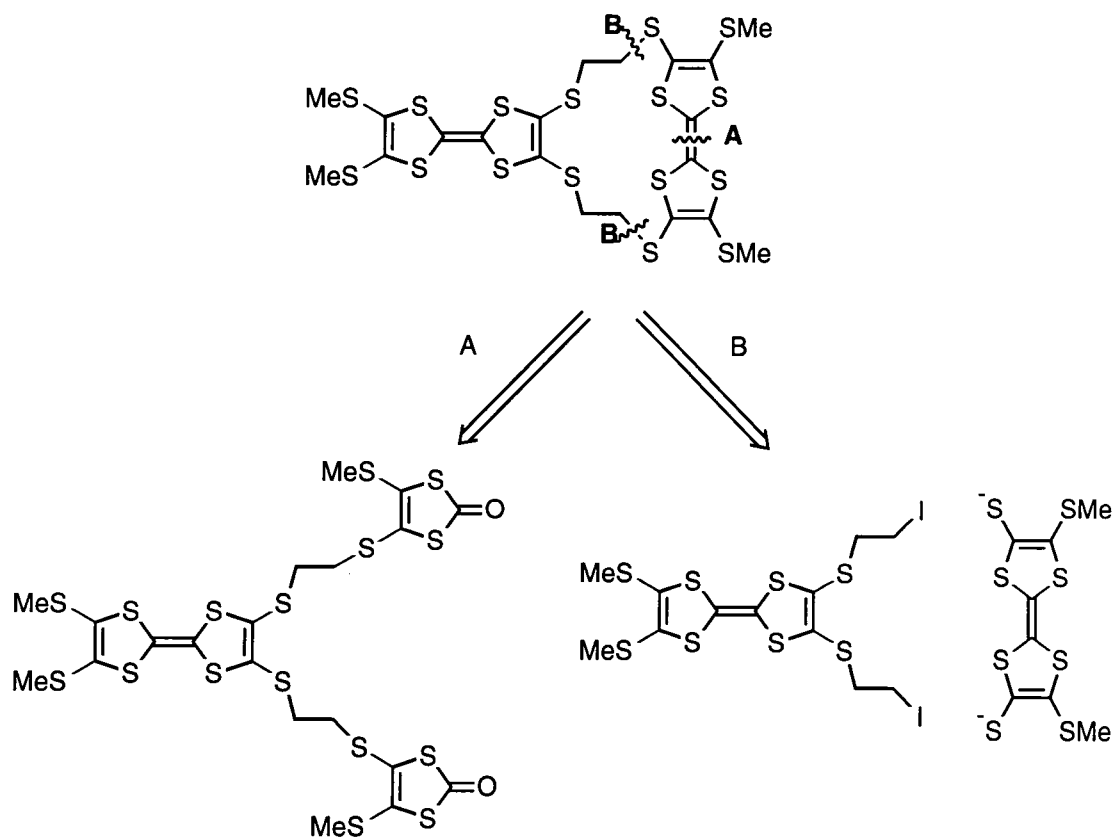
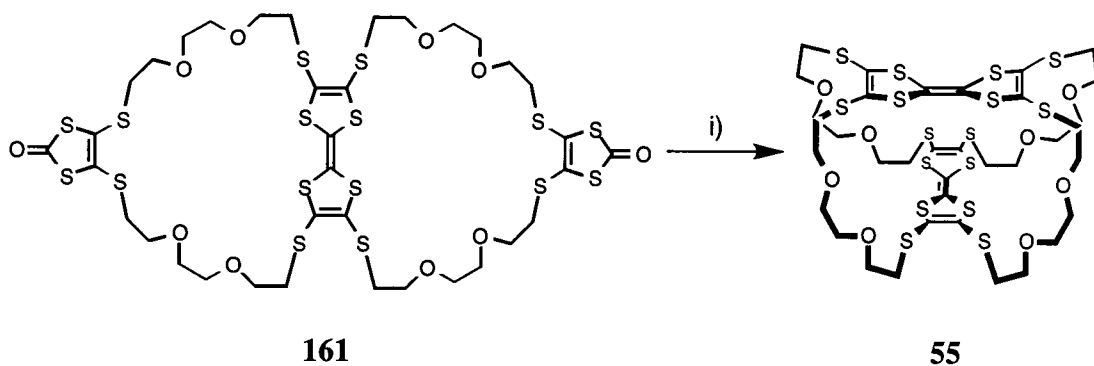
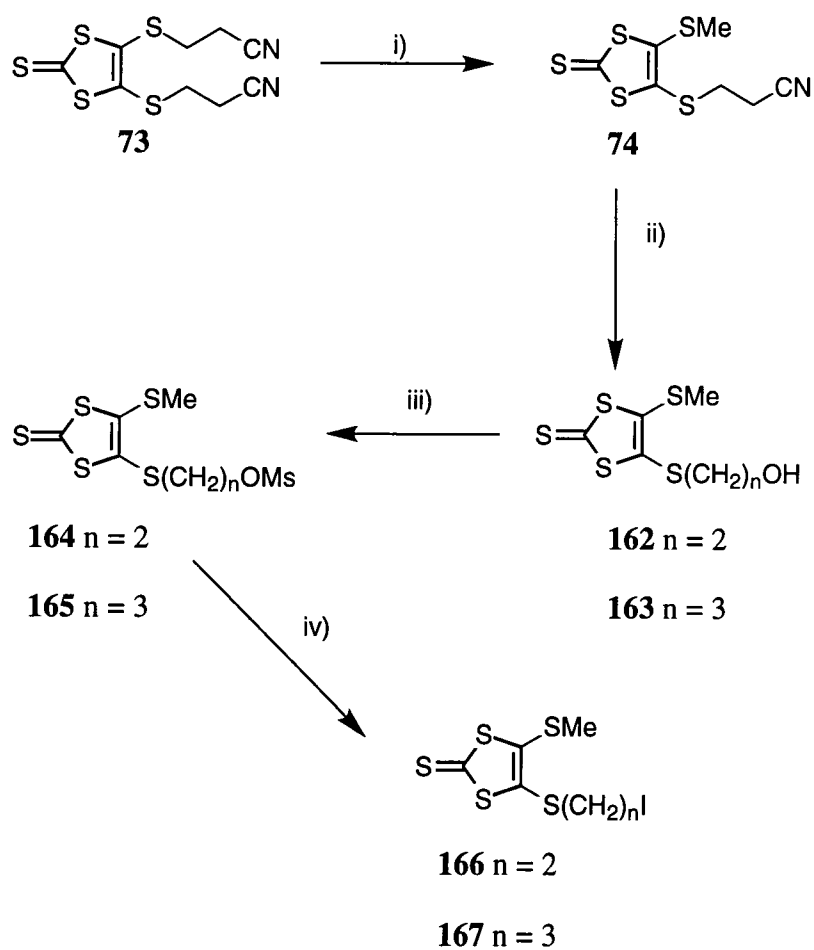

Figure 3.2 Proposed disconnections for novel TTFphanes.



Scheme 3.8 Reagents and conditions: i) P(OEt)₃, toluene, 120°C.

Disconnection **B** is based on the chemistry of Becher and involves a high dilution cyclisation of a *bis*alkylating TTF with a *bis*thiolate derived from **153**. The synthetic scheme for the first disconnection **A** is outlined below (Scheme 3.9).



Scheme 3.9 Reagents and conditions. i) CsOH(1 equiv), MeI; ii) NaOEt, EtOH, 2-chloroethanol or 3-bromopropanol; iii) NEt₃, DCM, MsCl; iv) NaI, acetone, reflux.

Compound **74** was synthesised either by the literature route shown,^{110b} or via a modification to give a one pot process by sequential addition of the required stoichiometric amounts of methyl iodide and 3-bromopropionitrile to zincate salt **72**, followed by chromatography on silica. Deprotection with sodium ethoxide in ethanol followed by alkylation with either 2-chloroethanol or 3-bromopropanol gave **162** and **163** in 78 and 68% yields, respectively. Treatment of the alcohols with methanesulfonylchloride gave the mesylates **164** and **165**, which were refluxed with sodium iodide in acetone to give the iodides **166** and **167**.

To a solution of *bis*protected TTF **94** in THF/MeOH (1:1 v/v) was added NaH, followed by the iodo compounds **166** or **167** which upon work up gave compounds **168** and **169** in 65 and 72% yield, respectively (Scheme 3.10). In order to obtain the more reactive 1,3-dithiole-2-one derivatives, both **168** and **169** were treated with Hg(OAc)₂ in AcOH/CHCl₃.

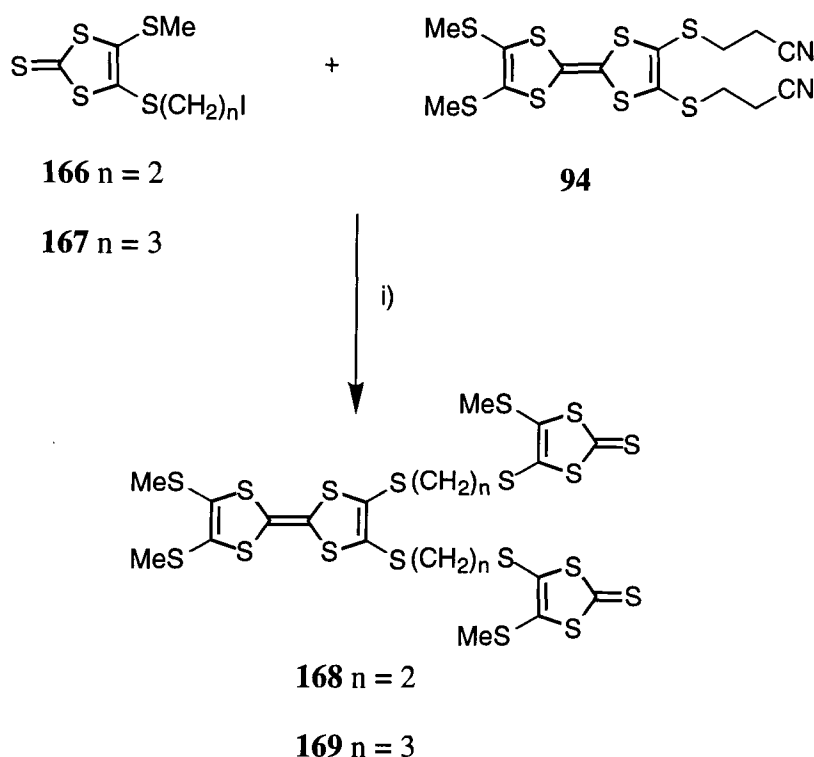

Scheme 3.10 Reagents and conditions. i) THF/MeOH, NaH, **166** or **167**.

However, both products of this reaction were contaminated with an unknown impurity which proved impossible to remove chromatographically and so it was decided to abandon this reaction sequence and move on to the second proposed disconnection **B**, involving a high dilution cyclisation of a *bis*TTF thiolate with a *bis*alkylating TTF derivative.

To a sodium ethoxide solution of **94** was added either 2-chloroethanol or 3-bromopropanol to give *bis*alcohols **170** and **171** in 67 and 66% yield, respectively. Mesylation and displacement with iodide gave diiodo compounds **176** and **177**. While this work was in progress, Becher *et al.*¹⁵⁷ published the synthesis of **177** via the tosylate with comparable yields. Diiodo compound **176** proved to be unstable at room temperature but was stable when stored at -10°C under argon. This compound was best prepared and used immediately in the next reaction in order to minimise decomposition (Scheme 3.11).

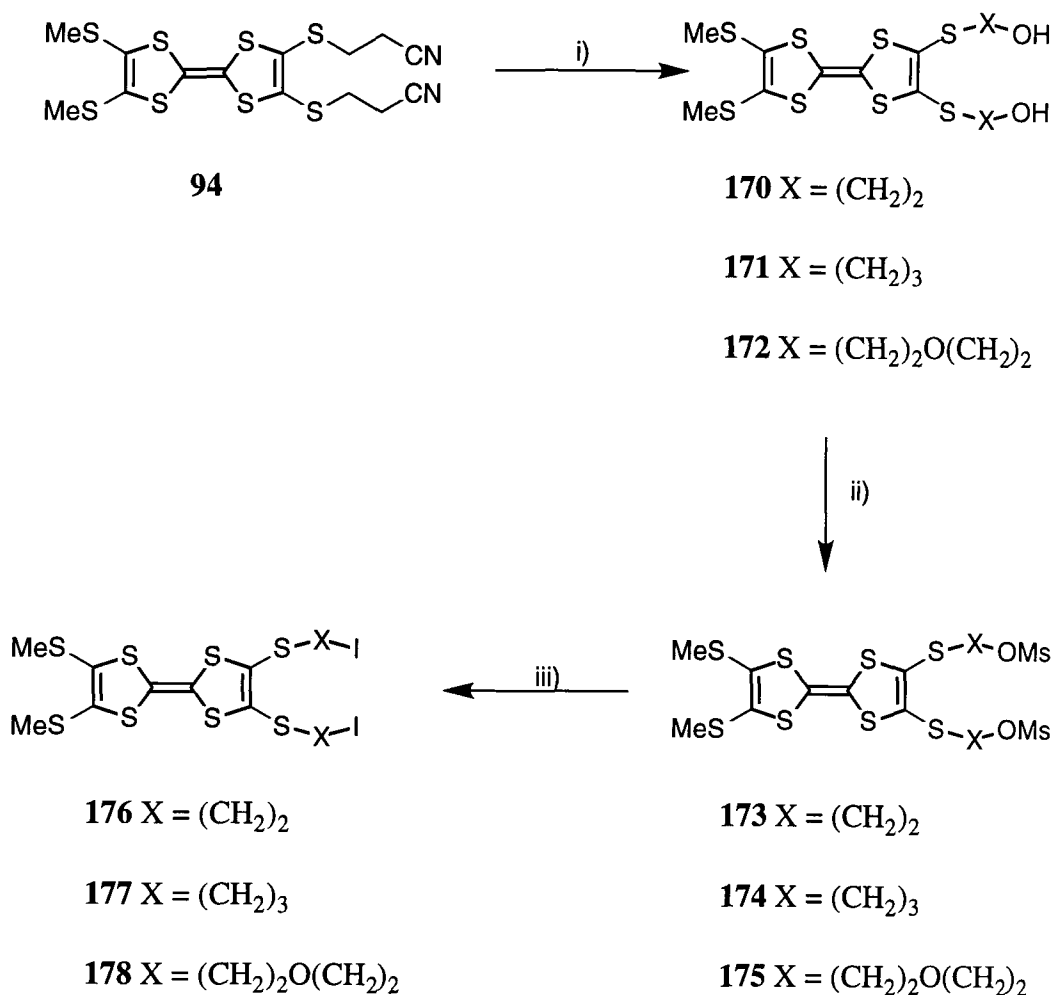

Scheme 3.11 Reagents and conditions: i) NaOEt, EtOH, [2-chloroethanol, 3-bromopropanol, or 2-(2-chloroethoxy)ethanol]; ii) NEt₃, MsCl, DCM, 0°C; iii) NaI, acetone, reflux.

*Bis*protected TTF **153** was obtained as a mixture of *cis* and *trans* isomers.¹⁰¹ Deprotection of a DMF solution of **153** followed by high dilution mixing of the *bis*thiolate generated with either of the diiodoTTFs **176** and **177** gave, after work up, *bis*TTFs **156** and **157** in 60 and 54% yields respectively.

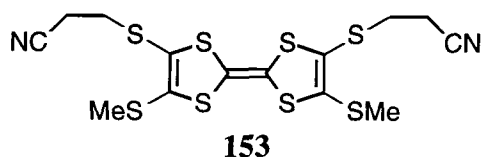

Compound **156** was isolated as red prisms after recrystallisation from DCM/hexane. Based on a sharp melting point and ^1H and ^{13}C NMR spectroscopic data, it was postulated that only the symmetrical *cis* isomer had been obtained. This was later confirmed by a single crystal X-ray study which showed the conformation of the bridging TTF to be *cis* with a highly bent structure (Figure 3.3). For **157** it was not possible to obtain X-ray quality crystals and so no definitive statement about the stereochemistry could be made; however, both ^1H and ^{13}C NMR evidence supported the formation of the *cis* isomer exclusively.

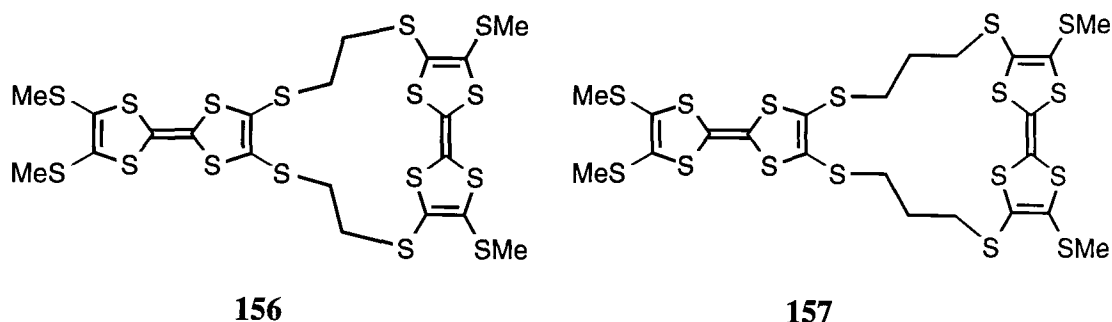

Other variations on the linking groups were attempted. The glycol analogue **158** was synthesised by reaction of **94** with 2-(2-chloroethoxy)ethanol followed by mesylation and replacement with iodide to give diiodoTTF **178**. This was reacted under high dilution conditions to give *bis*TTF **158** as a red oil in 65% yield. The presence of **158** as a mixture of *cis/trans* isomers was unequivocally shown by the multiple resonances for the thiomethyl groups in the ^1H NMR, and by TLC evidence which showed that compound **158** was composed of two very close running spots which were not separable by standard column chromatography.

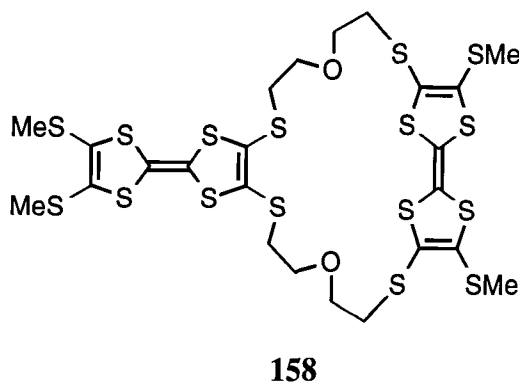

The *bis*TTF **160** with benzylic linkers was synthesised by the coupling of **179** to the thiolate generated from **153** over 16h using high dilution conditions to give **160** in 52% yield as a mixture of *cis/trans* isomers. The dibenzylchloride substituted TTF **179** was synthesised in 46% yield by the addition of a large excess of α,α -dichloro-*p*-xylene to a solution containing the *bis*thiolate generated from **94**.

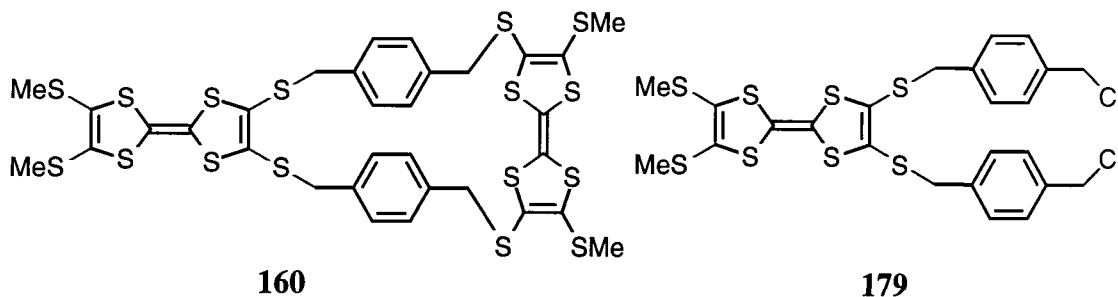

After this work had been completed, Becher *et al.*¹⁵⁶ published a synthesis of an analogue of this series of *bis*TTF phanes with a longer diethylene glycol ether chain **159**, primarily for incorporation into new catenane structures. The synthetic route also involved the reaction of **153** with a bisalkylating TTF derivative under high dilution conditions. As expected, with large linkers a mixture of inseparable *cis/trans* isomers was obtained.

In order to obtain more information about the solid state structures of these compounds and especially since it was not possible to obtain X-ray quality crystals of **157** which we predicted to be the pure *cis* stereoisomer on the basis of NMR evidence, the synthesis of the model compound **183** was undertaken. Similar compounds had been synthesised by Becher¹⁵⁶ and Otsubo⁸⁶ by variations on a high dilution cyclisation of a dithiolate with a *bis*alkylating TTF; but no crystal structure data had been reported. The diiodo substituted 1,3-dithole-2-thione derivative **182** was synthesised from zincate salt **72** using our mesylation, iodination sequence. Coupling of this with **153** under high dilution conditions gave **183** in 24% yield as a mixture of *cis* and *trans* isomers as observed by ¹H NMR spectroscopy (Scheme 3.12).

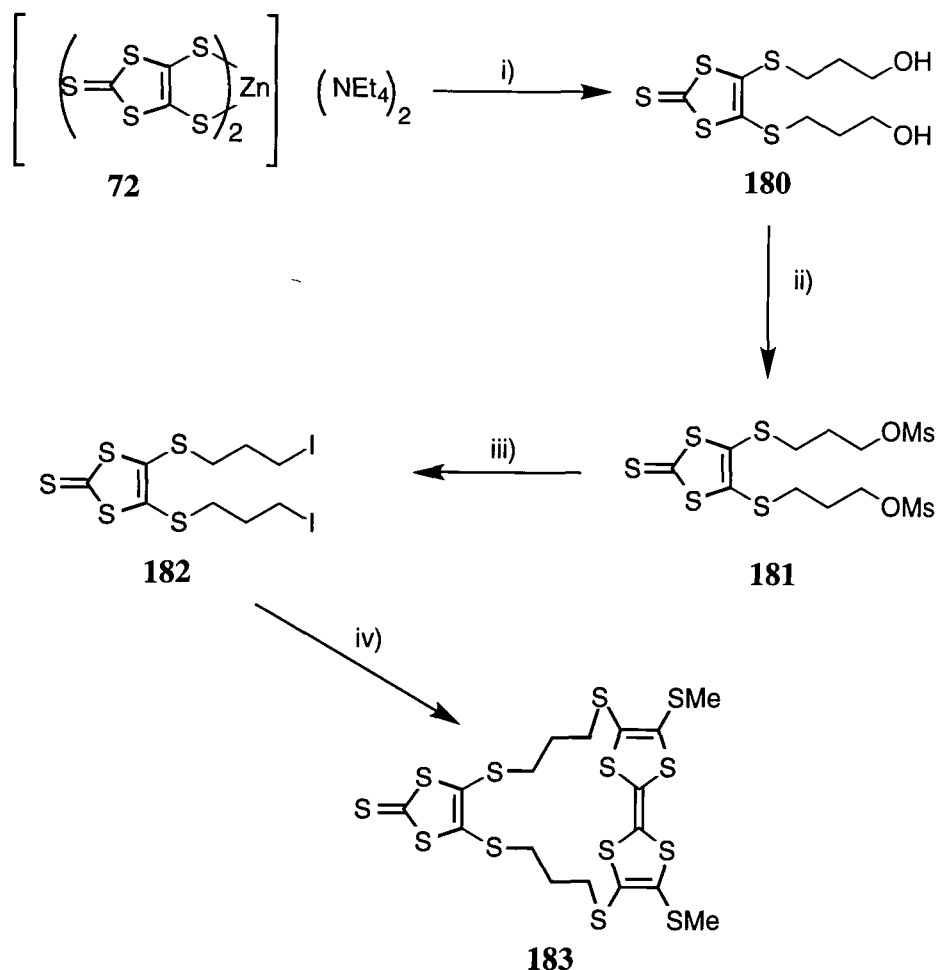

Scheme 3.12 Reagents and Conditions: i) MeCN, 3-bromopropanol; ii) MsCl, pyridine, DCM; iii) NaI, acetone, reflux; iv) **153**, CsOH, DMF, high dilution.

Recrystallisation from DCM/hexane gave a red crystalline solid which was calculated to be >95% *cis* isomer as observed by ^1H NMR in CDCl_3 which had been stored over NaHCO_3 in order to suppress isomerisation in solution by trace acid. An X-ray study of a well-formed crystal revealed it to be the *cis* isomer (Figure 3.4).

3.4 X-RAY CRYSTAL STRUCTURES OF **156** AND **183**

Crystals of **156** suitable for X-ray structure determination were grown by diffusion of hexane into a CS_2 solution of the compound (Figure 3.3). In the neutral molecule both TTF moieties are folded along the $\text{S}\cdots\text{S}$ vectors in a boat conformation; the dihedral angle (θ) between the outer SCCS parts is 33° in moiety **A** and 65° in moiety **B**. Molecules in the crystal assemble in pairs, so that each molecule's **B** moiety fits into the cavity of another molecule, while moiety **A** of each molecule contacts face-to-face with that of another dimer (with two short $\text{S}\cdots\text{S}$ contacts of 3.61\AA).

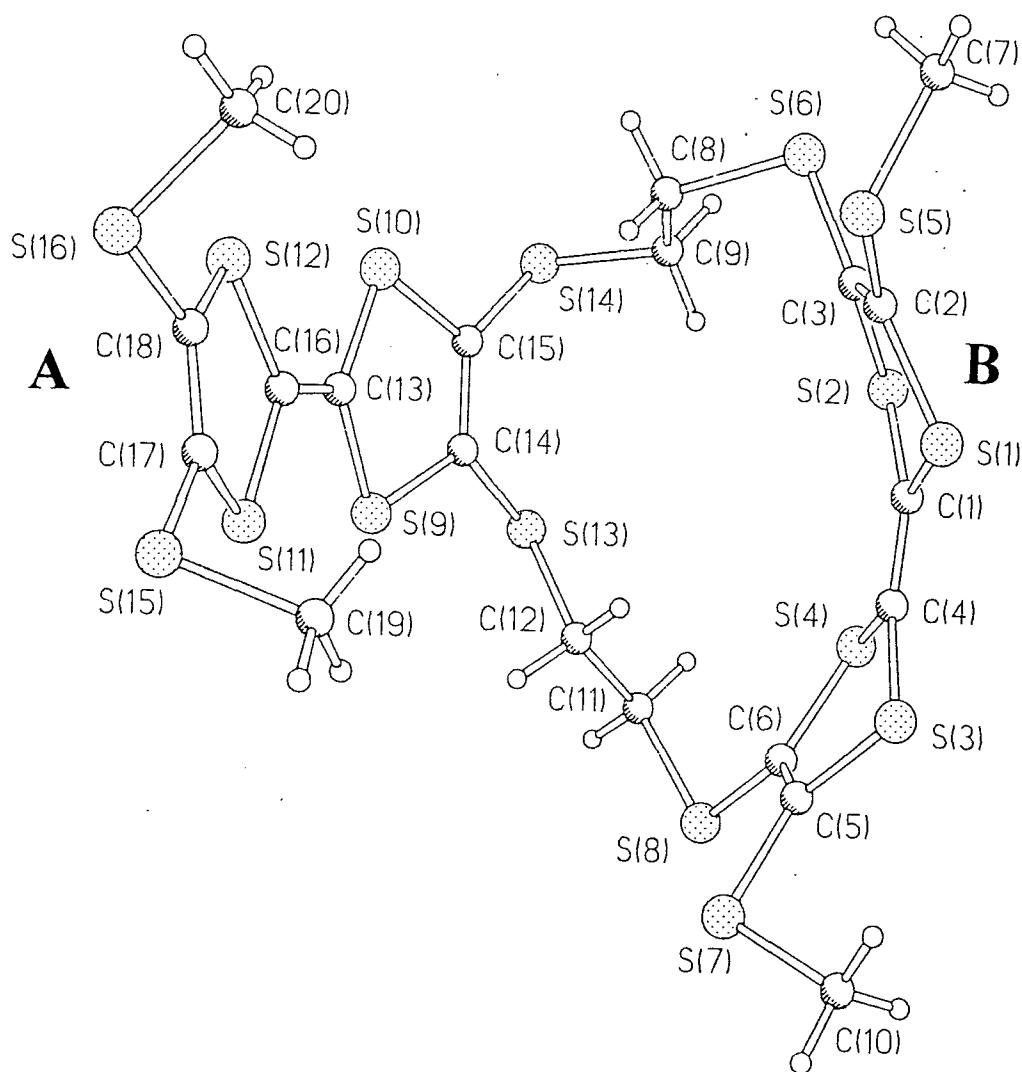

Figure 3.3 Crystal structure of **156**.

Compound **183** was also characterised by an X-ray structural study. The TTF moiety adopts a boat-like conformation, folding along the S(1)⋯S(2) and S(3)⋯S(4) vectors by 29.6° and 21.0°, respectively (figure 3.4a). This distortion is not necessarily due to the bridge, since a similar folding (by 26.5 and 23.6°) was observed in the monoclinic polymorph of tetrathiomethyl-TTF **93**¹⁵⁸ (although the latter molecule is planar in its triclinic polymorph).¹⁵⁹ The C₂S₃ system is planar, with S(9) and S(10) deviating from its plane by *ca.* 0.1 Å in opposite directions. The molecular conformation is fairly compact, with the transannular contacts S(9)⋯C(1) (3.54 Å) and S(9)⋯C(4) (3.60 Å) characteristic of close packing.¹⁴⁸ In the crystal, the TTF moieties contact each other face-to-face, in a continuous herringbone motif (figure 3.4b), each moiety participating in four intermolecular S⋯S contacts of 3.55 Å, and four of 3.65 Å (*cf.* the standard van der Waals contact of 3.62 - 3.68 Å). Notably, the C₂S₃ system forms no such contacts closer than 3.77 Å.

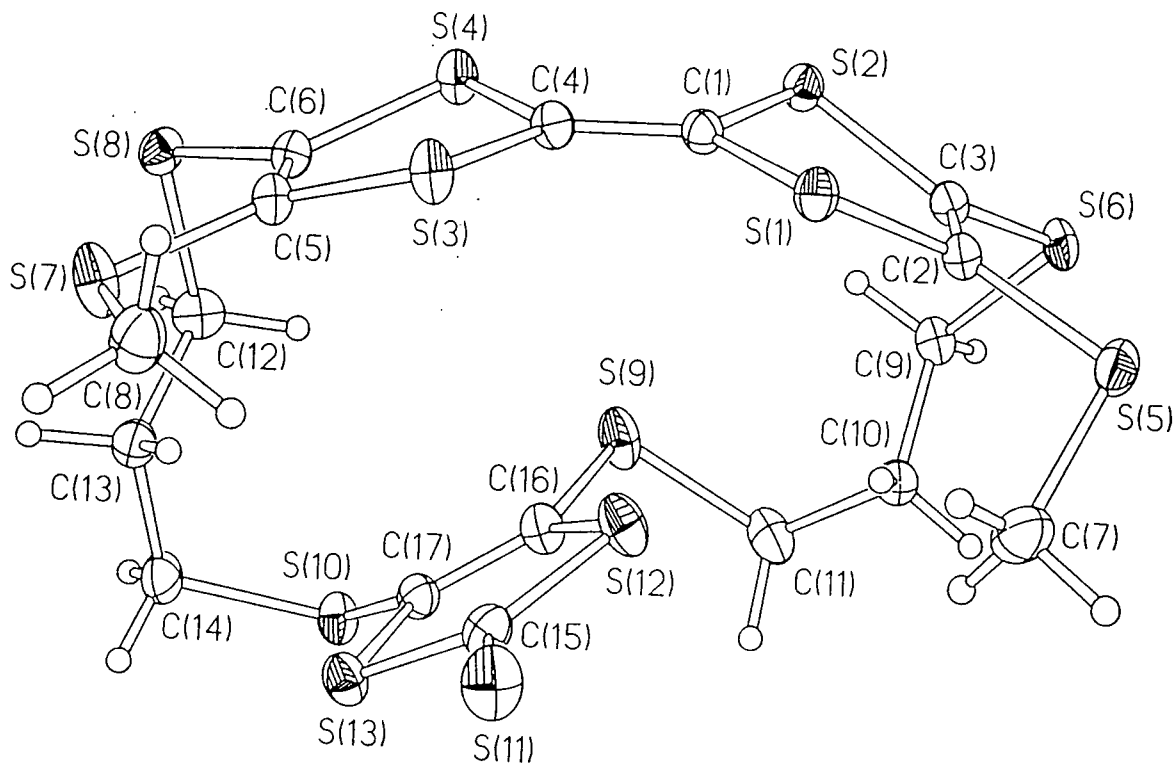

Figure 3.4a Crystal structure of **183** (50% probability ellipsoids).

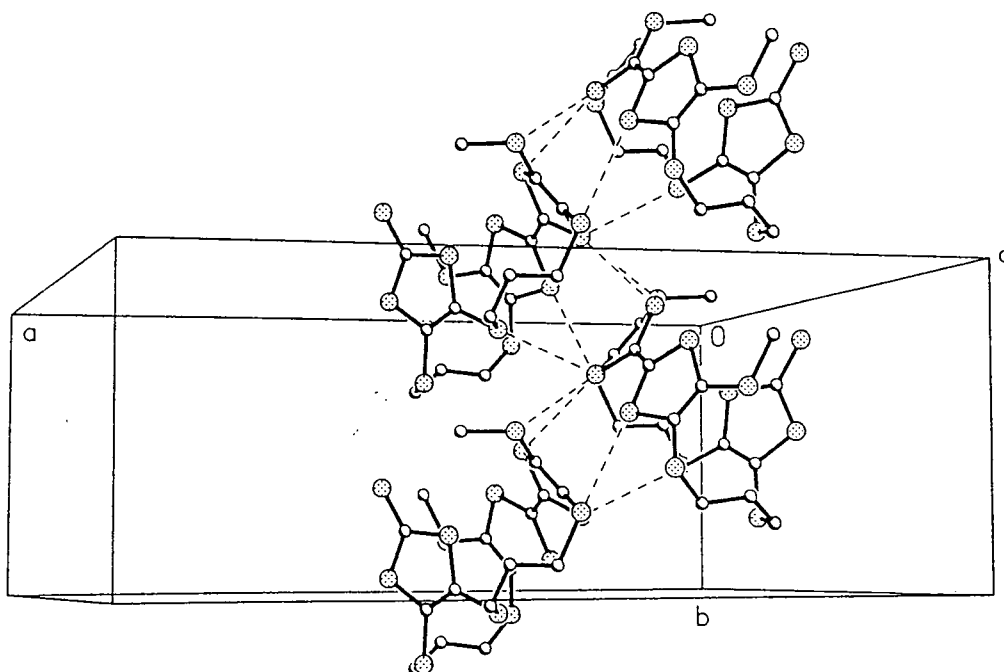

Figure 3.4b Crystal packing of **183** (H atoms omitted).

3.5 SALTS OF **156**

None of the new donors **157-160** gave any complexes when mixed with either TCNQ or Br₂TCNQ. Electrochemical oxidation of **156** in a two compartment cell (current 1.5 μA, electrolyte NBu₄ClO₄ in DCM) for 2 weeks at 20°C in the dark, resulted in partial evaporation of the solvent and the formation of shiny black needles of the 2:1 perchlorate salt (**156**)₂⁺·ClO₄⁻ (i.e. 4 TTF units to each perchlorate anion). An X-ray crystallographic analysis (Figure 3.5) revealed that the unit cell of (**156**)₂⁺·ClO₄⁻ comprises of two molecules of **156** with similar geometry and one perchlorate anion, which shows strong libration or disorder. The TTF moiety **B** retains the folding (mean θ = 57°) and bond lengths it had in the neutral form, while moiety **A** is almost flattened (θ = 5°). These latter moieties of the two independent molecules of **156** are essentially parallel and form an infinite stack (along the Y-axis of the lattice) with uniform interplanar separations of *ca.* 3.46 Å. The non-oxidised TTF moieties of adjacent molecules contact face-to-face and form infinite chains of short S...S contacts (3.42-3.48 Å, *cf.* van der Waals radius of sulfur, 1.81 - 1.84 Å),¹⁴⁸ parallel to the stacking direction *y*. There is also a chain of very short intrastack S...S contacts (3.36 Å) in the *x* direction.

An iodide salt of **156** (stoichiometry 1:8 as judged by elemental analysis) was obtained by slow diffusion of iodine vapour into a solution of compound **156** in DCM at room temperature.

In the crystal of **156**⁺·I₈⁻ (Figure 3.6), the cation radical of **156** lies on a crystallographic mirror plane (*m*). The geometry of the B moiety remains the same (θ = 60°), while A adopts a slight chair-like folding (by 8 and 6° along the S...S vectors). Bond distances in the latter are consistent with the +1 oxidation state.¹⁶⁰ Both SMe substituents at moiety A, which adopt an out of plane conformation in **156**, switch in **156**⁺·I₈⁻, (as in (**156**)₂⁺·ClO₄⁻) to the conjugated in-plane orientation. There are eight iodine atoms per cation consisting of an isolated linear I₃⁻ moiety lying astride the mirror plane, and five other iodine atoms situated inside the cation cavity which although heavily disordered may be modelled as a possible infinite chain of neutral I₂ molecules, i.e. the true formula is **156**⁺·I₃⁻·2.5(I₂).

Single crystal conductivity measurements (two probe data) on the salts (**156**)₂⁺·ClO₄⁻ and **156**⁺·I₈⁻; established that the perchlorate salt is a semiconductor (σ_{rt} = 10⁻² Scm⁻¹) whereas the iodide salt has a considerably lower conductivity (σ_{rt} = *ca.* 10⁻⁹ Scm⁻¹). These data are consistent with the uniform partially oxidised stack structure of the perchlorate salt, and the lack of close stacking in the iodide salt.

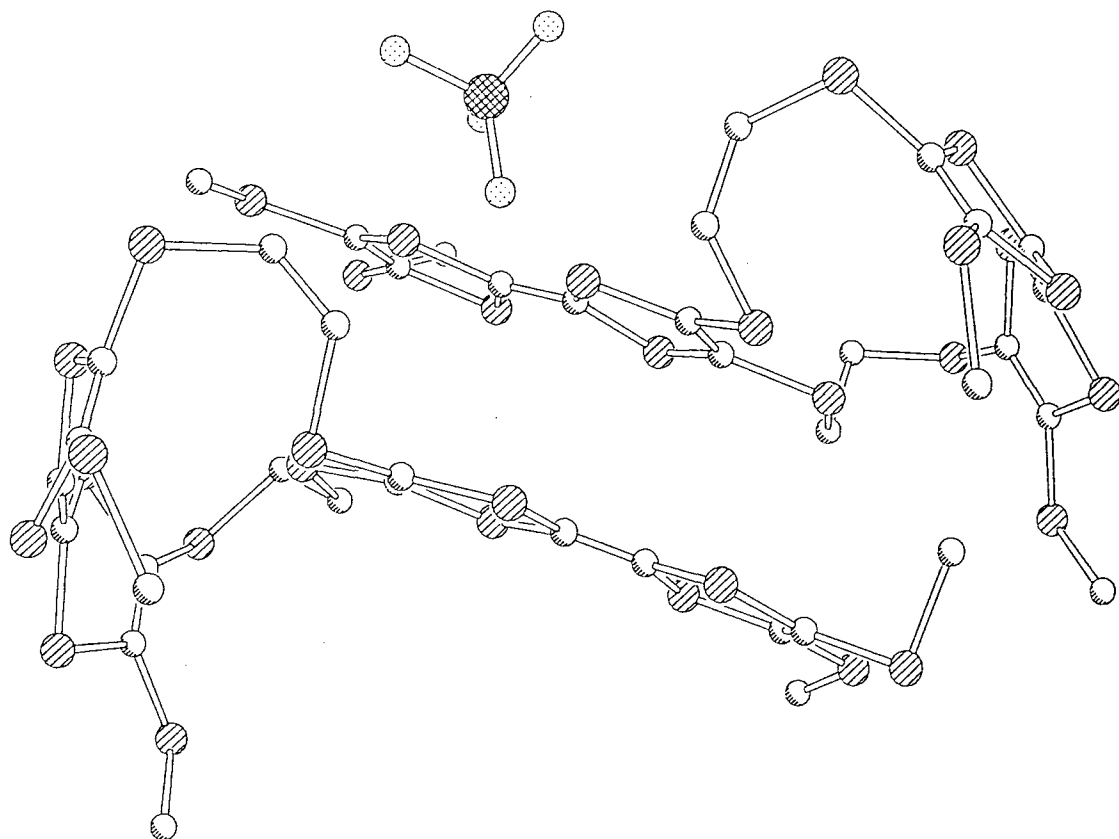

Figure 3.5a Crystal structure of $(156)_2^+ \cdot \text{ClO}_4^-$ showing two independent cations of **156** and a perchlorate anion.

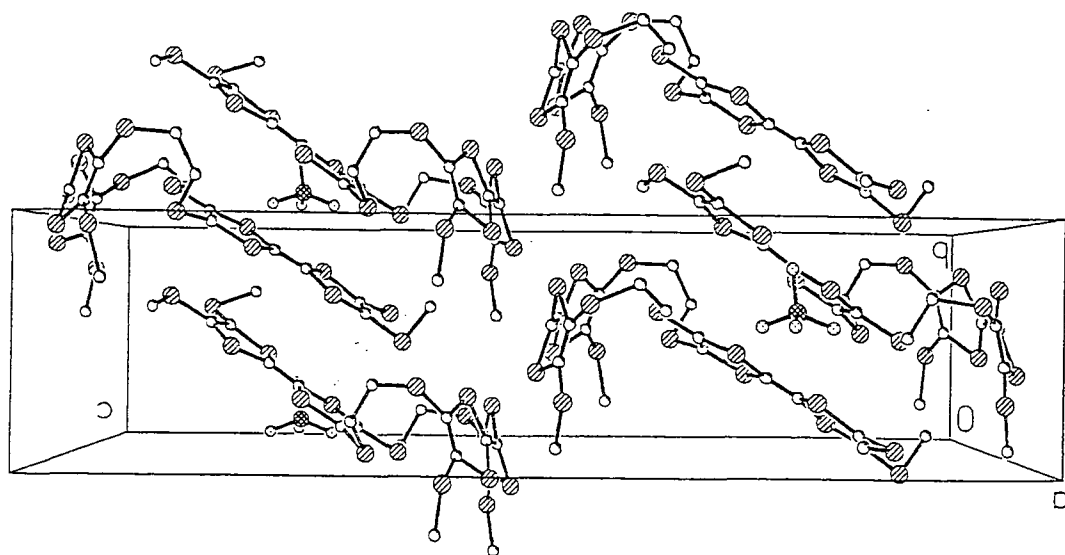

Figure 3.5b Crystal packing of $(156)_2^+ \cdot \text{ClO}_4^-$ (H atoms omitted).

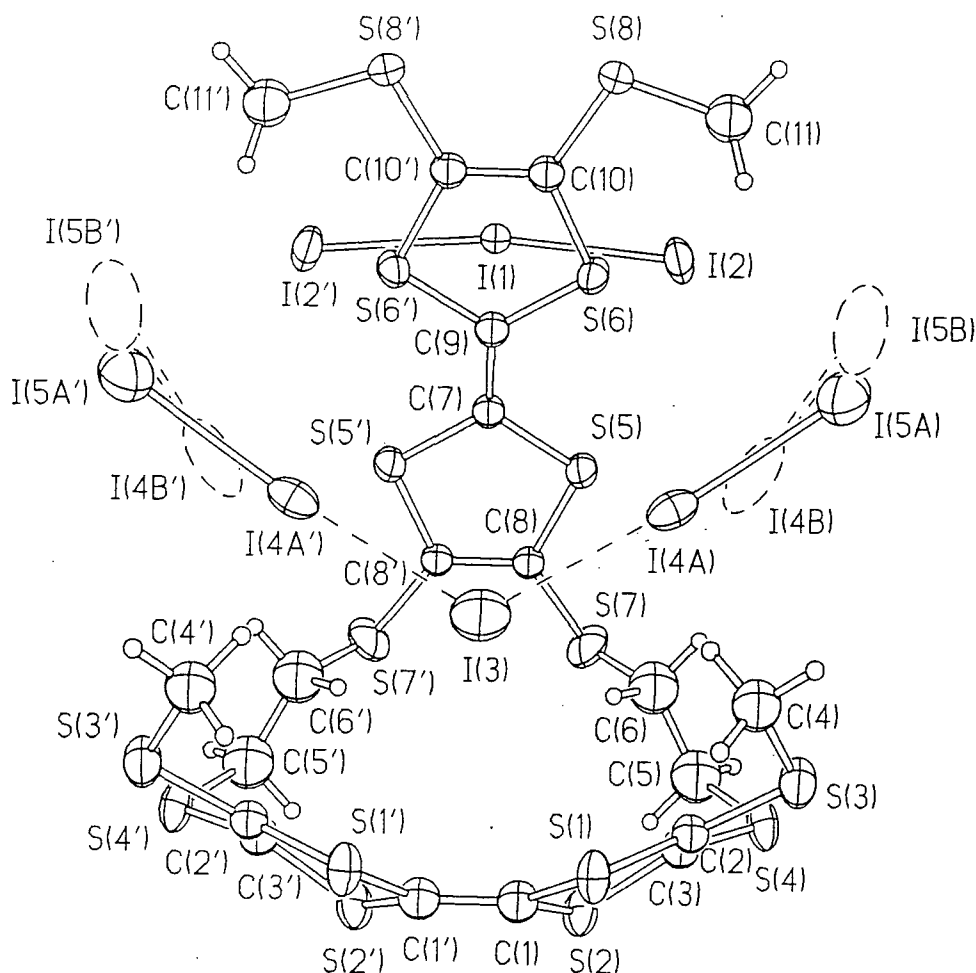

Figure 3.6 Crystal structure of $156^+\cdot I_8^-$ showing one of the possible network patterns arising from two orientations of the I(4)-I(5) group.

3.6 SOLID AND SOLUTION STATE STRUCTURES OF TTF-PHANES

From the X-ray structures obtained of the new *bis*TTF derivative **156** it has been shown to possess a distorted structure (arising from the short bridges between the two TTF moieties) and to exist as only one isomer, the *cis*, out of a possible mix of *cis/trans* structures. It yields cation radical salts in which the less-restricted TTF unit (TTF **A**) is oxidised or partially oxidised, while the more buckled TTF (TTF **B**) remains neutral.

The buckled structures observed both in the tethered TTF **B** and the unstrained TTF **A** are of special interest as to date a full systematic description of the conformational states of TTF both in oxidised and neutral species and the effects of distortion on its electrochemistry has yet to be undertaken.

The distortion of the TTF ring in this, and in most cases, is not a simple two-dimensional bending but a combination of folding along several different vectors to give a buckled structure. However a simplified semi-quantitative idea of the size of distortion is the value of the angle θ (Figure 3.7).

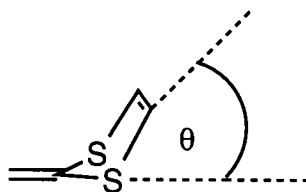

Figure 3.7 Definition of bending angle θ .

The planarity of TTF as a highly π -conjugated system has often been an *a priori* assumption of many researchers, based on the planar structures of both polymorphs of unsubstituted TTF in the solid state.¹⁶¹ However, in the gas phase, electron diffraction studies indicate a bent conformation with $\theta = 13.5^\circ$.¹⁶² Many neutral derivatives of TTF with distorted structures are known which are not constrained within macrocyclic environments. Examples such as TTFC(O)NMe₂⁴⁶ where distortion is a purely electronic effect arising from the interaction between the HOMOs of the TTF molecules where they associate as dimeric species in the solid state. Such interaction may occur *inter* or *intra* molecularly, examples of the latter may occur in multi TTF species linked via a covalent bond or a directly conjugated linkage. For example, in TTF-Te-Te-TTF **31b**⁶⁸ one TTF is buckled with θ values of 13-19° while the other remains planar.

Several structures of distorted TTF macrocycles are known from the literature,^{153, 154, 163} most of them involving TTFphanes or cage structures with short linking chains. Contrary to the popular belief of TTF as a rigid molecule, *ab initio* calculations¹⁶⁴ have shown that although the energy minimum for an isolated molecule is indeed a planar structure, the energy cost of folding both dithiole rings to $\theta = 5^\circ$ is practically zero (0.016 kcal mol⁻¹) and those for $\theta = 10, 15,$ and 20° are also relatively small (0.1, 0.4, and 1 kcal mol⁻¹) respectively. Thus TTF although favouring a planar conformation possesses a high degree of flexibility and mechanical deformation within a macrocyclic structure does not necessarily carry a high thermodynamic penalty. The distortion often leads to the predominance of the *cis* bridging structures due to the smaller amount of transannular ring strain. Alternatively, where a *cis/trans* mixture is obtained, separation of the isomers may be achieved by fractional crystallisation. To date, there have been no examples where TTF isomers have been separated chromatographically.

3.7 ELECTROCHEMISTRY OF NEW *BISTTFS*

The classical description of TTF as an electron rich olefin is a good approximation, as the TTF HOMO is heavily localised on the central C_2S_4 moiety. Folding of the dithiole rings disrupts the extended π -system and enhances this localisation still further. In agreement with this description, oxidation potentials of strongly bent bridging TTF derivatives are higher than the parent undistorted analogues.

In systems with more than one TTF unit the picture is complicated by the possibility of through-bond, or through-space interactions between the TTF moieties. Typically, this can result in the lowering of the first oxidation potential by the formation of a sandwich structure for the stabilisation of the monocationic species with the unoxidised TTF sharing electron density with the cationic species.⁵⁴ The formation of the second radical cation also occurs at a higher potential (typically 100-150 mV) due to coulombic repulsion between the two positively charged centres.

Analogously, the donation may occur from other electron rich species, for example, the oxidation potentials of macrocycle **184**^{163g} occur at 0.27 and 0.57 V despite its highly strained structure. This anomalous result has been explained by a stabilising interaction between the pyridine lone-pairs and the TTF radical cation. A similar effect was proposed for the relatively low oxidation potentials of *cis/trans* **185**¹⁶⁵ with the diphenylmethane moiety acting as a donor.

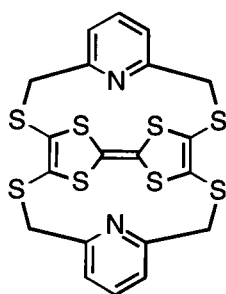

184

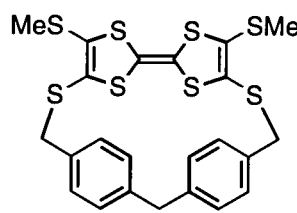

185

Robert *et al.*^{83,154} have shown for systems such as **145** and **146** where an isomerically pure bridged TTF is obtained, isomerisation can occur upon one-electron oxidation. TTFs **145** and **146** which are obtained as pure *trans* isomers, when oxidised electrochemically, undergo a rapid isomerisation to the *cis* forms. This isomerisation was observable in the CV and was confirmed by the presence of the *cis* isomer in electrocrystallised salts of *trans* **145** and **146**. This same effect has been observed by Otsubo *et al.*,⁸⁴ upon electrocrystallisation of the *cis/trans* isomer of tetrathiafulvalenophane **48**. X-ray characterisation of the ClO_4^- salt of **48** revealed that an isomerisation had occurred to give the *trans/trans* isomer. Similarly, Becher *et al.*¹⁶⁵ showed that starting from isomerically pure *cis* or *trans* **185**; upon oxidation to the

cation radical a rapid chemical isomerization occurred to give *cis/trans* mixtures which could be observed in the CV by repeated cycling of the potential.

Our systems which had been obtained isomerically pure, could therefore, potentially, undergo conformational change upon electrochemical oxidation, which should be detectable either in the cyclic voltammogram or upon salt formation.

Cyclic voltammetry of **156** in DCM/MeCN revealed four sequential oxidations. However, due to an absorptive process at the working electrode it was not possible to determine if these oxidations were truly reversible. Changing the solvent to PhCN lead to the coalescence of the final two oxidation waves to give, two, reversible, one-electron oxidations at 0.57 and 0.70 V followed by a reversible, two-electron oxidation at 0.80V. The four, sequential, one-electron oxidations were revealed more clearly by the DPV in DCM/MeCN (Figure 3.8).

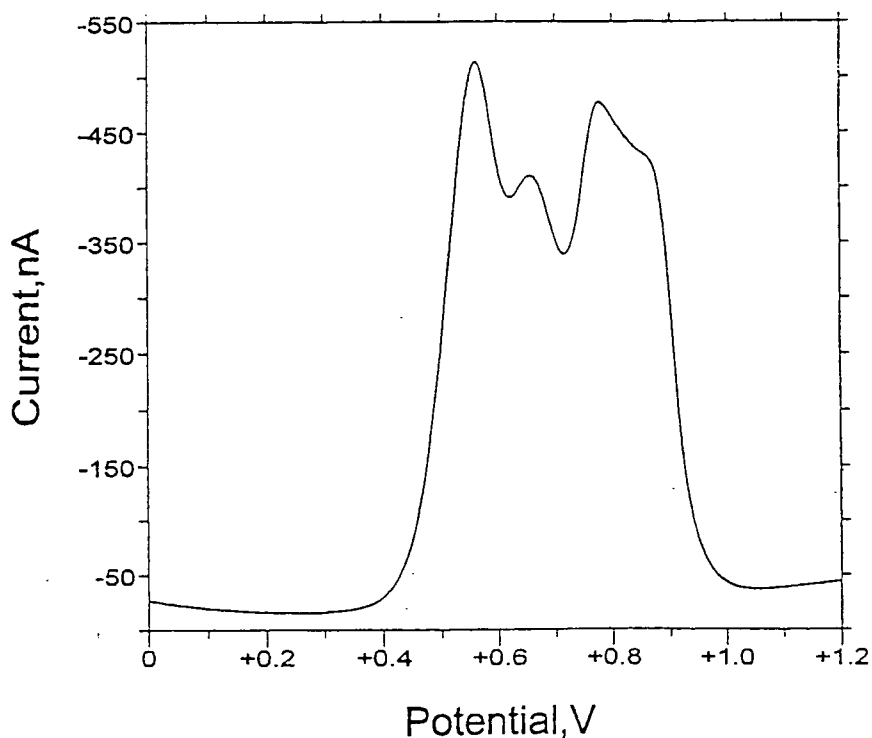

Figure 3.8 DPV of **156**, platinum electrode, electrolyte: $n\text{-Bu}_4\text{NClO}_4$, (0.01 M), $\text{CH}_2\text{Cl}_2/\text{MeCN}$, 20°C , values measured in volts relative to Ag/AgCl , and corrected to Me_{10}Fc .

This result is consistent with no significant interaction occurring between the charged states of the two TTF units. The oxidation waves at $E_1^{\text{ox}} = 0.56$ and $E_3^{\text{ox}} = 0.77$ V are assigned to the consecutive one-electron oxidations of the 4,5-disubstituted (unstrained) TTF unit **A**, with the corresponding waves for the 4,4'-disubstituted (strained) TTF unit **B** occurring at the higher potentials $E_2^{\text{ox}} = 0.66$ and $E_4^{\text{ox}} = 0.86$ V, with the anodic shift caused by the bending of the TTF unit. *Bis*TTF **157** displayed

three, reversible redox waves at 0.56, 0.67 and 0.77 V by CV, while *bis*TTF **158** displayed two reversible waves at 0.48 and 0.74 V; similar to **157**, *bis*TTF **160** displayed three reversible waves in its CV; the first broad oxidation wave gives two poorly resolved oxidations at 0.49, 0.56, (in the DPV these first two oxidations coalesce) and a third well defined wave follows at 0.79 V. The CV for TTF **183** with the bridging dithiole, showed two reversible oxidation waves at 0.65 and 0.82 V, followed by an irreversible oxidation at 1.25 V corresponding to the oxidation of the 1,3-dithiole-2-thione moiety. Table 3.1 gives the oxidation potentials of our TTFphanes as measured by DPV for comparison.

Compound	E_1^{ox}	E_2^{ox}	E_3^{ox}	E_4^{ox}
156	0.56	0.66	0.77	0.86
157	0.54	0.69	0.78	-
158	0.46	0.72	-	-
160	0.50	0.77	-	-
183	0.64	0.83	1.27	-

Table 3.1 Oxidation potentials of TTF-phane derivatives, platinum electrode, vs. Ag/AgCl, electrolyte: n-Bu₄NClO₄, (0.01 M), CH₂Cl₂, 20°C.

Overall, compound **156** is the hardest to oxidise, with the oxidation assigned to the most strained TTF unit appearing at 0.86 V. Compound **157** is marginally less difficult to oxidise with the first two, one-electron oxidations at 0.54 and 0.69 V similar to **156** and the two-electron wave at 0.78 *ca.* 90 mV less than E_4^{ox} of compound **156**. The DPV data for compound **183** allow us to compare the contribution from the bent TTF moiety in isolation; the two, one-electron oxidations at 0.64 and 0.83 V when compared with those of the bent moiety in **156** of 0.66 and 0.86 V show, as expected, a slight decrease in oxidation potential due to reduced ring strain (it is reasonable to assume that the value of θ in **157** is similar to **183**, but the contribution of the strained moiety is not resolved in either the CV or DPV). Compounds **158** and **160** both show slightly lower first oxidation potentials than either **156**, **157** or **183**.

We have assumed that interactions between the two TTF units are minimal and hence each oxidation wave is assignable to each subunit as if it were in isolation. The classical orientation for maximum orbital overlap between two TTF moieties is the so called "ring over bond" overlap which requires the two TTFs to be parallel. In the case of **156** due to the short bridging ethyl chains this is not possible, and it is unlikely to occur in **160** due to the rigid benzylic linkages. For compounds such as **157** and **158** some interactions may be possible due to the longer, more flexible linkages. Similar results were observed in the criss-cross TTF-phanes of Otsubo⁸⁹ and Sugawara,⁹⁰ where

longer chain lengths resulted in the appearance of multiredox phenomena. It was proposed that the flexible chains could allow one TTF unit to swivel and thus stabilise the radical cation generated on the other. In our case, such interactions may be responsible for the lowered first oxidation potential in the CV of our more flexible analogue **158**. For **160** donation from the benzene rings may be responsible for the slightly lower first oxidation potential. The possibility that the splitting observed in compounds **156**, **157**, and **160** is due to simple coulombic interactions cannot be ruled out.

In contrast with the results of Robert^{83,154} and Becher¹⁶⁵ no isomerisation of **156** or **183** was observed in solution as monitored by NMR; similarly, no isomerisation was observed by CV despite repeated cycling and varying scan speeds.

3.8 SPECTRAL CHARACTERISATION OF DISTORTED TTF SYSTEMS

One consequence of the distortion of the TTF unit when it is constrained in macrocycles is the gradual destruction of the TTF chromophore as the extended π -system is disrupted. TTF compounds are typically bright orange or yellow colours depending on substituents. However, compounds such as **150** and **184** which are amongst the most distorted TTFs known, are colourless or very pale yellow substances indicating that such systems are electronically very different from planar (or near planar) TTF compounds. To date there exists very little UV data on strained TTF compounds, which is often due to the high insolubility of these materials. In general, the more distorted the TTF becomes, λ_{max} will move to shorter wavelengths reflecting the reduction in π -delocalisation.¹⁶ In the case of our *bis*TTFs the presence of contributions from both the strained and unstrained TTF moieties means no definite conclusions can be drawn from the UV spectra.

A more empirical test of the degree of bending in a TTF compound was proposed by Müllen *et al.*¹⁶⁶ who demonstrated that distortion of the TTF unit caused a notable downfield shift of the central fulvalenic carbons. Otsubo *et al.*^{89b} have tabulated the results for his series of TTF-phanes and has demonstrated the direct correlation between this downfield shift and the degree of distortion of the TTF unit. In the case of our distorted systems the overlap between the ¹³C resonances of the two TTF moieties means no such assignment can be attempted.

3.8.1 TRISTTF-PHANES AND BEYOND

With the current advance in TTF chemistry it is now synthetically possible to achieve systems beyond the simple *bis*TTF cyclophane structures discussed here. Both

Becher¹⁵⁶ and Otsubo⁸⁶ have synthesised *tris*TTFphanes of structures **186-188** which contain the "edge-to-face" orientation seen in **156**, although no crystal structures or conducting salts have been reported.

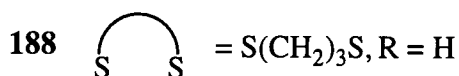
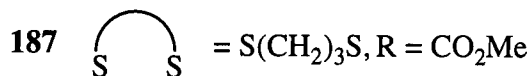
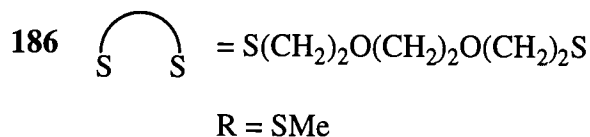
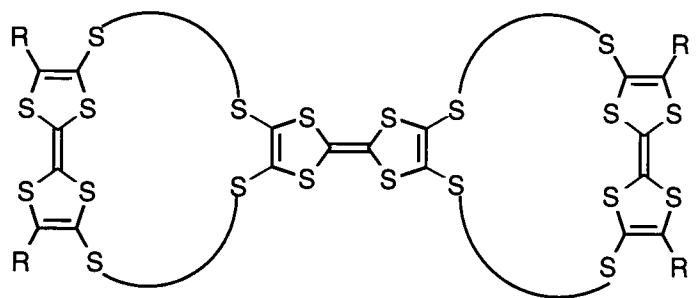

In theory, the iterative, protection-deprotection-alkylation sequence can be used to build up large arrays of interconnected cyclophane molecules, the most spectacular example of this is the synthesis of a so-called TTF molecular ribbon **189** by Becher *et al.*¹⁵⁶

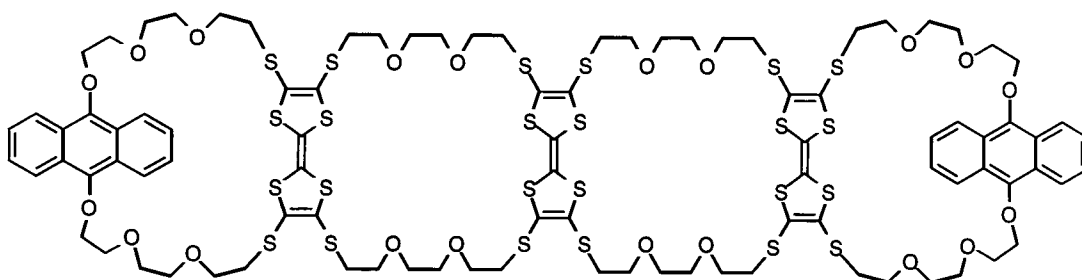

189

3.9 CONCLUSIONS

In summary, we have synthesised a new series of *bis*TTF derivatives **156-160**. **156** has been shown to possess a distorted structure arising from the short bridges between the two TTF moieties. It yields cation radical salts in which the less restricted TTF unit is oxidised, or partially oxidised, while the more buckled TTF unit remains

neutral. The perchlorate salt of **156** is one of the few salts of TTF cyclophanes to display a uniformly stacked structure and to display electronic conductivity. This salt provides a remarkable example of the propensity of partially oxidised TTF systems to form ordered stacks even when carrying bulky substituents (in this case another TTF unit).

While the distorted structure of one of the TTF moieties in **156** seems to preclude its participation in charge transfer salts, it is possible that other less strained analogues could form salts with both TTF units participating with the possibility of new multidimensional networks in the solid state.

Chapter Four

Molecular Cavities Incorporating TTF

4.1 INTRODUCTION: The Use Of TTF In Host-Guest Chemistry

While the use of cyclophane derivatives of TTF as donors for organic conductors is a new and burgeoning field of research; their use as redox-active receptors or "hosts" in the supramolecular sense is still in its infancy. Stoddart *et al.*,¹⁶⁷ showed that the charge-transfer interaction between TTF and bipyridinium cations could be used as a template for the self-assembly of complex rotaxanes and catenanes. Subsequently, Becher *et al.*,¹⁶⁸ have developed the chemistry of sulfur-substituted TTFs which can be selectively and sequentially deprotected and alkylated in high yields, to synthesise a series of macrocyclic multi-TTF systems. Many of these systems were designed primarily to serve as hosts for catenanes constructed with the π -electron accepting cyclophane cyclobis(paraquat-*p*-phenylene). Representative examples of these systems are illustrated below, **190-191** (Figure 4.1).

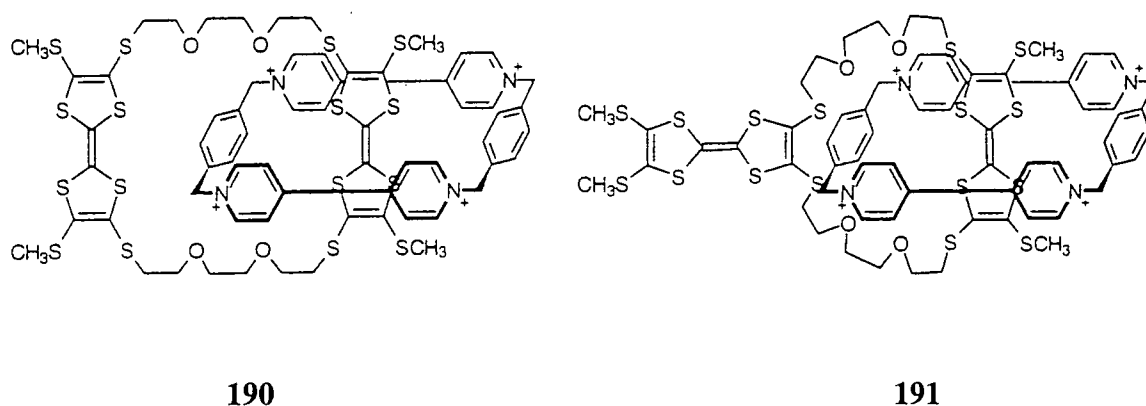

Figure 4.1 Catenanes incorporating TTF macrocycles.

The logical development of these systems is to move from open structures such as **190-91** to closed macrocyclic structures; *i.e.*, "bowl"- or "cage"-shaped molecules. The use of three-dimensional structures as hosts in supramolecular chemistry is a topic of much current interest,¹⁶⁹ with the work of Cram and Vögtle especially contributing much to this area.¹⁷⁰ The incorporation of redox active groups into systems such as these is still largely unexplored.¹⁷¹ The use of TTF or ferrocene as electronic sensors for metal cations has been demonstrated by several groups,¹⁷²

usually by attaching pendant crown ether or cryptand groups to the redox active moiety.

TTF has also been covalently attached to host systems such as β and γ -cyclodextrin¹⁷³ but no binding studies have yet been reported. However, the use of charge-transfer interactions of the TTF moiety to regulate binding of an electron-deficient guest has received scant attention. Such charge-transfer interactions may enhance not only the inclusion ability but also the specificity of host molecules. Systems of this type can, in principle, be designed to signal electrochemically the binding of any charged or neutral guest. Oxidising and reducing the TTF units *in situ* should have significant effects upon binding ability and may even lead to direct control over the mode of action of the receptor cavity, with binding and expulsion of the guest under electrochemical control. The use of supramolecular host systems as catalysts for reactions is a subject of much current interest;¹⁷⁴ the recent use of TTF as a radical transfer reagent by Murphy *et al.*¹⁷⁵ raises the possibility that such chemistry may be performed inside redox-active hosts incorporating TTF.

4.2 HOST SYSTEMS INCORPORATING TTF

A small number of examples of TTF macrocycles designed as host systems are known. The *bis*TTF system **26** synthesised by Sugawara *et al.*^{62, 63} adopts a U-shaped conformation in its neutral state,^{62b} with the cavity thus formed filled by another molecule of the twin donor.

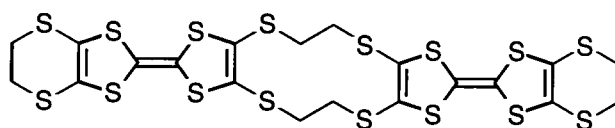

26

Theoretical calculations showed that due to the flexible nature of the ethyl bridging groups, inclusion complexes with planar molecules of about 3.5 Å and spherical molecules of about 10 Å diameter were possible. It was noted that the cavity size in well documented host systems such as γ -cyclodextrin is *ca.* 9-10 Å.

As expected, **26** formed an inclusion complex with the planar organic acceptor DDQ.^{62b} The crystal structure of the complex showed that the DDQ penetrated deeply inside the donor cavity formed by the two TTF units (Figure 4.2a).

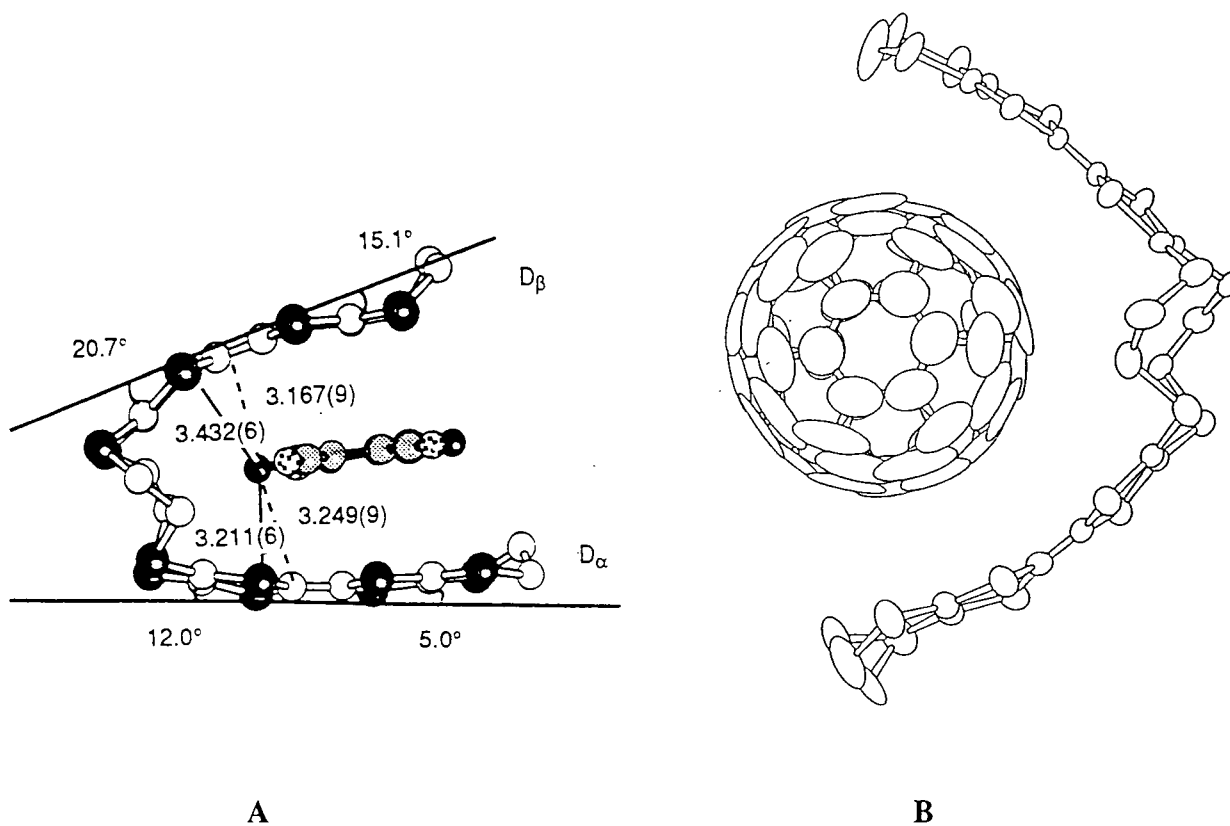

Figure 4.2 Complexes of Donor **26** with a) DDQ; b) C₆₀.

An X-ray study^{62a} of the complex **26**·C₆₀ revealed that C₆₀ is included within the cavity of the donor molecule (Figure 4.2b). Due to the flexibility of the linker groups the volume of the cavity is larger than that in the uncomplexed **26**.

Several analogues of *bisdonor* **26** have been synthesised.^{64, 65} For example, a polyether analogue of **26** was synthesised by Becher *et al.*⁶⁴ which gave a charge-transfer complex with polyiodide anions but no inclusion complexes have yet been reported.

The criss-cross overlapped tetrathiafulvalenophanes synthesised by Otsubo⁸⁹ and Sugawara⁹⁰ (mainly with the aim of preparing new organic conductors and superconductors), also displayed some inclusion ability. Due to the short linkers the cavity formed is small and the TTF units are distorted, but in the homologue with a five carbon linkage **54d**, a more open structure is obtained. The crystal structure of neutral **54d** revealed the inclusion of a molecule of chloroform within the cavity. The salt of **54d**·Br shows the inclusion of a molecule of ethanol within the cavity.

Becher *et al.*⁹¹ synthesised the diethyleneglycol analogue of this system **55** with the aim of preparing a larger cavity which would allow complexation of cyclobis(paraquat-*p*-phenylene). The crystal structure of the neutral twin-donor reveals an inclusion complex with a molecule of chloroform occupying the cavity (Figure 4.3). The formation of the catenane proceeded easily to form the complex with the paraquat units threading through the cavity thus formed between the two TTF moieties.

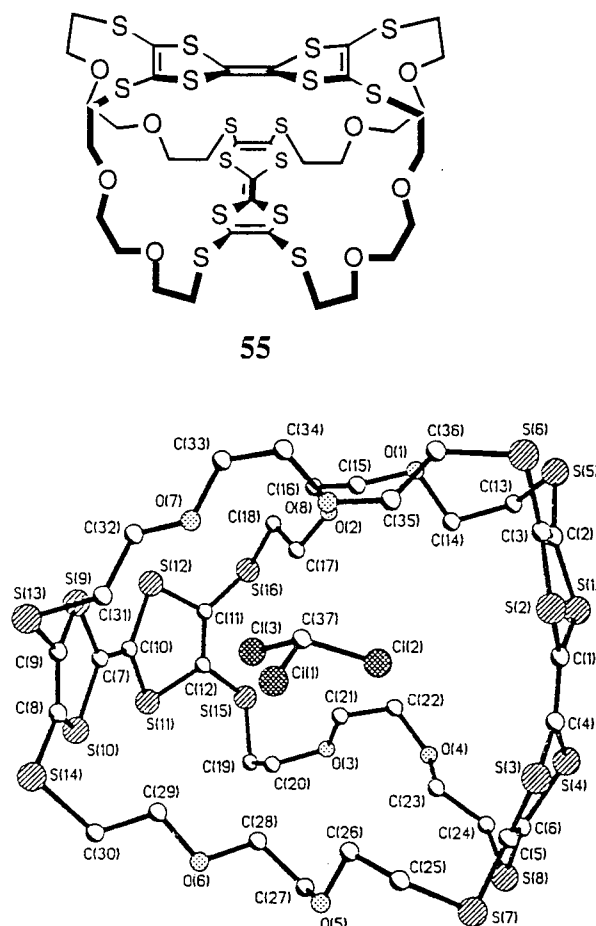

Figure 4.3 Crystal structure of **55** showing inclusion of a molecule of chloroform.

A series of macrocyclic *tris*TTFs of types **192a-d** and **193a-d** (Figure 4.4) have been synthesised by Becher *et al.*¹⁷⁶ Although both molecules display attractive cavities when modelled, for **192a-d** the presence of *cis/trans* isomers leads to several isomeric structures with the TTFs pointing away from the cavity. The more rigid structures of **193a-d** do not display this problem, but the TTF moieties are not now directly involved within the molecular cavity formed.

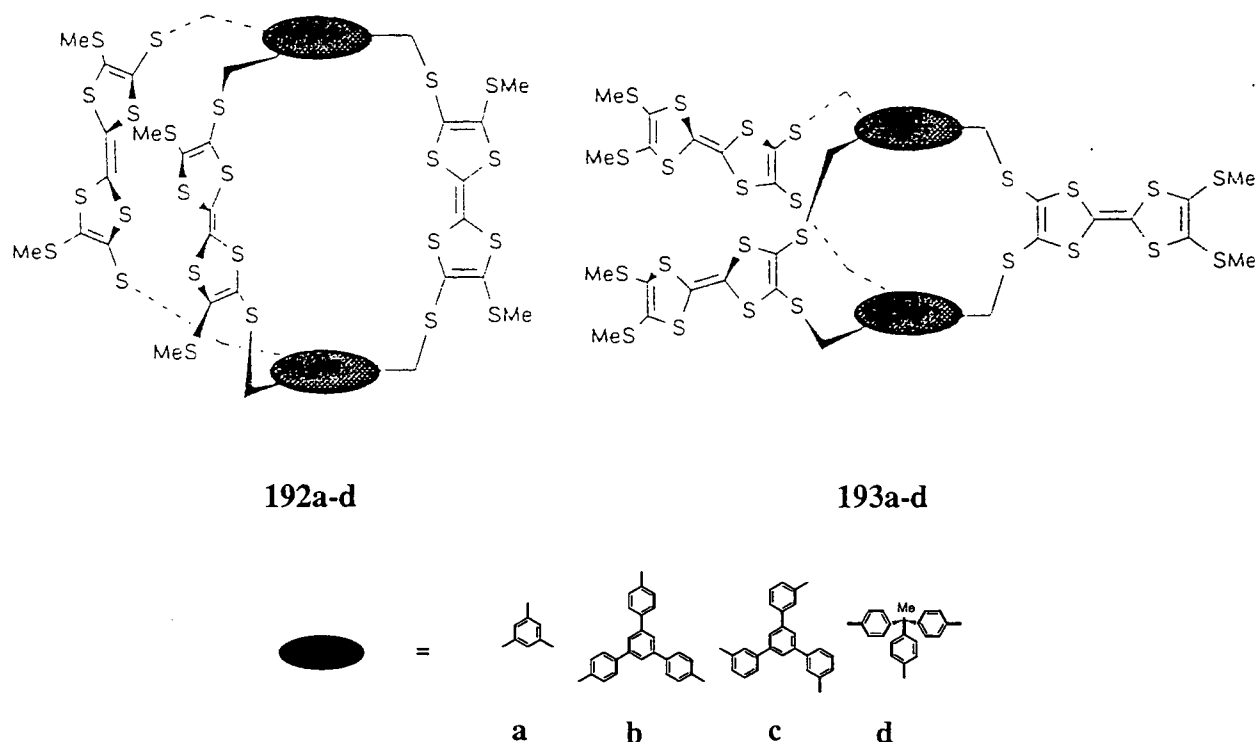

Figure 4.4 Triply bridged TTF macrocycles.

4.2.1 Guest Molecules

Suitable guest molecules for TTF-based receptors should take advantages of the ability of TTF to form complexes with many different organic electron acceptors and also with some neutral molecules such as nitrobenzenes.¹⁷⁷ Recently, Stoddart *et al.* published the crystal structure of the complex between TTF and cyclobis(paraquat-*p*-phenylene)¹⁷⁸ in which the TTF moiety is encapsulated within the cavity between the two bipyridinium acceptors by strong charge-transfer interactions (Figure 4.5).

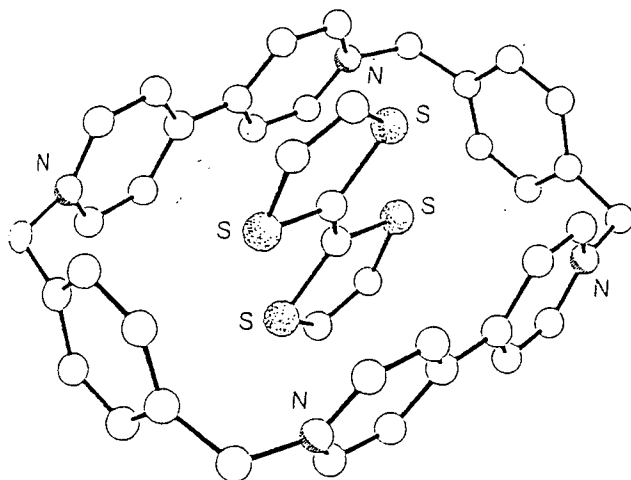

Figure 4.5 Complex of TTF with cyclobis(paraquat-*p*-phenylene).

In solution, this complexation constant was measured to be of the order of $2600 \text{ dm}^3\text{mol}^{-1}$.¹⁷⁹ Becher *et al.* have used this interaction in the synthesis of an unusual directly linked TTF-cyclobis(paraquat-*p*-phenylene) system¹⁸⁰ which functioned as a molecular switch, as complexation and decomplexation could be controlled by heating or cooling a solution of the molecule. Using TTF macrocycles to encapsulate bipyridinium derivatives is a methodology utilised by both Becher and Stoddart in the self-assembly of catenanes and rotaxanes.

Another guest molecule of topical interest, C_{60} , possesses few of the features usually targeted for molecular recognition; it possesses no hydrogen bonding sites and is a neutral species. For efficient complexation, a very precise steric fit is needed to maximise the weak π - π stacking and Van der Waals interactions between a host molecule and C_{60} . Modified calixarene derivatives¹⁸¹ are typical of the molecules reported to act as hosts for C_{60} ; being bowl shaped, with aromatic moieties capable of interacting with the π -system of C_{60} .

The highest binding constants measured in solution for a calixarene derivative are *ca.* $2120 \text{ dm}^3\text{mol}^{-1}$.¹⁸² C_{60} is a redox active species and up to six, one-electron reductions have been observed in solution.¹⁸³ Photo-induced charge transfer has been observed between C_{60} and various donor molecules including TTF in solution.¹⁸⁴ In the complex between C_{60} and **26** and between C_{60} and BEDT-TTF **5**¹⁸⁵ weak charge-transfer bands have been observed in the UV spectrum which gives rise to the possibility that receptors containing the TTF moiety may display a greater affinity for C_{60} than the calixarene receptors.

4.3 SYNTHESIS OF TRISTTF MACROCYCLES

The synthesis of the series of cyclic TTF oligomers **197-199** by Becher *et al.*¹⁵⁷ was a logical extension of the work of Sugawara.^{62, 63} CPK models of **197** and higher analogues revealed that one possible conformation is a calix-type geometry or bowl shape. The linking groups were predicted to be flexible enough to allow a number of different cavity sizes to be accommodated. Derivatives with $n = 1, 2,$ and 3 and analogues with pendant hydroxyethyl group substitution were synthesised (Scheme 4.1). The rationale behind the hydroxy groups was the possibility of intramolecular hydrogen bonding which may give a more rigid structure to the macrocycle. Unfortunately, no crystals of a suitable quality for X-ray determination were obtained so the size and nature of the cavity formed remained conjectural.

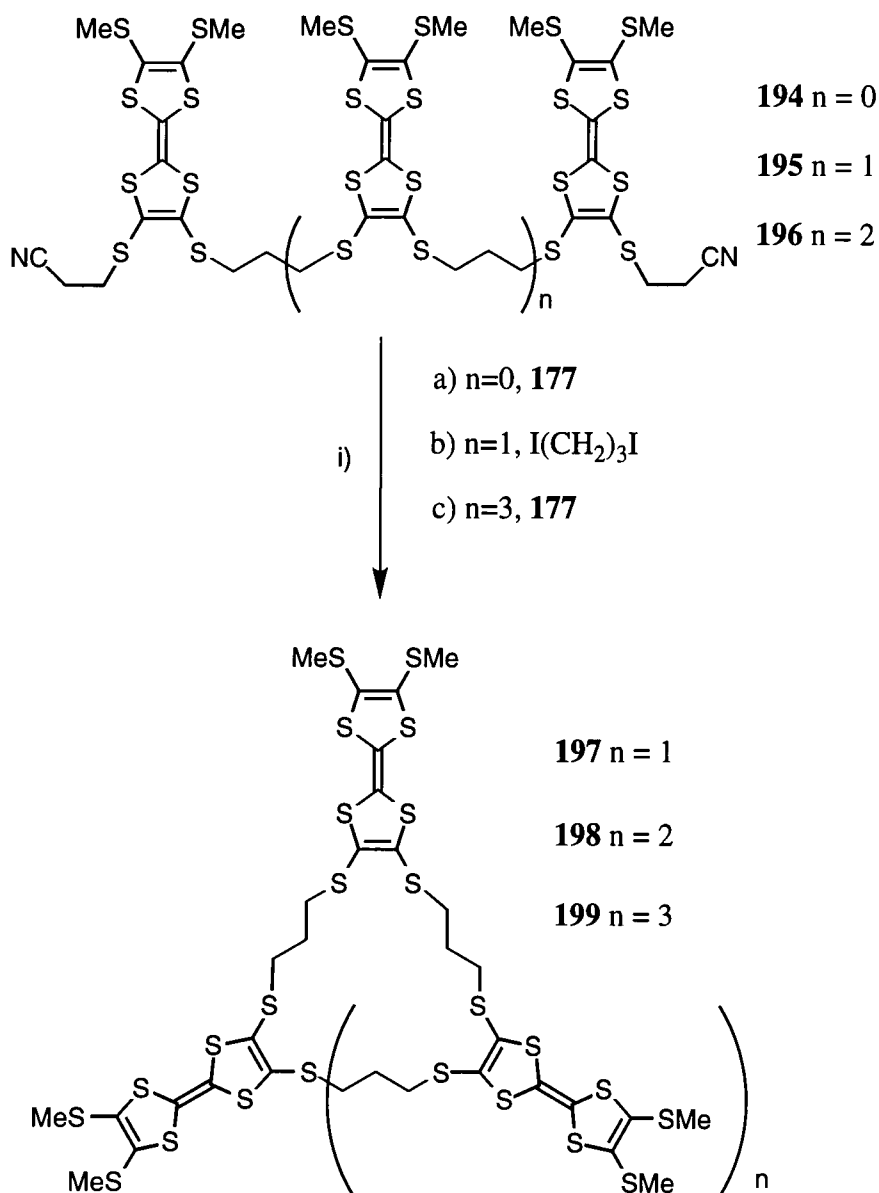

Scheme 4.1 Reagents and conditions: i) CsOH (2 equiv), DMF, (a, b, or c), high dilution.

The synthesis of more rigidly linked systems was the next modification of this series which we undertook. The bisalkylating TTFs **176** and **179** (whose synthesis was discussed in Chapter 3) seemed ideal building blocks. The replacement of the propylene units with aromatic systems or ethylene units should give more rigid macrocycles which it was hoped would facilitate crystal structure determination and elucidation of the solid state conformation of these systems.

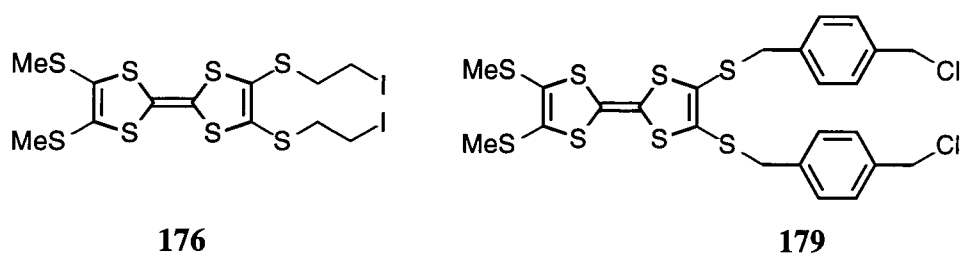

Following the procedure of Becher, formation of the *bis*TTFs **200** and **201** proceeded smoothly and in good yield, although characterisation of **201** was hindered by its low solubility in common solvents (Scheme 4.2). Reaction of **200** and **201** with **179** and **176** respectively, under high dilution conditions yielded the macrocyclic *tris*TTFs **202** and **203** in 77% and 73% yields, respectively (Scheme 4.3). These were readily purified from baseline impurities by a simple filtration through a plug of silica. The *tris*TTF macrocycle **203** was obtained as fine hairs which were sparingly soluble in chlorinated solvents; attempts to grow crystals suitable for X-ray analysis from a variety of solvents proved futile. *Tris*TTF **202** was isolated as a red oil which was soluble in a wide range of organic solvents but this material resisted all attempts at crystallisation.

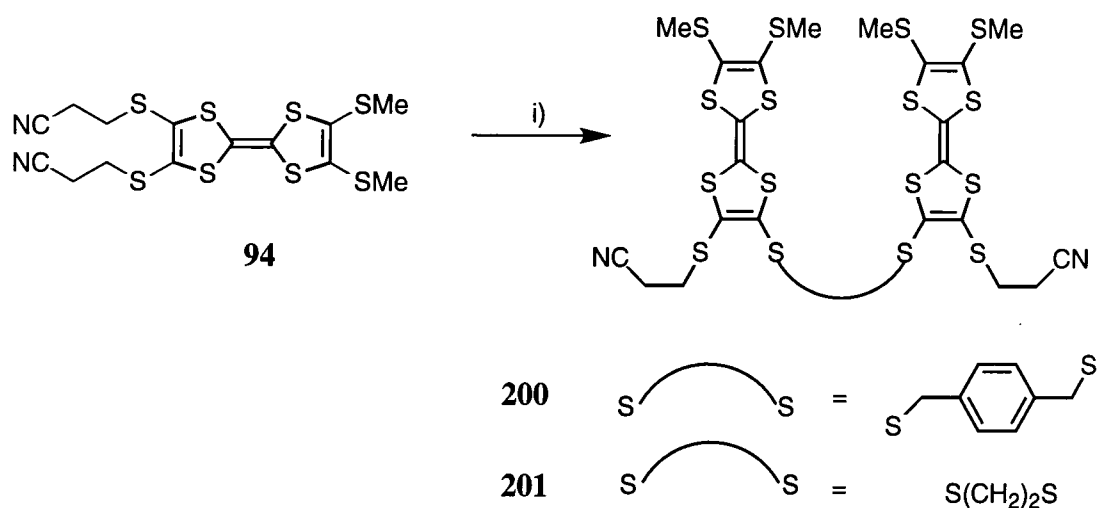

Scheme 4.2 *Reagents and Conditions* : i) CsOH (1 equiv), 1,2-dibromoethane or α,α -dibromo-*p*-xylene, DMF.

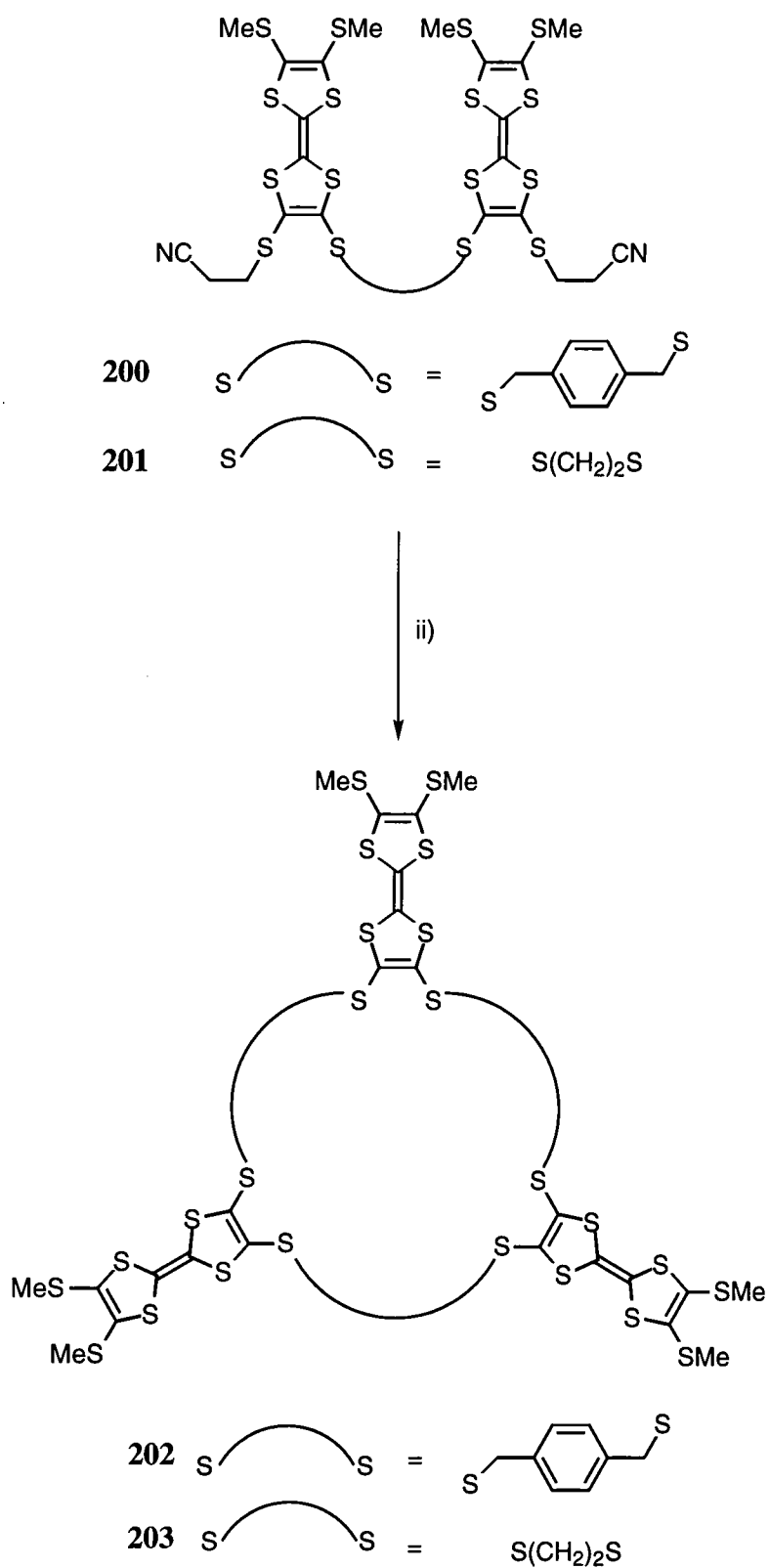

Scheme 4.3 *Reagents and Conditions* : i) CsOH (2 equiv), **176** or **179**, DMF, high dilution.

4.4 TRIPLE-BRIDGED CAGE MOLECULES CONTAINING TTF

In order to progress from bowl shaped molecules to more rigid cage-like species, it is necessary that three (or more) TTF moieties be linked together via a suitable trifunctionalised linker. Vögtle¹⁸⁶ has rationalised the synthesis of such triple-bridged cage molecules into a number of retrosynthetic pathways illustrated below, both convergent and linear (Figure 4.6).

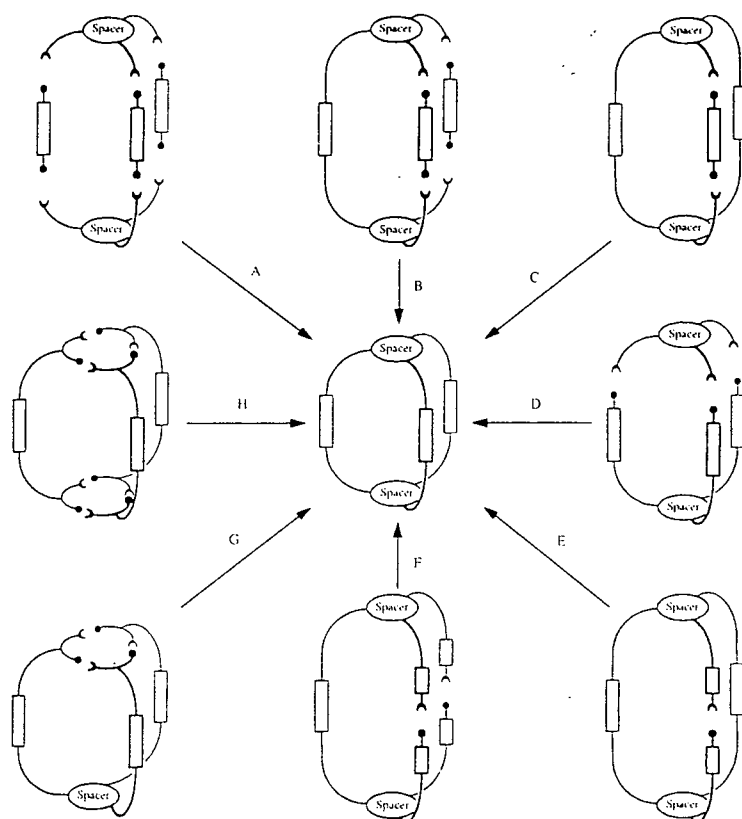
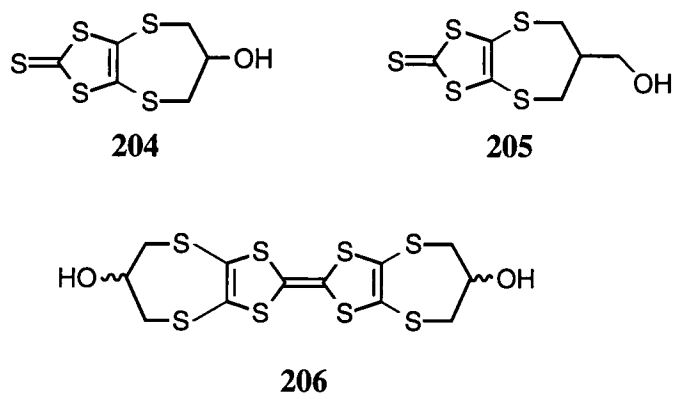

Figure 4.6 Retrosynthesis of triply-bridged macrocycles.

As the synthetic route to our *trismacrocycles* **202-203** was efficient and repeatable, route **D** seemed the approach most likely to give results. The TTFs needed to be functionalised appropriately to react with the trifunctionalised moiety used in the capping reaction.

The problem inherent in the cage systems synthesised previously by Becher *et al.*¹⁷⁶ is the occurrence of multiple *cis/trans* isomers, which will always arise if the TTFs are unsymmetrically functionalised. Hence, hypothetical structures like **192** as formed from the reaction of a trithiolate with a trialkylating cap will inevitably give a mixture of isomers, and such structures when modelled by CPK can adopt conformations with the TTFs pointing away from the cavity.

One solution to this isomer problem are the 1,3-dithiole alcohols **204** and **205** proposed by Bryce *et al.*¹⁸⁷ These were used to synthesise TTF systems such as **206**. Compound **206** has been shown to be a useful bifunctionalised TTF core and may be used as a building-block for more complex systems in which the problem of *cis/trans* isomers is undesirable.



For instance, Stoddart *et al.*¹⁸⁸ has used **206** as the basis for a rotaxane, while Becher and Sauvage have utilised it in the synthesis of a copper(I) catenane.¹⁸⁹

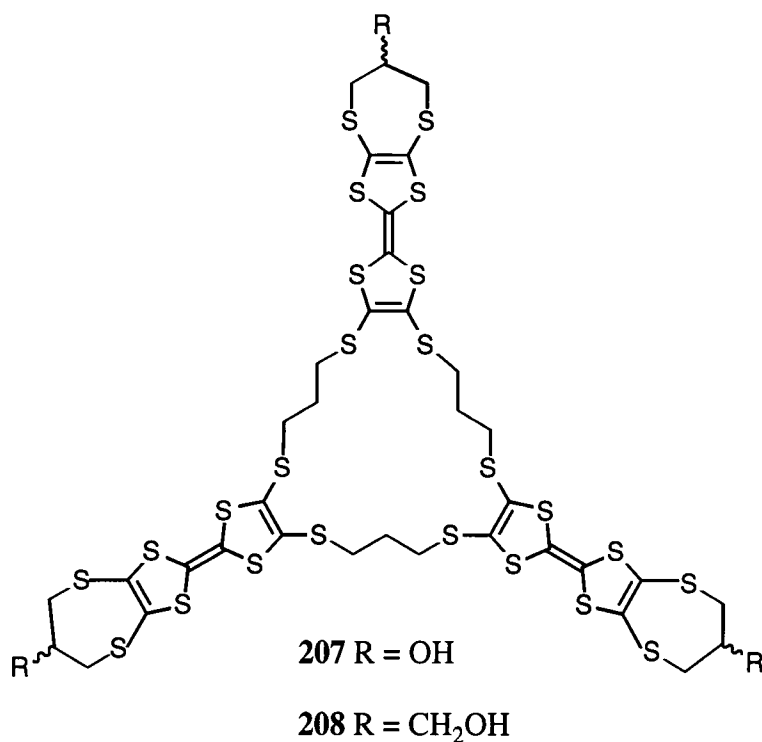

Alcohols **204-205** have been shown to react with a wide variety of electrophiles,¹⁸⁷ such as: acid and sulfonyl chlorides, isocyanates and chlorosilanes. Therefore, **204-205** seemed to be suitable precursors for our functionalised macrocycles. We envisaged that the macrocyclic *tris*TTF triols **207** and **208** should provide a system with suitable reactive handles which could be capped by reaction with a trifunctionalised species as shown in Scheme 4.4.

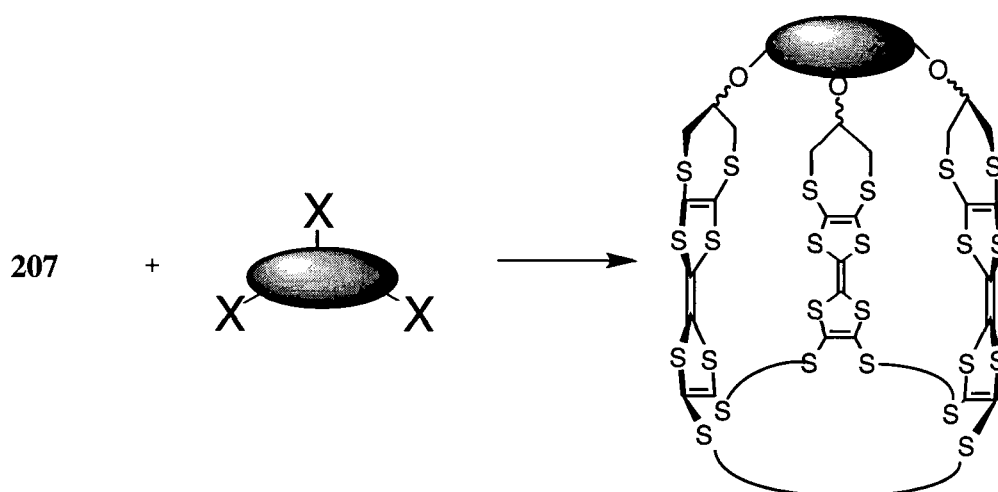

Scheme 4.4 Formation of triply bridged macrocycle by reaction of **207** with a suitable trifunctionalised species.

4.4.1 Synthesis

The synthesis of the alcohol **204** is accomplished via the reaction of zincate salt **72** with 1,3-dibromopropan-2-ol followed by chromatography to separate the alcohol from oligomeric byproducts,¹⁸⁷ or via the two step reaction of 1,3-dichloroacetone with zincate salt **72** followed by the reduction of the ketone **209** with sodium borohydride.¹⁹⁰ The second route is preferable as being more suitable to scale up and no chromatography is necessary at any stage (Scheme 4.5).

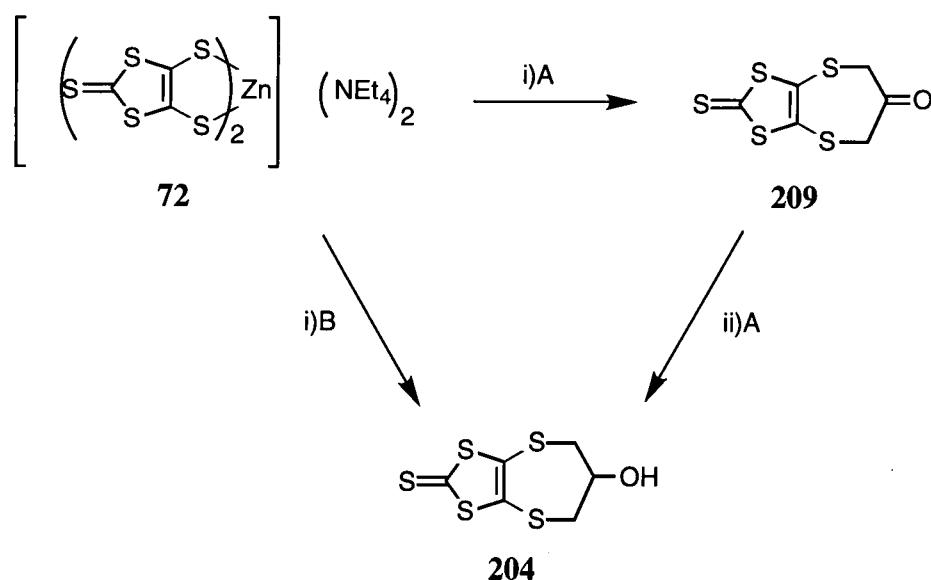

Scheme 4.5 Reagents and Conditions: **Route A**, i) 1,3-dichloroacetone, MeCN, reflux; ii) NaBH_4 , EtOH, 0°C ; **Route B**, i) 1,3-dibromopropanol, MeCN, reflux.

Reaction of 3-bromo-2-(bromomethyl)propan-1-ol **210** with zincate salt **72** in refluxing acetonitrile afforded alcohol **205** in 70% yield (Scheme 4.6). The starting 3-bromo-2-(bromomethyl)propan-1-ol **210** was prepared by borane reduction of commercially available 3-bromo-2-(bromomethyl)propanoic acid in 90% yield.¹⁹¹

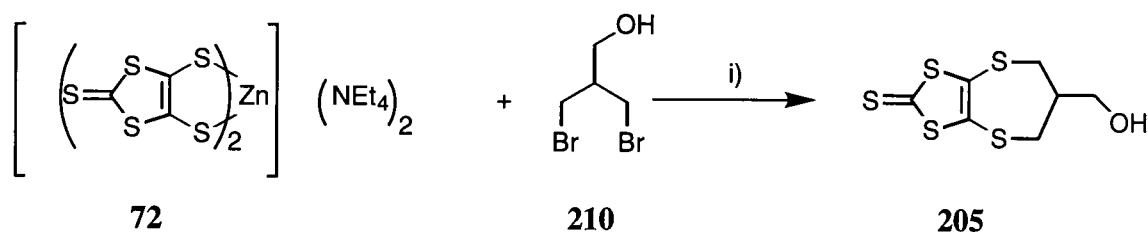

Scheme 4.6 Reagents and conditions: i) MeCN, reflux, 6h.

The alcohol functionality generally does not survive the conditions of the standard phosphite coupling reaction^{187,192} so **204** was protected as its diphenyl-*t*-butylsilyl ether **211** in 90% yield. Cross coupling of this with ketone **76** gave TTF system **212** in 56% yield as yellow needles (Scheme 4.7). However, all attempts to regenerate the parent alcohol **213** using tetrabutylammonium fluoride (TBAF) failed, giving intractable mixtures of products. We rationalised that either the TBAF or the alkoxide generated was basic enough to remove the cyanoethyl protecting groups. We considered retaining the silyl group until the end of the synthetic sequence but this was not favoured as products would most likely be either oils or gums.

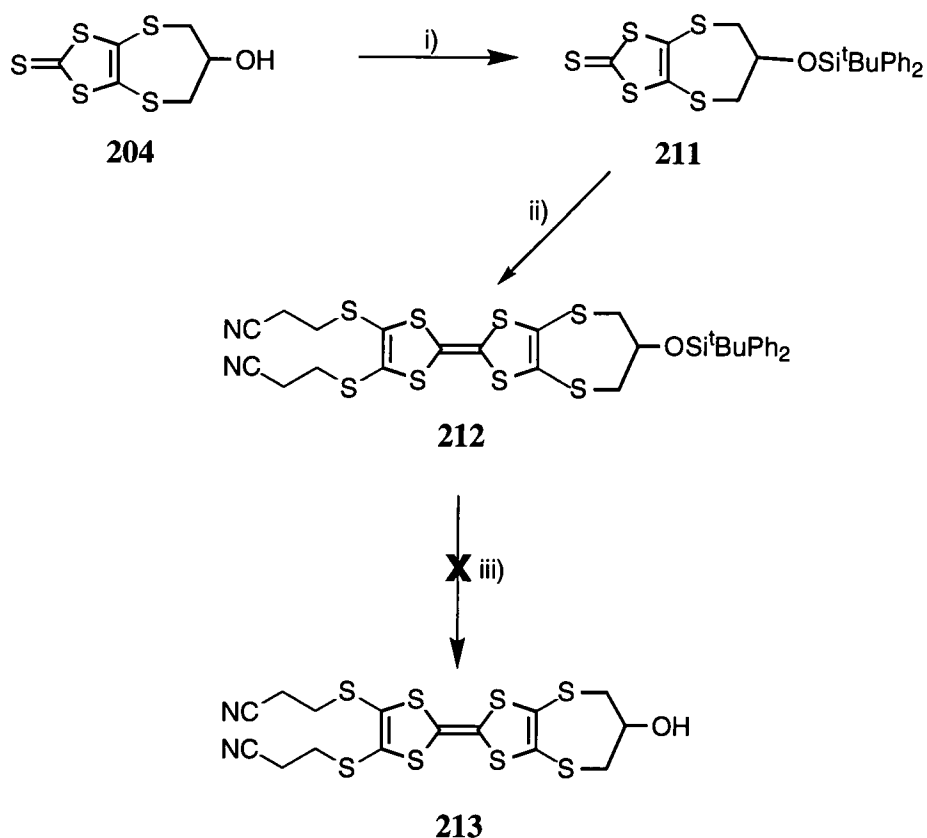

Scheme 4.7 Reagents and conditions: i) DMF, imidazole, $\text{Ph}_2\text{tBuSiCl}$, rt; ii) $\text{P}(\text{OEt})_3$, 110°C , 90 min; iii) TBAF, THF.

Instead, we returned to the parent alcohol **204** and protected it as the acyl derivative **214** by reaction with acetic anhydride in 86% yield. This could then be removed under acidic conditions thus avoiding competing deprotection of the thiolates. Cross-coupling of the acylated alcohol with **76** proceeded in 54% yield. Removal of the protecting group by refluxing with TsOH in EtOH proceeded smoothly in 87% yield to give **213**. Similarly, the primary alcohol **205** was acylated in 88% yield, cross-coupled to give **217** in 45% yield and hydrolyzed to give **220** in 94% yield (Scheme 4.8).

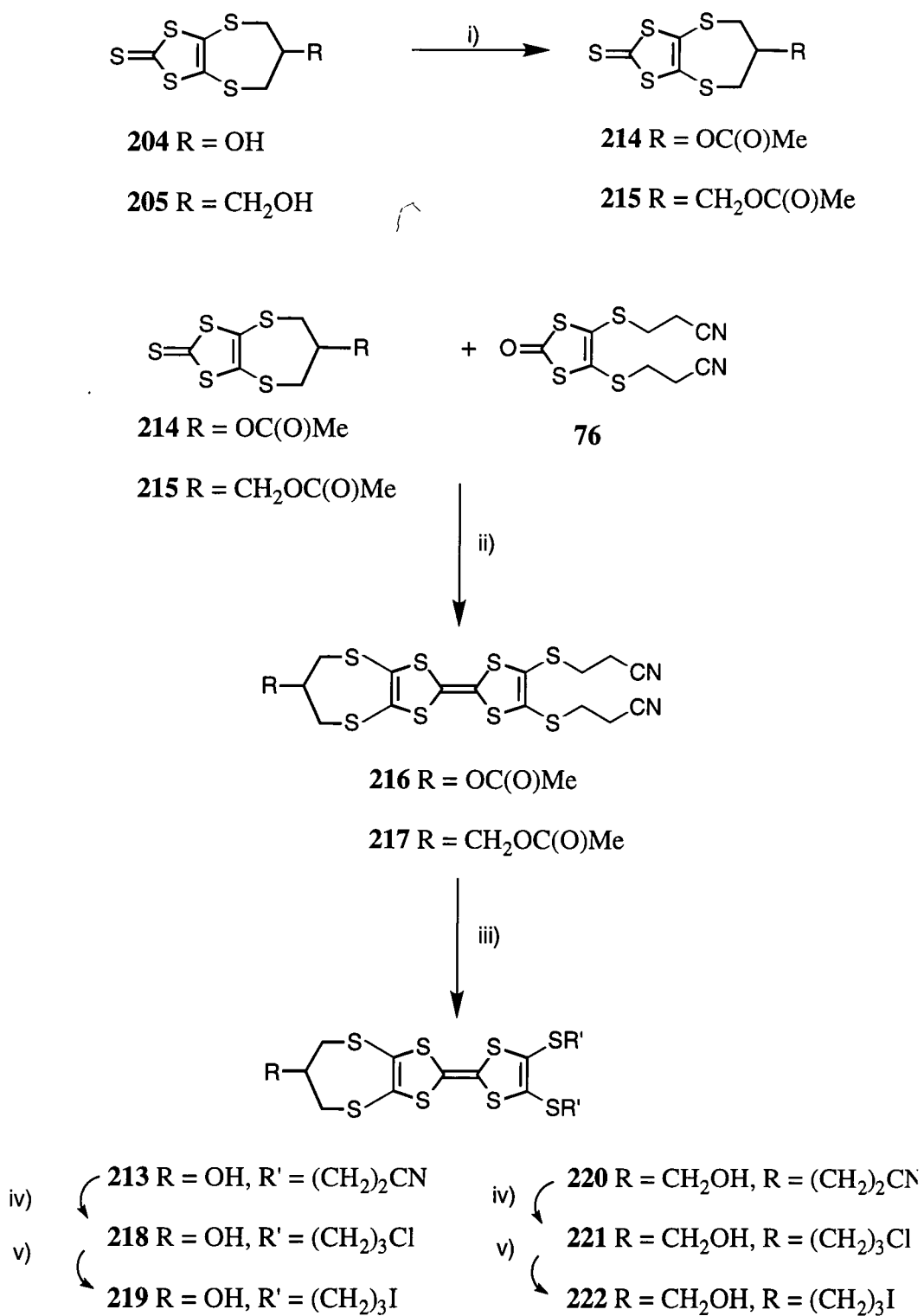

Scheme 4.8 Reagents and conditions: i) Ac₂O, pyridine; ii) P(OEt)₃, 120°C, 90 min ; iii) TsOH, EtOH, reflux, 16h; iv) CsOH, DMF, 1-bromo-3-chloropropane; v) NaI, acetone, reflux, 16h.

Deprotection of **213** and **220** with CsOH and alkylation with 1-bromo-3-chloropropane gave dichloro derivatives **218** and **221** in 81% and 75% yields respectively, treatment of which with NaI in refluxing acetone gave the diiodo compounds **219** and **222** via the Finkelstein reaction in 78% and 85% yields respectively.

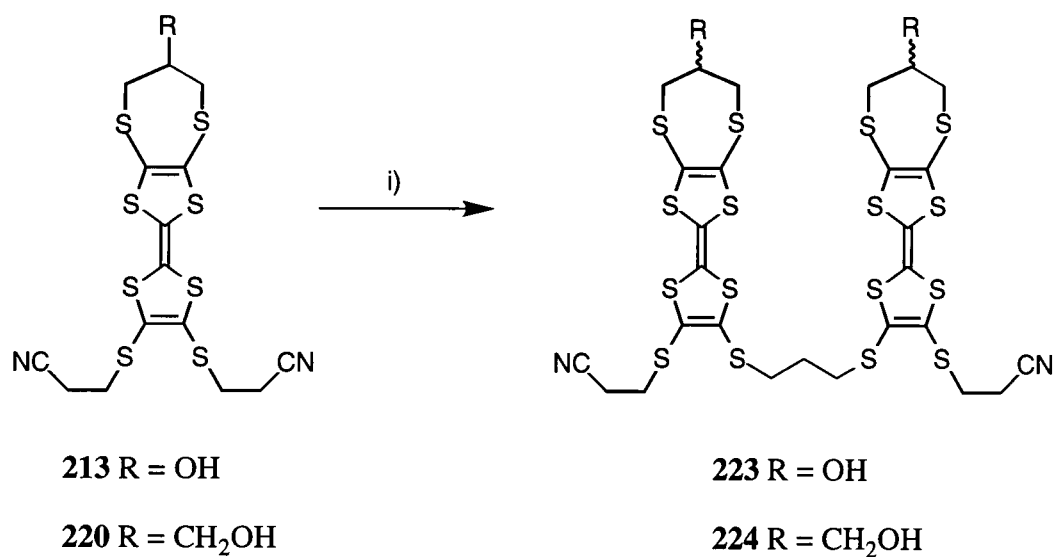

Scheme 4.9 Reagents and conditions: i) CsOH (1 equiv), DMF, 1,3-diiodopropane.

Mono-deprotection of **213** and **220** by addition of one equivalent of CsOH, followed by 0.5 equivalents of diiodopropane gave *bis*TTFs **223** and **224** in 71% and 65% yields respectively (Scheme 4.9). **219** and **223** were then coupled under high dilution conditions in DMF, to give **207** in 78% yield after recrystallisation from dioxane/MeOH. Coupling of **222** and **224** proceeded under the same conditions as **219** and **223** but it was not possible to obtain macrocycle **208** in a pure form from the reaction.

4.5 ATTEMPTED CAPPING REACTIONS

Alcohols **204** and **205** have been used as nucleophiles in a wide variety of reactions particularly of acid and sulfonyl chlorides. The formation of the *tris*TTF **227** (Scheme 4.10) via a three-fold esterification by Bryce *et al.*¹⁹³ suggested that benzenetricarbonyl chloride **226** would be a suitable trifunctionalised moiety to react with our *tris*TTF macrocycle **207**. Such a reaction could be used to tie together the three alcohol moieties of **207** thus forming a triply-bridged cage of structure **228**, which when modelled by CPK displays a rigid cavity with all three TTFs facing into it irrespective of the *endo* or *exo* conformation of the bridging linkers.

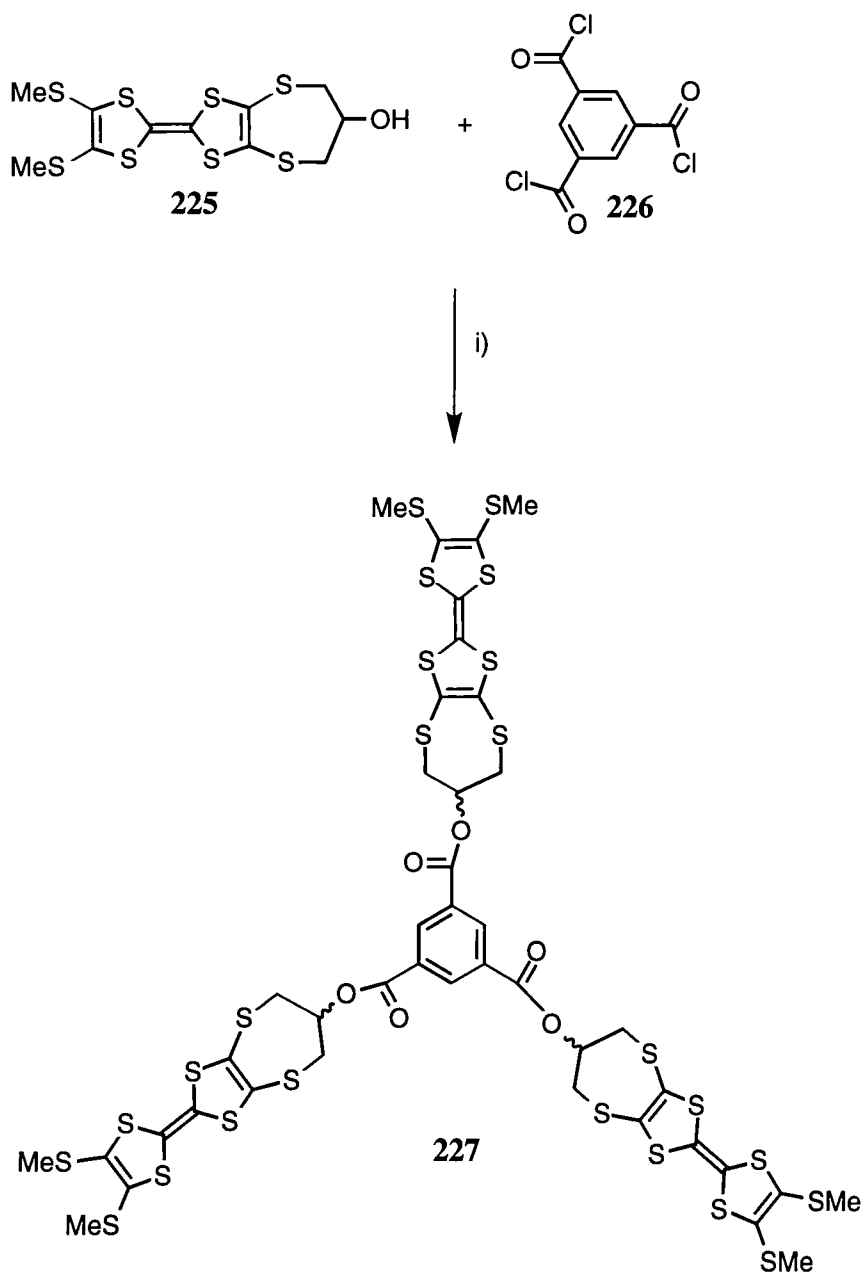

Scheme 4.10 Reagents and Conditions: i) NEt₃, DCM, 16h.

Simultaneous addition of solutions of the macrocyclic triol **207** and benzene tricarbonyl chloride **226** to a solution of triethylamine in DMF gave after workup a quantitative recovery of the starting material. In a model reaction, macrocycle **207** was reacted with benzoyl chloride in the presence of triethylamine; this gave a complex mixture of products by TLC which were not identified. Clearly, further investigations of this reaction are needed.

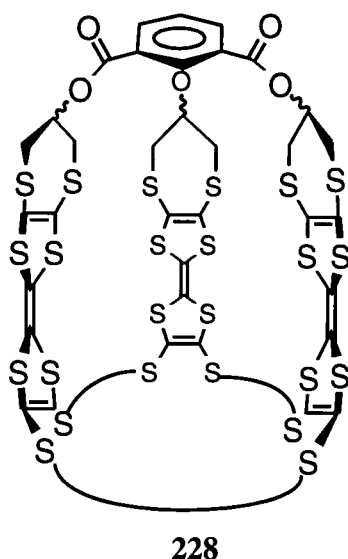

4.7 ELECTROCHEMISTRY

The electrochemical redox properties of new *bis* and *tris*TTFs synthesised in this chapter were studied by cyclic voltammetry (CV) and differential pulse voltammetry (DPV). The CVs of the *bis*TTFs **201**, **202**, **223**, and **224** showed two, reversible two-electron oxidations (Table 4.1). No evidence of any through space interactions between the TTF units was observed. However, *bis*TTF **224** did show some evidence of interaction in the DPV with the first wave splitting into two separate oxidations at $E_1^{ox} = 521$ mV and $E_2^{ox} = 574$ mV followed by a 2-electron oxidation wave at $E_3^{ox} = 806$ mV.

*Tris*TTFs **202** and **203** both showed two, reversible oxidations, again with no evidence of any through space interactions between the TTF units, although there is some slight broadening of the first oxidation wave for **202**. The *tris*TTF **207** showed two, reversible, oxidations and also showed a broadening of the first oxidation wave.

COMPOUND	$E_1^{1/2}/\text{mV}$	$E_2^{1/2}/\text{mV}$
201a	494	757
200a	484	743
223a	504	782
224a	525	783
202b	487	746
203a	495	763
207c	510	681

Table 4.1 CV of *bis*TTF donors, platinum electrode, electrolyte: n-Bu₄NClO₄, (0.01 M), a) PhCN; b) DCM/MeCN; c) DMF, 20°C. Values measured in milli volts relative to Ag/AgCl, and corrected to Me₁₀Fc.

4.5 CONCLUSIONS

Preliminary attempts to construct three-dimensional redox active macromolecules containing TTF derivatives have proved unsuccessful. However, it has been shown that new building blocks such as **213** and **220** which combine the thiolate chemistry of Becher with the alcohol derivatives of Bryce, can be used to construct new macrocyclic structures such as **207** which have the potential to serve as precursors for such systems. Further investigation of the reactivity of *trismacrocyclic* **207** with various species should prove fruitful, especially if conditions for a successful capping of this macrocycle can be obtained.

Chapter Five
Experimental Procedures

5.1 GENERAL EXPERIMENTAL METHODS

All reactions which required inert atmospheres were carried out under a blanket of argon which was dried by passage through a column of phosphorous pentoxide. Diethyl ether, toluene and tetrahydrofuran were dried and distilled over sodium metal. Dichloromethane, acetone and acetonitrile were dried and distilled over calcium hydride. Ethanol and methanol were dried and distilled over magnesium turnings. Anhydrous dimethylformamide and N-methylpyrrolidinone were obtained directly from Aldrich. All other reagents were of commercial quality and used as supplied unless otherwise stated. All reactions are at room temperature unless otherwise stated.

^1H and ^{13}C spectra were obtained on a Varian Unity 300, Oxford 200 and Varian VXR 400s; chemical shifts are quoted in ppm, relative to tetramethylsilane (TMS) as an internal reference (0 ppm). Mass spectra were recorded on a Micromass Autospec spectrometer operating at 70eV with the ionisation mode as indicated. Plasma Desorption Mass Spectra (PDMS) were obtained on a BioIon 10K instrument at the Department of Chemistry, University of Odense, Denmark. Melting points were recorded on a Reichert-Kofler hot-stage microscope and are uncorrected. Infra-red spectra were recorded using a Paragon 1000 FTIR spectrometer operated from a Grams Analyst 1600; samples were embedded in KBr discs unless otherwise stated. Electronic absorption spectra were obtained on a Unicam UV-2 instrument operating with 1 cm quartz cells. Elemental analyses were obtained on a Carlo-Erba Strumentazione instrument.

Column chromatography was carried out using either Prolabo silica (70 - 230 mesh) or Merck alumina (activity I to II, 70 - 230 mesh); the latter was neutralised by presoaking in ethyl acetate for 24 hr prior to use. Solvents were distilled prior to use for chromatography, with the exception of dichloromethane, and chloroform, which were used as supplied.

Cyclic voltammetry¹⁹⁴ and differential pulse voltammetry data were measured using a BAS CV50 electrochemical analyser with internal resistance compensation. Experiments were performed in a one-compartment cell with platinum working and counter electrodes and aqueous Ag/AgCl as reference. The experiments were carried out with 5 ml of *ca.* 10^{-4} M solution of the donor in an anhydrous and degassed 0.1 M solution of tetrabutylammonium hexafluorophosphate as the supporting electrolyte in the solvent system specified. Where stated, the potentials have been corrected *vs.* the decamethylferrocene redox couple.¹⁹⁵

Electrocrystallisation¹⁹⁶ experiments were carried out in a two compartment cell with platinum wire cathode and anode. The experiments were carried out on *ca.* 1×10^{-4} M solution of the donor in a 1×10^{-1} M solution of the supporting electrolyte in

the solvent system specified. The experiment was carried out using a six channel constant current source supplied by Chemistry Dept, U.C.N.W., Bangor. Conductivity experiments were carried out by the two-probe compressed pellet method using the apparatus designed by Bryce *et al.*¹⁹⁷

5.2 EXPERIMENTAL PROCEDURES FOR CHAPTER 2.

4-Bis(4',5,5'-trimethyltetrathiafulvalenyl) (**120**)

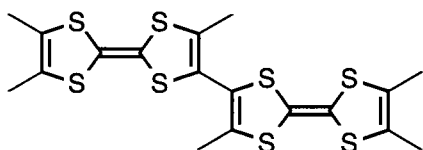

Method A

Copper powder (343 mg, 54 mmol) was added to a solution of Trim-I **119**, (200 mg, 0.54 mmol) in anhydrous DMF (15 ml). The

mixture was then refluxed under argon for 4 h. The resulting solution was diluted with toluene (50 ml) and filtered through a bed of celite with washings of hot toluene. The filtrate was washed with water (3 x 200 ml) the organic phase was dried (MgSO_4) and the solvent removed *in vacuo*. Recrystallisation from acetonitrile afforded **120** as orange crystals; yield: 77mg (58%); mp 190-192°C; (Analysis found: C, 43.85, H, 3.49%; $\text{C}_{18}\text{H}_{18}\text{S}_8$ requires: C, 44.05; H, 3.70%); m/z (CI) 491 (MH^+ , 45%), 317 (40), 285 (100), 177 (80); δ_{H} (CDCl_3) 1.95 (6H, s), 1.93 (12H, s); δ_{C} (CDCl_3) 132.5, 123.2, 122.7, 119.0, 110.5, 106.3, 14.5, 13.1; ν_{max} (KBr) 2910, 2848, 1433, 1145, 1088, 778 cm^{-1} ; λ_{max} (ϵ) 473 (2.4×10^3), 390 (sh, 1.2×10^4), 334 (4.5×10^4), 326 (6.4×10^4), 230 (2.6×10^4) nm; CV(MeCN): $E_1^{1/2}$ 0.38, $E_2^{1/2}$ 0.46 V, E_3^{ox} 0.83, E_3^{red} 0.75 (2e) V

Method B.

Copper(thiophene-2-carboxylate) (150 mg, 0.8 mmol) was added to a solution of Trim-I **119**, (100 mg, 0.27 mmol) in anhydrous NMP (5 ml). The solution was stirred for 1 h then diluted with ethyl acetate (100 ml). A solution of 15% aqueous NH_3 was added until a clear blue aqueous layer had formed. This layer was back extracted with EtOAc (50 ml). The organic extracts were combined and washed with water (2 x 100 ml), brine (1 x 100 ml), dried (MgSO_4) and the solvent removed *in vacuo*. Recrystallisation from acetonitrile afforded **120**; yield: 39 mg (59%) which was identical to that prepared above.

Complex of **120** and TCNQ

A complex was prepared by mixing hot solutions of **120** (2×10^{-5} mol) and TCNQ (4×10^{-5} mol) in acetonitrile and filtering the dark green powder which formed upon cooling. Analysis for 1:1 complex (found: C, 51.56, H, 3.04, N, 7.98%; $C_{30}H_{22}N_4S_8$ requires: C, 51.84, H, 3.19, N, 8.06%); ν_{\max} (KBr) 2199 cm^{-1} ; $\sigma_{\text{IT}} = 1.2 \times 10^{-2} \text{ Scm}^{-1}$.

Complex of **120** and Br_2TCNQ

A complex was prepared by mixing hot solutions of **120** (1.4×10^{-5} mol) and Br_2TCNQ (2.8×10^{-5} mol) in acetonitrile and filtering the dark green powder which formed upon cooling. Analysis uncertain; ν_{\max} (KBr) 2187 cm^{-1} ; $\sigma_{\text{IT}} = 9 \times 10^{-3} \text{ Scm}^{-1}$

Complex of **120** and F_4TCNQ

A complex was prepared by mixing hot solutions of **120** (1.4×10^{-5} mol) and F_4TCNQ (2.8×10^{-5} mol) in acetonitrile and filtering the black powder which formed upon cooling. Analysis for 1:1 complex (found: C, 46.38, H, 2.01, N, 7.20%; $C_{30}H_{18}S_8F_4N_4$ requires: C, 46.98, H, 2.36, N, 7.30%); ν_{\max} (KBr) 2183 cm^{-1} ; $\sigma_{\text{IT}} = 1.4 \times 10^{-3} \text{ Scm}^{-1}$.

Complex of **120** and ClO_4^-

A complex was prepared by electrolysing a solution of **120** (1.4×10^{-4} mol) in anhydrous THF containing Bu_4NClO_4 at a constant current of $0.7 \mu\text{A}$ for 2 weeks after which, a black amorphous solid was collected from the bottom of the cell. Analysis uncertain; $\sigma_{\text{IT}} = 3.2 \times 10^{-6} \text{ Scm}^{-1}$.

4-Iodo-5-Methyl-4',5'-bis(thiomethyl)tetrathiafulvalene (**126**)

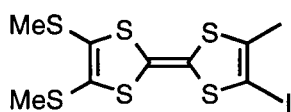

Compound **124** (600 mg, 1.93 mmol) was dissolved in anhydrous diethyl ether (75 ml) under an atmosphere of argon. The solution was cooled to -78°C and LDA (1.4 mls, 2.15 mmol) was added dropwise over 2 min. The reaction was stirred at -78°C for 3 h then perfluorohexyliodide (0.83 ml, 3.8 mmol) was added and the reaction was allowed to reach room temperature overnight. The mixture was concentrated *in vacuo* and the residue was dissolved in toluene (100 ml); the extract was washed with water ($3 \times 100 \text{ ml}$) and dried (MgSO_4). Purification by column chromatography on silica gel (eluent: hexane/toluene 5:1, v/v) followed by recrystallisation from CH_2Cl_2 /hexane gave **126** (550 mg, 65%) as red crystals; mp $89\text{--}90^\circ\text{C}$; (Analysis found: C, 24.95, H, 1.95%; $C_9H_9IS_6$ requires: C, 24.76, H, 1.95%); m/z (CI) 437 (MH^+ , 100%), 312 (60),

195 (12); δ_{H} (CDCl_3) 2.41 (6H, s), 2.07 (3H, s); ν_{max} (KBr) 1284, 918, 880, 771, 713 cm^{-1} ; CV(MeCN): $E_1^{1/2}$ 0.46, $E_2^{1/2}$ 0.72 V.

Complex of **126** and TCNQ

A complex was prepared by mixing hot solutions of **126** (2.3×10^{-5} mol) and TCNQ (2.3×10^{-5} mol) in acetonitrile and filtering the long black needles of the 1:1 complex which formed upon cooling. (Stoichiometry determined by X-ray analysis); $\sigma_{\text{IT}} = 1.9 \times 10^{-9}$ S cm^{-1} ; ν_{max} (KBr) 2206 cm^{-1} .

4-Bis[5-methyl-4',5'-bis(thiomethyl)tetrathiafulvalenyl] (**128**)

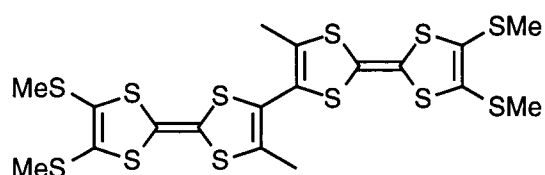

Method A .

Copper powder (300 mg, 4.6 mmol) was added to a solution of **126** (200 mg, 0.46 mmol) in anhydrous DMF (15 ml) under an atmosphere of argon. The mixture was then refluxed for 4 h. The reaction was diluted with CH_2Cl_2 and filtered through a bed of celite with washings of CH_2Cl_2 . The filtrate was washed with water (3 x 200 ml), dried (MgSO_4) and the solvent removed *in vacuo*. Recrystallisation from CH_2Cl_2 /hexane afforded **128** as yellow crystals after several weeks in the freezer; yield: (88 mg, 60%); mp 109-111 $^\circ\text{C}$; (Analysis found: C, 34.63 H, 2.82%; $\text{C}_{18}\text{H}_{18}\text{S}_{12}$ requires: C, 34.92, H, 2.93%; m/z (EI) 618 (M^+ , 100%), 380 (92), 230 (85), 198 (73); δ_{H} (CDCl_3) 2.41 (12H, s), 1.97 (6H, s); δ_{C} (CDCl_3) 132.3, 127.8, 127.2, 118.0, 112.3, 107.6; ν_{max} (KBr) 1577, 1422, 1143, 961, 888, 777 cm^{-1} ; $\lambda_{\text{max}}(\epsilon) = 250 (14 \times 10^4)$, 314 (17.4×10^4), 336 (18.5×10^4), 392 (5×10^4), 494 (3×10^3) nm.

Method B.

Compound **126** (200 mg, 0.46 mmol) was dissolved in anhydrous NMP (5 ml) under an atmosphere of argon. CuTC (263 mg, 1.3 mmol) was added and the mixture was stirred for 1 h at room temperature, then diluted with ethyl acetate (100 ml). A solution of 15% aqueous NH_3 was added until a clear blue aqueous layer had formed. This layer was back extracted with ethyl acetate (50 ml). The organic extracts were combined and washed with water (2 x 100 ml), brine (1 x 100 ml), dried (MgSO_4) and the solvent removed *in vacuo*. Recrystallisation from CH_2Cl_2 /hexane afforded **128** yield: (115 mg, 80%) which was identical to that prepared above.

Complex of **128** and Br₂TCNQ

A complex was prepared by mixing hot solutions of **128** (1.6×10^{-5} mol) and Br₂TCNQ (3.2×10^{-5} mol) in CH₂Cl₂ and filtering the black powder which formed upon cooling. Analysis uncertain; ν_{\max} (KBr) 2180 cm⁻¹; $\sigma_{\text{rt}} = 8.5 \times 10^{-4}$ S cm⁻¹.

4-Iodo-5-methyl-4',5'-ethylenedithiotetrathiafulvalene (**127**)

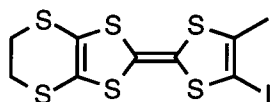

TTF **125** (600 mg, 1.95 mmol) was dissolved in anhydrous THF (60 ml) under an atmosphere of argon. The solution was cooled to -78°C and LDA (1.43 ml, 2.15 mmol) was added dropwise over 2 min. The reaction was stirred at -78°C for 3h then perfluorohexyl iodide (0.86 ml, 4.0 mmol) was added and the reaction was allowed to reach room temperature overnight. The mixture was concentrated *in vacuo* and the residue was dissolved in toluene (100 ml) which was washed with water (3 x 100 ml) and the organic layer was separated and dried (MgSO₄), and the solvent removed *in vacuo*. Purification by column chromatography on silica gel (eluent: hexane/toluene 3:1, v/v) followed by recrystallisation from benzonitrile gave **127** (380 mg, 45%) as deep red crystals; mp 143°C (decomp); (Analysis found: C, 25.09, H, 1.58%; C₉H₇IS₆ requires: C, 24.88, H, 1.62%); m/z (EI) 434 (M⁺, 100%); δ_{H} (DMSO-d₆) 3.37 (3H, s), 2.04 (4H, s); ν_{\max} (KBr) 1284, 918, 880, 771, 713 cm⁻¹; CV(PhCN): E₁^{1/2} 0.44, E₂^{1/2} 0.78 V.

4-Bis(5-methyl-4',5'-ethylenedithiotetrathiafulvalenyl) (**129**)

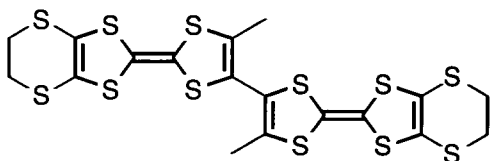

Copper powder (290 mg, 4.6 mmol) was added to a solution of compound **127** (200 mg, 0.46 mmol) in anhydrous DMF (15 ml) under an atmosphere of argon. The mixture was then refluxed under argon for 3 h. The reaction was diluted with toluene (100 ml) and filtered through a bed of celite with washings of hot toluene. The filtrate was washed with water (3 x 200 ml), dried (MgSO₄), and the solvent removed *in vacuo*. Recrystallisation from toluene afforded **129** as orange crystals (87 mg, 62%); mp 220°C (decomp); (Analysis found: C, 35.17, H, 2.30%; C₁₈H₁₄S₁₂ requires: C, 35.15, H, 2.29%); m/z (EI) 618 (M⁺, 100%); δ_{H} (CDCl₃) 2.41 (12H, s), 1.97 (6H, s); δ_{C} (CDCl₃) 132.3, 127.8, 127.2, 118.0, 112.3, 107.6; ν_{\max} (KBr) 1579, 1145, 775 cm⁻¹; $\lambda_{\max}(\epsilon) = 316 (9.7 \times 10^4), 340 (8 \times 10^4), 386 (2 \times 10^4)$ nm.

Complex of **129** and ClO_4^-

A complex was prepared by electrolysing a solution of **129** (1.4×10^{-4} mol) in anhydrous 1,1,2-trichloroethane containing $\text{N}(\text{Bu}_4)\text{ClO}_4$ at a constant current of 2.5 μA . After 3-4 days, black shiny crystals of the 1:1 **129**: ClO_4^- salt were harvested from the anode; (stoichiometry determined by X-ray analysis); $\sigma_{\text{rt}} = 1.6 \times 10^{-3} \text{ S cm}^{-1}$.

Complex of **129** and Br_2TCNQ

A complex was prepared by mixing hot solutions of **129** (1.6×10^{-5} mol) and Br_2TCNQ (3.2×10^{-5} mol) in 1,1,2-trichloroethane and filtering the black powder which formed upon cooling. Analysis for 1:1 complex (found: C, 36.28, H, 1.65, N, 5.74%; $\text{C}_{30}\text{H}_{16}\text{Br}_2\text{N}_4\text{S}_{12}$ requires: C, 36.88, H, 1.65, N, 5.73%); $\sigma_{\text{rt}} = 8.7 \times 10^{-4} \text{ Scm}^{-1}$; ν_{max} (KBr) 2175 cm^{-1} .

4-Carbomethoxy-5-thiomethyl-4',5'-bis(2-cyanoethylthio)tetrathiafulvalene (**132**)

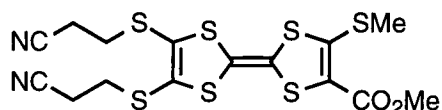

4,5-Bis(2'-cyanoethylthio)-1,3-dithiole-2-thione **131** (1.21 g, 4.2 mmol) and 4-(methylthio)-5-(carbomethoxy)-1,3-dithiole-

2-thione **76** (1.0 g, 4.2 mmol) were suspended in dry toluene (30 ml) under an atmosphere of argon. Triethyl phosphite (15 ml) was added and the mixture was refluxed for 90 min. The toluene was removed *in vacuo* and MeOH (200 ml) was added to the residue. The precipitated solid was filtered and washed with MeOH (3 x 50 ml). The crude product was purified by column chromatography on silica gel eluting firstly with CH_2Cl_2 and then with $\text{CH}_2\text{Cl}_2/\text{EtOAc}$ (98:2, v/v). The second orange fraction was isolated and recrystallised from $\text{CHCl}_3/\text{MeOH}$ to give **132** (1.2 g, 59%) as an orange powder; mp 124-125°C; (Analysis found: C, 37.48, H, 2.86, N, 5.77%; $\text{C}_{15}\text{H}_{14}\text{N}_2\text{O}_2\text{S}_7$ requires: C, 37.63, H, 2.94, N, 5.85%; m/z (EI) 478 (M^+ , 66%), 250 (66), 130 (80), 88 (100); δ_{H} (CDCl_3) 3.79 (3H, s), 3.08 (4H, t, $J = 7$ Hz), 2.73 (4H, t, $J = 7$ Hz), 2.59 (s, 3H); δ_{C} (CDCl_3) 160.3, 148.2, 128.5, 127.5, 117.4, 117.3, 113.1, 112.6, 107.9, 52.4, 31.3, 31.2, 18.9, 18.8, 18.2; ν_{max} (KBr) 2949, 1685, 1493, 1427, 1254, 1084 cm^{-1} .

4-Carbomethoxy-4',5,5'-tris(thiomethyl)tetrathiafulvalene (133)

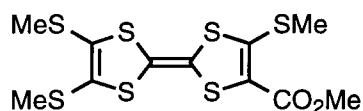

Sodium methoxide (305 mg, 5.65 mmol) was added to a mixture of anhydrous MeOH/THF (1:3, v/v, 50 ml) under an atmosphere of argon. Compound **132**

(900 mg, 1.88 mmol) was added and the reaction was left to stir for 30 min until a deep red colour had developed. Methyl iodide (0.47 ml, 7.52 mmol) was then added, after which the reaction was stirred for a further 15 min. The solvents were removed *in vacuo* and the residue was dissolved in CH₂Cl₂ (100 ml). The extract was washed with water (3 x 100 ml) and dried (MgSO₄), and the solvent removed *in vacuo*. Purification by column chromatography on silica gel (eluent CH₂Cl₂) followed by recrystallisation from CHCl₃/MeOH gave **133** (610 mg, 81%) as a pink powder; mp 86-88°C; (Analysis found: C, 32.74, H, 2.96%; C₁₁H₁₂O₂S₇ requires: C, 32.97, H, 3.01%; m/z (EI) 400 (M⁺, 21%), 385 (5), 57 (100); δ_H (CDCl₃) 3.72 (3H, s), 2.53 (3H, s), 2.35 (6H, s); ν_{max} (KBr) 1695, 1492, 1427, 1248, 1083 cm⁻¹).

4',5,5'-Tris(thiomethyl)tetrathiafulvalene (134)

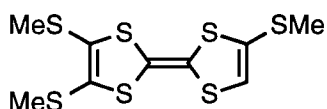

Compound **133** (250 mg, 0.63 mmol) was dissolved in DMF (10 ml) under an atmosphere of argon. Lithium bromide (1.08 g, 0.0125 mol) was added and the

mixture was heated at 140°C for 90 min. After cooling, the reaction was diluted with brine (100 ml), and extracted with CH₂Cl₂ (2 x 50 ml). The organic extracts were combined and washed with brine (3 x 100 ml) and dried (MgSO₄). Removal of the solvent *in vacuo* gave **134** (200 mg, 95%) as a deep red oil; m/z (EI) 342 (M⁺, 100%), 327 (43), 192 (58); δ_H (CDCl₃) 6.27 (1H, s), 2.40 (9H, m); δ_C (CDCl₃) 128.7, 127.3, 119.2, 114.7, 108.4, 19.4, 19.1; CV(MeCN): E₁^{1/2} 0.45, E₂^{1/2} 0.73 V.

4-Iodo-4',5,5'-tris(thiomethyl)tetrathiafulvalene (135)

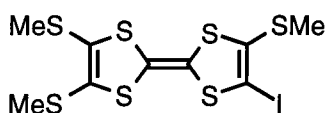

Compound **134** (935 mg, 2.73 mmol) was suspended in anhydrous diethyl ether (100 ml) under an atmosphere of argon. The solution was cooled to -78°C and LDA

(2 ml, 3 mmol) was added dropwise over 3 min. A thick yellow precipitate was seen to form once addition was complete. The reaction was stirred at -78°C for 3 h then perfluorohexyliodide (1.18 ml, 5.46 mmol) was added and the reaction was allowed to reach room temperature overnight. The reaction was diluted with water (100 ml) and

extracted with toluene (3 x 50 ml). The organic extracts were combined and washed with water (2 x 100 ml), brine (1 x 100 ml) and dried (MgSO₄). Removal of the solvents *in vacuo* and recrystallisation from CH₂Cl₂/hexane gave **136** (1.16 g, 91%) as an orange powder; mp 60-61°C; (Analysis found: C, 23.00, H, 1.93%; C₉H₉IS₇ requires: C, 23.07, H, 1.93); m/z (EI) 468 (M⁺, 98%), 254 (77), 128 (100); δ_H (CDCl₃) 2.42 (9H, s); δ_C (CDCl₃) 130.5, 127.5, 127.4, 114.5, 111.1, 71.6, 19.24, 19.23, 19.21; ν_{max} (KBr) 1416, 1307, 974, 897, 766 cm⁻¹; CV(MeCN): E₁^{1/2} 0.50, E₂^{1/2} 0.73 V.

4-Bis[4',5,5'-tris(thiomethyl)tetrathiafulvalenyl] (136)

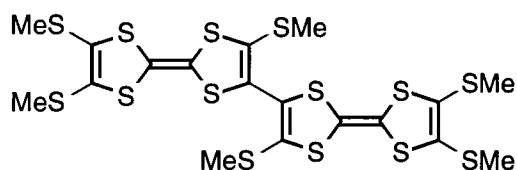

Compound **135** (200 mg, 0.43 mmol) was dissolved in anhydrous NMP (5 ml) under an atmosphere of argon. CuTC (244 mg, 1.28 mmol) was added and the

mixture was stirred for 1 h at room temperature. The reaction was then diluted with ethyl acetate (100 ml) and a solution of 15% aqueous NH₃ was added until a clear blue aqueous layer had formed. The organic extracts were combined, washed with water (2 x 100 ml), brine (1 x 100 ml), dried (MgSO₄) and the solvent removed *in vacuo*. The residue was then dissolved in a small amount of CH₂Cl₂, filtered through a plug of silica and recrystallised from CH₂Cl₂/hexane to give **136** (106 mg, 72%) as an orange powder; mp 160-161°C; (Analysis found: C, 31.38, H, 2.65%; C₁₈H₁₈S₁₄ requires: C, 31.64, H, 2.65); m/z (EI) 682 (M⁺, 77%), 444 (100), 207 (49); δ_H (CDCl₃) 2.42 (18H, s); δ_C (CDCl₃) 131.2, 127.7, 127.2, 122.8, 110.8, 110.7, 19.6, 19.2; λ_{max}(ε)= 264 (22 x 10⁴), 312 (22.5 x 10⁴), 334 (21 x 10⁴), 412 (5.2 x 10⁴) nm; ν_{max} (KBr) 1420, 954, 885, 771 cm⁻¹. DPV(CH₂Cl₂) E₁^{ox} 0.53, E₂^{ox} 0.60, E₃^{ox} 0.77 (2e⁻) V.

4-Carbomethoxy-4',5'-bis(thiomethyl)tetrathiafulvalene (139)

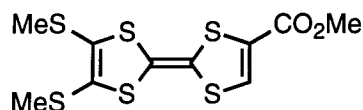

Tetrathiafulvalene **138**^{144a-b} (3.76g, 9.5 mmol) was dissolved in DMF (40 ml) under an atmosphere of argon. Lithium bromide (2.5 g, 2.9 mmol)

was added and the mixture was heated at 110°C for 20 min. The reaction was followed by TLC and stopped when the diester had disappeared. After cooling, the reaction was diluted with brine (100 ml), and extracted with CH₂Cl₂ (2 x 100 ml). The organic extracts were combined and washed with brine (3 x 200 ml) and dried

(MgSO₄). Removal of the solvent *in vacuo* gave **139** (2.92 g, 91%) as a deep red oil, which solidified after several days under vacuum; mp 72°C (Lit.¹⁴⁴, not given); m/z (EI) 354 (M⁺, 100%), 204 (54); δ_H (CDCl₃) 7.20 (1H, s), 3.73 (3H, s), 2.40 (6H, s); ν_{max} (KBr) 1719, 1701, 1562, 1553, 1259 cm⁻¹.

4-Carbomethoxy-5-iodo-4',5'-bis(thiomethyl)tetrathiafulvalene (**140**)

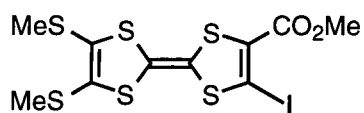

Compound **139** (1 g, 2.8 mmol) was dissolved in anhydrous THF (100 ml) under an atmosphere of argon. The solution was cooled to -78°C and LDA

(2.07 ml, 3.1 mmol) was added dropwise over 2 min. The reaction was stirred at -78°C for 3 h then perfluoroiodide (1.25 ml, 5.6 mmol) was added and the reaction was allowed to reach room temperature overnight. The mixture was concentrated *in vacuo* and the residue was dissolved in CH₂Cl₂ (100 ml) and the extract was washed with water (3 x 100 ml) and dried (MgSO₄), and the solvent removed *in vacuo*. Purification by column chromatography on silica gel (eluent: hexane/CH₂Cl₂ 2:1, v/v) followed by recrystallisation from CH₂Cl₂/hexane gave **140** (330 mg, 24%) as red crystals; mp 89-90°C; (Analysis found: C, 25.07, H, 1.90%; C₁₀H₉IO₂S₆ requires: C, 25.00, H, 1.88%); m/z (EI) 480 (M⁺, 63%), 330 (17), 44 (100); δ_H (CDCl₃) 3.82 (3H, s), 2.41 (6H, s); ν_{max} (KBr) 1722, 1712, 1518, 1282, 1236, 1065 cm⁻¹; CV(MeCN): E₁^{1/2} = 0.57, E₂^{1/2} = 0.82 V.

4-Bis[5-carbomethoxy-4',5'-bis(thiomethyl)tetrathiafulvalenyl] (**141**)

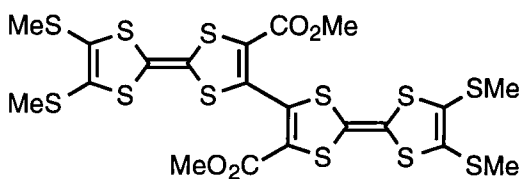

Compound **140** (140 mg, 0.29 mmol) was dissolved in anhydrous NMP (5 ml) under an atmosphere of argon. CuTC (167 mg, 0.87 mmol) was added

and the mixture was stirred for 1 h at room temperature. The reaction was then diluted with ethyl acetate (100 ml) and a solution of 15% aqueous NH₃ was added until a clear blue aqueous layer had formed. The organic extracts were combined, washed with water (2 x 100 ml), brine (1 x 100 ml), dried (MgSO₄), and the solvent removed *in vacuo*. Purification by column chromatography on silica gel (eluent: hexane/CH₂Cl₂ 2:1, v/v) followed by recrystallisation from CH₂Cl₂/MeOH gave **141** (67 mg, 65%); mp 168-170°C; (Analysis found: C, 33.97, H, 2.56%; C₂₀H₁₈O₄S₁₂ requires: C, 33.90, H, 2.56%); m/z (CI) 708 (MH⁺, 100%); δ_H (CDCl₃) 3.77 (6H, s),

2.42 (12H, s); δ_{C} (CDCl_3) 131.2, 127.75, 127.28, 122.85, 110.85, 110.79, 19.63, 19.24; ν_{max} (KBr) 1716, 1703 cm^{-1} .

4-Bis[4',5'-Bis(thiomethyl)tetrathiafulvalenyl] (109)

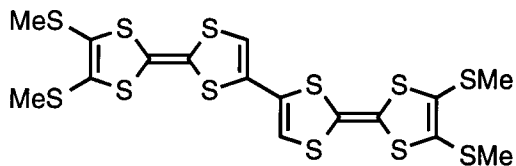

Compound **141** (40 mg, 5.6×10^{-5} mol) was dissolved in DMF (10 ml) under an atmosphere of argon. Lithium bromide (430 mg, 5 mmol) was added and the

mixture was heated at 140°C for 90 min. After cooling, the reaction was diluted with brine (100 ml), and extracted with CH_2Cl_2 (2 x 50 ml). The organic extracts were combined and washed with brine (3 x 100 ml) and dried (MgSO_4). The solution was then filtered through a plug of silica (eluent: CH_2Cl_2). Removal of the solvent *in vacuo* gave **109** (20 mg, 95%) as a tan solid; mp 172°C (lit.¹³³ $172\text{-}173^\circ\text{C}$); δ_{H} (CDCl_3) 6.22 (2H, s), 2.42 (12H, s); $\lambda_{\text{max}}(\epsilon) = 264 (1.8 \times 10^4), 312 (1.9 \times 10^4), 328 (1.9 \times 10^4), 412 (1 \times 10^4)$ nm.

5.3 EXPERIMENTAL METHODS FOR CHAPTER 3

4-(Methylthio)-5-(2-cyanoethylthio)-1,3-dithiole-2-thione (74)

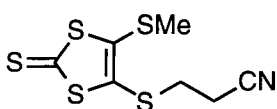

Zincate salt **72** (5 g, 7 mmol) was dissolved in MeCN (100 ml), to this solution was added methyl iodide (0.9 ml, 14 mmol) and the mixture was left to stir for 20 min

under argon. To this was added 3-bromopropionitrile (1.75 ml, 21 mmol) and the mixture was refluxed for 2 h. The MeCN was then removed *in vacuo*, and the residue was dissolved in CH_2Cl_2 (100 ml), washed with water (3 x 100 ml), and dried (MgSO_4). The product was columned on silica gel (eluent CH_2Cl_2 /hexane 2:1) and recrystallised from CH_2Cl_2 /hexane to yield **74** as yellow needles (2.9g, 78%); mp $88\text{-}89^\circ\text{C}$ (lit.^{110b} $90\text{-}91^\circ\text{C}$); δ_{H} (CDCl_3) 3.10 (2H, t, $J = 7$ Hz), 2.83 (2H, t, $J = 7$ Hz), 2.58 (3H, s).

4-(2-Hydroxyethylthio)-5-methylthio-1,3-dithiole-2-thione (162)

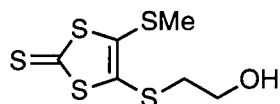

Compound **74** (4 g, 15 mmol) was added to a solution of sodium ethoxide, generated from sodium (860 mg, 38 mmol) in anhydrous EtOH (100 ml) and left to stir for 90 min under argon until a deep red solution had formed. To this solution was then added 2-chloroethanol (4 ml, 60 mmol) and the reaction was left to stir overnight. The solvents were removed *in vacuo* and the residue was taken up in CH₂Cl₂ (100 ml) and washed with water (3 x 100 ml), and dried (MgSO₄). The product was obtained as a red oil which crystallised from (CH₂Cl₂/hexane) to give **162** (3 g, 78%) as a yellow powder; mp 46-47°C; (Analysis found: C, 27.81, H, 3.22%; C₆H₈OS₅ requires: C, 28.10, H, 3.14%); m/z (CI) 257 (MH⁺, 100%); δ_H (CDCl₃) 3.77 (2H, t, J = 7 Hz), 3.00 (2H, t, J = 7 Hz), 2.61(1H, s), 2.51 (3H, s); δ_C (CDCl₃); 210.6, 142.0, 130.0, 60.2, 39.8, 19.2; ν_{max} (KBr) 3386, 1459, 1421, 1062 cm⁻¹.

4-(2-Methylsulfonylethylthio)-5-methylthio-1,3-dithiole-2-thione (164)

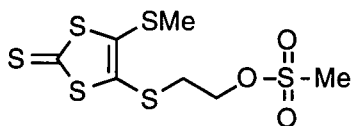

To an ice-cooled solution of **162** (2.3 g, 9 mmol) in anhydrous CH₂Cl₂ (100 ml) under argon was added NEt₃ (3.1 ml, 23 mmol) and methane sulfonylchloride (2 ml, 23 mmol) and the reaction was allowed to reach room temperature overnight. The solvents were then removed *in vacuo* and the residue was taken up in CH₂Cl₂ (100 ml) and washed with water (3 x 100 ml), and dried (MgSO₄). The crude product was columned on silica (eluent CH₂Cl₂) and crystallised from CH₂Cl₂/hexane to give **164** (2.3 g, 77%) as yellow crystals; mp 96-98°C; (Analysis found: C, 24.79, H, 2.96%; C₇H₁₀O₃S₆ requires: C, 25.13 H, 3.01%); m/z (CI) 335 (MH⁺, 100%), 165(86); δ_H (CDCl₃) 4.40 (2H, t, J = 7 Hz), 3.17 (2H, t, J = 7 Hz), 3.07 (3H, s), 2.54 (3H, s); δ_C (CDCl₃) 210.1, 143.6, 127.5, 67.0, 37.7, 35.2, 19.0; ν_{max} (KBr) 1265, 1068, 739, 704 cm⁻¹.

4-(2-Iodoethylthio)-5-methylthio-1,3-dithiole-2-thione (166)

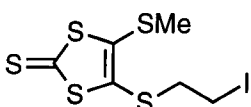

To a solution of mesylate **164** (1.2 g, 3.6 mmol) in acetone (100 ml) was added NaI (6.5 g, 43 mmol) and the mixture was refluxed under argon for 1 h. The solvents were

removed *in vacuo* and the residue was taken up in CH_2Cl_2 (100 ml) and washed with water (3 x 100 ml), and dried (MgSO_4). The resulting red oil was crystallised from CH_2Cl_2 /hexane to give **166** (1.1 g, 83%) as a yellow solid; mp 55-56°C; (Analysis found: C, 19.58, H, 1.84%; $\text{C}_6\text{H}_7\text{IS}_5$ requires: C, 19.67, H, 1.92%); m/z (CI) 367 (MH^+ , 100%), 279 (10), 137 (15); δ_{H} (CDCl_3) 3.2-3.42 (4H, m), 2.54 (3H, s); δ_{C} (CDCl_3); 210.2, 143.1, 127.8, 38.9, 19.0; ν_{max} (KBr) 1341, 1328, 1163, 1067, 977 cm^{-1} .

4,5-Bis[2-(4-methylthio-1,3-dithione)-ethylthio]-4',5'-bis(methylthio)tetrathiafulvalene (**168**)

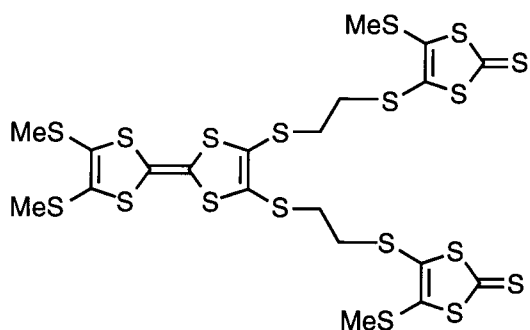

Protected TTF **94** (340 mg, 0.73 mmol) was dissolved in a 1:1 mixture of THF/MeOH (50 ml) and to this was added NaH (60% dispersion in oil, 63 mg, 1.6 mmol) and the mixture was left to stir for 30 min. Compound **166** (800 mg, 2.2 mmol) was added and

the reaction was left to stir overnight. The solvents were removed *in vacuo* and the residue was taken up in CH_2Cl_2 (100 ml) and washed with water (3 x 100 ml), and dried (MgSO_4). The crude product was columned on silica (eluent: CH_2Cl_2 /hexane 1:1) and recrystallised from CH_2Cl_2 /hexane to give **168** (400 mg, 65%) as an orange solid; mp 60-61°C; (Analysis found: C, 28.81, H, 2.37%; $\text{C}_{20}\text{H}_{20}\text{S}_{18}$ requires: C, 28.68; H, 2.40%); m/z (EI) 836 (M^+ , 6%), 612 (7), 148 (45), 76 (100); δ_{H} (CDCl_3) 3.08 (8H, s), 2.53 (6H, s), 2.44(6H, s); δ_{C} (CDCl_3); 209.1, 141.4, 127.6, 126.7, 126.6, 112.0, 107.2, 35.3, 34.6, 18.3, 18.1; ν_{max} (KBr) 1419, 1063 cm^{-1} .

4-(3-Hydroxypropylthio)-5-methylthio-1,3-dithiole-2-thione (**163**)

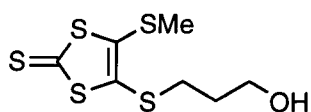

To a stirred suspension of **74** (3.75 g, 14 mmol) in anhydrous EtOH (100 ml) under argon was added a solution of sodium ethoxide generated from sodium (0.48 g, 21 mmol) in anhydrous EtOH (25 ml). The mixture was stirred for 30 min until a deep red solution had formed, then 3-bromopropanol (6.3 ml, 70 mmol) was added and the mixture was left stirring at room temperature overnight. The solvents were removed *in vacuo* and the residue was taken up in CH_2Cl_2 (100 ml) and washed with water (3 x 100 ml), and dried (MgSO_4). The excess 3-bromopropanol

was removed by kügelröhr distillation and the crude product was columned on silica (eluent CH_2Cl_2) to give **163** (2.57 g, 68%) as a red oil; m/z (CI) 271 (MH^+ , 100%); δ_{H} (CDCl_3) 3.73 (2H, t, $J = 7$ Hz), 2.96 (2H, t, $J = 6$ Hz), 2.48 (3H, s), 2.21 (1H, s), 1.88 (2H, quin, $J = 7$ Hz); δ_{C} (CDCl_3) 210.9, 139.6, 132.3, 60.5, 32.0, 19.1; ν_{max} (KBr) 3374, 2919, 2877, 1463, 1424, 1063, 907 cm^{-1} .

4-(3-Methylsulfonylpropylthio)-5-methylthio-1,3-dithiole-2-thione (165)

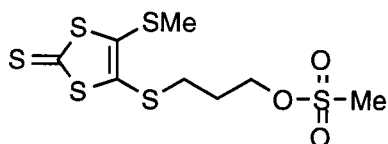

To an ice-cooled solution of alcohol **163** (3.5 g, 13 mmol) in dry CH_2Cl_2 (100 ml) was added pyridine (2.1 ml, 26 mmol) and mesyl chloride (2 ml, 26 mmol). The mixture was left to stir overnight under argon. The solvents were removed *in vacuo* and the residue was taken up in CH_2Cl_2 (100 ml) and washed with water (3 x 100 ml), and dried (MgSO_4). The resulting oil was columned on silica (eluent CH_2Cl_2) and the product was crystallised from CH_2Cl_2 /hexane to give **165** (3.6 g, 80%) as yellow needles; mp 70-72°C; (Analysis found: C, 27.66, H, 3.45%; $\text{C}_8\text{H}_{12}\text{O}_3\text{S}_6$ requires: C, 27.57, H, 3.47%); m/z (CI) 349 (MH^+ , 100%), 239 (10), 179 (17), 133 (21); δ_{H} (CDCl_3) 4.36 (2H, t, $J = 6$ Hz), 3.02 (2H, s), 2.97 (2H, t, $J = 7$ Hz), 2.50 (3H, s), 2.08 (2H, quin, $J = 6$ Hz); δ_{C} (CDCl_3) 210.4, 141.6, 129.7, 67.2, 37.2, 32.4, 28.8, 19.0; ν_{max} (KBr) 1345, 1167, 1061, 918, 524 cm^{-1} .

4-(3-Iodopropylthio)-5-methylthio-1,3-dithiole-2-thione (167)

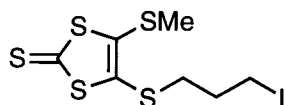

Method A.

To a solution of mesylate **165** (1.1 g, 3.2 mmol) in acetone (100 ml) was added NaI (4.8 g, 32 mmol) and the mixture was refluxed under argon for 1 h. The solvents were removed *in vacuo* and the residue was taken up in CH_2Cl_2 (100 ml) and washed with water (3 x 100 ml), and dried (MgSO_4). The crude product was columned on silica (eluent CH_2Cl_2 /hexane 1:1) to give **167** as a red oil (1.1 g, 90%); m/z (CI) 381 (MH^+ , 100%), 179 (24); δ_{H} (CDCl_3) 3.32 (2H, t, $J = 7$ Hz), 2.96 (2H, t, $J = 7$ Hz), 2.52 (3H, s), 2.10 (2H, quin, $J = 7$ Hz); δ_{C} (CDCl_3) 210.6, 141.2, 130.7, 37.2, 32.5, 19.2, 3.8; ν_{max} (KBr) 2915, 1665, 1422, 1208, 1062 cm^{-1} .

Method B.

CsOH (1.39 g, 8.3 mmol) was added to a solution of compound **74** (2 g, 7.5 mmol) in anhydrous DMF (40 ml) and the mixture was left to stir for 15 min. This solution was then added over 16 h using a syringe pump to a solution of 1,3-diiodopropane (5.2 ml, 45 mmol) in anhydrous DMF (50 ml) under argon. The solvents were removed *in vacuo* and the residue was taken up in CH₂Cl₂ (100 ml) and washed with water (3 x 100 ml), and dried (MgSO₄). The crude product was columned on silica (eluent CH₂Cl₂/hexane 1:1) to give **167** as a red oil (1.84 g, 64%) identical to that prepared above.

4,5-Bis[3-(4-methylthio-1,3-dithione)-propylthio]-4',5'-bis(methylthio)tetrathiafulvalene (**169**)

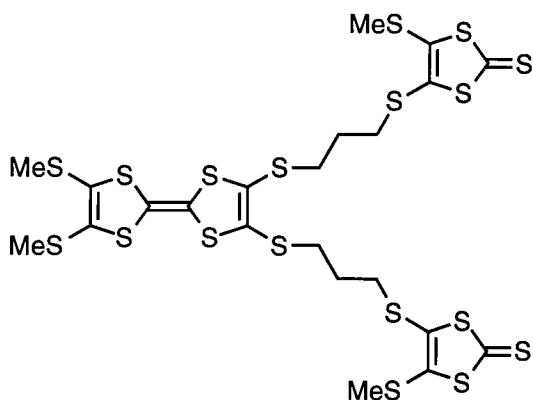

Protected TTF **94** (650 mg, 1.4 mmol) was dissolved in a 1:1 mixture of THF/MeOH (80 ml) and to this was added NaH (60% dispersion in oil, 161 mg, 4.2 mmol) and the mixture was left to stir for 30 min. Compound **167** (1.6 g, 4.2 mmol) was added as a solution in THF (15 ml) and the reaction was left to stir overnight

The solvents were removed *in vacuo* and the residue was taken up in CH₂Cl₂ (100 ml) and washed with water (3 x 100 ml), and dried (MgSO₄). The crude product was columned on silica (eluent: CH₂Cl₂/hexane 1:1) to give **169** (870 mg, 72%) as a red oil; δ_{H} (CDCl₃) 2.94-3.04 (8H, m), 2.53 (6H, s), 2.44 (6H, s), 1.99 (4H, quin, J = 7 Hz); δ_{C} (CDCl₃); 210.4, 140.1, 130.7, 128.0, 127.4, 111.6, 109.6, 35.0, 34.5, 29.2, 19.2, 19.19; ν_{max} (KBr) 1265, 1065, 738 cm⁻¹.

4,5-Bis(methylthio)-4',5'-bis[2-(hydroxyethoxy)ethylthio] tetrathiafulvalene (**172**)

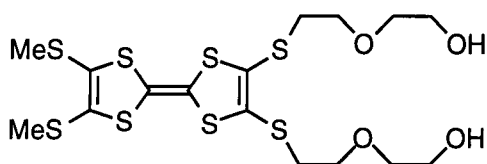

To a solution of sodium ethoxide generated from sodium (246 mg, 11 mmol) in anhydrous EtOH (100 ml) was added protected TTF **94** (1 g, 2.15 mmol) and the mixture was stirred for 1 h under argon. Then 2-(2-chloroethoxy)ethanol (0.88 ml, 11 mmol) was added and the reaction was refluxed

overnight. The solvents were removed *in vacuo* and the residue was taken up in CH_2Cl_2 (100 ml) and washed with water (3 x 100 ml), and dried (MgSO_4). The crude product was columned on silica (eluent: acetone/hexane 1:1) and recrystallised from CH_2Cl_2 /hexane to give **172** (720 mg, 62%) as an orange powder; mp 56°C ; (Analysis found: C, 35.47, H, 4.09%; $\text{C}_{16}\text{H}_{24}\text{O}_4\text{S}_8$ requires: C, 35.79; H, 4.50%); m/z (CI) 537 (MH^+ , 100%); δ_{H} (CDCl_3) 3.72 (4H, t, $J = 4$ Hz), 3.67 (4H, t, $J = 6$ Hz), 3.56 (4H, t, $J = 4$ Hz), 3.02 (4H, t, $J = 6$ Hz), 2.40 (6H, s); δ_{C} (CDCl_3); 128.0, 127.4, 111.3, 110.1, 72.2, 69.2, 61.6, 35.7, 19.2; ν_{max} (KBr) 3345, 2860, 1126, 1045 cm^{-1} .

4,5-Bis(methylthio)-4',5'-bis[2-(methanesulfonylethoxy)ethylthio] tetrathiafulvalene (175)

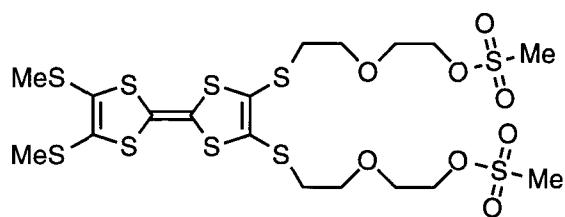

To an ice-cooled solution of compound **172** (1.0 g, 1.85 mmol) in dry CH_2Cl_2 (100 ml) under argon, was added methanesulfonyl chloride (0.72 ml, 9.3 mmol) followed

by dropwise addition of NEt_3 (1.3 ml, 9.3 mmol). The reaction was left to stir overnight. The solvents were removed *in vacuo* and the residue was taken up in CH_2Cl_2 (100 ml) and washed with water (3 x 100 ml), and dried (MgSO_4). The crude product was columned on silica (eluent: acetone/hexane 1:1) to give **175** as a red oil (1.0 g, 78%); m/z (EI) 692 (M^+ , 56%), 238 (25), 123 (87), 79 (100); δ_{H} (CDCl_3) 4.38-4.33 (4H, m), 3.76-3.73 (4H, m), 3.69 (4H, t, $J = 6$ Hz), 3.07 (6H, s), 3.00 (4H, t, $J = 5$ Hz), 2.42 (6H, s); ν_{max} (KBr) 2863, 1350, 1166, 1071 cm^{-1} .

4,5-Bis(methylthio)-4',5'-bis[2-(iodoethoxy)ethylthio] tetrathiafulvalene (178)

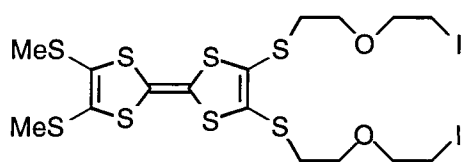

To a solution of mesylate **175** (400 mg, 0.57 mmol) in acetone was added NaI (866 mg, 5.7 mmol) and the reaction was refluxed under argon for 1 h. The

solution was concentrated *in vacuo* and the residue was taken up in CH_2Cl_2 (100 ml) and washed with water (3 x 100 ml), and dried (MgSO_4). The product was then filtered through a plug of silica (eluent: CH_2Cl_2) and the solvents removed *in vacuo* to give **178** as a red oil (323 mg, 75%); m/z (EI) 692 (M^+ , 56%), 238 (25), 123 (87), 79 (100); δ_{H} (CDCl_3) 3.75 (4H, t, $J = 6.4$ Hz), 3.69 (4H, t, $J = 6.4$ Hz), 3.26 (4H, t, $J =$

6.8 Hz), 3.02 (4H, t, $J = 6.4$ Hz), 2.43 (6H, s); δ_C (CDCl₃) 127.6, 127.2, 111.6, 110.1, 71.4, 69.3, 35.3, 13.1, 2.7; ν_{\max} (KBr) 2854, 1137, 1065 cm⁻¹.

BisTTF (158) *cis/trans*

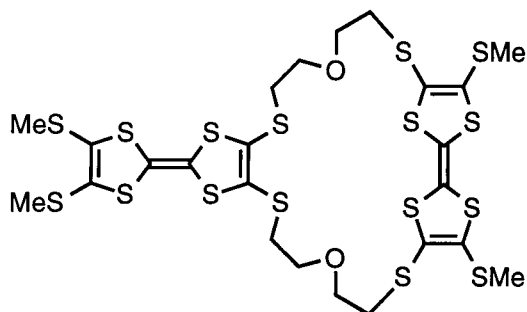

To a solution of protected TTF **153** (370 mg, 0.8 mmol) in anhydrous DMF (40 ml), was added CsOH (332 mg, 2 mmol) in anhydrous MeOH (10 ml), and the reaction was left to stir for 30 min. Iodide **178** (600 mg, 0.8 mmol) was dissolved in anhydrous DMF

(50 ml) and the two solutions were added simultaneously to anhydrous DMF (80 ml) over 4 h. The solvents were removed *in vacuo* and the residue was taken up in CH₂Cl₂ (100 ml) and washed with water (3 x 100 ml), and dried (MgSO₄). The crude product was columned on silica (eluent: CH₂Cl₂) to give **158** (440 mg, 65%) as a red oil; m/z (PDMS) 859.6 (M⁺); δ_H (CDCl₃) *cis* isomer: 2.39 (6H, s), 2.41 (6H, s), 2.91-2.98 (8H, m), 3.60-3.66 (8H, m); ν_{\max} 2915, 1418, 1108, 885 cm⁻¹; $\lambda_{\max}(\epsilon) = 226$ (19.8 x 10⁴), 260 (16.9 x 10⁴), 312 (16.6 x 10⁴), 334 (17 x 10⁴), 386 (3.7 x 10⁴) nm; CV(CH₂Cl₂/MeCN) $E_1^{1/2} = 0.48$, $E_2^{1/2} = 0.74$ V.

4,5-Bis(methylthio)-4',5'-bis(2-hydroxyethylthio)tetrathiafulvalene (170)

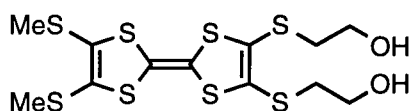

Protected TTF **94** (2 g, 4.3 mmol) was added to a solution of sodium ethoxide generated from sodium (300 mg, 13 mmol) in anhydrous

EtOH (100 ml) and the reaction was left to stir under argon for 2 h. To this solution was added 2-chloroethanol (1.15 ml, 17 mmol) and the reaction was left to stir overnight. The solvents were removed *in vacuo* and the residue was taken up in CH₂Cl₂ (100 ml) and washed with water (3 x 100 ml), and dried (MgSO₄). The crude product was columned on silica (eluent: CH₂Cl₂/ethyl acetate 4:1) and recrystallised from ethyl acetate/petroleum-ether (b.p. 60-80°C) to give **170** as orange crystals (1.3 g, 67%); mp 106-107°C; (Analysis found: C, 32.00, H, 3.59%; C₁₂H₁₆O₂S₈ requires: C, 32.11, H, 3.59%); m/z (CI) 449 (MH⁺, 100%), 209 (75), 135 (65); δ_H (CDCl₃) 3.73 (4H, $J = 6$ Hz), 3.19 (2H, s), 2.98 (4H, t, $J = 6$ Hz), 2.41 (6H, s); δ_C (CDCl₃) 128.1, 127.4, 112.2, 109.4, 59.9, 39.2, 19.2; ν_{\max} (KBr) 3318, 2913, 1072, 891 cm⁻¹.

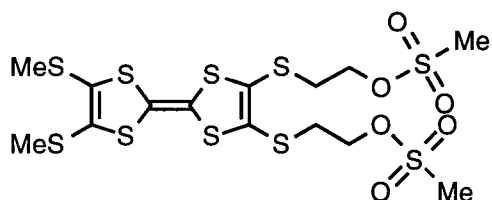
4,5-Bis(methylthio)-4',5'-bis(2-methanesulfonylethylthio)tetrathiafulvalene (174)

Compound **170** (1 g, 2.2 mmol) was dissolved in anhydrous CH_2Cl_2 (100 ml) and cooled to 0°C . To this solution was added methanesulfonylchloride (0.8 ml, 11 mmol) and NEt_3 (1.5 ml, 1 mmol)

was added dropwise. The reaction was left to stir overnight. The solvents were removed *in vacuo* and the residue was taken up in CH_2Cl_2 (100 ml), washed with water (3 x 100 ml), and dried (MgSO_4). The crude product was columned on silica (eluent: CH_2Cl_2 then CH_2Cl_2 /Ethyl acetate 5:1) and recrystallised from CH_2Cl_2 /petroleum-ether (b.p. $60\text{-}80^\circ\text{C}$) to give **174** (1.03 g, 77%); mp $103\text{-}105^\circ\text{C}$; (Analysis found: C, 27.71, H, 3.42%; $\text{C}_{14}\text{H}_{20}\text{O}_6\text{S}_{10}$ requires: C, 27.79, H, 3.33%); m/z (CI) 605 (MH^+ , 6%), 387 (81), 236 (100), 209 (61); δ_{H} (CDCl_3) 4.34 (4H, t, $J = 6$ Hz), 3.14 (4H, t, $J = 6$ Hz), 3.06 (6H, s), 2.41 (6H, s); ν_{max} (KBr) 1349, 1166, 855 cm^{-1} .

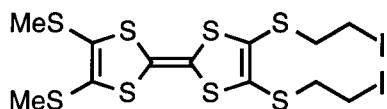
4,5-Bis(methylthio)-4',5'-bis(2-iodoethylthio)tetrathiafulvalene (176)

To a solution of mesylate **170** (1 g, 1.7 mmol) in acetone (60 ml) was added NaI (2.55 g, 17 mmol) and the mixture was refluxed under argon for 1h.

The solvents were removed *in vacuo* and the residue was taken up in CH_2Cl_2 (100 ml), washed with water (3 x 100 ml), and dried (MgSO_4). The crude product was recrystallised from CH_2Cl_2 /hexane to give **176** (840 mg, 77%) as orange crystals, which rapidly darkened upon standing in air but were stable when stored at -10°C ; mp $72\text{-}74^\circ\text{C}$; (Analysis found: C, 21.64, H, 2.08%; $\text{C}_{12}\text{H}_{14}\text{I}_2\text{S}_8$ requires: C, 21.55; H, 2.11%); m/z (EI) 668 (M^+ , 20%), 386 (100), 388 (47); δ_{H} (CDCl_3) 3.35-3.22 (8H, m), 2.45 (6H, s); ν_{max} (KBr) 1417, 1151, 892 cm^{-1} .

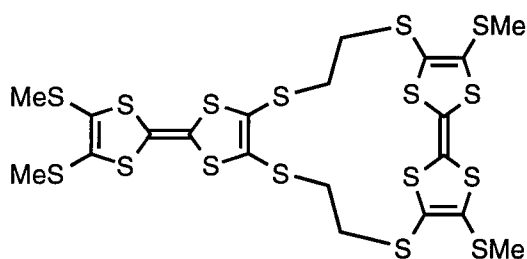
BisTTF (156)

To a solution of TTF **153** (445 mg, 0.96 mmol) in anhydrous DMF (45 ml) was added CsOH (354 mg, 2.1 mmol) as a solution in MeOH (5 ml) and then left to stir for 1 h. Compound **176** (640 mg, 0.96 mmol) was dissolved in anhydrous DMF (50 ml) and the two solutions were added to anhydrous DMF (50 ml) over 16 h under high dilution conditions. The solvents were removed *in vacuo* and the residue was taken up in CH₂Cl₂ (100 ml), washed with water (3 x 100 ml), and dried (MgSO₄). The crude product was columned on silica (eluent: CH₂Cl₂/hexane 1:1) to give **156** as red crystals (400 mg, 54%); mp 192-194°C; (Analysis found: C, 31.02, H, 2.61%; C₂₀H₂₀S₁₆ requires: C, 31.06, H, 2.60%); m/z (PDMS) 774.5 (M⁺); δ_H (CDCl₃) 3.05 (8H, s), 2.47 (6H, s), 2.41(6H, s); δ_C (CDCl₃); 130.0, 129.2, 127.5, 123.2, 118.0, 112.2, 110.3, 36.6, 33.7, 19.7, 19.3; ν_{max} (KBr) 1414, 1196, 885, 772 cm⁻¹; λ_{max}(ε)= 262 (24.5 x 10⁴), 310 (sh, 17 x 10⁴), 334 (23.6 x 10⁴), 386 (4.3 x 10⁴) nm; DPV(CH₂Cl₂/MeCN) E₁^{ox} = 0.56, E₂^{ox} = 0.66, E₃^{ox} = 0.77, E₄^{ox} = 0.86 V.

Complex of 156 and ClO₄⁻

A complex was prepared by electrolysing a solution of **156** (1.6 x 10⁻⁴ mol) in anhydrous CH₂Cl₂ containing Bu₄NClO₄ at a constant current of 1.5 μA for 2 weeks; after which, partial evaporation of the solvent precipitated black needles of the 2:1 perchlorate salt (**156**)₂⁺·ClO₄⁻ (Stoichiometry determined by X-ray); σ_{rt} = 1 x 10⁻² Scm⁻¹.

Complex of 156 and I₃⁻

A complex was prepared by slow diffusion of iodine vapour into a solution of compound **156** (1.6 x 10⁻⁴ mol) in CH₂Cl₂ at room temperature. After 2 days, black lustrous crystals of the iodide salt **156**⁺·I₃⁻ were collected. Analysis for 1:8 complex: (found: C, 13.62, H, 1.19%; C₂₀H₂₀I₈S₁₆ requires: C, 13.43, H, 1.13%); σ_{rt} = 1 x 10⁻⁹ Scm⁻¹.

4,5-Bis(methylthio)-4',5'-bis(3-hydroxypropylthio)tetrathiafulvalene (171)

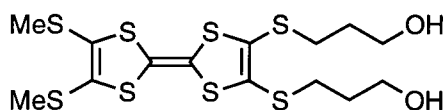

To a suspension of protected TTF **95** (2.0 g, 4.3 mmol) in anhydrous EtOH (100 ml) under argon was added sodium ethoxide solution generated from sodium (0.49 g, 22 mmol) in anhydrous EtOH (50 ml). The reaction was left to stir for 1 h until a deep red solution had formed. 3-Bromopropanol (1.95 ml, 22 mmol) was added and the reaction was left to stir overnight. The mixture was then concentrated *in vacuo* and the residue was extracted with CH₂Cl₂ (100 ml) washed with water (3 x 100 ml), dried over MgSO₄ and the solvents removed *in vacuo* to give an orange solid which was recrystallised from CH₂Cl₂/hexane to give **171** (1.36 g, 66%) as orange needles. mp 70-71°C (lit.¹⁵⁷ 79-80°C); (Analysis found: C, 35.08, H, 4.23%; C₁₄H₂₀O₂S₈ requires: C, 35.26, H, 4.22%); m/z (CI) 477 (MH⁺, 35%), 367 (80), 279 (92), 137 (100); δ_H (CDCl₃) 3.76 (4H, t, J = 6 Hz), 2.93 (4H, t, J = 7 Hz), 2.42 (6H, s), 2.09 (2H, s), 1.88 (4H, m).

4,5-Bis(methylthio)-4',5'-bis(3-methanesulfonylpropylthio)tetrathiafulvalene (174)

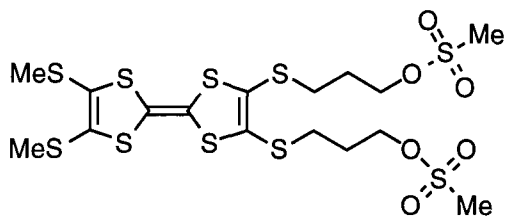

To an ice-cooled solution of compound **171** (1.36 g, 2.9 mmol) in dry CH₂Cl₂ (70 ml) under argon was added NEt₃ (2 ml, 14 mmol) followed by methanesulfonylchloride (1 ml, 14 mmol). The reaction was left to stir overnight. The mixture was then concentrated *in vacuo* and the residue was extracted with CH₂Cl₂ (100 ml), washed with water (3 x 100 ml), dried over MgSO₄ and the solvents removed *in vacuo* to give a yellow solid which was purified by column chromatography on silica (eluent CH₂Cl₂, then CH₂Cl₂/ethyl acetate 4:1) and recrystallised from CH₂Cl₂/hexane to give **174** (1.2 g, 66%); mp 85-86°C; (Analysis found: C, 30.26, H, 3.97%; C₁₆H₂₄O₆S₁₀ requires: C, 30.36, H, 3.82%); m/z (CI) 634 (MH⁺); δ_H (CDCl₃) 4.37 (4H, t, J = 6 Hz), 3.04 (6H, s), 2.95 (4H, t, J = 7 Hz), 2.43 (6H, s), 2.07 (4H, m); ν_{max} (KBr) 2293, 2343, 1335, 1166, 984 cm⁻¹.

4,5-Bis(methylthio)-4',5'-bis(3-iodopropylthio) tetrathiafulvalene (**177**)

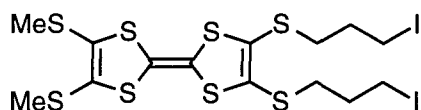

NaI (2.85 g, 19 mmol) was added to a solution of **174** (1.2 g, 1.9 mmol) in acetone (100 ml) under argon. The mixture was refluxed for 1 h.

The mixture was then concentrated *in vacuo* and the residue was extracted with CH₂Cl₂ (100 ml) washed with water (3 x 100 ml), dried over MgSO₄ and the solvents removed *in vacuo*. The crude product was purified by column chromatography on silica (eluent CH₂Cl₂/hexane 1:2) to give **177** (1.12g, 88%) as a red oil (lit.¹⁵⁷ red solid, mp. 47-49°C); δ_H (CDCl₃) 3.30 (4H, t, J = 6 Hz), 2.91 (4H, t, J = 7 Hz), 2.43 (6H, s), 2.09 (4H, m).

BISTTF (**157**)

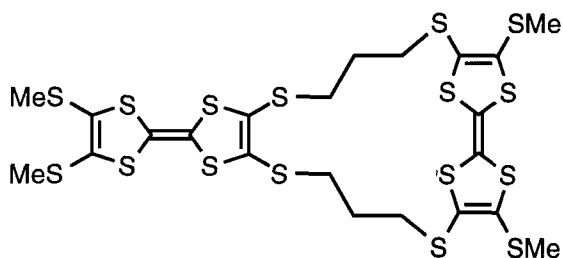

To a solution of protected TTF **153** (700 mg, 1.5 mmol) in anhydrous DMF (40 ml) was added CsOH (530 mg, 3.15 mmol) in anhydrous MeOH (5 ml), and the mixture was left to stir for 45 min. Compound

177 (1 g, 1.5 mmol) was dissolved in anhydrous DMF (45 ml) and the two solutions were added over 3 h to anhydrous DMF (75 ml) under argon. The solvents were removed *in vacuo* and the residue was taken up in CH₂Cl₂ (100 ml), and washed with water (3 x 100 ml), and dried (MgSO₄). The crude product was columned on silica (eluent: CH₂Cl₂/hexane 1:1) to give **157** as yellow crystals (700 mg, 58%); mp 98-100°C; (Analysis found: C, 32.88, H, 3.00%; C₂₂H₂₄S₁₆ requires: C, 32.97; H, 3.01%); m/z (PDMS) 799.4 (M⁺); δ_H (CDCl₃) 2.94-2.85 (8H, m), 2.47 (6H, s), 2.40 (6H, s), 1.95 (4H, quin, J = 7 Hz); δ_C (CDCl₃) 130.5, 127.7, 127.4, 124.5, 115.0, 111.35, 110.2, 34.4, 31.5, 29.9, 19.6, 19.2; ν_{max} (KBr) 2912, 1412, 880, 772 cm⁻¹; λ_{max}(ε)= 262 (20.8 x 10⁴), 310 (sh, 15.9 x 10⁴), 334 (20.5 x 10⁴), 382 (4.3 x 10⁴) nm; CV(MeCN/CH₂Cl₂) E₁^{1/2} = 0.56, E₂^{1/2} = 0.66, E₃^{1/2} = 0.77 V.

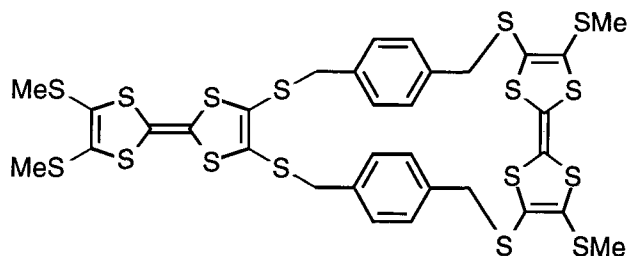
BISTTF (160) *cis/trans*

Protected TTF **153** (730 mg, 1.6 mmol) was dissolved in anhydrous degassed DMF (45 ml) under argon. A solution of CsOH (553 mg, 3.3 mmol) in anhydrous MeOH (5 ml)

was added and the reaction was left to stir for 1 h. Compound **179** (1.0 g, 1.6 mmol) was dissolved in anhydrous degassed DMF (50 ml), and the two solutions were added to DMF (40 ml) over 16 h under high dilution conditions. The DMF was then removed *in vacuo* and the residue was dissolved in CH₂Cl₂ (100 ml), washed with water (3 x 100 ml), and dried (MgSO₄). The product was columned on silica gel (eluent CH₂Cl₂/hexane 1:1) and recrystallised from CH₂Cl₂/hexane to yield **160** as an orange powder (750 mg, 52%); mp 88-89°C; (Analysis found: C, 41.33, H, 2.93%; C₃₂H₂₈S₁₆ requires: C, 41.52, H, 3.04%); m/z (PDMS) 925.3 (M⁺); δ_H (CDCl₃) 7.32-7.22 (8H, m), 4.10-3.80 (8H, m), (2.43, 2.42, 2.17, 2.10, 12H, SMe, as *cis/trans* mixture); ν_{max} (KBr) 2914, 1507, 1418, 1261, 1083, 771 cm⁻¹; λ_{max}(ε)= 312 (27.8 x 10⁴), 332 (30.7 x 10⁴), 392 (6.6 x 10⁴) nm; CV(CH₂Cl₂/MeCN) E₁^{1/2} = 0.49, E₂^{1/2} = 0.56, E₃^{1/2} = 0.79 V.

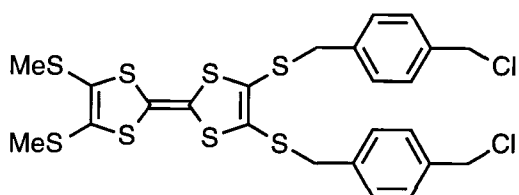
4,5-Bis(methylthio)-4',5'-bis(4-chloromethylbenzylthio)tetrathiafulvalene (179)

Protected TTF **94** (2 g, 4.3 mmol) was dissolved in anhydrous DMF (40 ml). To this solution was added CsOH (1.52 g, 9 mmol) in anhydrous MeOH (5 ml), and the reaction was stirred for 90

min, then α,α-dichloro-*p*-xylene (7.5g, 43 mmol) was added and the reaction was left to stir for a further 1 h. The reaction was then diluted with CH₂Cl₂ (200 ml) and washed with brine (4 x 200 ml), dried over MgSO₄ and the solvents removed *in vacuo*. The residue was columned on silica (eluent CH₂Cl₂/hexane 1:3, to remove unreacted α,α-dichloro-*p*-xylene, then 1:1). The product was crystallised from CH₂Cl₂/hexane to give **179** as orange needles (1.27 g, 46%); mp 89-90°C; (Analysis found: C, 45.02, H, 3.44%; C₂₄H₂₂Cl₂S₈ requires: C, 45.19, H, 3.47%); m/z (EI) 638 (M⁺, 14%), 497 (11), 139 (65), 104 (100); δ_H (CDCl₃) 7.32 (4H, d, J = 8 Hz), 7.23 (4H, d, J = 8 Hz), 4.55 (4H, s), 3.83 (4H, s), 2.43 (6H, s); δ_C (CDCl₃); 136.9, 136.8, 129.4, 129.2, 128.8, 127.3, 45.8, 40.3, 19.1; ν_{max} (KBr) 2916, 1511, 1419, 1268, 896 cm⁻¹.

4,5-Bis(3-hydroxypropylthio)-1,3-dithiole-2-thione (180)

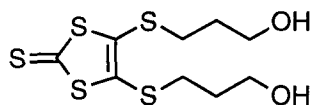

To a stirred solution of zincate salt **72** (14.37 g, 0.02 mol) in acetonitrile (250 ml) under argon was added 3-bromopropanol (13.9 g, 0.1 mol). The mixture was refluxed overnight. The solvent was removed *in vacuo* and the residue taken up in CH_2Cl_2 (200 ml). The solution was then filtered through a bed of celite, washed with water (3 x 200 ml), dried over MgSO_4 and concentrated *in vacuo*. Excess 3-bromopropanol was removed by kugelrohr distillation, and the residue was then filtered through a plug of silica (eluent acetone: CH_2Cl_2 , 1:4) to yield the diol **180** as a red oil (5.65 g, 90%); m/z (CI) 314 (MH^+ , 100%); δ_{H} (CDCl_3) 3.75 (4H, t, $J = 6$ Hz), 3.00 (4H, t, $J = 7$ Hz), 2.47 (2H, s), 1.90 (4H, m); ν_{max} (KBr) 3355, 2932, 2876, 1421, 1265, 1063, 888 cm^{-1} .

4,5-Bis(3-methanesulfonylpropylthio)-1,3-dithiole-2-thione (181)

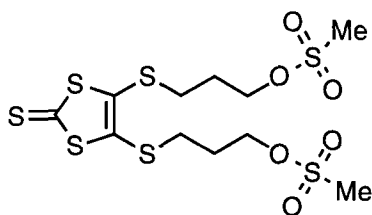

To a stirred solution of diol **180** (5.4 g, 17 mmol) in dry CH_2Cl_2 was added methanesulfonylchloride (13.37 ml, 0.17 mol) and anhydrous pyridine (13.7 ml, 0.17 mol). The reaction was left to stir under argon overnight. The mixture was then concentrated *in vacuo* and the residue taken up in CH_2Cl_2 (150 ml), washed with water (3 x 200 ml), dried over MgSO_4 and the solvents removed *in vacuo* to yield a red oil which crystallised from CH_2Cl_2 /hexane to give **181** as a yellow solid (5.19 g, 65%); mp 66–68°C; (Analysis found: C, 27.97, H, 3.83%; $\text{C}_{11}\text{H}_{18}\text{O}_6\text{S}_7$ requires: C, 28.07, H, 3.85%); m/z (EI) 470 (M^+ , 100%), 137 (84), 44 (100); δ_{H} (CDCl_3) 4.3 (4H, t, $J = 6$ Hz), 3.00 (6H, s), 2.97 (4H, t, $J = 7$ Hz), 2.05 (4H, m); δ_{C} (CDCl_3) 210.3, 136.0, 67.2 37.0, 32.3, 28.7; ν_{max} (KBr) 3031, 1339, 1167, 1065, 994 cm^{-1} .

4,5-Bis(3-iodopropylthio)-1,3-dithiole-2-thione (182)

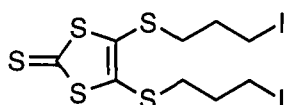

To a stirred solution of mesylate **181** (1.8 g, 3.8 mmol) in acetone was added NaI (5.7 g, 38 mmol). The reaction was refluxed under argon for 1 h. The mixture was then concentrated *in vacuo* and the residue was extracted with CH_2Cl_2 (100 ml), washed with water (3 x 100 ml), dried over MgSO_4 and the solvents removed *in vacuo* to give a yellow solid which was recrystallised from CH_2Cl_2 /hexane to give **182** as yellow

plates (1.3 g, 64%); mp 60-61°C; (Analysis found: C, 20.26, H, 2.19%; C₉H₁₂I₂S₅ requires: C, 20.23, H, 2.26%); m/z (EI) 534 (M⁺, 100%); δ_H (CDCl₃) 3.32 (4H, t, J = 7 Hz), 3.00 (4H, t, J = 7 Hz), 2.14 (4H, quin, J = 7 Hz); δ_C (CDCl₃) 209.9, 135.8, 37.0, 32.3, 4.2; ν_{max} (KBr) 1169, 1150, 1056, 1029 cm⁻¹.

TTF derivative (183)

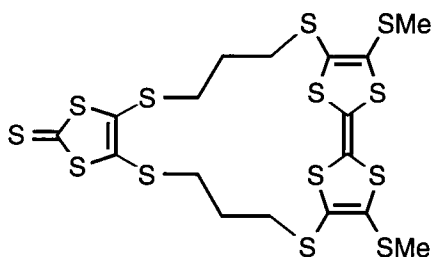

To a solution of protected TTF **153** (1.3 g, 2.8 mmol) in anhydrous DMF (40 ml) was added CsOH (900 mg, 5.6 mmol) in anhydrous MeOH (5 ml). Compound **182** (1.5 g, 2.8 mmol) was dissolved in anhydrous DMF (25 ml) and the two solutions were added over 4 h

to anhydrous DMF (80 ml) under argon. The mixture was then concentrated *in vacuo* and the residue was extracted with CH₂Cl₂ (100 ml), washed with water (3 x 100 ml), dried over MgSO₄ and the solvents removed *in vacuo* to give a yellow solid which was purified by column chromatography on silica (eluent 1:1 CH₂Cl₂/hexane). Recrystallisation from CH₂Cl₂/hexane gave **183** (445 mg, 25%) as a red crystalline solid; mp 180-181°C; (Analysis found: C, 32.01, H, 2.80%; C₁₇H₁₈S₁₃ requires: C, 31.94, H, 2.83%); m/z (PDMS) 637.2 (M⁺); δ_H (CDCl₃) *cis* isomer: 2.87 (8H, q, J = 7Hz), 2.45 (6H, s), 1.95 (4H, quin, J = 7Hz); δ_C (CDCl₃) *cis* isomer: 210.4, 136.1, 131.6, 121.2, 115.4; ν_{max} (KBr) 2909, 1417, 1058 cm⁻¹; CV (CH₂Cl₂/MeCN) E₁^{1/2} = 0.65, E₂^{1/2} = 0.82, E₃^{ox} = 1.25 V.

5.4 EXPERIMENTAL PROCEDURES FOR CHAPTER 4

1,4-Bis[4-(2-cyanoethylthio)-4',5'-bis(methylthio)tetrathiafulvalene-5-ylthiomethylene]benzene (200)

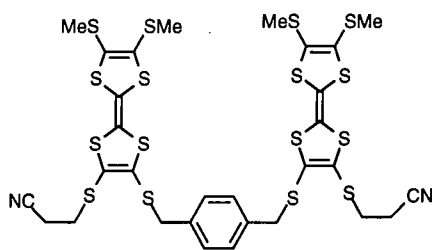

Protected TTF **94** (0.93 g, 2 mmol) was dissolved in dry DMF (50 ml) and to this was added CsOH (350 mg, 2 mmol) in dry MeOH (5 ml) dropwise over 30 min. When addition was complete the reaction was stirred for a further 20 min. To this mixture was added

α,α -dibromo-*p*-xylene (264 mg, 1 mmol) and the reaction was left to stir overnight. The reaction was poured into water (200 ml) and the resultant precipitate was filtered, and dried *in vacuo*, then recrystallised from toluene to give **200** as an orange powder (640 mg, 69%); mp 150°C; (Analysis found: C, 38.82, H, 2.99, N, 2.96%; C₃₀H₂₈N₂S₁₆ requires: C, 38.76, H, 3.03, N, 3.01%); *m/z* (PDMS) 929 (M⁺); δ_{H} (CDCl₃) 7.28 (4H, s), 4.03 (4H, s), 2.81 (4H, t, J = 7 Hz), 2.44 (12H, s), 2.33 (4H, t, J = 7 Hz); ν_{max} (KBr) 2917, 2242, 1413 cm⁻¹; CV(PhCN): E₁^{1/2} = + 0.48, E₂^{1/2} = + 0.74 V.

TRISTTF (202)

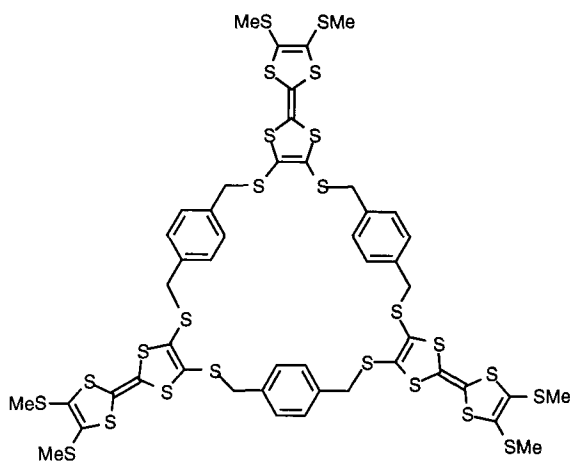

To a solution of **200** (464 mg, 0.5 mmol) in dry DMF (45 ml) was added CsOH (210 mg, 1.25 mmol) in dry MeOH (5 ml) and the resulting solution was left to stir for 1 h. This solution and a solution of compound **179** (401 mg, 0.6 mmol) were added to dry DMF (50 ml) under high dilution conditions using a syringe pump over 16h.

The DMF was removed *in vacuo* and the residue was dissolved in toluene (100 ml) and washed with water (2 x 100 ml), dried (MgSO₄), and filtered through a plug of silica. The solvents were removed *in vacuo* to give **202** (536 mg, 77%) as a red oil; (Analysis found: C, 41.27, H, 2.94%; C₄₈H₄₂S₂₄ requires: C, 41.52, H, 3.04%); *m/z* (PDMS) 1389 (MH⁺, 100%); δ_{H} (CDCl₃) 7.17 (12H, s), 3.73 (12H, s), 2.43 (18H, s); δ_{C} (CDCl₃) 136.0, 129.4, 129.4, 127.4, 110.8, 110.2, 40.3, 19.0; ν_{max} (KBr) 2915, 1418, 1095 cm⁻¹; CV(CH₂Cl₂/MeCN): E₁^{1/2} = + 0.49, E₂^{1/2} = + 0.75 V.

1,2-Bis{4-(2-cyanoethylthio)-4',5'-bis(methylthio)tetrathiafulvalene-5-ylthio}ethane (201)

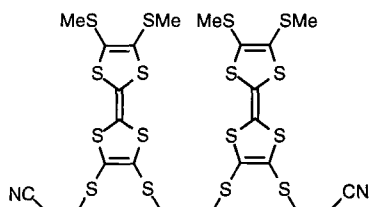

CsOH (700 mg, 4.2 mmol) in dry MeOH (6 ml) was added dropwise over 45 min to a solution of TTF **94** (1.86 g, 4 mmol) in dry DMF (50 ml). The solution was left to stir for a further 20 min and then dibromoethane (0.17 ml, 2 mmol) was added. The

reaction was left to stir overnight then diluted with water (200 ml) and the resulting precipitate was filtered, and dried *in vacuo*. The crude product was then recrystallised from toluene/cyclohexane to give **201** as an orange powder (1.25 g, 73%); mp 158-160°C. (Analysis found: C, 33.98, H, 2.63, N, 2.94%; C₂₄H₂₄N₂S₁₆ requires: C, 33.77; H, 2.83, N, 3.28%); m/z (PDMS) 853 (M⁺); δ_H (DMSO-d₆) 3.14-3.10 (8H, m), 2.84 (4H, t, J = 7Hz), 2.41 (6H, s), 2.40 (6H, s); ν_{max} (KBr) 2248, 1420, 890 cm⁻¹; CV(PhCN): E₁^{1/2} = + 0.49, E₂^{1/2} = + 0.76 V.

TRISTTF (203)

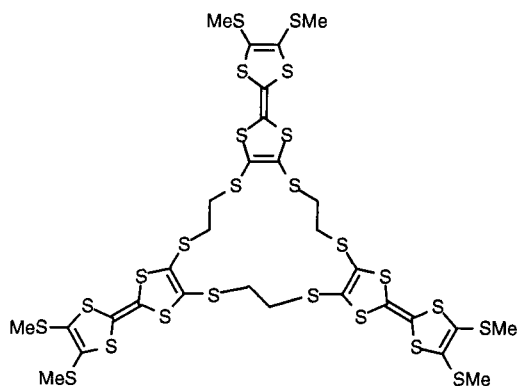

To a solution of **201** (512 mg, 0.6 mmol) in dry DMF (40 ml) was added CsOH (221 mg, 1.3 mmol) in dry MeOH (5 ml) and the resulting solution was stirred for 45 min. This solution and a solution of **176** (401 mg, 0.6 mmol) in dry DMF (45 ml) were added to dry DMF (50 ml) under high

dilution conditions using a syringe pump over 16 h. The solvents were reduced in volume to 40 ml and the reaction was placed in the freezer for several hours. The orange precipitate formed was filtered off and dissolved in hot CHCl₃ (150 ml) and filtered through a plug of silica. The solvents were removed *in vacuo* and the residue recrystallised from CHCl₃/MeOH to give **203** as an orange powder (510 mg, 73%); mp 158-160°C. (Analysis found: C, 31.09, H, 2.60%; C₃₀H₃₀S₂₄ requires: C, 31.06, H, 2.53 %); m/z (PDMS) 1163 (M⁺⁺³); δ_H (CDCl₃) 3.12 (12H, s), 2.44 (18H, s); ν_{max} (KBr) 2913, 1414, 888 cm⁻¹; CV(PhCN): E₁^{1/2} = + 0.50, E₂^{1/2} = + 0.76 V.

4,5-Bis(2-cyanoethylthio)-4',5'-[2-(*tert*-butyldiphenylsilyloxymethyl)propylene-1,3-dithio]tetrathiafulvalene (212)

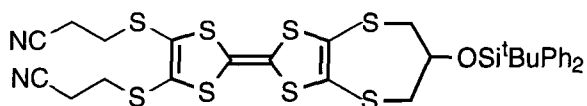

Compounds **211** (5.11 g, 0.01 mol) and **76** (4.32 g, 0.015 mol) were suspended in $\text{P}(\text{OEt})_3$ (70 ml)

under argon and heated at 110°C for 90 min. The mixture was allowed to cool and then poured into MeOH (750 ml) and placed in the fridge overnight. The precipitate formed was filtered off and subjected to column chromatography on silica (eluent: CH_2Cl_2). The middle broad band was isolated and recrystallised from $\text{CHCl}_3/\text{MeOH}$ to give **212** as yellow needles (4.11 g, 56%); mp $96\text{--}98^\circ\text{C}$; (Analysis found: C, 50.58, H, 4.37, N 3.76%; $\text{C}_{31}\text{H}_{32}\text{N}_2\text{OS}_8\text{Si}$ requires: C, 50.78, H, 4.39, N, 3.82%); m/z (PDMS) 733 (M^+ , 100%); δ_{H} (CDCl_3) 7.61 (4H, dd, $J_1 = 8$ Hz, $J_2 = 2$ Hz), 7.48-7.41 (6H, m), 4.06 (1H, m), 3.00-3.10 (4H, m), 2.75-2.80 (6H, m), 2.70 (2H, dd, $J_1 = 9$ Hz, $J_2 = 14$ Hz), 1.08 (9H, s); δ_{C} (CDCl_3) 135.6, 133.1, 130.1, 127.9, 117.4, 39.0, 31.3, 26.8, 19.1, 18.9; ν_{max} (KBr) 2250, 1062, 704 cm^{-1} .

4,5-[2-(Acetyl)propylene-1,3-dithio]-1,3-dithiole-2-thione (214)

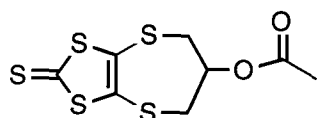

Compound **204** (2 g, 7.8 mmol) was suspended in acetic anhydride (50 ml) under an atmosphere of nitrogen. Anhydrous pyridine (3 ml, excess) was

added and the reaction was left to stir overnight. The mixture was then poured onto crushed ice and the yellow precipitate was filtered and washed with water (100 ml) and MeOH (50 ml). After drying *in vacuo*, the yellow solid was recrystallised from toluene/petroleum ether (b.p. $60\text{--}80^\circ$) to yield **214** (2 g, 86%) as yellow crystals; mp $128\text{--}130^\circ\text{C}$; (Analysis found: C, 32.30, H, 2.54%; $\text{C}_8\text{H}_8\text{O}_2\text{S}_5$ requires: C, 32.41, H, 2.72%); m/z (EI) 296 (M^+ , 89%), 236 (24), 88 (87), 43 (100); δ_{H} (CDCl_3) 5.29 (1H, tt, $J_1 = 3$ Hz, $J_2 = 9$ Hz), 3.06 (2H, dd, $J_1 = 3$ Hz, $J_2 = 14$ Hz), 2.76 (2H, dd, $J_1 = 9$ Hz, $J_2 = 14$ Hz), 2.10 (3H, s); δ_{C} (CDCl_3) 209.8, 169.3, 138.9, 73.9, 35.9, 20.9; ν_{max} (KBr) 1722, 1240, 1083 cm^{-1} .

4,5-Bis(2-cyanoethylthio)-4',5'-[2-(acetyl)propylene-1,3-dithio]tetrathiafulvalene (216)

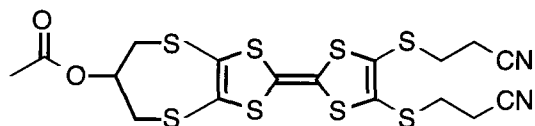

Compounds **214** (1.5 g, 5 mmol) and **76** (2.16 g, 7.5 mmol) were suspended in triethyl phosphite

(50 ml) under an atmosphere of nitrogen. The mixture was heated to 110°C for 90 min. After cooling, the reaction was diluted with MeOH (500 ml) and placed in the freezer overnight. The precipitated solid was filtered off, washed with MeOH (2 x 100 ml) and dried *in vacuo*. The crude product was purified by column chromatography on silica gel eluting first with CH₂Cl₂ then CH₂Cl₂/ethyl acetate (20:1). The second broad band was isolated and recrystallised from CH₂Cl₂/MeOH to give **216** (1.46 g, 54%) as a yellow powder; mp 124-126°C; (Analysis found: C, 38.07, H, 2.86, N, 5.16%; C₁₇H₁₆N₂O₂S₈ requires: C, 38.03, H, 3.00, N, 5.21%); *m/z* (EI) 536 (M⁺, 40%), 208 (19), 88 (74), 43 (100); δ_H (CDCl₃) 5.21 (1H, tt, J₁ = 3 Hz, J₂ = 9 Hz), 3.16-2.89 (6H, m), 2.76-2.57 (6H, m), 2.08 (3H, s); δ_C (CDCl₃); 169.2, 130.1, 127.8, 117.4, 114.0, 109.5, 106.3, 74.6, 35.8, 31.2, 20.9, 18.7; ν_{max} (KBr) 2247, 1725, 1231, 1026 cm⁻¹.

4,5-Bis(2-cyanoethylthio)-4',5'-[2-(hydroxy)propylene-1,3-dithio]tetrathiafulvalene (213)

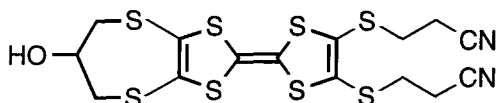

Compound **216** (2 g, 3.7 mmol) was suspended in EtOH (200 ml). TsOH (1 g, 5.2 mmol) was added and the mixture

was refluxed overnight. After cooling, the reaction was poured into water (500 ml) and placed in the fridge for 3 h. The resultant precipitate was filtered, and dried overnight in a desiccator. The crude product was dissolved in boiling toluene (150 ml) and treated with activated charcoal. After filtration through a bed of celite the filtrate was placed in the freezer overnight to give **213** (1.6 g, 87%) as large yellow needles; mp 126-129°C. (Analysis found: C, 36.55, H, 2.76, N, 5.54%; C₁₅H₁₄N₂OS₈ requires: C, 36.41, H, 2.85, N, 5.66%); *m/z* (EI) 494 (M⁺, 24%), 236 (35), 54 (100); δ_H (DMSO-d₆) 5.63 (1H, s), 3.94 (1H, m), 3.14 (4H, dt, J₁ = 2 Hz, J₂ = 7 Hz), 2.94 (2H, dd, J₁ = 2 Hz, J₂ = 14 Hz), 2.86 (4H, dt, J₁ = 2 Hz, J₂ = 7 Hz), 2.46 (2H, dd, J₁ = 10 Hz, J₂ = 14 Hz); δ_C (DMSO-d₆) 129.4, 127.6, 118.9, 111.0, 110.8, 72.9, 38.2, 31.0, 18.3; ν_{max} (KBr) 3494, 2246, 1406, 1166, 1045 cm⁻¹.

4,5-Bis(3-chloropropylthio)-4',5'-[2-(hydroxy)-propylene-1,3-dithio]tetrathiafulvalene (218)

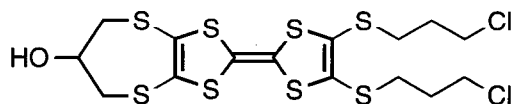

Compound **213** (1.5 g, 3 mmol) was dissolved in dry degassed DMF (50 ml).

CsOH (1.07 g, 6.4 mmol) was added over 10 min in dry degassed MeOH (8 ml). The reaction was left to stir for 30 min, then 1-bromo-3-chloropropane (6 ml, 60 mmol) was added. The reaction was left to stir overnight. The DMF was then removed *in vacuo*, and the residue was dissolved in CH₂Cl₂ (100 ml), washed with water (3 x 100 ml), and dried (MgSO₄). The product was columned on silica gel (eluent CH₂Cl₂) and recrystallised from CH₂Cl₂/hexane to give **218** (1.36 g, 81%) as yellow crystals; mp 68-70°C. (Analysis found: C, 32.97, H, 3.26%; C₁₅H₁₈Cl₂OS₈ requires: C, 33.25; H, 3.34%); m/z (EI) 542 (M⁺, 100%), 430 (45), 266 (68); δ_H (CDCl₃) 4.20 (1H, s), 3.68 (4H, t, J = 6 Hz) 3.00-2.83 (8H, m), 2.07 (4H, quin, J = 7 Hz); δ_C (CDCl₃); 131.2, 127.9, 112.1, 111.8, 42.8, 39.8, 33.2, 32.0; ν_{max} (KBr) 3260, 2913, 1435, 1266, 1057 cm⁻¹.

4,5-Bis(3-iodopropylthio)-4',5'-[2-(hydroxy)propylene-1,3-dithio]tetrathiafulvalene (219)

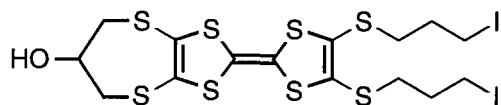

Compound **218** (800 mg, 1.5 mmol) and NaI (4.44 g, 0.03 mol) were refluxed together in acetone (100 ml) under argon

overnight. The acetone was removed *in vacuo*, and the residue was taken up in CH₂Cl₂ (100 ml), washed with water (3 x 100 ml) and dried (MgSO₄). The solution was then filtered through a plug of silica, the solvent evaporated *in vacuo* and the residue recrystallised from CH₂Cl₂/hexane to give **219** as yellow crystals (848 mg, 78%); mp 66-68°C. (Analysis found: C, 25.03, H, 2.50%; C₁₅H₁₈I₂OS₈ requires: C, 24.86; H, 2.50%); m/z (EI) 724 (M⁺, 8%), 428 (26), 296 (34), 169 (100); δ_H (CDCl₃) 4.38 (1H, s), 3.30 (4H, t, J = 7 Hz), 2.97-2.70 (8H, m), 2.08 (4H, quin, J = 7 Hz); ν_{max} (KBr) 3273, 1410, 1208 cm⁻¹.

1,3-Bis{4-(2-cyanoethylthio)-4',5'-[2-(hydroxy)propylene-1,3-dithio]}tetrathiafulvalene-5-ylthio}propane (223)

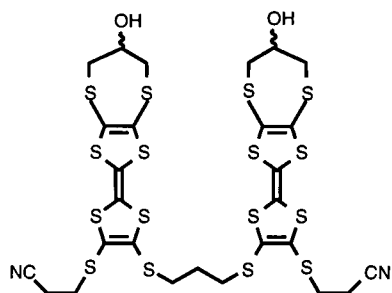

Compound **213** (600 mg, 1.2 mmol) was dissolved in dry degassed DMF (40 ml). CsOH (204 mg, 1.2 mmol) was added dropwise in dry MeOH (10 ml) over 10 min. The reaction was left to stir for 20 min, then 1,3-diiodopropane (0.07 ml, 0.6 mmol) was added and the reaction was left to stir for 1 h. The reaction was diluted with

water (200 ml) and the yellow precipitate which formed was filtered, washed with water (100 ml) and MeOH (50 ml) and dried *in vacuo*. The crude product was recrystallised from CH₂Cl₂/MeOH to give **223** as a yellow solid (790 mg, 71%); mp 90-92°C. (Analysis found: C, 35.31, H, 2.70, N, 2.70%; C₂₇H₂₆N₂O₂S₁₆ requires: C, 35.11, H, 2.83, N, 3.03%); m/z (PDMS) 923 (M⁺); δ_H (DMSO-d₆) 5.62 (2H, s), 3.97 (2H, m), 3.11 (4H, t, J = 7Hz), 2.92-2.99 (8H, m), 2.80-2.82 (4H, m), 2.43-2.50 (4H, m), 1.91 (2H, q, J = 7Hz); ν_{max} (KBr) 3420, 2250, 1919, 1409, 1024 cm⁻¹; CV(PhCN): E₁^{1/2} = + 0.50, E₂^{1/2} = + 0.78 V.

TRISTTF (207)

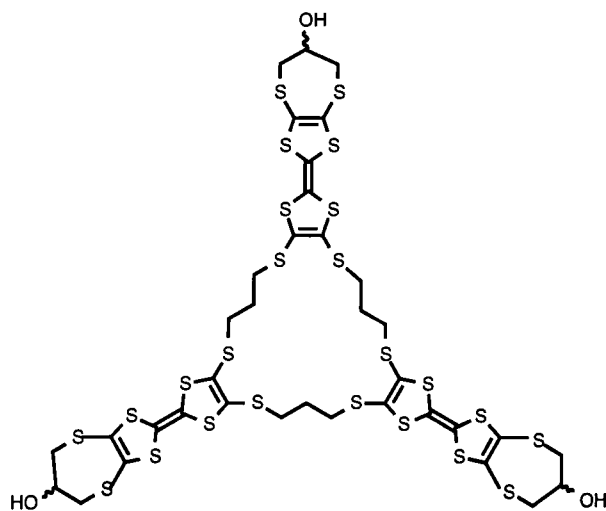

*Bis*TTF **217** (580 mg, 0.63 mmol) was suspended in dry degassed DMF (45 ml). CsOH (232 mg, 1.4 mmol) was added in dry MeOH (5 ml), and the reaction was left to stir under argon for 20 min. This solution and a solution of compound **216** (455 mg, 0.63 mmol) in dry DMF (50 ml) were added to dry DMF (50 ml) under high dilution

conditions using a syringe pump over 16 h. Once the addition was complete, the DMF was removed *in vacuo*. The residue was dissolved in THF (100 ml) and filtered through a plug of silica. The THF was removed *in vacuo* and the residue was recrystallised from dioxane/MeOH to give **207** (635 mg, 78%) as an orange powder; mp 130°C (dec); (Analysis found: C, 34.02, H, 3.25; C₃₆H₃₆O₃S₂₄ requires: C, 33.62, H, 2.82); m/z (PDMS) 1288 (M⁺⁺); δ_H (CDCl₃) 5.71 (3H, s), 4.01 (3H, m), 2.98

(12H, m), 2.54 (12H, m), 1.95 (6H, m); ν_{\max} (KBr) 3414, 1903, 1658; CV(DMF): $E_1^{1/2} = +0.51$, $E_2^{1/2} = +0.68$ V.

4,5-[2-(Acetylmethyl)propylene-1,3-dithio]-1,3-dithiole-2-thione (215)

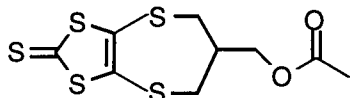

Alcohol **205** (3.37 g, 12.5 mmol) was suspended in acetic anhydride (50 ml) under an atmosphere of nitrogen. Anhydrous pyridine (5 ml, excess) was added and the reaction was left to stir overnight. The mixture was then poured onto crushed ice and the yellow precipitate was filtered and washed with water (100 ml) and MeOH (50 ml). After drying *in vacuo*, the yellow solid was recrystallised from CH_2Cl_2 /Hexane to yield **315** (2 g, 86%) as orange needles; (3.4 g, 88%); mp 87-88°C; (Analysis found: C, 34.66, H, 3.21%; $\text{C}_9\text{H}_{10}\text{O}_2\text{S}_5$ requires: C, 34.81, H, 3.21%); m/z (EI) 310 (M^+ , 100%); δ_{H} (CDCl_3) 4.20 (2H, m), 3.00-2.94 (2H, m), 2.75-2.66 (3H, m), 2.06 (3H, s); δ_{C} (CDCl_3) 210.6 170.4, 139.0, 65.4, 42.0, 35.0, 20.7; ν_{\max} (KBr) 1736, 1252, 1053 cm^{-1} .

4,5-Bis(2-cyanoethylthio)-4',5'-[2-(acetylmethyl)propylene-1,3-dithio]tetrathiafulvalene (217)

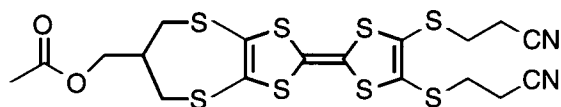

Compound **215** (3.1 g, 10 mmol) and ketone **76** (4.32 g, 15 mmol) were suspended in triethyl phosphite (60 ml) under an atmosphere of nitrogen. The mixture was heated to 120°C for 90 min. After cooling, the reaction was diluted with MeOH (500 ml) and placed in the freezer overnight. The precipitated solid was filtered off; washed with MeOH (2 x 100 ml) and dried *in vacuo*. The crude product was purified by column chromatography on silica gel eluting with CH_2Cl_2 . The second broad band was isolated and recrystallised from CH_2Cl_2 /hexane to give **217** (2.46 g, 45%) as a yellow powder; mp 92-94°C. (Analysis found: C, 39.14, H, 3.25, N, 5.11%; $\text{C}_{18}\text{H}_{18}\text{N}_2\text{O}_2\text{S}_8$ requires: C, 39.24, H, 3.29, N, 5.08%); m/z (EI) 550 (M^+ , 11%), 292 (15), 53 (100); δ_{H} (CDCl_3) 4.20 (2H, s), 3.07 (4H, t, $J = 7$ Hz), 2.88-2.84 (2H, m), 2.72 (4H, t, $J = 7$ Hz), 2.60-2.57 (3H, m), 2.07 (3H, s); δ_{C} (CDCl_3); 170.6, 130.1, 127.9, 117.4, 115.6, 109.1, 65.6, 35.0, 31.2, 20.8, 18.8; ν_{\max} (KBr) 2343, 1739, 1232, 1035 cm^{-1} .

4,5-Bis(2-cyanoethylthio)-4',5'-[2-(hydroxymethyl)propylene-1,3-dithio]tetrathiafulvalene (220)

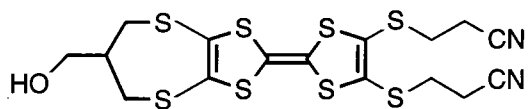

Compound **217** (2 g, 3.6 mmol) was suspended in EtOH (200 ml). TsOH (1g, 5.2 mmol) was added and the mixture was refluxed overnight. After cooling, the reaction was poured into water (500 ml) and extracted with ethyl acetate (2 x 150 ml), washed with water (3 x 100 ml), and dried (MgSO₄). The product was columned on silica gel (eluent: ethyl acetate). The product was dissolved in boiling toluene and placed in the freezer overnight to give **220** (1.72 g, 94%) as a yellow powder; mp 96-98°C. (Analysis found: C, 37.84, H, 3.13, N, 5.36%; C₁₆H₁₆N₂OS₈ requires: C, 37.71; H, 3.16, N, 5.50%); m/z (EI) 508 (M⁺, 57%), 250 (38), 54 (100); δ_H (CDCl₃) 3.46 (2H, d, J = 6 Hz), 3.14 (4H, t, J = 7 Hz), 2.94 (2H, dd, J₁ = 14 Hz, J₂ = 2 Hz), 2.88-2.84 (4H, m), 2.57-2.50 (2H, m), 2.24-2.19 (1H, m); δ_C (CDCl₃) 129.3, 127.5, 118.9, 112.2, 110.1, 62.9, 34.5, 30.9, 18.2; ν_{max} (KBr) 3400, 2292, 2247, 1410, 1277, 1028 cm⁻¹.

4,5-Bis(3-chloropropylthio)-4',5'-[2-(hydroxymethyl)propylene-1,3-dithio]tetrathiafulvalene (221)

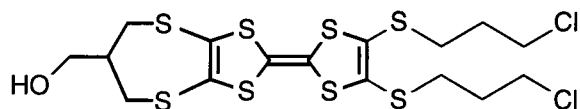

Compound **220** (600 mg, 1.2 mmol) was dissolved in dry degassed DMF (50 ml). CsOH (0.41 g, 2.5 mmol) was added over 10 min in dry degassed MeOH (8 ml). The reaction was left to stir for 30 min, then 1-bromo-3-chloropropane (2.3 ml, 24 mmol) was added. The reaction was left to stir overnight. The DMF was then removed *in vacuo*, and the residue was dissolved in CH₂Cl₂ (100 ml), washed with water (3 x 100 ml), and dried (MgSO₄). The product was columned on silica gel (eluent CH₂Cl₂) and recrystallised from CH₂Cl₂/hexane to give **221** (500 mg, 75%) as yellow plates; mp 104-105°C. (Analysis found: C, 34.32, H, 3.55%; C₁₆H₂₀Cl₂OS₈ requires: C, 34.58, H, 3.63%); m/z (EI) 555 (M⁺, 48%), 441 (43), 130 (58), 88 (100); δ_H (CDCl₃) 3.78 (2H, m), 3.68 (4H, t, J = 6.4 Hz), 2.97 (4H, dt, J₁ = 2 Hz, J₂ = 7 Hz), 2.90 (2H, dd, J₁ = 2 Hz, J₂ = 14 Hz), 2.59 (2H, dd, J₁ = 8 Hz, J₂ = 14 Hz), 2.44 (1H, m), 2.06 (4H, quin, J = 7 Hz); δ_C (CDCl₃); 130.0, 127.9, 113.1, 111.2, 64.7, 42.9, 35.0, 33.2, 32.0; ν_{max} (KBr) 3445, 2343, 1265, 1056 cm⁻¹.

4,5-Bis(3-iodopropylthio)-4',5'-[2-(hydroxymethyl)propylene-1,3-dithio]tetrathiafulvalene (222)

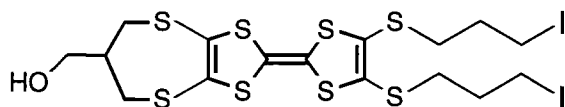

Compound **221** (480 mg, 0.86 mmol) and NaI (2.58 g, 17 mmol) were refluxed together in acetone

(100 ml) under argon overnight. The acetone was removed *in vacuo*, and the residue was taken up in CH₂Cl₂ (100 ml), washed with water (3 x 100 ml) and dried (MgSO₄). The solution was then filtered through a plug of silica and the solvents evaporated *in vacuo*. The residue was recrystallised from CH₂Cl₂/hexane to give **222** as yellow crystals (540 mg, 85%); mp 72-74°C; (Analysis found: C, 26.20, H, 2.67%; C₁₆H₂₀I₂OS₈ requires: C, 26.01; H, 2.72%); m/z (EI) 738 (M⁺, 15%), 442 (100), 169 (58); δ_H (CDCl₃) 3.78 (2H, d, J = 6 Hz), 3.31 (4H, t, J = 7 Hz), 2.88-2.92 (6H, m), 2.56-2.62 (2H, m), 2.46 (1H, m), 2.09 (4H, quin, J = 7 Hz); ν_{max} (KBr) 3420, 2920, 1411, 1207 cm⁻¹.

1,3-Bis{4-(2-cyanoethylthio)-4',5'-[2-(hydroxymethyl)propylene-1,3-dithio]tetrathiafulvalene-5-ylthio}propane (224)

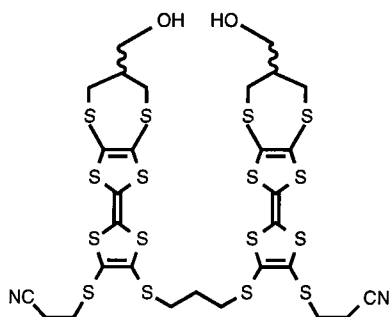

Compound **220** (650 mg, 1.27 mmol) was dissolved in dry degassed DMF (40 ml). CsOH (214 mg, 1.27 mmol) was added dropwise in dry MeOH (10 ml) over 10 min. The reaction was left to stir for 20 min then 1,3-diiodopropane (0.07 ml, 0.64 mmol) was added and the reaction was left to stir for 1 h. The DMF was removed *in*

vacuo and the residue taken up in CH₂Cl₂ (100 ml), washed with water (3 x 100 ml) and dried (MgSO₄). The crude product was recrystallised from CH₂Cl₂/MeOH to give **224** as a yellow solid (395 mg, 65%); mp 82-84°C; (Analysis found: C, 36.46, H, 2.92, N, 2.51%; C₂₉H₃₀N₂O₂S₁₆ requires: C, 36.60, H, 3.17 N, 2.94%); m/z (PDMS) 951 (M⁺, 100%); δ_H (DMSO-d₆) 4.80 (2H, m), 3.45 (4H, m), 3.10 (4H, t, J = 7 Hz), 2.91-2.98 (8H, m), 2.79-2.83 (4H, m), 2.54-2.56 (4H, m), 2.21 (2H, m), 1.87-1.90 (2H, m); δ_C (DMSO-d₆) 129.4, 129.12, 129.1, 125.63, 125.58, 118.7, 112.1, 110.6, 110.5, 62.9, 34.5, 33.8, 31.0, 29.6, 18.3; ν_{max} (KBr) 3420, 1919, 2250, 1409, 1024 cm⁻¹; DPV(PhCN): E₁^{ox} = + 0.52, E₂^{ox} = + 0.57, E₃^{ox} = + 0.81 V.

References

1. M. R. Bryce, *Chem. Soc. Rev.*, 1991, **20**, 355.
2. a) H. Shirakawa, E. J. Louis, A. G. MacDiarmid, C. K. Chiang, A. J. Heeger, *J. Chem. Soc., Chem. Commun.*, 1977, 578; b) M. M. Labes, P. Lowe, and L. F. Nichols, *Chem. Rev.*, 1979, **79**, 1; c) J. Roncali, *Chem. Rev.*, 1992, **92**, 711.
3. a) A. E. Underhill and D. M. Watkins, *Chem. Soc. Rev.*, 1980, **9**, 429; b) P. I. Clemenson, *Coord. Chem. Rev.*, 1990, **106**, 171.
4. a) J. R. Ferraro and J. M. Williams, *Introduction to Synthetic Electrical Conductors*, Academic Press, London, 1987; b) T. Ishiguro, and K. Yamaji, *Organic Superconductors*, Springer-Verlag, Berlin, 1990; c) J. M. Williams, J. R. Ferraro, R. J. Thorn, K. D. Carlson, U. Geiser, H. H. Wang, A. M. Kini, and M. -H. Whangbo, *Organic Superconductors (Including Fullerenes)*, Prentice Hall, Englewood Cliffs, NJ, 1992; d) *The Physics and Chemistry of Organic Superconductors*, G. Saito, and S. Kagoshima (Eds.), Springer-Verlag, Heidelberg, 1990; e) *Organic Superconductivity*, V. Kreisin, and W. Little (Eds.), Plenum Press, New York, 1990.
5. M. R. Bryce and M. C. Petty, *Nature (London)*, 1995, **374**, 771.
6. a) T. K. Hansen, and J. Becher, *Adv. Mater.*, 1993, **5**, 288; b) R. Dieing, V. Morisson, A. J. Moore, L. M. Goldenberg, M. R. Bryce, J. M. Raoul, M. C. Petty, J. Garín, M. Savirón, I. K. Lednev, R. E. Hester, and J. N. Moore, *J. Chem. Soc., Perkin Trans. 2*, 1996, 1587.
7. M. R. Bryce, *Adv. Mater.*, 1999, **11**, 11.
8. a) L. van Hink, G. Schukat, and E. Fanghänel, *J. Prakt. Chem.*, 1979, **321**, 299; b) M. R. Bryce, A. C. Chissel, J. Gopal, P. Kathirgamanathan, and D. Parker, *Synth. Met.*, 1991, **39**, 397; c) S. Frenzel, S. Arndt, R. M. Gregorius, and K. Müllen, *J. Mater. Chem.*, 1995, **5**, 1529; d) T. Shimizu and T. Yamamoto, *J. Mater. Chem.*, 1997, **7**, 259.
9. a) M. R. Bryce, W. Devonport, and A. J. Moore, *Angew. Chem. Int. Ed. Engl.*, 1994, **33**, 1761; b) C. A. Christensen, L. M. Goldenberg, M. R. Bryce, and A. J. Moore, *Chem. Commun.*, 1998, 509.
10. *An Introduction to Molecular Electronics*, M. C. Petty, M. R. Bryce, and D. Bloor (Eds.), Edward Arnold, 1995.
11. a) H. N. McCoy and W. C. Moore, *J. Am. Chem. Soc.*, 1911, **33**, 273; b) H. J. Kraus, *J. Am. Chem. Soc.*, 1913, **34**, 1732.
12. H. Akamatu, H. Inokuchi, and Y. Matsunga, *Nature*, 1954, **173**, 168.
13. J. Kommandeur and F. R. Hall, *J. Chem. Phys.*, 1961, **34**, 129.

14. L. R. Melby, R. J. Harder, W. R. Hertler, R. E. Benson, and W. E. Mochel, *J. Am. Chem. Soc.*, 1962, **84**, 3374.
15. F. Wudl, G. M. Smith, and E. J. Hufnagel, *J. Chem. Soc., Chem. Commun.*, 1970, 1453.
16. T. E. Phillips, T. J. Kistenmacher, J. P. Ferraris and D. O. Cowan, *J. Chem. Soc., Chem. Commun.*, 1973, 471.
17. T. J. Kistenmacher, T. E. Phillips, and D. O. Cowan, *Acta Crystallogr.*, 1973, **B30**, 763.
18. K. Bechgaard, C. S. Jacobsen, K. Mortensen, H. J. Pedersen, and N. Thorup, *Solid State Commun.*, 1980, **33**, 1119.
19. A. M. Kini, U. Geiser, H. H. Wang, K. D. Carlson, J. M. Williams, W. K. Kwok, K. G. Vandervoot, J. E. Thompson, D. L. Stupka, D. Jung, M. -H. Whangbo, *Inorg. Chem.*, 1990, **29**, 2555.
20. J. M. Williams, A. M. Kini, H. H. Wang, K. D. Carlson, U. Geiser, L. K. Montgomery, G. J. Pyrka, D. M. Watkins, J. K. Kommers, S. J. Boryschuk, A. V. Crouch, W. K. Kwok, J. E. Schirber, D. L. Overmeyer, D. Jung, and M. -H. Whangbo, *Inorg. Chem.*, 1990, **29**, 3274.
21. a) D. Jérôme and H. J. Schultz, *Adv. Phys.*, 1982, **31**, 299; b) P. M. Chakin and R. L. Greene, *Physics Today*, 1986, **39**, 24.
22. J. Bardeen, L. N. Cooper, and J. R. Schrieffer, *Phys. Rev.*, 1957, **108**, 1175.
23. a) J. S. Chappell, A. N. Bloch, W. A. Bryden, M. Maxfield, T. O. Pöehler and D. O. Cowan, *J. Am. Chem. Soc.*, 1981, **103**, 2442; b) R. Comès, *Chemistry and Physics of One-Dimensional Metals*, H. J. Keller (Ed.), Plenum Press, New York, 1977, p. 315; c) S. Hünig, G. Kiesslich, H. Quast, and D. Scheitzov, *Liebigs Ann. Chem.*, 1973, 310; d) B. A. Scott, J. B. Torrance, B. Welber, F. B. Kaufman, and P. E. Seider, *Phys. Rev. B*, 1979, **B19**, 730.
24. H. Frölich, *Proc. R. Soc. London Ser. A*, 1954, **223**, 296.
25. R. E. Peierls, *Quantum Theory of Solids*, Oxford University Press, London, 1955.
26. D. O. Cowan, in *New Aspects of Organic Chemistry*, Z. Yoshida, T. Shiba, and Y. Oshiro (Eds.), V.C.H., New York, 1989, 177.
27. a) J. B. Torrance, *Acc. Chem. Res.*, 1979, **12**, 79; b) F. Wudl, *Acc. Chem. Res.*, 1984, **17**, 227; c) J. M. Williams, M. A. Beno, H. H. Wang, P. C. W. Leung, T. J. Emge, U. Geiser, and K. D. Carlson, *Acc. Chem. Res.*, 1985, **18**, 261.

28. J. P. Ferraris, T. O. Poehler, A. N. Bloch, and D. O. Cowan, *Tetrahedron Lett.*, 1973, 2553.
29. J. B. Torrance, J. J. Mayerle, V. Y. Lee, and K. Bechgaard, *J. Am. Chem. Soc.*, 1979, **101**, 4747.
30. K. Bechgaard, K. Carneiro, M. Olsen, B. Rasmussen, and C. S. Jacobsen, *Phys. Rev. Lett.*, 1981, **46**, 852.
31. Y. A. Jackson, C. L. White, M. V. Lakshmikantham, and M. P. Cava, *Tetrahedron Lett.*, 1987, **28**, 5635.
32. M. D. Mays, R. D. McCullough, D. O. Cowan, T. O. Poehler, W. A. Bryden, and T. J. Kistenmacher, *Solid State Commun.*, 1988, **65**, 1089.
33. J. M. Williams, M. A. Beno, H. -H. Wang, T. J. Emge, P. T. Copps, N. L. Hall, K. D. Carlson, and G. W. Crabtree, *Philos. Trans. R. Soc. London, Ser. A*, 1985, **314**, 83.
34. M. Mizuno, A. F. Garito, and M. P. Cava, *J. Chem. Soc., Chem., Commun.*, 1978, 18.
35. K. Bechgaard, in *Structure and Properties of Molecular Crystals*, ed. M. Pierrot, Elsevier, Amsterdam, 1990, p. 235.
36. H. H. Wang, L. K. Montgomery, U. Geiser, L. C. Porter, K. D. Carlson, J. R. Ferraro, J. M. Williams, C. S. Cariss, R. L. Rubenstein, and J. R. Whitworth, *Chem. Mater.*, 1989, **1**, 140.
37. a) E. B. Yagubskii, I. F. Schegolev, V. N. Laukin, P. A. Karatsovnik, M. V. Karatsovnik, A. V. Zvarykina, and L. I. Buravov, *J. E. T. P. Lett. (Engl. Trans.)*, 1984, **39**, 12; b) J. E. Schreiber, L. J. Azevedo, J. K. Kwak, E. L. Venturini, P. C. W. Leung, M. A. Beno, H. H. Wang, and J. M. Williams, *Phys. Rev. B*, 1986, **33**, 1987; c) K. Murata, M. Tokumoto, H. Anzai, H. Bando, K. Kajimura, and T. Ishiguro, *Synth. Met.*, 1986, **13**, 3.
38. P. J. Nigrey, B. Morosin, J. K. Kwak, E. L. Venturini, and R. J. Baughman, *Synth. Met.*, 1986, **16**, 1.
39. a) G. C. Papavassiliou, G. A. Mousdis, J. S. Zambounis, A. Terzis, A. Hountas, B. Hilti, C. W. Mayer, and J. Pfeiffer, *Synth. Met.*, 1988, **B27**, 379; b) A. M. Kini, M. A. Beno, D. Son, H. H. Wang, K. D. Carlson, L. C. Porter, U. Welp, B. A. Vogt, J. M. Williams, D. Jung, M. Evain, M. -H. Whangbo, D. L. Overmyer, and J. E. Schirber, *Solid State Commun.*, 1989, **69**, 503.
40. K. Kikuchi, Y. Honda, Y. Ishikawa, K. Saito, I. Ikemoto, K. Murata, H. Anzai, T. Ishiguro, and K. Kobayashi, *Solid State Commun.*, 1988, **66**, 405.

41. D. Cowan and A. Kini, in *The Chemistry of Organic Selenium and Tellurium Compounds*, S. Patai (Ed.), Wiley, Chichester, vol. 2, 1987, 463.
42. G. R. Desiraju, *Crystal Engineering: The Design of Organic Solids*, Elsevier, Amsterdam, 1989.
43. M. R. Bryce, *J. Mater. Chem.*, 1995, **5**, 1481.
44. P. Blanchard, M. Sallé, G. Duguay, M. Jubault, and A. Gorgues, *Tetrahedron Lett.*, 1992, **33**, 2685.
45. P. Blanchard, M. Sallé, K. Boubekour, G. Duguay, M. Jubault, A. Gorgues, J. D. Martin, E. Canadell, P. Auban-Senzier, D. Jérôme, and P. Batail, *Adv. Mater.*, 1992, **4**, 579.
46. a) A. S. Batsanov, M. R. Bryce, G. Cooke, A. S. Dhindsa, J. N. Heaton, J. A. K. Howard, A. J. Moore, and M. C. Petty, *Chem. Mater.*, 1994, **6**, 1419; b) A. J. Moore, M. R. Bryce, A. S. Batsanov, C. W. Lehmann, and J. A. K. Howard, *Synth. Metals*, 1997, **86**, 1901.
47. a) Z. Yoshida, T. Kawase, H. Awaji, I. Sugimoto, T. Sugimoto, and S. Yoneda, *Tetrahedron Lett.*, 1983, **24**, 3469; b) Z. Yoshida, T. Kawase, S. Yoneda, and H. Awaji, *Heterocycles*, 1982, **18**, 123; c) T. Sugimoto, H. Awaji, I. Sugimoto, Y. Misaki, T. Kawase, S. Yoneda, and Z. Yoshida, *Chem. Mater.*, 1989, **1**, 535.
48. a) V. Y. Khodorkovskii, L. N. Veselova, and O. Y. Neilands, *Khim. Geterotsikl., Soedin.*, 1990, 130; *Chem. Abstr.*, 1990, **113**, 22868t; b) A. J. Moore, M. R. Bryce, D. Ando, and M. B. Hursthouse, *J. Chem. Soc., Chem. Commun.*, 1991, 320; c) T. K. Hansen, M. V. Lakshmikantham, M. P. Cava, R. M. Metzger, and J. Becher, *J. Org. Chem.*, 1991, **56**, 2720.
49. M. R. Bryce, A. Chesney, S. Yoshida, A. J. Moore, A. S. Batsanov, and J. A. K. Howard, *J. Mater. Chem.*, 1997, **7**, 381.
50. a) M. R. Bryce, A. J. Moore, D. Lorcy, A. S. Dhindsa, and A. Robert, *J. Chem. Soc., Chem. Commun.*, 1990, 470; b) M. R. Bryce, A. J. Moore, M. A. Coffin, M. B. Hursthouse, A. I. Karaulov, K. Müllen, and H. Scheich, *Tetrahedron Lett.*, 1991, **32**, 6029; c) Y. Yamashita, K. Ono, S. Tanaka, K. Imaeda, and H. Inokuchi, *Adv. Mater.*, 1994, **6**, 295.
51. M. R. Bryce, A. J. Moore, M. Hasan, G. J. Ashwell, A. T. Frazer, W. Clegg, M. B. Hursthouse, and A. I. Karaulov, *Angew. Chem., Int. Ed. Engl.*, 1990, **29**, 1450.
52. a) M. Adam and K. Müllen, *Adv. Mater.*, 1994, **6**, 439; b) T. Otsubo, Y. Aso, and K. Takimiya, *Adv. Mater.*, 1996, **8**, 203.

53. K. Bechgaard, K. Lerstrup, M. Jørgensen, I. Johannsen, and J. Christensen, in *The Physics and Chemistry of Organic Superconductors*, G. Saito and S. Kagoshima (Eds.), Springer-Verlag, Berlin, 1990, p. 383.
54. M. Jørgensen, K. A. Lerstrup, and K. Bechgaard, *J. Org. Chem.*, 1991, **56**, 5684.
55. M. R. Bryce, G. J. Marshallsay, and A. J. Moore, *J. Org. Chem.*, 1992, **57**, 4859.
56. I. V. Sudmale, G. V. Tormos, V. Y. Khodorkovsky, A. S. Edzina, O. J. Neilands, and M. P. Cava, *J. Org. Chem.*, 1993, **58**, 1355.
57. a) K. Lerstrup, M. Jørgensen, I. Johannsen, and K. Bechgaard, in *The Physics and Chemistry of Organic Superconductors*, G. Saito and S. Kagoshima (Eds.), Springer-Verlag, 1990, p. 349; b) M. Fourmigué, C. Mézière, E. Canadell, D. Zitoun, K. Bechgaard, and P. Auban-Senzier, *Adv. Mater.*, 1999, **11**, 766.
58. G. Ringdorf, N. Thorup, K. Lerstrup, and K. Bechgaard, *Acta Crystallogr., Sect. C*, 1990, **46**, 695.
59. A. Dolbecq, K. Boubekur, P. Batail, E. Canadell, P. Auban-Senzier, C. Coulon, K. Lerstrup, and K. Bechgaard, *J. Mater. Chem.*, 1995, **5**, 1707.
60. A. Izuoka, R. Kumai, and T. Sugawara, *Chem. Lett.*, 1992, 285.
61. T. Otsubo and F. Ogura, *Bull. Chem. Soc. Jpn.*, 1985, **58**, 1343.
62. a) A. Izuoka, T. Tachikawa, T. Sugawara, Y. Saito, and H. Shinohara, *Chem. Lett.*, 1992, 1049; b) T. Tachikawa, A. Izuoka, and T. Sugawara, *J. Chem. Soc., Chem. Commun.*, 1993, 1227.
63. a) T. Tachikawa, A. Izuoka, R. Kumai, T. Sugawara, and Y. Sugawara, *Solid State Commun.*, 1992, **82**, 19; b) A. Izuoka, R. Kumai, T. Tachikawa, and T. Sugawara, *Mol. Cryst. Liq. Cryst.*, 1992, **218**, 213.
64. T. Akutawa, Y. Abe, Y. Nezu, T. Nakamura, M. Kataoka, A. Yamanaka, K. Inoue, T. Inabe, C. A. Christensen, and J. Becher, *Inorg. Chem.*, 1998, **37**, 2330.
65. K. B. Simonsen, J. Becher, and N. Thorup, *Synthesis*, 1997, 1399.
66. E. Nishikawa, H. Tatemitsu, Y. Sakata, and S. Misumi, *Chem. Lett.*, 1986, 2131.
67. M. R. Bryce, G. Cooke, A.S. Dhindsa, D. J. Ando, and M. B. Hursthouse, *Tetrahedron Lett.*, 1988, **33**, 1783.

68. a) J. D. Martin, E. Canadell, J. Y. Becker, and J. Bernstein, *Chem. Mater.*, 1993, **5**, 1199; b) J. Y. Becker, J. Bernstein, S. Bittner, J. A. R. P. Sharma, and L. Shahal, *Tetrahedron Lett.*, 1988, **29**, 6177; c) J. Y. Becker, J. Bernstein, S. Bittner, and S. S. Shaik, *Pure Appl. Chem.*, 1990, **62**, 467; d) J. Y. Becker, J. Bernstein, M. Dayan, and L. Shahal, *J. Chem. Soc., Chem. Commun.*, 1992, 1048.
69. M. Fourmigué and Y. -S. Shang, *Organometallics*, 1993, **12**, 797.
70. a) M. Fourmigué and P. Batail, *J. Chem. Soc., Chem. Commun.*, 1991, 1370; b) M. Fourmigué and P. Batail, *Bull. Soc. Chim. Fr.*, 1992, **129**, 29.
71. a) V. Y. Khodorkovsky, J. Y. Becker, and J. Bernstein, *Synth. Met.*, 1993, **6**, 1931; b) E. Aquad, J. Y. Becker, J. Bernstein, A. Ellern, V. Khodorkovsky, and L. Shapiro, *J. Chem. Soc., Chem. Commun.*, 1994, 2775; c) C. Wang, A. Ellern, J. Y. Becker, and J. Bernstein, *J. Chem. Soc., Chem. Commun.*, 1994, 2115; d) C. Wang, A. Ellern, J. Y. Becker, and J. Bernstein, *Tetrahedron Lett.*, 1994, **35**, 8489.
72. H. Fujiwara, E. Arai, and H. Kobayashi, *J. Mater. Chem.*, 1998, **8**, 829.
73. T. Otsubo, Y. Kochi, A. Bitoh, and F. Ogura, *Chem. Lett.*, 1994, 2047.
74. M. L. Kaplan, R. C. Haddon, and F. Wudl, *J. Chem. Soc., Chem. Commun.*, 1977, 388.
75. a) M. Iyoda, Y. Kuwatani, N. Ueno, and M. Oda, *J. Chem. Soc., Chem. Commun.*, 1992, 158; b) M. Iyoda, M. Fukuda, M. Yoshida, and S. Sasaki, *Chem. Lett.*, 1994, 2369; c) M. Iyoda, M. Fukuda, S. Sasaki, and M. Yoshida, *Synth. Metals*, 1995, **70**, 1171; d) U. Kux and M. Iyoda, *Synth. Metals*, 1995, **70**, 1173.
76. V. Y. Lee, R. R. Schumaker, E. M. Engler, and J. J. Mayerle, *Mol. Cryst. Liq. Cryst.*, 1982, **86**, 317.
77. J. Y. Becker, J. Bernstein, A. Ellern, H. Gershtenman, and V. Khodorkovsky, *J. Mater. Chem.*, 1995, **5**, 1557.
78. a) P. Wolf, H. Naarmann, and K. Müllen, *Angew. Chem., Int. Ed. Engl.*, 1988, **27**, 288; b) H. -J. Räder, U. Scherer, P. Wolf, and K. Müllen, *Synth. Met.*, 1989, **32**, 15; c) M. Adam, P. Wolf, H. -J. Räder, and K. Müllen, *J. Chem. Soc., Chem. Commun.*, 1990, 1625.
79. C. Wang, A. Ellern, J. Y. Becker, and J. Bernstein, *Adv. Mater.*, 1995, **7**, 644.
80. a) E. M. Engler, V. V. Patel, and R. R. Schumacher, *J. Chem. Soc., Chem. Commun.*, 1979, 516; b) R. R. Schumacher and E. M. Engler, *J. Am. Chem. Soc.*, 1980, **102**, 6651; c) Y. Misaki, H. Nishikawa, T. Yamabe, T. Mori, and S. Tanaka, *Chem. Lett.*, 1992, 2321; d) Y. Misaki, H. Nishikawa, T. Yamabe,

- T. Mori, and S. Tanaka, *Chem. Lett.*, 1993, 729; e) M. Ashizawa, M. Aragaki, T. Mori, Y. Misaki, and T. Yamabe, *Chem. Lett.*, 1997, 649; f) Y. Misaki, K. Kawakami, H. Fujiwara, T. Miura, T. Kochi, M. Taniguchi, T. Yamabe, T. Mori, H. Mori, and S. Tanaka, *Mol. Cryst. Liq. Cryst.*, 1997, **296**, 77.
81. Y. Misaki, N. Higuchi, H. Fujiwara, T. Yamabe, T. Mori, H. Mori, and S. Tanaka, *Angew. Chem. Int. Ed. Engl.*, 1995, **34**, 1222.
82. J. Ippen, C. Tao-pen, B. Starker, D. Schweitzer, and H. A. Staab, *Angew. Chem. Int. Ed. Engl.*, 1980, **19**, 67.
83. A. Souizi, A. Robert, P. Batail, and L. Ouahab, *J. Org. Chem.*, 1987, **52**, 1610.
84. a) K. Takimiya, Y. Aso, F. Ogura, and T. Otsubo, *Chem. Lett.*, 1995, 735; b) K. Takimiya, Y. Aso, and T. Otsubo, *Synth. Met.*, 1997, **86**, 1891.
85. K. Takimiya, A. Oharuda, A. Morikami, Y. Aso, and T. Otsubo, *Angew. Chem. Int. Ed. Engl.*, 1998, **37**, 619.
86. S. Yunoki, K. Takimiya, Y. Aso, and T. Otsubo, *Tetrahedron Lett.*, 1997, **38**, 3017.
87. M. Adam, V. Enkelmann, H. J. Räder, and K. Müllen, *Angew. Chem. Int. Ed. Engl.*, 1992, **31**, 309.
88. K. Matsuo, K. Takimiya, Y. Aso, T. Otsubo, and F. Ogura, *Chem. Lett.*, 1995, 523.
89. a) K. Takimiya, Y. Shibata, K. Imamura, A. Kashihara, Y. Aso, T. Otsubo, and F. Ogura, *Tetrahedron Lett.*, 1995, **36**, 5045; b) K. Takimiya, K. Imamura, Y. Shibata, Y. Aso, F. Ogura, and T. Otsubo, *J. Org. Chem.*, 1997, **62**, 5567.
90. a) J. Tanabe, T. Kudo, M. Okamoto, Y. Kawada, G. Ono, A. Izuoka, and T. Sugawara, *Chem. Lett.*, 1995, 579; b) A. Izuoka, J. Tanabe, T. Sugawara, Y. Kawada, R. Kumai, A. Asamitsu, and Y. Tokura, *Mol. Cryst. Liq. Cryst.*, 1997, **306**, 265; c) J. Tanabe, G. Ono, A. Izuoka, T. Sugawara, T. Kudo, T. Saito, M. Okamoto, and Y. Kawada, *Mol. Cryst. Liq. Cryst.*, 1996, **296**, 61.
91. M. Brønsted-Nielsen, N. Thorup, and J. Becher, *J. Chem. Soc., Perkin Trans. 1*, 1998, 1305.
92. S. Triki, L. Ouahab, J-F. Halet, O. Pe-a, J. Padiou, D. Grandjean, C. Garrigou-Lagrange, and P. Delhaes, *J. Chem. Soc., Dalton Trans.*, 1992, 1217.
93. a) A. Krief, *Tetrahedron*, 1986, **52**, 1209; b) G. Schukat, A. M. Richter, and E. Fanghänel, *Sulfur Reports*, 1987, **7**, 155; c) G. Schukat and E. Fanghänel, *Sulfur Reports*, 1993, **14**, 245.

94. a) A. J. Moore and M. R. Bryce, *Synthesis*, 1997, 407; b) R. L. Meline, and R. L. Elsenbaumer, *Synthesis*, 1997, **6**, 617; c) R. L. Meline and R. L. Elsenbaumer, *J. Chem. Soc., Perkin Trans. 1*, 1998, **16**, 2407; d) R. L. Meline and R. L. Elsenbaumer, *J. Chem. Soc., Perkin Trans. 1*, 1999, **2**, 221.
95. Calculated using the program CAMEO (quoted in: G. J. Marshallsay, Ph.D. Thesis, Durham 1994).
96. a) D. C. Green, *J. Chem. Soc., Chem. Commun.*, 1977, 161; b) D. C. Green and R. W. Allen, *J. Chem. Soc., Chem. Commun.*, 1978, 832; c) D. C. Green, *J. Org. Chem.*, 1979, **44**, 1476.
97. J. Garín, J. Orduna, S. Uriel, A. J. Moore, M. R. Bryce, S. Wegener, D. S. Yufit, and J. A. K. Howard, *Synthesis*, 1994, 489.
98. a) E. Aharon-Shalom, J. Y. Becker, J. Bernstein, S. Bittner, and S. Shaik, *Tetrahedron Lett.*, 1985, **26**, 2783; b) S. -Y. Hsu, and L. Y. Chiang, *J. Org. Chem.*, 1987, **52**, 3444; c) G. Saito, *Pure Appl. Chem.*, 1987, **59**, 999; d) V. Y. Lee, *Synth. Metals*, 1987, **20**, 161; e) A. M. Kini, B. D. Gates, M. A. Beno, and J. M. Williams, *J. Chem. Soc., Chem. Commun.*, 1989, 169; f) A. J. Moore, M. R. Bryce, G. Cooke, G. J. Marshallsay, P. J. Skabara, A. S. Batsanov, J. A. K. Howard, and S. T. A. K. Daley, *J. Chem. Soc., Perkin Trans. 1*, 1993, 1403.
99. a) C. T. Pedersen, *Sulfur Rep.*, 1980, **1**, 1; b) N. Svenstrup, and J. Becher, *Synthesis*, 1995, 215; c) K. Takimiya, A. Morikami, and T. Otsubo, *Synlett*, 1997, 319.
100. a) G. Steimecke, H. -J. Sieler, R. Kirmse, and E. Hoyer, *Phosphorus Sulfur*, 1979, **7**, 49; b) T. K. Hansen, J. Becher, T. Jørgensen, K. S. Varma, R. Khedekar, and M. P. Cava, *Org. Synth.*, 1996, **73**, 270; c) C. Wang, A. S. Batsanov, M. R. Bryce, and J. A. K. Howard, *Synthesis*, 1998, 1615.
101. J. Becher, J. Lau, P. Leriche, P. Mørk, and N. Svenstrup, *J. Chem. Soc., Chem. Commun.*, 1994, 2715.
102. K. Hartke, T. Kissel, J. Quante, and R. Matusch, *Chem. Ber.*, 1980, **113**, 1898.
103. F. Wudl and M. L. Kaplan, *J. Org. Chem.*, 1974, **39**, 369.
104. J. M. Fabre, E. Torreilles, J. P. Gilbert, M. Chanaa, and L. Giral, *Tetrahedron Lett.*, 1977, 4033.
105. N. C. Gonnella and M. P. Cava, *J. Org. Chem.*, 1978, **43**, 369.
106. K. Lerstrup, I. Johannsen, and M. Jørgensen, *Synth. Met.*, 1988, **27**, B9.
107. M. Narita and C. U. Pittman, *Synthesis*, 1976, 489.

108. L. Binet, J. M. Fabre, C. Montginoul, K. B. Simonsen, and J. Becher, *J. Chem. Soc., Perkin Trans. 1*, 1996, 783.
109. N. Svenstrup, K. M. Rasmussen, T. K. Hansen, and J. Becher, *Synthesis*, 1994, 809.
110. a) J. Lau, O. Simonsen, and J. Becher, *Synthesis*, 1995, **5**, 521; b) K. B. Simonsen, N. Svenstrup, J. Lau, O. Simonsen, P. Mørk, G. J. Kristensen, and J. Becher, *Synthesis*, 1996, 407; c) K. B. Simonsen and J. Becher, *Synlett*, 1997, 1211.
111. a) G. Le Coustumer and Y. Mollier, *J. Chem. Soc., Chem. Commun.*, 1980, 38; b) R. Andreu, J. Garin, J. Orduna, J. Barbera, J. L. Serrano, T. Sierra, M. Sallé, and A. Gorgues, *Tetrahedron*, 1998, **54**, 3895.
112. G. R. Desiraju, *Angew. Chem. Int. Ed. Engl.*, 1995, **34**, 2311.
113. V. R. Pedireddi, D. S. Reddy, R. S. Goud, D. C. Craig, A. D. Rae, and G. R. Desiraju, *J. Chem. Soc., Perkin Trans. 2*, 1994, **11**, 2353.
114. M. Jørgensen and K. Bechgaard, *Synthesis*, 1989, 207.
115. M. Iyoda, H. Suzuki, S. Sasaki, H. Yoshino, K. Kiguchi, K. Saito, I. Ikemoto, H. Matsuyama and T. Mori, *J. Mater. Chem.*, 1996, **6**, 501.
116. M. Iyoda, Y. Kuwatani, K. Hara, E. Ogura, H. Suzuki, H. Ito and T. Mori, *Chem. Lett.*, 1997, 599.
117. R. Gompper, J. Hock, K. Polborn, E. Dormann and H. Winter, *Adv. Mater.*, 1995, **7**, 41.
118. (a) Y. N. Kreizberga, A. S. Edzhinya, R. B. Kampare and O. Neiland, *Zh. Org. Khim.*, 1989, **25**, 1456; Y. N. Kreizberga, A. S. Edzhinya, R. B. Kampare and O. Neilands, *J. Org. Chem. USSR (Engl. Transl.)*, 1989, 1312; (b) M. R. Bryce and G. Cooke, *Synthesis*, 1991, 263; (c) C. Wang, A. Ellern, V. Khodorkovsky, J. Bernstein, and J. Y. Becker, *J. Chem. Soc., Chem. Commun.*, 1994, 983; (d) T. Otsubo, Y. Kochi, A. Bitoh, and F. Ogura, *Chem. Lett.*, 1994, 2047.
119. T. Imakubo, H. Sawa and R. Kato, *Synth. Met.*, 1995, **73**, 117.
120. E. O. Sclemper and D. Britton, *Acta Crystallogr.*, 1965, **18**, 419.
121. A. S. Batsanov, A. J. Moore, N. Robertson, A. Green, M. R. Bryce, J. A. K. Howard and A. E. Underhill, *J. Mater. Chem.*, 1997, **7**, 387.
122. Y. Kuwatani, E. Ogura, H. Nishikawa, I. Ikemoto, and M. Iyoda, *Chem. Lett.*, 1997, 817.

123. T. Imakubo, H. Sawa, and R. Kato, *J. Chem. Soc., Chem. Commun.*, 1995, 1097.
124. T. Imakubo, H. Sawa, and R. Kato, *J. Chem. Soc., Chem. Commun.*, 1995, 1667.
125. T. Imakubo, H. Sawa, and R. Kato, *Synth. Met.*, 1997, **86**, 1847.
126. M. R. Bryce, G. Cooke, A. S. Dhindsa, D. Lorcy, A. J. Moore, M. C. Petty, M. B. Hursthouse, and A. I. Karaulov, *J. Chem. Soc., Chem. Commun.*, 1990, 816.
127. J. Nakayama, N. Toyoda and M. Hoshino, *Heterocycles*, 1986, **24**, 1145.
128. J. K. Stille, *Pure and Appl. Chem.*, 1985, **57**, 1771.
129. S. P. Stanforth, *Tetrahedron*, 1998, **54**, 263.
130. E. Negishi, *Acc. Chem. Res.*, 1982, **15**, 340.
131. N. Miyaura, T. Yanagi, and A. Suzuki, *Synth. Commun.*, 1981, **11**, 513.
132. P. J. Skabara, K. Müllen, M. R. Bryce, J. A. K. Howard, and A. S. Batsanov, *J. Mater. Chem.*, 1998, **8**, 1719.
133. H. Tatemitsu, E. Nishikawa, Y. Sakata and S. Misumi, *Synth. Met.*, 1987, **19**, 565.
134. a) H. Tatemitsu, M. Kusakabe, T. Watanabe and K. Sako, *Synth. Met.*, 1995, **71**, 1949; b) K. Sako, M. Kusakabe, T. Watanabe, H. Takemura, T. Shinmyozu, and H. Tatemitsu, *Mol. Cryst. Liq. Cryst.*, 1997, **296**, 31.
135. M. Iyoda, E. Ogura, K. Hara, Y. Kuwatami, H. Nishikawa, T. Sato, K. Kiguchi, I. Ikemoto, and T. Mori, *J. Mater. Chem.*, 1999, **9**, 335.
136. A. J. Moore, unpublished results.
137. D. E. John, A. J. Moore, M. R. Bryce, A. S. Batsanov, and J. A. K. Howard, *Synthesis*, 1998, 826.
138. M. R. Bryce, A. J. Moore, A. S. Batsanov, A. Chesney, C. L. Wood and J. A. K. Howard, in *Electrical, Optical and Magnetic Properties of Organic Solid State Materials IV*, J. R. Reynolds, A. K. -Y. Jen, M. F. Rubner, L. Y. Chiang, and L. R. Dalton (Eds.), Materials Research Society, Warrendale, PA., 1998, p. 483.
139. M. Fourmigué, F. C. Krebs, and J. Larsen, *Synthesis*, 1993, 509.
140. Compound **134** was synthesised but not isolated in: R. D. McCullough, J. A. Belot, and J. Seth, *J. Org. Chem.*, 1993, **58**, 6480.

141. V. Khodorkovsky and O. Neilands, *Chem. Heterocycl. Comp. (Engl. Trans.)*, 1985, **21**, 475.
142. R. P. Parg, J. D. Kilburn, M. C. Petty, C. Pearson, and T. G. Ryan, *J. Mater. Chem.*, 1995, **5**, 1609.
143. L. Liebeskind, D. Zhang, and S. Zhang, *J. Org. Chem.*, 1997, **62**, 2312.
144. a) R. R. Schumaker and E. M. Engler, *J. Am. Chem. Soc.*, 1980, **102**, 6651; b) P. Hudhomme, P. Blanchard, M. Sallé, S. LeMoustarder, and A. Riou, *Angew. Chem. Int. Ed. Engl.*, 1997, **36**, 878; c) G. C. Papavassiliou, J. S. Zambounis, G. A. Mousdis, V. Gionis, and S. Y. Yiannopoulos, *Mol. Cryst. Liq. Cryst.*, 1998, **156**, 269.
145. A. J. Moore, M. R. Bryce, A. S. Batsanov, J. C. Cole, and J. A. K. Howard, *Synthesis*, 1995, 274.
146. S. Flandrois and D. Chasseu, *Acta Crystallogr. Sect. B*, 1977, **33**, 2744.
147. a) R. E. Long, R. A. Sparks, and K. N. Trueblood, *Acta Crystallogr.*, 1965, **18**, 932; b) E. D. Stevens and A. Sayed, *Amer. Cryst. Assoc. Ann. Meeting, Ser. 2*, 1984, **12**, 38.
148. R. S. Rowland and R. Taylor, *J. Phys. Chem.*, 1996, **100**, 7384.
149. S. C. Nyburg and C. H. Faerman, *Acta Crystallogr. Sect. B*, 1985, **41**, 274.
150. a) T. Dahl and O. Hassell, *Acta Chem. Scand.*, 1970, **24**, 377; b) G. R. Desiraju and R. L. Harlow, *J. Am. Chem. Soc.*, 1989, **111**, 6757, and references therein.
151. F. Vögtle, *Cyclophane Chemistry*, Wiley, Chichester, 1993.
152. a) M. Yoshida, H. Tatemitsu, Y. Sakata, and S. Misumi, *Tetrahedron Lett.*, 1976, **42**, 3821; b) H. A. Staab and H. -E. Encke, *Tetrahedron Lett.*, 1978, **22**, 1955; c) H. A. Staab and G. H. Knaus, *Tetrahedron Lett.*, 1979, **44**, 4261; d) K. B. Simonsen, K. Zong, R. D. Rodgers, M. P. Cava, and J. Becher, *J. Org. Chem.*, 1997, **62**, 679; e) R. M. Moriarty, A. Tao, R. Gilardi, Z. Song, and S. M. Tuladhar, *Chem. Commun.*, 1998, 157.
153. H. A. Staab, J. Ippen, C. Tao-Pen, C. Krieger, and B. Starker, *Angew. Chem. Int. Ed. Engl.*, 1980, **19**, 66.
154. a) F. Bertho-Thoraval, A. Robert, A. Souizi, K. Boubekour, and P. Batail, *J. Chem. Soc., Chem. Commun.*, 1991, 843; b) K. Boubekour, C. Lenoir, P. Batail, R. Carlier, A. Tallec, M. -P. Le Paillard, D. Lorcy, and A. Robert, *Angew. Chem. Int. Ed. Engl.*, 1994, **33**, 1379.

155. C. Wang, M. R. Bryce, A. S. Batsanov, and J. A. K. Howard, *Chem. Eur. J.*, 1997, **3**, 1679.
156. M. B. Nielsen, Z. -T. Li, and J. Becher, *J. Mater. Chem.*, 1997, **7**, 1175.
157. J. Lau and J. Becher, *Synthesis*, 1997, 1015.
158. C. Katayama, M. Honda, H. Kumagai, J. Tanaka, G. Saito, and H. Inokuchi, *Bull. Chem. Soc. Jpn.*, 1985, **58**, 2272.
159. H. Endres, *Z. Naturforsch. Teil. B*, 1986, **41**, 1351.
160. Generally, the central C=C and C-S bonds of the TTF system lengthen and shorten, respectively, in the oxidised state. See: a) D. A. Clemente and A. Marzotto, *J. Mater. Chem.*, 1996, **6**, 941; b) M. Umeya, S. Kawata, H. Matzuzaka, S. Kitagawa, H. Nishikawa, K. Kiguchi, and I. Ikemoto, *J. Mater. Chem.*, 1998, **8**, 295; and reference 158.
161. a) W. F. Cooper, N. C. Kenny, J. W. Edmonds, A. Nagel, F. Wudl, and P. Coppens, *J. Chem. Soc., Chem. Commun.*, 1971, 869; b) A. Ellern, J. Bernstein, J. Y. Becker, S. Zamir, L. Shahal, and S. Cohen, *Chem. Mater.*, 1994, **6**, 1378.
162. I. Hargittai, J. Brunvoll, M. Kolonits, and V. Khodorkovsky, *J. Mol. Struct.*, 1994, **317**, 273.
163. a) T. Jørgensen, B. Girmay, T. K. Hansen, J. Becher, A. E. Underhill, M. B. Hursthouse, M. E. Harman, and J. D. Kilburn, *J. Chem. Soc., Perkin Trans. 1*, 1992, 2907; b) M. Adam, V. Enkelmann, H. -J. Räder, J. Röhrich, and K. Müllen, *Angew. Chem. Int. Ed. Engl.*, 1992, **31**, 309; c) T. K. Hansen, T. Jørgensen, F. Jensen, P. H. Thygesen, K. Christiansen, M. B. Hursthouse, M. E. Harman, M. A. Malik, B. Girmay, A. E. Underhill, M. Begtrup, J. D. Kilburn, K. Belmore, P. Roepstorff, and J. Becher, *J. Org. Chem.*, 1993, **58**, 1359; d) C. S. Wang, M. R. Bryce, A. S. Batsanov, and J. A. K. Howard, *Chem. Eur. J.*, 1997, **3**, 1679; e) K. Boubekour, P. Batail, F. Bertho, and A. Robert, *Acta Crystallogr. Sect. C*, 1991, **47**, 1109; f) B. Girmay, J. D. Kilburn, A. E. Underhill, K. S. Varma, M. B. Hursthouse, M. E. Harman, J. Becher, and G. Bojesen, *J. Chem. Soc., Chem. Commun.*, 1989, 1406.
164. A. S. Batsanov, M. R. Bryce, J. N. Heaton, A. J. Moore, P. J. Skabara, J. A. K. Howard, E. Ortí, P. M. Viruela, and R. Viruela, *J. Mater. Chem.*, 1995, **5**, 1689.
165. J. Lau, P. Blanchard, A. Riou, M. Jubault, M. P. Cava, and J. Becher, *J. Org. Chem.*, 1997, **62**, 4936.
166. J. Röhrich, P. Wolf, V. Enkelmann, and K. Müllen, *Angew. Chem. Int. Ed. Engl.*, 1988, **27**, 1377.

167. a) P. R. Ashton, R. A. Bissell, N. Spencer, J. F. Stoddart, and M. S. Tolley, *Synlett*, 1992, 923; b) P. R. Ashton, D. Philp, N. Spencer, and J. F. Stoddart, *J. Chem. Soc., Chem. Commun.*, 1992, 1125; c) D. B. Amabilino, and J. F. Stoddart, *Chem. Rev.*, 1995, **95**, 2725.
168. a) M. B. Nielsen and J. Becher, *Liebigs Ann. Recueil*, 1997, 2177; b) J. Becher, Z.-T. Li, P. Blanchard, N. Svenstrup, J. Lau, M. B. Nielsen, and K. B. Simonsen, in *Molecular Recognition and Inclusion*, A. W. Coleman (Ed.), Kluwer, Dordrecht, 1998, 85.
169. J. L. Atwood, J. E. D. Davies, D. D. MacNicol, F. Vögtle (Eds.), *Comprehensive Supramolecular Chemistry, Volume 2: Molecular Recognition, Receptors For Molecular Guests*, Pergamon Press, Oxford, 1996.
170. a) J.-M. Lehn, *Supramolecular Chemistry*, VCH, Weinheim, 1995; b) C. Steel, and F. Vögtle, *Angew. Chem. Int. Ed. Engl.*, 1992, **31**, 528; c) D. J. Cram, and J. M. Cram, in *Container Molecules and Their Guests*, Monographs in Supramolecular Chemistry, J. F. Stoddart (Ed.), RSC, Cambridge.
171. M. C. Grossel, D. G. Hamilton, P. N. Horton, S. Neveu, R. A. Parker, and P. S. Walker, *Synthesis*, 1998, 78.
172. a) P. D. Beer, *Chem. Rev.*, 1989, **18**, 409; b) T. K. Hansen, T. Jørgensen, P. C. Stein, and J. Becher, *J. Org. Chem.*, 1992, **57**, 6403.
173. Y. Lebras, M. Sallé, P. Leriche, C. Mingotaud, P. Richomme, and J. Møller, *J. Mater. Chem.*, 1997, **7**, 2393.
174. *Comprehensive Supramolecular Chemistry, Volume 10: Supramolecular Technology*, J. L. Atwood, J. E. D. Davies, D. D. MacNicol, F. Vögtle (Eds.), Pergamon Press, Oxford, 1996.
175. a) C. Lampard, J. A. Murphy, F. Rasheed, N. Lewis, M. B. Hursthouse, and D. E. Hibbs, *Tetrahedron Lett.*, 1994, **35**, 8675; b) M. J. Begley, J. A. Murphy, and S. J. Roome, *Tetrahedron Lett.*, 1994, **35**, 8679.
176. a) P. Blanchard, N. Svenstrup, and J. Becher, *J. Chem. Soc., Chem. Commun.*, 1996, 615. b) P. Blanchard, N. Svenstrup, J. Rault-Berthelot, and J. Becher, *Eur. J. Org. Chem.*, 1998, 1743.
177. a) M. R. Bryce, A. S. Secco, J. Trotter, and L. Weiler, *Can. J. Chem.*, 1982, **60**, 2057; b) M. R. Bryce, S. R. Davies, M. B. Hursthouse, and M. Motevalli, *J. Chem. Soc., Perkin Trans. 2*, 1988, 1713.
178. D. Philp, A. M. Z. Slavin, N. Spencer, J. F. Stoddart, and D. J. Williams, *J. Chem. Soc., Chem. Commun.*, 1991, 1584.
179. W. Devonport, M. R. Bryce, M. A. Blower, and L. M. Goldenberg, *J. Org. Chem.*, 1997, **62**, 885.

180. M. B. Nielsen, S. B. Nielsen, and J. Becher, *Chem. Commun.*, 1998, 475.
181. K. Tsubaki, K. Tanaka, T. Kinoshita, and K. Fuji, *Chem. Commun.*, 1998, 895.
182. T. Haino, M. Yanase, and Y. Fukazawa, *Angew. Chem. Int. Ed. Engl.*, 1997, **36**, 259.
183. Q. Xie, E. Perez-Cordero, and L. Echegoyen, *J. Am. Chem. Soc.*, 1992, **114**, 3978.
184. a) J. Llacay, J. Veciana, J. Vidal-Gancedo, J. L. Bourdelande, R. Gonzalez-Moreno, and C. Rovira, *J. Org. Chem.*, 1998, **63**, 5201; b) J. Llacay, J. Veciana, J. Vidal-Gancedo, J. L. Bourdelande, R. Gonzalez-Moreno, and C. Rovira, *J. Org. Chem.*, 1998, **63**, 9144.
185. A. Izuoka, T. Tachikawa, T. Sugawara, Y. Suzuki, M. Konno, Y. Saito, and H. Shinohara, *J. Chem. Soc., Chem. Commun.*, 1992, 1472.
186. F. Vögtle in *Comprehensive Supramolecular Chemistry, Volume 10: Supramolecular Technology*, J. L. Atwood, J. E. D. Davies, D. D. Macnicol, F. Vögtle (Eds.), Pergamon Press, Oxford, 1996, p. 215.
187. a) G. J. Marshallsay, M. R. Bryce, G. Cooke, T. Jørgensen, J. Becher, C. D. Reynolds, and S. Wood, *Tetrahedron*, 1993, **49**, 6849; b) M. R. Bryce, A. J. Moore, M. A. Coffin, G. J. Marshallsay, G. Cooke, P. J. Skabara, A. S. Batsanov, J. A. K. Howard, and W. Clegg, *Phosphorus, Sulfur, Silicon*, 1993, **74**, 279; c) W. J. Devonport, M. R. Bryce, G. J. Marshallsay, A. J. Moore, and L. M. Goldenberg, *J. Mater. Chem.*, 1998, **8**, 1361.
188. P. R. Ashton, R. A. Bissell, N. Spencer, J. F. Stoddart, and M. S. Tolley, *Synlett*, 1992, 923.
189. T. Jørgensen, J. Becher, J. -C. Chambron, and J. -P. Sauvage, *Tetrahedron Lett.*, 1994, **35**, 4339.
190. V. S. Russkikh, and G. G. Abashev, *Chem. Heterocycl. Comp. (Engl. Trans.)*, 1990, **4**, 403.
191. A. A. Ansari, T. Frejd, and G. Magnusson, *Carbohydrate Res.*, 1997, **161**, 225.
192. G. J. Marshallsay, T. K. Hansen, A. J. Moore, M. R. Bryce, and J. Becher, *Synthesis*, 1994, 926.
193. W. Devonport, M. R. Bryce, G. J. Marshallsay, A. J. Moore, and L. M. Goldenberg, *J. Mater. Chem.*, 1998, **8**, 1361.
194. a) J. Heinze, *Angew. Chem. Int. Ed. Engl.*, 1984, **23**, 831; b) J. F. Rusling and S. L. Smith, *Adv. Mater.*, 1994, **6**, 922.

195. a) J. L. Robbins, N. Edelstein, and B. Spenser, *J. Am. Chem. Soc.*, 1982, **104**, 1882; b) P. G. Gassman, D. W. Macomber, and J. W. Hershberger, *Organometallics*, 1983, **2**, 1470.
196. P. Batail, K. Boubekour, M. Fourmigué, and J. -C. P. Gabriel, *Chem. Mater.*, 1998, **10**, 3005.
197. F. Wudl and M. R. Bryce, *J. Chem. Ed.*, 1990, **67**, 717.

Appendix One
Crystallographic Data

A 1.1

4-Bis(4',5,5'-trimethyltetrathiafulvalenyl) (120)

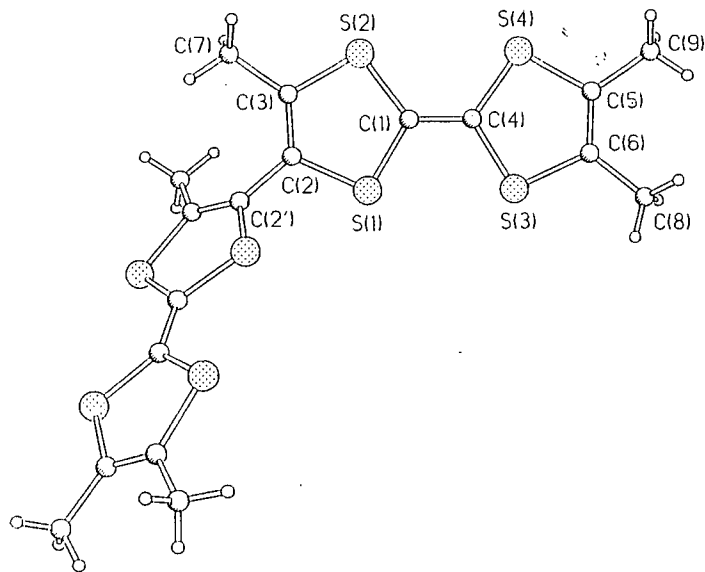

Table 3. Bond lengths [Å] and angles [deg] for 1.

S(1)-C(1)	1.764(2)	S(1)-C(2)	1.772(2)
S(2)-C(1)	1.760(2)	S(2)-C(3)	1.768(2)
S(3)-C(4)	1.761(2)	S(3)-C(5)	1.764(2)
S(4)-C(4)	1.763(2)	S(4)-C(6)	1.769(2)
C(1)-C(4)	1.349(3)	C(2)-C(3)	1.345(3)
C(2)-C(2')	1.471(4)	C(3)-C(7)	1.499(3)
C(5)-C(6)	1.339(3)	C(5)-C(8)	1.505(3)
C(6)-C(9)	1.504(3)	C(7)-H(71)	0.99(3)
C(7)-H(72)	0.95(3)	C(7)-H(73)	0.92(3)
C(8)-H(81)	0.95(4)	C(8)-H(82)	0.94(4)
C(8)-H(83)	0.91(4)	C(9)-H(91)	0.92(3)
C(9)-H(92)	0.89(4)	C(9)-H(93)	0.96(3)
C(1)-S(1)-C(2)	95.34(9)	C(1)-S(2)-C(3)	96.27(9)
C(4)-S(3)-C(5)	95.58(10)	C(4)-S(4)-C(6)	95.17(10)
C(4)-C(1)-S(2)	125.6(2)	C(4)-C(1)-S(1)	120.3(2)
S(2)-C(1)-S(1)	114.12(11)	C(3)-C(2)-C(2')	128.0(2)
C(3)-C(2)-S(1)	117.9(2)	C(2)-C(2)-S(1)	113.99(11)
C(2)-C(3)-C(7)	127.3(2)	C(2)-C(3)-S(2)	116.3(2)
C(7)-C(3)-S(2)	116.4(2)	C(1)-C(4)-S(3)	120.6(2)
C(1)-C(4)-S(4)	125.0(2)	S(3)-C(4)-S(4)	114.43(11)
C(6)-C(5)-C(3)	126.8(2)	C(6)-C(5)-S(3)	117.2(2)
C(8)-C(5)-S(3)	116.0(2)	C(5)-C(6)-C(9)	125.8(2)
C(5)-C(6)-S(4)	117.6(2)	C(9)-C(6)-S(4)	116.6(2)
C(3)-C(7)-H(71)	112(2)	C(3)-C(7)-H(72)	109(2)
H(71)-C(7)-H(72)	108(2)	C(3)-C(7)-H(73)	109(2)
H(71)-C(7)-H(73)	107(2)	H(72)-C(7)-H(73)	111(2)
C(5)-C(8)-H(81)	111(2)	C(5)-C(8)-H(82)	108(2)
H(81)-C(8)-H(82)	104(3)	C(5)-C(8)-H(83)	112(3)
H(81)-C(8)-H(83)	113(3)	H(82)-C(8)-H(83)	108(3)
C(6)-C(9)-H(91)	112(2)	C(6)-C(9)-H(92)	113(2)
H(91)-C(9)-H(92)	107(3)	C(6)-C(9)-H(93)	110(2)
H(91)-C(9)-H(93)	106(3)	H(92)-C(9)-H(93)	108(3)

Symmetry transformations used to generate equivalent atoms (primed): -x,y,-z+1/2

Table 1. Crystal data and structure refinement

Identification code	97srv112
Empirical formula	C18 H18 S8
Formula weight	490.80
Temperature	150(2) K
Wavelength	0.71073 Å
Crystal system	Monoclinic
Space group	C2/c
Unit cell dimensions	a = 13.629(1) Å alpha = 90 deg. b = 7.187(1) Å beta = 91.82(1) deg c = 21.688(1) Å gamma = 90 deg.
Volume	2123.3(3) Å ³
Z	4
Density (calculated)	1.535 g/cm ³
Absorption coefficient	0.843 mm ⁻¹
F(000)	1016
Crystal size	0.35 x 0.20 x 0.15 mm
Theta range for data collection	1.88 to 30.34 deg.
Index ranges	-18<=h<=18, -10<=k<=10, -27<=l<=30
Reflections collected	10735
Independent reflections	2985 [R(int) = 0.0435]
Observed reflections, I>2sigma(I)	2432
Absorption correction	Semiempirical
Max. and min. transmission	0.8936 and 0.7925
Refinement method	Full-matrix least-squares on F ²
Data / restraints / parameters	2972 / 0 / 155
Goodness-of-fit on F ²	1.154
Final R indices [I>2sigma(I)]	R1 = 0.0360, wR2 = 0.0705
R indices (all data)	R1 = 0.0519, wR2 = 0.0929
Extinction coefficient	0.0005(2)
Largest diff. peak and hole	0.348 and -0.327 e.Å ⁻³

A 1.2

4-Bis[4',5,5'-tris(thiomethyl)tetrathiafulvalenyl] (136)

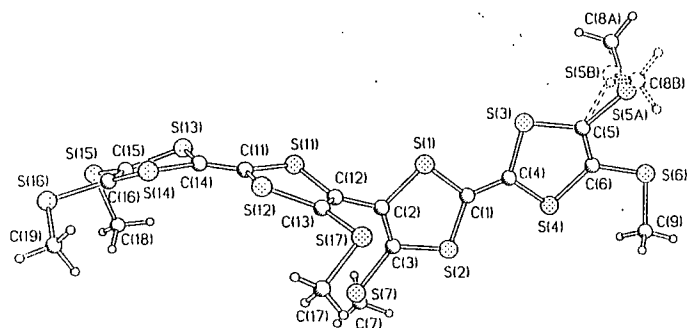

Table 3. Bond lengths [Å] and angles [deg]

S(1)-C(2)	1.752(8)	S(1)-C(1)	1.761(8)
S(2)-C(1)	1.766(8)	S(2)-C(3)	1.770(9)
S(3)-C(4)	1.754(8)	S(3)-C(5)	1.777(10)
S(4)-C(6)	1.747(9)	S(4)-C(4)	1.762(8)
S(5A)-C(5)	1.794(10)	S(5A)-C(8A)	1.80(2)
S(5B)-C(5)	1.790(11)	S(5B)-C(8B)	1.85(3)
S(6)-C(6)	1.760(9)	S(6)-C(9)	1.780(10)
S(7)-C(3)	1.743(9)	S(7)-C(7)	1.806(12)
S(11)-C(11)	1.761(8)	S(11)-C(12)	1.767(8)
S(12)-C(13)	1.763(8)	S(12)-C(11)	1.765(8)
S(13)-C(14)	1.757(8)	S(13)-C(15)	1.770(8)
S(14)-C(16)	1.754(8)	S(14)-C(14)	1.764(8)
S(15)-C(15)	1.745(8)	S(15)-C(18)	1.803(10)
S(16)-C(16)	1.750(8)	S(16)-C(19)	1.813(9)
S(17)-C(13)	1.749(8)	S(17)-C(17)	1.814(10)
C(1)-C(4)	1.339(11)	C(2)-C(3)	1.338(12)
C(2)-C(12)	1.469(11)	C(5)-C(6)	1.342(13)
C(11)-C(14)	1.339(11)	C(12)-C(13)	1.349(12)
C(15)-C(16)	1.359(12)		
C(2)-S(1)-C(1)	95.4(4)	C(1)-S(2)-C(3)	95.0(4)
C(4)-S(3)-C(5)	94.7(4)	C(6)-S(4)-C(4)	94.7(4)
C(5)-S(5A)-C(8A)	96.2(7)	C(5)-S(5B)-C(8B)	89.6(10)
C(6)-S(6)-C(9)	103.3(4)	C(3)-S(7)-C(7)	101.6(5)
C(11)-S(11)-C(12)	94.4(4)	C(13)-S(12)-C(11)	94.4(4)
C(14)-S(13)-C(15)	93.8(4)	C(16)-S(14)-C(14)	94.1(4)
C(15)-S(15)-C(18)	99.2(4)	C(16)-S(16)-C(19)	101.7(4)
C(13)-S(17)-C(17)	100.7(4)	C(4)-C(1)-S(1)	120.3(6)
C(4)-C(1)-S(2)	125.2(6)	S(1)-C(1)-S(2)	114.5(5)
C(3)-C(2)-C(12)	126.2(8)	C(3)-C(2)-S(1)	117.9(7)
C(12)-C(2)-S(1)	115.9(6)	C(2)-C(3)-S(7)	122.8(7)
C(2)-C(3)-S(2)	117.2(7)	S(7)-C(3)-S(2)	119.8(5)
C(1)-C(4)-S(3)	121.4(6)	C(1)-C(4)-S(4)	123.7(6)
S(3)-C(4)-S(4)	114.9(5)	C(6)-C(5)-S(3)	116.3(7)
C(6)-C(5)-S(5B)	125.4(7)	S(3)-C(5)-S(5B)	113.4(6)
C(6)-C(5)-S(5A)	123.7(8)	S(3)-C(5)-S(5A)	118.5(6)
C(5)-C(6)-S(4)	118.5(7)	C(5)-C(6)-S(6)	121.8(7)
S(4)-C(6)-S(6)	119.6(5)	C(14)-C(11)-S(11)	124.4(5)
C(14)-C(11)-S(12)	121.9(6)	S(11)-C(11)-S(12)	113.7(4)
C(13)-C(12)-C(2)	124.8(7)	C(13)-C(12)-S(11)	116.9(6)
C(2)-C(12)-S(11)	118.1(6)	C(12)-C(13)-S(17)	124.0(6)
C(12)-C(13)-S(12)	117.2(6)	S(17)-C(13)-S(12)	118.5(5)
C(11)-C(14)-S(13)	124.4(7)	C(11)-C(14)-S(14)	122.1(7)
S(13)-C(14)-S(14)	113.4(5)	C(16)-C(15)-S(15)	125.4(5)
C(16)-C(15)-S(13)	116.7(6)	S(15)-C(15)-S(13)	117.9(5)
C(15)-C(16)-S(16)	123.6(6)	C(15)-C(16)-S(14)	116.7(6)
S(16)-C(16)-S(14)	119.4(5)		

Table 1. Crystal data and structure refinement

Identification code	98srv092
Empirical formula	C ₁₈ H ₁₈ S ₁₄
Formula weight	683.16
Temperature	120(2) K
Wavelength	0.71073 Å
Crystal system	Monoclinic
Space group	P2(1)/n (No. 14)
Unit cell dimensions	a = 8.374(1) Å alpha = 90 deg. b = 12.684(2) Å beta = 96.20(1) deg. c = 26.295(3) Å gamma = 90 deg.
Volume	2776.6(6) Å ³
Z	4
Density (calculated)	1.634 g/cm ³
Absorption coefficient	1.104 mm ⁻¹
F(000)	1400
Crystal size	0.5 x 0.4 x 0.2 mm
Theta range for data collection	1.78 to 26.16 deg.
Index ranges	-9<h<9, -14<k<15, -31<l<30
Reflections collected	21201
Independent reflections	5026 [R(int) = 0.0317]
Observed reflections, I>2sigma(I)	4639
Absorption correction	MultiScan
Max. and min. transmission	0.6938 and 0.4647
Refinement method	Full-matrix least-squares on F ²
Data / restraints / parameters	5020 / 0 / 314
Goodness-of-fit on F ²	1.210
Final R indices [I>2sigma(I)]	R1 = 0.0724, wR2 = 0.2020
R indices (all data)	R1 = 0.0773, wR2 = 0.2053
Largest shift/e.s.d. ratio	0.000
Largest diff. peak and hole	1.028 and -0.545 e.Å ⁻³

A 1.3

4-Bis(5-methyl-4',5'-ethylenedithiotetrafulvaleny) · ClO₄ Complex

Table 1. Crystal data and structure refinement

Identification code	98srv045
Empirical formula	C18 H14 Cl O4 S12
Formula weight	714.46
Temperature	150(2) K
Wavelength	1.54184 Å
Crystal system	Orthorhombic
Space group	P2(1)2(1)2
Unit cell dimensions	a = 11.074(3) Å alpha = 90 deg. b = 24.139(7) Å beta = 90 deg. c = 4.876(2) Å gamma = 90 deg.
Volume	1303.4(7) Å ³
Z	2
Density (calculated)	1.820 g/cm ³
Absorption coefficient	10.545 mm ⁻¹
F(000)	726
Crystal size	0.30 × 0.08 × 0.02 mm
Theta range for data collection	3.66 to 74.90 deg.
Index ranges	-13 ≤ h ≤ 12, -30 ≤ k ≤ 27, -1 ≤ l ≤ 5
Reflections collected	1429
Independent reflections	1288 [R(int) = 0.0609]
Observed reflections, I > 2σ(I)	993
Absorption correction	Psi-scan
Max. and min. transmission	1.0000 and 0.5506
Refinement method	Full-matrix least-squares on F ²
Data / restraints / parameters	1277 / 0 / 129
Goodness-of-fit on F ²	1.063
Final R indices [I > 2σ(I)]	R1 = 0.1276, wR2 = 0.3278
R indices (all data)	R1 = 0.1737, wR2 = 0.4067
Absolute structure parameter	0.0(2)
Largest shift/e.s.d. ratio	0.000
Largest diff. peak and hole	1.518 and -0.936 e.Å ⁻³

Table 3. Bond lengths [Å] and angles [deg]

S(1)-C(1)	1.74(3)	S(1)-C(2)	1.76(2)
S(2)-C(3)	1.74(3)	S(2)-C(4)	1.75(3)
S(3)-C(5)	1.73(2)	S(3)-C(4)	1.77(3)
S(4)-C(4)	1.73(2)	S(4)-C(6)	1.76(3)
S(5)-C(5)	1.74(2)	S(5)-C(8)	1.30(2)
S(6)-C(6)	1.72(3)	S(6)-C(9)	1.81(3)
C(1)-C(4)	1.32(3)	C(2)-C(3)	1.39(4)
C(2)-C(2')	1.42(5)	C(3)-C(7)	1.48(4)
C(5)-C(6)	1.39(3)	C(9)-C(9)	1.52(4)
Cl-O(2)	1.38(4)	Cl-O(3)	1.42(7)
Cl-O(4)	1.44(5)	Cl-O(1)	1.45(3)
C(1)-S(1)-C(2)	97.1(12)	C(3)-S(2)-C(4)	98.3(14)
C(5)-S(3)-C(4)	95.7(11)	C(4)-S(4)-C(6)	96.8(12)
C(4)-S(5)-C(8)	99.7(13)	C(5)-S(6)-C(9)	105.0(12)
C(4)-C(1)-S(1)	126(2)	C(4)-C(11)-S(2)	122(2)
S(1)-C(1)-S(2)	113(2)	C(3)-C(2)-C(2')	127(3)
C(3)-C(2)-S(1)	116(2)	C(2')-C(2)-S(1)	117(3)
C(2)-C(3)-C(7)	126(3)	C(2)-C(3)-S(2)	115(2)
C(7)-C(3)-S(2)	119(2)	C(1)-C(4)-S(4)	124(2)
C(1)-C(4)-S(3)	121(2)	S(4)-C(4)-S(5)	114.3(13)
C(6)-C(5)-S(3)	118(2)	C(6)-C(5)-S(6)	135(3)
S(3)-C(5)-S(6)	117.2(14)	C(5)-C(6)-S(4)	131(2)
C(5)-C(6)-S(4)	115(2)	S(5)-C(6)-S(4)	114(2)
C(9)-C(8)-S(5)	116(2)	C(8)-C(9)-S(6)	114(2)
O(2)-Cl-O(3)	110(3)	O(2)-Cl-O(4)	107(3)
O(3)-Cl-O(4)	116(3)	O(2)-Cl-O(1)	112(2)
O(3)-Cl-O(1)	110(3)	O(4)-Cl-O(1)	103(3)

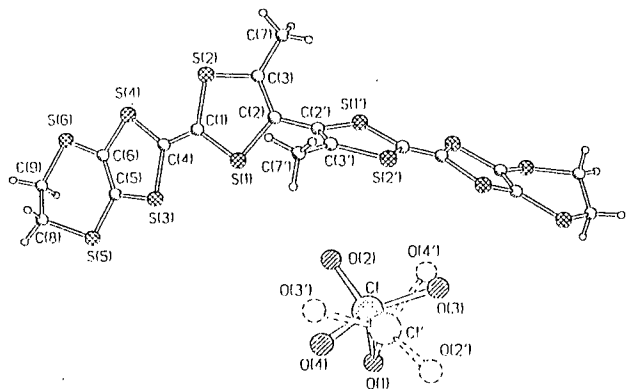
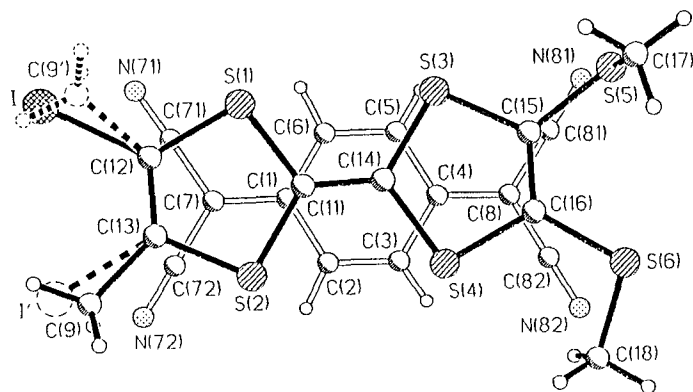

Table 3. Bond lengths [Å] and angles [deg]

I-C(2)	2.029(3)	I'-C(13)	1.985(3)
S(1)-C(11)	1.759(3)	S(1)-C(2)	1.759(3)
S(2)-C(3)	1.753(3)	S(2)-C(11)	1.761(3)
S(3)-C(4)	1.760(3)	S(3)-C(5)	1.762(3)
S(4)-C(6)	1.759(3)	S(4)-C(4)	1.764(3)
S(5)-C(5)	1.757(3)	S(5)-C(8)	1.812(3)
S(6)-C(6)	1.750(3)	S(6)-C(9)	1.803(4)
C(1)-C(4)	1.357(4)	C(2)-C(3)	1.339(5)
C(2)-C(7')	1.615(10)	C(3)-C(7)	1.606(8)
C(5)-C(6)	1.348(4)	C(8)-H(81)	0.93(4)
C(8)-H(82)	0.92(4)	C(8)-H(83)	0.98(4)
C(9)-H(91)	0.98(4)	C(9)-H(92)	0.90(4)
C(9)-H(93)	0.97(4)	C(11)-C(17)	1.386(4)
C(11)-C(16)	1.447(4)	C(11)-C(12)	1.450(4)
C(12)-C(13)	1.349(4)	C(12)-H(12)	0.99(3)
C(13)-C(14)	1.448(4)	C(13)-H(13)	0.92(3)
C(14)-C(18)	1.389(4)	C(14)-C(15)	1.444(4)
C(15)-C(16)	1.358(4)	C(15)-H(15)	0.94(3)
C(16)-H(16)	0.98(3)	C(17)-C(71)	1.432(4)
C(17)-C(72)	1.433(4)	C(18)-C(82)	1.430(4)
C(18)-C(81)	1.444(4)	C(71)-N(71)	1.159(4)
C(72)-N(72)	1.155(4)	C(81)-N(81)	1.152(4)
C(82)-N(82)	1.150(4)		
C(1)-S(1)-C(2)	95.3(1)	C(3)-S(2)-C(1)	95.7(1)
C(4)-S(3)-C(5)	95.2(1)	C(6)-S(4)-C(4)	95.3(1)
C(5)-S(5)-C(8)	99.7(1)	C(6)-S(6)-C(9)	103.0(2)
C(4)-C(1)-S(1)	122.8(2)	C(4)-C(1)-S(2)	123.1(2)
S(1)-C(1)-S(2)	114.2(1)	C(3)-C(2)-C(7')	135.3(4)
C(3)-C(2)-S(1)	117.6(2)	C(7')-C(2)-S(1)	107.1(4)
C(3)-C(2)-I	119.6(2)	S(1)-C(2)-I	122.8(2)
C(2)-C(3)-C(7)	133.2(4)	C(2)-C(3)-S(2)	117.1(2)
C(7)-C(3)-S(2)	109.7(3)	C(2)-C(3)-I'	118.7(2)
S(2)-C(3)-I'	124.1(2)	C(1)-C(4)-S(3)	123.7(2)
C(1)-C(4)-S(4)	122.0(2)	S(3)-C(4)-S(4)	114.3(2)
C(6)-C(5)-S(5)	124.9(2)	C(6)-C(5)-S(3)	117.4(2)
S(5)-C(5)-S(3)	117.7(2)	C(5)-C(6)-S(6)	122.6(2)
C(5)-C(6)-S(4)	117.1(2)	S(6)-C(6)-S(4)	120.2(2)
S(5)-C(8)-H(81)	105(2)	S(5)-C(8)-H(82)	110(2)
H(81)-C(8)-H(82)	106(3)	S(5)-C(8)-H(83)	109(2)
H(81)-C(8)-H(83)	110(3)	H(82)-C(8)-H(83)	117(3)
S(6)-C(9)-H(91)	103(2)	S(6)-C(9)-H(92)	112(2)
H(91)-C(9)-H(92)	117(3)	S(6)-C(9)-H(93)	112(2)
H(91)-C(9)-H(93)	108(3)	H(92)-C(9)-H(93)	106(3)
C(17)-C(11)-C(16)	121.1(3)	C(17)-C(11)-C(12)	120.5(2)
C(16)-C(11)-C(12)	118.3(2)	C(13)-C(12)-C(11)	120.9(2)
C(13)-C(12)-H(12)	117(2)	C(11)-C(12)-H(12)	122(2)
C(12)-C(13)-C(14)	121.0(3)	C(12)-C(13)-H(13)	122(2)
C(14)-C(13)-H(13)	117(2)	C(18)-C(14)-C(15)	121.8(2)
C(18)-C(14)-C(13)	120.1(2)	C(15)-C(14)-C(13)	118.0(2)
C(16)-C(15)-C(14)	121.3(2)	C(16)-C(15)-H(15)	121(2)
C(14)-C(15)-H(15)	117(2)	C(15)-C(16)-C(11)	120.4(2)
C(15)-C(16)-H(16)	116(2)	C(11)-C(16)-H(16)	124(2)
C(11)-C(17)-C(71)	122.2(3)	C(11)-C(17)-C(72)	121.8(3)
C(71)-C(17)-C(72)	116.0(3)	C(14)-C(18)-C(82)	121.8(2)
C(14)-C(18)-C(81)	121.6(3)	C(82)-C(18)-C(81)	116.5(2)
N(71)-C(71)-C(17)	178.3(3)	N(72)-C(72)-C(17)	179.1(3)
N(81)-C(81)-C(18)	178.2(3)	N(82)-C(82)-C(18)	178.6(3)

Table 1. Crystal data and structure refinement

Identification code	97srvl66
Empirical formula	C ₂₁ H ₁₃ I N ₄ S ₆
Formula weight	640.61
Temperature	150(2) K
Wavelength	0.71073 Å
Crystal system	Triclinic
Space group	P-1
Unit cell dimensions	a = 7.635(1) Å alpha = 91.20(1) deg. b = 7.959(1) Å beta = 88.64(1) deg. c = 20.021(1) Å gamma = 97.21(1) deg.
Volume	1200.7(2) Å ³
Z	2
Density (calculated)	1.772 g/cm ³
Absorption coefficient	1.874 mm ⁻¹
F(000)	632
Crystal size	0.40 × 0.16 × 0.13 mm
Theta range for data collection	2.06 to 30.17 deg.
Index ranges	-10 ≤ h ≤ 10, -11 ≤ k ≤ 11, -26 ≤ l ≤ 27
Reflections collected	13517
Independent reflections	6399 [R(int) = 0.0277]
Observed reflections, I > 2σ(I)	5505
Absorption correction	Integration
Max. and min. transmission	0.8095 and 0.5932
Refinement method	Full-matrix least-squares on F ²
Data / restraints / parameters	6362 / 0 / 352
Goodness-of-fit on F ²	1.242
Final R indices [I > 2σ(I)]	R ₁ = 0.0407, wR ₂ = 0.0801
R indices (all data)	R ₁ = 0.0528, wR ₂ = 0.0923
Largest diff. peak and hole	0.475 and -0.406 e.Å ⁻³

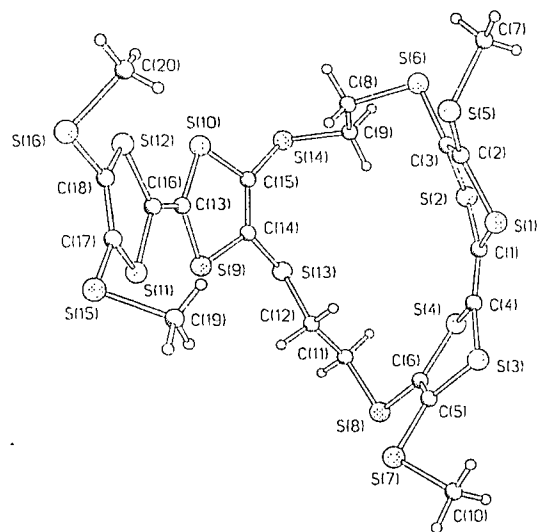

Table 1. Crystal data and structure refinement

Identification code	97SRV009	
Empirical formula	C ₂₀ H ₂₀ S ₁₆	
Formula weight	773.32	
Temperature	150(2) K	
Wavelength	0.71073 Å	
Crystal system	Triclinic	
Space group	P-1	
Unit cell dimensions	a = 11.524(1) Å	alpha = 68.13(1) deg
	b = 12.176(1) Å	beta = 78.21(1) deg
	c = 12.352(1) Å	gamma = 75.55(1) deg
Volume	1545.6(2) Å ³	
z	2	
Density (calculated)	1.662 g/cm ³	
Absorption coefficient	1.133 mm ⁻¹	
F(000)	792	
Crystal size	0.40 × 0.35 × 0.21 mm	
Theta range for data collection	1.79 to 30.66 deg.	
Index ranges	-16<=h<=15, -14<=k<=16, -16<=l<=16	
Reflections collected	13849	
Independent reflections	8147 [R(int) = 0.0201]	
Observed reflections, I>2sigma(I)	7443	
Absorption correction	Integration	
Max. and min. transmission	0.8202 and 0.7099	
Refinement method	Full-matrix least-squares on F ²	
Data / restraints / parameters	8117 / 0 / 405	
Goodness-of-fit on F ²	1.133	
Final R indices [I>2sigma(I)]	R1 = 0.0249, wR2 = 0.0585	
R indices (all data)	R1 = 0.0290, wR2 = 0.0651	
Largest diff. peak and hole	0.530 and -0.355 e.Å ⁻³	

Table 3. Bond lengths [Å] and angles [deg]

S(1)-C(1)	1.756(2)	S(1)-C(2)	1.754(2)
S(2)-C(1)	1.759(2)	S(2)-C(3)	1.776(2)
S(3)-C(4)	1.761(2)	S(3)-C(5)	1.783(2)
S(4)-C(4)	1.756(2)	S(4)-C(6)	1.772(2)
S(5)-C(2)	1.753(2)	S(5)-C(7)	1.812(2)
S(6)-C(3)	1.753(2)	S(6)-C(8)	1.832(2)
S(7)-C(5)	1.755(2)	S(7)-C(10)	1.807(2)
S(8)-C(6)	1.757(2)	S(8)-C(11)	1.827(2)
S(9)-C(13)	1.762(2)	S(9)-C(14)	1.765(2)
S(10)-C(13)	1.762(1)	S(10)-C(15)	1.768(2)
S(11)-C(17)	1.760(2)	S(11)-C(16)	1.751(2)
S(12)-C(16)	1.756(2)	S(12)-C(18)	1.764(2)
S(13)-C(14)	1.755(2)	S(13)-C(12)	1.834(2)
S(14)-C(15)	1.760(2)	S(14)-C(9)	1.832(2)
S(15)-C(17)	1.755(2)	S(15)-C(19)	1.802(2)
S(16)-C(18)	1.749(2)	S(16)-C(20)	1.809(2)
C(1)-C(4)	1.343(2)	C(2)-C(3)	1.354(2)
C(5)-C(6)	1.351(2)	C(8)-C(9)	1.515(2)
C(11)-C(12)	1.521(2)	C(13)-C(16)	1.242(2)
C(14)-C(15)	1.354(2)	C(17)-C(18)	1.353(2)
C(1)-S(1)-C(2)	94.21(7)	C(1)-S(2)-C(3)	93.99(7)
C(4)-S(3)-C(5)	92.68(7)	C(4)-S(4)-C(6)	92.73(7)
C(2)-S(5)-C(7)	103.36(7)	C(3)-S(6)-C(8)	103.35(8)
C(5)-S(7)-C(10)	100.56(8)	C(6)-S(8)-C(11)	100.39(7)
C(13)-S(9)-C(14)	94.56(7)	C(13)-S(10)-C(15)	94.49(7)
C(17)-S(11)-C(16)	94.74(7)	C(16)-S(12)-C(18)	95.11(7)
C(14)-S(13)-C(12)	100.92(7)	C(15)-S(14)-C(9)	102.23(7)
C(17)-S(15)-C(19)	99.25(9)	C(18)-S(16)-C(20)	102.24(9)
C(4)-C(1)-S(1)	123.86(11)	C(4)-C(1)-S(2)	123.38(11)
S(1)-C(1)-S(2)	112.79(8)	C(3)-C(2)-S(5)	130.28(12)
C(3)-C(2)-S(1)	116.87(11)	S(5)-C(2)-S(1)	112.35(8)
C(2)-C(3)-S(6)	126.21(12)	C(2)-C(3)-S(2)	115.90(11)
S(6)-C(3)-S(2)	117.55(8)	C(1)-C(4)-S(4)	122.59(11)
C(1)-C(4)-S(3)	123.76(11)	S(4)-C(4)-S(3)	113.42(8)
C(6)-C(5)-S(7)	125.00(12)	C(6)-C(5)-S(3)	116.23(11)
S(7)-C(5)-S(3)	118.74(8)	C(5)-C(6)-S(8)	124.95(12)
C(5)-C(6)-S(4)	116.90(11)	S(8)-C(6)-S(4)	117.97(8)
C(8)-C(9)-S(6)	113.66(11)	C(8)-C(9)-S(14)	113.76(11)
C(12)-C(11)-S(8)	113.34(11)	C(11)-C(12)-S(13)	107.73(12)
C(16)-C(13)-S(9)	121.59(11)	C(16)-C(13)-S(10)	124.48(12)
S(9)-C(13)-S(10)	113.88(8)	C(15)-C(14)-S(13)	124.52(11)
C(15)-C(14)-S(9)	117.03(11)	S(13)-C(14)-S(9)	118.01(9)
C(14)-C(15)-S(14)	126.20(12)	C(14)-C(15)-S(10)	116.91(11)
S(14)-C(15)-S(10)	116.70(8)	C(13)-C(16)-S(12)	123.54(11)
C(13)-C(16)-S(11)	122.57(12)	S(12)-C(16)-S(11)	113.33(8)
C(18)-C(17)-S(15)	126.10(12)	C(18)-C(17)-S(11)	117.24(12)
S(15)-C(17)-S(11)	116.48(9)	C(17)-C(18)-S(16)	124.93(12)
C(17)-C(18)-S(12)	116.53(12)	S(16)-C(18)-S(12)	117.69(9)

A 1.6

TTF DERIVATIVE (183)

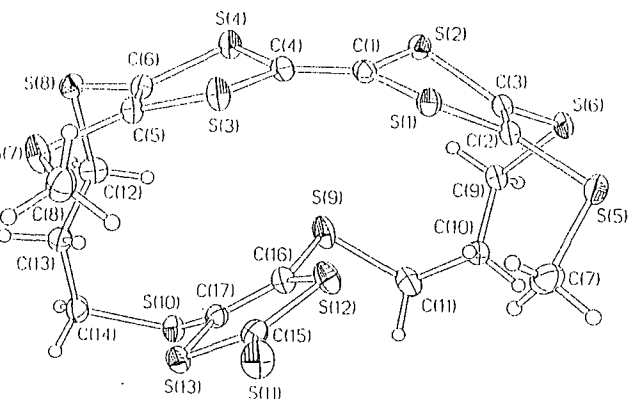

Table 1. Crystal data and structure refinement

Identification code	97srv083	
Empirical formula	C ₁₇ H ₁₈ S ₁₃	
Formula weight	639.09	
Temperature	150(2) K	
Wavelength	0.71073 Å	
Crystal system	Monoclinic	
Space group	C ₂ /c	
Unit cell dimensions	a = 24.272(2) Å	alpha = 90 deg.
	b = 9.203(1) Å	beta = 90.48(1) deg.
	c = 22.790(1) Å	gamma = 90 deg.
Volume	5090.5(7) Å ³	
Z	8	
Density (calculated)	1.668 g/cm ³	
Absorption coefficient	1.119 mm ⁻¹	
F(000)	2624	
Crystal size	0.4 × 0.3 × 0.24 mm	
Theta range for data collection	1.8 to 30.5 deg.	
Index ranges	-34<h<=34, -12<k<=12, -25<l<=31	
Reflections collected	20137	
Independent reflections	7118 [R(int) = 0.0308]	
Observed reflections, I>2sigma(I)	6053	
Absorption correction	Integration	
Max. and min. transmission	0.7917 and 0.7073	
Refinement method	Full-matrix least-squares on F ²	
Data / restraints / parameters	7103 / 0 / 344	
Goodness-of-fit on F ²	1.152	
Final R indices [I>2sigma(I)]	R1 = 0.0304, wR2 = 0.0600	
R indices (all data)	R1 = 0.0419, wR2 = 0.0677	
Extinction coefficient	0.00059(4)	
Largest diff. peak and hole	0.413 and -0.292 e.Å ⁻³	

Table 3. Bond lengths [Å] and angles [deg] for 1.

S(1)-C(1)	1.764(2)	S(1)-C(2)	1.776(2)
S(2)-C(1)	1.757(2)	S(2)-C(3)	1.772(2)
S(3)-C(4)	1.762(2)	S(3)-C(5)	1.767(2)
S(4)-C(4)	1.760(2)	S(4)-C(6)	1.771(2)
S(5)-C(2)	1.744(2)	S(5)-C(7)	1.805(2)
S(6)-C(3)	1.757(2)	S(6)-C(9)	1.827(2)
S(7)-C(5)	1.758(2)	S(7)-C(8)	1.799(2)
S(8)-C(6)	1.757(2)	S(8)-C(12)	1.833(2)
S(9)-C(16)	1.762(2)	S(9)-C(11)	1.832(2)
S(10)-C(17)	1.757(2)	S(10)-C(14)	1.832(2)
S(11)-C(15)	1.650(2)	S(12)-C(15)	1.730(2)
S(12)-C(16)	1.754(2)	S(13)-C(15)	1.740(2)
S(13)-C(17)	1.756(2)	C(1)-C(4)	1.349(2)
C(2)-C(3)	1.351(3)	C(5)-C(6)	1.349(3)
C(7)-H(71)	0.94(3)	C(7)-H(72)	0.96(3)
C(7)-H(73)	0.93(3)	C(8)-H(81)	0.95(2)
C(8)-H(82)	0.95(3)	C(8)-H(83)	0.95(3)
C(9)-C(10)	1.524(3)	C(9)-H(91)	0.98(2)
C(9)-H(92)	0.98(3)	C(10)-C(11)	1.530(3)
C(10)-H(101)	0.96(3)	C(10)-H(102)	0.99(2)
C(11)-H(111)	1.05(2)	C(11)-H(112)	0.99(3)
C(12)-C(13)	1.526(3)	C(12)-H(121)	1.00(2)
C(12)-H(122)	0.96(3)	C(13)-C(14)	1.521(3)
C(13)-H(131)	0.96(3)	C(13)-H(132)	1.00(3)
C(14)-H(141)	0.94(2)	C(14)-H(142)	0.98(3)
C(15)-C(17)	1.352(3)		
C(1)-S(1)-C(1)	93.02(8)	C(1)-S(2)-C(3)	93.43(8)
C(4)-S(3)-C(5)	94.44(8)	C(4)-S(4)-C(6)	94.24(8)
C(2)-S(5)-C(7)	101.94(10)	C(3)-S(6)-C(9)	97.02(9)
C(5)-S(7)-C(8)	102.76(9)	C(6)-S(8)-C(12)	101.59(9)
C(15)-S(9)-C(11)	101.61(10)	C(17)-S(10)-C(14)	102.51(9)
C(15)-S(12)-C(16)	98.10(9)	C(15)-S(13)-C(17)	97.85(9)
C(4)-C(1)-S(1)	122.35(14)	C(4)-C(1)-S(2)	124.32(14)
S(2)-C(1)-S(1)	113.41(9)	C(3)-C(2)-S(5)	123.84(14)
C(3)-C(2)-S(5)	116.82(13)	S(5)-C(2)-S(1)	119.10(10)
C(2)-C(3)-S(6)	126.24(14)	C(2)-C(3)-S(2)	116.48(13)
S(6)-C(3)-S(2)	117.28(10)	C(1)-C(4)-S(4)	123.42(14)
C(1)-C(4)-S(3)	122.62(14)	S(4)-C(4)-S(3)	113.96(10)
C(6)-C(5)-S(7)	123.92(14)	C(6)-C(5)-S(3)	116.85(14)
S(7)-C(5)-S(3)	119.20(10)	C(5)-C(6)-S(8)	126.18(14)
C(5)-C(6)-S(8)	117.09(14)	S(8)-C(6)-S(4)	115.34(10)
S(5)-C(7)-H(71)	113(2)	S(5)-C(7)-H(72)	107(2)
H(71)-C(7)-H(72)	110(3)	S(5)-C(7)-H(73)	111(2)
H(71)-C(7)-H(73)	110(3)	H(72)-C(7)-H(73)	106(2)
S(7)-C(8)-H(81)	109(2)	S(7)-C(8)-H(82)	111(2)
H(81)-C(8)-H(82)	113(2)	S(7)-C(8)-H(83)	105(2)
H(81)-C(8)-H(83)	110(2)	H(82)-C(8)-H(83)	109(2)
C(10)-C(9)-S(5)	112.88(13)	C(10)-C(9)-H(91)	111.2(13)
S(5)-C(9)-H(91)	106.5(13)	C(10)-C(9)-H(92)	110.7(14)
S(5)-C(9)-H(92)	106.9(14)	H(91)-C(9)-H(92)	108(2)
C(9)-C(10)-C(11)	111.5(2)	C(9)-C(10)-H(101)	110(2)
C(11)-C(10)-H(101)	110(2)	C(9)-C(10)-H(102)	110.9(14)
C(11)-C(10)-H(102)	109.1(13)	H(101)-C(10)-H(102)	106(2)
C(10)-C(11)-S(9)	113.65(14)	C(10)-C(11)-H(111)	110.7(14)
S(9)-C(11)-H(111)	106.9(13)	C(10)-C(11)-H(112)	111(2)
S(9)-C(11)-H(112)	106(2)	H(111)-C(11)-H(112)	109(2)
C(13)-C(12)-S(8)	110.92(14)	C(13)-C(12)-H(121)	108.9(14)
S(8)-C(12)-H(121)	111.2(14)	C(13)-C(12)-H(122)	111(2)
S(8)-C(12)-H(122)	104(2)	H(121)-C(12)-H(122)	111(2)
C(14)-C(13)-C(12)	115.7(2)	C(14)-C(13)-H(131)	109(2)
C(12)-C(13)-H(131)	108(2)	C(14)-C(13)-H(132)	107.4(14)
C(12)-C(13)-H(132)	111(2)	H(131)-C(13)-H(132)	105(2)
C(13)-C(14)-S(10)	116.06(14)	C(13)-C(14)-H(141)	111(2)
S(10)-C(14)-H(141)	102.6(14)	C(13)-C(14)-H(142)	112(2)
S(10)-C(14)-H(142)	106.3(14)	H(141)-C(14)-H(142)	108(2)
S(11)-C(15)-S(13)	124.29(12)	S(11)-C(15)-S(12)	123.36(12)
S(12)-C(15)-S(13)	112.35(11)	C(17)-C(16)-S(9)	115.87(14)
C(17)-C(16)-S(9)	124.5(2)	S(12)-C(16)-S(9)	119.45(11)
C(16)-C(17)-S(10)	124.09(14)	C(16)-C(17)-S(13)	115.81(14)
S(10)-C(17)-S(13)	119.92(10)		

A 1.7

[BISTTF (156)]₂ · ClO₄ COMPLEX

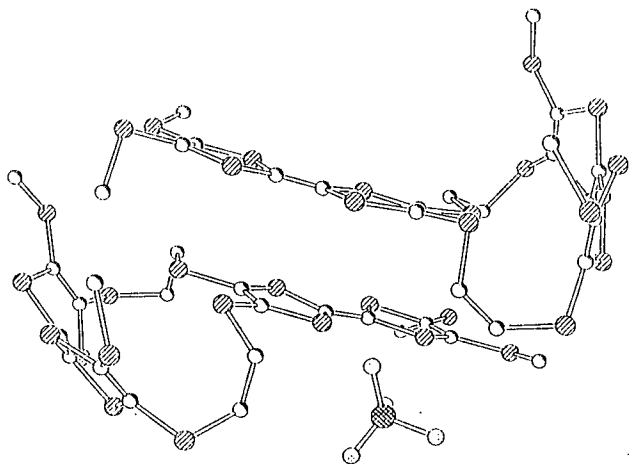

Table 3. Bond lengths [Å] and angles [deg]

S(1A)-C(2A)	1.757(14)	S(1A)-C(1A)	1.785(13)
S(2A)-C(3A)	1.734(14)	S(2A)-C(1A)	1.764(14)
S(3A)-C(5A)	1.74(2)	S(3A)-C(4A)	1.753(14)
S(4A)-C(6A)	1.74(2)	S(4A)-C(4A)	1.772(13)
S(5A)-C(2A)	1.721(14)	S(5A)-C(7A)	1.80(2)
S(6A)-C(3A)	1.754(14)	S(6A)-C(8A)	1.79(2)
S(7A)-C(5A)	1.74(2)	S(7A)-C(10A)	1.80(2)
S(8A)-C(11A)	1.73(2)	S(8A)-C(6A)	1.77(2)
S(9A)-C(14A)	1.69(2)	S(9A)-C(13A)	1.71(2)
S(10A)-C(15A)	1.71(2)	S(10A)-C(13A)	1.73(2)
S(11A)-C(17A)	1.74(2)	S(11A)-C(16A)	1.75(2)
S(12A)-C(16A)	1.71(2)	S(12A)-C(18A)	1.78(2)
S(13A)-C(14A)	1.74(2)	S(13A)-C(12A)	1.81(2)
S(14A)-C(9A)	1.76(2)	S(14A)-C(15A)	1.83(2)
S(15A)-C(17A)	1.69(2)	S(15A)-C(19A)	1.92(4)
S(16A)-C(18A)	1.74(2)	S(16A)-C(20A)	1.81(3)
C(1A)-C(4A)	1.33(2)	C(2A)-C(3A)	1.36(2)
C(5A)-C(6A)	1.43(2)	C(8A)-C(9A)	1.46(2)
C(11A)-C(12A)	1.57(3)	C(13A)-C(16A)	1.40(3)
C(14A)-C(15A)	1.41(3)	C(17A)-C(18A)	1.42(3)
S(1B)-C(1B)	1.80(2)	S(1B)-C(2B)	1.81(2)
S(2B)-C(1B)	1.77(2)	S(2B)-C(3B)	1.84(2)
S(3B)-C(4B)	1.74(2)	S(3B)-C(5B)	1.77(2)
S(4B)-C(4B)	1.75(2)	S(4B)-C(6B)	1.818(14)
S(5B)-C(2B)	1.76(2)	S(5B)-C(7B)	1.78(2)
S(6B)-C(3B)	1.71(2)	S(6B)-C(8B)	1.84(2)
S(7B)-C(5B)	1.731(14)	S(7B)-C(10B)	1.85(2)
S(8B)-C(6B)	1.730(14)	S(8B)-C(11B)	1.84(2)
S(9B)-C(14B)	1.77(2)	S(9B)-C(13B)	1.82(2)
S(10B)-C(13B)	1.76(2)	S(10B)-C(15B)	1.75(2)
S(11B)-C(16B)	1.75(2)	S(11B)-C(17B)	1.79(2)
S(12B)-C(16B)	1.76(2)	S(12B)-C(16B)	1.78(2)
S(13B)-C(14B)	1.67(2)	S(13B)-C(12B)	1.87(2)
S(14B)-C(15B)	1.74(2)	S(14B)-C(9B)	1.90(2)
S(15B)-C(17B)	1.73(2)	S(15B)-C(19B)	1.85(2)
S(16B)-C(18B)	1.74(2)	S(16B)-C(20B)	1.84(3)
C(1B)-C(4B)	1.33(2)	C(2B)-C(3B)	1.29(2)
C(5B)-C(6B)	1.35(2)	C(8B)-C(9B)	1.37(3)
C(11B)-C(12B)	1.50(3)	C(13B)-C(16B)	1.29(3)
C(14B)-C(15B)	1.38(3)	C(17B)-C(18B)	1.36(3)
Cl-O(4)	1.37(3)	Cl-O(1)	1.38(3)
Cl-O(2)	1.39(4)	Cl-O(3)	1.43(2)
C(2A)-S(1A)-C(1A)	94.1(6)	C(3A)-S(2A)-C(1A)	95.3(6)
C(5A)-S(3A)-C(4A)	95.0(7)	C(6A)-S(4A)-C(4A)	93.7(8)
C(2A)-S(5A)-C(7A)	101.7(8)	C(3A)-S(6A)-C(8A)	102.7(8)
C(5A)-S(7A)-C(10A)	101.4(7)	C(11A)-S(8A)-C(6A)	98.9(9)
C(14A)-S(9A)-C(13A)	95.9(10)	C(15A)-S(10A)-C(13A)	94.9(9)
C(17A)-S(11A)-C(16A)	97.0(10)	C(16A)-S(12A)-C(18A)	94.5(10)
C(14A)-S(13A)-C(12A)	102.2(10)	C(9A)-S(14A)-C(15A)	96.2(9)
C(17A)-S(15A)-C(19A)	97.4(13)	C(18A)-S(16A)-C(20A)	105.7(13)
C(4A)-C(1A)-S(2A)	122.4(11)	C(4A)-C(1A)-S(1A)	124.9(11)
S(2A)-C(1A)-S(1A)	112.7(7)	C(3A)-C(2A)-S(1A)	117.1(11)
C(3A)-C(2A)-S(5A)	125.7(11)	S(1A)-C(2A)-S(5A)	117.1(11)
C(2A)-C(3A)-S(2A)	117.4(11)	C(2A)-C(3A)-S(6A)	125.0(11)
S(2A)-C(3A)-S(6A)	117.6(8)	C(1A)-C(4A)-S(3A)	125.9(11)
C(1A)-C(4A)-S(6A)	120.7(11)	S(3A)-C(4A)-S(4A)	112.9(7)
C(6A)-C(5A)-S(7A)	114.7(12)	C(6A)-C(5A)-S(7A)	121.3(12)
S(3A)-C(5A)-S(7A)	123.9(9)	C(5A)-C(6A)-S(4A)	116.8(13)
C(5A)-C(6A)-S(8A)	131.3(13)	S(4A)-C(6A)-S(8A)	119.9(11)
C(9A)-C(8A)-S(6A)	116.5(13)	C(8A)-C(9A)-S(14A)	118.8(13)
C(12A)-C(11A)-S(8A)	115(2)	C(11A)-C(12A)-S(13A)	113.9(14)
C(16A)-C(13A)-S(9A)	122(2)	C(16A)-C(13A)-S(10A)	121(2)
S(9A)-C(13A)-S(10A)	116.4(12)	C(15A)-C(14A)-S(9A)	116(2)
C(15A)-C(14A)-S(13A)	122(2)	S(9A)-C(14A)-S(13A)	121.9(12)
C(14A)-C(15A)-S(10A)	116(2)	C(14A)-C(15A)-S(14A)	120(2)
S(10A)-C(15A)-S(14A)	123.5(11)	C(13A)-C(16A)-S(12A)	125(2)
C(13A)-C(16A)-S(11A)	118(2)	S(12A)-C(16A)-S(11A)	115.6(12)
C(18A)-C(17A)-S(15A)	121(2)	C(18A)-C(17A)-S(11A)	114(2)
S(15A)-C(17A)-S(11A)	124.6(13)	C(17A)-C(18A)-S(16A)	122(2)
C(17A)-C(18A)-S(12A)	117(2)	S(16A)-C(18A)-S(12A)	120.4(13)
C(1B)-S(1B)-C(2B)	92.3(7)	C(1B)-S(2B)-C(3B)	94.1(7)
C(4B)-S(3B)-C(5B)	94.6(7)	C(4B)-S(4B)-C(6B)	93.5(7)
C(2B)-S(5B)-C(7B)	105.9(8)	C(3B)-S(6B)-C(8B)	102.6(8)
C(5B)-S(7B)-C(10B)	102.5(7)	C(6B)-S(8B)-C(11B)	102.0(8)
C(14B)-S(9B)-C(13B)	95.6(8)	C(13B)-S(10B)-C(15B)	97.9(9)
C(16B)-S(11B)-C(17B)	95.9(9)	C(18B)-S(12B)-C(16B)	95.6(9)
C(14B)-S(13B)-C(12B)	108.0(9)	C(15B)-S(14B)-C(9B)	102.8(10)
C(17B)-S(15B)-C(19B)	101.7(10)	C(18B)-S(16B)-C(20B)	101.1(12)
C(4B)-C(1B)-S(1B)	123.1(13)	C(4B)-C(1B)-S(1B)	126.0(13)

S(2B)-C(1B)-S(1B)	110.8(8)	C(3B)-C(2B)-S(5B)	121.7(12)
C(3B)-C(2B)-S(1B)	119.5(12)	S(5B)-C(2B)-S(1B)	119.3(8)
C(2B)-C(3B)-S(6B)	128.3(12)	C(2B)-C(3B)-S(2B)	114.1(11)
S(6B)-C(3B)-S(2B)	117.3(8)	C(1B)-C(4B)-S(3B)	124.3(12)
C(1B)-C(4B)-S(4B)	121.3(12)	S(3B)-C(4B)-S(4B)	114.5(8)
C(6B)-C(5B)-S(7B)	122.9(11)	C(6B)-C(5B)-S(3B)	117.3(11)
S(7B)-C(5B)-S(3B)	119.8(8)	C(5B)-C(6B)-S(3B)	129.7(11)
C(5B)-C(6B)-S(4B)	115.1(11)	S(8B)-C(5B)-S(4B)	114.7(8)
C(9B)-C(8B)-S(6B)	119(2)	C(8B)-C(9B)-S(14B)	113(2)
C(12B)-C(11B)-S(8B)	115(2)	C(11B)-C(12B)-S(13B)	111.5(14)
C(16B)-C(13B)-S(10B)	126(2)	C(16B)-C(13B)-S(9B)	121(2)
S(10B)-C(13B)-S(9B)	112.6(10)	S(15B)-C(14B)-S(13B)	124.1(14)
C(15B)-C(14B)-S(9B)	117.7(13)	S(13B)-C(14B)-S(9B)	118.3(10)
C(14B)-C(15B)-S(14B)	123(2)	C(14B)-C(15B)-S(10B)	116(2)
S(14B)-C(15B)-S(10B)	120.4(11)	C(13B)-C(16B)-S(11B)	127(2)
C(13B)-C(16B)-S(12B)	119(2)	S(11B)-C(16B)-S(12B)	114.5(10)
C(18B)-C(17B)-S(11B)	127(2)	C(18B)-C(17B)-S(11B)	115.1(14)
S(15B)-C(17B)-S(11B)	115.7(10)	C(17B)-C(18B)-S(16B)	123(2)
C(17B)-C(18B)-S(12B)	117.7(14)	S(16B)-C(18B)-S(12B)	118.8(10)
O(4)-Cl-O(1)	104(2)	O(4)-Cl-O(2)	109(2)
O(1)-Cl-O(2)	113(2)	O(1)-Cl-O(3)	111(2)
O(1)-Cl-O(3)	101.5(14)	O(2)-Cl-O(3)	112(2)

Table 1. Crystal data and structure refinement

Identification code	97svv059
Empirical formula	C40 H40 Cl O4 S32
Formula weight	1546.09
Temperature	150(2) K
Wavelength	0.71073 Å
Crystal system	Orthorhombic
Space group	Pna2(1)
Unit cell dimensions	a = 22.545(2) Å b = 8.3544(6) Å c = 34.184(3) Å
Volume	6467(1) Å ³
Z	4
Density (calculated)	1.691 g/cm ³
Absorption coefficient	1.133 mm ⁻¹
F(000)	3364
Crystal size	0.35 × 0.17 × 0.10 mm
Theta range for data collection	1.80 to 25.00 deg.
Index ranges	-31<h<=30, -9<k<=11, -47<l<=46
Reflections collected	37238
Independent reflections	10539 [R(int) = 0.0795]
Observed reflections, I>2sigma(I)	9050
Absorption correction	None
Refinement method	Full-matrix least-squares on F ²
Data / restraints / parameters	10490 / 1 / 474
Goodness-of-fit on F ²	1.098
Final R indices [I>2sigma(I)]	R1 = 0.1215, wR2 = 0.2945
R indices (all data)	R1 = 0.1432, wR2 = 0.3267
Absolute structure parameter	0.2(3)
Largest shift e.s.d. ratio	0.022
Largest diff. peak and hole	3.661 and -1.286 e.Å ⁻³

A 1.8

BISTTF (156) · I₈ COMPLEX

Table 1. Crystal data and structure refinement

Identification code	98srv006
Empirical formula	C ₂₀ H ₂₀ I ₈ S ₁₆
Formula weight	1788.52
Temperature	150(2) K
Wavelength	0.71073 Å
Crystal system	Orthorhombic
Space group	Pnma
Unit cell dimensions	a = 25.961(2) Å alpha = 90 deg. b = 20.548(2) Å beta = 90 deg. c = 8.512(1) Å gamma = 90 deg.
Volume	4540.7(9) Å ³
Z	4
Density (calculated)	2.616 g/cm ³
Absorption coefficient	6.219 mm ⁻¹
F(000)	3280
Crystal size	0.35 × 0.19 × 0.004 mm
Theta range for data collection	1.86 to 25.00 deg.
Index ranges	-32 ≤ h ≤ 33, -26 ≤ k ≤ 26, -11 ≤ l ≤ 8
Reflections collected	25927
Independent reflections	4122 [R(int) = 0.1769]
Observed reflections, I > 2σ(I)	2596
Absorption correction	Integration
Max. and min. transmission	0.9754 and 0.2910
Refinement method	Full-matrix least-squares on F ²
Data / restraints / parameters	3944 / 0 / 174
Goodness-of-fit on F ²	1.152
Final R indices [I > 2σ(I)]	R1 = 0.0949, wR2 = 0.2093
R indices (all data)	R1 = 0.1635, wR2 = 0.2736
Extinction coefficient	0.00021(8)
Largest shift.e.s.d. ratio	0.009
Largest diff. peak and hole	2.165 and -2.788 e.Å ⁻³

Table 3. Bond lengths [Å] and angles [deg]

I(1)-I(2)	2.922(1)	I(1)-I(2)#1	2.922(1)
I(3)-I(4A)	3.043(3)	I(3)-I(4A)#1	3.043(3)
I(4A)-I(5A)	2.828(5)	I(4B)-I(5B)	2.577(11)
I(4B)-I(5B)#2	3.051(11)	I(5B)-I(4B)#3	3.051(11)
S(1)-C(2)	1.76(2)	S(1)-C(1)	1.77(2)
S(2)-C(1)	1.73(2)	S(2)-C(3)	1.76(2)
S(3)-C(4)	1.75(2)	S(3)-C(2)	1.76(2)
S(4)-C(3)	1.75(2)	S(4)-C(5)	1.79(3)
S(5)-C(8)	1.72(2)	S(5)-C(7)	1.73(2)
S(6)-C(9)	1.70(2)	S(6)-C(10)	1.70(2)
S(7)-C(8)	1.74(2)	S(7)-C(6)	1.92(3)
S(8)-C(10)	1.74(2)	S(8)-C(11)	1.79(2)
C(1)-C(1)#1	1.36(4)	C(2)-C(3)	1.36(3)
C(5)-C(6)	1.46(4)	C(7)-C(9)	1.39(4)
C(7)-S(5)#1	1.73(2)	C(8)-C(8)#1	1.40(4)
C(9)-S(6)#1	1.70(2)	C(10)-C(10)#1	1.39(4)
I(2)-I(1)-I(2)#1	167.5(1)	I(4A)-I(3)-I(4A)#1	120.3(1)
I(5A)-I(4A)-I(3)	175.9(1)	I(5B)-I(4B)-I(5B)#2	98.8(2)
I(4B)-I(5B)-I(4B)#3	173.1(2)	C(2)-S(1)-C(1)	93.7(9)
C(1)-S(2)-C(3)	95.1(10)	C(4)-S(3)-C(2)	103.6(11)
C(3)-S(4)-C(5)	101.6(12)	C(8)-S(5)-C(7)	97.8(10)
C(9)-S(6)-C(10)	96.0(10)	C(8)-S(7)-C(6)	97.5(11)
C(10)-S(8)-C(11)	99.9(10)	C(1)#1-C(1)-S(2)	122.5(7)
C(1)#1-C(1)-S(1)	123.5(7)	S(2)-C(1)-S(1)	113.5(11)
C(3)-C(2)-S(1)	124(2)	C(3)-C(2)-S(1)	117(2)
S(3)-C(2)-S(1)	119.1(11)	C(2)-C(3)-S(4)	125(2)
C(2)-C(3)-S(2)	116(2)	S(4)-C(3)-S(2)	118.4(12)
C(6)-C(5)-S(4)	112(2)	C(5)-C(6)-S(7)	110(2)
C(9)-C(7)-S(5)#1	123.5(8)	C(9)-C(7)-S(5)	123.5(8)
S(5)#1-C(7)-S(5)	113(2)	C(8)#1-C(8)-S(5)	115.5(6)
C(8)#1-C(8)-S(7)	124.7(6)	S(5)-C(8)-S(7)	119.7(11)
C(7)-C(9)-S(6)	121.8(8)	C(7)-C(9)-S(6)#1	121.8(8)
S(6)-C(9)-S(6)#1	116(2)	C(10)#1-C(10)-S(6)	116.9(7)
C(10)#1-C(10)-S(8)	121.2(6)	S(6)-C(10)-S(8)	122.9(11)

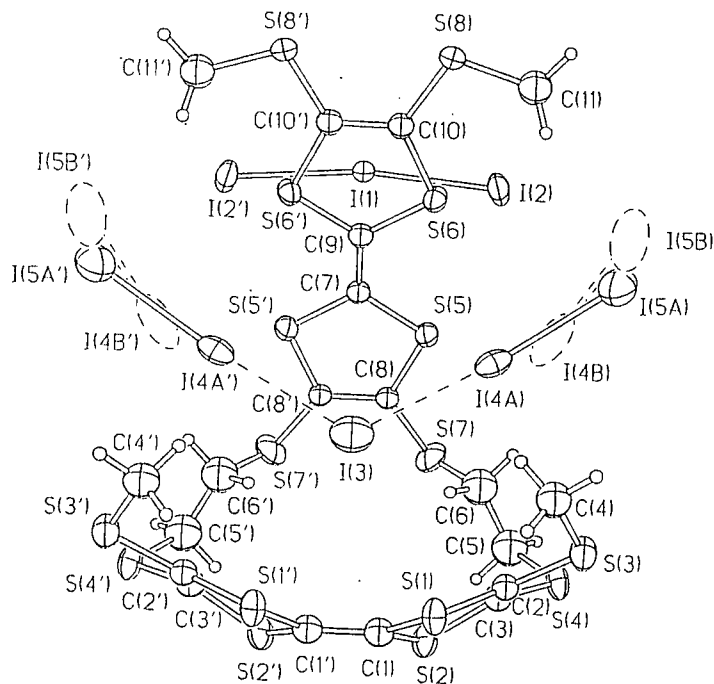
Symmetry transformations used to generate equivalent atoms:
 #1 x, -y+1/2, z #2 -x+1/2, -y+1, z+1/2 #3 -x+1/2, -y-1, z-1/2

Appendix Two
Research Colloquia

A. 2.1 RESEARCH COLLOQUIA

The author attended the following colloquia.

1995

- October 11 Prof. P. Lugar, Frei Univ Berlin, FRG
Low Temperature Crystallography
- October 13 Prof. R. Schmutzler, Univ Braunschweig, FRG.
Calixarene-Phosphorus Chemistry: A New Dimension in
Phosphorus Chemistry
- October 18 Prof. A. Alexakis, Univ. Pierre et Marie Curie, Paris,
Synthetic and Analytical Uses of Chiral Diamines
- October 25 Dr.D.Martin Davies, University of Northumbria
Chemical reactions in organised systems.
- November 1 Prof. W. Motherwell, UCL London
New Reactions for Organic Synthesis
- November 3 Dr B. Langlois, University Claude Bernard-Lyon
Radical Anionic and Psuedo Cationic Trifluoromethylation
- November 8 Dr. D. Craig, Imperial College, London
New Stategies for the Assembly of Heterocyclic Systems
- November 15 Dr Andrea Sella, UCL, London
Chemistry of Lanthanides with Polypyrazoylborate Ligands
- November 17 Prof. David Bergbreiter, Texas A&M, USA
Design of Smart Catalysts, Substrates and Surfaces from Simple
Polymers

November 22 Prof. I Soutar, Lancaster University
A Water of Glass? Luminescence Studies of Water-Soluble
Polymers.

November 29 Prof. Dennis Tuck, University of Windsor, Ontario, Canada
New Indium Coordination Chemistry

December 8 Professor M.T. Reetz, Max Planck Institut, Mulheim
Perkin Regional Meeting

1996

January 10 Dr Bill Henderson, Waikato University, NZ
Electrospray Mass Spectrometry - a new sporting technique

January 17 Prof. J. W. Emsley , Southampton University
Liquid Crystals: More than Meets the Eye

January 24 Dr Alan Armstrong, Nottingham Univesity
Alkene Oxidation and Natural Product Synthesis

January 31 Dr J. Penfold, Rutherford Appleton Laboratory,
Soft Soap and Surfaces

February 7 Dr R.B. Moody, Exeter University
Nitrosations, Nitrations and Oxidations with Nitrous Acid

February 12 Dr Paul Pringle, University of Bristol
Catalytic Self-Replication of Phosphines on Platinum(O)

February 14 Dr J. Rohr, Univ Gottingen, FRG
Goals and Aspects of Biosynthetic Studies on Low Molecular
Weight Natural Products

February 21 Dr C R Pulham , Univ. Edinburgh
Heavy Metal Hydrides - an exploration of the chemistry of
stannanes and plumbanes

1995 - 1996 (August 1 - July 31)/continued

- February 28 Prof. E. W. Randall, Queen Mary & Westfield College
New Perspectives in NMR Imaging
- March 6 Dr Richard Whitby, Univ of Southampton
New approaches to chiral catalysts: Induction of planar and metal centred asymmetry
- March 7 Dr D.S. Wright, University of Cambridge
Synthetic Applications of Me₂N-p-Block Metal Reagents
- March 12 RSC Endowed Lecture - Prof. V. Balzani, Univ of Bologna
Supramolecular Photochemistry
- March 13 Prof. Dave Garner, Manchester University
Mushrooming in Chemistry
- April 30 Dr L.D.Pettit, Chairman, IUPAC Commission of Equilibrium Data
pH-metric studies using very small quantities of uncertain purity

1996

- October 9 Professor G. Bowmaker, University Auckland, NZ
Coordination and Materials Chemistry of the Group 11 and Group 12 Metals : Some Recent Vibrational and Solid State NMR Studies
- October 14 Professor A. R. Katritzky, University of Gainesville, University of Florida, USA
Recent Advances in Benzotriazole Mediated Synthetic Methodology

- October 16 Professor Ojima, Guggenheim Fellow, State University of New York at Stony Brook
Silylformylation and Silylcarbocyclisations in Organic Synthesis
- October 22 Professor Lutz Gade, Univ. Wurzburg, Germany
Organic transformations with Early-Late Heterobimetallics: Synergism and Selectivity
- October 22 Professor B. J. Tighe, Department of Molecular Sciences and Chemistry, University of Aston
Making Polymers for Biomedical Application - can we meet Nature's Challenge?
Joint lecture with the Institute of Materials
- October 23 Professor H. Ringsdorf (Perkin Centenary Lecture), Johannes Gutenberg-Universitat, Mainz, Germany
Function Based on Organisation
- October 29 Professor D. M. Knight, Department of Philosophy, University of Durham.
The Purpose of Experiment - A Look at Davy and Faraday
- October 30 Dr Phillip Mountford, Nottingham University
Recent Developments in Group IV Imido Chemistry
- November 6 Dr Melinda Duer, Chemistry Department, Cambridge
Solid-state NMR Studies of Organic Solid to Liquid-crystalline Phase Transitions
- November 12 Professor R. J. Young, Manchester Materials Centre, UMIST
New Materials - Fact or Fantasy?
Joint Lecture with Zeneca & RSC
- November 13 Dr G. Resnati, Milan
Perfluorinated Oxaziridines: Mild Yet Powerful Oxidising Agents

November 18	Professor G. A. Olah, University of Southern California, USA Crossing Conventional Lines in my Chemistry of the Elements	January 29	Synthesis and Properties of Alternating Polyketones Dr Julian Clarke, UMIST What can we learn about polymers and biopolymers from computer-generated nanosecond movie-clips?
November 19	Professor R. E. Grigg, University of Leeds Assembly of Complex Molecules by Palladium-Catalysed Queuing Processes	February 4	Dr A. J. Banister, University of Durham From Runways to Non-metallic Metals - A New Chemistry Based on Sulphur
November 20	Professor J. Earnshaw, Department of Physics, Belfast Surface Light Scattering: Ripples and Relaxation	February 5	Dr A. Haynes, University of Sheffield Mechanism in Homogeneous Catalytic Carbonylation
November 27	Dr Richard Templer, Imperial College, London Molecular Tubes and Sponges	February 12	Dr Geert-Jan Boons, University of Birmingham New Developments in Carbohydrate Chemistry
December 3	Professor D. Phillips, Imperial College, London "A Little Light Relief" -	February 18	Professor Sir James Black, Foundation/King's College London My Dialogues with Medicinal Chemists
December 4	Professor K. Muller-Dethlefs, York University Chemical Applications of Very High Resolution ZEKE Photoelectron Spectroscopy	February 19	Professor Brian Hayden, University of Southampton The Dynamics of Dissociation at Surfaces and Fuel Cell Catalysts
December 11	Dr Chris Richards, Cardiff University Stereochemical Games with Metallocenes	February 25	Professor A. G. Sykes, University of Newcastle The Synthesis, Structures and Properties of Blue Copper Proteins
<u>1997</u>		February 26	Dr Tony Ryan, UMIST Making Hairpins from Rings and Chains
January 15	Dr V. K. Aggarwal, University of Sheffield Sulfur Mediated Asymmetric Synthesis	March 4	Professor C. W. Rees, Imperial College Some Very Heterocyclic Chemistry
January 16	Dr Sally Brooker, University of Otago, NZ Macrocycles: Exciting yet Controlled Thiolate Coordination Chemistry	March 5	Dr J. Staunton FRS, Cambridge University Tinkering with biosynthesis: towards a new generation of antibiotics
January 21	Mr D. Rudge, Zeneca Pharmaceuticals High Speed Automation of Chemical Reactions		
January 22	Dr Neil Cooley, BP Chemicals, Sunbury		

March 11	Dr A. D. Taylor, ISIS Facility, Rutherford Appleton Laboratory Expanding the Frontiers of Neutron Scattering	Studies of the Heck reaction
March 19	Dr Katharine Reid, University of Nottingham Probing Dynamical Processes with Photoelectrons	November 11 Professor V Gibson, Imperial College, London Metallocene polymerisation
<u>1997</u>		November 12 Dr J Frey, Department of Chemistry, Southampton University Spectroscopy of liquid interfaces: from bio-organic chemistry to atmospheric chemistry
October 8	Professor E Atkins, Department of Physics, University of Bristol Advances in the control of architecture for polyamides: from nylons to genetically engineered silks to monodisperse oligoamides	November 19 Dr G Morris, Department of Chemistry, Manchester Univ. Pulsed field gradient NMR techniques: Good news for the Lazy and DOSY
October 15	Dr R M Ormerod, Department of Chemistry, Keele University Studying catalysts in action	November 20 Dr L Spiccia, Monash University, Melbourne, Australia Polynuclear metal complexes
October 21	Professor A F Johnson, IRC, Leeds Reactive processing of polymers: science and technology	November 25 Dr R Withnall, University of Greenwich Illuminated molecules and manuscripts
October 22	Professor R J Puddephatt (RSC Endowed Lecture), University of Western Ontario Organoplatinum chemistry and catalysis	November 26 Professor R W Richards, University of Durham, Inaugural Lecture A random walk in polymer science
October 23	Professor M R Bryce, University of Durham, Inaugural Lecture New Tetrathiafulvalene Derivatives in Molecular, Supramolecular and Macromolecular Chemistry: controlling the electronic properties of organic solids	December 2 Dr C J Ludman, University of Durham Explosions
October 29	Professor R Peacock, University of Glasgow Probing chirality with circular dichroism	December 3 Professor A P Davis, Department of Chemistry, Trinity College Dublin. Steroid-based frameworks for supramolecular chemistry
October 28	Professor A P de Silva, The Queen's University, Belfast Luminescent signalling systems".	December 10 Sir G Higginson, former Professor of Engineering in Durham and retired Vice-Chancellor of Southampton Univ. 1981 and all that.
November 5	Dr M Hii, Oxford University	December 10 Professor M Page, Department of Chemistry, University of Huddersfield The mechanism and inhibition of beta-lactamases

October 27	Professor W Roper FRS, University of Auckland, New Zealand	Surprises in the photochemistry of tropospheric ozone	
<u>1998</u>			
January 14	Professor D Andrews, University of East Anglia Energy transfer and optical harmonics in molecular systems	February 24	Professor R Ramage, University of Edinburgh The synthesis and folding of proteins
January 20	Professor J Brooke, University of Lancaster What's in a formula? Some chemical controversies of the 19th century	February 25	Dr C Jones, Swansea University Low coordination arsenic and antimony chemistry
January 21	Professor D Cardin, University of Reading	March 4	Professor T C B McLeish, IRC of Polymer Science Technology, Leeds University The polymer physics of pyjama bottoms (or the novel rheological characterisation of long branching in entangled macromolecules)
January 27	Professor R Jordan, Dept. of Chemistry, Univ. of Iowa, USA. Cationic transition metal and main group metal alkyl complexes in olefin polymerisation	March 11	Professor M J Cook, Dept of Chemistry, UEA How to make phthalocyanine films and what to do with them.
January 28	Dr S Rannard, Courtaulds Coatings (Coventry) The synthesis of dendrimers using highly selective chemical reactions	March 17	Professor V Rotello, University of Massachusetts, Amherst The interplay of recognition & redox processes - from flavoenzymes to devices
February 3	Dr J Beacham, ICI Technology The chemical industry in the 21st century	March 18	Dr J Evans, Oxford University Materials which contract on heating (from shrinking ceramics to bullet proof vests)
February 4	Professor P Fowler, Department of Chemistry, Exeter University Classical and non-classical fullerenes		
February 11	Professor J Murphy, Dept of Chemistry, Strathclyde University		
February 17	Dr S Topham, ICI Chemicals and Polymers Perception of environmental risk; The River Tees, two different rivers		
February 18	Professor G Hancock, Oxford University		

Appendix Three

Publications

A. 3.1 PUBLICATIONS

Part of the work presented in this thesis has been reported in the following publications.

1. D. E. John, A. J. Moore, M. R. Bryce, A. S. Batsanov, and J. A. K. Howard, *Synthesis*, **1998**, 826.
2. D. E. John, M. R. Bryce, A. S. Batsanov, and J. A. K. Howard, *Adv. Mater.*, **1998**, 16, 1360.

