

Durham E-Theses

*An investigation of the resource implications of the
introduction of "new taylorism" into the Cleveland
constabulary*

Kevin Barry Halliwell

How to cite:

Halliwell, Kevin Barry (1999) An investigation of the resource implications of the introduction of "new taylorism" into the Cleveland constabulary. Doctoral thesis, Durham University.

Use policy

The full-text may be used and/or reproduced, and given to third parties in any format or medium, without prior permission or charge, for personal research or study, educational, or not-for-profit purposes provided that:

- a full bibliographic reference is made to the original source
- a <https://etheses.durham.ac.uk/id/eprint/4299/> is made to the metadata record in Durham E-Theses
- the full-text is not changed in any way

The full-text must not be sold in any format or medium without the formal permission of the copyright holders.

Please consult the [full Durham E-Theses policy](#) for further details.

**AN INVESTIGATION OF THE RESOURCE IMPLICATIONS OF THE
INTRODUCTION OF "NEW TAYLORISM" INTO THE CLEVELAND
CONSTABULARY**

by

Kevin Barry Halliwell

A Thesis Presented in Fulfilment of the Degree Master of Philosophy at the
University of Durham

Durham University Business School

February 1999

The copyright of this thesis rests with the author. No quotation from it should be published without the written consent of the author and information derived from it should be acknowledged.



- 2 NOV 1999

4154
(6)

THESIS-

ACKNOWLEDGEMENTS

I would like to acknowledge the sound advice and encouragement received from my supervisor Professor Richard Hall and the assistance given by my colleague Len Ross who helped me through the difficult periods.

I owe thanks to my family and friends who have supported me throughout my studies, in particular my wife Mary and children, Susan, Catherine, John and Angela.

ABSTRACT

The research is concerned with analysing the impact that organisational 'change' is having on the police service and in particular the effect that change has on individual systems within the Cleveland Constabulary.

The theoretical part of the research examined the rationale for change within public sector organisations, the reasons for adopting this rationale and the likely effects on organisations that follow this programme. In order to place this in context a review of literature relating to private and public sector strategic management issues was carried out.

The empirical part of the research involved interviews with a wide selection of senior police officers within the Cleveland Constabulary. This was followed by a forcewide survey of police officers of all ranks and a case study of the organisation. The focus of the research is to evaluate the cause and effect of change on all key elements that play a major part in determining the organisation's strategic direction.

The word 'strategy' has been given many different meanings and defined in many ways. One of the simplest and most used definition for defining an organisation's strategy is given by Hofer and Schendel (1978):

"Fundamental pattern of present and planned resource deployments and environmental interactions that indicates how the organisation will achieve its objectives." (Hofer and Schendel, 1978 :25)

Corporate strategy can be regarded as the configuration of the activities of an organisation, allocating resources to each activity and co-ordinating the activities to meet the organisational objectives. The key elements of strategy are grouped under the generic headings of: human resources; financial

resources; technological systems; and legal/political systems. The research has analysed the inter-relationships and effect that change has on the various elements by breaking it down into four specific areas for investigation:

- Overall efficiency - has the change resulted in increased or decreased overall efficiency;
- Resources - Has the change led to increased or decreased resource consumption;
- Operational efficiency - Has the change led to increased or decreased productivity;
- Bureaucracy - Has the change led to increased or decreased bureaucracy

The purpose of the research is to develop a framework that can be applied to managerial issues and problems that are not amenable to rigorous analysis or are difficult to evaluate in strict mathematical terms. The framework developed can be regarded as a 'heuristic' programme, that provides a significant contribution to determining the impact that change can have on inter-related systems. It is hypothesised that if the impact of change programmes that have already been implemented can be evaluated, then we may learn from them, building these lessons into a model for determining the impact of future change.

The main finding of the research was that the implementation of initiatives or techniques developed in the private sector, such as quality control, cost control and computerised production techniques, are not readily transferable to the public sector. Consequently, the projected cost savings and improvements in productivity failed to materialise. In many cases the introduction of new initiatives has resulted in:

- Increased cost;
- Decreased overall efficiency;
- Decreased productivity;
- Increased bureaucracy.

There has been an identified drift into 'negative' efficiency, which is detrimental to the health of the organisation. The research identifies a need for immediate remedial action that can only take place when the organisation has developed the ability to recognise the symptoms. The organisation is progressive and will no doubt develop the focus to recognise the weaknesses inherent in its present strategies and those of the external bodies and agencies influencing the environment. This research provides a methodology to develop that focus and provides a framework to evaluate present and future strategies.

CONTENTS

	Page
Chapter 1	19
1 POLICING IN AN INCREASINGLY DYNAMIC AND TURBULENT ENVIRONMENT	
1.1 Introduction	19
1.2 The prevailing environment of policing	19
1.3 Scope of the research	28
1.3.1 Overview and objectives	28
1.4 Structure of the thesis	31
1.5 Summary	32
1.5.3 Introduction to Chapter 2	32
Chapter 2	33
2 HISTORICAL PERSPECTIVE	
2.1 Introduction	33
2.2 Section A. A brief history of policing	33
2.2.1 Policing outside London and the introduction of policing to Cleveland	36
2.3 Section B. The organisational structure of the police	40
2.3.1 Military tradition	41
2.3.2 Bureaucracy	43
2.3.3 Scientific management	49
2.4 Section C. Professionalism and management style	54
2.5 Summary	59
2.5.1 Introduction to Chapter 2	63
Chapter 3	65
3 THE ORIGINS OF 'MANAGERIALISM' AND 'SOCIAL MARKETS' IN THE PUBLIC SECTOR AND THEIR POTENTIAL IMPACT ON THE POLICE SERVICE	
3.1 Introduction	65
3.2 Section A. Origins of managerialism	66

3.2.1	The Pre-Thatcher era	66
3.2.2	The Thatcher era	66
3.2.3	New managerialism	71
3.2.4	The development of the concept of social markets	77
3.3	Section B. The combined pressures on the police service to change	84
3.3.1	The future direction of policing	87
3.3.2	The impact of change on organisational complexity	95
3.4	Section C. Organisational policing	96
3.4.1	The use of managerial cybernetics in modern management techniques	113
3.5	Summary of the main provisions of Chapter 5	121
3.5.1	Section A	121
3.5.2	Section B	122
3.5.3	Section C	123
3.5.4	Conclusion of the theoretical work and introduction to the empirical work	124
3.5.5	The safest methodology to follow	127
3.5.6	Introduction to Chapter 4	129
Chapter 4	THE EMPIRICAL WORK	130
4.1	Introduction and the research framework	130
4.2	The researcher	130
4.3	The research constraints	131
4.4	The interviews with senior officers	132
4.5	The forcewide survey	134
4.6	Interviews with four members of ACPO	136
4.6.1	Interview with the Chief Constable Mr Shaw	137
4.6.2	Interview with the Deputy Chief Constable Mr Robertson	138

	4.6.3 Interview with Assistant Chief Constable 'Operations' Mr Horner	140
	4.6.4 Interview with Assistant Chief Constable 'Administration' Mr Wood	142
	4.7 Research to determine the current position of the Cleveland Constabulary	143
	4.8 Summary	144
	4.8.1 Introduction to Chapter 5	145
Chapter	5 THE INTERVIEWS WITH SENIOR POLICE POLICE OFFICERS	146
	5.1 Introduction	146
	5.2 Interpreting the data	148
	5.3 The composition of the interview	150
	5.3.1 Section A. The role of the police service	150
	5.3.2 Summary of the main issues raised in section A	155
	5.4 Section B. Resources	155
	5.4.1 Summary of the main issues raised in section B	158
	5.5 Section C. Consumerism and the police service	159
	5.5.1 Summary of the main issues raised in section C	163
	5.6 Section D. Personnel issues	164
	5.6.1 Summary of the main issues raised in section D	177
	5.7 Section E. Technological systems	177
	5.7.1 Summary of the main issues raised in section E	188
	5.8 Section F. Legislation	189
	5.8.1 Summary of the main issues raised in section F	198
	5.9 Section G. External influences on the police	198
	5.9.1 Summary of the main issues raised in section G	203
	5.10 Section H. The future direction of the police service	204
	5.10.1 Summary of the main issues raised in section H	205
	5.10.2 Introduction to Chapter 6	206

Chapter 6	THE FORCEWIDE QUESTIONNAIRE	207
6.1	Introduction	207
6.1.1	Questionnaire design	207
6.1.2	Question 1	207
6.1.3	Discussion on the responses to question 1	213
6.1.4	Question 2	214
6.1.5	Discussion on the responses to question 2	220
6.1.6	Question 3	221
6.1.7	Discussion on the responses to question 3	226
6.1.8	Question 4	227
6.1.9	Discussion on the responses to question 4	233
6.1.10	Question 5	234
6.1.11	Discussion on the responses to question 5	239
6.1.12	Question 6	240
6.1.13	Discussion on the responses to question 6	246
6.1.14	Question 7	246
6.1.15	Discussion on the responses to question 7	252
6.2	Summary of the main findings of Chapter 6	253
6.2.1	Introduction to Chapter 7	254
Chapter 7	THE ORGANISATION IN CYBERNETIC TERMS	256
7.1	Introduction	256
7.2	Section A. The emergent situation of the Cleveland Constabulary	257
7.2.1	Summary of the main issues of section A	276
7.3	Section B. Modelling corporate strategy	277
7.3.1	Beer's model of policing	278
7.3.2	Principle of requisite variety	278
7.3.3	The inadequacies of present organisational understanding	285
7.3.4	The relevance of the viable system model to	292

	policing	
7.3.5	Summary of Section B. The implications for police management	294
7.4	Section C. A practical application of the viable system model to operational policing	299
7.4.1	The police area	299
7.4.2	The problem unstructured	301
7.4.3	Resources available	301
7.4.4	The programme in cybernetic terms	305
7.4.5	The introduction of the traffic safety Speedmaster system into Cleveland Constabulary	306
7.4.6	Relationship with the external environment	310
7.4.7	Summary of the main issues of section C	313
7.4.8	Introduction to Chapter 8	315
Chapter 8	CONCLUSIONS AND RECOMMENDATIONS	316
8.1	Introduction	316
8.2	The findings in relation to the literature review	316
8.2.1	Conclusion	320
8.3	The value of the research to police management	320
8.3.1	Conclusion	323
8.4	The strengths and weaknesses of the study	324
8.5	Further work required	325

List of Figures

2.1	The organisational structure in 1993	48
3.1	The viable systems model	103
3.2	Management control function	106
3.3	Beer's diagram demonstrating the role of the regulatory centre	109
3.4	Triple Loop Learning	116

7.1	A cybernetic model of policing	283
7.2	The two dimensional model of corporate strategy	287
7.3	System structure of the police service showing the effects of policy	289
7.4	The impact of an arrest on other organisation showing interactions with the environment	292
7.5	The introduction of speed detection cameras	311

List of tables

3.1	Current state of five public services	83
4.1	Composition of respondents interviewed	133
4.2	The population and the composition of respondents to the forcewide survey	136
5.1	Quantified data relating to question 1 (Section A)	151
5.2	Quantified data relating to question 2 (Section A)	152
5.3	Quantified data relating to question 3 (Section A)	155
5.4	Quantified data relating to question 2 (Section B)	157
5.5	Quantified data relating to question 1 (Section C)	159
5.6	The respondents scores indicating the rate of change for the seven key areas affecting police officers	166
5.7	The respondents scores indicating their perceptions as to the impact that change has had on the four subject areas.	181
5.8	The respondents scores illustrate the different of the two systems	181
5.9	Quantified data from question 2 (Section E)	187
5.10	The respondents scores indicating their perceptions as to the impact that change has had on the four subject areas.	194
6.1	Levels of significance for question 1	213
6.2	Levels of significance for question 2	215
6.3	Levels of significance for question 3	226
6.4	Levels of significance for question 4	228

6.5	Levels of significance for question 5	239
6.6	Levels of significance for question 6	241
6.7	Levels of significance for question 7	247
7.1	District performance targets	300
7.2	Force performance indicators	300
7.3	Productivity levels and deployment of the speed camera	307
7.4	Relationships between cost and efficiency	309

List of charts

5.1	The cumulative rate of change for the periods 1974 to 1984 and 1984 to 1993	168
5.2	Change in the level of skills required by police officers 1974 to 1993	169
5.3	Change in the knowledge of law required by police officers 1975 to 1993	170
5.4	Change in the knowledge of procedures required by police officers 1974 to 1993	171
5.5	The Wilcoxon matched signed-ranks test: difference in paired scores for the periods 1974-84 and 1984-93 given by the 27 respondents to question 1: 'Range of skills required.'	173
5.6	The Wilcoxon matched signed-ranks test: difference in paired scores for the periods 1974-84 and 1984-93 given by the 27 respondents to question 3: 'Knowledge of procedures'.	174
5.7	The Wilcoxon matched signed-ranks test: difference in paired scores for the periods 1974-84 and 1984-93 given by the 27 respondents to question 7: 'Stress levels'.	175
5.8	The Police National Computer System	182

5.9	The Centralisation of Communications	183
5.10	The CRIMES System	184
5.11	The respondents perception on the effects of introducing new technology and computer systems into the Cleveland Constabulary.	186
5.12	The Police and Criminal Evidence Act 1984	195
5.13	The tape recording of interviews (1988)	196
5.14	Home Office Circular on Equal Opportunities	197
6.1	Question 1 - What type of service do you think the police should provide?	209
6.2	Question 1 - What type of service do you think the police should provide: responses to statements 1.1 to 1.3	210
6.3	Question 1 - What type of service do you think the police should provide: responses to statements 1.4 to 1.6	211
6.4	Question 1 - What type of service do you think the police should provide: responses to statements 1.7 to 1.9	212
6.5	Question 2 - Crime at the present time is receiving wide media coverage. What do you think the Force aims should be in respect of crime.	216
6.6	Question 2 - Crime at the present time is receiving wide media coverage. What do you think the Force aims should be in respect of crime. Responses to statements 2.1 to 2.3.	217
6.7	Question 2 - Crime at the present time is receiving wide media coverage. What do you think the Force aims should be in respect of crime. Responses to 2.4 to 2.6.	218
6.8	Question 2 - Crime at the present time is receiving wide	219

- media coverage. What do you think the Force aims should be in respect of crime. Responses to 2.7 to 2.9.
- 6.9 Question 3 - If you consider resources as personnel, equipment, vehicles and finance, what do you think are the key limiting resources that control the achievement of the service you would like to produce 222
- 6.10 Question 3 - If you consider resources as personnel, equipment, vehicles and finance, what do you think are the key limiting resources that control the achievement of the service you would like to produce? Responses to statements 3.1 to 3.3. 223
- 6.11 Question 3 - If you consider resources as personnel, equipment, vehicles and finance, what do you think are the key limiting resources that control the achievement of the service you would like to produce? Responses to statements 3.4 to 3.6. 224
- 6.12 Question 3 - If you consider resources as personnel, equipment, vehicles and finance, what do you think are the key limiting resources that control the achievement of the service you would like to produce? Responses to statements 3.7 to 3.9. 225
- 6.13 Question 4 - Do you feel that the use of foot patrol officers (bobby on the beat) is a cost effective way of policing? 229
- 6.14 Question 4 - Do you feel that the use of foot patrol officers (bobby on the beat) is a cost effective way of policing?. Responses to statements 4.1 to 4.3. 230
- 6.15 Question 4 - Do you feel that the use of foot patrol officers (bobby on the beat) is a cost effective way of policing?. Responses to statements 4.4 to 4.6. 231
- 6.16 Question 4 - Do you feel that the use of foot patrol 232

	officers (bobby on the beat) is a cost effective way of policing?. Responses to statements 4.7 to 4.9.	
6.17	Question 5 - Do you feel that the Cleveland Constabulary cares about the people it employs and values their contribution to the service provision? Arithmetic mean scores for statements 5.1 to 5.9	235
6.18	Question 5 - Do you feel that the Cleveland Constabulary cares about the people it employs and values their contribution to the service provision? Responses to statements 5.1 to 5.3.	236
6.19	Question 5 - Do you feel that the Cleveland Constabulary cares about the people it employs and values their contribution to the service provision? Responses to statements 5.4 to 5.6.	237
6.20	Question 5 - Do you feel that the Cleveland Constabulary cares about the people it employs and values their contribution to the service provision? Responses to statements 5.7 to 5.9.	238
6.21	When considering the value of computer information technology systems in the Force. What measures do you think should be used to assess the success or failure of such systems. Arithmetic mean scores for statements 6.1 to 6.9.	242
6.22	When considering the value of computer information technology systems to the Force. What measures do you think should be used to assess the success or failure of such systems? Responses to statements 6.1 to 6.3.	243
6.23	When considering the value of computer information technology systems in the Force. What measures do you think should be used to assess the success or	244

	failure of such systems. Responses to statements 6.4 to 6.6.	
6.24	When considering the value of computer information technology systems in the Force. What measures do you think should be used to assess the success or failure of such systems. Responses to statements 6.7 to 6.9.	245
6.25	Do you feel that those bodies, e.g. the Home Office, the HMI, the Audit Commission, who legislate, control and influence the police service, adequately take into account the effects that their changes have on the police service, or can it be improved? Arithmetic mean scores for statements 7.1 to 7.9.	248
6.26	Do you feel that those bodies, e.g. the Home Office, the HMI, the Audit Commission, who legislate, control and influence the police service, adequately take into account the effects that their changes have on the police service, or can it be improved? Arithmetic mean scores for statements 7.1 to 7.9.	249
6.27	Do you feel that those bodies, e.g. the Home Office, the HMI, the Audit Commission, who legislate, control and influence the police service, adequately take into account the effects that their changes have on the police service, or can it be improved? Responses to statements 7.4 to 7.6.	250
6.28	Do you feel that those bodies, e.g. the Home Office, the HMI, the Audit Commission, who legislate, control and influence the police service, adequately take into account the effects that their changes have on the police service, or can it be improved? Responses to statements 7.7 to 7.9.	251
7.1	Cleveland Constabulary employment statistics	266

	1987-1996	
7.2	Cleveland Constabulary crime figures 1974-96	268
7.3	Recorded crime in Cleveland 1972 - 1996	270
7.4	Cleveland Constabulary reported incidents 1987 - 1996	271
7.5	Numbers of officers retiring on medical grounds 1983 - 1996	273
7.6	The financial position of Cleveland Constabulary 1989 - 1992	274
7.7	The financial position of Cleveland Constabulary 1993-96	275
7.8	Relationships between the national prison population and crime in Cleveland 1986-97	297
7.9	Cleveland Constabulary road traffic statistics showing the relationship between injury accidents and police actions 1987-96	303
7.10	Breath tests carried out in by Cleveland Constabulary	304

APPENDICES

		Pages
Appendix 'A'	Semi-structured interview for the interviews with the senior officers.	328
Appendix 'B'	Semi-structured interview for the interviews with the four ACPO officers.	339
Appendix 'C'	Statistical calculations showing the Wilcoxon matched pair scoring for question 1: 'Range of skills required'; 'Knowledge of procedures'; and 'Stress levels'.	340
Appendix 'D'	The forcewide survey and correspondence.	343
Appendix 'E'	A sample calculation showing the complex Chi squared calculations for question 1.2	348

CHAPTER 1 POLICING IN AN INCREASINGLY DYNAMIC AND TURBULENT ENVIRONMENT

1.1 INTRODUCTION

The purpose of the research is to examine the foundations on which the plethora of changes emanating in the external environment are being advocated and introduced into the police service. Miles, Snow, Pfeffer, 1974, posed these questions:

"To what extent are organisations shaped by their environments, that is, by the network of individuals, groups, agencies, and organisations with whom they interact? Are there organisational characteristics, strategies, technologies, structures, processes - which are appropriate for one environment but which may lead to failure in another? More pointedly, are there linkages across these characteristics which determine organisational success, are there, for example, particular structures and processes which fit certain technologies or strategies but not others?"

(Miles, Snow, Pfeffer, 1974 :244)

These issues, which form a central part of the research, will be developed exploring the differing organisational characteristics of the public sector and the private sectors. Evaluating the consequences of applying the dominant logic of the free market approach being advocated by Central Government, into a public service organisation, that at this present time is not ruled by a profit and loss balance sheet.

1.2 THE PREVAILING ENVIRONMENT OF POLICING

The survival of policing in its present form, providing a wide range of services to all members of society on demand and free of charge, is under threat from a diverse and seemingly interlinked number of different sources. Never in the relatively brief history of policing has there been such an intense period of enquiry, review and investigation into the very essence, structure and ethos of policing. In June 1993, this simultaneous scrutiny, climaxed with the

publication of three major reports in the space of three weeks:

- The White Paper: "Police Reform - the Governments Proposals for the Police Service in England and Wales." (Cmnd 2281);
- The Inquiry into Police Responsibilities and Rewards; (Known as the Sheehy Report, Cmnd 2280)
- The Royal Commission into the Criminal Justice System. (Known as the Runciman Report)

The reports, individually and collectively, can be regarded as 'catalysts for change'. The police service has over the last decade, already been subjected to a wide range of legislation, initiatives or imposed change that has shaped or influenced their strategic direction. The list below gives an indication of the level of change:

- 22 major programmes of legislation;
- 531 Home Office circulars;
- 12 Audit Commission police papers;
- The Operational Police Review;
- The Quality of Service Initiative and Statement of Common Purposes and Values;
- The Value for Money Programme, including performance indicators and devolved financial management;
- Organisational restructuring;
- The Citizen's Charter.

The argument for continuous change has been widely articulated and received support within the police service from many eminent officers:

"In the real world of course managing the dynamics, the pace and complexity of change is the bedrock of organisational success and police executives will be judged by their performance as change agents."
(O'Dowd, 1993 :48)

In support of dynamic and continuous change Peters (1987) described successful organisations as those that had the ability to thrive on chaos. Sir Harvey-Jones expressed the view that:

"Management in particular is not about the preservation of the status quo, it is about maintaining the highest rate of change that the organisation and people can stand." (Sir Harvey-Jones, 1988 :14)

The prevailing impetus for change within the police service stems from Central Governments strategy to reduce the Public Sector Borrowing Requirement, which for the year 1993/94 was £50 billion. There is a commonly stated view that the police service has received a greater increase in resources than most other public sector services, with the overall expenditure on the police for 1993/94 being £6.2 billion, an increase in real terms of 88% since 1979. (White Paper, 1993, Cmnd 2281 :5)

Between 1988 and 1993 the Audit Commission (the Commission) carried out a series of 'special' enquiries into the police service. In an address to the Association of Chief Police Officers (ACPO) at their autumn conference in 1990, the then controller of the Audit Commission, Howard Davies, stated:

"The police service is in what used to be known as 'an interesting condition'. It is pregnant with possibilities. The existence of 43 forces does bring great fertility of thinking and experimentation. The Audit Commission performs what is essentially a 'bee' function. Occasionally stinging, but mainly involved in the business of cross-pollination." (Davies, 1990 :150)

In 1992, Davies completed his term of office with the Commission, taking over the post as head of the Confederation of British Industry (CBI). Davies then produced a paper titled 'Fighting Leviathan: Building Social Markets that Work.' Although Davies points out that these are his own views and not those of the Commission, they are his 'vision' for all public sector services. The recommendations contained within this paper have far reaching implications for

all public sector bodies. The recipe for improvement is based on the formation of 'social markets' both internal and external, that will expose all services to the discipline of competition. It is evident, on close analysis of the contents of the aforementioned White Paper and the Sheehy Report, that many of the suggestions and recommendations that appear in Davies' paper, have been accepted and may be regarded as a blueprint for the future of all public services. Davies indicated that the police in particular are in need of radical reform:

"The delivery and financing of the police service, are more in need of reform than any other public service. Accountability for police expenditure is hopelessly blurred. The Tripartite structure of Home Secretary, police authority and chief constable allows each of the three partners to take refuge behind the other two. The breadth of police functions must be fundamentally questioned, civilianisation could be extended. The police show all the characteristics of a badly designed system, ripe for fundamental reappraisal." (Davies, 1992 :10)

The principle proposition advanced for change, not only of the police service but also for the whole spectrum of public sector services is a continuum of the Thatcher era. This instils the virtues of the private sector and the requirement of an organisation to demonstrate success by making a profit. Greenwood (1988) indicated that the dominant political logic of this era was that the private sector is good and the public sector is bad. Pollitt (1986) saw this period as that of having an ideological commitment to privatise or contract out. The alternative offered was to adopt the mechanisms and working practices of the private sector:

"For those parts of the public sector that could not be privatised or subjected to the sanitising forces of the market." (Pollitt 1986 :159)

Davies has also advanced this proposition in line with the principles incorporated in 'The Next Steps' papers, that advocate the market testing of services and the creation of internal markets:

"Successful public sector agencies need to adopt the same characteristics as successful private sector concerns. They need to be responsive to their customers and constantly in search of efficiency gains and quality improvements. These desirable characteristics cannot be imposed from the top down. They are created by the operation of market systems which impose competitive pressure." (Davies 1992 :9)

The dominant logic is that public sector organisations do not provide a satisfactory level of service commensurate to the scale of financial resources provided. The only way to significantly improve value for money is to adopt the organisational mechanisms and characteristics of the private sector that have been honed and fine tuned through the disciplines of the 'free market'. It is suggested that this approach can be universally applied and will be beneficial to all public services. The proposition further states that the difference between public sector bodies and the private sector is not as great as stated. Davies, in particular argued that in the police service this gap has been exaggerated by police managers and put forward purely as a 'barrier to change'. The argument was later developed in the Sheehy Report:

"There has been a tendency on occasion - some feel an exaggerated tendency - to claim special status for police officers when this is not justified." (Sheehy Report 1993 :4)

The police themselves profess that they are not averse to change. Eastwood Chair of the Police Federation in his speech at Wembley, (22 July 1993), to a mass meeting of police officers opposed to the Sheehy Report's recommendations, stated:

"Saying 'no' to Sheehy is not the same as saying 'no' to change. Dinosaurs belong in the cinema and not the police stations. There are those outside this hall who are only too happy to portray us as Luddites. But we are not only in favour of change, the Police Federation over the years has been in the vanguard of change." (Eastwood, 1993 :7)

This research is being carried out at a time of increased turbulence and complexity in the external environment of the police service. The need for rapid change may well be interlinked to a time scale set between two General

Elections, with the issue of 'Law and Order' featuring prominently in all the major parties' manifesto. The Thatcher Government reforms of the public sector have received wide criticism, especially those that have effected the Health Service, the Education Service and the Prison Service. Despite this, the reforms of the police service proposed in the recent White Paper, and the Sheehy Report, have invariably followed the same formula. The Police can no longer be regarded as immune from the political agenda. That agenda seeks to replace the professional skills of police managers with those of the business manager, who does not have a basic knowledge of policing. This will invariably resort to the dominant logic of finance becoming the primary measure for the success of all activities. There is an increased emphasis being placed on the provision of cheaper services, delivered by a less skilled workforce, through the auspices of 'market testing'. Issues such as productivity and profit have risen to the fore and the customer valid only for their contribution to the force's statistics.

The White Paper on Police Reform (1993) moves away from the eight duties of Police Officers listed in the Report of the Royal Commission on Police in 1964, the final one being:

"They have by long tradition a duty to befriend anyone who needs their help, and they may at any time be called upon to cope with minor or major emergencies." (Cmnd 1728, 1964 :23)

The enquiry and report by Lord Scarman (1981) focused attention on the dichotomy between law enforcement and peace keeping, recognising that the detention of suspects should, on occasions, be a secondary consideration:

"The law is the law. It extends to all and it must be applied firmly and fairly. But it must also be applied sensitively." (Lord Scarman, 1981 :155)

These sentiments were incorporated into the 'Police Service Statement of Common Purpose and Values' (1990) in which the service commits itself to:

"Uphold the law fairly and firmly; to prevent crime; to pursue and bring to

justice those who break the law; to keep the Queen's Peace; to protect help, and reassure the community; and be seen to do this with integrity, common sense and judgement."

The police service in response to these calls for change, have adopted many initiatives, such as Housing Estate Project Teams (HEPT schemes), that are customer centred, providing identified problem areas with a higher density of police officers than the norm, are however, by their very nature high cost schemes. The police now find themselves being pulled in two diverging directions. One that is customer centred and high cost and the other that requires the provision of high volume core services at the lowest unit cost, and focuses mainly on the issue of crime:

"The Government will set key objectives which it will expect the police to secure. These objectives will reflect the Government's belief that fighting crime and the protection of the public should be the top priority in police work. Police performance will be measured against these objectives."
(Cmnd 2281, 1993 :2)

The author speculates that these measures have been designed to deflect criticism from the Government. To compensate for their desire to reduce finance to the public sector, and the cost of new legislation that does not achieve the desired results and invariably raises costs. Of this there are many recent examples: The Community Charge; The Criminal Justice Act 1991; Performance measurement in schools; The Health Service Reforms; The introduction of 'Fresh Start' into the Prison service.

It is noticeable that there has been a change of emphasis in the methodology of government reviews. There are an increasing number of reviews being carried out by accountancy based management consultants, rather than 'Commissions' that include professionals from the area under review. This situation was particularly evident in the Sheehy review, where none of the five-member team had previous knowledge of policing. The final report read like a profit and loss account as such criticised heavily by all Police staff associations.

The question must be asked: "Are the professional values of accountancy more compatible with market forces than the ethics and realities of professional policing?" Johnson (1992) expresses the view that the subordination of technical and professional skills in the boardroom of American industry to those of the accountant has resulted in employees spending the majority of their efforts satisfying performance measures and not the needs of the customers. This in turn has led to the demise of many of the leading industries. Similar observations were made by Crouch and Marquand:

"It has long been the complaint that, compared with German, Japanese, French and Scandinavian industry, British industry is dominated by short-term financial accounting to the neglect of technology and research and development. While the leading figures in the great companies of the former countries are usually professional engineers, chemists and technologists, in Britain they are accountants. Perhaps, in subordinating the professions in the public sector to an accountancy-based management, the government is only trying to help those services become more like British industry." (Crouch and Marquand, 1992 :4)

The gentle wind of change passing over the police in the last decade has now turned into a hurricane heralding the new era of policing. What will emerge from this maelstrom? Will it be one that meets the needs of: the consumers of the service; the professional needs of police officers; the aspirations of the Treasury to reduce cost; or the aspirations of private security firms and venture capitalists to increase business and enhance profits? Indications emanating from the Commission increasingly demonstrate that the emphasis may be focused on satisfying the latter two points:

"What should a police force be expected to provide free of charge as part of its normal public service, and what should it provide only if a charge for that service is paid?" (Audit Commission, 1990, Paper 7 :4)

The Commission's tentative answer to this question is that it must be right to provide basic emergency services free of charge. Other services, particularly those where significant profits can be made can be divested from the police and

taken on by the private sector. The real danger from a police officer's perspective is that there is another alternative. The potential to develop a two-tier system of policing with those who can pay receiving private policing tailored to meet their demands, whereas those that cannot pay receive a lesser service. The danger of such a system is immediately apparent in that those who tend to need the service most, predominately fall into the category of those that cannot pay.

Flynn (1992) demonstrates that charging for services in this way can reduce demand. Flynn cites the example that the change from the provision of free eyesight tests to one where a fee was paid reduced demand for the service by forty percent. The extension of this system is still under review, Portillo (1993) the then Treasury Chief Secretary considered the introduction of a 'medicard' to replace the flat rate prescription fee charged for medicines. Forecasts indicate reduced demand and that it will claw back finance from the eighty-two percent of the populace whom presently pay nothing for prescriptions.

The key principles of 'market forces' are demonstrated in these examples. Market demand for public sector services can be reduced by the introduction of charges. Those who have the ability to pay, for public services, that were traditionally regarded as being provided by the State, at no cost to the consumer, will be made to pay a greater percentage of the cost, this being determined by their ability to pay.

1.3 SCOPE OF THE RESEARCH

1.3.1 Overview and Objectives

This section has given the reader an indication of the current environmental factors affecting the police. The researcher's task is now to present a structured analysis of the main issues and to determine a way forward that will assist the

police in improving the quality of service provided to the public. However, he must remind the reader, that at the present time, the police, (in general) have an open-ended commitment to providing a free service, available on demand, twenty-four hours a day. Its ability to maximise profit does not form part of the criteria on which its performance is assessed, unlike that of a private sector organisation. The relationships between productivity and profitability take on a connotation that is counter-intuitive, increased productivity, in the form of arrests or proceedings instigated, increases financial costs, some of which can be significant. To give the reader an insight into this phenomenon a very simple example will be given to demonstrate the relationships and the complexity that can be generated.

The example used is the enforcement of road traffic offences by means of prosecution. Every offender detected and reported for summons becomes a cost implication to the police and in some cases this can escalate dramatically. This can be illustrated by two scenarios:

Scenario one - an offender is stopped driving a motor vehicle and reported for summons for minor road traffic infringement and is issued with form HORT 1 for production of driving documents. Produces documents, these are in order. The summons is processed and issued by post. Magistrates hear the case and impose fine. The offender pays the fine.

Scenario two - As above however, the offender fails to produce documents. A police officer attends address and reports for document offences. Summonses are issued and sent by post. The offender fails to acknowledge receipt. The Magistrates will not hear case until there is proof of receipt. A police officer attends address and serves summonses personally. The offender pleads 'not guilty' and requires all police officers involved at every stage to attend Court. Three police officers attend Court however the case is adjourned due to unanticipated illness of accused. A new date is fixed, all police officers attend

Court, the accused is found guilty and a financial penalty is imposed. The offender lodges an appeal, all police officers have to attend Crown Court. The appeal dismissed. The offender fails to pay fine, a warrant is issued for arrest. This is executed by a police officer, the offender is lodged overnight in custody then transported to Court.

In scenario one the costs are small. In scenario two however, the routine issue of a summons by a police officer turns into a heavy financial cost, that can go on and on. In either case, these costs are not recoverable by the police.

These and other similar relationships add to the complexity of the environment affecting policing. These issues will be encountered and explored in detail within the research. Policing is an activity of great complexity, being carried out in an era of complexity. Beer (1974) explains the term 'complexity' and its relationship to management:

"Man is a prisoner of his own way of thinking and of his own stereotypes of himself. His machine for thinking, the brain, has been programmed to deal with a vanished world. This old world was characterised by the need to manage *things* - stone, wood, iron.

The new world is characterised by the need to manage *complexity*. Complexity is the very stuff of today's world. The tool for handling complexity is *organisation*. But our concepts of organisation belong to the much less complex old world not to the much more complex today's world. Still less are they adequate to deal with the next epoch of complexification - in a world of explosive change." (Beer, 1974 :15)

The research is focused on developing a model that can assist the Cleveland Constabulary in evaluating and understanding organisational complexity. The research proposes a model based on Beer's Viable System Model (VSM). The VSM assists in identifying complexity in the internal and external environment and the impact that change has on the collection of systems that make up an organisation. It is intended to link this model to a heuristic framework that views change in terms of: overall efficiency; operational efficiency; resources;

and bureaucracy.

Beer recognises that it is essential to have a common metric for evaluation. He proposes that *money* is the established metric of society, however it ought to be viewed essentially as the metric of constraint. In the case of the police this will inevitably become the key-limiting factor determining the responses that can be provided to regulate societies conduct. The researcher recognises the value of using money as a metric, for it represents the primary rationale for many of the reforms proposed, and where appropriate, change will be quantified in this way.

Porter (1991) identifies that to develop a strategy that truly reflects the competitive position of an organisation and the factors that lead to competitive advantage is extremely complex. He proposes a 'dynamic theory of strategy' that separates the theory of strategy into the causes of superior performance at a given period of time. This is termed the cross-sectional problem, and the dynamic process by which competitive positions are created, termed the longitudinal problem.

Porter advises that there are two further elements fundamental to determining strategy. One 'the chain of causality' that can be regarded as identifying the cause and effect of change. This involves investigating how the organisation reached: its present position; why it is in that position; has it been forced there by environmental pressures; or has it significantly influenced the environment. The second element is termed, 'the time horizon'. This involves determining a period of time, over which to measure and understand competitive success or failure. A point in time has to be identified from where to start the study, and from there, explore the factors that have led to the organisations present position, and the reasons why they have chosen the paths that have been followed in reaching and sustaining this position.

The research utilises these concepts to determine how the Cleveland

Constabulary has reached its present position and what the dominant environmental factors are. This will involve reviewing the history of the police, exploring its past, and identifying the key issues in the process of on-going development.

1.4 STRUCTURE OF THE THESIS

Chapter One, has provided an introduction to and overview of the objectives of the study.

Chapter Two, will outline the history of policing in England and Wales, examining the organisational structure, bureaucracy, management style and working practices.

Chapter Three, constitutes a literature review of public sector management and a review literature in the field of strategic management, with specific reference to cybernetics.

Chapter Four, introduces the empirical work, giving details of the researcher, the research constraints and the research programme.

Chapters Five and Six, set out the results and findings of the empirical work.

Chapter Seven, explores the use of the viable systems model and its applicability to analysing organisational complexity within the Cleveland Constabulary.

Chapter Eight, draws conclusions and makes recommendations for further work that may be carried out.

1.5 SUMMARY

In this Chapter consideration has been given to the purpose of the research and identifies that the researcher proposes to examine the environmental factors affecting the police service. In particular the research seeks to develop a model that assists the organisation to: analyse the effects of change; the impact that change has on the many variables that form the organisation's activities; and the strategic and financial implications.

1.5.1 Introduction to Chapter 2

The next chapter will explore the development of the English Law and trace how the basic principles that have emerged from Common Law have been instrumental in the design of modern policing. The origins of policing will be traced and the major factors that have contributed towards the development of the organisational structure, style of management and nature of service provided will be identified. The military origins of police will be discussed together with a review of literature that demonstrates the need for the police to maintain a bureaucratic and hierarchical organisational structure. The issues of professionalism, management style and working practices will be evaluated in particular the unique and special responsibilities held by the police to maintain the Queen's Peace.

CHAPTER 2 HISTORICAL PERSPECTIVE

2.1 INTRODUCTION

This Chapter consists of three sections. The purpose of section A is to trace the basic principles and the major influences that have shaped the modern British police force. In section B the literature relating to the organisational structure of the police and nature of policing will be examined, and in section C police management practices will be identified and evaluated.

2.2 SECTION A. A BRIEF HISTORY OF POLICING

In order to gain an insight into the current functioning of the police service in England and Wales, it is helpful to take a historic perspective and explore how the key organisational and operational principles have emerged.

The development of the police service has been a continuous process, with the basic principles emerging through the centuries to become part of the present system of policing. The Statute of Winchester, 1285, laid down a system of policing, much of which derived from the Saxon times, in which:

- The responsibility for law and order rested with the citizen, who was required to have arms according to his means;
- In each town the citizens had to be prepared to act as watchmen at night to ensure that the gates of the town were closed, to detect and question strangers, and to hand over wrongdoers to the appointed constable in the morning;
- The constable was appointed for a year and would be responsible for detaining wrongdoers and bringing them before a court. The constable would also be expected to report unlawful activities in his domain;
- Felons who escaped capture by the watchmen would be pursued by all the able bodied men led by the sheriff;

- Every citizen had not only the right to arrest wrongdoers, but also a duty to do so. (Garvin, 1993 :9)

In the period that followed many important changes occurred with the development of itinerant judges and quarter sessions, and in the law itself with the fusing of common law into statute law. In 1361, The Justice of the Peace Act was enacted. The office of sheriff was superseded by that of a locally appointed justice of the peace, appointed by and holding allegiance to the Crown. This meant that they were to an extent, independent of the powerful nobility. In each county, three or four constables were appointed to "restrain offenders and rioters and to arrest, take and chastise them... according to the Law and Customs of the realm." (HMSO, 1992 :2-3) Three basic principles emerged from this period:

- The community itself is responsible for making law and maintaining order;
- These goals have been historically achieved through development of the office of justice of the peace;
- That constables were locally appointed to aid the Justice of the Peace.

In 1663, the City of London began to employ paid watchmen to guard the streets. The pittance they were paid only attracted old and infirm men to the job who were nicknamed 'Charlies' after King Charles II. Some attempts were made to improve the policing of London. In 1748, Henry Fielding, the novelist, became the chief magistrate at Bow Street. Together with his half brother John, they instituted patrols known as the 'Bow Street Runners.' In 1805, they were joined by the Bow Street Horse Patrol a troop of forty-four former cavalry troopers. They helped to clear the roads into London of highwaymen and were the first law officers to wear uniform and were armed with pistol, cutlass and truncheon. This embryo police force in all but name could not control the crime of the booming city of London and its activities were severely limited by lack of finance. (Critchley, 1978 :9-22)

By the beginning of the nineteenth century organised crime and serious rioting in the rapidly developing towns and cities resulting from the industrial revolution had become a national scandal. Large scale incidences of civil disorder periodically occurred and were dealt with by calling in the army. In the summer of 1819, what became known as the 'Peterloo Massacre' took place in Manchester. Yeomen armed with sabres were sent to a public meeting addressed by a well known radical orator, Henry Hunt, with a view to arresting him. The yeomanry charged the 60,000 crowd, killing 11 and injuring 400.

In 1821, Sir Robert Peel became the Home Secretary and commenced a programme aimed at reviewing and reforming the criminal law. In 1828 he set up a committee to examine the policing of London. The Government accepted their report and on the 15th April 1829, the Metropolitan Police Bill was introduced to Parliament. Royal assent was given on 19th June 1829 and on this basis the first professional police force in the world evolved.

The statute provided for two justices of the peace to act as commissioners for the new force. Peel appointed a lawyer Sir Richard Mayne and Colonel Charles Rowan, a retired soldier who was expected to enforce discipline. Rowan emphasised that the police were not soldiers, however he chose to organise the police force on established military lines. (Critchley, 1978 :51)

The official accommodation was at 4, Whitehall Place, which backed onto a narrow lane known as Scotland Yard, from which the headquarters of the Metropolitan police force later took its name. The Metropolitan district was divided into seventeen police divisions each under the control of a superintendent. The superintendent had four inspectors, sixteen sergeants and one hundred and forty-four constables. (Lobban, 1976 :46) This type of structure mirrored that of the army platoon, company, battalion and division, with a similar form of rank structure. However, whereas an armies' task in times of war, against an identifiable enemy, can be regarded as straightforward,

the police would find that they had to interact with a society that contained both law abiding citizens and law breakers and that the dividing line was frequently blurred. The objectives of the police force were set by Sir Robert Peel:

"The primary object of an efficient police force is the prevention of crime: the next the detection and apprehension of offenders when crime is committed. To these ends, all the efforts of the police must be directed.

The protection of life and property, the preservation of public tranquillity and the absence of crime will alone prove whether the efforts of the police have been successful, and whether the objects for which the police were appointed have been attained.

Every member of the Force must remember that his duty is to protect and help members of the public, no less than to apprehend guilty persons. Consequently, whilst prompt to prevent crime and arrest criminals, he must look upon himself as the servant and guardian of the general public and treat all law abiding citizens, irrespective of their social position with unfailing patience, courtesy and good humour." (Operational Police Review, 1990 :51)

2.2.1 Policing outside London and the Introduction of Policing to Cleveland

Civil disorder and crime continued to be a major concern in the large cities and towns outside London, necessitating increased Government legislation to alleviate the situation. In 1831, the Special Constables Act came into force. This allowed the swearing in of local citizens to the office of 'special constable' to deal with disorder and crime. In 1835, the Municipal Corporation Act established a form of democratic local control in 178 chartered boroughs. In 1839, the County Police Act empowered justices of the quarter sessions to establish full time police forces in the counties. In 1856, the County Borough Police Act compelled all authorities, both town and county, to set up their own police forces. The Government would pay for a quarter of the expense provided that their Inspectors certified that a Force was up to the desired standard of efficiency. The following year there were 239 police forces in England and Wales.

In 1855 the first police force to be established in the area now known as Cleveland County was the Durham Constabulary. Durham Magistrates used their powers under the County Police Act, 1839, to create a Force of 65 men under the command of a Chief Constable. The rapidly growing town of Middlesbrough was the next to form a police force. In 1855, 4 constables were appointed under the supervision of a superintendent of police, William Hannen (appointed by the justice of North Riding). This appointment carried an annual salary of £50 paid quarterly. It coincided with the purchase of the Exchange Hotel that was converted into a lock-up with eight cells and residence for the superintendent. Shortly afterwards, the Force was increased to eleven constables. To pay for this increase in establishment it was decided at a council meeting that a 'Watch rate' of 4d in the pound be levied on all property within the Borough. (Minutes of Council meeting - 9th November 1854) This was an early indication that local police forces were to be dependent for finance on the local authority.

Middlesbrough in the latter nineteenth century experienced a rapid period of industrial expansion. This led to the formation of new communities in Dormanstown, Grangetown and South Bank. Such an increase in population demanded an expansion of the police establishment to maintain law and order. In 1878 the establishment was for 52 police officers at a total cost of £4,422. In 1892 this had risen to 76 police officers, at a total cost of £6,483. (Report of Inspector of Constabulary, 1897 and Chief Constables report, 1893.)

By the same Act, Her Majesty's Inspectors of Constabulary were appointed to carry out four duties:

- To visit and inquire into the state and efficiency of the police appointed to every county and borough;
- To inquire whether the provisions of the Acts under which such police are appointed are duly observed and carried into effect;

- To inquire into the state of police stations, charge rooms, cells or lock-ups, or other premises occupied for the use of such police;
- To report generally upon such matters to the Home Secretary.

The newly formed police forces replicated their structures on the military model adopted by the Metropolitan police. The influence of Government and Her Majesty's Inspectors (HMI) ensured that uniform standards and practices were followed nation-wide. In 1919 pay and conditions for all police forces were standardised. This smoothed the way for the amalgamation of police forces, which was encouraged, in the interests of economy and efficiency.

The Royal Commission on Police (1963) listed the police duties as:

- To maintain law and order and to protect persons and property;
- To prevent crime;
- To detect criminals and in the course of interrogating suspected persons, they have a part to play in the early stages of the judicial process, acting under judicial restraint;
- To decide whether or not to prosecute persons suspected of criminal offences;
- To conduct and prosecute the less serious offences;
- To control road traffic and advice Local Authorities on traffic issues;
- To carry out certain duties on behalf of Government Departments. For example, they conduct inquiries into applications made by persons who wish to be granted British nationality;
- To befriend anyone who needs their help, and they may at any time be called upon to cope with minor or major emergencies. (Cmnd. 1728, 1962)

The report of the Royal Commission resulted in the Police Act 1964, which created the 'tripartite structure'. This specified the relationships between and the responsibilities of the Police Authority, the chief constable and the

Secretary of State.

Police Authority

The police authority (committee) shall consist of:

- Two thirds shall be members of that county council;
- One third shall be magistrates of that county.

The functions of the police authority were to secure the maintenance of an adequate and an efficient police force for that area, and to exercise for that purpose the powers conferred on a police authority by the Act.

The police authority, subject to the approval of the Secretary of State, has powers to appoint the chief constable and determine the number of persons of each rank in the Force. They must also provide and maintain suitable buildings, vehicles and other equipment.

The Chief Constable

The chief constable of the Force was made responsible for its direction and control with the duty to report to the police authority. The chief constable decides how the Force is run, but is ultimately responsible to the police authority who appointed him. The Police Authority has the powers of dismissal over the chief constable, yet they cannot issue instructions on the management or operational functions of the Force.

The Secretary of State

The Secretary of State maintains the power to influence all police forces as to their government, administration and conditions of service. These include:

- The ranks to be held by members of the police force;
- The qualifications for appointment and promotion;

- Period of service on probation;
- Discipline regulations;
- The hours of duty, leave, pay and allowances. (Burke, 1964 :Section 48/4)

At the time of the Act the central government agreed to pay 50% of the overall costs (now 51%). This can only be paid on provision that Her Majesty's Inspectorate of Constabulary certifies that the Force is maintaining an efficient police service.

The Act also provided the Home Secretary with powers to promote police efficiency including the compulsory amalgamation of police forces. Alderson, (1984 :95) identified that: "Roy Jenkins set about the amalgamation with gusto. By the time that he had finished, the 126 police forces were reduced to 49." Further amalgamations followed the Local Government Act of 1974 that reduced separate forces from 49 to 43.

The proposals of the Police and Magistrates Courts Act 1994 have paved the way for a much simpler process for the voluntary or compulsory amalgamations and there is much speculation that there will be a regionalisation of police forces or the creation of a national framework.

2.3 SECTION B. THE ORGANISATIONAL STRUCTURE OF THE POLICE

In a study of the organisational structure of British policing Sanderson illustrated that police forces are large, complex entities with organisational characteristics, structures and processes rooted in their nineteenth century

origins. In developing a theme of poor organisational communication, he identifies the interaction of three core features of police organisation:

"First the police are seen to be essentially bureaucratic in character with the design of police organisation following principles of rational formal bureaucracy. Secondly, military tradition is seen to be a powerful influence on the mode of management adopted by the police. Finally the process of professionalisation of the organisation is observed to be a modern feature of the police and is a major detriment of the development of policing." (Sanderson, 1985 :8)

Sanderson argues that the interactions of these three powerful features not only mutually sustain each other, but the combined effect is to totally dominate organisational activity. This theme will be developed later in the Chapter where the author will explore the effects that these features each have on the variety, complexity, and resource demands generated in the internal and external environment by adherence to them.

2.3.1 Military Tradition

When developing the framework of the Metropolitan Police Force, Sir Robert Peel identified that:

"The police must be stable, efficient and organised along military grounds." (Walters and McGrath, 1974 :24)

As mentioned earlier, one of the first two commissioners of the Metropolitan Police, Colonel Charles Rowan, a veteran of Wellingtons' Peninsular army, organised the police on military lines. This structure closely follows the tenets of classical organisation theory and was subsequently replicated and used as a model by all other British police forces. Despite the tremendous changes in society that has occurred since 1829, the organisational structure and style of management has remained intact. The primary duties remain the prevention and detection of crime and the maintenance of law and order.

However, Palmer (1988 :69) argues that policing can be more correctly associated with the general regulation or government and it can therefore be viewed more as a socio-political function rather than a legal one. Clearly modern policing came as a direct result of social disorder brought about by the industrial revolution, urbanisation and the inability of a corrupt and inefficient system of justice to cope with these problems:

"The first British police were public order police, tested in Ireland and then established on the mainland in 1829 by Sir Robert Peel's Police Act. Not only did they harass thieves and criminals but they were used against nascent working class movements, such as the National Union of Public Working Classes, batoned into defeat in the battle of Cold Bath Fields in May 1883. Thereafter the police were used, physically to restrain the growing power of organised labour." (Bowden, 1978 :21)

The police were therefore provided with the powers to use physical force. They have increasingly become regarded as: 'The specialist repository of the state's monopoly of legitimate force.' (Reiner 1992) The police are frequently called upon to exercise this use of force when taking decisive action to deal with disorder or crime:

"The policeman, and the policeman alone is equipped, entitled, and required to deal with every exigency in which force may have to be used." (Bitter, 1985 :114)

To respond to major incidents the police have retained the military structure and built up a capacity to swiftly deploy significant numbers of police officers, fully equipped, to contain or deal with any type of civil emergency. For the police to achieve the militaristic capabilities to quell public order and to fight crime, they must retain the main features associated with the military model. Morgan, (1986 :20-22) exemplifies a military model designed by Frederick the Great of Prussia:

- The introduction of ranks and uniforms;
- The extension and standardisation of regulations;

- Increased specialisation of tasks;
- The use of standardised equipment;
- The creation of a command language;
- Systematic training that included army drill;
- The distinction between advisory and command functions. (Morgan 1986 :20-22)

These and other properties exist in the modern police force. Further examples include: national standards for equipment and training; creation of highly specialised units; the saluting of senior officers; and the gold, silver and bronze command language and structure.

Morgan hypothesised that the development of this type of 'mechanised' military model was influential in the later design of efficient and mechanistic management systems. Morgan observed the important contribution that Max Weber made to the movement and whose work is worthy of examining in some depth.

2.3.2 Bureaucracy

The structures of the British police forces are rational, hierarchical arrangements that reflect the influence of Weber, an academic sociologist and leading contributor to the classical organisational theorist approach. Weber expressed the view that the bureaucratic organisation was a logical, rational organisation and technically superior to all forms.

A bureaucratic organisation has to be rational and to be rational the structure must contain certain characteristics. The most salient ones applicable to the police service have been identified:

- The various positions in the organisation are arranged hierarchically, with each official responsible to a superior and responsible for subordinates;

- Each official carries out his duties without regard to any personal or family commitment, impartially and without emotion. His authority is confined to the discharge of his official duties and he is motivated both by a sense of duty and by a promise of a career;
- Candidates are selected for promotion on the basis of technical qualifications. They are appointed not elected;
- They are remunerated by fixed salaries graded according to the rank in the hierarchy;
- There is a system of promotion according to seniority or achievement or both; and promotion is dependent on the judgement of a superior;
- An elaborate system of rules governs the manner in which each official carries out his duties and decisions are recorded and preserved so as to constitute precedents to guide future decisions;
- There is a system of strict systematic discipline and control in the conduct of office. (Weber, 1921 :76)

Beetham (1985 :64-65) identifies that Weber regarded bureaucracy, purely as a supremely effective technical instrument. However, he recognised that there was an inherent tendency to exceed its instrumental function and to become a separate force capable of influencing the goals and character of its original purpose and subjugating these with those to satisfy their own self interests.

Weber regarded the advance towards bureaucratic officialdom as a yardstick for modernisation. It would replace the officialdom present at that time who were put in places through patriarchal and patrimonial systems. Senior officers were appointed to positions of authority by virtue of their position, status or social standing rather than ability. Under this traditional system, Weber identified that scope to change the law or other procedures was limited by a belief in the sanctity of the past. This system was viewed as charismatic and involved allegiance to the leader.

The alternative system of bureaucracy introduced 'legal authority' based on two

new qualities:

"Both qualities are central to bureaucratic administration. Allegiance to impersonal rules and procedural correctness is the hallmark of the official: he is disciplined to treat like cases alike, irrespective of the personal status of the individual, and to apply rules consistently, even though he may disagree with their content. At the same time bureaucracy forms part of a total structure of authority, which has the capacity to change law at will according to a change in circumstances or in the personnel occupying positions of power; the administration as a whole is conditioned to obey political masters with widely different policies and ideals, provided that they proceed in a manner that is formally correct." (Weber, 1972 :128)

A further element of bureaucracy was the replacement of procedures based on tradition or habit with systems that involved the explicit definition of goals and precise methods based on measurement and calculations to find the most effective way of achieving them. Weber identified this process as 'rationality' because it involved control on the basis of particular specialised knowledge, and operated in accordance with intellectually analysable rules. Beetham describes this process as:

"A pattern of activity was 'rationalised', to that extent that it was governed by explicitly formulated rules, that its scope was precisely delimited and involved the application of specialised concepts and knowledge, and that it was systematised into a coherent whole. ... These rational characteristics of bureaucracy guaranteed it a superiority in technical performance over all other forms of administration, as great as the machine over the non-mechanical forms of production." (Beetham, 1985 :68-69)

The concept of bureaucracy relied on the employment of skilled or expert personnel with specialist knowledge. This raised the need for academic achievement as this became a prerequisite for entry into and promotion through the structure. Weber viewed the attainment of educational qualifications as giving a person 'social status' and the opportunity to obtain a salaried post with a salary commensurate to that of an educated man. This position in a bureaucracy provided security, a position from which they could not be dismissed and the certainty of progressive advancement until retirement. In

return there was a requirement to display high levels of integrity and to follow unquestionably the internal 'order' of the system.

Some elements of the 'Weberian bureaucracy' have persisted and been incorporated in classical organisational theories associated with Henri Fayol, Luther Gulick and L.F. Urwick. Morgan (1986 :25-26) summarises the main principles of the classical management theory and suggests that: "These principles, many of which were first used by Frederick the Great and other military experts to develop armies into military machines, provided the foundation of management theory in the first half of this century, and their use is still widespread today." Morgan identified these as:

- **Unity of command:** an employee should receive orders from only one superior;
- **Scalar chain:** the line of authority from superiors to subordinate, which runs from top to bottom of the organisation; this chain, which results from the unity of command principle, should be used as a channel for communication and decision making;
- **Span of control:** the number of people reporting to one superior must not be so large that it creates problems of communication and co-ordination;
- **Staff and line:** staff personnel can provide valuable advisory services, but must be careful not to violate line authority;
- **Initiative:** to be encouraged at all levels of the organisation;
- **Division of work:** management should aim to achieve a degree of specialisation designed to achieve the goal of the organisation in an efficient manner;
- **Authority and responsibility:** attention should be paid to the right to give orders and to exact obedience; an appropriate balance between authority and responsibility should be achieved. It is meaningless to make someone responsible for work if they are not given appropriate authority to execute that responsibility;
- **Centralisation (of authority):** always present in some degree, this must vary to optimise the use of faculties of personnel;

- **Discipline:** obedience, application, energy, behaviour and outward marks of respect in accordance with agreed rules and customs;
- **Subordination of individual interest to general interest:** through firmness, example, fair agreements and constant supervision;
- **Equity:** based on kindness and justice, to encourage personnel in their duties, and fair remuneration which encourages morale yet does not lead to over payment;
- **Stability of tenure of personnel:** to facilitate the development of abilities;
- **Esprit de corps:** to facilitate harmony as a basis of strength. (Ibid :26)

Figure 2.1 illustrates a traditional police organisational structure, hierarchical in nature, with nine layers of management spanning the ranks of constable to chief constable. Since the implementation of the Police and Magistrates Court Act 1994, one tier of management has been removed from the structure, that of the deputy chief constable.

This type of organisational structure can be considered to reflect both the traditional and classical organisation theories. The traditionalists believe that man is an essentially idle, passive worker who needs to be introduced to work,

Organisational Structure of Cleveland Constabulary 1993

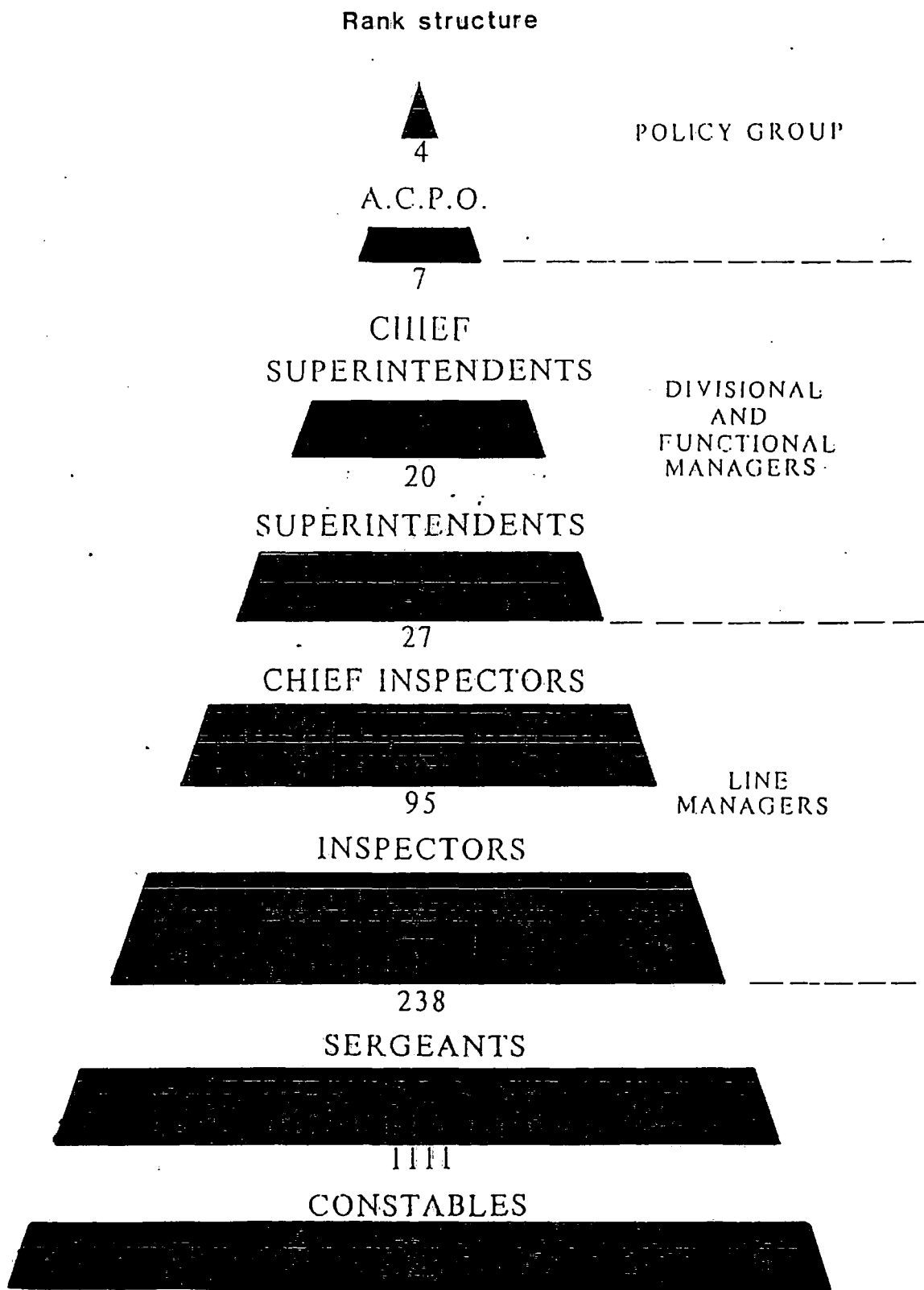

and who will not spontaneously further the ends of anyone but himself, least of all the organisation for which he is working. Many of these premises are based on the work of Frederick Winslow Taylor (1911), who was deeply concerned about the relationship between management and the workforce in the industrial institutions of America. Although his work has been reviewed by the major author's in the field of organisation and management studies over the past eighty years and may be considered, by some as 'dated'. The principles he demonstrated are particularly relevant to this research and will be examined in some detail.

2.3.3 Scientific management

Taylor identified that one of the basic principles of scientific management was that the relationship between the employer and the employee need not and should not be antagonistic. That the good fortunes of both are tied together, the employer seeks low labour costs and the employee high wages. This position can only be attained when both interests are satisfied, with the production process being carried out with the smallest combined expenditure of human effort, resources and other material overheads. Taylor recognised that the most important object of both the workman and the management was the training and development of each individual in the organisation. So that the worker could achieve at his fastest pace and with the maximum efficiency, to ensure the highest class of work for which his natural abilities fit him.

Taylor saw the need to change the role and nature of management, giving them greater responsibility for ensuring that every element of work, worker and equipment operated with machine-like precision. He specified the duties that management would have to undertake:

First. They develop a science for each element of a man's work, which replaces the old rule-of-thumb method;

Second. They scientifically select then train, teach, and develop the

workman, whereas in the past he chose his own work and trained himself as best he could;

Third. They heartily co-operate with the men so as to ensure all of the work being done is done in accordance with the principles of science which has been developed;

Fourth. There is an almost equal division of the work and the responsibility between the management and the workman. The management take over all work for which they are better fitted than the workmen, while in the past almost all the work and the greater part of the responsibility were thrown upon the men." (Ibid :36-7)

This process was designed to reduce each element of work to rules, laws, and formulae, all in some way, capable of being measured. These would replace the judgement or initiative of the worker, thereby taking the responsibility away from him to think about the task that he was performing. The workman was therefore reduced to the role of an automaton concentrating on the one task, whereas management became responsible for planning the worker's day.

Taylor conducted an experiment at Bethlehem steel that involved the loading of 80,000 tons of pig iron onto railway wagons. A gang of 75 men loaded this at the rate of 12.5 tons each per day. He determined, after a period of observation, that the proper rate should be 47 tons per day. From the 75 men he selected a Dutchman called Schmidt and made him the offer of becoming a 'high priced man'. If Schmidt achieved the rate of 47 tons per day he would receive \$1.85 a day instead of the normal rate of \$1.15, an increase of sixty per cent.

To earn this Schmidt had to strictly follow the instructions of a supervisor:

"When he tells you to pick up a pig and walk, you pick it up and walk, and when he tells you to sit down and rest, you sit down. You do that right straight through the day, and what's more, no back talk."(Ibid :48)

This experiment demonstrated three principles of scientific management: the careful selection and training of the worker; that labour based tasks could be reduced to a formula; that when a worker achieves a high quantified output, he

receives more pay. (Ibid :64)

Taylor recognised the value of splitting each task into individual elements to be performed by the individual, so that each workers performance could be measured separately. Rather than as a 'gang' and the individual be paid according to his own achievements. This would stop what he identified as being the culture of group working, that is, to work at a lesser rate, or 'soldier'. Taylor introduced a system at Bethlehem Steel whereby the management were required to prepare a plan each day for 600 shovelers and labourers. They were given instructions as to what task they had to do what equipment would be needed, they also received a daily report as to how well they had performed the previous day. Failure to achieve a high rate of work could mean being moved to other less well paid tasks:

"Dealing with every workman as a separate individual in this way involved the building of a labour office for the superintendent and clerks who were in charge of this section of the work. In this office every labourer's work was planned out well in advance. The workmen were all moved from place to place by clerks with elaborate diagrams or maps of the yard before them, very much as chessmen are moved on a chess board." (Ibid :69)

As the degree of complexity increased, there was increased reliance on specialist supervisors. For example, in the planning room: a specialist to prepare written instructions for each piece of work; a specialist in the proper speed of machines and cutting tools; a specialist analysing the best and quickest motions to be made in setting the work up in the machine and removing it; a time study man makes out a time table giving the proper speed for carrying out all the work. On the actual shop floor a further seven specialists regulated each task, three to teach and train: the inspector ensures that the worker understands the drawings; the gang boss, to set up the job in the machine; the speed boss, to ensure that the best speed and tools for each job are used. There were four other foremen: the repair boss; the time clerk; the route clerk; and in case a workman got into trouble with any of the foremen, a 'disciplinarian' was responsible for

interviewing and dealing with him.

Taylor although convinced that his system of scientific management was superior and could result in significant increase in production. He did however issue a warning:

"Precisely the same mechanism will in one case produce disastrous results and in another the most beneficent. The same mechanism which will produce the finest results when made to serve the underlying principles of scientific management, will lead to failure or disaster if accompanied by the wrong spirit in those using it.... When, however, the elements of this mechanism, such as time study, functional foremen, etc., are used without being accompanied by the true philosophy of management, the results are in many cases disastrous. And, unfortunately, even when men who are thoroughly in sympathy with the principles of scientific management undertake to change too rapidly from the old to the new, without heeding the warnings of those who have had years of experience in making this change, they frequently meet with serious troubles, and sometimes with strikes, followed by failure." (Ibid :128-30)

Taylor highlighted the need for gradual and systematic change, with a complete revolution in the mental attitude of management and through this gaining the support of the workforce. Taylor expressed the view that it was essential to convince the individual of the benefits of change and only when this had been achieved, should change progress. Once a certain proportion had been won over and could see the benefits of the new system, then more rapid change could take place. Taylor placed great emphasis on the need to train the functional foremen in the new methods. To instil in them the belief that new techniques would bring greater prosperity, for not only the employer but also the employee. Taylor's worst fears were that the process would merely be viewed as a method of getting the workers to produce more for the same or less money, a cost cutting exercise.

Taylor summarised the system of scientific management as:

- Science, not rule of thumb;

- Harmony not discord;
- Co-operation not individualism;
- Maximum output in place of restricted output;
- The development of each man to his greatest efficiency and prosperity.

(Ibid :140)

Morgan (1986) recognised that although Taylor was one of the most maligned and criticised organisational theorists, he was also one of the most influential. Morgan, expresses clear views that Taylor's work principles had clear parallels to those of Frederick the Great:

"The effect of Taylor's scientific management on the workplace has been enormous, increasing productivity manyfold while accelerating the replacement of skilled craftspeople by unskilled workers. And it is for this reason that it has been so influential yet so maligned. For the increases in productivity have often been achieved at great human cost, reducing many humans to automatons, just as the army reforms of Frederick the Great did to his soldiers 150 years earlier." (Ibid :31)

The concept of reducing work to simple functions has meant that workers can be trained quickly and cheaply to perform the one function. Measurement of quantifiable output is simplified, necessitating low levels of management with each element of the workforce becoming easy to replace. This mechanistic approach can be highly successful in specific environments. Morgan identifies the following characteristics:

- When there is a straightforward task to perform;
- When the environment is stable enough;
- When one wishes to produce exactly the same product time and time again;
- When precision is at a premium. (Ibid :34)

Typical examples of successful systems are vehicle assembly production lines

or products or services that are suitable for franchising, such as the McDonalds food chain. The design of premises, interiors, uniforms, staff training, menus, recipes and accounting conventions are determined centrally by a highly skilled and professional group of employees. The headquarters planning phase reduces all activities to one of simplicity. For example the cash tills have pictures of product and not prices so that they are simple to operate. The staff are trained to interact with customers according to a detailed code of conduct, when to smile, what greeting to use. Each of these elements can then be subject to a simple checklist for monitoring compliance. Once the overall formula has been tried, tested and evaluated, it can easily be replicated anywhere in the world. Performance can be monitored against a standard costing criteria. The company will benefit from low labour costs employing a predominantly unskilled workforce. These can be part-time workers and easily replaceable.

2.4 SECTION C. PROFESSIONALISM AND MANAGEMENT STYLE

The organisational characteristics of the rational machine based bureaucracy, that incorporate a traditional military style of management, are found in the police service in general and Cleveland Constabulary in particular. This not only necessitates but also demands a certain type of manager. One that follows and rigorously applies rules, procedures, one that is capable of acting in a prescribed manner and instilling in subordinates the need to act in a disciplined manner. Butler described the police management style and culture of the 1980's as:

"The disciplined and hierarchical nature of police organisations encouraged an authoritarian and centralised culture. Decisions were taken within a rigid framework of rules which had their history in the belief that when a mistake occurred, it was essential to create a new rule at least to cover the rule-makers' backs. Innovation and imagination were not actively discouraged, but did not flourish in such a culture. Therefore police organisations were often inert systems which pursued tradition and yesterday's solutions." (Butler, 1992 :24)

The service itself does not act in isolation but exists in a wider environment that requires it to display certain characteristics:

- Individuals are made highly accountable and required to follow formal rules, procedures and orders, responsible through an internal hierarchy to their superiors who they themselves are made accountable to others;
- Superior rank within the police service is often sufficient to prevent open expression, criticism or challenges from the lower ranks;
- There are a wide and diverse range of external bodies to whom the police are accountable. For example, the Home Office, the HMI; the judiciary. These bodies create rules and procedures that police managers have little choice but to conform to even at chief constable level;
- Decisions at times have to be made that are coercive and often unpopular;
- Decisions made and courses of action taken must comply strictly with the law and legal procedures.

Yet the range of tasks that police officers are expected to deal with in this highly professional manner are diverse and seem to grow ever longer. Phillips (1990 :125) states: "Professionalism entails a combination of ethical standards and knowledge and skills." He believes the police possess these properties and should therefore be classed as a profession. Phillips believes that the business of policing is now so complex, and that the expectations of the Courts and public are so high that for the survival of policing in its present form, the police require:

"Genuine professionalism based upon an ethical code, a comprehensive formulation of knowledge, practical and principle and a system of qualification is now imperative. Failure to grasp these essentials will lead to the hiving-off of more responsibility (we have plenty of precedents - the Crown Prosecution Service, the Police Complaints Authority and so on) and, in step with diminished respect and standing, the progressive evolution of a low tech, low pay, parish pump patrol service." (Phillips, 1991 :199)

There is a belief held by police officers that if they are to be regarded as a professional body, they have to be technically proficient and utilise the latest

technology in the interests of efficiency:

"The most advanced modern technology must be engaged to centralise, sift and transmit information to overtake the modern criminal. There must be specialist units to match the specialisation of crime: the drug squad, the vice squad, the fraud squad, the experts on thefts of art and antiques, not to mention the Special Branch. There must be advanced forensic facilities. There must be centralisation of control, inter-regional and international co-operation. The police must be seen as professional soldiers in a war against crime, to be organised and equipped as such." (Radzinowicz and King, 1984 :164)

The pressure to introduce bigger and better computerised information systems into the police service continues with three influential bodies supporting and mutually reinforcing each other: the Home Office; the HMI; and the Audit Commission. The former Home Secretary Douglas Hurd (1989), in a speech to the Association of Chief Police Officers (ACPO), indicated that he had high expectations of new technology:

"In my view the biggest opportunity to improve police effectiveness by means of technology lies in the field of information technology... these systems will be large and expensive undertakings and will need a good deal of careful planning by the Home Office and the police service working together." (Hurd, 1989)

The rationale for the introduction of these systems lies in the belief that the private sector has used new technology to improve productivity. Therefore these systems are bound to have a similar effect in the police service. In addition computerised systems are required to service new management techniques such as devolved financial management, performance measurement and decentralised organisational structures. This has a direct impact on managerial style. The author suggests that the importance given to information technology systems in the police service has caused a managerial shift of emphasis to a point where I.T. is being serviced at the expense of operational police officers. This effect will be explored in greater detail later in the research.

However, Bradley, Walker and Wilkie (1989) formed the view that police managers would have to face up to the fact that technical change generally brings in fewer returns than had been initially hoped for, and that there were usually unexpected and unwelcome organisational consequences. They indicated that:

"Most police officers operating in the field, have a far from glamorous view of the technical changes affecting their work and that police managers in the 1980's would have to be more circumspect and cautious about the introduction of new technology than their predecessors were in the 1970's." (Ibid :17)

Hough (1985) carried out a number of studies on computer systems used by the police. He pointed out that: "The assumptions underlying attempts to introduce computer technology to policing assumes an 'administration model' of policing and ignores the lack of clear task differentiation which impacts on the concepts of productivity and efficiency." (Ibid :25-26) He highlighted that if the members of an organisation simultaneously pursue multiple objectives, which were sometimes conflicting, severe problems of quantification may arise. Hough commented on command and control systems in particular:

"The analysis of individual elements of (command and control) systems is typified by the recently published Home Office study on Duty States, an application development which has not produced encouraging results. It appears that attempts to maximise the use of CAD (Computer Aided Dispatch) information by modelling techniques has proved inconclusive because of the complexities in defining the nature of policing." (Ibid :28)

Clearly the history of the police relationship with computer technology, is one of the technologies failing to match managerial expectations. However, if there are obvious signs that the introduction of new technology is not regarded as being successful, the question must be asked: "Why are police forces spending money, time and effort introducing them?" The reality is I.T. systems are seen as ways of managing large amounts of information more quickly. The police

organisation is demand led but performance indicator managed. To produce those indicators required at a local and national level I.T. systems must be sophisticated and the new managers competent at managing the data flow. Sanderson argues that the interactive effect between professionalisation of the organisation, rational bureaucracy and the traditional style of management forms a self reinforcing process:

"The efforts of the police to professionalise are shaped by organisational structure and process and by managerial philosophy towards professionalisation of organisational performance. This is to be achieved through technical specialisation developments and the command and control of its lowest incumbents. The professionalisation of most organisational members is incongruent to a rational bureaucracy managed through a militaristic ideology. The process of professionalisation of the organisation is facilitated through greater bureaucratic rationalisation and 'command' management." (Sanderson, 1985 :25-26)

The senior police officers within Cleveland Constabulary form part of a wider bureaucratic structure that is dominated by the influence of Her Majesty's Inspectorate and the Home Office. The appointment of chief officers has always been subject to formal approval of the Home Secretary. Chief officers attend the Police Staff College senior command course, which is now a mandatory element of the system. The course teaches management techniques and develops each officer so that they conform to a standard approved model. Home Office rules state that a chief officer cannot be promoted through two ranks at ACPO level in their own Force. This provides for standardisation of procedures and thought processes restricting promotion for those who hold alternative views to the centre or dare to criticise. Reiner expressed the view that the selection of chief officers incorporated certain elements that filtered out undesirable characteristics:

"They will have been exposed to the same nationally designed curriculum for senior officers. If this is not enough, none will have been appointed unless they have first been approved by the Home Office as suitable to be short listed for interview. The chances of a rogue appointment being made are clearly minuscule." (Reiner, 1991 :73)

Conflict may well be intense when an individual's professionalism attempts to emerge within an organisation that has a highly bureaucratic structure. Etzioni, believes that decision making which is conformist and adheres to the organisations views is desirable:

"The ultimate justification for an administrative act is that it is in line with the organisation's rules and regulations, and that it has been approved directly or by implications by a superior ranking official." (Etzioni, 1964 :77)

Such a system ensures that the individual 'free thinker' or non-conformist will either be converted to the dominant logic of the organisation or be eliminated from the pool of promotion contenders to higher office.

2.5 SUMMARY

Modern policing in England and Wales is based on military lines with a hierarchical and bureaucratic structure with narrow spans of control and output regulated through a system of written standing orders, practices and procedures. The amalgamation of small police forces into larger forces has served to remove much of the initial variations. The work of the HMI, the training and selection of senior officers has helped to shape the individual police forces into centrally Home Office approved types.

Throughout the 1970's and 1980's, the police were increasingly called on to exhibit socio-political control over striking workers and the populace of some of the inner cities during large scale outbreaks of public disorder. The police adopted, improved and refined a para-military capability during this period creating a centralised system for the control and deployment of 'mutual aid'. Despite the para-military nature of these units they have remained essentially unarmed, committed to using minimum force and refraining from the use of

firearms or plastic bullets. The need to retain this capability is apparent with sporadic outbursts of disorder continuing through the 1990's. There is a need to fight the war against crime, against criminals who are becoming increasingly sophisticated and displaying a willingness to use high levels of violence with the increased use of firearms.

It has been identified the police operate within a bureaucracy and that the military style of management is best fitted to a bureaucracy that possesses and utilises a para-military capability. The concepts of the individual components that are associated with the 'Weberian classical bureaucracy' have been examined. Although the concept of bureaucracy is generally regarded in a pejorative manner, there is evidence to suggest that for an organisation like the police force, there is a need to incorporate the values derived from this type of structure:

- There is a need for consistency of action when dealing with members of the public, particularly when police officers are acting in an enforcement capacity. The law must be enforced equally without regard to position or social status;
- There is a constant requirement to train and educate police officers to a high level to maintain and up date their knowledge of law and procedures;
- There is a need for highly prescribed and complex recording systems to ensure the integrity of the systems and the accountability of all personnel;
- The police require a command structure that is based on the hierarchy of rank as they are often required to act as disciplined units, exercising coercive powers.

However, certain elements of bureaucracy can be regarded as being detrimental to the police. The notion that policy decisions made by the highest level in the organisation, once determined and codified into the organisations rules and procedures, must be followed slavishly as directives, not open to debate or

dispute, can stifle the creativity and professionalism of the individual. Managers are conditioned to follow procedures and this process becomes more important than meeting the needs of the public.

The review of scientific management identified a particular style of management. The main feature of which relies primarily on the process of reducing the activities of the worker into quantifiable units. The most efficient method of work and performance measures for individual workers can then be formulated. This process formed the basis of 'time and motion studies.' The principles of scientific management were adapted widely throughout the industrialised world as the concept of mass production spread. However, these techniques epitomised by the white coated engineer, armed with a stop watch and clipboard, dissecting and quantifying each component of work in the factory, became vilified and resented by the workforce. The concept of 'Taylorism' became synonymous with a hierarchical, mechanistic and authoritative style of management. The techniques became regarded as cost cutting exercises designed to gain the maximum output from the workforce for the minimum reward, and their rigid application became associated with wide scale industrial disputes.

Taylor identified and warned others that his techniques could not universally be utilised in every organisation and that their success was dependent on the organisation adopting his total 'philosophy of management.' This philosophy recognised the need not only for the organisation to prosper, but also that the employees needed to benefit through higher wages and to have the opportunity for personal advancement in the workplace.

Despite these criticisms there can be no doubt that many of his principles have been successfully incorporated into contemporary management practices. For example, McDonalds fast food restaurants have designed highly regulated systems that ensure each worker displays the correct corporate behaviour and

practices when dealing with customers.

Morgan identified that for the techniques of scientific management to be successful they had to meet certain criteria: the tasks have to be simple; easily replicated; and carried out in a stable environment. Yet, it would appear that these techniques are now being advocated by central government in their reforms of the public sector as being suitable for universal incorporation into all manner and type of public sector organisation, irrespective of the nature or diversity of service that they provide. However from the examples that Taylor gives, it becomes apparent that even for the regulation of a simple task such as shovelling, there is a requirement to develop a complex structure for the control, deployment and measurement of the workers' activities. If such systems are to be extended into complex organisations whose activities are made up of literally thousands of discrete activities, then the degree of complexity generated could well increase the need for the development of bureaucratic processes and control mechanisms. These issues will be explored later in the research.

The police service is presently under intense pressure to change, to become more businesslike and to adopt the working, accounting and technological techniques associated with the private sector. This concerns not only the working practices but the organisational structures with the development of strategic business units and a matrix type structure with decentralised management. There are indications that there is a desire to reduce the number of police forces. One argument for change advanced in the White Paper, Police Reform (Cmnd, 1993 :42) is that: "The technical advances of the last 30 years have made it much more important to ensure compatibility and interoperability of equipment between police forces and that the larger the number of police forces that there is the more difficult this becomes to achieve."

It appears unlikely that members of ACPO will question the concept of the

increased use of new technology for fear that they may no longer be viewed as 'modern' or 'progressive.'

2.5.1 Introduction to Chapter 3

The next chapter will explore the development of management techniques and their suitability for introduction into the public sector. The investigation will outline the trend for the Government to identify the successful features of the private sector and to endeavour to replicate these within public sector organisations in the hope of improving efficiency.

This concept will be reviewed from the perspective of the politician, civil servant, practitioner and leading academics with particular emphasis on evaluating the prospect of successful implementation. The host of changes which were primarily introduced whilst the Thatcher government was in power have been termed by academics as 'Thatcherism' or 'New Taylorism'. These concepts will be examined and compared with those introduced by F.W. Taylor.

The work of Howard Davies will be examined, in particular his belief that a single model can be introduced universally into all public sector bodies, so that they emulate the characteristics and values of private sector organisations. The effect that the introduction of this framework has had on the police will be examined together with the impact of legislative changes.

Organisational theory will be examined to explore the on-going debate amongst academic writers and organisational designers to determine if there is a preferred or universal model for the design of organisations. The work of Beer will be evaluated to see if the viable system model can be utilised in the design of the police structure. The work of Flood, Romm and Jackson will be examined to assess the practicable use of the viable system in diagnosing

systems problems within organisations.

**CHAPTER 3 THE ORIGINS OF 'MANAGERIALISM' AND 'SOCIAL
MARKETS' IN THE PUBLIC SECTOR AND THEIR POTENTIAL
IMPACT ON THE POLICE SERVICE**

3.1 INTRODUCTION

This Chapter consists of three sections. The purpose of section A is to examine the literature primarily associated with public sector organisations and to trace the origins of the rationale for the series of 'changes' that have been instigated into a wide range of public sector organisations since 1979. The changes are primarily associated with the former Prime Minister Mrs Thatcher and generically termed 'Thatcherism' or 'Managerialism'. The relationship between the private sector origins of managerialism will be examined together with their suitability for transference into a public sector bureaucracy. The research examines the characteristics of public sector management and the effects that the introduction of techniques and controls based primarily on the concept of measurement can have on organisational systems. The research will explore the emergence of the 'Social Market Research Foundation' and in particular the work of Howard Davies. Section B reviews the literature associated with the methodology for the transference of these concepts or processes into the police service, and considering the likely impact that their implementation will have on the future of policing. The section includes a review of the major legislation that the police will be required to implement in future years. It explores the impact that these changes will have on the type of service provided to the public and reviews the effect that change will have on organisational complexity. Section C relates organisational complexity to organisational theory and explores Beer's cybernetic models and their application to the police service.

3.2 SECTION A. ORIGINS OF MANAGERIALISM

The principles upon which many of the later management initiatives in the public sector are based stem primarily from the enquiry into the Civil Service, 1966-68, chaired by Lord Fulton, vice-chancellor of the University of Sussex, which is referred to as: 'The Fulton Report'. (HMSO, 1975, Cmnd 3638)

The report identified the need for radical managerial change within the civil service recommending the setting up of cost centres against which finance could be allocated and reducing the hierarchical structure that included 22 separate tiers of management.

3.2.1 The Pre-Thatcher Era

The 1960's and 1970's have been described by Skidelsky (1988) and Pollitt (1993), as being period's of political failure and increasing financial crisis. The Wilson - Callaghan governments of 1974-79 initially bought off the trade unions by conceding their pay demands. This led to spiralling inflation and a worsening economic position resulting in the sterling crisis of 1975 and in 1976, the negotiation of an I.M.F. loan. In 1978, the country witnessed the 'winter of discontent' that exemplified the accumulated power of the trade unions, particularly those within the public sector. These conditions formed the background to the 1979, Conservative Party victory and election of Mrs Thatcher as Prime Minister

3.2.2 The Thatcher Era

Mrs Thatcher was regarded as a dynamic and positive leader, whose stated objectives included the reform of the 'public sector'. Skidelsky (1989) identified Mrs Thatcher's vision as that of:

"A world in which small businesses could compete freely for the favours of the individual family consumer; in which the State keeps law and order, including the elements of a moral order to protect family decency, and provide succour for the genuine unfortunates who cannot help themselves." (Ibid :1-2)

The Conservatives' election manifesto was based on the theme of monetarist policies, and the concept of 'rolling back the frontiers of the State'. It suggested that the government should get off the backs of its citizens and taxpayers that the focus should be on private sector wealth creation, rather than public sector wealth consumption. Wilson, J. (1993) expresses the view that there was a clear ideological and political commitment to reduce the scope of public sector activity and increasing that of the private sector. Wilson. J. believed that the cornerstone for the intellectual substructure of Conservative thinking was: "The kernel of the orthodoxy was a belief in the efficacy of market forces as a mechanism for achieving socially efficient allocation of resources." (Ibid :25)

Wilson theorised that the need for significant change in the 1979 Conservative government stemmed from the failure of the policies and strategies of 'corporatism'. He identified that in the United Kingdom this meant a tripartite form of government whereby the TUC (Trades Union Congress) and CBI (Confederation of British Industry) were involved in the national decision making process. Wilson suggests that Thatcher regarded this as a derogation of governmental authority which:

"Strengthened extra-parliamentary organisations, particularly trade unions. A combination of weak government, powerful unions, and excessive public sector activity subverted parliamentary democracy, undermined individual freedom and resulted in economic sclerosis." (Ibid :26)

The essence of the new right philosophy was the rejection of Keynesian collectivism and governmental interventionism, with a desire to restore power to the government yet reducing its economic role. To achieve this Wilson, J. believed that entrepreneurialism and individual incentives to work had to be

increased by, *inter alia*, reducing union power, promoting the private sector and reducing state activity thereby facilitating reductions in public expenditure and direct taxation. Greenwood, (1988) Pollitt (1986), and Wilson, J (1993), identify that the private sector was regarded as being intrinsically superior to the public sector with:

"The latter having to be energised and coerced into efficiency whereas the former contained an internal dynamic in the form of competition which guaranteed efficiency and innovation." (Wilson, J 1993 :27)

Theakston (1990) believed that much of the 1980's management shake-ups in Whitehall could be attributed to the findings of the Fulton report and that their resurrection and continuance should form a central element of the Thatcher reforms. The catalyst for reform was an efficiency unit formed and headed by Lord Rayner, comprising of both civil servants and external consultants. This unit was located within the Prime Minister's office reporting directly to her, hence it could be regarded as having 'political clout'. Metcalfe and Richards (1990 :2) concluded that: "The powerful combination of careful planning and ideological commitment provided the driving force behind this component of Thatcherism."

The unit commenced a series of efficiency studies, titled 'scrutinies'. The initial object of the scrutinies was to demonstrate that there were serious shortcomings in the management of the civil service and that the examinations could lead to the elimination of waste, inefficiency and duplication. They highlighted that something positive could be done about poor performance. The secondary objective was to collect, consolidate and integrate the evidence from scrutinies to build a case for reform that would be credible within the civil service as well as outside it. The scrutinies were hailed as a great success whereby substantial financial savings could be achieved. When Sir Derek Rayner relinquished his position at the end of 1982, over 133 scrutinies had been completed. In the first

six years a total of 266 scrutinies were reported to have saved £600 million. (Metcalfe and Richards, 1990 :10)

Rayner however, was deeply concerned with carrying out 'lasting reforms' in changing the way that public and civil servants thought about resource management and improving efficiency. In July 1981, he took the opportunity of giving evidence to the House of Commons Select Committee. In 1981-82 the Treasury and Civil Service Select Committee produced a report titled: "Efficiency and Effectiveness in the Civil Service." (HC 236-1) The report contained evidence from a wide range of influential government officials, with great weight in particular being attributed to Rayner's views.

The Committee highlighted the fact that the quest for efficiency and effectiveness should not be confined to the civil service alone, but all other public sector bodies utilising the same standards and principles. Another recommendation was that:

"The departmentally related Select Committee should be able to ask the Comptroller and Auditor General to carry out reviews of efficiency and effectiveness. These would be deemed independent of the executive." (Ibid Ch. 7, para 97).

The later acceptance of this recommendation resulted in the National Audit Office being empowered to conduct audits and value for money studies within any organisation in receipt of public funding.

The Financial Management Initiative (FMI) was launched in May 1982 as part of the government's response to the Select Committee report. The report made recommendations not only on financial matters but on a wide range of management issues. The main areas have been summarised:

- Increasing delegation and decentralisation, making managers responsible for agreeing the detailed objectives and performance measures against which they were held accountable. This involved clear definitions of managerial responsibility and accountability and included devolving responsibility for budgets within the overall policy framework set out by ministers. Units of accountability should be set up, including budget centres and cost centres, to identify financial responsibility for activity;
- The establishment of information systems capable of translating overall objectives into more specific aims, targets and statements giving the costs of activities, performance against objectives and specific targets;
- The development of costing systems that could make managers aware of costs to enable them to exercise control;
- Devising suitable performance measures, including those for activities without easily definable measures of final output;
- Increasing the range of available skills, including the recruitment of more accountants and the greater use of management consultants; increasing the interchange of staff with those working in private sector organisations, to improve the cross fertilisation of ideas;
- Improving internal audit procedures and encouraging value for money studies to reinforce many of the elements of good managerial practices.

The requirements of the FMI demonstrated the need for pervasive change in management practices and highlighted the need for fiscal accountability. Henkel (1991) believed that its main value was to induce a culture of cost consciousness and resource management within the civil service. Metcalfe and Richards identify that the report incorporated many of themes and practices advocated by Fulton and Rayner. They regarded this report as being a significant benchmark in changing the organisational culture of the public sector. Metcalfe and Richards, who are generally supportive of these initiatives, did, however, view the task of completing a programme for implementing all the proposed changes as being immense: "A quantum leap from the implementation problems associated with individual scrutinies and multi-departmental reviews." (Ibid :184)

3.2.3 New Managerialism

The term 'new managerialism' can be described as the importation of private sector concepts and techniques into the public sector that have been associated with reforms introduced under the initial Thatcher government. Hughes, (1992) identifies that most articles in public administration literature have been critical of this trend. The reforms are seen as being against the traditions of public service, inimical to service delivery and somehow undemocratic, even lacking a: "Solid intellectual or philosophical basis." (Painter, 1988:2) Although the critics have not had it all their own way, there have been other articles countering these views and supporting the widespread changes (Keating 1990, Metcalfe and Richards, 1990).

There is however, recognition that public sector management cannot be derived, simply by injecting private management techniques into the public sector. Allison (1982) believes that the improvement of public sector management will come not from the massive borrowing of specific private management skills and understanding, but that it would come from a gradual articulation, understanding and introduction of private management techniques. Hughes recognised that it is important to recognise the differences that exist between the two sectors, which he lists as:

- The public sector has more forms of accountability;
- Public sector decisions are frequently coercive;
- Public decisions must be firmly based in law and cannot be arbitrary;
- The public service manager must cope with an agenda largely set by the political leadership;
- The public sector has inherent difficulties in measuring output or efficiency in production;

- Its size and diversity makes any control or co-ordination difficult. (Ibid: 294)

Although there are clearly wide gaps to be bridged, Hughes argues that poorly founded criticism by academics of managerialism merely serves to increase the gap between academic study and practice, rather than working towards the development of new theory.

There are, however, a wide range of opposing academic views that question, the ethics, principles and techniques that Thatcherism and managerialism are founded on. Kingdom (1990) argues that managerialism has created a need for a new type of manager, one who essentially displays mute obedience to central authority. Kingdom believes that under the Thatcher regime discussion and argument are regarded not as a legitimate part of democratic government, but that of unconstitutional behaviour. This style of manager:

"Deprives democracy of an important level of discussion and moderation, reducing or eliminating completely the opportunity to consider fully the implications and possible unwelcome spin-offs from proposed policy. It removes from the executive any responsibility for arguing through its policies against logical objections." (Ibid: 21)

Kingdom identifies the new managerialism of Thatcher as being essentially concerned with driving the organisation from the top in line with centralised power structure that is represented by an increasingly authoritarian and bureaucratic administration.

Pollitt (1990) determined that the terms Thatcherism and managerialism were based on the same principles. He argues that when Mrs Thatcher came to power in 1979, with a mandate to roll back the frontiers of the state, the intellectual foundation on which the theme 'superiority of the market' was founded, is too narrow. That it was driven not on the basis of sound policy and scientific principles but on that of charisma. He argues that the UK New Right threw up

only fairly small units, such as the centre for Policy Studies or the Adam Smith Foundation. While this kind of organisation may have been quite adequate for embellishing the general theme of superiority of the markets, there was little sign that they could muster the resources necessary to evaluate major programmes in any detail. Consequently, managerialism was founded on a pot pourri of beliefs and ideologies rather than on concrete theoretical remedies that could be subjected to testing or analysis. The primary measure of success was that of increased efficiency, which became expressed only in the narrow headline terms of either cost reduction or the reducing the head count of public servants employed.

Pollitt (1990) believes that the transfer of managerialism from the private sector to welfare state services, represents the injection of an ideological 'foreign body' into a sector previously characterised by quite different traditions of thought. Pollitt identifies that the prevailing dominant logic is now one that incorporates specific beliefs and values:

- The main route to social progress now lies through the achievement of continuing increase in economically defined productivity;
- Such productivity increase will mainly come from the application of ever-more-sophisticated technologies. These include information and organisational technologies as well as the technological 'hardware' for producing material goods. Organisationally, the large, multi-functional corporation or state agency has rapidly emerged as a dominant form;
- The application of these technologies can only be achieved with a labour force, 'Disciplined in accordance with the productivity ideal.' (Alvesson, 1987 :158)
- Management is a separate and distinct organisational function and one that plays the crucial role in planning, implementing and measuring the necessary improvements in productivity. Business success will depend increasingly on the qualities of professional managers;
- To perform this crucial role managers must be granted reasonable 'room to manoeuvre' (that is the right to manage). (Pollitt, 1990 :2-3)

Thatcher and her supporters had clearly identified the value of 'good' management. Michael Heseltine stated: "Efficient management is the key to the national revival... And the management ethos must run right through our national life, private and public companies, civil service, nationalised industries, local government, the National Health Service." (Heseltine 1980)

However, until 1979 the basis of administration within the public sector had primarily followed that of Gulick and Urwick's classical papers on the science of administration, that placed heavy emphasis on long term planning and the setting of objectives:

Planning - Organising - staffing - directing - Co-ordinating - reporting - budgeting.

Whereas the new approach to management detailed in the FMI took a narrower view in which managers at all levels would have:

- A clear view of their objectives; and means to assess, and wherever possible measure, outputs or performance in relation to those objectives;
- Well-defined responsibility for making the best use of their resources, including a critical scrutiny of output and value for money;
- The information (particularly about costs), the training and the access to expert advice that they need to exercise their responsibilities effectively. (Cmnd 9058, 1983)

The increased emphasis on measurement and finance invoked a tendency for managers to focus more on economy and efficiency rather than effectiveness. Indeed greater economy may damage greater effectiveness, for example when front line staff are reduced in a hospital, it may increase waiting times. Increased class sizes in schools can lead to less effective teaching and learning as teachers have to deal with larger number of pupils who all have specific and multiple learning needs. Increased economy may militate against increased efficiency. Pollitt theorises that Thatcherite changes have what he terms a 'Neo-Taylorian' aspect about them. Pollitt identifies some of the similarities:

Firstly, the Taylorist concept concerned with the processes of measuring, determining, and fixing effort levels for work. This system has been universally adopted and proceeded with on the basis that previously unmeasured aspects of the work process could and should be measured by management and then used for controlling and rewarding effort. Throughout the public sector, performance indicators, individual performance review and merit pay have been introduced. Pollitt, states that these principles are in line with the time and motion spirit of Taylorism: "A concentration on the immediate, concrete controllable things which go on within ones' own organisation and an avoidance of entanglement with wider-value questions of the fairness, equity or social usefulness of the product." (Ibid :60)

Secondly, the process of reducing elements of 'professional tasks or work' into simplified procedures so that they can be performed by less skilled workers. For example nurse helpers, non-certificated teachers and the escort of those in police custody to the prisons, heralds the prospect of de-skilling and the undermining of professional territory.

Thirdly, the decentralisation of functions to accountable units, for example, the creation of 'free' standing Trust Hospitals, and the Local Management of Schools. This technique serves the purpose of breaking institutions down into their component parts, in some cases placing wage negotiations onto a local basis. Management will have to decide local agreements, within an externally determined budget, rather than relying on national ones. This follows Taylor's concept of negotiating with the individual wherever possible rather than a group. This has been typified by the decrease in the range of public-service jobs that are tenured and permanent, while the proportion of short-term performance related appointments have increased.

Pollitt (1990) argues that the chief features of both Taylorism and its 1980's descendant were that they were, above all, concerned with *control*, and that this control was to be achieved through an essentially *administrative* approach - the fixing of effort levels that were to be expressed in quantitative terms. Rewards were then to be geared to above-average performance that was often externally determined. In parallel with this increasingly detailed control of measurable activity went a de-control of employment relationship, that is to move away from 'standard terms and conditions' affecting large groups of workers, to one where negotiations would take place with the smallest group possible. Managers were to have greater discretion to negotiate, or impose, local terms that would more closely reflect local labour market conditions and their cost centre budget. The budget would be set in accordance with central policy and subjected to tight fiscal constraints. Hence, one worker's pay rise can mean another's job, or alternatively a reduction in the level of services provided. This has the effect of pushing the accountability levels for unpopular decisions away from central government and down to the individual manager, who is forced to balance pay against cuts in service. This whole set of changes was conducted within a larger framework of ideas that upgraded the importance of 'management' and distinguished this activity from 'politics'.

Collectively this style of management has brought to the public sector, not only its stated objective of greater cost awareness, but the increased control of staff rather than their development, focus on measurement rather than encouragement, on money rather than leadership or morale. Pollitt (1993) believes that this style of management abandons the whole ethos and findings of the human resource school of management.

3.2.4 The Development of Social Markets

The Social Market Foundation's declared aims are to: "Research and gain acceptance for policies based on the concept of the Social Market." The first paper titled: "The Social Market Economy" set the stage for a series of papers concerned with spreading these concepts into the public sector.

"The use of the phrase 'social market economy' signifies a choice in favour of the market economy. It means we turn to the market as a first resort and the government as a last resort, not the other way round. It means that our first instinct is to use the market, not to override it; and that we are not afraid to apply the logic of this matters of thought, expression and behaviour, which most governments, not least Mrs Thatcher's, have an incurable urge to control." (Skidelskey, 1989 :4)

Skidelsky defines the role of government within this market as:

- To create and maintain an appropriate legal framework for market exchange;
- To limit and supplement the market where necessary;
- To ensure that the market is politically acceptable. (Ibid :4)

Skidelsky charts the rise of the ethos of the market economy in Britain, identifying four key milestones:

The first, the progressive failure of Keynesian macro-economics to secure the internal and external balance of economy. The philosophy of maintaining high levels of employment by increased taxation and borrowing led to high inflation. The situation becoming increasingly problematical with strong public sector unions and high wage demands. This resulted in the decline of Britain's competitiveness on the world market to the extent that Britain has ceased to function as a market economy;

The second, relates to the excessive power of the trade unions and the lack of legal restraint. The cost of damaging strikes in the public sector was funded by the taxpayer. Irrespective of the costs involved, the industries themselves did not go out of business, they just received more public finance;

The third, was that the government itself began to look incompetent, public services seemed to exist to benefit those who served in them, and became increasingly regarded as overstuffed and inefficient. Government seemed to be getting bigger, costlier, more incompetent and more ineffective at the same time. Skidelsky believed that: "A powerful reaction to all this was less government and more market."

The fourth, was the explosion in new technology that brought down the barriers to entry in some of the traditional industries, by reducing the advantages of 'economies of scale'. (Ibid :8)

Throughout the early 1980's despite inter-political party debates about the ethics and validity of the public - v - private sector ideology and privatisation of significant sectors of British industry continued. British Telecom, British Steel, and British Airways were transferred to private sector management. However, for those parts of public service that could not be privatised in their entirety, alternative measures became increasingly available. Compulsory Competitive Tendering led to the contracting out of generally low skill level services, for example cleaning services. *Improving Management in Government: The Next Steps* (1988) recommended the reduction of the Civil service into a small core of policy makers, and transferring other officials to work under free standing agency boards. The White Paper, *Competing for Quality* (1991), required government departments to identify areas of work currently undertaken by civil servants to be tested against the private sector, a process known as 'Market

Testing'. If the in-house service is at the lowest cost, then the service will remain in-house, if not, then it can be put out to tender by the private sector.

Davies (1992) draws heavily on the work that he carried out during his period as Controller of the Audit Commission (1987-92). Davies seeks to develop the argument for the extension of private sector practices into virtually all types of public sector service.

Davies contends that one of the main problems in the public sector is that the growth in spending on the public services, has not been matched by improvements in the services provided. Davies identifies that until recently complaints from the public about services have typically been answered by a promise to increase expenditure on that service. Examples of this are: when recorded crime rises, the Home Secretary has a tendency to promise to put more officers on the beat; when the prisons were at the height of unrest, the promise was to increase expenditure on new prisons.

To counter the political philosophy of spending its way out of trouble, Davies is wholly in favour of adopting the characteristics of successful private sector concerns. These are regarded as being responsive to their customers needs and constantly in search of efficiency gains and quality improvement. The discipline created by the operation of market systems is associated with imposing competitive pressure. Davies suggests that government should therefore construct social markets around each major area of service provision that are not necessarily straightforward copies of the private sector models:

"There is a need for adaptations to match the requirements of each service, however they must start from the premise that the aim is to duplicate the conditions which exist in competitive markets, making only those adaptations which are essential." (Ibid :9)

Davies views the implementation of the Citizens' Charter as being a step in the right direction with service providers moving closer to the customer, however,

he urges caution. Davies recognises that if increased emphasis is placed on meeting the individual's needs and of enhancing the customer's voice, this may accelerate expenditure by drawing attention to the citizens' entitlement to services that they may otherwise have been ignored. He concludes that if the service remains free, and their quality improves, then so will demand for them. (This was demonstrated by Flynn in Chapter 1, where the introduction of charges for eyesight tests, resulted in a reduction in demand of 40%)

Davies acknowledges the conflicting arguments advanced by those in the public sector that militate against change. These can be summarised:

"The first argues that public services are inherently different from the private sector, profit seeking concerns: that the public sector, unlike the private sector, is about service without fear or favour and with no regard for the ability to pay; that the public sector managers are motivated by higher concerns than personal reward - that the public service whose whole existence is threatened by aggressive private sector practices - the introduction of market pressures will, at best, create a 'two tier' service as only part of the system responds to competitive pressure."

"The alternative rejects this entirely. It maintains that there is nothing wrong with the public sector that a good dose of competition and customer choice will not solve; that one should empower consumers to purchase services directly from a range of competing providers and seek to create fully fledged market places wherever possible, they should pay directly for services, to create a powerful cash nexus between provider and consumer, If needy users cannot afford services they should be put into funds to do so through the benefit system." (Ibid :18-19)

Davies identifies that there are tendencies for consumers to use and abuse services, purely because they are free. Consequently they do not behave as consumers do in the private sector. Due to these characteristics, Davies argues that consumers of public services, do not necessarily make rational choices and cannot themselves easily assess the value for money offered.

Davies sees the creation of the two-tier market as being essential to improve services. He identifies that monopolies lack competition and as a result, exploit the consumer.

"So to argue, as did critics of the NHS reforms that GP fund holding practices, by putting pressure on hospitals on behalf of patients would create a two tier health service is entirely to miss the point. They are supposed to create differential levels of performance to provide a needed stimulus to improvement throughout the system." (Ibid :19)

To resolve these and other problems Davies puts forward the view that there is a need to identify the main factors that lead to success in competitive markets. Then to assess how far those different factors can be recreated in the public sector, to underpin a systems architecture that will work towards efficiency and effectiveness.

Davies identifies that there has been a great deal of innovation in public service delivery over the last decade and that there has been some experimentation with the introduction of market systems into the public sector. He acknowledges that whilst some schemes have been successful, others have not. Davies believes that the government has so far been reluctant to evaluate its own reforms, or to set out its overall approach to public sector management. This has motivated him to produce a framework designed to fulfil this purpose. The application of the framework explores the differences between public services and the private sector. The framework identifies the positive factors found in private markets that need he believes need to be replicated in the public sector in order to create social markets that promote efficiency and effectiveness.

Davies specifies ten elements that form a social market framework:

- A rational financial framework;
- Clearly defined outputs;

- A purchaser/provider split;
- Market testing and competitive providers;
- Contracts;
- Customer choice;
- A strong realistic customer voice;
- Comparative data on performance;
- Strong lay management;
- Independent inspection and audit. (Ibid :39)

Davies believes that these ten characteristics form a framework on which every type of public sector organisation can be examined. He demonstrates this by comparing five public services. (Table 3.1.)

Davies concludes that although the government has made some progress in the reform of the public sector:

"Some attention is needed to the systems architecture in all areas, with the police standing out as particularly deserving of attention." (Ibid :51)

Since the publication of this paper, the police have been subjected to reviews of both structure and working practices that are the most far-reaching reform of policing since the Police Act 1964. Many of the recommendations have been drawn together in The Police and Magistrates Courts Act, that was introduced in April 1995. The Act and other ancillary legislation have addressed all the areas of the police service that Davies identified as being most in need of reform. The Act will ensure that the police undertake a metamorphosis and become practitioners of managerialism and the social market economy ideology.

Table 3.1 Current State of Five Public Services (Davies, 1992 :50)

	National financial framework	Defined outputs	Purchaser/ Provider Split	Market testing	Use of contracts
Refuse collection	Yes, subject to illogicality of whole local govt system	Yes	Partial	Imposed by law	Yes
Social Services	Emerging in 1993	No	Rare so far	Encouraged but rare	Rare
NHS	Generally yes (though complex for fundholders)	Partly and growing	Yes	Only at the margin	Yes
Schools	No	Conflicts hindering progress	No except 16-19	Almost none	No
Police	No	Few but developing	No	No	No
	Choice	Consumer voice	Comparative data	Professional strength	Non professional inspection/ audit
Refuse collection	'Client' can choose; not 'Citizen'	Customers unaware of standards	Little now but coming under Citizen's Charter	Low	Yes
Social Services	Only effective where care managers exist	Defined lobbies are effective, individuals not	Little now, but coming under Citizen's Charter	Still high	Inspection still part of profession. Audit quite strong
NHS	Growing, but still very restricted for individuals	Reducing CHC's locus now less	Govt reluctant to expose to independent scrutiny	High, but under challenge	Growing, through clinical audit still too closed
Schools	Growing but heavily constrained	Parent-governors add power	Schools' and Citizen's Charter	High	Inspection being reformed. Audit being downgraded
Police	No	Consultative groups sometimes effective. Police authorities on the whole not	Citizen's Charter	Very high	Inspectorate of Constabulary ex-policemen Audit quite effective

3.3 SECTION B. THE COMBINED PRESSURES ON THE POLICE SERVICE TO CHANGE.

The transfer of the concepts of managerialism into the police service has been accomplished by a combination of pressures exerted by key bodies in the external environment.

The Audit Commission - Established in the Local Government Finance Act 1982. The Commission is independent of central and local government control, it is self financing and raises income from fees from the local government audit. Its stated objectives are two fold: to promote the integrity of local government by ensuring that local authorities spend their money in accordance with the law; to promote value for money. Buttery (1989) and Garvin (1992) identify that the Commission works closely with the Treasury and they are in effect, a watchdog for local government spending practices. Garvin speculates that the Commission's power lies in its close affiliation with the Treasury that effectively controls the purse strings of the public sector: "Consequently any sector failing to respond to the Commission's suggestions could become severely cash limited." (Garvin :25)

The Home Office - In response to the issues raised by the FMI they produced, Home Office Circular 114 of 1983, titled: 'Manpower, Effectiveness and Efficiency in the Police Service'. The circular recognised that although the demands on the police service had increased substantially, so had the costs. They stated that the public purse could not sustain such continued growth, consequently the police service would have to make more effective use of available resources. If more police officers were required then the police force would have to demonstrate that they were fully utilising existing police officers effectively. The Home Office commissioned the HMIC to devise measures for the examination of financial information. In particular the costing of options for

the deployment of resources and to determine if value for money was being achieved.

Home Office circular 114/83 was subsequently reinforced by Home Office circular 105/88 that included a comprehensive list of posts that had been identified as being suitable for civilianisation. In doing this the circular adopted some of recommendations of the Commission's first report 'Administrative Support for Operational Police Officers' (Paper 1, HMSO, 1988). The report identified that the way forward was to remove a wide range of administrative tasks from operational police officers identifying that these could be carried out by civilians. To illustrate this they posed the question, 'What tasks can be removed from the operational police officer?' They answered:

"All activities which can be performed at least as economically, efficiently and effectively by a specialist group as they can be an operational police officer." (Paper 1, 1988 :12)

The Treasury - In October 1988, the Treasury concerned with the lack of 'value for money' studies in the police service offered to carry out a joint research project with HMIC to determine a methodology for evaluating the performance of the police and equating this to manpower bids. The terms of reference were:

"To examine and assess the methods available for quantifying the relationships between police manpower (officers and civilian staff) and to recommend improvements." (HMSO, 1989 :para 1.2.2)

The combined group reported in 1989, the main recommendations can be summarised:

- The standardisation of incident categories;
- The standardisation of activity analysis;

- Standardisation of manpower allocation, based on assessed need for policing, the HMIC being directed to develop a manpower allocation formula and decision support system to be used in considering manpower bids;
- HMIC should develop a structure for the matrix of performance indicators;
- HMIC should use an indicator which measures the proportion of police time spent on the streets;
- The Home Office should develop aggregate measures of crime, weighted by seriousness and police workload. These should be used to develop measures of clear-up rates and crimes cleared up per officer;
- The Home Office should undertake a structural research programme into the effectiveness and value of police activities;
- When information systems were sufficiently developed, unit cost measures of activities should be designed to encourage efficiency in the use of resources;
- Each civilianisation decision should be based on considerations of cost-effectiveness.

The report highlighted the commitment of central government to the issues of incident categorisation, activity analysis, manpower allocation, efficiency measures, performance indicators and cost. It sought to standardise those measures and apply them universally to all police forces. The publication of this report led to much speculation that standardisation and the use of formula for resource allocation was a prelude to the formation of a national police force:

"The easiest way for central government to remedy unequal distribution of manpower (Merseyside has one officer to every 303 residents, whilst Northumbria has one every 400) is to do away with local boundaries. Are we about to take another unsuspecting step on the road towards a national police force." (Hilliard, 1991 :20)

Her Majesty's Inspector of Constabulary - The role of the HMIC is to monitor a police force in a manner prescribed by the Police Act 1964 and, Home Office Circular 114/83. In doing this it is required to take a wider perspective than that of the auditor, to gauge the police force as a whole, taking into account the way

that it is organised and managed. To fulfil this role, HMIC has become heavily reliant on the process of 'measurement'. Morris (Her Majesty's Chief Inspector of Constabulary since 1993) stated that:

"The value of performance indicators is increased if they can be viewed, in appropriate circumstances, with the results of public opinion and internal surveys. But in judging forces we also have regard to the data on HMIC matrix; the contents of chief constables annual reports; the results of diagnostic models; activity analysis; plus the effective supervision and management; random sampling of documentation and the many and wide ranging functions of in-force performance review units." (Morris, 1992 :5)

This commitment to measurement was extended in January 1992, by the implementation of 'quality of service' initiatives that detailed 45 performance indicators. Morris indicated that in the future there may well be a need for a wider range of indicators, which would be dependant on the findings of: The Sheehy Report, The Royal Commission into Criminal Justice; The Local Government Review; and the Home Office Study into police funding. He did however raise certain questions that would have to be addressed in the future:

"Can data for measures be provided from existing sources or will additional finance and technology be necessary? How will data be analysed, validated and interpreted and by whom? Will it be understood by those who need to be informed, will it be useful? Do the measurers themselves need to design measures to assess their own performance?" (Morris, Ibid :8)

3.3.1 The Future Direction of Policing

The police have been at the centre of national, political and local debate throughout the late 1980s and early 1990s. Their integrity has been repeatedly questioned by a lengthy list of 'wrongful convictions'. The most notable being the 'Birmingham six' and the 'Guilford four'. Questions have also been raised about the inability of the police to reduce the rising levels of crime. This has ensured that the very issue of 'law and order' has remained at top of all major

political parties' agendas. In a speech to Parliament on 23rd March 1992, the then Home Secretary Kenneth Clarke laid before Parliament proposals to reform the police. The proposals included: business-like police authorities with lay managers; giving police authorities greater freedom on what to spend their money on; responsibility for setting local performance measures for the police; reformed funding arrangements for police forces; and simplifying procedures for amalgamation. Clarke hypothesised that if local police stations became virtually free standing agencies, receiving fewer services from headquarters, then: "As a result we may no longer need 43 separate headquarters maintaining 43 parallel organisations." (Clarke, 1992 :6)

The proposals culminated in two major reviews: The Police Reform and The Sheehy Report.

The Sheehy Report

The team chosen to carry out the enquiry into 'Police Responsibilities and Rewards' was headed by Sir Patrick Sheehy, Chairman of British and American Tobacco. The four other members were: John Bullock, senior partner, Coopers and Lybrand; Professor Colin Campbell, University of Nottingham; Eric Caines, director of personnel, National Health Service; and Sir Paul Fox former managing director of BBC television. None of the members had prior experience of policing. The terms of reference were: 'To examine the rank structure, remuneration and conditions of service of the police service in England and Wales, in Scotland and Northern Ireland.' (Police, 1993 :2) The main recommendations are summarised:

- *Rank structure* - the report proposed the reduction of 5230 supervisory officers and their replacement by 3000 extra constables;
- *Severance payments* - officers leaving as a result of this reduction should receive a lump sum;

- *Reward structure* - there will be a lower basic rate of pay, automatic annual rises would be abolished, increases where merited would be based on performance and competence;
- *Pay levels* - pay levels in the non-manual private sector would be used as a benchmark for police salaries, with only two thirds of the total settlement being added to basic pay, the remaining third to be used at the discretion of the chief constable;
- *Pay-related allowances* - Overtime would not normally be paid but reflected in the pay levels of individual posts. Housing and other allowances will be phased out;
- *Fixed term contracts* - All newly appointed officers will enter under fixed term contracts, initially for 10 years, and subsequently for 5 years. There will be no automatic right to the renewal of contracts;
- *Determining conditions of service* - Police regulations will be abolished and replaced by a limited non-statutory national code of standards and local arrangements decided by the chief constable in consultation with officers and their representatives;
- *Sick pay* - restricted to 6 months with a further 6 months on half pay;
- *Pensions* - the fixed term for payment will rise from 30 to 40 years service, and will be paid at 60 years of age. Pension contributions reduced from 11% to 7%. (Tipstaff, 1993)

The recommendations of this Report transform the conditions of service of the police force into those similar to the private sector organisation. There is no doubt that if they were to be implemented in full, significant cost savings will be made. It will also allow the police to adopt the organisational characteristics of a private sector organisation.

The White Paper

The recommendations of the White Paper on Police reform specified: the direction that the police will move in; the style in which it will be managed; the objectives and the priorities that it will focus on. The Government clearly states its position as being committed to: "Upholding the rule of law, supporting the

police and fighting crime." (Ibid :1). The Paper recognises that the police cannot achieve this alone, that they need the active support and involvement of the communities they serve. The Paper indicates that this can be achieved by increasing the number of people from the voluntary sector, such as special constables, the extension of neighbourhood watch into 'streetwatch schemes', as well as the expansion of other groups like 'victim support'. The Paper specifies the main aims of the police:

- To fight and prevent crime;
- To uphold the law;
- To bring to justice those who break the law;
- To protect, help and reassure the community;
- In meeting those aims, to provide good value for money. (Ibid :2)

The Paper then sets out its proposals for enabling the police to meet these aims.

The main provisions have been summarised:

- The Government will set the key objectives that it will expect the police to secure. These objectives will reflect the Government's belief that fighting crime and the protection of the public should be the top priority in police work. Police performance will be measured against these objectives;
- Chief constables will be empowered to deliver a service that responds better to local needs. They will be held more accountable for the performance of their forces;
- Local police authorities will be strengthened and made more effective. They will be smaller and have broader local representation. The composition of the police authority will be, nine members from relevant councils, three magistrates and five appointed lay members. The appointed chairman will be salaried. They will ensure that policing meets local needs and the Government's key objectives. They will be held to account for the results;
- In keeping with the Citizen's Charter police authorities will have a duty to consult local people. They will be required to take account of the views of

local people in setting priorities and to tell people how well their force has done;

- The management should be streamlined, devolving resources and responsibility for local policing to local commanders;
- The funding system will change, the Government will relinquish detailed control of finance and manpower. Central government grant will in future be cash limited;
- The independent Inspectorate of Constabulary will be strengthened, with the addition of professional lay members to ensure that standards are maintained;
- In view of the recommendations of the Sheehy report, there will be changes to the police rank structure, pay and conditions of service;
- The procedures for amalgamating police forces will be simplified so that changes where justified can be implemented;
- There will be new procedures to ensure that poor performance by individual officers is dealt with fairly and effectively. (Ibid :2-3)

The White Paper titled: 'Police Reform - A Police Service for the Twenty-First Century', recommends the most significant changes to the police force since the Police Act of 1964. It narrows the role of the police force, moving away from the eight functions of the 1964 Act, to a role that will be increasingly focused on policing through enforcement and policing by results. The Paper recommends that the tri-partite structure be restructured into a hierarchical structure that clearly defines accountability. The Home Office will set the government's priorities, the police authority the local priorities. The chief constable will be held accountable to both for performance measured against defined standards. The changed financial arrangements mean that the chief constable can determine the mix of police - civilian personnel - vehicles - equipment, within a government cash limited framework. However, the local component raised through domestic rates is not cash limited. Consequently if local circumstances and political will dictates, expenditure on the police can actually rise.

Through the combined recommendations of the Sheehy Report and the White Paper, it is apparent that the police service will now adopt all the characteristics of the framework determined by Howard Davies. To place this in the context of the police, chief constables will have to prioritise resources to satisfy their performance indicators, within a cash limited budget. Unit costs will either have to be reduced or services cut.

It is apparent that in order to be competitive and to ensure that they do not feature at the bottom of a league table. Chief constables denied the cushion of increased funding, and bids for increased manpower to match demand, will have to reconfigure the mix of their police resources to provide a cheaper service.

The main recommendations of the White Paper and some minor recommendations of the Sheehy Report, have now been stated within The Police and Magistrates' Court Act 1994. The Act changes the status of the police authority to that of a free standing corporate body. This will involve considerable changes to the present working practices and relationships with the County Council and the civilian workforce. The provisions of the Local Government Act 1988 and the Local Government Act 1992 will now apply. These extended compulsory competitive tendering to a range of both blue collar activities such as cleaning and catering, and professional services such as legal, finance and personnel. Significant tranches of support service work currently being carried out in conjunction with the County Council or in-house will in future be exposed to competition. This can mean a move away from permanent, salaried, and pensioned staff to fixed and short-term contracts or external private sector contractors.

It must be pointed out that many of these changes have been welcomed by police: "The police are undergoing a period of unprecedented change, much of which is self generated and welcomed by the service." (ACPO 'factsheet' July 1994) Some police managers view them as part of their evolutionary process and acknowledge the benefits that they will bring. Chief constables will have much greater freedom to manage their finances, to fix staffing levels according to local need and to find more cost effective ways of delivering core tasks. The principal areas of concern appear to be those of the prospect of privatisation of core policing services. The paper recognises that cheapness in the provision of services is not always the most important thing. They compare the relative values of each.

PUBLIC POLICING

Accountable to the people

Motivated by a desire to serve the public

Free at point of contact with the public

Independent complaints system

Open to public scrutiny

Highly trained to national standards

Always there and will help if they can

PRIVATE POLICING

Often accountable to no one

Motivated by a desire to return a profit

Payment at point of contact

No independent complaints system

Largely secretive behind financial confidentiality

Limited training

Work to small print of a contract

The factsheet stresses that the role of the police is not just about catching criminals, but that the police provide balanced services to meet a wide range of societies needs. These form an integral part of the values and characteristics that lie at the very heart of British policing. Although these sentiments are clearly in opposition to those in the White paper, members of ACPO regard their retention as imperative and indicate that these should not be abandoned to meet the Government's drive for cost effectiveness:

"We are not only in the business of crime detection. We are the first emergency service, a genuine 24-hour a day service when people are in need of trouble or need advice and always on hand to deal with incidents as they arise - a break-in, a road accident, a major disaster, or a domestic dispute. We are also an important presence in the community, whether working with other agencies to promote crime prevention and support the victims of crime or speaking to schoolchildren about the dangers of drugs."
(Ibid :4)

Ross believes that this radical agenda for change is based on the misguided public perception that portrays the image of the public sector as one that is malfunctioning and inefficient. Ross believes that this perception has been encouraged by government agencies to bring about this whirlwind of legislative and policy change. The Government is turning the spotlight of public criticism onto providers of service, thereby deflecting criticism away from central budgetary constraints. He identifies that: "The subtlety of the strategy allows for radical reforms supported by public opinion." (Ross, 1993 :17)

3.3.2 The Impact of Change on Organisational Complexity

Butler (1992) believes that the approach that the Audit Commission has adopted in its studies is too narrow, wholly mechanistic and based purely on the use of figures to measure police performance. Butler suggests that there are two major flaws:

"First the enthusiasm for defining outputs to quantifiable figures; second, the failure to appreciate the powerful role played by the organisational culture and style of police forces in determining the extent to which services are effective and efficient." (Ibid :25)

He concludes that their methodology is: "Too tightly focused on determining the cost whilst ignoring the value." and that the reliance on: "Quantifiable outputs is both naive and misleading." (Ibid :26) Butler points out that their approach to performance measurement is not that of satisfying the customer or developing and refining systems by their use, but purely one of control. This control will increasingly become associated with reward or punishment. For example, if the district commanders fail to achieve their performance targets, (which have been determined externally), they will be subjected to some form of sanction. Similarly, if the chief constable fails to achieve satisfactory performance against externally set targets, then the police authority is empowered to require resignation. The control mechanism will be reinforced by

the enhanced relationship of the HMI and the new power of the Secretary of State to direct the police authority to comply with recommendations made.

The cumulative effect of the introduction of such a wide range of changes into the police in such a relatively short period of time has created internalised resources problems within the police force. The internal police management role has expanded to facilitate the new managerialism and market philosophies, with the creation of ever wider and more sophisticated measures of performance. These have been designed to collect more and more data, to measure every conceivable component that goes into the satisfaction of performance indicators. This role is presently being expanded particularly within the Cleveland Constabulary with the introduction of a whole host of private sector management techniques designed to support the 'new structure'. These include: team briefing; the NHS derived Dynamic Standard Setting System, (DYSSS) for measuring quality of service; appraisal and performance related pay; individual performance measures; an expansion of marketing and media services; service level agreements; and many more. The emphasis has changed from providing front line services to one where it is more important to measure the performance of the individual officer, then to articulate and express the performance in a professional manner.

3.4 SECTION C. ORGANISATIONAL POLICING

This section examines organisational policing in an age of great complexity when the nature of the police organisation and how it is managed are topics of increasing interest to police professionals, members of the public, local and national government. If policing is to become more efficient in its use of resources, management must look closely at their methods of programme management and the measurement of effectiveness. The research has taken a systematic look at the way in which the police organisation relates to the

environment within which it has to function. From this approach the research maps out potential (or perceived) strategic management problems at a time of rapid technological change that is impacting on the organisational structure. The interactions and consequences must be understood by managers if they are to maintain the valuable assets which the police service presently enjoy, those of dominant market position and public support. To do this we will examine the development of management and organisational theory and relate these to organisational policing issues.

The analyses carried out in sections A, B and C of police management point to similarities rather than differences between police and 'other management'. The analyses point to the fact that the organisational models followed by the police are based on scientific management and bureaucracy with heavy reliance on stringent administrative procedures for control. The author suggests that the present models are too simplistic to cope with the relationships and interrelationships of the 'new managerialism'. What is required is a three dimensional model that examines the reaction with the environment.

Waelchli (1989) explores the issues of whether there is one universal law that can be regarded as the 'law of management' and to mark one end of the philosophical spectrum he cites Lederman:

"A single and economical law of nature, valid throughout the universe for all time. The quest for such a unified scientific law has been undertaken and advanced by all nations and all creeds. Indeed, the idea of the unity of sciences has been a major force in developing the unity of humanity." (Lederman, 1984 :40)

Waelchli identifies that the middle ground is well populated including Warfield's 'Typology of Laws' (1986) for the sciences, and Jay Galbraith (1977) in organisation theory, whilst organisational contingency theorists occupy the other extremes:

"One of the consequences of the contingency view is a rejection of simplistic statements concerning universal principles of organisation design and management practice." (Kast and Rosenzweig, 1979 :115)

"The contingency approach denies the universal assumption and pragmatically relates the environment to appropriate management concepts and techniques." (Luthans, 1976 :54)

The approach of the early management theorists apparently shared Lederman's faith. For example, Frederick Taylor (1911) Gulwick and Urwick (1937) Henri Fayol (1916) searched for and prescribed a group of universal principles based on 'one best way' to guide managerial action along a 'scientific path'. Thus scientific management brought together organisational structure, behaviour and technology and together these were task orientated to achieve the organisational goals, for example, to maximise profit. The essential ingredients for the organisations' activities were identified as the need to:

- Plan ahead;
- Write down and formalise policies;
- Define tasks;
- Specialise and delegate;
- Measure;
- Be decisive;
- Limit spans of control.

These principles depend ultimately on a unity of command in order to preserve hierarchy of authority based on rank. As organisations kept growing and complexity increased, the centralisation of authority and control of performance became more necessary.

It was claimed by proponents of scientific management that it worked well in tight and inflexible organisations. However, during the 1930's research began to

indicate how changing production techniques put inflexible organisations under strain. Labour became recognised as an important part of the organisation and that to focus the organisation's processes solely on efficiency and low cost production could bring about tension, cause industrial unrest and labour disputes. The Human Relations school (Mayo, 1933) was born out of the process of according the human being an important place in the organisation. The quality as well as the quantity of work was recognised as being important in making the organisation tick. Much criticism was directed towards the earlier Taylorist principles of management that were viewed as turning a workman as near as possible into a machine:

"This was accomplished by specifying a detailed program of behaviour... that would transform a general purpose mechanism, such as a person, into a more efficient special purpose mechanism." (March and Simon, 1958 :13)

Waelchli points out that in cybernetic terms Taylor behaved as if he believed that the workman was a source of entropy in the workplace. This view is supported by Kanter:

"In turn-of-the-century organisation theory and its 'scientific management' legacy, individuals constituted not assets but sources of error. The ideal organisation was designed to free itself from human error or human intervention, running automatically to turn out predictable products and predictable profits." (Kanter, 1983 :18)

Much of the descriptive and historical literature of the police reviewed earlier assumes a model of police organisation based on militaristic and bureaucratic lines. However, there is now a dominant logic of doing more with less. At a time when complexity is increasing the police service is removing layers of management (see Chapter 7). Indeed, even the most recent research of Plumridge and Males (1983) and Punch (1983) when commenting on organisational control suggest a model of police organisation that is essentially 'classical', but with important gaps. Both Plumridge and Males suggest an

absence of forward planning on the part of police organisations. Punch also suggests that much of police policy is not written down, more specifically that policy making tends to be secret and policy relating to practical policing is different to the professional imagery of managerial policing.

Barnard (1983) and Simon (1957) together with Cyert and March (1963) view the organisation as a collection of individuals concerned with solving problems and making decisions. In doing so, the individual acts as an economic man making calculations limited only by his own 'bounded rationality' due to an inability to possess all information. Organisation man consequently in Simon's terms: "Is goal seeking but satisficing due to his inability to optimise." (1957 :202) Simon perceives the individual's ability to take information from the environment is limited and that despite the information being available the individual has difficulty or is unable to process it. Of course, how can any individual cope with the enormous variety that exists. Each individual or organisation must optimise through a process of reduction, filtering and calculating so that complexity becomes manageable. This is Simon's view of 'bounded rationality'; it is the limits imposed by complexity and the need to achieve a position of what we shall see later is requisite variety.

To deal with and understand organisational complexity, various approaches have been developed. The 'hard systems' approach of applying mathematical techniques. The 'soft systems' approach for looking for problem situations within the people of the system and using mathematical and social techniques to rectify such situations. While Checkland (1981) looks for a root definition to the problem, Ackoff looks at the mess (1974). In effect the focus is to make order out of disorder.

Waelchli (1989) believes that the work of Ashby (1956) and Beer (1972) brought about a discipline of managerial cybernetics that may lead

organisational theorists back towards Lederman and the possibility of developing universal laws for organisations. The cybernetic approach to the analysis of the organisation provides a framework for the examination of information flows, critical inter-reactions, control and communications within organisations. Beer brings to bear a model of organisational structure and systems analogous to the human body with its capacity to absorb new information and change to meet circumstances. Its adaptability Beer suggests is a recursiveness to systems consisting of component parts:

Control - communication - co-ordination - intelligence - implementation

These components work together to make a new system viable. Beer states:

"If a viable system contains a viable system, then the organisational structure must be recursive." (Beer, 1972 :228)

The model Beer proposes provides an invaluable tool for understanding and planning organisational changes in the police service. For the police service, the scope and range of bodies, agencies and elements in their total environments are diverse and becoming increasingly complex. The research suggests that the need to identify and understand this concept is vital in order to ensure that the police organisation is structured to facilitate the transmission and reception of messages and actions. Due to the interaction between the organisation and environment it is essential that they are simplified and understood by all parties concerned. Examples of this technique will be demonstrated in chapter 7.

Clearly, within the environment there is order and form, each part is a part of the environmental equilibrium, in cybernetic terms there is adequate variety absorption. Yet, change is constantly taking place. For example, people are born and die, they move from one county to another, groups come together or divide, organisations have to adjust constantly.

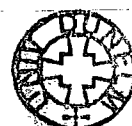

For the contingency theorists there is no one best way, task uncertainty requires analysis of information and an organisational capacity to cope. Thus, for Galbraith (1977), to survive an organisation must be flexible in organisational terms the organisation must process information in all directions; horizontally, diagonally as well as vertically.

This principle is important to the police organisation for the reasons given by Koolhaas (1982). The more complete the model used then the more variables or influences which can be handled. This then means that more organisational action can be routinized leaving greater organisational capacity to handle new situations. For the police to achieve this state, control and communications problems must be overcome. Beer states:

"Today, however control as a business is something much more than the interaction of its senior managers. It has to do with information of an extent and complexity beyond the capacities of those senior people to absorb and interpret it. Therefore, it has to do with the structure of information flows, with the method of information handling, with techniques of information reduction and so forth." (Beer, 1972 :80)

So it is that the comparison of the police organisation with the human body can be made. The body adjusts itself constantly taking account of the information signals being received; taking autonomic action in some cases, passing the signal from the receivers to the brain which controls other parts of the body. For example, if you touch a hot metal surface with your finger a message is automatically transmitted to the brain causing the finger to withdraw from danger and a self-healing process immediately commences.

Insofar as the organisation is concerned Beer proposes the application of the viable system model (VSM) to facilitate this comparison. A simplified version is shown at Figure 3.1. The VSM consists of five functional elements identified as systems 1, 2, 3 4, and 5 that are interconnected through a complex of information and control loops. The five functional elements are:

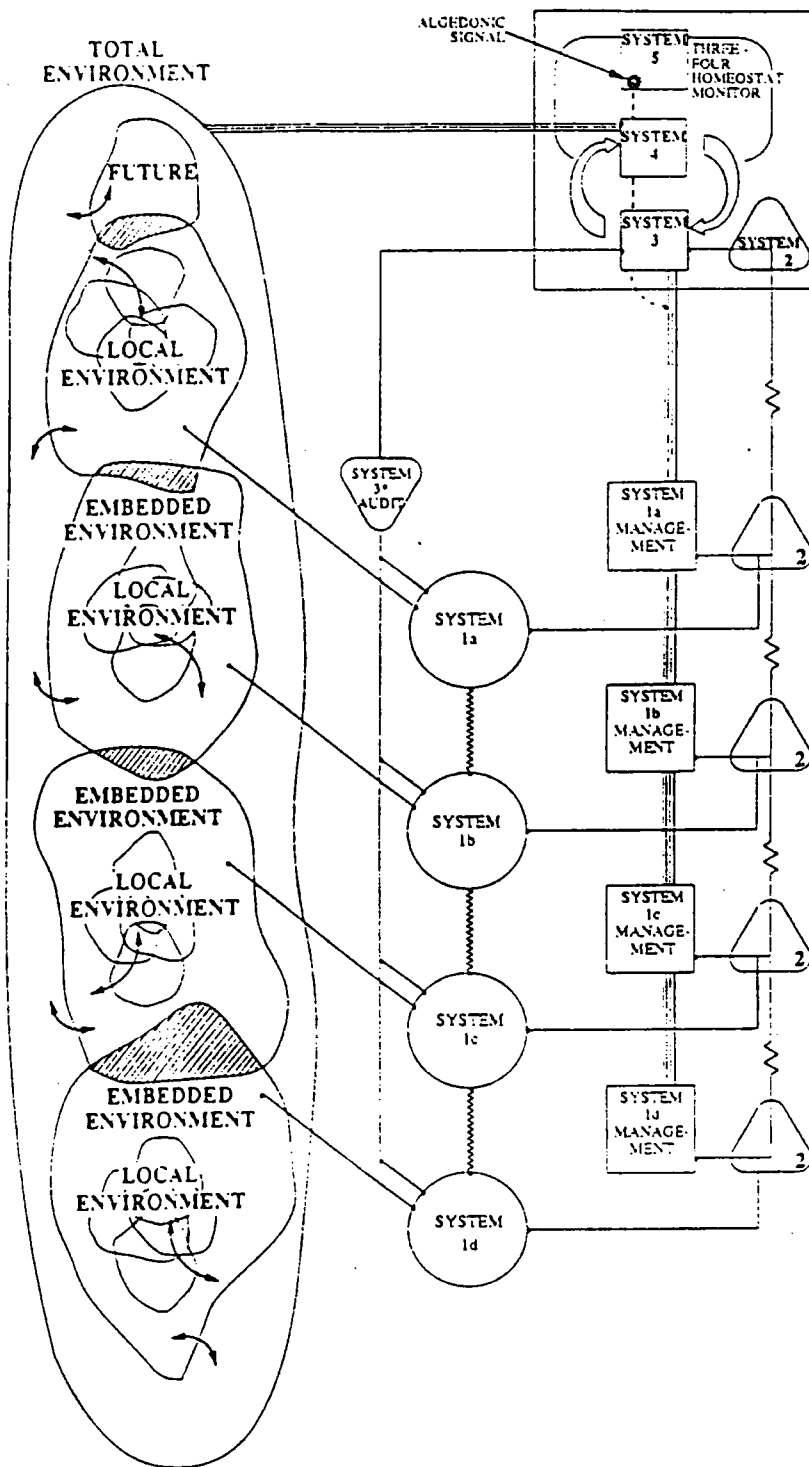

Figure 3.1 The Viable System Model developed by Beer (Flood and Jackson, 1991 :91)

System 1

- This is directly concerned with implementation or doing the task;
- Each element is autonomous in its own right;
- Therefore each element must exhibit all the features of the viable system itself, including all five functions. In the simplified diagram systems 3, 4 and 5 are shown in the individual system boxes, for example 'system 1a management';
- Each element of the system is connected to and interfaces with the environment and absorbs some of the overall environmental variety.

System 2

- Is the viable system's anti-oscillatory device for system 1 and is concerned with the regulation of oscillatory behaviour, for example production control;
- Co-ordinates the parts that make up System 1 in a harmonious manner.

System 3

- Is responsible for the internal and immediate functions of the enterprise, its here and now and day to day management;
- Is a control function that ultimately maintains internal stability;
- Interprets policy decisions of senior management;
- Distributes and allocates resources to parts of system 1 and obtains accountability for them;
- Monitors effective implementation of policy;
- Audit is a typical 3* function carried out at this level by someone who is highly knowledgeable of system 1.

System 4

- Is concerned with managing the outside and then with such functions as, research and development, market research and corporate planning;
- An intelligence gathering reporting function that captures all relevant information about a system's total environment;

- Provides a model of the organisation's environment;
- Distributes environmental information upwards or downwards;
- Brings together internal and external information in some form of operational planning;
- Rapidly transmits urgent information from systems 1, 2 and 3 to system 5. Alerting system 5 through the algedonic signal.

System 5

- Represents the outside and then management of the essential qualities of the whole system to any wider system of which it is part;
- Is responsible for policy;
- Responds to significant algedonic signals that emanate from systems 1, 2, 3 and 4;
- Arbitrates between systems 3 and 4 over antagonistic internal and external demands.

Beer uses a series of diagrammatic conventions in his models that need to be identified with a brief explanation as to their purpose:

- The square encloses all managerial activity needed to run the operation;
- The circle encloses the operations system;
- The amoeboid shape represents the total environment;
- The triangle is the regulatory centre and is the focus of homeostasis between management and operations;
- The $\wedge\wedge$ represents the attenuator a device that reduces variety;
- The $\rightarrow\leftarrow$ represents an amplifier that increases variety;
- The arrows refer to the necessary interactions between the entities, each stands for a multiplicity of channels whereby the entities effect each other.

To assist in the understanding of the VSM we must first look at some of the basic principles and relationships between the systems. Figure 3.2 depicts the relationship between the environment, operations and management. What we are looking at is the part of any working organisation that is often invisible. The doing, or the manipulation of people, materials, machinery, and money to produce a product or service. Beer believes that this is not a simple process but a highly complex one:

"Yet there is a more fundamental manipulation that occurs: it applies to the biological cell as a viable system, as well as to a giant corporation or to a government. What is going on is the **MANAGEMENT OF COMPLEXITY**. In order to discuss this, a special term is enrolled. It offers a *measure* of the complexity with which management has to deal. The term is **VARIETY**. Variety is a measure of complexity, because it counts the number of possible states of a system." (Beer, 1985 :21)

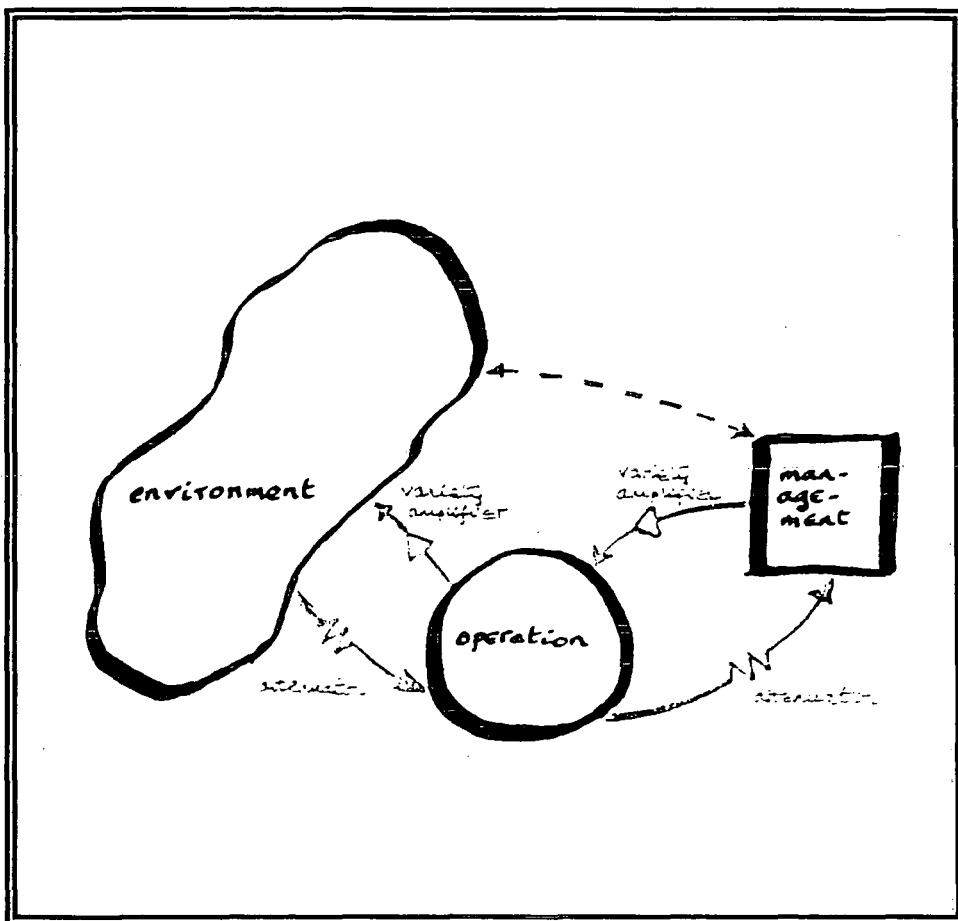

Figure 3.2 Beer's diagram illustrating the law of requisite variety (Beer 1985 :27)

If we examine this proposition it can be seen that the management box has lower variety than the circle which represents the operations. The basis for this assumption is that management can never know what every worker is doing or everything that happens in the work place. In a similar way the operational system has lower variety than the environment. To explain this proposition in policing terms, the environment of a town will typically contain thousands of individuals, regulated by a wide diversity of criminal, social laws and procedures. Each individual has the capacity to generate variety as either a criminal or a victim. The variety capable of being generated is multiplicative. The ratio of police to population is typically 1 to 500 (Ibid :33), hence the police must seek to manage the variety generated in the environment by techniques such as gathering information through informants, imposing curfews on known offenders or the use of technical systems designed to identify individuals, for example, fingerprinting. The ultimate aim is to reduce the criminal population dealt with by imprisonment this limits the individual's ability to create variety. Beer identifies that:

"So the basic axiom will assuredly hold, that the variety of the environment greatly exceeds that of the operation that serves or exploits it, which will in turn greatly exceed the variety of the management that regulates it." (Ibid :22)

It is therefore necessary to reduce the information received to manageable proportions, to attenuate. This is achieved by the identification of patterns or crime trends. Once a trend has been identified a police resource can be assigned, for example, the use of covert observations or a high profile patrol. The critical issue is that information must be managed and that there must be a capacity within the system to achieve this, hence the value of police resources are maximised and officers do not patrol on a random basis.

The balance between the information transmitted through the system must be maintained to prevent either overload or instability. In cybernetics this is a

question of homeostasis; where the whole system 'strikes the balance', the internal environment is stable despite an unpredictable external environment.

If the organisation is to maintain homeostasis, an internal equilibrium, it has to maintain a capacity capable of coping with the unpredictable activities generated in its external environment. In other words policing has to cope with variety. The law of requisite variety (only variety can absorb variety). We are in fact dealing with continuous loops of variety involvement that will either require attenuation or amplification as we are continually seeking balance through requisite variety. Beer states that:

"The problem of management itself, which is that of regulating an immense proliferation of variety, is less horrific once the underlying homeostatic regulators are perceived, properly designed, and allowed to absorb the variety of others' entities. This is the essence of viability."
(Ibid :29)

Beer identifies that managerial, operational and environmental varieties diffusing through an institutional system tend to equate and it is essential that they do so with the minimum damage to people and cost. What he is saying is that viable system's of whatever size and structure are self-organising. If they were not, then the management would be totally overwhelmed by the variety generated in the lower level systems. But as we have seen variety absorbs variety and systems run to homeostasis, because all the subsystems are interconnected, and complexities cancel each other out. Variety is soaked up at the lower levels by procedures, working practices and supervisory officers. All five systems are mutually interdependent, and all subsystems are vital to viability.

The regulatory centre (system 2) is designed to assist the interface and processes involved in management of system 1, to achieve the objectives of the organisation. This is shown diagrammatically in Figure 3.3.

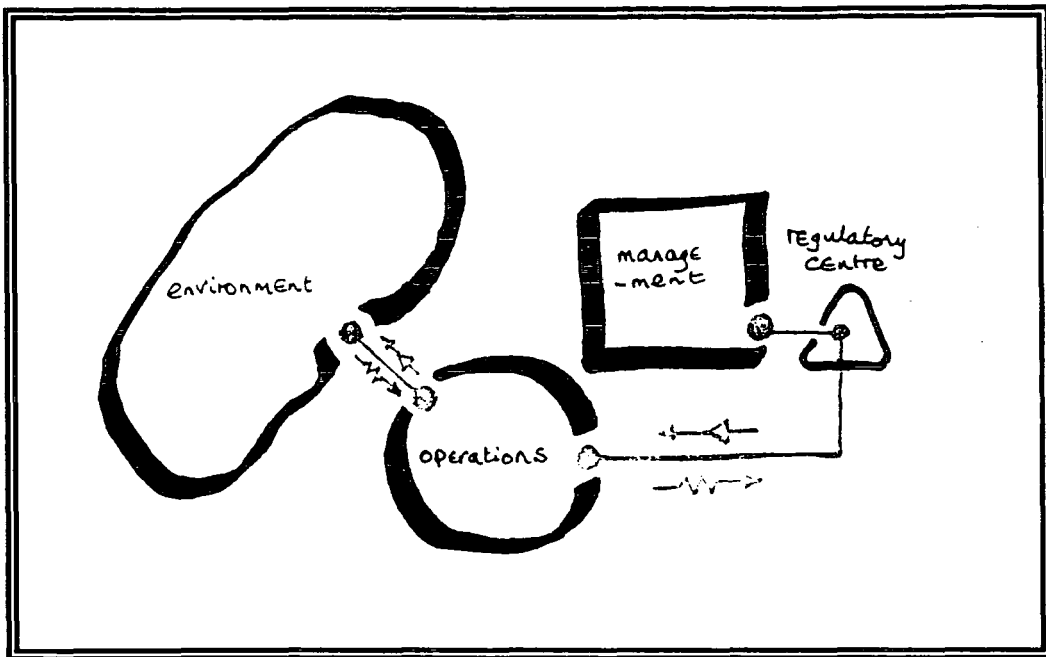

Figure 3.3 Beer's diagram demonstrating the role of the regulatory centre
(Beer 1985 :43)

The principle function of system 2 is co-ordination and to ensure that in the short term no part of the organisation fails. It aims to overcome difficulties in implementation through co-operation between the individual parts for the benefit of the whole. Management is given the job of conducting operations in accordance with a resource bargain struck with senior management. For example, in police organisations' officers and equipment is provided to Districts to reduce crime, arrest offenders, maintain the peace and ensure safety on the roads. The transmission of plans and programmes designed to achieve the organisations' purpose to the operational circle should be regarded as an act of regulation. Beer describes this function as:

"This regulation, as the diagram shows, amplifies managerial variety: the basic details of the resource bargain must be elaborated. This regulation also attenuates operational variety: operational potentiality must be harnessed to agreed objectives. Thus the regulatory centre (the activities of which are marked diagrammatically, by a triangle) is the focus of homeostasis between management and operations." (Ibid :41)

Beer identifies the need to regulate operations to the management's chosen objectives. The regulatory function is to monitor and report significant deviance

from the objectives and other matters that have influenced the smooth running of the operations or other environmental disturbances. Not everything that happens in a given time period should be passed to senior management. Indeed if you consider that senior management may well be controlling more than one operational function their ability to absorb and make sense of the information would be quickly swamped. Hence, the need to attenuate information that can be reported as trends or deviance from formalised targets. In the police service systems have been introduced to reduce or limit response to incidents for example crime screening and a graded response to reported incidents. Clearly each function has a capacity to handle and make sense of variety and each function must be designed with this capacity in mind. For example, a supervisor may only be able to manage the variety generated by five subordinates, in a similar way a middle manager may only be capable of controlling five supervisors. Beer states that it is essential condition in an organisation that:

"The four directional channels carrying information between the management unit, the operation, and the environment must have a higher capacity to transmit a given amount of information relevant to variety selection in a given time than the originating subsystem has to generate in that time." (Ibid :45)

If we next look at system 3 whose function is control and whose aim is to achieve internal stability. The functions typically involve; budgetary control; personnel; management information; operational planning and quality systems. The aim of this function is to promote the exchange of relevant information that can be used to assess how well things are doing. Information is received from system 2, particularly when it is experiencing difficulties in managing processes. It also receives inputs from audit, intelligence and policy. Control has to interpret policy decisions and effect their implementation using all available information. Control allocates resources to implementation. When difficulty in achieving control occurs and the implementation is not going

according to plan, and required targets are not being met, information from intelligence is sought.

Intelligence is represented by system 4 and typically includes functions such as market research; research and development; corporate planning and is involved in identifying opportunities and constraints in the external environment. System 4 is not only engaged in managing the outside - and - then, but represents a learning function in the organisation and provides policy with information that may be of significant long term importance. The problem that occurs in some organisations is the conflict between system 3 and system 4 and the dangers that may arise from over resourcing elements within system 4 that then become self-satisfying or suboptimising. Beer recognises this dilemma:

"Investment of (yes) money, (but also of) time, care, talent, attention, reward must be properly balanced, homeostatically. Too much of this investment in Four, and the inside - and - now of the enterprise may collapse beneath your feet. Too much of this investment, in Three, and you may be making the world's best buggy-whips, in which (notoriously) there is no future. The outside- and - then will go ahead without you."
(Ibid :118)

Policy is represented in system 5, which is responsible for defining and setting the organisation's identity and of creating a corporate ethos. Within policy there is generally 'the boss' who can retain the right to make decisions, or have the final say. Primarily system 5 maintains ultimate authority of action and Beer describes the boss as: "A variety sponge of gigantic capacity." (Ibid :125) One function of system 5 is to balance the activity of the system 3 - 4 homeostat and to determine: what are the most important factors affecting the organisation; what are the most important to expansion; what opportunities or threats can be identified in the external environment; and to focus on internal safety and survival.

Beer's Viable System Model provides a way of presenting organisations as 'organic', of being capable of self-regulation and self-adaptation (of being contingent in the true sense). Management becomes a process of continuous adjustment, utilising and interpreting quantitative and qualitative information. Beer expresses the belief that one of the key issues of an organisations' viability is its ability to create a structure that will allow the smooth flow of information through its structure.

Of great importance to Beer is the principle of variety reduction. Taking Ashby's law of Requisite Variety, that only variety absorbs variety, Beer points out that any system existing in a state of equilibrium requires regulators and amplifiers of variety in order to maintain stability. Beer also proposes that:

"If the structure is dysfunctional, then no amount of financial wizardry, of insightful man-management, of business technique, will save the day. Increasingly, it seems to me, the organisational structures we have inherited do not work." (Beer, 1985 :x)

Yet, whilst the structure of police organisation may be dysfunctional it continues to function, it is viable, how is this. The answer lies in the very issue of viability itself. An organisation consists of many parts associating themselves, to a greater or lesser extent with the purpose or multiple purposes of the organisation. The collection of goal seeking activists achieve a level of performance that is dictated by a number of factors. Not least amongst the factors is the clarity with which the organisation has identified its goals and is structured and services its purpose. However, to achieve a level of performance that maintains the organisation's viability requires managerial regulation. One of the greatest challenges facing the police organisation is to match its present management capability (which at the commencement of the research) was used to dealing with relatively simple performance measures. To an environment that requires management to meet the demands of externally imposed complex performance measures and values, which will increase organisational

complexity. The complexity will affect not only management but also impact on systems 1, 2, 3, 4 and 5. This issue will be discussed in greater depth in Chapter 7.

3.4.1 The Use of Managerial Cybernetics in Modern Management Techniques

Beer has carried out significant work in the implementation of a full scale Viable Systems Model that became a decentralised real-time regulatory system for the whole social economy of Chile and which was installed for President Allende in 1971-73. The story of this project is reproduced by Beer in *Brain of the Firm* (1972) and was clearly a colossal enterprise. However, it is not the intention to consider the use of such a wide scale system in the course of this research, but to utilise elements of cybernetic techniques as tools to assist the researcher in his analysis of the Cleveland Constabulary. Flood and Jackson (1991) identify that Beer's Viable System Model provides a platform for the thorough working out of ideas from the science of organisation, or cybernetics and that it employs systems of modelling which can involve complex networks of interrelated mathematical formulae. However, they consider that the modelling systems are: "Phenomenally complicated and inaccessible articulations of certain aspects of reality." (Ibid :88) and question their use to the everyday manager, planner, or decision maker. They suggest that this type of modelling is best utilised in machine or organic systems and that they do not cope equally as well with less predictable systems involving human beings.

Flood and Jackson identify that the cybernetic conceptions can be utilised in dealing with social systems and that the VSM can be successfully applied for diagnosing organisational problems and introduce the term 'Viable System Diagnosis' (VSD). They value VSD when dealing with complex problematic systems that comprise purposeful organised parts and that are open to a changing environment and argue that:

"The utility of the cybernetic approach comes to the fore when, for example, issues in business or a firm are characterised by particular defects of pathologies, possibly localised, that are resistant to or ignored by normal treatment. In such circumstances, the viable system view assumes that natural scientific laws are being violated - hence the need for diagnosis and the use of cybernetic findings in reorganisation." (Flood and Jackson, 1991 :88)

The philosophy that drives this belief in the use of VSD to deal with changes in the twentieth century organisation is that new ways are needed to deal with the difficulties associated with change. Flood and Jackson list the main points:

- **Organisational and social 'problems' arise because of new degrees of complexity (organisational, technological, informational and so on) and are characterised by interdependency;**
- **Scientifically based management taking advantage of technological advances (for example increased information processing capability) is vital because more traditional approaches are quite simply too trivial, and in isolation are not well worked out. Therefore, a scientific model that is based on cybernetic principles and which encompasses many ideas from management science is fundamental in our efforts to deal with modern complexities;**
- **Since control is the main concern, then the best approach is to replicate a well tried and tested 'control system'. This being evident in the neurocybernetic processes of the human brain and nervous system as it has evolved over millennia (the same control can, however, be derived from cybernetic first principles and is applicable to all systems);**
- **Organisations ideally are ordered so as to achieve efficient and effective realisation of set goals. Although the goals themselves have to be continually reconsidered in response to a rapidly changing environment through self-questioning, learning by assessing future scenarios. (Ibid :89)**

However, they primarily utilise the VSM/VSD to deal with qualitative aspects in areas of social context and stress how their use can portray a powerful image of a well-organised business. The value of the VSM is that it focuses on organisation rather than structure.

Flood and Romm (1996) stress the importance of identifying and defining organisational characteristics and in particular focus on the issue of 'power' within the organisation. They indicate that this issue will significantly impact on the mode of methodology chosen to carry out research within the organisation. They introduce a new concept to management theory and organisational intervention that they term 'Triple Loop Learning'. The theory is based on the interaction of three loops of learning and is about increasing the fullness and deepness of learning about the diversity of issues and dilemmas faced in an organisation and ways of managing them:

"It wants to establish tolerance between all three centres of learning and preserve the diversity therein. It does this by bringing the three centres of learning from the three loops in one overall awareness. Are we doing things right, and are we doing the right things, and is rightness buttressed by mightiness and/ or mightiness buttressed by rightness?" (Flood and Romm, 1996, :xii)

Flood and Romm indicate that the first two loops consider the third one problematic because it is regarded as ideologically based and not scientific. They identify that the critical question is whether mightiness is acting as too much of a support for definitions of rightness or conversely any presumed right way is becoming too forceful. The process of triple loop learning is about increasing the fullness and deepness of learning about the diversity of issues and dilemmas facing an organisation and ways of managing them. It is suggested that by bringing together the three centres of learning through the three loops into one overall awareness, then the researchers whole consciousness becomes more than the sum of its parts, encouraging awareness of the interlinked dilemmas involved when addressing the three key issues. The concept of triple loop learning is represented in figure 3.4. Each loop represents one of the three issues of learning. The loops interlink through C, that represents the interventionists' consciousness or awareness of all three centres of learning which are encircled by a loop. The dotted areas shown gives C access to each centre of learning.

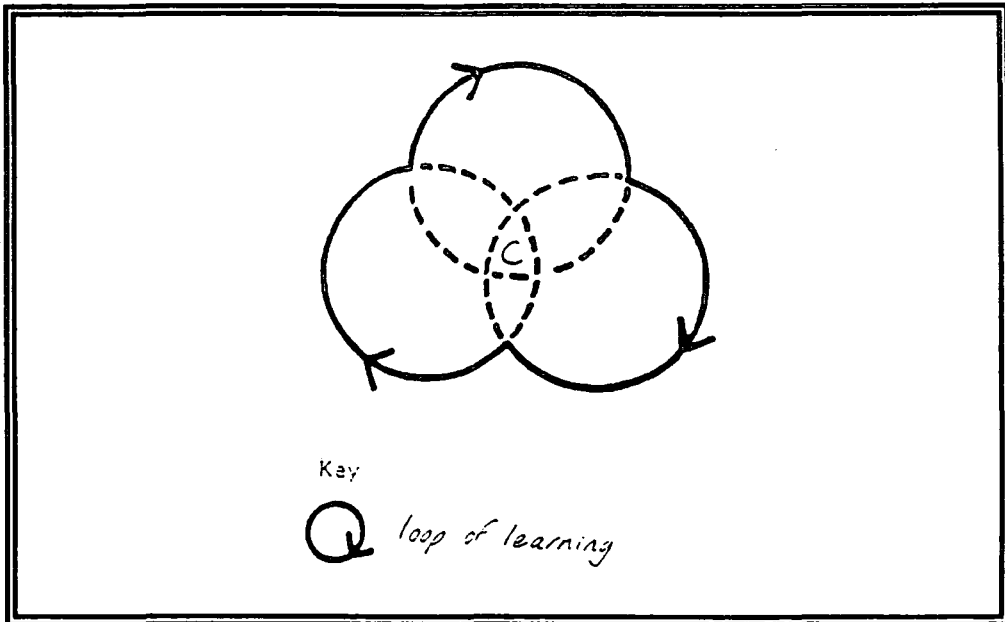

Figure 3.4 Triple Loop Learning (Flood and Romm 1996 :xiii)

They point to consciousness of the provisional character of answers to the questions raised in each centre of learning. Flood and Romm highlight that:

"Triple loop learning when invoking these questions does not imply a search for harmonious consensuality in society but it does recognise that we are implicated in each other's lives." (Ibid :12)

They indicate that might-right management deals with disempowering social practices that can lead to:

"A lack of relevance of designs to (many of or some of) those who have to live with experienced consequences of them. Or a lack of influence in debating processes leaving decisions ill considered for (many of or some of) those who have to live with the consequences of them." (Ibid :62)

Flood and Romm stress that the failure to consider power as entrenched in social relationships may mean, inter alia that people:

- Fail to activate areas of conflict over issues that people seem to have consented to;

- Fail to allow continued moral deliberation over issues which appear resolved;
- Fail to alert participants to the way in which debates may become rigged by the arguments are (mis)used;
- Fail to consider ways in which conversation may become stacked by the excessive reliance on the force of valid argument as a means of generating fair practice;
- Fail to consider and practice counter manoeuvres to address forcefulness of administrative apparatuses which discipline and routinise patterns of relationships. (Ibid :71)

Flood and Romm in their study of liberating systems thinking suggest that those involved in developing theory and knowledge have to be aware of the way in which judgements are made in this development particularly in those organisations that have an entrenched might-right culture, stating that:

"Knowledge judgements often represent the outcome of the operation of political forces in which forms of knowledge have been culturally suppressed. What becomes agreed as a best way of thinking may easily echo governing forms of thinking that have become dominant in society through the *force of tactic rather than the force of reason*. This means that appeals to consensus, even when hoping to ground this in force of the better judgement, may not constitute a defence of a judgement made." (Ibid :48)

There are clearly dangers involved in exploring organisational change, in particular those where there is a dominant culture influenced by powerful external agencies. Flood and Romm urge a cautionary note:

"Arguments used to vindicate judgements are never foolproof. Judgements are easily ruled by dominant modes of reasoning in society and this, at least, has to be kept in mind by those willing to be guided by a sensitivity to power that is (often invisibly) built into knowledge and action-based decisions." (Ibid :56)

To deal with this type of situation Flood and Romm (1996) recommend practising what they term an 'oblique' intervention:

"We explore an option for might-right management that amounts to redirection of models and methodologies in terms of purposes not normally associated with them and not provided for in the theoretical underpinning proposed by their proponents. We call this kind of option the 'oblique' use of purposes." (Ibid :207)

One of the options proposed in dealing with this type of situation is to work with the organisation and make the best of it, accepting that some of the key issues may have to be temporarily sidelined, even though one understands that these issues are of primary concern. This scenario can involve risks and one may pose the question 'Why fight?' Flood and Romm answer:

"That is not to say risk taking can ever be avoided. Risk taking has to proceed in the light of possible bad news and also in the light of other possibilities (themselves admittedly not risk free)." (Ibid :211)

Flood and Romm illustrate the oblique use of cybernetics where the model was used as part of a process to develop new visions rather than primarily new structures: "Or rather the process was about developing new visions with structure being used to support this process." (Ibid :214) They identify that:

"Cybernetics on its own is primarily geared to treating intervention as grounded in the fulfilment of needed functions. It offers a design which makes provision for these functions to be met. It is not adjusted in itself to the purpose of activating a new ethos that tackles knowledge-power plays. What is preferable, then, if knowledge-power gaming is considered particularly problematic, is to proceed in terms of the rationale we are developing in this chapter. What can be achieved through this rationale beyond the immediate output sought is encouragement for people through an oblique vision to become less defensive about their positions. There may be the beginnings of a shift in consciousness across the organisation." (Ibid :215)

They identify that cybernetics is a form of systemic modernism, which supposes that modern societal and organisational systems are a product of science and technology. Society is organised around scientific and technical knowledge. The theory advocates social control by large-scale technical systems. This cybernetic thinking conceives complexity in terms of a system of

causal laws, of many interacting variables, which are subject to co-ordination and control in order to achieve set goals. Once goals have been set it is possible to determine optimal actions in social contexts. Control and performance require individuals to adapt their actions for the benefit that the system offers, so that their actions become compatible with the system's goals. Rational action requires individual to submit to the laws of organisational life, which working scientists are geared to establish. A working example of the oblique use of the VSM is demonstrated by Flood (1993) in his investigation into quality management in the service sector conducted into and in conjunction with the North Yorkshire Police. Flood identified that the Force faced a multitude of technical, cultural and political difficulties with a leadership style that he described as being a hierarchical paramilitary bureaucracy. A viable system model was developed to structure this problem area and was designed to deal with the rigidity of bureaucracy, the paramilitary culture, reward by promotion and the integration of technical and cultural dimensions. Flood indicated that:

"The traditional bureaucratic structure is replaced by a viable system structure that will help to reshape the organisation's design over time. The paramilitary culture is also replaced in this way." (Flood, 1993, :244)

One might feel that this is far too simplistic a solution to tackle major problems with. That its use is to focus the minds of those in power so that they at least consider or recognise that they do have significant problems in their midst. The process of recognition may stimulate some form of remedial action. Flood and Jackson (1991) demonstrated a similar use of the VSD in action in their study of tourism in Zania. They observed that management styles in Zania tended to be autocratic. Their challenge was to seek to introduce a more liberated democratic style for the lower staff levels. The VSD was utilised to model and diagnose the existing system. The study concluded that the overall system was a non-viable organisation close to total collapse/failure and that there was a "Crying need for some form of organisation now, or bust." (Ibid :109) The

viable system re(organisation) proved to be acceptable to the staff and offered advantages in that it helped remove corruption, increased equability and democracy. Flood and Jackson indicated that this use of the VSD provided:

"Possibilities for learning and future viability were also offered in a competitive business, and uncertain and unstable political environments." (Flood and Jackson, 1991 :110)

Flood and Jackson (1991) highlight that one of the major problems in modern management is that of handling the increasing diversity of issues that confronts humankind in contemporary organisational and societal affairs. Initially this problem had been addressed by people managing the increasing diversity of issues they confronted by increasing the diversity of types of model, methodologies and theories available to do the job. However, this created a brand new range of issues to be managed, how to choose between the models, methodologies and theories. Flood and Jackson (1991) recognise and argue that that there could never be a super methodology that can address all types of issue.

"In the modern world we are faced with innumerable and multifaceted difficulties and issues which cannot be captured in the minds of a few experts and solved with the aid of some super-method. We are faced with 'messes', sets of interacting problems, which range from the technical and organisational to the social and political, and embraces concerns about the environment, the framework of society, the role of corporations and the motivation of individuals." (Flood and Jackson, 1991 :xi)

The best strategy therefore, is skilfully and sensitively to select whatever methodologies seem most promising and appropriate for each set of issues faced. Elstob reviews and supports this position:

"Once the true significance of this strategy is understood, it becomes clear that problem solving practitioners who adopt it must indeed see themselves as creative (critical) problem solvers, for the fundamental point is that on each occasion the practitioner will need iteratively to

evolve creative (critical) solution suited to the particularities of the situation." (Elstob, 1992 :62)

Flood and Romm conclude that those involved in systems thinking should be encouraged to get a firm hold on three critical research points:

- To accept the diversity of issues confronting decision makers;
- To continue developing a rich variety of models and methodologies;
- To address continually the question, Which model(s) and/or methodology(ies) should be used, when and why? (Flood and Romm, 1996, :44)

Quite clearly research will not satisfy all parties involved in an organisation. It is therefore for the researcher to carry it out in an impartial and unbiased manner and to continually challenge, sensitively and diplomatically existing systems striving for continuous improvement.

3.5 SUMMARY OF THE MAIN PROVISIONS OF CHAPTER 3

3.5.1 Section A

The review of the public sector related literature identified the origins of 'managerialism' and the transfer of private sector practices and techniques into public sector organisations since 1979. It has been identified that there is an implicit assumption that: 'private sector' = good management practices; 'public sector' = bad management practices. The dominant logic prevailing is that market forces will sharpen up public sector management, improve productivity, customer satisfaction and reduce costs.

The literature review highlighted that this hypothesis was not based on solid intellectual or practical foundations. That little effort had been dedicated to identifying the costs involved in the actual 'change' process or analysis of the final outcome of change, to establish if the projected cost or efficiency savings

had been achieved. Pollitt believes that the changes primarily revolve around the introduction of 'Neo-Taylorism' and relies on the basic principles outlined in Chapter 2:

- Reduce workers activity to measurable elements;
- Monitor and control through measurement;
- Negotiate with the smallest group possible, preferably with the individual; this overcomes the workers natural state of work avoidance;
- The simplification of tasks allows for the de-skilling of labour; labour becomes cheaper and easily replaceable;
- Reward by results, the individual not the group;
- Management should be made accountable for the productivity of groups of workers.

Many academic writers believe that there has not been enough debate prior to the introduction of these changes and that the autocratic nature of the power base within the public sector will not tolerate contrary views. The totalities of such systems have become associated with strong centralised political control of the public services.

The work of the Social Market Research Foundation was reviewed, particularly that of Howard Davies. The review demonstrated his commitment to the standardisation of virtually all public sector organisations based on his ten point framework. The researcher suggests that the basis of his work is firmly founded in Taylorism and bureaucratic control.

3.5.2 Section B

A review was carried out of the literature related to the process of transferring public sector ideologies into the police force and the relationship between the principle agencies concerned. The agencies appeared to be closely inter-related

forming self reinforcing and fulfilling processes. Current proposals incorporated in the new Police Act will radically change the way in which the police operate and there are suggestions that it will move more towards quantifiable outputs associated with enforcement. The proposals of the Sheehy report were found to contain many factors directly associated with Taylorism.

The section explored the likely impact that these changes will have on the police. It was identified that the police are being forced into a position where their activities are being increasingly controlled from the centre and monitored by means of externally imposed performance criteria. It is suggested that a crucial element had been omitted from the change process, the actual cost of administering these measures. In this respect there appears to be a significant gap in the literature, as little post implementation assessment and cost benefit analysis have either been encouraged or permitted to take place.

3.5.3 Section C

Beer's VSM was examined and it is suggested that it can be utilised within the police service. The use of the VSM can provide management with a strategic opportunity to identify and understand the variety and complexity of environmental demand and consider how to amplify the organisation's resources to meet this demand. The research will continue to build a picture of the police organisation by looking at the role of police management and the contribution that the VSM can have in understanding the complexity of the research area. We will then be in a position to draw together the implications for managers. Beer identifies the need for formalised procedures to assist all processes so that deviations from the norm can be monitored and amplified. The primary task for police management becomes the effective design of the amplifiers or attenuators as these functions are critical to the organisations' capacity to manage variety and complexity.

The work of Flood, Romm and Jackson in the use of the VSM/VSD has been reviewed, in particular the use of the VSM in an 'oblique' form when dealing with 'might-right' management situations. Their research highlights the dangers of working in organisations where powerful management displays might-right characteristics and how this can effect the type of methodology used and the need to display sensitivity in presenting solutions that may be unacceptable to the power base. The authors suggest that in this type of situation reliance could not be placed on a single type of model to carry out an investigation, but that the researcher should utilise whatever technique would be the most acceptable.

3.5.4 Conclusion of the Theoretical Work and Introduction to The Empirical Work

The work of Flood, Romm and Jackson highlight the need to be sensitive when working within 'might-right' management situations. The researcher has been acutely aware of the political significance of the research that he has carried out at a period of rapid change within the public sector. This influenced the choice of methodology used in this research. The researcher has therefore utilised techniques and models that appear to be the most appropriate and beneficial to remain within the research constraints. It is suggested that the differing techniques do combine to provide a comprehensive review of how the Cleveland Constabulary has reached its present position and the key factors that will influence future development.

Porter (1991) identified the value of determining the 'longitudinal position' of an organisation. This involves identifying the purpose of the organisation and what key environmental factors have influential in its development. The literature review identified that the police structure is based on military lines, that the management structure involves classical organisational principles and is bureaucratic in nature. However, it has been demonstrated that bureaucracy is not viewed in a pejorative sense, but as a necessary and essential practice to

ensure compliance with tightly regulated rules and procedures designed to produce fairness and consistency of output. The activities of policing have changed little since the formation of the first police force and principle objectives remain basically the same, maintaining law and order and tackling crime. However, there is still a need to maintain a para-military role in society and for the police retain the legitimate right to use force. It is therefore essential to have a disciplined and well trained police force that is highly accountable for the actions that it takes.

The literature review traced the origins of change within the public sector and highlighted the perspective that the police appeared to be averse to change holding an inherent belief that they are a special type of organisation and should be treated differently. This stance became subject to a sustained attack commencing with the Audit Commission's publication of its first special study of police functions published in 1988. This was followed up by intense pressure exerted by an amalgamation of bodies that resulted in the publication of a series of reports and White papers which have significantly impacted on the police working practices, in particular, the role of management and conditions of employment. The police have since adopted the characteristics outlined in Davies social market framework and the majority of the recommendations of the Sheehy report.

From the literature surrounding organisational theory it became apparent that there is no one universal model or system that can be utilised for designing or investigating all types of organisation. However, the literature review demonstrated that the changes in public sector organisations in the last decade are based on a standard model. The model is accountancy based, relying on the concepts of Taylorism, which some authors have termed 'New Taylorism'. The dominant logic is that the Taylorist principles can be applied to any type of organisation. However, as we have seen some academics identify that for the

concept to be successfully applied it must deal with simplistic situations that involve mundane and repetitious tasks. The concepts of Taylorism are synonymous with hierarchical, mechanistic and authoritative styles of management associated with cost cutting designed to get the maximum from the workforce with the minimum reward.

The introduction of this model has been accompanied by a race to introduce new control mechanisms. Taylor introduced control through the use of 'bosses' however the police have in line with the Sheehy report drastically reduced levels of supervision. Consequently the police are dependent on the introduction of new technology, particularly in the areas of management information systems which can be harnessed to measure variables and increase managerial control. The belief is that if complex systems of measurement can be introduced, larger areas of the workforce can be 'controlled' by an increasingly smaller number of 'managerial' staff. The proposition is that increased mechanistic control can lead to a less skilled and lower cost workforce.

Reiner (1991) identified that the Home Office and Her Majesty's Inspectorate exerts influence to ensure that senior officers follow narrow centralised views and that is a mandatory requirement to be modern and progressive. Hence, once a philosophy is advanced, for example 'new technology is good' then there is an implicit duty to be compliant with this proposition. It has been argued that to be successful and achieve promotion, you must maintain a position as the cutting edge of 'change'. Conversely it is disadvantageous to evaluate the effects or consequences associated with the introduction of change. This type of evaluation may prove to undermine the perceived benefits of change and can be perceived as negative or career limiting. From the characteristics identified within the literature review the police service can be regarded as autocratic with a centralised power structure dominated by the Home Office and Her Majesty's

Inspectorate. The police service clearly displays the characteristics of a might-right orientated organisation.

3.5.5 The Safest Methodology to Follow

The researcher initially intended to utilise Beer's VSM to analyse the implications of introducing new technology into the Cleveland Constabulary however, this approach proved highly problematical. What we have demonstrated in the literature is the dangers of holding contrary views in a bureaucratic organisation. In particular the work of Flood and Romm demonstrated that a new type of methodology is required to deal with this type of organisation. They have developed a system they term 'Triple Loop Learning' to focus the researcher on useful techniques when dealing with these difficult areas.

Clearly the issue of evaluation of new technology is a highly political and dangerous area to be involved in. At an early stage of the research it was identified that any investigation into new systems must be carried out with the consent of the organisation and must not be regarded as purely the views of the researcher. The researcher believed that the best approach was to involve the whole workforce, who after all are or will be required to use these systems and have to live and work with changes in procedures. They have hands on experience and a collective wealth of experiential knowledge waiting to be explored.

The researcher did however, make use of the VSM in Chapter 7, primarily as a diagnostic tool that was used to explore the inter-relationships between the police and the internal/external environments.

The literature review served to identify the key areas and concepts for change within the police service. It also highlighted areas of change that had already occurred. The issues initially formed the basis for the interviews with the senior officers, then later the forcewide questionnaire.

The initial stage of this process involved a series of semi-structured interviews with a wide selection of senior officers, during which the key issues identified through the literature review were explored in depth. The topics under investigation were associated with the police changing from a traditional public sector organisation to one that adopted the characteristics of the private sector. The issues of change associated with the introduction of new technology, legislation, personnel issues and new procedures were explored in an effort to quantify the effect of change in terms of: efficiency; resources; operational efficiency; and bureaucracy. This process was designed to fill the gap identified during the literature review relating to the cost benefit analysis of change in a public sector organisation. The research demonstrated how that we could learn from previous experiences by exploring and quantifying the effect of 'changes' that have already been implemented. Hence, the research has explored a range of issues for the period from the 1970's to the present day. If this process is successful and we find that we can learn from the past and that quantifiable information can be gleaned from raw data, it is argued that this knowledge should be utilised in designing systems for the future.

The key themes identified during this process were formulated into a questionnaire that was distributed to the whole workforce. The questionnaire was deliberately designed to include a wide range of topics as well as those specifically under investigation and relevant to the main field of research. At the time of the survey the workforce were being literally bombarded by questionnaires. To make the questionnaire more attractive to respondents a number of high profile and contentious issues were included. Although these

may be regarded as questions where the respondents had little option but to agree they were successful in stimulating interest in the questionnaire and gave respondents an opportunity to give their views in the space provided which invited comments about any topic. It is noteworthy that of the 130 respondents who used this facility, 115 responses related to the two questions concerning the Sheehy enquiry.

3.5.4 Introduction to Chapter 4

The next Chapter will introduce the researcher, the research programme and highlight the difficulties of carrying out research in ones own organisation. The Chapter provides details of the interviews held with the four chief officers within the Force and how they perceive the changes advocated by external bodies affect their ability to police Cleveland. The interviews with senior officers will explore the key issues of change identified during the literature review. The findings of the interviews will form the basis for the forcewide questionnaire.

CHAPTER 4 THE EMPIRICAL WORK

4.1 INTRODUCTION THE RESEARCH FRAMEWORK

The purpose of this Chapter is to outline the research programme. The research involves investigating the relationships between the main elements that are regarded by the key informants as being the essential constituents of corporate strategy: human resources; financial resources; technological systems; and legal/political systems. The research seeks to analyse the simultaneous cause and effect that change has on the various elements by considering if change has increased or decreased in four areas:

- Overall efficiency;
- Resources;
- Operational efficiency;
- Bureaucracy.

The Chapter also describes the researcher and outlines the sensitive nature of the research that is being carried out into his own organisation, the research constraints and the research programme. The research programme involved four stages: interviews with the four members of ACPO; semi-structured interviews with twenty-seven police officers occupying senior positions within the Force; a forcewide survey of police officers of all ranks; and a research to determine the present position of the organisation. The results of each of these stages will be examined in detail in Chapters 5, 6 and 7.

4.2 THE RESEARCHER

In research into organisation phenomena, the status of the researcher and his position within the organisation needs to be recognised for it influences both the researcher's perspectives or biases and the organisation's response to him.

The researcher, a police officer of twenty years service holds the rank of inspector. He recognised the dangers of becoming enmeshed in the bias that may occur when translating and evaluating theoretical and conceptual ideas in terms of their cause and effect on the imprecise science of operational policing. There is also the danger that the researcher, removed from the centre of the organisation, became remote from the corporate or visionary issues adopted by the senior corporate team, the reasons for following the paths chosen and the alternatives rejected.

The recognition of this dichotomy allowed the researcher to include compensatory balances in the project, particularly in the formative stages. This process involved the inclusion of a range of police officers from different levels and positions within the organisation to contribute, constructively criticise and validate each phase of the research.

4.3 THE RESEARCH CONSTRAINTS

The research has taken place within the researcher's parent organisation. The obvious advantage for the 'internal' researcher is the ease of access to the organisation and its members. However, this must be balanced with the equally obvious constraints placed upon him as a continuing member of that organisation. Just as the benefits of being able to 'see' the problems and access the relevant data, come more easily to the internal researcher so do the consequences of reporting what is seen if the findings are viewed by the organisation as critical or threatening. Hall (1994) argues that there is a natural tendency to think highly of our own judgement and that this position is reinforced by a tendency to accept information that supports that position and to reject information that is in conflict with it.

The researcher, concerned with developing a strategy that matches existing resources to the environment, finds that he seeks evidence and facts to support this position and that these do not always match the dominant logic of the prevailing political or corporate climate. Hall identifies that:

"The visionary leader is unlikely to welcome the constant testing of his vision by a 'Popperian' disciple; such a disciple might find that his behaviour was severely career limiting." (Hall, 1994 :3)

The researcher, faced with this dilemma, adopted the position that he had to both respect the confidence and trust implicit in the freedom of access given in a fair and justifiable way, and in return trust that the judgement of the organisation will be supportive and fair.

4.4 INTERVIEWS WITH SENIOR POLICE OFFICERS

The purpose of this stage carried out between 29 March and 26 April 1993 was to gain a view of the organisation from the perspective of the senior officers of the Force. The officers control and hold responsibility for the whole range of policing functions, and manage the resources of the Force; to tease out the main issues causing concern within the Force. These issues would later form the basis of a forcewide survey. All respondents were offered anonymity, only one requested this facility. Following this request it was decided to extend the facility to all respondents by preparing a consolidated response for each question with respondents being identified only by number. The respondents were selected using the criteria that:

- They were in command of a District, Department or Branch;
- Occupied a unique or key position within the Force;
- Demonstrated a willingness to participate;
- Their knowledge of the subject matter.

Of the thirty officers asked to participate all agreed to be interviewed however, due to unavoidable commitments, it was only possible to interview twenty-seven. The sample selected ensured that all police functions within the Force were represented. It included representatives from the Police Federation (one sergeant, one chief inspector), and the Superintendents Association (two superintendents). It is noteworthy that the combined length of police service of the respondents amounted to seven hundred and eighty three years of policing experience. The composition of the respondents is shown in Table 4.1

Rank of Respondent	District responsibility	Departmental responsibility	Percentage of rank sampled	Average Service (years)
Chief Superintendent	3	2	100%	32
Superintendent	5	7	70%	27.9
Chief inspector	4	5	36%	26
Sergeant (Fed)		1	n/a	23
TOTALS	12	17	n/a	27

Table 4.1 Composition of respondents interviewed.

The interview structure.

The interview structure and the topics for enquiry were formulated in conjunction with three senior police officers that all possessed wide ranging and in some cases highly specific, District and Departmental experience. They agreed to undertake the role of 'key informants'. Jankowicz (1991) identified the value of carrying out key informant interviews with respondents selected for their idiosyncratic or specialised knowledge, citing Tremblay (1982) who suggests that the use of key informants is especially useful in: defining the essential characteristics of some issue by drawing on the personal experience

and understanding of the people involved; identifying the boundaries, constraints and extremes within which these definitions are seen to apply; and increasing your knowledge of the issue itself;

The researcher found this technique particularly valuable in that the three respondents not only assisted the researcher in putting together a balanced interview structure that captured and reflected the key issues facing the organisation, at the macro and micro level, but they also acted as a counter balance that nullified the researcher's in-built bias and compensated for his gaps of knowledge in respect of specific parts of the organisation.

The final interview format was based on the use of a semi-structured interview technique consisting of seven sections. Each section contained a number of questions that invited an open reply. This gave the respondents the latitude to cover the topics in their own order and manner of presentation. Three of the sections contained a questionnaire that possessed a longitudinal dimension where data was elicited from as far back as 1974. The interview length varied between one hour forty minutes and three hours with the average length being two hours thirty minutes. Contemporaneous notes were taken which were typed at the earliest opportunity and forwarded to the respondent to ensure accuracy. A copy of the interview format and correspondence is included at Appendix 'A'.

4.5 THE FORCEWIDE SURVEY

The purpose of the forcewide survey carried out in July 1993, was to obtain data from as large a sample of police officers as possible. The questionnaire was formulated to include the key issues highlighted by the senior officers, in the preceding stage. The same three officers referred to in the last paragraph validated the questionnaire. In addition the chief constable was asked to

approve the contents prior to distribution, he did make several suggestions for improvement. These were considered and incorporated into the questionnaire. Many of the issues raised were specific and unique to the Cleveland Constabulary, consequently it was deemed inappropriate to explore these issues by surveying police officers external to Force. The issues raised within the questionnaire are fundamental to the working practices of all police officers within Cleveland. With this in mind the researcher decided to survey all fourteen hundred and ninety-five officers in the Force. From the researcher's experience of being involved with numerous surveys in the Force, it was suggested that a response rate of 50% could be expected from the constable rank with slightly higher responses from supervisory ranks.

Seven hundred and twenty-one questionnaires were returned a response rate of 48.2%. This response rate was slightly below that anticipated with a response rate from constables of only 45%. The probable reasons for this are:

- Four separate surveys were carried out prior to or simultaneously to this one. Three relating to academic dissertations and one to a Force project. Respondents could well be suffering from 'questionnaire fatigue';
- The questionnaire was lengthy, with sixty-three questions;
- The survey took place at the peak annual leave period. (This was reflected in the low response rate of ACPO)

The composition of the population and the respondents is shown in Table 4.2.

Rank	Establishment (No. issued)	Number of respondents	Percentage response
ACPO	4	1	25%
Chief superintendent	5	4	80%
Superintendent	14	8	57%
Chief inspector	27	21	78%
Inspector	92	60	65%
Sergeants	239	129	54%
Constables	1114	498	45%
TOTAL	1495	721	48%

Table 4.2 The population and the composition of respondents to the forcewide survey

4.6 INTERVIEWS WITH THE FOUR MEMBERS OF ACPO

The purpose of the interview stage was to explore macro level issues determined by those responsible for formulating and implementing policy.

This stage involved all four members of the Association of Chief Police Officers (ACPO), the chief constable, the deputy chief constable, and the two assistant chief constable's who hold specific responsibility for 'administration' and 'operations'. A semi-structured interview format was used, the length of interview was determined by the respondent and varied between one and three hours. Contemporaneous notes were taken which were typed and forwarded to the respondent for verification to ensure accuracy. A copy of the interview format and correspondence is included at Appendix 'B'.

4.6.1 Interview with the Chief Constable, Mr Shaw

Mr Shaw identified that he wished to provide a service that meets the needs of the local people with particular emphasis on tackling crime, drugs, public order, road safety and providing an emergency response to urgent situations. Furthermore that the police to be involved in community work, particularly with young people to educate them and make them realise the impact that their conduct has on their victims and the local community.

His vision for improving policing in Cleveland was based on five key areas:

1. QUALITY AND DELIVERY OF SERVICE

To improve the quality and method of delivery of the police service to the public taking into account the desires and expectations of the people of Cleveland.

2. PERFORMANCE MONITORING

To develop adequate performance indicators and measures to evaluate police activity.

3. OPERATIONAL AVAILABILITY

To increase the operational availability of officers and the total number of hours spent on operational tasks.

4. DEVOLVED RESPONSIBILITY

To increase district autonomy.

5. MANAGEMENT STYLE

To create an open and participative style of management with equal opportunities for all. (Interview Shaw, 1993 :2)

He stressed that the police must deliver a service in these areas to the satisfaction of the people of Cleveland and that within the organisation we must create a climate of mutual support to take people forward.

Mr Shaw expressed concern over the move towards adopting a consumerist approach to policing:

"In terms of adopting an approach similar to that of a free market economy, there are many effective management techniques in the private sector that can be used successfully in the public sector, however there are many that are inappropriate, and should not be imported into the police service. The techniques of the free market in some cases rely on identifying a single product or group of products, keeping to a narrow band, then trying to become a monopoly supplier charging what the market is prepared to pay. Whereas the police have difficulty in defining their market. Traditionally we have befriended people and provided help either on demand or where we felt that people needed it. In many cases Statute dictates that we enforce certain laws and types of regulation. Therefore we cannot define the market that we wish to operate in ourselves. In a private sector company, the principle stakeholders are often shareholders, and your survival is tied into satisfying their needs. That relationship can be improved by marketing products, for example, Marks and Spencers who have achieved a reputation built on quality.

The police on the other hand have a much wider range of stakeholders to satisfy, many of whom do not want to sample our product. Many of the stakeholders require different things from us: Political accountability; financial accountability; public accountability. These cumulatively restrict the ways in which we operate or make use of our financial resources." (Ibid :5)

Mr Shaw expressed concerns for the future stating that the police were being subjected to several major reviews that were creating uncertainty and affecting the force's ability to plan ahead. However, he concluded on a positive note that the police must keep trying to provide a service despite the obstacles being placed in their path by everyone.

4.6.2 Interview with the Deputy Chief Constable Mr Robertson

Mr Robertson stated that policing was a social support service designed to achieve social control that maintained the status quo of society. He stressed that

crime was one of the major concerns as this undermined the social fabric of society and that significant resources should be deployed to tackle this problem. He stressed that:

"Policing is not just about crime, people have a wide range of everyday problems that they choose to come to us with for help. The public, in general, give us support, this in turn allows us to go about our everyday duties, unarmed." (Interview Robertson, 1993 :2)

Mr Robertson displayed a passion for improving the quality of service that the Cleveland police provide:

"I believe that we provide a high quality of service and that we are capable of providing one of even higher quality. To achieve this I intend to create a debate that will go on at different levels in the organisation to define the Cleveland style, so that every member of the Force can determine, *'what I am proud of now'* *'what can I aspire to in the future'*. We have a lot of positive elements that we can harness. I believe that to maximise the forces potential we need to change the 'culture' to ensure that everyone is proud of the Force, and that if we all pull in the same direction, then we can improve our already high standards." (Ibid :4)

Mr Robertson expressed concern about the proposals for the police to move towards the concepts and practices relating to the business world. He pointed out some prominent failures in their pursuit of profit, Robert Maxwell, Asil Nadir and Ernest Saunders. Mr Robertson stated that "Where profit becomes the primary motive ethics tend to be swept aside." (Ibid :5)

However, he remained positive as the ability of the police to survive and prosper in any environment:

"Although I am sad to see these proposed changes, I believe that if they come about, although I am not optimistic for their success, I believe that we will be given the opportunity of surprising such a body by demonstrating our proficiency, skills and thoroughness in managing in a complex bureaucratic environment. They may in fact, and I sincerely hope they do, learn from us." (Ibid :6)

On the issue of external agencies influencing the police, Mr Robertson was critical of the Audit Commission for taking a too narrow perspective based mainly on accounting principles which assumes that everything has a cost value and that every phenomenon can be legislated against. He expressed the view that:

"If they advance a concept and we implement it and it does not work, they merely state that the police do not have sufficient skills to implement or manage the change. They never seem to admit that their initial concept was flawed." (Ibid :7)

Mr Robertson maintained a firm commitment to policing in the future:

"I am an optimist, policing is now being performed by police officers who are better skilled, better trained and of a higher calibre than thirty years ago. My personal challenge is how to help them, to give them the resources and the means to improve. The most potent part of an organisation is its staff, we must harness their energy." (Ibid :7)

4.6.3 Interview with Assistant Chief Constable 'Operations' Mr Horner

Mr Horner acknowledged that it was difficult to precisely define the nature of service provided by the police:

"We must provide a service that the public want, however how you define this is not so easy. It has to be a mixture of social service and law enforcement. We must continue to provide a twenty four hour help line that is available to all members of society which is capable of giving a full and comprehensive response." (Interview Horner, 1993 :1)

However, he was in favour of 'neighbourhood' policing involving small units being deployed to an area rather than them being based in police stations. He suggested that they could be situated in accommodation such as shops augmented by central bridewells to deal with arrests. This would ensure that policing needs were determined locally to meet the individual needs of the populace.

Mr Horner recognised the resource implications of such initiatives:

"If I could devote all my resources to local policing, then there would be little left to deal with some of the major issues, e.g. drugs, serious crime, firearms vehicle related crime etc. It is complex to find the level and number of skilled staff to deal with such issues in a Force this size. Perhaps some of these will have to be carried out on a national basis or by larger forces. In some areas such as drugs and fraud we are merely scratching the surface, yet we do not have the resources or equipment to deal with these in any other way." (Ibid :4)

He identified that this situation was exacerbated by external agencies who produce legislation or directives that do not take into account practical issues and absorb resources:

"All these increase demands on our resources and which seem to counteract the philosophy of putting more people back on the beat. Every time that we put an officer back on the streets, there is something else that comes along and pulls them away." (Ibid :5)

Mr Horner was critical of the concept of applying performance measures to policing. He stated that we should be judged on outcomes not outputs and that the notion policing performance could be judged on the number of arrests or offences processed was completely wrong:

"I would like to actually reduce the number of fixed penalty tickets issued, lets face it, if the purpose of the exercise is to maintain a free flow of traffic, then the use of fixed penalty tickets should be viewed as a last resort. Not only that, we cannot afford to process them. My only concern is for the safety of the public and fixed penalty tickets don't necessarily enhance that." (Ibid :7)

Mr Horner was not in favour of adopting the principles of business. He stated that the police had to deal with incidents for the benefit and safety of the public irrespective of the costs and that we should not enter into costed policing. He was also critical of external agencies that influence the police:

"In particular, the Audit Commission influence the Home Office and the HMI and whilst anxious to achieve value for money. I think on some occasions we may live to regret the vigour at which we are encouraged to follow some initiatives. Are local accountability and value for money natural bedfellows? I am not convinced that they always are." (Ibid :7)

4.6.4 Interview with the Assistant Chief Constable (Administration) Mr Wood

Mr Wood identified that policing was a mixture of law enforcement and social policing and that the consistency of the mix was dependent on the individual community, local needs and priorities. He recognised that crime was of particular concern and that the police alone could not tackle the root causes of unemployment, urban decay or social deprivation. However, he suggested that the police must work closely with other agencies to tackle these issues. Mr Wood identified that the greatest problem facing the force was lack of finance, he gave an example:

"The greatest problem that we face is finance. We are now having to reduce headquarters support staff and the system is now starting to crumble. There is no money to pay for temps to fill in at peak times or when personnel are off sick. This leads to more stress, more illness and creates an ever increasing workload that particularly effects the small Branches. Overall this means that headquarters cannot provide the level of support that it should do to the Districts." (Interview Wood, 1993 :1)

Mr Wood identified the resource implications of the force information technology systems as causing him concern. He indicated that he had to draw operational police officers into headquarters to carry out training, thereby reducing the number of officers on the streets.

Mr Wood was highly critical of the Audit Commission:

"I do not feel that they understand the police or the nature of policing. They are financially based and do not take into account reality. If we work to their formulas to save money, we find that they don't work out, e.g. the centralisation of communications, it has been found that the overall costs have increased significantly, not reduced as projected. The

HMI has always pushed the Audit Commission reports, and I believe that they should examine them more carefully and carry out feasibility studies before advancing them as best practice. This would help us to make more informed decisions. It must be remembered that each local community and its police force is different, we must therefore always try and address their needs and resource them accordingly." (Ibid :4)

Mr Wood expressed concern for the future relating to the findings of the Sheehy Report. In particular the impact that it was having on the morale of police officers and the potential for a reduction in the standards of recruitment for police officers.

4.7 RESEARCH TO DETERMINE THE CURRENT POSITION OF THE CLEVELAND CONSTABULARY

The purpose of this research is to draw together the data gathered in the surveys, to carry out historical analysis and to draw tentative conclusions to determine:

- The present position of the Cleveland Constabulary;
- How it reached this position;
- Inter- relationships with the environment;
- The strength of the environmental forces;
- The strategy that the Force will have to adopt to satisfy the competing demands placed on resources.

These issues were identified in Chapter 1.4 however, it is as well to remind the reader of some of the issues previously raised. Miles, Snow and Pfeffer, identified the importance of environmental forces on an organisations performance, posing the question "are there organisational characteristics, strategies, technologies, structures, processes - which are appropriate for one environment but which may lead to failure in another." (Ibid :244)

Porter argued that the reason why firms succeed or fail is perhaps the central question in strategy and that what is required is a truly dynamic theory of strategy that:

"Separates the theory of strategy into the causes of superior performance at a given period in time (termed the cross-sectional problem) and the dynamic process by which competitive positions are created (termed the longitudinal problem). The cross-sectional problem is logically prior to a consideration of dynamics, and better understood." (Porter, 1991 :95)

The researcher recognised the need to determine a longitudinal position, this is reflected in the research and examines how the Force reached its present position. The research has focused on identifying the key environmental forces that influence the organisation and charting them through the years until the present day, providing an up to date cross-sectional appraisal.

4.8 SUMMARY

In this Chapter consideration has been given to the nature of the empirical research, the researcher, the research constraints, methodology, the scale of the survey work and the characteristics of the respondents. Particular attention has been focused on the difficulties of carrying out research into the researcher's own organisation and the difficulty of moderating bias and the compensating factors introduced to achieve this.

The interviews with the four Chief officers identified that they fully realise the difficulties that the organisation faces in adopting the working practices of the private sector. However, despite this realisation recognise that the proposed changes will be on a national basis and they have little option but to implement.

Mr Horner in particular was critical of the use of performance measures that would mean the Force increasing levels of prosecution. He recognised that

although each fixed penalty ticket issued would represent a contribution to satisfying the performance targets, it would not improve road safety and cost the Force money.

4. 8.1 Introduction to Chapter 5

The next Chapter will introduce the reader to a technique known as grounded theory that is designed to interpret and manage raw data so that key issues are identified and opened up for further analysis. The researcher interviewed twenty-seven senior officers who represented all key areas of policing within Cleveland Constabulary. The interviews with the four members of ACPO outlined in Chapter 4, formed the basis for the selection of subject material on which the semi-structured interviews were carried out. The interviews explored a wide range of policing topics and included four sections that provide an opportunity to collect data that permitted evaluation of new technology, legislation and working practices. During the interviews consideration was given to identifying the main factors that influence the direction that the police service is following.

5.1 INTRODUCTION

The purpose of this Chapter is to present the results of the interviews held with twenty-seven police officers occupying senior or command positions within the Cleveland Constabulary. The officers represented all the key policing functions and geographical areas of the Force. The semi-structured interview format utilised contains seven sections each one focusing on specific areas associated with policing both locally and nationally. The areas examined incorporate the central themes being explored within the research.

- **Overall efficiency** - has the change resulted in increased or decreased overall efficiency;
- **Resources** - has the change led to increased or decreased resource consumption;
- **Operational efficiency** - has the change led to increased or decreased productivity;
- **Bureaucracy** - has the change led to increased or decreased bureaucracy.

It must be pointed out that this type of research has not been previously carried out within the organisation. Consequently there is no ready-made yardstick, mechanism or reference point for evaluating these subject areas. Hence, the respondents were asked to carefully consider each area and to quantify their perception of the changes taking place in an attempt to understand this complex phenomena. The eight sections are:

Section A. The Role of the Police Service

The section examines the current thinking about what tasks the police should

perform, how the performance of these tasks affect the public and what areas of policing should be prioritised.

Section B. Resources

The section examines the resource requirements of policing and the respondent's views on the introduction of new financial management techniques advocated by the Home Secretary and the Audit Commission.

Section C. Consumerism and the police service

The section explores some of the issues associated with the commitment by the Home Office to introduce performance measurement into policing and the effect that this may have on the level of service provision.

Section D. Personnel

The section, which contains a quantifiable element, explores the changing nature of policing and the effect that this has on the individual police officer. It also introduces the subject of bureaucracy and examines its impact on the role of the senior manager.

Section E. Technological systems

The section examines from the police officer's perspective the value of external and internally created computerised systems and how the respondents perceive the introduction of such systems has affected the four key areas being evaluated. The section contains quantified data that evaluates the effect of change resulting from the introduction of technological systems.

Section F. Legislation

The section examines from a police perception the impact on policing of introducing legislation and new initiatives that have been determined by external bodies. It again seeks to quantify the effect that change has on the four subject areas of policing under investigation.

Section G. External influence on the police service

The section explores the respondent's views on the impact of 'changes', that have been or will be introduced as a result of the Home Office, Audit Commission and Her Majesty's Inspectorate of Constabulary initiatives. The subject areas are: civilianisation; performance measurement; and financial accountability.

Section H. The future of policing

The section gives respondents the opportunity to express their views on the direction that the police service should take.

5.2 INTERPRETING THE DATA

The survey resulted in the collection of a significant amount of text. This was compiled in a structured format that shows the question, the twenty-seven replies to that question, grouped by rank, then sequentially numbered. The length of the consolidated response amounts to one hundred and thirty pages.

At this stage the researcher recognising the wealth and depth of information gathered was faced with the problems: "what do I do with all this data that I have collected?" and "how can I get the maximum benefit from the richness of data, and still present the findings in a format that the reader will readily understand." For an answer, he turned to the use of technique known as 'grounded theory' developed by researchers in the field of social science. (Glaser and Strauss, 1967) This technique enables the researcher to gain a better understanding of social phenomena through the qualitative analysis of data designed specially for generating and testing theory. Strauss describes this approach:

"The methodological thrust of the grounded theory approach to qualitative data is toward the development of theory, without any particular commitment to specific kinds of data, lines of research, or theoretical

interests. So, it is not really a specific method or technique. Rather, it is a style of doing qualitative analysis that includes a number of distinct features, such as theoretical sampling, and certain methodological guidelines, such as the making of constant comparisons and the use of a coding paradigm, to ensure conceptual development and density."
(Strauss, 1987 :5)

Strauss recognised that social phenomena are complex and this complexity cannot be isolated or ignored. Hence, the grounded theory methodology emphasises the need for developing many concepts and their linkages in order to capture the great deal of variation that characterises the central phenomena being studied. The research process involves:

Raising *generative questions*. These determine the key issues to be investigated, the hypotheses to be tested and concepts and relationships to be explored;

The *coding* of data into categories that reflect the key issues that data can be sorted into for comparative or quantitative purposes;

The use of a *coding paradigm*. This is central to the coding procedures, it functions as a reminder to code data into categories and sub-categories relevant to whatever phenomena is being examined. In each case consideration must be given to the following;

Conditions; Interaction among the actors; strategies and tactics; consequences.

The process of *integration*, determining which of the categories, linkages, interactions are the most important, most salient, to the core of the evolving theory.

Jankowicz (1991 :86) describes the use of this technique as particularly useful in dealing with management and organisational problems that are very complex, and do not sit within the neat boundaries of academic knowledge. These typically form the corporate issues to be tackled by senior decision-

makers. Jankowicz identifies that these problems are regarded as being 'messy'.

"Professional problem-solving is value-driven (e.g. most issues of corporate strategy and business policy), it may have social consequences (e.g. issues of quality in manufacturing and service management), and it is frequently intertwined in contradictory assumptions about social policy (e.g. the problems of management in the Prison Service)." (Ibid :87)

Jankowicz recognised the value of developing theory from the careful processing and coding of information to a point where the theory emerges by induction from the realities of the situation demonstrated in the data, rather than being imposed from the outside.

5.3 COMPOSITION OF THE INTERVIEW

5.3.1 Section A. The Role of the Police Service

This section contains three questions that focus on determining what functions the police should carry out, or 'what business should they be in'. The responses to each question were unstructured, however patterns began to emerge from the main themes that were quantified and appear in the tables below.

Question 1. What type of service do you think the police should provide?

Main issues raised by respondents N = 27	(agree)	Total	
		[n]	[%]
Law enforcement was identified as being the primary role of the police		23	85
That the police should be involved in social policing.		17	63
That the police should become a more victim focused and caring service.		7	30
That the police should consult the public to determine their needs, then satisfy these needs.		15	55
That the level and type of service provision would be dependent on the finance available		15	55

Table 5.1 Quantified data relating to question 1 (Section A)

The majority of respondents (85%) identified that the primary role of the police was law enforcement:

"The police service is a law enforcement agency who regulate societies conduct through legislation. In achieving this it does not mean that we shouldn't have a social input, but we must prioritise the use of our resources focusing on enforcement." (Superintendent, respondent 7);

Seventeen respondents (63%), believed that the police should become more involved with social policing:

"We must provide a dual service with law enforcement being our primary role. Our secondary role should involve being a more responsive social agency, with those staff who have direct contact with the public being more responsive and sensitive to the needs of the public."
(Chief superintendent, respondent 3)

Concern was also expressed that:

"At the present time we do not have the resources to become involved in social issues, they may be desirable, but not if they are funded to the detriment of operational policing." (Superintendent, respondent 20)

Balanced views were expressed about determining and satisfying the needs of the public. Fifteen respondents (55%) indicated their willingness to adopt this

proposition. Fifteen respondents (55%) identified that the level and type of service provision would increasingly become dependent on finance. Respondents indicated that there appeared to be significant tensions building up within the policing system that faced increased crime rates, the effects of new initiatives and legislation:

"At the present time we adopt so many schemes we lose sight of our primary objectives, we cannot do everything, we should focus on our key priorities and do these well. We must resist the pressures to achieve everything otherwise we will end up providing a mediocre service, rather than an excellent one." (Chief Inspector, respondent 23)

Questions 2 and 3 deal with similar issues in respect of crime and the effects that positive law enforcement can have in reducing crime, hence, they will be dealt with together:

Question 2 - Crime at the present time is receiving wide media coverage. What do you think the force aims should be in respect of crime?

Question 2(i) - Do you regard law enforcement as making a significant contribution towards crime prevention and the maintenance of law and order?

Question 2(ii) - Do you feel that enforcement can lead to the alienation of certain sectors of the community?

Main issues raised by respondents n = 27	(agree)	Question number	Total	
			[n]	[%]
The police should concentrate on arresting offenders, this will reduce crime		2	23	85
The police should concentrate on crime prevention to reduce the fear of crime		2	13	48
The police should put resources into identifying and targeting known offenders		2	9	31
Detection and punishment are seen as a very effective deterrent		3(i)	27	100
The criminal justice systems and the Courts let the police and the public down		3(i)	13	48
The police recognise that enforcement particularly in areas of road traffic or minor offences can alienate the public		3(ii)	22	81
The police need to have the discretion over who and what offences are prosecuted or cautioned		3(ii)	20	74

Table 5.2 Quantified responses to question 2 (Section A)

The majority of respondents (85%) supported the view that police officers

should concentrate their attentions on bringing offenders to justice:

"Detection is the best form of crime prevention, take out the offenders who commit the most crime and providing that the courts deal with them properly, this will save us work." (Superintendent, respondent 12);

"The Force should put more emphasis and more resources into the detection of crime and the arrest of offenders, that is what the government expect us to do and how they judge our success." (Chief Inspector, respondent 20)

There were mixed views on the issue of deploying police resources into crime prevention with fourteen respondents (52%) being against police carrying out this role. Several respondents suggested that this role should be carried out by other agencies with the police taking a purely advisory role:

"We must encourage others to design out crime, e.g. car parks, motor cars, however many of these issues can be resolved by legislation demanding minimum standards of security." (Superintendent, respondent 9);

Eighteen respondents (67%) did not favour the targeting of known offenders, as they believed they had inadequate resources:

"Resources have not kept pace with the increased volume of crime being committed, consequently those on the front line visiting scenes: uniformed officers; scenes of crime; CID; have been put under severe pressure and struggle to find time and equipment to deal with all crimes. The emphasis is now focused on recording the details of crimes properly rather than investigating each crime thoroughly." (Superintendent, respondent 17)

Question 3(i) - Do you regard law enforcement as making a significant contribution towards crime prevention and the maintenance of law and order?

There was a unanimous response from all respondents (100%) that prison is an effective deterrent:

"We can never make a significant contribution unless all the agencies involved work together, pulling in the same direction. If the system does not support us, and it should be remembered that we are acting on behalf of those law abiding members of the community, then we have little chance of

winning the fight in terms of preventing crime. I can give many examples to illustrate this, however one specific example springs to mind, where a youth was arrested seventeen times in a six month period, and he kept being given bail by the Courts. Perhaps as many as ninety victims of his crimes, regard the police as being unsuccessful and blame us, and begin to regard us as being in-effective." (Superintendent, respondent 6)

A minority (48%) supported the view that the criminal justice system let the police down:

"I am a traditionalist in relation to law enforcement, I believe it is the duty of the police to arrest and process offenders. From my experience this is what the public expect and wish to see the police doing. However, I do not see punishment as being a concern of the police."

(Chief Superintendent, respondent 2)

Question 3(ii) Do you feel that enforcement can lead to the alienation of certain sectors of the community?

The majority of respondents (81%) identified that the prosecution of minor offences by the police could alienate the public, with (74%) supporting the proposition that the police should retain the discretion to prosecute, caution or otherwise deal with an offender. Many respondents expressed the view that it was up to the police to determine what offences they should focus their efforts on to detect, determined in conjunction with the community. It was identified that there was a danger of being regarded as being merely a collector of revenue for the government:

"We must have the discretion to put public relations before prosecution, we do have a system of both formal cautioning and verbal cautioning, and if this suffices we should forgo prosecution. I do appreciate that although this system works in the majority of cases, some individuals will not respond and need to be prosecuted" and

"I have discussed this issue with the Home Secretary and have advised him that we are in danger of being viewed as a quasi-enforcement/revenue collection service. Since the income based fines system came into being, where the motorist in particular is being fined large amounts of money, our public standing and support may be affected."

(Chief Superintendent, respondent 2)

5.3.2 Summary of the Main Issues Raised in Section A

The respondents indicate that they are in favour of continuing in the traditional role of policing, with heavy emphasis being placed on the arrest of persistent or hard core offenders and bringing them to justice. There is an implicit belief that if these offenders are dealt with by means of imprisonment, this will help reduce crime by keeping them off the streets, and act as a deterrent. It has been identified that there is a real danger of the police prosecuting those offences that are easy to detect, for example speeding, to enhance their performance. However, it was recognised that this would inevitably affect relationships with the public.

5.4 SECTION B. RESOURCES

This section consists of two questions that explore the respondents' views on resource distribution and changes in the Force system of financial management.

Question 1. If you consider resources as personnel, equipment, vehicles and finance, what do you think are the key limiting resources that control the achievement of the service you would like to provide?

Main issues raised by respondents n = 27	(agree)	Total	
		[n]	[%]
Personnel		22	82
Equipment		20	74
Vehicles		15	55
Finance		21	78
Resources should be linked to demand		17	63

Table 5.3 Quantified responses to questions 3, (Section A)

The majority of respondents identified the lack of personnel (82%), finance (78%), equipment (74%) as being the key limiting resources. However, only fifteen respondents (55%) regarded the lack of vehicles as being a key factor. A significant proportion of respondents (63%) indicated that they believed that the

level of resources provided to the police should be linked to the demands placed on the service it provides and that when required to take on new services or initiatives the cost implications should be recognised. Several respondents linked the issue of resources to other factors, particularly those emanating in the external environment:

"The volume of change required by external agencies and authorities has been so rapid and fundamental that they have soaked up the Force energies. Change has therefore tended to be dramatic rather than incremental but has not been accompanied by adequate training to develop the new skills required." (Chief superintendent, respondent 3);

"Some current Chief Constables and many current HMI's have in the days of plenty, been grossly negligent in their custodianship of the police service. They have been seduced by high technology and have not increased personnel in line with increased resources available to them. We are now paying the price." (Superintendent, respondent 16)

The increased expenditure on new technology was highlighted by many of the respondents who identified that increased expenditure in one area had to be paid for by reductions in other areas:

"The only growth areas within the Force appear to be computing and statistics, operational policing seems to have become the poor relation of the Force." (Chief inspector, respondent 18)

Question 2

The Home Secretary, Kenneth Clarke, announced on the 23 March 1993, that Chief Constables would be given greater freedom to manage resources and in the choice of what they spend their money on.

2(i). Do you believe that District/Departmental commanders should have complete freedom in deciding the mix and roles of all personnel and equipment to meet their own local goals and priorities, e.g. police or civilian; CID or uniform; mobile or foot patrol; levels of supervision?

2(ii). If so, what changes, if any, do you think will have to be made to the present systems to ensure that this initiative is successful?

Main issues raised by respondents N = 27	Question number	(agree)	Total	
			[n]	[%]
Yes, we should have complete freedom	2(i)		6	22
No, I don't support this initiative	2(i)		10	37
Yes, but with reservations and conditions	2(i)		11	41
Financial backup and support is required	2(ii)		15	56
More training is required	2(ii)		3	11
Better computer systems are required	2(ii)		6	22

Table 5.4 Quantified responses to questions 2, (section B)

The respondents have mixed views on the issue of devolved financial management (DFM) with only six (22%) unconditionally supporting this proposition, and eleven, although recognising the value of the initiative, expressed reservations:

"It is appealing, but the success will be dependant on having a realistic budget set to achieve high standards throughout the Force. There are some areas that cause concern, each Basic Command Unit needs co-ordination from the centre, each one cannot be allowed to drift into their own pet or specialist areas, to their own satisfaction, there must be universal standards of service delivery throughout the County. The problems that make up policing are many, diverse and continually shifting and specific problems can appear anywhere in the Force, at any time. So for a period of time one area may have significant problems, which need extra resources. This will require the development of a sensitive budgetary allocation process." (Chief inspector, respondent 15)

Ten respondents (38%) opposed DFM completely viewing it as problematical and in some cases it was viewed as passing the problems of policing lower down the ladder:

"I have reservations about the proposals, it seems to be an opt out of local government control into central government control, and significantly alters the local nature of the service. I am not sure that ACPO and District/Departmental commanders have sufficient acumen to carry out these proposals. I firmly believe that the system will allow central government the opportunity to pass down accountability, blame and criticism to a local level, thereby avoiding their responsibility for being unable to find a solution for tackling crime." (Sergeant, respondent 27)

The low level of support for DFM appears to have influenced the responses to question 2(ii) with only three respondents (11%) addressing the issues of training and six (22%) that of improved computer systems. The majority however identified that they would require improved financial support in terms of, experienced personnel, and back up facilities. Even with this type of support, the introduction of this type of initiative was viewed as creating an increased workload as well as being problematical for operational police officers.

5.4.1 Summary of the Main Issues Raised in Section B

The respondents indicated that their main concerns were the lack of personnel available to perform duties as operational police officers. There was a growing concern that the lack of finance was becoming increasingly paramount. The respondents identified that the requirements to introduce change were generally accompanied by an increase in administration and bureaucracy. To service this demand investments had to be made in computer systems that would have to be paid for by reducing police personnel, thereby compounding the problems already being experienced by operational officers.

The respondents saw the introduction and extension of devolved financial management throughout the Force as being complex and problematic. Concern was expressed that administrators could end up being responsible for operational matters, when they had little or no knowledge of operational policing. This situation was viewed as being detrimental to operational policing. The respondents recognised that for the system to become successful it would require considerable investment in terms of management training and the upgrading of computer systems and skills. They also recognised that the system would be more likely to increase their workload rather than reducing it.

5.5 SECTION C. CONSUMERISM AND THE POLICE SERVICE

The section consists of three questions that explore issues surrounding the adoption of new techniques, which have been viewed as 'the way forward' for public sector organisations. Many of the techniques proposed have emerged from the business world and are based on performance measurement and the use of 'costing' procedures for determining if initiatives and services are deemed to be successful.

Question 1. The Home Secretary appears to have support from the Audit Commission, the Home Office and Her Majesty's Inspectorate. He has indicated that the police service should become more consumer oriented, with a range of performance measures being introduced to ensure that police forces provide value for money through improved productivity. If the police service is to be examined using measures designed and applied to the private sector and assessed like a business. Do you think the Force should:

Question 1(i). Prioritise the deployment of resources to areas of high numerical or quantifiable productivity?

Question number:		Total [n]	[%]
1(i) Prioritise the deployment of resources to areas of high numerical or quantifiable productivity?	Yes	1	4
	No	26	96
1(ii) Reduce the range of services provided?	Yes	23	85
	No	4	15
1(iii) Charge for an increased range of services?	Yes	19	70
	No	8	30
1(iv) Contract out or divest certain services?	Yes	20	74
	No	7	26

Table 5.5 Quantified responses to questions 1, (section C)

The proposition contained within this question was unacceptable with only one respondent (4%) supporting the movement of resources into areas high productivity. Many respondents found the underlying assumption that the police should become like a business totally unacceptable:

"I don't believe that we are a business, we are a service and I don't believe that the principles of the private sector should apply to the police. The motivation of the private sector is 'profit' and this does not seem compatible with the police service's aims for improving quality of service. There is a danger of becoming business like and behaving like a business, only taking on easy jobs that produce high outputs and avoiding the hard jobs. It will allow the underclass to develop unrestrained. Putting resources into easy areas for quantifiable results will alienate the public and ultimately damage society." (Superintendent, respondent 16)

Question 1(ii). Reduce the range of services provided? Please give examples.

The majority of respondents (85%) favoured reducing the range of services provided. The favoured options for disposal included: lost and found property (eleven respondents); stray dogs, dangerous dogs (ten respondents); school crossing patrols (seven respondents); traffic wardens (five respondents). The views of one respondent summarised the present position:

"We have always taken on everything that no-one else wants."
(Chief Inspector, respondent 13)

One respondent did however express a cautionary note:

"In the first instance public pressure generally leads to the production of new laws. These are then given to the police, e.g. the Dangerous Dogs Act. Who will satisfy this need if the police opt out, there is still a requirement for someone to service the public's need." (Sergeant, respondent 27.)

Question 1(iii). Charge for an increased range of services. If yes, please specify.

Many respondents expressed concern and were totally against the charging for core services:

"We are a public service and the people who need our services more than anyone are the poor and unemployed." (Superintendent, respondent 15)

However, nineteen respondents (70%) were in favour of charging for an increased range of ancillary services. These included: crime prevention; vetting

of employees; assistance to industry; abnormal loads; Royal visits; summonses; warrants; Home Office statistics, and others.

Question 1(iv). Contract out or divest certain services. If yes, please specify.

Twenty respondents (70%) were in favour of contracting out or divesting certain services. Suggestions were wide-ranging and included: underwater search; prison escorts; parking tickets; school crossing patrols; crime prevention; police hostel; abnormal loads. There was a preference expressed by many respondents for the police to contract out, rather than divest services, thereby enabling them to maintain some form of quality control of the services:

"At the present time the National Car Park company has suggested that they can take over responsibility for the enforcement of speeding regulations at road works. I have no real objections to this provided that standards are not eroded and that if we are involved in the processing side we charge for our services. There are some advantages to be gained, in that when traffic wardens were introduced to enforce parking restrictions, they took the blame away from the police for the issue of the unpopular parking tickets. However, there will need to be some regulation otherwise the systems may fall into disrepute and end up faced with similar problems as the wheel clampers are experiencing. I suppose the principle issue involved, is *'should we be paid to punish people'*." (Superintendent, respondent 15)

Question 2. There is a common perception that the answer to all policing problems can be resolved by putting more police officers "back on the beat".

2(i). What does the term 'bobby on the beat' mean to you?

Twenty-one respondents (78%) indicated that the 'bobby on the beat' was an officer based in a specific location, area or community. Twenty-two respondents (82%) believed that the term referred to an officer who patrolled mainly or exclusively on foot.

"A police officer walking about, in their own regular area, providing

reassurance and getting to know people. They must have the time to be approachable and available for helping the community." (Chief inspector, respondent 13)

The respondents expressed mixed views as to the value of the beat bobby:

"This is a nostalgic dream that appears to be politically correct. The public have been brainwashed into thinking that seeing an officer on the street will reassure them, however, the chance of seeing one, with the number of officers that we have, is very slim." (Superintendent, respondent 7)

2(ii). Do you feel that it is a cost effective way of policing?

Twenty-two respondents (81%) indicated that they did not feel that this was a cost effective method of policing:

"No, in one sense it is what the public will say they like to see, but in reality we cannot possibly provide. To achieve a satisfactory level in Stockton I would estimate that I would need a 150% more officers than my present establishment of 281, plus a lot more vehicles, equipment and facilities." (Chief superintendent, respondent 2);

Question 3. The consumerist approach links rewards to productivity. However, the police service at the present time does not receive income from much of the work it carries out, for example fines resulting from arrest or process. Consequently the more productive it becomes, the more administration it creates, and this in turn increases costs.

Do you think that the Force finance should be linked to its overall productivity. If so, how can this be achieved?

This question split the respondents with fourteen (52%) rejecting the whole concept with many emotive responses being raised:

"No, this would force us into more law enforcement and limit our ability to provide a service.. *'There would be a tendency to enforce the easy laws and like the Russian trawlers go into areas and decimate, concentrating on those that can't defend themselves, hoover up the cod and herring, but the sharks will still be there'*. It also acts contrary to the service ethos that we are trying to develop that is focused on identifying the needs of the

public, then satisfying them." (Superintendent, respondent 16)

Thirteen respondents (48%) were in favour of linking finance to productivity. Respondents expressed concern that if performance related pay was introduced it could lead to increased prosecutions, alienation of the public, increased bureaucracy and costs.

5.5.1 Summary of the Main Issues Raised in Section C

The respondents found the concept of becoming business like, with performance measures based on the ability to prosecute offences, minor as well as serious, and the effect that this could have on their relationships with the public, as being untenable. Many respondents identified the police role as being the provider of a public 'service', whose paramount duty was to protect society and that this service should be available, free and on demand.

The respondents displayed a willingness to reduce services. However, they identified that in most cases there was still a need for someone to provide those services and that for some of them there would be few takers.

The respondents were totally against charging for what they regard as core services, for example, attending crimes, dealing with domestic disputes and arresting offenders. They identified that those who were most in need of the services of the police were often the poor, living in anti-social conditions. The respondents displayed a willingness to charge for ancillary services.

The respondents were willing to contract out services rather than divest themselves of the service to a private contractor, so that they could maintain some form of quality control.

The respondents identified that the public valued the 'bobby on the beat'. They

identified that the cost of re-introducing this type of policing throughout the Force would require an estimated 100% increase in police officers and equipment.

The issue of linking rewards or finance to productivity was a contentious issue that split the respondents almost equally. There was a realisation that if police officer's pay were linked to performance, like their contemporaries on a production line, then a productivity based system for law enforcement may well have to be introduced, despite the damaging effects that it could have relationships with the public.

5.6 SECTION D. PERSONNEL ISSUES

This section consists of seven questions that examine personnel issues, the changing role of police officers and the nature of the work carried out by them. Question one takes the form of a questionnaire that contains a longitudinal dimension eliciting data for the periods 1974-84 and 1984-1993.

The questionnaire originally consisted of six subjects (1-6). However, during the course of the survey a respondent indicated that he felt one of the main personnel issues was that of "stress." The respondent identified the possibility that the reduction in senior and middle ranking officers may make this one of the key issues of the future. The researcher considered this request, realised the prominence of this condition and included it in the questionnaire as subject 7.

Question 1. Role of police officers.

The role of a police officer and the range of work carried out have undergone many changes over the last twenty years. If you consider 1974, as being a base year or starting point can you please indicate to your best knowledge, what you believe the situation was ten years later, in 1984. Then regarding 1984 as the

base year, how do you regard it now, in 1993. Please score between "1" and "10" on the following basis:

"1" insignificant increase "5" moderate increase "10" significant increase

If you believe that there has been a decline in any of the subject areas, please indicate using a negative prefix on the following basis:

"-1" insignificant decrease "-5" moderate decrease "-10" significant decrease.

The seven subject areas under investigation are:

(i) Range of skills required. These can be regarded as the specialist abilities, aptitudes and techniques that a police officer requires to be trained in and proficient at.

(ii) Knowledge of law. The specific level of information about the criminal law that a police officer requires to understand when called upon to deal with the full range of normal police duties.

(iii) Knowledge of procedures. The way police officers conduct themselves when complying with legislation or dealing with police duties that have to be dealt with in a tightly prescribed manner to comply with regulations and agreed working practices.

(iv) Complexity of paperwork. The manner in which police officers collect, record and present evidence for criminal proceedings, or in dealing with prescribed routines such as the detailed forms that are required to be completed in connection with the custody of those arrested.

(v) Professional standards required. The competence, skills, attitude and bearing that a police officer must display when dealing with the enforcement of

legislation, such as presenting evidence to a Court or in dealing with general police incidents for example, road traffic accidents, children missing from home and sudden deaths.

(vi) **Physical capabilities.** Those capabilities relating to the bodily functions, such as fitness, strength, stamina, that a police officer must possess to deal with various duties that a police officer performs.

(vii) **Stress levels.** Those capabilities relating to mental or emotional strain that affect police officers in carrying out their duties.

The arithmetic mean of the respondents scores for each subject area has been calculated. The mean scores and ranking for 1984 and 1993 are compared in Table 5.6.

	1984	Ranking	1993	Ranking
1. Range of skills required	5.33	1	8.74	2
2. Knowledge of law	4.15	5	8.00	5
3. Knowledge of procedures	4.59	2	8.88	1
4. Complexity of paperwork	4.18	3=	8.29	4
5. Professional standards required	3.85	6	7.33	6
6. Physical capabilities	3.65	7	7.26	7
7. Stress levels	4.18	3=	8.70	3

Table 5.6 The respondents scores indicating the rate of change for the seven key areas affecting police officers

It is noticeable that over the range of seven questions the rate of increase in change for the period 1974 to 1984 averages 4.28 which falls between the insignificant (1) to moderate increase (5) on the rating scale. Whereas for the period 1984 to 1993 the rate of change has increased substantially, the average is 8.17 which falls between the moderate (5) to significant increase (10) on the rating scale, with one area increasing by 108% (question 7, stress levels). The

cumulative rates of change for both periods are illustrated in Chart 5.1.

The three subject areas which record the highest rate of change for the period 1974-84 are: (1) "range of skills" (2) "knowledge of procedures" (3) "stress levels", these again record the highest rate of change for the period 1984-93 albeit they are ranked in a differing order. The consistency of scoring for each of these three areas are illustrated in Charts 5.2, 5.3, and 5.4.

Respondents indicate that the nature of policing is changing at an accelerating rate as police officers take on new initiatives, legislation, tasks and reforms, for example, The Dangerous Dogs Act 1991, The Children Act 1992, The Policing of Housing Estates. It is not possible therefore, to identify why respondents have scored individual subject areas higher than others, however the significance of the scoring can be statistically evaluated.

The technique to be utilised analyses the direction of differences in scores when matched pairs of subjects are compared to examine the respondents' consistency of scoring. Two statistical techniques are recognised as being appropriate, the "Sign Test" and the "Wilcoxon Matched-pairs Signed Ranks Test." Greene and D'Oliveira, (1984) express the view the Wilcoxon Test should be used in preference to the Sign Test as it is regarded as being more sensitive, analysing not only the direction of scoring but also the relevant size and differences in scores.

This test consists of comparing the scoring of the 27 respondents to each question for the period 1974-84, with the scores given to the same questions for the period 1984-93. The null hypothesis is that there will be no significant difference to the scores for each subject and that if scores were distributed at random there should be roughly an equal number of high and low scores in the plus and minus directions for each subject area.

The cumulative rate of change for the periods
1974 to 1984 and 1984 to 1993

Chart 5.1

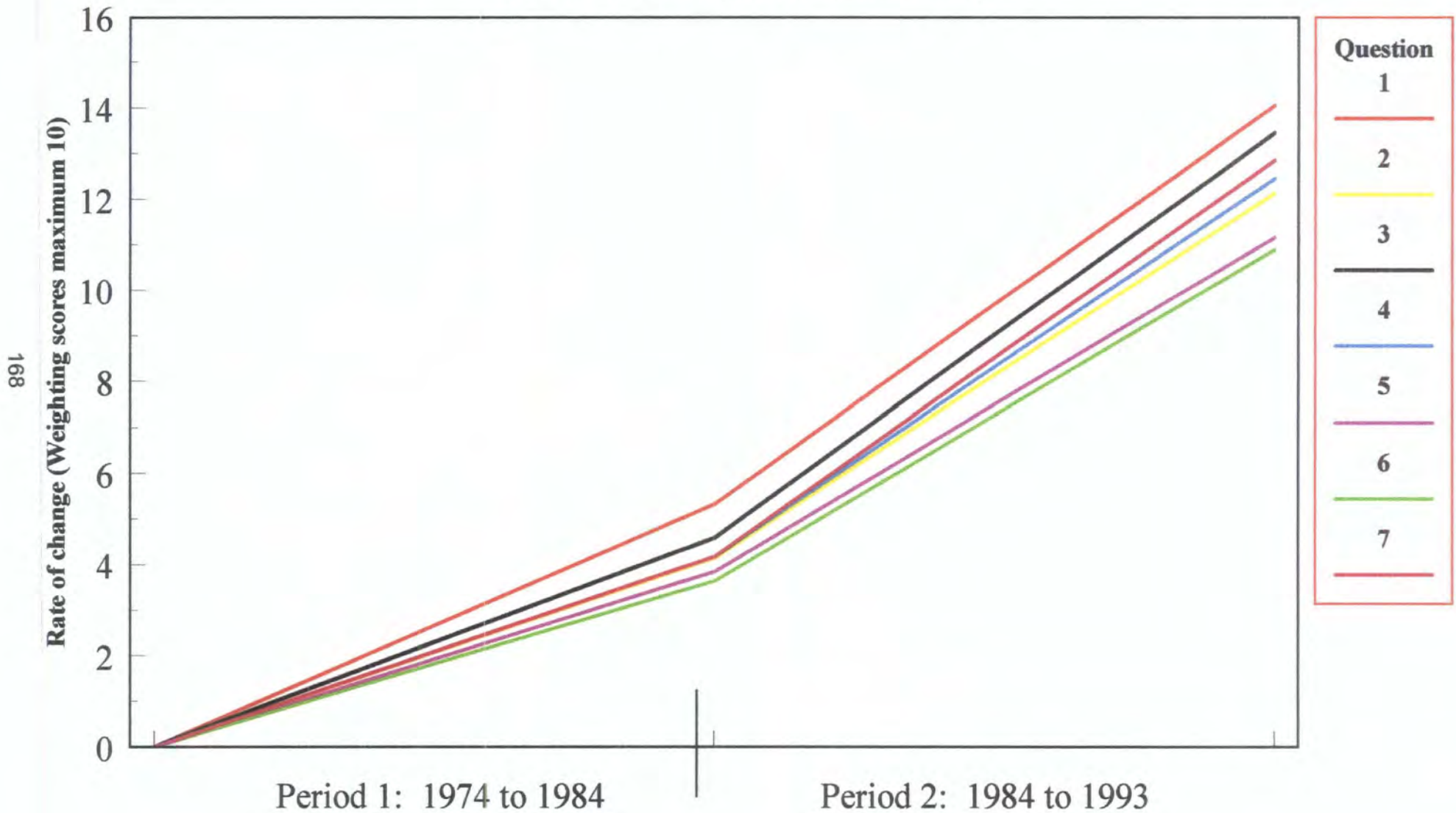

Change in the level of skills required by police officers 1974 to 1993

Range of skills required 1974 to 1984

Observation - the respondents indicate a moderate increase in skills required during this period with an arithmetic mean of +5.33

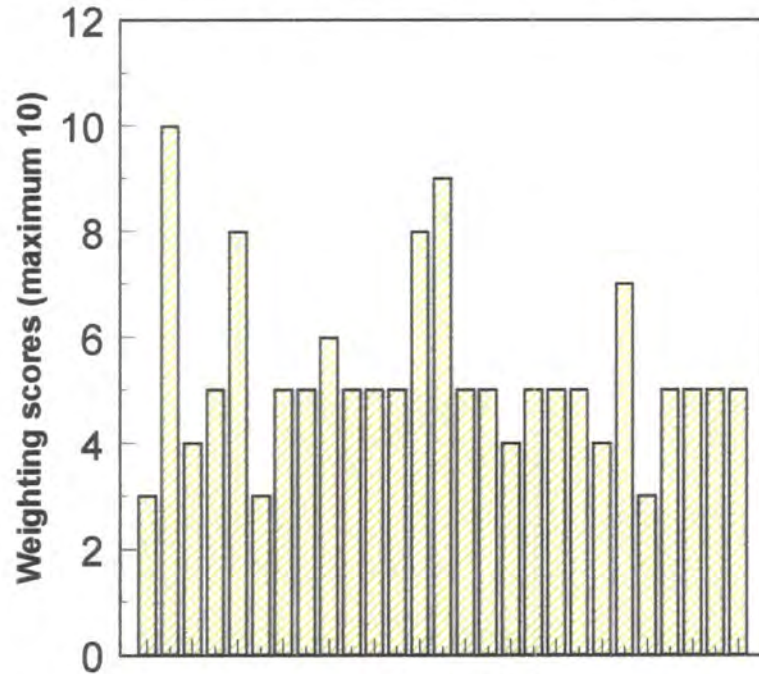

1974 to 1984

1974 = 0

Respondents = 27

+10 = significant increase

-10 = significant decrease

Range of skills required 1984 to 1993

Observation - the respondents indicate a very high level of increase in skills required during this period with an arithmetic mean of +8.74

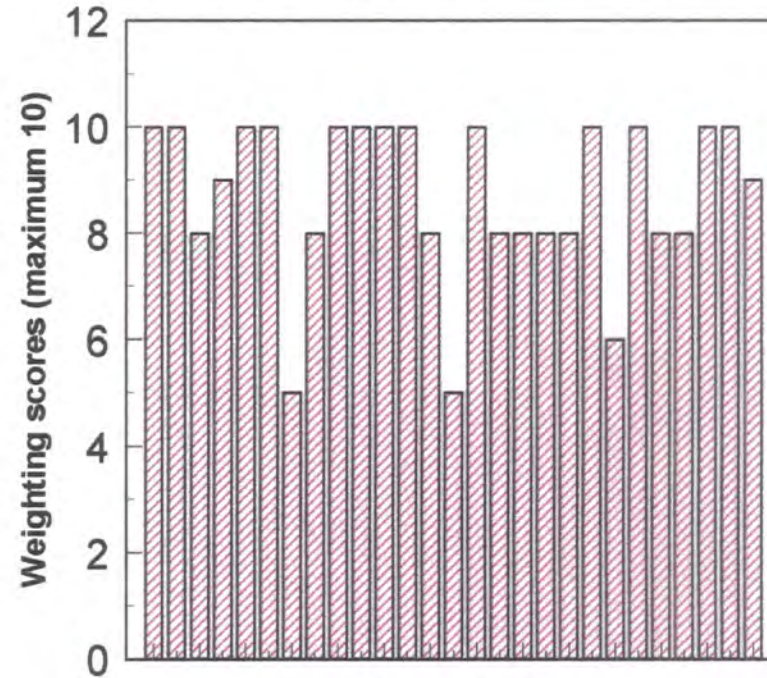

1984 to 1993

1984 = 0

Respondents = 27

+10 = significant increase

-10 = significant decrease

Change in the knowledge of law required by police officers 1974 to 1993

Chart 5.3

Knowledge of law required 1974 to 1984

Observation - the respondents indicate a moderate increase in the level of knowledge required during this period with an arithmetic mean of +4.15

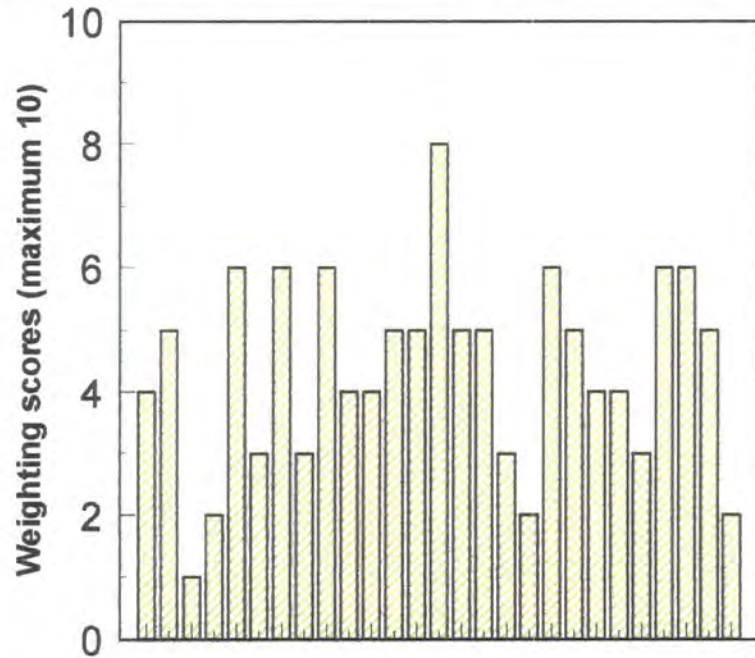

1974 to 1984

1974 = 0

Respondents = 27

+10 = significant increase

-10 = significant decrease

Knowledge of law required 1984 to 1993

Observation - the respondents indicate a high level of increased knowledge of law has been required during this period with an arithmetic mean of +8

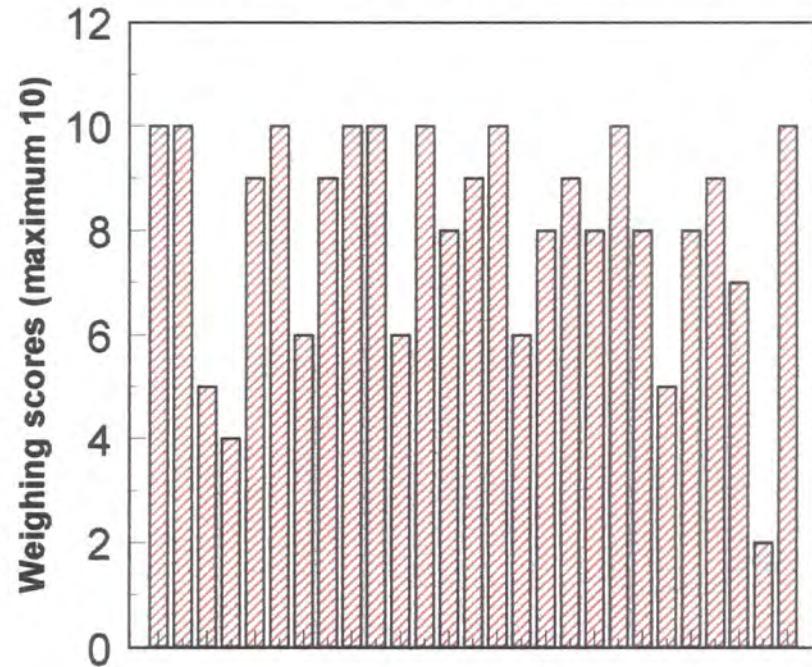

1984 to 1993

1984 = 0

Respondents = 27

+10 = significant increase

-10 = significant decrease

Change in the knowledge of procedures required by police officers 1974 to 1993

Chart 5.4

Knowledge of procedures required 1974 to 1984

Observation - the respondents indicate a moderate increase in procedures during this period with an arithmetic mean of 4.59

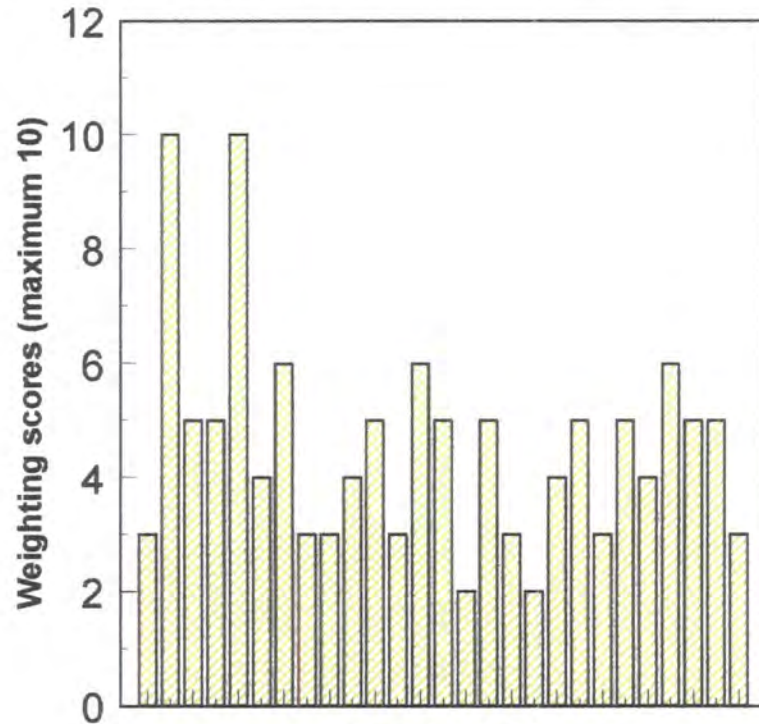

1974 to 1984

1974 = 0

Respondents = 27

+10 = significant increase

-10 = significant decrease

Knowledge of procedures required 1984 to 1993

Observation - the respondents indicate very high levels of increase in procedures during this period with an arithmetic mean of 8.88.

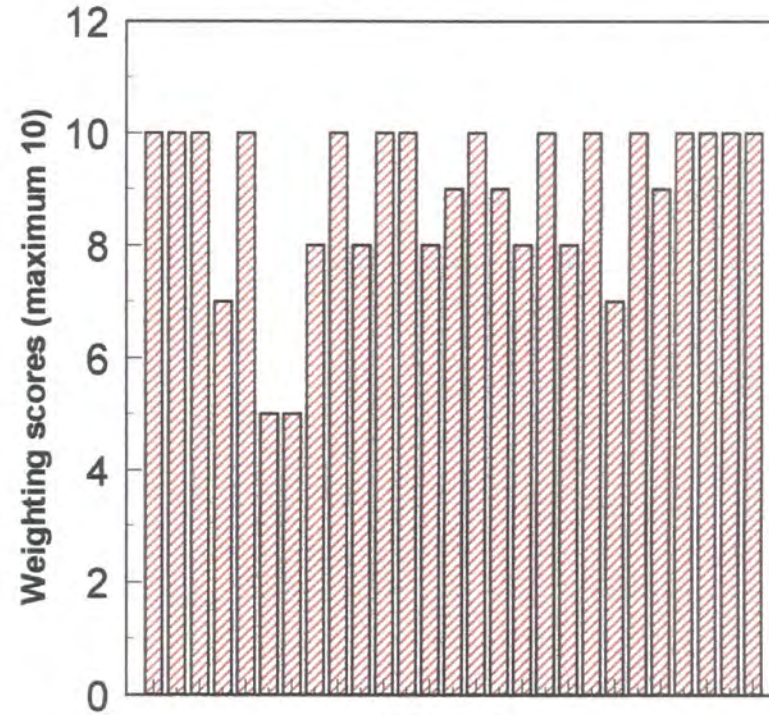

1984 to 1993

1984 = 0

Respondents = 27

+10 = significant increase

-10 = significant decrease

The "Wilcoxon Test" examines the relative scores of each respondent and the direction and magnitude of scoring. If the differences in scoring are found to be not likely to have been caused by random fluctuations, as determined by the "null hypothesis", and that this can be rejected, then the more confident you can become that the findings are significant. The results of the "Wilcoxon Test" for the periods 1974-84 and 1984-93 are shown in Charts 5.5, 5.6 and 5.7. The statistical calculations for the seven subject areas indicate that the results were significant at a 99% level of confidence and in each case the null hypothesis can be rejected. The statistical calculations are given in Appendix 'C'. (Please note that due to the cumulative ranking process utilised in the Wilcoxon ranked sign test, the ranked scoring range shown in charts 5.5 to 5.7 will exceed the normal scoring range of 1 to 10, featured in the actual questionnaire).

Question 2. It has been suggested by the Audit Commission and others that the police service is over-supervised and that only supervisory positions which "add value" should be retained.

Do you believe that officers of your rank and in your present role add value and contribute to the overall efficient running of the Force?

Twenty-four respondents (89%) indicated that their supervisory positions were required by the organisation. Twenty of these (74%) identified that their main contributions to the efficient running of the organisation included, knowledge of law, procedures and acquired experience. Concern is expressed that a reduction in supervisory officers could lead to an increased workload for those remaining:

"I add experience, leadership, breadth of knowledge especially of law and procedures. This allows me to understand the overall situation and balance the use of resources. I also have a wealth and depth of experience in major crime investigations." (Superintendent, respondent 12);

Question 3. Research indicates that the organisational structure of the police service with the present Tripartite system of control resembles that of a 'classical bureaucracy' in which personnel spend significant parts of their time

The Wilcoxon matched signed-ranks test: difference in paired scores for the periods 1974-84 and 1984-93 given by the 27 respondents to question 1: 'Range of skills required'.

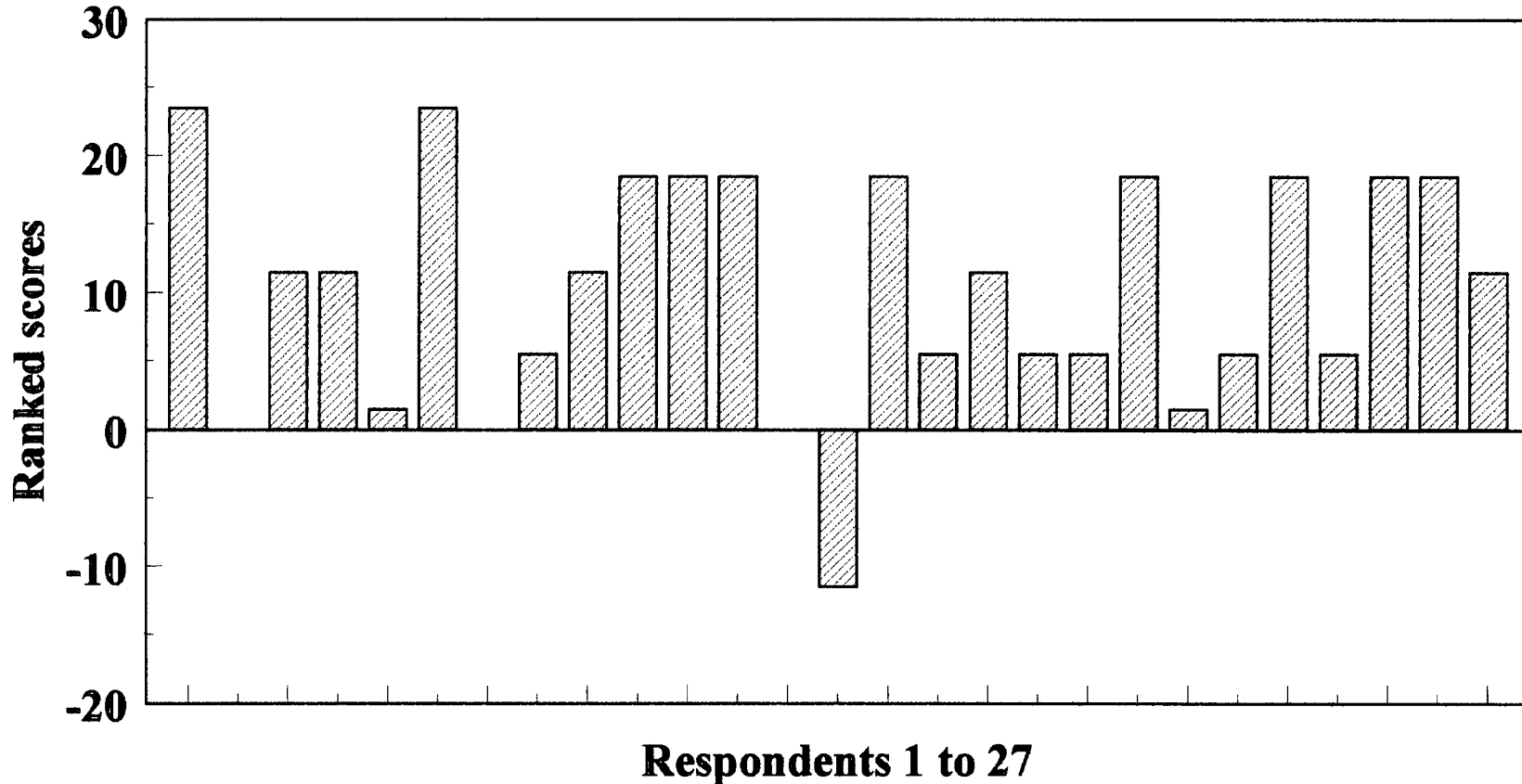

The critical value of T for N = 24 (27-3 tied scores) is 55. The actual value of T is 11.5. The results are significant at a 99% level of confidence.

The Wilcoxon matched signed-ranks test: difference in paired scores for the periods 1974-84 and 1984-93 given by the 27 respondents to question 3: 'Knowledge of Procedures'.

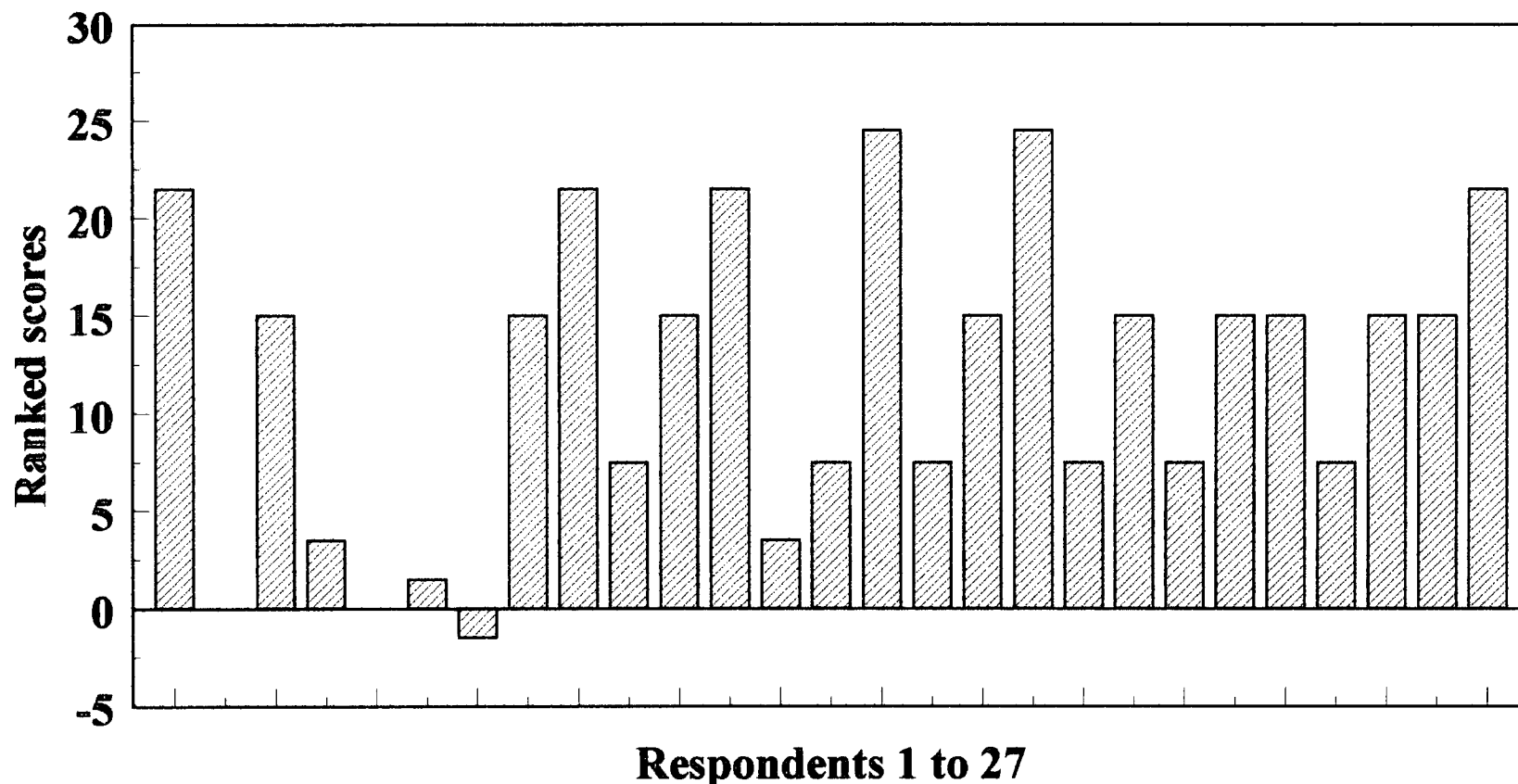

174

The critical value of T for N = 25 (27-2 tied scores) is 68. The actual value of T is 1.5. The results are significant at a 99% level of confidence.

The Wilcoxon matched signed-ranks test: difference in paired scores for the periods 1974-84 and 1984-93 given by the 27 respondents to question 7: 'Stress Levels'.

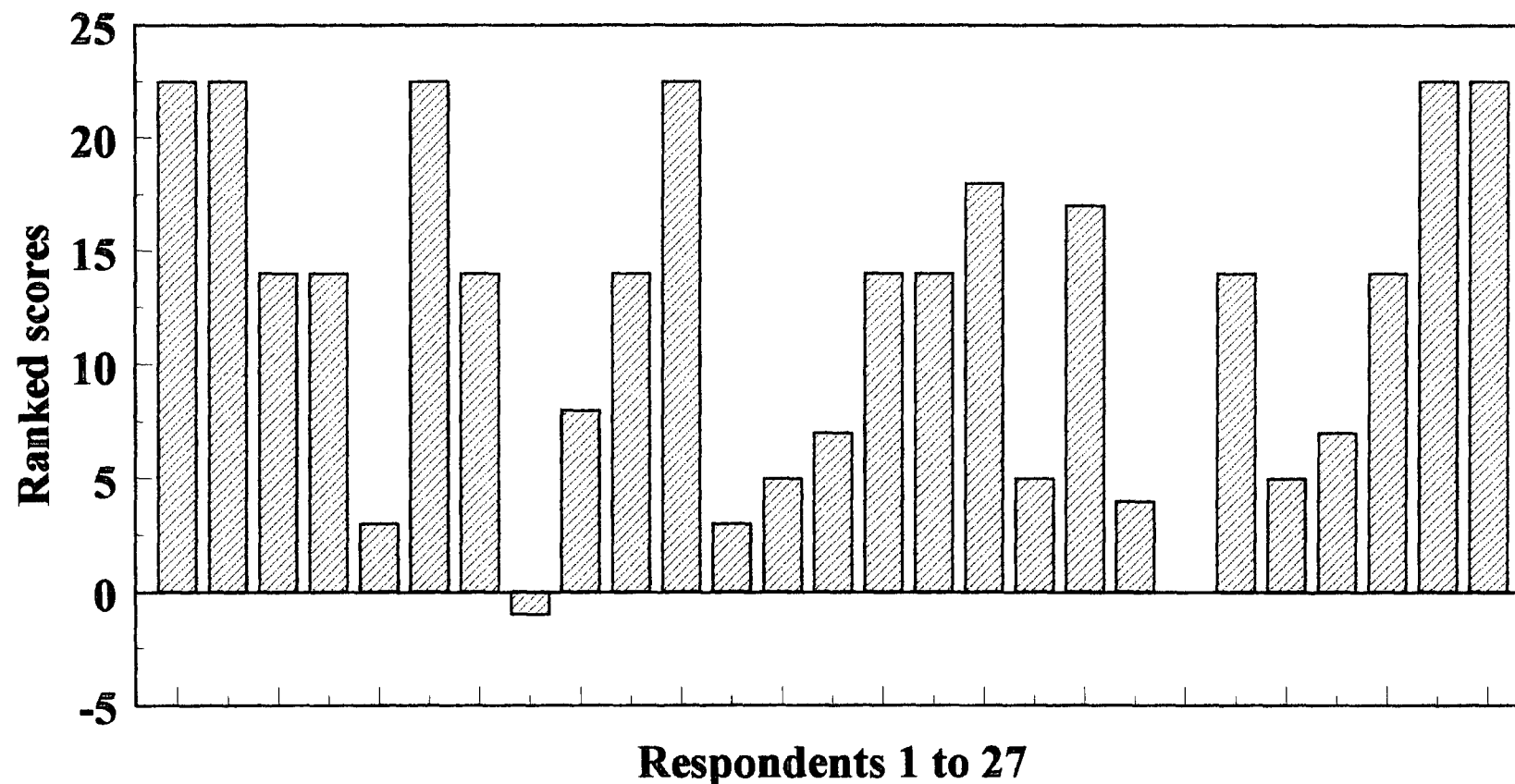

The critical value of T for $N = 26$ (27-1 tied scores) is 76. The actual value of T is 1. The results are significant at a 99% level of confidence.

employed in activities associated with: keeping records; information processing; paperwork; applying rules regulations and policies determined by others. The chief constable of the Metropolitan police force, Sir Paul Condon, in evidence to the Home affairs Select Committee (BBC 23.3.93) stated that he believed the police service was being submerged in bureaucracy and paperwork.

Do you feel that the requirements of 'bureaucracy'

3(i). Influences your style of management?

All twenty-seven respondents indicated that they were influenced and constrained by bureaucracy. Many expressed strong views and saw the requirements of centrally imposed initiatives, or regulations as being excessively time consuming and detrimental to operational policing:

"We have to divert the time and effort that we would spend on the core issues, to concentrate on satisfying the needs of outside bodies. In effect we are focusing our resources away from meeting the needs of the community, to satisfying the requirements of a remote and centralised bureaucracy." (Chief superintendent, respondent 5);

Question 3(ii) - (Bureaucracy) Effects the overall cost of the service provided?

All twenty-seven respondents agreed with this proposition. Many expressed strong sentiments that the tasks they performed and regarded as 'bureaucracy' such as form filling, collection of statistics, compliance with precise procedures, the keeping of records, were the enemy of policing:

"The cost of bureaucracy is increasing with more personnel being moved into non-operational jobs to service administration and statistics, resulting in less operational police officers." (Superintendent 13);

"The additional cost of bureaucracy is very high. However, many of the requirements for bureaucracy come from outside the service, i.e. legislation, the Home Office, HMI. They impose bureaucracy and we

absorb the costs." (Chief inspector, respondent 22)

5.6.1 Summary of the Main Issues Raised in Section D

The respondents identified that the rate of change relating to the skills, capabilities, competencies, and physical or mental capabilities that a police officer requires to possess (evaluated in question 1) were all increasing at a significantly faster rate for the period 1984-93, than in the preceding period of 1974-84. This is reflected in the high level of medical retirements now being experienced by the Cleveland Constabulary that will be explored in Chapter 7.

On the issue of levels of supervision, the respondents recognised the need to reduce cost wherever possible. However, concern was expressed about who would be left to do the work, and would those left be increasingly prone to become victims of 'stress'.

The respondents were unanimous in their condemnation of the levels of bureaucracy involved in police work, particularly with the level of statistics and information that has to be collected to satisfy the requirements of external bodies. They also identified that bureaucracy appeared to be increasing and was absorbing an ever increasing slice of the Force resources to the detriment of operational policing.

5.7 SECTION E. TECHNOLOGICAL SYSTEMS

This section investigates the use of computer and information technology within the Cleveland Constabulary. Question 1 asks the respondents to consider computer systems that they are familiar with and to score each of four subject areas using the conventions described below.

Question 1. Information and computer technology:

Since the introduction of the Police National Computer system (PNC) in 1974, the Force has become increasingly reliant on the use of information and computer technology. In order to establish if you feel that these systems provide value for money, I would like you to assess five systems or networks. Could you please rate each element of the system indicated on a scale of (+ or -) "1" to "10", on the following basis:

- Efficiency** - indicate if you believe it is more or less efficient than the system it replaced.
(-"10" low efficiency "0" no change +"10" high efficiency)
- Resources** - indicate if the system requires more or less resources than the system it replaced.
(-"10" less resources "0" no change +"10" more resources)
- Operational** - indicate if it has resulted in a worse or improved service to operational officers, than the system it replaced.
(-"10" worse service "0" no change +"10" improved service)
- Bureaucracy** - indicate if it has resulted in more or less paperwork or administration being created, than the system it replaced.
(-"10" less bureaucracy "0" no change +"10" more bureaucracy)

The respondents were asked to consider and score each of the four subject areas for the five systems only if they were familiar with the system and they felt that they had sufficient knowledge to make valid judgements in scoring.

To assist the reader who is not familiar with these systems a brief resume will be given of each system:

The Police National Computer (PNC)

The Police National Computer system is a centralised main frame system that is linked into facilities external to the Police, such as the Vehicle licensing centre at Swansea. This can provide information on vehicle ownership, vehicle excise licence details and disqualified drivers. The system interfaces with Criminal

Records and can provide information as to a person's status, such as, that they are known to the police or have a police record, if they are wanted anywhere in the Country for a criminal offence. The system was developed nationally in 1974 to replace manual systems that provided similar information.

Criminal Intelligence System (CIS)

This system was introduced in 1991 and was developed in-house by the Cleveland Constabulary computer development unit (CDU). It provides a database of local criminals known to the police, intelligence about their activities, vehicles and their current Court or warrant status. It has a relational database that interfaces with other computer system to provide a comprehensive intelligence package.

Home Office Large Major Enquiry System (HOLMES)

The system was designed at a national level to meet the requirements for handling high volumes of paperwork for major crime enquiries or other large scale incidents such as the Hillsborough football stadium disaster.

The Crime Recording and Management Enquiry System (CRIMES)

The system was designed in-house by the CDU and introduced in 1988 when it replaced a paper-based system. The computerised system was until 1994 based on a centralised bureau situated at Force headquarters. Reports of crime were either telephoned in direct from the scene or the local police station. The computerised system provides facilities for searching on a wide range of categories and fields, such as: property; location; modus operandi. It is capable of producing a wide range of management and statistical information. However, it is regarded as complex and difficult to operate, therefore the majority of police officers are unable to take full advantage of the range of facilities it offers.

Cleveland Constabulary centralised communication system (COMMS)

The centralised communications system introduced in 1991 brought together under one roof at police headquarters seven previously separate communications centres. The system is controlled via the 'Intergraph' command and control computer system that is equipped with a digital mapping facility and when fully completed an integral management information system. The system is technically sophisticated and places the Cleveland Constabulary at the forefront of innovation in the use of new technology.

The initiative for centralising communications in one centre stems from the Audit Commission Paper number 5 published in 1988 titled "Calling All Forces: Improving Police Communications Rooms." The concept is based primarily on the savings that can be achieved from exploiting 'economies of scale', that is by bringing a group of workers together, in one location to cover peak working periods. It was forecast that the actual number employed in communications would decrease, this would lead to a reduction in costs.

To give the reader some guidance as to the type of system that it is desired to create an example will be given of an 'ideal' system.

Desired characteristics	Ideal scoring range
Increase in overall efficiency	= +5 to +10
Stable or reduced resource costs	= 0 to -10
Improvement in operational efficiency	= +5 to +10
Stable or reduced bureaucracy	= 0 to -10

The arithmetic mean of the respondents scores for each subject area has been calculated. The mean scores are shown in Table 5.7.

System	Number of respondents	Overall efficiency	Resources	Operational efficiency	Bureaucracy
1. PNC	27	+9.15	+0.07	+9.15	-1.5
2. CIS	21	+6.85	+0.95	+1.45	-0.4
3. HOLMES	23	+6.74	+3.81	+5.55	+1.41
4. CRIMES	24	+0.29	+6.75	-1.13	+5.38
5. COMMS	22	-2.66	+7.48	-3.66	+2.28

Table 5.7 The respondents scoring indicating their perceptions as to the impact that change to the systems has had on the four subject areas.

The nature and consistency of scoring for the PNC, centralised communications and CRIMES systems are illustrated in Charts 5.8, 5.9, and 5.10.

A hypothesis to be tested is that computer systems designed to meet the operational needs of police officers, such as the PNC system and CIS, are highly regarded and valued by those who utilise their outputs. Whereas those systems that have been designed to handle administrative tasks and provide management information, are regarded as less successful, resource intensive with a tendency to increase rather than reduce bureaucracy.

The PNC system displays characteristics that indicate it can be regarded as a model for success. Whereas the centralised communications system is regarded as displaying characteristics of inefficiency. These are shown in Table 5.8.

PNC		Centralised communications	
High overall efficiency	+9.15	Lower overall efficiency	-2.66
Stable resource costs	+0.07	High resource costs	+7.48
High operational efficiency	+9.15	Lower operational efficiency	-3.66
Small decrease in bureaucracy	-1.5	Small increase in bureaucracy	+2.28

Table 5.8 The respondents scores illustrate the different perceptions of the two systems.

The Police National Computer System

Chart 5.8

Author's interpretation - the system displays characteristics that indicate it is regarded by the respondents as being efficient and cost effective. The characteristics of this system can be regarded as a 'model' for other systems:

High overall efficiency	+9.15	Low resource costs	+0.07
High operational efficiency	+9.15	Decreased bureaucracy	-1.5

Overall efficiency of the system

+10 = High efficiency
-10 = Low efficiency

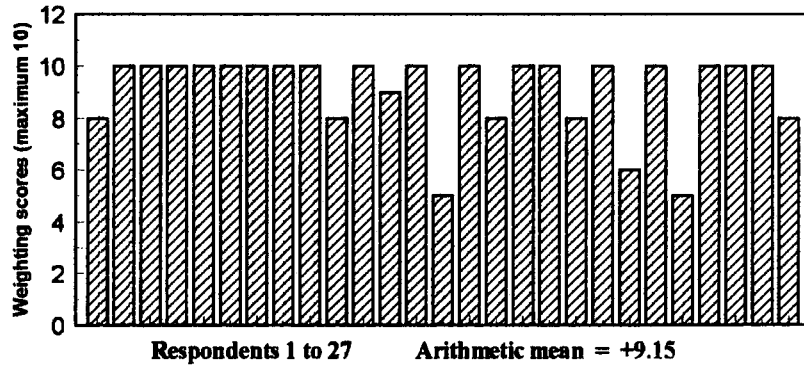

Resource requirements of the system

+10 = Increase in resources to operate system
-10 = Decrease in resource requirements of the system

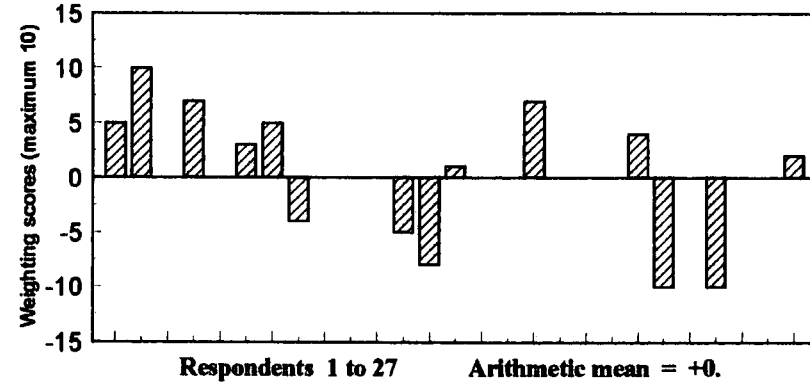

Operational efficiency of the system

+10 = Significantly improved service for operational officers
-10 = Significantly worse service for operational officers

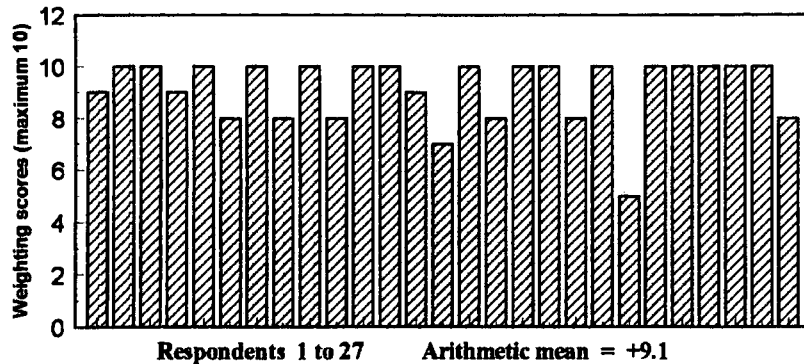

Levels of bureaucracy related to system

+10 = A significant increase in bureaucracy
-10 = A significant decrease in bureaucracy

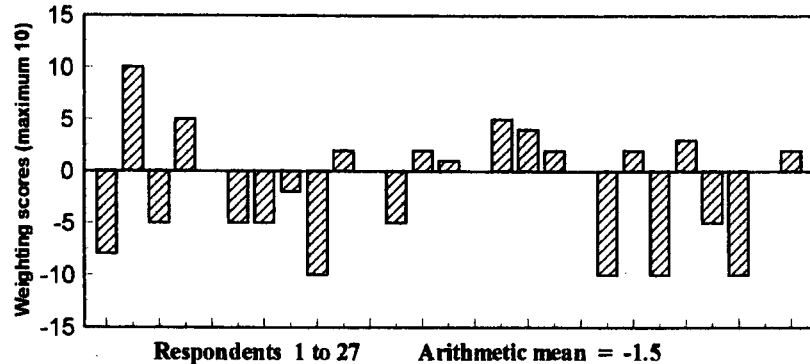

The Centralisation of Communications

Chart 5.9

Author's interpretation - The respondents have indicated that the system displays characteristics that are regarded as being in-efficient, costly and operationally in-effective. The system can be regarded as being in need of review:

Low overall efficiency	-2.66	High resource cost	+7.48
Low operational efficiency	-3.66	Increased bureaucracy	+2.28

Overall efficiency

+10 = high efficiency system
-10 = low efficiency system

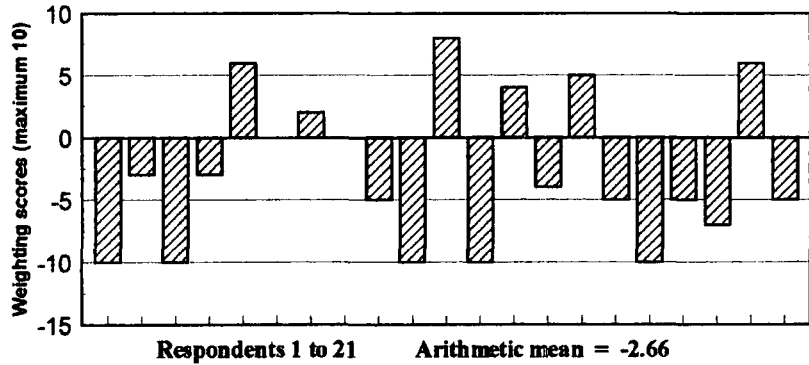

Resource implications

+10 = more resources
-10 = less resources

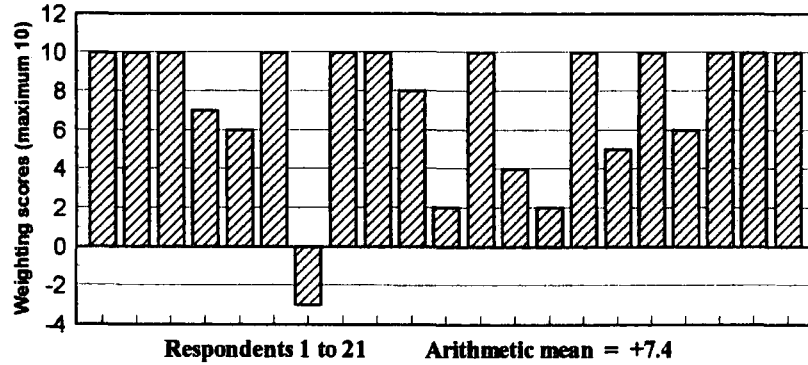

Operational efficiency

+10 = improved service
-10 = worse service

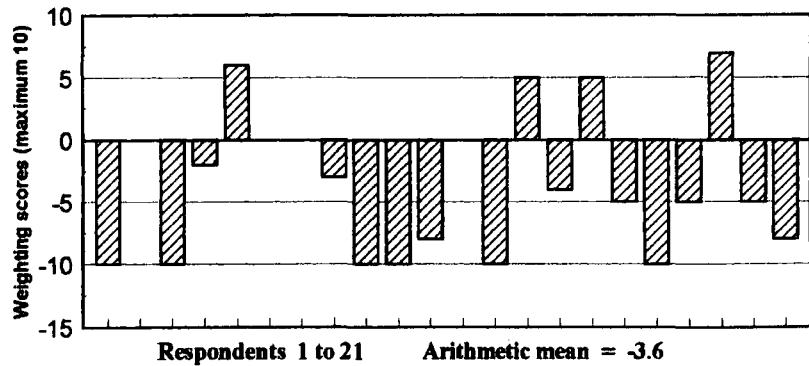

Bureaucracy

+10 = more bureaucracy
-10 = less bureaucracy

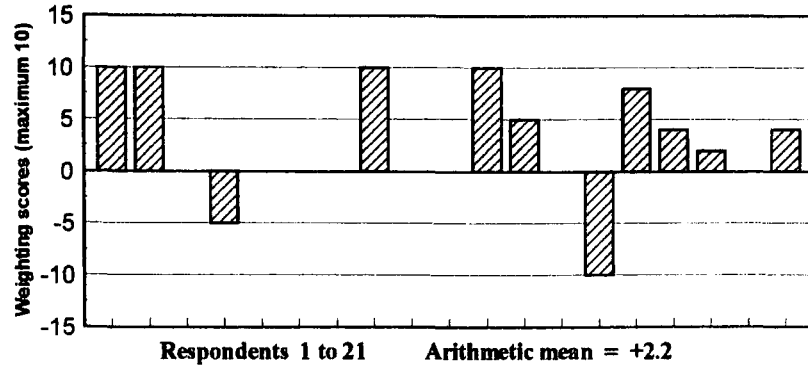

The CRIMES system

Author's interpretation - the system displays characteristics that indicate it is regarded by the respondents as being in-efficient, costly, bureaucratic and operationally in-effective. The system can be regarded as being in need of review:

Low overall efficiency +0.29

High resource cost +6.75

Low operational efficiency -1.13

High levels of bureaucracy +5.38

Overall efficiency of the system

+10 = high efficiency system

-10 = low efficiency

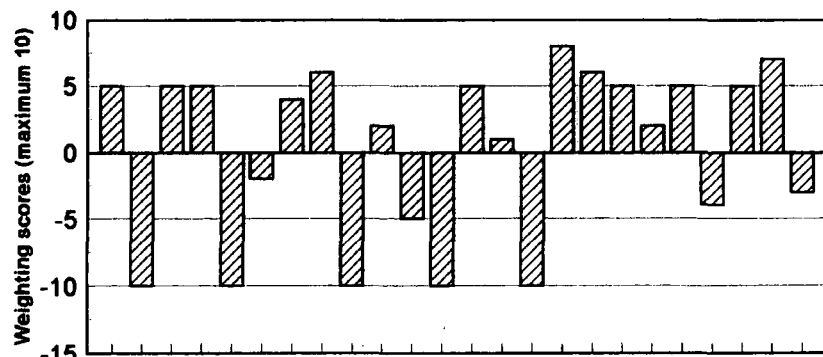

Respondents 1 to 24 Arithmetic mean = +0.29

Resource implications

+10 = more resources

-10 = less resources

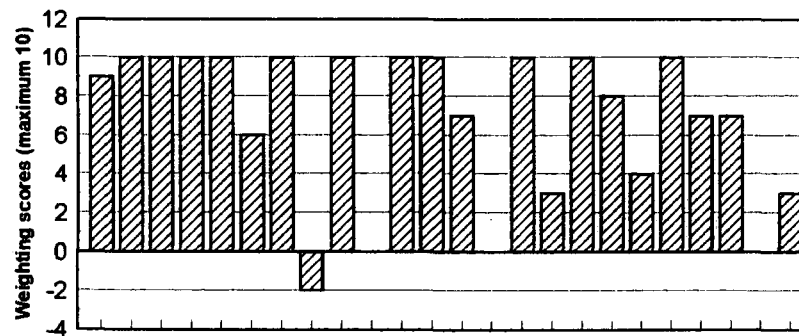

Respondents 1 to 24 Arithmetic mean = +6.7

Operational efficiency

+10 = improved service

-10 = worse service

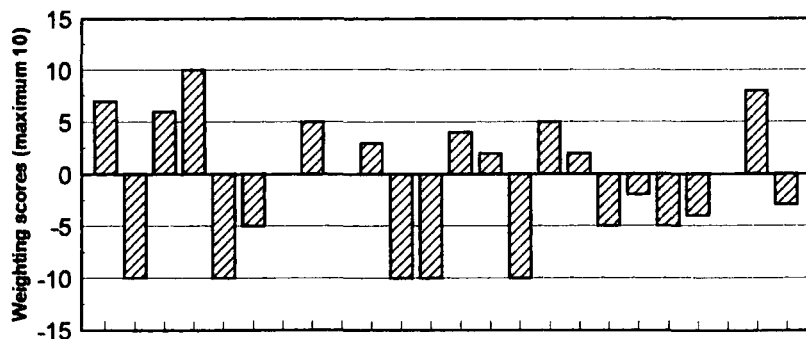

Respondents 1 to 24 Arithmetic mean = -1.

Bureaucracy

+10 = more bureaucracy

-10 = less bureaucracy

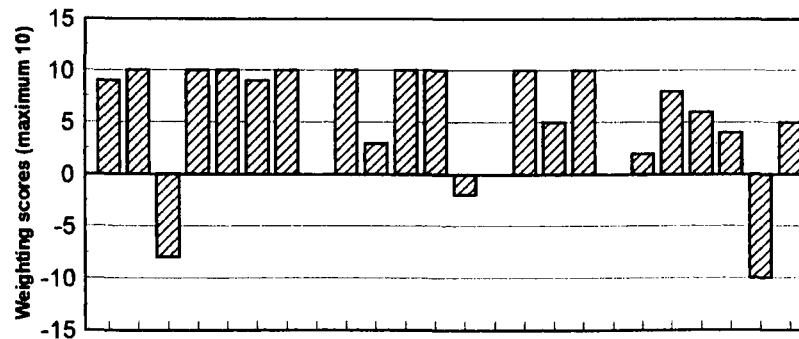

Respondents 1 to 24 Arithmetic mean = +5.3

The five systems and the four subject areas that are being evaluated are compared in Chart 5.11. The manner and consistency of scoring illustrated in the graphical presentation shows that respondents express a clear belief that two systems, central communications and CRIMES are: resource intensive; have increased bureaucracy; reduced operational efficiency, and in the case of centralised communications reduced overall efficiency.

The respondent's perceptions on the effect of introducing new technology and computer systems into the Cleveland Constabulary

Chart 5.11

186

Changes in 'overall efficiency' since implementation
(+10 = significant increase -10 = significant decrease)

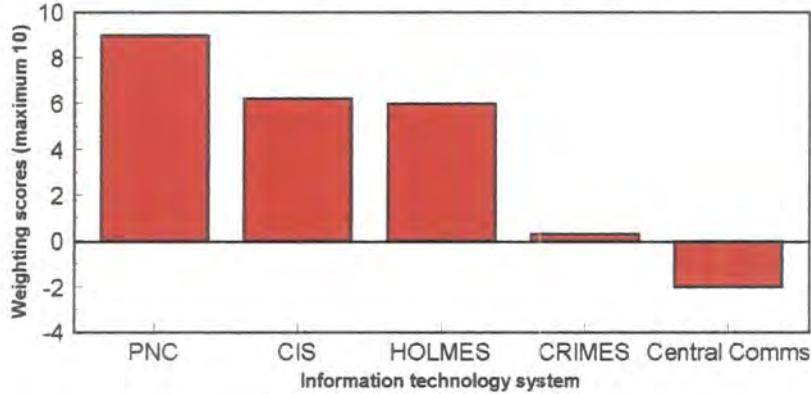

Changes in 'resources' since implementation
(+10 = significant increase -10 = significant decrease)

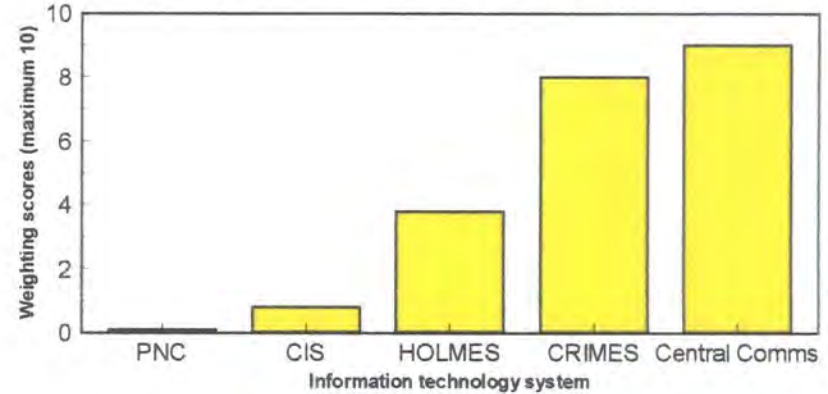

Changes in 'operational efficiency' since implementation
(+10 = significant increase -10 = significant decrease)

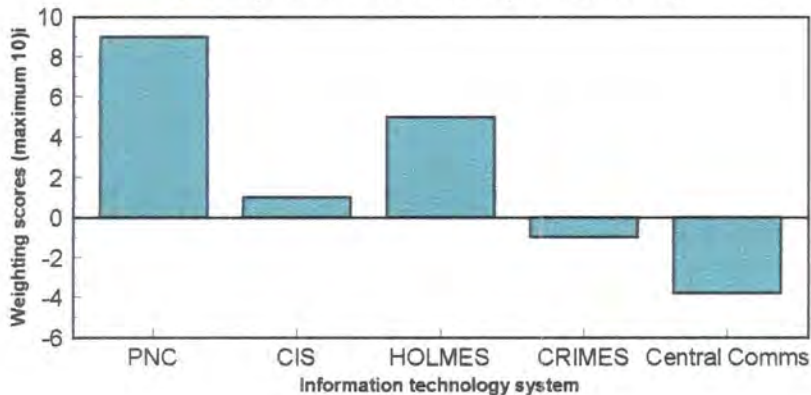

Changes in 'bureaucracy' since implementation
(+10 = significant increase -10 = significant decrease)

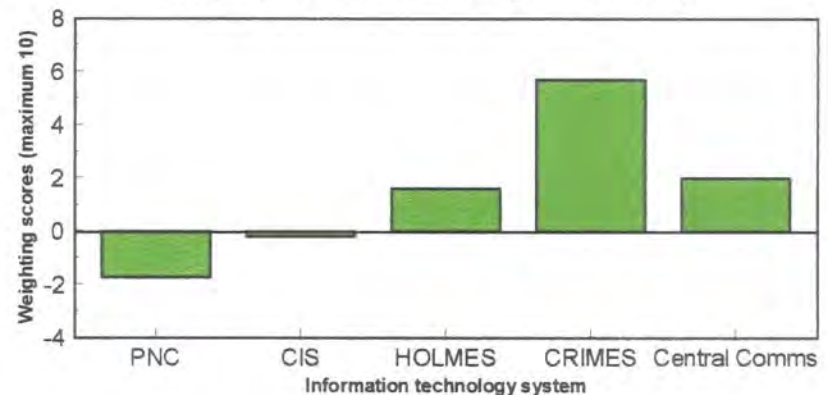

Question 2. What measures do you think should be used to assess the success/failure of such systems?

The main issues that the respondents considered must be satisfied in order that the system can be regarded as being successful: (n = 27)	Total	
(agree)	[n]	[%]
That the system should improve overall efficiency	20	74
That the system should be designed to meet the users needs	16	59
That the system should not increase costs	22	81
That the system should reduce bureaucracy	12	44

Table 5.9 Quantified data from question 2 (Section E)

The overwhelming feeling emanating from the respondents was that the computer systems within the Cleveland Constabulary did not satisfy the basic criteria listed above. Many respondents expressed the view that computerisation was expensive and in-efficient:

"They must exist to serve officers and not the other way round with officers existing to serve a computerised bureaucracy. They should not increase costs, they are a luxury item, not a basic requirement." (Chief superintendent, respondent 5);

"We have a tendency to turn paper based bureaucracies into computer bureaucracies. The systems must be designed to the users specifications and not to satisfy the ambitions of the designer." (Sergeant, respondent 27)

Question 3. What are your views on the gathering of evidence by new technology, for example closed circuit television (CCTV); remote cameras, etc.?

All of the respondents (100%) were in favour of introducing and extending the use of new technology for operational policing. The use of CCTV was viewed as being particularly beneficial for gathering evidence. However, eighteen respondents (67%) identified that the police would have to invest more finance for its provision:

"I totally support the use of new technology and we must keep up with technological advances to stay ahead of the criminals, but this will require investment. What is really needed is the development of national systems

so that the whole of the country will be using compatible systems." (Chief inspector, respondent 25)

Question 4. If closed circuit television or other automatic detection devices are to be utilised on a wider scale, for example, town centre streets, public car parks. Do you feel that this function should be carried out by the police, or in partnership with other agencies?

All respondents (100%) favoured a partnership approach to CCTV. Many indicated the Force had already entered into schemes with other organisations under the initiatives known as 'safer cities' in Hartlepool and 'city challenge' in Stockton. Eighteen (67%) suggested that the role of the police should be primarily that of encouraging self development and the provision of knowledge, skills in respect of procedures to ensure that the intelligence gained can be utilised as evidence in Court proceedings:

"The system that we are currently working on will be centrally controlled by the Council and we will have monitoring facilities. There needs to be close co-operation, sharing skills, to ensure that the procedures created are well defined and protect the integrity of the system and the evidence gathered from it." (Chief superintendent, respondent 5)

Question 5. What are your views on entering into a commercial partnership with other agencies to fund such systems?

The majority of respondents, twenty-five (93%) were in favour of entering a commercial partnership with other agencies, the main reason expressed was that the police could not afford to finance the schemes themselves. However, some had reservations that the police were compromising their independence or that the partnership may end and the police would become responsible for financing the scheme:

"I fully support the partnership approach providing that the funding is secured on a long term basis and that it doesn't dry up leaving the police to pick up the tab." (Chief superintendent, respondent 3)

5.7.1 Summary of the Main Issues Raised in Section E

The respondents scoring of the five systems and the four individual elements under evaluation in question 1 clearly indicate that there are high levels of dissatisfaction with computerised systems within the Cleveland Constabulary.

Question 2 explored the reasons for this dissatisfaction and respondents stated that the design of some computer systems appeared to have changed manual based systems into computer based bureaucracies. These systems are resource intensive and in-efficient and in some cases the increased expenditure had been funded to the detriment of operational policing.

The respondents indicated in question 3 that they were in favour of the use of new technology in the field of operational policing. They suggested that the Force should have invested heavily in these areas at a much earlier stage. The respondents saw the use of close circuit television and covert surveillance equipment as the way forward for the gathering and presenting evidence to the Courts.

The respondents were fully supportive of adopting a partnership approach with other organisations for developing and running close circuit television systems. The police viewed their role in the partnership as that of providing expertise and making use of the output of the systems.

5.8 SECTION F. LEGISLATION

1. The police service over the last decade has been affected by a vast range of legislation, directives and initiatives' directives all requiring some level of 'change'.

To assess how the main changes have affected the Force, can you select four changes from the list that you are familiar with and that you believe have had

the most significant impact on the way that police officers carry out their duties. One of these changes should be the Police and Criminal Evidence Act 1984 (PACE)

Can you please rate how you feel that these changes have affected the key areas indicated on a scale of (+ or -) "1" to "10" on the following basis:

Efficiency - Indicate if you believe that the change has led to a more or less efficient service

("-10" very low efficiency "0" no change "+10" very high efficiency)

Resources - indicate if you believe that the change has led to an increase or decrease in resources required.

("-10" less resources "0" no change "+10" more resources)

Operational - indicate what you believe the effect has been on productivity.

("-10" decreased productivity "0" no change "+10" increased productivity)

Bureaucracy - indicate how you believe the change has resulted in more or less bureaucracy (can be regarded as rules, regulations, procedures).

("-10" less bureaucracy "0" no change "+10" more bureaucracy)

Police and Criminal Evidence Act 1984	Children Act 1991
Home Office circular pre-trial issues	Criminal Justice Act 1991
Home Office circular equal opportunities	Road Traffic Act 1991
Home Office circular career development	HMI quality of service initiatives
Home Office circular domestic violence	Tape recording of interviews

The respondents were asked to complete the PACE question and then select three other subjects with which they were familiar and that they felt they had sufficient knowledge to make valid judgements in scoring.

To assist the reader who is not familiar with these subjects a brief resume will be given of each change:

The Police and Criminal Evidence Act 1984 (PACE)

This major piece of legislation was introduced in 1986 and has since been refined and amended (1991). It dictates the way in which people coming into contact with the police are dealt with. The majority of recommendations deal with people who are suspected of committing an offence. It covers such areas as: stop and search; searching of vehicles and premises; rights and conditions of detention for those arrested; the conduct of police officers when interviewing suspects.

Home Office Circular on pre-trial issues

This circular contained one hundred and fifty-five recommendations relating to the preparation of case files for the Crown Prosecution Service (CPS).

Home Office Circular on Equal Opportunities

The acceptance of this circular led to the creation of an equal opportunities unit and the implementation of a training programme for all personnel in the Force.

Home Office Circular on Career Development

This circular recommended the introduction of a 'tenure of service' policy whereby departmental postings such as: road traffic patrols; criminal investigation; drugs squad; that were classified as involving specialist knowledge were subjected to fixed lengths of service ranging from two to seven years.

Home Office Circular on Domestic Violence

The circular highlighted the need to take more positive action through arrest and prosecution when dealing with domestic violence. This can lead to an increasing number of prosecution files.

Children Act 1989

The Act came into being in October 1991 and introduced significant changes to the police procedures in respect of children. The changes included the

introduction of a 'designated' officer for dealing with the rights of children. The Act also directed a closer liaison between the police and other agencies that necessitated additional training requirements.

Criminal Justice Act 1991

The Act came into being in March 1992, and introduced a wide range of measures for dealing with those convicted of offences as well as procedures for processing evidence. The Act introduced income related fines and the citing of previous convictions for the purposes of sentencing. The main impact of the Act on the police was contained in clause 44 that introduced the use of video recorded interviews with children who were the victims of sexual or physical abuse. This necessitated the creation in Cleveland of four studios equipped with video facilities, secure storage facilities, viewing facilities and associated administrative systems to ensure the integrity of the taped interviews.

Road Traffic Act 1991

The Act allows the use of automatic detection for the detection of speeding offences and traffic light violations. This gives the capacity to increase levels of prosecution for this type of offence however this will result in a requirement to increase processing capacity.

Her Majesty's Inspectorate of Constabulary (HMIC) Quality of Service Initiatives

The new HMIC statistical returns require the provision of significant amounts of extra data, all of which requires collection, analysis, monitoring and interpretation.

Tape Recording of Interviews with persons in police custody

This initiative was introduced progressively throughout Cleveland between 1988 and 1992. It allows for a high integrity record to be made of interviews with suspects. However, the Courts have shown a reluctance to actually play the

recordings and will only do so under the provision that a full written record is prepared. A trained audio typist takes on average seven hours to transcribe one forty-five minute interview.

To give the reader guidance as to the type of changes in legislation that is regarded as desirable to the police service, an example will be given:

Desired characteristics	Ideal scoring range
Increase in overall efficiency	= +5 to +10
Stable or reduced resource costs	= 0 to -10
Improvement in operational efficiency	= +5 to +10
Stable or reduced bureaucracy	= 0 to -10

The arithmetic mean of the respondents scores for each subject area has been calculated. The mean scores are compared in Table 5.10.

Legislation	Number of Respondents	Overall efficiency	Resources	Operational efficiency	Bureaucracy
1. PACE	27	-0.3	+7.44	+5.04	+8.56
2. Taped interviews	17	+5.29	+3.24	+0.11	+5.35
3. Equal opportunities	16	-3.18	+6.38	-3.81	+8.5
4. Pre trial issues	14	-2.7	+6.66	-3.4	+8.4
5. HMIC quality of service	8	+0.28	+5	0	+5.25
6. Career development	7	+0.28	+4.14	+0.75	+8.14
7. Criminal Justice Act	7	-6.57	+5.42	-6.71	+4.14
8. Domestic violence	5	+3.2	+3.4	+2.8	+3.6
9. Children Act	1	N/A	N/A	N/A	N/A
10. Transport Act	1	N/A	N/A	N/A	N/A

Table 5.10 The respondents scoring indicating their perceptions as to the impact that change has had on the four subject areas.

The nature and consistency of scoring for PACE, tape recording of interviews and equal opportunities are illustrated in Charts 5.12, 5.13, and 5.14.

A hypothesis to be tested is that changes in legislation that the police have to implement often result in high resource costs and increased bureaucracy. That

The Police and Criminal Evidence Act 1984

Author's interpretation - since the implementation of PACE police practices in respect of those arrested and other procedures have standardised and improved, this has resulted in high costs and increased bureaucracy, this has effected operational effectiveness:

No change in overall efficiency

-0.3

High resource costs

+7.44

Moderate decrease in operational efficiency

-5.04

Significant increase in bureaucracy

+8.56

Overall efficiency since implementation

Resource implications

+10 = High efficiency

+10 = Increase in resources

-10 = Low efficiency

-10 = Decrease in resources

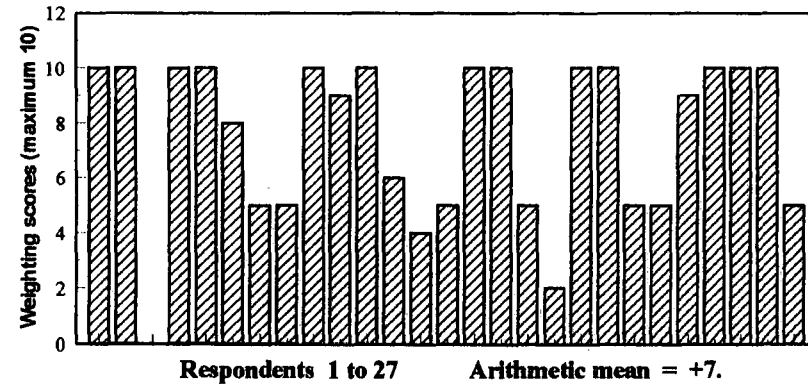
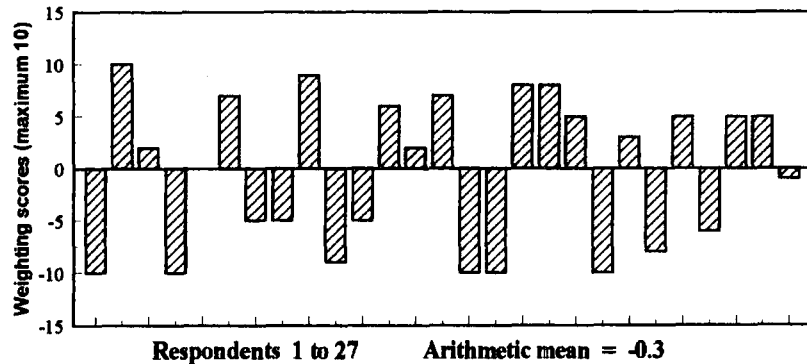

Effect on operational police officers

+10 = Significantly improved conditions for operational officers

-10 = Significantly worse conditions for operational officers

Level of bureaucracy since implementation

+10 = A significant increase in bureaucracy

-10 = A significant decrease in bureaucracy

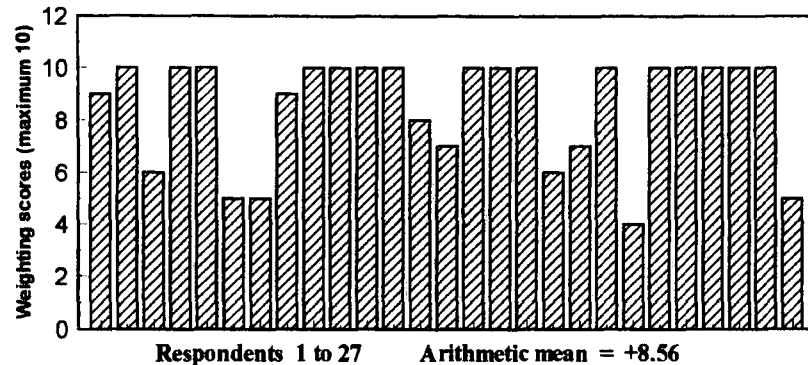
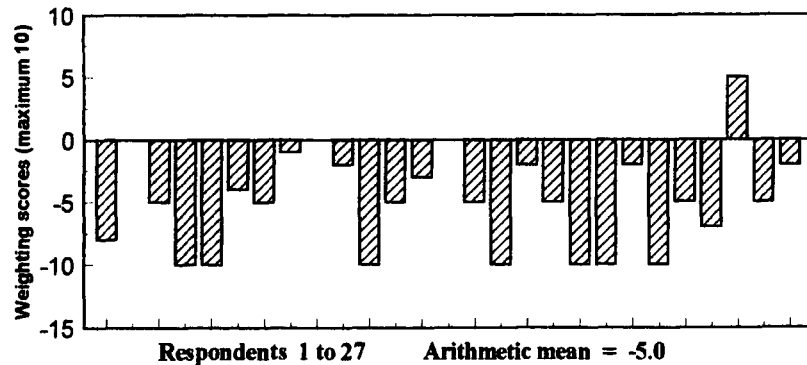

The tape recording of interviews (1988)

Chart 5.13

Author's interpretation - since the introduction of these recommendations there has been a moderate improvement in overall efficiency achieved with a small rise in resource costs and a moderate increase in bureaucracy. There appears to have been little change in operational efficiency:

Moderate increase in overall efficiency	+5.29	Slight increase in resource costs	+3.24
No change in operational efficiency	+0.11	Moderate increase in bureaucracy	+5.35

Overall efficiency since introduction

+10 = High efficiency
-10 = Low efficiency

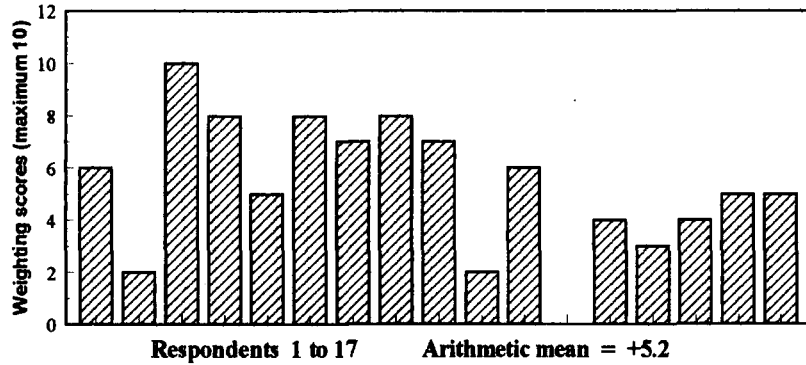

Resource implications

+10 = Increase in resources
-10 = Decrease in resources

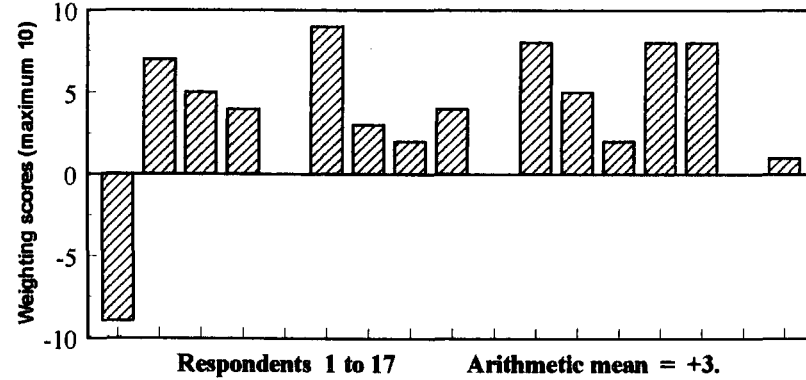

Effect on operational police officers

+10 = Significantly improved conditions for operational officers
-10 = Significantly worse conditions for operational officers

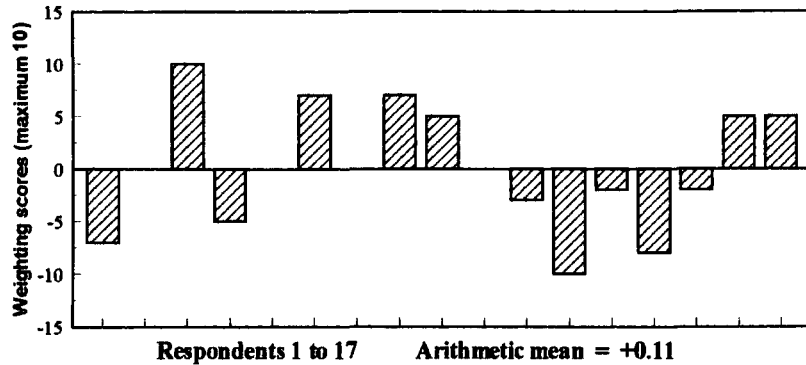

Level of bureaucracy since implementation

+10 = A significant increase in bureaucracy
-10 = A significant decrease in bureaucracy

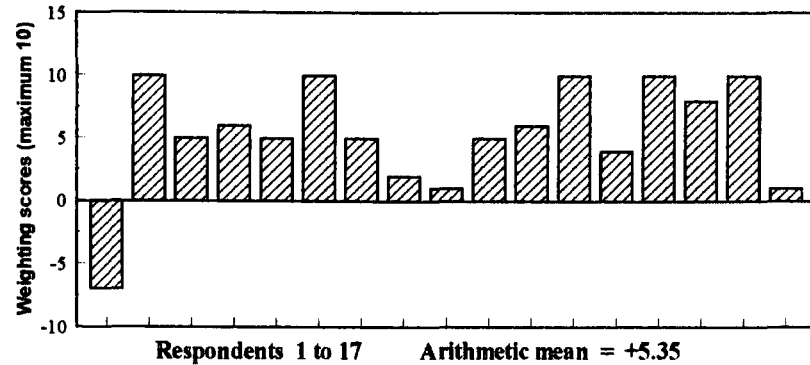

Home Office circular on Equal Opportunities

Author's interpretation - The implementation has resulted in high costs and increased bureaucracy, this in turn has effected operational effectiveness:

Small reduction in overall efficiency -3.18 High resource costs +6.38

Small reduction in operational efficiency -3.81 Significant increase in bureaucracy +8.5

Overall efficiency since implementation

+10 = high efficiency
-10 = low efficiency

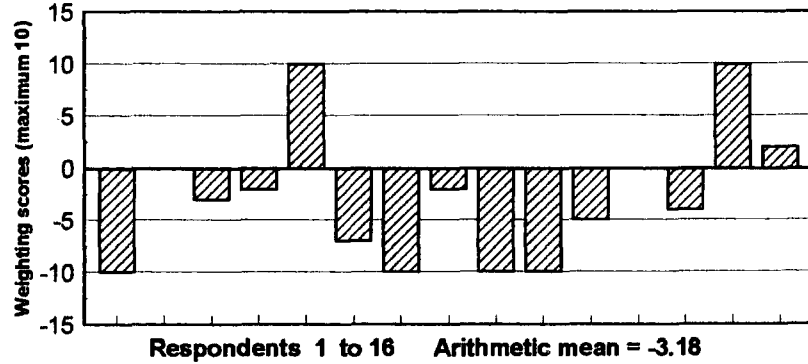

Resource implications

+10 = more resources
-10 = less resources

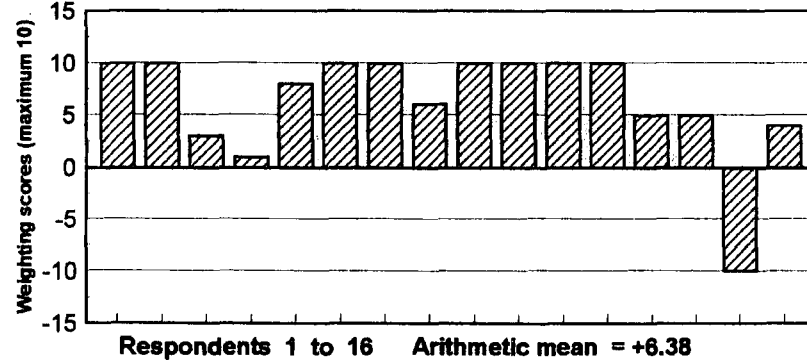

Operational efficiency

+10 = improved service
-10 = worse service

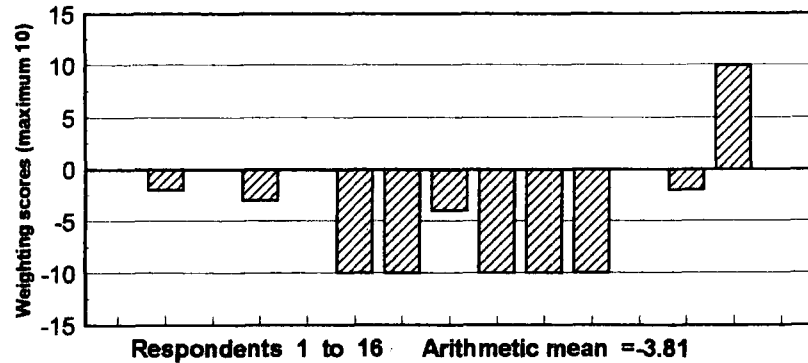

Bureaucracy

+10 = more bureaucracy
-10 = less bureaucracy

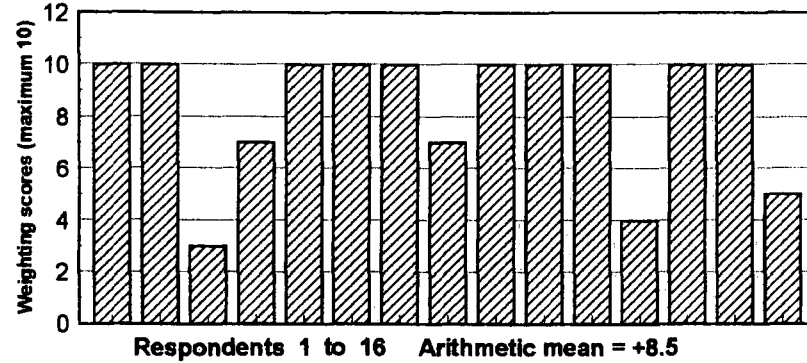

increases in these two areas can impact on the areas of overall efficiency and operational efficiency.

The overall picture that emerges from this research is that the impact of implementing change fails to be considered or if it is, ignored, by those in the external environment who formulate legislation.

5.8.1 Summary of the Main Issues Raised in Section F

The cost of implementing changes in legislation has to be met from existing budgets. This means that extra, often resource intensive work, such as additional training, the design or modification of administrative systems and procedures, has to be undertaken. This is achieved by diverting resources away from operational policing.

5.9 SECTION G. EXTERNAL INFLUENCES ON THE POLICE SERVICE

The section consists of five questions, the first three relate to the Audit Commission. The questions were preceded by the following explanation.

The Audit Commission

In February 1987, the Audit Commission commenced its 'special study' into the police service. Howard Davies, the former controller outlined that the studies were 'to develop methodologies which would be of use to authorities and their auditors in getting to grips with issues surrounding value for money'. Davies believes that the police are over controlled by the Home Office, Police Authorities and by Force headquarters. That performance can be enhanced by a major push to delegate responsibility and accountability downward.

The Commission has produced a series of eleven papers. I have extracted from these, what I believe are the key themes and I would like your views on these or

any other issues you may wish to raise. It is appreciated that some of the issues were raised prior to the studies, for example Home Office Circular 113/84, Economy, Efficiency and Effectiveness. However, the Commission has added their own dimension to these issues.

Civilianisation

Question 1 The Commission consistently state that most tasks that a police officer carries out can be carried out cheaper by a non-police officer.

1(i). The concept of civilianisation appears to rely on employing predominately single skilled or unskilled personnel on relatively low pay compared to that of a police officer.

(a). Do you feel that this limits your scope for deployment of such personnel? Please discuss

(b). Do you think that the Force should improve career development opportunities for civilian personnel by widening their skill base? Please discuss

Twenty-six respondents (96%) indicated that the replacement of police officers by civilians could lead to a loss of flexibility in deployment. That this could lead to an increased costs and additional training requirements:

"A police officer is multi-functional skilled in a wide range of areas many of which overlap. A civilian can generally be only used in one role, therefore you need more and costs rise."

(Chief superintendent, respondent 1)

On the issue of career development training, twenty-one respondents (78%) were in favour whilst six were against. Of those in favour many expressed the view that there was a danger that costs would begin to increase. Examples of both sides of this debate will be given:

"This may raise expectations and cost. If we have employed for one reason, to save money, then we should stick to it. If you actually take into account the loss of experience when police officers go off sick and the cost of pensions. This solution may not be the very cost effective one which was

sold to the police in the first place." (Chief superintendent, respondent 1)

"Yes, but it will cost. Additional responsibilities and skills attract a re-grade. However, if you leave someone in a low skilled job when they wish to develop you may find that they show little commitment to that job or the police service." (Chief inspector, respondent 26)

Performance measurement

Question 2. Davies states that 'performance measurement is the cornerstone of delegation' (Controller's address to ACPO 3 October 1990).

What do you think will be the effect of the development and implementation of:

2(i). National performance measures

2(ii). District/Departmental performance measures

On the issue of national performance measures all twenty-seven respondents (100%) were against their use. Many expressing concern that their use could lead to a diversion of resources into quantifiable areas to the detriment of locally determined needs:

"I think this will be detrimental with senior officers worrying about getting the right ticks in the right boxes, losing sight of the service we should be providing to the public. We may become producers of statistics, sacrificing quality for quantity." (Superintendent, respondent 14)

"The police service will become a commercial rather than a caring organisation. It may end up purely as a law enforcement agency to the detriment of the public." (Chief inspector, respondent 23)

On the issue of District/Departmental performance measures there was a virtual split with fifteen respondents (55%) being in favour and twelve (45%) being against their use:

"Certain departments can be judged on performance, but there are a wide range of intangible factors that can't be measured. You end up being judged on quantity and not quality, for example the traffic department tends to be judged on the number of offences processed. This does not always benefit the public." (Chief inspector, respondent 18)

Financial accountability

Question 3. The Commission recommends that supervisory officers at all levels should develop a management role that integrates financial and operational responsibility. Davies states (Controllers address to ACPO 3 October 1990) *'the starting point should be to ensure that the financial framework reinforces the structure of accountability'*. This system leads to and relies on top-down control.

Alternative views are being expressed that this type of system has severely damaged American industry, where over the last forty years finance has become the dominant discipline with the work force manipulating processes to achieve quantified targets. Johnson states *'if companies are to compete effectively, they must remove accounting information from their operational control systems and relieve their accounting departments of responsibility for providing information to control business operations'*. (Johnson, *Relevance Regained* 1992 :xi) Johnson argues that financial accounting processes act in opposition to total quality management and that what is required is the bottom-up empowerment of those workers who are close to the customer and who carry out the processes.

3(i) What are your views on this issue of extending financial accountability downwards and the effects this may have on the quality of service provided?

Eighteen of the respondents (66%) were against the extension of devolved financial management. Their main concerns were inadequate financial systems, autocratic control and that to pay for the system, services to the public would have to be cut. Nine (44%) were in favour of extending such systems, however eight of these expressed reservations that there would be a need to improve management training in finance prior to implementation;

"I don't think that it should be extended downwards, to be effective we should relieve the front line of all financial constraints. It can also lead to a de-skilled and de-motivated work force, following fixed cost procedures. I

see this as leading to a decline in the quality of service that we provide to the public." (Chief inspector, respondent 24)

"I can see finance becoming the dominant influence dictating what you can do and how you do it. Total financial control will create a large bureaucracy. We do not have the expertise to deal with finance, and the bureaucratic systems required will invariably lead to an increase in costs. The budget holder has little control and will be heavily influenced by external bodies, in effect they will have less control than ever."
(Chief inspector, respondent 26)

"I agree with Johnson and although we must be aware of what everything costs, we must also remember that we are trying to improve the quality of service provided. We don't really have the skills within the police to manage those new initiatives. There is a danger that we will end up building a separate tier of management, paid for at the expense of the operational officers, similar to that of the Health Service."
(Sergeant, respondent 27)

The role of Her Majesty's Inspectorate

Question 4. The role of Her Majesty's Inspectorate (HMI) together with that of the Audit Commission was described by a management consultant Mr Denis Bourne (Police Review 20 November 1992) as being:

"Providing an inspection service that is supposed to help forces maintain high standards. But, because of the way they are constituted, the Inspectorate and the Commission focus more on the visible, superficial and structural rather than the fundamental, developmental and critical. In particular, the Inspectorate's pre-inspection report, combined with its matrix of performance indicators, consumes vast amounts of Force resources and provides little in return. Their recommendations frequently have the effect of diktats, whether or not they have any real relation to the needs of the Force or the service it is trying to provide to the community."

Question 4(i) Do you feel that the service provided by the HMI is satisfactory or could it be improved?

Twenty-four respondents (89%) found the service provided by the HMI as unsatisfactory. Thirteen did however offer suggestions for improvement. Three respondents found the service to be satisfactory and two of these offered suggestions for improvement;

"I see the benefits of the HMI system, they have raised issues that we may not have been aware of. But I don't like it when they recommend systems for us to implement without providing any supporting evidence of their benefits. Perhaps they don't apply the same critical examination as we do. Unfortunately their recommendations become or are seen as diktats." (Chief superintendent, respondent 4)

"It is no longer a Inspectorate, it has moved to the position of being a 'Directorate', out of touch with reality and constraining the healthy development of the police service. I do not see them as providing a service, they just dictate and don't seem prepared to listen. They could be significantly improved by including people with management skills and expertise and adopting a consumer oriented approach." (Chief inspector, respondent 24)

5.9.1 Summary of the Main Issues Raised in Section G

Question 1 explores the issue of civilianisation and the perceived cost benefits highlighted by the Commission. The respondents were not convinced that the civilianisation programme had yielded the cash savings prophesied by the Commission. Examples were given where the exchange of a multi skilled police officer for a civilian, who was single skilled and only trained to do a portion of the police officers duties, had led to the need to employ more than one civilian, this in turn had increased costs. One respondent pointed out that the more people you employ, the more your ancillary costs will rise.

Respondents were in favour of having a defined career structure for civilians similar to that of police officers. There was a realisation that this would inevitably lead to increased costs. That improved career prospects or indeed the retention of staff who are on incremental scales would reduce the benefits of civilianisation.

Question 2 explored the use of both national and local performance measures. The respondents rejected the use of national performance measures as being of little value, putting quantity before quality and increasing bureaucracy. There was a feeling that these were purely a political tool to be quoted and exploited

by politicians. On the issue of local performance measures, many of the respondents indicated that provided these were designed in conjunction with local managers to meet their needs, they could provide a valuable framework to monitor and improve performance.

Question 3 examined the respondent's views on pushing financial accountability downwards. The majority of respondents were not in favour of this approach recognising that this could lead to a bureaucratic system of unit costing, similar to that utilised in industry. This process was viewed as detrimental to the quality of service, customer focused culture that the police service were trying to introduce. One respondent expressed fears that police officers received a low level of training in financial management and that this may lead to a requirement for additional civilian managers similar to the Health Service. It was recognised and that this would increase costs.

Question 4 reviewed the role of the HMI. The majority of respondents found the present system unsatisfactory. The main reasons given were that it was dictatorial, bureaucratic and highly prescriptive demanding the collection of vast quantities of information. Respondents identified that the HMI frequently recommended the introduction of new systems or changes that had not been fully evaluated in terms of cost/benefit.

5.10 SECTION H. THE FUTURE DIRECTION OF THE POLICE SERVICE

This section consists of one question:

Question 1. What are your views on the future direction that the police service should take?

The respondent's views of this issue were wide ranging and introduced many different concepts. Eleven (41%) identified that there was a real need for

policing to be locally based, with locally determined priorities identified in conjunction with the community. Three respondents also felt that the police should return 'back to basic principles of policing':

"There is a need for the views of operational commanders and middle management to be recognised in determining legislation. They always seem to want a quick answer, there is a lack of police research, we do not have the ability to respond in-depth. Too many major issues are determined without proper research being carried out, so that the implications are not taken into consideration. We must undertake more research that takes in the views of those carrying out the job." (Chief superintendent, respondent 5)

"The future will see smaller, better equipped forces who will privatise or divest themselves of some marginal activities. It must reduce self inflicted bureaucracy but will find it hard to do the same in relation to the demands of the criminal justice system. However, it must resist more strenuously the administrative demands of bodies such as the Crown Prosecution Service. If experience of other public sector organisations held out by our politicians as shining examples is anything to go by, the value for money approach which we are being pushed towards will actually increase bureaucracy and the number of persons involved in administrative management rather than reduce them. It is not just the police who need to make up their minds about the future of policing." (Superintendent, respondent 17)

"I would like to see a service that is seen as being more professional. It has the time and resources to do things right. It appears that at the present time the motivation for change coming from Central Government is focused on deflecting the blame away from them onto Local Authorities, and at the same time saving money by providing a less professional service. I fear that the new initiatives will lead to an increase in administrative costs to the detriment of operational, policing." (Sergeant, respondent 27)

5.10.1 Summary of the Main Issues Raised in Section H

The respondents expressed clear views that they regarded policing as a public service rather than a business and that they would like to return to a simplified form of policing that is closely tied to the needs and wishes of the community.

The respondents identified a real need to reduce administration and bureaucracy so that they could put more resources on the front line of operational policing. One respondent indicated that he believed that this could not be achieved by

following the Governments present value for money initiatives. It was recognised that their introduction into the Health service and Education Service appeared to have led to an increase in bureaucracy and a need for more administrators.

5.10.2 Introduction to Chapter 6

The next Chapter will present the findings of the forcewide questionnaire. The questionnaire incorporates and seeks to explore the issues raised during the interviews with the four members of ACPO and the twenty-seven senior officers. The questionnaire was distributed to officers of all ranks within the Force, this allows for the comparison and evaluation of the differing views of those who develop policy and those who carry out operational policing.

The questionnaire was initially piloted within the management services department at police headquarters with the help of police and civilian support staff who had a wealth of experience in questionnaire design. Field tests were later carried out with police officers from the Langbaugh District.

To validate the findings of the questionnaire, the data collected was subjected to rigorous statistical analysis using a 'complex chi squared technique'. This technique indicates to what extent the findings can be relied on or if the respondents have randomly distributed the scores. The questionnaire not only collected numerical data but also encouraged respondents to provide written comments. Where appropriate some of the comments have been included within the Chapter. Graphical presentations have been used wherever possible for ease of understanding.

CHAPTER 6 THE FORCEWIDE QUESTIONNAIRE

6.1 INTRODUCTION

The purpose of this Chapter is to report and discuss the findings of the forcewide survey conducted of all serving police officers in Cleveland Constabulary. The survey examined the perceptions of every rank so that comparisons can be made between those responsible for developing strategy (senior management - ACPO, superintendent and chief inspectors), managing its implementation (middle management - inspectors and sergeants), and those primarily responsible for carrying it out (constables).

6.1.1 Questionnaire Design

The questionnaire consisted of seven key areas of policing identified during the key informant interviews. It was designed to explore the key issues facing the force. The seven themes represent the fundamental and inter-related basic issues of contemporary policing. Each question consisted of nine sub-issues to fully explore each theme. The survey explores the strength of feeling on each issue from the perception of officers of all ranks throughout the force. The respondents were asked to score each question on the rating scale of 1 (strongly agree) to 7 (strongly disagree). The final section of the questionnaire invited comments on any of the issues raised. A total of 178 of respondents (25%) took advantage of this facility. (Appendix D)

6.1.2 Question 1. What type of service do you think the police should provide?

The purpose of question one is to gain some understanding of the basic dilemma facing the police in a period where it is being forced down a multitude of paths by a wide range of agencies and is operating within a fixed or diminishing budget. To progress as an organisation it is essential to determine

'what type of business are we in', and what key functions should be performed. The questions explore issues from the perception of all ranks to determine if there are areas where there is a consensus view or areas where there is diversity between the perception of different ranks of police officers.

The arithmetic mean scores for statements 1.1 to 1.9 are illustrated in Chart 6.1. The scores have been calculated by multiplying the scores given to each statement by the individual respondents, taking the sum of these scores, then dividing by the number of respondents in each group (constables, sergeants and inspectors and senior officers). This technique is utilised in all seven questions. The scores for statements 1.1 to 1.9 are illustrated in Charts 6.2, 6.3 and 6.4.

A complex Chi squared significance test has been carried out for each question that examines the distribution of scores by each group of respondents. The test is valid providing the numbers in less than a fifth of the cells are under 5. The null hypothesis is that the scores given by respondents are distributed at random. The values of Chi squared have been calculated and are illustrated in Table 6.2. For statements 1.1, 1.3, 1.4, 1.5 1.6 and 1.8 the obtained value of Chi squared exceeds the tabulated value at the 0.05 level (two-tailed test). For statements 1.2, 1.7 and 1.8, the obtained value of Chi squared exceeds the tabulated value at the 0.01 level (two-tailed test). For all statements the null hypothesis can therefore be rejected. (Appendix E shows a sample calculation)

Question 1 - What type of service do you think the police should provide?

Author's interpretation - there is a remarkable consistency of scoring from all officers for many of the statements. However for statements 1.5 and 1.7 there is a considerable difference between the scoring of senior officers and constables. For statement 1.5 the mean is 3.46, with senior officers scoring 2.53 and constables 3.62. For statement 1.7 the mean is 4.87, with senior officers scoring 4.59 and constables 5.80. This indicates that for issues of policy the perceptions of those making it, differ from the operational officers who carry it out.

Rating

Arithmetic mean score for statements 1.1 to 1.9



Statement number	1.1	1.2	1.3	1.4	1.5*	1.6	1.7*	1.8	1.9
All officers (721)	2.64	2.80	2.29	2.41	3.46	1.89	4.87	2.94	2.43
Constables (498)	2.57	2.86	2.19	2.40	3.62	1.99	5.80	3.02	2.47
Insp/Sgts (189)	2.43	2.68	2.50	2.45	3.22	2.07	5.08	3.39	2.36
Senior officers (34)	2.85	2.59	2.59	2.47	2.53	1.53	4.59	2.41	2.15

Question 1 - What type of service do you think that the police should provide?

Chart 6.2

Strongly disagree



Strongly agree

Statement 1.1 - High profile policing is the best way to make the streets safer the streets safer.

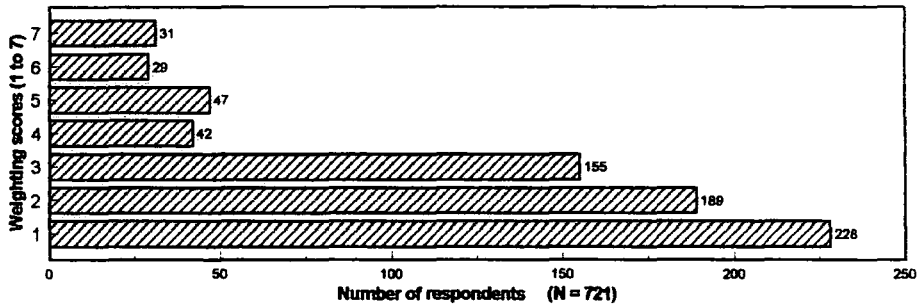

Author's interpretation - the data indicates that there is a strong belief that high profile policing is very desirable, 79.6% of respondents scored between 1 and 3 on the 'agree' scale.

Strongly disagree



Strongly agree

Statement 1.2 - We should provide a balanced service to the public involving both law enforcement and social policing.

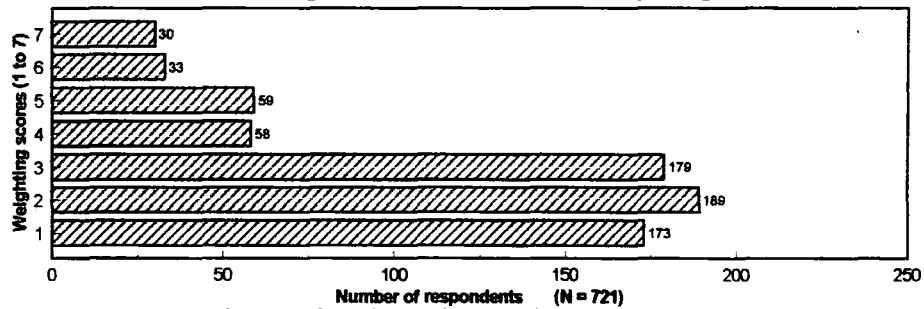

Author's interpretation - the data indicates that there is a desire to provide a service that is not purely regarded as law enforcement, 75% of respondents scored between 1 and 3 on the 'agree' scale.

Strongly disagree



Strongly agree

Statement 1.3 - Law enforcement should be our major role to combat the ever increasing rise in lawlessness.

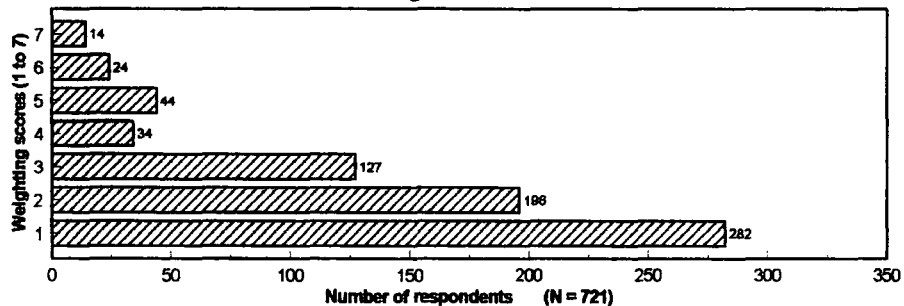

Author's interpretation - the data indicates that there is a very strong desire to enforce the law in relation to offences involving anti-social behaviour, 83.9% of respondents scored between 1 and 3 on the 'agree' scale.

Question 1 - What type of service do you think that the police should provide?

Chart 6.3

Strongly disagree



Strongly agree

Statement 1.4 - Social policing initiatives may be desirable but not if they are funded to the detriment of operational policing.

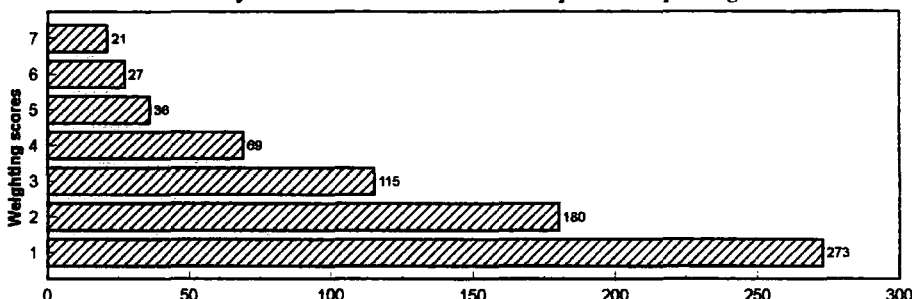

Author's interpretation - the data indicates that there is a realisation that the police have limited resources and that operational policing should be given priority, 78.8% scored between 1 and 3 on the 'agree' scale.

N = 721

Strongly disagree



Strongly agree

Statement 1.5 - There is an ever increasing need for adopting a multi-agency approach.

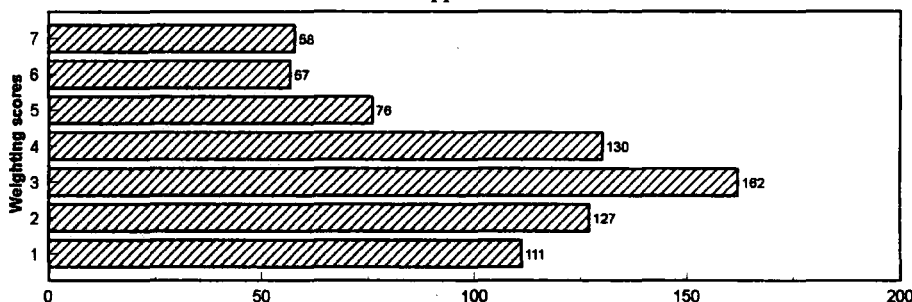

Author's interpretation - the data indicates mixed feelings over this issue, 55.5% of respondents scored between 1 and 3 on the 'agree' scale, 18% scored the mid-point 4.

N = 721

Strongly disagree



Strongly agree

Statement 1.6 - I do not believe that we should become social workers.

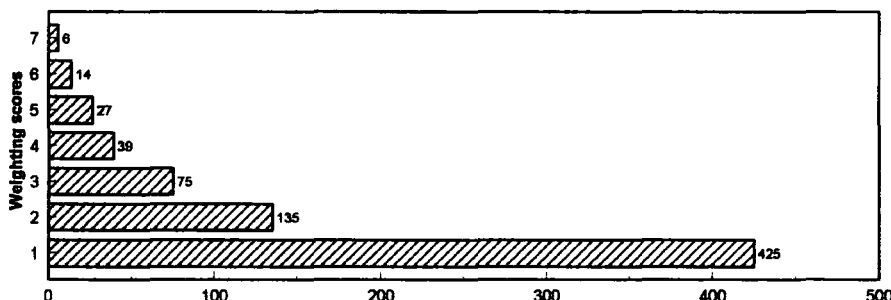

Author's interpretation - the data indicates that officers resent any further involvement into what they regard as 'social work', 84.7% of respondents scored between 1 and 3 on the 'agree' scale.

N = 721

Question 1 - What type of service do you think that the police should provide?

Chart 6.4

Strongly disagree



Strongly agree

Statement 1.7 - The police should concentrate more resources into enforcing road traffic laws to improve road safety.

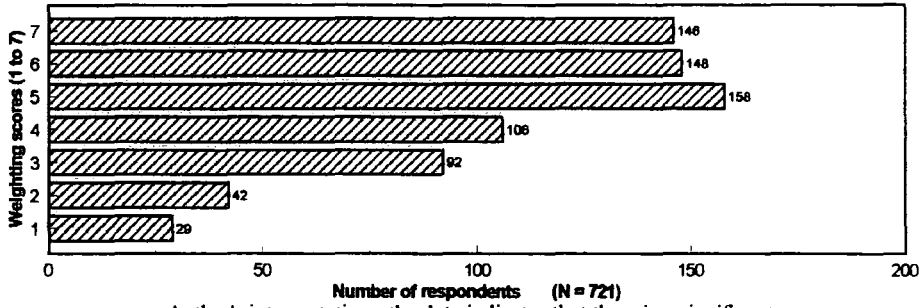

Author's interpretation - the data indicates that there is a significant disagreement with this proposition, only 22.6% of respondents scored between 1 and 3 on the 'agree' scale.

Strongly disagree



Strongly agree

Statement 1.8 - The police should adopt a more community based policing approach being very close to and part of the community.

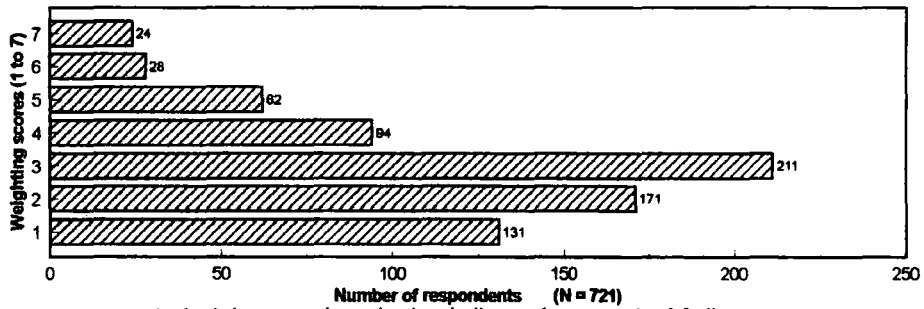

Author's interpretation - the data indicates there are mixed feelings over this issue, although 71.4% scored between a and 3 on the 'agree' scale there is a central tendency with 211 respondents scoring '3'.

Strongly disagree



Strongly agree

Statement 1.9 - The more we take on, the less the standard of service that we provide becomes.

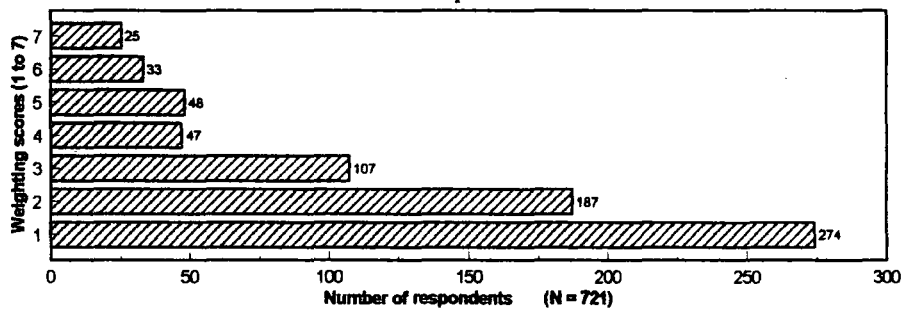

Author's interpretation - the data indicates that the respondents realise that resources have not been increased to meet new services, 79.1% of respondents scored between 1 and 3 on the 'agree' scale.

Statement 1 - "What type of service do you think the police should provide?"	Calculated value of X	Levels of significance at 12 degrees of freedom. Tabulated values: 2 X at 0.05 = 21.03 (95% confidence level) 2 X at 0.10 = 18.55 (90% confidence level)
1.1	26.90	0.05
1.2	20.56	0.10
1.3	32.22	0.05
1.4	25.73	0.05
1.5	41.58	0.05
1.6	25.33	0.05
1.7	19.20	0.10
1.8	20.99	0.10
1.9	22.08	0.05

Table 6.1 Levels of significance for question 1.

Overall observations on the scoring

There is a remarkable consistency of scoring for most statements by all officers except for statements 1.5 and 1.7 where there are considerable differences in scoring between senior officers and constables. For statement 1.5 the mean score for all officers is 3.46, with senior officers scoring 2.53 and constables 3.62. For statement 1.7 the mean score for all officers is 4.87, with senior officers scoring 4.59 and constables 5.80. This indicates that in some cases there is difference in perceptions of those making policy and those carrying out the practical aspects.

6.1.3 Discussion on the Responses to Question 1

There is a high consistency of scoring which indicates that officers of all ranks are firmly in favour of the police maintaining primarily an enforcement role carried out by high profile uniformed officers who take action against crime and other anti-social behaviour. (statements 1.1, 1.3, 1.8,) However, there is

significant opposition to the police rigorously enforcing road traffic laws (statement 1.7). Strong feelings are expressed that the police should not become social workers however there is also a realisation that the police cannot control society by itself and that they must work together with other agencies to tackle the root causes of crime. (statements 1.2, 1.4, 1.5, 1.6)

"Policing, no matter how well it is carried out cannot deal with inadequate social conditions, inadequate education, poverty and the inequalities in society. Until these issues are dealt with, until victims see that the criminal justice system is not simply designed to keep the legal profession rich and powerful, then the police of this country will never be able to influence the law and order issues." (Inspector, 20-24 years service)

There is a recognition by all ranks that the police cannot keep taking on more and more services with existing financial resources as this reduces the overall standard of service provided (statement 1.9).

6.1.4 Question 2. Crime at the present time is receiving wide media coverage. What do you think the Force aims should be in respect of crime?

The purpose of question two is to determine how the force should deal with crime. The issue of crime is high on the agenda of all three leading political parties together with a commitment to reduce the number of crimes committed. It is vital that the police should adopt a clear strategy when dealing with crime not only by arresting offenders which has been their traditional role, but to look at the wider issues associated with criminals. The question explores '*what type of service should the police provide to the public*', and takes into account the perception of all ranks to determine if there are areas where there is a consensus view or areas where there is diversity between the perception of different ranks of police officers. The arithmetic mean scores for statements 2.1 to 2.9 are illustrated in Chart 6.5. The scores for statements 2.1 to 2.9 are illustrated in Charts 6.6, 6.7 and 6.8.

A complex Chi squared significance test has been carried out for each question in a similar manner to question 1. The null hypothesis is that the scores given by respondents are distributed at random. The values of Chi squared have been calculated and are illustrated in Table 6.2. For statements 2.1, 2.2, 2.3, 2.4, 2.7 and 2.9, the calculated value of Chi squared exceeds the tabulated value at the 0.05 level (two-tailed test). However, for statements 2.5, 2.6 and 2.8 the value of Chi squared does not exceed the tabulated value and the null hypothesis cannot be rejected.

	Calculated Value of χ^2	Levels of significance at 12 degrees of freedom. Tabulated values: 2 X at 0.05 = 21.03 (95% confidence level) 2 X at 0.10 = 18.55 (90% confidence level)
Statement 2 - "Crime at the present time is receiving wide media coverage. What do you think the Force aims should be in respect of crime?"	X	
2.1	24.50	0.05
2.2	29.75	0.05
2.3	17.40	Not significant
2.4	33.25	0.05
2.5	27.17	0.05
2.6	9.03	Not significant
2.7	53.95	0.05
2.8	17.15	Not significant
2.9	28.38	0.05

Table 6.2 Levels of significance for question 2.

Question 2 - Crime at the present time is receiving wide media coverage. What do you think the Force aims should be in respect of crime?

Chart 6.5

Author's interpretation - there is a remarkable consistency of scoring from all officers. The only significant variation occurs for question 2.8 where the mean is 4.72, with senior officers scoring 5.17 and constables 4.67. This indicates that senior officers have a greater desire to retain the existing strength of the Criminal Investigation Department.

Rating

Strongly disagree



Strongly agree

Arithmetic mean score for statements 2.1 to 2.9

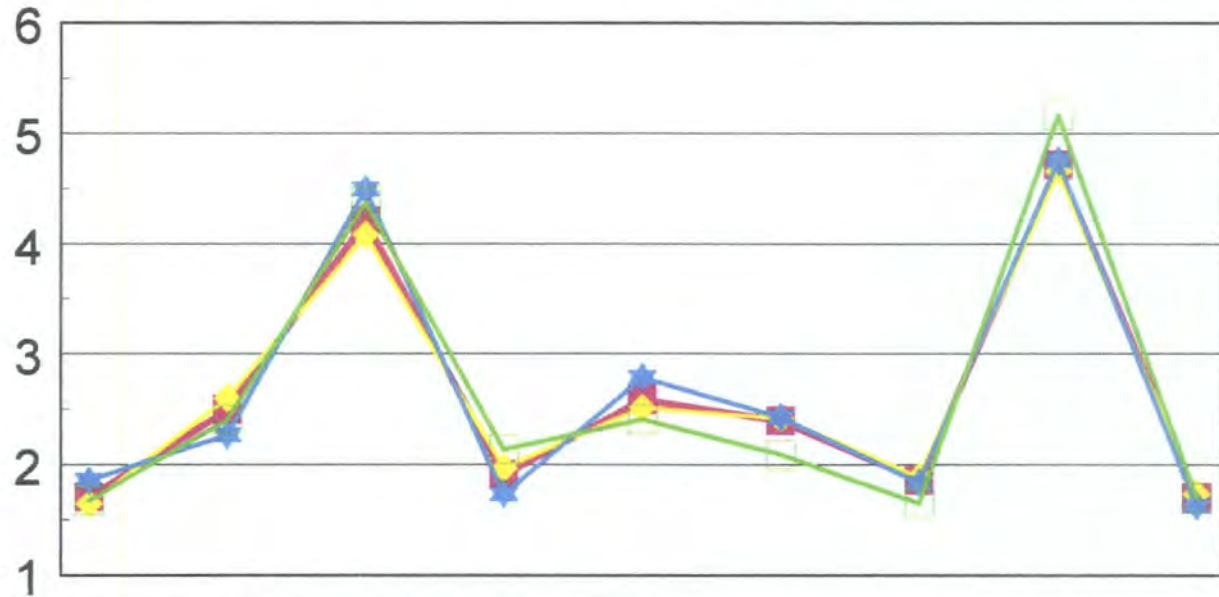

Statement number	2.1	2.2.	2.3	2.4	2.5	2.6	2.7	2.8*	2.9
All officers (721)	1.71	2.50	4.21	1.91	2.59	2.40	1.86	4.72	1.71
Constables (498)	1.65	2.60	4.09	1.97	2.52	2.42	1.89	4.67	1.74
Insp/Sgts (189)	1.86	2.27	4.50	1.74	2.79	2.43	1.84	4.76	1.63
Senior officers (34)	1.68	2.41	4.38	2.14	2.41	2.09	1.65	5.17	1.71

Question 2 - Crime at the present time is receiving wide media a coverage. What do you think the force aims should be in respect of crime?

Chart 6.6

Strongly disagree



Strongly agree

Statement 2.1 - The public like to see the police having success in arresting offenders.

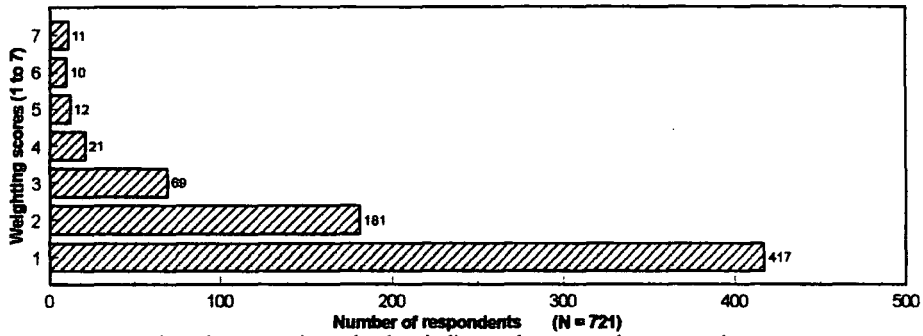

Author's interpretation - the data indicates that respondents strongly support this proposition with 93.9% scoring between 1 and 3 on the 'agree' scale.

Strongly disagree



Strongly agree

Statement 2.2 - The way to make people safer is to have local police officers on the beat.

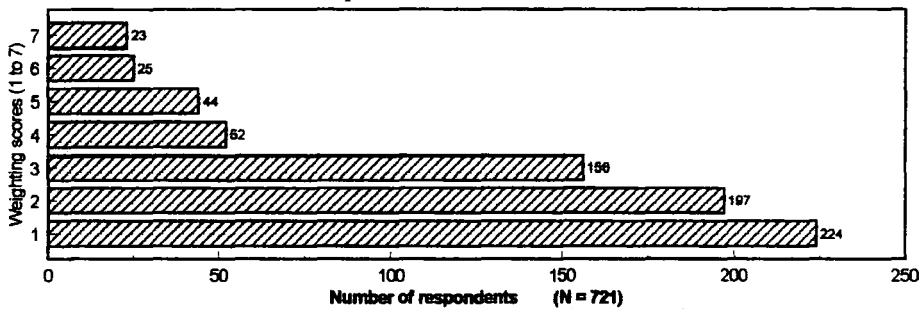

Author's interpretation - the data indicates that there is significant support for this proposition, 80.7% of respondents scored between 1 and 3 on the 'agree' scale.

Strongly disagree



Strongly agree

Statement 2.3 - If the strength of CID was increased to match the number of offences committed, then real progress could be made in tackling the crime problem.

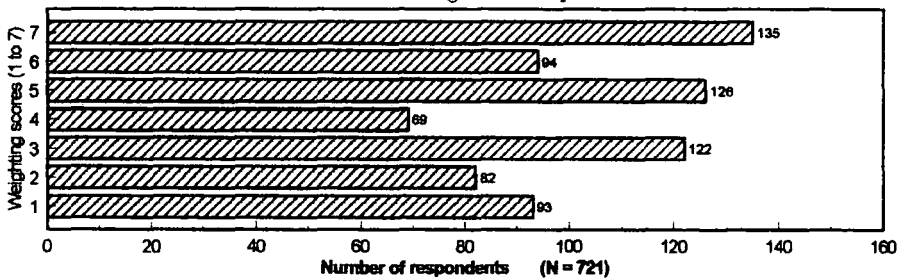

Author's interpretation - the data indicates that there are very mixed feelings to this proposition with scores being randomly distributed across the scoring range, 49.2% of respondents scored between 5 and 7 on the 'disagree' scale.

Question 2 - Crime at the present time is receiving wide media a coverage. What do you think the force aims should be in respect of crime?

Chart 6.7

Strongly disagree



Statement 2.4 - We should try and influence the criminal justice system by gathering hard facts to substantiate our views and those of the public.

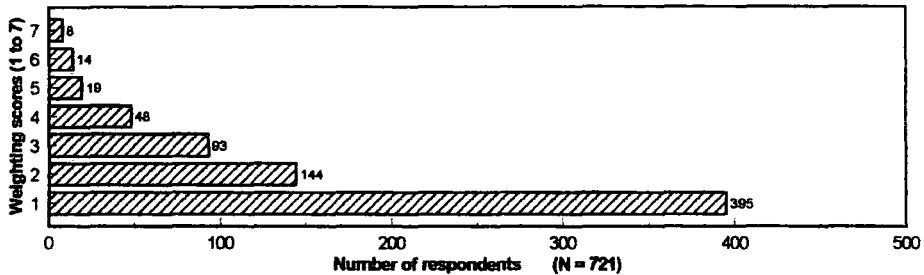

Strongly agree

Author's interpretation - the data indicates that there is a strong desire amongst the respondents to make their views and those of the public heard, 87.7% of respondents scored between 1 and 3 on the 'agree' scale.

Strongly disagree



Statement 2.5 - Detection is paramount 'offenders are the cause of the problem'.

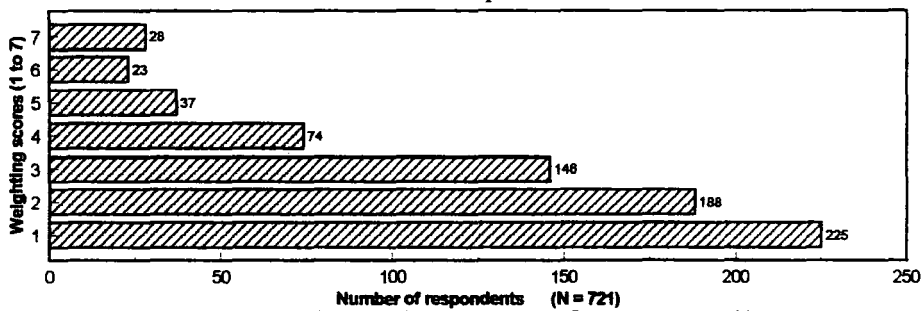

Strongly agree

Author's interpretation - the data indicates that firm views are held by the respondents that crime can be contained by arresting offenders, 77.8% scored between 1 and 3 on the 'agree' scale.

Strongly disagree



Statement 2.6 - First of all we must try and prevent crime, prevention is better than cure.

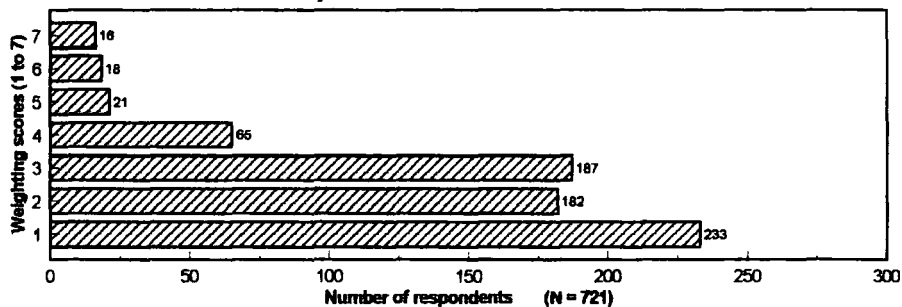

Strongly agree

Author's interpretation - the data indicates that there is strong support for improving crime prevention, 83.5% of respondents scored between 1 and 3 on the 'agree' scale.

Question 2 - Crime at the present time is receiving wide media a coverage. What do you think the force aims should be in respect of crime?

Chart 6.8

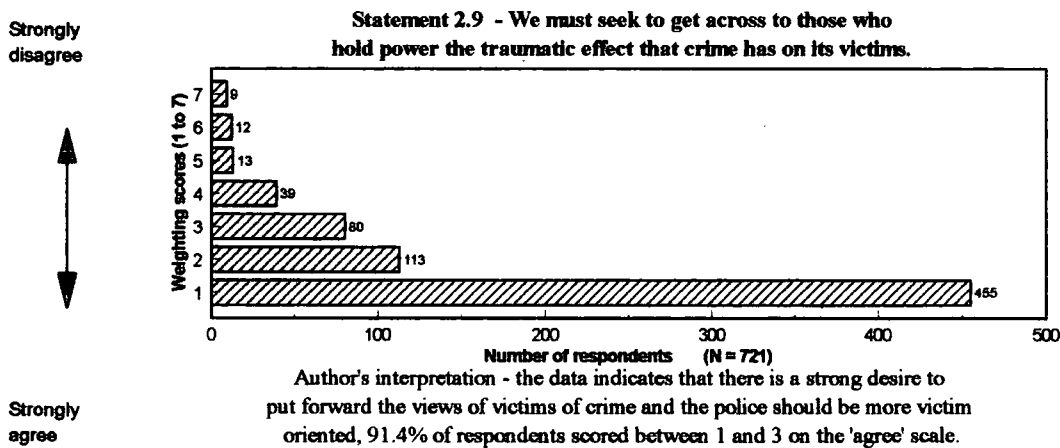
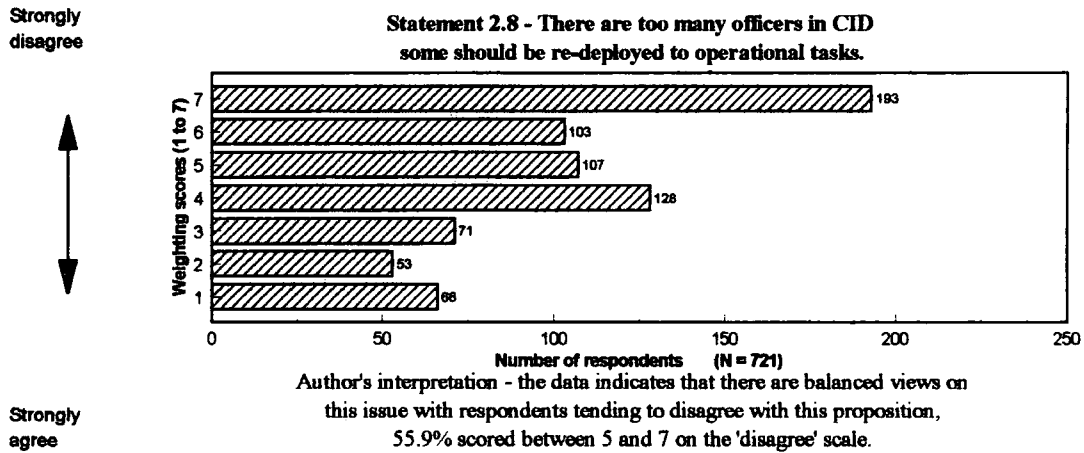
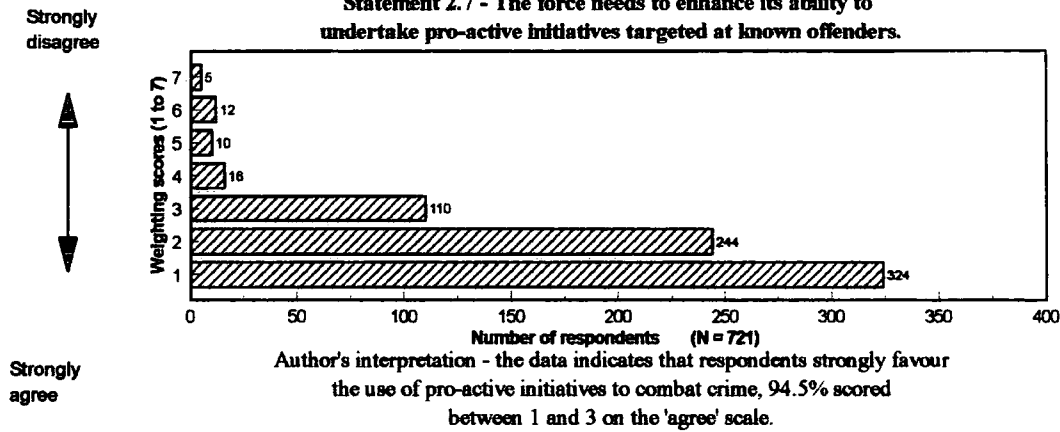

Overall observations on the scoring

There is a high consistency of scoring from all officers for each statement except 2.3, 2.6 and 2.8. Statements 2.3 and 2.8 relate to the strength of CID. There is a central tendency when scoring which indicates that there is some uncertainty as to the value of CID from the perception of all officers. For statement 2.8, senior officers clearly indicated that the strength of CID should not be reduced and officers redeployed to uniformed operational task. For statement 2.6 senior officers averaged 2.09 which indicated that they were strongly in favour of increasing the role of crime prevention.

6.1.5 Discussion on the Responses to Question 2

There are clear indications that police officers feel that the way ahead in dealing with crime is to focus on targeting and arresting those responsible for committing crime. There is a strong desire to influence the criminal justice system. However, there is recognition that this issue cannot be dealt with purely by voicing opinions, argument must be based on sound research and evidence. There is overwhelming desire with 455 respondents scoring 1 (strongly agree) on the issue of raising the plight of victims of crime with those who hold power. That their views should be taken into account when dealing with offenders, passing more meaningful sentences that will not only serve as punishment but act as a deterrent

"The way forward is to ignore opinionated politicians and newspapers and for senior officers to stand up for the police service and victims of crime whose views must be taken into account by the Court." (Constable 5 to 9 years service)

Of the respondents who made comments to this question, the majority related to the issue of punishing offenders and the criminal justice system:

"Instead of constantly looking at the police to cut costs and increase 'value for money' the government should look at other parts of the criminal justice system where millions of pounds of tax payers money is

wasted on protecting known and repetitive criminals at the expense of the victims. Why don't they protect and compensate the victims and keep criminals off the streets." (Constable, 4 years service)

6.1.6 Question 3. "If you consider resources as personnel, equipment, vehicles and finance, what do you think are the key limiting resources that control the achievement of the service you would like to produce."

The purpose of question three is to explore the views of all officers on the present distribution of resources within the force and to identify '*what should the force allocate finance to in order to improve the service delivery*'. The issues raised in the statements have been designed to investigate if the present allocation system is viewed as being suitable for policing in the environment of the 1990's. The question explores issues from the perception of all ranks to determine if there are areas where there is a consensus view or areas where there is diversity between the perception of different ranks of police officers. The arithmetic mean scores for statements 3.1 to 3.9 are illustrated in Chart 6.9. The scores for statement 3.1 to 3.9 are illustrated in Charts 6.10, 6.11 and 6.12.

A complex Chi squared significance test has been carried out for each question in a similar manner to question 1. The null hypothesis is that the scores given by respondents are distributed at random. The values of Chi squared have been calculated and are illustrated in Table 6.3. For statements 3.1, 3.2, 3.3, 3.4, 3.5, 3.6, 3.8 and 3.9, the calculated value of Chi squared exceeds the tabulated value at the 0.05 level (two-tailed test). However, for 3.7 the level of significance exceeds the 0.10 confidence level. In all cases the calculated value of Chi squared exceeds the tabulated value and the null hypothesis can be rejected.

Question 3 - If you consider resources as personnel, equipment, vehicles and finance, what do you think are the key limiting resources that control the achievement of the service you would like to produce?

Chart 6.9

Author's interpretation - there is a consistency of scoring from all officers. The only significant variation occurs for questions 3.1, and 3.2. In 3.1 the mean is 2.73 with constables, sergeants and inspectors scoring between 2.60 and 2.69, and senior officers scoring 3.65. In 3.2 the mean is 4.49, with constables scoring 4.26 and senior officers 5.41. These serve to illustrate the differing views of those determining policy and the officers actually carrying out operational duties.

Rating

Strongly disagree



Strongly agree

Arithmetic mean score for statements 3.1 to 3.9

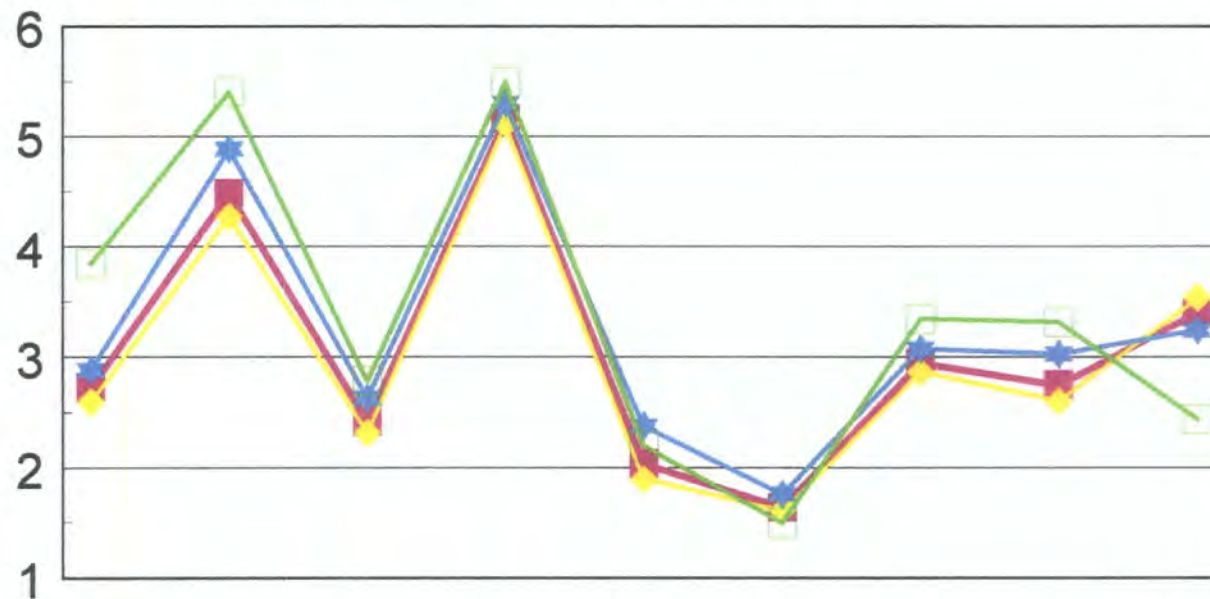

Statement number	3.1*	3.2*	3.3	3.4	3.5	3.6	3.7	3.8	3.9
All officers (721)	2.73	4.49	2.42	5.16	2.04	1.64	2.95	2.75	3.41
Constables (498)	2.60	4.28	2.32	5.11	1.90	1.61	2.87	2.61	3.54
Insp/Sgts (189)	2.89	4.89	2.63	5.31	2.38	1.76	3.08	3.03	3.25
Senior officers (34)	3.85	5.41	2.79	5.50	2.20	1.50	3.35	3.32	2.44

Question 3 - If you consider resources as personnel, equipment, vehicles and finance, what do you think are the key limiting resources that control the achievement of the service you would like to produce?

Chart 6.10

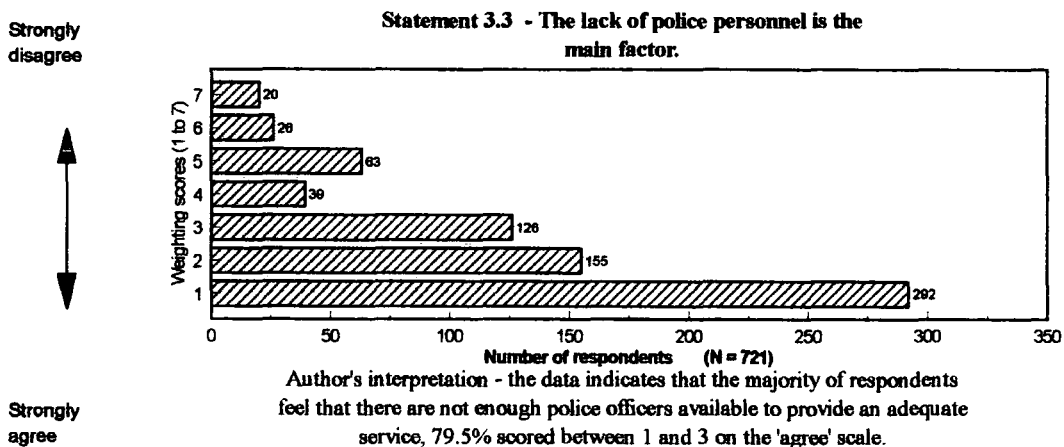
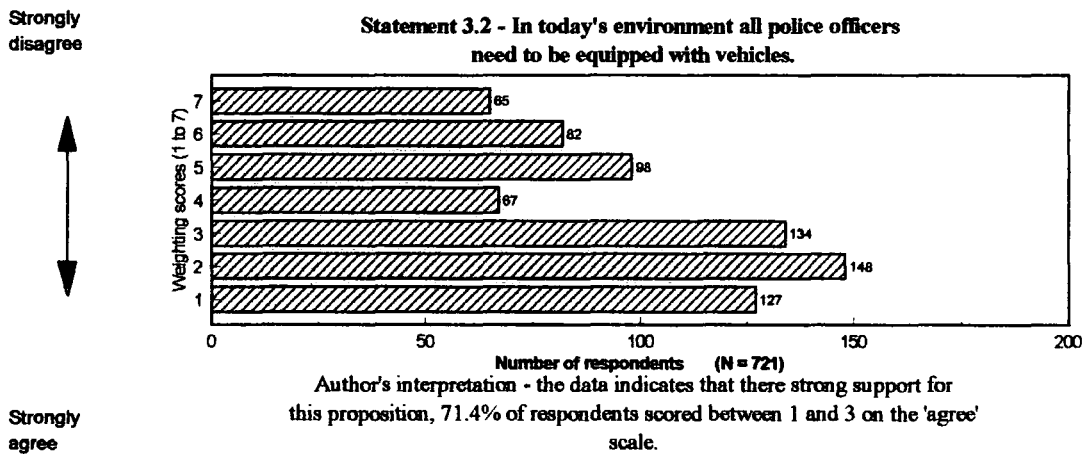
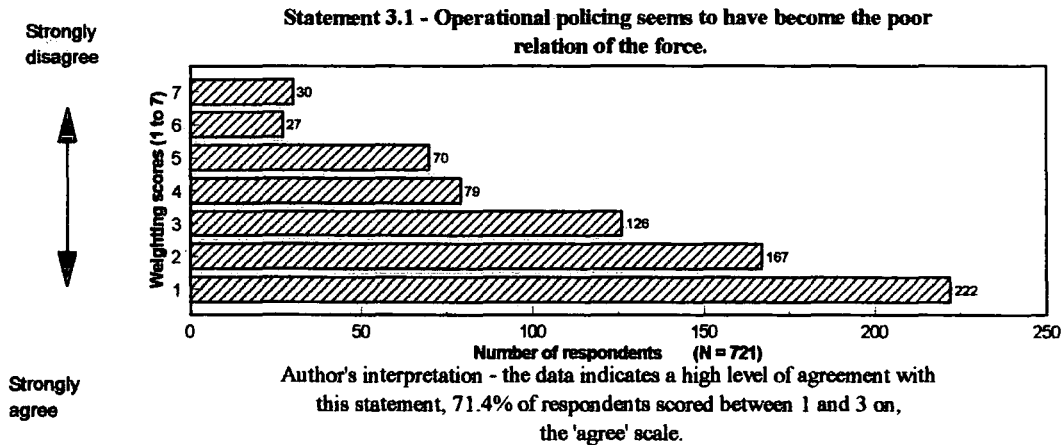

Question 3 - If you consider resources as personnel, equipment, vehicles and finance, what do you think are the key limiting resources that control the achievement of the service you would like to produce?

Chart 6.11

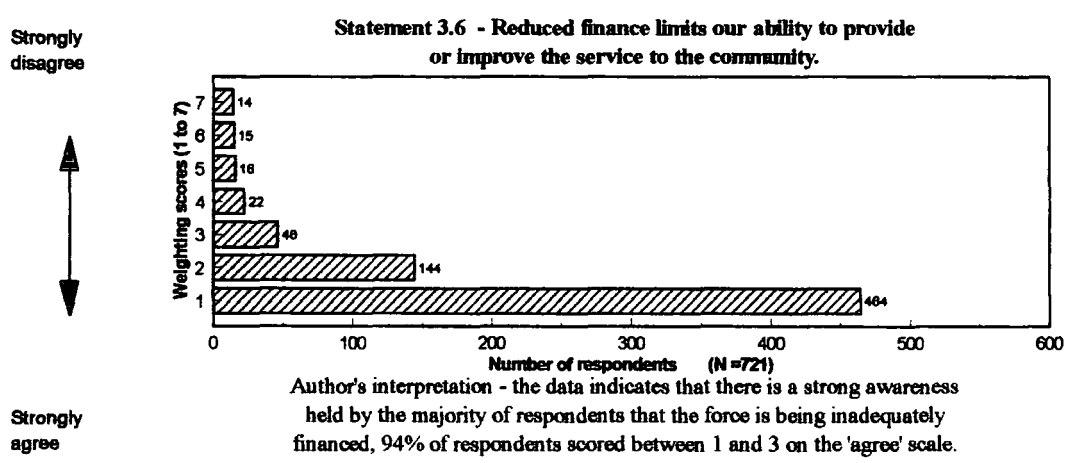
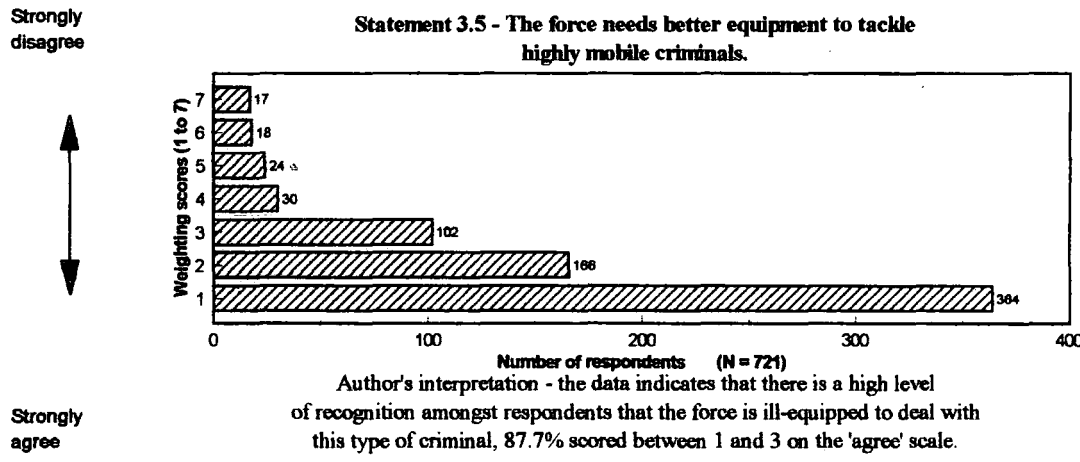
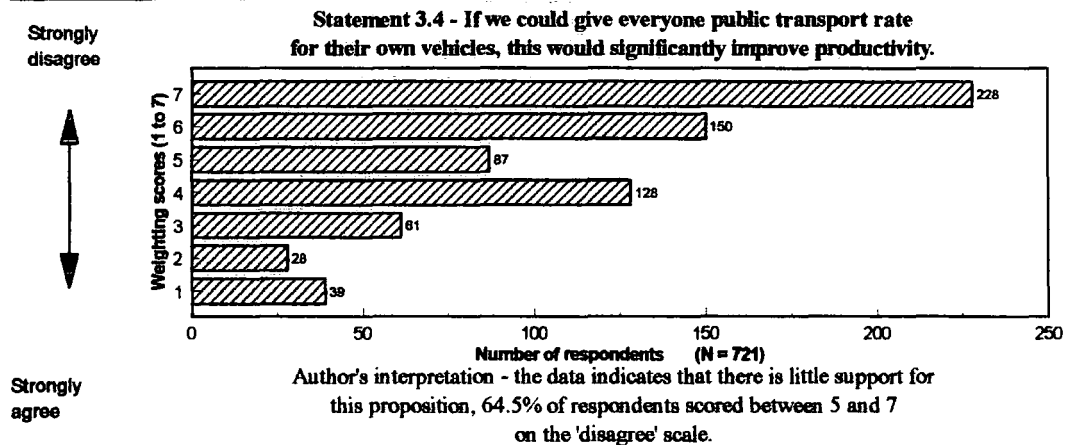

Question 3 - If you consider resources as personnel, equipment, vehicles and finance, what do you think are the key limiting resources that control the achievement of the service you would like to produce?

Chart 6.12

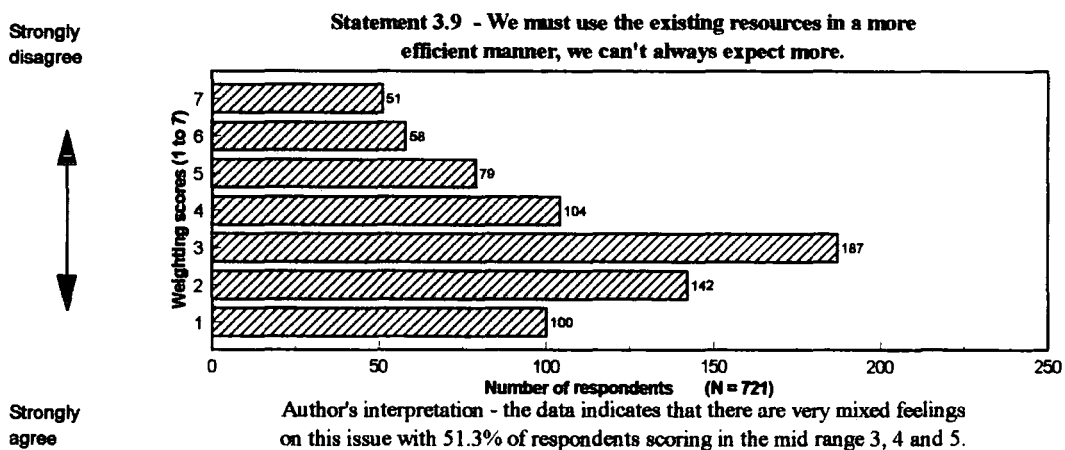
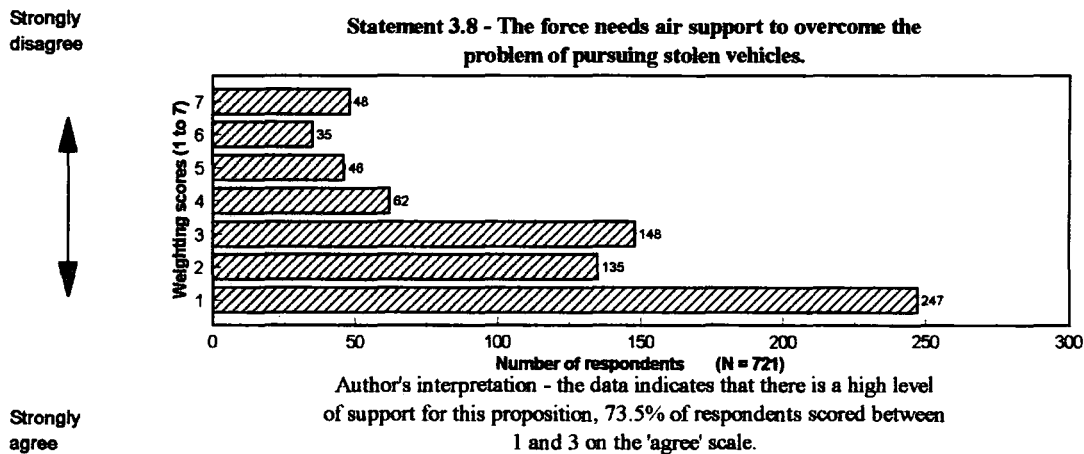
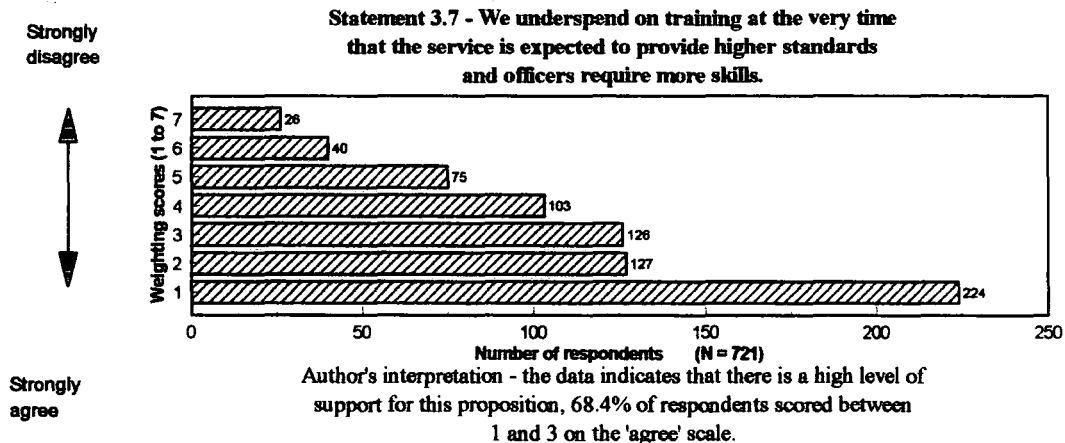

Statement 3 - "If you consider resources as personnel, equipment, vehicles and finance, what do you think are the key limiting resources that control the achievement of the service you would like to produce?"	Calculated value of 2 X	Levels of significance at 12 degrees of freedom. Tabulated values: 2 X at 0.05 = 21.03 (95% confidence level) 2 X at 0.10 = 18.55 (90% confidence level)
3.1	41.71	0.05
3.2	41.14	0.05
3.3	30.32	0.05
3.4	23.39	0.05
3.5	53.08	0.05
3.6	30.94	0.05
3.7	19.72	0.10
3.8	30.84	0.05
3.9	37.42	0.05

Table 6.3 Levels of significance for question 3.

Overall observations on the scoring

For statements 3.3, 3.4,3.5,3.6,3.7 and 3.8 there is a high consistency of scoring between all ranks. However, for statements 3.1 and 3.2 that concern operational deployment there is a significant divergence of views from the officers who are actually performing operational duties and senior officers. This could indicate that the senior officers are not in touch with important issues in operational policing. In particular they do not appear to see the need to equip officers with vehicles.

6.1.7 Discussion on the Responses to Question 3

There are clear indications that police officers feel that to become more efficient they need to increase the number of operational officers and ensure that they are highly trained and well equipped. They must then be provided

with high quality equipment such as air support. There is a high level of recognition that the financial constraints are effecting all levels of operational policing.

"In order to operate effectively the police need better vehicles and general equipment i.e. radios that actually 'work' and 'side handled batons' to protect officers. I also believe that we need several air support units and the very latest technology to combat crime." (Constable 0 - 4 years)

"I am dismayed at the degree to which financial constraints have eroded the police service in recent years. Granted, there may have been wasteful practices in the past and some remain to this day but to provide half a service at half the cost has nothing to do with efficiency. How on earth when the nation is screaming for more policeman can our County seek to justify reducing the strength of the force? I am deeply concerned at the long term consequences." (Inspector 25 - 29 years)

6.1.8 Question 4. "Do you feel the use of foot patrol officers (bobby on the beat) is a cost effective way of policing?"

The purpose of question four is to investigate the views of all officers to determine if they believe that traditional foot patrol policing is efficient and to establish '*what are their views on traditional foot patrol style of policing*'. The issue of foot patrols again features widely in the political arena with a universal commitment from all the main political parties to ensure that more officers perform this role. However, if this style of policing is truly desirable then it is essential to recognise the resource implications. The questions explore these issues from the perception of all ranks to determine if there are areas where there is a consensus view or areas where there is diversity between the perception of different ranks of police officers.

The arithmetic mean scores for statements 4.1 to 4.9 are illustrated in Chart 6.13. The scores for statement 4.1 to 4.9 are illustrated in Charts 6.14, 6.15 and 6.16.

A complex Chi squared significance test has been carried out for each question in a similar manner to question 1. The null hypothesis is that the scores given by respondents are distributed at random. The values of Chi squared have been calculated and are illustrated in Table 6.4. For statements 4.1, 4.2, 4.3, 4.4, 4.6, and 4.9, the calculated value of Chi squared exceeds the tabulated value at the 0.05 level (two-tailed test). However, for 4.5, 4.7 and 4.8 the level of significance exceeds the 0.10 confidence level. In all cases the calculated value of Chi squared exceeds the tabulated value and the null hypothesis can be rejected. (for calculations see appendix H)

Statement 4 - "Do you feel the use of foot patrol officers (bobby on the beat) is a cost effective way of policing?"	Calculated Value of X ²	Levels of significance at 12 degrees of freedom. Tabulated values: 2 X at 0.05 = 21.03 (95% confidence level) 2 X at 0.10 = 18.55 (90% confidence level)
4.1	22.50	0.05
4.2	21.19	0.05
4.3	22.22	0.05
4.4	43.46	0.05
4.5	20.26	0.10
4.6	21.41	0.05
4.7	20.86	0.10
4.8	19.54	0.10
4.9	35.02	0.05

Table 6.4 Levels of significance for question 4.

Question 4 - Do you feel that the use of foot patrol officers (bobby on the beat) is a cost effective way of policing?

Chart 6.13

Author's interpretation - there is a consistency of scoring from all officers with minor variations on either side of the mean in all cases.

Overall police officers appear supportive of the use of foot patrols, however there is a realisation that financial constraints will limit their use. There is a noticeable central tendency for some of the statements given.

Rating

Strongly disagree



Strongly agree

Arithmetic mean score for statements 4.1 to 4.9

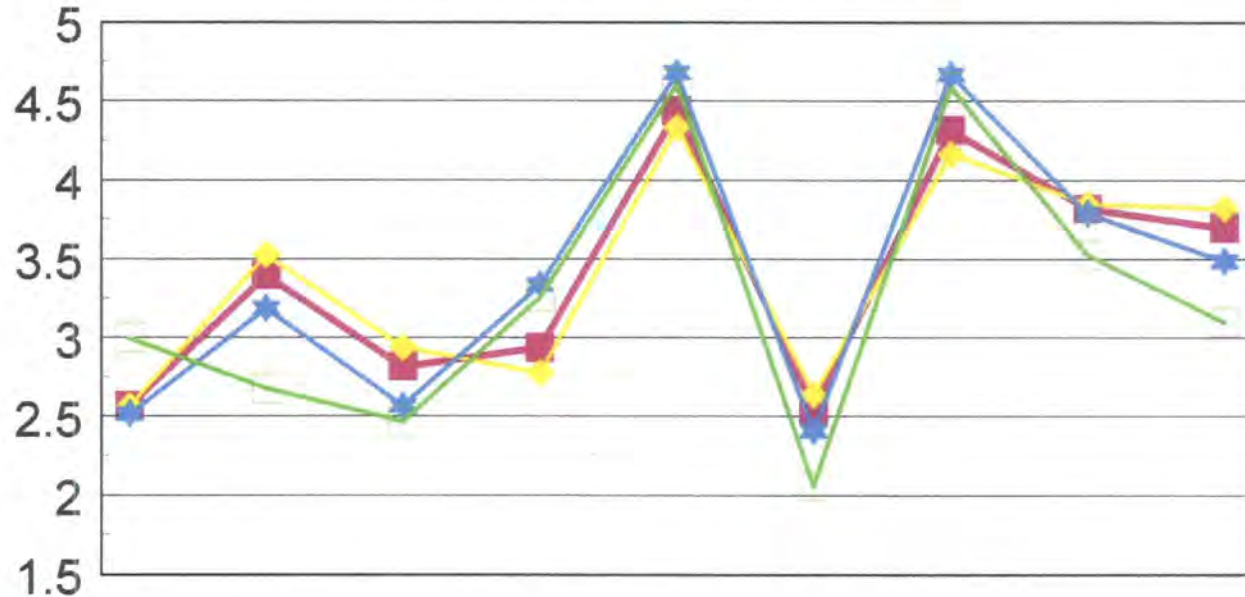

Statement number	4.1	4.2	4.3	4.4	4.5	4.6	4.7	4.8	4.9
All officers (721)	2.57	3.40	2.82	2.94	4.44	2.55	4.32	3.82	3.70
Constables (498)	2.57	3.53	2.94	2.78	4.34	2.64	4.17	3.85	3.82
Insp/Sgts (189)	2.52	3.19	2.57	3.34	4.68	2.41	4.67	3.79	3.49
Senior officers (34)	3.00	2.68	2.47	3.26	4.61	2.06	4.59	3.53	3.10

Question 4.3 - Do you feel that the use of foot patrol officers (bobby on the beat) is a cost effective way of policing?

Chart 6.14

Strongly disagree



Strongly agree

Statement 4.1 - We would need to at least double the uniform strength to provide an effective foot patrol service forcewide.

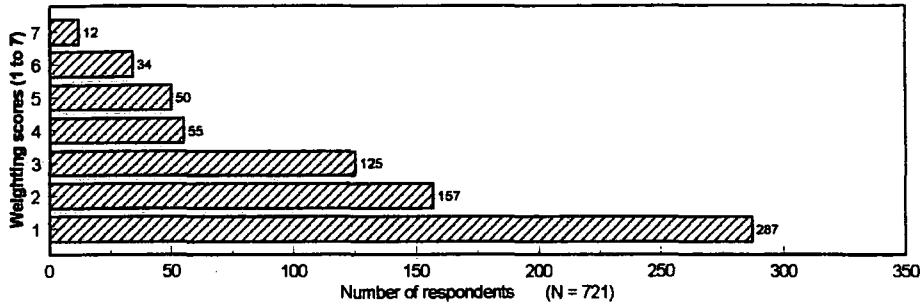

Author's interpretation - the data indicates that the majority of respondents recognise the resource implications of universally applying this style of policing forcewide, 76.3% scored between 1 and 3 on the 'agree' scale.

Strongly disagree



Strongly agree

Statement 4.2 - The Housing Estate Project Teams are the way forward.

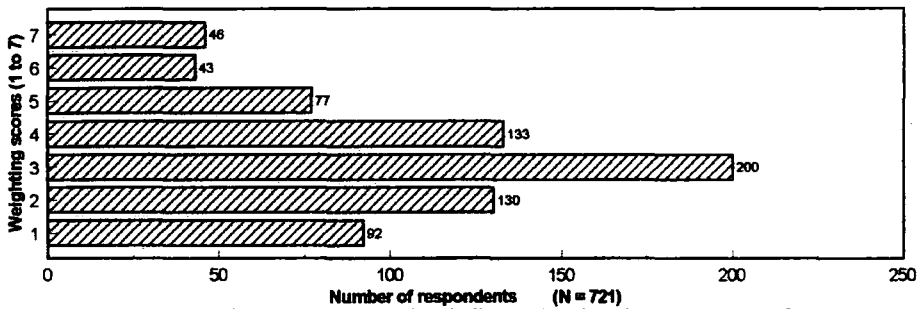

Author's interpretation - the data indicates that there is no consensus of opinion on this issue, 56.8% of respondents scored in the central range of 3, 4 and 5.

Strongly disagree



Strongly agree

Statement 4.3 - Police officers patrolling on foot form the basis of policing by consent, we need more of them.

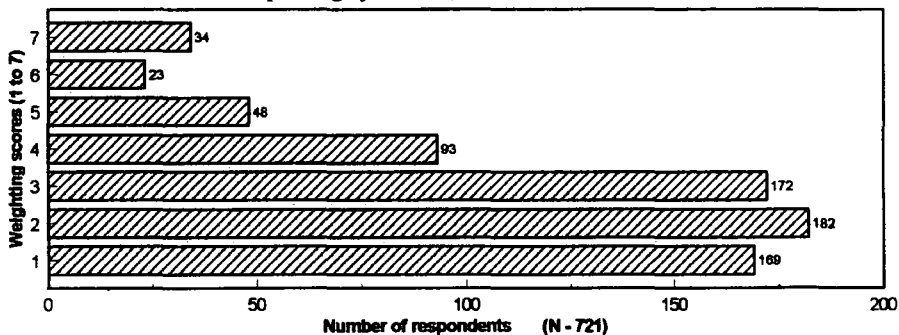

Author's interpretation - the data indicates that the majority of respondents support this statement, 72.8% scored between 1 and 3 on the 'agree' scale.

Question 4.3 - Do you feel that the use of foot patrol officers (bobby on the beat) is a cost effective way of policing?

Chart 6.15

Strongly disagree



Strongly agree

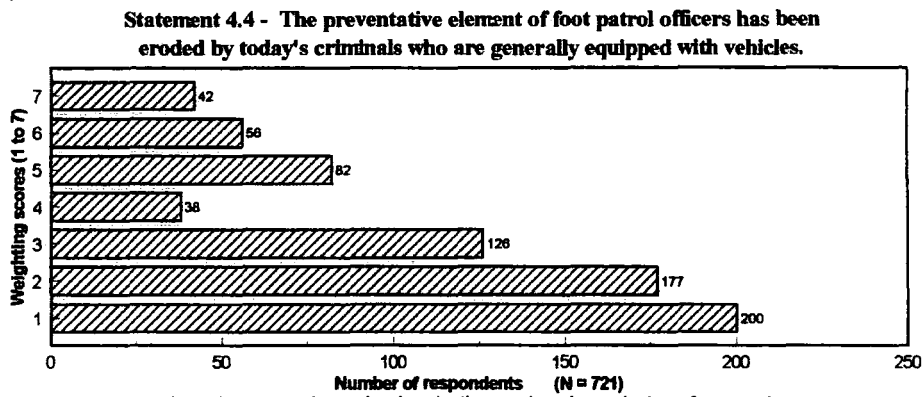

Author's interpretation - the data indicates that the majority of respondents support this proposition, 69.8% scored between 1 and 3 on the 'agree' scale.

Strongly disagree



Strongly agree

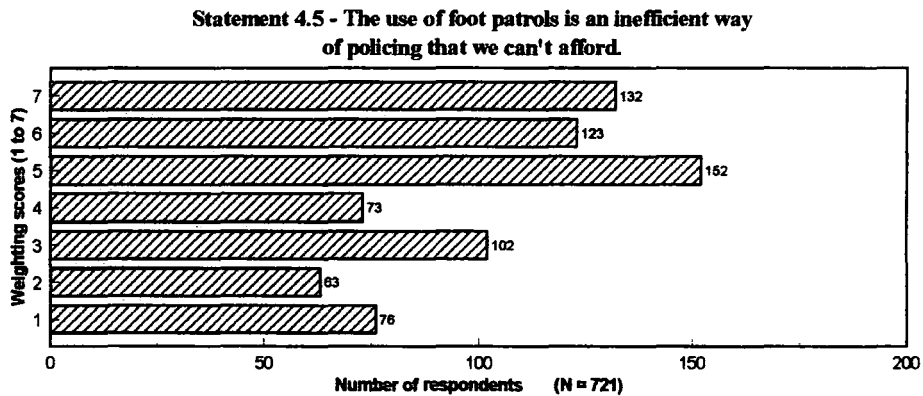

Author's interpretation - the data indicates that there are mixed views on this issue, 45.5% of respondents scored in the central range of 3, 4 and 5.

Strongly disagree



Strongly agree

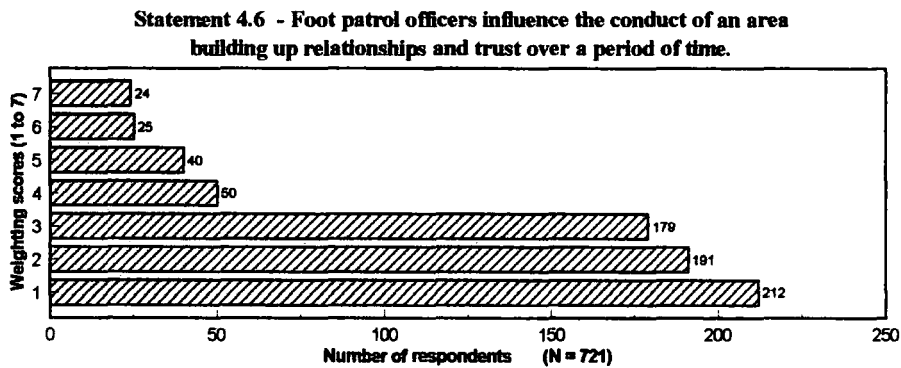

Author's interpretation - the data indicates that there is significant support for the use of foot patrols and the long term benefits they produce, of respondents scored between 1 and 3 on the 'agree' scale.

Question 4.3 - Do you feel that the use of foot patrol officers (bobby on the beat) is a cost effective way of policing?

Chart 6.16

Strongly disagree



Strongly agree

Statement 4.7- The use of foot patrols is a nostalgic dream that appears to be politically correct.

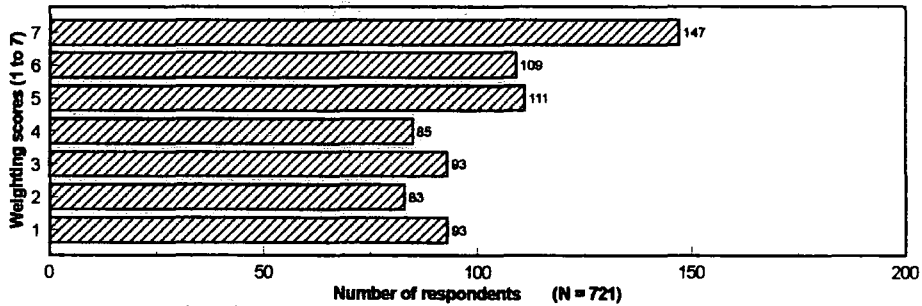

Author's interpretation - the data indicates that there is no consensus of opinion on this issue with respondents scoring fairly evenly across the whole range.

Strongly disagree



Strongly agree

Statement 4.8 - The sight of a police officer patrolling on foot is a great deterrent to offenders.

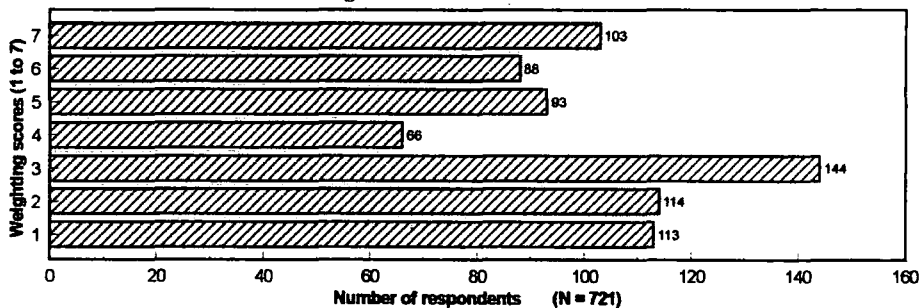

Author's interpretation - the data indicates that there is no consensus of opinion on this issue, respondents scored evenly across the whole range.

Strongly disagree



Strongly agree

Statement 4.9 - The police should give the public what they want, more foot patrols.

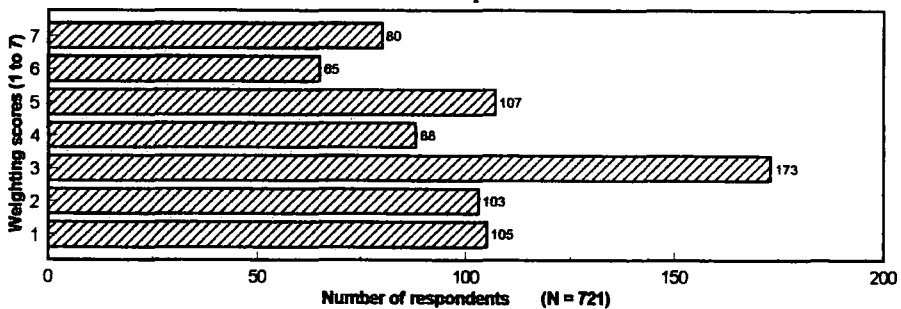

Author's interpretation - the data indicates that there is no consensus of opinion on this issue with respondents scoring fairly evenly across the whole range.

Overall observations on the scoring

There is consistency of scoring from all officers for statements 4.3, 4.4, 4.5, 4.6, 4.7 4.8. However, for statements 4.1, 4.2 and 4.9 there is a variance particularly between constables and senior management.

6.1.9 Discussion on the Responses to Question 4

As the demand on resources has increased there has been fewer officers deployed on traditional foot patrol. From the author's two years experience as a relief inspector at Stockton, he can recall deploying foot patrol officers on only four occasions during this period. Statement 4.1 indicates that there is a need to at least double the uniform strength, this is recognised by those actually on the ground and to a lesser extent by senior management. Responses to statements 4.2, 4.5 and 4.6 indicate that all officers recognise the value of foot patrols particularly in building up relationships with the public. However, responses to 4.8 indicate that officers do not see this type of policing as being a deterrent to offenders. The issue of foot patrol has always been an emotive issue within the police force as all officers carry out these duties when first joining, however for those with more service the memories may be different from policing today's housing estates. This is indicated by some of the responses:

"Foot patrol officers are desirable but inefficient they spend most of their time going to and from jobs. The public want a fast response when they need a police officer." (Constable 15 - 19 years service)

"Take a look at policing in the late sixties when towns such as Middlesbrough were divided into foot beats and patrolled twenty-four hours. The constables got to know the criminals and vice-versa. Strong links were forged with the community. However, with the population shift from town centres to rural areas, this type of policing could not be carried on without increasing the number of officers. The reverse has happened with less and less officers patrolling. Unfortunately we can no longer afford foot patrols." (Constable 25 - 29 years service)

6.1.10 Question 5. "Do you feel that the Cleveland Constabulary cares about the people it employs and values their contribution to the service provisions?"

The purpose of question five is to investigate the views of all officers to determine if the traditional attitude of police officers who regard their force as a family, with responsibility for looking after the individual's welfare and career development prevails. It examines *'how officers perceive the force values its personnel'*. If an organisation is to be successful then it has to maximise the efforts of all personnel to meet its goals. It is highly unlikely that a demotivated workforce will achieve this. The statements explore issues from the perception of all ranks to determine if there are areas where there is a consensus view or areas where there is diversity between the perception of different ranks of police officers.

The arithmetic mean scores for statements 5.1 to 5.9 are illustrated in Chart 6.17. The scores for statement 5.1 to 5.9 are illustrated in Charts 6.18, 6.19 and 6.20.

A complex Chi squared significance test has been carried out for each question in a similar manner to question 1. The null hypothesis is that the scores given by respondents are distributed at random. The values of Chi squared have been calculated and are illustrated in Table 6.5. For all statements the calculated value of Chi squared exceeds the tabulated value at the 0.05 level (two tailed test), the null hypothesis can be rejected.

Question 5 - Do you feel that the Cleveland Constabulary cares about the people it employs and values their contribution to the service provision?

Chart 6.17

Author's interpretation - there are marked variations in the scoring by the 3 categories of police officers for virtually every question. The senior officers appear to have significantly differing views that the constables and insp/sgts. The senior officers in many cases being supportive of the Force policies in respect of personnel, whereas the other ranks are highly critical of it.

Rating

Strongly disagree



Strongly agree

Arithmetic mean score for statements 5.1 to 5.9

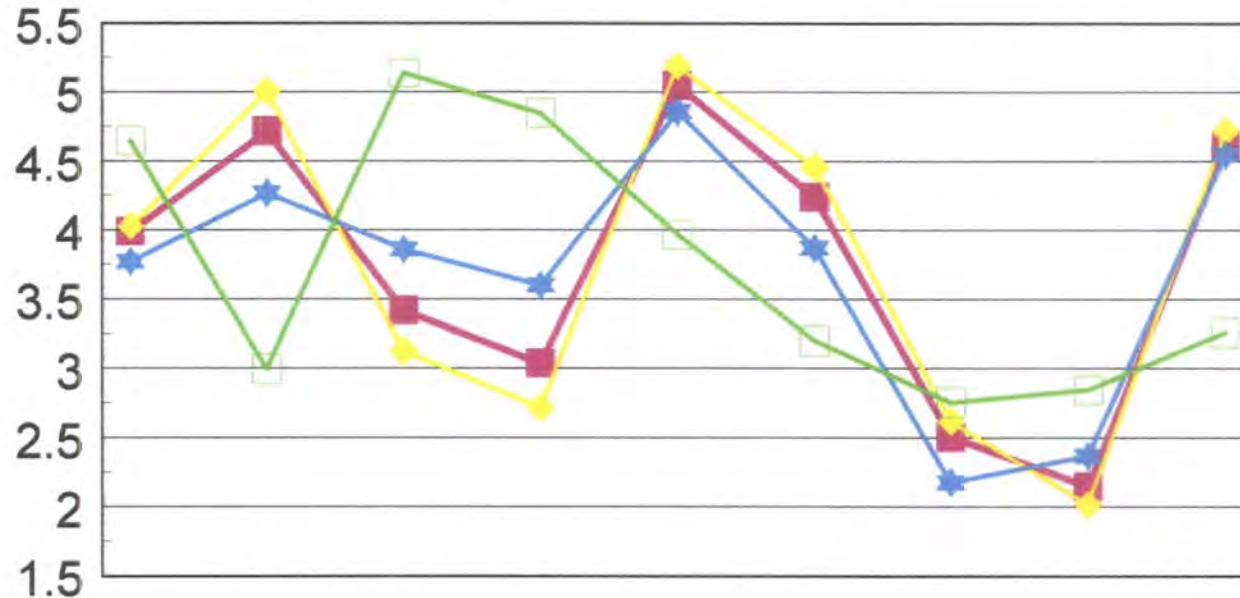

Statement number	5.1	5.2	5.3	5.4	5.5	5.6	5.7	5.8	5.9
All officers (721)	3.99	4.72	3.42	3.04	5.05	4.24	2.51	2.15	4.61
Constables (498)	4.03	5.01	3.13	2.72	5.19	4.46	2.62	2.02	4.72
Insp/Sgts (189)	3.77	4.27	3.86	3.60	4.86	3.87	2.18	2.37	4.55
Senior officers (34)	4.65	3.00	5.14	4.85	3.97	3.20	2.76	2.85	3.26

Question 5.3 - Do you feel that the Cleveland Constabulary cares about the people it employs and values their contribution to the service provision?

Strongly disagree



Strongly agree

Statement 5.1 - Middle management seem to care but not top management.

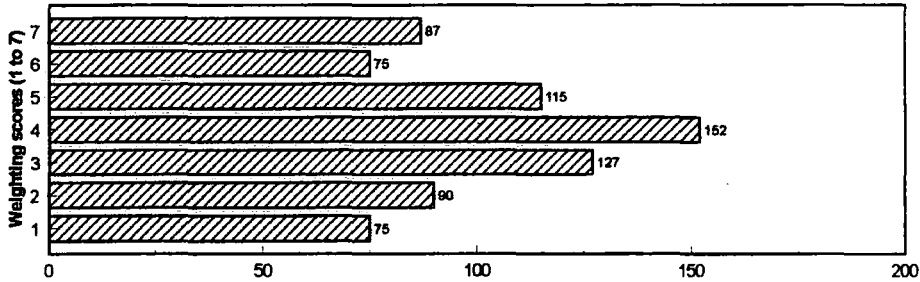

Author's interpretation - the data indicates that there are mixed views on this issue, 21.1% of respondents elected to score 4, the neither agree/disagree point on the rating scale.

Strongly disagree



Strongly agree

Statement 5.2 - The whole force is becoming more caring towards it's personnel.

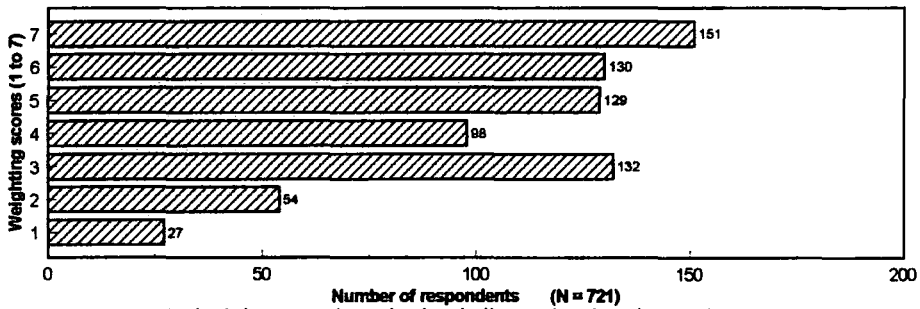

Author's interpretation - the data indicates that there is a tendency to disagree with this proposition, 56.9% of respondents scored between 5 and 7 on the 'disagree' scale.

Strongly disagree



Strongly agree

Statement 5.3 - It is obvious from some of the policies adopted e.g. tenure of post, that we don't really care.

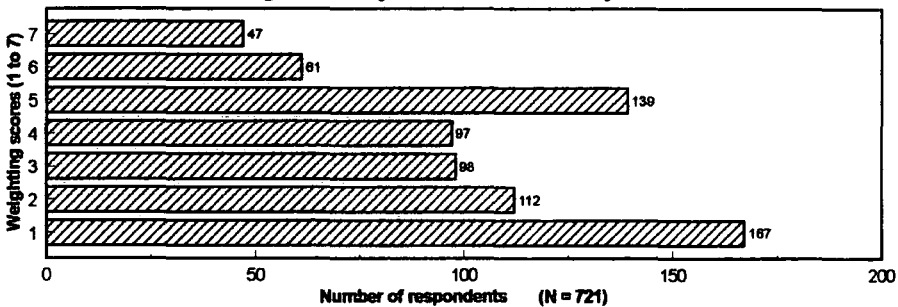

Author's interpretation - the data indicates that there is a tendency to support this statement, 52.3% of respondents scored between 1 and 3 on the 'agree' scale.

Question 5.3 - Do you feel that the Cleveland Constabulary cares about the people it employs and values their contribution to the service provision?

Chart 6.19

Strongly disagree



Strongly agree

Statement 5.4 - Nobody listens to the opinions of lower ranking officers

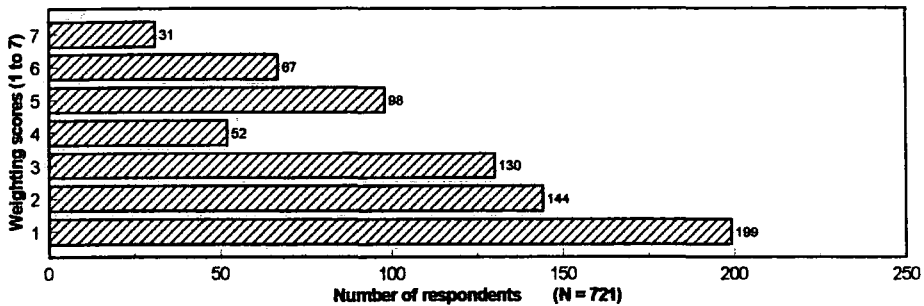

Author's interpretation - the data indicates that there is significant support for this statement, 52.3% of respondents scored between 1 and 3 on the 'agree' scale.

Strongly disagree



Strongly agree

Statement 5.5 - We are getting across the message to all staff that they are important.

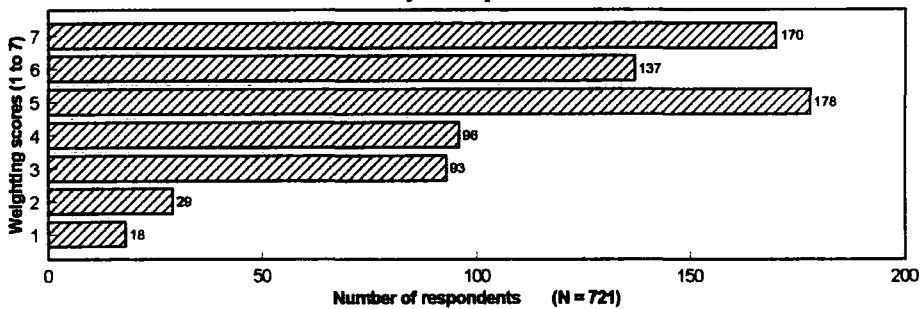

Author's interpretation - the data indicates that there is significant opposition to this statement, 63.7% of respondents scoring between 5 and 7 on the 'disagree' scale.

Strongly disagree



Strongly agree

Statement 5.6 - We provide very good welfare arrangements for all employees.

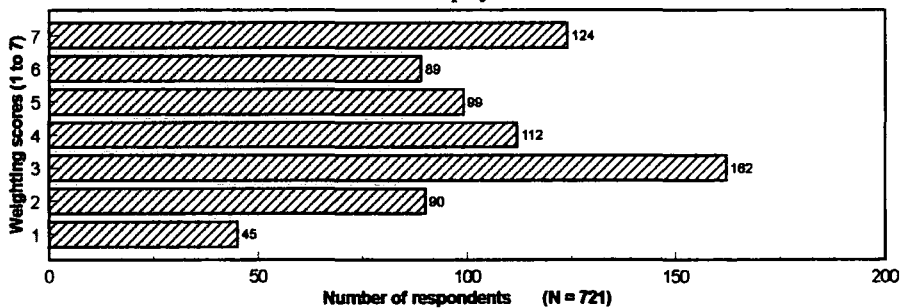

Author's interpretation - the data indicates that evenly balanced views are held on this issue, 42.2% of respondents scored between 1 and 3 on the 'agree' scale, 43.3% scored between 5 and 7 on the 'disagree' scale.

Question 5.3 - Do you feel that the Cleveland Constabulary cares about the people it employs and values their contribution to the service provision?

Chart 6.20

Strongly disagree



Statement 5.7 - Career development and other departments are collecting more information about police officers but don't seem to know what to do with it.

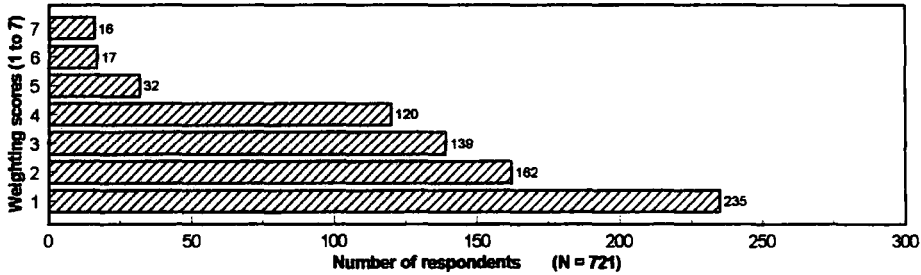

Strongly agree

Author's interpretation - the data indicates that there is very strong support for this statement, 74.8% of respondents scored between 1 and 3 on the 'agree' scale.

Strongly disagree



Statement 5.8 - There are so many questions being asked about a police officers worth, that it is damaging morale.

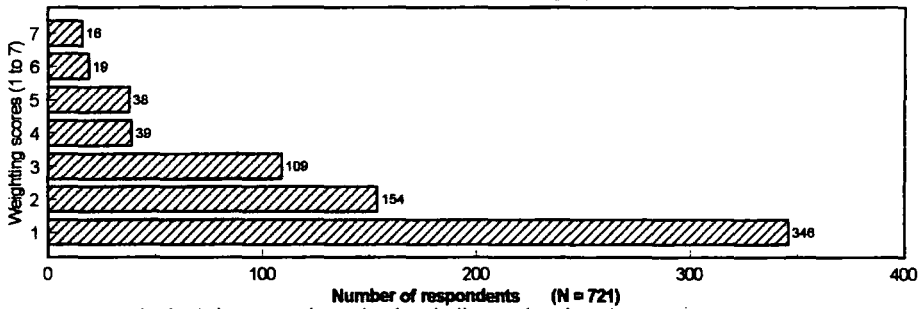

Strongly agree

Author's interpretation - the data indicates that there is very strong support for this statement, 74.8% of respondents scored between 1 and 3 on the 'agree' scale.

Strongly disagree



Statement 5.9 - New leadership at the top is improving the way that provide we care about the individual's needs.

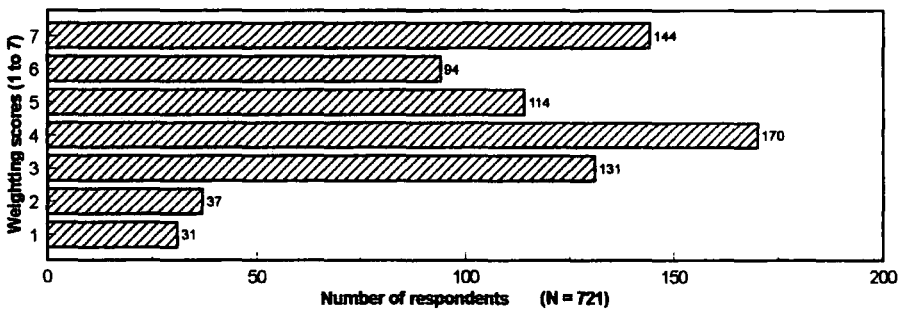

Strongly agree

Author's interpretation - the data indicates that there are mixed views on this issue, 23.4% of respondents scored the mid position 4 and 49% scored between 5 and 7 on the 'disagree' scale.

Statement 5 - "Do you feel that the Cleveland Constabulary cares about the people it employs and values their contribution to the service provisions?"	Calculated value of χ^2	Levels of significance at 12 degrees of freedom. Tabulated values: χ^2 χ^2 at 0.05 = 21.03 (95% confidence level) χ^2 χ^2 at 0.10 = 18.55 (90% confidence level)
5.1	41.726	0.05
5.2	90.73	0.05
5.3	75.43	0.05
5.4	87.04	0.05
5.5	47.17	0.05
5.6	42.54	0.05
5.7	32.36	0.05
5.8	45.02	0.05
5.9	44.71	0.05

Table 6.5 Levels of significance for question 5.

Overall observations on the scoring

There are marked and in some cases significant variations in scoring between all ranks and in particular constable and senior management on all issues except 5.7. Here there is a consensus of opinion that there is too much information being collected about police officers.

6.1.11 Discussion on the Responses to Question 5

There are clearly significant differences of opinion to the responses for statements 5.1, 5.2, 5.3 and 5.7 that deal with the issue of 'caring' for police officers. Senior management hold the perception that they are caring, whilst the constables view the senior management as uncaring and distant. Statement 5.4 deals with the issue of listening to the workforce, again there is a significant difference of views between senior management who believe they do, and

constables who feel that no-one listens to them. The final statement relates to new management, clearly the views of senior officers differ markedly from the rest of the workforce. This gap has been identified by respondents:

"Senior management lack the willingness or the ability to think strategically. A short-term fix is preferred to a long-term solution. Policies of the government are implemented without recourse to the financial cost in terms of staff, equipment and systems. The police service must challenge policies constructively. Senior police officers pay lip service to the needs of the individual. National initiatives affecting the police service are aimed at de-skilling police officers to provide what is termed a core service. Police management is being stripped out and civilians are replacing police officers in key functions. The priorities are not to assess the skills of the police manager over civilian staff but to strip out managers without regard to experience, skills knowledge, know how or any thought who is going to take on the additional workloads. If the present initiatives continue there will be a loss of quality of service and efficiency/effectiveness." (Inspector 20 - 24 years service)

6.1.12 Question 6. "When considering the value of computer information technology systems to the Force. What measures do you think should be used to assess the success or failure of such systems?"

The purpose of question six is to investigate the views of all officers to determine '*their views on the value of computer technology*'. It has been identified in chapter 3 that the Home Office and the Audit Commission highly recommend the use of computer based systems to assist operational policing. It is essential to evaluate the value of computer systems from the perspective of the operational police officers. The statements explore issues from the perception of all ranks to determine if there are areas where there is a consensus view or areas where there is diversity between the perception of different ranks of police officers.

The arithmetic mean scores for statements 6.1 to 6.9 are illustrated in Chart 6.21. The scores for statement 6.1 to 6.9 are illustrated in Charts 6.22, 6.23 and 6.24).

A complex Chi squared significance test has been carried out for each question in a similar manner to question 1. The null hypothesis is that the scores given by respondents are distributed at random. The values of Chi squared have been calculated and are illustrated in Table 6.6. For statements 6.1,6.2, 6.4, 6.5, 6.6, 6.7, and 6.8, the calculated value of Chi squared exceeds the tabulated value at the 0.05 level (two-tailed test). For statements 6.3 and 6.9 the calculated value of Chi squared exceeds the tabulated value 1t the 0.10 level (two-tailed test). In all cases the null hypothesis can be rejected.

Statement 6 - "When considering the value of computer information technology systems to the Force. What measures do you think should be used to assess the success or failure of such systems?"	Calculated value of χ^2	Levels of significance at 12 degrees of freedom. Tabulated values: 2 X at 0.05 = 21.03 (95% confidence level) 2 X at 0.10 = 18.55 (90% confidence level)
6.1	28.43	0.05
6.2	22.75	0.05
6.3	19.59	0.10
6.4	25.39	0.05
6.5	39.53	0.05
6.6	43.26	0.05
6.7	32.02	0.05
6.8	25.82	0.05
6.9	19.39	0.10

Table 6.6 Levels of significance for question 6.

Question 6 - When considering the value of computer information technology systems to the Force. What measures do you think should be used to assess the success or failure of such systems?

Chart 6.21

Author's interpretation - there is a high level of consistency of scoring from all officers with only minor variations on either side of the mean in all cases. The scores recorded in statements 6.6 to 6.9 indicate that there is wide dissatisfaction with the present computer systems: 6.6 that they are designed to satisfy the designer; 6.7 not enough training is provided; 6.8 the systems satisfy administrative needs rather than operational; 6.9 the use of computers has increased paperwork not decreased it.

Rating

Strongly disagree



Strongly agree

Arithmetic mean score for statements 6.1 to 6.9

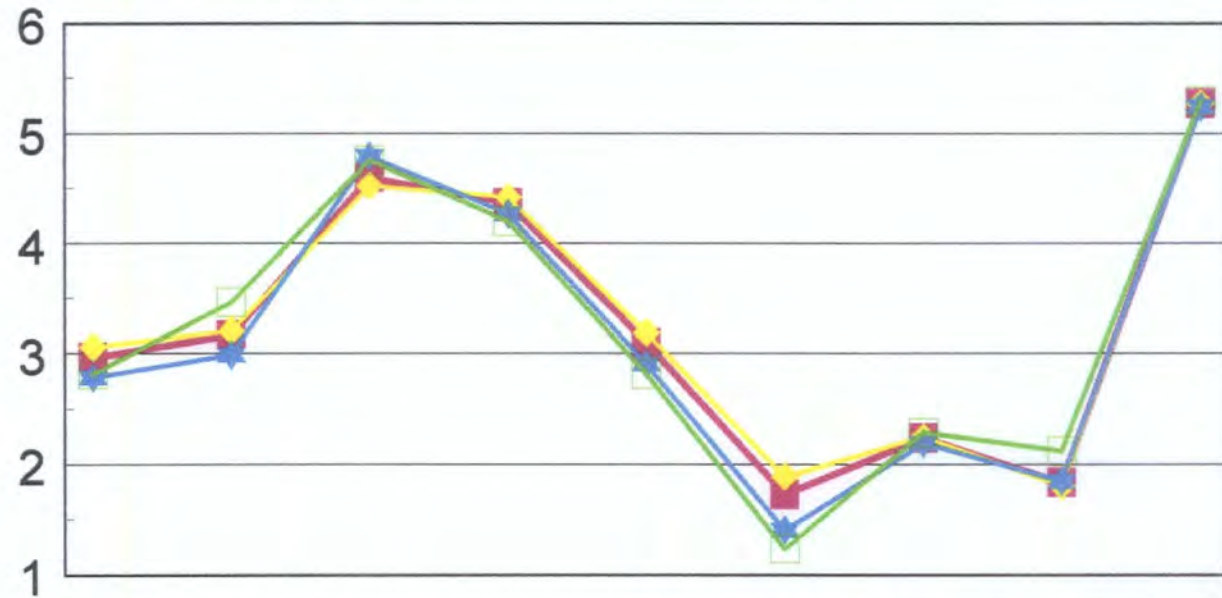

Statement number	6.1	6.2	6.3	6.4	6.5	6.6	6.7	6.8	6.9
All officers (721)	2.97	3.17	4.60	4.37	3.10	1.73	2.24	1.84	5.27
Constables (498)	3.06	3.21	4.53	4.42	3.19	1.89	2.25	1.81	5.27
Insp/Sgts (189)	2.79	2.99	4.80	4.27	2.91	1.41	2.19	1.85	5.24
Senior officers (34)	2.82	3.47	4.76	4.20	2.82	1.24	2.29	2.12	5.29

Question 6 - When considering the value of computer information technology systems to the force. What measures do you think should be used to assess the success or failure of such systems.

Chart 6.22

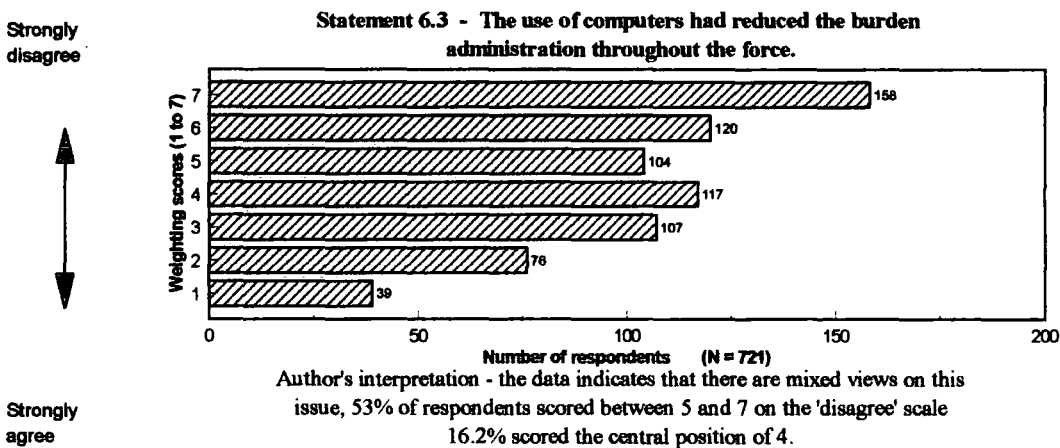
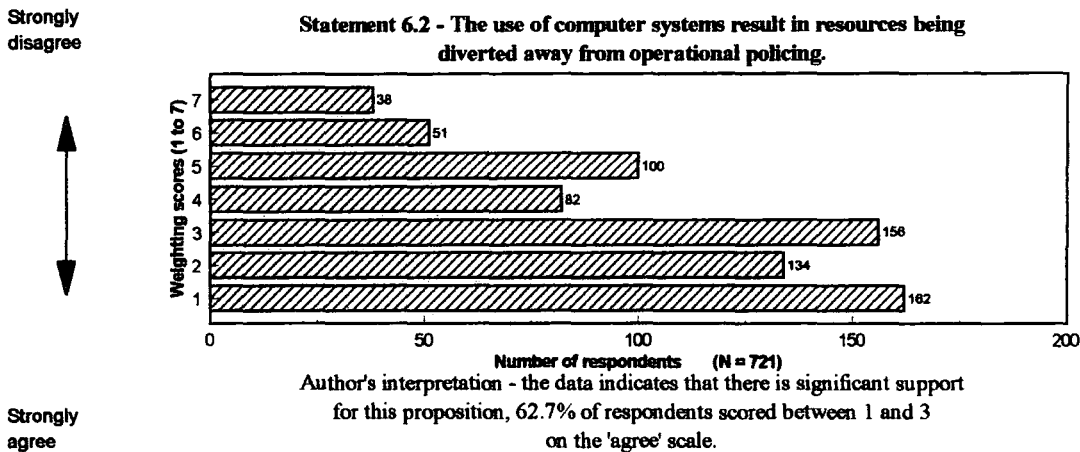
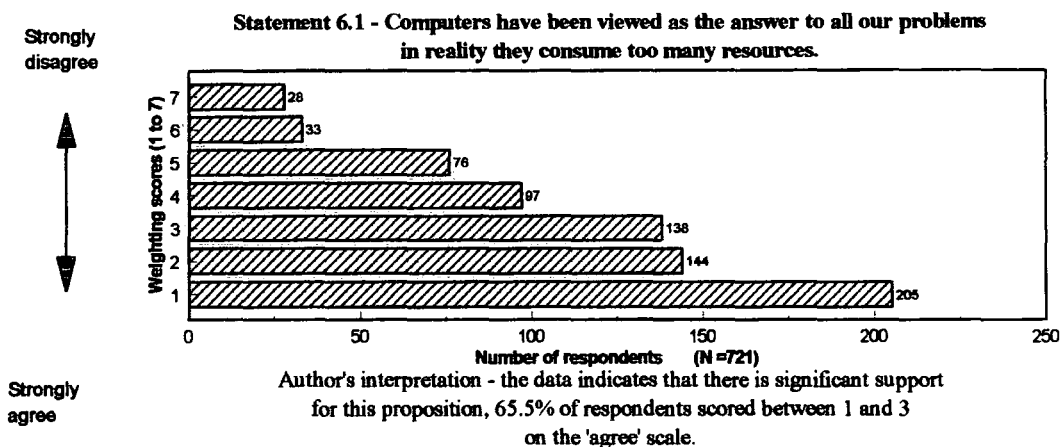

Question 6 - When considering the value of computer information technology systems to the force. What measures do you think should be used to assess the success or failure of such systems.

Chart 6.23

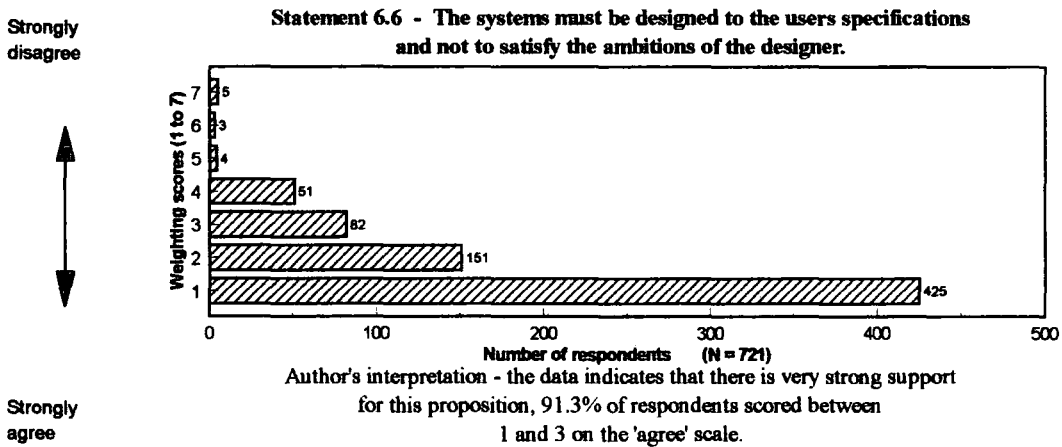
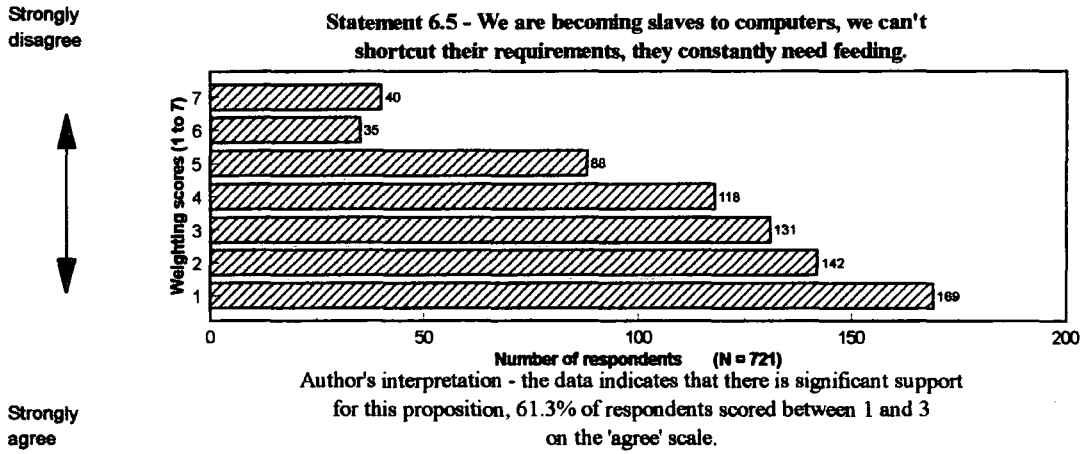
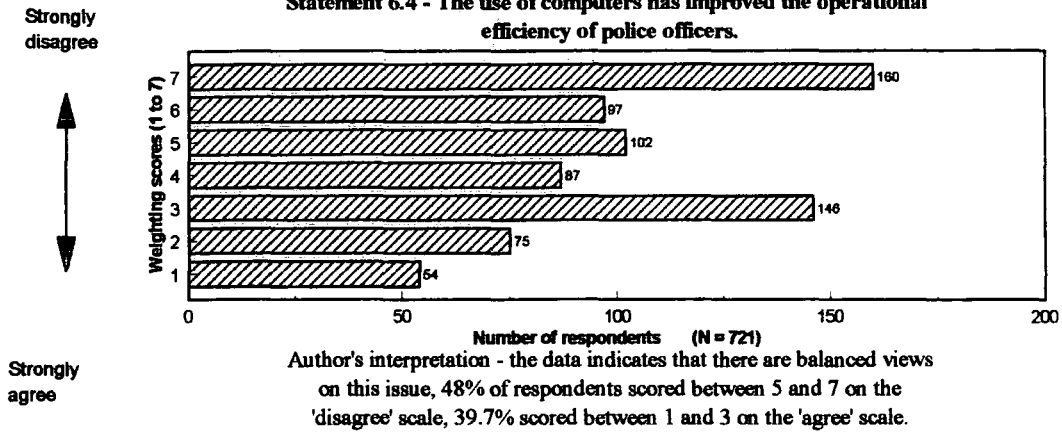

Question 6 - When considering the value of computer information technology systems to the force. What measures do you think should be used to assess the success or failure of such systems.

Chart 6.24

Strongly disagree



Strongly agree

Statement 6.7 - There are never enough people trained to use the systems properly.

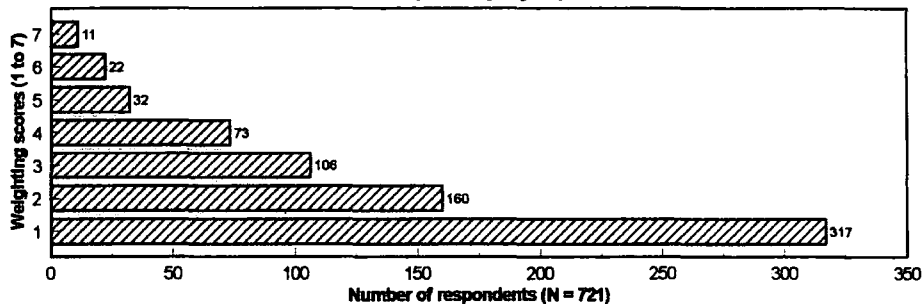

Author's interpretation - the data indicates that there is very strong support for this proposition, 88.5% of respondents scored between 1 and 3 on the 'agree' scale.

Strongly disagree



Strongly agree

Statement 6.6 - Computer systems must be designed to satisfy operational needs rather than administrative requirements.

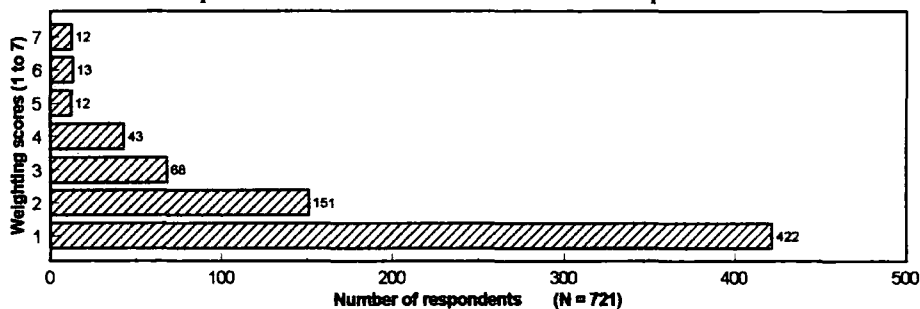

Author's interpretation - the data indicates that there is very strong support for this proposition, 88.5% of respondents scored between 1 and 3 on the 'agree' scale.

Strongly disagree



Strongly agree

Statement 6.9 - The use of computer systems has reduced paperwork within the force.

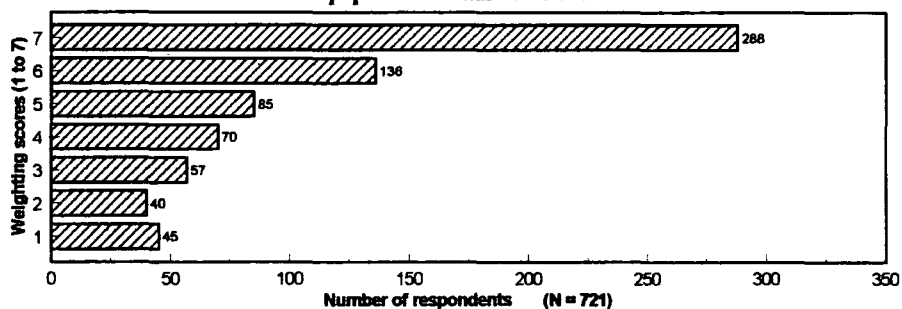

Author's interpretation - the data indicates that there is little support for this proposition, 20.9% of respondents scored between 1 and 3 on the 'agree' scale.

Overall observations on the scoring

There is a remarkable consistency of scoring for all statements. This indicates that there are clear and well defined views on these issues.

6.1.13 Discussion on the Responses to Question 6

From the response to statement 6.1, the respondents indicate that there is clear dissatisfaction with the force computer systems. Coupled with the response to statements 6.2 and 6.3, there is a view that their value to operational policing is not recognised. The response to statements 6.3, 6.5 and 6.9 indicate the systems are not perceived as reducing the administrative burden within the force and that they in fact create their own administrative workload that increases paperwork. Strong views have been expressed to statements 6.6 and 6.8, that the computer systems have been designed to meet the ambitions of the designer and that they are not designed primarily to meet the operational needs of police officers. There are clear views that the training provided is inadequate and therefore systems are not used to their full potential.

"The centralisation of communications is an expensive and complete flop. Despite the increased person power and more efficient computers, I feel that they provide a poorer service to the operational police officer..... too few people seem to know how to use it and even fewer seem to know how to use it properly." (Constable 5 - 9 years service)

"Computers should be a very useful tool for the operational officer. However, the operational officer now has to produce more facts and figures to satisfy the needs of the administrator, hence creating vast quantities of additional paperwork." (Inspector 25 - 30 years service)

6.1.14 Question 7. "Do you feel that those bodies e.g. the Home Office, the Audit Commission, who legislate, control and influence the police service, adequately take into account the effects that their changes have on the police service, or can it be improved?"

The purpose of question seven is to investigate the views of all officers to determine how they perceive the police service handles the issues of 'change'

emanating in the external environment and to gain '*their views on the changes that effect police officers*'. The statements explore issues that at the time of the questionnaire were highly topical from the perception of all ranks to determine if there are areas where there is a consensus view or areas where there is diversity between the perception of different ranks of police officers. The arithmetic mean scores for statements 7.1 to 7.9 are illustrated in Chart 6.25. The scores for statement 7.1 to 7.9 are illustrated in Charts 6.26, 6.27 and 6.28.

A complex Chi squared significance test has been carried out for each question in a similar manner to question 1. The null hypothesis is that the scores given by respondents are distributed at random. The values of Chi squared have been calculated and are illustrated in Table 6.7. For all statements the calculated value of Chi squared exceeds the tabulated value at the 0.05 level (two-tailed test), the null hypothesis can be rejected.

	Calculated value of	Levels of significance at 12 degrees of freedom.
Statement 7 - "Do you feel that those bodies e.g. the Home Office, the Audit Commission, who legislate, control and influence the police service, adequately take into account the effects that their changes have on the police service, or can it be improved?"	2 X	Tabulated values: 2 X at 0.05 = 21.03 (95% confidence level) 2 X at 0.10 = 18.55 (90% confidence level)
7.1	21.48	0.05
7.2	49.78	0.05
7.3	21.85	0.05
7.4	2033.04	0.05
7.5	211.30	0.05
7.6	485.54	0.05
7.7	228.26	0.05
7.8	184052	0.05
7.9	211155.9	0.05

Table 6.7 Levels of significance for question 7.

Question 7 - Do you feel that those bodies , e.g. the Home Office, the HMI, the Audit Commission, who legislate, control and influence the police service, adequately take into account the effects that their changes have on the police service, or can it be improved?

Author's interpretation - there is a high level of consistency for scoring from all officers with only minor variations on either side of the mean in all cases. The scoring of the individual statements indicate that all officers believe that external agencies are unduly affecting the performance of the police service and that police officers should become more involved in the policy making process.

Rating

Strongly disagree



Strongly agree

Arithmetic mean score for statements 7.1 to 7.9

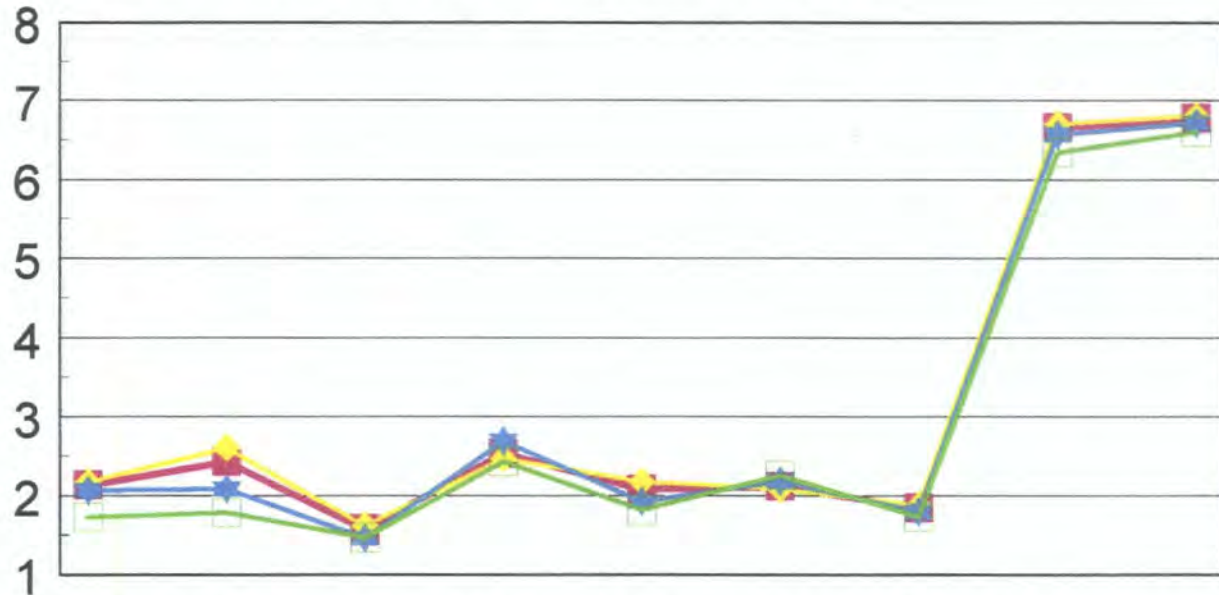

Statement number	7.1	7.2	7.3	7.4	7.5	7.6	7.7	7.8	7.9
All officers (721)	2.14	2.44	1.58	2.54	2.09	2.12	1.85	6.66	6.78
Constables (498)	2.18	2.61	1.62	2.48	2.18	2.09	1.88	6.71	6.81
Insp/Sgts (189)	2.07	2.09	1.46	2.70	1.93	2.19	1.80	6.57	6.72
Senior officers (34)	1.73	1.79	1.47	2.44	1.82	2.26	1.73	6.35	6.61

Question 7 - Do you feel that those bodies, e.g. the Home Office, the HML, the Audit Commission, who legislate, control and influence the police service, adequately take into account the effects that their changes have on the police service or can it be improved?

Chart 6.26

Strongly disagree



Statement 7.1 - We are always taking on changes despite the fact that we don't have the resources to fund them. This means that we end up giving a poorer service in other areas.

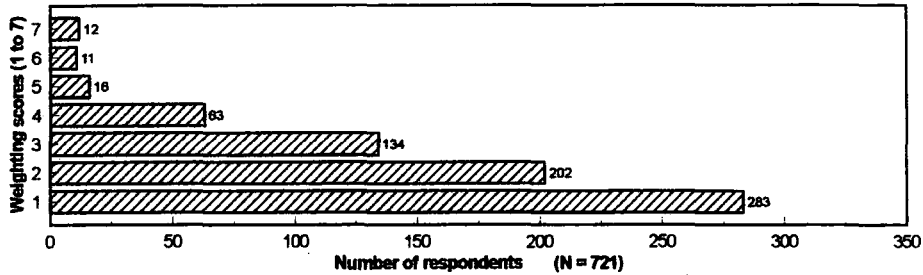

Strongly agree

Author's interpretation - the data indicates that there is significant support for this statement, 86.5% of respondents scored between 1 and 3 on the 'agree' scale.

Strongly disagree



Statement 7.2 - There should be a national process to evaluate the cost benefit of legislation or changes proposed.

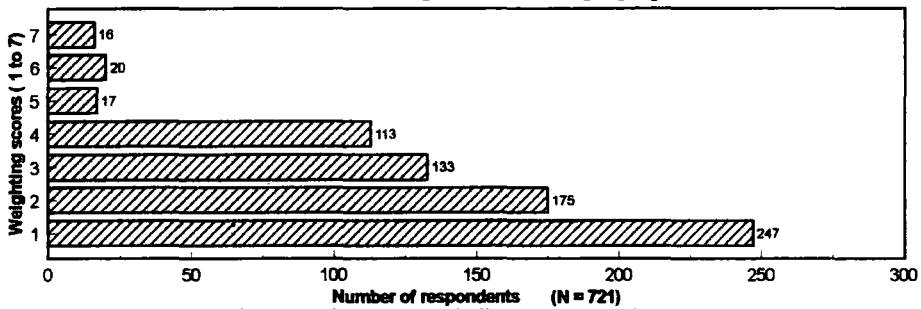

Strongly agree

Author's interpretation - the data indicates that there is strong support for this proposal, 77.9% of respondents scored between 1 and 3 on the 'agree' scale.

Strongly disagree



Statement 7.3 - Those officers who have to live with and implement change should be involved in the evaluation process, they may well recognise problems likely to be experienced and determine how these effect policing.

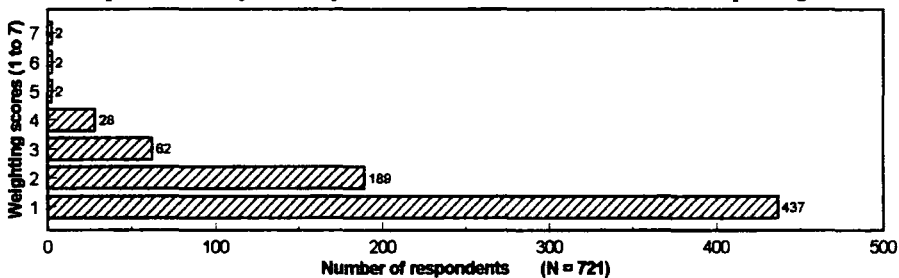

Strongly agree

Author's interpretation - the data indicates that there is extremely strong support for this proposal, 95.6% of respondents scored between 1 and 3 on the 'agree' scale.

Question 7 - Do you feel that those bodies, e.g. the Home Office, the HMI, the Audit Commission, who legislate, control and influence the police service, adequately take into account the effects that their changes have on the police service or can it be improved?

Chart 6.27

Strongly disagree



Strongly agree

Statement 7.4 - Everything new that comes out creates more work for the operational police officers.

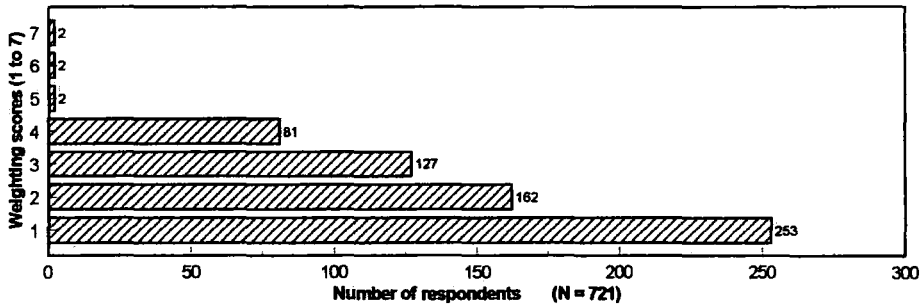

Author's interpretation - the data indicates that there is significant support for this statement, 75.2% of respondents scored between 1 and 3 on the 'agree' scale.

Strongly disagree



Strongly agree

Statement 7.5 - Changes that have significant cost implications for the police are implemented to the detriment of operational policing, e.g. the disclosure of evidence rules.

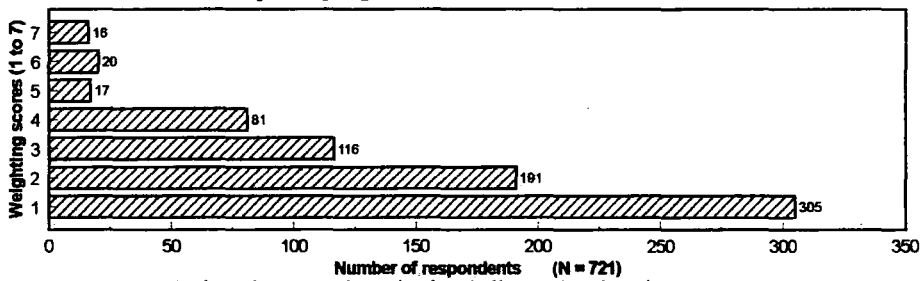

Author's interpretation - the data indicates that there is very strong support for this proposal, 77.9% of respondents scored between 1 and 3 on the 'agree' scale.

Strongly disagree



Strongly agree

Statement 7.6 - The Audit Commission keep recommending things that seem to make us inefficient and increase our costs, e.g. the centralisation of communications.

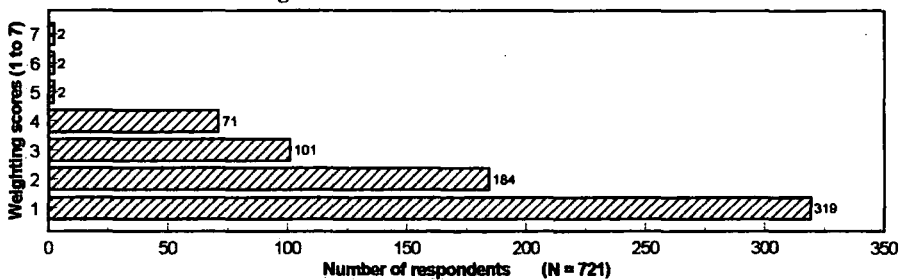

Author's interpretation - the data indicates that there is very strong support for this statement, 83.8% of respondents scored between 1 and 3 on the 'agree' scale.

Question 7 - Do you feel that those bodies, e.g. the Home Office, the HMI, the Audit Commission, who legislate, control and influence the police service, adequately take into account the effects that their changes have on the police service or can it be improved?

Chart 6.28

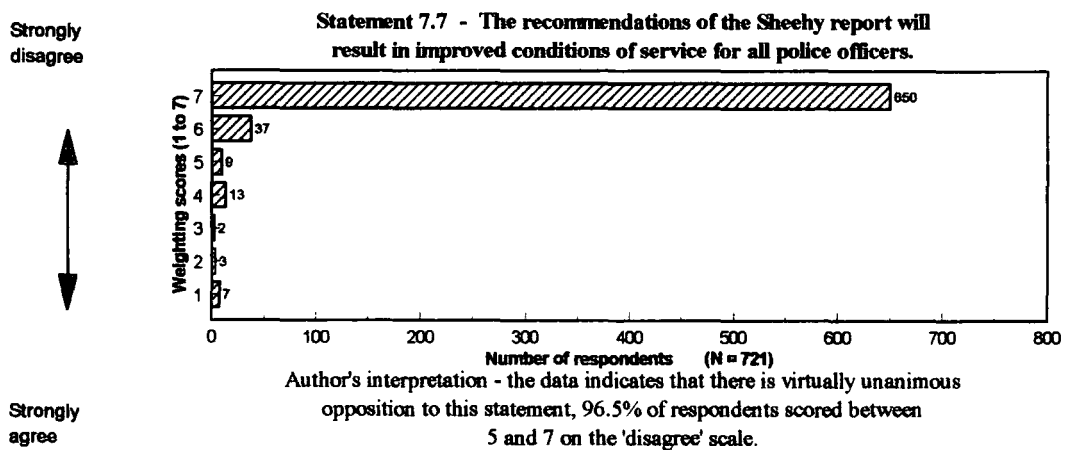
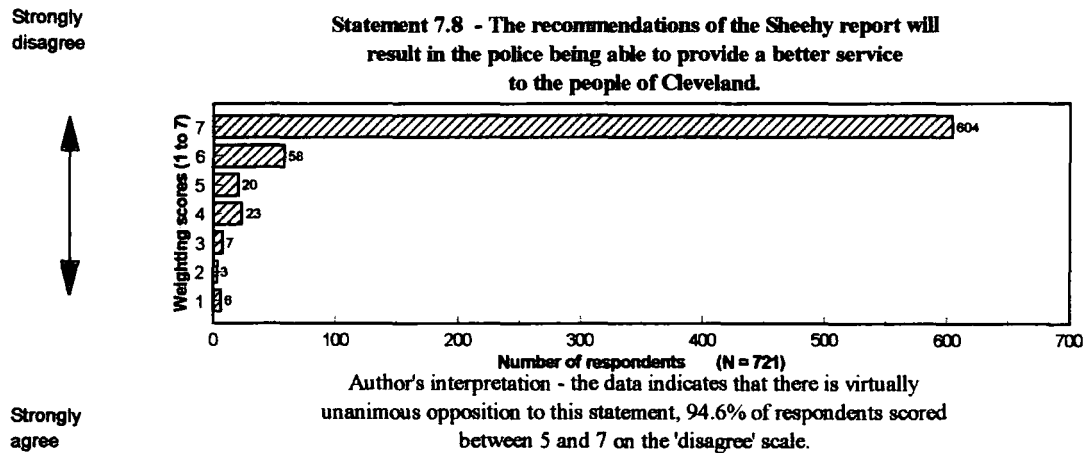
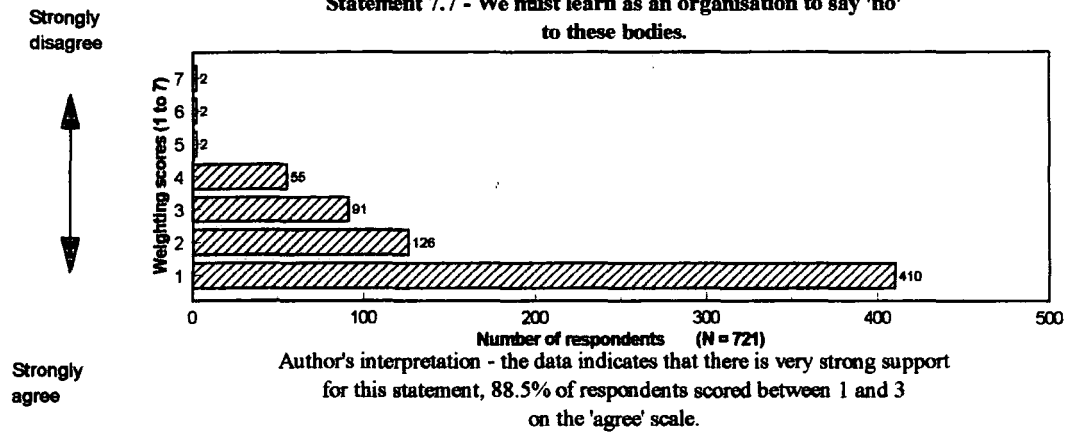

Overall observations on the scoring

There is a remarkable consistency of scoring for all statements. This indicates that there are clear and well defined views on these issues shared by all members of the force.

6.15 Discussion on the Responses to Question 7

Statements 7.1, 7.2, 7.4, 7.5 and 7.6 indicate wide dissatisfaction by all levels of the force to the influence emanating in the external environment that cause changes to working practices and procedures within the force. There is a universal recognition that new working practices invariably generate more work for the operational officer and that this has to be absorbed from existing resources. The response to statement 7.3 indicated operational officer should form part of the evaluation process received overwhelming supports with 437 respondents scoring 1 on the 'agree' scale. There was a collective view expressed by the majority of respondents that the police should say 'no' to these bodies with 421 scoring '1' on the 'agree' scale.

Statements 7.8 and 7.9 related to the recommendations of the Sheehy Report that was designed to bring the police service into the same business world environment of the private sector. There was a virtually unanimous rejection of the values of this report to the people of Cleveland, with 604 respondents scoring '7' and on the issue of improving police conditions 650 respondents scored '7' on the disagree scale.

"If the Sheehy enquiry is accepted then a long term effect will be seen in new recruits. No longer will it be classed as a career and will deter the higher class of people applying, so that people with less skills and abilities will be accepted." (Constable 0 - 4 years service)

"If Sheehy is implemented and police officers are made accountable for what they do, the public will suffer, i.e. minor offenders and motorists. Morale will drop amongst officers and this will impact on the public. Sheehy is about cost cutting and policing does not come cheap."

(Constable, 5 - 9 years service)

6.2 SUMMARY OF THE MAIN FINDINGS OF CHAPTER 6.

The questionnaire was designed to complete a cross sectional analysis to determine the present position of the Cleveland Constabulary. It explored the basic and fundamental principles of policing. Looking backwards to determine traditional views as well as looking forward to identify future trends in policing. It is argued that for an organisation to develop and progress it must look at itself, assess its own values, learn from its own mistakes and consolidate this information into its strategy for the future.

The questionnaire addressed some of the more contentious issues of policing: the cost effectiveness of foot patrols; the issues of crime and that of police challenging the criminal justice system; the effects of diminishing financial resources on operational policing; the use of computer technology and the influence of external agencies.

The key findings are that police officers are strongly in favour of maintaining a police service that is based on 'law enforcement' through the arrest and punishment of serious offenders primarily relating to criminal offences. There is a strong consensus view that prison should be used as a deterrent. Very strong views have been expressed that the police should take a pro-active approach to influencing the judicial system and getting the criminal justice system to take into account the impact that crime has on victims.

There is recognition particularly from those officers involved in operational patrol work that they appear to take the brunt of financial cuts and there are less officers available for patrol duties. The officers feel that they are in need of high quality and high technology operational equipment to tackle well equipped criminals.

The views held by constables, sergeants and inspectors indicate that the organisation is becoming less caring and does not value police personnel. There are strong views that more and more information is collected about officers and their performance, but no value comes from this information. Evidence suggests that senior management does not take into account the views of operational officers when determining policy.

There is evidence to suggest that police officers do not reject the use of computers out of hand. They do see value from some systems however, concern has been expressed that the second generation command and control systems collect vast quantities of management information that is not used, is difficult to understand and is of little value to the operational officer. The system does not appear to have been designed to meet the needs of operational officers and although it may be technically advanced has increased the paper based workload of the force.

The views of all respondents to the issues raised in question 7 were virtually unanimous. There is a strong consensus view that the force has been adversely influenced by external agencies and has been forced into a position whereby it has accepted many of the values and working practices of the private sector. Significant concerns have been expressed that policing in its present form is endangered and that the public will receive a deteriorating quality of service in the future.

6.2.1 Introduction to Chapter 7

In Chapter 7 we will continue to investigate and develop some of the key issues raised in the empirical work. The research involved a review of the Cleveland Constabulary annual reports to identify key factors that have affected and shaped the Force since it came into existence in 1974. The research will explore the relationships between finance, new legislation, civilianisation, child abuse,

new technology, crime, and increased demands for police services.

The practicality of Beer's (1970) model for national policing will be investigated utilising a typical policing problem to demonstrate the concept of requisite variety. The value of modelling corporate strategy will be debated giving specific examples of the practical use of the VSM to explore inter-relationships between the police and other agencies.

CHAPTER 7 THE ORGANISATION IN CYBERNETIC TERMS

7.1 INTRODUCTION

The purpose of the Chapter is to examine the principles on which the changes affecting the public sector are based and how they affect the working practices of the Cleveland Constabulary. So far the author has: explored the nature of policing; identified that the organisational structure is based on military lines with a hierarchical rank structure; identified the need for a bureaucratic system to ensure conformity of output; discussed the nature of police management; and demonstrated the complexity of the service provided. The earlier chapters explored the implications of adopting the model specified by Howard Davies that produced one best system for all types of public sector organisation. This had led to the emergence of a new form of 'scientific management' based on accounting principles and the ability to reduce all work related phenomena to quantifiable measures. The ethos of scientific management is focused on cost reduction, adopting the values of the 'McDonalds bureaucracy'. This concept relies on a methodology that involves: simplification of tasks making them easily replicable; minimal training; low staffing costs; centralised research; development of standardised products; and standard performance measurement. It is argued that policing is not a task that can easily simplified and that simplification can lead to increased complexity in the internal and external environments that must be considered when evaluating the impact of change. This process will be demonstrated later in the chapter.

Section A will review the force's past and present position examining the key factors influencing the future direction of Cleveland Constabulary. Section B will review the current model used by the Cleveland Constabulary in determining corporate strategy and explores the viable system model in the context of policing. Section C demonstrates the use of the Viable System Model

(VSM) by illustrating a practical application. This will show how the system can improve organisational understanding of the impact of change.

7.2 Section A. The Emergent Situation of the Cleveland Constabulary

The section will investigate the past and present position of the Force, identifying the key dynamic processes and the chain of causality. This will give an insight into how the organisation has reached its present position, why it is in that position, and how it has been forced there by environmental pressures.

On the 1 April 1974, Cleveland Constabulary was formed as part of the reorganisation of local government taking in elements from the North Yorkshire and Durham constabularies. Its jurisdiction covered the whole area of the new County of Cleveland, 144,023 acres, with a population of 567,759, as a complete and independent constabulary with its own Police Authority.

The Force with its headquarters situated at Dunning Road had an establishment of 1,411 police officers, 348 full time and 78 part-time civilian employees.

In 1978, following the review carried out by a committee chaired by Lord Edmund Davies, pay and conditions of service for police officers were radically improved. This immediately had an effect on the Force manning level that had fallen to 1278 police officers, 140 below strength.

The Force budget for 1978/79 was £10,630,000, approximately 80% was expended on pay, 17.5% on running expenses and 2.5% on loan charges and other expenses.

In 1979, the Force was able to recruit up to its new establishment of 1,418 officers, this caused the Chief Constable to comment

"However satisfying these trends may be, it has long been felt that the authorised establishment of the Force is inadequate having regard to all inherent features and risks. Cleveland County, with a density of population estimated at 9.8 to the hectare and with its vast industrial complexes predominantly steel, petrochemical and shipping can be likened more to a Metropolitan area than a Shire County." (Payne, annual report 1980 :1)

Due to the growth of new town areas and the resettlement of segments of the populace away from traditional town centre locations, it was identified that there was a need for new police stations in Thornaby, Eston and Coulby Newham.

The Force continued to play a leading role in computer development within the police service. All sub-divisional stations were linked via the Force computer that also gave access to the Police National Computer (PNC). This was regarded by police officers as a valuable tool and in the first 5 months officers made over 12,000 enquiries.

In 1981, the chief constable indicated that the financial position of the Force would be the dominant factor in not only determining the police establishment but the civilian establishment. Although the Police Authority had supported increases in both, the County Council declined to provide finance.

Following publication of the report by Lord Scarman on the Brixton disorders, emphasis was placed on police forces to foster and improve relations with all members of the community. Although extensive arrangements already existed in Cleveland for consultation, with 60 officers attending in excess of 150 committees and interest groups. It was recognised that there was considerable scope to enhance the role of the local beat officer and the community relations department to create closer and more meaningful relationships with the community.

Following the recommendations of the Scarman Report (1981), greater emphasis was placed on increasing the number of foot patrol officers, to foster closer links with the community. In addition, a third tier of policing, the 'first response vehicles' were introduced providing a rapid response to emergency calls.

At the beginning of 1984, the key outstanding issues remaining were: to increase operational police strength; to implement the civilianisation programme; to complete the police building programme. However, the main factor affecting the progress of these issues was the inability of the Police Authority and the Cleveland County Council to provide the necessary finance. The programme faced another major setback when a £1 million cut was imposed on the Force. This amounted to 3.5% of the overall revenue budget. The Force absorbed the majority of this cut by reducing police and civilian overtime by 50% and by the closure of Thornaby police station. However, the closure prompted considerable public disquiet that resulted in the provision of a counter service at Appleby House, Thornaby. This was a temporary measure until a new police station could be built.

The Force remained committed to developing new initiatives to improve the service provided to the public. Examples are: prevention and detection of drug abuse as street level; revised procedures for dealing with rape victims and victims of domestic violence; crime prevention initiatives; development of community based schemes; inspector stations; and a vigorous recruitment campaign to double the number of special constables. The Force also continued to develop computerised systems for providing improved management information and a cost accounting system.

In 1985, there was an easing of the fiscal constraints, with an increase of £92,000 in the revenue budget. Unfortunately this growth was immediately

swallowed up by the requirement for all officers to attend training courses in readiness for the implementation of the Police and Criminal Evidence Act 1984 (PACE). The civilianisation programme remained firmly on the Force agenda. It was given a welcome boost when the Police Authority and the County Council approved funding for 41 new civilian posts to allow 17 officers to return to operational duties. This was on the provision that the Force would not recruit to fill 24 police officer vacancies.

The Force continued to develop computerised systems that included, a statistical and digital mapping package, fixed penalty tickets and overtime.

Coulby Newham introduced a pilot neighbourhood watch scheme. The object was to improve community interest in the prevention and detection of crime and to develop closer ties between the police and members of the community.

In 1986, the funding formula was changed from a 50% - 50% split between Central Government and Cleveland County Council, to one whereby Central Government provided 51% of the funding. This gave the Force a growth budget of £798,830, of which £615,330 was directly attributable to the increase of 1% in the police grant. This allowed implementation of the civilianisation programme with 41 new employees being recruited, a further 16 posts were identified as being suitable for civilianisation.

The Force continued to display a commitment to working with other agencies within the County. Following the success of the Coulby Newham neighbourhood watch scheme, 23 schemes were commenced in other localities. The computer development unit was bolstered by the recruitment of 6 civilian employees. During the year the unit implemented the extended fixed penalty system and the Home Office Large Major Enquiry System (HOLMES).

The 1987/88 budget provided a gross expenditure of £35,124,400. This represented a growth budget of £590,600 that was utilised to reinstate the previous cuts in police overtime and to finance the civilianisation programme, with 21 further posts being created within the financial year.

In 1987 a judicial review into the procedures for handling allegations of child sexual abuse commenced under the chairmanship of a High Court Judge Mrs Butler-Sloss. In response to the enquiry, on 1 July 1987, a child abuse unit was formed. This unit allowed an inter-change of personnel between the police and social services to develop new procedures and created facilities for joint training.

The issue of crime, particularly violent crime was becoming increasingly paramount. To tackle crime, the Force adopted a system of 'high profile' policing, targeted at specific areas for short periods at a time. In support of this initiative the chief constable stated:

"There is no doubt that uniform officers patrolling the streets on foot, with effective vehicle support has a good deterrent effect. Unfortunately, such operations are manpower intensive and are difficult to sustain in particular areas over long periods. Crime prevention is not, however, a matter for the police alone. There is a need for members of the public to be actively involved." (Payne, annual report 1988 :1)

Neighbourhood watch schemes that now numbered 214, and it was increasingly apparent that members of the public were viewed as a resource in the fight against crime.

The 1988/89 budget provided a gross expenditure of £38,960,500. This included growth of £458,200, the majority of which was utilised to fund additional civilian posts and child abuse unit.

In February 1988, a review of the Force establishment identified a significant increase in demand in virtually all areas of policing. This led to the submission of a bid to the Home Office for an increase of 20 police officers. The Home Office approved an increase of 15 officers, raising the establishment figure from 1474 to 1489.

Following the publication of the Butler-Sloss report the child abuse unit was expanded to 24 officers and placed under the command of a chief inspector. The role of the unit was to take responsibility for the investigation of all offences involving abuse against children. The unit worked in conjunction with the Regional Health Authority and the Social Services. Practices and procedures were developed and refined for: joint investigations; medical examinations; special assessment teams; child abuse centres; and continuous research and training.

The Force continued to move away from a predominantly enforcement role, to one of prevention and diverting offenders, particularly the young away from crime and anti-social behaviour. Officers participated in such initiatives as 'change your ways' and in the establishment of juvenile liaison panels.

The 1989/90 budget provided a gross expenditure of £42,496,900. The budget included growth of £677,900, to pay for the increase of 15 police officers, and to continue the civilianisation programme. However, during the year, the County Council who were also faced with the prospect of 'charge capping' imposed financial constraints.

In January, the Force put in a bid for an increase of 2 sergeants and 16 constables. The bid received support from the Police Authority and the County Council, who despite their poor financial position informed the Home Office:

"The provision of additional police officers whether by increased civilianisation or by an increase in uniformed establishment is a major priority of the County Council." (Payne, annual report 1990 :1)

The Home Office approved an increase in the Force establishment to 1502 officers.

On 1 February, a child protection unit was established to replace the child abuse unit. In its first full year officers from the unit attended 1,435 meetings and dealt with 1,274 child abuse referrals.

In 1990 Christopher Payne retired, his successor, Keith Hellowell QPM, LLB, MSc, joined the Force on promotion from the Humberside Constabulary. He recognised that the Force was in the grip of financial constraint and in the second year of no-growth budget. This together with changes introduced by the Home Office that affected the rules for the allocation of capital finance, meant that the Force faced a daunting task in trying to meet the ever increasing demands placed on the service from a declining resource base.

The Force remained committed to community policing with the introduction of a new scheme called 'the policing of housing estates'. In support of this initiative the Chief Constable stated:

"In an attempt to combat anti-social behaviour, reduce the fear of crime and improve the service we provide, we introduced a project team into each of the six most deprived estates in the County. Dedicated teams of officers (housing estate project teams) work with other agencies, with a view to improving the quality of life of residents." (Hellowell, foreword to the 1990 Annual report)

In the financial year 1991/92, the Force had to cope with its third consecutive year of no-growth budget. In reality the budget, due to unavoidable growth commitments meant that there was a shortfall of £474,000. Consequently the

projected increase in police officers to meet increased demand and staff the housing estate project teams, did not materialise.

In January 1991, the chief constable drew up a policing strategy for the next five years that necessitated a major review of virtually all systems and working practices within the Force. He stated:

"I have had a development programme drawn up in which reorganisation of the Force, the introduction of new technology, reduction in administration and better management of staff are prioritised. When the programme is complete I anticipate that the level of resources appropriate to the scale of demand will be available for the two key areas of front line response and public confidence patrols." (Hellowell, annual report, 1991 :7)

The main objective of this review was to achieve financial savings in police management costs. Some senior ranks were exchanged for those of a constable the surplus finance used to employ extra civilian personnel.

During 1991, the Force was able to complete the implementation of the digital telephone network, centralising telephone answering at headquarters and placing a contract for a new command and control room. The initiative was designed to produce significant improvements in the quality of service provided to the public and to improve the control and use of resources.

In 1992 the rise in crime continued to cause concern, the chief constable remarked:

"It is both disconcerting and demoralising to find the same persons, often juveniles, being repeatedly arrested whilst on bail for similar offences. It is clear that there is a crisis of confidence in the criminal justice which must be rapidly addressed if our cherished system is not to fall into disrepute." (Hellowell, foreword to annual report, 1992)

Finance remained a key problem and the Force identified that it would have to cope with fewer police officers in the forthcoming year.

In 1993 the Force worked with other agencies to develop a youth strategy for Cleveland that would lead to the launch of a 'Charter for Youth'. An increase in violence towards police officers resulted in the issue of protective vests and the deployment of armed response vehicles on a 24-hour patrol specifically to respond to firearm's incidents. The financial position had not improved and the projected vacancy level for police officers was set at 87. (Chart 7.1) The force introduced devolved financial management and zero based budgeting, designed to increase the responsibility and accountability of District and Departmental commanders.

Cleveland Constabulary employment statistics 1987 - 1996.

Chart 7.1

Police officers and civilian staff

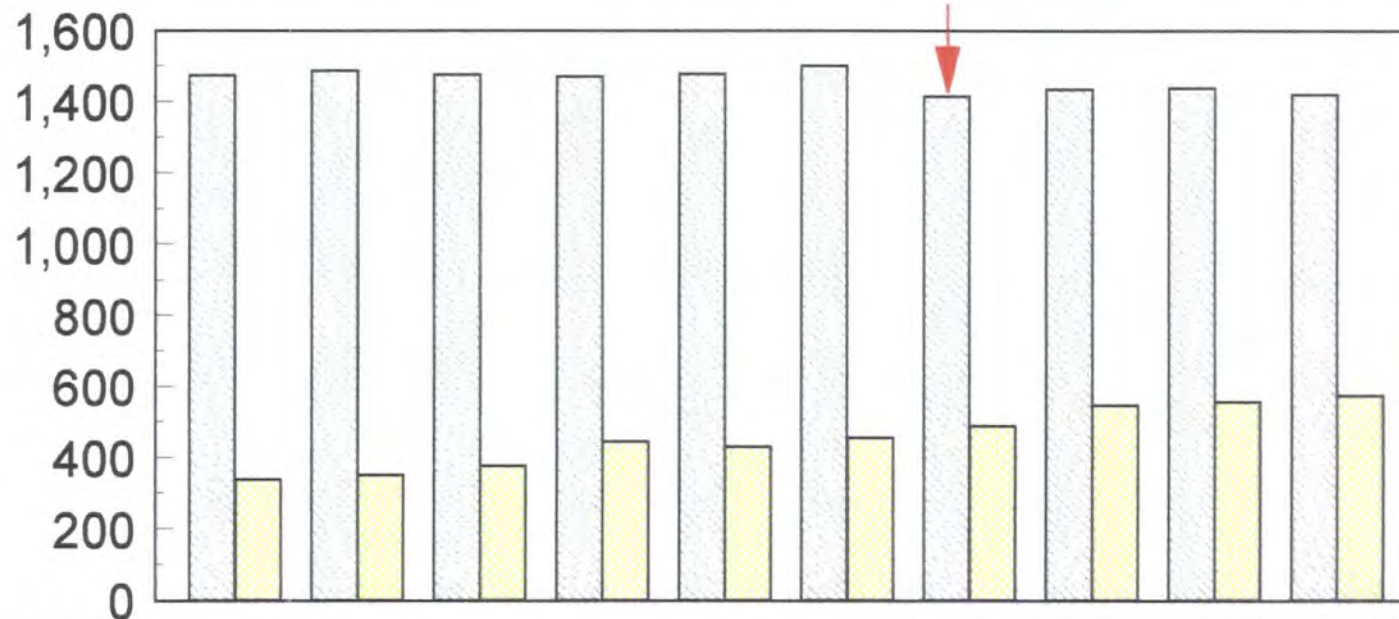

Year	1987	1988	1989	1990	1991	1992	1993	1994	1995	1996
Police officers	1,474	1,486	1,475	1,470	1,477	1,501	1,414	1,434	1,438	1,419
Civilians (FTE)	339	351	377	445	431	457	489	547	556	574

The 1996 figure represents the actual number of officers at the 1st April 1996

In 1994 crime increased to 75,313. This high level necessitated the introduction of new measures for dealing with crime and involved changing the way in which crime was recorded. Until then crimes could only be reported in person to a police officer who would record the details, then forward these to the centralised CRIMES bureau. The Force introduced crime desks that provided a single point in each District for victims of crime to report their crime over the telephone. If the victim agreed that there was no useful purpose in a police officer attending the scene then the crime would be recorded. If no lines of enquiry were identified, the crime could be finalised straight away. Early indications were that 35% of crimes could be recorded without the attendance of a police or scenes of crime officer. This clearly reduced demand for scene of crimes' examinations allowing these officers to spend more time on the serious crimes such as house burglaries, auto and violent crime. (Chart 7.2)

The chief constable expressed appreciation for the success of the forces new partnerships:

"I am grateful to the many voluntary and statutory agencies, business organisations and ordinary members of the public who join us in multi-agency initiatives to prevent and reduce crime. Notable partnerships during the year involved the zero tolerance domestic violence campaign and the development of closed circuit television projects in our town centres." (Shaw, foreword to annual report, 1994)

The Force remained at the forefront of innovation in the field of information technology with the introduction of mobile data terminals. The terminals are fitted to operational police vehicles and allowed officers to access computer messages and carry out P.N.C and intelligence enquiries direct from the on-board computer terminal.

To improve value for money the Force continued to reduce ranks, 7 chief superintendent posts were abolished and 21 superintendent posts reduced to

Cleveland Constabulary crime figures 1974 - 1996

Chart 7.2

Violent crime

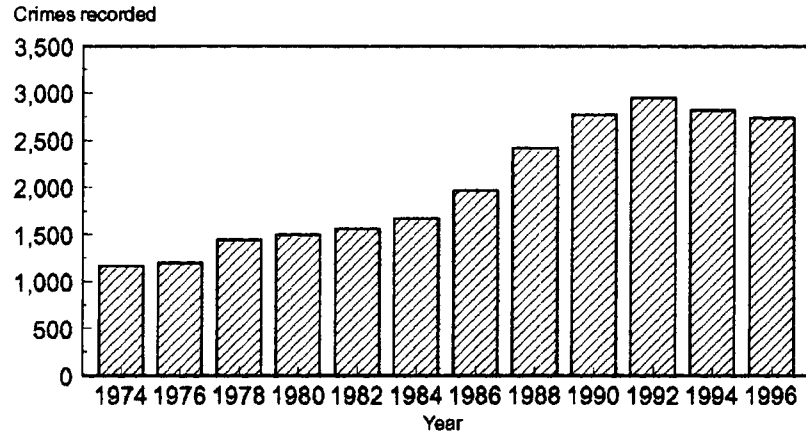

House burglaries

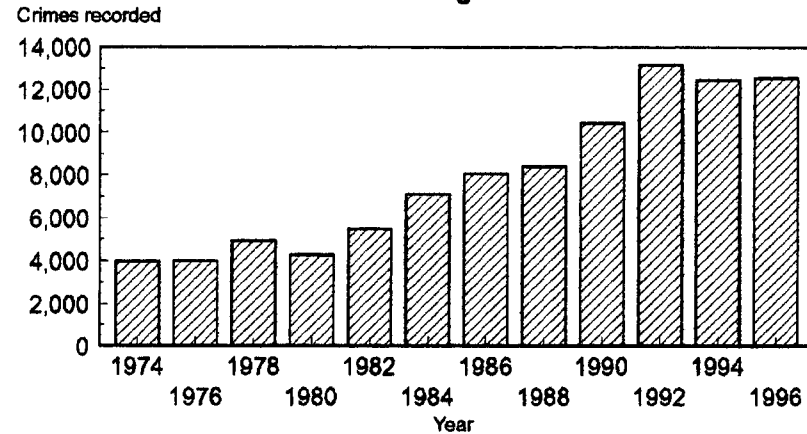

Auto crime, thefts of and from motor vehicles

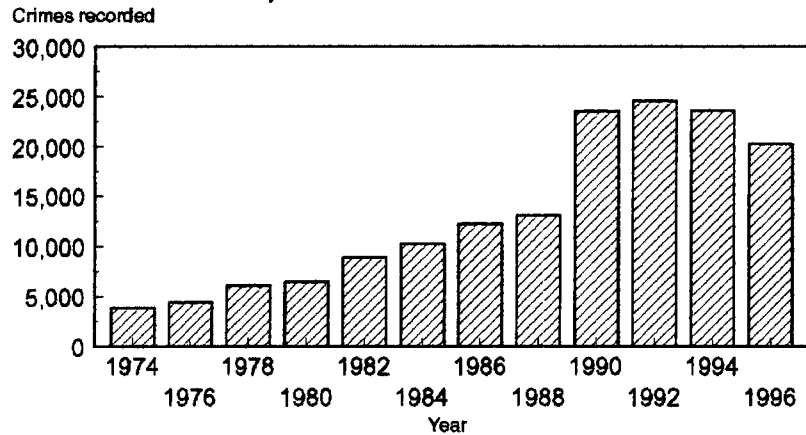

Scenes of crime examined

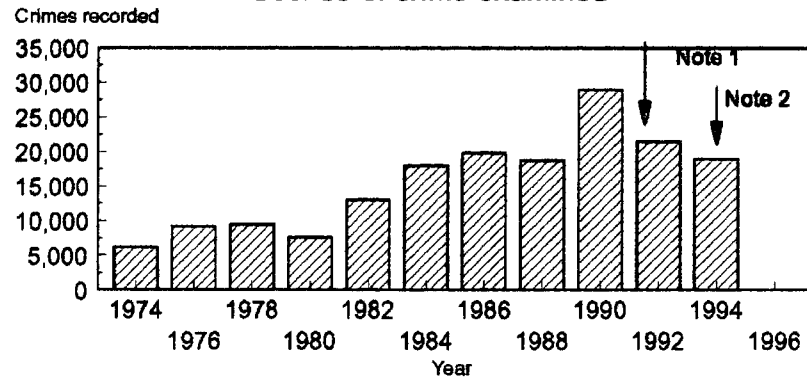

Note 1 - thefts from motor vehicles were excluded from examination

Note 2 - introduction of crime desks reduced demand

14. Despite these savings there it was necessary to maintain an average vacancy level of 60 officers.

On 1 April 1995, a new police authority came into being created as an independent corporate body. The initial cash limited budget fell short of the funding required to maintain the existing services and it was necessary to transfer £2.5 million from support functions to operational policing. The production of the annual report has been changed to coincide with the financial year. The report showed an actual decline of 4.89% in the level of crimes committed from 76153 to 72426. (Chart 7.3)

The Force together with Durham and Northumbria formed a Northeast Air Support Unit. The unit operates both a fixed wing plane and a helicopter that in its first year flew over 1000 missions in Cleveland and was involved in 118 arrests. The use of CCTV continued to expand with equipment being installed at Hartlepool, Middlesbrough, Redcar and in Grangetown. It proved highly successful and a major factor in reducing crime.

The 1995-96 annual report identified the level of work that members of the Cleveland Constabulary had to deal with every day.

- 583 incidents
- 233 '999' calls
- 201 crimes
- 56 arrests
- 158 traffic offences (1995-96 annual report :27)

The level of activity throughout the force continues to increase on an annual basis. Chart 7.4 shows the number of incidents recorded by the Force control room. It must be remembered that virtually every incident recorded needs some type of police response and generally requires an officer to attend the scene.

Recorded Crime in Cleveland 1972 to 1996

Crimes recorded

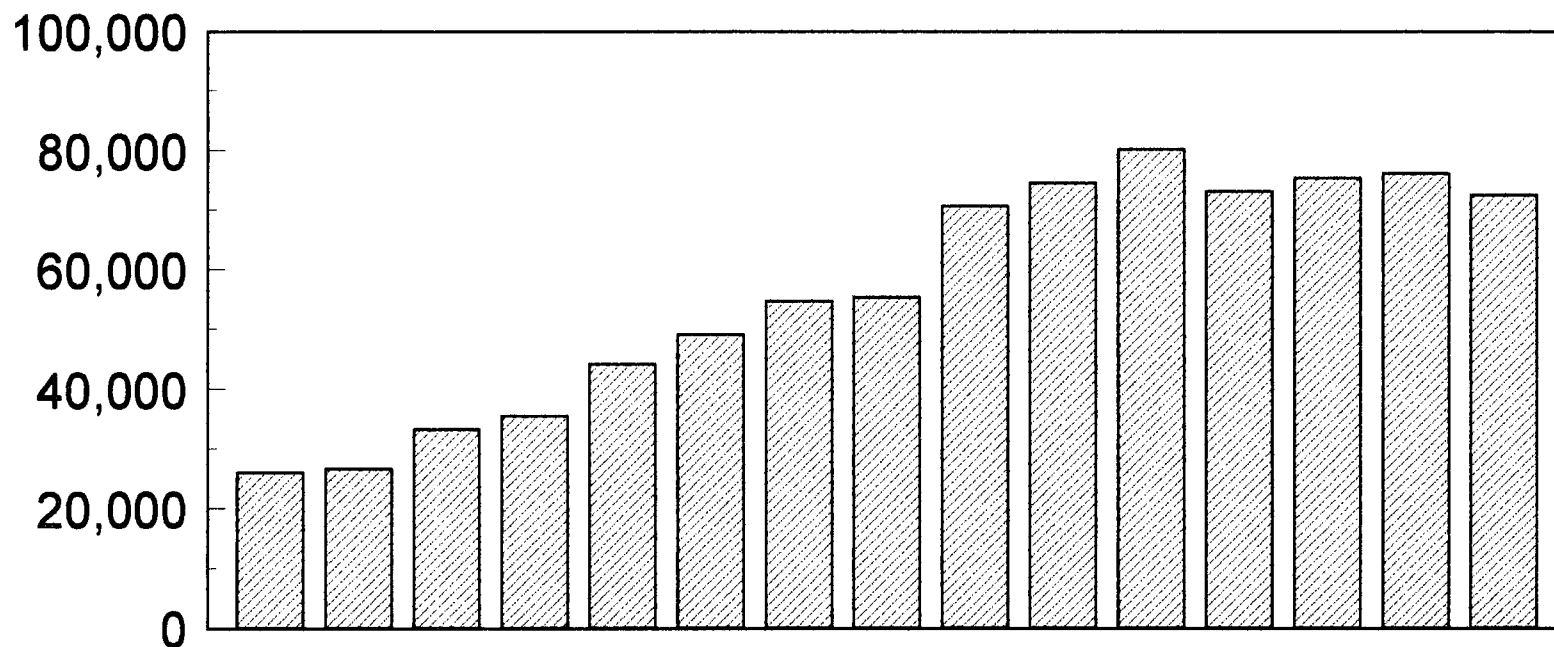

Year	1974	1976	1978	1980	1982	1984	1986	1988	1990	1991	1992	1993	1994	1995	1996
Recorded crimes	26,032	26,652	33,235	35,449	44,140	49,058	54,655	55,316	70,668	74,477	80,168	73,057	75,313	76,153	72,426

Cleveland Constabulary reported incidents
1987-1996

Chart 7.4

Demands placed on the Force control room

Reported incidents

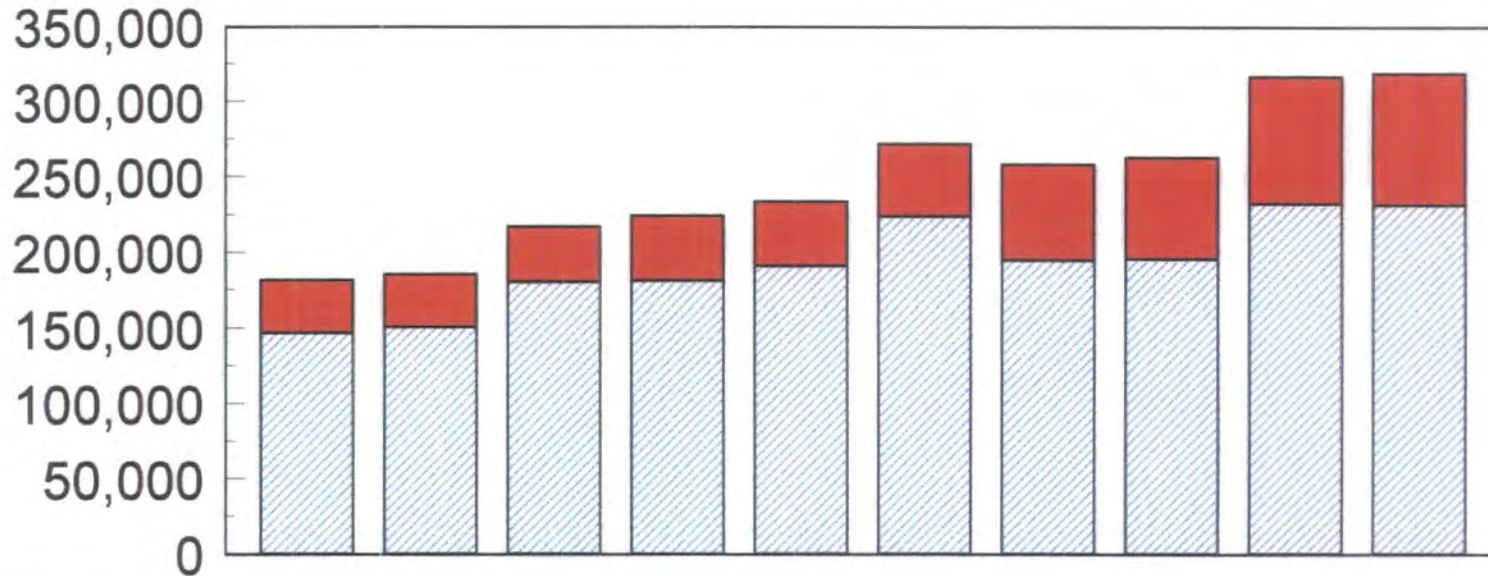

Year	1987	1988	1989	1990	1991	1992	1993	1994	1995	1996
Reported incidents 	147,359	151,126	180,100	181,100	190,800	224,100	194,750	195,508	232,500	231,637
'999' calls 	34,263	34,469	37,200	43,500	42,900	47,800	63,500	67,398	84,346	87,253

A particularly worrying trend within the Force is the high level retirement of police officers on medical grounds. To give a full picture of this trend a chart has been prepared starting at 1983. (Chart 7.5) The trend is beginning to have a significant effect on the Force finances. This is as a direct result of the way in which police pensions are financed. There is no actual pension fund, the pension payments of serving officers pay for the pensions of the retired. In normal circumstances this has worked out relatively well, for example on average 50 officers retire each year and 50 join. However, this equation has been distorted, particularly since 1993 when the numbers of police officers reduced from 1501 to 1414 in a twelve month period. Consequently the deficit is financed from the revenue budget. (Charts 7.6 and 7.7)

The number of police officers employed continues to fall, consequently the financial situation appears to be in spiral of decline and if additional finance is not made available there appears to be little prospect of employing more officers to finance the current level of pensions.

Number of officers retired on medical grounds
1983 - 1996

Chart 7.5

Police officers

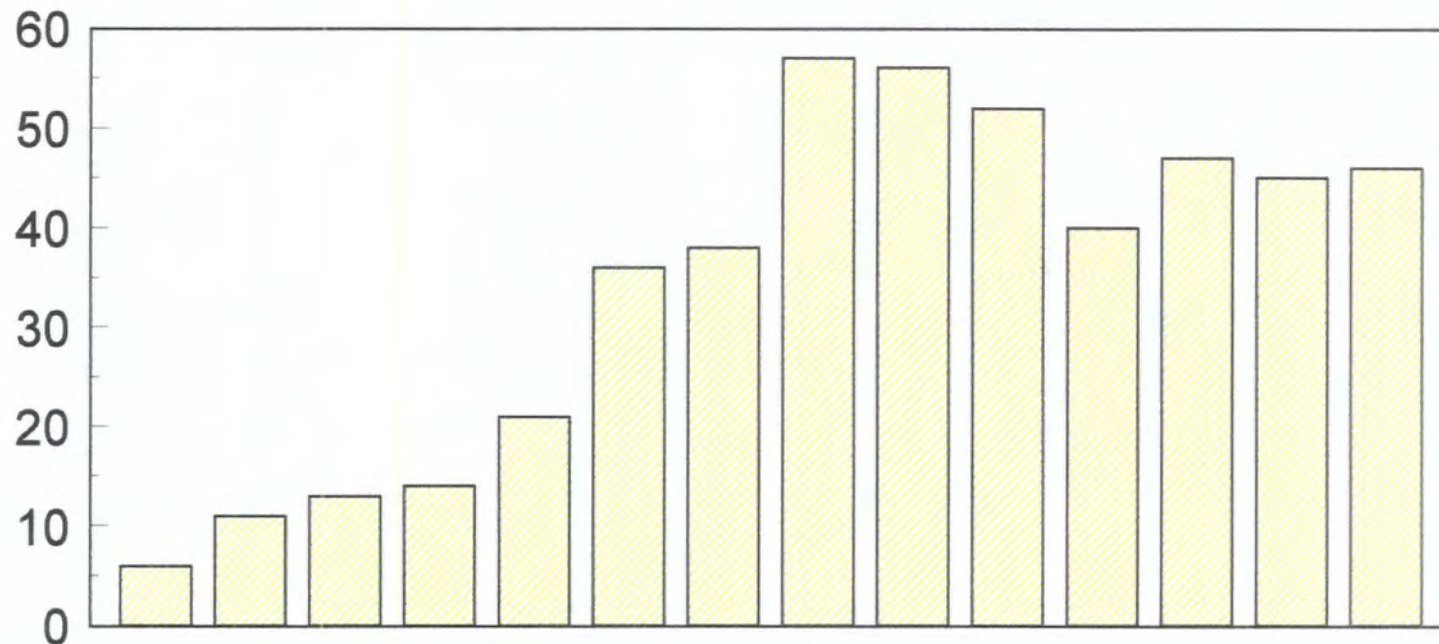

Year	1983	1984	1985	1986	1987	1988	1989	1990	1991	1992	1993	1994	1995	1996
Officers retiring 	6	11	13	14	21	36	38	57	56	52	40	47	45	46

The financial position of the Cleveland Constabulary 1989-92

Chart 7.6

Cleveland Constabulary budget 1989
£39,857,000

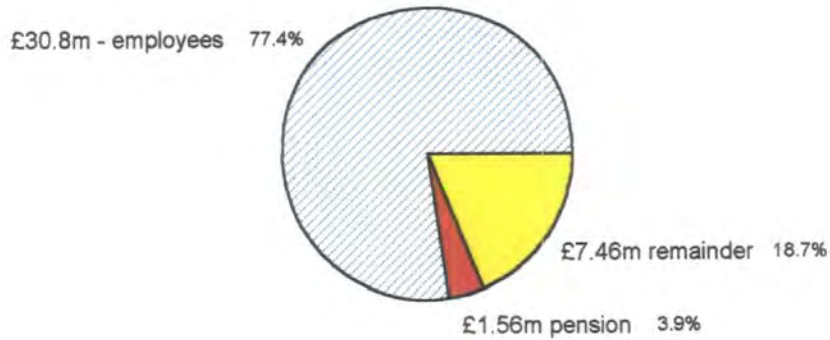

Cleveland Constabulary budget 1990
£43,760,000

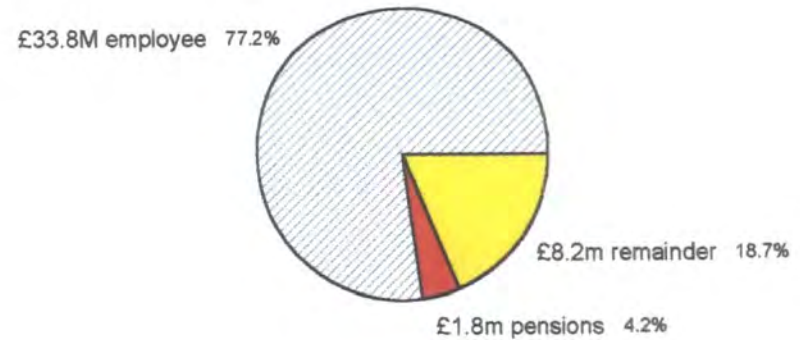

Cleveland Constabulary budget 1991
£47,922,000

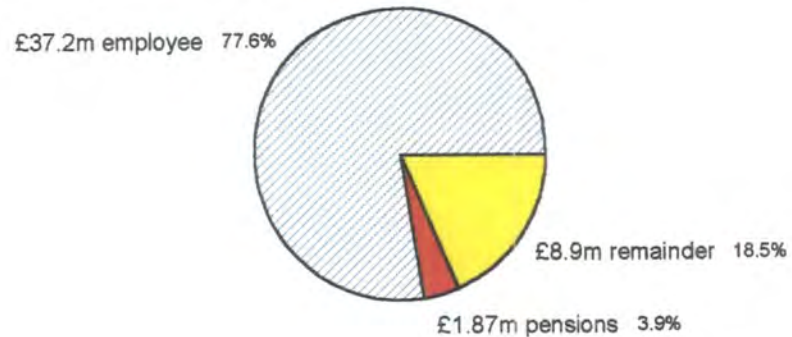

Cleveland Constabulary budget 1992
£52,086,000

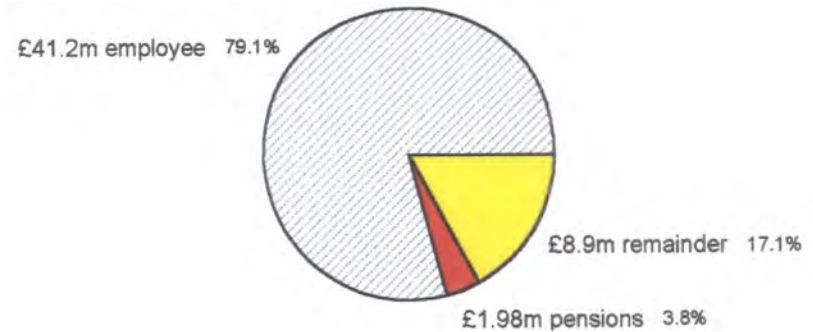

The financial position of the Cleveland Constabulary 1993-96

Chart 7.7

Cleveland Constabulary budget 1993
£46,685,000

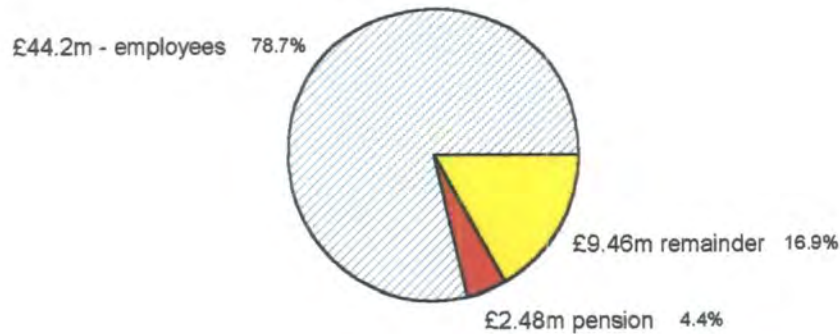

Cleveland Constabulary budget 1994
£63,667,000

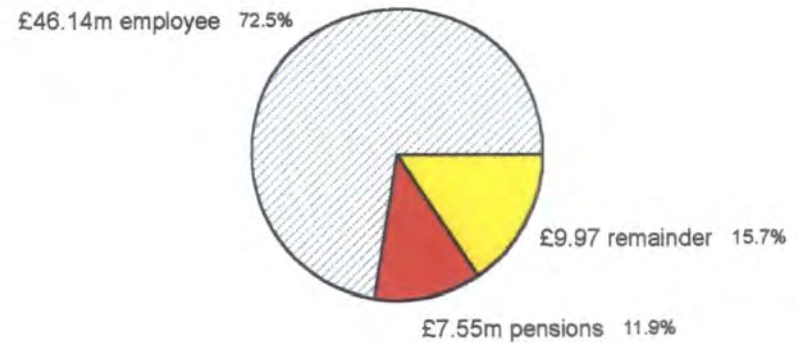

Cleveland Constabulary budget 1995
£69,246,000

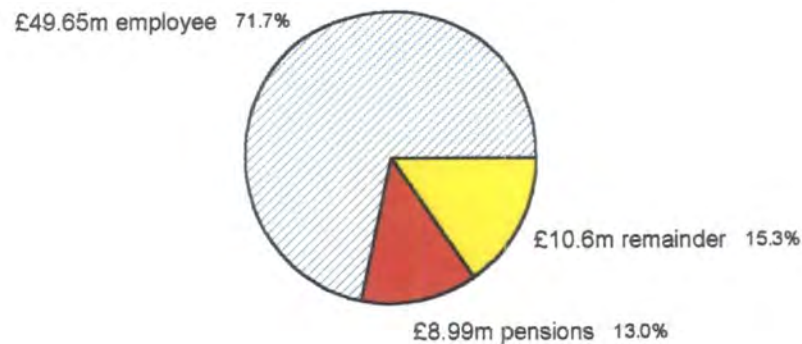

Cleveland Constabulary budget 1996
70,740,000

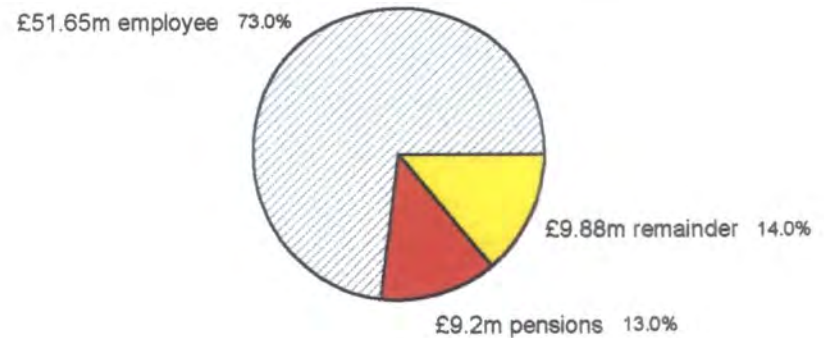

7.2.1 Summary of the Main Issues of Section A

Finance has been a key limiting factor in the growth of Cleveland Constabulary. During the mid 1990's the method used for balancing the budget was to reduce the number of police officers. Since 1994 this has been accompanied by a sharp reduction in senior supervisory ranks. The reduction has been accompanied by similar cuts in more junior ranks, by 1996 the inspector rank had declined from 96 to 78, and the sergeant rank from 236 to 226.

The drive to civilianise police posts has continued, however, since the introduction of the findings of the Sheehy report in 1995, the cost savings are no longer as great. Revised pay scales and the removal of housing allowance have reduced the pay of new police officers. What is clear is that fewer opportunities are available for police officers to serve in posts away from the operational 'front line'. The perceptions of the senior officers interviewed indicate that for the period 1984 to 1994 "range of skills" "knowledge of procedures" and "stress levels" had increased by 8.74, 8.88 and 8.70 respectively. This is classed as a significant rate of increase. (Chapter 5, table 5.6) These factors may in some way account for the increase in medical retirements, particularly those related to 'stress'. Consequently the predicted cost savings from the civilianisation programme have not materialised.

Despite the continuing increase in the demand placed on the police for their services, there appears little likelihood of getting an actual increase in the number of police officers that have now reverted to the 1979 level. The Force has tried different methods of limiting demand for its services, for example, the decision in 1992, not to fingerprint theft from motor vehicles, and the introduction of crime desks in 1994, led to a reduction in the number of crime scenes examined.

Throughout the periods of financial constraint the Force has maintained a commitment to the introduction of new technology. One of the major projects is the centralisation of communications and the Intergraph command and control system. During the interviews with the senior officers it became apparent that there was dissatisfaction with internal computer systems particularly the CRIMES system and centralisation of communications. The systems were identified as being "resource intensive" with increases of +6.75 and +7.48, and operational efficiency decreasing -1.13 and -3.66 respectively. (Chapter 5, Charts 5.9 and 5.10) These perceptions, received support from the findings of the forcewide survey that identified computer systems appeared to be designed to meet administrative needs rather than operational needs of police officers. (Chapter 6, Charts 6.22 and 6.24)

7.3 SECTION B. MODELLING CORPORATE STRATEGY

In Chapter five the majority of the senior officers interviewed were opposed to some of the key issues of change outlined at the start of this chapter. In particular the use of performance measures and the replacement of police officers with less skilled civilian personnel. The quantifiable areas of research identified that the modern day police officer has to cope with an ever increasing and complex workload with fewer resources being allocated to operational duties. This is evidenced by the significant increase in demand led policing from the public demonstrated in section A. Yet despite the views of senior officers who can be regarded as the 'intelligentsia' within the Force, the measures they were so resolutely against have virtually all been introduced in the relatively short period since the survey. One may ask 'why is this'.

One possible explanation for this was touched on by Sanderson (Chapter 2) who outlined that a prerequisite for promotion, certainly to the ranks of ACPO was conformance with the central ideology of policing. Sanderson identified

that it can be career enhancing to be associated with being at the cutting edge of change, conversely it can be career limiting to be regarded as being 'negative' or adverse to change.

It will be clear to the reader that the emergent picture of the police organisation is that police managers are continuously performing a series of balancing acts that are undergoing change at an increasingly quicker pace. If we consider that the basic purpose of management is to regulate activity with the intention of making the organisation more effective and that this entails balancing resources against competing demands generated both inside and outside the police organisation. Managers will typically use some form of model to aid their understanding. It is suggested that the models presently used do not reflect or are able to cope with the complexity of today's dynamic environment. This section will examine Beer's model of policing and it is anticipated this will increase understanding of how the police organisation works.

7.3.1 Beer's Model of Policing

On 29 October 1970, Beer delivered the 6th Frank Newsam Lecturer to senior police officers at the Bramshill Staff College. (Beer, 1975) The principle theme was a cybernetic view of the British police force and the development of a cybernetic model to ensure compliance with the law. Beer used simple analogies to get across his message, applying theoretical concepts to the police system.

7.3.2 Principle of requisite variety

Beer hypothesised that to maintain a law abiding society a police officer should be attached and would remain with each citizen for 24 hours every day. If the citizen began to depart from what is legal, the police officer would restrain him.

If the citizen were illegally handled by another, the police officer would protect him.

"This is the perfect regulatory set-up. It is a naive exemplification of the principle of requisite variety - known as Ashby's Law, after its discoverer. Let me explain. Whatever element of a system needs keeping in control (and the element of a social system is the individual citizen), this element is capable of generating a certain amount of variety. The measure of variety is the total number of states available to that element. Requisite Variety in the controller of a system entails a capacity - somehow or another - to match that number of states for the system at large. Every quirk, every action, every change of mind ... each would be monitored and checked." (Beer, 1970 :194)

However, once that officer is taken away from the citizen, the citizen is free to generate variety either as a lawbreaker or a victim. Beer identifies that if one or more citizen get together to undertake unlawful acts, and each citizen is an element of the overall system and capable of generating variety, then:

"The variety they are capable of generating between them is gigantic. Variety is exponentially combinatorial, that is to say it works like the football pools." (Ibid :195)

Beer establishes a generalised measure by dividing the number of citizens by the number of police officers. At that period of time 50,000,000 citizens by 100,000 police, then poses the question: "How do we arrange for the policeman to win a game where the odds are five hundred to one?" (Ibid :195) It would appear that although this rationale is valid Beer has totally underestimated the actual magnitude or variety attenuation required. In Cleveland typically 56.7% of all officers are deployed on operational patrol duties, in 1996 this amounted to 804 officers. The officers are equally divided into 4 reliefs, minus abstractions such as annual leave or training courses, hence at any one time you could expect about 150 officers to be on patrol. The population of Cleveland is approximately 557,000. Hence, each officer is responsible for 3713 members of

the public dispersed over a wide geographical area that includes 2290 kilometres of road. (CIPFA statistics 1996 :17)

Beer advances three methods for achieving requisite variety. The first one has already been discussed, one to one policing. The second consists of cutting down the variety available to the elements of the system. This can be achieved for example by imprisoning prolific offenders as confinement to a cell limits their ability to create variety. Another example of variety reduction as a regulatory technique is fingerprinting, this allows the narrowing of a search area, by eliminating suspects.

The police are presently engaged in a wide range of activities to reduce variety and to identify suspects. For example, the use of D.N.A. testing allows comparisons to be made from a pattern built up from samples taken from a suspect from those recovered from the scene of a crime. The police have invested heavily in creating a national database of D.N.A. profiles by taking samples from suspects charged with certain categories of offences, such as, sexual or violent offences.

The third method Beer proposes is to amplify the control variety. Beer clarifies the critical issues:

"It must by now become evident that all the processes we are discussing deal in one basic commodity: not money, not establishments but information. Please be careful about this word. It is used in a precise scientific sense, and not loosely. We are talking about the commodity which alone matches criminal variety... According to cybernetics the problem of amplifying information is a problem of selection." (Ibid :196)

The key issue is how do the police make this selection, how do the police decide what and who to check. The police do make great use of information particularly in the area of known offenders. For example if fingerprint marks are found at the scene of a burglary, they are compared with a list of known and

suspected burglars who are believed to operate in that area. Pictures of known criminals are circulated in police stations. However, the dangers of the present systems are that amplification in many cases lies in specific and localised knowledge of individual officers. The larger the systems created the more remote they become from the individual officer. Beer identifies that the development of information handling systems is problematical:

"The problem you have stands revealed as concerned with the collection and manipulation of information: above all, it is concerned with the cybernetic design of information devices capable of multi-dimensional selection, and hence of information amplification to a known degree - namely, five hundred times. Then the problems of organisation is just how this can be made to happen." (Ibid :197)

The key issues to be addressed are how to develop a system that reacts to every type of scenario. For example, a criminal may seek to amplify his own variety by moving from town to town. Beer also identifies that:

"The enormous combinatorial power of information inputs - which means that every added scrap of information slices away a great chunk of the criminal variety in question. In general, one bit of information halves the area of search. The minute you know 'its a woman' you can forget about half the population." (Ibid :197)

Beer debates how to 'measure the worth' of the service the police provide to the public. He suggests the commodity that the police force seeks to maximise is eudemony which he defines as: "We shall define eudemony for police purposes as a public sense of security, or which can be termed public satisfaction." (Ibid :202) What can then be measured is the year by year change, or rate of change between satisfied and dissatisfied members the public.

Beer designed an initial model to demonstrate how cybernetics could be used to organise the police service and demonstrates the inter-connectivity of the main components. Although the model was prepared purely as a draft version to highlight the causal effects of citizen's behaviour on levels of lawlessness. It

demonstrated the need to absorb variety by increasing money supply to the police and increasing the number of officers to control increases in variety. It is worth examining the focus of this model bearing in mind that it was produced in 1970, and many changes have occurred since then. (Fig. 7.1)

Absolute law is determined by parliament to meet the needs and wishes of the citizens and is developed to meet changing circumstances. For example, drink-driving legislation was introduced in 1972, to combat the rise in alcohol related road traffic accidents. This legislation will be used as an example to demonstrate how the model works.

The police force provides a service that enforces the law, hence affecting the level of lawfulness. Those citizens who obey the law remain in their own box (all citizens). To reduce variety, police officers utilise a breathalyser device to screen out or attenuate the number who will be subjected to arrest. Only those who provide a positive sample will be arrested. A further test involving the chemical analysis of breath, blood or urine will reduce the number subsequently prosecuted. Of those prosecuted all will face a mandatory period of disqualification from driving, and some will face prison sentences.

For the police to achieve 'absolute law enforcement' they would have to amplify the number of officers available for this type of enforcement to a level whereby one officer remained permanently with each potential driver. So a compromised and balanced situation is always in existence between lawfulness and absolute law. This in some ways can be viewed as a sensible arrangement, for if absolute law were enforced, then the court and prison systems would soon become overloaded.

Fig. 7.1

A cybernetic model of policing

(Beer, 1975 :211)

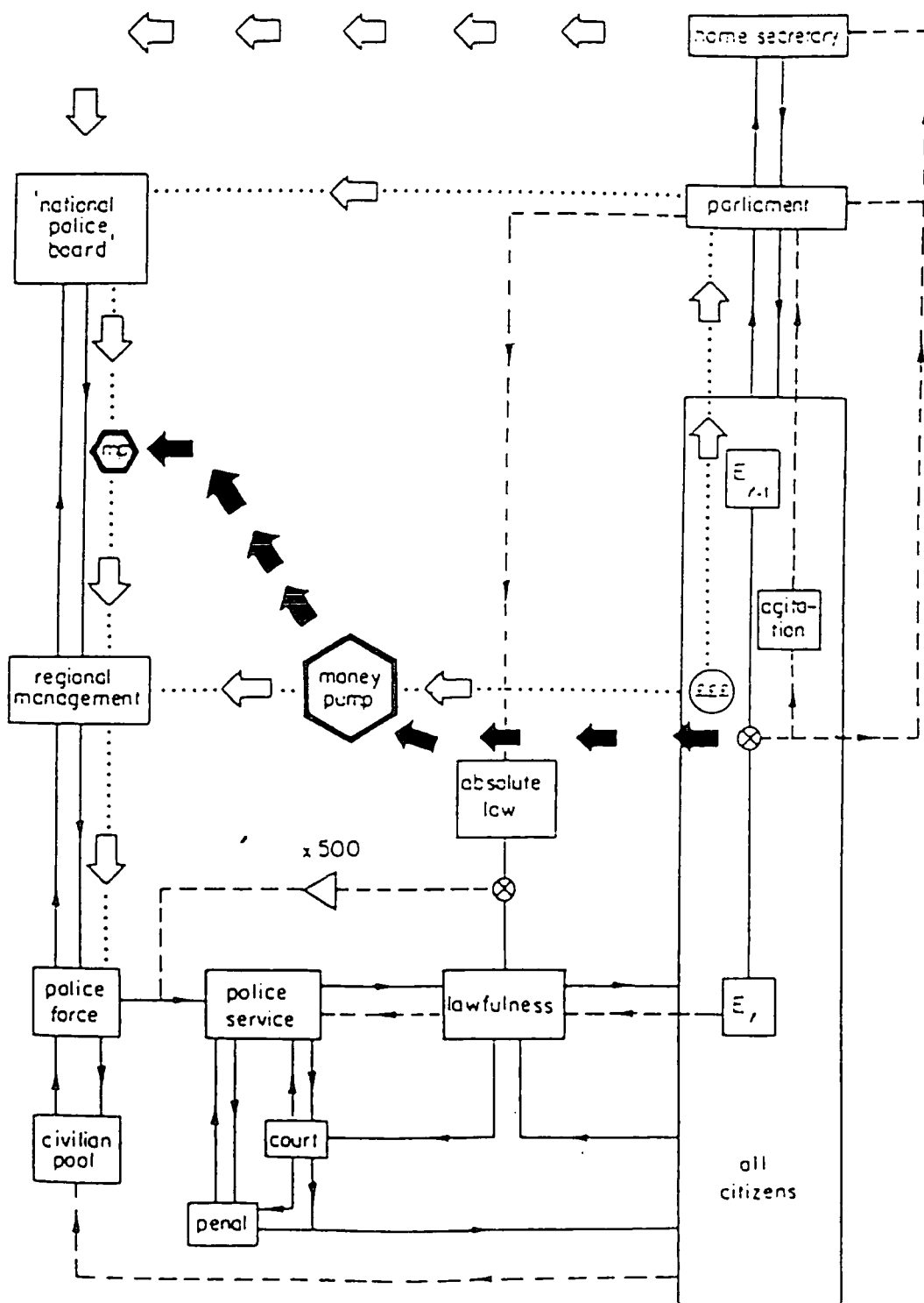

Public satisfaction is measured through an eudemonic loop, E_t represents the time period 'now' this is compared by means of a comparator with E_{t-1} that represents previous eudemony, hence provides an indication of 'are we more or less satisfied than before'. Agitation can be detected and fed through to parliament recommending a change in the law. For example a campaign to reduce the permissible level of alcohol, or an increase in penalties for those convicted. Changes in legislation are then fed through national and regional bodies to individual police forces and police officers.

Beer recognises the importance of linking public satisfaction to finance, the thick black arrows linking the eudemonic comparator to a money pump at both regional and national levels. If social stress is detected for example during the Toxteth riots (1981), then finance for additional officers and equipment must be made quickly available.

Beer recognised that his model has four main problems:

"The requirement is clear. There is need to measure eudemonic change scientifically, by behavioural analysis undertaken on principles agreed by all concerned. And there is need to feed back eudemonic signal across the heart of the diagram. It cannot be done at the level of operations, because the whole concept is metasystemic. It will not work at the ministerial level, because of lags. Regional management is in command, and regional management needs the continuous eudemonic input. The eudemonic feedback should be used to operate what I call a 'money pump'. The purpose of the money pump is to gear the police system to the public need, according to the principle: maximise eudemony. The only control signal that counts is the eudemonic measure. The only competent decision taker is the police authority.. the only objective is to maintain law and order - by providing, most notably a five-hundred fold amplifier." (Ibid :210)

Beer listed the main problems as: the changing demand that this system would put on the public purse, however, he proposed that this could be overcome by a special or contingency fund; that if the regulatory system for the police became

too powerful it could have a destabilising effect on the remainder of the system. For if the police were too successful then the courts and prison would be overwhelmed. This could however, destabilise the whole social system, as the overall cost for the police, courts and prisons all come out of the same Home Office budget. Beer argues that such a system would require significant organisational change at a national level stating that: "Both the planning of variety amplifiers and the administration of eudemonic regulation are national tasks." (Ibid :212)

Finally, Beer identified the difficulties of getting this type of system accepted and poses the question:

"Whether the nation will accept a new arrangement and one likely to cost it in money." He concludes by saying "then let us get at the facts through the use of the model, its quantification and simulation; and let those facts be published." (Ibid :212)

7.3.3 The Inadequacies of Present Organisational Understanding

The results of the forcewide survey indicated that the majority of officers believed that their primary role was that of detecting crime principally by arresting offenders, and this aligned to the government commitment to reduce crime. This represented a simple message that was easily communicated and measured, for example crimes committed, crimes detected, persons arrested.

However, as Beer demonstrated each viable system contains a viable system albeit they are formed into a hierarchical structure. In our police organisation therefore we will find in each police officer the attributes of the VSM. Of course, we can also view the organisation in more conventional ways; the operational system being operational police activities, regulation by first line supervisors and system management at District level. Viewed in this way it will be readily apparent that organisational actors always perform in more than one

system. For example, superintendents primarily perform a system three role, however, they will regularly contribute to system four and five and on occasions be involved in the operational field of system one.

Beer emphasis the vital fulcrum that exists at system three:

- | | | |
|----|----|----------------------|
| | 5. | (Policy) |
| | 4. | (Intelligence) |
| 3. | 3. | (Control/management) |
| 2. | | (Regulation) |
| 1. | | (Operations) |

System three bridges the roles of assessing the "outside - and - then" whilst controlling the "inside - and - now." In terms of this model we must recognise that information variety is controlled by reduction (attenuation) to a level that can be managed. For example, the operational superintendent does not need to know what every officer has dealt with, only those items that require further action, generally the more serious incidents. The remainder is filtered out through the normal supervision process controlled by the sergeant and inspector. Policy decisions will filter from system 5 and will need amplifying into action, again through a chain of supervision and on the basis that not everyone needs to know everything. The organisational systems' performance will be dictated by the ability of the District resources to adequately match the variety generated in the external environment in such a manner that it meets the district and Force objectives.

In the early 1990's Force strategy was determined by means of a simple and well known two dimensional model that took into account: personnel; technology; finance; and environmental issues. (Figure 7.2) However, it must

be pointed out that this model was primarily a tool utilised at a macro level by the policy makers and whilst taking into account system 5 interfaces with the environment and other financial, personnel and technical considerations. It does not tend to recognise the impact of change, that changes in policy have on these functions in systems, 4,3, 2 and most importantly of all, at the operational level that is represented by system 1.

The Two Dimensional Model of Corporate Strategy

Fig. 7.2

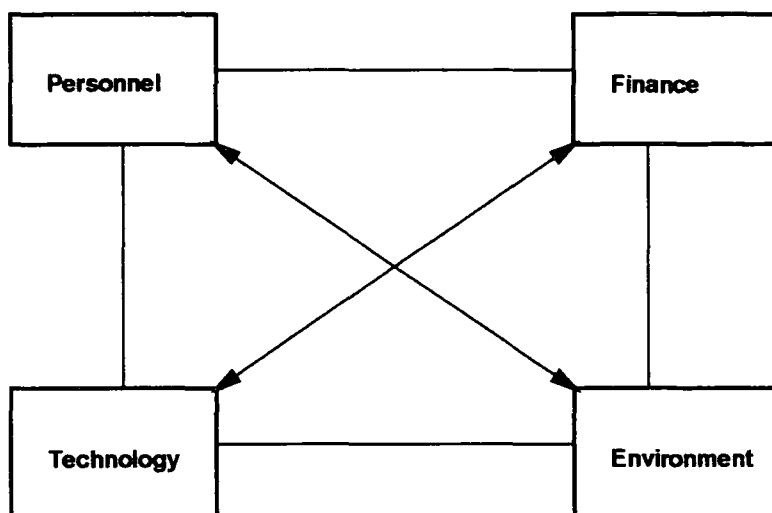

Since this time the police service together with a wide array of public sector organisations have aligned with national trends that have adopted the values advocated by the Audit Commission and the Home Office. The police have been encouraged to take on the values of the private sector, where even those arrested and detained are to be regarded as customers. It is at this stage that the two dimensional model tends to run out of steam as it now has to take into account a whole array of different expectations, values and resource implications from both the internal and external environments, some of which are diametrically opposed. For example: the commitment to deploy more officers on foot patrol against the need to respond to high priority calls within

tightly prescribed response times. (Nationally determined response times require police to attend emergency incidents in urban areas within 10 minutes, rural areas within 20 minutes.)

Consequently the two dimensional model tends to oversimplify, concentrating on one or two of the concepts, or attempts are made to identify dependent and independent variables. It is suggested that to capture the new relationships we must construct models that will allow the manager to gain a greater insight into the dynamic processes of the systems involved.

Within the police system, at a national level the government now sets multiple objectives and targets for the police to achieve. Each police force sets its own system objectives taking into account the national set of objectives, and locally determined police authority priorities and the resources that it has at its disposal. Within each force, districts set their own objectives, once again taking the same criteria into account. Within each station, each patrol section will set its own objectives for each officer. At each level the strategic as against the tactical level of objective setting will move as we come down the system. (Fig 7.3)

System structure of the police service showing the effects of policy

Fig 7.3

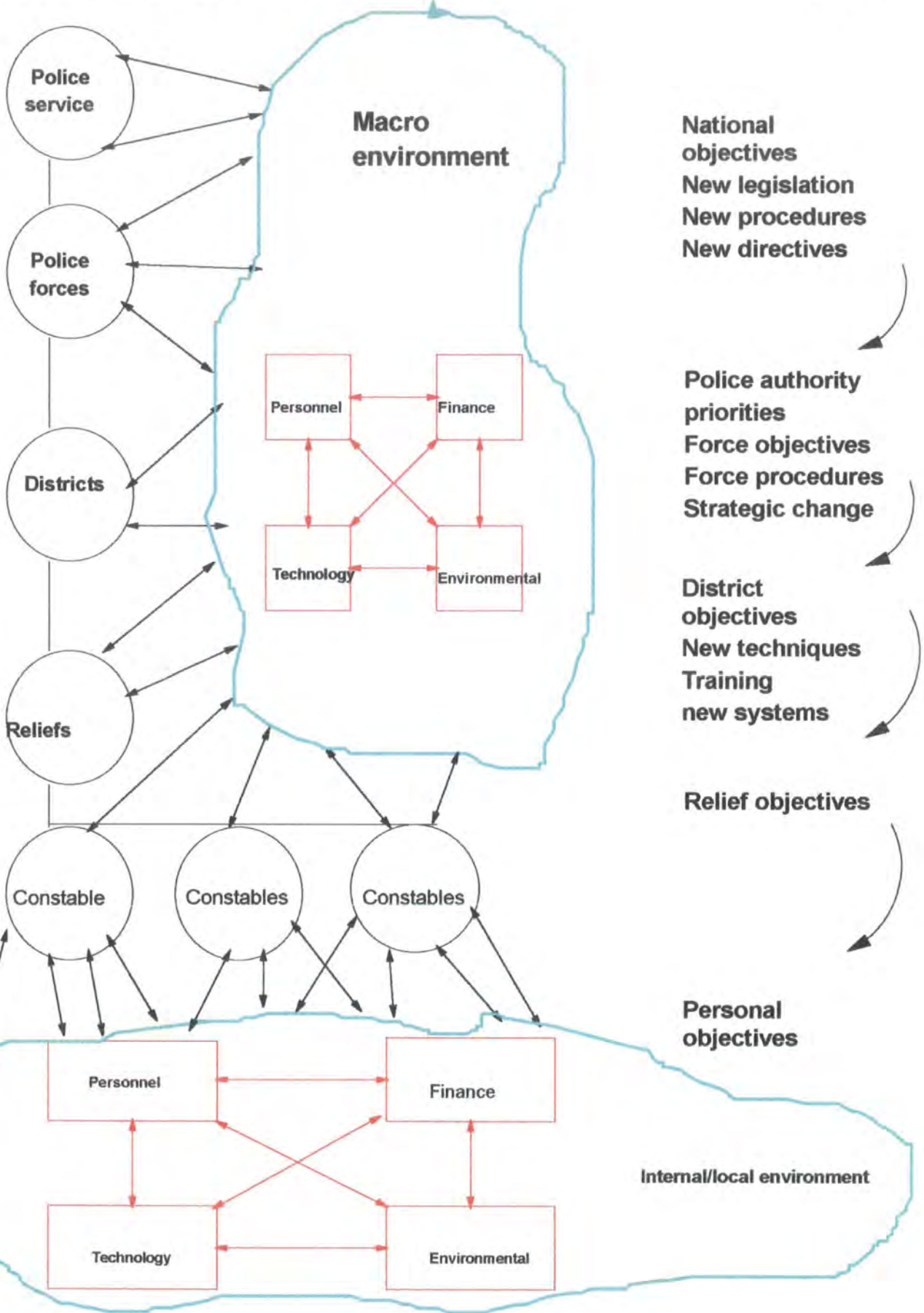

Figure 7.3 illustrates how policy, legislation, procedures and objectives emanating at the national level flow downward through the policing system until they finally reach the individual officer. The actions of the officer in interpreting the instructions has the potential not only to influence and generate variety in the internal/local environment but has the potential to impact on the macro environment. Failure to conform or correctly interpret procedures can result in civil claims, appeals to the High Court or major reviews and enquiries into police practices. For example, the actions of medical staff and the perceived failure of the police and social services to deal properly with victims of child abuse in Cleveland led to the Butler-Sloss enquiry. The enquiry and subsequent report resulted in a wide range of recommendations for changes in the police and social services procedures. The report called for new legislation and stringent procedures for dealing with child abuse situations. Legislation was drafted and implemented nationally and affected every police force in the country.

Consequently, although we acknowledge that management is recognised in terms of hierarchy and accorded positions of power and status. It ought to be clear by now that the model developed here accords each part of our system equal importance. Certainly, we must recognise that any viable system must be capable of self-regulation. How can the huge variety generated be handled if not through a decentralised process of self-adjustment. Thus, whilst we may accord hierarchical status to rank structures, in system terms we must recognise that the constable on the beat is as important as the chief constable. The constable has to apply on a day to day basis the complex laws of the land following Force policy and legal procedures. Their performance alone virtually determines the success or failure of the Force and its ability to meet its performance measures.

The individual Police officer has the potential to create enormous variety when carrying out normal patrol duties, take for example a typical scenario where an officer is patrolling the street. The officer's attention is drawn to a young man smoking a hand rolled cigarette. The officer has two possible courses of action, the first is to walk past the youth and do nothing. This course of action does not generate variety, or consume resources, in effect it is an operationally and financially neutral course of action.

However, if the officer approaches the youth and recognises the symptoms of illegal drug use and takes positive action searching his person and finding illegal drugs such as cannabis and amphetamine. The officer would at this stage arrest the youth. By taking this action the officer has commenced a chain of actions that has the capability to generate variety with the potential to expand exponentially. The level of variety is not confined purely to the police system but impacts on a wide range of agencies in the external environment. The arrest may well have significant resource implications for all concerned. These relationships are demonstrated in Figure 7.4.

The Impact of an Arrest on Other Organisations

Fig 7.4

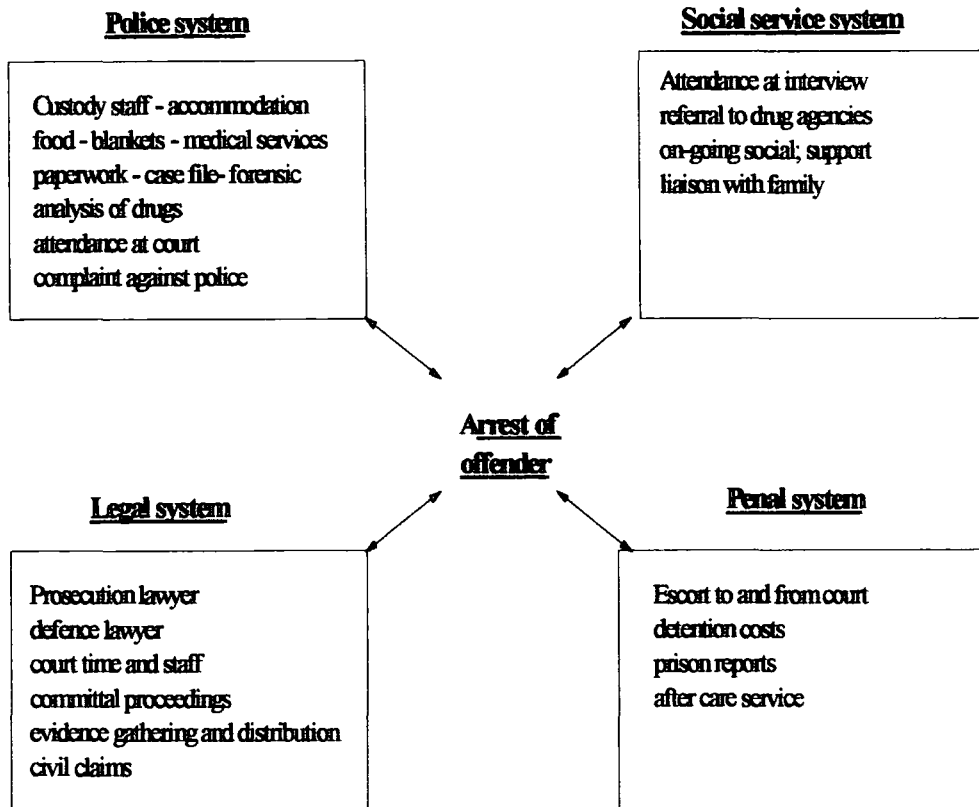

With the concerted demands of central government, the Home Office and Audit Commission to improve efficiency, police managers must use all means at their disposal to achieve this. However, this requires a full understanding of the organisation and the complex intra-relationships that exist between the many variables. In particular it is of paramount importance to understand the relationships between police activity and finance.

7.3.4 The Relevance of the Viable Systems Model to Policing

As we have seen in this section policing is a complex and dynamic activity. Although policy is determined by system 5, this will affect and have implications for systems 4, 3, 2 and 1. The VSM focuses attention on the relationships, inter-actions and inter-dependencies of each system, it has been demonstrated that an activity carried out in system 1, will have to be controlled

and monitored by system 2 and has the capacity to impact on systems 3, 4 and 5. At each stage there are potential resource implications for the organisation as well as inter-actions with other organisations in each of the system's internal and external environments. The police manager, by using the VSM can identify the potential resource implications of policy, strategy or a proposed course of action and the impact that these will have on each environment.

It is apparent that an increase in the flow of policy or directives caused by system 5 will need amplifying through systems 4, 3, 2 to system 1, so that all operational actors understand their role and what is required of them. It is essential to closely monitor system 1 to ensure that policy is followed and that their efforts are directed towards achieving the Force objectives and performance measures. One of the primary roles of senior management is to look at the strategic issues, the direction, aims and performance of the Force. Once this strategy is formulated then resources are allocated and operational supervision is given the job of developing tactical plans. A knowledge of specific management and organisational models gives management and supervisors a capacity to maintain coherent linkages between strategies, tactics and operations and ensures that whilst the majority of activity is at the discretion of the lowest organisational level, the constable, its direction and presentation fits into a controllable pattern.

Clearly a knowledge of higher level language, cybernetics, systems theory and the application of Beer's VSM is not essential to the successful implementation of strategies. What is useful however, about organisational models and theory is the ability to construct frameworks of management control and understanding against which plans can be assessed before, during and after implementation. The use of the VSM helps the manager to conceptualise and think through the key systems that are likely to be affected by change. Once these have been

identified consideration can then be given to the impact of change on the systems, and most particularly focus in on the resource implications.

7.3.5 Summary of Section B. The Implications for Police Management

Whilst our model consists of the culture, technology, finance, structure and goal constructs, and is acted out as a viable system, being part of, and containing other viable systems, there are people performing roles within the model. The police organisation consists of a collection of individuals, each acting his or her part. Each performs an equally important role, there would be no chief constable without the constables. The actions of one influence the actions of others.

To ensure consistency of action there needs to be managerial control at all levels within the organisation. If system 1 is given total freedom it has the capacity to create enormous variety and significantly increase costs or otherwise affect the performance of the organisation. For example if system 1 becomes totally focused on prosecution then this will impact on the custody offices, the administration support units and the whole legal system. High levels of prosecution for what are regarded as minor offences can alienate the public. Alternatively if the arrest, detention and interview does not follow tightly prescribed procedures, rules and regulations and is not conducted to a high standard this can result in civil claims, complaints against the police, judicial reviews and appeals against conviction. Take for example the recent case of the 'Bridgewater Four', who were initially convicted in 1978 of the murder of Carl Bridgewater. They have subsequently been freed on appeal after serving eighteen years in prison, due to an alleged malpractice by relatively junior detective officers (a sergeant and constable). The case has cast serious doubt on the integrity of the police and the impartiality of the judiciary. Chief constable Mr Ray White the ACPO president, following the appeal stated:

"No system of justice operated by human beings can ever be infallible - there can be no absolute guarantee that miscarriages of justice will never occur in the future. But sustained progress in improving the criminal justice system, coupled with the determination of the police service to ensure the highest standards of behaviour whilst remaining operationally effective, will together contribute towards ensuring that such events are increasingly rare." (Police Review, 28th February, 1997 :4)

It is vital that the police maintain high moral standards and integrity and that these are maintained by acting as a disciplined body ensuring that performance and standards are rigorously monitored at all levels. Consequently, it is essential that a bureaucratic structure exists to ensure that the decentralised action at system 1 is consistent to the needs of the organisation. If the higher system functions make new policy decisions, these will need communicating within the system and will require amplification. The resultant actions will need constant monitoring to ensure that they meet the objectives of the Force within a strict code of practice.

The forcewide questionnaire indicated that 87.7% of respondents believed the police should influence the criminal justice system (Chapter 6, Chart. 7) to take into account the views of the police and public. All of the 27 senior officers interviewed expressed the view that detection and punishment were seen to be the most effective means of dealing with crime (Chapter 5, Table 5.2). This was upheld by Mr Howard, who in his period as home secretary clearly expressed views that prison worked. He advocated the introduction of a further Criminal Justice Bill that introduced the concept of minimum sentences for repeat offenders. Mr Howard said:

**"That the measures were needed because the public had a right to more protection from serious and violent criminals and persistent offenders."
(Times 26th October, 1996)**

If we place the use of prison in the same context as Beer, that is, whilst in prison a person's ability to create variety is severely reduced. Then clearly this

should have an impact on the levels of crime. Chart 7.8 illustrates the relationship between prison and crime. The changes highlighted are the Criminal Justice Act 1988, which restricted the use of custody for offenders under 21; Criminal Justice Act 1991, which limited the use of custody to serious offences and previous convictions could only be used in determining sentence if they were specifically relevant; Criminal Justice Act 1993, reversed the decision on the use of previous convictions (Prison statistics England and Wales 1995 :143-5). It is clear that periods of low imprisonment coincide with high crime levels. However, it must be pointed out there is a time lapse between being caught and being sentenced, typically a year. This should be taken into consideration when interpreting the chart. If the police can continue to influence the politicians and the judiciary, to maintain high levels of imprisonment then, this has the potential for reducing variety created by the criminal. What the police must do is to clearly and scientifically identify this link and articulate their findings through the media at each and every opportunity. It can prove to be a cost-effective way of policing.

What is apparent is that due to the forces present financial position it is unlikely to ever reach its former establishment figure of 1502 officers. The supervisory ranks that have in effect been sold off, like the family silver are unlikely to be replaced. Hence, the police must always look for new ways of dealing with or reducing variety. Prosecution as we have already seen can be an expensive option. The Force has already moved into partnerships with a wide range of agencies to deal with social issues as well as crime. It has also harnessed the power of the local citizens to help them in monitoring the streets through neighbourhood watch schemes. These initiatives must be regarded as the way forward.

Relationships between the national prison population and crime in Cleveland 1986- 1997

Chart 7.8

Recorded crimes

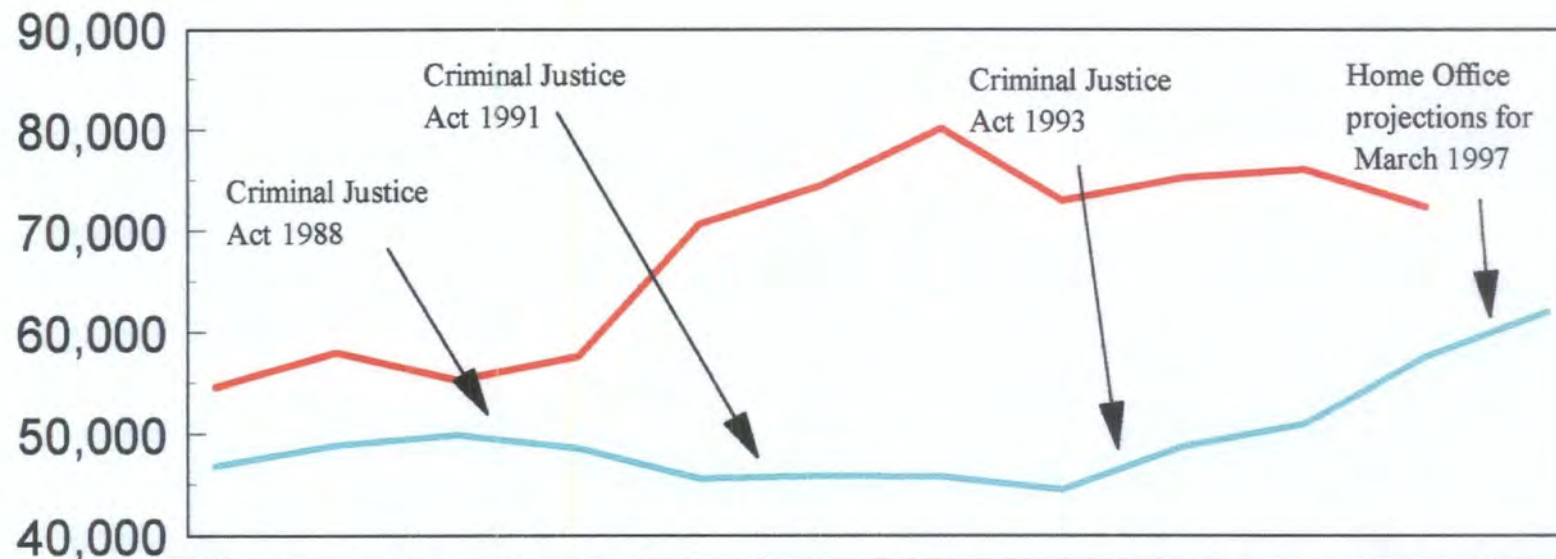

Year	1986	1987	1988	1989	1990	1991	1992	1993	1994	1995	1996	1997
	54,655	58,058	55,316	57,667	70,668	74,477	80,168	73,057	75,313	76,153	72,426	
	46,889	48,963	49,949	48,610	45,656	45,897	45,817	44,566	48,794	51,047	57,600	62,000

*Note - the figure for March 1997 is based on Home Office projections. It is estimated that the prison population will reach 73,000 by the year 2011.

(Times 26.10.97)

Beer recognised that the police model is involved with the environment in a variety of ways and that information receptors work at all levels. He identified that to reduce variety to manageable proportions there was a need to handle vast amounts of information and that the need to structure computerised information systems to handle variety requires such systems to replicate the information links of our model, that is a decentralised system. A computer system that services system four and is designed to primarily produce management information will not meet the needs of system one, the operations.

The PNC has been designed to meet the needs of system 1. The survey results indicated that it is highly regarded as an operational tool. Whereas those systems that have been designed internally such as CRIMES to increasingly satisfy the needs of systems 3 and 4, (the management) were regarded as bureaucratic and resource intensive. The factors for success or failures of such systems require urgent examination if the Force is to achieve value for money in the use of information technology systems.

7.4 SECTION C A PRACTICAL APPLICATION OF THE VIABLE SYSTEM MODEL TO OPERATIONAL POLICING

This section will review an area of policing using the principles of the viable systems model. The research relates to issues of road safety and the introduction of automatic speed detection techniques into the Cleveland Constabulary.

7.4.1 The Police Area

The Force polices an area of 59,000 hectares, with a resident population of 556,000. The area is predominately urban in nature with the following social and economic characteristics:

- A high population density - 9.4 people/hectare (national average 3.4) In Middlesbrough District this rises to 26.6 people/hectare;
- A high rate of unemployment - 13.5%; (national average 8.4%)
- A high proportion of single parent families - 5.5%; (national average 3.7%)
- A high proportion of children of school age (175 children aged 5-16 years per 1000 population; (national average 153 per 1000 population)
- 2290 kilometres of road consisting of: 334 km 'A' class; 71 km 'B' class; and 1884 km other types of road. (There are no motorways in the Force area.)

'Target 2000' is a national campaign to reduce road accident casualties by 33% by the year 2000. Each of the four Districts has a performance target to help the Force to achieve this objective. (Table 7.1)

District	Performance 1995/96	Target 1996/97	Change
Hartlepool	303	288	-5%
Stockton	563	557	-1%
Middlesbrough	550	522	-5%
Langbaugh	407	387	-2%

Table 7.1 District Performance Targets

In addition the Force is required to produce statistics for performance measurement determined by three separate bodies that allow national comparisons. The Force achieved the following results. (Table 7.2)

Indicator	Performance	Ranking (43 forces)
1. Number of traffic offences per 100 police officers and traffic wardens (HMIC)	4612.5	27th
2. Percentage of traffic offences dealt with by extended fixed penalty ticket. (HMIC)	43.5%	37th
3. Number of screening breath tests administered. (Audit Commission)	28427	4th
4. The percentage positive or refused. (Audit Commission)	3.8%	43rd
5. The number of road traffic accidents involving death or personal injury. (Audit Commission)	1823	40th
6. The percentage of such accidents in which at least one driver tested positive for alcohol. (Audit Commission)	1.6%	40th
7. Percentage of satisfaction expressed by victims of road traffic accidents with police service standards at the scene. (ACPO)	92.4%	21st

Table 7.2 Force Performance Indicators

7.4.2 The problem unstructured

The Road Traffic department consists of a number of integrated units with an on-going commitment to improving road safety. In 1993 this was focused through the national campaign 'Target 2000' that requires a reduction from the 1992 level of 1996 accidents to 1317 accidents by the year 2000. In 1993 the traffic management section carried out an analysis of accidents to identify the main causes, these were determined as excess speed or bad driving associated with excess alcohol. As will be seen later the Force has developed a programme to tackle excess speed. In addition the Force runs two high profile: 'Don't drink and Drive' campaigns annually, during the summer and in the lead up to Christmas. One of the major difficulties facing the Force is that 82% of roads are minor roads in and around town centres that are often narrow in high population urban centres, heavily populated by children. Consequently these are difficult to patrol and police.

7.4.3 Resources available

Traffic patrols - consist of a double-crewed traffic car which are capable of high speeds and contain a variety of equipment to detect speeding motorists. These include Vascar, Muniquip and police pilot speed detection devices. They also have a full range of equipment for dealing with accidents and other emergencies. Traffic patrols have responsibility for detecting vehicle related crime, and they are permitted to engage in high speed pursuits.

Accident units - these units are self-contained accident investigation units with officers trained to high levels of proficiency in accident investigation. They predominantly deal with the more serious accidents, particularly fatal accidents.

Motor cycle patrols - these are utilised for general patrol and escort of abnormal load duties. However, they tend to specialise in the regulation of heavy goods vehicles. In 1995 the unit purchased a number of unmarked 'off the road' motorcycles for carrying out patrols over rough ground and in housing estates.

Traffic management - analyse accidents to identify the main causes. Also accident blackspots, for targeting either by enforcement or high profile policing. Since 1989 the Force has endeavoured to raise the public's awareness of the dangers of drinking and driving and the increased probability of being caught. The Force adopted a policy of requiring all drivers involved in accidents, moving traffic offences or who were suspected of having alcohol in their bodies, to provide a breath test. This policy was widely publicised and in 1989 resulted in a 263% increase in tests administered, followed by a further increase of 27% in 1990. This would appear to be a major contributory factor in reducing the number of accidents recorded by 10.5% in 1991. (Chart 7.9) It can be noted that in 1996 high levels of breath tests and enforcement of road traffic laws combined to reduce the accident level to the lowest of the decade. A most satisfying trend is that although the Force has continued to place great emphasis on breath testing. The proportion that is testing positive has declined to 3.8%, which is one of the lowest levels in the country. (Chart 7.10)

The scenario dictates that once policy has been determined centrally, at a national level, the Force will determine a strategy to conform to the policy. This will need amplifying to operational officers, who will then take action. Results can be quantified and monitored allowing the programme to be assessed. However, it is argued that this traditional approach does not fully capture the complexity of the chain of action or causality determined by the policy decision. What is required is to explore the complexity of relationships and inter-actions, particularly the resource implications. Tasks that can be

Cleveland Constabulary road traffic statistics showing the relationship between injury accidents and police actions. Chart 7.9

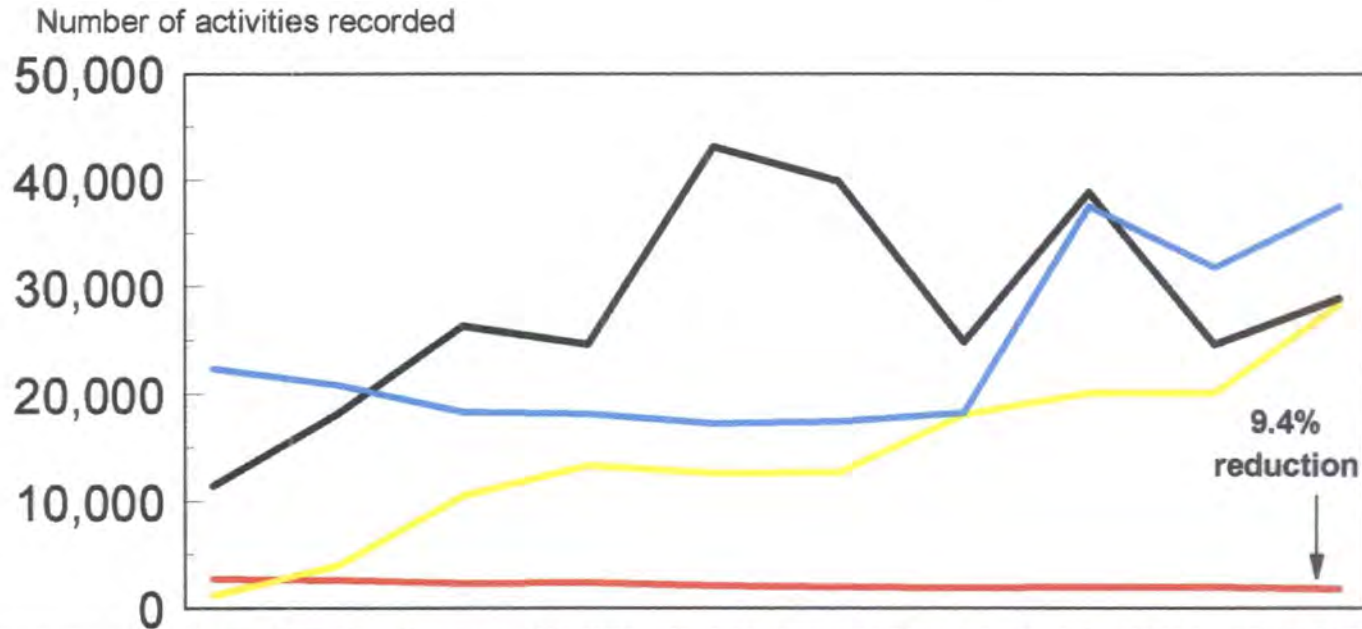

Year	1987	1988	1989	1990	1991	1992	1993	1994	1995	1996
Injury accidents	2,804	2,660	2,380	2,405	2,145	1,996	1,926	2,015	2,018	1,823
breath tests	1,256	4,010	10,545	13,396	12,675	12,761	18,142	20,125	20,128	28,427
Fixed penalties	11,487	18,213	26,411	24,644	43,193	39,949	24,914	38,940	24,670	28,949
Prosecutions	22,446	20,912	18,346	18,150	17,311	17,459	18,303	37,585	31,873	37,602

To reach the target figure of 1317 accidents by the year 2000 the Force must maintain a reduction of approximately 10% for the next 3 years.

Breath Tests Carried Out in the Cleveland Constabulary
1987-96

Chart 7.10

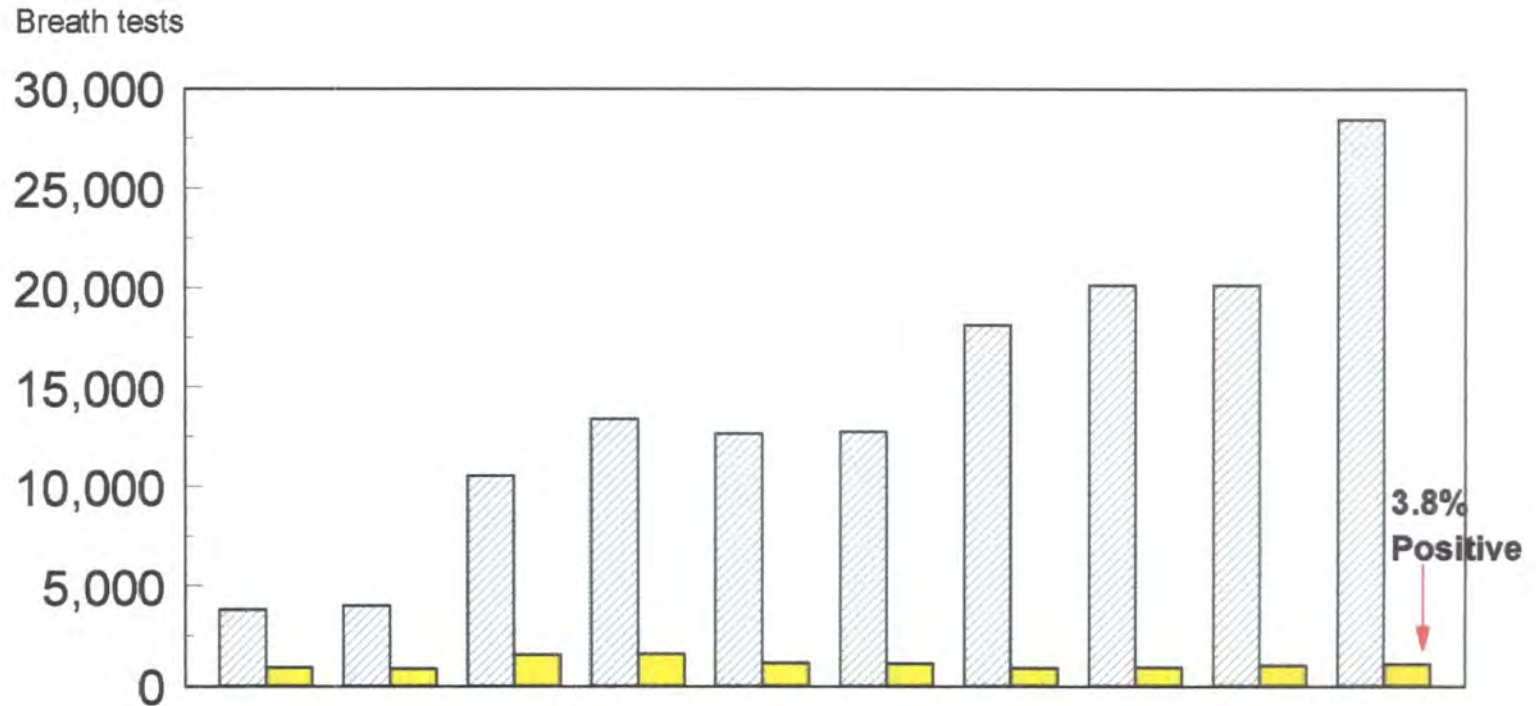

Year	1987	1988	1989	1990	1991	1992	1993	1994	1995	1996
Breath tests 	3,812	4,010	10,545	13,396	12,675	12,761	18,142	20,125	20,128	28,427
Number positive 	914	874	1,586	1,589	1,140	1,104	891	920	1,026	1,080

carried out by electronic devices are coming to prominence in policing, for example the use of automatic speed detection cameras to police our roads. The devices appear to be the ideal solution to the speeding problem, a single video camera can capture hundreds of offenders in one day. Processing costs are relatively cheap and if the devices were in the hands of a private sector entrepreneur they could be regarded as a hugely profit making venture, with the more cameras deployed the more revenue collected. However, for the police the situation is quite different and many more factors have to be taken into consideration. It is proposed to demonstrate how these factors can be identified and evaluated to determine the true value of these systems to the police.

7.4.4 The programme in Cybernetic Terms.

To improve performance and achieve a reduction in accidents by the year 2000 the Force will either have to increase resources, amplify the use of available resources or reduce the variety generated by the motorist.

We know that once goals have been set these will impact on the internal structure of the organisation and effect the personnel, finance, internal environment and technological systems. Changes affecting one construct impact on the others and local changes to a police service will impact not only on the police organisation but also on other organisations in the surrounding environment.

It appears highly unlikely that the Force will be in a position to increase personnel levels available to traffic. Hence, we must look for new ways to absorb variety or find alternative methods to change driver behaviour. For example, road calming measures, road congestion, educating drivers and pedestrians and developing community support. If resources remain fixed or continue to decline, we will need to harness the energy of other organisations

from external environment and bring them into the Force organisational/internal environment.

7.4.5 The Introduction of the Traffic Safety Speedmaster System Into Cleveland Constabulary.

Initially research was carried out to identify the main accident blackspots in Cleveland. Five sites were identified one at Hartlepool, Stockton, Langbaugh and two at Middlesbrough. These locations were made permanent sites with road signs erected warning the public that speed cameras were in use. In addition the Force has facilities for a portable unit that can be set up on any road. A device consisting of three rubber tubes is placed across the road and attached to a computerised measuring system. When a car passes over the tubes, air is expelled into a censor box that calculates the speed of the vehicle. In a thirty mile an hour speed limit the device will activate a video camera at speeds above 35 miles per hour. The police have the discretion to caution those whose speed is between 35 and 41 mph. Speeds between 42 and 55 mph will be dealt with by an extended fixed penalty ticket that means a fine of £40 and three penalty points being endorsed on the driver's licence. Over 55 mph is dealt with by reporting the driver for summons and preparing a full prosecution file. The equipment is deployed and operated by one police constable who witnesses and records each infringement. The officer is the primary witness to the offence and if a prosecution follows, which is disputed, the officer will provide the primary evidence of the speed recorded and attendant circumstances.

Between 25 September 1996 and 24 February 1997 the equipment was used on a trial basis. In this period the equipment recorded 830 prosecutable and 5565 cautionable offences. However, as this was an experimental stage all were issued with written cautions. It was found that the clerical support could not cope with this level of transaction that required 6,395 PNC enquiries and letters

to all offenders. Consequently, when the programme became fully operational it was decided to no action with those offenders who warranted only a caution. Despite carrying out a well-publicised campaign in the local newspapers and media that published weekly detection figures, the initial indications are that the use of these devices has little or no effect on driver behaviour.

On 25 February 1997 the system went into full operational use with prosecutions based on this equipment. The results for March and April 1997 are shown below: (Table 7.3)

	March	April
Prosecutions	407	429
Cautions	1567	2444
Deployment time	32 hours 45 mins	42 hours 21 mins
Highest productivity	121 prosecutions in 2hrs 16 mins	68 prosecutions in 2hrs 18 mins

Table 7.3 Productivity Levels and Deployment of the Speed Camera

An analysis of the limited figures available indicates that of the 407 offences detected in March, 138 will require a second letter, 20 a third letter, and 41 will not respond to the extended fixed penalty enquiry in the normal way, causing further work to be carried out. At the present time one full time clerk plus the part services of a second clerk can cope with this level of prosecution. However, a significant increase in the level of deployments would have to be

dealt with by employing extra staff. In addition it is anticipated that the uncleared backlog will continue to grow and require on-going attention.

If we now look at the system in terms of our earlier model it can be noted that the system has the following characteristics; high overall efficiency, low operational efficiency; low resource costs; high bureaucracy. At this early stage it is difficult to judge the systems overall value. However, despite high levels of cautioning between September and February there appears to be little impact on the levels of prosecution achievable in the relatively short periods of deployment. (Table 7.4)

<p style="text-align: center;"><u>Operational efficiency</u></p> <p>No contact with driver; No opportunity for immediate advice and guidance. No checks carried out on the driver to establish if; Disqualified; Under the influence of alcohol; That person is the owner of the vehicle; That they have the correct driving documents; insurance; licence; MOT certificate; excise licence; No opportunity to carry out vehicle examination to see if vehicle safe to drive</p>	<p style="text-align: center;"><u>Overall efficiency</u></p> <p>Low cost of service at point of delivery Low cost in comparison to traffic patrol; Reliable Can cope with high volumes at fixed costs</p>
<p style="text-align: center;"><u>Bureaucracy</u></p> <p>System to check if driver has previous cautions for speeding; PNC checks for ownership; Generation of letters and Notice of Intended Prosecution (NIP); Record of sending letter; If letter returned and driver admits liability generate extended fixed penalty ticket; If fails to respond send second/third letter and further NIP; If fails to respond generate follow up enquiries that may involve foreign forces. Develop system for monitoring 400+ prosecutions per month; DVLCC enquiry where registered keeper fails to respond.</p>	<p style="text-align: center;"><u>Resources</u></p> <p>Follow up enquiries for the drivers who do not return completed forms. Preparation of Court files. Storage of video tapes Cost of letter preparation and postage PNC transactions</p>

Table 7.4 Relationships Between Cost and Efficiency

The average cost per prosecution has been estimated at £38 (PRSU, July 1996) and as such compared with the deployment of a double-crewed patrol car

represents good value for money. However, when the whole picture emerges the cost benefit comes less apparent. The fixed penalty tickets issued if paid on demand, will attract a fixed penalty of £40, this fine is paid directly into the Court and thereafter to the Home Office. The police do not receive any income from this transaction and they are not permitted to attach costs for work they have carried out. From the initial data available, it is estimated that in 6 out of 10 cases additional work will be required, hence costs incurred by the police will increase. Consequently from a business point of view the more the police prosecute, the greater their costs become.

However, from the performance indicators previously listed, it can be seen that two are be satisfied by this process: the number of offences dealt with by police officers and traffic wardens; and the percentage of traffic offences dealt with by extended fixed penalty ticket. Hence, it is quite clear that the Force is being invited to follow this path. If the initial characteristics of the operations continue, that is, prosecution has little effect on the motorist's speed, then for every camera system deployed we can expect to produce similar levels of quantifiable output. The net result of this process will be that increased clerical support will be required which must be paid for by reducing operational policing and overall operational resilience throughout the Force.

7.4.6 Relationship With the External Environment

If we now consider the relationships with the external environment, the police do not act alone and their actions will impact on the following systems:

- Health system;
- Local authority highways department;
- Education;
- Ambulance service;
- Media;
- Court and legal systems; (Figure 7.5)

The Introduction of Speed Detection Cameras

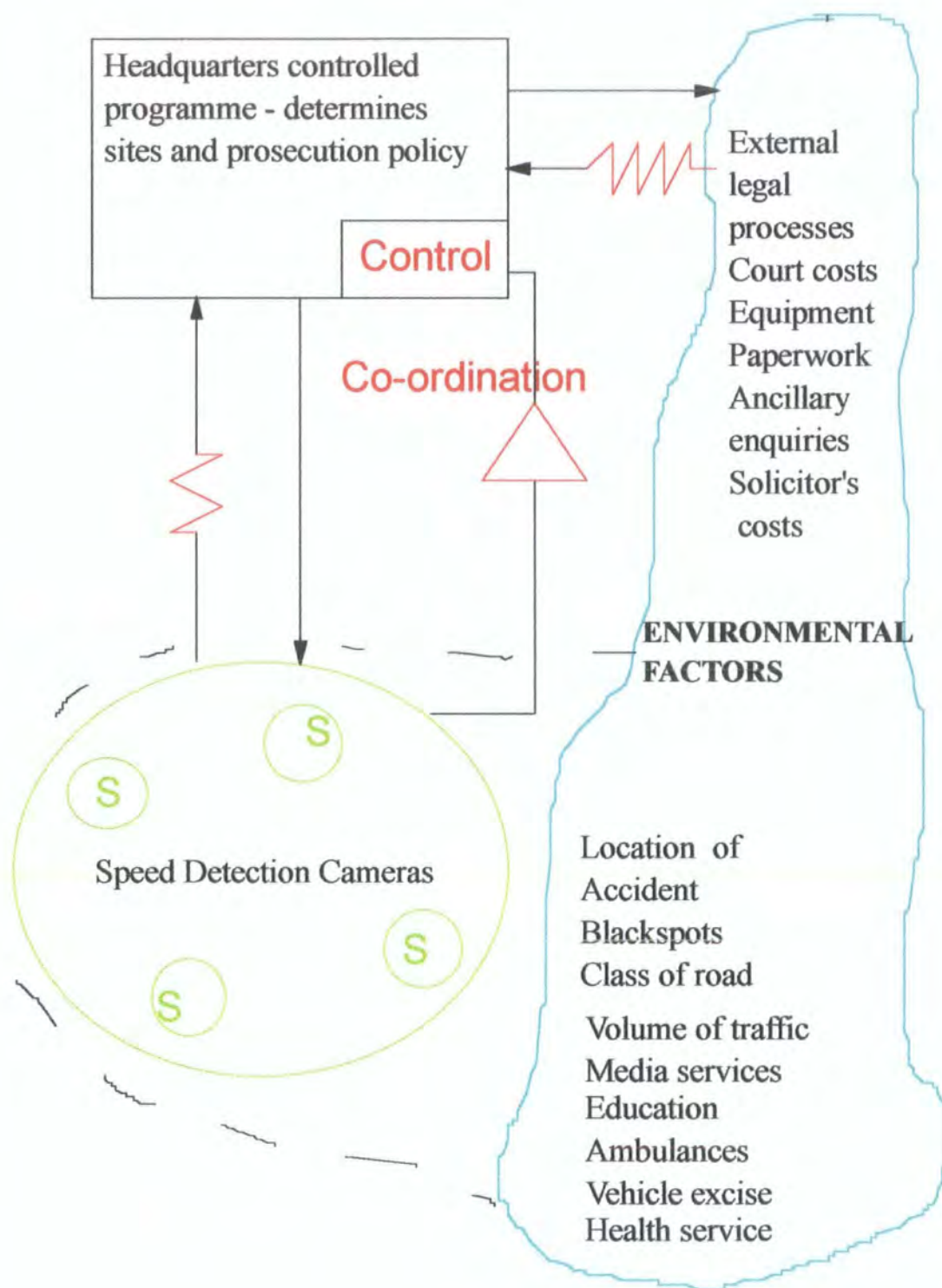

As we indicated earlier the police must consider bringing these systems into its own environment to maximise the full potential of its actions. It has been demonstrated that although performance indicators can be easily satisfied by the use of automatic speed detection so far there has been little effect the behaviour of drivers. The police must continue to influence the environment, this can be achieved by identification of problem areas and directly taking positive action to remove that problem. Take for example one location that had a history of high levels of prosecution. This was completely eradicated by the introduction of road calming measures that reduced a two-lane carriageway into a single carriageway on its approach to the town centre. For the police this is a financially viable solution and as such must be encouraged.

If we now consider the health system and ambulance service, every road traffic accident has significant financial implications for each agency. The cost of a serious road traffic accident has been estimated at £48,500 (PRSU, July 1996). Yet despite the police commitment to reduce injury accidents there is no financial benefit for them. The police must now consider closer links to these agencies, to fully identify the cost of carrying out joint advertising campaigns targeted at road safety.

The author suggests that a new approach is required one that is hard hitting and tackles the sources of traffic offending rather than relying on prosecution and ensures that the maximum impact is achieved from each campaign. This will require the co-operation of all agencies concerned, to work together for the common good. Such a programme must be based on the simple proposition that if the police are to act in a business like manner, variety and complexity must be reduced, not increased. Whereas the downside of automatic devices are that although they satisfy performance measures, they become accepted by the public as just another hazard to the motorist. For the police, enormous variety is generated which then has to be managed.

The Cleveland Constabulary has committed itself to problem orientated policing which identifies the cause of a problem then tackles the cause rather than dealing with the outcomes. If we consider road traffic enforcement it is noticeable that the police have moved into a system whereby for the convenience of the offender and the courts, a prosecution is conducted from a distance by means of a fixed penalty ticket. The offender is not inconvenienced and minimal Court time is taken up. A minor offence is dealt with by mail, there is no immediate sanction, no words of warning, no discussion or debate on the ethics of the offence or the impact on society of the type of conduct that the prosecution is trying to deter. This may have some effect on the individual, however, it is unlikely to effect the motoring public. It is suggested that what is required are high publicity campaigns involving the media, health, and schools, which portray the consequences of driver behaviour. This is followed by intensive prosecution campaigns with all offenders being reported for summons and being required to attend specifically designated Courts on nominated days. The Court proceedings should be highly publicised with Magistrates using their full range of powers to deal with offenders and where appropriate giving exemplary sentences. Again maximum publicity can be given and as we saw in the interviews with senior officers there was a strong sense of feeling that deterrent sentences worked.

7.4.7 Summary of the Main Issues Raised in Section C

The police have been and continue to be heavily influenced by the external environment that requires the production of a vast quantity of performance measures to aid national comparisons. This Force must recognise the full cost implications of satisfying relatively simple performance measures and balance these against the actual value to society. It is suggested that what must be retained is a classical bureaucratic system that ensures that all incidents and offenders are dealt with in a similar manner, that the system remains of high

integrity and every enquiry is pursued to the final outcome. For if gaps appear within the system where follow up enquiries are ignored, then the systems will fall into disrepute and the reputation of the police diminish.

Clearly the use of automatic speed detection devices does have value. However, due to the inadequacies of the present system, the police do not achieve their full potential. For example, if the police required all those detected exceeding the speed limits to produce their driving documents and current excise licence for examination, this would undoubtedly create vast quantities of document offences for the police to deal with. (It is estimated that one car in every 10 does not have the correct documentation.) However, this again would create massive variety that would require a new approach to deal with the volume of work. The resource implications would be high and could not be considered in the present environment without the police having the facility to charge or generate income from the activities it carries out.

It can be seen that the adoption of the simplistic model of policing advocated by Howard Davies in Chapter 3, can cause significant problems for the police who are constrained by the confines of externally generated rules, regulations and procedures that limit their ability to charge for the cost of administration. It has been demonstrated that the police are not similar to a production line and that the introduction of technological systems can have diverse consequences and resource implications.

What has been elaborated by Beer, in the model and scenario explored in section B, is an idealistic solution to the policing problem. Absolute law can be enforced by increasing the number of officers available to tackle the 'drink-drive' problem, that is providing unlimited resources are made available. To achieve this the system must recognise the resource implications of policy and that finance is balanced within the system by a money pump. Once the problem

is satisfactorily resolved finance can be diverted elsewhere. In reality the Cleveland Constabulary has constantly failed to attract sufficient finance to employ the number of police officers that it requires to effectively police the streets.

In view of the financial constraints placed on the Force it must now consider ways to reduce or limit the demand for its services. A simple example of this would be to raise the speed limit for prosecution from 42 to 45mph. Alternatively to seek changes in the way offenders are dealt with as previously described.

7.4.8 Introduction to Chapter 8

In Chapter 8 the findings of the research will be drawn together making conclusions and recommendations and identifying areas for further work.

CHAPTER 8 CONCLUSIONS AND RECOMMENDATIONS

8.1 INTRODUCTION

The purpose of this Chapter is to: discuss the findings in relation to the literature review; to discuss the value and implications of the research findings for the management of the police force; to discuss the strengths and weaknesses of the research; and to identify areas for further work.

The objectives of the literature review were to:

- Examine the rationale for change within the public sector;
- Identify the reasons for change;
- Examine issues in public and private sector strategy;
- Explore the change process within the public sector;
- Investigate the work of the Social Market Foundation;
- Review the concept of the viable system model.

8.2 THE FINDINGS IN RELATION TO THE LITERATURE REVIEW

In Chapter 1 it was identified that the dominant logic of Central Government was to implement a programme of change throughout the public sector, wherever possible privatising organisations or exposing services to competitive tendering. This programme received support from senior managers in the police and in industry O'Dowd (1993) and Harvey-Jones (1988). The logic was that 'change' benefited organisations and that they should maintain the highest possible rate of change. Davies (1992) in his role as Comptroller of the Audit Commission acted as a catalyst for change in the public sector focusing attention squarely on the police, whom he regarded as in need of urgent and drastic change.

However, not all parties were in favour of the recipe advocated for change. Johnson (1992) and Crouch and Marquand (1992) identified the dangers of adopting accountancy based management techniques and performance measures that became the priority for the organisation to satisfy with the concomitant danger that the needs of the customer become a secondary concern.

The review of the historic development, organisational structure and nature of policing identified that the police are structured along military lines and that there was a necessity to maintain a paramilitary capacity. Morgan (1986) identified the relationships between military structure and mechanistic systems associated with Taylor's (1911) scientific management. Morgan saw the value of such systems in completing repetitive tasks, however he identified that both systems relied on turning the worker into a sort of automaton forced to work at maximum capacity. The review of Weber's (1947) bureaucratic structure identified the need for the police to follow the basic and fundamental characteristics of bureaucracy to ensure high integrity systems that provide consistent outputs. This necessitates a highly skilled workforce with specialist knowledge committed to the ethos of the organisation.

Sanderson (1985) identified that the system for appointing senior officers ensured that all potential members of ACPO consistently adhered to and followed the key logic of a centrally dominated police system. Senior police managers are constantly encouraged to introduce new technology systems to their organisation so that they can be regarded as modern or progressive.

Metcalf and Richards (1990) reviewed the key concepts of new managerialism, the ethos of the free market economy and the introduction of 'New Taylorism'. They debated the problems associated with such systems and their relevance to public sector organisations that have different values than the private sector. Metcalf and Richards expressed concern that this new style of

management was not founded on a sound theoretical base and had not been properly evaluated. Kingdom (1991) viewed managerialism as a move from democratic management to one that required unquestioning obedience to the basic concepts and principles.

The review of the work carried out by the Social Market Research Foundation revealed an ideological commitment to reduce the scale of the public sector and transfer responsibility and accountability wherever possible to the private sector. Davies advocated the introduction of a single 'model' for application to virtually all public sector organisations, to ensure that they function in the same way and their performance measured. The model adopted many of the characteristics associated with Taylorism. For example: measure the output of the individual worker; negotiate wages not nationally but with the individual; make the individual accountable for their own performance; de-skill tasks; employ single skilled workers on reduced wages; introduce short-term performance related contracts.

If one recalls the experiment carried out by Taylor where he succeeded in getting Schmidt to move 47 tons of pig iron every day and to do this with blind obedience, and that once this had been achieved it became the norm for other workers. One must raise the question of what became of Schmidt and his fellow workers when they could no longer manage to operate at their maximum level of output. The recommendations of Davies completely disregard the progress made in the field of human resource management since Mayo (1933) and turn back the clock to reintroduce a mechanistic style of management. In Chapters 5 and 7 it was demonstrated that increased pressure of work could effect the performance of workers. The research highlighted that as stress levels increase, so does ill health and in the case of the police, medical retirements. Hence, increased levels of work and changes to working practices do not always achieve the cost savings predicted.

The model developed by Davies received political and Home Office support and led to a wide range of reforms, most notably the Sheehy Report and the Police and Magistrates Court Act 1994. In contrast the forcewide survey indicated that 94.6% of respondents felt the implementation of the findings of the Sheehy report would lead to a worse service for members of the public and 96.5% felt that the recommendations would result in worse conditions of service for police officers. Despite the wide-ranging opposition to the recommendations the majority have been implemented.

Butler (1992) identified that the cumulative effect of change on the police had caused internal resource implications and these were increasing with the introduction of more private sector practices. The interviews with the senior officers indicated that the introduction of devolved financial management was viewed as being problematical, resource intensive and that it would create increased bureaucracy. Concerns were expressed that operational policing was too complex to be dominated by finance. The financial implications of a simple police action and the relationships between performance indicators and finance were explored in chapter 7. This identified the strange relationships that exist in a public sector organisation that is performance indicator driven, financially accountable yet has no control over costs once a decision has been made to arrest or prosecute. It was identified in Chapter 5 that the senior officers wished to maintain a traditional stance and that the police should not be seen as purely an enforcement agency raising revenue for the Home Office and that they should not be rewarded for punishing people. These values, however ethical do not fit in with maintaining a financially healthy organisation. There is urgent need for the police to reconsider these important issues.

The review of organisational theory suggested that there was no one best system to determine strategy in an organisation but that strategy must be designed and adopted to meet the needs of the individual organisation. Beer identified that business has become increasingly more complex and that

managers need to develop a capacity for dealing with and handling information. Beer's viable systems model was utilised, this demonstrated the inter-connectivity of systems and their relationship with the environment and examined the proposition that variety can only be absorbed by variety within a system. In simplistic terms this means that all activities carried out by system 1 will affect systems 2, 3, 4 and 5. It has been demonstrated that police activity in system 1 invariably has cost implications that can escalate and become completely out of the control.

8.2.1 Conclusion

The literature review achieved the stated objectives bringing together the key elements of theory developing and exploring the relationships between historic and present day management techniques.

The literature review highlighted the organisational characteristics and nature of policing. The researcher firmly believes that it is essential to understand the nature of an organisation before subjecting it to change. However, this is an area that has received little scrutiny from academic writers and it is hoped that this research will go some way towards filling the knowledge gap and contribute towards the debate surrounding organisational change within the police service.

8.3 THE VALUE OF THE RESEARCH TO POLICE MANAGEMENT

The research has demonstrated that the police occupy a unique position, that they form a classical bureaucracy, dealing with a precise legal system that demands exceptionally high standards of accountability. In recent years, as a result of a series of high profile miscarriages of justice, levels of accountability within the police have risen. Greater emphasis has been placed on the integrity of the police and intense examination has been carried out of the procedures

and working practices they adopt. It is suggested that standards cannot be lowered, consequently change becomes increasingly complex and must take into consideration the wide range of variables that it impacts on, maintaining high standards of integrity at all levels. It is suggested that this process cannot stop inside the police organisation but consideration must be given to how change impacts on the external organisations that interface with the police.

The research identified that the arguments for change within the police force are based on the principles, that new technology and the values of the private sector can be readily implanted into the public sector and by doing so performance will automatically be improved.

It is argued that to modernise the police it is not simply a matter of replacing old machinery in a factory with the latest high technology equipment, then measuring success by increased production and return on capital investment. The research endeavoured to identify the key characteristics of the police and explored the consequences of implementing change into an organisation that has unusual and unique characteristics.

During the research areas of concern were identified particularly in the field of information technology. The introduction of new technology has been the driving force behind many of the changes proposed by external agencies, such as the Home Office, the Audit Commission and Her Majesty's Inspectorate. New technology has affected the working practices of the police, however the introduction has led to a wide range of unforeseen consequences.

The interviews with the senior officers and the forcewide survey indicated that the value of new technology systems was becoming increasingly questionable. The research demonstrated that internally designed computer systems displayed the characteristics of: low overall efficiency; low operational efficiency; increased bureaucracy and high resource costs. (Chart 5.11) It was identified

that the training programmes were not adequate, with few officers fully understanding how the systems worked. In general terms officers felt that the computer systems were designed to satisfy the aspirations of the designer and not to meet the needs of the operational officer. The researcher suggests that it is vital for the success of the Cleveland Constabulary to identify the full resource implications of new technology systems. It is suggested that the model used for evaluation in the research can be refined and utilised for this purpose.

The researcher suggests that the Force would benefit from the use of Beer's VSM in the design and evaluation of systems and as a diagnostic tool. The VSM can be used to explore the inter-relationships with the internal and external environments for each system under investigation. The VSM was used in Chapter 7 to demonstrate the introduction of automatic speeding devices and the relationships that develop within the internal and external environment. The model demonstrated that policing is complex and that because of the rules and regulations governing police activities, the introduction of new technology can significantly increase the cost of service provision.

The recognition that these relationships exist and that they must be considered and incorporated into the design of systems, is a starting point. The researcher believes that the understanding of the interactions can be crucial to the success or failure of a system. Once the interactions are understood the resource implications can be identified for all elements of the system. It is suggested that the elements can then be evaluated in the terms described in the research: overall efficiency; operational efficiency; bureaucracy; and resources. The research has developed a very simple model that has been presented for illustrative purposes. The challenge for the future will be to refine the model and to consider each element in financial terms.

8.3.1 Conclusion

The research achieved its stated objectives in that it explored the cause and effect that change associated with the introduction of new techniques can have on the resource implications of the police service and that the change process can have unexpected consequences for the organisation.

The research produced a heuristic model to simplify and demonstrate the effect that change has on individual elements within policing and endeavoured to quantify what has been previously regarded as unquantifiable. The research demonstrated that valuable information concerning the change process can be gained from those who have experiential knowledge of policing. The researcher believes that this knowledge cannot be ignored and must be incorporated into the design of new systems. The challenge will be to gain support for the use and development of this type of methodology.

The research made use of Beer's VSM to understand the complexity of policing. It is believed that the use in this context is unique within policing. It has provided an invaluable insight into understanding the cause and effect of change and the inter-relationships between elements within internal systems and those in the external environment. It is suggested that there is great scope within the police service to utilise the VSM for diagnostic purposes, to review existing systems and in the evaluation of future systems.

The researcher believes that he could have achieved greater value from the research by utilising the VSM in all stages of the research, in particular the evaluation of new technology systems. It must be stated that at the outset of the research this was indeed the intention. However, the research commenced during a period of turmoil within the Cleveland Constabulary with the centralisation of communications implemented not on a consensual basis, but through the exercise of executive power. Consequently it has not been prudent

or indeed practical to carry out specific research in this area. This resulted in a change in the selection of methodology, to one that involved interviews and surveys. Hence the views and comments that emerged from the research represent those who have a working and practical knowledge of the systems under investigation.

8.4 THE STRENGTHS AND WEAKNESSES OF THE RESEARCH AND THE FURTHER WORK INDICATED

The strengths of the research are believed to be:

- The originality of the subject area;
- At the time this was believed to be the largest survey of serving police officers in respect of academic research;
- The large scale interview of senior officers which explored past as well as current issues in policing;
- The interviews with the four chief officers in the Force;
- The application of Beer's VSM to the resource issues of policing;
- The development of a model to evaluate the efficiency of policing systems.

The research has weaknesses that are believed to be:

The research covers too wide an area of policing within the Force. This was by necessity rather than by choice. The author would have liked to focus in on one key area of information technology to carry out an in-depth cost/efficiency analysis using the model detailed in chapter 5. However, the advisers to the author discouraged this as it may have led to conflict within the Force.

The research commenced in 1991 and has taken longer than anticipated to

complete. Hence many of the changes discussed have already moved through to the implementation stage and there has been little scope within the research to evaluate their progress.

The four areas identified to evaluate change were not adequately defined and although the author had the facility at each interview to explain what was required the terms "overall efficiency" and "operational efficiency" could be confused by someone not familiar with policing terminology.

The author chose to use the VSM, however, these concepts are little known outside academia and for the majority of police officers terms like 'cybernetics' and 'requisite variety' are difficult to conceptualise. Consequently there is a need to develop simple terminology to get the message across.

8.5 FURTHER WORK REQUIRED

There is a need to develop the proposals for evaluating the effect that change has on elements of new systems and the component parts of; overall efficiency; operational efficiency; resources; and bureaucracy. Further work is required to refine the model used in the research, so that each element under investigation is clearly defined to ensure consistency of evaluation. It would be beneficial to examine systems utilised in public and private sector organisations to see how they evaluate change, what critical factors they use to determine if a system is successful or unsuccessful.

Further work should be carried out in organisations that have been affected by the public sector changes to establish how they have coped with change and identify positive benefits that they may have achieved.

The use of the VSM provides an opportunity to identify the internal and

external implications of policing operations. There is a need to identify and explore the cause and effect of police operations on other organisations and develop programmes that will ensure that the maximum benefit will be gained from police operations.

In the course of establishing the Forces past and present position the researcher identified the present difficulties that the Force is experiencing with pension contributions. However, one factor that has not previously been identified is the unique position that existed in 1978/79 when the Force recruited approximately 190 officers in one year, three times its normal rate. These officers will start to retire in the next decade significantly affecting the whole pension system. Further work should be carried out to assess the financial impact of this.

Further work is needed to fully evaluate the resource implications of satisfying performance indicators and to consider the introduction of a system for charging for administrative work associated with prosecutions.

Finally, policing is of national concern, the success or failure of the police service can impact on the quality of life of the whole of society. The researcher acknowledges that the police maintain a vital fulcrum between law and disorder. This represents a delicate balancing act that is constantly subjected to diverse range of oscillatory powers and external influences. It is suggested that for real progress to be made and to bring the management practices of the police into the twenty-first century, they must slow down the current rate of change. The police must learn from the techniques available to them in academia and from the experiences of external organisations, particularly those in the private sector, where an error of judgement may have fatal consequences for that organisation. It is vital that the impact of change is fully evaluated post implementation and that this process is carried out on a regular basis to determine if the predicted benefits have been fully achieved or whether there has been unforeseen consequences.

Appendices 'A' to 'E'

and

References

Interviews with the 27 senior police officers

Section A

THE ROLE OF THE POLICE SERVICE

1. What type of service do you think the police should provide?
2. Crime at the present time is receiving wide media coverage. What do you think the Force aims should be in respect of crime?
3. Traditional law enforcement by police officers has centred around the arrest, process and punishment of offenders. Recent debate in the media indicates that there are two opposing views to enforcement.

'public relations should come before prosecutions' (Edwards, Evening Gazette 25.3.93)

'30 years of stupid liberalism has meant that people think that they can get away with it. We must return to sanity' (Ingham, BBC2 25.3.93)

- (i) Do you regard law enforcement as making a significant contribution towards crime prevention and the maintenance of law and order?
- (ii) Do you feel that enforcement can lead to the alienation of certain sectors of the community?

Section B

RESOURCES

1. If you consider resources as personnel, equipment, vehicles and finance, what do you think are the key limiting resources that control the achievement of the service you would like to provide?

2. The Home Secretary, Kenneth Clarke, announced on the 23rd March 1993, that Chief Constables would be given greater freedom to manage resources and in the choice of what they spend their money on.
 - (i) Do you believe that District/Departmental commanders should have complete freedom in deciding the mix and roles of all personnel and equipment to meet their own local goals and priorities, e.g. police or civilian; CID or uniform; mobile or foot patrol; levels of supervision?

 - (ii) If so, what changes, if any, do you think will have to be made to the present systems to ensure that this initiative is successful?

Section C

CONSUMERISM AND THE POLICE SERVICE

1. The Home Secretary, who appears to have support from the Audit Commission, the Home Office and Her Majesty's Inspectorate, has indicated that the police service should become more consumer oriented, with a range of performance measures being introduced to ensure that police forces provide value for money through improved productivity. If the police service is to be examined using measures designed and applied to the private sector and assessed like a business. Do you think the Force should:
 - (i) Prioritise the deployment of resources to areas of high numerical or quantifiable productivity?
 - (ii) Reduce the range of services provided to the public? Please give examples.
 - (iii) Charge for an increased range of services. If yes, please specify.
 - (iv) Contract out or divest certain services. If, yes please specify.
2. There is a common perception that the answer to policing problems can be resolved by putting more police officers 'back on the beat'.
 - (i) What does the term 'bobby on the beat' mean to you?
 - (ii) Do you feel that this is a cost-effective way of policing?
3. The consumerist approach links rewards to productivity. However the police service at the present time does not receive income from much of the work it carries out, e.g. fines resulting from arrests or process. Consequently the more productive it becomes, the more administration it creates, and this in turn increases costs.
 - (i) Do you think that the Force finance should be linked to its overall productivity?. If so how can this be achieved?

PERSONNEL

Section D

Role of police officers:

- The role of a police officer and the range of work carried out has undergone many changes over the last twenty years. If you consider 1974, as being a base year or starting point can you please indicate to your best knowledge, what you believe the situation was ten years later in 1984, and how you regard it now in, 1993.

Please score between "1" and "10" on the following basis:

"1" Insignificant increase "5" Moderate increase "10" Significant increase.

If you believe there has been a decline in any of the subject areas, please indicate using a negative prefix on the following basis:

"-1" Insignificant decrease "-5" Moderate decrease "-10" Significant decrease

	1984	1993
1. Range of skills required		
2. Knowledge of law.		
3. Knowledge of procedures.		
4. Complexity of paperwork.		
5. Professional standards required.		
6. Physical capabilities.		
7. Stress levels.		

1974 = 0

- It has been suggested by the Audit Commission and others that the police service is over-supervised and that only supervisory positions which 'add value' should be retained. Do you believe that officers of your rank and in your present role add value and contribute to the overall efficient running of the Force? Please discuss.

3. Research indicates that the organisational structure of the police service with the present tripartite system of control resembles that of a 'classical bureaucracy' in which personnel spend significant parts of their time employed in activities associated with: keeping records; information processing; paperwork; applying rules and regulations and policies determined by others.

The Chief Constable of the Metropolitan police force, Paul Condon, in evidence to the Home Affairs Select Committee (BBC 23.3.93) stated that he believed the police service was being submerged in bureaucracy and paperwork.

Do you feel that the requirements of 'bureaucracy'

- (i) Influences your style of management?
- (ii) Effects the overall cost of the service provided?

4. In a recent paper titled 'creating a vision for the future of policing', the Chief Constable of Northamptonshire David O'Dowd stated: It is a truism that people are the most valuable asset of an organisation, nowhere is it more true than in the police service, where human resources account for at least 85% of the resource budget. The logo of my Force is:

"People who care about people".

Do you feel that the Cleveland Constabulary cares about the people it employs and values their contribution to the service provision?

5. Do you feel that the Cleveland Constabulary offers equal conditions of service and incentives for officers of all ranks, particularly those serving on the front line, to complete their full thirty years of service? What are your views on this issue.

Section E

TECHNOLOGICAL SYSTEMS.

Information and computer technology.

1. Since the introduction of the Police National Computer system (PNC) in 1974, the Force has become increasingly reliant on the use of information and computer technology. In order to establish if you feel that these systems provide value for money, I would like you to assess five systems or networks.
Could you please rate each element of the system indicated on a scale of (+ or -)"1" to "10", on the following basis:

Efficiency - indicate if you believe it is more or less efficient than the system it replaced.
("-10" low efficiency "0" no change "+10" high efficiency)

Resources - indicate if the system requires more or less resources than the system it replaced.
("-10" less resources "0" no change "+10" more resources)

Operational - indicate if it has resulted in a worse or improved service to operational officers, than the system it replaced.
("-10 worse service "0" no change "+10" improved service)

Bureaucracy - indicate if it has resulted in more or less paperwork/administration being created, than the system it replaced.
("-10 less bureaucracy "0" no change "+10" more bureaucracy)

System	Efficiency	Resources	Operational	Bureaucracy
1. PNC				
2. HOLMES				
3. Centralised communications				
4. CRIMES				
5. CIS				

2. What measures do you think should be used to assess the success/failure of such systems?

The use of new technology for operational policing

3. What are your views on the gathering of evidence by new technology e.g. closed circuit television (CCTV); remote cameras, etc.?
4. If closed circuit television or other automatic detection devices are to be utilised on a wider scale, e.g. town centre streets, public car parks, do you feel that this function should be carried out by the police, or in partnership with other agencies.
5. What are your views on entering into a commercial partnership with other agencies to fund such systems?

Section F

LEGISLATION

1. The police service over the last decade has been affected by a vast range of legislation, directives and initiatives' directives all requiring some level of 'change'. To assess how the main changes have affected the Force, can you select four changes from the list that you are familiar with and that you believe have had the most significant impact on the way that police officers carry out their duties. One of these changes should be the Police and Criminal Evidence Act 1984 (PACE)

Can you please rate how you feel that these changes have affected the key areas indicated on a scale of (+ or -) "1" to "10" on the following basis:

Efficiency - Indicate if you believe that the change has led to a more or less efficient service

("-10" very low efficiency "0" no change "+10" very high efficiency)

Resources - indicate if you believe that the change has led to an increase or decrease in resources required.

("-10" less resources "0" no change "+10" more resources)

Operational - indicate what you believe the effect has been on productivity.

("-10" decreased productivity "0" no change "+10" increased productivity)

Bureaucracy - indicate how you believe the change has resulted in more or less bureaucracy (can be regarded as rules, regulations, procedures.)

("-10" less bureaucracy "0" no change "+10 more bureaucracy)

Police and Criminal Evidence Act 1984
 Home Office circular pre-trial issues
 Home Office circular equal opportunities
 Home Office circular career development
 Home Office circular domestic violence

Children Act 1991
 Criminal Justice Act 1991
 Road Traffic Act 1991
 HMI quality of service initiatives
 Tape recording of interviews

Change	Efficiency	Resources	Operational	Bureaucracy
1. PACE				
2.....				
3.....				
4.....				

Section G

EXTERNAL INFLUENCES ON THE POLICE SERVICE

The Audit Commission

In February 1987, the Audit Commission commenced its 'special study' into the police service. The purpose of these studies was given by Howard Davies, the former controller as 'to develop methodologies which would be of use to authorities and their auditors in getting to grips with issues surrounding value for money'. The key themes of Mr Davies are that police forces are over controlled by the Home Office, Police Authorities and by Force headquarters and that performance can be enhanced by a major push to delegate responsibility and accountability downwards.

The Commission has produced a series of eleven papers. I have extracted from these, what I believe are the key themes and I would like your views on these or on any other issues you may wish to raise. It is appreciated that some of these issues were raised prior to these studies, e.g. by Home Office circular 114/83, Economy, Efficiency and Effectiveness, however the Commission has added their own dimension to these issues.

Civilianisation.

1. The Commission consistently state that most tasks that a police officer carries out can be carried out cheaper by a non-police officer.

(i) Do you feel that cost alone should be the dominant factor in the selection and deployment of personnel? Please discuss.

(ii) The concept of civilianisation appears to rely on employing predominantly single skilled or unskilled personnel on relatively low pay compared to that of police officers.

(a) Do you think that this limits your scope for deployment of such personnel? Please discuss.

(b) Do you think that the Force should improve the career development opportunities for civilian personnel, by widening their skill base? Please discuss.

Performance measurement

2. Mr Davies stated that 'performance measurement is the cornerstone of delegation' (Controller's address to ACPO 3rd October 1990).

What do you think will be the effect of the development and implementation of:

- (i) National performance measures;
 - (ii) District/Departmental performance measures;
Financial accountability
3. The Commission recommends that supervisory officers at all levels should develop a management role which integrates financial and operational responsibility. Davies states (Controllers address to ACPO 3rd October 1990) *'the starting point should be to ensure that the financial framework reinforces the structure of accountability'* This system leads to and relies on top-down control.

Alternative views are being expressed that this type of system has severely damaged American industry, where over the last forty years finance has become the dominant discipline, with the workforce manipulating processes to achieve quantified targets. Johnson states *'if companies are to compete effectively, they must remove accounting information from their operational control systems and relieve their accounting departments of responsibility for providing information to control business operations'* (Johnson, Relevance regained). He argues that financial accounting processes act in opposition to total quality management and that what is required is the bottom-up empowerment of those workers who are close to the customer and who carry out the processes.

- (i) What are your views on this issue of extending financial accountability downwards and the effects this may have on the quality of service provided?

THE ROLE OF HER MAJESTY'S INSPECTORATE

4. The role of the Her Majesty's Inspectorate (HMI) together with that of the Audit Commission was described by a management consultant Mr Denis Bourne (Police review 20th November 1992), as being:

Providing an inspection service, that is supposed to help forces maintain high standards. But, because of the way they are constituted, the Inspectorate and the Commission focus more on the visible, superficial and structural rather than the fundamental, developmental and critical. In particular, the Inspectorate's pre-inspection report, combined with its matrix of performance measures, consumes vast amounts of Force resources and provided little, if anything, in return. Their recommendations frequently have the effect of diktats, whether or not they have any real relation to the needs of the Force or the service it is trying to provide to the community'.

- (i) Do you feel that the service provided by the HMI is satisfactory or could it be improved?

IMPACT ON THE POLICE SERVICE

5. Do you feel that those bodies who legislate, control and influence the police service, adequately take into account:
- (i) The impact that their changes have on individual police forces working practices?
Please discuss.
 - (ii) The individual police forces ability to finance or resource such changes?
Please discuss
 - (iii) The effect on administration and bureaucracy within a police force.
Please discuss.
 - (iv) Do you feel that the present system is satisfactory, if not, have you suggestions for improvement.

Section H

1. What are your views on the future direction that the police service should take?

This concluded the survey. Thank you very much for your co-operation.

Semi-structured interview for interviews with the four chief officers.

1. What type of service do you think the Cleveland Constabulary should provide?
2. What is your vision for policing in Cleveland.
3. Do you favour adopting a consumerist approach to policing.
4. What are your views on the proposals recently announced by the Home Secretary, in respect of the inclusion of five members of the business community in a new type of Police Authority and the proposals to change the method for funding the police.
5. Do you feel that bodies in the external environment such as the Home Office, The HMI, the Audit Commission, unduly influence the ability of a police force to determine the type and level of service that meets the needs of a local community.

Finally, are there any other issues that you wish to comment on.

The Wilcoxon matched pairs signed-ranks test

SECTION D - Data from question 1 - Range of skills required.

Subject pair	Condition A 1984	Condition B 1994	d (A-B)	Ranks of d	Smaller signed sum
1	3	10	+7	23.5 (+)	
2	10	10	0		
3	4	8	+4	12.5 (+)	
4	5	9	+4	12.5 (+)	
5	8	10	+2	2 (+)	
6	3	10	+7	23.5 (+)	
7	5	5	0		
8	5	8	+3	6.5 (+)	
9	6	10	+4	12.5 (+)	
10	5	10	+5	19 (+)	
11	5	10	+5	19 (+)	
12	5	10	+5	19 (+)	
13	8	8	0		
14	9	5	-4	12.5 (-)	-12.5
15	5	10	+5	19 (+)	
16	5	8	+3	6.5 (+)	
17	4	8	+4	12.5 (+)	
18	5	8	+3	6.5 (+)	
19	5	8	+3	6.5 (+)	
20	5	10	+5	19 (+)	
21	4	6	+2	2 (+)	
22	7	10	+3	6.5 (+)	
23	3	8	+2	2 (+)	
24	5	8	+3	6.5 (+)	
25	5	10	+5	19 (+)	
26	5	10	+5	19 (+)	
27	5	9	+4	12.5 (+)	

Number of + signs = 287.5

Number of - signs = 12.5

Total sample = 27

N = 27 - 3 (tied scores) = 24

The null hypothesis is that there is no difference between the scores attributed to each condition.

The results were significant at a 95% level of confidence. Using Wilcoxon's test (N = 24, T = 12.5, two tailed hypothesis), the critical value of T from the tables for the level of confidence $p = 0.05$, is T = 81. The proportion of the smaller signed sum is less than this (12.5), therefore the null hypothesis can be rejected.

The Wilcoxon matched pairs signed-ranks test

SECTION D - Data from question 3 - Knowledge of procedures

Subject pair	Condition A 1984	Condition B 1994	d (A-B)	Ranks of d	Smaller signed sum
1	3	10	+7	23 (+)	
2	10	10	0		
3	5	10	+5	15 (+)	
4	5	7	+2	2 (+)	
5	10	10	0		
6	4	10	+6	20.5 (+)	
7	5	10	+5	15 (+)	
8	4	9	+5	15 (+)	
9	3	10	+7	23 (+)	
10	4	8	+4	6.5 (+)	
11	5	10	+5	15 (+)	
12	3	10	+7	23 (+)	
13	6	9	+3	3 (+)	
14	5	9	+4	6.5 (+)	
15	2	10	+8	24.5 (+)	
16	5	9	+4	6.5 (+)	
17	3	8	+6	20.5 (+)	
18	2	10	+8	24.5 (+)	
19	4	8	+4	6.5 (+)	
20	5	10	+5	15 (+)	
21	3	7	+4	6.5 (+)	
22	5	10	+5	15 (+)	
23	4	9	+5	15 (+)	
24	6	10	+4	6.5 (+)	
25	5	10	+5	15 (+)	
26	5	10	+5	15 (+)	
27	3	10	+7	23 (+)	

Number of + signs = 366.5

Number of - signs = 0

Total sample = 27

$N = 27 - 2$ (tied scores) = 25

The null hypothesis is that there is no difference between the scores attributed to each condition.

The results were significant at a 95% level of confidence. Using Wilcoxon's test ($N = 25$, $T = 0$, two tailed hypothesis), the critical value of T from the tables for the level of confidence $p = 0.05$, is $T = 90$. The proportion of the smaller signed sum is less than this (0), therefore the null hypothesis can be rejected.

The Wilcoxon matched pairs signed-ranks test

SECTION D - Data from question 7 - Stress levels

Subject pair	Condition A 1984	Condition B 1994	d (A-B)	Ranks of d	Smaller signed sum
1	3	10	+7	23.5 (+)	
2	3	10	+7	23.5 (+)	
3	5	0	10	14 (+)	
4	5	10	+5	14 (+)	
5	8	10	+2	3 (+)	
6	2	9	+7	23.5 (+)	
7	5	10	+5	14 (+)	
8	7	8	+1	1 (+)	
9	5	7	+2	3 (+)	
10	6	10	+4	8 (+)	
11	5	10	+5	14 (+)	
12	3	10	+7	23.5 (+)	
13	6	8	+2	3 (+)	
14	5	8	+3	5.5 (+)	
15	1	5	+4	8 (+)	
16	5	10	+5	14 (+)	
17	5	10	+5	14 (+)	
18	4	10	+6	19.5 (+)	
19	3	9	+6	19.5 (+)	
20	5	10	+5	14 (+)	
21	3	6	+3	5.5 (+)	
22	0	0	0		
23	3	8	+5	14 (+)	
24	6	10	+4	8 (+)	
25	5	10	+5	14 (+)	
26	3	10	+7	23.5 (+)	
27	2	9	+7	23.5 (+)	

Number of + signs = 351

Number of - signs = 0

Total sample = 27

N = 27 - 1 (tied scores) = 26

The null hypothesis is that there is no difference between the scores attributed to each condition.

The results were significant at a 95% level of confidence. Using Wilcoxon's test (N = 26, T = 0, two tailed hypothesis), the critical value of T from the tables for the level of confidence $p = 0.05$, is T = 98. The proportion of the smaller signed sum is less than this (0), therefore the null hypothesis can be rejected.

The forcewide survey

<p>Question 1 - What type of service do you think the police should provide?</p> <p><i>The following statements were made in response to this question, please indicate how you feel about these statements by circling the appropriate number on the following basis:</i></p> <p>'1' strongly agree '4' neither agree/disagree '7' strongly disagree</p>	<p>Question 2 - Crime at the present time is receiving wide media coverage. What do you think the Force aims should be in respect of crime?</p> <p><i>The following statements were made in response to this question, please indicate how you feel about these statements by circling the appropriate number on the following basis:</i></p> <p>'1' strongly agree '4' neither agree/disagree '7' strongly disagree</p>
<p>1.1 High profile policing is the best way to make the streets safer. 1 2 3 4 5 6 7</p> <p>1.2 We should provide a balanced service to the public involving both law enforcement and social policing. 1 2 3 4 5 6 7</p> <p>1.3 Law enforcement should be our major role to combat the ever increasing rise in lawlessness. 1 2 3 4 5 6 7</p> <p>1.4 Social policing initiatives may be desirable, but not if they are funded to the detriment of operational policing. 1 2 3 4 5 6 7</p> <p>1.5 There is an ever increasing need for adapting a multi-agency approach. 1 2 3 4 5 6 7</p> <p>1.6 I do not believe that we should become social workers. 1 2 3 4 5 6 7</p> <p>1.7 The police should concentrate more resources into enforcing road traffic laws to improve road safety. 1 2 3 4 5 6 7</p> <p>1.8 The police should adopt a more community based policing approach, being very close to and part of the community. 1 2 3 4 5 6 7</p> <p>1.9 The more that we take on, the less the standard of service that we provide becomes. 1 2 3 4 5 6 7</p>	<p>2.1 The public like to see the police having success in arresting offenders. 1 2 3 4 5 6 7</p> <p>2.2 The way to make people feel safe from crime is to have local police officers on the beat. 1 2 3 4 5 6 7</p> <p>2.3 If the strength of CID was increased to match the number of offences committed, then real progress could be made in tackling the crime problem. 1 2 3 4 5 6 7</p> <p>2.4 We should try and influence the criminal justice system by gathering hard facts to substantiate our views and those of the public. 1 2 3 4 5 6 7</p> <p>2.5 Detection is paramount 'offenders are the cause of the problem'. 1 2 3 4 5 6 7</p> <p>2.6 First of all we must try and prevent crime, prevention is better than cure. 1 2 3 4 5 6 7</p> <p>2.7 The Force needs to enhance its ability to undertake pro-active initiatives targeted at known offenders. 1 2 3 4 5 6 7</p> <p>2.8 There are too many officers in CID, some should be re deployed to operational tasks. 1 2 3 4 5 6 7</p> <p>2.9 We must seek to get across to those who hold power the traumatic effects that crime has on its victims. 1 2 3 4 5 6 7</p>

<p>Question 3 - If you consider resources as personnel, equipment, vehicles and finance, what do you think are the key limiting resources that control the achievement of the service you would like to produce?</p> <p><i>The following statements were made in response to this question, please indicate how you feel about each of these statements by circling the appropriate number on the following basis:</i></p> <p>'1' strongly agree '4' neither agree/disagree '7' strongly disagree</p>	<p>Question 4 - Do you feel that the use of foot patrol officers (bobby on the beat) is a cost effective way of policing?</p> <p><i>The following statements were made in response to this question, please indicate how you feel about each of these statements by circling the appropriate number on the following basis:</i></p> <p>'1' strongly agree '4' neither agree/disagree '7' strongly disagree</p>
<p>3.1 Operational policing seems to have become the poor relation of the Force. 1 2 3 4 5 6 7</p> <p>3.2 In today's environment, all police officers need to be equipped with vehicles. 1 2 3 4 5 6 7</p> <p>3.3 The lack of police personnel is the main factor. 1 2 3 4 5 6 7</p> <p>3.4 If we could give everyone public transport rate for their own vehicles, this would significantly increase productivity. 1 2 3 4 5 6 7</p> <p>3.5 The efficiency of District CID has been reduced by lack of vehicles. 1 2 3 4 5 6 7</p> <p>3.6 Finance is the major detriment, it effects our ability to provide or improve the service to the community. 1 2 3 4 5 6 7</p> <p>3.7 We underspend on training at the very time that the service is expected to provide higher standards and officers require more skills. 1 2 3 4 5 6 7</p> <p>3.8 The Force needs air support to overcome the problem of pursuing stolen vehicles. 1 2 3 4 5 6 7</p> <p>3.9 We have to live in the real world and manage the resources made available to us better. 1 2 3 4 5 6 7</p>	<p>4.1 We would need to at least double the uniform strength to provide an effective foot patrol service forcewide. 1 2 3 4 5 6 7</p> <p>4.2 The Housing estate project teams are the way forward. 1 2 3 4 5 6 7</p> <p>4.3 Police officers patrolling on foot form the basis of policing by consent, we need more of them. 1 2 3 4 5 6 7</p> <p>4.4 The preventative element of foot patrol officers has been eroded by today's criminals who are generally equipped with vehicles. 1 2 3 4 5 6 7</p> <p>4.5 It is an inefficient way of policing that we can't afford. 1 2 3 4 5 6 7</p> <p>4.6 Foot patrol officers influence the conduct of an area by building up relationships and trust over a period of time. 1 2 3 4 5 6 7</p> <p>4.7 The use of foot patrols is a nostalgic dream, that appears to be politically correct. 1 2 3 4 5 6 7</p> <p>4.8 The sight of a police officer patrolling on foot is a great deterrent to criminals. 1 2 3 4 5 6 7</p> <p>4.9 The police should give the public what they want, more foot patrols. 1 2 3 4 5 6 7</p>

<p>Question 5 - Do you feel that the Cleveland Constabulary cares about the people it employs and values their contribution to the service provision?</p> <p><i>The following statements were made in response to this question, please indicate how you feel about each of these statements by circling the appropriate number on the following basis:</i></p> <p>'1' strongly agree '4' neither agree/disagree '7' strongly disagree</p>	<p>Question 6 - When considering the value of computer or information technology systems to the Force. What measures do you think should be used to assess the success or failure of such systems?</p> <p><i>The following statements were made in response to this question, please indicate how you feel about each of these statements by circling the appropriate number on the following basis:</i></p> <p>'1' strongly agree '4' neither agree/disagree '7' strongly disagree</p>
<p>5.1 Middle management seem to care, but not top management. 1 2 3 4 5 6 7</p> <p>5.2 The Force is becoming more caring towards its personnel. 1 2 3 4 5 6 7</p> <p>5.3 It is obvious from some of the policies adopted e.g. tenure of post, that we don't really care. 1 2 3 4 5 6 7</p> <p>5.4 There is little regard paid to the needs of the rank and file officers. 1 2 3 4 5 6 7</p> <p>5.5 We need to get across the message to all staff that they are important. 1 2 3 4 5 6 7</p> <p>5.6 We provide very good welfare arrangements for all employees. 1 2 3 4 5 6 7</p> <p>5.7 We are collecting more information about police officers, but we don't seem to know what to do with it. 1 2 3 4 5 6 7</p> <p>5.8 There are so many questions being asked about a police officers worth, that it is damaging morale. 1 2 3 4 5 6 7</p> <p>5.9 It is starting to care now that we are getting new leadership at the top. 1 2 3 4 5 6 7</p>	<p>6.1 Computers have been viewed as the answer to all our problems, in reality they consume too many resources. 1 2 3 4 5 6 7</p> <p>6.2 The use of computer systems result in resources being diverted away from operational policing. 1 2 3 4 5 6 7</p> <p>6.3 Computers have reduced the burden of administration throughout the Force. 1 2 3 4 5 6 7</p> <p>6.4 The use of computers has improved the operational efficiency of police officers. 1 2 3 4 5 6 7</p> <p>6.5 We are becoming slaves to computers, we can't short circuit their requirements, they constantly need feeding. 1 2 3 4 5 6 7</p> <p>6.6 The systems must be designed to the users specifications and not to satisfy the ambitions of the designer. 1 2 3 4 5 6 7</p> <p>6.7 There are never enough people trained to use the systems properly. 1 2 3 4 5 6 7</p> <p>6.8 Computer systems must be designed to satisfy operational rather than administrative requirements. 1 2 3 4 5 6 7</p> <p>6.9 The use of computer systems has reduced paperwork within the Force. 1 2 3 4 5 6 7</p>

Question 7 - Do you feel that those bodies e.g. the Home Office, the HMI, the Audit Commission, who legislate, control and influence the police service, adequately take into account the effects that their changes have on the police service, or can it be improved?

The following statements were made in response to this question, please indicate how you feel about each of these statements by circling the appropriate number on the following basis:

'1' strongly agree

'4' neither agree/disagree

'7' strongly disagree

<p>7.1 We always take on changes, despite the fact that we don't have the resources to fund them. This means that we end up giving a poorer service in other areas.</p> <p>1 2 3 4 5 6 7</p>	<p>7.4 Everything new that comes out, creates more work for operational police officers.</p> <p>1 2 3 4 5 6 7</p>
<p>7.2 There should be a national process to evaluate the cost benefit of any legislation or changes proposed.</p> <p>1 2 3 4 5 6 7</p>	<p>7.5 Changes that have significant cost implications for the police are implemented to the detriment of operational policing e.g. the disclosure of evidence rules.</p> <p>1 2 3 4 5 6 7</p>
<p>7.3 Those officers who have to live with and implement change, Inspectors, Sergeants, Constables should be involved in the evaluation process, they may well recognise the problems likely to be experienced and determine exactly how proposals will effect operational policing.</p> <p>1 2 3 4 5 6 7</p>	<p>7.6 The Audit Commission keep recommending things that seem to make us inefficient and increases our costs e.g. the centralisation of communications.</p> <p>1 2 3 4 5 6 7</p> <p>7.7. We must learn as an organisation to say 'no' to these bodies.</p> <p>1 2 3 4 5 6 7</p>

Please indicate which of the following is applicable to your personal circumstances by placing a circle around the appropriate category number.

Rank		Length of service (years)					
Constable	1	Superintendent	5	0 - 4	1	20 - 24	5
Sergeant	2	Ch. Supt	6	5 - 9	2	25 - 29	6
Inspector	3	ACPO	7	10 - 14	3	30+	7
Ch. Insp.	4			15 - 19	4		

If there are any comments that you would like to make about policing, in addition to the above, please use the space provided. (Please continue overleaf if necessary).

Thank you for taking the time to complete the questionnaire, please return it to me in the attached envelope.

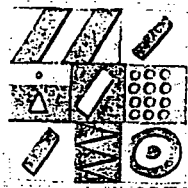

Durham University Business School

Dear Colleague,

The following questionnaire is part of a research programme that I am carrying out at Durham University. The purpose of the questionnaire is to establish how police officers of all ranks, feel about the present arrangements for policing in Cleveland. In effect, have we got things right or can they be improved?

The questionnaire has been developed from some of the main points brought up during interviews with twenty-six senior police officers and a representative from the Police Federation.

The Chief Constable is committed to developing a more open and participative style of management which encourages the free exchange of views within the Force. Clearly your views have value and I hope that you will exercise this freedom to contribute to the Force debate by completing the questionnaire.

At the top of each column you will see the original question highlighted in bold print. This is followed by a number of statements made by the interviewees and reflect the broad range of views expressed. I would like you to indicate the extent that you agree or disagree with each of the statements on the following basis:

'1' strongly agree
disagree

'4' neither agree/disagree

'7' strongly

When completing the questionnaire keep the following points in mind:

There are no right or wrong answers

Answer the questions honestly

Try to make a decision one way or the other and avoid the neutral score of '4' unless it is really appropriate to you.

Thank you for your co-operation.

K.B.Halliwell,
Inspector.

Appendix 'E'

A sample calculation showing the complex Chi squared calculations for question 1.2

		1	2	3	4	5	6	7	TOTAL
PC		122	120	119	47	43	25	22	498
SGT		40	57	58	9	11	7	7	189
SEN MGT		11	12	2	2	5	1	1	34
		173	189	179	58	59	33	30	721
	RESULTS								SUM X2
PC		119.4924	130.5437	123.6366	40.06103	40.75173	22.79334	20.72122	
	X2	0.052624	0.851588	0.173892	1.2019	0.124036	0.21363	0.078918	2.696578
SGT		45.34951	49.54369	46.92233	15.20388	15.46602	8.650485	7.864078	
	X2	0.631039	1.122173	2.615274	2.53147	1.289623	0.314907	0.094942	8.599428
SEN MGT		8.158114	8.912621	8.441054	2.73509	2.782247	1.556172	1.414702	
	X2	0.989974	1.069484	4.914929	0.197565	1.76779	0.198774	0.121565	9.26008
									20.55609

REFERENCES

Ackoff, R. (1974) 'Redesigning the Future.' John Wiley and Sons. Chichester.

Alderfer, C.P. and Smith, K.K. (1982) 'Studying Intergroup Relations Embedded in Organisations.' Administrative Science Quarterly, 1982, Vol 27, Pages 35-65.

Alderson, J. (1984) 'Law and Disorder.' Hamish Hamilton, London.

Allison, G. (1982) 'Public and Private Management: Are They Fundamentally Alike in all Unimportant Respects?' in Lane.F.S (Ed) Current Issues in Public Administration, St Martin's Press, New York.

Alvesson, M. (1987) 'Organization theory and Technocratic Consciousness: Rationality, Ideology and Quality of Work.' New York: de Gruyter. In Pollitt, C. (1990). Managerialism and the Public Services. Blackwell, Oxford.

Ashby, W.R. (1956) 'An Introduction to Cybernetics.' Chapman Hall, London.

Association of Chief Police Officers 'Setting the Standards for Policing: Meeting Community Expectations.' Association of Chief Police Officers, London.

Audit Commission for England and Wales Police Paper No.1, (1988). 'Administrative Support for Operational police Officers.' H.M.S.O.

Audit Commission for England and Wales, Police Paper No.7, (1990). 'Take Care of the Coppers - Income Generation by Provincial Police Forces.' H.M.S.O, London.

Barnard, C. (1983) 'The Function of the Executive.' Harvard University Press.

Beer, S. (1972) 'Brain of the Firm.' John Wiley and Sons. Chichester.

Beer, S. (1974) 'Platform for Change.' John Wiley and Sons. Chichester.

Beer, S. (1979) 'The Heart of the Enterprise.' John Wiley and Sons. Chichester.

Beer, S. (1985) 'Diagnosing the System for Organisations.' John Wiley and Sons. Chichester.

Beetham, D. (1985) 'Max Weber and the Theory of Modern Politics.' Polity Press.

Bitter, E.A (1985) 'Theory of the Police: in the Politics of the Police.' Operational Policing Review (1990), Section on Efficiency and Effectiveness, Page 6.

Bowden, T. (1978) 'Beyond the Limits of Law.' Penguin, Harmondsworth.

Bradley, D., Walker, N. and Wilkie, R. (1989) 'Managing the Police, Law Organisation and Democracy.' Political Quarterly, Volume 53, Number 2, pp 180-190.

Burke, J. (1964) 'Current Law Statutes Annotated.' Sweet and Maxwell.

Butler, A.J.P. (1992) 'Developing Quality Assurance in Police Services.' Public Money and Management, January to March 1992, pp 77-91.

Buttery, R. (1989) 'Audit in the Public Sector.' Woodhead, Falker. In Garvin, P. (1993) Flattening the Pyramid. Unpublished MBA dissertation, University of Teesside.

Cabinet Office (1962) 'Final Report of the Royal Commission on the Police.' HMSO Cmnd 1728.

Cabinet Office (1993) 'The Inquiry into Police Responsibilities and Rewards.' Cmnd 2280, H.M.S.O.

Cabinet Office (1993) Police Reform. 'The Government Proposals for the Police Service in England and Wales.' Cmnd 2281, H.M.S.O.

Chapman, L. (1978) 'Your Disobedient Servant.' Chatto and Windus, London.

Checkland, P. (1981) 'Systems thinking, Systems Practice.' John Wiley and Sons. Chichester

Clarke, K. (1993) 'Home Secretaries Speech to Parliament.' The Times Newspaper, 23 March 1993

Chief Constable's Annual Report 30.5.1893, Middlesbrough Reference Library.

Cleveland Constabulary Annual Report 1976. Police headquarters

Cleveland Constabulary Annual Report 1980. Police headquarters

Cleveland Constabulary Annual Report 1983. Police headquarters

Cleveland Constabulary Annual Report 1987. Police headquarters
Cleveland Constabulary Annual Report 1988. Police headquarters
Cleveland Constabulary Annual Report 1989. Police headquarters
Cleveland Constabulary Annual Report 1990. Police headquarters
Cleveland Constabulary Annual Report 1991. Police headquarters
Cleveland Constabulary Annual Report 1992. Police headquarters
Cleveland Constabulary Annual Report 1993. Police headquarters
Cleveland Constabulary Annual Report 1994. Police headquarters
Cleveland Constabulary Annual Report 1995-6. Police headquarters

Critchley, T.A. (1978) 'A History of the Police in England and Wales.' Constable and Company, London.

Crouch, C. and Marquand, D. (1992) 'Community, Professions, Customers and Business.' The Political Quarterly. January - March, 1992, Vol.63, Nr.1. Page 4.

Cyert, R. and March, J. (1963) 'A Behavioural Theory of the Firm.' Prentice Hall.

Davies, H. (1990) Address to the Association of Chief Police Officers at their Autumn Conference in 1990. Available in the Audit Commission guide, to auditor.

Davies, H. (1992) 'Fighting Leviathan - Building Social Markets that Work.' Social Market Research Foundation, 1992.

Dean, M. (1982) 'The Finger on the Policemans Collar.' Political Quarterly, Volume 53, Number 2., April to June 1982. In Bradley, D., Walker, N. and Wilkie, R. (198) Managing the Police, Law Organisation and Democracy. Page 17.

Derbyshire, J.D. (1984) 'An Introduction to Public Administration.' McGraw-Hill Book Company (UK) Limited.

Devlin, J.D. (1966) 'Police Procedure, Administration and Organisation.' Butterworth, London.

Eastwood, (1993) Unpublished speech made at the Police Federation meeting, Wembley arena, 22nd July 1993.

Eastwood, A. (1993) 'Police.' Joint Central Committee of the Police Federation of England and Wales. Surbiton, Surrey.

'Efficiency and Effectiveness in the Civil Service.' Government Observations from the Third report from the Treasury and Civil Service Committee, Session 1981-82, House of Commons. London HMSO Cmnd 8616.

Elstob, M. (1992) 'Creative Problem Solving.' in Flood, R.L and Romm, N.R.A (1996) 'Diversity Management. Triple Loop Learning.' John Wiley and Sons. Chichester

Etzioni, A. (1964) 'Modern Organizations.' Prentice Hall, Englewood Cliffs, New Jersey.

Factsheet. (July 1994) 'Your Police: A Service to Value.' Association of Chief Police Officers.

Fayol, H. (1916) 'General and Industrial Management.' (Storrs translation, 1949). London, Pitman.

'Final Report of the Royal Commission on the Police.' Cmnd. 1728. London: Her Majesty's Stationary Office, May 1962.

Flood, R.L and Jackson, M.C (1991) 'Creative Problem Solving. Total Systems Intervention.' John Wiley and Sons. Chichester

Flood, R.L. (1993) 'Beyond TQM.' John Wiley and Sons, Chichester

Flood, R.L and Romm, N.R.A (1996) 'Diversity Management. Triple Loop Learning.' John Wiley and Sons. Chichester

Flynn, N. (1992) 'Public Sector Management.' Harvester Wheatsheaf, 1992.

Galbraith, J.R. (1977) 'Organization Design.' Reading, Mass. Addison-Wesley.

Garvin, P. (1993) 'Flattening The Police Pyramid: A Strategic Review of the Police Service Organisation.' Unpublished MBA dissertation, University of Teesside.

Greenwood, J. (1988) 'Mrs Thatcher's Whitehall Revolution.' Teaching Politics, May 1988, pp 208.

Gulick, L.H. (1937) 'Notes on the Theory of Organisation.' in Papers on the Science of Administration (eds. Gulick, L.H. and Urwick, L.F.). New York: Columbia University Press.

Hall, R. (1994) 'Reflections of the Nature of Judgement and the Problem of Hyper-Reality.' Unpublished paper, Durham University.

Harvey-Jones, J (Sir) (1988) 'Making it Happen.' Collins, 1988.

Henkel, M. (1991) 'The New Evaluative State.' Public Administration, Vol. 69, Spring 1991, :121-136. In Wilson, E. 1993. Culture and Managerialism. Tudor Publishing Ltd, Merseyside.

Heseltine, M. (1980) 'Ministers and Management in Whitehall.' Management services in government, 35. In Pollitt, C. (1990). Managerialism and the Public Services. Blackwell, Oxford.

Hilliard, B. (1991) Editorial article in the Police Review, 19th April, 1991.

Hollinshead, B. (1983) Policy Studies Institute. In Uglow, S. (1983) 'Policing Liberal Societies.' Oxford, New York.

H.M.S.O. (1983) Home Office Circular 114/1983: 'Manpower, Effectiveness and Efficiency in the Police Service.' H.M.S.O, London.

H.M.S.O. (1988) Home Office Circular 105/1988 'Civilian Staff in the Police Service.' H.M.S.O. London.

H.M.S.O. J1295NJ (1992). 'The Police Serving The Community.' HMSO, London.

Hough, J.M. (1985) 'Managing With Less Technology.' Policing Today, July 1995, pp 55-60.

Hughes, O. (1992). 'Public Management or Administration.. Australian Journal of Public Administration. Vol. 51. No. 3. September 1992. pp 280-292.

Hurd, D. (1989) 'Douglas Hurd Speaking to the Superintendents.' Association, 26 September 1989, quoted Home Office, Police Department, Police R & D Advisory Board paper, 1-2 November 1989, page 109. In Operational Police Review, Section Policing in the 1990's pp 39-40.

'Independent Committee of Inquiry into the Role and Responsibilities of the Police.' August 1994. Policy Studies Institute. London.

Jankowicz, A.D. (1991) 'Business Research Projects for Students.' Chapman and Hall. Page 194.

Johnson, H.T. (1992) 'Relevance Regained - From Top Down to Bottom Up Empowerment.' Preface P.vii - xi. Free Press.

Kanter, R.M. (1983) 'The Change Masters.' Unwin paperbacks, England.

Kast, F.E and Rosenzweig, J.E. (1979) 'Organisation and Management: a Systems and Contingency Approach.' 3rd Edn. New York, McGraw-Hill.

Keating, M. (1989) 'Quo Vadis? Challenges of Public Administration.' Australian Journal of Public Management, Vol. 48. No.2. pp 187-195.

Kempner, T (1987) 'The Penguin Management Handbook.' Penguin Books, England.

King, D.S. (1987) 'The New Right.' Macmillan Education, London.

Kingdom, J. (1990) 'Public Administration or Public Implementation - A Discipline in Crisis.' Public Policy and Administration Volume 5, No.2, Summer 1990.

Koolhaas, J. (1982) 'Organisation Dissonance and Change.' John Wiley and Sons. Chichester.

Lawton, A. Rose, A. (1991) 'Organisation and Management in the Public Sector.' Pitman Publishing, London.

Lederman, L.M. (1984) 'The Value of Fundamental Science.' Scientific American November 204 - 13. In The Viable System Model (eds. R. Espejo and R. Harnden) John Willey and Sons, Chichester.

Lobban, R.D. (1976) 'The Police.' B.T.Batsford, London, The Anchor Press Limited.

Luthans, F. (1976) 'Introduction to Management: a Contingency Approach.' New York, McGraw - Hill.

Males, S. (1982) 'Police Management on Division and Sub-Division.' Bramshill Library

Mayo, E. (1933) 'The Human Problems of an Industrial Civilianisation.' New York, McMillan.

Meacher, M. (1979) 'Whitehalls Short Way with Democracy, in What Went Wrong.' (ed.) K. Coates, Nottingham: Spokesman Books.

Metcalfe, L. and Richards, S. (1987) 'Improving Public Management.' Sage Publications Ltd, London.

Metcalfe, L. and Richards, S. (1990) 'New Managerialism and the Public Sector.' Sage Publications Ltd, London.

Miles, R. E, Snow, C. and Pfeffer, J. (1974) 'Organization, Environment, Concepts and Issues.' Industrial Strategy Management Journal Vol. 13, 1974.

Minutes of Council meeting - 9th November 1854, Middlesbrough Archivist.

Mitroff, I. (1974) 'The Subjective Side of Science.' Elsevier: Amsterdam. Cited in an unpublished thesis Dr J.B. Sanderson 'Organisational Communications in the Police'.

Morgan, G. (1986) 'Images of Organisation.' Sage publications.

Morris, T.A. (1992) 'Performance Measurement.' The Inspectorate View. Paper presented to the AMA Conference "Minding the Quality - Police Authorities and Police Performance." Friday 20th November 1992.

O'Dowd, D.J. (1993) 'Creating a Vision for Future Policing.' The Police Journal, January 1993. pp 144-158.

Palmer, S.H. (1988) 'Police and Protest in England and Ireland 1780-1850.' Cambridge, Cambridge University Press.

Painter, L. (1989) 'Public Management Fad or Fallacy.' Australian Journal of Public Administration Vol. 47. No. 1.

Phillips, J.D. (1990) 'Professionalism.' The Police Journal Volume LXIV, Nr. 2, April 1990. pp 120-132.

Phillips, J.D. (1991) 'A "General Staff" for the Police Service.' The Police Journal, Volume LXIV Nr. 3 June 1991, pp 192-200.

Plumridge, M.D. (1983) 'A study of Police Management and Command Roles.' The Police Staff College, unpublished paper, July 1983.

Pollitt, C. (1986) 'Beyond the Managerial Model.' Financial Accountability and Management, Autumn 1986. pp 150-165.

Pollitt, C. (1990) 'Managerialism and the Public Services.' Blackwell, Oxford.

Pollitt, C. (1993) 'Occasional Excursions: A Brief History of Policy Evaluation in the UK.' Political quarterly. Vol. 46. Nr.3 July 1993.

Police Manpower. 'Report of a Joint Home Office/ treasury Working Group.' June 1989. London.

Police Research Support Unit, Circular, July 1996.

Portillo, M. (1993) 'Let the Healthy Pay for the NHS.' Cited in The Times, 22 May 1993.

Porter, M.E. (1991) 'Towards a Dynamic Theory of Strategy.' Strategic Management Journal, Vol. 12, pp 95 - 117.

'Prison Statistics England and Wales 1995.' Home Office Cmnd. 3355.

Punch, M. (1983) 'Organisational Control of Police.' M.I.T. Press.

Radzinowicz, L. and King, J. (1977) 'The Growth of Crime.' Hamilton, London

Reiner, R. (1991) 'Beyond Law and Order, Criminal Justice Policy and Politics Into the 1990's.' British Sociological Association.

Report of Inspector of Constabulary, 24.3.1879, Middlesbrough Reference Library.

Richards, S. (1987) 'The Financial Management Initiative.' 22-41. In A. Harrison and J. Gretton, Reshaping Central Government, Oxford: Policy Journals.

Richards, S. (1992) 'Changing patterns of Legitimation in Public Management.' Public Policy and Administration Volume 7 No.3, Winter 1992.

Rollo, J. (1980) 'The Special Patrol Group.' Hamish Hamilton, London.

Ross, L.B. (1993) 'A Review of Civilianisation Within the Police Service and The Strategic Implications For Cleveland Constabulary.' Unpublished MBA dissertation, University of Teesside.

Runciman, (1993). 'The Royal Commission into the Criminal Justice System.'

Sanderson, J.B. (1985) 'Organisational Communication in the Police.' Unpublished Ph.D thesis. University of Lancaster.

Scarman, (Lord). (1981) 'The Scarman Report.' Penguin Books, Harmondsworth.

Select Committee Report, (1822) 'Select Committee Report on the Police for the Metropolis.' 17 June 1822, H.M.S.O.

Simon, H. 'Administrative Behaviour.' McMillan 1957. Page 202.

Skidelsky, R. 1988 'Thatcherism.' Chatto and Windus, London.

Skidelsky, R. (1989) 'The Social Market Economy.' The Social Market Foundation, London.

Smith, J. (1994) 'Police Chief Accuses Ministers of Distrust.' The Times, Monday, October 17, 1994.

Stephens, M. (1988) 'Policing the Critical Issues.' Harvester, Wheatsheaf.

Taylor, F.W. (1911) 'The Principles of Scientific Management.' Norton Library, New York.

Theakston, K. 1990 'Labour, Thatcher and the Future of the Civil Service.' Public Policy and Administration Volume 5 No.1 Spring 1990.

The Civil Service Volume 1. Report of the Committee, 1966-8. London HMSO 1975, Cmnd 3638.

'The Operational Policing Review.' (1990) The Joint Consultative Committee, 15-17 Langley Road, Surrey.

Third Report from the Treasury and Civil Service Committee Session 1981-82. 'Efficiency and Effectiveness in the Civil Service.' House of Commons 236-1.

The Tipstaff. August 1993. Cleveland Constabulary.

Tremblay, M.A. (1982) 'The Key Informant Technique: a Non-ethnographic Application.' Cited in Jankowicz (1991), Page 194.

Ugnow, S. (1983) 'Policing Liberal Societies.' Oxford, New York.

Waelchli, F. (1989) 'The VSM and Ashby's Law as Illuminates of Historical Management Thought.' In The Viable System Model (eds. R. Espejo and R. Harnden) John Willey and Sons, Chichester.

Walters. J. and McGrath, S. (1974) 'Introduction to Law Enforcement.' Charles. E. Merrill: Columbus, Ohio.

Warfield, J.N. (1986) 'A Typology of Laws.' Paper presented to the Annual Meeting of American Society for Cybernetics, Virginia Beach, Va February.

Weber, M. (1947) 'Economy and Society Vols. I - III.' Badmington Press, New York.

Weber, M (1972) 'Wirtschaft und Gesellschaft.' 5th Edn., Tubingen, in Beetham, 1985, Max Weber and the Theory of Modern Politics, Polity Press, Page 68.

Weber, M. (1921), 'Gesammelte Politische Schriften.' 1st Edn., Munchen, in Beetham, 1985, Max Weber and the Theory of Modern Politics, Polity Press, Page 76.

Williams, L. (1993) Police. Joint Central Committee of the Police Federation of England and Wales. Surbiton, Surrey.

Wilson, J. (1993) 'Political Environment and Public Service Activity. In Public Services and the 1990s.' Tudor Business, Great Britain.

