

Durham E-Theses

Heterogeneous catalytic hydrogenation and purification applied to commercial processes

Paul Willett

How to cite:

Willett, Paul (2002) Heterogeneous catalytic hydrogenation and purification applied to commercial processes. Doctoral thesis, Durham University.

Use policy

The full-text may be used and/or reproduced, and given to third parties in any format or medium, without prior permission or charge, for personal research or study, educational, or not-for-profit purposes provided that:

- a full bibliographic reference is made to the original source
- a <https://etheses.durham.ac.uk/id/eprint/4099/> is made to the metadata record in Durham E-Theses
- the full-text is not changed in any way

The full-text must not be sold in any format or medium without the formal permission of the copyright holders.

Please consult the [full Durham E-Theses policy](#) for further details.

Heterogeneous Catalytic Hydrogenation and Purification Applied to Commercial Processes

Paul Willett

The copyright of this thesis rests with the author. No quotation from it should be published in any form, including Electronic and the Internet, without the author's prior written consent. All information derived from this thesis must be acknowledged appropriately.

Submitted for the Degree of
Doctor of Philosophy

University of Durham
Department of Chemistry

2002

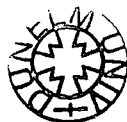

11 JUN 2002

Intellectual Property and Confidentiality

This report is covered by the agreement between Davy Process Technology and The University of Durham dated 10th June 1996. Particular attention is drawn to articles 6 and 7 covering these issues, as some of the concepts contained herein are commercially sensitive.

The catalysts used for this work were all supplied from specialist catalyst manufacturers. All were obtained under a strict non-analysis/non-disclosure agreement and hence precise details of each catalyst could not be given in the text that follows. For further information and samples of these catalysts the suppliers (details can be found in the relevant sections) must be contacted directly.

The material in this thesis has not been submitted for examination for any other degree or part thereof, at the University of Durham or any other institution. The material contained herein is the sole work of the author except where formally acknowledged by reference.

The copyright of this thesis rests with the author. No quotation of it should be published without his prior consent. Information derived from it should be acknowledged.

Acknowledgements

I would like to thank Davy Process Technology for the sponsorship of this Degree and providing me with the challenge contained herein. I would particularly like to thank Barry Scuffham and Norman Harris for facilitating this course of study, Mike Wood for his enduring patience and finally the shift chemists at Davy Process Technology for minding the experiments on a 24-hour basis for me when I could not be there in the depths of the night.

Abstract

Three distinct chemical processes have been investigated, with the aim of producing high purity 1,5-pentanediol (PDO), 1,4-butanediol (BDO) and tetrahydrofurfuryl alcohol (THFA) and thereby improving the efficiency of their manufacture.

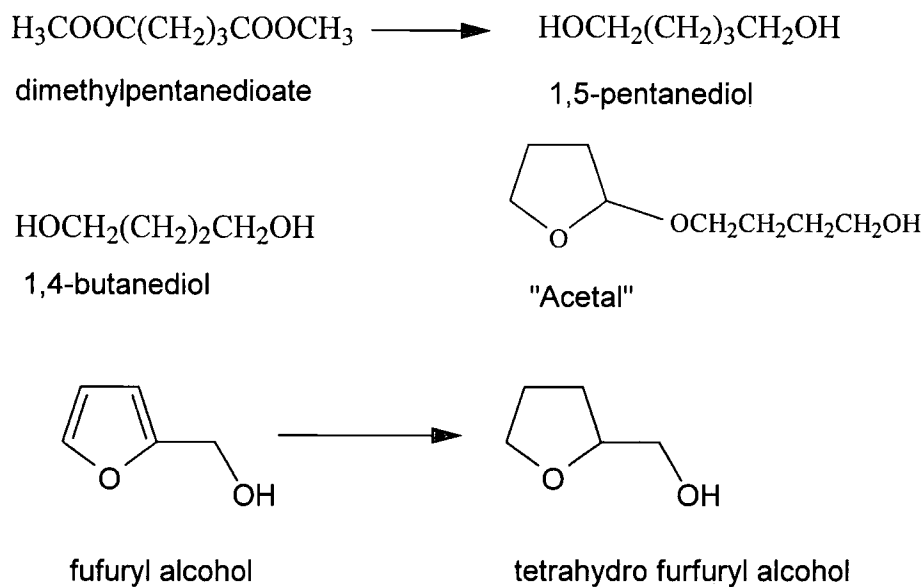

The production of 1,5-pentanediol via the low-pressure vapour phase hydrogenation of 1,5-dimethylpentanedioate has been studied using a copper manganese heterogeneous catalyst system and found to be as good as the usually favoured copper chrome, which is now becoming difficult to operate commercially due to toxicity concerns. The optimum conditions were determined for a commercial process. The purification of the PDO produced, to the high standards dictated by polymer manufacture, has also been examined. Simple distillation was not possible because reactive oligomeric species were present. To overcome this, a reactive distillation scheme was developed and demonstrated experimentally.

During the manufacture of 1,4-butanediol, a by-product (4-hydroxybutyl)-2-tetrahydrofuran, known commercially as "Acetal", is formed during hydrogenation and proves very difficult to remove by conventional means. By conversion of this compound to more volatile species, by hydrogenation over a nickel catalyst, it was demonstrated that the purity of BDO obtained was greater than that previously possible.

The production of THFA from furfuryl alcohol, concluding the work, uses a novel reactor system to avoid problems usually encountered with highly exothermic hydrogenations. The system uses recycled product to quench the exotherm, allowing less than 1% by-products to be formed at relatively harsh conditions of over 90°C.

In all the systems studied the life span of the catalyst was determined, as this is critical to commercial operation. In all cases an optimum set of conditions was determined where catalyst life time was acceptable.

CONTENTS

Page Number

Chapter 1

Heterogeneous Catalytic Hydrogenation

1.1	Introduction	1
1.2	Examples of Heterogeneous Catalysis	1
1.3	Catalyst Selection	6
1.4	The Basis of Heterogeneous Catalysis	9
1.5	Processes Leading to Catalysis	9
1.6	Mechanism at the Catalyst Surface	12
1.7	The Nature of the Catalyst Surface	16
1.8	Hydrogenation Catalysts	16
1.9	Reactor design for Testing and Utilising catalysts	17
1.10	Deactivation of Catalysts	18
1.11	Conclusions	19
	References	20

Chapter 2

The Application of Low Pressure Vapour Phase Hydrogenation to the Production of 1,5-Pentanediol

2.1	Aims	22
2.2	Commercial Background	23
2.3	Introduction	23
2.4	Experimental	27
2.5	Gas Chromatography	27
2.6	Reactor System	28
2.7	Calibration and Testing	31
2.8	Catalyst Activation Procedure	32
2.9	Selection of Conditions	33
2.10	Statistical Testwork	35
2.11	Effect of Pressure	44

2.12	Catalyst Deactivation	46
2.13	Conclusions	48
	References	51

Chapter 3

The Recovery of High Purity 1,5-Pentanediol by Distillation

3.1	Aims	53
3.2	Introduction	54
3.3	Experimental	57
3.4	Equipment Details	57
3.5	Vapour Liquid Equilibrium Still	57
3.6	Operation of the Vapour liquid Equilibrium Still	59
3.7	VLE Data for Pure Components	59
3.8	Relative Volatility Experiments	62
3.9	Relative Volatility Experimental Results	63
3.10	Distillation Equipment	64
3.11	Distillation Experiments	67
3.12	Conclusions and Potential for Further Work.	78
	References	82

Chapter 4

The Removal of the 'Acetal' Impurity from 1,4-Butanediol

4.1	Aims	83
4.2	Commercial Background	84
4.3	Chemistry of the Acetal Impurity	85
4.4	Introduction	87
4.5	Experimental	89
4.6	Experimental Procedure for Estimating Peak Acetal Concentration	89
4.7	The Preparation of Acetal	90
4.8	Autoclave Description	90

4.9	Fixed bed reactor	91
4.10	Catalyst Activation Procedure	92
4.11	Autoclave Testwork	93
4.12	Fixed bed Liquid Recycle Tests	96
4.13	Catalyst Life	101
4.14	Acetal Polishing - Synthetic BDO	104
4.15	Effect of GBL Addition to Synthetic BDO	105
4.16	Conclusions	107
	References	108

Chapter 5

The Application of a Liquid Recycle Reactor to the Production of Tetrahydrofurfuryl Alcohol

5.1	Aims	110
5.2	Commercial Background	111
5.3	Introduction	111
5.4	Reactor Design to Minimise the Effects of Exothermic Reactions	112
5.5	Chemistry	115
5.6	Fixed Bed Reactor	116
5.7	Pilot Plant Liquid Recycle Reactor	117
5.8	Liquid Feed System	118
5.9	Gas System	118
5.10	Reactors 1 and 2	118
5.11	Recycle Loop	119
5.12	Product System	119
5.13	Catalyst Loading	119
5.14	Catalyst Activation	120
5.15	Analytical Procedures	120
5.16	Calibration and Tests	120
5.17	Testwork	120

5.18	Fixed Bed Testwork	121
5.19	Catalyst A Studies	122
5.20	Catalyst B Studies	126
5.21	Catalyst C Studies	129
5.22	Comparison of Catalysts A,B and C	134
5.23	Catalyst Lifetest	135
5.24	Lifetest Results and Discussion	137
5.25	Optimisation	141
5.26	Optimisation Results and Discussion	142
5.27	Conclusions	145
	References	146

Appendix 1

Analytical Methods Employed

Appendix 2

Publications

Abbreviations Used

ATDP	Approach to Dew Point
BDO	Butanediol
DM ²	Dimethyl Maleate
DMP	Dimethyl Pentanedioate
DPT	Davy Process Technology
δVAL	delta Valerolactone
GBL/γBL	gamma Butyrolactone
GC	Gas Chromatography
GC/MS	Gas Chromatography with Mass Spectrometer Detector
HBA	Hydroxy Butyraldehyde
LHSV	Liquid Hourly Space Velocity
LRC	Liquid Recycle
MFC	Mass Flow Controller
MFM	Mass Flow Meter
NLPH	Normal Litres per Hour
PBT	Polybutyleneterephthalate
PDO	Pentanediol
PFD	Process Flow Diagram
PI	Pressure Indicator
PSIG	Pounds per Square Inch Gauge (1 bar = 14.5 psi)
R/C	Recycle
RX	Reactor
T/C	Thermocouple
THF	Tetrahydrofuran
THFA	Tetrahydrofurfuryl Alcohol
TIC	Temperature Indicator Controller
TPR	Temperature Program Reduction
VLE	Vapour Liquid Equilibrium
VP	Vapour Pressure

Chapter 1

Heterogeneous Catalytic Hydrogenation

1.1 Introduction

This study is an investigation into the applications of heterogeneous catalytic hydrogenation to a number of valuable commercial processes. The fundamentals of heterogeneous catalysts are outlined in this Chapter as background. The commercial application of such catalysts then forms the work detailed in subsequent chapters.

Chapters 2 and 3 describe the development of a commercial process for the production of the valuable monomer 1,5-pentanediol. Chapter 4 concerns solving the problem caused by the presence of a mixed acetal impurity in 1,4-butanediol by hydrogenation of it to easily removed products. Finally, in Chapter 5 the use of a liquid recycle reactor suited to exothermic reactions is examined for the hydrogenation of furfuryl alcohol to tetrahydrofurfuryl alcohol, a recently identified solvent that is both non-toxic and obtained from renewable feedstocks.

1.2 Examples of Heterogeneous Catalysis

“It has been estimated that about 90% of the current practised chemical and refinery processes are catalytic in nature”. This statement by J.M.Thomas¹ shows the importance of catalysis to industrial processing and hence the continued interest in investigating novel systems. Of this 90%, the vast majority are heterogeneous in nature. This is largely due to the ready separation of the catalyst from the products, the robust nature of heterogeneous catalysts and the relatively lower cost.

Due to the large volumes of products produced industrially by heterogeneous catalysis, large amounts of resource are assigned each year by both catalyst



manufacturers and producing companies to improving current technologies. This research is highly proprietary in nature and rarely published; however the following examples serve to show the wide variety of applications possible with heterogeneous catalysts.

Addition of hydrogen²

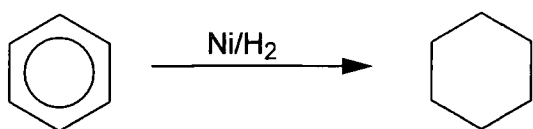

Redox Reactions; These form the largest set of applications. Some examples follow, the first also illustrates hydrogen transfer³.

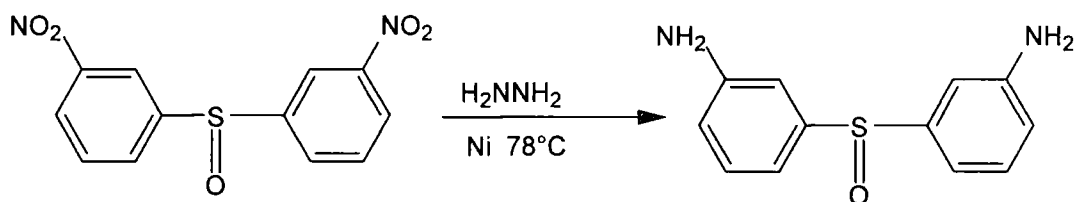

Hydrogenolysis⁴ (i.e. cleavage of C-X bond)

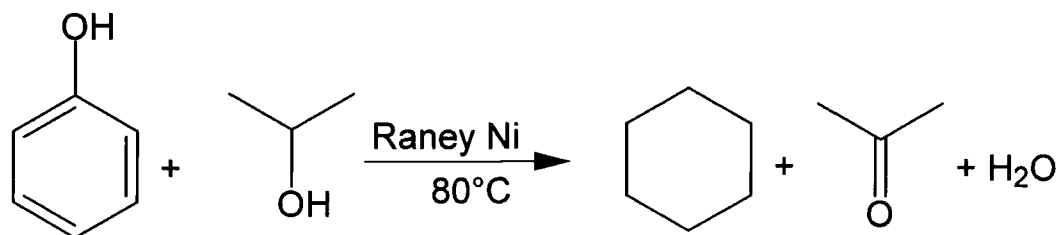

Oxidation⁵

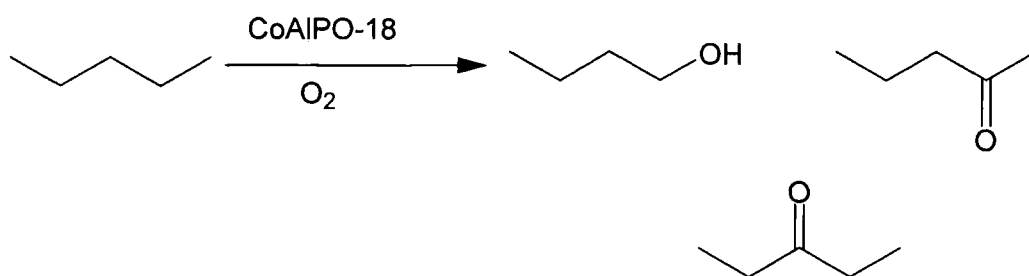

The Co anchored onto a molecular sieve, is a highly regioselective catalyst and the ratio of the above products can be tuned by variations in the molecular sieve and metal centre.

Addition/Elimination⁶

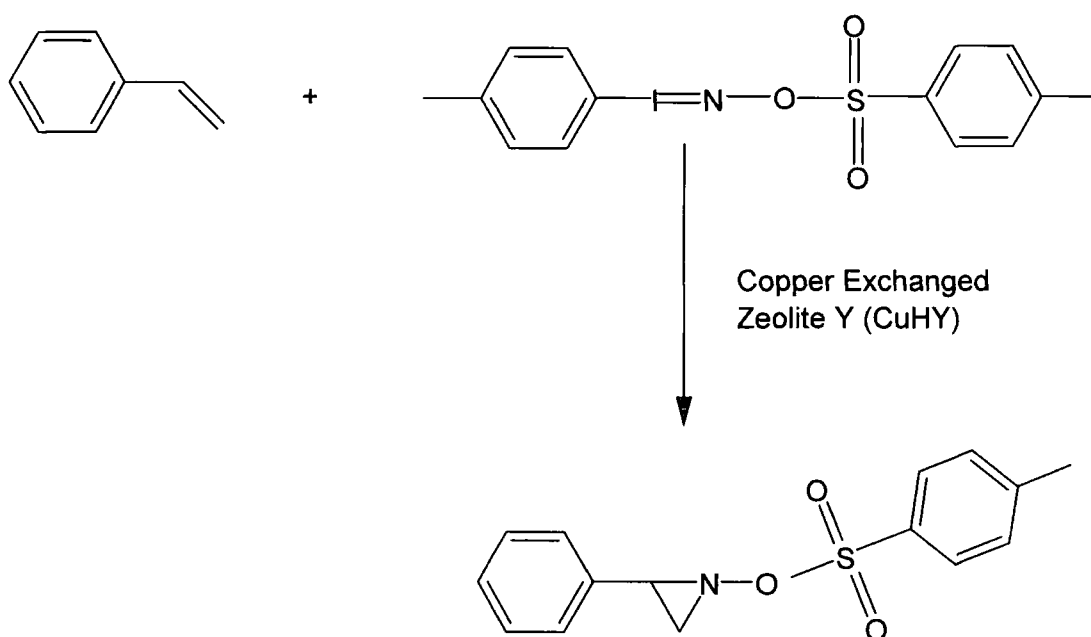

Cyclisation⁷

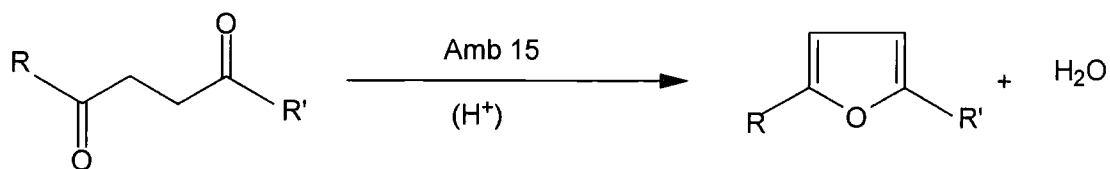

Substitution⁸

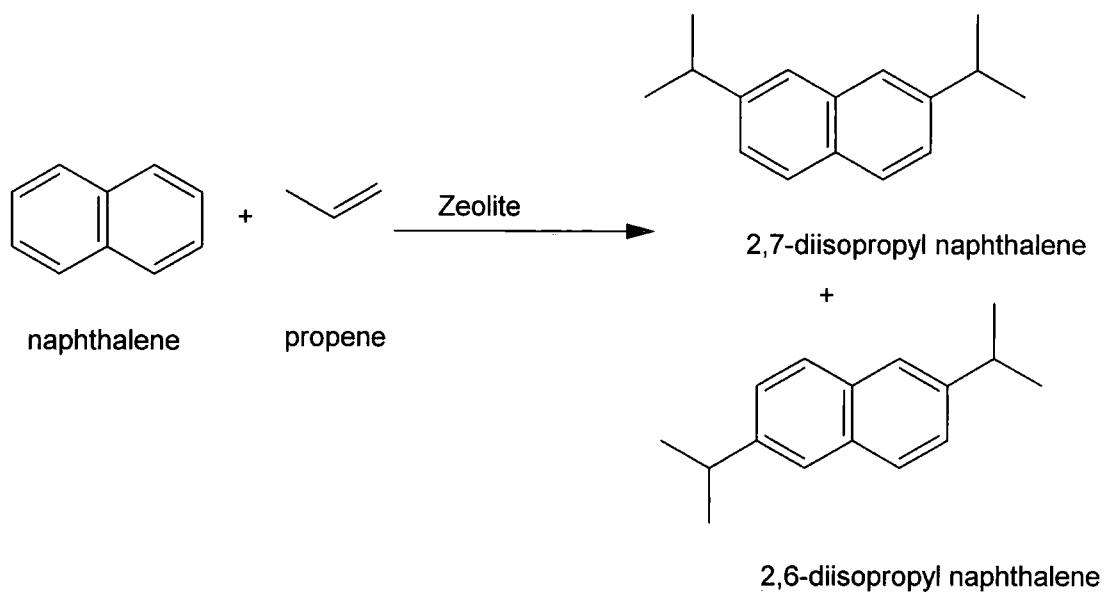

Rearrangements⁹

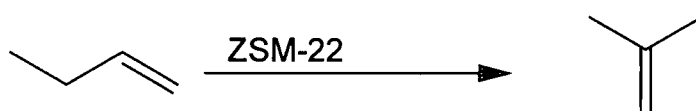

Heterogeneous catalysis also has wide applications in fine chemicals as well as the traditional bulk chemical market, for example, in the fragrance industry, and even some enantioselective transformations, as follows.

Fine Chemical Applications¹⁰

Such as the synthesis of the ambral/woody fragrance

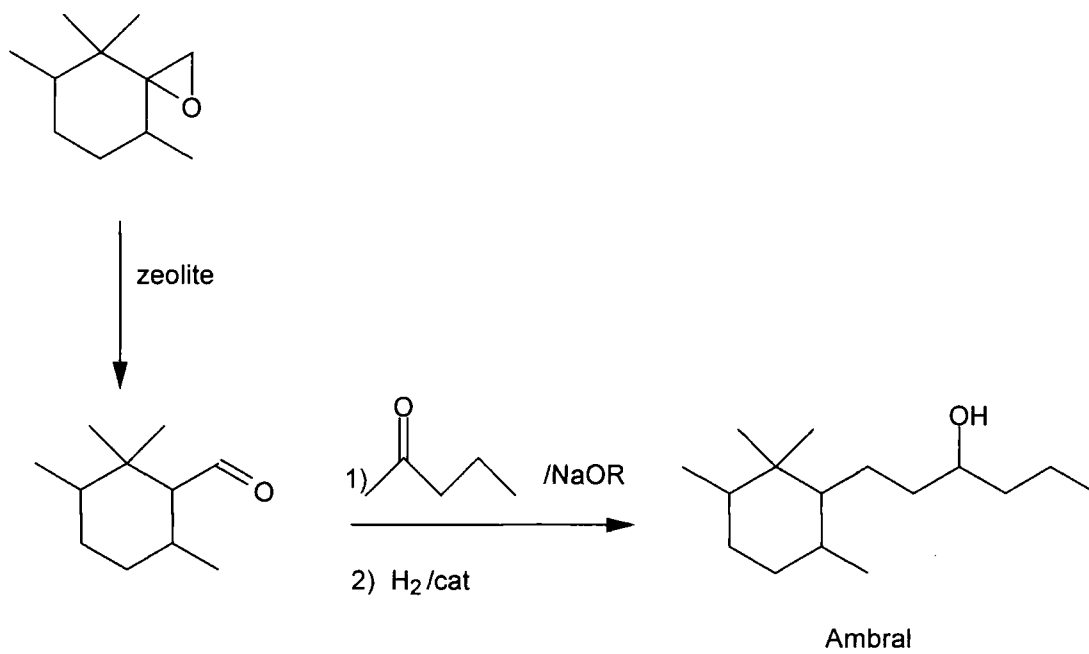

Chiral¹¹

By using chiral modified ligands supported on a polymer, true heterogeneous enantioselective transformations can be achieved. An example is the Sharpless oxidation.

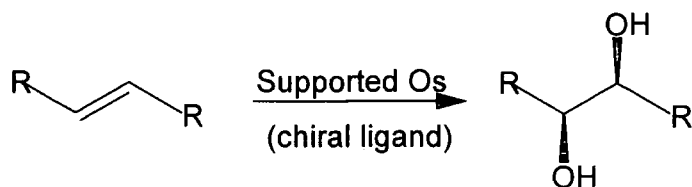

1.3 Catalyst Classification and Selection

Catalysis can be broken down into three distinct areas; catalyst preparation and activation, catalyst characterisation and kinetics¹². From an understanding of these a system for industrial synthesis of a target transformation can be developed.

Heterogeneous catalysts can be classified in many ways but a simple system is to divide them up as follows;

Metals (&alloys)

E.g. Pt, Pd, Mo, Ni, Cu.

Metal Oxides

E.g. Molybdates, mixed metal oxides, ZnO.

Acids

E.g. Acidic ion exchange resins, silica/alumina, zeolites.

Metals plus acids

E.g. Pt/acidified support, Pd/zeolite.

This study will deal exclusively with metal and metal oxide catalysts. The classification above does not give any help with the choice of catalyst when a particular route of interest is identified and an attempt must be made to identify a catalyst to perform the desired reaction scheme. Whilst it is still not possible to define a catalyst to precisely facilitate specific reaction pathways some general observations have been made¹³ to allow initial selection prior to empirical studies leading to optimisation.

One example is the classification of metals by their ability to chemisorb different gases. Since the reactants must be chemisorbed to the catalyst surface during the chemical process, only those metals capable of chemisorbing the proposed reagents will show activity. This approach is limited however as it only applies to the metal in its elemental state. The following classification¹⁴ takes this into account.

Class of Solid	Families of Reaction	Examples
Metals (conductors)	Hydrogenations Dehydrogenations Hydrogenolysis	Fe, Co, Ni, Ru, Rh, Pd, Ir, Pt, Ag, Cu
Metal Oxides and Sulphides (semi-conductors)	Oxidations Dehydrogenations Cyclizations Hydrogenations Desulphurisations Denitrogenations	NiO, CuO, ZnO, CoO, Cr ₂ O ₃ , V ₂ O ₅
Oxides and Acids	Hydrations Dehydrations Isomerisations Polymerisations Alkylations Cracking	Zeolites IER's SiO ₂ -Al ₂ O ₃

The selectivity of a catalyst is difficult to establish by theoretical considerations and hence reference to known systems is usually the major factor in selection.

Activity and selectivity are not the only factors when considering possible catalysts for industrial use. A methodology for finding the first catalysts to study for a given use has been outlined¹⁵ that takes into account all the factors, see the example below.

Criteria \ Catalyst	A	B	C	D	E	F	G
Activity	+	+	+	+	+	+	+
Selectivity	+			+	+	+	+
Stability in reaction environment		+		+		+	+
Low cost	+			+		+	
No patent/prior art issues			+	+		+	+
Totals	3	2	2	5	2	5	4

To construct such a table to allow a catalyst to be identified for a process an initial selection of catalysts (in the case above labelled A to G) must be made based on literature reference, experience and catalyst manufacturer's recommendations. The first three criteria (activity, selectivity and stability) can be obtained from literature reference or by testing the catalyst experimentally. The cost if the catalyst can be estimated or supplied from the manufacturer and then any prior art obtained from literature survey. When complete the totals rank the suitability of the catalysts. From this example catalysts 'D' and 'F' would be most suitable.

Finally the physical form of the catalyst must be considered. Most catalysts will be initially produced as a powder; however, a powder must be fabricated into a larger solid form to be used in fixed bed applications. The variety of shapes available is huge, ranging from spheres, rings and simple pellets through to complex extrudates that maximise the surface area of the catalyst particle. Similarly if the catalyst is a metal on an inert support a range of supports will be available. For example carbon, commonly used as a support for precious metals, comes in a wide variety of grades depending on the natural source from where it was obtained. Again size and shape of particles are variable.

The choice of shape and size of the catalyst pellet depends on a number of factors, the properties of the raw powder may dictate to an extent the range of supports achievable. More important is the design of the reactor in which the

catalyst will eventually be used. In designing a commercial process the physical form of the catalyst pellet selected needs to be finalised early in the development to ensure work performed on optimisation is representative of the full-scale plant design.

1.4 The Basis of Heterogeneous Catalysis

Catalysis is a very broad field combining physical chemistry, chemical engineering, inorganic chemistry and organic chemistry. The phenomenon of catalysis was first recognised by Berzelius in 1836 who suggested that reactions could occur at surfaces and the latter possessed "catalytic force".

The most basic definition of a catalyst is a substance that speeds up the rate of a reaction without itself being changed. The laws of thermodynamics say a catalyst can increase the rate of only those processes that are thermodynamically favourable, i.e., only those that involve a decrease in free energy, thus a catalyst facilitates the approach to equilibrium of a given chemical change. A heterogeneous catalyst is one that is in different phase for the reactants and products, usually a solid.

1.5 Processes Leading to Catalysis

Chemisorbtion of reagents at a surface is the fundamental property that allows catalysis to proceed. However 5 distinct steps can be identified in the catalytic process. These are:

1. diffusion of reactants,
2. chemisorption,
3. transformation of species,
4. desorption of products,
5. diffusion of products.

The diagram below shows the processes that govern the ultimate transport of reagents from the bulk phase to the active site of the catalyst¹⁶, steps 1 and 5 above.

Flick's Law, the flow-rate of a molecule, which is proportional to its gradient of partial pressure or concentration, governs these movements.

Figure 1.1 The Processes Occurring on The Catalyst Pellet Leading to Catalysis

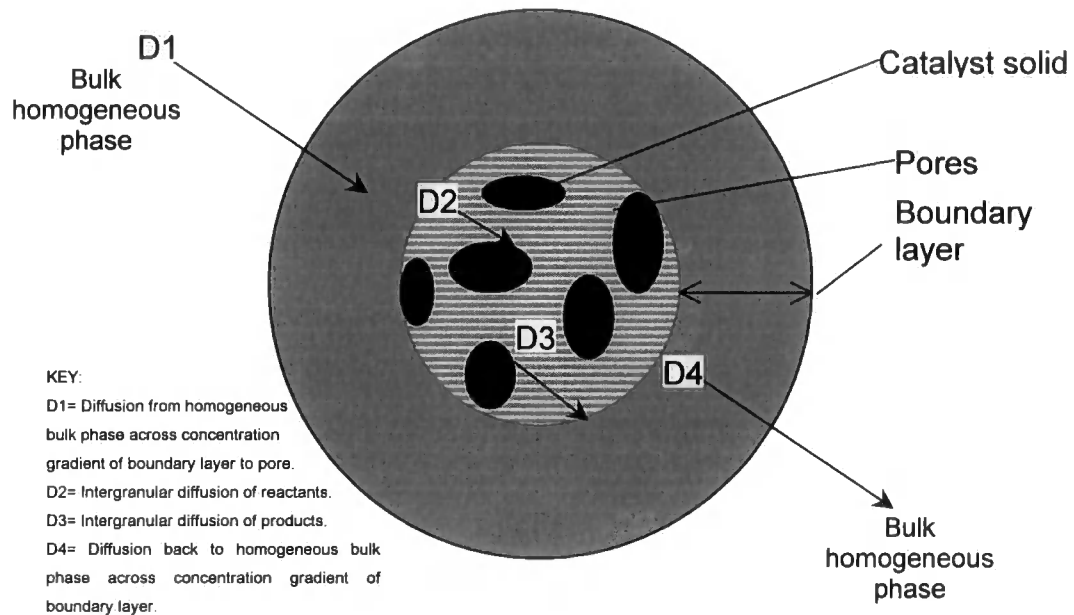

Ultimately these processes may govern the observed rate of reaction, as it cannot proceed faster than the maximum rate of diffusion of the reacting species. The physical properties of the catalyst used, e.g. pore size distribution, will obviously have an influence on these processes and hence need attention during catalyst design and optimisation.

The catalyst surface is the key to its activity and aspects of catalyst surfaces are discussed below. Once the reactants arrive at the catalyst surface at least one has to be activated. This is one essential function of the catalyst - the lowering of the energy barrier for reaction to occur. Using the example of ammonia synthesis the reaction path for both the catalysed and uncatalysed conversion is illustrated below¹⁷.

Figure 1.2 Catalytic Reaction Path for Ammonia Synthesis

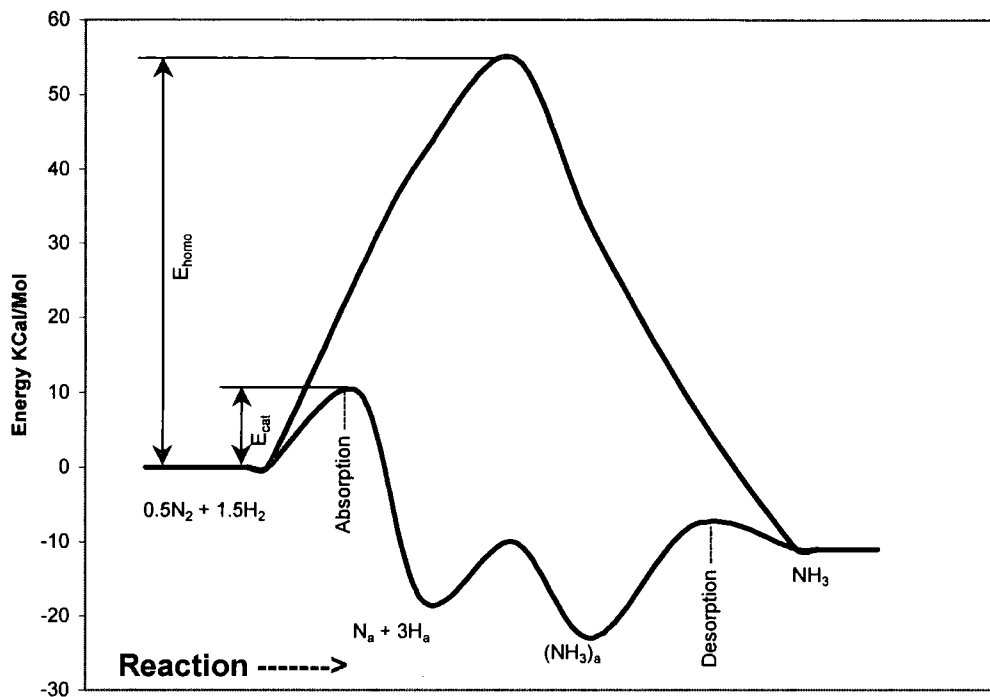

Nitrogen and hydrogen molecules combine homogeneously (without a catalyst) at an extremely low rate. Breaking their bonds to form fragments requires large amounts of energy, leading to an activation energy of 57 Kcal/mol. The probability of finding these fragments together is small. This can be quantified using the Arrhenius equation in the form of

$$k = PZ_{AB}e^{-E/RT}$$

where k is the rate constant, E is the activation energy, Z_{AB} is the number of collisions between molecules A and B and P represents the fraction of the total number of collisions that are effective from a point of view of mutual orientation of the molecules¹⁸. It is the combination of decreasing the energy requirements to break the bonds involved and the bringing together of the molecules on the surface to allow them to react that gives a catalyst its activity. In the case of the

example above of ammonia synthesis, the rate of the catalysed reaction is 3×10^{13} times faster than the uncatalysed equivalent.

The desorption and diffusion away from the catalyst are the reverse of the processes described above. A point to note is that the products must not be too strongly adsorbed onto the catalyst surface otherwise they will act in the same manner as a catalyst poison.

1.6 Mechanism at the Catalyst Surface

Studies into the mechanism of reaction at the catalyst surface are notoriously difficult¹⁹ under typical operating conditions. It is because of this difficulty that fundamental research into heterogeneous catalysts has lagged behind industrial developments. Even in the simple case of paraffin cracking, the species cannot positively be identified as hydride ions, methyl ions, or carbonium ions. Hence the optimisation of heterogeneous systems tends to rely largely on empirical study of the bulk effects as opposed to the study of mechanism usually undertaken in homogeneous systems.

Having established that the mechanism may not be fully understood, it is obvious that to react there must be an amount of mobility of the reacting species on the catalyst surface. The processes occurring at the surface are illustrated in the figure 1.3 below.

Figure 1.3 Processes on the Catalyst Surface

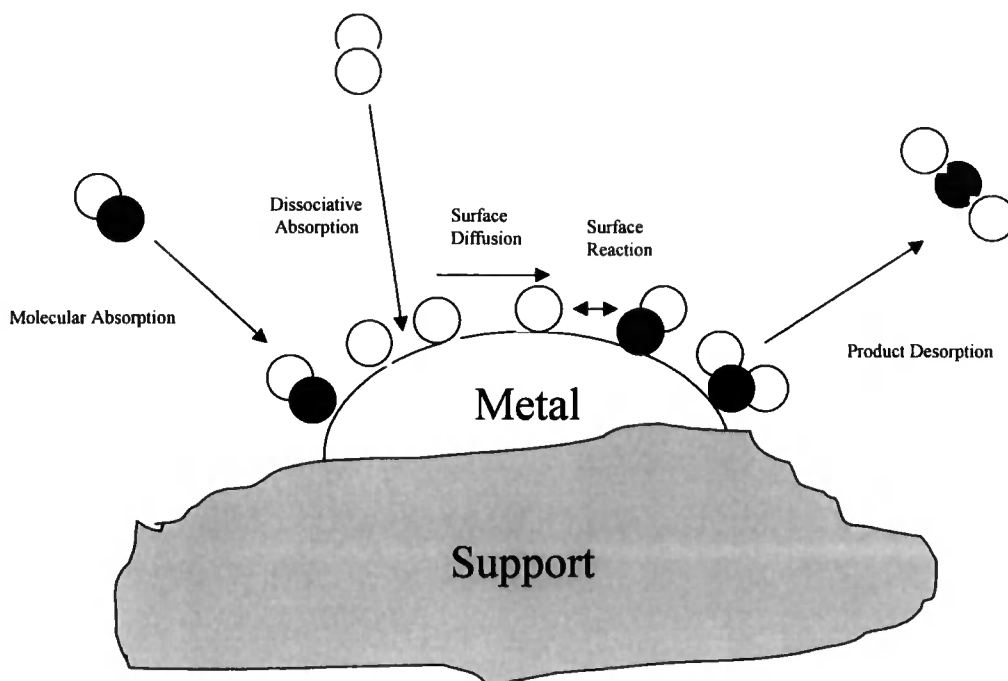

It has already been stated that chemisorption is fundamental to the catalytic process on a surface. It is possible to chemisorb compounds onto the catalyst surface at temperatures much lower than that needed for reaction to occur. Figure 1.4 shows a potential energy diagram (for a diatomic molecule X_2) for the processes involved in chemisorption.

Chemisorption exhibits the same characteristics as a true chemical reaction; it brings about the formation of covalent (or electrovalent) bonds of the same kind that hold together the atoms of a molecule, except that the chemisorption bonds exist between the solid surface and the adsorbed molecule. Like chemical reactions, chemisorption is subject to the same laws of thermodynamics and kinetics; it exhibits both reversibility at low temperatures as well as irreversibility at high temperatures and conditions when the chemisorbed molecules become dissociated and unable to reconstitute the original compound. This irreversibility is demonstrated by the dissociative

chemisorption of saturated hydrocarbons on metals and of reducing compositions on oxides.

Chemisorption can be thought of as resulting from solid-surface atoms that have free valences, so that the driving force is the tendency of these valences to saturate themselves selectively by reacting with certain molecules from the surrounding medium.

Frontier orbital theory²⁰ gives an explanation of these process of chemisorption. In essence, if the orientation and symmetry of the antibonding orbital of the incoming reagent allow interaction with filled orbitals on the catalyst, electrons can be donated from the metal catalyst to the reagent antibonding orbital and from the reagent bonding orbital to the metal causing bond weakening (activation).

Figure 1.4 Potential Energy Diagram of Chemisorption vs Physical Absorption

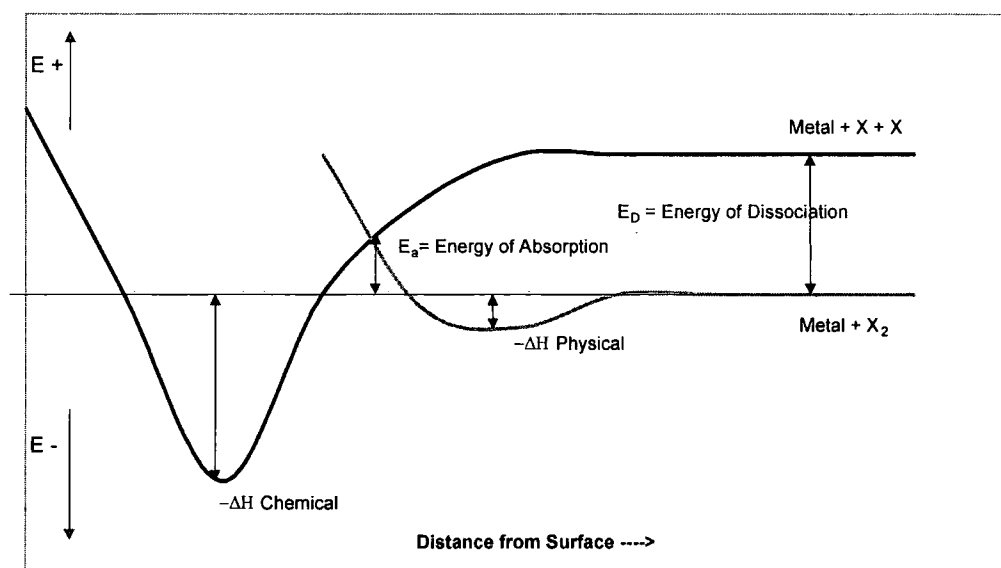

Chemisorption can proceed in two distinct manners, described as dissociative and associative. Saturated molecules tend to be adsorbed in the dissociative manner, with the molecules cleaving into radicals or ions that have free valences to attach themselves to the adsorbing surface. Unsaturated molecules tend to be adsorbed in the associative manner by opening the double bond and forming two new covalent bonds with the adsorbing surface. Dissociative adsorption is illustrated by the adsorption of hydrogen on platinum, associative by the adsorption of ethylene.

Figure 1.5 The Different Mechanisms of Adsorption

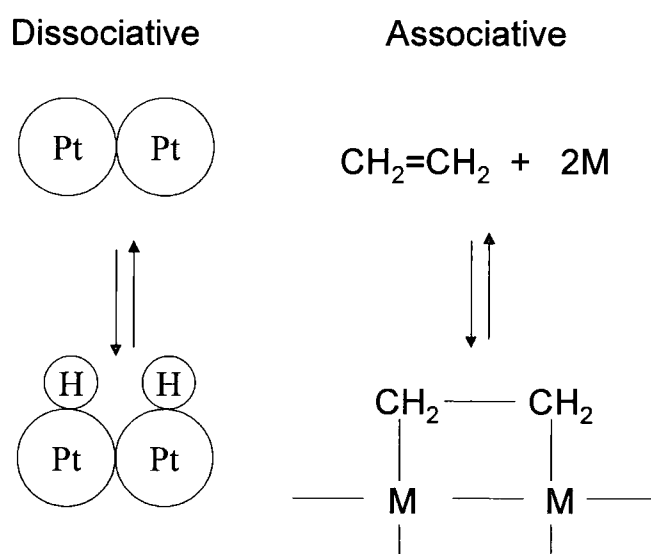

Certain molecules exhibit a less clearly defined adsorbed state, as for example carbon monoxide.

Figure 1.6 The Adsorbed State of CO

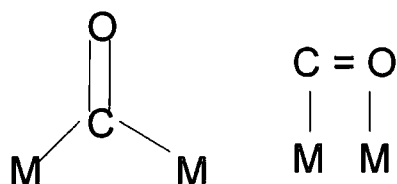

Chemisorption is limited to only one layer of molecules and, unlike physical absorption, is specific, so that different molecules will not be adsorbed on the surface in the same way or in the same amount. The nature of the catalyst surface controls this behaviour.

1.7 The Nature of the Catalyst Surface

The nature of the surface involved in heterogeneous catalysis is crucial to its performance. The surface 'rests' on the bulk and so is related to the bulk structure. The coordination of the atoms in each surface plane (as described by the Miller indices) are different. Generally, surfaces with lower coordination surface atoms have the highest surface free energy, the highest reactivity for absorption and the strongest binding of the adsorbate. This has a significant effect on reactivity as does the number and nature of any defects in the crystalline surface. Examples of these are edges, kinks, steps, terraces and vacant sites²¹. These defects sometimes play a crucial role in the catalysts function. The study of the nature and function of the catalyst surface is an area where a huge amount of research is published. However; as this work focuses on the application of heterogeneous catalysts these aspects of catalysis will not be considered further.

1.8 Hydrogenation Catalysts

Hydrogen is the most useful reducing agent²². This generalisation is based on the mild conditions employed, wide applicability, large pool of knowledge available, generally high conversion and selective reactions and the ease of scale up.

The transition metals of group 8,9 and 10 represent the most active hydrogenation catalysts²³, the most commonly used are nickel, palladium and platinum. Despite their cost they compete with base metals due to superior activity.

Generally, choice of catalyst for a particular transformation is based on reference to similar systems reported in the literature. The technique of heterogeneous catalytic hydrogenation extends to many substrates²⁴. These include aldehydes and ketones, aromatic nitro groups, olefins, aromatics and poly aromatics and nitriles.

1.9 Reactor design for Testing and Utilising catalysts

Once a catalyst is selected, it is vital for the working environment of the catalyst to be considered. This environment is dictated by the design of the reactor it is tested in, and care must be taken to identify the effects observed that are due to the behaviour of the catalyst from those due to the performance of the reactor. Furthermore, if the data obtained from small-scale experiments is to be used for process engineering work-up, care must be taken to ensure that the selected test reactor produces information obtained under similar, or at least transferable to, the full-scale reactor. For example, the flow when studying either liquid or gas phase fixed bed reactors is critical.

In the liquid phase, the reagent liquids and the gaseous/dissolved hydrogen must fully wet and contact the catalyst. Failure to ensure contact may result in the liquid 'channelling' along the walls of the reactor and contacting only a fraction of the catalyst.

Gas phase reactors can also suffer from such phenomena. For example the relationship between the catalyst pellet size, reactor diameter, catalyst bed depth and gas flow rate is expressed as the particle Reynolds number²⁵. Two distinct flow regimes can exist, laminar flow and turbulent flow. Under each condition the desired transformation will occur but the conversion and selectivity observed will be different under each regime. Hence, it will be a feature of the reactor that is determining the catalyst performance. This is analogous to mass transfer effects observed in homogeneous catalytic studies.

1.10 Deactivation of Catalysts

Any catalyst system that is selected for an application will only be of any practical use if the activity and selectivity can be maintained and/or regenerated.

There are a number of mechanisms that can cause deactivation of a catalyst, and include poisoning, sintering, pore blockage, leaching and physical attrition²⁶.

Poisoning results from a species bonding strongly in some way to the metal centre responsible for performing the catalysis. Classic examples are elements of group 15 and 16 of the periodic table of which sulphur stands out due to its wide occurrence in feedstocks.

Poisoning needs to be distinguished from inhibition, which is preferential reversible binding with a species other than the reactants.

Sintering occurs when the catalyst is subjected to high temperatures. This leads to an increase in crystal growth and hence increases the metal crystallite size, an example of this is given later in Chapter 2.

Leaching is the removal from the reactor of some parts or all of the catalyst by the feed and/or products. For example, a strong acid may dissolve the catalyst support or the presence of oxygen in the feed may form a volatile metal oxide.

Pore blockage physically prevents the reagents from reaching the active site of the catalyst. During ester hydrogenation for example the formation of polyesters can cause this²⁷.

Finally attrition may occur if the catalyst is damaged as a result of external physical factors, such as extreme temperature fluctuations causing expansion/contraction. If severe, the resulting crushing can lead to disruption of the microscopic structure and hence affect activity and/or selectivity.

In conclusion the maintenance of catalytic activity needs considerations of the fundamental chemistry as well as the bulk environment in which the catalyst operates. These factors need to be addressed when designing a viable synthesis of a product using heterogeneous catalysts.

1.11 Conclusions

This chapter has outlined the principles on which catalyst choice is made. The subsequent chapters of this work will be devoted to the application of these principles. It follows that many factors must be considered simultaneously when dealing with heterogeneous catalysts. The work is focused on evaluating and optimising the performance of the systems studied to a level that will allow commercial application. This is achieved by experimentation followed by the modification of operating conditions, feedback and subsequent validation at the identified optimal conditions.

References

1. J.M.Thomas, *Principles and Practice of Heterogeneous Catalysis*, VCH,1997,1.
2. J.March, *Advanced Organic Chemistry*, 3rd Edition, Wiley, 1985, 700.
3. R.A.W.Johnstone and A.H. Wilby, *Chem. Rev.*,1985,**85**,129
4. C.N.Pillai and B. Viswanathan, *Research and industry*, 1989, 34,307.
5. J.M.Thomas, R.Raja, G.Sankar and R.G.Bell, *Nature*,1999,**398**,227.
6. C.Langham, P.Piaggio, D. Bethell, D.F.Lee and P.McMorn, *Chem. Commun.*, 1998, 1601.
7. T.L.Gilchrist, *Heterocyclic Chemistry*, Longman,1997,211.
8. R.A.Sheldon and R.S.Downing, *Appl. Catal. A*,1999,**189**,2,163.
9. P. Merrauden and C.Naccache, *Adv. Catal.*, 1999, **44**, 505.
- 10.W.F.Holderrich, F.Holderich and D.Heinz ,*Catalysis*,1999,**14**,148.
- 11.C. Bolm and A.Gerlach, *Eur. J. Org. Chem.*, 1998, 21.
- 12.Van Santen, *Chemical Kinetics and Catalysis*, Plenium Press NY,1995,3.
- 13.J.F. Le Page, *Applied Heterogeneous Catalysis*, Technip, p56.
- 14.Ibid p52
- 15.Ibid p60
- 16.Ibid p4
17. J.T.Richardson, *Principles of Catalyst Development*, Plenium Press NY, 1989, 2.
18. K.J.Laidler and J.H.Meiser, *Physical Chemistry*, Benjamin/Cummings Pub. Co. Inc., 1982, 376.
- 19.Dr M Ormerod, *Studying catalysts in Action*, Lecture, Durham University, October 1997.
- 20.Van Santen, *Chemical Kinetics and Catalysis*, Plenium Press NY,1995,229.
21. M.Bowker, *The Basis and Applications of Heterogeneous Catalysis*, Oxford Uni. Press, 1998, 12.
- 22.P.N.Rylander, *Hydrogenation Methods*, Academic Press, 1990, 104.
23. R.A.Rajadhyaksha, *Principles of Liquid Phase Catalytic Hydrogenation*, 477-505, in Multiphase Reactor Operations.

24. H.U. Blaser, H.Steiner and M.Studer, *Transition metals in organic synthesis*, Vol 2, 1998, 81.
25. J.M.Winterbottom and M.B.King, *Reactor Design for Chemical Engineers*, 1999, Stanley Thomas UK, 287.
26. C.H.Bartholomew, *Chemical Engineering*, November 1984, 96.
27. Davy Process Technology/ Sud-Chemi, Private Communication.

Chapter 2

The Application of Low Pressure Vapour Phase Hydrogenation to the Production of 1,5-Pentanediol

2.1 Aims

- 1.To investigate the use of non-chrome containing copper heterogeneous catalysts (Sud-Chemi T4489) in the production of 1,5-pentanediol from dimethyl-pentanedioate.
- 2.To study the parameters of the reaction in the chosen catalyst system, and hence determine the optimum set for commercial operation.
- 3.To obtain data on the time dependent deactivation of the catalyst and hence predict the lifetime of the catalyst under reaction conditions.

2.2 Commercial Background

The commercial production of Nylon generates a number of by-product streams including the so-called 'AGS' stream, consisting of adipic, glutaric and succinic acids, with only the adipic being able to be recycled. This is a loss of efficiency to the process and hence ways are constantly being sought to convert these products into saleable products.

Davy Process Technology (DPT) licences a number of processes based on hydrogenation of esters. It is the application of this generic methodology to the hydrogenation of dimethyl glutarate to produce 1,5-pentanediol that forms the work presented in this chapter.

Other DPT commercially developed systems produce 1,4-butanediol, cyclohexanedimethanol and C₁₂-C₁₆ alcohols. Whilst it was expected that the 1,5-pentanediol system would be similar to these, the fine detail required to design and build a multi-thousand tonne commercial plant will be the subject of the research reported here.

2.3 Introduction

The methods for achieving the transformation of the ester functional group to the lower oxidation state parent alcohol, RCO₂R' → RCH₂OH, have been well known for some time. A method employed for synthesis and very small-scale commercial use is the reduction by complex metal hydrides¹, usually LiAlH₄, which will reduce virtually any ester and does not reduce olefin functions also present in the molecule. LiBH₄ also gives the reaction, but NaBH₄ generally does not, although exceptions are known². Catalytic methods for reducing esters are also well known and examples of both homogeneous and heterogeneous systems are found.

Homogeneous ester hydrogenation is a difficult process³. Both anionic ruthenium hydride catalysts⁴ and neutral ruthenium^{5, 6} catalysts have been reported, although little work has been done in this area. The use of a

homogeneous catalyst would in some ways be a benefit as the largest cost associated with a vapour phase fixed bed plant is the purchase and running of a recycle compressor. Fixed bed offers the obvious advantage of ease of separation of the catalyst.

Heterogeneous systems are more widely documented and have been known for some time⁷. Copper chromite catalysts (e.g. PG85/1 supplied by Sud-Chemi) are the most commonly used and have been used industrially, mainly for the production of detergent alcohols from fats⁸.

The surface science of the dissociation of hydrogen on copper is complex and has been extensively studied⁹ though typically under very low pressures. These studies generally show that the catalyst surface is dynamic, with the adsorption of hydrogen dependent upon the atomic arrangement of the copper atoms. Experiments are typically conducted at high vacuum on a single crystal surface. Unfortunately it is not practical to conduct detailed investigations of the catalyst surface under the typical conditions used when these catalysts are operating commercially.

What can be noted from these studies is the important relationship between the atomic arrangement of the copper atoms and the ability to adsorb, and therefore catalyse reactions with hydrogen. This is particularly evident during the reduction of the manufactured catalyst from its oxide form to the active metallic state.

This feature is not limited to copper catalysts, and an attempt has been made to classify the factors which influence the reduction step¹⁰. These have been identified as the dispersion of the metal, support interaction, reduction conditions and additives. As the work below is based on commercially available catalysts only, the influence of the reduction conditions on the generation of the active catalyst is relevant. A number of laboratory scale techniques have been developed to investigate the relationship between reduction conditions and activity. However, "the difficulties in reproducing on a laboratory scale such complex processes [as practised industrially] and of obtaining meaningful data have caused a marked lack of research in this subject"¹¹. The most useful

study is temperature programmed reduction (TPR), whereby the catalyst is heated progressively following a defined temperature gradient in a stream of reducing gas and the uptake of the gas exiting the system is measured. This realistically only gives an indication of the temperature needed to effect reduction. Some workers¹² have used TPR in combination with testing of the catalyst in action (on methyl acetate) to gain a correlation between the TPR data and catalyst performance. The procedure used in this work was based on that developed by DPT in association with the University of Glasgow¹³. This was developed by modifying the reduction procedure recommended by the supplier, then testing the catalyst on a pilot plant scale. If the catalyst showed superior activity when a modified reduction procedure was used samples were then sent for analysis to determine the possible reasons for the enhanced activity.

The procedure that was eventually identified gives the best known activity to the catalyst by minimising copper crystallite size, and therefore maximising the available copper surface area. It was demonstrated that smaller, and hence more active, crystallites were obtained when this procedure was used compared to that recommended by the catalyst manufacturer. This use of this procedure is detailed later.

It is possible to hydrogenate esters over a copper catalyst¹⁴. However improved stability, activity and selectivity can be obtained by the addition of promoters to the catalyst. The use of zinc as a promoter in methyl acetate hydrogenation is reported¹⁵ to increase the selectivity and activity with increasing zinc concentration. This is ascribed to creating a different copper containing phase on the active surface of the catalyst. Other workers¹⁶ dispute this interpretation and assign the enhancement to the increased stability of the system. An extensive study by Catiglioni et al¹⁷ examined the performance of copper chrome catalysts with and without additional promoters zinc and cadmium. This study showed a small decrease in activity with added zinc and an almost total loss with cadmium, ascribed to the formation of copper cadmium alloys, during the reduction phase. It serves to demonstrate the

important relationship between catalyst composition and function but also emphasises the critical nature of catalyst preparation and activation.

Process patents¹⁸ describing the use of vapour phase ester hydrogenation are predominately assigned to DPT. Among these patents¹⁹ is the description of non-chrome based catalysts for dimethylcyclohexanedicarboxylate hydrogenation and particularly butanediol production due to the low amount of 'Acetal' produced on these catalysts (see Chapter 4 for a full description of this impurity). The copper manganese alumina based catalyst described in this patent was used for the work described below.

Copper manganese has been studied for the oxidation of carbon monoxide²⁰, the conclusion drawn being that the copper provides the redox behaviour, whilst manganese remains in the Mn(II) oxidation state. The use of a copper/manganese catalyst for methanol synthesis²¹ also demonstrates its high activity and highlights the importance of the precipitation method employed during its preparation. The combination of alumina with copper manganese is not widely reported; however, the effects of alumina supports in copper zinc catalysts²² have been investigated for maleic anhydride hydrogenation. The use of alumina was also shown to improve the activity of copper chromite allowing a low reaction temperature with the concurrent low by-product production. However low mechanical strength was a problem if the catalyst was not correctly calcined and pelletised. Finally this study hinted that work to define the role of porosity could yield major improvements in the usefulness of such catalysts. This work was indeed undertaken²³ on copper manganese alumina systems and the catalyst so developed is now widely used for commercial ester hydrogenation.

Before further proceeding with this development, one further question posed is the possibility of hydrogenating the acid (or anhydride) directly. Catalysts exist which are capable of performing such a transformation. Some examples are ruthenium/tin/alumina on sol gel systems²⁴ that operate under relatively mild conditions (240°C, 1160psig) and the BP GEMINOX process²⁵ operating at high pressure (115°C, 3500 psig) using a palladium/silver/rhenium on carbon

catalyst. The resulting products from the hydrogenation of acids are alcohol and water whereas during ester hydrogenolysis only two moles of alcohol are produced. It is well known that significant amounts of water can be detrimental to catalyst life span by the promotion of sintering. This has been proven to be the case when the GEMINOX route was commercially applied²⁵.

2.4 Experimental

The following sections first describe the techniques and equipment used, then the initial conditions selected for the work are outlined and finally the experiments performed are discussed.

2.5 Gas Chromatography

Gas chromatography was used as the main analytical technique in this work. The methods of analysis used to identify and quantify the individual components in both feed and product materials are detailed in Appendix 1.

The compounds were identified by a combination of reference to known compounds, either bought or synthesised, and GC/MS. Calibration standards were prepared by accurately weighing (to 4 decimal places) amounts of known high purity materials into a stock mixture. If pure components were not available or the component has not been identified, response factors were applied to the unknowns based on their assumed structure, or assigning it to the closest related known compound. These calibration mixtures and samples of feed and crude product were used to establish operating parameters for the GC to give good chromatographic separation of the components. Calibration standards and the response factors assigned to unknown components were employed to calculate relative response factors for all components. These factors were then used during any subsequent analysis of samples to calculate the concentration of each component, known or unknown.

2.6 Reactor System

Two vapour phase hydrogenation, laboratory scale pilot units were employed in this testwork. The units were almost identical to each other in design and any differences are minor. The units were designated 10/1 and 12/2 denoting in which laboratory the rig was situated. Figure 2.1 shows a typical schematic layout of a pilot unit.

Figure 2.1 – Schematic Diagram of The Vapour Phase Test Rig

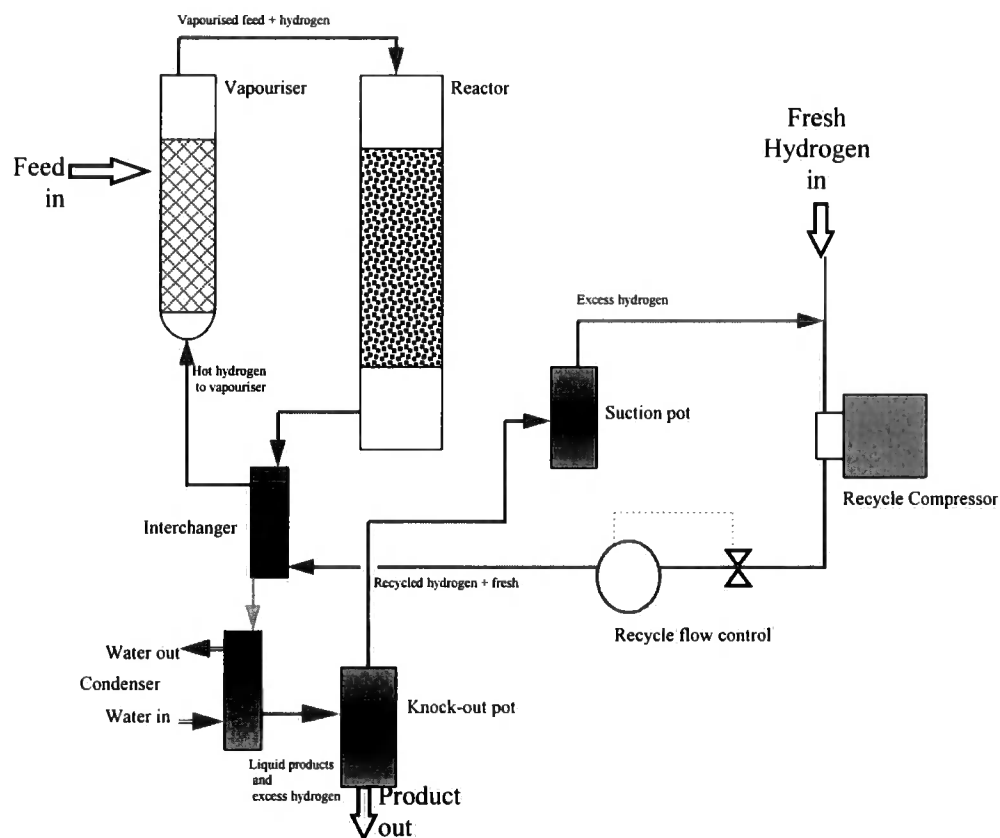

The system can be divided into various sections:

- a) Liquid Feed.
- b) Feed Vaporisation.

- c) Reactor.
- d) Product Condensation.
- e) Hydrogen Gas Recycle.

The feedstock, dimethylpentanedioate supplied by Monsanto, was initially transferred from a 200 litre drum to a tared 10 litre vessel. Portions of this were then placed into a 1 - 2 litre glass storage vessel inter-connected to a calibrated burette, which allowed the feed rate to be measured. Low level alarms were used on the glass feed vessel and burette and the feed was kept under an atmosphere of nitrogen to prevent moisture ingress.

The feed solution was pumped, by means of a metering pump capable of transferring accurate flows at high pressures, into the equipment via a non-return valve. The metered liquid feed passed through heated stainless steel lines into the vaporiser, where it was mixed and vaporised with pre-heated hydrogen.

The vaporiser for the units comprised an insulated 2" nominal bore, 316 L stainless steel tube, packed with glass Raschig rings (6 mm x 6 mm). The liquid feed from the high pressure pump to the vaporiser passed through heated lines and was distributed onto the packing from a centrally located tube turned through 90° such that it pointed in the opposite direction to the gas flow. The hydrogen recycle stream was distributed through a simple gas sparger. The temperature of the vaporised feed and hydrogen was maintained at the desired level by a TIC. The vapour mixture from the vaporiser passed through electrically heat-traced lines, a TIC being used to achieve the desired temperature of the gas entering the reactor. The control philosophy for this system was to operate with the vaporiser exit temperature 5°C lower than the catalyst inlet temperature. This ensured that the gas entering the vaporiser was away from its saturation point (dew point), hence preventing the catalyst from becoming wetted.

The hydrogenation reactors, flanged stainless steel tubes with an internal diameter of 1", contained catalyst supported on glass balls; these in turn were supported at the base of the reactor by a plug of stainless steel wire mesh (Knitmesh), extending from the bottom flange to above the bottom gas outlet in

order to prevent glass rings blocking the outlet line. Glass balls were packed on top of the catalyst to ensure good gas distribution.

The reactor flanges were heated to a temperature 10°C above the catalyst temperature using a TIC and electric tapes, preventing potential cold spots and minimising any liquid droplet formation or condensation. The reactor was heat traced and controlled so as to operate adiabatically. This was achieved by having a dual thermocouple system. One was placed on the reactor wall; the other was on the heating element that was separated from the wall by a layer of insulation. The heating element was then able to be matched to the temperature of the reactor wall giving a true adiabatic system as there can be zero heat flow across the inner layer of insulation, Figure 2.2.

Figure 2.2 Diagram Showing the Method Used to Achieve an Adiabatic Reactor

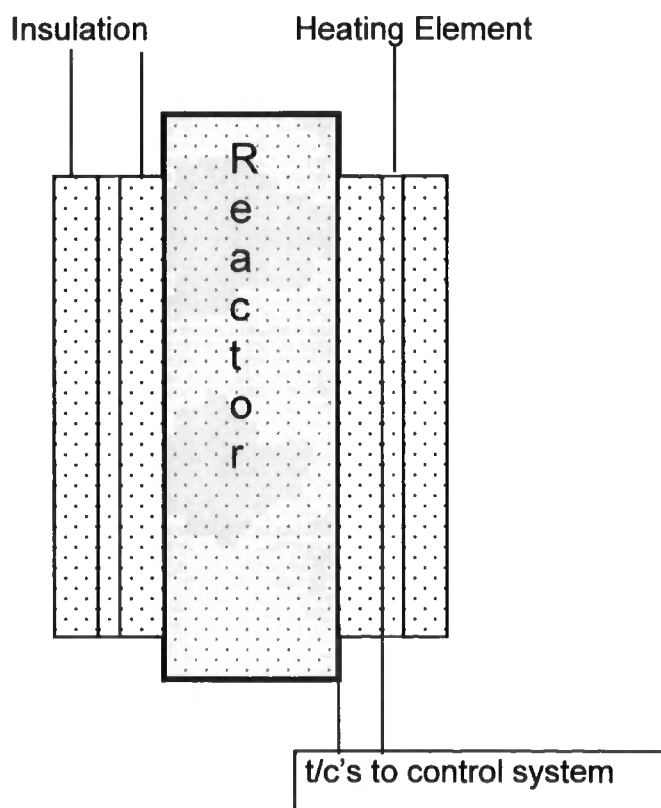

Vaporised feed materials passed down the catalyst bed where a number of reactions occurred, some endothermic and some exothermic. In general, an increase in catalyst bed temperature of only about 1°C or 2°C occurred under normal operating conditions for conversion of dimethylpentanedioate to 1,5-pentanediol. Product, unreacted feedstock and recycle hydrogen from the bottom outlet of the reactor were cooled against the recycled hydrogen stream to the vaporiser through an interchanger. Product was further cooled in a series of cooler/knock-out pots, these being air and/or water cooled and designed to reduce the temperature gradually. This design prevented mist formation caused by too rapid cooling, which then causes knock-on effects by attempting to recycle biphasic gas/liquid mixtures.

The hydrogen stream, cooled to about 45°C, and therefore stripped of the bulk of the condensable material (1,5 pentanediol product, by-products etc), was passed to the recycle compressor, an air-driven double-headed reciprocating unit, fitted with a spill-back control valve to control the rate. Flow of gas recycled to the vaporiser, via a coriolis mass flowmeter, was controlled automatically by adjusting the amount of gas spilled back around the compressor with an air-actuated valve. Make-up hydrogen was supplied via a thermal mass flow controller, this being programmed via a Moore's 252E to supply hydrogen to maintain the reactor pressure at the desired level to ± 1 psig. Hydrogen was supplied from high-pressure cylinder packs at a purity of 99.99 mole%.

2.7 Calibration and Testing

Vessels The vessels employed in the hydrogenation system were fabricated in 316L stainless steel and hydraulically pressure tested to pressures much in excess of the working pressures used in the testwork.

Mass Flow Meters (MFM) The coriolis MFM's used in the testwork (Rosemount Model No D6) were supplied with a test certificate and did not require further calibration.

Pressure Transducers Pressure transducers used on the test equipment were supplied and calibrated by the manufacturer. All pressure transducers were checked periodically against a reference pressure calibrator, a Druck DPI602 instrument with a calibration traceable to the National Physics Laboratory.

Chart Recorders All chart recorders, used for recording temperature, were the subject of a service contract with the manufacturer which ensured regular maintenance and a yearly calibration check was performed.

2.8 Catalyst Activation Procedure

Prior to charging the catalyst the reactor was cleaned by washing with methanol followed by acetone and then dried with clean compressed air. A woven wire plug of Knitmesh was located in the bottom of the reactor tube and the bottom flange assembled. A fixed predetermined quantity of glass balls, approximately 1/4" diameter, were dropped onto the wire plug. The depth of the Knitmesh and balls was measured to ensure correct location of the catalyst bed relative to the thermocouple sheaths located sideways (alternative sides), every 6 inches. The bulk density of the catalyst was accurately measured and used to determine the weight of catalyst to be loaded into the reactor for a pre-selected volume: 250 mls. This was carefully loaded in up to 5 portions onto the glass balls and a further quantity of glass balls placed over the catalyst to a predetermined depth. The addition of each layer of glass balls and catalyst was accompanied by tapping of the reactor to produce a settled bed. After each tapped addition of material, the depth was measured from the top of the reactor in order to give an accurate location of the catalyst bed. The top flange was then located and tightened prior to leak testing and subsequent catalyst activation.

Catalyst reduction (activation) was carried out by setting up a recycle loop concentration of hydrogen of 0.1 mole% at 50 psig and heating the system to 160°C. Once hydrogen pick-up ceased the concentration was increased to 0.2

then 0.5 mole%, again waiting until pickup ceased. The temperature was then raised to 170°C and after any pickup ceased the hydrogen concentration was slowly increased to 100 mole%. The operating temperature and pressure were then established and maintained for >4 hours before the feed was introduced.

2.9 Selection of Conditions

The following sections describe how the initial value of the four variables studied were chosen:

Pressure The maximum pressure of experimental work was limited to 1000 psig by equipment design. It is also undesirable to go above this as capital costs for the plant equipment increase exponentially as pressure increases much above this level. Hence the range of pressures examined had a maximum limit of 1000 psig.

Temperature In vapour phase ester hydrogenation processes, the economics generally improve with increasing temperature. This is due to the increased vapour pressure of the feed ester. Consequently less hydrogen is required to vaporise it, and therefore the amount of recycled hydrogen required is reduced. Therefore a smaller recycle compressor is required and also the compressor power requirement is reduced. The compressor is one of the most expensive capital items on a commercial plant.

Increasing temperature also reduces the volume of catalyst required to effect complete reaction due to increasing reaction rate. However factors such as the impact on the chemistry, in particular the possible increase in undesirable by-products, must also be considered in selecting the maximum operating temperature as must any impact on catalyst life.

In the production of 1,4-butanediol, the maximum temperature is restricted to about 200°C, because at higher temperatures undesirable by-products increase to a point where they cannot be removed without modification to the purification

section of the commercial plant. In C_{12} - C_{18} ester hydrogenation processes, the upper temperature can be raised to about 235°C before penalties associated with by-product formation outweigh the advantages of lower catalyst volume and lower hydrogen recycle costs.

Another factor taken into consideration in selecting the operating temperature is that all catalysts deactivate and that the commercial design must accommodate this. One approach is to adopt a strategy that allows the catalyst to lose 75% of its initial activity before it is regenerated or replaced. This is achieved commercially by dividing the catalyst into two beds and by combating deactivation by increasing the temperature as the catalyst deactivates. As the temperature is increased the amount of hydrogen recycle required to maintain vapour phase operation is reduced, hence the gaseous reactants residence time in the reactor increases and productivity of the catalyst is maintained. The two reactors are operated individually in turn, then, when the catalyst in both reactors has deactivated, they are both brought on line in parallel to further extend the working range of the catalyst charge.

Based on this management strategy in the cyclohexanedimethanol process the catalyst temperature at the end of its working life is 240°C . This corresponds to a start of life temperature of 220°C at double the residence time. As cyclohexanedimethanol and 1,5-pentanediol have similar vapour pressures a temperature range of $200 - 220^{\circ}\text{C}$ was selected to study.

Approach to Dew Point (ATDP) The dew point is the temperature at which a vapour begins to condense, therefore the approach to dew point temperature is the difference between an actual temperature (such as the temperature a reactor is operating at) and the dew point temperature. The ATDP is used in calculations to determine the amount of gas flow required to ensure vapour phase operation of a reactor.

So for a component 'A', the vapour pressure, at the operating temperature minus the ADTP, is determined from tables/references/VLE measurement to give ' $Vp_{A_{ATDP}}$ ', therefore

$$\text{Moles gas required per hour} = \frac{\text{moles A fed per hour} \times \text{system pressure}}{Vp_{\text{ATDP}}}$$

To ensure vapour phase operation, conditions were selected such that at any point in the catalytic reactor the mixture of hydrogen, feed ester and/or products was several degrees above the dew point. 1,5-Pentanediol has a significantly lower vapour pressure than dimethyl-pentanedioate. Therefore, the limiting point was where the 1,5-pentanediol content of the vapour was at its maximum, ie at the exit to the catalyst bed. Consequently all ATDP calculations refer to conditions at the exit of the reactor bed.

For a commercial design, it is usual to operate at a minimum of 5°C above the dew point; this value was used for the tests below based on vapour pressure data generated (see chapter 3).

Liquid Hourly Space Velocity (LHSV) The LHSV is the volume of feed (ester) fed hourly to the reactor relative to the volume of catalyst employed; the units are therefore time^{-1} . The LHSV employed depends on the activity of the catalyst, the conversion required and the operating conditions used.

The LHSV used for the test series was determined during the first experiments described below before undertaking the full statistical design.

2.10 Statistical Testwork

A statistically designed series of tests was used to allow the efficient evaluation of the parameters that affect the process. The advantage of this approach is that all of the variables are studied simultaneously, whereas a conventional optimisation would involve examining the effect of one variable at a time while the others remain fixed. A number of test protocols are available that go from those with minimal numbers of experiments providing estimation of gross effects only through to tests as complex as a traditional approach that fully quantify all effects occurring. The test protocol used, a half-factorial design, halved the number of

tests required when compared to the conventional approach but only provided an indication of the gross effects. The effects that are not identified in this test are mainly second order interactions. For example if the pH effect on a reaction were being studied it might be that the reaction occurred under basic conditions at low temperature or acidic conditions at high temperature but not at a neutral pH. This would be a second order interaction between temperature and pH. For this process it was assumed that no such interactions would be occurring. This can be said as the system was likely to be very similar to 1,4-butanediol, such knowledge of the system studied is a prerequisite when using the simpler test protocols of this type.

In the section above four variables were identified as significant (LHSV, pressure, temperature and ATDP). It is another advantage of the half-factorial design that it can accommodate variables such as those listed, which cannot be independently changed. For example, at a fixed temperature and pressure the ATDP cannot be altered without changing the LHSV for obvious reasons.

The responses to the changes in variable were conversion and selectivity.

$$\text{Conversion} = \frac{\% \text{ reagent present in feed}}{\% \text{ reagent present in product}}$$

$$\text{Selectivity to Product 'X'} = \frac{\% \text{Product 'X'}}{\% \text{ All Products produced}}$$

Of the four variables the range to be investigated had been previously estimated except for the LHSV which was determined by the first set of tests.

The unit was started up at an LHSV of 0.44 (see table 2.1) and the LHSV increased stepwise over the course of 5 runs until a noticeable drop in the conversion resulted.

Table 2.1 – Conditions and Results of Tests used to Establish Initial LHSV

Run number	5/96	6/96	7/96	8/96	9/96
Time on Line / hr	23.5	27.0	39.0	50.5	55.0
Inlet Temp / °C	200.0	204.0	205.0	205.0	205.0
Exit Temp / °C	201.0	207.0	207.0	208.0	208.0
Reactor Pressure / psig	884.0	835.0	835.0	835.0	835.0
Gas Rate / gs -1	0.21	0.16	0.17	0.18	0.18
H ₂ :Ester Ratio	508.2 :1	335.8:1	318.4:1	322.5:1	297.9:1
LHSV (hr-1)	0.44	0.49	0.55	0.60	0.64
Residence Time* / S	3.69	4.72	4.45	4.04	4.05
Conversion (mole %)	99.91	99.93	99.88	99.72	99.66
Selectivity to 1,5-pentanediol / %	93.40	92.41	93.45	94.41	94.39

*Residence Time = $\frac{\text{Catalyst Volume}}{\text{Gas Flow}}$

It quickly became apparent that for the first set of conditions being studied conversion of dimethyl-pentanedioate, 99.9 mole%, was too high to be used for the test series planned as it needs to be at a level where it can go up as well as down. Hence the LHSV was reduced step-wise, until a level of conversion was achieved which would respond to the change applied (99.5%, run 9/96).

Having now established the initial values of the four variables studied the full test series could be started. Table 2.2 shows the design of the test series. For a half factorial design a high and a low value for each parameter studied was selected, in this case based on the reasons given in the sections above. The high and low values corresponded to the '+' and '-' in the left-hand portion of the table. The corresponding high and low values are shown in the right-hand side, it is these values that were used for each of the tests within the series.

Table 2.2 Hydrogenation Tests, Reactor 12/2, Design Set of Experiments and result analysis.

Run No	Temp	Pressure	LHSV	ATDP	Inlet Temp °C	RX Pressure psig	LHSV hr ⁻¹	ATDP °C
17/96	+	+	+	+	215.00	920.00	1.00	20
16/96	-	+	-	+	205.00	920.00	0.70	20
15/96	+	-	-	+	215.00	835.00	0.70	20
14/96	-	-	+	+	205.00	835.00	1.00	20
13/96	+	+	-	-	215.00	920.00	0.70	10
12/96	-	+	+	-	205.00	920.00	1.00	10
11/96	+	-	+	-	215.00	835.00	1.00	10
10/96	-	-	-	-	205.00	835.00	0.70	10

The results from this set of experiments showed temperature had a major effect on both the conversion and selectivity, over the ranges studied. LHSV had a major effect on conversion. Other variable results were considered minor effects over this range. (Figures 2.3 to 2.6). The detailed results are shown in Table 2.3.

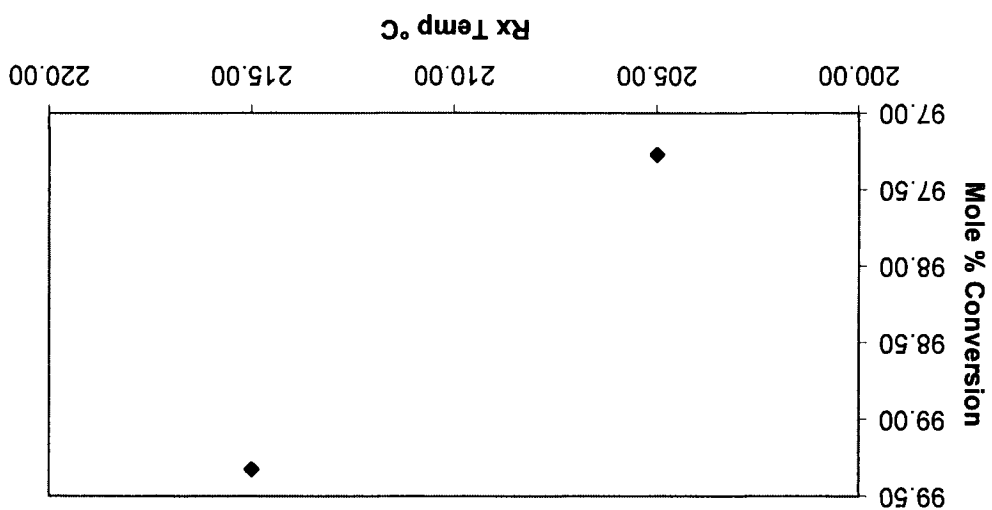

Figure 2.4 Conversion of Dimethylpentanedioate vs Reactor Temperature at LHSV=1hr-1 & 835psig

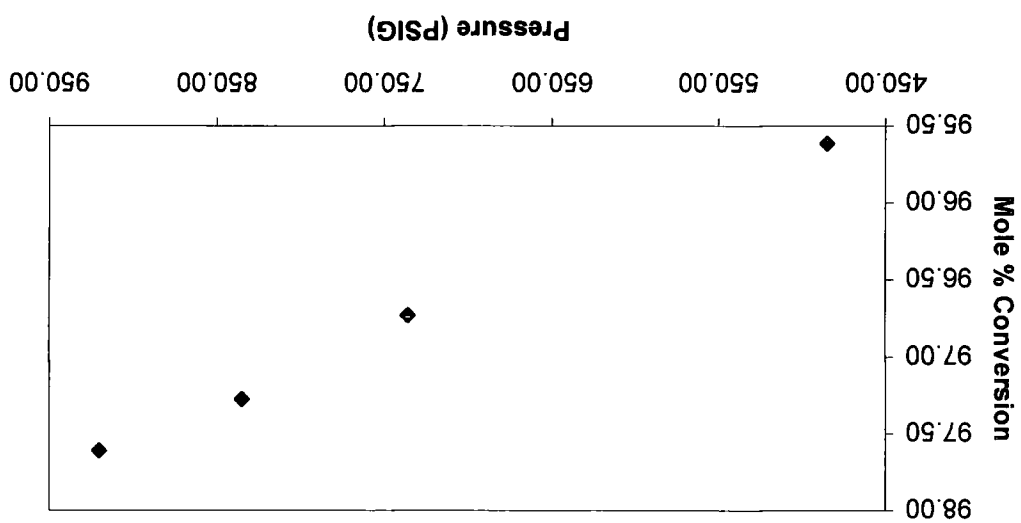

Figure 2.3 Conversion of dimethylpentanedioate vs Reactor Pressure of Hydrogen at 205°C & LHSV=1hr-1

Figure 2.5 LHSV vs Conversion of Dimethylpentanedioate at 835 psig & 205°C

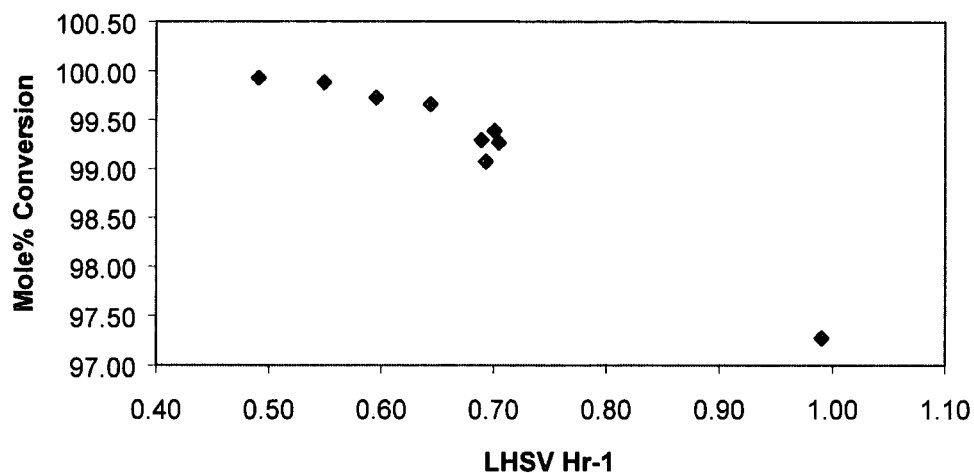

Figure 2.6 Total by-product Selectivity vs LHSV at Constant Temperature & Pressure

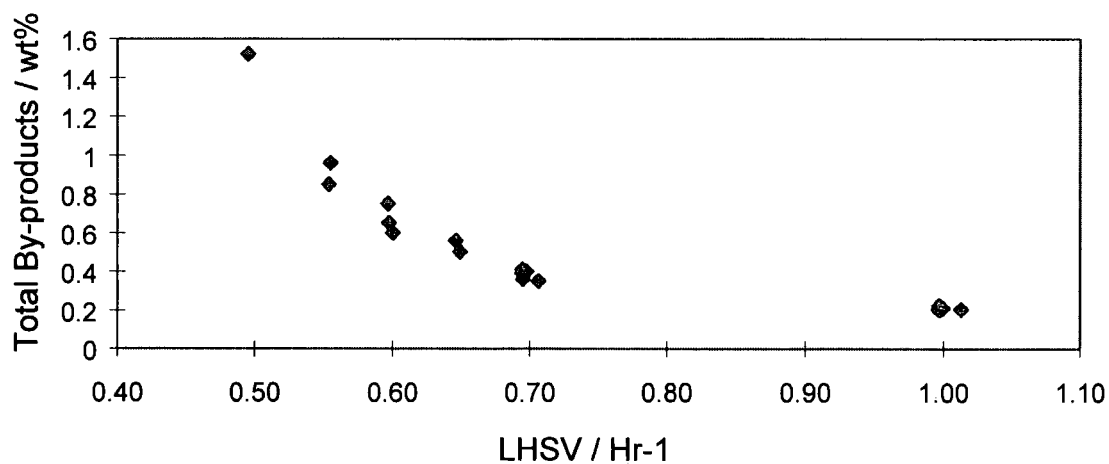

Table 2.3 – Data Obtained from Half-Factorial Test Series

Run number	10/96	11/96	12/96	13/96	14/96	15/96	16/96	17/96
Time on Line / hr	71.00	80.00	95.50	112.25	141.50	159.50	173.00	191.00
Inlet Temperature / °C	205.00	215.00	205.00	215.00	205.00	215.00	206.00	215.00
Exit Temperature / °C)	208.00	220.00	208.00	218.00	208.00	217.00	208.00	218.00
Reactor Pressure / psig	835.00	835.00	920.00	921.00	835.00	835.00	920.00	920.00
Gas Rate / DNLPH	8489	8405	13480	6484	18159	8725	13652	13464
Hydrogen to Ester ratio	318:1	222:1	353:1	242:1	482:1	331:1	514:1	354:1
LHSV / hr-1	0.70	0.99	1.00	0.71	0.99	0.69	0.70	1.00
Residence Time /S	3.48	3.43	2.41	4.91	1.63	3.32	2.38	2.36
Methanol	35.72	36.11	35.11	36.43	34.34	35.97	33.61	34.38
Tetrahydropyran	0.35	0.50	0.20	0.52	0.21	0.60	0.27	0.39
n-Pentanol	0.27	0.48	0.17	0.57	0.19	0.64	0.26	0.42
1,5-pentanediol	59.83	57.72	59.35	58.20	59.75	58.14	61.61	60.15
d-VAL	1.10	1.70	0.94	1.32	1.08	1.46	0.87	1.25
dimethyl-pentanedioate	0.60	0.65	2.33	0.16	2.69	0.25	1.11	1.15
Pentanediol ether	0.19	0.33	0.11	0.35	0.13	0.43	0.18	0.29
Water	0.43	0.57	0.33	0.63	0.33	0.87	0.42	0.54
Others	0.92	1.33	0.87	1.20	0.67	0.98	1.05	0.82
Conversion (mole %)	99.39	99.33	97.61	99.84	97.27	99.74	98.89	98.84
Selectivity to 1,5-pentanediol	95.04	92.72	95.83	93.27	95.72	92.89	95.53	94.49

Table 2.2 shows the design of the test series, table 2.3 the data obtained. From this design, tables were constructed to analyse the results, Tables 2.4. and 2.5. Two were constructed to evaluate the behaviour of conversion and the behaviour of selectivity with the change in the variables studied. The method was to insert the result obtained in each of the tests into the corresponding cell, with the sign corresponding to whether the test was at the high or low value of the variable concerned, '+' and '-' respectively.

The values are then summed and the result obtained for each variable by dividing the sum by the number of variables studied (four in this case). The result then predicts the change in conversion or selectivity per change in variable between

the two levels studied. For example an increase in temperature of 10°C whilst keeping all other variables constant predicts conversion will increase by 1.15 mole% and selectivity to 1,5-pentanediol will decrease by 2.19 mole%.

This analysis shows that pressure and ATDP have a small effect per change between levels while increasing temperature and decreasing LHSV have the larger impact in increasing conversion. For selectivity temperature alone has the major effect but with the opposite sign, i.e. increasing temperature decreases selectivity.

Table 2.4 Result analysis of Data - Conversion.

	Variation with Temperature	Variation with Pressure	Variation with LHSV	Variation with ATDP	Run Number
	98.84	98.84	98.84	98.84	17/96
	-98.89	98.89	-98.89	98.89	16/96
	99.74	-99.74	-99.74	99.74	15/96
	-97.27	-97.27	97.27	97.27	14/96
	99.84	99.84	-99.84	-99.84	13/96
	-97.61	97.61	97.61	-97.61	12/96
	99.33	-99.33	99.33	-99.33	11/96
	-99.39	-99.39	-99.39	-99.39	10/96
Sum	4.59	-0.55	-4.81	-1.43	
Result	1.15	-0.14	-1.20	-0.36	

Table 2.5 Result analysis of Data – Selectivity.

	Variation with Temperature	Variation with Pressure	Variation with LHSV	Variation with ATDP	Run Number
	94.49	94.49	94.49	94.49	17/96
	-95.53	95.53	-95.53	95.53	16/96
	92.89	-92.89	-92.89	92.89	15/96
	-95.72	-95.72	95.72	95.72	14/96
	93.27	93.27	-93.27	-93.27	13/96
	-95.83	95.83	95.83	-95.83	12/96
	92.72	-92.72	92.72	-92.72	11/96
	-95.04	-95.04	-95.04	-95.04	10/96
Sum	-8.75	2.75	2.03	1.77	
Result	-2.19	0.69	0.51	0.44	

As a check on deactivation the conditions for run 18/96 were a repeat of run 10/96, see Table 2.6. This was important, as the catalyst may have been deactivating during the period of the above tests giving false results. The results showed that there was no appreciable loss in activity of the catalyst during the intervening period, but the by-product spectrum had changed slightly showing a lower tetrahydropyran make (0.25 c.f. 0.35). This phenomenon is also observed in butanediol systems in which the tetrahydrofuran yield similarly reduces.

Table 2.6 Repeat Hydrogenation Tests to Test for Catalyst Deactivation.

Run number	10/96	18/96
Time on Line / hr	71.00	205.00
Inlet Temperature / °C	205.0	204.0
Exit Temperature / °C	208.0	207.0
Reactor Pressure / psig	835.0	835.0
Gas Rate / DNLPH	8489.3	8605.3
H ₂ :Ester Ratio	318 :1	328:1
LHSV / hr-1	0.70	0.69
Residence Time / S	3.48	3.44
Conversion (mole %)	99.39	99.29
Selectivity to 1,5-pentanediol	95.04	95.52

2.11 Effect of pressure

The hydrogen pressure used for experiments in this study was discussed above. High pressure hydrogen is not always available commercially so the feasibility of operating at a lower pressure was investigated to determine the flexibility of the process. Two runs were then carried out at much reduced pressure (runs 19/96 and 20/96, Table 2.7). The runs were carried out at 485 and 736 psig. The main effect of reduced pressure was to decrease the conversion by about 4%, and hence increase selectivity to the half ester; methyl-(5-hydroxy)pentanoate (see the reaction scheme below), and increase the δ -valerolactone produced. From the reaction scheme proposed later it can be seen that 2 moles of hydrogen are involved in the equilibrium between 1,5 pentanediol and δ -valerolactone. Because of this giving an exponential relationship between partial pressure of hydrogen and the δ -valerolactone produced a relatively small decrease in pressure leads to a large increase in δ -valerolactone in the crude hydrogenation product. This increase in the δ -valerolactone level may lead to difficulties in the distillation

scheme, see chapter 3. It was therefore concluded that lower pressure operation is not a viable alternative.

Table 2.7 -Reduced pressure

Run number	19/96	20/96
Time on Line / hr	219.00	231.50
Inlet Temp /°C	205.0	205.0
Exit Temp /°C	212.0	210.0
Reactor Pressure /psig	485.0	736.0
Gas Rate DNLPH	7156.4	10846.7
H ₂ :Ester Ratio	187:1	287:1
LHSV /hr-1	1.00	0.99
Residence Time /S	2.41	2.40
Methanol	34.88	34.53
Tetrahydropyran	0.25	0.16
n-Pentanol	0.27	0.20
1,5-pentanediol	54.55	58.34
methyl-(5-hydroxy)pentanoate	0.11	0.06
dimethyl-pentanedioate	4.24	3.20
Water	0.47	0.37
Others	1.12	1.01
Conversion (mole %)	95.62	96.73
1,5-pentanediol:dVAL	15.53	37.62
Selectivity to 1,5-pentanediol	90.80	94.77

2.12 Catalyst Deactivation

Having obtained data on the behaviour of the system the effect on the catalyst over an extended period of operation was studied to ascertain its suitability for longer term commercial use. The reactor was packed with 800 mls (1433.9 g) of copper manganese alumina catalyst. The catalyst was activated following the standard procedure mentioned above. Following activation the initial conditions were established as follows:

Pressure, psig	885
Temperature, °C	200 to the reactor inlet
Hydrogen Flowrate, NLPH	20250

Initially an LHSV of 0.5 hr^{-1} with a catalyst temperature of 200°C was necessary to minimise by-product make during the initial high activity phase for this catalyst (full details of all runs in Table 2.8). The ATDP was kept at 12°C based on exit reactor conditions.

At the required liquid feed rate the mass balances obtained were approximately 100%, indicating the vaporiser and cooling system were working efficiently. Over subsequent runs the ATDP was reduced to $5 - 8^\circ\text{C}$ and the LHSV increased in stages to 0.9 hr^{-1} , and the temperature to 215°C to obtain $>99\%$ conversion, whilst checking the mass balances were 100% at each step.

These conditions were then maintained for the rest of the experiment. This allowed data to be gathered on deactivation of the catalyst (approximately 250 - 400 hours on-line).

Over the ensuing 150 hours the conversion dropped from 99.4% to 99.0%. The by-product spectrum and diol: lactone ratio remained roughly constant throughout this time period. The results are shown graphically in Figure 2.7.

Table 2.8 Catalyst Lifetime Evaluation Results

Run No	1/96	2/96	3/96	4/96	5/96	6/96	7/96	8/96	9/96	10/96	11/96	12/96	13/96	14/96
Time On Line /hr	50	87.5	112.5	124.5	185	207	219	242	272	297	321	333	369	393
Inlet Temp /°C	197	197	197	196	199	199	199	204	203	203	203	203	202	203
Exit Temp /°C	203	203	204	204	209	210	210	216	216	215	215	216	215	215
Reactor Pressure /psig	885	885	885	885	885	885	885	884	885	885	886	885	885	885
Gas Rate /DNLPH	20250	21167	21331	21248	20756	20729	20946	17402	17203	18632	18777	20597	18523	18624
H ₂ Ester Ratio	335:1	292:1	289:1	289:1	190:1	188:1	191:1	160:1	158:1	172:1	173:1	190:1	169:1	170:1
LHSV / hr ⁻¹	0.50	0.60	0.61	0.60	0.90	0.90	0.90	0.89	0.89	0.89	0.89	0.89	0.90	0.90
Residence Time / S	4.99	4.78	4.73	4.75	4.81	4.81	4.76	5.65	5.72	5.29	5.26	4.78	5.32	5.29
Methanol	37.2	37.2	37.4	37.6	34.2	36.5	36.6	36.7	36.9	37.2	36.8	36.6	37.4	37.6
Tetrahydropyran	0.30	0.10	0.09	0.08	0.05	0.05	0.05	0.09	0.09	0.08	0.08	0.08	0.08	0.08
n-Pentanol	0.27	0.19	0.18	0.17	0.16	0.16	0.15	0.28	0.27	0.25	0.24	0.24	0.24	0.23
1,5-pentanediol	59.5	59.8	59.4	59.6	61.6	59.4	59.0	58.7	58.4	58.3	58.7	58.7	58.1	57.5
d-VAL	0.78	0.84	0.86	0.88	0.99	1.12	1.12	0.46	1.47	1.44	1.33	1.40	1.40	1.36
methyl-(5-hydroxy)pentanoate	0.13	0.08	0.07	0.05	0.20	0.09	0.10	0.08	0.09	0.07	0.15	0.11	0.12	0.04
dimethyl-pentanedioate	0.035	0.15	0.17	0.19	0.90	1.10	1.06	0.58	0.71	0.72	0.78	0.81	0.91	0.99
Water	0.47	0.35	0.34	0.33	0.34	0.33	0.32	0.44	0.44	0.44	0.39	0.39	0.38	0.33
Others	0.60	0.67	0.83	0.52	0.76	0.67	0.75	0.97	0.93	0.88	0.80	0.88	0.62	1.05

Figure 2.7 The Effect of Extended Operation on Catalyst Selectivity and Conversion

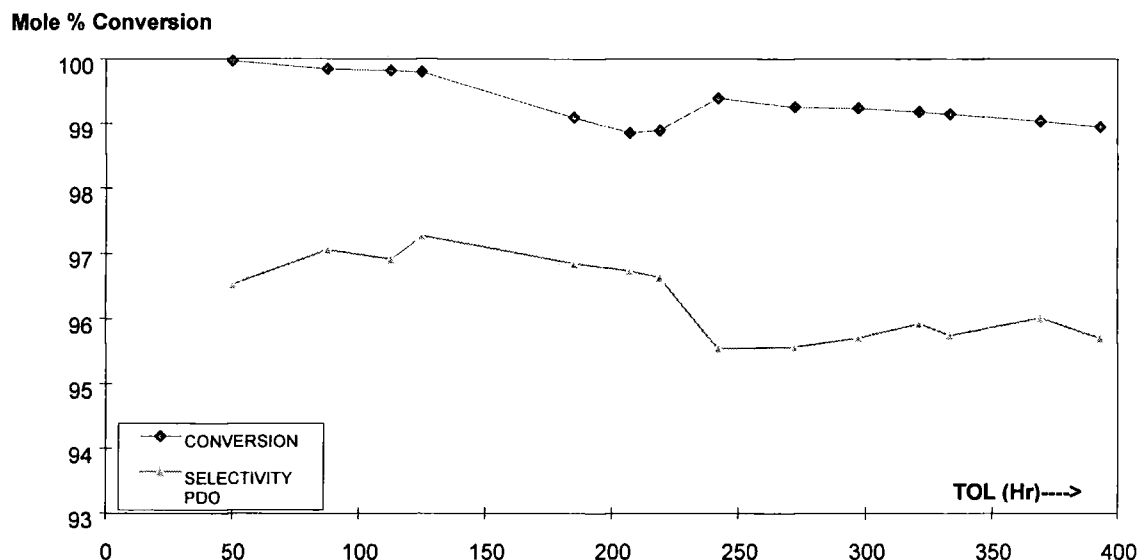

2.13 Conclusions

This work has demonstrated the feasibility of hydrogenating dimethyl-pentanedioate to 1,5 pentanediol at moderate temperatures and pressures using the chrome-free copper catalyst, DRD 92/89. The main differences between this and more well documented ²⁶ 1,4-butanediol production are the levels of by-products produced. In the 1,4-butanediol process typical selectivities to the cyclic compounds tetrahydrofuran and γ -butyrolactone are 2 and 8% mole respectively. In the 1,5 pentanediol process observed tetrahydropyran and δ -valerolactone selectivities are <1 mole% and 5 mole%. This means a potentially greater yield of 1,5 pentanediol per mole of dimethyl-pentanedioate feed over the 1,4-butanediol process. However this may not be the full story as polymeric lactone species were later found to be present during the next phase of this work. The difference in observed selectivities is not surprising when the ring size, and

therefore bond angles, in each cyclic compound are considered due to the inherent stability and strain in each. The catalyst showed only minor deactivation over the period of the testwork, as expected for a diol system²⁷, and should provide adequate life span in a commercial situation.

After refining, as described in chapter 3, the 1,5-pentanediol produced was sent for application testing in the polymer with terephthalic acid, polyethyl terephthalate PPT as this is the proposed end use for the final purified 1,5-pentanediol product. It was found to be superior to any other source tested by the manufacturer to date.

The reaction pathway has been studied for the 1,4-butanediol system^{28,29} and suggests the diester mainly undergoes hydrogenolysis to the lactone which then forms the resulting diol. The diol then dehydrates to the cyclic ether or reacts further with other moieties present to give the observed by-product spectrum. These reactions are shown below in the proposed reaction scheme for the C₅ system studied.

In summary this work demonstrated that the production of 1,5-pentanediol is feasible using a previously unreported copper/manganese/alumina catalyst. The by-products produced from side reactions were identified and quantified and, along with the parameters that effect conversion, the operating envelope of the process has been determined. Finally the catalyst life has been shown to be adequate. This work provides all the required data to produce a commercial design.

Figure 2.8 Proposed Reaction Scheme

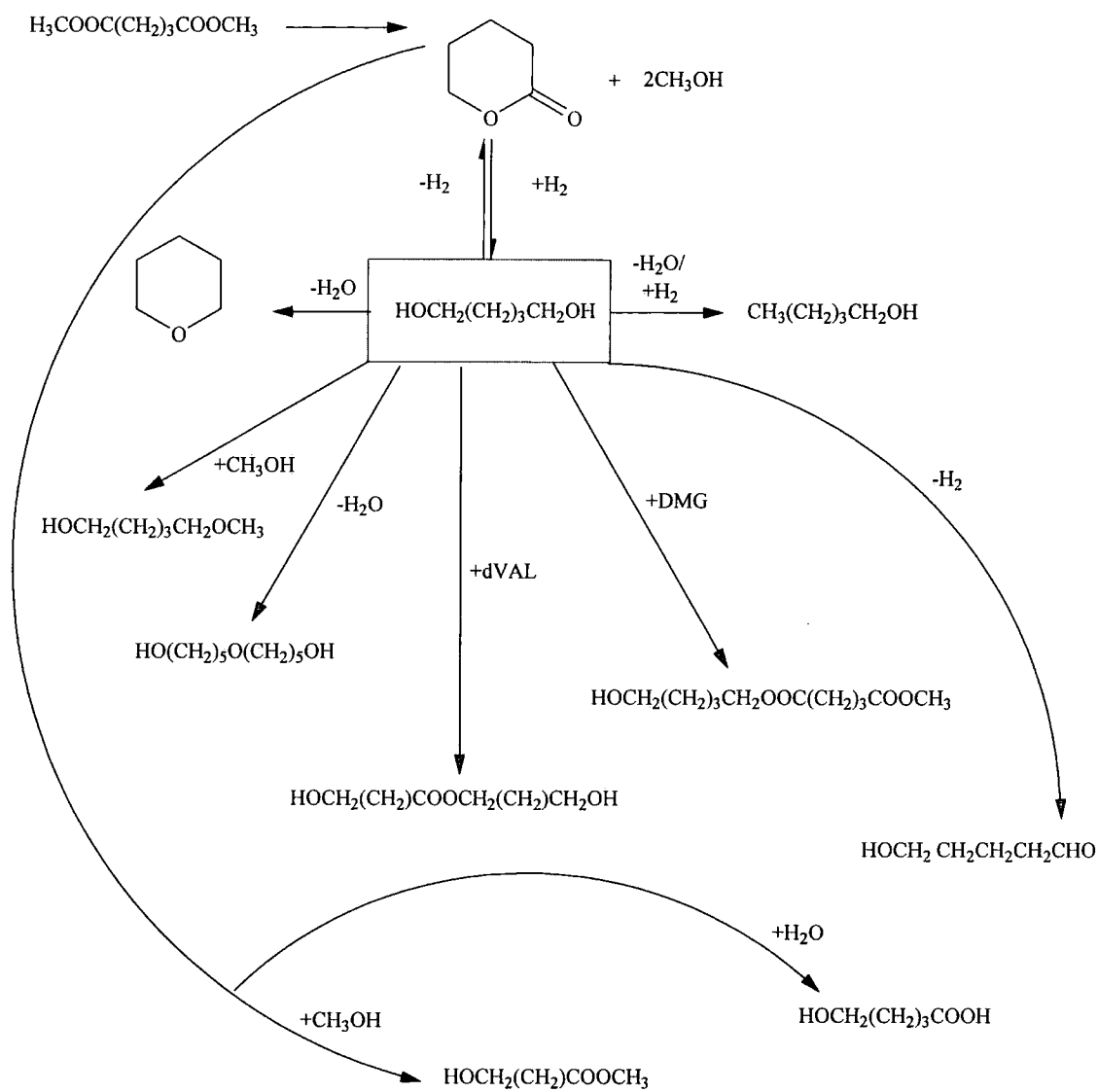

References

1. N.G. Gaylord , *Reduction with Complex Metal Halides*, Interscience inc. , New York, 1956, 391.
2. M.S.Brown and H.Rapoport, *J. Org. Chem.*, 1963, **28**, 3261.
3. H.T.Teunissen and C.J.Elsevier, *Chem.Commun.*, 1997, 667.
4. R.Grey, G.P.Pez and A.Walo,, *J.Am.Chem.Soc.*, 1981, **103**, 7536.
5. U.Matteoli, G.Menchi, M.Bianchi and F.Piacenti, *J.Mol.Catal.*, 1988, **44**,347.
6. U.Matteoli, G.Menchi, M.Bianchi, F.Piacenti and S.Ianelli,
J.Organomet.Chem., 1995, **498**,177.
7. H.Adkins, *Organic Reactions.*, Vol 8. Wiley, New York, 1954, 27.
8. Kirk-Othmer Encyclopedia of Chemical Technology, 4th Edition, Wiley, 1991, Vol 9, 317.
9. A.J.Elliot, B.Sakakini, J. Tabatabaei, K.C.Waugh and F.W.Zemicael,
J.Chem.Soc.Faraday Trans., 1995, **90**, 20, 3659.
10. B.Delmon and M.Houalla, *Studies in Surface Science and Catalysis.*, Vol 3, Elsvier, 1979,439.
11. N.Pernicone and F.Traina, *Studies in Surface Science and Catalysis.*, Vol 3, Elsvier, 1979,321.
12. D.S.Brands, E.K.Poels and A.Bliek, *Stud Surf Sci Catal*, **101** (Pt. B, 11th International Congress on Catalysis--40th Anniversary, 1996), 1085.
13. G.Webb, *Characterisation of Copper-Chromite Catalysts*. Private Communication, 1987.
14. M.A.Kohler, *Ind. Eng. Chem. Res.*, 1987, **26**, 652.
15. F.T.Van de Scheur and L.H.Staal, *Applied Catalysis A: General*, 1994, 63.
16. P. Porta, S.D.Rossi, G.Ferraris, M.L.Jacono and G. Minelli, *Journal of Catalysis*, **109**, 1988, 367.
17. G.L.Castilioni, A.Vicari, G.Fiero, M.Inversi and M.L.Jacono, *Applied Catalysis A: General*, 1995, **123**, 123.
18. , P.Eastland, J.Scarlett, M.W.M.Tuck and M.A.Wood, patent US5406004, 1993.

19. , J Scarlett, M.A.Wood, patent US5395986, 1993.
20. M.Nomura, *Jpn J Appl Phys.*, 1993, **32**, 2 ,496.
21. X.Q.Liu, Y.T.Wu, S.Z.Luo, Y.C.Yang and Z.X.Jia, *J. Nat. Gas Chem.*, 1999, **8**, 3, 203.
22. G.L. Castoni, A.Guericio and A.Vaccari, *Journal of Porous Materials*, 1995, **2**, 79.
23. Davy Process Technology, Confidential report, Ref No SN118/2/12, 1994.
24. M.Toba, S.Tanaka, S.Niwa, F.Mizukami and Z.Koppany, *Applied Catalysis A: General*, 1999,**189**, 243.
25. R. Caruso and V.Chong, *Process Economics Program*, SRI Consulting, California, 1998, 95-1-4R, 1.
26. Davy Process Technology , Confidential report, Ref No SN118/1, 1992.
27. G.L.Castigilioni, C.Fumagalli, A.Guercio and R.Lancia, M.Messori, *Erdol & Kohle Erdgas Petrochemie*, 1994, **47**, 9, 337.
28. T.Turek, D.L.Trimm, D.StC.Black, and N.W.Cant, *Applied Catalysis A: General*, 1994, **116**, 137.
29. M.Messori and A.Vaccari, *Journal of Catalysis*, 1994, **150**, 177.

Chapter 3

The Recovery of High Purity 1,5-Pentanediol by Distillation

3.1 Aims

1. To determine the physical properties of components and mixtures within the crude product produced during hydrogenation of dimethylpentanedioate.
2. To define the operating parameters of potential distillation schemes and determine the occurrence of reactions.
3. To propose and demonstrate a method for producing 1,5-pentanediol of a sufficiently high purity for commercial use.

3.2 Introduction

The product obtained from the hydrogenation of dimethylpentanedioate, detailed in the previous chapter, is typical of a crude commercial product in that it contains many by-products and unreacted starting material. Although optimisation of the hydrogenation reaction can usually minimise these by-products and increase the conversion to reduce the unreacted starting material, there will come a point where this process becomes uneconomical, and distillation must be used to separate the by-products and feed material for recycling or disposal. The distillation conditions for every commercial product are unique and the eventual distillation scheme developed will depend on a combination of the final purity requirements of the product and the product's physical properties. Generally the higher the purity required the more complex will be the distillation scheme. This will then be further complicated if any chemical reactions are occurring between the chemical species involved in the distillation.

High purity 1,5-pentanediol was required for polymer use and the hydrogenation product requiring distillation was found to have certain reactive components that necessitated a distillation scheme capable of accommodating them. A design was achieved by first experimentally obtaining detailed physical property data on the components and mixtures, using these data to devise and then test a number of potential distillation methods until a product of satisfactory purity was obtained in a yield that would be commercially acceptable.

The approach allowed the conditions required for the distillation to be estimated and after performing some experimental distillations, computer modelling of the data was then performed (for this project it was carried out using the package PROII¹) to facilitate a commercial design.

When a model was obtained, it was verified experimentally, discrepancies identified, and the model modified accordingly. In the case of a system involving chemical reaction during the distillation (such as was found during

these investigations), further empirical work was also needed to identify the reactions involved, and overcome problems affecting fractional distillation.

The fundamental data needed to determine, firstly, the viability of separation by distillation and, secondly if the separation is possible, the physical conditions needed were obtained using an equilibrium still, as shown in Figure 3.1.

Figure 3.1 Diagrammatic Representation of an Equilibrium Still

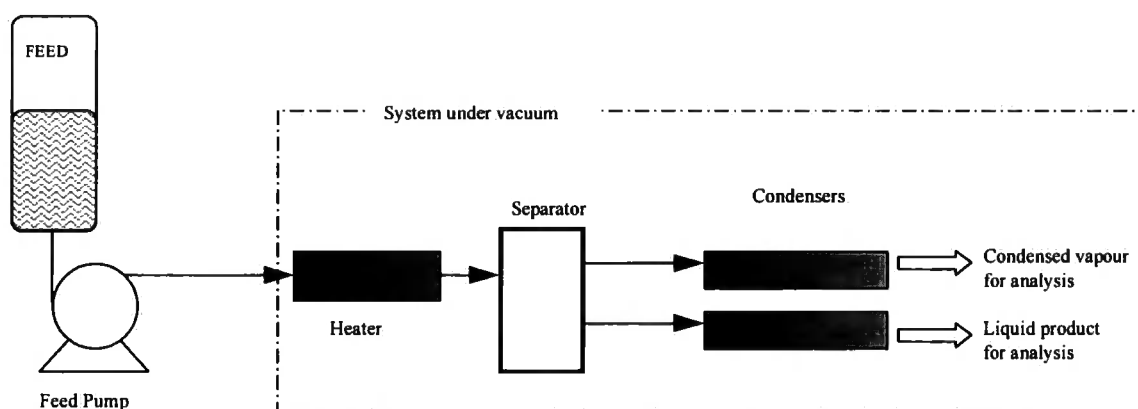

The data obtained from such a still, which is in effect a single stage distillation process, are the temperature of the liquid and vapour as they exit the separator, the system pressure and, by analysis, the composition of liquid and vapour streams.

In the case of a liquid containing only a single component, the data obtained will only yield a boiling point/pressure relationship. In the case of a two component system, the relationship of pressure/temperature/composition can be obtained by performing experiments at constant pressure, or constant temperature followed by analysis of the liquid and vapour streams. Using various feed mixtures, standard P-x-y or T-x-y plots of the vapour-liquid equilibrium² are generated.

From the boiling point data obtained on pure compounds, the approximate pressure required to conduct separations industrially by distillation can be determined. Two component data are useful for identifying azeotropes that

exist between any two components, and useful for providing data for computer simulations, but in reality, a crude mixture that requires purification by distillation will contain a complex mixture of components. In this case, the equilibrium still can be used to rapidly ascertain the ease with which any such mixture can be separated into fractions by calculating the volatility of each component relative to the others. The method to give α , the relative volatility³ is demonstrated later in this chapter.

The relative volatility, α , is the ratio of a compound's volatility to a reference compound within the same mixture. The closer the value to unity the more difficult it will be to separate the two components by distillation. In practice, by taking the product from the equilibrium still and re-passing it back through the still, a value for the ratio of the mole fraction in the vapour to that in the liquid for each component in each pass is obtained to give an indication of the component's volatility. This is then ratioed to that of the main component to obtain the relative volatility. The greater the deviation from an α value of 1 the more easy the separation. A value of 1 obtained after repeated passes is indicative of an azeotrope being present and hence the two components cannot be separated by conventional distillation.

Armed with the data obtained from the vapour-liquid equilibrium, still distillation was attempted. Generally distillation may be carried out in one of two general ways. The vapours produced from the boiling liquid may simply be condensed without any condensate being returned to the still. Alternatively, part of the condensate may be returned under such conditions that it is brought into contact with vapours going into the condenser. The latter method is called rectification or fractionation. If fractionation is not used, a large difference between the boiling points of the components is needed to get a marked degree of separation. Hence non-fractionation tends to be only applicable to flash distillation of solvents.

If reaction occurs between components within the mixture, separation becomes even more complex. The method of reactive distillation is well known⁴ for the manufacture of chemical products; however, the converse problem of

suppressing reactions occurring during conventional distillation is less well documented as a general technique, and solutions must be found on a case by case basis.

3.3 Experimental

All chemicals used for single and binary vapour-liquid equilibrium experiments were obtained from the Aldrich Chemical Company and used without further purification. Mixtures used for the relative volatility experiments were those produced during the course of the work reported in Chapter 2.

Gas Chromatography was solely used, details being given in Chapter 2.

3.4 Equipment Details

Historically many methods of obtaining vapour-liquid equilibrium data have been cited, both static^{6,7,8,9,10,11,12} and flow^{13,14,15,16} methods (analogous to batch and continuous distillation) being described. The equipment used in this work, described below, is a flow still, and has two distinct advantages over traditional methods. These are (i) the short residence time of mixtures in the heater, minimising any chemical reaction between the feed components, and (ii) an electrically controlled adiabatic separation section, negating any heat loss which would occur on conventional vacuum jacketed equipment. This has been demonstrated to give a high degree of accuracy with results surpassing the accuracy of most physical data reported in the literature.

3.5 Vapour-Liquid Equilibrium Still

The vapour-liquid equilibrium experiments were performed using a vapour-liquid equilibrium still based on the layout shown in Figure 3.1, consisting of a feed pump, short residence time heater and an adiabatic separation section.

The feed pump was of a standard piston, constametric type, capable of precisely delivering a constant flow at higher than ambient pressure or vacuum. The range of the pump was from 0-600mlshr⁻¹. The heating element operates to give a short contact time to prevent any potential reactions. The separator is shown below in Figure 3.2, and is the key component in obtaining accurate data. The exact construction of the separator is proprietary information to Davy Process Technology, such units being obtained under strict non-examination agreements. Following the separator, the vapour stream is condensed and the liquid stream cooled using standard laboratory, double skinned, glass condensers.

Figure 3.2 Diagram Of Vapour-Liquid Equilibrium Still Separator

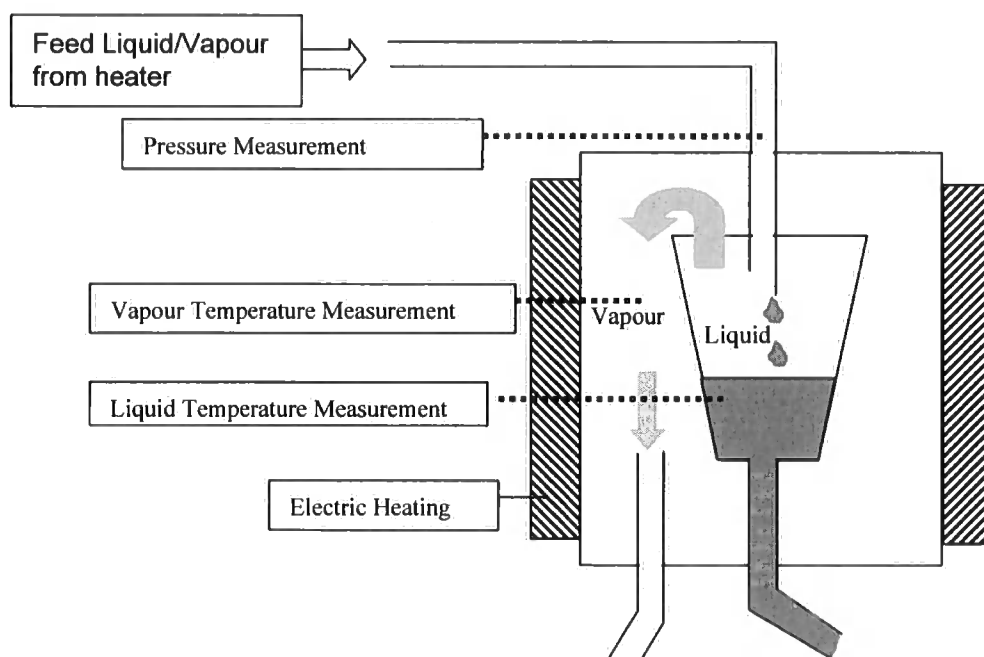

To ensure collection of reliable temperature data, a Pt resistance device was used in place of the usual K type thermocouples. The Pt resistance device has a greater accuracy, the disadvantage being the cost, which is an order of magnitude greater. Pressure transducers were electronic, manufactured by Rosemount, and supplied calibrated. They were checked periodically against a reference pressure calibrator, a Druck DPI602 instrument, with a calibration traceable to the National Physics Laboratory.

3.6 Operation of The Vapour-liquid Equilibrium Still

The procedure adopted was to set the pressure (typically 50-150 mmHg) of the equipment, using a vacuum pump, and feed the test component or mixture to the heater at about $300 \text{ cm}^3 \text{ hr}^{-1}$. At this point, the liquid all collected in the liquid receiver of the still. The power supplied to the heater was then increased until condensed vapour reached a significant amount, found by previous workers¹⁷ to be greater than 10% of the total flow. At this point the material collected was discarded and further material collected used for analysis purposes. Temperature and pressure data during the collection of this material were recorded.

3.7 VLE Data for Pure Components

The vapour pressures of the dimethylpentanedioate and 1,5 pentanediol were measured using the vapour liquid equilibrium still as described above. The purposes of this experiment were to firstly allow calculation of the H_2 : ester ratios from the vapour pressure data used in the hydrogenation work described in Chapter 2, secondly predict the pressure at which to conduct initial distillation experiments, and finally provide data for computer modelling. Results are given in Tables 3.1 and 3.2 and plotted in Figure 3.3. The vapour pressure curve for dimethylpentanedioate showed an abnormal inflection, which was thought to be due to the presence of C_4 and C_6 homologues identified by GC in the

dimethylpentanedioate feed. The data was checked by repeating the experiment and found to be consistent. 1,5-Pentanediol gave a normal vapour pressure curve. Only boiling point data at a single pressure were found in the literature for these compounds as given below and where they are compared with the data obtained in this work.

	Vapour pressure Obtained	Literature Value
1,5 Pentanediol	212.0°C @ 768.1mmHg	238.8°C@ 760mmHg ¹⁸
Dimethylpentanedioate	99.5@ 14.5mmHg	103.4°C@ 14.25mmHg ¹⁹

The boiling point of 1,5-pentanediol is lower than literature value, even allowing for the differing pressures at which the two values were obtained. The discrepancy may be due to the literature data being from a number of experiments at ambient pressure, which may have assumed to be 760mmHg. Dimethylpentanedioate is closer to the literature data, the slight depression probably due to minor levels of C₄ and C₆ homologues present in the feed used for this work.

**Table 3.1 Dimethylpentanedioate
Vapour Pressure Data**

Temp, °C	mmHg
212.0	768.1
207.0	692.0
202.0	641.0
196.5	590.0
191.6	544.0
185.6	490.0
180.2	441.0
174.0	390.0
169.7	350.0
167.0	300.0
163.0	250.0
158.5	200.1
151.6	160.2
145.0	103.4
128.1	63.5
99.5	14.5

**Table 3.2 1,5 Pentanediol Vapour
Pressure Data**

Temp, °C	mmHg
242.0	758.8
240.0	707.0
238.0	670.0
236.0	640.0
234.0	600.0
232.0	551.0
228.0	500.0
225.0	450.0
221.0	395.0
217.0	349.0
212.0	301.0
207.0	257.0
201.0	205.0
194.0	149.0
182.6	100.0
169.3	56.0
134.3	9.5

Figure 3.3 - 1,5-Pentanediol & dimethylpentanedioate Vapour Pressure Data

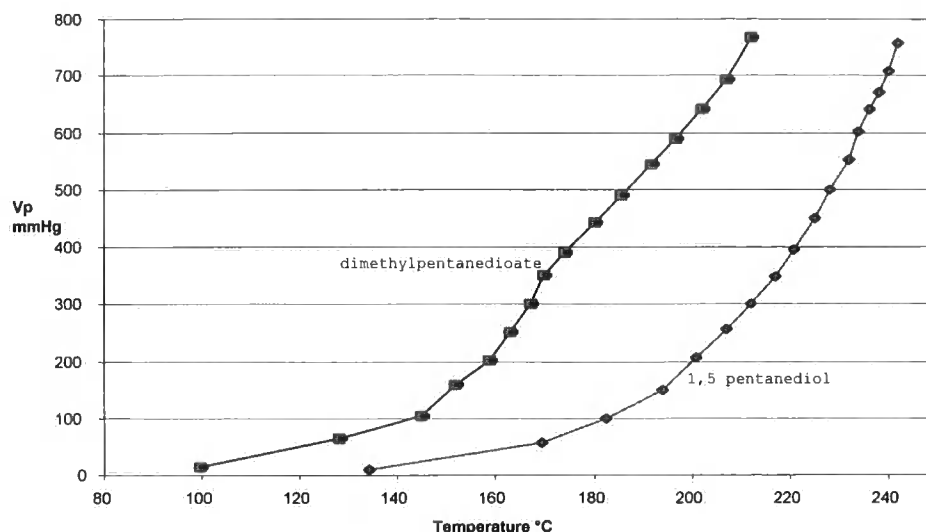

3.8 Relative Volatility Experiments

The usefulness of single component and binary vapour-liquid equilibrium data are limited when undertaking the purification of a complex mixture of components as is the case in this work. Relative volatility, α , data are far more informative about ease of separation. The procedure adopted was to pass the feed through the vapour-liquid equilibrium still as described above, collecting the liquid and vapour produced at steady state operation, this being when the desired split of liquid to vapour had been achieved as described above and when the temperature and pressure showed no fluctuation, within the resolution of the instruments being used, $\pm 0.1^\circ\text{C}$ and ± 0.1 mmHg. The liquid and vapour collected during this phase were called 'a pass'. When one pass was complete the procedure was repeated using the liquid fraction as the feed for a 'second pass' through the unit. Samples of vapour and liquid were taken from each pass and analysed using capillary GC.

After three passes the majority of lighter components were removed (according to GC analysis); the feed for the fourth pass was then split into three portions to simulate different distillation conditions. Two were passed at 150 mmHg, one following heat treatment. This was done by simply heating in a round bottomed flask at the temperature of distillation predicted from the data above for 1,5-pentanediol (approximately 150°C) for 1 hour. This was an attempt to promote any potential reactions taking place. The third portion was passed at a lower pressure (50 mmHg) to study the effect of changes in pressure.

3.9 Relative Volatility Experimental Results

The relative volatilities of all the components present after the fourth pass with no further treatment were calculated (see Table 3.3), as well as the ratio of δ -valerolactone to 1,5 pentanediol obtained in the three tests undertaken to investigate reactivity (see Table 3.4). Note that other compounds present showed no change at any of the conditions studied. The data show that there should be no problems with separation by distillation on the basis of the physical properties, as the α values are well away from unity. However, due to the reactivity of delta-valerolactone, indicated by the differing α values obtained after heating, some problems may be encountered.

At this point no further information that could help in developing a distillation scheme could be obtained from vapour-liquid equilibrium experiments so further work focused on actual distillation studies.

Table 3.3 Relative Volatilities at 150 mmHg.

COMPONENT	α
Methanol	482.41
Tetrahydropyran	17.47
n – Pentanol	206.74
1, 4 Butanediol	32.66
1, 5 Pentanediol	1.00
δ – Valerolactone	2.38
Methyl-(5-hydroxy)pentanoate	0.55
Dimethylpentandioate	10.67

Table 3.4 δ -Valerolactone:1,5 Pentanediol vapour-liquid equilibrium data using modified procedures

	mm Hg	δ -VAL α Values
No Treatment	150	2.11
Lower Pressure	50	3.09
After Heating at 150°C	150	2.47

3.10 Distillation Equipment

Two units were used, a batch still and a continuous distillation column. The batch distillation still comprised a three litre round-bottom flask and a column containing 25 mm diameter Sulzer laboratory structured packing (see figure 3.4). The amount of packing was equivalent to 20 theoretical stages. The reflux splitter was manually adjusted to give the required reflux ratio by using control valves to regulate the off-take and return. Automatic vacuum control was via a 'vacuum general' system.

Figure 3.4 Batch Distillation Column and Equipment

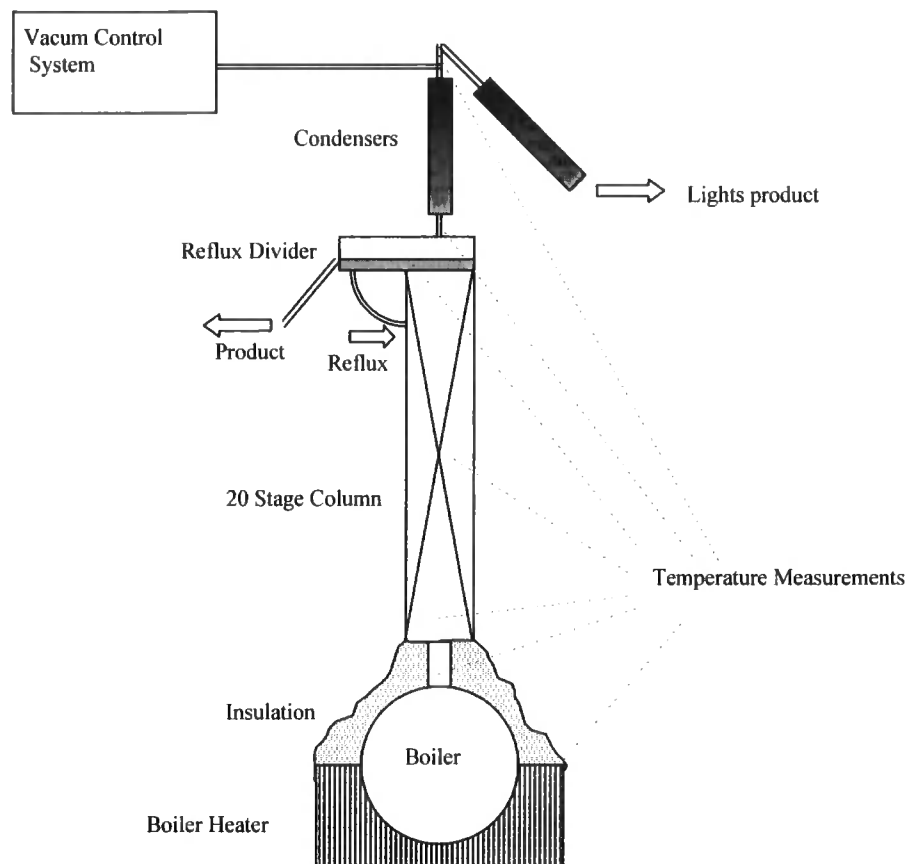

The batch still was modified by removing the boiler and fitting a falling film hot oil reboiler to give a continuous system as shown in Figure 3.5. A feed point was fitted toward the centre of the column supplied by a constametric feed pump. A vapour draw was fitted to allow removal of material from the column and a second feed point toward the top of the column was then fitted to allow the reflux or a wash to be pumped into the column.

Figure 3.5 Continuous Distillation Column and Equipment

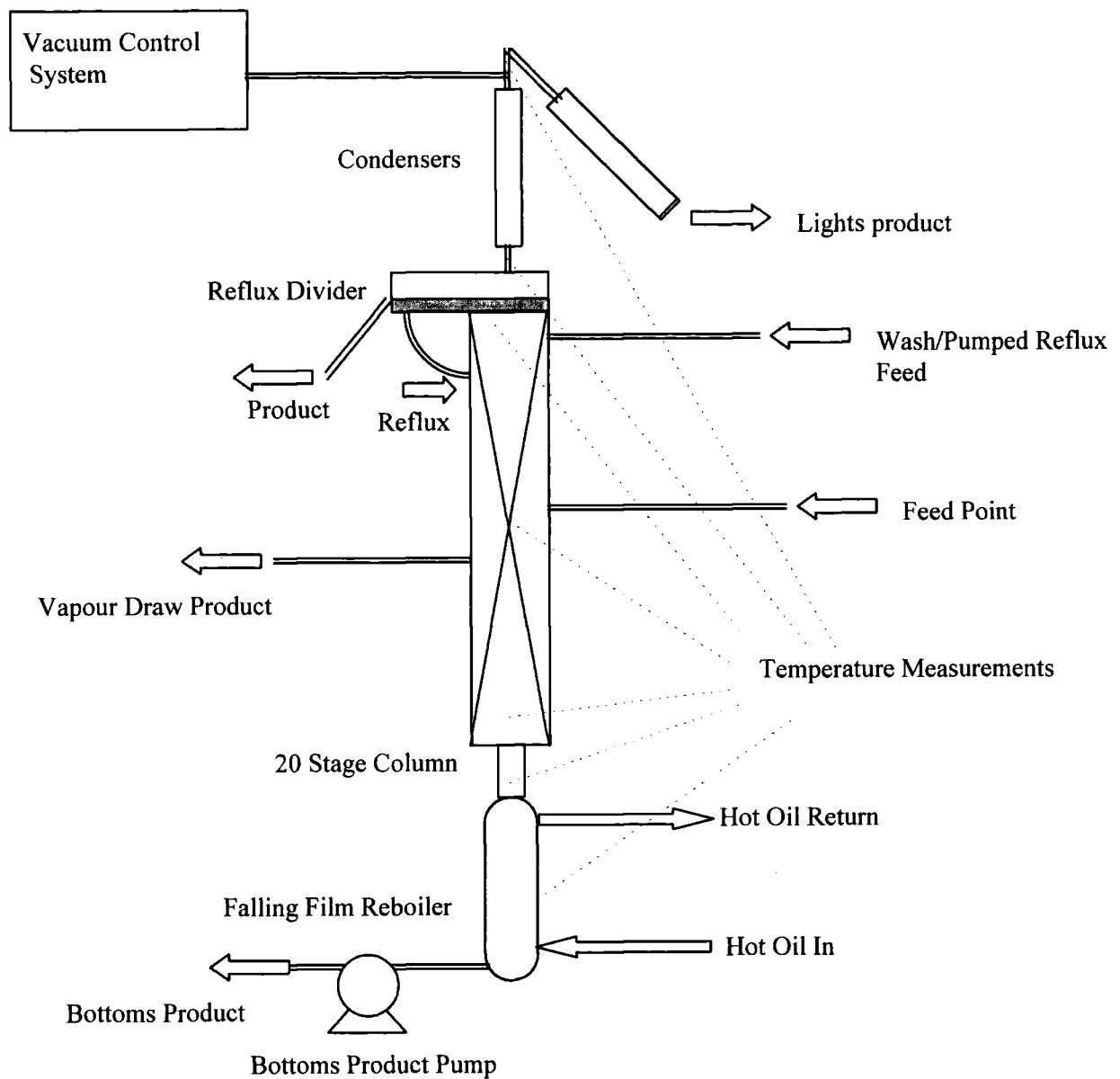

3.11 Distillation Experiments

The initial concept for a commercial unit, based on vapour-liquid equilibrium data obtained, was to have a maximum of two continuous distillation columns to keep capital costs down whilst removing all the detected by-products. This methodology was therefore simulated in initial laboratory distillations. The column used consisted of approximately 20 theoretical stages with the feed line towards the top of the column and a vapour draw towards the bottom, (Figure 3.5).

Product obtained from hydrogenation reactions reported in Chapter 2 was "topped", i.e. the more volatile components removed, (mainly methanol) using the vapour-liquid equilibrium still described above at atmospheric pressure. This simulated the first of the two distillation columns, which simply removes light boiling components. This gave a residual methanol content of about 4% and the remaining liquid following this treatment and this was then used as feed. The continuous distillation unit was started at a pressure of 150 mmHg and, after allowing the system to stabilise, the overheads vapour draw and bottoms products were analysed, (see Table 3.7).

Table 3.7 Initial Distillation Data, Showing Weight% of Major Components in Each Stream.

	1,5-PDO	δ -VAL	HDO	MeOH	% Going to Each Stream
Overheads	68.81	7.36	0.03	12.76	19.8
Vapour Draw	98.99	0.18	0.34	0.05	59.8
Bottoms	96.35	0.43	1.50	0.01	20.3

The data for methanol and hexanediol content in each stream were as demonstrated from the vapour-liquid equilibrium data collected, but δ -

valerolactone reported at a higher level in both the bottoms and overheads than the vapour draw, suggesting something was not behaving as a simple distillation. To further investigate this, the product from the vapour draw was re-passed through the distillation unit under similar conditions (see Table 3.8).

Table 3.8 Continuous Distillation Re-passing of Vapour Draw Material, Showing Weight% of Major Components in Each Stream

	1,5 PDO	δ -VAL	HDO	MeOH	% Going to Each Stream
Overheads	← Not Analysed →			-	36.4
Vapour Draw	99.07	0.04	0.29	0.01	46.9
Bottoms	← Not Analysed →				0.0

Finally, the system was put on total reflux for two hours and the overheads and bottoms sampled (see Table 3.9).

Table 3.9 Continuous Distillation Column on Total Reflux, Showing Weight% of Major Components in Each Stream

	1,5 PDO	δ -VAL	HDO	MeOH	% Going to Each Stream
Overheads	94.28	1.49	0.39	0.29	-
Bottoms	98.60	0.15	0.67	0	-

The data produced from the two continuous runs was not consistent with that obtained in the vapour-liquid equilibrium work as the α values indicated an easy separation of these components. However, switching to total reflux for two hours (see Table 3.9) showed that δ -valerolactone and 1,5 pentanediol could be separated and gave a relative volatility of 1.7. This was as predicted from the

relative volatility work described, where the prolonged heating during distillation was simulated, showing a reaction was occurring as indicated by differing α values before and after the heat treatment.

During these continuous tests it became apparent that either a thermally unstable complex was formed between δ -valerolactone and 1,5 pentanediol or the δ -valerolactone was polymerising on standing and then decomposing during distillation as differences were observed between predictions from the vapour-liquid equilibrium data and results obtained during the distillation testwork. Literature stated that δ -Valerolactone forms a polymer "with about 7 recurring units"⁵, which could explain this. The polymer was presumably formed spontaneously in the crude hydrogenation product, which was stored for several weeks prior to distillation. In the distillation column this polymer slowly decomposed in the reboiler and appeared as free δ -valerolactone in the vapour draw. This then erroneously indicated the δ -valerolactone to be less volatile than vapour-liquid equilibrium suggested i.e. a more difficult separation from 1,5-pentanediol.

It was therefore decided to operate the column in a batch mode to enable thermal breakdown of the complex or polymer to occur in the boiler (see Figure 3.4), thus removing the δ -valerolactone. In the vapour-liquid equilibrium data reported above, the effect of pressure on separation over a range 50 - 150 mmHg was minimal. It was decided that a pressure of 50 mmHg would be employed to reduce the temperature at the base of the column to about 180°C and hence reduce by-product formation during the longer residence time encountered in a batch still boiler. This was used in the first batch distillation (run 3/96, Table 3.10), after initially removing methanol at 400 mmHg. A light boiling fraction, containing the residual methanol, pentanol and tetrahydropyran, was collected as the pressure was gradually reduced from 400 to 50 mmHg.

Table 3.10 First Batch Distillation Test Results.

Fraction Identity	Lights	7	12	Final Pot Contents
Pressure /mmHg	400 → 50	50	50	-
Reflux Ratio	∞	5:1	∞	-
Pot °C	37 - 127	170	171	-
O/Head °C	up to 50	167	166	-
Analysis Wt%				
n-PeOH	1.53	Trace	Trace	0
1,4 BDO	0.87	0.03	0.07	0.09
1,5 pentanediol	64.29	98.14	99.46	94.13
δ-VAL	10.55	1.11	0.25	0.01
DMP	12.37	0.01	0	0.01
1,6 HDO	0.04	0.02	0.02	3.32
DHPE	0	0	0	0.91

Total Number of Fractions Taken = 13

Initially the distillation results looked promising, in that the lights fraction was rich in δ -valerolactone. However, subsequent fractions settled into a uniform composition, containing about 99% 1,5 pentanediol and 1% δ -valerolactone. In an attempt to remove the residual δ -valerolactone from the boiler the column was put onto total reflux, taking a small sample every hour. This eventually got the level of δ -valerolactone down to 0.025%; however 1,6 hexanediol (present in the crude product) was now starting to be taken overhead as well. The distillation was therefore shutdown at this point. The δ -valerolactone component balance indicated that up to 50% more δ -valerolactone was removed from the overheads than could be accounted for by the analysis of the crude product charged. It was thought that this increase in the δ -valerolactone balance was due to polylactone

being present, and not seen in analysis of the crude feed to the distillation system by GC.

The problem appeared to be the time required for total breakdown of the polylactone. In the above distillation, by the time the polymer had decomposed the inventory of 1,5 pentanediol was minimal. Based on this data, another lot of crude product was batch distilled, run 4/96, this time running in total reflux mode from the start of the distillation. As can be seen from the results in Table 3.11, there was little difference between this test and the previous one. Distillation run 5/96, Table 3.12, was carried out in a similar manner to run 3, but based on the vapour-liquid equilibrium data for dimethylpentanedioate/ δ -valerolactone. Dimethylpentanedioate (DMP), a lower boiling point component, was added to maximise δ -valerolactone removal and minimise 1,5 pentanediol removal.

Table 3.11 Batch Distillation, Run 4/96

Fraction Identity	5	12	26	35	Final Pot Contents
Pressure /mmHg	49	50	50	50	-
Reflux Ratio	∞	∞	∞	38:1	-
Pot $^{\circ}$ C	169	175	178	179	-
O/Head $^{\circ}$ C	157	162	165	165	-
Analysis Wt%					
n-PeOH	0.04	0.01	0.01	0	0
1,4 BDO	2.28	0.42	0.01	0.01	0.01
1,5 Pentanediol	36.61	95.65	98.73	99.34	96.49
δ -VAL	34.39	2.89	0.44	0.03	0.01
DMP	18.91	0.02	0.02	0.01	0.01
1,6 HDO	0.01	0	0.02	0.04	1.29
DMPE	0	0	0	0	0.35

Total Number of Fractions Taken = 38

Table 3.12 Batch Distillation, Run 5/96

Fraction Identity	19	Pot (pre DMP Addition)	22 (DMP Addition)	50	63	Final Pot Contents
Pressure/mmHg	49	-	50	49	49	-
Reflux Ratio	90:1	-	∞	∞	34:1	-
Pot $^{\circ}$ C	171	-	170	172	175	-
O/Head $^{\circ}$ C	166	-	161	167	166	-
Analysis Wt%						
n-PeOH	0.02	0	0.01	0	0	0
1,4 BDO	0.01	0.03	0.03	0.03	0	0
1,5 Pentanediol	96.52	97.54	63.52	99.61	99.59	94.85
δ -VAL	2.70	0.13	2.87	0.05	0	0
DMP	0.03	0.01	32.78	0.08	Trace	0.02
1,6 HPE	0.01	0.88	0.01	0	0	2.33
DHPE	0	0.22	0	0	0	0.42

Total Number of Fractions Taken = 63

As the overheads composition approached that of run 4/96 where the % δ -valerolactone was <0.5% (0.13%), a further quantity of dimethylpentanedioate was added (20g) to the boiler. The distillation was then re-started. The column was again run under total reflux with intermittent withdrawal of small overhead fractions. In the initial fraction the δ -valerolactone and dimethylpentanedioate levels were 2.87 and 32.78 wt% respectively with 63.52 wt% 1,5 pentanediol. The δ -valerolactone and dimethylpentanedioate level was eventually reduced to a consistent low level giving 1,5 pentanediol of >99.5% (see Figure 3.6). It can be seen that a lactone mass balance of >100% was again achieved. This is further evidence of polymeric lactone material present in the feed.

Figure 3.6 Batch Distillation Number 5/96 - Progress with Time

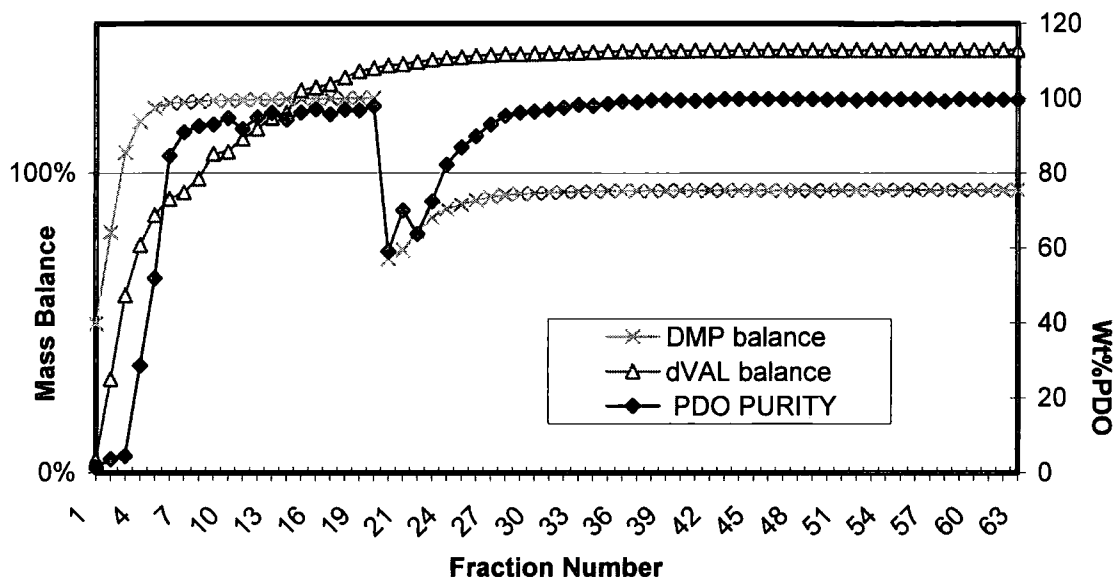

Based on these results the distillation column was configured to allow the continuous addition of dimethylpentanedioate towards the top of the column, as an aid to strip out δ -valerolactone from 1,5 pentanediol – a so-called ‘wash’.

The boiler was charged with about 1.5 kg of crude hydrogenation product from which the majority of methanol and lights (tetrahydropyran and pentanol) had been removed (see Table 3.13). The distillation (Batch 6/96) was then started using similar conditions to those used in the previous runs, (50 mmHg, 170°C boiler temperature). After removing a small amount of residual light boiling components, the dimethylpentanedioate wash was started. Unfortunately, due to an equipment failure, a large amount of dimethylpentanedioate was added very quickly. After rectifying the fault, the wash was reinstated at a rate of about 10 cm³hr⁻¹.

These conditions were maintained until the δ -valerolactone detected in the dimethylpentanedioate removed as overheads, had dropped to a constant low level, (see Figure 3.7); when the dimethylpentanedioate wash was turned off.

The column was then put into total reflux with small fractions being taken to remove residual dimethylpentanedioate. Following this, pure pentanediol was removed.

Figure 3.7 Batch Distillation Number 6/96 – Progress with Time

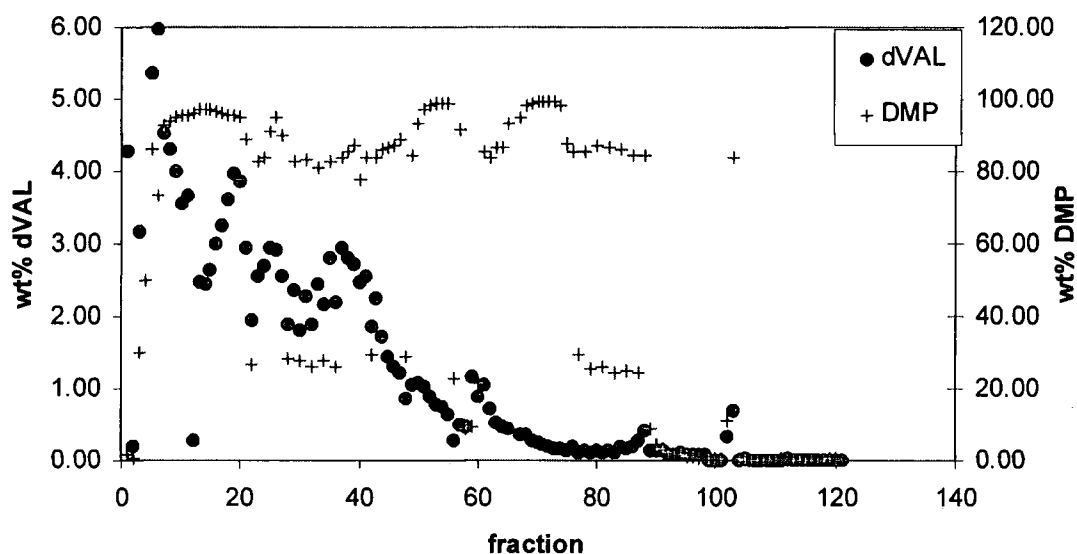

The equipment was then re-configured to allow the dimethylpentanedioate wash to be fed directly into the boiler. It was hoped this would assist in the removal of δ -valerolactone by prolonging the time the pentanediol resided in the boiler. The distillation was then operated (Batch 7/96) at the same conditions as above. The data are shown in Figure 3.8 and Table 3.14.

Figure 3.8 Batch Distillation Number 7/96- Progress with Time

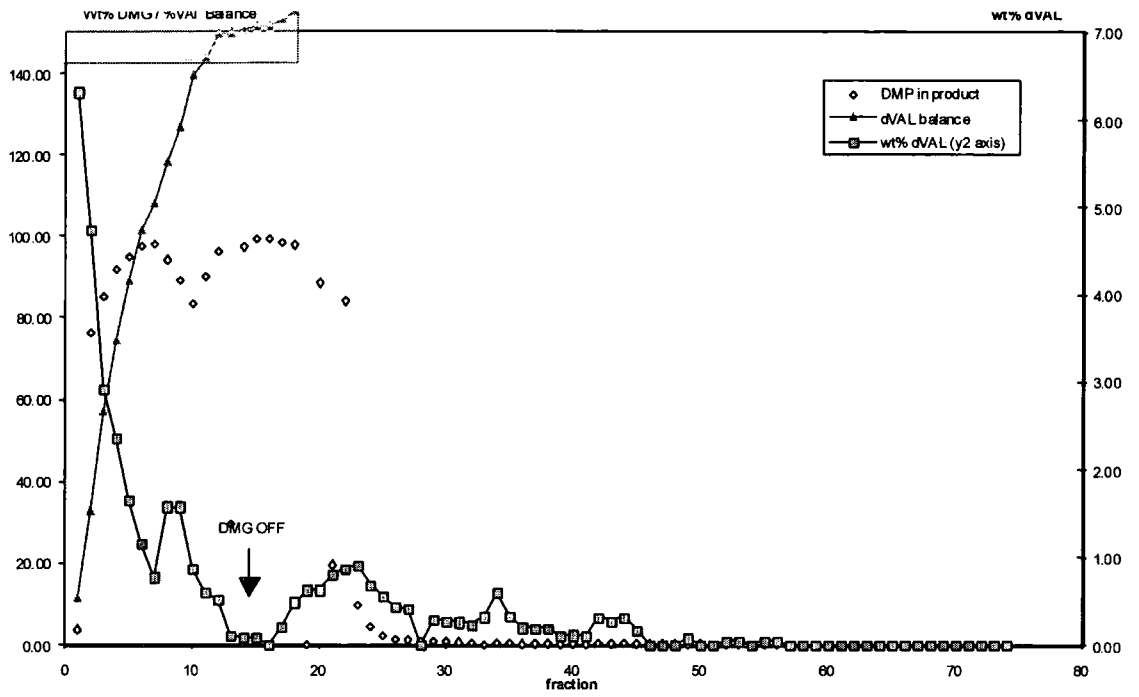

Table 3.13 Distillation with Continuous Addition of DMP to Column

Fraction	Feed	10	20	30	40	50	60	70	80	90	Pot
DMP Rate / ml ^s hr ⁻¹	-	11	11	11	16	11	10	0	0	0	-
Pressure / mmHg	-	50	50	50	50	50	49	50	50	50	-
Reflux Ratio	-	50:1	50:1	45:1	50:1	65:1	35:1	∞	40:1	40:1	-
Pot. / °C	-	169	176	170	170	170	169	170	170	172	-
O/Head / °C	-	132	134	134	132	133	139	166	166	167	-
Analysis wt%											
1,4 BDO	0.01	0.14	0.29	0.14	0.01	0	0	0	0	0	0.015
1,5-pentanediol	92.35	0.09	11.96	8.87	0.46	11.79	10.10	96.40	99.45	99.67	92.20
δ-VAL	1.60	2.63	2.70	2.72	0.90	0.47	0.14	0.13	0	0	0
DMG	1.53	96.81	83.91	87.38	98.11	86.81	87.64	3.34	0.40	0.21	0
1,6 HDO	0.99	0.05	0.06	0.06	0.06	0.05	0.06	0	0	0	1.14
DMPE	0.03	0	0	0	0	0	0	0	0	0.02	2.74

Table 3.14 Distillation with Continuous Addition of DMP to Boiler

Fraction	Feed	5	10	20	30	40	50	60	70	Pot (*)
DMG Rate /mls hr ⁻¹	-	20	21	0	0	0	0	0	0	-
Pressure /mmHg	-	49	50	49	49	50	50	50	50	-
Reflux Ratio	-	25:1	30:1	25:1	50:1	∞	40:1	23:1	30:1	-
Pot /°C	-	170	170	173	174	176	178	180	198	-
O/head /°C	-	132	142	165	166	167	166	167	166	-
Analysis wt%										
1,4 BDO	0.35	0.25	0.01	0.07	0	0.02	0	0	0	0
1,5-pentanediol	96.40	2.23	14.60	88.09	98.33	98.94	99.65	99.70	99.44	75.19
δ-VAL	1.00	1.65	0.86	0.91	0.33	0.28	0.05	0	0	0
DMG	1.60	94.90	83.88	9.82	0.49	0.23	0.08	0.07	0.05	0.13
1,6 HDO	0.55	0.01	0	0	0	0	0	0	0	0
DMPE	0.23	0	0	0	0	0	0	0	0.26	1.3

The Figures show that the δ -valerolactone was removed in fewer fractions than the previous test, but apart from this, there was little difference between batch 6/96 and 7/96. Again high purity 1,5 pentanediol was produced. Additionally the losses of 1,5-pentanediol overhead were reduced in the second test. At the time of switching off the dimethylpentanedioate wash in batch 6, 7.8% of the 1,5 pentanediol had been carried over versus 1.9% in batch 7.

3.12 Conclusions and Potential for Further Work.

The results validate the proposition that the δ -valerolactone forms a non-volatile compound that interferes with conventional distillation to separate 1,5-pentanediol from its by-products, but can be thermally decomposed, albeit slowly. This could be potentially investigated further by LC/MS. Long distillation times were required to produce δ -valerolactone free PDO. Results suggest that a reactive distillation scheme is required with a continuously fed boiler of long residence time coupled to a short column the overhead stream of which is used as a vapour feed. The mixture contained in this vapour, containing no δ -valerolactone based heavy boiling compounds, can then be subjected to distillation in a conventional continuous distillation column. This, coupled with the dimethylpentanedioate wash/reflux (demonstrated above), is the final solution to producing high purity 1,5-pentanediol.

Comparisons with other systems are hard to draw. The main problem in the lower C₄ homologue, 1,4-butanediol, distillation is due to the 'Acetal' impurity that cannot be separated, so other means are sought (detailed in the next chapter). The homologous lactone, gamma-butyrolactone, does not form a polymer similar to that of delta-valerolactone and therefore presents no problems. Work on hydrogenation to produce the C₆ homologue shows very little lactone present at all in the crude product²⁰ and again poses no problems to the purification of the 1,6-hexanediol product.

1,5-Pentanediol produced by these methods was supplied to the Monsanto Chemical Company and found to be of a far higher purity than any other

previously obtained commercially. The GC plots of the crude and final product (obtained under identical GC conditions) are shown below (Figures 3.9 and 3.10) and illustrate graphically the complexity of the crude mixture and the purity of the final 1,5-pentanediol obtained using the methods developed in this work.

Figure 3.9 Gas Chromatogram of The Crude Hydrogenation Product

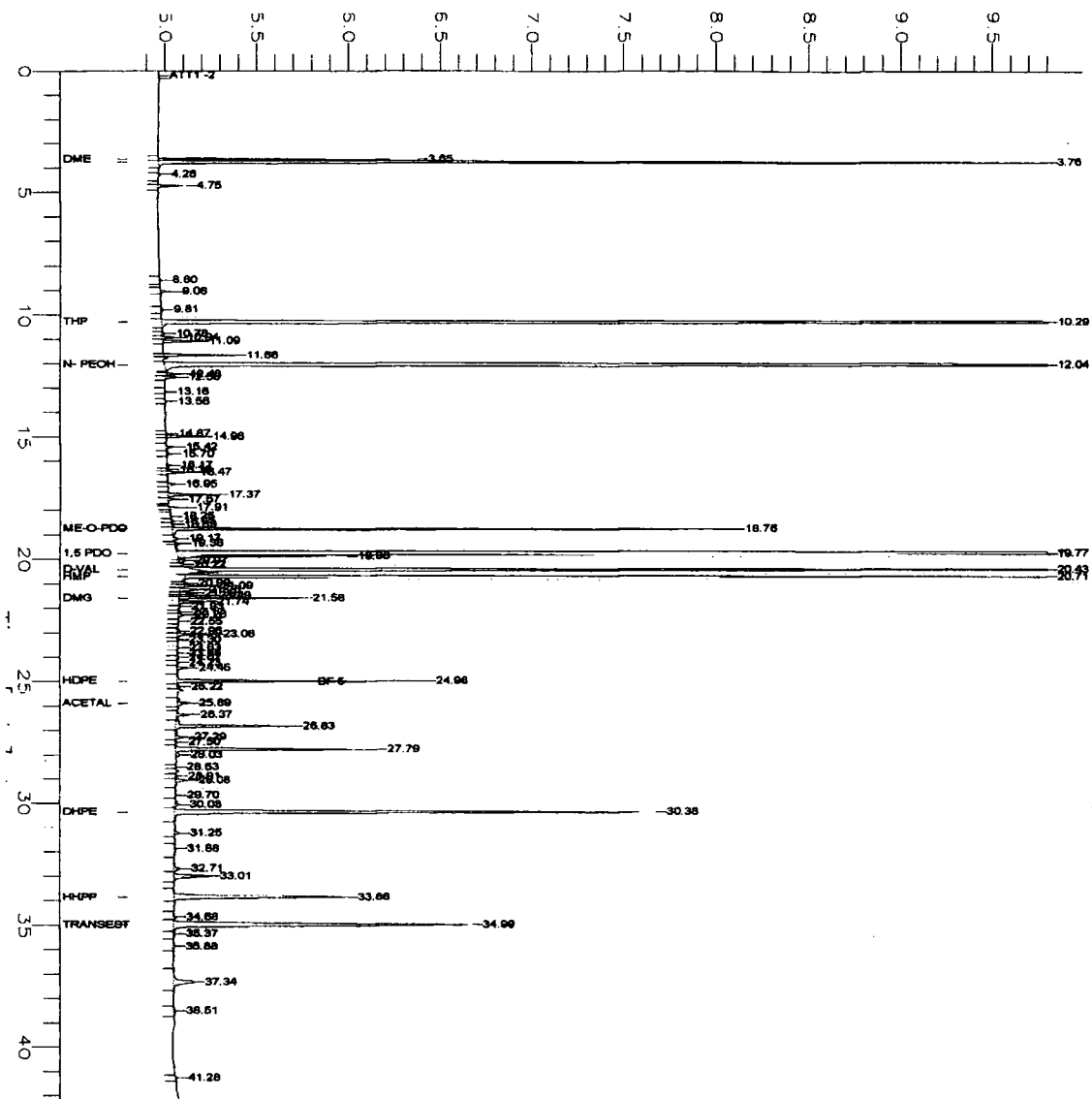
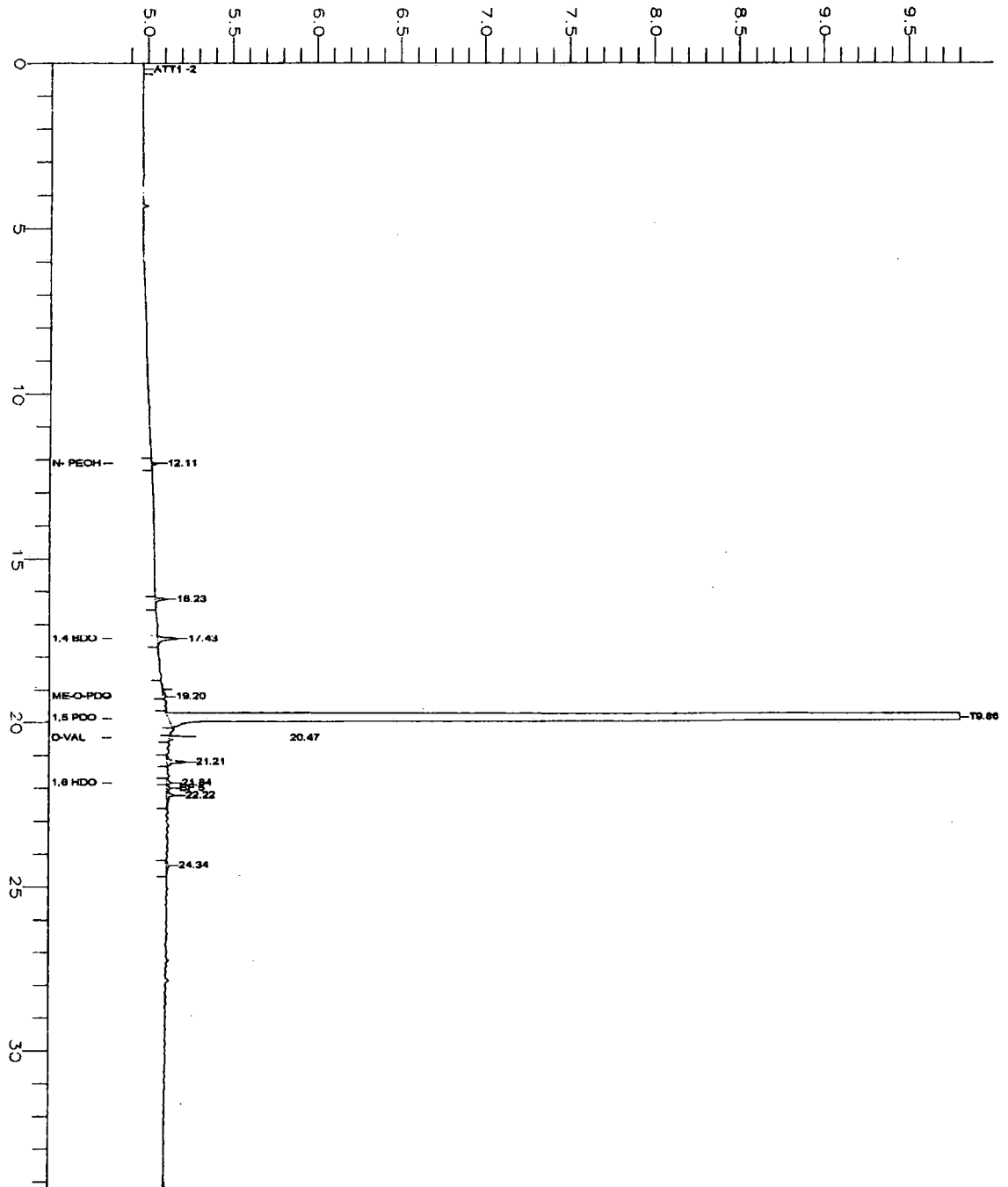

Figure 3.10 Gas Chromatogram of The Distilled 1,5-pentanediol Product



References

1. M.W.Tuck ,Davy Process Technology, Private Communication.
2. J.M.Coulson, *Chemical Engineering – Unit Operations*, Pergamon Press, 1978, pp412.
3. Ibid. 416.
4. R.Taylor, *Chemical Engineering Science*, 2000, **55**, 5184.
5. Kirk-Othmer Encyclopedia of Chemical Technology, 3rd Edition, Wiley, 1990, **9**, 317.
6. T.J.Rigas, D.F.Mason and G.Thodos, *Ind. Eng. Chem.*, 1958, **50**, 1297.
7. A.E.Lindroos and B.F.Dodge, *Chem. Eng. Progr. Symp.*, 1952, **48**, 3, 10.
8. J.Sameshima, *J.Amer. Chem. Soc.*, 1918, **40**, 1482.
9. G.Scatchard, G.M.Wilson and F.G.Satkiewicz, *J.Amer. Chem. Soc.*, 1964, **86**, 125.
10. H.Stage and E.Muller, *Chemiker Ztg.*, 1961, **85**,387.
11. H.T.T.Verschoye, *Trans. Roy. Soc. (London) A*, 1931, **230**, 189.
12. I. Wichterle and E.Hala, *Ind. Eng. Chem. Fundamentals*, 1963, **2**, 155.
13. J.Cathala, D.Hardic and R.Leclerc, , *Ind. Eng. Chem.*, 1951, **27**, 565.
14. A.P.Colburn, E.M. Schoenborn and D.Shilling, , *Ind. Eng. Chem.*, 1943, **35**, 1250.
15. C.H.G.Hands and W.S.Norman, *Trans. Inst. Chem. Engr.*, 1945, **23**, 76.
16. F.H. McDowall, *N.Z.J.Sci. Technol.*, 1955, **37**, 1.
17. C.M.Shariff, DPT, - private communication.
18. Data collections of the National Institute of Standards and Technology (US) – <http://webbook.nist.gov/>.
19. Frinton Laboratories Inc., 1986.
20. M.A.Wood, Davy Process Technology, Private Communication.

Chapter 4

The Removal of the 'Acetal' Impurity from 1,4-Butanediol

4.1 Aims

1. To devise a process capable of permanently removing the Acetal impurity from 1,4-butanediol.
2. To identify the optimal feed and conditions for the removal process to operate.
3. To use the data obtained to develop a continuous reactor system as the basis for a productive commercial system.

4.2 Commercial Background

1,4-Butanediol, a major chemical in the petrochemical sector with the market set to rise to nearly 1,000,000 mt/annum by 2003¹, is manufactured commercially via a number of routes². Of these, the use of butane as a feedstock for oxidation to maleic anhydride, esterification and reduction (see Chapter 2) has found much favor recently as the preferred commercial route³. One of the reasons is the high purity product this route yields.

However, one impurity which is a characteristic of 1,4-butanediol manufactured by this route, is 2-(4-hydroxy butyl)-tetrahydrofuran, known as Acetal (see below).

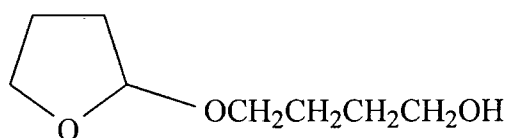

Acetal

The end use of 1,4-butanediol is primarily in the polymer PBT, polybutyleneterephthalate and the Acetal impurity has a detrimental effect on the polymerisation process, acting as an end capper. Consequently, the users of 1,4-butanediol put tight specifications on the levels of the Acetal in the product, typically less than 0.15 wt%.

The impact of the tight specification on the Acetal is not immediately obvious. The amount produced over the catalyst with time increases slowly as the catalyst ages⁴. A point is therefore reached when the Acetal reaches unacceptable levels in the product 1,4-butanediol and the commercial unit has to be shut down and the catalyst replaced for fresh. The catalyst remains active for the main hydrogenation

reaction to produce butanediol, and hence the formation of Acetal limits the working life of the catalyst charge. With the catalyst costing in the region of £760,000 for a typical commercial unit the potential exists for huge cost savings if the Acetal can be removed or its formation prevented.

The removal of Acetal is not economical by conventional means such as distillation⁵, and whilst substantial improvements have been made to the hydrogenation catalyst⁶ to reduce the Acetal levels since this production route was first commercially operated, the production of Acetal during catalytic hydrogenation is still the limiting factor governing catalyst life. Hence, the addition of a further step in the process to remove Acetal by catalytic hydrogenation has been studied to improve both the quality of the product and save many thousands of pounds annually on the cost of catalyst replacement.

4.3 Chemistry of the Acetal Impurity

The potential pathway for the formation of Acetal is shown below.

Equation 4.1 – Butanediol / 4-Hydroxybutyraldehyde equilibrium

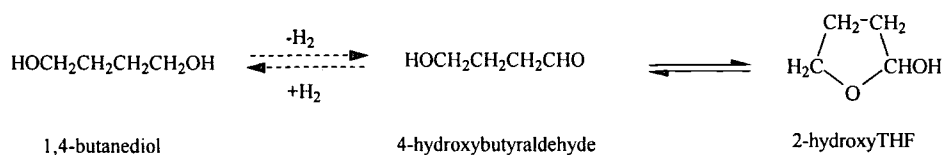

Equation 4.2 – The Formation of Acetal

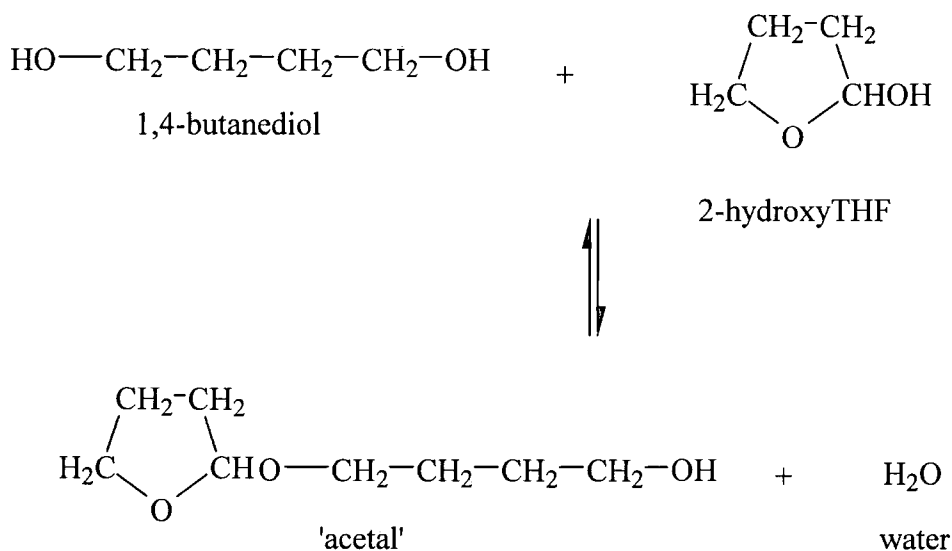

Equation 4.1 shows the equilibrium that can exist between 1,4-butanediol and the dehydrogenation product, 4-hydroxybutyraldehyde. Under the conditions that exist in the hydrogenation reactor, the equilibrium obviously lies well over to the left-hand side. However, a small amount of the hydroxyaldehyde will be present. This aldehyde is in subsequent equilibrium with 2-hydroxytetrahydrofuran, as shown in equations 4.1 and 4.2. In the presence of large amounts of 1,4-butanediol the equilibrium shown in equation 4.2 is driven to the Acetal product.

4.4 Introduction

Aldehydes and ketones are readily hydrogenated to the corresponding alcohols over platinum, rhodium, nickel or ruthenium catalysts under mild conditions⁷. Other catalysts such as copper chrome have also been demonstrated for this application⁸. Direct hydrogenolysis of Acetal species is also reported over Pd catalysts⁹. From the equations 4.1 and 4.2 above it can be seen that two potential approaches exist for the removal of Acetal; (i) direct reduction of the Acetal species or (ii) hydrolysis of the Acetal and subsequent hydrogenation of the resulting aldehyde.

There are numerous examples of carbonyl hydrogenation reported in the literature. The heterogeneous catalysts mentioned above can all be used as carbonyls are readily hydrogenated, being more reactive to hydrogenation than aromatic compounds but less reactive than olefins.

Homogeneous hydrogenation of simple ketones is difficult¹⁰ although examples do exist with enantioselective hydrogenation a possibility¹¹ using rhodium catalysts with a suitable chiral ligand.

Supported catalysts are available for aldehyde hydrogenation. For example¹², the ferrocene complex shown in Figure 4.1 can be anchored to a support whilst providing a chelate phosphine ligand for rhodium. Selective catalysis is achieved in the presence of nitro, oxime and halide groups which are not reduced. Ruthenium supported in carbon nanotubes has also shown potential for aldehyde hydrogenation¹³.

Figure 4.1 Ferrocene aldehyde hydrogenation ligand.

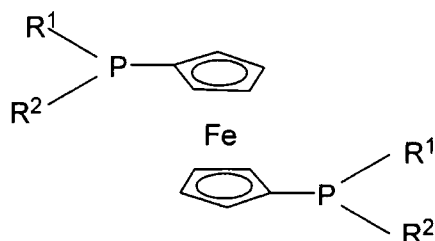

R₁, R₂ = Alkyl up to C₃₀.

The selectivity of heterogeneous carbonyl hydrogenation catalysts can be improved if necessary by modification. For example the selectivity to the unsaturated alcohol when hydrogenating α,β -unsaturated aldehydes has been shown to depend on the precipitation method used when making cobalt/silica catalysts¹. Similarly¹⁵ different TiO₂ phases in platinum/titania have been shown to affect selectivity in the same reaction. Even enantioselectivity can be tuned by catalyst pretreatment¹⁶, with differing thermal pre-treatment of platinum/alumina catalysts yielding selectivity variations in the hydrogenation of β -ketoesters.

Despite the wide range of catalysts listed above, for industrial applications nickel still has the big advantage of its low cost. There are many examples of the use of nickel for heterogeneous catalysis, the biggest use being the hydrogenation of fats¹⁷. However, for this application nickel is now starting to be replaced by palladium. Nickel is also used on a large scale for the hydrogenation of acetophenone¹⁸ and is now replacing stoichiometric reducing agents such as iron/HCl in the fine chemical industry¹⁹.

Many patents describe the hydrogenation of aldehydes. For example, simple alcohols, such as n-propanol, can be really manufactured over cobalt catalysts²⁰ or by vapour phase hydrogenation over copper chrome²¹. Nickel features widely, being used for neopentyl glycol production²² and the production of 2-

ethylhexanol²³. Direct hydrogenolysis of acetals is also described²⁴ over a supported platinum halide catalyst.

This chapter describes the work done to achieve indirect hydrogenation of the aldehyde formed by hydrolysis of Acetal. The transformation is possible using Ni catalysts which are significantly cheaper than other potential catalysts, and therefore offer a commercial advantage.

4.5 Experimental

The following sections describe the techniques and equipment used, the initial testwork in autoclaves, and finally the verification of the continuous process.

The same analytical techniques were used to obtain weight percent analysis data for the feedstocks and products as described in Chapter 2 and in appendix 1.

4.6 Experimental Procedure for Estimating Peak Acetal Concentration

Results obtained in experiments studying butanediol purification in the laboratory do not necessarily reflect those that would have been obtained on a commercial plant²⁵. Experiments can be performed on material obtained from a number of points during the process flow sheet. After tests are completed, further refining to produce the final butanediol product can affect the equilibria involved in the Acetal system. Thus a product apparently free of Acetal can, after heating and concentration, show Acetal levels of over 1% when processing is complete. The most reliable method found to estimate the final Acetal concentration, was to simulate the refining of BDO by removing the lighter boiling components (up to

160°C) by simple distillation in a round bottomed glass flask, and then heating the resulting mixture for 2 hours. The Acetal level then observed was similar to that obtained after submitting the crude product to the full distillation procedure used in 1,4-butanediol manufacture.

4.7 The Preparation of Acetal

To enable the study of the hydrogenation of Acetal in BDO to be carried out, a method of preparation of Acetal was devised so that feed mixtures could be prepared directly, without the added work needed to obtain representative material from the hydrogenation product.

Butanediol (1.62kg, 18 mol), 2,3-Dihydrofuran (0.140kg, 2 mol) and Amberlyst 15 (0.1kg) were added to a 5 litre round bottomed flask fitted with overhead stirrer, condenser, and temperature controller. The mixture was heated to 50°C for 24 hours. Upon cooling and filtering, the GC showed no residual dihydrofuran and contained only Acetal and 1,4-BDO at a ratio of about 1:9.

4.8 Autoclave Description

A Parr 125ml hastalloy autoclave was used for initial testwork. A schematic diagram of the equipment is shown in Figure 4.2. The pressure in the autoclave was maintained by using a Rosemount mass flow controller (MFC) and an externally adjustable pressure relief valve. The temperature was controlled using the built-in heating element and controller. Feed was charged to the autoclave using a constametric pump over about 10 minutes.

Figure 4.2 Autoclave used for Initial Tests to Evaluate the Hydrogenation of Acetal using Ni Catalysts.

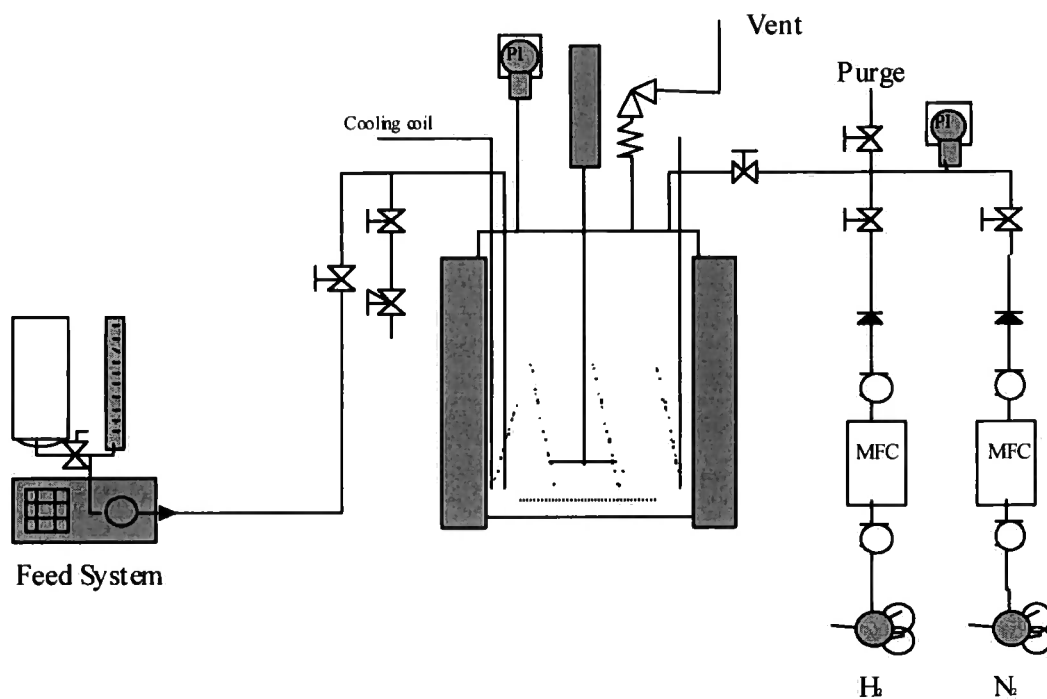

4.9 Fixed Bed Reactor

The reactor system used for the work described in this chapter is illustrated in Figure 4.3. For a full description of this reactor see Chapter 5, section 5.4, figure 5.1 (p113) where the same reactor system was used.

Figure 4.3 Schematic of the Fixed Bed Reactor used for the Hydrogenation of Acetal over Nickel Catalysts.

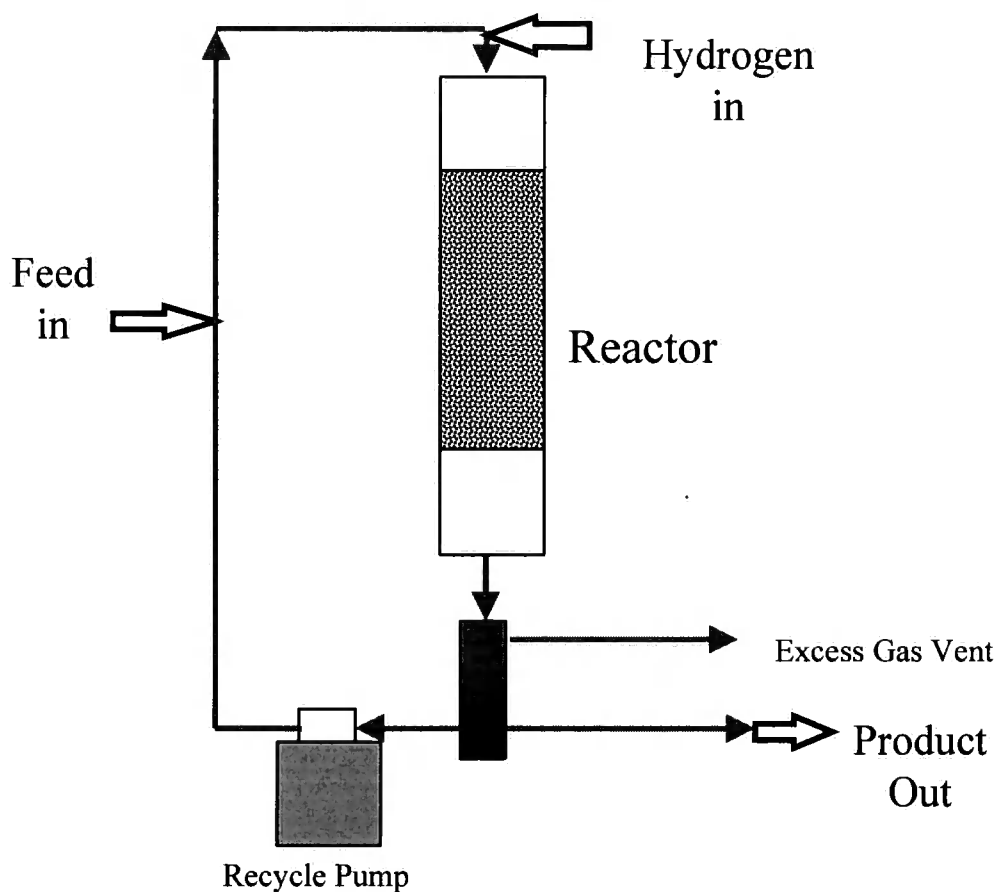

4.10 Catalyst Activation Procedure

The catalyst used for the work was a commercially produced 1/24" nickel extrudate (ex. Engelhard E-482ER). As with most hydrogenation catalysts, the nickel catalyst employed first had to be reduced, this was done following the manufacturers recommendations as closely as possible.

a) The reactor was gradually heated up to 100°C under a flow of 600 NLPH of N₂.

- b) The reactor temperature was then gradually increased from 100°C to 140°C.
- c) At 140°C, H₂ was introduced at a concentration of 0.1 mole% in N₂ and held for 1 hour.
- d) The H₂ concentration was gradually increased from 0.1 mole% to 1 mole% in N₂ over a 1 hour period, whilst holding the reactor temperatures at 140°C.
- e) The H₂ concentration was increased from 1 mole% to 10 mole% slowly, again keeping the reactor temperature at 140°C.
- f) The H₂ concentration was increased from 10 mole% to 100 mole% slowly.
- g) The system was then pressurised to 900 psi H₂ and held for 2 hours at 140°C.

4.11 Autoclave Testwork

Before work using the fixed bed reactor described below, a small number of tests were undertaken in the autoclave shown in figure 4.2, to determine the feasibility of the process and to establish the nature of the feed to be used. Essentially there was a choice of feeds that relate to the stages in the BDO refining process. The first choice was the product obtained before any refining occurs, the so-called 'crude product' the advantage with this feed being that the water added to facilitate the removal of Acetal would be removed during the later refining process. The other, less desirable, feed chosen was the pure BDO product after refining, the disadvantage of this feed being the need to remove the water after the Acetal removal stage.

The experiments were performed at 100°C, using 4wt% water added to the feed, and 20wt% catalyst. The reaction time in each case was 24 hours and the hydrogen pressure was 150 psig with the exception of test 2 at 450psig. The Tables below show the results from these tests.

Table 4.1 shows the analysis of a peak Acetal test as described above on the crude hydrogenation product without undergoing any further treatment. The Acetal

content rose from 0.03wt% to 0.18wt%. This result gives a base to which the others can be compared. In tests 1 to 3, using crude BDO, the peak Acetal level observed was higher than that in the base case. At first this result appears surprising; however, it may be due to the production of Acetal precursors (compounds that can react to give Acetal, eg HBA) formed from the many species present in the crude BDO mixture. Increasing the pressure (test 2) did not have any impact on this result and repeating the test (test 3) confirmed the data. Test 3 is of interest since the initial Wt% Acetal in the product differed from that in the previous test under these conditions. It was only when the peak Acetal test, described above, was concluded that the results matched up. The final test (test 4) used feed simulating purified BDO. The higher Acetal concentration in the feed reflected that expected at this stage of processing. The result of hydrogenation was the best of the four, as the Acetal level was significantly reduced and, more importantly stayed lower than the feed after the peak Acetal procedure. This stream was therefore identified from these tests as the one with the most chance of having Acetal permanently removed by hydrogenation and it was this feedstock that was used for the more involved testwork that follows.

Table 4.1 Peak Acetal Determination on Crude BDO

	Wt % of Component in Feed	Wt % of Component After 'Peak Acetal Procedure'
Methanol	43.67	0.72
THF	2.96	0.00
butanol	0.85	0.87
GBL	8.56	12.46
BDO	43.20	84.16
DM2	0.01	0.04
Acetal	0.03	0.18
Unks by diff	0.72	1.57

Table 4.2 'Acetal Hydrogenation' of Crude BDO – Test 1.

	Wt % of Component in Feed to Test 1	Wt % of Component after Test 1	Wt % of Component After 'Peak Acetal Procedure'
Methanol	43.67	38.65	0.06
THF	2.96	2.15	0.02
Butanol	0.85	0.92	0.01
GBL	8.56	8.74	13.28
BDO	43.20	48.12	84.67
DM2	0.01	0.11	0.00
Acetal	0.03	0.05	0.49
Unks by diff	0.72	1.27	1.47

Table 4.3 'Acetal Hydrogenation' of Crude BDO at Increased Pressure – Test 2

	Wt % of Component in Feed to Test 2	Wt % of Component after Test 2	Wt % of Component After 'Peak Acetal Procedure'
Methanol	43.67	42.90	0.06
THF	2.96	2.56	0.01
Butanol	0.85	0.87	0.02
GBL	8.56	8.08	12.44
BDO	43.20	44.44	85.25
DM2	0.01	0.04	0.00
Acetal	0.03	0.01	0.59
Unks by diff	0.72	1.10	1.63

Table 4.4 'Acetal Hydrogenation' of Crude BDO – Test 3

	Wt % of Component in Feed to Test 3	Wt % of Component after Test 3	Wt % of Component After 'Peak Acetal Procedure'
Methanol	43.67	41.59	0.07
THF	2.96	2.54	0.03
Butanol	0.85	0.84	0.01
GBL	8.56	7.89	12.51
BDO	43.20	44.94	85.38
DM2	0.01	0.09	0.00
Acetal	0.03	0.27	0.45
Unks by diff	0.72	1.84	1.55

Table 4.5 'Acetal Hydrogenation' of Pure BDO – Test 4

	Wt % of Component in Feed to Test 4	Wt % of Component after Test 4	Wt % of Component After 'Peak Acetal Procedure'
Methanol	0.04	0.01	0.00
THF	0.03	0.05	0.00
Butanol	0.00	0.01	0.00
GBL	0.13	0.11	0.16
BDO	97.80	98.92	97.82
DM2	0.03	0.03	0.00
Acetal	1.36	0.44	0.58
Unks by diff	0.61	0.43	1.44

4.12 Fixed bed Liquid Recycle Tests

The reactor, described above, was packed with 250 mls, 237.4 g, of 1/16" nickel catalyst spheres. The commercial feed used contained 0.175wt% Acetal (see Table 4.6, below) and had water added as in the tests above.

Table 4.6 Feed Analysis.

	Runs 1 – 8 Wt%	Runs 9 – 12 Wt%	Runs 13 – 15 Wt%	Runs 16 – 19 Wt%
H ₂ O	3.92	4.03	2.30	0.98
Ethanol	0.013	0.013	0.013	0.013
THF	0.003	0.003	0.003	0.003
GBL	0.44	0.44	0.45	0.46
BDO	94.99	94.89	96.59	97.89
DES	0.013	0.013	0.013	0.013
Acetal	0.18	0.18	0.18	0.18

The first 4 runs were carried out to determine the benefit, if any, of liquid recycle on the amount of Acetal removed. The conditions were:

LHSV	1 hrs ⁻¹
Temperature	110°C
Pressure	900 psig
H ₂ Flow	24 NLPH

Run 1 was carried out with a liquid recycle rate of 2 kg hr⁻¹. The product was analysed by GC and gave an Acetal content of 0.065 wt%. For run 2 a liquid recycle rate of 1 kg hr⁻¹ was used. After a period of steady operation (3 hours) samples were taken and analysed. The Acetal content had reduced slightly to 0.057 wt%. Run 3 used a liquid recycle rate of 0.6 kg hr⁻¹ samples were analysed until the Acetal content was constant. The Acetal value was 0.050 wt%. Run 4 was carried out using no liquid recycle, the pump being isolated to avoid any possibility of liquid circulation. The Acetal content was 0.058 wt% (see Table 4.7). Peak Acetal tests, as described above were carried out on selected samples (see Table 4.8). Runs 5 to 12 (see Table 4.9) were performed to determine the effect of the H₂ purge flow on Acetal removal efficiency. During these runs the other parameters were set at

LHSV	1 hrs ⁻¹
Temperature	110°C,
Liquid recycle	0
Pressure	900psig.

The obvious trend from these experiments was that the hydrogen flow had little, if any impact on the removal of Acetal. For a hydrogenation reaction this may appear an odd result. However this may be due to the low concentration of Acetal at these process conditions.

Table 4.7 Acetal Polishing Tests at 900 Psig

Run No	Temp, °C	H ₂ Flow NLPH	LHSV hrs ⁻¹	Liquid Recycle kg/hr ⁻¹	Feed H ₂ O % wt	Feed Acetal % wt	Product Acetal % wt
1	110	20	1.0	2	4.0	0.17	0.063
2	110	24	1.0	1.0	4.0	0.17	0.057
3	108	24	0.8	0.6	4.0	0.17	0.050
4	107	24	1.1	<0.5	4.0	0.17	0.058
5	109	6	1.01	<0.05	4.0	0.17	0.070
6	110	36	1.05	<0.05	4.0	0.17	0.048
7	110	12	1.07	<0.05	4.0	0.17	0.059
8	110	24	0.86	<0.05	4.0	0.17	0.039
9	111	24	1.18	<0.05	4.0	0.7	0.049
10	110	3	0.8	<0.05	4.0	0.17	0.036

Table 4.8 Peak Acetal Test Results From Selected Runs

Run No	Crude Acetal wt%	Peak Acetal wt%	Reactor Pressure Psig	Temp °C	LHSV hr ⁻¹	H ₂ Flow NLPH	Recycle rate kg/hr
1	0.073	0.076	900	110	1	20	2
5	0.070	0.076	900	110	1	6	0
10	0.036	0.049	900	110	0.8	3	0
11	0.030	0.057	900	110	0.8	1.5	0

Table 4.9 Tests Showing the Effect of Hydrogen Flow

Run No	H ₂ Flow NLPH	Acetal Wt%
5	6	0.07
6	36	0.05
7	12	0.06
10	3	0.04
11	1.5	0.03
12	0.5	0.03

The peak Acetal test data detailed in Table 4.8 were each obtained from the products obtained from experiments conducted under very different conditions, and indicated that very little reformation of Acetal occurred even in product produced using lowest H₂ flows, ie runs 10 and 11. These data showed the high potential of this process for Acetal removal and prompted further investigations and optimisation of this methodology.

Evaluation of the effect of water on the reaction started with 1,4 BDO with 4% water added, resulted in a product with 0.04 wt% Acetal, but subsequently, water contents of 1 and 2 wt% levels were investigated. The 1,4 BDO used was from the same source as used in all previous testwork and contained 0.20 wt% Acetal. The results are shown below in Table 4.10.

Table 4.10 The Effect of Feed Water Concentration on Acetal Removal

Run No	10/96	13/96	19/96
Pressure /psig H ₂	885	885	885
Temperature /°C	110	110	111
LHSV /hr ⁻¹	0.8	0.83	0.87
H ₂ Flow /NLPH	3	3	3
H ₂ O, wt% in feed	4.03	2.3	0.98
Acetal wt% in product	0.04	0.05	0.08

The data show that decreasing the amount of water present increases the Acetal in the product. Industrially, the aim is to have as little water present as possible as its removal adds to the overall cost of the process; hence the level of 4wt% was unchanged for the remainder of the work.

The usual method of combating the loss of activity of a catalyst with time is to increase the operating temperature as activity is lost. Before undertaking a lifetest on the catalyst this approach was simulated by doubling the LHSV, to simulate a 50% loss in activity, followed by an increase in catalyst temperature until the Acetal value was equivalent to that obtained before increasing the LHSV. The increase in LHSV resulted in the Acetal content increasing from 0.052 up to 0.099 wt%. The catalyst temperature was then increased in 5°C increments, whilst all other conditions were maintained. The results are shown below in Table 4.11.

Table 4.11 Simulation of Reduced Catalyst Activity, with Compensation by Temperature Increase

Run No	20/96	21/96	22/96	23/96	24/96
Temperature /°C	110	115	120	125	130
Acetal, wt%	0.099	0.084	0.041	0.08	0.06

The data showed a 10°C increase in temperature compensated for the 50% loss in catalyst activity that was being simulated. At temperatures greater than 120°C the Acetal content started to increase. This could be due to a reduction in the H₂ solubility at the higher temperature. It was also noticed that the level of THF, produced from increased dehydration of 1,4 BDO, increased at the higher temperature.

The next run (24/96) was to identify the effect hydrogen pressure had on Acetal concentration. The conditions for this run were a temperature of 130°C, Hydrogen flow of 3 NLPH H₂ and a feed rate equivalent to an LHSV of 1 hr⁻¹. The Acetal level was 0.06wt%, showing that the reaction is favored with increased pressure.

4.13 Catalyst Life

One of the most important factors in the success of a commercial process is the ability of the catalyst to sustain its activity over a long timeframe, avoiding costly replacement. To determine the potential life span and the factors that affect it, a further series of experiments were performed on a fresh charge of catalyst.

Two batches of feed were prepared for these tests (see Table 4.12). One was prepared from BDO obtained from a commercial plant the second from a laboratory supplier. The reasons for this choice will become apparent during the discussion of this work.

Table 4.12 Feed Analysis for Catalyst Life Tests

Source	wt% Acetal	wt% Water	wt% γ BL
Commercial	0.465	4.97	0.609
Aldrich	0.563	4.2	Not Detected



The catalyst charge was a Ni extrudate, (1/4", 100 mls (78.1 g)). The initial conditions chosen were based on work previously carried out employing the Ni sphere catalysts and the catalyst was activated according to the method described previously.

The initial conditions were:

Rx Temperature /°C	110
H ₂ Flow /NLPH	8
Rx Pressure /psig H ₂	900
LHSV /hr ⁻¹	1.0

An Acetal level in the product of about 0.1 wt% was observed so the LHSV was reduced to 0.75. This gave an Acetal level of about 0.05 wt% as required, hence; these conditions were maintained for up to 100 hours. A sample taken during this time containing 0.07 wt% Acetal, was used for a 'peak Acetal test'. The final Acetal content observed was 0.09 wt% indicating that this would be the final amount if the product was taken through the final distillation column. This is an acceptable product and demonstrated the catalyst was successfully removing both Acetal and its precursors. It also had a similar activity to that observed in earlier tests using the Ni spheres. The LHSV was then increased to 1.0 hr⁻¹ and held for 25 hours giving an Acetal level in the product of about 0.07 wt%. A further increase to 1.5 hr⁻¹ gave an Acetal content of 0.13 wt%. At this time the product was observed to be dark in colour and significant deactivation appeared to be occurring (see Figure 4.4).

Figure 4.4 Deactivation of Ni Catalyst Using a Commercial Feed

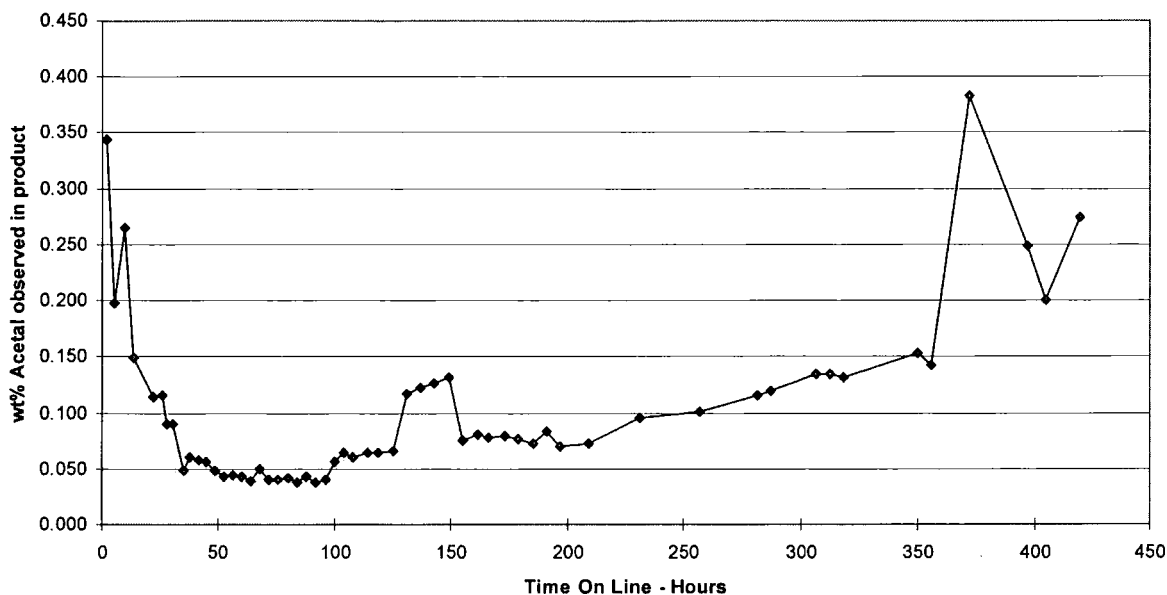

To confirm this deactivation the conditions were held for 150 hours, but during which time the Acetal content rose to about 0.15 wt%. This loss in activity was not observed in previous work and was ascribed to the prolonged storage and multiple heating/cooling cycles that the commercial feed had been taken through. These cycles could have resulted in some degradation of the feed, for example metals leaching into the feed, as indicated by the increased colour of the feed. The final conditions used during this testwork were an attempt to quantify the loss in activity by reducing the feedrate, to increase conversion. However, no significant change in conversion was observed, and the conversion was considered too low to continue with the run.

4.14 Acetal Polishing - Synthetic BDO

To further investigate the rapid deactivation, a synthetic feed was made up to eliminate any complications arising from the use of an aged commercial feed, and a new run started on a fresh batch of catalyst. The nickel catalyst was reduced using the standard procedure and the initial conditions were selected as follows:

Rx Temperature /°C	110
Pressure /psig	900
H ₂ Flow /NLPH	8
LHSV /hr ⁻¹	1.0

The product for the first 50 hours indicated no Acetal conversion, see Figure 4.5.

Figure 4.5 Lifetest Using Synthetic Feed

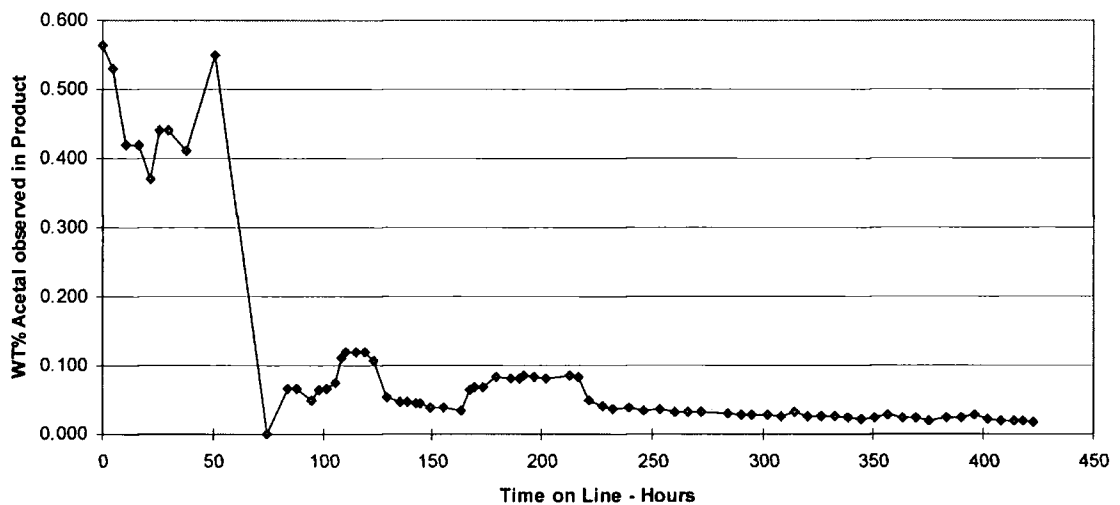

Due to the lack of conversion of the Acetal, the activity of the catalyst was confirmed using ethyl acetate (specifically the hydrogenation of by-product carbonyls) as a model system. The results obtained indicated high activity and normal selectivity when compared to data on this catalyst obtained commercially. It

was postulated therefore that any differences between the synthetic and commercial feeds could be leading to the observed absence of catalytic activity with the Acetal. The major difference was the presence of small amounts of residual gamma-butyrolactone (GBL) in the commercial feed. It was further assumed that this lactone could hydrolyse to small amounts of 4-hydroxybutyric acid in the presence of water and thereby acid catalyse the hydrolysis of Acetal to its reducible precursors. Equation 4.2. (p86) shows the hydrolysis of Acetal.

4.15 Effect of GBL Addition to Synthetic BDO

In an attempt to quantify this effect, the amount of GBL in the synthetic feed was varied over the next 150 hours, (see runs 102/6/98 - 102/12/98, and Figure 4.6).

Table 4.13 Effect of γ BL on Acetal Removal

Run	% γ BL in Feed	% Acetal in Product
102/5/98	<0.01	0.41
102/6/98	0.6	0.05
102/7/98	0.2	0.09
102/8/98	<0.01	0.12
102/9/98	0.6	0.04
102/10/98	1.2	0.04
102/11/98	<0.01	0.07
102/12/98	0.5	0.03

Figure 4.6 The Effect of γ BL on Acetal Removal

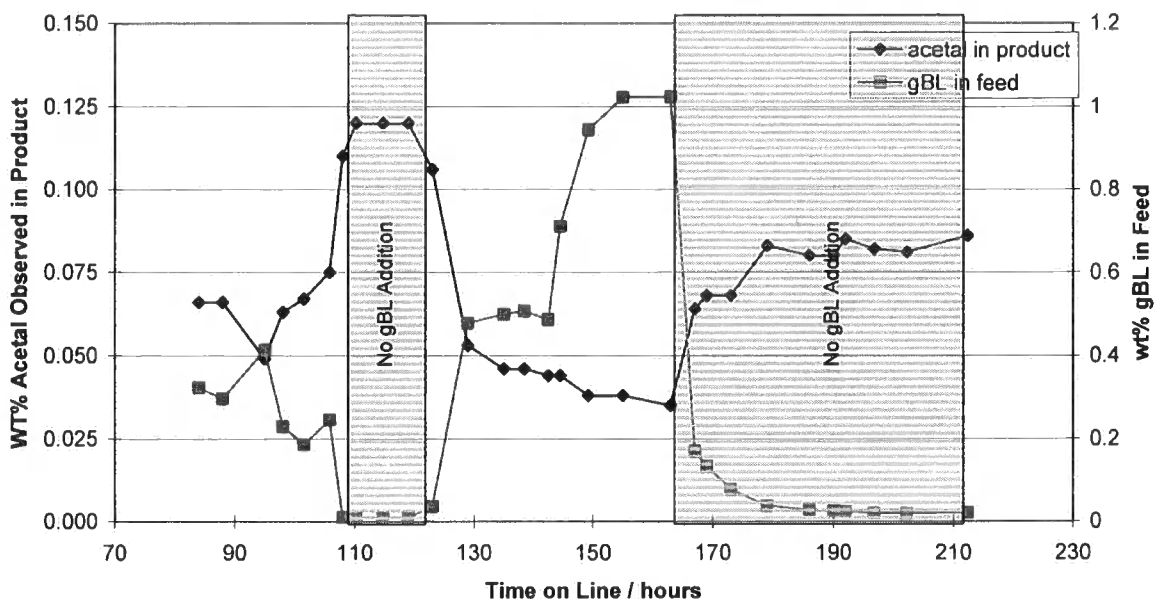

The data conclusively demonstrated the need for GBL to be present for reaction to occur. Acid catalysis by the GBL/4-Hydroxybutyric acid appears to be the most likely explanation. The potential for further work exists using other acids, both organic and mineral, to fully investigate this aspect of the Acetal removal process. However, as GBL is always present in commercial BDO this lies outside the scope of the work presented here.

When reverting to γ BL free feed the Acetal level did not revert to that observed at the start-of-run. This may be due to the high affinity of this type of catalyst to acid species creating a 'memory effect'.

The catalyst life still had not been evaluated so the conditions for the final run were held for a further 200 hours to compare deactivation with the previous tests (Figure

4.5, above). The conversion remained constant during this period suggesting the catalyst is suitable for this application.

4.16 Conclusions

The removal of Acetal by hydrogenation is a unique solution to a unique problem and therefore hard to relate to literature precedents. The hydrogenation of aldehydes is however well documented and the work presented above uses one of the potential catalysts found in the literature presented in the introduction. The conditions used were based on those required for economic commercial operation and optimised during the course of the work.

When attempting to remove Acetal by catalytic hydrogenation it is the control of the equilibria involved and the choice of feedstock that allow the removal to be achieved, meaning that not only the Acetal itself, but also its precursors must be removed. The addition of water to the feedstock was found to facilitate this. The role of residual gamma-butyrolactone found in the typical commercial feed used for the work was also found to be critical, as it appears to participate as an acid catalyst in the hydrolysis of Acetal to hydrogenateable precursors.

A method of estimating the predicted Acetal content that would be obtained after full refining of any mixtures produced was developed. This allowed the results obtained to be properly evaluated for commercial use.

This work has led to the Acetal removal stage being incorporated into two new commercial units one being built in Malaysia (Petronas) and one now operational in Taiwan (TCCC).

References

1. J.Baker, *Chemtec*, 2000, **28**,46.
2. Kirk-Othmer Encyclopedia of Chemical Technology, 4th Edition, Wiley, Canada, 1991, **1**, 210.
3. *Chemical Week NY*, Ed D.Hunter, Aug 9th 2000, **162**, 6.
4. Davy Process Technology , Confidential Report, SN118/1, 1987.
5. Davy Process Technology, Confidential Report, SN149/2/19, 1989.
6. Davy Process Technology, Confidential Report, SN158/3, 1997.
7. R.L.Augustine, *Catal. Rev. Sci. Eng.*, 1976, **13**, 285.
8. J.Jenck and J.E.Gramain, *J.Catal.*, 1980, **65**, 133.
9. M.E.Fakley and F.King, *Solid Supports in Catalytic Organic Synthesis*, Horwood, Chichester UK, 1992, 275.
10. T.Ohkuma, and R.Noyori, *Trans. Met. Org. Synth.*, 1998, **2**, 25.
11. T.Ohkuma and R.Noyori, *Compr Asymmetric Catal I-III*, Springer-Verlag, Berlin, 1999, 199.
12. M.J.Burk, and A.Gerlach, patent WO 01/26807, 2001,.
13. J.M.Planeix, N.Coustel, B.Coq, V.Brotons and P.S. Kumbhar, *J.Am.Chem.Soc.*, 1994, **116**, 7935.
14. Y.Nitta, Y.Hiramatsu and T.Imanaka, *Chem. Express*, 1989, **4**, 4, 281.
15. S.Schimph and D.Honicke, *C₄ Chemistry – Manufacture and Use of C₄ Hydrocarbons*, Aachen, 1997, 287.
16. H.U.Blaser, H.P.Jalett and D.M. Monti, *Appl. Catal.*, 1989, **52**, 19.
17. Kirk-Othmer Encyclopedia of Chemical Technology, 5th Edition, Wiley, Canada, 1999, **5**, 174.
18. Repsol/DPT, Private Communication.
19. M.V.Rajashekharan, *J. Sci & Ind Res.*, 1997, **56**, 10, 595.
20. J.D. Unruh, D.A. Ryan and S.L. Dugan, patent US5866725, 1999.

21. P. Chao-Chyan, patent EP0008767, 1979.
22. T.Salmi, V. Serra-Holm, T.K.Rantakyla, P.Maki-Arvela and L.P.Lindfros, patent WO 01/02330, 2001
23. G.E.Harrison and A.J.Dennis, patent US5093535, 1992.
24. J.R.Watts and W.Lewis, patent US4088700, 1978.
25. Davy Process Technology, Confidential Report.

Chapter 5

The Application of a Liquid Recycle Reactor to the Production of Tetrahydrofurfuryl Alcohol

5.1 Aims

1. To investigate the use of a liquid recycle reactor to control the highly exothermic hydrogenation of furfuryl alcohol to tetrahydrofurfuryl alcohol.
2. To assess the suitability of a nickel catalyst in the above system.
3. To study the parameters of the reaction and hence determine the optimum set for commercial operation.
4. To obtain data on the time dependent deactivation of the catalyst and hence predict the lifetime of the catalyst under reaction conditions.

5.2 Commercial Background

Currently the market for tetrahydrofurfuryl alcohol (THFA) is limited¹, its only use being as an intermediate for the production of dihydropyran². It is currently produced by batch, slurry phase hydrogenation of furfuryl alcohol³ which in turn is derived from furfural. Furfural producers are constantly seeking new applications of furfural and its downstream products, and THFA has been tested and found to be a useful solvent for many applications. It has the advantage of being relatively non-toxic and obtained from a renewable feedstock source. If it is to find use as a solvent a cheap, continuous method of manufacture must be sought. The work that is reported in this chapter sets out to achieve this objective.

5.3 Introduction

The production of THFA from furfuryl alcohol is based on catalytic hydrogenation, in this case the saturation of the aromatic ring of the furfuryl alcohol. Industrially the hydrogenation of aromatics is an important process. For example the production of cyclohexane from benzene over nickel or platinum has a value exceeding 3 billion pounds per annum in the US. Also of great importance is the saturation of the mixture of aromatics found in diesel fuel⁵. Whilst examples of homogeneous systems do exist⁶ the vast majority of work both industrially and academically has focused on heterogeneous catalysis, as does this work.

A number of metal systems are capable of performing the hydrogenation of benzene; the activity has been found to be as follows⁷:



Nickel, used for the work reported in this chapter, has been extensively studied for this reaction in many forms including Raney Nickel⁸, nickel on silica/alumina⁹

and nickel loaded zeolites¹⁰. The hydrogenation of benzene can be stopped at cyclohexene¹¹, for example when using Ru in the presence of water, though generally the reaction proceeds all the way through to cyclohexane. The hydrogenation of benzene is so well understood that it is used as a model reaction¹² when evaluating new catalysts; however the hydrogenation of furans is less well documented. By far the most work has been carried out on the hydrogenation of furan itself to produce the commercially valuable tetrahydrofuran¹³. Again many catalysts can be used; for example palladium has been studied¹⁴. However, cost and catalyst life span favour the use of nickel which is the catalyst chosen commercially for tetrahydrofuran production¹⁵. Typical conditions are 150°C and 500psi hydrogen in a batch reactor.

5.4 Reactor Design to Minimise the Effects of Exothermic Reactions

“Aside from the discovery and development of unique catalysts, the economic success of the refining, petrochemicals, and chemical industries has relied heavily on the design of innovative reactors to minimise capital and energy requirements to efficiently convert raw materials into products in industrial process plants.”¹⁶

Reactive distillation, mentioned in Chapter 3, is a good example of how a process can be made commercially viable using a novel reactor design for example in the alkylation of benzene¹⁷. Other examples include membrane reactors for the production of synthesis gas¹⁸ and the Davy ‘liquid recycle reactor’¹⁹ (LRC) for exothermic reactions. The concept is simple; if a reaction is kept sufficiently dilute the diluent will provide a heat sink and keep the reaction under control. In the Davy LRC system this is done by using product from the reaction. Figure 5.1 illustrates this concept.

Figure 5.1 The Davy Liquid Recycle Reactor

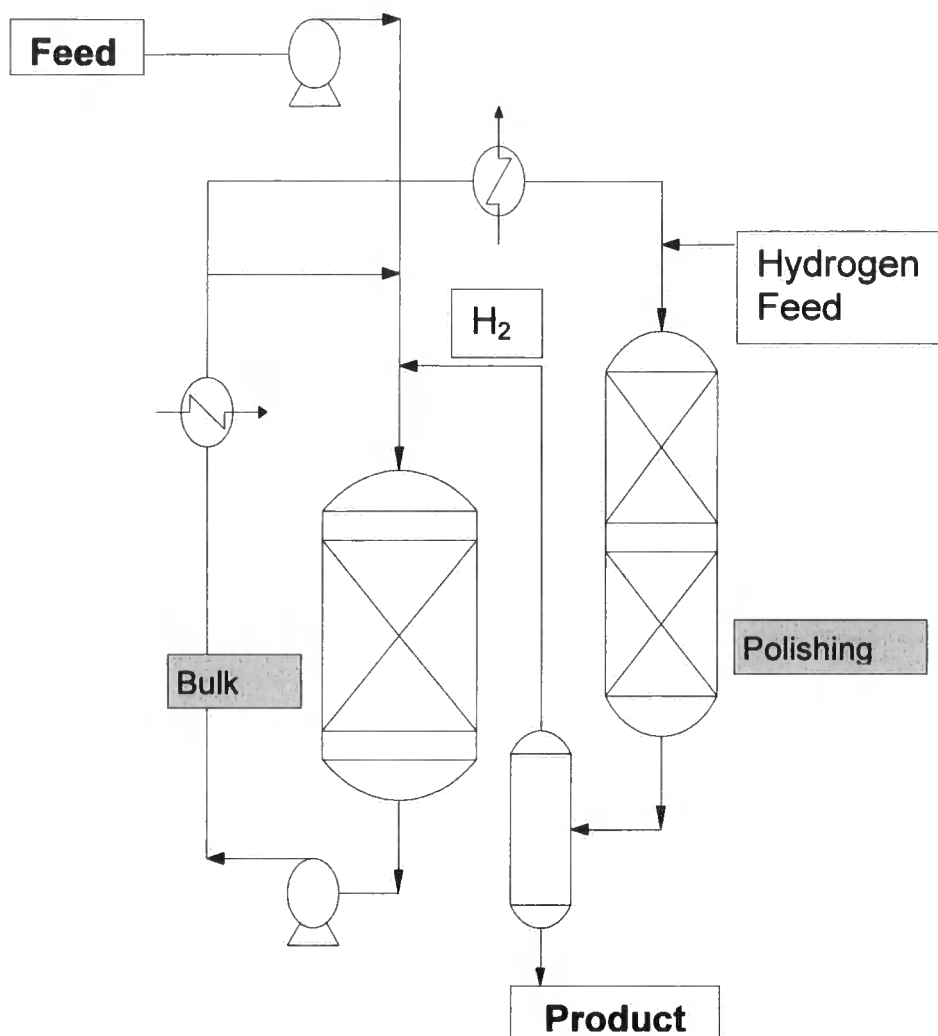

This configuration can be tuned to precisely control the temperature in the reactor by varying the proportion of recycled product. The more that is recycled the less the exotherm and corresponding temperature increase in the reactor. As well as any safety issues associated with an exothermic reaction, LRC also tends to improve the selectivity of a reaction when compared to a traditional fixed bed reactor and also tends to improve catalyst life span. This is achieved by virtue of the elimination of small hotspots that occur on the catalyst when the reaction is operated in traditional batch or continuous modes.

An example of its use is found in the hydrogenation of benzene to cyclohexane²⁰. It is known that the by-product methylcyclopentane is formed at

high temperature. When the LRC is used the amount in the product drops from 0.1wt% found in conventional fixed bed to 0.01wt%. The hydrogenation of furfuryl alcohol also suffers from the production of unwanted by-products, and in current batch processes between 10% and 30% of the feed stock is lost to 1,5-pentanediol and 1,2-pentanediol. Currently these by-products are removed by distillation. It is the aim of the work reported here to establish if the LRC concept can produce THFA with levels of diols less than 1.5%, which will then be of a suitable quality for commercial use without costly distillation.

The equipment used is described below; it has been designed to allow scale-up directly to full-scale operation without the need for a traditional hundreds of kilogram stage. This is achieved by the use of adiabatic reactor temperature control (see Chapter 2, pg27, for details of this control system) and more importantly by operating at similar liquid velocities across the catalyst to those found commercially. During scale-up, laminar flow may remain laminar, but heat and mass transfer will not remain constant. By operating at commercial velocities these scale-up effects can be minimised.

5.5 Chemistry

The compounds encountered in this work are shown below.

Main Reaction

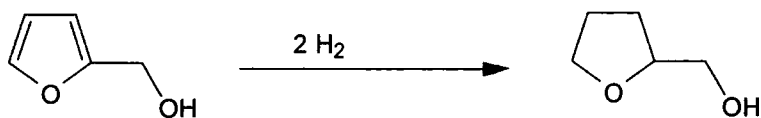

Furfuryl alcohol (FA)
(main feedstock)

Tetrahydro Furfuryl alcohol (THFA)
(main product)

By-Products / Impurities

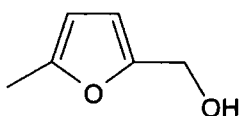

5-Methyl Furfuryl alcohol (5MFA)
(present in feed)

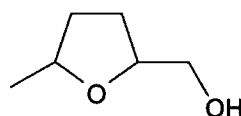

5-Methyl Tetrahydrofurfuryl alcohol (5MTHFA)
(by-product from 5MFA)

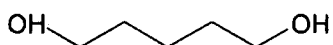

1,5 Pentanediol (1,5-PDO)
(present in feed and product)

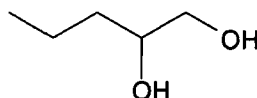

1,2 Pentanediol (1,2-PDO)
(present in feed and product)

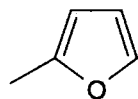

2-Methyl Furan (2MF)
(present in feed)

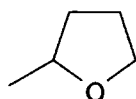

2-Methyl Tetrahydrofuran (2MTHF)
(by-product from 2MF)

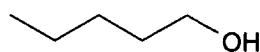

1-Pentanol (POH)
(by-product)

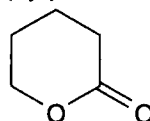

delta Valerolactone (dVal)
(by-product from 1,5-PDO)

5.6 Fixed Bed Reactor

A single fixed bed reactor was used for the initial work on catalyst screening and initial investigations into the optimum parameters for the reaction.

The reactor utilised for this work was an oil jacketed fixed bed system of 24.5 mm internal diameter. About 35 mls of catalyst was used for each test as this was deemed to be the minimum amount required to allow both inlet and exit thermocouples to be in the catalyst bed. The layout is shown below in Figure 5.2

Figure 5.2 Diagram of the Fixed Bed Reactor

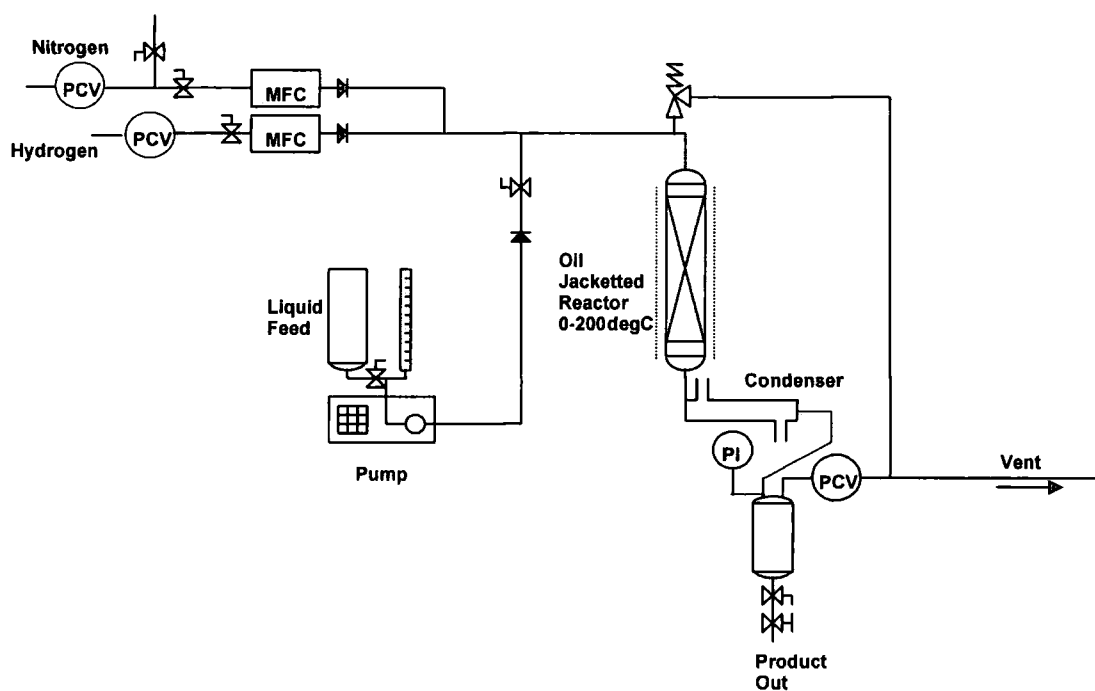

5.7 Pilot Plant Liquid Recycle Reactor

A fully automated plant consisting of two reactors (one reactor for the bulk reaction and one reactor for the polishing reaction) was used for the life test and final optimisation. A schematic Process Flow Diagram (PFD) for the equipment is shown in Figure 5.3.

Figure 5.3 Pilot Plant Liquid Recycle Reactor Scheme

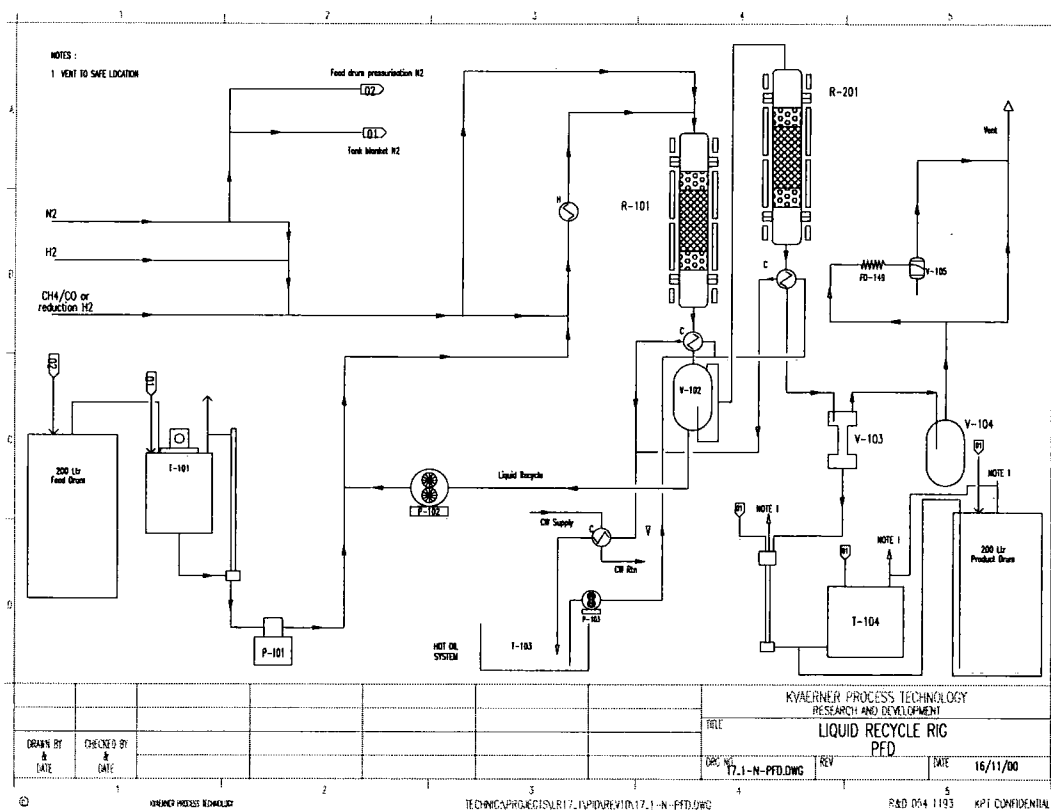

5.8 Liquid Feed System

The furfuryl alcohol feed was supplied from a 200 litre drum by slightly pressurising it (10 psig) using a secondary nitrogen supply and this enabled the furfuryl alcohol to be transferred through a ¼ inch pipe into the feed tank T-101. The level in the tank was measured using a ΔP cell and refilled as required from the feed drum. A positive displacement piston pump (P-101) was used to transfer feed to the reactor; feed rate was controlled automatically by varying the stroke length, feed rate being measured by timing the flow from a calibrated burette.

5.9 Gas System

The flow of all gases was controlled using Brookes mass flow controllers (MFC). Nitrogen was supplied from the building ring main and was used for nitrogen blanketing vessels, as a diluent during catalyst activation and for emergency shutdown. The nitrogen flow meter had a flow range of 0 -600 NLPH. Hydrogen, used for the activation, was supplied from cylinders via a MFC with a range of 0 - 120 NLPH. Hydrogen was also supplied from a larger MFC, having a range of 0 - 1000 NLPH, used during normal operation. A regulator to control the gas purge was situated after the product vessels, the flow controlling the reactor pressure. An additional vent flow via an automated ball valve and capillary coil was present as part of the trip logic for depressurising the reactor system.

5.10 Reactors 1 and 2

Reactor 1 (R-101) used for this testwork had an internal diameter of 25 mm, holding up to 1450 cm³ of catalyst; reactor 2 (R-201) had an internal diameter of 20.9 mm holding up to 500 cm³ of catalyst. Each reactor was equipped with

four heating elements, one surrounding the top nut, one on the top half, one on the bottom half of the reactor and one on the bottom nut. The two main heating elements on the reactor were designed to operate either adiabatically (zero ΔT) or to heat the reactors.

5.11 Recycle Loop

Liquid product from reactor 1 was passed through a heat exchanger to cool the product if required. The vessel after reactor 1 was fitted internally with an 8 mm pipe protruding half way up the vessel which acted as an overflow for excess liquid and gas passing to the second reactor. Liquid was drawn from the sump of this vessel through filters to the liquid recycle gear pump. The liquid passed through a coriolis mass flow meter then a heater and finally a trim heater before returning to reactor 1. Fresh feed was supplied to the recycle loop upstream of the main heater whilst gas feed was fed to the top of the reactor.

5.12 Product System

Liquid product and excess gas from the second reactor were cooled and collected in a separation vessel the liquid level being controlled using a control valve and ΔP cell. The product was collected in either a local storage vessel or a 200 litre drum. Excess gas separated from the liquid product, passed through a secondary collection vessel and was vented to atmosphere through a pressure regulator.

5.13 Catalyst Loading

Prior to loading the reactors, a stainless steel knitmesh plug was inserted into the bottom of the reactor to act as catalyst support and prevent catalyst ingress into the exit pipe. Glass balls were then charged on top of this plug and then the catalyst.

5.14 Catalyst Activation

The catalyst used for this testwork was charged to the two reactors in a reduced stabilised form and activated before use. The procedure followed was detailed in the section on catalyst activation in Chapter 4, pg 90.

5.15 Analytical Procedures

The analytical procedure for analysing the liquid feed and product samples by gas chromatography and titration can be found in Appendix 1.

5.16 Calibration and Tests

The instruments (pressure indicators, flow meters, thermocouples etc) used on this reactor are of the same type as those detailed in Chapter 2. The calibration procedures adopted were therefore the same.

5.17 Testwork

The work was divided into three distinct stages. Firstly three catalysts were tested from each of three different manufacturers asked for a nickel aromatic hydrogenation catalyst. During this catalyst screening exercise, an initial attempt at finding the optimum conditions for the reaction was also performed. The work then progressed to the pilot plant described above, where the catalyst was operated for an extended period to determine if any time related deactivation was occurring. The final phase was varying reaction parameters on the pilot plant to determine whether the product specification could be achieved. This final phase was performed last to ensure the catalyst was aged as freshly charged catalysts can sometimes give high activity/ low selectivity before they are fully 'bedded in'.

5.18 Fixed Bed Testwork

Initial screening and condition scans were performed using the small fixed bed reactor described previously. The recycled THFA that is inherent in the reactor configuration proposed for this application, was simulated by adding THFA to the feed. Three catalysts were supplied by three different manufacturers Engelhard, CRI and Sud-Chemi. The suppliers were told the application and supplied the most suitable catalyst they sell. All were subject to non-analysis agreements. The reactor was initially charged with 30.2 g (36.5 mls) of nickel catalyst (catalyst A, supplied by Engelhard). The catalyst was activated as described in Chapter 4, pg92, above.

The initial conditions (400 psig, 50°C, LHSV = 1.0hr⁻¹) chosen for study were determined by reference²² to a batch autoclave test.. The feed was diluted to 10wt% in THFA. Further runs were then performed at LHSV=0.5 hr⁻¹, 70°C and 100°C then returning to initial conditions to check for deactivation. Full details of all three catalysts screened are given in Tables 5.1–5.14 and presented in Figure 5.4. Evaluation of the second reactor, the polishing reactor, was then performed by re-passing the product obtained from the bulk reactor simulation over the catalyst at a feed rate equivalent to that which would be used on this reactor design, the same rate as on the bulk reactor.

The second catalyst was then charged 30.2g (catalyst B, supplied by CRI) to the fixed bed reactor and reduced using the same procedure. Temperature was further investigated running at 150°C and 125°C; the effect of feed dilution was also investigated. During one such run the hydrogen supply was insufficient due to the mass flow controller used and this obviously had a serious impact on conversion (see Figure 5.4). The next run was in polishing mode. The final run on this catalyst was a return to initial conditions after leaving the unit in stand-by mode for three days with a small purge of hydrogen.

Catalyst C (supplied by Sud-Chemi) was then evaluated using 30.2 g of catalyst and activating as described in Chapter 4. The initial conditions chosen

were those used for all catalysts previously evaluated, 50°C, LHSV = 0.5hr⁻¹, 10 wt% furfuryl alcohol in THFA feed. An extended run was then performed in an attempt to get an indication of catalyst life. Harsher conditions were chosen than previously used to fully test the catalyst (LHSV = 0.75 hr⁻¹, 400 psig and 115°C). These conditions were held for 70 hours at which point the feed LHSV was increased to 1.0 hr⁻¹, until 90 hours on-line.

The unit was then switched to polishing mode, the oil temperature being adjusted to give approximately that of the bulk bed. The temperature was then reduced to 100°C. Finally the polishing reactor feed was spiked with 1% and then 5% furfuryl alcohol to determine how effective this system was in this mode.

To act as a further indication of catalyst life the unit was returned to the original feed and conditions used at the start of the extended run, and finally the initial conditions used for catalyst evaluation were re-tested.

5.19 Catalyst A Studies

At the initial conditions chosen (LHSV = 1.0 hr⁻¹, 50°C), the level of furfuryl alcohol observed in the product was 9 wt%, compared with 10 wt% in the feed, ie a conversion of only 10% over the bed. At first sight this appears low, but when considered as part of the overall LRC flowsheet, this would equate to a conversion of approximately 90%, as pure furfuryl alcohol would be fed to the reactor with the composition exiting the first bed being the 9wt% observed in the simulation of this reactor above. Halving the LHSV reduced the furfuryl alcohol observed in the product by approximately 1%.

The product from these runs was bulked and re-passed over the catalyst to simulate the polishing reactor. This reduced the furfuryl alcohol to 5.5wt% suggesting that harsher conditions may be required to get to less than 0.1wt% furfuryl alcohol required commercially. Running at 70°C resulted in the furfuryl alcohol level dropping to about 6.5%. This run was extended overnight to detect any gross deactivation of the catalyst. The conversion, once steady,

remained constant for 12 hours. The following runs at 100°C, and 100°C with a small excess of hydrogen, showed a small increase in conversion.

The conditions were returned to initial start-of-life parameters to enable a check on loss of activity over the course of these runs. This showed the catalyst was not as active as at the start of life, suggesting that deactivation was occurring; however, the rate of deactivation observed was fully investigated in the next phase of the work

Table 5.1 Catalyst A Results from Bulk Mode, LHSV = 1.0 hr⁻¹, 50°C, Showing the Wt% of Each Component with Time

Time on Line / hr	Furfuryl alcohol	THFA	1,2 PDO	1,5 PDO	Unknowns
1.0	9.24	89.6	0.02	0.05	1.09
1.8	9.26	90.45	0	0.04	0.25
3.5	9.07	90.75	0	0.04	0.14
4.5	9.07	90.72	0.02	0.04	0.15

Table 5.2 Catalyst A Results from Bulk Mode, LHSV = 0.5 hr⁻¹, 50°C, Showing the Wt% of Each Component with Time.

Time on Line / hr	Furfuryl alcohol	THFA	1,2 PDO	1,5 PDO	Unknowns
1.1	6.88	92.89	0.02	0.04	0.17
2.2	7.3	92.47	0.02	0.04	0.17
3.2	7.59	92.23	0	0.04	0.14
4.3	7.84	91.91	0.02	0.04	0.19

Table 5.3 Catalyst A Results from Polishing Mode, LHSV = 1.0 hr⁻¹, 50°C, Showing the Wt% of Each Component with Time

Time on Line / hr	Furfuryl alcohol	THFA	1,2 PDO	1,5 PDO	Unknowns
3	5.51	94.35	0.02	0.04	0.08
4.25	5.65	94.22	0	0.04	0.09

Table 5.4 Catalyst A Results from Bulk Mode, LHSV = 0.5 hr⁻¹, 70°C, Showing the Wt% of Each Component with Time

Time on Line / hr	Furfuryl alcohol	THFA	1,2 PDO	1,5 PDO	Unknowns
2.00	5.45	94.29	0.03	0	0.23
3.25	6.31	93.5	0	0	0.19
4.00	6.76	93.06	0	0	0.18
5.50	6.78	93.04	0	0	0.18
8.00	7.03	92.93	0	0	0.04
10.75	7.16	92.79	0	0	0.05
12.25	7.24	92.59	0.05	0	0.06
14.00	7.7	92.05	0.1	0	0.03
15.75	7.81	91.88	0.13	0	0.03
17.50	7.81	91.86	0.16	0	-0.01
19.00	7.93	91.71	0.17	0	0
20.50	7.84	9.78	0.18	0	82
22.00	7.84	91.76	0.19	0	0
23.50	7.88	91.7	0.19	0	0.02

Table 5.5 Catalyst A Results from Bulk Mode, LHSV = 0.5 hr⁻¹, 100°C, Showing the Wt% of Each Component with Time

Time on Line / hr	Furfuryl alcohol	THFA	1,2 PDO	1,5 PDO	Unknowns
1.5	4.48	95.17	0.09	0.09	0.1
2.5	6.16	93.7	0.04	0.04	0.06
4.5	6.59	93.28	0.03	0.04	0.06
6	6.44	93.43	0.03	0.03	0.07
6.75	6.74	93.16	0.03	0	0.07

Table 5.6 Catalyst A Results from Bulk Mode, LHSV = 0.5 hr⁻¹, 100°C, Showing the Wt% of Each Component with Time

Time on Line / hr	Furfuryl alcohol	THFA	1,2 PDO	1,5 PDO	Unknowns
1.00	1.84	97.7	0	0.2	0.26
2.17	3.19	96.56	0.05	0.09	0.11
3.00	4.18	95.65	0.04	0.05	0.08
4.58	5.02	94.83	0.03	0.05	0.07

Table 5.7 Catalyst A Results from Bulk Mode, LHSV = 0.5 hr⁻¹, 50°C, Showing the Wt% of Each Component with Time

Time on Line / hr	Furfuryl alcohol	THFA	1,2 PDO	1,5 PDO	Unknowns
1.17	8.55	91.25	0.07	0	0.05
2.58	9.02	90.82	0.04	0	0.06
3.58	9.05	90.8	0.04	0	0.06
5.17	9.11	90.8	0.03	0	0.03

Figure 5.4 Catalyst A – wt% Furfuryl Alcohol observed in hydrogenation Product with time for each condition studied.

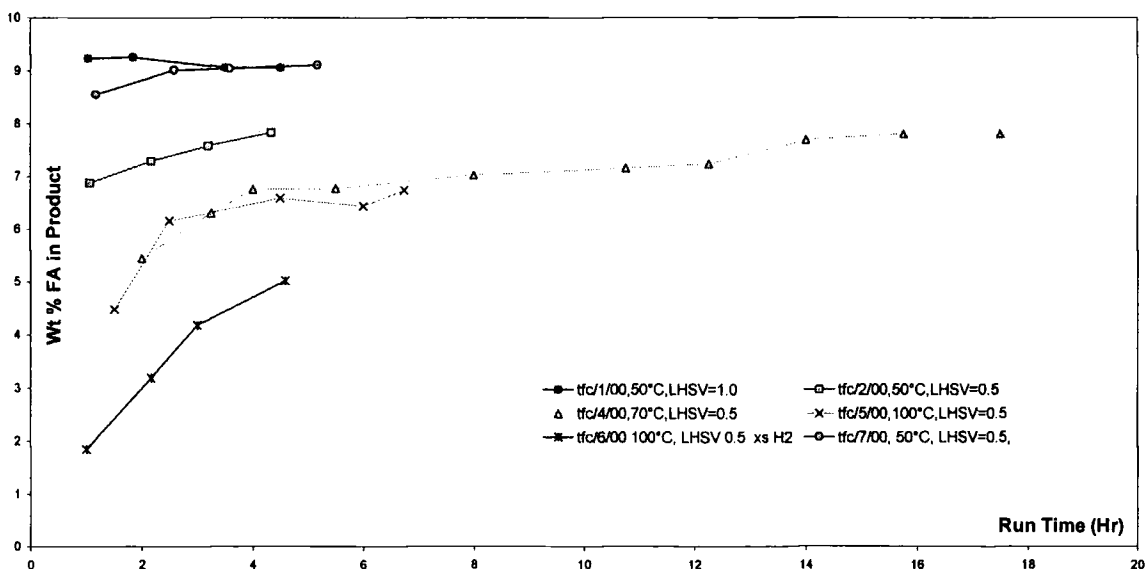

5.20 Catalyst B Studies

Catalyst B was initially checked at the same mild conditions, showing slightly higher activity than catalyst A, before the increased temperature run was attempted.

At the elevated temperature of 150°C, complete conversion of the furfuryl alcohol was observed; however, the by-product make was much higher, although still within the target of less than 1.5 wt%. These by-products were identified by GC/MS as 1,2 and 1,5 pentanediol, from ring opening reactions and 5-methyl tetrahydrofurfuryl alcohol from 5-methyl furfuryl alcohol present in the feedstock.

The temperature was then reduced to approximately 120°C in an attempt to see breakthrough of furfuryl alcohol, but again none was observed in the product, although by-products were reduced. Further reduction in temperature to 100°C with extended operation gave only 0.5 wt% furfuryl alcohol in the product.

This was surprising when compared with the results obtained on the previous catalyst charge; however, this may be due to modifications performed to the rig after the first charge allowing the hydrogen to be "topped-up" after sampling. Starvation of hydrogen may have been the cause of the observed lower activity and deactivation over the course of the previous tests.

As this observed higher activity was encouraging, in the next run, feedstock was prepared with double the concentration of furfuryl alcohol. The conversion, initially high, rapidly declined mainly due to the inability of the equipment to supply all the hydrogen required for the reaction. For subsequent runs the equipment was modified to accommodate this.

A polishing run was then performed giving a product of less than 1 wt% furfuryl alcohol. Finally an activity check showed no loss in conversion over the course of these tests.

Limitations of the rig did not allow higher concentrations of feedstock to be investigated, but this series of tests demonstrated the temperature envelope. Modifications were then performed to operate under flow control allowing a greater consumption of hydrogen.

Table 5.8 Catalyst B Results from Bulk Mode, LHSV = 0.5 hr⁻¹, 50°C, Showing the Wt% of Each Component with Time

Time on Line / hr	Furfuryl alcohol	THFA	1,2 PDO	1,5 PDO	Unknowns
0.83	5.63	94.12	0.05	0.06	0.14
1.92	5.4	94.5	0	0.04	0.06
3.00	5.69	94.18	0.04	0.03	0.06
3.83	5.98	93.96	0	0	0.06

Table 5.9 Catalyst B Results from Bulk Mode, 150°C, LHSV = 0.5 hr⁻¹, Showing the Wt% of Each Component with Time

Time on Line / hr	Furfuryl alcohol	1,2 PDO	1,5 PDO	THFA	Unknowns
2.50	0	0.51	0.7	97.7	1
4.00	0	0.51	0.61	98.01	0.76
5.50	0	0.5	0.56	98.21	0.6
7.00	0	0.53	0.53	98.25	0.54
8.50	0	0.52	0.53	98.28	0.51
10.00	0	0.45	0.45	98.56	0.36
11.50	0	0.51	0.47	98.44	0.41
13.00	0	0.54	0.51	98.3	0.48
14.63	0	0.53	0.51	98.33	0.46
16.00	0	0.53	0.51	98.34	0.45
17.25	0	0.54	0.52	98.34	0.43

Table 5.10 Catalyst B Results from Bulk Mode, 125°C, LHSV = 0.5 hr⁻¹, Showing the Wt% of Each Component with Time

Time on Line / hr	Furfuryl alcohol	1,2 PDO	1,5 PDO	THFA	Unknowns
1.33	0	0.3	0.23	99.18	0.12
2.17	0	0.3	0.2	99.21	0.12
2.58	0	0.28	0.18	99.28	0.09

Table 5.11 Catalyst B Results from Bulk Mode, LHSV = 0.5 hr⁻¹, 100°C, Showing the Wt% of Each Component with Time

Time on Line / hr	Furfuryl alcohol	1,2 PDO	1,5 PDO	THFA	Unknowns
1.00	0	0.28	0.18	99.28	0.09
2.08	0.14	0.19	0.1	99.31	0.08
3.08	0.33	0.17	0.07	99.23	0.03
4.50	0.43	0.17	0.06	99.15	0.02
6.00	0.48	0.17	0.05	99.09	0.04

Table 5.12 Catalyst B Results from Bulk Mode, LHSV = 1.0 hr⁻¹, 100°C, 20 wt% FA Feed, Showing the Wt% of Each Component with Time

Time on Line / hr	Furfuryl alcohol	1,2 PDO	1,5 PDO	THFA	Unknowns
1.25	0.87	0.36	0.23	98.07	0.32
2.75	0.87	0.36	0.23	98.06	0.32
4.42	14.66	0.21	0.06	84.8	0.13
6.00	18.89	0.15	0.06	80.68	0.08

Table 5.13 Catalyst B Results from Polishing Mode, LHSV = 1.0 hr⁻¹, 85°C, Showing the Wt% of Each Component with Time

Time on Line / hr	Furfuryl alcohol	1,2 PDO	1,5 PDO	THFA	Unknowns
2.08	0.87	0.36	0.23	98.07	0.32
3.33	1.20	0.24	0.09	98.06	0.25
4.83	0.91	0.24	0.1	98.44	0.16
6.92	0.65	0.25	0.1	98.64	0.2
7.92	0.49	0.25	0.1	98.81	0.2

Table 5.14 Catalyst B Results from Bulk Mode, LHSV = 0.5 hr⁻¹, 50°C, Showing the Wt% of Each Component with Time

Time on Line / hr	Furfuryl alcohol	1,2 PDO	1,5 PDO	THFA	Unknowns
2.25	5.22	0.16	0.03	94.39	0.04
3.75	4.74	0.16	0.03	94.85	0.06
5.25	4.68	0.16	0.05	94.87	0.08

Figure 5.5 Catalyst B – wt% Furfuryl Alcohol observed in the Hydrogenation Product with time for each condition studied.

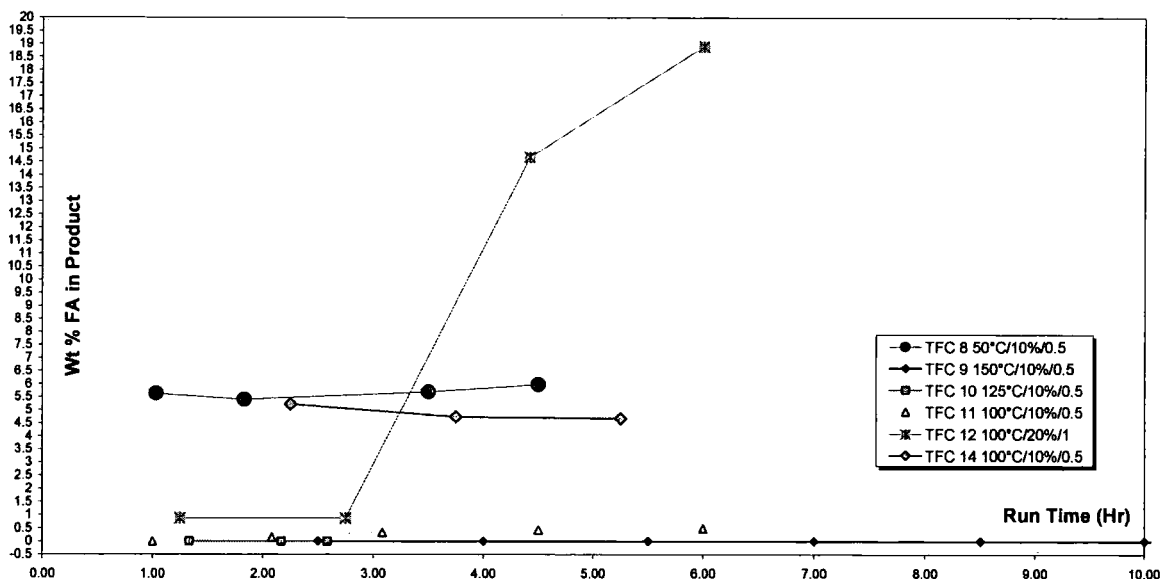

5.21 Catalyst C Studies

All data are given in Tables 5.15-5.22 and shown in Figures 5.6 – 5.8. The results from the initial condition compared favourably with the other catalysts screened (see Table 5.15).

For the life test the feed used was material bulked from previous runs and spiked to approximately 15wt% furfuryl alcohol (see Table 5.16). During the

time this feedstock was used (see Figure 5.6), operation was not as stable as would have been expected; however a typical analysis is given in Table 5.17. Changing feed to a second batch of catalyst C resulted in a surprising drop in the observed level of furfuryl alcohol in the product, which remained stable for the remainder of the operation in bulk mode.

The increase in LHSV by 25% to 1.0 hr^{-1} slightly increased the level of conversion with a corresponding small increase in by-products. This surprising effect was initially postulated to be due to increased utilisation of the catalyst at the higher more turbulent flow, but this was later proved not to be the case on the pilot unit. This condition probably represents the upper limit of the operating envelope for this system.

Switching to polishing mode resulted in undetectable levels of furfuryl alcohol in the product, with low by-product make over this section of the process when compared to the bulk mode (see Table 5.18) reducing the temperature by 20°C still resulted in no observable furfuryl alcohol in the product.

Reducing the gas rate to only 10% of total required for the overall reaction still did not result in furfuryl alcohol breakthrough. By-product make remained almost constant during all these runs reinforcing the observation above that once formed THFA is more stable than the starting material.

Remaining at these conditions and spiking the feed with 1 wt% and then 5 wt% furfuryl alcohol still did not yield furfuryl alcohol breakthrough and still little change in by-products (see Table 5.19). These final results suggest that milder conditions could be used for the bulk phase, extending the temperature range downwards.

Another bulk run was performed to test this theory at 100°C . Even at this temperature only approximately 3% furfuryl alcohol was observed in the product.

The final run with this feedstock (TFC 12/01), was a duplicate of the first on this feedstock. Only enough feed for one sample remained, which at 0.63 wt% was within the range of conversion observed at the start; however, it was at the upper level of this range.

The return to the conditions used for catalyst testing gave a more reliable result (see Table 5.21, Figure 5.7), indicating some activity had been lost over the course of the runs, a total time (bulk and polish) of about 250 hours.

Table 5.15 Catalyst C Results from Initial Activity Check, Showing the Wt% of Each Component with Time

Time on Line / hr	Furfuryl Alcohol	1,2 PDO	1,5 PDO	THFA	Unknowns
2.00	4.32	0.04	0.02	95.45	0.16
3.50	4.11	0.04	0	95.76	0.07
5.00	4.93	0.03	0.02	94.95	0.05
6.50	5.29	0	0	94.66	0.09
7.50	5.19	0	0	94.72	0.09

Table 5.16 Feed Analysis for The Catalyst Life Test Showing the Wt% of Each Component

	Light Unknowns	Furfuryl Alcohol	THFA	1,2 PDO	1,5 PDO	Heavy Unknowns
Feed Batch 1	0.24	15.96	83.23	0.23	0.18	0.06
Feed Batch 2	0.21	15.93	83.02	0.24	0.18	0.08

Table 5.17 Results from differing conditions in bulk mode Showing the Wt% of Each Component

	Light Unknowns	Furfural Alcohol	THFA	1,2 PDO	1,5 PDO	Heavy Unknowns
TFC3/01	0.16	0.39	98.45	0.21	0.19	0.04
TFC4/01	0.31	0.09	98.11	0.40	0.37	0.04
TFC5/01	0.24	0.14	98.03	0.42	0.39	0.04

Table 5.18 Catalyst C Results Showing Overall by-product make over both bulk and polish

	Light Unknowns	Furfuryl Alcohol	THFA	5MeTHFA	1,2 PDO	1,5 PDO	Heavy Unknowns
Feed to Bulk, wt%	0.21	15.93	83.02	0.10	0.24	0.18	0.08
Moles	≅0	0.16	0.81	0.00	0.00	0.00	0.00

Bulk Reaction

Bulk Product wt%	0.31	0.21	98.03	0.14	0.41	0.38	0.05
Moles	0.004	0.002	0.958	0.001	0.004	0.004	≅0
Mole make	0.001	-0.149	0.136	≅0	0.002	0.002	≅0

Polish Reaction

Polish Product wt%	0.31	0.00	97.99	0.14	0.42	0.41	0.04
Moles	0.004	0.000	0.957	0.001	0.004	0.004	≅0
Mole Make	≅0	-0.002	≅0	0.0000	≅0	≅0	-≅0

Table 5.19 Product Analysis for Life Test - Polish Mode, Showing the Wt% of Each Component

	Details	Light Unknowns	furfuryl Alcohol	THFA	1,2 PDO	1,5 PDO	Heavy Unknowns
TFC/6/01	Conditions matched to bulk	0.32	0.00	98.02	0.43	0.41	0.03
TFC/7/01	Reduced H ₂ flow	0.34	0.00	97.85	0.42	0.40	0.06
TFC/8/01	Reduced temperature	0.33	0.00	97.94	0.42	0.40	0.07
TFC/9/01	1% FA feed	0.31	0.00	98.02	0.42	0.40	0.04
TFC/10/01	5% FA feed	0.33	0.00	97.96	0.43	0.41	0.05

Table 5.20 Catalyst C Results in Bulk Mode at 100°C

	Light Unknowns	Furfural Alcohol	THFA	1,2 PDO	1,5 PDO	Heavy Unknowns
TFC/11/01	0.06	2.69	96.59	0.11	0.06	0.04

Table 5.21 Catalyst C Final Activity Check, Showing the Wt% of Each Component with Time

Time on line / hr	Furfural Alcohol	1,2 PDO	1,5 PDO	THFA	Unknowns
1.25	6.99	0	0	92.84	0.17
3.25	7.14	0	0.02	92.7	0.14
6.25	7.34	0	0	92.54	0.1
8.25	7.15	0	0	92.75	0.08

Figure 5.6 Life test on Catalyst C Furfural Alcohol Hydrogenation with Time on Line

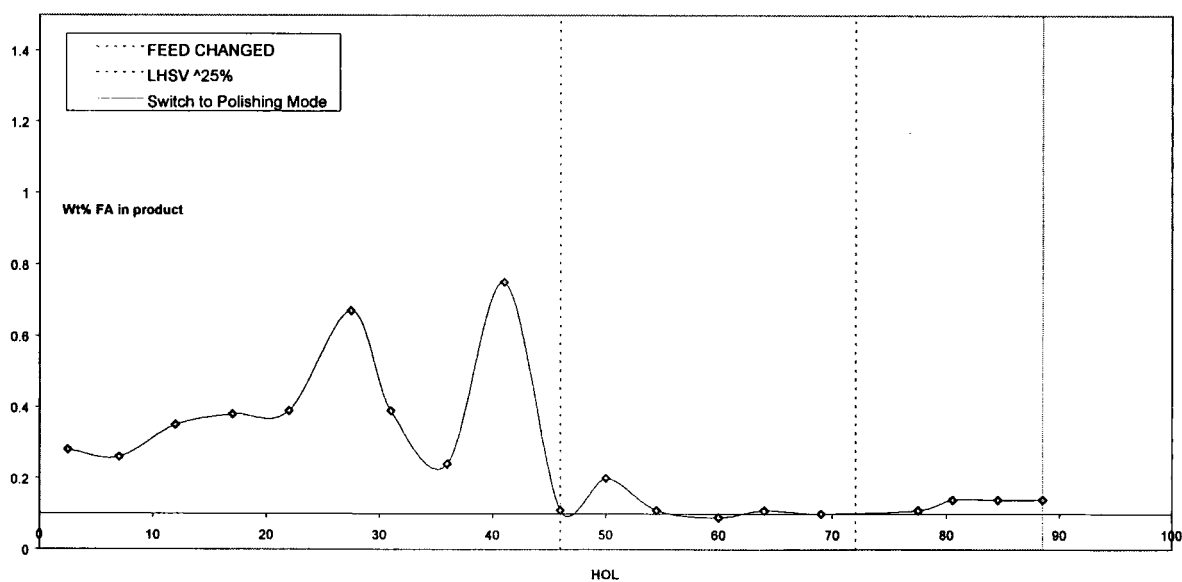
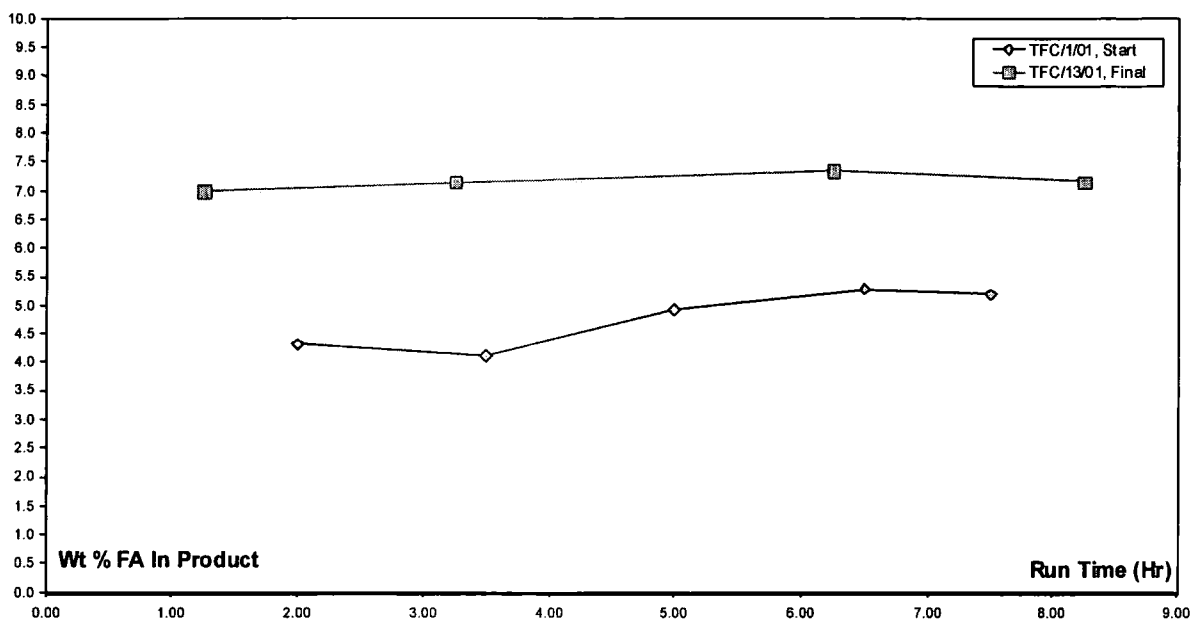

Figure 5.7 Hydrogenation Tests Using Catalyst C at Similar Conditions, Start and End of Run, Showing Deactivation



5.22 Comparison of Catalysts A, B and C

As well as obtaining initial operating data on the system an objective of this series of tests was to evaluate three catalysts from different manufacturers. Figure 5.8 clearly shows the difference between these catalysts with Catalyst C showing the lowest level of residual furfuryl alcohol in the product and hence the highest activity. Consultation with the three manufacturers determined that catalyst C could also be obtained more cheaply (on a weight for weight basis) than the other catalysts and hence was chosen for the life test prior to its use in the final commercial unit.

Figure 5.8 Catalysts A,B and C, Showing furfuryl alcohol in the product vs time at identical test conditions

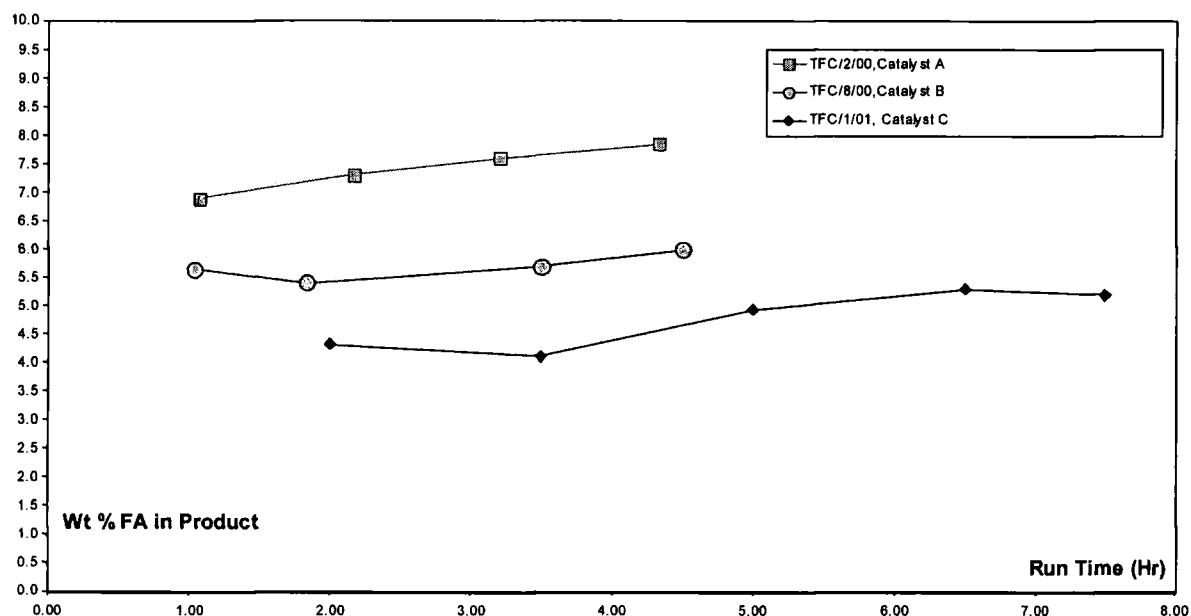

5.23 Catalyst Lifetest

From the work described above the predicted operating envelope for furfuryl alcohol hydrogenation was deemed to be 50°C–125°C, 400 psig, LHSV = 0.5–2.0 hr⁻¹ recycle ratio 10:1 to 5:1. Using this information the pilot unit described above (figure 5.3) was used to for a life test on the catalyst.

The reactor was packed with 500 mls (340 g) of catalyst in both the bulk and polishing reactors. Due to the differing reactor diameters this resulted in a different bed length in each, the bulk reactor bed being approximately half the length of the polishing bed.

Nitrogen was introduced at a GHSV of 100 hr⁻¹ and the reactor warmed to 150°C. The exit gas was then checked for residual CO₂ from the catalyst stabilisation but none was detected.

Hydrogen was then introduced at 0.5 mole% and increased over the next 10 hours until the gas inlet was about 10 mole% hydrogen. Over the next 9 hours

the nitrogen flow systematically reduced, eventually giving pure hydrogen. The pressure was then increased to 400 psig and held for approximately 8 hours. At this point the catalyst in both reactors was deemed active. The bulk reactor was then cooled to 60°C and product from the work above was fed into the unit until it was hydraulically full, denoted by product being observed exiting the second reactor. The recycle pump in the bulk reactor was then started and left for 8 hours to remove any catalyst fines in the filter system. Only one filter change after 8 hours was needed.

The hydrogen flow was then established at 225 NLPH, equivalent to a 10% excess at LHSV = 0.75 hr⁻¹, the pressure being controlled by a regulator after the second reactor. Furfuryl alcohol feed was then introduced, aiming for LHSV = 0.75 hr⁻¹ using ¼, ½, ¾ and full rate step-wise over 2 hours. After the conditions had stabilised the polishing reactor was running at a temperature of 115°C due to an exotherm caused by insufficient conversion in the bulk reactor. The feedrate was therefore halved to 0.375 and the temperature increased in the bulk reactor to 80°C. This had the desired effect. Reducing the recycle rate from 15.5 kg/hr⁻¹ to 11.5 kg/hr⁻¹ enhanced the effect by increasing the exotherm across the bulk bed and hence the conversion. The polishing bed then over-cooled, due to heat loss between the reactors, which was rectified by changing from adiabatic control to external heating. These conditions were then used for the remainder of the life test, ie:

LHSV / hr ⁻¹	0.375 (187 mlhr ⁻¹)
Pressure/ psig	450
Bulk temperature/ °C	90 (inlet)
Polishing temperature/ °C	90 (exit)
R/C rate/ kghr ⁻¹	11.5

These actions took the time on-line to about 75 hours. Following this period, the conditions were held until 340 hours on-line when feed pump malfunction resulted in a period of operation at a 50% increase in throughput. Following rectification of this problem a further 125 hours on-line were accrued.

5.24 Lifetest Results and Discussion

All data are shown graphically in Figures 5.8 (p135) to 5.10 (p139). Starting up at the conditions described above 10% furfuryl alcohol was observed to exit the bulk reactor whereas of the order of 5–7 wt was expected. Calculation²³, (see Figures 5.12 and 5.13), predicted a 70°C exotherm in the polishing bed, which was close to the 60°C observed. The figures show that to keep the exotherm <10°C, <1.5 wt% furfuryl alcohol should be present in the product from the bulk reactor passed to the polishing reactor. No heating or cooling existed between the two reactors, therefore, ten degrees was chosen as the maximum exotherm. The polishing reactor therefore runs at approximately the same temperature as the bulk reactor exit. The changes in operation that yielded the conditions for the test given above reduced the furfuryl alcohol content to 0.5 wt% (see Figure 5.11) resulting in on-specification furfuryl alcohol concentration (<0.1 wt%) exit the polishing reactor.

However, once at steady state the by-product production rate meant that the THFA produced failed to meet the specification set commercially at 98% minimum. This was due to formation of a combination of 1,2-pentanediol (1,2-PDO) and 1,5-pentanediol (1,5-PDO), both at 0.7 wt%, pentanol at 0.2 wt% and heavy and light unknowns at 1.0 wt% and 0.1 wt%, respectively. The heavy unknowns were mainly due to one compound, the identity of which by GC/MS analysis proved unclear. These values remained roughly steady for the subsequent 250 hours on-line.

The feed pump malfunction problems disclosed above, which caused the feed flow to increase by 50%, gave the surprising effect of increasing the amount of by-product. Whilst the 1,5-pentanediols content dropped slightly, the remaining by-products increased to >2 wt%. This was investigated during the optimisation study performed later. Following this period, returning to the correct conditions to give a total of 600 hours on-line, the product and by-product levels again remained stable.

During this entire time, the FA level exiting in the polishing reactor never rose above the specification limit of 0.1 wt%; however, the apparent amount of FA appeared to “bounce” during the initial 300 hours on-line. However this was an artefact due to cross contamination on the GC between the bulk and polishing reactor samples. A change in the protocol remedied this problem. The true value will be much lower than that recorded.

The absence of any observed deactivation was encouraging, as it suggested no gross deactivation was occurring. It should be noted that the feedstock to the reactors had already been treated with a Cu/Cr catalyst during its production, removing any poisons. The other main deactivation mechanisms would be sintering, which is unlikely at this temperature, and coking, which again is unlikely due to the dilution effect of the liquid recycle stream.

Figure 5.9 Furfuryl Alcohol, wt% in Products from Bulk and Polishing Reactors during the life test

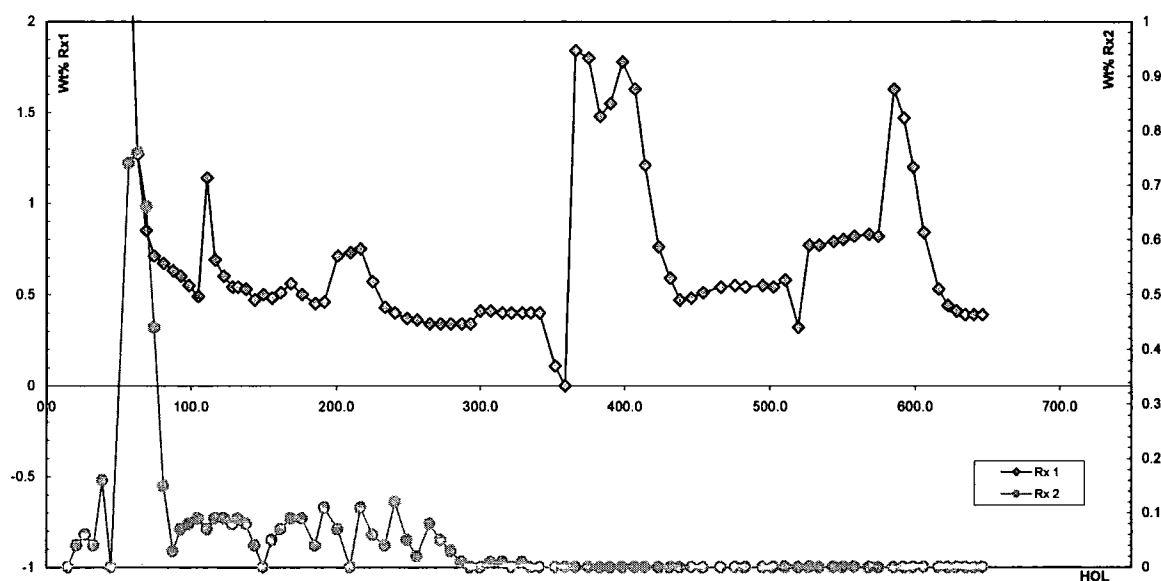

Figure 5.10 Reactor Temperatures against Time Plot for the life test

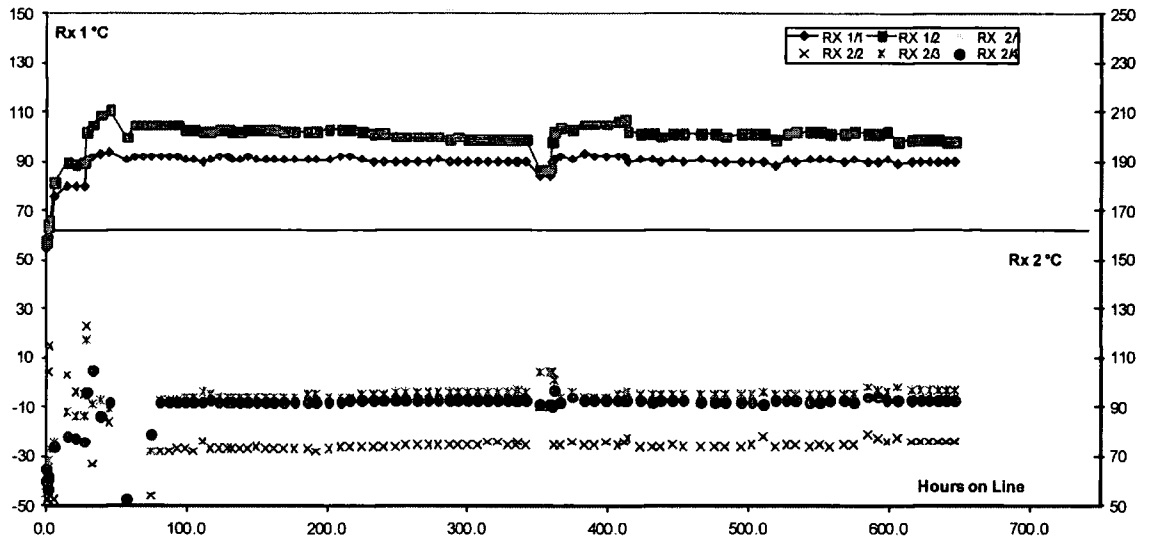

Figure 5.11 By-products and THFA Content of the Product from the Polishing Reactor, wt% with time during the life test

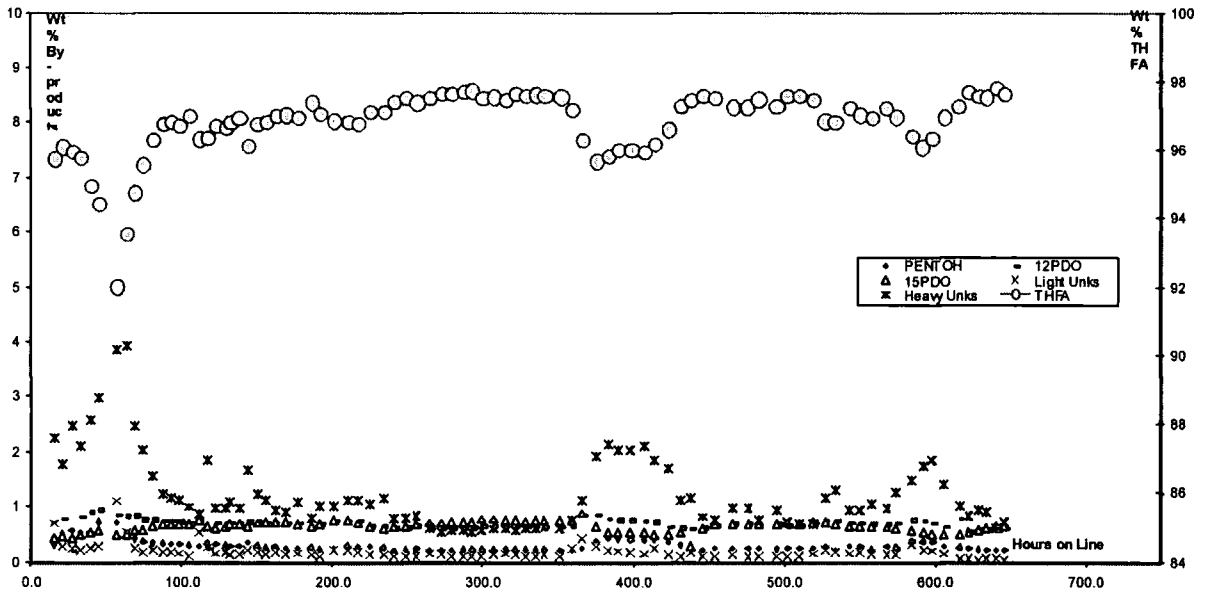

Figure 5.12 Predicted exotherm at differing recycle rates for furfural alcohol hydrogenation during the bulk reaction based on published thermodynamic data

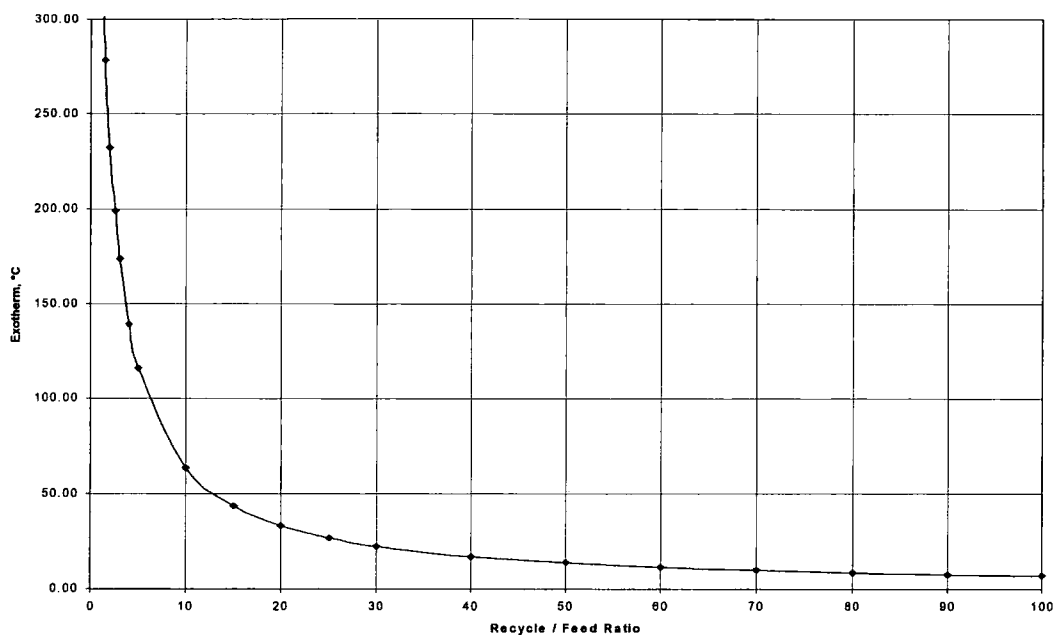
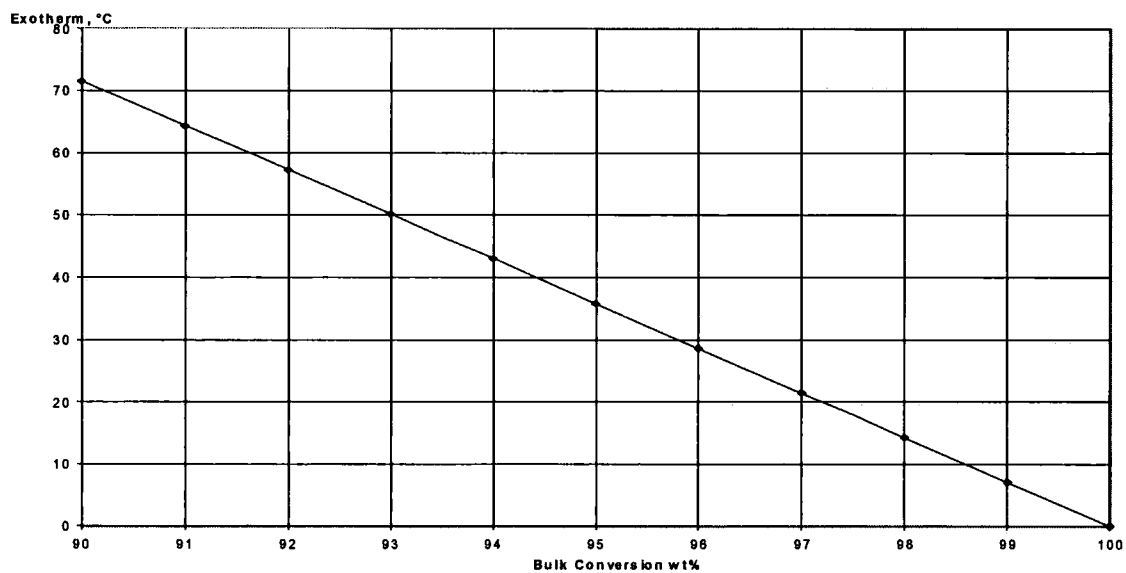

Figure 5.13 Predicted exotherm in the polishing reactor at differing conversions in the bulk reactor for furfural alcohol hydrogenation based on published thermodynamic data



5.25 Optimisation

Following directly on from the life test (Run Number 171/1/01) the experimental design below was followed:

Run (171/X/01)	1	2	3	4	5	6	7	8
LHSV, hr ⁻¹	0.33	0.5	0.33	0.5	0.5	0.5	0.5	0.33
Pressure, psig	450	450	700	700	700	700	700	450
Temperature, °C	90	90	90	90	90	110	80	90
H ₂ , equivalents	2.2	2.2	2.2	2.2	1.1	2.2	2.2	2.2

These were chosen as follows:

LHSV – During the initial phase of the life test the LHSV was established at 0.33, this giving the desired exotherms in the bulk and polishing reactors. Unfortunately, due to the size of the unit, at this LHSV the inventory of the reactor system takes > 12 hours to turn over. This would lead to unacceptable times for each test during scanning work for the unit to reach steady state operation. The LHSV was therefore increased for most of the scanning work.

Pressure – During initial autoclave work pressure appeared to have little effect on the conversion. However, since there was evidence during the life test to suggest that some by-products were reduced with increasing conversion, it was postulated that by-products might reduce with increasing pressure. Hence a higher pressure was investigated.

Temperature – Two temperatures, one above and one below that used for life test were used to check for conversion and selectivity effects.

Hydrogen flow – The initial hydrogen flow was chosen based on a throughput LHSV of 0.75Hr⁻¹. During the initial phase of the life test this LHSV was halved hence the life test operated at 2.2 equivalents of hydrogen. A test was performed to determine that minimal hydrogen excess (1.1 equivalents) would not have a detrimental effect on conversion or selectivity.

Run 17/8/01 was a return to the life test conditions to check for deactivation..

5.26 Optimisation Results and Discussion

All data are shown graphically in Figures 5.14 – 5.15 and listed fully in Table 5.22

The initial increase in LHSV increased the residual furfuryl alcohol level from 1.3wt% to 2.2wt% in the bulk reactor. Note, that none was observed exiting the polishing reactor at any time during this period of the testwork. The main effect was a large increase in the heavy by-products, approximately double.

Run 171/3/01 returned to the lower LHSV to examine the effect of pressure. It was postulated that as the heavy impurity decreased with conversion, increasing pressure may help reduce the heavy impurity level. This indeed was the case and it was during this run that on-specification (>98%) THFA was produced.

Run 171/4/01 was performed at increased pressure at the higher LHSV, which took the product off specification as expected.

Reducing the hydrogen flow to only 10% above stoichiometry had little impact on the conversion but did appear to reduce the heavy by-products. The reasons for this are not clear.

Two subsequent runs 171/6/01 and 171/7/01 examined the effect of temperature. The effects were as expected increasing temperature increased by-product make (mainly pentanediols) and decreased residual furfuryl alcohol, reducing temperature had the reverse effects.

Finally returning to the starting conditions showed very little change, indicating no gross deactivation over this period of the testwork.

In conclusion the tests demonstrated that on-specification THFA can be produced from the commercial feedstock used.

Figure 5.14 THFA assay and wt% by-products in the product during optimisation tests

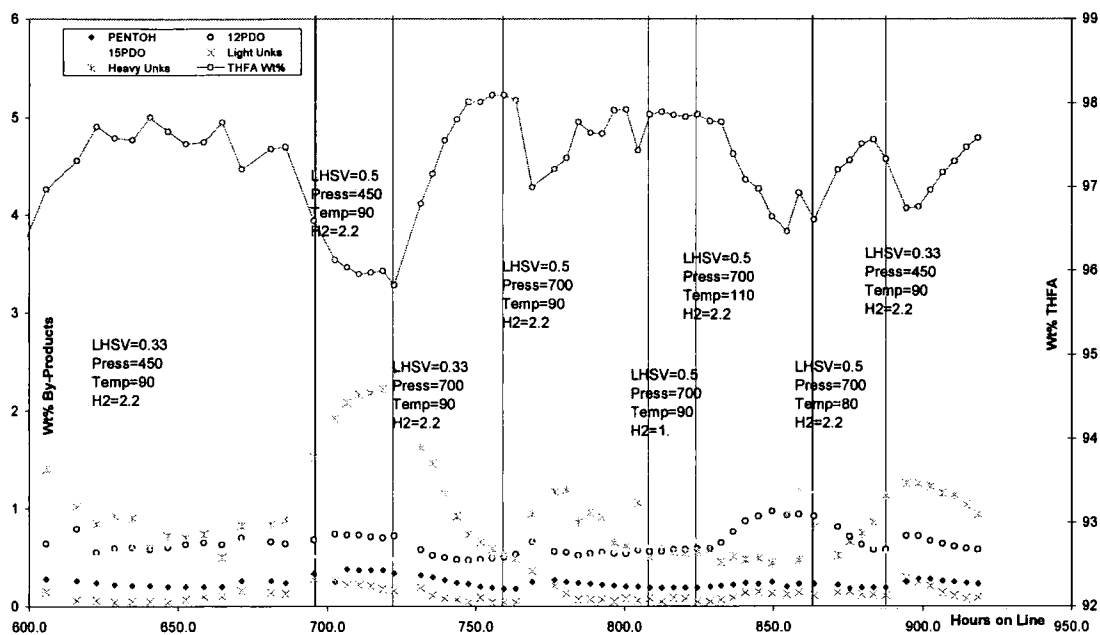

Figure 5.15 Furfuryl Alcohol in the product from reactors 1 and 2 during Optimisation Tests

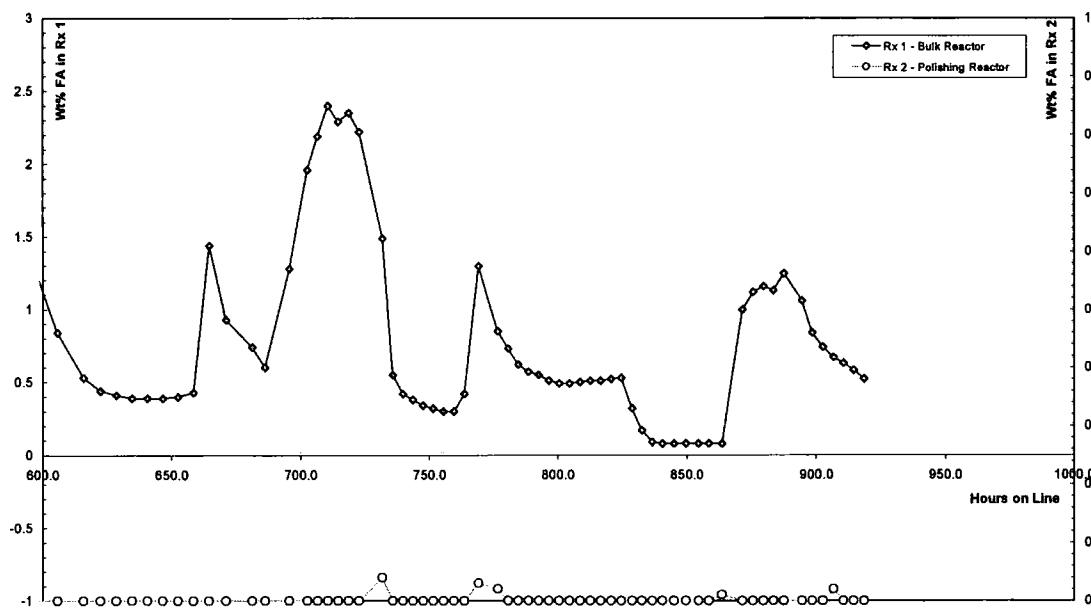

Table 5.22 Results from Optimisation Tests

Run Number	171/1/01	171/2/01	171/3/01	171/4/01	171/5/01	171/6/01	171/7/01	171/8/01
Time On Line / Htr	686	723	760	801	825	864	888	919
Hydrogen Flow / NLPH	222.3	222.3	222	222.6	137.3	222.3	222.3	222.6
Feed Flow / Mlhr-1	173.3	251.4	176.2	246.8	253.7	247.4	247.4	174.3
Rx1 Inlet / °C	87	87	87	88	87	106	78	87
Rx1 Exit / °C	101	107	101	106	107	125	97	99
Rx1 Pressure / psig	449	445	709	720	709	716	715	465
Rx2 Pressure / psig	448	443	704	718	702	714	713	465
Rx2 Inlet / °C	53	52	50	48	51	53	46	48
Rx2 Exit / °C	94	94	93	91	92	110	81	91
Recycle Flow / Kghr-1	11.5	11.6	11.4	11.5	11.4	11.6	11.5	11.5
	Reactor 1 (Bulk) Analysis wt%							
Furfuryl alcohol	0.60	2.22	0.30	0.49	0.53	0.08	1.25	0.52
THFA	96.65	92.29	97.68	97.37	97.15	96.61	96.24	96.97
12PDO	0.63	0.69	0.50	0.54	0.59	0.96	0.55	0.57
5-Methyl furfuryl alcohol	0.02	0.04	0.03	0.02	0.03	0.03	0.02	0.02
15PDO	0.59	0.47	0.58	0.58	0.69	1.17	0.55	0.52
UNKS <THFA	0.07	0.17	0.04	0.04	0.04	0.13	0.07	0.04
UNKS >THFA	1.21	3.87	0.62	0.73	0.74	0.73	1.12	1.15
Water	0.05	0.03	0.10	0.05	0.05	0.07	0.05	0.04
	Reactor 2 (polish) Analysis wt%							
Furfuryl alcohol	0.00	0.00	0.00	0.00	0.00	0.01	0.00	0.00
THFA	97.47	95.82	98.09	97.92	97.86	96.60	97.33	97.58
12PDO	0.64	0.72	0.50	0.54	0.59	0.92	0.58	0.58
5-Methyl furfuryl alcohol	0.02	0.02	0.03	0.03	0.03	0.03	0.02	0.02
15PDO	0.58	0.50	0.55	0.58	0.68	1.18	0.57	0.53
UNKS <THFA	0.13	0.16	0.04	0.08	0.05	0.11	0.11	0.09
UNKS >THFA	0.89	2.40	0.53	0.62	0.56	0.81	1.13	0.94
Water	0.03	0.03	0.06	0.05	0.04	0.07	0.05	0.03

5.27 Conclusions

The work demonstrated the feasibility of hydrogenating furfuryl alcohol to tetrahydrofurfuryl alcohol at moderate temperature (90°C) and pressure (700 psig) using a liquid recycle reactor concept and a nickel based catalyst.

The major by-products produced are 1,5-pentanediol and 1,2-pentanediol, as expected for this system, however due to the inherent advantage of the LRC the amounts drop from about 10-30wt% observed during batch production to <1.5wt%. Other minor impurities are largely already present in the feedstock. A single heavy component appears at low conversions; unfortunately this could not be identified by GC/MS methods, although its presence in the final product is not envisaged to pose a threat to the final commercial application. Literature²⁴ suggests that a dimer of furfural is readily formed. The unidentified by-product increases with decreasing conversion so it is possible that this component is the hydrogenated equivalent of this dimer.

The commercial specification was achieved under optimal conditions of temperature and pressure without the need for refining of the final hydrogenation product. Improvements to the feedstock quality would offer opportunities to widen the operating envelope and incorporate greater flexibility into the system.

The catalyst life was found to be acceptable, with no decrease in conversion over the two beds observed in over 900 hours on-line.

A commercial plant is being constructed based on these data.

References

1. K.J.Zeitsch, *The Chemistry and Technology of Furfural and its Many By-Products.*, Elsevier, Amsterdam, 2000, p223.
2. B.H. Wojcik, *Ind. Eng. Chem.*, 1948, **40**, 210.
3. W. VanRijn, Transfuran Chemicals, Private Communication.
4. P.N.Rylander, *Catalytic Hydrogenation in Organic Synthesis*, Academic Press, 1985.
5. B.H.Cooper and B.B.L.Donnis, *App. Catal.*, 1996, **137**, 203.
6. E.L.Muetterties and J.R.Bleeke, *Acc. Chem. Res.*, 1979, **12**, 9, 324.
7. J.A.Mouijn and V.Pontec, *Stud. Surf. Sci. Catal.*, 1993, **79**, 156.
8. J.Petro, *Chemical Industries.*, 2001, **82**, 1.
9. M.F.Wilson, P.R.Manwaring, J.R.Brown and J.F.Kritz, *Appl.Catal.*, 1988, **41**, 177.
10. B.Coughlan and M.A.Keane, *Catal. Lett.*, 1990, **5**, 101.
11. P.J.Van Der Steen and J.J.F.Scholten, *Appl. Catal.*, 1990, **58**, 291.
12. R.Szymanski, H.Charcosset, P.Gallezot, J.Massardier and L.Tournayan, *J.Catal.*, 1986, **97**, 366.
13. Kirk-Othmer Encyclopedia of Chemical Technology, 3rd Edition, Wiley, 1991, Vol 11, 519.
14. C.Godawa, A.Gaset, P.Kalck, and Y.Maire, *J.Mol.Catal.*, 1986, **34**, 199.
15. W.W.Prichard, patent US4146741, 1977,
16. *Process Economics Program – Innovative Reactor Design* , SRI Consulting, California, 2001, 1.
17. J.Chen, patent US5866736, 1997.
18. T.J.Mazance, *Proc Electrochem Soc*, 1997, **95**, 24, 16.
19. G.E.Harrison and A.J.Dennis , patent US5093535, 1992.
20. Davy Process Technology – Confidential Report, SN152/1, 1979.
21. E.B.Nauman, *Scaleup of Chemical Processes*, Wiley, NY, 1985, 407.
22. R.Henderson, Davy Process Technology, Unpublished work.
23. R.Spratt, Davy Process Technology, Private Communication

24. Kirk-Othmer Encyclopedia of Chemical Technology, 3rd Edition, Wiley, 1991, Vol 11, 510.

Appendix 1 – Analytical Methods

Contents:

Introduction

Butanediol – Purity - Capillary GC.

Davy Process Technology Analytical Method HY325/1

	Page No.
Scope	1
Outline	1
Precautions	1
Apparatus and Reagents	1
Preparation of Apparatus	2
Operating Conditions	2
Calibration	2
Procedure	3
Calculation	3
Component Constants	4
Typical Chromatogram	5

Butanediol - Water Content – Karl Fisher

Davy Process Technology Analytical Method HY168/2

	Page No.
Scope	1
Outline	1
Precautions	1
Apparatus and Reagents	2
Preparation of Apparatus	2
Calibration	3
Procedure	3
Calculation	4

Furfuryl Alcohol – Composition – Capillary GC

Davy Process Technology Analytical Method HY460/0

	Page No.
Scope	1
Outline	1
Precautions	1
Apparatus and Reagents	1
Preparation of Apparatus	2
Operating Conditions	2
Calibration	3
Procedure	3
Calculation	3
Component Constants	4
Typical Chromatogram	5

Introduction

The analytical methods that follow were developed at Davy Process Technology specifically for analysing the compounds encountered during the course of the work described above. They are also used for quality control purposes at production sites around the world and therefore were developed to be reproducible to accommodate different users and accurate to allow process control to be performed and reliable 'spec. analysis' to be obtained. Typically the GC methods used have been demonstrated to give 3-4 significant figures of accuracy, 2 in the case of water analysis. Where appropriate the sensitivity was to PPM levels.

The GC method given below for BDO was also used for the work in Chapters 2 and 3, where PDO was studied, with changes in retention times where necessary. The method described for BDO water analysis was used for all water analysis.

Kvaerner Process Technology	SPECIFICATION NUMBER / REVISION:	HY 325/1	
	ANALYTICAL PROCEDURE		SHEET 1 of 5
	TITLE: BUTANEDIOL – PURITY – CAPILLARY GC		

1 SCOPE

- 1.1 This method covers the determination of the purity of product 1,4 butanediol from the MKII butanediol process.

2 OUTLINE OF METHOD

- 2.1 A suitable volume of sample, 0.1 microlitre, is injected into the splitter system of a capillary gas chromatograph containing a 25 m DB1 column.
- 2.2 Impurities which may be present and eluted include methanol, tetrahydrofuran, gamma-butyrolactone, dimethyl succinate and 4-hydroxybutoxy-tetrahydrofuran (acetal).
- 2.3 The concentration of each component is determined by measurement of peak areas corrected by response factors determined from previously prepared standard mixtures.

3 PRECAUTIONS

- 3.1 THE SAMPLER MUST BE AWARE OF THE KNOWN HAZARDS ASSOCIATED WITH THE PRODUCT BEING ANALYSED.
- 3.2 GLOVES AND GOGGLES MUST BE WORN WHEN TAKING SAMPLES AND ANY SPLASHED ON THE SKIN WASHED OFF IMMEDIATELY.

4 APPARATUS AND REAGENTS

- 4.1 Air, hydrogen, helium, compressed gas supplies

Chromatograph, capillary, e.g.) Unicam Model 610 or its equivalent, equipped with a flame ionisation detector, injection splitter, temperature programmer, heated injection and detector systems
 - column - 25 m x 0.32 mm O.D. J&W DB1 with a 1 micron film thickness

Computing integrator, e.g.) Unicam Model 4815 or equivalent

Flask, volumetric, 100 ml

Syringe, 1 µl

- 4.2 1,4-Butanediol, pure

Dimethyl succinate, pure

This document contains confidential information of Kvaerner Process Technology

Kvaerner Process Technology	SPECIFICATION NUMBER / REVISION:	HY 325/1	
	ANALYTICAL PROCEDURE		SHEET 2 of 5
	TITLE: BUTANEDIOL – PURITY – CAPILLARY GC		

Gamma-Butyrolactone, pure

Methanol, AR

Tetrahydrofuran, pure

5 PREPARATION OF APPARATUS

- 5.1 Install the DB1 capillary column into the apparatus according to the manufacturers instructions. Normally capillary columns do not require any conditioning as this has already been completed by the column manufacturer. Adjust the operating conditions to those specified.

6 OPERATING CONDITIONS

- | | | | |
|-----|--------------------------------------|---|--|
| 6.1 | Column oven | - | hold at 60°C for 5 minutes, and programme from 60°C to 250°C at 8°C/minute. Hold at 250°C until end of chromatogram (10 minutes) |
| | Injection port | - | 250°C |
| | Detector | - | 250°C |
| | Carrier gas | - | helium |
| | Carrier gas pressure at column inlet | - | 20 psi |
| | FID hydrogen | - | set to manufacturers recommended flow |
| | FID air | - | set to manufacturers recommended flow |
| | Sample inlet splitter ratio | - | 50:1 |
| | Sample size | - | 0.1 µl |

7 CALIBRATION

- 7.1 Prepare known mixtures containing the components at concentrations covering the ranges expected in samples to be analysed.
- 7.2 Inject 0.1 µl into the chromatograph capillary column.

Kvaerner Process Technology	SPECIFICATION NUMBER / REVISION:	HY 325/1	
	ANALYTICAL PROCEDURE		SHEET 3 of 5
	TITLE: BUTANEDIOL – PURITY – CAPILLARY GC		

7.3 Record chromatograms of each calibration blend used.

7.4 Calculate the calibration factor (RF) for each component relative to butanediol.

$$\frac{C'}{C} \times \frac{A}{A'} = F$$

where A,A' = peak area for butanediol and component respectively

C,C' = known weight percent of butanediol and component respectively

7.5 As it is not possible to obtain 4-hydroxybutoxy tetrahydrofuran (acetal) commercially use the response factor for butanediol for quantifying this compound.

7.6 Programme the computing integrator with the retention times of each component and its relative calibration factor for calculations by normalisation method.

8 PROCEDURE

8.1 Introduce the sample to be analysed, 0.1 µl, under identical operating conditions employed during calibration.

8.2 From the chromatogram obtain peak area measurements for each component.

9 CALCULATION

9.1 This is normally calculated by the computing integrator automatically used the following method. It can be carried out manually, if required.

$$\frac{A \times RF \times 100}{D} = \text{component, \%, by weight}$$

where A = area of peak of component

D = total area of all components peaks (corrected by RF's)

RF = calibration factor for component

This document contains confidential information of Kvaerner Process Technology

© 1996 Kvaerner Process Technology Limited (formerly Davy Process Technology Ltd). Information on this sheet may be used only for the purpose for which it is supplied by KPT Ltd. This sheet and all copies must be returned on demand.

G:\Admin\Pool\Analyt\HY325Kv.230899

Kvaerner Process Technology	SPECIFICATION NUMBER / REVISION:	HY 325/1	
	ANALYTICAL PROCEDURE		SHEET 4 of 5
	TITLE: BUTANEDIOL – PURITY – CAPILLARY GC		

10 COMPONENT CONSTANTS

10.1 (Note: the retention times are given as a guide only and will vary between instruments and capillary columns).

Component	Retention Time, minutes
Methanol	1.80
Tetrahydrofuran	3.35
Butanol	3.79
Gamma-Butyrolactone	11.30
Butanediol	12.30
di-Methyl Succinate	14.00
4-Hydroxybutoxy-Tetrahydrofuran	19.60

Prepared by:	D Blackburn		Rev: 1
Approved by:	T F Shevels		Date: 24.03.99

TITLE: BUTANEDIOL - PURITY - CAPILLARY GC

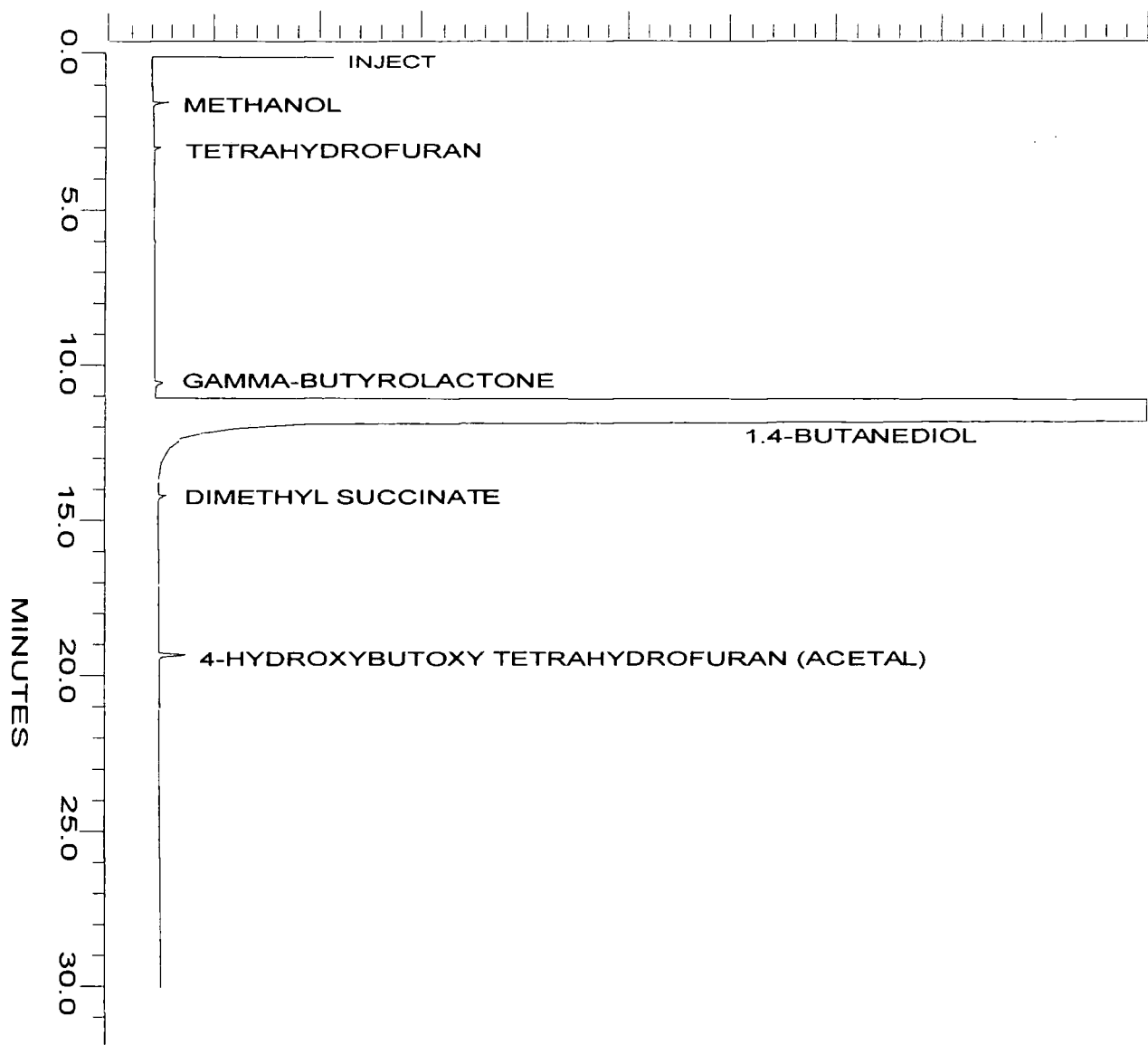

TYPICAL CHROMATOGRAM

FIGURE 1

This document contains confidential information of Kvaerner Process Technology

© 1996 Kvaerner Process Technology Limited (formerly Davy Process Technology Ltd). Information on this sheet may be used only for the purpose for which it is supplied by KPT Ltd. This sheet and all copies must be returned on demand.

G:\Admin\Pool\Analyt\HY325Kv.230899

Kvaerner Process Technology	SPECIFICATION NUMBER / REVISION:	HY 168/2
	ANALYTICAL PROCEDURE	SHEET 1 of 4
	TITLE: BUTANEDIOL – WATER CONTENT – KARL FISCHER	

1 SCOPE

1.1 This method covers the determination of the water content of butanediol, tetrahydrofuran and gamma-butyrolactone products and the intermediate process streams associated with the butanediol process.

By suitable selection of sample size, water contents from parts per million to percentage levels may be determined.

1.2 Although this method has been written especially for the operation of the Aquapal Model 3, it is applicable in a general way to other manufacturer's instruments based upon this same analytical technique.

2 OUTLINE OF METHOD

2.1 The method is based on a combination of microcoulometry and Karl Fischer titration. The water present in the anode compartment of the titration cell is coulometrically titrated to a predefined end point at which there is a minute excess of free iodine present.

Stoichiometrically 2 mole of water will react with 1 mole of iodine; therefore 18 mg H₂O is equivalent to 193 coulombs of electricity.

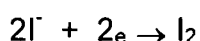

3 PRECAUTIONS

3.1 THE REAGENTS USED IN THE ANODE AND CATHODE COMPARTMENTS OF THE TITRATION CELL ARE TOXIC AND MUST THEREFORE BE HANDLED WITH CARE TO AVOID UNNECESSARY INHALATION OR SKIN CONTACT.

3.2 THE SAMPLER MUST BE AWARE OF THE KNOWN HAZARDS ASSOCIATED WITH THE COMPOUNDS FOUND IN THE MKII BUTANEDIOL PROCESS SAMPLES.

3.3 WHEN MEASURING THE WATER CONTENT OF PRODUCT TETRAHYDROFURAN A SYRINGE FITTED WITH A TWIST VALVE MUST BE USED TO PREVENT LOSS OF SAMPLE DURING THE WEIGHING AND SAMPLE TRANSFER OPERATION.

This document contains confidential information of Kvaerner Process Technology

© 1996 Kvaerner Process Technology Limited (formerly Davy Process Technology Ltd). Information on this sheet may be used only for the purpose for which it is supplied by KPT Ltd. This sheet and all copies must be returned on demand.

G:\Admin\Pool\Analyt\HY168Kv.270899

Kvaerner Process Technology	SPECIFICATION NUMBER / REVISION:	HY 168/2
	ANALYTICAL PROCEDURE	SHEET 2 of 4
	TITLE: BUTANEDIOL – WATER CONTENT – KARL FISCHER	

4 APPARATUS AND REAGENTS

4.1 Balance, analytical

Flask, volumetric, 50 ml

Karl Fischer, Coulometric Titration Apparatus, e.g.) Aquapal MKIII or its equivalent

Syringe, Hamilton, 1000 µl, 100 µl, 50 µl, 10 µl

Syringe, Hamilton, Sample Lock, 1 ml, 2.5 ml, 5.0 ml

4.2 Coulometric Cathode Reagent, e.g.) Hydranal Coulomat C

Coulometric Anode Reagent, e.g.) Hydranal Coulomat A

Molecular sieve, 1.6 - 2.5 mm beads

Hydranal Water Standard, 10 mg H₂O/gm

5 PREPARATION OF APPARATUS

5.1 Assemble the titration apparatus as specified in the manufacturers manual taking particular notice of the following points.

5.2 When installing the generator electrode ensure that sufficient clearance is allowed to prevent any possible damage by the stirrer bar.

Like-wise, position the detector electrode on the opposite side of the cell.

5.3 Fill the drying tube with molecular sieve beads and install it on the top of the generator electrode.

5.4 Fit a PTFE faced septum into the sample injection cap, the PTFE face must be on the inside of the vessel.

5.5 By means of a suitable funnel charge the cell with 100 ml of the anode reagent e.g.) Hydranal Coulomat A or equivalent. Fill up to the line marked on the cell.

5.6 Charge the generator electrode with 5 ml of cathode reagent, eg) Hydranal Coulomat C or equivalent.

This document contains confidential information of Kvaerner Process Technology

© 1996 Kvaerner Process Technology Limited (formerly Davy Process Technology Ltd). Information on this sheet may be used only for the purpose for which it is supplied by KPT Ltd. This sheet and all copies must be returned on demand.

G:\Admin\Pool\Analyt\HY168Kv.270899

Kvaerner Process Technology	SPECIFICATION NUMBER / REVISION:	HY 168/2
	ANALYTICAL PROCEDURE	SHEET 3 of 4
	TITLE: BUTANEDIOL – WATER CONTENT – KARL FISCHER	

5.7 The generator electrode must be positioned so that the reagent level is 2 - 3 mm below the level of anode reagent in the outer part of the cell.

The two reagents are separated by a glass diaphragm but over a period of time their levels will equilibrate.

5.8 After charging the reagents, in order to remove all traces of moisture from the cell walls; gently swirl the reagent around the cell. Take care not to mix the reagents when carrying this out as this would reduce their life.

5.9 The size of the titration cell allows for a total of 50 to 60 ml of samples to be added during the life of the reagents.

5.10 100 ml of anode reagent will analyse up to 1000 mg of H₂O before saturation, and 5 ml of cathode reagent up to 250 mg H₂O.

6 CALIBRATION

6.1 The analyser operates on first principles (see 2.1), with the output of the cell being directly proportional to the micrograms of water titrated, no calibration is required.

6.2 It is advisable, and good practise, to routinely check the operation of the instrument for validity of results by periodically injecting 100 mg of 10 mg/gm water standard and verifying that the recovery is correct. If this is found to be low then suspect a fault with either the cell reagents, electrodes or electronics, which must be rectified.

7 PROCEDURE

7.1 With the power switch of the Aquapal turned to the on position, check that the display shows 0µg.

7.2 Adjust the stirrer speed as required.

7.3 Press "CELL" button, display will show PRECONµg.

The instrument is now in the pre-conditioning mode and an arrow on the third line of the display indicates that electrolysis current is being applied.

7.4 When any residual water in the cell has been titrated the display will show a value of µg and the message END/WAIT.

This document contains confidential information of Kvaerner Process Technology

© 1996 Kvaerner Process Technology Limited (formerly Davy Process Technology Ltd). Information on this sheet may be used only for the purpose for which it is supplied by KPT Ltd. This sheet and all copies must be returned on demand.

G:\Admin\Pool\Analyt\HY168Kv.270899

Kvaerner Process Technology	SPECIFICATION NUMBER / REVISION:	HY 168/2
	ANALYTICAL PROCEDURE	SHEET 4 of 4
	TITLE: BUTANEDIOL – WATER CONTENT – KARL FISCHER	

7.5 When the baseline becomes stable the display will indicate a drift value and the message END/RDY.

The cell is now ready to receive and analyse a sample.

7.6 Fill a suitable sized syringe with a volume of sample that is expected to contain between 500 and 5000 µg of water. For samples of product tetrahydrofuran use a Sample Lock syringe to prevent loss of sample.

7.7 Weigh the syringe plus sample.

7.8 Press the "START" button.

7.9 Inject the sample into the cell.

7.10 Re-weigh the syringe and calculate the weight of sample that has been injected (W).

7.11 When the titration is complete, read the quantity of water found titrated in µg from the display (A).

8 CALCULATION

8.1 Water content (ppm wt% = $\frac{A}{W}$)

where A = µg of water found

W = weight (g) of sample injected.

Prepared by:	D Blackburn		Rev: 2
Approved by:	T F Shevels		Date: 27.8.99

This document contains confidential information of Kvaerner Process Technology

© 1996 Kvaerner Process Technology Limited (formerly Davy Process Technology Ltd). Information on this sheet may be used only for the purpose for which it is supplied by KPT Ltd. This sheet and all copies must be returned on demand.

G:\Admin\Pool\Analyt\HY168Kv.270899

Kvaerner Process Technology	SPECIFICATION NUMBER / REVISION:	HY460/0
	ANALYTICAL PROCEDURE	SHEET 1 of 5
	TITLE: FURFURYL ALCOHOL – COMPOSITION - CAPILLARY GC	

1 SCOPE

- 1.1 This method covers the determination of impurities in furfuryl alcohol including furfural, furfurylmethylcarbinol, tetrahydrofurfural alcohol, 1,2-pentanediol, 5-methylfurfuryl alcohol and 1,5-pentanediol.

2 OUTLINE OF METHOD

- 2.1 A suitable volume, 0.2 µl, of sample is injected into the splitter system of a capillary chromatograph containing a 30 m DBI capillary column and fitted with a flame ionisation detector.
- 2.2 The concentration of each component is determined by measurement of peak areas which are corrected by response factors determined from previously prepared standard mixtures.

3 PRECAUTIONS

- 3.1 THE SAMPLER MUST BE AWARE OF THE KNOWN HAZARDS ASSOCIATED WITH COMPOUNDS FOUND IN SAMPLES THE FURFURYL ALCOHOL PROCESS.
- 3.2 GLOVES AND GOGGLES MUST BE WORN WHEN TAKING SAMPLES AND ANY SPLASHED ONTO THE SKIN WASHED OFF IMMEDIATELY.

4 APPARATUS AND REAGENTS

- 4.1 Air, hydrogen, helium, compressed gas supplies

Balance, analytical

Chromatograph capillary, e.g.) Hewlett Packard 6890 or its equivalent, equipped with flame ionisation detector, injection splitter, temperature programmer, heated injector and detector systems
- column – 30 m x 0.32 mm O.D. DBI with 1 micron phase thickness

Chromatography Data Station, e.g.) Hewlett Packard Chem Station or equivalent

Flask, volumetric, 25 ml

Pipettes, Pastuer

Syringes, 500 µl, 1 µl

Kvaerner Process Technology	SPECIFICATION NUMBER / REVISION:	HY460/0	
	ANALYTICAL PROCEDURE		SHEET 2 of 5
	TITLE: FURFURYL ALCOHOL – COMPOSITION - CAPILLARY GC		

- 4.2 Furfural alcohol, pure
- Furfural, pure
- 5-Methylfurfuryl alcohol, pure
- 1,2-Pentenediol, pure
- 1,5-Pentenediol, pure
- Tetrahydrofurfural alcohol, pure

5 PREPARATION OF APPARATUS

- 5.1 Install the DBI capillary column into the apparatus according to the manufacturers instructions. Normally capillary columns do not require any conditioning as this has already been completed by the column manufacturer. Adjust the operating conditions to those specified.

6 OPERATING CONDITIONS

- | | | | |
|-----|--------------------------------------|---|--|
| 6.1 | Column Oven | - | 60°C for 5 minutes, then 8°C/min to 100°C and hold for 4 minutes, then to 250°C and hold for 5 minutes |
| | Injection Port | - | 250°C |
| | Detector | - | 300°C |
| | Carrier Gas Pressure At Column Inlet | - | Helium |
| | FID Hydrogen | - | set to manufacturers recommended flow |
| | FID Air | - | set to manufacturers recommended flow |
| | Sample Inlet Splitter Ratio | - | 50:1 |
| | Sample Size | - | 0.2 µl |

Kvaerner Process Technology	SPECIFICATION NUMBER / REVISION:	HY460/0	
	ANALYTICAL PROCEDURE		SHEET 3 of 5
	TITLE: FURFURYL ALCOHOL – COMPOSITION - CAPILLARY GC		

7 CALIBRATION

- 7.1 Prepare mixtures of the components of interest in pure furfuryl alcohol covering the ranges expected in the samples to be analysed.
- 7.2 Inject 0.2 µl of the calibration standards in turn into the chromatograph operating at the conditions specified in section 6.1.
- 7.3 Record the chromatograms and integrated areas for each standard.
- 7.4 Calculate reponse factors for each component from:

$$RF = \frac{C}{A}$$

where RF = response factor for component

C = known weight percent for component in standard

A = peak area for component

- 7.5 Programme the chromatography data station with the retention times and response factors for each component for calculations by the normalisation method.

8 PROCEDURE

- 8.1 Introduce the sample to be analysed, 0.2 µl, under identical conditions to those employed during calibration.
- 8.2 From the chromatogram obtain peak area measurements for each component.

9 CALCULATION

- 9.1 This is normally calculated automatically by the chromatography data station, it may be carried out manually if required as follows:

$$\frac{A \times RF \times 100}{D} = \text{component \% , by weight}$$

where A = peak area for component

RF = response factor for component

D = total area of all components, corrected by their individual response factors

Kvaerner Process Technology	SPECIFICATION NUMBER / REVISION:	HY460/0	
	ANALYTICAL PROCEDURE		SHEET 4 of 5
	TITLE: FURFURYL ALCOHOL – COMPOSITION - CAPILLARY GC		

10 COMPONENT CONSTANTS

10.1 (Note: the retention times are given as a guide only and will vary between instruments and capillary columns).

Component	Retention Time, minutes
Furfural	10.61
Furfuryl Alcohol	11.93
Furylmethylcarbinol	12.89
Tetrahydrofurfural Alcohol	13.00
1,2-Pentenediol	14.93
5-Methylfurfuryl Alcohol	15.82
1,5-Pentenediol	18.70

Prepared by:	P A Kendrick		Rev: 0
Approved by:	T F Shevels		Date: .11.06.01

Kvaerner Process Technology	SPECIFICATION NUMBER / REVISION:	HY460/0	
	ANALYTICAL PROCEDURE		SHEET 5 of 5
	TITLE: FURFURYL ALCOHOL - COMPOSITION - CAPILLARY GC		

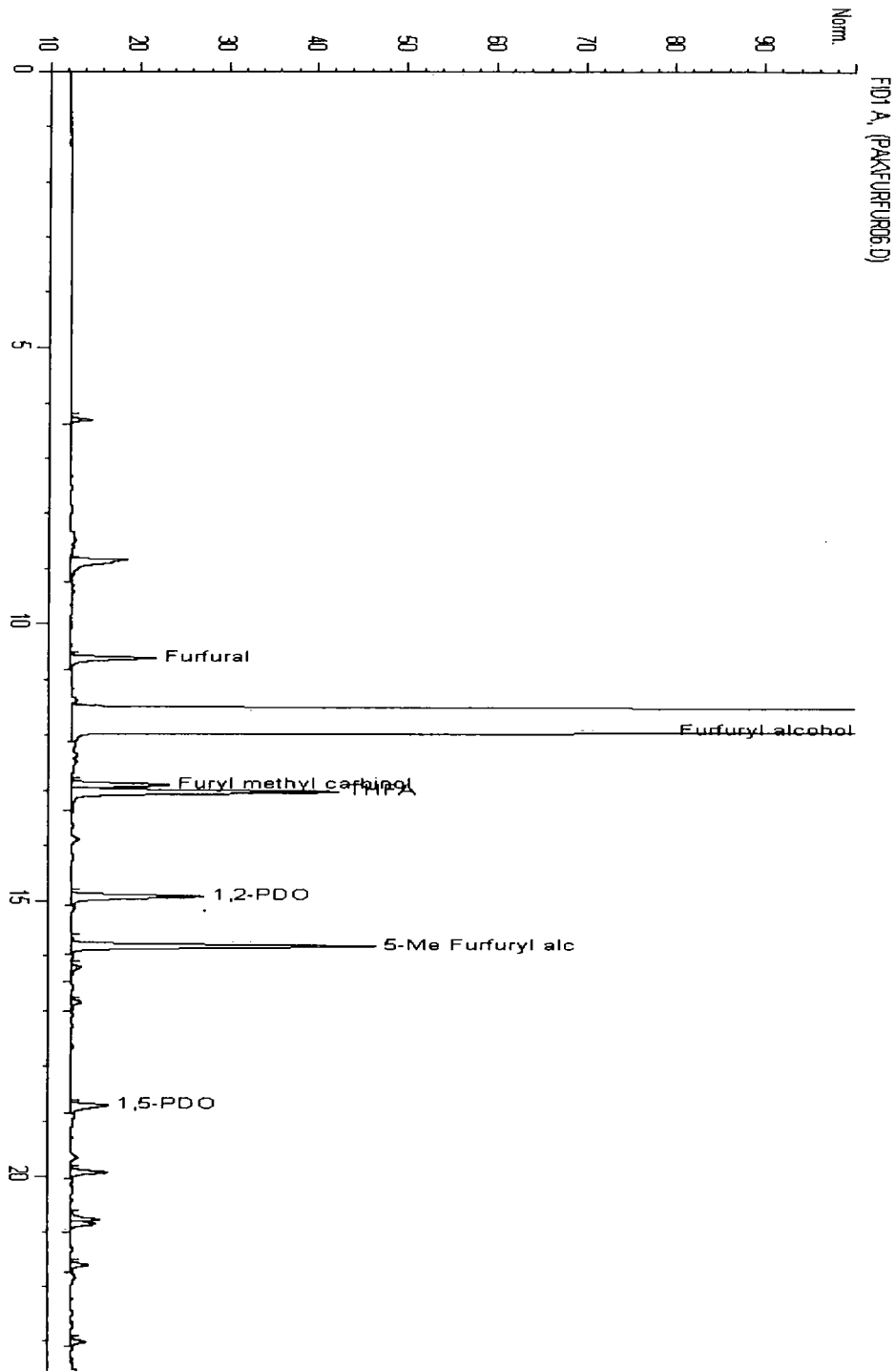

TYPICAL CHROMATOGRAPH

FIGURE 1

Appendix 2– Publications

Relating to the Work in this Thesis

US 6137016 Process for the Purification Of 1,4-Butanediol (attached)

US 6265624 Process for Preparing Pentane-1,5-diol (attached)

Other Publications by the Same Author

EP 1108702 Process for the co-production of aliphatic diols and cyclic ethers.

EP1179524 Process for the carbonylation of oxiranes

PCT/GB 97/00879 Production of 1,4-butanediol.

GB 2267704 & GB 2267706 The Production of Ultra-White N,N-ethylene-bis-(tetrabromophthalimide).

Pilot Plants and Scale-up of Chemical processes, RSC, September 1996.

Poster presented; Efficient Commercial Reactor design based on High Scale-up Factors.

UNITED STATES PATENT APPLICATION

Our file: CTE/PL62403US

Your reference: 62403

Applicants: John Scarlett, Michael Anthony Wood and Paul Willett

Assignee: Kvaerner Process Technology Limited

Application No: 09/553,255

Filing date: 19 April 2000

Title: Process

Priority date claimed: 27 April 1999 from European Patent Application No. 99303236.6

PROCESS

This invention relates to a process for the production of pentane-1,5-diol.

Pentane-1,5-diol (or pentamethylenediol) has the formula:

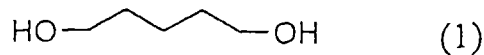

It is a specialty chemical which has potential for use in the plastics industry as a monomer from which to make polyesters. Pentane-1,5-diol is commercially available at a purity of 96% with a quoted boiling point of 242°C.

One method of producing pentane-1,5-diol is by hydrogenation of a dialkyl glutarate, such as dimethyl glutarate, according to the following equation:



However, a byproduct of this reaction is δ -valerolactone of the formula:

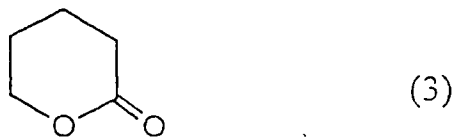

which is a reactive compound. Thus δ -valerolactone can polymerise to form a polymer of the formula:

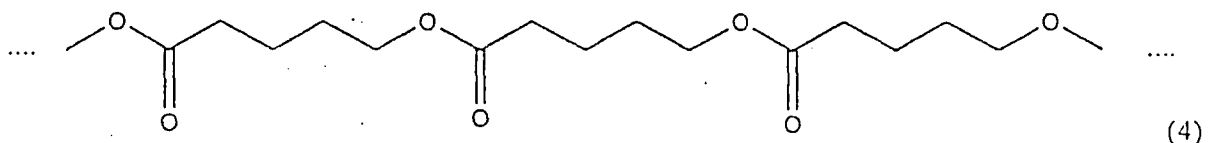

Such polymers cause difficulties in the purification of pentane-1,5-diol because they tend to break down during distillation, thereby reforming δ -valerolactone. Another

possible reaction is that between the alkanol, e.g. methanol, present in the crude hydrogenation product to form methyl 5-hydroxypentanoate according to the reaction:

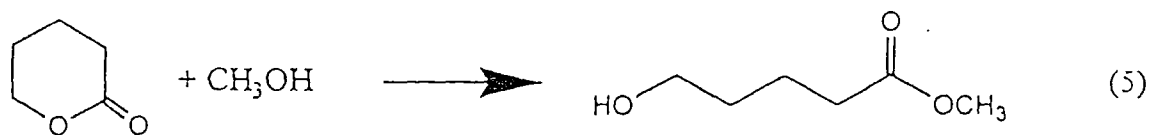

5 These reaction products tend to form spontaneously even at ambient temperature and slowly decompose during distillation of the crude pentane-1,5-diol, thereby reforming δ -valerolactone. In addition conditions in a distillation column can favour the formation of polyesters and other
 10 heavy byproducts, including methyl 5-hydroxypentanoate. According to the published literature δ -valerolactone is commercially available at a purity of 99%. Such a commercial product has a quoted melting point of 38°C to 40°C and a boiling point of 256°C. Since the boiling point of δ -
 15 valerolactone is close to that of pentane-1,5-diol, its separation from pentane-1,5-diol during distillation of the crude hydrogenation product is problematic because δ -valerolactone behaves non-ideally during distillation and tends to report with pentane-1,5-diol in the distillation
 20 step. Hence it is difficult to avoid small amounts of δ -valerolactone contaminating the pentane-1,5-diol distillation product.

It would accordingly be desirable to provide a process for the purification of crude pentane-1,5-diol from a crude
 25 hydrogenation product containing same, for example a crude hydrogenation product resulting from the hydrogenation of a dialkyl glutarate, such as diethyl glutarate or, preferably, dimethyl glutarate. It would further be desirable to provide such a process that can be operated continuously.

30 The present invention accordingly seeks to provide a

process for the purification of a crude pentane-1,5-diol which contains minor amounts of δ -valerolactone so as to produce a pentane-1,5-diol product that is substantially free from δ -valerolactone. It further seeks to provide a
5 process for the recovery from a crude product containing pentane-1,5-diol and δ -valerolactone of substantially pure pentane-1,5-diol. Yet another objective of the invention is to provide a continuous process for the recovery of pentane-1,5-diol from a crude product containing both pentane-1,5-
10 diol and δ -valerolactone.

According to one aspect of the present invention there is provided a process for the continuous recovery of substantially pure pentane-1,5-diol from a crude product stream containing pentane-1,5-diol and δ -valerolactone which
15 comprises:

continuously supplying the feed stream to a vaporisation zone maintained under temperature and pressure conditions effective for the vaporisation of pentane-1,5-diol and conducive to the thermal decomposition of reaction
20 products of δ -valerolactone thereby to form a vaporous stream;

continuously supplying resulting vaporous stream to an intermediate section of a distillation zone, said intermediate section lying below an upper distillation
25 section and above a lower distillation section;

continuously supplying to the upper section of the distillation zone a reflux stream of dimethyl glutarate;

continuously recovering from the upper section of the distillation zone an overhead vapour product stream
30 comprising δ -valerolactone and dimethyl glutarate;

continuously recovering from the distillation zone an intermediate stream comprising substantially pure pentane-1,5-diol; and

continuously recovering from the bottom section of the distillation zone a bottoms product.

In a preferred process the bottoms product is recycled to the vaporisation zone.

5 It will thus be appreciated that the process of the invention involves the use of a vaporisation zone which precedes and is separate from the distillation zone. By use of such an arrangement it can effectively be ensured that reaction products from δ -valerolactone do not enter the
10 distillation zone but remain in the sump section of the vaporisation zone. Thus, although the vapour stream supplied to the distillation zone contains δ -valerolactone, it cannot reform undesirable products and thus does not behave in a non-ideal way. Hence the separation of traces
15 of δ -valerolactone from the pentane-1,5-diol product is facilitated.

The dimethyl glutarate used as reflux stream has a higher boiling point than δ -valerolactone and hence helps to ensure that in the distillation zone δ -valerolactone remains
20 vaporous and hence cannot condense and form undesirable condensation products.

Dimethyl glutarate has a published boiling point of 93°C to 95°C at 13 mm Hg (1733.19 kPa), i.e. a boiling point lower than pentane-1,5-diol, and hence, when it is used as
25 the material of the reflux stream, it reports in the vaporous overhead stream from the upper section of the distillation zone. This vaporous overhead stream can then be condensed. When the process used for the production of pentane-1,5-diol involves hydrogenation of dimethyl
30 glutarate, then the resulting condensate can be recycled to the hydrogenation zone to form the feed, or a part of the feed, thereto.

Hence according to another aspect of the present

invention there is provided a process for the continuous production of pentane-1,5-diol which comprises:

supplying a feed stream comprising dimethyl glutarate in admixture with hydrogen to a hydrogenation zone
5 containing a charge of an ester hydrogenation catalyst maintained under temperature and pressure conditions effective for the hydrogenation of dimethyl glutarate to pentane-1,5-diol;

recovering from the hydrogenation zone a hydrogenation
10 product mixture comprising unreacted hydrogen, methanol, δ -valerolactone and pentane-1,5-diol;

separating from the hydrogenation product mixture a crude reaction product stream comprising δ -valerolactone and pentane-1,5-diol;

15 continuously supplying the crude reaction product stream to a vaporisation zone maintained under temperature and pressure conditions effective for the vaporisation of pentane-1,5-diol and conducive to the thermal decomposition of reaction products of δ -valerolactone thereby to form a
20 vaporous stream;

continuously supplying resulting vaporous stream to an intermediate section of a distillation zone, said intermediate section lying below an upper distillation section and above a lower distillation section;

25 continuously supplying to the upper section of the distillation zone a reflux stream of dimethyl glutarate;

continuously recovering from the upper section of the distillation zone an overhead vapour product stream comprising δ -valerolactone and dimethyl glutarate;

30 continuously recovering from the distillation zone an intermediate stream comprising substantially pure pentane-1,5-diol;

continuously recovering from the bottom section of the

distillation zone a bottoms product; and

recycling material of the overhead vaporous stream from the distillation zone to the hydrogenation zone.

In such a process the hydrogenation catalyst is preferably a reduced copper chromite catalyst, for example, that sold under the designation DRD92/89 by Kvaerner Process Technology Limited of P.O. Box P.O. Box 37, Bowsfield Lane, Stockton-on-Tees, Cleveland TS18 3HA. Typical reaction conditions include use in the hydrogenation zone of a hydrogen : dimethyl glutarate molar ratio of from about 200:1 to about 600:1, a temperature in the range of from about 180°C to about 250°C, and a total pressure of from about 450 psig to about 1000 psig (about 3102 kPag to about 6894 kPag).

Preferably the vaporisation zone and the distillation zone are operated at substantially the same pressure. The pressure of operation is preferably atmospheric (e.g. about 101.325 kPa) or sub-atmospheric, e.g. a pressure in the range of from about 100 Pa up to about 100 kPa, more preferably in the range of from about 1 kPa up to about 60 kPa, and even more preferably at a pressure in the range of from about 2 kPa up to about 20 kPa. The temperature of operation of the vaporisation zone is selected in accordance with the pressure of operation so as to cause pentane-1,5-diol to boil and thus ensure that a vaporous overhead stream is formed comprising pentane-1,5-diol. Likewise the distillation zone is operated under temperature conditions selected so as to ensure that pentane-1,5-diol boils at the prevailing pressure and hence an overhead vaporous fraction is recovered overhead from the upper section of the distillation zone that contains light end products such as methanol and also δ -valerolactone and dimethyl glutarate, and so that the requisite side stream of substantially pure

pentane-1,5-diol is also formed.

In order that the invention may be clearly understood and readily carried into effect a preferred process in accordance with the invention will now be described, by way of example only, with reference to the accompanying
5 diagrammatic drawing which is a flow sheet of a plant designed for recovery of substantially pure pentane-1,5-diol from a crude product containing, in addition to pentane-1,5-diol, also δ -valerolactone.

10 Referring to the drawing, a crude pentane-1,5-diol stream is supplied in line 1 to a vaporiser 2 which is operated at a pressure of about 6.67 kPa. The crude product in line 1 is, for example, a stream obtained by preliminary distillation of a crude product stream recovered from a
15 hydrogenation zone in which dimethyl glutarate is hydrogenated in the vapour phase over a reduced copper chromite catalyst. Such a crude product stream contains, in addition to pentane-1,5-diol also some δ -valerolactone, as well as methanol. It also contains reaction byproducts
20 caused by reaction of δ -valerolactone with itself or with methanol, i.e. a condensation polymer of δ -valerolactone and/or methyl 5-hydroxypentanoate. From the top of vaporiser 2 there is recovered a vaporous stream in line 3 which comprises pentane-1,5-diol and δ -valerolactone. This
25 is fed to an intermediate section of a distillation column 4. A reflux stream consisting of pure dimethyl glutarate is supplied in line 5 under the influence of pump 6, this stream of dimethyl glutarate having been preheated in heat exchanger 7 to an appropriate temperature. Since dimethyl
30 glutarate has a lower boiling point than pentane-1,5-diol, it appears in the overhead product in line 8 from distillation column 4, together with δ -valerolactone present in the vaporous stream in line 3. The overhead product in

line 8 is condensed by means of condenser 9 and is recycled as a part of the feed to the hydrogenation zone (not shown). From a lower part of the distillation column 4 there is recovered a side draw stream consisting of substantially pure pentane-1,5-diol in line 11. A bottoms product is recovered from the bottom of distillation column 4 in line 12. Part is purged from the plant in line 13 while the remainder is recycled in line 14 to the vaporiser 2 which thus replaces the usual reboiler required in a distillation zone.

The invention is further illustrated in the following Examples.

Example 1

A mixture of methanol and δ -valerolactone was heated under reflux at a temperature of 65°C. The reaction mixture was analysed by gas chromatography with the results set out in Table 1.

TABLE 1

Time (hours)	MeOH	HMP	δ -VAL (solid)
0	85.5	-	13.89
3	91.8	0.9	6.0
5	92.0	0.9	6.3
8	91.4	0.6	6.7
12	91.5	0.6	6.9
16	92.1	0.5	6.7
19	91.2	1.1	6.7

Notes: MeOH = methanol
HMP = methyl 5-hydroxypentanoate
 δ -VAL = δ -valerolactone

Example 2

15 A laboratory scale batch distillation column fitted with a separate vaporiser was used in this Example. Its vaporiser was charged with 1.5 kg of crude pentane-1,5-diol obtained by hydrogenation in the vapour phase of dimethyl glutarate using a reduced copper chromite catalyst. The
20 composition of this feed was as follows:

butane-1,4-diol (BDO)	0.01 wt%
pentane-1,5-diol (PDO)	92.35 wt%
methyl 5-hydroxypentanoate	1.60 wt%
dimethyl glutarate (DMG)	1.53 wt%
25 hexane-1,6-diol (HDO)	0.99 wt%
di-(5-hydroxypentyl) ether (DHPE)	0.03 wt%

Preheated dimethyl glutarate was supplied as a reflux stream near the top of the distillation column. After an initial period during which dimethyl glutarate was supplied at a
30 rate which proved to be too high, the rate of supply of dimethyl glutarate was reduced to about 10 ml per hour. 10

ml fractions were taken overhead and analysed by gas chromatography with the results summarised in Table 2.

Fraction	Analysis wt%									
	10	20	30	40	50	60	70	80	90	Pot
DMG feed rate (ml/h)	11	11	11	16	11	10	0	0	0	-
Pressure (kPa)	6.67	6.67	6.67	6.67	6.67	6.53	6.67	6.67	6.67	-
Reflux ratio	50:1	50:1	45:1	50:1	65:1	35:1	T/R	40:1	40:1	-
Pot (°C)	169	176	170	170	170	169	170	170	172	-
Overhead (°C)	132	134	134	132	133	139	166	166	167	-
Butane-1,4-diol	0.01	0.14	0.29	0.14	0.01	N/D	N/D	N/D	N/D	-
Pentane-1,5-diol	0.09	11.96	8.87	0.46	11.79	10.10	96.40	99.45	99.67	92.20
δ-valerolactone	2.63	2.70	2.72	0.90	0.47	0.14	0.13	N/D	N/D	N/D
Dimethyl glutarate	96.81	83.91	87.38	98.11	86.81	87.64	3.34	0.40	0.21	N/D
Hexane-1,6-diol	0.05	0.06	0.06	0.06	0.05	0.06	N/D	N/D	N/D	1.14
Di-(5-hydroxypentyl) ether (DHPE)	N/D	N/D	N/D	N/D	N/D	N/D	N/D	N/D	0.02	2.74

Example 3

The procedure of Example 2 was repeated except that the dimethyl glutarate was supplied to the vaporiser. The results listed in Table 3 were obtained.

TABLE 3

Fraction	5	10	20	30	40	50	60	70	Pot
DMG feed rate (ml/h)	20	21	0	0	0	0	0	0	-
Pressure (kPa)	6.53	6.67	6.53	6.53	6.67	6.67	6.67	6.67	-
Reflux ratio	25:1	30:1	25:1	50:1	T/R	40:1	23:1	30:1	-
Pot (°C)	170	170	173	174	176	178	180	198	-
Overhead (°C)	132	142	165	166	167	166	167	166	-
Analysis wt%									
Butane-1,4-diol	0.25	0.01	0.07	N/D	0.02	N/D	N/D	N/D	N/D
Pentane-1,5-diol	2.23	14.60	88.09	98.33	98.94	99.65	99.70	99.44	75.19
δ-valerolactone	1.65	0.86	0.91	0.33	0.28	0.05	N/D	N/D	N/D
Dimethyl glutarate	94.90	83.88	9.82	0.49	0.23	0.06	0.07	0.05	0.13
Hexane-1,6-diol	0.01	N/D	N/D	N/D	N/D	N/D	N/D	N/D	N/D
Di-(5-hydroxy-pentyl) ether (DHPE)	N/D	N/D	N/D	N/D	N/D	N/D	N/D	0.26	1.3

CLAIMS:-

1. A process for the continuous recovery of substantially pure pentane-1,5-diol from a crude product stream containing pentane-1,5-diol and δ -valerolactone which comprises:
 - 5 continuously supplying the feed stream to a vaporisation zone maintained under temperature and pressure conditions effective for the vaporisation of pentane-1,5-diol and conducive to the thermal decomposition of reaction products of δ -valerolactone thereby to form a vaporous
10 stream;
 - continuously supplying resulting vaporous stream to an intermediate section of a distillation zone, said intermediate section lying below an upper distillation section and above a lower distillation section;
 - 15 continuously supplying to the upper section of the distillation zone a reflux stream of dimethyl glutarate;
 - continuously recovering from the upper section of the distillation zone an overhead vapour product stream comprising δ -valerolactone and dimethyl glutarate;
 - 20 continuously recovering from the distillation zone an intermediate stream comprising substantially pure pentane-1,5-diol; and
 - continuously recovering from the bottom section of the distillation zone a bottoms product.
 - 25 2. A process according to claim 1, in which the bottoms product is recycled to the vaporisation zone.
 3. A process according to claim 1, in which the overhead vaporous stream from the distillation zone is condensed.
 4. A process according to claim 1, in which the
30 vaporisation zone and the distillation zone are operated at substantially the same pressure.

5. A process according to claim 4, in which the pressure of operation is atmospheric or sub-atmospheric.
6. A process according to claim 5, in which the pressure of operation is in the range of from 1 kPa up to about 60 kPa.
7. A process according to claim 6, in which the pressure of operation is in the range of from about 2 kPa up to about 20 kPa.
8. A process for the continuous production of pentane-1,5-diol which comprises:
- supplying a feed stream comprising dimethyl glutarate in admixture with hydrogen to a hydrogenation zone containing a charge of an ester hydrogenation catalyst maintained under temperature and pressure conditions effective for the hydrogenation of dimethyl glutarate to pentane-1,5-diol;
- recovering from the hydrogenation zone a hydrogenation product mixture comprising unreacted hydrogen, methanol, δ -valerolactone and pentane-1,5-diol;
- separating from the hydrogenation product mixture a crude reaction product stream comprising δ -valerolactone and pentane-1,5-diol;
- continuously supplying the crude reaction product stream to a vaporisation zone maintained under temperature and pressure conditions effective for the vaporisation of pentane-1,5-diol and conducive to the thermal decomposition of reaction products of δ -valerolactone thereby to form a vaporous stream;
- continuously supplying resulting vaporous stream to an intermediate section of a distillation zone, said intermediate section lying below an upper distillation

section and above a lower distillation section;

continuously supplying to the upper section of the distillation zone a reflux stream of dimethyl glutarate;

continuously recovering from the upper section of the distillation zone an overhead vapour product stream comprising δ -valerolactone and dimethyl glutarate;

continuously recovering from the distillation zone an intermediate stream comprising substantially pure pentane-1,5-diol;

continuously recovering from the bottom section of the distillation zone a bottoms product; and

recycling material of the overhead vaporious stream from the distillation zone to the hydrogenation zone.

ABSTRACT

PROCESS

A process is described for the continuous recovery of substantially pure pentane-1,5-diol from a crude product stream (1) containing pentane-1,5-diol and δ -valerolactone. The feed stream (1) is continuously supplied to a vaporisation zone (2) maintained under temperature and pressure conditions effective for the vaporisation of pentane-1,5-diol and conducive to the thermal decomposition of reaction products of δ -valerolactone thereby to form a vaporous stream. The resulting vaporous stream is continuously supplied to an intermediate section of a distillation zone (4). A reflux stream (5) of dimethyl glutarate is fed to an upper section of the distillation zone (4) and an overhead vapour product stream (8) comprising δ -valerolactone and dimethyl glutarate is taken. Also an intermediate stream (11) comprising substantially pure pentane-1,5-diol is taken from the distillation zone (4), while from the bottom section of the distillation zone there is recovered a bottoms product (12).

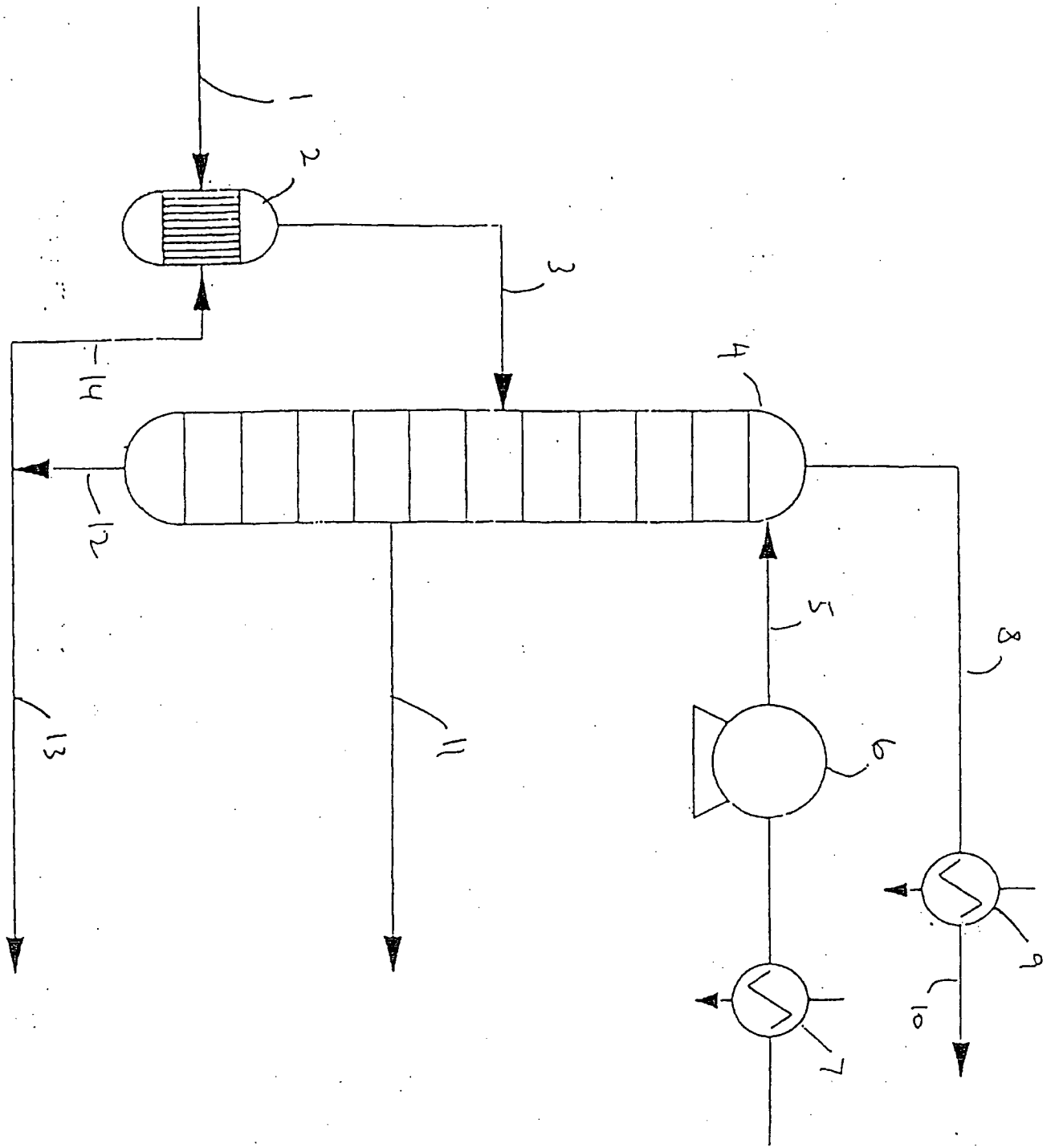



US006137016A

United States Patent [19]

[11] **Patent Number:** **6,137,016**

Wood et al.

[45] **Date of Patent:** ***Oct. 24, 2000**

[54] **PROCESS FOR THE PURIFICATION OF BUTANE-1,4-DIOL**

[75] **Inventors:** **Michael Anthony Wood**, Middlesbrough; **Paul Willett**, Witton le Wear; **Stephen William Colley**, Redcar; **Mohammad Shariff**, Middlesbrough, all of United Kingdom

[73] **Assignee:** **Kvaerner Process Technology Limited**, London, United Kingdom

[*] **Notice:** This patent issued on a continued prosecution application filed under 37 CFR 1.53(d), and is subject to the twenty year patent term provisions of 35 U.S.C. 154(a)(2).

[21] **Appl. No.:** **09/155,441**

[22] **PCT Filed:** **Mar. 27, 1997**

[86] **PCT No.:** **PCT/GB97/00879**

§ 371 Date: **May 3, 1999**

§ 102(e) Date: **May 3, 1999**

[87] **PCT Pub. No.:** **WO97/36846**

PCT Pub. Date: **Oct. 9, 1997**

[30] **Foreign Application Priority Data**

Mar. 29, 1996 [EP] European Pat. Off. 96302259

[51] **Int. Cl.⁷** **C07C 27/26**

[52] **U.S. Cl.** **568/868**

[58] **Field of Search** **568/868**

[56] **References Cited**

U.S. PATENT DOCUMENTS

2,768,214	10/1956	McKinley	568/868
4,383,895	5/1983	Ernst et al.	203/77
4,584,419	4/1986	Sharif et al.	568/864
4,751,334	6/1998	Turner et al.	568/864
4,795,824	1/1989	Kippax et al.	560/204
5,008,408	4/1991	Fischer et al.	549/429
5,397,439	3/1995	Kandori	568/868

FOREIGN PATENT DOCUMENTS

58-167532	3/1983	Japan
61-197534	1/1986	Japan
WO 88/00937	2/1988	WIPO
WO 90/08127	7/1990	WIPO

OTHER PUBLICATIONS

International Search Report, PCT/GB 97/00879, Oct. 7, 1997 (3 pages).

Primary Examiner—Michael L. Shippen

Attorney, Agent, or Firm—Senniger, Powers, Leavitt & Roedel

[57] **ABSTRACT**

The invention provides a process for the purification of a butane-1,4-diol feed containing a minor amount of the cyclic acetal, 2-(4'-hydroxybutoxy)-tetrahydrofuran, which comprises hydrogenating the butane-1,4-diol feed in a hydrogenation zone in the presence of a minor amount of water and a hydrogenation catalyst, and recovering from the hydrogenation zone a butane-1,4-diol product that has a reduced 2-(4'-hydroxybutoxy)-tetrahydrofuran content compared with the butane-1,4-diol feed.

13 Claims, No Drawings

tion under conditions wherein subjecting all of the water present in the crude butane-1,4-diol is first removed and then the butane-1,4-diol with reduced water content is further distilled to remove the colour-forming materials sufficiently to provide a product for use in the preparation of polyesters.

In JP-A-61/197534 there is taught a method of purifying crude butane-1,4-diol in which crude butane-1,4-diol containing at least one of the compounds, 2-(4'-hydroxy-butoxy)-tetrahydrofuran, 2-(4'-oxobutoxy)-tetrahydrofuran and 1,4-di-(2'-tetrahydrofuroxy)-butane, is hydrogenated in the presence of a hydrogenation catalyst, such as a supported platinum catalyst. The crude butane-1,4-diol can be prepared by acetoxylation of butadiene to yield diacetoxybutene which is then subjected to hydrogenation using a palladium or nickel catalyst and hydrolysis in the presence of a strongly acidic cation exchange resin. The specification goes on to describe how water and acetic acid are removed from the resulting hydrolysis product by distillation to yield the crude butane-1,4-diol which is the starting material for the method of purification. Since water has been removed by distillation, the crude starting material for the method product is substantially anhydrous. It is then described how aldehydes and acetals in the crude butane-1,4-diol are readily converted to compounds which can be separated easily from the butane-1,4-diol as a result of the hydrogenation method used for the purification method of this proposal. The document goes on to state that 2-(4'-hydroxy-butoxy)-tetrahydrofuran, 2-(4'-oxobutoxy)-tetrahydrofuran and 1,4-di-(2'-tetrahydrofuroxy)-butane are converted by hydrogenation to tetrahydrofuran, butane-1,4-diol, butanol, and ditetramethylene glycol, etc. The hydrogenated crude butane-1,4-diol is then subjected to distillation in two stages, a light boiling fraction containing water, tetrahydrofuran and butanol being recovered from the first distillation column. The second distillation column acts as the purifier, with butane-1,4-diol containing some light-boiling compounds being taken off from the top, butane-1,4-diol containing some heavy-boiling compounds being taken from the bottom, and the target purified butane-1,4-diol being taken from the side of the column.

It is accordingly an object of the present invention to provide an improved process for the purification of butane-1,4-diol which yields a butane-1,4-diol product stream that is essentially free from the cyclic acetal, i.e. 2-(4'-hydroxybutoxy)-tetrahydrofuran.

It is a further object of the present invention to provide an improved process for the production of butane-1,4-diol in which loss of potentially valuable butane-1,4-diol through formation of 2-(4'-hydroxybutoxy)-tetrahydrofuran as by-product is substantially obviated.

It is a still further object of the present invention to provide a process for the conversion of trace amounts of 2-(4'-hydroxybutoxy)-tetrahydrofuran present in butane-1,4-diol product streams to further butane-1,4-diol.

According to the present invention there is provided a process for the purification of a substantially anhydrous butane-1,4-diol feed containing a minor amount of the cyclic acetal, 2-(4'-hydroxybutoxy)-tetrahydrofuran, which comprises hydrogenating the butane-1,4-diol feed in a hydrogenation zone in the presence of a hydrogenation catalyst, and recovering from the hydrogenation zone a butane-1,4-diol product that has a reduced content of 2-(4'-hydroxybutoxy)-tetrahydrofuran, characterised in that hydrogenation is effected in the presence of from about 0.5% by weight up to about 5% by weight, based upon the weight of the butane-1,4-diol feed, of water. In such a process the added amount of water may correspond to a water:2-(4'-hydroxybutoxy)-tetrahydrofuran molar ratio of from about 20:1 to about 500:1.

Although the mechanism of the reaction has not been explored in detail, one plausible explanation is that, in the presence of the minor amount of water, the cyclic acetal is converted to a hemiacetal:

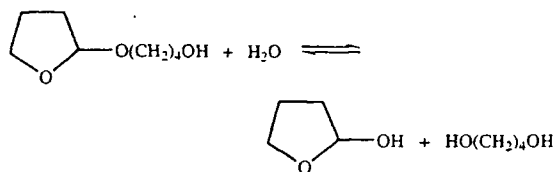

This hemiacetal is itself in equilibrium with the open chain compound, 4-hydroxybutyaldehyde:

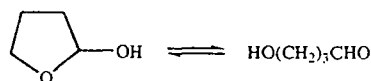

This can then be hydrogenated to butane-1,4-diol:

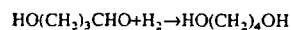

This is in contrast to the reactions involved in the purification method of JP-A-61/197534, in which the crude butane-1,4-diol used as starting material has already been distilled to remove acetic acid and water and so there is little or no possibility of the cyclic acetal, 2-(4'-hydroxy-butoxy)-tetrahydrofuran, being converted to the hemiacetal.

In a typical process according to the invention the butane-1,4-diol feed may contain from about 0.05% by weight up to about 1.0% by weight, typically about 0.1% by weight up to about 0.4% by weight, of 2-(4'-hydroxybutoxy)-tetrahydrofuran.

The hydrogenation catalyst is preferably a Group VIII metal-containing hydrogenation catalyst. Such Group VIII metal-containing catalysts typically contain from about 0.1% by weight up to about 2% by weight of a Group VIII metal or metals. As examples of Group VIII metals there can be mentioned nickel, palladium, platinum, rhodium, iridium, rhenium and the like, as well as mixtures of two or more thereof. The Group VIII metal or metals is or are deposited on an inert support, for example, graphite, alumina, silica-alumina, silica, zirconia, thoria, a diatomaceous earth or the like. A particularly preferred catalyst is a nickel catalyst. This can contain, for example, from about 10% by weight up to about 60% by weight or more of nickel. Another is a palladium-on-carbon catalyst, preferably containing from about 0.1% by weight up to about 4% by weight of palladium. A suitable nickel catalyst is that sold under the designation 86/4 by Kvaerner Process Technology Limited, of 30 Eastbourne Terrace, London W2 6LE.

Although the hydrogenation reaction can be conducted in the vapour phase, it is more conveniently carried out as a liquid phase reaction, using either a slurry of the catalyst or, more preferably, a fixed bed of catalyst. When operating with a fixed bed of catalyst the catalyst particles preferably have a particle size in the range of from about 0.5 mm to about 5 mm. The particles may be of any convenient shape, e.g. spheres, pellets, rings or saddles. When using a fixed bed of catalyst the reactor can be a shell-and-tube reactor, which can be operated substantially isothermally; however, it is preferably an adiabatic reactor. The use of an adiabatic reactor is advantageous since its capital cost is much lower than that of a shell-and-tube reactor and it is generally much easier to charge the reactor with the chosen catalyst.

TABLE I-continued

Run No.	1	2	3	4	5	6	7	8	9	10	11	32	13	14
mils/hr LHSV, h ⁻¹	0.5	1	1	1.5	0.5	2.7	3.65	1.1	1	1	1	1	1	1
Feed Composition	Wt/Wt Percent													
EtOH	0.18	0.18	0.18	0.18	0.18	0.18	0.18	0.18	0.18	0.18	0.18	0.18	0.18	0.18
THF	0.008	0.008	0.008	0.008	0.008	0.008	0.008	0.008	0.008	0.008	0.008	0.008	0.008	0.008
GBL	0.606	0.606	0.606	0.606	0.606	0.606	0.606	0.606	0.606	0.606	0.606	0.606	0.606	0.606
BDO	94.403	94.403	94.403	94.403	94.403	94.403	94.403	94.403	94.403	97	97	97	96	94
HVS	0.612	0.612	0.612	0.612	0.612	0.612	0.612	0.612	0.612	1.015	0.015	0.015	1.015	1.015
Acetal	0.191	0.191	0.191	0.191	0.191	0.191	0.191	0.191	0.191	0.191	0.191	0.191	0.191	0.191
H ₂ O	4	4	4	4	4	4	4	4	4	1	2	2	2	4
Product	Wt/Wt Percent													
EtOH	0.152	0.203	0.189	0.081	0.226	0.083	0.026	0.02	0.077	0.077	0.077	0.077	0.077	0.077
THF	0.027	0.017	0.06	0.045	0.12	0.037	0.05	0.03	0.039	0.039	0.039	0.039	0.039	0.039
GBL	0.588	0.607	0.613	0.582	0.595	0.59	0.58	0.57	0.574	0.606	0.606	0.606	0.606	0.606
BDO	94.56	94.41	94.314	94.672	94.421	94.61	94.65	94.76	94.685	96.4	95	96	96	94
HVS	0.594	0.676	0.782	0.579	0.611	0.59	0.594	0.56	0.513	1.76	2.188	1.199	1.134	1.231
Acetal	0.059	0.067	0.042	0.041	0.027	0.090	0.100	0.060	0.052	0.118	0.090	0.079	0.144	0.047
H ₂ O	4	4	4	4	4	4	4	4	4	1	2	2	2	4

Notes to Table I:

THF = tetrahydrofuran

GBL = γ -butyrolactone

BDC = butane-1,4-diol

HVS = "heavies"

Acetal = 2-(4'-hydroxybutoxy)-tetrahydrofuran

LHSV = liquid hourly space velocity (h⁻¹)

EXAMPLE 2

30

A further experimental test rig, similar to that used in Example 1 but with provision for recycle of product butane-1,4-diol from the exit end of the hydrogenation zone for dilution of the crude butane-1,4-diol feed, was used in this example. It was charged with 250 ml (237.4 g) of the same catalyst as used in Example 1 which was activated in the same way. A series of 12 Runs was carried out. The analysis of the wet feed butane-1,4-diol, obtained by adding water to a crude butane-1,4-diol of the type used in Example 1, was as set out in Table II.

TABLE II

	Runs 1-8	Runs 9-12
Water	3.92	4.03
Ethanol	0.013	0.013
Tetrahydrofuran	0.003	0.003
γ -butyrolactone	0.444	0.443
Butane-1,4-diol	94.985	94.876
Diethyl succinate	0.013	0.013
2-(4'-hydroxybutoxy)-tetrahydrofuran	0.175	0.175

35

40

45

TABLE III

Run No.	Temp. ° C.	H ₂ Flow NLPH	LHSV h ⁻¹	Liquid Recycle kg/h ⁻¹	Feed H ₂ O % wt	Feed Acetal % wt	Product Acetal % wt
1	110	20	1.0	2	4.0	0.17	0.063
2	110	24	1.0	1.0	4.0	0.165	0.057
3	108	24	0.8	0.6	4.0	0.17	0.050
4	107	24	1.1	0	4.0	0.17	0.058
5	109	6	1.01	0	4.0	0.17	0.070
6	110	36	1.05	0	4.0	0.17	0.048
7	110	12	1.07	0	4.0	0.17	0.059
8	110	24	0.86	0	4.0	0.17	0.039
9	111	24	1.18	0	4.0	0.7	0.049
10	110	3	0.6	0	4.0	0.17	0.036
11	110	1.5	0.8	0	4.0	0.17	0.030
12	110	0.5	0.8	0	4.0	0.17	0.025

Notes

NLPH = normalised liters per hour

LHSV = liquid hourly space velocity

50 Acetal = 2-(4'-hydroxybutoxy)-tetrahydrofuran

55

EXAMPLE 3

In the first 4 Runs the effects of liquid recycle were investigated using an LHSV of 1.0 h⁻¹, a temperature of 110° C., a pressure of 900 psia (62.05 bar), and a hydrogen flow rate of 24 NLPH. In Run 1 the recycle rate was 2 kg h⁻¹, in Run 2 1 kg h⁻¹, in Run 3 0.6 kg h⁻¹, and in Run 4 0 kg h⁻¹. In Runs 5 to 12 the effects of hydrogen flow rate were investigated. Run 9 repeated the conditions of Run 8 after a weekend shutdown of the rig. Runs 10 to 12 used lower hydrogen flow rates. The results are summarised in Table III below.

60

65

A sample of the crude butane-1,4-diol used as feed in Example 2 and a sample of a butane-1,4-diol product after treatment by the procedure described in Example 2 were transferred to respective round-bottomed flasks blanketed with nitrogen. The temperature of the flasks was increased to 160° C., while allowing any water and "lights" to distill off. Samples were taken for analysis at intervals after the temperature reached 160° C. The results are set out in Table IV below.

TABLE IV

Sample Time	Crude	Product
	Acetal	Acetal
0	0.033	0.03
40	0.06	0.04
100	0.16	0.05
160	0.17	0.057
300	0.17	0.057

Note: Acetal = 2-(4'-hydroxybutoxy)-tetrahydrofuran

EXAMPLE 4

The general procedure of Example 1 is repeated using a 2% palladium on carbon catalyst, following the supplier's recommendations for activating the catalyst. At a temperature in the range of 100° to 125° C. using a hydrogen pressure of 200 psia (13.79 bar) to 900 psia (62.05 bar) similarly good results are obtained.

EXAMPLE 5

In this Example there was further investigated the effects of varying the amount of water added to a crude butane-1,4-diol of the type used in Example 1, using the apparatus of Example 2 and the same catalyst charge. The results obtained are set out in Table V.

Comparison of Runs 1, 3, and 9 of Table V shows that reducing the water content of the feed from 4.03% to 2.3%

substantially constant. These results indicate that a 10° C. increase in temperature would compensate for a 50% loss in catalyst activity.

At temperatures greater than 120° C. the acetal content started to increase; in addition the content of tetrahydrofuran increased as a result of dehydration of butane-1,4-diol.

Runs 15 to 17 of Table V showed that varying the pressure under otherwise substantially identical conditions affected the acetal content of the product. Run 17 produced essentially the same acetal content as Run 14, thus indicating that there was no significant loss of catalyst activity during the period of operation at the higher temperature.

In Runs 18 and 19 of Table V the activity of the catalyst was checked.

The γ -butyrolactone content of the feed was increased to 6% for Run 20 of Table V. This indicated that the presence of γ -butyrolactone does not appear to inhibit the removal of acetal from the purified butane-1,4-diol product.

TABLE V

Run No.	Temp. (° C.)	Pressure (psig) [bar]	LHSV (hr ⁻¹)	H ₂ flow (NLPH)	Feed H ₂ O (%)	Acetal in product (wt %)	Acetal converted (%)
1	110	885 [62.03]	0.9	3.0	4.03	0.036	—
2	110	887 [62.17]	0.77	0.4	4.03	0.025	79.75
3	110	908 [63.62]	0.83	3.0	2.3	0.052	61.28
4	110	909 [63.69]	0.89	1.4	2.3	0.047	67.32
5	110	897 [62.86]	0.87	0.4	2.3	0.047	66.53
6	110	879 [61.62]	0.95	0.5	2.3	0.054	64.77
7	110	917 [64.24]	0.94	0.4	0.98	0.081	46.45
8	110	900 [63.07]	0.90	1.4	0.98	0.083	42.55
9	111	908 [63.62]	0.87	3.0	0.98	0.083	10.89
10	111	910 [63.76]	1.73	3.0	1.99	0.099	64.40
11	115	900 [63.07]	1.73	3.0	1.99	0.084	69.87
12	120	900 [63.07]	1.68	3.0	1.99	0.049	81.94
13	125	900 [63.07]	1.68	3.0	1.99	0.081	70.15
14	130	900 [63.07]	1.69	3.0	1.99	0.072	73.53
15	130	700 [49.28]	1.68	3.0	1.99	0.085	68.57
16	130	500 [35.49]	1.68	3.0	1.99	0.032	88.21
17	130	900 [63.07]	1.68	3.0	1.99	0.066	75.67
18	110	900 [63.07]	1.05	24.0	1.99	0.046	72.87
19	110	900 [63.07]	1.05	24.0	1.99	0.041	75.82
20	110	900 [63.07]	1.05	24.0	1.99	0.029	82.90

and then to 0.98% results in an increase of acetal in the product from 0.036% to 0.052% and to 0.08% respectively under otherwise similar conditions. The results set out in Table V also indicate that reducing the H₂ flow rate from 3.0 NLPH (normalised litres per hour, i.e. liters per hour at 0° C. and 1 ata [1.01 bar]) to 0.5 NLPH had a minimal effect upon acetal removal at the three water levels tested.

Runs 10 to 14 of Table V were intended to simulate the effect of an approximately 50% reduction in the activity of the catalyst by doubling the liquid hourly space velocity (LHSV) followed by an increase in catalyst temperature until the acetal content in the product was equivalent to that obtained at the lower LHSV. This resulted in the acetal content of the product increasing from 0.052% up to 0.099%. The catalyst temperature was increased in 5° C. increments whilst the other conditions were maintained

We claim:

1. A process for the purification of a substantially anhydrous butane-1,4-diol feed containing a minor amount of the cyclic acetal, 2-(4'-hydroxybutoxy)-tetrahydrofuran, which comprises hydrogenating the butane-1,4-diol feed in a hydrogenation zone in the presence of a hydrogenation catalyst, and recovering from the hydrogenation zone a butane-1,4-diol product that has a reduced content of 2-(4'-hydroxybutoxy)-tetrahydrofuran, characterised in that hydrogenation is effected in the presence of from about 0.5% by weight up to about 5% by weight, based upon the weight of the butane-1,4-diol feed, of water.

2. The process according to claim 1 wherein the butane-1,4-diol feed contains from about 0.1% by weight up to about 0.4% by weight of 2-(4'-hydroxybutoxy)-tetrahydrofuran.

3. The process according to claim 1 wherein the butane-1,4-diol feed is a substantially anhydrous material obtained by the hydrogenolysis of a di-(C₁ to C₄ alkyl) maleate followed by distillation of the hydrogenolysis reaction product to separate therefrom components including water and the alkanol formed by hydrogenolysis.

4. The process according to claim 1 wherein the hydrogenation step is conducted at a feed temperature in the range of from about 50° C. to about 125° C. and at a feed pressure in the range of from about 150 psia (about 10.34 bar) to about 1000 psia (about 68.95 bar).

5. The process according to claim 1 wherein the hydrogenation step is conducted using an amount of water corresponding to a water:2-(4'-hydroxybutoxy)-tetrahydrofuran molar ratio of from about 20:1 to about 500:1.

6. The process according to claim 1 wherein the hydrogenation catalyst is a Group VIII metal-containing catalyst.

7. The process according to claim 6 wherein the hydrogenation catalyst is a palladium-on-carbon catalyst containing from about 0.1% by weight up to about 4% by weight of palladium.

8. The process according to claim 7 wherein the hydrogenation catalyst is a nickel catalyst.

9. The process according to claim 1 wherein the butane-1,4-diol product from the hydrogenation step is distilled under an inert gas atmosphere to remove remaining traces of water therefrom.

10. The process according to claim 1 wherein the butane-1,4-diol feed is supplied to the hydrogenation zone at a rate corresponding to a liquid hourly space velocity of from about 0.5 h⁻¹ to about 4.0 h⁻¹.

11. The process according to claim 1 wherein the butane-1,4-diol feed is diluted with an inert diluent prior to entering the hydrogenation zone.

12. The process according to claim 11 wherein the inert diluent comprises butane-1,4-diol product recovered from the exit end of the hydrogenation zone.

13. The process according to claim 12 wherein the inert diluent:butane-1,4-diol feed ratio is in the range of from about 5:1 to about 100:1 by volume.

* * * * *

