

Durham E-Theses

Bosonic construction of superstring theory and related topics

Auttakit Chattaraputi

How to cite:

Chattaraputi, Auttakit (2002) Bosonic construction of superstring theory and related topics. Doctoral thesis, Durham University.

Use policy

The full-text may be used and/or reproduced, and given to third parties in any format or medium, without prior permission or charge, for personal research or study, educational, or not-for-profit purposes provided that:

- a full bibliographic reference is made to the original source
- a <https://etheses.durham.ac.uk/id/eprint/3884/> is made to the metadata record in Durham E-Theses
- the full-text is not changed in any way

The full-text must not be sold in any format or medium without the formal permission of the copyright holders.

Please consult the [full Durham E-Theses policy](#) for further details.

Bosonic construction of superstring theory and related topics

Auttakit Chattaraputi

The copyright of this thesis rests with the author.
No quotation from it should be published without
his prior written consent and information derived
from it should be acknowledged.

A Thesis presented for the degree of
Doctor of Philosophy



17 SEP 2002

Centre for Particle Theory
Department of Mathematical Sciences
University of Durham
England

June 2002



to My Parents

Bosonic construction of superstring theory and related topics

Autakit Chattaraputi

Submitted for the degree of Doctor of Philosophy

June 2002

Abstract

This thesis splits into two parts. In the first part we introduce a bosonic construction of the ten-dimensional fermionic theories. This construction relies on a consistent truncation procedure which can produce fermions out of bosons. We illustrate this truncation procedure in the case of type II superstring theories, which emerge as the truncation of the 26-dimensional closed bosonic string theory compactified on the weight lattice of $E_8 \times E_8$. The same truncation procedure can be applied to the unoriented bosonic string theory compactified on the above lattice and produces the type I superstring theory with the Chan-Paton gauge group reduced from $SO(2^{13})$ to $SO(32)$. We also demonstrate that the BPS D-branes in Type I theory can be obtained from the bosonic D-branes wrapping on the above lattice by using the technique of Boundary Conformal Field Theory.

In the second part, we construct new four-dimensional configurations of oppositely charged static black hole pairs (diholes) which are solutions of the low-energy effective action of string theories. The black holes are extremal and carry four different charges. We also generalize the dihole solution to a theory which has an arbitrary number of abelian gauge fields and scalars where the diholes are composite objects. We uplift the dihole solutions to higher dimensions in order to describe intersecting brane-anti-brane configurations in string theory. The properties of the strings and membranes stretched between the brane and anti-brane are discussed.

Declaration

The work in this thesis is based on research carried out at the Centre for Particle Theory, the Department of Mathematical Sciences, University of Durham, England. No part of this thesis has been submitted elsewhere for any other degree or qualification and it all my own work unless referenced to the contrary in the text.

Copyright © 2002 by Auttakit Chattaraputi.

“The copyright of this thesis rests with the author. No quotations from it should be published without the author’s prior written consent and information derived from it should be acknowledged”.

Acknowledgements

I wish to thank in the first place my supervisor, Dr. Anne Taormina not only for all her help and guidance in the research, but also for her encouragement and her patience to her students. I also thank Dr. Roberto Emparan, for his collaboration on my research and his inside knowledge in the subject of black holes and D-branes.

It is also my pleasure to acknowledge Prof. François Englert, as well as Dr. Laurent Houart, who gave me the opportunity to work in an exciting subject and who provide advice and discussion.

I give my special thanks to Jafar Sadeghi who has been a good friend and colleague for the last four years. I should not forget to thank “Imran” who prepared this wonderful Latex template, and also all my friends and staff of the Department of Mathematical Sciences at the University of Durham for their warm friendship and continuous help. I must thank Haruko Miyata for her kind support.

Finally, I would like to acknowledge the Royal Thai Government and the DPST project for awarding me the PhD scholarship.

Contents

Abstract	iii
Declaration	iv
Acknowledgements	v
1 Introduction	1
1.1 Non-BPS states and brane–anti-brane system	1
1.2 Fermions from bosons	2
1.3 Layout of this thesis	4
2 Background in Strings and D-branes	6
2.1 Bosonic String	6
2.1.1 Covariant gauge and equations of motion	7
2.1.2 Light-cone quantization	9
2.2 Vacuum amplitude	11
2.2.1 Torus partition function	15
2.2.2 Klein-bottle amplitude	17
2.2.3 Annulus amplitude	19
2.2.4 Möbius amplitude	20
2.3 Brief review of Superstring theory	23
2.3.1 Superstring in the NSR formulation	23
2.3.2 GSO-projection	25
2.3.3 Consistent string models	27
2.3.4 Low energy supergravity	28

2.4	A little note on branes and their solutions	31
2.4.1	The p -brane ansatz	31
2.4.2	The extremal dilatonic p -brane solutions	34
2.4.3	Branes in string and M-theory	35
2.4.4	The harmonic functions rule	39
3	Superstring from bosonic string	41
3.1	Introduction	41
3.2	Compactification of the bosonic theory	43
3.2.1	Review of the Englert-Neveu compactification	44
3.2.2	Lattice characters and their modular transformations	47
3.3	Open string descendants on lattice torus	51
3.3.1	Partition function and Klein bottle amplitude	51
3.3.2	Cardy's condition and annulus amplitude	53
3.3.3	Möbius amplitude	55
3.3.4	Consistency condition	56
3.3.5	Boundary state of a wrapped D-brane on an E-N lattice	57
3.4	Truncation of the bosonic string theory	61
3.4.1	Truncation in closed string sector	61
3.4.2	Fermionic representations and their operators	64
3.4.3	Truncation in open string sector	70
3.5	Type I BPS D-branes from bosonic D-branes	72
3.5.1	Setting up the configuration	72
3.5.2	Interaction Amplitudes	74
3.5.3	Truncation of the bosonic D-brane	76
3.5.4	Boundary state construction for the truncated branes	78
3.6	Discussions and outlook	81
4	Black diholes and intersecting brane–anti-brane configurations	82
4.1	Introduction	82
4.2	Single-charge diholes	85
4.3	Multi-charged diholes	90

4.3.1	String/M-theory diholes with four charges	91
4.3.2	$U(1)^n$ composite diholes	97
4.4	Intersecting brane–anti-brane configurations	99
4.4.1	Some explicit examples	100
4.4.2	The strings and membranes stretched between branes and anti-branes	105
4.5	Discussion and Outlook	108
5	Conclusion	112
	Bibliography	115

List of Figures

2.1	A Torus surface (a) can be described as a periodic lattice (b) with the fundamental domain in (c).	12
2.2	A Klein bottle surface.	13
2.3	An annulus surface.	14
2.4	A Möbius strip.	14
4.1	Geometry of the $p - p'$ brane and $\bar{p} - \bar{p}'$ brane intersections.	100

List of Tables

2.1	Closed string R-R spectrum in terms of $SO(8)$ representations.	27
3.1	Shows the relations between hatted and un-hatted characters.	49
3.2	Shows the simply laced Lie group that satisfy Cardy's condition.	54
3.3	Shows the fusion rule for $SO(4m)$ lattice characters ($m > 1$).	54
3.4	All ten dimensional closed string models can be truncated from 26-D bosonic string.	65
3.5	Shows the system of a D19-brane and background D25-branes and an orientifold plane.	73
4.1	The four D3-brane intersection at the limit $\theta \rightarrow 0$ of (4.55)	102
4.2	The two M5 and two M2-branes intersection at the limit $\theta \rightarrow 0$	103

Chapter 1

Introduction

In an attempt to explain the quantum theory of gravity, superstring theory seems to be the most promising candidate. Moreover, it was proposed as a theory that could unify all interactions present in nature.

Over the last few years string theorists have made a lot of major advances in the subject [1, 2]. One example is the string dualities conjecture which identifies the distinct superstring theories as different corners on the moduli space of a unique theory, so-called M-theory. However, the bosonic string theory is not included in the web of dualities. One could argue it is because the bosonic string has tachyons and no space-time fermions in its perturbative spectrum. However, these features are shared by the type 0A string theory which has recently found its place in the M-theory family [3]. It therefore seems a good idea to investigate a potential connection of bosonic string with M-theory. In the “old” string theory, there has been a suggestion that superstrings are in fact hidden in the Hilbert space of the bosonic string theory. This conjecture is the main discussion of this thesis.

1.1 Non-BPS states and brane–anti-brane system

String duality is an equivalence map between two different string theories. In general, this equivalence map relates the weakly coupled region of one theory to the strongly coupled region of another theory or vice versa. The strong/weak duality is rather difficult to test due to the lack of knowledge of the strong coupling regime of string



theory. Thus, supersymmetry is called to our rescue. If the two theories are dual to each other, we expect the low-energy limit of the two theories to be equivalence. The low-energy actions involve the massless spectrum which is completely fixed by supersymmetry and not affected by string loop corrections. Other evidence for duality relies on a special class of states called BPS-states. Since the BPS-states are stable as they are protected by supersymmetry, we expect them to survive in the strong coupling limit.

However, most states in the spectrum of superstring they are non-BPS. Without taking into account these non-extremal states, the proof of dualities cannot be complete. Following this idea, Sen proposed a test of dualities beyond BPS-level by studying the strong/weak duality between the $SO(32)$ heterotic string and Type I string theory. His argument is based on the fact that the $SO(32)$ spinor particles in the heterotic string spectrum are non-BPS and stable. Sen identified these spinor particles with the non-BPS D0-branes in Type I theory [4].

A D0-brane is a soliton of the D-string-anti-D-string pair. This system exhibits an open string tachyon as the string stretching between brane and anti-brane has the “wrong” GSO-projection. This tachyon has an effective potential which contains a “false vacuum” which signals that the system is unstable. Sen demonstrated that tachyons can condensate in a non-trivial way where the tachyon configuration can be interpreted as a localized particle which he called a non-BPS D0-brane. Sen then identified this particle with the $SO(32)$ spinor particles of the heterotic string. Thus a non-BPS proof of string dualities does exist.

Inspired by Sen’s conjecture, we might expect the tachyon in bosonic string to condensate to its true vacuum (if any such vacuum exists). There was a conjecture in [5], that such condensation might produce the superstring theory. However, this still remains pure speculation.

1.2 Fermions from bosons

Before we go further, let us discuss the relation between bosons and fermions. In two-dimensional Quantum Field Theory, fermions and bosons are closely related. We

can construct fermions from purely bosonic degrees of freedom by the “bosonization” method. More precisely, fermions are coherent states of bosons and there seems to be two different descriptions of the same thing. Then such an equivalence should be possible *a priori* depends on the fact that spin is not defined in two dimensions. The equivalence of bosonic and fermionic two-dimensional systems has been well-known for a long time. To our knowledge, it was Schwinger who first noticed it in the context of Quantum Electrodynamics (QED) [6]. He found that massless QED is equivalent to a massive free scalar field theory in two-dimensional space-time. The bosonization idea became increasingly popular a decade later, when Coleman made the remarkable discovery that the quantum solitons in the Sine-Gordon model are in fact fermions of the Thirring model [7]. Coleman’s conjecture has been further developed by Dashen, *et al.*, Mandelstam and others. Since then bosonization has become an important technique in Conformal Field Theory and Statistical Mechanics.

In string theory, we can apply the bosonization on world-sheet coordinates. An important example is the fermionic construction of the heterotic string. We replace the internal bosonic degrees of freedom compactified on a 16-dimensional torus by 32 world-sheet (bosonized) fermionic degrees of freedom¹. However, this procedure cannot produce space-time fermions. We need to find another mechanism which can provide space-time fermions from bosonic degrees of freedom.

Jackiw and Rebbi, Hasenfratz and ’t Hooft, and Goldhaber [8] showed that fermionic degrees of freedom can emerge from the bosonic configuration of a 3+1 dimensional $SU(2)$ gauge theory. More precisely, the bound state of an $SU(2)$ ’t Hooft-Polyakov monopole with a scalar particle that transforms in the fundamental of $SU(2)$ is a fermionic state. As ’t Hooft and Hasenfratz demonstrated that the spin quantum number of such bound state depends on the isospin of the fundamental particle, a particle in a half integer representation will have spin half integer. Therefore, it is a space-time fermion.

Nearly twenty years ago, Casher, Englert, Nicolai and Taormina [9], generalized

¹This process is sometimes referred to as “fermionization” in the literature as it is the reverse procedure of bosonization.

the 't Hooft-Hasenfratz mechanism to the bosonic string theory. They suggested that the ten-dimensional superstring theories (Type IIA/B and the two heterotic strings) are indeed hidden in the closed bosonic string spectrum. The emergence of space-time fermions and of supersymmetry from the bosonic string, anticipated by Freund [10], is a remarkable phenomenon. The authors in [9] demonstrated that by toroidally compactifying the closed bosonic string theory on the $E_8 \times E_8$ group lattice one can produce the spectrum of Type IIA/B superstring. The bosonic spectrum must be truncated in an appropriated way which guarantees the modular invariance of the resulting theory. The truncated theory has a new Lorentz group whose transverse part is $diag(SO(8)_{trans} \otimes SO(8)_{int})$. We refer to $SO(8)_{trans}$ as the subgroup of the transverse bosonic Lorentz group $SO(24)_{trans}$ and $SO(8)_{int}$ as a regular subgroup of $SO(16) \subset E_8$. The adjoint representations of $E_8 \times E_8$ ($E_8 \times SO(16)$) will give the spinor representation of the new Lorentz group. We will discuss more about this subject in Chapter 3.

1.3 Layout of this thesis

This thesis has five chapters in total. After the introduction and historical review in this chapter, we briefly survey the essential background material in Chapter 2. Then, we present our results in Chapters 3 and 4. Finally, we discuss our results in the last chapter.

The aim of Chapter 2 is to give an introduction to the theory of string and D-branes. Accordingly, this chapter contains a brief review of the light-cone quantization of the bosonic string in Section 2.1, and Section 2.3 contains a very brief review of the Neveu-Schwarz-Ramond superstring theory and its low energy effective action. (In Chapter 3, we will focus more on its bosonic construction.) In Section 2.2, we go on to discuss the four vacuum amplitudes of unoriented bosonic theory, namely, the torus, the Klein-bottle, the annulus and the Möbius amplitude. We will use this information to construct the open descendants of the bosonic closed states in Chapter 3. In the last section of this chapter, we review how to calculate a p-brane solution from the supergravity action and introduce the harmonic function

rule.

In Chapter 3 we review the toroidal compactification of bosonic string on a particular class of Lie group lattices called Englert-Neveu lattices. In Section 3.3 we construct the consistent open string theory compactified on such lattice by using the boundary conformal technique of Sagnotti in [11]. The results in this section have appeared before in Englert, Houart and Taormina [12]. Although, we used a different approach, we have no claim of originality in presenting them. In Section 3.4 we summarise the rules for the truncation procedure and introduce the corresponding (bosonized) fermionic operators. The result in Section 3.5 is new. Motivated by the results in [12] namely that the type I superstring can be obtained by the truncation of open and closed bosonic string theory, we show the evidence that the BPS D-branes of Type I can emerge from the truncation of wrapped bosonic D-brane.

The results in Chapter 4 are published in [13] with Emparan and Taormina. In Section 4.2 we review the solution for single charge diholes discovered by Emparan [14]. The dihole is a pair of oppositely charge extremal black hole in four dimensions. Then in Section 4.3, we construct a new exact solution of four-dimensional General Relativity describing oppositely charged, static black hole pairs, where the black holes are extremal and have an arbitrary number of different charges. We conclude that our solution describes composite of diholes. In Section 4.4, we uplift the solution in 4.3 to ten and eleven dimensions and interpret them as systems of intersecting brane and intersecting anti-brane configurations. Motivated by the works of Sen in [15], in Section 4.4.2, we attempt to test the connections between supergravity solutions and non BPS states described by brane–anti-brane type of configurations.

Chapter 2

Background in Strings and D-branes

The aim of this chapter is to provide the necessary background for Chapters 3 and 4. We will briefly review the theory of bosonic strings, superstrings and D-branes. Therefore the material in this chapter is by no means original. The main references we have used are [1, 2] (for Sections 2.1 and 2.3), [11] (for Section 2.2) and [16, 17] (for Section 2.4).

2.1 Bosonic String

Let us start with the bosonic string theory in a D -dimensional Minkowski space-time. We can write the corresponding Polyakov action as [18]

$$S = -\frac{1}{4\pi\alpha'} \int_{\Sigma} d^2\xi \sqrt{-\gamma} \gamma^{\alpha\beta} \partial_{\alpha} X^{\mu} \partial_{\beta} X^{\nu} \eta_{\mu\nu} + \frac{\langle\phi\rangle}{4\pi} \int_{\Sigma} d^2\sigma \sqrt{-\gamma} \mathcal{R}, \quad (2.1)$$

where $\eta_{\mu\nu}$ is the space-time metric with mostly negative signature, $(1, -1, \dots, -1)$, and the world-sheet surface, Σ , is described by the coordinates $(\xi^1, \xi^2) \equiv (\sigma, \tau)$. The second term in (2.1) is proportional to the Euler characteristic, χ_{Euler} , of the world-sheet surface. It is a topological invariant and does not affect the dynamics of the string. The perturbative expansion of the theory is suppressed by the factor $g_s^{-\chi_{Euler}}$, where the string coupling constant g_s is determined by the vacuum expectation value of the dilaton field ϕ , namely, $g_s = e^{\langle\phi\rangle}$. In this thesis, in particular in Chapter 3, we

will consider the unoriented closed string theory which also contains an unoriented open string sector in its spectrum. In this case the world-sheet is a Riemann surface with Euler characteristic

$$\chi_{Euler} = \frac{1}{4\pi} \int d^2\sigma \sqrt{-\gamma} \mathcal{R} = 2 - 2h - b - c, \quad (2.2)$$

where h , b and c respectively represent the number of handles, boundaries and crosscaps of the Riemann surface Σ . The spectrum of the unoriented string theory is encoded in the four vacuum amplitudes with vanishing Euler characteristic: torus, Klein bottle, annulus and Möbius strip. After quantizing the theory, we will determine these four vacuum amplitudes in Section (2.2).

2.1.1 Covariant gauge and equations of motion

The action (2.1) has local world-sheet reparametrization invariance and global D -dimensional space-time Poincaré invariance. Moreover, at least in the classical theory, the action has a local Weyl scaling invariance. Note that the latter is not included in the world-sheet reparametrization invariance. Conformal symmetry is purely accidental and does not manifest itself in higher dimensional extended objects such as membranes. As in gauge theory, the physical degrees of freedom are fewer than those appearing in the action. We can reduce the degrees of freedom due to the world-sheet reparametrization invariance and conformal symmetry by fixing a gauge. The first symmetry can be used to reduce the world-sheet metric $\gamma_{\alpha\beta}$ of signature $(+, -)$ from three independent components to one degree of freedom i.e. the metric becomes $\gamma_{\alpha\beta} = \Lambda(\xi)\eta_{\alpha\beta}$ where $\eta = \text{diag}(1, -1)$. This choice of gauge is called *conformal gauge*. An unknown conformal factor $\Lambda(\xi)$ can be dropped from the classical action (2.1). We can simplify the metric further by exploiting the conformal symmetry. This choice of gauge is the *covariant gauge* and the metric is simply

$$\gamma_{\alpha\beta} = \eta_{\alpha\beta}. \quad (2.3)$$

By using the Euler-Lagrange equations, we can derive the equations of motion as

$$\partial_\alpha \left(\sqrt{-\gamma} \gamma^{\alpha\beta} \partial^\beta X^\mu \right) = \left(\partial_\tau^2 - \partial_\sigma^2 \right) X^\mu = 0, \quad (2.4)$$

that reduces to the one-dimensional wave equation in the covariant gauge. In addition to the equations of motion, we also get the constraint equations

$$T_{\alpha\beta} = \partial_\alpha X^\mu \partial_\beta X_\mu - \frac{1}{2} \gamma_{\alpha\beta} \partial^\gamma X^\mu \partial_\gamma X_\mu = 0, \quad (2.5)$$

where $T_{\alpha\beta}$ can be interpreted as the energy-momentum tensor for a two-dimensional field theory of D free scalar fields X^μ .

Before moving on to quantize the theory, we consider the general solution of (2.4) for closed and open strings. For the *closed string*, the world-sheet coordinate σ is identified with $\sigma + \pi$. The solution to the string equations of motion can be separated into right movers X_R^μ and left movers X_L^μ , in a way consistent with the periodic boundary conditions, namely,

$$X^\mu = X_R^\mu(\tau - \sigma) + X_L^\mu(\tau + \sigma), \quad (2.6)$$

where

$$\begin{aligned} X_R^\mu &= \frac{q^\mu}{2} + \sqrt{\alpha'} p^\mu(\tau - \sigma) + \frac{i}{2} \sum_{n \neq 0} \frac{\sqrt{2\alpha'}}{n} \alpha_n^\mu e^{-2in(\tau - \sigma)}, \\ X_L^\mu &= \frac{q^\mu}{2} + \sqrt{\alpha'} p^\mu(\tau + \sigma) + \frac{i}{2} \sum_{n \neq 0} \frac{\sqrt{2\alpha'}}{n} \tilde{\alpha}_n^\mu e^{-2in(\tau + \sigma)}. \end{aligned} \quad (2.7)$$

The dynamics of the closed string is described by q^μ and $p^\mu = \sqrt{\frac{2}{\alpha'}} \alpha_0 = \sqrt{\frac{2}{\alpha'}} \tilde{\alpha}_0$ where q^μ is equally distributed between $X_L^\mu(\tau + \sigma)$ and $X_R^\mu(\tau - \sigma)$ while the oscillations of the string are described by the oscillators α_m^μ and $\tilde{\alpha}_m^\mu$.

For *open strings*, we take $0 \leq \sigma \leq \pi$. The requirement of the action (2.1) to be stationary still gives us the equations of motion (2.4) but in addition it implies the fields must satisfy appropriate boundary conditions. More precisely, $\delta S = 0$ implies that the boundary term vanishes i.e.

$$\int dx \delta X^\mu (\partial_\sigma X_\mu) = 0. \quad (2.8)$$

To satisfy (2.8), we can choose either Neumann boundary conditions $\partial_\sigma X^\mu = 0$ at $\sigma = 0, \pi$ which preserve the Poincaré symmetry or Dirichlet boundary conditions $\delta X^\mu = 0$ at $\sigma = 0, \pi$ which imply the endpoints of the open string are fixed in the μ -direction. These boundary conditions can be chosen independently for each

component of X^μ . For example, we can choose an open string with one of its endpoints constrained to a $(p + 1)$ -dimensional hyperplane i.e. $X^\lambda|_{\sigma=0} = x^\lambda$, for $\lambda = p + 1, \dots, D$ and another endpoint confined on a $(D - p + 1)$ -dimensional hyperplane $X^\nu|_{\sigma=\pi} = y^\nu$ for $\nu = 1, \dots, p$.

A remark is in order here. When the Dirichlet boundary conditions are introduced, the Poincaré symmetry is broken. The hyperplanes which confine the endpoints of an open string are called Dirichlet-branes or “D-branes”. These objects play an important role in string theory and in this thesis, as we will discuss in detail in the following section. Here we consider only the open string with Neumann boundary condition at both endpoints, and we call it a (NN)-string.

In the case of open strings, the left- and right-mover oscillator terms are related by the boundary conditions (2.8), thus a separation into left- and right-movers is not useful. The solution for the equations of motion for the (NN)-string is given by

$$X^\mu = q^\mu + 2\alpha' p^\mu \tau + i \sum_{n \neq 0} \frac{\sqrt{2\alpha'}}{n} \alpha_n^\mu e^{-in\tau} \cos(n\sigma) . \quad (2.9)$$

2.1.2 Light-cone quantization

Although we have chosen the covariant gauge (2.3), not all the gauge freedom has been removed and we can impose a further gauge condition that reduces the number of components of X^μ and leaves only the physical dynamical degrees of freedom. The procedure is analogous to the light-cone formulation of Electrodynamics. We start by defining the light-cone coordinates

$$X^\pm = \frac{1}{\sqrt{2}}(X^0 \pm X^{D-1}) . \quad (2.10)$$

The residual gauge invariance can be used to identify the target-space coordinate X^+ and world-sheet time τ , and to remove all oscillators in X^+ , so that

$$X^+ = q^+ + 2\alpha' p^+ \tau , \quad (2.11)$$

where q^+ and p^+ are constant. The coordinate X^- can now be written in terms of transverse coordinates X^1, \dots, X^{D-2} . By substituting (2.11) into the constraint equation (2.5), we obtain

$$2\sqrt{2}\alpha' p^+ \partial_\pm X^- = \partial_\pm X^i \partial_\pm X^i , \quad i = 1, \dots, D - 2, \quad (2.12)$$

and their zero-modes can be written in more useful form as

$$2p^+p^- = \frac{2}{\alpha'} (L_0 + \bar{L}_0 - 2a), \quad (2.13)$$

where

$$L_0 = \frac{1}{2} \sum_{n \in \mathbb{Z}} : \alpha_{-n}^i \alpha_n^i :, \quad (2.14)$$

is the zero-mode of the transverse Virasoro operators $L_m = \frac{1}{2} \sum_{n \in \mathbb{Z}} : \alpha_{m-n}^i \alpha_n^i :$, which satisfy the Virasoro algebra with central charge $c = D - 2$,

$$[L_m, L_n] = (m - n)L_{m+n} + \frac{D - 2}{12} m(m^2 - 1) \delta_{m+n,0}. \quad (2.15)$$

A similar expression holds for \bar{L}_0 . The factor a in (2.13), arising from the normal ordering “ $:\cdots:$ ” in L_0 and \bar{L}_0 , can be determined by using ζ -function regularization with $\zeta(s) = \sum_{n=1}^{\infty} n^{-s}$, analytically continued to $s = -1$. We then obtain,

$$a = -\frac{D - 2}{2} \zeta(-1) = \frac{D - 2}{24}. \quad (2.16)$$

The mass-shell condition is defined by

$$M^2 = p^2 = \left(2p^+p^- - p^i p^i \right) = \frac{2}{\alpha'} (N_{nc} + \bar{N}_{nc} - 2a), \quad (2.17)$$

where $N_{nc} = \sum_{n \neq 0} \alpha_{-n}^i \alpha_n^i$ and $\bar{N}_{nc} = \sum_{n \neq 0} \tilde{\alpha}_{-n}^i \tilde{\alpha}_n^i$ are the number operators for left and right movers respectively. The subscript nc refer to “non-compact” dimensions, in anticipation of considerations to come on torus compactification. Equation (2.17) together with the level-matching condition $L_0 = \bar{L}_0$ define physical states for the closed string spectrum. The full spectrum of closed string theory can be constructed by acting with products of oscillators α_{-n}^i and $\tilde{\alpha}_{-n}^i$ on ground states $|0\rangle_L$ and $|0\rangle_R$ for left and right movers respectively, and form the product of the right and left mover states.

Only for the *critical dimension* $D = 26$, $a = 1$, are the first excited states massless. They describe a metric fluctuation $h_{\mu\nu}$, an antisymmetric tensor $B_{\mu\nu}$, and the dilaton ϕ whose vacuum expectation value $\langle \phi \rangle$ determines the string coupling constant g_s . The critical dimension also ensures the theory does not have any quantum anomalies spoiling the Lorentz invariance [1].

For the open string sector, a similar procedure can be considered. The mass-shell condition for open string is

$$M^2 = \frac{1}{\alpha'} (N_{nc} - a), \quad (2.18)$$

where this time $N_{nc} = \sum_{n \neq 0} \alpha_{-n}^i \alpha_n^i$ is referred to as an open string oscillator number operator.

The biggest disadvantage of the bosonic string is the presence of tachyons in both open and closed sectors. This suggests that we are at risk to define the perturbation theory in a wrong vacuum. An interesting idea is that the tachyons could condense to the true vacuum and lead to a supersymmetric theory. We will discuss this possibility in Chapter 3. Unfortunately, although there has been a lot of progress in understanding tachyon condensation in open string theory recently [19], the closed string tachyon is still not manageable.

2.2 Vacuum amplitude

According to the formula (2.2), there are four surfaces with vanishing Euler characteristic. The torus ($h = 1, b = 0, c = 0$), the Klein bottle ($h = 0, b = 0, c = 2$), the annulus ($h = 0, b = 2, c = 0$) and the Möbius strip ($h = 0, b = 1, c = 1$).

1) Torus : ($h = 1, b = 0, c = 0$)

In general all of these surfaces can be mapped into the plane. Let us start with the torus which can be mapped into the parallelogram with opposite side identified by the arrow as shown in Figure 2.1. We can rescale the horizontal side to be of unit length, and thus the shape of the complex surface is controlled by the Teichmüller parameter, $\tau = \tau_1 + i\tau_2$. However, not all values of τ correspond to inequivalent tori. In fact, all values of τ related by a transformation of the modular group $SL(2, \mathbb{Z})/\mathbb{Z}_2$ describe equivalent tori. The modular group is generated by the two *modular transformations*:

$$T : \tau \rightarrow \tau + 1, \quad S : \tau \rightarrow -\frac{1}{\tau}, \quad (2.19)$$

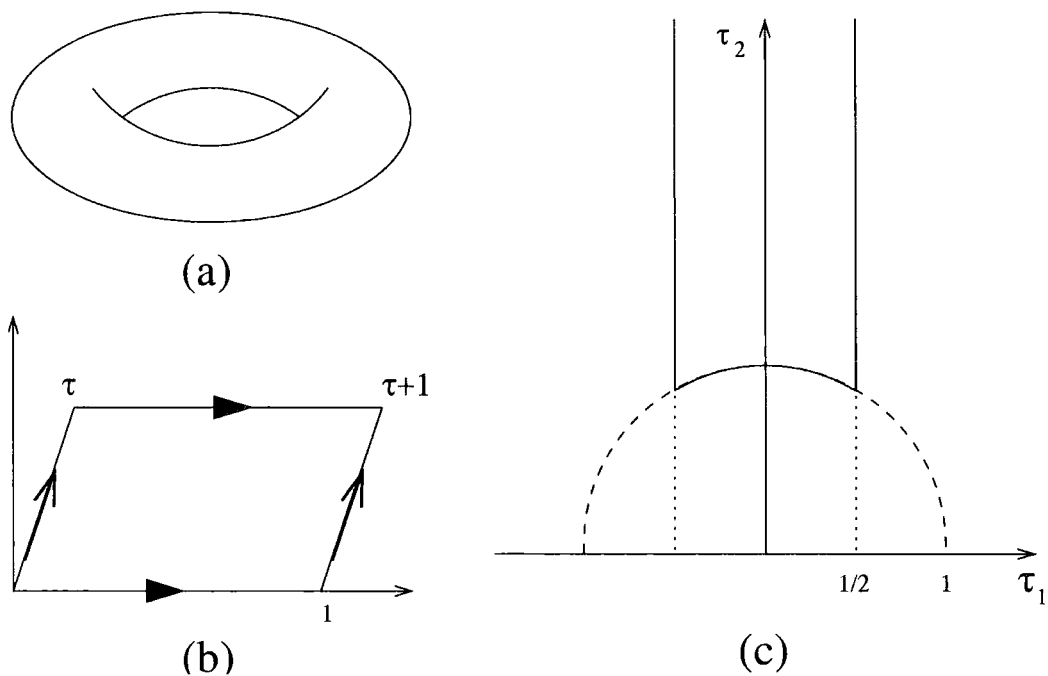

Figure 2.1: A Torus surface (a) can be described as a periodic lattice (b) with the fundamental domain in (c).

which satisfy the relation $S^2 = (ST)^3$ in $SL(2, \mathbb{Z})$. Consequently, the values of τ giving inequivalent tori lie in a fundamental region

$$\mathcal{F} = \left\{ -\frac{1}{2} < \tau_1 \leq \frac{1}{2}, |\tau| \geq 1 \right\}, \quad (2.20)$$

as shown in Figure 2.1(c).

2) Klein bottle : ($h = 0, b = 0, c = 2$)

Let us consider the Klein bottle surface. This surface has two choices for the corresponding polygons shown in Figure 2.2 (b). The first polygon has horizontal sides of unit length with opposite orientations, while has vertical sides of length $i\tau_2$. The fundamental domain can be obtained from the doubly-covering torus of imaginary Teichmüller parameter $2i\tau_2$, with the lattice transformation supplemented by the anti-conformal involution $z \rightarrow 1 - \bar{z} + i\tau_2$. We refer to the world-sheet time τ_2 as the *vertical* time.

The second choice of polygon is obtained by doubling the vertical sides while halving the horizontal sides, thus leaving the area unchanged (the area with dark

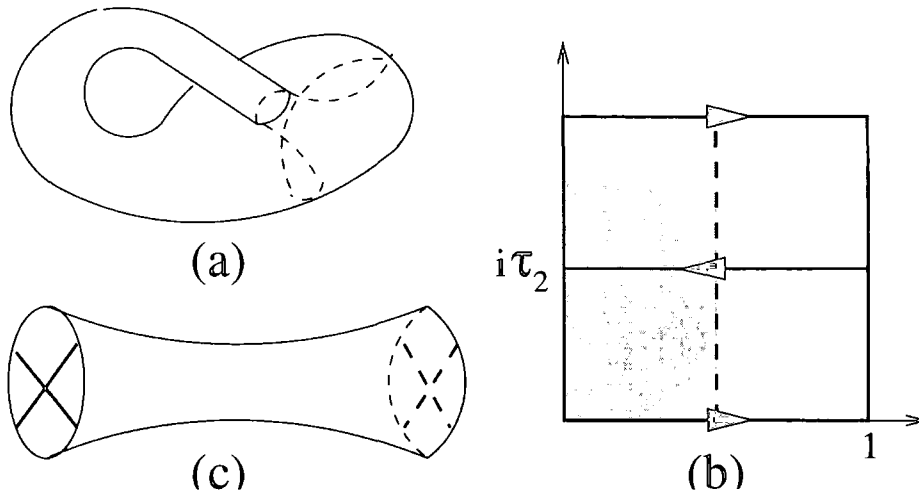

Figure 2.2: A Klein bottle surface.

colour in Figure 2.2 (b)). The two vertical lines are identified as the two cross-caps. The horizontal lines now have the same orientations and are identified as the *horizontal* time which describes closed strings propagating between two crosscaps (Figure 2.2 (c)).

3) Annulus : ($h = 0, b = 2, c = 0$)

The fundamental region of the annulus is obtained by horizontal doubly-covering torus as shown in Figure 2.3 (b). The original polygon has vertices at 1 and $i\tau_2$ with the horizontal sides identified. The two vertical sides represent the two boundaries of the surface which are the fixed points of the lattice transformations and the involutions $z \rightarrow -\bar{z}$ and $z \rightarrow 2 - \bar{z}$. Thus we obtain the annulus from the doubly-covering torus. The Teichmüller parameter is again imaginary. The *vertical* time τ_2 describes an open string propagating along the annulus. We can also consider the *horizontal* time which describes the exchange of closed string modes between two boundaries as shown in Figure 2.3 (c).

4) Möbius strip : ($h = 0, b = 1, c = 1$)

The Möbius strip has two choices of polygons as in Figure 2.4 (b). The first polygon has vertices at 1 and $i\tau_2$ with the horizontal sides having opposite orientations. We identify the parameter τ_2 as the *vertical* time which describes an open

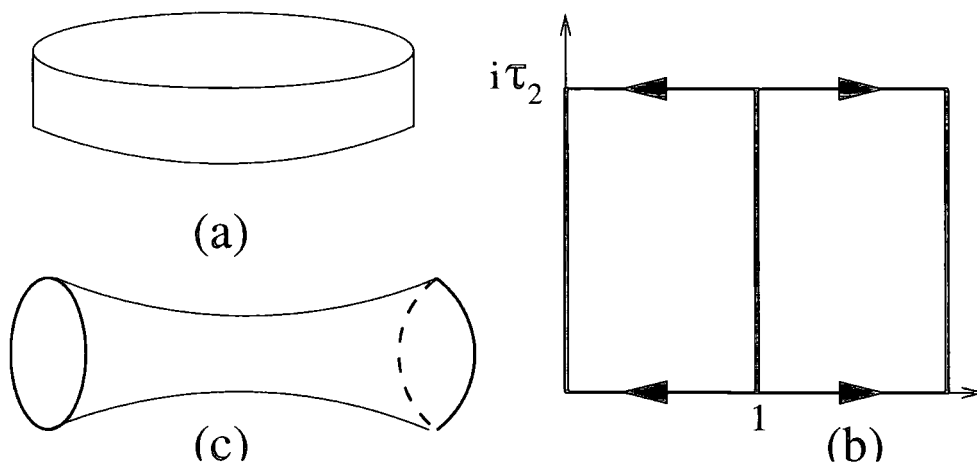

Figure 2.3: An annulus surface.

string propagating on the Möbius surface. The second choice of polygon is obtained by doubling the vertical sides and halving the horizontal sides. As a result, one of the two vertical side is a boundary, while the other is identified as a crosscap where points are identified by the involution $z \rightarrow 1 - \bar{z} + i\tau_2$. The *horizontal* time describes a closed string propagating between the boundary and the crosscap.

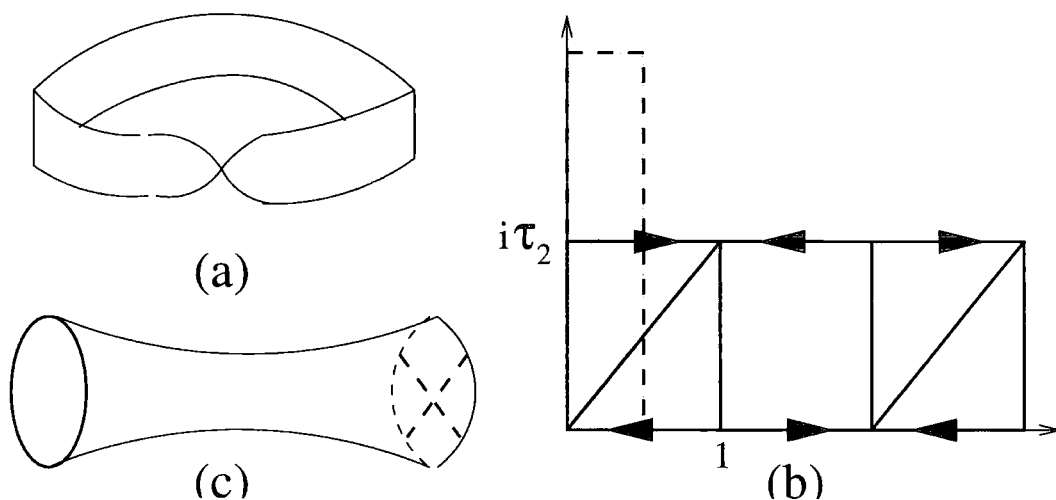

Figure 2.4: A Möbius strip.

The fundamental region of the Möbius strip is obtained from the doubly-covering torus of Teichmüller parameter $\tau = i\tau_2/2 + 1/2$. The fact that τ is not purely imaginary has some crucial effects. First, on the Klein bottle and annulus surfaces, the *vertical* and *horizontal* times are related by the modular S-transformation. On the other hand, on the Möbius strip, the two choices of times are related by the

P-transformation defined by

$$P : \frac{1}{2} + i\frac{\tau_2}{2} \rightarrow \frac{1}{2} + i\frac{1}{2\tau_2}. \quad (2.21)$$

The P-transformation can be written in terms of the S and T transformations as

$$P = TST^2S, \quad (2.22)$$

and satisfies $P^2 = S^2 = (ST)^3$. Second, it leads to technical subtleties when calculating string amplitudes as will be investigated in the next section.

2.2.1 Torus partition function

Let us consider the one-loop vacuum amplitude for the oriented closed bosonic string theory. (We follow the discussion in [11].) Like in Quantum Field Theory, the vacuum amplitude in string theory can be determined from the path integral formula as

$$\Gamma = -\frac{V_D}{2(4\pi)^{D/2}} \int_{\epsilon}^{\infty} \frac{dt}{t^{D/2+1}} \text{tr} \left(e^{-tM^2} \right), \quad (2.23)$$

where t is a Schwinger parameter and ϵ is an ultraviolet cutoff. We define V_D as the volume of space-time. For a closed bosonic string in 26-dimensional space-time, the mass square is given in (2.17). Moreover, we have to impose the level matching condition $L_0 = \bar{L}_0$ to eliminate the unphysical states. This can be done by adding a δ -function to the above equation. The total amplitude reads

$$\Gamma = -\frac{V_{26}}{2(4\pi)^{13}} \int_{-\frac{1}{2}}^{\frac{1}{2}} ds \int_{\epsilon}^{\infty} \frac{dt}{t^{14}} \text{tr} \left(e^{-\frac{2}{\alpha'}(L_0 + \bar{L}_0 - 2)t} e^{2\pi i(L_0 - \bar{L}_0)s} \right). \quad (2.24)$$

Since $L_0 - \bar{L}_0 \in \mathbb{Z}$ has integer eigenvalues, the integral on s vanishes except at $L_0 = \bar{L}_0$. The above amplitude could be modified into the more powerful form

$$\Gamma = -\frac{V_{26}}{2(4\pi^2\alpha')^{13}} \int_{-\frac{1}{2}}^{\frac{1}{2}} d\tau_1 \int_{\epsilon}^{\infty} \frac{d\tau_2}{\tau_2^{14}} \text{tr} \left(q^{L_0-1} \bar{q}^{\bar{L}_0-1} \right), \quad (2.25)$$

where we define the complex Schwinger parameter

$$\tau = \tau_1 + i\tau_2 = s + i\frac{t}{\alpha'\pi}, \quad (2.26)$$

and the q -variables

$$q = e^{2\pi i\tau}, \quad \bar{q} = e^{-2\pi i\bar{\tau}}. \quad (2.27)$$

At one-loop, the dynamics of closed strings is described by the torus amplitude, which the complex Schwinger parameter τ being identified with the Teichmüller parameter. The integration domain in (2.25) is restricted to a fundamental region of the modular group, $\mathcal{F} = \left\{ -\frac{1}{2} < \tau_1 \leq \frac{1}{2}, |\tau| \geq 1 \right\}$, defined in Equation (2.20). This choice of domain introduces an effective ultraviolet cutoff of the order of the string scale for all string modes. Thus, after rescaling, the torus amplitude for the non-compactified 26-dimensional bosonic string reads

$$\Gamma_{nc}^T = \frac{V_{26}}{(4\pi^2\alpha')^{13}} \int_{\mathcal{F}} \frac{d\tau^2}{\tau_2^2} \mathcal{T}_{nc}(\tau, \bar{\tau}), \quad (2.28)$$

where

$$\mathcal{T}_{nc}(\tau, \bar{\tau}) = \frac{1}{\tau_2^{12}} \frac{1}{|\eta(\tau)|^{48}}. \quad (2.29)$$

Note that the Dedekind function, η , is defined by

$$\eta(\tau) = q^{\frac{1}{24}} \prod_{n=1}^{\infty} (1 - q^n). \quad (2.30)$$

In order to guarantee the amplitude (2.28) is meaningful, $\mathcal{T}_{nc}(\tau, \bar{\tau})$ must not depend on the region we choose i.e. \mathcal{T}_{nc} must be modular invariant. This property can easily be observed using the fact that the Dedekind function transforms under modular transformation as,

$$T : \eta(\tau + 1) = e^{\frac{i\pi}{12}} \eta(\tau), \quad S : \eta\left(-\frac{1}{\tau}\right) = \sqrt{-i\tau} \eta(\tau). \quad (2.31)$$

Consequently, the combination $\sqrt{\tau}|\eta|^2$ is invariant independently of the dimension of space-time i.e. does not depend on the total central charge c , as a result, implies the modular invariant of \mathcal{T}_{nc} .

Equation (2.29) can be reexpressed as the integral over the transverse momenta

$$\begin{aligned} \mathcal{T}_{nc}(\tau, \bar{\tau}) &= (\alpha')^{12} \int d^{24}p \left| \frac{q^{\alpha'p^2/4}}{\eta(\tau)^{24}} \right|^2, \\ &= (\alpha')^{12} \int d^{24}p \bar{\chi}_p(\bar{\tau}) \chi_p(\tau), \end{aligned} \quad (2.32)$$

where $\chi_p(\tau) = q^{\alpha'p^2/4}/\eta(\tau)^{24}$ is a Virasoro character. Equation (2.32) exhibits a continuum of distinct ground states with corresponding towers of excited states. Each tower is a Verma module in conformal field theory. The squared masses of the

ground states are determined by the conformal weight h_i of the primary fields. The information of Verma modules is encoded in characters $\chi_i(\tau)$ which are generally defined as

$$\chi_i(\tau) = \text{tr}(q^{L_0 - c/24})_i = q^{h_i - c/24} \sum_k d_k q^k, \quad (2.33)$$

where d_k is simply the positive integer counting the excitation states of weight $(h_i + k)$. Thus, in terms of these characters, a general expression for \mathcal{T} is

$$\mathcal{T}_{nc}(\tau, \bar{\tau}) = \sum_{i,j} \bar{\chi}_i(\bar{\tau}) X_{ij} \chi_j(\tau), \quad (2.34)$$

where X_{ij} are integers. This is the case for both compactified and uncompactified strings. We will investigate this point further in Section 3.3.1.

2.2.2 Klein-bottle amplitude

Let us consider the unoriented closed string theory obtained by world-sheet parity Ω . The action of Ω simply reverses the left and right moving oscillators:

$$\Omega : \quad \alpha_n^\mu \leftrightarrow \tilde{\alpha}_n^\mu. \quad (2.35)$$

Under the world-sheet parity operator, the closed string spectrum splits into two subsets of states corresponding to its eigenvalue ± 1 . We only keep states that are even under the world-sheet parity. The tachyon contains no oscillators, it is even and survives the projection. In the first excited state, only the symmetric part, dilaton and graviton, are even. The massless antisymmetric field is projected out.

In order to take such projection into account in the partition function, we project out states in the torus amplitude by identifying left and right modes. By doing just that, we obtain a Klein bottle amplitude which describes the vacuum diagram of a closed string undergoing a reversal of its orientation. More explicitly, the full amplitude can be written as

$$\begin{aligned} \Gamma_{nc}^K &= \frac{V_{26}}{(4\pi^2\alpha')^{13}} \int_{\mathcal{F}_K} \frac{d^2\tau}{\tau_2^2} \frac{1}{\tau_2^{12}} \text{tr} \left(q^{L_0 - 1} \bar{q}^{\bar{L}_0 - 1} \frac{\Omega}{2} \right), \\ &= \frac{V_{26}}{(4\pi^2\alpha')^{13}} \int_0^\infty \frac{d^2\tau_2}{\tau_2^2} \mathcal{K}_{nc}(2i\tau_2), \end{aligned} \quad (2.36)$$

and the function \mathcal{K}_{nc} can be determined as follow. By using $\Omega|L, R\rangle = |R, L\rangle$, the trace in (2.36) can be written

$$\begin{aligned} \sum_{L,R} \langle L, R | q^{L_0-1} \bar{q}^{\bar{L}_0-1} \frac{\Omega}{2} | L, R \rangle &= \frac{1}{2} \sum_{L,R} \langle L, R | q^{L_0-1} \bar{q}^{\bar{L}_0-1} | R, L \rangle, \\ &= \frac{1}{2} \sum_L \langle L, L | (q\bar{q})^{L_0-1} | L, L \rangle, \end{aligned} \quad (2.37)$$

where the restriction to the diagonal subset $|L, L\rangle$ leads to the identification of L_0 and \bar{L}_0 . After performing the trace, we obtain

$$\mathcal{K}_{nc}(2i\tau_2) = \frac{1}{2\tau_2^{12}} \frac{1}{\eta^{24}(2i\tau_2)}. \quad (2.38)$$

Since the Klein-bottle has the modulus of a doubly-covering torus, the amplitude (2.38) depends naturally on $2i\tau_2$. The integration domain is necessarily the whole positive imaginary axis of the complex plane.

The amplitude $\frac{1}{2}\mathcal{T} + \mathcal{K}$ is the partition function of the closed unoriented string theory. This can be easily shown by comparing the q expansions of \mathcal{T}_{nc} and \mathcal{K}_{nc} which correspond to on-shell physical states. Neglecting the powers of τ_2 , the expansions of (2.29) and (2.38) are

$$\begin{aligned} \frac{1}{2}\mathcal{T}_{nc} &\rightarrow \frac{1}{2} \left((q\bar{q})^{-1} + (24)^2 (q\bar{q})^0 + \dots \right), \\ \mathcal{K}_{nc} &\rightarrow \frac{1}{2} \left((q\bar{q})^{-1} + (24) (q\bar{q})^0 + \dots \right). \end{aligned} \quad (2.39)$$

We can see that the massless states are reduced from $(24)^2$ states (in the oriented theory) to $24(24+1)/2$ states (the graviton and the dilaton).

As stressed before, we have two choices of time. The vertical time τ_2 defines the *direct channel* amplitude as expressed in (2.38), while the horizontal time $l = 1/2\tau_2$ defines the amplitude of a closed string propagating between two crosscaps. As in [11], we refer to the amplitude in this channel as the *transverse channel* amplitude. In the transverse channel, the corresponding Klein bottle amplitude, which we denote by $\tilde{\mathcal{K}}_{nc}$, take the form

$$\tilde{\Gamma}_{nc}^K = 2^{13} \frac{V_{26}}{(4\pi^2\alpha')^{13}} \int_0^\infty d^2l \tilde{\mathcal{K}}_{nc}(il), \quad (2.40)$$

where

$$\tilde{\mathcal{K}}_{nc}(il) = \frac{1}{2} \frac{1}{\eta^{24}(il)}. \quad (2.41)$$

The transverse amplitude (2.40) can be obtained from the S-transformation of Equations (2.36).

2.2.3 Annulus amplitude

In order to add the open string sector to the full spectrum of the theory, we have to generalize its spectrum further. In an oriented open string, the two endpoints are distinct from each other. We can generalize this by assuming the open string carries a “Chan-Paton charge” at its endpoints. Consequently, one of the endpoints will transform as a fundamental \mathbf{N} -dimensional representation of the Lie group $U(N)$ while the other endpoint transforms as the conjugate representation $\bar{\mathbf{N}}$. Since the whole open string transforms as $\mathbf{N} \times \bar{\mathbf{N}}$ which is the adjoint representation of $U(N)$, we can decompose an open string wave function into a basis of $N \times N$ matrices, λ , i.e. the generators of $U(N)$. As the Chan-Paton degrees of freedom are non-dynamical, the M-point scattering will have the factor of the trace of the product of Chan-Paton factors, $Tr(\lambda_1 \lambda_2 \dots \lambda_M)$. In the presence of Chan-Paton factors, the space-time theory has $U(N)$ gauge symmetry rather than the $U(1)$ symmetry in the original open string. Note that without Chan-Paton factors, the gauge fields are projected out by world-sheet parity. However, λ do transform under world-sheet parity. We can choose $\lambda \rightarrow \lambda^T$ which reflects the fact that world-sheet parity interchanges the endpoints. Consequently, the gauge fields with antisymmetric λ survive the projection and the gauge symmetry is reduced to $O(N)$. As we will show later, the appropriate Chan-Paton group for the open and closed bosonic string is $SO(2^{13})$, its spectrum contains the closed string states mentioned above and the open string state i.e. gauge fields in the adjoint representation of $SO(2^{13})$.

Let us start from the direct channel, where an annulus amplitude can be obtained by tracing over the open string spectrum. In the unoriented theory, we take into account the Chan-Paton gauge symmetry by adding a factor N^2 related to the N degrees of freedom at each end of an open string. After some rescaling, the total

annulus amplitude is

$$\begin{aligned}\Gamma_{nc}^A &= \frac{N^2}{2} \frac{V_{26}}{(4\pi^2\alpha')^{13}} \int_0^\infty \frac{d^2\tau_2}{\tau_2^2} \frac{1}{\tau_2^{12}} \text{tr} \left(q^{\frac{1}{2}(L_0-1)} \right), \\ &= \frac{V_{26}}{(4\pi^2\alpha')^{13}} \int_0^\infty \frac{d^2\tau_2}{\tau_2^2} \mathcal{A}_{nc} \left(i \frac{\tau_2}{2} \right),\end{aligned}\tag{2.42}$$

and, by calculating the trace above, \mathcal{A}_{nc} is given by

$$\mathcal{A}_{nc} \left(i \frac{\tau_2}{2} \right) = \frac{N^2}{2} \frac{1}{\tau_2^{12}} \eta^{-24} \left(i \frac{\tau_2}{2} \right).\tag{2.43}$$

Note that the amplitude in (2.43) is expressed in terms of the modulus $i\tau_2/2$ of the doubly-covering torus. In the transverse channel, the horizontal time $l = 2\tau_2$ describes an amplitude of closed strings propagating between two boundaries. We define the corresponding expression, $\tilde{\Gamma}_{nc}^A$, by

$$\tilde{\Gamma}_{nc}^A = 2^{-13} \frac{V_{26}}{(4\pi^2\alpha')^{13}} \int_0^\infty d^2l \tilde{\mathcal{A}}_{nc}(il),\tag{2.44}$$

where we define

$$\tilde{\mathcal{A}}_{nc}(il) = \frac{N^2}{2} \eta^{-24}(il).\tag{2.45}$$

The amplitude in (2.44) can be obtained from (2.42) by the S-transformation in (2.19). The Chan-Paton charge, N in (2.45), determines the reflection coefficients for the closed string spectrum at the boundaries.

2.2.4 Möbius amplitude

Let us consider an unoriented open string theory. The world sheet parity operator defining the Möbius amplitude will be

$$\Omega = \epsilon (-1)^{N_{nc}},\tag{2.46}$$

where N_{nc} is the open string oscillator number operator defined in (2.18) and $\epsilon = \pm 1$.

The modulus of the Möbius strip is that of the doubly-covering torus, but it is not purely imaginary i.e. it has a fixed real part equal to $\frac{1}{2}$. To ensure that the amplitude has real value, we follow the work of Sagnotti et al in [11], by defining the ‘‘hatted’’ characters,

$$\hat{\chi}_i(i\tau_2 + 1/2) = q^{h_i - c/24} \sum_k (-1)^k d_k q^k,\tag{2.47}$$

where $q = e^{-2\pi\tau_2}$. The expression in (2.47) differs from $\chi_i(i\tau_2 + 1/2)$ by the overall phase $e^{-i\pi(h_i - c/24)}$ which ensures that $\hat{\chi}_i(i/\tau_2 + 1/2)$ is real. In this “hatted” definition, the transformation that relates the direct and transverse Möbius amplitudes is

$$\hat{P} = T^{1/2}ST^2ST^{1/2}, \quad (2.48)$$

where we define the operators $T_{ij}^{1/2} = \delta_{ij}e^{i\pi(h_i - c/24)}$. Let us define the matrix $\mathcal{C} = S^2$ and by using the constraint $S^2 = (ST)^3$, we can show that

$$\mathcal{C} = \hat{P}^2 = S^2 = (ST)^3. \quad (2.49)$$

In Section 3.3 we will demonstrate the rôle of the operators \hat{P} , \mathcal{C} and the identity (2.49) in boundary conformal field theory.

For the unoriented non-compactified bosonic string theory in 26-dimensional space-time, the full direct channel Möbius amplitude can be written as

$$\Gamma_{nc}^M = \frac{V_{26}}{(4\pi^2\alpha')^{13}} \int_0^\infty \frac{d^2\tau_2}{\tau_2^2} \mathcal{M}_{nc}(i\tau_2/2 + 1/2), \quad (2.50)$$

where

$$\mathcal{M}_{nc}(i\tau_2/2 + 1/2) = \frac{\epsilon N}{2} \frac{1}{\tau_2^{12}} \hat{\eta}^{-24}(i\tau_2 + 1/2). \quad (2.51)$$

The parameter ϵ in (2.51) takes the values $\epsilon = \pm 1$ and encodes the action of Ω on the vacuum. The factor $\frac{1}{2}$ in the argument of the Dedekind function in (2.51) is the result from the twist operator $(-1)^N$.

In the transverse channel, the Möbius amplitude describes a closed string propagating between a boundary and a crosscap with the horizontal time $l = 1/2\tau_2$. By applying the \hat{P} -transformation on the direct amplitude in (2.50), we obtain

$$\tilde{\Gamma}_{nc}^M = 2 \frac{V_{26}}{(4\pi^2\alpha')^{13}} \int_0^\infty d^2l \tilde{\mathcal{M}}_{nc}(il + 1/2), \quad (2.52)$$

where

$$\tilde{\mathcal{M}}_{nc}(il + 1/2) = \frac{\epsilon N}{2} \hat{\eta}^{-24}(il + 1/2). \quad (2.53)$$

Note that under the \hat{P} -transformation, the “hatted” Dedekind function transforms as

$$\hat{\eta}\left(i\frac{1}{2t} + \frac{1}{2}\right) = \sqrt{t}\hat{\eta}\left(it/2 + \frac{1}{2}\right). \quad (2.54)$$

The amplitude $\mathcal{A}_{nc} + \mathcal{M}_{nc}$ is the partition function of the open unoriented string theory. The q -expansions of \mathcal{A}_{nc} and \mathcal{M}_{nc} read

$$\begin{aligned}\mathcal{A}_{nc} &\rightarrow \frac{N^2}{2} \left((\sqrt{q})^{-1} + (24)q^0 + \dots \right), \\ \mathcal{M}_{nc} &\rightarrow \frac{\epsilon N}{2} \left((\sqrt{q})^{-1} - (24)q^0 + \dots \right).\end{aligned}\quad (2.55)$$

For the case of $\epsilon = +1$, the amplitude $\mathcal{A}_{nc} + \mathcal{M}_{nc}$ gives $N(N-1)/2$ massless vectors in one to one correspondence with the generators of the orthogonal gauge group $SO(N)$, while in the case of $\epsilon = -1$, the corresponding group is the symplectic gauge group $Sp(N)$ (for N even). The value of N is fixed by the ultraviolet behaviour of the theory.

The modular invariance protects the torus amplitude from short-distance singularities as the ultraviolet region is not included in the fundamental domain \mathcal{F} . On the other hand, the Klein bottle, the annulus and the Möbius amplitudes suffer from ultraviolet divergences. In order to investigate this further, it is convenient to consider the transverse amplitudes, where the divergences appear in the infrared region in the $l \rightarrow \infty$ limit. In this limit, by dropping the integrand, the transverse amplitudes (2.40), (2.44) and (2.52) can be written as

$$\begin{aligned}\tilde{\Gamma}_{nc}^K &\rightarrow \frac{2^{13}}{2} \left((\sqrt{q})^{-1} + (24)q^0 \right), \\ \tilde{\Gamma}_{nc}^A &\rightarrow \frac{2^{-13} N^2}{2} \left((\sqrt{q})^{-1} + (24)q^0 \right), \\ \tilde{\Gamma}_{nc}^M &\rightarrow 2 \frac{\epsilon N}{2} \left((\sqrt{q})^{-1} - (24)q^0 \right).\end{aligned}\quad (2.56)$$

This means only the tachyon and massless fields can propagate. In general, a field with mass M gives a contribution $\int_0^\infty dl e^{-M^2 l} = \frac{1}{M^2}$, which shows that the divergence comes from the dilaton field, as the propagator for the scalar field, $1/(p^2 + M^2)$, is singular for the massless states of zero momentum. However, this dilaton tadpole divergence can be eliminated by choosing an appropriate value of the Chan-Paton charge N . Using (2.56), we can impose the constraint

$$\left(\tilde{\Gamma}_{nc}^K + \tilde{\Gamma}_{nc}^A + \tilde{\Gamma}_{nc}^M \right) \sim \frac{1}{2} (2^{13} + 2^{-13} N^2 - 2\epsilon N) = \frac{2^{13}}{2} (2^{13} - \epsilon N)^2 = 0, \quad (2.57)$$

which implies $\epsilon = +1$ and $N = 2^{13}$. Therefore, the uncompactified open string theory in 26-dimensional space-time with $SO(2^{13})$ Chan-Paton gauge group is divergence-

free. By satisfying the dilaton tadpole condition (2.57), we also eliminate the gauge and gravitational anomalies as shown in [41].

2.3 Brief review of Superstring theory

2.3.1 Superstring in the NSR formulation

Let us start by considering the superstring theory in the Neveu-Schwarz-Ramond (NSR) formalism. We generalize the action in (2.1) by adding to it the world-sheet spinors Ψ^μ , the supersymmetric partners of the bosonic coordinates X^μ . The NSR superstring is described by the action

$$S = -\frac{1}{4\pi\alpha'} \int_{\Sigma} d^2\sigma \sqrt{\gamma} (\gamma^{\alpha\beta} \eta_{\mu\nu} \partial_\alpha X^\mu \partial_\beta X^\nu - i \bar{\Psi}^\mu \rho^\alpha \partial_\alpha \Psi_\mu) , \quad (2.58)$$

where the two-dimensional γ -matrices are defined by $\rho^0 = \sigma^2$ and $\rho^1 = i\sigma^1$ such that they satisfy the usual anticommutation relations $\{\rho^\alpha, \rho^\beta\} = \eta^{\alpha\beta} I$ (σ^1 and σ^2 are Pauli matrices).

The action (2.58) has the same symmetry as its bosonic counterpart but in addition, it is invariant under an on-shell global world-sheet supersymmetry transformation :

$$\delta X^\mu = \bar{\xi} \Psi^\mu \quad \delta \Psi^\mu = -i \rho^\alpha \partial_\alpha X^\mu \xi . \quad (2.59)$$

For the fermionic sector, it is more convenient to write the world-sheet spinor in components as

$$\Psi^\mu = \begin{pmatrix} \Psi_R^\mu \\ \Psi_L^\mu \end{pmatrix} . \quad (2.60)$$

We can choose the *covariant gauge* explained in Section 2.1.1. Consequently, the variation of (2.58) gives the equations of motion for the fermionic coordinates which can be written as a pair of equations,

$$(\partial_\tau + \partial_\sigma) \Psi_R^\mu = 0, \quad (\partial_\tau - \partial_\sigma) \Psi_L^\mu = 0 . \quad (2.61)$$

Consequently, Ψ_R^μ is a function of $\tau - \sigma$ which describes right-moving degrees of freedom and Ψ_L^μ is a function of $\tau + \sigma$ which describes the left-moving degrees of

freedom. Equation (2.61) together with the wave equation in (2.4), yield the full equations of motion of the theory.

In addition to the equations of motion, we also get the constraint equations

$$T_{\alpha\beta} = \partial_\alpha X^\mu \partial_\beta X_\mu + \frac{i}{4} \bar{\Psi}^\mu (\rho_\alpha \partial_\beta + \rho_\beta \partial_\alpha) \Psi_\mu - \frac{\eta_{\alpha\beta}}{2} (\partial^\gamma X^\mu \partial_\gamma X_\mu + \frac{i}{2} \bar{\Psi}^\mu \rho^\gamma \partial_\gamma \Psi_\mu) = 0, \quad (2.62)$$

$$J_{susy}^\alpha = \frac{1}{2} \rho^\beta \rho^\alpha \Psi^\mu \partial_\beta X_\mu = 0, \quad (2.63)$$

where J_{susy}^α is the world-sheet supersymmetric current, and $T_{\alpha\beta}$ now represents the energy-momentum tensor the scalar fields X^μ and the Majorana spinor fields Ψ^μ in the two-dimensional supergravity.

In the case of closed superstrings, the mode expansion for the left and right moving fermions depends on the boundary conditions, which are

$$\Psi_R^\mu(\tau, \sigma + \pi) = \pm \Psi_R^\mu(\tau, \sigma), \quad \Psi_L^\mu(\tau, \sigma + \pi) = \pm \Psi_L^\mu(\tau, \sigma). \quad (2.64)$$

The periodic boundary condition is referred to as the *Ramond* boundary condition (R) and the anti-periodic boundary condition as the *Neveu-Schwarz* boundary condition (NS). The choice of boundary conditions can be made independently for the right and left movers. Thus, we can write the mode expansion for the right and left moving fermions as :

$$\Psi_R^\mu = \sum_{d \in \mathbb{Z} + \nu} \psi_d^\mu e^{-2id(\tau - \sigma)}, \quad \Psi_L^\mu = \sum_{d \in \mathbb{Z} + \nu} \tilde{\psi}_d^\mu e^{-2id(\tau + \sigma)}, \quad (2.65)$$

where $\nu = 0$ for the R-sector and $\nu = \frac{1}{2}$ for the NS-sector. Canonical quantization gives rise to the (anti) commutation relations,

$$[\alpha_m^\mu, \alpha_n^\nu] = [\tilde{\alpha}_m^\mu, \tilde{\alpha}_n^\nu] = m \eta^{\mu\nu} \delta_{m+n,0}, \quad [q^\mu, p^\nu] = i\eta^{\mu\nu}, \\ \{\psi_r^\mu, \psi_s^\nu\} = \{\tilde{\psi}_r^\mu, \tilde{\psi}_s^\nu\} = \eta^{\mu\nu} \delta_{r+s,0}. \quad (2.66)$$

In the next chapter, we will show that the fermionic oscillators ψ_d^μ could be written in terms of the bosonic operators.

In the open sector, variation of the action (2.58) implies the boundary term vanishes if and only if the fermion fields satisfy the condition :

$$(\Psi_R^\mu \delta \Psi_R^\mu - \Psi_L^\mu \delta \Psi_L^\mu) |_{\sigma=0,\pi} = 0. \quad (2.67)$$

This implies two possibilities of boundary conditions, $\Psi_L^\mu(\tau, \pi) = \pm \Psi_R^\mu(\tau, \pi)$ where the \pm signs denote R and NS sector respectively. As in the case of bosonic coordinates, the right- and left-mover are not independent of each other. Their mode expansion could be written as

$$\Psi_R^\mu = \frac{1}{\sqrt{2}} \sum_{d \in \mathbb{Z} + \nu} \psi_d^\mu e^{-id(\tau - \sigma)}, \quad \Psi_L^\mu = \frac{1}{\sqrt{2}} \sum_{d \in \mathbb{Z} + \nu} \tilde{\psi}_d^\mu e^{-id(\tau + \sigma)}, \quad (2.68)$$

where $\nu = 0$ for R sector and $\nu = \frac{1}{2}$ for NS sector. The factors of $\frac{1}{\sqrt{2}}$ are conventional. As for the bosonic string, we will use the light-cone gauge with the coordinates

$$X^\pm = \frac{1}{\sqrt{2}}(X^0 \pm X^{D-1}), \quad \Psi^\pm = \frac{1}{\sqrt{2}}(\Psi^0 \pm \Psi^{D-1}). \quad (2.69)$$

The combination of world-sheet reparametrization and local Weyl scaling removes some residual degrees of freedom and selects a gauge such that

$$X^+(\tau, \sigma) = q^+ + \sqrt{\alpha'} p^+ \tau, \quad \Psi^+ = 0, \quad (2.70)$$

where the second equation is obtained from world-sheet supersymmetry. The coordinates X^- and Ψ^- can now be written in terms of the transverse components X^i and Ψ^i , leaving only physical degrees of freedom. The super-Virasoro generators read

$$L_m = \frac{1}{2} \sum_{n \in \mathbb{Z}} : \alpha_{m-n}^\mu \alpha_{\mu n} : + \frac{1}{2} \sum_{r \in \mathbb{Z} + \nu} r : \psi_{m-r}^\mu \psi_{\mu r} : + a \delta_{m,0}, \quad (2.71)$$

where $r \in \mathbb{Z} + \nu$ with $\nu = 0$ in R-sector and $\nu = \frac{1}{2}$ in NS-sector. The normal-order factor $a = a_R = 0$ in the R-sector and $a = a_{NS} = \frac{(D-2)}{16}$ in the NS-sector. The normal-order constant a_R vanishes in the R-sector because of the exact cancellation between bosonic and fermionic contributions. By using the ζ -function regularization, each Ramond fermionic degree of freedom contributes $-\frac{1}{24}$ to a_R while each Neveu-Schwarz fermionic degree of freedom contributes $\frac{1}{48}$ to a_{NS} , and each bosonic degree of freedom contributes $\frac{1}{24}$ to both sectors. We will consider superstrings in the *critical dimension*, $D = 10$ and $a = 0$ ($\frac{1}{2}$) for R (NS) sector. Note that only for $D = 10$ are the first excited states massless and the Lorentz algebra is closed.

2.3.2 GSO-projection

In order to discuss the spectrum of superstring theory, we introduce the operator

$$(-1)^F, \quad (2.72)$$

where F is the world-sheet fermionic operator. The operator in (2.72) anticommutes with the world-sheet fermion fields ψ^μ . It gives the eigenvalue -1 when acting on the NS ground state and acts as Γ_{11} on the R-ground state.

In the light-cone gauge, the superstring spectrum can be constructed by acting with the products of oscillators α_{-n}^i and ψ_{-r}^i on the ground state. Let us consider the open string case. In the NS-sector, $a = \frac{1}{2}$, the lowest state $|0, k\rangle_{NS}$ is tachyonic with mass square $m^2 = -\frac{1}{2\alpha'}$ and has the eigenvalue $(-1)^F = -1$. At the first excited level, we have the massless vector which could be obtained by acting with $e_i \psi_{-\frac{1}{2}}^i$ on the tachyonic vacuum (e_i is a polarization vector). Note that the unphysical polarizations were already removed by the light-cone gauge quantization. These massless vectors transform in the 8_v representation of the $SO(8)$ group.

In the R-sector, $a = 0$, the lowest states are $u_A |A; k\rangle_R$ where A is the spinor index and u_A is a spinor. The fact that these states are massless is consistent with the constraint equation which implies the massless Dirac's equation. These states have positive or negative chirality. The positive chirality states have the eigenvalue $(-1)^F = +1$ and transform under a spinor representation of $SO(8)$. On the other hand, the states with negative chirality have $(-1)^F = -1$ and transform under the conjugate spinor representation of $SO(8)$.

For the closed superstring, the spectrum can be constructed by acting with the products of the left(right) handed oscillators on the left(right) handed ground state and forming the product of the resulting left and right moving states. In the NS-NS sector, we have the closed string tachyon with $m^2 = -\frac{2}{\alpha'}$. Since the tachyon has eigen value $((-1)^F, (-1)^{\bar{F}}) = (-1, -1)$, we shall denote the sector which contains tachyonic states by $(NS-, NS-)$. Note that the sectors $(NS+, NS-)$ and $(NS-, NS+)$ have no states, since they were projected out for not satisfying the matching condition. In the $(NS+, NS+)$ -sector, the physical states lie in the $8_v \times 8_v$ representation of $SO(8)$ and are identified as the graviton (35), antisymmetric tensor (28) and dilaton (1).

In the R-R sector, the closed string spectrum contains the antisymmetric fields, R-R fields, which are presented in table (2.1).

For the NS-R sector, the spectrum contains spinors and gravitini. For example,

<i>Sector</i>	<i>Representation</i>
$(R+, R+)$	$8_s \times 8_s = 1 + 28 + 35_+$
$(R+, R-)$ and $(R-, R+)$	$8_s \times 8_c = 8_v + 56$
$(R-, R-)$	$8_c \times 8_c = 1 + 28 + 35_-$

Table 2.1: Closed string R-R spectrum in terms of $SO(8)$ representations.

states in $(NS+, R+)$ transform in $8_v \times 8_s = 8_c + 56$.

2.3.3 Consistent string models

To obtain a consistent string theory, we need to project out some states in the spectrum because the full spectrum is not modular invariant i.e. the scattering amplitudes are not well defined. The choice of projection is not unique. We can choose to project out some states in such a way that the resulting theory is supersymmetric and tachyonic-free. Note that, as in [2], we can obtain a consistent string theory which contains tachyonic states and is non-supersymmetric, but we will limit our considerations to the supersymmetric case in this thesis.

In order to obtain the supersymmetric string model, we perform the Gliozzi-Scherk-Olive projection (GSO) in the full closed string spectrum. In the NS-NS sector, we project out tachyons in the $(NS-, NS-)$ sector. While in the R-R sector, we can either choose the GSO-projection $P_{GSO} = (1 + (-1)^F)/2$ which projects out all states in $R-$ or, on the other hand, choose the projection $P_{GSO} = (1 - (-1)^F)/2$ which projects out all states in $R+$. Both choices of GSO projection can be applied independently on the left and the right sector and give rise to the so-called Type II superstring theory. Type II superstring then can be divided into two inequivalent model, namely,

$$\text{Type IIA : } (NS+, NS+) \oplus (NS+, R-) \oplus (R+, NS+) \oplus (R+, R-) \quad (2.73)$$

$$\text{Type IIB : } (NS+, NS+) \oplus (NS+, R+) \oplus (R+, NS+) \oplus (R+, R+) \quad (2.74)$$

Both type IIA and Type IIB are space-time supersymmetric. Type IIB has chiral-supersymmetry as the gravitini have the same chirality while Type IIA is a non-chiral theory.

From Type IIB superstring theory, we can obtain another superstring model by projecting out states which are not invariant under the world-sheet parity symmetry Ω . When this symmetry is gauged, the theory becomes unoriented. In NS-NS sector, the antisymmetric tensor is projected out and only graviton and dilaton are left in the spectrum. In the fermionic sector, only the combination of NS-R and R-NS sectors survives i.e. only one gravitino is left. On the other hand, in the R-R sector, only the antisymmetric two-form potential survives the projection. It turns out that unoriented closed string theories are not consistent because they develop space-time gravitational anomalies. To solve this problem, the theory needs to be modified by adding in the open string sector.

In order to add the open string sector, we assume the open string carries “Chan-Patan charge” as in the bosonic string case. It turns out that the appropriate Chan-Patan group for the unoriented open and closed superstring, the so-called Type I theory is $SO(32)$. The open string GSO-projection eliminates the open string tachyon and keeps only states with even world-sheet fermionic number. The spectrum of Type I theory contains the closed string states mentioned above and the open string states which are the gauge fields and spinors in the adjoint representation of $SO(32)$.

2.3.4 Low energy supergravity

As we have seen in the previous sections, the spectrum of superstring theories contains massless states together with towers of infinite massive oscillations. However, as the massive modes might be of the order of 10^{18} GeV, we are mainly interested in the massless states. Although in Quantum Field Theory we can integrate out the massive fields leaving only the effective theory of massless fields, the same approach cannot be applied here. The problem is simply because we do not have the second quantization of string fields. We have to use an indirect approach by computing scattering amplitudes of on-shell physical states in perturbation theory. Then, we construct the classical action for these massless fields that produce the same interacting amplitudes.

In this chapter, we will consider the type II superstring in ten-dimensional space-

time and the eleven-dimensional supergravity. The low-energy effective actions of Type II superstring are Type IIA and Type IIB supergravity. Let us start our review by the eleven-dimensional supergravity as it is related both to Type IIA and M-theory. We will restrict ourselves to the bosonic part of the action.

Eleven-dimensional supergravity

The bosonic part of the eleven-dimension supergravity action is very simple as the theory contains two massless bosonic fields. The physical degrees of freedom can be written in terms of the representations of the $SO(9)$ transverse group. The first massless field is the metric $g_{\mu\nu}$ which gives a traceless symmetric tensor of 44 states. The second bosonic field is the 3-form potential A_3 , a rank 3 antisymmetric tensor of 84 independent states, with field strength $F_4 = dA_3$ ¹. Together with the 128 fermion states from the gravitino, an $SO(9)$ vector spinor, these states form a short multiplet of the supersymmetry algebra with 32 supercharges. The bosonic part of the action is given by [20]

$$I_{11} = \frac{1}{16\pi G_{11}} \left(\int d^{11}x \sqrt{-g} \left\{ R - \frac{1}{48} F_4^2 \right\} + \frac{1}{6} \int A_3 \wedge F_4 \wedge F_4 \right), \quad (2.75)$$

where the last term in (2.75) is the Chern-Simons term which is required by supersymmetric properties of the theory. Note that for the Newton constant in D -dimensional space-time G_D , we have

$$16\pi G_D = 2\kappa_D^2 \quad (2.76)$$

Type IIA supergravity

The ten-dimensional Type IIA supergravity action written in the so-called *string frame* is given by [21]

$$I_{IIA} = \frac{1}{16\pi G_{10}} \int d^{10}x \sqrt{-g_S} \left\{ e^{-2\phi} \left(R_S + 4\partial_\mu \phi \partial^\mu \phi - \frac{1}{12} \hat{H}_3^2 \right) - \frac{1}{4} F_2^2 - \frac{1}{48} F_4'^2 \right\} + \frac{1}{16\pi G_{10}} \frac{1}{2} \int B_2 \wedge F_4 \wedge F_4. \quad (2.77)$$

¹We use conventions for the n -forms such that $F_n = \frac{1}{n!} F_{\mu_1 \dots \mu_n} dx^{\mu_1} \wedge \dots \wedge dx^{\mu_n}$.

Here we define $\hat{H}_3 = dB_2$, $F_2 = dC_1$, $F_4 = dC_3$ and $F'_4 = F_4 + C_1 \wedge \hat{H}_3$. The terms that have a factor $e^{-2\phi}$ in front describe the NS-NS fields in the closed string spectrum i.e. a graviton (g), a dilaton (ϕ) and a NS-NS two-form (B_2). The other terms describe R-R potentials C_p with field strengths $F_{p+1} = dC_p$.

In general, it is more convenient to keep a unique coupling constant in front of the whole action. In order to do this we can write the action in the *Einstein frame* by rescaling the metric in (2.77) by

$$g_{\mu\nu}^S = e^{\phi/2} g_{\mu\nu}^E, \quad (2.78)$$

$g_{\mu\nu}^E$ is the metric in Einstein frame. Note that both frames coincide with each other at infinity. Using (2.78), we can write the action in Einstein frame in the following way,

$$I_{IIA} = \frac{1}{16\pi G_{10}} \int d^{10}x \sqrt{-g_E} \left\{ R_E - \frac{1}{2} \partial_\mu \phi \partial^\mu \phi - \frac{1}{12} e^{-\phi} \hat{H}_3^2 - \frac{1}{4} e^{\frac{3}{2}\phi} F_2^2 - \frac{1}{48} e^{\frac{1}{2}\phi} F_4'^2 \right\} + \frac{1}{16\pi G_{10}} \frac{1}{2} \int B_2 \wedge F_4 \wedge F_4, \quad (2.79)$$

Type IIB supergravity

The low-energy effective action of ten-dimensional Type IIB superstring theory, in string frame, is given as

$$I_{IIB} = \frac{1}{16\pi G_{10}} \int d^{10}x \sqrt{-g_S} \left\{ e^{-2\phi} \left(R_S + 4\partial_\mu \phi \partial^\mu \phi - \frac{1}{12} \hat{H}_3^2 \right) - \frac{1}{2} \partial_\mu \chi \partial_\mu \chi - \frac{1}{12} F_3'^2 - \frac{1}{240} F_5'^2 \right\} + \frac{1}{16\pi G_{10}} \frac{1}{2} \int C_4 \wedge F_3 \wedge \hat{H}_3. \quad (2.80)$$

The first term describes the NS-NS field exactly in the same way as it is described in the case of Type IIA. In the R-R sector, we have $F_3 = dC_2$, $F'_3 = F_3 - \chi \hat{H}_3$ and $F'_5 = dC_4 + C_2 \wedge \hat{H}_3$. Note that the fields χ , A_2 and A_4 are in the $(R+, R+)$ -sector as shown in Table 2.1. In order to obtain the equations of motion for Type IIB [22], we have to impose a self-duality condition on the five-form field strength i.e. $F'_5 = *F_5'$ together with the action (2.80). However, for our convenience, in the following section we will impose the self-duality condition on the final solutions.

We can write the action of Type IIB supergravity in the Einstein frame as

$$I_{IIB} = \frac{1}{16\pi G_{10}} \int d^{10}x \sqrt{-g_E} \left\{ R_E - \frac{1}{2} \partial_\mu \phi \partial^\mu \phi - \frac{1}{12} e^{-\phi} \hat{H}_3^2 - \frac{1}{2} e^{2\phi} \partial_\mu \chi \partial^\mu \chi - \frac{1}{12} e^\phi F_3'^2 - \frac{1}{240} F_5'^2 \right\} + \frac{1}{16\pi G_{10}} \frac{1}{2} \int C_4 \wedge F_3 \wedge \hat{H}_3, \quad (2.81)$$

2.4 A little note on branes and their solutions

Consider the field strength F_{p+2} of rank $p+2$ which can be obtained from a potential A_{p+1} of rank $p+1$. For our convenience, we define an integer

$$n = p + 2, \quad p \in \mathbb{Z}, \quad (2.82)$$

thus we get $F_n = F_{p+2}$. The A_{n-1} potential couples electrically to the world-volume of a p -dimensional extended object, a p -brane, by the term

$$\mu_p \int_{\Sigma^{p+1}} A_{p+1}, \quad (2.83)$$

where Σ^{p+1} is the world-volume of the p -brane and μ_p can be interpreted as the electric charge of the potential A_{p+1} . However, we can define the Hodge dual of F_{p+2} which is the $(D - p - 2)$ -form field strength $\tilde{F}_{D-(p+2)} = *F_{p+2}$. Consequently, there is a magnetic potential which satisfies $\tilde{F}_{D-(p+2)} = d\tilde{A}_{D-(p+2)-1}$. The magnetic potential can couple to a p' -brane where $p' = D - p - 4$ by the following term

$$g_{p'} \int_{\Sigma^{p'+1}} \tilde{A}_{p'+1}, \quad (2.84)$$

where $g_{p'}$ is the magnetic charge. Note that the existence of both p -branes and p' -branes imposes a Dirac-like quantization of their charges.

2.4.1 The p -brane ansatz

Let us go on to finding p -brane solutions for classical supergravities. The eleven-dimensional supergravity and ten-dimensional Type II supergravity actions (Einstein frame) described in Section 2.3.4, can be written in general as

$$I_D = \frac{1}{16\pi G_D} \int d^D x \sqrt{-g} \left\{ R - \frac{1}{2} \partial_\mu \phi \partial^\mu \phi - \frac{1}{2} \sum_I \frac{1}{n_I!} e^{\alpha_I \phi} F_{n_I}^2 \right\}, \quad (2.85)$$

where α_I is the dilaton coupling. We can reduce the action (2.85) to the eleven dimensional supergravity by having $D = 11$ and only the 4-form field strength. We set $\alpha_4 = 0$ as the dilaton field is not relevant. For Type II supergravities ($D = 11$), we take $\alpha_3 = -1$ for the NS-NS three form while setting $\alpha_n = (5 - n)/2$ for the R-R n -form.

The equations of motion can be obtained by varying the above action. We get

$$R_\nu^\mu = \frac{1}{2} \partial^\mu \phi \partial_\nu \phi + \frac{1}{2} \sum_I \frac{e^{\alpha_I \phi}}{n_I!} \left(n_I F^{\mu\lambda_2 \dots \lambda_{n_I}} F_{\nu\lambda_2 \dots \lambda_{n_I}} - \frac{n_I - 1}{D - 2} \delta_\nu^\mu F_{n_I}^2 \right), \quad (2.86)$$

$$\nabla^2 \phi = \frac{1}{\sqrt{-g}} \partial_\mu (\sqrt{-g} g^{\mu\nu} \partial_\nu \phi) = \frac{1}{2} \sum_I \frac{\alpha_I}{n_I!} e^{\alpha_I \phi} F_{n_I}^2, \quad (2.87)$$

$$\partial_\mu \left(\sqrt{-g} e^{\alpha_I \phi} F^{\mu\lambda_2 \dots \lambda_{n_I}} \right) = 0. \quad (2.88)$$

The Bianchi identity for F_{n_I} can be written as

$$\partial_{[\mu_1} F_{\mu_2 \dots \mu_{n_I+1}]} = 0. \quad (2.89)$$

Let us introduce the p -brane solution to the equations of motion (2.88). We assume a p -brane lives in a flat D -dimensional space-time. For a single brane solution, there are p space-like directions taken to be *longitudinal* to the brane and $d \equiv D - p - 1$ space-like directions identified as *transverse* to the brane. We introduce the coordinates $x^\mu = (t, y^i, x^a)$ where $\mu = 0, \dots, D - 1$. The coordinates y^i ($i = 1, 2, \dots, p$) are identified as the longitudinal directions while X^a ($a = 1, 2, \dots, d$) represent the transverse coordinates. We define t as the time-like direction. As we consider a static uniform brane, the solution is invariant under space-time translations in the world-volume directions (t and x^i) and has an $SO(p)$ rotational symmetry in the longitudinal directions. In the transverse directions, the translation symmetry is broken as the brane localizes at a point. However, the $SO(d)$ rotation symmetry is preserved as the brane has no angular momentum. The general solution that has all the symmetries above can be written as

$$ds^2 = -B^2 dt^2 + C^2 \delta_{ij} dy^i dy^j + F^2 dr^2 + G^2 r^2 d\Omega_{d-1}^2, \quad (2.90)$$

where $r^2 = \sum_{a=1}^d (x^a)^2$ and $d\Omega_{d-1}^2 = d\theta_1^2 + \sin^2 \theta_1 d\theta_2^2 + \dots + (\sin^2 \theta_1 \dots \sin^2 \theta_{d-2}) d\theta_{d-1}^2$. The coefficients B , C , F , and G are functions of the transverse coordinates.

A remark is in order here. We already mentioned that p-branes can couple either electrically to the the field strength or magnetically to the dual field strength. To be more precise, we generalize the Hodge dual of the field strength F_n by taking into account a dilaton factor. The definition of the generalized dual field strength is

$$\sqrt{-g}e^{\alpha\phi}F^{\mu_1\dots\mu_n} = \frac{1}{(D-n)!}\epsilon^{\mu_1\dots\mu_n\nu_1\dots\nu_{D-n}}\tilde{F}_{\nu_1\dots\nu_{D-n}}, \quad \epsilon^{1\dots(D-n)} = 1. \quad (2.91)$$

By this definition, we can rewrite the equations of motion in exactly the same form as (2.88) by replacing F_n by F_{D-n} , n replaced $D-n$ and $\alpha \rightarrow -\alpha$ (or equivalently $\phi \rightarrow -\phi$). This duality is analogous to the electric-magnetic duality in Electrodynamics. As a result, we have two ansätze for the n -form field strength namely the *electric ansatz* and the *magnetic ansatz*.

In the first ansatz, the n -form potential has the following form

$$F_{ti_1\dots i_p r} = \epsilon_{i_1\dots i_p} \partial_a E(r), \quad (2.92)$$

which satisfies the Bianchi identity. By substituting (2.92) into the equation of motion for the field strength in (2.88), we can write

$$F_{ti_1\dots i_p r} = \epsilon_{i_1\dots i_p} BC^p F e^{-\alpha\phi} \frac{Q}{(Gr)^{d-1}}, \quad (2.93)$$

where the integration constant Q is proportional to the electric charge of the brane. By using (2.91), the dual field strength can be written as

$$\tilde{F}_{\theta_1\dots\theta_{d-1}} = \sqrt{\gamma_{d-1}} \epsilon_{\theta_1\dots\theta_{d-1}} Q, \quad (2.94)$$

where $\sqrt{\gamma_{d-1}}$ is the metric of S^{d-1} ($\sqrt{-g} = BC^p F (Gr)^{d-1} \sqrt{\gamma_{d-1}}$). Recall the indices $\theta_1 \dots \theta_{d-1}$ represent the coordinates on the unit sphere S^{d-1} in transverse space and $F_{\theta_1\dots\theta_{d-1}}$ is the only non-vanishing component. By using this information, we can calculate the total charge of the brane as following

$$\mu_p = \frac{1}{\sqrt{16\pi G_D}} \int_{S^{d-1}} \tilde{F}_{d-1} = \frac{V_{\Omega_{d-1}}}{\sqrt{16\pi G_D}} Q, \quad (2.95)$$

where $V_{\Omega_{d-1}}$ is the volume of S^{d-1} i.e. $V_{\Omega_d} = 2\pi^{(d+1)/2} / \Gamma(\frac{d+1}{2})$.

For the magnetic ansatz, the p -brane couples magnetically to the field strength F_n where in this case $n = D - (p + 2) = d - 1$. By using (2.94), we obtain the non-zero components of F_{d-1} as

$$F_{\theta_1\dots\theta_{d-1}} = \sqrt{\gamma_{d-1}} \epsilon_{\theta_1\dots\theta_{d-1}} Q. \quad (2.96)$$

In this case, Q is proportional to the magnetic charge,

$$g_p = \frac{1}{16\pi G_D} \int_{S^{d-1}} F_{d-1} = \frac{V_{\Omega_{d-1}}}{16\pi G_D} Q. \quad (2.97)$$

2.4.2 The extremal dilatonic p-brane solutions

In this section we consider the special class of p-brane solutions called *extremal solutions*. We are interested in such solutions because their equations of motion are easily solved and because of their relation to the supersymmetric branes in string and M-theory. From the supersymmetric point of view, the extremal branes are Bogomol'nyi-Prasad-Sommerfield (BPS) states which in general preserve a portion of supersymmetry. The force between any extremal branes does vanish.

The equations of motion in (2.88) can be simplified by choosing coordinates (the so called the *isotropic gauge*) such that $F = G$. With this choice of coordinates, the metric depends only on the variable r of the transverse directions.

As the solution saturates a BPS bound, the p -brane has the lowest possible energy. From the point of view of the world-volume theory, the brane carries no energy at all which, this can be achieved by taking $B = C$. As a result, the world-sheet of the p -brane is a flat $p + 1$ -dimensional space-time with an $SO(1, p)$ Lorentz invariant. Note that any mass excitation in the world-volume directions will break the Lorentz symmetry i.e. $B \neq C$ and the configuration ceases to be extremal. For the extremal dilatonic solution with single charge, we get

$$B = C = H^{-(d-2)\Delta}(r), \quad F = G = H^{p+1/\Delta}(r), \quad (2.98)$$

where

$$H(r) = 1 + \frac{1}{d-2} \sqrt{\frac{\Delta}{2(D-2)}} \frac{|Q|}{r^{d-2}} \equiv 1 + \left(\frac{h}{r}\right)^{d-2}, \quad (2.99)$$

$$\Delta = (p+1)(d-2) + \frac{1}{2}\alpha^2(D-2). \quad (2.100)$$

In the electric ansatz, the dilaton and field strength can be written as

$$\begin{aligned} e^\phi &= H^{\alpha(D-2)/\Delta}(r), \\ F_{ty_1\dots y_p r} &= \partial_r A_{ty_1\dots y_p r} = (\pm) \sqrt{\frac{2(D-2)}{\Delta}} \partial_r (H^{-1}(r)), \\ A_{ty_1\dots y_p r} &= \sqrt{\frac{2(D-2)}{\Delta}} (H^{-1} - 1). \end{aligned} \quad (2.101)$$

While in the magnetic ansatz, by using electro-magnetic duality and equation (2.96), we obtain

$$e^\phi = H^{-\alpha(D-2)/\Delta}(r), \quad F_{t\theta_1\dots\theta_{d-1}} = \sqrt{\gamma_{d-1}} Q. \quad (2.102)$$

The metric for an extremal p-brane is given by

$$ds^2 = H^{-2(d-2)/\Delta} \left(-dt^2 + dx_1^2 + \dots + dx_p^2 \right) + H^{2(p+1)/\Delta} \left(dr^2 + r^2 d\Omega_{d-1}^2 \right) \quad (2.103)$$

2.4.3 Branes in string and M-theory

Let us start by considering the branes in M-theory, so-called M-branes. In the low energy limit, the theory is described by the eleven-dimensional supergravity which has only a four-form field strength and no dilaton ($\alpha_4 = 0$). There are two types of branes, namely M2-brane and M5-brane. The M2-brane can couple electrically to the four-form field strength while the M5-brane couples magnetically. In this case the value of Δ defined in (2.100) is $\Delta = 3.6 = 18$. By using (2.103), the solution for the M2-brane is

$$ds_{M2}^2 = H^{-2/3} (-dt^2 + dy_1^2 + dy_2^2) + H^{1/3} (dx_1^2 + \dots + dx_8^2), \quad (2.104)$$

$$F_{ty_1y_2r} = \partial_r(H^{-1}). \quad (2.105)$$

For the magnetic ansatz, we obtain the solution for M5-brane as

$$ds_{M5}^2 = H^{-1/3} (-dt^2 + dy_1^2 + dy_5^2) + H^{2/3} (dx_1^2 + \dots + dx_5^2),$$

$$F_{\theta_1\dots\theta_4} = \sqrt{-\gamma_4} Q. \quad (2.106)$$

Let us now considering Type II theory in ten-dimensional space-time. In this case, there are two classes of p-brane solutions. The first class is charged under the field from the NS-NS sector while the second class contains the R-R charge.

For the NS-NS sector, we have a NS-NS 3-form field strength with $\alpha = -1$. This field strength couples electrically to a fundamental string which we shall refer to as an F-string. We have $\Delta = 2.6 + 1.8/2 = 16$ and the solution for an F-string in the Einstein frame can be written as

$$ds_F^2 = H^{-3/4} (-dt^2 + dy_1^2) + H^{1/4} (dx_1^2 + \dots + dx_8^2),$$

$$e^\phi = H^{-1/2}, \quad F_{ty_1r} = \partial_r(H^{-1}). \quad (2.107)$$

And the solution for a NS5-brane is

$$\begin{aligned} ds_{NS5}^2 &= H^{-1/4}(-dt^2 + dy_1^2 + \cdots + dy_5^2) + H^{3/4}(dx_1^2 + \cdots + dx_4^2), \\ e^\phi &= H^{1/2}, \quad F_{\theta_1 \dots \theta_3} = \sqrt{-\gamma_3} Q. \end{aligned} \quad (2.108)$$

The F-string and NS5-brane metrics can be written in the string frame as

$$ds_F^2 = H^{-1}(-dt^2 + dy_1^2) + dx_1^2 + \cdots + dx_8^2, \quad (2.109)$$

$$ds_{NS5}^2 = -dt^2 + dy_1^2 + \cdots + dy_5^2 + H(dx_1^2 + \cdots + dx_4^2). \quad (2.110)$$

The string frame metrics represented in the above equations are solutions for Type II supergravity actions in (2.77) and (2.80).

We are now considering the R-R sector of Type II superstring. In this sector we have the R-R n -form field strengths with the dilaton coupling constant $\alpha_n = (5 - n)/2$. By using the p -brane ansatz and recalling that $n = p + 2$, we obtain the following results. The p -branes couple electrically to the $p + 2$ -form field strengths with $\alpha = (3 - p)/2$ in the electrical ansatz, and couple to the magnetic $8 - p$ -form field strengths with $\alpha = -(3 - p)/2$ in the magnetic ansatz. As these p -branes are charged under the R-R fields, we will refer to them as Dp -branes.

We can easily show that $\Delta = (p + 1)(7 - p) + (3 - p)^2 = 16$. The metric for a Dp -brane is

$$\begin{aligned} ds_{Dp}^2 &= H^{-(7-p)/8}(-dt^2 + dy_1^2 + \cdots + dy_p^2) + H^{(p+1)/8}(dx_1^2 + \cdots + dx_{9-p}^2), \\ e^\phi &= H^{(3-p)/4} \end{aligned} \quad (2.111)$$

The $p + 2$ -form, F_{p+2} , can be easily calculated from equations (2.101) and (2.102) for the electric and magnetic ansatz respectively. In the string frame the solution for Dp -brane becomes

$$ds_{Dp}^2 = H^{-1/2}(-dt^2 + dy_1^2 + \cdots + dy_p^2) + H^{1/2}(dx_1^2 + \cdots + dx_{9-p}^2). \quad (2.112)$$

Note that, this string frame solution satisfies the Type IIA supergravity action in (2.77) for even value of p and satisfies the Type IIA supergravity action in (2.80) for odd value of p .

Together with the branes described above, we can construct another class of solutions by the dimensional reduction procedure. We refer to them as the *Kaluza-Klein* (KK) charged objects which are the branes living in compactified space-time. The KK charged objects couple electrically (or magnetically) to the two-form field strength which is generated from the Kaluza-Klein dimensional reduction from $D+1$ dimensions to D dimension. In the D -dimensional space these KK charged objects correspond to an electric 0-brane and a magnetic $(D-4)$ -brane. The first object corresponds to a KK-wave in $D+1$ dimensional space-time and the second is the dimensional reduction of the KK-monopole. The KK-wave and KK-monopole solution are purely geometry as the metric is the only non-trivial field in the configurations. We will construct the metric of KK-wave and KK-monopole by simply reversing the KK procedure to construct a $D+1$ dimensional metric from a D -dimensional configuration. This reversed KK procedure is so called “oxidation”.

Let us start by reviewing the Kaluza-Klein procedure. We write the $D+1$ dimensional metric in the following form,

$$ds^2 = g_{MN}^{D+1} dx^M dx^N = g_{\mu\nu} dx^\mu dx^\nu + e^{2\sigma} (dy + A_\mu dx^\mu)^2. \quad (2.113)$$

After transforming the D -dimensional metric $g_{\mu\nu} = e^{-2\sigma/(D-2)} \tilde{g}_{\mu\nu}$, the action in $(D+1)$ -dimensions is reduced to the D -dimensional action as (for convenience, we will drop the tildes),

$$\begin{aligned} & \frac{1}{16\pi G_{D+1}} \int d^{D+1}x \sqrt{-g^{D+1}} R(g^{D+1}) \\ & \rightarrow \frac{1}{16\pi G_D} \int d^Dx \sqrt{-g} \left\{ R - \frac{D-1}{D-2} \partial_\mu \varphi \partial^\mu \varphi - \frac{1}{4} e^{2\frac{D-1}{D-2}\sigma} F^2 \right\}. \end{aligned} \quad (2.114)$$

The Newton constant in D -dimensional space-time can be written as $G_D = \frac{G_{D+1}}{2\pi R}$ where R is the radius of the compact space y . We can simplify the action (2.114) further by redefining the scalar field σ by $\phi = \sqrt{\frac{2(D-1)}{D-2}} \sigma$. We obtain

$$I = \frac{1}{16\pi G_D} \int d^Dx \sqrt{-g} \left\{ R - \frac{1}{2} \partial_\mu \phi \partial^\mu \phi - \frac{1}{4} e^{\sqrt{2(D-1)/(D-2)} \phi} F^2 \right\}. \quad (2.115)$$

The action in (2.115) is equivalent to the action in (2.85), if we identify

$$\alpha_2 = \sqrt{\frac{2(D-1)}{(D-2)}}. \quad (2.116)$$

We are now in a position to write down the KK-wave solution. We will first introduce the D -dimensional 0-brane metric, and then uplift it to $D + 1$ dimensions. By substituting the value of α_2 in (2.116) into (2.100), we have $\Delta = 2(D - 2)$. We have (from (2.103)),

$$ds_D^2 = -H^{-(D-3)/(D-2)} dt^2 + H^{1/(D-2)} (dx_1^2 + \cdots + dx_{D-1}^2), \quad (2.117)$$

$$e^\phi = H^{\alpha_2/2}, \quad A_t = H^{-1} - 1, \quad H = 1 + \frac{1}{D-3} \frac{Q}{r^{D-3}}. \quad (2.118)$$

Before uplifting the metric to $D + 1$ dimensions, we reverse the KK-process by rescaling the metric in (2.117) by $\hat{g}_{\mu\nu} = e^{2\phi/\alpha_2(D-2)} \tilde{g}_{\mu\nu} = H^{-1/(D-2)} g_{\mu\nu}$. As a result, the $D + 1$ dimensional metric is expressed in the Einstein frame,

$$ds_{D+1}^2 = -H^{-1} dt^2 + dx_1^2 + \cdots + dx_{D-1}^2 + H \left[dy + (H^{-1} - 1) dt \right]^2, \quad (2.119)$$

where y is the compactified direction. If we introduce the new harmonic function K such that $H = 1 + K$, we obtain the metric of KK-wave,

$$ds_{D+1}^2 = -dt^2 + dy^2 + K \left[dt - dy \right]^2 + dx_1^2 + \cdots + dx_{D-1}^2. \quad (2.120)$$

We are now turning to consider the KK-monopole. Since the D -dimensional metric is identified as a magnetic $(D - 4)$ -brane, it is more convenient for us to start from a four-dimensional configuration and obtain the five dimensional KK-monopole metric. After oxidation, we generalise the metric to $D + 1$ -dimensions by adding to the five-dimensional metric $D - 5$ flat compactified directions. In four-dimensional space-time, $\alpha_2 = \sqrt{3}$ and $\Delta = 4$, and we have the magnetic solution

$$ds_4^2 = -H^{1/2} dt^2 + H^{1/2} \left(dr^2 + r^2 d\Omega_2^2 \right), \quad (2.121)$$

$$e^\phi = H^{-\sqrt{3}/2}, \quad H = 1 + \frac{Q}{r}. \quad (2.122)$$

The magnetic field strength and potential can be written as

$$F_{\theta\varphi} = Q \sin \theta, \quad A_\varphi = Q(1 - \cos \theta). \quad (2.123)$$

Before going to 5 dimensions, we rescale the metric in (2.122) by $\hat{g}_{\mu\nu} = H^{-1}$. The five-dimensional metric is

$$ds_5^2 = -dt^2 + H^{-1} \left(dy + Q(1 - \cos \theta) d\varphi \right)^2 + H (dr^2 + r^2 d\Omega_2^2) \quad (2.124)$$

By adding to the above metric the $D - 5$ flat compactified directions, we obtain the $D + 1$ dimensional KK-monopole

$$ds_{KK}^2 = -dt^2 + dx_1^2 + \cdots + dx_{D-5}^2 + H^{-1} \left(dy + Q(1 - \cos \theta) d\varphi \right)^2 + H(dr^2 + r^2 d\Omega_2^2), \quad (2.125)$$

where the last two terms describe the Euclidean Taub-NUT space [23]. The direction y is called the NUT-direction. In order to avoid the conical singularity at $r = 0$ we identify $y \sim y + 4\pi Q$.

Note that for $D = 10$, the Type IIA D0-brane (D6-brane) can be obtained from the KK-wave metric (KK-monopole) of M-theory by compactifying on a circle.

2.4.4 The harmonic functions rule

In this section we will consider a systematic rule to obtain the intersecting brane configurations in string and M-theory. Our starting point is the eleven-dimensional supergravity. Following closely the discussion in [24], we rewrite the metric for Mp -brane, $p = 2, 5$, as

$$ds_{11}^2 = H_p^{(p+1)/9}(x) \left\{ H_p^{-1}(x) (-dt^2 + dy_1^2 + \cdots + dy_p^2) + dx_1^2 + \cdots + dx_{10-p}^2 \right\}. \quad (2.126)$$

We can observe the structure of the metric is such that each squares of the coordinates belong to the world-volume directions of the p -brane is multiplied by the inverse power of the corresponding harmonic function. The general rule which applies to any supersymmetric combination of orthogonally intersecting p -branes was proposed by Tseytlin in [24] is:

“If the coordinate y belongs to several constituent p -branes (p_1, \dots, p_n) then its contribution to the metric is multiplied by the product of inverse powers of the harmonic functions corresponding to each of the p -branes it belongs to, i.e. $H_{p_1}^{-1} \dots H_{p_n}^{-1}$. The harmonic function factors thus play the rôle of labels of the constituent p -branes.”

This rule is a consequence of the fact that intersecting configurations are required to be supersymmetric. We can superimpose BPS states and parametrize them by the harmonic function. Note that the harmonic function rule can also be derived directly from the supergravity equations of motion, see for an example in [25].

By using the harmonic function rule, the metric of two M2-branes intersecting over a point is

$$ds_{11}^2 = H_1^{1/3}(x)H_2^{1/3}(x)\left\{-H_1^{-1}(x)H_2^{-1}(x)dt^2 + H_1^{-1}(x)(dy_1^2 + dy_2^2) + H_2^{-1}(x)(dy_3^2 + dy_4^2) + dx_1^2 + \cdots + dx_6^2\right\}, \quad (2.127)$$

where the factors H_1^{-1} and H_2^{-1} label the first and the second M2-brane. The directions y_1 and y_2 are longitudinal directions of the first brane while y_3 and y_4 belong to the second brane.

Let us consider another example in Type II theory where the Dp -brane metric in Einstein frame can be written as

$$ds_{11}^2 = H_p^{(p+1)/8}(x)\left\{H_p^{-1}(x)(-dt^2 + dy_1^2 + \cdots + dy_p^2) + dx_1^2 + \cdots + dx_{9-p}^2\right\}. \quad (2.128)$$

By using the harmonic function rule, we can determine the metric of two intersecting D3-branes in Type IIB. We get

$$ds_{10}^2 = H_1^{1/2}(x)H_2^{1/2}(x)\left\{H_1^{-1}(x)H_2^{-1}(x)(-dt^2 + dy_1^2) + H_1^{-1}(x)(dy_2^2 + dy_3^2) + H_2^{-1}(x)(dy_4^2 + dy_5^2) + dx_1^2 + \cdots + dx_4^2\right\}. \quad (2.129)$$

Here, the factors H_1^{-1} and H_2^{-1} label the first and the second D3-brane. The directions y_2 and y_3 are longitudinal directions of the first brane while y_4 and y_5 belong to the second brane. Both D3-branes have the same longitudinal direction y_1 .

Chapter 3

Superstring from bosonic string

3.1 Introduction

Already in the very early days of string theory, the presence of tachyonic modes in the bosonic string spectrum overshadowed the excitement of having constructed a theory which included gravity and was finite. Supersymmetry was then called to the rescue, and one of its many phenomenal successes in the context of string theory was to project the tachyon out and with it, all the inconsistencies it leads to. And even though experiments have failed so far to confirm supersymmetry is a symmetry of nature, its virtues are so magical that the “theory of everything” (M-theory) conjecture does not include the bosonic string. However, many years ago, a number of works [10], [9], [5] and [29] suggested that all ten-dimensional closed fermionic string theories could emerge from a consistent “truncation” of the Hilbert space of the 26-dimensional closed bosonic string theory compactified on specific group lattices. The mechanism whereby bosons give rise to space-time fermions is argued to be similar to the one described in [8] in the context of 3+1 dimensional $SU(2)$ gauge theory in the presence of monopoles, and has been recently used to study the duality conjecture between non-supersymmetric strings [30].

In particular, toroidal compactification of the closed bosonic string on an $E_8 \times E_8$ group lattice produces the states of Type IIA/B theory, while compactification on an $E_8 \times SO(16)$ torus yields the non-supersymmetric Type 0A/B spectrum. However, it was realized in [5] that all closed fermionic string could be obtained from

compactification on $E_8 \times SO(16)$. The bosonic theory must be truncated in a very specific but universal way, which ensures the modular invariance of the resulting theory. All states in the truncated theory transform under a new Lorentz group whose transverse part is $diag(SO(8)_{trans} \otimes SO(8)_{int})$ with $SO(8)_{trans}$ the subgroup of the transverse bosonic Lorentz group and $SO(8)_{int}$ a regular subgroup of $SO(16)$. The adjoint representation of the group $E_8 \times E_8$ (or $E_8 \times SO(16)$) will give the spinor representations 8_s and 8_c of the new Lorentz group.

Recently [12] the truncation procedure has been extended to the theory of open bosonic strings and yields the supersymmetric Type I or the non-supersymmetric Type 0 string. Although the uncompactified open and closed bosonic theory has an enormous $SO(2^{13})$ Chan-Paton gauge group, the rank of the group can be reduced dramatically by compactifying on a torus with background torsion [11]. For compactification on a group lattice [12], the tadpole condition of the compactified theory gives the correct symmetry group which can give rise to the anomaly free Type I and Type 0 theories after the truncation. This truncation mechanism may provide new relationships for non-supersymmetric string theory [26] and may prove the existence of a bosonic M-theory [32].

However, as commented in [33], although the emergence of all fermionic strings from the truncation of the bosonic theory is very impressive, it is still unclear that the truncation will give us all the properties of the fermionic string. One of the important features of superstring theory is the presence of BPS D-branes in its spectrum. The BPS D-branes are sources for the Ramond-Ramond gauge fields [34]. Their existence is required by T-duality and they play an important rôle in establishing dualities between all consistent superstring theories [35]. By contrast, the bosonic string theory does not contain Ramond-Ramond gauge fields. Although the authors in [12] argue that the bosonic D25-brane directly truncates to the D9-brane in Type I (or Type 0) theory and gives the correct Chan-Paton gauge groups, the emergence of other lower-dimensional D-branes in Type I and Type II by truncation was not discussed. In this chapter, we study wrapped bosonic D-branes and prove that we can truncate them to Type I D-branes. We also construct BPS boundary states in the truncated closed bosonic theory which can be interpreted as Type II D-branes.

Our result ensures the existence of D-branes after truncation.

The outline of the chapter is as follows: in Section 3.2, we review the toroidal compactification of the bosonic string on a particular class of Lie group lattices called Englert-Neveu (E-N) lattices [36]. In Section 3.3, by using the boundary conformal field theory techniques, we derive the consistent open string theory compactified on such lattice and also write down the boundary state of D25-branes wrapped on the lattice. In Section 3.4, we summarise the rules for the truncation process and introduce the fermionic operators corresponding to the fermionic string in both the Neveu-Schwarz-Ramond and the Green-Schwarz formalism. Then, in Section 3.5, we show the evidence that the BPS D-branes in Type I superstring theory can emerge from the truncation of the wrapped bosonic D-branes. Finally, we discuss our results in the last section.

3.2 Compactification of the bosonic theory

In this section, we consider the bosonic string theory in 26 dimensional space-time. We compactify the bosonic string on a non-Cartesian d-dimensional torus. The dynamics of this system can be described by the action,

$$S = \frac{-1}{4\pi\alpha'} \int d\sigma d\tau \left\{ [g_{ab}\partial_\alpha X^a \partial^\alpha X^b + b_{ab}\epsilon^{\alpha\beta}\partial_\alpha X^a \partial_\beta X^b] + \eta_{\mu\nu}\partial_\alpha X^\mu \partial^\alpha X^\nu \right\}, \quad (3.1)$$

where g_{ab} and b_{ab} are the constant background metric and antisymmetric tensor in the compact directions. We define $\eta_{\mu\nu}$ as the flat metric describing the non-compact directions and note that the world-sheet metric is $\gamma_{\alpha\beta} = \eta_{\alpha\beta} = \text{diag}(-1, +1)$. Also, $\epsilon^{01} = \epsilon^{\tau\sigma} = 1 = -\epsilon^{10}$ and $0 \leq \sigma \leq \pi$.

We assume that the open strings in non-compact directions ($\mu = 0, \dots, 25-d$) satisfy the Neumann boundary condition,

$$\partial_\sigma X^\mu |_{\sigma=0,\pi} = 0. \quad (3.2)$$

Note that we will consider more general boundary conditions in Section 3.5.

3.2.1 Review of the Englert-Neveu compactification

Let us consider the lattice directions $a = 26 - d, \dots, 25$ in more detail. In order for the action (3.1) to be extremal, one must satisfy the following condition in the lattice directions:

$$(g_{ab} \partial_\sigma X^b - b_{ab} \partial_\tau X^b) \delta X^a |_{\sigma=0, \pi} = 0, \quad (3.3)$$

i.e. the open string coordinates must satisfy either Dirichlet or (generalized) Neumann boundary conditions. For the Dirichlet conditions $\delta X^a = 0$, the solution for the open string coordinates is,

$$X_D^a(\sigma, \tau) = q^a + 2l^a \sigma + \sqrt{2\alpha'} \sum_{n \neq 0} \frac{1}{n} \alpha_n^a \sin n\sigma e^{-in\tau}, \quad (3.4)$$

with the commutation relations $[\alpha_m^a, \alpha_n^b]_D = m\delta_{m+n,0} g^{ab}$. The winding operator l^a commutes with the operators q^a and α_n^a , and has integer eigenvalue ω^a . The mass formula for the Dirichlet open string is given by

$$\begin{aligned} \alpha' M_D^2 &= \frac{1}{\alpha'} \omega^a g_{ab} \omega^b + \sum_{n>0} g_{ab} \alpha_{-n}^a \alpha_n^b + N_{(n.c.)}^o - 1 \\ &= \frac{\mathbf{L} \cdot \mathbf{L}}{\alpha'} + \sum_{n>0} g_{ab} \alpha_{-n}^a \alpha_n^b + N_{(n.c.)}^o - 1, \end{aligned} \quad (3.5)$$

where $N_{(n.c.)}^o$ is the number operator for the open string oscillators in the non-compact directions. We define the vector \mathbf{L} as,

$$\mathbf{L} = \omega^a \mathbf{e}_a, \quad \omega^a \in \mathbb{Z}. \quad (3.6)$$

The basis vectors \mathbf{e}_a span the periodic lattice $\mathbf{t} = 2\pi\omega^a \mathbf{e}_a$ and the metric can be written as

$$g_{ab} = \mathbf{e}_a \cdot \mathbf{e}_b. \quad (3.7)$$

If $\sqrt{2/\alpha'} \mathbf{L}$ belongs to an even lattice, there is a degeneracy of the mass spectrum between oscillator and winding states. We will consider the case where the lattice coincides with the root lattice of a simply laced group \mathcal{G} . In this case the symmetry of the open string is enlarged to \mathcal{G} and

$$\mathbf{e}_a = \frac{1}{2} \sqrt{2\alpha'} \mathbf{r}_a, \quad (3.8)$$

where \mathbf{r}_a are basis vectors of the root lattice Λ_{Root} which we choose to be the simple roots. The dual vectors $\mathbf{e}^a = g^{ab}\mathbf{e}_b$ span the momentum lattice with vectors $\mathbf{p} = m_a\mathbf{e}^a$ where m_a is the integer eigenvalue of the momentum operator p_a conjugate to q^a , $[q^a, p_b]_D = i\delta_b^a$.

Let us now consider the generalized Neumann condition. We can write the open string coordinates as,

$$\begin{aligned} X_N^a(\sigma, \tau) = & q^a + 2\alpha' B^{ab} p_b \sigma + 2\alpha' G^{ab} p_b \tau + i\sqrt{2\alpha'} \sum_{n \neq 0} \frac{1}{n} \alpha_n^a \cos n\sigma e^{-in\tau} \\ & - \sqrt{2\alpha'} \sum_{n \neq 0} \frac{1}{n} B^{ac} (G^{-1})_{cb} \alpha_n^b \sin n\sigma e^{-in\tau}, \end{aligned} \quad (3.9)$$

with the commutation relations,

$$[q^a, p_b]_N = i\delta_b^a, \quad [\alpha_m^a, \alpha_n^b]_N = G^{ab} m \delta_{m+n, 0}, \quad (3.10)$$

where the eigenvalues of the momentum operators p_a are integers m_a .

We introduce the tensor $E_{ab} = g_{ab} + b_{ab}$ and its inverse $(E^{-1})^{ab} = G^{ab} + B^{ab}$. The tensors G^{ab} and B^{ab} are the E-dual metric and antisymmetric tensors,

$$(g_{ab} + b_{ab})(G^{bc} + B^{bc}) = \delta_a^c, \quad (3.11)$$

and can be re-expressed in the following more useful form,

$$\begin{aligned} g_{ab} - b_{ac} g^{cd} b_{db} &= (G^{-1})_{ab} \\ g^{ac} b_{cb} &= -B^{ac} (G^{-1})_{cb}. \end{aligned} \quad (3.12)$$

The mass spectrum of the open string with generalized Neumann conditions is,

$$\begin{aligned} \alpha' M_N^2 &= \alpha' m_a (G^{ab}) m_b + \sum_{n>0} (G^{-1})_{ab} \alpha_{-n}^a \alpha_n^b + N_{(n.c.)}^o - 1 \\ &= \alpha' \tilde{\mathbf{p}} \cdot \tilde{\mathbf{p}} + \sum_{n>0} (G^{-1})_{ab} \alpha_{-n}^a \alpha_n^b + N_{(n.c.)}^o - 1. \end{aligned} \quad (3.13)$$

We define the lattice momentum such that

$$\tilde{\mathbf{p}} = m_a \tilde{\mathbf{e}}^a, \quad (3.14)$$

with the E-dual basis $\tilde{\mathbf{e}}^a$ taken such that

$$G^{ab} = \tilde{\mathbf{e}}^a \cdot \tilde{\mathbf{e}}^b. \quad (3.15)$$

If we choose b_{ab} as in [28], namely,

$$b_{ab} = \begin{cases} g_{ab} & a > b \\ 0 & a = b \\ -g_{ab} & a < b \end{cases}, \quad (3.16)$$

the matrix E_{ab} is triangular as well as its inverse $(E^{-1})^{ab}$. So we can write,

$$B^{ab} = \begin{cases} G^{ab} & a > b \\ 0 & a = b \\ -G^{ab} & a < b \end{cases}. \quad (3.17)$$

This implies that the norms of the diagonal elements of g_{ab} are the inverse of the norms of the diagonal elements of G^{ab} . Given the definition (3.8) and $\mathbf{r} \cdot \mathbf{r} = 2$, we have $g_{aa} = \alpha'$ and thus $G^{aa} = 1/\alpha'$. Therefore,

$$\tilde{\mathbf{e}}_a = E_{ab} \mathbf{e}^b. \quad (3.18)$$

Since $g_{ab} = (\alpha'/2)A_{ab}$ where A_{ab} is the Cartan matrix of the simply laced group \mathcal{G} , we get the conditions,

$$\frac{2}{\alpha'}g_{ab} \in \mathbb{Z} \quad , \quad \frac{2}{\alpha'}b_{ab} \in \mathbb{Z}. \quad (3.19)$$

So all the elements of E_{ab} are either $\pm\alpha'$ or 0. This implies $\tilde{\mathbf{e}}_a/\sqrt{2\alpha'}$ is a vector on the weight lattice (Λ_W) and $\sqrt{2\alpha'}\tilde{\mathbf{e}}^a$ is on the root lattice (Λ_R).

The mass spectra (3.5) and (3.13) are equivalent when,

$$\mathbf{L} = \alpha'\tilde{\mathbf{p}}. \quad (3.20)$$

This follows from the duality between the Dirichlet and Neumann conditions for open string which can be viewed as a duality between the bases of Λ_R and Λ_W .

Let us now consider the theory in the closed string sector. The closed string mode expansion in the compact coordinates can be written as,

$$X^a = q^a + 2\omega^a \sigma + (2\alpha'g^{ab}m_b + 2g^{ab}b_{bc}\omega^c)\tau + \frac{i}{2} \sum_{n \neq 0} \frac{\sqrt{2\alpha'}}{n} (\alpha_n^a e^{-2in(\tau-\sigma)} + \tilde{\alpha}_n^a e^{-2in(\tau+\sigma)}). \quad (3.21)$$

We can split (3.21) into left and right moving modes,

$$\begin{aligned} X_R^a &= q^a/2 + (\alpha'g^{ab}m_b + g^{ab}b_{bc}\omega^c - \omega^a)(\tau - \sigma) + \text{oscillators} , \\ X_L^a &= q^a/2 + (\alpha'g^{ab}m_b + g^{ab}b_{bc}\omega^c + \omega^a)(\tau + \sigma) + \text{oscillators} . \end{aligned} \quad (3.22)$$

where we can define the left and right momenta in terms of the lattice basis,

$$\begin{aligned}\mathbf{P}_R &= [(\frac{m_a}{2} + b_{ab} \frac{\omega^b}{2\alpha'})\mathbf{e}^a - \frac{\omega^a}{2\alpha'}\mathbf{e}_a] = [\frac{m_a}{2} - (g_{ab} - b_{ab})\frac{\omega^b}{2\alpha'}]\mathbf{e}^a, \\ &= (\frac{m_a}{2} - E_{ab}^t \frac{\omega^b}{2\alpha'})\mathbf{e}^a,\end{aligned}\quad (3.23)$$

and

$$\begin{aligned}\mathbf{P}_L &= [(\frac{m_a}{2} + b_{ab} \frac{\omega^b}{2\alpha'})\mathbf{e}^a + \frac{\omega^a}{2\alpha'}\mathbf{e}_a] = [\frac{m_a}{2} + (g_{ab} + b_{ab})\frac{\omega^b}{2\alpha'}]\mathbf{e}^a, \\ &= (\frac{m_a}{2} + E_{ab} \frac{\omega^b}{2\alpha'})\mathbf{e}^a.\end{aligned}\quad (3.24)$$

We see that $\sqrt{2\alpha'}\mathbf{P}_L$ and $\sqrt{2\alpha'}\mathbf{P}_R$ span the weight lattice of \mathcal{G}_L and \mathcal{G}_R respectively. The special case where $\mathcal{G}_L = \mathcal{G}_R = \mathcal{G}$ is called the Englert-Neveu compactification. Note that modular invariance requires $\sqrt{2\alpha'}(\mathbf{P}_R - \mathbf{P}_L)$ is on the root lattice Λ_{Root} , i.e. $\sqrt{2\alpha'}\mathbf{P}_R$ and $\sqrt{2\alpha'}\mathbf{P}_L$ are in the same conjugacy class. The tensors g_{ab} and b_{ab} are defined to characterise a toroidal compactification on an Englert-Neveu (E-N) lattice.

3.2.2 Lattice characters and their modular transformations

Let us consider the toroidal compactification of a closed string on a $\mathcal{G}_L \times \mathcal{G}_R$ *self-dual Lorentzian lattice*. Recalling the definitions in [31], the Lorentzian lattice, Λ , is the set of points in a vector space with Lorentzian inner product. If, for any pair of vectors v and $w \in \Lambda$, $v \cdot w \in \mathbb{Z}$, the lattice is *integral*. And if the integral lattice has $v^2 = 0 \pmod{2}, \forall v \in \Lambda$, it is *even*. The lattice is called self-dual if the corresponding vector space is self-dual.

This self-dual Lorentzian lattice admits a coset decomposition $\Lambda^{\mathcal{G}_L \times \mathcal{G}_R} / \Lambda_{(o,o)}^{\mathcal{G}_L \times \mathcal{G}_R}$. We define $\Lambda^{\mathcal{G}_L \times \mathcal{G}_R}$ as the full weight lattice of $\mathcal{G}_L \times \mathcal{G}_R$ and $\Lambda_{(o,o)}^{\mathcal{G}_L \times \mathcal{G}_R}$ represents an even Lorentzian lattice characterised by a vector $\sqrt{2\alpha'}\mathbf{P}_{(o,o)} = (\sqrt{2\alpha'}\mathbf{P}_{L(o)}, \sqrt{2\alpha'}\mathbf{P}_{R(o)})$ where $\sqrt{2\alpha'}\mathbf{P}_{L(o)}$ and $\sqrt{2\alpha'}\mathbf{P}_{R(o)}$ span the root lattice of \mathcal{G}_L and \mathcal{G}_R respectively. This decomposition follows from the fact that any even lattice is integral and that any integral lattice is a sublattice of its dual. Then we can decompose such lattice into an integer number \mathcal{N} of its cosets:

$$\Lambda^{\mathcal{G}_L \times \mathcal{G}_R} = \bigoplus_{i=1}^{\mathcal{N}_L} \bigoplus_{i=1}^{\mathcal{N}_L} \Lambda_{(\beta_i, \beta_j)}^{\mathcal{G}_L \times \mathcal{G}_R}, \quad (3.25)$$

where \mathcal{N}_L and \mathcal{N}_R are integer number of cosets of the total weight lattice $\Lambda^{\mathcal{G}_L}$ and $\Lambda^{\mathcal{G}_R}$ respectively, and also equal to the order of the centres of the covering group of \mathcal{G}_L and \mathcal{G}_R . Note that $\Lambda_{(\beta_i, \beta_j)}^{\mathcal{G}_L \times \mathcal{G}_R}$ are $\mathcal{N} = \mathcal{N}_L \times \mathcal{N}_R$ sublattices isomorphic to the lattice $\Lambda_{(o, o)}$ and characterised by the indices β_i i.e. for the case $i = 0$, the index $\beta_0 = o$ represents the root (sub)lattice ($\Lambda_o = \Lambda_{Root}$).

The partition function of closed strings compactified on the sublattice $\Lambda_{(\beta_i, \beta_j)}$ can be written as

$$\gamma_{(\beta_i, \beta_j)}(\tau, \bar{\tau}) = \chi_{\beta_i}^{\mathcal{G}_R}(\tau) \bar{\chi}_{\beta_j}^{\mathcal{G}_L}(\bar{\tau}), \quad (3.26)$$

where $\chi_{\beta_i}^{\mathcal{G}_R}(\tau)$, the ‘‘lattice character’’, is defined as:

$$\begin{aligned} \chi_{\beta_i}(\tau) &= \sum_{\sqrt{2\alpha'} \mathbf{p}_o \in \Lambda_o^{\mathcal{G}_R}} \exp\left\{2i\pi\tau\left[\alpha'(\mathbf{p}_o + \mathbf{p}_{\beta_i})^2 + N_R^{(c)} - \frac{d}{24}\right]\right\}, \\ &= \sum_{\sqrt{2\alpha'} \mathbf{p}_o \in \Lambda_o^{\mathcal{G}_R}} \frac{\exp(2i\pi\alpha'\tau(\mathbf{p} + \mathbf{p}_{\beta_i})^2)}{\eta(\tau)^d}, \\ &= \sum_{\sqrt{2\alpha'} \mathbf{p}_o \in \Lambda_o^{\mathcal{G}_R}} q^{\alpha'(\mathbf{p} + \mathbf{p}_{\beta_i})^2} / \eta(\tau)^d, \end{aligned} \quad (3.27)$$

with $q = e^{i2\pi\tau}$ and $\sqrt{2\alpha'} \mathbf{p}_{\beta_i}$ represents an arbitrarily chosen vector of a sublattice $\Lambda_{(\beta_i)}^{\mathcal{G}_R}$ in the coset decomposition $\Lambda^{\mathcal{G}_R} / \Lambda_{(o)}^{\mathcal{G}_R}$. The Dedekind function in (3.27) is the contribution from the oscillators and cosmological constant in the compact directions. A similar expression holds for $\bar{\chi}_{\beta_j}^{\mathcal{G}_L}(\bar{\tau})$. Note that if \mathcal{G}_R is a direct product of simply laced groups, the character $\chi_{\beta_i}^{\mathcal{G}_R}(\tau)$ can be further factorised accordingly.

Let us continue by studying the modular transformations of the lattice characters. Under the transformation :

$$T : \tau \rightarrow \tau + 1, \quad S : \tau \rightarrow -\frac{1}{\tau}, \quad (3.28)$$

lattice characters transform as :

$$\chi_i^{\mathcal{G}}(\tau + 1) = \sum_{j=1}^{\mathcal{N}} T_{ij}^{\mathcal{G}} \chi_j^{\mathcal{G}}(\tau), \quad (3.29)$$

$$\chi_i^{\mathcal{G}}\left(-\frac{1}{\tau}\right) = \sum_{j=1}^{\mathcal{N}} S_{ij}^{\mathcal{G}} \chi_j^{\mathcal{G}}(\tau). \quad (3.30)$$

It is straightforward to show that

$$T_{i,j}^{\mathcal{G}} = e^{i\pi d/12} \exp\{-i\pi(\sqrt{2\alpha'} \mathbf{p}_{\beta_i})^2\} \delta_{ij}. \quad (3.31)$$

The matrix $S^{\mathcal{G}}$ can be determined by using the Poisson re-summation formula

$$\sum_{n_i \in \mathbb{Z}} e^{-\pi n^T A n + 2i\pi B^T n} = \frac{1}{\sqrt{\det(g)}} \sum_{\{m_i\} \in \mathbb{Z}} e^{-\pi(m-B)^T A^{-1}(m-B)}, \quad (3.32)$$

where A and B are any $\mathcal{N} \times \mathcal{N}$ matrices. Moreover, since the volume of the root lattice is equal to the square root of the number of conjugacy classes of the lattice group $V(\Lambda_{(o,o)}) = \sqrt{\det(g)} = \sqrt{\mathcal{N}}$, we obtain

$$S_{ij}^{\mathcal{G}} = \frac{1}{\sqrt{\mathcal{N}}} \exp(-4i\pi\alpha' \mathbf{p}_{\beta_i} \cdot \mathbf{p}_{\beta_j}). \quad (3.33)$$

In order to calculate the Möbius amplitude, it is convenient to define “hatted” lattice characters by

$$\hat{\chi}_{\beta_i}^{\mathcal{G}}(i\tau_2 + \frac{1}{2}) = e^{-i\pi\{\alpha'(\mathbf{p}_{\beta_i})^2 - \frac{d}{24}\}} \chi_{\beta_i}^{\mathcal{G}}(i\tau_2 + \frac{1}{2}). \quad (3.34)$$

In the case where $\mathcal{G} = SO(2n)$ ($n > 1$) and $\mathcal{G} = E_8$, equation (3.34) can be shown as the result in Table 3.1. Note that $SO(2n)$ has four conjugacy classes. The indices o , v , s and c represent the root, vector, spinor and conjugate spinor respectively. The E_8 group contain only the root conjugacy class, o .

Group	Hatted characters
$SO(2n)$ $n > 1$	$\hat{\chi}_o^{SO(2n)}(i\tau_2 + \frac{1}{2}) = e^{i\pi/24} \chi_o^{SO(2n)}(i\tau_2 + \frac{1}{2})$
	$\hat{\chi}_v^{SO(2n)}(i\tau_2 + \frac{1}{2}) = e^{i\pi(\frac{n}{24} - \frac{1}{2})} \chi_v^{SO(2n)}(i\tau_2 + \frac{1}{2})$
	$\hat{\chi}_s^{SO(2n)}(i\tau_2 + \frac{1}{2}) = e^{i\frac{3n\pi}{24}} \chi_s^{SO(2n)}(i\tau_2 + \frac{1}{2})$
	$\hat{\chi}_c^{SO(2n)}(i\tau_2 + \frac{1}{2}) = e^{i\frac{2n\pi}{24}} \chi_c^{SO(2n)}(i\tau_2 + \frac{1}{2})$
E_8	$\hat{\chi}_o^{E_8}(i\tau_2 + \frac{1}{2}) = e^{i8\pi/24} \chi_o^{E_8}(i\tau_2 + \frac{1}{2})$

Table 3.1: Shows the relations between hatted and un-hatted characters.

As we emphasized in Section 2.2.4, the direct and transverse Möbius amplitudes are related by the P modular transformation (2.21). Under this transformation, the “hatted” characters transform as $\hat{\chi}_{\beta_i}^{\mathcal{G}}(i\tau_2 + \frac{1}{2}) = \sum_{j=1}^{\mathcal{N}} P_{ij}^{\mathcal{G}} \hat{\chi}_{\beta_j}(i\frac{1}{\tau_2} + \frac{1}{2})$ where [11]

$$P^{\mathcal{G}} = (T^{\mathcal{G}})^{1/2} S^{\mathcal{G}} (T^{\mathcal{G}})^2 S^{\mathcal{G}} (T^{\mathcal{G}})^{1/2}. \quad (3.35)$$

The matrix $(T^{\mathcal{G}})^{1/2}$ is defined by $(T^{\mathcal{G}})^{1/2}_{ij} = e^{i\pi d/24} \exp\{-i\frac{\pi}{2}(\sqrt{2\alpha'} \mathbf{p}_{\beta_i})^2\} \delta_{ij}$.

Note that $T^{\mathcal{G}}$ is unitary and diagonal and $S^{\mathcal{G}}$ is unitary and symmetric, and satisfy

$$\begin{aligned}
 C_{ij} &= (S^{\mathcal{G}})_{ij}^2 = (S^{\mathcal{G}}T^{\mathcal{G}})_{ij}^3 = (P^{\mathcal{G}})_{ij}^2 \\
 &= \frac{1}{\mathcal{N}} \sum_{k=1}^{\mathcal{N}} \exp(-4\pi i \alpha' \mathbf{p}_{\beta_k} \cdot \mathbf{p}_{\beta_i}) \exp(-4\pi i \alpha' \mathbf{p}_{\beta_k} \cdot \mathbf{p}_{\beta_j}) \\
 &= \delta_{(\mathbf{p}_{\beta_i} + \mathbf{p}_{\beta_j} + \mathbf{p}_0)} ,
 \end{aligned} \tag{3.36}$$

where $\sqrt{2\alpha'} \mathbf{p}_0$ is an arbitrary vector of the root lattice.

In most of this chapter, we are interested in $SO(2n)$ sublattices where n is an even positive integer. In this case, we have ($\mathcal{N} = 4$)

$$S^{SO(2n)} = \frac{1}{2} \begin{pmatrix} 1 & 1 & 1 & 1 \\ 1 & 1 & -1 & -1 \\ 1 & -1 & e^{-in\pi/2} & -e^{-in\pi/2} \\ 1 & -1 & -e^{-in\pi/2} & e^{-in\pi/2} \end{pmatrix} , \tag{3.37}$$

and for the T-transformation of $SO(2n)$ lattice character, we have

$$T^{SO(2n)} = e^{-in\pi/12} \text{diag}(1, -1, e^{in\pi/4}, e^{in\pi/4}) . \tag{3.38}$$

Consequently, the P -matrix can be written as

$$P^{SO(2n)} = \begin{pmatrix} c & s & 0 & 0 \\ s & -c & 0 & 0 \\ 0 & 0 & \zeta c & i\zeta s \\ 0 & 0 & i\zeta s & \zeta c \end{pmatrix} , \tag{3.39}$$

with $c = \cos(n\pi/4)$, $s = \sin(n\pi/4)$ and $\zeta = e^{-in\pi/4}$. Also the \mathcal{C} becomes

$$\mathcal{C} = \text{diag}(1, 1, (\sigma_1)^n) , \tag{3.40}$$

where σ_1 denotes the usual Pauli matrix. Note that the matrices (3.37), (3.38), (3.39) and (3.40) derived from the lattice partition function are the same as the corresponding matrices for $SO(2n)$ characters published in [11].

3.3 Open string descendants on lattice torus

In order to explain how the open superstring theories can be obtained by truncation from the compactified 26-dimensional bosonic string, we have to understand the construction of open string descendants from closed string compactified on the E-N lattice of a semi-simple Lie group \mathcal{G} of rank d .

3.3.1 Partition function and Klein bottle amplitude

In general, the torus partition function of an oriented closed string theory with gauge symmetry $\mathcal{G}_L \times \mathcal{G}_R$, compactified on the $\mathcal{G}_L \times \mathcal{G}_R$ lattice, is

$$\Gamma^T = \frac{V_{26-d}}{(4\pi^2\alpha')^{(26-d)/2}} \int_{\mathcal{F}} \frac{d^2\tau}{\tau_2^{14-d/2}} \left| \frac{1}{\eta(\tau)} \right|^{48-2d} \gamma_{\mathcal{G}_L \times \mathcal{G}_R}(\tau, \bar{\tau}), \quad (3.41)$$

where we define

$$\gamma_{\mathcal{G}_L \times \mathcal{G}_R}(\tau, \bar{\tau}) = \sum_{i=1}^{\mathcal{N}_R} \sum_{j=1}^{\mathcal{N}_L} X_{ij} \gamma_{(\beta_i, \beta_j)}(\tau, \bar{\tau}). \quad (3.42)$$

This partition function encodes all spectrum of a bulk conformal field theory. The conformal field theory contains infinitely many conformal fields, which can be unified into conformal families. Each family is identified by the corresponding primary field $\phi_{i,\bar{i}}(s, t)$ with conformal weight (h_i, \bar{h}_i) . In this chapter, we shall consider the case of “rational” conformal field theory where we have a finite number of conformal families. In this case, X_{ij} is a finite-dimensional matrix of non-negative integers and modular invariance of (3.42) requires

$$(S^{\mathcal{G}})^{\dagger} X S^{\mathcal{G}} = X, \quad (T^{\mathcal{G}})^{\dagger} X T^{\mathcal{G}} = X. \quad (3.43)$$

However, we consider an E-N lattice, where both left and right sectors of the closed string spectrum are in the same conjugacy class i.e. we choose $X_{ij} = \delta_{ij}$. In this case, each holomorphic character is coupled to a single anti-holomorphic character. The field $\phi_{i\bar{i}}$ associated to each conformal family can be characterised by its holomorphic label and we label each family by $[\phi_i]$. We recall here for future reference that the information about an operator product expansion of any pair of fields is encoded in the fusion algebra

$$[\phi_i] \times [\phi_j] = \sum_k \mathcal{F}_{ij}^k [\phi_k]. \quad (3.44)$$

The fusion-rule coefficients, \mathcal{F}_{ij}^k , are non-negative integers that describe how any pair of conformal fields interact with each other. They can be related to the S-transformation matrix by the Verlinde formula [37]

$$\mathcal{F}_{ij}^k = \sum_{l=1}^{\mathcal{N}} \frac{S_{il}^g S_{jl}^g (S^g)_{lk}^\dagger}{S_{1l}^g}, \quad (3.45)$$

$$= \frac{1}{\mathcal{N}} \sum_{l=1}^{\mathcal{N}} \exp\{-4\pi i \alpha' \mathbf{p}_{\beta_l} \cdot (\mathbf{p}_{\beta_i} + \mathbf{p}_{\beta_j} + \mathbf{p}_{\beta_k})\}. \quad (3.46)$$

As in noncompactified case, the compactified unoriented closed strings are obtained by acting on the closed string theory with the world-sheet parity projection operator $\frac{1}{2}(1 + \Omega_c)$ where $\Omega_c |L, R\rangle = |R, L\rangle$. The Klein bottle amplitude Γ^K can be obtained from the Torus partition function in (3.42) by inserting in it the operator $\Omega_c/2$. As the world-sheet parity operator Ω_c interchanges all states of left and right sectors, not all generic values of g_{ab} and B_{ab} are allowed. The world-sheet parity requires $\mathbf{P}_L = \mathbf{P}_R$ in the compact directions which, from (3.23) and (3.24), gives

$$m_a + (g_{ab} + b_{ab}) \frac{\omega^b}{\alpha'} = m_a - (g_{ab} - b_{ab}) \frac{\omega^b}{\alpha'}. \quad (3.47)$$

The above constraint is satisfied by Equation (3.19) and implies $\omega^a = 0$. We can see that the direct channel amplitude is not affected by B_{ab} and the full Klein bottle amplitude can be written as

$$\Gamma^K = \frac{V_{26-d}}{(4\pi^2 \alpha')^{(26-d)/2}} \int_0^\infty \frac{d\tau_2}{\tau_2^{14-d/2}} \frac{1}{\eta^{24-d}(2i\tau_2)} \mathcal{K}(2i\tau_2), \quad (3.48)$$

where V_{26-d} is the volume of the non-compact space-time. $\mathcal{K}(2i\tau_2)$ encodes the content in the d compactified dimensions and is a sum over lattice characters. The choice of $\mathcal{K}(2i\tau_2)$ is not unique in general, however, we will only consider here the canonical choice:

$$\mathcal{K}(2i\tau_2) = \frac{1}{2} \sum_{i=1}^{\mathcal{N}} \chi_{\beta_i}^g(2i\tau_2). \quad (3.49)$$

The transverse Klein bottle amplitude $\tilde{\Gamma}^K$, obtained by the S-transformation of (3.48), is

$$\tilde{\Gamma}^K = 2^{13-\frac{d}{2}} \frac{V_{26-d}}{(4\pi^2 \alpha')^{(26-d)/2}} \int_0^\infty dl \frac{1}{\eta^{24-d}(il)} \tilde{\mathcal{K}}(il), \quad (3.50)$$

where the S-transformation of \mathcal{K} in (3.49) reads

$$\tilde{\mathcal{K}}(il) = \frac{1}{2} \sqrt{\mathcal{N}} O_g(il), \quad (3.51)$$

where $O_{\mathcal{G}}(il)$ represents a character for the “root” lattice of \mathcal{G} . The choice of \mathcal{K} in (3.49) is crucial to eliminate the dilaton tadpole as its S-transform $\tilde{\mathcal{K}}$ contains only root characters, $O_{\mathcal{G}}(il)$. It is required by the consistency conditions in Section 3.3.4.

3.3.2 Cardy’s condition and annulus amplitude

In the open string sector, we are interested in the annulus amplitude. In the direct channel, the annulus amplitude for an open string toroidally compactified on the lattice of a group \mathcal{G} can be written as

$$\Gamma_{25,25}^A = \frac{V_{26-d}}{(4\pi^2\alpha')^{(26-d)/2}} \int_0^\infty \frac{d\tau_2}{\tau_2^{14-d/2}} \frac{1}{\eta^{24-d}(i\tau_2/2)} \mathcal{A}_{25,25}(i\tau_2/2), \quad (3.52)$$

where $\mathcal{A}_{25,25}(i\tau_2/2)$ is a sum of lattice characters. We label the amplitude by a number “25” due to the fact that it describes the dynamics of open string fields which satisfy Neumann boundary conditions in all coordinates i.e. an open string stretching between two (wrapped)D25-branes. The corresponding transverse amplitude, representing the exchange of closed string modes between two boundaries, can be obtained by the S-transformation of equation (3.52) as

$$\tilde{\Gamma}_{25,25}^A = 2^{-(13-\frac{d}{2})} \frac{V_{26-d}}{(4\pi^2\alpha')^{(26-d)/2}} \int_0^\infty dl \frac{1}{\eta^{24-d}(il)} \tilde{\mathcal{A}}_{25,25}(il), \quad (3.53)$$

where $\tilde{\mathcal{A}}_{25,25}(il)$ is a sum of lattice characters in the transverse channel. We shall show how to determine $\mathcal{A}_{25,25}(i\tau_2/2)$ and $\tilde{\mathcal{A}}_{25,25}(il)$ by using well-known facts in boundary conformal field theory.

Let us consider the E-N compactification where $X_{ij} = \delta_{i,j}$. Observe that the matrices \mathcal{C} and X defined in (3.36) and (3.42) will satisfy “Cardy’s condition”,

$$X_{ij} = \mathcal{C}_{ij} (= \delta_{ij}), \quad (3.54)$$

if and only if, $\mathbf{p}_{\beta_i} + \mathbf{p}_{\beta_j} = \mathbf{p}_0$ for any β_i and β_j . This implies that the centre of the covering group of \mathcal{G} contains elements of order less than or equal to two. We shall consider the E-N compactification on such groups or direct product of them. The simple simply laced Lie group obeying Cardy’s condition are listed in Table (3.2). Note that in the last two columns of Table (3.2), we relate the factor $\sqrt{\mathcal{N}}/2^{d/2}$ to the rank of the antisymmetric tensor b_{ab} which will be used when we consider the

tadpole condition. Note that, in general, Cardy's condition can be $X_{ij} = C_{ij} = \delta_{i\sigma(j)}$ where $\sigma(j)$ denotes a permutation of the label i.e. the partition function (3.42) is permutation invariant.

Group	Rank (d)	Centre	$\sqrt{\mathcal{N}}/2^{d/2}$	Rank of b_{ab}
$SU(2)$	1	\mathbb{Z}_2	2^0	0
$SO(4m) \ m > 1$	$2m$	$\mathbb{Z}_2 \times \mathbb{Z}_2$	2^{1-m}	$2m - 2$
E_7	7	\mathbb{Z}_2	2^{-3}	6
E_8	8	1	2^{-4}	8

Table 3.2: Shows the simply laced Lie group that satisfy Cardy's condition.

	O_{4m}	V_{4m}	S_{4m}	C_{4m}
O_{4m}	O_{4m}	V_{4m}	S_{4m}	C_{4m}
V_{4m}	V_{4m}	O_{4m}	C_{4m}	S_{4m}
S_{4m}	S_{4m}	C_{4m}	O_{4m}	V_{4m}
C_{4m}	C_{4m}	S_{4m}	V_{4m}	O_{4m}

Table 3.3: Shows the fusion rule for $SO(4m)$ lattice characters ($m > 1$).

Using Cardy's method, the direct channel amplitude is related to the fusion-rule coefficients by

$$\mathcal{A}_{25,25}(i\tau_2/2) = \frac{1}{2} \sum_{i,j,k} \mathcal{F}_{ij}^k n_{\beta_i} n_{\beta_j} \chi_{\beta_k}^g(i\tau_2/2). \quad (3.55)$$

In the transverse channel, the Verlinde formula guarantees that

$$\begin{aligned} \tilde{\mathcal{A}}_{25,25}(il) &= \frac{1}{2} \sum_{i=1}^{\mathcal{N}} \chi_{\beta_i}^g(il) \left(\sum_{j=1}^{\mathcal{N}} \frac{S_{ji}^g}{\sqrt{S_{1j}^g}} n_{\beta_j} \right)^2 \\ &= \frac{1}{2} \frac{1}{\sqrt{\mathcal{N}}} \sum_{i=1}^{\mathcal{N}} (a_{\beta_i})^2 \chi_{\beta_i}^g(il), \end{aligned} \quad (3.56)$$

where we define¹

$$a_{\beta_i} = \sum_{j=1}^{\mathcal{N}} \exp(-4\pi i \alpha' \mathbf{p}_{\beta_i} \cdot \mathbf{p}_{\beta_j}) n_j. \quad (3.57)$$

¹This is equivalent to the ansatz used in [12].

Let us consider, for example, a bosonic string compactified on the lattice group of $\mathcal{G} = SO(2d = 4m)$. By using the $SO(4m)$ fusion rules in Table 3.3, the direct channel amplitude (3.55) is expressed in terms of lattice characters of $SO(4m)$ lattice. There are four such lattice characters, O_d , V_d , S_d , and C_d , corresponding to the four sublattice of the $SO(4m)$ weight lattice. We obtain

$$\begin{aligned} \mathcal{A}_{25,25}(i\tau_2/2) = & \frac{1}{2} \{ (n_o^2 + n_v^2 + n_s^2 + n_c^2) O_d(i\tau_2/2) + 2(n_o n_v + n_s n_c) V_d(i\tau_2/2) \\ & + 2(n_o n_s + n_v n_c) S_d(i\tau_2/2) + 2(n_o n_c + n_v n_s) C_d(i\tau_2/2) \} . \end{aligned} \quad (3.58)$$

The amplitude (3.58) has two important features: first, the coefficient of the root character is a sum of squares; second, the coefficients in all other conjugacy class-character terms are sum of products $n_{\beta_i} n_{\beta_j}$ where $i \neq j$. This indicates that n_o , n_v , n_s and n_c label distinct Chan-Paton multiplicities.

3.3.3 Möbius amplitude

Let us consider the unoriented open string sector. In order to determine the explicit form of a Möbius amplitude, we use the group invariant operator defined by Englert and Neveu in [36]

$$\Omega_{\mathcal{G}} = \epsilon \exp\{i\pi[N + \alpha'(\mathbf{p}_o)^2]\} , \quad (3.59)$$

where eigenvalues of \mathbf{p}_o span the root lattice of \mathcal{G} and $\epsilon = \pm 1$. Since, $\alpha'(\mathbf{p}_o)^2$ is an integer, the operator $\Omega_{\mathcal{G}}$ shifts both the argument of the Dedekind function and the lattice character by a half unit. In the direct channel, the Möbius amplitude can be written in the form

$$\Gamma_{25}^M = \frac{V_{26-d}}{(4\pi^2\alpha')^{(26-d)/2}} \int_0^\infty \frac{d\tau_2}{\tau_2^{14-d/2}} \frac{1}{\hat{\eta}^{24-d}(i\tau_2/2 + 1/2)} \mathcal{M}_{25}(i\tau_2/2 + 1/2) , \quad (3.60)$$

where \mathcal{M}_{25} is a summation of ‘‘hatted’’ lattice characters defined in (3.34). We can obtain the transverse channel by performing the P-transformation and changing variable to $l = 1/2\tau_2$ which in the transverse channel describes closed strings propagating between boundary states and crosscaps. The transverse Möbius amplitude can be written as

$$\tilde{\Gamma}_{25}^M = 2 \frac{V_{26-d}}{(4\pi^2\alpha')^{(26-d)/2}} \int_0^\infty dl \frac{1}{\hat{\eta}^{24-d}(il + 1/2)} \tilde{\mathcal{M}}_{25}(il + 1/2) . \quad (3.61)$$

By following Cardy's ansatz, the canonical choice for $\tilde{\mathcal{M}}_{25}(il + \frac{1}{2})$ is

$$\tilde{\mathcal{M}}_{25} = \frac{\epsilon}{2} \sum_{i,j=1}^{\mathcal{N}} \hat{\chi}_{\beta_i}^{\mathcal{G}} \left(\frac{P_{1i}^{\mathcal{G}} S_{ij}^{\mathcal{G}} n_{\beta_j}}{S_{1i}^{\mathcal{G}}} \right). \quad (3.62)$$

For $\mathcal{G} = SO(4m)$ and E_8 , the above ansatz gives

$$\tilde{\mathcal{M}}_{25} = \frac{\epsilon \delta_{\mathcal{G}}}{2} \left(\sum_{i=1}^{\mathcal{N}} n_{\beta_i} \right) \hat{O}_{\mathcal{G}}(il + \frac{1}{2}), \quad (3.63)$$

where $\delta_{\mathcal{G}}$ is the phase factor depending on the group \mathcal{G} ; $\delta_{\mathcal{G}} = +1$ for E_8 and $\delta_{\mathcal{G}} = (-1)^m$ for $SO(8m)$. For $SU(2)$, $SO(8m+4)$, and E_7 , $\tilde{\mathcal{M}}$ is not proportional to the root character $\hat{O}_{\mathcal{G}}$. The direct channel \mathcal{M}_{25} is

$$\mathcal{M}_{25} = \frac{\epsilon}{2} a_o \hat{O}_{\mathcal{G}}(i\tau_2/2 + \frac{1}{2}). \quad (3.64)$$

3.3.4 Consistency condition

In order to have a consistent open string theory, we must meet two requirements. First, $\Gamma_{25,25}^A + \Gamma_{25}^M$ must describe the partition function of unoriented open strings with product of Chan-Paton group $SO(n)$ or $USp(n)$ and second, each term in the $e^{-2\pi l}$ power series expansion of the integrand of the total transverse channel $\tilde{\Gamma}^K + \tilde{\Gamma}_{25,25}^A + \tilde{\Gamma}_{25}^M$ must be a perfect square.

The first condition is always satisfied for compactification on E-N lattices of the groups of Table 3.2. The Chan-Paton groups are determined by the massless vector contributions to $\Gamma_{25,25}^A + \Gamma_{25}^M$, which appear as q -independent terms ($q = e^{-\pi\tau_2}$) in the expansion of the integrand of equations (3.52) and (3.60). Note that the expansions for η , $\hat{\eta}$, $O_{\mathcal{G}}$, and $\hat{O}_{\mathcal{G}}$ can be written as

$$\eta^{-(24-d)}(i\tau_2/2) \sim e^{(24-d)\pi\tau_2/24} \left(1 + \frac{d}{24} e^{-\pi\tau_2} + \dots \right), \quad (3.65)$$

$$\hat{\eta}^{-(24-d)}(i\tau_2/2 + 1/2) \sim e^{(24-d)\pi\tau_2/3} \left(1 - \frac{d}{24} e^{-\pi\tau_2} + \dots \right), \quad (3.66)$$

$$O_{\mathcal{G}}(i\tau_2/2) \sim e^{d\pi\tau_2/24} \left(1 + (\text{number of roots})_{+\mathcal{d}} e^{-\pi\tau_2} + \dots \right), \quad (3.67)$$

$$\hat{O}_{\mathcal{G}}(i\tau_2/2 + 1/2) \sim e^{d\pi\tau_2/24} \left(1 - (\text{number of roots})_{+\mathcal{d}} e^{-\pi\tau_2} + \dots \right). \quad (3.68)$$

These q -independent terms are of two types:

i) \mathcal{G} -scalars terms - terms arising from level zero of η and $\hat{\eta}$ and level one in $O_{\mathcal{G}}$ and $\hat{O}_{\mathcal{G}}$ are group-scalars.

ii) *Vectors terms* - terms arising from the level one in η and $\hat{\eta}$ and level zero in $O_{\mathcal{G}}$ and $\hat{O}_{\mathcal{G}}$ are vectors.

The number of massless vectors is $\sum_{i=1}^{\mathcal{N}} n_{\beta_i} (n_{\beta_i} - \epsilon)/2$. Thus, we get \mathcal{N} direct products of orthogonal Chan-Paton groups for $\epsilon = +1$ and symplectic Chan-Paton group for $\epsilon = -1$ respectively. The total multiplicity $\sum_{i=1}^{\mathcal{N}} n_{\beta_i}$ verifies the second condition.

These consistent theories also have two types of massless particles in the closed string channel: particles created by oscillators in non-compact dimensions and the \mathcal{G} -scalars. Massless exchanges generate divergences in the $e^{-2\pi l}$ independent terms in the expansion of the integrand of $\tilde{\Gamma}^K + \tilde{\Gamma}_{25,25}^A + \tilde{\Gamma}_{25}^M$. These massless state exchanges are encoded in the terms proportional to $O_{\mathcal{G}}$ (and $\hat{O}_{\mathcal{G}}$) in equation (3.53) (and (3.61)). The dilaton and the graviton are exchanged at level one in $O_{\mathcal{G}}$ and level zero in η . These divergences are all eliminated by imposing the dilaton tadpole condition:

$$\frac{2^{13}}{2} \frac{\sqrt{\mathcal{N}}}{2^{d/2}} + \frac{2^{-13}}{2} \frac{2^{d/2}}{\sqrt{\mathcal{N}}} a_o^2 - \delta_{\mathcal{G}} \epsilon a_o = \frac{2^{13}}{2} \frac{2^{d/2}}{\sqrt{\mathcal{N}}} (a_o - \delta_{\mathcal{G}} \epsilon 2^{13} \frac{\sqrt{\mathcal{N}}}{2^{d/2}})^2 = 0. \quad (3.69)$$

Choosing ϵ such that $\delta_{\mathcal{G}} \epsilon = +1$, we obtain the total Chan-Paton multiplicity:

$$\sum_{i=1}^{\mathcal{N}} n_{\beta_i} = 2^{13} \frac{\sqrt{\mathcal{N}}}{2^{d/2}}. \quad (3.70)$$

3.3.5 Boundary state of a wrapped D-brane on an E-N lattice

Using the boundary conformal field theory approach emphasized in the previous sections, it is quite straightforward to construct the boundary states corresponding to D-branes wrapped on the lattice. Let us now construct the boundary state for a D25-brane with “ d ” of its longitudinal directions wrapped on the lattice of a rank d Lie group \mathcal{G} . In other words, we choose the open string coordinates in the lattice directions to satisfy the generalized Neumann condition,

$$(g_{ab} \partial_{\sigma} X^b - b_{ab} \partial_{\tau} X^b) |_{\sigma=0,\pi} = 0. \quad (3.71)$$

In order to avoid confusion, in this section, we redefine the closed string world-sheet variables as s and t where $0 \leq s \leq \pi$ (instead of σ and τ). Let us perform a

conformal transformation [38]

$$\begin{aligned}\sigma &\longrightarrow t = \frac{\pi}{T}\sigma \\ \tau &\longrightarrow s = \frac{\pi}{\bar{T}}\tau,\end{aligned}\tag{3.72}$$

which maps the open string sector to the closed string sector, $(\sigma, \tau) \rightarrow (t, s)$ with $0 \leq s \leq \pi$, $0 \leq t \leq \bar{T}$ and $\bar{T} = \pi^2/T$. The boundary conditions now become

$$\begin{aligned}\partial_t X^\mu |_{t=0, \bar{T}} &= 0, \\ (g_{ab} \partial_t X^b - b_{ab} \partial_s X^b) \delta X^a |_{t=0, \bar{T}} &= 0.\end{aligned}\tag{3.73}$$

We would like to construct the boundary states which describe the D-brane at $t = 0$ and $t = \bar{T}$. Note that we will work in light-cone gauge where $X^\pm = (X^0 \pm X^9)/2$. Thus, in this Section, the index $\mu = 1, \dots, 8, 10, \dots, 25 - d$.

The construction of the boundary state in the non-compact directions, $|B_\mu\rangle$, is quite well-known². It is defined as the coherent state:

$$|B_\mu\rangle \sim \delta^{9-p}(q-y) \exp\left\{\sum_{n>0} -\frac{1}{n} \alpha_{-n}^\mu \delta_{\mu\nu} \tilde{\alpha}_{-n}^\nu\right\} |0\rangle_L \otimes |0\rangle_R.\tag{3.74}$$

For the compact directions, we apply the formalism in [40] to the Englert-Neveu compactification. Assume that the compact part of the boundary state, $|B_a\rangle$, satisfies:

$$(g_{ab} \partial_t X^b - b_{ab} \partial_s X^b) |_{t=0} |B_a\rangle = 0.\tag{3.75}$$

The following constraints for the zero-mode and oscillator parts of the boundary state $|B_a\rangle$ are obtained by substituting the closed string mode expansion (3.21) into condition (3.75) :

$$[P_R^a + (E^{-1})^{ab} E_{bc}^t P_L^c] |B_a\rangle_{zero-mode} = 0,\tag{3.76}$$

and,

$$(\alpha_n^a + (E^{-1})^{ab} E_{bc}^t \tilde{\alpha}_{-n}^c) |B_a\rangle_{osc} = 0.\tag{3.77}$$

Note that $|B_a\rangle = |B_a\rangle_{zero-mode} \otimes |B_a\rangle_{osc}$. The constraint (3.76) implies $m_a = 0$.

²For recent reviews see ref. [38] and [39].

This means that $|B_a\rangle_{zero-mode}$ only contains winding modes. We get

$$\begin{aligned}\mathbf{P}_R &= -E_{ab}^t \frac{\omega^b}{2\alpha'} \mathbf{e}^a, \\ \mathbf{P}_L &= E_{ab} \frac{\omega^b}{2\alpha'} \mathbf{e}^a,\end{aligned}\tag{3.78}$$

where the basis vectors $\mathbf{e}^a = 2(2\alpha')^{-1/2} \mathbf{w}^a$ are expressed in terms of the fundamental weights \mathbf{w}^a . As can be seen by using (3.19), the vectors $\sqrt{2\alpha'} \mathbf{P}_L$ and $\sqrt{2\alpha'} \mathbf{P}_R$ do actually span the weight lattice, Λ_W . Thus the general solution for (3.76) may be written as,

$$|B_a\rangle_{zero-mode} = \sum_{\beta_i=1}^{\mathcal{N}} a_{\beta_i} |W, \beta_i^{\mathcal{G}}\rangle,\tag{3.79}$$

where a_{β_i} is a constant parameter defined in (3.57), and

$$|W, \beta_i^{\mathcal{G}}\rangle = \sum_{\vec{\omega} \in \Lambda_W} |\vec{\omega}, \beta_i^{\mathcal{G}}\rangle,\tag{3.80}$$

is a state obtained by summing over all weights in the conjugacy class labelled by $\beta_i^{\mathcal{G}}$. On the other hand, the solution $|B_a\rangle_{osc}$ for the constraint (3.77) is,

$$|B_a\rangle_{osc} \sim \exp \left\{ \sum_{n>0} -\frac{1}{n} \alpha_{-n}^a (G^{-1})_{ab} \tilde{\alpha}_{-n}^b \right\} |0\rangle_L \otimes |0\rangle_R.\tag{3.81}$$

Adding together (3.79), (3.81), and the non-compact contribution, we get the full boundary state for a wrapped D25-brane as

$$|D_{25}\rangle = \sum_{\beta_i=1}^{\mathcal{N}} a_{\beta_i} |B_{25}, \beta_i^{\mathcal{G}}\rangle,\tag{3.82}$$

where

$$\begin{aligned}|B_{p+d}, \beta_i^{\mathcal{G}}\rangle &= \mathcal{N}_{25} \exp \left\{ \sum_{n>0} -\frac{1}{n} \alpha_{-n}^\mu \delta_{\mu\nu} \tilde{\alpha}_{-n}^\nu \right. \\ &\quad \left. + \sum_{n>0} -\frac{1}{n} \alpha_{-n}^a (G^{-1})_{ab} \tilde{\alpha}_{-n}^b \right\} |B, \beta_i^{\mathcal{G}}\rangle^{(0)}.\end{aligned}\tag{3.83}$$

We define the vacuum,

$$|B, \beta_i^{\mathcal{G}}\rangle^{(0)} = |0\rangle_L \otimes |0\rangle_R \otimes |W, \beta_i^{\mathcal{G}}\rangle.\tag{3.84}$$

The normalisation factor \mathcal{N}_{25} is related to the tension of the wrapped D-brane. In order to determine its value, we now calculate the interaction between two parallel

D25-branes both in the open and in the closed string channel and compare the two results. Let us start by calculating the interaction in the closed string tree channel, the cylinder amplitude, which is given by [38],

$$\begin{aligned}\tilde{\Gamma}_{25}^A &= \alpha' \pi \int \frac{dl}{2} \langle D_{25} | e^{-\frac{\pi l}{2} H_{closed}} | D_{25} \rangle \\ &= \alpha' \pi \int \frac{dl}{2} \sum_{i=1}^{\mathcal{N}} (a_{\beta_i})^2 \langle B_{25}, \beta_i^{\mathcal{G}} | e^{-\frac{\pi l}{2} H_{closed}} | B_{25}, \beta_i^{\mathcal{G}} \rangle .\end{aligned}\quad (3.85)$$

The Hamiltonian for the closed string on an E-N lattice is

$$\begin{aligned}H_{closed} &= [\alpha' \hat{p}^2 + 2 \sum_n \eta_{\mu\nu} (\alpha_{-n}^\mu \alpha_n^\nu + \tilde{\alpha}_{-n}^\mu \tilde{\alpha}_n^\nu) + 4(\frac{24-d}{24})] \\ &+ [2\alpha'(P_L^2 + P_R^2) + 2(N_c + \tilde{N}_c) + 4(\frac{d}{24})] .\end{aligned}\quad (3.86)$$

The first term in (3.86) is the contribution from the non-compact dimensions while the last term comes from the compactified dimensions. The operator \hat{p} is the momentum operator in the non-compact Neumann directions. We define the left and right moving number operators as

$$N_{(c)} = \sum_n \alpha_{-n}^a g_{ab} \alpha_n^b , \quad \tilde{N}_{(c)} = \sum_n \tilde{\alpha}_{-n}^a g_{ab} \tilde{\alpha}_n^b .\quad (3.87)$$

For the non-compact dimensions, the contribution to the amplitude (3.85) is

$$\tilde{\Gamma}_{non-compact}^A \sim V_{26-d} \eta(il)^{-(24-d)} .\quad (3.88)$$

In the compact part of the amplitude (3.85), the contribution from each conjugacy class can be written in terms of the lattice character:

$$\begin{aligned}\chi_{\beta_i}^{\mathcal{G}}(il) &= \langle B_{25}, \beta_i^{\mathcal{G}} | \exp\{-\frac{\pi l}{2} [2\alpha'(P_L^2 + P_R^2) + 2(N_c + \tilde{N}_c) + 4(\frac{d}{24})]\} | B_{25}, \beta_i^{\mathcal{G}} \rangle \\ &= \sum_{\omega \in Z_d} \exp(-\frac{\pi l}{2\alpha'} (G^{-1})_{ab} \omega^a \omega^b) \eta(il)^{-d} , \\ &= \sum_{\tilde{L}/\sqrt{2\alpha'} \in \Lambda_{\beta_i}} \exp(-\frac{\pi l}{2\alpha'} \tilde{L} \cdot \tilde{L}) \eta(il)^{-d} ,\end{aligned}\quad (3.89)$$

where the winding mode $\tilde{L} = \omega^a \tilde{e}_a$. The matrix $G_{ab}^{-1} = \tilde{e}_a \tilde{e}_b$ where $\tilde{e}_a = E_{ab} \mathbf{e}^b$. Since, $\tilde{e}_a/\sqrt{2\alpha'}$ is a basis of Λ_W , the vector $\tilde{L}/\sqrt{2\alpha'}$ belongs to the weight lattice.

So, the sum in (3.89) is exactly the lattice character \mathcal{G} defined in (3.27). Then, the total contribution from compact directions is

$$\tilde{\Gamma}_{compact}^A \sim \sum_{i=1}^{\mathcal{N}} (a_{\beta_i})^2 \chi_{\beta_i}^{\mathcal{G}}(il) . \quad (3.90)$$

Combining (3.88) and (3.90) together with the overall factors, the full amplitude in (3.85) can be written as,

$$\tilde{\Gamma}_{25}^A = \alpha' \pi \mathcal{N}_{25}^2 V_{26-d} \int dl \frac{1}{\eta(il)^{(24-d)}} \sqrt{\mathcal{N}} \tilde{\mathcal{A}}_{25,25} . \quad (3.91)$$

Comparing equation (3.91) with the transverse annulus amplitude in (3.53), we can obtain the value of the normalisation constant

$$\mathcal{N}_{25}^2 = \frac{1}{8} \left[\frac{\pi}{\sqrt{\mathcal{N}} 2^{8-d/2}} (4\pi^2 \alpha')^{-14+\frac{d}{2}} \right] . \quad (3.92)$$

3.4 Truncation of the bosonic string theory

In this Section, we briefly review the emergence of Type II superstrings from the 26-dimensional bosonic string via the truncation mechanism as advocated in [9] and [5].

3.4.1 Truncation in closed string sector

The starting point is a toroidal compactification of the 26-dimensional bosonic theory on the lattice of the Lie group $E_8 \times E_8$ both in left and right sectors. Note that the E_8 lattice is a sublattice of the $SO(16)$ lattice which is needed to obtain Type 0 non-supersymmetric strings.

A crucial ingredient for the consistency of the truncation is that the group $E_8 \times E_8$ contains a subgroup $SO(8)_{int}$ in a regular embedding. The subgroup is vital in constructing the Lorentz algebra of the truncated theory. Indeed, the original $SO(25, 1)$ Lorentz group breaks into $SO(9, 1) \times E_8 \times E_8$ in both sectors, but the transverse subgroup $SO(8)_{trans} \subset SO(9, 1)$ does not possess spinorial representations to describe fermionic states. In order to circumvent this problem, the authors in [9] proposed a

stringy generalization of the 't Hooft-Hazenfratz mechanism [8] in non-abelian gauge theory, whereby the transverse Lorentz algebra of the truncated theory is,

$$so(8)_{diag} = diag[so(8)_{trans} \times so(8)_{int}] , \quad (3.93)$$

where $so(8)_{int}$ exhibits spinorial representations. The corresponding Lorentz generators are given by,

$$J^{\mu\nu} = L^{\mu\nu} + K_0^{\mu\nu} \quad ; \quad \mu, \nu = 1 \cdots 8, \quad (3.94)$$

where the $L^{\mu\nu}$ generate the transverse group $SO(8)_{trans}$ and the $K_0^{\mu\nu}$ are the zero-modes of the Kac-Moody algebra generated in the compact dimensions from the bosonic vertex generators. It was proven in [5, 9] that the generators $\{J^{\mu\nu}, J^{\mu\pm}, J^{+-}\}$ close on an $so(9, 1)$ algebra which becomes the Lorentz algebra of the fermionic theory emerging from the bosonic string theory via a truncation procedure we now describe.

Let us first try to remove “by hand” all states (oscillators and zero-modes) pertaining to E_8 and $SO(8)'$ when considering the branching $E_8 \times E_8 \supset E_8 \times SO(8)' \times SO(8)_{int}$, so that the truncation only keeps states whose internal degrees of freedom are oscillators and zero-modes of $SO(8)_{int}$. Then, the mass-shell formula for the truncated theory reads,

$$\frac{\alpha' M_{L,R}^2}{4} = \alpha' P_{L,R}^2[SO(8)_{int}] + N_{L,R}^{(12)} - c , \quad (3.95)$$

where $N_{L,R}^{(12)}$ is the oscillator number in (8+4) dimensions and c is the intercept. The closure of the Lorentz algebra requires $c = 1/2$, and comparison with the mass spectrum of the compactified bosonic theory before truncation, namely,

$$\frac{\alpha' M_{L,R}^2}{4} = \alpha' P_{L,R}^2[E_8 \times E_8] + N_{L,R}^{(24)} - 1 , \quad (3.96)$$

leads to the conclusion that the truncation procedure described above must be revisited. Indeed, compatibility of (3.95) and (3.96) requires

$$\alpha' P_{L,R}^2[E_8 \times SO(16)] = \alpha' P_{L,R}^2[SO(8)_{int}] + \frac{1}{2} , \quad (3.97)$$

where the term $1/2$ can be shown to correspond to the contribution of a fixed weight vector of norm 1 in the $SO(8)'$ lattice. There are two choices for such “ghost”

vectors in $SO(8)'$; either $(\sqrt{2\alpha'}\mathbf{p}'_v, \sqrt{2\alpha'}\mathbf{p}'_s)$ or $(\sqrt{2\alpha'}\mathbf{p}'_v, \sqrt{2\alpha'}\mathbf{p}'_c)$ where p'_v, p'_s and p'_c are vectors characterizing the three conjugacy classes of $SO(8)'$ other than the root lattice. The term $1/2$ in (3.97) is exactly the energy required to remove the zero-point energy $(-\frac{12}{24})$ in the compact directions.

It is now straightforward to study the effect of truncation on the spectrum of a compactified bosonic theory by observing how it affects the representations of $SO(16)$. Let us decompose the conjugacy classes of the $SO(16)$ in terms of $SO(8)'$ \times $SO(8)_{int}$ conjugacy classes:

$$\begin{aligned} (o)_{16} &= [(o)'_8 \oplus (o)_8] + [(v)'_8 \oplus (v)_8] \\ (v)_{16} &= [(o)'_8 \oplus (v)_8] + [(v)'_8 \oplus (o)_8] \\ (s)_{16} &= [(s)'_8 \oplus (s)_8] + [(c)'_8 \oplus (c)_8] \\ (c)_{16} &= [(s)'_8 \oplus (c)_8] + [(c)'_8 \oplus (s)_8], \end{aligned} \quad (3.98)$$

where $(o), (v), (s), (c)$ represent the root, vector, spinor and conjugate spinor conjugacy class of $SO(16)$ and $SO(8)$. If the truncation process keeps the directions $(\sqrt{2\alpha'}\mathbf{p}'_v, \sqrt{2\alpha'}\mathbf{p}'_s)$ in $SO(8)'$ (we shall refer to it as choice **A**), the conjugacy classes are truncated as follows:

$$\mathbf{A} : \quad (o)_{16} \rightarrow (v)_8, \quad (v)_{16} \rightarrow (o)_8, \quad (s)_{16} \rightarrow (s)_8, \quad (c)_{16} \rightarrow (c)_8. \quad (3.99)$$

On the other hand, if the truncation keeps the directions $(\sqrt{2\alpha'}\mathbf{p}'_v, \sqrt{2\alpha'}\mathbf{p}'_c)$ (we shall refer to it as choice **B**), we get:

$$\mathbf{B} : \quad (o)_{16} \rightarrow (v)_8, \quad (v)_{16} \rightarrow (o)_8, \quad (s)_{16} \rightarrow (c)_8, \quad (c)_{16} \rightarrow (s)_8. \quad (3.100)$$

In order for the truncated theory to be modular invariant, the truncation procedure described above must be accompanied by sign flips of some of the truncated lattice characters. Using the definition (3.42), to implement (3.99) and (3.100), the prescription for truncation-flip is as follows:

$$\mathbf{A} : \quad \begin{cases} O_{16} \rightarrow V_8, & S_{16} \rightarrow -S_8 \\ V_{16} \rightarrow O_8, & C_{16} \rightarrow -C_8 \end{cases} \quad (3.101)$$

or

$$\mathbf{B} : \quad \begin{cases} O_{16} \rightarrow V_8, & S_{16} \rightarrow -C_8 \\ V_{16} \rightarrow O_8, & C_{16} \rightarrow -S_8 \end{cases} \quad (3.102)$$

By applying these choices **A** and **B** for truncation of closed bosonic string compactified on the lattice group mentioned above, we can obtain all ten-dimensional closed fermionic string models. For example, we can obtain Type IIB superstring by compactifying the closed bosonic string on $E_8 \times E_8$ lattice and applying truncation **A** in both left and right sectors. The partition function for closed string on such lattice can be derived from (3.42). Since $E_8 \times E_8$ has only one conjugacy class i.e. $\mathcal{N} = 1$, we get

$$\begin{aligned} \gamma_{E_8 \times E_8}(\tau, \bar{\tau}) &= O_{E_8 \times E_8}(\tau) \times \bar{O}_{E_8 \times E_8}(\bar{\tau}), \\ &= O_{E_8}(O_{16} + S_{16})(\tau) \times \bar{O}_{E_8}(\bar{O}_{16} + \bar{S}_{16})(\bar{\tau}). \end{aligned} \quad (3.103)$$

Truncation **A** in (3.101), implies that

$$\left\{ O_{E_8} O_{E_8} = O_{E_8}(O_{16} + S_{16}) \right\} \rightarrow \left\{ V_8 - S_8 \right\}, \quad (3.104)$$

after applying in both left and right-sectors, we obtain

$$\gamma_{E_8 \times E_8}^{trunc}(\tau, \bar{\tau}) = (V_8 - S_8)(\bar{V}_8 - \bar{S}_8), \quad (3.105)$$

which is exactly the partition function of Type IIB.

It turns out that any modular invariant compactification of the 26-dimensional bosonic string on $\mathcal{G}_L \times \mathcal{G}_R$, where \mathcal{G}_L and \mathcal{G}_R are simply laced group of rank 16, remains modular invariant after truncation in one or both sectors. Some of the results from truncation of the bosonic string are present in Table 3.4. Note that in the case of Heterotic string, the compactification is not E-N type.

3.4.2 Fermionic representations and their operators

In order to explain the truncation in more detail, we will discuss the bosonisation of world-sheet coordinates and characterise further the three fermionic representations of our new Lorentz algebra. Let us start by consider the sublattice $SO(8)_{int}$ of the $E_8 \times E_8$ lattice. We define the set of operators

$$q_r^{\beta_i} = \int \frac{dz}{2\pi iz} z^r z^{\beta_i^2/2} : \exp(i\beta_i \cdot X(z)) : , \quad (3.106)$$

where we take $z = e^t e^{-is}$ and β_i represents a weight vector of $SO(8)_{int}$. The contour of the integral is a unit circle. The operator $q_r^{\beta_i}$ can be obtained by fermionization of

10-D Models	\mathcal{G}_L	choice	\mathcal{G}_R	choice
<i>IIA</i>	$E_8 \times E_8$	B	$E_8 \times E_8$	A
<i>IIB</i>	$E_8 \times E_8$	A	$E_8 \times E_8$	A
0A	$E_8 \times SO(16)$	B	$E_8 \times SO(16)$	A
0B	$E_8 \times SO(16)$	A	$E_8 \times SO(16)$	A
Heterotic	$E_8 \times E_8$	None	$E_8 \times SO(16)$	A
	$E_8 \times SO(16)$			

Table 3.4: All ten dimensional closed string models can be truncated from 26-D bosonic string.

the lattice bosonic coordinates as explained in [5, 9]. The integrand in (3.106) is not single-valued as the function $z^{\beta_i^2/2}$ has a cut in the z -plane for $\beta_i^2/2 \in \mathbb{Z} + 1/2$. To solve this problem, we have to either fix r to half-integer value, or allow only half-integer values of $\beta_i \cdot (\sqrt{2\alpha'} \mathbf{p})$. The second choice constrains the $SO(8)_{int}$ conjugacy classes on which the q -operator can act and leads to the following three sectors of the fermionic string:

- (i) Ramond sector for $r \in \mathbb{Z} + \frac{1}{2}$ and $q_r^{\beta_v}$ acting on 8_s (or 8_c).
- (ii) Neveu-Schwarz sector for $r \in \mathbb{Z}$ and $q_r^{\beta_v}$ acting on 8_v .
- (iii) Green-Schwarz superstring for $r \in \mathbb{Z}$ and $q_r^{\beta_s}$ (or $q_r^{\beta_c}$) acting on both 8_v and 8_c (or 8_v and 8_s).

In the next step, we introduce the massless vacuum states on which the q -operators can act in a sensible way. Let us consider the possible candidates for such states. As the original compactified bosonic strings have a symmetry $SO(8)_{trans} \times (E_8 \times E_8)$, the massless states must belong to the following irreducible representations:

$$(8_v \otimes 1) + (1 \otimes adj(E_8 \times E_8)) . \quad (3.107)$$

The states in $8_v \otimes 1$ are obtained by applying the oscillators in the lattice directions to the tachyonic ground state. They are not a good choice as it seems unnatural to keep such states while projecting out the tachyon. We are thus led to consider the states belonging to the adjoint of $E_8 \times E_8$. It turns out that the adjoint representation of

$SO(8)_{int} \times SO(8)' \times E_8 \subset E_8 \times E_8$ contains 8_v , 8_s , and 8_c which can represent the correct vacua for the fermionic string theories. However, the $SO(8)_{int}$ states in those representations are eight-fold degenerate, which makes the theories inconsistent. This can be solved by fixing some weight vectors in $SO(8)'$, the ghost vectors, as explained in the previous section. The truncation will project out all states in $SO(8)'$ which do not correspond to the ghost vectors. We now arrive at the following vacuum states:

$$\begin{aligned} |8_v\rangle_0 &\equiv |\beta_v, \eta_v\rangle \\ |8_s\rangle_0 &\equiv |\beta_s, \eta_s\rangle \\ |8_c\rangle_0 &\equiv |\beta_c, \eta_c\rangle . \end{aligned} \quad (3.108)$$

The vectors β_i ($i = v, s$ and c) are the weight vectors of $SO(8)_{int}$ while the vectors η_i represent the ghost vectors. Note that the vectors (β_i, η_j) belong to the E_8 root lattice.

The action of the q -operators on a state with arbitrary lattice momentum β with no Cartan subalgebra excitation are [5]:

$$q_r^\delta |\beta, \eta\rangle = \frac{1}{\zeta!} \frac{d^\zeta}{dz^\zeta} e^{i\delta \cdot Q_<(z)} \Big|_{z=0} |\beta + \delta, \eta\rangle , \quad (3.109)$$

where $\zeta = -(r + \frac{1}{2} + \beta \cdot \delta)$ and the operator $Q_<(z)$ is defined as

$$Q_<^i(z) = -i \sqrt{\frac{\alpha'}{2}} \sum_{n>0} \frac{1}{n} \alpha_n^i z^n . \quad (3.110)$$

The derivative produces a sum over the creation operators at level θ . The mass of the states in (3.109) are calculated by using (3.96), giving:

$$\begin{aligned} \frac{\alpha' M^2}{4} &= \frac{1}{2} (\beta + \delta)^2 + \frac{1}{2} \eta^2 + \zeta - 1 \\ &= \frac{1}{2} \beta^2 + \frac{1}{2} \eta^2 - 1 - r . \end{aligned} \quad (3.111)$$

Thus, an operator q_r^δ decreases the mass of a state by r . We can apply this q -operator with $r > 0$ on the vacuum states to generate all fermionic string spectra.

For NS-operators, the mass of the excited states can take half-integer value. This can cause problems, since the bosonic spectrum contains only integer-value as it is compactified on the even lattice. This is because the NS-operator maps even-weights

to odd-weights which do not belong to the root lattice of E_8 . The problem is solved by keeping only those states with even-number of NS-operators i.e. the states that belong to the root lattice of E_8 . This is equivalent to applying the GSO-projection on the NS-sector.

In the R-sector, an odd number of q-operators changes the chirality of $SO(8)_{int}$ spinors and produces states which do not belong to the E_8 root lattice. To avoid this problem we introduce the $SO(8)'$ Dirac gamma matrices ρ^v which can map the ghost vector η_s to η_c and vice versa. The same problem arises for the GS-operators, and it can be solved in a similar way i.e. by introducing gamma matrices ρ^c . The matrices ρ^v and ρ^c have the following properties:

$$\begin{aligned}\rho^v|\eta_s\rangle &= |\eta_c\rangle, & \rho^v|\eta_c\rangle &= |\eta_s\rangle, \\ \rho^c|\eta_v\rangle &= |\eta_s\rangle, & \rho^c|\eta_s\rangle &= |\eta_v\rangle.\end{aligned}\tag{3.112}$$

The Ramond spectrum is obtained by applying the R-operators on the ground states $|\delta_s\rangle_0$ and $|\delta_c\rangle_0$. The GSO projection only keeps the states which contain the ghost vector η_s (or η_c). Let us redefine the NS, R and GS-operators as N, R and G which are defined by the following:

$$\begin{aligned}N_r^{\beta_v} &= q_r^{\beta_v} \gamma_{\beta_v}, \\ R_d^{\beta_v} &= q_d^{\beta_v} \gamma_{\beta_v} \rho^v, \\ G_n^{\beta_s} &= q_n^{\beta_s} \gamma_{\beta_s} \rho^c, \\ G_n^{\beta_c} &= q_n^{\beta_c} \gamma_{\beta_c} \rho^c,\end{aligned}\tag{3.113}$$

where $r \in \mathbb{Z} + \frac{1}{2}$ and $d, n \in \mathbb{Z}$. The matrices γ_{β_i} satisfy the Clifford algebra in four dimensions. We will explain their important rôle shortly. In order to make contact with fermionic oscillators, we rewrite the fermionic operators N, R and G in the real basis:

$$\begin{aligned}N_r^{\pm v_j} &= \frac{1}{\sqrt{2}}(\psi_r^{\mu=2j-1} \mp i\psi_r^{\mu=2j}), \\ R_d^{\pm v_j} &= \frac{1}{\sqrt{2}}(\psi_d^{\mu=2j-1} \mp i\psi_d^{\mu=2j}), \\ G_n^{\pm s_j} &= \frac{1}{\sqrt{2}}(S_n^{A=2j-1} \mp iS_n^{A=2j}), \\ G_n^{\pm c_j} &= \frac{1}{\sqrt{2}}(S_n^{\dot{A}=2j-1} \mp iS_n^{\dot{A}=2j}),\end{aligned}\tag{3.114}$$

where v_j , s_j and c_j are the weight vectors belonging to the conjugacy classes 8_v , 8_s , and 8_c . The indices μ, A, \dot{A} run from 1 to 8. Consequently, the vacua are now reparametrized as:

$$|8_v\rangle_0 \rightarrow |8_v, \mu\rangle_0, \quad |8_s\rangle_0 \rightarrow |8_s, A\rangle_0 \quad \text{and} \quad |8_c\rangle_0 \rightarrow |8_c, \dot{A}\rangle_0. \quad (3.115)$$

The gamma matrices, γ_{β_i} , in (3.113) ensure the fermion operators satisfy the anti-commutation relations:

$$\begin{aligned} \{\psi_r^\mu, \psi_s^\nu\} &= \delta^{\mu\nu} \delta_{r+s,0}, \quad \{\psi_d^\mu, \psi_f^\nu\} = \delta^{\mu\nu} \delta_{d+f,0}, \\ \{S_n^A, S_m^B\} &= \delta^{AB} \delta_{n+m,0}, \quad \{S_n^{\dot{A}}, S_m^{\dot{B}}\} = \delta^{\dot{A}\dot{B}} \delta_{n+m,0}, \end{aligned} \quad (3.116)$$

where $r, s \in \mathbb{Z} + \frac{1}{2}$ and $d, f, m, n \in \mathbb{Z}$. Note that the operators N and R do not change the space-time statistics while G does. We can identify the operators ψ_r^μ as world-sheet fermions and the operators S_n^A as space-time fermions.

We now want to discuss how the spectrum of Type IIA and IIB string theories emerge after truncation. To show this, we work in the GS-formalism where no GSO-projection is needed. By applying the truncation (3.100) in both left and right sectors, we obtain the vacuum state

$$(|8_v, \mu\rangle_0 + |8_c, \dot{A}\rangle_0)_L \otimes (|8_v, \mu\rangle_0 + |8_c, \dot{A}\rangle_0)_R, \quad (3.117)$$

and generate the complete spectrum by acting with the operators $G_n^{\pm s_i}$ ($n < 0$ and $i = 1, \dots, 4$) on the vacuum state in all possible permutations. In the left sector, for instance, we can show that the action of G-operators on the vacuum yields states corresponding to weight vectors in one of the following form:

$$P_v = \sum_i n_i o_i + (1, 0, 0, 0), \quad \text{or} \quad P_c = \sum_i n_i o_i + \left(\frac{1}{2}, \frac{1}{2}, \frac{1}{2}, -\frac{1}{2}\right), \quad (3.118)$$

where o_i are the root vectors and $n_i \in \mathbb{Z}$. All vectors in the $SO(8)$ sublattices Λ_v and Λ_c are of the form P_v and P_c respectively. We can identify the states described by P_v with the bosonic states belonging to the $(NS+)$ sector, and identify the states described by P_c with the fermionic states belonging to the $(R+)$ sector. The full spectrum is the direct sum $(NS+) \oplus (R+)$. Thus, the spectrum of Type IIB superstring can be represented in terms of:

$$\text{Type IIB :} \quad (NS+, NS+) \oplus (NS+, R+) \oplus (R+, NS+) \oplus (R+, R+). \quad (3.119)$$

To arrive at Type IIA, we apply the truncation (3.99) in the right sector while, on the left, we again apply the truncation (3.100). This will flip the right sector of the vacuum state into:

$$(|8_v, \mu\rangle_0 + |8_s, A\rangle_0)_R . \quad (3.120)$$

The full spectrum can be obtained by acting with the operator $G_n^{\pm s_i}$ on the left and the operator $\tilde{G}_n^{\pm c_i}$ on the right sector. By the same analysis as above, the Type IIA spectrum can be represented as:

$$\text{Type IIA : } (NS+, NS+) \oplus (NS+, R-) \oplus (R+, NS+) \oplus (R+, R-) , \quad (3.121)$$

where the states in $(R-)$ are identified with the states belonging to the lattice $\Lambda_s^{SO(8)}$.

In order to make contact with the fermionic string in NSR-formalism, we take the Ramond ground state to be the 16-dimensional representation of the Clifford algebra of the zero-modes of the R-operators, ψ_0^μ i.e. $(|8_s, A\rangle, |8_c, \dot{A}\rangle)$. They can be obtained by applying the operator ψ_0^μ on the highest weight state of 8_s . The even number of R-operators gives the states belonging to the spinor representation while the odd number gives the states in the conjugate spinor representation. One can see that the truncation (3.100) is equivalent to taking the GSO projection acting on the Ramond ground state as:

$$(-1)^{F^d} (|8_s, A\rangle, |8_c, \dot{A}\rangle) = (-|8_s, A\rangle, |8_s, \dot{A}\rangle) , \quad (3.122)$$

where F^d is the world-sheet R-fermion number operator. On the other hand, the truncation (3.99) gives the opposite projection. In the NS sector, the lowest mass state after truncation is the massless vacuum state $|8_v, \mu\rangle_0$, which is GSO invariant and belongs to the E_8 root lattice. In order to implement the boundary state formalism we need to define the NS tachyonic state $|NS\rangle_0$ via the following relation:

$$|8_v, \mu\rangle_0 = \psi_{-\frac{1}{2}}^\mu |NS\rangle_0 . \quad (3.123)$$

Thus, the full spectrum of the NS sector can also be built by acting with the NS-oscillators on this tachyon state. We can define the GSO-projection in this sector as:

$$\hat{P}_{GSO} = (-1)^{2F^r-1} , \quad (3.124)$$

where F^r is the NS fermion number operator.

3.4.3 Truncation in open string sector

We now follow the discussion in [12] to study the truncation in open string sector of the unoriented string theory which was described in Section 3.3. We are interested in the truncation of open strings wrapped on the $E_8 \times E_8$ lattice and show that the theory can be truncated to the ten-dimensional supersymmetric Type I string theory. Note that the discussion about Type 0 model described in [12] is not discussed here.

In the case of strings compactified on $E_8 \times E_8$ there is only one conjugacy class ($\mathcal{N} = 1$). The direct channel amplitudes can be read from equation (3.48), (3.52) and (3.60). We get

$$\Gamma^K = \frac{V_{10}}{(4\pi^2\alpha')^5} \int_0^\infty \frac{d\tau_2}{\tau_2^6} \frac{1}{\eta^8(i\tau_2)} O_{E_8}(i\tau_2) O_{E_8}(i\tau_2), \quad (3.125)$$

$$\Gamma_{25,25}^A = n^2 \frac{V_{10}}{(4\pi^2\alpha')^5} \int_0^\infty \frac{d\tau_2}{\tau_2^6} \frac{1}{\eta^8(i\tau_2/2)} O_{E_8}(i\tau_2/2) O_{E_8}(i\tau_2/2), \quad (3.126)$$

$$\Gamma_{25}^M = \epsilon n \frac{V_{10}}{(4\pi^2\alpha')^5} \int_0^\infty \frac{d\tau_2}{\tau_2^6} \frac{1}{\hat{\eta}^8(i\frac{\tau_2}{2} + 1/2)} \hat{O}_{E_8}(i\frac{\tau_2}{2} + \frac{1}{2}) \hat{O}_{E_8}(i\frac{\tau_2}{2} + \frac{1}{2}). \quad (3.127)$$

The transverse channel amplitudes are given by equation (3.50), (3.53) and (3.61), with $\delta_{\mathcal{G}} = \delta_{E_8 \times E_8} = 1$, we obtain

$$\tilde{\Gamma}^K = \frac{2^5}{2} \frac{V_{10}}{(4\pi^2\alpha')^5} \int_0^\infty dl \frac{1}{\eta^8(il)} O_{E_8}(il) O_{E_8}(il), \quad (3.128)$$

$$\tilde{\Gamma}_{25,25}^A = \frac{n^2 2^{-5}}{2} \frac{V_{10}}{(4\pi^2\alpha')^5} \int_0^\infty dl \frac{1}{\eta^8(il)} O_{E_8}(il) O_{E_8}(il), \quad (3.129)$$

$$\tilde{\Gamma}_{25}^M = \epsilon n \frac{V_{10}}{(4\pi^2\alpha')^5} \int_0^\infty dl \frac{1}{\hat{\eta}^8(il + 1/2)} \hat{O}_{E_8}(il + \frac{1}{2}) \hat{O}_{E_8}(il + \frac{1}{2}). \quad (3.130)$$

We can determine the Chan-Paton group by counting the massless states in $\Gamma_{25,25}^A + \Gamma_{25}^M$. Recalling the mass formula for open string states $\alpha' M = \alpha' p^2 + N - 1$, and the expansions,

$$\eta^{-8}(i\tau_2/2) \sim e^{\pi\tau_2/3} (1 + 8e^{-\pi\tau_2} + \dots), \quad (3.131)$$

$$\hat{\eta}^{-8}(i\tau_2/2 + 1/2) \sim e^{\pi\tau_2/3} (1 - 8e^{-\pi\tau_2} + \dots), \quad (3.132)$$

$$\left[O_{E_8}(i\tau_2/2) \right]^2 \sim e^{2\pi\tau_2/3} (1 + 2(248)e^{-\pi\tau_2} + \dots), \quad (3.133)$$

$$\left[\hat{O}_{E_8}(i\tau_2/2 + 1/2) \right]^2 \sim e^{2\pi\tau_2/3} (1 - 2(248)e^{-\pi\tau_2} + \dots), \quad (3.134)$$

the number of massless vectors is obtained via the formula

$$\frac{1}{2}(n^2 - \epsilon n) = \frac{1}{2}n(n - \epsilon). \quad (3.135)$$

By imposing the dilaton tadpole to vanish in (3.69), the constraint in equation (3.70) implies that

$$n = 2^{13-(16/2)} = 2^5, \quad \epsilon = +1. \quad (3.136)$$

Then, it turns out from equations (3.135) and (3.136) that the Chan-Paton group of the theory is reduced from $SO(2^{13})$ to $SO(32)$ by compactifying on an E-N lattice in the presence of a B-field b_{ab} .

Let us apply the truncation of choice **A** in (3.101) in the open string sector. Recall that the truncation of the $E_8 \times E_8$ lattice character is

$$\left\{ O_{E_8} O_{E_8} = O_{E_8} (O_{16} + S_{16}) \right\} \rightarrow \left\{ V_8 - S_8 \right\}. \quad (3.137)$$

After truncation, the transverse amplitude (3.128), (3.129) and (3.130) become

$$\tilde{\Gamma}^{K;trunc} = \tilde{\Gamma}_{25,25}^{A;trunc} = \frac{2^5}{2} \frac{V_{10}}{(4\pi^2\alpha')^5} \int_0^\infty dl \frac{1}{\eta^8(il)} (V_8 - S_8)(il), \quad (3.138)$$

$$\tilde{\Gamma}_{25}^{M;trunc} = -2^5 \frac{V_{10}}{(4\pi^2\alpha')^5} \int_0^\infty dl \frac{1}{\hat{\eta}^8(il + 1/2)} (\hat{V}_8 - \hat{S}_8)(il + \frac{1}{2}). \quad (3.139)$$

We can truncate in the direct channel amplitude (3.126) and (3.126) which gives

$$\Gamma_{25,25}^{A;trunc} = \frac{2^{10}}{2} \frac{V_{10}}{(4\pi^2\alpha')^5} \int_0^\infty \frac{d\tau_2}{\tau_2^6} \frac{1}{\eta^8(i\tau_2/2)} (V_8 - S_8)(i\tau_2/2), \quad (3.140)$$

$$\Gamma_{25}^{M;trunc} = -\frac{2^5}{2} \frac{V_{10}}{(4\pi^2\alpha')^5} \int_0^\infty \frac{d\tau_2}{\tau_2^6} \frac{1}{\hat{\eta}^8(i\tau_2/2 + 1/2)} (\hat{V}_8 - \hat{S}_8)(i\frac{\tau_2}{2} + \frac{1}{2}). \quad (3.141)$$

The amplitude (3.138) (3.139) (3.140) and (3.141) are in the same form as the corresponding amplitudes in Type I theory. Some massless modes in both open and closed string channels, created by oscillators in non-compact directions, become massive after truncation, and a subset of massless \mathcal{G} -scalar from compact directions plays the rôle of massless modes. In the closed string channel, these \mathcal{G} -scalars become massless spinors i.e. R-R and NS-NS fields. The NS-NS and R-R tadpoles are eliminated by the condition (3.136). We can also check that the amplitudes (3.140) and (3.141) give the $SO(32)$ Chan-Paton gauge group.

The fact that the Chan-Paton group is preserved under truncation has an interesting consequence. From a geometrical point of view, unoriented string theory can be described in terms of D-branes and orientifold planes. The authors in [12] claim that, in order to preserve the Chan-Paton symmetry, a bosonic D25-brane wrapped

on the $E_8 \times E_8$ lattice transmute to a BPS D9-brane of Type I theory. In the next section, we will prove that BPS Type I D-branes can be obtained by truncation of bosonic D-branes.

3.5 Type I BPS D-branes from bosonic D-branes

We start with the unoriented open/closed bosonic string theory compactified on the lattice group $G = E_8 \times E_8$, and truncated á la Casher, Englert, Nicolai and Taormina [12]. In this scenario, the bosonic D25-branes are truncated to BPS Type I D9-branes. Let us consider the system of a D25-brane and a $D\theta$ -brane wrapped on the lattice group G where we define

$$\theta = 12 + \left(\frac{3p-1}{2}\right), \quad (3.142)$$

where the parameter p takes positive integral values $0 \leq p \leq 9$. We will show that, by applying the truncation in the bulk theory, a bosonic $D\theta$ -brane wrapped on some directions of the $E_8 \times E_8$ lattice will truncate to a Dp -brane in Type I theory. The interaction amplitudes of the $D\theta$ -branes and the background are calculated. We will prove that, after applying the truncation, the interaction of a $D\theta$ -brane are exactly the same as the interactions of a Dp -brane in Type I theory.

3.5.1 Setting up the configuration

Let us consider the open and closed bosonic string theory compactified on the torus of the lattice group $G = E_8 \times E_8$. We are interested in the dynamics of a probe $D\theta$ -brane moving in a background of wrapped D25-branes and an orientifold plane, O25. We define the coordinates by taking the directions X^μ where $\mu = 0, \dots, 9$ to be the non-compact directions and compactifying the coordinates X^a where $a = 10, \dots, 25$ on a $E_8 \times E_8$ torus.

In order to perform the truncation, we may consider the group $E_8 \times SO(16) \supset E_8 \times E_8$. It will be useful for us to split the $SO(16)$ direction in the $E_8 \times SO(16)$ lattice in to $SO(8)' \times SO(8)_{int}$. We will take the coordinates X^{10}, \dots, X^{13} to represent the $SO(8)_{int}$ sublattice.

Let us consider for example, as shown in Table (3.5)³, the case of $\theta = 19$ (or $p = 5$). We set the bosonic $D\theta$ -brane to occupy the torus in the 14 directions, leaving the 10th and 11st direction unwrapped. We expect this wrapped D19-brane to become a D5-brane in Type I theory after performing the truncation in the bulk theory. In this case, the internal subgroup $SO(8)_{int}$ is broken to $SO(4) \times SO(4)$. The four bosonized world-sheet fermions from the X^{10} and X^{11} bosonic coordinates get Dirichlet boundary conditions.

<i>brane</i>	1	2	3	4	5	6	7	8	10	11	12	13	14	15	...	25
D25	+	+	+	+	+	+	+	+	+	+	+	+	+	+	...	+
D19	+	+	+	+	-	-	-	-	-	-	+	+	+	+	...	+
O25	+	+	+	+	+	+	+	+	+	+	+	+	+	+	...	+

Table 3.5: Shows the system of a D19-brane and background D25-branes and an orientifold plane.

In general, the bosonization conditions require p to be odd. The presence of Dirichlet conditions breaks the group G to G^{new}

$$G \rightarrow G^{new} = E_8 \times SO(8' + p - 1) \times SO(9 - p), \quad (3.143)$$

or, specifically, the subgroup $SO(8)_{int} \subset SO(16)$ is broken to $SO(p-1) \times SO(9-p)$. The characters of $SO(16)$ can be decomposed in terms of $SO(8'+p-1)$ and $SO(9-p)$ characters as,

$$\begin{aligned} O_{16} &= O_{8'+p-1}O_{9-p} + V_{8'+p-1}V_{9-p} , \\ V_{16} &= V_{8'+p-1}O_{9-p} + O_{8'+p-1}V_{9-p} , \\ S_{16} &= S_{8'+p-1}S_{9-p} + C_{8'+p-1}C_{9-p} , \\ C_{16} &= C_{8'+p-1}S_{9-p} + S_{8'+p-1}C_{9-p} . \end{aligned} \quad (3.144)$$

³The “+ (-)” signs in Table (3.5) represent Neumann (Dirichlet) boundary conditions of the corresponding open-strings. Note that we take X^0 and X^9 to be light-cone directions.

3.5.2 Interaction Amplitudes

In moving the stack of wrapped bosonic D θ -branes for the bosonic string theory, we should consider not only the interaction of D θ -branes with themselves, encoded in the annulus amplitude $\Gamma_{\theta,\theta}^A$, but also their interaction with the background D25-branes and with the O25-plane. Then we need to calculate the annulus amplitude, $\Gamma_{\theta,25}^A$, and Möbius amplitude, Γ_{θ}^M . For D θ -branes compactified $E_8 \times E_8$ lattice, with $p + 1$ longitudinal dimensions and $9 - p$ transverse dimensions in non-compact directions, we can write the complete direct channel string amplitude as

$$\Gamma_{\theta,\theta}^A = \frac{V_{p+1}}{(4\pi^2\alpha')^{(p+1)/2}} \int \frac{d\tau_2}{\tau_2^{(p+3)/2}} \frac{1}{\eta(i\tau_2/2)^8} \mathcal{A}_{\theta,\theta}(i\tau_2/2), \quad (3.145)$$

$$\Gamma_{\theta,25}^A = \frac{V_{p+1}}{(4\pi^2\alpha')^{(p+1)/2}} \int \frac{d\tau_2}{\tau_2^{(p+3)/2}} \frac{\mathcal{A}_{\theta,25}(i\tau_2/2)}{\eta(i\tau_2/2)^{p-1}} \left(\frac{\eta}{\vartheta_4}\right)^{\frac{(9-p)}{2}}, \quad (3.146)$$

$$\Gamma_{\theta}^M = \frac{V_{p+1}}{(4\pi^2\alpha')^{(p+1)/2}} \int \frac{d\tau_2}{\tau_2^{(p+3)/2}} \frac{\mathcal{M}_{\theta}(i\frac{\tau_2}{2} + \frac{1}{2})}{\hat{\eta}(i\frac{\tau_2}{2} + \frac{1}{2})^8} \left(\frac{2\eta}{\vartheta_2}\right)^{\frac{(9-p)}{2}}. \quad (3.147)$$

In the transverse channel, we get

$$\tilde{\Gamma}_{\theta,\theta}^A = \frac{V_{p+1}}{(8\pi^2\alpha')^{(p+1)/2}} \int \frac{dl}{l^{(9-p)/2}} \frac{1}{\eta(il)^8} \tilde{\mathcal{A}}_{\theta,\theta}(il), \quad (3.148)$$

$$\tilde{\Gamma}_{\theta,25}^A = \frac{V_{p+1}}{(8\pi^2\alpha')^{(p+1)/2}} \int dl \frac{\tilde{\mathcal{A}}_{\theta,25}(il)}{\eta(il)^{p-1}} \left(\frac{2\eta}{\vartheta_2}\right)^{\frac{(9-p)}{2}}, \quad (3.149)$$

$$\tilde{\Gamma}_{\theta}^M = \frac{V_{p+1}}{(8\pi^2\alpha')^{(p+1)/2}} \int dl \frac{\tilde{\mathcal{M}}_{\theta}(il + \frac{1}{2})}{\hat{\eta}(il + \frac{1}{2})^8} \left(\frac{2\eta}{\vartheta_2}\right)^{\frac{(9-p)}{2}}. \quad (3.150)$$

The interaction between two D θ -branes is quite trivial. In the direct channel, the annulus amplitude for a stack of D θ -branes is,

$$A_{\theta,\theta} = \frac{d^2}{2} (O_{8'+p-1}O_{9-p} + V_{8'+p-1}V_{9-p} + S_{8'+p-1}S_{9-p} + C_{8'+p-1}C_{9-p}), \quad (3.151)$$

where the multiplicity d represents the corresponding Chan-Paton group. Note that because we work on the $E_8 \times E_8$ lattice, only four conjugacy classes of $SO(8' + p - 1) \times SO(9 - p)$ contribute to the amplitude (we ignore the contributions from the E_8 factor and from the non-compactified directions).

We can move from direct to transverse channels by applying the S-transformation defined in (3.37) to (3.151). So, the transverse channel amplitude is given by

$$\tilde{A}_{\theta,\theta} = 2^{-(a+1/2)} d^2 (O_{8'+p-1}O_{9-p} + V_{8'+p-1}V_{9-p} + S_{8'+p-1}S_{9-p} + C_{8'+p-1}C_{9-p}), \quad (3.152)$$

and determines the tension of the $D\theta$ -branes. The decomposition of the $SO(8' + p - 1) \times SO(9 - p)$ characters does not play an important role in this case but will be very crucial in the case of the D25- $D\theta$ amplitude. The latter is more easy to calculate in the transverse channel. The resulting closed string amplitude is

$$\tilde{A}_{\theta,25} = 2^{-5}n \times d(O_{8'+p-1}O_{9-p} - V_{8'+p-1}V_{9-p} - S_{8'+p-1}S_{9-p} + C_{8'+p-1}C_{9-p}). \quad (3.153)$$

The parameters d and n represent the multiplicities of the $D\theta$ and D25-branes respectively. The “-” signs between the different contributions break the $SO(16)$ group and reflect the presence of the Dirichlet boundaries of the $D\theta$ -branes. This sign difference is consistent with the direct channel where the annulus amplitude represents an open-string with one of its ends confined on a $D\theta$ -brane while the other lives on the D25-brane. The open string coordinates in the $SO(9 - p)$ directions get mixed Neumann-Dirichlet conditions. As a result, the bosonized world-sheet fermions are twisted i.e. the open-string modes in the Ramond sector become half-integer-moded while the Neveu-Schwarz sector modes become integer-moded. In the lattice language, the twist is equivalent to a shift by a spinor (or conjugated spinor) on the sublattice $SO(9 - p)$ of $SO(8 + p - 1) \times SO(9 - p)$ weight lattice. This implies the resulting direct amplitude must be written in terms of the products of a bosonic character of $SO(8' + p - 1)$ and a fermionic character of $SO(9 - p)$ (or vice versa). So, the direct amplitude corresponding to (3.153) is

$$\begin{aligned} A_{\theta,25} = & \frac{n \times d}{2} [(O_{8'+p-1} + V_{8'+p-1})(S_{9-p} + C_{9-p}) \\ & + (S_{8'+p-1} + C_{8'+p-1})(O_{9-p} + V_{9-p}) \\ & - e^{-i(9-p)\pi/4} (O_{8'+p-1} - V_{8'+p-1})(S_{9-p} - C_{9-p}) \\ & - e^{-i(8'+p-1)\pi/4} (S_{8'+p-1} - C_{8'+p-1})(O_{9-p} - V_{9-p})]. \end{aligned} \quad (3.154)$$

The amplitude (3.154) is inconsistent unless we require $p = 1, 5, 9$. This means only D13, D19 and D25-branes are allowed in this construction.

The interactions of $D\theta$ -branes and a O25-plane can be determined by the Möbius amplitude. In the transverse channel, we can automatically write down the Möbius amplitude as:

$$\tilde{M}_{\theta} = -d(\hat{O}_{8'+p-1}\hat{O}_{9-p} - \hat{V}_{8'+p-1}\hat{V}_{9-p} - \hat{S}_{8'+p-1}\hat{S}_{9-p} + \hat{C}_{8'+p-1}\hat{C}_{9-p}). \quad (3.155)$$

The direct channel Möbius amplitude can be written as:

$$\begin{aligned}
M_\theta = & -\frac{d}{2} \{ (\hat{O}_{8'+p-1} \hat{O}_{9-p} - \hat{V}_{8'+p-1} \hat{V}_{9-p}) \\
& + \cos \frac{(p-5)\pi}{4} (\hat{S}_{8'+p-1} \hat{S}_{9-p} - \hat{C}_{8'+p-1} \hat{C}_{9-p}) \\
& + i \sin \frac{(p-5)\pi}{4} (\hat{S}_{8'+p-1} \hat{C}_{9-p} - \hat{C}_{8'+p-1} \hat{S}_{9-p}) \}. \quad (3.156)
\end{aligned}$$

The Möbius amplitude (3.156) is inconsistent with the direct channel amplitude (3.151), unless $\sin \frac{(p-5)\pi}{4}$ vanishes. This also implies that only D13 and D19-branes are allowed.

3.5.3 Truncation of the bosonic D-brane

In order to calculate the effect of truncation on the $D\theta$ -branes, it is more convenient for us to write down the interaction amplitudes in terms of the $SO(8') \times SO(p-1) \times SO(9-p)$ characters. We can rewrite the transverse channel amplitudes as

$$\begin{aligned}
\tilde{A}_{\theta,\theta} = & 2^{-(p+1)/2} d^2 \{ O_{8'}(O_{p-1}O_{9-p} + V_{p-1}V_{9-p}) + V_{8'}(V_{p-1}O_{9-p} + O_{p-1}V_{9-p}) \\
& + S_{8'}(S_{p-1}S_{9-p} + C_{p-1}C_{9-p}) + C_{8'}(C_{p-1}S_{9-p} + S_{p-1}C_{9-p}) \}, \quad (3.157)
\end{aligned}$$

$$\begin{aligned}
\tilde{A}_{\theta,25} = & 2^{-5} n \times d \{ O_{8'}(O_{p-1}O_{9-p} - V_{p-1}V_{9-p}) + V_{8'}(V_{p-1}O_{9-p} - O_{p-1}V_{9-p}) \\
& - S_{8'}(S_{p-1}S_{9-p} - C_{p-1}C_{9-p}) - C_{8'}(C_{p-1}S_{9-p} - S_{p-1}C_{9-p}) \}, \quad (3.158)
\end{aligned}$$

$$\begin{aligned}
\tilde{M}_\theta = & -d \{ \hat{O}_{8'}(\hat{O}_{p-1}\hat{O}_{9-p} - \hat{V}_{p-1}\hat{V}_{9-p}) + \hat{V}_{8'}(\hat{V}_{p-1}\hat{O}_{9-p} - \hat{O}_{p-1}\hat{V}_{9-p}) \\
& - \hat{S}_{8'}(\hat{S}_{p-1}\hat{S}_{9-p} - \hat{C}_{p-1}\hat{C}_{9-p}) - \hat{C}_{8'}(\hat{C}_{p-1}\hat{S}_{9-p} - \hat{S}_{p-1}\hat{C}_{9-p}) \}, \quad (3.159)
\end{aligned}$$

and also the direct channel amplitudes:

$$\begin{aligned}
A_{\theta,\theta} = & \frac{d^2}{2} \left\{ O_{8'}(O_{p-1}O_{9-p} + V_{p-1}V_{9-p}) + V_{8'}(O_{p-1}V_{9-p} + O_{p-1}V_{9-p}) \right. \\
& \left. + S_{8'}(S_{p-1}S_{9-p} + C_{p-1}C_{9-p}) + C_{8'}(C_{p-1}S_{9-p} + S_{p-1}C_{9-p}) \right\}, \quad (3.160) \\
A_{\theta,25} = & \frac{n \times d}{2} \left\{ (O_{8'} + V_{8'})(O_{p-1} + V_{p-1})(S_{9-p} + C_{9-p}) \right. \\
& + (S_{8'} + C_{8'})(S_{p-1} + C_{p-1})(O_{9-p} + V_{9-p}) \\
& - e^{-i(9-p)\pi/4} (O_{8'} - V_{8'})(O_{p-1} - V_{p-1})(S_{9-p} - C_{9-p}) \\
& \left. - e^{-i(8'+p-1)\pi/4} (S_{8'} - C_{8'})(S_{p-1} - C_{p-1})(O_{9-p} - V_{9-p}) \right\}, \quad (3.161)
\end{aligned}$$

$$\begin{aligned}
M_\theta = & -\frac{d}{2} \left\{ \hat{O}_{8'} (\hat{O}_{p-1} \hat{O}_{9-p} - \hat{V}_{p-1} \hat{V}_{9-p}) + \hat{V}_{8'} (\hat{V}_{p-1} \hat{O}_{9-p} - \hat{O}_{p-1} \hat{V}_{9-p}) \right. \\
& + \cos \frac{(p-5)\pi}{4} [\hat{S}_{8'} (\hat{S}_{p-1} \hat{S}_{9-p} - \hat{C}_{p-1} \hat{C}_{9-p}) \\
& \quad \left. + \hat{C}_{8'} (\hat{C}_{p-1} \hat{S}_{9-p} - \hat{S}_{p-1} \hat{C}_{9-p})] \right. \\
& + i \sin \frac{(p-5)\pi}{4} [\hat{S}_{8'} (\hat{S}_{p-1} \hat{C}_{9-p} - \hat{C}_{p-1} \hat{S}_{9-p}) \\
& \quad \left. + \hat{C}_{8'} (\hat{C}_{p-1} \hat{C}_{9-p} - \hat{S}_{p-1} \hat{S}_{9-p}) \right] \}. \quad (3.162)
\end{aligned}$$

Let us now perform the truncation in the bulk theory i.e. project out all states belonging to the E_8 and $SO(8')$ lattice directions and keep only the zero-modes belonging to the vector and spinor weight lattice of $SO(8')$. At the boundary, although the presence of the Dirichlet boundary conditions breaks the $SO(8)$ internal symmetry, the truncation can be applied by taking,

$$\begin{aligned}
O_{8'} & \rightarrow 0, & V_{8'} & \rightarrow 1, \\
S_{8'} & \rightarrow -1, & C_{8'} & \rightarrow 0,
\end{aligned} \quad (3.163)$$

which is equivalent to the truncation of choice **A** in (3.101). We can perform the truncation in (3.163) on the amplitudes (3.157), (3.158) and (3.159), we obtain the following results in the transverse channel,

$$\tilde{A}_{p,p} = \frac{2^{-(p+1)/2}}{2} d^2 \{V_{p-1} O_{9-p} + O_{p-1} V_{9-p} - S_{p-1} S_{9-p} - C_{p-1} C_{9-p}\} \quad (3.164)$$

$$\tilde{A}_{p,9} = 2^{-5} n \times d \{V_{p-1} O_{9-p} - O_{p-1} V_{9-p} + S_{p-1} S_{9-p} - C_{p-1} C_{9-p}\} \quad (3.165)$$

$$\tilde{M}_p = -d \{ \hat{V}_{p-1} \hat{O}_{9-p} - \hat{O}_{p-1} \hat{V}_{9-p} + \hat{S}_{p-1} \hat{S}_{9-p} - \hat{C}_{p-1} \hat{C}_{9-p} \} \quad (3.166)$$

By applying the truncation (3.163) on the amplitudes (3.160), (3.161) and (3.162), we obtain the resulting direct channel amplitudes as:

$$A_{p,p} = \frac{d^2}{2} \{V_{p-1} O_{9-p} + O_{p-1} V_{9-p} - S_{p-1} S_{9-p} - C_{p-1} C_{9-p}\} \quad (3.167)$$

$$\begin{aligned}
A_{p,9} = & \frac{n \times d}{2} [(O_{p-1} + V_{p-1})(S_{9-p} + C_{9-p}) - (S_{p-1} + C_{p-1})(O_{9-p} + V_{9-p}) \\
& + e^{-i(9-p)\pi/4} (O_{p-1} - V_{p-1})(S_{9-p} - C_{9-p}) \\
& + e^{-i(p-1)\pi/4} (S_{p-1} - C_{p-1})(O_{9-p} - V_{9-p})], \quad (3.168)
\end{aligned}$$

$$\begin{aligned}
M_p = & -\frac{d}{2} \{ \hat{O}_{p-1} \hat{V}_{9-p} - \hat{V}_{p-1} \hat{O}_{9-p} - \cos \frac{(p-5)\pi}{4} (\hat{S}_{p-1} \hat{S}_{9-p} - \hat{C}_{p-1} \hat{C}_{9-p}) \\
& - i \sin \frac{(p-5)\pi}{4} (\hat{S}_{p-1} \hat{C}_{9-p} - \hat{C}_{p-1} \hat{S}_{9-p}) \}. \quad (3.169)
\end{aligned}$$

In the case where $p = 1, 5$ the amplitudes in (3.164)-(3.169) agree with the interaction of the D1 and D5-brane in Type I theory as expressed in Dudas, Mourad and Sagnotti in [11]. Moreover, we can test our assumption by matching the tension of the wrapped D θ -brane to Type I D p -brane. The tension of a wrapped bosonic D θ -brane is given by

$$T_{D\theta}^{bos} = \tilde{T}_{D\theta}^{bos} \times V_{sd}^{\theta}, \quad (3.170)$$

where the unwrapped bosonic D θ -brane tension, $\tilde{T}_{D\theta}^{bos}$, is

$$\tilde{T}_{D\theta}^{bos} = \sqrt{\frac{\pi}{2^8 \kappa_{26}^2}} (4\pi^2 \alpha')^{(11-\theta)/2}, \quad (3.171)$$

and V_{sd}^{θ} is the self-dual lattice volume that the D θ -brane is wrapped on. We have

$$V_{sd}^{\theta} = (4\pi^2 \alpha')^{(\theta-p)/2}. \quad (3.172)$$

Recall that the Newton constant in 26 and 10 dimensions are related by the square root of the volume of the $E_8 \times E_8$ lattice

$$\kappa_{26} = \kappa_{10} \times \sqrt{V_{E_8 \times E_8}}, \quad (3.173)$$

where the volume of compact space is,

$$V_{E_8 \times E_8} = 2^{-8} (4\pi^2 \alpha')^8. \quad (3.174)$$

By substituting (3.171)-(3.174) into (3.170), we get

$$T_{D\theta}^{bos} = \sqrt{\frac{\pi}{\kappa_{10}^2}} (4\pi \alpha')^{(3-p)/2}, \quad (3.175)$$

which is exactly the tension of a Type I D p -brane.

3.5.4 Boundary state construction for the truncated branes

In this section, we present more evidence that the BPS D-branes can emerge from the bosonic string theory. Similar to the way we describe bosonic D-branes by their boundary state in section 3.3.5, we can construct the boundary states for the truncated theory which describe BPS D-branes. Although the construction of boundary states for Type II D-branes is well known, the fact that such boundary states can be written in terms of purely bosonic variables is a non-trivial result.

Let us start by considering the conformal field theory on the closed string world-sheet. We introduce the left and right-handed currents $J^\mu(z)$ and $\tilde{J}^\mu(\bar{z})$ associated to the $\hat{so}(8)$ algebra, with the oscillator modes J_n^μ and \tilde{J}_n^μ respectively. The boundary condition for $|z| = |\bar{z}| = 1$ can be written as:

$$J_n^\mu + v(\tilde{J}_{-n}^\mu) = 0, \quad (3.176)$$

where v is an inner or outer automorphism of $\hat{so}(8)$. For the Neumann boundary condition, v is taken to be 1 and for the Dirichlet boundary condition $v = -1$. In this subsection, for our convenience, we need to modify the convention of the indices as:

$$\left\{ \underbrace{1, \dots, p+1}_{\text{Neumann } \{i\}}, \underbrace{p+2, \dots, 8}_{\text{Dirichlet } \{i\}} \right\}. \quad (3.177)$$

The Neumann directions are now in $I = 1, \dots, p+1$ and the world-volume of the D-brane is Euclidean. Note that we use light-cone gauge, the time direction X^0 is transverse to the brane, and one can perform a double Wick's rotation after doing any calculation with this D-brane.

The solutions that satisfy the boundary condition (3.176) are called the Ishibashi states [44]. By following the current algebraic approach demonstrated in [45], we can derive the Ishibashi states corresponding to the BPS D p -branes in Type IIB. In the NSR-formalism, the R-R part of a Type IIB D-brane boundary state is given by:

$$|F_p, RR\rangle = \frac{1}{2}(|F_p, +\rangle_{RR} + |F_p, -\rangle_{RR}). \quad (3.178)$$

We define

$$|F_p, \pm\rangle = \exp\left[\pm i \sum_{d>0} \psi_{-d}^\mu M_{\mu\nu} \tilde{\psi}_{-d}^\nu\right] |F_p, \pm\rangle_0^{RR}, \quad (3.179)$$

and the basis,

$$\begin{aligned} |F_p, \pm\rangle_0^{RR} &= M_{\dot{A}\dot{B}}(|8_c, \dot{A}\rangle_0)_L \otimes (|8_c, \dot{B}\rangle_0)_R \\ &\quad \pm i M_{AB}(|8_s, A\rangle_0)_L \otimes (|8_s, B\rangle_0)_R. \end{aligned} \quad (3.180)$$

The matrices $M_{\mu\nu}$, M_{AB} and $M_{\dot{A}\dot{B}}$ are defined as:

$$\begin{aligned} M_{\mu\nu} &= (\delta_{IJ}, -\delta_{ij}) , \\ M_{AB} &= (\gamma^{I_1} \bar{\gamma}^{I_2} \gamma^{I_3} \bar{\gamma}^{I_4} \dots \gamma^{I_p} \bar{\gamma}^{I_{p+1}})_{AB} , \\ M_{\dot{A}\dot{B}} &= (\bar{\gamma}^{I_1} \gamma^{I_2} \bar{\gamma}^{I_3} \gamma^{I_4} \dots \bar{\gamma}^{I_p} \gamma^{I_{p+1}})_{\dot{A}\dot{B}} . \end{aligned} \quad (3.181)$$

The matrices $\gamma_{\dot{A}\dot{B}}^I$ and $\bar{\gamma}_{\dot{A}\dot{B}}^I$ are the $SO(8)$ gamma matrices in the real-Weyl basis. One can show that the boundary state (3.178) is actually invariant under the GSO-projection defined in (3.122).

The NS-NS part of the boundary state can be defined as:

$$|F_p, NSNS\rangle = \frac{1}{2}(|F_p, +\rangle_{NSNS} - |F_p, -\rangle_{NSNS}) , \quad (3.182)$$

where

$$|F_p, \pm\rangle_{NSNS} = \exp\left[\pm i \sum_{r>0} \psi_{-r}^\mu M_{\mu\nu} \tilde{\psi}_{-r}^\nu\right] |NS\rangle_0 . \quad (3.183)$$

Note that the tachyon state, $|NS\rangle_0$, is defined as in (3.123). One can use the definition (3.124) to show that the state in (3.182) is GSO-invariant. Then the full boundary state of a BPS D-brane can be written as:

$$|D_p\rangle_{IIB} = (|F_p, NSNS\rangle \pm i |F_p, RR\rangle) \otimes |B_\mu\rangle , \quad (3.184)$$

the “+” sign represent the D-branes, Dp , and the “−” sign implies the anti-branes, $\bar{D}p$. Note that the bosonic part of the boundary state, $|B_\mu\rangle$, is defined as in (3.74) with $\delta_{\mu\nu}$ replaced by the matrix $M_{\mu\nu}$ as we are now including Dirichlet boundary conditions.

If necessary one can define the boundary state in the GS-formalism [46] as well. The boundary state can be written as:

$$|F_p\rangle_{GS} = \exp\left[-(\pm i) \sum_{n>0} S_{-n}^A M_{AB} \tilde{S}_{-n}^B\right] |F_p, \pm\rangle_0^{GS} , \quad (3.185)$$

where

$$|F_p, \pm\rangle_0^{GS} = M_{\mu\nu} (|\mathfrak{s}_\nu, \mu\rangle_0)_L \otimes (|\mathfrak{s}_\nu, \nu\rangle_0)_R \pm i M_{\dot{A}\dot{B}} (|\mathfrak{s}_c, \dot{A}\rangle_0)_L \otimes (|\mathfrak{s}_c, \dot{B}\rangle_0)_R . \quad (3.186)$$

We use the notation where the “−” sign implies the anti-brane.

3.6 Discussions and outlook

Although the truncation mechanism we study in this chapter is very promising, there are still some aspects which need to be improved. We must ensure the truncation gives us the properties of the fermionic string. This aspect was our main motivation for this work. We showed that the BPS D-branes of Type I superstring theory can be obtained by truncating the bosonic D-branes. These bosonic D-branes wrap on the $E_8 \times E_8$ lattice in such a way that the bosonized fermions satisfy the appropriate boundary conditions. As the truncation preserves the mass of solitons, we can show that the tension of the wrapped bosonic D-brane is exactly the same as the tension of a Type I D-brane. Moreover, we can construct the boundary state of BPS D-branes from purely bosonic operators. Our results imply that the truncation can produce theories with BPS solitons which is one of the most important properties of superstring theory.

Another interesting perspective concerns the dynamics of the truncation process. As we have to truncate a very large number of bosonic particles, it is not clear where these particles go. Moreover, we have to ensure that these particles will not reappear again in higher order of the perturbation series. Clearly, an understanding of the dynamics of the truncation is necessary. There is a conjecture in [5] that the string field expectation value in the string field theory may provide a mechanism that could move the vacua of bosonic string theory into the superstring vacua. Although this is only speculation, we hope that studying the truncation of non-perturbative objects such as D-branes might point us towards the dynamical origin of the truncation. This aspect is very challenging and under investigation at the moment.

Chapter 4

Black diholes and intersecting brane–anti-brane configurations

In this chapter we study the physics of D-brane from the supergravity point of views. Most of the results presented here were published in [13]

4.1 Introduction

The physics of D-branes is perhaps one of the most exciting outcomes of the so-called “second string revolution”. On the one hand, D-branes are best described by boundary conformal field theory, on the other hand as supergravity solitons. Both definitions of D-branes play a major rôle in understanding the microscopic description of black hole entropy [49] and the AdS/CFT correspondence [48]. However, the progress in the construction of exact solutions for self-gravitating brane configurations lags far behind our understanding of those same configurations in string perturbation theory. To mention one outstanding example, we are still far from a satisfactory description of self-gravitating localized brane intersections, despite much effort and some progress in certain cases [50].

In this chapter we are interested in a particular configuration of D-branes, the brane—anti-brane system. This configuration was originally studied in the context of string duality beyond BPS level. Supersymmetric D-branes of type II theories

are examples of BPS states, which form a very special class of states in the Hilbert space of string and field theories. Most non-perturbative tests of the string duality conjecture are based on such BPS states, mainly because they are stable, protected from quantum corrections, and hence, easier to handle. However, these states do not account for the full spectrum of any string theory - most of the states in string theories are non-BPS. Therefore, the study of non-BPS D-branes is needed. The works pioneered by Sen [4] show that stable non-BPS states are related to the brane—anti-brane configuration. Indeed, such configurations of D-branes are not only useful in the subject of string duality, but also play a rôle in modern cosmology (see for examples [52] and [53]). Moreover, their connection to K-theory provides spectacular results in understanding the physics of D-branes [54].

Following the interpretation that BPS D-branes are classical solutions to type II supergravities, there have been some efforts to construct supergravity solutions describing a particular class of non-BPS branes corresponding to the D-brane—anti-D-brane configurations. For instance, the four-dimensional Kaluza-Klein dipole constructed in [55] can be embedded in eleven-dimensional supergravity in order to provide a static $D6-\overline{D6}$ brane configuration of type IIA string theory suspended in an external magnetic field [15, 56]. More recently, exact solutions to Einstein-Maxwell theory, with and without dilaton, describing static (but unstable) pairs of extremal black holes with opposite charges (hereafter, *diholes*) were constructed in a background magnetic field, and were argued to admit an interpretation in terms of a system of intersecting branes and intersecting antibranes in higher dimensions, after a suitable uplifting of the four-dimensional solutions when the dilaton coupling takes one of four special values [14]. The explicit task of uplifting the solutions in this way has been undertaken since then in [57]. Other recent studies of configurations of this type in the context of string theory include [58].

The main subject of this chapter is to generalize these configurations to the case where the charges of the branes are not equal. In Section 4.2 we follow the known case of single charge diholes. Then in Section 4.3, we construct a new exact solution of four-dimensional General Relativity describing oppositely charged, static black hole pairs, where the black holes are extremal and have an arbitrary number

n of different charges. Black holes of this sort can be regarded as composites of n extremal, singly charged black holes. Therefore, our solutions describe composites of n diholes. However, we mostly concentrate on the $n = 4$ case with two electric and two magnetic charges, because of the well-known consistent truncation of a wide class of low energy superstring theory compactifications to a four-dimensional action with bosonic sector [59, 60] and [61],

$$I = \frac{1}{16\pi G} \int d^4x \sqrt{-g} \left\{ R - \frac{1}{2} [(\partial\eta)^2 + (\partial\sigma)^2 + (\partial\rho)^2] - \frac{e^{-\eta}}{4} [e^{-\sigma-\rho} F_{(1)}^2 + e^{-\sigma+\rho} F_{(2)}^2 + e^{\sigma+\rho} F_{(3)}^2 + e^{\sigma-\rho} F_{(4)}^2] \right\}. \quad (4.1)$$

This is the starting point of our analysis when considering four abelian gauge fields. Our construction is inspired by two known results. First of all, when the branes carry different charges, the corresponding four-dimensional black holes appear as solutions to theories with four $U(1)$ gauge fields and three scalars of type (4.1) [59]. Second of all, four-charge pairs of black holes accelerating apart were found in [62, 63], which, when adequately written, are very suggestive of the form their static counterparts might take. (Composites with two charges, which can be obtained as a particular case of the four-charge case, are also of interest, see [64, 65]).

As with other diholes, the composite dihole solutions in an asymptotically flat space suffer from conical singularities along the axis of symmetry. These singularities can be removed by suspending the diholes in external magnetic fields, a procedure we will examine in some detail. It should be noted that, for reasons similar to those discussed in [14], composite diholes are unstable equilibrium configurations.

Although these new composite diholes solution are four-dimensional solutions of General Relativity, they can be embedded in ten or eleven-dimensional supergravities, and interpreted as systems of intersecting branes and intersecting anti-branes. This is discussed in Section 4.4, in an attempt to test any relevant connections between supergravity solitons and non BPS states described by brane—anti-brane type of configurations.

4.2 Single-charge diholes

Let us start by reviewing the single-charge dihole solutions studied by Emparan in [14]. However, for our convenience, we will present the solution in coordinates that differ from the ones used in previous literature.

We consider the Einstein-Maxwell-Dilaton theory in four dimensional space-time which can be described by the action

$$I = \frac{1}{16\pi G} \int d^4x \sqrt{-g} (R - 2(\partial\phi)^2 - e^{-2\alpha\phi} F^2) , \quad (4.2)$$

where R is the Ricci scalar, ϕ represents the dilaton field and F is the electromagnetic tensor. This theory appears in many areas of physics with different fixed values of the dilatonic coupling constant α . For the special case, $\alpha = 0$ we obtain Einstein-Maxwell theory, for $\alpha = 1$ the action (4.2) describes the low energy dynamics of superstring theory and for $\alpha = \sqrt{3}$ we have the Kaluza-Klein theory.

It was shown in Bonnor [66], Davidson and Gedalin [67] that the field equations of (4.2) admit axisymmetric solutions with metric

$$ds^2 = \left(\frac{\Delta + a^2 \sin^2 \theta}{\Sigma} \right)^{\frac{2}{1+\alpha^2}} \left[-dt^2 + \frac{\Sigma^{\frac{4}{1+\alpha^2}}}{(r^2 - \gamma^2 \cos^2 \theta)^{\frac{3-\alpha^2}{1+\alpha^2}}} \left(\frac{dr^2}{\Delta} + d\theta^2 \right) \right] + \frac{\Delta \sin^2 \theta}{\left(\frac{\Delta + a^2 \sin^2 \theta}{\Sigma} \right)^{\frac{2}{1+\alpha^2}}} d\varphi^2 , \quad (4.3)$$

where the dilaton field is defined by the following expression

$$e^{-\phi} = \left(\frac{\Delta + a^2 \sin^2 \theta}{\Sigma} \right)^{\frac{\alpha}{1+\alpha^2}} , \quad (4.4)$$

and magnetic one-form gauge potential,

$$A = \frac{2}{\sqrt{1+\alpha^2}} \frac{M(r+M)a}{\Delta + a^2 \sin^2 \theta} \sin^2 \theta d\varphi . \quad (4.5)$$

Note that, we define

$$\begin{aligned} \Delta &= r^2 - \gamma^2 , \\ \Sigma &= (r+M)^2 - a^2 \cos^2 \theta , \end{aligned} \quad (4.6)$$

and, for later convenience, we introduce the parameter

$$\gamma^2 \equiv M^2 + a^2 . \quad (4.7)$$

Actually, at fixed value of the dilaton coupling α , the two parameters defining the solution can be taken to be γ and a .

In order to compare these solutions to those in [14, 66, 67] and to the literature on similar solutions, we need to perform a shift of the radial coordinate r :

$$r \rightarrow r - M . \quad (4.8)$$

Recently, the authors in [72] reviewed the method used in [67] in more detail and also found the other type of dihole solution describing a pair of extremal dilatonic black holes carrying unbalanced charges, i.e. each of the black holes carries a magnetic charge that is of different sign as well as magnitude. In contrast with our solution, diholes in [72] have a non-zero net magnetic charge which is not a good candidate to describe the brane-anti-branes configuration.

A solution with electric field, dual to the magnetic solution above, can be readily constructed. In this case, the dilaton changes from ϕ to $-\phi$, and the electric gauge potential becomes

$$A = -\frac{2}{\sqrt{1+\alpha^2}} \frac{Ma \cos \theta}{\Sigma} dt . \quad (4.9)$$

We now follow the analysis in [14]. The solution is clearly asymptotically flat as $r \rightarrow \infty$, and in this asymptotic region the gauge field is that of a dipole. Although the solution contains apparent singularities at $r = \gamma$ (where $\Delta = 0$), the actual situation is somewhat subtle. Notice first that the axis of symmetry of the solution (the fixed-point set of the Killing vector ∂_φ) consists of the semi-infinite lines $\theta = 0, \pi$ (running from $r = \gamma$ to ∞), and the segment $r = \gamma$ that stretches in between them (running from $\theta = 0$ to π). The crucial feature of these solutions is that at each of the poles ($r = \gamma, \theta = 0$) and ($r = \gamma, \theta = \pi$), lies a (distorted) extremal charged dilatonic black hole. In order to see this, change coordinates r, θ to $\rho, \bar{\theta}$,

$$\begin{aligned} r &= \gamma + \frac{\rho}{2}(1 + \cos \bar{\theta}) , \\ \sin^2 \theta &= \frac{\rho}{\gamma}(1 - \cos \bar{\theta}) , \end{aligned} \quad (4.10)$$

and examine the solution for small values of ρ . On doing so, the metric in this region

takes the form

$$ds^2 \rightarrow g^{\frac{2}{1+\alpha^2}}(\bar{\theta}) \left[- \left(\frac{\rho}{q} \right)^{\frac{2}{1+\alpha^2}} dt^2 + \left(\frac{q}{\rho} \right)^{\frac{2}{1+\alpha^2}} (d\rho^2 + \rho^2 d\bar{\theta}^2) \right] + \left(\frac{q}{\rho} \right)^{\frac{2}{1+\alpha^2}} \frac{\rho^2 \sin^2 \bar{\theta}}{g^{\frac{2}{1+\alpha^2}}(\bar{\theta})} d\varphi^2, \quad (4.11)$$

with

$$g(\bar{\theta}) = \cos^2(\bar{\theta}/2) + \frac{a^2}{\gamma^2} \sin^2(\bar{\theta}/2), \quad (4.12)$$

and

$$q \equiv \frac{M(\gamma + M)}{\gamma}. \quad (4.13)$$

For the case of Einstein-Maxwell theory without a dilaton, $\alpha = 0$, this geometry is that of a Bertotti-Robinson universe ($AdS_2 \times S^2$), albeit distorted by the factor $g(\bar{\theta})$. That is, we find a geometry just like that of the region close to the horizon ($\rho = 0$) of an extremal Reissner-Nordström black hole, but, instead of being spherically symmetric, it is elongated along the axis in a prolate shape. For other values of α the solution at $\rho = 0$ has a curvature singularity which is just like the one at the core of extremal charged dilaton black holes, although, again, the geometry is not spherically symmetric due to the distorting factor $g(\bar{\theta})$. Hence we see that the dipolar field of the full solution is created by two oppositely charged extremal black holes which we shall refer to as a *dihole*¹.

That the dipolar field is originated by a pair of extremal black holes, and not by, say, a pointlike or linear singularity or a pair of charges of a different kind, is obviously a non trivial issue. Apparently, Bonnor's dipole (*i.e.*, the $\alpha = 0$, non-dilatonic solution found in [66]) was originally thought to describe a singular pointlike (or segment-like) dipole. The first identification of a self-gravitating pole-antipole configuration was made for the case of Kaluza-Klein theory ($\alpha = \sqrt{3}$) in [55], and then refined in [56]. However, in those papers the interpretation was made on the basis of topological arguments that depend on the higher-dimensional structure of

¹In [67] it was argued that for the case $\alpha = 1$, and only for this case, the solution contains regular non-extremal horizons, and describes a black hole-white hole configuration. This interpretation is not consistent with what we have just described: two extremal horizons, regular for $\alpha = 0$ and singular for $\alpha > 0$.

Kaluza-Klein theory, and which cannot be applied to solutions with other values of the dilaton. The Kaluza-Klein dipole was later analyzed in [15] by means of essentially the same transformation as (4.10). That the solutions (4.3) of [67] actually describe a dihole for arbitrary values of α , including the case $\alpha = 0$ which has regular horizons, was first proven by Emparan in [14].

Given the two-black hole interpretation, it would be natural to expect the dihole solutions to contain the single black hole solutions as the limiting case where one of the holes is pulled infinitely away from the other. This is indeed the case. Working in coordinates $\rho, \bar{\theta}$, if the parameter a is taken to infinity while keeping all other quantities finite, then the solution reduces precisely to that of a single extremal dilatonic black hole. The parameter a plays then the rôle of a measure of the separation between the holes. However, this is just a qualitative statement, since the proper spatial distance between the extremal horizons (for $\alpha = 0$) is actually infinite. A more accurate statement is to say that increasing a , while keeping the holes' charge fixed, increases the value of the dipole moment (the relation, however, becomes approximately linear only for large a).

We are primarily interested, however, in the situation where both black holes are present in the solution, and therefore we consider finite values of a . The attraction, gravitational and electromagnetic, that they exert on one another is not balanced by any external field, so the geometry reacts, as is usual in these situations, by producing conical singularities along the symmetry axis [14, 67]. On physical grounds, it is clear that an external magnetic field aligned with the dihole could provide the force to balance the configuration. An exact solution containing such a field can be constructed by applying a Harrison transformation to (4.3). This was done in [14], and results in the metric

$$ds^2 = \Lambda^{\frac{2}{1+\alpha^2}} \left[-dt^2 + \frac{\Sigma^{\frac{4}{1+\alpha^2}}}{(r^2 - \gamma^2 \cos^2 \theta)^{\frac{3-\alpha^2}{1+\alpha^2}}} \left(\frac{dr^2}{\Delta} + d\theta^2 \right) \right] + \frac{\Delta \sin^2 \theta}{\Lambda^{\frac{2}{1+\alpha^2}}} d\varphi^2, \quad (4.14)$$

the dilaton, $e^{-\phi} = \Lambda^{\frac{\alpha}{1+\alpha^2}}$, and the gauge potential,

$$A = \frac{\frac{2}{\sqrt{1+\alpha^2}} Ma(r+M) + \frac{1}{2} B[(r+M)^2 - a^2]^2 + \Delta a^2 \sin^2 \theta}{\Lambda \Sigma} \sin^2 \theta d\varphi, \quad (4.15)$$

with

$$\Lambda = \frac{1}{\Sigma} \left\{ \Delta + a^2 \sin^2 \theta + 2\sqrt{1 + \alpha^2} BM(r + M)a \sin^2 \theta + \frac{1 + \alpha^2}{4} B^2 \sin^2 \theta \left[((r + M)^2 - a^2)^2 + \Delta a^2 \sin^2 \theta \right] \right\}, \quad (4.16)$$

and Δ and Σ still given by (4.6). At distances much larger than the size of the dipole ($r \gg a, M$) the solution asymptotes to the dilatonic Melvin universe, which describes a self-gravitating, cylindrically symmetric magnetic field. It is of interest now to examine what effect the external field has on the black hole horizons. To see this, change coordinates again as in (4.10), and then focus on small values of ρ . One finds a geometry just like (4.11), but now the deformation function is

$$g(\bar{\theta}) = \cos^2(\bar{\theta}/2) + \left(\frac{a}{\gamma} + Bq\sqrt{1 + \alpha^2} \right)^2 \sin^2(\bar{\theta}/2), \quad (4.17)$$

q being the parameter defined in (4.13). Notice that if we tune the external magnetic field to the value

$$B = \frac{1}{q\sqrt{1 + \alpha^2}} \left(1 - \frac{a}{\gamma} \right) = \frac{1}{\sqrt{1 + \alpha^2}} \frac{\gamma - a}{M(\gamma + M)}, \quad (4.18)$$

then $g(\bar{\theta}) = 1$, and the distortion of the holes disappears². It was shown in [14] that this very same value of the magnetic field produces a cancellation of the conical defects along the symmetry axis, with the choice $\Delta\varphi = 2\pi$. It is quite peculiar that the horizons recover their spherical symmetry precisely when the forces in the system are balanced and the two black holes are suspended in (unstable) equilibrium in the external field. In a sense, the latter exactly compensates for the distortions of the horizon induced by the presence of the other hole.

In the dual electric case the background Melvin field cannot be introduced by means of a solution-generating transformation as in the magnetic case. Nevertheless, the electric solution can be constructed by straightforward dualization of the magnetic one. The dilaton reverses sign as usual, and we find the electric potential

²There is a second value of B that yields $g(\bar{\theta}) = 1$, but here we have chosen the one for which $B \rightarrow 0$ as $a \rightarrow \infty$.

to be

$$A = \left[B \cos \theta \left(r - 2M + \frac{aBM\sqrt{1+\alpha^2}}{2} (2 + \sin^2 \theta) \right) - \frac{2Ma \cos \theta (1 - \frac{1}{2}aB\sqrt{1+\alpha^2} \sin^2 \theta)^2}{\sqrt{1+\alpha^2}\Sigma} \right] dt. \quad (4.19)$$

This form of the potential manifestly shows how the potential tends to a “uniform” field $A_t \rightarrow Br \cos \theta$ as $r \rightarrow \infty$. In this case B is the asymptotic electric field along the axis.

The physical charge of the holes can be easily read by examining the gauge potentials in the region near the horizons. If we keep the field B arbitrary, instead of fixing it to the equilibrium value (4.18), then, as $\rho \rightarrow 0$, the dilaton goes to

$$e^{-\phi} \rightarrow \left(\frac{\rho}{q} g(\bar{\theta}) \right)^{\frac{\alpha}{1+\alpha^2}} \quad (4.20)$$

so when the balance condition (4.18) is achieved the angular dependence disappears.

The potential, in its turn, becomes

$$A \rightarrow \frac{q}{\sqrt{1+\alpha^2}} \left(\frac{a}{\gamma} + Bq\sqrt{1+\alpha^2} \right) \frac{1 - \cos \bar{\theta}}{g(\bar{\theta})} d\varphi, \quad (4.21)$$

or, in the electric case,

$$A \rightarrow -\frac{1}{\sqrt{1+\alpha^2}} \left(\frac{a}{\gamma} + Bq\sqrt{1+\alpha^2} \right) \frac{\rho}{q} dt, \quad (4.22)$$

(here we have gauged away a constant) with, of course, a reversal in the sign of the dilaton. From here we infer that the charge is,

$$Q = \frac{1}{\sqrt{1+\alpha^2}} \frac{q}{\frac{a}{\gamma} + Bq\sqrt{1+\alpha^2}} \frac{\Delta\varphi}{2\pi} \quad (4.23)$$

in either the electric or magnetic solutions.

4.3 Multi-charged diholes

We address now the construction of new dihole solutions in theories with richer field content than the single-gauge field theories of (4.2).

4.3.1 String/M-theory diholes with four charges

In this subsection we consider a theory containing four abelian gauge fields and three scalars, with action (4.1), which appears as a consistent truncation of a large variety of compactifications of low energy string theory, such as toroidally compactified heterotic, IIA and IIB string theories, and also $D = 11$ supergravity [57,61,68]. Correspondingly, there is a large number of possible higher dimensional interpretations of the different gauge fields and their charge sources. A few of all these possible oxidations will be discussed in Sec. 4.4.

Black hole solutions to this theory were constructed in [59]. The black holes carry charges Q_i , $i = 1 \dots, 4$ under each of the gauge fields, the charges Q_1, Q_3 being of magnetic type, and Q_2, Q_4 electric (or viceversa, if we consider a dual configuration). When only s out of the four possible charges are equal and non-zero, and the rest are zero, then the theory, and its solutions, reduce to those of the Einstein-Maxwell-dilaton theory with coupling $\alpha = \sqrt{(4-s)/s}$. This is, solutions with 1, 2, 3 or 4 equal charges correspond to dilaton coupling $\alpha = \sqrt{3}, 1, 1/\sqrt{3}$ and 0, respectively. The extremal black hole solutions can be constructed following the “harmonic function rule” (see *e.g.*, [24]). Each gauge field enters in the solution through products of harmonic functions, in a manner that does essentially not depend on the other gauge fields. In [62,63] it was shown that solutions with two such black holes accelerating apart could also be found for these theories (see [65] for the solutions in a $U(1)^2$ theory). We are interested here in configurations where the two black holes with opposite charges are static.

We have managed to construct exact solutions to the field equations for these theories with $U(1)^4$ dipole fields. Their metric is

$$\begin{aligned}
 ds^2 &= (T_1 T_2 T_3 T_4)^{1/2} \left[-dt^2 + \frac{\Sigma_1 \Sigma_2 \Sigma_3 \Sigma_4}{(r^2 - \gamma^2 \cos^2 \theta)^3} \left(\frac{dr^2}{\Delta} + d\theta^2 \right) \right] \\
 &+ \frac{\Delta \sin^2 \theta}{(T_1 T_2 T_3 T_4)^{1/2}} d\varphi^2 .
 \end{aligned} \tag{4.24}$$

Here

$$\Delta = r^2 - \gamma^2, \quad (4.25)$$

$$\Sigma_i = (r + M_i)^2 - a_i^2 \cos^2 \theta, \quad (4.26)$$

$$T_i = \frac{\Delta + a_i^2 \sin^2 \theta}{\Sigma_i}, \quad i = 1, \dots, 4. \quad (4.27)$$

The magnetic gauge potentials $A_{(1)}$, $A_{(3)}$, are given by

$$A_{(i)} = \frac{2a_i M_i (r + M_i) \sin^2 \theta}{\Delta + a_i^2 \sin^2 \theta} d\varphi, \quad i = 1, 3 \quad (4.28)$$

whereas the electric potentials $A_{(2)}$, $A_{(4)}$, are

$$A_{(i)} = -\frac{2a_i M_i \cos \theta}{\Sigma_i} dt, \quad i = 2, 4. \quad (4.29)$$

The scalar fields, in turn, take the form

$$e^{-2\eta} = \frac{T_1 T_3}{T_2 T_4}, \quad e^{-2\sigma} = \frac{T_1 T_4}{T_2 T_3}, \quad e^{-2\rho} = \frac{T_1 T_2}{T_3 T_4}. \quad (4.30)$$

The solutions are parameterized in terms of five independent parameters. Physically, the parameters can be regarded as fixing the four charges of the holes and the “separation” between the pair. In practice, we will choose the independent parameters to be γ (which we take to be positive) and all the a_i (satisfying $|a_i| \leq \gamma$). The other parameters M_i are not independent, but rather given by

$$M_i^2 = \gamma^2 - a_i^2. \quad (4.31)$$

When $a_i^2 = \gamma^2$ for all i , then all the M_i 's vanish and the metric is that of flat space. In general we can have some $M_i = 0$ for some values of i , and nonzero for others, and get a non-trivial solution.

There are several non-obvious aspects in going from the solutions of the single-gauge field theory to the solutions of the $U(1)^4$ theory. One of them is that the combination $a_i^2 + M_i^2$ should take the same value for all i , so with our choice of radial coordinate, the function Δ is the same for all values of i . Another point is related to the characteristic way in which the metric functions in (4.24) factorize into contributions from each separate gauge field (a similar factorization had been observed also for Melvin fields and accelerating black holes in [63]). The way the

factorization happens in these solutions relies crucially on our choice of the radial coordinate, explained in the previous section. To see this, realize that when more than one parameter M_i is involved, the radial shift (4.8) cannot be properly undone³. The factorization suggests that the $U(1)^4$ dihole can then be thought of as a composite of four diholes. For an isolated $U(1)^4$ black hole it is possible to separate, at zero cost in energy, each of the constituents from the other three, *i.e.*, the black hole can be regarded as a composite of four marginally bound components [61]. However, it is not clear whether we can separate, at zero energy cost, the single-charge component diholes of a composite dihole. It may well be that what was in isolation a state bound at threshold (the four-charge extremal black hole) becomes non-marginally bound in the presence of its anti-state.

It is also a straightforward matter to check that the dilatonic dihole solutions (4.3) for $\alpha = \sqrt{3}, 1, 1/\sqrt{3}$ and 0 are recovered by taking 1, 2, 3 or 4 non-zero and equal values of M_i .

The analysis of these solutions can be done in exactly the same manner as we have done for Bonnor's dipole and its dilatonic counterparts. Coordinate singularities occur when $r = \gamma$, and these turn out to be, away from the poles, conical singularities. Again, a straightforward analysis of the conical deficits along the various portions of the symmetry axis reveals that it is not possible to eliminate the deficit along the segment $r = \gamma$ with the natural choice of period $\Delta\varphi = 2\pi$ which cancels the deficit along the lines $\theta = 0, \pi$. However, these singularities can be resolved by introducing magnetic background fields in our axisymmetric solutions by means of the generalized Harrison transformation constructed in [63] for the $U(1)^4$ theory, and by subsequently tuning them to a value which eliminates the conical deficit. The latter point, we will see, becomes somewhat subtle when more than one gauge field is present.

After applying the generalized Harrison transformation, the metric of the $U(1)^4$

³Notice that this implies that the "modified harmonic function" rule conjectured in [57] on the basis of the solutions with a single gauge field is of little use in trying to get to the new solutions with different charges, since that rule was based on a choice of radial coordinate that is inappropriate for this purpose.

dipole solution becomes

$$ds^2 = (\Lambda_1 \Lambda_2 \Lambda_3 \Lambda_4)^{1/2} \left[-dt^2 + \frac{\Sigma_1 \Sigma_2 \Sigma_3 \Sigma_4}{(r^2 - \gamma^2 \cos^2 \theta)^3} \left(\frac{dr^2}{\Delta} + d\theta^2 \right) \right] + \frac{\Delta \sin^2 \theta}{(\Lambda_1 \Lambda_2 \Lambda_3 \Lambda_4)^{1/2}} d\varphi^2, \quad (4.32)$$

the magnetic and electric potentials are given by:

$$A_{(i)} = \frac{1}{\Lambda_i \Sigma_i} \left\{ 2a_i M_i (r + M_i) \sin^2 \theta + \frac{1}{2} B_i \sin^2 \theta \left[((r + M_i)^2 - a_i^2)^2 + a_i^2 \Delta \sin^2 \theta \right] \right\} d\varphi, \quad i = 1, 3 \quad (4.33)$$

or

$$A_{(i)} = \left[B_i \cos \theta \left(r - 2M_i + \frac{a_i B_i M_i}{2} (2 + \sin^2 \theta) \right) - \frac{2M_i a_i \cos \theta (1 - \frac{1}{2} a_i B_i \sin^2 \theta)^2}{\Sigma_i} \right] dt, \quad i = 2, 4. \quad (4.34)$$

We define the scalar fields by,

$$e^{-2\eta} = \frac{\Lambda_1 \Lambda_3}{\Lambda_2 \Lambda_4}, \quad e^{-2\sigma} = \frac{\Lambda_1 \Lambda_4}{\Lambda_2 \Lambda_3}, \quad e^{-2\rho} = \frac{\Lambda_1 \Lambda_2}{\Lambda_3 \Lambda_4}, \quad (4.35)$$

where

$$\Lambda_i = \frac{1}{\Sigma_i} \left\{ \Delta + a_i^2 \sin^2 \theta + 2B_i a_i M_i (r + M_i) \sin^2 \theta + \frac{1}{4} B_i^2 \sin^2 \theta \left[((r + M_i)^2 - a_i^2)^2 + a_i^2 \Delta \sin^2 \theta \right] \right\}. \quad (4.36)$$

This solution obviously reduces to the previous one if we set $B_i = 0$. We have denoted the external fields collectively as B_i , even if for $i = 2, 4$ they are electric fields. Observe that the metric and scalars can be obtained from (4.24) and (4.30) by simply substituting Λ_i for T_i .

Along the outer semi-axes $\theta = 0, \pi$ the conical deficit is given by $\delta_{(\theta=0,\pi)} = 2\pi - \Delta\varphi$, no matter what the value of the external fields B_i is. We thus choose $\Delta\varphi = 2\pi$ in order to remove the conical deficit on that portion of the symmetry

axis. On the other hand, the deficit along the inner segment of the axis, $r = \gamma$, is calculated to be,

$$\delta_{(r=\gamma)} = 2\pi - \prod_{i=1}^4 \left(\frac{a_i}{\gamma} + B_i q_i \right)^{-1} \Delta\varphi, \quad (4.37)$$

where we have defined

$$q_i \equiv \frac{M_i(\gamma + M_i)}{\gamma}. \quad (4.38)$$

We can see that, for the choice of period in the variable φ we made earlier, *i.e.*, $\Delta\varphi = 2\pi$, the conical singularity along $r = \gamma$ disappears when

$$\prod_{i=1}^4 \left(\frac{a_i}{\gamma} + B_i q_i \right) = 1. \quad (4.39)$$

A *very particular* solution of this equation is obtained by requiring each of the factors on the l.h.s. to be equal to 1, *i.e.*, set the strength of the external fields to the values

$$B_i = \frac{\gamma - a_i}{M_i(\gamma + M_i)} = \frac{2M_i}{(\gamma + M_i + a_i)^2}, \quad i = 1 \dots, 4 \quad (4.40)$$

which can be interpreted as a separate force-balance condition for each of the gauge fields. Nevertheless, it should be kept in mind that (4.40) is by no means a typical solution. On the contrary, the balance of forces will typically be achieved with different contributions from each factor in (4.39). As a matter of fact, it is even possible to satisfy (4.39) for diholes with four different charges by turning on only one external field, say B_1 .

Although the metric still appears to be singular at the endpoints of the $U(1)^4$ dipole, one can actually reveal its true structure by studying the solution near the throat as we did in the previous section. As before, we may explore this region by changing coordinates from (r, θ) to $(\rho, \bar{\theta})$ as in (4.10) and by keeping ρ much smaller than any other scale in the problem. Near $r = \gamma, \theta = 0$, the metric becomes⁴,

$$ds^2 = g^2(\bar{\theta}) \left[-\frac{\rho^2}{q^2} dt^2 + \frac{q^2}{\rho^2} d\rho^2 + q^2 d\bar{\theta}^2 \right] + \frac{q^2 \sin^2 \bar{\theta}}{g^2(\bar{\theta})} d\varphi^2, \quad (4.41)$$

where $q = (q_1 q_2 q_3 q_4)^{1/4}$, and where $g(\bar{\theta}) = [g_1(\bar{\theta}) g_2(\bar{\theta}) g_3(\bar{\theta}) g_4(\bar{\theta})]^{1/4}$ with

$$g_i(\bar{\theta}) = \cos^2(\bar{\theta}/2) + \left(\frac{a_i}{\gamma} + B_i q_i \right)^2 \sin^2(\bar{\theta}/2) \quad (4.42)$$

⁴We are assuming here that all four charges are non-zero. The modifications for the case where some of them vanish can be inferred easily.

a function such that $g_i(\bar{\theta}) = 1$ when the field B_i is tuned to the value (4.40). However, for more generic cases the deformation function $g(\bar{\theta})$ will be different from 1 even if the conical singularities are cancelled through (4.39), and the horizons will in general be deformed. This feature is particular to theories with more than one gauge field. In any event, we see that near the poles the solution exhibits, apart from the distortion, the same structure as a four-charge black hole near its horizon.

The gauge fields are also distorted near the throat, where they are given by

$$\begin{aligned} A_{(i)} &= \frac{q_i}{g_i(\bar{\theta})} \left(\frac{a_i}{\gamma} + B_i q_i \right) (1 - \cos \bar{\theta}) d\varphi, \quad i = 1, 3 \\ A_{(i)} &= -\frac{\rho}{q_i} \left(\frac{a_i}{\gamma} + B_i q_i \right) dt, \quad i = 2, 4 \end{aligned} \quad (4.43)$$

and the corresponding physical charges are

$$Q_i = \frac{\Delta\varphi}{2\pi} \frac{q_i}{\frac{a_i}{\gamma} + B_i q_i}. \quad (4.44)$$

Finally, the scalar fields in this limiting region are

$$e^{-2\eta} = \frac{q_2 q_4}{q_1 q_3} \frac{g_1(\bar{\theta}) g_3(\bar{\theta})}{g_2(\bar{\theta}) g_4(\bar{\theta})}, \quad e^{-2\sigma} = \frac{q_2 q_3}{q_1 q_4} \frac{g_1(\bar{\theta}) g_4(\bar{\theta})}{g_2(\bar{\theta}) g_3(\bar{\theta})}, \quad e^{-2\rho} = \frac{q_3 q_4}{q_1 q_2} \frac{g_1(\bar{\theta}) g_2(\bar{\theta})}{g_3(\bar{\theta}) g_4(\bar{\theta})}, \quad (4.45)$$

which present the unusual feature that, in general, they will vary as we move along the horizon.

The deformation of the black hole horizons allows us to check a non-trivial aspect of the entropy-area law for black holes. Notice that when all four charges are turned on, the black holes have a non-singular, deformed horizon with non-vanishing area. Now, for an *isolated* extremal black hole the area is entirely determined by its physical charges Q_i as $\mathcal{A}_h = 4\pi\sqrt{Q_1 Q_2 Q_3 Q_4}$. This area can be associated, through the Bekenstein-Hawking law, with an entropy. On physical grounds we would expect the entropy of the system to remain unchanged if its physical charges, which fix the state, remain fixed, no matter what the distortion of the horizon may be. It is by no means clear that the solutions given above should satisfy this property. Nonetheless, the area of each of the horizons in the dihole configuration is

$$\mathcal{A}_h = 4\pi\sqrt{q_1 q_2 q_3 q_4} = 4\pi\sqrt{Q_1 Q_2 Q_3 Q_4}, \quad (4.46)$$

where the last equality is obtained when the singularities are cancelled by requiring (4.39) (but not necessarily (4.40)) and $\Delta\varphi = 2\pi$. Hence, the area as a function of the physical charges remains unaltered, despite the deformation of the black hole horizon. A similar test of the invariance of the entropy under deformations of the horizon was performed in [63].

Finally, it is a straightforward exercise to show that when one of the holes is pulled away by making γ large, while keeping $r - \gamma$, $\gamma \sin^2 \theta$ and M_i finite, we get $\Sigma_i \simeq 2\gamma(\rho + M_i)$, $q_i \simeq M_i \simeq Q_i$ and $\Lambda_i \simeq (1 + \frac{Q_i}{\rho})^{-1}$, so that the metric becomes that of an isolated extremal $U(1)^4$ black hole.

4.3.2 $U(1)^n$ composite diholes

The results we have just described can be generalized to the following theories containing n gauge fields and $n - 1$ independent scalars with action

$$I = \frac{1}{16\pi G} \int d^4x \sqrt{-g} \left\{ R - \frac{1}{2n^2} \sum_{i=1}^n \sum_{j=i+1}^n (\partial\sigma_i - \partial\sigma_j)^2 - \frac{1}{n} \sum_{i=1}^n e^{-\sigma_i} F_{(i)}^2 \right\}, \quad (4.47)$$

and with the scalars satisfying

$$\sum_{i=1}^n \sigma_i = 0. \quad (4.48)$$

Such theories were considered in [63] as a generalization of the theories with four abelian gauge fields we have just considered. In general, these $U(1)^n$ theories do not seem to be related to low energy string/M-theory, nor to any other supergravity theory in four dimensions. Nevertheless they exhibit the same peculiarities as the $U(1)^4$ theories, which are merely a particular case of the above type of theory, as described in [63]. All these theories admit black hole solutions which follow the ‘‘harmonic function rule’’, as well as solutions with two black holes accelerating apart [63]. It is therefore natural to expect that dihole solutions can be constructed as well. Indeed, their metric is

$$ds^2 = \prod_{i=1}^n T_i^{2/n} \left[-dt^2 + \frac{\prod_{i=1}^n \Sigma_i^{4/n}}{(r^2 - \gamma^2 \cos^2 \theta)^3} \left(\frac{dr^2}{\Delta} + d\theta^2 \right) \right] + \frac{\Delta \sin^2 \theta}{\prod_{i=1}^n T_i^{2/n}} d\varphi^2, \quad (4.49)$$

where Δ , Σ_i and T_i take the same form as in (4.25),(4.26),(4.27). The potentials (in magnetic form) are

$$A_{(i)} = \frac{2a_i M_i (r + M_i) \sin^2 \theta}{\Delta + a_i^2 \sin^2 \theta} d\varphi, \quad i = 1, \dots, n \quad (4.50)$$

and the scalars

$$e^{-\sigma_i} = T_i^2 \prod_{j=1}^n T_j^{-2/n}. \quad (4.51)$$

The qualitative features of these solutions are precisely the same as for the $U(1)^4$ case of the previous subsection, so our discussion will be rather cursory. These solutions have $n + 1$ independent parameters, $\{\gamma, a_i, i = 1, \dots, n\}$, while M_i are fixed by $M_i^2 = \gamma^2 - a_i^2$. By setting $n = 1$ and shifting the coordinate r to $r - M_1$, one recovers Bonnor's magnetic dipole solution of non-dilatonic Einstein-Maxwell theory [66]. The dilatonic solutions of [67] can also be recovered in a simple manner for rational values of α^2 [63]. To this effect, take s out of the n possible parameters M_i (say, $i = 1, \dots, s$) to be equal and non-zero, and the remaining $M_i, i = s+1, \dots, n$ to be vanishing. In this way, the solutions (4.3) are recovered, with dilaton coupling $\alpha = \sqrt{n/s - 1}$, and with the fields identified as

$$\begin{aligned} \sigma_1 &= \dots = \sigma_s = 2\alpha\phi, & \sigma_{s+1} &= \dots = \sigma_n = -\frac{2}{\alpha}\phi, \\ F_{(i)} &= \sqrt{\alpha^2 + 1} F, & i &= 1, \dots, s. \end{aligned} \quad (4.52)$$

The conical singularities that the solutions possess can be removed by means of the generalized Harrison transformation for the $U(1)^n$ theory constructed in [63], and by subsequently tuning them to a value which eliminates the conical deficit.

After applying the generalized Harrison transformation, the $U(1)^n$ dipole solution becomes,

$$ds^2 = \prod_{i=1}^n \Lambda_i^{2/n} \left[-dt^2 + \frac{\prod_{i=1}^n \Sigma_i^{4/n}}{(r^2 - \gamma^2 \cos^2 \theta)^3} \left(\frac{dr^2}{\Delta} + d\theta^2 \right) \right] + \frac{\Delta \sin^2 \theta}{\prod_{i=1}^n \Lambda_i^{2/n}} d\varphi^2, \quad (4.53)$$

$$e^{-\sigma_i} = \Lambda_i^2 \prod_{j=1}^n \Lambda_j^{-2/n}, \quad (4.54)$$

where the magnetic gauge potentials and Λ_i are given in (4.33) and (4.36).

All the features of the $U(1)^4$ solutions we described in the previous subsection carry over to the generic $U(1)^n$ case modulo some obvious adjustments.

4.4 Intersecting brane–anti-brane configurations

We already pointed out that the solutions to the $U(1)^4$ theory admit embeddings into higher dimensional supergravity theories arising from string/M-theory at low energies. When uplifted to $D \geq 5$ dimensions, each individual charge (4.44) will typically be interpreted as the charge (density) of a p -brane, with all its spatial directions wrapped around a p -torus, and delocalized in $D-p-4$ transverse directions. We are referring to branes in a manner loose enough to allow for pp-waves and KK monopoles to be introduced in a straightforward way in the discussion. More precisely, any charge that would naturally enter a solution through a harmonic function can be paired up with its anticharge to provide a characterization of brane-antibrane systems.

Solutions with just one out of four non-vanishing charges correspond to single brane solutions, whereas solutions with more than one charge describe brane intersections or marginal bound states of branes. A $U(1)^4$ dihole solution, when viewed in this way, can be oxidized to describe an intersection of up to four branes and an ‘anti-intersection’ of the corresponding anti-branes. We have tried to sketch such a configuration in Fig. 4.1. The direction labelled p denotes directions along the p -brane which are transverse to the p' -brane, and viceversa. The same applies for the *anti-intersection* $\bar{p} - \bar{p}'$. The p - and \bar{p} -branes are parallel. In the solutions described in the text the branes are delocalized in their relative transverse directions, and also in all but three overall transverse dimensions (r, θ, φ) . Of the latter directions, only the symmetry axis is shown in the figure. When infinitely separated from the other intersection ($\gamma \rightarrow \infty$), the p - and p' -branes we consider are marginally bound to each other. Each brane is parallel to its anti-brane, and the whole system is delocalized in such a way that the branes are localized in the overall transverse directions only.

The construction of brane-antibrane solutions based on the $U(1)^4$ dihole solutions described in Sec. 4.3 does not significantly differ in its concept from the way a one-black hole solution with four or less charges is uplifted to a brane configuration. Indeed, it was pointed out in [14] (see also [57]) that the diholes solution of Einstein-Maxwell-dilaton theory could be uplifted in a straightforward way to intersecting brane-anti-brane configurations of the sort just described, with the severe restriction

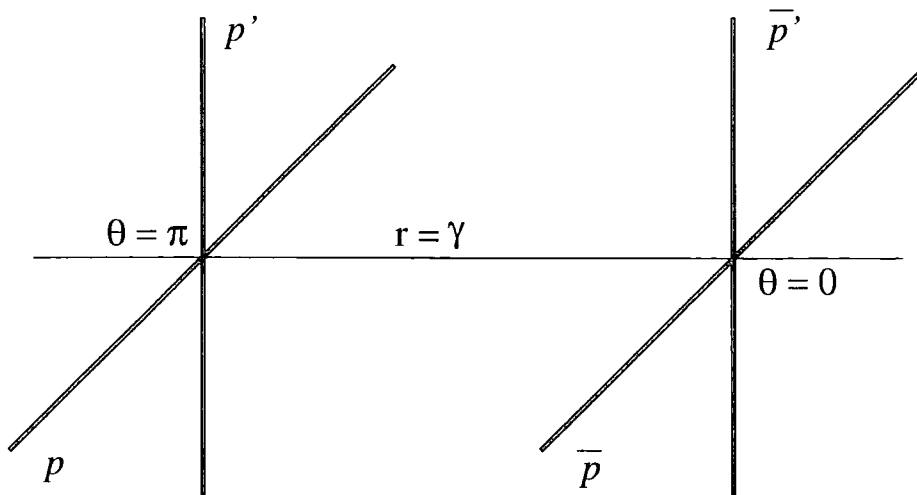

Figure 4.1: Geometry of the $p - p'$ brane and $\bar{p} - \bar{p}'$ brane intersections.

that the charges of the intersecting branes should all be equal. This restriction can be relaxed when using our new $U(1)^4$ solutions, which allow for a richer catalog of configurations. The factorized form of the solutions, particularly that of the scalar fields involved, greatly helps in deducing the form of the higher dimensional (internal) metric components from those of ordinary brane configurations: the harmonic functions H_i of the latter get replaced by the functions T_i^{-1} or Λ_i^{-1} , whose inverses were introduced in (4.27) and (4.36). We stress that this rule, however, applies only to the internal dimensions and not to the four-dimensional part of the solution.

Note that we are unable to consider non-extremal branes, since a solution describing a pair of non-extremal charged black holes is not available. Let us also emphasize that solutions *without* an external field contain conical singularities along the symmetry axis, and a physical interpretation in string/M-theory in terms of, *e.g.*, local cosmic strings, is not clear. Nevertheless, it is possible to remove these singularities by introducing an external magnetic field, using a similar procedure to the one described in the previous sections.

4.4.1 Some explicit examples

We now illustrate the uplifting of our $U(1)^4$ dihole solutions to three different brane-antibrane configurations.

(1) The $3 \perp 3 \perp 3 \perp 3$ and $\bar{3} \perp \bar{3} \perp \bar{3} \perp \bar{3}$ system in $D = 10$ type IIB theory.

Let us consider the ten-dimensional metric,

$$\begin{aligned}
ds_{10}^2 = & (T_1 T_2 T_3 T_4)^{1/2} \left[-dt^2 + \frac{\Sigma_1 \Sigma_2 \Sigma_3 \Sigma_4}{(r^2 - \gamma^2 \cos^2 \theta)^3} \left(\frac{dr^2}{\Delta} + d\theta^2 \right) \right] \\
& + \frac{\Delta \sin^2 \theta}{(T_1 T_2 T_3 T_4)^{1/2}} d\varphi^2 + \left(\frac{T_1 T_2}{T_3 T_4} \right)^{1/2} dx_1^2 + \left(\frac{T_1 T_3}{T_2 T_4} \right)^{1/2} dx_2^2 + \left(\frac{T_1 T_4}{T_2 T_3} \right)^{1/2} dx_3^2 \\
& + \left(\frac{T_2 T_3}{T_1 T_4} \right)^{1/2} dx_4^2 + \left(\frac{T_2 T_4}{T_1 T_3} \right)^{1/2} dx_5^2 + \left(\frac{T_3 T_4}{T_1 T_2} \right)^{1/2} dx_6^2.
\end{aligned} \tag{4.55}$$

with the functions Σ_i and T_i defined in (4.26), (4.27). The ten-dimensional dilaton is constant, and the five-form field strength is given by,

$$\begin{aligned}
F_{[5]} = & dA_1 \wedge dx_4 \wedge dx_5 \wedge dx_6 + dA_2 \wedge dx_1 \wedge dx_4 \wedge dx_5 \\
& + dA_3 \wedge dx_1 \wedge dx_3 \wedge dx_5 + dA_4 \wedge dx_3 \wedge dx_5 \wedge dx_6.
\end{aligned} \tag{4.56}$$

with the magnetic potentials $A_{1/3}$ given in (4.28) and the electric potentials $A_{2/4}$ given in (4.29). We also use $r^2 = x_7^2 + x_8^2 + x_9^2$. The compactification of the above type IIB solution on a six-dimensional torus yields the $U(1)^4$ dipole solution (4.24). To check that the system indeed contains brane-antibrane pairs, one may change coordinates from (r, θ) to $(\rho, \bar{\theta})$ as in (4.10). In the limit where the parameter a_i is large, and where $\theta \rightarrow 0$, the function T_i becomes the inverse of the harmonic function of a delocalized D3-brane $T_i \rightarrow \tilde{T}_i = \left(1 + \frac{Q_i}{\rho}\right)^{-1}$, and the metric becomes

$$\begin{aligned}
ds_{10}^2 = & \left(\tilde{T}_1 \tilde{T}_2 \tilde{T}_3 \tilde{T}_4 \right)^{1/2} (-dt^2) + \left(\tilde{T}_1 \tilde{T}_2 \tilde{T}_3 \tilde{T}_4 \right)^{-1/2} (d\rho^2 + \rho^2 (d\bar{\theta}^2 + \sin^2 \bar{\theta} d\varphi^2)) \\
& + \left(\frac{\tilde{T}_1 \tilde{T}_2}{\tilde{T}_3 \tilde{T}_4} \right)^{1/2} dx_1^2 + \left(\frac{\tilde{T}_1 \tilde{T}_3}{\tilde{T}_2 \tilde{T}_4} \right)^{1/2} dx_2^2 + \left(\frac{\tilde{T}_1 \tilde{T}_4}{\tilde{T}_2 \tilde{T}_3} \right)^{1/2} dx_3^2 \\
& + \left(\frac{\tilde{T}_2 \tilde{T}_3}{\tilde{T}_1 \tilde{T}_4} \right)^{1/2} dx_4^2 + \left(\frac{\tilde{T}_2 \tilde{T}_4}{\tilde{T}_1 \tilde{T}_3} \right)^{1/2} dx_5^2 + \left(\frac{\tilde{T}_3 \tilde{T}_4}{\tilde{T}_1 \tilde{T}_2} \right)^{1/2} dx_6^2.
\end{aligned} \tag{4.57}$$

This is exactly the solution for the four D3-branes intersection described in Table (4.1) which is constructed in [69, 70].

The solution for four anti-D3-branes intersection (i.e. for four D3-branes with opposite charge) is obtained when taking the $\theta \rightarrow \pi$ limit instead of the $\theta \rightarrow 0$ limit. However, in order to show that the system consists of the intersection of four D3-branes together with the intersection of four $\overline{D3}$ -branes in ten dimensions, one



<i>potential</i>	<i>brane</i>	0	1	2	3	4	5	6	7	8	9
Magnetic A_1	D3	+	+	+	+	-	-	-	-	-	-
Electric A_2	D3	+	+	-	-	+	+	-	-	-	-
Magnetic A_3	D3	+	-	+	-	+	-	+	-	-	-
Electric A_4	D3	+	-	-	+	-	+	+	-	-	-

Table 4.1: The four D3-brane intersection at the limit $\theta \rightarrow 0$ of (4.55)

must consider finite values of a_i and take the near horizon limit of (4.55) in complete analogy with the four-dimensional case. As already mentioned earlier, this solution has a conical deficit along the symmetry axis, which pulls the branes apart from each other. However, as can be anticipated from the discussion of $U(1)^n$ diholes suspended in external magnetic fields, such a brane/anti-brane configuration can be cured of any conical deficit along the symmetry axis by tuning the magnetic field B to an appropriate value. The relevant ten-dimensional metric is then given by (4.55), where the four functions T_i are replaced by the functions Λ_i given in (4.36). The five-form field-strength is again formally written as in (4.56), with the magnetic potentials $A_{1/3}$ and electric potentials $A_{2/4}$ given by (4.33) and (4.34) respectively. In the near horizon limit, and with a_i large ($r \gg M_i$), the functions Λ_i , for $\theta \rightarrow 0$, become the harmonic functions \tilde{T}_i involved in the description of the four D3-brane intersections, and the limiting metric is (4.57). If $\theta \rightarrow \pi$ instead, one obtains the four $\overline{D3}$ -brane intersections. One concludes that the metric

$$\begin{aligned}
ds_{10}^2 = & (\Lambda_1 \Lambda_2 \Lambda_3 \Lambda_4)^{1/2} \left[-dt^2 + \frac{\Sigma_1 \Sigma_2 \Sigma_3 \Sigma_4}{(r^2 - \gamma^2 \cos^2 \theta)^3} \left(\frac{dr^2}{\Delta} + d\theta^2 \right) \right] \\
& + \frac{\Delta \sin^2 \theta}{(\Lambda_1 \Lambda_2 \Lambda_3 \Lambda_4)^{1/2}} d\varphi^2 + \left(\frac{\Lambda_1 \Lambda_2}{\Lambda_3 \Lambda_4} \right)^{1/2} dx_1^2 + \left(\frac{\Lambda_1 \Lambda_3}{\Lambda_2 \Lambda_4} \right)^{1/2} dx_2^2 + \left(\frac{\Lambda_1 \Lambda_4}{\Lambda_2 \Lambda_3} \right)^{1/2} dx_3^2 \\
& + \left(\frac{\Lambda_2 \Lambda_3}{\Lambda_1 \Lambda_4} \right)^{1/2} dx_4^2 + \left(\frac{\Lambda_2 \Lambda_4}{\Lambda_1 \Lambda_3} \right)^{1/2} dx_5^2 + \left(\frac{\Lambda_3 \Lambda_4}{\Lambda_1 \Lambda_2} \right)^{1/2} dx_6^2. \tag{4.58}
\end{aligned}$$

is that of a system made of the intersection of four D3-branes and of the intersection of four $\overline{D3}$ -branes.

(2) The $2 \perp 2 \perp 5 \perp 5$ and $\bar{2} \perp \bar{2} \perp \bar{5} \perp \bar{5}$ system in $D = 11$ supergravity.

This system may be described by the $D = 11$ metric,

$$\begin{aligned}
ds_{11}^2 = & (T_2 T_4)^{2/3} (T_1 T_3)^{1/3} \left[-dt^2 + \frac{\Sigma_1 \Sigma_2 \Sigma_3 \Sigma_4}{(r^2 - \gamma^2 \cos^2 \theta)^3} \left(\frac{dr^2}{\Delta} + d\theta^2 \right) \right] \\
& + \frac{\Delta \sin^2 \theta}{(T_2 T_4)^{1/3} (T_1 T_3)^{2/3}} d\varphi^2 + \left(\frac{T_2^2 T_1}{T_4 T_3^2} \right)^{1/3} dx_1^2 + \left(\frac{T_2^2 T_3}{T_4 T_1^2} \right)^{1/3} dx_2^2 \\
& + \left(\frac{T_4^2 T_1}{T_2 T_3^2} \right)^{1/3} dx_3^2 + \left(\frac{T_4^2 T_3}{T_2 T_1^2} \right)^{1/3} dx_4^2 + \left(\frac{T_1 T_3}{T_2 T_4} \right)^{1/3} (dx_5^2 + dx_6^2 + dx_7^2), \quad (4.59)
\end{aligned}$$

with four-form field strength,

$$\begin{aligned}
F_{[4]} = & 3dA_1 \wedge dx_2 \wedge dx_4 - 3dA_2 \wedge dx_1 \wedge dx_2 \\
& + 3dA_3 \wedge dx_1 \wedge dx_3 - 3dA_4 \wedge dx_3 \wedge dx_4. \quad (4.60)
\end{aligned}$$

The magnetic potentials $A_{1/3}$ are again defined by (4.28) and the electric potentials $A_{2/4}$ by (4.29). Here, $r^2 = x_8^2 + x_9^2 + x_{10}^2$. In the $(\rho, \bar{\theta})$ coordinate system, and in the limit of a_i large and $\theta \rightarrow 0$, $T_{2/4}^{-1}$ and $T_{1/3}^{-1}$ become the harmonic functions required for the description of electric M2 branes and magnetic M5 branes as describe in Table (4.2). The solution describes the system of intersecting branes (two M2 and two M5) and intersecting anti-branes (two $\overline{\text{M2}}$ branes and two $\overline{\text{M5}}$ -branes), and becomes the dipole solution in $U(1)^4$ theory when compactified on a seven-torus. Once again,

<i>potential</i>	<i>brane</i>	0	1	2	3	4	5	6	7	8	9	10
Magnetic A_1	M5	+	+	-	+	-	+	+	+	-	-	-
Electric A_2	M2	+	+	+	-	-	-	-	-	-	-	-
Magnetic A_3	M5	+	-	+	-	+	+	+	+	-	-	-
Electric A_4	M2	+	-	-	+	+	-	-	-	-	-	-

Table 4.2: The two M5 and two M2-branes intersection at the limit $\theta \rightarrow 0$ of (4.59)

we may construct an analog solution in the presence of an external magnetic field in order to remove any conical singularity arising in the above solution. Replacing T_i by Λ_i everywhere in (4.59), and taking the potentials to be (4.33) and (4.34), one obtains a solution to $D = 11$ supergravity which again describes a system of

intersecting branes (two M2 and two M5) and intersecting anti-branes (two $\overline{\text{M2}}$ branes and two $\overline{\text{M5}}$ -branes), but this time with non-zero magnetic field B .

(3) The $2 \perp 2 \perp 2 \perp 6$ and $\bar{2} \perp \bar{2} \perp \bar{2} \perp \bar{6}$ system in $D = 10$ type IIA theory.

We end this subsection with a configuration we can relate to the $D6\text{---}\overline{D6}$ system studied by Sen, and which we will employ later in order to characterize the string stretching between the branes and anti-branes using arguments similar to those in [15].

The configuration is described by a solution to type IIA supergravity with metric

$$\begin{aligned}
 ds_{10}^2 = & T_1^{1/8} (T_2 T_3 T_4)^{5/8} \left[-dt^2 + \frac{\Sigma_1 \Sigma_2 \Sigma_3 \Sigma_4}{(r^2 - \gamma^2 \cos^2 \theta)^3} \left(\frac{dr^2}{\Delta} + d\theta^2 \right) \right] \\
 & + \frac{\Delta \sin^2 \theta}{T_1^{7/8} (T_2 T_3 T_4)^{3/8}} d\varphi^2 + \frac{T_1^{1/8} T_2^{5/8}}{T_3^{3/8} T_4^{3/8}} (dx_1^2 + dx_2^2) \\
 & + \frac{T_1^{1/8} T_3^{5/8}}{T_2^{3/8} T_4^{3/8}} (dx_3^2 + dx_4^2) + \frac{T_1^{1/8} T_4^{5/8}}{T_2^{3/8} T_3^{3/8}} (dx_5^2 + dx_6^2)
 \end{aligned} \tag{4.61}$$

and dilaton

$$e^{4\phi} = \frac{T_1^3}{T_2 T_3 T_4}, \tag{4.62}$$

with the functions Σ_i and T_i defined in (4.26),(4.27). Here, T_1 is associated with the $D6$ brane while $T_i, i = 2, 3, 4$ are associated with the three $D2$ branes. We first discuss in which context this metric corresponds to a $D6\text{---}\overline{D6}$ system. Setting to zero the charges q_2, q_3, q_4 of the three $D2$ branes, one indeed obtains the following $D6\text{---}\overline{D6}$ configuration,

$$ds_{10}^2 = T_1^{1/8} \left(-dt^2 + \sum_{i=1}^6 dx_i^2 \right) + T_1^{1/8} \Sigma_1 \left(\frac{dr^2}{\Delta} + d\theta^2 \right) + \frac{\Delta \sin^2 \theta}{T_1^{7/8}} d\varphi^2, \tag{4.63}$$

which coincides with the metric constructed following [15,56] once the radial variable is shifted from $r \rightarrow r - M$ and the string frame is used (see *e.g.*, [57] for the explicit expression). Note that compactification on a T^6 torus yields the metric,

$$ds_4^2 = T_1^{1/2} \left[-dt^2 + \Sigma_1 \left(\frac{dr^2}{\Delta} + d\theta^2 \right) \right] + \frac{\Delta \sin^2 \theta}{T_1^{1/2}} d\varphi^2, \tag{4.64}$$

describing the Einstein-Maxwell dilatonic single charge dihole (4.3) when the coupling to the dilaton is $\alpha = \sqrt{3}$. Also, (4.63) may be uplifted to eleven dimensions

to obtain

$$ds_{11}^2 = -dt^2 + \sum_{i=1}^6 dx_i^2 + \Sigma_1 \left(\frac{dr^2}{\Delta} + d\theta^2 \right) + T_1 (dx_{11} - 2A_\varphi d\varphi)^2 + \frac{\Delta \sin^2 \theta}{T_1} d\varphi^2, \quad (4.65)$$

where the magnetic potential is given by,

$$A_\varphi = \frac{a_1 M_1 (r + M_1) \sin^2 \theta}{\Delta + a_1^2 \sin^2 \theta}. \quad (4.66)$$

After shifting $r \rightarrow r - M$ in the above metric, one exactly recovers the Gross-Perry Kaluza-Klein dipole [55] embedded in eleven dimensions, which is the starting point of Sen's analysis of the $D6-\overline{D6}$ system.

We would like to stress at this point that, instead of performing a straightforward Kaluza-Klein compactification along the x_{11} direction in (4.65) to recover the configuration (4.63) (which possesses conical singularities along the axis), one may reduce along a twisted direction [15, 56]. In this way one obtains a configuration of $D6-\overline{D6}$ branes suspended in a magnetic field. Precisely the same result is obtained if a Harrison transformation with the appropriate value of the dilaton coupling is performed directly on the reduced solution. As a matter of fact, the equivalence between twisted KK reductions and Harrison transformations in the reduced KK theory was proven in [71]. In the case at hand, we know that the effect of performing a Harrison transformation on the metric (4.63) is just to replace T_1 by Λ_1 in (4.63).

4.4.2 The strings and membranes stretched between branes and anti-branes

The proper length of a string stretched between the poles where branes intersect depends in an essential way on the number of branes that intersect. These strings stretch along the line $r = \gamma$, parametrized by θ , $0 < \theta < \pi$. If there are less than four branes at the intersection then the proper spatial distance between poles is finite, but if all four branes are present then this distance is infinite. A situation where things can be studied further is that where a IIA configuration can be uplifted to $D = 11$ supergravity. The line $r = \gamma$ is fibered with the extra dimensions and becomes a surface. As a consequence, the string stretching between branes becomes

a membrane. For the case of the $D6-\overline{D6}$ the study of such a membrane was carried out in [15]. The configuration in (3) in the previous subsection is also suitable for such an analysis, and will allow us to recover as a particular case the results of [15].

When we uplift (4.61) to eleven dimensions we obtain a Kaluza-Klein dipole superposed to a system of three intersecting delocalized $M2$ branes and three intersecting delocalized $M2$ anti-branes, that is,

$$\begin{aligned}
 ds_{11}^2 &= (T_2 T_3 T_4)^{2/3} \left[-dt^2 + \frac{\Sigma_1 \Sigma_2 \Sigma_3 \Sigma_4}{(r^2 - \gamma^2 \cos^2 \theta)^3} \left(\frac{dr^2}{\Delta} + d\theta^2 \right) \right] \\
 &+ \frac{\Delta \sin^2 \theta}{T_1 (T_2 T_3 T_4)^{1/3}} d\varphi^2 + \frac{T_1}{(T_2 T_3 T_4)^{1/3}} (dx_{11} - 2A_\varphi d\varphi)^2 + \frac{T_2^{2/3}}{T_3^{1/3} T_4^{1/3}} (dx_1^2 + dx_2^2) \\
 &+ \frac{T_3^{2/3}}{T_2^{1/3} T_4^{1/3}} (dx_3^2 + dx_4^2) + \frac{T_4^{2/3}}{T_2^{1/3} T_3^{1/3}} (dx_5^2 + dx_6^2). \tag{4.67}
 \end{aligned}$$

In M-theory, the open string state should be described by a membrane wrapped on the surface $r = \gamma$. In order to distinguish it from the other, self-gravitating $M2$ -branes in the configuration, we will denote this one as an $m2$ -brane. As we just said, it wraps the surface $r = \gamma$. This surface is a bolt of the Killing vector

$$\mathbf{q} = \frac{\partial}{\partial x_{11}} + \frac{a_1}{2M_1(M_1 + \gamma)} \frac{\partial}{\partial \varphi}. \tag{4.68}$$

It is convenient for us to define the new “adapted” coordinate

$$\phi = \varphi - \frac{a_1}{2M_1(M_1 + \gamma)} x_{11} \tag{4.69}$$

such that

$$\mathbf{q}\phi = 0. \tag{4.70}$$

In this new coordinates the metric on the bolt is given by

$$\begin{aligned}
 ds_B^2 &= \prod_{i=2}^4 \left[a_i^4 \left(\frac{2q_i}{\gamma} + \frac{a_i^2 \sin^2 \theta}{\gamma^2} \right) \right]^{1/3} \frac{(\gamma + M_1)^2 - a_1^2 \cos^2 \theta}{\gamma^4 \sin^2 \theta} d\theta^2 \\
 &+ \prod_{i=2}^4 \left[\frac{\gamma^2}{a_i^2} \left(\frac{2q_i}{\gamma} + \frac{a_i^2 \sin^2 \theta}{\gamma^2} \right) \right]^{1/3} \frac{4M_1^2 (\gamma + M_1)^2}{(\gamma + M_1)^2 - a_1^2 \cos^2 \theta} d\phi^2. \tag{4.71}
 \end{aligned}$$

Now, when all four charges are turned on, this surface is topologically a cylinder. Its shape, and therefore that of the $m2$ -brane that wraps it, is like a sphere with two infinite funnels at its poles. This is most easily understood by looking at the

geometry near the poles in $D = 11$, after changing to the coordinates (4.10). We know that near the poles the geometry is, up to some angular distortion, the same as that of the core of an intersection between a KK monopole and three M2-branes. But the latter is

$$\begin{aligned}
 ds_{11}^2 &= -dt^2 + \sum_{i=1}^6 dx_i^2 + \frac{(q_2 q_3 q_4)^{1/3}}{q_1} (dx_{11} + q_1 \cos \bar{\theta} d\varphi)^2 \\
 &\quad + (q_2 q_3 q_4)^{1/3} q_1 \left(\frac{d\rho^2}{\rho^2} + d\bar{\theta}^2 + \sin^2 \bar{\theta} d\varphi^2 \right). \quad (4.72)
 \end{aligned}$$

and we explicitly see that $\rho = 0$ is down an infinite funnel of constant curvature fibered with x_{11} (there will be some angular distortion in the situation at hand, though).

The proper area of the bolt

$$\begin{aligned}
 A &= \int d\theta d\phi \sqrt{g_{\theta\theta} g_{\phi\phi}} \\
 &= 2M_1(\gamma + M_1) \int d\theta d\phi \prod_{i=2}^4 \left(\frac{2a_i q_i}{\gamma^2} + \frac{a_i^3 \sin^2 \theta}{\gamma^3} \right)^{1/3} \frac{1}{\sin \theta}, \quad (4.73)
 \end{aligned}$$

is infinite due to the divergence of the integration at $\theta = 0, \pi$. Since the energy of the m_2 -brane is $E = T_{m_2} A$, where T_{m_2} is the membrane tension, we reach the conclusion that the energy of the m_2 -brane stretched inbetween the poles is infinite! Notice that it remains infinite even if we set $a_1 = 0$ (so that $\gamma = M_1$). If the latter is to be considered as the limit of coincidence of the branes and antibranes, then the conclusion is even more striking than that reached in [15].

The situation, however, is different if one sets one, two or three M2 charges to zero in (4.71). Say that n of these charges are different from zero. Then, neglecting the angular distortion, the geometry near the poles is

$$\begin{aligned}
 ds_{11}^2 &= -dt^2 + \sum_{i=1}^6 dx_i^2 + \frac{\tilde{q}^{1/3}}{q_1} \rho^{1-n/3} (dx_{11} + q_1 \cos \bar{\theta} d\varphi)^2 \\
 &\quad + \tilde{q}^{1/3} q_1 \rho^{-1-n/3} (d\rho^2 + \rho^2 (d\bar{\theta}^2 + \sin^2 \bar{\theta} d\varphi^2)). \quad (4.74)
 \end{aligned}$$

where \tilde{q} is the product of the non-zero M2 charges. It is straightforward to see that if $n \neq 0, 3$, the geometry is singular. When $n = 0$ the geometry is just $\mathbb{R}^{10,1}$, since this is the core of a KK monopole. The singularity for $n = 1, 2$ is nevertheless a finite

spatial distance away, so the $m2$ -brane is topologically a sphere, with curvature singularities at the poles. Its proper area A , and the energy of the $m2$ -brane, is finite.

Let us now consider the limit where the branes and antibranes are coincident. It is not obvious what choice of parameters in the solution should correspond to this limit. One would certainly require any external fields to be absent, since their effect is to pull apart the poles. For the $D6\text{---}\overline{D6}$ system it was argued in [15] that one should also require $a = 0$, since this minimizes the distance between poles. In the present case, if we set all the a_i to zero then we would have all M_i equal to each other, and as a consequence all charges would be equal, which seems too restrictive. In order to motivate other alternatives, notice first that all the branes at an intersection move together, since they all intersect at the same pole. Then, it might be enough to set just one of the a_i to zero. This would leave us with four parameters, which can be regarded as the four charges of the branes, as desired. Since a_1 is singled out as characterizing the twist in the eleventh direction, then, at least in the context of M-theory, it probably makes more sense to define the coincidence limit by setting only $a_1 = 0$ (so that $\gamma = M_1$), while leaving a_2, a_3, a_4 arbitrary.

With this choice, the conclusions we had above for the $m2$ -brane stretched between branes and antibranes still hold in the coincidence limit: when any of the charges of the $M2$ -branes is zero the proper area of the $m2$ -brane is finite, whereas it is infinite when all charges are turned on. This conclusion, which may be taken as a ‘prediction’ about the strong coupling limit of this brane-antibrane configuration, is even more striking than that reached in [15] for $D6\text{---}\overline{D6}$ branes.

4.5 Discussion and Outlook

In this chapter, we constructed supergravity solutions describing the systems of intersecting brane—anti-brane. Motivated by an earlier work of Sen [15] on a $D6\text{---}\overline{D6}$ configuration of type IIA string theory, which he relates to the Kaluza-Klein dipole solution of Gross and Perry [55] (Euclidean 4d Kerr metric) embedded in eleven dimensions, and also by the recent work of Emparan [14] on black diholes, we

have identified new classical exact solutions to four dimensional General Relativity containing n abelian gauge fields and $n - 1$ independent scalar fields, whose generic lagrangians are given by (4.47). As we already noted in the introduction of this chapter, the case of two electric and two magnetic charges ($n = 4$) is particularly interesting since the corresponding lagrangian (4.1) arises as a consistent truncation of a wide class of low energy superstring compactifications, and therefore, the new four dimensional solutions can be uplifted to higher dimensional space-time and interpreted as rather sophisticated brane—anti-brane systems.

For general values of n , our four dimensional solutions depend on $n+1$ parameters $\{\gamma, a_i, i = 1, \dots, n\}$. They are static, axisymmetric solutions and describe composite diholes. Indeed, the near horizon analysis of these solutions reveals they contain two throats which one can identify, for arbitrary values of the parameters (which label the n charges and the separation between the holes), with the throats of two oppositely charged extremal composite black holes. Although the composite dihole configurations suffer from conical singularities, it is possible to suspend them in external magnetic fields via generalised Harrison transformations, and tune these fields to values which eliminate the conical deficit and keep the configurations in equilibrium. This equilibrium however is unstable i.e. a slight deviation along the symmetry axis from the equilibrium configuration is enough [56] to make the composite black holes collapse onto each other or accelerate apart. This instability, however, is of a completely different nature from the tachyonic instability appearing in perturbative string theory [4]. One might even wonder if the latter is a feature that survives when the string coupling is increased and the effects of self-gravity become important. An attempt to describe the tachyon instability in supergravity solutions is explained in [51], but is beyond the scope of this chapter.

The total charge of the $U(1)^4$ composite diholes is zero while their ADM mass, whether or not they are suspended in external fields, is given by $E = \frac{1}{2} \sum_{i=1}^4 M_i = \frac{1}{2} \sum_i (\gamma^2 - a_i^2)^{1/2}$ and is generically strictly positive.⁵ These configurations are therefore non extremal, and when analysed in a context of supersymmetry, break all

⁵We are not considering the possibility of diholes made out of ‘massless’ black holes.

supersymmetries, an observation which is particularly obvious in the presence of external fields, which are asymptotically Melvin and therefore have no Killing spinors associated to them. The absence of Killing spinors implies our solutions, as we expect, break all supersymmetries although they consist of a pair of extremal D-brane and anti-D-brane. Note that it might be possible to construct supergravity solutions representing brane—anti-brane configurations where branes and anti-branes are non-extremal (for example, by uplifting non-extremal dihole solutions in [73])

Another interesting observation is that the mass of the two composite extremal black holes, which is equal to $2M_{bh} = \frac{1}{2} \sum_{i=1}^4 \frac{M_i(M_i+\gamma)}{\gamma}$, exceeds the ADM mass E of the composite dihole: the latter is therefore non-marginally bound. When uplifted to ten or eleven dimensions, it becomes a supergravity soliton and can be interpreted as a system of four intersecting branes and four intersecting anti-branes as sketched in Figure 1, with the (anti)branes localized in the overall transverse directions only. Each brane is charged under a different $U(1)$ and has its corresponding anti-brane parallel to it. The existence of such configurations of branes and antibranes at arbitrary (large) separation 2γ when $a_i \gg M_i$ is another indication that the static force vanishes between the branes and antibranes.

We thus succeeded in providing classical solutions to supergravity theories which describe static, zero charge configurations which appear as a cluster of intersecting charged branes and a cluster of intersecting charged anti-branes. They are non-trivial generalisations of the $D6-\overline{D6}$ systems analysed by Sen, who recognised that systems with *coincident* branes and anti-branes could in particular be used to construct stable non-BPS states of a new type, via orientifolding and orbifolding. Since, Sen's analysis relies on the perturbative description of D-branes, it would be very instructive to study whether one can deform the supergravity solitons associated to brane—anti-brane systems in such a way that the resulting solutions (if any) describe these new stable non-BPS states. A first step in this direction should involve the study of the coincidence limit of the branes and antibranes in configurations of the sort we have been discussing. However, it appears that in the presence of gravity these systems exhibit features markedly different to those seen at the perturbative level, in particular, the size of membranes (and strings) stretched between the branes

and antibranes remains non-zero (even infinite) in the limit of coincidence branes. This may underline the difficulties of comparisons between calculations performed at the weakly (CFT) and strongly coupled (supergravity) regimes.

Chapter 5

Conclusion

All consistent ten-dimensional supersymmetric string theories have been conjectured to occupy different corners of the moduli space of a single theory in eleven dimensions called M-theory. More recently, the type 0A theory, which is tachyonic and has no space-time fermions in its perturbative spectrum, has also found a place in the web of dualities which inter-connects the string theories mentioned above. This state of affairs raises several important issues one must address if string theory is to be considered a serious candidate to describe all interactions of Nature at the most fundamental level.

In this thesis, we asked two simple questions and provided clues for their resolutions. The first one was whether one could somehow relate the 26-dimensional bosonic string theory to its fermionic ten-dimensional cousins. At a very deep level, we were really asking whether the fermionic degrees of freedom are really fundamental in the description of our world. Unfortunately, we are unable to conclude at this stage, as the work presented here only gives compelling evidence at a kinematical level and all results could be viewed as an unavoidable consequence of how tightly group theory and conformal invariance constrain the whole theory. Although there are hints of an underlying dynamics in the truncation procedure - for instance the prediction of the tension of fermion Dirichlet nine-branes from purely bosonic considerations - we are still looking for a dynamical mechanism where non-perturbative effects most probably will play an important rôle.

Our contribution to this exciting programme is described in Chapter 3, where we

first highlight some important aspects of preexisting literature on the subject [9,12]. All ten-dimensional fermionic strings (supersymmetric or not, tachyonic or not) can emerge from the truncation of the bosonic string compactified on the $E_8 \times SO(16)$ group lattice. The fermionic oscillators may be obtained via a bosonization procedure of the world sheet coordinates in the compactified directions. This allows us to compare the bosonic formalism with the Neveu-Schwarz-Ramond and Green-Schwarz formalism of superstring theory as in Section 3.4.2.

Here we almost always used the $E_8 \times E_8$ root lattice which is a sublattice of the $E_8 \times SO(16)$ weight lattice ($\Lambda_{E_8} = \Lambda_{(o)_{16}} + \Lambda_{(s)_{16}}$) because we chose to develop our arguments in the context of type II or type I theories. We also used a different truncation in the left and right sector of the 26-dimensional bosonic string theory to obtain the type IIA theory (as opposed to the same truncation in left and right sectors for type IIB). This leads to an unsatisfactory outcome as the bosonic fusion rules do not lead to a unique set of fermionic fusion rules after truncation, as first pointed out by L. Houart. The resolution of this problem is fortunately simple and provides more insight in the structure of the whole construction. It amounts to compactify the bosonic string on the lattice of $(E_8 \times) \widetilde{SO(16)}/\mathbb{Z}_2^+$ or $(E_8 \times) \widetilde{SO(16)}/\mathbb{Z}_2^-$ to obtain type IIB, and of $(E_8 \times) \widetilde{SO(16)}/(\mathbb{Z}_2^+ \times \mathbb{Z}_2^-)$ to obtain type IIA, where $\mathbb{Z}_2^+ \times \mathbb{Z}_2^-$ is the centre of the covering group $\widetilde{SO(16)}$. The latter is not an Englert-Neveu compactification, but the corresponding lattice being even self-dual Lorentzian, it leads to a consistent, modular invariant truncated theory. The implications of this very recent discovery are the object of a forthcoming publication [74]. In particular, it allows to obtain not only the space filling fermionic D-branes but also all lower dimensional D-branes in the various ten-dimensional theories. The fate of the latter was actually our main concern when the paper by Englert, Houart and Taormina [12] was explained to us. We thought the truncation should capture all properties of superstrings, especially the non-perturbative effects. This was our motivation in Section 3.5, where we showed that the BPS D-branes in type I theory can be obtained from wrapped D-branes in the bosonic theory. The latter wrap the $E_8 \times E_8$ lattice in such a way that the bosonized fermions satisfy the appropriate boundary conditions. This suggests the truncation should be valid in the non-perturbative regime. Note that

the generalization to the D-branes in Type II theory should be straightforward.

The second question we asked was whether one could extend the checks of duality to non-BPS states in string theory, as there was concern the sought for dualities were intimately related to supersymmetry and the fact BPS states saturate the energy bound. We therefore thought constructing explicit non-BPS states might help understand their nature better and give us clues on their behaviour under duality.

In Chapter 4, we succeeded in constructing new exact solutions which describe composite dihole configurations. The conical singularities in our solutions can be resolved by applying external magnetic fields via a (generalized) Harrison transformation and by tuning these fields to the values which eliminate the conical deficit. The external magnetic fields keep the solution in equilibrium. Motivated by the works of Sen [15] on a $D6-\overline{D6}$ configuration of type IIA string theory, we uplifted the composite dihole solutions to ten and eleven dimensions in order to describe a configuration which contains a cluster of intersecting branes and a cluster of intersecting anti-branes in string and M-theory.

We also studied the properties of an open string stretching between branes and anti-branes. According to perturbative string theory, we expect the classical mass of the open string to vanish when the separation between the two clusters of branes and anti-branes becomes zero (the coincident limit of branes and anti-branes). In contrast, our calculations in Section 4.4.2 showed the mass of an open string stretching between the clusters of branes and anti-branes is infinity! (And it becomes finite but not zero if we turn off the M2 charges to recover Sen's solution.)

Moreover, although our brane–anti-brane configurations are balanced in a magnetic field, a slight relative displacement of the pair of intersecting branes without an accompanying change in the magnetic field, will make the configuration off balance. This phenomenon and the absence of tachyon instability do not correspond to the feature of brane–anti-brane systems in perturbative string theory. To understand this problem, we might require the knowledge of superstring in Ramond-Ramond background which is not fully developed at this stage.

Bibliography

- [1] M.B. Green, J. Schwarz and E. Witten, *Superstring Theory*, volumes 1 and 2, Cambridge University Press (1987).
- [2] J. Polchinski, *String Theory*, volumes 1 and 2, Cambridge University Press (1998).
- [3] M.S. Costa and M. Gutperle, *The Kaluza-Klein Melvin solution in M-theory*, **JHEP0103** (2001) 27, hep-th/0012072.
- [4] A. Sen, *Non-BPS states and branes in string theory* hep-th/9904207, and references therein.
- [5] F. Englert, H. Nicolai and A. Schellekens, *Superstrings from 26 dimensions*, Nucl. Phys. **B274** (1986) 315.
- [6] J. Schwinger, *Gauge invariance and mass II*, Phys. Rev. **128** (1962) 2425.
- [7] S. Coleman, *Quantum sine-Gordon equation as the massive Thirring model*, Phys. Rev. **D11** (1975) 2088.
S. Mandelstam, *Soliton operators for the quantized sine-Gordon equation*, Phys. Rev. **D11** (1975) 3026.
B. Dashen, B. Hasslacher and A. Neveu, *The particle spectrum in model field theories from semiclassical functional integral techniques*, Phys. Rev. **D11** (1975) 3424.
- [8] R. Jackiw and C. Rebbi, *Spin from isospin in a gauge theory*, Phys. Rev. Lett. 36 (1976) 1116.
P. Hasenfratz and G. 't Hooft, *A Fermion-Boson Puzzle in Gauge Theory*,

- Phys. Rev. Lett. 36 (1976) 1119.
- A.S. Goldhaber, *Spin and Statistic Connection for Charge-Monopole Composites*, Phys. Rev. Lett. 36 (1976) 1122.
- [9] A. Casher, F. Englert, H. Nicolai and A. Taormina, *Consistent Superstrings as Solutions of the D=26 Bosonic String Theory*, Phys. Lett. **B162** (1985) 121.
- [10] P.G.O. Freund, *Superstring from Twenty-Six Dimensions?*, Phys. Lett. **B151** (1985) 387.
- [11] G. Pradisi and A. Sagnotti, *Open String Orbifolds*, Phys. Lett. **B216** (1989) 59.
- M. Bianchi and A. Sagnotti, *On Systematics of Open String Theories*, Phys. Lett. **B247** (1990) 517.
- M. Bianchi and A. Sagnotti, *Twist Symmetry and Open-String Wilson Lines*, Nucl. Phys. **B361** (1991) 519.
- M. Bianchi, G. Pradisi and A. Sagnotti, *Toroidal Compactification and symmetry Breaking in Open-String Theories*, Nucl. Phys. **B376** (1992) 365.
- A. Sagnotti, *Some Properties of Open String Theories*, hep-th/9702093.
- E. Dudas, J. Mourad, and A. Sagnotti, *Charged and uncharged D-branes in various string theories*, Nucl. Phys. **B620** (2002) 109, hep-th/0107081.
- C. Angelantonj and A. Sagnotti, *Open String*, hep-th/0204089.
- [12] F. Englert, L. Houart, and A. Taormina, *Brane fusion in the bosonic string and the emergence of fermionic strings*, **JHEP0108** (2001) 013, hep-th/0106235.
- [13] A. Chattaraputi, R. Emparan and A. Taormina, *Composite dihole and intersecting brane-antibrane configurations in string/M-theory*, Nucl. Phys. **B573** (2000) 291, hep-th/9911007.
- [14] R. Emparan, *Black diholes*, Phys. Rev. **D61** (2000) 009, hep-th/9906160.
- [15] A. Sen, *Strong coupling dynamics of branes from M theory*, **JHEP10**, (1997) 002 hep-th/9708002.

- [16] B. Craps, *D-branes and boundary states in closed string theories*, Katholieke Universiteit Leuven Ph.D. Thesis (2000), hep-th/0004198.
- [17] K.S. Stelle, *BPS Branes in Supergravity*, hep-th/9803116.
R. Argurio, *Brane Physics in M-theory*, Université Libre de Bruxelles Ph.D. Thesis (1998), hep-th/9807171.
- [18] A.M. Polyakov, *Quantum geometry of bosonic strings*,
Phys. Lett. **B103** (1981) 207.
A.M. Polyakov, *Quantum geometry of fermionic strings*,
Phys. Lett. **B103** (1981) 211.
- [19] N. Berkovits, A. Sen and B. Zwiebach, *Tachyon condensation in superstring field theory*, Nucl. Phys. **B587** (2000) 147, hep-th/0002211.
L. Rastelli, A. Sen and B. Zwiebach, *Vacuum string field theory*, hep-th/0106010.
- [20] E. Cremmer, B. Julia and J. Scherk, *Supergravity theory in eleven-dimensions*, Phys. Lett. **B76** (1978) 409.
- [21] I.C.G. Campbell and P. West, *$N=2$ $D=10$ nonchiral supergravity and its spontaneous compactification*, Nucl. Phys. **B243** (1984) 112.
F. Giani and M. Pernici, *$N=2$ supergravity in ten-dimension*, Phys. Rev. **D30** (1984) 325.
M. Huq and M.A. Namazie, *Kaluza-Klein supergravity in ten-dimension*, Class.Quant.Grav. **2** (1985) 293.
- [22] J.H. Schwarz, *Covariant field equations of Chiral $N=2$ $D=10$ supergravity*, Nucl. Phys. **B226** (1983) 269.
P.S. Howe and P. West, *The complete $N=2$, $D=10$ supergravity*, Nucl. Phys. **B238** (1984) 181.
- [23] S.W. Hawking, *Gravitational instantons*, Phys. Lett. **A60** (1977) 81.
- [24] A.A. Tseytlin, *Harmonic superpositions of M-branes*, Nucl. Phys. **B475**, 149 (1996), hep-th/9604035.

- [25] R. Argurio, F. Englert and L. Houart, *Intersection rules for p-branes*, Phys.Lett.**B408** (1997) 151, hep-th/9712170.
- [26] O. Bergman and M.R. Gaberdiel, *Non-supersymmetric Open String Theory and S-Duality*, Nucl.Phys.**B499** (1997) 183, hep-th/9701137.
- [27] O. Bergman and M.R. Gaberdiel, *Dualities of type 0 strings*, **JHEP9907** (1999) 22, hep-th/9906055.
- [28] S. Elitzur, E. Gross, E. Rabinovici and N. Seiberg, *Aspects of Bosonization in String Theory*, Nucl. Phys. **B283** (1987) 413.
- [29] H. Nicolai, and A.N. Schellekens, *Topics in String Theory*, in Proceedings of the 5th Adriatic Meeting on Superstrings, Anomalies and Unification, Dubrovnik (1986).
- [30] J. A. David, S. Minwalla and C. Nunez, *Fermions in Bosonic String Theories*, hep-th/0107165.
- [31] W. Lerche, A. Schellekens and N.P. Warner, *Lattices and Strings*, Physics Reports **177** (1989) 1.
- [32] G.T. Horowitz and L. Susskind, *Bosonic M-Theory*, hep-th/0012037.
- [33] M. Kaku, *Introduction to String Theory*, Springer-Verlag, 1987.
- [34] J. Polchinski, *Dirichlet-branes and Ramond-Ramond Charges*, Phys. Rev. Lett. **75** (1995) 4724, hep-th/9510017.
- [35] J. Polchinski, S. Chaudhuri and C.V. Johnson, *Note on D-branes*, hep-th/9602052.
J. Polchinski, *TASI lectures on D-branes*, hep-th/9611050.
- [36] F. Englert, and A. Neveu, *Non-Abelian Compactification of the Interacting Bosonic String*, Phys. Lett. **B163** (1985) 349.
- [37] E. Verlinde, *Fusion rules and Modular transformations in 2-D conformal field theory*, Nucl. Phys. **B300** (1988) 360.

- [38] P. Di Vecchia and A. Liccardo, *D-Brane in string theory I/II*, hep-th/9912161 and hep-th/9912275.
- [39] M.R. Gaberdiel, *Lecture on Non-BPS Dirichlet branes*, Class. Quant. Grav. 17 (2000) 3483, hep-th/0005029.
- [40] S. Elitzur, E. Rabinovici and G. Sarkissian, *On Least Action D-branes*, Nucl. Phys. **B541** (1999) 246, hep-th/9807161.
- [41] J. Polchinski and Y. Cai, *Consistency of Open Superstring Theories*, Nucl. Phys. **B296** (1988) 91.
- [42] C.G. Callan, C. Lovelace, C.R. Nappi and S.A. Yost, *Adding Holes and Cross-caps to the Superstring*, Nucl. Phys. **B293** (1987) 83.
C.G. Callan, C. Lovelace, C.R. Nappi and S.A. Yost, *Loop Corrections to the Superstring Equation of Motions*, Nucl. Phys. **B308** (1988) 221.
- [43] M. Frau, L. Gallot, A. Lerda and P. Strigazzi, *Stable Non-BPS D-Branes in Type I String Theory*, Nucl. Phys. **B564** (2000) 60, hep-th/9903123.
- [44] N. Ishibashi, *The Boundary and Crosscap States in Conformal Field Theories*, Mod. Phys. Lett. A4 (1989) 251.
M. Kato and T. Okada, *D-Branes on Group Manifolds*, Nucl. Phys. **B499** (1997) 583, hep-th/9612148.
S. Stanciu, *D-Branes in Group Manifolds*, **JHEP001** (2000) 025, hep-th/9909163.
- [45] P. Mukhopadhyay, *Unstable Non-BPS D-Branes of Type II string Theories in Light-cone Green-Schwarz Formalism*, Nucl. Phys. **B600** (2001) 285, hep-th/0011047.
- [46] M.B. Green and M. Gutperle, *Light-cone Supersymmetry and D-branes*, Nucl. Phys. **B476** (1996) 484, hep-th/9604091.
- [47] J.A. Harvey, S. Kachru, G. Moore and E. Silverstein, *Tension is Dimension*, **JHEP0003** (2000) 1, hep-th/9909072.

- [48] J. Maldacena, *The large N limit of superconformal field theories and supergravity*, Adv. Theor. Math. Phys. **2** (1998) 231, hep-th/9711200.
- [49] A. Strominger and C. Vafa, *Microscopic Origin of the Bekenstein-Hawking Entropy*, Phys. Lett. **B379** (1996) 99, hep-th/9601029.
- [50] See *e.g.*, A. Peet, *Baldness/Delocalization in intersecting brane systems* hep-th/9910098, and references therein.
- [51] P. Brax, G. Mandal and Y. Oz, *Supergravity description of non-BPS branes*, Phys. Rev. **D63** (2001) 008, hep-th/0005242.
- [52] S. Alexander, *Inflation from D - \bar{D} brane annihilation*, Phys. Rev. **D65** (2002) 507, hep-th/0105032.
- [53] M. Majumdar and A.C. Davis, *Cosmological creation of D -branes and anti- D -branes*, JHEP 0203 (2002) 056, hep-th/0202148.
- [54] E. Witten, *D -branes and K -theory*, JHEP **9812** (1998) 019, hep-th/9810188.
K. Olsen and R.J. Szabo, *Brane descent relations in K -theory*, Nucl.Phys. **B566** (2000) 562, hep-th/9904153.
- [55] D.J. Gross and M.J. Perry, *Magnetic Monopoles In Kaluza-Klein Theories*, Nucl. Phys. **B226**, 29 (1983).
- [56] F. Dowker, J.P. Gauntlett, G.W. Gibbons and G.T. Horowitz, *Nucleation of p -branes and fundamental strings*, Phys. Rev. **D53**, 7115 (1996) hep-th/9512154.
- [57] D. Youm, *Delocalized supergravity solutions for brane/anti-brane systems and their bound states*, Nucl. Phys. **B573** (2000) 223, hep-th/9908182.
- [58] S. Mukherji, *On the heterotic dipole at strong coupling*, hep-th/9903012;
B. Janssen and S. Mukherji, *Kaluza-Klein dipoles, brane/anti-brane pairs and instabilities*, hep-th/9905153.
- [59] M. Cvetič and D. Youm, *Dyonic BPS saturated black holes of heterotic string on a six torus*, Phys. Rev. **D53**, 584 (1996) hep-th/9507090.

- [60] M. Cvetič and A.A. Tseytlin, *Solitonic strings and BPS saturated dyonic black holes* Phys. Rev. **D53**, (1996) 5619, hep-th/9512031.
M. Cvetič and D. Youm, *General static spherically symmetric black holes of heterotic string on a six torus* Nucl. Phys. **B472** (1996) 249, hep-th/9512127.
- [61] J. Rahmfeld, Phys.Lett. **B372**, 198 (1996), hep-th/9512089.
- [62] R. Emparan, *Massless black hole pairs in string theory*, Phys. Lett. **B387**, 721 (1996), hep-th/9607102.
- [63] R. Emparan, *Composite black holes in external fields*, Nucl. Phys. **B490**, 365 (1997), hep-th/9610170.
- [64] R. Kallosh, A. Linde, T. Ortin, A. Peet and A. Van Proeyen, *Supersymmetry as a cosmic censor*, Phys. Rev. **D46**, 5278 (1992) hep-th/9205027.
- [65] S.F. Ross, *Pair production of black holes in a $U(1) \times U(1)$ theory*, Phys. Rev. **D49**, 6599 (1994) hep-th/9401131.
- [66] W.B. Bonnor, *An exact solution of the Einstein-Maxwell equation referring to a magnetic dipole*, Z. Phys. **190**, 444 (1966)
- [67] A. Davidson and E. Gedalin, *Finite magnetic flux tube as a black and white dihole*, Phys. Lett. **B339**, 304 (1994) gr-qc/9408006.
- [68] M.J. Duff, J.T. Liu and J. Rahmfeld, *Four dimensional string/string/string triality*, Nucl.Phys. **B459**(1996)125-159, hep-th/9508094.
- [69] V. Balasubramanian and F. Larsen, *On D-branes and black holes in four-dimensions*, Nucl. Phys. **B478**, 199 (1996) hep-th/9604189.
- [70] I. Klebanov and A.A. Tseytlin, *Intersecting M-branes as four-dimensional black holes*, Nucl. Phys. **B475**, 179 (1996) hep-th/9604166.
- [71] F. Dowker, J.P. Gauntlett, D.A. Kastor and J. Traschen, *Pair creation of dilatonic black holes* Phys. Rev. **D49** (1994) 2909, hep-th/9309075.

- [72] Y.C. Liang and Edward Teo, *Black dihole with unbalanced magnetic charges*, Phys. Rev. **D64** (2001) 019, hep-th/0101221.
- [73] R. Emparan and Edward Teo, *Macroscopic and Microscopic description of black Diholes*, Nucl. Phys. **B610** (2001) 190, hep-th/0104206.
- [74] A. Chattaraputi, F. Englert, H. Houart and A. Taormina, *The bosonic mother of fermionic D-branes*, in preparation.

