

Durham E-Theses

Polyfluorinated systems resulting from free radical addition reactions

Christel M. Olivarès

How to cite:

Olivarès, Christel M. (2001) Polyfluorinated systems resulting from free radical addition reactions. Doctoral thesis, Durham University.

Use policy

The full-text may be used and/or reproduced, and given to third parties in any format or medium, without prior permission or charge, for personal research or study, educational, or not-for-profit purposes provided that:

- a full bibliographic reference is made to the original source
- a <https://etheses.durham.ac.uk/id/eprint/3861/> is made to the metadata record in Durham E-Theses
- the full-text is not changed in any way

The full-text must not be sold in any format or medium without the formal permission of the copyright holders.

Please consult the [full Durham E-Theses policy](#) for further details.

University of Durham

A Thesis Entitled

**Polyfluorinated Systems resulting from
Free Radical addition Reactions**

Submitted by

Christel M. Olivarès
University of Montpellier

A Candidate for the degree of Doctor of Philosophy
2001

The copyright of this thesis rests with the author. No quotation from it should be published in any form, including Electronic and the Internet, without the author's prior written consent. All information derived from this thesis must be acknowledged appropriately.



- 8 MAR 2002

*"Si toute notre connaissance débute avec l'expérience,
cela ne prouve pas qu'elle dérive toute de l'expérience"*

Kant, Critique de la Raison Pure, 1781.

Acknowledgements

I would like to thank Professor R. D. Chambers, Dr. Sandford and Dr. A. M. Kenwright for their invaluable advice and help through this work.

This Thesis could not have been completed without the precious help of Dr. M. Jones and Miss L. Turner (mass spectrometry); Mrs. J. Dostal (elemental analysis); Mr. L. Lauchlan (gas chromatography); Mrs. J. Say, Mrs. C. Heffernan and Mr. I. McKeag (NMR); Mr. R. Hart, Mr. G. Haswell and Mr. M. Richardson (glass blowing); Mr. D. Hunter (high pressure laboratory); Mr. J. Lincoln and Mr. J. Peel (store); Dr. A. Royston (IT service); Mrs. I. Harries, Mrs. C. Hubrey and Mrs. A. Carrahar (secretariat staff).

Finally, I would like to thank my family and friends for their support throughout this period of study.

Memorandum

The work described in this thesis has been carried out at the University of Durham between May 1998 and April 2001. This Thesis is the work of the author, except where acknowledge by reference and has not been submitted for another degree. No part of this Thesis should be reproduced without the author written agreement.

The work has been presented at :

TMR Seminar, Montpellier, April 1999

Abbreviations

NMR	Nuclear Magnetic Resonance
IR	Infrared
GC/MS	Gas Chromatography/Mass Spectrometry
HFP	Hexafluoropropene
BDE	Bond dissociation energy
DTBP	Di- <i>tert</i> -butyl peroxide

Abstract

The first part of this work was to synthesise partially fluorinated reactive compounds and then to study their reactivity towards nucleophiles and electrophiles. These reactive compounds were obtained in a two step process from both cyclopentane and adamantane and in a three step process for cyclopentanol. The first step was the free radical addition of the cycloalkanes, cycloalcohol to hexafluoropropene *via* thermal and/or radiochemical alkylations :

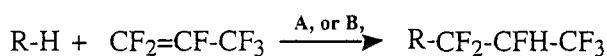

A, γ rays, RT, 10 days

B, DTBP, 140°C, 24 h

R : cyclopentane, adamantane and cyclopentanol

For the cyclic alkane derivatives, the second step was a stereospecific dehydrofluorination of the fluorocarbon chain, whereas for the cyclic alcohol, a dehydration and then dehydrofluorination were performed to give the conjugated diene. Finally, the fluoroalkene reactivity was studied *via* nucleophilic and electrophilic addition reactions.

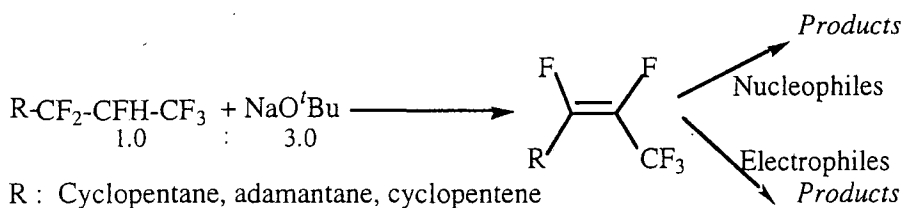

The second part of my work was to study the free radical addition of tertiary amines to hexafluoropropene, an example is illustrated below.

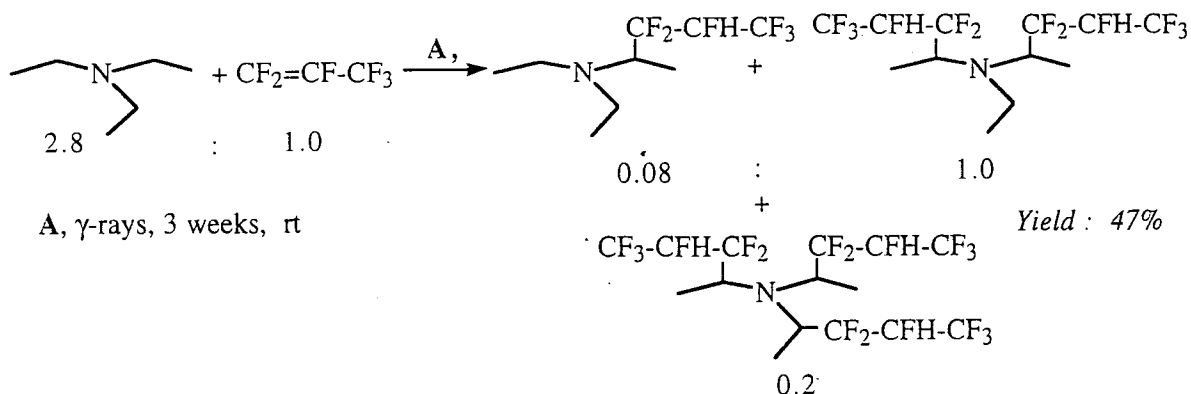

Contents

Chapter 1 : General Introduction	1
1.1. Properties	2
1.2. Applications	2
1.2.a. Low fluorinated compounds	2
1.2.b. Highly fluorinated compounds	5
1.3. Conclusion	6
1.4. Free radical additions	6
1.4.a. Generation of free radicals	7
1.4.b. Radical structure and stability	9
1.4.c. Influence of fluorine on radical structure	11
1.4.d. Stability of fluorinated radical	12
1.4.e. Reactivity of free radicals	13
1.5. Free radical additions to fluoroalkenes	17
1.5.a. Mechanism of the free radical addition to fluoroalkenes	18
1.5.b. Hexafluoropropene	18
1.5.c. Orientation of free radical addition to hexafluoropropene	18
1.5.d. Polar effects	19
1.6. Addition of oxygen containing compounds to hexafluoropropene	20
1.6.a. Alcohols	20
1.6.b. Diols	23
1.6.c. Ethers	24
1.6.d. Esters	29
1.6.e. Addition of nitrogen containing compounds to hexafluoropropene	30
1.6.f. Addition of sulphur containing compounds to hexafluoropropene	33
1.6.g. Addition of alkanes to hexafluoropropene	34
1.6.h. Other systems	37
1.7. Conclusion	38
Chapter 2 : Free radical addition to hexafluoropropene	39
2.1. Introduction	39
2.2. NMR spectroscopy techniques	39
2.3. Free radical additions of adamantane	41
2.3.a. Monoadduct (36) and diadduct (39)	42

2.3.b. Triadduct (40) and tetraadduct (41)	46
2.4. Free radical additions of cyclopentane	47
2.4.a. 1-(1,1,2,3,3,3-hexafluoropropyl)cyclopentane (43)	48
2.4.b. trans-1,1,2,3,3-hexafluoro-1-[3-(1,1,2,3,3,3-hexafluoropropyl)cyclopentyl]propane (44b)	49
2.5. Free radical additions of cyclopentanol	52
2.6. Conclusion	54

Chapter 3 : Dehydration and dehydrofluorination reactions 56

3.1. Introduction	56
3.2. Dehydration	56
3.2.a. Introduction	56
3.2.b. Dehydration of 1-(1,1,2,3,3,3-hexafluoropropyl)cyclopentanol (46)	57
3.3. Dehydrofluorination reactions	58
3.3.a. Vicinal difluoroalkanes	59
3.3.b. Geminal difluorides	59
3.3.c. Dehydrofluorination from a polyfluoroalkyl chain	59
3.3.d. Polyfluoro compounds	62
3.3.e. Vinylic fluorides	62
3.3.f. Mechanism	63
3.4. Dehydrofluorination of hexafluoropropene adducts	64
3.4.a. Adamantane monoadduct (36)	64
3.4.b. Cyclopentane adducts (43) and (44b)	65
3.4.c. Cyclopentene monoadduct (49)	68
3.5. Conclusion	69

Chapter 4 : Z-Alkene Chemistry Studies 71

4.1. Introduction	71
4.2. Nucleophilic addition reactions	71
4.2.a. Regioselectivity	71
4.2.b. Factors influencing the reactivity of the orientation attack	72
4.2.c. Mechanism	73
4.3. Examples of nucleophilic addition reactions	73
4.3.a. Reactions involving oxygen centred nucleophile	73
4.3.b. Reactions involving nitrogen centred nucleophile	80
4.3.c. Reactions involving carbon centred nucleophile	81
4.4. Electrophilic addition reactions	83

4.4.a.	Orientation of electrophilic attack	83
4.4.b.	Halogenation	83
4.4.c.	Interhalogenation	84
4.5.	Epoxidation reactions	84
4.5.a.	Oxygen centred as nucleophile	84
4.5.b.	Oxygen centred as electrophile	85
4.6.	Nucleophilic additions involving oxygen as nucleophile	86
4.6.a.	Using alkoxides derivatives	86
4.6.b.	Saturated alcohols	86
4.6.c.	Unsaturated alcohols	90
4.6.d.	Diol	103
4.7.	Nucleophilic additions involving nitrogen as nucleophile	103
4.7.a.	Ammonia	103
4.7.b.	Diethylamine	104
4.8.	Nucleophilic additions involving carbon as nucleophile	105
4.8.a.	Organolithium compounds	105
4.9.	Electrophilic addition reactions	108
4.9.a.	Elemental bromine	108
4.10.	Epoxidation reactions	109
4.11.	Conclusion	109
4.11.a.	Z-alkene (54b) from adamantane adduct	109
4.11.b.	Z-alkene (57b) from cyclopentene adduct	110

Chapter 5 : Free radical addition of amines to HFP 111

5.1.	Introduction	111
5.2.	Free radical addition to acyclic amines	112
5.2.a.	Triethylamine	112
5.2.b.	N,N-dimethylethylamine	114
5.2.c.	N,N-diisopropylethylamine	115
5.3.	Free radical addition to cyclic amines	115
5.3.a.	N-methyl pyrrolidine	115
5.3.b.	N-methyl piperidine	116
5.3.c.	N-ethyl piperidine	119
5.3.d.	N-methyl morpholine	120
5.3.e.	N-ethyl morpholine	121
5.4.	Influence of various factors over the free radical process	121
5.4.a.	Temperature	121
5.4.b.	Dibenzoyl peroxide	122

5.5.	1,4-dimethyl piperazine	122
5.6.	Dehydrofluorination Reactions	123
5.7.	Conclusion	123
Experimental Section		125
Instrumentation and Reagents		125
Chapter 6 : Experimental to Chapter 2		126
6.1.	General procedure for free radical additions to hexafluoropropene	126
6.1.a.	Peroxide initiation	126
6.1.b.	γ -ray initiation	126
Chapter 7 : Experimental to Chapter 3		128
7.1.	Dehydration	128
7.2.	General procedure for dehydrofluorinations reaction	128
Chapter 8 : Experimental to Chapter 4		130
8.1.	Nucleophilic substitution reactions : oxygen as nucleophile	130
8.1.a.	General procedure for alkoxide derivatives	130
8.1.b.	General procedure for silyl derivatives	133
8.2.	Nucleophilic substitution reactions : nitrogen as nucleophile	133
8.3.	Nucleophilic substitution reactions : carbon as nucleophile	134
8.3.a.	General procedure for organolithium derivatives	134
8.3.b.	General procedure for sodium malonate derivatives	135
8.3.c.	Grignard reagent	135
8.4.	Electrophilic substitution reactions	135
8.4.a.	General procedure for halogenation reactions	135
8.5.	Epoxidation reactions	136
8.5.a.	General procedure	136
Chapter 9 : Experimental to Chapter 5		138
9.1.	Free radical addition to HFP using γ -rays	138
9.2.	Influence of various factors over the free radical process	141
9.3.	Dehydrofluorination reactions	141

Appendices

Appendix A : NMR Spectra

Appendix B : Mass Spectra

Appendix C : IR Spectra

Appendix D : X-ray Crystal Structure

References

143

Chapter 1 : General Introduction

Fluorine is the most abundant halogen in the Earth's crust (0.065%) and ranks thirteenth of all elements^{1, 2}. Fluorine can be found combined with other elements in minerals such as fluorspar (CaF_2), cryolite (Na_3AlF_6) and fluorapatite ($[\text{Ca}_3(\text{PO}_4)_2 \text{Ca}(\text{F},\text{Cl})_2]$). However, organofluorinated compounds are rare in Nature, Table 1 shows some naturally occurring organofluorinated compounds³. Some such as fluoroacetic acid (1), fluoroacetone (2), ω -fluorofatty acid (3) originate from plants while others originate from microorganisms (nucleocidin (4) and 4-fluorothreonine (5)).

Compounds	
	$\text{CH}_2\text{FCO}_2\text{H}$ (1)
	$\text{CH}_2\text{FCOCH}_3$ (2)
	$\begin{array}{c} \text{OH} \quad \text{OH} \\ \quad \\ \textit{threo} \text{ CH}_2\text{F}(\text{CH}_2)_7\text{CH}-\text{CH}(\text{CH}_2)_7\text{CO}_2\text{H} \end{array}$ (3)
	 (4)
	$\begin{array}{c} \text{OH} \\ \\ \text{CH}_2\text{FCHCHCO}_2\text{H} \\ \\ \text{NH}_2 \end{array}$ (5)

Table 1

The replacement of a fluorine by a hydrogen atom, in an organic system, introduces only small steric and geometric perturbations relative to the hydrocarbon moiety. Because of the non abundance of organofluorinated compounds in Nature and the unique character of fluorine (i. e. no distortion of the system geometry by

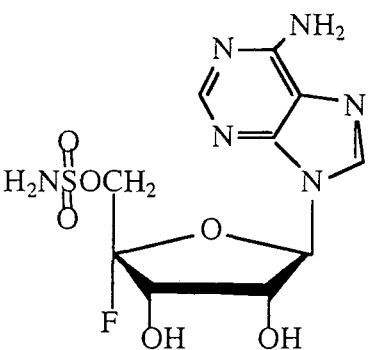

substitution of a hydrogen by a fluorine), organofluorine chemistry has been an important field of study for many years and the subject still constitutes a major branch of organic chemistry⁴. Several factors make fluorine as an unusual substituent in organic molecules.

1.1. Properties :

By comparison with the other halogens (Table 2), fluorine is the most electronegative element which gives rise to a strong polarisation of the C-F bond and the strongest single bond to carbon, with a bond dissociation energy of 110 kcal/mol. This gives increased thermal and chemical stabilities to some highly fluorinated compounds. With an atomic radius of 1.47Å, which is not so much larger than that for the hydrogen (1.20Å), fluorine is the smallest of the halogens.

X	Bond Dissociation Energy CH ₃ -X (kcal mol ⁻¹)	Electronegativity (Pauling Scale)	Van Der Waal's radius (Å)	Bond Length C-X (Å)
F	110	4.0	1.47	1.39
Cl	85	3.0	1.80	1.78
Br	71	2.8	1.95	1.93
I	57	2.5	2.15	2.14
H	99	2.2	1.20	1.09

Table 2

The electronic effects of fluorine in a molecule can potentially change the physical and biological as well as chemical reactivities of hydrogenated analogues. Fluorine also has unshared *p* electron pairs⁵ available for conjugation with other *p* orbitals from other atoms in the same row of the Periodic Table such as a carbon atom.

1.2. Applications :

1.2.a. Low fluorinated compounds :

Organofluorine chemistry is a growing field with diverse applications of fluorinated compounds used in a wide range of industrial areas such as the pharmaceutical, medicinal, agrochemical and chemical industries. Some examples are given below.

1.2.a.i. Medicinal and pharmaceutical :

Desflurane $\text{CF}_3\text{CFHOCF}_2\text{H}$, Isoflurane $\text{CF}_3\text{CClHOCF}_2\text{H}$ and Sevoflurane $(\text{CF}_3)_2\text{CHOCFH}_2$, are volatile anaesthetics commonly used in operation theatres.

Table 3 illustrates the most famous chemicals used to fight diseases. Their biological uses can be explained by various factors⁶. Firstly, as shown in Section 1, introduction of a fluorine atom does not perturb the geometry of the molecule and only provides a change in the chemical properties. Thus the fluorinated derivative and the active analogues would not be sterically distinguishable to the active site of the enzyme, therefore enabling the fluorinated derivative to act as an anti metabolite. Secondly, the replacement of hydrogens with fluorines can increase the lipid solubility, therefore the transport of the active molecule is facilitated and speeded up across the lipid membranes. Lastly, because of the electron withdrawing effect of the fluorine atoms, the reactivity as well as the stability of the neighbouring functional groups can be altered.

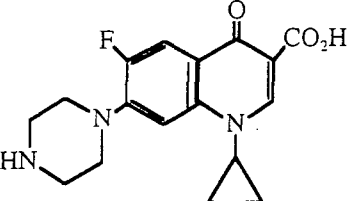
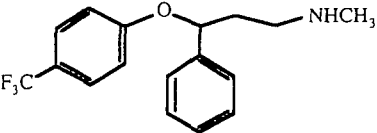
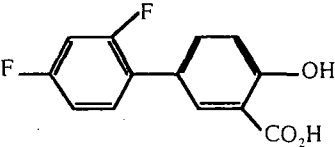
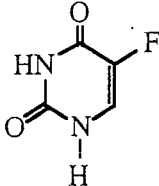
Compounds	Applications
<p style="text-align: center;">Ciprofloxacin</p> 	Antibacterial
<p style="text-align: center;">Fluoxetine</p> 	Anti-depressant
<p style="text-align: center;">Diflunisal</p> 	Analgesic, anti-inflammatory, anti-pyretic
<p style="text-align: center;">5-Fluorouracil (5-FU)</p> 	Anti-cancer agent

<p style="text-align: center;">Fluconazole</p> 	Anti-fungal
<p style="text-align: center;">6-[¹⁸F]Fluoro-L-Dopa</p> 	Anti-Parkinsonian
<p style="text-align: center;">Dexamethasone</p> 	Glucocorticoids, anti-inflammatories
<p style="text-align: center;">Fluprednisolone</p> 	Glucocorticoids, anti-inflammatories

Table 3

1.2.a.ii. Agrochemical :

Chemical crop protection agents such as (6), (7) and (8) are used to protect crops against pest and disease as well as loss *via* weed competition⁷ (Table 4).

Compounds	Applications
<p style="text-align: center;">Butafenacil (6)</p> 	Herbicide
<p style="text-align: center;">Trifloxystrobin (7)</p> 	Fungicide
<p style="text-align: center;">Lufenuron (8)</p> 	Acaricide, insecticide

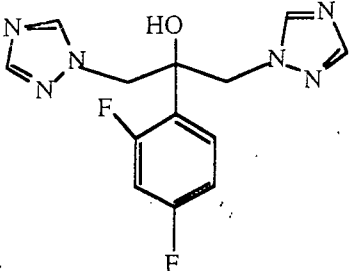
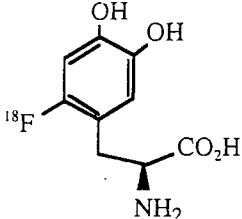
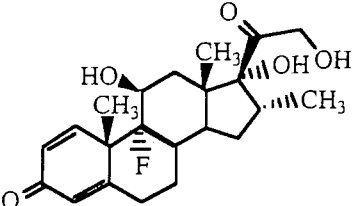
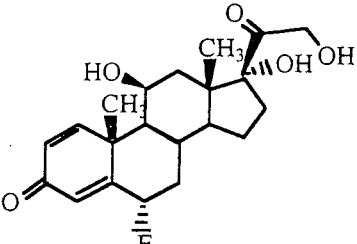
Table 4

1.2.a.iii. Common uses : fire extinguishants, refrigerants

Hydrofluorocarbon (HFC) agents are used as refrigerants⁸ e. g. HFC 134a (CF₃CH₂F) and fire extinguishants (Halon). Halon 1301 (CF₃Br) and 1211 (CF₂BrCl) are most commonly used because they do not produce corrosive or abrasive residues and are non conducting (i. e. can be used safely).

1.2.b. Highly fluorinated compounds :

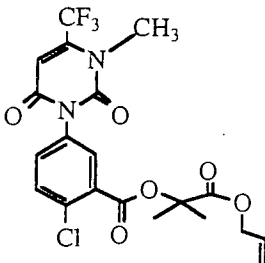
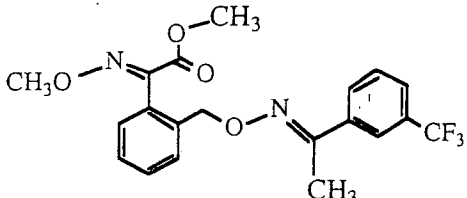
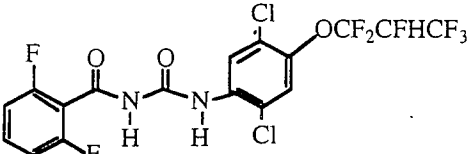
The presence of several fluorine atoms confers to these compounds high thermal and chemical stabilities (linked to the strength of the C-F bond) as well as low surface energy, leading to hydrophobic and anti-fouling properties. These highly fluorinated compounds can be used in a wide range of areas. Some examples are illustrated below⁹.

1.2.b.i. Electrical insulators :

Polytetrafluoroethylene $-(CF_2)_n-$ is a good electrical insulator because of its high thermal and chemical stability and anti-stick properties.

1.2.b.ii. Coating material :

Polyvinylfluoride $-(CH_2-CHF)_n-$ is a weather resistant material because of its ability to resist to bacterial oxidation.

1.2.b.iii. Surface treatment reagents :

Copolymers of perfluoroalkyl containing acrylates (9) or methacrylate esters (10) as well as sulfonamides (11) can be used as grease-proofing agents for paper or stain repellents for textiles (Scheme 1).

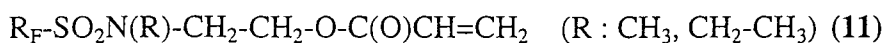
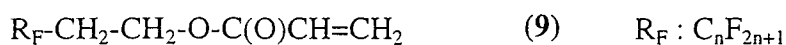

Scheme 1

1.3. Conclusion :

Fluorine containing compound applications are diverse and constantly expanding as their uses are needed in every day life. Incorporation of one or more fluorine atoms in a molecule, yields specific chemical properties without altering the geometry of these compounds. This is quite important for biological applications as the mimic effect can be optimised.

1.4. Free radical additions :

Some of the most interesting reactions in organic chemistry are the addition of reagents across a double bond of olefins¹⁰. This process can occur according to various mechanisms where the intermediate can be electrophilic, nucleophilic or radical. Radical reactions are influenced by oxygen and other inhibitors (eg. hydroquinone) and proceed *via* Kharasch addition (anti-Markovnikov orientation).

The first pathway involving synthesis by free radical additions appeared in 1937 by Hey and Waters with the homolytic phenylation of aromatic substrates. This was followed by Kharasch who reported the anti-Markovnikov addition of hydrogen bromide to alkenes¹¹.

In general, the reaction involves a chain process⁴ where A-B is added across a double bond involving transient free radicals as intermediates. The generalised process can be described as a succession of four important steps which are : initiation, addition, propagation and termination (Scheme 2).

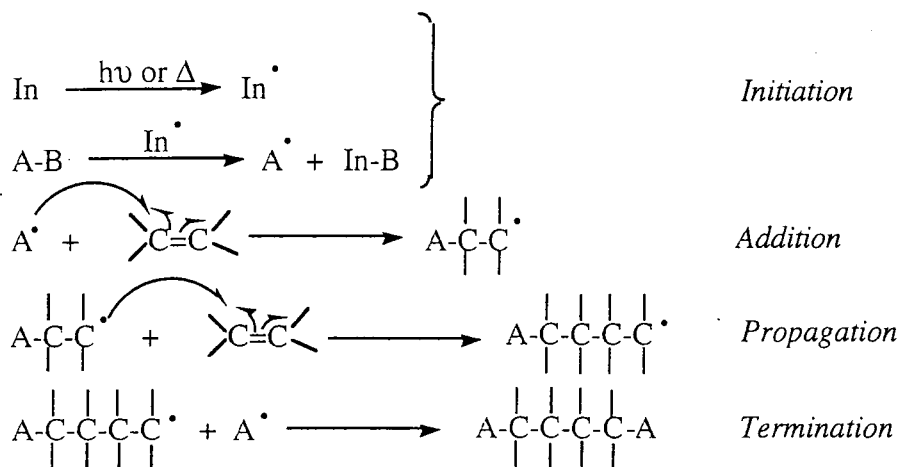

Scheme 2

This chain process is only possible, if the AB concentration is sufficiently high and if the A-B bond is weak enough to be broken.

1.4.a. Generation of free radicals :

The first step in a free radical process involves formation of free radicals by homolytic cleavage of a σ -bond. This can be induced by heat or light (i. e. thermolysis, photolysis, radiolysis and oxidation-reduction processes) depending on the type of bond¹².

1.4.a.i. Thermolysis :

Free radicals are formed at high temperatures, which increases the vibrational energy of a molecule. The internal energy gained by the molecule can then be lost by homolytic fission. To obtain free radicals at temperatures below 150°C, weak bonds with a bond dissociation energy about 30 to 40 kcal mol⁻¹ are required. For this purpose, suitable peroxides (12) and azoalkanes (13), are used as chemical initiators (Scheme 3). Then the free radicals formed can initiate an exothermic hydrogen chain transfer reaction. Decomposition of peroxides yields slightly electrophilic radicals¹³ (acyloxyl or oxyl) which lead to strong O-H bonds.

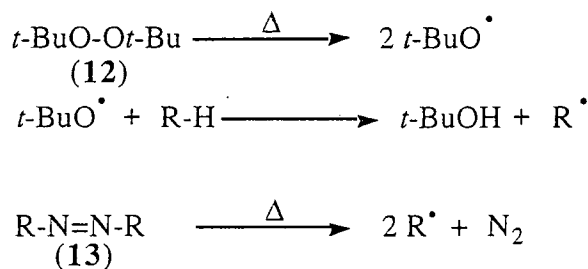

Scheme 3

1.4.a.ii. Photolysis :

This method is based on the ability of an organic molecule to absorb radiation in the ultra-violet or visible range. The light absorbed has sufficient energy to excite electrons in the molecule and cause the homolytic fission of a covalent bond. This energy follows Planck's law, expressed in the equation below, where h is the Planck constant, c the speed of the light and λ the wavelength of the light.

$$E = hc/\lambda$$

For example, using light of wavelength 254 nm, methyl iodide can be dissociated into "hot" methyl radicals (with an excess of energy) and iodine atoms¹⁴.

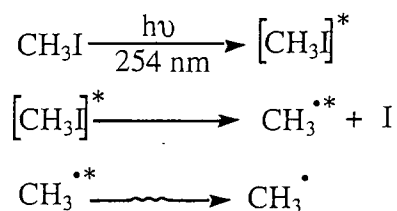

Scheme 4

This process is used for homolytic rupture of bonds which requires high temperatures if performed by thermolysis. An example of such a process is the homolytic cleavage of the Cl-Cl bond by exposure to the sunlight (if done by thermolysis requires a temperature up to 200°C) (Scheme 5).

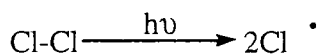

Scheme 5

1.4.a.iii. Radiolysis :

Radicals can also be produced by direct action of high energy radiation (X-rays or γ -rays) to neutral organic molecules which possess a C-H bond with low bond dissociation energy. Horowitz¹⁵ showed that free radicals are obtained *via* complex

steps (Scheme 6). In the primary steps, the absorbed radiation generates cations and electronically excited molecules. These excited molecules can then cleave to give free radical or other products.

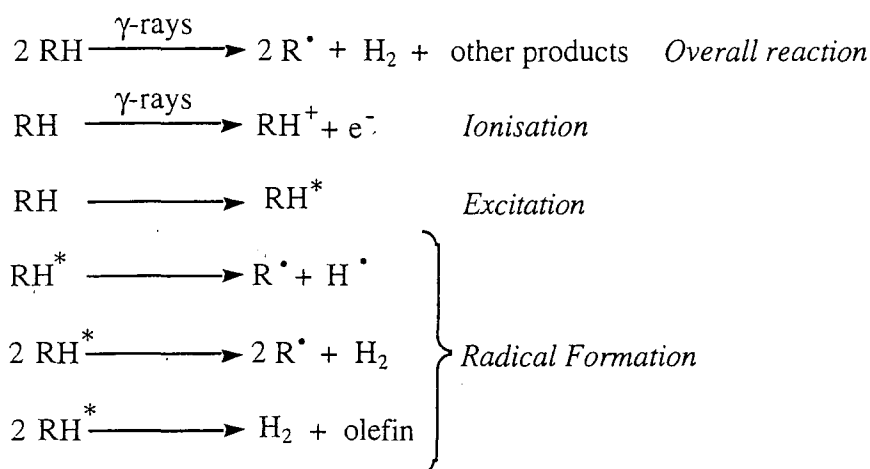

Scheme 6

In the initiation process for radiolysis, a cluster of radicals is formed along the trajectory of the γ -radiation instead of a homogeneous distribution of excited states. As for photolysis initiation, radiolysis can be performed at room temperature or at higher temperature.

1.4.a.iii. Oxidation-reduction processes :

These types of reactions involve one-electron transfer and fragmentation of the radical¹², using metal ions or electrochemical reactions (Scheme 7).

Oxidation :

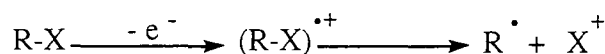

Reduction :

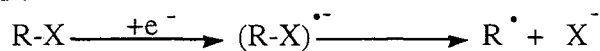

Scheme 7

1.4.b. Radical structure and stability :

1.4.b.i. Structure :

The geometry or configuration of radical centres have been investigated *via* *esr* (electron spin resonance). An alkyl radical can be planar, if the unpaired electron

is accommodated in a p orbital, or pyramidal if the unpaired electron is accommodated in an sp^3 hybrid orbital^{12, 16} (Scheme 8). The *esr* spectrum of $^{13}\text{CH}_3$, showed that the methyl radical is planar.

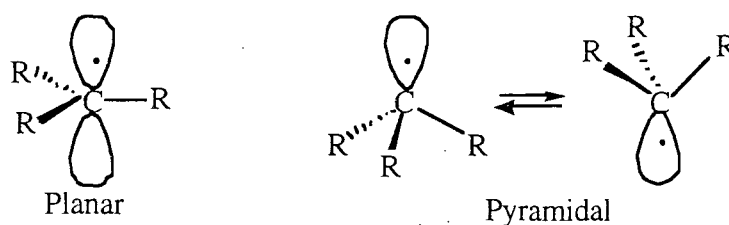

Scheme 8

1.4.b.ii. Stability :

The relative stability of the alkyl radicals have been assessed according to the values of bond dissociation energies¹⁷ (BDEs) (Table 5); the higher the BDE, the less stable the radical.

C-H	BDEs (kcal mol ⁻¹)
(CH ₃) ₃ C-H	93.0
(CH ₃) ₂ CH-H	94.5
CH ₃ -CH ₂ -H	98.0
CH ₃ -H	105.0

Table 5

This give rises to the relative stability of the alkyl radicals which follows the order :

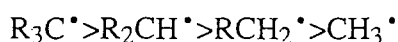

1.4.b.iii. Influence of a π -donor substituent in an α position to the radical centre :

Mesomerism is another factor responsible for stability of the radical¹². Unsaturated systems as well as heteroatoms in the α position of a radical centre, contribute to the stability of the radical because of the conjugation effect (Scheme 9).

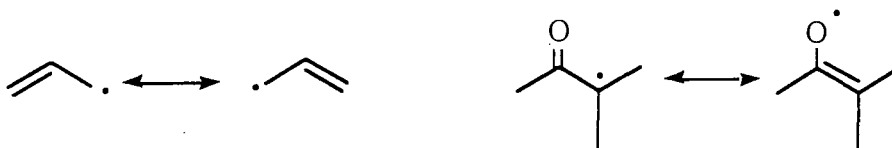

Scheme 9

Conjugation with the lone pair of the heteroatom (O, N, S, halogen) stabilises the radical by increasing the electron density at the reaction centre (e. g. the carbon) (Scheme 10).

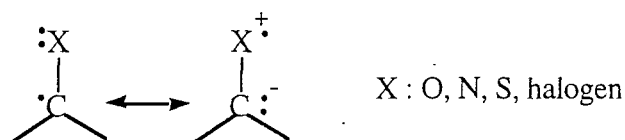

Scheme 10

The increased stability can be described in terms of frontier orbital theory¹⁸ which involves the interaction between the SOMO (singly occupied molecular orbital) of the radical and the heteroatom lone pair of the halogen (Scheme 11).

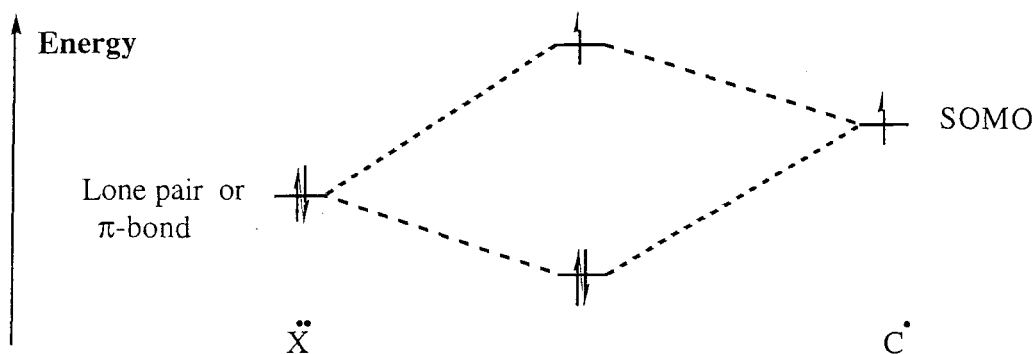

Scheme 11

1.4.c. Influence of fluorine on radical structure :

The replacement of one or more hydrogen atoms in a methyl radical by fluorine atoms has a dramatic effect on the structure of the radical. The radical structure goes from planar for the methyl radical, to tetrahedral for the trifluoromethyl radical. This was shown by the *esr* ¹³C spectrum¹⁹ and is illustrated in Table 6.

Radicals				
	$\cdot\text{CH}_3$	$\cdot\text{CH}_2\text{F}$	$\cdot\text{CHF}_2$	$\cdot\text{CF}_3$
a (¹³ C)	38.5	54.8	148.8	272.0

Table 6

Each replacement of one hydrogen by a fluorine atom affects the value of a (¹³C) (the *esr* ¹³C hyperfine splitting constants) which give a useful indicator of the geometry since the non planarity of the radical introduces an s character into the

orbital containing the unpaired electron. An increasing value of a (^{13}C) indicates an increasing non planarity of the radical. The strong effect of fluorine substituents on the geometry of a radical (pyramidalisation of the radical) is due to the σ inductive influence of the fluorine substituent. As the number of fluorine atoms increases, the s character of the half-filled orbital increases too, across the series :

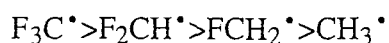

Hybridisation is one of the reasons for pyramidalisation of the radical site, but it has also been suggested^{4, 20} that pyramidalisation is the result of diminishing electronic repulsion (destabilising effect) due to the unshared lone pair of each fluorine.

1.4.d. Stability of fluorinated radicals :

Dolbier¹⁹ has shown the factors which influence fluorinated radical stability are the same which affect the radical structure. Table 7 shows the different BDEs obtained by replacing 1, 2 or 3 hydrogen atoms by fluorine in methane and ethane.

C-H	BDEs (kcal mol ⁻¹)
CH ₃ -H	104.8
CH ₂ F-H	101.2
CHF ₂ -H	103.2
CF ₃ -H	106.7
CH ₃ -CH ₂ -H	101.1
CH ₃ -CF ₂ -H	99.5

Table 7

According to these results, 1 or 2 fluorine substituents in the α position have a slight stabilising effect on the radical being formed as the BDEs decrease, whereas 3 fluorines atoms have a destabilising effect. As the s character of the radical orbital increases (i. e. increase of non planarity which leads to pyramidalisation) by introduction of fluorines, resonance stabilisation by the fluorine α to the radical centre (Section 1.4.b.iii.) is diminished and therefore reduced interactions result in destabilisation (Scheme 12).

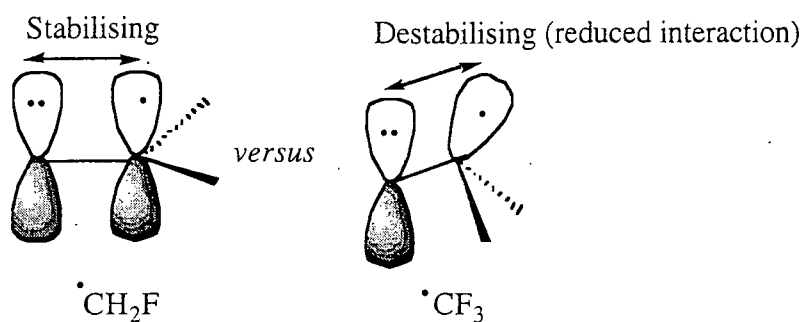

Scheme 12

Table 8 illustrates the BDE resulting from replacing hydrogen atoms by fluorines.

C-H	BDEs (kcal mol ⁻¹)
CH ₃ -CH ₂ -H	101.1
CF ₃ -CH ₂ -H	106.7
CF ₃ -CF ₂ -H	102.7

Table 8

Although experimental data for the ethanes is incomplete, it appears as if 2 fluorines in the β position, have a stabilising effect, whereas a trifluoromethyl group is destabilising. Further calculations on some missing members of the fluorinated ethyl compounds (Table 9) indicate that the presence of one fluorine in β position is sufficient to destabilise the ethyl radical.

C-H	BDEs (kcal mol ⁻¹)
CH ₃ -CH ₂ -H	97.7
CH ₂ F-CH ₂ -H	99.6
CHF ₂ -CH ₂ -H	101.3
CF ₃ -CH ₂ -H	102.0

Table 9

The structure of the ethyl derived radical is planar resulting from the overlap between the $2p$ orbital containing the unpaired electron and the π^* orbital of the alkyl group adjacent to the radical centre. The overlap accounts for the stabilising effect by delocalisation of the radical by hyperconjugation. With the introduction of a fluorine, the planarity of the system diminished, hyperconjugation is not observed and thus stabilisation of the radical is not obtained.

1.4.e. Reactivity of free radicals :

Energy factors such as BDEs, enthalpy of reaction and structural factors which depend on polar, steric and conformational effects control the reactivity of free radicals.

1.4.e.i. Hydrogen abstraction step :

The reactivity of the radical can be measured by its ability to abstract a hydrogen atom during the hydrogen transfer process. The overall enthalpy²¹ is the difference in bond dissociation energy of the substrate (X-H) and the strength of the new bond (R-H) being formed (Scheme 13).

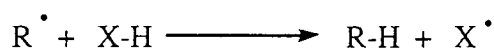

$$\Delta H = D(X-H) - D(R-H)$$

Scheme 13

One of the illustrations of this is the hydrogen abstraction by a phenyl radical¹² where the rate constant for the hydrogen abstraction increases as the BDEs decrease and therefore the exothermicity of the reaction increases (Table 10).

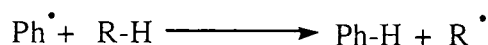

R-H	Primary	Secondary	Tertiary
BDEs (kcalmol ⁻¹)	101	99	95
ΔH (kcalmol ⁻¹)	-10	-12	-16
k 10 ⁻⁵ (M ⁻¹ s ⁻¹)	0.35	3.3	16.0

Table 10

1.4.e.ii. Polar effects :

Tedder²² showed that hydrogen abstraction by trifluoromethyl radicals is an exothermic process while hydrogen abstraction by methyl radical is thermoneutral. This was explained in terms of the polarity of the radicals. Trifluoromethyl radicals are *electrophilic* and react readily with the more *nucleophilic* centres (i. e. tert>sec>prim>CH₄).

A radical can be *electrophilic* or *nucleophilic* which is due to its electron affinity¹² (Scheme 14).

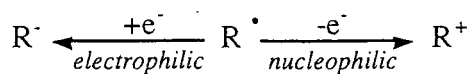

Scheme 14

The radical is *electrophilic* when it has a high electron affinity and pulls electron from the bond being broken. If the ionisation potential of the radical is low, then the radical gives up an electron and is *nucleophilic*. The *nucleophilicity* of an X-C \cdot radical increases in the following sequence (Scheme 15) :

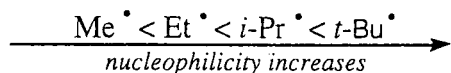

Scheme 15

The radical is *electrophilic* when X is an electron withdrawing group : -NO₂, -CN, -COR, -CO₂R, -CF₃.

The frontier orbital interactions for an *electrophilic* and a *nucleophilic* radicals are illustrated in Scheme 16. Radicals bearing electron attracting substituents will have low energy SOMO. These radicals show *electrophilic* character and will react strongly with an alkene bearing electron donating substituents on the double bond (e. g. high HOMO and LUMO). Whereas radicals with high energy SOMO (bearing electron donating substituents), will react with an electron poor olefin (low LUMO). Thus the *nucleophilic* character of the radical favours strong HOMO-LUMO interactions.

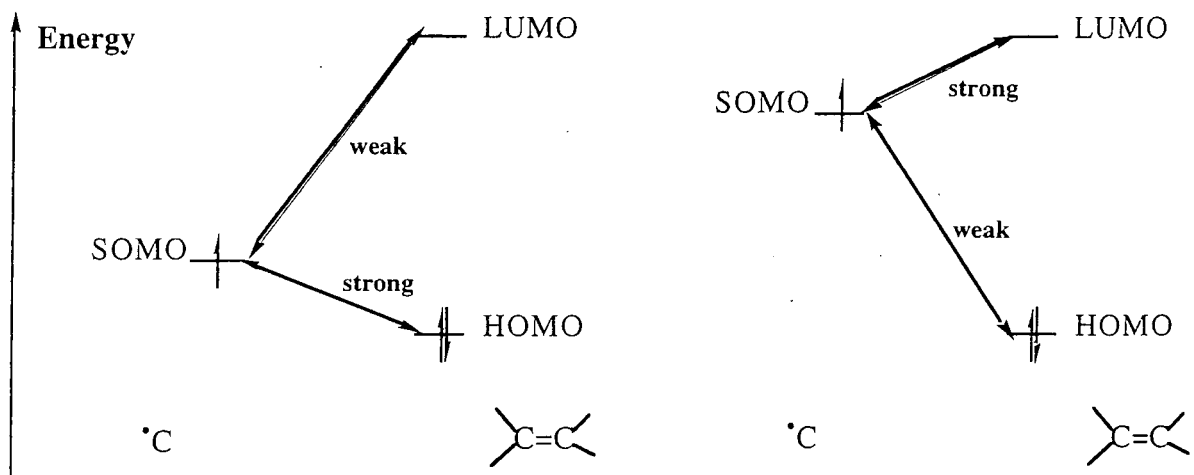

Electrophilic radical

Nucleophilic radical

Scheme 16

Different substituents on the radical or the olefin give different results. An example of this, is the reaction cyclohexyl radical (*nucleophilic*) with different Z substituents at the C α position of the double bond of the olefin (Table 11).

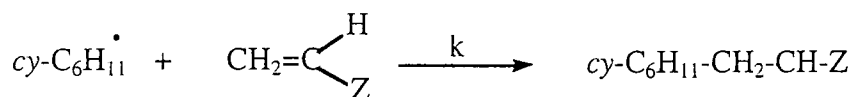

Z	<i>n</i> -Bu	Ph	CO ₂ Me	CN	CHO
<i>k</i> _{rel}	1	84	3000	6000	8500

Table 11

*k*_{rel} increases with the increasing of the electron attracting character of the Z substituent (lowering the LUMO energy). This reflects the greater the reactivity with the *nucleophilic* cyclohexyl radical since the SOMO-LUMO interactions are favoured and strong.

The influence of different substituents on the radical lead to different selectivities depending on the polarity of the obtained radical (Table 12).

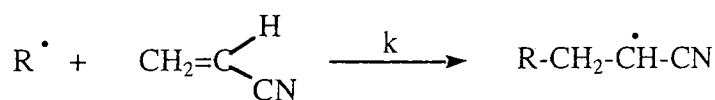

R $\dot{\text{C}}$	R $\dot{\text{C}}$ _{prim} (14)	R $\dot{\text{C}}$ _{sec} (15)	R- $\dot{\text{C}}$ -CN (16)
<i>k</i> _{rel}	1	7.3	0.0015

Table 12

The reaction of an electron poor olefin, with a radical bearing electron donor substituents (*nucleophile* such as (14) and (15)) is greater than the reaction with an *electrophile* radical such as (16), bearing an electron attractor substituent.

1.4.e.iii. Steric effects :

Three different steric effects control radical attack²³ : steric hindrance from substituents on the alkene inhibits the radical approaching a particular reaction centre (Scheme 17), steric inhibition of resonance inhibits stabilisation by electron delocalisation of the new radical being formed and finally, steric compression (Scheme 18) which is partially released by formation of the new radical (release of steric strain, torsional strain).

* Steric hindrance :

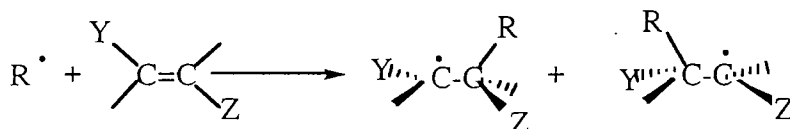

Scheme 17

The reaction is favoured at the less substituted carbon when the substituents are bigger than hydrogen. The regioselectivity is dictated by the less steric crowded side of the alkene.

* Steric compression :

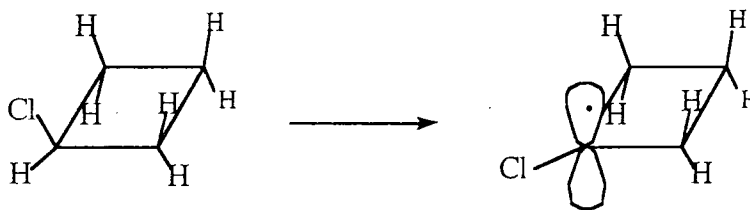

Scheme 18

Formation of the (1-chlorocyclobutyl) radical is accompanied by release of the ring steric strain.

1.5. Free radical additions to fluoroalkenes :

After a literature review about general free radical addition reactions, this part of the Chapter will concern free radical additions to fluoroalkenes, as these reactions were used in the first step of the synthesis of our reactive precursor. Various fluoroalkenes have been used and studied for these reactions, but in our work we will concentrate on only one : hexafluoropropene.

Haszeldine and co-workers showed in their various patents that free radical additions to hexafluoropropene are a useful way to introduce a fluoroalkyl group into an organic compound^{24, 25}.

1.5.a. Mechanism of the free radical addition to fluoroalkene:

The radical chain mechanism of the reaction is that shown in the Scheme 19, where the fluorinated alkene is inserted into the C-H bond²⁶. The free radical reaction was thermally initiated.

The mechanism is a 3 step process :

- first scission of the telogen,
- addition of the free radical to the double bond,
- and then a hydrogen is transferred from another molecule of substrate to the intermediate radical.

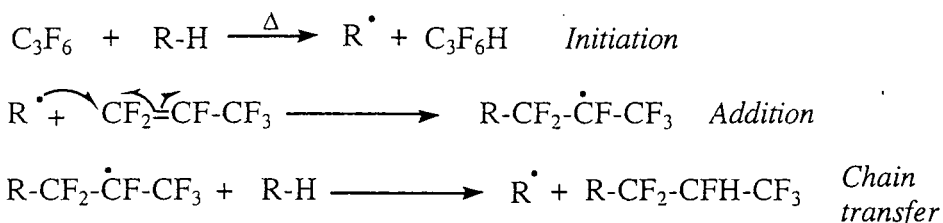

Scheme 19

1.5.b. Hexafluoropropene :

Hexafluoropropene is industrially available. It forms only homopolymers under extreme conditions²⁷ (because of the steric inhibition of the CF₃ group), in consequence no products from telomerisation are observed. The hexafluoropropene unit can be inserted into a C-H bond, which does not make part of an aromatic ring, in a highly controlled manner.

1.5.c. Orientation of free radical addition to hexafluoropropene :

Polar, steric and electronic effects are quite important in the orientation of free radical addition²⁸. As it was shown in Section 1.4.e.ii., alkyl radicals are *nucleophilic* and react readily with electrophiles. Because of the inductive effects from both the fluorine atom and the trifluoromethyl group, fluorinated alkenes are very electrophilic, they will react with a nucleophilic system to give a radical intermediate (Scheme 20).

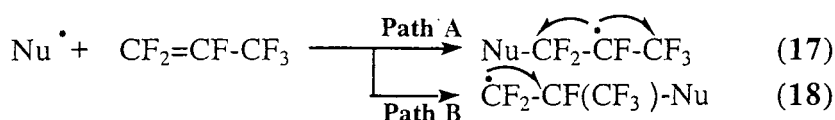

Scheme 20

Two pathways are possible for the free radical attack : pathway A, where the attack occur at the CF_2 position to give radical (17) and pathway B, where the attack occur at the CF position to give (18). The more the *nucleophilic* radical is, this yields to a radical attack according to path A. Firstly because the CF_2 site is the less hindered of the fluoro olefin and secondly because a tertiary intermediate radical if formed (*via* path A), *versus* a secondary radical (*via* path B). As it was shown in Section 1.4.b.ii., the production of the radical (17) preferentially reflects the relative stability of the intermediate radical and the new bond being formed. Moreover the trifluoromethyl group and the fluorine atoms are electron withdrawing and stabilise the radical. The radical adds preferentially to the terminal position because this also leads to the strongest new bond being formed because of the lowest steric interactions.

1.5.d. Polar effects :

Free radical additions of thiols to hexafluoropropene proceeded smoothly under photochemical or thermal conditions²⁹. Reactions of trifluoromethanethiol, trifluoroethanethiol and methanethiol gave, *via* a sulphur centred radical, the 1:1 adducts in good yield. Polar effects are important in this reaction as illustrated in the thiol reaction (Scheme 21).

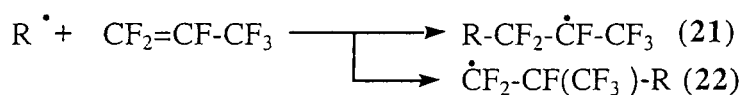

Scheme 21

R	(19) (%)	(20) (%)
CF_3S	45	55
$\text{CF}_3\text{CH}_2\text{S}$	70	30
CH_3S	91	9

Table 13

Table 13 shows that the increasing electrophilic character of the R group (from R : CF₃ electrophilic group, to R : CH₃ nucleophilic group) is quite clear. This shows that a thiol containing a nucleophilic R group leads preferentially to the free radical addition at the CF₂ position to give the radical (21) (leading to (19)). Whereas a thiol containing an electrophilic R group leads preferentially to the formation of (20) *via* the radical (22). These results underline the fact that the polar character of the R group is important in free radical addition to hexafluoropropene.

Formation of regioisomer (obtained *via* (22)), can be rationalised by the inductive effect of the trifluoromethyl group and then relative *electrophilicity* of the thiyl radical, leading to the transition state illustrated in the Scheme 22.

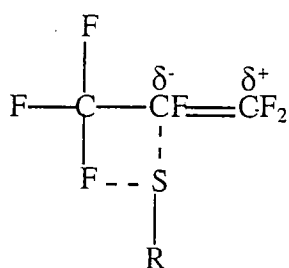

Scheme 22

1.6. Addition of oxygen containing compounds to hexafluoropropene :

1.6.a. Alcohols :

1.6.a.i. Mechanism :

In the presence of an initiating reagent radical, alcohols form free radicals by losing a hydrogen atom from the carbon attached to the oxygen (Scheme 23), because the radical centre is stabilised by the oxygen (Section 1.4.b.iii.). This interaction also increases the *nucleophilicity* of the alkoxy radical. The free radical adds to the double bond of the hexafluoropropene to form a new alcohol in a normal chain process³⁰.

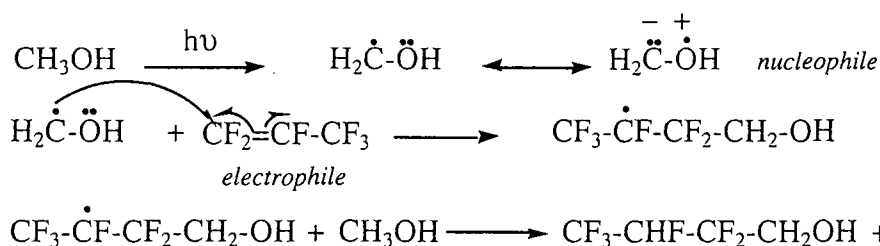

Scheme 23

In all the reactions, using a slight excess of hexafluoropropene, only the 1:1 adducts were obtained in high yield. The high selectivity of these reactions was attributed to 2 factors where the oxygen atom is responsible. The first one was the extreme *electrophilicity* of the radical being formed (23) which influenced the abstraction of a hydrogen from an electron rich alcohol (Scheme 24). The second one was, because of the oxygen electron withdrawing character, it deactivated the other sites which favoured free radical addition at another carbon atom than the one bearing the hydroxyl group.

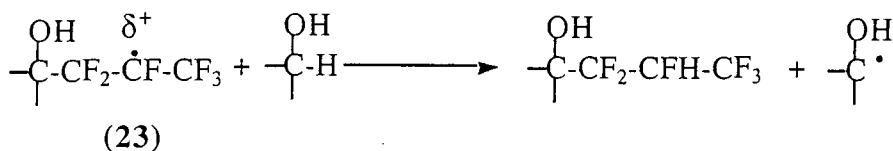

Scheme 24

1.6.a.ii. Acyclic alcohols :

The first free radical addition to hexafluoropropene was performed by Lazerte with methanol using benzoyl peroxide as chemical initiator³¹ (Scheme 25).

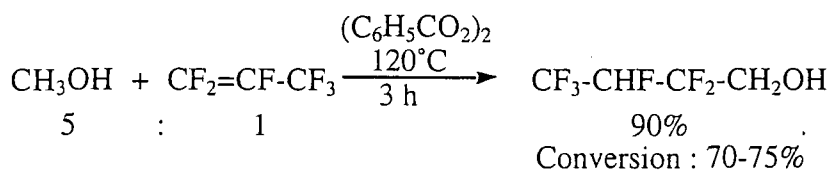

Scheme 25

Various reaction conditions were used in the aim to investigate their effects on conversions and yields. Only one product was obtained. The mole ratio of the reactants is important in this reaction because if the ratio used is 1:1, the conversion is only of 50% instead of 70-75% obtained for a ratio of 5:1 or 3:1.

Later Haszeldine³² studied the effects of the different initiating methods for the free radical addition of methanol, ethanol, *i*-propanol, *i*-butanol and butanol. Photochemical and peroxide initiated reactions gave high yields. The 1:1 adduct products were obtained in all the reactions as major products. For the methanol and the butanol, other 1:1 adducts were obtained by reaction of the intermediate radical to the carbon on the centre of the hexafluoropropene unit.

Most recent work has been carried out by Cirkva et al³³. All the free radical additions performed yielded two products : the major product from free radical addition at the CF₂ position and the minor obtained by free radical addition at the CF position of the hexafluoropropene unit (Scheme 26).

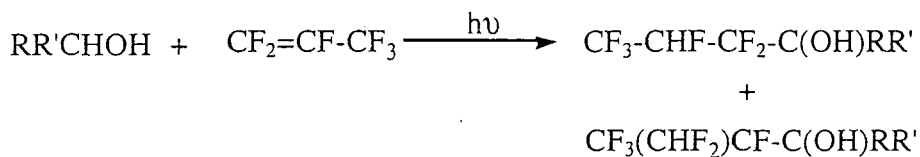

Scheme 26

1.6.a.iii. Cyclic systems :

Work on cyclic alcohols has been done in this laboratory³⁰ and the various results obtained are summarised in Table 14.

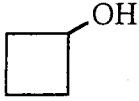
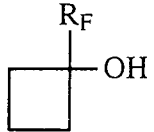
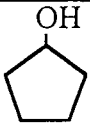
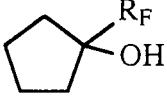
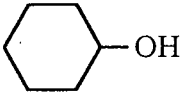
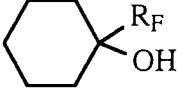
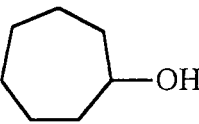
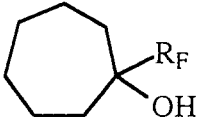
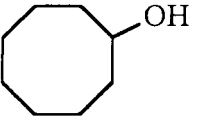
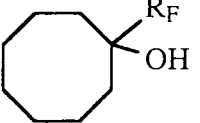
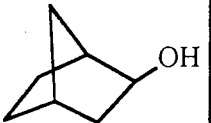
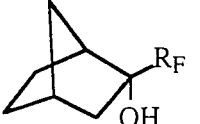
Cyclic Alcohols	Conditions HFP:Substrate	Products and Yields	
		Monoadduct (%) (R _F : CF ₂ -CFH-CF ₃)	Diadduct (%)
	A, 1.15:1.0	 A, 78	Trace
	A, 1.14:1.0 B, 1.07:1.0	 A, 72 B, 65	Trace
	A, 1.18:1.0 B, 1.10:1.0	 A, 76 B, 65	Trace
	A, 1.18:1.0	 A, 68	Trace
	A, 1.15:1.0	 A, 18	A, 40
	A, 1.18:1.0	 A, 54	A, 11

A, γ -rays, rt, 10 d; B, di-*tert*-butyl peroxide, 140°C, 24 h.

Table 14

1.6.b. Diols :

Cirkva *et al* carried out free radical addition of hexafluoropropene to 4 different diols³³ using photochemical initiation. Using butane-1,3-diol, diethylene glycol and propane-1,2-diol, no 1:1 adduct was obtained. For the butane-1,4-diol, curiously using methanol as sensitiser, the major product of the reaction was hexafluorobutanol (22%) while the 1:1 and 1:2 adducts were formed in smaller yields (Scheme 27).

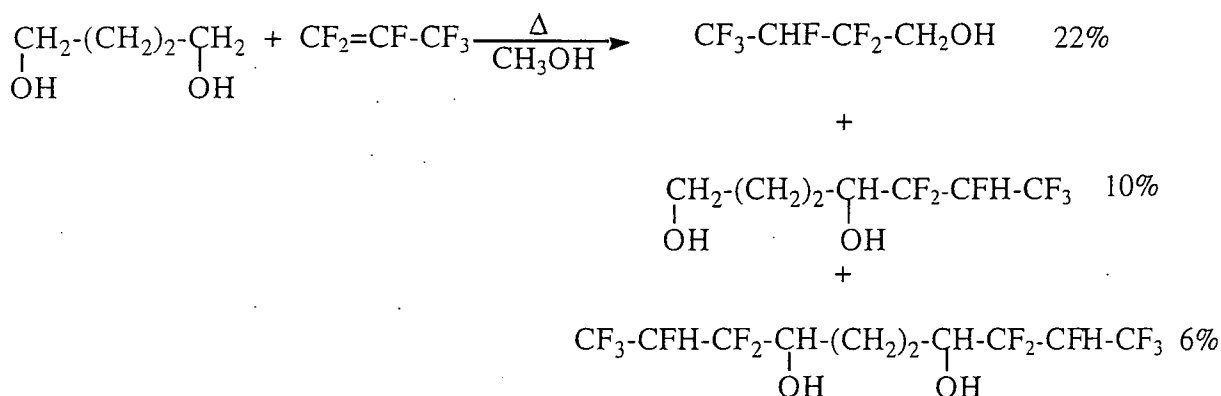

Scheme 27

The free radical addition occurred at the carbon bearing the hydroxyl group as for the alcohol systems. The fact that hexafluorobutanol was the major product, was rationalised by the authors by the photochemical initiation of methanol. This was the predominant reaction which yielded a radical which by reaction with hexafluoropropene formed hexafluorobutanol (Scheme 28).

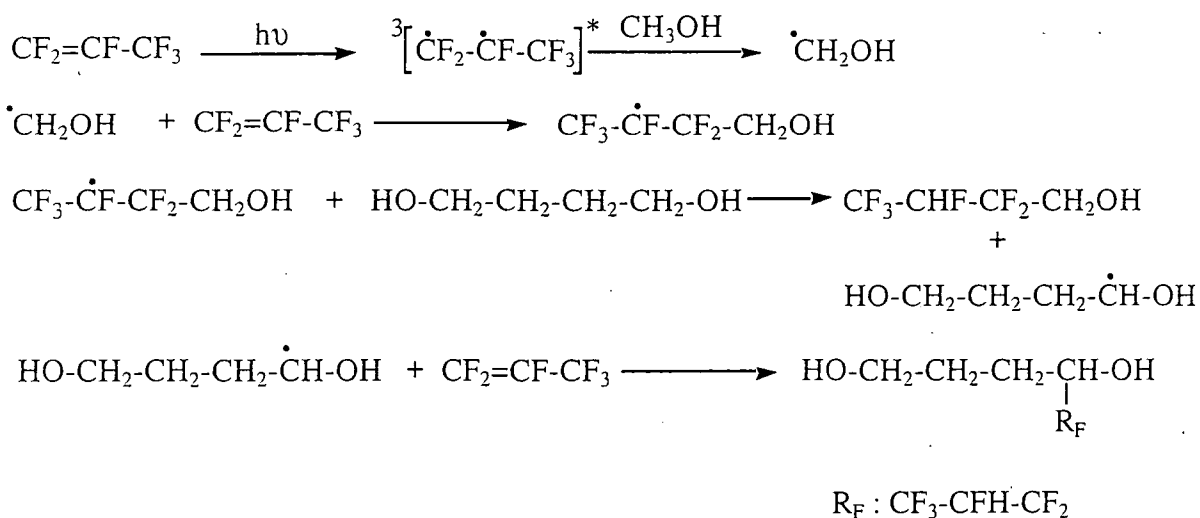

Scheme 28

In his studies on various diols, Dunn³⁰ showed the 1:2 adduct is the major product using a 2 fold excess of hexafluoropropene (Table 15). However cyclohexane-1,3-diol gave both 1:1 and 1:2 adducts and cyclohexane-1,2-diol did not give any product, as the reaction site was deactivated by the one adjacent hydroxyl groups. The *nucleophilicity* of the radical decreased because of the electron withdrawing character of the adjacent hydroxyl groups deactivating the site. Free radical additions of diols are governed by the same factors as free radical additions of alcohols.



Cyclic Diols	Conditions HFP:Substrate	Products and Yields	
		Monoadduct (%)	Diadduct (%)
	2.36:1.0		 63
	2.25:1.0		
	2.27:1.0	 30	 45
	2.27:1.0		 83

Table 15

1.6.c. Ethers :

Similar additions occur to ethers which readily lose a hydrogen α to the oxygen.

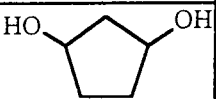
1.6.c.i. Acyclic ethers :

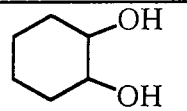
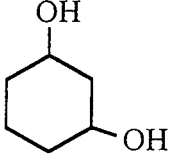
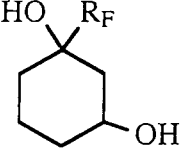
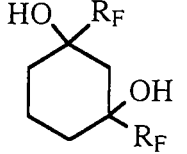
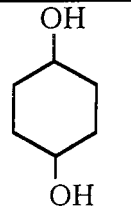
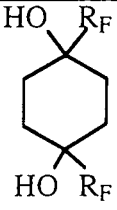
Various investigations showed that different addition products can be obtained depending on the reaction conditions³⁴.

Muratmasu^{35, 36} observed that the reaction of diethyl ether with 2 equivalents of hexafluoropropene led to the diadduct and suggested that its production occurred *via* an intramolecular hydrogen abstraction (6 membered transition state) (Scheme 29).

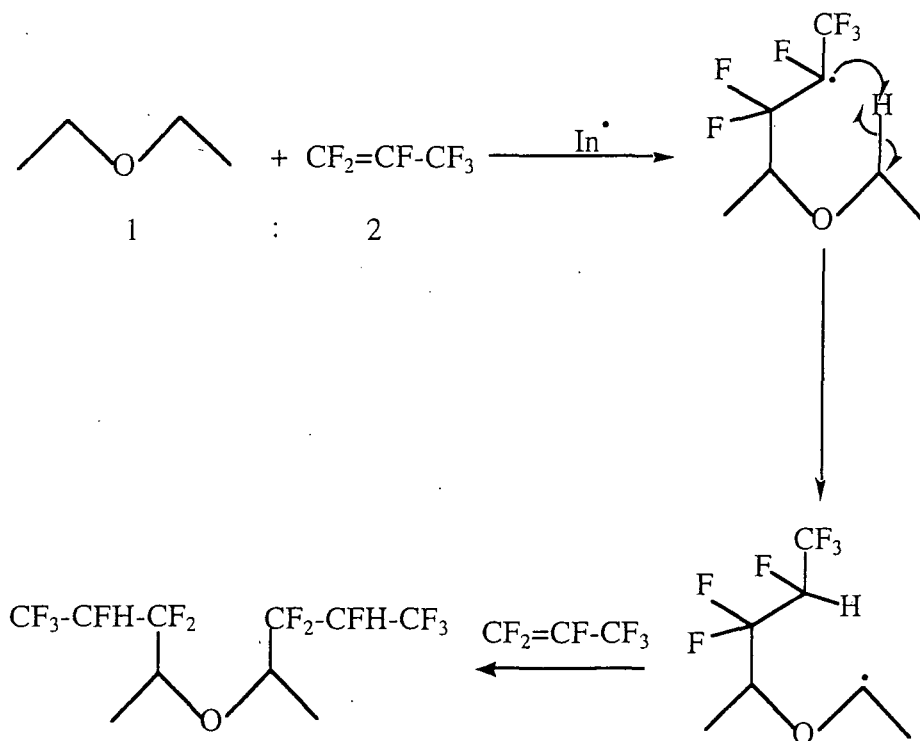

Scheme 29

In more recent studies, Grievson and co-workers³⁴ showed the influence of substituents on the reactivity of the ethers. The results are summarised in Table 16.

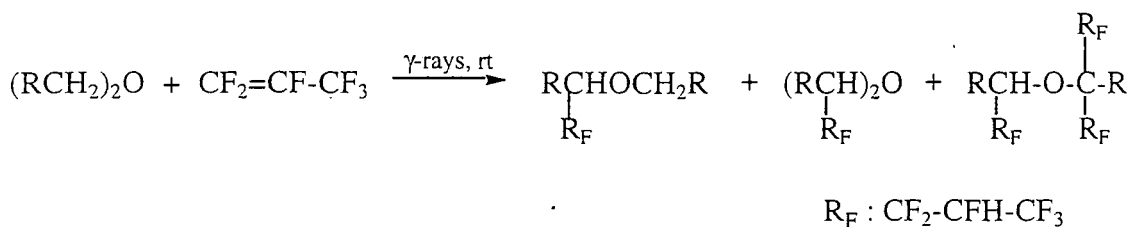

R	Products (% composition)		
H	100	-	-
Me	47	53	-
Et	30	70	-
Pr ⁿ	23	40	37

Table 16

The free radical reactions were performed using γ -ray initiation. Dimethyl ether gave exclusively the 1:1 adduct, whereas the 1:1 and the 1:2 adducts were obtained for both diethyl and dipropyl ethers. For dibutyl ether mono-, di- and tri-adducts were obtained. These results underlined the effect of the oxygen atom on formation of radicals from ethers and their stabilisation. During further investigation Grievson and co-workers were unable to couple the 1:1 adduct from dimethyl ether, *via* the intermediated radical obtained by radiolysis or thermolysis, by heating with di-*tert*-butyl peroxide to give the 1:2 adduct (Scheme 30).

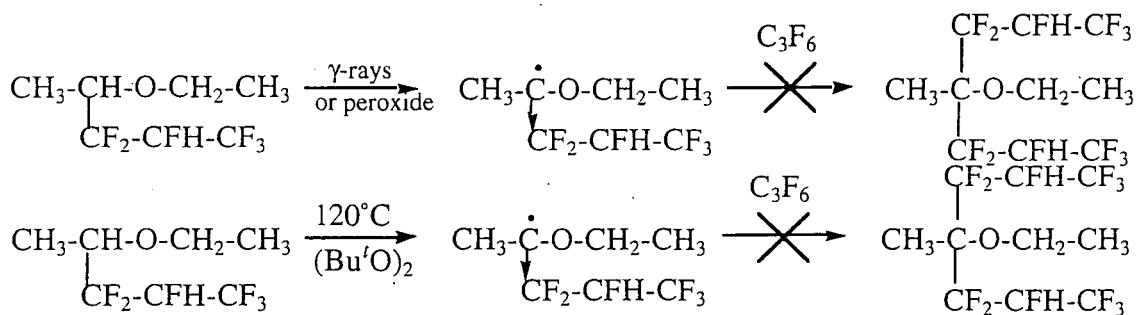

Scheme 30

The low reactivity of the 1:1 adduct towards fluoroalkenes can be explained by the fact that the introduction of a perfluoroalkyl group deactivated the sites adjacent to the oxygen inhibiting further hydrogen abstraction. This confirmed the fact that the 1:2 and 1:3 adducts were obtained *via* an intramolecular hydrogen transfer.

1.6.c.ii. Acyclic polyethers :

The effect of one oxygen atom on formation of a radical from an ether is well known as shown above. Free radical addition reactions to polyethers showed the influence of a second oxygen atom present in the system³⁷. Two systems were studied and for both of them 1:1, 1:2 and 1:3 adducts were obtained, their amount increased with the increasing amount of hexafluoropropene (Scheme 31).

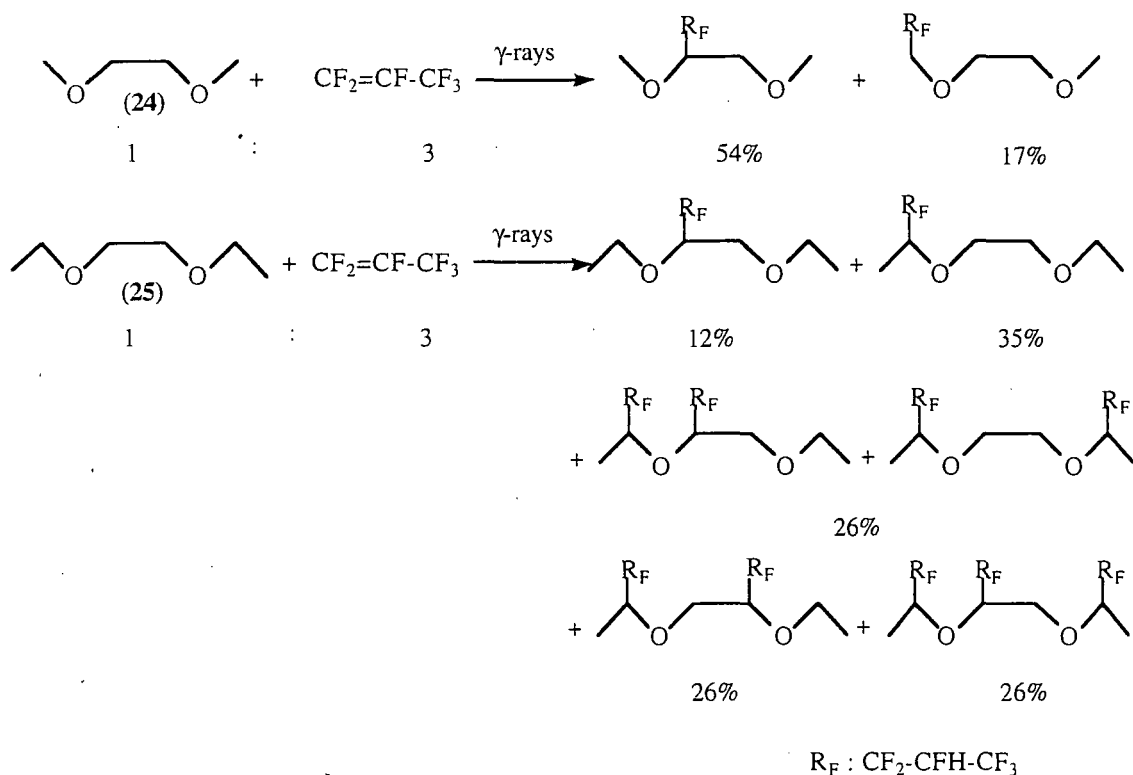

Scheme 31

The main difference between these 2 systems is the regioselectivity of the free radical addition as in (24) where the attacked site was the CH_2 group in $-O-\underline{CH}_2-CH_2-O-$, whereas for (25) the attacked position preferred was the CH_2 group in $CH_3-\underline{CH}_2-O-$. This gives rise to the following order of reactivity of sites in polyethers.



The site reactivity order in polyethers can be attributed to the presence of a second oxygen atom which offsets the effect of the first one by withdrawing charge away from the radical centre reducing the *nucleophilicity* of the radical (Scheme 32).

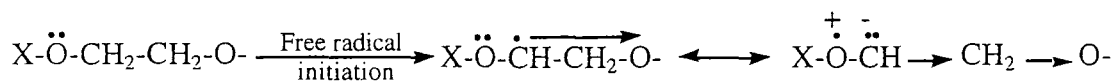

Scheme 32

1.6.c.iii. Cyclic ethers :

A lot of work has been reported on cyclic ethers and conformation studies have been an interesting topic about these reactions. Courtieu and co-workers³⁸ studied the free radical additions of hexafluoropropene to several heterocycles. Asymmetric centre formation yielded diastereoisomers, NMR studies allowed determination of some diastereoisomer couples (Scheme 33).

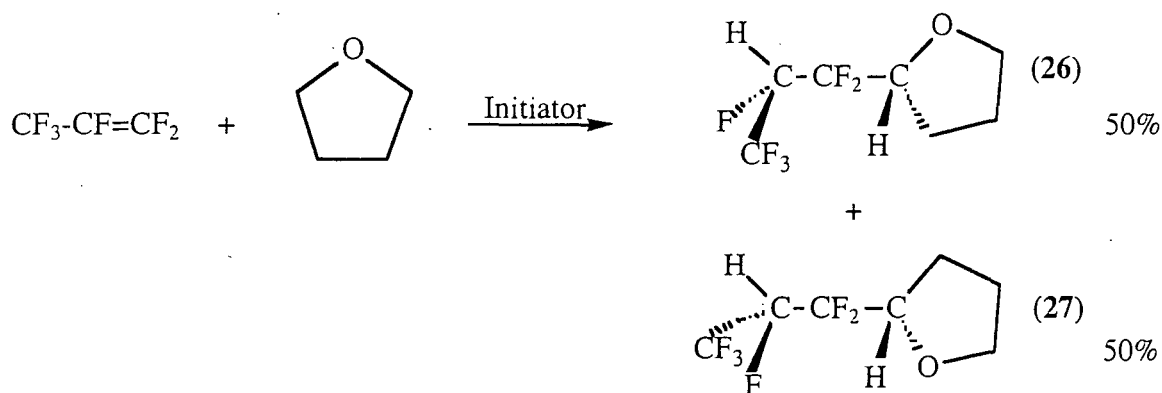

Scheme 33

¹⁹F NMR and ¹H NMR spectra showed differences between the 2 structures (26) and (27). Determination of the conformation for each diastereoisomer couple has been done by NMR studies and calculations. For example (26) and (27) appeared to be a racemic SS+RR where CF₃ and F are in "cis" position to H_b and C_αH (Scheme 34).

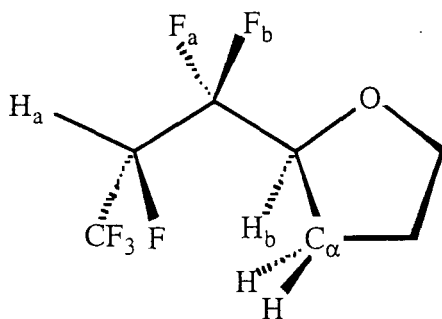

Scheme 34

1.6.c.iiii. Cyclic polyethers :

As for acyclic systems, a lot of work has been carried out in this area. One of the most recent example of these reactions has been performed by Cirkva and co-workers³⁹. In their work, they reported the free radical additions of methylated 1,3-dioxolanes to hexafluoropropene using photochemical or thermal initiating methods (Scheme 35). The additions proceeded easily, rapidly and almost total conversion of fluoroolefins was obtained.

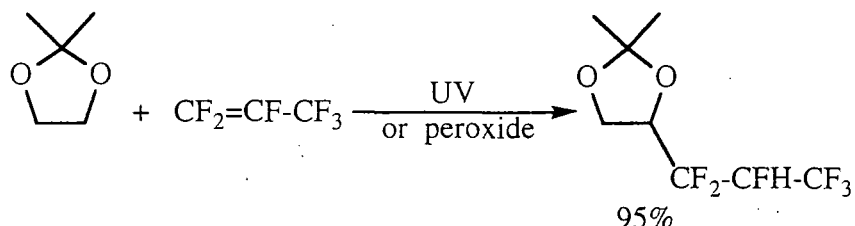

Scheme 35

1.6.d Esters :

Grievson and co-workers³⁴ studied the free radical addition of systems with general formula X-O-Me. For this experiment X chosen was an electron withdrawing group such as MeCO, HCO. Scheme 36 illustrated the products obtained from the reactions with methyl formate and methyl acetate, using di-*tert*-butyl peroxide as chemical initiator at 120°C.

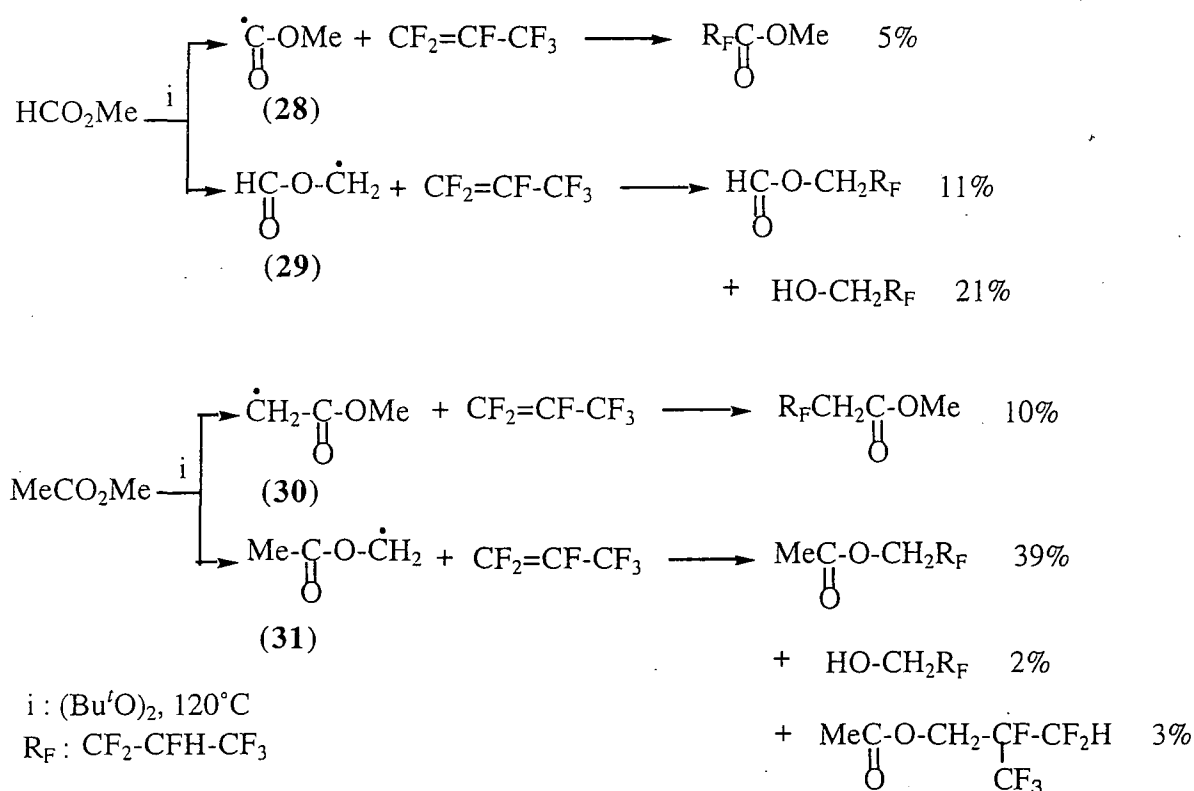

Scheme 36

For each reaction, two 1:1 adducts were obtained in low yields. This was due to the competition reaction between the formation of the radical centre. For the methyl formate, the hydrogen abstraction can occur either at the carbonyl group (28) or at the methyl position (29). For the methyl acetate, the hydrogen abstraction can occur either at the methyl in α to the carbonyl function (30) or in α to the oxygen atom (31). These results showed the hydrogen abstraction occurred preferentially at the α position of the oxygen atom rather than at the α position of the carbonyl group. Alcohol formation also occurred during these reactions and can be explained by peroxide initiated decarbonylation of the fluorinated esters.

1.6.e. Addition of nitrogen containing compounds :

1.6.e.i. Amines :

The same principles outlined for the ethers can be applied for the amine⁴⁰. The only exception is that there is a possible competing nucleophilic attack due to the lone pair on the nitrogen which can attack hexafluoropropene to give an alkylammonium salt (32) and a volatile compound identified as hexafluoropropene under dimer form (33) (Scheme 37).

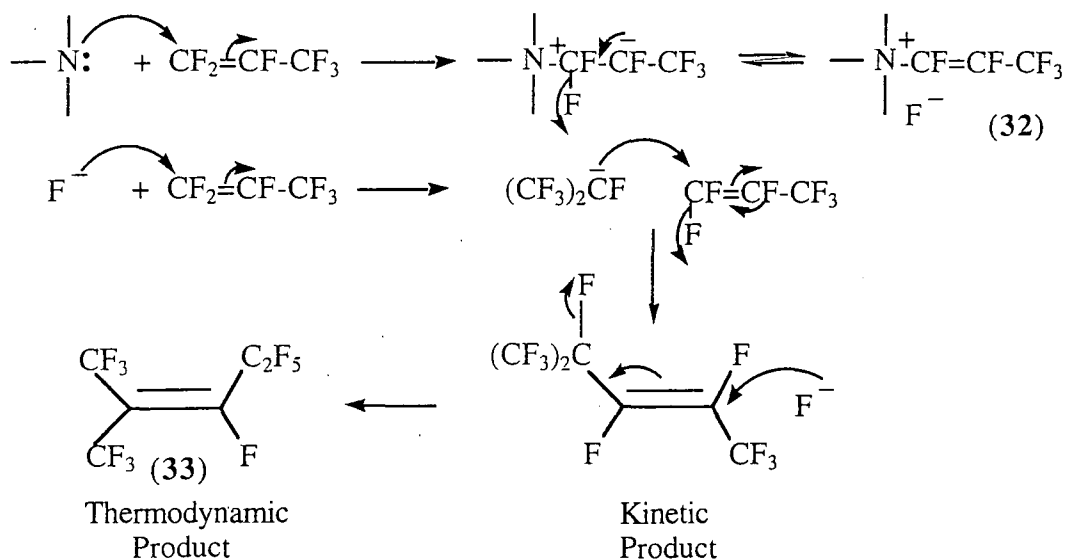

Scheme 37

Nevertheless, the results showed that the free radical addition competes successfully at room temperature, with the nucleophilic attack to give the monoadduct in a good yield (Scheme 38).

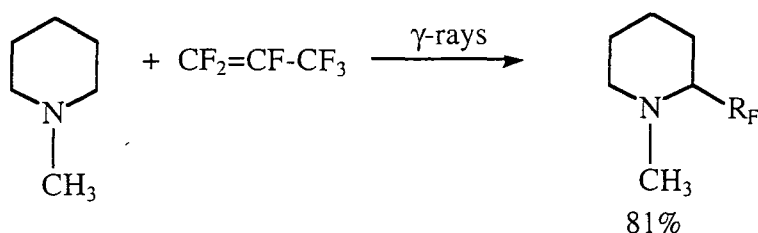

Scheme 38

Chambers and co-workers⁴¹ demonstrated that stereoelectronic effects may influence the reactivity of the amines in this process (Scheme 39).

The free radical addition may occur following two pathways :

-Path A : the intermediate radical could react intermolecularly with another amine to give a 1:1 adduct (34),

-Path B : there is an intramolecular hydrogen transfer from the hydrocarbon chain to the fluorocarbon chain which leads to a 1:2 adduct (35).

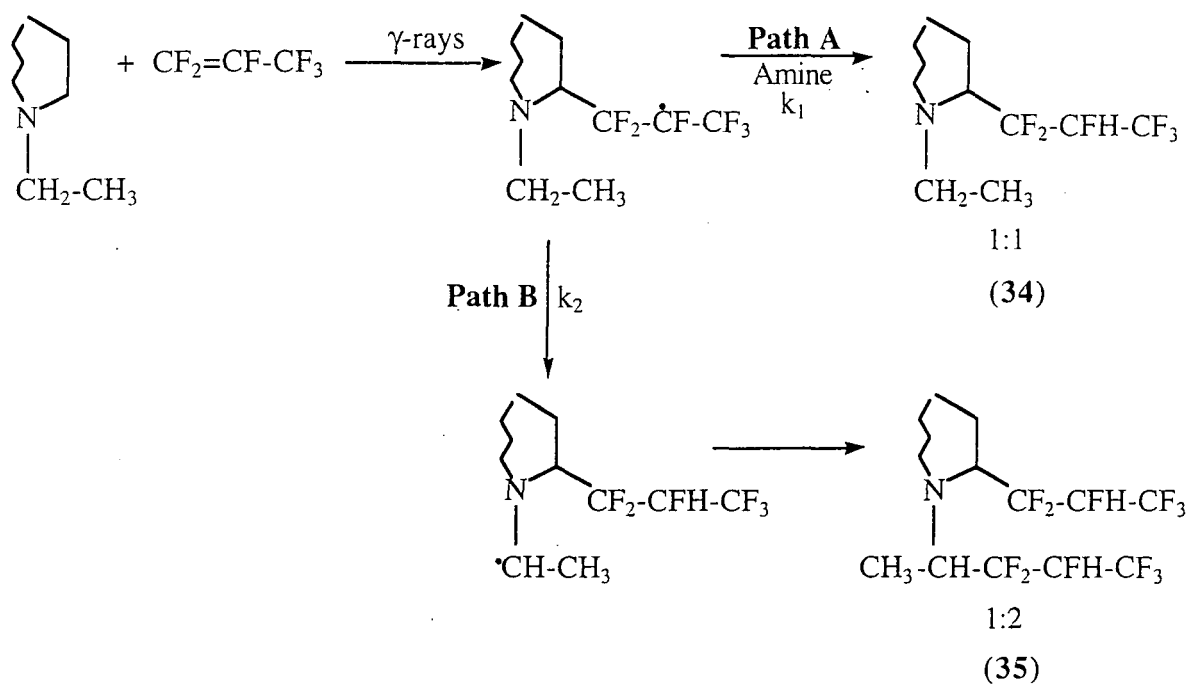

* Results :

1:1	75%	46%	19%
1:2	21%	52%	76%

Table 17

This table illustrates the percentage of products obtained *via* an intermolecular hydrogen transfer which yield to (34) and *via* an intramolecular which yields (35).

k_1 (rate constant for (34) formation) varies in this series, the order of reactivity increases with the value of the dihedral angle θ which is the angle between the lone pair on the nitrogen and the C-H breaking bond during the abstraction process (Scheme 40).

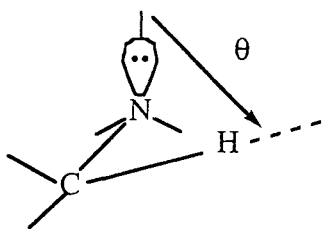

Scheme 40

If θ is small, the more stable intermediate radical is preferred (which is stabilised by the fluorine atoms). This leads preferentially to the 1:1 adduct formation *via* intermolecular process.

1.6.e.ii. Amides :

Jones⁴⁰ studied the reactivity of secondary amide towards hexafluoropropene using γ -ray initiation. For N-methylacetamide and 2-pyrrolidone the 1:1 adduct was obtained in good yields. Free radical additions occurred in α position to the amine function rather than the carbonyl one (Scheme 41).

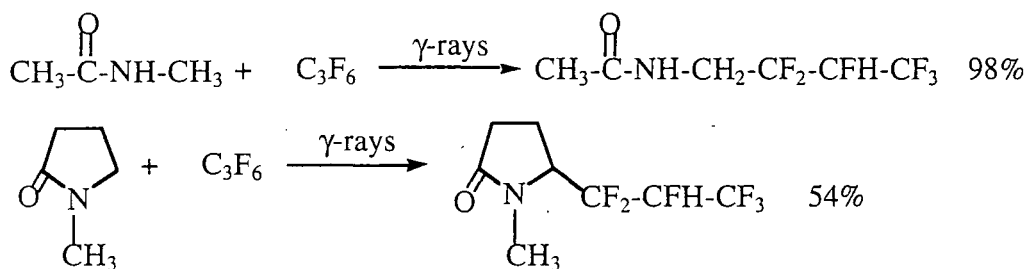

Scheme 41

1.6.f. Addition of sulphur containing compounds :

1.6.f.i. Thioethers :

1,4-thioxane reacted with hexafluoropropene to give a mixture of 1:1 adducts⁴². These 1:1 adducts corresponded to the free radical addition at the carbon in α position to the sulphur atom or to the free radical addition at the carbon in α position to the oxygen atom (Scheme 42).

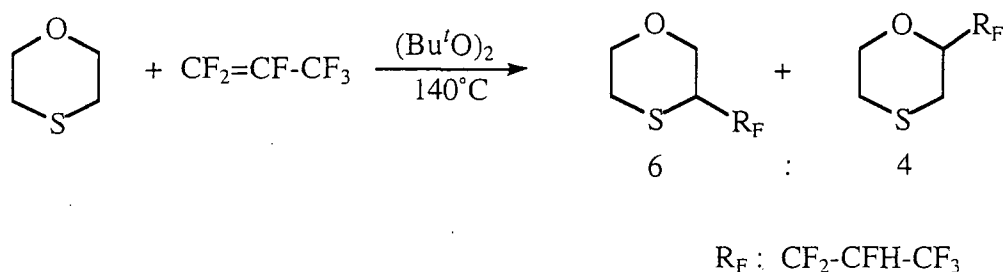

Scheme 42

According to the ratio of the obtained products, the carbon atom α to the sulphur is more reactive. Sulphur is less electronegative than oxygen and therefore stabilised better the neighbouring radical.

1.6.f.ii. Competition reactions between oxygen containing compounds and sulphur containing compounds :

Competition reactions between tetrahydrothiophene and tetrahydrofuran were also studied⁴², by reaction under thermolysis initiation, of an equimolar mixture of each with hexafluoropropene (Scheme 43).

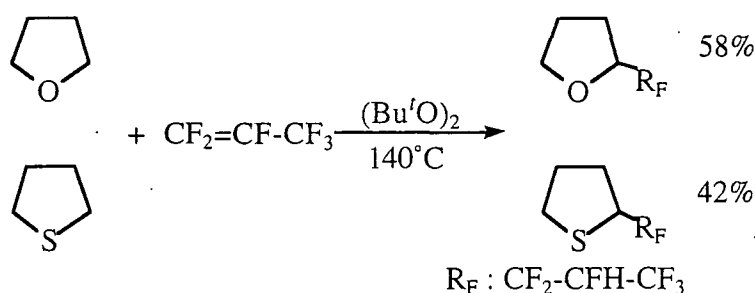

Scheme 43

Similar reactivity was observed for each system. Lower yield was obtained for the tetrahydrothiophene which can be attributed to its lower stability under thermal conditions.

1.6.g. Addition of alkanes to hexafluoropropene :

1.6.g.i. Acyclic alkanes :

Several short, straight-chained alkanes were added to hexafluoropropene using thermal and UV initiating methods^{24, 25, 43}.

In the laboratory, similar reactions have been carried out (Table 18) using γ -rays and di-*tert*-butyl peroxide⁴⁴.

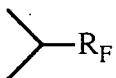
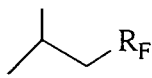
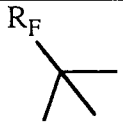
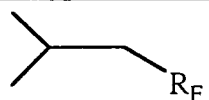
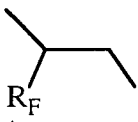
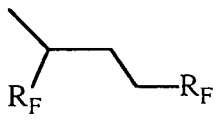
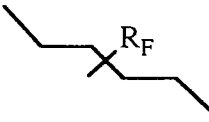
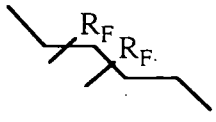
Cyclic Alkanes	Conditions HFP:Substrate	Products and Yields (%)	
		$R_F : CF_2-CFH-CF_3$	
CH ₄	B, 1.0:1.0	-	-
C ₃ H ₈	A, 1.2:1.0 B, 1.5:1.0	 A, 19 B, 75	 A, 1 B, 3
<i>i</i> -C ₄ H ₁₀	A, 1.2:1.0 B, 1.3:1.0	 A, 42 B, 80	 B, 3
C ₄ H ₁₀	A, 2.0:1.0	 A, 6	 A, 11
C ₆ H ₁₄	B, 2.0:1.0	 B, 1	 B, 8

A, γ -rays, rt, 10 d; B, di-*tert*-butyl peroxide, 140°C, 24 h.

Table 18

γ -rays initiated reactions gave lower yield than di-*tert*-butoxide initiated ones (with appearance of minor isomers). This showed again that addition occurred preferentially at secondary or tertiary sites rather than primary. For the *n*-butane, the major product was the diadduct obtained *via* a 6 membered ring hydrogen abstraction.

1.6.g.ii. Cyclic alkanes :

Cycloalkane additions to hexafluoropropene have also been performed using a 3 fold-excess of cycloalkanes^{24, 25}. Only the monoadduct was obtained in each case (Table 19).







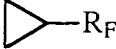

Cyclic alkanes	Cyclic alkanes : HFP	Conditions	Products and yields (%)	
			$R_F : CF_2-CFH-CF_3$	
	3:1	310°C		5
	3:1	290°C		43
	3:1	UV, ~50°C		
	3:1	280°C		54
	3:1	UV, ~50°C		38

Table 19

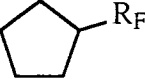
Spink⁴⁴ carried out similar reactions using γ -rays and di-*tert*-butyl peroxide (Table 20). The yields were higher than using thermal and UV initiations.

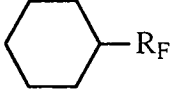
Cyclic alkanes	Conditions	Products and Yields	
		Monoadduct (%)	Diadduct (%)
		$R_F : CF_2-CFH-CF_3$	
	A, B,		
		86	9
	A, B,		
		90	4
		85	6

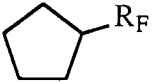
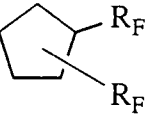
A, γ -rays, rt, 10 d; B, di-*tert*-butyl peroxide, 140°C, 24 h.

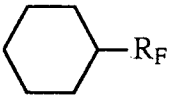
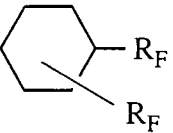
Table 20

1.6.g.iii. Polycyclic alkanes :

Free radical addition to adamantane have been firstly reported by Podkhalyuzin and co-workers^{45, 46}. In their work, they studied radiochemical polyfluoroalkylation of adamantane. The reactions were carried out in a liquid phase, in presence of solvent (without solvent, no reaction occurred). They showed that the reaction product was the 1-polyfluoroalkyl adamantane (Scheme 44). In their further studies, they investigated the thermal polyfluoroalkylation of adamantane in the

absence of solvent. The selectivity and the yield for this reaction were lower than for the radiochemical initiated one.

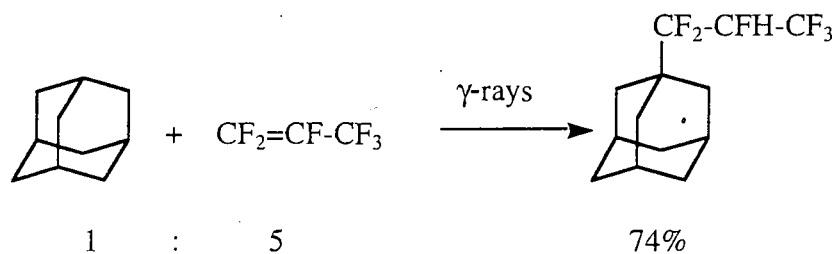

Scheme 44

Later, Zagorets et al⁴⁷ studied radiochemical polyfluoroalkylation methods in the liquid phase at 10-100°C. They showed that by using γ -rays, the tetraadduct can be obtained as final product.

Recently, Spink⁴⁴ showed that the tri- and tetra-adducts can be obtained by using peroxide initiation (Scheme 45).

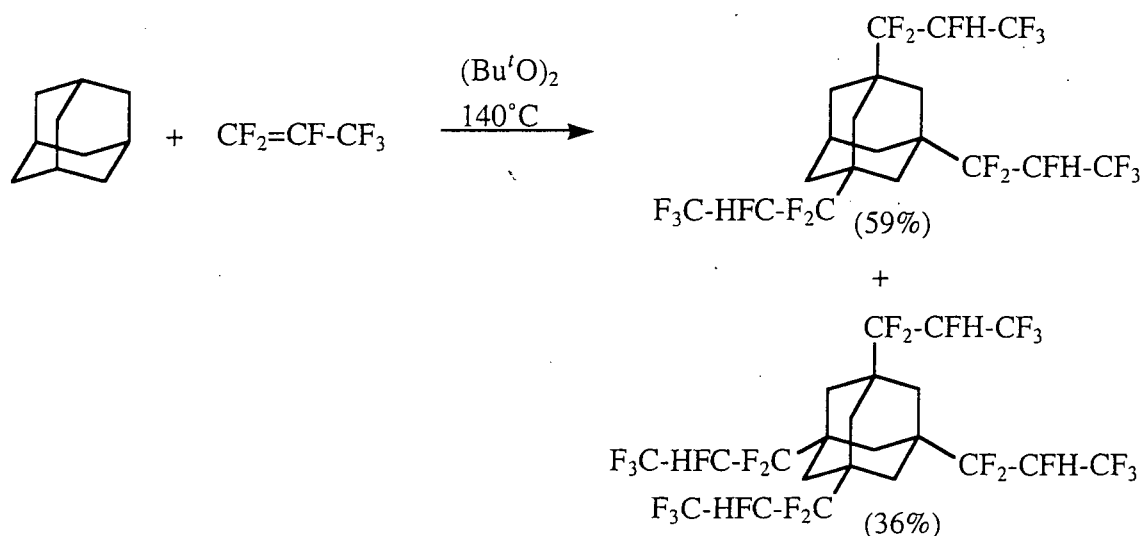

Scheme 45

1.6.h. Other systems :

1.6.h.i. Borate :

Trimethyl borate has been reacted with hexafluoropropene under γ -ray initiation at room temperature³⁴. The borate system is a powerful conjugated system due to the (MeO)₃B group which is an electron withdrawing group (Scheme 46).

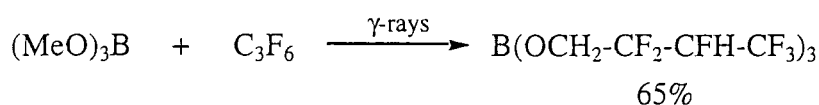

Scheme 46

1.6.h.ii. Siloxane :

Free radical additions of hexafluoropropene to silyl derivative have been performed⁴¹, they yielded the monoadduct in good yield. The free radical addition occurred in α position to the oxygen atom because of the electron donor character of the silicon atom (Scheme 47).

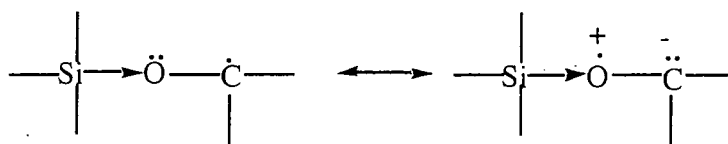
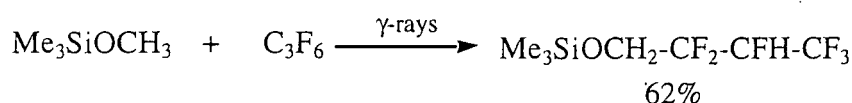

Scheme 47

1.7. Conclusion :

Free radical addition to hexafluoropropene is a powerful tool for the introduction of fluorine atoms or fluorinated groups into an organic compound.

These reactions proceeded easily because of the *nucleophilicity* of the radical being formed and the electrophilicity of the fluoroalkenes. These notions have been rationalised *via* frontier orbital theories.

The high regioselectivity in these reactions is governed mainly by both electronic and polar effects attributed to the fluorine atoms.

Free radical addition to hexafluoropropene had been studied for many years and various systems had been used during these studies. Since these last few years, a lot of work had been carried out in the area of oxygen containing compounds, such as alcohols³⁰, ethers^{34, 37} and also in alkane systems^{24, 25, 43, 44}. Nevertheless, very little work had been performed in the area of nitrogen containing compounds (i. e. amines), therefore this field of study was a good subject to develop (Chapter 5).

Chapter 2 : Free radical addition to hexafluoropropene

2.1. Introduction :

Chapter 2 will illustrate the first step of a multiple step process, allowing the synthesis of the partially fluorinated reactive compounds (i. e. containing a double bond). Several systems have been studied including cyclic alkanes such as adamantane, cyclopentane and cyclic alcohols such as cyclopentanol. This first step amounts to the functionalisation of a C-H bond of each compound by introduction of the hexafluoropropene unit (Scheme 48). This has been achieved *via* the free radical addition process described in Chapter 1 (Section 1.5.a., Scheme 19). The following chapter (Chapter 3), will illustrate the last steps for obtaining alkenes *via* dehydrofluorination and finally in Chapter 4, the alkenes reactivity will be studied.

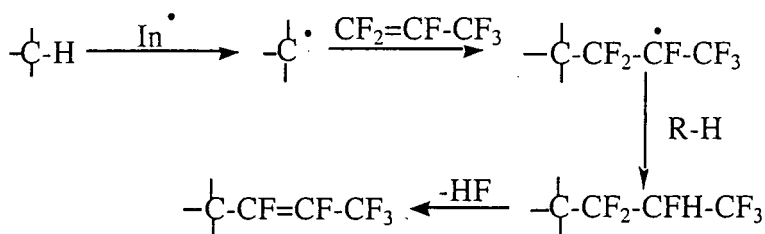

Scheme 48

As illustrated in Sections 1.6.a. and 1.6.g., a lot of work has been performed in the area of free radical addition of cyclopentanol (Section 1.6.a.iii.), cyclopentane (Section 1.6.g.ii.) and adamantane (Section 1.6.g.iii.) to hexafluoropropene. The polyfluoroalkylation of these systems can be carried out using γ -ray or peroxide initiating methods to give good yields of the mono- and/or di-adducts (depending on the molar ratio of the reactants used). The procedures used to perform these reactions were similar to the ones reported in the literature^{30, 44}.

¹⁹F NMR spectroscopy along with ¹H NMR and ¹³C NMR, have been frequently used as analytical tools, either for structural determination or monitoring the reactions (see Chapters 3 and 4). Because of their importance in this work, the first paragraph of this chapter will state a general review of these analysing methods as well as some ¹H,X and ¹⁹F,X (where X can be ¹⁹F, ¹H or ¹³C) spin-spin couplings. In this Chapter and the following ones, these values will sometimes be used as reference for structural determination.

2.2. NMR spectroscopy techniques :

^{19}F NMR is as old as ^1H NMR spectroscopy and similarities in the nuclei properties make them little differentiable⁴⁸ (Table 21). The three nuclei possess a spin quantum number of $I=1/2$, which make spectra analysis identical. ^{19}F nucleus is as easy as ^1H nucleus to observe since their relative abundance (99.98% for the ^1H and 100% for the ^{19}F) and their receptivity (100 for the ^1H and 83.3 for the ^{19}F) are nearly the same.

Species	Nuclear Spin I	Relative Sensitivity	Natural Abundance (%)
^1H	1/2	100.00	99.98
^{13}C	1/2	1.59	1.11
^{19}F	1/2	83.30	100.00

Table 21

For the ^{13}C nucleus, the situation is different as with a relative abundance of 1.11% and a receptivity of 0.0159 (relative to $^1\text{H}=100$), the sensitivity of ^{13}C is therefore much lower than for the ^{19}F and ^1H nuclei. In the following Chapters, determination of spin-spin couplings involving $^1\text{H},\text{X}$ ($\text{X} : ^1\text{H}$ or ^{19}F) and $^{19}\text{F},\text{X}$ ($\text{X} : ^1\text{H}$, ^{19}F or ^{13}C) were attributed according to general features established in the literature^{48, 49, 50, 51}. A general survey of geminal, vicinal as well as long range $^1\text{H},\text{X}$ (Table 22) and $^{19}\text{F},\text{X}$ (Table 23) are illustrated in the following Tables.

Bonds	Spin-Spin Couplings	Range of Values (Hz)
H-C-H Geminal	$^2J_{\text{HH}}$	0-25
H-C-C-H Vicinal	$^3J_{\text{HH}}$	0-25
H-C=C-H Cis	$^3J_{\text{HH}}$	7-11
H-C=C-H Trans	$^3J_{\text{HH}}$	12-18
H-C-C-C-H	$^4J_{\text{HH}}$	0-3
H-C-C-C-C-H	$^5J_{\text{HH}}$	0-2

Table 22

The vicinal coupling ${}^3J_{\text{HH}}$ is dependent of three factors⁵¹ : the dihedral angle ϕ , the bond length and the valence angles θ and θ' (Scheme 49).

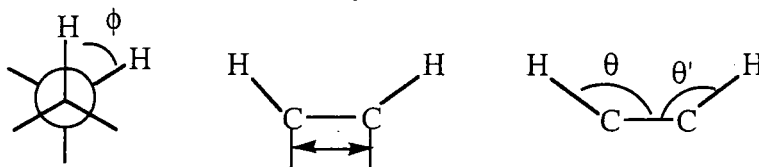

Scheme 49

The relationship between the dihedral angle and the vicinal coupling constant, is given by the Karplus equation. The coupling constant is largest when the dihedral angle is 180° (i. e. when the hydrogens are antiperiplanar), slightly smaller when $\phi=0^\circ$ and the lowest when $\phi=90^\circ$. This result implies therefore : ${}^3J_{\text{gauche}} < {}^3J_{\text{cis}} < {}^3J_{\text{trans}}$.

Bonds	Spin-Spin Couplings	Range of Values (Hz)
H-C-F	${}^2J_{\text{FH}}$	45-80
H-C-C-F	${}^3J_{\text{FH}}$	0-50
H-C=C-F	${}^3J_{\text{FH}}$	0-100
H-C-C-C-F	${}^4J_{\text{FH}}$	0-5
H-C-C-C-C-F	${}^5J_{\text{FH}}$	0-1.5
F-C-F	${}^2J_{\text{FF}}$	120-320
F-C-C-F	${}^3J_{\text{FF}}$	0-40
F-C=C-F Cis	${}^3J_{\text{FF}}$	18-40
F-C=C-F Trans	${}^3J_{\text{FF}}$	110-130
C-F	${}^1J_{\text{CF}}$	160-370
C-C-F	${}^2J_{\text{CF}}$	20-50
C-C-C-F	${}^3J_{\text{CF}}$	0-25
C-C-C-C-F	${}^4J_{\text{CF}}$	0-5

Table 23

2.3. Free radical additions of adamantane :

Functionalisation of polycyclic molecules using various groups is stimulating because of the possibility of the practical applications of these new compounds.

Adamantane is a good subject to study, as this system is characterised by its high thermal and radiation stability. The selectivity of the free radical addition reaction of adamantane to hexafluoropropene was studied firstly by monopolyfluoro- and dipolyfluoro-alkylations.

2.3.a. Monoadduct (36) and diadduct (39) :

The monoadduct (36) and diadduct (39) were synthesised by thermal polyfluoroalkylation of adamantane with hexafluoropropene using di-*tert*-butyl peroxide as chemical initiator. The reaction was carried out over 16 hours. Almost complete conversion (98.7%) of hexafluoropropene was achieved (Scheme 50).

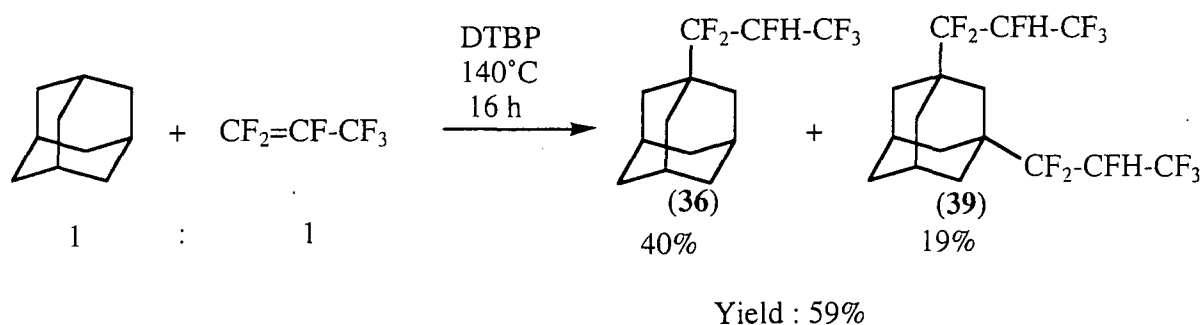

Scheme 50

After sublimation of the starting material, the mono- and di-adducts were separated by fractional distillation under reduced pressure.

The appearance of 1:1 and 1:2 (HFP) adducts in the ratio 1.0:0.8, showed that the 1:1 ratio of adamantane:HFP did not allow formation of the monoadduct preferentially. However the reaction proceeded in high selectivity as only the tertiary C-H bond was cleaved, during the hydrogen abstraction step (Section 1.5.a.), to give the products (36) and (39). Traces of other products were only observed by GC and GC/MS. They were assumed to be products from reverse addition (Sections 1.5.c. and 1.5.d.), as no characterisation by NMR spectroscopy was possible.

2.3.a.i. 1-adamantanyl-1,1,2,3,3,3-hexafluoropropane (36) :

The structure of the monofluoroalkylated product was determined by NMR spectroscopy (Scheme 51).

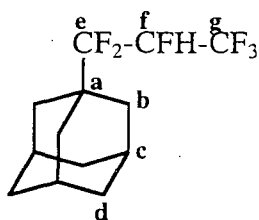

(36)

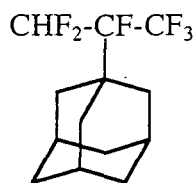

(37)

Reverse addition product

Scheme 51

* Orientation of the addition to the fluoroalkene :

The fact that the major isomer obtained was the one with a R_F : $CF_2-CFH-CF_3$ (36) and not R_F : $CF(CF_3)CF_2H$ (37), was shown up by DEPT spectrum. A doublet of doublets of doublets of quartets was observed at 83.4 ppm for the C_f . The signal was split into a doublet due to the coupling with the fluorine of the C_f , then a triplet due to the coupling with the 2 fluorines of C_e (which were not equivalent) and then a quartet due to the coupling with the 3 fluorines of the C_g . This confirmed the fact that the observed carbon was a CFH group (as DEPT is a proton decoupling spectrum which allows to observe only carbon containing hydrogen atom, not quaternary atom and carbon-fluorine coupling) instead of a triplet signal if it was the CF_2H group (Scheme 52).

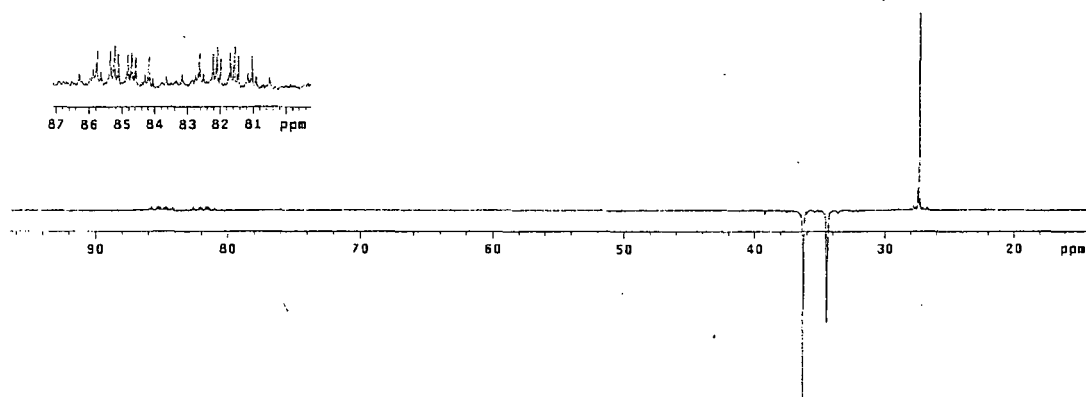

Scheme 52

* Site of addition to adamantane :

According to adamantane structure, which contains 4 methyne and 6 methylene groups, the reaction may occur following two pathways :

-Path A : cleavage of the tertiary C-H bond at one of the bridgehead position to give the monoadduct (36).

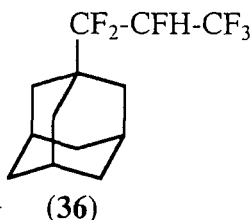

Scheme 53

-Path B : chain transfer with cleavage of the C-H bond in the methylene group to give another monoadduct (38).

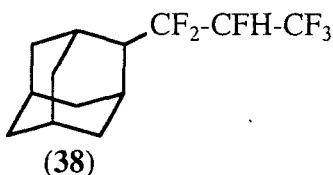

Scheme 54

The ¹H NMR spectrum gave only 3 signals corresponding to 3 different kind of protons : multiplet at 1.8 ppm with an integration of 12 protons for the 6 CH₂ groups, a singlet at 2.1 ppm with an integration of 3 protons showed all the 3 CH groups were equivalent and at 4.9 ppm a doublet of doublets of quartets for the proton of the CFH group with ²J_{FH} 44.0 Hz, ³J_{FH} 19.8 Hz and ³J_{FH} 6.0 Hz.

The fact that only 3 signals were present for 16 protons, showed that the product obtained was symmetric and so that the fluoroalkyl chain can only be on the bridgehead position to give the symmetric molecule (36), even if it was harder to generate a radical at the bridgehead position¹⁶. The bridgehead radical is pyramidal and can not invert.

* ¹⁹F NMR spectrum :

At -74.3 ppm a multiplet was obtained for the CF₃. At -122.6 ppm and -130.0 ppm, an AB system is observed with a ²J_{FF} 273.9 Hz for the difluoromethylene group, underlining the fact that the 2 fluorine atoms were magnetically inequivalent, i. e. they are diastereotopic and couple to each other strongly. Finally, at -206.9 ppm a doublet of quartets is obtained for the CF₂ with ²J_{FH} 43.8 Hz and ³J_{FF} 7.9 Hz.

* ^{13}C NMR spectrum :

Two different carbons corresponding to the CH_2 groups were found at 27.7 ppm as a singlet for the C_d and at 34.8 ppm as a singlet for the one in β position to the CF_2 group i. e. C_b . Only one signal was present at 36.6 ppm for the three carbons corresponding to the CH groups. This results underlined again that the molecule is symmetric. The quaternary carbon was observed at 40.2 ppm, as a triplet showing that the carbon coupled equally with the 2 chemically non equivalent fluorine atoms with a $^2J_{\text{CF}}$ 21.3 Hz. The carbon from the CFH gives a doublet of quartets of triplets at 83.8 ppm ($^1J_{\text{CF}}$ 197.4 Hz, $^2J_{\text{CF}}$ 33.6 Hz and $^2J_{\text{CF}}$ 8.0 Hz). This also showed that the carbon coupled equally with the 2 fluorines of the CF_2 as a triplet was observed. Whereas at 119.2 ppm a doublet of doublets of doublets was observed for the carbon of the CF_2 group showing this time that the carbon bearing the 2 non equivalent fluorines coupled differently with them with $^1J_{\text{CF}}$ 260.2 Hz and $^1J_{\text{CF}}$ 246.8 Hz. Finally, at 121.4 ppm a quartet of doublets was observed for the carbon corresponding to the CF_3 group ($^1J_{\text{CF}}$ 283.1 Hz and $^2J_{\text{CF}}$ 25.9 Hz).

2.3.a.ii.1,1,2,3,3,3-hexafluoro-1-[3(1,1,2,3,3,3-hexafluoropropyl)adamantanyl]propane (39) :

Further distillation led to the diadduct (39). Similar pathways were observed for the diadduct formation :

-Chain transfer with cleavage of the C-H bond at another bridgehead to give the diadduct (39).

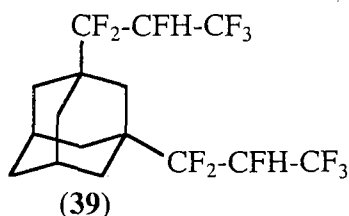

Scheme 55

-Chain transfer with cleavage of the C-H bond in the methylene group to give another diadduct (40).

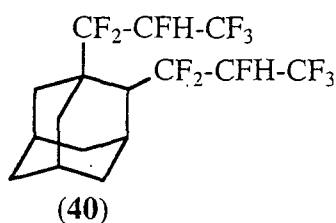

Scheme 56

As for the monoadduct (36), the structure of the product was determined by NMR spectroscopy. The results showed that the introduction of the second fluoroalkyl chain did not destroy the symmetry of the molecule. The mechanism proceeded *via* the same pathway as for the monoadduct (36) (Section 2.3.a.i.) and the second hydrogen abstraction occurred at the bridgehead position of the adamantane to give (39).

2.3.b. Triadduct (41) and tetraadduct (42) :

Synthesis of higher polyfluorinated compounds was carried out by reaction of adamantane with a 6.2 fold excess of hexafluoropropene (Scheme 57).

The tri- (41) and tetra-adduct (42) were synthesised using a higher molar ratio of hexafluoropropene in its reaction with adamantane. The separation of the 2 compounds was made by dissolving and recrystallising in hexane. The triadduct passed into the hexane and the tetraadduct recrystallised.

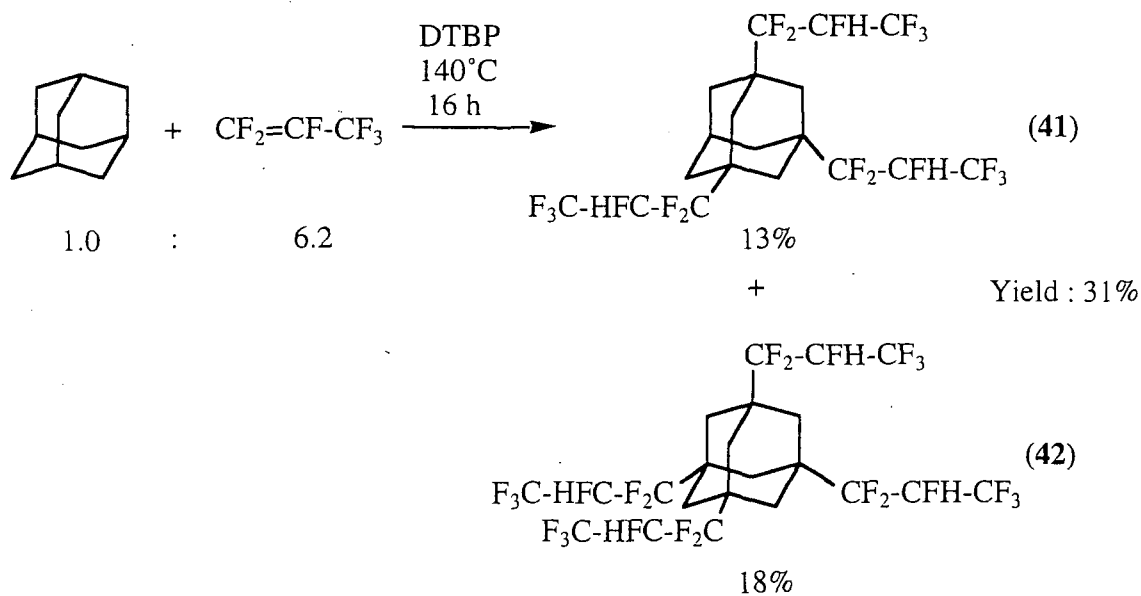

Scheme 57

The compounds were characterised by spectroscopy studies (as above). For the triadduct (41), the ^{13}C NMR and DEPT spectra, confirmed that only one CH group remained after the trifluoroalkylation process as tertiary carbon has been observed. For the tetraadduct (42), no signal from a proton corresponding to the proton from a CH group was observed. This confirmed the fact that all the fluoroalkylation occurred at the bridgehead position of the adamantane.

2.4. Free radical additions of cyclopentane :

Cyclopentane was studied as second cyclic alkane. Free radical addition of cyclopentane to hexafluoropropene have been carried out using 2 different initiating methods : using di-*tert*-butyl peroxide and γ -rays.

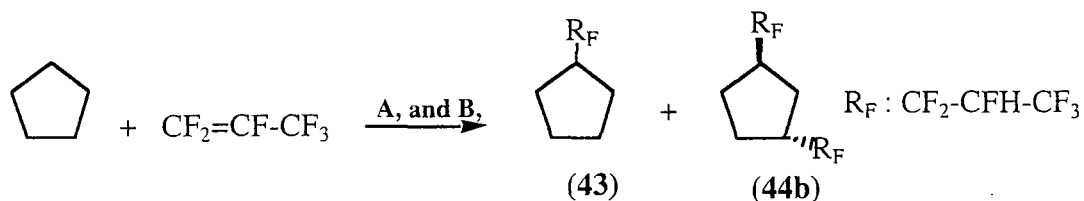

A, γ -rays, rt, 10 days	16.0	:	1.0	Yield : 86%
B, DTBP, 140°C, 24 h	4.0	:	1.0	Yield : 74%

Scheme 58

Different results were obtained using the 2 different method of initiation, these results are summarised in the following Table.

Conditions	Ratio HFP:Substrate	Conversion (%)	Yields Crude Products (%)	Crude Composition Mono/Di- (%) (Ratio)	Isolated Yields (%) Mono/Di- (Ratio)
A,	1.6:1.0	56.1	96	88/9	81/5
				9.8:1.0	16.2:1.0
B,	1.0:1.0	73.0	94	43/38	59/15
				1.1:1.0	3.9:1.0

Table 24

One of the main differences in these 2 initiating methods results in the fact that the γ -ray initiation was more selective than peroxide and led mainly the monoadduct. For the thermal initiation, the mono:di ratio was ca. 1.0:1.0.

The second difference was for the conversion of the 2 reactions. Using about a same ratio of reagent : i. e. a slight excess of hexafluoropropene, the conversion of the 2 reactions were totally different. For the thermal initiation, a nearly complete conversion was obtained (73%) whereas for the γ -rays a conversion of 56% was obtained. Nevertheless, the crude reaction yield of both reactions was good (above 90%) and nearly the same. After distillation, the total isolated yield (including mono- and di-adducts) was of 86% for the radiochemical initiation whereas for the thermal it was 74%.

It appeared as if firstly γ -ray initiation is more selective yielding exclusively to the monoadduct (43) and as if secondly the use of the hexafluoropropene is more effective. The conversion can be increased with increasing the time for the γ -ray initiation.

2.4.a. 1-(1,1,2,3,3,3-hexafluoropropyl)cyclopentane (43) :

Distillation at atmospheric pressure gave one fraction identified as the monoadduct (43). The product structure was confirmed by NMR spectroscopy data.

However, an interesting thing to point out is that in the ^1H NMR spectrum, H_c and H_d were equivalent. This was unexpected as, if we refer to the cyclopentane ring which is in the envelope conformation, they are magnetically inequivalent because they couple to each other (axial-axial, equatorial-equatorial, axial-equatorial) and to the fluorine atoms differently (Scheme 59). Therefore different chemical shifts would have been expected but that was not the case, presumably because of accidental degeneracy.

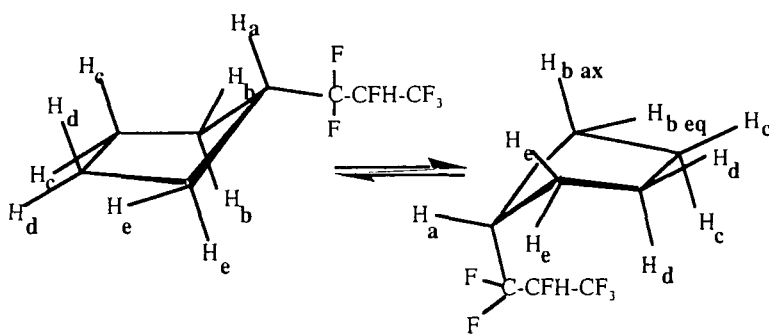

Scheme 59

2.4.b. trans-1,1,2,3,3-hexafluoro-1-[3-(1,1,2,3,3,3-hexafluoropropyl)cyclopentyl] propane (44b) :

The diadduct (**44b**) was obtained by distillation under reduced pressure (15mmHg) of the crude mixture. From the cyclopentane ring, 2 isomers as well as their cis-trans stereoisomers are possible (if the diastereoisomers are excluded) : the cis-trans 1,3 and the cis-trans 1,2 (Scheme 60).

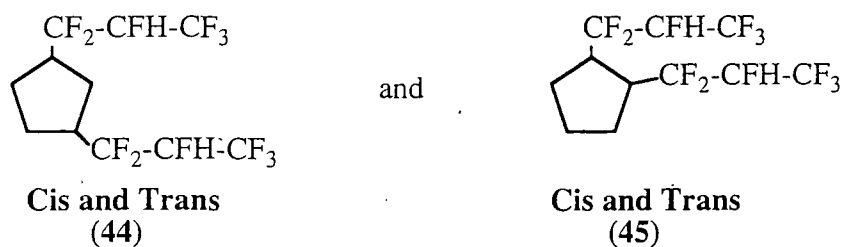

The NMR spectra showed that only one stereoisomer was exclusively formed. The analysis allow us to tell which stereoisomer was obtained and whether it was the 1,3-(**44**) or the 1,2-(**45**).

* Stereochemistry of the diadduct isomer obtained :

The ^1H NMR spectrum showed only 5 signals, with each an integration of two protons for the 10 protons present in the molecule. This information told us that the molecule is symmetric. If firstly the cis stereoisomer of each isomer is considered, both of them are equivalent and this is due to a plane of symmetry. For the cis 1,3-isomer (**44a**) the plane cuts the $\text{CH}_2\text{-CH}_2$ carbon bond and passes through the last CH_2 group. For the cis 1,2-isomer (**45a**), the plane cuts the CH-CH carbon bond and passes through the carbon of the CH_2 group which is in the middle of the 2 other CH_2 groups. Whatever the cis-isomer is (**44a**) or (**45a**), 6 signals corresponding to 6 different types of proton would be expected (Scheme 61).

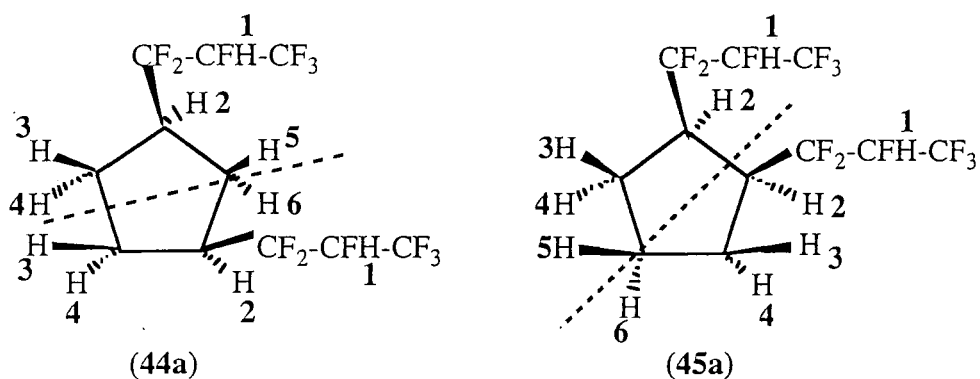

Scheme 61

Whereas the trans-stereoisomer of each isomer are both symmetric according to a C_2 axis, whatever the isomer is. Only 5 proton signals corresponding to 5 different types of protons would be observed (Scheme 62).

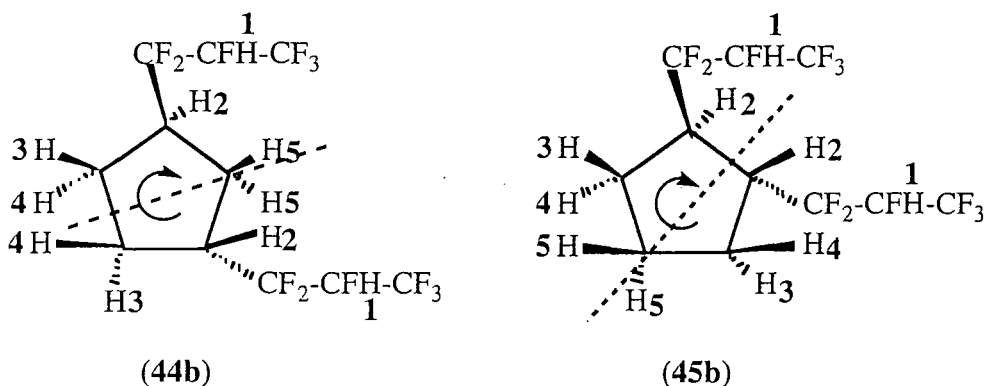

Scheme 62

In the ^1H NMR spectrum, the number of proton signals allowed definition of the stereochemistry at the chiral centres. This showed that the trans isomer is exclusively obtained. As three multiplets with each an integration of two protons are obtained at 1.8 ppm, 1.9 ppm and 2.0 ppm. Then a singlet at 2.7 ppm for the two protons at the carbon bearing the two perfluoroalkyl chains. Finally at 4.8 ppm a doublet of multiplets is observed for the 2 CFH groups with a $^3J_{\text{FH}}$ 31.2 Hz.

* Isomer obtained :

The COSY showed clearly that the trans 1,3-diadduct (44b) was exclusively obtained. The COSY or Correlated Spectroscopy, allows to identify nuclei which are coupled to each other, long range spin-spin coupling can also be observed. It showed that the proton of the CH group of the cyclopentane ring showed 4 coupling with the protons of the CH_2 groups (Scheme 63).

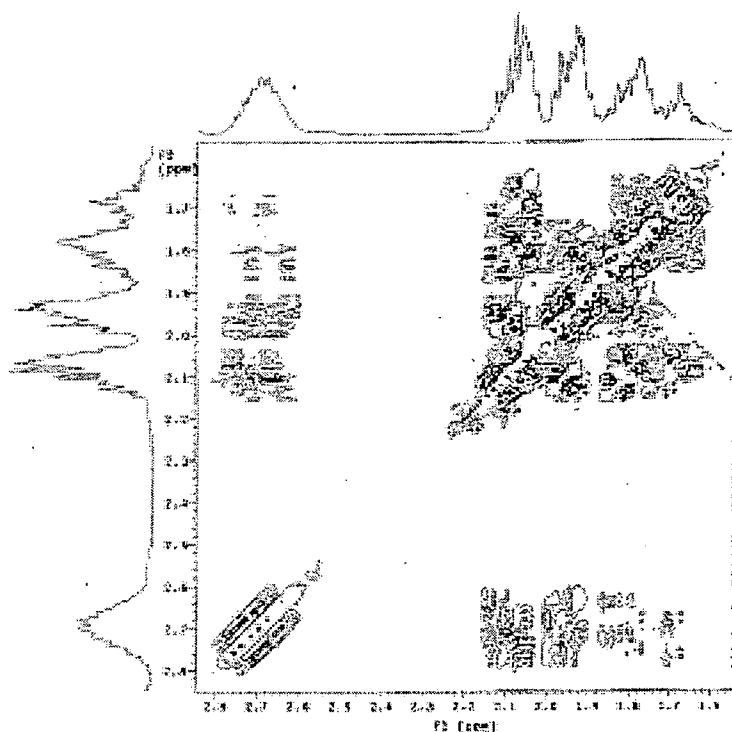

Scheme 63

If it was **(45b)**, the proton H_a will show only 2 couplings with the 2 cis and trans protons of the **e** position (to give a $^3J_{HH}$). The same will be true for the equivalent proton H_b .

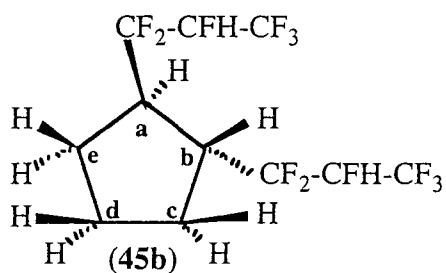

Scheme 64

Whereas if we have **(44b)**, for the proton H_a , 2 strong and 2 weak coupling are observed for the cis and trans coupling to the 4 protons at the **b** and **e** positions. This is what was observed in the COSY spectrum.

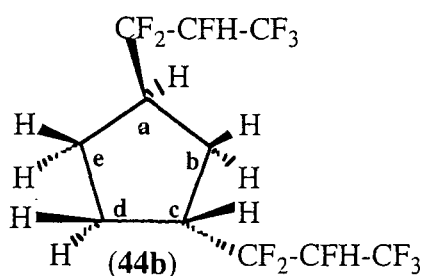

Scheme 65

The free radical addition of cyclopentane to hexafluoropropene yielded to the trans 1,3- (44b) as the major diadduct. This result could have been predicted by two factors: steric and also electronic effects. The fact that steric hindrance in the trans 1,2-isomer is stronger than in the trans 1,3-isomer acts in favour of the trans 1,3-isomer formation. But also the introduction of a first fluoroalkyl chain deactivated the carbon at the **b** position. The *nucleophilicity* of the potentially formed radical (at the **b** position) decreased because of the electron withdrawing character of the fluoroalkyl group, this deactivated the site. Whereas this electronic effect did not affect the carbon at the **c** position, where the second fluoroalkyl chain was introduced, yielding to trans 1,3- (44b).

2.5. Free radical additions of cyclopentanol :

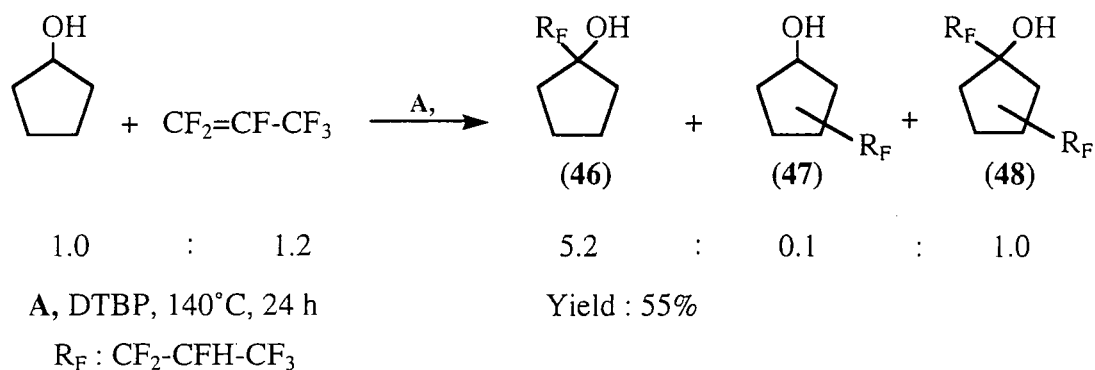

Scheme 66

Free radical addition of cyclopentanol to hexafluoropropene was carried out using di-*tert*-butyl peroxide as initiating reagent. The moderate yield obtained (55%) for this reaction is due to the fact that only (46) has been isolated and the yield has been calculated only with the isolated product. The reaction was less selective than using the cyclopentane as starting material in the way that the radical derived from the alcohol is more *nucleophilic* (Section 1.6.a.i.), it should enhance the reactivity towards hexafluoropropene but above all, favoured the production of only one product for the monoadduct. In reality 3 different products (containing 2 different

monoadducts in a ratio of 5.2:0.1) were observed in the crude mixture by GC and GC/MS. The major one was isolated by distillation at atmospheric pressure and corresponded to the monoadduct (46) obtained by free radical addition at the tertiary carbon of the cyclopentanol.

The 2 other products could not be separated after distillation under reduced pressure or even by column chromatography. They were observed only by GC/MS and not isolated. One of them corresponds to a mono-polyfluoroalkylated product (47), obtained by free radical addition at one of the two secondary carbons of the cyclopentane ring and the other one (48) corresponded to the di-polyfluoroalkylated product, an isomeric and diastereoisomeric mixture. Structural determination of (46) was achieved as above. The presence of the hydroxyl group was proved by ^1H NMR spectroscopy. The fact that the free radical addition occurred at the α position of the hydroxyl group was proved from the ^{13}C NMR and HETCOR spectra.

* ^1H NMR spectrum :

The position of the resonance for the OH proton is unpredictable because of the hydrogen bonding process and the concentration dependent factor. The signal was observed as a singlet at 1.9 ppm in the same area than the CH_2 signals of the cyclopentanol i. e. between 1.6-2.1 ppm. A D_2O shake experiment was performed, as with D_2O a rapid exchange between the deuteron and proton occur, therefore confirming the fact that this was the real signal. With D_2O , an DHO peak was obtained at 4.8 ppm as a singlet and the OH peak moved towards higher frequency : 2.0 ppm. The intensity of the OH signal decreased after D_2O treatment (Scheme 67).

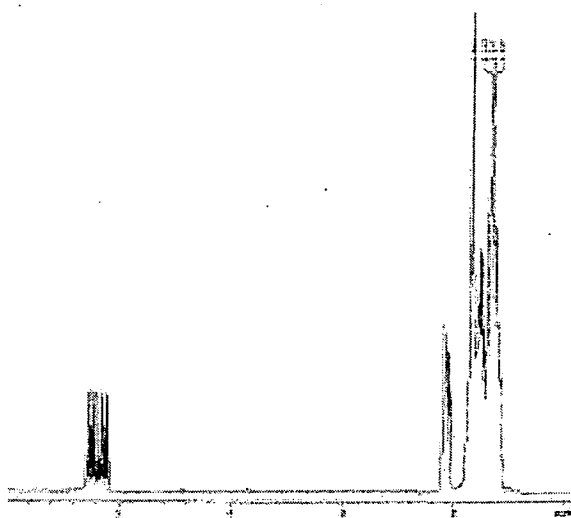

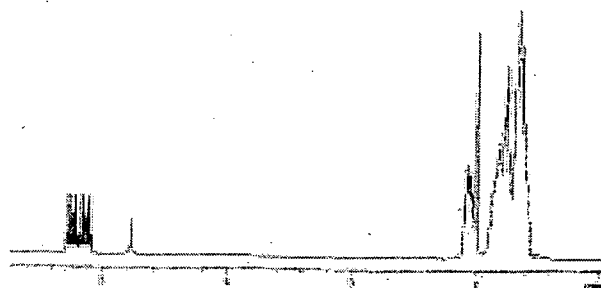

Scheme 67

* ¹³C NMR spectrum :

It showed that the free radical addition occurred at the tertiary carbon bearing the OH group as a quaternary carbon was observed, at 83.6 ppm as a multiplet rather than a tertiary one, confirming previous results from the literature³⁰.

2.6. Conclusion :

Free radical addition reactions to hexafluoropropene were the first step in the precursor synthesis.

* Adamantane :

As it has been described in various examples from the literature⁴⁴⁻⁴⁷, the mono-, di-, tri- and tetra-polyfluoroalkylations of adamantane occurred at the bridgehead position. However even though generation of a radical at a bridgehead position is harder than at a alkyl site¹⁶, the process succeeded and this maybe explained by the fact that this is an unstrained position⁴⁴. The mono- (**36**) and di-adducts (**39**) were obtained in moderated yields (respectively 40% and 19%) whereas the tri- (**41**) and tetra-adducts (**42**) were obtained in low yields (respectively 13% and 18%).

* Cyclopentane :

The free radical additions were performed using γ -rays and peroxide initiations. The selectivity in the monoadduct formation rather than the diadduct was higher for the γ -rays as it yielded exclusively the monoadduct. The isolation of the diadduct, obtained from the reaction initiation with di-*tert*-butoxide, allowed us to show that the introduction of the second fluoroalkyl chain in the system proceeded

via high regioselectivity and stereoselectivity as the major product was the trans 1,3-**(44b)**.

* Cyclopentanol :

For the cyclopentanol, the great regioselectivity expected³⁰, due to the presence of the hydroxyl group, has not been observed as 3 product formations were observed. However no structural data for the other monoadduct (**47**) and the diadduct (**48**) were obtained. The major monoadduct derived from the free radical addition of hexafluoropropene at the carbon bearing the hydroxyl group.

Chapter 3 : Dehydration and dehydrofluorination reactions

3.1. Introduction :

In this Chapter, we will see the last steps of the precursor synthesis (i. e. preparation of reactive alkenes and diene). For 1:1 cyclopentane and adamantane hexafluoropropene adducts, they will be obtained *via* dehydrofluorination of the polyfluoroalkyl bond (Scheme 68).

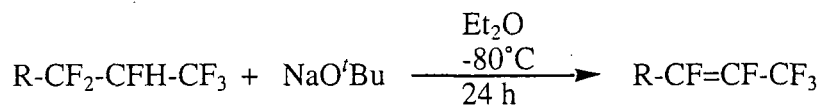

Scheme 68

However, for the 1:1 cyclopentanol hexafluoropropene adduct, the first step is a dehydration and then a dehydrofluorination to give the reactive diene (Scheme 69).

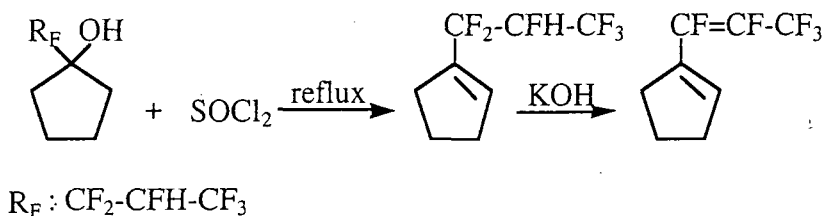

Scheme 69

A literature review about the dehydration and dehydrofluorination reactions will be done before interpreting the results obtained for these compounds.

3.2. Dehydration :

3.2.a. Introduction :

Formation of a C=C double bond by a dehydration reaction can be achieved using several reagents⁵². Usually protonation of the hydroxyl group using an acid (H₂SO₄, H₃PO₄) is sufficient to induce the loss of water⁵³ (Scheme 70).

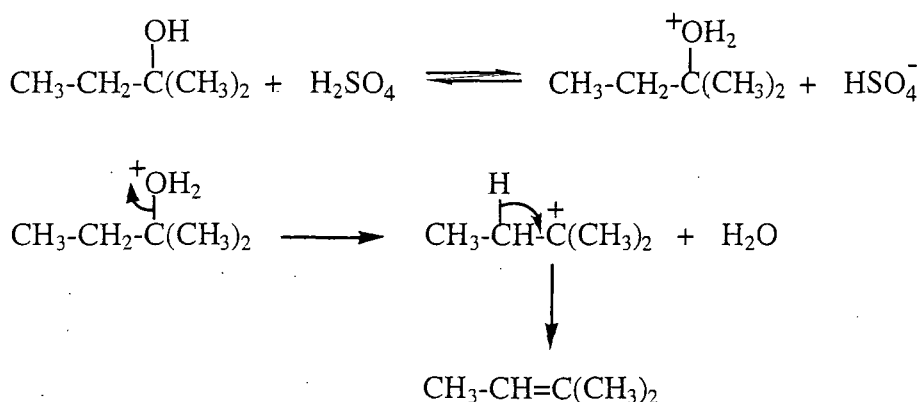

Scheme 70

In some cases, the hydroxyl group is converted into a better leaving group by using reagents such as thionyl chloride and phosphorus halides. Few dehydrations^{30, 54-57} have been reported using thionyl chloride as a reagent. The reactions were carried by refluxing with thionyl chloride or stirring a mixture of an amine (generally pyridine) and thionyl chloride at room temperature. The reaction is thought to proceed *via* a nucleophilic displacement of the chloride ion, which can then promote the elimination by acting as a base.

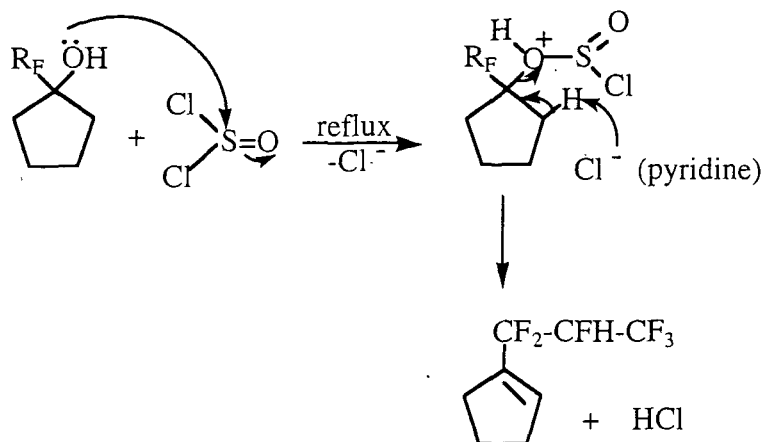

Scheme 71

3.2.b. Dehydration of 1-(1,1,2,3,3,3-hexafluoropropyl)cyclopentanol (46) :

After obtaining the 1:1 adduct of cyclopentanol (Section 2.5.), the first step towards the diene formation was dehydration of the 1:1 adduct (46). The reaction was performed using the recent literature procedure³⁰ involving refluxing thionyl chloride as described above (Scheme 72).

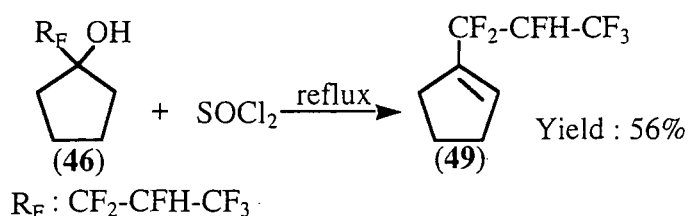

Scheme 72

Characterisation of the product (49) was done according to the literature³⁰. A few NMR points will be illustrated as they were found to be interesting.

* ¹⁹F NMR spectrum :

For the CF₃ and the CFH groups, the chemical shifts remained essentially unchanged from the starting material. However, for the AB system (from the CF₂ group) the influence of the new double bond being introduced in the cyclopentane ring was notable as the signal moved to higher frequency. The A signal shifted from -121.4 ppm to -104.5 ppm and the B from -127.2 ppm to -109.7 ppm. The signal shapes were also modified. In both cases a doublet of unresolved multiplets was observed (²J_{FF} 272.9 ppm and ²J_{FF} 272.9 ppm).

In the ¹H NMR and ¹³C NMR spectra, the alkene presence is readily detectable, as hydrogen atoms bound to *sp*² hybridised carbons resonate at higher frequency and are more strongly deshielded than the corresponding alkanes.

The presence of the ethylenic proton at 6.2 ppm (m), corresponding to the CH group of the alkene double bond in the cyclopentane ring, confirmed the fact that the dehydration occurred and gave a proton deshielding of at least 4.1 ppm.

A shift to higher frequency was also observed for the ethylenic carbon as Ca was observed at 135.0 ppm and Ce at 135.8 ppm.

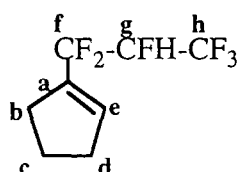

Scheme 73

3.3. Dehydrofluorination reactions :

The second and last step of the precursor synthesis was the dehydrofluorination of the polyfluoroalkyl chain. This step was common for the three

1:1 hexafluoropropene adducts. A wide range of methods have been reported in the literature and several of them are illustrated below according to the fluorine positions in every compound.

3.3.a. Vicinal difluoroalkanes :

The dehydrofluorination of vicinal dihaloalkanes was studied by Matsuda et al⁵⁸. They compared the reactivity of vicinal dihaloalkanes towards alkoxides : sodium methoxide, potassium ethoxide or sodium butoxide.

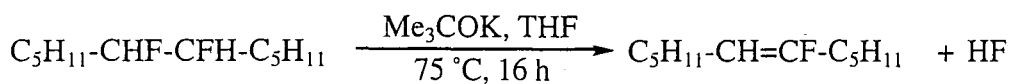

Scheme 74

The presence of potassium tertiary butoxide in tertiary butyl alcohol, benzene or toluene increases the reaction rates.

3.3.b. Geminal difluorides :

D. Strobach et al⁵⁹ provided an easy way to form 1-fluorocycloalkenes. A reaction using a stoichiometric amount of alumina (neutral and anhydrous γ -alumina or Woelm alumina) lead to dehydrofluorination of the geminal difluorocycloalkane under mild conditions to give various 1-fluorocycloalkenes (Scheme 75).

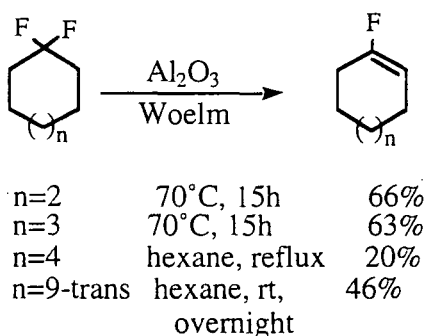

Scheme 75

All the dehydrofluorination reactions showed a ketone as side product which was obtained by hydrolysis of the difluoro compound on the alumina surface.

3.3.c. Dehydrofluorination from a polyfluoroalkyl chain :

3.3.c.i. Polycyclic systems :

Dehydrofluorination of compounds in which a single hydrogen neighbored a fluorinated group was achieved by refluxing, during 6 hours, the fluorosubstituted alkyladamantane in an alcohol solution of alkali hydroxide⁶⁰.

A mixture of stereoisomers (*Z* and *E*) of the alkene was obtained with 75% yield but no separation was possible. The dehydrofluorination showed that the hydrogen fluoride elimination occurred only between the CF₂ and the CFH in the fluoroalkyl chain. This result is explained by the fact that the energy of the C-F bond in the CF₂ group is lower than that in the CF₃ group making the fluorine abstraction of the CF₂ group easier than for the CF₃.

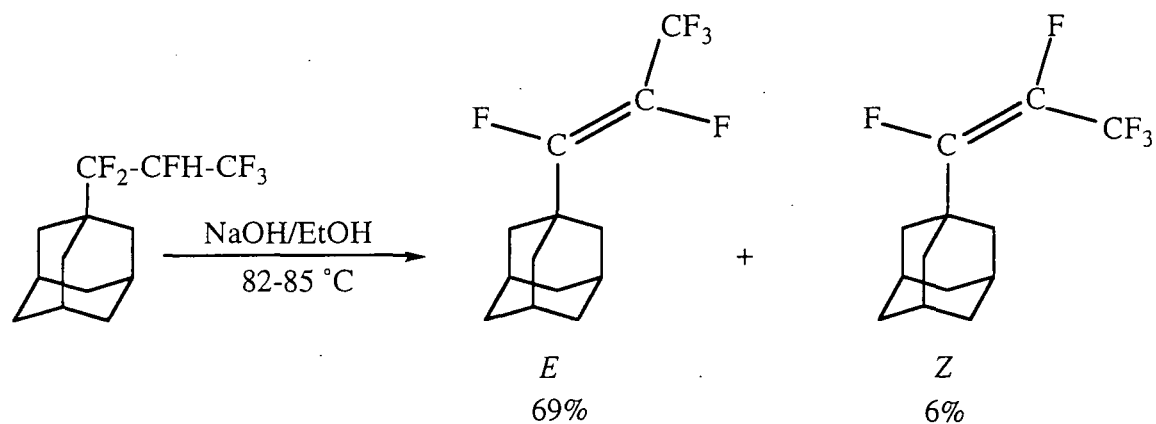

Scheme 76

3.3.c. ii. Heterocyclic and linear systems :

Hydrogen fluoride eliminations have been carried out on heterocyclic systems. 2H-1-(2-tetrahydrofuryl)-hexafluoropropane⁶¹ was dehydrofluorinated using powdered KOH at 110-120 °C for 8 hours or using sodium *tert*-butoxide in *tert*-butyl alcohol at 25 °C for 7 hours. No matter what base was used, the *Z*-isomer was stereoselectively obtained in good yield (75% and 71% respectively).

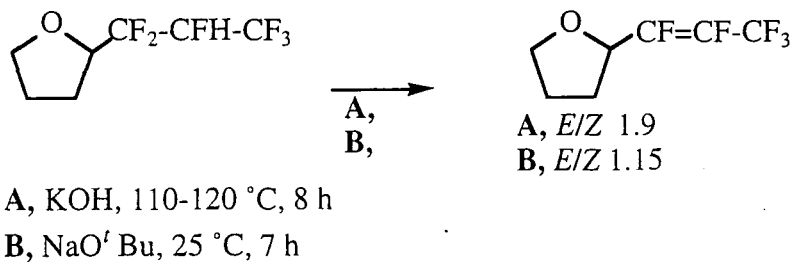

Scheme 77

The fact that the *E*-isomer was preferentially formed under thermodynamic conditions was explained by the conformational stability of the carbanion intermediates involved (Section 3.3.f.).

Dehydrofluorination of hexafluoropropene ether monoadducts was achieved in this laboratory⁶², using potassium hydroxide in diglyme at 120°C (Scheme 78).

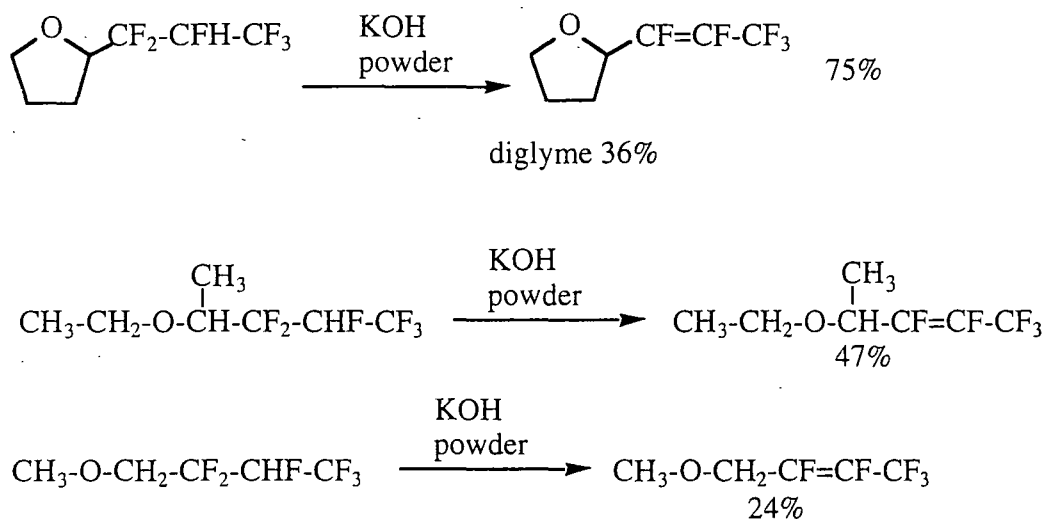

Scheme 78

With diglyme, the reaction gave low yield and the purification process was not easy. The reactions were repeated using powdered KOH, moderate yields were obtained and decreased with decreasing of the adduct boiling point.

Swales⁶³ performed the dehydrofluorination of an acyclic ether by heating the diethyl ether/hexafluoropropene monoadduct with potassium hydroxide pellets in a sealed system and improved the yield from 47% to 78%. When triethylamine and tri-*n*-butylamine were used as bases, no reaction occurred.

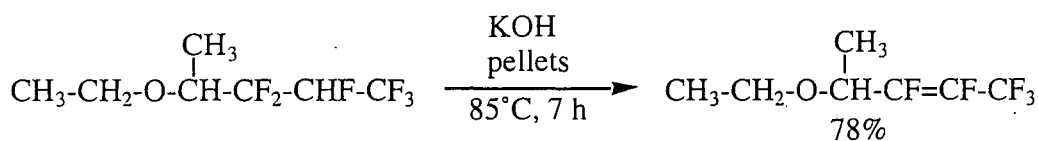

Scheme 79

Similar reactions were carried out with 2-(2H-hexafluoropropyl)pyrrolidine⁶² and 2-(2H-hexafluoropropyl)-*N*-methyl pyrrolidine⁶³, as starting materials (Scheme 80).

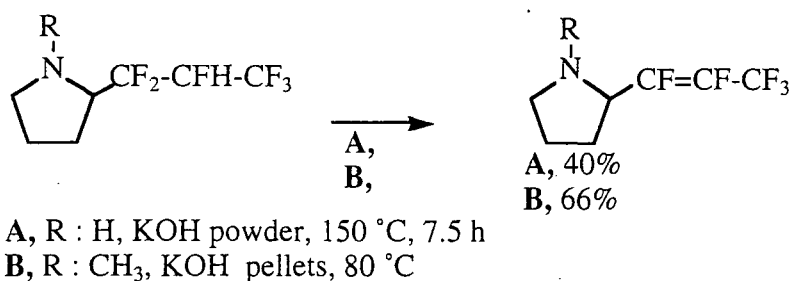

Scheme 80

The alkene was produced exclusively in comparable yield with the ether. The reactions showed that the presence of the amine function did not influence the reaction.

3.3.d. Polyfluoro compounds :

J. Tatlow et al⁶⁴ studied the dehydrofluorination of highly fluorinated compounds using aqueous alkali solution.

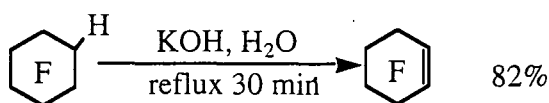

Scheme 81

Perfluorocyclohexene was obtained by reaction of the undecafluorocyclohexane with a concentrated aqueous alkali solution. Similar dehydrofluorination reactions occurred with polyfluorinated heterocycles.

3.3.e. Vinylic fluorides :

The dimethyl ester (**50**) was reacted⁶⁵ with Et₃N.BF₃ to give both the allene (**51**) and pyran (**52**) by following 2 directions : elimination of the vinyl fluorine atom and of the fluorine atom of the trifluoromethyl group leading to the diene compound.

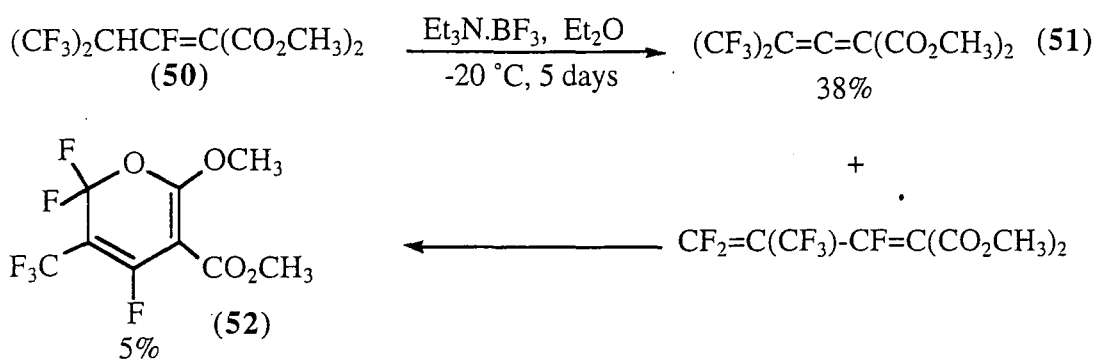

Scheme 82

3.3.f. Mechanism :

For compounds in which the hydrogen is "acidified" enough by β -fluorine atoms and contains a poor nucleofuge group, it is likely that the reaction occurs via an E1cB mechanism⁶⁶ (elimination unimolecular from the conjugate base). Anti-elimination *via* transition states resembling **a** (Scheme 83) is favoured at -80°C yielding preferentially to the *Z*-isomer. It was suggested that the preference for the **a** transition state is due to low energy interactions that occurs between the CF_3 and R groups such as hydrogen bonding⁴⁴.

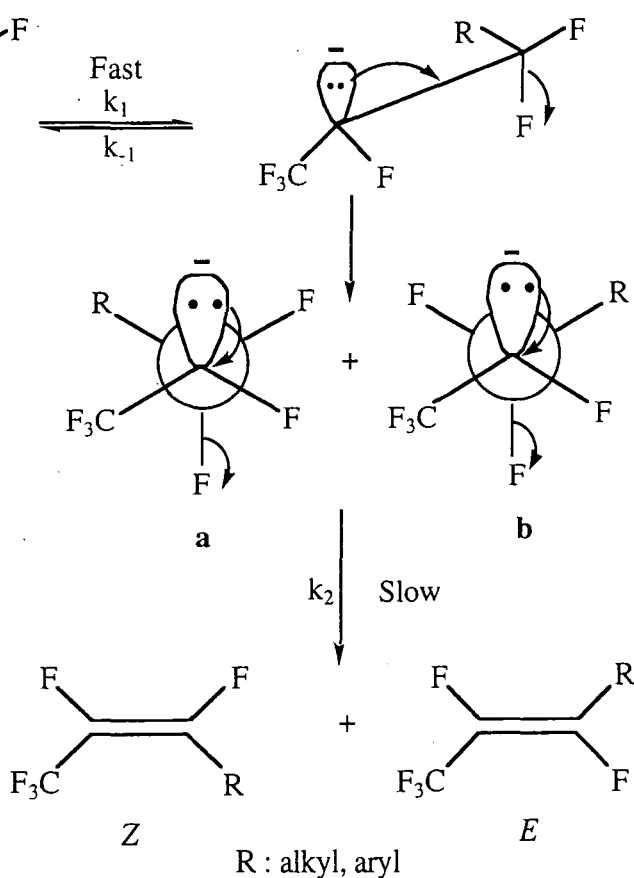

Scheme 83

The dehydrofluorination mechanism is a 2 step process: The proton is firstly removed to give a carbanion as an intermediate species. This step is reversible, fast and involves a proton exchange with the base. Then in the slower second step, the fluorine atom which is antiperiplanar with the lone pair on the carbon atom will be lost to give the alkene. The conjugated base of the substrate gives up the leaving group. This mechanism is likely to be observed with substrates containing X_2CH-CF_3 (X : halogen) due to the following conditions :

-The electronegativity of the halogen X on the β -carbon makes the β -hydrogen more acidic,

-A carbanion intermediate is stabilised by the electron withdrawal by the halogen,

-The leaving group is not very labile because fluorine is a poor leaving group.

After reviewing the methods used to dehydrofluorinate various fluorinated compound, we now move towards our results obtained. Firstly we will see the dehydrofluorination of 1:1 adamantane adduct, followed by 1:1 and 1:2 cyclopentane adducts.

3.4. Dehydrofluorination of hexafluoropropene adducts :

3.4.a. Adamantane monoadduct (36) :

1-adamantanyl-1,2,3,3,3-pentafluoroprop-1-ene (**53**) was synthesised by dehydrofluorination of (**36**) using potassium *tert*-butoxide. The reaction was carried out at -80°C according to previous work⁴⁴. Complete conversion of starting material was achieved and the alkene (**53**) was recovered by fractional distillation under reduced pressure (20 mmHg) to give 2 isomeric forms.

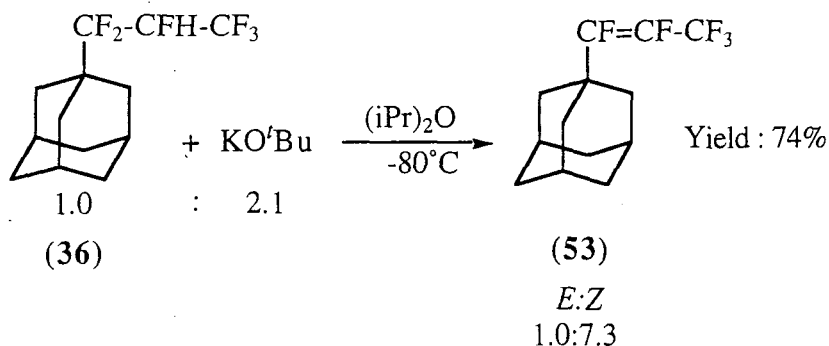

Scheme 84

Earlier work showed that the *E*-isomer was preferentially formed when the reaction was carried out at room temperature (Section 3.3.f.). This result was explained by the fact this is the more thermodynamically stable product.

Here, the reaction was carried out at -80°C and therefore kinetic control dominated and gave the *Z*-isomer as the major product. The assignment for the major isomer was done following previous work⁴⁴ as *cis* vicinal F, F spin-spin coupling could not be observed in the ^{19}F NMR and quantitative interpretation of the line shape was not possible.

^{19}F NMR of the mixture showed the disappearance of both signals representing the AB system of the 2' fluorines of the CF_2 group at -122.6 ppm and -130.0 ppm and of the fluorine signal for the CFH group at -206.9 ppm.

For the minor isomer, at -67.6 ppm a doublet of doublets is observed and gives $^4J_{\text{FF}}$ 22.6 Hz and $^3J_{\text{FF}}$ 10.2 Hz. At -149.3 ppm a doublet of quartets is observed. The first doublet represents the F,F coupling with a $^3J_{\text{FF}}$ 132.1 Hz and the quartets, the coupling between the fluorine and the 3 other fluorines of the CF_3 . At -175.6 ppm, a doublet of quartets with a $^3J_{\text{FF}}$ 122.7 Hz and a $^3J_{\text{FF}}$ 10.5 Hz is observed. The values for $^3J_{\text{FF}}$ obtained for the signal at -149.3 ppm and -175.6 ppm are in reasonable agreement with the observed value from the literature^{49, 50, 51} and are consistent with the $^3J_{\text{FFtrans}}$ values. Therefore, it is likely to be the *E*-isomer (**53a**) which is the minor isomer and the *Z*-isomer (**53b**) the major, obtained by dehydrofluorination reaction at -80°C .

3.4.b. Cyclopentane adducts (43) and (44b) :

3.4.b.i. Monoadduct (43) :

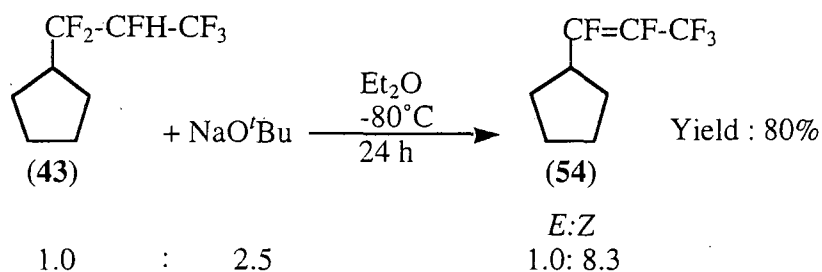

Scheme 85

Likewise of the adamantane monoadduct (**36**), the dehydrofluorination of (**43**) was performed at -80°C using sodium *tert*-butoxide and monitored by ^{19}F NMR (conv. 99%). The product was obtained, after distillation at atmospheric pressure, as a mixture of *Z*, *E*-isomers in a ratio of 8.3:1.0. The compounds were characterised as above.

In this case, the fact that the *Z*-isomer (**54b**) was the major isomer was proved by ^{19}F NMR by calculating the coupling constants $^3J_{\text{FF}}$ between the 2 fluorine atoms present on the double bond for both isomers and the data are summarised in Scheme 86.

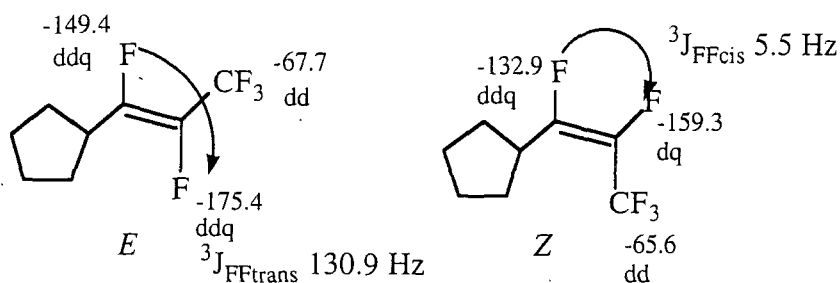

3.4.b.ii. Diadduct (**44b**) :

Dehydrofluorination of the diadduct (**44b**) was performed using a 4 fold excess of base (Scheme 87).

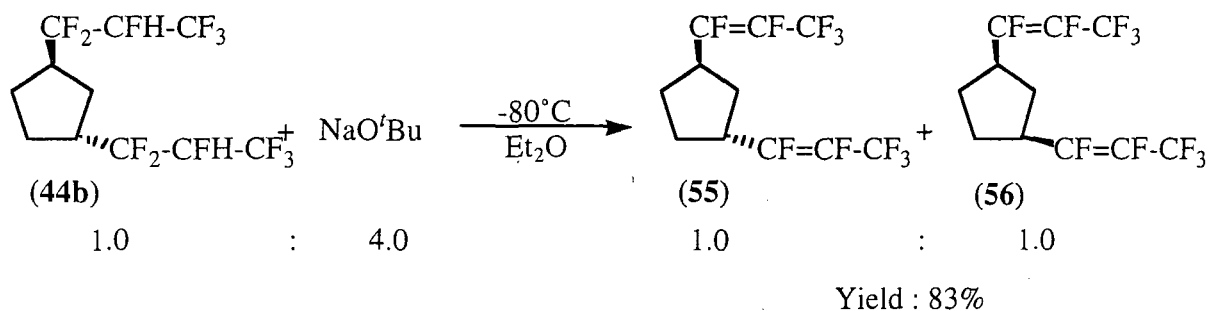

While the yield was good, the selectivity was zero. The 2 products obtained had similar molecular ions (m/z 330) and nearly the same fragmentation pattern.

It was thought that the structural difference between the 2 compounds could be caused by a difference in the stereochemistry of one of the 2 double bonds. The products can be a mixture of (*E,Z*) and (*Z,E*) or (*E,E*) and (*Z,Z*). ^{19}F NMR would be an useful tool in this case as the calculation of the $^3J_{\text{FF}}$ will distinguish the stereochemistry of the 2 double bonds of each compound. Only three ^{19}F resonances were present in the spectrum, indicating that in both structures the 2 fluoroalkyl chains were equivalent. This eliminated compounds having one of the fluoroalkyl chain bearing Ff and Fg in the *E*-configuration and the other one in the *Z*-configuration. Therefore the 2 compounds could be either (*Z,Z*) or (*E,E*). Measurement of the coupling constants at -134.7 ppm showed a doublet of quartets

with ${}^3J_{\text{FF}}$ 4.5 Hz and ${}^4J_{\text{FF}}$ 8.7 Hz and at -157.8 ppm a quartet of doublets with ${}^3J_{\text{FF}}$ 11.7 Hz and ${}^3J_{\text{FF}}$ 4.5 Hz. The 4.5 Hz is likely to be *cis*, therefore, only the (*Z,Z*) form is present.

It was also thought that the relative chirality of one of the chiral centres was different and the reaction had given epimers. The NMR spectral data confirmed this result. Both of these compounds are symmetric according either to a plane or a rotational axis bisecting the **Cd-Ce** bond and passing through **Cb** and therefore, for each compound, **Ha** will be equivalent to **Hc** and **Hd** to **He** as well as **Ca** will be equivalent to **Cc** and **Cd** to **Ce** (Scheme 88).

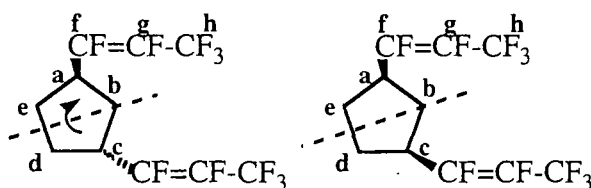

Scheme 88

In the ${}^1\text{H}$ NMR spectrum, because of the symmetry, it was expected only 5 resonances in the spectrum. Two different signals, one for each compound, for **He_{ax}** and **eq** and **Hd_{ax}** and **eq**, they were observed at 1.8-1.9 ppm and 2.0-2.1 ppm. Then 2 different signal for **Hb**, but because of the complexity of the signals and the overlapping, only one resonance has been observed at 1.9-2.0 ppm. And finally, 2 resonances for **Ha** and **Hc** which were observed at 3.2 ppm and 3.3 ppm. In the ${}^{13}\text{C}$ NMR spectrum, 12 signals were expected and were observed.

Epimerisation of the chiral carbon occurred during the dehydrofluorination reaction. It appears that the epimerisation process was favoured or catalysed by the base, as no other species was present in the reaction mixture and the 2 compounds were already observed in the crude mixture (i. e. they did not result from the work up). To better understand how epimerisation occurred and whether one of the two epimers (**55**) and (**56**) could be exclusively obtained, the pure mixture was added to a 4 fold excess of sodium *tert*-butoxide at -80°C (i. e. the same conditions used to perform the dehydrofluorination). After a similar work up, distillation yielded the same ratio mixture of epimers. The epimerisation process is similar to the racemisation process encountered for enantiomers, when one enantiomer equilibrates with its mirror image. The mechanism is likely to involve a planar achiral carbanion as intermediate, where the proton attack in the second step can occur equally from either side of the intermediate (Scheme 89).

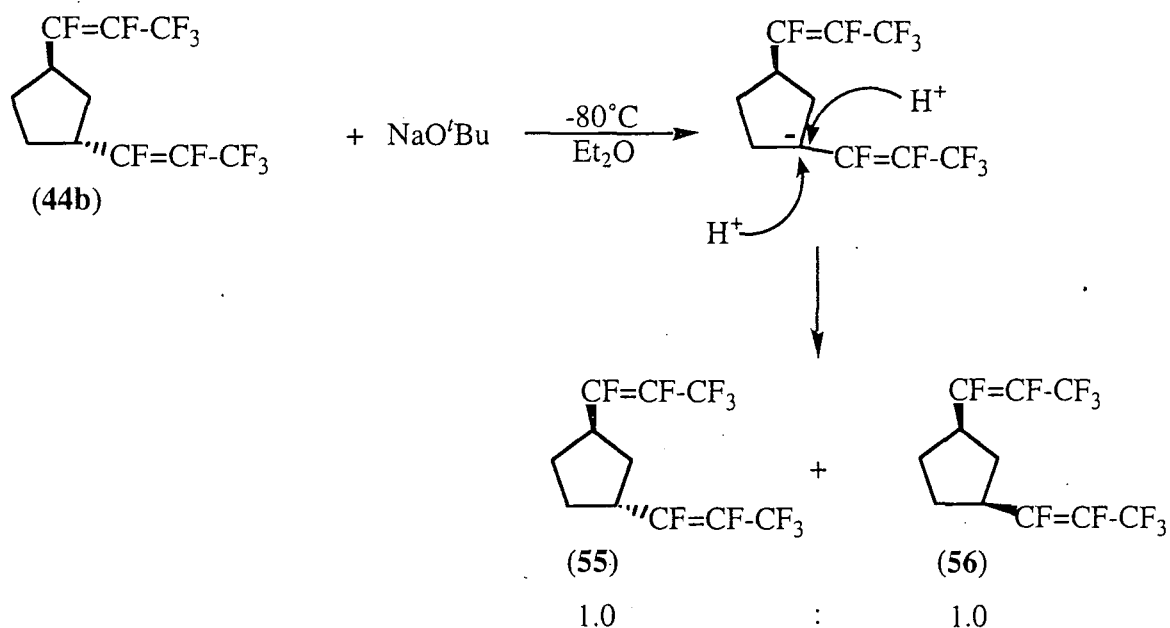

Scheme 89

Several attempts to prove the mechanism using NMR spectroscopy were made. In a first attempt, the pure epimer mixture was dissolved in deuterated chloroform and a drop of deuterated butanol was incorporated. The aim of this was to replace the hydrogen atom by the deuterium one (*α secondary isotope effects*), where these effects are correlated with the carbanionic character. The evolution was followed for one week by ¹H NMR by integrating the signals at 3.2 ppm and 3.3 ppm (C-H tertiary signal). After 7 days, the initial ratio and the final ratio were identical. In the second attempt, some sodium *tert*-butoxide was added to this mixture and the evolution was again monitored by ¹H NMR. After 7 days, the ratio remained unchanged. The last attempt was carried out by considering the temperature dependent reaction factor since the dehydrofluorination reaction was carried out at -80°C. ¹H NMR spectra were taken as the temperature of the mixture was varied from -50°C (above the freezing point of the CDCl₃) to +50°C. Still the same integration ratios were obtained after these experiments. In all 3 cases a ¹⁹F NMR was taken, to make sure that no nucleophilic additions took place rather than the replacement of the hydrogen by the deuterium. The mechanism of the reaction could not be proved *via* deuterium exchange as the 2 forms seem to be in equilibrium.

3.4.c. Cyclopentene monoadduct (49) :

Dehydrofluorination of the 1:1 cyclopentene adduct (49) was performed using KOH flakes (dried overnight) instead of sodium *tert*-butoxide. The advantages of this method are : it avoids the use of a solvent as the reaction was carried out using vacuum line transfer techniques, the product is obtained without the need for further

purification and it is a temperature independent reaction. The dehydrofluorination reaction allows the introduction of a second double bond in the fluoroalkyl chain, leading to a conjugated diene (Scheme 90).

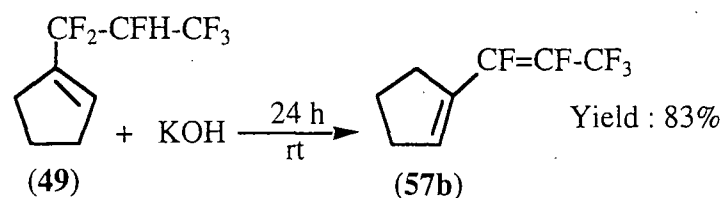

1.0 : 4.9
E: *Z*
 1:19

Scheme 90

Only traces of the minor isomer (*E*) appear in the NMR spectra. By integrating the two CF_3 signals for both isomers in the ^{19}F NMR, a ratio of 19:1 was observed. Only the NMR data for the major isomer could be recorded.

The stereochemistry of the double bond, for the major isomer, was determined using ^{19}F NMR and this confirmed the fact that the 2 fluorine atoms were in *cis* position in the double bond and that the *Z*-isomer was exclusively formed.

Dehydrofluorination using KOH favoured, as dehydrofluorination using sodium *tert*-butoxide at -80°C , favoured exclusive production of the kinetically stable isomer : *Z*-isomer (57b). The reaction is highly stereoselective as a ratio major:minor of 19:1 was observed.

3.5. Conclusion :

* Cyclopentene monoadduct (49) :

Dehydration and dehydrofluorination reactions yielded a fluorinated conjugated diene (57b). The reactions proceeded smoothly in good yields (56% and 83% respectively). Dehydrofluorination using potassium hydroxide under anhydrous conditions and in *vacuo*, appears to be a good dehydrofluorination method to obtain the *Z*-isomer as high stereoselectivity was observed with a *Z*:*E* ratio of 19:1.

* Adamantane (36) and cyclopentane (43) monoadducts :

The stereoselective synthesis of the *Z*-pentafluoro olefin with general formula R-CF=CF-CF_3 (R : cyclopentane and adamantane) was achieved in high yields (80% and 74% respectively) using sodium or potassium *tert*-butoxide as reagent at -80°C .

The reactions proceeded by a E1cB mechanism with stereochemical elimination being the controlling factor.

* Cyclopentane diadduct (44b) :

Dehydrofluorinating the trans 1,3-(44b) led to epimerisation of the product. A ratio of 1:1 of the epimers was obtained. Various experiments has been performed to try to prove the carbanionic mechanism of the epimerisation process without success.

Chapter 4 : Z-Alkene chemistry studies

4.1. Introduction :

This Chapter will concentrate on the study of the precursor (i. e. the Z-alkene) reactivity towards nucleophiles and electrophiles (Scheme 91).

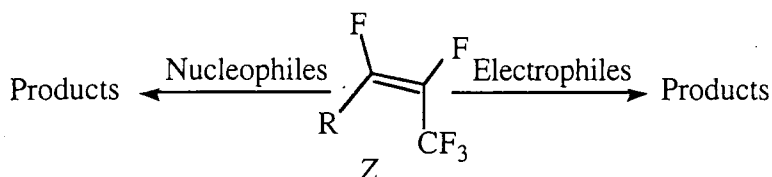

R : Cyclic alkanes and cyclic alkene

Scheme 91

The few first paragraphs of this Chapter will constitute a literature review of nucleophilic and electrophilic addition reactions to fluoroalkenes as some general features such as the regioselectivity of the addition and the mechanism of the various reactions need to be established. As it was shown in Section 1.5.c., fluoroalkenes are very electrophilic, making their chemistry dominated by nucleophilic substitution reactions⁶⁷.

4.2. Nucleophilic addition reactions :

4.2.a. Regioselectivity :

In the first step of the nucleophilic addition reactions, a vinyl carbanionic intermediate is formed (58), implying that the reactivity and orientation of the nucleophilic attack depends on the stability of the intermediate⁶⁷ (Scheme 92).

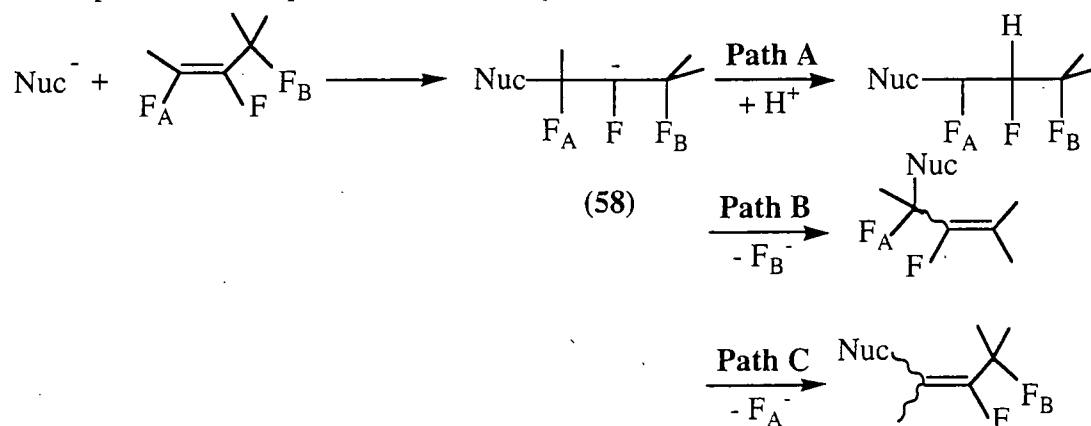

Scheme 92

Three pathways, leading to different products, are possible after addition of the nucleophile :

-Path A : an addition product is obtained by protonation of the carbanionic species,

-Path B and/or C : an elimination product is obtained *via* fluoride ion elimination.

4.2.b. Factors influencing the reactivity of the orientation attack :

4.2.b.i. Polar effects :

Due to the fluorine having the highest electronegativity of all the halogens, a greater reactivity is observed for alkenes bearing a fluorine atom rather than a chlorine (Section 1.1.).

4.2.b.ii. Electronic effects :

One fluorine atom in the α position to a carbanion have a stabilising effect. However calculation and experimental work disagree on the effect of a β -fluorine to a carbanionic stability, it has always been considered^{67, 68} that fluorine in the β position has a stabilising effect due to its electron withdrawing character ($-\text{I}\sigma$) (Scheme 93).

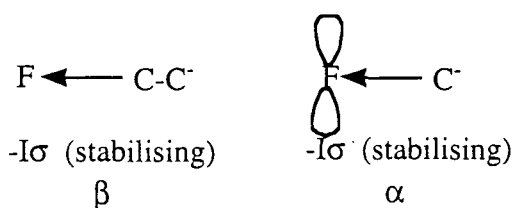

Scheme 93

4.2.b.iii. Orientation of the attack :

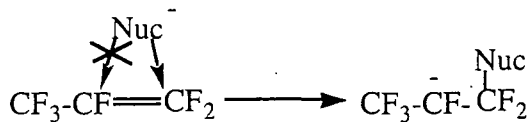

Scheme 94

Scheme 94 shows that the CF_2 position is exclusively attacked by nucleophiles and this regioselectivity can be rationalised by 2 factors. The first factor is that the CF_3 group attached directly to the carbanion causes a stabilisation effect.

4.3.a.i. Saturated alcohols :

The first reactions on fluoroalkenes of this type, were carried out by Hanford and Rigby^{73, 74} in 1946. They performed the addition of alcohols to tetrafluoroethylene and fluoroalkenes of the general formula $\text{XFC}=\text{CF}_2$ (X : H or hal) in presence of a base as a catalyst (Scheme 97).

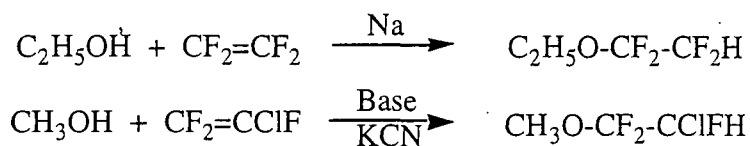

Scheme 97

In each reaction, the difluoromethylene group in the chlorotrifluoroethylene was preferentially attacked rather than the monofluoromethylene. They only obtained products resulting in addition across the double bond.

Miller and co-workers⁷⁵ showed that the regioselectivity of the attack was due to the resonance effect of fluorine. They studied the addition of ethoxide to trifluorochloroethylene using base as a catalyst. The reaction was exothermic and fast, resulting in an unsaturated ether produced by the addition elimination process (Scheme 98).

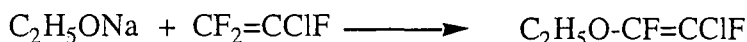

Scheme 98

Work has been carried out at Durham^{76, 77}, Dmowski⁶¹ performed one of the first reactions, reacting the compound (59) with various sodium alkoxides (Scheme 99).

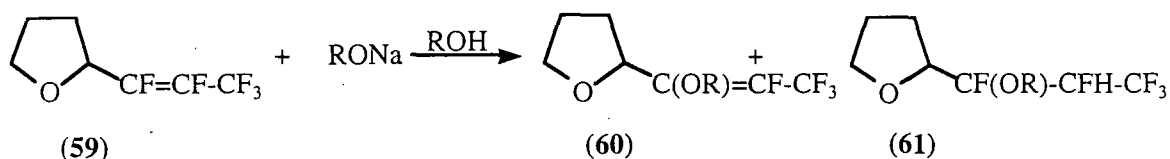

R : C_2H_5^- , $n\text{-C}_3\text{H}_7^-$, $iso\text{-C}_3\text{H}_7^-$, $cyclo\text{-C}_5\text{H}_9^-$,
 $\text{CF}_3\text{-CH}_2^-$, $(\text{C}_2\text{H}_5)_2\text{NCH}_2\text{-CH}_2^-$

Scheme 99

All the reactions studied showed that a product (60) was obtained from addition elimination across the double bond. Nucleophilic attack occurred each time

exclusively at the carbon bearing the tetrahydrofuryl group. Addition elimination was rationalised by the high electron density of the Ca of the carbanionic species (Scheme 100), which makes the fluoride ion elimination faster than the hydrogen abstraction from another molecule of alcohol.

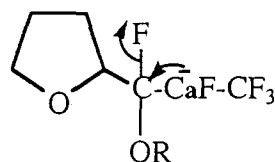

Scheme 100

4.3.a.ii. Unsaturated alcohols :

By performing a nucleophilic addition of allylic or vinylic alkoxide derivative to the Z-alkene, a fluoroalkyl ether will be formed and maybe rearranged to give the corresponding ketone *via* the Claisen rearrangement.

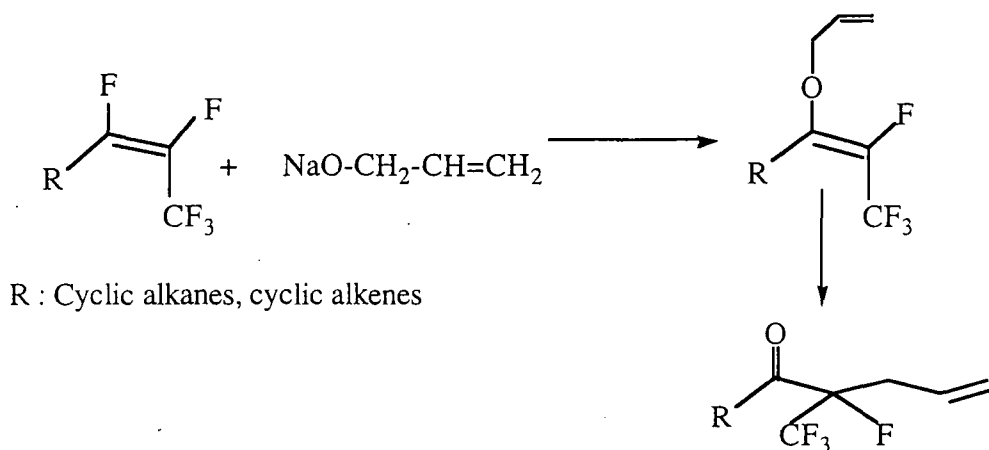

Scheme 101

Asymmetric synthesis of a molecule containing fluorine or trifluoromethyl group is a difficult task to achieve. However, their preparation is industrially important (Section 1.2.). The Claisen rearrangement has been a useful tool for stereocontrolled C-C formation, since its discovery in 1912⁷⁸. The asymmetric Claisen rearrangement provides a good way to induce chirality transfer⁷⁹⁻⁸¹ for creation of at least one chiral center and stereoselective formation of a double bond.

* Mechanism :

The mechanism of Claisen rearrangement, involves a pericyclic [3,3'] sigmatropic reaction with the migration of a σ bond within the conjugated π -system^{82, 83}.

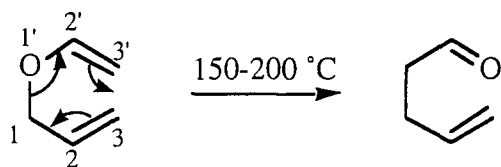

Scheme 102

This reaction implies a suprafacial pathway^{81, 84} with a chair like transition state because of the favourable LUMO C_3 and HOMO C_3' interactions (Scheme 103).

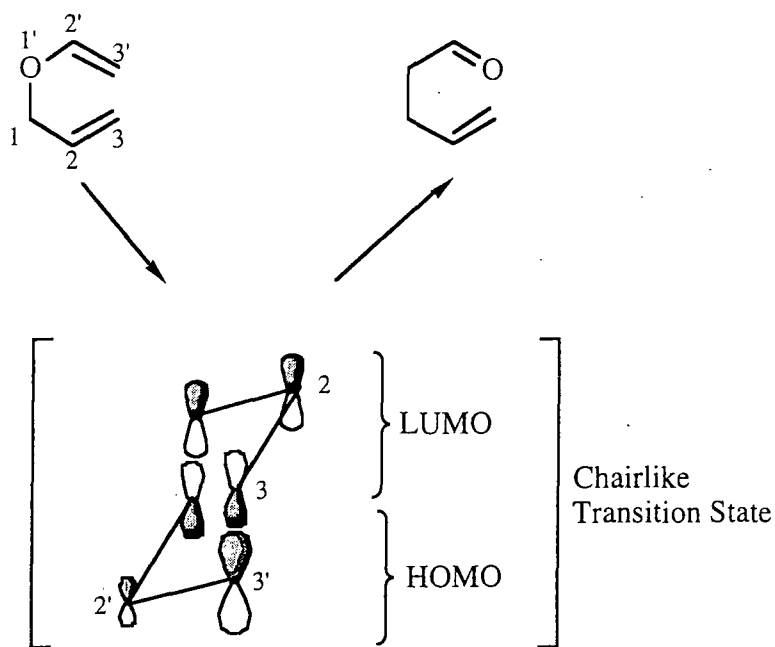

Scheme 103

Whereas unfavourable interactions between the LUMO C_2 and HOMO C_2' in the boat like transition state are observed (Scheme 104).

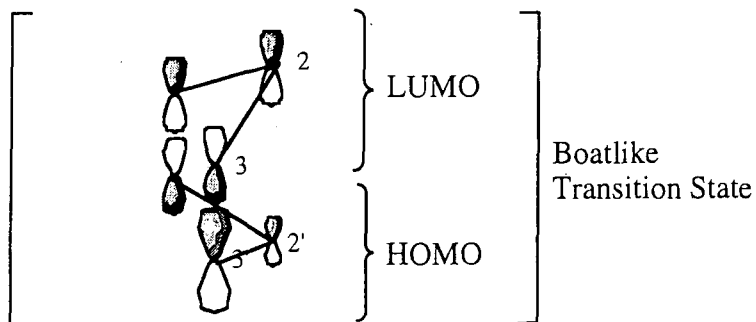

Scheme 104

* Stereocontrol :

The stereochemical outcome of the reaction, i. e. stereochemistry of the chiral centre obtained as well as the geometry of the new double bond being formed, depends on 2 factors :

-The geometry of the double bond of the parent substrate (Scheme 105). The stereochemistry of the 2 adjacent chiral centres, obtained in the ketone, can be anti or syn.

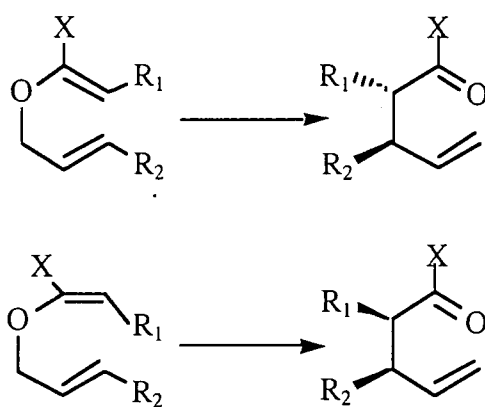

Scheme 105

-The chirality of the parent substrate, if the substrate is chiral at the 1-position, a different product can be obtained according to the configuration of the carbon (Scheme 106).

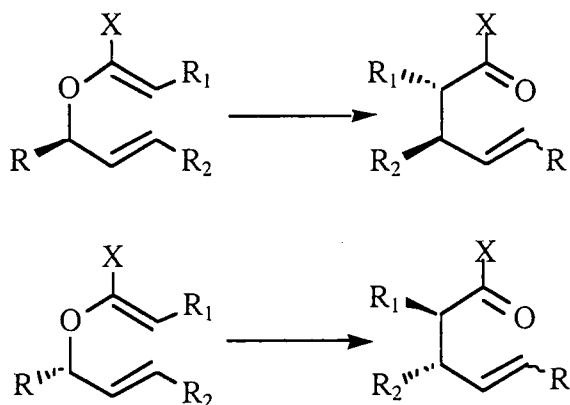

Scheme 106

Therefore, the conformation of the transition state is controlled by both steric and electronic effects.

4.3.a.iii. Claisen rearrangement involving fluorine containing molecules :

One of the earliest Claisen rearrangements of fluorine containing molecules was discovered in 1967 by Krespan⁸⁵. He reacted allyl alcohol with octafluoroisobutene and obtained 4-pentenyl ester with the intermediate rearranging at a temperature below 50°C. It was observed that the presence of fluorine in the vinylic moiety accelerated the Claisen rearrangement. This result was correlated by Andreev and co-workers⁸⁶ who observed formation of a side product (63) in a 15% yield, by reaction of octafluoroisobutylene with allyl alcohol in the presence of a base (KF). Product formation was rationalised by the Claisen rearrangement of (62), where the carbanionic species rearranged *via* fluoride elimination. Andreev *et al*⁸⁶ showed that in proton acceptor solvents such as DMF, DMSO and KF, the ketone (63) was obtained in 60% yield, even at -30°C (Scheme 107).

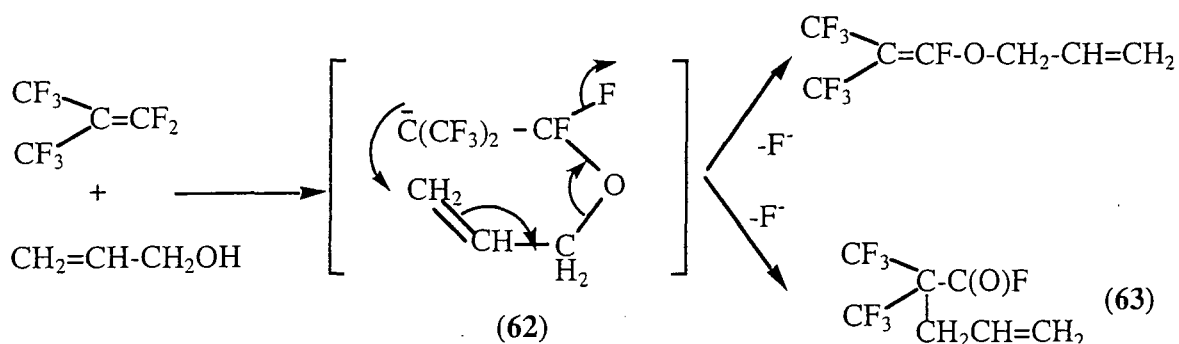

Scheme 107

Similar reactions were performed using propargyl alcohol. This reaction was exothermic in presence of KF and solvent even at 0°C and -15°C and gave an allene as rearranged product (64) (Scheme 108).

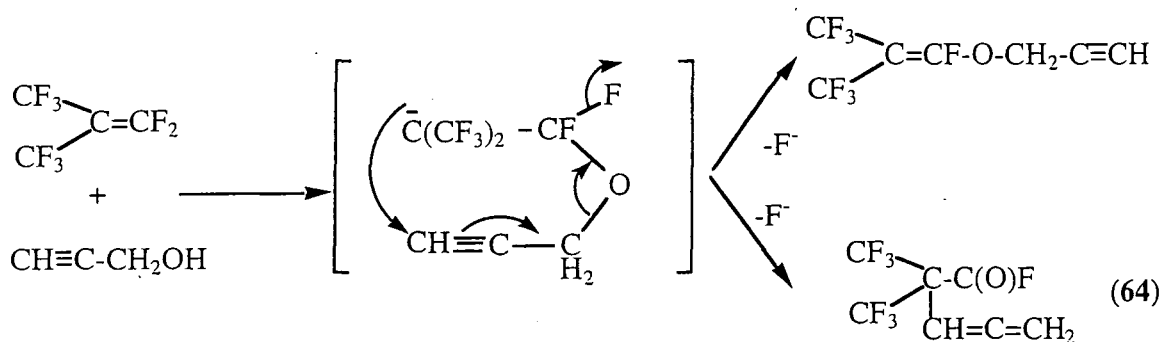

Scheme 108

Both carbanionic species gave a sigmatropic rearrangement. The introduction of fluorine atoms in a vinylic system results in lower temperature being used to accomplish the Claisen rearrangement.

4.3.a.iv. Effects of a CF₃ group at C1 position :

Little effect on the rearrangement rate has been observed when the allyl vinyl ether is substituted at the C-1 position. Burger and co-workers⁸⁷⁻⁸⁹ showed in reactions between (65) with allyl alcohol, the nucleophilic substitution occurred at the 5-position. Surprisingly they could not isolate the allyl vinyl intermediate (66) which undergoes Claisen rearrangement at room temperature to give (67) (Scheme 109).

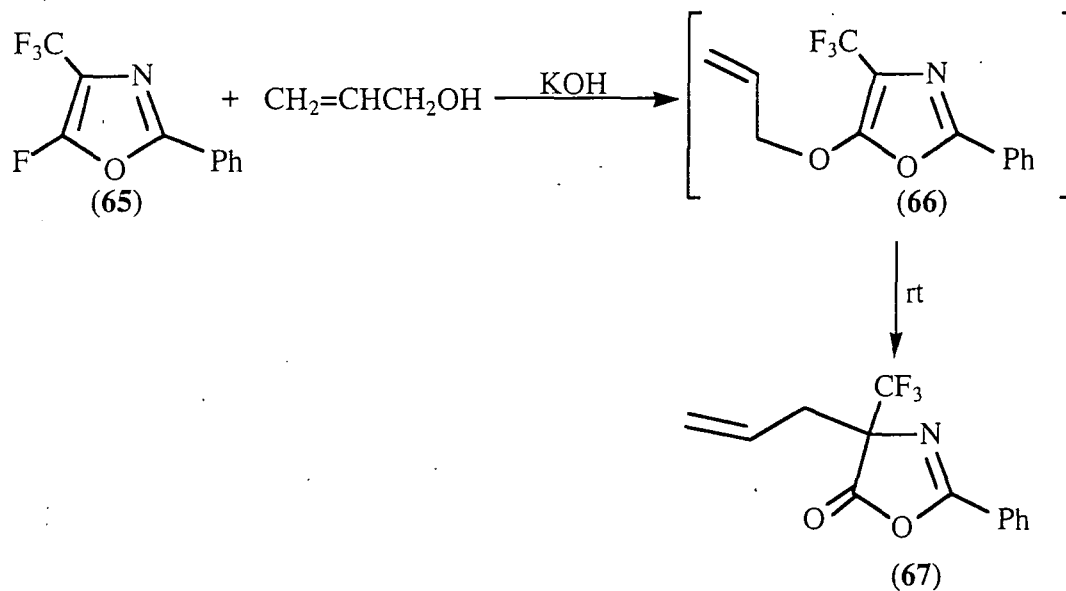

Scheme 109

However, in their studies on benzyl type alcohols, they showed that the allyl vinyl intermediate could be isolated (Scheme 110).

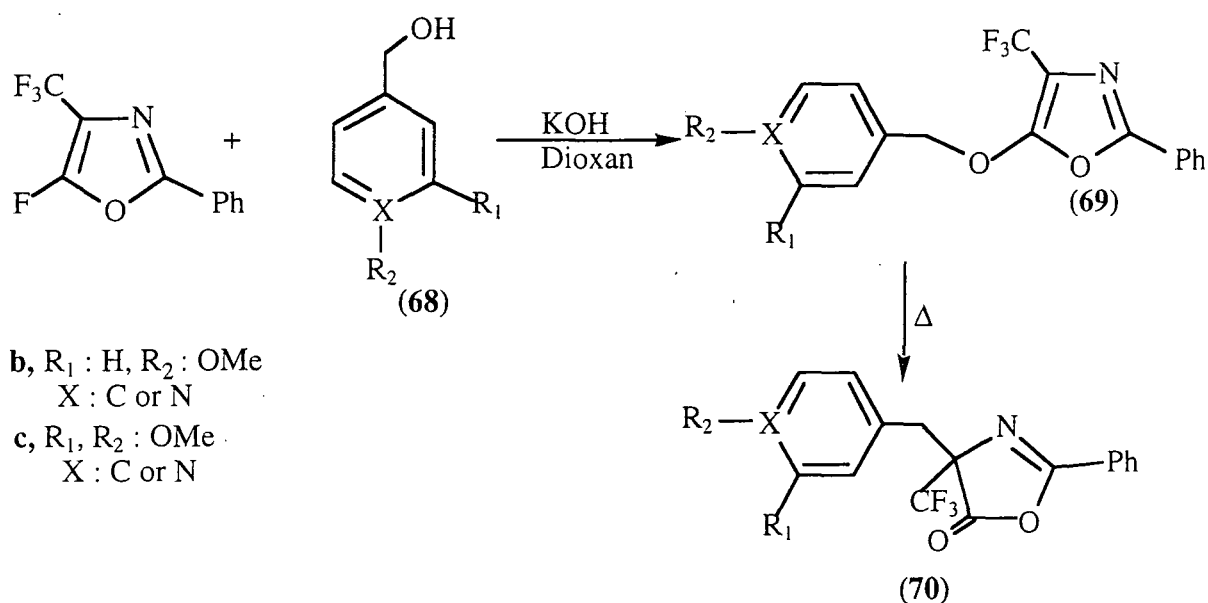

Scheme 110

The rearrangement of (69) into the ketone was performed depending on the substituent nature on the benzyl ring. For example, the rearrangement of the dimethoxy-derivative (69c) into the dopa-derivative (70c), took place at room temperature in less than 24 hours, whereas the 4-methoxy derivative (69b) rearranged in 5-6 weeks.

Because of the accelerating effect that fluorine atoms can have on the rate of the Claisen rearrangement, a lot of systems containing fluorine have been studied these last few years. The various examples in the literature⁹⁰⁻⁹⁸ showed that the subject is still a field of interest.

4.3.b. Reactions involving nitrogen centred nucleophile :

Little work has been reported^{99, 100} using nitrogen systems as nucleophiles. The most common reagent involved in these reactions was ammonia. Tetrafluoroethylene, for example, has been reacted by Rigby and co-workers⁹⁹, to yield difluoroacetonitrile (71), which readily trimerised to give (72) (Scheme 111).

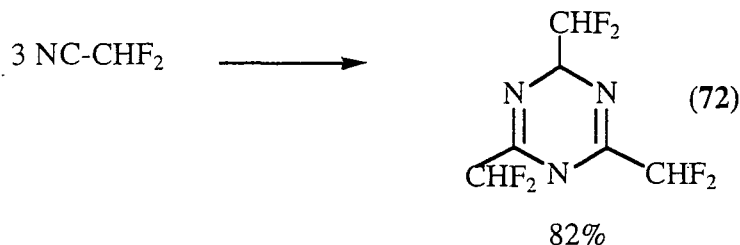
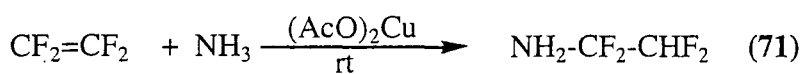

Scheme 111

Primary and secondary amines have also been reported to react with fluorinated alkenes¹⁰⁰ (Scheme 112).

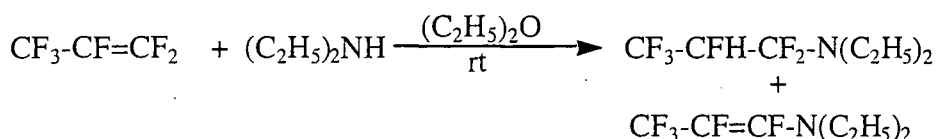

Scheme 112

A mixture of saturated and unsaturated (resulting from the dehydrofluorination of the fluoroalkyl chain) products were obtained by reaction of hexafluoropropene with diethylamine.

4.3.c. Reactions involving carbon centred nucleophile :

Organolithium and organomagnesium derivatives add to fluoroalkenes to give the addition elimination product.

4.3.c.i. Organolithium compounds :

Addition of fluoroolefin to organolithium derivatives has been a subject of interest since 1955. Mc Grath and Levine¹⁰¹ reacted a 2 fold excess of phenyllithium with tetrafluoroethylene, in refluxing ether which led to the diaddition product (Scheme 113).

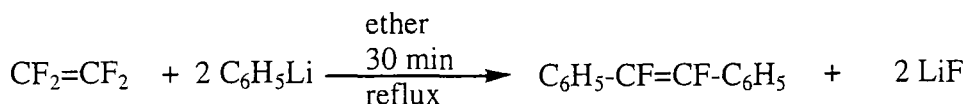

Scheme 113

The mechanism involves for these syn addition and elimination processes is the following one :

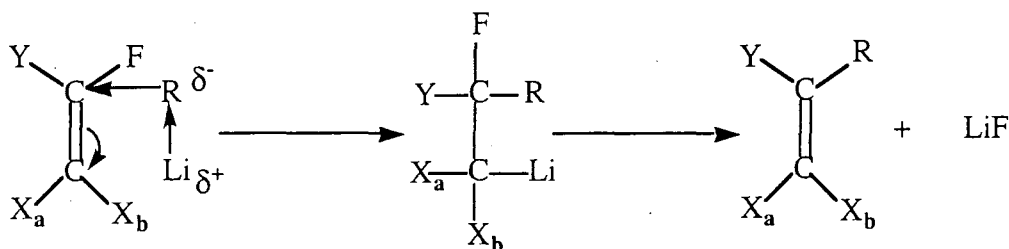

Scheme 114

Dixon¹⁰² reported that the reaction proceeded better when Y : F, X_a and X_b are electronegative. R is reacting with the positive carbon atom of the double bond, to form an unstable intermediate which will, by lithium fluoride elimination yield the alkene. More recently, other perfluoroalkenes have been reacted with organolithium derivatives¹⁰³.

4.3.c.ii. Organomagnesium compounds :

Grignard reagents have been proved to react successfully with fluoroolefins^{103, 104} as illustrated in the reaction between the perfluoroalkene (73) with phenylmagnesium bromide (Scheme 115). The presence in high yield of biphenyl indicated that this time a free radical process *via* a one-electron transfer is involved in the first step.

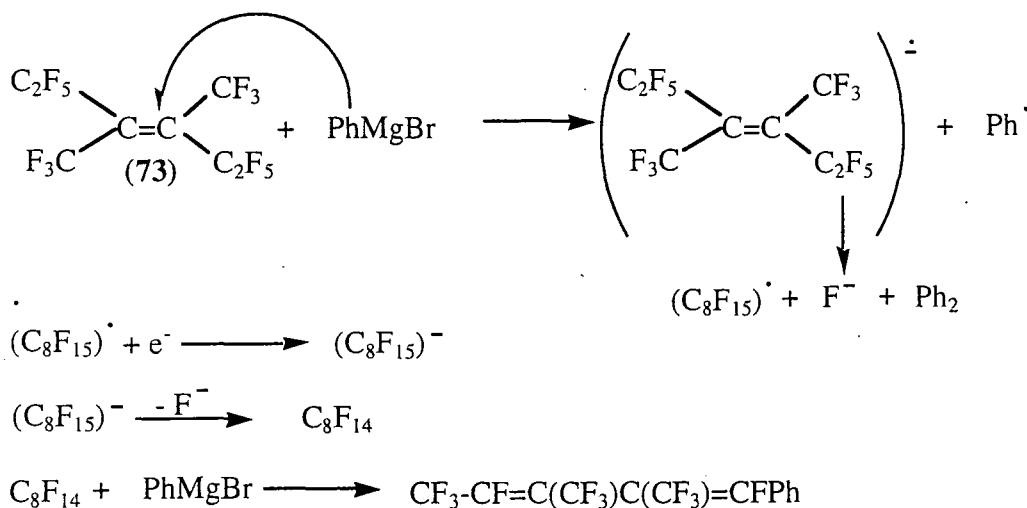

Scheme 115

4.3.c.iii. Sodium malonate derivatives :

Finally sodium malonate derivatives have been reported to react with fluoroalkenes. Rozov and co-workers¹⁰⁵ proved that sodium malonate derivatives reacted successfully with hexafluoropropene in dimethylformamide to give the ester (74) in a good yield (Scheme 116).

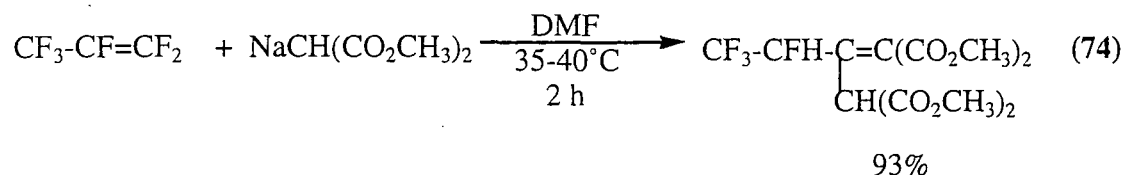

Scheme 116

4.4. Electrophilic addition reactions :

After studying nucleophile reactions of fluoroalkenes, it seems natural to show an interest towards reaction of fluoroalkenes with electrophilic reagents. Because of the electron withdrawing influence of fluorine, fluoroalkenes are electrophiles (Section 1.5.c.). Therefore, they should react poorly with electrophiles and sometimes require drastic conditions¹⁰⁶.

4.4.a. Orientation of electrophilic attack :

The addition proceeds according to the double bond polarisation, which depends on the σ inductive effect of the fluoroalkyl group and the electronic effect of the fluorine atoms on the double bond¹⁰⁷. As shown in Section 1.1., fluorine possesses an unshared p electron pair which stabilises the carbocation whereas a trifluoromethyl group directly attached have a destabilising effect (Scheme 117).

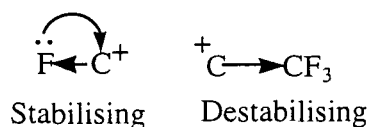

Scheme 117

4.4.b. Halogenation :

In most cases, additions of electrophiles to a fluorinated double bond proceed *via* a radical mechanism induced either thermally or photochemically. However some bromination reactions appear to occur *via* a ionic mechanism, such as addition to perfluorovinyl ethers and perfluorovinyl amines (Scheme 118), under mild condition

at 0°C. The polarisation of the double bond is mainly due to the unshared electron pair of both heteroatoms.

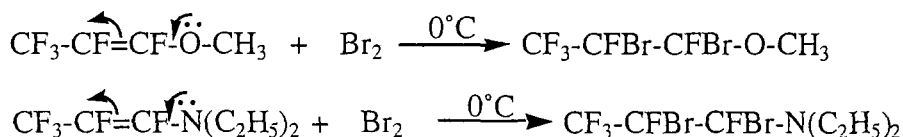

Scheme 118

Douglas¹⁰⁸, studied in more detail the ionic process involved in this reaction. For acyclic alkenes, an anti addition of the bromine to the double bond is observed involving a bromonium ion as intermediate (Scheme 119).

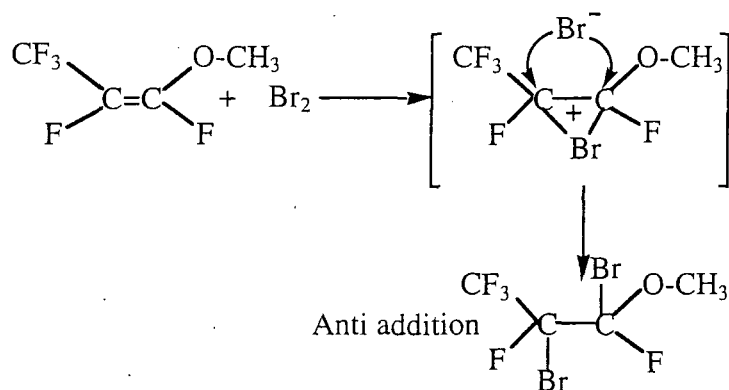

Scheme 119

4.4.c. Interhalogenation :

In this process, involving species such as (IBr, BrF, ClF), ionic processes are observed because of the polarity of these mixed halogens.



Scheme 120

4.5. Epoxidation reactions :

Epoxidation reactions can be either carried out using oxygen centred nucleophiles or oxygen centred electrophiles. Therefore, this reaction seemed suitable to compare the double bond reactivity and to finish off the fluoroalkene reactivity studies.

4.5.a. Oxygen centred as nucleophile :

4.5.a.i. Sodium hypochlorite :

These reactions are usually carried out using aqueous sodium hypochlorite, in alkaline solution and acetonitrile¹⁰⁹⁻¹¹¹. They usually occur at room temperature to give the epoxide in good yield (Scheme 121).

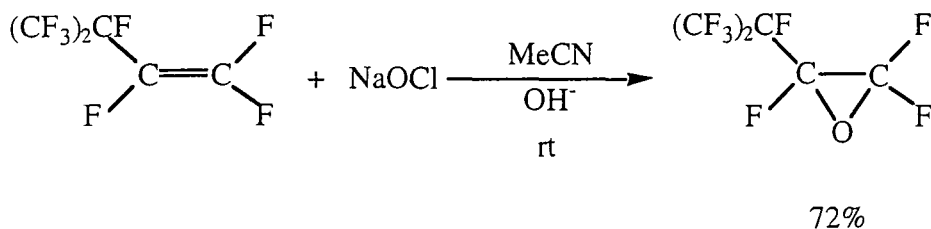

Scheme 121

4.5.a.ii. Peroxide :

An aqueous solution of H₂O₂ in presence of a base, at room temperature, has been used to obtain the hexafluoropropylene epoxide¹¹² (Scheme 122).

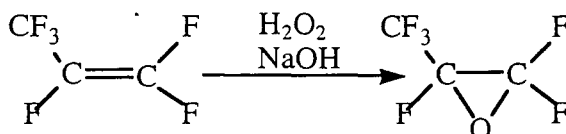

Scheme 122

4.5.b. Oxygen centred as electrophile :

The most common reagents to perform these reactions is *meta*-chloroperbenzoic acid.

4.5.b.i. *meta*-chloroperbenzoic acid :

These reactions proceed smoothly at room⁷⁷ temperature to give the resulting epoxide. For example Fujita and co-workers¹¹³, studied the epoxidation reaction of allylic fluorides. They obtained 2 products with different stereochemistry.

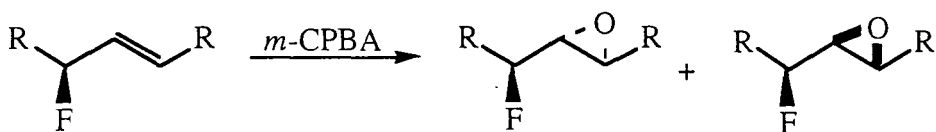

R : *n*-Hex, *i*-Pr, *tert*-Bu

Scheme 123

After the literature review about the various reactivity studies effected on different fluoroalkenes, the following part of the Chapter will concentrate on the work carried out in the laboratory.

4.6. Nucleophilic additions involving oxygen as nucleophile :

4.6.a. Using alkoxide derivatives :

The reactions were performed using 3 classes of reagents : saturated alcohols (ethanol, methanol), unsaturated alcohols (allyl, propargyl, but-1-en-3-ol, crotyl, benzyl, geraniol and 4,4,4-trifluoro-but-2-en-1-ol) and at last, diols such as propane-1,3-diol. For each reactions, the Z-alkene was reacted with the powerful nucleophilic ion RO⁻, prepared by removal of a proton from the alcohol, using sodium metal (Scheme 124).

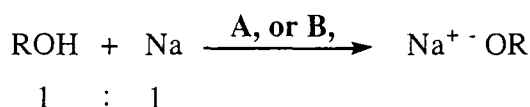

A, alcohol as solvent, rt, 24 h

B, THF, 50 °C, 24 h

Scheme 124

The fact that the alcohol was deprotonated in the first step, avoided the formation of the addition product. This product could be obtained by addition of the alcohol across the alkene double bond to form a saturated ether as a side product (Scheme 125).

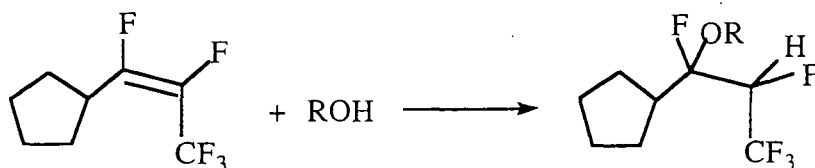

Scheme 125

All the reactions were heated at reflux and monitored by ¹⁹F NMR, observing the disappearance of the Ff signal of each system studied with a general formula :
R-CFf=CFg-CF₃.

4.6.b. Saturated alcohols :

4.6.b.i. 1-(Z-pentafluoroprop-2-enyl)cyclopentane (54b) and sodium ethoxide :

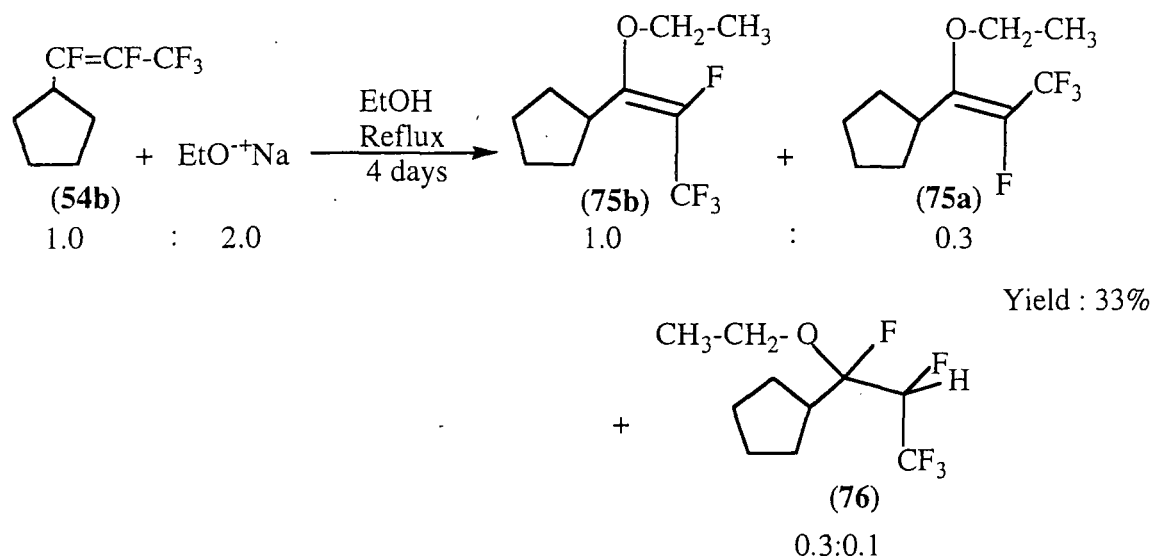

Scheme 126

A mixture of 4 products was obtained for this reaction. The *E*- and *Z*-isomers (**75a**) and (**75b**) in a ratio 1.0:0.3 and product from the addition reaction across the double bond (**76**) (as a diastereoisomeric mixture) were obtained. Theoretically, because of the introduction of 2 chiral centres, 4 diastereoisomers of the addition product (**76**) should be obtained and therefore in the NMR spectra, only 2 set of signals should be observed as RR=SS and RS=SR and this is the case. The presence of the addition product maybe due to the fact that as ethanol was used as solvent, thus present in excess in the reaction mixture, leading to its addition across the double bond. The addition product formation can also be due to the fact that the intermediate carbanion picked up a proton from the solvent.

As expected, the replacement of a fluorine by an ethoxy group did not have a significant influence in the NMR spectra, maybe because of their similar electron withdrawing character and electronegativity, leading to similar chemical shifts and coupling constants.

* Z-isomer (75b) :

A long range coupling constant was observed for **Cb** and **Ce** with a $^4J_{\text{FF}}$ 2.3 Hz, which was not observed in the fluoroalkene (**54b**) (Scheme 127).

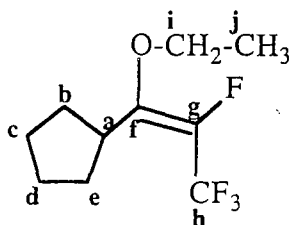

Scheme 127

* *E*-isomer (75a) :

Not all the carbons could be assigned due to the low yield of this isomer. For **Ha** a well resolved signal was obtained with a doublet of doublets of quartets at 2.9 ppm. As for the *Z*-isomer, a long range C,F spin-spin coupling was observed at 30.0 ppm for **Cb** and **Ce** ($^4J_{CF}$ 3.0 Hz) (Scheme 128).

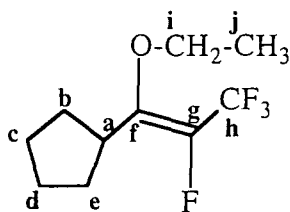

Scheme 128

Curiously, examination of the 1H , ^{13}C and ^{19}F NMR spectra recorded after few days, showed that the ketone (77) was the only product in the mixture (Scheme 129).

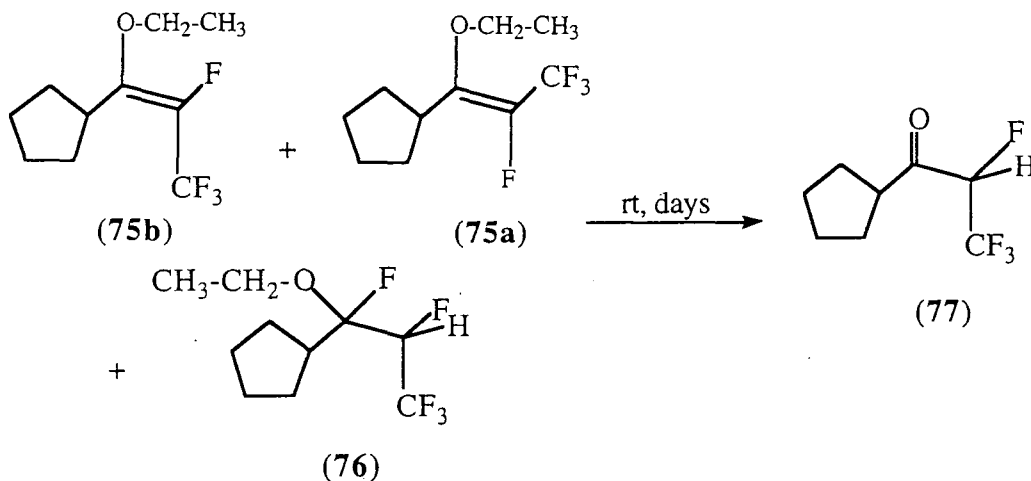

Scheme 129

The infrared spectrum confirmed this result with the appearance of a strong C=O vibration band at 1734 cm^{-1} . The fact that the ketone (77) was obtained can be

explained by the mechanism illustrated in Scheme 130. Where firstly, some traces of NaF salt could have been sufficient to induce the transformation of the 2 diastereoisomers (76) into the *Z*- and *E*-isomers (75b) and (75a) generating HF.

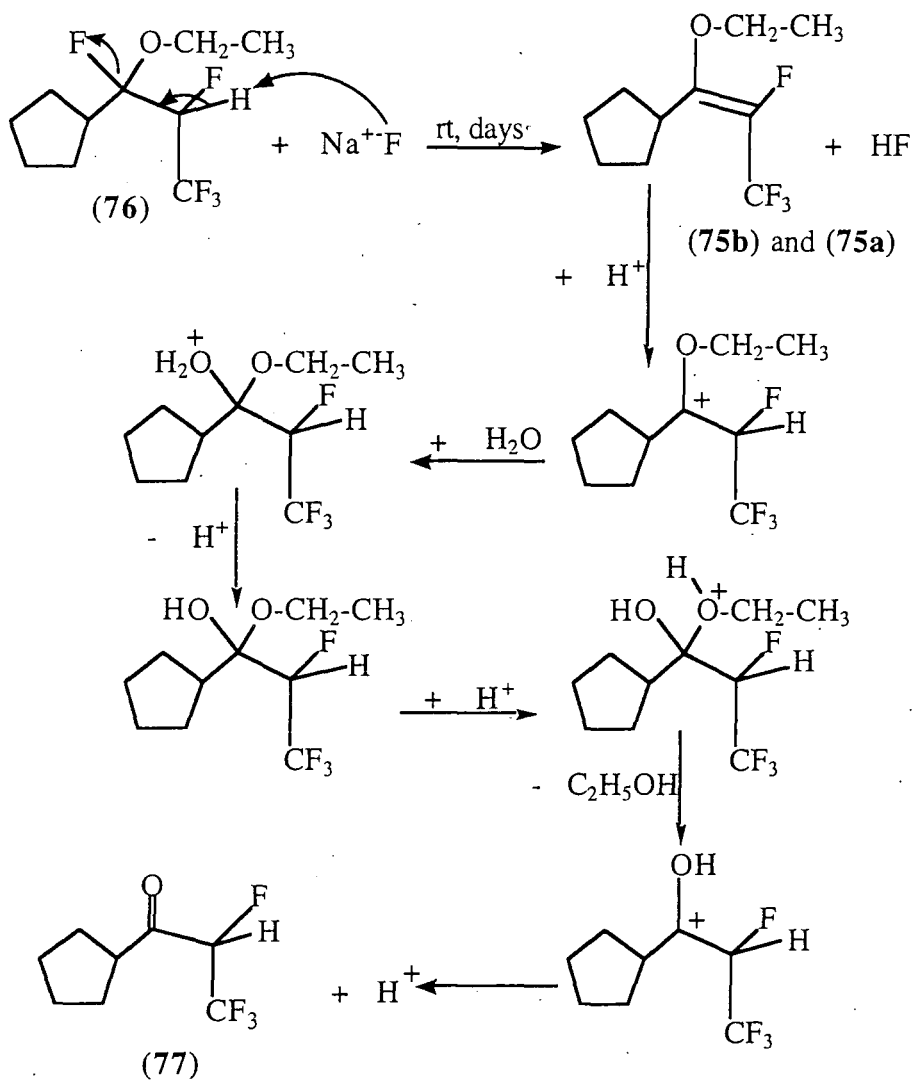

Scheme 130

The vinylic ethers were readily hydrolysed by the acid present in the mixture according to the previous mechanism. The first protonation did not occur at the oxygen but on the β carbon.

4.6.b.ii. 1-(*Z*-pentafluoroprop-2-enyl)cyclopentane (54b) and sodium methoxide :

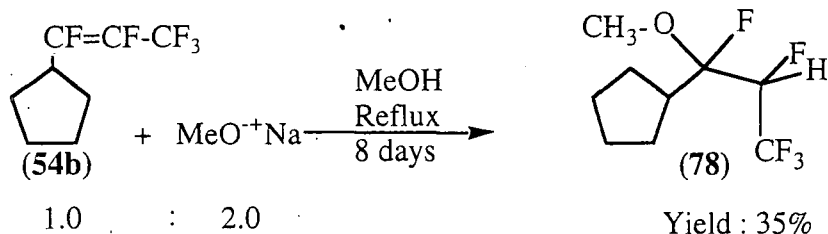

Scheme 131

The Z-alkene (**54b**) was refluxed in methanol with sodium methoxide, in the same way as the previous reaction. No nucleophilic substitution reaction was observed as the only product was the addition product (**78**). This created 2 chiral centres inducing the presence of 4 diastereoisomers which will yield 2 sets of signals in the NMR spectra. Only one set was observed by NMR spectroscopies, therefore implying that at most 2 diastereoisomers (RR and SS, SR and RS) were present in the final product. The mass spectrum failed to show any molecular ion, however the NMR data were consistent with the product structure.

4.6.c. Unsaturated alcohols :

Various unsaturated alcohols were studied in order to compare their reactivity.

4.6.c.i. 1-(Z-pentafluoroprop-2-enyl)cyclopentane (**54b**) and allyl alcohol :

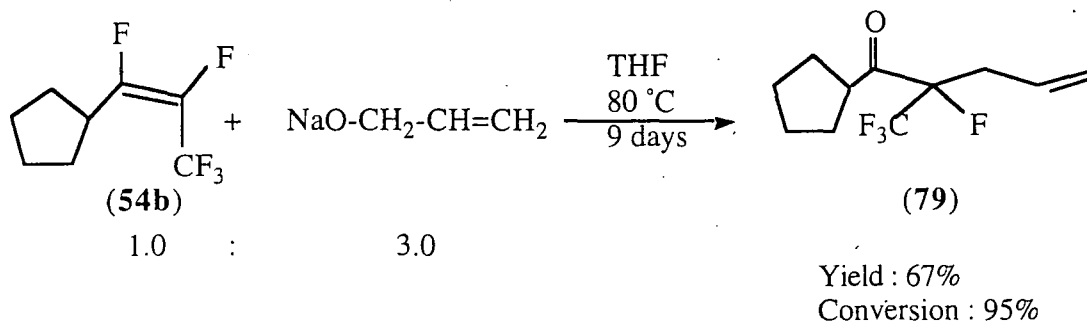

Scheme 132

1-cyclopentyl-2-fluoro-2-trifluoromethyl-4-penten-1-one (**79**) was obtained via a Claisen rearrangement of the allyl alkyl ether (Section 4.3.a.ii.). The mechanism of the reaction is illustrated in the following Scheme 133.

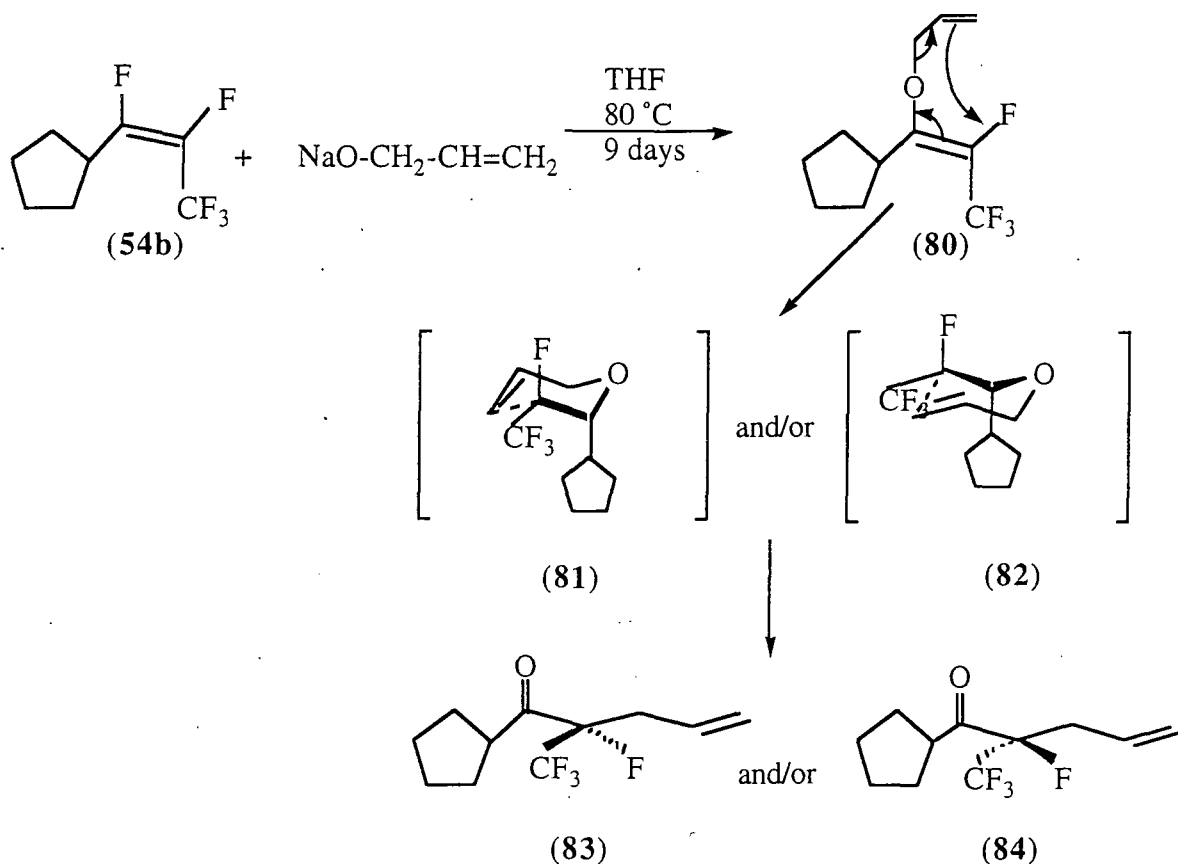

Scheme 133

The fact that the Claisen rearrangement took place and that the ketone (79) was obtained rather than the ether (80), was shown firstly by the appearance of a C=O vibration band at 1731 cm⁻¹ in the infrared spectrum. The presence of the carbonyl group was confirmed by the ¹³C NMR spectrum where the carbonyl carbon resonated at 206.9 ppm as a doublet (²J_{CF} 27.5 Hz). This signal at high frequency is characteristic of a ketone, as they are usually observed between 200.0 ppm and 210.0 ppm.

The Claisen rearrangement was observed by ¹⁹F NMR with the disappearance of the signal of the vinyl fluorine NMR signal at -133.6 ppm (which is similar to that observed for the starting material (54b) and emphasised, as in Section 4.6.b.i., that the replacement of a fluorine by an oxygen does not affect the chemical shift of the neighbouring fluorine) and appearance of a signal at -180.0 ppm (Scheme 134).

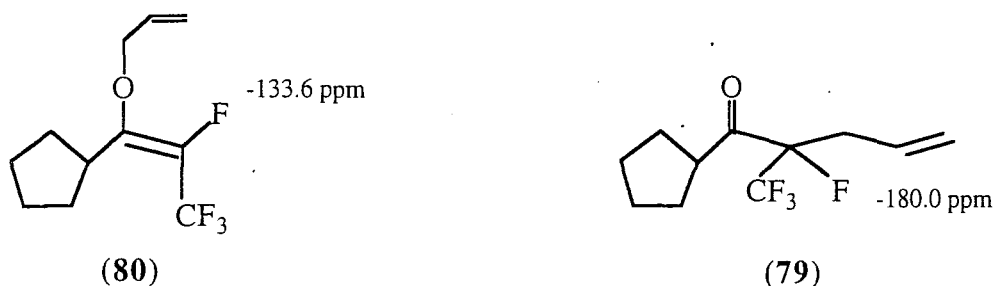

Scheme 134

The loss of the double bond as well as the presence in the β position of the carbonyl function dramatically affected the fluorine chemical shift by about 50 ppm. A similar thing was observed for the 3 fluorine atoms of the trifluoromethyl group as a difference of 10 ppm was observed. The ^{19}F NMR proved that the rearrangement did not occur immediately. In fact the allyl ethers (80) and its *E*-isomer were visible, since 2 doublets corresponding to the CF_3 groups were present at -63.1 ppm and -64.5 ppm. Therefore the Claisen rearrangement was not immediate and the reaction was completed after 9 days.

By rearranging into the ketone (79), the achiral starting material yielded a racemate, as a stereogenic centre C^* has been created α to the carbonyl group (Scheme 135).

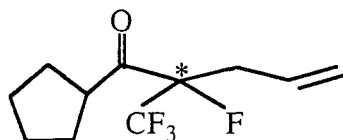

Scheme 135

As shown in the mechanism, the 2 transition states (81) and (82) led to 2 enantiomers (83) and (84). The presence of one chiral centre would lead to 2 enantiomers R and S, but by NMR spectroscopy they would not be distinguishable.

* ^1H NMR :

The 2 protons of the methylene CH_2 group are non-equivalent and diastereotopic and the methylene carbon is a prochiral centre (Scheme 136).

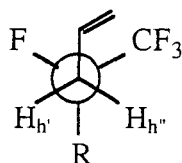

R : cyclopentane

Scheme 136

Such protons $\text{H}_{\text{h}'}$ and $\text{H}_{\text{h}''}$ coupled to each other at a different chemical shift. A doublet of doublets of doublets was observed at 2.6 ppm for one of them ($^3J_{\text{FH}}$ 13.2 Hz, $^2J_{\text{HH}}$ 14.4 Hz and $^3J_{\text{HH}}$ 6.8 Hz) and for the other one, at 2.8 ppm a doublet of doublets of doublets ($^3J_{\text{FH}}$ 34.6 Hz, $^2J_{\text{HH}}$ 14.4 Hz and $^3J_{\text{HH}}$ 7.6 Hz).

* ^{13}C NMR :

If the ^1H NMR spectrum placed all the protons of the CH_2 groups in the cyclopentane ring to be equivalent between 1.6-1.9 ppm, the ^{13}C NMR spectrum allowed distinction of 2 kind of carbons in the cyclopentane ring. C_c and C_d resonated at 22.9 ppm and C_b and C_e resonated at 26.1 ppm with a long range F,C spin-spin coupling $^4J_{\text{CF}}$ 5.0 Hz. C_a coupled also with the fluorine atoms to give a doublet of quartets at 36.0 ppm ($^3J_{\text{CF}}$ 20.2 Hz and $^4J_{\text{CF}}$ 1.2 Hz). Curiously a F,C spin-spin coupling was observed at 127.7 ppm for C_i with a doublet ($^3J_{\text{CF}}$ 2.7 Hz) whereas no F,C spin-spin coupling was observed for the nearer C_h (Scheme 137).

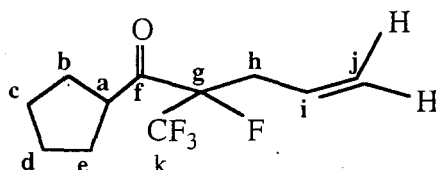

Scheme 137

4.6.c.ii. 1-(Z-pentafluoroprop-2-enyl)cyclopentane (54b) and propargyl alcohol :

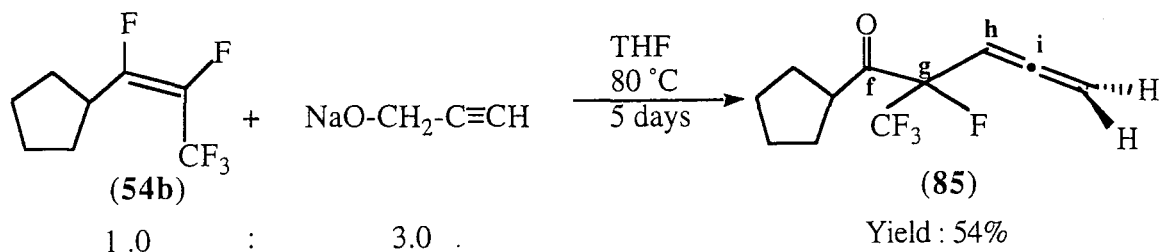

Scheme 138

The reaction of the *Z*-alkene (**54b**) with the propargyl alkoxide gave exclusively the allene (**85**) in moderate yield (54%). The infrared spectrum confirmed this result with the two characteristic C=C=C band at 1983 cm⁻¹ and 1955 cm⁻¹ and the C=O vibration at 1732 cm⁻¹. In contrast to the allyl alcohol, the reaction was completed faster (5 days instead of 9 days) and the reaction intermediate, corresponding to the ether before the Claisen rearrangement, was not visible by ¹⁹F NMR. As for the previous alcohols, the stereochemical outcome of the reaction could not be elucidated. The structural determination of the allene (**85**), has been done as above.

However it is interesting to point out that the carbons belonging to the carbonyl and the allene were assigned using the ¹³C NMR spectra. Two doublets were present at 209.3 ppm and 204.1 ppm. One corresponding to the carbon of the carbonyl group and the other one corresponding to the centered allene carbon. The differentiation of the chemical shift for both of them was done by calculating the coupling constant with the fluorine atom. C_f was coupling with the fluorine atom *via* 2 bonds, C_i was coupling with the fluorine atom *via* 3 bonds. The fact that ²J_{CF} 26.4 > ⁴J_{CF} 8.4 Hz allowed attribution of the chemical shift of both of them and gave δ_{C=O} 204.1 ppm and δ_{C=C=C} 209.3 ppm.

4.6.c.iii. 1-(*Z*-pentafluoroprop-2-enyl)cyclopentane (**54b**) and crotyl alcohol :

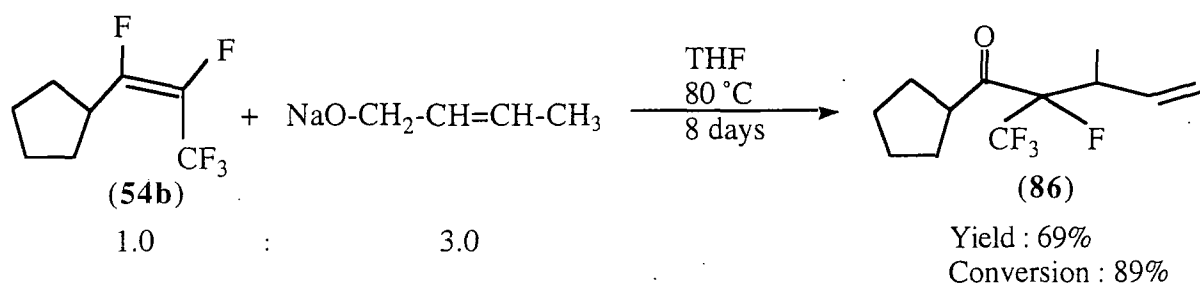

Scheme 139

After 5 days, the conversion was 89% but the ¹⁹F NMR showed the product was exclusively the ether form (i. e. no Claisen rearrangement had occurred). This was already observed for the allyl alcohol as the conversion was 90% the third day and the reorganisation needed at least 4 days to give the ketone product (**79**). The reaction was stopped after 8 days, as no change in the ¹⁹F NMR was detected. Curiously after the work up and distillation at reduced pressure, a light yellow oil was identified as the ketone (**86**). The infrared spectrum confirmed the presence of the carbonyl function with a band observed at 1729 cm⁻¹. This result underlined the fact that at low temperature, (80°C) in this case, no Claisen rearrangement occurred, but higher temperatures are required (used during the purification step). This can be

The reaction was completed in 10 days, as after 5 days the conversion was still moderate (62%). But in contrast to the allyl and crotyl alcohols, the major species in the reaction mixture was the ketone (**87**) (only observed by ^{19}F NMR) (Scheme 141). The Claisen rearrangement occurred faster in this reaction than the nucleophilic substitution reaction. This observation was in agreement with the fact that, as underlined by Carpenter, the rate of the Claisen rearrangement was dictated by the 2 accelerating effects from the donor substituents at C_2 and C_4 positions rather than the rate retarding effect from the CF_3 at the C_1 position (Scheme 142).

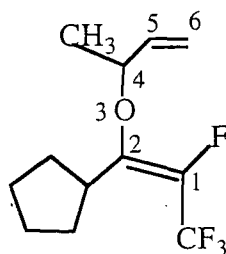

Scheme 142

The fact that the conversion after 5 days was lower than for the allyl and crotyl alcohol showed that the steric hindrance from the CH_3 group acted in the disfavour of the nucleophilic substitution, slowing it.

Curiously, after a silica column chromatography, using *n*-hexane:ethyl acetate as eluants, the only product recovered was the cyclopentane carboxylic acid (**88**) in low yield (44%). Apparently, this compound is the result of the ketone (**87**) decomposition through the column chromatography. A mechanism has been assumed for the carboxylic acid (**88**) production *via* an acid catalysed process (Scheme 143).

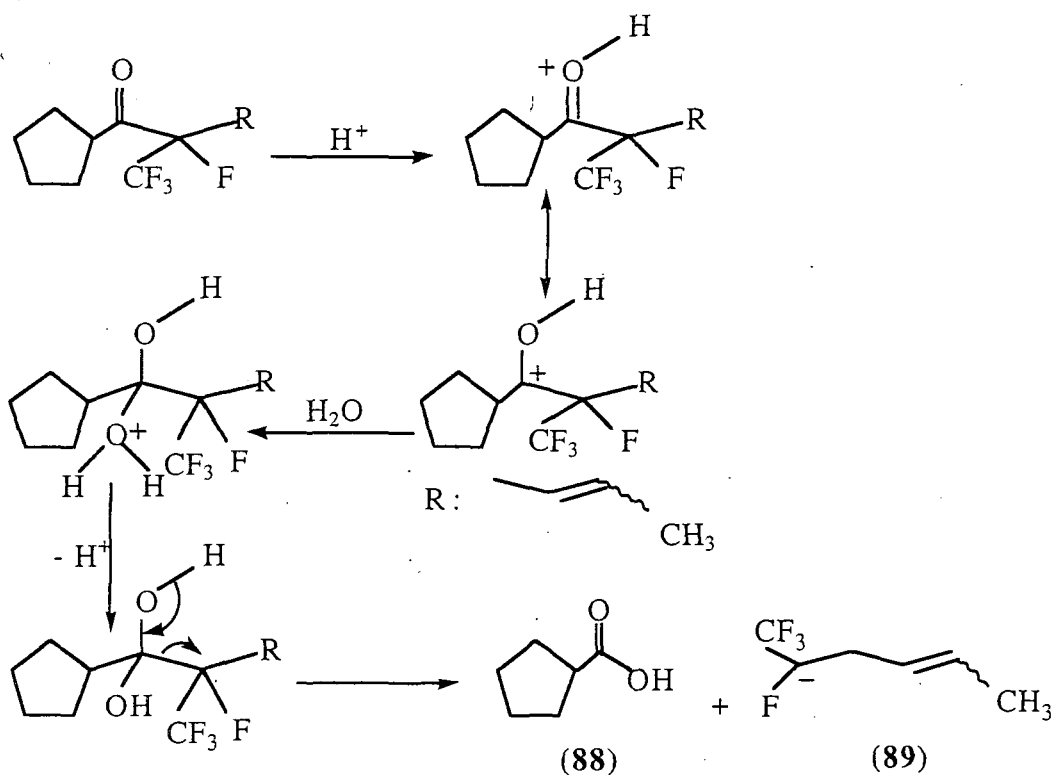

Scheme 143

Structure of the acid (88) was proved by ^1H NMR and ^{13}C NMR spectra.

4.6.c.v. 1-(Z-pentafluoroprop-2-enyl)cyclopentane (54b) and 4,4,4-trifluorobut-2-en-1-ol :

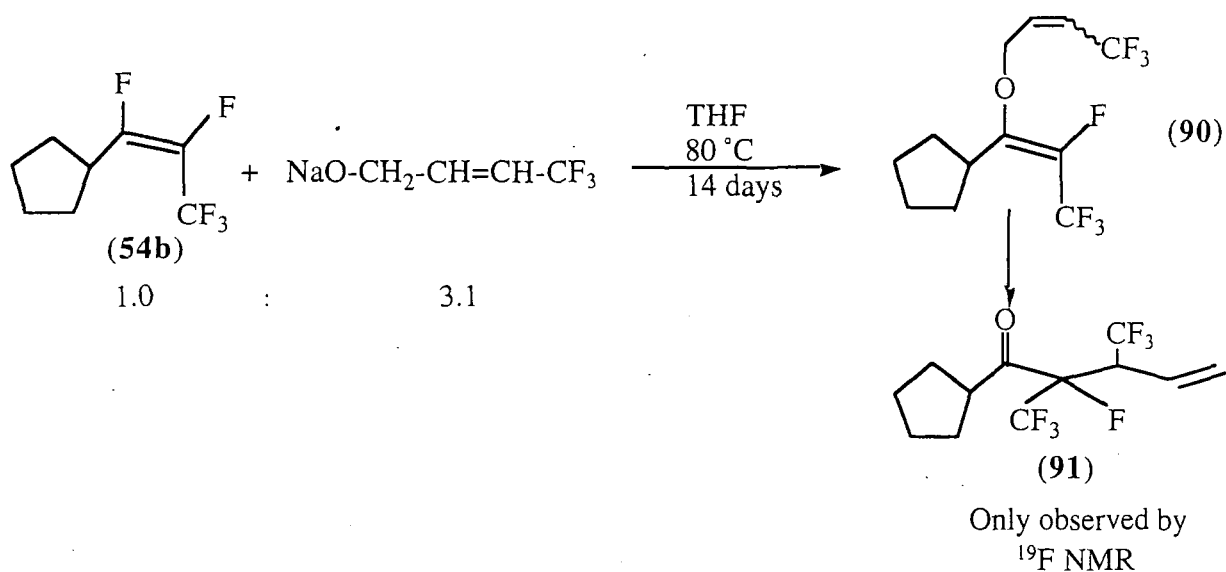

Scheme 144

The previous alcohol used (but-1-en-3-ol), illustrated the effect of an electron donating group (CH₃) at the C₃ position of the alcohol, leading to a secondary alcohol. A reaction was carried out using a primary alcohol where the terminal unsaturation contained a CF₃ group, thus aiming to compare the Claisen rate of reaction for different allyl and crotyl alcohols. After 6 days, as for the allyl and crotyl alcohols, the conversion was moderate (57%) and in contrast to the but-1-en-3-ol, only the ether (**90**) was present in the crude mixture. It took 8 days for the Claisen rearrangement to occur, this was due to the presence of the two CF₃ substituents which have a rate retarding effect on the Claisen rearrangement. However, contrary to the crotyl alcohol, no higher temperature was needed for the [3,3]-sigmatropic reaction to happen. Purification by either distillation or column chromatography, was not successful, but ¹⁹F NMR of the crude mixture allow us to say that firstly the nucleophilic substitution reaction occurred and secondly that the ether (**90**) intermediate rearranged to give the ketone (**91**).

4.6.c.vi. 1-(Z-pentafluoroprop-2-enyl)cyclopentane (**54b**) and geraniol :

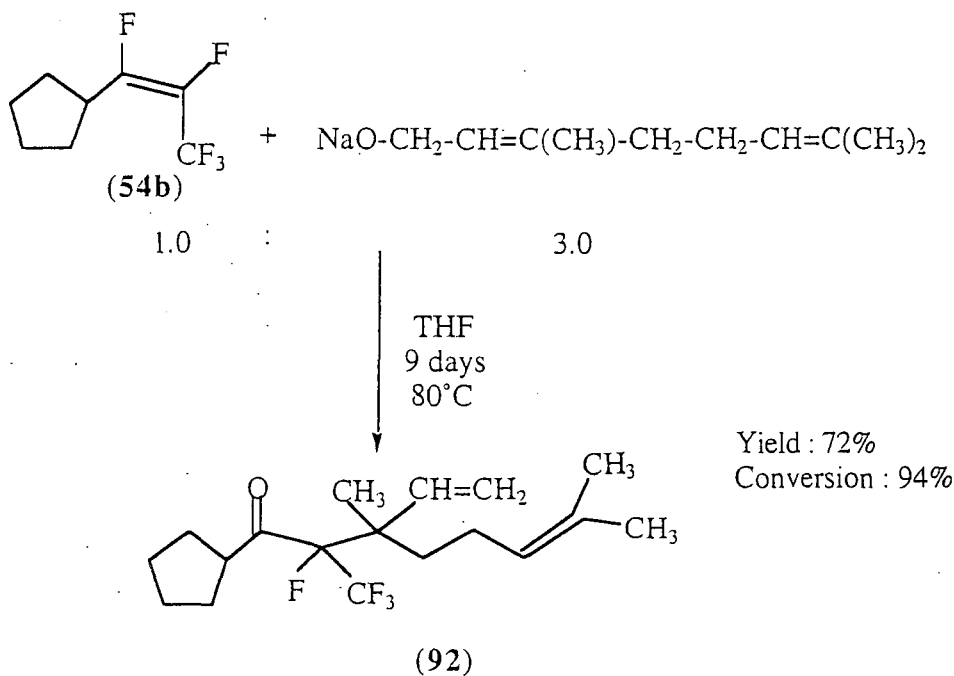

Scheme 145

This time, the reaction was performed with a rather crowded alcohol : geraniol. The reaction gave in a good yield the ketone (**92**) as a mixture of diastereoisomers in a ratio 6.8:1.0. The fact that the alcohol used was crowded did not seem to affect the rate of the rearrangement, as the reaction was completed in 9 days. The attribution of the chemical shifts as well as the atom assignments were done using DEPT, COSY and HETCOR. The relative chirality of the asymmetric centres

could not be determined by analysing the ^1H or ^{13}C NMR spectra. However the compound formed was complex but all the carbon, proton and fluorine atoms were assigned.

4.6.c.vii. 1-(1,2,3,3,3-pentafluoro-Z-prop-1-enyl)cyclopentene (57b) and geraniol :

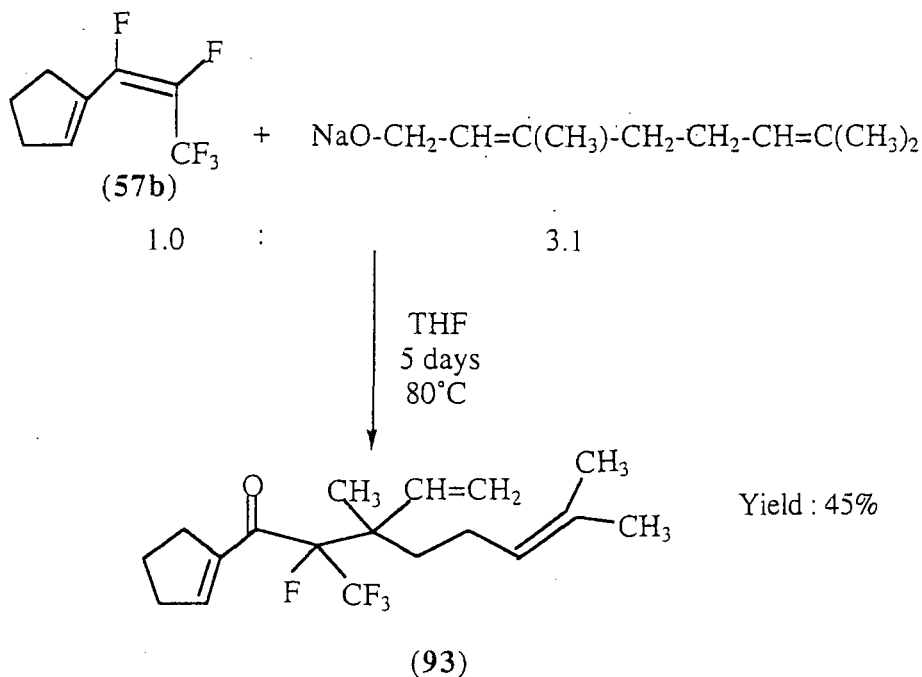

Scheme 146

A similar reaction was carried out with the conjugated diene (**57b**) (Scheme 146). Although the reaction was completed faster, the ketone (**93**) was obtained in moderate yield (45%). This is possibly due to loss of the product during the work up. Because of the conjugation of the reactive double bond with the one in the cyclopentane ring, it made the system more reactive towards nucleophilic attack. The attribution of the chemical shift and the coupling constant were done as above.

4.6.c.viii. 1-(Z-pentafluoroprop-2-enyl)cyclopentane (54b) and benzyl alcohol :

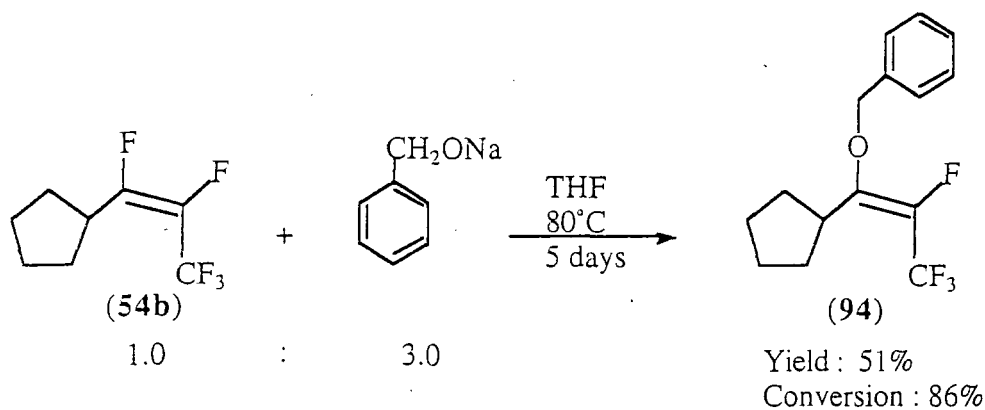

Scheme 147

The last unsaturated alcohol studied was benzyl alcohol. As the literature underlined, the aromatic Claisen rearrangement occurred less frequently because of several problems^{81, 84}. No Claisen rearrangement occurred after reaction of the *Z*-alkene with the alkoxide derivative, even after distillation the ether (94) was obtained (Scheme 147). The reaction lasted 5 days and the ether (94) was obtained, under 2 isomeric forms in a ratio 320:1, in a moderate yield (51%). This was an interesting result because it showed that the reaction was highly stereoselective and formed exclusively one isomer. A slight stereoselectivity was already observed for the nucleophilic substitution reaction using ethanol, but because the product obtained was not pure enough, stereochemical studies could not have been performed (Section 4.6.b.i.). The recovery of the pure ether (94), allowed elucidation of the stereochemical outcome of the reaction. If we assume that the nucleophilic attack proceeds from a plane perpendicular to the double bond, retention of configuration is expected to happen, considering the transition state (95a) in Scheme 148. But because the intermediate is carbanionic (95b), the stereochemistry of the obtained double bond depends on the carbanionic lifetime as well as its internal rotation. If the leaving group i. e. the fluorine, leaves faster than internal rotation occurs, retention of configuration will be observed. Whereas if internal rotation is faster, a stereoconversion will be observed.

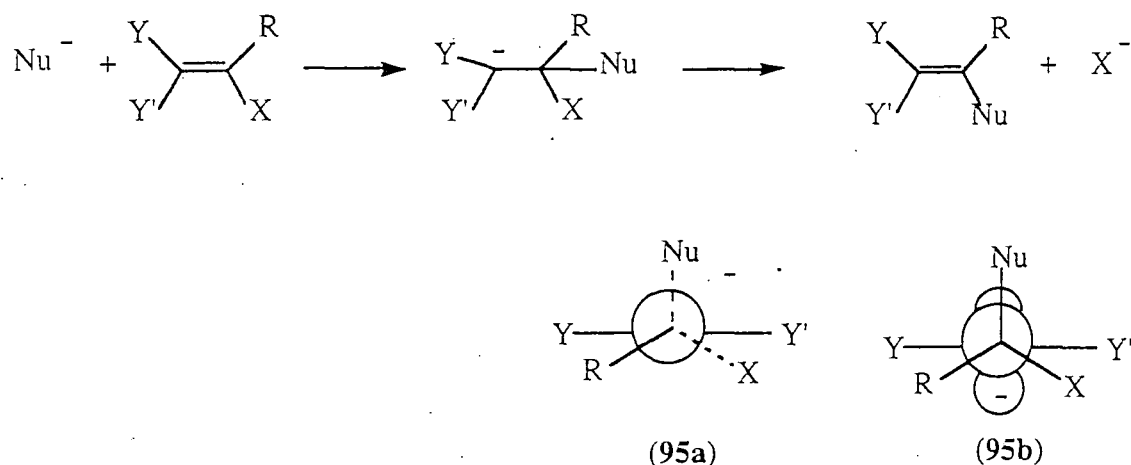

Scheme 148

This stereochemical outcome has been elucidated by ^1H - $\{^{19}\text{F}\}$ NOE difference spectroscopy experiment (nuclear Overhauser effect). Two magnetic nuclei can interact in two ways⁵¹: through the bonds to give spin-spin coupling, or through space. This interaction is revealed when one of the nuclei is irradiated at its resonance frequency, leading to a more intense or weaker signal for the other nucleus. Structural assignment of the carbon, proton and fluorine atoms were accomplished based on the NMR data which showed well resolved resonances.

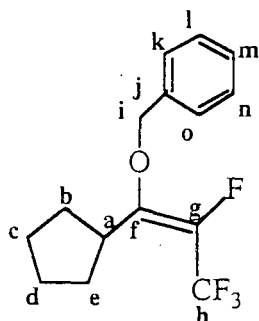

Scheme 149

For the ^1H - $\{^{19}\text{F}\}$ NOE difference experiment, preirradiation of the fluorine signal at -156.9 ppm (fluorine atom of the CF group), led to an enhancement of the proton signal at 5.2 ppm, previously identified as H_i and the signal at 7.4 ppm identified as the aromatic protons. Conversely, preirradiation of the fluorines of the trifluoromethyl group at -63.0 ppm, led to enhancement of the proton signals at 2.9 ppm (corresponding to H_a) and between 1.6-1.7 ppm (corresponding to proton band of the cyclopentane ring) (Scheme 150). This is consistent with the fact that the *Z*-isomer was exclusively obtained by retention of configuration.



```

CO 16 73 442848-000 1774648360 CF1
Pulse Sequence: mpsa
Run on Nov 11 1978
Solvent: CDCl3
Inlet Temperature
File: /data/1774648360/1774648360
Pulse Sequence: mpsa
Pulse delay 0.100 sec
Pulse 10, 0 degrees
vcg: 1100 0.721 sec
width 2000.0 Hz
IS (conditions)
OBSERVE: 90, 100.626012 MHz
DECOUPLE: 90, 100.626012 MHz
Power 10 dB
OFF during acquisition
DATA PROCESSING
Line processing 1.0 Hz
F2: 100.626012
Total accumulation time 3.000000

```

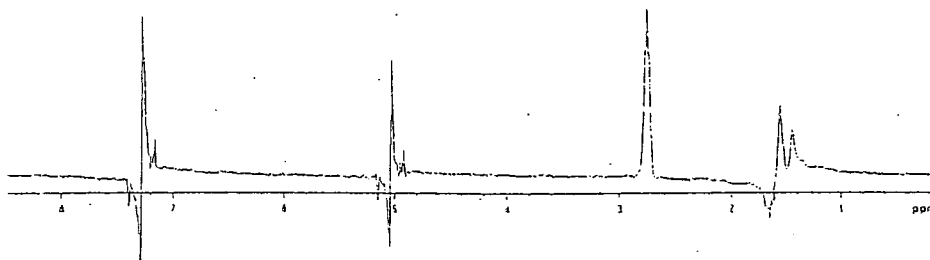

```

CO 16 73 442848-000 1774648360 CF1
Pulse Sequence: mpsa
Run on Nov 11 1978
Solvent: CDCl3
Inlet Temperature
File: /data/1774648360/1774648360
Pulse Sequence: mpsa
Pulse delay 0.100 sec
Pulse 10, 0 degrees
vcg: 1100 0.721 sec
width 2000.0 Hz
IS (conditions)
OBSERVE: 90, 100.626012 MHz
DECOUPLE: 90, 100.626012 MHz
Power 10 dB
OFF during acquisition
DATA PROCESSING
Line processing 1.0 Hz
F2: 100.626012
Total accumulation time 3.000000

```

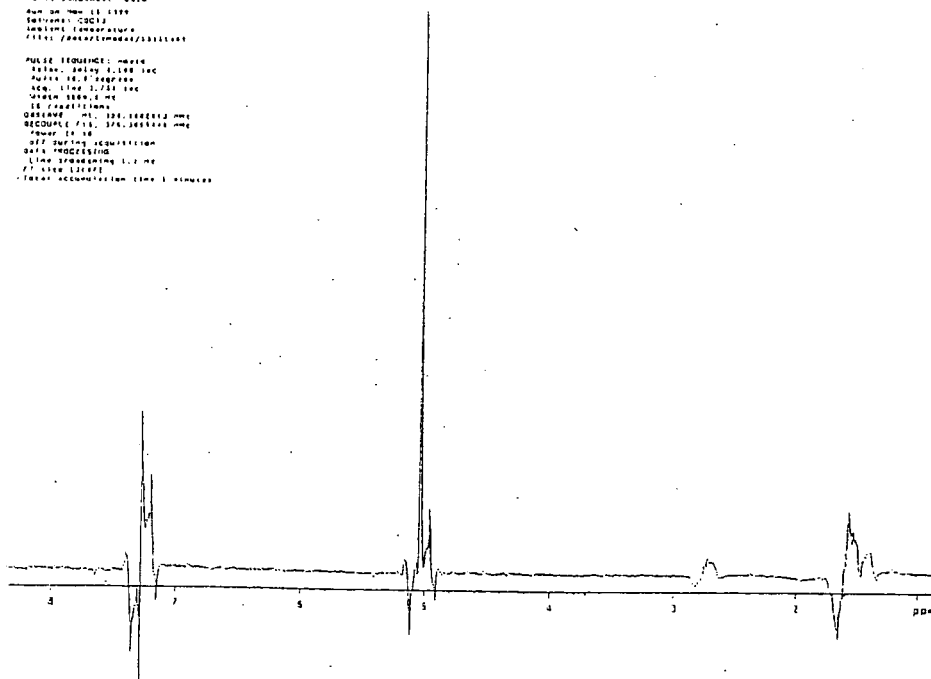

Scheme 150

Because of the poor reactivity of fluoroalkenes towards alkoxide derivatives (i. e. low yields and long reaction time), nucleophilic addition reactions were carried out using the alcohol silyl derivatives as they are systems involving oxygen as nucleophile¹⁷.

Three attempts of this type of reaction were performed using crotyl alcohol, but-1-en-3-ol and geraniol but the reaction did not proceed. The difference of reactivity between the alkoxide and the silyl derivative may be explained by the fact that in nucleophiles containing the same reactive atom, the more negatively charged attacking species is the more powerful nucleophile⁵³.

4.6.d. Diol :

The reactivity of the fluoroalkene (**54b**) towards nucleophiles containing oxygen has been proven in various reactions with saturated and unsaturated alcohols. In this last reaction the aim was the formation of a dimer product (**96**) (Scheme 151). For this purpose, the fluoroalkene (**54b**) was reacted in a 2 fold excess with the alkoxide derivative.

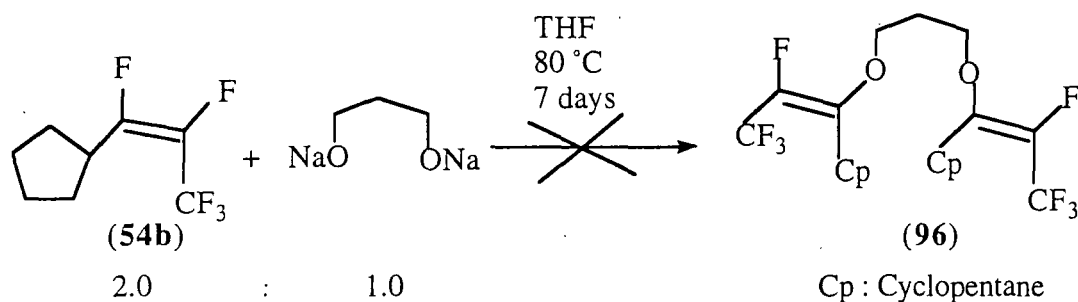

Scheme 151

After heating the reaction mixture at reflux for 7 days, no change in the ¹⁹F NMR was observed. There seemed to be no displacement of vinylic fluorine atom and/or also no appearance of a CFH group. Then the reaction was repeated using a ratio 1:1 of Z-alkene (**54b**):diol. However still no reaction was observed. It seems as if propane-1,3-diol does not react in the same way as other saturated alcohols, even a bulky alcohol such as geraniol. This maybe due to the electron withdrawing character of the two oxygen atom which decrease the nucleophilicity of the diol.

4.7. Nucleophilic additions involving nitrogen as nucleophile :

Various systems, containing nitrogen centred nucleophiles, have been reacted successfully with fluoroethylene as well as highly fluoro olefins^{99, 100}. Therefore nucleophilic displacement using these compounds was tried on Z-alkene (**54b**). As previously, the reactions were monitored by ¹⁹F NMR.

4.7.a. Ammonia :

The first reaction was carried out using ammonia which had reacted readily with the other systems⁹⁹. An attempt to form the product (97) was done by heating at reflux an aqueous solution of ammonia with the Z-alkene for 4 days (Scheme 152).

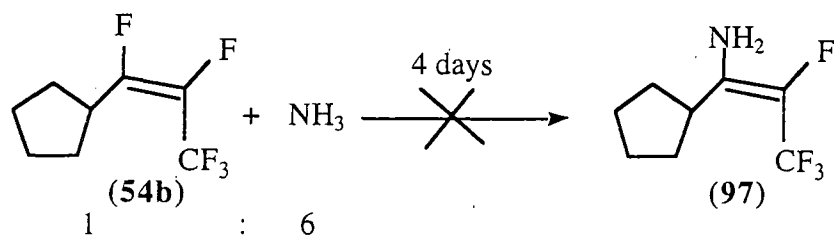

Scheme 152

The reaction was stopped as there was no change in the ^{19}F NMR, not even an addition of ammonia across the double bond.

4.7.b. Diethylamine :

Diethylamine was the second amine to be heated at reflux temperature with the Z-alkene (54b). However, this time, a sodium amide derivative, which is more nucleophilic, was preformed by reaction of the amine with sodium metal. Then the Z-alkene was added and the reaction mixture was refluxed for 6 days (Scheme 153). No product formation could be detected by ^{19}F NMR.

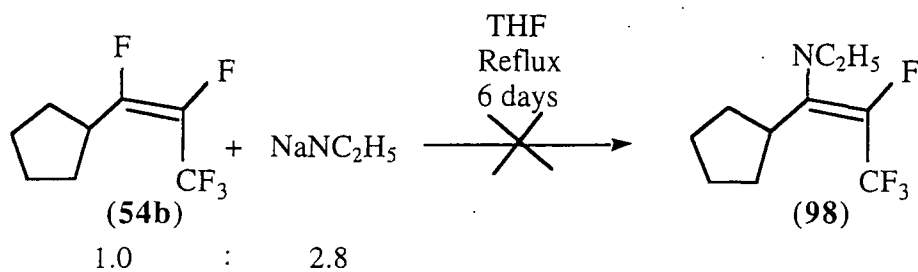

Scheme 153

The fact that the nitrogen containing systems did not react with the Z-alkene was strange as the nucleophilic character of a species decreased from the left to the right of the periodic table⁵³. This implies that nitrogen containing species should be more reactive than oxygen ones. However, it still should be borne in mind that for reactions involving oxygen as a nucleophile, the conjugated base was used, and charged species are always more reactive than neutral ones⁵³. However in reactions involving the diethylamine, the conjugated base was used and therefore should have

been more reactive. With the *Z*-alkene (**54b**), oxygen as nucleophile is far more reactive than nitrogen as a nucleophile.

4.8. Nucleophilic additions involving carbon as nucleophile :

After having described several reactions of oxygen and nitrogen centred nucleophiles with the *Z*-alkene (**54b**), the reactivity studies will now concentrate on its reactivity towards carbon centred nucleophile such as : organolithium, organomagnesium and sodium salts of malonate derivatives. According to what was established in Section 4.7.b., the nucleophilicity of the carbon centred nucleophile should be the highest of the 3 classes of nucleophile studied⁵³.

4.8.a. Organolithium compounds :

4.8.a.i. Butyllithium :

The first carbon nucleophile system studied was the organolithiums. Commonly reactions involving lithium derivatives are carried out at low temperatures (from 0°C to -80°C). However, the general procedure used for these systems consisted of heating the lithium derivative¹⁰¹ at reflux with the *Z*-alkene (**54b**) in THF (Scheme 154).

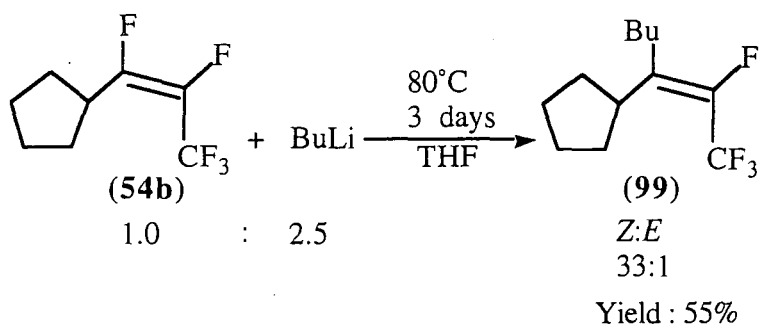

Scheme 154

The reaction proceeded for 3 days resulting in a moderate yield. The reaction was highly stereoselective as an isomer was preferentially obtained in a 33:1 ratio. The structure of the major isomer was elucidated using ¹H-¹⁹F NOE difference spectroscopy experiment. Preirradiation of the CF₃ signal at -64.3 ppm yielded an enhancement of the signal at 2.9 ppm, corresponding to the proton of the CH group in the cyclopentane ring. Preirradiation of the CF signal at -131.3 ppm, enhanced the signals between 0.9 and 2.1 ppm, identified as the proton from the alkyl chain.

The nucleophilic displacement proceeded again with retention of configuration to give the *Z*-isomer (**99**) as major one. The mechanism of the reaction is illustrated in Section 4.3.c.i.. The addition elimination processes produced lithium fluoride and the resulting *Z*-alkene (**99**). This isomer is the less thermodynamically stable isomer. It has been shown^{44, 115}, that fluoride ion can induce isomerisation of the double bond. In this case the starting material was the *Z*-isomer and the obtained product is the *Z*-isomer too, therefore retention of configuration is observed for this reaction. Thus the fluoride ion produced is not strong enough to induce isomerisation of the double bond. As with the replacement of the fluorine atom by an oxygen atom, the replacement of a fluorine by a carbon atom did not influence the chemical shift of the proton and carbon atoms and characterisation of the product has been done as previously.

4.8.a.ii. tert-butyllithium :

Similar reaction were used for the reaction involving *tert*-butyllithium (Scheme 155).

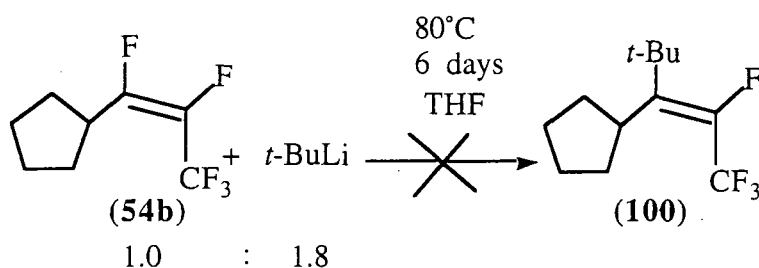

Scheme 155

The reaction mixture was heated at reflux for 6 days but after the work up only starting material was recovered. This was presumably due to steric hindrance of the tertiary alkyl group on the organo lithium compound which inhibits approach to the reactive centre.

4.8.a.iii. Phenyllithium :

Lastly, phenyllithium was used as a reagent because of the rigidity of the system which can inhibit reaction with the *Z*-alkene (**54b**).

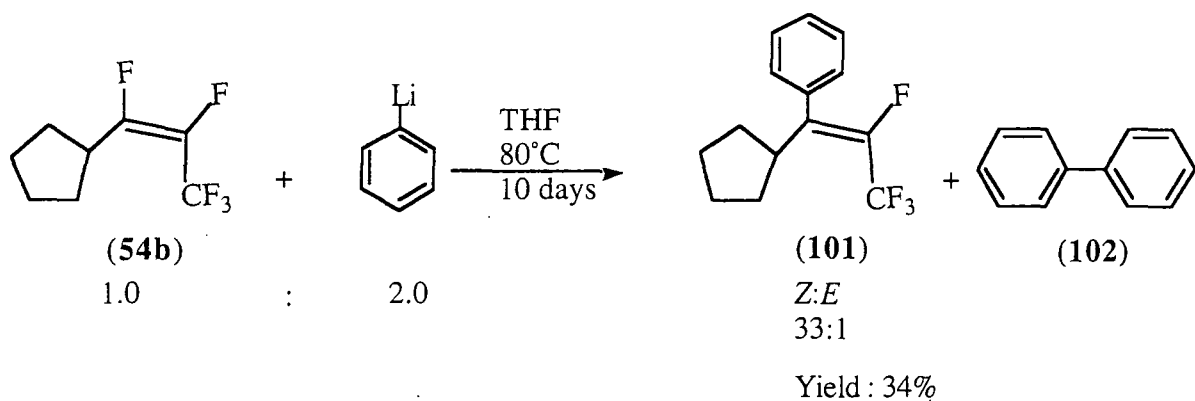

Scheme 156

As with butyllithium, the reaction proceeded with high stereoselectivity in favour of the *Z*-isomer production. However, the reaction time was longer (10 instead of 3 days) and the yield rather low (34%). This underlined the fact that steric hindrance from the phenyl ring acted in disfavour of the nucleophilic substitution reaction by slowing it. Another product, identified by NMR spectroscopies and GC/MS as biphenyl (**102**), was present in a ratio 33:1 *Z,E*-isomer:biphenyl of 3.5:1.0. Its presence indicated a free radical process *via* a one-electron transfer in the first step as described in Section 4.3.c.ii.. The structural determination was done as above.

Similar reactions were carried out with an allylic Grignard reagent (Scheme 157) (allyl magnesium bromide) in the aim to perform a carbon analog of the Claisen rearrangement i. e. the Cope rearrangement and malonate derivatives (Scheme 158). Both systems did not react with the *Z*-alkene (**54b**).

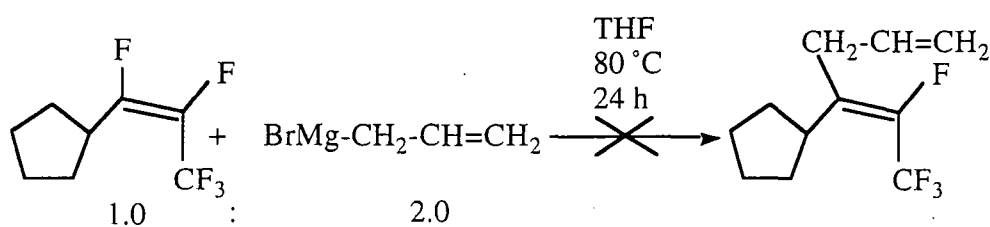

Scheme 157

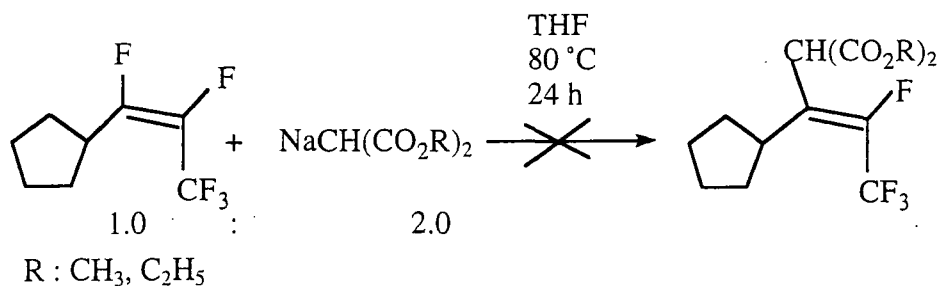

Scheme 158

The difference in reactivity between the organolithium, organomagnesium and sodium derivatives can be rationalised by the fact that the organolithium compounds were quite reactive with the *Z*-alkene even at -80°C . This was shown by Cooper¹¹⁶, in a reaction between the adduct derivative from cyclohexane and the organolithium compounds. Whereas for the organomagnesium and sodium malonate derivatives, more drastic reaction conditions maybe required.

4.9. Electrophilic addition reactions :

After studying the reactivity of the *Z*-alkene (**54b**) towards nucleophiles, its reactivity towards electrophilic systems was investigated by addition of halogen derivatives. Three compounds were reacted with the *Z*-alkene, elemental bromine, iodine monochloride and iodine bromide.

4.9.a. Elemental bromine :

A mixture of elemental bromine and *Z*-alkene (**54b**) was stirred at room temperature for 24 hours. Addition of bromine across the double bond yielded the formation of 2 chiral centres in the molecule (C^*) (Scheme 159). Distillation at reduced pressure gave (**103**) a mixture of diastereoisomers which were not separated in a ratio of 1.0:0.6 and a moderate yield (42%). The mechanism of the electrophilic anti addition has been illustrated in Section 4.4.b..

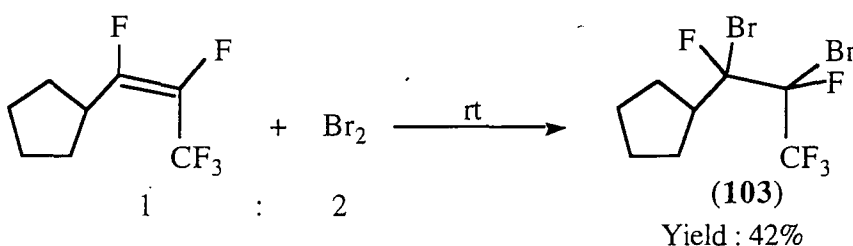

Scheme 159

The fact that bromine added across the double bond, was showed in the GC/MS pattern. Because of the isotopic abundance of bromine, ^{79}Br and ^{81}Br show an isotopic abundance in the ratio 1:1, therefore molecular ions containing various number of bromines will show different patterns⁵¹. These patterns have been observed for the fragmentation of the various diastereoisomers (Spectrum no. 26).

Addition of the bromine across the double bond, yielded 2 chiral centres and therefore 2 set of signals should be observed in the NMR spectra.

In the ^{19}F NMR, the fact that the fluorine atom is neighbouring the bromine atom, shifted the fluorine chemical shift of at least 20 ppm, towards lower frequency :

from -132.9 ppm to -101.7 ppm and -106.2 ppm and from -159.3 ppm to -124.7 ppm and -126.2 ppm. A small shifting towards higher field was observed for the three fluorines of the CF₃ group (from -65.6 ppm to -71.9 ppm and -72.4 ppm).

No significant change was noticed for the chemical shifts in the ¹H NMR and ¹³C NMR, except for the carbons bearing the bromines and fluorine atoms; a shift towards lower frequency of 20 ppm has been observed from 120.2 ppm to 102.5 ppm and 103.6 ppm and from 134.5 ppm to 112.6 ppm and 113.3 ppm. Similar thing has been observed for the carbon belonging to the CF₃ group. Structural determination has been done as above.

Iodine monochloride and iodine bromide were reacted with the Z-alkene (**54b**), but no products were recovered even after column chromatography.

4.10. Epoxidation reactions:

Several epoxidation reactions, involving fluorine containing double bonds have been reported in the literature⁶²⁻⁶⁴. The reactions were easy to perform and gave the epoxide in good yield at room temperature. Various reactions have been carried out using the Z-alkenes (**53b**) and (**54b**) under different conditions with the aim to form the epoxide but these reactions were unsuccessful.

4.11. Conclusion :

Various nucleophiles and electrophiles have been used to study the Z-alkenes reactivity.

4.11.a. Z-alkene (**54b**) from cyclopentane adduct :

* Nucleophiles :

Both methanol and ethanol did not react successfully with the Z-alkene (**54b**), as methanol gave the addition product and ethanol a mixture of addition and addition elimination products. However, allylic alcohols have been shown to react with the Z-alkene to give a ketone (after Claisen rearrangement). But the reaction times were long and the yields moderate. Benzyl alcohol gave an ether intermediate underlying the fact that no rearrangement occurred. No reaction was observed using nitrogen centred nucleophiles even after trying different conditions. Three systems were studied carbon centred as nucleophiles : organolithium, organomagnesium and

sodium malonate derivatives. Only the organolithium compounds reacted stereoselectively to give the Z-alkenes (**99**) and (**101**).

* Electrophiles :

Elemental bromine and cohalogens were reacted with the Z-alkene, only elemental bromine led to the addition product of bromine across the double bond.

* Epoxidations :

Epoxidation reactions using nucleophiles and electrophile systems have been tried as well as various different condition reactions. None of them have been successful.

The Z-alkene (**54b**) reactivity is poor towards nucleophiles as well as electrophiles. Only few systems have been proved to react. However for the nucleophilic displacement using benzyl alcohol and lithium derivative, the stereochemical outcome of the reaction has been solved using ^1H - $\{^{19}\text{F}\}$ NOE difference spectroscopy experiment.

4.11.b. Z-alkene (57b) from cyclopentene adduct :

Nucleophilic addition using geraniol has been performed and yielded the corresponding ketone in a moderate yield but faster than for the cyclopentane adduct (**54b**).

Chapter 5 : Free radical addition of amines to hexafluoropropene

5.1. Introduction :

In this last chapter, free radical addition of several amines to hexafluoropropene is studied as little work has been done in this area (Section 1.4.e.i.). The reactivity of tertiary, secondary and primary sites in α position to nitrogen will be compared in cyclic and acyclic amine systems (Scheme 160).

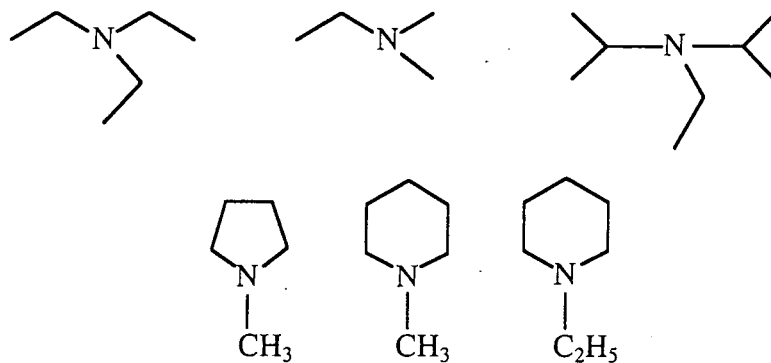

Scheme 160

Then, the influence of a second heteroatom in the cyclic system will be described (Scheme 161).

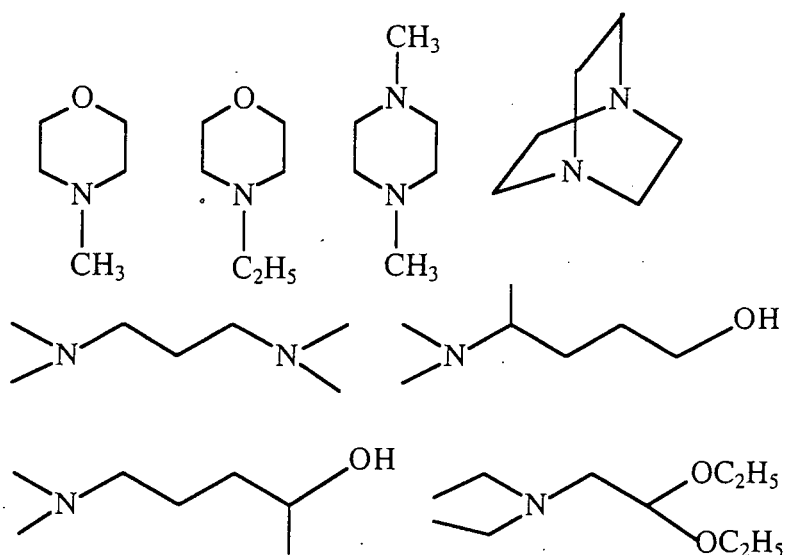

Scheme 161

Before beginning to review the work carried out and the various results obtained, it is important to recall some general features of free radical addition of amines to HFP. A radical centre adjacent to a nitrogen is stabilised by interaction with

the lone pair (Section 1.6.b.iii.). Because the nitrogen lone pair is more readily available than an oxygen lone pair, in principle, a radical stabilised by nitrogen should be more stable than one stabilised by oxygen.

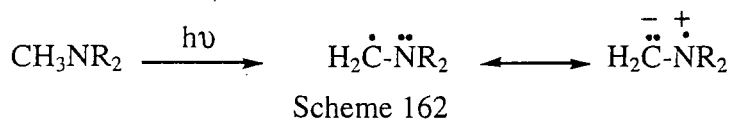

Free radical addition of amines to hexafluoropropene have been performed at room temperature using γ -ray initiation. The reason for preferential use of the radiochemical initiation method, rather than the thermal initiation was to avoid the formation of the competition product (i. e. an alkylammonium salt and leading to HFP dimerisation) by nucleophilic substitution reaction (Section 1.6.e.i.).

5.2. Free radical addition to acyclic amines :

Three amines were studied : triethylamine, N,N-dimethylethylamine and N,N-diisopropylethylamine because they possess primary, secondary as well as tertiary C-H sites which are readily available for the free radical attack.

5.2.a. Triethylamine :

Triethylamine was used to study the reactivity of the secondary C-H sites (Scheme 163). The mono-(**104**), di-(**105**) and tri-(**106**) adducts were obtained after column chromatography using cyclopentane as eluant.

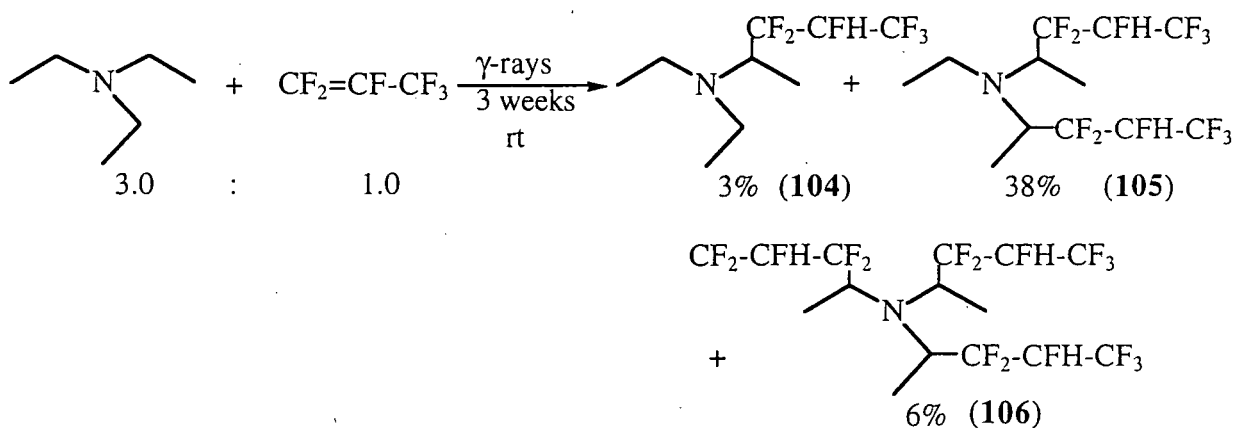

5.2.a.i. Monoadduct (**104**) :

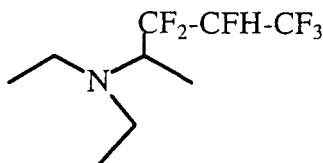

Scheme 164

Two chiral centres have been created, therefore 4 diastereoisomers are expected. As shown previously (Chapter 3), in the NMR spectra, 2 sets of signals should be observed as RR=SS and SR=RS. They were observed in a ratio 1.0:0.4.

The DEPT and HETCOR spectra showed that the first free radical addition occurred at the secondary site rather than the primary one. The appearance of a CH signal at 54.9 ppm for the major diastereoisomers (a doublet of doublets) and at 54.0 ppm for the minor diastereoisomers (a doublet of doublets) showed that the CH₂ group was preferentially the site of attack. These results were correlated with the ¹H NMR spectrum where a signal at 3.2 ppm with an integration of one proton was observed for the major diastereoisomers (as a doublet of multiplets) and at 3.6 ppm with an integration of one proton for the minor diastereoisomers. This stereoselectivity can of course be rationalised by the stabilisation of the newly formed radical by the lone pair of the nitrogen. The product was characterised using the same methodology as described in Chapter 2.

5.2.a.ii. Diadduct (105) :

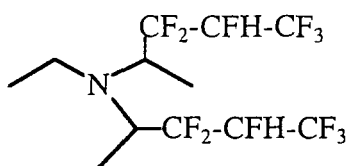

Scheme 165

The diadduct (**105**), was obtained as the major product even when using a 3 fold excess of amine. The same stereoselectivity, i. e. secondary site is favoured over the primary site, has been observed again by the DEPT spectrum which shows appearance of a carbon signal corresponding to a CH groups of the various diastereoisomers. The resulting diadduct (**105**), appeared as a mixture of major and minor diastereoisomers which have been observed by NMR spectroscopy. In each case, the fluorine atoms of the 2 fluoroalkyl chains appeared to be equivalent as only 6 signals for the fluorines of the CF₃, CFH and CF₂ groups for both major and minor has been observed instead of the 12 signals expected. A similar observation in the ¹H NMR and ¹³C NMR spectrum was made. The diadduct is obtained *via* an

intramolecular hydrogen abstraction process where the transition state is a 6 membered ring (Scheme 166).

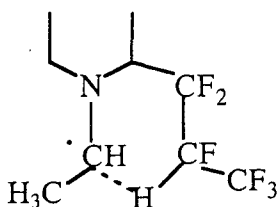

Scheme 166

5.2.a.iii. Triadduct (106) :

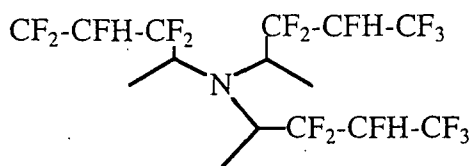

Scheme 167

Finally the triadduct (**106**) was obtained by recrystallisation from hexane, with a ratio of 1.0:0.5:0.3:0.3:0.3:0.2 of diastereoisomers. As the NMR spectra were complex, characterisation of the triadduct (**106**) was done as previous and the DEPT spectrum allowed again affirmation that the polyfluoroalkylation occurred at the CH₂ position of the alkyl chain rather than the primary one. Single crystal X-ray diffraction confirmed the crystal and molecular structure of one of the triadduct (**106**) diastereoisomers as illustrated in Appendix D.

5.2.b. N,N-dimethylethylamine :

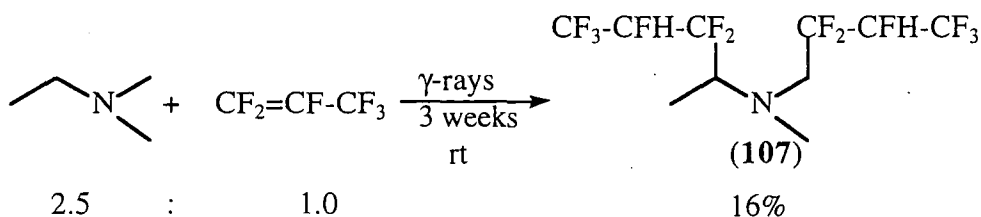

Scheme 168

A 2.5 fold excess of N,N-dimethylethylamine was reacted with hexafluoropropene in order to compare the reactivity of primary and secondary sites. The reaction led only to the formation of the diadduct (**107**), in poor yield (16%). As previously, the regioselectivity of the attack was proved by analysis of the NMR spectra. In view of the diadduct structure and the fact that the monoadduct was not

obtained, it was assumed that the secondary site has a greater selectivity than the primary. This is due to the fact that the amine used as starting material, possesses 2 CH₃ and one CH₂ groups in α position to the nitrogen.

5.2.c. N,N-diisopropylethylamine :

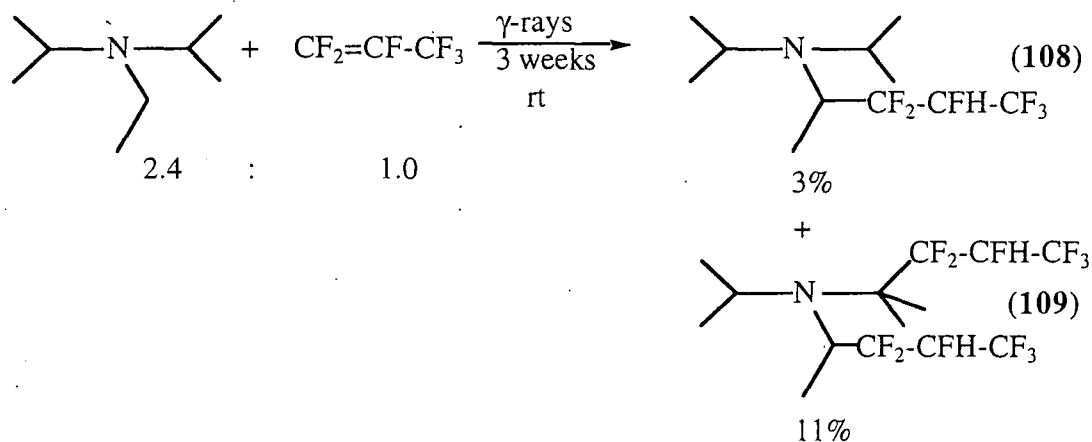

Scheme 169

Using this last acyclic amine, the reactivity of the tertiary *versus* secondary C-H site was studied by reacting a 2.4 fold excess of amine with hexafluoropropene. After separation by column chromatography, using first *n*-hexane then dichloromethane as eluants, the monoadduct (**108**) and the diadduct (**109**) were obtained as mixtures of diastereoisomers. As with the previous reactions, the diadduct (**109**) was the major product, showing again that the intramolecular hydrogen abstraction is favoured over the intermolecular one. However, characterisation of the monoadduct (**108**) by NMR spectroscopy showed that in this case the secondary site was more reactive than the tertiary one. It seems reasonable to presume that this was due to the steric hindrance from the isopropyl group which favoured free radical addition at the secondary site rather than the tertiary.

In the view of these 3 experiments, we can already establish a general reactivity order : CH₂>CH>CH₃ which is not in agreement with the order of stability of the radical being formed (Section 1.4.b.ii.).

5.3. Free radical addition to cyclic amines :

5.3.a. N-methyl pyrrolidine :

Polyfluoroalkylation reactions were performed using a slight excess of N-methyl pyrrolidine in a ratio amine:HFP of 1.5:1.0. Analysis of the crude mixture was performed using GC/MS which showed that there were a large number of products present. The major product was hexafluoropropene dimer while only traces of monoadduct product (7.2 %) were observed.

Distillation, first at atmospheric pressure, then at reduced pressure did not result in a pure compound as only hexafluoropropene dimer and a black tar (maybe due to the amine decomposition) were recovered. Therefore, the reaction was repeated using the same conditions and a great excess of the amine (2.9:1.0). This time, the monoadduct (**110**) was obtained as the exclusive product.

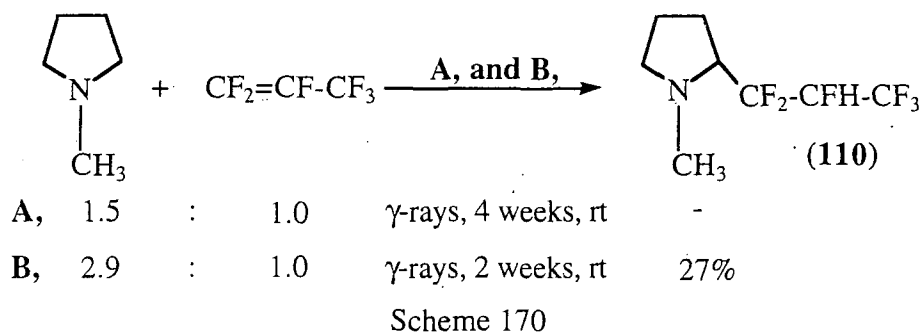

The structure determination was done as above and again underlined the fact that the secondary site (i. e. the CH₂ in the cyclopentane ring) is more reactive than the primary site.

5.3.b. N-methyl piperidine :

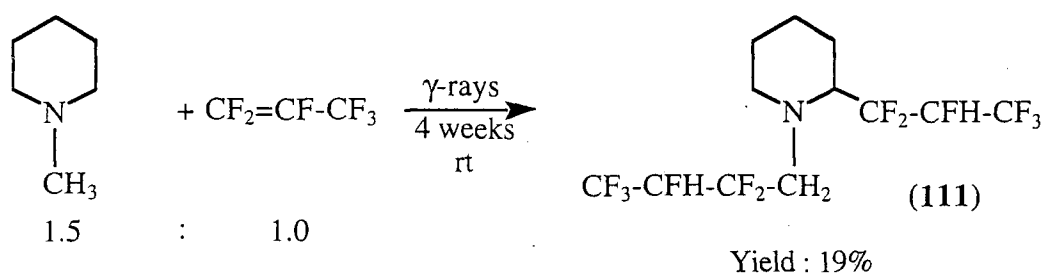

Scheme 171

The free radical addition of N-methyl piperidine to hexafluoropropene was performed using a amine:hexafluoropropene ratio of 1.5:1.0. Similar reaction conditions as those for the reaction using N-methyl pyrrolidine were used (4 weeks at room temperature). The analysis of the crude mixture by GC/MS and ¹⁹F NMR showed that for the same conditions used, the present reaction was far cleaner than that with the N-methyl pyrrolidine. Nevertheless, the GC/MS showed as for the N-

methyl pyrrolidine that the major product obtained was the hexafluoropropene dimer and that the polyfluoroalkylated amine obtained contained more than one polyfluoroalkyl chain. Only traces of monoadduct product were observed by GC and GC/MS and have not been isolated. Distillation at reduced pressure gave a pure fraction of diastereoisomers of the diadduct (**111**).

Because of the low yield of diadduct obtained for this reaction (19%), the free radical addition to hexafluoropropene did not compete very well with the nucleophilic substitution reaction.

The structure for the dipolyfluoroalkylated product could be :

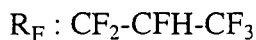
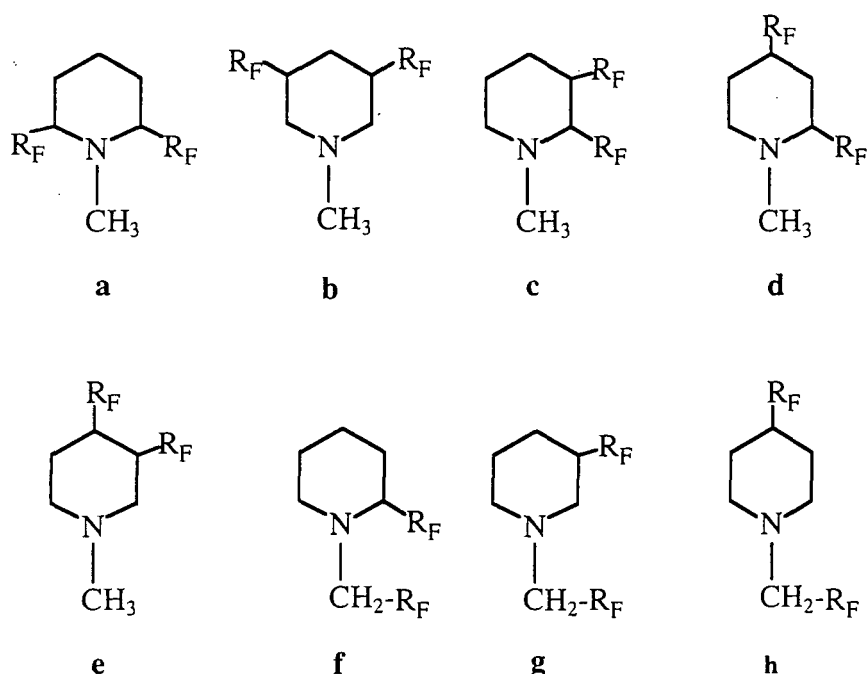

Scheme 172

According to the NMR data 2 forms can be eliminated as they are symmetric (**a** and **b**) and the spectra obtained are too complicated to come from a symmetric molecule.

If the mechanistic side of the reaction is considered, the reaction proceeds initially *via* free radical addition of the amine to hexafluoropropene unit. The first free radical can be formed whether by abstraction of a hydrogen of a CH_2 group in the cycloalkane ring or by a hydrogen abstraction of a hydrogen of the CH_3 on the nitrogen (Scheme 173).

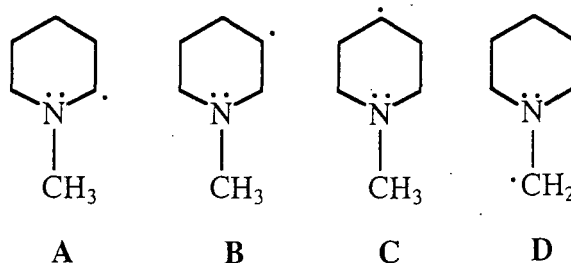

Scheme 173

Because of the strong stabilisation of an α -amino radical, the radical of the structures **B** and **C** can be eliminated and therefore the resulting dipolyfluoroalkylated products. Due to the order of stability of the alkyl radical, which increases with the number of alkyl groups borne by the carbon $\dot{\text{C}}\text{H}_3 < \text{R}-\dot{\text{C}}\text{H}_2 < \text{R}'\text{R}''\dot{\text{C}}\text{H} < \text{R}'\text{R}''\dot{\text{C}}\text{R}'''$, it is likely that the first step of the reaction occurs *via* abstraction of the α -amino hydrogen of the CH_2 group in the cycloalkane ring (form **A**) rather than the one from the CH_3 group (form **D**). This allows elimination of structures **g** and **h**.

The NMR data using DEPT spectrum allowed us to determine that the product obtained was the **f** structure as there is no CH_3 peak observed. The methyl group on the nitrogen loses a hydrogen during the third step i. e. the second hydrogen abstraction process to give :

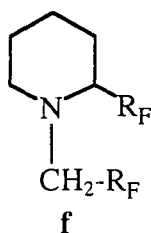

Scheme 174

This result was confirmed by the HETCOR, DEPT and ^{13}C NMR spectra. The HETCOR firstly points out that the diadduct (**111**) is present as 12 different carbon signals are visible and corresponding to **Cb**, **Cc**, **Cd**, **Ce**, **Cf** and **Cg** of each isomer.

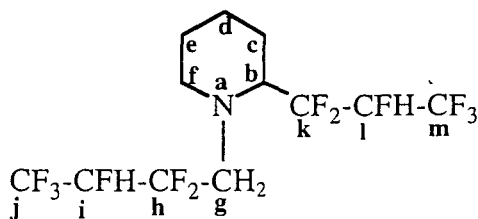

Scheme 175

The fact that 6 carbons are deshielded between 48.0 ppm and 57.0 ppm, corresponding to the 4 CH₂ groups and the 2 CH, underlined the fact that they must be neighbouring to the nitrogen and this confirms the structure of the product.

In order to study whether the first free radical addition occurred at the secondary site or primary site, the reaction was repeated this time using a 10 fold excess of amine and only a reaction time of 2 weeks in order to obtain the monoadduct. However after distillation, only the diadduct (**111**) was recovered in 24% yield. The fact that similar low yield is obtained for a shorter reaction time showed that the side reaction is important as hexafluoropropene dimer is formed rather than reacting with the amine.

5.3.c. N-ethyl piperidine :

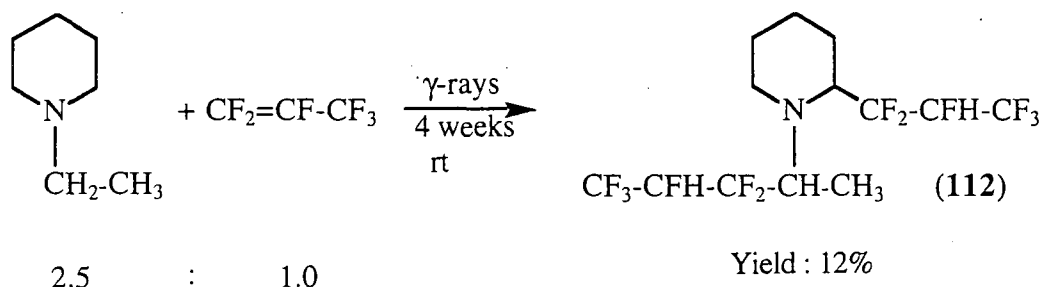

Scheme 176

The reaction of the N-ethyl piperidine with hexafluoropropene was also studied. Interest in this molecule is due to the fact that 3 CH₂ groups on the nitrogen can be functionalised as well as the CH₃ group. This may yield different products than the N-methyl piperidine. The reaction was carried out first for 4 weeks using an excess of the amine in a ratio of 2.5:1.0 and this led to the formation of diadduct (**112**).

The diadduct structure has been assigned according to the DEPT and the ¹³C NMR. They both showed that the CH₃ group, from the ethyl substituent, remained after dipolyfluoroalkylation. Moreover, only 1 CH₂ neighbouring the nitrogen was observed between 40.0 ppm and 44.0 ppm and at least 2 CH groups neighbouring the 2 CF₂ groups of the 2 polyfluoroalkyl chains are observed between 54.0 ppm and 60.0 ppm. This is consistent with the product structure (**112**).

The intramolecular chain transfer reaction which yields the second hydrogen abstraction for both the N-methyl piperidine and the N-ethyl piperidine, seems faster than the termination step of the free radical addition reaction leading to the diadduct formation rather than the monoadduct one. The fact that higher adduct products are not obtained maybe due to the steric hindrance of the cyclohexane ring.

In order to compare the reactivity of both secondary sites (the CH₂ group belonging to the alkyl chain and the one belonging to the cyclohexane ring), the reaction was repeated using a 8.8 fold excess of the amine. As for the N-methyl piperidine, only traces of monoadduct which has not been isolated, have been observed by GC and GC/MS. Distillation under reduced pressure gave the diadduct (**112**) as exclusive product in a yield of 18%.

5.3.d. N-methyl morpholine :

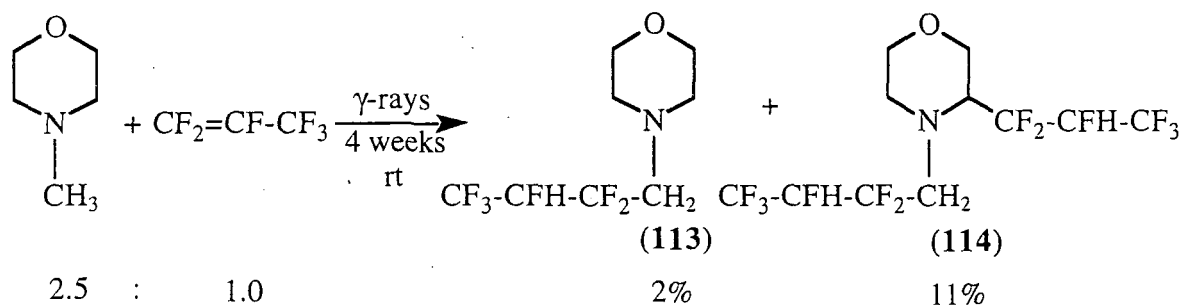

Scheme 177

The fact that the first hydrogen abstraction occurred at the CH₃ position of the alkyl chain rather than the CH₂ position of the ring was proved by analysing the DEPT and the ¹³C NMR spectra of the obtained monoadduct (**113**). The DEPT showed 2 things : first that the major isomer was obtained by free radical addition at the CH₃ position as the peak representing the CH₃ group disappeared in the DEPT and the ¹³C NMR spectra. Secondly it showed that 2 minor isomers were obtained *via* free radical addition at the CH₂ positions of the ring as 2 peaks representing the CH₃ groups of the 2 isomers at 43.2 ppm and 44.2 ppm were observed in the ¹³C NMR and in the ¹H NMR spectra (2 singlets at 2.35 ppm and 2.36 ppm). This result underlined 2 main things : first the fact that in the presence of a second heteroatom in the cyclic system, the site reactivity order can be attributed to the presence of the second oxygen atom which offsets the effect of the nitrogen by withdrawing charge away from the radical centre reducing the *nucleophilicity* of the radical (Scheme 178) and therefore facilitating the first free radical attack at the CH₃ position.

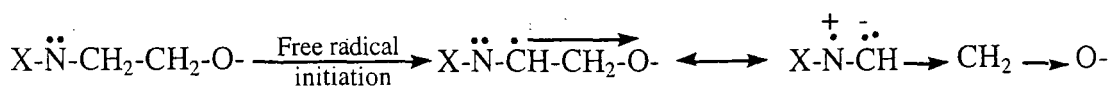

Scheme 178

The second important thing that these results underlines is that the free radical addition occurs only at the position α to the nitrogen atom rather than the oxygen one. This can be explained by the fact that the nitrogen containing compounds are stronger

bases than the oxygen equivalent ones. Thus, the nitrogen lone pair is more readily available than an oxygen lone pair, making a radical stabilised by a nitrogen more stable than an oxygen stabilised.

5.3.e. N-ethyl morpholine :

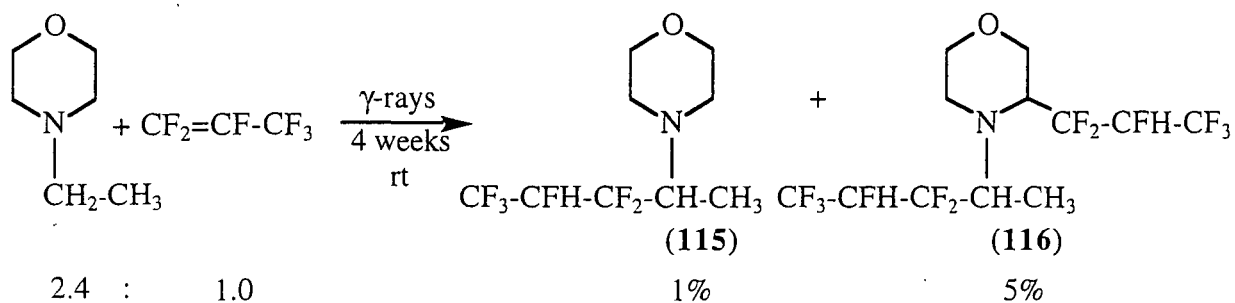

Scheme 179

Both monoadduct (115) and diadduct (116) were obtained in poor yield in that reaction. Nevertheless, the monoadduct (115) recovered, (structure *via* the COSY spectrum) allowed a determination of the mechanism of the free radical process. The COSY spectrum showed that the first hydrogen abstraction process occurred at the CH₂ group of the alkyl chain rather than the CH₂ group of the cyclohexane ring. This was proven by the fact that in the COSY spectrum the 3 protons of the CH₃ group at 1.2 ppm correlated with a signal at 3.1 ppm representing a proton of the CH-R_F as an integration of one proton has been observed in the ¹H NMR. The fact that the first hydrogen abstraction occurred at the CH₂ group of the alkyl group rather than a ring CH₂ site, maybe explained again by the effect of the oxygen (see above).

5.4. Influence of various factors over the free radical process :

Because of the low yields obtained for the several reactions, attempts to form and isolate the nucleophilic product were done. This was done by evaluating the influence of the temperature and other initiating methods over the free radical process. Two different experiments have been performed using 4-ethyl morpholine as amine in a 3 fold excess. Reactions were performed without any initiator and using dibenzoyl peroxide.

5.4.a. Temperature :

A blank reaction was carried out to see if temperature control could yield the nucleophilic product. After 24 hours at 80°C, only the starting material was recovered.

5.4.b. Dibenzoyl peroxide :

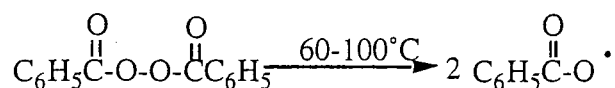

Benzoyloxy radical

Scheme 180

The reaction was performed in an autoclave, 24 hours at 80°C. After purification, a mixture of products was recovered. The mixture consists of benzoic acid (decomposition product of the dibenzoyl peroxide) and the product obtained from the nucleophilic substitution reaction. As these products could not be separated, the reaction was repeated a second time. This time, a work up was performed using a saturated solution of sodium hydrogen carbonate. However again the separation between the acid and the product could not be made.

5.5. 1,4-dimethyl piperazine :

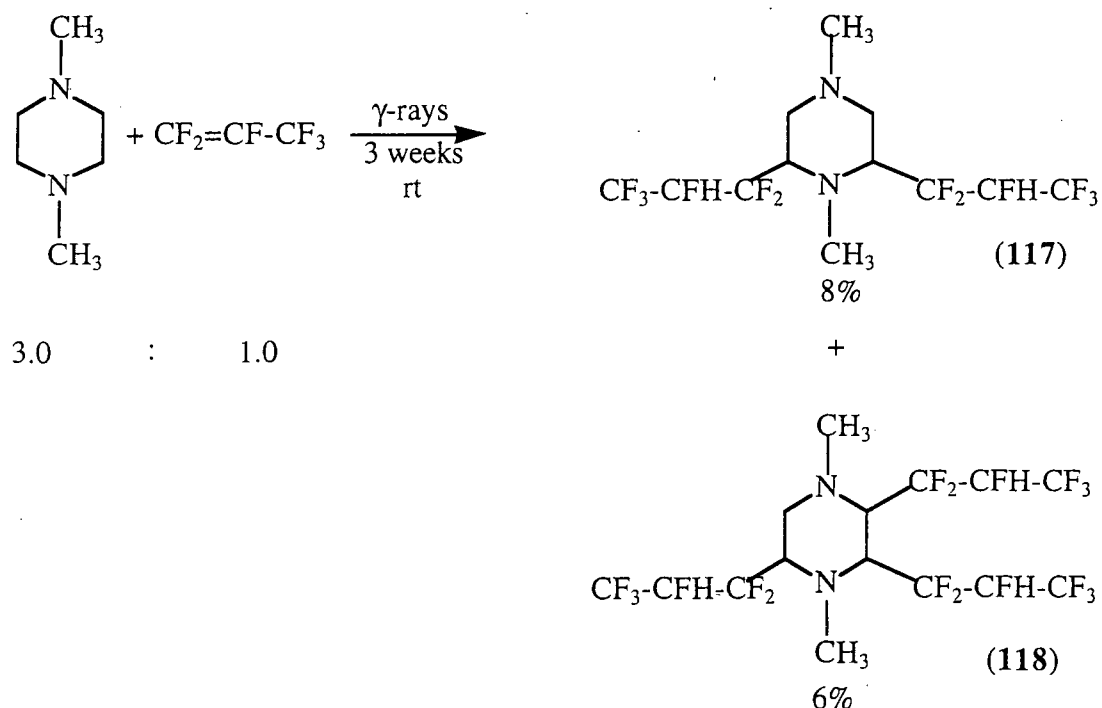

Scheme 181

The diadduct (117) and triadduct (118) product of 1,4-dimethyl piperazine were separated using chromatography columns first using *n*-hexane:CH₂Cl₂ and then CH₂Cl₂ as eluants. The examination of the NMR spectra showed without doubt that all the polyfluoroalkylation occurred at the secondary sites of the cyclohexane ring rather than the primary ones (i. e. the CH₃ groups). But on the contrary to the morpholine system, the presence of the second nitrogen atom did not affect the nucleophilicity of the radical leading to polyfluoroalkylation exclusively at the secondary sites. The fact that the diadduct structure was the one where the two polyfluoroalkyl chains are not neighbouring was proved with the COSY spectrum.

Other reactions using amines such as : N,N,N',N'-tetramethyl-1,4-butane diamine, 1,4-diazabicyclo[2,2,2]octane, 1-diethylamino-2-propanol, 3-diethylamino-1-propanol and (diethylamino)acetaldehyde diethyl acetal were tried but no useful product was recovered.

5.6. Dehydrofluorination reactions :

Dehydrofluorinations of the 1:2 methyl and ethyl piperidine hexafluoropropene adducts were carried out using a 4 fold excess of sodium *tert*-butoxide. Only the dehydrofluorinated product from the compound (112) was recovered and NMR analyses showed that exclusively the (*Z,Z*) stereoisomer was obtained at -80°C. Characterisation of the product has been described in Chapter 3.

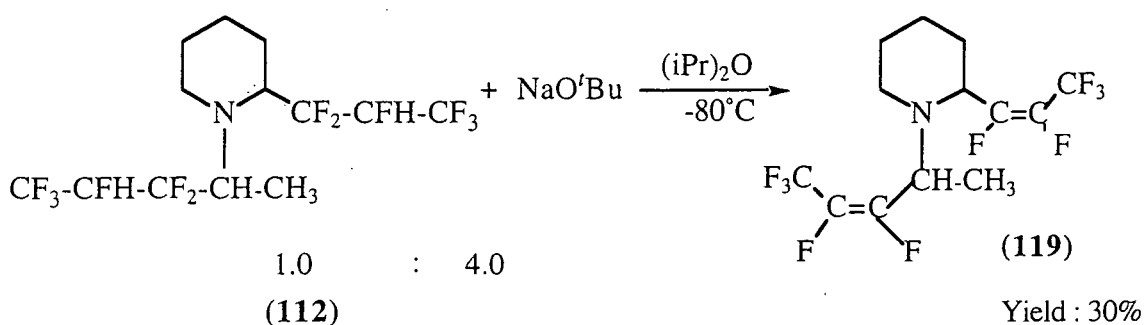

Scheme 182

5.7. Conclusion :

In view of the various results obtained from free radical addition to hexafluoropropene, some general features can be established. The reactivities of sites α to the nitrogen are in the following order : CH₂>CH>CH₃. This has been illustrated by free radical addition to acyclic amines as well as systems such as pyrrolidine and piperidine.

However when a second heteroatom such as oxygen is introduced the reactivity can be attributed to the presence of the second oxygen atom which offsets the effect of the nitrogen by withdrawing charge away from the radical centre reducing the *nucleophilicity* of the radical. This has been illustrated with the morpholine systems. But surprisingly when the second heteroatom is a nitrogen atom, such as for the 1,4-piperazine, the site reactivity is still secondary.

Dehydrofluorination of the 1:2 ethyl piperidine adduct gave a fluoroalkene via high stereoselectivity as the two double bond are *Z,Z*, showing again that at -80°C , the kinetic control dominates to give the less thermodynamic stable product.

Instrumentation and Reagents

Elemental Analyses :

Elemental analyses (carbon, hydrogen, and fluorine atoms) were carried out on an Exeter Analytical CE-440 elemental analysis machine.

FT-IR :

IR spectra were recorded on a Perkin-Elmer 1600 FT-IR spectrophotometer using conventional techniques (i. e. KBr or NaCl plates).

Gas liquid Chromatography (GLC) :

GLC was performed on a Hewlett Packard 5890A series II gas chromatograph fitted with a 25m cross-linked methyl silicone or 5% phenyl methyl silicone capillary column. Preparative scale GLC was performed on a Shimadzu GC-8A (catharometer detector) gas liquid chromatograph fitted with a 4m SE 30 packed column.

Mass Spectra :

Mass spectra were recorded on a Fisons VG trio 1000 spectrometer coupled with a Hewlett Packard 5890A series II gas chromatograph. Accurate Mass measurements were effected on a Micromass Autospec Mass Spectrometer. CI experiments were performed using ammonia as ionising gas.

NMR Spectra :

NMR spectra were recorded in deuterated chloroform or deuterated acetone on either a Varian Gemini 200, a Varian VXR 400S, a Bruker AC 250, a Varian Mercury 200 or a Unity Inova 500 spectrometer using trimethylsilane and trichlorofluoromethane as internal standards. Chemical shifts are given in ppm, coupling constants in Hz. In ^{19}F NMR spectra, upfield shifts are quoted as negative.

Boiling points :

Boiling points were either recorded during distillation or using a Gallenkamp apparatus at atmospheric pressure and are uncorrected.

Melting points :

Melting points were recorded using a Gallenkamp apparatus at atmospheric pressure and are uncorrected.

Reagents and solvents :

All materials were used as supplied by Aldrich or Apollo, solvents were dried using standart methods and stored where appropriate.

Chapter 6 : Experimental to Chapter 2

6.1. General procedure for free radical additions to hexafluoropropene :

6.1.a. Peroxide initiation :

The reaction was carried out in 500 ml autoclave, fitted with a bursting disc (maximum working pressure 200 bar). The autoclave was charged with the alkane or alcohol or amine, peroxide and then sealed using an annealed copper gasket. The autoclave was degassed 3 times using a freeze-thawing method. Hexafluoropropene was transferred into a rotaflow (50 ml) frozen with liquid air, degassed 3 times by freeze-thawing and then transferred into the liquid air cooled autoclave using standard vacuum line techniques. The autoclave valve was closed and transferred in a dewar flask of liquid air to a purpose built high pressure cell where it was allowed to warm and then heated in a thermostatically controlled rocking furnace for 24 hours at 140°C. On completion, the autoclave was cooled (liquid air) and any remaining hexafluoropropene was recovered in a liquid air cooled rotaflow (50 ml) as it returned to room temperature. Then the products were collected and separated by distillation.

6.1.b. γ -ray initiation :

The reaction was carried out in a pyrex carius tube (volume ca. 60 ml). The carius tube was charged with the alkane or amine then degassed 3 times using a freeze-thawing method. Hexafluoropropene was transferred into a rotaflow (50 ml) frozen with liquid air, degassed 3 times by freeze-thawing and then was transferred into the liquid air cooled carius tube using standard vacuum line techniques. The carius tube was sealed *in vacuo* while frozen, placed inside a metal sleeve and then allowed to reach room temperature within a fumehood. The carius tube was then placed in the $\gamma^{60}\text{Co}$ source and irradiated (55Krad hr^{-1}) 10 cm from the source at room temperature. On termination, the carius tube was cooled down (liquid air) and opened. The remaining HFP was recovered as it returned to room temperature and the products were collected.

Adamantane and HFP (peroxide initiation). Adamantane (13.8 g, 0.11 mol), di-*tert*-butyl peroxide (0.7 g, 4.8 mmol) and hexafluoropropene (17.5 g, 0.12 mol) gave after distillation *1-adamantanyl-1,1,2,3,3,3-hexafluoropropane* (**36**) (12.7 g, 40%, 99% conv.) as a colourless liquid; bp 100-110°C (9mmHg) (bp¹¹⁷ 99-101°C); (Found: C, 54.3; H, 5.6. C₁₃H₁₆F₆ requires: C, 54.6; H, 5.6%); NMR spectrum no. 1; Mass spectrum no. 1; IR spectrum no. 1 and *1,1,2,3,3,3-hexafluoro-1-[3-(1,1,2,3,3,3-hexafluoropropyl)adamantanyl]propane* (**39**) (9.3 g, 19%) as a colourless viscous liquid; bp 122-130°C (9mmHg) (bp¹¹⁷ 124-126°C); (Found: C, 44.1; H, 3.6.

$C_{16}H_{16}F_{12}$ requires C, 44.1; H, 3.7%); NMR spectrum no. 2; Mass spectrum no. 2; IR spectrum no. 2.

Adamantane and a 6.2 fold excess of HFP (peroxide initiation). Adamantane (2.7 g, 22.1 mmol), di-*tert*-butyl peroxide (0.5 g, 3.4 mmol) and a 6.2 fold excess of hexafluoropropene (20.8 g, 138.7 mmol) gave, after dissolving in hexane, *1-[3,5-bis(1,1,2,3,3,3-hexafluoropropyl)adamantanyl]-1,1,2,3,3,3-hexafluoropropane* (**41**) (1.7 g, 13%, 60% conv.) as a light yellow oil; bp 140-145°C (bp¹¹⁷ 143-145°C); (Found: $[M-H]^+$, 585.089706 $C_{19}H_{15}F_{18}$ requires $[M-H]^+$, 585.000000); NMR spectrum no. 3; Mass spectrum no. 3; IR spectrum no. 3 and *1,1,2,3,3,3-hexafluoro-1-[3,5,8-tris(1,1,2,3,3,3-hexafluoropropyl)adamantanyl]propane* (**42**) (3.0 g, 18%) as a white powder; mp 114°C (mp⁴⁴ 110-112°C); (Found: C, 35.6; H, 2.2. $C_{22}H_{16}F_{24}$ requires: C, 35.9; H, 2.2%); NMR spectrum no. 4; Mass spectrum no. 4; IR spectrum no. 4.

Cyclopentane and HFP (peroxide initiation). Cyclopentane (71.0 g, 1.01 mol), di-*tert*-butyl peroxide (6.0 g, 41.1 mmol) and hexafluoropropene (163.0 g, 1.09 mol) gave after fractional distillation *1-(1,1,2,3,3,3-hexafluoropropyl)cyclopentane* (**43**) (130.5 g, 59%, 73% conv.) as a colourless liquid; bp 138-142°C (bp⁴⁴ 134-135°C); (Found: C, 43.5; H, 4.6. $C_8H_{10}F_6$ requires C, 43.7 ; H, 4.6%); NMR spectrum no. 5; Mass spectrum no. 5; IR spectrum no. 5 and after fractional distillation at reduced pressure, *trans-1,1,2,3,3-hexafluoro-1-[3-(1,1,2,3,3,3-hexafluoropropyl)cyclopentyl]propane* (**44b**) (56.9 g, 15%) as a viscous liquid; bp 89-93°C (15mmHg) (bp³⁶ 80-81°C); (Found: C, 35.8; H, 2.7. $C_{11}H_{10}F_{12}$ requires C, 35.7; H, 2.7%); NMR spectrum no. 6; Mass spectrum no. 6; IR spectrum no. 6.

Cyclopentane and HFP (γ -ray initiation).

Cyclopentane (7.1 g, 0.10 mol) and hexafluoropropene (24.4 g, 0.16 mol), after distillation, gave *1-(1,1,2,3,3,3-hexafluoropropyl)cyclopentane* (**43**) (17.9 g, 81%, conv. 56%) as a colourless liquid and *trans-1,1,2,3,3-hexafluoro-1-[3-(1,1,2,3,3,3-hexafluoropropyl)cyclopentyl]propane* (**44b**) (1.9 g, 5%) as a viscous liquid; spectral and physical data are as above.

Cyclopentanol and HFP (peroxide initiation). Cyclopentanol (86.0 g, 1.00 mol), di-*tert*-butyl peroxide (6.0 g, 41.1 mmol) and hexafluoropropene (174.0 g, 1.16 mol) gave, after distillation, *1-(1,1,2,3,3,3-hexafluoropropyl)cyclopentanol* (**46**) (130.5 g, 55%, 71% conv.) as a colourless liquid; bp 150-160°C (bp¹¹⁸ 37-38°C); (Found: C, 40.7; H, 4.3. $C_8H_{10}F_6O$ requires C, 40.7; H, 4.3%); NMR spectrum no. 7; Mass spectrum no. 7; IR spectrum no.7.

Chapter 7 : Experimental to Chapter 3

7.1. Dehydration :

1-(1,1,2,3,3,3-hexafluoropropyl)cyclopentanol (46). A 250 ml one-necked round bottom flask was charged with 1-(1,1,2,3,3,3-hexafluoropropyl)cyclopentanol (**46**) (18.6 g, 78.8 mmol) and thionyl chloride (74 ml, 888 mmol) at room temperature. The reaction mixture was refluxed and the HCl emitted was released and passed through a potassium hydroxide solution. On completion the mixture was allowed to cool down to room temperature and carefully added dropwise to a dichloromethane and ice mixture. The organic layer was extracted using dichloromethane, washed with water and then dried over MgSO₄. Distillation at atmospheric pressure gave 1-(1,1,2,3,3,3-hexafluoropropyl)cyclopentene (**49**) (9.7 g, 56%) as a colourless liquid; bp 150-160°C (bp³⁰ 128-130°C); (Found: C, 44.2; H, 3.8. C₈H₈F₆ requires C, 44.1; H, 3.7%); NMR spectrum no. 8; Mass spectrum no. 8; IR spectrum no. 8.

7.2. General procedure for dehydrofluorinations reactions:

In a 250 ml two-necked flask, sodium *tert*-butoxide (dried over the night under vacuum) and anhydrous solvent were added under nitrogen and stirred. The mixture was cooled down (-80°C) and the hexafluoropropene adduct was added. On termination, the mixture obtained was poured into water and neutralised with hydrochloric acid (10%). The organic layer was extracted with dichloromethane and dried over MgSO₄. Distillation gave the different solvents, tertiary butanol and products.

1-adamantanyl-1,1,2,3,3,3-hexafluoropropane (36). Dry sodium *tert*-butoxide (1.7 g, 17.7 mmol) in diethyl ether (10 ml) and 1-adamantanyl-1,1,2,3,3,3-hexafluoropropane (**36**) (2.5 g, 8.7 mmol) gave after distillation 1-adamantanyl-1,2,3,3,3-pentafluoroprop-1-ene (**53**) (1.8 g, 74%) as a colourless liquid and as a mixture of isomers which were not separated (ratio *Z:E*, 7.3:1.0); bp 210-220°C (20 mm Hg) (bp⁴⁴ 219-221°C); (Found: C, 58.6; H, 5.7%. C₁₃H₁₅F₅ requires C, 58.7; H, 5.7%); NMR spectrum no. 9; Mass spectrum no. 9; IR spectrum no. 9.

1-(1,1,2,3,3,3-hexafluoropropyl)cyclopentane (43). Dry sodium *tert*-butoxide (55.0 g, 0.57 mol) in diethyl ether (40 ml) and 1-(1,1,2,3,3,3-hexafluoropropyl)cyclopentane (**43**) (50.0 g, 0.22 mol) gave after distillation 1-(pentafluoroprop-2-enyl)cyclopentane (**54**) (36.2 g, 80%) as a colourless liquid and as a mixture of isomers which were not separated (ratio *Z:E*, 8.3:1.0); bp 130-140°C

(bp⁴⁴ 119-121°C); (Found: C, 47.7; H, 4.6%. C₈H₉F₅ requires C, 48.0; H, 4.5%); NMR spectrum no. 10; Mass spectrum no. 10; IR spectrum no. 10.

trans-1,1,2,3,3-hexafluoro-1-[3-(1,1,2,3,3,3-hexafluoropropyl)cyclopentyl]propane (44b). Dry sodium *tert*-butoxide (8.3 g, 86.5 mmol) in diethyl ether (20 ml) and *trans*-1,1,2,3,3-hexafluoro-1-[3-(1,1,2,3,3,3-hexafluoropropyl)cyclopentyl]propane (**44b**) (8.0 g, 21.6 mmol) gave after distillation *l*-[(1*R*,3*R*)-3-((1*Z*)-1,2,3,3,3-pentafluoroprop-1-enyl)cyclopentyl](1*Z*)-1,2,3,3,3-pentafluoroprop-1-ene (**55**) and *l*-[(3*S*,1*R*)-3-((1*Z*)-1,2,3,3,3-pentafluoroprop-1-enyl)cyclopentyl](1*Z*)-1,2,3,3-pentafluoroprop-1-ene (**56**) (6.0 g, 83%) as a mixture of epimers and as a viscous liquid; bp 150-175°C (bp⁴⁶ 76-77°C); (Found: C, 39.9; H, 2.4%. C₁₁H₈F₁₀ requires C, 40.0; H, 2.4%); NMR spectrum no. 11; Mass spectrum no. 11; IR spectrum no. 11.

1-(1,1,2,3,3,3-hexafluoropropyl)cyclopentene (49). In a round bottom flask potassium hydroxide flakes (4.0 g, 71.4 mmol) were dried under vacuum over night. Then 1-(1,1,2,3,3,3-hexafluoropropyl)cyclopentene (**49**) (3.2 g, 14.6 mmol) was transferred into the flask, at reduced pressure, and the mixture was stirred at room temperature for 24 hours. On completion the volatiles were transferred to give *l*-(1,2,3,3,3-pentafluoro-*z*-prop-1-enyl)cyclopentene (**57b**) (2.3 g, 83%) as a colourless liquid; bp 126°C; (Found: M⁺, 198.046564. C₈F₅H₇ requires M⁺, 198.046792); NMR spectrum no. 12; Mass spectrum no. 12; IR spectrum no. 12.

Chapter 8 : Experimental to Chapter 4

8.1. Nucleophilic substitution reactions : oxygen as nucleophile

8.1.a. General procedure for alkoxide derivatives :

A 250 ml two-necked flask was charged with the alcohol, anhydrous tetrahydrofuran and sodium metal under an atmosphere of nitrogen. The solution was stirred at 65°C until all the sodium metal dissolved. Then, the mixture was cooled down to 0°C and the alkene was added. The mixture was stirred at 80°C and monitored by ¹⁹F NMR. After cooling, water was added (30 cm³) and neutralised with aqueous HCl 10%. The organic layer was extracted into dichloromethane and dried over MgSO₄. The solvents were removed by rotary evaporation and further distillation, under reduced pressure, gave the product.

1-(Z-pentafluoroprop-2-enyl)cyclopentane (54b) with ethanol. Ethanol (15.0 g, 0.33 mol), sodium (0.9 g, 39.1 mmol) and 1-(Z-pentafluoroprop-2-enyl)cyclopentane (**54b**) (4.0 g, 20.0 mmol) gave, after distillation at reduced pressure, a mixture of *1-cyclopentyl-1-ethoxy-2,3,3,3-tetrafluoroprop-1-ene (75)*; NMR spectrum no. 13; Mass spectrum no. 13; IR spectrum no. 13 and *1-cyclopentyl-1-ethoxy-1,2,3,3,3-pentafluoropropane (76)* (1.5 g, 33%) as a light yellow oil; bp 52°C (20 mmHg); NMR spectrum no. 14; Mass spectrum no. 14; IR spectrum no. 14.

After a few days, ¹⁹F NMR analysis showed that *1-cyclopentyl-2,3,3,3-tetrafluoropropan-1-one (77)* was the only product in the mixture; NMR spectrum no. 15; Mass spectrum no. 15; IR spectrum no. 15.

1-(Z-pentafluoroprop-2-enyl)cyclopentane (54b) with methanol. Methanol (15.0 g, 0.47 mol), sodium (0.2 g, 8.7 mmol) and 1-(Z-pentafluoroprop-2-enyl)cyclopentane (**54b**) (3.0 g, 15.0 mmol) gave after distillation *1-cyclopentyl-1,2,3,3,3-pentafluoro-1-methoxypropane (78)* (1.6 g, 35%) as a light oil; bp 100-125°C; NMR spectrum no. 16; Mass spectrum no. 16; IR spectrum no. 16.

1-(Z-pentafluoroprop-2-enyl)cyclopentane (54b) with allyl alcohol. Allyl alcohol (2.6 g, 45 mmol), sodium (0.9 g, 37.5 mmol) in THF (15 ml) and 1-(Z-pentafluoroprop-2-enyl)cyclopentane (**54b**) (3.0 g, 15.0 mmol) gave, after distillation at reduced pressure, *1-cyclopentyl-2-fluoro-2-trifluoromethyl-4-penten-1-one (79)* (2.4 g, 67%) as a colourless oil; bp 50 °C (6mmHg); (Found: M⁺, 238.096216.

$C_{11}F_4OH_{14}$ requires M^+ , 238.098078); NMR spectrum no. 17; Mass spectrum no. 17; IR spectrum no. 17.

1-(Z-pentafluoroprop-2-enyl)cyclopentane (54b) with propargyl alcohol. Propargyl alcohol (2.6 g, 46.4 mmol), sodium (0.9 g, 39.1 mmol) in THF (15 ml) and 1-(Z-pentafluoroprop-2-enyl)cyclopentane (54b) (3.0 g, 15.0 mmol) gave, after distillation at reduced pressure, *1-cyclopentyl-2-fluoro-2-trifluoromethyl-3,4-pentadien-1-one (85)* (1.9 g, 54%) as a colourless oil; bp 110-135°C (20 mmHg); (Found: C, 56.3; H, 5.2. $C_{11}H_{12}F_4O$ requires C, 55.9; H, 5.1%); NMR spectrum no. 18; Mass spectrum no. 18; IR spectrum no. 18.

Allene function reduction. In a two-necked flask, equipped with a condenser and a pressure equalising dropping funnel, propane-1,3-diamine (1.5 ml) was added to powdered potassium hydride (1.0 g, 25 mmol). After hydrogen evolution ceased, the reaction mixture was cooled to -5°C and 1-cyclopentyl-2-fluoro-2-trifluoromethyl-3,4-pentadien-1-one (85) (1.0 g, 4 mmol) in propane-1,3-diamine (3 ml) was added. After 20 min, ice (10.0 g) was added and the mixture extracted with petroleum ether. The combined extracts were washed and dried over $MgSO_4$. Evaporation of the solvent gave a black tar which was not analysed further.

1-(Z-pentafluoroprop-2-enyl)cyclopentane (54b) with crotyl alcohol. Crotyl alcohol (3.2 g, 44.4 mmol), sodium (0.9 g, 39.1 mmol) in THF (15 ml) and 1-(Z-pentafluoroprop-2-enyl)cyclopentane (54b) (3.0 g, 15.0 mmol) gave, after distillation at reduced pressure, *1-cyclopentyl-2-fluoro-3-methyl-2-trifluoromethyl-4-penten-1-one (86)* (2.6 g, 69%) as a colourless oil and as a mixture of diastereoisomers which were not separated (ratio 4.6:1.0); bp 50°C (<0.1mmHg); (Found: C, 57.4; H, 6.2. $C_{12}H_{16}F_4O$ requires C, 57.1; H, 6.3%); NMR spectrum no. 19; Mass spectrum no. 19; IR spectrum no. 19.

1-(Z-pentafluoroprop-2-enyl)cyclopentane (54b) with but-1-en-3-ol. But-1-en-3-ol (2.2 g, 30.6 mmol), sodium (0.6 g, 26.1 mmol) in THF (15 ml) and 1-(Z-pentafluoroprop-2-enyl)cyclopentane (54b) (2.0 g, 10.0 mmol) gave, after column chromatography on silica gel using *n*-hexane:ethyl acetate (5:1) as eluant, *cyclopentane carboxylic acid (88)* (0.5 g, 44%) as a yellow oil; bp 205°C (bp¹¹⁹ 214-215°C); (Found: M^+ , 114.067894 $C_6H_{10}O_2$ requires M^+ , 114.068068); NMR spectrum no. 20; Mass spectrum no. 20; IR spectrum no. 20.

1-(Z-pentafluoroprop-2-enyl)cyclopentane (54b) with 4,4,4-trifluoro-but-2-en-3-ol. 4,4,4-trifluoro-but-2-en-3-ol (2.5 g, 19.8 mmol), sodium (0.4 g, 17.4 mmol) in

THF (15 ml) and 1-(*Z*-pentafluoroprop-2-enyl)cyclopentane (**54b**) (1.3 g, 6.5 mmol) were refluxed at 80°C for 14 days (conv. 79%). After column chromatography on silica gel using *n*-hexane:ethyl acetate (5:1) as eluant, no product was recovered.

1-(*Z*-pentafluoroprop-2-enyl)cyclopentane (54b) with geraniol. Geraniol (6.9 g, 44.8 mmol), sodium (0.9 g, 39.1 mmol) in THF (15 ml) and 1-(*Z*-pentafluoroprop-2-enyl)cyclopentane (**54b**) (3.0 g, 15.0 mmol) gave, after distillation at reduced pressure, *1-cyclopentyl-3-ethenyl-2-fluoro-3,7-dimethyl-2-trifluoromethyl-6-octen-1-one* (**92**) (3.6 g, 72%) as a colourless oil and a mixture of diastereoisomers (ratio 6.8:1.0) which were not separated; bp 110-120°C (7mmHg); (Found: C, 64.32; H, 7.90. C₁₈H₂₆F₄O requires C, 64.67; H, 7.78%); NMR spectrum no. 21; Mass spectrum no. 21; IR spectrum no. 21.

1-(1,2,3,3,3 pentafluoro-*Z*-prop-1-enyl)cyclopentene (57b) with geraniol. Geraniol (1.9 g, 12.3 mmol), sodium (0.2 g, 8.7 mmol) in THF (15 ml) and 1-(1,2,3,3,3 pentafluoro-*Z*-prop-1-enyl)cyclopentene (**57b**) (0.8 g, 4.0 mmol), gave after distillation at reduced pressure, *1-cyclopent-1-enyl-2-fluoro-3,7-dimethyl-2-(trifluoromethyl)-3-vinyloct-6-en-1-one* (**93**) (0.6 g, 45%) as a colourless oil; bp 60°C (<0.1mmHg); (Found: M⁺, 332.176564. C₁₈H₂₄F₄O requires M⁺, 332.176329); NMR spectrum no. 22; Mass spectrum no. 22; IR spectrum no. 22.

1-(*Z*-pentafluoroprop-2-enyl)cyclopentane (54b) with benzyl alcohol. Benzyl alcohol (4.9 g, 45.4 mmol), sodium (0.9 g, 39.1 mmol) in THF and 1-(*Z*-pentafluoroprop-2-enyl)cyclopentane (**54b**) (3.0 g, 15.0 mmol) gave, after distillation at reduced pressure, *(1-cyclopentyl-2,3,3,3-tetrafluoro-1-propenoxy)methylbenzene* (**94**) (2.2 g, 51%) as a colourless oil and a mixture of isomers which were not separated (ratio *Z*:*E*, 320:1); bp 56°C (5mmHg); (Found: C, 62.6; H, 5.5. C₁₅H₁₆F₄O requires C, 62.5; H, 5.6%); NMR spectrum no. 23; Mass spectrum no. 23; IR spectrum no. 23.

1-(1,2,3,3,3 pentafluoro-*Z*-prop-1-enyl)cyclopentene (57b) with benzyl alcohol. Benzyl alcohol (2.1 g, 19.4 mmol), sodium (0.4 g, 17.4 mmol) in THF and 1-(1,2,3,3,3 pentafluoro-*Z*-prop-1-enyl)cyclopentene (**57b**) (1.2 g, 6.1 mmol) gave after distillation a colourless liquid identified as the starting material.

1-(*Z*-pentafluoroprop-2-enyl)cyclopentane (54b) with propane-1,3-diol. Propane-1,3 -diol (1.2 g, 15.3 mmol), sodium (0.4 g, 17.4 mmol) in THF (15 ml) and 1-(*Z*-pentafluoroprop-2-enyl)cyclopentane (**54b**) (4.0 g, 40.0 mmol) were refluxed at 80°C. The reaction was stopped after 7 days as no change in the ¹⁹F NMR was observed.

8.1.b. General procedure for silyl derivatives :

A 250 ml three-necked flask, equipped with a septum, was charged under nitrogen at 0°C, with alcohol and trimethylsilyl chloride in THF. The reaction mixture was refluxing and the HCl emitted was released and passed through a potassium hydroxide solution. The reaction mixture was stirred at room temperature until total disappearance of gas emission (pH 7). CsF and the alkene were added. The mixture was stirred at 80°C and monitored by ¹⁹F NMR. On termination, the resulting solution was poured carefully into water. The organic layer was extracted with dichloromethane and dried over MgSO₄.

1-(Z-pentafluoroprop-2-enyl)cyclopentane (54b) with crotyl alcohol. Crotyl alcohol (1.9 g, 26.4 mmol), pyridine (1.4 g, 15.4 mmol), Me₃SiCl (2.2 ml, 17.2 mmol) in THF (15 ml), CsF (0.5 g, 3.3 mmol) and 1-(Z-pentafluoroprop-2-enyl)cyclopentane (**54b**) (2.6 g, 13.0 mmol) were refluxed. The reaction was stopped after 5 days as no change in the ¹⁹F NMR was observed.

1-(Z-pentafluoroprop-2-enyl)cyclopentane (54b) with but-1-en-3-ol. But-1-en-3-ol (1.9 g, 26.4 mmol), Me₃SiCl (0.3 ml, 32.4 mmol) in THF (15 ml), CsF (0.5 g, 3.3 mmol), 1-(Z-pentafluoroprop-2-enyl)cyclopentane (**54b**) (2.6 g, 13.0 mmol) were refluxed. The reaction was stopped after 8 days as no change in the ¹⁹F NMR was observed.

1-(Z-pentafluoroprop-2-enyl)cyclopentane (54b) with geraniol. Geraniol (4.0 g, 27.0 mmol), Me₃SiCl (0.3 ml, 32.4 mmol) in THF (15 ml), CsF (0.5 g, 3.3 mmol), 1-(Z-pentafluoroprop-2-enyl)cyclopentane (**54b**) (2.6 g, 13.0 mmol) were refluxed. The reaction was stopped after 8 days as no change in the ¹⁹F NMR was observed.

8.2. Nucleophilic substitution reactions : nitrogen as nucleophile

1-(Z-pentafluoroprop-2-enyl)cyclopentane (54b) with ammonia. A round bottom flask was charged with 1-(Z-pentafluoroprop-2-enyl)cyclopentane (**54b**) (2.0 g, 10.0 mmol) and ammonia (solution 33% in water) (50 ml, 0.6 mol). The reaction mixture was stirred at room temperature and then refluxed for 4 days. The reaction was monitored by ¹⁹F NMR. The reaction was stopped as no change in the ¹⁹F NMR was observed.

1-(Z-pentafluoroprop-2-enyl)cyclopentane (54b) with diethylamine. Similar general procedure than for the alcohol was used. Diethylamine (12.5 ml, 28.4 mmol), sodium (0.6 g, 26.1 mmol) in THF (15 ml) and 1-(Z-pentafluoroprop-2-enyl)cyclopentane (**54b**) (2.0 g, 10.0 mmol) were refluxed at 80°C. The reaction was stopped after 6 days as no change in the ¹⁹F NMR was observed.

8.3. Nucleophilic substitution reactions : carbon as nucleophile

8.3.a. General procedure for organolithium derivatives :

A 250 ml three-necked flask, equipped with a septum, was charged under nitrogen at -78°C, with organolithium derivative in hexane, THF and 1-(pentafluoroprop-2-enyl)cyclopentane (**54b**). The mixture was stirred, warmed at 80°C and monitored by ¹⁹F NMR. On completion, the crude mixture was allowed to return to room temperature, poured into ice, neutralised with aqueous HCl (10%) and extracted into dichloromethane. The solvents were removed by rotary evaporation and further distillation, under reduced pressure, gave the product.

1-(Z-pentafluoroprop-2-enyl)cyclopentane (54b) with BuLi. BuLi (15.6 ml, 25.0 mmol) in hexane, THF (15 ml) and 1-(Z-pentafluoroprop-2-enyl)cyclopentane (**54b**) (2.0 g, 10.0 mmol) gave, after distillation at reduced pressure, (*1-butyl-2,3,3,3-tetrafluoro-1-propenyl*)cyclopentane (**99**) (1.3 g, 55%) as a colourless liquid and as a mixture of isomers which were not separated (ratio *Z:E*, 33.4:1.0); bp 32°C (7mmHg); (Found: C, 60.5; H, 7.7. C₁₂H₁₈F₄ requires C, 60.5; H, 7.6%); NMR spectrum no. 24; Mass spectrum no. 24; IR spectrum no. 24.

1-(Z-pentafluoroprop-2-enyl)cyclopentane (54b) with *t*-BuLi. *t*-BuLi (14.8 ml, 22.5 mmol) in hexane, THF (15 ml) and 1-(Z-pentafluoroprop-2-enyl)cyclopentane (**54b**) (2.5 g, 12.5 mmol) gave the starting material after 6 days.

1-(Z-pentafluoroprop-2-enyl)cyclopentane (54b) with PhLi. PhLi (16.7 ml, 30 mmol) in hexane and THF (15 ml) and 1-(Z-pentafluoroprop-2-enyl)cyclopentane (**54b**) (3.0 g, 15.0 mmol) gave, after distillation at reduced pressure, (*1-phenyl-2,3,3,3-tetrafluoro-1-propenyl*)cyclopentane (**101**) (1.3 g, 34%) as a colourless liquid and as a mixture of isomers which were not separated (ratio *Z:E*, 33:1); bp 66-70°C (1mmHg); (Found: M⁺, 258.103130 C₁₄H₁₄F₄ requires M, 258.103164) and 22% of biphenyl derivative (not isolated); NMR spectrum no. 25 (lit. ¹²⁰); Mass spectrum no. 25; IR spectrum no. 25.

8.3.b. General procedure for sodium malonate derivatives :

A 100 ml two-necked flask was charged under nitrogen, at -78°C , with an equimolar amount of malonate derivative in solvent and 1-(pentafluoroprop-2-enyl)cyclopentane (**54b**). The reaction mixture was stirred at room temperature and monitored by ^{19}F NMR. On termination, the resulting solution was poured into water. The organic layer was extracted with dichloromethane and dried over MgSO_4 .

1-(Z-pentafluoroprop-2-enyl)cyclopentane (54b) with dimethyl malonate. Dimethyl malonate (1.7 g, 20.2 mmol), sodium (0.3 g, 13.0 mmol), isopropyl ether (15 ml) and 1-(Z-pentafluoroprop-2-enyl)cyclopentane (**54b**) (2.2 g, 11.0 mmol) were stirred for 24 hours. The reaction was stopped as no change in the ^{19}F NMR was observed.

1-(Z-pentafluoroprop-2-enyl)cyclopentane (54b) with diethyl malonate. Diethyl malonate (1.7 g, 10.9 mmol), sodium (0.2 g, 8.7 mmol), THF (15 ml) and 1-(Z-pentafluoroprop-2-enyl)cyclopentane (**54b**) (1.0 g, 5.0 mmol) were stirred for 5 days. The reaction was stopped as no change in the ^{19}F NMR was observed.

8.3.c. Grignard reagent :

1-(Z-pentafluoroprop-2-enyl)cyclopentane (54b) with allyl magnesium bromide. To allyl magnesium bromide (30 ml, 30 mmol) and THF (25 ml) contained in a three-necked flask, equipped with a septum, a condenser and under nitrogen atmosphere, 1-(Z-pentafluoroprop-2-enyl)cyclopentane (**54b**) (3.0 g, 15.0 mmol) was added dropwise at room temperature. After 1 day, the crude mixture was allowed to return to room temperature, poured carefully into water, neutralised with a aqueous solution of NaHCO_3 , extracted into diethyl ether and dried over MgSO_4 . The solvents were removed by rotary evaporation and a colourless liquid identified as 1-(pentafluoroprop-2-enyl)cyclopentane (**54b**) was recovered.

8.4. Electrophilic substitution reactions :

8.4.a. General procedure for halogenation reactions :

A 250 ml two-necked flask, equipped with a condenser and a pressure equalising dropping funnel, was charged under 0°C , with the halogen derivative and 1-(pentafluoroprop-2-enyl)cyclopentane (**54b**). The mixture was stirred at room temperature for 24 hours. On completion, the crude mixture was diluted in

dichloromethane and washed with 10% aqueous sodium metabisulphate. The organic layer was extracted with dichloromethane and dried over MgSO₄. The solvents were removed by rotary evaporation and further distillation, under reduced pressure, gave the product.

1-(Z-pentafluoroprop-2-enyl)cyclopentane (54b) with bromine. 1-(Z-pentafluoroprop-2-enyl)cyclopentane (**54b**) (2.0 g, 10.0 mmol) and elemental bromine (3.2 g, 20.0 mmol) gave, after distillation at reduced pressure, *1,2-dibromo-1-cyclopentyl-1,2,3,3,3-pentafluoropropane (103)* (1.5 g, 42%) as a colourless liquid and as a mixture of diastereoisomers which were not separated (ratio 1.0:0.6); bp 55-60°C (10 mmHg); (Found: M⁺, 359.896442 C₈H₉F₅Br₂ requires M⁺, 359.897068); NMR spectrum no. 26; Mass spectrum no. 26; IR spectrum no. 26.

1-(Z-pentafluoroprop-2-enyl)cyclopentane (54b) with iodine monochloride. 1-(Z-pentafluoroprop-2-enyl)cyclopentane (**54b**) (2.0 g, 10.0 mmol) and iodine monochloride (3.2 g, 19.7 mmol) gave after work up and column chromatography on silica gel using CH₂Cl₂ as eluant a colourless liquid identified as the starting material.

1-(Z-pentafluoroprop-2-enyl)cyclopentane (54b) with iodine bromide. 1-(Z-pentafluoroprop-2-enyl)cyclopentane (**54b**) (2.0 g, 10.0 mmol) and iodine bromide (4.1 g, 19.8 mmol) gave after work up and column chromatography on silica gel using CH₂Cl₂ as eluant a colourless liquid identified as the starting material.

8.5. Epoxidation reactions :

8.5.a. General procedure

A two-necked flask, equipped with a cold finger and a dropping funnel was charged with NaOCl and CH₃CN. The reaction mixture was then basified with a aqueous solution of NaOH (pH 10-11), the alkene added and then stirred for 2 days. The lower layer was separated, washed with water and extracted with CH₂Cl₂ and dried over MgSO₄.

1-(Z-pentafluoroprop-2-enyl)cyclopentane (54b) with sodium hypochlorite. NaOCl (20 ml), CH₃CN (2 ml) and 1-(Z-pentafluoroprop-2-enyl)cyclopentane (**54b**) (2.0 g, 10.0 mmol) gave after evaporation of the solvent a colourless liquid identified as the starting material.

(1Z)-1-adamantanyl-1,2,3,3,3-pentafluoroprop-1-ene (53b) with sodium hypochlorite. NaOCl (15 ml), CH₃CN (1.5 ml) and (1Z)-1-adamantanyl-1,2,3,3,3-pentafluoroprop-1-ene (**53b**) (3.0 g, 11.0 mmol) gave after evaporation of the solvent a colourless liquid identified as the starting material.

1-(Z-pentafluoroprop-2-enyl)cyclopentane (54b), sodium hypochlorite and BDTAC. 1-(Z-pentafluoroprop-2-enyl)cyclopentane (**54b**) (3.0 g, 15.0 mmol) in CH₂Cl₂ (37.5 ml) was added to a mixture of meso-5,10,15,20-tetraphenyl-21H,23H-porphyrin manganese (III) chloride (0.07 g, 0.09 mmol) and benyldimethyltetradecylammonium chloride (0.08 g, 0.19 mmol) in NaOCl (40.5 ml). The reaction mixture was stirred at room temperature for 4 days. On completion, the reaction mixture was passed through a column of silica gel (eluant, *n*-hexane:diethyl ether (3:1)). After evaporation, a colourless liquid identified as 1-(pentafluoroprop-2-enyl)cyclopentane (**54b**) was obtained.

1-(Z-pentafluoroprop-2-enyl)cyclopentane (54b) with *m*-CPBA. *m*-CPBA (3.3 g, 9.1 mmol) was dissolved in CH₂Cl₂ (25 ml), then 1-(Z-pentafluoroprop-2-enyl)cyclopentane (**54b**) (1.0 g, 10 mmol) was added at room temperature. The reaction mixture was stirred for 13 days at room temperature then cooled down to 0°C, filtered and washed with a saturated solution of Na₂S₂O₃. The aqueous phase was extracted 2 times into dichloromethane. Then the organic layers were collected, washed with a saturated solution of NaHCO₃ and a solution of NaCl and dried over MgSO₄. Evaporation gave a colourless liquid identified as the starting material.

Chapter 9 : Experimental to Chapter 5

9.1. Free radical addition to HFP using γ -rays :

General procedure for γ -ray initiated reactions described in Chapter 6.

Triethylamine and HFP. Triethylamine (17.0 g, 0.17 mol) and hexafluoropropene (8.5 g, 56.7 mmol), after column chromatography on silica gel using cyclopentane as eluant, gave as an isomer mixture (ratio 1.0:0.4) of *diethyl(2,2,3,4,4,4-hexafluoro-1-methylbutyl)amine* (**104**) as a colourless liquid (1.3 g, 3%); bp 119.4°C; (Found: [M-H]⁺, 250.104248 C₉H₁₄F₆N requires [M-H]⁺, 250.103044); NMR spectrum no. 27; Mass spectrum no. 27; IR spectrum no. 27, *bis(2,2,3,4,4,4-hexafluoro-1-methylbutyl)ethylamine* (**105**) as a mixture of diastereoisomers (ratio : 1.0:0.2) and a colourless oil (26.0 g, 38%); bp 201.6°C; (Found: C, 35.9; H, 3.8; N, 3.7. C₁₂H₁₅F₁₂N requires C, 35.9; H, 3.8; N, 3.5%); NMR spectrum no. 28; Mass spectrum no. 28; IR spectrum no. 28 and *tris(2,2,3,4,4,4-hexafluoro-1-methylbutyl)amine* (**106**) as a mixture of diastereoisomers (ratio 1.0:0.5:0.3:0.3:0.3:0.2) and a white solid (5.7 g, 6%); mp 74°C; (Found: C, 33.0; H, 2.8; N, 2.6. C₁₅H₁₅F₁₈N requires C, 32.7; H, 2.7; N, 2.5%); NMR spectrum no. 29; Mass spectrum no. 29; IR spectrum no. 29.

N,N-dimethylethylamine and HFP. N,N-dimethylethylamine (17.0 g, 0.23 mol) and hexafluoropropene (11.7 g, 78.0 mmol), after column chromatography on silica gel using *n*-hexane and then CH₂Cl₂ as eluants, gave an isomer mixture (ratio 1:1) of *(2,2,3,4,4,4-hexafluorobutyl)(2,2,3,4,4,4-hexafluoro-1-methylbutyl)methylamine* (**107**) as a colourless oil (11.7 g, 16%); bp 198.2°C; (Found: C, 32.3; H, 3.0; N, 3.9. C₁₀H₁₄F₁₂N requires C, 32.2; H, 3.0; N, 3.8%); NMR spectrum no. 30; Mass spectrum no. 30; IR spectrum no. 30.

N,N-diisopropylethylamine and HFP. N,N-diisopropylethylamine (17.0 g, 0.13 mol) and hexafluoropropene (8.2 g, 54.7 mmol), after column chromatography on silica gel using *n*-hexane as eluant, gave an isomer mixture (ratio 1.0:0.2) of *bis(methylethyl)(2,2,3,4,4,4-hexafluoro-1-methylbutyl)amine* (**108**) as a pale yellow liquid (1.2 g, 3%); bp 141°C; (Found: C, 47.1; H, 6.9; N, 5.1. C₁₁H₁₉F₆N requires C, 47.3; H, 6.9; N, 5.0%); NMR spectrum no. 31; Mass spectrum no. 31; IR spectrum no. 31 and after column chromatography on silica gel using CH₂Cl₂ as eluant, *(2,2,3,4,4,4-hexafluoro-1,1-dimethylbutyl)(2,2,3,4,4,4-hexafluoro-1-methylbutyl)(methylethyl)amine* (**109**) as a mixture of diastereoisomers (ratio 1.0:0.3) and a yellow

oil (6.1 g, 11%); bp 201.3°C; (Found: C, 39.0; H, 4.5; N, 3.4. C₁₄H₁₉F₁₂N requires C, 39.2; H, 4.5; N, 3.3%); NMR spectrum no. 32; Mass spectrum no. 32; IR spectrum no. 32.

N-methyl pyrrolidine and HFP. N-methyl pyrrolidine (17.0 g, 0.17 mol) and hexafluoropropene (10.0 g, 66.7 mmol), after column chromatography on silica gel using *n*-hexane and then CH₂Cl₂ as eluants, gave an isomer mixture (ratio 1.0:0.4) of 2-(1,1,2,3,3,3-hexafluoropropyl)-1-methylpyrrolidine (**110**) as a yellow pale viscous liquid (12.7 g, 27%); bp 138.6°C; (Found: C, 40.6; H, 4.5; N, 5.7. C₈H₁₁F₆N requires C, 40.9; H, 4.7; N, 6.0%); NMR spectrum no. 33; Mass spectrum no. 33; IR spectrum no. 33.

N-methyl piperidine and HFP. N-methyl piperidine (12.2 g, 0.12 mol) and hexafluoropropene (11.7 g, 78.0 mmol), after distillation at reduced pressure, gave a diastereoisomer mixture of 1-(2,2,3,4,4,4-hexafluorobutyl)-2-(1,1,2,3,3,3-hexafluoropropyl)piperidine (**111**) as a yellow liquid (9.2 g, 19%); bp 60°C (8 mBar); (Found: C, 36.1; H, 3.2; N, 3.5. C₁₂H₁₃F₁₂N requires C, 36.1; H, 3.3; N, 3.5%); NMR spectrum no. 34; Mass spectrum no. 34; IR spectrum no. 34.

N-methyl piperidine and HFP (2 weeks). N-methyl piperidine (12.2 g, 0.12 mol) and hexafluoropropene (11.7 g, 78.0 mmol), after distillation at reduced pressure, gave a diastereoisomer mixture of 1-(2,2,3,4,4,4-hexafluorobutyl)-2-(1,1,2,3,3,3-hexafluoropropyl)piperidine (**111**) as a yellow liquid (11.7 g, 24%); spectral and physical data are as above.

N-ethyl piperidine and HFP. N-ethyl piperidine (16.3 g, 0.14 mol) and hexafluoropropene (8.7 g, 54.7 mmol), after distillation at reduced pressure, gave 1-(2,2,3,4,4,4-hexafluoro-1-methylbutyl)-2-(1,1,2,3,3,3-hexafluoropropyl)piperidine (**112**) as an orange liquid (6.7 g, 12%); bp 58-60°C (13 mBar); (Found: C, 38.0; H, 3.8; N, 3.7. C₁₃H₁₅F₁₂N requires: C, 37.8; H, 3.6; N, 3.4%); NMR spectrum no. 35; Mass spectrum no. 35; IR spectrum no. 35.

N-ethyl piperidine and HFP (2 weeks). N-ethyl piperidine (17.0 g, 0.15 mol) and hexafluoropropene (2.6 g, 17.3 mmol), after distillation at reduced pressure, gave 1-(2,2,3,4,4,4-hexafluoro-1-methylbutyl)-2-(1,1,2,3,3,3-hexafluoropropyl)piperidine (**112**) (10.5 g, 18%); spectral and physical data are as above.

4-methyl morpholine and HFP. 4-methyl morpholine (17.0 g, 0.17 mol) and hexafluoropropene (10.1 g, 67.3 mmol), after distillation at reduced pressure, gave an

isomer mixture (ratio : 0.4:1.0) of 4-(2,2,3,4,4,4-hexafluorobutyl)morpholine (**113**) a colourless viscous liquid (0.7 g, 2%); bp 54°C (3.6 mBar); (Found: C, 38.0; H, 4.3; N, 5.3. C₈H₁₁F₆NO requires : C, 38.3; H, 4.4; N, 5.6%); NMR spectrum no. 36; Mass spectrum no. 36; IR spectrum no. 36 and 4-(2,2,3,4,4,4-hexafluorobutyl)-3-(1,1,2,3,3,3-hexafluoropropyl)morpholine (**114**) as a mixture of diastereoisomers (ratio 1:1) and a yellow oil (7.4 g, 11%); bp 84-86°C (3.6 mBar); (Found: C, 32.7; H, 2.7; N, 3.4. C₁₁H₁₁F₁₂NO requires C, 32.9; H, 2.8; N, 3.5%); NMR spectrum no. 37; Mass spectrum no. 37; IR spectrum no. 37.

4-ethyl morpholine and HFP. 4-ethyl morpholine (17.0 g, 0.14 mol) and hexafluoropropene (8.9 g, 59.3 mmol), after distillation at reduced pressure, gave a diastereoisomer mixture (ratio 1.7:1.0) of 4-(2,2,3,4,4,4-hexafluoro-1-methylbutyl)morpholine (**115**) as a colourless viscous liquid (0.4 g, 1%); bp 40°C (1.5 mBar); NMR spectrum no. 38; Mass spectrum no. 38; IR spectrum no. 38 and 4-(2,2,3,4,4,4-hexafluoro-1-methylbutyl)-3-(1,1,2,3,3,3-hexafluoropropyl)morpholine (**116**) as a mixture of diastereoisomers and a yellow oil (3.1 g, 5%); bp 64°C (1.5 mBar); (Found: C, 34.7; H, 3.0; N, 3.4. C₁₂H₁₃F₁₂NO requires C, 34.7; H, 3.2; N, 3.4%); NMR spectrum no. 39; Mass spectrum no. 39; IR spectrum no. 39.

1,4-dimethyl piperazine and HFP. 1,4-dimethyl piperazine (17.0 g, 0.15 mol) and hexafluoropropene (7.5 g, 50.0 mmol), after column chromatography on silica gel using *n*-hexane:CH₂Cl₂ (1:1) and then CH₂Cl₂ as eluants, gave an isomer mixture (ratio 1.0:0.8:0.8:0.8) of 2,6-bis(1,1,2,3,3,3-hexafluoropropyl)-1,4-dimethylpiperazine (**117**) as a yellow pale oil (5.2 g, 8%); bp 243.6°C; (Found: C, 34.5; H, 3.1; N, 6.5. C₁₂H₁₄F₁₂N₂ requires C, 34.8; H, 3.4; N, 6.8%); NMR spectrum no. 40; Mass spectrum no. 40; IR spectrum no. 40 and after column chromatography on silica gel using CH₂Cl₂ as eluant, 1,4-dimethyl-2,3,5-tris(1,1,2,3,3,3-hexafluoropropyl)piperazine (**118**) as a mixture of diastereoisomers (ratio 0.3:1.0) and a brown oil (5.3 g, 6%); bp 214.4°C; (Found: C, 31.7; H, 2.3; N, 4.9. C₁₅H₁₄F₁₈N requires C, 31.9; H, 2.5; N, 5.0%); NMR spectrum no. 41; Mass spectrum no. 41; IR spectrum no. 41.

N,N,N',N'-tetramethyl-1,4-butanediamine and HFP. N,N,N',N'-tetramethyl-1,4-butanediamine (17.0 g, 0.13 mol) and hexafluoropropene (5.9 g, 39.3 mmol) gave a brown liquid crude product mixture (20.2 g) containing N,N,N',N'-tetramethyl-1,4-butanediamine and hexafluoropropene dimer (bp 50°C).

1-diethylamino-2-propanol and HFP. 1-diethylamino-2-propanol (17.0 g, 0.13 mol) and hexafluoropropene (8.3 g, 55.3 mmol) gave a yellow liquid crude product mixture (22.3 g) containing 1-diethylamino-2-propanol and hexafluoropropene dimer.

3-diethylamino-1-propanol and HFP. 1-diethylamino-2-propanol (17.0 g, 0.13 mol) and hexafluoropropene (8.3 g, 55.3 mmol) gave a yellow liquid crude product mixture (23.4 g) containing 1-diethylamino-2-propanol and hexafluoropropene dimer.

(diethylamino)acetaldehyde diethyl acetal and HFP. (diethylamino)acetaldehyde diethyl acetal (17.0 g, 93.0 mmol) and hexafluoropropene (4.5 g, 30 mmol) gave a brown yellow liquid as crude product mixture (16.4 g) containing (diethylamino)acetaldehyde diethyl acetal and hexafluoropropene dimer.

1,4-diazabicyclo[2,2,2]octane and HFP. 1,4-diazabicyclo[2,2,2]octane (17.0 g, 0.15 mol), hexafluoropropene (8.9 g, 59.3 mmol) and acetone (20 ml) gave a mixture of a brown liquid and a black solid as crude product mixture (17.8 g) containing 1,4-diazabicyclo[2,2,2]octane and hexafluoropropene dimer.

9.2. Influence of various factors over the free radical process :

General procedure for peroxide initiated reactions described in Chapter 6.

4-ethyl morpholine and HFP. An autoclave was charged with 4-ethyl morpholine (17.0 g, 0.15 mol), hexafluoropropene (7.6 g, 50.7 mmol) and rocked for 24 hours at 80°C. On completion a brown liquid as crude product mixture (12.3 g) containing the 4-ethyl morpholine and hexafluoropropene dimer was obtained.

4-ethyl morpholine and HFP (peroxide initiation, temperature 80°C). 4-ethyl morpholine (17.0 g, 0.15 mol), dibenzoyl peroxide (1.2 g, 5.0 mmol) and hexafluoropropene (7.6 g, 50 mmol) gave a dark liquid as crude product mixture (21.6 g) containing the nucleophilic substitution product, hexafluoropropene dimer and benzoic acid. Neutralisation with a saturated solution of NaHCO₃ then extraction with CH₂Cl₂ gave the nucleophilic product and the benzoic acid. Further treatment with the saturated solution of NaHCO₃ did not allow separation of these 2 products.

9.3. Dehydrofluorination reactions :

General procedure for dehydrofluorination reactions described in Chapter 7.

1-(2,2,3,4,4,4-hexafluoro-1-methylbutyl)-2-(1,1,2,3,3,3-hexafluoropropyl) piperidine (112). Dry sodium *tert*-butoxide (3.7 g, 38.5 mmol) in isopropyl ether (20 ml) was cooled down to -80°C. 1-(2,2,3,4,4,4-hexafluoro-1-methylbutyl)-2-

(1,1,2,3,3,3-hexafluoropropyl)piperidine (**112**) (4.0 g, 9.7 mmol) gave, after fractional distillation under reduced pressure, 1-((2Z)-2,3,4,4,4-pentafluoro-1-methylbut-2-enyl)-2-((1Z)-1,2,3,3,3-pentafluoroprop-1-enyl)piperidine (**119**) (1.1 g, 30%) as a colourless liquid; bp 40°C (<0.1mmHg); (Found: C, 41.6; H, 3.5; N, 3.8. C₁₃H₁₃F₁₀N requires C, 41.8; H, 3.5; N, 3.8%); NMR spectrum 42; Mass spectrum 42; IR spectrum 42.

1-(2,2,3,4,4,4-hexafluorobutyl)-2-(1,1,2,3,3,3-hexafluoropropyl)piperidine (111). Dry sodium *tert*-butoxide (3.7 g, 38.5 mmol) in isopropyl ether (20 ml) was cooled down to -80°C. 1-(2,2,3,4,4,4-hexafluorobutyl)-2-(1,1,2,3,3,3-hexafluoropropyl)piperidine (**111**) (4.0 g, 10.0 mmol) was added and the mixture was stirred for 24 hours. After work up, ¹⁹F NMR showed a disappearance of the AB system, but after distillation, the product was not obtained, a tar, due to the amine decomposition, remained in the round bottom flask.

On the second attempt, a column chromatography using CH₂Cl₂ as eluant was tried but the product remained on the column.

Appendix A : NMR Spectra

- No. 1 1-adamantanyl-1,1,2,3,3,3-hexafluoropropane (36)
- No. 2 1,1,2,3,3,3-hexafluoro-1-[3-(1,1,2,3,3,3-hexafluoropropyl)adamantanyl]propane (39)
- No. 3 1-[3,5-bis(1,1,2,3,3,3-hexafluoropropyl)adamantanyl]-1,1,2,3,3,3-hexafluoropropane (41)
- No. 4 1,1,2,3,3,3-hexafluoro-1-[3,5,8-tris(1,1,2,3,3,3-hexafluoropropyl)adamantanyl]propane (42)
- No. 5 1-(1,1,2,3,3,3-hexafluoropropyl)cyclopentane (43)
- No. 6 1,1,2,3,3,3-hexafluoro-1-[3-(1,1,2,3,3,3-hexafluoropropyl)cyclopentyl]propane (44b)
- No. 7 1-(1,1,2,3,3,3-hexafluoropropyl)cyclopentanol (46)
- No. 8 1-(1,1,2,3,3,3-hexafluoropropyl)cyclopentene (49)
- No. 9 (1*E*)-1-adamantanyl-1,2,3,3,3-pentafluoroprop-1-ene (53a) and (1*Z*)-1-adamantanyl-1,2,3,3,3-pentafluoroprop-1-ene (53b)
- No. 10 1-(*E*-pentafluoroprop-2-enyl)cyclopentane (54a) and 1-(*Z*-pentafluoroprop-2-enyl)cyclopentane (54b)
- No. 11 1-[(1*R*,3*R*)-3-((1*Z*)-1,2,3,3,3-pentafluoroprop-1-enyl)cyclopentyl](1*Z*)-1,2,3,3,3-pentafluoroprop-1-ene (55) and 1-[(3*S*,1*R*)-3-((1*Z*)-1,2,3,3,3-pentafluoroprop-1-enyl)cyclopentyl](1*Z*)-1,2,3,3,3-pentafluoroprop-1-ene (56)
- No. 12 1-(1,2,3,3,3-pentafluoro-*Z*-prop-1-enyl)cyclopentene (57b)
- No. 13 (1*E*)-1-cyclopentyl-1-ethoxy-2,3,3,3-tetrafluoroprop-1-ene (75a) and (1*Z*)-1-cyclopentyl-1-ethoxy-2,3,3,3-tetrafluoroprop-1-ene (75b)
- No. 14 1-cyclopentyl-1-ethoxy-1,2,3,3,3-pentafluoropropane (76)
- No. 15 1-cyclopentyl-2,3,3,3-tetrafluoropropan-1-one (77)
- No. 16 1-cyclopentyl-1,2,3,3,3-pentafluoro-1-methoxypropane (78)
- No. 17 1-cyclopentyl-2-fluoro-2-trifluoromethyl-4-penten-1-one (79)
- No. 18 1-cyclopentyl-2-fluoro-2-trifluoromethyl-3,4-pentadien-1-one (85)
- No. 19 1-cyclopentyl-2-fluoro-3-methyl-2-trifluoromethyl-4-penten-1-one (86)
- No. 20 cyclopentane carboxylic acid (88)
- No. 21 1-cyclopentyl-3-ethenyl-2-fluoro-3,7-dimethyl-2-trifluoromethyl-6-octen-1-one (92)
- No. 22 1-cyclopent-1-enyl-2-fluoro-3,7-dimethyl-2-(trifluoromethyl)-3-vinyloct-6-en-1-one (93)

- No. 23 Z-(1-cyclopentyl-2,3,3,3-tetrafluoro-1-propenoxy)methylbenzene (94)
- No. 24 Z-(1-butyl-2,3,3,3-tetrafluoro-1-propenyl)cyclopentane (99)
- No. 25 Z-(1-phenyl-2,3,3,3-tetrafluoro-1-propenyl)cyclopentane (101)
- No. 26 1,2-dibromo-1-cyclopentyl-1,2,3,3,3-pentafluoropropane (103)
- No. 27 diethyl(2,2,3,4,4,4-hexafluoro-1-methylbutyl)amine (104)
- No. 28 bis(2,2,3,4,4,4-hexafluoro-1-methylbutyl)ethylamine (105)
- No. 29 tris(2,2,3,4,4,4-hexafluoro-1-methylbutyl)amine (106)
- No. 30 (2,2,3,4,4,4-hexafluorobutyl)(2,2,3,4,4,4-hexafluoro-1-methylbutyl)methylamine (107)
- No. 31 bis(methylethyl)(2,2,3,4,4,4-hexafluoro-1-methylbutyl)amine (108)
- No. 32 (2,2,3,4,4,4-hexafluoro-1,1-dimethylbutyl)(2,2,3,4,4,4-hexafluoro-1-methylbutyl)(methylethyl)amine (109)
- No. 33 2-(1,1,2,3,3,3-hexafluoropropyl)-1-methylpyrrolidine (110)
- No. 34 1-(2,2,3,4,4,4-hexafluorobutyl)-2-(1,1,2,3,3,3-hexafluoropropyl)piperidine (111)
- No. 35 1-(2,2,3,4,4,4-hexafluoro-1-methylbutyl)-2-(1,1,2,3,3,3-hexafluoropropyl)piperidine (112)
- No. 36 4-(2,2,3,4,4,4-hexafluorobutyl)morpholine (113)
- No. 37 4-(2,2,3,4,4,4-hexafluorobutyl)-3-(1,1,2,3,3,3-hexafluoropropyl)morpholine (114)
- No. 38 4-(2,2,3,4,4,4-hexafluoro-1-methylbutyl)morpholine (115)
- No. 39 4-(2,2,3,4,4,4-hexafluoro-1-methylbutyl)-3-(1,1,2,3,3,3-hexafluoropropyl)morpholine (116)
- No. 40 2,6-bis(1,1,2,3,3,3-hexafluoropropyl)-1,4-dimethylpiperazine (117)
- No. 41 1,4-dimethyl-2,3,5-tris(1,1,2,3,3,3-hexafluoropropyl)piperazine (118)
- No. 42 1-((2Z)-2,3,4,4,4-pentafluoro-1-methylbut-2-enyl)-2-((1Z)-1,2,3,3,3-pentafluoroprop-1-enyl)piperidine (119)

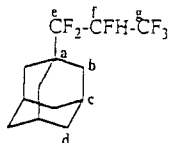

NMR	Chemical Shift (ppm)	Multiplicity	Coupling Constant (Hz)	Relative Intensity	Assignment
^1H	1.8	m		12	b, d
	2.1	s (br)		3	c
	4.9	d	$^2J_{\text{FH}}$ 44.0	1	f
		d	$^3J_{\text{FH}}$ 19.8		
		q	$^3J_{\text{FH}}$ 6.0		
^{19}F	-74.3	m		3	g
	-122.6	syst AB dm	$^2J_{\text{FF}}$ 273.9	1	e
	-130.0	syst AB dm	$^2J_{\text{FF}}$ 273.9	1	e
	-206.9	d	$^2J_{\text{FH}}$ 43.8	1	f
		q	$^3J_{\text{FF}}$ 7.9		
^{13}C	27.7	s			c
	34.8	s			b
	36.6	s			d
	40.2	t	$^2J_{\text{CF}}$ 21.3		a
	83.8	d	$^1J_{\text{CF}}$ 197.4		f
		q	$^2J_{\text{CF}}$ 33.6		
		t	$^2J_{\text{CF}}$ 8.0		
	119.6	d	$^1J_{\text{CF}}$ 260.2		e
		d	$^1J_{\text{CF}}$ 246.8		
		d	$^2J_{\text{CF}}$ 21.4		
	121.4	q	$^1J_{\text{CF}}$ 283.1		g
d		$^2J_{\text{CF}}$ 25.9			

No. 2 1,1,2,3,3,3-hexafluoro-1-[3-(1,1,2,3,3,3-hexafluoropropyl)adamantanyl]propane (39)

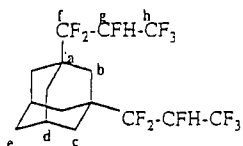

NMR	Chemical Shift (ppm)	Multiplicity	Coupling Constant (Hz)	Relative Intensity	Assignment
^1H	1.8	m		12	b
	2.3	s (br)		2	d
	4.9	d	$^2J_{\text{FH}}$ 44.0	2	g
		d	$^3J_{\text{FH}}$ 20.0		
		q	$^3J_{\text{FH}}$ 6.0		
^{19}F	-74.2	m		6	h
	-121.7	syst AB dm	$^2J_{\text{FF}}$ 274.7	2	f
	-129.4	syst AB dm	$^2J_{\text{FF}}$ 274.7	2	f
	-207.1	d	$^2J_{\text{FH}}$ 34.6	2	g
		q	$^3J_{\text{FF}}$ 8.7		
^{13}C	27.0	s			d
	31.9	m			b
	35.3	s			c
	36.6	s			e
	40.7	t	$^2J_{\text{CF}}$ 22.1		a
	83.9	d	$^1J_{\text{CF}}$ 198.1		g
		q	$^2J_{\text{CF}}$ 33.6		
		t	$^2J_{\text{CF}}$ 9.2		
	119.2	d	$^1J_{\text{CF}}$ 261.7		f
		d	$^1J_{\text{CF}}$ 245.7		
		d	$^2J_{\text{CF}}$ 22.5		
121.2	q	$^1J_{\text{CF}}$ 283.4		h	
	d	$^2J_{\text{CF}}$ 26.3			

No. 3 1-[3,5-bis(1,1,2,3,3,3-hexafluoropropyl)adamantany]adamantany]propane (41)

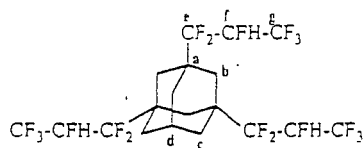

NMR	Chemical Shift (ppm)	Multiplicity	Coupling Constant (Hz)	Relative Intensity	Assignment
^1H	1.8	m		6	b
	1.9	m		6	c
	2.5	s (br)		1	d
	4.9	m		3	f
^{19}F	-74.1	s		9	g
	-120.6	syst AB dm	$^2J_{\text{FF}} 276.8$	3	e
	-128.6	syst AB dm	$^2J_{\text{FF}} 276.8$	3	e
	-207.2	s (br)		3	h
^{13}C	26.6	s			d
	31.5	s			c
	33.2	s			b
	41.2	t	$^2J_{\text{CF}} 20.9$		a
	84.1	d	$^1J_{\text{CF}} 197.8$		f
		m			
	118.8	d	$^1J_{\text{CF}} 262.0$		e
		d	$^2J_{\text{CF}} 247.9$		
		d	$^2J_{\text{CF}} 23.0$		
	120.9	q	$^1J_{\text{CF}} 283.3$		g
	d	$^2J_{\text{CF}} 26.5$			

No. 4 1,1,2,3,3,3-hexafluoro-1-[3,5,8-tris(1,1,2,3,3,3-hexafluoropropyl)adamantany]propane (42)

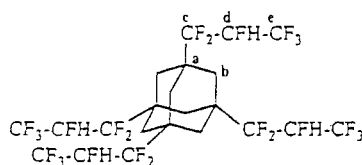

NMR	Chemical Shift (ppm)	Multiplicity	Coupling Constant (Hz)	Relative Intensity	Assignment
^1H	2.1	m		12	b
	6.0	d	$^2J_{\text{FH}} 42.0$	4	d
		d	$^3J_{\text{FH}} 20.5$		
		q	$^3J_{\text{FH}} 6.5$		
^{19}F	-75.0	s		12	e
	-122.1	syst AB dm	$^2J_{\text{FF}} 275.3$	4	c
	-128.0	syst AB dm	$^2J_{\text{FF}} 275.3$	4	c
	-207.8	d	$^2J_{\text{FH}} 32.0$	4	d
	q	$^3J_{\text{FF}} 7.9$			
^{13}C	30.9	s			b
	42.3	t	$^2J_{\text{CF}} 22.4$		a
	84.0	d	$^1J_{\text{CF}} 198.1$		d
		q	$^2J_{\text{CF}} 33.6$		
		t	$^2J_{\text{CF}} 9.2$		
	119.8	d	$^1J_{\text{CF}} 261.1$		c
		d	$^2J_{\text{CF}} 248.7$		
		d	$^2J_{\text{CF}} 21.7$		
	122.2	q	$^1J_{\text{CF}} 282.6$		e
		d	$^2J_{\text{CF}} 25.9$		

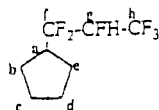

NMR	Chemical Shift (ppm)	Multiplicity	Coupling Constant (Hz)	Relative Intensity	Assignment
^1H	1.6	m		2	c, d ax or eq
	1.7	m		4	c, d ax or eq
	1.9	m		2	b, e ax or eq
	2.5	m		1	a
	4.8	d	$^2J_{\text{FH}} 44.0$	1	g
			$^3J_{\text{FH}} 15.2$		
			$^3J_{\text{FH}} 6.0$ $^3J_{\text{FH}} 5.2$		
^{19}F	-71.8	s		3	h
	-111.5	syst AB dm	$^2J_{\text{FF}} 264.6$	1	f
	-115.8	syst AB dm	$^2J_{\text{FF}} 264.6$	1	f
	-208.5	s		1	g
^{13}C	25.1	d	$^3J_{\text{CF}} 4.2$		b or e
		d	$^3J_{\text{CF}} 2.2$		
	25.6	s			c or d
	25.8	s			c or d
	26.1	d	$^3J_{\text{CF}} 6.1$		b or e
		m			
	42.4	t	$^2J_{\text{CF}} 22.1$		a
	85.9	d	$^1J_{\text{CF}} 196.7$		g
		q	$^2J_{\text{CF}} 37.8$		
		t	$^2J_{\text{CF}} 32.0$		
	120.1	d	$^1J_{\text{CF}} 260.2$		f
		d	$^1J_{\text{CF}} 246.8$		
	d	$^2J_{\text{CF}} 24.0$			
120.8	q	$^1J_{\text{CF}} 282.3$		h	
	d	$^2J_{\text{CF}} 26.0$			

No. 6 1,1,2,3,3-hexafluoro-1-[3-(1,1,2,3,3,3-hexafluoropropyl)cyclopentyl]propane (44b)

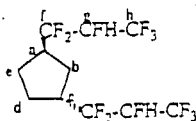

NMR	Chemical Shift (ppm)	Multiplicity	Coupling Constant (Hz)	Relative Intensity	Assignment
^1H	1.8	m		2	CH_2
	1.9	m		2	CH_2
	2.0	m		2	CH_2
	2.7	s		2	2 CH
	4.8	d	$^2J_{\text{FH}} 31.2$		g
^{19}F	-73.0	s		6	h
	-115.0	m		4	f
	-209.3	s		2	g
^{13}C	24.0-26.4	m			3 CH_2
	42.1	m			CH
	42.3	m			CH
	85.8	d	$^1J_{\text{CF}} 195.9$		g
		m			
	119.3	t	$^1J_{\text{CF}} 254.1$		f
		m			
	120.8	q	$^1J_{\text{CF}} 282.7$		h
	d	$^2J_{\text{CF}} 27.0$			

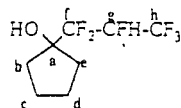

NMR	Chemical Shift (ppm)	Multiplicity	Coupling Constant (Hz)	Relative Intensity	Assignment
^1H	1.6-2.1	m		8	b, c, d, e
	1.9	s		1	OH
	5.2	d	$^2J_{\text{FH}}$ 43.4	1	g
		d	$^3J_{\text{FH}}$ 19.2		
		q	$^3J_{\text{FH}}$ 6.4		
^{19}F	-74.5	m		3	h
	-121.4	syst AB d	$^2J_{\text{FF}}$ 274.6	1	f
		d	$^3J_{\text{FF}}$ 13.6		
		q	$^3J_{\text{FH}}$ 6.4		
	-127.2	syst AB d	$^2J_{\text{FF}}$ 274.6	1	f
		hept	$^3J_{\text{FH}}$ 10.2		
	-210.0	d	$^2J_{\text{FH}}$ 43.3	1	g
		m			
^{13}C	23.3	s			c or d
	24.5	d	$^4J_{\text{CF}}$ 1.9		c or d
	34.3	q	$^3J_{\text{CF}}$ $^4J_{\text{CF}}$	4.2	b or e
	35.4	d	$^4J_{\text{CF}}$ 6.4		b or e
	83.4	d	$^1J_{\text{CF}}$ 194.8		g
		d	$^2J_{\text{CF}}$ 39.1		
		d	$^2J_{\text{CF}}$ 34.3		
		q	$^2J_{\text{CF}}$ 24.4		
	83.6	m			a
	118.6	d	$^1J_{\text{CF}}$ 262.0		f
		d	$^1J_{\text{CF}}$ 247.2		
		d	$^2J_{\text{CF}}$ 23.6		
d		$^1J_{\text{CF}}$ 282.7			
d		$^2J_{\text{CF}}$ 25.9			

No. 8 1-(1,1,2,3,3,3-hexafluoropropyl)cyclopentene (49)

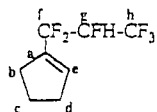

NMR	Chemical Shift (ppm)	Multiplicity	Coupling Constant (Hz)	Relative Intensity	Assignment
^1H	2.0	quint	$^3J_{\text{HH}}$ 7.6	2	c
	2.5	m		4	b, d
	4.8	d	$^2J_{\text{FH}}$ 43.9	1	g
		d	$^3J_{\text{FH}}$ 11.5		
		d	$^3J_{\text{FH}}$ 6.0		
		q	$^3J_{\text{FH}}$ 5.8		
6.2	m			1	e
^{19}F	-74.8	m		3	h
	-104.5	syst AB dm	$^2J_{\text{FF}}$ 272.9	1	f
	-109.7	syst AB dm	$^2J_{\text{FF}}$ 272.9	1	f
	-210.1	d	$^2J_{\text{FH}}$ 43.7	1	g
sext		$^3J_{\text{FF}}$ 11.7			
^{13}C	23.2	s			c
	30.8	q	$^3J_{\text{CF}}$ $^4J_{\text{CF}}$	2.2	b
	32.7	t	$^4J_{\text{CF}}$ 1.3		d
	86.2	d	$^1J_{\text{CF}}$ 198.1		g
		sext	$^2J_{\text{CF}}$ 34.0		
	115.5	t	$^1J_{\text{CF}}$ 244.5		f
		d	$^2J_{\text{CF}}$ 22.9		
	120.6	q	$^1J_{\text{CF}}$ 283.4		h
		d	$^2J_{\text{CF}}$ 25.7		
	135.0	t	$^2J_{\text{CF}}$ 24.0		a
135.8	t	$^4J_{\text{CF}}$ 7.2		e	
	d	$^5J_{\text{CF}}$ 3.1			

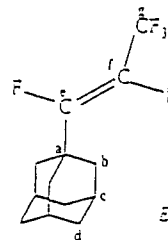

NMR	Chemical Shift (ppm)	Multiplicity	Coupling Constant (Hz)	Relative Intensity	Assignment
^1H	1.74	m		6	b
	1.96	d	$^3J_{\text{HH}}$ 1.2	6	d
	2.06	s (br)		3	c
^{19}F	-67.6	d	$^4J_{\text{FF}}$ 22.6	3	g
		d	$^3J_{\text{FF}}$ 10.2		
	-149.3	d	$^3J_{\text{FF}}$ 132.1	1	CF (e)
		q	$^4J_{\text{FF}}$ 23.3		
	-175.6	d	$^3J_{\text{FF}}$ 122.7	1	CF (f)
		q	$^3J_{\text{FF}}$ 10.5		
^{13}C	27.7	s			c
	36.3	s			b
	37.8	t	$^5J_{\text{CF}}$ 3.8		d
	39.4	s			a
	119.4	d	$^1J_{\text{CF}}$ 272.3		f
		d	$^2J_{\text{CF}}$ 36.2		
		q	$^2J_{\text{CF}}$ 3.4		
	137.7	d	$^1J_{\text{CF}}$ 248.6		e
		d	$^2J_{\text{CF}}$ 129.3		
		d	$^3J_{\text{CF}}$ 29.1		
	160.4	q	$^1J_{\text{CF}}$ 220.1		g
		d	$^2J_{\text{CF}}$ 35.7		
	d	$^3J_{\text{CF}}$ 2.7			

No. 9 (1Z)-1-(adamantanylidene)-1,2,3,3,3-pentafluoroprop-1-ene (53b)

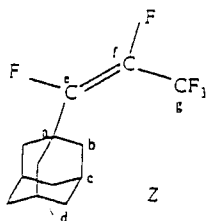

NMR	Chemical Shift (ppm)	Multiplicity	Coupling Constant (Hz)	Relative Intensity	Assignment
^1H	1.7	m		6	b
	1.9	d	$^3J_{\text{HH}}$ 2.8	6	d
	2.1	s (br)		3	c
^{19}F	-60.2	t	$^3J_{\text{FF}}$ $^4J_{\text{FF}}$ 8.7	3	g
	-125.2	q	$^4J_{\text{FF}}$ 8.7	1	CF (e)
	-154.8	q	$^3J_{\text{FF}}$ 10.2	1	CF (f)
^{13}C	27.8	s			c
	36.2	s			b
	37.9	t	$^5J_{\text{CF}}$ $^6J_{\text{CF}}$ 2.3		d
	39.2	s			a
	120.0	d	$^1J_{\text{CF}}$ 270.2		f
		d	$^2J_{\text{CF}}$ 35.4		
		q	$^2J_{\text{CF}}$ 9.2		
	137.7	d	$^1J_{\text{CF}}$ 248.7		e
		d	$^2J_{\text{CF}}$ 43.1		
		q	$^3J_{\text{CF}}$ 29.0		
	160.7	q	$^1J_{\text{CF}}$ 263.8		g
		d	$^2J_{\text{CF}}$ 13.0		
	d	$^3J_{\text{CF}}$ 4.6			

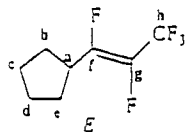

NMR	Chemical Shift (ppm)	Multiplicity	Coupling Constant (Hz)	Relative Intensity	Assignment
^1H	1.6	m		2	b, e ax or eq
	1.7	m		4	b, e ax or eq
	1.9	m		2	c, d ax or eq
	3.0	m		1	c, d ax or eq a
^{19}F	-67.7	d	$^4J_{\text{FF}}$ 22.0	3	h
		d	$^3J_{\text{FF}}$ 11.7		
	-149.4	d	$^3J_{\text{FF}}$ 130.9	1	CF (f)
		d	$^3J_{\text{FH}}$ 32.2		
		q	$^4J_{\text{FF}}$ 21.8		
	-175.4	d	$^3J_{\text{FF}}$ 131.0	1	CF (g)
		d	$^3J_{\text{FF}}$ 11.5		
		d	$^4J_{\text{FH}}$ 5.2		
^{13}C	26.3	s			c
	29.1	s			b
	36.7	m			a
	119.3	q	$^1J_{\text{CF}}$ 271.4		h
		d	$^2J_{\text{CF}}$ 32.0		
		d	$^3J_{\text{CF}}$ 4.2		

No. 10 1-(Z-pentafluoroprop-2-enyl)cyclopentane (54b)

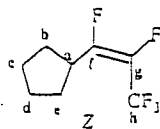

NMR	Chemical Shift (ppm)	Multiplicity	Coupling Constant (Hz)	Relative Intensity	Assignment
^1H	1.6	m		2	b, e ax or eq
	1.7	m		4	b, e ax or eq
	1.9	m		2	c, d ax or eq
	3.0	d	$^3J_{\text{FH}}$ 35.2		c, d ax or eq
		m			a
^{19}F	-63.6	d	$^3J_{\text{FF}}$ 11.7	3	h
		d	$^4J_{\text{FF}}$ 9.0		
	-132.9	d	$^3J_{\text{FH}}$ 34.7	1	CF (f)
		d	$^3J_{\text{FF}}$ 5.5		
		q	$^4J_{\text{FF}}$ 9.2		
	-159.3	q	$^3J_{\text{FF}}$ 12.0	1	CF (g)
		d	$^3J_{\text{FF}}$ 5.5		
		d			
^{13}C	26.3	s			c
	29.6	s			b
	36.6	d	$^2J_{\text{CF}}$ 20.9		a
		m			
	120.2	q	$^1J_{\text{CF}}$ 270.0		h
		d	$^2J_{\text{CF}}$ 34.7		
		d	$^3J_{\text{CF}}$ 9.6		
	134.5	d	$^1J_{\text{CF}}$ 249.5		g
		d	$^2J_{\text{CF}}$ 40.2		
		q	$^2J_{\text{CF}}$ 24.2		
	155.3	d	$^1J_{\text{CF}}$ 262.3		f
	d	$^2J_{\text{CF}}$ 6.6			
	q	$^3J_{\text{CF}}$ 3.4			

1,2,3,3,3-pentafluoroprop-1-ene (55) and 1-((3S,1R)-3-((1Z)-1,2,3,3-pentafluoroprop-1-enyl)cyclopentyl)(1Z)-1,2,3,3-pentafluoroprop-1-ene (56)

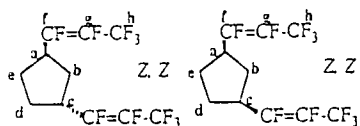

NMR	Chemical Shift (ppm)	Multiplicity	Coupling Constant (Hz)	Relative Intensity	Assignment
¹ H	1.8-1.9	m		4	e, d _{ax} or eq
	1.9-2.0	m		4	b
	2.0-2.1	m		4	e, d _{ax} or eq
	3.2	m		2	a, c
	3.3	m		2	a, c
¹⁹ F	-66.2	d	³ J _{FF} 11.5	12	h
		d	⁴ J _{FF} 8.7		
	-134.7	d	³ J _{FF} 4.5	4	CF (f)
		q	⁴ J _{FF} 8.7		
	-157.8	q	³ J _{FF} 11.7	4	CF (g)
		d	³ J _{FF} 4.5		
¹³ C	28.6	s			b
	30.1	s			b
	31.7	s			d, e
	32.3	s			d, e
	36.5	d	² J _{CF} 22.1		a, c
		m			
	36.9	d	² J _{CF} 22.5		a, c
		m			
	120.0	q	¹ J _{CF} 270.4		h
		d	² J _{CF} 34.7		
	120.1	q	¹ J _{CF} 262.1		h
	d	² J _{CF} 34.7			
135.2	d	¹ J _{CF} 232.2		g	
	m				
153.6	d	¹ J _{CF} 264.0		f	
	d	² J _{CF} 11.1			
	q	³ J _{CF} 3.5			

1-(1,2,3,3,3-pentafluoro-Z-prop-1-enyl)cyclopentene (57b)

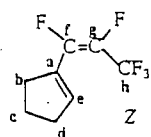

NMR	Chemical Shift (ppm)	Multiplicity	Coupling Constant (Hz)	Relative Intensity	Assignment
¹ H	2.0	quint	³ J _{HH} 7.2	2	c
	2.5	m		2	d
	2.6	m		2	b
	6.3	d	⁴ J _{FH} 6.8	1	e
		t	³ J _{HH} 2.4		
		t	⁴ J _{HH} 0.2		
¹⁹ F	-64.6	d	³ J _{FF} 11.7	3	h
		d	⁴ J _{FF} 8.7		
	-120.9	s (br)		1	CF (f)
	-155.8	d	³ J _{FF} 11.3	1	CF (g)
		q	³ J _{FF} 11.3		
¹³ C	23.5	s			c
	32.4	d	³ J _{CF} 1.8		b
		q	⁵ J _{CF} 1.6		
	33.2	s			d
	120.0	q	¹ J _{CF} 270.0		h
		d	² J _{CF} 34.7		
		d	³ J _{CF} 8.9		
	129.4	d	² J _{CF} 21.0		a
		m			
	135.5	d	¹ J _{CF} 254.8		g
		d	² J _{CF} 41.0		
	q	² J _{CF} 25.8			
140.2	d	³ J _{CF} 7.2		e	
	d	⁴ J _{CF} 6.1			
	q	⁵ J _{CF} 2.3			
149.0	d	¹ J _{CF} 254.4		f	

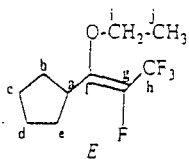

NMR	Chemical Shift (ppm)	Multiplicity	Coupling Constant (Hz)	Relative Intensity	Assignment	
^1H	1.2	t	$^3J_{\text{HH}}$ 6.8	3	j	
	1.6	m		2	b, e <i>ax</i> or <i>eq</i>	
	1.7	m		6	b, e <i>ax</i> or <i>eq</i> , c, d	
	2.9	d	$^3J_{\text{HH}}$ 8.4	1	a	
		d	$^3J_{\text{HH}}$ 8.3			
		d	$^4J_{\text{FH}}$ 4.0			
d		$^3J_{\text{HH}}$ 7.2				
^{19}F	-66.9	d	$^3J_{\text{FF}}$ 10.2	3	h	
	-161.6	e	$^3J_{\text{FF}}$ 13.2	1	g	
^{13}C	30.0	d	$^4J_{\text{CF}}$ 3.0		b, e	
	31.0	s				c, d
	38.5	m				a

No. 13 (1Z)-1-cyclopentyl-1-ethoxy-2,3,3,3-tetrafluoroprop-1-ene (75b)

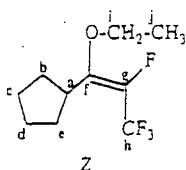

NMR	Chemical Shift (ppm)	Multiplicity	Coupling Constant (Hz)	Relative Intensity	Assignment	
^1H	1.3	t	$^2J_{\text{HH}}$ 7.0	3	j	
	1.6	m		2	b, e <i>ax</i> or <i>eq</i>	
	1.7	m		6	b, e <i>ax</i> or <i>eq</i> , c, d	
	2.8	quint	$^3J_{\text{HH}}$ 7.6	1	a	
		d	$^2J_{\text{HH}}$ 6.8			
		q	$^3J_{\text{HH}}$ 3.6			
^{19}F	-62.9	d	$^3J_{\text{FF}}$ 10.2	3	h	
	-159.1	d	$^3J_{\text{FF}}$ 7.2	1	g	
^{13}C	18.0	s	$^4J_{\text{CF}}$ 2.3		j	
	26.3	s			b	
	30.2	d			e	
	31.2	s			c, d	
	38.0	m			a	
	58.2	s			i	
	121.4	q			$^1J_{\text{CF}}$ 270.1	h
		d			$^2J_{\text{CF}}$ 36.8	
	133.5	d			$^1J_{\text{CF}}$ 241.1	g
		q			$^2J_{\text{CF}}$ 38.9	
	149.3	quint			$^2J_{\text{CF}}$ $^3J_{\text{CF}}$ 2.6	f

No. 14 1-cyclopentyl-1-ethoxy-1,2,3,3,3-pentafluoropropane (76)
Major Diastereoisomers

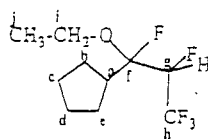

NMR	Chemical Shift (ppm)	Multiplicity	Coupling Constant (Hz)	Relative Intensity	Assignment
^1H	1.6-1.9	m		8	b, c, d, e
	2.4	m		1	a
	4.8	d	$^2J_{\text{FH}}$ 44.4	1	g
		quint	$^3J_{\text{FH}}$ 6.4		
^{19}F	-74.3	d	$^3J_{\text{FF}}$ 10.2	3	h
		d	$^3J_{\text{FH}}$ 10.2		
		d	$^4J_{\text{FF}}$ 7.2		
	-126.0	m		1	f
	-207.7	d	$^2J_{\text{FH}}$ 43.7	1	g
		m			

No. 14 1-cyclopentyl-1-ethoxy-1,2,3,3,3-pentafluoropropane (76)
Minor Diastereoisomers

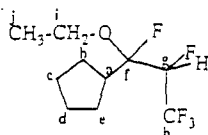

NMR	Chemical Shift (ppm)	Multiplicity	Coupling Constant (Hz)	Relative Intensity	Assignment
^1H	1.6-1.9	m		8	b, c, d, e
	2.4	m		1	a
	5.2	d	$^2J_{\text{FH}}$ 43.7	1	g
		d	$^3J_{\text{FH}}$ 21.8		
		q	$^3J_{\text{FH}}$ 6.0		
^{19}F	-77.2	d	$^3J_{\text{FF}}$ 7.2	3	h
		q	$^3J_{\text{FH}}$ 7.3		
	-130.0	m		1	f
	-207.3	d	$^2J_{\text{FH}}$ 43.7	1	g
		m			

No. 15 1-cyclopentyl-2,3,3,3-tetrafluoropropan-1-one (77)

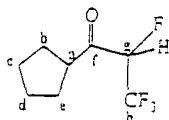

NMR	Chemical Shift (ppm)	Multiplicity	Coupling Constant (Hz)	Relative Intensity	Assignment
^1H	1.7-1.8	m		8	b, c, d, e
	3.3	quint	$^3J_{\text{HH}}$ 5.2	1	a
		d	$^4J_{\text{HH}}$ 3.5		
		d	$^4J_{\text{FH}}$ 1.0		
	5.0	d	$^2J_{\text{FH}}$ 47.2	1	g
		d	$^3J_{\text{FH}}$ 7.0		
^{19}F	-75.2	d	$^3J_{\text{FF}}$ 11.7	3	h
		d	$^3J_{\text{FH}}$ 7.2		
	-205.0	d	$^2J_{\text{FH}}$ 48.2	1	g
		q	$^3J_{\text{FF}}$ 11.7		
^{13}C	26.2	d	$^4J_{\text{CF}}$ 7.0		b, e
	28.6	s			c or d
	29.0	s			c or d
	47.5	s			a
	89.0	d	$^1J_{\text{CF}}$ 201.5		g
		q	$^3J_{\text{CF}}$ 32.4		
	120.8	q	$^1J_{\text{CF}}$ 282.9		h
		d	$^2J_{\text{CF}}$ 25.6		
	203.2	d	$^2J_{\text{CF}}$ 22.9		f

No. 16 1-cyclopentyl-1,2,3,3,3-pentafluoro-1-methoxypropane (78)

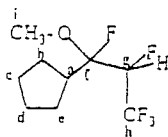

NMR	Chemical Shift (ppm)	Multiplicity	Coupling Constant (Hz)	Relative Intensity	Assignment
^1H	1.6-1.7	m		8	b, c, d, e
	2.4	m		1	a
	3.2	s		3	i
	4.9	d	$^2J_{\text{FH}}$ 44.4	1	g
		quint	$^5J_{\text{HH}}$ 6.8		
^{19}F	-74.3	d	$^3J_{\text{FF}}$ 10.5	3	h
		d	$^3J_{\text{FH}}$ 10.2		
		d	$^4J_{\text{FF}}$ 7.2		
	-128.1	m		1	f
	-207.7	d	$^2J_{\text{FH}}$ 45.2	1	g
		quint	$^3J_{\text{FF}}$ 11.7		
^{13}C	25.6	s			c or d
	25.8	s			c or d
	26.2	d	$^3J_{\text{CF}}$ 5.9		b or e
		d	$^4J_{\text{CF}}$ 3.5		
	26.5	d	$^3J_{\text{CF}}$ 2.3		b or e
	29.7	s			i
	43.9	m			a

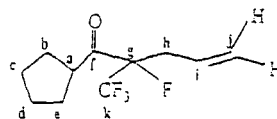

NMR	Chemical Shift (ppm)	Multiplicity	Coupling Constant (Hz)	Relative Intensity	Assignment
^1H	1.6-1.8	m		8	b, c, d, e
	2.6	d	$^3J_{\text{FH}}$ 13.2	1	h
		d	$^2J_{\text{HH}}$ 14.4		
		d	$^3J_{\text{HH}}$ 6.8		
	2.8	d	$^2J_{\text{FH}}$ 34.6	1	h
		d	$^2J_{\text{HH}}$ 14.4		
		d	$^3J_{\text{HH}}$ 7.6		
	3.3	quint	$^3J_{\text{HH}}$ 10.8	1	a
		d	$^4J_{\text{FH}}$ 2.8		
	5.2	m		2	j
	5.6	quint	$^3J_{\text{HH}}$ 8.0	1	i
		d	$^4J_{\text{FH}}$ 2.8		
^{19}F	-77.7	d	$^3J_{\text{FF}}$ 7.5	3	k
	-180.0	d	$^3J_{\text{FH}}$ 35.4	1	g
		m			
^{13}C	22.9	s			c, d
	26.1	d	$^4J_{\text{CF}}$ 5.0		b, e
	36.0	d	$^3J_{\text{CF}}$ 20.2		a
		q	$^4J_{\text{CF}}$ 1.2		
	47.3	s			h
	97.8	d	$^1J_{\text{CF}}$ 201.6		g
		q	$^2J_{\text{CF}}$ 29.0		
	121.9	q	$^1J_{\text{CF}}$ 285.7		k
		d	$^2J_{\text{CF}}$ 28.7		
	122.2	s			j
127.7	d	$^3J_{\text{CF}}$ 2.7		i	
206.9	d	$^2J_{\text{CF}}$ 27.5		f	

No. 18 1-cyclopentyl-2-fluoro-2-(trifluoromethyl)-3,4-pentadien-1-one (85)

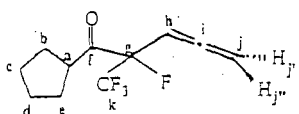

NMR	Chemical Shift (ppm)	Multiplicity	Coupling Constant (Hz)	Relative Intensity	Assignment
^1H	1.6	m		2	c, d ax or eq
	1.7	m		2	c, d ax or eq
	1.8	m		4	b, e
	3.3	t	$^3J_{\text{HH}}$ 4.0	1	a
		t	$^3J_{\text{HH}}$ 4.0		
		d	$^3J_{\text{FH}}$ 8.0		
	5.15	d	$^2J_{\text{HH}}$ 3.6	1	j' or j''
	5.16	d	$^2J_{\text{HH}}$ 3.6	1	j' or j''
	5.4	d	$^3J_{\text{FH}}$ 16.5	1	h
		t	$^4J_{\text{HH}}$ 6.5		
^{19}F	-77.8	d	$^3J_{\text{FF}}$ 8.7	3	k
	-171.3	m		1	g
^{13}C	26.2	d	$^3J_{\text{CF}}$ 11.9		b, e
	29.2	d	$^4J_{\text{CF}}$ 5.2		c or d
	29.4	d	$^4J_{\text{CF}}$ 1.4		c or d
	46.9	s			a
	81.3	s			j
	85.4	d	$^2J_{\text{CF}}$ 23.9		h
		q	$^3J_{\text{CF}}$ 2.8		
	93.7	d	$^1J_{\text{CF}}$ 202.0		g
		q	$^2J_{\text{CF}}$ 30.5		
	121.5	q	$^1J_{\text{CF}}$ 285.8		k
		d	$^2J_{\text{CF}}$ 30.0		
	204.1	d	$^2J_{\text{CF}}$ 26.4		f
	209.3	d	$^3J_{\text{CF}}$ 8.4		i

No. 19 1-cyclopentyl-2-fluoro-3-methyl-2-trifluoromethyl-4-penten-1-one (86)

Major Diastereoisomers

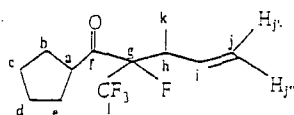

NMR	Chemical Shift (ppm)	Multiplicity	Coupling Constant (Hz)	Relative Intensity	Assignment	
^1H	1.2	d	$^3J_{\text{HH}}$ 6.7	3	k	
	1.6-1.8	q	$^5J_{\text{FH}}$ 1.5	8	b, c, d, e	
		m				
	3.0	d	$^3J_{\text{FH}}$ 29.5	1	h	
		d	$^3J_{\text{HH}}$ 11.0			
	3.2	q	$^3J_{\text{HH}}$ 7.5	1	a	
		quint	$^3J_{\text{HH}}$ 8.5			
	5.09	d	$^4J_{\text{FH}}$ 4.0	$^3J_{\text{HHtrans}}$ 17.5	1	j'
		d	$^3J_{\text{HHtrans}}$ 17.5			
		d	$^3J_{\text{HHcis}}$ 10.0			
d		$^3J_{\text{HHtrans}}$ 17.5				
5.12	d	$^3J_{\text{HHcis}}$ 10.0	$^3J_{\text{HHcis}}$ 10.0	1	j''	
	d	$^3J_{\text{HHtrans}}$ 17.5				
	d	$^3J_{\text{HH}}$ 8.0				
^{19}F	-72.9	d	$^3J_{\text{FF}}$ 5.6	3	l	
	-189.1	d	$^3J_{\text{FH}}$ 29.0	1	g	
		m				
^{13}C	14.3	s	$^2J_{\text{CF}}$ 19.5		k	
	25.9-29.7	s			b, c, d, e	
		d				h
	47.6	s			a	
	119.3	s			j	
	135.1	m			i	

No. 19 1-cyclopentyl-2-fluoro-3-methyl-2-trifluoromethyl-4-penten-1-one (86)

Minor Diastereoisomers

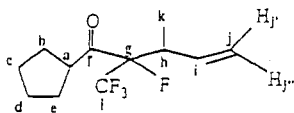

NMR	Chemical Shift (ppm)	Multiplicity	Coupling Constant (Hz)	Relative Intensity	Assignment
^1H	1.1	d	$^3J_{\text{HH}}$ 7.0	3	k
	1.6-1.8	m		8	b, c, d, e
		m			
	2.8	m		1	h
	3.3	m		1	a
	5.17	d	$^3J_{\text{HHcis}}$ 10.0	1	j'
	5.20	d	$^3J_{\text{HHtrans}}$ 17.5	1	j''
m				i	
^{19}F	-72.9	d	$^3J_{\text{FF}}$ 6.0	3	l

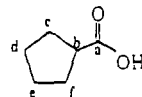

NMR	Chemical Shift (ppm)	Multiplicity	Coupling Constant (Hz)	Relative Intensity	Assignment
¹ H	1.5	m	³ J _{HH} 8.0	2	d, e ax or eq
	1.6	m		2	d, e ax or eq
	1.78	m		2	c, f ax or eq
	1.83	m			c, f ax or eq
	2.7	quint			b
	14.0	s			OH
¹³ C	25.8	s			d, e
	29.9	s			c, f
	43.7	s			b
	183.6	s			a

21 1-cyclopentyl-3-ethenyl-2-fluoro-3,7-dimethyl-2-trifluoromethyl-6-octen-1-ol (92)

Diastereoisomers

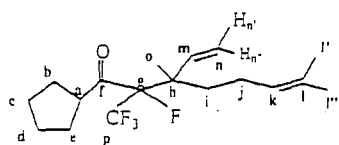

NMR	Chemical Shift (ppm)	Multiplicity	Coupling Constant (Hz)	Relative Intensity	Assignment
¹ H	1.2	s		3	o
	1.5-1.7	m		8	b, c, d, e
	1.5	s		3	l' or l''
	1.7	s		3	l' or l''
	1.7	d	² J _{HH} 8.4	2	j
		m			
	1.8	d	² J _{HH} 13.6	2	i
		m			
	3.3	m		1	a
	5.04	d	³ J _{HH} 6.8	1	k
	5.05	d	³ J _{HHtrans} 17.6	1	n'
	5.2	d	³ J _{HHcis} 10.8	1	n''
5.9	d	³ J _{HHcis} 10.8	1	m	
	d	³ J _{HHtrans} 17.6			
¹⁹ F	-68.7	d	³ J _{FF} 5.6	3	p
	-177.9	s (br)		1	g
¹³ C	16.0	q	⁴ J _{CF} 2.3		o
	17.8	s			l' or l''
	22.3	s			e
	25.8	d	⁷ J _{CF} 1.5		l' or l''
	26.4	s			c or d
	28.2	d	⁴ J _{CF} 1.1		j
	31.2	s			i
	34.5	q	⁵ J _{CF} 2.3		b
	46.3	d	² J _{CF} 19.1		h
	48.5	s			a
	100.0	q	¹ J _{CF} 204.3		p
		d	² J _{CF} 26.8		
	117.5	s			n
	122.3	d	¹ J _{CF} 288.4		g
		q	² J _{CF} 30.0		
	124.0	s			k
	132.2	s			l
138.6	d	³ J _{CF} 3.1		m	
207.9	d	² J _{CF} 29.0		f	

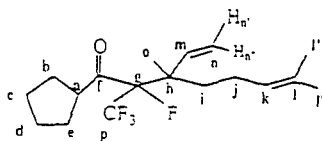

NMR	Chemical Shift (ppm)	Multiplicity	Coupling Constant (Hz)	Relative Intensity	Assignment
¹ H	1.2	s		3	o
	1.4-1.8	m		8	b, c, d, l
	1.5-1.7	s		6	l' or l''
	1.5-1.7	m		4	i, j
	3.3	m		1	a
	5.05	m		1	k
	5.1	d	³ J _{HHtrans} 17.6	1	n'
	5.2	d	³ J _{HHcis} 10.8	1	n''
¹⁹ F	-69.0	d	³ J _{FF} 6.0	3	p
	-177.0	s (br)		1	g
¹³ C	16.3	m			o
	17.8	s			l' or l''
	22.3	s			e
	25.8	s			l' or l''
	26.3	s			c, d
	28.3	d	⁴ J _{CF} 1.2		j
	31.3	s			i
	34.5	q	⁵ J _{CF} 2.5		b
	46.7	d	² J _{CF} 19.1		h
	48.7	s			a
	100.0	q	¹ J _{CF} 204.3		p
		d	² J _{CF} 26.8		
	117.1	s			n
	122.3	d	¹ J _{CF} 288.4		g
		q	² J _{CF} 30.0		
123.9	s			k	
132.2	s			l	
138.3	d	³ J _{CF} 4.5		m	
208.0	d	² J _{CF} 29.0		f	

22 1-cyclopent-1-enyl-2-fluoro-3,7-dimethyl-2-(trifluoromethyl)-3-vinyloct-6-ene (93)

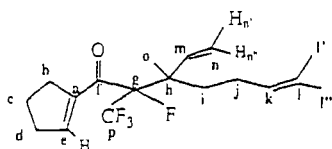

NMR	Chemical Shift (ppm)	Multiplicity	Coupling Constant (Hz)	Relative Intensity	Assignment
¹ H	1.2	s		3	o
		m		6	b, c, d
	1.6	s		3	l' or l''
	1.7	s		3	l' or l''
	1.8	m		2	j
	1.9	m		2	i
	4.6	m		1	e
	5.0-5.1	m		2	k
	5.1	d	³ J _{HHtrans} 17.2	1	n''
	5.2	d	³ J _{HHcis} 10.4	1	n'
¹⁹ F	-64.3	d	³ J _{FF} 6.0	3	p
	-169.6	m		1	g
¹³ C	21.2	q	⁴ J _{CF} 2.3		o
	22.5	s			l' or l''
	26.5-39.5	m			b, c, d
	27.5	s			j
	30.7	s			i
	40.4	d	⁷ J _{CF} 3.0		l' or l''
	100.8	s			e
	115.5	s			n
	121.7	s			k
	136.9	s			m
	196.3	d	² J _{CF} 25.9		f

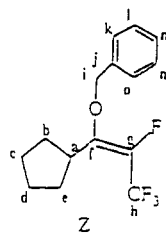

NMR	Chemical Shift (ppm)	Multiplicity	Coupling Constant (Hz)	Relative Intensity	Assignment
^1H	1.6	m		2	c, d ax or eq
	1.7	m		6	c, d ax or eq, b, e
	2.9	quint	$^3J_{\text{HH}}$ 7.0	1	a
	5.2	d	$^2J_{\text{HH}}$ 5.0	2	i
	7.4	m		5	o, n, m, l, k
^{19}F	-63.0	d	$^3J_{\text{FF}}$ 8.7	3	h
	-156.9	q	$^3J_{\text{FF}}$ 8.7	1	g
		d	$^4J_{\text{FH}}$ 3.0		
^{13}C	26.4	s			c, d
	30.3	d	$^4J_{\text{CF}}$ 1.9		b, e
	38.8	q	$^4J_{\text{CF}}$ 2.0		a
	74.9	d	$^4J_{\text{CF}}$ 12.9		i
	121.4	q	$^1J_{\text{CF}}$ 270.4		h
		d	$^2J_{\text{CF}}$ 36.9		
	128.0	s			m
	128.5	s			n, l
	128.8	s			o, k
	134.0	d	$^1J_{\text{CF}}$ 242.4		g
		q	$^2J_{\text{CF}}$ 39.0		
	137.0	d	$^5J_{\text{CF}}$ 2.0		j
	149.3	d	$^2J_{\text{CF}}$ 3.0		f
	q	$^3J_{\text{CF}}$ 3.0			

No. 24 Z-(1-butyl-2,3,3,3-tetrafluoro-1-propenyl)cyclopentane (99)

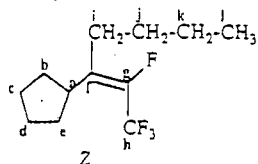

NMR	Chemical Shift (ppm)	Multiplicity	Coupling Constant (Hz)	Relative Intensity	Assignment
^1H	0.9	t	$^3J_{\text{HH}}$ 6.8	3	l
	1.4	m		2	b, e ax or eq
	1.4	m		4	j, k
	1.6	m		4	c, d
	1.7	m		2	b, e ax or eq
	2.1	m		2	i
	2.9	quint	$^3J_{\text{HH}}$ 9.2	1	a
^{19}F	-64.2	d	$^3J_{\text{FF}}$ 7.2	3	h
	-131.3	m		1	g
^{13}C	13.8	s			l
	23.3	s			k
	25.6	d	$^5J_{\text{CF}}$ 0.7		c, d
	25.8	d	$^3J_{\text{CF}}$ 5.4		i
	31.00	s			b or e
	31.02	s			b or e
	31.6	m			j
	38.5	d	$^3J_{\text{CF}}$ 1.9		a
		q	$^4J_{\text{CF}}$ 1.9		
	120.1	q	$^1J_{\text{CF}}$ 272.8		h
		d	$^2J_{\text{CF}}$ 43.1		
	131.3	d	$^2J_{\text{CF}}$ 8.7		f
		q	$^3J_{\text{CF}}$ 2.6		
	142.2	d	$^1J_{\text{CF}}$ 246.8		g
	q	$^2J_{\text{CF}}$ 37.4			

No. 25 Z-(1-phenyl-2,3,3,3-tetrafluoro-1-propenyl)cyclopentane (101)

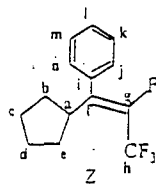

NMR	Chemical Shift (ppm)	Multiplicity	Coupling Constant (Hz)	Relative Intensity	Assignment
^1H	1.4	m		2	b, e ax or eq
	1.6	m		4	c, d
	1.8	m		2	b, e ax or eq
	3.2	quint	$^3J_{\text{HH}} 8.4$	1	a
	7.2	d	$^3J_{\text{HH}} 7.8$	2	j, n
	7.4	m		3	k, l, m
^{19}F	-64.5	d	$^3J_{\text{FF}} 7.5$	3	h
	-125.0	q	$^3J_{\text{FF}} 7.2$	1	g
^{13}C	24.9	s			c, d
	31.1	d	$^4J_{\text{CF}} 3.1$		b, e
	38.9	d	$^3J_{\text{CF}} 1.5$		a
	120.2	q	$^1J_{\text{CF}} 273.2$		h
		d	$^2J_{\text{CF}} 43.3$		
	128.2	s			i
	128.4	s			k, m
	129.1	d	$^4J_{\text{CF}} 0.8$		j, n
	131.9	d	$^2J_{\text{CF}} 9.9$		f
		q	$^3J_{\text{CF}} 2.7$		
	132.8	d	$^3J_{\text{CF}} 3.4$		i
	142.0	d	$^1J_{\text{CF}} 249.6$		g
	q	$^2J_{\text{CF}} 37.8$			

Major Diastereoisomers

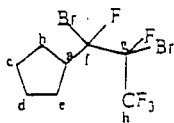

NMR	Chemical Shift (ppm)	Multiplicity	Coupling Constant (Hz)	Relative Intensity	Assignment
^1H	1.6-2.0	m	$^3J_{\text{HH}} \ ^3J_{\text{FH}}$ 8.0	8	b, c, d, e
	2.7	sext		1	a
^{19}F	-72.4	d	$^4J_{\text{FF}}$ 10.9	3	h
		d	$^3J_{\text{FF}}$ 8.7		
	-106.2	d	$^3J_{\text{FF}}$ 24.8	1	CF (f)
		d	$^3J_{\text{FH}}$ 7.2		
		q	$^4J_{\text{FF}}$ 11.5		
	-126.2	d	$^3J_{\text{FF}}$ 26.0	1	CF (g)
		q	$^3J_{\text{FF}}$ 8.7		
^{13}C	25.3	s			c or d
	25.6	s			c or d
	25.7	d	$^3J_{\text{CF}}$ 1.1		b or e
	26.1	d	$^3J_{\text{CF}}$ 1.2		b or e
	48.5	d	$^2J_{\text{CF}}$ 19.4		a
		m			
	103.6	d	$^1J_{\text{CF}}$ 271.3		g
		d	$^2J_{\text{CF}}$ 31.4		
		q	$^2J_{\text{CF}}$ 35.1		
	113.3	d	$^1J_{\text{CF}}$ 265.3		f
	d	$^2J_{\text{CF}}$ 26.3			
120.2	q	$^1J_{\text{CF}}$ 288.4		h	
	d	$^2J_{\text{CF}}$ 31.3			

No. 26 1,2-dibromo-1-(1,2,3,3,3-pentafluoropropyl)cyclopentane (103)

Minor Diastereoisomers

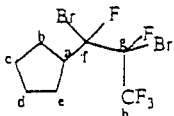

NMR	Chemical Shift (ppm)	Multiplicity	Coupling Constant (Hz)	Relative Intensity	Assignment
^1H	1.6-2.0	m	$^3J_{\text{HH}} \ ^3J_{\text{FH}}$ 8.4	8	b, c, d, e
	2.8	sext		1	a
^{19}F	-71.9	d	$^4J_{\text{FF}}$ 13.0	3	h
		d	$^3J_{\text{FF}}$ 8.8		
	-107.1	d	$^3J_{\text{FF}}$ 23.0	1	CF (f)
		d	$^3J_{\text{FH}}$ 9.0		
		q	$^4J_{\text{FF}}$ 12.6		
	-124.7	d	$^3J_{\text{FF}}$ 21.8	1	CF (g)
		q	$^3J_{\text{FF}}$ 8.7		
^{13}C	29.7	d	$^3J_{\text{CF}}$ 4.4		b or e
		d	$^4J_{\text{CF}}$ 3.1		
	29.8	m			c, d
	30.6	d	$^3J_{\text{CF}}$ 4.8		b or e
		d	$^4J_{\text{CF}}$ 2.7		
	49.0	d	$^2J_{\text{CF}}$ 18.6		a
		m			
	102.5	d	$^1J_{\text{CF}}$ 269.6		g
		d	$^2J_{\text{CF}}$ 31.5		
		q	$^2J_{\text{CF}}$ 34.4		
112.6	d	$^1J_{\text{CF}}$ 263.8		f	
	d	$^2J_{\text{CF}}$ 25.5			
120.8	q	$^1J_{\text{CF}}$ 285.4		h	
	d	$^2J_{\text{CF}}$ 30.1			

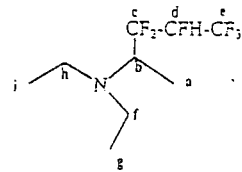

27 diethyl(2,2,3,4,4,4-hexafluoro-1-methylbutyl)amine (104)
or Diastereoisomers

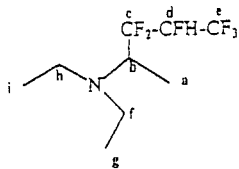

NMR	Chemical Shift (ppm)	Multiplicity	Coupling Constant (Hz)	Relative Intensity	Assignment
^1H	1.1	t	$^3J_{\text{HH}}$ 7.0	6	i, g
	1.3	d	$^3J_{\text{HH}}$ 7.0	3	a
	2.9	q	$^3J_{\text{HH}}$ 7.0	4	f, h
	3.6	d	$^3J_{\text{FH}}$ 21.5	1	b
		d	$^4J_{\text{HH}}$ 2.5		
	d	$^4J_{\text{HH}}$ 2.0			
	5.8	q	$^3J_{\text{HH}}$ 7.0		
		d	$^2J_{\text{FH}}$ 45.0	1	d
		d	$^3J_{\text{FH}}$ 17.5		
		d	$^3J_{\text{FH}}$ 4.0		
q		$^3J_{\text{FH}}$ 6.0			
^{19}F	-74.3	d	$^3J_{\text{FH}}$ 4.7	3	e
		q	$^3J_{\text{FF}}$ $^4J_{\text{FF}}$ 11.1		
	-117.6	syst AB dm	$^2J_{\text{FF}}$ 266.8	1	c
	-120.8	syst AB dm	$^2J_{\text{FF}}$ 266.8	1	c
	-211.6	d	$^2J_{\text{FH}}$ 44.1	1	d
^{13}C	8.9	s			a
	14.4	s			i, g
	14.6	s			i, g
	41.8	s			h, f
	54.0	d	$^2J_{\text{CF}}$ 20.7		b
		d	$^2J_{\text{CF}}$ 20.4		
	82.7	d	$^1J_{\text{CF}}$ 195.6		d
	120.8	m			
q		$^1J_{\text{CF}}$ 282.9		e	
d	$^2J_{\text{CF}}$ 25.9				

NMR	Chemical Shift (ppm)	Multiplicity	Coupling Constant (Hz)	Relative Intensity	Assignment
^1H	1.0	t	$^3J_{\text{HH}}$ 6.5	6	i, g
	1.2	d	$^3J_{\text{HH}}$ 6.5	3	a
	2.4	d	$^2J_{\text{HH}}$ 10.2	2	f, h
	2.6	q	$^3J_{\text{HH}}$ 5.0		
		d	$^2J_{\text{HH}}$ 12.7	2	f, h
	3.2	q	$^3J_{\text{HH}}$ 7.0		
		d	$^3J_{\text{FH}}$ 28.0	1	b
	5.5	m			
		d	$^3J_{\text{FH}}$ 22.4	1	d
		d	$^3J_{\text{FH}}$ 19.7		
q		$^3J_{\text{FH}}$ 6.5			
^{19}F	-74.1	d	$^3J_{\text{FH}}$ 4.5	3	e
		q	$^3J_{\text{FF}}$ $^4J_{\text{FF}}$ 10.9		
	-120.8	syst AB dm	$^2J_{\text{FF}}$ 265.6	1	c
	-127.4	syst AB dm	$^2J_{\text{FF}}$ 265.6	1	c
	-212.3	d	$^2J_{\text{FH}}$ 40.7	1	d
^{13}C	5.1	s			a
	12.8	s			i, g
	13.8	s			i, g
	44.2	s			h, f
	54.9	d	$^2J_{\text{CF}}$ 27.3		b
		d	$^2J_{\text{CF}}$ 21.4		
	84.8	d	$^1J_{\text{CF}}$ 199.8		d
	121.5	m			
q		$^1J_{\text{CF}}$ 283.9		e	
d	$^2J_{\text{CF}}$ 24.4				

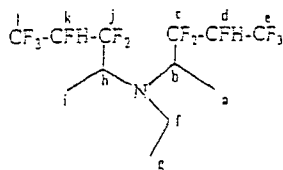

NMR	Chemical Shift (ppm)	Multiplicity	Coupling Constant (Hz)	Relative Intensity	Assignment
^1H	1.0	t	$^3J_{\text{HH}}$ 7.2	3	g
	1.3	m		6	a, i
	2.9	m		1	f
	2.9	m		1	f
	3.5	m		2	b, h
	4.8	d	$^2J_{\text{FH}}$ 45.8	2	d, k
		d	$^3J_{\text{FH}}$ 18.4		
		d	$^3J_{\text{FH}}$ 2.8		
		q	$^3J_{\text{FH}}$ 6.0		
^{19}F	-74.3	m		6	e, l
	-116.0,	m		4	c, j
	-125.0				
	-210.6	m		2	d, k
^{13}C	9.1	s			a, i
	14.7	s			g
	41.4	s			f
	54.8	m			b, h
	85.0	d	$^1J_{\text{CF}}$ 232.2		d, k
		m			
		q			
	120.9	d	$^1J_{\text{CF}}$ 282.7		e, l
		d	$^2J_{\text{CF}}$ 25.9		
	120.9	d	$^1J_{\text{CF}}$ 258.4		c, j
	d	$^1J_{\text{CF}}$ 252.1			
	d	$^2J_{\text{CF}}$ 25.6			

No. 28 bis(2,2,3,4,4,4-hexafluoro-1-methylbutyl)ethylamine (105)
Minor Diastereoisomers

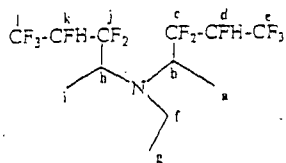

NMR	Chemical Shift (ppm)	Multiplicity	Coupling Constant (Hz)	Relative Intensity	Assignment
^1H	1.1	t	$^3J_{\text{HH}}$ 7.2	3	g
	1.3	m		6	a, i
	2.6	d	$^2J_{\text{HH}}$ 13.6	1	f
		q			
	2.8	d	$^2J_{\text{HH}}$ 11.6	1	f
		q	$^3J_{\text{HH}}$ 7.6		
	3.5	d	$^3J_{\text{FH}}$ 27.2	2	b, h
		m			
	5.3	d	$^2J_{\text{FH}}$ 42.8	2	d, k
		d			
	q	$^3J_{\text{FH}}$ 6.4			
^{19}F	-74.3	m		6	e, l
	-116.0,	m		4	c, j
	-125.0				
	-211.7	d	$^2J_{\text{FH}}$ 43.7	2	d, k
	m				
^{13}C	10.7	s			a, i
	14.1	s			g
	43.0	s			f
	56.4	d	$^2J_{\text{CF}}$ 26.7		b, h
		d		$^2J_{\text{CF}}$ 20.6	
	80.0-85.0	m			d, k
	116.8-125.2	m			c, e, j, l

No. 29 tris(2,2,3,4,4,4-hexafluoro-1-methylbutyl)amine (106)

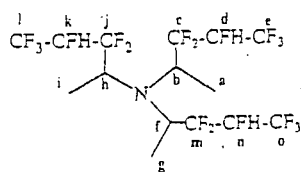

NMR	Chemical Shift (ppm)	Multiplicity	Coupling Constant (Hz)	Relative Intensity	Assignment	
^1H	1.38	d	$^3J_{\text{HH}}$ 7.2	3	a, i, g	
	1.42	d	$^3J_{\text{HH}}$ 7.2	3	a, i, g	
	1.42	d	$^3J_{\text{HH}}$ 7.2	3	a, i, g	
	1.31	d	$^3J_{\text{HH}}$ 6.8	3	a, i, g	
	1.32	d	$^3J_{\text{HH}}$ 6.8	3	a, i, g	
	1.41	d	$^3J_{\text{HH}}$ 6.8	3	a, i, g	
	3.7	m		3	b, h, f	
	3.8	m		3	b, h, f	
	4.8	d	$^2J_{\text{FH}}$ 44.2	3	d, k, n	
			d	$^3J_{\text{FH}}$ 17.2		
			d	$^3J_{\text{FH}}$ 5.6		
			q	$^3J_{\text{FH}}$ 7.6		
	5.4	d	$^2J_{\text{FH}}$ 43.1	3	d, k, n	
			d	$^3J_{\text{FH}}$ 20.2		
			d	$^3J_{\text{FH}}$ 3.2		
		c	$^3J_{\text{FH}}$ 6.4			
^{19}F	-74.3	d	$^3J_{\text{FH}}$ 4.5	9	e, o, l	
		q	$^3J_{\text{FF}}$ $^4J_{\text{FF}}$ 10.2			
	-74.0	m			e, o, l	
	-74.4	m			e, o, l	
	-110.7	syst AB dm	$^2J_{\text{FF}}$ 282.0	3	c, j, m	
	-119.1	syst AB dm	$^2J_{\text{FF}}$ 282.0	3	c, j, m	
	-116.9	syst AB dm	$^2J_{\text{FF}}$ 282.0		c, j, m	
	-128.1	syst AB dm	$^2J_{\text{FF}}$ 282.0		c, j, m	
	-114.1	syst AB dm	$^2J_{\text{FF}}$ 282.0		c, j, m	
	-121.3	syst AB dm	$^2J_{\text{FF}}$ 282.0		c, j, m	
	-209.6	d	$^2J_{\text{FH}}$ 45.2	3	d, n, k	
	m					
-210.7	m		3	d, n, k		
^{13}C	8.9	m			a, g, i	
	11.4	m			a, g, i	
	12.2	m			a, g, i	
	14.4	m			a, g, i	
	13.5	m			a, g, i	
	51.2	m			b, f, h	
	52.8	d	$^2J_{\text{CF}}$ 28.0		b, f, h	
		d	$^2J_{\text{CF}}$ 19.5			
	80.8	d	$^1J_{\text{CF}}$ 190.8		d, k, n	
		m				
	83.7	d	$^1J_{\text{CF}}$ 188.5		d, k, n	
		m				
	117.6	d	$^1J_{\text{CF}}$ 264.5		c, j, m	
	d	$^1J_{\text{CF}}$ 253.5				
	d	$^2J_{\text{CF}}$ 24.4				
119.6	q	$^1J_{\text{CF}}$ 282.9		e, l, o		
	d	$^2J_{\text{CF}}$ 25.9				
117.0-120.0	m			c, j, m, e, l, o		

No. 30 (2,2,3,4,4,4-hexafluorobutyl)(2,2,3,4,4,4-hexafluoro-1-methylbutyl)methylamine
(107)

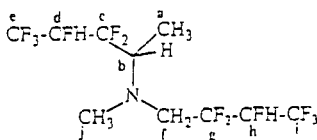

NMR	Chemical Shift (ppm)	Multiplicity	Coupling Constant (Hz)	Relative Intensity	Assignment
¹ H	1.23	d	³ J _{HH} 7.2	3	a
	1.24	d	³ J _{HH} 7.2	3	a
	2.5	s		6	j
	2.9-3.2	m		4	f
	3.3	d	³ J _{FH} 25.4	2	b
		m			
	4.9	d	² J _{FH} 43.6	2	h
		m			
	5.3	d	² J _{FH} 42.4	2	d
		d	³ J _{FH} 20.4		
		d	³ J _{FH} 8.4		
		a	³ J _{FH} 6.0		
¹⁹ F	-74.3	m		6	e or i
	-74.6	m		6	e or i
	-119.0	syst AB dm	² J _{FF} 274.7	2	c or g
	-125.2	syst AB dm	² J _{FF} 274.7	2	c or g
	-112.0	syst AB dm	² J _{FF} 281.9	2	c or g
	-116.4	syst AB dm	² J _{FF} 281.9	2	c or g
	-211.5	d	² J _{FH} 43.7	1	d or h
		m			
	-211.7	d	² J _{FH} 43.5	1	d or h
		m			
	-212.3	d	² J _{FH} 48.2	1	d or h
		m			
-212.4	d	² J _{FH} 45.5	1	d or h	
	m				
¹³ C	4.8	s			a
	5.0	s			a
	39.9	s			j
	40.4	s			j
	55.3	t	² J _{CF} 22.9		f
		m			
	55.9	t	² J _{CF} 22.9		f
		m			
	59.5	d	² J _{CF} 29.4		b
		d	² J _{CF} 20.9		
	60.0	d	² J _{CF} 29.6		b
		d	² J _{CF} 21.0		
	83.1	d	¹ J _{CF} 166.9		d or h
		m			
	84.8	d	¹ J _{CF} 179.7		d or h
		m			
	118.6	d	¹ J _{CF} 258.6		c or g
		d	¹ J _{CF} 248.5		
	d	² J _{CF} 24.8			
118.6	d	¹ J _{CF} 247.3		c or g	
	d	¹ J _{CF} 246.2			
	d	² J _{CF} 24.4			
120.7	q	¹ J _{CF} 282.1		e or i	
	d	² J _{CF} 25.9			
121.2	q	¹ J _{CF} 283.0		e or i	
	d	² J _{CF} 26.7			

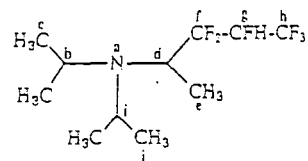

NMR	Chemical Shift (ppm)	Multiplicity	Coupling Constant (Hz)	Relative Intensity	Assignment
¹ H	1.02	d	³ J _{HH} 6.4	6	c or j
	1.04	d	³ J _{HH} 6.8	6	c or j
	1.3	d	³ J _{HH} 6.8	3	e
		m			
	3.2	sept	³ J _{HH} 6.8	2	b, i
	3.3	m		1	d
	5.0	d	² J _{FF} 44.0	1	g
		d	³ J _{FF} 13.6		
		d	³ J _{FF} 7.6		
		q	³ J _{FF} 6.0		
¹⁹ F	-74.3	m		3	h
	-116.9	syst AB dm	² J _{FF} 267.6	1	f
	-119.6	syst AB dm	² J _{FF} 267.6	1	f
	-211.9	d	² J _{FF} 45.2	1	g
		sext	³ J _{FF} 10.2		
¹³ C	13.2	m			e
	21.9	s			c or j
	23.6	s			c or j
	45.9	s			b, i
	52.2	d	² J _{CF} 22.9		d
		d	² J _{CF} 22.9		
	84.9	d	¹ J _{CF} 195.9		g
		d	² J _{CF} 35.6		
		d	² J _{CF} 26.3		
		q	² J _{CF} 33.2		
	119.6	d	¹ J _{CF} 256.7		f
		d	¹ J _{CF} 251.0		
		d	² J _{CF} 21.7		
121.3	q	¹ J _{CF} 282.7		h	
	d	² J _{CF} 25.9			

No. 31 bis(methylethyl)(2,2,3,4,4,4-hexafluoro-1-methylbutyl)amine (108)
Minor Diastereoisomers

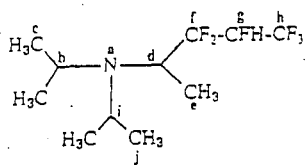

NMR	Chemical Shift (ppm)	Multiplicity	Coupling Constant (Hz)	Relative Intensity	Assignment
¹ H	1.02	d	³ J _{HH} 6.4	6	c or j
	1.06	d	³ J _{HH} 7.2	6	c or j
	1.3	d	³ J _{HH} 7.2	3	e
	3.2-3.4	m		2	b, i
	3.2-3.4	m		1	d
	5.0	d	² J _{FF} 42.5	1	g
		d	³ J _{FF} 19.8		
		q	³ J _{FF} 6.8		
¹⁹ F	-74.0	m		3	h
	-119.6	syst AB dm	² J _{FF} 273.2	1	f
	-119.9	syst AB dm	² J _{FF} 273.2	1	f
	-211.9	d	² J _{FF} 46.3	1	g
¹³ C	10.9	m			e
	21.5	s			c or j
	23.7	m			c or j
	49.5	s			b, i
	50.5	d	² J _{CF} 28.5		d
		d	² J _{CF} 19.8		
	82.9-86.7	m			g
	116.9-126.7	m			f, h

No. 32 (2,2,3,4,4,4-hexafluoro-1,1-dimethylbutyl)(2,2,3,4,4,4-hexafluoro-1-methylbutyl)(methylethyl)amine (109)

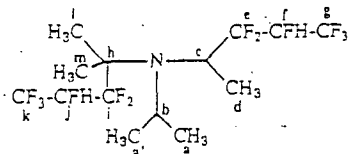

NMR	Chemical Shift (ppm)	Multiplicity	Coupling Constant (Hz)	Relative Intensity	Assignment
^1H	1.0-1.2	m		15	a, a', d, l, m
	3.4-4.2	m		2	b, c
	4.7	d	$^2J_{\text{FH}}$ 27.2	1	j or f
		d	$^3J_{\text{FH}}$ 22.0		
		d	$^3J_{\text{FH}}$ 21.6		
		q	$^3J_{\text{FH}}$ 5.6		
	5.6	d	$^2J_{\text{FH}}$ 36.4	1	j or f
		m			
^{19}F	-74.2	m		3	k or g
	-74.4	d	$^3J_{\text{FH}}$ 5.6	3	k or g
		q	$^3J_{\text{FF}}$ $^4J_{\text{FF}}$ 11.7		
	-111.0,	m		4	e, f
	-120.7				
	-206.9	d	$^2J_{\text{FH}}$ 35.8	1	f, j
		m			
-210.7	d	$^2J_{\text{FH}}$ 33.9	1	f, j	
		m			
^{13}C	15.0-26.6	m			a, a', d, l, m
	50.0-55.0	m			b, c
	60.0-70.0	m			b
	83.1	d	$^1J_{\text{CF}}$ 210.6		j or f
		m			
	85.1	d	$^1J_{\text{CF}}$ 185.0		j or f
		m			
	116.0-126.0	m			e, i
	119.6	q	$^1J_{\text{CF}}$ 283.5		k or g
		d	$^2J_{\text{CF}}$ 25.9		
121.2	q	$^1J_{\text{CF}}$ 283.0		k or g	
	d	$^2J_{\text{CF}}$ 25.9			

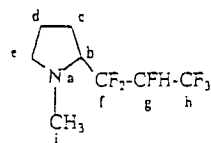

110 2-(1,1,2,3,3,3-hexafluoropropyl)-1-methylpyrrolidine (110)
Major Diastereoisomers

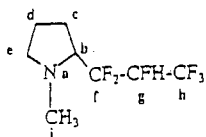

NMR	Chemical Shift (ppm)	Multiplicity	Coupling Constant (Hz)	Relative Intensity	Assignment
¹ H	1.8	m		2	d
	2.0	m		2	c
	2.3	m		1	e
	2.5	s		3	i
	2.9-3.1	m		1	b
	3.2	m		1	e
	5.3	d	² J _{FH} 45.6	1	g
		d	³ J _{FH} 21.0		
		d	³ J _{FH} 4.2		
		q	³ J _{FH} 6.4		
¹⁹ F	-74.4	m		3	h
	-112.7	syst AB dm	² J _{FF} 270.2	1	f
	-118.3	syst AB dm	² J _{FF} 270.2	1	f
	-213.3	d	² J _{FH} 41.0	1	g
¹³ C	24.3	d	⁴ J _{CF} 1.5		d
	26.3	d	³ J _{CF} 7.0		c
		d	³ J _{CF} 5.0		
		d	⁴ J _{CF} 2.0		
	42.7	d	⁴ J _{CF} 2.5		i
		m			
	57.9	s			e
	67.1	d	² J _{CF} 26.9		b
		d	² J _{CF} 22.1		
	85.0-81.7	m			g
116.8-125.3	m			f	
116.8-125.3	m			h	

NMR	Chemical Shift (ppm)	Multiplicity	Coupling Constant (Hz)	Relative Intensity	Assignment
¹ H	1.8	m		2	d
	2.0	m		2	c
	2.3	m		1	e
	2.5	s		3	i
	2.9-3.1	m		1	b
	3.1	m		1	e
	5.1	d	² J _{FH} 42.6	1	g
	d	³ J _{FH} 20.6			
	q	³ J _{FH} 6.4			
¹⁹ F	-74.0	d	³ J _{FF} 13.7	3	h
		d	⁴ J _{FF} 11.7		
		d	⁴ J _{FF} 11.7		
		d	³ J _{FH} 6.0		
	-120.9	syst AB dm	² J _{FF} 265.2	1	f
	-127.7	syst AB dm	² J _{FF} 265.2	1	f
	d	² J _{FH} 43.7	1	g	
	m				
¹³ C	23.9	s			d
	25.3	m			c
	43.6	d	⁴ J _{CF} 2.2		i
	57.6	s			e
	65.4	d	² J _{CF} 29.6		b
		d	² J _{CF} 21.3		
	83.5	d	¹ J _{CF} 189.8		g
		d	² J _{CF} 41.7		
		d	² J _{CF} 24.6		
		q	² J _{CF} 33.9		
	119.5	d	¹ J _{CF} 254.8		f
		d	¹ J _{CF} 249.3		
		d	² J _{CF} 26.4		
121.1	q	¹ J _{CF} 282.6		h	
	d	² J _{CF} 25.9			

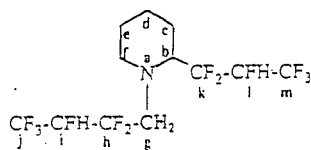

NMR	Chemical Shift (ppm)	Multiplicity	Coupling Constant (Hz)	Relative Intensity	Assignment
^1H	1.5	m		2	e ax or eq
	1.6	m		2	e ax or eq
	1.7	m		2	d ax or eq
	1.8	m		4	c
	1.9	m		2	d ax or eq
	2.7	m		2	f ax or eq
	3.0-3.6	m		2	f ax or eq
	3.2	m		4	g
	4.9	m		2	i, l
	5.3	m		2	i, l
^{19}F	-74.2	m		6	m or j
	-74.6	m		6	m or j
	-114.1	syst AB dm	$^2J_{\text{FF}} 266.1$	2	h or l
	-117.6	syst AB dm	$^2J_{\text{FF}} 266.1$	2	h or l
	-115.1	syst AB dm	$^2J_{\text{FF}} 264.8$	2	h or l
	-118.3	syst AB dm	$^2J_{\text{FF}} 264.8$	2	h or l
	-211.2	m		4	l or i
	-211.6	d	$^2J_{\text{FH}} 43.3$	2	l or i
		m			
	-212.2	d	$^2J_{\text{FH}} 42.2$	2	l or i
	m				
^{13}C	17.9	s			c
	18.3	s			c
	19.1	s			e
	19.8	s			e
	20.1	s			d
	20.3	s			d
	48.8	s			f
	49.6	s			f
	55.2	d	$^2J_{\text{CF}} 29.0$		g
		d	$^2J_{\text{CF}} 20.2$		
	55.9	d	$^2J_{\text{CF}} 29.0$		g
		d	$^2J_{\text{CF}} 20.2$		
	58.6	d	$^2J_{\text{CF}} 27.9$		b
		d	$^2J_{\text{CF}} 22.5$		
	59.5	d	$^2J_{\text{CF}} 25.1$		b
		d	$^2J_{\text{CF}} 24.8$		
	83.6	m			i, l
	118.2	t	$^1J_{\text{CF}} 261.5$		h or k
	119.1	q	$^1J_{\text{CF}} 255.6$		j or m
	119.2	q	$^1J_{\text{CF}} 256.4$		j or m
119.6	t	$^1J_{\text{CF}} 281.6$		h or k	
120.8	t	$^1J_{\text{CF}} 261.5$		h or k	
120.9	q	$^1J_{\text{CF}} 283.0$		j or m	
	d	$^2J_{\text{CF}} 26.3$			
121.4	q	$^1J_{\text{CF}} 281.9$		j or m	
	d	$^2J_{\text{CF}} 25.5$			
122.5	t	$^1J_{\text{CF}} 281.6$		h or k	

No. 35 1-(2,2,3,4,4,4-hexafluoro-1-methylbutyl)-2-(1,1,2,3,3,3-hexafluoropropyl) piperidine (112)

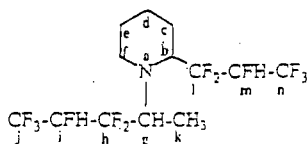

NMR	Chemical Shift (ppm)	Multiplicity	Coupling Constant (Hz)	Relative Intensity	Assignment
^1H	1.4	d	$^3J_{\text{HH}}$ 7.2	3	k
	1.5	m		2	e
	1.7	m		2	d
	1.8	m		1	c
	1.9	m		1	c
	3.0	m		2	f
	3.4-3.6	m		1	g
	3.4-3.6	m		1	b
	4.7-5.0	m		2	i, m
^{19}F	-74.2	m		6	j, n
	-115.2	syst AB dm	$^2J_{\text{FF}}$ 275.2	1	h or l
	-116.1	syst AB dm	$^2J_{\text{FF}}$ 275.2	1	h or l
	-118.1	syst AB dm	$^2J_{\text{FF}}$ 263.5	1	h or l
	-122.4	syst AB dm	$^2J_{\text{FF}}$ 263.5	1	h or l
	-210.4	d	$^2J_{\text{FH}}$ 46.3	1	m or i
		m			
	-212.7	d	$^2J_{\text{FH}}$ 43.7	1	m or i
	m				
^{13}C	13.0	m			k
	20.3	d	$^4J_{\text{CF}}$ 1.5		d
	21.6	s			c
	23.2	s			e
	42.9	s			f
	57.6	d	$^2J_{\text{CF}}$ 26.6		b
		d	$^2J_{\text{CF}}$ 20.2		
	60.2	t	$^2J_{\text{CF}}$ 20.6		g
	80.0-90.0	m			i, m
	115.0-125.0	m			j, h, l, n

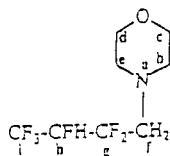

NMR	Chemical Shift (ppm)	Multiplicity	Coupling Constant (Hz)	Relative Intensity	Assignment
^1H	2.5-2.6	m		2	b, e ax or eq
	2.6-2.7	m		2	b, e ax or eq
	2.8	m		2	f
	3.7	t	$^3J_{\text{HH}} 4.4$	4	c, d
	5.2	d	$^2J_{\text{FH}} 43.2$	1	h
^{19}F	-74.3	m		3	i
	-113.4	syst AB dm	$^2J_{\text{FF}} 272.6$	1	g
	-116.0	syst AB dm	$^2J_{\text{FF}} 272.6$	1	g
	-213.1	d	$^2J_{\text{FH}} 43.7$	1	h
^{13}C	54.5	s			b, e
	58.7	d	$^2J_{\text{CF}} 29.4$		f
		d	$^2J_{\text{CF}} 22.8$		
	67.0	s			c, d
	83.8	d	$^1J_{\text{CF}} 192.8$		h
		d	$^2J_{\text{CF}} 36.2$		
		d	$^2J_{\text{CF}} 34.5$		
		q	$^2J_{\text{CF}} 25.5$		
	119.1	d	$^1J_{\text{CF}} 253.8$		g
		d	$^1J_{\text{CF}} 248.5$		
	d	$^2J_{\text{CF}} 24.3$			
	121.0	q	$^1J_{\text{CF}} 281.9$		i
		d	$^2J_{\text{CF}} 25.9$		

No. 36 4-(2,2,3,4,4,4-hexafluorobutyl)morpholine (113)

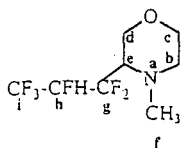

NMR	Chemical Shift (ppm)	Multiplicity	Coupling Constant (Hz)	Relative Intensity	Assignment
^1H	2.7-3.0	m		3	b, e
	3.6	m		2	c, d ax or eq
	3.8	m		3	f
	3.9	m		2	c, d ax or eq
	5.2-5.4	m		i	h
^{19}F	-74.2	m		3	i
	-116.2	syst AB dm	$^2J_{\text{FF}} 282.3$	1	g
	-117.7	syst AB dm	$^2J_{\text{FF}} 282.3$	1	g
	-211.1	d	$^2J_{\text{FH}} 43.7$	1	h
^{13}C	54.2	s			b, e
	59.4	m			f
	66.1	s			c, d
	82.0-85.0	m			h
	116.4-125.3	m			g, i

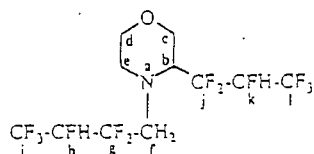

NMR	Chemical Shift (ppm)	Multiplicity	Coupling Constant (Hz)	Relative Intensity	Assignment
^1H	2.6-2.7	m		2	e _{ax} or e _q
	3.0	m		2	b
	3.2-3.3	m		2	f
	3.2-3.4	m		2	f
	3.4-3.5	m		2	e _{ax} or e _q
	3.5-3.6	m		2	f
	3.5-3.6	m		2	d _{ax} or e _q
	3.7-3.8	m		2	d _{ax} or e _q
	4.10	s		2	c _{ax} or e _q
	4.14	s		2	c _{ax} or e _q
	4.9	d	$^2J_{\text{FH}}$ 43.2	2	h or k
		m			
		5.2	d	$^2J_{\text{FH}}$ 42.4	2
	m				
^{19}F	-74.1	m		6	i or l
	-74.5	m		6	i or l
	-113.1	syst AB dm	$^2J_{\text{FF}}$ 275.2	2	j or g
	-114.1	syst AB dm	$^2J_{\text{FF}}$ 275.2	2	j or g
	-117.1	syst AB dm	$^2J_{\text{FF}}$ 263.5	2	j or g
	-118.2	syst AB dm	$^2J_{\text{FF}}$ 263.5	2	j or g
	-210.4	d	$^2J_{\text{FH}}$ 46.3	2	h or k
		m			
	-211.0	t	$^2J_{\text{FH}}$ 43.7	2	h or k
^{13}C	47.6	s			e
	48.0	s			e
	55.1	m			f
	58.7	d	$^2J_{\text{CF}}$ 22.5		b
		d	$^2J_{\text{CF}}$ 10.0		
	59.0	d	$^2J_{\text{CF}}$ 22.3		b
		d	$^2J_{\text{CF}}$ 10.3		
	61.3	m			c
	61.6	d	$^3J_{\text{CF}}$ 3.1		c
	63.4	s			d
	64.2	s			d
	80.0-87.0	m			h, k
	118.2	d	$^1J_{\text{CF}}$ 251.5		j or g
		d	$^1J_{\text{CF}}$ 250.1		
		d	$^2J_{\text{CF}}$ 22.5		
	118.4	d	$^1J_{\text{CF}}$ 275.5		j or g
		d	$^1J_{\text{CF}}$ 249.6		
	d	$^2J_{\text{CF}}$ 23.6			
116.6-125.2	m			i or l	
120.6	q	$^1J_{\text{CF}}$ 258.3		i or l	
	d	$^2J_{\text{CF}}$ 25.6			
120.9	q	$^1J_{\text{CF}}$ 286.3		i or l	
	d	$^2J_{\text{CF}}$ 29.6			
120.9	q	$^1J_{\text{CF}}$ 290.7		i or l	
	d	$^2J_{\text{CF}}$ 28.7			

Major Diastereoisomers

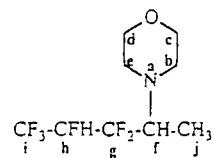

NMR	Chemical Shift (ppm)	Multiplicity	Coupling Constant (Hz)	Relative Intensity	Assignment
^1H	1.2	d	$^3\text{J}_{\text{HH}}$ 1.2	3	j
	2.5	m	$^4\text{J}_{\text{FH}}$ 7.2	2	b, e ax or eq
	2.7	m		2	b, e ax or eq
	3.1	m		1	f
	3.7	m		4	c, d
	5.4	d	$^2\text{J}_{\text{FH}}$ 42.2	1	h
			d q	$^3\text{J}_{\text{FH}}$ 20.6 $^3\text{J}_{\text{FH}}$ 6.4	
^{19}F	-74.2	d	$^3\text{J}_{\text{FF}}$ 11.7	3	i
		d	$^3\text{J}_{\text{FH}}$ 6.0		
		t	$^4\text{J}_{\text{FF}}$ 11.7		
	-120.3	syst AB dm	$^2\text{J}_{\text{FF}}$ 270.7	1	g
	-124.9	syst AB dm	$^2\text{J}_{\text{FF}}$ 270.7	1	g
	-212.3	d	$^2\text{J}_{\text{FH}}$ 42.2	1	h
		m			
^{13}C	4.3	s (br)			j
	50.1	m			b, e
	59.7	d	$^2\text{J}_{\text{CF}}$ 28.4		f
		d	$^2\text{J}_{\text{CF}}$ 21.0		
	67.5	s			c, d
	83.5	d	$^1\text{J}_{\text{CF}}$ 191.7		h
		m			
	120.2	t	$^1\text{J}_{\text{CF}}$ 242.0		g
121.7	q	$^1\text{J}_{\text{CF}}$ 268.0		i	

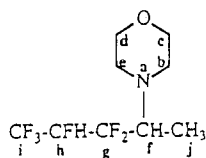
No. 38 4-(2,2,3,4,4,4-hexafluoro-1-methylbutyl)morpholine (115)
Minor Diastereoisomers

NMR	Chemical Shift (ppm)	Multiplicity	Coupling Constant (Hz)	Relative Intensity	Assignment
^1H	1.17-1.23	m		3	j
	2.5	m		2	b, e ax or eq
	2.7	m		2	b, e ax or eq
	3.1	m		1	f
	3.7	m		4	c, d
	5.2-5.6	m		1	h
^{19}F	-74.8	m		3	i
	-116.2	syst AB dm	$^2\text{J}_{\text{FF}}$ 269.1	1	g
	-118.1	syst AB dm	$^2\text{J}_{\text{FF}}$ 269.1	1	g
	-219.6	d	$^2\text{J}_{\text{FH}}$ 44.4	1	h
		sext	$^3\text{J}_{\text{FF}}$ 10.2		
^{13}C	5.1	m			j
	49.9	m			b, e
	61.1	d	$^2\text{J}_{\text{CF}}$ 26.7		f
		d	$^2\text{J}_{\text{CF}}$ 22.1		
	67.4	s			c, d
	85.5	d	$^1\text{J}_{\text{CF}}$ 191.7		h
		m			
	119.7	t	$^1\text{J}_{\text{CF}}$ 255.0		g
121.7	q	$^1\text{J}_{\text{CF}}$ 269.0		i	

No. 39 4-(2,2,3,4,4-hexafluoro-1-methylbutyl)-3-(1,1,2,3,3,3-hexafluoropropyl)
morpholine (116)

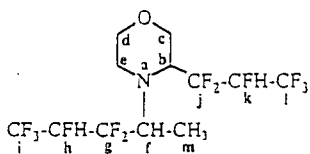

NMR	Chemical Shift (ppm)	Multiplicity	Coupling Constant (Hz)	Relative Intensity	Assignment
¹ H	1.36	d	³ J _{HH} 4.0	3	m
	1.37	d	³ J _{HH} 4.8	3	m
	2.7	d	² J _{HH} 66.8	2	c
		d	³ J _{HH} 12.4		
	3.2	d	² J _{HH} 51.6	2	c
		t	⁴ J _{FH} 10.8		
		d	³ J _{HH} 3.6		
	3.5	m		2	f
	3.6	m		2	b
	3.6	d	² J _{HH} 12.4	2	d, e ax or eq
		d	³ J _{HH} 3.6		
	3.7	d	² J _{HH} 12.3	2	d, e ax or eq
		d	³ J _{HH} 3.6		
	3.8	d	² J _{HH} 11.6	2	d, e ax or eq
		d	³ J _{HH} 3.6		
3.9	d	² J _{HH} 11.2	2	d, e ax or eq	
	d	³ J _{HH} 3.6			
	5.2	m		4	k, h
¹⁹ F	-74.2	d	³ J _{FF} 9.4	6	i or l
		d	³ J _{FH} 4.5		
		q	10.2		
	-74.4	d	³ J _{FF} 6.0	6	i or l
		q	¹ J _{FF} 11.7		
	-110.4	syst AB dm	² J _{FF} 281.2	1	j or g
	-115.1	syst AB dm	² J _{FF} 281.2	1	j or g
	-114.5	syst AB dm	² J _{FF} 284.2	1	j or g
	-116.9	syst AB dm	² J _{FF} 284.2	1	j or g
	-118.5	syst AB dm	² J _{FF} 262.9	1	j or g
	-120.6	syst AB dm	² J _{FF} 262.9	1	j or g
	-120.6	syst AB dm	² J _{FF} 270.2	1	j or g
	-125.4	syst AB dm	² J _{FF} 270.2	1	j or g
	-210.3	d	² J _{FH} 42.2	1	h or k
		q	³ J _{FF} 10.2		
-210.5	d	² J _{FH} 43.7	1	h or k	
	q	³ J _{FF} 8.7			
-211.1	d	² J _{FH} 35.6	1	h or k	
	m				
-211.2	d	² J _{FH} 53.8	1	h or k	
	m				
	-212.7	d	² J _{FH} 45.2	1	h or k
		m			
¹³ C	8.0	s			m
	11.9	s			m
	41.0	s			c
	59.5	m			f or b
	60.6	d	² J _{CF} 28.3		f or b
		d	³ J _{CF} 20.6		
	66.3	s			d or e
	67.4	s			d or e
	84.3	d	¹ J _{CF} 192.2		h, k
		m			
116.0-123.0	m			i, j, g, l	
120.5	q	¹ J _{CF} 282.2		i or l	

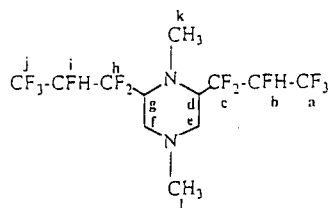

NMR	Chemical Shift (ppm)	Multiplicity	Coupling Constant (Hz)	Relative Intensity	Assignment
^1H	2.33	s		6	k or l
	2.35	s		6	k or l
	2.36	s		6	k or l
	2.5	s		6	k or l
	2.6-2.8	m		16	e, f
	3.5	m		8	d, g
	5.1	m		8	b, i
^{19}F	-74.0	d q	$^3J_{\text{FH}} 5.6$ $^3J_{\text{FF}} 4J_{\text{FF}}$ 10.2	12	a, j
	-74.4	m		6	a, j
	-74.6	m		6	a, j
	-111.3	syst AB dm	$^2J_{\text{FF}} 277.2$	1	h or l
	-114.0	syst AB dm	$^2J_{\text{FF}} 277.2$	1	h or l
	-113.7	syst AB dm	$^2J_{\text{FF}} 270.6$	1	h or l
	-114.6	syst AB dm	$^2J_{\text{FF}} 270.6$	1	h or l
	-117.3	syst AB dm	$^2J_{\text{FF}} 272.9$	1	h or l
	-118.5	syst AB dm	$^2J_{\text{FF}} 272.9$	1	h or l
	-118.0	m		2	h, l
	-211.0	d m	$^2J_{\text{FH}} 43.7$	2	b, i
	-211.4	d m	$^2J_{\text{FH}} 42.6$	2	b, i
	-214.3	d m	$^2J_{\text{FH}} 41.0$	2	b, i
	-217.3	m		2	b, i
	^{13}C	38.6	s		
44.5		s			e, f
45.0		s			e, f
45.8		s			e, f
46.5		s			k or l
48.0		s			e, f
59.0		t	$^2J_{\text{CF}} 18.6$		d, g
59.8		t	$^2J_{\text{CF}} 18.0$		d, g
60.2		t	$^2J_{\text{CF}} 20.6$		d, g
82.0-85.2		m			b, i
121.3		q d	$^1J_{\text{CF}} 226.0$ $^2J_{\text{CF}} 20.8$		a, j
116.0-125.0	m			a, c, h, j	

No. 41 1,4-dimethyl-2,3,5-tris(1,1,2,3,3,3-hexafluoropropyl)piperazine (118)

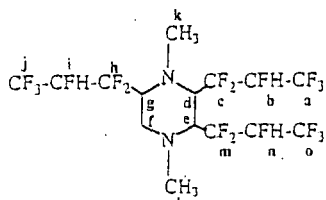

NMR	Chemical Shift (ppm)	Multiplicity	Coupling Constant (Hz)	Relative Intensity	Assignment
^1H	2.55	s		3	k or l
	2.56	s		3	k or l
	2.65	s		3	k or l
	2.0-3.0	m			f
	3.0-3.4	m			d, e, g
	4.9	d	$^2J_{\text{FH}} 46.7$		b, n, i
	5.2	m	$^2J_{\text{FH}} 43.2$		b, n, i
^{19}F	-74.1	m		3	a or j or o
	-74.3	m		3	a or j or o
	-74.5	m		3	a or j or o
	-110.1	m		6	c, h, m
	-130.0				
	-211.1	m		1	b or i or n
	-211.4	d	$^2J_{\text{FH}} 45.2$	1	b or i or n
	-212.6	m	$^2J_{\text{FH}} 43.3$	1	b or i or n
^{13}C	39.9-44.8	s			f, k, l
	54.0-59.5	m			d, e, g
	82.3-87.0	m			b, i, n
	116.0-123.0	m			a, c, h, j, m, o

No. 42 1-((Z,Z)-2,3,4,4,4-pentafluoro-1-methylbut-2-enyl)-2-((1Z)-1,2,3,3,3-pentafluoroprop-1-enyl)piperidine (119)

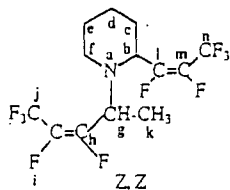

NMR	Chemical Shift (ppm)	Multiplicity	Coupling Constant (Hz)	Relative Intensity	Assignment
^1H	1.4	d	$^3J_{\text{HH}}$ 7.2	3	k
	1.5	m		1	e ax or eq
	1.6	m		2	d
	1.8	m		3	c, e ax or eq
	2.6	m		1	f
	3.2	m		1	f
	3.6	d	$^3J_{\text{FH}}$ 30.0	1	b
		d	$^3J_{\text{HH}}$ 8.4		
	3.9	d	$^3J_{\text{FH}}$ 33.2	1	g
		q	$^3J_{\text{HH}}$ 7.2		
^{19}F	-66.4	s		3	n or j
	-67.4	s		3	n or j
	-131.0	d	$^3J_{\text{FH}}$ 31.9	1	l or h
	-132.4	d	$^3J_{\text{FH}}$ 26.3	1	l or h
	-156.2	quint	$^3J_{\text{FF}}$ 10.2	1	CF (i or m)
	-157.4	m			
	quint	$^3J_{\text{FF}}$ 12.8	1	CF (i or m)	
	m				
^{13}C	16.3	s			k
	22.9	s			e
	25.7	s			d
	31.5	s			c
	46.1	d	$^4J_{\text{CF}}$ 3.5		f
	52.0	d	$^2J_{\text{CF}}$ 19.0		g
	55.3	d	$^2J_{\text{CF}}$ 17.2		b
	119.4	d	$^1J_{\text{CF}}$ 271.4		h or i or
		d	$^2J_{\text{CF}}$ 41.5		j or l or m
		m			or n
	136.5	d	$^1J_{\text{CF}}$ 257.1		h or i or
		m			j or l or m
				or n	
154.0	d	$^1J_{\text{CF}}$ 274.2		h or i or	
	d	$^2J_{\text{CF}}$ 46.3		j or l or m	
	m			or n	

Appendix B : Mass Spectra

- No. 1 1-adamantanyl-1,1,2,3,3,3-hexafluoropropane (36)
- No. 2 1,1,2,3,3,3-hexafluoro-1-[3-(1,1,2,3,3,3-hexafluoropropyl)adamantanyl]propane (39)
- No. 3 1-[3,5-bis(1,1,2,3,3,3-hexafluoropropyl)adamantanyl]-1,1,2,3,3,3-hexafluoropropane (41)
- No. 4 1,1,2,3,3,3-hexafluoro-1-[3,5,8-tris(1,1,2,3,3,3-hexafluoropropyl)adamantanyl]propane (42)
- No. 5 1-(1,1,2,3,3,3-hexafluoropropyl)cyclopentane (43)
- No. 6 1,1,2,3,3,3-hexafluoro-1-[3-(1,1,2,3,3,3-hexafluoropropyl)cyclopentyl]propane (44b)
- No. 7 1-(1,1,2,3,3,3-hexafluoropropyl)cyclopentanol (46)
- No. 8 1-(1,1,2,3,3,3-hexafluoropropyl)cyclopentene (49)
- No. 9 (1*E*)-1-adamantanyl-1,2,3,3,3-pentafluoroprop-1-ene (53a) and (1*Z*)-1-adamantanyl-1,2,3,3,3-pentafluoroprop-1-ene (53b)
- No. 10 1-(*E*-pentafluoroprop-2-enyl)cyclopentane (54a) and 1-(*Z*-pentafluoroprop-2-enyl)cyclopentane (54b)
- No. 11 1-[(1*R*,3*R*)-3-((1*Z*)-1,2,3,3,3-pentafluoroprop-1-enyl)cyclopentyl](1*Z*)-1,2,3,3,3-pentafluoroprop-1-ene (55) and 1-[(3*S*,1*R*)-3-((1*Z*)-1,2,3,3,3-pentafluoroprop-1-enyl)cyclopentyl](1*Z*)-1,2,3,3,3-pentafluoroprop-1-ene (56)
- No. 12 1-(1,2,3,3,3-pentafluoro-*Z*-prop-1-enyl)cyclopentene (57b)
- No. 13 (1*E*)-1-cyclopentyl-1-ethoxy-2,3,3,3-tetrafluoroprop-1-ene (75a) and (1*Z*)-1-cyclopentyl-1-ethoxy-2,3,3,3-tetrafluoroprop-1-ene (75b)
- No. 14 1-cyclopentyl-1-ethoxy-1,2,3,3,3-pentafluoropropane (76)
- No. 15 1-cyclopentyl-2,3,3,3-tetrafluoropropan-1-one (77)
- No. 16 1-cyclopentyl-1,2,3,3,3-pentafluoro-1-methoxypropane (78)
- No. 17 1-cyclopentyl-2-fluoro-2-trifluoromethyl-4-penten-1-one (79)
- No. 18 1-cyclopentyl-2-fluoro-2-trifluoromethyl-3,4-pentadien-1-one (85)
- No. 19 1-cyclopentyl-2-fluoro-3-methyl-2-trifluoromethyl-4-penten-1-one (86)
- No. 20 cyclopentane carboxylic acid (88)
- No. 21 1-cyclopentyl-3-ethenyl-2-fluoro-3,7-dimethyl-2-trifluoromethyl-6-octen-1-one (92)
- No. 22 1-cyclopent-1-enyl-2-fluoro-3,7-dimethyl-2-(trifluoromethyl)-3-vinyloct-6-en-1-one (93)

- No. 23 Z-(1-cyclopentyl-2,3,3,3-tetrafluoro-1-propenoxy)methylbenzene (94)
- No. 24 Z-(1-butyl-2,3,3,3-tetrafluoro-1-propenyl)cyclopentane (99)
- No. 25 Z-(1-phenyl-2,3,3,3-tetrafluoro-1-propenyl)cyclopentane (101)
- No. 26 1,2-dibromo-1-cyclopentyl-1,2,3,3,3-pentafluoropropane (103)
- No. 27 diethyl(2,2,3,4,4,4-hexafluoro-1-methylbutyl)amine (104)
- No. 28 bis(2,2,3,4,4,4-hexafluoro-1-methylbutyl)ethylamine (105)
- No. 29 tris(2,2,3,4,4,4-hexafluoro-1-methylbutyl)amine (106)
- No. 30 (2,2,3,4,4,4-hexafluorobutyl)(2,2,3,4,4,4-hexafluoro-1-methylbutyl)methylamine (107)
- No. 31 bis(methylethyl)(2,2,3,4,4,4-hexafluoro-1-methylbutyl)amine (108)
- No. 32 (2,2,3,4,4,4-hexafluoro-1,1-dimethylbutyl)(2,2,3,4,4,4-hexafluoro-1-methylbutyl)(methylethyl)amine (109)
- No. 33 2-(1,1,2,3,3,3-hexafluoropropyl)-1-methylpyrrolidine (110)
- No. 34 1-(2,2,3,4,4,4-hexafluorobutyl)-2-(1,1,2,3,3,3-hexafluoropropyl)piperidine (111)
- No. 35 1-(2,2,3,4,4,4-hexafluoro-1-methylbutyl)-2-(1,1,2,3,3,3-hexafluoropropyl)piperidine (112)
- No. 36 4-(2,2,3,4,4,4-hexafluorobutyl)morpholine (113)
- No. 37 4-(2,2,3,4,4,4-hexafluorobutyl)-3-(1,1,2,3,3,3-hexafluoropropyl)morpholine (114)
- No. 38 4-(2,2,3,4,4,4-hexafluoro-1-methylbutyl)morpholine (115)
- No. 39 4-(2,2,3,4,4,4-hexafluoro-1-methylbutyl)-3-(1,1,2,3,3,3-hexafluoropropyl)morpholine (116)
- No. 40 2,6-bis(1,1,2,3,3,3-hexafluoropropyl)-1,4-dimethylpiperazine (117)
- No. 41 1,4-dimethyl-2,3,5-tris(1,1,2,3,3,3-hexafluoropropyl)piperazine (118)
- No. 42 1-((2Z)-2,3,4,4,4-pentafluoro-1-methylbut-2-enyl)-2-((1Z)-1,2,3,3,3-pentafluoroprop-1-enyl)piperidine (119)

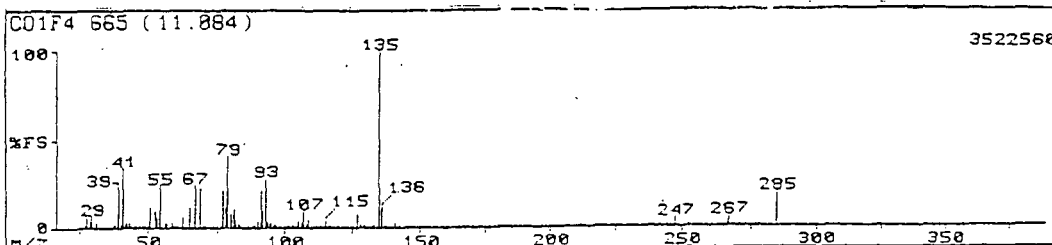

Mass	Rel Int	Mass	Rel Int	Mass	Rel Int	Mass	Rel Int
20	0.16	85	1.20	140	0.95	194	0.05
21	0.01	86	0.24	141	1.89	195	0.14
25	0.08	87	0.50	142	0.81	197	0.55
26	5.49	88	0.58	143	0.53	198	0.07
27	3.58	89	1.60	144	0.29	199	0.27
28	6.69	90	3.58	145	1.08	201	0.09
29	3.26	91	21.74	146	0.40	202	0.22
31	0.93	92	9.88	147	0.35	205	1.04
33	0.04	93	38.49	148	0.14	206	0.11
35	0.12	94	4.01	149	0.22	207	0.13
36	1.67	95	3.20	150	0.47	209	0.89
37	1.56	96	1.85	151	2.24	210	0.15
38	21.25	97	1.95	152	0.31	211	0.53
39	2.35	98	0.53	153	0.60	212	0.05
40	34.42	99	0.53	154	0.37	213	0.07
41	2.94	100	0.52	155	0.41	215	0.11
42	3.11	101	1.69	156	0.18	217	0.31
43	1.45	102	0.92	157	0.17	218	0.05
44	0.52	103	2.21	158	0.49	219	0.46
45	0.22	104	1.42	159	0.55	220	0.06
46	1.78	105	1.95	160	0.14	221	0.07
47	0.17	106	2.94	161	0.12	223	0.68
48	0.25	107	10.12	162	0.10	224	0.07
49	4.04	108	1.83	163	0.34	225	0.36
50	11.51	109	4.88	164	0.33	226	0.12
51	9.77	110	1.16	165	0.79	227	0.16
52	5.78	111	0.63	166	0.13	229	1.10
53	24.19	112	0.55	167	0.19	230	0.20
54	2.97	113	2.18	168	0.12	231	0.48
55	2.73	114	1.41	169	0.33	232	0.03
56	3.14	115	3.66	170	0.15	233	0.03
57	0.31	116	1.18	171	0.31	235	0.02
58		117	1.29	172	0.08	237	0.22
59		118	0.59	173	0.21	238	0.06
60		119	1.72	174	0.04	239	0.06

No. 2 1,1,2,3,3,3-hexafluoro-1-(3-(1,1,2,3,3,3-hexafluoropropyl)adamantanyl)propane (39)

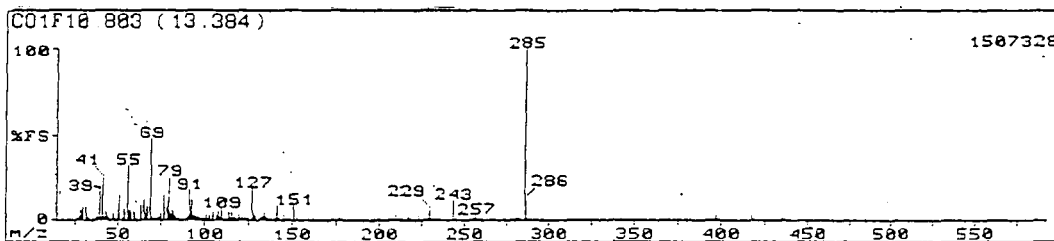

Mass	Rel Int	Mass	Rel Int	Mass	Rel Int	Mass	Rel Int
20	0.73	85	1.72	139	1.10	195	0.64
21	0.06	86	0.45	140	3.18	197	1.58
24	0.35	87	0.93	141	8.56	198	0.09
25	0.63	88	1.31	142	2.02	199	0.58
26	2.46	89	2.17	143	1.24	200	0.17
27	6.11	90	4.03	144	0.82	201	0.35
28	5.77	91	17.19	145	2.46	203	0.45
29	7.88	92	8.15	146	1.12	203	0.76
31	7.54	93	11.41	147	0.99	204	0.12
32	2.12	94	2.48	148	0.38	205	0.55
33	1.10	95	3.29	149	0.54	205	0.58
35	0.08	96	2.11	150	2.07	206	0.16
36	0.15	97	2.19	151	8.83	207	0.17
37	1.46	98	0.71	152	0.97	209	1.43
38	1.77	99	1.06	153	1.70	209	1.52
39	16.24	100	1.17	154	0.90	210	0.62
40	1.63	101	3.07	155	1.38	211	0.91
41	24.72	102	1.39	156	0.42	212	0.10
42	2.06	103	2.92	157	0.45	213	0.24
43	4.55	104	1.75	158	0.85	214	0.04
44	2.63	105	4.82	159	1.97	215	0.15
45	0.82	106	2.50	160	0.34	217	1.68
47	1.48	107	4.42	161	0.44	217	2.55
48	0.23	108	1.99	162	0.20	218	0.18
50	5.57	109	7.20	163	0.89	219	0.31
51	14.40	110	1.36	164	0.80	220	0.03
52	2.22	111	0.82	165	0.90	221	0.11
53	6.39	112	1.15	166	0.29	223	2.79
55	32.07	113	4.55	167	0.51	224	0.33
56	5.91	114	2.28	168	0.33	225	0.53
57	5.71	115	5.30	169	0.89	226	0.04
59	5.03	116	1.80	170	0.44	228	0.34
60	0.75	117	2.04	171	0.89	229	4.42
61	1.41	118	1.05	172	0.34	229	5.84
62	8.36	119	2.68	173	0.61	231	1.21
65	11.96	120	1.14	174	0.33	231	1.34
66	7.55	121	1.53	175	0.34	233	0.17
67	7.68	122	1.14	176	0.62	234	0.03
68	47.55	123	1.87	177	1.55	235	0.18
70	1.56	124	0.56	178	0.39	235	0.19
71	1.01	125	0.74	179	0.51	237	0.96
72	0.70	126	3.80	180	0.16	239	0.10
73	1.95	127	18.48	181	0.36	241	0.83
74	1.87	128	3.97	182	0.48	242	0.44
75	3.75	129	2.70	183	1.09	243	11.89
76	3.36	130	0.95	184	0.18	245	0.68

No. 3 1-[3,5-bis(1,1,2,3,3,3-hexafluoropropyl)adamantanyl]-1,1,2,3,3,3-hexafluoro propane (41)

M⁺ = 586

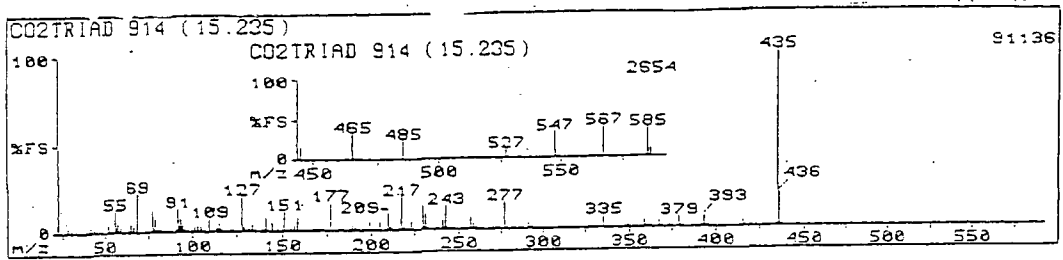

Mass	Rel Int	Mass	Rel Int	Mass	Rel Int	Mass	Rel Int
28	3.20	98	0.61	153	2.18	208	0.57
29	0.35	99	0.75	154	0.71	209	9.27
32	1.51	100	0.54	155	1.52	210	1.46
39	1.16	101	3.16	156	0.39	211	2.50
40	0.45	102	1.05	157	3.27	212	0.43
41	3.32	103	3.95	158	0.90	213	0.74
42	0.33	104	1.23	159	7.87	214	0.37
43	0.99	105	2.60	160	1.02	215	0.80
44	0.39	106	1.49	161	0.85	216	0.28
47	1.53	107	0.62	162	0.36	217	19.10
51	4.04	108	0.55	163	1.53	218	2.05
52	0.30	109	7.58	164	1.25	219	2.42
53	1.28	110	1.25	165	2.07	220	0.39
54	0.62	111	0.83	166	0.56	221	0.99
55	12.36	112	0.28	167	2.12	222	0.37
56	2.72	113	3.18	168	0.24	223	4.56
57	5.20	114	1.53	169	1.76	224	0.92
58	0.37	115	5.20	170	0.44	225	0.70
59	2.70	116	2.02	171	2.25	227	0.90
61	1.10	117	2.18	172	0.83	228	0.53
63	0.38	118	0.46	173	2.16	229	13.13
64	0.49	119	1.21	174	0.30	230	1.70
65	5.06	120	0.50	175	0.45	231	9.13
66	0.96	121	2.42	176	1.07	232	1.16
67	2.46	122	1.23	177	5.06	233	0.53
68	0.52	123	1.58	178	0.92	235	1.33
69	21.75	124	0.40	179	1.35	237	1.58
70	0.90	125	0.53	180	0.32	238	0.33
71	0.68	126	0.38	181	1.14	239	0.52
73	7.11	127	19.94	182	1.18	241	4.71
74	0.27	128	1.20	183	1.98	242	1.14
75	1.35	129	2.74	184	0.51	243	13.76
76	0.25	130	0.79	185	2.12	244	1.81
77	13.06	131	1.69	186	0.40	245	0.89
78	2.76	132	1.39	187	0.95	246	0.33
79	7.44	133	3.95	188	0.42	247	0.83
80	2.00	134	1.16	189	3.27	249	1.11
81	1.90	135	1.53	190	0.74	251	0.40
82	1.90	136	0.39	191	2.83	252	0.44
83	2.33	137	0.67	192	0.48	255	1.30
84	1.26	138	0.24	193	0.53	256	0.30
85	1.53	139	1.44	195	1.70	257	6.53
86	0.32	140	2.12	196	0.68	258	0.87
87	0.86	141	8.15	197	2.32	259	2.55
88	0.48	142	1.69	198	0.96	260	0.45
89	2.07	143	1.18	199	5.06	261	0.53
90	2.11	145	4.85	200	0.77	263	0.75
91	13.55	146	1.42	201	1.02	264	0.23
92	1.62	147	2.26	202	0.52	265	1.00
93	8.08	148	0.38	203	1.76	267	1.23
94	3.88	149	0.42	204	0.34	269	1.12
95	5.13	150	0.40	205	4.37	270	0.28
96	1.95	151	11.66	206	0.62	271	0.73
97	2.39	152	1.16	207	1.35	272	0.28
171	1.04	211	0.26	360	0.63	415	1.92
174	0.31	212	0.23	361	0.92	416	0.71
175	0.25	213	0.60	362	0.19	417	0.24
177	15.38	217	0.32	367	3.79	419	0.22
178	1.53	221	0.22	368	0.49	427	0.55
179	0.98	223	0.25	369	0.37	434	0.34
281	0.65	327	0.37	373	1.70	435	100.00
282	0.27	329	0.47	374	0.32	436	15.26
283	2.00	331	0.42	375	0.82	437	1.47
284	1.01	332	9.37	379	6.25	445	0.41
285	1.18	335	6.50	380	0.95	446	0.90
287	0.22	336	3.10	381	0.90	456	0.20
291	2.48	339	0.51	387	0.47	485	0.67
292	0.54	341	0.69	391	0.55	527	0.29
293	0.71	343	0.11	392	0.15	547	0.90
294	0.24	347	0.93	393	5.55	548	0.16
295	0.41	348	0.14	394	0.84	567	1.10
297	0.28	349	1.90	395	1.07	585	1.08
299	0.21	350	0.26	396	0.18	586	0.29
303	0.43	353	0.59	399	0.20		
305	0.19	355	1.19	405	0.30		
309	0.51	359	3.95	407	0.26		

No. 5 1-(1,1,2,3,3,3-hexafluoropropyl)cyclopentane (43)

M⁺ = 220

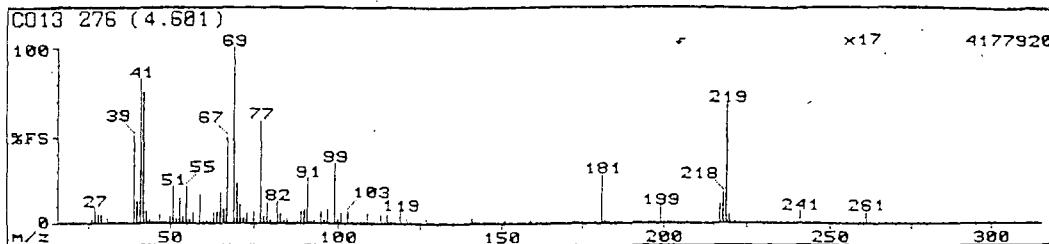

Mass	Rel Int	Mass	Rel Int	Mass	Rel Int	Mass	Rel Int
20	0.05	84	1.96	148	0.08	209	0.05
24	0.08	85	2.52	149	0.11	211	0.07
25	2.08	86	0.44	150	0.50	213	0.03
27	8.82	87	0.40	151	2.08	215	0.01
28	5.07	88	1.72	152	0.25	217	0.59
29	4.39	89	6.76	153	0.37	218	1.02
31	2.50	90	7.65	155	1.13	219	4.00
32	0.61	91	26.67	156	0.14	220	0.27
33	0.86	92	1.40	157	0.27	221	0.10
34	0.02	93	1.59	158	0.67	222	0.04
35	0.09	95	7.25	159	2.38	225	0.03
36	0.19	96	1.96	160	0.67	227	0.05
37	1.27	97	7.45	161	1.37	228	0.02
39	50.20	99	34.90	162	0.26	229	0.08
40	12.16	100	1.99	163	0.25	231	0.14
41	82.15	101	6.15	164	0.09	233	0.05
42	74.51	103	6.76	165	0.13	235	0.04
43	6.17	104	0.82	166	0.07	237	0.03
44	1.50	105	0.37	167	0.13	239	0.03
45	1.31	106	0.17	169	0.05	241	0.39
46	1.36	107	0.80	171	0.12	243	0.03
47	5.27	108	0.75	172	0.41	245	0.04
48	0.23	109	5.76	172	0.22	246	0.01
49	0.43	110	0.63	173	0.37	247	0.05
50	3.53	111	1.05	174	0.05	249	0.06
51	21.57	113	4.66	175	0.04	251	0.01
52	2.75	114	0.57	176	0.10	253	0.02

No. 6 1,1,2,3,3-hexafluoro-1-[3-(1,1,2,3,3,3-hexafluoropropyl)cyclopentyl]propane(44b)

M⁺ = 370

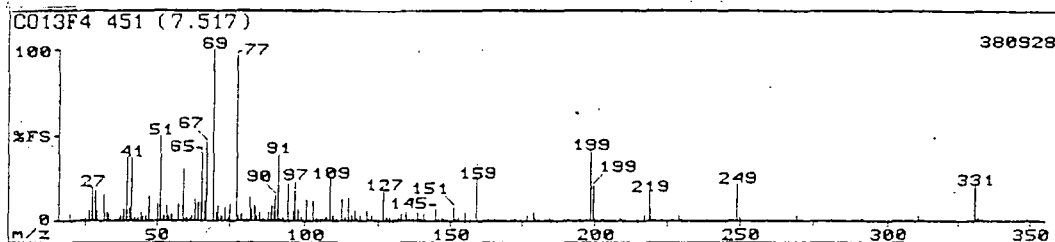

Mass	Rel Int	Mass	Rel Int	Mass	Rel Int	Mass	Rel Int
20	3.44	78	3.19	132	0.78	203	0.50
24	0.82	79	1.53	133	3.98	204	0.20
25	1.68	80	0.55	135	4.64	205	0.61
26	6.05	82	13.31	136	0.14	205	0.31
27	19.09	82	7.12	137	0.42	207	0.10
28	17.47	83	8.40	139	4.44	209	1.92
29	5.91	84	3.23	140	0.76	209	0.87
31	15.93	85	5.24	141	3.71	210	0.14
32	5.11	86	0.53	145	6.38	215	0.06
33	3.68	88	4.50	146	0.43	217	2.59
35	0.24	89	8.94	147	1.81	219	16.87
36	0.71	90	14.72	148	0.23	219	6.92
37	2.50	91	38.98	149	0.25	220	0.68
38	6.32	92	1.41	151	8.06	223	0.18
39	36.56	93	2.42	152	0.34	227	0.88
40	8.06	95	30.97	153	2.27	229	3.02
41	37.17	96	6.12	155	4.44	230	0.25
42	2.42	97	17.47	157	0.31	235	0.15
43	1.48	98	6.45	159	24.19	239	0.14
44	4.97	99	1.55	161	0.21	241	0.57
45	2.99	101	12.43	163	0.70	245	0.23
46	2.91	102	1.28	165	1.18	247	0.65
47	14.11	103	11.29	165	0.57	249	21.77
48	0.75	104	1.56	167	0.58	250	1.58
50	9.34	105	1.00	169	0.46	259	0.42
51	49.46	106	0.30	171	0.98	261	0.20
52	3.31	107	1.68	172	0.19	265	0.33
53	8.94	108	1.60	173	1.19	267	0.71
54	2.72	109	23.92	174	0.05	269	3.29
55	3.43	110	2.47	177	2.79	271	0.41
57	9.48	111	0.99	179	4.50	281	0.31
59	30.38	113	12.43	179	2.37	285	0.27
60	1.73	114	2.10	180	0.28	289	0.04
61	1.34	115	13.98	183	0.55	291	1.11
62	2.92	116	2.45	183	0.28	292	0.14
63	12.23	117	5.38	185	1.66	305	0.10
64	11.16	118	0.47	185	0.77	309	0.21
65	39.78	119	2.62	189	0.78	311	1.01
66	11.56	121	6.18	189	0.58	312	0.37
67	45.70	122	0.42	191	0.50	329	0.20
69	100.00	123	2.91	191	0.23	331	20.16
70	4.50	124	0.12	195	0.37	332	2.13
71	9.07	125	0.46	195	0.20	333	0.13
72	1.19	127	17.20	197	0.34	349	0.35
73	8.11	129	2.12	197	0.60	350	0.15
74	2.25	129	2.02	199	40.85	351	0.17
75	9.34	131	3.11	199	20.43		
77	95.70	132	1.80	200	2.05		

No. 7 1-(1,1,2,3,3,3-hexafluoropropyl)cyclopentanol (46)

M⁺ = 236

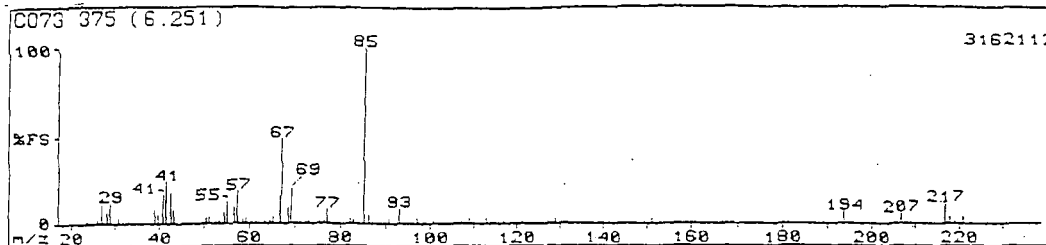

Mass	Rel Int	Mass	Rel Int	Mass	Rel Int	Mass	Rel Int
20	0.05	61	1.51	104	0.11	145	0.17
24	0.01	64	1.87	105	0.32	146	0.02
26	1.98	65	4.27	106	0.49	147	0.16
27	10.36	66	15.80	107	2.00	149	1.02
28	5.83	67	48.19	108	0.16	151	2.78
29	11.92	68	8.42	109	3.04	153	0.13
31	2.95	69	19.56	110	0.26	154	0.15
32	0.21	70	0.72	111	0.23	155	0.46
33	0.44	71	0.99	113	2.62	157	0.98
36	0.01	72	0.63	114	0.23	159	2.03
37	0.16	73	1.57	115	1.64	160	0.26
38	0.70	74	0.52	116	0.22	161	0.04
39	7.51	75	1.34	117	1.57	163	0.02
39	5.21	76	1.88	118	0.12	167	1.77
41	16.06	77	7.42	119	0.77	168	0.10
41	24.48	78	0.62	120	0.05	169	0.12
42	17.10	79	0.46	121	0.53	171	0.04
43	7.32	82	2.72	122	0.02	174	0.67
44	0.91	83	2.33	123	0.23	175	0.23
45	0.62	85	100.00	124	0.08	177	0.08
47	0.67	86	4.79	125	0.06	179	0.06
47	0.70	87	1.17	126	0.34	180	0.34
48	0.28	88	0.26	127	1.62	187	1.62
49	0.71	89	1.03	128	0.09	188	0.09
50	2.82	90	0.20	129	2.46	194	2.46
51	3.82	91	2.86	130	0.12	195	0.12
52	1.40	92	8.68	131	0.57	197	0.57
53	2.17	94	0.25	132	0.47	199	0.47
54	6.22	95	1.74	133	0.34	200	0.34
55	12.82	96	0.27	134	0.03	207	0.03
56	3.62	97	2.43	135	0.37	208	0.37
57	18.01	98	0.39	136	0.02	209	0.02
58	2.07	99	0.36	137	0.41	217	0.41
59	2.82	100	0.19	139	0.34	218	0.34
60	0.41	101	1.73	140	0.07	219	0.07
61	0.47	102	0.08	143	0.47	221	0.47
62	0.76	103	0.81	145	0.02	226	0.02

No. 8 1-(1,1,2,3,3,3-hexafluoropropyl)cyclopentene (49)

M⁺ = 218

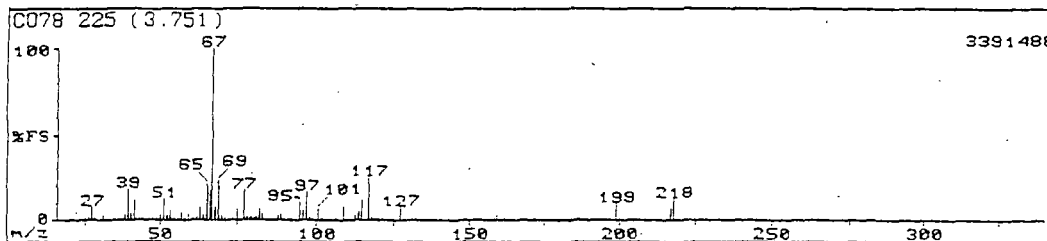

Mass	Rel Int	Mass	Rel Int	Mass	Rel Int	Mass	Rel Int
20	0.84	78	1.93	138	0.19	192	0.02
21	0.05	79	2.02	139	0.88	193	0.02
24	0.32	80	0.48	140	0.20	194	0.01
25	0.56	81	1.65	141	0.26	195	0.11
26	2.23	82	6.52	142	0.04	196	0.11
27	7.43	83	4.11	143	0.07	197	0.79
28	1.93	84	1.11	144	0.04	198	0.24
29	0.64	85	0.87	145	1.31	199	10.02
31	2.99	86	0.21	146	0.29	200	0.81
32	0.68	87	0.51	147	0.39	201	0.04
33	0.59	88	3.05	148	0.11	203	0.06
35	0.10	89	3.44	149	0.10	203	0.06
36	0.15	90	1.36	150	0.09	205	0.03
37	1.15	91	1.32	151	0.83	205	0.02
38	3.02	92	0.23	152	0.11	207	0.02
39	18.84	93	0.79	153	0.33	209	0.12
40	3.83	95	10.87	154	0.06	211	0.03
41	11.33	96	5.53	155	0.11	213	0.01
42	0.57	97	16.43	156	0.12	216	0.21
43	0.20	98	1.79	157	0.32	217	5.49
44	0.79	99	0.78	158	0.33	218	12.44
45	0.42	101	7.28	159	3.29	219	1.04
46	0.33	102	1.06	160	0.43	220	0.04
47	0.85	103	0.85	161	0.16	221	0.01
48	0.15	104	0.15	162	0.02	222	0.01
49	0.53	105	0.26	163	0.24	223	0.01
50	3.15	106	0.28	164	0.09	225	0.03
51	13.04	107	1.22	165	0.14	227	0.05
52	2.72	109	7.97	166	0.05	229	0.21
53	5.62	110	0.88	167	0.11	230	0.02
54	0.34	111	0.58	168	0.02	231	0.02
55	0.20	113	3.11	169	0.09	233	0.02
56	0.51	114	4.41	170	0.07	235	0.01
57	4.44	115	11.47	171	0.18	237	0.03
58	0.39	117	25.00	172	0.05	239	0.05
59	3.82	118	1.51	173	0.04	241	0.09
60	0.44	119	0.89	174	0.01	242	0.01
61	0.97	120	0.28	175	0.04	243	0.03
62	2.36	121	0.56	176	0.05	245	0.05
63	7.73	122	0.07	177	0.97	247	0.06
64	2.99	123	0.07	178	0.97	249	0.09
65	21.14	124	0.04	179	1.45	253	0.02
66	17.39	125	0.44	180	0.51	254	0.00
67	100.00	127	7.73	181	0.09	255	0.06
68	8.21	128	1.34	182	0.04	257	0.06
69	23.55	129	1.15	183	0.09	258	0.01
70	2.45	130	0.41	184	0.02	259	0.21
71	2.26	131	0.37	185	0.06	260	0.03
72	0.46	132	0.78	186	0.02	263	0.02
73	0.30	133	1.20	187	0.01	265	0.04
74	0.82	134	0.21	189	0.01	267	0.03
75	7.16	135	0.42	189	0.08	269	0.01
76	1.20	136	0.09	190	0.04	271	0.02
77	17.51	137	0.39	191	0.06	273	0.03
275	0.04	282	0.00	293	0.02		
277	0.01	283	0.01	295	0.02		
281	0.01	291	0.01	316	0.00		

M⁺ = 266

(53a)

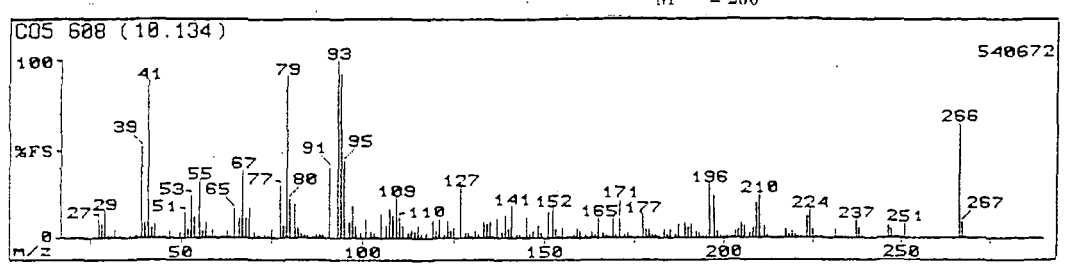

Mass	Rel Int	Mass	Rel Int	Mass	Rel Int	Mass	Rel Int
20	0.04	83	2.53	142	2.26	198	1.98
26	0.39	84	1.96	143	2.05	199	2.15
27	10.32	85	2.36	145	11.88	200	0.49
28	7.91	86	1.05	146	1.89	201	2.23
29	15.53	87	2.23	147	3.60	202	0.61
30	0.44	88	2.17	148	6.39	203	3.84
31	0.45	89	2.14	149	2.96	204	4.83
32	4.92	91	19.58	151	14.77	205	8.41
33	0.72	93	100.00	152	17.61	206	6.32
36	0.03	94	92.42	153	4.69	207	1.22
37	0.18	95	43.75	154	1.22	208	6.16
38	1.63	96	8.85	155	5.54	209	20.64
39	51.52	97	18.37	156	1.30	210	25.57
40	8.95	98	6.44	157	1.17	211	6.49
41	87.88	99	2.46	158	1.82	212	1.88
42	5.45	101	10.98	159	5.59	213	0.26
43	7.77	102	1.41	160	3.55	215	0.10
44	0.88	103	3.13	161	2.20	216	0.09
45	0.53	104	0.73	162	0.66	217	4.59
46	0.17	105	13.45	163	4.31	218	2.12
47	4.21	106	6.39	164	1.81	219	3.98
48	0.14	107	16.86	165	11.79	220	1.83
50	2.78	108	12.31	166	2.71	221	0.74
51	14.77	109	22.92	167	2.05	222	1.31
52	5.16	110	11.41	168	0.60	223	12.69
53	24.43	111	6.58	169	11.79	224	16.48
54	11.17	112	3.22	170	1.89	225	4.45
55	32.77	113	4.50	171	10.89	226	0.74
56	4.21	114	4.02	172	1.69	227	1.82
57	9.00	115	6.87	173	2.64	228	0.32

(53b)

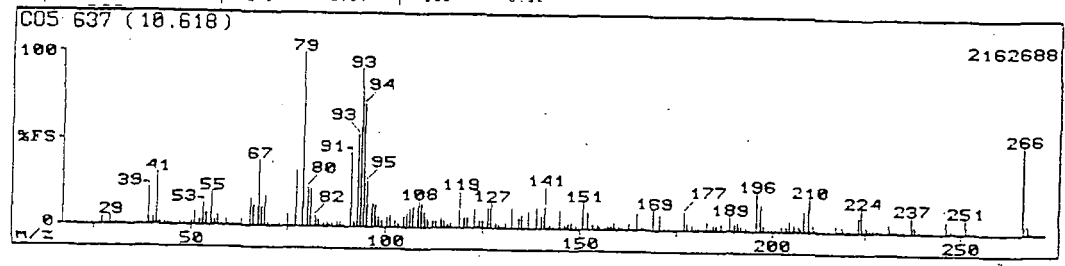

Mass	Rel Int	Mass	Rel Int	Mass	Rel Int	Mass	Rel Int
20	0.01	85	2.56	135	7.72	194	1.17
27	4.25	86	0.35	137	9.23	196	21.97
28	1.16	87	1.82	139	12.12	197	15.15
29	4.59	88	2.56	140	6.68	198	2.59
30	0.10	89	2.51	141	12.31	199	1.23
31	0.20	91	1.22	142	2.02	200	0.13
32	0.17	92	42.61	143	1.10	201	1.68
33	0.25	93	2.50	145	10.75	203	3.03
37	0.17	94	53.79	146	2.19	204	3.17
39	21.78	95	91.67	147	3.36	205	5.78
40	3.98	96	71.21	148	3.50	206	1.42
41	10.30	97	26.14	149	2.07	207	4.17
42	2.21	98	13.26	151	15.53	207	2.97
43	2.40	99	12.88	152	9.99	208	2.13
44	0.16	100	6.25	153	3.27	209	12.07
45	0.22	101	3.69	155	2.98	210	19.89
47	1.73	102	6.16	156	2.24	211	3.84
48	0.03	103	6.91	157	1.33	212	1.07
50	1.74	104	3.41	158	2.11	213	0.16
51	7.62	105	2.02	159	1.95	215	0.20
52	3.13	106	6.16	160	3.60	217	3.98
53	12.88	107	11.08	161	2.12	218	1.23
54	7.10	108	8.39	162	3.31	219	3.03
55	19.70	109	15.15	163	3.98	220	1.21
56	1.01	110	15.15	165	9.71	221	0.37
57	6.30	111	13.64	166	1.79	222	0.90
58	0.23	112	8.38	167	1.33	223	8.29
59	4.26	113	5.11	169	11.55	225	13.83
60	0.36	114	3.88	171	8.71	227	2.89
61	0.95	115	4.12	172	1.34	227	0.46
62	0.83	116	5.49	173	1.31	227	1.33
63	3.84	117	3.74	175	0.58	228	0.19
65	15.91	118	1.52	175	0.32	231	4.64
66	11.55	119	2.47	177	10.75	232	0.30
67	37.88	119	9.94	178	3.79	233	0.64
68	10.94	120	6.30	179	2.82	234	0.08
69	17.23	121	6.25	180	0.90	235	0.03
70	1.73	123	10.23	181	1.01	237	9.71
71	1.11	124	0.50	182	0.54	238	4.17
72	0.35	124	3.79	183	4.55	239	0.32
73	2.36	125	3.98	184	0.61	246	7.15
75	6.58	126	11.22	185	3.03	247	2.33
77	12.20	127	14.39	186	2.97	248	0.21
79	100.00	128	2.95	187	4.31	251	8.57
80	22.54	129	1.89	189	9.00	252	0.79
81	21.02	130	1.22	190	4.21	253	0.03
82	5.78	131	3.17	191	4.64	266	50.75
83	4.36	133	11.65	192	2.60	267	5.30
84	1.88	134	6.01	193	1.72	268	0.32

(54a)

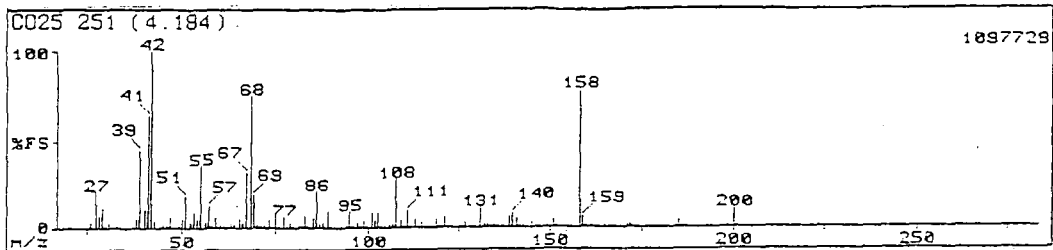

Mass	Rel Int	Mass	Rel Int	Mass	Rel Int	Mass	Rel Int
20	0.06	64	1.91	102	1.40	143	0.15
25	0.05	65	4.45	103	8.96	145	3.56
26	2.78	66	1.45	104	0.59	146	0.24
27	20.99	67	32.46	105	0.13	147	0.11
28	6.52	68	75.00	106	1.49	149	0.94
29	11.57	69	19.40	107	1.75	151	1.40
30	0.26	70	1.87	108	28.16	152	0.79
31	1.08	71	1.13	109	2.94	153	1.21
32	0.50	72	2.10	110	0.12	154	1.14
33	1.25	73	4.97	111	9.79	155	0.09
37	1.42	74	1.10	112	1.30	158	77.99
38	4.59	75	6.34	113	4.59	159	6.06
39	44.40	76	0.78	114	1.17	160	0.26
40	10.82	77	7.18	115	3.19	161	1.49
41	64.18	78	0.51	116	0.34	162	0.15
42	100.00	79	1.01	117	1.18	163	0.29
43	4.17	80	0.78	119	4.90	165	1.63
44	0.55	81	2.43	120	0.71	166	0.11
45	1.49	82	0.96	121	5.43	167	0.75
46	1.28	83	6.44	122	0.71	168	0.04
47	5.97	84	1.04	123	0.11	169	0.04
48	0.20	85	5.14	125	0.85	171	1.48
49	0.47	86	20.99	126	0.97	172	2.16
50	4.80	87	1.63	127	1.08	173	0.14
51	18.00	88	2.54	128	0.16	177	0.16
52	2.45	89	9.24	129	0.61	179	0.18
53	8.40	90	1.14	131	11.66	180	1.33
54	4.55	91	1.42	132	1.91	181	0.41
55	16.19	93	1.41	133	1.84	185	4.27
56	3.38	94	0.50	134	0.33	186	0.28
57	12.97	95	9.51	135	1.63	198	0.08
58	1.27	96	1.04	136	0.71	200	11.01
59	5.90	97	2.94	137	1.31	201	0.78
60	2.10	98	0.24	139	5.43	207	0.09
61	0.94	99	4.34	140	7.93	281	0.05
62	1.17	100	0.52	143	4.99		
63	3.19	101	8.86	143	0.40		

(54b)

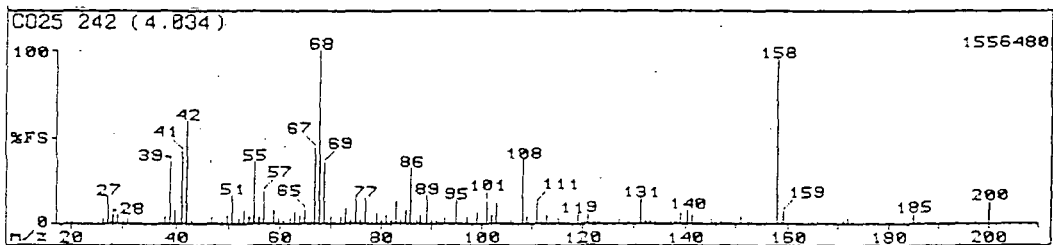

Mass	Rel Int	Mass	Rel Int	Mass	Rel Int	Mass	Rel Int
20	0.02	63	6.45	102	4.74	143	0.19
26	3.06	64	3.54	103	11.45	145	2.93
27	15.26	65	7.83	104	0.67	146	0.23
28	5.33	66	1.37	106	2.07	147	0.28
29	5.33	67	43.95	108	36.58	149	0.79
30	0.10	68	100.00	109	4.21	151	4.31
31	2.58	69	35.00	111	11.71	152	0.97
32	0.16	70	3.78	112	1.43	153	1.37
33	0.88	71	1.23	113	4.93	154	1.30
37	1.17	72	3.87	114	1.41	155	0.10
38	4.03	73	8.36	115	3.22	158	94.74
39	16.05	74	1.97	116	0.37	159	6.64
40	8.16	75	14.41	117	1.05	160	0.31
41	42.11	76	1.66	119	3.39	161	1.37
42	58.95	77	14.87	120	0.40	162	0.07
43	2.25	78	0.42	121	5.26	163	0.32
44	0.45	79	6.13	122	16.41	165	1.88
45	1.10	80	1.46	123	0.11	166	0.15
46	0.97	81	5.33	125	1.05	167	0.73
47	1.82	82	1.91	126	1.17	168	0.03
48	0.11	83	12.57	127	3.04	169	0.04
49	0.10	84	1.78	128	0.34	171	1.39
50	4.80	85	7.81	129	0.46	172	2.98
51	16.84	86	31.58	131	14.41	173	0.18
52	2.43	87	2.32	132	2.11	177	0.16
53	7.57	88	4.74	133	2.11	180	3.40
54	4.34	89	16.25	134	0.16	181	0.42
55	36.32	90	1.86	135	1.38	183	0.04
56	4.11	91	2.24	136	0.81	185	5.92
57	19.16	93	3.04	137	1.48	186	0.31
58	1.22	95	13.68	138	0.83	200	12.50
59	7.43	96	1.33	139	5.53	201	0.68
60	2.85	97	3.85	140	7.43	207	0.04
61	1.69	99	7.11	141	5.07		
62	2.59	101	12.50	142	0.37		

No. 11 1-((1R,3R)-3-((1Z)-1,2,3,3,3-pentafluoroprop-1-enyl)cyclopentyl)((1Z)-1,2,3,3,3-pentafluoroprop-1-ene (55) and 1-((3S,1R)-3-((1Z)-1,2,3,3,3-pentafluoroprop-1-enyl)cyclopentyl)((1Z)-1,2,3,3,3-pentafluoroprop-1-ene (56)

M⁺ = 330

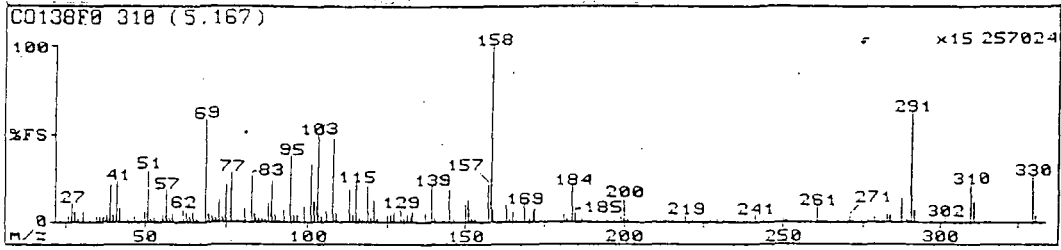

Mass	Rel Inc	Mass	Rel Inc	Mass	Rel Inc	Mass	Rel Inc
26	2.74	70	4.58	115	22.71	170	2.22
27	10.66	71	2.66	116	2.14	171	6.87
28	5.53	72	1.77	117	1.15	172	7.57
29	1.92	73	12.85	118	20.12	173	1.25
31	5.75	74	2.51	120	1.99	178	1.11
33	1.13	75	21.22	121	12.45	181	3.81
35	3.01	77	27.39	122	1.74	182	1.33
36	2.49	78	1.21	125	3.86	184	20.12
37	2.89	79	1.03	126	4.03	185	4.71
38	4.09	80	1.24	127	5.70	187	2.04
39	21.41	81	7.67	129	2.29	189	1.28
40	4.16	83	25.29	130	1.74	195	1.57
41	22.91	84	4.53	131	3.81	197	1.06
42	7.97	85	2.14	132	4.16	199	3.21
44	1.39	86	2.42	133	5.63	200	2.19
45	1.74	87	2.09	137	5.25	201	1.79
47	3.14	88	10.66	139	20.72	207	1.04
49	1.09	89	23.21	140	2.32	213	1.87
50	6.00	90	3.83	141	1.77	215	1.08
51	18.13	91	1.43	145	13.13	219	3.98
52	1.57	93	5.67	146	1.54	221	1.06
53	2.59	95	17.45	150	9.56	225	1.14
55	1.79	96	4.08	151	12.15	227	1.53
56	3.71	97	3.53	152	2.22	229	1.87
57	18.82	99	8.26	153	1.87	231	1.87
58	1.34	101	33.07	157	21.71	241	1.93
59	4.98	102	11.95	158	100.00	250	1.53
61	1.23	103	49.80	159	6.17	251	2.04
62	2.19	104	2.51	161	1.02	261	9.47
63	5.25	106	5.93	163	9.56	270	1.16
64	3.26	108	47.41	164	2.12	271	2.54
65	6.23	109	4.43	165	5.78	291	4.21
66	1.53	113	18.73	166	1.04	310	1.44
69	58.57	114	4.13	169	9.96	330	1.77

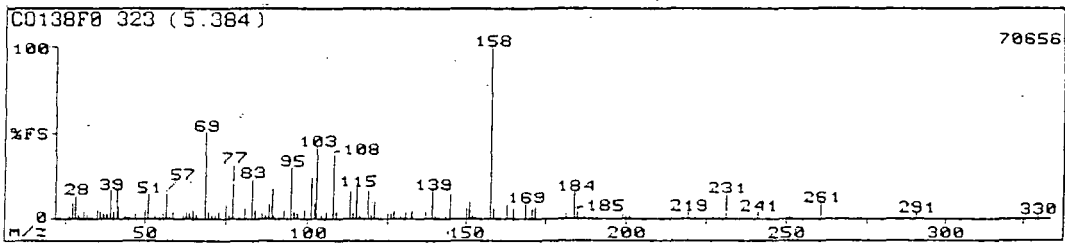

Mass	Rel Inc	Mass	Rel Inc	Mass	Rel Inc	Mass	Rel Inc
26	2.17	65	5.28	108	16.96	159	5.63
27	3.70	66	1.52	109	3.94	163	7.52
28	13.22	69	50.72	113	15.95	164	1.05
29	1.72	70	2.80	114	3.37	165	5.53
31	4.21	71	2.33	115	18.48	169	2.51
32	2.16	72	1.47	116	1.79	170	1.05
35	4.51	73	4.05	119	16.21	171	5.59
36	4.29	75	7.51	120	1.77	172	6.51
37	1.06	76	2.04	121	10.14	177	1.22
38	2.58	77	20.47	125	3.03	181	2.97
39	16.30	81	5.68	126	1.22	182	1.20
40	3.49	83	23.55	127	4.98	184	15.31
41	15.12	84	4.78	129	1.56	185	3.83
42	6.61	85	2.54	130	1.12	187	1.45
44	1.56	87	1.52	131	3.60	189	2.47
45	1.31	88	8.15	132	3.89	200	1.70
47	2.83	89	17.03	133	4.37	201	1.54
50	4.42	90	1.95	137	4.10	213	1.37
51	14.86	91	1.09	138	1.01	219	3.44
52	1.45	93	4.52	139	16.30	225	1.22
53	2.22	95	33.07	140	2.06	227	1.38
55	1.33	96	1.51	143	1.63	229	1.21
56	2.60	97	2.69	145	15.04	231	2.74
57	14.13	99	5.19	146	1.30	241	3.46
58	1.44	101	24.54	150	6.25	250	1.02
59	1.75	102	8.97	151	10.05	251	1.58
62	1.72	103	41.30	152	1.77	261	8.51
63	4.08	104	2.13	153	1.25	291	2.25
64	2.76	106	4.28	158	100.00	330	2.38

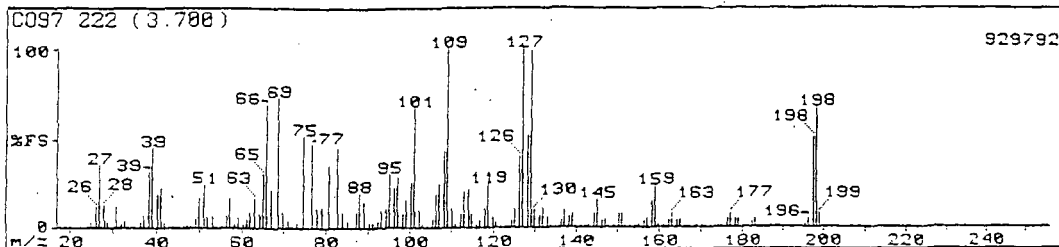

Mass	Rel Int	Mass	Rel Int	Mass	Rel Int	Mass	Rel Int
20	1.16	75	51.10	128	51.54	177	7.71
24	1.31	77	46.26	129	98.68	178	4.92
25	2.53	78	10.35	130	9.80	179	4.74
26	11.78	79	11.34	131	7.05	180	0.63
27	34.80	81	35.24	132	11.01	181	0.53
28	12.67	83	44.49	133	5.48	193	2.34
29	3.36	84	9.14	134	0.74	193	4.68
31	12.00	85	3.95	135	0.22	184	6.44
32	1.59	87	8.70	136	3.94	155	0.08
33	3.44	88	19.60	137	9.80	186	0.05
34	0.25	89	14.21	138	6.22	187	0.05
35	0.71	90	2.56	139	7.60	138	0.95
36	2.51	91	2.56	140	1.11	139	0.10
37	6.83	92	3.69	141	0.24	190	0.04
39	31.28	93	9.69	142	0.92	191	0.07
39	44.93	94	11.01	143	1.98	192	0.05
40	18.50	95	29.96	144	7.49	193	0.10
41	22.14	96	32.69	145	15.97	194	0.38
42	3.06	97	28.19	146	4.35	195	1.90
43	0.92	98	7.93	147	4.46	196	5.12
44	1.60	99	15.53	148	0.77	198	50.22
45	1.42	100	25.44	149	2.29	198	66.52
46	1.47	101	66.52	150	7.49	199	7.38
47	2.31	102	9.91	151	8.04	200	0.38
48	0.78	103	2.34	152	1.30	201	0.09
49	4.60	104	1.13	153	0.23	202	3.03
50	16.30	105	5.26	154	0.34	203	0.04
51	23.79	106	18.17	155	1.76	206	0.03
52	6.28	107	23.79	156	4.13	207	0.06
53	6.53	108	42.73	157	4.87	208	0.07
54	0.85	109	100.00	158	14.10	209	0.04
55	0.82	110	10.57	159	23.35	212	0.03
56	7.16	111	2.26	160	2.40	213	0.05
57	16.41	112	7.93	161	0.52	214	0.05
58	1.74	113	20.15	162	4.02	215	0.08
59	6.14	114	21.70	163	7.82	216	0.11
60	1.48	115	7.38	164	3.50	219	0.30
61	4.46	116	2.09	165	4.85	213	0.90
62	8.81	117	3.88	166	0.45	219	0.16
63	16.74	118	13.8	167	0.34	220	0.03
64	8.04	119	24.34	168	0.74	221	0.04
65	10.40	120	6.08	169	1.90	227	0.05
66	69.16	121	2.45	170	1.84	232	0.02
67	21.15	122	0.48	171	0.47	235	0.06
69	72.69	131	0.75	172	0.10	245	0.06
70	9.14	134	3.91	173	0.15	253	0.05
71	3.41	135	11.01	174	0.74		
72	1.40	126	40.09	175	1.36		
73	3.30	127	100.00	176	4.57		

No. 13 (1Z)-1-cyclopentyl-1-ethoxy-2,3,3,3-tetrafluoroprop-1-ene (75a) and (1Z)-1-cyclopentyl-1-ethoxy-2,3,3,3-tetrafluoroprop-1-ene (75b)

M⁺ = 226

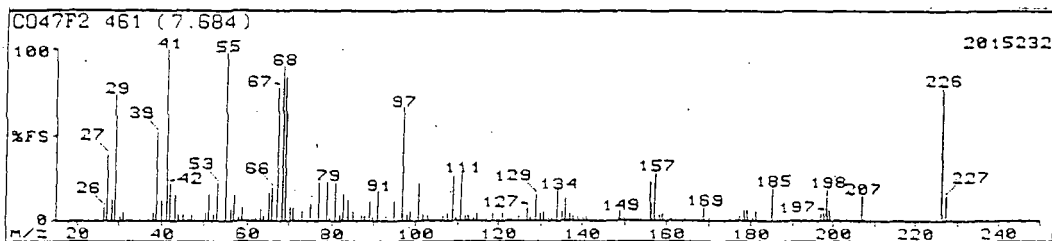

Mass	Rel Int	Mass	Rel Int	Mass	Rel Int	Mass	Rel Int
20	0.15	77	22.56	132	1.70	183	0.97
24	0.22	78	1.19	133	1.61	185	20.33
25	1.00	79	32.97	134	18.50	186	1.41
26	8.18	80	1.47	135	5.49	187	0.31
27	38.62	81	22.15	136	13.62	188	0.18
28	12.75	82	4.17	137	5.03	189	0.36
29	73.98	83	15.85	138	2.49	190	0.10
30	2.03	84	12.30	139	2.87	191	0.17
31	4.37	85	5.64	140	1.56	191	0.15
32	0.76	86	0.83	141	3.25	195	0.20
33	0.97	87	4.17	142	0.47	195	0.09
35	0.19	88	2.76	143	0.70	197	3.40
36	0.42	89	12.04	144	0.30	197	5.13
37	2.41	90	1.91	145	1.28	198	11.82
38	4.57	91	17.28	146	0.46	199	7.01
39	51.63	92	11.32	147	0.95	200	0.62
40	11.43	93	3.18	148	1.55	201	0.50
41	100.00	95	11.84	149	5.49	202	0.08
42	21.14	97	65.85	150	2.08	203	0.08
43	15.85	98	4.27	151	1.08	204	0.12
44	3.40	99	5.39	152	0.37	205	0.20
45	3.46	101	21.95	153	0.28	207	15.65
46	0.48	102	3.66	154	0.37	208	1.33
47	3.66	103	3.01	156	23.78	209	1.32
48	0.31	104	0.58	156	11.03	210	0.18
49	0.86	105	0.60	157	29.27	211	0.28
50	4.88	106	1.30	158	3.76	213	0.23
51	15.45	107	2.67	159	4.93	215	0.38
52	3.76	108	4.42	160	1.28	216	0.03
53	21.95	109	25.81	161	2.27	217	0.10
						55	98.37
						56	6.90
						57	15.24
						58	1.84
						59	8.23
						60	0.88
						61	0.74
						62	1.98
						63	7.06
						64	3.25
						65	16.26
						66	19.72
						67	77.24
						68	90.24
						69	84.55
						70	7.52
						71	7.52
						72	1.45
						73	5.79
						75	9.91
						110	7.43
						111	28.05
						112	2.60
						113	3.96
						114	1.54
						115	4.57
						116	1.44
						117	2.10
						119	5.23
						120	0.58
						121	5.08
						122	1.33
						123	1.27
						124	0.26
						125	3.13
						127	7.72
						128	1.51
						129	15.45
						130	5.13
						131	6.15
						162	0.49
						163	0.79
						164	0.32
						165	1.04
						166	0.10
						167	0.58
						168	2.02
						169	9.10
						170	2.03
						171	1.12
						172	0.16
						173	0.20
						175	0.42
						176	0.45
						177	2.49
						178	6.35
						179	6.40
						180	2.36
						181	5.69
						182	0.71
						219	0.0
						221	1.0
						223	0.0
						226	78.0
						227	15.0
						228	0.0
						230	0.0
						231	0.0
						233	0.0
						235	0.0
						237	0.0
						239	0.0
						241	0.0
						243	0.0
						245	0.0
						247	0.0
						249	0.0

Minor Diastereoisomer.

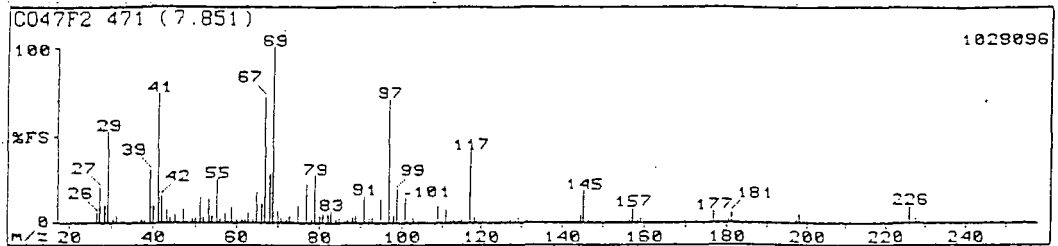

Mass	Rel Int	Mass	Rel Int	Mass	Rel Int	Mass	Rel Int
20	0.35	69	100.00	121	1.35	167	0.16
24	0.22	70	6.67	122	0.22	169	0.46
25	0.68	71	2.89	123	0.59	169	0.16
26	5.35	72	1.54	124	0.35	170	0.39
27	20.02	73	3.49	125	1.37	171	0.13
28	9.66	74	0.27	126	0.55	172	0.29
29	52.19	75	9.76	127	1.24	173	0.07
30	1.97	77	22.51	128	0.95	174	0.01
31	3.59	78	2.27	129	2.59	175	0.08
32	1.34	79	27.09	130	0.25	177	6.77
33	1.08	80	1.49	131	1.25	178	1.29
35	0.23	81	5.00	132	0.45	179	0.93
36	0.49	82	4.43	133	1.00	180	1.97
37	1.57	83	5.37	134	0.80	181	6.10
38	2.39	84	1.94	135	0.61	182	0.54
39	31.08	85	3.06	136	0.90	183	0.12
40	9.46	86	0.60	137	0.49	185	1.00
41	73.31	87	1.49	138	0.41	187	0.10
42	15.44	88	2.74	139	1.32	187	0.30
43	7.87	89	3.98	140	0.94	188	0.05
44	2.61	91	15.24	141	1.87	189	0.04
45	5.33	92	1.11	142	0.26	191	0.04
46	0.83	93	2.74	143	0.20	193	0.02
47	7.37	95	13.45	145	3.66	195	0.11
48	0.32	97	70.92	145	18.82	197	1.69
49	1.79	98	3.59	146	1.67	198	4.38
50	3.14	99	19.12	147	0.42	199	1.79
51	14.94	101	14.74	148	0.14	200	0.54
52	2.59	102	0.85	149	0.54	201	0.19
53	13.75	103	3.24	150	0.18	202	0.03
54	3.98	104	0.45	151	0.11	204	0.02
55	25.00	105	0.24	152	0.13	206	0.87
56	2.12	106	0.21	153	0.11	207	0.47
57	4.66	107	0.92	154	0.04	208	0.07
58	0.36	109	9.46	155	0.36	209	0.03
59	8.47	110	0.87	156	2.39	211	0.22
60	1.48	111	7.77	157	8.37	217	0.02
61	1.53	112	0.87	158	1.59	219	0.03
62	2.32	113	1.62	159	2.91	221	0.06
63	5.55	114	1.03	160	0.87	226	10.16
64	2.22	115	3.99	161	0.87	227	3.19
65	17.83	117	41.83	162	0.27	228	0.31
66	11.06	118	3.44	163	0.39	245	0.06
67	71.71	119	1.21	164	0.07	247	0.08
68	27.89	120	0.53	165	0.11	255	0.04

Major Diastereoisomer.

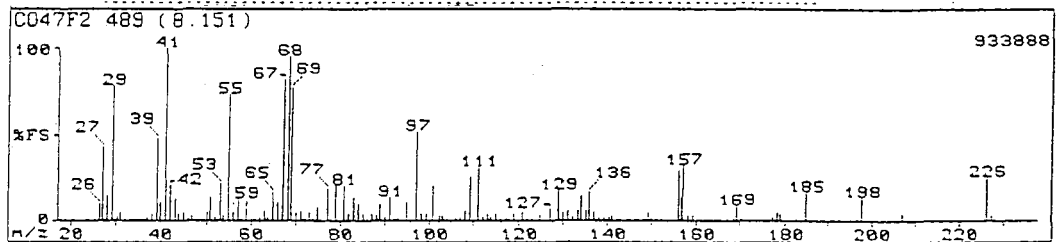

Mass	Rel Int	Mass	Rel Int	Mass	Rel Int	Mass	Rel Int
20	0.25	67	81.14	118	0.51	167	0.33
24	0.42	68	95.61	119	3.84	168	1.97
25	1.36	69	76.32	121	5.04	169	8.99
26	9.65	70	5.04	122	1.38	170	1.78
27	42.98	71	5.00	123	1.11	171	0.39
28	15.02	72	0.92	125	2.96	172	0.05
29	77.53	73	5.07	127	7.02	173	0.08
30	2.08	74	0.39	129	17.11	175	0.18
31	4.47	75	8.22	130	4.66	176	0.22
32	1.19	77	18.64	131	5.35	177	1.64
33	1.03	78	1.45	132	1.69	178	4.80
34	0.03	79	20.18	133	5.54	179	4.25
35	0.17	81	20.39	134	15.02	180	1.35
36	0.48	82	1.84	135	5.95	181	1.31
37	2.25	83	13.16	136	16.13	182	0.22
38	4.36	84	9.98	137	4.82	183	0.73
39	47.81	85	4.33	138	2.25	185	16.23
40	10.75	86	0.73	139	2.28	186	0.97
41	100.00	87	3.56	140	1.47	187	0.15
42	20.83	88	2.99	141	2.74	189	0.03
43	13.05	89	9.98	142	0.36	191	0.07
44	3.59	90	2.06	143	0.56	193	0.06
45	4.47	91	13.93	144	0.33	195	0.08
46	0.73	92	1.17	145	1.08	197	1.40
47	3.29	93	2.36	146	0.27	198	13.16
48	0.20	95	10.86	147	0.67	199	1.35
49	1.31	97	51.32	148	1.43	200	0.15
50	4.69	98	3.65	149	4.99	201	0.11
51	13.15	99	4.25	150	1.89	205	0.03
52	2.17	101	20.83	151	0.62	207	1.76
53	21.05	102	3.32	152	0.23	208	0.34
54	3.02	103	2.55	153	0.19	209	0.16
55	72.81	104	0.55	154	0.17	211	0.16
56	5.07	106	1.97	156	29.39	213	0.07
57	12.17	107	2.14	156	13.38	215	0.06
58	1.00	108	5.54	157	31.58	221	0.14
59	6.83	109	25.44	158	3.34	224	0.05
60	0.64	111	10.70	159	3.29	226	25.66
61	1.08	112	2.34	160	0.93	227	2.77
62	1.81	113	3.76	161	1.33	228	0.27
63	6.25	114	1.71	162	0.19	235	0.09
64	1.89	115	3.87	163	0.54		
65	16.34	116	1.35	164	0.28		
66	10.31	117	1.69	165	0.85		

Ion Mode: CI+

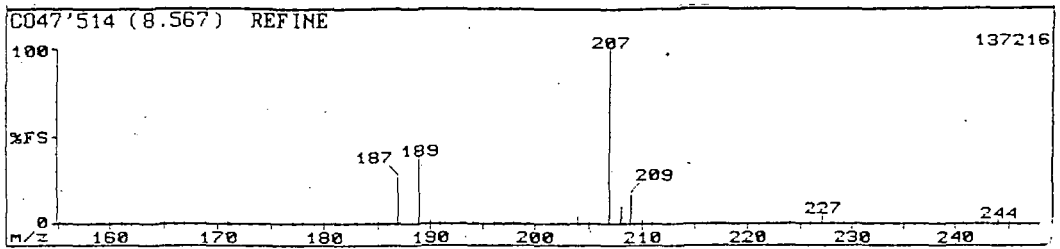

Mass	Rel Int	Mass	Rel Int	Mass	Rel Int	Mass	Rel Int
50	0.09	105	0.19	140	1.24	183	0.72
52	59.70	106	0.08	141	1.52	184	0.74
53	0.56	107	1.67	142	0.94	185	0.17
55	0.10	108	0.82	143	0.15	187	25.75
56	0.21	109	0.83	144	0.38	189	37.37
58	1.08	110	0.16	149	0.38	190	2.27
60	0.96	111	0.13	150	0.19	191	0.20
61	0.27	112	0.36	151	1.20	193	0.11
63	0.91	112	0.30	152	0.10	194	0.09
69	0.22	114	1.19	153	2.39	196	0.24
70	0.23	116	0.15	154	0.55	198	0.47
72	0.78	117	0.20	155	0.58	204	1.59
74	0.52	120	0.11	159	0.10	205	0.48
77	0.30	121	0.12	160	0.08	207	100.00
80	0.25	122	0.52	161	0.12	208	9.38
81	0.46	123	0.47	165	0.20	209	16.60
82	0.39	124	0.22	165	0.17	210	1.46
84	0.58	125	0.47	166	0.19	211	0.09
86	1.31	126	1.00	167	0.19	222	0.08
88	0.64	128	0.91	168	0.10	224	0.51
91	0.35	130	0.25	169	0.26	226	0.45
93	0.17	133	0.10	171	0.27	227	5.27
94	0.72	134	0.18	171	0.64	228	0.30
95	0.85	135	0.27	177	0.09	242	0.09
96	0.59	136	0.13	178	0.28	244	2.40
98	0.34	137	0.34	180	0.14	245	0.29
100	1.29	139	0.87	180	0.25		
102	0.65	139	1.07	181	0.37		

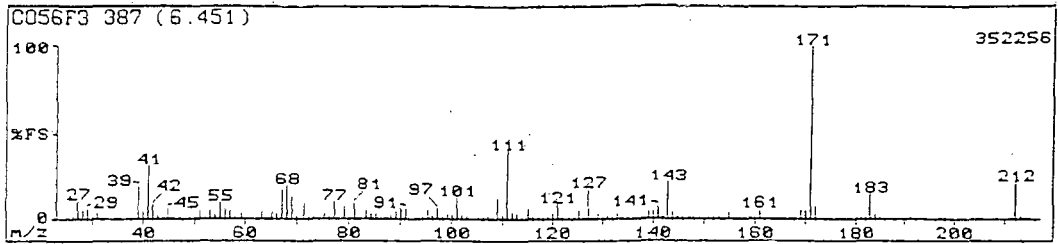

Mass	Rel Int	Mass	Rel Int	Mass	Rel Int	Mass	Rel Int
26	1.62	70	1.67	111	39.83	152	0.55
27	10.32	71	8.79	112	3.42	153	1.82
28	5.23	72	1.34	113	2.85	154	0.85
29	6.10	73	1.12	114	1.38	155	4.11
30	0.57	74	0.21	115	5.52	156	0.37
31	2.93	75	3.31	116	0.43	157	0.76
32	0.30	76	0.50	117	1.11	158	0.45
33	1.01	77	9.88	118	0.15	159	1.89
35	0.14	78	0.83	119	2.40	160	0.60
37	0.35	79	6.32	120	3.23	161	5.81
38	1.33	80	0.91	121	8.28	162	0.52
39	18.10	81	9.01	122	0.71	163	0.41
40	3.98	82	0.85	123	1.15	164	0.12
41	30.81	83	4.38	124	0.14	165	1.36
42	7.34	84	2.82	125	5.01	166	0.14
43	2.38	85	3.36	126	0.60	167	0.35
44	0.39	86	0.76	127	5.45	168	0.17
45	5.45	87	0.59	128	1.27	169	4.80
46	0.38	88	1.84	129	2.80	170	5.01
47	1.06	89	4.23	130	0.16	171	100.00
49	0.09	90	5.52	131	1.91	172	6.47
50	1.10	91	5.60	132	0.98	173	0.85
51	4.87	92	0.52	133	2.82	174	0.06
52	0.99	93	0.99	134	0.38	177	0.32
53	5.09	94	0.74	135	0.74	178	0.16
54	1.87	95	4.55	136	0.36	179	0.55
55	9.96	96	1.65	137	0.50	180	0.75
56	5.38	97	5.67	138	0.35	181	2.36
57	4.43	98	0.69	139	3.42	182	0.15
58	1.16	99	2.94	140	4.02	183	14.24
59	2.47	100	2.42	141	7.19	184	2.87
60	0.18	101	12.65	142	0.63	185	0.16
61	0.28	102	1.93	143	20.93	191	0.09
62	0.46	103	1.65	144	4.32	192	0.08
63	4.32	104	0.30	145	2.00	193	0.16
64	0.97	105	0.45	146	0.18	197	1.24
65	4.02	106	0.61	147	1.04	198	0.12
66	2.98	107	1.58	148	0.15	211	0.61
67	16.50	108	0.77	149	1.45	212	20.93
68	19.48	109	12.06	150	0.22	213	1.93
69	12.43	110	1.65	151	1.25	214	0.16

M⁺ = 238

Major Diastereoisomer

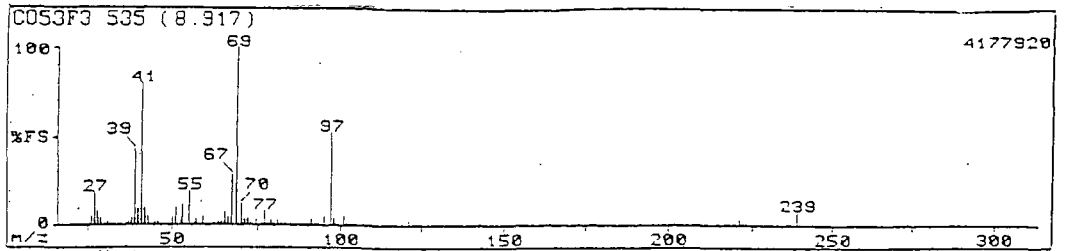

Mass	Rel Int	Mass	Rel Int	Mass	Rel Int	Mass	Rel Int
20	0.44	79	1.55	142	0.06	208	0.03
21	0.02	80	0.56	143	0.11	209	0.04
24	0.37	81	1.77	145	0.19	210	0.02
25	0.81	82	0.42	146	0.10	211	0.06
26	4.90	83	1.27	147	0.20	213	0.03
27	18.24	84	0.30	149	0.75	214	0.02
28	7.84	85	0.74	150	0.21	215	0.02
29	4.36	86	0.08	151	0.44	217	0.11
30	0.17	87	0.21	152	0.07	218	0.13
31	1.72	88	0.50	153	0.12	219	1.04
32	0.26	89	0.82	154	0.03	220	0.09
33	0.52	90	1.20	155	0.10	221	2.92
34	0.03	91	3.58	156	0.11	222	0.35
35	0.03	92	0.32	157	0.18	223	0.21
36	0.13	93	0.78	159	0.42	224	0.04
37	1.91	95	4.75	161	0.29	225	0.03
38	3.80	97	52.16	162	0.09	226	0.01
39	42.75	98	3.43	163	0.17	227	0.01
40	8.51	99	0.74	164	0.10	229	0.02
41	80.00	101	4.90	165	0.11	231	0.02
42	9.51	102	0.75	167	0.16	232	0.03
43	4.63	103	0.80	168	0.05	235	0.02
44	1.44	104	0.13	169	0.18	236	0.03
45	2.16	105	0.34	171	1.17	237	0.17
46	1.96	106	0.17	172	0.07	239	7.75
47	0.92	107	0.48	173	0.15	240	0.90
48	0.19	109	1.37	175	0.47	241	0.14
49	0.76	110	0.17	176	0.06	242	0.02
50	3.80	111	0.19	177	0.32	243	0.01
51	9.51	113	0.81	177	0.24	244	0.01
52	2.92	114	0.37	178	0.09	245	0.01
53	11.67	115	0.47	179	0.13	247	0.02
55	19.22	116	0.32	181	0.19	249	0.02
56	1.30	117	0.22	182	0.03	251	0.01
57	2.92	119	0.53	183	0.06	255	0.01
59	4.39	121	2.52	185	0.09	256	0.01
60	0.28	122	0.89	187	0.04	257	0.02
61	0.34	123	0.36	189	0.14	259	0.11
62	0.62	124	0.11	191	0.10	260	0.03
63	1.76	125	0.20	191	0.05	261	0.07
64	2.01	127	0.96	193	0.10	262	0.02
65	6.96	128	0.27	195	0.05	265	0.01
66	1.80	129	0.38	195	0.04	269	0.01
67	27.84	130	0.13	197	0.48	271	0.01
69	100.00	131	0.31	198	0.15	273	0.02
70	11.37	133	0.34	199	0.53	277	0.01
71	3.33	134	0.05	200	0.13	279	0.02
72	3.97	135	0.20	201	0.54	281	0.01
73	1.12	136	0.11	202	0.05	285	0.01
75	3.36	137	0.21	203	0.07	287	0.01
76	0.90	139	0.32	204	0.02	289	0.02
77	7.45	140	0.45	205	0.11	310	0.01
78	0.93	141	0.42	207	0.09		

Minor Diastereoisomer

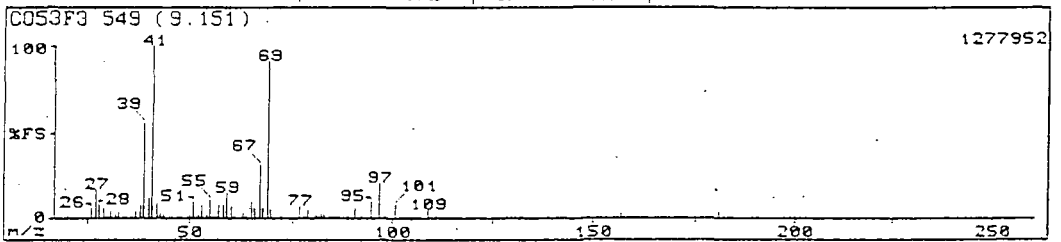

Mass	Rel Int	Mass	Rel Int	Mass	Rel Int	Mass	Rel Int
20	1.50	52	0.90	106	0.11	161	0.43
24	0.43	53	3.15	107	0.79	162	0.08
25	0.98	54	1.07	109	5.07	163	0.05
26	4.09	55	10.10	110	0.50	165	0.03
27	16.91	56	5.77	111	1.48	167	0.14
28	8.17	57	11.41	112	0.13	169	0.08
29	5.37	58	5.09	113	0.48	170	0.05
30	0.49	59	91.03	114	0.24	171	0.04
31	4.05	70	4.75	115	0.88	172	0.03
32	1.52	71	1.17	116	0.13	173	0.04
33	1.55	72	0.50	117	0.29	175	0.05
34	0.11	73	0.93	119	0.52	177	0.10
35	0.11	74	0.26	120	0.15	178	0.45
36	0.44	75	1.25	121	0.66	179	0.89
37	3.43	77	6.55	122	0.19	181	4.19
38	8.09	78	1.28	123	0.17	182	0.23
39	55.45	79	4.81	125	0.11	183	0.07
40	11.30	80	1.03	127	0.98	184	0.01
41	100.00	81	2.26	129	1.76	185	0.02
42	8.89	82	2.86	130	0.08	189	0.04
43	2.68	83	2.22	131	0.31	190	0.06
44	1.90	84	0.48	132	0.12	195	0.13
45	1.03	85	1.02	133	0.33	197	0.32
46	0.43	86	0.12	135	0.28	199	0.96
47	1.32	87	0.33	137	1.00	200	0.06
48	0.13	88	0.45	139	0.30	201	0.03
49	0.75	89	0.32	141	0.86	203	0.11
50	2.08	91	5.77	142	0.09	209	0.04
51	9.38	92	0.36	143	0.05	211	0.03
52	1.62	93	1.03	145	0.12	217	0.02
53	8.17	95	9.62	147	0.12	218	0.26
54	1.38	97	20.15	149	0.50	219	0.12
55	10.26	98	1.24	150	0.10	221	0.07
56	1.22	99	0.76	151	0.10	238	0.25
57	7.45	101	7.77	153	0.07	239	0.13
58	7.53	102	0.18	155	0.10	258	0.04
59	14.50	103	0.59	157	2.90		
60	7.05	104	0.11	159	1.72		
61	0.76	105	0.31	160	0.19		

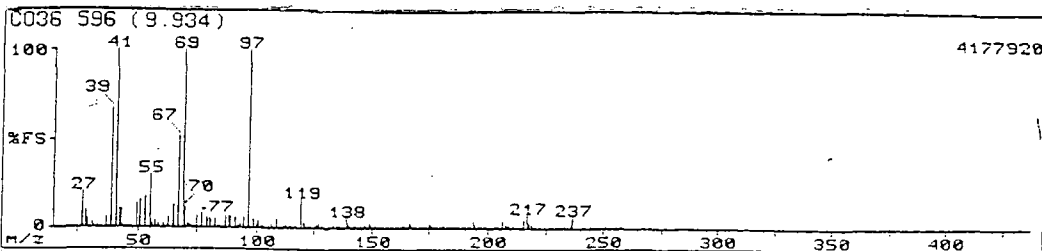

Mass	Rel Inc	Mass	Rel Inc	Mass	Rel Inc	Mass	Rel Inc	Mass	Rel Inc	Mass	Rel Inc	Mass	Rel Inc	Mass	Rel Inc
20	1.27	100	2.23	157	0.22	210	0.04	63	5.27	132	1.45	185	0.13	247	0.00
21	0.04	101	3.65	158	1.04	211	0.06	65	12.45	133	1.57	187	0.75	249	0.00
24	0.77	102	1.27	159	0.77	212	0.09	67	51.37	134	0.49	187	0.75	250	0.00
26	9.90	103	1.24	160	0.54	214	0.36	69	100.00	135	0.27	189	1.01	252	0.00
27	20.49	105	1.11	161	0.54	215	1.25	70	11.13	136	0.34	189	0.50	254	0.00
28	10.10	107	2.11	162	1.09	216	4.39	71	1.59	137	1.37	190	0.32	255	0.00
29	5.29	109	4.98	163	0.86	217	7.55	72	0.56	138	5.76	191	0.17	255	0.00
31	3.33	110	0.66	164	0.48	217	2.87	73	1.18	139	3.16	192	0.93	257	0.00
32	0.63	111	0.67	165	0.35	219	1.39	75	7.16	140	0.90	194	1.90	257	0.00
33	0.78	112	1.08	166	2.45	221	0.17	77	7.75	141	-0.39	194	2.30	258	0.00
35	0.27	113	1.99	167	2.35	223	0.08	79	6.27	142	0.19	195	0.80	267	0.00
37	5.34	114	1.26	168	0.86	224	0.03	81	4.95	143	0.18	197	1.13	271	0.00
39	67.06	115	1.40	169	0.40	227	0.04	84	4.53	144	0.89	197	0.61	277	0.00
41	100.00	116	0.67	170	0.19	227	0.03	85	1.16	145	1.14	199	1.24	283	0.00
42	10.19	117	0.91	171	0.21	228	0.04	87	5.96	147	2.21	199	0.58	284	0.00
43	10.78	119	15.18	172	0.94	229	0.02	89	7.16	149	1.38	201	0.76	285	0.00
44	1.34	120	2.67	173	0.75	231	0.05	98	6.86	149	1.38	201	0.32	287	0.00
45	0.81	121	0.97	174	1.38	232	0.02	99	7.16	151	2.31	203	1.12	305	0.00
46	0.34	122	0.45	175	1.25	233	0.04	91	6.27	150	1.01	203	0.49	313	0.00
47	0.56	123	0.54	176	0.94	235	0.05	92	1.04	151	0.59	204	0.10	375	0.00
50	13.53	124	1.35	177	0.47	236	2.55	95	5.86	153	0.46	207	3.55	420	0.00
51	15.59	125	2.35	178	0.57	236	2.55	97	100.00	154	0.55	207	1.59	432	0.00
53	17.65	126	2.30	179	0.17	237	6.37	98	1.82	155	0.44	208	0.33		
55	29.80	127	1.09	180	0.67	239	0.24	99	4.66	156	0.23	209	0.09		
56	1.54	128	1.19	181	0.59	240	0.02								
57	3.97	129	0.53	183	0.45	241	0.01								
59	2.06	130	0.47	183	0.20	243	0.03								
61	1.91	131	0.63	185	0.28	245	0.03								

No. 19 1-cyclopentyl-2-fluoro-3-methyl-2-trifluoromethyl-4-penten-1-one (86)

M⁺ = 252

Ion Mode: Cl⁺

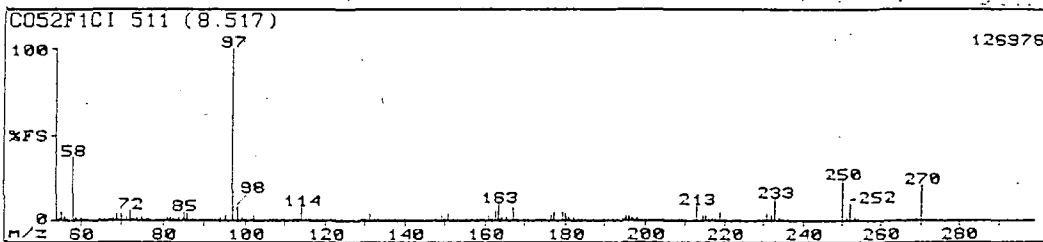

Mass	Rel Inc	Mass	Rel Inc	Mass	Rel Inc	Mass	Rel Inc
54	0.55	105	0.38	151	3.48	198	1.56
55	4.79	106	0.09	152	0.70	199	0.40
56	2.19	107	0.72	153	0.42	200	0.43
58	36.49	108	0.80	154	0.28	202	0.11
59	1.47	109	1.00	155	0.19	202	0.11
60	1.99	110	0.34	156	0.34	203	0.57
61	1.15	111	0.50	157	0.16	204	0.12
62	0.10	112	1.05	158	0.24	205	0.10
63	0.43	113	0.64	159	0.50	206	0.14
65	1.21	114	7.66	160	0.34	207	0.37
66	0.32	115	0.59	161	3.02	208	0.20
67	1.20	116	0.21	162	0.62	208	0.20
68	1.81	118	0.46	163	5.95	209	0.50
69	3.78	118	0.62	163	9.32	210	0.59
70	1.53	119	0.29	164	2.03	212	0.97
71	1.49	121	0.54	165	2.12	213	8.87
72	5.90	121	0.47	167	8.22	215	3.97
73	0.17	123	0.43	168	1.30	215	2.58
74	1.65	133	0.26	169	0.32	216	0.26
75	2.36	134	0.88	170	0.38	217	1.60
76	0.44	135	0.57	171	0.40	218	0.40
77	0.71	126	0.35	173	0.50	219	4.49
78	0.36	127	0.20	174	0.16	220	0.36
79	0.28	128	0.22	174	0.27	222	0.22
80	0.96	129	0.21	175	0.62	223	0.09
81	2.03	130	0.44	177	3.15	224	0.24
82	2.26	131	3.98	177	4.49	229	0.35
83	0.37	132	0.74	179	4.39	230	1.44
84	1.97	133	0.26	180	3.93	231	3.43
85	5.04	134	0.57	181	2.13	232	3.28
86	3.43	135	0.52	182	1.89	233	12.15
87	0.76	136	0.64	184	1.02	234	2.13
88	0.77	137	0.37	184	1.39	235	0.76
89	0.57	138	0.57	185	0.40	236	0.88
90	0.37	139	0.75	186	1.01	244	0.61
91	0.54	140	0.56	187	0.37	250	23.19
92	0.20	140	0.68	188	0.38	251	2.27
93	1.07	141	0.52	189	0.38	252	9.93
94	2.02	143	1.11	190	0.30	253	1.46
95	2.85	143	1.37	191	0.42	254	0.35
97	100.00	144	0.43	192	0.40	264	0.10
98	7.81	145	0.34	192	0.27	267	0.10
99	1.55	146	0.55	193	0.80	268	0.37
100	1.22	147	0.59	195	2.23	269	0.09
101	0.25	148	0.19	195	2.85	270	19.96
102	2.90	149	2.73	196	2.90	271	1.40
104	0.19	150	0.19	197	1.66	272	0.23

Ion Mode: CI+

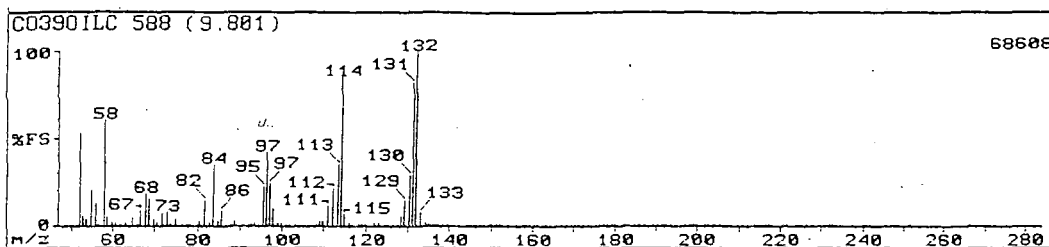

Mass	Rel Int	Mass	Rel Int	Mass	Rel Int	Mass	Rel Int
50	0.65	98	9.70	146	0.90	192	0.28
52	52.24	99	2.01	147	1.08	194	0.56
53	5.19	100	1.61	148	1.27	196	0.17
54	3.50	101	0.59	149	1.38	198	0.37
55	20.15	102	1.03	150	1.17	199	0.27
56	12.97	103	0.78	151	0.43	200	0.29
58	60.07	108	0.51	152	0.76	202	0.27
59	5.20	109	2.68	154	0.47	203	0.35
60	2.03	110	3.31	156	0.24	204	0.30
61	1.68	111	11.85	158	0.33	204	0.29
62	0.36	112	21.08	158	0.26	205	0.15
63	1.59	113	34.70	159	0.65	208	0.36
65	4.59	114	85.45	160	0.77	210	0.61
66	1.29	115	7.09	161	1.00	211	0.26
67	8.86	116	2.03	162	0.97	212	0.21
68	18.19	117	0.44	163	0.63	214	0.35
69	15.21	118	0.48	164	0.72	216	0.16
70	3.52	119	0.68	165	0.35	217	0.16
71	2.19	120	0.64	167	0.21	218	0.19
72	6.81	122	1.54	168	0.52	220	0.31
73	7.46	123	1.59	169	0.26	222	0.19
74	1.35	124	0.62	170	0.23	224	0.17
75	3.73	125	0.89	171	0.54	225	0.31
77	1.03	126	0.69	172	0.62	226	0.48
78	0.72	127	1.27	173	0.47	227	0.19
79	0.26	128	5.36	174	0.55	228	0.33
80	1.21	129	14.93	175	0.28	232	0.15
81	2.94	130	28.73	176	0.64	233	0.28
82	14.18	131	81.34	177	0.41	237	0.32
83	2.43	132	100.00	178	0.37	240	0.18
84	35.07	133	9.21	179	0.34	241	0.15
85	2.80	134	1.61	180	0.39	242	0.14
86	8.30	135	0.78	182	0.53	244	0.32
87	0.37	136	0.51	182	0.28	247	0.30
89	3.03	137	0.95	183	0.23	252	0.23
91	0.61	138	0.50	186	0.26	258	0.14
93	0.31	139	0.44	186	0.48	266	0.32
94	1.91	140	0.46	187	0.45	280	0.09
95	22.11	142	0.53	189	0.52		
97	42.16	144	0.74	190	0.52		
97	24.63	145	0.68	191	0.18		

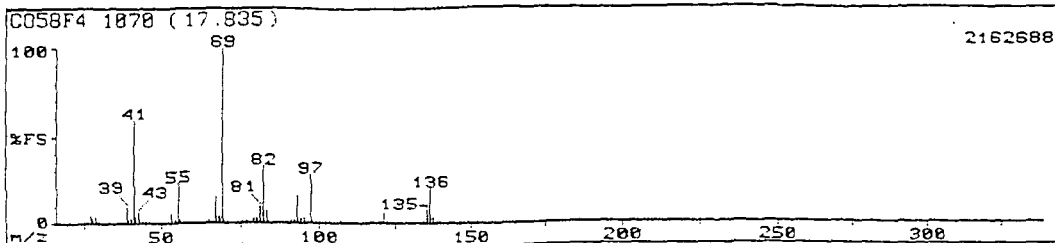

Minor Diastereoisomer

Mass	Rel Int	Mass	Rel Int	Mass	Rel Int	Mass	Rel Int	Mass	Rel Int	Mass	Rel Int	Mass	Rel Int		
20	0.02	81	9.38	135	7.43	190	0.07	59	0.59	113	0.16	167	0.13	223	0.0
25	0.02	82	12.77	136	20.83	191	0.10	60	0.05	114	0.09	168	0.03	225	0.0
26	0.23	83	8.05	137	4.31	192	0.12	61	0.25	115	0.46	169	0.75	227	0.0
27	4.78	84	0.63	138	0.40	193	0.40	62	0.06	116	0.07	170	0.09	228	0.0
28	2.62	85	0.79	139	0.21	194	0.08	63	0.22	117	0.12	171	0.03	229	0.0
29	4.12	86	0.08	140	0.05	195	0.10	64	0.11	118	0.04	172	0.13	231	0.0
30	0.11	87	0.13	141	0.19	196	0.03	65	2.36	119	0.54	174	0.06	232	0.0
31	0.10	88	0.08	142	0.03	197	0.07	66	0.94	120	0.49	175	0.28	233	0.0
32	0.51	89	0.23	143	0.04	198	0.03	67	15.34	121	6.30	176	0.06	234	0.0
33	0.05	90	0.09	144	0.01	199	0.04	68	3.93	122	0.73	177	0.16	235	0.0
36	0.02	91	1.87	145	0.11	200	0.02	69	100.00	123	9.33	178	0.04	236	0.0
37	0.07	92	1.83	146	0.05	201	0.07	70	6.39	124	0.11	179	0.29	237	0.0
38	0.25	93	16.10	147	0.11	202	0.03	71	0.51	125	0.51	180	0.23	238	0.0
39	9.47	94	2.75	148	0.05	203	0.11	72	0.09	126	0.10	181	0.20	239	0.0
40	2.62	95	2.81	149	0.22	204	0.03	73	0.28	127	0.37	182	0.04	240	0.0
41	59.09	96	1.37	150	0.05	205	0.09	74	0.05	128	0.08	183	0.15	243	0.0
42	3.84	97	28.41	151	0.23	207	0.10	75	0.19	129	0.11	184	0.03	245	0.0
43	6.63	98	2.07	152	0.17	208	0.03	76	0.05	130	0.03	185	0.05	246	0.0
44	0.38	99	0.85	153	0.13	209	0.05	77	2.19	131	0.06	186	0.01	247	0.0
45	0.07	100	0.11	154	0.26	210	0.02	78	0.38	132	0.04	187	0.07	248	0.0
46	0.04	101	0.33	155	0.13	211	0.06	79	2.73	133	0.38	188	0.03	249	0.0
47	0.27	102	0.08	156	0.07	212	0.01	80	2.78	134	0.36	189	0.22	251	0.0
49	0.03	103	0.30	157	0.07	213	0.03	252	0.02	274	0.03	294	0.01	320	0.0
50	0.20	104	0.10	158	0.01	214	0.01	253	0.03	275	0.01	301	0.05	334	0.0
51	1.02	105	0.71	159	0.15	215	0.06	259	0.02	281	0.01	302	0.01	335	0.0
52	0.46	106	0.17	160	0.11	216	0.28	265	0.08	291	0.28	306	0.03		
53	5.78	107	2.14	161	0.18	217	0.12	271	0.03	292	0.05	316	0.03		
54	1.49	108	0.82	162	0.07	218	0.04	272	0.12	292	0.09	319	0.07		
55	22.92	109	1.29	163	0.36	219	0.16								
56	1.96	110	0.22	164	0.08	220	0.05								
57	0.99	111	0.34	165	0.13	221	0.13								
58	0.09	112	0.11	166	0.13	222	0.08								

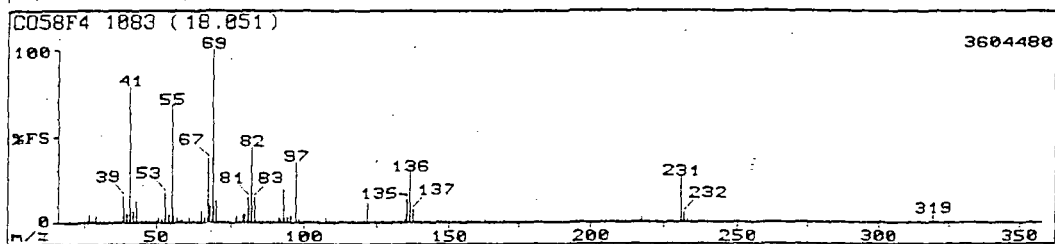

Major Diastereoisomer

Mass	Rel Int	Mass	Rel Int	Mass	Rel Int	Mass	Rel Int	Mass	Rel Int	Mass	Rel Int	Mass	Rel Int	Mass	Rel Int
20	0.02	80	4.55	137	7.61	194	0.08	250	0.01	269	0.02	285	0.32	311	0.0
24	0.01	81	14.43	138	0.77	195	0.18	251	0.15	271	0.13	286	0.05	314	0.2
25	0.03	82	42.64	139	0.42	196	0.04	252	0.04	272	0.02	287	0.02	315	0.0
26	0.33	83	14.32	140	0.15	197	0.11	253	0.06	273	0.14	289	0.01	316	0.0
27	4.94	84	1.17	141	0.36	198	0.06	255	0.02	274	0.03	291	0.42	319	5.1
28	1.23	85	1.14	142	0.06	199	0.09	257	0.05	275	0.02	292	0.06	320	0.8
29	3.78	86	0.13	143	0.09	200	0.02	258	0.02	277	0.06	293	0.03	321	0.0
30	0.08	87	0.25	144	0.08	201	0.12	259	0.04	278	0.02	295	0.80	334	0.6
31	0.11	88	0.13	145	0.20	202	0.04	261	0.01	279	0.04	300	0.14	335	0.0
32	0.10	89	0.30	146	0.11	203	0.70	263	0.03	281	0.06	301	0.07	354	0.1
33	0.07	91	2.47	147	0.21	204	0.12	265	0.05	282	0.01	302	0.01		
36	0.02	92	2.41	148	0.06	205	0.15	266	0.02	284	0.04	305	0.03		
37	0.13	93	19.43	149	0.31	206	0.02								
38	0.48	94	2.90	150	0.08	207	0.13								
39	15.45	95	3.64	151	0.25	208	0.04								
40	5.26	97	35.00	152	0.07	209	0.07								
41	78.64	98	2.30	153	0.27	210	0.11								
42	6.53	99	0.76	154	0.50	211	0.11								
43	12.16	100	0.34	155	0.27	212	0.02								
44	0.47	101	0.48	156	0.15	213	0.10								
45	0.14	102	0.11	157	0.30	214	0.03								
46	0.10	103	0.68	158	0.03	215	0.11								
47	0.65	104	0.25	159	0.28	216	0.08								
48	0.03	105	0.75	160	0.07	217	0.35								
49	0.30	107	3.27	161	0.34	218	2.44								
50	0.65	108	1.12	163	2.05	219	0.35								
51	3.27	109	1.45	164	0.24	220	0.05								
52	1.60	110	0.29	165	0.45	221	0.22								
53	17.05	111	0.45	166	0.21	222	0.06								
54	4.74	112	0.16	167	0.23	223	0.07								
55	68.18	113	0.42	168	0.05	224	0.02								
56	5.51	114	0.24	169	0.43	225	0.09								
57	2.78	115	0.58	170	0.06	226	0.02								
58	0.24	116	0.12	171	0.05	227	0.09								
59	1.74	117	0.20	173	0.20	228	0.02								
60	0.17	118	0.21	174	0.07	229	0.08								
61	2.61	119	0.96	175	0.45	231	25.91								
62	0.27	121	2.27	176	0.23	232	5.51								
63	0.74	121	11.59	177	0.25	233	2.05								
64	0.38	122	1.44	178	0.06	234	0.29								
65	6.68	123	0.91	179	0.44	235	0.06								
66	2.95	124	0.28	180	0.21	236	0.10								
67	36.82	125	0.72	181	0.45	237	0.09								
68	10.11	126	0.24	182	0.07	238	0.08								
69	100.00	127	0.70	183	0.15	239	0.10								
70	12.39	128	0.17	184	0.02	240	0.02								
71	0.90	129	0.20	185	0.08	241	0.02								
72	0.21	130	0.04	187	0.12	243	0.07								
73	0.56	131	0.10	188	0.05	244	0.03								
74	0.11	132	0.16	189	1.02	245	0.10								
75	0.39	133	0.65	190	0.28	246	0.02								
77	3.78	134	1.82	191	0.17	247	0.11								
78	0.67	135	13.18	192	0.04	248	0.02								
79	4.40	136	29.09	193	0.39	249	0.05								

Minor Diastereoisomer

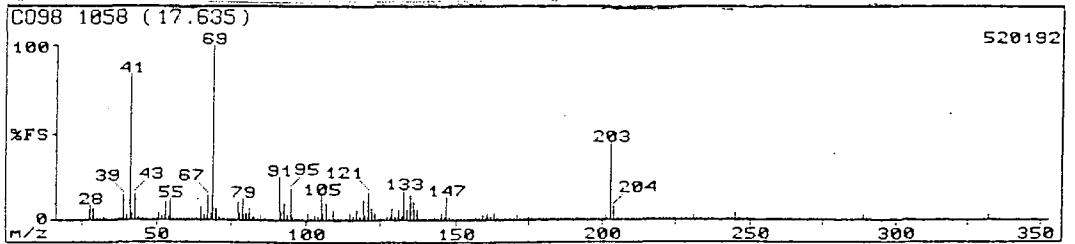

Mass	Rel Int	Mass	Rel Int	Mass	Rel Int	Mass	Rel Int	Mass	Rel Int	Mass	Rel Int	Mass	Rel Int	Mass	Rel Int
20	0.07	81	6.59	117	5.46	191	0.78	61	0.24	117	6.20	171	1.15	225	0.00
26	0.27	82	2.42	118	0.85	192	0.13	62	0.18	118	2.03	172	0.47	226	0.00
27	6.05	83	2.17	119	0.51	193	0.54	63	0.94	119	11.91	173	1.28	227	0.00
28	8.56	84	0.10	140	0.18	194	0.21	64	0.48	120	2.52	174	0.38	228	0.00
29	5.74	85	2.78	141	1.24	195	1.44	65	7.68	121	15.73	175	1.92	229	1.00
30	0.15	86	0.27	142	0.81	196	0.41	66	3.10	122	6.64	176	0.29	230	0.00
31	0.31	87	0.22	143	1.55	197	1.30	67	14.57	123	3.74	177	0.68	231	2.00
32	2.07	88	0.08	144	1.40	198	0.22	68	3.49	124	0.51	178	0.16	232	0.00
33	0.14	89	0.32	145	1.99	199	0.31	69	100.00	125	0.40	179	0.32	233	0.00
35	0.11	91	25.20	146	1.75	200	0.22	70	6.45	126	0.28	180	0.39	234	0.00
36	0.45	92	5.17	147	13.58	201	2.53	71	2.10	127	1.71	181	0.91	235	1.00
37	0.18	93	9.99	148	2.10	202	0.60	72	0.25	128	2.37	182	0.28	236	2.00
38	0.55	94	1.05	149	1.29	203	44.49	73	0.55	129	7.09	183	0.63	237	0.00
39	14.37	95	18.11	150	0.39	204	7.48	74	0.11	130	1.62	184	0.16	238	0.00
40	1.40	96	1.38	151	0.78	205	1.13	75	0.29	131	5.51	185	3.53	239	0.00
41	63.46	97	1.06	152	0.80	206	0.18	76	0.23	132	1.75	186	0.20	240	0.00
42	4.13	98	0.20	153	0.65	207	0.69	77	10.43	133	17.91	187	1.08	241	0.00
43	15.16	99	0.45	154	0.26	208	0.27	78	3.49	134	5.91	188	0.39	242	0.00
44	1.59	101	3.84	155	0.63	209	0.53	79	12.50	135	14.57	189	0.73	244	0.00
45	0.35	102	0.56	156	0.42	210	0.23	80	3.59	136	10.53	190	0.32	245	3.00
46	0.08	103	2.92	157	1.48	211	0.19	246	0.59	262	0.20	277	0.09	304	0.00
47	0.32	104	1.83	158	0.46	212	0.12	247	0.42	263	0.55	278	0.09	305	0.00
49	0.21	105	14.37	159	2.84	213	0.57	248	0.16	264	0.22	282	0.03	306	0.00
50	0.59	106	3.69	160	0.75	214	0.22	249	0.30	265	0.06	285	0.05	314	0.00
51	3.84	107	9.55	161	3.59	215	0.49	250	0.11	267	-0.04	287	0.08	315	0.00
52	1.60	108	0.89	162	2.17	216	0.29	251	0.15	269	0.14	288	0.10	317	0.00
53	10.83	109	6.00	163	3.64	217	0.58	252	0.15	270	0.10	289	3.25	318	0.00
54	1.61	110	0.79	164	0.68	218	0.15	253	0.08	271	1.35	290	0.16	320	0.00
55	12.60	111	0.60	165	0.54	219	0.50	254	0.05	272	0.45	291	0.07	322	2.00
56	1.17	112	0.19	166	0.19	220	0.15	257	0.30	273	0.45	292	0.16	323	0.00
57	1.45	113	0.89	167	0.62	221	2.39	258	0.10	274	0.05	293	0.36	324	0.00
58	0.16	114	0.19	168	0.19	222	0.36	259	0.25	275	0.16	300	0.09	331	0.00
59	0.78	115	4.33	169	0.41	223	0.30	260	-0.15	276	0.16	302	0.04	348	0.00
60	0.08	116	1.59	170	0.30	224	0.08	261	0.72	276	0.15	303	0.16		

Major Diastereoisomer

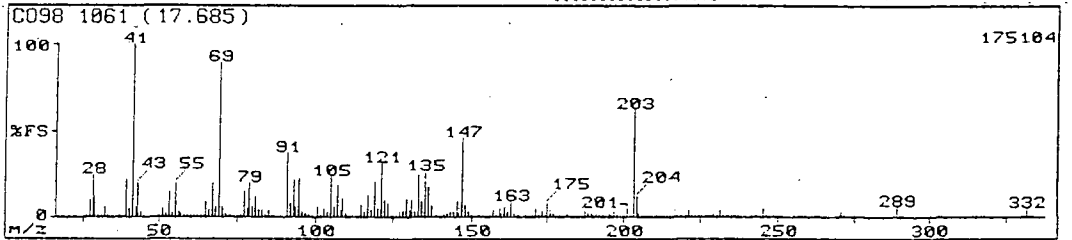

Mass	Rel Int	Mass	Rel Int	Mass	Rel Int	Mass	Rel Int	Mass	Rel Int	Mass	Rel Int	Mass	Rel Int	Mass	Rel Int
20	0.12	82	4.09	119	1.06	193	0.94	61	0.15	118	3.65	172	0.90	226	0.00
26	0.49	83	3.69	140	0.21	194	0.28	62	0.23	119	20.03	173	2.78	227	0.00
27	9.80	84	0.68	141	2.34	195	2.38	63	1.25	120	4.86	174	0.38	228	0.00
28	23.83	85	3.40	142	1.49	196	0.79	64	0.35	121	31.43	175	7.49	229	1.00
29	12.13	86	0.28	143	2.74	197	3.45	65	9.17	122	9.36	176	1.65	230	0.00
30	0.42	87	0.39	144	2.67	198	0.47	66	3.76	123	3.11	177	1.32	231	4.00
31	0.32	89	1.13	145	3.70	199	1.32	67	19.30	124	1.32	178	0.35	232	0.00
32	5.70	91	16.55	146	2.38	200	0.41	68	5.03	125	0.40	179	1.43	233	0.00
33	0.24	92	8.15	147	45.61	201	5.19	69	88.89	126	0.57	180	0.45	234	0.00
35	0.26	93	20.91	148	6.62	202	1.24	70	5.96	127	2.78	181	1.67	235	2.00
36	1.03	94	5.41	149	3.25	203	62.57	71	1.95	128	4.17	182	0.58	236	0.00
37	0.37	95	22.08	150	1.01	204	11.25	72	0.20	129	10.67	183	1.21	237	0.00
38	1.00	96	3.07	151	1.20	205	1.98	73	0.95	130	3.65	184	0.36	239	0.00
39	21.35	97	1.99	152	0.92	206	0.37	74	0.17	131	9.80	185	0.37	241	0.00
40	5.23	98	0.46	153	1.24	207	1.30	75	0.43	132	3.35	186	0.41	242	0.00
41	100.00	99	0.60	154	0.56	208	0.86	76	0.32	133	24.56	187	2.52	243	1.00
42	5.96	101	5.70	155	1.16	209	1.18	77	14.33	134	8.48	188	1.50	244	0.00
43	19.59	102	0.90	156	0.91	210	0.55	78	4.64	135	20.03	189	1.72	245	4.00
44	3.25	103	4.42	157	3.40	211	0.41	79	19.01	136	17.25	190	1.10	246	0.00
45	0.37	104	3.03	158	0.98	212	0.48	80	5.10	137	7.05	191	1.54	247	1.00
47	0.38	105	23.39	159	4.79	213	0.90	81	11.34	138	1.32	192	0.35	248	0.00
49	0.16	106	6.03	160	1.51	214	0.25	249	0.49	264	0.39	288	0.15	315	1.00
50	0.97	107	18.13	161	6.25	215	0.70	250	0.29	269	0.12	289	5.37	317	0.00
51	5.15	108	4.17	162	3.36	216	0.41	251	0.25	270	0.28	290	1.08	318	0.00
52	2.23	109	10.96	163	8.33	217	0.82	252	0.20	271	3.11	291	0.17	320	5.00
53	14.91	110	1.82	164	1.56	218	0.28	257	0.59	272	1.05	293	0.22	332	1.00
54	2.34	111	1.40	165	1.22	219	0.86	258	0.45	273	0.31	299	0.64	334	0.00
55	19.44	112	0.43	166	0.35	220	0.40	259	0.33	274	0.18	300	0.15		
56	2.89	113	0.41	167	0.98	221	4.31	261	1.42	275	0.40	303	0.20		
57	2.27	114	0.36	168	0.28	222	0.86	262	0.42	276	1.12	304	0.10		
58	0.30	115	7.16	169	0.89	223	0.64	263	0.95	277	0.29	314	0.24		
59	1.14	116	2.56	170	0.54	224	0.38								
60	0.16	117	12.43	171	4.61	225	0.47								

M⁺ = 238

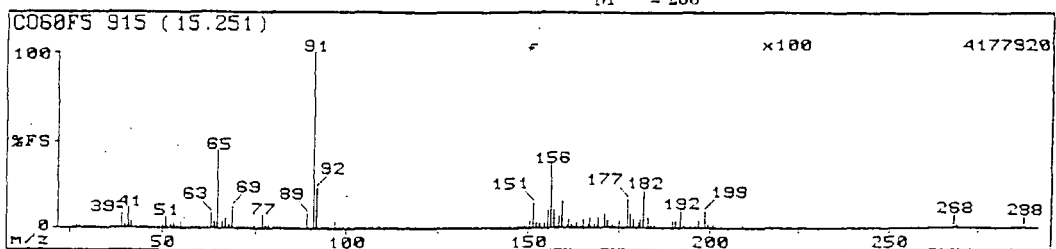

Mass	Rel Int	Mass	Rel Int	Mass	Rel Int	Mass	Rel Int
26	0.41	73	0.33	121	0.14	155	0.05
27	1.91	74	0.59	122	0.07	166	0.02
29	0.60	75	1.75	123	0.13	167	0.06
29	1.15	75	0.90	124	0.01	168	0.02
30	0.04	77	8.24	125	0.07	169	0.06
31	0.19	78	1.57	127	0.56	171	0.07
32	0.03	79	2.16	128	0.28	172	0.04
33	0.07	80	0.35	129	0.24	173	0.02
37	0.17	81	1.10	130	0.10	175	0.03
38	0.81	82	0.38	131	0.09	177	0.15
39	9.22	83	0.99	132	0.07	178	0.08
40	1.74	84	0.29	133	0.21	179	0.05
41	11.13	85	0.25	134	0.07	180	0.03
42	1.90	86	0.23	135	0.04	181	0.05
43	0.10	87	0.33	136	0.13	182	0.23
44	0.07	89	5.43	137	0.21	183	0.06
45	0.16	91	100.00	138	0.04	184	0.01
46	0.10	92	22.94	139	0.10	185	0.02
47	0.15	93	1.00	140	0.05	190	0.04
49	0.13	94	0.04	141	0.15	191	0.04
50	1.84	95	0.58	142	0.05	192	0.10
51	6.47	97	4.02	143	0.04	193	0.01
52	1.99	98	0.30	144	0.04	195	0.01
53	2.48	99	0.34	145	0.09	196	0.02
54	0.49	100	0.17	146	0.08	197	0.04
55	1.53	101	1.22	147	0.06	199	0.09
56	0.23	102	0.21	148	0.02	200	0.02
57	0.88	103	0.26	149	0.07	201	0.02
58	0.08	104	0.13	150	0.04	203	0.01
59	0.48	105	1.15	151	0.15	207	0.01
60	0.08	106	0.24	152	0.03	209	0.02
61	0.33	107	0.41	153	0.03	211	0.01
62	1.86	109	1.59	154	0.01	215	0.01
63	8.92	110	0.20	155	0.10	217	0.02
64	3.73	111	0.14	156	0.37	219	0.01
65	44.71	112	0.03	157	0.11	225	0.01
66	4.04	113	0.30	158	0.07	237	0.02
67	5.03	114	0.11	159	0.15	239	0.01
68	2.35	115	0.24	160	0.02	245	0.01
69	12.45	116	0.07	161	0.05	268	0.08
70	0.96	117	0.20	162	0.02	269	0.02
71	0.56	119	0.29	163	0.03	288	0.07
72	0.13	120	0.07	164	0.01		

No. 24 Z-(1-butyl-2,3,3,3-tetrafluoro-1-propenyl)cyclopentane (99)

M⁺ = 238

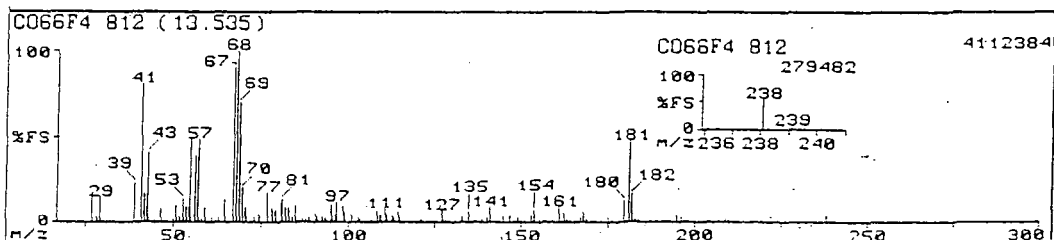

Mass	Rel Int	Mass	Rel Int	Mass	Rel Int	Mass	Rel Int
20	0.02	77	17.63	119	1.10	166	0.50
24	0.00	78	7.47	119	0.78	167	2.99
27	14.34	79	6.77	121	1.59	168	5.55
28	2.61	81	11.95	121	1.54	169	1.97
29	14.84	81	13.94	123	1.23	170	0.20
30	0.33	82	8.27	123	1.37	171	0.07
31	0.16	83	8.27	125	1.25	173	0.28
32	0.10	84	3.29	125	0.71	175	2.54
33	0.31	85	9.25	127	6.97	176	0.54
37	0.20	86	0.84	127	6.17	177	0.75
39	23.41	87	1.46	128	1.13	180	12.95
41	80.38	88	1.54	129	0.50	181	47.41
42	15.43	89	2.44	131	0.47	182	15.93
43	40.54	90	4.56	131	0.36	183	1.54
44	1.44	91	3.34	133	2.34	184	0.13
45	0.26	93	2.94	133	3.56	187	0.03
47	7.77	93	1.97	135	5.90	189	2.04
48	0.18	95	10.96	136	0.47	190	0.15
50	1.56	95	10.16	137	1.23	191	0.06
51	9.56	96	3.41	139	1.59	192	0.01
52	2.99	97	11.25	140	2.76	193	0.09
53	14.04	99	9.56	141	9.15	195	1.78
54	8.57	99	5.40	142	0.73	196	2.36
55	48.21	101	5.28	143	0.71	197	0.43
56	39.04	102	0.42	145	2.56	198	0.04
57	49.00	103	3.14	147	3.88	199	0.10
58	2.39	103	1.64	148	1.41	200	0.02
59	8.57	105	0.98	149	2.69	203	0.25
60	0.55	105	0.73	150	0.60	204	0.04
61	3.04	107	2.04	151	0.59	207	0.03
62	0.59	107	1.19	153	3.33	209	2.14
63	3.19	109	6.47	154	6.77	210	0.37
65	13.84	109	3.98	155	1.87	211	0.04
67	90.44	111	7.97	156	0.14	217	0.10
68	100.00	111	5.00	157	0.97	218	0.06
69	70.12	113	4.11	159	2.12	219	0.03
70	19.92	113	2.91	161	9.06	221	0.20
71	8.27	115	5.48	162	5.23	224	0.03
72	0.97	115	3.29	163	2.42	238	3.81
73	3.36	117	0.96	164	0.44	239	0.47
75	4.71	117	0.53	165	0.99	240	0.04

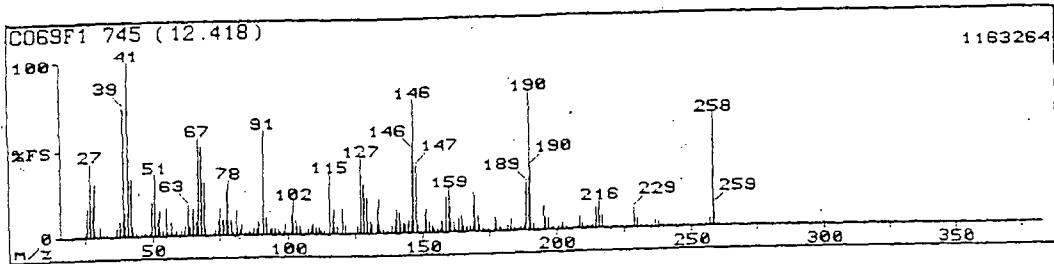

Mass	Rel Int	Mass	Rel Int	Mass	Rel Int	Mass	Rel Int
20	1.39	79	9.07	138	4.29	193	0.80
21	0.03	80	2.27	139	7.66	194	0.37
24	1.17	81	14.44	140	13.12	195	14.00
25	2.86	82	2.51	141	11.53	196	6.95
26	16.55	83	6.16	142	5.90	197	6.43
27	42.61	84	1.13	143	5.26	198	1.43
28	18.31	85	2.31	144	7.13	199	1.54
29	10.63	86	2.07	146	47.18	201	1.50
31	5.72	87	4.14	146	77.11	202	4.29
32	0.64	88	1.70	147	19.08	203	3.51
33	2.22	89	7.66	148	4.89	204	1.91
36	0.65	91	60.56	149	1.11	204	0.82
37	4.91	92	10.12	151	11.09	206	0.89
38	8.45	93	2.79	151	13.73	207	0.97
39	71.59	94	3.46	152	5.72	208	0.19
40	13.47	95	4.14	153	3.81	209	6.60
41	100.00	96	2.77	154	2.20	210	3.04
42	13.10	97	1.54	155	1.69	211	0.92
43	6.25	98	1.78	157	6.43	212	0.15
44	1.54	99	5.37	157	5.48	213	0.75
45	1.25	100	0.79	159	20.69	214	2.35
46	0.75	101	11.80	159	25.70	215	11.44
47	2.20	102	19.19	160	14.35	215	15.49
48	0.74	103	7.83	161	5.52	217	6.87
49	1.61	104	5.04	162	2.22	218	0.98
50	19.89	105	3.37	164	8.01	219	0.87
51	36.27	106	1.18	164	9.68	220	0.31
52	9.95	107	3.24	165	3.98	221	0.39
53	14.26	108	5.24	167	2.62	222	0.24
54	2.77	109	5.63	167	2.46	223	0.76
55	16.46	110	3.50	169	22.36	224	0.15
56	1.98	111	3.48	169	20.07	225	0.11
57	7.48	112	1.78	171	8.80	226	0.08
58	0.75	113	1.92	171	4.34	227	1.12
59	3.24	115	14.51	172	1.67	228	0.98
60	0.90	116	8.19	173	1.06	229	10.39
61	2.53	117	13.91	175	2.18	230	4.51
62	6.16	118	4.29	175	1.45	231	0.93
63	17.08	120	14.61	177	7.48	232	0.15
64	4.45	121	4.45	177	5.81	233	0.24
65	15.58	122	1.20	179	1.85	234	0.18
66	7.75	123	0.96	180	1.52	235	0.27
67	56.34	125	4.25	180	1.22	236	0.40
68	51.06	127	43.66	182	2.44	237	3.81
69	30.63	128	28.52	183	7.04	238	3.17
70	4.12	129	20.51	184	2.33	239	1.12
71	1.08	130	6.51	185	1.09	240	0.24
72	0.50	131	5.99	186	0.34	241	0.28
73	3.32	133	13.29	187	1.56	242	0.06
74	8.98	133	19.89	188	3.92	243	1.20
75	15.40	134	4.69	189	26.76	244	0.20
76	8.80	135	2.20	190	79.23	245	0.38
77	26.06	136	0.45	190	36.62	246	0.09
78	32.39	137	1.34	191	4.36	247	0.17
248	0.04	267	0.14	286	0.05	311	0.06
249	0.10	268	0.05	287	0.07	315	0.04
251	0.11	269	0.11	288	0.05	316	0.03
253	0.07	271	0.65	289	0.03	317	0.06
254	0.09	272	0.06	291	0.05	319	0.03
255	0.12	273	0.08	292	0.04	321	0.07
256	1.08	274	0.04	293	0.04	322	0.03
257	4.34	275	0.06	295	0.06	323	0.11
258	64.79	276	0.06	296	0.02	324	0.04
259	11.18	277	0.06	297	0.05	325	0.06
260	0.91	278	0.04	298	0.05	326	0.03
261	0.05	279	0.06	299	0.69	327	0.07
262	0.04	280	0.04	300	0.14	328	0.03
263	0.02	281	0.04	301	0.04	329	0.03
264	0.03	283	0.05	303	0.04	330	0.03
265	0.10	284	0.04	309	0.05	331	0.03
266	0.05	285	0.11	310	0.04	332	0.03

M⁺ = 360

Major Diastereoisomer

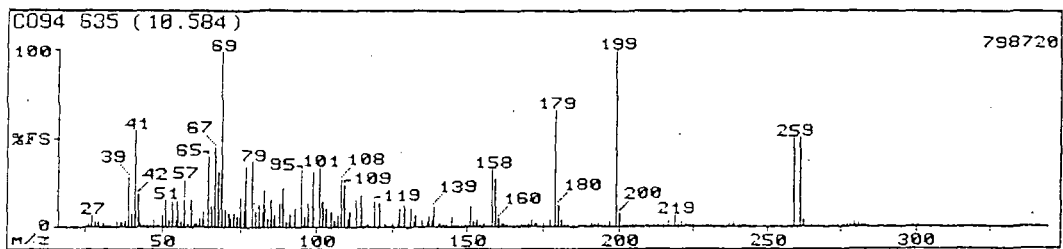

Mass	Rel Inc	Mass	Rel Inc	Mass	Rel Inc	Mass	Rel Inc
20	0.03	80	3.72	147	0.78	217	3.11
24	0.04	81	12.31	148	0.40	219	6.35
25	0.26	82	18.59	149	0.93	220	0.84
26	1.90	83	21.03	151	11.28	221	2.95
27	6.15	84	5.29	152	2.32	222	0.40
28	3.30	85	15.25	153	4.07	223	0.25
29	2.56	86	7.21	154	0.91	224	0.15
31	2.08	88	13.72	155	1.98	225	0.11
32	0.21	89	22.13	158	12.82	228	0.03
33	0.56	90	3.24	159	27.44	229	0.04
35	2.53	91	7.31	160	5.06	230	0.20
37	3.08	93	10.77	161	2.08	231	0.10
38	4.26	95	31.92	162	1.76	233	0.53
39	27.95	96	5.54	163	1.23	235	0.35
40	7.34	97	13.85	164	0.58	237	1.59
41	54.16	99	10.77	165	1.21	238	0.10
42	18.72	101	33.85	166	0.34	239	2.50
43	1.43	102	14.10	167	0.58	240	0.13
44	0.88	103	10.33	168	1.17	241	0.87
45	1.28	105	8.33	169	0.95	242	0.09
46	1.27	106	3.51	170	1.60	243	0.03
47	3.94	107	7.02	171	4.36	249	0.06
48	0.37	108	25.79	172	1.71	251	0.45
49	1.19	109	24.23	173	2.31	253	0.61
50	6.54	110	4.74	175	2.18	255	0.17
51	15.90	111	8.85	177	3.94	257	0.14
52	3.91	113	15.38	179	65.64	259	50.77
53	14.49	115	19.33	180	12.44	261	50.77
		116	1.29	191	3.43	262	1.56

Minor Diastereoisomer

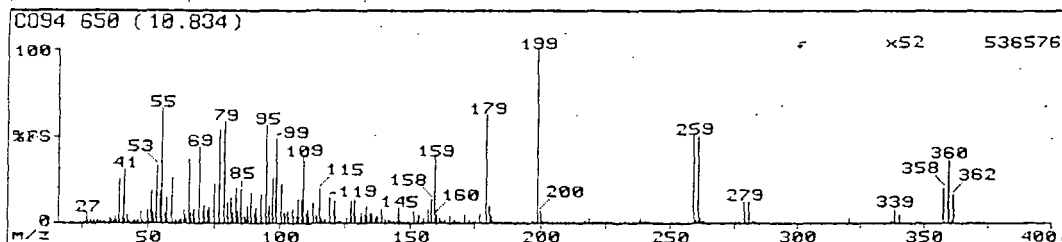

Mass	Rel Inc	Mass	Rel Inc	Mass	Rel Inc	Mass	Rel Inc
20	0.06	84	5.97	149	0.85	215	0.59
24	0.07	85	19.08	151	7.01	217	1.56
25	0.13	86	4.10	152	1.37	218	0.37
26	1.77	87	2.39	153	5.25	219	3.20
27	5.82	88	9.40	154	0.80	220	0.99
28	2.21	89	17.75	155	2.53	221	1.28
29	2.39	90	5.77	157	8.21	222	0.07
31	2.14	91	8.49	158	11.36	223	0.07
32	0.13	93	15.03	159	38.17	224	0.11
33	1.17	95	55.49	160	5.10	225	0.12
35	2.59	96	10.92	161	3.15	226	0.06
36	3.10	97	25.53	162	1.32	227	0.09
37	2.42	99	48.09	163	1.48	231	0.11
38	3.96	101	22.71	165	3.72	233	0.13
39	25.57	102	5.15	166	0.51	233	0.15
40	4.25	103	7.16	167	1.51	234	0.14
41	31.30	105	7.92	168	0.80	235	0.13
42	4.68	106	4.29	169	0.52	236	0.30
43	0.54	107	11.55	171	5.20	237	0.43
44	0.32	108	13.93	172	0.91	238	0.24
45	1.53	109	37.40	173	1.54	239	2.59
46	1.34	110	5.96	174	0.25	240	0.19
47	6.54	111	8.15	175	1.10	240	0.60
48	0.27	112	11.59	177	5.20	241	1.35
49	1.25	114	4.25	179	51.33	242	0.20
50	7.97	115	13.27	180	9.59	245	0.25
51	18.13	116	1.50	181	3.72	247	0.35
52	5.44	117	1.74	182	0.27	250	0.04
53	33.21	119	14.31	183	0.70	251	0.13
54	19.32	121	12.40	184	0.33	253	0.13
55	66.41	122	1.45	185	0.58	254	0.04
56	6.01	123	0.89	186	0.20	257	0.17
57	14.12	125	3.15	187	0.54	259	50.38
59	26.53	126	8.40	188	0.24	260	1.88
60	1.66	127	12.98	189	0.53	261	49.52
61	1.80	129	13.93	191	0.56	262	2.98
62	2.27	130	3.86	192	0.07	263	0.10
63	7.78	131	5.68	193	0.71	274	0.05
64	5.20	132	4.77	194	0.26	275	0.07
65	36.83	133	9.35	195	0.36	276	0.05
66	5.11	134	4.39	197	1.16	277	0.27
67	7.54	135	5.34	199	100.00	279	12.79
69	43.70	136	3.05	200	5.54	280	0.57
70	7.01	137	1.82	201	0.97	281	12.21
71	9.78	139	7.49	202	0.13	282	0.36
72	7.11	140	1.74	203	0.13	283	0.04
73	8.44	141	1.84	205	0.55	295	0.05
75	22.52	142	0.33	207	0.57	299	0.03
77	53.44	143	0.44	208	0.07	321	0.05
79	58.02	145	3.58	209	0.09	337	0.05
80	11.50	145	3.30	210	0.10	339	0.17
81	14.12	146	1.11	211	0.11	341	0.09
82	5.34	147	1.19	212	0.08	358	0.40
83	20.04	149	0.23	213	0.37	360	0.72
161	0.04	162	0.31				

M⁺ = 251

Major Diastereoisomer

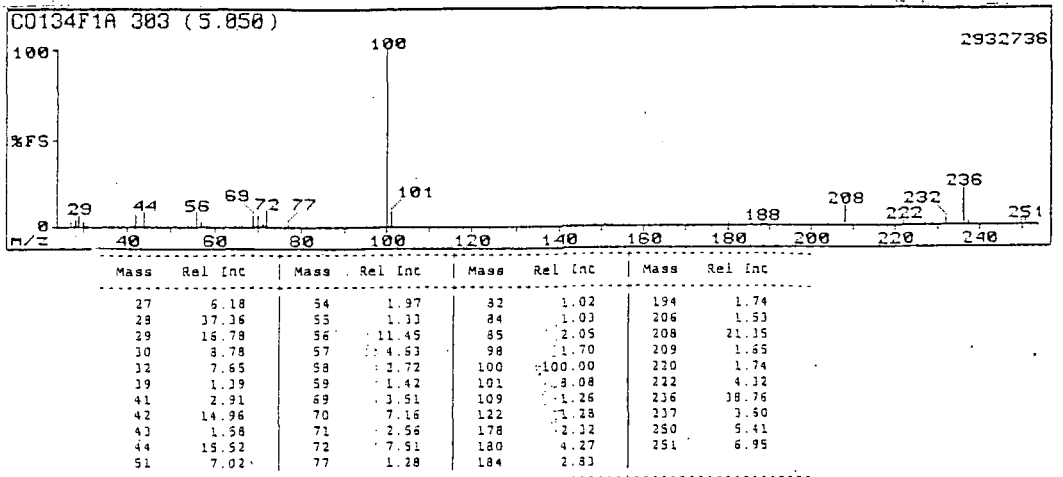

Minor Diastereoisomer

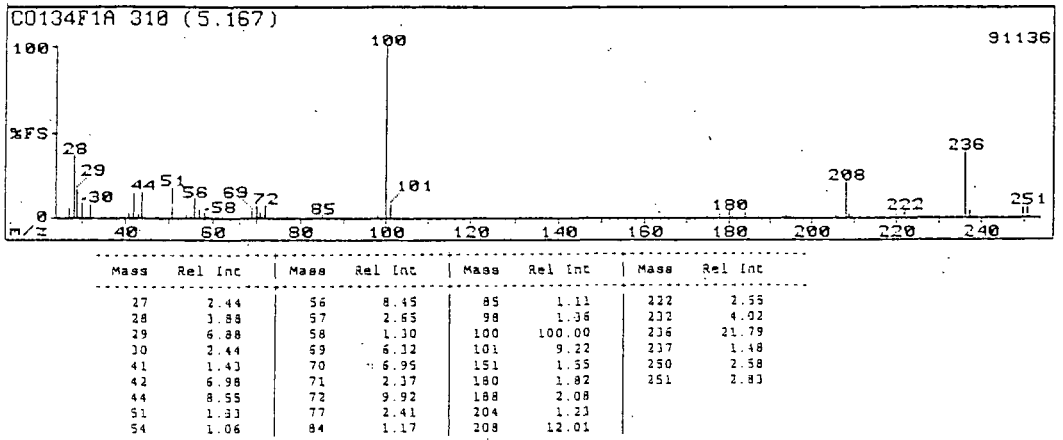

No. 28 bis(2,2,3,4,4,4-hexafluoro-1-methylbutyl)ethylamine (105)

M⁺ = 401

Minor Diastereoisomer

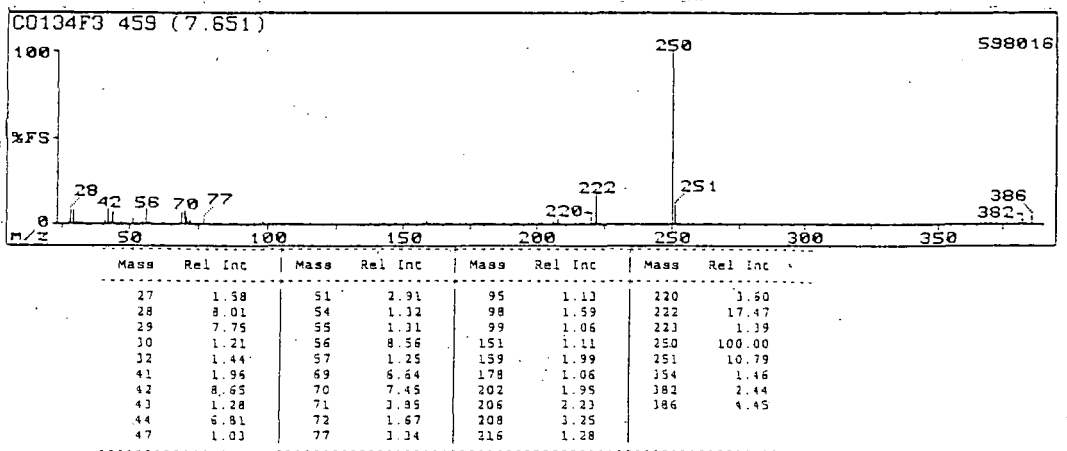

Major Diastereoisomer

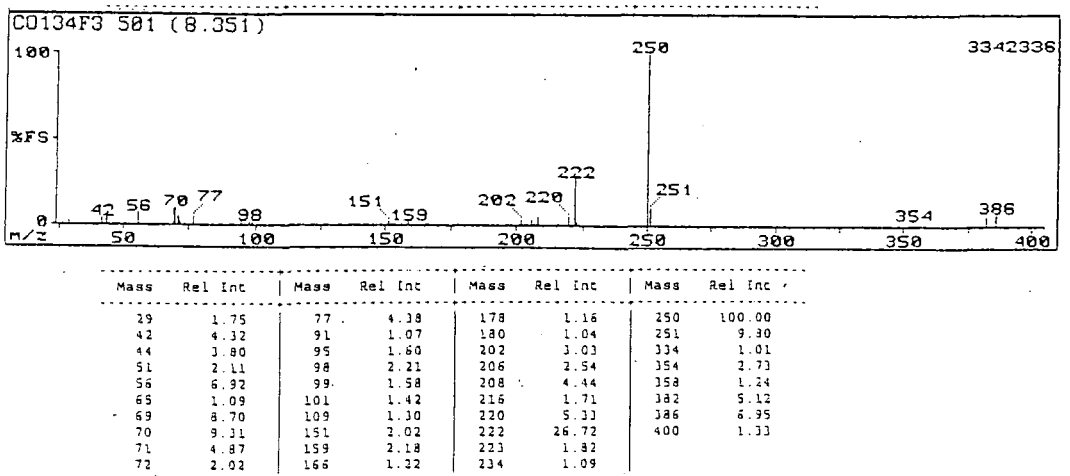

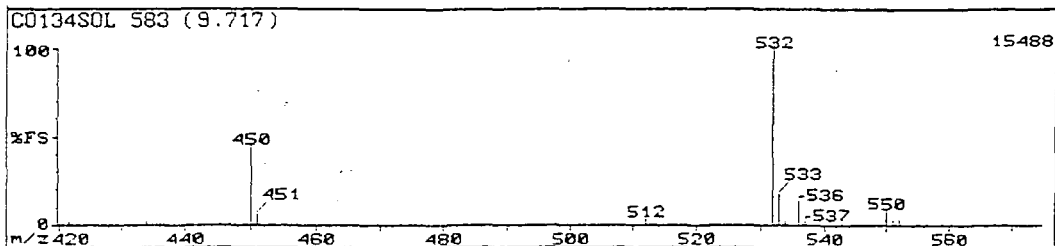

Mass	Rel Int	Mass	Rel Int	Mass	Rel Int	Mass	Rel Int
26	1.19	57	1.93	93	1.75	194	1.56
27	3.64	59	2.56	95	6.78	202	4.32
28	7.81	63	2.35	97	1.85	306	3.74
31	3.11	64	1.08	98	1.33	220	8.94
35	2.00	65	4.44	100	3.02	222	26.64
36	1.94	69	42.29	101	3.39	223	1.85
38	1.18	70	34.35	102	1.26	230	2.99
39	2.15	71	6.02	104	1.64	248	7.07
41	2.22	74	1.23	109	5.26	249	1.10
42	9.87	75	2.89	113	4.73	334	1.31
43	1.05	77	22.90	115	2.29	354	2.82
44	5.78	78	2.64	118	1.81	358	1.79
47	2.53	82	5.49	119	1.21	372	1.58
50	1.49	86	1.27	132	1.01	400	100.00
51	11.33	89	3.08	139	2.86	401	13.49
54	2.95	90	2.09	151	9.99	450	1.59
55	1.58	91	4.21	159	6.60	532	3.53
56	2.95	92	1.21	180	2.51		

Mass	Rel Int	Mass	Rel Int	Mass	Rel Int	Mass	Rel Int
422	0.07	498	0.02	533	0.52	551	0.11
434	0.06	512	0.15	534	0.06	552	0.11
436	0.03	513	0.02	536	0.48		
450	1.59	516	0.02	537	0.08		
451	0.20	532	3.53	550	0.29		

M⁺ = 373

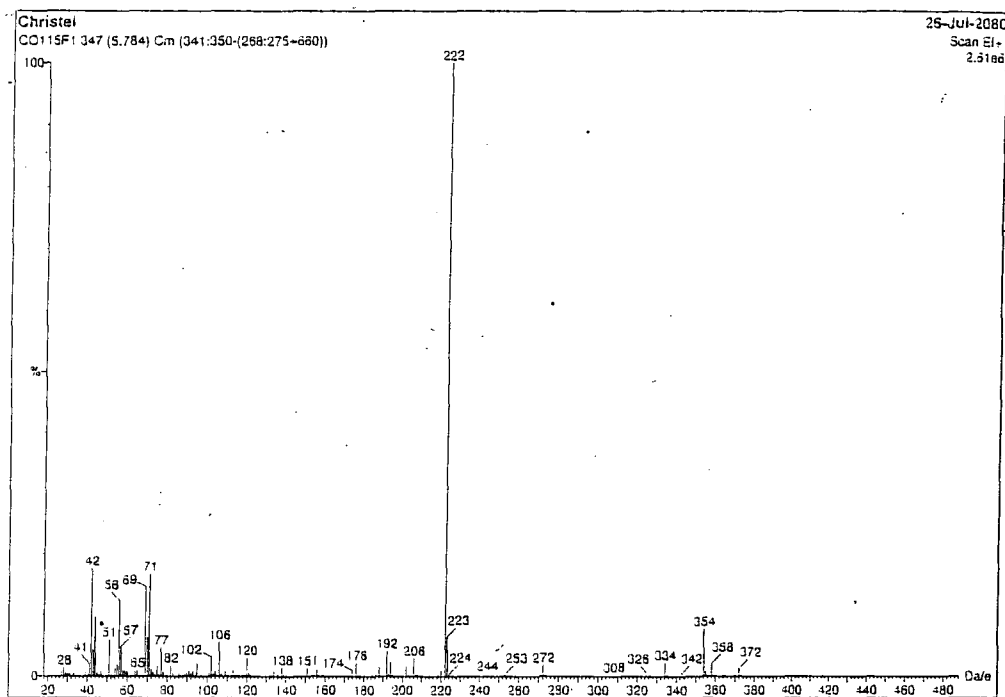

Spectrum Report

Data file: 2:\MASSLYNK\COMV\COL15F1 26-Jul-2080 12:35:49
 Scan: 347 (5.784)
 Function: Scan (19:920) EI-

Mass	IBPT	Mass	IBPT	Mass	IBPT	Mass	IBPT	Mass	IBPT	Mass	IBPT	Mass	IBPT
20	0.02	77	4.59	131	0.20	184	0.22	240	0.04	312	0.00	390	0.00
22	0.00	78	0.56	132	0.23	185	0.02	241	0.00	313	0.00	391	0.00
23	0.00	79	0.08	133	0.06	186	0.06	242	0.00	314	0.01	394	0.00
24	0.00	80	0.11	134	0.04	187	0.00	244	0.19	315	0.00	396	0.00
25	0.00	82	1.72	135	0.06	188	1.11	245	0.03	316	0.00	397	0.00
26	0.14	83	0.55	136	0.10	189	0.09	246	0.00	318	0.00	399	0.00
27	0.00	84	0.07	137	0.04	190	0.04	247	0.00	319	0.01	400	0.00
28	1.11	85	0.11	138	1.40	192	4.08	248	0.00	320	0.02	402	0.00
29	0.52	86	0.40	139	0.43	193	0.11	250	0.00	321	0.00	404	0.00
30	0.42	87	0.11	140	0.19	194	2.19	250	0.01	322	0.01	406	0.00
31	0.38	88	0.34	141	0.19	195	0.12	251	0.00	324	0.01	407	0.00
33	0.55	89	0.50	142	0.18	196	0.09	252	0.07	325	0.00	408	0.00
34	0.01	90	0.78	143	0.05	197	0.01	253	0.14	326	0.12	408	0.00
35	0.00	91	0.38	144	0.21	198	0.00	254	0.03	327	0.01	410	0.00
36	0.00	92	0.49	145	0.19	199	0.00	255	0.00	329	0.00	414	0.00
37	0.02	93	0.32	146	0.01	200	0.02	256	0.14	330	0.00	415	0.00
38	0.08	94	0.12	147	0.01	201	0.00	257	0.12	332	0.01	416	0.00
39	0.52	95	2.08	148	0.05	202	1.58	258	0.01	334	2.17	418	0.00
40	0.26	96	0.12	149	0.01	203	0.31	260	0.01	335	0.22	419	0.00
41	1.95	97	0.17	150	0.01	204	0.03	261	0.00	336	0.01	420	0.00
42	17.59	98	0.09	151	1.18	206	2.86	262	0.01	338	0.03	421	0.00
43	4.26	99	0.06	152	0.24	207	0.28	263	0.00	339	0.00	423	0.00
44	9.60	100	0.50	153	0.06	208	0.28	264	0.01	340	0.00	423	0.00
45	0.52	101	0.78	154	0.13	209	0.02	265	0.00	340	0.00	425	0.00
46	0.27	102	1.11	155	0.01	210	0.01	266	0.01	342	0.13	426	0.00
47	0.75	103	0.33	156	1.00	211	0.00	268	0.01	343	0.01	427	0.00
48	0.05	104	0.78	157	0.07	212	0.02	270	0.01	344	0.00	428	0.00
50	0.25	105	0.13	158	0.01	213	0.00	271	0.01	345	0.00	429	0.00
51	5.92	106	3.46	159	0.35	214	0.00	272	1.30	347	0.00	431	0.00
52	0.26	107	0.45	160	0.06	215	0.00	273	0.15	349	0.00	431	0.00
53	0.20	108	0.07	161	0.00	216	0.00	274	0.01	350	0.00	434	0.00
54	1.33	109	0.90	162	0.07	217	0.00	276	0.03	350	0.00	436	0.00
55	1.98	110	0.21	163	0.02	218	0.02	277	0.00	352	0.11	437	0.00
56	12.18	111	0.01	164	0.02	219	0.00	278	0.00	354	7.81	439	0.00
57	4.75	112	0.14	165	0.08	220	1.04	279	0.00	355	0.77	443	0.00
58	0.92	113	1.01	166	0.02	222	100.00	280	0.00	356	0.05	443	0.00
59	0.90	114	0.22	167	0.00	223	6.18	280	0.00	357	0.00	444	0.00
60	0.37	115	0.28	168	0.11	224	0.28	281	0.00	358	1.38	446	0.00
61	0.13	116	0.10	169	0.03	226	0.20	282	0.00	359	0.18	447	0.00
62	0.17	117	0.07	170	0.08	227	0.03	283	0.01	360	0.01	448	0.00
63	0.31	118	0.38	171	0.07	228	0.00	284	0.10	361	0.00	450	0.00
64	0.81	119	0.31	172	0.08	229	0.01	285	0.01	362	0.00	451	0.00
65	0.51	120	2.97	173	0.30	229	0.00	286	0.00	363	0.00	454	0.00
66	0.12	121	0.54	174	0.38	230	0.01	288	0.01	364	0.00	455	0.00
67	0.06	122	0.17	175	0.02	231	0.01	289	0.00	364	0.00	456	0.00
69	14.50	123	0.04	176	2.12	232	0.01	290	0.00	365	0.00	456	0.00
70	6.27	124	0.11	177	0.12	233	0.00	292	0.01	366	0.00	457	0.00
71	16.66	125	0.08	178	0.04	234	0.01	293	0.00	368	0.00	458	0.00
72	1.04	126	0.12	179	0.00	235	0.00	294	0.04	370	0.00	462	0.00
73	0.59	127	0.27	180	0.23	236	0.01	295	0.00	372	1.17	462	0.00
74	0.35	128	0.07	181	0.00	237	0.00	296	0.00	373	0.25	464	0.00
75	1.58	129	0.01	182	0.06	238	0.02	297	0.00	374	0.07	465	0.00
76	0.22	130	0.08	183	0.00	239	0.00	298	0.00	375	0.01	466	0.00
								299	0.00	376	0.00	467	0.00
								300	0.01	378	0.00	468	0.00
								301	0.00	379	0.00	470	0.00
								302	0.00	380	0.00	471	0.00
								304	0.00	382	0.00	472	0.00
								305	0.01	383	0.00	474	0.00
								306	0.02	385	0.00	475	0.00
								308	0.19	387	0.00	477	0.00
								309	0.01	387	0.00	479	0.00
								311	0.00	389	0.00	480	0.00

M⁺ = 279

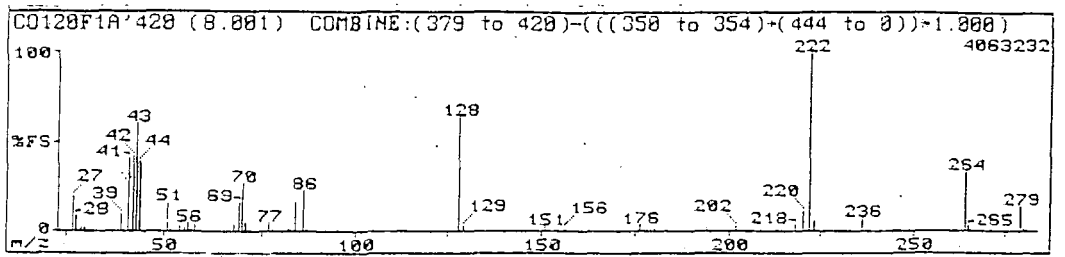

Mass	Rel Inc	Mass	Rel Inc	Mass	Rel Inc	Mass	Rel Inc
27	19.15	56	4.75	87	1.06	218	1.40
28	9.07	57	1.42	95	1.12	220	11.49
29	2.19	58	1.60	98	1.17	222	100.00
30	1.34	59	1.08	101	1.12	223	6.00
39	10.18	65	1.27	112	1.46	230	1.19
41	40.12	68	4.15	128	54.52	235	3.17
42	41.51	69	15.61	129	1.10	254	14.27
43	60.08	70	27.02	151	1.13	255	2.60
44	18.71	71	4.46	156	2.17	279	14.92
47	1.18	77	5.04	176	3.93	280	1.57
51	4.66	82	2.09	180	2.17		
54	2.90	84	15.33	194	1.56		
55	1.60	86	22.38	202	1.10		

No. 32 (2,2,3,4,4,4-hexafluoro-1,1-dimethylbutyl)(2,2,3,4,4,4-hexafluoro-1-methylbutyl)(methylthio)amine (109)

M⁺ = 429

Minor Diastereoisomer

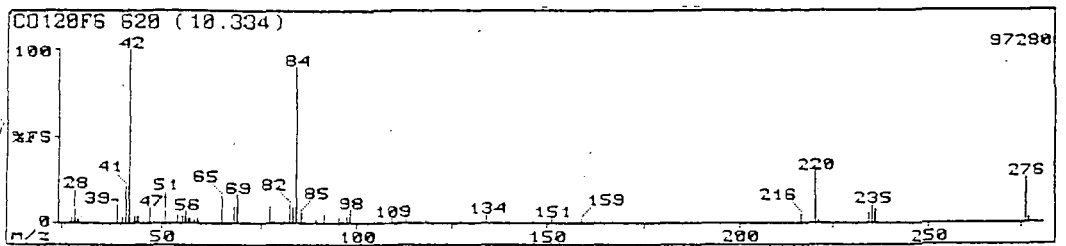

Mass	Rel Inc	Mass	Rel Inc	Mass	Rel Inc	Mass	Rel Inc
27	1.52	56	7.11	35	6.25	114	5.20
28	7.17	57	1.14	89	1.50	119	1.10
29	1.74	58	1.92	91	4.41	151	2.54
32	1.17	59	2.78	95	2.31	159	2.20
39	10.72	65	15.11	96	1.05	216	4.93
40	1.52	68	9.74	97	1.88	220	10.00
41	21.05	69	16.53	98	8.01	235	2.15
42	100.00	70	1.25	100	1.15	236	6.15
43	1.83	71	1.17	101	1.01	237	10.20
44	3.50	77	9.14	104	1.15	238	8.03
47	9.14	78	1.01	109	1.66	276	1.23
51	6.18	81	1.02	113	1.59	277	16.12
53	1.20	82	10.36	115	1.10		
54	4.30	83	8.68	118	1.63		
55	4.21	84	90.51	127	1.45		

Major Diastereoisomer

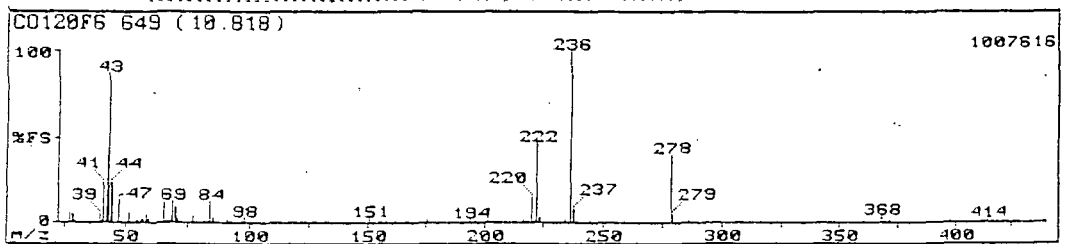

Mass	Rel Inc	Mass	Rel Inc	Mass	Rel Inc	Mass	Rel Inc
27	5.74	56	1.13	85	3.97	230	14.61
28	4.55	57	1.58	91	2.13	222	46.75
29	1.09	58	4.43	95	1.11	223	1.15
39	4.95	59	1.96	98	1.02	234	1.50
40	1.16	65	11.69	109	1.10	235	100.00
41	21.58	68	2.97	118	1.01	237	3.01
42	41.50	69	12.30	117	1.07	244	1.01
43	37.40	70	3.54	151	2.46	278	40.24
44	31.27	71	1.93	176	1.78	279	4.30
47	11.62	77	4.14	194	2.11	286	1.93
51	5.69	82	1.14	196	1.21	368	1.58
54	1.47	83	1.10	202	1.45	372	2.14
55	1.09	84	12.91	216	2.01	414	1.96

M⁺ = 235

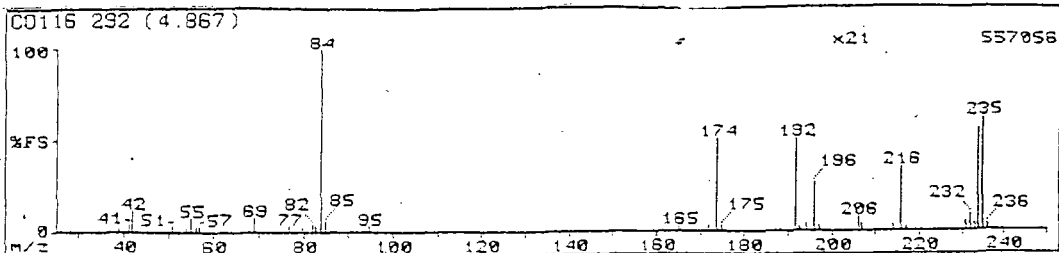

Mass	Rel Int	Mass	Rel Int	Mass	Rel Int	Mass	Rel Int
38	1.07	55	3.13	80	1.58	174	2.46
41	1.82	56	1.22	82	4.17	192	2.47
42	4.00	57	2.49	83	2.75	196	1.35
51	11.31	58	1.15	84	100.00	216	1.58
54	2.59	59	7.11	85	5.11	234	2.70
54	1.90	77	2.46	95	2.50	235	1.03

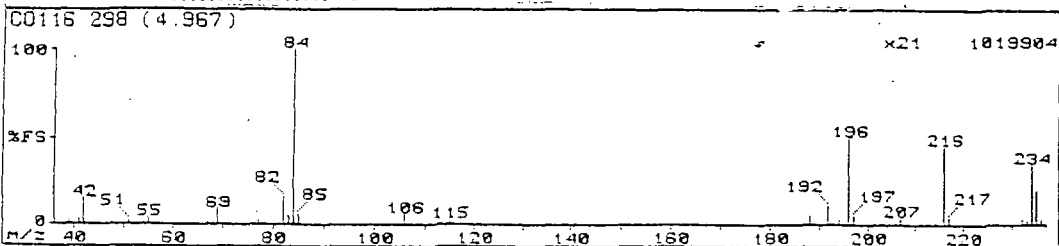

Mass	Rel Int	Mass	Rel Int	Mass	Rel Int	Mass	Rel Int
39	1.54	56	1.26	80	1.05	111	1.15
41	2.89	57	1.02	82	15.16	115	2.91
42	14.25	57	1.51	83	4.77	196	2.16
51	2.25	58	1.04	84	100.00	216	2.23
54	1.96	59	3.63	85	4.10	234	1.71
55	4.29	77	1.56	106	5.37		

No. 34 1-(2,2,3,4,4-hexafluoroburyl)-2-(1,1,2,3,3,3-hexafluoropropyl)piperidine (111)

M⁺ = 399

Ion Mode: CI+

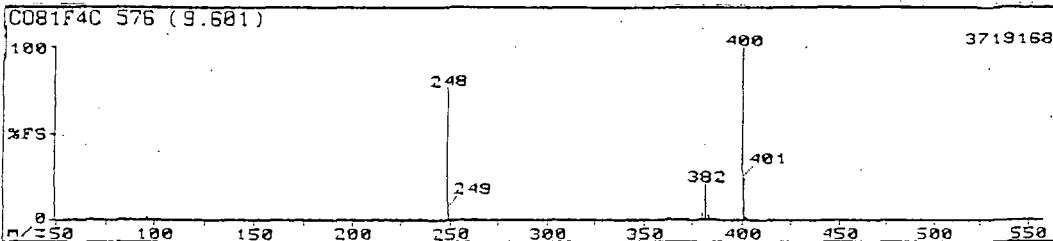

Mass	Rel Int	Mass	Rel Int	Mass	Rel Int	Mass	Rel Int	Mass	Rel Int	Mass	Rel Int	Mass	Rel Int
55	0.67	112	0.10	167	0.01	224	0.01	290	0.01	320	0.03	356	0.00
56	0.67	113	0.12	168	0.06	225	0.01	291	0.01	321	0.01	358	0.05
57	0.11	114	0.19	170	0.04	226	0.01	292	0.01	322	0.04	359	0.02
58	0.70	115	0.02	171	0.02	229	0.47	293	0.01	323	0.01	360	0.27
59	0.09	116	0.04	172	0.01	229	0.18	294	0.01	324	0.11	362	2.09
60	0.03	117	0.04	173	0.02	230	1.58	295	0.02	325	0.01	363	0.25
61	0.02	118	0.18	174	0.18	231	0.40	296	0.03	326	0.02	364	0.04
63	0.02	119	0.06	175	0.02	232	0.18	298	0.22	328	0.00	365	0.01
64	0.01	120	0.07	176	0.06	233	0.03	299	0.02	330	0.02	368	0.01
65	0.01	121	0.05	177	0.01	234	0.51	300	0.04	332	0.03	370	0.04
65	0.16	122	0.05	178	0.12	235	0.01	301	0.01	333	0.01	371	0.01
67	0.21	123	0.02	179	0.08	236	0.39	302	0.03	338	0.06	372	0.01
68	0.71	124	0.07	180	0.04	237	0.07	303	0.01	339	0.01	378	0.02
69	1.53	125	0.02	181	0.02	238	0.09	304	0.03	340	0.03	379	0.23
70	0.19	126	0.11	182	0.06	240	0.01	305	0.00	341	0.03	380	1.43
71	0.08	127	0.05	183	0.01	242	0.02	306	0.01	342	0.15	382	21.04
72	0.22	128	0.28	184	0.04	244	0.10	308	0.01	343	0.03	383	2.70
73	0.05	129	0.04	185	0.01	245	0.02	310	0.02	344	0.07	384	0.13
74	0.20	130	0.06	186	0.05	246	0.70	311	0.00	345	0.01	385	0.02
75	0.06	131	0.12	187	0.02	248	75.65	312	0.01	346	0.02	386	0.07
77	0.54	132	0.14	188	0.08	249	7.16	314	0.01	348	0.01	387	0.01
78	0.04	133	0.03	189	0.02	250	0.56	318	0.02	352	0.02	388	0.02
80	0.47	134	0.03	190	0.07	251	0.06						
81	0.21	135	0.02	192	0.26	252	0.03						
82	0.96	136	0.06	193	0.04	254	0.01						
83	0.69	137	0.01	194	0.24	255	0.01						
84	1.05	138	0.07	195	0.02	256	0.17						
85	0.10	139	0.03	196	0.08	257	0.02						
86	0.20	140	0.08	197	0.03	259	0.01						
87	0.07	141	0.01	198	0.03	260	0.01						
88	0.05	142	0.10	199	0.01	261	0.01						
89	0.02	143	0.02	200	0.08	262	0.06						
90	0.04	144	0.08	201	0.01	263	0.02						
91	0.09	145	0.07	202	0.06	264	0.04						
92	0.13	146	0.66	203	0.01	265	0.01						
93	0.14	147	0.08	204	0.02	266	0.03						
94	0.48	148	0.04	205	0.02	268	0.01						
95	0.35	150	0.06	206	0.14	270	0.01						
96	3.59	151	0.04	207	0.06	272	0.01						
97	2.01	152	0.01	208	0.23	271	0.00						
98	0.11	153	0.02	209	0.04	274	0.01						
99	0.06	154	0.04	210	0.81	275	0.01						
100	0.11	155	0.02	211	0.08	276	0.01						
101	0.06	156	0.07	212	0.04	278	0.02						
102	0.04	157	0.02	213	0.02	279	0.02						
103	0.10	158	0.07	214	0.20	280	0.04						
104	0.07	159	0.07	215	0.03	281	0.01						
105	0.04	160	0.35	216	0.14	282	0.01						
106	0.09	161	0.04	217	0.01	284	0.03						
107	0.04	162	0.03	218	0.10	285	0.01						
108	0.04	163	0.01	220	1.56	286	0.01						
109	3.04	164	0.05	221	0.12	287	0.00						
110	0.06	165	0.01	222	0.10	288	0.02						
111	0.03	166	0.04	223	0.02	289	0.01						

Ign Mode:CI+

C089C 537 (18.618)

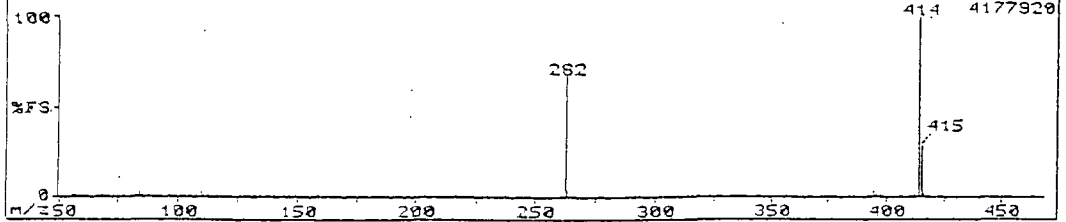

Mass	Rel Inc	Mass	Rel Inc	Mass	Rel Inc	Mass	Rel Inc	Mass	Rel Inc	Mass	Rel Inc	Mass	Rel Inc	Mass	Rel Inc
55	0.77	121	0.06	179	0.09	256	0.02	91	0.09	152	0.03	213	0.04	320	0.01
56	2.08	122	0.04	180	0.06	258	0.03	92	0.07	153	0.04	219	0.04	324	0.01
57	0.24	124	0.05	181	0.01	260	0.35	94	0.13	154	0.06	220	0.05	327	0.01
58	0.91	125	0.03	182	0.02	262	57.45	96	1.56	155	0.03	222	0.10	332	0.01
59	0.15	126	0.07	183	0.01	263	3.73	97	0.12	156	0.07	223	0.04	334	0.01
60	0.11	127	0.03	184	0.01	264	0.36	99	0.12	157	0.03	224	0.03	336	0.01
61	0.06	128	0.03	185	0.02	266	0.02	100	0.18	158	0.05	228	0.10	339	0.01
62	0.01	129	0.04	186	0.01	270	0.02	101	0.08	159	0.11	229	0.04	340	0.01
63	0.02	130	0.07	187	0.05	274	0.01	102	0.03	160	0.15	229	0.01	342	0.01
66	0.23	131	0.08	188	0.08	275	0.04	103	0.05	161	0.03	230	0.01	344	0.01
67	0.13	133	0.07	190	0.02	278	0.01	104	0.08	162	0.02	232	0.04	346	0.01
68	0.51	134	0.05	191	0.05	284	0.02	105	0.07	163	0.02	232	0.04	352	0.01
69	1.48	134	0.02	192	0.09	288	0.01	106	0.10	164	0.03	234	0.72	354	0.01
70	0.74	136	0.04	193	0.04	290	0.02	108	0.10	166	0.01	236	1.37	356	0.01
71	0.13	136	0.03	194	0.05	292	0.06	110	1.11	168	0.03	237	0.11	357	0.01
72	0.28	137	0.03	196	0.07	293	0.01	111	1.15	168	0.03	238	0.03	358	0.01
74	0.26	138	0.03	197	0.01	294	0.01	112	0.11	170	0.02	242	0.15	365	0.01
75	0.09	139	0.05	200	0.03	295	0.01	113	0.13	171	0.02	242	0.25	372	0.01
76	0.38	140	0.09	202	0.04	298	0.01	114	0.15	172	0.03	243	0.07	374	0.01
77	0.11	141	0.07	203	0.01	300	0.01	115	0.03	173	0.07	244	0.08	376	0.01
78	0.04	142	0.15	204	0.02	302	0.04	116	0.05	174	0.12	246	0.13	377	0.01
80	0.98	144	0.05	205	0.08	304	0.03	118	0.11	175	0.05	246	0.13	384	0.01
83	1.69	144	0.02	206	0.16	306	0.02	119	0.03	176	0.07	247	0.02	386	0.01
83	1.15	145	0.34	208	0.17	309	0.01	120	0.05	178	0.06	248	0.02	392	0.01
84	3.14	146	0.05	210	0.01	310	0.01	121	0.01	179	0.04	248	0.02	394	0.01
86	1.25	148	0.01	212	0.01	312	0.17	122	0.01	180	0.03	248	0.02	396	0.01
87	0.11	148	0.03	213	0.04	314	0.02	123	0.01	181	0.03	248	0.02	398	0.01
88	0.10	149	0.02	214	0.05	315	0.01	124	0.01	182	0.03	248	0.02	400	0.01
89	0.32	150	0.06	216	0.09	316	0.02	125	0.01	183	0.03	248	0.02	402	0.01
90	0.07	151	0.04	217	0.01	318	0.01	126	0.01	184	0.03	248	0.02	404	0.01

No. 36 4-(2,2,3,4,4-hexafluorobutyl)morpholine (113)

M⁺ = 251

C0182F3 383 (6.384)

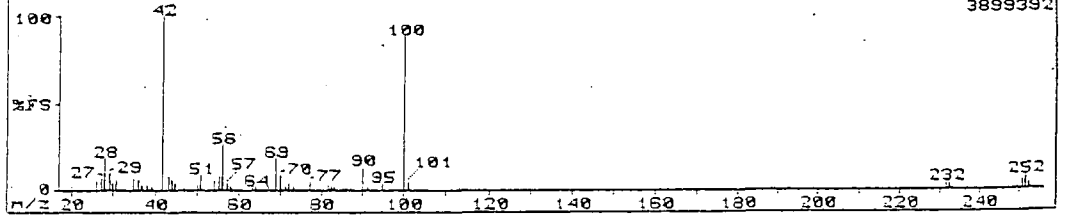

Mass	Rel Inc	Mass	Rel Inc	Mass	Rel Inc	Mass	Rel Inc
20	1.48	44	5.01	70	9.03	98	2.13
26	5.30	45	3.44	71	1.75	100	59.56
27	7.25	47	1.02	72	3.73	101	5.07
28	18.91	50	2.75	73	2.07	104	1.31
29	9.45	51	9.03	75	1.40	113	1.58
30	4.25	54	5.67	77	5.02	139	1.48
31	5.16	55	8.13	82	2.53	192	1.34
32	1.09	56	25.36	82	1.75	212	1.44
35	5.72	57	3.37	83	1.56	220	1.45
36	5.51	58	1.66	85	2.34	232	4.20
37	2.55	50	1.19	86	1.00	232	3.13
38	2.52	53	2.07	87	1.42	250	1.31
39	1.73	64	2.10	90	2.42	251	5.15
42	100.00	67	1.57	91	1.75	252	7.46
43	2.13	69	13.91	95	3.49	252	3.39

C0182F3 484 (6.734)

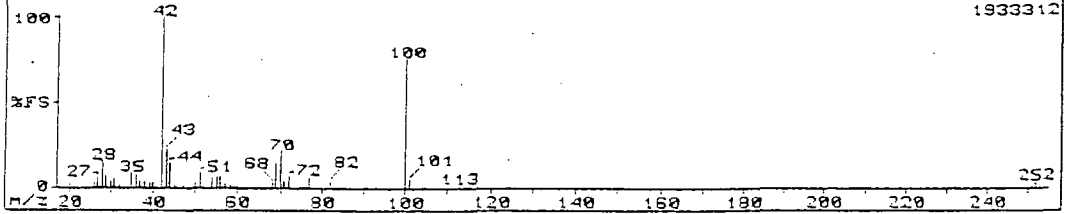

Mass	Rel Inc	Mass	Rel Inc	Mass	Rel Inc	Mass	Rel Inc
10	1.53	42	100.00	53	2.00	93	1.44
26	1.35	43	22.57	67	1.30	98	1.15
27	5.33	44	14.41	68	3.13	100	75.42
28	15.25	45	1.50	69	15.04	101	4.56
29	5.67	47	1.97	70	21.51	104	1.13
30	3.87	50	3.19	71	3.50	113	2.43
31	5.09	51	8.47	72	5.57	132	1.07
32	1.72	54	5.57	75	1.47	202	1.77
35	9.12	55	7.04	76	1.06	332	1.95
36	7.79	56	6.45	77	5.51	351	1.19
37	3.55	57	2.91	81	1.75	352	4.03
38	4.24	58	1.54	85	1.33		
39	3.28	59	1.05	90	1.95		
40	4.13	60	1.23	91	1.23		

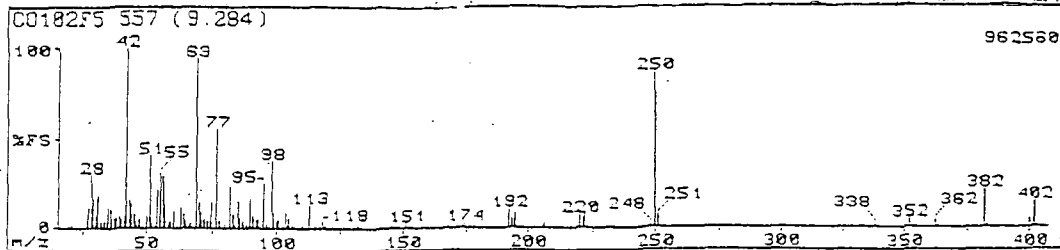

Mass	Rel Inc	Mass	Rel Inc	Mass	Rel Inc	Mass	Rel Inc
10	1.73	59	1.54	100	4.30	193	5.21
25	1.33	60	9.79	101	4.47	194	7.35
26	5.70	62	1.34	102	1.40	205	2.10
27	11.91	63	11.28	104	8.34	206	2.74
28	30.21	64	8.19	104	2.15	220	5.38
29	16.70	65	1.48	105	5.30	220	7.66
30	6.44	66	1.45	106	1.73	222	5.43
31	18.51	67	3.22	107	1.06	222	7.45
32	3.54	69	94.04	108	1.14	230	1.33
33	4.15	70	14.79	109	1.44	231	1.37
35	11.17	71	8.30	110	1.97	232	1.31
36	10.53	72	5.19	111	1.15	248	1.12
37	5.48	73	2.88	111	13.72	248	2.29
38	5.09	75	14.25	115	1.36	250	86.28
39	7.13	77	55.12	113	2.88	250	74.39
40	4.58	78	1.54	113	2.34	251	6.46
41	27.66	80	2.37	113	1.02	300	1.02
42	100.00	82	23.19	122	1.51	300	1.32
43	15.43	83	7.87	124	1.05	322	1.37
44	13.82	84	1.96	127	1.53	322	1.30
45	7.55	85	15.53	130	1.49	328	3.37
46	3.02	86	5.35	131	2.13	352	5.37
47	5.16	87	3.75	132	1.97	352	1.70
50	6.49	89	2.34	144	1.04	370	1.42
51	40.43	90	15.38	145	1.50	382	21.50
52	2.55	91	6.57	150	2.37	383	1.56
53	1.18	92	5.21	151	3.32	400	4.39
54	21.06	93	5.29	172	1.74	401	1.14
55	31.05	95	25.53	173	3.35	402	14.57
56	28.94	96	2.13	174	3.34	403	1.32
57	12.87	98	17.45	191	5.52		
58	1.06	99	9.04	192	10.85		

No. 38 4-(2,2,3,4,4,4-hexafluoro-1-methylbutyl)morpholine (115)

M⁺ = 265

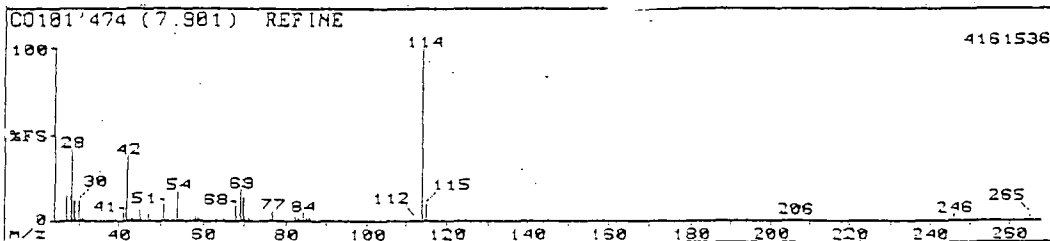

Mass	Rel Inc	Mass	Rel Inc	Mass	Rel Inc	Mass	Rel Inc
27	14.61	45	2.11	69	18.33	127	3.06
28	39.41	47	1.94	70	14.12	114	100.00
29	11.27	47	1.37	71	1.55	115	9.51
30	7.84	51	5.69	75	1.54	202	1.08
31	2.94	51	4.12	77	5.66	206	1.24
33	1.18	54	7.94	78	1.00	208	1.00
39	1.75	54	9.32	82	3.15	220	1.17
39	1.44	56	100.00	83	1.94	234	1.10
41	9.31	57	7.06	84	4.41	246	1.73
42	23.73	58	3.16	85	1.69	250	1.17
42	14.51	59	1.84	86	3.52	264	1.56
43	4.12	65	1.51	90	1.40	263	3.32
45	4.36	68	9.12	91	1.28		

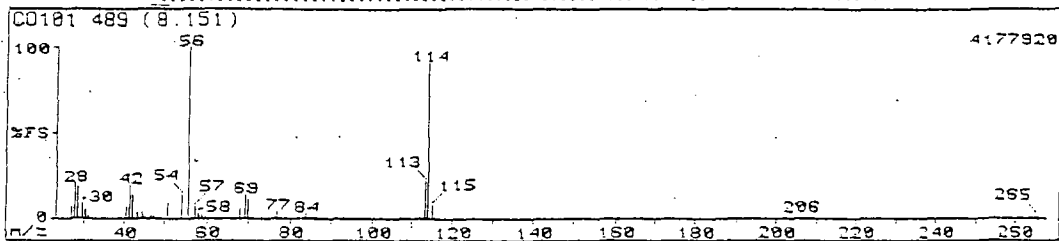

Mass	Rel Inc	Mass	Rel Inc	Mass	Rel Inc	Mass	Rel Inc
27	6.37	43	1.55	55	1.15	86	1.59
28	20.39	44	3.46	68	5.13	91	1.04
28	18.73	45	2.21	69	13.43	112	1.52
30	9.12	47	1.54	70	10.39	113	31.47
30	4.85	47	1.67	71	1.12	114	91.37
31	1.74	51	8.53	75	1.39	115	7.45
39	1.37	54	13.53	77	4.24	202	1.59
39	1.37	56	100.00	82	1.59	206	7.50
41	7.06	57	5.57	83	1.40	246	1.56
42	19.51	58	2.67	84	3.28	264	1.06
43	13.24	59	1.72	85	1.19	265	2.01

Major Diastereoisomer

Minor Diastereoisomer

M⁺ = 415

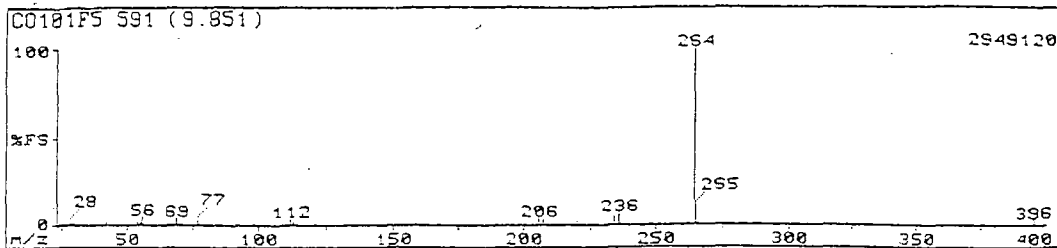

Mass	Rel Int	Mass	Rel Int	Mass	Rel Int	Mass	Rel Int
28	2.10	70	1.04	206	3.78	265	10.55
29	1.31	77	3.15	208	3.06	314	1.19
42	1.57	84	1.43	220	1.55	365	1.45
51	1.12	85	1.08	234	4.30	375	1.08
54	1.71	98	1.17	236	6.53	396	2.50
55	3.06	112	3.32	249	1.02		
56	4.79	113	1.68	262	1.35		
69	4.13	159	1.46	264	100.00		

No. 40 2,6-bis(1,1,2,3,3,3-hexafluoropropyl)-1,4-dimethylpiperazine (117)

M⁺ = 414

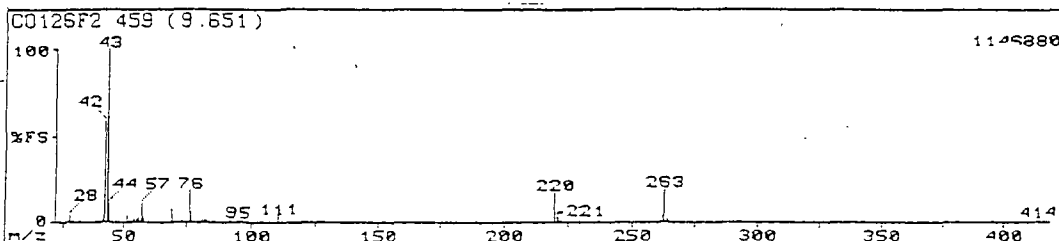

Mass	Rel Int	Mass	Rel Int	Mass	Rel Int	Mass	Rel Int
27	1.10	55	2.34	82	1.54	120	17.59
28	4.17	56	3.10	83	1.18	121	3.15
39	1.03	57	10.89	95	2.01	135	1.45
41	4.33	58	2.92	96	1.35	162	3.64
42	58.57	59	3.04	97	1.10	163	19.38
43	100.00	70	4.33	104	1.07	164	1.70
44	10.98	75	18.75	111	4.20	195	1.15
51	3.44	77	5.65	120	1.37	414	2.34
54	2.19	81	1.33	188	1.45		

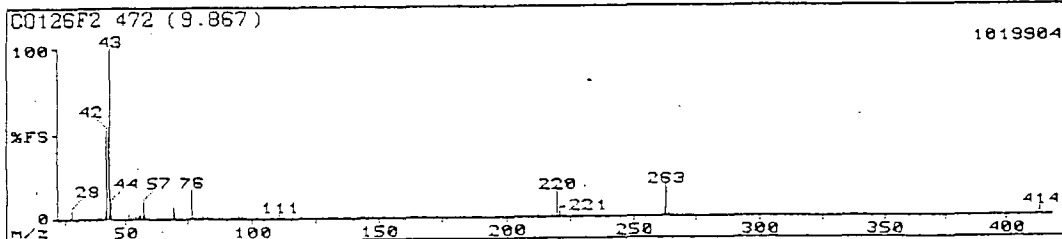

Mass	Rel Int	Mass	Rel Int	Mass	Rel Int	Mass	Rel Int
27	1.09	54	1.86	77	5.02	220	15.95
28	4.99	55	3.08	81	1.50	221	2.86
39	1.00	56	2.79	82	1.35	235	1.31
41	3.89	57	9.54	83	1.26	262	3.87
42	52.81	58	2.56	95	1.61	263	18.57
43	100.00	69	6.73	96	1.08	264	1.68
44	10.14	70	3.89	111	2.89	395	1.53
51	2.91	75	17.77	188	1.36	414	4.42

M⁺ = 564

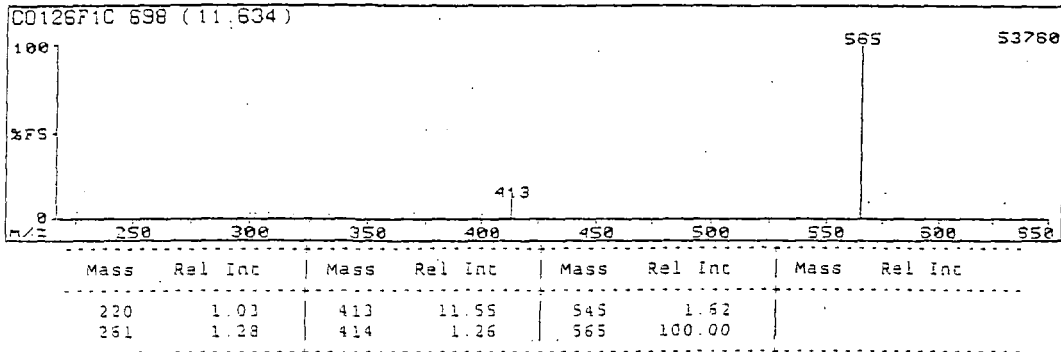
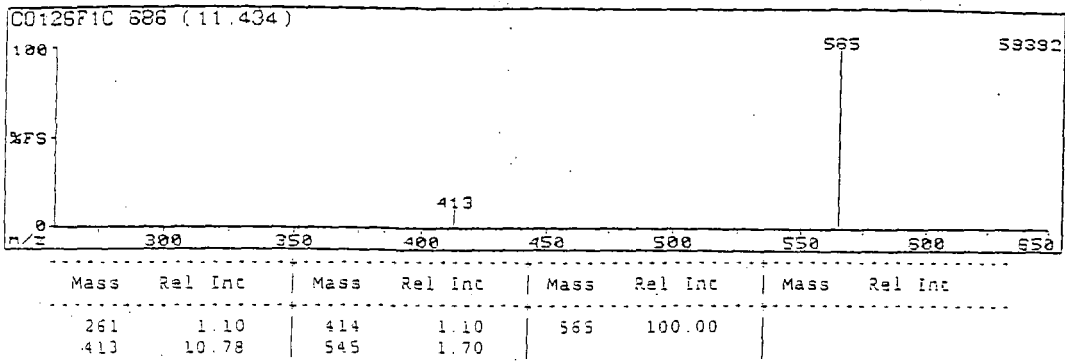

No. 42 1-((2Z)-2,3,4,4,4-pentafluoro-1-methylbut-2-enyl)-2-((1Z)-1,2,3,3,3-pentafluoroprop-1-enyl)piperidine (119)

M⁺ = 373

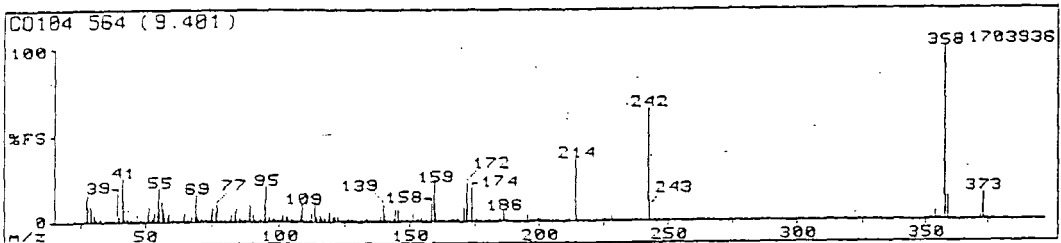

Mass	Rel Int	Mass	Rel Int	Mass	Rel Int	Mass	Rel Int
20	0.03	90	1.19	134	1.19	193	0.71
24	0.01	81	1.74	135	0.98	194	1.26
25	0.85	82	3.43	136	1.20	195	4.03
27	13.64	83	5.47	137	1.44	197	0.58
28	15.18	84	7.53	138	1.22	198	0.50
29	3.81	85	1.59	139	9.50	199	2.00
30	4.21	86	0.84	140	1.33	200	3.16
31	1.71	87	1.28	141	1.26	201	0.49
32	0.21	88	5.77	142	0.54	202	0.28
33	2.13	89	9.98	143	1.47	203	0.15
35	0.05	90	1.57	144	6.91	204	0.15
36	0.11	91	1.07	145	6.43	205	0.07
38	0.23	92	1.17	146	1.20	206	0.20
39	0.53	93	1.85	147	0.71	207	0.25
39	15.31	94	9.86	148	0.94	208	0.25
40	2.76	95	19.95	149	0.43	209	0.08
41	25.24	96	1.53	150	1.25	210	0.23
42	13.10	97	2.03	151	4.99	212	1.83
43	1.91	98	1.50	152	1.38	214	16.30
44	2.01	99	0.32	153	1.71	215	3.13
45	1.25	100	1.89	154	2.43	216	0.37
46	0.76	101	1.97	155	0.33	217	0.09
47	4.27	102	2.88	156	0.76	218	0.05
48	0.35	103	2.84	159	10.28	219	0.05
51	4.99	104	1.30	159	22.36	220	0.23
51	8.47	105	0.52	160	5.17	221	0.05
52	1.94	106	1.29	161	0.40	222	0.18
53	4.19	107	1.71	162	0.26	223	0.04
54	11.48	108	2.31	163	0.54	224	0.23
55	19.71	109	9.68	164	0.41	225	0.16
56	11.42	110	1.34	165	1.04	226	1.74
57	5.95	111	1.10	166	1.52	227	0.36
58	3.14	112	4.45	167	1.17	228	2.75
59	4.19	113	9.38	168	1.93	229	0.36
60	0.75	114	2.75	169	0.29	230	0.18
61	0.24	115	3.93	171	7.39	231	0.09
62	0.50	116	3.14	172	22.12	232	0.05
63	0.93	117	2.10	174	18.99	233	0.12
64	2.82	118	4.57	175	1.04	234	0.17
65	4.99	119	4.13	176	2.27	235	0.05
66	0.52	120	3.49	177	0.96	236	0.10
67	1.97	121	3.25	179	1.89	237	0.05
68	9.58	122	1.99	180	9.55	238	0.29
69	15.63	123	0.19	181	0.29	239	0.11
70	1.32	124	1.01	182	0.26	240	0.75
71	1.97	125	2.15	183	0.23	242	15.38
72	1.05	126	1.58	184	0.56	243	7.13
73	0.74	127	3.22	185	1.56	244	0.53
74	4.21	128	0.76	186	5.41	245	0.05
75	7.81	129	0.79	187	4.15	246	0.14
76	5.77	130	1.10	188	0.98	247	0.03
77	10.04	131	1.77	189	0.17	248	0.60
78	0.92	132	1.32	190	0.25	249	0.09
79	0.85	133	2.27	192	0.55	250	0.11

Appendix C : Mass Spectra

- No. 1 1-adamantanyl-1,1,2,3,3,3-hexafluoropropane (36)
- No. 2 1,1,2,3,3,3-hexafluoro-1-[3-(1,1,2,3,3,3-hexafluoropropyl)adamantanyl]propane (39)
- No. 3 1-[3,5-bis(1,1,2,3,3,3-hexafluoropropyl)adamantanyl]-1,1,2,3,3,3-hexafluoropropane (41)
- No. 4 1,1,2,3,3,3-hexafluoro-1-[3,5,8-tris(1,1,2,3,3,3-hexafluoropropyl)adamantanyl]propane (42)
- No. 5 1-(1,1,2,3,3,3-hexafluoropropyl)cyclopentane (43)
- No. 6 1,1,2,3,3-hexafluoro-1-[3-(1,1,2,3,3,3-hexafluoropropyl)cyclopentyl]propane (44b)
- No. 7 1-(1,1,2,3,3,3-hexafluoropropyl)cyclopentanol (46)
- No. 8 1-(1,1,2,3,3,3-hexafluoropropyl)cyclopentene (49)
- No. 9 (1*E*)-1-adamantanyl-1,2,3,3,3-pentafluoroprop-1-ene (53a) and (1*Z*)-1-adamantanyl-1,2,3,3,3-pentafluoroprop-1-ene (53b)
- No. 10 1-(*E*-pentafluoroprop-2-enyl)cyclopentane (54a) and 1-(*Z*-pentafluoroprop-2-enyl)cyclopentane (54b)
- No. 11 1-[(1*R*,3*R*)-3-((1*Z*)-1,2,3,3,3-pentafluoroprop-1-enyl)cyclopentyl](1*Z*)-1,2,3,3,3-pentafluoroprop-1-ene (55) and 1-[(3*S*,1*R*)-3-((1*Z*)-1,2,3,3,3-pentafluoroprop-1-enyl)cyclopentyl](1*Z*)-1,2,3,3,3-pentafluoroprop-1-ene (56)
- No. 12 1-(1,2,3,3,3-pentafluoro-*Z*-prop-1-enyl)cyclopentene (57b)
- No. 13 (1*E*)-1-cyclopentyl-1-ethoxy-2,3,3,3-tetrafluoroprop-1-ene (75a) and (1*Z*)-1-cyclopentyl-1-ethoxy-2,3,3,3-tetrafluoroprop-1-ene (75b)
- No. 14 1-cyclopentyl-1-ethoxy-1,2,3,3,3-pentafluoropropane (76)
- No. 15 1-cyclopentyl-2,3,3,3-tetrafluoropropan-1-one (77)
- No. 16 1-cyclopentyl-1,2,3,3,3-pentafluoro-1-methoxypropane (78)
- No. 17 1-cyclopentyl-2-fluoro-2-trifluoromethyl-4-penten-1-one (79)
- No. 18 1-cyclopentyl-2-fluoro-2-trifluoromethyl-3,4-pentadien-1-one (85)
- No. 19 1-cyclopentyl-2-fluoro-3-methyl-2-trifluoromethyl-4-penten-1-one (86)
- No. 20 cyclopentane carboxylic acid (88)
- No. 21 1-cyclopentyl-3-ethenyl-2-fluoro-3,7-dimethyl-2-trifluoromethyl-6-octen-1-one (92)
- No. 22 1-cyclopent-1-enyl-2-fluoro-3,7-dimethyl-2-(trifluoromethyl)-3-vinyl-6-en-1-one (93)

- No. 23 Z-(1-cyclopentyl-2,3,3,3-tetrafluoro-1-propenoxy)methylbenzene (94)
- No. 24 Z-(1-butyl-2,3,3,3-tetrafluoro-1-propenyl)cyclopentane (99)
- No. 25 Z-(1-phenyl-2,3,3,3-tetrafluoro-1-propenyl)cyclopentane (101)
- No. 26 1,2-dibromo-1-cyclopentyl-1,2,3,3,3-pentafluoropropane (103)
- No. 27 diethyl(2,2,3,4,4,4-hexafluoro-1-methylbutyl)amine (104)
- No. 28 bis(2,2,3,4,4,4-hexafluoro-1-methylbutyl)ethylamine (105)
- No. 29 tris(2,2,3,4,4,4-hexafluoro-1-methylbutyl)amine (106)
- No. 30 (2,2,3,4,4,4-hexafluorobutyl)(2,2,3,4,4,4-hexafluoro-1-methylbutyl)methylamine (107)
- No. 31 bis(methylethyl)(2,2,3,4,4,4-hexafluoro-1-methylbutyl)amine (108)
- No. 32 (2,2,3,4,4,4-hexafluoro-1,1-dimethylbutyl)(2,2,3,4,4,4-hexafluoro-1-methylbutyl)(methylethyl)amine (109)
- No. 33 2-(1,1,2,3,3,3-hexafluoropropyl)-1-methylpyrrolidine (110)
- No. 34 1-(2,2,3,4,4,4-hexafluorobutyl)-2-(1,1,2,3,3,3-hexafluoropropyl)piperidine (111)
- No. 35 1-(2,2,3,4,4,4-hexafluoro-1-methylbutyl)-2-(1,1,2,3,3,3-hexafluoropropyl)piperidine (112)
- No. 36 4-(2,2,3,4,4,4-hexafluorobutyl)morpholine (113)
- No. 37 4-(2,2,3,4,4,4-hexafluorobutyl)-3-(1,1,2,3,3,3-hexafluoropropyl)morpholine (114)
- No. 38 4-(2,2,3,4,4,4-hexafluoro-1-methylbutyl)morpholine (115)
- No. 39 4-(2,2,3,4,4,4-hexafluoro-1-methylbutyl)-3-(1,1,2,3,3,3-hexafluoropropyl)morpholine (116)
- No. 40 2,6-bis(1,1,2,3,3,3-hexafluoropropyl)-1,4-dimethylpiperazine (117)
- No. 41 1,4-dimethyl-2,3,5-tris(1,1,2,3,3,3-hexafluoropropyl)piperazine (118)
- No. 42 1-((2Z)-2,3,4,4,4-pentafluoro-1-methylbut-2-enyl)-2-((1Z)-1,2,3,3,3-pentafluoroprop-1-enyl)piperidine (119)

No. 1 1-adamantanyi-1,1,2,3,3,3-hexafluoropropane (36)

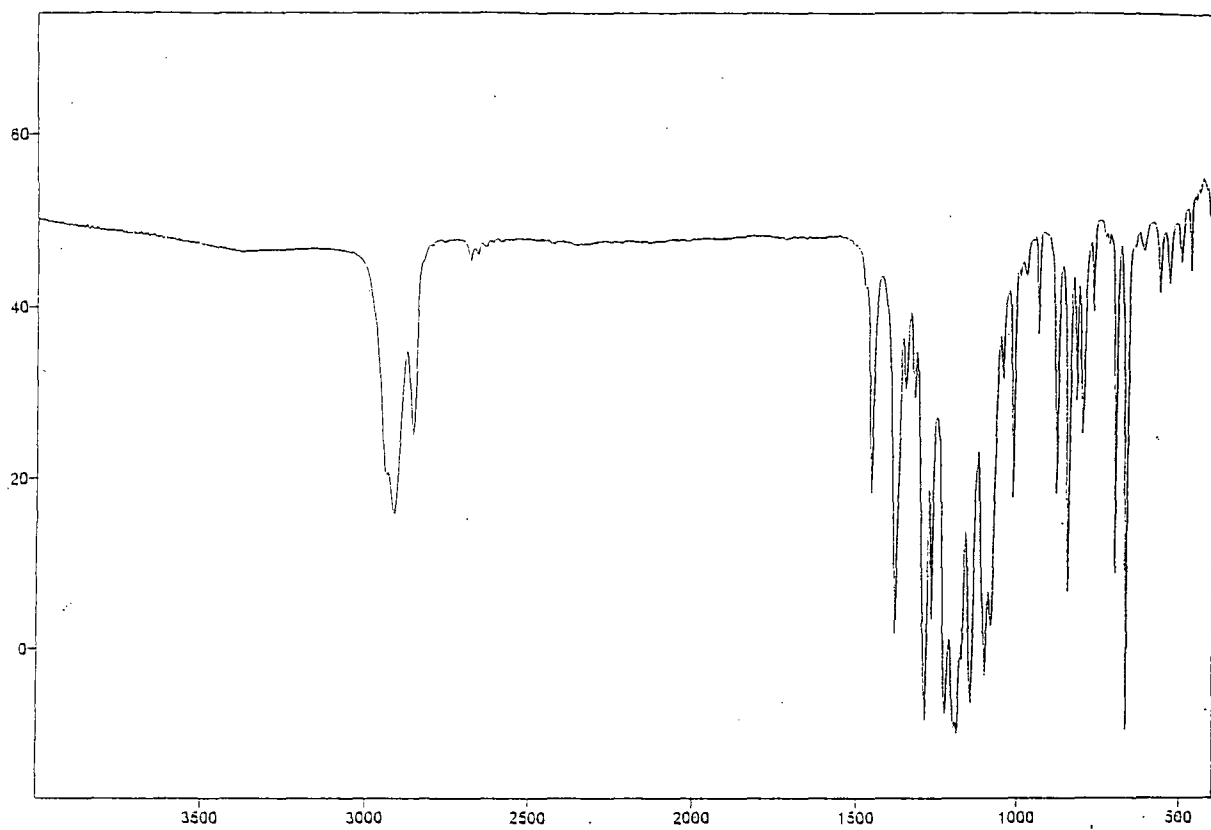

No. 2 1,1,2,3,3,3-hexafluoro-1-[3-(1,1,2,3,3,3-hexafluoropropyl)adamantanyl] propane (39)

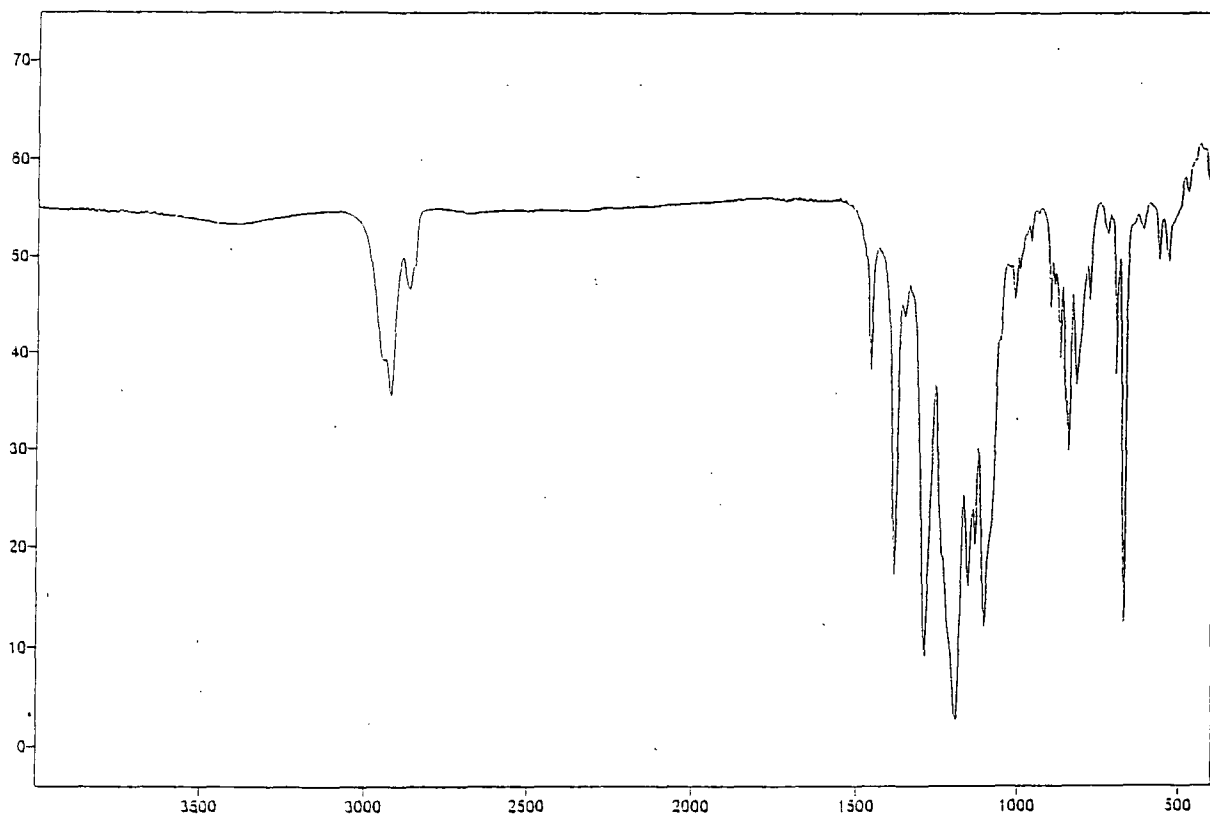

No. 3 1-[3,5-bis(1,1,2,3,3,3-hexafluoropropyl)adamantanyl]-1,1,2,3,3,3-hexafluoro propane (41)

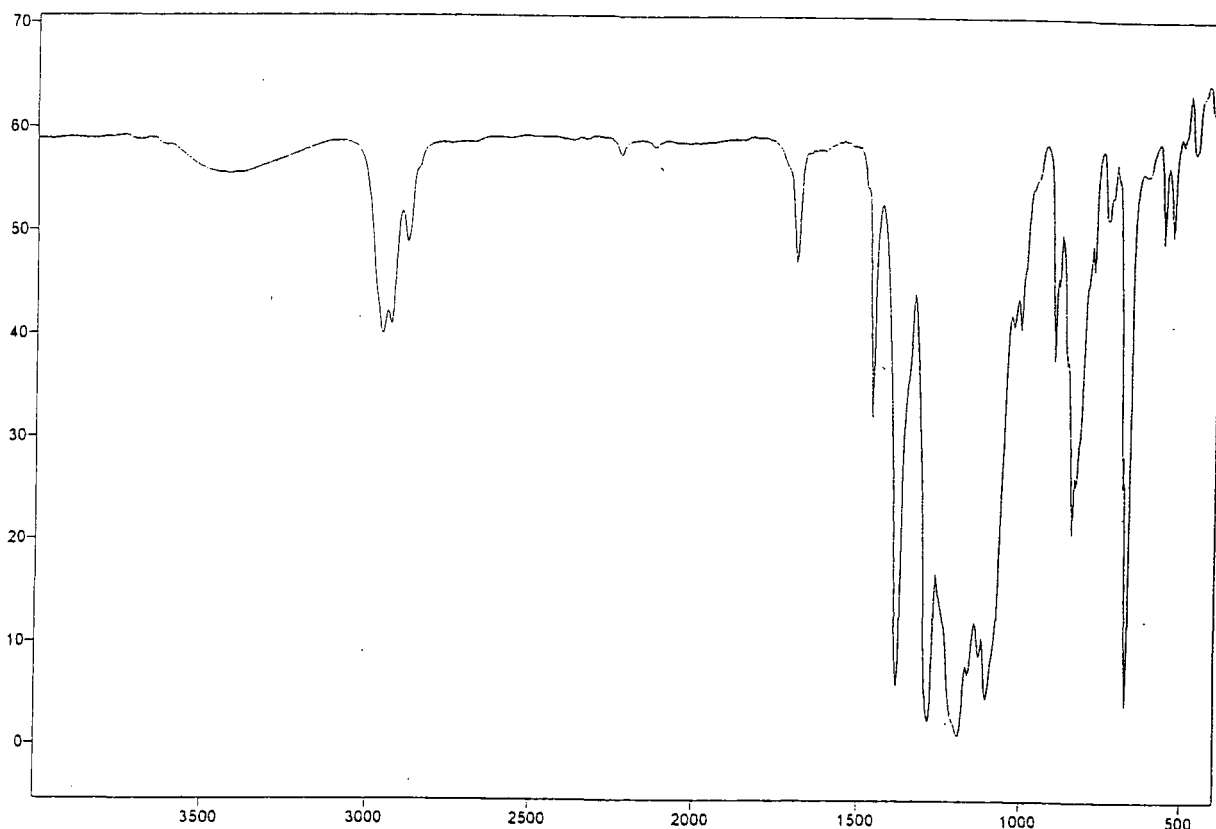

No. 4 1,1,2,3,3,3-hexafluoro-1-[3,5,8-tris(1,1,2,3,3,3-hexafluoropropyl)adamantanyl] propane (42)

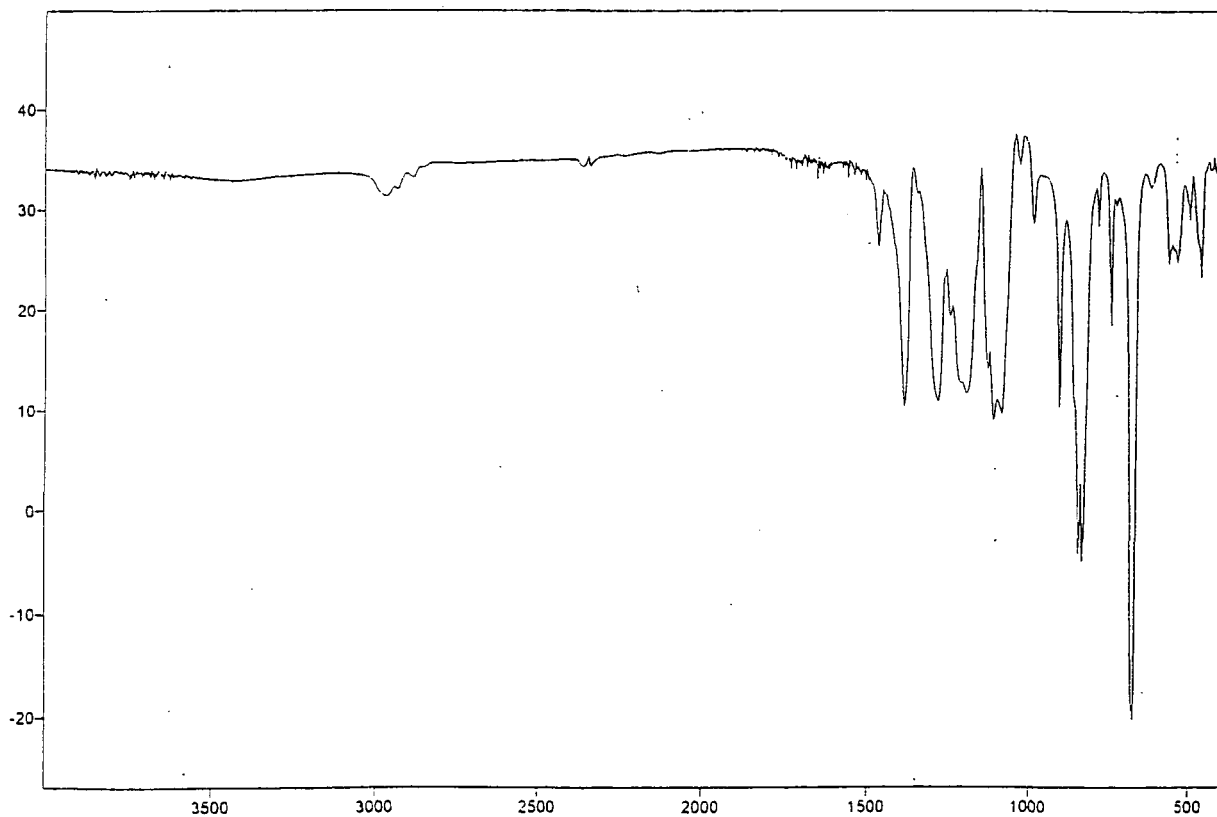

No. 5 1-(1,1,2,3,3,3-hexafluoropropyl)cyclopentane (43)

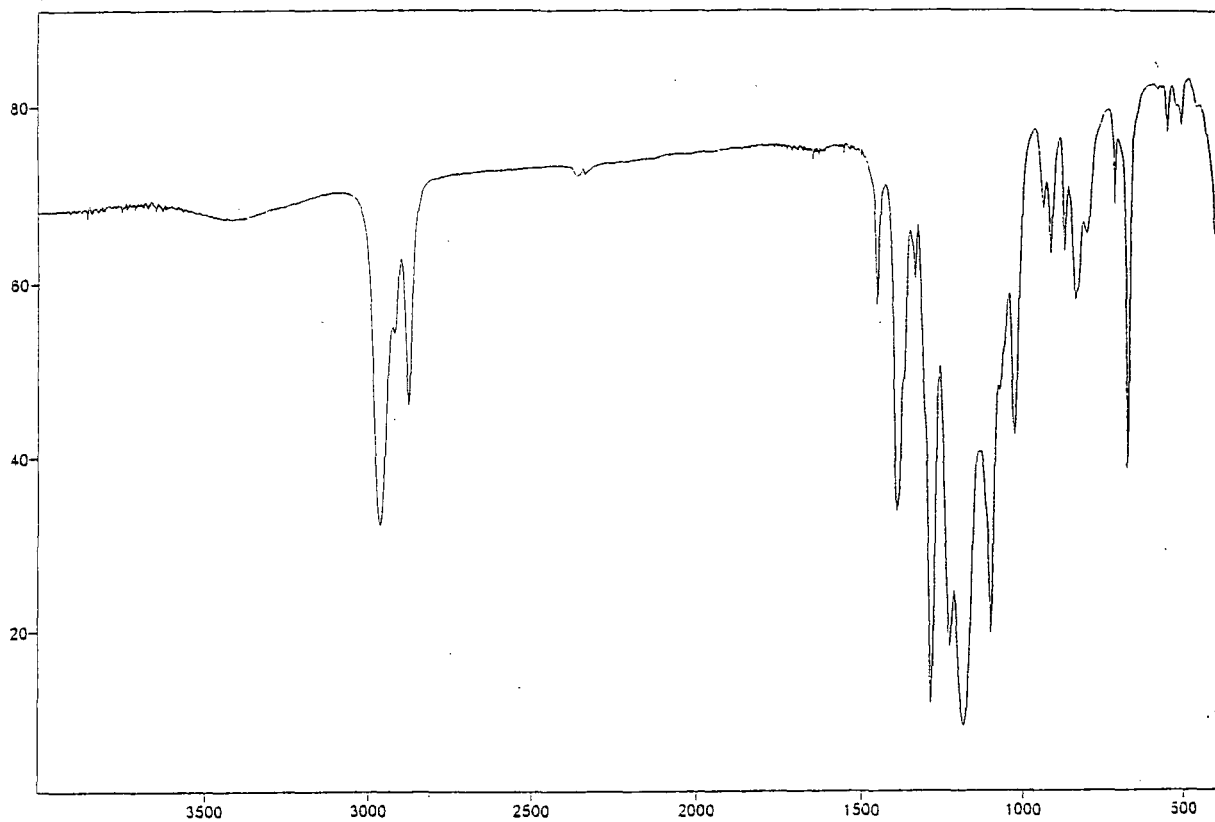

No. 6 1,1,2,3,3-hexafluoro-1-[3-(1,1,2,3,3,3-hexafluoropropyl)cyclopentyl]propane (44b)

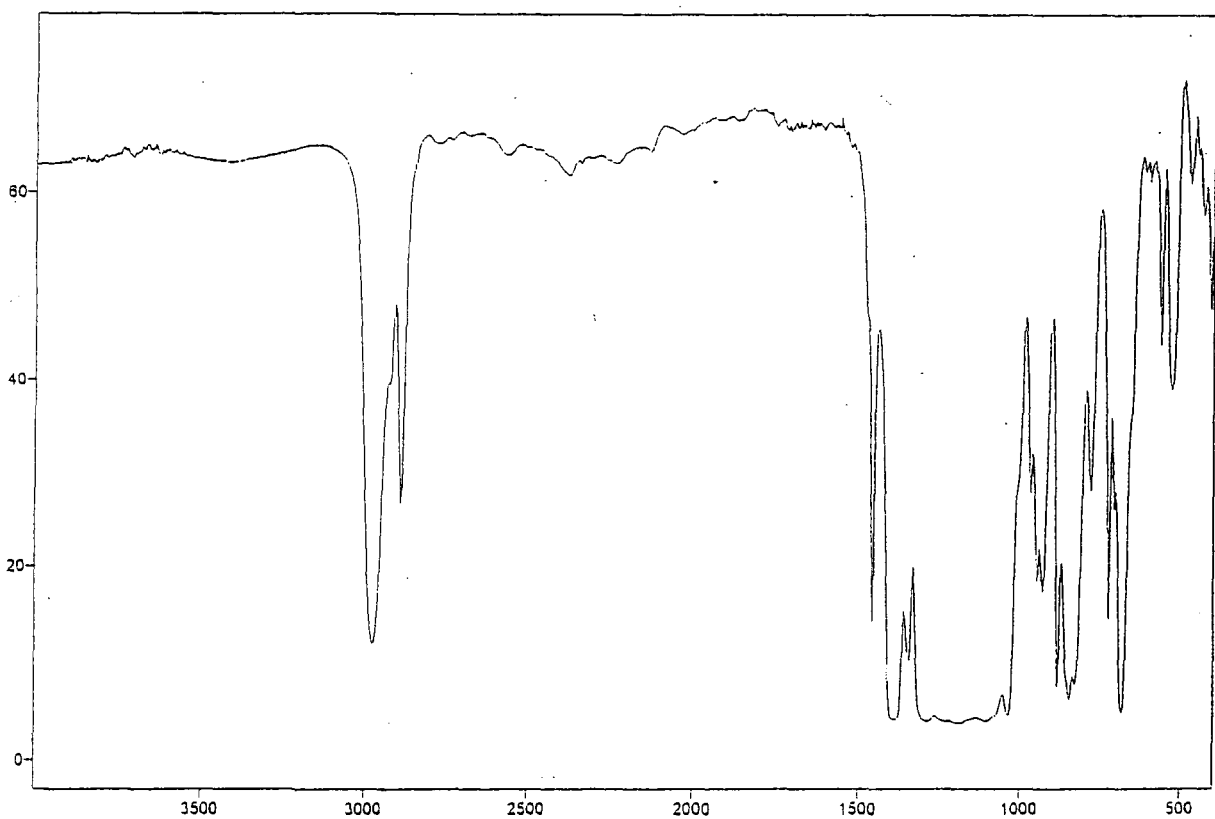

No. 7 1-(1,1,2,3,3,3-hexafluoropropyl)cyclopentanol (46)

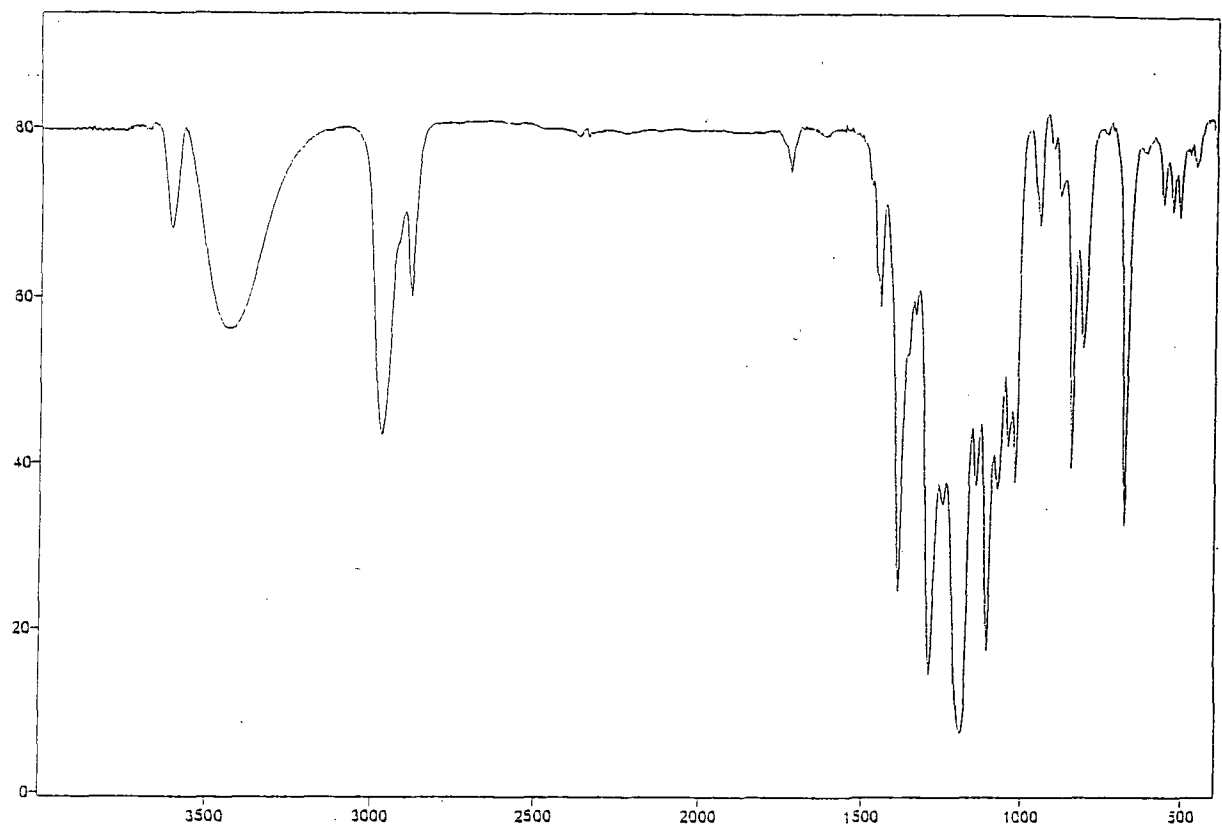

No. 8 1-(1,1,2,3,3,3-hexafluoropropyl)cyclopentene (49)

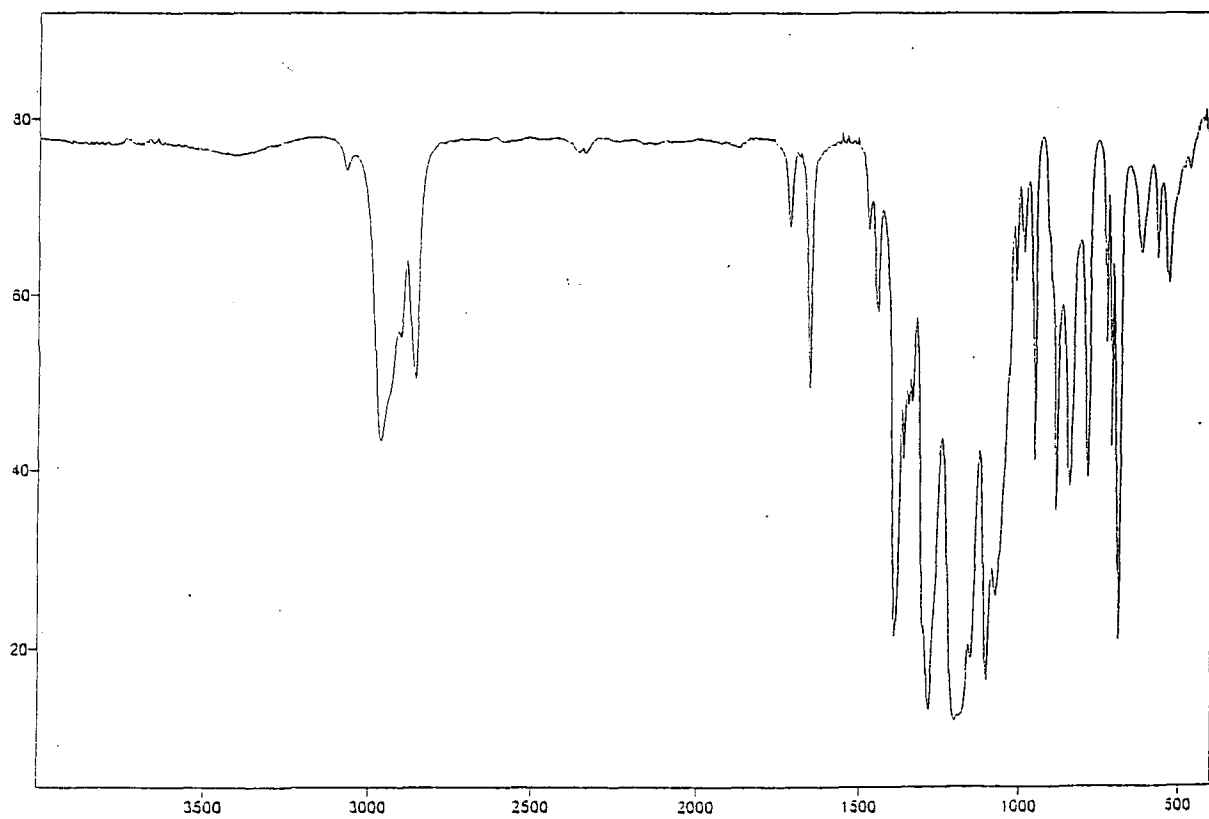

No. 9 (*E*)-1-adamantanyl-1,2,3,3,3-pentafluoroprop-1-ene (53a) and (*Z*)-1-adamantanyl-1,2,3,3,3-pentafluoroprop-1-ene (53b)

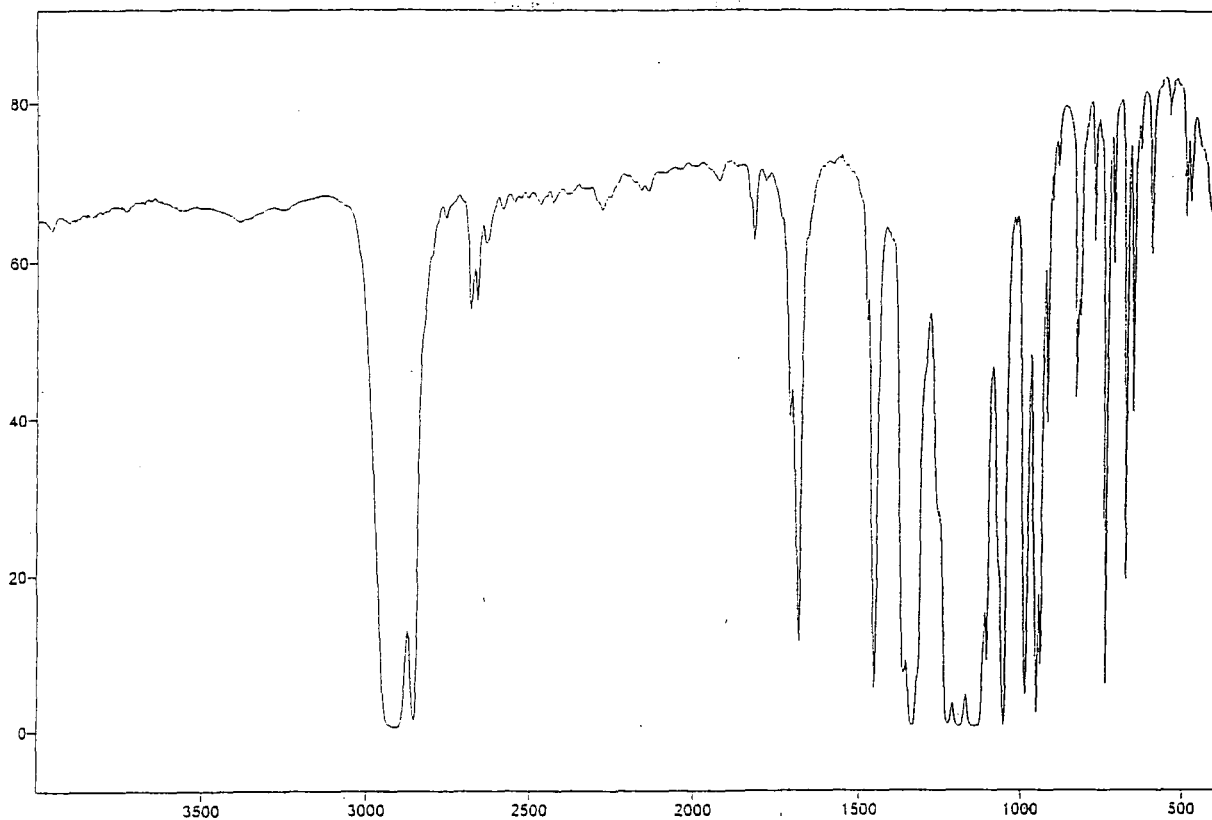

No. 10 1-(*E*-pentafluoroprop-2-enyl)cyclopentane (54a) and 1-(*Z*-pentafluoroprop-2-enyl)cyclopentane (54b)

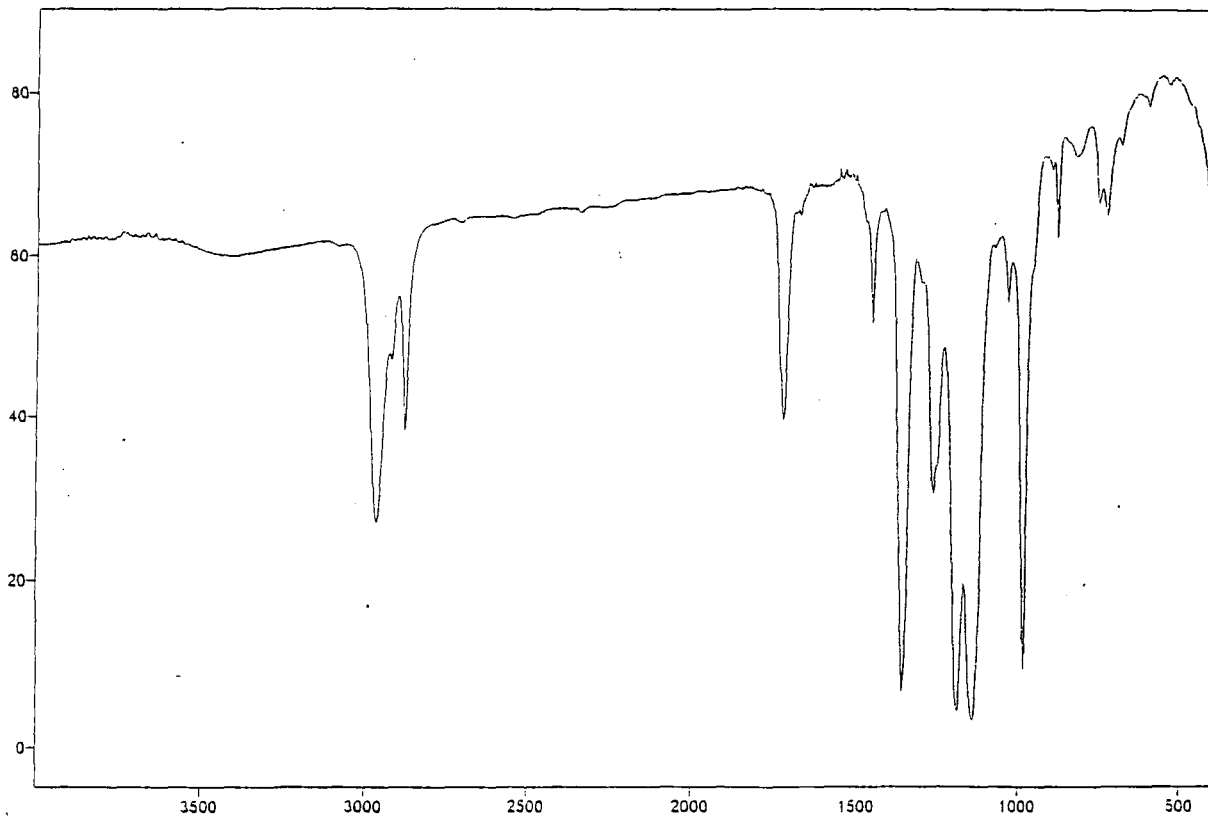

No. 11 1-[(1R,3R)-3-((1Z)-1,2,3,3,3-pentafluoroprop-1-enyl)cyclopentyl](1Z)-1,2,3,3,3-pentafluoroprop-1-ene (55) and 1-[(3S,1R)-3-((1Z)-1,2,3,3,3-pentafluoroprop-1-enyl)cyclopentyl](1Z)-1,2,3,3,3-pentafluoroprop-1-ene (56)

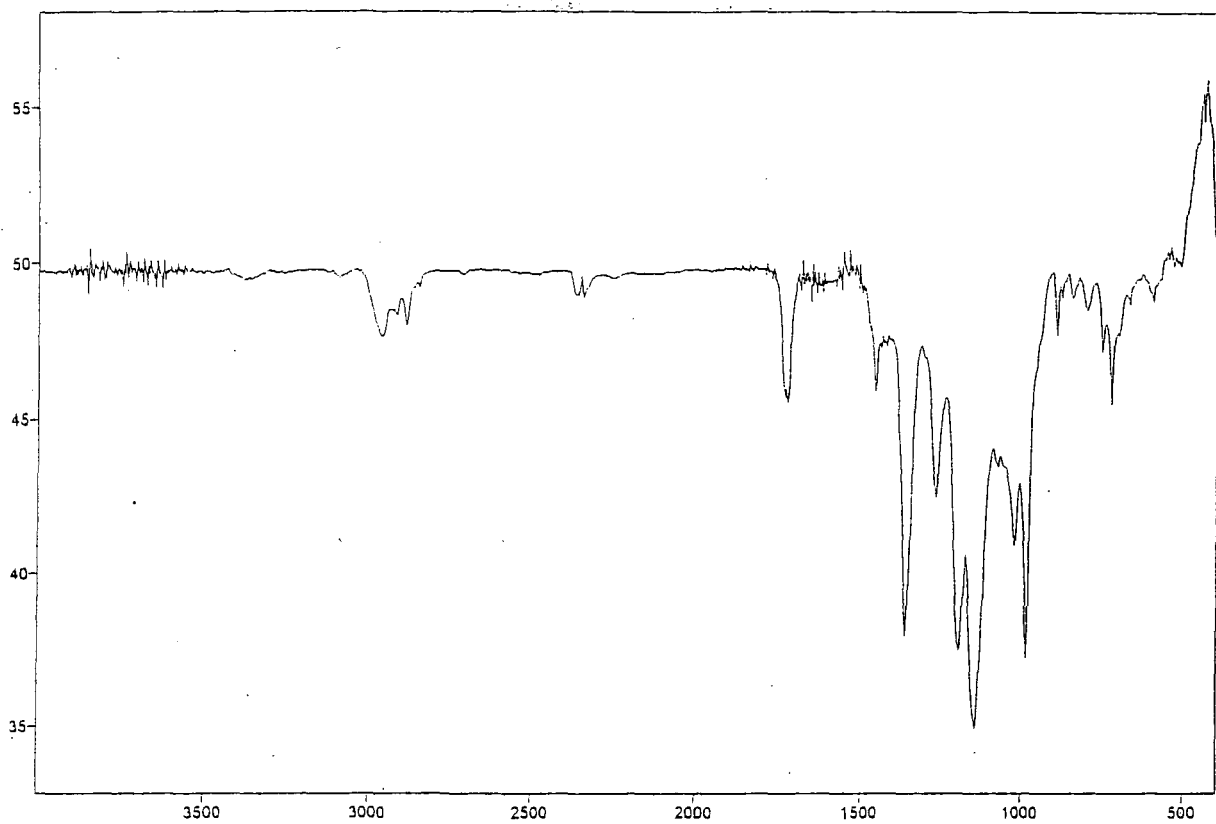

No. 12 1-(1,2,3,3,3-pentafluoro-Z-prop-1-enyl)cyclopentene (57b)

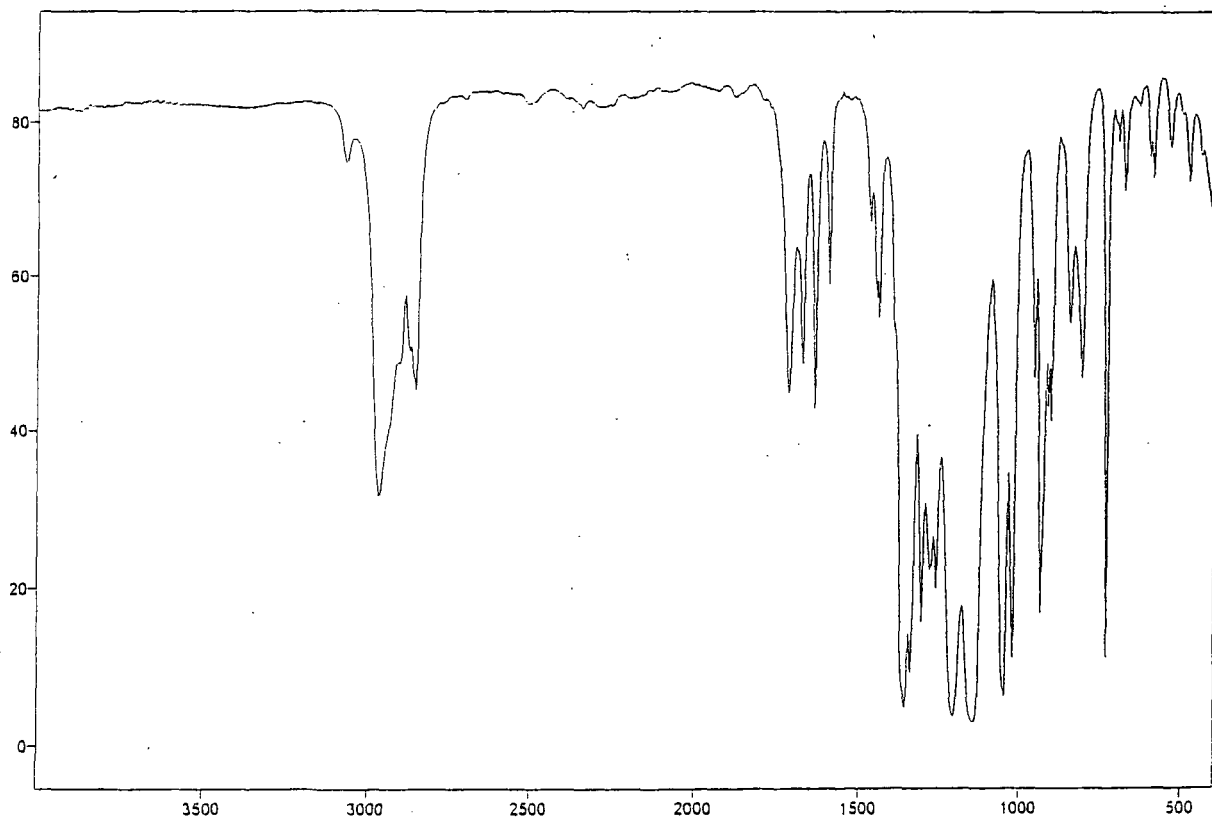

No. 13 (1*E*)-1-cyclopentyl-1-ethoxy-2,3,3,3-tetrafluoroprop-1-ene (75a) and (1*Z*)-1-cyclopentyl-1-ethoxy-2,3,3,3-tetrafluoroprop-1-ene (75b)

No. 14 1-cyclopentyl-1-ethoxy-1,2,3,3,3-pentafluoropropane (76)

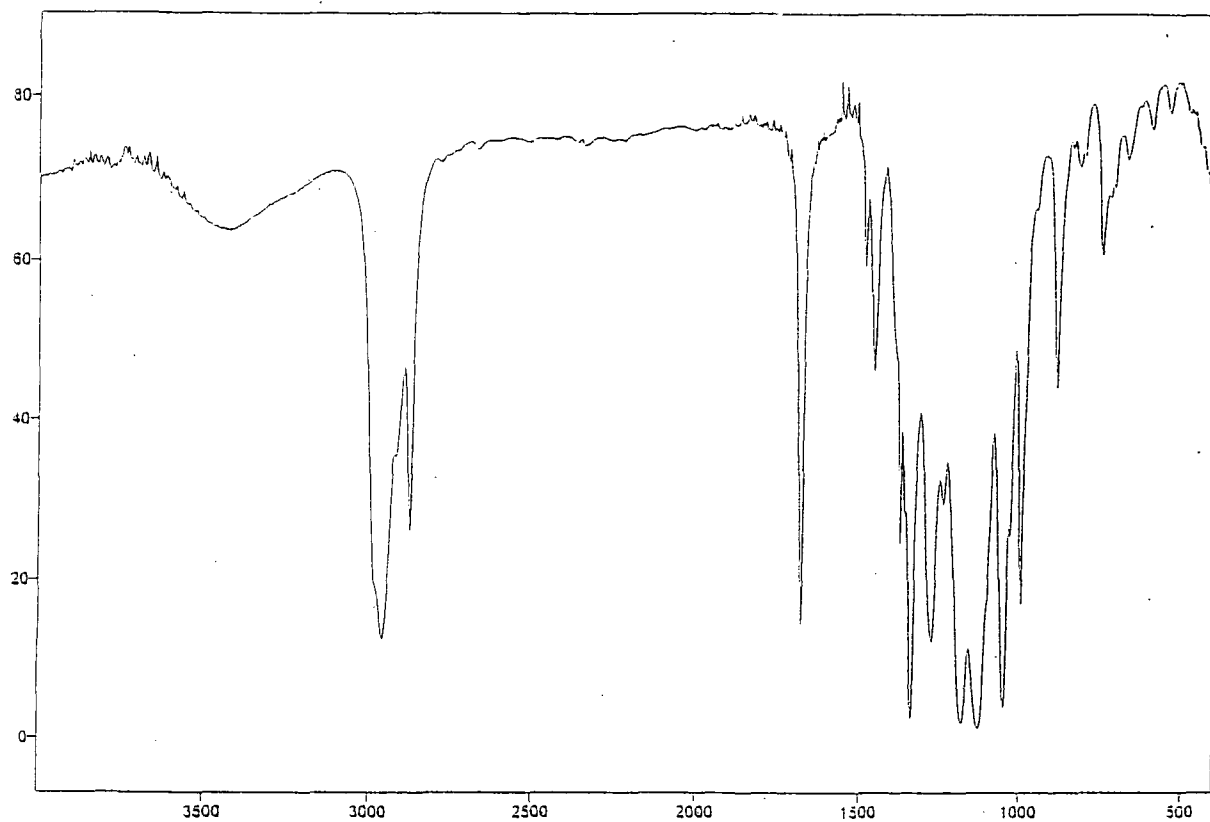

No. 15 1-cyclopentyl-2,3,3,3-tetrafluoropropan-1-one (77)

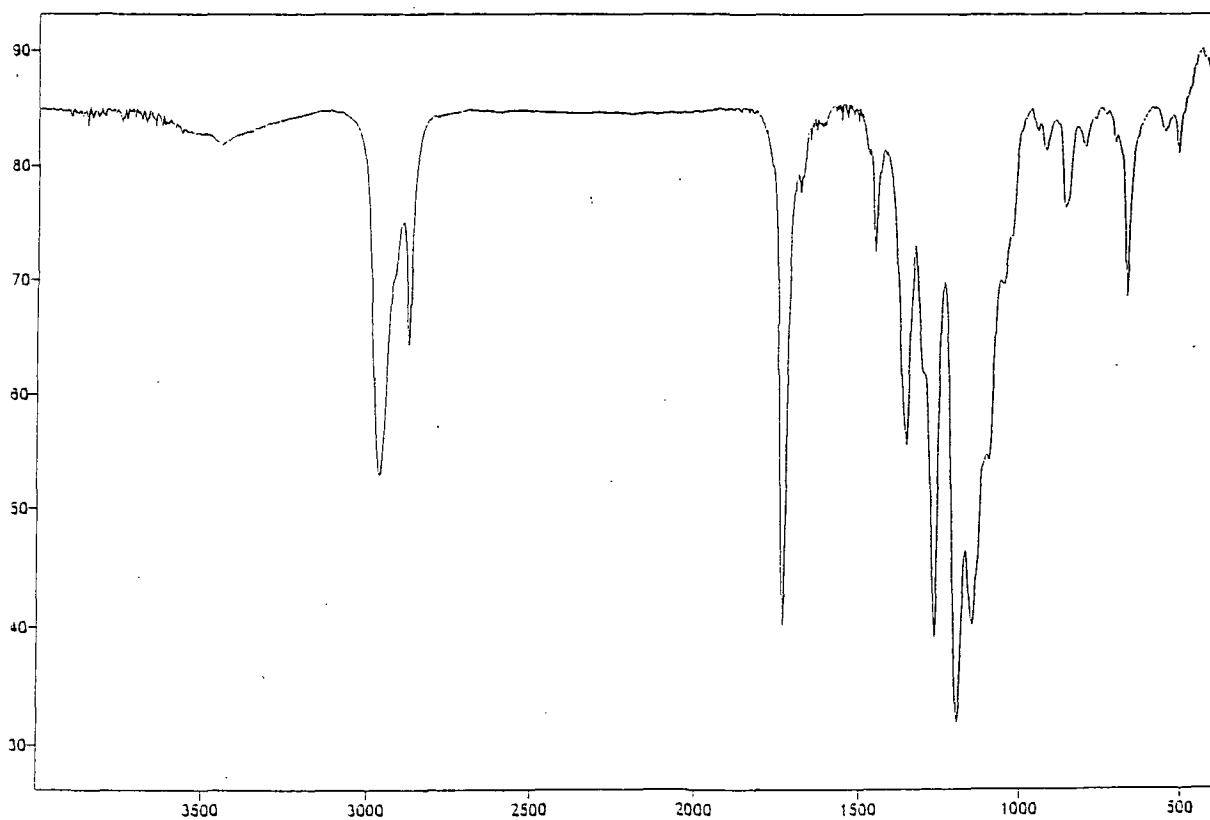

No. 16 1-cyclopentyl-1,2,3,3,3-pentafluoro-1-methoxypropane (78)

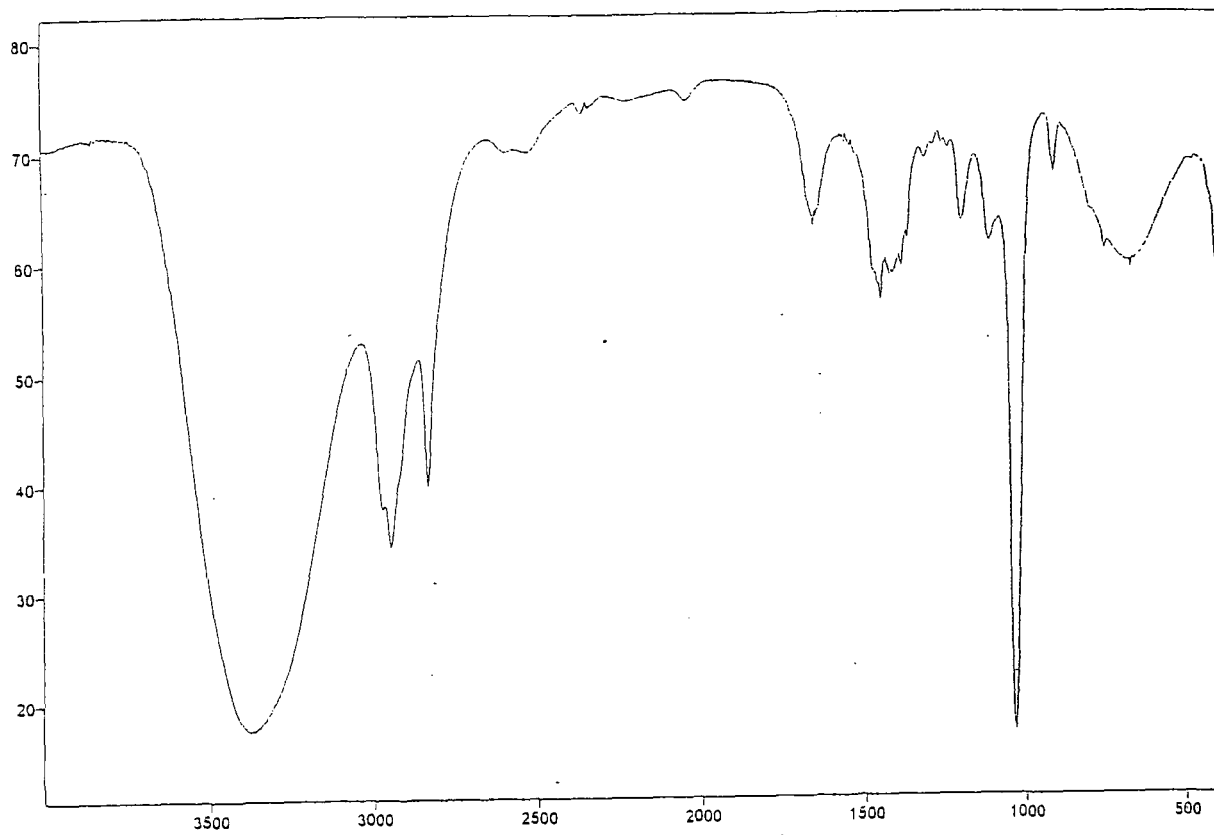

No. 17 1-cyclopentyl-2-fluoro-2-trifluoromethyl-4-penten-1-one (79)

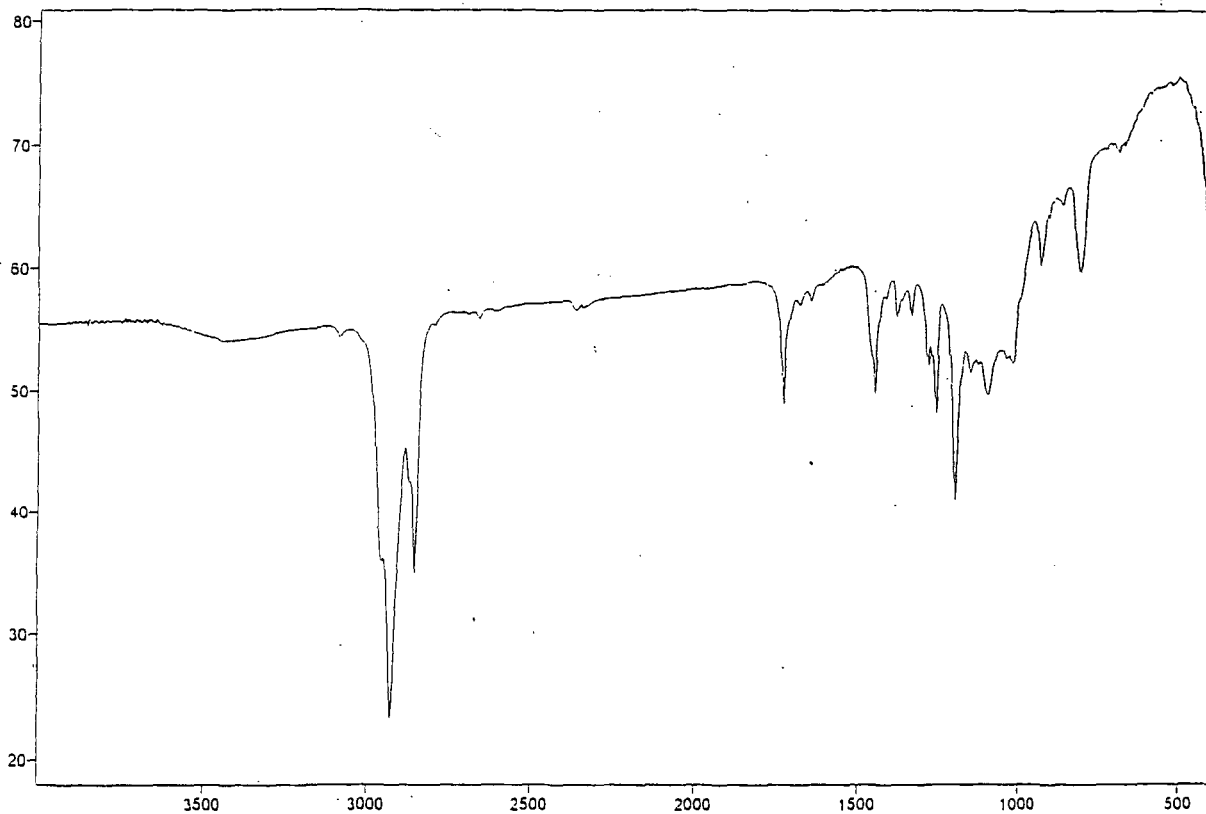

No. 18 1-cyclopentyl-2-fluoro-2-trifluoromethyl-3,4-pentadien-1-one (85)

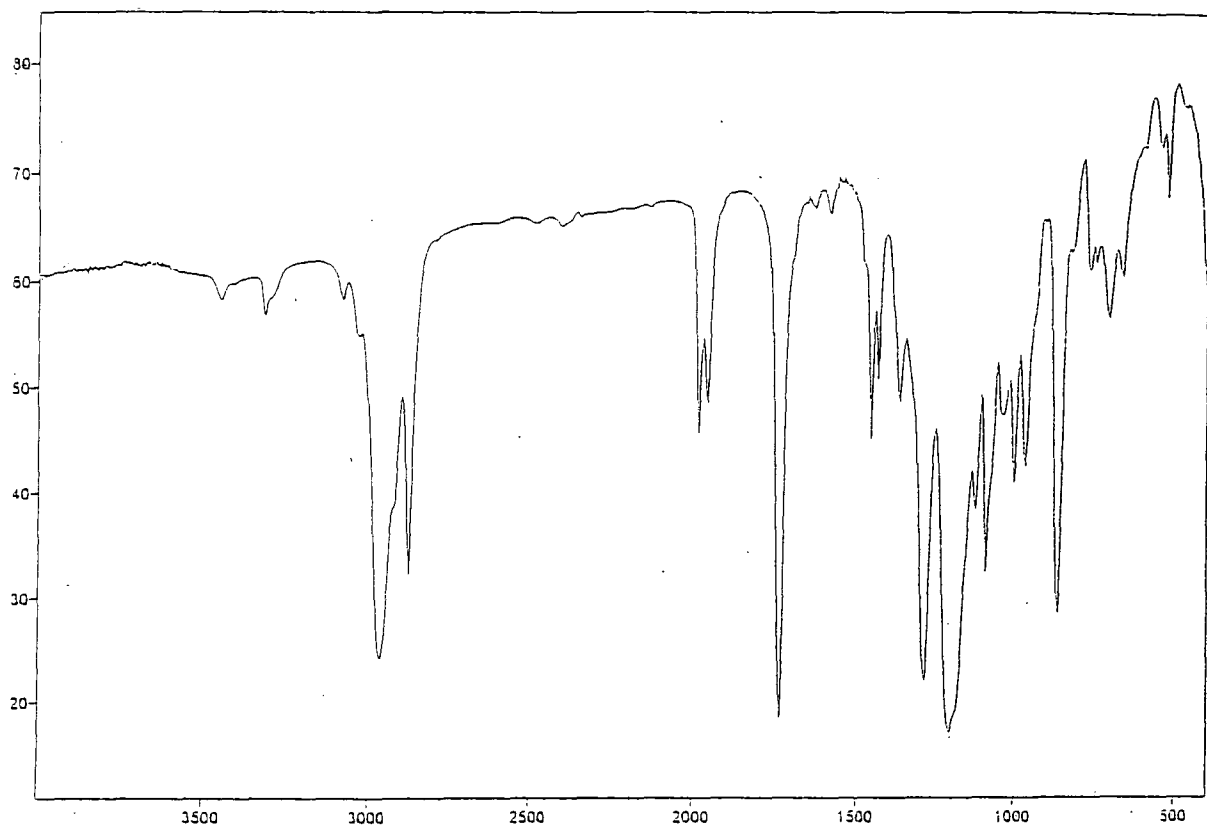

No. 19 1-cyclopentyl-2-fluoro-3-methyl-2-trifluoromethyl-4-penten-1-one (86)

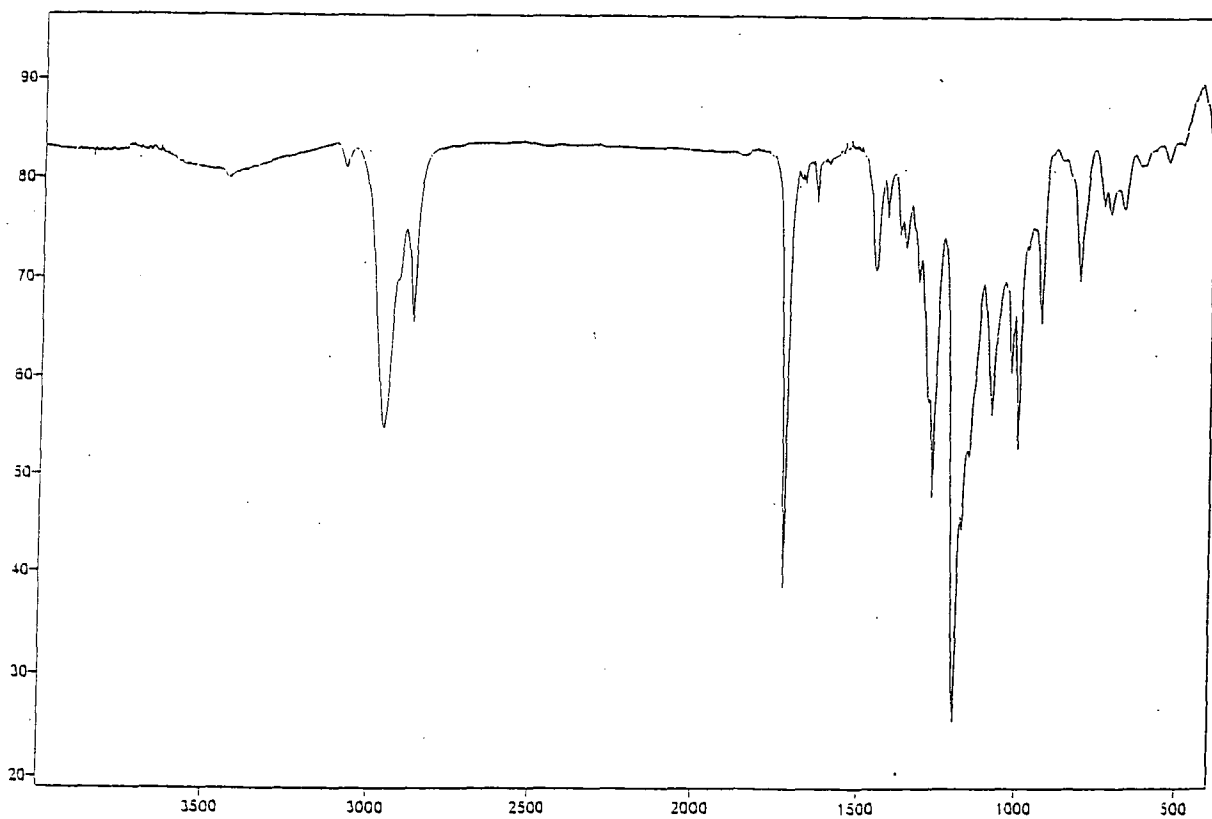

No. 20 cyclopentane carboxylic acid (88)

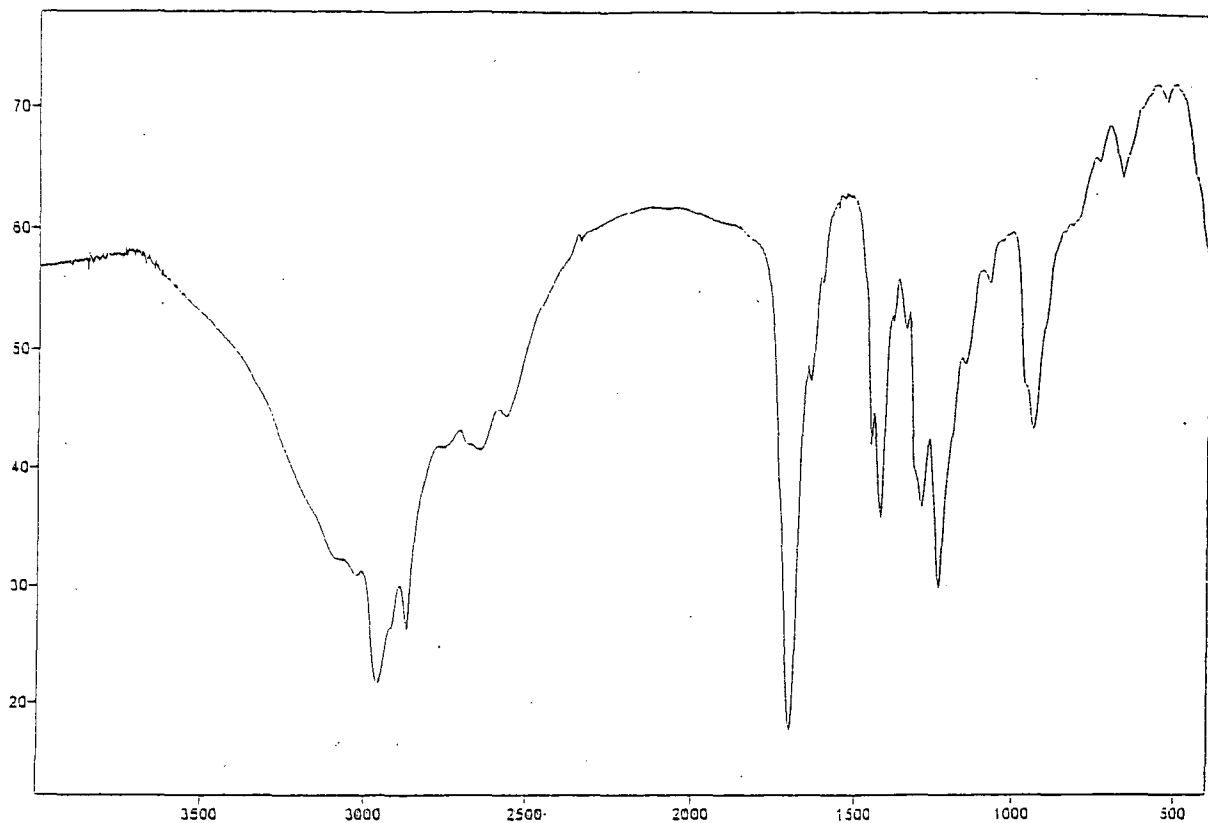

No. 21 1-cyclopentyl-3-ethenyl-2-fluoro-3,7-dimethyl-2-trifluoromethyl-6-octen-1-one (92)

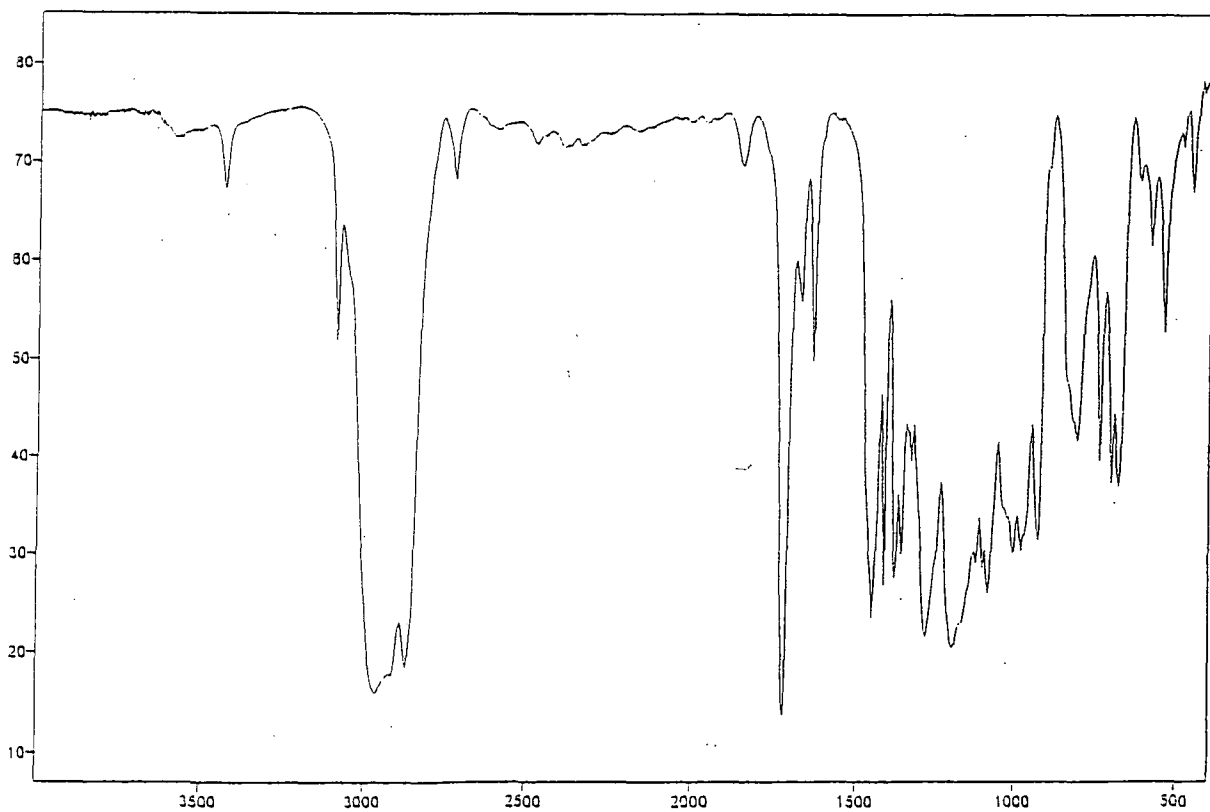

No. 22 1-cyclopent-1-enyl-2-fluoro-3,7-dimethyl-2-(trifluoromethyl)-3-vinyloct-6-eno-1-one (93)

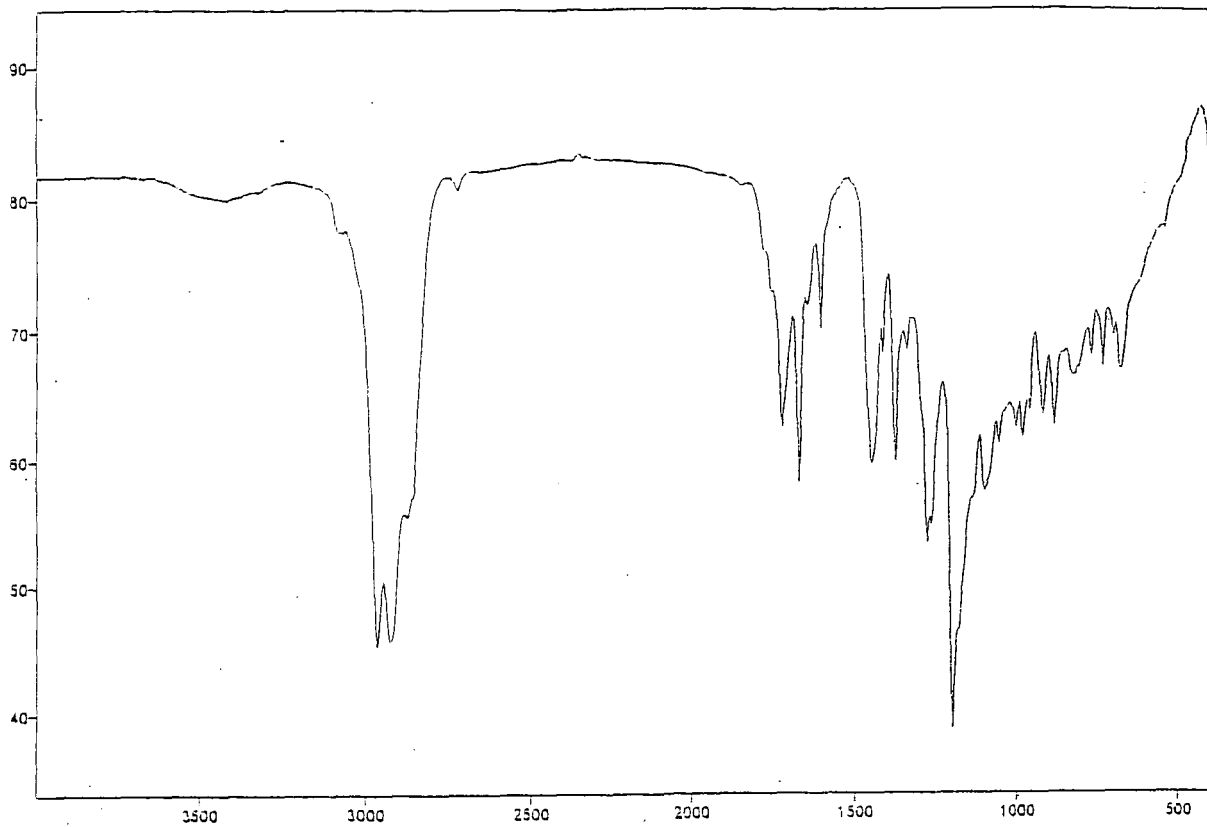

No. 23 Z-(1-cyclopentyl-2,3,3,3-tetrafluoro-1-propenoxy)methylbenzene (94)

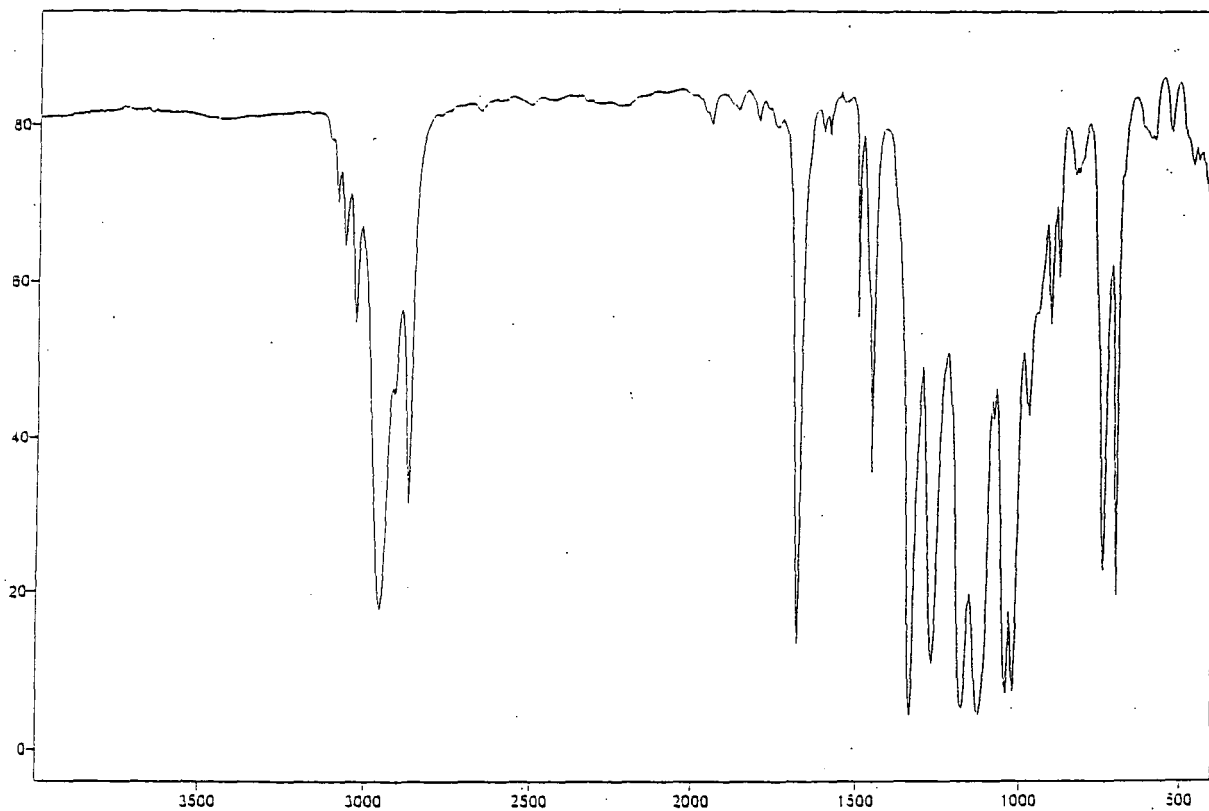

No. 24 Z-(1-butyl-2,3,3,3-tetrafluoro-1-propenyl)cyclopentane (99)

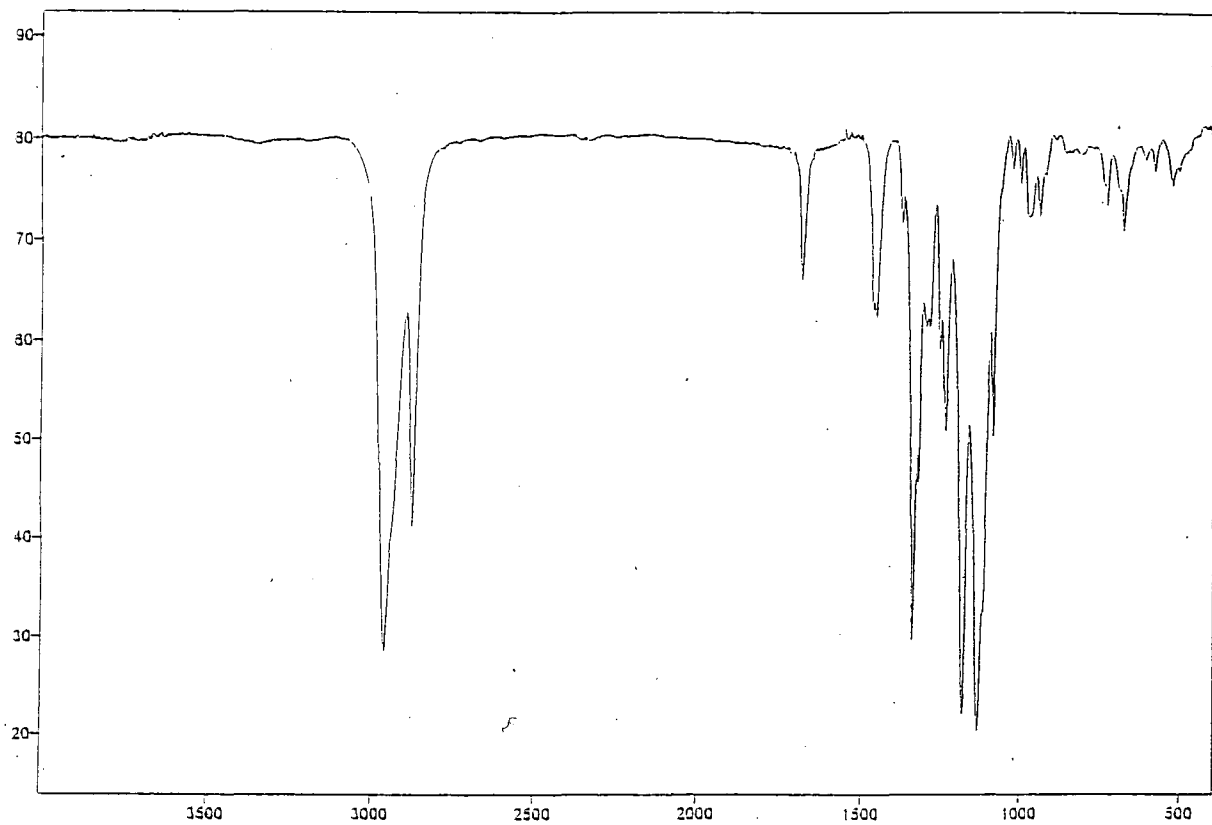

No. 25 Z-(1-phenyl-2,3,3,3-tetrafluoro-1-propenyl)cyclopentane (101)

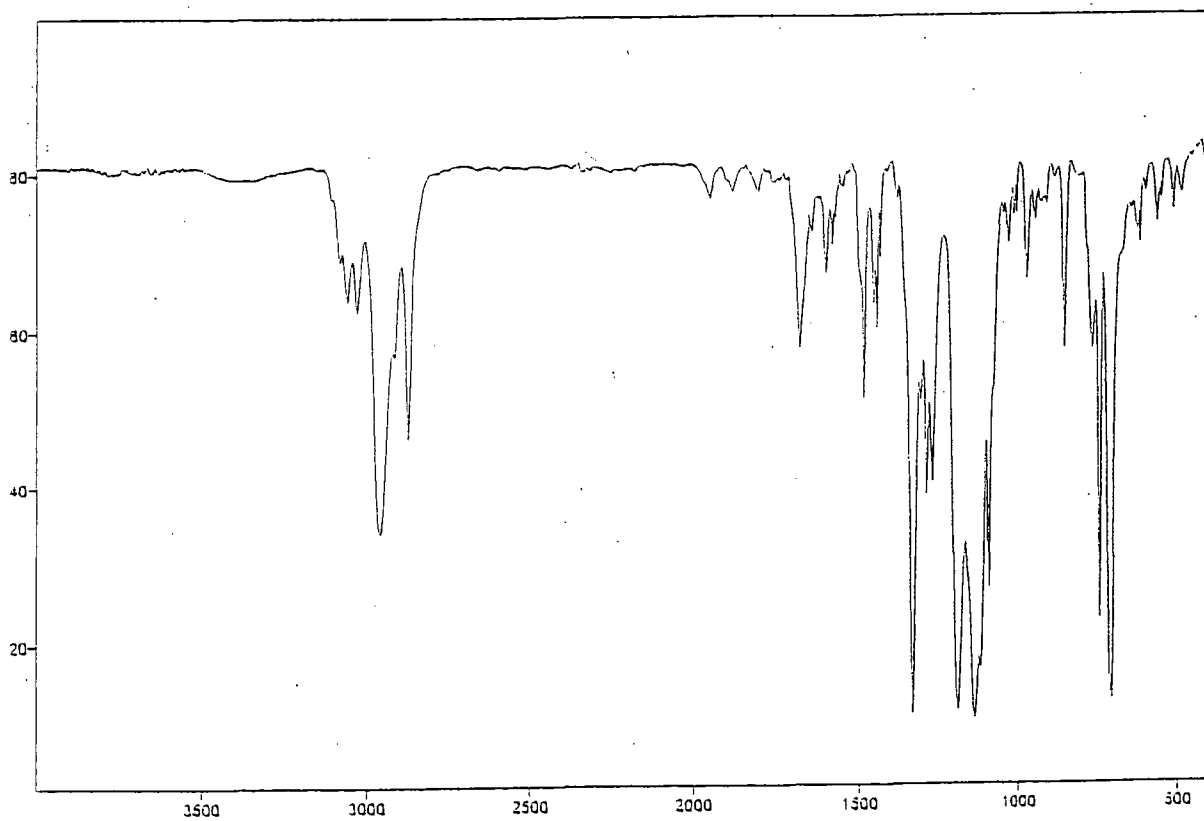

No. 26 1,2-dibromo-1-cyclopentyl-1,2,3,3,3-pentafluoropropane (103)

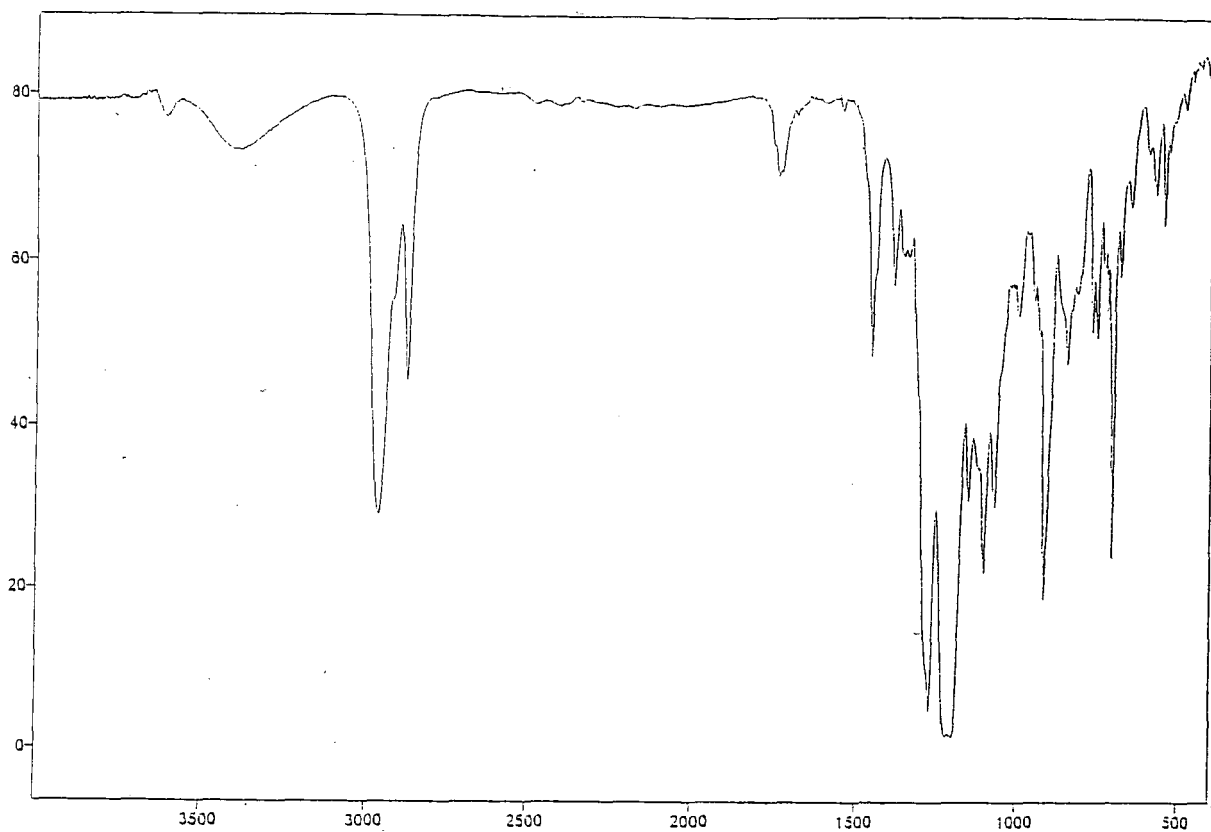

No. 27 diethyl(2,2,3,4,4,4-hexafluoro-1-methylbutyl)amine (104)

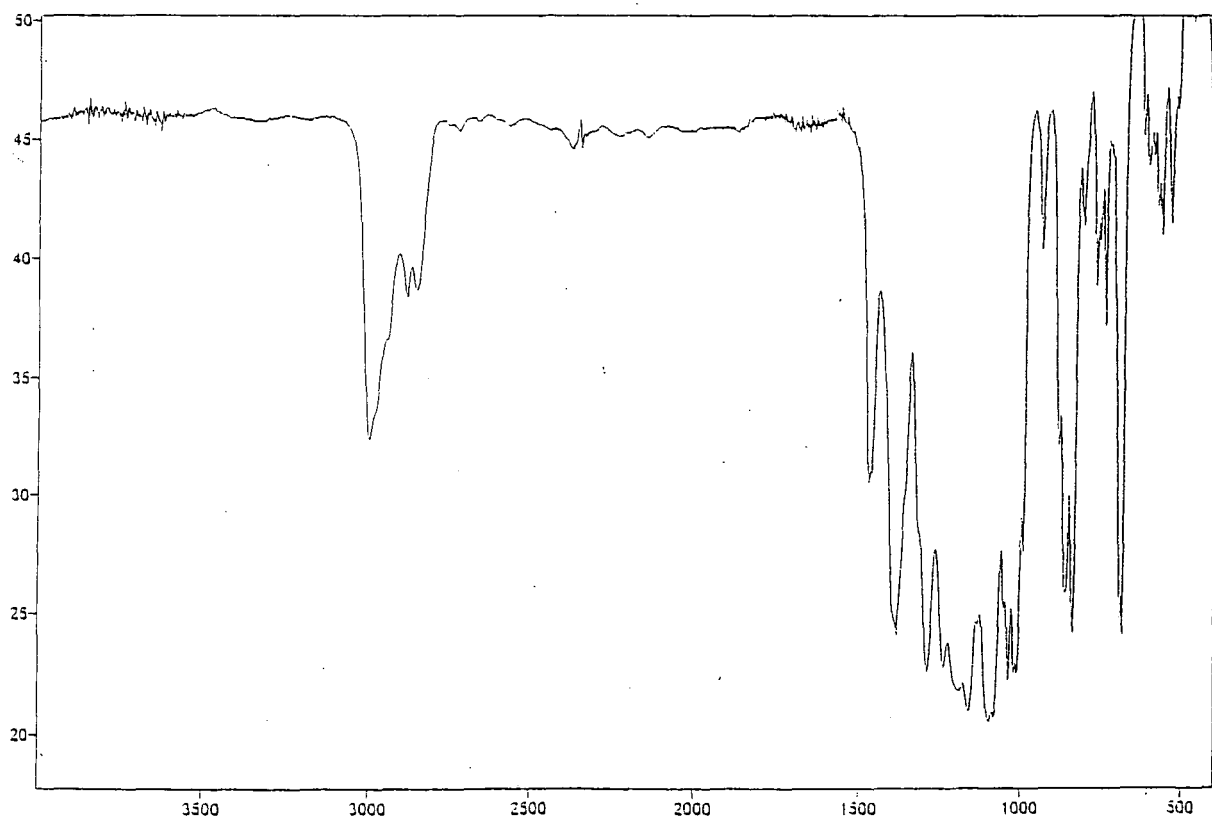

No. 28 bis(2,2,3,4,4,4-hexafluoro-1-methylbutyl)ethylamine (105)

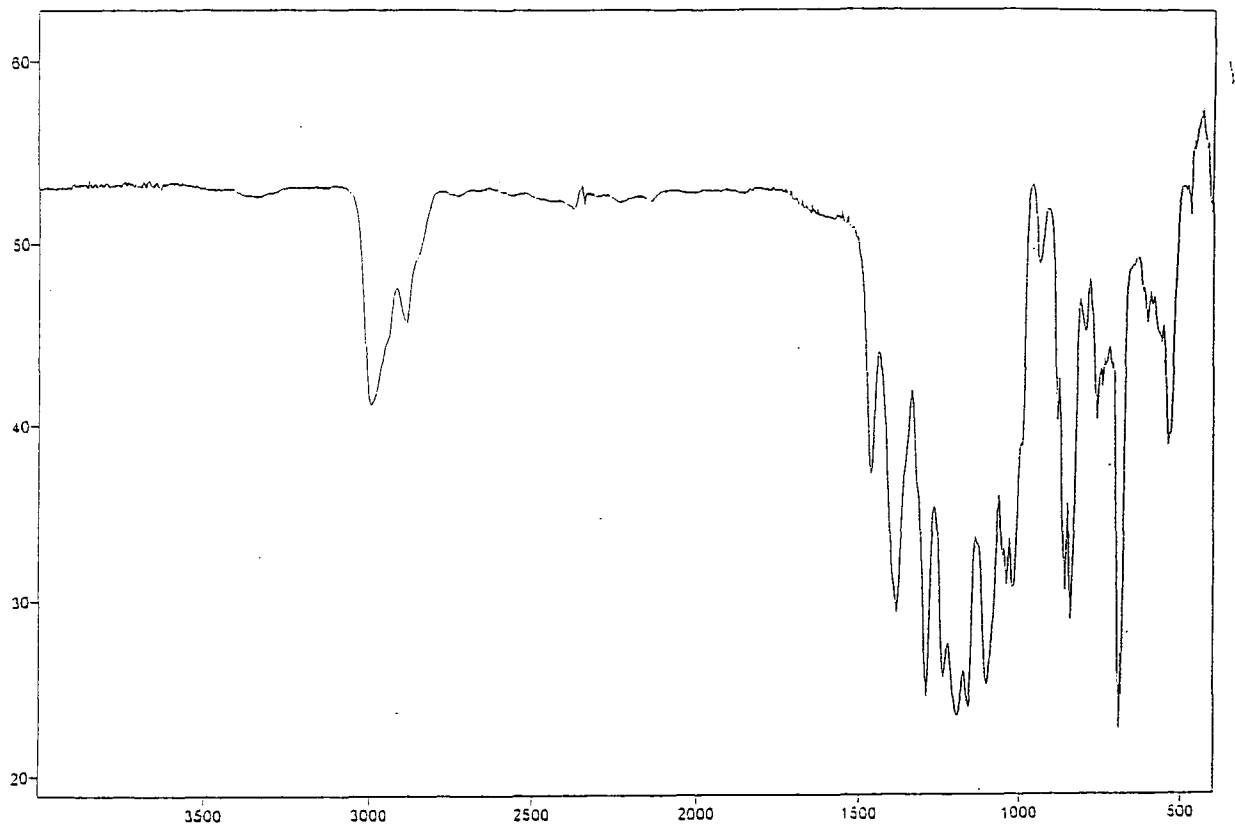

No. 29 tris(2,2,3,4,4,4-hexafluoro-1-methylbutyl)amine (106)

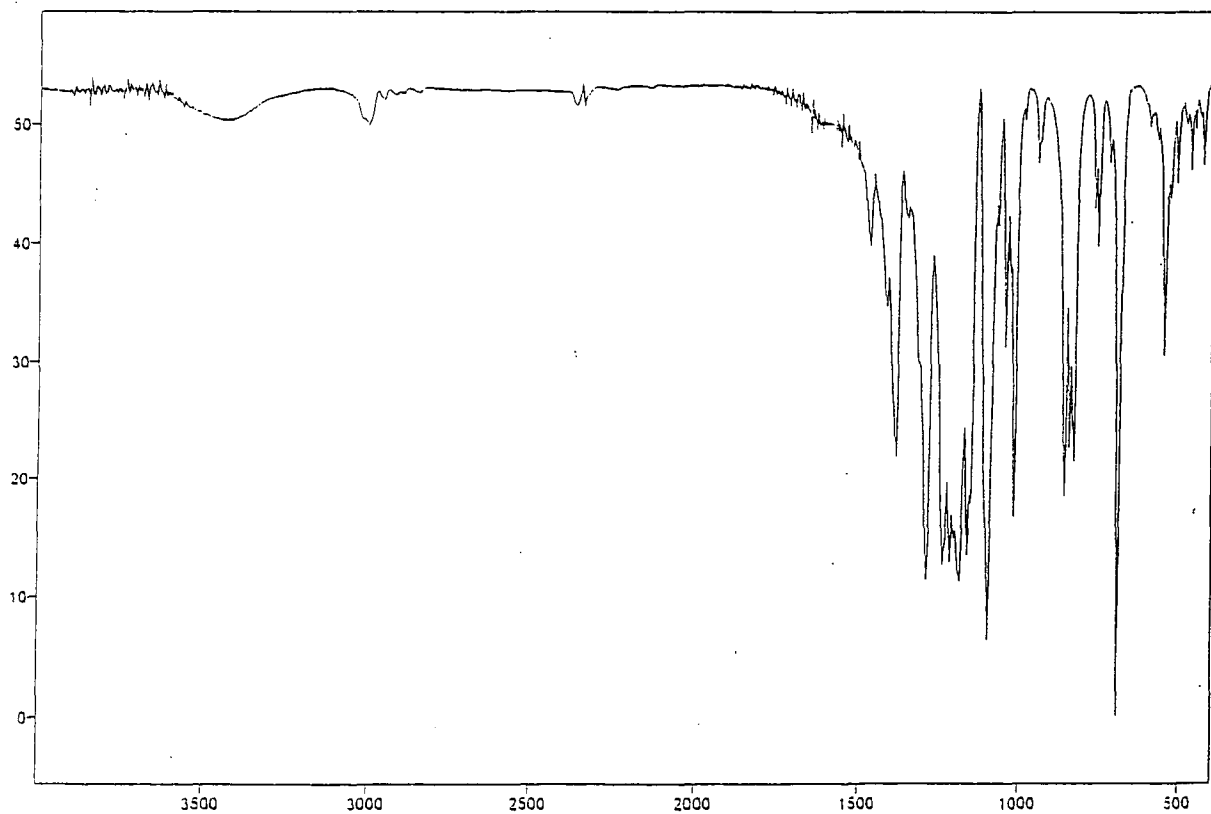

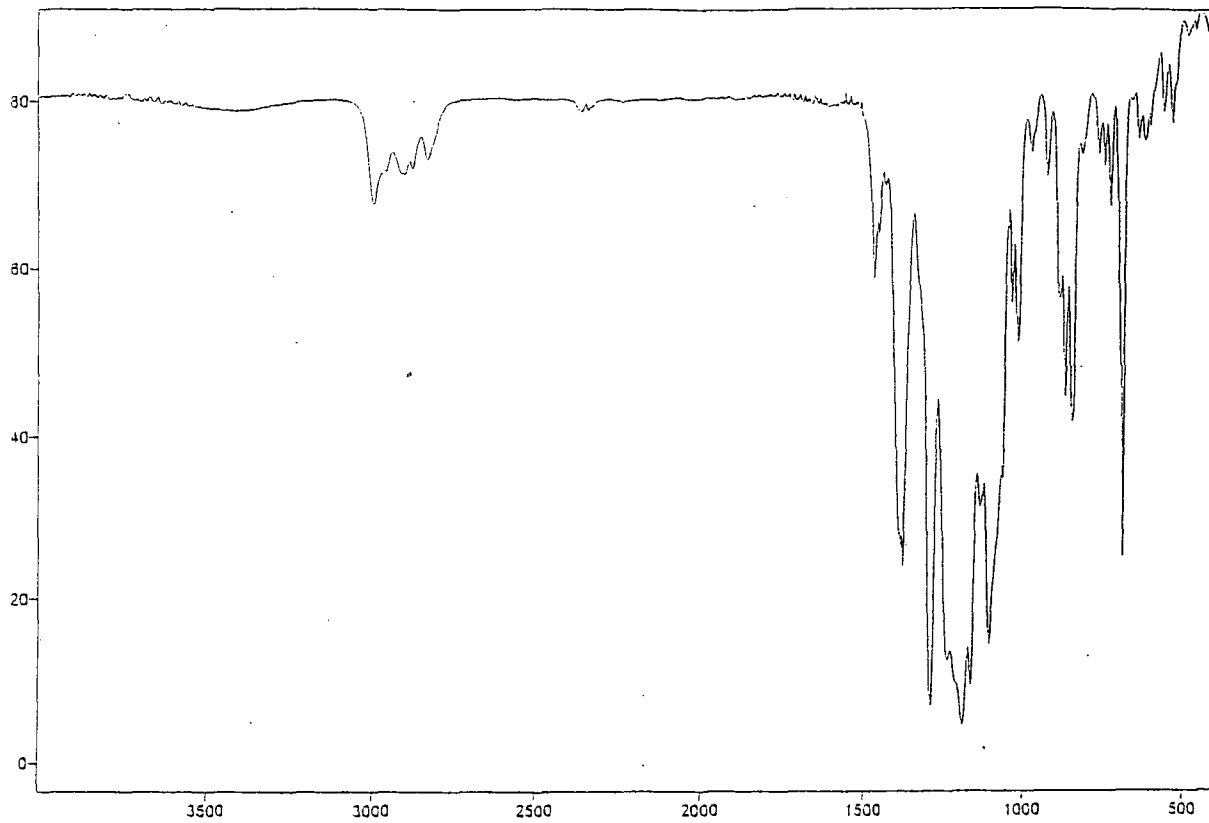

No. 31 bis(methylethyl)(2,2,3,4,4,4-hexafluoro-1-methylbutyl)amine (108)

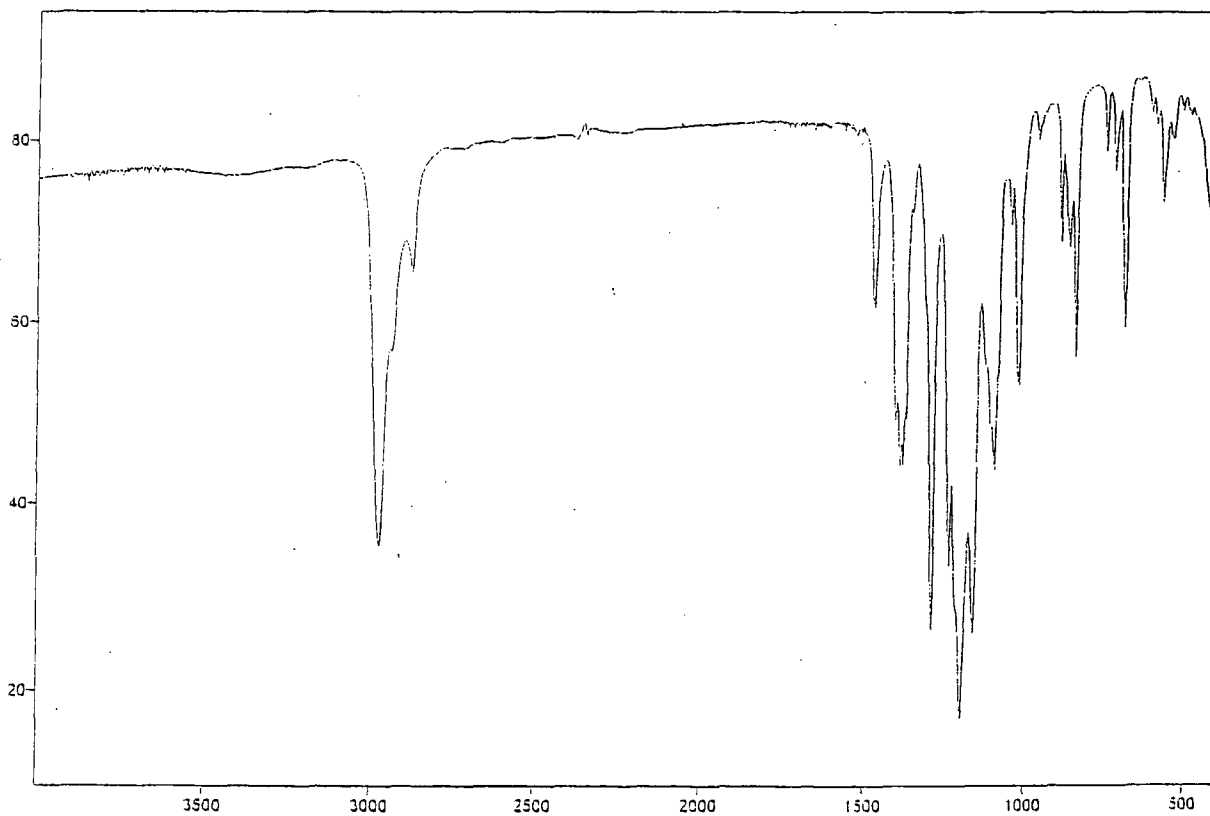

No. 32 (2,2,3,4,4,4-hexafluoro-1,1-dimethylbutyl)(2,2,3,4,4,4-hexafluoro-1-methylbutyl)(methylethyl)amine (109)

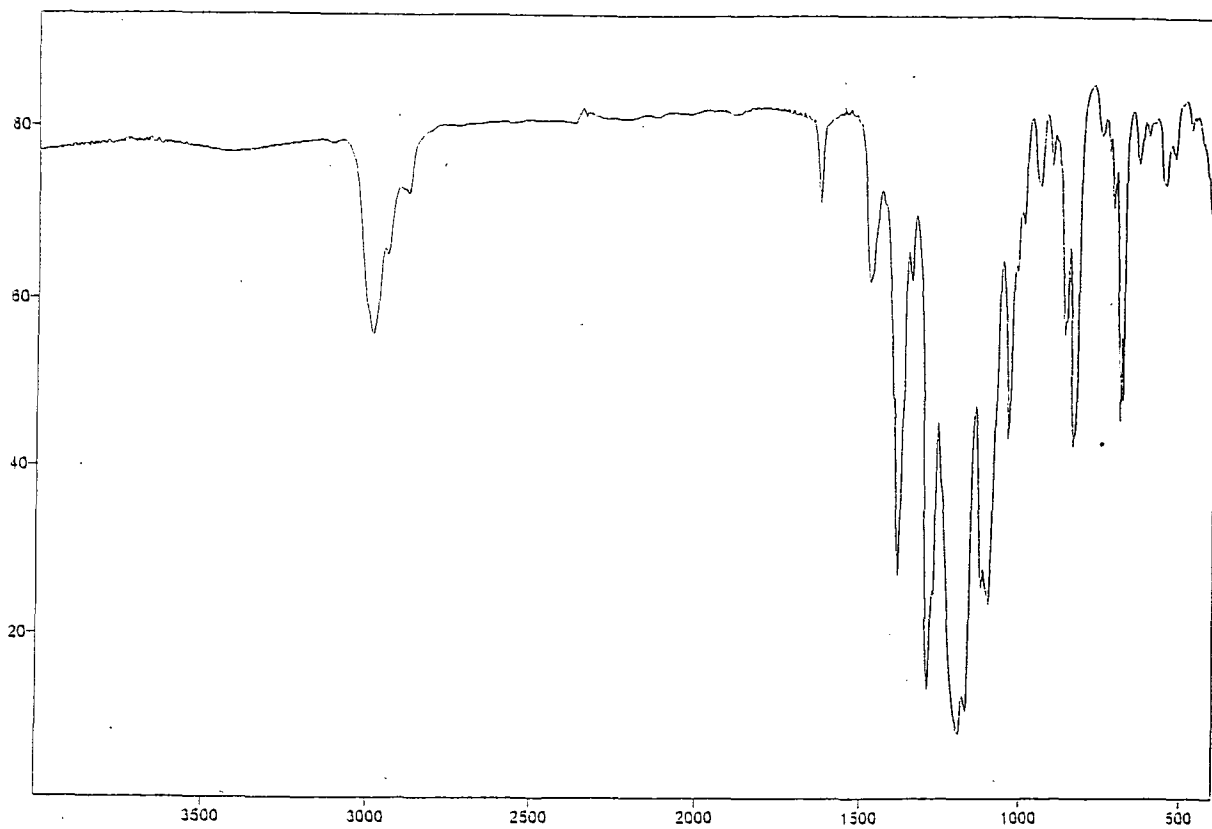

No. 33 2-(1,1,2,3,3,3-hexafluoropropyl)-1-methylpyrrolidine (110)

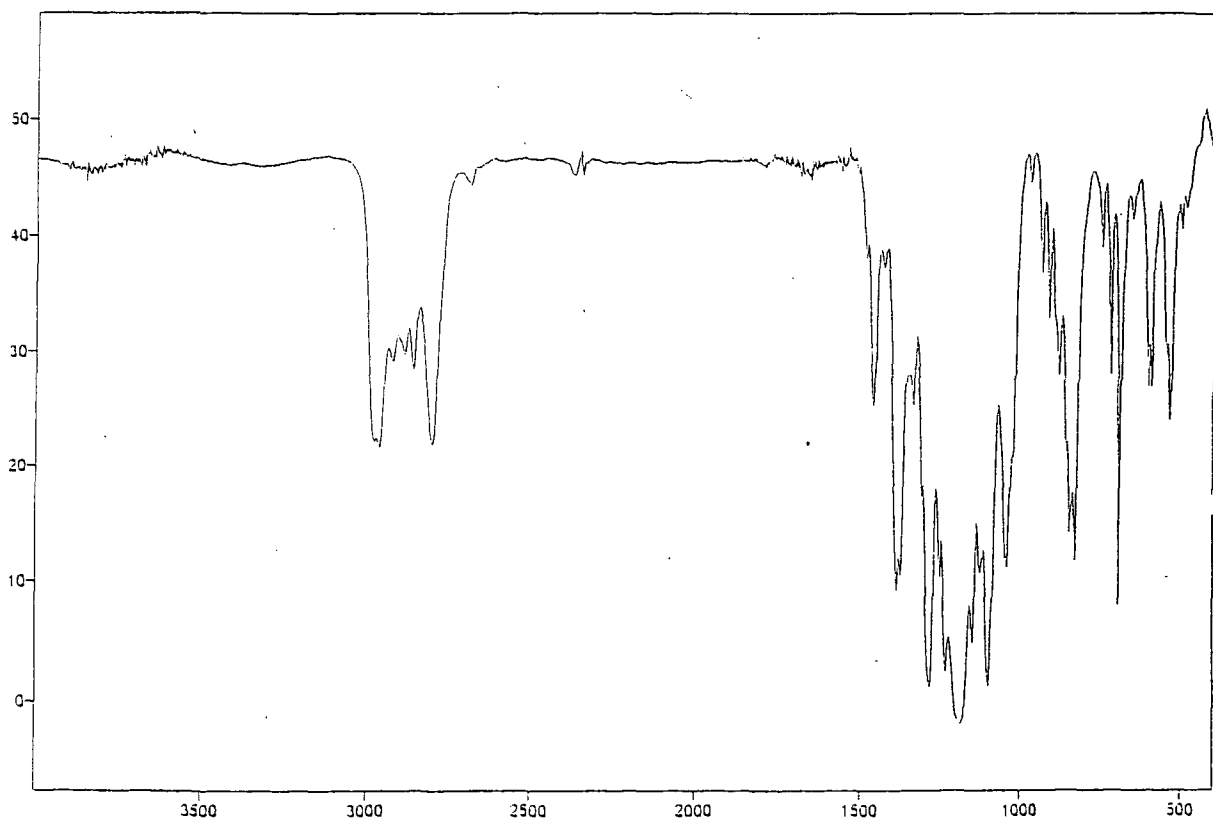

No. 34 1-(2,2,3,4,4,4-hexafluorobutyl)-2-(1,1,2,3,3,3-hexafluoropropyl)piperidine (111)

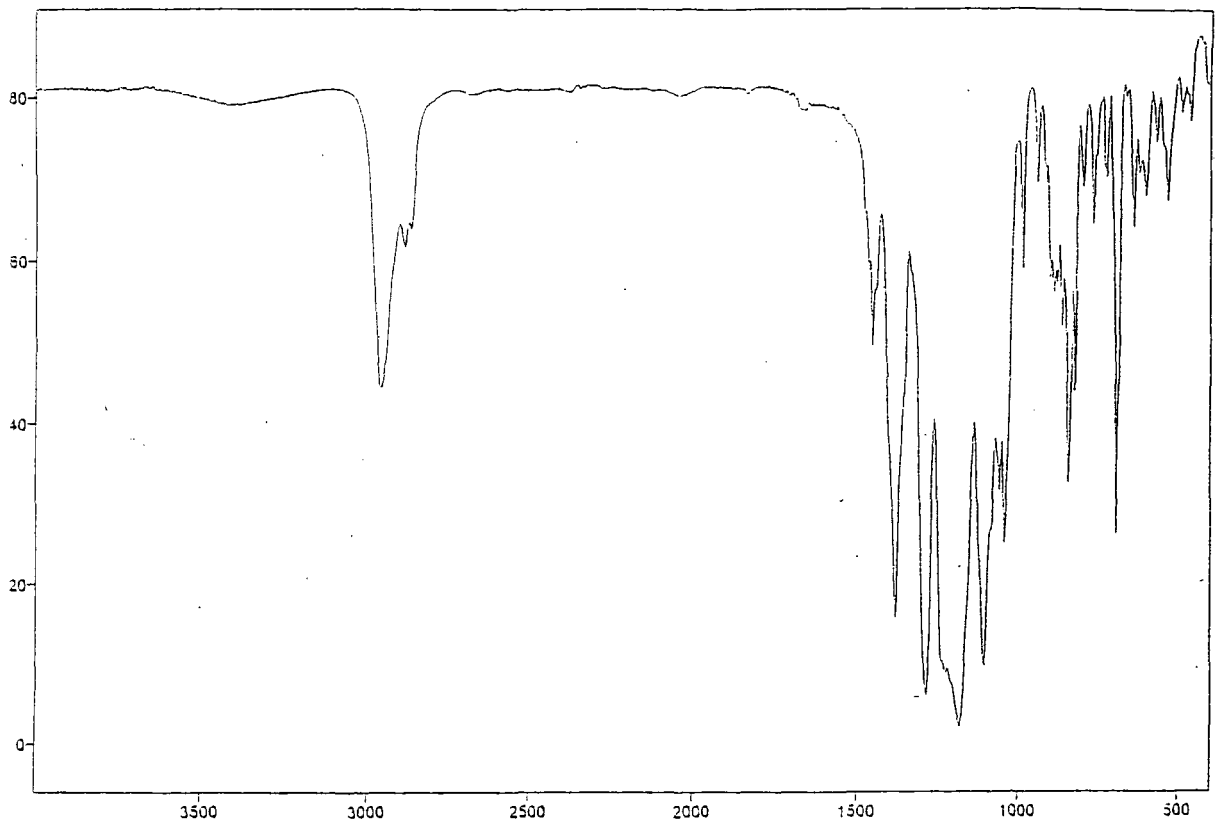

No. 35 1-(2,2,3,4,4,4-hexafluoro-1-methylbutyl)-2-(1,1,2,3,3,3-hexafluoropropyl) piperidine (112)

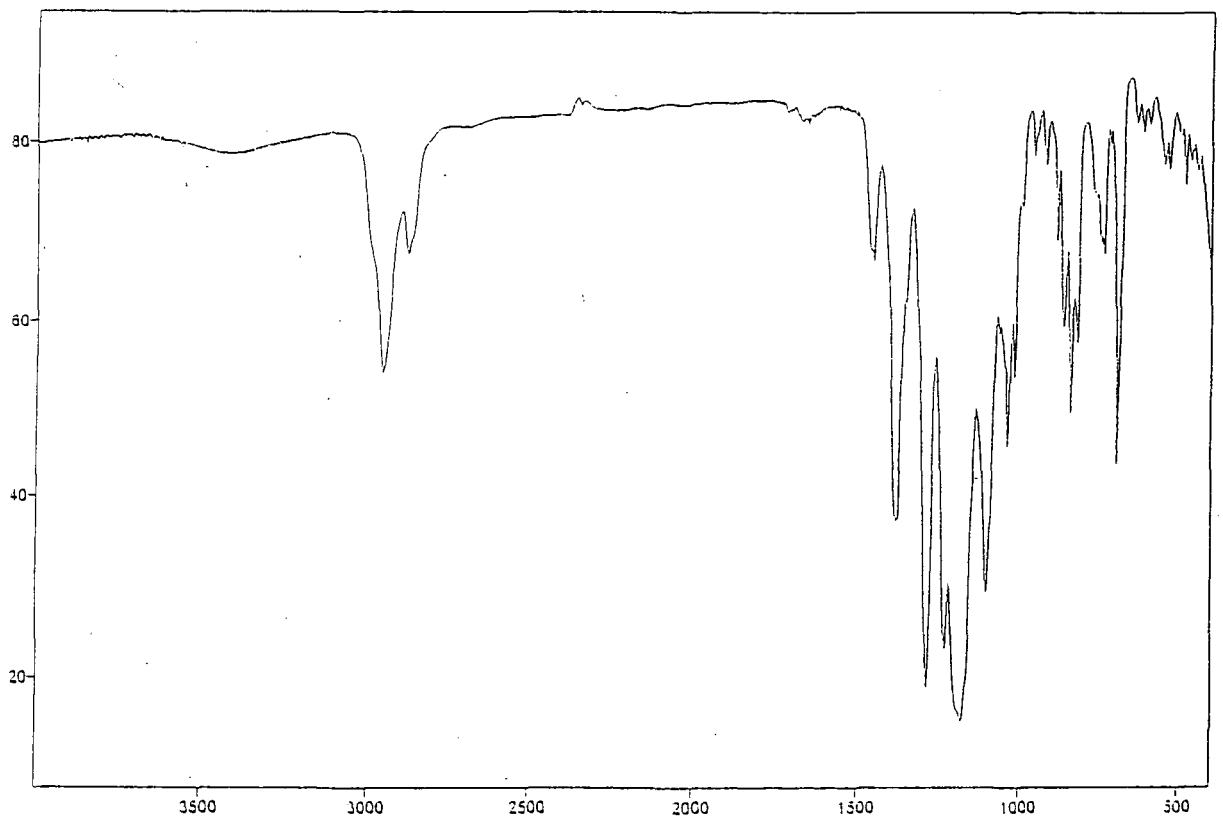

No. 36 4-(2,2,3,4,4,4-hexafluorobutyl)morpholine (113)

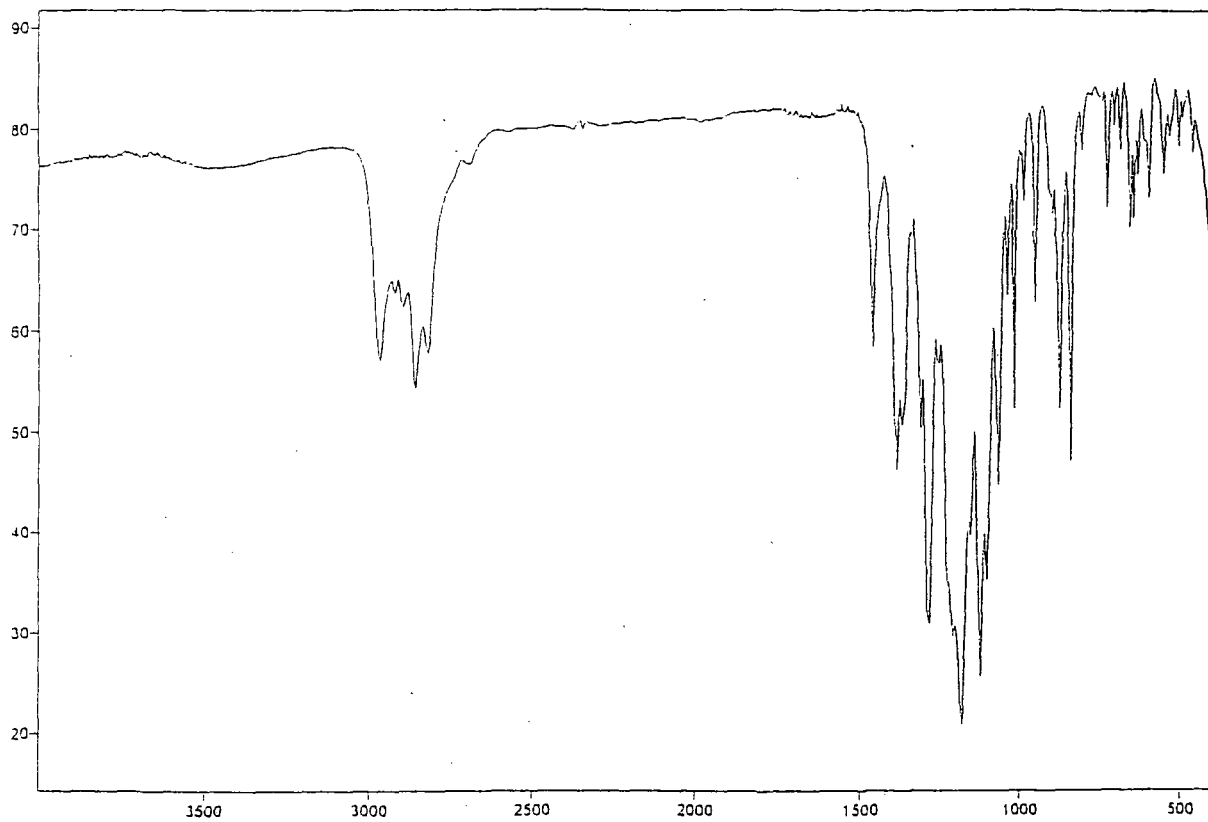

No. 37 4-(2,2,3,4,4,4-hexafluorobutyl)-3-(1,1,2,3,3,3-hexafluoropropyl)morpholine (114)

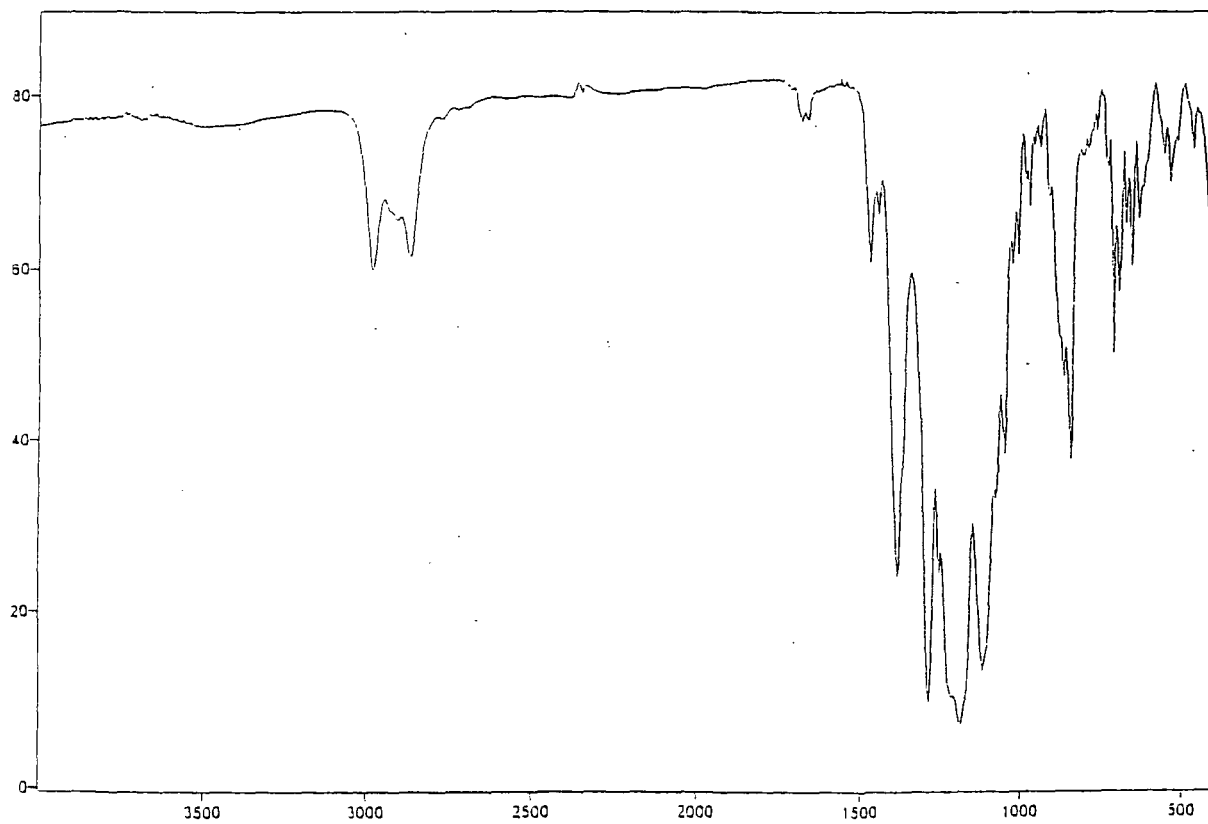

No. 38 4-(2,2,3,4,4,4-hexafluoro-1-methylbutyl)morpholine (115)

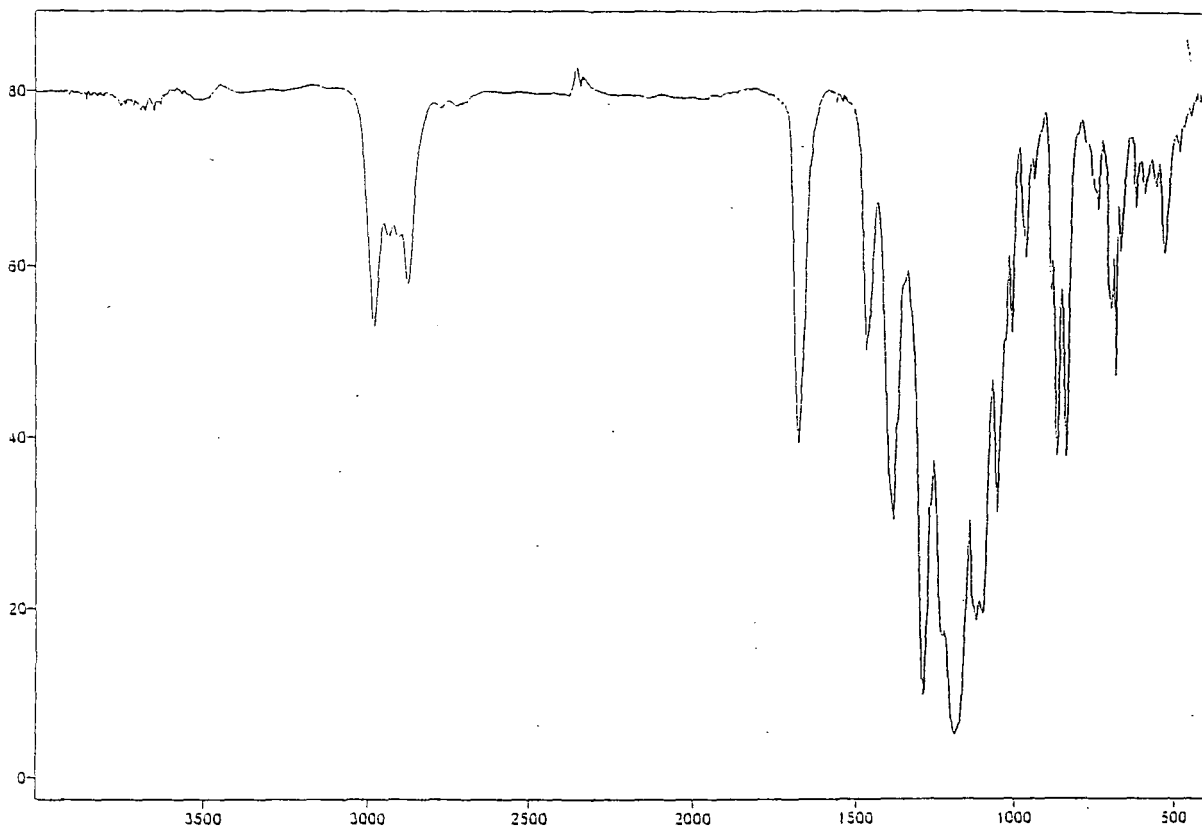

No. 39 4-(2,2,3,4,4,4-hexafluoro-1-methylbutyl)-3-(1,1,2,3,3,3-hexafluoropropyl) morpholine (116)

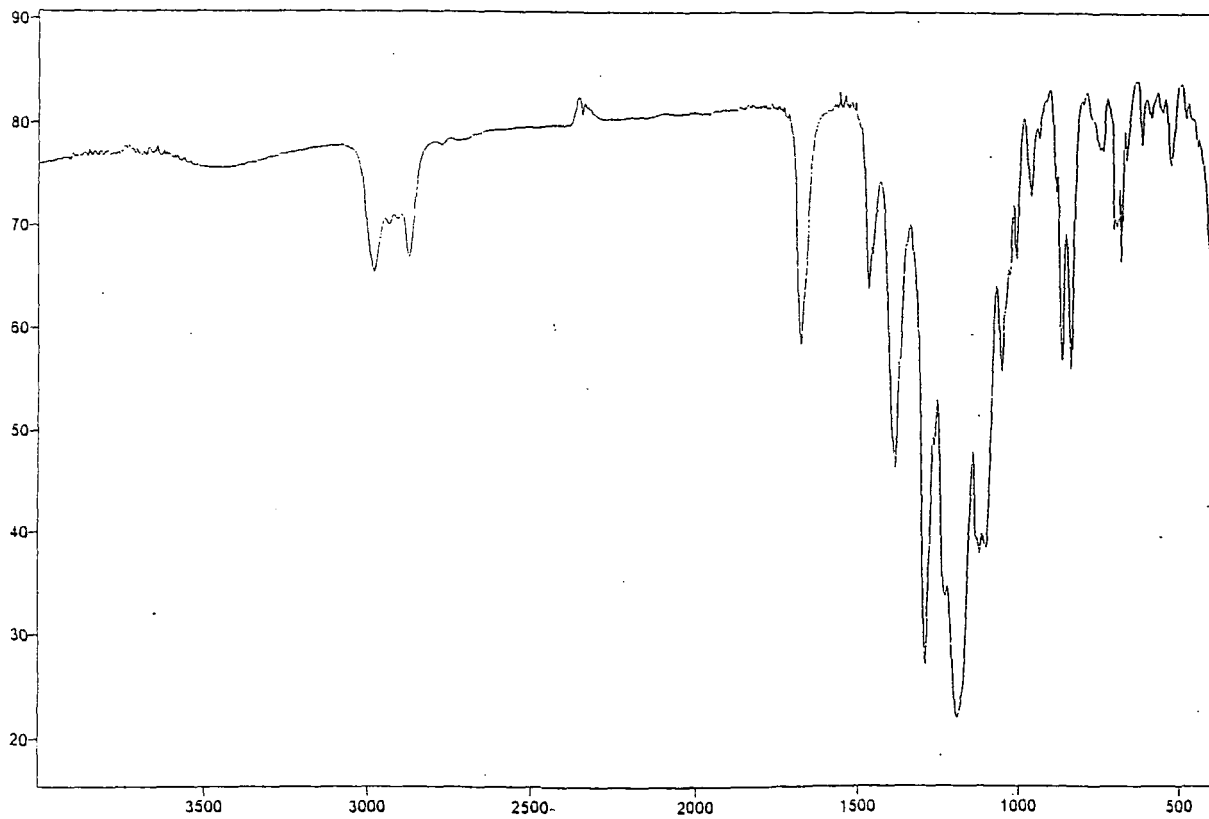

No. 40 2,6-bis(1,1,2,3,3,3-hexafluoropropyl)-1,4-dimethylpiperazine (117)

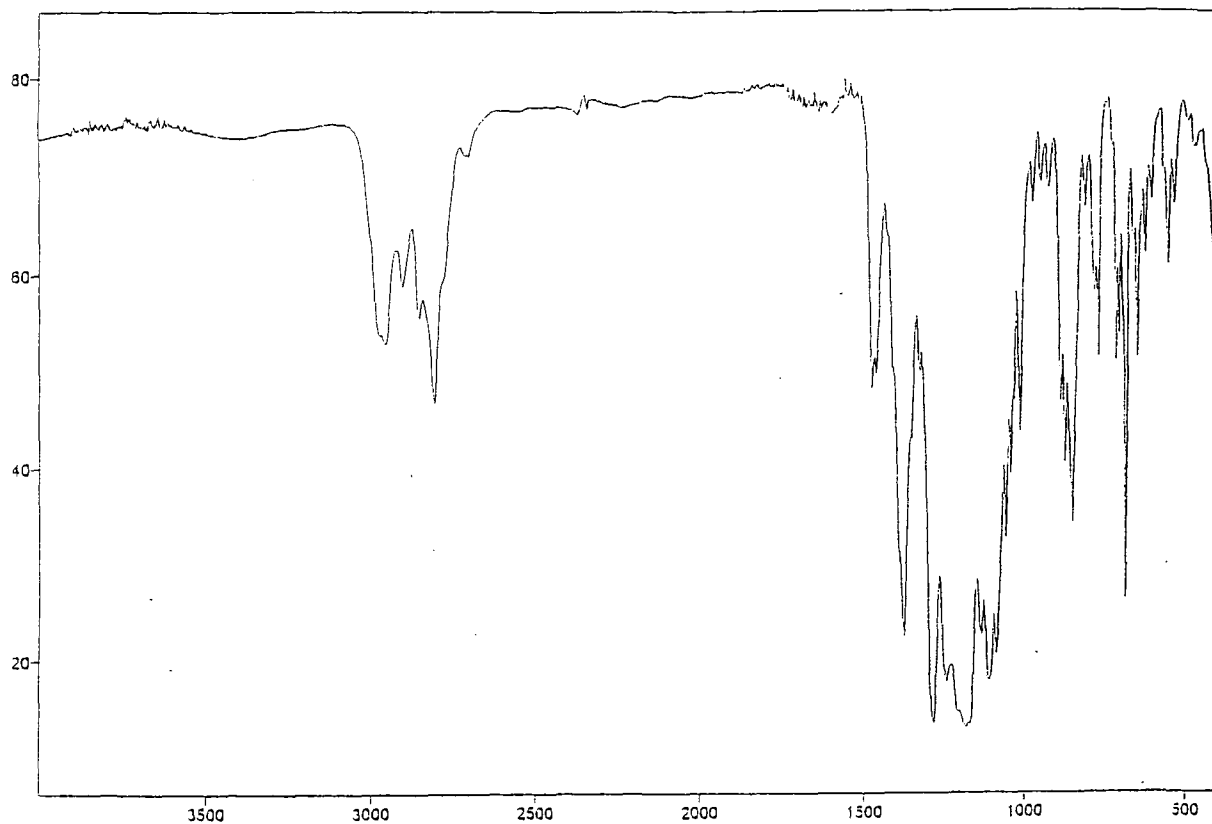

No. 41 1,4-dimethyl-2,3,5-tris(1,1,2,3,3,3-hexafluoropropyl)piperazine (118)

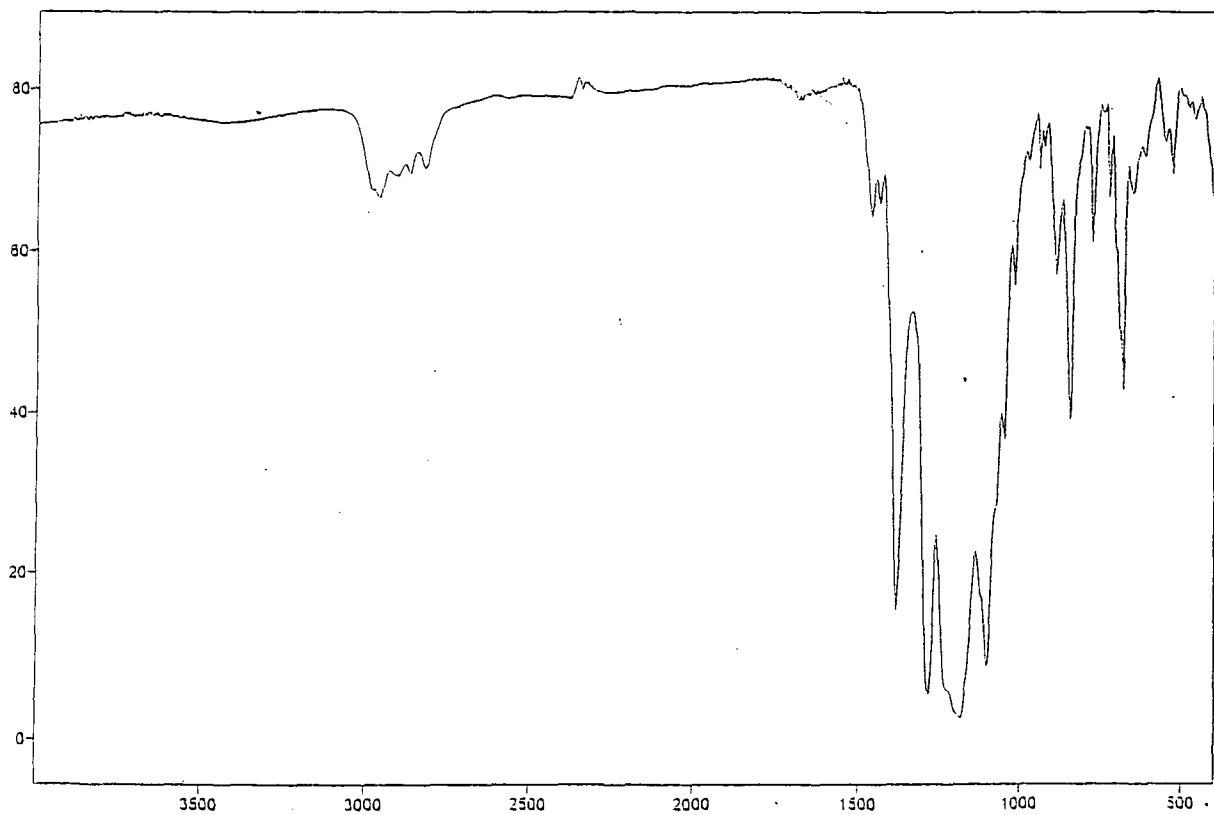

No. 42 1-((2Z)-2,3,4,4,4-pentafluoro-1-methylbut-2-enyl)-2-((1Z)-1,2,3,3,3-pentafluoroprop-1-enyl)piperidine (119)

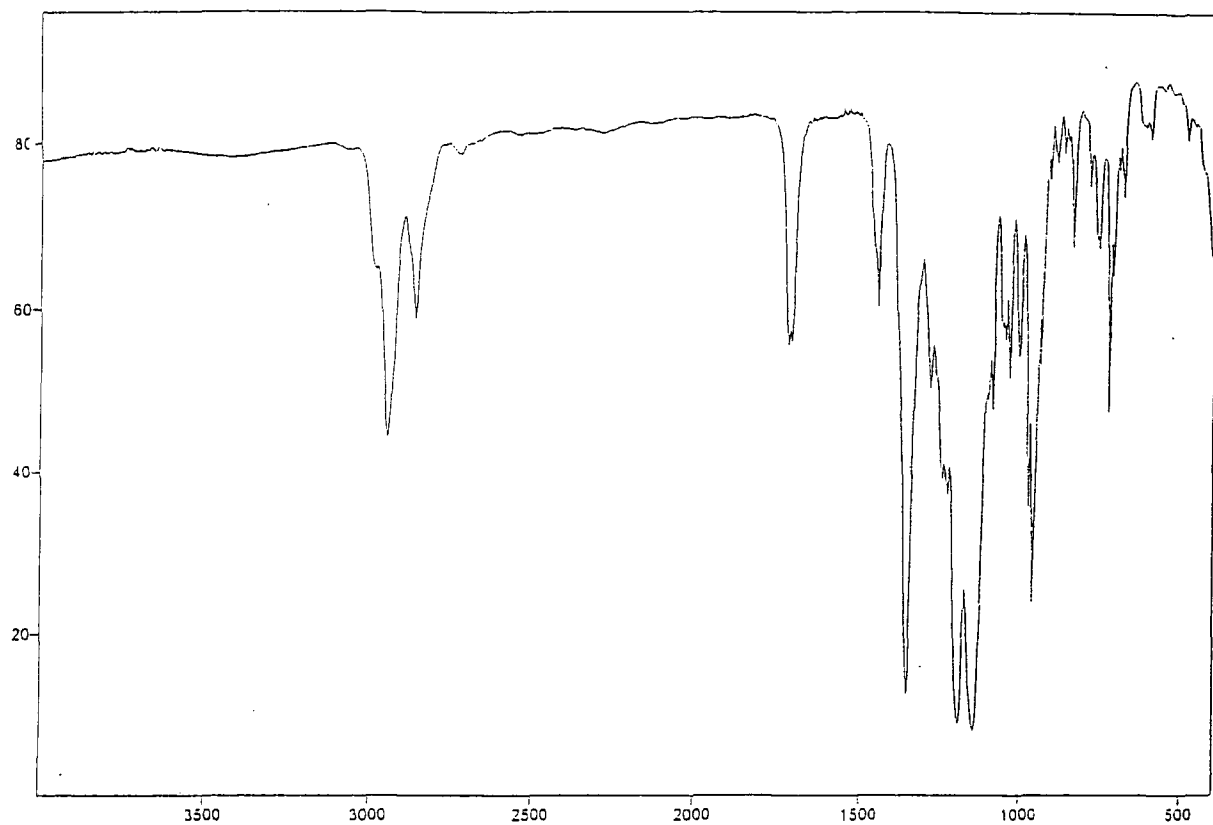

Appendix D : X-ray Crystal Structure

No. 1 tris(2,2,3,4,4,4-hexafluoro-1-methylbutyl)amine (106)

No. 1 tris(2,2,3,4,4,4-hexafluoro-1-methylbutyl)amine (106)

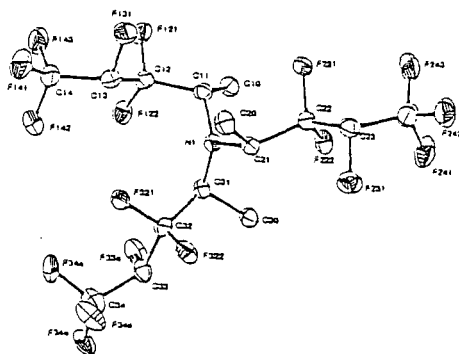

Table 1. Crystal data and structure refinement for 00arv360.

Identification code	00arv360
Empirical formula	C ₁₂ H ₁₄ F ₁₈ N
Formula weight	551.28
Temperature	100(2) K
Wavelength	0.71073 Å
Crystal system	Monoclinic
Space group	P2(1)/n
Unit cell dimensions	a = 11.6485(9) Å α = 90° b = 14.2664(10) Å β = 111.3+1(3)° c = 12.9773(9) Å γ = 90°
Volume	2001.3(3) Å ³
Z	4
Density (calculated)	1.829 Mg/m ³
Absorption coefficient	0.225 mm ⁻¹
F(000)	1096
Crystal size	0.25 x 0.25 x 0.25 mm ³
Theta range for data collection	2.01 to 27.48°
Index ranges	-15 ≤ h ≤ 5, -18 ≤ k ≤ 18, -16 ≤ l ≤ 18
Reflections collected	21066
Independent reflections	4589 [R(int) = 0.0538]
Completeness to theta = 27.48°	100.0 %
Absorption correction	None
Refinement method	Full-matrix least-squares on F ²
Data / restraints / parameters	4589 / 0 / 366
Goodness-of-fit on F ²	1.049
Final R indices [I > 2σ(I)]	R1 = 0.0520, wR2 = 0.1196
R indices (all data)	R1 = 0.0792, wR2 = 0.1330
Largest diff. peak and hole	0.469 and -0.287 e.Å ⁻³

Table 2. Atomic coordinates (x 10⁴) and equivalent isotropic displacement parameters (Å² × 10⁴) for 00arv360. U(eq) is deduced as one third of the trace of the orthogonalized tensor.

	x	y	z	U(eq)
N(1)	9261(2)	2800(1)	1041(2)	2(11)
F(121)	8911(2)	5350(1)	397(1)	36(1)
F(122)	8334(1)	4426(1)	1950(1)	33(1)
F(131)	11230(2)	4905(1)	1812(1)	37(1)
F(141)	11774(2)	5358(1)	2903(2)	52(1)
F(142)	10086(2)	4811(1)	3954(1)	49(1)
F(143)	10052(2)	6044(1)	2986(2)	52(1)
F(221)	9825(2)	2908(1)	-1039(1)	35(1)
F(222)	8578(1)	1778(1)	-1003(1)	31(1)
F(231)	-10796(2)	606(1)	-204(1)	36(1)
F(241)	9170(2)	509(1)	-223(2)	49(1)
F(242)	11012(2)	638(1)	-2267(2)	43(1)
F(243)	9776(2)	1817(1)	-2731(1)	49(1)
F(221)	9829(2)	2777(1)	2272(1)	35(1)
F(322)	9895(1)	1339(1)	2757(1)	31(1)
C(10)	7661(2)	3828(2)	-348(2)	28(1)
C(11)	3952(2)	3740(2)	549(2)	24(1)
C(12)	9166(2)	4507(2)	1431(2)	24(1)
C(13)	10463(2)	4582(2)	2320(2)	28(1)
C(14)	10591(3)	5212(2)	2292(2)	34(1)
C(20)	11482(2)	2561(2)	1290(2)	27(1)
C(21)	10123(2)	2216(2)	756(2)	22(1)
C(22)	9774(2)	2076(2)	-526(2)	24(1)
C(23)	10615(3)	1409(2)	-837(2)	27(1)
C(24)	10125(3)	1088(2)	-2044(2)	33(1)
C(30)	7814(2)	1550(2)	300(2)	28(1)
C(31)	3405(2)	2356(2)	1480(2)	23(1)
C(32)	9102(2)	2063(2)	2695(2)	22(1)
C(33)	8279(2)	1747(2)	2311(2)	30(1)
C(34)	3895(3)	1712(2)	4570(2)	41(1)
F(34A)	7221(5)	22771(4)	30121(5)	39(1)
F(34B)	7578(11)	25811(10)	32681(11)	63(2)
F(34C)	3996(4)	2630(2)	4966(2)	54(1)
F(34D)	9814(7)	2196(7)	5109(5)	61(2)
F(34E)	9951(3)	1357(3)	4941(3)	49(1)
F(34F)	9693(8)	771(6)	4654(6)	70(2)
F(34G)	8192(15)	1284(7)	5028(13)	42(2)
F(34H)	3110(30)	1595(13)	5010(30)	53(5)

Table 3. Bond lengths [Å] and angles [°] for O0srv360.

N(1)-C(11)	1.463(3)	C(10)-C(11)-C(12)	110.4(2)
N(1)-C(12)	1.468(3)	F(121)-C(12)-F(122)	105.23(19)
N(1)-C(11)	1.471(3)	F(121)-C(12)-C(13)	107.3(2)
F(121)-C(12)	1.366(3)	F(122)-C(12)-C(13)	108.4(2)
F(122)-C(12)	1.375(3)	F(121)-C(12)-C(11)	107.74(19)
F(131)-C(13)	1.383(3)	F(122)-C(12)-C(11)	110.9(2)
F(141)-C(14)	1.326(3)	C(13)-C(12)-C(11)	116.2(2)
F(142)-C(14)	1.339(3)	F(131)-C(13)-C(12)	107.0(2)
F(143)-C(14)	1.332(3)	F(131)-C(13)-C(14)	107.3(2)
F(221)-C(22)	1.373(3)	C(12)-C(13)-C(14)	114.9(2)
F(222)-C(22)	1.364(3)	F(141)-C(14)-F(143)	108.0(2)
F(231)-C(23)	1.380(3)	F(141)-C(14)-F(142)	106.9(2)
F(241)-C(24)	1.327(3)	F(143)-C(14)-F(142)	107.6(2)
F(242)-C(24)	1.336(3)	F(141)-C(14)-C(13)	110.5(2)
F(243)-C(24)	1.331(3)	F(143)-C(14)-C(13)	113.3(2)
F(321)-C(32)	1.363(3)	F(142)-C(14)-C(13)	109.8(2)
F(322)-C(32)	1.368(3)	N(1)-C(21)-C(20)	112.1(2)
C(10)-C(11)	1.526(3)	N(1)-C(21)-C(22)	115.0(2)
C(11)-C(12)	1.536(3)	C(20)-C(21)-C(22)	111.0(2)
C(12)-C(13)	1.524(4)	F(221)-C(22)-F(221)	105.70(19)
C(13)-C(14)	1.527(4)	F(222)-C(22)-C(23)	109.5(2)
C(20)-C(21)	1.531(3)	F(221)-C(22)-C(23)	105.2(2)
C(21)-C(22)	1.546(3)	F(222)-C(22)-C(21)	110.00(19)
C(22)-C(23)	1.524(4)	F(221)-C(22)-C(21)	111.1(2)
C(23)-C(24)	1.524(4)	C(23)-C(22)-C(21)	114.8(2)
C(30)-C(31)	1.532(3)	F(231)-C(23)-C(22)	109.3(2)
C(31)-C(32)	1.539(3)	F(231)-C(23)-C(24)	106.1(2)
C(32)-C(33)	1.526(4)	C(23)-C(23)-C(24)	115.3(2)
C(33)-F(33A)	1.372(7)	F(241)-C(24)-F(243)	108.1(2)
C(33)-F(33B)	1.431(15)	F(241)-C(24)-F(242)	107.4(2)
C(33)-C(34)	1.521(4)	F(243)-C(24)-F(242)	107.3(2)
C(34)-F(34B)	1.247(6)	F(241)-C(24)-C(23)	112.8(2)
C(34)-F(34C)	1.250(4)	F(243)-C(24)-C(23)	111.0(2)
C(34)-F(34F)	1.26(3)	F(242)-C(24)-C(23)	110.0(2)
C(34)-F(34E)	1.327(14)	N(1)-C(31)-C(30)	116.9(2)
C(34)-F(34A)	1.391(5)	N(1)-C(31)-C(32)	109.9(2)
C(34)-F(34D)	1.552(9)	C(30)-C(31)-C(32)	111.2(2)
F(33A)-F(33B)	0.506(11)	F(321)-C(32)-F(322)	104.97(19)
F(34A)-F(34B)	1.091(9)	F(321)-C(32)-C(33)	108.8(2)
F(34B)-F(34C)	1.236(9)	F(322)-C(32)-C(33)	106.8(2)
F(34C)-F(34D)	0.947(8)	F(321)-C(32)-C(31)	110.16(19)
		F(322)-C(32)-C(31)	110.64(19)
C(31)-N(1)-C(21)	119.53(19)	C(23)-C(32)-C(31)	115.0(2)
C(31)-N(1)-C(11)	118.17(19)	F(33A)-C(33)-F(33B)	24.9(4)
C(21)-N(1)-C(11)	118.72(19)	F(33A)-C(33)-C(34)	109.7(2)
N(1)-C(11)-C(10)	114.7(2)	F(33B)-C(33)-C(34)	96.0(5)
N(1)-C(11)-C(12)	112.3(2)	F(33A)-C(33)-C(32)	111.3(3)
		F(34B)-C(34)-F(34D)	96.9(6)
F(33B)-C(33)-C(32)	101.2(6)	F(34C)-C(34)-F(34D)	37.6(3)
C(34)-C(33)-C(32)	115.8(2)	F(34F)-C(34)-F(34D)	107.7(10)
F(34B)-C(34)-F(34C)	59.4(5)	F(34E)-C(34)-F(34D)	88.0(6)
F(34B)-C(34)-F(34F)	115.9(14)	F(34A)-C(34)-F(34D)	144.7(5)
F(34C)-C(34)-F(34F)	123.3(13)	F(331)-C(34)-F(34D)	97.4(4)
F(34B)-C(34)-F(34E)	123.2(7)	F(33B)-F(33A)-C(33)	83.0(19)
F(34C)-C(34)-F(34E)	108.9(7)	F(33A)-F(33B)-C(33)	72.1(19)
F(34F)-C(34)-F(34E)	19.9(12)	F(34B)-F(34A)-C(34)	58.8(4)
F(34B)-C(34)-F(34A)	48.5(5)	F(34A)-F(34B)-F(34C)	122.7(6)
F(34C)-C(34)-F(34A)	107.6(3)	F(34A)-F(34B)-C(34)	72.7(5)
F(34F)-C(34)-F(34A)	86.5(10)	F(34C)-F(34B)-C(34)	60.4(4)
F(34E)-C(34)-F(34A)	104.8(6)	F(34D)-F(34C)-F(34B)	149.0(8)
F(34B)-C(34)-C(33)	123.2(4)	F(34D)-F(34C)-C(34)	88.8(6)
F(34C)-C(34)-C(33)	115.5(3)	F(34B)-F(34C)-C(34)	80.2(4)
F(34F)-C(34)-C(33)	111.1(15)	F(34C)-F(34D)-C(34)	53.6(5)
F(34E)-C(34)-C(33)	111.9(7)		
F(34A)-C(34)-C(33)	107.4(3)		

Table 4. Anisotropic displacement parameters ($\text{\AA}^2 \times 10^3$) for 00srV360. The anisotropic displacement factor exponent takes the form: $-2\pi^2 [h^2 a^{*2} U^{11} + \dots + 2 h k a^* b^* U^{12}]$

	U^{11}	U^{22}	U^{33}	U^{23}	U^{13}	U^{12}
N(1)	19(1)	20(1)	21(1)	1(1)	8(1)	-1(1)
F(121)	46(1)	21(1)	32(1)	3(1)	6(1)	5(1)
F(122)	31(1)	35(1)	38(1)	-9(1)	18(1)	0(1)
F(131)	36(1)	41(1)	36(1)	-1(1)	16(1)	-12(1)
F(141)	51(1)	51(1)	41(1)	-15(1)	2(1)	-18(1)
F(142)	69(1)	52(1)	29(1)	-5(1)	23(1)	-8(1)
F(143)	84(2)	29(1)	36(1)	-6(1)	14(1)	6(1)
F(221)	58(1)	24(1)	25(1)	4(1)	18(1)	3(1)
F(222)	23(1)	41(1)	23(1)	-5(1)	2(1)	3(1)
F(231)	43(1)	31(1)	41(1)	9(1)	22(1)	9(1)
F(241)	45(1)	50(1)	53(1)	-28(1)	21(1)	-18(1)
F(242)	50(1)	45(1)	44(1)	-14(1)	29(1)	-4(1)
F(243)	76(1)	46(1)	23(1)	-5(1)	15(1)	3(1)
F(221)	39(1)	37(1)	22(1)	-3(1)	4(1)	-20(1)
F(222)	22(1)	38(1)	25(1)	7(1)	12(1)	10(1)
C(10)	26(1)	30(1)	24(1)	3(1)	4(1)	3(1)
C(11)	24(1)	24(1)	22(1)	2(1)	7(1)	0(1)
C(12)	27(1)	21(1)	25(1)	2(1)	11(1)	2(1)
C(13)	30(1)	27(1)	26(1)	0(1)	10(1)	-5(1)
C(14)	43(2)	30(1)	26(1)	-2(1)	8(1)	-4(1)
C(20)	22(1)	35(1)	24(1)	-3(1)	6(1)	0(1)
C(21)	22(1)	26(1)	19(1)	2(1)	8(1)	-1(1)
C(22)	26(1)	22(1)	23(1)	1(1)	8(1)	-1(1)
C(23)	28(1)	29(1)	26(1)	2(1)	13(1)	-4(1)
C(24)	37(2)	28(1)	36(2)	-8(1)	15(1)	-3(1)
C(30)	26(1)	33(1)	22(1)	-1(1)	5(1)	-8(1)
C(31)	21(1)	27(1)	21(1)	-3(1)	9(1)	-1(1)
C(32)	19(1)	24(1)	22(1)	0(1)	5(1)	-3(1)
C(33)	26(1)	40(2)	24(1)	-4(1)	11(1)	-6(1)
C(34)	30(2)	67(2)	26(1)	-2(1)	10(1)	-22(2)
F(23A)	26(2)	63(3)	34(3)	0(2)	18(2)	8(2)
F(23B)	55(8)	98(10)	42(6)	-2(5)	23(5)	29(5)
F(34A)	81(3)	52(2)	31(2)	-21(1)	24(2)	-19(2)
F(34B)	54(4)	100(6)	28(3)	-16(4)	16(3)	-46(4)
F(34C)	36(2)	83(3)	30(2)	16(2)	15(1)	12(2)
F(34D)	93(6)	74(5)	43(4)	25(4)	26(4)	4(5)
F(34E)	43(4)	67(5)	26(2)	-2(4)	19(2)	-25(4)
F(34F)	31(4)	100(14)	35(5)	-14(11)	21(4)	-12(10)

Table 5. Hydrogen coordinates ($\times 10^4$) and isotropic displacement parameters ($\text{\AA}^2 \times 10^3$) for 00srV360.

	x	y	z	U(eq)
H(103)	7580	3395	-955	42
H(102)	7532	4472	-630	42
H(101)	7041	3674	-29	42
H(111)	9550(30)	3871(19)	170(20)	28
H(131)	10740(30)	3920(20)	2610(20)	33
H(203)	11541	3181	1022	41
H(202)	12012	2120	1105	41
H(201)	11690	2567	2097	41
H(212)	10090(30)	1580(20)	1050(20)	27
H(231)	11430(30)	1720(20)	-670(20)	32
H(303)	7128	1771	48	42
H(302)	7054	1329	1155	42
H(301)	8152	1034	761	42
H(311)	7810(30)	2860(20)	1500(20)	27
H(2)	7970(30)	1130(20)	3070(30)	41(9)

References

1. C. Magron, *Ph. D. Thesis*, University of Durham, 1998.
2. D. B. Harper and D. O'Hagan, *Nat. Prod. Rep.*, 1994, **11**, 123.
3. R. E. Banks, *J. Fluorine Chem.*, 1998, **87**, 1.
4. R. D. Chambers, *Fluorine in Organic Chemistry*, Wiley-Interscience, New York, 1973.
5. D. Holtz, *Prog. Phys. Org. Chem.*, 1971, **8**, 1.
6. J. F. Liebman, A. Greenberg and W. R. Dolbier Jr., *Fluorine-Containing Molecules : Structure, Reactivity, Synthesis and Applications*, VCH Publishers, New York, 1988.
7. R. G. Hall, Abstracts of Papers, *16th International Symposium Fluorine Chemistry*, University of Durham, 16-21 July 2000.
8. M. L. Robin, Abstracts of Papers, *16th International Symposium Fluorine Chemistry*, University of Durham, 16-21 July 2000.
9. R. E. Banks, B. E. Smart and J. C. Tatlow, *Organofluorine Chemistry : Principles and Commercial Applications*, Plenum Press, New York, 1994.
10. C. Walling and E. S. Huyser, *Organic Reactions*, 1963, **13**, 91.
11. Cited by M. J. Perkins, *Radical Chemistry : The fundamentals Oxford Chemistry Primers*, Oxford University Press, 2000.
12. J. Fossey, D. Lefort and J. Sorba, *Free Radicals in Organic Chemistry*, Wiley and Sons, New York, 1995.
13. M. J. Jones, G. Moad, E. Rizzardo and D. H. Solomon, *J. Org. Chem.*, 1989, **54**, 1607.
14. D. C. Nonhebel, J. M. Tedder and J. C. Walton, *Radicals*, Cambridge University Press, 1977.
15. A. Horowitz, *ACS. Symp. Ser.*, 1978, **69**, 161.
16. P. Sykes, *Mechanism in Organic Chemistry*, 6th edition, Wiley and Sons, New York, 1985.
17. K. P. C. Vollhardt, *Organic Chemistry*, W. H. Freeman and Company, New York, 1987.
18. I. Fleming, *Frontier Orbitals and Organic Chemical Reactions*, Wiley, London, 1976.
19. W. R. Dolbier Jr., *Chem. Rev.*, 1996, **96**, 1557.
20. P. J. Krusic and R. C. Bingham, *J. Am. Chem. Soc.*, 1976, **98**, 230.
21. P. Gray, A. A. Herod and A. Jones, *Chem. Rev.*, 1971, **71**, 247.
22. J. M. Tedder, *Quart. Rev.*, 1960, **14**, 336.
23. J. M. Tedder, *Angew. Chem. Int. Ed.*, 1982, **21**, 401.

24. R. N. Haszeldine et al, *U. S. P.* 3, 816, 286/ 1974.
25. R. N. Haszeldine et al, *U. S. P.* 3, 917, 725/ 1975.
26. R. N. Haszeldine, M. Raynor and A. E. Tipping, *J. Chem. Soc., Perkin Trans. 1*, 1982, 2219.
27. B. Ameduri and B. Boutevin, *Topics in Current Chemistry*, 1997, **192**, 165.
28. J. M. Tedder and J. C. Walton, *Acc. Chem. Res.*, 1976, **9**, 183.
29. J. F. Harris Jr. and F. W. Stacey, *J. Am Chem. Soc.*, 1961, **83**, 840.
30. R. D. Chambers, P. Diter, S. N. Dunn, C. Farren, G. Sandford, A. S. Batsanov and J. A. K. Howard, *J. Chem. Soc., Perkin Trans. 1*, 2000, 1639.
31. J. D. Lazerte and R. J. Koshar, *J. Am. Chem. Soc.*, 1955, **77**, 910.
32. R. N. Haszeldine, R. Rowland, R. P. Sheppard and A. E. Tipping, *J. Fluorine Chem.*, 1985, **28**, 291.
33. V. Cirkva, R. Polak and O. Paleta, *J. Fluorine Chem.*, 1996, **80**, 135.
34. R. D. Chambers, B. Grievson and N. M. Kelly, *J. Chem. Soc., Perkin Trans. 1*, 1985, 2209.
35. H. Muramatsu, K. Inukai and T. Ueda, *Bull. Chem. Soc. Jpn.*, 1967, **40**, 903.
36. H. Muramatsu, H. Kimoto and K. Inukai, *Bull. Chem. Soc. Jpn.*, 1969, **42**, 1155.
37. R. D. Chambers, J. Hutchinson, N. M. Kelly, A. K. Joel, A. J. Rees and P. T. Telford, *Israel Journal of Chemistry*, **39**, 1999, 133.
38. J. Courtieu, J. Jullien and N. T. Lai, *Tetrahedron*, 1976, **32**, 669.
39. V. Cirkva and O. Paleta, *J. Fluorine Chem.*, 1999, **94**, 141.
40. S. L. Jones, *Ph. D. Thesis*, University of Durham, 1987.
41. R. D. Chambers, S. L. Jones, S. J. Mullins, A. Swales, P. Telford and M. L. H. West, *Selective Fluorination in Organic and Bioorganic Chemistry (ACS Symposium Series 456)*, Ed. Welch, J. T. American Chemical Society, Washington, D. C. , 1991.
42. J. Chen, R. L. Kirchmeier and J. M. Shreeve, *Inorg. Chem.*, 1996, **35**, 6676.
43. T. Davies, R. N. Haszeldine, R. Rowland and A. E. Tipping, *J. Chem. Soc., Perkin Trans. 1*, 1983, 109.
44. R. D. Chambers, R. W. Fuss, R. C. H. Spink, M. P. Greenhall, A. M. Kenwright, A. S. Batsanov and J. A. K. Howard, *J. Chem. Soc., Perkin Trans. 1*, 2000, 1623.
45. A. T. Podkhalyuzin, V. A. Morozov and A. Z. Yankelevich, *Dokl. Akad. Nauk. SSSR*, 1976, **228**, 609.
46. A. T. Podkhalyuzin, V. V. Vikulin, V. A. Morozov, M. P. Nazora and I. V. Vereshchinskii, *Radiat. Effects*, 1977, **32**, 9.
47. P. A. Zagorets, A. G. Shostenko, N. P. Tarassova, V. V. Fedorov, A. T. Podkhalyuzin, I. V. Dobrov and R. A. Zamyslov, *Radiat. Phys. Chem.*, 1983, **22**, 35, 881.
48. H. Gunther, *NMR Spectroscopy*, Wiley, Stuttgart, 1980.

49. S. Berger, S. Braun and H-O. Kalinowski, *NMR Spectroscopy of Non-metallic Elements*, Wiley and Sons, New York, 1997.
50. J. W. Emsley, L. Phillips and V. Wray, *Fluorine Coupling Constants*, Pergamon Press, Oxford, 1977.
51. D. H. Williams and I. Fleming, *Spectroscopic Methods in Organic Chemistry*, Mc Graw-Hill, London, 1989.
52. R. C. Larock, *Comprehensive Organic Transformations*, Wiley, London, 1989.
53. S. H. Pine, J. B. Hendrickson, D. J. Cram and G. S. Hammond, *Organic Chemistry*, Fourth Edition, 1980.
54. W. S. Allen and S. Bernstein, *J. Am. Chem. Soc.*, 1955, **77**, 1028.
55. A. Schwartz and P. Madan, *J. Org. Chem.*, 1986, **51**, 5463.
56. S. N. Dunn, *Ph. D. Thesis*, University of Durham, 1996.
57. G. H. Posner, E. M. Shulman-Roskes, C. Ho Oh, J-C Carry, J. V. Green, A. B. Clark, H. Dai and T. E. N. Anjeh, *Tetrahedron. Lett.*, 1991, **32**, 6489.
58. H. Matsuda, T. Hamatani, S. Matsubara and M. Schlosser, *Tetrahedron*, 1988, **44**, 2865.
59. D. R. Strobach and G. A. Boswell, Jr. , *J. Org. Chem.*, 1971, **36**, 818.
60. A. T. Podkhalyuzin, M. P. Nazarova and A. Z. Yankelevich, *Zh. Org. Kim.*, 1976, **12**, 910.
61. W. Dmowski, *J. Fluorine Chem.*, 1980, **15**, 299.
62. S. L. Jones, *Ph. D. Thesis*, University of Durham, 1987.
63. A. P. Swales, *Ph. D. Thesis*, University of Durham, 1989.
64. P. L. Coe, A. W. Mott and J. C. Tatlow, *J. Fluorine Chem.*, 1982, **20**, 167.
65. L. A. Rozov, Y. V. Zeifman, N. P. Gambaryan, Y. A. Cheburkov and I. L. Knunyants, *Izv. Akad. Nauk SSSR, Ser. Khim.*, 1976, 275.
66. J. March, *Advanced Organic Chemistry*, Second Edition, MC Graw-Hill, 1977.
67. M. J. Silvester, *Aldrichimica Acta*, 1995, **28**, 2, 45.
68. G. A. Olah, R. D. Chambers and K. S. Prakash, *Synthetic Fluorine Chemistry*, Wiley and Sons, New York, 1992.
69. Z. Rappoport, *Adv. Phys. Org. Chem.*, 1969, **7**, 1.
70. Z. Rappoport and A. Gazit, *J. Org. Chem.*, 1985, **50**, 3184.
71. Z. Rappoport and A. Gazit, *J. Org. Chem.*, 1986, **51**, 4112.
72. Z. Rappoport and A. Gazit, *J. Am. Chem. Soc.*, 1987, **109**, 6698.
73. W. E. Hanford and G. W. Rigby, *U. S. P. 2409274/1946; Chem. Abst.*, 1947, **41**, 982b.
74. D. D. Coffman, M. S. Raasch, G. W. Rigby, P. L. Barrick and W. E. Hanford, *J. Org. Chem.*, 1949, **14**, 747.
75. W. T. Miller Jr., E. W. Fager, P. H. Griswold, *J. Am. Chem. Soc.*, 1948, **70**, 431.

76. R. C. H. Spink, *Ph. D. Thesis*, University of Durham, 1996.
77. C. Farren, *Ph. D. Thesis*, University of Durham, 1999.
78. L. Claisen, *Ber. Dtsch. Chem. Ges.*, 1912, **45**, 3157.
79. T. Konno, H. Nakano and T. Kitazume, *J. Fluorine Chem.*, 1997, **86**, 81.
80. K. Funabiki, Y. Fukushima, T. Inagaki, E. Murata, M. Matsui and K. Shibata, *Tetrahedron Lett.*, 1998, **39**, 1913.
81. H. Ito and T. Taguchi, *Chem. Soc. Rev.*, 1999, **28**, 43.
82. F. E. Ziegler, *Chem. Rev.*, 1988, **88**, 1423.
83. J. J. Gajewski, K. R. Gee and J. Jurayj, *J. Org. Chem.*, 1990, **55**, 1813.
84. B. M. Trost and B. Martin, *Comprehensive Organic Synthesis*, Pergamon Press, Oxford, 1991, **5**, 832.
85. C. G. Krespan, *Tetrahedron*, 1967, **23**, 4243.
86. V. G. Andreev, A. F. Kolomiets, G. A. Sokolskii, *Dokl. Akad. Nauk. SSSR*, 1980, **250**, 1386.
87. K. Burger, D. Hubl and K. Geith, *Synthesis*, 1988, 194.
88. K. Burger, K. Geith and K. Gaa, *Angewandte Chemie*, 1988, **100**, 6, 860.
89. K. Burger, K. Geith, K. Gaa and C. Schierlinger, *Synthesis*, 1989, 850.
90. J-P. Bégué, D. Bonnet-Delpon, S-W. Wu and A. M'Bida, *Tetrahedron Lett.*, 1994, **35**, 2907.
91. C. Driss, M. M. Chaabouni and A. Baklouti, *Synthetic Communications*, 1993, **23**, 13, 1887.
92. T. Yamazaki, H. Umetani, T. Kitazume, *Tetrahedron Lett.*, 1997, **38**, 6705.
93. F. Tellier, M. Audouin, M. Baudry and R. Sauvêtre, *Tetrahedron Lett.*, 1998, **39**, 5041.
94. F. Tellier, M. Audouin, M. Baudry and R. Sauvêtre, *J. Fluorine Chem.*, 1999, **94**, 27.
95. H. M. Park, T. Uegaki, T. Konno, T. Ishihara and H. Yamanaka, *Tetrahedron Lett.*, 1999, **40**, 2985.
96. J. M. Percy and M. E. Prime, *J. Fluorine Chem.*, 1999, **100**, 147.
97. S. Peng and F-L. Qing, *J. Chem. Soc., Perkin Trans. 1*, 1999, 3345.
98. F. Tellier, M. Audouin, M. Baudry and R. Sauvêtre, *Eur. J. Org. Chem.*, 2000, 1933.
99. S. W. Ridgy, *U. S. P. 2484528/1949*; *Chem. Abst.*, 1950, **44**, 5925c.
100. D. C. England, L. R. Melby, M. A. Dietrich and R. V. Lindsey, Jr., *J. Am. Chem. Soc.*, 1960, **82**, 5116.
101. T. F. Mc Grath and R. Levine, *J. Am. Chem. Soc.*, 1955, **77**, 4168.
102. S. Dixon, *J. Org. Chem.*, 1956, **21**, 400.
103. S. Bartlett, R. D. Chambers, J. R. Kirk and A. A. Lindley, *J. Chem. Soc., Perkin Trans. 1*, 1983, 1235.

104. P. Tarrant and D. A. Warner, *J. Am. Chem. Soc.*, 1954, **76**, 1624.
105. L. A. Rozov, Y. V. Zeifman, Y. A. Cheburkov and I. L. Knunyants, *Isv. Akad. Nauk. SSSR, Ser. Khim.*; 1975, 188.
106. B. L. Dyatkin, E. P. Mochalina and I. L. Knunyants, *Fluorine Chemistry Review*, ed. Tarrant and M. Dekker, New York, 1964, **3**, 45.
107. V. A. Petrov and V. V. Bardin, *Topics in Current Chemistry*, 1997, **192**, 39.
108. D. G. Naae, *J. Org. Chem.*, 1980, **45**, 1394.
109. A. Y. Zapevalov, T. A. Filyakova and I. P. Kolenko, *Isv. Akad. Nauk. SSSR, Ser. Khim.*, 1979, 2812.
110. M. R. Bryce, R. D. Chambers and J. R. Kirk, *J. Chem. Soc., Perkin Trans. 1*, 1984, 1391.
111. I. P. Kolenko, T. A. Filyakova, A. Y. Zapevalov and E. P. Lur'e, *Isv. Akad. Nauk. SSSR, Ser. Khim.*, 1979, 2509.
112. Dupont de Nemours, *U. K. P.* 904877/1963.
113. M. Fujita, H. Ishizuka and K. Ogura, *Tetrahedron Lett.*, 1991, **32**, 6355.
114. B. K. Carpenter, *Tetrahedron*, 1978, **34**, 1877.
115. T. I. Filyakova, A. Ya. Zapevalov, I. P. Kolenko and L. S. German, *Isv. Akad. Nauk. SSSR, Ser. Khim.*, 1979, 2789.
116. J. Cooper, *Ph. D. Thesis*, University of Durham, 2000.
117. V. A. Morozov, R.A. Zamyslov and A. T. Podkalyuzin, *J. Appl. Chem. USSR*, 1980, **53**, 656.
118. J. A. Wilkinson, *Chem. Rev.*, 1992, **92**, 505.
119. E. Haworth and W.H. Perkin, *J. Chem. Soc.*, 1894, **65**, 86.
120. H-O. Kalinowski, S. Berger and S. Braun, *Carbon-13 NMR Spectroscopy*, Wiley and Sons, New York, 1988.

