

Durham E-Theses

A large-D Weyl invariant string model in anti-de sitter space

Ian James Davies

How to cite:

Davies, Ian James (2002) A large-D Weyl invariant string model in anti-de sitter space. Doctoral thesis, Durham University.

Use policy

The full-text may be used and/or reproduced, and given to third parties in any format or medium, without prior permission or charge, for personal research or study, educational, or not-for-profit purposes provided that:

- a full bibliographic reference is made to the original source
- a <https://etheses.durham.ac.uk/id/eprint/3838/> is made to the metadata record in Durham E-Theses
- the full-text is not changed in any way

The full-text must not be sold in any format or medium without the formal permission of the copyright holders.

Please consult the [full Durham E-Theses policy](#) for further details.

A Large-D Weyl Invariant String Model in Anti-de Sitter Space

Ian James Davies

The copyright of this thesis rests with the author.
No quotation from it should be published without
his prior written consent and information derived
from it should be acknowledged.

A Thesis presented for the degree of
Doctor of Philosophy



29 JAN 2003

Centre for Particle Theory
Department of Mathematical Sciences
University of Durham
England

July 2002

FOR MY PARENTS

A Large- D Weyl Invariant String Model in Anti-de Sitter Space

Ian James Davies

Submitted for the degree of Doctor of Philosophy
July 2002

Abstract

In this thesis we present a novel scheme for calculating the bosonic string partition function on certain curved backgrounds related to Anti-de Sitter (AdS) space. We take the concept of a large N expansion from nonlinear sigma models in particle physics and apply it to the bosonic string theory sigma model, where the analogous large dimensionless parameter is the dimension of the target space, D . We then perform a perturbative expansion in negative powers of D , rather than in positive powers of α'/l^2 (the conventional expansion parameter).

As a specific example of a curved geometry of interest, we focus on an example of the metric proposed by Polyakov [1] to describe the dynamics of the Wilson loop of pure $SU(N)$ Yang-Mills theory, namely AdS space. Using heat kernel methods, we find that within the large- D scheme one can obtain different conditions for Weyl invariance than those found in [2]. This is because our scheme is valid for backgrounds where α'/l^2 is no longer small. In particular, we find that it is possible to have a dilaton that depends on the holographic coordinate only, provided one allows mixing of the ghost and matter sectors of the worldsheet theory. This field preserves Poincaré invariance in the gauge theory, unlike the conventional dilaton. We also compute a simple string amplitude by constructing certain vertex operators for a scalar field in AdS , and discuss the consequences for the string spectrum.

Declaration

The work in this thesis is based on research carried out at the Centre for Particle Theory in the Department of Mathematical Sciences, University of Durham, UK. No part of this thesis has been submitted elsewhere for any other degree or qualification and it is all the author's own work unless referenced to the contrary in the text.

Chapter 3 of this thesis is included as a literature review, and no claim of originality is made for the material presented there. The beta function calculations in Chapter 2 and the calculations presented in Chapters 4-6 are original work, done in collaboration with my supervisor Professor Paul Mansfield.

Copyright © 2002 by Ian James Davies.

The copyright of this thesis rests with the author. No quotations from it should be published without the author's prior written consent and information derived from it should be acknowledged.

Acknowledgements

It has been a great pleasure to work under the supervision of Professor Paul Mansfield, whose patience, knowledge and expert guidance have been invaluable and much appreciated. I would also like to acknowledge Professor Ray Bishop, who first inspired me to venture into the world of theoretical physics research.

I would like to thank my family for all their unconditional love and support throughout my career. I can't tell you how much that has meant to me. I wouldn't have been able to do any of this without you all, and for that I'll always be in your debt.

A big "cheers" to the lads from the office: James Gregory, Ken "Lord" Lovis, Tony Padilla and Dave Page. Life in the Durham Maths department would have been a very different prospect without all the laughs and nonsense supplied by you lot. You're all much appreciated! Also, big thanks to Dominic Bre(a)cher and Paul Saffin - again, the place wouldn't have been the same without you!

I'd like to thank all of my other good friends that I've made during my time in Durham. Special thanks go to Louise Blundell, Nick Blackwood and Russell Hill - I've got many a good evening in the Swan and Three to thank you for! And to Kat, George, Cath, Viola, José and Gran - thanks for making life at University College bearable!

Thanks also to Andrea, Sam, Baz, Em, Jim, Ramz, Evo, Donk, and a host of other fine people with funny nicknames that are just too numerous to mention here!

Finally, a few words of love and thanks for my wonderful girlfriend, Kerrie. A couple of sentences couldn't possibly do you justice; but for all your love, your understanding, and your unrivalled ability to make me feel like the world is a great place to be - thank you.

Contents

Abstract	iii
Declaration	iv
Acknowledgements	v
1 Introduction	1
2 The Weyl Anomaly in Perturbative String Theory	4
2.1 Strings in flat spacetimes	4
2.1.1 The path integral approach	5
2.1.2 The Weyl anomaly	8
2.1.3 Heat kernel regularization	10
2.2 Strings in curved spacetimes	12
2.2.1 The dilaton beta function	14
2.2.2 The graviton beta function	19
2.2.3 Discussion	20
3 Gauge Fields – Strings Duality	23
3.1 A brief history of duality	23
3.2 The AdS/CFT correspondence	26
3.3 Loop space and Polyakov’s conjecture	29
3.3.1 Loop space calculus and the loop equation	32
3.3.2 A loop space dictionary	36
3.3.3 The conjecture	36
3.3.4 Zigzag symmetry and AdS space	38

4	The ($1/D$) Expansion and the Weyl Anomaly	43
4.1	Moving beyond “almost flat” spacetimes	43
4.1.1	The $O(N)$ nonlinear sigma model	44
4.1.2	Target space dimension as a perturbative parameter	46
4.2	The Polyakov metric and Weyl invariance	48
4.3	Definition of the partition function for AdS	50
4.4	The effective action for z	52
4.5	Exact computation of the Weyl anomaly	57
4.5.1	Setting the problem up	57
4.5.2	The heat kernel computation	60
5	The Conditions for Weyl Invariance	67
5.1	The effective action for \bar{z}	67
5.2	Analysis of the effective action	69
5.3	Cancelling the ϕ -dependence	71
5.3.1	The dilaton field as a counterterm	73
5.3.2	“Bosonization” of the ghost sector	75
5.3.3	Ghost-matter mixing and the dilaton	76
5.4	The ghost zero mode	78
5.5	The critical dimension	80
5.6	Summary	84
5.7	The correlation functions	85
5.8	A Weyl invariant amplitude	87
5.8.1	Weyl invariance and divergences	90
5.8.2	The ghost-dependent vertex operator	93
5.8.3	Higher order interactions	95
5.8.4	Evaluating the amplitude	99
5.8.5	An alternative approach	100
6	Discussion and Conclusions	103
6.1	Alternative derivation of the anomaly	103
6.2	Generalization to other geometries	106

6.3	Physical significance of the counterterms	107
6.4	Conclusions and outlook	109
	Appendix	117
A	The Green's function at coincident points	117
B	Gauge fixing and the conformal anomaly of the ghost sector	119
B.1	The Faddeev-Popov procedure	119
B.2	The Faddeev-Popov ghosts	120
B.3	Conformal field theory of the b, c ghost system	122
B.4	The ghost zero modes	126

List of Figures

2.1	A topological worldsheet expansion. Handles on the worldsheet correspond to string loops; hence, the Euler characteristic of the worldsheet is closely related to the string coupling constant.	6
3.1	An s-channel and a t-channel Feynman diagram (left), and their worldsheet equivalents (right). The conformal invariance of string theory ensures that both contributions are equal.	25
3.2	Contour deformation associated with the area derivative.	33
3.3	Contour deformation associated with the path derivative.	34
3.4	A string worldsheet ending at the zigzag symmetric location in AdS .	41
5.1	Function to be integrated in the calculation of $\text{Det}(\Upsilon)$	83
5.2	The self-energy diagram for W^i	85
5.3	Contour integral over the zero mode ψ_0	86
5.4	Schematic plots of $f_1(x)$ (left) and $f_2(x)$ (right) for fixed k, l and m .	89

Chapter 1

Introduction

This thesis is concerned with the Weyl anomaly of bosonic strings on certain curved backgrounds related to *AdS* space. Weyl invariance is a crucial property of string theory, required for consistency. We study the path integral approach to bosonic strings, and use an expansion in negative powers of the target space dimension D to obtain conditions sufficient for Weyl invariance up to $O(1)$ in $1/D$ ¹. The thesis is organized as follows:

In Chapter 2 we present an overview of the path integral approach to string theory, and in particular the way in which the Weyl anomaly is introduced by insisting that all integrals are kept explicitly reparametrization invariant. We outline the method of heat kernel regularization as a way of explicitly calculating the Weyl anomaly. We then move on to discuss the Weyl anomaly of bosonic strings on curved backgrounds, and derive the famous beta function equations [2] using heat kernels rather than the usual dimensional regularization. These calculations do not appear elsewhere in the literature, and reveal a disagreement with the literature concerning the overall normalization.

We then move on in Chapter 3 to present a review of the string description of gauge theory, including a discussion of the *AdS/CFT* correspondence [3] and the formulation of gauge theory in terms of loop space and the loop equation [4]. We

¹Often I will refer to results being correct up to $O(1)$ in D rather than $1/D$; this is just a choice of language and implies no difference in meaning.

then outline Polyakov's conjecture [1] for solving the loop equation via a string theory on a particular background geometry. This chapter is essentially a literature review, included in order to justify our interest in the geometry that is studied in detail in the rest of the thesis.

The standard beta function equations dictate that bosonic strings propagating on the metric proposed by Polyakov require a dilaton field that breaks Poincaré invariance at the location where the Wilson loop is situated. Since these beta functions are derived using a small α' expansion, we attempt to use a different expansion parameter to circumvent this problem. In Chapter 4 we show how the analogy with the $O(N)$ sigma model from particle physics suggests the use of the target space dimension D as an expansion parameter, taking D to be large (of the order of 26, suitable for bosonic strings). We concentrate on the case of closed bosonic strings in Euclidean AdS space (which is a particularly interesting example of the Polyakov geometry) and we treat the metric exactly in the sense that we define the partition function by using the explicit form of $G_{\mu\nu}(X)$ in Poincaré coordinates, rather than by expanding it in normal coordinates as is usually the case. Using heat kernel regularization once again, we derive the Weyl anomaly associated with integrating out the “flat” directions. We also identify the correct vacuum configuration of the worldsheet in the “holographic” coordinate about which we perform the expansion in $1/D$.

Chapter 5 is concerned with deriving certain conditions under which the theory is Weyl invariant within the $1/D$ expansion. By representing the Faddeev-Popov determinant associated with gauge-fixing the string by a single bosonic field we find that it is possible to cancel the anomalous term found in Chapter 4 exactly by coupling this “bosonic ghost” to the target space metric. This coupling can be interpreted (by integration by parts) as a dilaton field which is independent of the flat directions, and so does not break Poincaré invariance on the AdS boundary, unlike the conventional dilaton field required by [2]. We are left with a term which explicitly couples the ghost sector to the target space metric. By performing the path integral over the remaining target space field the critical dimension is found to be 26, in agreement with [2]. In addition, we show how the zero mode associ-

ated with our bosonic representation of the ghosts softens divergences present in higher-order correlation functions, preventing the generation of additional anomalous terms. Hence, our results appear to hold beyond $O(1)$ in D . We then go on to discuss the construction of a simple string amplitude by introducing vertex operators constructed from the wave equation for the background metric on which the string propagates.

Finally, in Chapter 6 we discuss various issues associated with the calculations presented here, including an alternative derivation of the Weyl anomaly using zeta function regularization and the generalization of these results to other examples of the Polyakov geometry. We also make some speculative observations concerning the interpretation of our dilaton field as the effective string coupling constant. The chapter ends with some concluding remarks about the results presented here, and their possible extension to more complicated systems (strings with boundaries, fermionic strings).

There are two Appendices. Appendix A gives a derivation of the Green's function at coincident points, a result that is used at various points in the main body of the text. Appendix B describes the Faddeev-Popov procedure for gauge-fixing the string, and also includes a derivation of the Weyl anomaly of the ghost sector using conformal field theory techniques. The material presented in the Appendices is standard and is included for completeness.

Chapter 2

The Weyl Anomaly in Perturbative String Theory

In this chapter we review some of the key features of standard perturbative string theory, both on trivial and nontrivial background spacetimes. We focus in particular on the Weyl anomaly - the breakdown of the independence of the theory on the worldsheet metric at the quantum level. We introduce the idea of heat kernel regularization, and show how one can use this to compute the Weyl anomaly for a flat background. We then go on to use heat kernel techniques to derive the famous beta function equations arising from string theory on nontrivial backgrounds, and find a different overall normalization from that found in the literature [2]. A discussion of the significance of these beta function equations is also included.

2.1 Strings in flat spacetimes

String theory can be tackled either from an operator approach [5] [6], or from a path integral approach [7] [8]. These approaches are believed to be equivalent, although no formal proof of this fact exists to date. In this thesis, we study strings from the path integral viewpoint. Therefore, we begin by presenting a brief overview of the basic concepts of the Polyakov path integral.

2.1.1 The path integral approach

String theory is the theory of worldsheets, in the same sense that field theory is the theory of worldlines. As such, the quantum theory of strings can be thought of as the quantum theory of surfaces, or quantum geometry. This idea was first investigated by Gervais and Sakita [9], where they attempted to formulate a theory of strings as a path integral over surfaces using the Nambu-Goto action:

$$S_{NG} \sim \int d^2\xi \sqrt{\det[\partial_a X^\mu \partial_b X^\mu]} \quad (2.1)$$

Unfortunately this approach proved to be fairly intractable due to the presence of the square root in the action. A more elegant and powerful approach was later put forward by Polyakov [7], in which it was shown how to set up a string functional integral via the introduction of a worldsheet metric. The initial postulate is that the scattering amplitude for a system of n strings is given by the following expression [8]:

$$\mathcal{A}_n = \sum_{\text{topologies}} \int \mathcal{D}X \mathcal{D}g \mathcal{N} V_1 \cdots V_n e^{-S[g, X] - \lambda x} \quad (2.2)$$

The Polyakov action is, for strings propagating on flat spacetime (we work everywhere in Euclidean signature in this thesis),

$$S[g, X] = \frac{1}{4\pi\alpha'} \int d^2\xi \sqrt{g} g^{ab} \partial_a X^\mu \partial_b X^\mu \quad (2.3)$$

where ξ^1, ξ^2 are coordinates on the 2-dimensional worldsheet, $g = \det(g_{ab})$ where g_{ab} is a 2-dimensional metric tensor, and $\partial_a = \partial/\partial\xi^a$. The constant α' has the dimensions of area, and is interpreted as the inverse string tension. We can think of $\sqrt{\alpha'}$ as setting the string length or the string scale (the scale at which the “stringiness” of the string becomes significant); in this sense, α' is analogous to \hbar in conventional quantum field theory. This action is completely equivalent to the Nambu-Goto action; one sees this by computing the equation of motion for g_{ab} and substituting it back in to the action.

The amplitude as defined in (2.2) is a sum of path integrals over the target space coordinates X and the worldsheet metrics g_{ab} . The V_i s are insertions (known as *vertex operators*) which encode the quantum numbers of the external string states that are being scattered in the process described by \mathcal{A}_n . The factor $e^{-\lambda x}$ counts

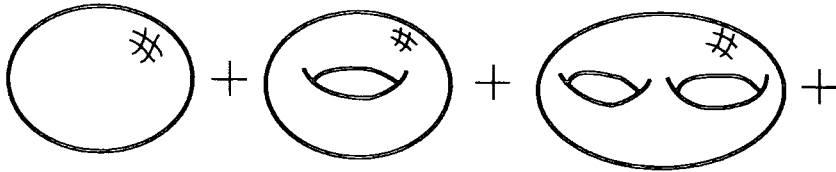

Figure 2.1: A topological worldsheet expansion. Handles on the worldsheet correspond to string loops; hence, the Euler characteristic of the worldsheet is closely related to the string coupling constant.

the number of loops that the given process involves; χ is the *Euler characteristic* of the worldsheet, which depends on the topology of the surface. If the surface has h handles and b boundaries, then

$$\chi = 2 - 2h - b \quad (2.4)$$

Hence, a closed string tree level diagram (i.e., a worldsheet with no boundaries and no handles, better known as a sphere) is weighted in the expression for \mathcal{A}_n by the factor $e^{-2\lambda}$. Therefore, every time we add a handle to a closed string worldsheet we add a factor of $e^{2\lambda}$ to the string amplitude. Adding a handle corresponds to emitting and re-absorbing a closed string, so the amplitude for emitting a closed string is proportional to e^λ . Hence we can think of the $e^{-\lambda\chi}$ term in (2.2) as controlling the string coupling constant,

$$g_s \sim e^\lambda$$

We will come back to discuss the parameter λ later on. The sum over topologies in (2.2) can then be thought of as a sum over all possible loop diagrams in a string worldsheet expansion (see Figure 2.1), in analogy with the sum of Feynman diagrams familiar from conventional field theory.

The factor \mathcal{N} in (2.2) is a normalization constant, accounting for the fact that the action $S[g, X]$ has a large number of symmetries which need to be properly factored out in order for the amplitudes to make physical sense and not diverge. These issues are considered in Appendix B.

The action (2.3) has two local worldsheet symmetries. The first of these is reparametrization invariance (also known as diffeomorphism invariance). This is

simply invariance under a change of coordinate basis,

$$\xi \rightarrow \xi'(\xi),$$

so that $S[g', X'] = S[g, X]$. This symmetry is obviously a very physical attribute; the physics of the string should be invariant under changes of coordinate. There is a second local symmetry of the action (2.3); this is invariance under local rescalings of the metric g_{ab} :

$$g_{ab}(\xi) \rightarrow e^{\varphi(\xi)} g_{ab}(\xi)$$

This is known as Weyl invariance or conformal invariance. Notice that under a Weyl scaling, $X^\mu(\xi)$ is invariant. Since the action (2.3) is Weyl invariant, we have

$$\delta_\varphi S[g, X] = \int d^2\xi \sqrt{g} (\delta_\varphi g^{ab}) \frac{1}{\sqrt{g}} \frac{\delta S[g, X]}{\delta g^{ab}} = \int d^2\xi \sqrt{g} \varphi g^{ab} T_{ab} = 0$$

which implies that $g^{ab} T_{ab} = T_a^a = 0$. Hence, the stress-energy tensor T_{ab} is traceless as a consequence of Weyl invariance. We will see later on that this property of the stress-energy tensor is not necessarily preserved when one studies the quantum theory of the action (2.3); this is the famous Weyl anomaly (also sometimes called the trace anomaly).

In order to analyze the expression for string amplitudes given in (2.2), it is useful to isolate the following expression, known as the string *partition function*:

$$Z = \int \mathcal{D}X \mathcal{D}g e^{-S[g, X]} \quad (2.5)$$

Z is the basic object that appears in all computations of string scattering amplitudes. In particular, we will show in the next section how this object possesses a Weyl anomaly (unless certain conditions are imposed by hand in order to cancel it). If the Weyl anomaly is present, amplitudes calculated with (2.2) will suffer from pathologies such as loss of unitarity (in other approaches to string quantization [5] one can keep Weyl invariance explicit by fixing a spacetime gauge, such as the light-cone gauge. However, one then finds that Lorentz invariance is lost unless certain conditions hold; these conditions are the same as those required for the restoration of Weyl invariance in the Polyakov path integral approach). In addition, once the conditions for the Weyl invariance of Z have been found, it is necessary to ensure

that the insertions V_i in (2.2) are also Weyl invariant. This then gives the spectrum of physical string states. Hence, the cancellation of the Weyl anomaly in the partition function (2.5) and the scattering amplitudes (2.2) is of central importance to the consistency of string theory as a theory of spacetime interactions.

We now go on to see in more detail how the Weyl anomaly arises in the functional integral formalism, and how one can calculate it explicitly.

2.1.2 The Weyl anomaly

It is a well-known statement that bosonic string theory is only consistent in 26 dimensions [7]. From the canonical (operator) point of view, it is only in 26 dimensions that we obtain a consistent ghost-free spectrum of string states¹ ($D = 26$ is called the *critical dimension*). However, the picture from the functional point of view is perhaps more revealing, and suggests how one may be able to move beyond this restriction. To see how a critical dimension arises in this formalism, let us consider the following string partition function:

$$Z = \int \mathcal{D}X \mathcal{D}g \exp \left(- \int d^2\xi \sqrt{g} g^{ab} \partial_a X^\mu \partial_b X^\mu \right) \quad (2.6)$$

This string lives in D -dimensional flat spacetime. Looking at the string action in the exponent, we have seen that classically if we work in a gauge $g_{ab} = e^{\varphi(\xi)} \hat{g}_{ab}$ where \hat{g}_{ab} is independent of the worldsheet metric scale factor $\varphi(\xi)$, the action is also independent of $\varphi(\xi)$. We have a Gaussian integral over the X -fields to perform. However, we will now see that the functional measure associated with the X -fields depends on the worldsheet metric g_{ab} , and hence $\varphi(\xi)$. This is the origin of the conformal or Weyl anomaly; the classical independence of the theory on the scale $\varphi(\xi)$ is broken when we perform the functional integral (i.e., when we quantize the theory).

The organizing principle behind the path integral approach to string quantization is that all integrals should be explicitly reparametrization invariant. In general, any

¹The term “ghosts” here refers to states with negative norm. These are not to be confused with the Faddeev-Popov ghosts that we will encounter later on.

object of the form

$$\int d^2\xi \sqrt{g} F(\xi)$$

will be reparametrization invariant as long as $F(\xi)$ transforms as a scalar under changes of coordinate $\xi \rightarrow \xi'(\xi)$. We refer to such functions as *worldsheet scalars*. In order to define the integration measure we need to define the reparametrization invariant inner product on variations of the X^μ fields [8] (we define $\mathcal{D}X$ in analogy with the usual volume element for finite dimensional volume integrals). Now, integrating the string action by parts puts $S[X, g]$ in the form

$$S[X, g] = \int d^2\xi \sqrt{g} X^\mu \Delta X_\mu \quad (2.7)$$

where

$$\Delta = -\frac{1}{\sqrt{g}} \partial_a (\sqrt{g} g^{ab} \partial_b) \quad (2.8)$$

is the covariant worldsheet Laplacian. This suggests that the correct norm associated with the $\mathcal{D}X$ measure is

$$(\delta X^\mu, \delta X^\mu) = \|\delta X\|_g = \int d^2\xi \sqrt{g} (\delta X)^2 \quad (2.9)$$

since $X^\mu \Delta X_\mu$ is a worldsheet scalar. This inner product depends explicitly on $\varphi(\xi)$. Let us now fix the gauge on the worldsheet such that $g_{ab} = e^{\varphi(\xi)} \delta_{ab}$ (known as the conformal gauge). In order to do this gauge fixing consistently, one needs to use the Faddeev-Popov procedure; this is explained in some detail in Appendix B. For now, we notice that the action $S[X, g]$ is now a well-defined Gaussian with respect to the measure $\mathcal{D}X$, and so the result of performing the X -integration will be

$$Z \sim \int \mathcal{D}\varphi \left[\text{Det}^{-\frac{D}{2}} \Delta \right] [\text{Det}_{FP}] \quad (2.10)$$

where Det_{FP} is the Faddeev-Popov determinant arising from fixing the conformal gauge, as explained in Appendix B (note that we now have a functional integral over φ - we will discuss the measure $\mathcal{D}\varphi$ below). The $\text{Det}^{-\frac{D}{2}} \Delta$ piece depends explicitly on $\varphi(\xi)$ in this gauge:

$$\Delta = -e^{-\varphi(\xi)} \partial_a^2$$

and we therefore have a Weyl anomaly. The next stage in determining the critical dimension is to compute the dependence of these determinants on the scale $\varphi(\xi)$, and to do this we now introduce the technology of heat kernel regularization.

2.1.3 Heat kernel regularization

The determinants which we obtained above have an obvious interpretation as the infinite product of eigenvalues of the corresponding operator. The basic idea behind heat kernel regularization is that we can generalize the following identity for finite-dimensional matrices M ,

$$\delta \ln \det M = \int_0^\infty dt \operatorname{tr} (\delta M e^{-tM}) \quad (2.11)$$

to the infinite-dimensional case by introducing a short-time cutoff ϵ , e.g.,

$$\delta \ln \operatorname{Det} \Delta = \int_\epsilon^\infty dt \operatorname{Tr} (\delta \Delta e^{-t\Delta}) \quad (2.12)$$

(throughout, “Det” indicates an infinite-dimensional determinant as opposed to the finite-dimensional “det”). Notice that if we did not include the cutoff ϵ this expression would not be well defined, since it would involve the 2-dimensional delta function on the worldsheet at $\xi = 0$. Let us concentrate for the moment on the determinant of the worldsheet Laplacian, Δ . Since we are interested in the φ -dependence of this determinant, we need to compute how Δ behaves under an infinitesimal Weyl scaling $\varphi \rightarrow \varphi + \delta\varphi$. One readily finds that

$$\delta_\varphi \Delta = -\delta\varphi \Delta$$

and so

$$\delta_\varphi \ln \operatorname{Det} \Delta = -\operatorname{Tr} (\delta\varphi(\xi) e^{-\epsilon\Delta}) \quad (2.13)$$

where we have performed the t -integral. We can represent $e^{-\epsilon\Delta}$ in terms of an integral kernel which we denote by $\mathcal{K}(\xi, \xi'; \epsilon)$:

$$e^{-\epsilon\Delta} f(\xi) = \int d^2\xi' \sqrt{g(\xi')} \mathcal{K}(\xi, \xi'; \epsilon) f(\xi') \quad (2.14)$$

We can see from this equation that $\mathcal{K}(\xi, \xi'; t)$ satisfies the following differential equation,

$$\Delta \mathcal{K}(\xi, \xi'; t) = -\frac{\partial}{\partial t} \mathcal{K}(\xi, \xi'; t) \quad (2.15)$$

with the initial condition that

$$\lim_{t \rightarrow 0} \mathcal{K}(\xi, \xi'; t) = \frac{1}{\sqrt{g(\xi)}} \delta^2(\xi - \xi') \quad (2.16)$$

The equation (2.15) is the well-known diffusion equation or heat equation; hence, $\mathcal{K}(\xi, \xi'; t)$ is known as the *heat kernel*.

We see, therefore, that if we can evaluate the trace of the heat kernel at short times, $\mathcal{K}(\xi, \xi; \epsilon)$, we can evaluate the φ -dependence of our regulated determinant via equation (2.13). The evaluation of the heat kernel involves making an expansion about the heat kernel for the flat worldsheet Laplacian $\Delta_0 = -\partial_a^2$, including all those terms which do not vanish when we send the regulator $\epsilon \rightarrow 0$. We do not reproduce the details here, as our calculation of the Weyl anomaly for bosonic strings on an *AdS* background in Chapter 4 demonstrates the use of this expansion in full detail. Here, we quote the result that

$$\mathcal{K}(\xi, \xi; \epsilon) = \frac{1}{4\pi\epsilon} - \frac{e^{-\varphi} \partial_a^2 \varphi}{24\pi} + O(\epsilon) \quad (2.17)$$

The divergent piece can be removed by adding a local counterterm to the original string action; combining this result with the contribution from the Faddeev-Popov determinant derived in Appendix B finally gives the following expression for the partition function:

$$Z \sim \int \mathcal{D}\varphi \exp\left(-\frac{26-D}{96\pi} \int d^2\xi [(\partial_a \varphi)^2 + \lambda e^\varphi]\right) \quad (2.18)$$

The cosmological constant term λe^φ is the counterterm mentioned above. This theory, known as *Liouville theory*, looks on first inspection something like a Gaussian in φ - but there is a complication. Again, the functional measure associated with φ depends on the worldsheet metric, and hence on φ itself in a highly complicated way:

$$\|\delta\varphi\|_g = \int d^2\xi \sqrt{g} (\delta\varphi)^2 = \int d^2\xi e^{\varphi(\xi)} (\delta\varphi)^2 \quad (2.19)$$

This means that the functional measure for φ is not that of a canonical quantum field, and hence we do not know how to properly quantize it. The point is that it is only in 26 dimensions that the coefficient multiplying the Liouville action is zero, and hence the dependence on φ drops out of the partition function as an irrelevant volume factor. This is the origin of the critical dimension in the functional approach.

It must be noted that the integral (2.18) is not inconsistent in any way. If we were able to do it, we would in principle have consistent string theories in any

dimension we liked. So the statement that bosonic string theory is only consistent in 26 dimensions ought to be changed to the statement that we can't perform this functional integral as it stands. However, some progress has been made towards this end [10] [11]. The idea is to redefine the functional measure such that it does not depend on e^ϕ , but on a new reference or *fiducial* metric \hat{g}_{ab} :

$$\|\delta\varphi\|_g = \int d^2\xi \sqrt{\hat{g}} (\delta\varphi)^2$$

One must then compensate for this “change of variables” by including some Jacobian factor. The resulting theory can then be made Weyl invariant with respect to the fiducial metric, and things look to be well-defined. Unfortunately, in order to stabilize the vacuum of the theory one needs to add some kind of cosmological constant term, and when the effect of changing to the fiducial metric on this term is included, one finds that the resulting theory is only solvable for $D \leq 1$ or $D \geq 25$. Progress on writing a well-defined, tractable path integral in physically realistic dimensions has not, as yet, been made. For the remainder of this thesis we will therefore take the view that quantum Liouville theory has not been solved, and so a critical dimension is required for consistency.

2.2 Strings in curved spacetimes

We have seen that Weyl invariance is a key property of string theory on flat spacetimes. It is no surprise that this is also the case when one considers the generalization of the action (2.3) to curved backgrounds. In this section we consider the Weyl anomaly on nontrivial backgrounds in some detail, using the heat kernel method outlined above to regulate the various objects on the worldsheet that arise. The natural generalization of (2.3) to curved backgrounds is, fairly obviously,

$$S[g, X] = \frac{1}{4\pi\alpha'} \int d^2\xi \sqrt{g} g^{ab} \partial_a X^\mu \partial_b X^\nu G_{\mu\nu}(X) \quad (2.20)$$

where $G_{\mu\nu}(X)$ is the background metric (target space metric) on which the string propagates. The coupling of the target space metric to the string action in this way can be thought of as treating the background as some coherent ensemble of string

states, the effects of which on a “test” string are described by $S[g, X]$. To see this, one considers a metric of the form

$$G_{\mu\nu}(X) = \eta_{\mu\nu} + h_{\mu\nu}(X)$$

where $h_{\mu\nu}(X)$ is a perturbation about the flat metric. It can then be shown that including $G_{\mu\nu}(X)$ in the action as above corresponds to inserting the exponential of the graviton vertex operator into the path integral [5] [6] (hence the notion of a coherent state of gravitons).

The graviton is one of the massless states found in the bosonic string spectrum by considering the construction of the vertex operators V_i appearing in (2.2). Vertex operators are constructed such that they are worldsheet scalars (and are hence reparametrization invariant), and the masses and spins of the states that they represent are then determined by demanding that they also be Weyl invariant. One finds that the physical massless states for the closed string are then a graviton $G_{\mu\nu}(X)$ (a symmetric tensor field), an antisymmetric tensor field $B_{\mu\nu}(X)$, and a scalar field known as the dilaton, $\Phi(X)$. We do not consider the antisymmetric tensor field in this thesis, but we do wish to include the dilaton as this has far-reaching implications for Weyl invariance and the consistency of string backgrounds, as we shall see.

It is therefore natural to ask how one might include the dilaton in the string action. Since we found that exponentiating the graviton vertex operator led to the natural generalization of the string action to curved backgrounds, it is natural to do the same to the dilaton vertex operator. This leads to [12]

$$S = \frac{1}{4\pi\alpha'} \int d^2\xi \sqrt{g} \left[g^{ab} \partial_a X^\mu \partial_b X^\nu G_{\mu\nu}(X) + \alpha' R^{(2)} \Phi(X) \right] \quad (2.21)$$

where $R^{(2)}$ is the scalar curvature of the worldsheet metric $g_{ab}(\xi)$. Notice that the dilaton term is not Weyl invariant at the classical level. However, this should not worry us unduly as we are ultimately interested in the quantum theory; as long as the dilaton coupling is reparametrization invariant (which it is), Weyl invariance can be enforced once we have performed the necessary path integrals. Another way of looking at this is that the dilaton coupling term is of higher order in α' for dimensional reasons, and as such can be viewed as a quantum correction to the action. Therefore, it is not so surprising that Weyl invariance is not explicit.

2.2.1 The dilaton beta function

In this section we present a calculation of the conditions for Weyl invariance of the bosonic string on a curved background in the presence of a dilaton field. This calculation was first done in [2] using the background field method and dimensional regularization. Here, we will use heat kernel techniques to derive the same results; this way of computing the beta functions does not appear elsewhere in the literature. Interestingly, we find a disagreement between the overall normalization of the dilaton beta function in our calculation and the literature.

Our starting point is the Polyakov action,

$$S = \frac{1}{4\pi\alpha'} \int d^2\xi \sqrt{g} \left[g^{ab} \partial_a X^\mu \partial_b X^\nu G_{\mu\nu}(X) + \alpha' R^{(2)} \Phi(X) \right] \quad (2.22)$$

The functions $G_{\mu\nu}(X)$ and $\Phi(X)$ represent the graviton and dilaton respectively. However, we can also think of the action (2.22) as defining a nonlinear sigma model with spacetime dependent couplings $G_{\mu\nu}(X)$ and $\Phi(X)$. If the action is interpreted in this way, then we can ask whether these couplings remain scale invariant at the quantum level, or whether they become anomalous and “run” in the sense of the renormalization group. In other words, we can compute the *beta functions* of the couplings $G_{\mu\nu}(X)$ and $\Phi(X)$, which we denote as $\beta_{\mu\nu}^G$ and β^Φ respectively. This interpretation of the scale invariance of the theory (2.22) is then related to the question of Weyl invariance on the string worldsheet by writing the trace of the stress-energy tensor as

$$2\pi T_a^a = \beta^\Phi \sqrt{g} R^{(2)} + \beta_{\mu\nu}^G \sqrt{g} g^{ab} \partial_a X^\mu \partial_b X^\nu \quad (2.23)$$

Hence, vanishing of the sigma model beta functions implies vanishing of T_a^a , which indicates Weyl invariance as we saw above.

In order to proceed, we work in the conformal gauge $g_{ab}(\xi) = e^{\varphi(\xi)} \delta_{ab}$. In this gauge, we have the relation

$$\sqrt{g} R^{(2)} = -\partial_a^2 \varphi$$

Our strategy is to expand the X -fields about a point, $X^\mu(\xi) = C^\mu + x^\mu(\xi)$, and to use Gaussian normal coordinates such that the target-space metric becomes

$$G_{\mu\nu}(X) = \delta_{\mu\nu} - \frac{1}{3} R_{\mu\lambda\nu\kappa}(C) x^\lambda x^\kappa + \dots$$

Hence, the action becomes

$$S = \frac{1}{4\pi\alpha'} \int d^2\xi \left[\partial_a x^\mu \partial_a x^\nu \left(\delta_{\mu\nu} - \frac{1}{3} R_{\mu\lambda\nu\kappa} x^\lambda x^\kappa + \dots \right) - \alpha' \partial_a^2 \varphi \left(x^\mu \partial_\mu \Phi + \frac{1}{2} x^\mu x^\nu \partial_\mu \partial_\nu \Phi + \dots \right) \right]$$

Here, $\partial_\mu \Phi$ is shorthand for $\partial_\mu \Phi(X(\xi))|_{X(\xi)=C}$, and hence such terms are constant on the worldsheet. Expanding the exponential in the partition function up to $O(1)$ in α' gives

$$\begin{aligned} Z &= \int \mathcal{D}x \exp \left[-\frac{1}{4\pi\alpha'} \int d^2\xi (\partial_a x^\mu)^2 \right] \\ &\times \left(1 + \frac{1}{12\pi\alpha'} \int d^2\xi R_{\mu\lambda\nu\kappa} \partial_a x^\mu x^\lambda \partial_a x^\nu x^\kappa \right. \\ &\left. + \frac{1}{32\pi^2} \int d^2\xi x^\mu \partial_\mu \Phi \partial_a^2 \varphi \int d^2\xi' x^\nu \partial_\nu \Phi \partial_a^2 \varphi + \frac{1}{8\pi} \int d^2\xi \partial_a^2 \varphi x^\mu x^\nu \partial_\mu \partial_\nu \Phi \right) \end{aligned}$$

However, there is an extra piece that we must consider. The inner product on variations of the X -fields is

$$\|\delta x\|^2 = \int d^2\xi \sqrt{g} G_{\mu\nu}(X) \delta x^\mu \delta x^\nu = \int d^2\xi \sqrt{g} \left(\delta_{\mu\nu} - \frac{1}{3} R_{\mu\lambda\nu\kappa} x^\lambda x^\kappa \right) \delta x^\mu \delta x^\nu$$

and hence we have

$$\begin{aligned} \mathcal{D}X &= \mathcal{D}x \times \text{Det}^{1/2} \left(\delta_{\mu\nu} - \frac{1}{3} R_{\mu\lambda\nu\kappa} x^\lambda x^\kappa \right) \\ &= \mathcal{D}x \times \left(1 - \frac{1}{6} \text{Tr} R_{\mu\lambda\nu\kappa} x^\lambda x^\kappa \right) \end{aligned}$$

This involves taking the trace over a matrix, and writing the trace out in full we see that this object is divergent:

$$\text{Tr} [R_{\mu\lambda\nu\kappa} x^\lambda x^\kappa] = \int d^2\xi R_{\lambda\kappa} x^\lambda x^\kappa \delta(0) \quad (2.24)$$

The delta function evaluated at coincident points must be regulated, and we can do this by again introducing the heat kernel for the worldsheet Laplacian Δ at coincident points, denoted by $\mathcal{K}_\epsilon(\xi, \xi)$. As we have seen, the finite term introduced by this procedure is φ -dependent, and we find

$$\text{Tr} [R_{\mu\lambda\nu\kappa} x^\lambda x^\kappa] = \int d^2\xi R_{\lambda\kappa} x^\lambda x^\kappa \mathcal{K}_\epsilon(\xi, \xi) = \int d^2\xi R_{\lambda\kappa} x^\lambda x^\kappa \left(\frac{1}{4\pi\epsilon} - \frac{e^{-\varphi} \partial_a^2 \varphi}{24\pi} \right) \quad (2.25)$$

Combining this term with the rest of the partition function gives

$$\begin{aligned}
Z &= \text{Det}^{-\frac{D}{2}} \Delta \times \left(1 + \frac{1}{12\pi\alpha'} \int d^2\xi R (\langle \partial x \partial x \rangle \langle xx \rangle - \langle \partial x x \rangle^2) \right. \\
&+ \frac{1}{32\pi^2} \int d^2\xi \left(-2\pi\alpha' \varphi \partial_a^2 \varphi \partial_\mu \Phi \partial_\mu \Phi + 4\pi \langle xx \rangle \partial_a^2 \varphi \partial_\mu^2 \Phi \right) \\
&\left. - \frac{1}{6} \int d^2\xi R \langle xx \rangle \mathcal{K}_\epsilon(\xi, \xi) \right) \quad (2.26)
\end{aligned}$$

where the $\langle \rangle$ brackets indicate that we have contracted indices and are taking the average of the relevant quantity with respect to the Gaussian weight

$$\exp \left[-\frac{1}{4\pi\alpha'} \int d^2\xi (\partial_a x^\mu)^2 \right]$$

We have also used the definition

$$\langle x(\xi) x(\xi') \rangle = 2\pi\alpha' \frac{1}{-\partial_a^2} \delta(\xi - \xi')$$

We assume that we are working in the critical dimension $D = 26$, so the contribution from the determinant of Δ in (2.26) cancels against the ghost conformal anomaly as we saw in Section 2.1.3. We now need to evaluate the various 2-point functions, all of which are to be taken at coincident points on the worldsheet. Note that we must be careful to keep all terms up to $O(\epsilon)$, since in some places these 2-point functions appear multiplied together. Terms which may naïvely seem to disappear as $\epsilon \rightarrow 0$ may in fact contribute when multiplied by other terms of $O(1/\epsilon)$.

We will again use the heat kernel to obtain the required φ -dependence of the 2-point functions. We begin by considering $\langle xx \rangle$, which is given by

$$\langle x(\xi) x(\xi) \rangle = 2\pi\alpha' \mathcal{G}(\xi, \xi)$$

where $\mathcal{G}(\xi, \xi)$ is the Green's function at coincident points considered in Appendix A. Expanding this 2-point function in terms of the heat kernel $\mathcal{K}_\epsilon(\xi, \bar{\xi})$ we find

$$\delta_\varphi \langle xx \rangle = 2\pi\alpha' \int_0^\epsilon d\bar{s} \mathcal{K}_{\bar{s}}(\xi, \xi) \delta\varphi(\xi) \mathcal{K}_{\epsilon-\bar{s}}(\xi, \xi) \quad (2.27)$$

We know that the $O(1)$ piece of this expression is $\alpha' \delta\varphi/2$ - see Appendix A. The $O(\epsilon)$ piece has to be a scalar under reparametrizations, and so in general it can only contain terms like

$$\epsilon (\alpha\Delta + \beta R^{(2)}) \delta\varphi \quad (2.28)$$

where α and β are coefficients that we must determine. Now, consider the following expression:

$$\int d^2\xi \sqrt{g(\xi)} \delta_\varphi \mathcal{G}(\xi, \xi) \quad (2.29)$$

This can be written as (see Appendix A)

$$\int d^2\xi \sqrt{g(\xi)} \int_0^\epsilon d\bar{s} \mathcal{K}_\epsilon(\xi, \xi) \delta\varphi(\xi) = \epsilon \int d^2\xi \sqrt{g(\xi)} \mathcal{K}_\epsilon(\xi, \xi) \delta\varphi(\xi) \quad (2.30)$$

and we know that

$$\mathcal{K}_\epsilon(\xi, \xi) = \frac{1}{4\pi\epsilon} + \frac{R^{(2)}}{24\pi} + O(\epsilon)$$

Hence,

$$\int d^2\xi \sqrt{g(\xi)} \delta_\varphi \mathcal{G}(\xi, \xi) = \int d^2\xi \sqrt{g(\xi)} \left(\frac{1}{4\pi} + \frac{\epsilon R^{(2)}}{24\pi} \right) \delta\varphi \quad (2.31)$$

Comparing this with expression (2.28) we see that this must equal

$$\int d^2\xi \sqrt{g(\xi)} \left(\frac{\delta\varphi}{4\pi} + \epsilon (\alpha \Delta \delta\varphi + \beta \delta\varphi R^{(2)}) \right) \quad (2.32)$$

The term involving α is a total derivative which vanishes under the integration; hence, we can see that the coefficient β must be $1/24\pi$.

We also need to determine the coefficient α . To do this, notice that in the conformal gauge we have

$$(\alpha \Delta + \beta R^{(2)}) \delta\varphi = -\alpha e^{-\varphi} \partial^2 \delta\varphi - \beta \delta\varphi e^{-\varphi} \partial^2 \varphi$$

Expanding the exponentials to quadratic order in φ gives

$$\delta_\varphi \mathcal{G}(\xi, \xi) = \frac{\delta\varphi}{4\pi} + \epsilon (-\alpha \partial^2 \delta\varphi + \alpha \varphi \partial^2 \delta\varphi - \beta \delta\varphi \partial^2 \varphi)$$

For the RHS of this expression to make sense as the variation of a quantity with respect to φ , we see that we require $\alpha = -\beta$. Hence, combining all these results together we arrive at the conclusion that

$$\langle xx \rangle = \frac{\alpha'}{2} \varphi + \frac{\alpha' \epsilon}{12} (\partial^2 \varphi - \varphi \partial^2 \varphi) \quad (2.33)$$

Having obtained this result, is a simple matter to carry out the necessary differentiation to obtain the following expression:

$$\langle \partial xx \rangle = \frac{\alpha'}{4} \partial_a \varphi + O(\epsilon) \quad (2.34)$$

We also need to determine $\langle \partial x \partial x \rangle$. To do this, we will use the following identity:

$$\partial \langle \partial x x \rangle = \langle \partial^2 x x \rangle + \langle \partial x \partial x \rangle = \frac{\alpha'}{4} \partial_a^2 \varphi \quad (2.35)$$

Again, we will use the heat kernel method to determine $\langle \partial^2 x x \rangle$ and hence $\langle \partial x \partial x \rangle$ from the above formula. We have

$$\begin{aligned} \langle -\partial^2 x x \rangle &= 2\pi\alpha' \int_{\epsilon}^{\infty} ds \Delta e^{-s\Delta} \\ &= -2\pi\alpha' \int_{\epsilon}^{\infty} ds \frac{d}{ds} e^{-s\Delta} \\ &= 2\pi\alpha' e^{-\epsilon\Delta} \\ &= \frac{\alpha' e^{\varphi}}{2\epsilon} - \frac{\alpha'}{12} \partial_a^2 \varphi + O(\epsilon) \end{aligned}$$

since

$$e^{-\epsilon\Delta} = \int d^2\xi' \sqrt{g(\xi')} \mathcal{K}_{\epsilon}(\xi, \xi') \delta(\xi - \xi') = e^{\varphi} \left(\frac{1}{4\pi\epsilon} - \frac{e^{-\varphi} \partial_a^2 \varphi}{24\pi} \right)$$

at coincident points. Therefore, we see that

$$\langle \partial x \partial x \rangle = \frac{\alpha' e^{\varphi}}{2\epsilon} + \frac{\alpha'}{6} \partial_a^2 \varphi \quad (2.36)$$

We can now substitute these expressions back into (2.26), and pick out all the terms which multiply $(\partial_a \varphi)^2$. To see why, consider the following expression:

$$S \sim \int d^2\xi (\partial_a \varphi)^2 (\dots) \quad (2.37)$$

The stress tensor is

$$T_{ab} = \frac{\delta S}{\delta g^{ab}} \rightarrow \delta_{ab} e^{\varphi} \frac{\delta S}{\delta \varphi} \quad (2.38)$$

in conformal gauge. Therefore,

$$T_{ab} = \delta_{ab} e^{\varphi} (-\partial_a^2 \varphi) (\dots)$$

and so

$$T_a^a = g^{ab} T_{ab} \sim e^{\varphi} e^{-\varphi} (-\partial_a^2 \varphi) (\dots) = (-\partial_a^2 \varphi) (\dots) \quad (2.39)$$

which is just

$$\sqrt{g} R^{(2)} (\dots)$$

written in conformal gauge. Therefore, comparison with (2.23) allows us to identify (\dots) with the dilaton beta function we seek. We therefore obtain

$$Z = \exp \left(- \int d^2\xi (\partial_a \varphi)^2 \left(\alpha' \left(\frac{1}{144\pi} + \frac{1}{12\pi \cdot 16} + \frac{1}{12\pi \cdot 24} \right) R \right) \right)$$

$$+ \frac{\alpha'}{16\pi} (\partial_\mu \Phi \partial_\mu \Phi - \partial^2 \Phi) \Big) \Big)$$

This expression must vanish for conformal invariance, and this leads us to the desired form for the dilaton beta function:

$$\beta^\Phi = 4 \left((\partial_\mu \Phi)^2 - \partial^2 \Phi \right) - R + O(\alpha') \quad (2.40)$$

with $\beta^\Phi = 0$.

2.2.2 The graviton beta function

To obtain the graviton beta function we need to consider the conformal invariance of the 2-point functions defined by the action (2.22). As we have seen in our derivation of the dilaton beta function, the following terms will contribute to the Weyl dependence of the 2-point function:

$$\frac{1}{12\pi\alpha'} R_{\mu\lambda\nu\kappa} \partial_a x^\mu \partial_a x^\nu x^\lambda x^\kappa \quad (2.41)$$

$$-\frac{1}{6} R_{\mu\nu} x^\mu x^\nu \mathcal{K}_\epsilon(\xi, \xi) \quad (2.42)$$

$$\frac{1}{8\pi} \partial^2 \varphi \partial_\mu \partial_\nu \Phi x^\mu x^\nu \quad (2.43)$$

The first of these terms represents a 4-point vertex that gives an effective 2-point interaction when 2 of the legs are contracted in the path integral. There are three ways in which this can happen; these are

$$\begin{aligned} V'_2 &= \frac{1}{12\pi\alpha'} \int d^2\xi (x^\mu x^\nu R_{\mu\nu} \langle \partial x \partial x \rangle - 2 \partial_a x^\mu x^\nu R_{\mu\nu} \langle \partial x x \rangle) \\ &+ \frac{1}{12\pi\alpha'} \int d^2\xi (\partial_a x^\mu \partial_a x^\nu R_{\mu\nu} \langle x x \rangle) \end{aligned}$$

Now we can use the previous results for these correlation functions. We can ignore terms which are $O(1/\epsilon)$ as they can be removed by counterterms, and terms like $\partial^2 x$ only contribute to a *wavefunction renormalization* and can also be dropped. This is because the 2-point function is precisely the propagator associated with the operator ∂^2 , and so the term

$$\langle \partial^2 x x \rangle$$

amounts simply to a renormalization of the source term for x , or equivalently a multiplicative renormalization of x itself.² Hence, this expression along with the other two combine to give

$$V_2 = x^\mu x^\nu \left(R_{\mu\nu} \frac{1}{16\pi} + \frac{1}{8\pi} \partial_\mu \partial_\nu \Phi \right) \partial^2 \varphi \quad (2.44)$$

where we have also integrated by parts. Therefore Weyl invariance requires $\beta_{\mu\nu}^G = 0$, where

$$\beta_{\mu\nu}^G = R_{\mu\nu} + 2\partial_\mu \partial_\nu \Phi + O(\alpha') \quad (2.45)$$

2.2.3 Discussion

The results presented above for the beta functions of the couplings $G_{\mu\nu}(X)$ and $\Phi(X)$ are truly remarkable. Consider the case of a flat background metric for the moment, and let the target space dimension be 26. Then, the beta functions become

$$\beta^\Phi = 0, \quad \beta_{\mu\nu}^G = R_{\mu\nu}$$

We see that the dilaton beta function is identically zero, so Weyl invariance (and therefore consistency of the string theory) requires

$$R_{\mu\nu} = 0$$

which is just Einstein's equation in vacuum. Demanding the Weyl invariance of a 2-dimensional field theory has led us to the equation of motion for 26-dimensional gravity! This is surely one of the strongest hints that string theory really does have something to say about the nature of quantum gravity. In fact, this statement generalizes to backgrounds with curvature; the spacetime equations of motion defined by $\beta^\Phi = \beta_{\mu\nu}^G = 0$ can be derived from the 26-dimensional *spacetime* action

$$S = - \int d^{26} X \sqrt{G} e^{-2\Phi} [4(\partial_\mu \Phi)^2 + R] \quad (2.46)$$

Hence, we have derived a spacetime action principle from the requirement of conformal invariance of a two dimensional field theory.

²This is in contrast to the situation we will encounter in Chapter 5.

There is another aspect of string physics that we should mention briefly. As we saw, the dilaton field couples to the string action via

$$S_\Phi = \frac{1}{4\pi} \int d^2\xi \sqrt{g} R^{(2)} \Phi(X)$$

In fact, the integral over the worldsheet of the scalar curvature is equal to the Euler characteristic χ , given in equation (2.4). Therefore, the expectation value of the dilaton field can be thought of as the parameter λ that we saw in Section 2.1.1 above, and so

$$g_s \sim e^{(\Phi)} \quad (2.47)$$

This is another beautiful feature of string theory; there is no notion of a string coupling constant as a free parameter. The string coupling depends on the string background in a completely self-consistent way. We will return to discuss this interpretation of the dilaton field in Chapter 6.

Finally, a note on the overall normalization of the dilaton beta function (2.40) derived above. We assumed above that we were working in the critical dimension, $D = 26$, so that the $O(1/\alpha')$ term involving D was set to zero. If we keep it in, we find that

$$\beta^\Phi = \frac{2(D-26)}{3\alpha'} + 4((\partial_\mu \Phi)^2 - \partial^2 \Phi) - R + O(\alpha') \quad (2.48)$$

The coefficient here ($2/3\alpha'$) differs from that found in [2] (and reproduced in [5]), where it is found to be $1/3\alpha'$. We are unable to account for this overall factor of 2; it may be merely a difference in conventions somewhere (there is insufficient detail given in [2] to be able to check this). One possible explanation for this discrepancy is that the two results are related by a field redefinition of the X^μ s. To check this, we can consider adding an extra term to the action of the form

$$S_{new} = \frac{1}{4\pi\alpha'} \int d^2\xi \sqrt{g} g^{ab} \partial_a \Phi(X) \partial_b \Phi(X) \quad (2.49)$$

since if one expands this term as we have done above it is easy to see that this amounts to the redefinition

$$G_{\mu\nu}(X) \rightarrow G_{\mu\nu}(X) + \partial_\mu \Phi(X) \partial_\nu \Phi(X) \quad (2.50)$$

Such a redefinition obviously will not change the physical content of the equation of motion (2.40), but it might change its form and hence maybe account for the

difference in numerical factors that we have uncovered. However, when one includes this extra piece in the above analysis one finds that the extra terms introduced are of the form

$$\int d^2\xi \langle \partial_x \partial_x \rangle (\partial_\mu \Phi)^2 \sim \int d^2\xi (\partial_a^2 \varphi) (\partial_\mu \Phi)^2 \quad (2.51)$$

which vanishes since it is a total derivative (remember that $(\partial_\mu \Phi)^2$ is constant on the worldsheet). Hence, such a field redefinition does not account for the difference.

As a related matter, we would like to point out that there appears to be some disagreement in the various factors involved in this expression elsewhere in the literature. For instance, in [6] the dilaton beta function is given as

$$\beta^\Phi = \frac{D-26}{3\alpha'} + 2(\partial_\mu \Phi)^2 - \partial^2 \Phi + O(\alpha') \quad (2.52)$$

Note that the scalar curvature R does not appear here at all, and the relative normalization of the terms involving Φ disagrees both with our result and that presented in [2] and [5].

Chapter 3

Gauge Fields – Strings Duality

In this chapter we first present a brief overview of the search for a string theory description of strongly coupled gauge theories. We then describe in broad terms the *AdS/CFT* correspondence and some of its salient features. Finally, we discuss in rather more detail the conjecture proposed by Polyakov [1] and justify our interest in the background metric that we then go on to consider in detail in subsequent chapters.

3.1 A brief history of duality

String theory and strongly coupled gauge theories have always been closely linked. It is interesting to note that string theory, now widely regarded as a theory of quantum gravity, first appeared as a theory of the strong interactions in particle physics. Having been originally abandoned in this context in favour of QCD, it was only later that a theory of strings was proposed as a quantum “theory of everything” containing gravity. Meanwhile, those trying to solve the mysteries of the strongly coupled regime of QCD began to realize that, in certain limits, QCD itself resembled a theory of strings. Today, the description of strongly coupled gauge theories via supergravity and superstring theory has found its first concrete example in the Maldacena conjecture, or *AdS/CFT* correspondence, which we discuss below. Before describing some of the modern approaches to the string description of gauge theory, we briefly highlight some of the earlier evidence that QCD and string theory, rather

than being two distinct theories of the strong interactions, may in fact be one and the same thing.

A theory of strings first emerged as a phenomenological model of the hadrons in the late Sixties. It had been observed that hadrons existed in families, whose (masses)² and spins were linearly dependent. The scattering amplitudes were also known to be approximately dual; that is, contributions to the amplitudes from s -channel processes were approximately equal to contributions from t -channel processes. Veneziano [13] proposed a form for the 4-particle scattering amplitude which reproduced both of these features (this model was later generalized to describe processes involving arbitrary number of particles and was known as the *dual resonance model*). Several years later, it was shown in [14] that the Veneziano amplitude could be interpreted as arising from the quantum theory of a relativistic string. The duality property of the amplitude could be seen as a consequence of the fact that both s -channel and t -channel Feynman diagrams corresponded to the same worldsheet diagram for the string, as illustrated in Figure 3.1. However, this model was soon discarded as a realistic description of hadronic physics for several reasons, not least because it appeared to require 26 spacetime dimensions and predicted the existence of a massless spin 2 particle that was not observed in nature. The emergence of QCD as a theory of the strong interactions which explained all the above duality properties soon after then led to a decline in interest in the dual models and string theory. However, the fact that string theory predicted a massless spin 2 particle was soon to lead people to consider it as a fundamental theory of all the interactions, rather than as a phenomenological model of hadronic physics. This rogue particle played the role of the graviton.

While string theory was originally discounted as a theory of the strong interactions, it continued to appear in various forms as people tried to understand how to solve QCD in the strongly coupled regime. For instance, the attempts by Wilson [15] to put QCD on the lattice suggested that the phenomenon of confinement could be understood by the formation of $SU(3)$ -charged “flux tubes” between quarks. These flux tubes could then be interpreted as relativistic strings, unifying the QCD picture with the dual resonance model. Unfortunately, this result was only valid within

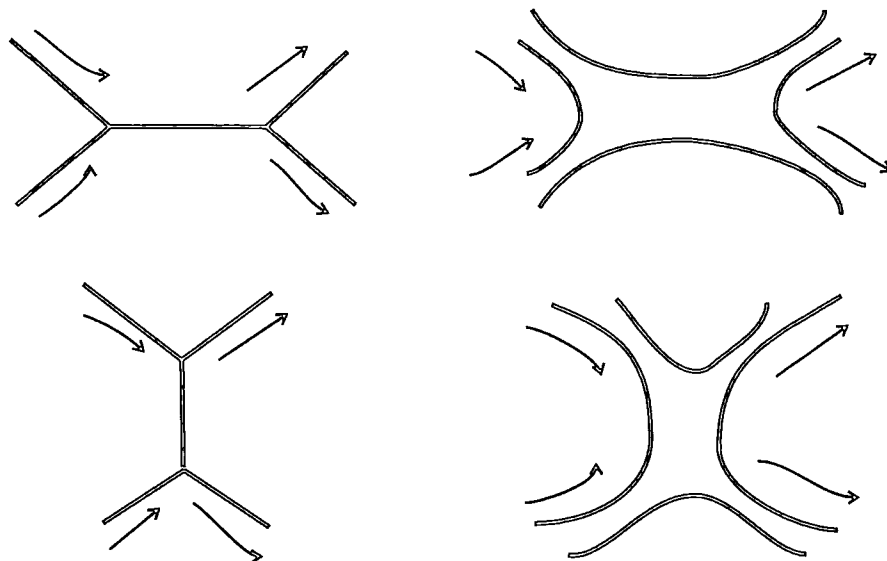

Figure 3.1: An s-channel and a t-channel Feynman diagram (left), and their worldsheet equivalents (right). The conformal invariance of string theory ensures that both contributions are equal.

the so-called “strong coupling expansion”, and it was not possible to take the correct limit that would extrapolate the physics on the lattice to continuum spacetime physics. Further evidence for a string description of gauge theory came in ’t Hooft’s studies of the large- N limit of QCD [16]. He found that the Feynman diagram expansion of QCD in the limit of large N (N being the number of colours) was dominated by so-called *planar diagrams*. The expansion organizes itself by topology; a diagram of genus (number of handles) h is of a certain order in N given by the formula [4]

$$\text{diagram of genus } h \sim \left(\frac{1}{N^2}\right)^h$$

Hence, this theory looks very similar to string theory - a topological expansion of surfaces as depicted in Figure 2.1 in Chapter 2. Notice also that if $N \rightarrow \infty$, the only diagrams that contribute are those with genus zero; i.e., those without handles. From a string theory point of view, this corresponds to taking the string coupling constant to zero so that no strings are emitted or absorbed (see Chapter 2). Hence, large- N theories seem to be described by *free* string theories. We will touch on this again in Chapter 6. Finally, it is interesting to note that although the topological

expansion for QCD is strictly only valid for “multicolour” QCD, where $N \rightarrow \infty$ and we keep the combination $g_{QCD}^2 N$ fixed (known as the *t Hooft limit*), there is certain phenomenological evidence that taking $N = 3$ is sufficiently large to make this analysis of QCD physically realistic.

The evidence over the years has clearly suggested that strongly coupled QCD may have a description in terms of a string theory. We now move on to describe some modern attempts at realizing this, beginning with Maldacena’s *AdS/CFT* correspondence.

3.2 The AdS/CFT correspondence

Undoubtedly the most successful attempt thus far to describe a gauge theory in terms of a string/gravity theory has been the famous *AdS/CFT* correspondence of Maldacena [17] [18] [19] [3]. This correspondence relies on the realization that there are certain non-perturbative objects within string theory called *D-branes* [6] [20]. From a perturbative point of view, Dp-branes are p -dimensional spacelike hypersurfaces in spacetime on which open strings end; in this sense, they can be thought of as a set of consistent boundary conditions for open strings (the “D” stands for Dirichlet boundary conditions). In addition, one finds that adding extra internal degrees of freedom on to the ends of open strings (known as *Chan-Paton factors*) incorporates gauge symmetries into the spacetime physics. The Chan-Paton factors live in representations of the gauge group¹. The low energy effective theory that lives on the D-brane is then given by the massless excitations of the open strings, and this theory will have a gauge symmetry corresponding to the Chan-Paton factors. The particular value of the Chan-Paton factor simply labels the D-brane that the open string ends on. For instance, a single D-brane may possess a $U(1)$ gauge symmetry. A system of N such branes would then have a $U(1)^N$ gauge symmetry. If these N D-branes are all placed at the same location, the gauge symmetry becomes enhanced from $U(1)^N$ to $U(N)$. Hence, a large number of coincident D-branes

¹Chan-Paton factors were originally introduced to make contact with the idea from gauge theory, referred to above, of quark-antiquark pairs connected by a flux tube.

describes a gauge theory with a large number of colours N .

In order to get a feel for how the *AdS/CFT* correspondence works, we consider a system of N parallel coincident D3-branes in a flat 10-dimensional spacetime within Type IIB superstring theory. As we saw above, the string theory on this background will consist of an open string sector describing excitations of the branes, and a closed string sector describing excitations in the bulk. At low energies (that is, neglecting all the massive string modes so that we only consider the massless states in the theory) the open string sector describes an $SU(N)$ super-Yang Mills theory with $\mathcal{N} = 4$ supersymmetry in 4 dimensions (which is known to be conformal). In addition, the closed string sector describes free Type IIB supergravity in the bulk. These two sectors are decoupled at low energies.

Now, we can also describe this same system from the point of view of a solution to supergravity itself (the D-branes can be thought of as classical solutions to supergravity). This supergravity solution will be described by some nontrivial 10-dimensional geometry. When one considers this geometry, one finds that there exists a horizon. Therefore, the energy of objects close to this horizon will get redshifted so that there are now two different notions of a low energy limit. One can either consider only free massless supergravity in the 10-dimensional bulk, or one can consider *all* excitations in the theory in the neighbourhood of the horizon (since all their energies will appear to be low due to the redshift). Again, these two sectors of the theory are decoupled.

Now, the near-horizon geometry defined by the D3-branes described above is found to be $AdS_5 \times S^5$. So, we have two alternative descriptions of the same physical system; one in which we have decoupled bulk supergravity and a 4-dimensional gauge theory, and another in which we have decoupled bulk supergravity and the complete spectrum of IIB string excitations on $AdS_5 \times S^5$. The conjecture, then, is that since the decoupled bulk supergravity is the same in both these cases, then so are IIB string theory on $AdS_5 \times S^5$ and 4-dimensional $\mathcal{N} = 4$ super-Yang Mills. Hence, we arrive at a conjectured string-theoretic description of a 4-dimensional gauge theory.

There are several initial clues that this is a reasonable conjecture. If these two theories really are one and the same, one would expect that the various symmetries

on both sides of the correspondence should match up, and in fact they do. For example, AdS_5 has the group of isometries $SO(4, 2)$ which is also the conformal group in 4 dimensions; this matches with the fact that the gauge theory here is conformally invariant. The 5-sphere has the obvious rotational symmetry $SO(6)$, and this is found to match with the $SU(4)$ R-symmetry group of the field theory ² (the algebra of $SO(6)$ is isomorphic to that of $SU(4)$).

How else might one go about proving this conjecture? To answer this, we need to consider under what conditions we are able to do concrete calculations on both sides of the correspondence, since this is what is required in order to check explicitly the equivalence of the two theories. On the field theory side, we only know how to calculate within perturbation theory where the effective coupling constant $g_{YM}^2 N$ is small. The details of the correspondence show that this relates to the string theory side such that

$$g_{YM}^2 N \sim \frac{l^4}{\alpha'^2} \ll 1$$

with l being the radius of curvature of the AdS space. In order to compare calculations in the field theory, we need to be able to compute related quantities in the string theory. While the full string theory on $AdS_5 \times S^5$ is poorly understood, it is possible to take a further low-energy limit such that the string length becomes very small compared to the curvature of the background. In this limit, the string theory reduces to the more tractable theory of IIB supergravity on $AdS_5 \times S^5$, and we have

$$\frac{l^4}{\alpha'^2} \sim g_{YM}^2 N \gg 1$$

Hence, we see that the perturbative regime of the field theory and the low energy regime of the string theory represent completely different regimes of the same theory. This is why they look so different, and why we do not have any contradiction between the two sides of the correspondence; strong coupling in one picture corresponds to weak coupling in the other, and vice versa. This has two obvious consequences, one very positive and the other less so. The positive consequence is that this duality allows one to access information about the extreme non-perturbative regime of the

²R-symmetry is a symmetry which allows one to rotate the supersymmetry generators into each other, and as such is a global symmetry of the gauge theory.

gauge theory via perturbative supergravity. The down side is that since we are only able to do computations in the weak coupling regimes on both sides of the correspondence, we are as yet unable to prove that the conjecture is true.

There are now many examples in the literature of computations which confirm the *AdS/CFT* correspondence. A few notable examples are [18] [19], where the so-called *bulk-boundary* correspondence is used to compute certain correlation functions in the gauge theory via supergravity. The precise identification is

$$\langle e^{\int d^4x \phi_0(x^i) \mathcal{O}(x^i)} \rangle_{CFT} = Z_{string} [\phi(x^i, z)|_{z=0} = \phi_0(x^i)];$$

that is, the generating functional of correlation functions in the field theory is set equal to the bulk string partition function, where the boundary values of the fields in the string theory act as sources for corresponding operators in the field theory. A certain subset of these correlation functions are also protected by non-renormalization theorems (i.e., they do not depend on the strength of the coupling constant), and so one is able to compute within perturbation theory on both sides of the correspondence and show that the above equality holds. Another interesting approach was shown in [21] [22], where the *AdS/CFT* correspondence is used to compute the expectation value of the gauge theory Wilson loop by computing minimal areas of string worldsheets in *AdS*. The ends of the string are interpreted as ending on the boundary of the *AdS* space, where the Wilson loop lives.

We will now move on to discuss an alternative form of gauge field – strings duality which is closely related to the approach of [21] [22], although different in several significant ways. The most obvious difference is that supersymmetry is not included. It is this approach that will inform the calculations that are presented in the remainder of this thesis.

3.3 Loop space and Polyakov's conjecture

An alternative approach to the description of gauge theory in terms of a string theory has been proposed by Polyakov [1] [23] [24]. This approach relies on reformulating the gauge theory in terms of *loop functionals* (an example of which is the Wilson loop). In this section, we present a fairly heuristic explanation of how gauge theory

can be re-written in terms of *loop space*. The line of argument given here follows closely the derivation given in [4], and no claim of originality is made for the material presented in this section. The issues discussed here are extremely involved, and many technical subtleties have been quite deliberately swept under the carpet. The purpose of the present discussion is merely to give a broad picture of how it is possible to rewrite gauge theory in terms of these loop functionals, and to introduce the main concepts underlying the resulting loop equations. Once we have done this we move on to describe the main features of the proposed duality, and show how one arrives at a certain form for the background metric on which the string theory propagates. The remainder of this thesis is then devoted to studying the Weyl anomaly of bosonic string theory on this background within a novel calculational scheme.

We begin by considering a pure $SU(N)$ gauge theory without supersymmetry. The Wilson loop is defined as

$$\langle W[C] \rangle = \frac{1}{N} \left\langle \text{Tr} P e^{i \oint_C A_\mu dx^\mu} \right\rangle \quad (3.1)$$

where the averaging is performed with the pure Yang-Mills action

$$S = \frac{1}{4g_{YM}^2} \int F_{\mu\nu} F^{\mu\nu} d^4x \quad (3.2)$$

and $F_{\mu\nu}$ is the field strength associated to the gauge field A_μ , which itself is a matrix in the adjoint of $SU(N)$ defined in terms of the generators t^a :

$$A_\mu^{ij}(x) = g_{YM} \sum_a A_\mu^a(x) [t^a]^{ij} \quad (3.3)$$

The P symbol in the definition of the Wilson loop denotes path-ordering; note also that we suppress the group indices in the definition of the Wilson loop since we are taking the trace. The Wilson loop is an interesting gauge invariant object to consider, since it acts as an order parameter for confinement.

In what follows, we will consider the Wilson loop as a *functional of the contour* C . C is an arbitrary, continuous closed loop. One begins by deriving the quantum equations of motion for the averaged Wilson loop. The procedure is simple; one shifts the gauge field in the path integral via $A_\mu(x) \rightarrow A_\mu(x) + \epsilon(x)$, and considers

this shift as a change of variables in the path integral. Since the measure and the value of the integral remain unchanged under this shift, one can expand the resulting expression up to $O(\epsilon)$ and demand that the integrand vanish. This looks a little like the usual Hamilton variational principle. The resulting equations for the averaged Wilson loop are known as *Schwinger-Dyson* equations, and are found to be

$$\left\langle \frac{1}{N} \text{Tr} P \nabla_\mu F_{\mu\nu}(x) e^{i \oint_C d\xi^\mu A_\mu} \right\rangle = \left\langle \frac{g_{YM}^2}{2N} \text{Tr} \frac{\delta}{\delta A_\nu(x)} P e^{i \oint_C d\xi^\mu A_\mu} \right\rangle \quad (3.4)$$

Here, ∇_μ is the covariant derivative in the adjoint of $SU(N)$:

$$\nabla_\mu B = \partial_\mu B - i[A_\mu, B] \quad (3.5)$$

Our aim now is stated as follows: We wish to rewrite equation (3.4) entirely in terms of objects and operations which are defined on loop space. The Wilson loop itself is defined on a loop C , so it meets our requirements. However, the variational derivative on the RHS, and the field strength and covariant derivative on the LHS need to be rewritten.

We need a more formal definition of what we mean by "loop space". As has already been mentioned, loop space consists of arbitrary continuous closed loops. We can describe these loops in terms of functions $x_\mu(\sigma) \in \mathcal{H}$, where \mathcal{H} is the Hilbert space of functions obeying the condition

$$\int_{\sigma_i}^{\sigma_f} x_\mu^2(\sigma) d\sigma < \infty \quad (3.6)$$

and σ is a parameter along the loop. These functions have the following properties [4]:

1. $x_\mu(\sigma_i) = x_\mu(\sigma_f)$ - the loops are closed.
2. The functions $x_\mu(\sigma)$ and $\Lambda_{\mu\nu} x_\nu(\sigma) + \alpha_\mu$ represent the same element of loop space. This is just rotational and translational invariance.
3. The functions $x_\mu(\sigma)$ and $x_\mu(f(\sigma))$ with $f'(\sigma) \geq 0$ represent the same loop. This is reparametrization invariance.

When we refer to elements of loop space, we are referring to contours C that can be parametrized in terms of functions $x_\mu(\sigma)$ that obey these restrictions.

The gauge fields A_μ are defined in terms of the generators of $SU(N)$. These generators obey a completeness relation:

$$\sum_{a=1}^{N^2-1} [t^a]^{ij} [t^a]^{kl} = \frac{1}{2} \left(\delta^{il} \delta^{kj} - \frac{1}{N} \delta^{ij} \delta^{kl} \right) \quad (3.7)$$

We can use this relation to derive the following formula:

$$\frac{\delta A_\mu^{ij}(y)}{\delta A_\nu^{kl}(x)} = \delta_{\mu\nu} \delta^{(4)}(x-y) \left(\delta^{il} \delta^{kj} - \frac{1}{N} \delta^{ij} \delta^{kl} \right) \quad (3.8)$$

Since the RHS of equation (3.4) involves the action of the variational derivative with respect to A_μ on an exponential of A_μ , we see that the result will involve the same exponential factor multiplied by the delta functions in (3.8). Hence, we can write the RHS entirely in terms of products of Wilson loops - which is what we require, since the Wilson loop is defined on loop space. The result we obtain is

$$\text{RHS} = i \frac{g_{YM}^2 N}{2} \oint_C dy_\nu \delta^{(4)}(x-y) \left[\langle W[C_{yx}] W[C_{xy}] \rangle - \frac{1}{N^2} \langle W[C] \rangle \right] \quad (3.9)$$

The contours C_{xy} and C_{yx} are the two “halves” of the contour C - the piece running from a spacetime point x to another point y , and the other piece running back from y to x . An important point to note here is that x and y are necessarily the same point in *spacetime* (due to the delta function $\delta^{(4)}(x-y)$), but they may be associated with different values of the *contour parameter* σ . Hence, the RHS of our equations of motion have a “pinched disk” form.

3.3.1 Loop space calculus and the loop equation

Having re-written the RHS of our gauge theory equations of motion (3.4) in terms of loop space, we now turn to the LHS. This is much more complicated. We see that the LHS involves a covariant derivative; hence, we require some notion of differential calculus on loop space. What is the effect of deforming a contour C on a loop functional such as $W[C]$?

It turns out that we require two differential operations defined in loop space. These are the *area derivative* and the *path derivative*.

1. **Area derivative.** The area derivative of a loop functional $F[C]$ at a point x is defined to be the following: Let C be an element of loop space, and C' be

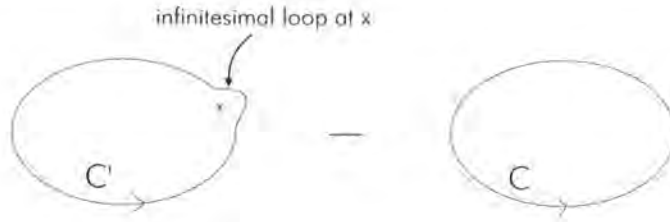

Figure 3.2: Contour deformation associated with the area derivative.

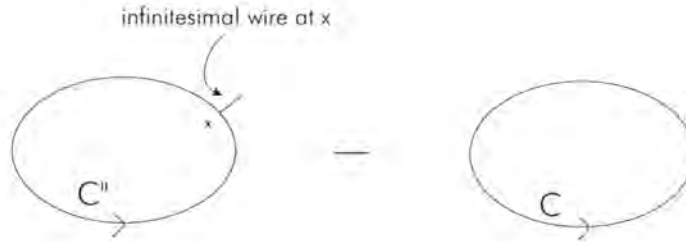

Figure 3.3: Contour deformation associated with the path derivative.

another element of loop space obtained from C by attaching an infinitesimal loop at a point x . The area enclosed by the infinitesimal loop is $|\delta\sigma_{\mu\nu}|$. The area derivative is then

$$\frac{\delta}{\delta\sigma_{\mu\nu}(x)} F[C] = \frac{1}{|\delta\sigma_{\mu\nu}|} (F[C'] - F[C]) \quad (3.10)$$

The contour deformation described here is shown in Figure 3.2.

2. **Path derivative.** The path derivative of a loop functional $F[C]$ at a point x is defined to be the following: Let C be an element of loop space, and let C'' be another element of loop space obtained from C by attaching an infinitesimal path or "wire" δx_μ to the loop at a point x . The length of the infinitesimal path is $|\delta x_\mu|$. The path derivative is then

$$\partial_\mu^x F[C] = \frac{1}{|\delta x_\mu|} (F[C''] - F[C]) \quad (3.11)$$

This deformation is shown in Figure 3.3.

In fact, these two operations are enough to rewrite the LHS of (3.4) in loop space. To see this, we consider first the action of the area derivative on the Wilson loop.

This is given by the *Mandelstam formula*:

$$\frac{\delta}{\delta\sigma_{\mu\nu}(x)} \left(\frac{1}{N} \text{Tr} P e^{i \oint_C A_\mu dx^\mu} \right) = \frac{i}{N} \text{Tr} P F_{\mu\nu}(x) e^{i \oint_C A_\mu dx^\mu} \quad (3.12)$$

This equation can be derived by adding an infinitesimal rectangular loop to the Wilson loop contour C and applying Stokes' theorem. The Mandelstam formula is really a geometrical statement: the field strength $F_{\mu\nu}(x)$ is a *curvature* associated to the *connection* $A_\mu(x)$. For our purposes, it is significant that the action of the area derivative on the Wilson loop brings down a factor of the field strength, as this is what we need to reproduce the LHS of (3.4).

It is important to note that the path derivative of the Wilson loop is *zero*. This can be easily seen by considering the properties of the phase factor. If A_μ were Abelian, then it is clear that the path derivative must be zero since we can apply Stokes' theorem to write the loop as

$$\langle W[C] \rangle = \frac{1}{N} \left\langle \text{Tr} \exp i \int_\Sigma F_{\mu\nu} ds_{\mu\nu} \right\rangle \quad (3.13)$$

where Σ is the area enclosed by C and $ds_{\mu\nu}$ is the measure associated with integrating over Σ . Since the path derivative does not change the area of the loop, it must give zero when acting on $W[C]$. In the non-Abelian case, the path-ordering operation ensures that this property is preserved. The fact that $\partial_\mu^x W[C] = 0$, along with reparametrization invariance, is an important property of the Wilson loop functional. It is known as *zigzag symmetry*, and more will be said about this later.

Although the path derivative of the Wilson loop functional is zero, the RHS of the Mandelstam formula (3.12) does not yield zero under this operation due to the presence of the field strength at the point x . In fact it can be shown that

$$\partial_\mu^x \left(\frac{i}{N} \text{Tr} P F_{\mu\nu}(x) e^{i \oint_C A_\mu dx^\mu} \right) = \frac{i}{N} \text{Tr} P \nabla_\mu F_{\mu\nu}(x) e^{i \oint_C A_\mu dx^\mu} \quad (3.14)$$

This is precisely what we need in order to write the LHS of (3.4) in loop space. We have

$$\langle \nabla_\mu F_{\mu\nu}(x) W[C] \rangle = i \partial_\mu^x \frac{\delta}{\delta\sigma_{\mu\nu}(x)} \langle W[C] \rangle \quad (3.15)$$

and hence we combine this with equation (3.9) to obtain the Schwinger-Dyson equa-

tions (3.4) in the form

$$\partial_\mu^x \frac{\delta}{\delta \sigma_{\mu\nu}(x)} \langle W[C] \rangle = \frac{g_{YM}^2 N}{2} \oint_C dy_\nu \delta^{(4)}(x-y) \left[\langle W[C_{yx}] W[C_{xy}] \rangle - \frac{1}{N^2} \langle W[C] \rangle \right] \quad (3.16)$$

This equation as it stands is not closed, since it gives the one-loop Wilson loop average $\langle W[C] \rangle$ in terms of a two-loop average $\langle W[C_{yx}] W[C_{xy}] \rangle$. However, in the large- N limit there is a remarkable factorization:

$$\langle W[C_{yx}] W[C_{xy}] \rangle = \langle W[C_{yx}] \rangle \langle W[C_{xy}] \rangle + \mathcal{O}\left(\frac{1}{N^2}\right) \quad (3.17)$$

This factorization property is a general property of the large- N limit which holds for correlation functions of products of *singlet* operators (that is, operators which transform as singlets under the gauge group). In this case, if we keep the combination $\frac{g_{YM}^2 N}{2}$ fixed as we take the large- N limit (this is the 't Hooft limit mentioned above in Section 3.1), we obtain a closed equation for the Wilson loop:

$$\partial_\mu^x \frac{\delta}{\delta \sigma_{\mu\nu}(x)} \langle W[C] \rangle = \frac{g_{YM}^2 N}{2} \oint_C dy_\nu \delta^{(4)}(x-y) \langle W[C_{yx}] \rangle \langle W[C_{xy}] \rangle \quad (3.18)$$

This is almost completely defined in loop space. However, notice that both sides at the moment still depend explicitly on the spacetime point x , which does not live in loop space. To remove this unwanted dependence, we integrate both sides over x along the contour C , giving

$$\oint_C dx_\nu \partial_\mu^x \frac{\delta}{\delta \sigma_{\mu\nu}(x)} \langle W[C] \rangle = \frac{g_{YM}^2 N}{2} \oint_C dx_\mu \oint_C dy_\nu \delta^{(4)}(x-y) \langle W[C_{yx}] \rangle \langle W[C_{xy}] \rangle \quad (3.19)$$

This equation, first derived in [25], is referred to as the *loop equation*, and represents the Schwinger-Dyson equations for the gauge field A_μ in loop space in the large- N limit. It has been shown to reproduce perturbation theory, as expected. The operator on the LHS,

$$\hat{L} \equiv \oint_C dx_\nu \partial_\mu^x \frac{\delta}{\delta \sigma_{\mu\nu}(x)} \quad (3.20)$$

is often referred to as the *loop operator* or the *loop Laplacian*. Notice that the action of the loop operator on a Wilson loop whose contour has no self-intersections yields zero, due to the presence of $\delta^{(4)}(x-y)$ on the RHS.

3.3.2 A loop space dictionary

In order to keep a clearer picture of what we mean when we talk about objects and operations in loop space, it is useful to pause and compare objects in ordinary space with their counterparts in loop space. The following list, reproduced from [4], gives some of the more important and illustrative relationships:

1. In ordinary space we talk about the **phase factor** appearing in the Wilson loop as a functional of the gauge fields, $\Phi[A_\mu]$. In loop space, we are concerned with **loop functionals** - that is, functionals of the contour C .
2. We have seen that the **field strength** $F_{\mu\nu}(x)$ in ordinary space is related to the **area derivative** $\frac{\delta}{\delta\sigma_{\mu\nu}(x)}$ in loop space (equation (3.12)).
3. The **covariant derivative** ∇_μ is associated with the **path derivative** ∂_μ^x in loop space, as we see by taking the path derivative of the RHS of equation (3.12).
4. It can be shown that the relation $\partial_\mu^x W[C] = 0$ corresponds to the **Bianchi identity** $\nabla \wedge F = 0$ in ordinary space.
5. Finally, we have seen that the **Schwinger-Dyson equations** (3.4) in ordinary space are translated into the **loop equation** (3.19) in loop space.

3.3.3 The conjecture

Now that we have seen how one can reformulate the gauge theory in loop space, we need to ask how one might go about solving the loop equation. The conjecture, made by Polyakov [1] [23] [24], is the following. In analogy with the solution of the wave equations by Feynman integrals over trajectories, we should solve the loop equation by integrals over *surfaces* whose boundaries trace out the contour C of the Wilson loop functional $W[C]$. This sum over surfaces is precisely the kind of thing we encounter in string theory [7], and this is how we arrive at a conjectured continuum string theory description of a gauge theory. We can state the ansatz for

the Wilson loop in the following way:

$$\langle W[C] \rangle = \int \mathcal{D}X \mathcal{D}g \exp -S[X, g] \quad (3.21)$$

where we take the string action to be the Polyakov action

$$S[X, g] = \frac{1}{4\pi} \int d^2\xi \sqrt{g} g^{ab} \partial_a X^\mu \partial_b X^\nu G_{\mu\nu}(X) \quad (3.22)$$

with $\alpha' = 1$. We will ignore other possible background fields (antisymmetric tensor field, fermionic terms, etc.) for the moment. To complete the ansatz, we need to include a boundary condition:

$$X|_{\partial M} = C \quad (3.23)$$

where ∂M is the boundary of the worldsheet M . This condition ensures that the boundaries of the surfaces we sum over trace out the contour C .

The next question we need to ask is: what is the string theory sigma-model action $S[X, g]$ that correctly reproduces the loop equation for $\langle W[C] \rangle$? In other words, how do we choose the string background metric $G_{\mu\nu}(X)$? We have seen in a previous chapter that quantum effects lead to the worldsheet scale factor becoming dynamical (note the kinetic term for φ in (2.18)). If we work in a gauge $g_{ab} = e^{\varphi(\xi)} \hat{g}_{ab}$, where \hat{g}_{ab} is independent of φ , the effective action for φ looks like

$$Z \sim \int \hat{\mathcal{D}}X \hat{\mathcal{D}}\varphi \exp \left(- \int d^2\xi \sqrt{\hat{g}} [\hat{g}^{ab} \partial_a X^\mu \partial_b X_\mu + \hat{g}^{ab} \partial_a \varphi \partial_b \varphi + \dots] \right) \quad (3.24)$$

as we saw in Chapter 2. This looks just like a string propagating in a background metric with φ playing precisely the same role as X^μ ! In other words, we are now considering a string propagating on a background

$$G_{MN}(X, \varphi) = d\varphi^2 + \sum_{i=1}^D dX_i^2 \quad (3.25)$$

In fact, we can be more general than this. There is no *a priori* reason for our $(D+1)$ -dimensional metric to be flat. However, if we wish our D -dimensional metric to be flat, the most general form of the metric we can use is

$$ds_{D+1}^2 = d\varphi^2 + z^2(\varphi) \sum_{i=1}^D dX_i^2 \quad (3.26)$$

At any given value of φ , the metric describing the transverse D -dimensional space is then flat.

So, given this construction we make the following observations. From the point of view of gauge fields – strings duality, we are attempting to describe a Wilson loop functional in 4 flat dimensions with a string functional integral. If we place the string itself in 4 flat dimensions, it will “grow” an extra spacetime dimension due to the quantum effects described above. Hence, it is claimed that a 4-dimensional gauge theory has a natural stringy description in 5 dimensions, with a metric given by (3.26) [1]. The question of which string background metric $G_{\mu\nu}(X)$ we should choose to reproduce the loop equation has now been refined to the following: What function $z^2(\varphi)$ should we use in the metric (3.26) in order to reproduce the loop equation for $W[C]$? It is clear that in order to answer this question we need some more information about the Wilson loop functional itself. In fact, there is an important symmetry present in the Wilson loop which lets us restrict the allowed string backgrounds. This symmetry is the zigzag symmetry referred to above, and is to this that we now turn our attention.

3.3.4 Zigzag symmetry and AdS space

The zigzag symmetry property of the Wilson loop functional turns out to have important consequences for constructing a string action, in accordance with the ansatz (3.21). We will see that the growth of an extra dimension under quantization is essential; without it, we would be unable to define a suitable string action with the correct symmetries.

As was explained previously, the properties of the non-Abelian phase factor present in the Wilson loop functional mean that the path derivative of $W[C]$ yields zero. In addition, the functions we use to parametrize the elements of loop space C are reparametrization invariant as was mentioned above. We can combine these two features in the following way: reparametrization invariance means that

$$W[x_\mu(\sigma)] = W[x_\mu(\sigma'(\sigma))] \quad (3.27)$$

with $\frac{d\sigma'(\sigma)}{d\sigma} \geq 0$. Now, since $\partial_\mu^x W[C] = 0$, we can add any piece of “wire” to the

contour C without changing the value of the Wilson loop, as long as the extra path introduced does not enclose any area. In particular, we can add a piece of wire which backtracks along C and then reverses on itself. This is just equivalent to the reparametrization (3.27), except we now lose the condition that $\sigma'(\sigma)$ be monotonic. In other words, the vanishing of the path derivative of the Wilson loop functional implies that it is invariant under all reparametrizations (3.27), not just those for which $\frac{d\sigma'(\sigma)}{d\sigma} \geq 0$. This extended reparametrization invariance is what is known as zigzag symmetry.

Standard string theory actions are, of course, reparametrization invariant. For example, the action (3.22) is invariant under the transformation

$$X^\mu(\xi) \rightarrow X^\mu(\xi'(\xi)) \quad (3.28)$$

for any $\xi'(\xi)$ with $\frac{d\xi'(\xi)}{d\xi} \geq 0$. Crucially, (3.22) is **not** invariant if $\frac{d\xi'(\xi)}{d\xi}$ changes sign, unlike the Wilson loop functional. This is because the factor of \sqrt{g} in the action is positive definite. If we consider a more general string sigma-model action with antisymmetric tensor fields, etc...

$$S = \int d^2\xi \left[\sqrt{g} g^{ab} \partial_a X^\mu \partial_b X^\nu G_{\mu\nu}(X) + \epsilon^{ab} \partial_a X^\mu \partial_b X^\nu B_{\mu\nu}(X) + \dots \right] \quad (3.29)$$

then it seems that the first term involving \sqrt{g} is forbidden by the requirement of zigzag symmetry [1]. This then implies that

$$G_{\mu\nu}(X) = 0 \quad (3.30)$$

which is a very strange condition, and does not appear to make much sense. However, we have already seen that if we wish to describe a 4-dimensional Wilson loop functional by a string theory, that string theory ought to live in 5 dimensions with background metric

$$ds_5^2 = d\varphi^2 + z^2(\varphi) \sum_{i=1}^4 dX_i^2 \quad (3.31)$$

The key point is that *we only require the zigzag symmetry in the four flat dimensions where the Wilson loop lives*. In other words, we simply require a particular location $\varphi = \varphi^*$ in the 5-dimensional space where the 4-dimensional flat part of the metric vanishes:

$$z^2(\varphi^*) = 0 \quad (3.32)$$

This is the extra condition we need in order to choose a suitable $z^2(\varphi)$.

A simple choice for $z^2(\varphi)$ that obeys the zigzag symmetry requirement is

$$z^2(\varphi) = \exp\left(\frac{2\varphi}{l}\right) \quad (3.33)$$

The zigzag-symmetric point is therefore $\varphi^* = -\infty$. Substituting this function into (3.31) and making a change of coordinates

$$y^2 \equiv l^2 \exp\left(-\frac{2\varphi}{l}\right) \quad (3.34)$$

gives a string background metric

$$ds_5^2 = \frac{1}{y^2} \left[l^2 dy^2 + \sum_{i=1}^4 dX_i^2 \right] \quad (3.35)$$

where we have rescaled the X 's to absorb the factor of l^2 - this is 5-dimensional anti-de Sitter spacetime (AdS_5) with radius of curvature l . We take the zigzag-symmetric point in the y -coordinate to be $y^* \rightarrow 0$; there is another zigzag-symmetric point at $y \rightarrow \infty$, but we do not concern ourselves with that here (this case is studied in [1]). We simply note that we are trying to describe a Wilson loop in 4 flat dimensions, and the point $y^* \rightarrow 0$ corresponds to the boundary of AdS_5 , which is indeed a flat 4-dimensional spacetime.

So, let us summarize what we have done. In attempting to describe a 4-dimensional Wilson loop with a string functional integral in 4 dimensions, we see that the string theory "grows" an extra dimension via quantum effects. In addition to this, the Wilson loop possesses zigzag symmetry and this clearly needs to be present in the string theory if the two are truly equivalent. Therefore, the background metric on which the string is allowed to propagate is restricted - it must have a zigzag-symmetric point somewhere where we can place the boundary of the worldsheet and trace out the contour of $W[C]$. An example of such a background metric is AdS_5 , which has a zigzag symmetric point at the boundary. This situation is represented pictorially in Figure 3.4. With this in mind, the original conjecture implies that

$$\text{String theory on } AdS_5 \iff \text{Gauge theory in 4 dimensions}$$

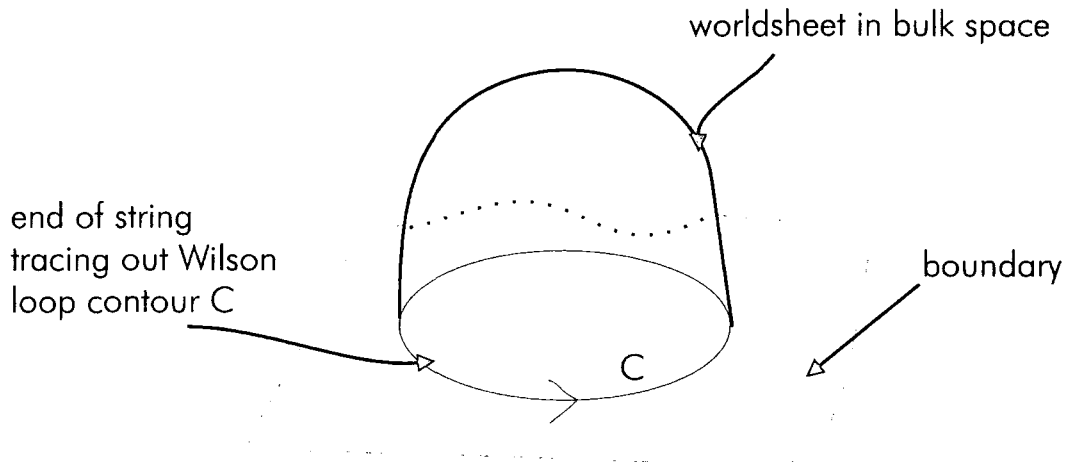

Figure 3.4: A string worldsheet ending at the zigzag symmetric location in AdS

This is beginning to resemble the AdS/CFT correspondence! But there are several important differences. For instance, everything in our construction up to now has been bosonic; we have not introduced supersymmetry at any stage, whereas SUSY is an integral part of the D-brane construction of the AdS/CFT correspondence. The important point is that we have been able to arrive at a conjectured duality which resembles AdS/CFT , just by worldsheet / sigma-model considerations. Note, however, that AdS space is just one example of a choice of the function $z^2(\varphi)$ that is consistent with the various symmetry requirements. This suggests a whole class of dualities based on the form of the metric (3.31). Clearly, the study of string theory on this more general background is of interest; in Chapter 6 we discuss how the calculations presented for the AdS metric can be generalized.

Going back to the AdS case, our ansatz (3.21) for the Wilson loop functional now reads

$$\langle W[C] \rangle = \int \mathcal{D}X \mathcal{D}y \mathcal{D}g \exp(-S[X, y, g]) \quad (3.36)$$

with the Polyakov action in AdS space

$$S[X, y, g] = \frac{1}{4\pi} \int d^2\xi \frac{\sqrt{g}}{y^2} g^{ab} [\partial_a X^i \partial_b X_i + l^2 \partial_a y \partial_b y] \quad (3.37)$$

and boundary conditions

$$\begin{aligned} X|_{\partial M} &= C \\ y|_{\partial M} &= 0 \end{aligned} \quad (3.38)$$

There is one extra hint that this conjecture may be true. It has been shown [24] that the action (3.37) does indeed satisfy the loop equation (3.19) *classically*; that is,

$$W[C] \sim \exp \left(-\frac{1}{4\pi} \min \int d^2\xi \frac{1}{y^2} [(\partial_a X^i)^2 + l^2(\partial_a y)^2] \right) \quad (3.39)$$

In other words, the minimal area in AdS space satisfies the loop equation. This is encouraging, and suggests that a dual gauge theory description of this particular string theory really does exist. Therefore, we will take seriously the idea that string theory propagating on the metric (3.31) really does have something to say about the dynamics of gauge theories and now move on to consider the physics of this system. In particular, we will show that the requirement of Weyl invariance is of central importance (as it always is in string theory) and we demonstrate that within a calculational scheme where the dimension of the target space is taken to be large it is possible to investigate the physics of strings on such geometries where we do not require that the background be only slowly varying at the string scale.

Chapter 4

The $(1/D)$ Expansion and the Weyl Anomaly

4.1 Moving beyond “almost flat” spacetimes

So far, we have seen how perturbative bosonic string theory can be formulated on a curved background via the nonlinear sigma model with spacetime-dependent couplings. These couplings represent the target space metric $G_{\mu\nu}(X)$ and the dilaton field $\Phi(X)$ (one can also include the antisymmetric tensor field $B_{\mu\nu}(X)$, but we do not consider this here). Remarkably, one finds that demanding conformal invariance of this sigma model (that is, requiring that the beta functions associated with each of these couplings vanish) gives the spacetime equations of motion for the metric and the dilaton. If we wish to study bosonic string theory in nontrivial backgrounds, we must ensure that the spacetime beta function equations are satisfied or the theory will not be Weyl invariant. A string theory with a Weyl anomaly yields unphysical scattering amplitudes, and is therefore not consistent. For example, the graviton beta function (2.45)

$$R_{\mu\nu} + 2\partial_\mu\partial_\nu\Phi = 0$$

shows that if the target space metric is not Ricci-flat (as is the case for Anti-de Sitter space), we must include a dilaton field in the string action for consistency.

However, there are several points to be made here. Firstly, we must consider the nature of the calculation that led us to these spacetime equations of motion for

the metric and the dilaton. We used a perturbative expansion in the dimensionless number α'/l^2 , where l is the characteristic radius of curvature of the target space metric. Therefore, these equations of motion must be viewed as being valid only when we take the string length to be much smaller than the radius of curvature of the metric. This then begs the question: what happens if the curvature of the metric is not negligible on scales comparable to the string length? This is a fairly sensible situation to consider since string theory is supposed to provide a consistent theory of quantum gravity, and it is precisely when gravitational effects become significant at very small scales that quantum gravity should come into play. It would be nice, therefore, if one could find a way to analyze the Weyl anomaly of the string on a curved background without making the approximation that the string length is small compared to the scale of the metric curvature.

How might one go about this? The fact that we would require $\alpha'/l^2 \sim 1$ suggests that this is not a problem that one could analyze in perturbation theory. The non-perturbative structure of string theory has been (and is) one of the great problems in the field at present, and the study of D-branes (non-perturbative states in the superstring spectrum) has led to many remarkable discoveries including the famous *AdS/CFT* correspondence discussed in Chapter 3, and the equivalence of the five known perturbative superstring theories as limits of M-theory. Powerful as these results are, almost everything that we have learned from this approach in terms of hard calculations has relied on taking the low-energy limit of the string theory (supergravity) - in this sense, these calculations are not very “stringy”. We would like to develop a calculational scheme in which we can really treat the string as a string. In order to see how this might be achieved, we will take our cue from the study of nonlinear sigma models in particle physics.

4.1.1 The $O(N)$ nonlinear sigma model

As a brief aside, consider the following quantum field theory for an N -component scalar field $\phi(x)$, where x is a spacetime coordinate:

$$Z = \int \mathcal{D}\phi(x) \left(\prod_x \delta(\phi(x)^2 - \frac{1}{g^2}) \right) e^{-S} \quad (4.1)$$

with

$$S = \frac{1}{2} \int d^2x (\partial_\mu \phi)^2 \quad (4.2)$$

This theory, known as the $O(N)$ nonlinear sigma model, was first considered as a description of a system that displays spontaneous symmetry breaking in 4 dimensions, as well as asymptotic freedom. Here, we consider the theory of an N -component field $\phi(x)$ in 2 dimensions, with the constraint that the “length” of the field $\phi^2 = \phi^i \phi^i = 1/g^2$. We will see that this theory describes dynamical mass generation. In order to proceed, introduce a Lagrange multiplier field $\lambda(x)$ to represent the delta function in Z :

$$\prod_x \delta(\phi(x)^2 - \frac{1}{g^2}) = \int \mathcal{D}\lambda(x) \exp\left(\frac{1}{2} \int d^2x \lambda(x) (\phi(x)^2 - \frac{1}{g^2})\right) \quad (4.3)$$

Substituting this into Z , we see that the integration over $\phi(x)$ is a simple Gaussian and can be done exactly. This gives

$$Z = \int \mathcal{D}\lambda(x) \exp\left(\frac{1}{2g^2} \int d^2x \lambda(x) - \frac{N}{2} \ln \text{Det}(-\partial_\mu^2 + \lambda(x))\right) \quad (4.4)$$

Now, one can approximate this integral by a *saddle point* if one assumes that the number N is large. In this case, the integral will be dominated by the configuration of $\lambda(x)$ that minimizes the exponent. The Euler-Lagrange equation for $\lambda(x)$ will give us this configuration (i.e., the classical configuration). We find that

$$\frac{N}{2} G(x, x; \lambda) = \frac{1}{2g^2} \quad (4.5)$$

where we have introduced the Green’s function

$$G(x, x'; \lambda) = \langle x | \frac{1}{-\partial_\mu^2 + \lambda} | x' \rangle \quad (4.6)$$

If we assume that the configuration of λ we are looking for is translationally invariant, we can represent this equation in momentum space by

$$1 = Ng^2 \int \frac{d^2p}{(2\pi)^2} \frac{1}{p^2 + \lambda} = \frac{Ng^2}{4\pi} \ln\left(\frac{\Lambda^2}{\lambda}\right) \quad (4.7)$$

where we have cut off the divergent integral at some momentum scale Λ , and so the quantity

$$\lambda = \Lambda^2 \exp\left(-\frac{4\pi}{Ng^2}\right)$$

represents a dynamically generated mass scale in the theory. This is the configuration of $\lambda(x)$ which minimizes the action, and therefore has the least energy of all possible translationally invariant configurations. Any perturbative calculations that we wish to perform within this scheme therefore need to consist of perturbations about this configuration. We will see later on that the string model we study looks very similar to this $O(N)$ sigma model; however, in that case the Euler-Lagrange equations are more complicated and there is in fact another solution, corresponding to $\lambda = 0$ here, that has a lower energy than $\lambda = \text{constant}$. The correct vacuum in that case does not correspond to dynamical mass generation. We will see this in some detail later on in this chapter.

The moral of this story is that in the study of nonlinear sigma models, the approximation that the number of components of a field N is large can be used to get physical results. In fact, the “large- N expansion” is a very powerful tool in quantum field theory as we have already seen in our discussion of the loop equation in gauge theory. We will now see that a similar kind of approximation may be what we need to set up a perturbative calculation for strings on strongly curved backgrounds.

4.1.2 Target space dimension as a perturbative parameter

Let’s go back to thinking about string theory. As we have seen, the Polyakov bosonic string in flat space can be represented by

$$Z = \int \mathcal{D}X \exp \left(- \int d^2\xi (\partial_a X^i)^2 \right) \quad (4.8)$$

(we will assume that we are in the critical dimension here, and hence discard the worldsheet metric for the moment). The X -integral is clearly Gaussian, and yields

$$Z = \text{Det}^{-D/2}(\Delta_0) = \exp \left(-\frac{D}{2} \ln \text{Det}(\Delta_0) \right) \quad (4.9)$$

This looks very much like the determinant that we encountered in our discussion of the $O(N)$ model, except the parameter N has here been replaced by the target space dimension D (since $X^i(\xi)$ is a D -component scalar field on the worldsheet). This leads us to consider the following: is it possible to construct a perturbative

expansion for string theory in which we take D to be large, rather than α'/l^2 to be small? This seems like a reasonable possibility, particularly for bosonic strings. We know that bosonic string theory only makes sense in 26 dimensions - and 26 is a (reasonably!) large number. Therefore, one might try to construct a calculation in which everything is arranged in inverse powers of D rather than in powers of α' . We will see that this expansion scheme is very different from the usual one, with terms of the same order in D being of different orders in α'/l^2 . Hence, there is no contradiction between the standard beta functions derived in Chapter 2 and the results presented in the remainder of this thesis since the two expansion schemes correspond to different physical regimes.

One may wonder whether we should expect that the critical dimension changes if the background becomes strongly curved. We expect that it won't for the following reason. The critical dimension is required to allow consistent string propagation; it is only when the target space metric satisfies this condition that the Weyl anomaly (a *local* quantity) vanishes. Since we require $D = 26$ for metrics that are slowly varying over the string scale we should expect that the same will be true even if the curvature is strong, since the Weyl anomaly is sensitive only to local physics on the worldsheet and we can always “zoom in” such that the metric appears flat over some small area¹. Indeed, we will show that when one does the calculation using the $1/D$ expansion the critical value of 26 is again found, up to $O(1)$ in D . This justifies the use of $1/D$ as a good expansion parameter, being of order $1/26$. Notice that the same arguments do not hold for the rest of the terms in the beta functions, since the string *spectrum* will be sensitive to changes in the spacetime curvature. This is related to the fact that the vertex operators for the massless string modes are constructed as perturbations around flat space.

¹Some authors [26] have suggested that the critical dimension of bosonic strings in *AdS* is 25 by treating the metric exactly. However, they use the standard expansion parameter and therefore their result is in direct conflict with the standard beta function calculations. We believe, therefore, that their conclusion is incorrect.

4.2 The Polyakov metric and Weyl invariance

One of the goals of studying string theory is to gain an understanding of strongly coupled gauge theories, as was explained in some detail in Chapter 4. The work of Polyakov has suggested that a string theory propagating on a $(D + 1)$ -dimensional metric of the form

$$ds^2 = d\varphi^2 + z^2(\varphi)dX^i dX^i \quad (4.10)$$

describes the dynamics of Wilson loops on the D -dimensional space where $z(\varphi^*)=0$ (from now on, we work with general D , and the index i runs from 1 to D . The Einstein summation convention is assumed). For this to really hold water, we must ensure that the string theory genuinely makes sense as a string theory, and as such does not possess a Weyl anomaly. The conditions for Weyl invariance in the standard picture are the vanishing of the beta functions of the sigma model describing the string, as derived previously. However, we now encounter a problem. The graviton beta function requires that

$$R_{\mu\nu} + 2\partial_\mu\partial_\nu\Phi = 0$$

For AdS space, for example, this means that $\partial_\mu\partial_\nu\Phi(X) \sim G_{\mu\nu}(X)$. In other words, Weyl invariance requires that we have a dilaton field in our higher-dimensional theory that depends on the X^i 's, as well as the ‘‘holographic’’ coordinate φ . This is a problem, since this means that the dilaton field at $\varphi = \varphi^*$ will break Poincaré invariance in the D -dimensional space. This is inconsistent with a Poincaré invariant gauge theory operator such as the Wilson loop, since we saw in Chapter 3 that elements of loop space are defined to be Poincaré invariant. In fact, the above equation does not even permit rotationally invariant solutions for AdS space. To see why, consider the AdS metric in the Poincaré coordinates used in equation (3.35) with l^2 set to 1. Suppose the dilaton is a function of $u = X \cdot X$ and y (and hence explicitly rotationally invariant in the X s). Then,

$$\frac{\partial^2\Phi}{\partial X^i\partial X^j} = \frac{\partial}{\partial X^i} \left(2X^j \frac{\partial\Phi}{\partial u} \right) = 2\delta^{ij} \frac{\partial\Phi}{\partial u} + 4X^i X^j \frac{\partial^2\Phi}{\partial u^2}$$

Now, since the beta function requires $\partial_\mu\partial_\nu\Phi(X) \sim G_{\mu\nu}(X)$, this means that

$$2\delta^{ij} \frac{\partial\Phi}{\partial u} + 4X^i X^j \frac{\partial^2\Phi}{\partial u^2} = \frac{1}{y^2} \delta^{ij}$$

This then implies that

$$\frac{\partial\Phi}{\partial u} = \frac{1}{2y^2}$$

(we can see this by considering the case $i \neq j$). However, we also have that

$$\frac{\partial^2\Phi}{\partial X^i\partial y} = 2X^i\frac{\partial^2\Phi}{\partial u\partial y} = 0$$

and we have a contradiction. Therefore, there is no rotationally invariant form for Φ that satisfies the graviton beta function equation.

This appears to be disastrous. However, we have shown above that it may be possible to derive new conditions for Weyl invariance in a completely different way, namely by expanding in negative powers of the target space dimension. This potentially releases us from the restriction that we need an X^i -dependent dilaton field. In fact, we will show that it is indeed possible to construct a Weyl invariant string theory in the higher-dimensional space using this new expansion where the dilaton field depends only on the holographic coordinate and not the X^i 's. The payoff for this success is that we need to add a new term to the metric which couples z to the Faddeev-Popov ghost sector of the worldsheet. This is a very strange conclusion; but if we view our goal as the construction of a worldsheet theory that describes the Wilson loop there is no philosophical objection. The physical meaning of this coupling remains unclear. However, it is striking that a calculational scheme in which the string background is *strongly* curved allows one to circumvent the problem of a dilaton that breaks Poincaré invariance in the gauge theory whilst maintaining Weyl invariance at the quantum level.

A word about the interpretation of our calculation. Remember that the holographic coordinate φ is the Liouville mode associated with the noncritical string propagating on the flat D -dimensional background, and as such is a dynamical worldsheet variable. In order for string theory propagating on any background to be consistent, it must be Weyl invariant. That is to say, the theory must be independent of the worldsheet metric g_{ab} , and so in particular if we split this metric into

$$g_{ab} \rightarrow e^{\phi(\xi)} \hat{g}_{ab}$$

with \hat{g}_{ab} independent of $\phi(\xi)$ then the theory must be independent of $\phi(\xi)$. Note

the important distinction between the Liouville mode $\varphi(\xi)$ which is dynamical and plays the role of a spacetime coordinate, and the variable $\phi(\xi)$ which represents an arbitrary split of the worldsheet metric in the $(D + 1)$ -dimensional background formed by the X^i 's and φ . We are going to investigate the conditions under which the theory in the higher-dimensional target space composed of the X^i 's and φ is independent of the split shown above. *We are not calculating the independence of the theory on the Liouville mode φ .* Despite this, the calculation of the ϕ -dependence of the string theory in the $(D + 1)$ -dimensional target space is mathematically identical to the usual Weyl anomaly calculation, as we shall see. To avoid confusion, we refer to the field $\phi(\xi)$ as the *scale* of the worldsheet metric in conformal gauge. When we refer to the *Liouville action* for $\phi(\xi)$ we mean an action for $\phi(\xi)$ of the form given in equation (2.18).

We now begin our analysis of bosonic string theory propagating on the Polyakov warped geometry by first choosing a convenient target space coordinate system, and specializing to the case of AdS space. We will then define the string partition function, and begin to compute the path integral using the $1/D$ expansion. (Note that while this approach is not suitable for a reliable description of 4 dimensional physics, it hopefully allows one to study *qualitative* aspects of bosonic string physics in “non-perturbative” regimes. The hope is that this will eventually shed some light on how one might begin to improve our understanding of the physics of superstrings (rather than supergravity) on lower-dimensional curved geometries such as $AdS_5 \times S^5$, and hence strongly coupled gauge theories.) The generalization to other geometries of the form given below in equation (4.11) will be discussed in Chapter 6.

4.3 Definition of the partition function for AdS

The $(D + 1)$ -dimensional metric we are interested in is

$$ds^2 = d\varphi^2 + z^2(\varphi)dX^i dX^i \quad (4.11)$$

where i runs from 1 to D . It is useful to treat the function z as a coordinate itself; hence, we write

$$ds^2 = \left(\frac{d\varphi}{dz}\right)^2 dz^2 + z^2 dX^i dX^i \quad (4.12)$$

Now, we absorb the “warp factor” z into the X coordinate by defining a new coordinate W^i such that

$$W^i = zX^i$$

This puts the metric into the form

$$ds^2 = \frac{1}{(z')^2} dz^2 + dW^i dW^i - \frac{2}{z} dz(W^i dW^i) + \frac{W^2}{z^2} dz^2 \quad (4.13)$$

where $z' = dz/d\varphi$. The zigzag symmetric point at which the D -dimensional flat metric vanishes is still $z^* = 0$; depending on the function z' , this will correspond to a certain value of the holographic coordinate φ . Now, the Polyakov action for a string on a curved background is

$$S = \frac{1}{4\pi\alpha'} \int d^2\xi \sqrt{g} g^{ab} \partial_a X^\mu \partial_b X^\nu G_{\mu\nu}(X) \quad (4.14)$$

Notice that we have not included a dilaton coupling here yet; the precise nature of this coupling will be determined by the Weyl anomaly that we encounter when we begin to look at the quantum theory of this action. For the moment we will concentrate on the case of AdS space, so that

$$z' = \frac{z}{l}$$

as we saw in Chapter 3. Substituting the target space metric into the Polyakov action then yields, after some integration by parts (we are working to tree level and with closed strings, so the worldsheet is topologically a sphere),

$$S = \frac{1}{4\pi\alpha'} \int d^2\xi \sqrt{g} \left[g^{ab} l^2 \frac{\partial_a z \partial_b z}{z^2} + W^i \left(\Delta - \frac{1}{z} \Delta z \right) W^i \right] \quad (4.15)$$

where Δ is the usual covariant worldsheet Laplacian,

$$\Delta = -\frac{1}{\sqrt{g}} \partial_a (\sqrt{g} g^{ab} \partial_b)$$

We therefore define the partition function of this string theory as

$$Z = \int \mathcal{D}g \mathcal{D}z \mathcal{D}W^i \exp(-S) \quad (4.16)$$

The aim of the perturbative calculation in $1/D$ that we are about to do is to determine under which conditions this object is Weyl invariant, and whether these conditions are compatible with a dilaton that depends only on z , and hence the holographic coordinate φ (since this would correspond to a dilaton field that does not break Poincaré invariance in the putative lower-dimensional gauge theory).

4.4 The effective action for z

The action (4.15) is Gaussian in the W^i 's, and so these fields can be integrated out exactly. The resultant effective action is

$$S' = \frac{1}{4\pi} \int d^2\xi \sqrt{g} l^2 \left(-\frac{1}{z} \Delta z \right) + \frac{D}{2} \text{Tr} \ln \left(\Delta - \frac{1}{z} \Delta z \right) \quad (4.17)$$

Here, we have chosen to work in units in which $\alpha' = 1$, and we have integrated the first term by parts. We will restore the factors of α' a little later on to demonstrate the difference between the $1/D$ expansion and the standard one. We have also not explicitly included the possible effect of zero modes of the operator

$$\left(\Delta - \frac{1}{z} \Delta z \right)$$

This is because such zero modes do not contribute when we work on the sphere [27], or indeed any worldsheet without a boundary. Essentially, the integration over the W^i 's yields the determinant above in equation (4.17), plus an integration over the zero mode coordinates. One then trades this integration for an integration over some collective coordinate, representing the centre of mass of the worldsheet in the W -directions. The Jacobian associated with this change then cancels the zero mode contribution in the determinant leaving an (infinite) integral over the collective coordinate, equal to the volume of target space. This, however, is merely an irrelevant overall constant.

The situation is far more complicated for open strings where the worldsheet is a manifold with a boundary; this is something that would have to be considered carefully if the calculations presented here were to be extended to the case of open strings. However, these questions have been considered extensively in [27] and therefore progress in this direction should be possible. In this thesis, however, we restrict ourselves to the simpler case of closed strings. We expect that, as for strings in flat spacetimes, the main features of the Weyl anomaly will be the same in both cases.

It will be convenient for our purposes to define the quantity f to be

$$f = -\frac{1}{z} \Delta z \quad (4.18)$$

Our task is to now analyze the determinant in the effective action. We need to know how it depends on $z(\xi)$, and how it depends on the scale of the worldsheet metric $\phi(\xi)$

when we fix the conformal gauge $g_{ab} = e^\phi \delta_{ab}$, as we know we can when working to tree level on the sphere. As we saw when we considered the $O(N)$ sigma model (4.4), it is possible to approximate the theory by computing the dominant configuration of $z(\xi)$. Our approach here will be to identify the minimal energy configuration of $z(\xi)$, and then construct a perturbation expansion about this configuration in powers of $1/D$. In the $O(N)$ sigma model we saw that the saddle point approximation led to a configuration of $\lambda(x)$ that was a constant, signalling dynamical mass generation. We will now show that the situation here is different, essentially because the analogous quantity to $\lambda(x)$ is $f(\xi)$, which depends both on $z(\xi)$ and derivatives of $z(\xi)$.

The Euler-Lagrange equation for $z(\xi)$ is

$$\frac{\delta S'(z)}{\delta z} = 0$$

By the Leibnitz rule,

$$\int d^2\xi \frac{\delta S'}{\delta f(\xi')} \frac{\delta f(\xi')}{\delta z(\xi)} = 0$$

and so we have two possibilities for extrema of the action S' . The condition

$$\frac{\delta f}{\delta z} = 0 \tag{4.19}$$

implies that $z(\xi)$ is a constant, which we denote by z_0 . The alternative,

$$\frac{\delta S'}{\delta f} = 0,$$

is the same as the Euler-Lagrange equation for $\lambda(x)$ that we saw when we considered the $O(N)$ model (4.4), and therefore implies that

$$-\frac{1}{z} \Delta z = \lambda_0 = \text{constant} \tag{4.20}$$

The question therefore is: which of these configurations minimizes the action (4.17)? Firstly, we notice that solutions to equation (4.20) will be of the form

$$z^*(\xi_a) \sim \exp\left(\sqrt{\lambda_0} \xi_a\right) + \exp\left(-\sqrt{\lambda_0} \xi_a\right)$$

where ξ_a is one of the worldsheet coordinates. This solution blows up and is therefore not normalizable. However, since $z(\xi)$ is an embedding of the worldsheet into the target space, this non-normalizability just means that some of the worldsheet is

located at the infinity in the z -direction in target space. This is a perfectly legitimate embedding, and as such we cannot discount such non-normalizable solutions on physical grounds. We need to consider the energetics of the system to identify the true vacuum about which we will perform our perturbative calculations.

Clearly if $z(\xi) = z_0$, the z -dependent part of the action is zero. We need to ask whether the action evaluated at $z(\xi) = z^*(\xi)$, where $z^*(\xi)$ solves equation (4.20), is greater or less than the action evaluated at $z(\xi) = z_0$. To do this, we use the momentum representation of the determinant in the action (4.17):

$$\text{Tr} \ln(\Delta + \lambda_0) \sim \int d^2\xi \left(\int_0^\infty d(p^2) \ln(p^2 + \lambda_0) \right) \quad (4.21)$$

In order to evaluate this integral, cut it off by introducing some large momentum scale $\Lambda^2 \gg 1$:

$$\int_0^{\Lambda^2} d(p^2) \ln(p^2 + \lambda_0) = (\Lambda^2 + \lambda_0) \ln(\Lambda^2 + \lambda_0) - \Lambda^2 - \lambda_0 \ln \lambda_0 \quad (4.22)$$

Therefore the z -dependent part of the action evaluated at $z(\xi) = z^*(\xi)$ is (ignoring the worldsheet metric for the moment)

$$S' = \frac{1}{4\pi} \int d^2\xi \left[l^2 \lambda_0 + \frac{D}{2} \left((\Lambda^2 + \lambda_0) \ln(\Lambda^2 + \lambda_0) - \Lambda^2 - \lambda_0 \ln \lambda_0 \right) \right] \quad (4.23)$$

Notice that the Lagrangian that appears here is a monotonically increasing function of λ_0 (for positive l^2) whose minimum value is at $\lambda_0 = 0$ where

$$S'_{\lambda_0=0} = \frac{D}{8\pi} \int d^2\xi \left[\Lambda^2 (\ln \Lambda^2 - 1) \right]$$

Λ^2 is necessarily a very large number, so that the above expression for the action is a good approximation to the determinant $\text{Tr} \ln(\Delta + \lambda_0)$. Hence, the action is everywhere greater than zero and does not exhibit a turning point. If l^2 is negative² then there exists a maximum, but the action evaluated at this saddle-point is again greater than zero for $\Lambda^2 \gg 1$. Hence, the z -dependent part of the action takes its minimum value when $\lambda_0 = 0$, at which point it is everywhere zero. For non-zero values of λ the action evaluated at any turning point is greater than zero. The z -independent piece is the same for all values of λ . So, the configuration $z(\xi) = z_0$ is

²In fact, we will see later on that l^2 gets renormalized such that it is indeed large and negative.

the true vacuum and we will therefore expand the field z in $O(1/\sqrt{D})$ fluctuations about this classical configuration:

$$z(\xi) = z_0 + \bar{z}(\xi) \quad (4.24)$$

There is no dynamical mass generation here; $z(\xi) = z_0$ corresponds to a worldsheet configuration that has shrunk to a point such that $f(\xi) = 0$. This is analogous to $\lambda(x) = 0$ in the $O(N)$ model (4.4).

When keeping terms up to a certain order in D , we must remember that the fluctuations in z are of higher order. We will see that if we work only to $O(1)$ in $1/D$, we will find an effective action for \bar{z} that is quadratic. We can see that our “field” f can be expanded about the constant piece of z ,

$$f = -\frac{1}{z}\Delta z = -\frac{1}{z_0}\Delta\bar{z} + \frac{1}{z_0^2}\bar{z}\Delta\bar{z} + \dots, \quad (4.25)$$

with the last term here being of order $1/D$. Hence, we can use the expansion of the logarithm

$$\ln(1+x) = \sum_{n=1}^{\infty} \frac{(-1)^{n+1}}{n} x^n \quad (4.26)$$

to expand our determinant:

$$\frac{D}{2}\text{Tr} \ln(\Delta + f) = \frac{D}{2}\text{Tr} \ln \Delta + \frac{D}{2} \sum_{n=1}^{\infty} \frac{(-1)^{n+1}}{n} \text{Tr} [\Delta^{-1} f]^n \quad (4.27)$$

The first term in this expansion is again the same determinant that we encountered when we considered the bosonic string in flat spacetime, and hence we know it contributes a central charge of $c = D$ to the Weyl anomaly. The new terms arise in the summation over n . We will now put back in the factors of α' for a moment. By counting dimensions (we know that the expression (4.27) must be dimensionless since it appears exponentiated in the effective action for z), the first of these terms is of order $1/\alpha'$:

$$\frac{D}{2\alpha'} \int d^2\xi \sqrt{g} \Delta^{-1}(\xi, \xi) f(\xi) \quad (4.28)$$

This term contains pieces that are of $O(\sqrt{D})$ and terms of $O(1)$ in D , by the expansion of f given in equation (4.25). The second term is

$$-\frac{D}{4\alpha'^2} \int d^2\xi \sqrt{g} \int d^2\xi' \sqrt{g'} \left[\Delta^{-1}(\xi, \xi') f(\xi') \Delta^{-1}(\xi', \xi) f(\xi) \right] \quad (4.29)$$

and this term is of $O(1)$ in D but also of $O(1/\alpha'^2)$. Hence, *terms of the same order in D are of different order in α'* . In fact, we can see that the high- n terms in the expansion (4.27) will be negligible in the large- D limit, but will dominate in the small- α' limit. The $1/D$ expansion therefore corresponds to a completely different regime from the standard α' expansion used to derive the usual beta functions; the two expansion parameters are small at opposite ends of the expansion (4.27). In this sense, the $1/D$ expansion is valid for backgrounds that are *strongly curved* at the string scale. There is therefore no contradiction between the results presented here and the standard conditions for Weyl invariance [2].

Let us go back and consider the expression (4.28), with $\alpha' = 1$. We see that this term contains the Green's function at coincident points, $\Delta^{-1}(\xi, \xi)$, and is therefore divergent. This divergence, when regulated, will generate a finite ϕ -dependence which contributes to the Weyl anomaly. There will also be a divergent (constant) piece, which we now calculate. Setting aside the ϕ -dependence for the moment, the divergent part of this term will be

$$\frac{D}{2} \int d^2\xi \sqrt{g} f(\xi) \left[\frac{1}{(2\pi)^2} \int d^2p \frac{1}{p^2 + m^2} \right] \quad (4.30)$$

where we have introduced a small mass m to regulate the IR divergence. We will see later on that this mass cancels with other terms in the expansion, as we would hope. However, we still need to deal with the short-distance (high momentum) divergence in this integral. To do this, we cut off the momentum integral at some scale Λ_0 :

$$\begin{aligned} \int_{p < \Lambda_0} d^2p \frac{1}{p^2 + m^2} &= \pi \int_0^{\Lambda_0} \frac{dy}{y + m^2} \\ &= \pi \ln \left(\frac{\Lambda_0^2 + m^2}{m^2} \right) \end{aligned}$$

and so the divergent piece of this first term in the expansion is

$$\frac{D}{8\pi} \int d^2\xi \sqrt{g} f(\xi) \ln \left(\frac{\Lambda_0^2 + m^2}{m^2} \right) \quad (4.31)$$

Writing this in terms of \bar{z} , we see that up to $O(1)$ in D this term becomes

$$\frac{D}{8\pi} \int d^2\xi \sqrt{g} \left(\frac{1}{z_0^2} \bar{z} \Delta \bar{z} \right) \ln \left(\frac{\Lambda_0^2 + m^2}{m^2} \right) \quad (4.32)$$

since the term linear in \bar{z} vanishes under integration over the worldsheet.

We now turn to the question of the ϕ -dependence of this term. In fact, a moment's thought reveals that we will have to do much more than this, since there are an infinite number of terms in this expansion which may introduce terms into the Weyl anomaly. Now, we do not need to worry about those terms which are, for instance, of order $1/\sqrt{D}$ and higher (just as in the standard calculations we do not worry about terms of order α'^2 and so on). But it turns out that one can actually compute the total Weyl dependence of the infinite series of terms; this will make our life considerably easier in the long run. The strategy is as follows: there is a standard result for the ϕ -dependence of the Green's function at coincident points (see Appendix A). We will show, by doing a rather lengthy heat kernel calculation (with a few neat tricks at the beginning), that the contribution from this divergent Green's function is precisely the same as that obtained by analyzing the entire determinant. The conclusion is, therefore, that *all the ϕ -dependence of the infinite sum of terms above is contained in the first term*. None of the higher-order terms can introduce any further terms into the Weyl anomaly. This turns out to be a powerful result, and allows us to make significant progress in constructing a Weyl invariant theory with all the properties that we are looking for. We will now move our attention away from the problem as it has been formulated above, and show how one can compute the Weyl anomaly of this determinant exactly.

4.5 Exact computation of the Weyl anomaly

4.5.1 Setting the problem up

The operator that we are interested in is

$$\Gamma = \left(\Delta - \frac{1}{z} \Delta z \right) \quad (4.33)$$

One can see that this is quite general and will appear when we consider any metric of the form (4.10). Let us pick a specific example of such a metric, namely AdS space. This corresponds to taking $z = \exp(\varphi/l)$, where l is the radius of curvature. We can write AdS space in so-called Poincaré coordinates, as shown in Chapter 3:

$$ds^2 = \frac{1}{y^2} (l^2 dy^2 + dX^i dX^i) \quad (4.34)$$

The Polyakov action on this background metric becomes

$$S = \frac{1}{4\pi} \int d^2\xi \frac{\sqrt{g}}{y^2} g^{ab} [\partial_a X^i \partial_b X_i + l^2 \partial_a y \partial_b y]$$

This expression is Gaussian in the X^i s, and as usual we can integrate them out exactly to obtain the following determinant:

$$\text{Det}^{-\frac{D}{2}} \left[-\frac{y^2}{\sqrt{g}} \partial_a \left(\frac{1}{y^2} \sqrt{g} g^{ab} \partial_b \right) \right] \equiv \text{Det}^{-\frac{D}{2}} (\Omega) \quad (4.35)$$

The form of the metric dictates that the inner product on variations of the X^i s is

$$(\delta X_1^i, \delta X_2^i) \equiv \int d^2\xi \frac{\sqrt{g}}{y^2} \delta X_1^i \delta X_2^i \quad (4.36)$$

and it is this that we have used to obtain the operator Ω . Working in the conformal gauge, this operator becomes

$$\Omega = -e^{-\phi} \partial_a^2 + 2e^{-\phi} (\partial_a \chi) \partial_a \quad (4.37)$$

where we have set $y = e^\chi$. We will denote the heat kernel for this operator as $K(\xi, \xi'; t)$, satisfying

$$\Omega K = -\frac{\partial K}{\partial t} \quad (4.38)$$

along with an initial condition that we will obtain in a moment. Now, notice that

$$\Omega(e^\chi \tilde{K}) = e^\chi (\Delta + e^{-\phi} ((\partial_a \chi)^2 - \partial_a^2 \chi)) \tilde{K} = -\frac{\partial(e^\chi \tilde{K})}{\partial t} \quad (4.39)$$

and so

$$(\Delta + e^{-\phi} ((\partial_a \chi)^2 - \partial_a^2 \chi)) \tilde{K} = -\frac{\partial \tilde{K}}{\partial t} \quad (4.40)$$

where $\tilde{K}(\xi, \xi'; t)$ is the heat kernel for $(\Delta + e^{-\phi} ((\partial_a \chi)^2 - \partial_a^2 \chi))$. The next step is to relate these expressions to our general operator Γ , (4.33). As we have seen, AdS space corresponds to setting $z = \exp(\varphi/l)$. Looking at the metric in Poincaré coordinates, it is clear that the coordinate χ is related to z via

$$\chi(\xi) = -\ln z(\xi)$$

Therefore, we can write Γ in terms of this function χ , and we find immediately that

$$\left(\Delta - \frac{1}{z} \Delta z \right) = (\Delta + e^{-\phi} ((\partial_a \chi)^2 - \partial_a^2 \chi)) \quad (4.41)$$

which is precisely the operator we encountered in equation (4.40). Hence, we know that the heat kernel for the operator Γ is $\tilde{K}(\xi, \xi'; t)$.

We are concerned with the ϕ -dependence of Γ . To see how we can access information about this, consider first the operator Ω obtained above. We have, from equation (2.12)

$$\delta_\phi \ln \text{Det} \Omega = \int_\epsilon^\infty dt \text{Tr} (\delta_\phi \Omega e^{-t\Omega}) \quad (4.42)$$

where ϵ is again a short-time cutoff. Performing the t -integral, and noting that $\delta_\phi \Omega = -\delta\phi\Omega$, we obtain

$$\delta_\phi \ln \text{Det} \Omega = -\text{Tr} (\delta\phi(\xi) e^{-\epsilon\Omega}) \quad (4.43)$$

We can represent $e^{-t\Omega}$ in terms of the heat kernel for Ω , $K(\xi, \xi'; t)$:

$$e^{-t\Omega} f(\xi) = \int d^2\xi' e^{\phi(\xi') - 2\chi(\xi')} K(\xi, \xi'; t) f(\xi') \quad (4.44)$$

and hence the heat equation (4.38) follows with K satisfying the initial condition

$$\lim_{t \rightarrow 0} K = e^{2\chi - \phi} \delta^2(\xi - \xi')$$

Note that the exponential factors multiplying the delta function here are determined by the inner product (4.36) that we are using. Now, we can derive the initial condition that the heat kernel of Γ must satisfy. Remember that the inner product on variations of the W^i s is given by

$$(\delta W_1^i, \delta W_2^i) \equiv \int d^2\xi \sqrt{g} \delta W_1^i \delta W_2^i,$$

as determined by the form of the string action for the W^i s. Therefore, we can see that the initial condition on \tilde{K} in (4.40) must be

$$\lim_{t \rightarrow 0} \tilde{K}(\xi, \xi'; t) = e^{-\phi} \delta^2(\xi - \xi')$$

Now, we see from equation (4.39), along with the initial conditions on K and \tilde{K} , that the two heat kernels K and \tilde{K} are related in the following way:

$$\tilde{K}(\xi, \xi'; t) = e^{-\chi(\xi) - \chi(\xi')} K(\xi, \xi'; t) \quad (4.45)$$

because the operator Ω only acts on $\chi(\xi)$ and does not pick up terms from $\chi(\xi')$. In particular, $\tilde{K}(\xi, \xi; t) = e^{-2\chi} K(\xi, \xi; t)$. Therefore, by equations (4.43) and (4.44) and the fact that

$$\delta_\phi(\Delta - \frac{1}{z}\Delta z) = -\delta\phi(\Delta - \frac{1}{z}\Delta z)$$

we have

$$\begin{aligned} \delta_\phi \ln \text{Det} \Omega &= \int d^2\xi e^{\phi-2\chi} K(\xi, \xi; \epsilon) \delta\phi \\ &= \int d^2\xi e^\phi \tilde{K}(\xi, \xi; \epsilon) \delta\phi \\ &= \delta_\phi \ln \text{Det} \left(\Delta - \frac{1}{z}\Delta z \right) \end{aligned}$$

This last expression tells us that we can use equation (2.12) and the heat kernel for Ω to determine the ϕ -dependence of $\text{Det}(\Gamma)$, *using the definition of the inner product (4.36)*. What we will see in the next section is that the ϕ -dependence of Ω can be computed without making any approximations in χ . This in turn means that we are able to derive the *full* Weyl anomaly associated with Γ , rather than just the contributions from the first few terms in the expansion of the determinant given in equation (4.27). As was mentioned above, this is a powerful result.

4.5.2 The heat kernel computation

We now present in some detail the rather lengthy calculation of $\delta_\phi \ln \text{Det} \Omega$. The Weyl anomaly is a local quantity on the worldsheet, as can be seen by the fact that we have introduced a short-time cutoff ϵ in the expression (2.12). Since we are looking at short-time effects, the diffusion process described by the heat kernel $\exp(-\epsilon\Omega)$ can only occur over a short time, and hence is localized on the string worldsheet. Therefore, we can suppose that the worldsheet metric we are considering is a perturbation about a flat metric, and we should be able to evaluate the heat kernel for Ω by expanding around the heat kernel for the flat-space worldsheet Laplacian $\Delta_0 = -\partial_a^2$. The “unperturbed” heat kernel satisfying the heat equation for Δ_0 is just

$$K_0 = \frac{e^{2\chi(\xi') - \phi(\xi')}}{4\pi t} e^{-\frac{|\xi - \xi'|^2}{4t}} \quad (4.46)$$

We know that

$$\int d^2\xi' e^{\phi(\xi')-2\chi(\xi')} K_0(\xi, \xi'; t-t') K_0(\xi', \xi; t') = K_0(\xi, \xi; t) = \frac{e^{2\chi(\xi)-\phi(\xi)}}{4\pi t}$$

from looking at the expansion of the heat kernel in eigenfunctions of its operator. Remember that the Weyl scaling behaviour of Ω is given in terms of the *trace* of its heat kernel, so we can use the following *heat kernel expansion* to evaluate $K(\xi, \xi; t)$, which we denote by the shorthand $K^t(\xi, \xi)$:

$$\begin{aligned} K^t(\xi, \xi) &= \frac{1}{4\pi t} + \int_0^t dt' \int d^2\xi' e^{2\chi-\phi} K_{\xi\xi'}^{t-t'} V(\xi') K_{\xi'\xi}^{t'} \\ &+ \int_0^t dt' \int_0^{t'} dt'' \int d^2\xi' e^{2\chi-\phi} \int d^2\xi'' e^{2\chi-\phi} K_{\xi\xi'}^{t-t'} V(\xi') K_{\xi'\xi''}^{t'-t''} V(\xi'') K_{\xi''\xi}^{t''} \\ &+ \dots \end{aligned} \quad (4.47)$$

where we have expanded the operator Ω around the flat-space Laplacian

$$\Omega = \Delta_0 + V(\xi)$$

and used the heat kernel (4.46). We need to calculate all the terms in (4.47) which are of $O(1)$ in the time variable t . Terms of order t will not contribute when we send the cutoff ϵ to zero. The heat equation for K_0 implies that the heat kernel for the operator $e^{-\phi(\bar{\xi})}\Delta_0$ where $e^{-\phi(\bar{\xi})}$ is a constant must be

$$\bar{K}_0(\xi, \xi'; t) = \frac{e^{2\chi(\xi')-\phi(\xi')}}{4\pi t} e^{\phi(\bar{\xi})} e^{-\frac{|\xi-\xi'|^2}{4t}} e^{\phi(\bar{\xi})} \quad (4.48)$$

and so we can write Ω as

$$\Omega = e^{-\phi(\bar{\xi})}\Delta_0 - V(\xi)$$

where

$$\begin{aligned} V(\xi') &= \left((\xi' - \bar{\xi})^a \partial_a \phi - \frac{1}{2} (\xi' - \bar{\xi})^a (\xi' - \bar{\xi})^b (\partial_a \phi \partial_b \phi - \partial_a \partial_b \phi) \right) e^{-\phi(\bar{\xi})} \Delta'_0 \\ &- 2 \left(1 - (\xi' - \bar{\xi})^a \partial_a \phi + \frac{1}{2} (\xi' - \bar{\xi})^a (\xi' - \bar{\xi})^b (\partial_a \phi \partial_b \phi - \partial_a \partial_b \phi) \right) \\ &\times \left(\partial_a \chi + (\xi' - \bar{\xi})^b \partial_b \partial_a \chi \right) e^{-\phi(\bar{\xi})} \partial'_a \end{aligned}$$

(primes on operators indicate that they act on functions of ξ'). We are now faced with the task of substituting this expression for V into the heat kernel expansion

(4.47) and evaluating all the relevant terms, using the heat kernel (4.48). This calculation, although now conceptually straightforward, is rather lengthy and technical. Essentially, it involves calculating a series of 2-dimensional Gaussian integrals; this is most easily done by constructing a “generating function” and taking derivatives in order to generate the required terms.

We begin by writing down the two contributions of the correct order from the second term of (4.47) (for notational simplicity we omit the $e^{2\chi(\xi)-\phi(\xi)}$ factor from these integrals here and reinstate them at the end, since they carry through as an overall factor):

$$\int_0^t dt' \int d^2\xi' K_{\xi\xi'}^{t-t'} e^{-\phi(\xi)} \left(-\frac{1}{2}(\xi' - \xi)^a(\xi' - \xi)^b (\partial_a\phi(\xi)\partial_b\phi(\xi) - \partial_a\partial_b\phi(\xi)) \right) \Delta' K_{\xi'\xi}^{t'} \quad (4.49)$$

and

$$\int_0^t dt' \int d^2\xi' K_{\xi\xi'}^{t-t'} e^{-\phi(\xi)} 2 \left((\xi' - \xi)^a \partial_a\phi(\xi)\partial_a\chi(\xi) - (\xi' - \xi)^b \partial_b\partial_a\chi(\xi) \right) \partial'_a K_{\xi'\xi}^{t'} \quad (4.50)$$

where we have chosen the constant $\bar{\xi} = \xi$. These Gaussian integrals can be evaluated using (4.48) and are found to equal

$$\frac{1}{24\pi} \left((\partial_a\phi(\xi))^2 - \partial_a^2\phi(\xi) \right) \quad (4.51)$$

and

$$\frac{1}{4\pi} \left(\partial_a^2\chi(\xi) - \partial_a\phi(\xi)\partial_a\chi(\xi) \right) \quad (4.52)$$

respectively.

We now turn to the third term of (4.47). There are four terms which contribute; the relevant pieces of $V(\xi')$ and $V(\xi'')$ respectively appearing in the integral are

$$\begin{aligned} (a) & : -2\partial_a\chi(\xi)e^{-\phi(\xi)}\partial'_a \times -2\partial_b\chi(\xi)e^{-\phi(\xi)}\partial''_b \\ (b) & : -2\partial_a\chi(\xi)e^{-\phi(\xi)}\partial'_a \times (\xi'' - \xi)^b\partial_b\phi(\xi)e^{-\phi(\xi)}\Delta''_0 \\ (c) & : (\xi' - \xi)^a\partial_a\phi(\xi)e^{-\phi(\xi)}\Delta'_0 \times -2\partial_b\chi(\xi)e^{-\phi(\xi)}\partial''_b \\ (d) & : (\xi' - \xi)^a\partial_a\phi(\xi)e^{-\phi(\xi)}\Delta'_0 \times (\xi'' - \xi)^b\partial_b\phi(\xi)e^{-\phi(\xi)}\Delta''_0 \end{aligned} \quad (4.53)$$

These integrals, while being Gaussian, are in practice rather complicated to evaluate. Let us begin with the first of these terms, (a), which involves two single derivatives

on the heat kernels.

$$\begin{aligned}
(a) &= \int_0^t dt' \int_0^{t'} dt'' \int d^2\xi' \int d^2\xi'' \frac{e^{\phi(\xi)}}{4\pi(t-t')} e^{-\frac{|-\xi-\xi'|^2 e^{\phi(\xi)}}{4(t-t')}} \\
&\times \partial'_a \left(\frac{e^{\phi(\xi)}}{4\pi(t'-t'')} e^{-\frac{|-\xi'-\xi''|^2 e^{\phi(\xi)}}{4(t'-t'')}} \partial''_b \left[\frac{e^{\phi(\xi)}}{4\pi t''} e^{-\frac{|-\xi''-\xi|^2 e^{\phi(\xi)}}{4(t'')}} \right] \right) \\
&= \int_0^t dt' \int_0^{t'} dt'' \int d^2\xi' \int d^2\xi'' \frac{e^{5\phi(\xi)}}{256\pi^3} \frac{(\xi' - \xi'')^a (\xi'' - \xi)^b}{(t-t')(t'-t'')^2 (t'')^2} \\
&\times e^{e^{\phi(\xi)} \left(-\frac{|-\xi-\xi'|^2}{4(t-t')} - \frac{|-\xi'-\xi''|^2}{4(t'-t'')} - \frac{|-\xi''-\xi|^2}{4(t'')} \right)}, \tag{4.54}
\end{aligned}$$

all multiplied by the factor $4(\partial_a\chi)(\partial_b\chi)e^{-2\phi(\xi)}$. The simplest way to tackle these integrals is to write them in the form of a matrix equation and use a 'generating function' approach. Begin by making a change of coordinates

$$X^a = (\xi' - \xi'')^a \quad Y^a = (\xi'' - \xi)^a$$

so the ξ part of the integral becomes

$$\frac{(\partial_a\chi)(\partial_b\chi)e^{3\phi}}{64\pi^3(t-t')(t'-t'')^2 t''^2} \int d^2X \int d^2Y (X^a)(Y^b) e^{\phi \left(-\frac{|X+Y|^2}{4(t-t')} - \frac{|X|^2}{4(t'-t'')} - \frac{|Y|^2}{4(t'')} \right)}$$

We can write the exponent now as *vector* \times *matrix* \times *vector*,

$$-\frac{1}{2} (X^1, X^2, Y^1, Y^2) \mathbf{A} (X^1, X^2, Y^1, Y^2)^T$$

where the matrix is

$$\mathbf{A} = \frac{e^{\phi}}{2} \begin{pmatrix} \frac{1}{t-t'} + \frac{1}{t'-t''} & 0 & \frac{1}{t-t'} & 0 \\ 0 & \frac{1}{t-t'} + \frac{1}{t'-t''} & 0 & \frac{1}{t-t'} \\ \frac{1}{t-t'} & 0 & \frac{1}{t-t'} + \frac{1}{t''} & 0 \\ 0 & \frac{1}{t-t'} & 0 & \frac{1}{t-t'} + \frac{1}{t''} \end{pmatrix}$$

Let us now define a "generating function" $Z(K)$:

$$Z(K) = \int d^2X \int d^2Y \exp \left(-\frac{1}{2} (X^a, Y^a) \mathbf{A} (X^a, Y^a)^T + K (X^a, Y^a)^T \right)$$

where K is a vector $(k_1^1, k_1^2, k_2^1, k_2^2)$. This generating function is readily evaluated to be

$$Z(K) = (\det \mathbf{A})^{-1/2} (2\pi)^2 \exp \left(\frac{1}{2} K \mathbf{A}^{-1} K^T \right) \tag{4.55}$$

We see that we can now write our integral as

$$\frac{(\partial_a \chi)(\partial_b \chi)e^{3\phi}}{64\pi^3(t-t')(t'-t'')^2 t''^2} (\partial_1)^a (\partial_2)^b Z(K)$$

evaluated at $K=0$. Here, $\partial_1^a \equiv \frac{\partial}{\partial k^a}$. Computing these derivatives and substituting in for t then gives

$$\begin{aligned} (a) &= \int_0^t dt' \int_0^{t'} dt'' \frac{-\delta^{ab}(\partial_a \chi)(\partial_b \chi)}{2\pi \sqrt{\frac{t^2}{t''^2(t'-t'')^2(t-t')^2}} (t-t')(t'-t'')t''} \\ &= -\frac{(\partial_a \chi)^2}{4\pi} \end{aligned}$$

We now consider term (b) of (4.53). In terms of the generating function, this is

$$(b) = \int_0^t dt' \int_0^{t'} dt'' \frac{(\partial_a \phi)(\partial_b \chi)e^{3\phi}}{64\pi^3(t-t')(t'-t'')^2 t''} (\partial_1)^a (\partial_2)^b \left(\frac{1}{t''} - \frac{\partial_2^2 e^\phi}{4t''^2} \right) Z(K)$$

It is implicitly understood that this expression is evaluated at $K=0$. This is found to be

$$\begin{aligned} (b) &= \int_0^t dt' \int_0^{t'} dt'' \frac{\delta^{ab}(\partial_a \phi)(\partial_b \chi) (t-2t'')}{2\pi \sqrt{\frac{t^2}{t''^2(t'-t'')^2(t-t')^2}} (t-t')(t'-t'')t^2 t''} \\ &= \frac{1}{12\pi} (\partial_a \phi)(\partial_a \chi) \end{aligned}$$

Next, we consider part (c) of (4.53). This is

$$\int_0^t dt' \int_0^{t'} dt'' \frac{(\partial_a \phi)(\partial_b \chi)e^{3\phi}}{64\pi^3(t-t')(t'-t'')t''^2} (\partial_1 + \partial_2)^a (\partial_2)^b \left(\frac{1}{(t'-t'')} - \frac{\partial_1^2 e^\phi}{4(t'-t'')^2} \right) Z(K)$$

again setting $K=0$. This gives

$$\begin{aligned} (c) &= \int_0^t dt' \int_0^{t'} dt'' \frac{2\delta^{ab}(\partial_a \phi)(\partial_b \chi)}{2\pi \sqrt{\frac{t^2}{t''^2(t'-t'')^2(t-t')^2}} t^2 (t'-t'')t''} \\ &= \frac{1}{6\pi} (\partial_a \phi)(\partial_a \chi) \end{aligned}$$

The last term in (4.53), (d), is

$$\frac{(\partial_a \phi)(\partial_b \phi)e^{3\phi}}{64\pi^3(t-t')(t'-t'')t''} (\partial_1 + \partial_2)^a (\partial_2)^b \left(\frac{1}{t'-t''} - \frac{e^\phi \partial_1^2}{4(t'-t'')^2} \right) \left(\frac{1}{t''} - \frac{e^\phi \partial_2^2}{4t''^2} \right) Z(K),$$

integrated over t' and t'' . This gives

$$\begin{aligned} (d) &= -\int_0^t dt' \int_0^{t'} dt'' \frac{\delta^{ab}(\partial_a \phi)(\partial_b \phi) (t^2 - 2tt' + 6t't'' - 6t''^2)}{2\pi \sqrt{\frac{t^2}{t''^2(t'-t'')^2(t-t')^2}} t^3 (t-t')(t'-t'')t''} \\ &= -\frac{(\partial_a \phi)^2}{24\pi} \end{aligned}$$

And so finally, combining results (a), (b), (c) and (d) with (4.51) and (4.52) we find the heat kernel for the operator Ω to be

$$K(\xi, \xi; \epsilon) = e^{2\chi(\xi) - \phi(\xi)} \left[\frac{e^\phi}{4\pi\epsilon} - \frac{1}{24\pi} \partial_a^2 \phi + \frac{1}{4\pi} (\partial_a^2 \chi - (\partial_a \chi)^2) + O(\epsilon) \right] \quad (4.56)$$

where we have restored the $e^{2\chi(\xi) - \phi(\xi)}$ factor. We can now use this result to evaluate $\delta_\phi \ln \text{Det} \Omega$ by taking $\epsilon \rightarrow 0$:

$$\delta_\phi \ln \text{Det} \Omega = \int d^2 \xi \delta \phi \left[\frac{1}{24\pi} \partial_a^2 \phi - \frac{1}{4\pi} (\partial_a^2 \chi - (\partial_a \chi)^2) \right] \quad (4.57)$$

We have removed the divergent term by adding a counterterm to the original string action of the form

$$-\frac{N}{4\pi\epsilon} \int d^2 \xi \sqrt{g}.$$

As a brief aside, notice that if we set χ to zero in the above, we will obtain the following result for the heat kernel of the usual covariant Laplacian, Δ :

$$\mathcal{K}(\xi, \xi; \epsilon) = \frac{1}{4\pi\epsilon} - \frac{e^{-\phi} \partial_a^2 \phi}{24\pi} + O(\epsilon) \quad (4.58)$$

This is the standard result quoted in equation (2.17). Written covariantly, we have

$$\mathcal{K}(\xi, \xi; \epsilon) = \frac{1}{4\pi\epsilon} + \frac{R^{(2)}}{24\pi} + O(\epsilon) \quad (4.59)$$

where $R^{(2)}$ is the worldsheet Ricci scalar curvature.

Now, we can integrate the expression (4.57) to obtain the Weyl anomaly that we seek, remembering that $\chi = -\ln z$:

$$\ln \text{Det}^{-D/2} \left(\Delta - \frac{1}{z} \Delta z \right) = \int d^2 \xi \left[\frac{D}{96\pi} (\partial_a \phi)^2 + \frac{D}{8\pi} \frac{\phi}{z} \Delta_0 z \right] \quad (4.60)$$

with $\Delta_0 = -\partial_a^2$. We recognize the first term here as the usual Weyl anomaly associated with the bosonic string on flat space. Comparing with our expansion of the determinant (4.27), this is the contribution from the first term. Therefore, the whole infinite series of terms that remain in (4.27) yields the second term in (4.60). Thinking back to the first of these terms (4.28), we can calculate its ϕ -dependence by analyzing the Green's function at coincident points. As is shown in Appendix A, the Weyl anomaly of this term is found to be precisely

$$\frac{D}{8\pi} \int d^2 \xi \left(\frac{\phi}{z} \Delta_0 z \right)$$

in the conformal gauge, which means that this is the only term in the expansion (4.27) that contributes any ϕ -dependence, as was advertised previously.

So far, then, we have succeeded in calculating the first term in the expansion of the determinant. This is, up to $O(1)$ in D ,

$$T_1 = \frac{D}{8\pi} \int d^2\xi \sqrt{g} \left[\left(\frac{1}{z_0^2} \bar{z} \Delta \bar{z} \right) \ln \left(\frac{\Lambda_0^2 + m^2}{m^2} \right) + \phi \left(-\frac{1}{z_0} \Delta \bar{z} + \frac{1}{z_0^2} \bar{z} \Delta \bar{z} \right) \right] \quad (4.61)$$

In the next chapter we move on to consider the next term in the expansion (which we call T_2), and show how this gives rise to a novel propagator for the \bar{z} field, as well as providing the necessary terms to cancel the arbitrary IR regulator m^2 that is present in T_1 . The worldsheet theory is also shown to be UV finite by a renormalization of the radius of curvature l^2 .

Chapter 5

The Conditions for Weyl Invariance

Now that we have computed the Weyl anomaly, we need to derive the rest of the terms that are present in the effective action for \bar{z} . Once we have done this, we will need to consider how we can ensure that this theory is Weyl invariant, and we will see that this requires us to add new pieces to our original action (i.e., counterterms). Before we begin to discuss these interesting issues, we need to consider the next term in the expansion (4.27).

5.1 The effective action for \bar{z}

The term we analyze next is

$$T_2 = -\frac{D}{4} \int d^2\xi \sqrt{g} \int d^2\xi' \sqrt{g'} \left[\Delta^{-1}(\xi, \xi') f(\xi') \Delta^{-1}(\xi', \xi) f(\xi) \right] \quad (5.1)$$

Now, since we know from the previous chapter that this term does not depend on the scale of the metric ϕ , we can make a projection and work on the plane. Hence,

$$T_2 = -\frac{D}{4} \int d^2x \int d^2y \left[\Delta^{-1}(x, y) f(y) \Delta^{-1}(y, x) f(x) \right] \quad (5.2)$$

It is convenient to work in momentum space for what follows, so we compute the Fourier transform of this expression. We find

$$\tilde{T}_2 = -\frac{D}{4} \int \frac{d^2p}{(2\pi)^2} \int \frac{d^2k}{(2\pi)^2} f(p) f(-p) \frac{1}{(p+k)^2 + m^2} \frac{1}{k^2 + m^2} \quad (5.3)$$

where m is again an arbitrary IR regulator. In order to proceed, we need to be able to integrate over the internal momentum k , which we now isolate from the above expression:

$$I = \frac{1}{(2\pi)^2} \int d^2k \frac{1}{(k-p)^2 + m^2} \frac{1}{k^2 + m^2} \quad (5.4)$$

where we have shifted $k \rightarrow k - p$, which we are free to do. Let us represent this integral by introducing two new variables t_1 and t_2 , which we integrate over:

$$I = \frac{1}{(2\pi)^2} \int_0^\infty dt_1 \int_0^\infty dt_2 \int d^2k \exp(-t_1(k^2 + m^2) - t_2((k-p)^2 + m^2)) \quad (5.5)$$

If we expand the $(k-p)^2$ bracket we obtain an integral over k which is Gaussian with a source term,

$$I = \frac{1}{(2\pi)^2} \int_0^\infty dt_1 \int_0^\infty dt_2 \int d^2k \exp(-(t_1 + t_2)k^2 + 2t_2k \cdot p - t_2p^2 - (t_1 + t_2)m^2) \quad (5.6)$$

This is readily integrated over k to obtain

$$I = \frac{1}{(2\pi)^2} \int_0^\infty dt_1 \int_0^\infty dt_2 \frac{\pi}{t_1 + t_2} \exp\left(-p^2 \left(t_2 - \frac{t_2^2}{t_1 + t_2}\right) - (t_1 + t_2)m^2\right) \quad (5.7)$$

Now, we make a simple change of variables $t_1 = \rho x$, $t_2 = \rho(1-x)$ where $0 < \rho < \infty$ and $0 < x < 1$. The Jacobian for this change of variables is $-\rho$. Hence, our integral becomes

$$I = -\frac{1}{(2\pi)^2} \int_0^1 dx \int_0^\infty d\rho \pi \exp(-p^2 x(1-x)\rho - m^2\rho) \quad (5.8)$$

The ρ -integral is simple, and gives

$$I = \frac{1}{(2\pi)^2} \int_0^1 dx \frac{\pi}{p^2 x(1-x) + m^2} = \frac{1}{(2\pi)^2} \int_0^1 dx \frac{\pi}{m^2 + p^2 - p^2(x-1/2)^2} \quad (5.9)$$

If we now define a new quantity

$$\alpha = \sqrt{\frac{m^2}{p^2} + \frac{1}{4}}$$

then we have

$$I = \frac{1}{(2\pi)^2} \int_0^1 dx \frac{\pi}{p^2 \alpha^2 - (x-1/2)^2} = \frac{1}{(2\pi)^2} \cdot \frac{\pi}{2\alpha p^2} \int_{-1/2}^{1/2} dx \left(\frac{1}{\alpha+x} + \frac{1}{\alpha-x} \right) \quad (5.10)$$

This is now a trivial integral, and we find that

$$I = \frac{1}{4\pi\alpha p^2} \ln\left(\frac{\alpha+1/2}{\alpha-1/2}\right) \quad (5.11)$$

We are interested in the regime where $p^2 \gg m^2$ (since we should be able to send m^2 arbitrarily close to zero). In this limit, we find that

$$I \sim \frac{1}{2\pi} \frac{\ln\left(\frac{p^2}{m^2}\right)}{p^2} \quad (5.12)$$

We can now use this result in our expression for T_2 , (5.3) to obtain

$$\tilde{T}_2 = -\frac{D}{4} \int \frac{d^2p}{(2\pi)^2} f(p)f(-p) \frac{1}{2\pi} \frac{\ln\left(\frac{p^2}{m^2}\right)}{p^2} \quad (5.13)$$

Writing this in terms of the variable \bar{z} , we find that up to $O(1)$ in D this expression becomes

$$\tilde{T}_2 = -\frac{D}{8\pi} \int \frac{d^2p}{(2\pi)^2} \frac{1}{z_0^2} \bar{z}(p)\bar{z}(-p)p^2 \ln\left(\frac{p^2}{m^2}\right) \quad (5.14)$$

We can now combine this result with the ϕ -independent piece of T_1 given in equation (4.61). Taking the Fourier transform of this term, we find that together we have

$$\frac{D}{8\pi} \int \frac{d^2p}{(2\pi)^2} \left[-\frac{1}{z_0^2} \bar{z}(p)\bar{z}(-p)p^2 \ln\left(\frac{p^2}{m^2}\right) + \frac{1}{z_0^2} \bar{z}(p)\bar{z}(-p)p^2 \ln\left(\frac{\Lambda_0^2 + m^2}{m^2}\right) \right] \quad (5.15)$$

We see that the $\ln m^2$ terms now cancel between these two pieces, as previously advertised. We are now in a position to combine all the results we have obtained so far into an expression for the effective theory of the \bar{z} fluctuations, up to $O(1)$ in D :

$$Z = \int \mathcal{D}\bar{z} \exp(-S') \quad (5.16)$$

$$\begin{aligned} S' &= \frac{1}{4\pi} \int d^2\xi \ell^2 \frac{(\partial_a z)^2}{z^2} - \frac{D}{8\pi} \int \frac{d^2p}{(2\pi)^2} \frac{1}{z_0^2} \bar{z}(p)\bar{z}(-p)p^2 \ln\left(\frac{\Lambda_0^2 + m^2}{p^2}\right) \\ &+ \frac{D}{8\pi} \int d^2\xi \left(\frac{1}{z_0} \partial_a^2 \bar{z} - \frac{1}{z_0^2} \bar{z} \partial_a^2 \bar{z} \right) \phi \\ &+ \frac{26 - D}{96\pi} S_L \end{aligned} \quad (5.17)$$

where we have included the contribution from the ghost sector in the last line (see Appendix B).

5.2 Analysis of the effective action

We must now discuss the properties of the action (5.17), bearing in mind that we are searching for a finite, Weyl invariant theory. The first thing we notice is that

the second term in the action is divergent, since it contains the momentum cutoff Λ_0 (the m^2 piece is irrelevant, since we can always absorb this into the definition of Λ_0). It is clear that we need to have some kind of dimensionful cutoff in the theory that we can use to absorb this divergence - in other words, the theory requires a “bare” parameter that we can renormalize to make everything UV finite. Clearly, it is in the definition of the first term in the action that we have this. In momentum space this term becomes

$$\int d^2\xi l^2 \frac{(\partial_a z)^2}{z^2} = - \int \frac{d^2p}{(2\pi)^2} l^2 \left[\frac{\bar{z}(p)\bar{z}(-p)}{z_0^2} p^2 \right] \quad (5.18)$$

Now, if we *redefine* our “scale” l^2 such that

$$l^2 = -\frac{D}{2} \ln \left(\frac{\Lambda_0^2 + m^2}{\Lambda^2} \right) \quad (5.19)$$

with Λ^2 finite then our effective action becomes

$$\begin{aligned} S' &= -\frac{D}{8\pi} \int \frac{d^2p}{(2\pi)^2} \frac{1}{z_0^2} \bar{z}(p)\bar{z}(-p) p^2 \ln \left(\frac{p^2}{\Lambda^2} \right) \\ &+ \frac{D}{8\pi} \int d^2\xi \left(\frac{1}{z_0} \partial_a^2 \bar{z} - \frac{1}{z_0} \bar{z} \partial_a^2 \bar{z} \right) \phi \\ &+ \frac{26-D}{96\pi} S_L \end{aligned} \quad (5.20)$$

where Λ^2 is some overall scale, analogous to Λ_{QCD} . This expression is now UV finite, as we require. In fact, we see that *dimensional transmutation* occurs on the worldsheet; what initially appeared as a coupling constant in the string action (α'/l^2) gets turned into a scale (Λ) in the quantum theory. This is in fact a well-known phenomenon in nonlinear sigma models, and as such is a consequence of the fact that we are treating the “flat” directions (the W^i fields) in the spacetime metric exactly. The integration over these directions is what makes the model reminiscent of the $O(N)$ nonlinear sigma model. (Remember, of course, that the dimensional transmutation here is occurring on the worldsheet, not in target space). Notice also that we require the renormalized l^2 to be negative. This appears to be a strange conclusion; however, a similar phenomenon occurs in QED and is a consequence of the fact that QED is not asymptotically free. If one were able to consider all the terms of higher order in D in our model, one would expect to find that more pieces would get added to l^2 such that at the end of the day it is positive. The minus sign

here is therefore believed to be a consequence of the fact that we are making an approximation.

We have seen that for *AdS* space the z field is of the form $\exp(\varphi/l)$. From the point of view of this theory as a noncritical string in D dimensions the field φ is the Liouville mode of the worldsheet metric, so we can write

$$z \sim \left(\sqrt{\hat{g}}\right)^{1/l}$$

We require that the theory be independent of how we split this metric. If

$$\left(\sqrt{\hat{g}}\right)^{1/l} \rightarrow \left(e^{\phi(\xi)}\sqrt{\hat{g}}\right)^{1/l} = z e^{\phi(\xi)/l}$$

then we must require that Green's functions of the combination $z e^{\phi(\xi)/l}$ be independent of $\phi(\xi)$. Conversely, viewed as a critical string theory propagating in the $(D+1)$ -dimensional background, we expect Green's functions of z to be independent of $\phi(\xi)$. However, we have seen that l is necessarily divergent. Therefore, $z e^{\phi(\xi)/l} \sim z$ and we see that these two different interpretations of the theory lead to the same mathematical treatment of the Weyl anomaly.

5.3 Cancelling the ϕ -dependence

We now consider the ϕ -dependent term in (5.20). In the standard beta function calculations, such a term appears in the following way. Expanding the target space metric in Gaussian normal coordinates leads one to consider terms of the form

$$R_{\mu\lambda\nu\kappa} \partial_a x^\mu x^\lambda \partial_a x^\nu x^\kappa$$

This 4-point vertex contributes to the 2-point function when we make contractions of any two of the x s, and hence contributes to the graviton beta function as we saw in Chapter 2. In particular, if we contract the x^λ and the x^κ , we generate a diagram with two external legs representing the $\partial_a x$ terms and a loop representing the x terms. This loop is divergent, and introduces some ϕ -dependence. Integration by parts then gives two terms, one of the form $\partial_a^2 \phi \langle x x \rangle$ and another of the form $\langle \partial_a^2 x x \rangle \phi$. This last term is what we have calculated in equation (5.20); effectively it has arisen from the contraction of the W^i fields. In the standard calculation, this

term does *not* contribute since the $\partial_a^2 x$ term just constitutes a local wavefunction renormalization of x and does not affect the 2-point propagator, as was discussed in Chapter 2. This is because the 2-point function we are considering is precisely the propagator associated with the operator ∂_a^2 . Now, in our calculation the \bar{z} propagator is *not* the usual one (whose Fourier representation is $1/p^2$) but some more complicated one whose Fourier representation is given in the first term of equation (5.20). We therefore cannot discard the ϕ -dependent term here. This again illustrates the fundamental difference between the standard beta function calculations and our $1/D$ expansion; the novel \bar{z} propagator in equation (5.20) has arisen because we are considering a completely different set of terms in the expansion of the determinant (4.27) than if we had expanded in powers of α' .

How are we to treat this new ϕ -dependent term? One possible option would be to just leave it in at this stage, since we still have the path integral over \bar{z} to consider. The theory as it stands in (5.20) does not necessarily have to be Weyl invariant, as long as the final expression for the partition function Z is. The approach to performing the \bar{z} integral would be to realize that since the Weyl anomaly is a local quantity, one can attempt to integrate out the \bar{z} field by expanding the exponential and considering only those terms that are quadratic in ϕ . This is because the scale of the metric ϕ necessarily becomes dynamical, as we have seen in Chapter 2. In particular, the action for ϕ will be of the same form as the Liouville action appearing in (2.18), which in the conformal gauge only contains terms $\sim (\partial_a \phi)^2$ (plus cosmological constant-type terms which are not important to this discussion). This is the unique local theory for ϕ that does not contain dimensionful couplings. Hence, we can be sure that only terms that are quadratic in ϕ (and proportional to p^2 in momentum space) can contribute to the remaining Weyl anomaly once all the target space fields have been integrated out. At the end of the day, we will be left with some coefficient multiplying the Liouville action for ϕ , and we will be able to tune the parameter D to cancel this term and make the theory Weyl invariant.

This approach is fine up to a point. The problem occurs when we begin to consider the n -point correlation functions defined by the theory (5.20). These correlation functions are crucial, since if this is really a *bona fide* string theory we should

be able to compute scattering amplitudes of string states by inserting suitable vertex operators (we shall consider this in some detail later on). This amounts to computing correlation functions on the worldsheet for the W^i and \bar{z} fields (also, if we wish to extend our analysis to open strings the inclusion of boundary terms will have a similar effect, notwithstanding the extra complications introduced by zero modes). Now, if the leading order $\phi\bar{z}$ term is present here, we have a pathology in these n -point functions. Any Feynman diagram I consider can have insertions of $O(\sqrt{D})$ that are linear in ϕ , and these will obviously spoil Weyl invariance. The calculation of the “critical dimension” as outlined in the previous paragraph does not ensure that these correlation functions are also Weyl invariant, since each of these diagrams will introduce extra $O(\sqrt{D})$ terms that will alter the result of that calculation. Hence, one would be left with a situation where the critical dimension of the theory would depend on the specific correlation function under consideration, and this is clearly undesirable. We are led to the conclusion that the $\phi\bar{z}$ term in (5.20) must be cancelled by the addition of some counterterm in order for the theory to make proper sense. This is perhaps not surprising, since we know from the usual beta function calculation that *AdS* spacetime requires a dilaton field for Weyl invariance in that approximation. Maybe this condition also holds here? We will see that we can indeed cancel this term (in part) with a dilaton that depends only on the holographic coordinate. This is precisely what we were hoping for - such a field will not break the Poincaré invariance that we require on the boundary in order to describe the gauge theory Wilson loop there. However this is not sufficient to completely kill the offending term, and an extra piece mixing the ghost and matter sectors of the theory is also needed in this approach, as we will see.

5.3.1 The dilaton field as a counterterm

We have seen that we need to cancel the term

$$\frac{D}{8\pi} \int d^2\xi \left(\frac{1}{z_0} \partial_a^2 \bar{z} - \frac{1}{z_0^2} \bar{z} \partial_a^2 \bar{z} \right) \phi$$

If we are to use a z -dependent dilaton field to achieve this, we need to couple it to the string action in the correct way, which is via the worldsheet scalar curvature,

$R^{(2)}$:

$$\int d^2\xi \sqrt{g} R^{(2)} \Phi(z)$$

In the conformal gauge this counterterm becomes

$$\int d^2\xi (-\partial_a^2 \phi) \Phi(z)$$

Since we are working within an expansion in (negative) powers of D , we need to Taylor expand the dilaton field in terms of the fluctuations \bar{z} (which are $O(1/\sqrt{D})$) about the constant value z_0 :

$$\Phi(z) = \Phi(z_0) + \bar{z} \Phi'(z_0) + \frac{1}{2} \bar{z} \bar{z} \Phi''(z_0) + \dots \quad (5.21)$$

Our counterterm is therefore (up to $O(1)$),

$$\int d^2\xi (-\partial_a^2 \phi) \left[\bar{z} \Phi'(z_0) + \frac{1}{2} \bar{z} \bar{z} \Phi''(z_0) \right] \quad (5.22)$$

Now, we need to consider each of these terms separately, and see if we can arrange for them all to cancel the troublesome $\phi \bar{z}$ term in (5.20) order by order. The first piece, proportional to \bar{z} , can be made to cancel simply by integrating the dilaton term by parts and choosing

$$\Phi'(z_0) = \frac{D}{8\pi z_0}$$

This implies that the dilaton field is

$$\Phi(z) = \frac{D}{8\pi} \ln z$$

and hence

$$\Phi''(z_0) = -\frac{D}{8\pi z_0^2}$$

Substituting this into the counterterm, we find a problem. Integrating by parts to isolate the ϕ field we obtain the term we want, namely

$$\frac{D}{8\pi} \frac{\phi}{z_0^2} \bar{z} \partial_a^2 \bar{z}$$

plus an extra piece that we don't want,

$$\frac{D}{8\pi} \frac{\phi}{z_0^2} (\partial_a \bar{z})^2.$$

This term arises because we now have two powers of \bar{z} present, and therefore integrating by parts generates an extra piece. Whilst the first of these terms cancels against the Weyl anomaly as required, the second one does not and is left over as an $O(1)$ contribution to the final result. We are therefore faced with the same problem as we described above, namely the critical dimension being dependent on the particular correlation function under consideration. Although we have now “softened” the problem from $O(\sqrt{D})$ to $O(1)$, we are not really any better off. After all, a difference of 1 between the critical dimension as calculated for a 2-point and a 3-point function is as much a pathology as a difference of 5! It seems clear, then, that a dilaton field alone does not do the job.

In order to proceed, we need to find some way of removing the offending term exactly. This will ensure that it vanishes to all orders, avoiding the difficulties we have just seen. The question is: do we have any freedom left to add counterterms consistently to this theory? After all, they must depend on the metric scale ϕ , and typically the only way that a field can couple explicitly to ϕ is via the dilaton coupling that we have just considered. Since this has failed, things look bleak. However, there is one other part of this theory that we have not really considered yet. This is the ghost sector, and we will see in the next section how this can be used to achieve the cancellation we seek.

5.3.2 “Bosonization” of the ghost sector

The ghost sector of the bosonic string is considered in some detail in Appendix B. The bottom line is that the Faddeev-Popov determinant that we need to properly gauge fix the string path integral leads to a factor of

$$\Delta_{FP} = \exp \left(-\frac{26}{96\pi} \int d^2\xi [(\partial_a\phi)^2] \right) \quad (5.23)$$

in the partition function (the ghost zero modes having been treated separately). We shall now represent this factor itself as a path integral over some bosonic field ψ in the following way:

$$\Delta_{FP} = \int \mathcal{D}\psi \exp \left(-\frac{1}{96\pi} \int d^2\xi \sqrt{g} [\psi \Delta \psi + 2\beta R^{(2)}\psi] \right) \quad (5.24)$$

which in the conformal gauge is

$$\Delta_{FP} = \int \mathcal{D}\psi \exp \left(-\frac{1}{96\pi} \int d^2\xi [(\partial_a\psi)^2 - 2\beta(\partial_a^2\phi)\psi] \right) \quad (5.25)$$

To see how this works, we evaluate this integral by performing a shift in the integration variable $\psi \rightarrow \psi - \beta\phi$, where ϕ is the scale of the metric in conformal gauge (the value of the integral is unchanged under such a shift). Hence,

$$(\partial_a\psi)^2 \rightarrow (\partial_a\psi)^2 + \beta^2(\partial_a\phi)^2 - 2\beta\partial_a\psi\partial_a\phi$$

and

$$-2\beta(\partial_a^2\phi)\psi \rightarrow 2\beta\partial_a\psi\partial_a\phi - 2\beta^2(\partial_a\phi)^2$$

where we have integrated by parts in the first term. We can see that the cross terms in ψ and ϕ cancel and we are left with

$$\int \mathcal{D}\psi \exp \left(-\frac{1}{96\pi} \int d^2\xi [(\partial_a\psi)^2 - \beta^2(\partial_a\phi)^2] \right) \quad (5.26)$$

Now, the ψ -integral is just the integral over a single free boson, and hence yields

$$\exp \left(\frac{1}{96\pi} \int d^2\xi [(\partial_a\phi)^2] \right)$$

in the usual way. Therefore, we have

$$\Delta_{FP} = \exp \left(-\frac{1}{96\pi} \int d^2\xi [(\partial_a\phi)^2 - \beta^2(\partial_a\phi)^2] \right) \quad (5.27)$$

and this must equal

$$\exp \left(-\frac{26}{96\pi} \int d^2\xi [(\partial_a\phi)^2] \right).$$

Therefore, we require that $\beta^2 = -25$, or $\beta = 5i$. It will turn out to be important later on that β^2 is an $O(D)$ quantity (remember that we expect $D = 25$ for a $(D + 1)$ -dimensional spacetime). In any case, we have found that we can represent the contribution of the Faddeev-Popov ghosts in the conformal gauge by the path integral (5.25), provided $\beta^2 = -25$.

5.3.3 Ghost-matter mixing and the dilaton

We now return to the problem in hand, namely how to cancel the term

$$-\frac{D}{8\pi} \int d^2\xi \frac{\phi}{z} \Delta_0 z \quad (5.28)$$

in the effective action (5.20). Here, we have written this term exactly in terms of z , and $\Delta_0 = -\partial_a^2$ as before. Can we modify the ghost action (5.25) to cancel this piece? The answer is yes - all we need to do is add

$$S_{ct} = \frac{D}{8\pi\beta} \int d^2\xi \frac{\psi}{z} \Delta_0 z \quad (5.29)$$

since when we perform the integration variable shift $\psi \rightarrow \psi - \beta\phi$ we generate exactly the right piece to cancel the ϕ -dependent term above. This is clearly what we need - but what is the physical significance of this counterterm? Can we relate it to anything that we see in the standard string calculations?

We saw above that the conventional way to couple a dilaton to the string action is via the scalar curvature,

$$\int d^2\xi \sqrt{g} R^{(2)} \Phi$$

In fact, there is another way to do this. If one bosonizes the ghost sector of the theory (as we have done), the dilaton can be included by coupling it to the bosonic ghost in the following way [28]:

$$\int d^2\xi \sqrt{g} g^{ab} \partial_a \Phi \partial_b \psi \quad (5.30)$$

Again, when one shifts the ψ variable to do the integration, this generates the coupling to the scalar curvature that is required. The remaining term is then treated as a higher-order correction to the target space metric that depends on Φ , and is discarded in the usual small- α' calculations. Now, consider our counterterm (5.29) written for a general worldsheet metric,

$$\frac{D}{8\pi\beta} \int d^2\xi \sqrt{g} \frac{\psi}{z} \Delta z$$

Integrating by parts gives

$$\frac{D}{8\pi\beta} \int d^2\xi \sqrt{g} g^{ab} \left[\frac{\partial_a \psi \partial_b z}{z} + \psi \frac{\partial_a z \partial_b z}{z^2} \right] \quad (5.31)$$

We see that the first term here is of the same form as (5.30), with

$$\Phi(z) = \frac{D}{8\pi\beta} \ln z \quad (5.32)$$

In other words, this looks like we have coupled a dilaton field with logarithmic dependence on the spacetime coordinate z to the string worldsheet. In a sense,

this is not dissimilar to our earlier attempt to cancel the ϕ -dependence using the conventional dilaton coupling, where we found that the leading-order piece could be removed by a logarithmic dilaton field. However, we clearly have some new ingredients here; we also have an extra term

$$\frac{D}{8\pi\beta} \int d^2\xi \sqrt{g} g^{ab} \psi \frac{\partial_a z \partial_b z}{z^2}.$$

This piece mixes the coordinate z and the ghost field ψ in a way not compatible with the interpretation of a dilaton field - in fact, this looks like we have added an extra piece to the target space metric of the form

$$ds_{gh}^2 = \frac{D}{8\pi\beta} \frac{\psi}{z^2} dz^2 \quad (5.33)$$

This mixing of the ‘‘matter’’ field z and the ghost field is the extra ingredient we need to completely cancel the explicit ϕ -dependence in the \bar{z} effective action (5.20). We will postpone a discussion of the possible physical interpretation of this term until later on; for now, we return to the discussion of the Weyl anomaly of the partition function Z by first calculating the new effective action for \bar{z} obtained by cancelling the ϕ -dependence with the counterterm (5.29).

5.4 The ghost zero mode

Including the ghost-matter mixing counterterm (5.29) and performing the usual shift in integration variable in the ψ -integral cancels the ϕ -dependence in (5.20) and leaves us with the following integral over ψ left to do:

$$\int \mathcal{D}\psi \exp \left(-\frac{1}{96\pi} \int d^2\xi [(\partial_a \psi)^2 - \beta^2 (\partial_a \phi)^2] + \frac{D}{8\pi\beta} \int d^2\xi \frac{\psi}{z} \partial_a^2 z \right) \quad (5.34)$$

The last term clearly acts as a source for ψ , and hence we can perform this integral by completing the square in the usual way (we now disregard the β^2 term, since we know it just combines with the result of the ψ -integration to give the correct coefficient for the Liouville action for ϕ). The result of the ψ integral is found to be

$$\text{Det}^{-1/2}(\Delta) \times \exp \left(-\frac{3D^2}{8\pi\beta^2} \int d^2\xi \frac{\bar{z} \partial_a^2 \bar{z}}{z_0^2} \right) \quad (5.35)$$

where we have kept terms up to $O(1)$ in D , as usual (remember that β^2 is $O(D)$). The determinant here is just the piece that combines with the β^2 term ignored above to give the correct ghost contribution, and we have found an extra quadratic piece in \bar{z} that we must include in (5.20). In fact, this piece just contributes a renormalization of Λ , and we now have an effective action of the form

$$S' = -\frac{D}{8\pi} \int \frac{d^2p}{(2\pi)^2} \frac{1}{z_0^2} \bar{z}(p) \bar{z}(-p) p^2 \ln \left(\frac{p^2}{\Lambda^2} \right) + \frac{26-D}{96\pi} S_L \quad (5.36)$$

In fact, there is a subtlety involved in our treatment of the ghost sector that we have overlooked so far, and must now discuss. When we represented the Faddeev-Popov ghost determinant by the path integral over ψ , we did not take account of the possibility of *zero modes* in ψ . Note that this is *not* the same thing as the zero modes considered at the end of Appendix B. The factor that we are representing by the integral over ψ , (5.23), is obtained by omitting the b, c zero modes, which themselves are dealt with by making insertions in the path integral as explained in the Appendix. The zero mode in ψ is a consequence of the way in which we are representing (5.23), and therefore needs to be considered separately. On the sphere, the only permissible normalizable zero modes are the constants; therefore the action for such zero modes, which we denote by ψ_0 , is

$$S_0 = \frac{\beta\psi_0}{48\pi} \int d^2\xi \sqrt{g} R^{(2)} + \frac{D}{8\pi\beta} \int d^2\xi \sqrt{g} \frac{\psi_0}{z} \Delta z \quad (5.37)$$

The first term here is actually topological; the expression

$$\frac{1}{4\pi} \int d^2\xi \sqrt{g} R^{(2)}$$

is equal to the Euler characteristic of the worldsheet. For the sphere this is just 2, so we know that

$$\frac{\beta\psi_0}{48\pi} \int d^2\xi \sqrt{g} R^{(2)} = \frac{\beta\psi_0}{6} = iC\psi_0 \quad (5.38)$$

where C is some (positive) constant. The second term written in terms of the fluctuations \bar{z} in the conformal gauge is

$$-\frac{D}{8\pi\beta} \int d^2\xi \frac{\psi_0}{z_0^2} \bar{z} \partial_a^2 \bar{z}, \quad (5.39)$$

and we must integrate the whole partition function over the zero mode ψ_0 . (Notice, however, that this term is $O(1/\sqrt{D})$). In standard string theory calculations, the

b, c ghost field zero mode integration makes the entire expression vanish unless one makes insertions that kill this off [29]. In our case, however, this integration does not yield zero because the zero mode ψ_0 is coupled to \bar{z} . As we shall see later on when we discuss possible higher-order effects, this zero mode actually changes the \bar{z} propagator in such a way that the n -point correlation functions of the W^i fields which contain internal \bar{z} loops remain Weyl invariant. This is an unexpected bonus; normally one would expect divergent loop momenta to introduce extra ϕ -dependence, but here these divergences are “softened” by the coupling of ψ_0 to \bar{z} . For the moment, however, we continue with our analysis of the effective action (5.36), and discard the zero mode piece for the moment since for our present purposes it can be simply thought of as a higher order renormalization of Λ . The \bar{z} dependent part up to $O(1)$ is therefore just

$$S' = -\frac{D}{8\pi} \int \frac{d^2p}{(2\pi)^2} \frac{1}{z_0^2} \bar{z}(p) \bar{z}(-p) p^2 \ln \left(\frac{p^2}{\Lambda^2} \right) \quad (5.40)$$

We see that this effective action is quadratic in \bar{z} , and as such integrating over \bar{z} will yield a functional determinant that may depend on the scale ϕ . As we will see in the next section, the result of the \bar{z} integration is to contribute just the right amount to the overall Weyl anomaly to ensure that the critical dimension is 26, as we hoped. Since the explicit ϕ -dependence present in (5.20) is no longer present, this result can be trusted up to $O(1)$ in D for all the n -point functions of the theory.

5.5 The critical dimension

The effective action (5.40) indicates that the result of integrating out \bar{z} to this order will be the determinant of an operator. What can we say about this operator? Well, we can read off its Fourier transform from the expression given above, so that

$$\tilde{\Upsilon}_0(p) \equiv p^2 \left[\ln \left(\frac{p^2}{\Lambda^2} \right) \right] \quad (5.41)$$

is the Fourier transform of the ϕ -independent piece of some differential operator Υ , and it is this operator’s functional determinant that we seek. Now, we go back and consider the term (5.1) from which Υ is derived. By looking at the definition of the

Green's function for Δ

$$\Delta \mathcal{G}(x, y) = \frac{\delta(x - y)}{\sqrt{g(y)}},$$

we can see that $\mathcal{G}(x, y)$ is independent of $\phi(\xi)$ for $x \neq y$. In fact, the solution to the above equation is found to be

$$\mathcal{G}(x, y) = \frac{1}{4\pi} \ln |x - y|^2 \quad (5.42)$$

We will use this result later. Since $\mathcal{G}(x, y) = \Delta^{-1}(x, y)$ (this is what we mean by $\Delta^{-1}(x, y)$) we see that equation (5.1) is actually *independent* of ϕ , since the ϕ -dependence of the factors of Δ which appear in the factors of $f(\xi)$ is cancelled by that of the \sqrt{g} terms. This is in complete analogy with the case of the worldsheet Laplacian for strings in flat space, where

$$\int d^2\xi \sqrt{g} X^i \Delta X^i$$

is independent of ϕ . However, we know that it is the inner product on the X^i s that determines the ϕ -dependence of the quantized theory, and the same will be true of the \bar{z} s in our calculation. The reparametrization invariant inner product on variations of z is the same as that for the X^i fields here,

$$(\delta z, \delta z) = \int d^2\xi \sqrt{g} (\delta z)^2 \quad (5.43)$$

Therefore, if we vary the operator Υ with respect to ϕ , it will transform in the same way as Δ , namely

$$\delta_\phi \Upsilon = -\delta\phi \Upsilon \quad (5.44)$$

This simple behaviour under variations with respect to ϕ allows us to compute the ϕ -dependence that we need. Using expression (2.12) for the variation of the logarithm of the determinant of Υ with respect to ϕ , we obtain the formula

$$\delta_\phi \ln \text{Det} \Upsilon = -\text{Tr} \delta\phi e^{-\epsilon \Upsilon} \quad (5.45)$$

Our strategy is now to expand the heat kernel $e^{-\epsilon \Upsilon}$ in powers of ϕ up to linear order. For the reasons given previously in section 5.3, we know that the final result can only be of the form of the Liouville action and hence we need only consider terms

quadratic in ϕ (the other power of ϕ coming from the factor of $\delta\phi$ which we shall integrate up at the end). Using the fact that

$$\Upsilon = \Upsilon_0 - \phi\Upsilon_0 + \dots$$

we find the piece quadratic in ϕ to be

$$\text{Tr}\delta\phi e^{-\epsilon\Upsilon} = \dots + \text{Tr}\delta\phi e^{-(\epsilon-\tau)\Upsilon_0} \phi \frac{\partial}{\partial\tau} e^{-\tau\Upsilon_0} + \dots \quad (5.46)$$

Now, since we know the Fourier transform of Υ_0 , it makes sense to go over into momentum space. Hence, this expression becomes

$$\text{Tr}\delta\phi e^{-\epsilon\Upsilon} = \dots + \int_0^\epsilon d\tau \int \frac{d^2q d^2p}{(2\pi)^4} \delta\phi(p)\phi(p) e^{-(\epsilon-\tau)\tilde{\Upsilon}_0(p+q)} \frac{\partial}{\partial\tau} e^{-\tau\tilde{\Upsilon}_0(q)} + \dots \quad (5.47)$$

where we have expressed the trace as an integral over the variable τ and $\tilde{\Upsilon}_0$ is given in equation (5.41). We now isolate the q -integral and analyze it separately:

$$I = \int d^2q \int_0^\epsilon d\tau \exp\left(-(\epsilon-\tau)\tilde{\Upsilon}_0(p+q) - \tau\tilde{\Upsilon}_0(q)\right) \tilde{\Upsilon}_0(q) \quad (5.48)$$

We can see that to obtain a non-zero result as we send the regulator $\epsilon \rightarrow 0$, we need a factor of $1/\epsilon^c$ (where c is some number) to be generated from the integral over q . Therefore, we need to study the large- q regime of this integral. We thus proceed by making an expansion for $p \ll q$, and examining the terms proportional to p^2 . We make a change of variables such that $Q = q^2$, and then put $x = Q \ln(Q/\Lambda^2)$. Our integral is now

$$I = \pi p^2 \int_0^\epsilon d\tau \int_0^\infty dx \frac{dQ}{dx} x e^{-\epsilon x} \left((\epsilon-\tau)\tilde{f}_1(Q) + (\epsilon-\tau)^2\tilde{f}_2(Q) \right),$$

integrated over p . The functions \tilde{f}_1 and \tilde{f}_2 are the Taylor coefficients arising from the expansion in powers of p . Integrating out τ then leaves us with an integral over x of the form

$$\int_0^\infty dx e^{-\epsilon x} (\epsilon^2 F_1(x) + \epsilon^3 F_2(x))$$

$F_1(x)$ and $F_2(x)$ are functions which contain the Taylor coefficients re-expressed in terms of x , and the factor dQ/dx . The function Q is found to be

$$Q(x) = \frac{x}{W(x/\Lambda^2)} \quad (5.49)$$

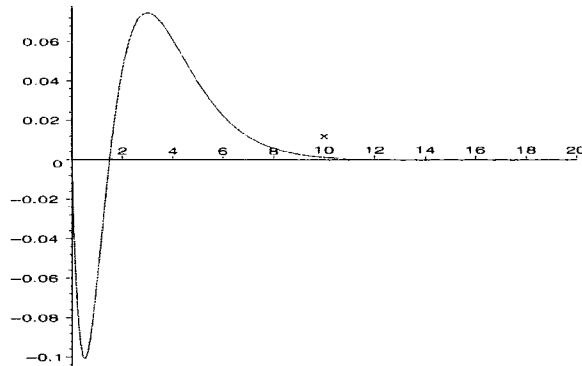

Figure 5.1: Function to be integrated in the calculation of $\text{Det}(\Upsilon)$

where $W(x)$ is the Lambert W -function. Now, if we replace the lower limit in our integral with some number a , we know that the result should be independent of a as we send $\epsilon \rightarrow 0$. Thus, the integral can be computed numerically using a standard quadrature formula such as Simpson's Rule. In fact, by computing the functions $F_1(x)$ and $F_2(x)$ on a computer algebra package one can plot the function to be integrated as a function of x , as in Figure (5.1). When one does this numerical integration, one finds that the result is approximately $1/6$. Importantly, this result is *independent of Λ* - Figure (5.1) is the same for any value of this constant. In fact, we can go further than this by performing the same calculation to find the determinant of the standard covariant worldsheet Laplacian Δ , the result of which we know from the heat kernel calculation. One finds that the function to be integrated over in this case is *precisely the same as the one found above*. The somewhat surprising conclusion, then, is that both these determinants have the same Weyl dependence, and

$$\delta_\phi \text{Det}^{-1/2}(\Upsilon) = \delta_\phi \text{Det}^{-1/2}(\Delta) \quad (5.50)$$

The result of integrating out the fluctuations \bar{z} in the effective action (5.40) is therefore to contribute the same Weyl anomaly as a single free boson. Combining this result with the previous factor of $(26 - D)S_L$ that we obtained above, we find that the remaining dependence on ϕ drops out of the functional integral when

$$26 - (D + 1) = 0 \quad (5.51)$$

showing that the critical dimension for AdS_{D+1} spacetime is 26, as was previously advertised.

5.6 Summary

In this and the previous chapter we have presented a detailed calculation of the string partition function defined on the AdS_{D+1} metric, using a large D expansion. By integrating out the W^i fields exactly, we have been able to derive an effective action for the z field in terms of its fluctuations \bar{z} . The radius of curvature l^2 is dimensionally transmuted into a scale Λ on the worldsheet, yielding a UV finite theory. We have also found a leading order ϕ -dependent term that has to be cancelled if we require the n -point functions in this theory to be Weyl invariant (which is central to the requirement that string scattering amplitudes be Weyl invariant). A conventional dilaton field cannot be coupled to the string metric via the scalar curvature in such a way as to cancel this term to all orders, and we can generate the necessary counterterm by adding a novel matter-ghost mixing term to the bosonized ghost sector. We have found that this corresponds to having a dilaton field that depends logarithmically on z , as well as an extra piece in the background metric that is coupled to the ghost. Finally, the remaining integration over the fluctuations to $O(1)$ has shown that the critical dimension for this system is 26, as we expected.

Notice that while the conditions we have derived here are *sufficient* to ensure Weyl invariance at this order, they may not be *necessary*. It is possible that there are other alternative ways of cancelling the anomaly, other than using the ghost sector as we have here.

In the next section we move on to discuss some aspects of the higher order corrections to these results. In particular we must discuss the effect of the ghost zero mode ψ_0 , and see how this effects the Weyl dependence of the correlation functions of this theory. We will then demonstrate how a Weyl invariant string amplitude can be constructed.

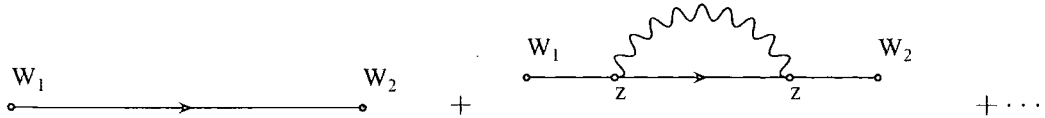
Figure 5.2: The self-energy diagram for W^i

5.7 The correlation functions

We have found a set of conditions which make our model Weyl invariant within our calculational scheme up to $O(1)$ in D . We now discuss what happens when possible higher order effects are included. In particular, we will discuss the n -point correlation functions associated with the W^i fields, since it is here that potential problems arise. We will see that the ghost zero mode ψ_0 plays a role here, and acts to prevent any extra ϕ -dependence being generated by \bar{z} -loops. Consider again the original string action (4.15). Since this action is quadratic in the W^i 's, the z -dependence of the operator

$$\left(\Delta - \frac{1}{z} \Delta z \right)$$

indicates that the 2-point function for W^i can be expanded in powers of the fluctuations in z , as shown in Figure (5.2). The wavy line indicates the \bar{z} -propagator, and the solid line represents the usual Feynman propagator associated with Δ . Notice that the self-energy diagram is of higher order in D , and hence does not affect the results obtained previously. However, we now consider the effect of the ghost zero mode piece given in equation (5.39) on this self-energy diagram. The term (5.39) represents an $O(1/\sqrt{D})$ correction to the \bar{z} propagator defined by equation (5.40). Remembering that β is imaginary, we see that diagrams like that given in Figure (5.2) will involve an integral over the zero mode of the form

$$I = \int d\psi_0 \frac{1}{p^2 \left[\ln \left(\frac{p^2}{\Lambda^2} \right) + i\gamma\psi_0 \right]} e^{iC\psi_0} \quad (5.52)$$

where γ is some positive constant. (In fact, we have rescaled $\psi_0 \rightarrow -|\beta|\gamma\psi_0$. Hence, γ is an $O(1/\sqrt{D})$ quantity. We have then redefined $C \rightarrow C/|\beta|\gamma$. Since C is positive from equation (5.38), γ is also positive.) We can now perform this integral over ψ_0 using contour integration in the usual way. The contour to be integrated over is

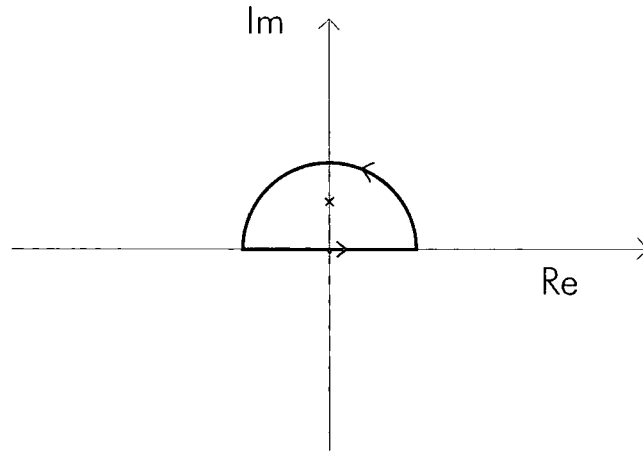
Figure 5.3: Contour integral over the zero mode ψ_0

given in Figure (5.3), with the pole indicated at

$$\psi_0 = \frac{i}{\gamma} \ln \left(\frac{p^2}{\Lambda^2} \right)$$

The value of the integral is then given by the residue, which is

$$I \sim \exp \left(-\frac{1}{\gamma} \ln \left(\frac{p^2}{\Lambda^2} \right) \right) = \left(\frac{p^2}{\Lambda^2} \right)^{-\frac{1}{\gamma}} \quad (5.53)$$

Now, remembering that γ is some small number (it is $O(1/\sqrt{D})$), we see that this factor acts as a kind of “damping term” in the loop integral in Figure (5.2):

$$\begin{aligned} I_{loop} &\sim \int d^2p \int d^2k \int d\psi_0 \frac{1}{(p^2 + m^2)^2} \frac{1}{k^2 + m^2} \frac{1}{(p+k)^2 \left[\ln \left(\frac{(p+k)^2}{\Lambda^2} \right) + i\gamma\psi_0 \right]} e^{iC\psi_0} \\ &\sim \int d^2p \int d^2k \frac{1}{(p^2 + m^2)^2} \frac{1}{k^2 + m^2} \frac{1}{\left(\frac{(p+k)^2}{\Lambda^2} \right)^{\frac{1}{\gamma}}} \\ &= \Lambda^{2/\gamma} \int d^2p \int d^2k \frac{1}{(p^2 + m^2)^2} \frac{1}{(p-k)^2 + m^2} \frac{1}{k^{2/\gamma}} \end{aligned} \quad (5.54)$$

The factor of $k^{2/\gamma}$ prevents the k -integral from diverging in the UV, and therefore we do not have to regulate it. Consequently, diagrams like that in Figure (5.2) do not introduce any extra Weyl dependence arising from divergent momentum integrals. Also, since the W^i fields are not self-interacting, we see that all the n -point functions behave in the same way. The n -point functions for the \bar{z} fields are also explicitly Weyl invariant for the same reason; the \bar{z} propagator does not diverge.

This now completes our analysis of the bosonic string partition function on the Euclidean AdS geometry in the large- D expansion. We have found that this model is Weyl invariant up to $O(1)$ in D if the $(D + 1)$ -dimensional metric is given by

$$ds^2 = \left(l^2 + \frac{D}{8\pi\beta} \psi \right) \frac{dz^2}{z^2} + dW^i dW^i - \frac{2}{z} dz (W^i dW^i) + \frac{W^2}{z^2} dz^2 \quad (5.55)$$

where $i = 1, \dots, D$, and we include a dilaton-like field of the form

$$\Phi(z) = \frac{D}{8\pi\beta} \ln z \quad (5.56)$$

with $\beta = 5i$. The dimension of the target space metric (i.e., $D + 1$) must equal 26.

5.8 A Weyl invariant amplitude

We now move on to consider the construction of a simple string amplitude, using the results of the previous chapters. As was pointed out in Chapter 2, Weyl invariance of vertex operators representing the scattering of string states leads to equations for the masses of particles in the spectrum. We shall see this happening explicitly in what follows. Our aim is to see whether one can construct a Weyl invariant string amplitude within the calculational scheme that we have employed in this thesis.

Let us begin by considering flat spacetime. The expression for the n -point tachyon scattering amplitude is

$$\mathcal{A}_n = \int \mathcal{D}X \left(\prod_n \int d^2\xi_n \sqrt{g_n} e^{ik_n \cdot X(\xi_n)} \right) e^{-S[g, X]} \quad (5.57)$$

where $S[g, X]$ is the usual flat space Polyakov action. We wish to consider a theory not on flat space, but on AdS space. How should we alter the vertex operators to reflect this? One possibility is to “dress” the vertex operator with extra dependence on the spacetime fields, as in [30]. The AdS metric in Poincaré coordinates is

$$ds^2 = \frac{1}{y^2} (l^2 dy^2 + dX_i^2) \quad (5.58)$$

We can write down a wave equation for this metric,

$$(\square + m^2) \phi(y, X) = 0 \quad (5.59)$$

and then construct the dressed vertex operator in the form

$$V = \int d^2\xi \sqrt{g} \phi(y, X) \quad (5.60)$$

This operator should then correspond to a scalar particle in AdS with mass m . Since the metric is flat in the X^i directions, we make the ansatz

$$\phi(y, X) = f(k, y) \exp(ik \cdot X)$$

so that the vertex operator is

$$\int d^2\xi \sqrt{g} f(k, y) e^{ik \cdot X} \quad (5.61)$$

and the function $f(k, y)$ satisfies

$$\left(y^{(D+1)} \frac{\partial}{\partial y} \left(y^{1-D} \frac{\partial}{\partial y} \right) - y^2 l^2 k^2 + l^2 m^2 \right) f(k, y) = 0 \quad (5.62)$$

This can be solved using a computer package, yielding the general solution

$$f(k, y) = A f_1(k, y) + B f_2(k, y) \quad (5.63)$$

with

$$\begin{aligned} f_1(k, y) &= y^{D/2} I_\nu(lky) \\ f_2(k, y) &= y^{D/2} K_\nu(lky) \quad \nu = \frac{1}{2} \sqrt{D^2 - 4m^2 l^2} \end{aligned} \quad (5.64)$$

where $I_\nu(x)$ and $K_\nu(x)$ are the *modified Bessel functions of the first and second kind* of order ν , and A and B are constants. We will demand that the solution be well behaved over the whole range of y . This requires us to set $A = 0$ since the solution involving $I_\nu(x)$ is divergent as $y \rightarrow \infty$, whilst the other solution is everywhere finite as can be seen by plotting both $I_\nu(x)$ and $K_\nu(x)$ as in Figure (5.4). However, we wish to perform our calculation of the amplitude within a large D expansion, and so it is useful to consider a different way of solving the wave equation. We will make use of a series expansion in powers of the wavenumber k [30]:

$$f(k, y) = \sum_{n=0}^{\infty} a_n(y) k^{2n} \quad (5.65)$$

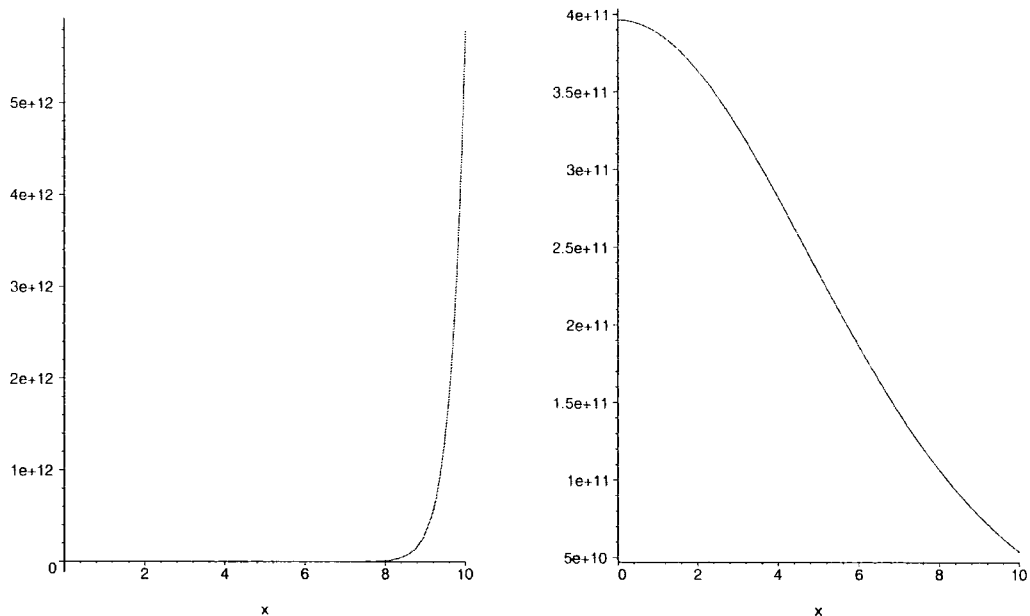

Figure 5.4: Schematic plots of $f_1(x)$ (left) and $f_2(x)$ (right) for fixed k, l and m

Substituting this into the above equation and equating coefficients of k leads to

$$\sum_{n=0}^{\infty} \left[y^2 a_n''(y) - (D-1) y a_n'(y) + m^2 l^2 a_n(y) \right] = l^2 y^2 \sum_{n=1}^{\infty} a_{n-1}(y) \quad (5.66)$$

where primes denote derivatives with respect to y . This is an iterative equation and can be solved for $n = 0, 1, 2, \dots$ and so on. We find, of course, that there are two independent solutions:

$$f_1(k, y) = y^{\alpha_+} \left(1 + \frac{y^2 k^2}{\alpha_+^2 + (4-D)\alpha_+ + 4 + m^2 l^2 - 2D} + O(k^4) \right) \quad (5.67)$$

$$f_2(k, y) = y^{\alpha_-} \left(1 + \frac{y^2 l^2 k^2}{\alpha_-^2 + (4-D)\alpha_- + 4 + m^2 l^2 - 2D} + O(k^4) \right) \quad (5.68)$$

where

$$\alpha_{\pm} = \frac{1}{2} \left(D \pm \sqrt{D^2 - 4m^2 l^2} \right) \quad (5.69)$$

Now, we make the approximation that

$$D^2 \gg 4m^2 l^2$$

appropriate for large D (note that this is also consistent with the large curvature regime where the radius of curvature l^2 is small). In this case,

$$\alpha_+ \sim D \quad \alpha_- \sim 0 \quad (5.70)$$

and we have

$$f_1(k, y) = y^D \left(1 + \frac{k^2 y^2}{4 + m^2 l^2 + 2D} + O(k^4) \right) \quad (5.71)$$

$$f_2(k, y) = 1 + \frac{y^2 k^2 l^2}{4 + m^2 l^2 - 2D} + O(k^4) \quad (5.72)$$

We see that $f_1(k, y)$ consists of at least D factors of y , which will correspond to at least D insertions into the path integral, or the D -point functions of the y -sector of the worldsheet theory. The second independent solution $f_2(k, y)$ looks much easier to deal with since it does not involve raising y to the power of D , which we know to be large. In fact, we know that one of these solutions corresponds to the unphysical divergent Bessel function solution that we discarded above. Comparing plots of these solutions for large D clearly shows that $f_1(k, y)$ is the unphysical solution, and we therefore discard it and concentrate on $f_2(k, y)$.¹

Writing $y = 1/z$ and making our usual expansion about $z = z_0$, we see that

$$\begin{aligned} f_2(k, y) &= 1 + \frac{k^2 l^2}{z_0^2(4 + m^2 l^2 - 2D)} - \frac{2\bar{z}k^2 l^2}{z_0^3 \sqrt{D}(4 + m^2 l^2 - 2D)} + \dots \\ &\approx 1 - \frac{k^2 l^2}{2Dz_0^2} + \frac{\bar{z}k^2 l^2}{z_0^3 D^{3/2}} \end{aligned} \quad (5.73)$$

which consists of a constant piece plus $O(1/D^{3/2})$ corrections involving the \bar{z} s. Furthermore, plugging the expression for $f_2(k, y)$ back into the iterative differential equation shows that terms of higher order in k come in at still higher order in D . Hence, to leading order in D it is legitimate to treat $f_2(k, y)$ as a constant in \bar{z} . Let us see what happens in this case.

5.8.1 Weyl invariance and divergences

We will work in our usual coordinate system z, W . We are going to compute the n -point scattering amplitude defined by

$$\mathcal{A}_n = \int \mathcal{D}g \mathcal{D}z \mathcal{D}W \left(\prod_n \int d^2 \xi_n \sqrt{g_n} e^{i \frac{k_n \cdot W(\xi_n)}{z(\xi_n)}} \right) \exp(-S[g, z, W]) \quad (5.74)$$

where we have omitted the constant factor arising from $f_2(k, y)$ since up to $O(1)$ in D it is just 1. The action here contains all the necessary ingredients (i.e., the

¹Indeed, this is the solution considered in [30].

ghost-matter mixing terms, etc.) to make the partition function without insertions Weyl invariant, as has been shown in preceding chapters. Let us consider the sector of this theory which is coupled to W :

$$S_W = \frac{1}{4\pi} \int d^2\xi \sqrt{g} \left[W^i \left(\Delta - \frac{1}{z} \Delta z \right) W^i \right] - i \sum_n \frac{k_n \cdot W(\xi_n)}{z(\xi_n)} \quad (5.75)$$

We can write this whole expression under the integral sign by introducing a 2-dimensional delta function,

$$S_W = \frac{1}{4\pi} \int d^2\xi \sqrt{g} \left[W^i \left(\Delta - \frac{1}{z} \Delta z \right) W^i - 2i \sum_n \frac{\delta^2(\xi - \xi_n)}{\sqrt{g}} \frac{k_n \cdot W(\xi)}{z(\xi)} \right] \quad (5.76)$$

with normalization

$$\frac{1}{2\pi} \int d^2\xi \sqrt{g} \frac{\delta^2(\xi - \xi_n)}{\sqrt{g}} f(\xi) = f(\xi_n) \quad (5.77)$$

This is now of the form

$$S_W = \frac{1}{4\pi} \int d^2\xi \sqrt{g} \left[W^i \left(\Delta - \frac{1}{z} \Delta z \right) W^i - i(J \cdot W) \right] \quad (5.78)$$

where

$$J^i = \frac{1}{2\pi} \sum_n \frac{\delta^2(\xi - \xi_n)}{\sqrt{g}} \frac{k_n^i}{z} \quad (5.79)$$

We can now perform the integral over the W^i fields in the usual way. If we denote

$$\Gamma = \left(\Delta - \frac{1}{z} \Delta z \right)$$

then the result of the W -integration is to produce a factor

$$\text{Det}^{-D/2}(\Gamma) \exp(-S') \quad (5.80)$$

where

$$S' = -\frac{1}{8\pi^2} \int d^2\xi_1 \sqrt{g_1} \int d^2\xi_2 \sqrt{g_2} \sum_{p,q} k_p \cdot k_q \frac{\delta^2(\xi_1 - \xi_p)}{\sqrt{g_1} z(\xi_1)} \Gamma^{-1}(\xi_1, \xi_2) \frac{\delta^2(\xi_2 - \xi_q)}{\sqrt{g_2} z(\xi_2)} \quad (5.81)$$

We now make an expansion in negative powers of D , as usual:

$$z(\xi) = z_0 + \frac{\bar{z}(\xi)}{\sqrt{D}}$$

In particular,

$$\Gamma^{-1}(\xi_1, \xi_2) = \Delta^{-1}(\xi_1, \xi_2) + O(1/\sqrt{D}) \quad (5.82)$$

and so up to $O(1)$ in D we have

$$S' = -\frac{1}{8\pi^2} \sum_{p,q} k_p \cdot k_q \int d^2\xi_1 \sqrt{g_1} \int d^2\xi_2 \sqrt{g_2} \frac{1}{z_0^2} \frac{\delta^2(\xi_1 - \xi_p)}{\sqrt{g_1}} \Delta^{-1}(\xi_1, \xi_2) \frac{\delta^2(\xi_2 - \xi_q)}{\sqrt{g_2}} \quad (5.83)$$

Absorbing the delta functions gives

$$S' = -\frac{1}{2z_0^2} \sum_{p,q} k_p \cdot k_q \Delta^{-1}(\xi_p, \xi_q) \quad (5.84)$$

Now, the 2-dimensional Green's function $\Delta^{-1}(\xi_p, \xi_q)$ is given by [8]

$$\Delta^{-1}(\xi_p, \xi_q) = \frac{1}{4\pi} \ln |\xi_p - \xi_q|^2 \quad (5.85)$$

when $p \neq q$, as was mentioned previously. When p and q are equal, we have to evaluate the Green's function at coincident points, as in Appendix A. This introduces dependence on the scale of the metric. In the conformal gauge, we obtain

$$S' = -\frac{1}{2z_0^2} k^2 \left(\frac{1}{\epsilon} + \frac{\phi}{4\pi} + O(\epsilon) \right) - \frac{1}{8\pi z_0^2} \sum_{p>q} k_p \cdot k_q \ln |\xi_p - \xi_q|^2 \quad (5.86)$$

where $k^2 = k_p^\mu k_p^\mu$. Let us now substitute this back into the expression for the n -point amplitude. We know that the z -dependent part of this theory is, up to this order, completely determined by its Weyl anomaly which we have shown cancels away when $D + 1 = 26$. What we are left with is, in conformal gauge,

$$\mathcal{A}_n = \prod_n \int d^2\xi_n e^\phi \exp \left(\frac{1}{2z_0^2} k^2 \left(\frac{1}{\epsilon} + \frac{\phi}{4\pi} \right) + \frac{1}{8\pi z_0^2} \sum_{p>q} k_p \cdot k_q \ln |\xi_p - \xi_q|^2 \right) \quad (5.87)$$

We now see that there is a problem. Firstly, note that the divergence arising from the Green's function is multiplied by z_0 . In the usual flat space calculation the divergence can be absorbed by a redefinition of some normalization constant. The same cannot be done in our case; z_0 is to be integrated out eventually and one cannot just absorb it into a constant. The only way to remove this divergence, then, is to demand that $k^2 = 0$. However, this leaves us with a factor of e^ϕ which spoils Weyl invariance. Again, in the usual flat space case one can tune k^2 to be some c -number that cancels the ϕ -dependence arising from the \sqrt{g} in the vertex operator; this cannot be done here since this would require that k^2 be a function of z_0 . This is inconsistent.

We clearly have a problem. The vertex operator that we have constructed does not lead to a Weyl invariant amplitude and therefore must be changed in some way. However since we are asking that it represent a solution to the target space wave equation we are not free to add any new pieces that depend on the target space coordinates. Since we have seen before that the ghost sector can be utilized to achieve Weyl invariance in the partition function, it seems logical to suppose that by dressing the vertex operator with ghost dependence we may be able to solve this problem. Hence, let us further dress the vertex via

$$\int d^2\xi \sqrt{g} f_2(k, y) e^{ik \cdot X} \rightarrow \int d^2\xi \sqrt{g} f_2(k, y) e^{\alpha\psi(\xi)} e^{ik \cdot X} \quad (5.88)$$

where α is some c -number. This new ghost insertion will act as a source term in the integral over ψ , generating new terms which may allow us to construct a Weyl invariant amplitude by tuning α .

5.8.2 The ghost-dependent vertex operator

We now repeat the above calculation but with the extra ψ -dependent insertion. The integration over W proceeds in exactly the same way, producing the action (5.81) as well as the usual z -dependent determinant. The ghost sector is

$$\int \mathcal{D}\psi e^{\alpha\psi(\xi_n)} \exp\left(-\frac{1}{96\pi} \int d^2\xi \sqrt{g} [\psi \Delta \psi + 2\beta R^{(2)}\psi] + \frac{D}{8\pi\beta} \int d^2\xi \sqrt{g} \frac{\psi}{z} \Delta z\right) \quad (5.89)$$

As before, we perform this integration by shifting the integration variable $\psi \rightarrow \psi - \beta\phi$. Remember that this shift produces a term multiplying ϕ and z which cancels the anomaly arising from the W -integration, as well as generating the correct Faddeev-Popov determinant coming from the gauge fixing. In the calculation of the partition function we saw that an extra z -dependent term is also generated since the $\psi - z$ term in the ghost action acts as a source. We now have basically the same situation except this source term is now

$$\frac{D}{8\pi\beta} \int d^2\xi \sqrt{g} \psi \left(\frac{1}{z} \Delta z + \frac{4\alpha\beta \delta^2(\xi - \xi_n)}{D \sqrt{g}} \right) \quad (5.90)$$

and we have a factor of

$$\exp(\phi(\xi_n) - \alpha\beta\phi(\xi_n)) \quad (5.91)$$

coming from the \sqrt{g} and the $\alpha\psi$ coupling in the vertex operator. Performing the exact ψ integral in the conformal gauge therefore generates a factor of

$$I = \exp \left(\frac{3D^2}{8\pi\beta^2} \sum_{r,s} \int d^2\xi_1 \int d^2\xi_2 \left(\frac{1}{z_1} \partial_a^2 z_1 + \frac{4\alpha\beta}{D} \delta^2(\xi_1 - \xi_r) \right) \right. \\ \left. \times \Delta^{-1}(\xi_1, \xi_2) \left(\frac{1}{z_2} \partial_a^2 z_2 + \frac{4\alpha\beta}{D} \delta^2(\xi_2 - \xi_s) \right) \right) \quad (5.92)$$

where z_1 means $z(\xi_1)$. We now expand this out up to $O(1)$ in D as usual, using the basic property of the Green's function

$$\Delta \Delta^{-1}(\xi, \xi') = \frac{\delta^2(\xi - \xi')}{\sqrt{g(\xi)}} \quad (5.93)$$

and remembering that β is necessarily an $O(\sqrt{D})$ quantity. We will assume for now that α is at most an $O(1)$ quantity; this will be confirmed when we determine the tuning conditions for α . We therefore find

$$I = \exp \left(\sum_{r,s} -\frac{3D}{8\pi\beta^2 z_0^2} \int d^2\xi \bar{z} \partial_a^2 \bar{z} + 24\pi\alpha^2 \Delta^{-1}(\xi_r, \xi_s) \right. \\ \left. - \frac{3\alpha\sqrt{D}}{z_0\beta} \int d^2\xi \partial_a^2 \bar{z} \Delta^{-1}(\xi - \xi_s) + \dots \right) \quad (5.94)$$

The first term here we recognize from the partition function calculation. However, we can see that now there are several extra pieces, one of which is independent of the \bar{z} and includes the Green's function at coincident points once again. This will introduce a divergent piece as well as ϕ -dependence. Now, remember that the amplitude includes the factor (5.81) which, up to $O(1)$, generates the troublesome ϕ -dependence and the divergence multiplying z_0 . The inclusion of the ghost piece in the vertex operator now allows us to demand that $k^2 = 0$, removing the offending divergences and ϕ -dependent terms. Where before we were left with a factor of e^ϕ that could not be removed, we now have a factor of

$$\exp(\phi(\xi_n) [6\alpha^2 - \alpha\beta + 1]) \quad (5.95)$$

with the α^2 term coming from the Green's function referred to above. Hence, we can remove this factor by tuning α such that

$$6\alpha^2 - \alpha\beta + 1 = 0 \rightarrow \alpha = \frac{1}{12} \left(\beta \pm \sqrt{\beta^2 - 24} \right) \quad (5.96)$$

We will choose the minus sign here to make α an $O(1/\sqrt{D})$ imaginary quantity. The factor α/β is then a real $O(1/D)$ quantity. In fact, in this case we see that $\alpha = 1/6i$ so that $\alpha/\beta = -1/30$.

The divergence which also arises from the Green's function can be removed by including some normalization constant ζ in the definition of the vertex operator, and defining it such that

$$\tilde{\zeta} = \zeta e^{\frac{24\pi\alpha^2}{\epsilon}}$$

is finite.

Having tuned the value of α we can now write down the expression for the amplitude up to $O(1)$:

$$\begin{aligned} \mathcal{A}_n &\sim \prod_n \int d^2\xi_n \exp\left(\frac{1}{8\pi z_0^2} \sum_{p>q} k_p \cdot k_q \ln |\xi_p - \xi_q|^2\right) \\ &= \prod_n \int d^2z_n \prod_{p>q} |z_p - z_q|^{\frac{k_p \cdot k_q}{4\pi z_0^2}} \end{aligned} \quad (5.97)$$

where we have performed the integration over \bar{z} and enforced Weyl invariance by demanding that $D + 1 = 26$ and $k^2 = 0$. In the second line we have gone over to complex coordinates z, \bar{z} (not to be confused with the *AdS* coordinate $\bar{z}(\xi)$ - that has now been integrated out!) However, before proceeding with this calculation it is worthwhile asking what happens at higher order. The fact that we have tuned α to be a small number means that we are effectively throwing away all of the interactions in this model. Perhaps the richer structure of the theory at higher order may allow us to relax the rather stringent condition that k^2 must be zero. It would seem rather cavalier to just ignore all of this structure, and so to look into this possibility we now go back and expand the theory out to the next order and examine the \bar{z} interaction terms.

5.8.3 Higher order interactions

We begin by writing out the term (5.81) up to $O(1/\sqrt{D})$. This is

$$\begin{aligned} I_1 &= \exp\left(\frac{1}{2} \sum \frac{k_p \cdot k_q}{z_0^2} \left(\Delta^{-1}(\xi_p, \xi_q) - \frac{1}{\sqrt{D}z_0} (\bar{z}(\xi_p) + \bar{z}(\xi_q))\right) \Delta^{-1}(\xi_p, \xi_q)\right) \\ &+ \frac{1}{\sqrt{D}z_0} (\Delta^{-1}(\xi_p, \xi_q))^2 \Delta \bar{z} \end{aligned} \quad (5.98)$$

Similarly, the factor arising from the ghost integration is

$$I_2 = \exp \left(\frac{3}{8\pi} \int d^2x_1 d^2x_2 \left(\frac{4\alpha\sqrt{D}}{\beta z_0} \Delta \bar{z}(x_1) \Delta^{-1}(x_1, x_2) \delta^2(x_2 - x_s) \right. \right. \\ \left. \left. - \frac{4\alpha}{\beta z_0^2} \bar{z}(x_1) \Delta \bar{z}(x_1) \Delta^{-1}(x_1, x_2) \delta^2(x_1 - x_r) + (r \leftrightarrow s, x_1 \leftrightarrow x_2) \right) \right)$$

where we have treated the \bar{z} -independent term and the piece which arose in the partition function calculation, namely equation (5.35), separately. The \bar{z} -independent term is just the term which produces the factor of $6\alpha^2\phi$ that we saw above.

When we expand these two exponentials out and multiply them together we will end up with various terms involving products of two \bar{z} fields. To integrate over the \bar{z} , we must contract these fields together, using the \bar{z} propagator that we have derived previously. It is in fact easier to work in position space for what follows. The propagator derives from the expression (5.1), and its Fourier representation is given in (5.40). From these two expressions, we see that the \bar{z} propagator in position space is

$$\langle \bar{z}(x_1) \bar{z}(x_2) \rangle = 4\pi z_0^2 \int d^2y \frac{1}{\Delta(x_1) \Delta^{-1}(x_1, y) \Delta^{-1}(y, x_2) \Delta(x_2)} \quad (5.99)$$

We will also use the normalization of the delta function given by (5.77) and the definition (5.93). The presence of the constant zero mode ψ_0 is left implicit here; it does not alter the conclusion of what follows since it can be absorbed into the renormalization of Λ in (5.40).

Our task is now to multiply everything together and evaluate all the contractions that arise. This is a somewhat opaque exercise, so rather than writing everything out in detail we will just discuss the general structure of the terms that one finds. Remember that our basic problem is the existence of the term

$$\frac{k^2}{2z_0^2} \Delta^{-1}(0)$$

It is conceivable that the interaction terms will generate extra pieces such that this term becomes

$$\frac{1}{2z_0^2} \Delta^{-1}(0) (k^2 + f(\alpha, \beta) + k^2 g(\alpha, \beta))$$

One could then tune k^2 to be a certain function of α and β to remove this. The separate condition on α , namely that $6\alpha^2 - \alpha\beta + 1 = 0$ (required to cancel the \sqrt{g}

in the vertex operator), would then fix the value of k^2 . Is this actually the case, or are we still forced to set $k^2 = 0$?

The first type of interaction term we encounter is of the form

$$\begin{aligned}
 I_1 &\sim \frac{\alpha}{\beta} \int d^2x_1 \langle \bar{z}(x_1) \Delta(x_1) \bar{z}(x_1) \rangle \Delta^{-1}(x_1, x_s) \\
 &\sim \frac{\alpha}{\beta} \int d^2x_1 \int d^2y (\Delta^{-1}(x_1, x_s) \Delta(x_1) \Delta(x_1) \Delta^{-1}(x_1, y)) \\
 &\sim \frac{\alpha}{\beta} \int d^2y \delta^2(y - x_s) \\
 &\sim \# \times \frac{\alpha}{\beta}
 \end{aligned} \tag{5.100}$$

and we see that no divergences are introduced here². To get this result we have used the fact that

$$\int d^2y \frac{1}{\Delta^{-1}(x, y) \Delta^{-1}(y, z)} = \frac{1}{2\pi} \Delta(x) \Delta(z) \tag{5.101}$$

This identity can be confirmed by inverting the left hand side and acting on it with the right hand side. One obtains just the delta function $\delta^2(x - z)$, confirming that the right hand side of the above expression really is the inverse operator of $\Delta^{-1}(x, y) \Delta^{-1}(y, z)$. (Compare, for example, with the definition (5.93)).

Next are terms of the form

$$\begin{aligned}
 I_2 &\sim \frac{k_p \cdot k_q \alpha}{z_0^4 \beta} \Delta^{-1}(\xi_p, \xi_q) \int d^2x_1 \langle \bar{z}(x_1) \Delta(x_1) \bar{z}(x_1) \rangle \Delta^{-1}(x_1, x_s) \\
 &\sim \frac{k_p \cdot k_q \alpha}{z_0^2 \beta} \Delta^{-1}(\xi_p, \xi_q)
 \end{aligned} \tag{5.102}$$

and we see that for $p = q$ we will get a contribution that goes like

$$\frac{k^2 \alpha}{z_0^2 \beta} \Delta^{-1}(0)$$

One also finds terms like

$$I_3 \sim \frac{k_p \cdot k_q \alpha}{z_0^4 \beta} [\Delta^{-1}(\xi_p, \xi_q)]^2 \Delta(\xi_p) \left\langle \bar{z}(\xi_p) \left(\int d^2x_1 \Delta(x_1) \bar{z}(x_1) \right) \Delta^{-1}(x_1, x_s) \right\rangle \tag{5.103}$$

and this is also found to be proportional to the Green's function at coincident points.

Finally, we have

$$I_4 \sim \frac{k_p \cdot k_q \alpha}{z_0^4 \beta} \left\langle \bar{z}(\xi_p) \Delta^{-1}(\xi_p, \xi_q) \left(\int d^2x_1 \Delta(x_1) \bar{z}(x_1) \right) \Delta^{-1}(x_1, x_s) \right\rangle \tag{5.104}$$

²For notational simplicity we have used $\Delta = -\partial_a^2$; the factors of \sqrt{g} all cancel out.

and this too is proportional to the divergence.

Collecting all these terms together and being careful to get all the numerical factors correct, one obtains the following divergent contribution from the interactions:

$$\frac{1}{2} \frac{k^2}{z_0^2} \Delta^{-1}(0) \left(1 - 48\pi \frac{\alpha}{\beta} \right) \quad (5.105)$$

We can now see that the k^2 dependence factors out, and therefore if $k^2 \neq 0$ then this expression can only be tuned to zero by requiring

$$\alpha = \frac{\beta}{48\pi}$$

Unfortunately, we also require that $6\alpha^2 - \alpha\beta + 1 = 0$ and these two requirements are incompatible. The conclusion is, then, that even when we include the higher order interactions of the theory we still require $k^2 = 0$ in order to get a finite, Weyl invariant theory. Note that if we do demand that $\alpha = \beta/48\pi$, the residual ϕ dependence is

$$\sim \exp(1.15\phi)$$

and it is hard to see how one might add any ingredients to the original vertex operator to cancel this.

So, given that we seem to have no choice but to demand $k^2 = 0$, how should we interpret this? We have asked that our vertex operator be a solution to the wave equation in AdS . Within the $1/D$ approximation that we are using, we have found that $f_2(k, y) = \text{constant}$ is such a solution. The wave equation (5.62) in this case reads

$$m^2 = y^2 k^2 \quad (5.106)$$

This is the (approximate) on-shell condition. Combining this with the Weyl invariance conditions then tells us that we have a *massless scalar particle* in the spectrum of this string model. Note that this equation relates the mass of the particle in the full AdS background to the wavenumber k associated with the flat directions only. This is an encouraging result, since we found in our partition function calculation that we needed to add counterterms which corresponded (in part) to a dilaton field, which is itself a massless scalar. The fact that we have now found a massless scalar particle in the string spectrum suggests that this is a consistent theory at the level

of approximation we are working to. We also note that the requirement that k^2 should be zero in order to remove the divergences multiplying z_0 seems to exclude the possibility of a tachyon - an intriguing and unexpected result. However, it must be borne in mind that this result is heavily dependent on the form of the vertex operator that we have chosen to work with, and as we will see this apparent removal of the tachyon from the spectrum does not persist if we drop the requirement that the vertex operator be a solution to the AdS wave equation. Therefore we do not claim to have found a rigorous set of principles which lead to a tachyon-free bosonic spectrum.

5.8.4 Evaluating the amplitude

Let us now return to the evaluation of the amplitude up to $O(1)$, given by equation (5.97). This expression as it stands is divergent for reasons familiar from flat-space string theory [8]. Although we derived this amplitude by working in the conformal gauge $ds^2 = e^\phi dzd\bar{z}$, the result at this order is manifestly independent of ϕ . Therefore, changes of coordinate which change the value of ϕ will leave \mathcal{A}_n invariant. As is discussed at the end of Appendix B, the group of such transformations is the non-compact group $SL(2, C)$ so the integral in \mathcal{A}_n produces an infinite overcounting, leading to a divergent result.

To overcome this problem, we will factor out the infinity (i.e., the volume of the infinite group $SL(2, C)$). The infinitesimal form of the transformations is given by

$$\delta z = U^z = a_1 + a_2 z + a_3 z^2 \quad (5.107)$$

with a_1, a_2, a_3 being arbitrary complex numbers. So, we can write three of the complex coordinates z_i in terms of three fixed points y_i which are acted on by the transformation U ,

$$z_i = y_i + U^z(z_i) \quad i = 1, 2, 3$$

Hence,

$$\prod_{i=1,2,3} d^2 z_i \rightarrow \prod_{n=1,2,3} d^2 a_n \left| \det \left(\frac{\partial U^z(z_i)}{\partial a_j} \right) \right|^2 \quad (5.108)$$

Computing the determinant readily gives

$$\prod_{i=1,2,3} d^2 z_i = \prod_{n=1,2,3} d^2 a_n |z_1 - z_2|^2 |z_2 - z_3|^2 |z_3 - z_1|^2 \quad (5.109)$$

Since the integrand is independent of the a_n , the integral just produces the infinite volume factor of $SL(2, C)$. The b, c ghost zero modes also generate an infinite factor in the partition function, again equal to the volume of $SL(2, C)$ (again, see Appendix B). However, since they are fermionic ghosts the factor appears in the denominator and cancels against the integral over the a_n s, leaving a finite result. So, we have the result that

$$\mathcal{A}_n = |z_1 - z_2|^2 |z_2 - z_3|^2 |z_3 - z_1|^2 \prod_{n>3} \int d^2 z_n \prod_{p>q} |z_p - z_q|^{\frac{k_p \cdot k_q}{4\pi z_0^2}} \quad (5.110)$$

with $z_{1,2,3} = y_{1,2,3}$. This can be made even simpler by picking values for the y_i s such that $y_1 = 0, y_2 = 1, y_3 = \infty$. Then one obtains

$$\mathcal{A}_n = \int \left(\prod_{n>3} d^2 z_n |z_n|^{\frac{k_1 \cdot k_n}{4\pi z_0^2}} |1 - z_n|^{\frac{k_2 \cdot k_n}{4\pi z_0^2}} \right) \prod_{p>q>3} |z_p - z_q|^{\frac{k_p \cdot k_q}{4\pi z_0^2}} \quad (5.111)$$

If we consider the first nontrivial case where $n = 4$, this is

$$\mathcal{A}_4 = \int d^2 z_4 |z_4|^{\frac{k_1 \cdot k_4}{4\pi z_0^2}} |1 - z_4|^{\frac{k_2 \cdot k_4}{4\pi z_0^2}} \quad (5.112)$$

5.8.5 An alternative approach

Finally, we mention a different way of approaching the construction of the vertex operator that does in fact allow one to leave k^2 unrestricted. We asked that the vertex operator be constructed out of a solution to the wave equation in AdS . While this seems a very natural way to proceed (indeed, this approach has been used in [30] with some success), there is actually no *a priori* reason to impose this condition. Our only real guiding principle is that the vertex operators that we construct should be local functions of the worldsheet coordinates ξ_a which preserve Weyl invariance when inserted into the string path integral. In flat space this reduces to the on-shell condition (by which we mean the condition that the wave equation be solved), but this does not necessarily hold in curved backgrounds [31] [32]. Can we construct a

suitable operator without restricting to such fields? To answer this question, let us consider what happens when we work with an operator of the form

$$V = \int d^2\xi \sqrt{g} e^{\alpha\psi(\xi)} e^{f(k,z)} e^{i\frac{k \cdot W}{z}} \quad (5.113)$$

where the function $f(k, z)$ is now to be determined solely by the condition that the amplitude obtained by using such a vertex operator be Weyl invariant. We keep the same W -dependence, as this ensures that this operator transforms correctly under translations in the W -directions.

In fact, we have already done most of the work. To see the effect of this additional z -dependence, we note that

$$\exp(f(k, z)) = \exp(f(k, z_0)) \times \exp\left(\frac{\bar{z}}{\sqrt{D}} f'(k, z_0) + \dots\right) \quad (5.114)$$

where the prime denotes derivative with respect to z . The first exponential factor here is just an overall constant. We now have the possibility of extra interaction terms arising from the multiplication of the \bar{z} -dependent piece with those terms that we have already considered in the previous section. Up to the order that we have been considering, there is only one extra piece. This is

$$\frac{k_p \cdot k_q \alpha}{z_0^3 \beta} \left\langle \bar{z}(\xi_n) f'(k, z_0) \Delta^{-1}(\xi_p, \xi_q) \left(\int d^2x_1 \Delta(x_1) \bar{z}(x_1) \right) \Delta^{-1}(x_1, x_s) \right\rangle \quad (5.115)$$

which has the effect of changing the divergent piece (5.105) such that it now reads

$$\frac{1}{2} \frac{k^2}{z_0^2} \Delta^{-1}(0) \left(1 - 48\pi \frac{\alpha}{\beta} \left(1 - z_0 f'(k, z_0) \right) \right) \quad (5.116)$$

(remember that we also have the factor (5.95) coming from the ghost integration). Now, we have the freedom to pick $f'(k, z_0)$ such that the k^2 dependence of this divergence is removed. In particular, we can ask that

$$1 - 48\pi \frac{\alpha}{\beta} \left(1 - z_0 f'(k, z_0) \right) = \pm \frac{2z_0^2}{k^2} \quad (5.117)$$

so that expression (5.116) just reduces to $\pm \Delta^{-1}(0)$. This requires

$$f'(k, z_0) = \frac{1}{z_0} - \frac{\beta}{48\pi\alpha z_0} \left(1 \pm \frac{2z_0^2}{k^2} \right) \quad (5.118)$$

which implies that

$$f(k, z) = \left(1 - \frac{\beta}{48\pi\alpha} \right) \ln(z) \pm \frac{\beta}{48\pi\alpha k^2} z^2 \quad (5.119)$$



Having fixed $f(k, z)$ in this way, we are left with the factor (5.95) as well as the $\pm\Delta^{-1}(0)$ coming from (5.116). Hence, α is then determined by demanding that

$$\phi \left(6\alpha^2 - \alpha\beta + \left(1 \pm \frac{1}{4\pi} \right) \right) = 0 \quad (5.120)$$

(the $1/\epsilon$ piece can be removed by a simple redefinition of some irrelevant normalization constant in the operator). So, the conclusion is that the amplitude constructed from vertex operators of the form

$$V = \int d^2\xi \sqrt{g} e^{\alpha\psi(\xi)} \left(z^{(1-\frac{\beta}{48\pi\alpha})} e^{\pm\frac{\beta}{48\pi\alpha k^2} z^2} \right) e^{i\frac{k\cdot W}{z}} \quad (5.121)$$

is Weyl invariant for all values of k^2 , provided α satisfies (5.120). Note that the function

$$\phi(k, z, W) = \left(z^{(1-\frac{\beta}{48\pi\alpha})} e^{\pm\frac{\beta}{48\pi\alpha k^2} z^2} \right) e^{i\frac{k\cdot W}{z}} \quad (5.122)$$

is not a solution to the wave equation in AdS , $(\square + m^2)\phi = 0$. It is therefore possible, as expected, to construct vertex operators which are not solutions to the wave equation, but which do preserve Weyl invariance in curved backgrounds.

It is interesting to note that in the standard picture, where one calculates by perturbing about flat space, the vertex operators for the massless fields can be obtained by computing the variational derivative of the beta functions [31]. Hence, the Weyl invariance conditions and the vertex operators are intimately linked. Perhaps one could uncover some similar (or maybe quite dissimilar!) relationship between the vertex operators derived above and the conditions for Weyl invariance found within our $1/D$ expansion? The precise way in which to tackle this problem is, at present, rather unclear. However, it would certainly be something that one would like to try and understand, since such a relationship would surely be of value in interpreting further the results that we have found using this novel calculational scheme.

Chapter 6

Discussion and Conclusions

We now discuss some further issues relating to the calculations presented in the previous two chapters, and also make some speculative observations regarding the physical significance of the counterterms we have derived above. We conclude by drawing attention to various questions that are raised by the present work, and several potentially interesting avenues of research based on the work presented here.

6.1 Alternative derivation of the anomaly

As we saw in Section 4.1.1, the large N approximation for the $O(N)$ nonlinear sigma model leads one to consider a saddle point approximation in which the Lagrange multiplier field $\lambda(x)$ is a non-zero constant. While this approximation is not suitable for the string action (4.17), it is interesting to note that the same form for the Weyl anomaly can be obtained by the following calculation. If we write the action in terms of

$$f = -\frac{1}{z}\Delta z$$

then we have

$$S = \frac{1}{4\pi} \int d^2\xi \sqrt{g} l^2 f + \frac{D}{2} \text{Tr} \ln (\Delta + f) \quad (6.1)$$

and we might attempt to analyze this action naïvely by approximating f as a constant, in analogy with the $O(N)$ sigma model (which, as we know from studying the Euler-Lagrange equations, is actually incorrect since the vacuum configuration for the z field corresponds to $f(\xi) = 0$). Let us see how this calculation proceeds.

In assuming that we can take $f(\xi)$ to be a constant, we are essentially saying that this is the dominant configuration of $f(\xi)$ and this looks like a saddle-point approximation (although at no point in what follows do we need to determine what this saddle-point value actually is). However, we do need to be a little careful over defining what exactly we mean when we refer to the saddle point. In the standard nonlinear sigma model *field* theory (4.4), the field $\lambda(x)$ was a scalar field. Now, in the *string* theory the field f is a worldsheet scalar which depends on the metric g_{ab} and hence the scale of the metric $\phi(\xi)$. It therefore makes sense to consider a new quantity, the *scalar density* of f , which is independent of the scale of the metric. This scalar density is given by

$$\rho(\xi) = \sqrt{g} f(\xi) \quad (6.2)$$

The key point is that the saddle point (a physical configuration of f) must be *reparametrization invariant*; therefore, we postulate that the correct way to write the saddle point for f is

$$\rho^* = \text{constant}$$

so that $f^* = (1/\sqrt{g})\rho^*$. Note that f^* itself is therefore not a constant, although the saddle point value of the scalar density, ρ , is. In this way, the string sigma model (6.1) reduces correctly to the field theory model (4.4) when we eliminate the worldsheet metric (i.e., we set $g_{ab} = \delta_{ab}$, so that $f(\xi) = \rho(\xi)$).

We can now naively expand the determinant in (6.1) about the “saddle point” value of f :

$$\frac{D}{2} \text{Tr} \ln (\Delta + f) = \frac{D}{2} \text{Tr} \ln (\Delta + f^*) + \dots \quad (6.3)$$

Since we are working within the saddle point approximation, this first term in the expansion of the determinant will dominate. A neat way of regulating a determinant of the form $(-\partial_a^2 + \text{const})$ is to use the *zeta function* $\zeta(s)$, defined by

$$\zeta(s) = \sum_{\lambda} \lambda^{-s}$$

where the λ s are the eigenvalues of the operator that we wish to regulate. If we work in the conformal gauge once again, we have

$$\frac{D}{2} \text{Tr} \ln (\Delta + f^*) = \frac{D}{2} \ln \text{Det} \left(\frac{-\partial_a^2 + \rho^*}{e^\phi} \right) \quad (6.4)$$

so that e^ϕ plays the role of a scale, making the determinant under consideration dimensionless. Hence, from the definition of the zeta function we see that

$$\ln \text{Det} \left(\frac{-\partial_a^2 + \rho^*}{e^\phi} \right) = -\zeta'(0)$$

where the prime on $\zeta(0)$ indicates that we differentiate it with respect to the variable s .

We now write the zeta function in terms of the heat kernel of the operator we are considering:

$$\zeta(s) = \frac{1}{\Gamma(s)} \int_0^\infty dt t^{s-1} K(\xi, \xi; t)$$

Since ρ^* is a constant, it acts like a mass term in the heat kernel and we can write it down explicitly,

$$K(\xi, \xi'; t) = \frac{e^\phi}{4\pi t} e^{-\frac{\mu^2 |\xi - \xi'|^2}{4t} - \frac{\rho^* t}{e^\phi}} \quad (6.5)$$

Substituting this heat kernel into the expression for the zeta function then gives

$$\zeta(s) = \int d^2\xi \left[e^\phi \left(\frac{\rho^*}{e^\phi} \right)^{1-s} \frac{1}{4\pi(s-1)} \right]$$

which then implies that

$$\ln \text{Det} \left(\frac{-\partial_a^2 + \rho^*}{e^\phi} \right) = \frac{1}{4\pi} \int d^2\xi \left(\rho^* - \rho^* \ln \left(\frac{\rho^*}{e^\phi} \right) \right) \quad (6.6)$$

Hence, the ϕ dependent part of this determinant is

$$\frac{1}{4\pi} \int d^2\xi \rho^* \phi = \frac{1}{4\pi} \int d^2\xi \sqrt{g} f^* \phi = -\frac{1}{4\pi} \int d^2\xi \sqrt{g} \frac{\phi}{z} \Delta z \quad (6.7)$$

which is in agreement with the anomaly we found in equation (4.60). It is interesting to see that we obtain the correct form of the anomaly even in this naïve treatment of the action (4.17). In addition, let us look again at the expression (4.22) which represents the determinant appearing in (6.1) approximated by some cutoff $\Lambda^2 \gg 1$. For $\Lambda^2 \gg \lambda_0$, this expression can be approximated by

$$(\Lambda^2 + \lambda_0) \ln(\Lambda^2 + (\Lambda^2 + \lambda_0) \frac{\lambda_0}{\Lambda^2}) - \Lambda^2 - \lambda_0 \ln \lambda_0 \quad (6.8)$$

which is itself approximated by

$$\Lambda^2 (\ln(\Lambda^2) - 1) + \lambda_0 \left(1 - \ln \left(\frac{\lambda_0}{\Lambda^2} \right) \right) \quad (6.9)$$

The first term is just a constant, while the second term is the same as the expression for the determinant we have found using the zeta function above if we identify λ_0 with ρ^* and the scale e^ϕ with Λ^2 . This is a nice cross-check, showing that we have been treating the regularization of the determinant consistently.

Why do we obtain the correct anomaly, despite expanding the determinant about the wrong value? The answer is that we are computing the anomaly associated with the functional integration over the W^i fields. All the information about this anomaly is contained in the action (6.1). The choice of the saddle point for $f(\xi)$ is an issue which relates to the evaluation of the functional integral over the z field; one needs to choose the correct vacuum about which to expand. However, the vacuum state of the z -sector of the theory is independent of the Weyl anomaly associated with the W -sector; hence, we can derive the Weyl anomaly term above by choosing $f(\xi)$ to be a constant (rather than zero) and still obtain the correct answer. Of course, the anomaly associated with the z sector of the theory can only be computed correctly if we expand about the correct point, and this is what we have calculated in Section 5.5.

6.2 Generalization to other geometries

In the calculations presented above we concentrated on AdS space as a specific example of the metric (4.11). However, we could have treated the metric in a more general way by writing it as

$$ds^2 = \frac{1}{(z')^2} dz^2 + dW^i dW^i - \frac{2}{z} dz(W^i dW^i) + \frac{W^2}{z^2} dz^2 \quad (6.10)$$

Obviously, the same determinant (4.33) will appear when we integrate out the W^i fields, and the analysis proceeds as before. Once again we will find that there is a divergence coming from the Green's function at coincident points, as in equation (5.17). In the AdS case, we removed this divergence by renormalizing l^2 . Clearly in the more general case, we have to choose the function z' such that the divergence is removed. This requires

$$\frac{1}{z'} = \frac{l}{z} + f(z) \quad (6.11)$$

where l is some dimensionful cutoff that absorbs the divergence, and $f(z)$ is some arbitrary finite function of $z(\xi)$. Notice that if $f(z) = 0$ the solution to the above equation is AdS space, and corresponds to the case that we have been considering in previous chapters. After cancelling the ϕ -dependent term by including extra terms in the ghost sector as above, this leaves us with an action of the form

$$S' = -\frac{D}{8\pi} \int \frac{d^2p}{(2\pi)^2} \frac{1}{z_0^2} \bar{z}(p) \bar{z}(-p) p^2 \ln \left(\frac{p^2}{\Lambda^2} \right) + \frac{1}{4\pi} \int d^2\xi f(z) (\partial_a z)^2 + \frac{26-D}{96\pi} S_L \quad (6.12)$$

Now, we notice that

$$\frac{1}{4\pi} \int d^2\xi f(z) (\partial_a z)^2 = \frac{1}{4\pi} \int d^2\xi (f(z_0) + O(\bar{z})) (\partial_a \bar{z})^2$$

which is an $O(1/D)$ contribution to the action. Hence, up to the order at which we have been working, the arbitrary function $f(z)$ is irrelevant to the question of Weyl invariance. Any solution to the equation (6.11) will correspond to a background that is Weyl invariant (and UV finite) under the conditions derived above up to $O(1)$. However, the zigzag symmetry conditions must also be satisfied if the background is to be consistent with Polyakov's ansatz for the Wilson loop. Also, the question of Weyl invariance of higher order corrections to the correlation functions of the theory will depend on $f(z)$.

6.3 Physical significance of the counterterms

Let us make a few observations about the nature of the dilaton field we have found. Written in terms of the original coordinates (4.10), $\Phi(z)$ becomes

$$\Phi(\varphi) = \frac{D}{8\pi\beta l} \varphi \quad (6.13)$$

We can now see how this bulk field behaves as we approach the zigzag symmetric point in AdS , $\varphi^* = -\infty$. The dilaton clearly diverges. As we saw in Chapter 2, the dilaton is of great importance in perturbative string theory, since its expectation value gives the effective string coupling constant,

$$g_s \sim e^{\langle \Phi \rangle}$$

Remarkably, we find that at the zigzag symmetric point where the Wilson loop is supposed to be defined, this quantity goes to zero. This suggests that at the point where the string action coincides with that of the lower dimensional gauge theory, the string theory becomes *free* (that is to say, there is no joining or splitting of strings in the sense of the topological expansion depicted in Figure 2.1). This is entirely consistent with the idea that the large- N limit of gauge theories ought to be described by a theory of free strings, as we mentioned in Chapter 3. Since the loop equation is only valid for a large N field theory, and it is this that ultimately we wish to solve by using the string background (4.10), the string theory defined on this background should describe a large N field theory. The behaviour of the dilaton that we have found perhaps provides some evidence for this. Another interesting point is that within the context of Polyakov's conjecture, the string theory only appears to be free at the zigzag symmetric point; in the bulk spacetime far from $\varphi^* = -\infty$ the effective string coupling runs in analogy with the renormalization group picture of Wilson. So the full string theory is *not* free in this picture; it just appears to be free when viewed from the lower dimensional space where the Wilson loop lives.

It must be borne in mind, of course, that we have only calculated the no-string-loop contributions to the partition function and the amplitudes in this thesis, since we have restricted our attention to worldsheets which have the topology of a sphere. String loop corrections to these results must also be considered if the above discussions are to be put on a really rigorous footing.

One other very obvious question arising from our results is: What does it mean to have ghost-matter mixing terms? One possible (though not at all definite) link is to that of the construction of "brane-like" vertex operators [33]. Here, one also finds ghost-matter mixing terms, and therefore this phenomenon in our calculation could indicate that we are indeed detecting non-perturbative effects. This clearly needs more detailed analysis before being taken seriously. However, it would be very interesting if it could be shown that such terms were generic when constructing string theories on strongly curved backgrounds. Note that this situation is not physically objectionable; it has been remarked [34] that the decoupling of ghosts and matter cannot be a valid fundamental principle. This observation is based on

the fact that classically Weyl invariant string theories necessarily possess a *BRST operator* Q which is nilpotent, $Q^2 = 0$. This nilpotency condition is anomalous, and the removal of the BRST anomaly leads to the usual conditions for cancellation of the Weyl anomaly in standard quantization procedures. The BRST operator can be interpreted as a generator of gauge transformations that mix matter and ghost degrees of freedom [35]. Hence, the decoupling of matter and ghost fields is really just a gauge condition rather than a deep physical principle.

6.4 Conclusions and outlook

The main conclusion of the work presented in this thesis is that it is possible, within the large- D calculational scheme presented here, to construct a Weyl invariant bosonic string theory on the background geometry proposed by Polyakov,

$$ds^2 = d\varphi^2 + z^2(\varphi)dX^i dX^i,$$

by allowing a dilaton field of the form

$$\Phi(\varphi) \sim \varphi$$

and by adding a term that mixes the ghost sector (represented by the bosonic field ψ) and the matter sector according to

$$ds_{gh}^2 \sim \psi d\varphi^2$$

This result holds up to $O(1)$ in D for closed strings in a 26-dimensional target space. Higher order corrections to this result are precluded by the effect of the zero mode of ψ , which softens divergences that would otherwise be present in the correlation functions of the theory. It is also possible to construct a Weyl invariant amplitude by making insertions of vertex operators which contain both matter and ghost fields. The amplitude corresponding to a scalar particle which satisfies the wave equation in *AdS* is Weyl invariant to this order only if the particle is massless. Hence, the addition of the counterterms given above is self-consistent. Interestingly, the tachyon appears to be absent from the spectrum. One can also construct vertex operators

which preserve Weyl invariance without restricting the value of k^2 by dropping the requirement that they be constructed from solutions to the wave equation.

Note that the results given here are *sufficient* for Weyl invariance; they may not be *necessary*. It would be interesting to investigate what other mechanisms could be used to achieve Weyl invariance within this scheme.

We will conclude by mentioning some issues which could be addressed by further investigations. An obvious and immediate question is to ask how one could properly extend the analysis described in this thesis to open strings. One area which would require particular care would be the correct treatment of zero modes when integrating out the W^i fields; if the string worldsheet has a boundary, there are many delicate issues involving the correct treatment of zero modes [27]. Clearly the extension to open strings is of the utmost importance if we wish to study this string theory in the context of gauge fields – strings duality. Imposing the correct boundary conditions will also be very important. Some recent work in this direction [36] is certain to be of relevance.

It is also very natural to ask whether the calculational scheme presented in this thesis can be extended to the case of fermionic strings, and ultimately superstrings. Of course, one might expect this approach to be less suited to the case of fermionic strings since in that case we expect the target space dimension to be considerably smaller (of the order of 10, rather than 26) and so the expansion in $1/D$ may be considerably less reliable. However, the principle of treating the target space metric exactly and expanding in $1/D$ seems to be readily applicable to the fermionic string sigma model, which is given by [12]

$$\begin{aligned}
S = & \int d^2\xi \sqrt{g} \left[\frac{1}{2} g^{ab} \partial_a X^\mu \partial_b X^\nu G_{\mu\nu}(X) + \frac{1}{2} i \bar{\psi}^\mu \gamma^a D_a \psi^\nu G_{\mu\nu}(X) \right. \\
& \left. + \frac{1}{12} R_{\mu\nu\kappa\lambda} \bar{\psi}^\mu \psi^\kappa \bar{\psi}^\nu \psi^\lambda + 2(\partial_a X^\mu + \bar{\chi}_a \psi^\mu) \bar{\psi}^\nu \gamma^b \gamma^a \chi_b G_{\mu\nu}(X) \right] \quad (6.14)
\end{aligned}$$

with

$$D_a \psi^\mu = \partial_a \psi^\mu + \Gamma_{\nu\lambda}^\mu \partial_a X^\lambda \psi^\nu \quad (6.15)$$

Fixing to the superconformal gauge $g_{ab} = e^\phi \delta_{ab}$, $\chi_a = \gamma_a \chi$ eliminates the “gravitino”

χ_a , since $\gamma_b \gamma_a \gamma^b = 0$ identically [37]. We are left with

$$S = \int d^2\xi \left[\frac{1}{2} \partial_a X^\mu \partial_a X^\nu G_{\mu\nu}(X) + \frac{1}{2} i \bar{\psi}^\mu \gamma^a D_a \psi^\nu G_{\mu\nu}(X) + \frac{1}{12} R_{\mu\nu\kappa\lambda} \bar{\psi}^\mu \psi^\kappa \bar{\psi}^\nu \psi^\lambda \right] \quad (6.16)$$

and we can now simply substitute in the Polyakov geometry for $G_{\mu\nu}(X)$ and then analyze the resultant action in analogy with the case presented in this thesis. One would first need to compute the Christoffel symbols $\Gamma_{\nu\lambda}^\mu$ and the Riemann tensor $R_{\mu\nu\kappa\lambda}$ for the geometry under consideration. As an example, for AdS_{D+1} space in Poincaré coordinates as given in equation (3.35) we have

$$\Gamma_{0\mu}^\mu = \Gamma_{\mu 0}^\mu = -\frac{1}{y} \quad \Gamma_{ii}^0 = \frac{1}{y} \quad (6.17)$$

where the index μ runs from zero to D , the index i runs from 1 to D and all other symbols are zero. $\mu = 0$ corresponds to the y -direction. The Riemann tensor is

$$R_{0i0i} = R_{ijij} = -\frac{1}{y^4} \quad (6.18)$$

with all others zero. Substituting these into the action gives

$$S = \int d^2\xi \left[\frac{1}{2y^2} ((\partial_a X^i)^2 + (\partial_a y)^2) - \frac{i}{2y^2} \bar{\psi}^\mu \gamma^a \left(\partial_a - \frac{(\partial_a y)}{y} \right) \psi^\mu + \frac{1}{12y^4} \bar{\psi}^\mu \psi^\mu \bar{\psi}^i \psi^i \right] \quad (6.19)$$

and we see that again we will have to analyze the various determinants arising from integrating out the X^i 's and the fermionic fields ψ . This seems like a problem that could well be tackled within the calculational scheme presented in this work.

* * *

I would like to conclude this thesis with a personal observation. There have undoubtedly been significant advances over the last ten years or so in our understanding of what string theory really is, and what it can tell us about Nature. The success of the AdS/CFT correspondence, for example, is now undisputed. There are literally thousands of recent papers confirming various aspects of the correspondence. This is clearly a good thing. However, it is worth bearing in mind that the

purpose of theoretical physics research is not only to calculate things which you have good reason to believe will work out nicely! There must always be a place for research projects which do not necessarily follow contemporary trends, but which try out novel ideas to see if they lead to any new understanding. I would like to think that the work presented in this thesis falls into this category. By approaching an old problem in a new way, we have obtained some interesting and unexpected results. The questions raised in this thesis, and the ideas and methods used to answer them, are in a sense rather unconventional. I hope that the reader will agree that this is no bad thing, and that in fact asking unconventional questions will always be a valuable part of scientific research - whatever the outcome.

Bibliography

- [1] A. M. Polyakov, “String theory and quark confinement”, Nucl. Phys. Proc. Suppl. **68** (1998) 1, hep-th/9711002.
- [2] C. G. Callan, E. J. Martinec, M. J. Perry, and D. Friedan, “Strings in background fields”, Nucl. Phys. **B262** (1985) 593.
- [3] O. Aharony, S. S. Gubser, J. Maldacena, H. Ooguri, and Y. Oz, “Large N field theories, string theory and gravity”, Phys. Rept. **323** (2000) 183–386, hep-th/9905111.
- [4] Y. Makeenko, “Large-N gauge theories”, hep-th/0001047.
- [5] M. B. Green, J. H. Schwarz, and E. Witten, “Superstring theory. Vol. 1: Introduction”, Cambridge, UK: Univ. Pr. (1987) 469 P. (Cambridge Monographs On Mathematical Physics).
- [6] J. Polchinski, “String theory. Vol. 1: An introduction to the bosonic string”, Cambridge, UK: Univ. Pr. (1998) 402 p.
- [7] A. M. Polyakov, “Quantum geometry of bosonic strings”, Phys. Lett. **B103** (1981) 207.
- [8] P. Mansfield, “String theory”, Rept. Prog. Phys. **53** (1990) 1183.
- [9] J.-L. Gervais and B. Sakita, “Functional-integral approach to dual-resonance theory”, Phys. Rev. **D4** (1971) 2291–2308.
- [10] F. David, “Conformal field theories coupled to 2-D gravity in the conformal gauge”, Mod. Phys. Lett. **A3** (1988) 1651.

- [11] J. Distler and H. Kawai, “Conformal field theory and 2-D quantum gravity or Who’s afraid of Joseph Liouville?”, Nucl. Phys. **B321** (1989) 509.
- [12] E. S. Fradkin and A. A. Tseytlin, “Effective field theory from quantized strings”, Phys. Lett. **B158** (1985) 316.
- [13] G. Veneziano, “Construction of a crossing - symmetric, Regge behaved amplitude for linearly rising trajectories”, Nuovo. Cim. **A57** (1968) 190–197.
- [14] P. Goddard, J. Goldstone, C. Rebbi, and C. B. Thorn, “Quantum dynamics of a massless relativistic string”, Nucl. Phys. **B56** (1973) 109–135.
- [15] K. G. Wilson, “Confinement of quarks”, Phys. Rev. **D10** (1974) 2445–2459.
- [16] G. ’t Hooft, “A planar diagram theory for strong interactions”, Nucl. Phys. **B72** (1974) 461.
- [17] J. Maldacena, “The large N limit of superconformal field theories and supergravity”, Adv. Theor. Math. Phys. **2** (1998) 231–252, hep-th/9711200.
- [18] E. Witten, “Anti-de Sitter space and holography”, Adv. Theor. Math. Phys. **2** (1998) 253–291, hep-th/9802150.
- [19] S. S. Gubser, I. R. Klebanov, and A. M. Polyakov, “Gauge theory correlators from non-critical string theory”, Phys. Lett. **B428** (1998) 105, hep-th/9802109.
- [20] J. Polchinski, “String theory. Vol. 2: Superstring theory and beyond”, Cambridge, UK: Univ. Pr. (1998) 531 p.
- [21] J. Maldacena, “Wilson loops in large N field theories”, Phys. Rev. Lett. **80** (1998) 4859–4862, hep-th/9803002.
- [22] S.-J. Rey and J. Yee, “Macroscopic strings as heavy quarks in large N gauge theory and Anti-de Sitter supergravity”, Eur. Phys. J. **C22** (2001) 379–394, hep-th/9803001.

- [23] A. Polyakov and V. Rychkov, “Gauge fields - strings duality and the loop equation”, Nucl. Phys. **B581** (2000) 116, [hep-th/0002106](#).
- [24] A. M. Polyakov and V. S. Rychkov, “Loop dynamics and AdS/CFT correspondence”, Nucl. Phys. **B594** (2001) 272–286, [hep-th/0005173](#).
- [25] Y. M. Makeenko and A. A. Migdal, “Exact equation for the loop average in multicolor QCD”, Phys. Lett. **B88** (1979) 135.
- [26] H. J. de Vega and N. Sanchez, “A new approach to string quantization in curved space- times”, Phys. Lett. **B197** (1987) 320.
- [27] O. Alvarez, “Theory of strings with boundaries: Fluctuations, topology, and quantum geometry”, Nucl. Phys. **B216** (1983) 125.
- [28] T. Banks, D. Nemeschansky, and A. Sen, “Dilaton coupling and BRST quantization of bosonic strings”, Nucl. Phys. **B277** (1986) 67.
- [29] E. D’Hoker and D. H. Phong, “The geometry of string perturbation theory”, Rev. Mod. Phys. **60** (1988) 917.
- [30] J. Polchinski and L. Susskind, “String theory and the size of hadrons”, [hep-th/0112204](#).
- [31] C. G. Callan and Z. Gan, “Vertex operators in background fields”, Nucl. Phys. **B272** (1986) 647.
- [32] S. P. de Alwis, “Strings in background fields: Beta functions and vertex operators”, Phys. Rev. **D34** (1986) 3760.
- [33] I. I. Kogan and D. Polyakov, “World sheet logarithmic CFT in AdS strings, ghost-matter mixing and M-theory”, Int. J. Mod. Phys. **A16** (2001) 2559–2576, [hep-th/0012128](#).
- [34] E. Witten, “Chern-Simons gauge theory as a string theory”, [hep-th/9207094](#).
- [35] W. Siegel, “Covariantly second-quantized strings 1,2”, Phys. Lett. **B151** (1985) 391,396.

- [36] V. Rychkov, “Wilson loops, D-branes, and reparametrization path integrals”, hep-th/0204250.
- [37] A. M. Polyakov, “Quantum geometry of fermionic strings”, Phys. Lett. **B103** (1981) 211.
- [38] D. Friedan, E. Martinec, and S. Shenker, “Conformal invariance, supersymmetry, and string theory”, Nucl. Phys. **B271** (1986) 93.
- [39] C. V. Johnson, “D-brane primer”, hep-th/0007170.
- [40] P. Ginsparg, “Applied conformal field theory”,. Lectures given at Les Houches Summer School in Theoretical Physics, Les Houches, France, Jun 28 - Aug 5, 1988.

Appendix A

The Green's function at coincident points

The Green's function associated with the covariant worldsheet Laplacian Δ is given by

$$\mathcal{G}(x, y) = \Delta^{-1}(x, y) \quad (\text{A.0.1})$$

At coincident points this propagator is divergent, and we must regularize it. This procedure will introduce explicit dependence on the Liouville mode, $\phi(x)$. Here, we calculate this finite ϕ -dependence by writing

$$\mathcal{G}(x, x) = \int_{\epsilon}^{\infty} ds e^{-s\Delta} \frac{1}{\sqrt{g(x)}} \Big|_{y=x} \quad (\text{A.0.2})$$

where we have introduced a proper-time cutoff ϵ . Since we know that $\delta_{\phi}\Delta = -\delta\phi\Delta$, we find

$$\begin{aligned} \delta_{\phi}\mathcal{G}(x, x) &= \int_{\epsilon}^{\infty} ds s(\delta\phi(x)\Delta) e^{-s\Delta} \frac{1}{\sqrt{g(x)}} \Big|_{y=x} \\ &\quad - \int_{\epsilon}^{\infty} ds e^{-s\Delta} \delta\phi(x) \frac{1}{\sqrt{g(x)}} \Big|_{y=x} \end{aligned}$$

where the second term comes from varying the square root of the determinant of the worldsheet metric, \sqrt{g} . This expression can now in turn can be written as

$$\begin{aligned} \delta_{\phi}\mathcal{G}(x, x) &= \int_{\epsilon}^{\infty} ds \int_0^s d\bar{s} e^{-\bar{s}\Delta} (\delta\phi(x)\Delta) e^{-(s-\bar{s})\Delta} \frac{1}{\sqrt{g(x)}} \Big|_{y=x} \\ &\quad - \int_{\epsilon}^{\infty} ds e^{-s\Delta} \delta\phi(x) \frac{1}{\sqrt{g(x)}} \Big|_{y=x} \end{aligned}$$

We now write this in terms of a total derivative with respect to s ,

$$\begin{aligned} \delta_\phi \mathcal{G}(x, x) &= - \int_\epsilon^\infty ds \int_0^s d\bar{s} \frac{\partial}{\partial s} \left(e^{-\bar{s}\Delta} \delta\phi(x) e^{-(s-\bar{s})\Delta} \frac{1}{\sqrt{g(x)}} \Big|_{y=x} \right) \\ &\quad - \int_\epsilon^\infty ds e^{-s\Delta} \delta\phi(x) \frac{1}{\sqrt{g(x)}} \Big|_{y=x} \end{aligned}$$

We can move the derivative with respect to s outside the \bar{s} integral by integrating by parts; this gives

$$\begin{aligned} \delta_\phi \mathcal{G}(x, x) &= \int_\epsilon^\infty ds \left(-\frac{\partial}{\partial s} \right) \int_0^s d\bar{s} e^{-\bar{s}\Delta} \delta\phi(x) e^{-(s-\bar{s})\Delta} \frac{1}{\sqrt{g(x)}} \Big|_{y=x} \\ &\quad - \int_\epsilon^\infty ds e^{-s\Delta} \delta\phi(x) \frac{1}{\sqrt{g(x)}} \Big|_{y=x} \\ &\quad + \int_\epsilon^\infty ds e^{-s\Delta} \delta\phi(x) \frac{1}{\sqrt{g(x)}} \Big|_{y=x}, \end{aligned}$$

and we see that the last two terms cancel. Performing the s -integral in the first term thus gives

$$\delta_\phi \mathcal{G}(x, x) = \int_0^\epsilon d\bar{s} e^{-\bar{s}\Delta} \delta\phi(x) e^{-(\epsilon-\bar{s})\Delta} \frac{1}{\sqrt{g(x)}} \Big|_{y=x} \quad (\text{A.0.3})$$

We now use the result presented in the main body of the thesis for the heat kernel at coincident points. We have

$$e^{-\epsilon\Delta} f(\xi) = \int d^2\xi \sqrt{g} \mathcal{K}(\xi, \xi; \epsilon) f(\xi) \quad (\text{A.0.4})$$

where

$$\mathcal{K}(\xi, \xi; \epsilon) = \frac{1}{4\pi\epsilon} - \frac{e^{-\phi} \partial_a^2 \phi}{24\pi} + O(\epsilon) \quad (\text{A.0.5})$$

as found in equation (4.59). Substituting this into our expression for the variation of $\mathcal{G}(x, x)$ gives

$$\delta_\phi \mathcal{G}(x, x) = \int_0^\epsilon d\bar{s} e^{-\bar{s}\Delta} \delta\phi \left(\frac{1}{4\pi\epsilon} - \frac{e^{-\phi} \partial_a^2 \phi}{24\pi} \right) e^{\bar{s}\Delta} \quad (\text{A.0.6})$$

where we have used $\sqrt{g} = e^\phi$. Therefore,

$$\delta_\phi \mathcal{G}(x, x) = \int_0^\epsilon d\bar{s} \delta\phi \left(\frac{1}{4\pi\epsilon} - \frac{e^{-\phi} \partial_a^2 \phi}{24\pi} \right) \quad (\text{A.0.7})$$

and performing the now trivial \bar{s} integral, along with integrating the ϕ -variation, gives the result that

$$\mathcal{G}(x, x) = \text{divergent piece} + \frac{\phi}{4\pi} + O(\epsilon) \quad (\text{A.0.8})$$

Hence, when we take the cutoff ϵ to zero we obtain the standard result.

Appendix B

Gauge fixing and the conformal anomaly of the ghost sector

Many of the calculations presented in this thesis have been performed in the conformal gauge. This gauge fixing introduces a conformal anomaly, which we here calculate using techniques from conformal field theory (CFT). Since this calculation relies only on the local properties of the worldsheet, the result is valid for all target-space metrics. All the calculations described here are entirely standard, and no claim is made of originality. They are included in this thesis for completeness. Good references are [38] [6] [20] [5] [39].

B.1 The Faddeev-Popov procedure

Let us consider the string partition function in its most general form:

$$Z = \int \mathcal{D}X \mathcal{D}g e^{-S[X,g]} \quad (\text{B.1.1})$$

where the X 's are target-space coordinates, and g is the worldsheet metric. This expression is rather ill-defined, since the action is invariant under reparametrizations (diffeomorphisms) and Weyl transformations. What we really need to do is divide this expression by the volume of the $\text{diff} \times \text{Weyl}$ gauge group [6]:

$$Z = \int \frac{\mathcal{D}X \mathcal{D}g}{V_{\text{diff} \times \text{Weyl}}} e^{-S[X,g]} \quad (\text{B.1.2})$$

To do this, we will use the famous Faddeev-Popov procedure. If we fix our worldsheet metric to some reference metric \hat{g} (often referred to as a *fiducial metric*), then we have the identity

$$1 = \Delta_{FP}(g) \int \mathcal{D}\gamma \delta(g - \hat{g}^\gamma) \quad (\text{B.1.3})$$

where $\mathcal{D}\gamma$ represents a gauge-invariant measure on the $\text{diff} \times \text{Weyl}$ group. The delta functional picks out those metrics g that are obtained by taking the fiducial metric and performing a $\text{diff} \times \text{Weyl}$ transformation on it (denoted by \hat{g}^γ). The determinant $\Delta_{FP}(g)$ ensures that the right hand side really equals 1. The trick is to then insert this into the partition function to obtain

$$Z = \int \frac{\mathcal{D}X \mathcal{D}g \mathcal{D}\gamma}{V_{\text{diff} \times \text{Weyl}}} e^{-S[X,g]} \Delta_{FP}(g) \delta(g - \hat{g}^\gamma) \quad (\text{B.1.4})$$

We can now do the integral over g , leaving us with

$$Z = \int \frac{\mathcal{D}X^\gamma \mathcal{D}\gamma}{V_{\text{diff} \times \text{Weyl}}} e^{-S[X^\gamma, \hat{g}^\gamma]} \Delta_{FP}(\hat{g}^\gamma) \quad (\text{B.1.5})$$

We have re-labelled the variable $X \rightarrow X^\gamma$. Now, we know that the measure $\mathcal{D}X^\gamma$, the Faddeev-Popov determinant Δ_{FP} and the action are all invariant under $\text{diff} \times \text{Weyl}$ transformations (i.e., γ -transformations), so we can write

$$Z = \int \frac{\mathcal{D}X \mathcal{D}\gamma}{V_{\text{diff} \times \text{Weyl}}} e^{-S[X, \hat{g}]} \Delta_{FP}(\hat{g}) \quad (\text{B.1.6})$$

Finally, we see that nothing in the integrand depends on γ , so the integral over $\mathcal{D}\gamma$ just produces the volume of the gauge group which cancels the factor of $V_{\text{diff} \times \text{Weyl}}$. Hence, the gauge-fixed partition function is

$$Z = \int \mathcal{D}X e^{-S[X, \hat{g}]} \Delta_{FP}(\hat{g}) \quad (\text{B.1.7})$$

The next stage is to compute the Faddeev-Popov determinant.

B.2 The Faddeev-Popov ghosts

Let us consider a general infinitesimal transformation of the worldsheet metric. This is a combination of a diffeomorphism and a Weyl scaling,

$$\delta g_{ab} = \delta \phi g_{ab} + \nabla_a \delta V_b + \nabla_b \delta V_a \quad (\text{B.2.8})$$

where ∇_a is the covariant derivative built out of g . We would like to use this in the expression (B.1.3) in order to compute $\Delta_{FP}(g)$. However, there are some diffeomorphisms that can themselves be obtained by Weyl scalings, and hence this expression for δg_{ab} does not split into orthogonal components as it stands. Therefore, we don't as yet know how to write down the measure over the gauge group, $\mathcal{D}\gamma$. The way round this problem is to introduce an operator P , defined by

$$(P\delta V)_{ab} = \frac{1}{2} (\nabla_a \delta V_b + \nabla_b \delta V_a - g_{ab} \nabla_c \delta V^c) \quad (\text{B.2.9})$$

This operator P thus acts on vectors to make them into symmetric 2-tensors. In terms of P , we have

$$\delta g_{ab} = (\delta\phi - \nabla_c \delta V^c) g_{ab} - 2(P\delta V)_{ab} \quad (\text{B.2.10})$$

This sorts the variation of the metric into two orthogonal components, and we can therefore write

$$\Delta_{FP}^{-1}(\hat{g}) = \int \mathcal{D}(\delta\phi) \mathcal{D}(\delta V) \delta [-(\delta\phi - \nabla_c \delta V^c) \hat{g} + 2(P\delta V)]$$

Let us now introduce a Lagrange multiplier symmetric tensor field λ_{ab} , and represent this functional delta function as a functional integral over λ :

$$\begin{aligned} \Delta_{FP}^{-1}(\hat{g}) &= \int \mathcal{D}(\delta\phi) \mathcal{D}(\delta V) \mathcal{D}\lambda \\ &\times \exp \left[2\pi i \int d^2\xi \sqrt{\hat{g}} \lambda^{ab} \left(-(\delta\phi - \nabla_c \delta V^c) \hat{g} + 2(\hat{P}\delta V) \right)_{ab} \right] \end{aligned}$$

(hats on an operator mean that it involves the fiducial metric). We now notice that we can perform the integral over $\delta\phi$. This will produce a delta functional which forces the constraint that λ_{ab} be traceless:

$$\int \mathcal{D}\delta\phi \exp \left[-2\pi i \int d^2\xi \sqrt{\hat{g}} \lambda^{ab} \delta\phi \hat{g}_{ab} \right] = \delta [\lambda^{ab} \hat{g}_{ab}] = \delta [\lambda_a^a] \quad (\text{B.2.11})$$

Hence, we now have

$$\Delta_{FP}^{-1}(\hat{g}) = \int \mathcal{D}(\delta V) \mathcal{D}\lambda' \exp \left[4\pi i \int d^2\xi \sqrt{\hat{g}} \lambda'_{ab} (\hat{P}\delta V)^{ab} \right] \quad (\text{B.2.12})$$

where the prime on λ indicates that it is now a traceless symmetric 2-tensor. Of course, what we really want is to invert this expression to obtain $\Delta_{FP}(\hat{g})$. To do

this, we need to replace the bosonic fields in this expression with anticommuting Grassman fields,

$$\delta V^a \rightarrow c^a \quad \lambda'_{ab} \rightarrow b_{ab}$$

Hence,

$$\Delta_{FP}(\hat{g}) = \int \mathcal{D}c \mathcal{D}b \exp \left[- \int d^2\xi \sqrt{\hat{g}} b_{ab} (\hat{P}c)^{ab} \right] \quad (\text{B.2.13})$$

up to normalization. We refer to the fields b, c as *Faddeev-Popov ghosts*. Finally, we can set our fiducial metric to $\hat{g}_{ab} = e^\phi \delta_{ab}$ and obtain the ghost action

$$S_{ghosts} = \int d^2z (b_{zz} \partial_{\bar{z}} c^z + \text{c.c.}) \quad (\text{B.2.14})$$

where we have gone to complex coordinates $z = \xi_1 + i\xi_2$, $\bar{z} = \xi_1 - i\xi_2$. Notice that this action is independent of ϕ , and hence Weyl invariant. This is because the covariant tensor $\nabla_{\bar{z}}$ acting on a tensor with z indices reduces to the usual partial derivative; one can see this by computing the connection tensor in this case.

B.3 Conformal field theory of the b, c ghost system

Let us first recall some basic facts about conformal transformations [40]. In D dimensions we define those coordinate transformations that leave the metric invariant up to a scale change as *global conformal transformations*,

$$g_{\mu\nu}(x) \rightarrow \Omega(x) g_{\mu\nu}(x). \quad (\text{B.3.15})$$

In two dimensions, the conformal transformations coincide with analytic coordinate transformations, of which there are infinitely many. Hence, the group of two dimensional conformal transformations is infinite, with the global conformal transformations described above forming a subgroup of this infinite group. If a field $\Phi(z, \bar{z})$ in a two dimensional conformal field theory transforms under analytic coordinate changes $z \rightarrow z'(z)$, $\bar{z} \rightarrow \bar{z}'(\bar{z})$ as

$$\Phi(z, \bar{z}) \rightarrow \left(\frac{\partial z}{\partial z'} \right)^h \left(\frac{\partial \bar{z}}{\partial \bar{z}'} \right)^{\bar{h}} \Phi(z', \bar{z}') \quad (\text{B.3.16})$$

then this field is referred to as *primary*. The numbers h, \bar{h} are the *conformal weights* of the field. Fields which transform in this way under global conformal transformations only are referred to as *quasi-primary*. Clearly, primary fields are automatically quasi-primary.

The action (B.2.14) actually defines a conformal field theory. If we work out the Euler-Lagrange equations for the fields b and c , we see that

$$\partial_z c^z = \partial_{\bar{z}} b_{zz} = 0 \tag{B.3.17}$$

which means that these fields are holomorphic functions of z . Hence, they transform as tensors under *analytic* coordinate transformations (i.e., the conformal transformations) and are primary fields. Since a general conformal transformation is a combination of a Weyl transformation and a coordinate transformation, we see that the conformal weights will coincide with the tensor indices (the ghost action is invariant under Weyl transformations). Thus, the field b_{zz} will have conformal weight $h = 2$ and the field c^z will have conformal weight $h = -1$. Now, the line element d^2z transforms like

$$d^2z \rightarrow d^2z' = \frac{\partial z'}{\partial z} \frac{\partial \bar{z}'}{\partial \bar{z}} d^2z$$

under conformal transformations. Hence, we see that the transformations of the b, c fields exactly compensates for the transformation of the line element, and the theory is classically conformally invariant. (One should bear in mind that there is an antiholomorphic sector of this theory with $\bar{h} = 2, -1$ respectively coming from the complex conjugate part of the action; we need not concern ourselves with this, as all the results are the same in both sectors).

We now use some of the machinery of conformal field theory to analyze this ghost system. We need to ask whether the algebra generated by infinitesimal analytic coordinate transformations (the Virasoro algebra) is preserved in the quantum theory, or whether we pick up a central charge term (i.e., an extra constant term c in the algebra). This central charge represents a conformal anomaly, in the same way that our calculations in the main body of this thesis revealed a conformal (Weyl) anomaly in the “matter” sector of the string theory (that is, in the quantum theory of the target-space coordinates). Since we require Weyl invariance of the full quantum

theory, we need to take into account the anomalies introduced by both the matter and ghost sectors of the theory and demand that the total central charge $c_m + c_{gh}$ be zero. As we will see, this is what leads to the value of the critical dimension¹.

Crucial to the whole story is the idea of an *operator product expansion (OPE)* [40]. In a general quantum field theory, singularities occur when two operators (fields) approach one another. The OPE tells us that we can encode these singularities as a product of a complete set of local operators in the theory,

$$\phi(x)\phi(y) \sim \sum_i C_i(x-y)\phi_i(y) \quad (\text{B.3.18})$$

where the coefficients $C_i(x-y)$ are singular and depend only on the distance between the points x and y . The operators on the left hand side are understood to be *time ordered*. In conformal field theory, one finds that the OPE of the stress-energy tensor $T(z)$ with a primary field in the theory $\Phi(y, \bar{y})$ is of the form

$$T(z)\Phi(y, \bar{y}) = \frac{h}{(z-y)^2}\Phi(y, \bar{y}) + \frac{1}{(z-y)}\partial_y\Phi(y, \bar{y}) + \dots \quad (\text{B.3.19})$$

where the ellipsis represents nonsingular terms. We see that by calculating this OPE with a given field, we can determine its conformal weight h (we calculate \bar{h} by taking the OPE of the field with the antiholomorphic part of the stress tensor, $\bar{T}(\bar{z})$). Hence, for our ghost field b_{zz} we would find

$$T(z)b_{zz}(y, \bar{y}) = \frac{2}{(z-y)^2}b_{zz}(y, \bar{y}) + \frac{1}{(z-y)}\partial_y b_{zz}(y, \bar{y}) + \dots, \quad (\text{B.3.20})$$

reflecting the fact that b_{zz} is a primary field of weight $h = 2$. Another equally useful identity arises when we compute the OPE of the stress tensor with itself:

$$T(z)T(y) = \frac{c}{2}\frac{1}{(z-y)^4} + \frac{h}{(z-y)^2}T(y) + \frac{1}{(z-y)}\partial_y T(y) + \dots \quad (\text{B.3.21})$$

where the number c is the central charge that we seek.² Hence, to evaluate the conformal anomaly of the ghost system, we need to obtain the stress-energy tensor of the theory and compute its OPE with itself.

¹It should be noted that the calculation of the ghost anomaly can be performed using heat kernel methods that are essentially the same as those used in the main body of the text; we will use CFT here as a demonstration of a technique that is widely used in string theory.

²The antiholomorphic counterpart \bar{c} is computed using $\bar{T}(\bar{z})$. It can be shown that we need $c = \bar{c}$ for a fully Lorentz invariant theory; this is the case for the ghost system here.

The stress tensor for the ghost system is readily obtained by Noether's theorem to be [38]

$$T_{gh}(z) =: c^z \partial_z b_{zz} : + : 2(\partial_z c^z) b_{zz} : \quad (\text{B.3.22})$$

where the colons indicate normal ordering. In order to compute the TT OPE, we will use Wick's theorem that time ordered expressions can be written as the sum of the normal ordered expression plus all possible contractions, e.g.,

$$\phi(x)\phi(y) =: \phi(x)\phi(y) : + \langle \phi(x)\phi(y) \rangle \quad (\text{B.3.23})$$

Since the ghost fields are essentially free fermions of the wrong spin, we can write down their propagators straight away using their anticommuting properties,

$$\begin{aligned} \langle b_{zz} c^y \rangle &= \langle c^z b_{yy} \rangle = \frac{1}{z-y} + \dots \\ \langle b_{zz} b^{yy} \rangle &= \langle c_z c^y \rangle = O(z-y) \end{aligned}$$

Now, we are interested only in the most singular part of the TT OPE, as this will give us the central charge c . We have

$$\begin{aligned} T_{gh}(z)T_{gh}(y) &= (: c^z \partial_z b_{zz} : + : 2(\partial_z c^z) b_{zz} :) (: c^y \partial_y b_{yy} : + : 2(\partial_y c^y) b_{yy} :) \\ &= : c^z \partial_z b_{zz} :: c^y \partial_y b_{yy} : + 2 : c^z \partial_z b_{zz} :: (\partial_y c^y) b_{yy} : \\ &+ 2 : (\partial_z c^z) b_{zz} :: c^y \partial_y b_{yy} : + 4 : (\partial_z c^z) b_{zz} :: (\partial_y c^y) b_{yy} : \end{aligned}$$

Using Wick's theorem and the propagators above, we see that the terms where we make 2 contractions with one b and one c field in each will produce the most singular terms and hence the piece of the TT OPE that we require. Hence,

$$\begin{aligned} T_{gh}(z)T_{gh}(y) &= \langle \partial_z b_{zz} c^y \rangle \langle c^z \partial_y b_{yy} \rangle + 2 \langle c^z b_{yy} \rangle \langle \partial_z b_{zz} \partial_y c^y \rangle \\ &+ 2 \langle \partial_z c^z \partial_y b_{yy} \rangle \langle b_{zz} c^y \rangle + 4 \langle \partial_z c^z b_{yy} \rangle \langle b_{zz} \partial_y c^y \rangle + \dots \\ &= -\frac{1}{(z-y)^4} + 4 \left(\frac{-2}{(z-y)^4} \right) - 4 \frac{1}{(z-y)^4} + \dots \\ &= \frac{-13}{(z-y)^4} + \dots \end{aligned}$$

Comparing this expression with (B.3.21) shows that the conformal anomaly of the b, c system is $c = -26$. In terms of the path integral, this means that the gauge-fixing procedure introduces extra dependence on the Liouville mode in the following way:

$$S_L^{gh} = \frac{26}{96\pi} \int d^2\xi (\partial_a \phi)^2 \quad (\text{B.3.24})$$

B.4 The ghost zero modes

Finally, we briefly mention a slight complication which we have overlooked in the above treatment of the Faddeev-Popov determinant. When we fix our worldsheet metric to the conformal gauge, we do not in fact completely fix the gauge freedom [5]. This is because a metric of the form

$$ds^2 = e^\phi dzd\bar{z}$$

in complex coordinates $z = \xi_1 + i\xi_2$, $\bar{z} = \xi_1 - i\xi_2$ can be written in terms of some new coordinate $F(z)$, where $F(z)$ is an analytic function of z , as

$$ds^2 = e^\phi \left| \frac{\partial z}{\partial F} \right| dzd\bar{z}$$

This is clearly still in the conformal gauge! In effect, we have just changed the value of ϕ . There are clearly still some coordinate transformations (diffeomorphisms) that we can make and still remain in the conformal gauge; hence, they represent a residual gauge symmetry that we haven't yet fixed.

The question then is: what is the group of transformations that correspond to these changes of coordinate? One finds for reasons of nonsingularity that on the sphere, these transformations are infinitesimally given by

$$\delta z = a + bz + cz^2$$

where a, b, c are arbitrary complex numbers. These transformations are the generators of the group $SL(2, C)$, and this is therefore the group of transformations whose volume we must factor out of the path integral, in the same way that we factored out the $\text{diff} \times \text{Weyl}$ group with the Faddeev-Popov determinant.

In order to see schematically how this works, consider again the ghost action (B.2.14). One needs to consider whether the ghost fields have any normalizable zero modes on the worldsheet. The results obtained in the previous sections ignored this possibility, and hence we really only calculated

$$\Delta'_{FP}$$

where the prime indicates omission of zero modes. These zero modes will obey the equations

$$\partial_{\bar{z}} c^z = 0 \quad \partial_{\bar{z}} b_{zz} = 0$$

plus complex conjugates. We see that these equations require that the zero modes be (anti)holomorphic functions on the worldsheet. In fact, one finds that these zero modes correspond precisely to the generators of the $SL(2, C)$ group discussed above.

Now, the expression

$$\Delta_{FP}(\hat{g}) = \int \mathcal{D}c\mathcal{D}b \exp \left[\int d^2z (b_{zz}\partial_z c^z + \text{c.c.}) \right] \quad (\text{B.4.25})$$

is formally zero due to the presence of these zero modes; hence, one has to make insertions in this path integral to absorb the effect and get a sensible, non-zero result [29]. These insertions, when integrated over, then generate the volume of the $SL(2, C)$ transformations which factors out the residual gauge symmetry, as required. String amplitudes calculated in this way are then finite, and have all the correct diffeomorphism symmetries required by the original form of the string action.

Note that these ghost zero modes are distinct from the zero mode ψ_0 considered in the main body of the text; this zero mode is introduced when we represent Δ'_{FP} itself as a path integral over ψ .

