

Durham E-Theses

Bilinguals' and second language learners' knowledge of Japanese syllable structure

Naomi Cross

How to cite:

Cross, Naomi (2002) Bilinguals' and second language learners' knowledge of Japanese syllable structure. Doctoral thesis, Durham University.

Use policy

The full-text may be used and/or reproduced, and given to third parties in any format or medium, without prior permission or charge, for personal research or study, educational, or not-for-profit purposes provided that:

- a full bibliographic reference is made to the original source
- a <https://etheses.durham.ac.uk/id/eprint/3835/> is made to the metadata record in Durham E-Theses
- the full-text is not changed in any way

The full-text must not be sold in any format or medium without the formal permission of the copyright holders.

Please consult the [full Durham E-Theses policy](#) for further details.

Bilinguals' and Second Language Learners' Knowledge of Japanese Syllable Structure

The copyright of this thesis rests with the author. No quotation from it should be published in any form, including Electronic and the Internet, without the author's prior written consent. All information derived from this thesis must be acknowledged appropriately.

Ph.D.

**Department of Linguistics and English Language
University of Durham**

Naomi Cross



28 MAY 2002

Abstract

The acquisition of second language phonology has been commanding researchers' attention in recent years. The aim of this thesis is to contribute to this area with a study on Japanese as a second language. The thesis explores both the development of phonological competence by post-puberty second language learners and the end state of pre-puberty bilingual acquisition.

Reviewing the literature on the theoretical aspects of mora, syllables and syllable structure, we see that the mora is distinctive and plays vital role in Japanese phonology. We next look at the acquisition theories proposed in recent years, and adopt a Universal Grammar-based approach. Comparing first, bilingual and second language acquisition, three research hypotheses are presented: 1) the Mora Assignment Hypothesis, 2) L2 phonological Acquisition and Age Onset Hypothesis, and the 3) Quality and Quantity of Input Hypothesis.

To test these hypotheses, a study was designed involving 24 bilingual children and adults, and 94 adult L2 learners of Japanese at varying levels of proficiency. The results provide evidence to support all three research hypotheses. First the data show that the both English-dominant bilinguals and second language learners at all levels deleted morae and all but the beginning second language learners added morae in oral and written production tasks, indicating non-native competence with respect to morae. In addition, learners attempt to preserve the overall mora count. Since English is not a mora sensitive language, the mora conservation exhibited here is from their Japanese. The learners, including English-dominant bilinguals, first become sensitive to the mora and only at a later stage assign segments to the correct mora slot. The difference in performance between English-dominant bilinguals and Japanese-dominant bilinguals was such that by the age of eight, those who had spent more years in Japan demonstrated native phonological competence, whereas the English-dominant bilinguals' performance pointed to non-native competence. With respect to the second and third hypotheses, results from the bilinguals indicate that in addition to age of onset, the amount of exposure to a second language must be taken into account as a factor influencing ultimate attainment. The study also reveals strong influence of literacy in both oral and written production of Japanese.

Acknowledgement

I would like to express my gratitude to Dr. Martha Young-Scholten, my supervisor. I am immensely indebted to her for her support and criticism, without which this work could not have been accomplished.

I am grateful to the members of staff at the Department of Linguistics and English Language for their support and encouragement. I would like to thank Professor Joe Emonds for encouraging me to apply and accepting me as a Ph.D. student, Dr. S. J. Hannahs for his advice and comments, Dr. Bonnie Schwartz for her encouragement.

I am also grateful to all my colleagues, both former and present, at the Department of East Asian Studies. In particular, I would like to thank Mr. Don Starr and Professor Emeritus Keith Pratt for their support and encouragement without which I could not have managed both work and study.

I would also like to thank my external examiners, Professor Toshiko Ishida and Professor Martha Pennington for their insightful comments and suggestions for future research.

I would like to thank my friends, Dr. Mamiko Akita and Dr. Ana Parrondo Rodriguez for their stimulating discussions, support and friendship.

Special thanks are due to all my informants. Without their cooperation, this research could not have started. I would also like to thank the Japanese Saturday School in Washington, Nissan Motors UK, Fujitsu, the University of Durham and the University of Northumbria for allowing the study to be carried out in their premises.

Finally, I must acknowledge all the support and patience of my family, and this thesis is dedicated to my long-suffering husband Malcolm and daughter Hannah.

Declaration

I confirm that this thesis is my own work and has not been previously submitted for any other academic award. Credit has been given to sources of reference that I have used.

Statement of Copyright

The copyright of the thesis rests with the author. No quotation from it should be published without her prior written consent and information from it should be acknowledged.

Table of contents

<i>Table of figures</i>	4
<i>Table of tables</i>	6
<i>Introduction</i>	9
Chapter 1	15
1.1 Introduction	15
1.2 Syllable Structure	15
1.2.1 Phonological Universals	16
1.2.2 Syllable	16
1.2.3 English Syllable Structure	26
1.2.4 Phonological Weight	30
1.2.5 Mora	33
1.2.6 Mora – moraic weight and durational timing	35
1.3 Japanese Syllable Structure	37
1.3.1 The Mora as a timing unit	40
1.3.2 The Bimoraic Foot	45
1.3.3 The Syllable in Japanese	46
1.3.4 Special Syllables Types: CVC, CVN and CVV	47
1.3.4.1 Geminate Consonants	48
1.3.4.2 Vowel Clusters	50
1.3.4.3 Nasals	53
1.4 Japanese and English Syllables	57
1.4.1 Lexical Characteristics of Japanese	57
1.4.2 Syllable Length	58
Chapter 2	60
2.1 Introduction	60
2.2 Universal Grammar	61
2.2.1 First Language Acquisition	62
2.2.2 L2 Acquisition and UG	63
2.2.2.1 The Initial State	63
2.2.2.2 Parameter Resetting	64
2.2.3 UG Access Models in L2A	64
2.2.3.1 Full Access Model	65
2.2.3.2 No Access Model	65
2.2.3.3 Indirect Model and Partial Access Model	67
2.3 L2 Acquisition of Phonology	68
2.3.1 Interlanguage Phonology	69
2.3.2 Critical Period – Age Dependent Effects	71
2.3.2.1 First Language Acquisition	71



2.3.2.2	Second Language Acquisition	72
2.3.2.3	The Age Factor in the L2 Phonology Acquisition	74
2.3.3	Bilingual Speakers	75
2.3.4	Input – ‘Quality’ and ‘Sufficiency’	78
2.3.5	Orthographic Input	79
2.3.5.1	Japanese Orthography	79
2.3.5.2	Literacy and Orthographic Input	81
2.3.5.3	Sufficiency of Input	82
2.3.5.4	‘Appropriate’ and ‘Inappropriate’ Input	83
2.3.6	The Role of Instruction in L2 Phonology	84
2.3.7	The Acquisition of Syllable Structure	85
2.3.7.1	Syllables and Syllabification	85
2.3.7.2	Syllables and Morae	86
2.4	Research Hypotheses	88
2.4.1	The Mora Assignment Hypothesis	88
2.4.2	L2 Phonological Acquisition and Age of Onset	90
2.4.3	Quantity and Quality of Input	90
2.4.4	Orthographic Influence	91
Chapter 3		92
3.1	Introduction	92
3.2	Methodology	93
3.2.1	Participant Profile	93
3.2.1.1	Bilingual Children	93
3.2.1.2	Bilingual Adults with Childhood Exposure to Japanese	95
3.2.1.3	Control Group – Japanese Monolingual Children	96
3.2.1.4	Control Group - Japanese Adults with Little Exposure to English	96
3.2.2	Test Words	97
3.2.2.1	Character Names: Japanese Story Character Names	98
3.2.2.2	Place Names: English Place Names	99
3.2.3	Procedure	100
3.2.3.1	Japanese Story Character Names	100
3.2.3.1.1	Bilingual Children	101
3.2.3.1.2	Bilingual Adults	102
3.2.3.1.3	Control Group	103
3.2.3.2	English Place Names as Loanwords	103
3.2.3.2.1	Bilingual Children	103
3.2.3.2.2	Bilingual Adults	104
3.2.3.2.3	Control Group	104
3.3	Results	104
3.3.1	Japanese Story Character Names	105
3.3.1.1	Control Group	105
3.3.1.2	Bilingual Children	105
3.3.1.3	Bilingual Adults	124
3.3.1.4	Bilingual Children vs Bilingual Adults	137
3.3.2	Word Familiarity and Phonological Competence	144

3.3.2.1	Control Group	145
3.3.2.2	Bilingual Children	146
3.3.2.3	Bilingual Adults	148
3.3.3	English Place Names as Loanwords	151
3.3.3.1	Control Group	151
3.3.3.2	Bilingual Children	153
3.3.3.3	Bilingual Adults	163
3.3.3.4	Bilingual Children vs Bilingual Adults	170
3.3.4	Exposure to Japanese and Phonological Competence	177
3.3.4.1	Subject Profile	178
3.3.4.2	Measure of Competence	179
3.3.4.3	Correlations between Exposure and Competence	181
3.4	Discussion	185
Chapter 4		188
4.1	Introduction	188
4.1.1	Participants' Profiles	189
4.1.1.1	Learner Category	189
4.1.1.2	Extra Treatment for Beginners	191
4.1.1.3	Control Group	192
4.1.2	Extra Instruction - Treatment	192
4.1.3	Test Words	193
4.1.3.1	Word List P	193
4.1.3.2	Word List A	194
4.1.3.3	Word List B	195
4.1.4	Test Procedures	196
4.1.4.1	Preliminary Assessment of Intermediate and Advanced Learners	198
4.1.4.2	Mora Counting with Word List A	199
4.2	Results	202
4.2.1	Preliminary Assessment	202
4.2.2	Mora Counting	204
4.2.2.1	Month 1	204
4.2.2.2	Month 9	208
4.2.2.3	Month 1 to Month 9 – Mora Counting	211
4.2.3	Written Production and Oral Production Tasks at Month 1	214
4.2.3.1	Beginner Level Learners	215
4.2.3.2	Intermediate Level Learners	220
4.2.3.3	Advanced Level Learners	224
4.2.3.4	Cross-sectional Comparison: Development	228
4.2.4	Development of Mora Awareness: Month 1 to Month 9	232
4.2.4.1	Written Production	232
4.2.4.2	Oral Production	236
4.3	Discussion	241
Chapter 5		244
Bibliography		250

Table of figures

Figure 3.1	Mora Count - JDBC.....	107
Figure 3.2	Mora Count - EDBC.....	107
Figure 3.3	Mora Count Deviation EDBC.....	110
Figure 3.4	Consonant Deletion and Insertion – Oral Production.....	112
Figure 3.5	Consonant Deletion and Insertion - Writing.....	113
Figure 3.6	Vowel Deletion and Insertion – Oral Production.....	116
Figure 3.7	Vowel Deletion and Insertion - Writing.....	116
Figure 3.8	Substitution and Compensation – Oral Production.....	119
Figure 3.9	Substitution and Compensation - Writing.....	120
Figure 3.10	Mora Count – Bilingual Adults.....	124
Figure 3.11	Mora Count Deviation.....	125
Figure 3.12	Consonant Deletion and Insertion – Oral Production.....	127
Figure 3.13	Consonant Deletion and Insertion - Writing.....	128
Figure 3.14	Vowel Deletion and Insertion – Oral Production.....	131
Figure 3.15	Vowel Deletion and Insertion - Writing.....	132
Figure 3.16	Substitution and Compensation – Oral Production.....	135
Figure 3.17	Substitution and Compensation - Writing.....	137
Figure 3.18	Mora Count – Adults vs Children.....	138
Figure 3.19	Consonant Deletion – Adults vs Children.....	140
Figure 3.20	Consonant Insertion – Adults vs Children.....	141
Figure 3.21	Vowel Deletion – Adults vs Children.....	142
Figure 3.22	Vowel Insertion – Adults vs Children.....	144
Figure 3.23	Word Familiarity and Oral Production.....	148
Figure 3.24	Word Familiarity and Writing.....	148
Figure 3.25	Word Familiarity and Oral Production.....	150
Figure 3.26	Word Familiarity and Writing.....	150
Figure 3.27	Mora Count - JCBC.....	155
Figure 3.28	Mora Count - EDBC.....	155
Figure 3.29	Mora Count Deviation – Place Names.....	156
Figure 3.30	Consonant Deletion and Insertion JDBC.....	159
Figure 3.31	Consonant Deletion and Insertion - EDBC.....	159
Figure 3.32	Vowel Deletion and Insertion - JDBC.....	161
Figure 3.33	Vowel Deletion and Insertion - EDBC.....	161
Figure 3.34	Mora Count Accuracy – Bilingual Adults.....	164
Figure 3.35	Mora Count Deviation.....	166
Figure 3.36	Consonant Deletion and Insertion.....	167
Figure 3.37	Vowel Deletion and Insertion.....	169
Figure 3.38	Mora Count Accuracy – Adults vs Children.....	171
Figure 3.39	Consonant Deletion – Adults vs Children.....	173
Figure 3.40	Consonant Insertion – Adults vs Children.....	173
Figure 3.41	Vowel Deletion – Adults vs Children.....	175
Figure 3.42	Vowel Insertion – Adults vs Children.....	176
Figure 3.43	Substitution – Adults vs Children.....	177
Figure 3.44	Correlation Coefficients – Oral Production.....	182

Figure 3.45	Correlation Coefficients - Writing.....	183
Figure 3.46	Correlation Coefficients - Reading.....	184
Figure 3.47	Correlation Coefficients - Writing.....	185
Figure 4.1	Mora Counting by Syllable Type – Word List A – Month 1.....	206
Figure 4.2	Mora Counting Accuracy – Word List B – Month 9.....	210
Figure 4.3	Mora Counting by Syllable ³ Type – Month 1 to Month 9.....	211
Figure 4.4	Intermediate – Advanced – Month 1 to Month 10.....	212
Figure 4.5	Beginner Written Production – Month 1.....	215
Figure 4.6	Beginner – Oral Production – Month 1.....	218
Figure 4.7	Intermediate – Written Production – Month 1.....	220
Figure 4.8	Intermediate – Oral Production – Month 1.....	223
Figure 4.9	Advanced – Written Production – Month 1.....	225
Figure 4.10	Advanced – Oral Production – Month 1.....	226
Figure 4.11	Written Production Accuracy – Word List A – Month 1.....	228
Figure 4.12	Adjusted Written Production Accuracy – Word List A – Month 1.....	230
Figure 4.13	Oral Production Accuracy – Word List A – Month 1.....	231
Figure 4.14	Adjusted Oral Production Accuracy – Word List A – Month 1.....	231
Figure 4.15	CV Written Production.....	233
Figure 4.16	VV Written Production.....	234
Figure 4.17	CVC Written Production.....	235
Figure 4.18	CVN Written Production.....	236
Figure 4.19	CV Oral Production.....	237
Figure 4.20	VV Oral Production.....	238
Figure 4.21	CVC Oral Production.....	239
Figure 4.22	CVN Oral Production.....	240

Table of tables

Table 3.1	Profile of Bilingual Children	94
Table 3.2	Bilingual Adults with Childhood Exposure to Japanese	95
Table 3.3	Japanese Children with Little English Exposure	96
Table 3.4	Japanese adults with limited exposure to English	97
Table 3.5	Test Character Names	99
Table 3.6	Test Place Names.....	100
Table 3.7	Bilingual Children – Mora Count Accuracy – Character Names	106
Table 3.8	Worst Three in Oral production - Mora Count – Bilingual Children	108
Table 3.9	Worst Four in Writing - Mora Count – Bilingual Children.....	108
Table 3.10	Mora Count Deviation – Eng-dom. Bilingual Children Character Names 109	
Table 3.11	Consonant Deletion and Insertion – Bilingual Children.....	111
Table 3.12	Consonant Deletion and Insertion – Eng-dom. Bilingual Children.....	114
Table 3.13	Vowel Deletions and Insertions – Bilingual Children.....	115
Table 3.14	Vowel Deletions and Insertions in the Same Word.....	117
Table 3.15	Vowel Deletion and Insertion – Bilingual Children – Character Names 117	
Table 3.16	Mora Count Preservation English-dominant Bilingual Children	118
Table 3.17	Compensatory Deletions & Insertions vs. Others.....	120
Table 3.18	Compensatory Deletions & Insertions vs. Others.....	122
Table 3.19	Mora Count Accuracy – Bilingual Adults – Character Names	124
Table 3.20	Mora Count Deviation – Bilingual Adults – Character Names	125
Table 3.21	Problematic Words in Oral Production and Writing – Character Names 126	
Table 3.22	Consonant Deletion and Insertion – Bilingual Adults – Character Names 127	
Table 3.23	Test Words Containing Moraic Nasals.....	129
Table 3.24	Consonant Deletion and Insertion – Bilingual Adults – Character Names 130	
Table 3.25	Vowel Deletion and Insertion - Bilingual Adults – Character Names .	130
Table 3.26	Vowel Deletion and Insertion – Bilingual Adults – Character Names.	133
Table 3.27	Compensatory Deletions & Insertions vs. Others – Bilingual Adults ..	134
Table 3.28	Compensatory Deletions & Insertions vs. Others – Bilingual Adults ..	136
Table 3.29	Mora Count Accuracy – Adults vs Children – Character Names.....	138
Table 3.30	Consonant Deletion - Character Names - Adults vs Children	139
Table 3.31	Consonant Insertion – Adults vs Children – Character Names	140
Table 3.32	Vowel Deletion – Adults vs Children – Character Names	142
Table 3.33	Vowel Insertion – Adults vs Children – Character Names.....	143
Table 3.34	Word Familiarity – Control Group – Character Names	145
Table 3.35	Word Familiarity – Bilingual Children - Character Names.....	146
Table 3.36	Word Familiarity and Mora Count Accuracy – English-dominant	147
Table 3.37	Familiarity with the Task Words – Bilingual Adults – Character Names 149	
Table 3.38	Word Familiarity and Correct Mora Count	149

Table 3.39	Variations in Pronunciation	151
Table 3.40	Percentage of Standard Numbers of Morae Produced.....	153
Table 3.41	Mora Count Accuracy - Bilingual Children – Place Names.....	153
Table 3.42	Mora Count Deviation – Bilingual Children – Place Names.....	156
Table 3.43	Consonant Deletion and Insertion – Bilingual Children – Place Names 157	
Table 3.44	Vowel Deletion and Insertion – Bilingual Children – Place Names	160
Table 3.45	Substitution and Compensation – Bilingual Children – Place Names .	162
Table 3.46	Substitution and Compensation – English-dominant – Reading	162
Table 3.47	Mora Count Accuracy – Bilingual Adults – Place Names	163
Table 3.48	Mora Count Deviation – Bilingual Adults – Place Names.....	164
Table 3.49	Consonant Deletion and Insertion – Bilingual Adults – Place Names .	166
Table 3.50	Vowel Deletion and Insertion - Bilingual Adults – Place Names	168
Table 3.51	Substitution and Compensation – Bilingual Adults – Place Names.....	169
Table 3.52	Substitution and Compensation – Bilingual Adults – Place Names.....	170
Table 3.53	Mora Count Accuracy – Children vs Adults – Place Names.....	171
Table 3.54	Consonant Deletion and Insertion – Adults vs Children – Place Names 172	
Table 3.55	Vowel Deletion and Insertion – Adults vs Children – Place Names....	174
Table 3.56	Substitution and Compensation – Adults vs Children – Place Names .	176
Table 3.57	Exposure to Japanese Indexes – Bilingual Adults.....	178
Table 3.58	Language at Home Factor.....	179
Table 3.59	Index F incorporating Home Language Factor.....	179
Table 3.60	Task 1 Deletions and Insertions – Bilingual Adults – Character Names 180	
Table 3.61	Task 2 Deletions and Insertions – Bilingual Adults – Place Names	180
Table 4.1	Participant Profile by Proficiency in Japanese	190
Table 4.2	Beginners – Extra treatment vs. No extra treatment.....	191
Table 4.3	Beginners – Formal Instruction and Extra Treatment	192
Table 4.4	Pre-Assessment Test Words	194
Table 4.5	Word List A	195
Table 4.6	Word List B	196
Table 4.7	Task Schedule.....	197
Table 4.8	Sample Words.....	200
Table 4.9	Preliminary – Written Production – Month 1	203
Table 4.10	Preliminary – Oral Production.....	203
Table 4.11	Mora Counting – Word List A – Month 1	204
Table 4.12	Mora-counting Accuracy by Syllable Type – Word List A – Month 1	205
Table 4.13	Correlation Coefficients – Mora Counting – Word List A.....	208
Table 4.14	Mora Counting – Word List B – Month 9	208
Table 4.15	Mora Counting Accuracy – Word List B – Month 9.....	209
Table 4.16	Correlation Coefficients – Mora Counting – Word List B.....	210
Table 4.17	Correlation Coefficients – Intermediate and Advanced Level Learners 213	
Table 4.18	Beginner – Written Production – Month 1	216

Table 4.19	Written Production of Mora by Beginners – Non-Intensive – Month 1	217
Table 4.20	Written Production of Mora by Beginners – Intensive – Month 1	217
Table 4.21	Beginner – Oral Production – Month 1	218
Table 4.22	Beginner – Non-Intensive – Oral Production – Month 1	219
Table 4.23	Beginner – Intensive – Oral Production – Month 1	219
Table 4.24	Intermediate – Written Production – Month 1	221
Table 4.25	Intermediate – Written Production – Month 1	222
Table 4.26	Intermediate – Oral Production – Month 1	223
Table 4.27	Intermediate – Oral Production – Month 1	224
Table 4.28	Advanced – Written Production – Month 1	225
Table 4.29	Advanced – Written Production - Month 1	226
Table 4.30	Advanced – Oral Production – Month 1	227
Table 4.31	Advanced – Oral Production – Month 1	227

Introduction

While hitherto neglected areas in second language acquisition have been commanding researchers' attention in recent years, much empirical research is still needed in the area of phonological acquisition. The aim of this thesis is to contribute to an even less researched area: the study of phonological bilingual acquisition of Japanese as a second language. This thesis explores both ultimate attainment in Japanese phonology by examining the phonological competence of English-Japanese bilinguals and development of and attainment of adult second language learners. The phonological competence of bilinguals and adult L2 learners is then compared and analysed in terms of age of onset and input.

By reviewing recent research findings, we establish the theoretical framework with respect to prosody and define Japanese syllable structure in Chapter 1. To this end, we first revisit the definition of the term *syllable*. Over the years, researchers have defined (see Hockett (1955)) and redefined (see e.g., Vennemann (1974) and Hooper (1972) in natural generative phonology), introduced new interpretations (e.g., Hankamer and Aissen (1974) and Selkirk (1984b) developing the Sonority Hierarchy), ignored and replaced with other phonological units (see Chomsky and Halle (1968/1991)), and again reintroduced (Kahn (1976/1980) among others) the notion of a syllable into the domain of phonological analysis. In this thesis, we adopt the model of the syllable structure proposed by Hockett (1955), as this facilitates a clear analysis of mora assignment in Japanese.

Japanese language, in particular, Japanese phonology is said to be 'simpler' in structure than that of English. This may be evident in the fact that the set of vowels and consonants in Japanese are subsets of English vowels and consonants. In addition, Japanese canonical syllable structure is CV, with few exceptions CVC, both of

which are, again, subsets of English syllable types. While the number of possible syllables in Japanese is limited to around 109, the number of possible English syllables is far in excess of this. In Japanese, there are neither complex onsets nor complex codas, with possibly only one exception¹. Given that Japanese phonology is simpler than that of English, one would assume that it is relatively easy for English speakers to acquire Japanese phonology. However, this is not so, as we find out in this study. Spanish, which is also considered to be simpler compared to English, can cause problems for adult English speakers acquiring it as their second language (Parrondo Rodoriguez (1999)). The difficulty Parrondo Rodoriguez finds is with nucleic glides in Spanish. In this thesis, the distinctive status of *mora* in Japanese is cited as the cause of difficulty in the acquisition of Japanese phonology by English speakers.

Reviewing the literature on the theoretical development of ideas about the mora, we find that mora does not play a role in English overtly, though it is identified as a weight-bearing unit (see Hyman (1985)). In Japanese, however, the mora is distinctive, and plays a vital role in phonology (see Vance (1987) among others). The distinction of one mora or two morae² is crucial in identifying the word in Japanese. The assignment of the mora to the constituents of syllable is therefore a crucial step in the formation of Japanese syllables. The distinctiveness of the mora is realised acoustically in terms of segment length. Syllables containing a long vowel or diphthong, a moraic nasal or first member of a geminate consonant have two morae assigned to them. Although in English there are some minimal pairs distinguished by long or short vowels, nasals and geminate consonants are not distinguished by their mora assignment.

¹ Kubozono (1996: 76) cites *Wuiinkko* 'Viennese person' as an exceptional case. It has a complex coda consisting of a moraic nasal and a geminate consonant.

² There are some loanwords such as 'toon' (tone) and 'koin' (coin) have three morae.

In Chapter 2, through a literature review of language acquisition, the theoretical framework for the acquisition of Japanese syllable structure under Universal Grammar is constructed. First, we take a look at first language acquisition.

Every child acquires his/her first language with ease, without fail. Furthermore, they appear to do so without presumed necessary input from the environment. Babies mimic what they hear (primary input), experiment with them and eventually learn to produce meaningful words, then progress to sentences. They formulate rules and develop the grammar of their first language based on the primary linguistic input. Primary input, however, does not cover all rules that are included in the adult grammar (underdetermination). The primary input is often degenerate, as people tend to talk to young children with limited vocabulary, with simpler sentence structure that may sometimes be grammatically incorrect, in a manner that is not used amongst adults (degeneracy). Also, the primary input does not normally contain negative evidence, i.e., no information about erroneous utterances or error correction. Underdetermination, degeneracy and the lack of negative evidence constitute to a poverty of stimulus, a puzzlement that is referred to as the projection problem, logical problem or learnability problem as discussed by White (1989) among many others.

The learnability problem has led Chomsky (1959) and his followers to the belief that the predisposition to develop grammatical competence is innate, and that language acquisition is governed by the *Universal Grammar* (UG) that is defined as “the set of properties, conditions, or whatever, that constitute the ‘initial’ state of the language learner, hence the basis on which knowledge of language develops” (Chomsky (1980b: 69)) Acquiring a language is therefore viewed as the growth of the mental organ of language triggered by certain “language experiences” or “input” afforded by interactions with adult-speakers of the language. Under the UG framework,

a collection of *principles* that are common to all languages are assumed to be present innately. A set of *parameters* whose values are language specific must then be set based on the input to form the L1 grammar. Many researchers take the view that UG facilitates first language acquisition. However, not all share the same view as to the role UG may or may not play in L2 acquisition. We also discuss these differing views of the role of UG in L2A in Chapter 2.

If UG is applicable to second language acquisition, particularly to adult second acquisition, because the principles remain accessible they are unchanged but a set of new parameter values needs to be acquired; a parameter must be re-set for the L2 if its value differs from that of L1. At the beginning of L2 acquisition, the initial values of principles and parameters are those of L1 (initial state). During the course of L2 acquisition, parameters are progressively re-set and the learner forms an *interlanguage*, which may be neither L1 nor the target language (TL), but nevertheless is a natural language (see Selinker (1972), Kellerman (1977), Tarone (1978) and Eckman (1987)). When all the parameters are set to the correct values for the TL (steady state), L2 acquisition is complete and the ultimate attainment level is said to be native competence. In reality, however, a native competence, particularly in phonology, is hard to achieve. We will consider factors that affect the ultimate attainment level in Chapter 2. These addressed in this study are primarily age of onset and the 'quality' and quantity of input.

If UG facilitates L1 but not necessarily L2 acquisition, what happens with bilinguals with early exposure to two languages? Do they develop both languages to native competence? Results from empirical research to date suggest that there are different categories of bilinguals with respect to their competence in each language. We review such findings and postulate the effects of age of onset and input on bilingualism.

Acquisition of native-like phonological competence is said to be difficult, particularly for adult L2 learners. If so, are there any ways the process of acquisition may be facilitated, promoted, or even accelerated or boosted? There are many claims, though not for phonology, in recent years that this is indeed possible. We review such studies and their empirical research findings.

Finally in Chapter 2, three research hypothesis are presented: the Mora Assignment Hypothesis, L2 Phonological Acquisition and Age Onset Hypothesis and Quality and Quantity of Input Hypothesis. To test these hypotheses, two studies were designed. One examined the phonological competence of the English-Japanese bilinguals, which is discussed, and the second looked at the study of the acquisition of Japanese phonology by the adult L2 learners.

Chapter 3 discusses the study of two groups of bilingual children and adults participated in a study of early exposure and what the data collected tell us about their ultimate attainment level in Japanese phonology. When the two languages and associating culture are so different not to mention the physical distance between Japan and, in this case, the UK, equally balanced bilinguals in both languages are exceptional. All subjects in the study were either Japanese-dominant or English-dominant bilinguals. There were two sub-groups of bilingual children: English-dominant bilingual children and Japanese-dominant bilingual children all aged eight and living in the UK. The English-dominant bilingual adults had a very similar background to the English-dominant bilingual children. While English-dominant bilinguals were generally from mixed Japanese and English parentage, the Japanese-dominant bilingual children were from Japanese parents living in the UK temporarily on job assignments. Because of their family circumstances, the timing and the amount of exposure to Japanese varied. English-dominant bilinguals showed evidence of non-native Japanese

phonology. The Japanese-dominant bilingual children, on the other hand, showed that their Japanese phonology was native-like.

In Chapter 4, we look at the L2 acquisition of Japanese phonology by 94 adult English speakers. The learners were at varying levels in their Japanese language acquisition: complete beginners, intermediate and advanced level learners. Using a series of production and perception tasks, particular stages of syllable structure are examined, and the results are compared across the learner categories and longitudinally.

Finally in Chapter 5, the findings of the two studies are summarised and conclusions are given. We conclude that the mora indeed plays a vital role in acquisition of Japanese phonology, and the acquisition of the mora tier in the syllable structure precedes the durational control of the mora and also the identification of segmental duration. The next stage in acquisition of Japanese phonology is to assign mora to the correct mora slot, which is linked with the segmental acquisition. While all Japanese-dominant bilinguals seem to have reached the level of native competence in Japanese phonology, adult L2 learners including English-dominant bilinguals have not. They must first become sensitive to mora and identify the mora tier in the syllable structure.

Chapter 1

Theoretical Framework

1.1 Introduction

The aims of this chapter are to set the context of this thesis by reviewing literature and present the theoretical framework for a study on the acquisition of the syllable structure of Japanese by second language learners.

We first explore the recent theories of the syllable and its constituents, especially the mora. The notion of mora as a weight-bearing unit is investigated. We then analyse Japanese syllable structure and the role mora plays as a timing unit.

1.2 Syllable Structure

In this section, we examine the definition of syllable and ideas about its structure within a generative phonology framework. We further examine the idea of phonological weight and the role of mora in syllable structure.

What are the similarities and differences between Japanese syllables and English syllables? To what extent is the syllable universal? In answering these questions, let us review the syllable in the context of phonological universals.

1.2.1 Phonological Universals

In segmental phonology, it is well attested that the vowel /a/ is found in all known languages. In other words, the existence of [a] in languages may be considered universal. If we term this type of universal as "Definitive Universal," then there are also "Implicational Universals." Implicational universals may be expressed in the format: If X, then Y, where X implies Y, but Y does not imply X.

Hyman (1985:15 -16) cites some examples of such implicational universals:

- a. If a language has /θ/, then it is likely the language has /s/.
- b. If a language has voiced stops, it is likely that it also has voiceless stops.
- c. If a language has nasalised vowels, it is likely that it also has oral vowels.

It is also well attested that there is a universal syllable structure, CV, which is found in all known languages. By calling the CV structure universal, we are assuming that all languages have at least the CV construct in their syllable structure. However, there has been much debate as to what a syllable is.

1.2.2 Syllable

As a prosodic model of syllable structure, Hockett (1955) proposed the framework in (1).

(1)

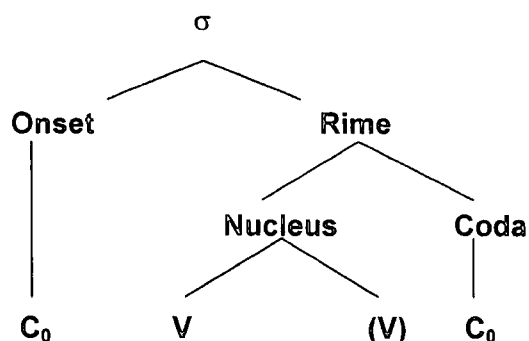

C₀ indicates that the consonant is optional, and at the same time there can be more than one C, i.e., a consonant cluster.

Hockett's model, syllable-as-branching-structure, is useful in phonological analysis. Some interesting linguistic phenomena, for example, the word game "Pig Latin" can be explained as:

(2) $Onset + Rime \implies Rime + Onset + "ey"$

Some speech errors where onsets of the first and second words are switched can also be analysed using Hockett's model:

(3) $car\ park \implies *par\ cark$

Despite Hockett's (1955) work, however, "syllable" remains as an illusive notion to a large extent. Chomsky and Halle (1968/1991) disregarded the notion "syllable" (as well as the notion of phonemes altogether) in favour of "strong and weak clusters" (1991: 25). In their framework, strong clusters consist of VC or VV, while weak clusters consist of CV, all in effect is another name for syllable. Strong clusters are then assigned stress in languages like English. While the idea of "strong and weak clusters" can explain stress assignment to a large extent, it involves rules, which are

more complicated and thus difficult to apply universally. It is not surprising, therefore, that many researchers (e.g., Vennemann (1972), Hooper (1972)) questioned the usefulness of replacing syllables with strong and weak clusters.

Natural Generative phonologists such as Vennemann (1972) and Hooper (1972) then reintroduced the notion of "syllable." Hooper argued for the need for formality and universality in defining the term within generative phonology, and provided Spanish data to demonstrate that there can be no descriptively adequate phonology of Spanish without reference to the position of segments within a syllable. Hooper then proposed that syllables be punctuated by the "syllable boundary," the boundary between two adjacent syllables, often represented as (.) or (\$), which is unique in having no lexical or grammatical correlate. Hooper argued that such syllable boundaries between certain sequences of segments are necessary to designate the domain of certain phonological rules. For example, Hooper illustrated that the \$-boundary is crucial in two rules: open syllable lengthening and final devoicing.

Kahn (1980) argued, however, that the "syllable boundary" approach is compromised by the existence of ambisyllabic words such as "hammer" and "happy" in English. Furthermore, Haraguchi (1994) argues that introducing yet another boundary to already existing large number of universal boundaries, such as the morpheme boundary (+), the single word boundary (#), the double word boundary (##) and the phonological phrase boundary (||), and language specific boundaries such as equal sign boundary (=) proposed by Chomsky and Halle (1968/1991) adds complications. Haraguchi also argues that the syllable boundary is different to all others in a sense that it has no phonetic reality, and therefore, it belongs to diacritic features that have a classificatory function.

(5) (1976: 47)

Associate S(syllable) with C (consonant)

(i)

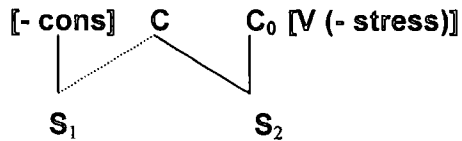

The left-most consonant (onset) of the unstressed syllable is associated by a dotted line with the preceding syllable, as a post-vocalic consonant (coda).

(ii)

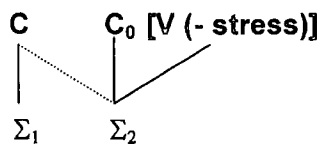

The syllable final consonant (coda) is associated with the subsequent syllable by a dotted line to form a syllable-initial consonant (onset).

Kahn's model as described above assumes that the syllable is a phonological unit and what this involves is a universal syllable template to arrive at a language-specific syllable structure. Steriade (1982) argued that such syllable templates were not necessary, and the information contained within templates was better served by the use of syllable-building rules, which were subject to language-particular well-formedness constraints. Steriade's framework consists of three rules: 1) Universal, 2) Onset Rule and 3) Coda Rule.

(6)

Rule 1 - Universal

Create (C)V = maximally unmarked

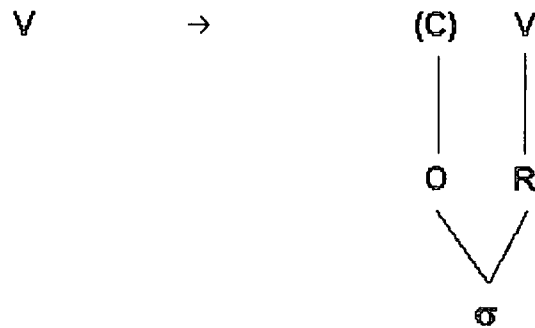

Rule 2 - Onset rule

Adjoin C to Onset = Branching Onset

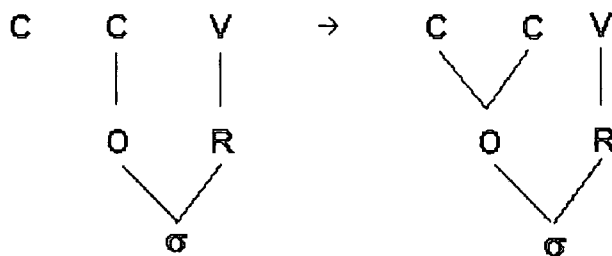

Rule 3 - Coda Rule

Adjoin C to Coda = branching rime

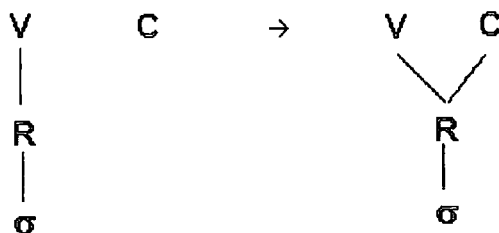

Sterade deals with any stray C's with the Stray Erasure Convention (Sterade (1982:82)):

Erase segment and skeleton slots unless attached to higher levels of structure (i.e., a position within the syllable or within a morphological template).

Steriade's model uses syllable-building rules that are subject to language-particular well-formedness constraints, the required minimal difference in sonority between members of a tautosyllabic cluster being the primary one. On this basis, Carlyle (1985) argues that Steriade's model has two problems when it is applied to a language such as Spanish. First, it is not possible to devise a sonority hierarchy that allows just the actually occurring tautosyllabic clusters in Spanish. Second, the sonority hierarchy, which deals with a type of surface phonotactics, cannot be extended to account for constraints on nucleus structure as tautosyllabic clusters.

To overcome these problems, Selkirk (1984a) takes a different approach in her analysis of Spanish, using a numerical sonority scale (7) and the syllable template.

(7) *Selkirk's numerical sonority scale (Selkirk (1984a:111))*

Sound	Sonority Index
a	10
e,o	9
i,u	8
r	7
l	6
m,n	5
s	4
v,z,ð	3

f	2
b,d,g	1
p,t,k	0.5

Carlyle (1985) questions if indeed it is necessary to have syllable templates to account for the phonotactics of a language, though acknowledging Selkirk's satisfactory account of Spanish syllable structure. In Selkirk's model, the syllable template is used to constrain syllable length, and it provides the internal structure of the syllable. Bearing in mind that Steriade's model makes use of the syllable-building rules to do what the template does in Selkirk's model, Carlyle combines two approaches: syllable-building rules (Steriade (1982)) and a numerical sonority scale (Selkirk (1984a)). To apply this to Spanish data, Carlyle introduces a dot tier (.) that captures rhyme constraints on both V's and C's. In order to incorporate the dot tier and at the same time do away with the CV tier, Carlyle uses the nucleus node, assuming that the nucleus is lexically specified.

(8) *Carlyle's Syllable-Building Rules (applied to Spanish) (1985: 44)*

Pre-condition (language specific)

Glide-Incorporation - Incorporate prevocalic glides into the nucleus

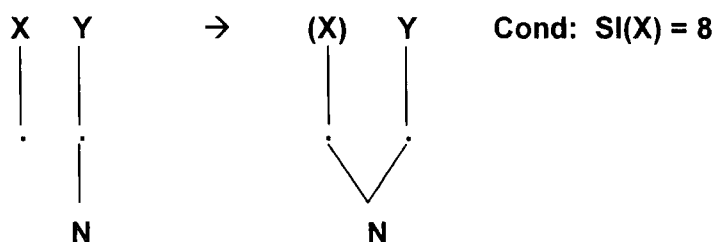

Key: Cond = condition SI = sonority index

Rule 1 Modified Universal (incorporates dot tier) CV is maximally unmarked

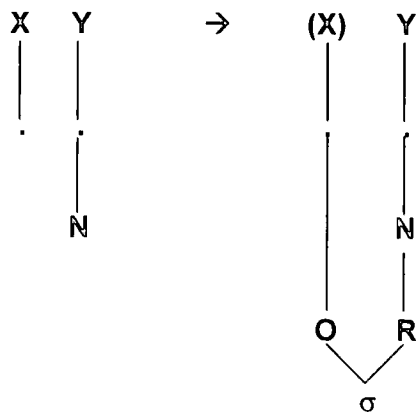

Rule 2 Onset Rule

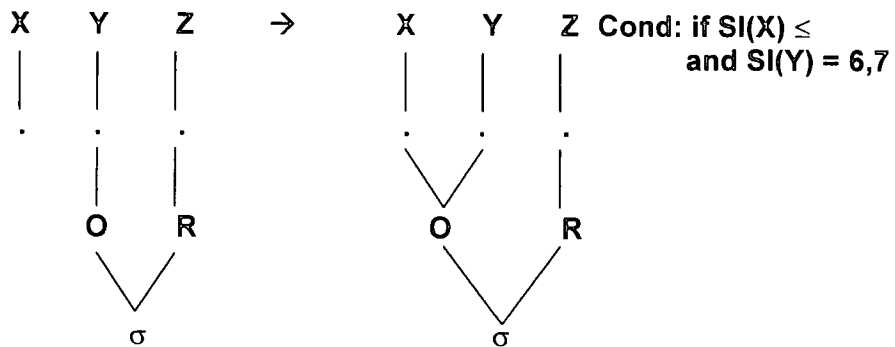

Key: Cond = condition SI = sonority index

Rule 3 Coda Rule

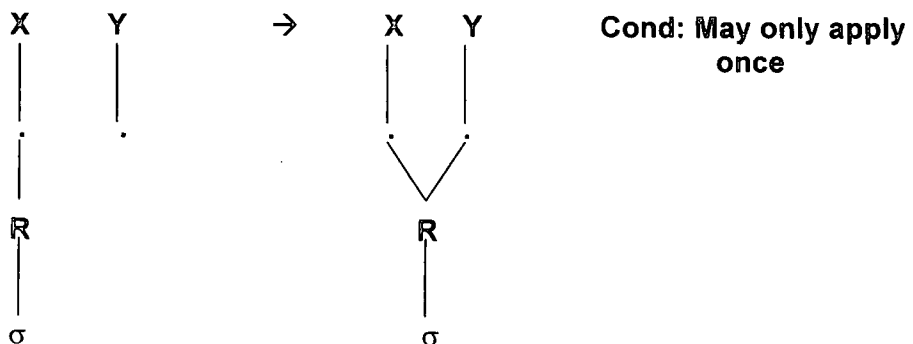

Rule 4 S-Adjunction

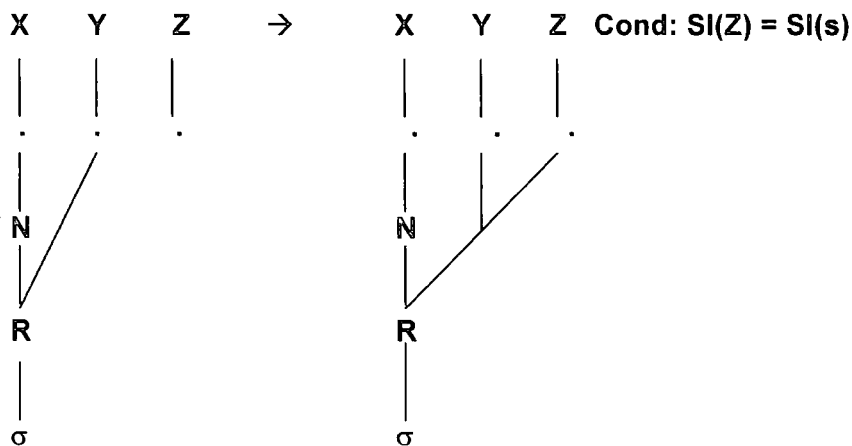

At one extreme of views on the syllable, Yoshida (1983) proposes moraic phonology to replace all syllable-based phonology including Natural Phonology, Autosegmental Phonology and Metrical phonology. In Yoshida's framework, a mora whose segmental composition is CV or V and a non-prevocalic C, all share a common psychological length. Yoshida argues then that recent trend in placing the syllable as the basic unit in a phonological and prosodic description has also required the notion of mora to compliment the gap left by syllable-only approaches.

There are other accounts of syllable structure, one of which is based on Government Phonology as in Yoshida (1990b), Yoshida (1990a), Kaye, Lowenstamm and Vergnaud (1985; (1990). For the purpose of this thesis, however, we will adhere to more widely accepted ideas on the syllable.

Most theories of phonology in the 1980s assume the adequacy of the syllable as a unit of hierarchical structure (Hyman, 1985), with the notion syllable playing a significant role in the analysis of the way sounds combine in a given language. What is

different from one theory to another is the way the internal structure of syllable is represented. I will return to the discussion of the internal structure of syllable later.

Proposing the syllable as significant phonological unit, Hyman (1985) argues that syllabicity can exist and may be acquired without syllable structure, citing the case of the Gokana language spoken in Eastern Nigeria, which permits at least up to six identical vowel lengths in sequence. In other words, while syllabicity is universal, syllable structures are not. Hyman claims that there may be extra-syllabic segments even in languages where syllable structure is attested and then proposes a theory of phonological weight, to be discussed in the following sections.

1.2.3 English Syllable Structure

We have seen in previous section that, while not everybody accepts the syllable as an essential notion in prosody, many agree on the role it plays in various languages. In this section, we examine theories regarding the internal structure of the syllable.

Following Selkirk (1980:565), a fixed hierarchy of prosodic levels is assumed as in (9).

(9) *Hierarchy of prosodic levels*

(phonological phrase)	
prosodic word	ω
foot	Σ
syllable	σ
(segment)	

(Levels in brackets are inserted by the author)

Each element at each level is thus composed of one or more elements at the next lower level.

Under this view the syllable as a branching structure consists of an onset and rime (=core), and the rime consists of a nucleus (= peak) and a margin (= coda). The syllable is the typical stress-bearing unit and as such, serves as the starting point for the construction of stress feet (Lieberman and Prince (1977), Selkirk (1980), Hayes 1981) and phonological phrases.

Ito and Mester (1986) argue that the syllable as a prosodic unit should be included in the same framework as other hierarchical structures such as the metrical foot, the phonological word and the intonational phrase. It is imperative that syllable theory maintains and adheres to certain principles and hypotheses inherent in Prosodic Phonology.

Returning to and basing on Hockett's model of syllable structure in (10) shown again here, new ideas have been put forward such as the Onset Principle by Ito (1989) and Prosodic Licensing by Ito (1986), Ito and Mester (1993).

(10)

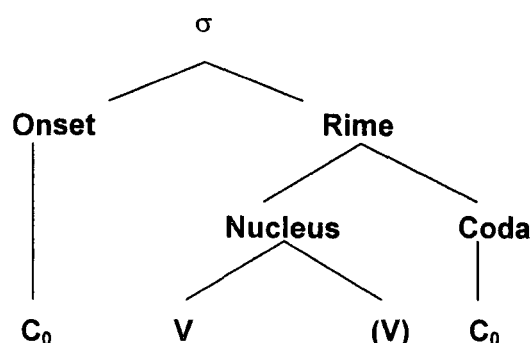

Ito (1989) argues that the grammar of every natural language contains the constraint "Avoid onsetless syllable" (Ito (1989:223)) and more recently Prince and

Smolensky (1993)³ have shown that absolute and relative enforcement of the Onset Principle has been shown to result from language-particular constraint ranking.

Under “prosodic licensing” (Ito (1986: 199)) the segment has internal structure, a “geometry”, or a hierarchical arrangement of nodes as shown in (11). Path Conditions are defined by Ito and Mester (1993) and for example deal with the minimal sonority requirement in Japanese with respect to morae and the avoidance of consonantal place in codas.

(11) *Segment-internal feature structure (1993:199)*

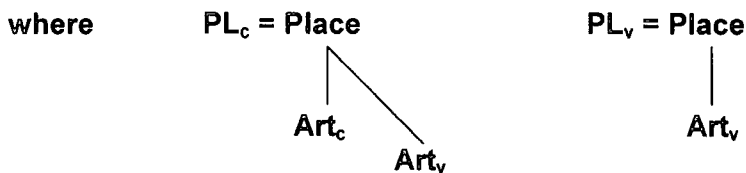
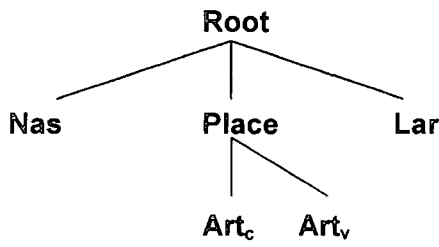

Key: Art_c = consonantal articulator, Art_v = vocalic articulator, PL= place)

A segment with the place configuration Place[Art_c] is a simplex consonant such as [p], Place[Art_cArt_v] is a consonant with a secondary articulation such as [pʏ].

Place[Art_v] characterises vocoids. In terms of headlessness, Head(Place) = Art_c, with Head(Place) = and with Head(Place) = Art_v only if Art_c=0.

³ Prince and Smolensky (1993) base analysis of the onset principle on their Optimality theoretic framework.

(12) *Path Conditions* (1993: 200)

a. Mora Sonority Threshold

b. Coda Place Condition

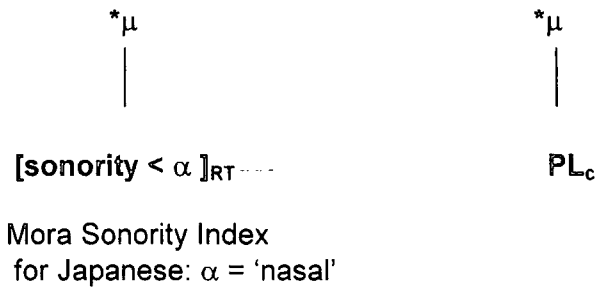

The Path Condition (12a) dictates that a Root node (RT) with less than α sonority is "unsafe." The value of the mora sonority index α is supplied by the grammar of each language. In the case of Japanese, Ito and Mester (1993) cite α = (nasal), i.e., the sonority of α must be greater than nasals. The Path Condition (12b) that forbids the linking of μ to consonantal Place (PL_c) bars consonantal place features from coda position in many languages. Ito and Mester (1993: 203) give examples in (13) and (14).

(13)

a. /kai/ 'shell'

b. */kap/

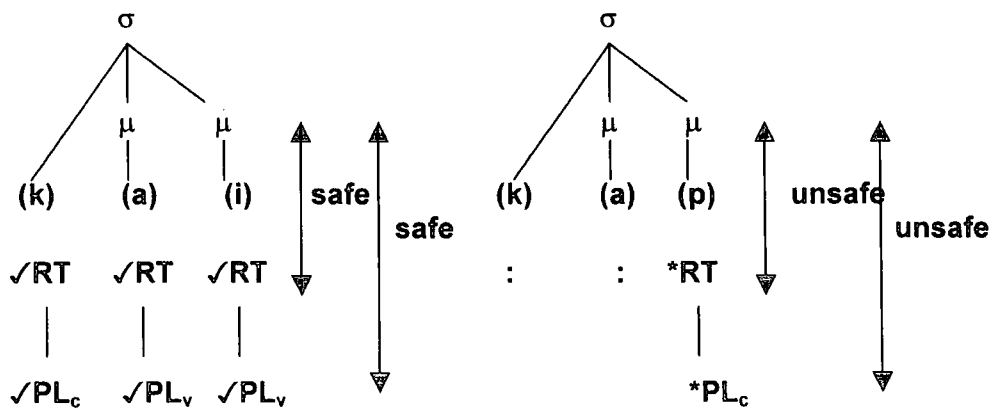

(✓ = safe, * = unsafe)

While in (13a), both the post-nuclear Root path [μ — RT(i)] and the post-nuclear Place path [μ — PL(i)] do not violate the relevant path conditions, since /i/ has a higher degree of sonority than nasals, and /i/ does not have consonantal place. Consequently, the segment /i/ is licensed. In case of (13b), however, both prosodic paths starting with the post-nuclear mora are unsafe, as the post-nuclear Root path [μ — RT(p)] violates the Mora Sonority Threshold since the sonority of obstruents is less than that of nasals, and the post-nuclear Place path [μ — PL(p)] violates the Coda Place Condition, since /p/ has the consonantal Place [labial].

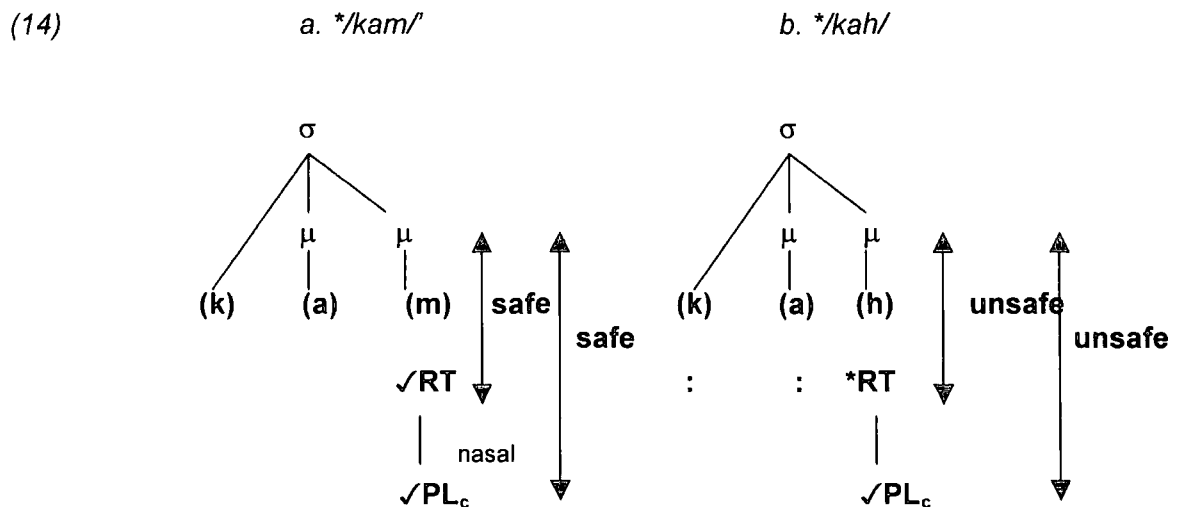

Examples in (14) show that the safety can be different for the two paths. Note that /m/ is different to /N/, which is a placeless nasal coda and therefore it, forms a well-formed syllable. We will return to these cases later in discussion of the Japanese moraic nasals.

1.2.4 Phonological Weight

The concept of syllable weight as discussed by Jakobson (1931; (1937) and Trubetzkoy (1939/1969) who observed it to be important in determining the placement of stress in various languages. McCarthy (1985/1979) and Hayes (1980/1985) have

further developed the concept and their work has contributed in forming the Branching Rime Hypothesis. The Branching Rime Hypothesis leads McCarthy (1982) to propose that the syllable universally consists of two primary constituents, onset and rime, for which the rime constitutes the prosodically active part of the syllable. The rime contains the vowel and any following consonants, while the Onset contains all prevocalic consonants.

Applying the branching rime hypothesis, "heavy" and "light" syllables may be represented as in (15).

(15) a. *light syllable* b. *heavy syllable* c. *heavy syllable*

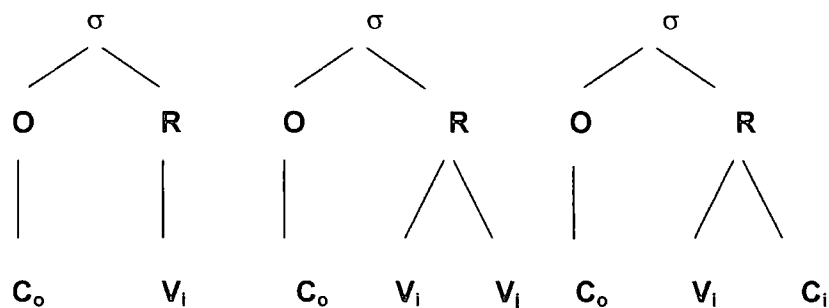

(Schematic representation based on Hyman (1985:6))

In (15), onset C_o is irrelevant for establishing syllable weight. V_i represents a short or lax vowel. V_i and V_j in (15b) indicate a two-vowel unit under a branching rime. (15a), whose rime does not branch, is a light syllable, and (15b) and (15c), whose rime branches are heavy syllables.

Halle and Vergnaud (1980) proposed to capture syllable weight in terms of the geometry of the syllable coupled with the notion of a "projection", introducing nucleus (N) and margin (M) as shown in (16) (given by Hyman (1985:6)). In order to establish whether the syllable is heavy or light, the only part that is "projected" is the rime.

(16) a. *light syllable* b. *heavy syllable* c. *heavy syllable*

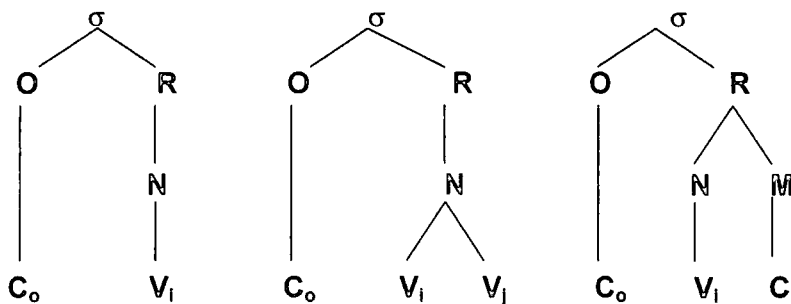

Where O = Onset (optional), R = Rime N = Nucleus, M= margin (=coda)

C_o = optional consonant, V_i and V_j may be a long vowel or a sequence of vowels

A light syllable consists of an optional onset (O), which is not relevant to defining syllable weight, and a rime (R) with a nucleus (N). N then dominates a single vowel (V). As is the case in (16b), a heavy syllable consists of an optional onset (O) and a branching rime that contains a nucleus, which dominates a tense or long vowel. A CVC syllable has an additional consonant in the margin (M), which closes that syllable. Strictly speaking, (16b) is a case of branching nucleus rather than that of rime.

Hyman (1985) questions the way the weight is treated as a property of the syllable, citing the example of Gokana that has no phonological syllables and which would therefore remain weightless. Hyman (1985:17) proposes light and heavy syllables to be expressed under an X-tier.

(17)

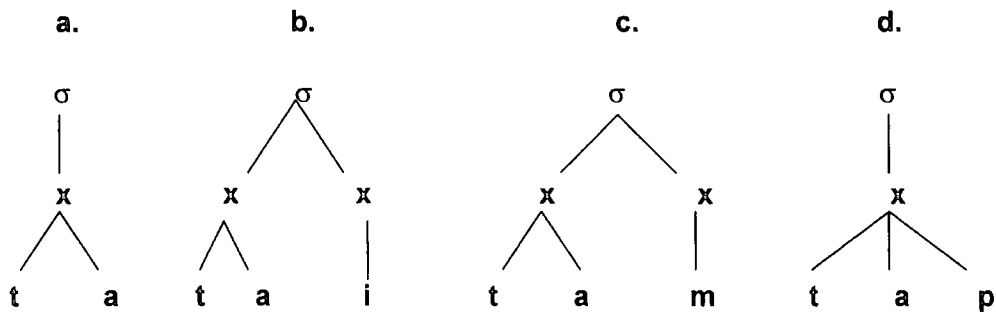

In (17a) a syllable node dominates a single x which in turn dominates a set of features represented by Cs and Vs. In (17b) and (17c), CVV and CVC syllables consist of a CV WU (weight-bearing unit) followed by a second WU having either [-cons] or a [+cons] segment matrix. In (17d), a CVC^[-son] syllable is dominated by a single x . As the x node represents a single WU, (18a) and (18d) are light syllables, while (18b) and (18c) are heavy syllables. Having proposed that the weight tier be independent of the syllable, Hyman (1985) proposes mora be the WU (weight-bearing unit).

1.2.5 Mora

Hyman (1985) argues that every segment is underlyingly assigned a mora, a WU (weight-bearing unit), the number of which determines the overall weight of a syllable. In Hyman's framework, the feature [cons] plays a key role as input to both OCR (Onset creation rule) and MCR (Margin creation rule) as well as to the distinction between high vowels and glides. According to Hyman's hypothesis, the maximal expanses of a single WU can be stated universally as in (18) (1985:119).

(18)

The maximal expanses of a single WU

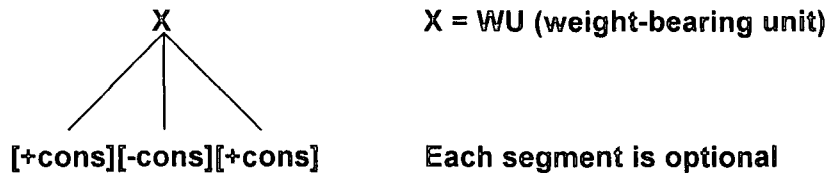

As single weight-bearing units, (18) yields CV, CC, VC and CVC.

Hayes (1989) proposed an alternative to Hyman's, claiming that short vowels are represented by one mora underlyingly, long vowels by two, and underlying geminates by one. Pulleyblank (1994) argues for Hayes' model by presenting tonal data from a Niger-Congo language of Nigeria. Tones must be pre-linked underlyingly, and the anchor for such pre-linking is the mora. Pulleyblank concludes on this basis that morae are not derived by a process of morification but are present underlyingly.

However, Pulleyblank (1994) rejects Hyman's proposal that every prosodic segment is assigned an underlying mora on the account that if all segments have morae underlyingly, then more tones than morae could be present on a morpheme, an option is impossible in the case of Yoruba. Pulleyblank also argues that, by pointing out that it would be impossible to derive the pattern of pre-linking as observed in Yoruba; if short vowels do not have morae, it is impossible to pre-link tone to them. McCarthy and Prince (1993) take the view that only long vowels and geminate consonants can be underlyingly assigned morae, while short vowels and consonants receive appropriate moraic structure in a predictable manner. Their view have a significance on the mora assignment in Japanese as we will discuss in the later section, though they do not refer to it directly.

We have seen mora being proposed as a weight-bearing unit. Is there any other evidence for mora being a valid prosodic unit? Next, we investigate additional recent ideas on the mora.

1.2.6 Mora – moraic weight and durational timing

Some languages, Japanese being one of them, are classified as “mora-timed languages,” implying that the mora is a timing unit and it plays a central role in that language’s prosody. McCawley (1968: 53) defined mora generally as “something of which a long syllable consists of two and a short syllable consists of one.” As a phonological unit, a mora consists of one or more segments, normally smaller than a syllable. As a rhythmic element, the mora has been considered largely irrelevant for most languages with the exception of e.g., Japanese or Ancient Greek. Since Hyman (1985) introduced the notion of universal mora as a weight bearing unit in syllable weight analysis, the notion of mora has been adopted by many researchers (including those in the field of language acquisition).

In the framework put forward by Hayes (1989), the mora has a dual role in X theory, where the prosodic tier, denoted as X tier, is incorporated in the syllable structure. First, the mora represents the well-known contrast between light and heavy syllables. A light syllable has one mora, and a heavy syllable has two morae. Second, the mora counts as a phonological position. A long segment is linked to two morae and a short segment is linked to a single mora. Onset consonants are directly linked to the syllable node and hence structurally not affiliated with syllable-weight units.

(20) Syllable Structure and Mora Assignment

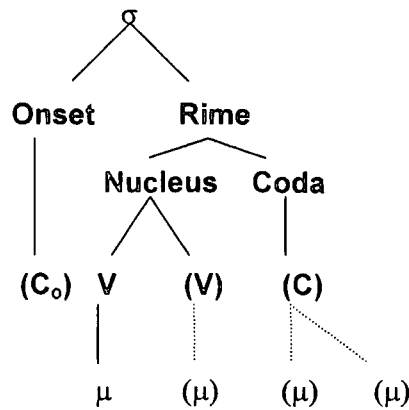

(C₀ = Onset Consonant. Bracketed constituents indicate that they are optional)

1.3 Japanese Syllable Structure

Having reviewed the research on syllable structure in general, now let us turn to the Japanese syllable structure and examine its characteristics.

Japanese syllables can be analysed in the same way as we have seen in the previous section: onset and rime. Evidence of this may be found in some Japanese word games and speech errors that indicate Japanese native speakers frequently separate the onset and the rime. For example, Haraguchi (1991) cites a case of the Babibu language game. The Babibu language game played by Japanese children has a simple rule where /b/ and a vowel matching the preceding vowel in the original word are inserted after each (CV).

(21)

- a. "tegami" → *tebegabamibi* letter
- b. "susi" → *subusibi* sushi

c.	“hosi”	→	hob <u>o</u> s <u>i</u> b <u>i</u>	star
d.	“sensoo”	→	se <u>b</u> en <u>b</u> u <u>s</u> o <u>b</u> o <u>o</u> b <u>o</u>	war
e.	“imooto”	→	ib <u>i</u> m <u>o</u> b <u>o</u> o <u>o</u> b <u>o</u> t <u>o</u> b <u>o</u>	younger sister
f.	“sinbun”	→	si <u>b</u> in <u>b</u> u <u>b</u> u <u>b</u> un <u>b</u> u	newspaper
g.	“minato”	→	mi <u>b</u> in <u>a</u> b <u>a</u> t <u>o</u> b <u>o</u>	harbour
h.	“tan’i”	→	ta <u>b</u> an <u>b</u> u <u>i</u> b <u>i</u>	unit (of measurement)
i.	“tani”	→	ta <u>b</u> an <u>i</u> b <u>i</u>	valley
j.	“kippu”	→	ki <u>b</u> it <u>s</u> u <u>b</u> u <u>p</u> u <u>b</u> u	ticket
k.	“kokki”	→	ko <u>b</u> o <u>t</u> s <u>u</u> b <u>u</u> k <u>i</u> b <u>i</u>	national flag

(Examples from Haraguchi (1994) and additional examples by the author)

Examples (21d) and (21f) include single nasals. After each nasal, a “bu” is inserted. These phenomena support the idea that native Japanese speakers treat single nasals as independent mora, though its representation is a single C. On the other hand, as seen in (21g), a nasal in CV sequence (onset nasal) is treated in exactly the same way as any other CV sequence. In (21h) and (21i), the difference between independent singular nasal and nasals in onset position is clearly illustrated. While (21h) is a three morae word, divided up as ta-n-i, (21i) is a two morae word, punctuated as ta-ni. (21d) and (21e) illustrate that for Japanese speakers long vowels are two distinct mora. In (21j) and (21k), a “tsu”⁴ is inserted in place of the geminate consonant, followed by “bu.”

⁴ In Japanese orthography, “tsu” written smaller than the rest of the characters to represent geminate consonants regardless of the adjoining consonant. In Babibu game, the geminate consonant is treated as an independent mora and a “tsu” attracts “bu” to follow.

From the analysis of the Babibu game, it is clear that the syllable onset is an important notion in Japanese phonology. In cases of a single nasal (moraic nasal) and geminate consonants, we have also seen evidence of the mora playing a role. Let us investigate the evidence for the mora further.

Kubozono (1989) uses speech errors as evidence for the mora as an important prosodic unit in Japanese. Kubozono illustrates blend errors in speech where Japanese speakers mix two distinct words with associated meaning and produce nonsensical words.

(22)	<i>Sequence A</i>	<i>Sequence B</i>	<i>Blend errors</i>
	A-B-C-D	W-X-Y-Z	→ A-B-Y-Z etc.
a.	to-ma-re "stop"	su-to-p-pu "stop" (loanword)	→ *to-ma-p-pu
b.	to-da-na "cupboard"	ho-n-da-na "bookshelf"	→ *to-n-da-na
c.	mu-u-do "mood"	hu-n-i-ki "atmosphere"	→ *mu-n-i-ki
d.	ta-ku-shi-i "taxi"	ha-i-ya-a "hired-car"	→ *ta-i-ya-a

(Adopted from Kubozono (1989:273))

From examples in (22), it is observed that the blending happens at mora level. In (22a), a geminate consonant is treated as an independent mora. So are long vowels, as in (22c), where a long vowel is treated as two separate mora.

A further example of a blend error involving a nasal is given in (23).

(23)

Sequence A	Sequence B		Blend errors
A-B-C-D	W-X-Y-Z	→	A-B-Y-Z etc.
to-n-ka-tsu	po-o-ku	→	*po-n-ka-tsu
“fried pork”	“pork” (loanword)		

The examples given in (22) and (23) provide evidence that the mora has phonological reality in Japanese.

1.3.1 The Mora as a timing unit

As was discussed in relation to the findings of Broselow, Chen and Huffman (1997) and Ham (1998) in the previous sections, the weight of a mora may be translated into a unit of time as is indeed the case in Japanese.

Japanese is said to be an example of a mora-timed language, where each mora is produced more or less at regular intervals. In this definition, the term “mora” is used to mean a beat of a sound that typically consists of a CV⁵. Based on this notion of mora, Yoshida (1990b) among many others considers the mora as 1) the basic unit for the description of pitch contours of Japanese phrases, and 2) a unit for measuring distances in accent placement.

If it is a timing-unit, are morae constant in duration? Does the mora have isochronicity? There has been much debate on the mora as a timing unit in Japanese in recent years.

⁵ Kubozono (1995) among others use the term mora synonymously with ‘haku,’ another notion used in conventional Japanese phonology, representing CV, V, or the coda C in CVC in case of moraic nasals and geminate consonants.

A number of researchers have investigated whether or not each mora possesses a constant duration in terms of production and perception (Sato (1993)). Kawakami (1977) argued that the essence of a mora was not the length of the sound, but the length of time. In other words, it is not the duration of a phon, but it was the “gap” or “time” it takes from the beginning of the mora to the beginning of the next mora, including the time when there is no sound. If the mora involves a CV, and C is a plosive, then the mora is measured from the instant when the consonant is released till the instant when the next mora begins.

(24)

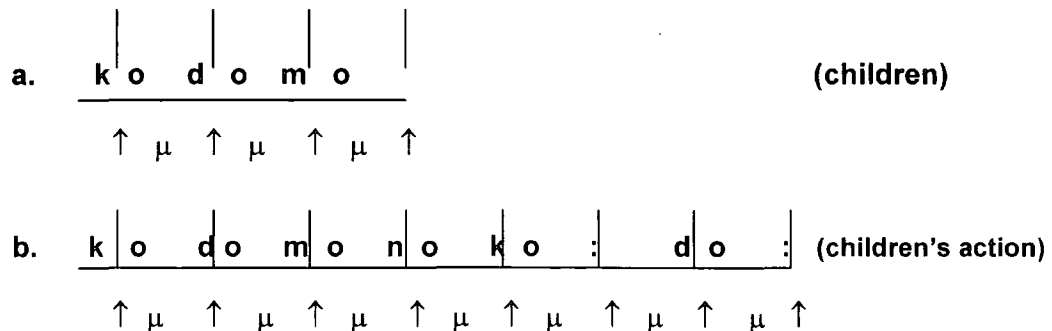

(: = long vowel sign, μ = mora, \uparrow = the moment the mora begins and ends)

(Kawakami 1977:143)

Homma (1981:280) also argued that mora length remains roughly equal because of Temporal Compensation. Beckman (1982), however, argues that there is no phonetic reality in the Japanese mora as a timing unit. Nagano-Madsen (1989) is also critical of a duration-only approach and proposes looking at both temporal and tonal dimensions. Han (1994) argues against Beckman's claim that the notion of Kana was promoted by literacy in Japanese. Han's research findings support the claim by Port, Dalby and O'Dell (1987) that mora isochronicity exists not at mora level but at word level. They conclude (1987: 1584) that 1) “the concept of the mora as an abstract

isochronous unit of timing in Japanese captures many of the most salient features of timing in this language,” and 2) “mora must be viewed as either a unit that exists only in larger units like words, or else that exists at an underlying articulatory level that is not directly revealed in the “acoustic edges” we measure on spectrograms.” Otake (1989) conducted two experiments examining English and Spanish and found evidence to support the hypothesis that the durational phenomena cited as evidence for mora-timing are inherent characteristics of Japanese. Otake reports from the results of his first experiment that the temporal compensation effect claimed by Port, Dalby and O'Dell (1987) occurred in English (stress-timed) and Spanish (syllable-timed). In the second experiment, the proportionality of word duration was tested. Though Port *et al.* assumed that the proportional word duration was a phenomenon specific to a mora-timed language like Japanese, Otake's results show that it can be found not only in Japanese but also in English and Spanish. Otake and Yoneyama (1994) found in a study of a Dutch listeners that they do not use the same listening process as the Japanese do. The results suggest that Japanese listeners are sensitive to duration, while the Dutch listeners are not.

Cross (1997) summarises the effects of durational change in mora, or between morae based on wave form analysis in (25) to (27).

(25) CV to CVC

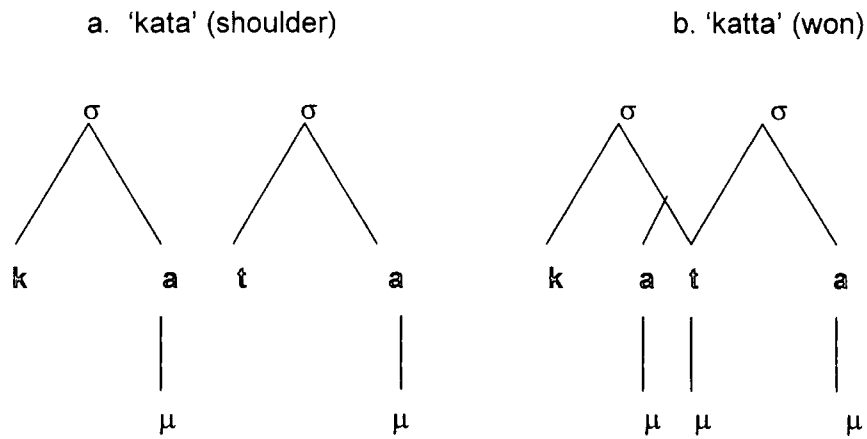

In (25a), an acoustic gap was inserted between the two morae. When the durational gap was over 2.5 times longer than the duration of the preceding mora, all six native speakers tested perceived it as (25b).

(26) CV to CVN

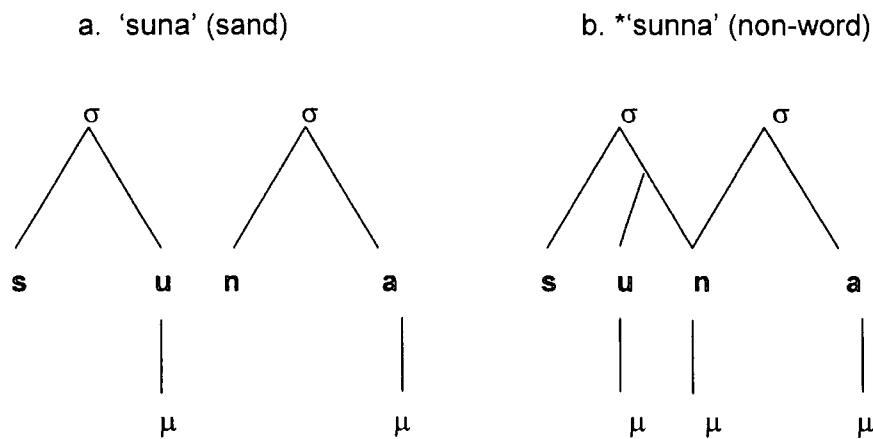

In (26a), the duration of the onset nasal was sustained. When the new segment measured over 1.5 times the preceding mora, native speakers perceived it as (26b).

(27) CV to CVV

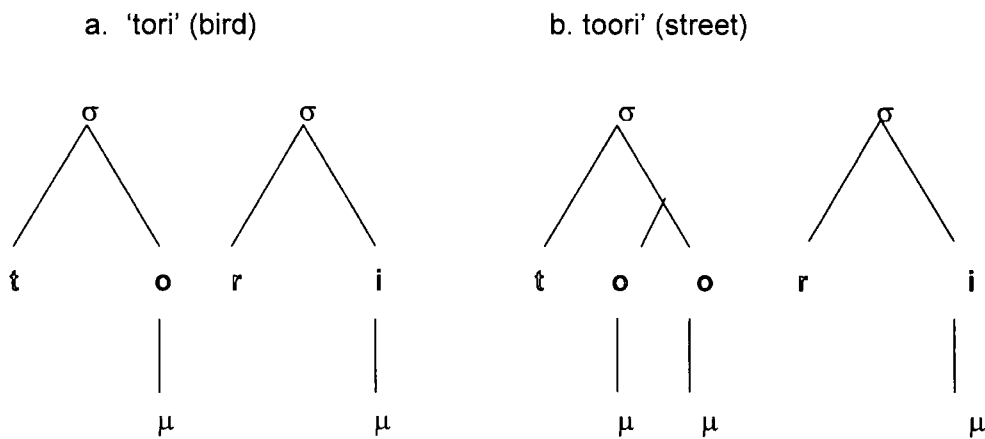

When the duration of the first mora in (27a) was lengthened by 1.5 times or over, native speakers perceived it as (27b). Cross concludes that, despite the apparent non-isochronicity in the mora, durational changes have effects on the perception of syllables.

Despite much debate on mora isochronicity (or lack thereof), phonologists such as Vance (1987: 71) and Kubozono (1999: 32) remain convinced of its status as a timing-unit in Japanese. Kubozono maintains that the mora is 1) a basic unit of temporal regulation, 2) a unit by which phonological distance is defined, 3) a segmentation unit whereby words/speech are broken into discrete chunks in speech production and 4) a segmentation unit used in speech perception. Kubozono agrees that mora as a unit of phonological distance measurement may not be specific to Japanese. However, in Japanese, phonological processes such as accent assignment can be analysed by counting number of morae and it therefore remains an important timing-unit.

The lack of the isochronous nature is not only associated with mora-timing, but also with syllable-timing (e.g., French) and stress-timing (e.g., English). Abercrombie (1967: 96-98, 131) claims that English has a stress-timed rhythm and stressed syllables occur at roughly equal intervals. Ladefoged (1982: 109-110, 224) cautions

that this is only a tendency. Ladefoged (1982:219-221), however, notes that native speakers of a language seem to agree on how many syllables any given word contains. Let us now summarise the status of the mora as timing-unit. In Japanese, mora count is distinctive regardless of disagreements over the exact state of its isochronicity. It is deduced from the arguments thus far, being a stress-timed language, the mora in English is not distinctive.

1.3.2 The Bimoraic Foot

Catford (1977: 85-92) claims that “in all languages initiator power is delivered in quantum-like bursts, containing a single peak of power.” These initiator power pulses are isochronous, i.e., roughly equal in duration at any given tempo, and these power pulses coincide with syllables in some languages. Abercrombie (1967: 96-98) labels each isochronous pulse in the stressed rhythm a *Foot*. Traditionally, the metrical foot has always been associated with stress and a heavy syllable. Heavy stressed syllables are, as we have discussed in previous sections, normally bimoraic. A heavy syllable that has two mora units assigned to it is a bimoraic foot. For example, in English, words consisting of a single syllable tend to have a tense vowel in the V position: tea, see, sea, loo, sue, pea, cue, key or diphthongs: eye, my, pay, say, cow, mow, may, how, and so on.

Poser (1990) proposes that a moraic foot whose properties are similar to those of stress feet in other languages such as English plays a significant role in Japanese. Poser presents voluminous data to support his argument, in particular the phenomenon of hypocoristic formation⁶. His hypothesis of bimoraic foot also explains the

⁶ Hypocoristic formation is the way Japanese personal names are shortened for the expression of intimacy. The truncated forms are subject to the bimoraic shape constraint and the hypocoristic suffix -tʃaŋ always

accentuation of compound nouns, although it is not relevant to this thesis and therefore not discussed in this study.

We have noted that thus far mora is an important prosodic unit in Japanese. We will now turn to syllable structure and examine how the mora may be related to the syllable.

1.3.3 The Syllable in Japanese

Let us see how Japanese may be expressed in the universal model of the syllable with mora as its weight-bearing unit.

Abe (1987) lists three types of Japanese syllables:

(28)

a. Light syllable (C)(G)V

“i” (stomach), “ki” (tree), “kyo” (dowelling, home), “cha” (tea)

b. Heavy syllable (C)(G)VV, (C)(G)VN, (C)(G)VO

“ai” (love), “kai” (shell), “jun” (pure), “kyuu” (grade), “chotto” (a little)

c. Super heavy syllable (C)(G)VVN, (C)(G)VVO

“baruun” (balloon), “soot-to” (quietly)

(Key: G = glides O = voiceless obstruents in geminates)

As a ultra heavy syllable, Kubozono (1993) cites the case of “Wiink-ko” (Vienesese people) that has the structure GVVNO, but it is acknowledged as exceptional.

For Japanese syllable structure, Abe (1987) proposes the following:

follows. For example, Kaoru becomes Kao-chan, and never Ka-chan, and Kenichi becomes Ken-chan and not Ke-chan or Keni-chan (Suzuki (1995:449)

(29)

Syllable template (Abe (1987:6))

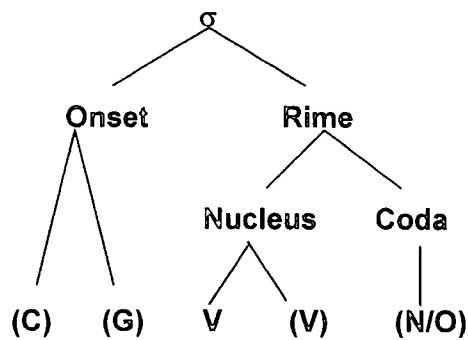

Key: C = consonant, G = glide, V = vowel, N = nasal, O = voiceless obstruents in geminate

Tabata (1989) questions the appropriateness of adopting the syllable template as shown in (29) for Japanese syllable structure as "it does not treat Japanese phonology in its right perspective" (1989: 148). Instead, Tabata makes a new proposal based on CV-skeleta and a template, applying X-bar theory to phonology. Although Tabata's complex model appears to account for all regional accents in Japanese, for the purpose of this research where only the Tokyo accent (generally considered to be the standard Japanese accent) is discussed, the unnecessarily elaborate syllable template is not required.

1.3.4 Special Syllables Types: CVC, CVN and CVV

In Japanese the unmarked syllable structure is CV. In this section, we examine special syllables, geminate consonants, nasals and vowel clusters and their relationship to Japanese syllable structure.

1.3.4.1 Geminate Consonants

While geminate consonants typically occur at the morpheme boundary, with voiceless obstruents after a short vowel, there are many exceptions particularly in loanwords of western language origin (Ono (1991)).

Under the prosodic licensing framework proposed by Ito and Mester (1993) a word containing geminate consonants is analysed as follows.

(30) *Kippu* 'ticket' (1993:204)

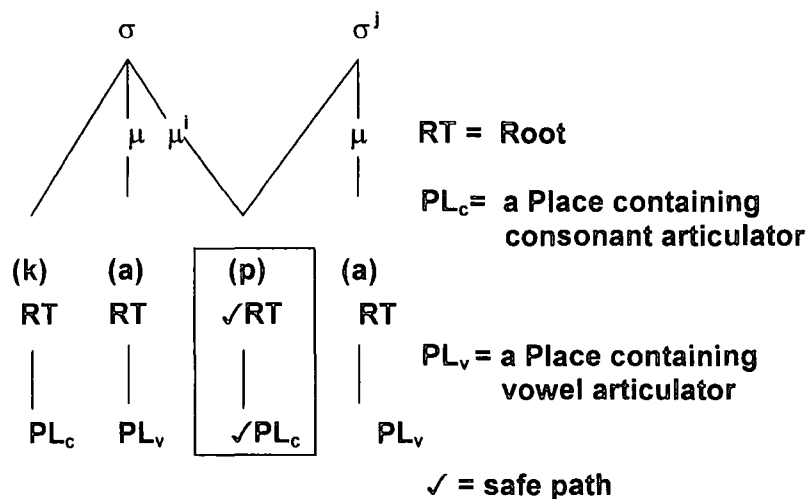

For the onset /k/ and both nuclei /a/ in (30), there are no licensing issues arising. However, the two prosodic paths originating from μ^i , the post-nuclear Root path $\langle \mu^i - RT(p) \rangle$ and the post-nuclear Place path $\langle \mu^i - PL_c(p) \rangle$ are unsafe, as they violate Path Conditions: Mora Sonority Threshold (the obstruent root /p/ is less sonorous than nasals) and Coda Place Condition (avoidance of consonantal places in codas) respectively. The violation of Path Condition, however, does not automatically lead to illformedness. In case of geminates, even though one of its paths to prosody is unsafe, there is another prosodic path which is perfectly safe. In case of (30), the onset path $\langle \sigma^j - RT(p) \rangle$, the onset path and RT(p) are therefore licensed. Similarly, PL_c(p) is also licensed as $\langle \sigma^j - PL_c(p) \rangle$ is a safe path. The segment /p/ is licensed as both

RT(p) and PL_c(p) are licensed. From these, Ito concludes that geminates have two prosodic paths, hence two potential sources of licensing.

Having established that the coda consonant position is occupied by a geminate consonant being licensed by having two prosodic paths, we re-examine Abe's (1987) syllable template model in view of loanword phonology.

Abe allowed only voiceless obstruents in the coda consonant position within the syllable structure. However, in loanwords, this is not always the case. For example, long-established loanwords of English origin are nativised having voiced geminate consonants as shown in (31).

(31)	<i>English Word</i>	<i>Japanese Word</i>
	dog	doggu
	bed	beddo
	goods	guzzu

The syllable template must therefore be revised as follows:

(32)

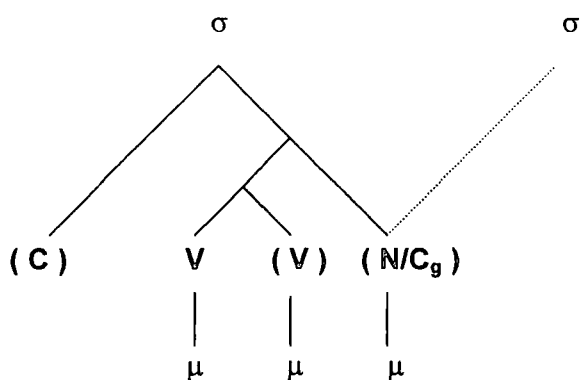

Key: C = consonant, V = vowel, N = nasal, = licensed path
C_g = geminate consonant

1.3.4.2 Vowel Clusters

There are many words in Japanese consisting solely of a vowel or combination of vowels, many of which are also homonyms.

- (33)
- a. *V words* *gloss*
- | | | | |
|-----|-----------|----------|------------|
| "i" | (stomach) | (well) | (thinking) |
| "e" | (picture) | (handle) | (branch) |
- b. *VV words*
- | | | | |
|------|---------|------------|--------------|
| "ue" | (above) | (planting) | (superior) |
| "ai" | (love) | (meeting) | (both sides) |
- c. *VVV words*
- | | | | |
|--------|---------------|-------------|----------|
| "ao-i" | (blue (adj.)) | (hollyhock) | |
| "oo-i" | (many) | (cover) | (throne) |
- d. *VVVV words*
- | | | | |
|---------|----------------|------------------------------|--|
| "ei-ei" | (strenuously) | (English-English dictionary) | |
| "oo-oo" | (occasionally) | | |

("-" = morpheme boundary)

Apart from examples shown in (33), there are many vowel sequences within words in the form CVV, CVVV, CVVVV and so on.

Such vowel clusters can be analysed in three different ways: 1) diphthong, 2) long vowel and 3) separate syllables. Kawakami (1977) lists Japanese diphthongs as

/ai, oi, ui, ae, ao, oe, jai, joi, jui⁷/. Kawakami argues that any two adjacent vowels have tendency to form a diphthong. The same sequence of vowels sometimes form a diphthong, therefore forming a nucleus of a syllable, and other times vowels are independent, forming two separate syllables. Kawakami illustrates this by giving example of the word "toita" ('solved' or 'door panel').

(34) a. *toi-ta* 'solved'

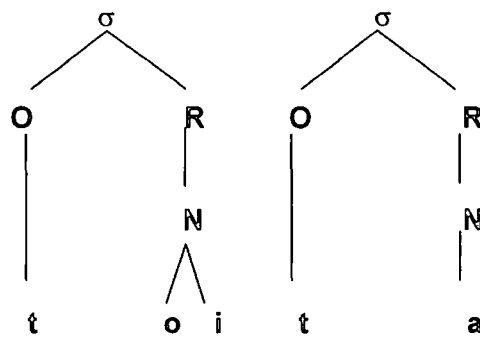

b. *to-i-ta* 'door panel'

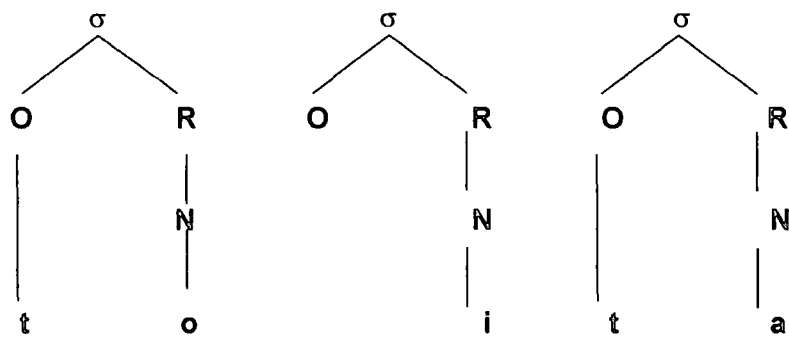

The syllable boundaries in vowel sequences tend to be determined morphologically, though in casual or careless speech, this may not always be maintained. In (34a) the morpheme boundary is found in between "toi-" (to solve) and "-ta" (past tense), while (34b) may be separated into "to" (door) and "ita" (panel).

⁷ Kawakami (1977) treats glides as nucleaic.

Haraguchi (1994 :221) notes that the syllabification of Japanese vowel clusters, depends on several factors: segmental features, morpheme boundaries, whether the syllable is accent bearing, if the accent shifts when incorporated in a compound word.

The same vowel sequence of o-o can be analysed in two ways:

(35) a. oo-I 'cover'

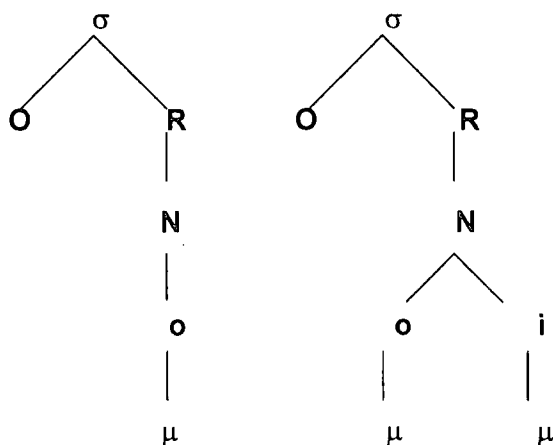

b. oo-I 'many'

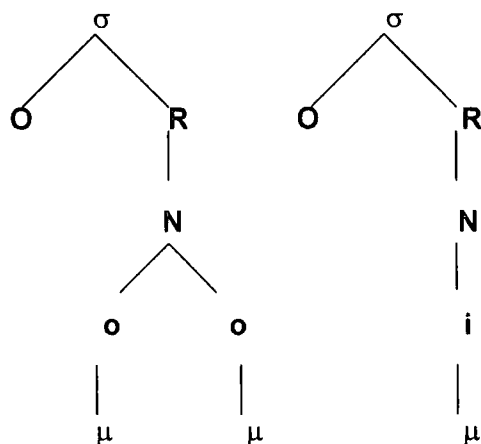

As we have seen, Japanese vowels may occupy a rime position singularly, or as double vowels (either a long vowel or a diphthong), form a branching nucleus under the rime node and each vowel is assigned a mora. Let us now turn to nasals.

1.3.4.3 Nasals

In Japanese, a nasal can be realised in onset position, or in rhyme position, gaining a moraic value. The distinction between moraic nasal (occupying a rime position) or non-moraic nasal (occupying the onset position) is made acoustically on the basis of segment duration. Han (1962: 70) presents the examples in (36).

(36)

- a. shi-nin "dead person"
- b. shin-in "real reason"
- c. shin-nin "newly appointed person"

("-" = syllable boundary: the segmentation is carried out by the author)

Otake and Yoneyama (1994) conducted experiments to investigate the difference between the onset nasal /n/ and the moraic nasal, represented as /N/, acoustically. The results show that duration plays important role in the recognition of a moraic nasal in speech perception by Japanese listeners. In this experiment, a nonsense word "te-no-po" was recorded as shown in (37), and native Japanese listeners were asked to recognise it.

(37) /tenopo/ (Otake (1994: 1428))

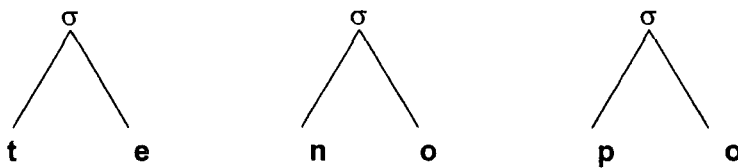

As shown in (37), the nasal is placed at the onset position. The word was heard by the native speakers of Japanese as "te-no-po."

Next, the duration of the nasal in (37) was artificially lengthened by 1.5 times.

The word was still recognised as it was, "te-no-po."

When the duration exceeded 1.5 times longer than the original one, however, it was recognised as /te-N-no-po/, as shown in (38). Note that Otake and Yoneyama (1994) analyse the additional nasal segment as a coda consonant, and present it as "moraic nasal" denoted by a capital N.

(38) /teNnopo/ (Otake (1994:1429))

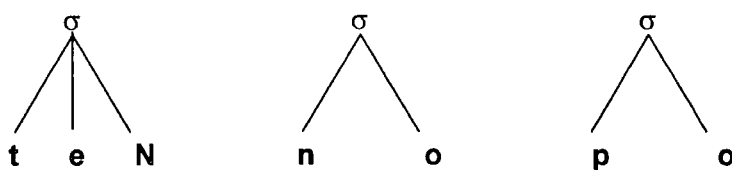

From the experiment results, where the lengthened onset nasal was perceived by the native Japanese speakers as two segments, one as a moraic nasal in the coda position and the other remaining in the onset position, Otake and Yoneyama (1994) conclude that segmental duration in Japanese is an important property.

Ito and Mester (1993) analyse nasals in coda position using the prosodic licensing theory. They argue that there are two distinctions in nasals, a regular nasal consonant in (39a) and placeless nasal segment (39b) transcribed as [N], post-nuclear elements, of which, only placeless nasal segments are admitted in Japanese.

(39) *Nasals in Post-nuclear position (Ito and Mester 1993: 208)*

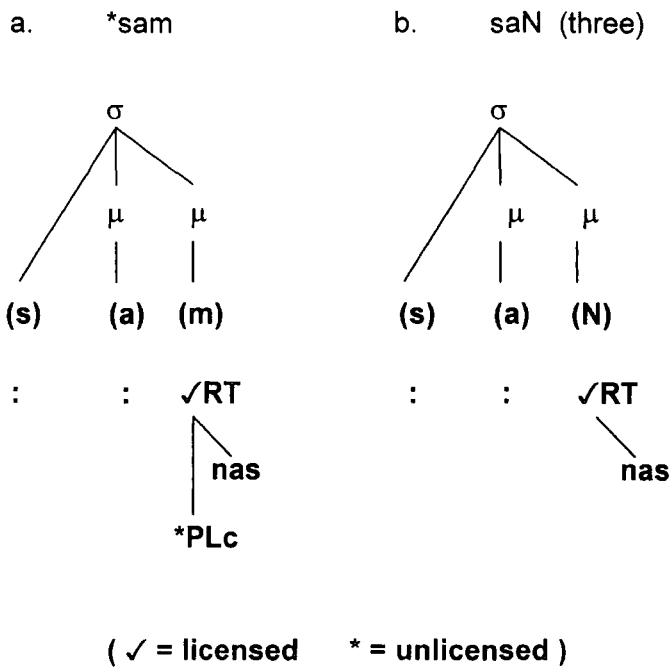

(40) *Nasal segments admitted in Japanese*

“saN” (number 3)

“kaN” (tin)

“i-chi-neN-kaN” (one year period)

In (39a), RT(m) is licensed, but PL(m) is not, making the entire segment /m/ unlicensed. The segment N in (39b), on the other hand, fulfils the Mora Sonority Threshold. At the same time, being headless and hence placeless, it trivially fulfils the Coda Place Condition. The segment /N/ is therefore licensed.

A word such as “sampo” (stroll) is therefore analysed as in (41).

(41)

a. *sampo* (preferred option)

b. *saNpo*

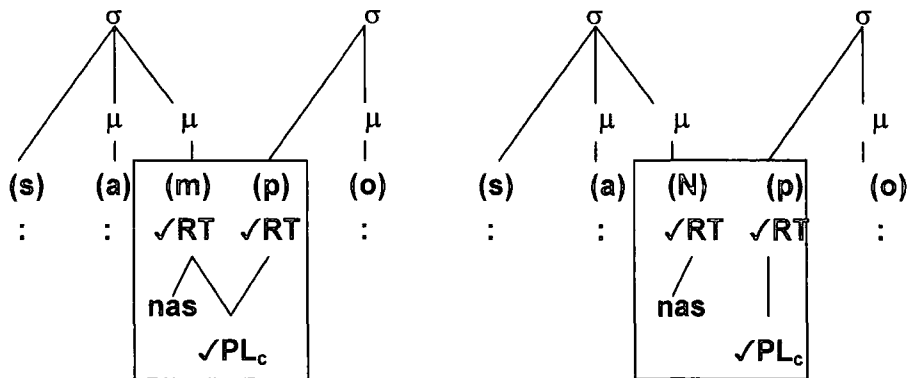

(Ito and Mester (1993: 209))

Though Ito and Mester have rejected the /m/ in (41a) as unlicensed segment, they argue that (41a) is a "preferred" option over (41b) when the segment is followed by another consonant, therefore generating NC clusters. Ito and Mester justify their stance by introducing the Segment Head Requirement (42) within the Optimality Theory framework, thereby ranking constraints.

(42) *Segment head Requirement:*

Roots are headed.

The Segment Head Requirement is placed as a higher-ranked constraint over the Segment Licensing condition, [Segment Licensing >> Segment Head] (modulo "Structure preservation" as a higher-ranking block of constraints).

In summary, Ito and Mester (1993) propose the ranking of constraints within the Optimality Theory framework (Prince and Smolensky (1993)) as in (43), where Path Safety Condition requires all prosodic paths to be safe.

(43) *Ranking of Conditions in Japanese*

Segment Licensing >> Segment Head >> Path Safety

The Path Safety Condition implies that closed syllables (CVN, CVC) are always more marked than open syllables even in languages like Japanese which only permit some nasal and geminate consonants in coda position.

We have reviewed recent research findings in phonology with respect to the syllable structure, and examined the three Japanese syllable types: CVV, CVC and CVN. Let us now return to the constituents of syllables and compare the characteristics of English and Japanese.

1.4 Japanese and English Syllables

Japanese is said to have maximum of around 104 possible syllables (Kindaichi (1972: 70-71)). The Japanese phonetic inventory consists of five vowels, two glides and twelve consonants, most of which are similar to those found in English. Compared with English, Japanese syllables are simpler and unmarked. So, is Japanese an easy language for English speakers to acquire? Let us now compare the syllables of the two languages paying particular attention to similarities and differences that may be of consequence to the acquisition of the syllable structure that will be discussed in the next chapter. We will first look at the lexical characteristics of Japanese.

1.4.1 Lexical Characteristics of Japanese

Japanese is a loanword rich language. In spoken Japanese, over 40% and in written Japanese, over 60% are loanwords of Chinese origin. These words are noted for their extremely high productivity in creating compound words and acronyms. Japanese words typically consist of four morae (38.8%)⁸ followed by three morae

⁸ Hayashi (1957) based on his analysis of approximately 47000 words in NHK Japanese Accent Dictionary (1951).

(22.7 %) and then 5 morae (17.7 %) (Hayashi (1957: 329)) Consequently, there are a large number of homonyms, as e.g. Kai in (44).

(44)

Kai 'shell' 'meeting' 'floor' 'lower level' 'added meaning'

When we include those with a different accent pattern, there are a further few to be added to the list.

In addition to the homonyms that can cause difficulties, non-native speakers have to be able to perceive the duration of a segment to identify number of mora.

1.4.2 Syllable Length

What is the maximum and minimum length of syllables? In the case of English, Giegerich (1992) argues that the maximal length of the English syllable is limited to three X positions in the rime based on the examination of the different possibilities of well-formed syllables by looking at the following monosyllabic examples:

(45)

a. free b. sit c. seal d. clamp e. */klaimp/ f. find

(45a) has a branching nucleus with a long vowel, and has two X positions. (45b) has a short vowel and a coda consonant, and therefore has two X positions. (45c) consists of a long vowel (two X positions) and a coda consonant (one X position), and therefore has three X positions. (45e) is not well-formed as it has four X positions. (44f) also has four positions, but it is well formed. There are a number of such syllables and what they have in common is that all the consonants violate the Sonority Sequencing Principle (SSP) (Kiparsky (1981), Clements and Keyser (1983)).

Notice that X positions equate to mora position in the syllable structure (Hyman 1985:17). We can then translate Giegerich's analysis of the syllable length into:

(46)

English syllables are minimally bimoraic and maximally tri-moraic.

What is the minimum and maximum number of morae in Japanese syllables?

Japanese syllables are typically CV (open syllable), and minimally monomoraic. There are many monomoraic words as we have seen in (33) under 3.4.2. Further examples are given in (47).

(47)

Me	'eye, shoot'	Ki	'tree'	Shi	'poem, death, number 4'
Sa	'difference'	To	'door'	E	'picture, handle'

As a maximum possible number of morae in a syllable, Kubozono (1993: 78) cites Wiinkko 'a Viennese person' as probably the only Japanese syllable with four morae. Japanese syllables are therefore minimally monomoraic, and maximally quartomoraic, though predominantly bimoraic and monomoraic.

Let us now turn to reviewing recent research finding in the area of phonological acquisition in the next chapter.

Chapter 2

The Second Language Acquisition of Syllable Structure

2.1 Introduction

The lack of extensive research into the field of phonological acquisition may be the result of a widely held view that the native competence attainment is less likely in phonology compared with other language components such as syntax and pragmatics. Children acquire knowledge of their first language with apparent ease and without fail. On the other hand, second languages are not always acquired easily and the native-like competence in them is not always achieved. Is this true? And if so, why?

The purpose of this chapter is in two fold; first to review recent researches in both first language (L1) and second language (L2) acquisition, particularly with respect to the acquisition of phonology and 2) formulate hypotheses on the process of L2 acquisition of syllable structure.

First, as the answer to the question of why children always seem to acquire their L1 with ease is offered by the Universal Grammar (UG) model. Does UG explain the process of L2 phonological acquisition? To address this question, the similarities and differences between L1A and L2A reported in the literature are reviewed.

Access to UG by L2 learners is a topic of debate in recent years. The full access model, the no access model and the partial or indirect access models are discussed.

The UG model of language acquisition is based on the principles that are common to all languages, and a set of parameters that have language specific values or settings. Assuming that UG facilitates, directly or indirectly, the acquisition of an L2, the concept of parameter resetting in the interlanguage, the developmental learner language that is independent from both L1 and L2 (Eckman (1987)) is examined.

Depending on the form of UG access the researcher proposes, the age of onset is considered a crucial factor influencing ultimate attainment. Comparing this with the extreme case of late age onset in L1A, research findings on the relationship between age onset and L2 acquisition are examined next.

Together with the age factor, the input in terms of its sufficiency and appropriateness is a focus of much discussion. Recent research findings in input for L2 acquisition are discussed.

If we were able to identify the kind of input needed to attain native phonological competence, would it be possible to give an "optimum" amount and quality of input? Would instruction targeting phonological acquisition facilitate and indeed accelerate this acquisition? These are the questions we hope to answer in the final section of this chapter.

2.2 Universal Grammar

Whether UG holds for L2 acquisition is a matter of much debate. Let us first look at L1A.

2.2.1 First Language Acquisition

The ways children acquire knowledge of their first language with apparent ease and without fail have led to much research in this field. Researchers in the Behaviourist school considered language acquisition as just one of the general learning process people go through: like any other "learning," language acquisition was achieved by "imitation" and "reinforcement." Chomsky (1959), dismissing Behaviourist terms such as "stimulus" and "response", led the attack on Behaviourist accounts of language learning, which had been largely based on animal behaviour in laboratory conditions. The alternative view proposed by Chomsky (1965) and Chomsky (1980a) is a mentalist approach, where the contribution of the learner rather than that of the environment is emphasised, though he does not completely rule out the possibility of explaining child L1A in terms of general cognitive development.

Chomsky and his followers' theoretical framework is based on the view that the predisposition to develop grammatical competence is innate. Chomsky (1980b: 69) defines Universal Grammar (UG) as "the set of properties, conditions, or whatever, that constitute the 'initial' state of the language learner, hence the basis on which knowledge of language develops." Acquiring a language is therefore viewed as the growth of the mental organ of language triggered by certain "language experiences" or "input" afforded by interactions with adult-speakers of the language. The basis for the idea of an innate predisposition lies in the notion of a logical problem in language acquisition, which refers to the insufficiency of input alone in language acquisition.

In the field of L1A, UG is now the most established account. Does UG apply in L2A? Let us now turn to the second language acquisition.

2.2.2 L2 Acquisition and UG

In recent years, many researchers have investigated the way UG may or may not be accessed by L2 learners. Schwartz (1991: 277-278) postulates three possibilities for what is actually responsible for language acquisition: 1) UG itself also contains “learning mechanisms”, in other words, UG is also the language acquisition device, LAD; 2) there is a separate system of “linguistic-specific” learning mechanisms, or 3) there are only general-learning mechanisms, applicable in all cognitive domains. Schwartz concludes that at the empirical level, a UG-based analysis for L2 acquisition is still to be preferred, especially in light of the predictive power of the two types of analyses under consideration. Schwartz (1998) argues that like native language (L1) development, L2 development, even by adults, relies on ‘language instincts,’ despite L1-L2 differences at intermediate stages and in ultimate attainment, and that a primary source of L1-L2 differences is differences in their respective initial states. Whereas in the L1 initial state, there is no language, there is at least a partially developed L1 at the initial state in case of L2A.

2.2.2.1 The Initial State

UG assumes that the initial state (S_0) of a child’s grammar contains the parameters set at their default or unmarked value. The steady state (S_S) or adult grammar contains the parameters set at the correct value for the particular language. The steady state indicates final competence. The process of acquisition is then seen as a succession of different states or grammars that move from S_0 to S_S (Fikkert (1994)).

(48) *The process of acquisition*

$$S_0 \longrightarrow S_1 \longrightarrow S_2 \longrightarrow S_3 \longrightarrow \dots \longrightarrow S_S$$

In the case of second language acquisition, states 1 to n indicate the various intermediate stages. Whether the initial state in L2A is the S_0 of the L1, or a clean state, S_0 , is a matter of debate regarding L1 influence or transfer.

2.2.2.2 Parameter Resetting

If UG is applicable to second language acquisition, the principles of UG remain unchanged and accessible but a set of new parameter values needs to be acquired; parameters must be re-set for the L2 if they differ from that of L1.

The principles and parameters model explains well why L2 learners go through various stages. At the initial stage, all parameters are set to L1 values. Inevitably, L1 settings influence the IL (transitional settings), hence the L1 transfer or influence on L2.

Vainikka and Young-Scholten (1996) argue that at the earliest stage of both L1A and L2A, only lexical categories are present as L1 influence, and functional projections develop in succession later. They take the view that parameter resetting takes place in the form of the development of these projections.

Clahsen (1990) on the other hand, takes the view that once parameters are set, they cannot be reset during acquisition. The learner sets parameters shared in the L2 in the way that have been set for L1. This entails complications where there is no evidence in the input for resetting the IL (inter-language) parameters so that the IL is aligned with L1. Indeed parameter re-setting seems to be gradual, going through State 1 to n, at each stage the resetting of some parameter occurs to move closer to the Steady State, or end state of native competence.

2.2.3 UG Access Models in L2A

Cook (1993:210) presents the schematic explanation for views on access to UG in L2 learning.

(49)

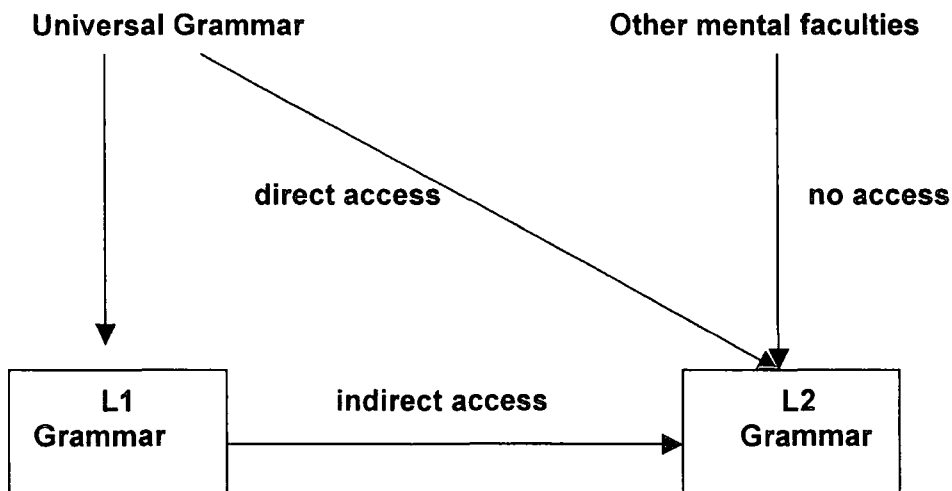

Cook's analysis (49) shows that there are three possible views: direct access, indirect access and no access to UG.

2.2.3.1 Full Access Model

The Full Access model assumes direct access, UG fully available to adult L2 learners. This model is supported by many researchers such as Vainikka and Young-Scholten (1996), Young-Scholten (1994) and Flynn (1993). Under this model, L2 acquisition is believed to be based on L1 parameter settings and, regardless of age of onset, full access to UG is possible.

2.2.3.2 No Access Model

There are also many researchers who subscribe to the UG Hypothesis in L1A but not in L2A. They take the view that L1A and L2A are fundamentally different. The poverty of the stimulus argument or logical problem of input has been under attack by many researchers. In second language acquisition, Ellis (1985) argues that L2 learners get non-degenerate input in the form of "foreigner talk" (p.133 – 138) and

“teacher-talk” (p. 145-146). Through this “rich” input, it is presumed, that the learnability problem is no longer a problem.

For example, Meisel (1991), as do Bley-Vroman, Felix and Ioup (1988) and Clahsen and Muysken (1989) proposes that knowledge of the L1 grammar together with general-learning mechanisms is what underlies L2 acquisition. Meisel argues that UG is not available any longer as a language acquisition device for adult L2 learners, although they may use their grammatical knowledge developed in L1 as well as operating principles and a number of additional pragmatic strategies in order to discover formal properties of the L2. Three kinds of evidence have been offered in support of these claims: 1) L2 acquisition typically involves “learning” in the traditional sense (trial and error, gradual approximation to the norm, etc.), whereas L1 development can be described adequately as the triggering of implicitly available knowledge, resulting in “instantaneous acquisition,” 2) the observed developmental patterns in L2 can be accounted for without referring to UG principles, 3) there are crucial differences between L1 development and L2 acquisition which cannot be explained as resulting from parameter resetting. Meisel further argues not only that this state of affairs obtains for all L2 acquisition beyond the age of six but also that linguistic-specific “operating principles” for language processing similar to those known from the work of Slobin (1973) are also utilised. Meisel’s argument is the following: if UG is not necessary to explain certain L2 developmental sequences, then any demonstration that UG can explain these same phenomena is insufficient reason to assume that UG obtains in L2 acquisition.

Birdsong (1991) observes that inter-linguistic output and elicited L2 data do not violate constraints on natural language. Inter-language grammars are consistent with the principles and parameters of UG. This does not, however, automatically support the Re-constructive Hypothesis, where UG is considered to be still active but in a

different way in that the learner sets parameters shared by the L1 and L2 in the way that have been set for the L1. Birdsong postulates that it is possible that UG-like knowledge is derivable from L1 knowledge, along the lines of the Parasitic Hypothesis, where UG is no longer active in second language acquisition and that traces of conformity to UG in the IL (interlanguage) may be traced back to features of L1 carried over into the developing grammar.

Researchers subscribing to this hypothesis reject UG access by L2 learners. UG facilitates only L1A, and UG no longer functions for L2A. Instead, learners use general learning strategies. Adult L2 learners do not achieve native competency. Their Interlanguage would result in impossible rules as evidence of no access to UG.

2.2.3.3 Indirect Model and Partial Access Model

The indirect access model assumes that L2 learners cannot directly access UG but can do so through the L1 as a mediator. The partial access model, on the other hand, assume that direct access to parts of UG is possible, and with the help of direct instruction, native competence is achievable. The assumption of UG being applicable to adult L2A is based on the notion that the "mental grammar" of the L1 is in fact equivalent to the "internalised grammar" in L2 acquisition (White (1989)).

There seem to be two groups of supporters to this hypothesis. One group takes the view that any aspect of UG accessed by the L1 can be accessed by the L2 through the L1. The other group subscribes to the Principles and Parameters approach where L2 learners initially set UG parameters for the L1, but they are re-settable later.

Bley-Vroman (1986) proposed the Fundamental Difference Hypothesis in which he claimed the language faculty changed with age and therefore L1 acquisition and L2 acquisition were fundamentally different. Adult L2 learners use their general problem-solving system combined with indirect and imperfect use of UG through L1.

White (1989) argues that elements of UG are utilised in L1A, and the same set of principles and parameters are then available in L2A. This hypothesis involves the claim that L2 grammars do not violate the principles of UG and that the acquisition of an L2 implies that parameters already fixed in the L1 have to be reset. From this viewpoint, however, it does not automatically follow that one should expect to find identical developmental patterns in L1 and L2 development. Quite the contrary; since parameters have already been set for the L1, one predicts that massive transfer from the L1 should occur. In other words, important differences are expected as well as substantial commonalities. The Full Transfer/Full Access model proposed by Schwartz and Sprouse (1996) is based on the L1 parameter settings and full L1 transfer, and regardless of age of onset, full target language acquisition is possible.

Most researchers who subscribe to a UG model for second language acquisition take the UG-is-mediated-by-L1 view. Furthermore, a principles and parameters approach, central to UG theory, seems to have the most explanatory power for L2 phenomena. In this thesis, I take adopt the UG model for the L2 acquisition as the starting point, and explore the form of the UG access.

2.3 L2 Acquisition of Phonology

Having decided on the adoption of the UG framework, let us now look at the recent research findings in the field of L2 phonology acquisition.

In recent years, an Optimality theoretic (Prince and Smolensky (1993)) approach, which replaces the principles and parameter approach, has been fast gaining support by many researchers. Optimality Theory (OT) views UG as a set of principles and a set of constraints; language-specific grammars are determined by ranking of constraints. Unlike parameters, constraints may be violated. In this thesis, I

have decided to continue referring to the principles and parameter model, as 1) constraint rankings can equate to a different formulation of the unmarked value of a parameter and therefore parameter settings can be considered under an OT account, and 2) there are still relatively few L2 acquisition research papers in phonology under the OT framework.

2.3.1 Interlanguage Phonology

The interlanguage hypothesis was proposed by Corder (1971) and Selinker (1972) and states that L2 learners internalise a system of rules that is distinct from their L1 and also from their L2. Interlanguage is a natural language the L2 learners appear to “use” before they acquire and internalise the grammar of the TL, the target language. Utterances by L2 learners do not belong entirely to the class of TL utterances nor to the class of NL utterances. These observations led Eckman (1987) to conclude that the grammar governing a learner’s utterances must be an independent system. Based on empirical data for Terminal Devoicing (in case of Spanish speakers acquiring English), Postvocalic Spirantization (exhibited by Spanish speakers as a neutralisation rule) and Schwa Paragoge (by Mandarin learners of English), Eckman defines interlanguage to be independent of the learner’s L1 and TL. Eckman (1987) argues that, since it is highly likely that a learner will not be able to maintain all of the phonological contrasts of the TL, at least not at the beginning stages, and at least some of the rules proposed for IL phonologies will be natural neutralisation rules.

Deletions and insertions are IL strategies often adopted by L2 learners when they face difficulty in resetting a parameter or acquiring a structure that is more complex than the L1. Broselow and Park (1995) claim that IL grammars contain a stage in which the L1 parameter setting is operative for the analysis of TL forms, while the L2 setting is operative in the production of these forms: a ‘split parameter setting’

(Broselow and Park (1995: 168)). The basis of their claim is an analysis of epenthesis in oral production data from Korean and Japanese speakers of English. In the IL of the Korean speakers, epenthesis occurs after a syllable with long vowel but not after a syllable with short vowel. Since Korean coda consonants are nonmoraic (1995: 154) and syllable nuclei are maximally monomoraic (1995: 159), the only explanation for the epenthesis in the IL is, Broselow and Park (1995) argue, that Korean speakers are attempting to preserve the perceived moraic structure of the English words. Given a target word 'bit' Korean subjects returned *bitto* rather than *bito*. When they were given the target word 'beat' they returned *biito* rather than *biitto* in order to preserve the perceived moraic structure.

(50)

- | | | |
|----|--------|---------|
| a. | 'bit' | bitto |
| b. | | *bito |
| c. | 'beat' | *biitto |
| d. | | biito |

Broselow and Park claim the mora conservation principle prevented mora loss in the TL (English) but did not prevent mora addition.

We have seen some evidence both in independence of IL and L1 influence. Will the learners' IL be subject to the age of onset? Let us now review studies on the age factor.

2.3.2 Critical Period – Age Dependent Effects

The relationship of language acquisition and age-dependency has been actively researched yet this is also an area that requires further empirical research. First, the age factor in unusual L1A cases are discussed. Next, the age factor in L2A in general is discussed.

2.3.2.1 First Language Acquisition

Lenneberg (1967) proposed that the limits for first language acquisition were between the ages of two and puberty. Before this time the child is too immature physically, and after this period the brain is too inflexible to acquire his/her L1.

Extreme cases such as Genie (Curtiss, 1982) and Chelsea (Curtiss, 1988) seem to support that the deprivation of normal language input during the early years in life prevents "normal" development. Genie had been left in total neglect and isolation until 13 years of age, and subsequently, when she got input, showed only limited and abnormal language development. Following her earlier comprehensive study on Genie, Curtiss (1982) discusses the effect of age of onset on L1 acquisition. While Genie's language development was severely impaired, she did nonetheless acquire some language, and made particularly good progress in vocabulary acquisition after puberty. The case of Genie can be interpreted in two ways: either it supports, at least partially, the Critical Period Hypothesis, or it does not support it, as is indeed possible to acquire language, even on L1 after puberty, though the attainment level may remain very low, particularly in morpho-syntax.

Curtiss (1989) has reported that access to UG declines when the triggering input diminishes, and this results in failure of language acquisition. Curtis cites the example of Chelsea, who had been born deaf to normal-hearing parents, deprived of hearing

aids, linguistic input and training for the first thirty years of her life. She showed violations of structure dependency (for example, finite verbs preceded by determiners) in her output.

2.3.2.2 Second Language Acquisition

As it was discussed in the previous sections on L2 access to UG, researchers who subscribe to the Full Access position reject the notion of a critical age. On the other hand, there are many researchers who believe that the age factor does affect the ultimate attainment level. As Strozer (1994) notes, all children in normal circumstances acquire their L1 with ease, and achieve native competence as a matter of course. In the case of L2A, however, native competence is hard to achieve by adults no matter how hard or how long they try even with the help of instruction. Researchers who subscribe to the idea of UG as the basis of language acquisition mechanisms, such as Flynn and Manuel (1991) focus on the idea of a critical period for access to UG but argue that UG still mediates adult L2 acquisition. Birdsong (1991), however, questions if it can be demonstrated that UG-like effects in a discussion of accented speech and loss of cortical plasticity (p.121) are causally linked to UG. Flynn and Manuel (1991) observe that available data are "more compatible with a gradual decline in propensity to acquire accent-free speech than with a hard and fast critical period." They report that adult native speakers of Japanese can discriminate contrasts that do not exist in Japanese, though this observation does not appear to be based on an extensive empirical research. Flynn and Manuel argue that at least in this linguistic domain, the ability to discriminate contrasts, suggest that there is no critical period effects.

Krashen (1979) argued that the research evidence supported his view that adolescents and adults are actually faster language learners in the initial stages, but that young children outperform them in their eventual attainment. Krashen attributes

this phenomenon to the Monitor, the function of 'learning'⁹ that monitors or edits the forms of utterances, which older learners use but younger children do not. Younger children are deemed to acquire the L2 like their L1, whilst adult learners¹⁰ have to use Monitor instead of their innate ability to acquire L1.

Long (1988) suggests that there is an initial short-term advantage for some older learners over children. However, only quite young children are capable of eventual native L2 attainment. Long (1993) maintains that age of onset is a robust predictor of long-term success in a second language, particularly as to whether or not they can reach native competence, though the relationship between age and ultimate attainment is not an inverse linear one. Long argues that age onset of 0-6 is sufficient for learners to reach native proficiency in all linguistic domains.

Meisel (1991) also provides evidence for a critical period, with an upper age of six, noting "In these cases one finds clear differences in ultimate attainment around age 10... We are... left with the problem that for morphology and syntax some of the children who start learning the L2 between age 6 and 10 apparently do achieve native-like competence" (1991:246).

McLaughlin (1984) argues against the Critical Period Hypothesis with counter evidence from his study on Canadian English-speaking children. McLaughlin maintains that research on syntactic and semantic factors consistently supports the argument that older learners are superior in both acquisition rate and the ultimate attainment level. McLaughlin (1985) found that Canadian English-speaking 12- and 13- year old children in 'late' French immersion programmes do just as well as children from the same background who were in 'early' French immersion program beginning in kindergarten

⁹ In Krashen's distinction, 'acquisition' refers exclusively to subconscious effect and conscious effort is referred to as 'learning.'

¹⁰ As possible underlying cause of lack of complete acquisition, Krashen (1985) also suggested affective variables.

and who had twice as many hours of exposure to French. McLaughlin concludes that early adolescence is the best age for language learning, both in terms of rate of learning and also ultimate attainment. The data from school-based investigations which seem to contradict the hypothesis that those who begin learning a second language in childhood in the long run generally achieve higher levels of proficiency than those who begin later in life, do not in fact bear on it, if one takes naturalistic situations as the basis for one's definition of 'long run', 'eventual', etc., since second language exposure time involved in studies focusing on formal learning situations never approaches that involved in long-term naturalistic studies. Though overall McLaughlin maintains that older learners are superior in both acquisition rate and ultimate attainment level, he also admits there is evidence, though not conclusive, that perhaps in the area of phonological development, younger children perform better than their older learners.

2.3.2.3 The Age Factor in the L2 Phonology Acquisition

The most obvious differences between success in native and non-native language acquisition are said to be found in phonology (Flynn and Manuel (1991)). Many researchers including Walsh and Diller (1981), Wode (1989) and Wode (1992) maintain that native attainment in a second phonology is highly unlikely or impossible for adult learners as they face neurological or motor skill constraints such as entrenched articulatory habits or restricted perceptual targets for phonetic categories and this prevents the adult learner from developing phonetically accurate targets for L2 sounds (see Wode (1992)).

With respect to phonology, Fathman (1975) found that six to ten-year-olds were more accurate in producing elicited phonological structures, whereas 11 to 15-year-olds performed better in morphological and syntactic tasks. When the amount of

exposure was constant, older learners were more able to learn and produce higher order structures, namely morpho-syntactic features and constructions more quickly than their younger counterparts.

Moyer (1999) challenges the Critical Period Hypothesis even in L2 phonology, having examined the phonological performance of highly motivated adult learners of German (themselves being language instructors who used German daily). Moyer's research results actually show that motivational and instructional variables can not override the impact of age, as all test subjects (learners of German) performed very well but still within a non-native range. Moyer argues, however, that age should not be examined in isolation from socio-psychological influences and the extent of exposure to the second language.

We have reviewed arguments for and against age factors in the L2 acquisition. If a child is exposed to more two languages from an early age, will the child develop both languages with a native competence? What will be the difference and similarities in bilingual acquisition and L2 acquisition? We now turn to bilingual issues.

2.3.3 Bilingual Speakers

Skutnabb-Kangas (1984:90) defines a bilingual speaker to be "someone who is able to function in two or more languages, either in monolingual or bilingual communities." There are many ways in which a child becomes bilingual (Hoffmann (1991: 38-40)). There are two competing hypotheses to account for the way a child maintains two languages. The unitary language system hypothesis holds that the bilingual child does not initially distinguish between the two language systems but the child starts by using one hybrid system. The hybrid system becomes separated later. Under this framework, Volterra and Taeschner (1978) proposed a three stage model: in the first stage, the child possesses one lexical system composed of lexical items from

both languages, in the second stage, the child distinguishes two separate lexical codes but has only one syntactic system, and finally the stage three, for the child the two linguistic codes are entirely separated. In recent years, however, this hypothesis has attracted much criticism from researchers such as Meisel (1986) and De Houwer (1990). Pointing out the lack of conclusive evidence to support the claim and methodological inconsistencies in the three-stage model employed by Padilla and Liebman (1975), Meisel questions the existence of an initial undifferentiated language system. Another hypothesis to account for the child's bilingual development is the separate or independent development hypothesis, supported by researchers such as Padilla and Liebman and Bergman (1976), who assume that the languages of bilingual children develop independently and children can differentiate the two languages from a very early age. The problem with either of the two hypotheses is not theoretical but the lack of empirical data on early childhood development to provide evidence to support either theoretical claim.

Lambert, Havelka and Gardner (1959) used the term 'balanced bilingual' to mean bilinguals who are fully competent in both languages. Hoffmann (1991: 22) notes, however, "the 'balanced bilingual', is likely to be something of an ideal, since most bilinguals tend to be more fluent or generally proficient in one language." As we have seen thus far, the language acquisition is triggered by input. Unless one receives an identical set of linguistic input in both languages, it is unlikely that one becomes a 'balanced bilingual.' Doyle, Champagne and Segalowitz (1978) reported that monolinguals had a larger vocabulary than bilinguals in their dominant language in the study involving 22 each of monolingual and bilingual children aged 3;6 and 5;7. Bilingual children, however, showed superior verbal fluency in their story-telling and in the number of concepts per story expressed by each child. Based on these results,

Hoffmann postulates that successful communication depends less on the size of the lexicon the child possesses than the way available ones are used (1985: 66).

Age of onset in bilingualism has also attracted much debate in recent years. Bearing in mind that the age of onset may play a vital role in ultimate attainment level, one question to be answered is where the dividing line is between bilingual and L2 development. When does bilingual acquisition stop and child L2 acquisition begin? If a child is exposed to a second language at an early age, say, six years of age, will the child develop native competence in the phonology of a second language? Neuropsychological studies (eg Friederici (1984)) suggest that lateralisation depends on the age of onset and suggest a critical age limit of around 6;0. If children begin acquiring both languages before age 6, the left hemisphere is dominant for both languages. If children are exposed to a second language after age 6, the left hemisphere is dominant for the first language but both hemispheres are involved in the second language processing.

Based on his study of children in a Japanese immersion program acquiring geminate consonants, Harada (2000: 5) reports "acoustically the immersion children clearly use a different set of norms from those of L1 speakers." Children on the immersion programme were aged between six and twelve. They received instruction only in Japanese during the kindergarten and the first grade years. In the second and third grade, they received 80% of instruction in Japanese and 20% in English. By fourth and fifth grade, the proportion changed to 60% Japanese and 40% English. The immersion children made a clear distinction between the phonetic norms for single: /p/, /t/, /k/ and geminate consonants: /pp/, /tt/ and /kk/. Their duration values were, however, seen to overshoot the native speaking children's norms. While the mean ratio for geminates to singletons produced by the monolinguals and the bilingual immersion teachers ranged from 1.8 to 2.3, the immersion children's mean ratio ranged

from 1.4 to 1.6. From these results, Harada concludes that the children in the immersion programme use a different phonetic category for the single and geminate consonants from both the monolinguals and the bilingual immersion teachers.

While we must caution ourselves of the size of his group (19 bilingual children, 5 bilingual teachers and 12 Japanese monolingual children), Harada (2000)'s conclusion implies that the age onset of six may be too late for native competence with respect to, at least, singleton and geminate consonants. Was it the age of onset, or the amount/quality of input that prevented them from developing into real bilinguals? McLaughlin (1984) suggests that older children are superior in both acquisition rate and the ultimate attainment level, at least syntactically and semantically, but perhaps not phonologically. In the instructed settings, is the age of onset the only factor? These questions lead us now to the importance of input.

2.3.4 Input – ‘Quality’ and ‘Sufficiency’

In phonology, sounds group together into natural classes subject to phonological rules. Generally these classes are defined in terms of phonological features that have a physiological basis. However, Ladefoged (1992) argues that there are natural classes that cannot be justified by reference to a physical property as in the case of geminate consonants involve something that has no acoustic reality but nevertheless have phonological reality. If there are not always phonetic cues for natural classes, how could children, who have no access to anything but acoustic input internalise a system? Ladefoged postulates that orthographic input may be the answer.

2.3.5 Orthographic Input

In second language acquisition, orthographic input, whether in the form of the L1 or L2 orthographic system, or more commonly in both, is/are almost inevitably present. The visual representation of the phonetics and phonology of both the L1 and L2 have been proposed to influence adult second language acquisition. Some sounds pattern together on a historical basis even after the original physical definitions of the features are lost. Ladefoged (1992:165) gives English vowels in terms of the feature Tense as an example. How, then, do children access to such historical knowledge? Ladefoged (1992:166) argues that English-speaking children from the age of six or seven onwards have access to the history of the language in the form orthography. Ladefoged reports that "there is considerable evidence that people can use orthographic knowledge as the basis for forming phonological classes" citing research findings by Moskowitz (1973), Ohala (1974) and Jaeger (1986).

2.3.5.1 Japanese Orthography

The Japanese orthography is based the Chinese characters called Kanji. From Kanji, two versions of a syllabic system called Kana; Hiragana and Katakana were developed. In modern Japanese, all three forms of orthography are used, each having particular function. Kanji are used to denote nouns and stems of verbs and adjectives. Hiragana is mainly used in grammatical function words. Katakana is normally used in loanwords of Western origin and in onomatopoeia. Each Kana has the same number of letters corresponding to the same set of sounds, which are given in (51).

(51)

		k g	s z	t d	n	h p b	m	y	r	w	N
a	a	ka ga	sa za	ta da	na	ha pa ba	ma	ya	ra	wa	N
	あ	か が	さ ざ	た だ	な	は ぱ ば	ま	や	ら	わ	ん
	ア	カ ガ	サ ザ	タ ダ	ナ	ハ パ バ	マ	ヤ	ラ	ワ	ン
i	i	ki gi	si zi	ti di	ni	hi pi bu	mi		ri		
	い	き ぎ	し じ	ち ぢ	に	ひ ぴ び	み		り		
	イ	キ ギ	シ ジ	チ チ	ニ	ヒ ピ ビ	ミ		リ		
u	u	ku gu	su zu	tu du	nu	hu pu bu	mu	yu	ru		
	う	く ぐ	す ず	つ づ	ぬ	ふ ぷ ぶ	む	ゆ	る		
	ウ	ク グ	ス ズ	ツ ツ	ヌ	フ プ ブ	ム	ユ	ル		
e	e	ke ge	se ze	te de	ne	he pe be	me		re		
	え	け げ	せ ぜ	て で	ね	へ ぺ べ	め		れ		
	エ	ケ ゲ	セ ゼ	テ デ	ネ	ヘ ペ ベ	メ		レ		
o	o	ko go	so zo	to do	no	ho po bo	mo	yo	ro	o	
	お	こ ご	そ ぞ	と ど	の	ほ ぽ ぼ	も	よ	ろ	を	
	オ	コ ゴ	ソ ゾ	ト ド	ノ	ホ ポ ボ	モ	ヨ	ロ	ヲ	

In addition to the standard set of Kana shown above, each representing a syllable, there is a set of CGV syllables, of which glides are denoted by a smaller version of Kana in the 'y' column after a Kana representing the CV. For example, *kya* is transcribed as きゃ in Hiragana and キャ in Katakana. Geminate consonants are moraic in Japanese, as discussed in Chapter 1, and are represented by a smaller version of Kana, either つ ツ regardless of the subsequent onset consonants. For example, a word Kappa 'an imaginary beast' is represented as かつば or カツパ and katto 'cut' as かつと or カット.

Note that the moraic nasal ん in Hiragana and ン in Katakana is very different to other nasals with an onset /n/: na ni nu ne no なにぬねの in Hiragana ナニヌネノ in Katakana. Long vowels are represented by a repetition of the vowel. For example, *kaa* is denoted by かあ or カア, in each case the same vowel in preceding CV is repeated.

2.3.5.2 Literacy and Orthographic Input

Geva and Siegel (2000) found that young L1 English, L2 Hebrew children appear to develop their word recognition skills with relative ease when the script is less complex, even in the absence of sufficient linguistic competence. The script-dependent hypothesis was supported by the fact that 1) children could read more accurately Hebrew (a transparent orthography) than English (a deep orthography), 2) the developmental profiles associated with English word recognition and Hebrew pseudo-word decoding, and 3) decoding error categories were orthography-specific. Inagaki, Hatano and Otake (2000) report that Japanese children's speech segmentation procedure changed from syllable-based to mora-based when they learnt and started reading and writing in Kana. Will there be a similar literacy effect with adult L2 learners? Wells (1995) investigated the relationship between speech errors and orthographic input. In his research, 33 native speakers of Japanese were asked to pronounce paired Japanese words that came up on the computer screen. Words were written in Hiragana (Japanese phonetic script, each character representing a single mora) and in Roma-ji (Roman alphabet). The procedure used in this investigation was a modified SLIP (Spoonerisms of Laboratory-Induced Predisposition) paradigm, a well-tested method for eliciting speech errors under laboratory conditions in English. The results are summarised in (51).

(52)

Summary of Speech Error Results

Type of Error	Mean number of errors per subject	
	Hiragana	Roma-ji
Mora	1.63	0.53
Consonant	0.25	1.3
Vowel	0.63	2.1

(Adopted from Wells (1995: 485))

These results show that orthography was the controlling factor in the types of errors subjects made. Wells postulates that highly literate speakers will be able to use knowledge of the cognitive segmentation process embodied in their writing system in on-line speech production and perception. Japanese children who have not yet learned to read Roman alphabet texts show difficulty on tasks involving segmenting speech at the sub-moraic level (Mann (1986)). Similarly, adults with reading difficulties seem unable to identify segments or phonemes in speech (Byrne and Ledez (1983)). Wells concludes that orthography wields a powerful influence in the mind of the literate speaker of any language, making new levels of processing and segmentation available. The Japanese speaker with access to both hiragana and Roma-ji orthography has access two levels of processing which can be differentially activated in the appropriate situational context.

2.3.5.3 Sufficiency of Input

Input can work in tandem with UG as a trigger for positing linguistic structure. In extreme cases such as Genie's and Chelsea's, the deprivation in input resulted in failure of L1 acquisition. Sufficient input is certainly also vital to successful L2 acquisition. Hamayan, Genesee and Tucker (1977) reported that the amount of exposure to the L2 was directly correlated with the level of competence for pre-puberty immersion learners. In their study, they examined the language exposure factors and proficiency level of English-speaking children learning French as L2. Children in the early immersion group, who had the highest exposure factor in French were the most competent of all three groups (early immersion, late immersion and the non-immersion/conventional L2 learner groups). They also reported that a high frequency of English use was negatively related to French oral proficiency for learners in all three groups.

Moyer (1999) found in her study of highly motivated adult learners of German that exposure to the target language is one of the important factors in fluency attainment for adult learners. Moyer reports that the length of immersion in L2 (German) and the length of instruction were directly linked with the learners' ultimate attainment level. Moyer also reports that input in the form of suprasegmental and segmental feedback had measurable effects on the adult learners attaining near-native score in the oral production tasks. Moyer concludes that Instruction, motivation, suprasegmental training, and self-perception of productive accuracy can have effects on ultimate attainment.

2.3.5.4 'Appropriate' and 'Inappropriate' Input

Input may take a different form in L1 and L2 acquisition. In L1 acquisition, input is utterances the learner hears and comprehends. In L2 acquisition, as well as these utterances, plenty of positive evidence may be given in the form of example utterances, memorised dialogues, or frames and sentence patterns under certain teaching methods in a language classroom. Negative evidence is, as the name suggests, information on sentences and structures that are ungrammatical and therefore are to be avoided by learners. In L2A, this may take the form of overt correction. In some cases, a lack of positive evidence may be interpreted as negative evidence. On the other hand, "positive evidence with negative effects" (Young-Scholten (1995:110)) is also inappropriate input and to be avoided. In case of L2 acquisition, input is often regulated and carefully controlled by the teacher for the purpose of learning the target language, who may not be a native speaker.

Ellis (1985: 161) argues that there are strong theoretical grounds for believing that a learning setting rich in features such as a high quantity of input directed at the learner, independent control of the prepositional content by the learner, the

performance of a range of speech acts by both native speaker/teacher and the learner, exposure to a high quantity of directives and extending utterances will lead to successful L2A, though there is little empirical proof yet.

2.3.6 The Role of Instruction in L2 Phonology

Focusing on the development of interlanguage, Pica (1983) examined the process of acquisition by three groups: naturalistic acquisition without instruction, instruction only, and the mixture of the two. Pica's findings in the area of morpho-syntax suggest that instruction can promote L2 acquisition effectively. Does instruction work in the acquisition of L2 phonology?

Moyer (1999) suggests that suprasegmental training can have significant effects on ultimate attainment. Based on a similar belief to Moyer's, some researchers have been showing interest in the possibility of accelerating acquisition of L2 phonology. Kawai and Hirose (1999) developed a computer-assisted-language-learning (CALL) system to measure the duration of mora and improve adult learners' perception and production. Their CALL system is used to teach learners the pronunciation of Japanese double-mora phonemes, which are spectrally almost identical but their phone durations differ significantly. Learners read minimal pairs to the CALL system. Using the speech recognition technology, the CALL system explained 1) what the learner's mistake was, 2) the severity of the error, and 3) how to correct his mistake. Targeted suprasegmental training has been shown to be effective, though Kawai and Hirose do not expect learners to attain complete nativeness through their CALL system.

Pennington and Ellis (2000) examined the performance of advanced Cantonese speakers of English on recognition memory for English sentences in which prosody discriminated otherwise identical sentence pairs. Pennington and Ellis observed a significant improvement in recognition for sentences that contained a marked and

unmarked information focus, 'contrastive stress' and 'neutral' sentence intonation when learners paid particular attention to intonation. Thirty advanced level adult Cantonese speakers took part in their study. The first experiment in untutored (implicit) condition was followed by the second experiment in a tutored (explicit) condition, both involving learners listening to 48 sentences and deciding whether or not each sentence they heard was exactly the same as the one in the sentences they had heard in the previous test. The results lead Pennington and Ellis to conclude that "the relatively universal relationship of enhanced prosody and marked meaning, as contrasted with neutral prosody and unmarked meaning – can be more readily taught than some other more language-specific aspects" (2000: 387). Pennington (1998:328) suggests that, a 'focused program in isolation from other skills that involves perceptual training such as audio and video feedback' can raise L2 prosodic awareness of contrastive pairs and may help the learners analyse the prosody of the target language as a representational system on a par with that of other systems of grammar.

These research findings discussed above support the view that targeted instructions in L2 phonology can be effective in bridging the gap left behind by the availability of UG and input

2.3.7 The Acquisition of Syllable Structure

2.3.7.1 Syllables and Syllabification

The process of analysing speech into segment can be an indication how the learner view the phonological structure of the language. There seems to have been, however, little research carried out into the segmentation process by L2 speakers to date. In comparison between English-dominant and French dominant bilinguals, Cutler,

Mehler, Norris and Segui (1986) reported that people listening to their L1 use a speech segmentation procedure that is language-specific. For example, French-dominant bilinguals use a syllable-based procedure, while English-dominant bilinguals use the non-syllable based (stress-timed) procedure. Golato (1998) had a second look at these findings and reported that language dominance interacts with markedness differences in segmentation strategies such that English-dominant bilinguals command two distinct segmentation routines while French dominant bilinguals command only one. According to Golato, English speakers are able to adopt a segmentation strategy that does not match the one in their dominant language because these are less marked.

2.3.7.2 Syllables and Morae

The acquisition of syllable structure may be examined from the viewpoint of the parameter resetting. In L1 acquisition, initial state (S_0) of a child's grammar contains the parameters set at their default or unmarked value (Fikkert (1994)). As discussed earlier, Broselow and Park (1995) claim that IL grammars contain a stage in which the setting of the L1 is operative for analysis of the target language forms, and the setting of L2 is operative in these forms. In their study of Korean and Japanese speakers of English, Broselow and Park (1995) argue that the universal principle of mora conservation (Hayes (1989)) promote vowel insertion by Korean speakers in their attempt to conserve their perceived moraic structure of the English words (p152).

In order for English speakers to acquire mora-based segmentation, their mental map of the syllable structure of Japanese must accommodate slots for mora. The initial state of the phonology template for L1 children is set at a null universal value (Fikkert (1994)). Subsequent interaction with this and linguistic input sets the parameters and forms the template for that particular language. Any sound segment that does not match the template will be rejected as a foreign sound, or linguistically

irrelevant information. Just as children develop their “grammar” they develop the prosodic template of their first language. Eventually an adult English speaker acquires the TL syllable structure. It is proposed here that L2 learners start with their L1 syllable template in acquisition of L2.

English speakers’ syllable structure has unmarked CVC slots.

Syllable structure - English

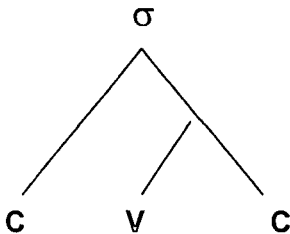

Japanese speakers’ syllable structure has, as we have already seen, an extra tier with mora slots.

Syllable structure - Japanese

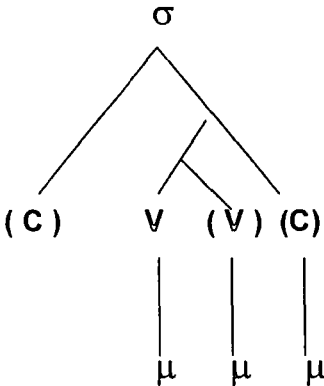

During the course of acquisition, learners are expected to develop IL syllable templates that will be governed by UG.

2.4 Research Hypotheses

We are now in a position to present the hypotheses adopted to investigate the acquisition of Japanese syllable structure by bilinguals and English speakers. The following assumptions and postulations lead to several research hypotheses.

First, the Mora Assignment Hypothesis (see Hyman (1985), Broselow and Park (1995), Kakehi and Hirose (1997) among others) is the basis for the process of prosodic acquisition. The mora tier is linked to the rime of the syllable, and has lexically listed mora slots.

Second, we hypothesise that there will be differences and similarities in the way children (L1A or bilingual acquisition) and adults (L2A) acquire Japanese phonology.

Third, the quantity and quality of input are identified as the trigger in the parameter resetting leading to acquisition of Japanese phonology.

Finally, we hypothesise that the orthographic input in the form of Kana interacts with the process of phonological acquisition of Japanese.

2.4.1 The Mora Assignment Hypothesis

In Chapter 1, we have seen that the mora is distinctive in Japanese. The mora has a specified position within the syllable. In English, though the mora plays a role as the weight-bearing unit in the stress assignment, it remains unspecified. We have also noted in Chapter 1 that Japanese syllables are often CV and monomoraic, but there are the CVC, CVV and CVN syllable that have extra mora.

(53)

a. CVC

katta 'won' 3 morae → kata 'shoulder' 2 morae

b. CVV

kiita 'listened' 3 morae → kita 'came' 2 morae

c. CVN

honne 'truth' 3 morae → hone 'bone' 2 morae

As English is not a mora-sensitive language at the phonological level, phonetic information such as the length of vowel or consonant/acoustic gap are not relevant for the beginners. Indeed, as we have stated in the research hypothesis earlier, English learners are predicted not to establish slots initially for these morae in their listings for Japanese words in their mental lexicon.

Under Full Transfer/Full Access view (Schwartz and Sprouse (1996)), L2 learners initially apply their L1 syllable structure to second language input. We predict that English learners will initially segment utterances into syllables, and ignore the mora. As they progress in the acquisition of Japanese, they will begin to reset parameters and identify mora and attempt to place them to mora slots.

The research hypothesis guiding this study is:

Research Hypothesis 1

Learners initially use their L1 syllable structure in the acquisition of their L2. The L1 syllable structure is modified and altered based on the input they receive and constrained by UG. Progressive parameter resetting triggered by input will lead the learner to become better able to identify

mora slots, and assign morae accordingly = The Mora Assignment Hypothesis.

2.4.2 L2 Phonological Acquisition and Age of Onset

As much work by researchers in bilingualism shows, if a child is exposed to an additional language in naturalistic environment at an early age, it is expected that the child's linguistic competence will develop normally and completely like a monolingual. However, little research has been carried out to date in the field of L2 Japanese phonological development at an early age.

In this study, we hypothesise that a bilingual child's phonological development in Japanese will resemble that of monolingual Japanese children.

Research Hypothesis 2

If a child is exposed to naturalistic input in a Japanese speaking environment from an early age, his/her phonological development in Japanese will resemble that for monolingual Japanese acquisition.

2.4.3 Quantity and Quality of Input

We have noted in previous sections that input triggers a change in the value of parameter. Based on the input (positive evidence) in large quantity new L2 values of parameters are progressively set. The amount of input relates to the acquisition environment. For example, when a child is placed in a naturalistic environment, the amount of input is sufficient and the native competence is achieved without fail. In the case of L2 acquisition, or with respect to a bilingual environment, the amount of input, and sometimes quality of input may suffer.

For example, learners are not always able to immerse themselves in an L2 environment. Even bilingual children tend to be dominant in one language as the input of the other is limited in the quantity. The quality of input in terms of a variety, suitability to individual needs and interests, appropriateness of the level and contents are all vital to a successful acquisition of the second language.

Research Hypothesis 3

The amount, quality and type of input is one of the key factors that influences the level of the ultimate attainment in L2 acquisition.

2.4.4 Orthographic Influence

As discussed earlier in this chapter, Japanese orthographic system includes Kana graphemes that are learnt by beginners. Kana has a one-to-one correspondence with the mora and this influences the way learners perceive and produce Japanese syllables.

Research Hypothesis 4

Kana literacy interacts with the L2 learners' perception and production of Japanese syllables.

Based on these four research hypotheses, a program of investigation into the acquisition of the Japanese syllable structure has been implemented. The detail of the investigation is discussed in the following two chapters.

Chapter 3

Bilinguals' Knowledge of Japanese Syllable Structure

3.1 Introduction

The differences in the syllable structure of Japanese and English, which are likely to be problematic for English learners of Japanese, are where syllables contain 1) geminate consonants, 2) moraic nasal and 3) vowel 'clusters' that are either long vowels or hetero-syllable sequences of more than two vowels. These problems may persist to advanced levels for adult L2 learners, as we will see in Chapter 4.

If a child acquires English and Japanese simultaneously, will the steady state of their Japanese phonology be the same as that of Japanese monolingual child? If the child's acquisition of Japanese in a naturalistic environment is halted temporarily, as is often the case, and exposure resumed in his/her early adulthood, will the learner's phonological development resemble more closely to that Japanese bilingual children or that of adult L2 Japanese learners? As we saw in Chapter 2, there has been very little work done on bilingual English-Japanese acquisition of phonology. Answers to these questions will give us indication to what factors might be involved in acquiring native-like competence in an L2.

The purpose of this chapter is therefore twofold. First we will explore the phonological knowledge of English-dominant vs. Japanese-dominant bilinguals children. Second, we will examine the phonological competence of adult English-dominant bilinguals who had been exposed to Japanese as young children and have presumably

reached their end state. Then, by comparing the results of both bilingual children and adults, we address research Hypothesis 2, the role of age, and Hypothesis 3, the role of input in attaining native-like competence.

3.2 Methodology

In this section, we will discuss the profiles of the participants, choice of test words and task design and testing procedures.

3.2.1 Participant Profile

There were two groups of Japanese-English bilingual participants: bilingual children and bilingual adults, and two control groups consisting of Japanese monolingual children and monolingual Japanese adults, both with limited exposure to English.

3.2.1.1 Bilingual Children

Twelve bilingual children living in the UK aged between 7;6 to 8;5 at the time of testing participated in the study. The mean age of participants was 7;9. They were all second-graders who attended a Japanese Saturday School where systematic Japanese language teaching for native speakers of Japanese is offered with an aim to keep them at age-level in their Japanese literacy. Assessment of their general Japanese language abilities were carried out by interviewing their class teachers and the Ministry of Education-appointed headmaster of the school. It was ascertained that they were all already capable of reading and writing words in Kana, as required by the Japanese National Curriculum. All participants were deemed to be at the required target for the age group under the Japanese National Curriculum.

The bilingual children were further split into two sub-groups: English-dominant and Japanese-dominant bilinguals. English-dominant children were all born in England and were from English-Japanese parentage. They had started at the Japanese Saturday School at the age of six to seven as is required by the Japanese educational system. At the time of this study, they had spent at least a year and half at the Japanese Saturday School. They were highly motivated to continue to develop Japanese literacy and were fully committed to and participated in all school activities including homework.

The Japanese-dominant children were all born in Japan to Japanese parents. They had come to the UK three to four years prior to the study. They all had started formal education at British schools at the age of four to five. By the time of this study, they had, as was the case with English-dominant children, spent two years at British schools.

The details of bilingual children are summarised in Table 3.1.

Table 3.1 Profile of Bilingual Children

Child	Sex	Age	Years in Japan	Dominant language	Home language	School language	Years at JapSat School
HS	F	7;1	0.5	English	Eng/Jap	English	1.6
JM	F	7;1	3	English	Eng/Jap	English	1.6
JS	F	7;7	0.5	English	Eng/Jap	English	1.6
MB	M	7;4	0.5	English	Eng/Jap	English	1.6
OB	M	7;4	0.5	English	Eng/Jap	English	1.6
JS	M	7;6	1	English	Eng/Jap	English	1.6
CM	F	7;1	4	Japanese	Japanese	English	1.6
YO	F	7;8	4	Japanese	Japanese	English	1.6
RO	F	7;11	4	Japanese	Japanese	English	1.6
MM	M	7;7	4	Japanese	Japanese	English	1.6
TT	M	7;6	4	Japanese	Japanese	English	1.6
HK	M	7;2	3	Japanese	Japanese	English	1.6

At the Japanese Saturday School, children receive three hours of Japanese language tuition every week in a similar manner to schools in Japan, using textbooks and supplementary materials provided by the Ministry of Education. Native-speaking Japanese teachers teach following the National Curriculum, under the close supervision of the headmaster, a Japanese language-teaching specialist appointed by the Ministry of Education. The classroom language is Japanese. There are normally 42 teaching weeks in a year.

3.2.1.2 Bilingual Adults with Childhood Exposure to Japanese

Twelve university students (at Durham, Oxford, London and Newcastle Universities) also participated in the study. Most of them had spent one to four years living in Japan during childhood, and had attended a Japanese Saturday School (six years in Primary School, three years in Junior High School) for one to nine years. Their predominant language, however, was English. Their profiles are summarised in Table 3.2.

Table 3.2 Bilingual Adults with Childhood Exposure to Japanese

Name	Sex	Age	Years in Japan				Language at home	Saturday School years
			Ages	Ages	Ages	Ages		
			0 to 2	2 to 6	6 to 12	12 to 18		
AB	F	19;6	0	0	0	0	Eng/Jap	3
KR	F	20;2	1.5	0	0	0	Eng/Jap	3
CC	F	19;8	0	0	0	2	English	2
CK	F	20;4	0.5	0.5	2	1	Japanese	5
EH	F	20;5	1.5	0	0	0	Eng/Jap	6
KA	F	21;5	0.5	0	0	1	Eng/Jap	5
MK	M	18;9	2	1	3	0	Japanese	5
AS	M	20;1	1	1.5	0	1	Eng/Jap	3
DS	M	20;5	1	0.5	0	0	Japanese	4
TS	M	20;7	0	0	0	1	Eng/Jap	1
DB	M	20;4	1	1	0	2	Japanese	6
LB	M	19;11	1	2	0	1	Eng/Jap	9

3.2.1.3 Control Group – Japanese Monolingual Children

As a control group, seven essentially monolingual Japanese speaking second-graders (aged seven to eight) who were at the Japanese Saturday School, with only two to five months' exposure to English language, i.e., relative newcomers to the United Kingdom, also participated in the study. At the time of testing, none of these children was able to speak English fluently, though their English language reading competence was deemed to be equivalent to that of five-year-old L1 English speaking children based on the English reading materials (Level 1, reception year level) they were using at their English schools. They had spent 12 to 15 months in Japanese primary schools prior to coming to the UK and their Japanese literacy were assessed by the Ministry of Education appointed headmaster of Japanese Saturday School as target for their age group.

Table 3.3 Japanese Children with Little English Exposure

Name	Sex	Age	Months in the UK
NT	F	7;6	5
MM	F	7;10	2
TT	M	7;5	2
TM	M	7;4	4
YK	M	7;9	2
JK	F	7;7	5
NK	F	7;3	5

3.2.1.4 Control Group - Japanese Adults with Little Exposure to English

Sixteen Japanese adults participated as an adult monolingual control group. They were the parents of Japanese children at the Saturday School including the seven children in Group 3. Their length of residency in the UK varied from one to 14 months at the time testing. All of them had lived and been educated in Japan until they

came to the UK. Their self-declared level of English was beginner to intermediate, based on the level of English language textbooks they were using at the time of testing. However, they had studied English for at least six years, some for 10 years throughout their secondary and tertiary education in Japan. Their spoken English was limited but they were competent in written English as is normally the case for Japanese English speakers.

Table 3.4 Japanese adults with limited exposure to English

Adult	Sex	Age	Months in the UK	Level in English	Parent of Group 3	
1	ST	F	30s	5	Beginner	Yes
2	SM	F	30s	2	Beginner	Yes
3	KT	F	30s	2	Beginner	Yes
4	AM	F	30s	4	Beginner	Yes
5	SK	F	30s	2	Beginner	Yes
6	MK	F	30s	5	Beginner	Yes
7	HK	F	40s	11	Intermediate	Yes
8	JS	F	30s	6	Beginner	No
9	KS	F	30s	6	Beginner	No
10	NT	F	30s	10	Beginner	No
11	NF	F	30s	6	Beginner	No
12	AT	M	30s	6	Intermediate	No
13	SM	M	40s	4	Beginner	No
14	TM	M	30s	5	Beginner	No
15	SA	M	30s	9	Beginner	No
16	KT	M	30s	8	Beginner	No

3.2.2 Test Words

As Doyle, Champagne and Segalowitz (1978) noted, bilingual children have smaller vocabulary but superior verbal fluency (see Chapter 2). In order to examine the state of bilingual children's syllable structure in Japanese systematically, selected lists of words rather than spontaneous speech were used. For the purpose of this

study, two word lists were drawn up. The first list consisted of nine Japanese names that contained long vowels (VV), geminate consonants (CVC) or moraic nasals (CVN), or any combination of these, and a name with simple CV structure as a control word. These names are from children's storybooks. Depending on the level of input they have received, children may or may not be familiar with them. In addition to the way children process words containing special syllable types, the effects of word familiarity in respect of input quality and quantity are examined using this list. The second list consisted of nine English place names that contained either or any combinations of VV, CVC and CVN, and a control word with the simple CV structure. This task aims to analyse the way bilinguals, particularly English-dominant bilinguals applying the Japanese loanword formation rules to their dominant language: English. Bilinguals must, therefore, override phonological rules that are governed by English.

The tasks were designed to measure subjects' mora count. If the participant perceived the correct moraic structure of a given word, it was expected that the person would be able to either produce orally, read or write what he/she had perceived. Though this does not necessarily mean the configuration of morae has to match exactly with that of the target word, the results were expected to indicate the participant's awareness of the moraic structure rather than just the syllable structure of a word.

3.2.2.1 Character Names: Japanese Story Character Names

Ten names character names from traditional Japanese children's stories were chosen. Authentic words, particularly those that may be considered relevant and appropriate for the age group for cultural understanding and appreciation were chosen to conform to the wishes of the Japanese Saturday School.

Each name, apart from the distracter, contains one or more of the following special type morae: geminate consonants, moraic nasals and long vowels. Test words are shown in Table 3.5. The moraic boundaries are represented by “ – ”.

Table 3.5 Test Character Names

TW	Name	IPA	No of σ	No of μ	GemC	Mora nasal	VV
1	Ki-c-cho-mu-saN	kʲɪttʃɔmsã	4	6	ts-ts	✓	-
2	Tsu-u	tsu:	1	2	-	-	u-u
3	O-sho-o-saN	ɔʃɔ:sã	3	5	-	✓	o-o
4	I-k-kyu-u-saN	ikkju:sã	3	6	k-k	✓	u-u
5	GeN-zo-o Ji-i-saN	genzɔ:jiisã	4	8	-	✓	o-o,i-i
6	Hyo-t-to-ko	hjo:ttɔkɔ	4	5	t-t	-	-
7	O-ji-zo-o-sa-N	ɔdʒizɔ:sã	5	6	-	✓	o-o
8	I-s-suN-bo-o-shi	issu:ɸɔ:ʃi	4	7	s-s	✓	o-o
9	Cho-o-ja-sa-ma	tʃɔɔdʒasama	4	5	-	-	o-o
10	O-ya-yu-bi-hi-me	ɔjaju:ɸihime	6	6	n/a	n/a	n/a

(Key: σ syllable, μ =mora, GemC =geminate consonants, MoraNas =moraic nasal, VV = long vowels)

The testing materials involved ten illustrations of each character in a picture book.

3.2.2.2 Place Names: English Place Names

The second set of words was English place names. Relatively familiar names were chosen to satisfy the requirements of relevance and usefulness set by the Japanese Saturday School. The selection of place names was familiar enough to test subjects living in the UK.

Table 3.6 Test Place Names

TW	Name	IPA	Borrowed Words	No of σ	No of μ	Gem C	Mora Nas	VV
1	Newcastle	nju:kɑ:sl	Nju-u ka-s-su-ru	4	6	s-s	-	u-u
2	Richmond	rɪtʃmænd	Ri-c-chi-mo-N-do	4	6	c-c	✓	-
3	Basingstoke	bɛɪzɪŋstouk	Be-i-ji-N-gu-su-to-o-ku	5	9	-	✓	e-i,o-o
4	Scotland	skɒtlənd	Su-ko-t-to-ra-N-do	5	7	t-t	✓	-
5	Tunbridge	tʌnbɪdʒ	To-N-bu-ri-j-ji	4	6	j-j	✓	-
6	Stratford	stratfɔ:d	Su-to-ra-t-to-fo-o-do	6	8	t-t	-	o-o
7	Banbury	bambɪɹɪ	Ba-N-bu-ri-l	3	5	-	✓	i-i
8	Darlington	dɑ:ɪŋtɪn	Da-a-ri-N-gu-to-N	3	7	-	✓	a-a
9	Oxford	ɒksfɔ:d	O-k-ku-su-fo-o-do	5	6	k-k	-	o-o
10	Bristol	bɪstɹl	Bu-ri-su-to-ru	5	5	n/a	n/a	n/a

(Key: σ syllable, μ =mora, GemC =geminate consonants, MoraNas =moraic nasal, VV = long vowels)

The test words were recorded in English by a native English speaker and also typed in English on ten separate cards.

3.2.3 Procedure

The tests were administered at various locations, usually at the University of Durham and at the Japanese Saturday School in Washington, Tyne and Wear, UK.

3.2.3.1 Japanese Story Character Names

All groups except the adult control group participated in this task as it was deemed to be too simple and the results from native speakers predictable. The interviewer delivered test words in a Tokyo accent.

3.2.3.1.1 *Bilingual Children*

For this task, the children were interviewed individually. Using illustrations from picture books showing all names in the test word list, a short dialogue in Japanese between the child and the interviewer took place. As an observer and assistant, another Japanese speaker was also present, but did not take part in the interview. The recording was made using Sony TCM-359V tape recorder discreetly. Parental consent for recording had been obtained, but children were not informed of the location of microphone, unless they noticed and asked. Later, the data were transcribed and double-checked by the interviewer and the assistant.

A typical dialogue consisted of (in Japanese):

Interviewer: Do you know who this is?

Child: I'm not sure...

Interviewer: The man was very witty, and he was always joking...

(Discussed the story)

Child: ...

Interviewer: He's got a funny name... Kicchomu-san!

Child: Kicchomu-san? Funny name!

Interviewer: Yes, Kicchomu-san. Can you write it down in Kana?

Child: Yes.

Each interview lasted 10 to 20 minutes, depending on the familiarity of children with these traditional Japanese children's stories. Though none of the participating children had heard all names, English-dominant children tended to ask more questions about the characters than their Japanese-dominant counterparts. Also, English-



dominant children were more self-conscious about speaking in Japanese with adults. The pronunciation they seemed to feel most comfortable was taken as their oral production data.

3.2.3.1.2 *Bilingual Adults*

Illustrations from the same set of picture books as the ones used for Bilingual children were used for bilingual adults. The interview took place individually, again with the presence of a silent observer.

Participants were asked to look at the ten illustrations but without any text. As with the children, the interviewer introduced each character orally to participants. Those who were familiar with the characters of these books were asked to orally produce and write down names on a sheet of paper in Kana. Those who were not familiar with the stories, or were not sure if they had remembered right were asked to listen to the interviewer reading short (under one minute) synopses of the stories. The interviewer used the name no more than three times.

Following the reading session, as with children a short dialogue between the interviewer and each participant regarding each character took place. This learning reinforcement session was necessary to ensure that participants were not repeating immediately after cues from the researcher. Participants were then asked to orally produce and then write down in Kana names of the characters as the interviewer pointed to the pictures.

The interviewer asked if they could guess the names of the story characters, if they had heard of the names. The participant repeated the name, checking their pronunciation. The pronunciation they seemed to feel most comfortable was taken as their oral production data.

Each test session took 10 to 15 minutes. Recording was made using the Sony tape-recorder TCM-359V.

3.2.3.1.3 Control Group

The seven Japanese monolingual aged 7 to 8, with minimum exposure to English underwent the same procedure. The test took place in the classroom, with a second native speaker to assess the accuracy of pronunciation. Using the picture book, the first interviewer asked children if they knew the name of each character. They responded at randomly, and the interviewer and the assistant listened to all children. As children agreed who each character was, they were asked to write down their names in Kana. No recording was made, as it was clear that their Japanese literacy corresponded to their awareness of Japanese syllables, and the results were predictable.

3.2.3.2 English Place Names as Loanwords

The second test using Japanese loanwords for English place names was carried out with all four groups: bilingual children, bilingual adults and the monolingual Japanese speaking child and adult control groups.

3.2.3.2.1 Bilingual Children

A week after the story character task, the place name task was carried out. The test was carried out individually, taking 10 to 15 minutes per child, in the staff room of a local school. And again, a native Japanese speaker was present as an assistant and observer.

Children were shown cards printed with the English place names given in Table 3.6. They were asked if they knew these places "in Japanese," or the way Japanese-speaking adults would refer to them. They orally produced these names, and then

were asked to write them down in Kana. Each session was recorded using a Sony TCM-359V tape recorder discreetly, and recorded material was transcribed and double-checked by the native speaker who was present at the test.

3.2.3.2.2 Bilingual Adults

A week to six weeks after the character name task, the bilingual adults took place name task, individually. Each session was recorded using Sony TCM-359V tape recorder, and the recorded material was transcribed and double-checked by a native speaker of Japanese. Each session took 10 to 15 minutes. First, the participants were shown cards with English place names and asked to give the Japanese equivalent. Then, they were asked to write them down in Kana. When they were not sure how Japanese native speakers would pronounce these names, they were offered some suggestions by the interviewer. They then decided what they thought was correct.

3.2.3.2.3 Control Group

Both children and adult newcomers participated in this task. They were shown cards of English place names and asked to pronounce and write them in Japanese way. Some adults and all children needed to hear the word pronounced in English. They listened to the English place names recorded by a native English speaker until they were comfortable in producing and writing in Japanese.

3.3 Results

The results of the tasks described in the previous section are now examined in terms of mora count, deletion and insertion of consonants and vowels, and substitutions and/or compensation. We first look at the results of the Japanese story character name task and then loanword task.

3.3.1 Japanese Story Character Names

We examine the data by participant category in this section. We first look at the data from the control group, then bilingual children and finally bilingual adults. We then compare the results from bilingual children and adults.

3.3.1.1 Control Group

All seven participants in the control group of Japanese-dominant monolingual children, the new arrivals to the UK, produced the target mora count in both oral production and writing in Kana for this task. There was no deletion, insertion or substitution made by the control group children. Let us now look at the results by the bilingual children.

3.3.1.2 Bilingual Children

Table 3.7 presents the results for the mora count for each word (TW). The data are presented for all twelve bilingual children, and as two sub-groups for the six each English-dominant and Japanese-dominant children. 'Freq' indicates the number of children in the group who produced the target number of morae for each word. The frequency is then presented as a percentage to the right of the raw number. The test word 'Kicchomusan' (1) for example, has six morae in Japanese. All children orally produced and wrote six morae, yielding a frequency of 12, while frequencies for English-dominant and Japanese-dominant bilingual children were six each.

Japanese-dominant bilingual children returned correct number of morae in both oral production and writing, except TW 6, Hyottoko. English-dominant bilingual children, on the other hand, showed 76.7% and 68.3% mean accuracy in oral production and writing respectively. They were least accurate in identifying correct

number of morae in TW5, Genzoo Jiisan (33.3%) and TW7, Ojizoosan (33.3%) in oral production, and in TW 6, Hyottoko (33.3%) in writing.

Table 3.7 Bilingual Children – Mora Count Accuracy – Character Names

TW	Japanese-dominant				English-dominant			
	Oral production		Writing		Oral production		Writing	
	Freq	%	Freq	%	Freq	%	Freq	%
1	6	100	6	100	6	100	6	100
2	6	100	6	100	6	100	4	66.7
3	6	100	6	100	3	50	3	50
4	6	100	6	100	6	100	3	50
5	6	100	6	100	2	33.3	3	50
6	5	83.3	6	100	5	83.3	2	33.3
7	6	100	6	100	2	33.3	4	66.7
8	6	100	6	100	5	83.3	4	66.7
9	6	100	6	100	6	100	6	100
10	6	100	6	100	5	83.3	6	100
Mean	5.9	98.3	6	100	4.6	76.7	4.1	68.3
Correlation Coefficient	N/A				0.391159129			

The research hypothesis 4 as discussed in Chapter 2 predicts the correlation between the literacy in Japanese and the awareness of the syllable structure. As one of the ways to test this hypothesis, correlation coefficients between oral production and writing data are calculated. The correlation coefficients for the Japanese-dominant bilinguals is not available as there is only one deviation from the 100% result in the data. The correlation coefficient for English-dominant bilinguals shows a low correlation between oral production and writing. Figures 3.1 and 3.2 present these data schematically.

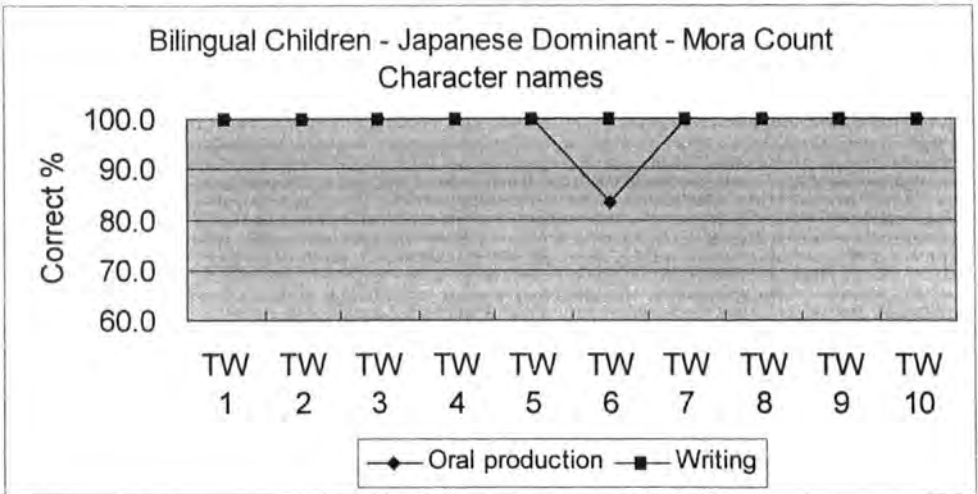

Figure 3.1 Mora Count - JDBC

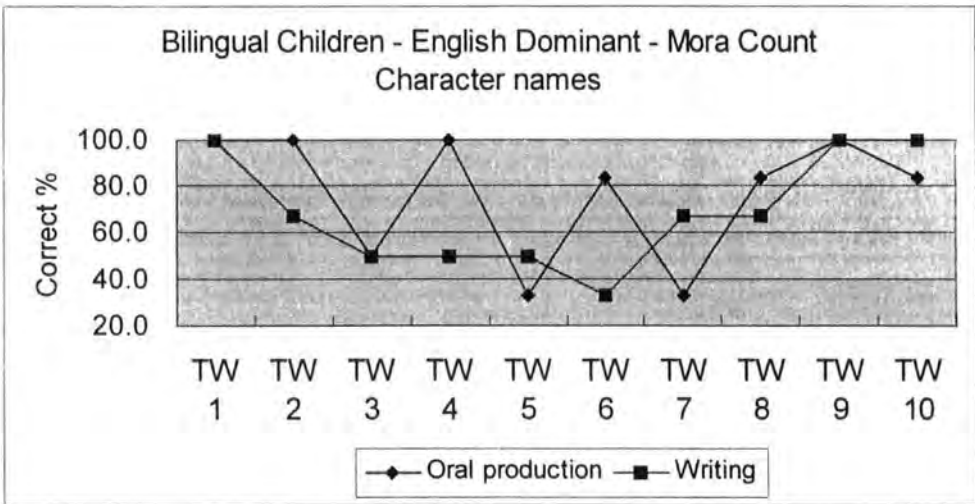

Figure 3.2 Mora Count - EDBC

The test words that caused the most problems in mora count were TW 3, TW 5 and TW 7 in oral production, and TW 3, TW 4, TW 5 and TW 6 in writing. The details are summarised in Tables 3.8 and 3.9.

Table 3.8 Worst Three in Oral production - Mora Count – Bilingual Children

TW	Name	IPA	No of σ	No of μ	Gem C	Mora Nas	LV
3	O-sho-o-saN	ɔʃɔ:sã	3	5	-	✓	o-o
5	GeN-zo-o Ji-i-saN	genzo:jiisã	4	8	-	✓	o-o,i-i
7	O-ji-zo-o-sa-N	ɔʃɔizɔ:sã	5	6	-	✓	o-o

Table 3.9 Worst Four in Writing - Mora Count – Bilingual Children

TW	Name	IPA	No of σ	No of μ	Gem C	Mora Nas	LV
3	O-sho-o-saN	ɔʃɔ:sã	3	5	-	✓	o-o
4	I-k-kyu-u-saN	ikkju:sã	3	6	k-k	✓	u-u
5	GeN-zo-o Ji-i-saN	genzo:jiisã	4	8	-	✓	o-o,i-i
6	Hyo-t-to-ko	hjoʃttoko	4	5	t-t	-	-

Table 3.9 suggests that bilingual children found long vowels and/or moraic nasals difficult to produce. In writing, on the other hand, difficulties were not only long vowels and moraic nasals but also geminate consonants.

Let us now look at these data in terms of deviation from the target number of morae. Table 3.11 shows mean deviation figures for the mora count. For example, zero indicates that there was no deviation. Positive numbers indicate that there were mora insertions, while negative numbers indicate mora deletions. The deviation figures are obtained by dividing the total number of deletions or insertions for the word divided by the total number of children in the sub-group.

Table 3.10 Mora Count Deviation – Eng-dom. Bilingual Children Character

Names

TW	English-dominant		Japanese-dominant	
	Oral production	Writing	Oral production	Writing
1	0	0	0	0
2	0	0.33	0	0
3	-0.5	-0.17	0	0
4	0	0.5	0	0
5	0.67	0.5	0	0
6	-0.17	0.67	0.17	0
7	-0.67	0.33	0	0
8	-0.17	0.33	0	0
9	0	0	0	0
10	-0.17	0	0	0
Correlation Coefficient	0.317852971		N/A	

The Japanese-dominant children produced the target number of morae for every word except TW 6, where one child produced five morae instead of expected six, i.e., a deletion of mora, in oral production. Thus the deviation of 0.17 represents a sixth of one mora.

Mora deletions and insertions in terms of mora count deviation are presented in Figure 3.3.

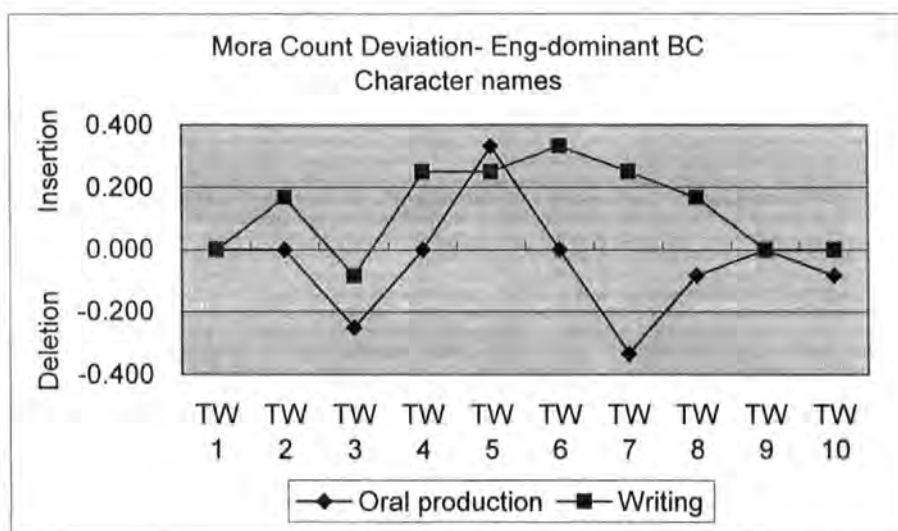

Figure 3.3 Mora Count Deviation EDBC

From Figure 3.3 we observe that the bilingual children show a greater tendency to insert morae in oral production than in writing. As already noted, test words that caused most deviation in mora count were TW 3, TW 5 and TW 7 in oral production, and TW 4, TW 5 and TW 6 in writing. In writing, TW 3 shows the figure of -0.08 . This figure derives from two deletions and one insertion. To see the magnitude of deviation, a different set of figures is needed.

Let us now have a look at the causes of such mora count deviation in detail. First, let us look at consonant deletions and insertions.

Table 3.11 summarises the deletion and insertion of consonants and vowels by the bilingual children.

Table 3.11 Consonant Deletion and Insertion – Bilingual Children

TW	Japanese-Dominant Bilingual Children								English-Dominant Bilingual Children							
	Oral Production				Writing				Oral Production				Writing			
	Deletion		Insertion		Deletion		Insertion		Deletion		Insertion		Deletion		Insertion	
	Gem C	MN	Gem C	ON	Gem C	MN	Gem C	ON	Gem C	MN	Gem C	ON	Gem C	MN	Gem C	ON
1	0 0.0%	0 0.0%	0 0.0%	0 0.0%	0 0.0%	0 0.0%	0 0.0%	0 0.0%	2 33.3%	0 0.0%	0 0.0%	0 0.0%	2 33.3%	0 0.0%	0 0.0%	0 0.0%
2	0 0.0%	0 0.0%	0 0.0%	0 0.0%	0 0.0%	0 0.0%	0 0.0%	0 0.0%	0 0.0%	0 0.0%	0 0.0%	0 0.0%	0 0.0%	0 0.0%	0 0.0%	0 0.0%
3	0 0.0%	0 0.0%	0 0.0%	0 0.0%	0 0.0%	0 0.0%	0 0.0%	0 0.0%	0 0.0%	0 0.0%	0 0.0%	1 16.7%	0 0.0%	1 16.7%	0 0.0%	1 16.7%
4	0 0.0%	0 0.0%	0 0.0%	0 0.0%	0 0.0%	0 0.0%	0 0.0%	0 0.0%	3 50.0%	0 0.0%	0 0.0%	0 0.0%	3 50.0%	0 0.0%	0 0.0%	3 50.0%
5	0 0.0%	0 0.0%	0 0.0%	0 0.0%	0 0.0%	0 0.0%	0 0.0%	0 0.0%	0 0.0%	0 0.0%	0 0.0%	4 66.7%	0 0.0%	0 0.0%	0 0.0%	1 16.7%
6	0 0.0%	0 0.0%	0 0.0%	0 0.0%	0 0.0%	0 0.0%	0 0.0%	0 0.0%	5 83.3%	0 0.0%	1 16.7%	0 0.0%	4 66.7%	0 0.0%	4 66.7%	0 0.0%
7	0 0.0%	0 0.0%	0 0.0%	0 0.0%	0 0.0%	0 0.0%	0 0.0%	0 0.0%	0 0.0%	1 16.7%	0 0.0%	1 16.7%	0 0.0%	0 0.0%	1 16.7%	2 33.3%
8	0 0.0%	0 0.0%	0 0.0%	0 0.0%	0 0.0%	0 0.0%	0 0.0%	0 0.0%	4 66.7%	0 0.0%	0 0.0%	2 33.3%	2 33.3%	0 0.0%	0 0.0%	2 33.3%
9	0 0.0%	0 0.0%	0 0.0%	0 0.0%	0 0.0%	0 0.0%	0 0.0%	0 0.0%	0 0.0%	0 0.0%	0 0.0%	0 0.0%	0 0.0%	0 0.0%	0 0.0%	0 0.0%
10	0 0.0%	0 0.0%	0 0.0%	0 0.0%	0 0.0%	0 0.0%	0 0.0%	0 0.0%	0 0.0%	0 0.0%	0 0.0%	0 0.0%	0 0.0%	0 0.0%	0 0.0%	0 0.0%
Mean	0 0.0%	0 0.0%	0 0.0%	0 0.0%	0 0.0%	0 0.0%	0 0.0%	0 0.0%	1.4 23.3%	0.1 1.7%	0.1 1.7%	0.8 13.3%	1.1 18.3%	0.1 1.7%	0.5 8.3%	0.9 15.0%

Consonant deletions were measured in terms of geminate consonants and moraic nasals, both of which lead to the observed mora count reductions. Consonant insertions were measured in terms of geminate consonants, which correspond to a mora gain, and onset nasals, which do not. The results of English-dominant children are schematically presented in Figures 3.4 and 3.5.

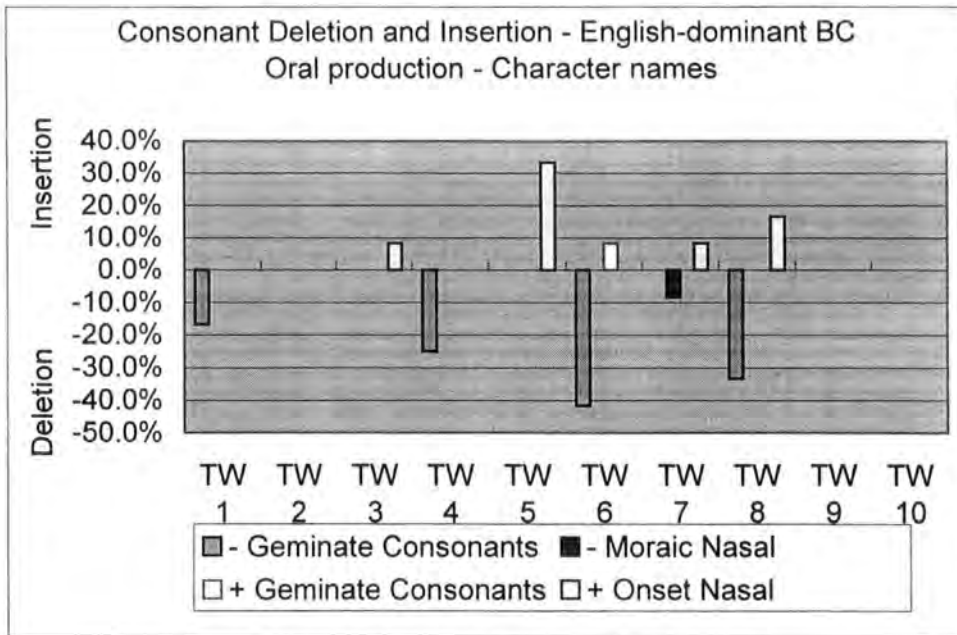

Figure 3.4 Consonant Deletion and Insertion – Oral Production

TW 1, 4, 6 and 8, the four test words that had geminate consonants, had geminate consonant deletions. TW 6 (Hyottoko) had both geminate consonant deletions and geminate consonant insertions, resulting in net gain of morae. Only TW 7 had moraic nasal deletion, though TW 1, 3, 4, 5, 7 and 8 had moraic nasals. TW 3, 5, 7 and 8 had onset nasal insertions.

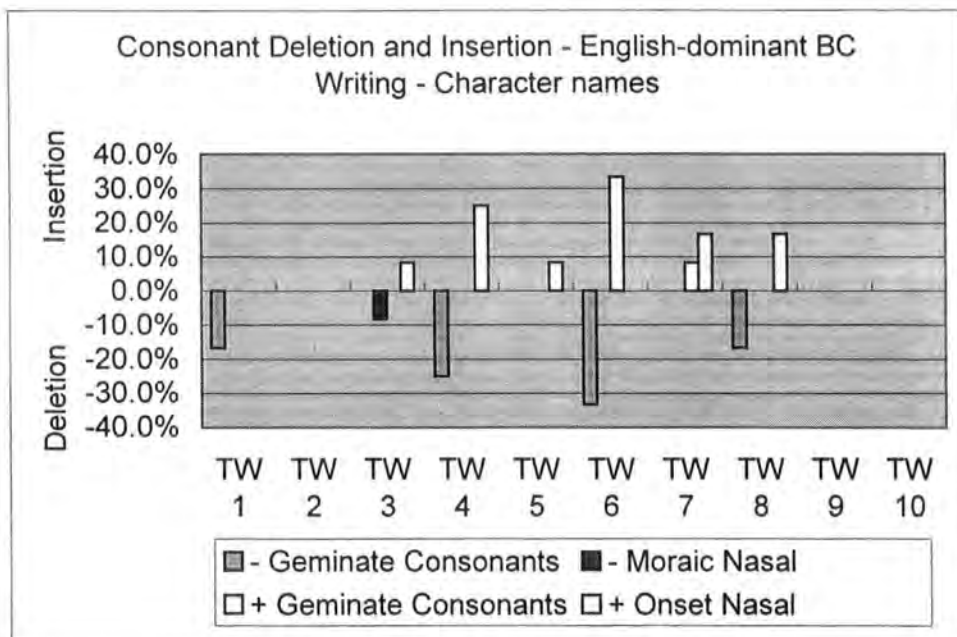

Figure 3.5 Consonant Deletion and Insertion - Writing

In writing, TW 1, 4, 6 and 8, test words with geminate consonants, were all subject to geminate consonant deletions. In TW 6, as was the case in oral production, there were geminate consonant insertions as well as deletions. TW 3 was the only test word that had both moraic nasal deletions and onset nasal insertions.

Let us now compare the results of oral production and writing, as shown in Table 3.12.

Table 3.12 Consonant Deletion and Insertion – Eng-dom. Bilingual Children

TW	Deletion		Insertion	
	Oral production %	Writing %	Oral production %	Writing %
1	2 33.3%	2 33.3%	0 0.0%	0 0.0%
2	0 0.0%	0 0.0%	0 0.0%	0 0.0%
3	0 0.0%	1 16.7%	1 16.7%	1 16.7%
4	3 50.0%	3 50.0%	0 0.0%	3 50.0%
5	0 0.0%	0 0.0%	4 66.7%	1 16.7%
6	5 83.3%	4 66.7%	1 16.7%	4 66.7%
7	1 16.7%	0 0.0%	1 16.7%	3 50.0%
8	4 66.7%	2 33.3%	2 33.3%	2 33.3%
9	0 0.0%	0 0.0%	0 0.0%	0 0.0%
10	0 0.0%	0 0.0%	0 0.0%	0 0.0%
Mean	1.5 25.0%	1.2 20.0%	0.9 15.0%	1.4 23.3%
Correlation Coefficients	0.91129318		0.195016204	

There is a strong correlation between the consonant deletion data of oral production and writing. There is little, however, in insertion.

We examine the vowel deletions and insertion data next. Table 3.13 summarises vowel deletions and insertions.

Table 3.13 Vowel Deletions and Insertions – Bilingual Children

TW	Japanese-dominant				English-dominant			
	Oral Production		Writing		Oral Production		Writing	
	Vowel Deletion	Vowel Insertion	Vowel Deletion	Vowel Insertion	Vowel Deletion	Vowel Insertion	Vowel Deletion	Vowel Insertion
1	0 0.0%	0 0.0%	0 0.0%	0 0.0%	0 0.0%	2 33.3%	0 0.0%	2 33.3%
2	0 0.0%	0 0.0%	0 0.0%	0 0.0%	0 0.0%	0 0.0%	0 0.0%	2 33.3%
3	0 0.0%	0 0.0%	0 0.0%	0 0.0%	4 66.7%	1 16.7%	2 33.3%	2 33.3%
4	0 0.0%	0 0.0%	0 0.0%	0 0.0%	0 0.0%	3 50.0%	0 0.0%	6 100.0%
5	0 0.0%	0 0.0%	0 0.0%	0 0.0%	0 0.0%	4 66.7%	0 0.0%	3 50.0%
6	0 0.0%	1 16.7%	0 0.0%	0 0.0%	0 0.0%	4 66.7%	0 0.0%	4 66.7%
7	0 0.0%	0 0.0%	0 0.0%	0 0.0%	4 66.7%	1 16.7%	2 33.3%	4 66.7%
8	0 0.0%	0 0.0%	0 0.0%	0 0.0%	2 33.3%	5 83.3%	1 16.7%	5 83.3%
9	0 0.0%	0 0.0%	0 0.0%	0 0.0%	0 0.0%	0 0.0%	0 0.0%	0 0.0%
10	0 0.0%	0 0.0%	0 0.0%	0 0.0%	1 16.7%	0 0.0%	0 0.0%	0 0.0%
Mean	0.0 0.0%	0.1 1.7%	0.0 0.0%	0.0 0.0%	1.1 18.3%	2.0 33.3%	0.5 8.3%	2.8 46.7%

There were no deletions or insertions in either oral production and writing for TW 9 (Choojasama) that has only a long vowel. On the whole, bilingual children deleted more vowels in oral production and inserted more vowels in writing.

These results are presented in Figures 3.6 and 3.7.

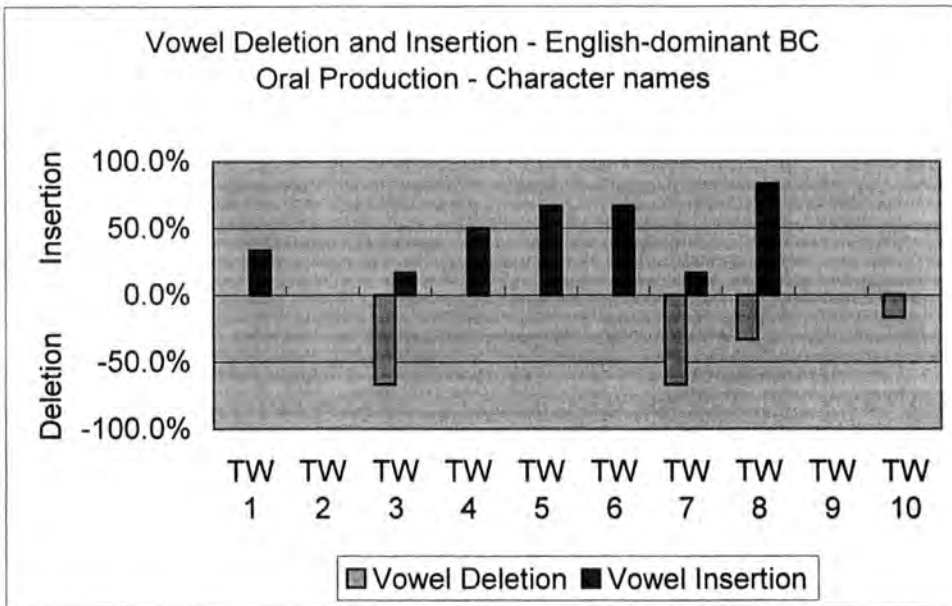

Figure 3.6 Vowel Deletion and Insertion – Oral Production

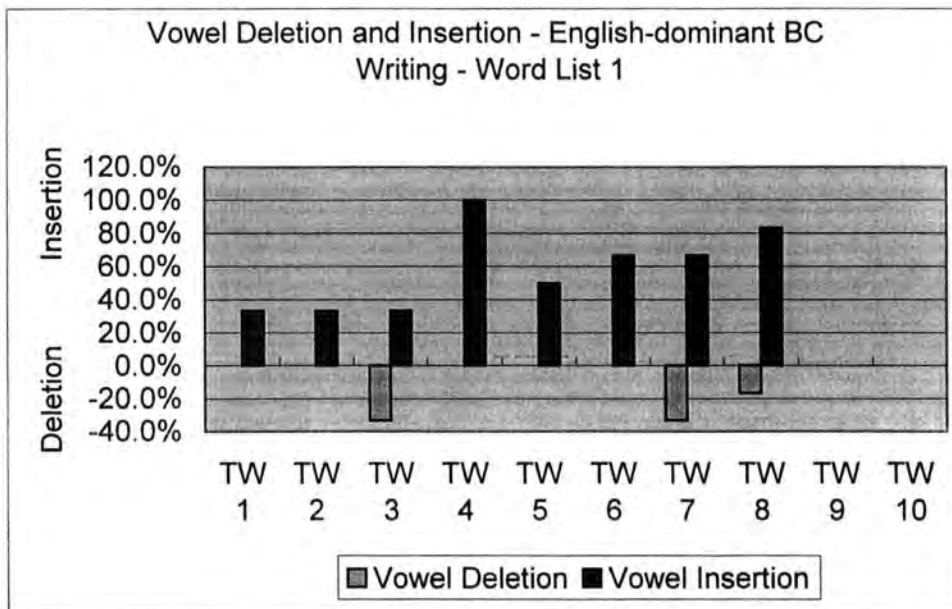

Figure 3.7 Vowel Deletion and Insertion - Writing

On the whole, bilingual children inserted more vowels than they deleted them.

TW 3, 7 and 8 had both vowel deletions and insertions in oral production, both in oral production and in writing, which are summarised in Table 3.14.

Table 3.14 Vowel Deletions and Insertions in the Same Word

TW	Name	IPA	No of σ	No of μ	Gem C	N	LV
3	O-sho-o-saN	ɔʃɔ:sā	3	5	-	✓	o-o
7	O-ji-zo-o-sa-N	ɔdʒɪzɔ:sā	5	6	-	✓	o-o
8	l-s-suN-bo-o-shi	ɪssuŋbɔ:ʃɪ	4	7	s-s	✓	o-o

On closer examination, it came to light that TW 3,7 and 8 in both oral production and writing were subject to shortening of long vowels, and at the same time, subject to insertion of vowels after onset nasals. As TW 3, 7 and 8 indicate, there seems to be some similarity in vowel deletions and insertions between oral production and writing. Let us now compare the two sets of data, as summarised in Table 3.15.

Table 3.15 Vowel Deletion and Insertion – Bilingual Children – Character Names

TW	Japanese-dominant				English-dominant			
	Deletion		Insertion		Deletion		Insertion	
	Oral production %	Writing %	Oral production %	Writing %	Oral production %	Writing %	Oral production %	Writing %
1	0 0.00%	0 0.00%	0 0.00%	0 0.00%	0 0.00%	0 0.00%	2 33.30%	2 33.30%
2	0 0.00%	0 0.00%	0 0.00%	0 0.00%	0 0.00%	0 0.00%	0 0.00%	2 33.30%
3	0 0.00%	0 0.00%	0 0.00%	0 0.00%	4 66.70%	2 33.30%	1 16.70%	2 33.30%
4	0 0.00%	0 0.00%	0 0.00%	0 0.00%	0 0.00%	0 0.00%	3 50.00%	6 100.00%
5	0 0.00%	0 0.00%	0 0.00%	0 0.00%	0 0.00%	0 0.00%	4 66.70%	3 50.00%
6	0 0.00%	0 0.00%	1 16.70%	0 0.00%	0 0.00%	0 0.00%	4 66.70%	4 66.70%
7	0 0.00%	0 0.00%	0 0.00%	0 0.00%	4 66.70%	2 33.30%	1 16.70%	4 66.70%
8	0 0.00%	0 0.00%	0 0.00%	0 0.00%	2 33.30%	1 16.70%	5 83.30%	5 83.30%
9	0	0	0	0	0	0	0	0

	0.00%	0.00%	0.00%	0.00%	0.00%	0.00%	0.00%	0.00%	0.00%
10	0 0.00%	0 0.00%	0 0.00%	0 0.00%	1 16.70%	0 0.00%	0 0.00%	0 0.00%	0 0.00%
Mean	0 0.00%	0 0.00%	0.1 1.70%	0 0.00%	1.1 18.30%	0.5 8.30%	2 33.30%	2.8 46.70%	
Correlation Coefficients	N/A		N/A		0.98254774		0.740696036		

Unlike was the case with consonants, there is a strong correlation between oral production and writing in both the deletion and insertion of vowels, as the correlation coefficients suggest.

From the results of consonants and vowel deletions and insertions, we still cannot see any clear pattern as to what English-dominant bilingual children's Japanese syllable template might look like. We need to investigate the data further.

Let us now look into the relationship between consonant and vowel deletion and insertion. As we have seen in previous sections, bilingual children compensate for a loss of mora with an insertion of another, resulting in preservation of mora count for that word. Table 3.16 summarises substitution and compensation made by English-dominant bilingual children. The Japanese-dominant bilingual children did not make any substitution and compensation.

Table 3.16 Mora Count Preservation English-dominant Bilingual Children

Character Names

TW	Recitation					Writing				
	Gem C with LV	LV with Gem C	Gem C with Gem C	LV with LV	MN with ON	Gem C with LV	LV with Gem C	Gem C with Gem C	LV with LV	MN with ON
1	2 33.3%	0 0.0%	0 0.0%	0 0.0%	0 0.0%	2 33.3%	0 0.0%	0 0.0%	0 0.0%	0 0.0%
2	0 0.0%	0 0.0%	0 0.0%	0 0.0%	0 0.0%	0 0.0%	0 0.0%	0 0.0%	0 0.0%	0 0.0%
3	0 0.0%	0 0.0%	0 0.0%	0 0.0%	0 0.0%	0 0.0%	0 0.0%	0 0.0%	0 0.0%	1 16.7%

4	3 50.0%	0 0.0%	0 0.0%	0 0.0%	0 0.0%	3 50.0%	0 0.0%	0 0.0%	0 0.0%	0 0.0%
5	0 0.0%	0 0.0%	0 0.0%	0 0.0%	0 0.0%	0 0.0%	0 0.0%	0 0.0%	0 0.0%	0 0.0%
6	3 50.0%	0 0.0%	1 16.7%	0 0.0%	0 0.0%	0 0.0%	0 0.0%	4 66.7%	0 0.0%	0 0.0%
7	0 0.0%	0 0.0%	0 0.0%	0 0.0%	2 33.3%	0 0.0%	1 16.7%	0 0.0%	2 33.3%	0 0.0%
8	2 33.3%	0 0.0%	0 0.0%	1 16.7%	2 33.3%	2 33.3%	0 0.0%	0 0.0%	0 0.0%	0 0.0%
9	0 0.0%	0 0.0%	0 0.0%	0 0.0%	0 0.0%	0 0.0%	0 0.0%	0 0.0%	0 0.0%	0 0.0%
10	0 0.0%	0 0.0%	0 0.0%	0 0.0%	0 0.0%	0 0.0%	0 0.0%	0 0.0%	0 0.0%	0 0.0%

In the table, Gem C stands for geminate consonants, LV for long vowels, MN for moraic nasals and ON for onset nasals. The results are schematically presented in Figures 3.8 and 3.9.

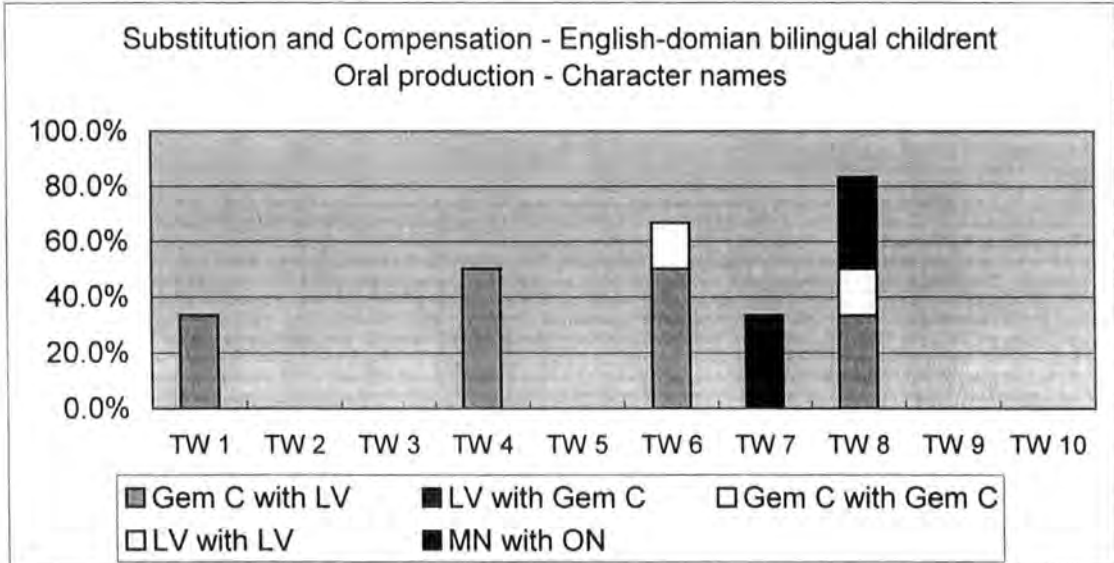

Figure 3.8 Substitution and Compensation – Oral Production

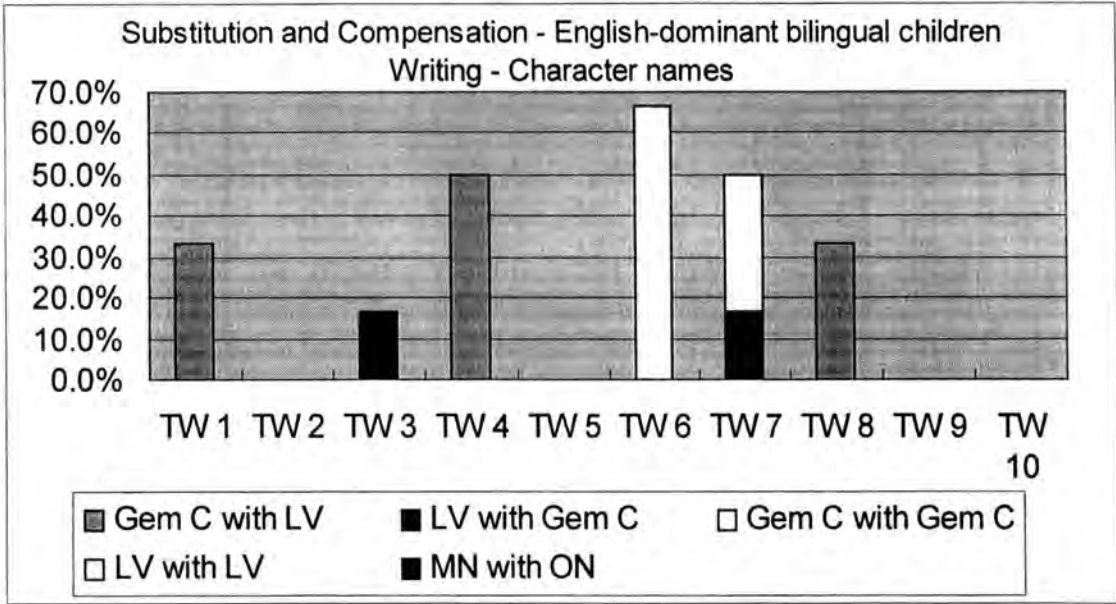

Figure 3.9 Substitution and Compensation - Writing

In both oral production and writing, there were no substitutions made in TW 2, 9 and 10.

Table 3.17 shows which deletion or insertion corresponds to a mora count preservation, and which does not.

Table 3.17 Compensatory Deletions & Insertions vs. Others

English-dominant Bilingual Children - Oral production

TW	Deletion and Insertion						Substitution and Compensation				
	Consonant Deletion		Consonant Insertion		Vowel Deletion	Vowel Insertion	Gem C with LV	LV with Gem C	Gem C with Gem C	LV with LV	MN with ON
	Gem C	MN	Gem C	ON							
1	2 16.7%	0 0.0%	0 0.0%	0 0.0%	0 0.0%	2 16.7%	2 16.7%	0 0.0%	0 0.0%	0 0.0%	0 0.0%
2	0 0.0%	0 0.0%	0 0.0%	0 0.0%	0 0.0%	0 0.0%	0 0.0%	0 0.0%	0 0.0%	0 0.0%	0 0.0%
3	0 0.0%	0 0.0%	0 0.0%	1 8.3%	4 33.3%	1 8.3%	0 0.0%	0 0.0%	0 0.0%	0 0.0%	0 0.0%
4	3 25.0%	0 0.0%	0 0.0%	0 0.0%	0 0.0%	3 25.0%	3 25.0%	0 0.0%	0 0.0%	0 0.0%	0 0.0%

5	0 0.0%	0 0.0%	0 0.0%	4 33.3%	0 0.0%	4 33.3%	0 0.0%	0 0.0%	0 0.0%	0 0.0%	0 0.0%
6	5 41.7%	0 0.0%	1 8.3%	0 0.0%	0 0.0%	4 33.3%	3 25.0%	0 0.0%	1 8.3%	0 0.0%	0 0.0%
7	0 0.0%	1 8.3%	0 0.0%	1 8.3%	4 33.3%	1 8.3%	0 0.0%	0 0.0%	0 0.0%	0 0.0%	1 8.3%
8	4 33.3%	0 0.0%	0 0.0%	2 16.7%	2 16.7%	5 41.7%	2 16.7%	0 0.0%	0 0.0%	1 8.3%	0 0.0%
9	0 0.0%	0 0.0%	0 0.0%	0 0.0%	0 0.0%	0 0.0%	0 0.0%	0 0.0%	0 0.0%	0 0.0%	0 0.0%
10	0 0.0%	0 0.0%	0 0.0%	0 0.0%	1 8.3%	0 0.0%	0 0.0%	0 0.0%	0 0.0%	0 0.0%	0 0.0%

The highlighted figures correspond to non-preserving substitution and compensation. For example, in TW 3 (Oshoosan) had a nasal inserted after the final moraic nasal. As Japanese does not allow a coda consonant unless it is a moraic nasal or a geminate consonant, it automatically attracted a vowel inserted. Thus, TW 3 'Oshoosan' became 'Oshoosannu.'

Apart from the onset nasal insertion and matching vowel insertion, there were four vowel deletions in TW 3. In all instances, long vowels were shortened.

TW 7 (Ojizoosan) has both moraic nasal deletion and onset nasal insertion. In this case, a moraic nasal was substituted by an onset nasal and a vowel, thus maintaining the total number of morae, resulting in 'Ojizoosanu.' This is caused by an overgeneralisation of the final open syllable in Japanese.

From Table 3.17, we can observe that in TW 1, 4, 6 and 8, bilingual children deleted geminate consonants and compensated for the loss of mora by substituting vowels, creating long vowels and thus maintaining the total number of morae for the words.

TW 6 was another test word that was subject to geminate consonant deletions. On three occasions, they were substituted with long vowels. On one occasion,

however, a child shifted the position of the geminate consonant. Thus, 'Hyottoko' became 'Hyotokko.' Another child simply inserted an extra geminate consonant, thus resulting in 'Hyottokko' and an additional mora.

Let us now see the summary of the writing data, as shown in Table 3.18.

Table 3.18 Compensatory Deletions & Insertions vs. Others

English-dominant Bilingual Children - Writing

TW	Deletion and Insertion						Substitution and Compensation				
	Consonant Deletion		Consonant Insertion		Vowel Deletion	Vowel Insertion	Gem C with LV	LV with Gem C	Gem C with Gem C	LV with LV	MN with ON
	Gem C	MN	Gem C	ON							
1	2 16.7%	0 0.0%	0 0.0%	0 0.0%	0 0.0%	2 16.7%	2 16.7%	0 0.0%	0 0.0%	0 0.0%	0 0.0%
2	0 0.0%	0 0.0%	0 0.0%	0 0.0%	0 0.0%	2 16.7%	0 0.0%	0 0.0%	0 0.0%	0 0.0%	0 0.0%
3	0 0.0%	1 8.3%	0 0.0%	1 8.3%	2 16.7%	2 16.7%	0 0.0%	0 0.0%	0 0.0%	0 0.0%	1 8.3%
4	3 25.0%	0 0.0%	0 0.0%	3 25.0%	0 0.0%	6 50.0%	3 25.0%	0 0.0%	0 0.0%	0 0.0%	0 0.0%
5	0 0.0%	0 0.0%	0 0.0%	1 8.3%	0 0.0%	3 25.0%	0 0.0%	0 0.0%	0 0.0%	0 0.0%	0 0.0%
6	4 33.3%	0 0.0%	4 33.3%	0 0.0%	0 0.0%	4 33.3%	0 0.0%	0 0.0%	4 33.3%	0 0.0%	0 0.0%
7	0 0.0%	0 0.0%	1 8.3%	2 16.7%	2 16.7%	4 33.3%	0 0.0%	1 8.3%	0 0.0%	2 16.7%	0 0.0%
8	2 16.7%	0 0.0%	0 0.0%	2 16.7%	1 8.3%	5 41.7%	2 16.7%	0 0.0%	0 0.0%	0 0.0%	0 0.0%
9	0 0.0%	0 0.0%	0 0.0%	0 0.0%	0 0.0%	0 0.0%	0 0.0%	0 0.0%	0 0.0%	0 0.0%	0 0.0%
10	0 0.0%	0 0.0%	0 0.0%	0 0.0%	0 0.0%	0 0.0%	0 0.0%	0 0.0%	0 0.0%	0 0.0%	0 0.0%

In TW 3 (Oshoosan), the same English-dominant bilingual child who inserted an onset nasal and an accompanying vowel did so in writing. In writing, however, she altered the status of the moraic nasal as well, thus turning it into an onset nasal, resulting in 'Oshoosanu.' The reason for this could be either overgeneralisation as

discussed regarding oral production data, or immaturity of orthographic competence. As she had shown sensitivity to the moraic nasal in the oral production task, the latter explanation is more probable.

In TW 6, four English-dominant children wrote the word 'Hyottoko' as 'Hyotokkoo', replacing one geminate consonant with another in different position, and lengthening the final vowel. As none of the children inserted a vowel at the end of the word in oral production, the insertion in writing seems to reveal a lag with respect to their development of literacy in Japanese.

In TW 7 (Ojizoson), one inserted a vowel making it a tense vowel in place of geminate consonants, resulting in 'Ojizossan.' Two children shortened vowels but lengthened the other, resulting in 'Ojizosaan.' In both cases, they preserved the total number of morae.

In TW 7 and 8 (Issunbooshi), two English-dominant children inserted an onset nasal together with a vowel, resulting in 'Ojizosannu' and 'Issunnubooshi' respectively. They also inserted onset nasals in oral production. These children were focusing on the moraic nasals that had to be transcribed differently to onset nasals. It would appear that they were over compensating and this resulted in perceiving both moraic and onset nasals

The substitution and compensation data indicate that the syllable template of English-dominant bilingual children was unstable and children were prone to overgeneralisation and overcompensating. We have also seen that many apparent correct mora counts were in fact constituted from various substitutions. The children usually got the number of morae in a word right, and then used a strategy to assign segments to mora slots. They tended to favour long vowels in place of geminate consonants in both oral production and writing.

3.3.1.3 Bilingual Adults

Let us now look at the results of bilingual adults for the story character name test.

Table 3.19 and Figure 3.10 show the mora count results in terms of correct number of morae produced by bilingual adults.

Table 3.19 Mora Count Accuracy – Bilingual Adults – Character Names

TW	Oral production		Writing	
	Freq	%	Freq	%
1	8	66.7	6	50.0
2	12	100.0	10	83.3
3	11	91.7	5	41.7
4	7	58.3	1	8.3
5	5	41.7	4	33.3
6	7	58.3	6	50.0
7	9	75.0	9	75.0
8	8	66.7	6	50.0
9	12	100.0	8	66.7
10	10	83.3	12	100.0
Mean	8.9	74.2	6.7	55.8
Correlation Coefficient			0.613165321	

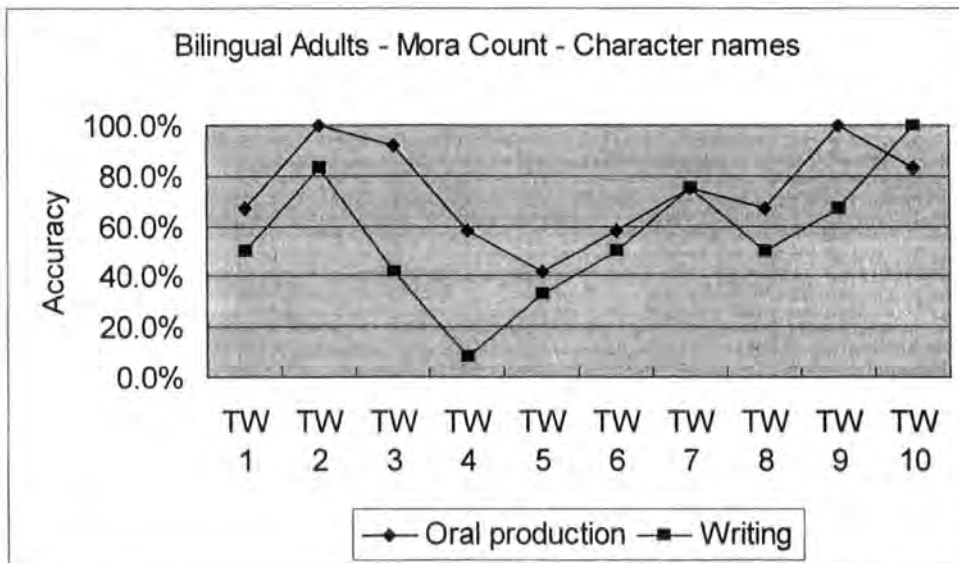

Figure 3.10 Mora Count – Bilingual Adults

The pattern of oral production results follows that of the writing, as the correlation coefficient figure of 0.613 attests. Since the correlation coefficient for English-dominant bilingual children's mora count accuracy was 0.391, this figure is significantly higher. On the whole, bilingual adults were more accurate in oral production than in writing. The data are further analysed in terms of mora count deviation, as summarised in Table 3.20 and presented schematically in Figure 3.11.

Table 3.20 Mora Count Deviation – Bilingual Adults – Character Names

TW	Oral production	Writing
1	0.3	0.5
2	0.0	0.2
3	-0.1	0.6
4	0.4	0.9
5	0.4	0.7
6	-0.4	0.1
7	-0.1	0.3
8	0.0	0.5
9	0.0	0.3
10	-0.2	0.0
Correlation Coefficient	0.8008333	

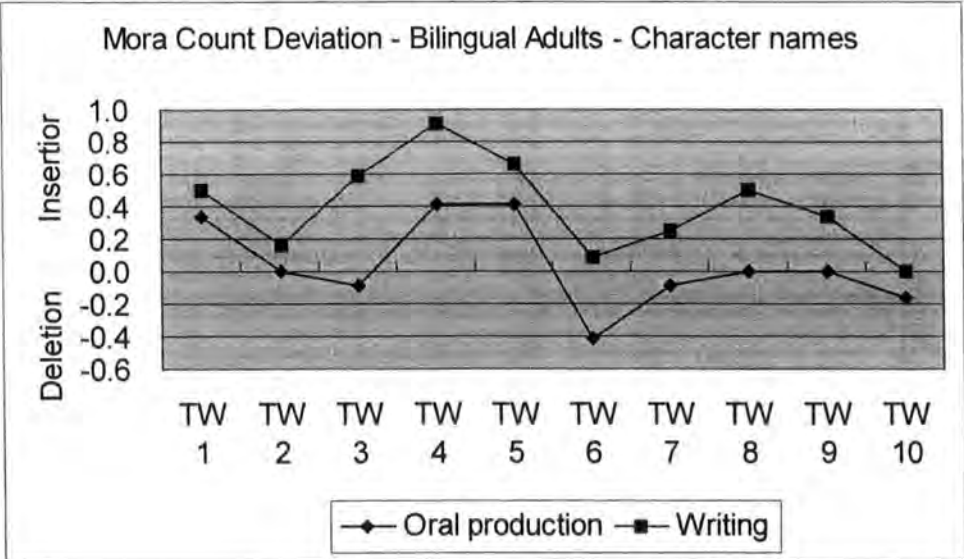

Figure 3.11 Mora Count Deviation

The most problematic words were TW 4, 5 and 6 in oral production and TW 3, 4 and 5 in writing, as shown in Table 3.21. English-dominant bilingual children found TW 3, 5 and 7 most problematic in oral production, and TW 3, 4, 5, and 6 in writing.

Table 3.21 Problematic Words in Oral Production and Writing – Character Names

TW	Name	IPA	No of σ	No of μ	Gem C	N	LV
3	O-sho-o-saN	ɔʃɔ:sã	3	5	-	✓	o-o
4	I-k-kyu-u-saN	ɪkkju:ɹsã	3	6	k-k	✓	u-u
5	GeN-zo-o Ji-i-saN	genzɔ:jiɹsã	4	8	-	✓	o-o,i-i
6	Hyo-t-to-ko	hjo:ttɔkɔ	4	5	t-t	-	-

TW 2 (Tsuu) that has one long vowel, and TW 10 (Oyayubihime) that has no geminate consonants, vowel clusters or moraic nasals, were the easiest in both oral production and writing.

Now let us examine the way bilingual adults deleted and inserted mora, starting with consonants. Table 3.22 summarises deletion and insertion of consonants and vowels.

Table 3.22 Consonant Deletion and Insertion – Bilingual Adults – Character Names

TW	Oral production								Writing							
	Deletion				Insertion				Deletion				Insertion			
	Gem C		MN		Gem C		ON		Gem C		MN		Gem C		ON	
	Freq	%	Freq	%	Freq	%	Freq	%	Freq	%	Freq	%	Freq	%	Freq	%
1	2	16.7	0	0.0	0	0.0	2	16.7	4	33.3	0	0.0	0	0.0	2	16.7
2	0	0.0	0	0.0	0	0.0	0	0.0	0	0.0	0	0.0	0	0.0	0	0.0
3	0	0.0	0	0.0	0	0.0	0	0.0	0	0.0	0	0.0	2	16.7	4	33.3
4	6	50.0	1	8.3	0	0.0	3	25.0	3	25.0	0	0.0	5	41.7	2	16.7
5	0	0.0	0	0.0	1	8.3	1	8.3	0	0.0	1	8.3	2	16.7	2	16.7
6	2	16.7	0	0.0	2	16.7	0	0.0	7	58.3	0	0.0	5	41.7	0	0.0
7	0	0.0	0	0.0	0	0.0	0	0.0	0	0.0	0	0.0	0	0.0	0	0.0
8	2	16.7	0	0.0	0	0.0	0	0.0	2	16.7	0	0.0	0	0.0	2	16.7
9	0	0.0	0	0.0	0	0.0	0	0.0	0	0.0	0	0.0	0	0.0	0	0.0
10	0	0.0	0	0.0	0	0.0	0	0.0	0	0.0	0	0.0	0	0.0	0	0.0
Mean	1.2	10	0.1	0.8	0.3	2.5	0.6	5	1.6	13	0.1	0.8	1.4	12	1.2	10

Figures 3.12 and 3.13 show the breakdown of consonant deletions and insertions schematically.

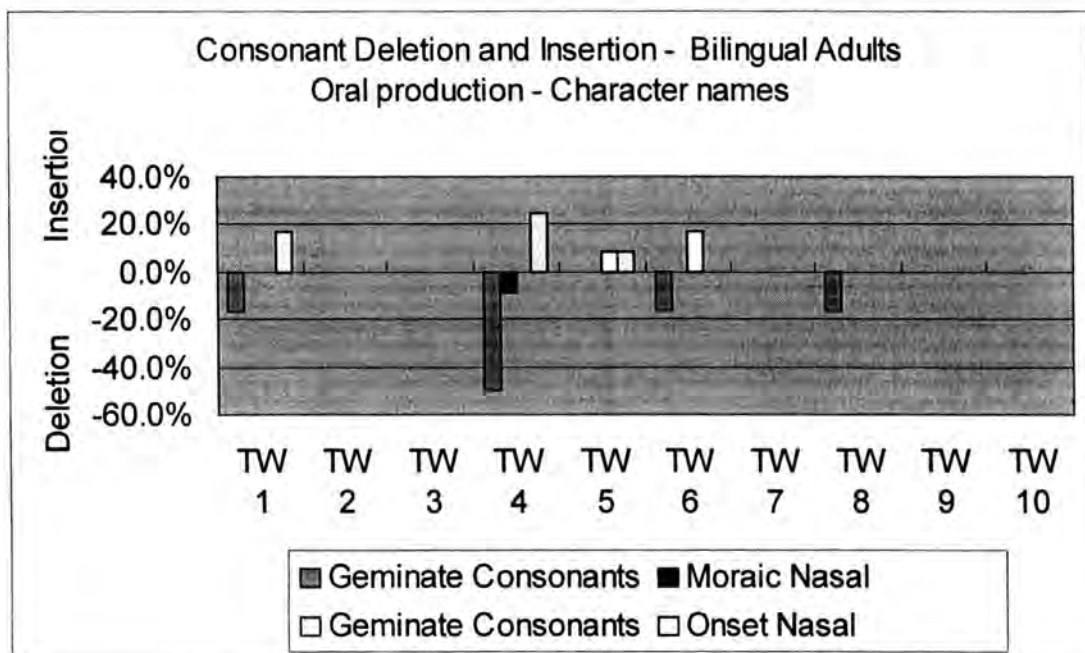

Figure 3.12 Consonant Deletion and Insertion – Oral Production

Geminate consonants were deleted in TW 1, 4, 6 and 8 and inserted in TW 5 and 6. There were no deletions or insertions in TW 2, 3, 7, 9 and 10.

Moraic nasal deletion occurred in TW 4 only. Onset nasal insertion occurred in TW 1, 4 and 5.

Comparing these results against those of English-dominant bilingual children, the pattern of similarities and differences emerge. For example, neither group made deletions or insertions in TW 2, 9 and 10. At the same time, TW1, 4, 5, 6 and 8 have been subject to deletions and insertions in both groups. We will compare these results in more details in later section of this chapter.

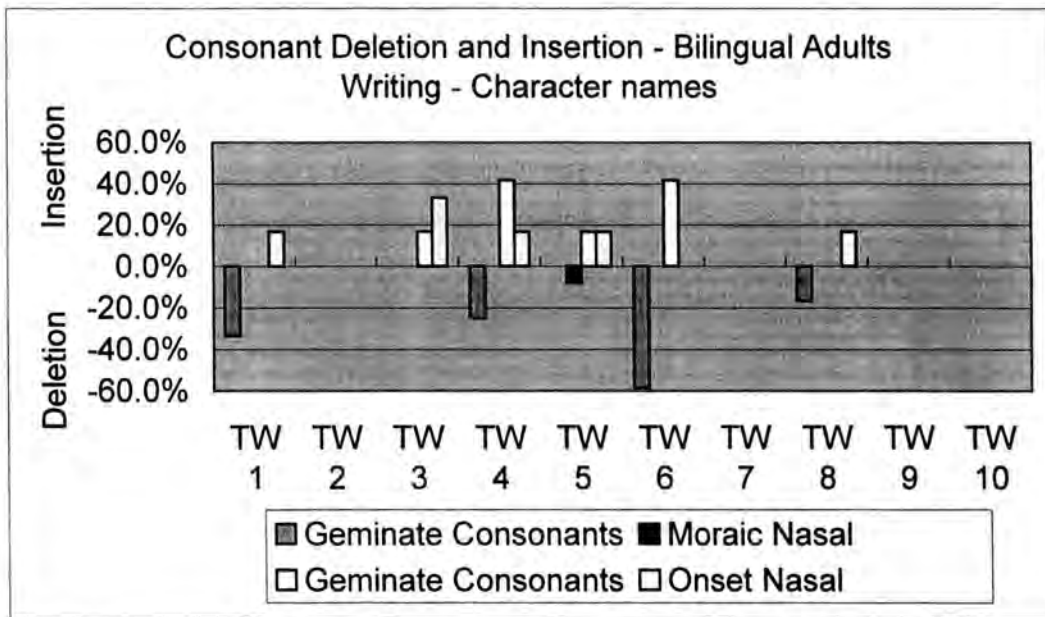

Figure 3.13 Consonant Deletion and Insertion - Writing

In writing, bilingual adults inserted and deleted consonants more frequently than in oral production. This was also the case with English-dominant bilingual children. In TW 3, 4 and 5, both geminate consonants and onset nasals were inserted. Geminate consonants were deleted in TW 1, 4, 6 and 8, as was the case in oral production. All

test words containing geminate consonants were, therefore, subject to consonant deletions in both oral production and in writing.

There were six test words that contained moraic nasals: TW 1, 3, 4, 5, 7 and 8, as shown in Table 3.23. While many of them were subject to consonant deletions and insertions, TW 7, 'Ojizoosan' was not affected. This was not the case with English-dominant bilingual children, and there were two cases on an onset nasal being inserted.

Table 3.23 Test Words Containing Moraic Nasals

TW	Name	IPA	No of σ	No of μ	Gem C	N	LV
1	Ki-c-cho-mu-saN	kɪttʃɔms̩ã	4	6	ts-ts	✓	-
3	O-sho-o-saN	ɔʃɔ:s̩ã	3	5	-	✓	o-o
4	l-k-kyu-u-saN	ɪkkju:s̩ã	3	6	k-k	✓	u-u
5	GeN-zo-o Ji-i-saN	genzɔ:ʃi:s̩ã	4	8	-	✓	o-o, i-i
7	O-ji-zo-o-sa-N	ɔdʒizɔ:s̩ã	5	6	-	✓	o-o
8	l-s-suN-bo-o-shi	ɪssu̯bɔ:ʃi	4	7	s-s	✓	o-o

Out of these six test words, TW 3 and TW 7 share the feature of having one moraic nasal and one long vowel, while others contain either geminate consonants or the second long vowel. TW 3 and 7 are therefore less complex in their structure. This explains the reason for no consonant deletions or insertions in case of TW 7. However, TW 3 was subject to both geminate consonant insertion and moraic nasal insertion.

This was also the case with English-dominant bilingual children. The only possible explanation for their apparent lack of consistency is that their IL is still unstable and their performance, in particular writing is immature. As Table 3.24 shows, there is some correlation between the oral production and writing results. This result

indirectly supports the argument of the bilingual adults' phonological competence being non-target.

Table 3.24 Consonant Deletion and Insertion – Bilingual Adults – Character Names

TW	Deletion		Insertion	
	Oral production %	Writing %	Oral production %	Writing %
1	16.7	33.3	16.7	16.7
2	0.0	0.0	0.0	0.0
3	0.0	0.0	0.0	50.0
4	58.3	25.0	25.0	58.3
5	0.0	8.3	16.7	33.3
6	16.7	58.3	16.7	41.7
7	0.0	0.0	0.0	0.0
8	16.7	16.7	0.0	16.7
9	0.0	0.0	0.0	0.0
10	0.0	0.0	0.0	0.0
Correlation Coefficient	0.529738075		0.669695185	

Now let us look at the results of vowel deletion and insertion, as summarised in Table 3.25.

Table 3.25 Vowel Deletion and Insertion - Bilingual Adults – Character Names

TW	Oral production				Writing			
	Deletion		Insertion		Deletion		Insertion	
	Freq	%	Freq	%	Freq	%	Freq	%
1	0	0.0	6	50.0	0	0.0	6	50.0
2	0	0.0	0	0.0	2	16.7	0	0.0
3	2	16.7	1	8.3	2	16.7	7	58.3
4	1	8.3	8	66.7	2	16.7	11	91.7
5	2	16.7	7	58.3	2	16.7	8	66.7
6	0	0.0	5	41.7	0	0.0	3	25.0
7	2	16.7	1	8.3	0	0.0	3	25.0
8	2	16.7	4	33.3	2	16.7	6	50.0
9	2	16.7	2	16.7	0	0.0	4	33.3
10	2	16.7	0	0.0	0	0.0	0	0.0
Mean	1.3	10.8	3.4	28.3	1.0	8.3	4.8	40.0

The results are presented in Figures 3.14 and 3.15.

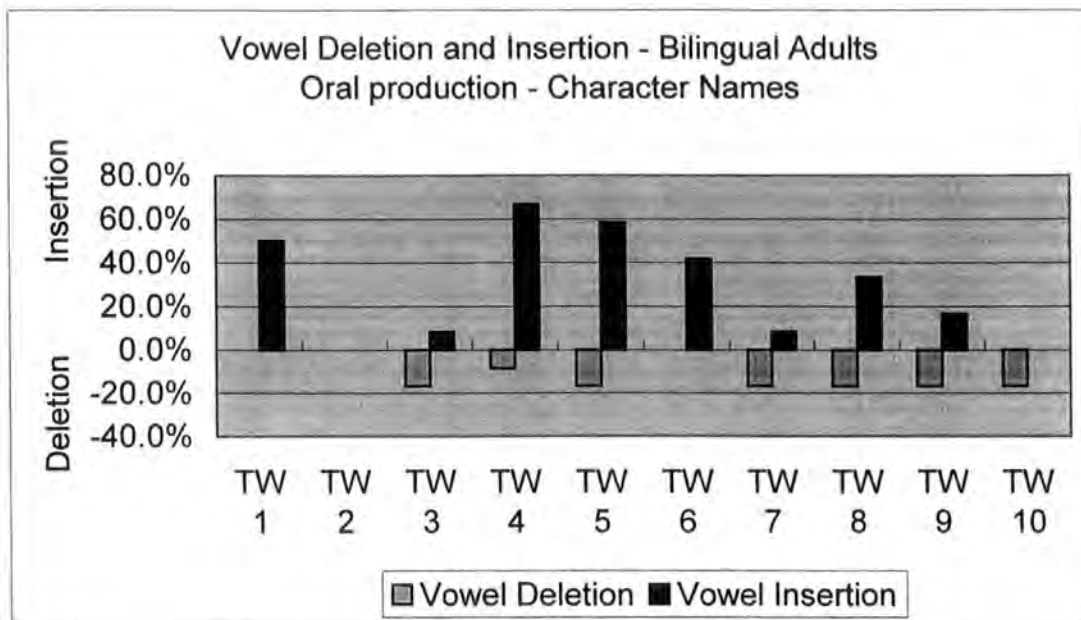

Figure 3.14 Vowel Deletion and Insertion – Oral Production

Overall, bilingual adults inserted vowels more often than they deleted them. This was also the case with English-dominant bilingual children.

There were no deletions or insertions in TW 2 (Tsuu) that consists of one syllable and two morae, as was the case with English-dominant bilingual children.

In oral production, TW 3, 4, 5, 7, 8 and 9 were subject to both the deletion and insertion of vowels. This resulted in the accidental production of correct mora count in some cases. For example, TW 9 showed 100% accuracy in mora count. On closer examination, however, it is clear that the counter-balancing of deletions and insertions achieved this accuracy. Recall the results from English-dominant bilingual children showing them deleting and inserting vowels in TW3, 7 and 8 only. This might have caused the bilingual children's data to look less favourable than their adult

counterparts' with respect to the mora count accuracy. We will see in more details in the subsequent section. Next, we look at the writing data.

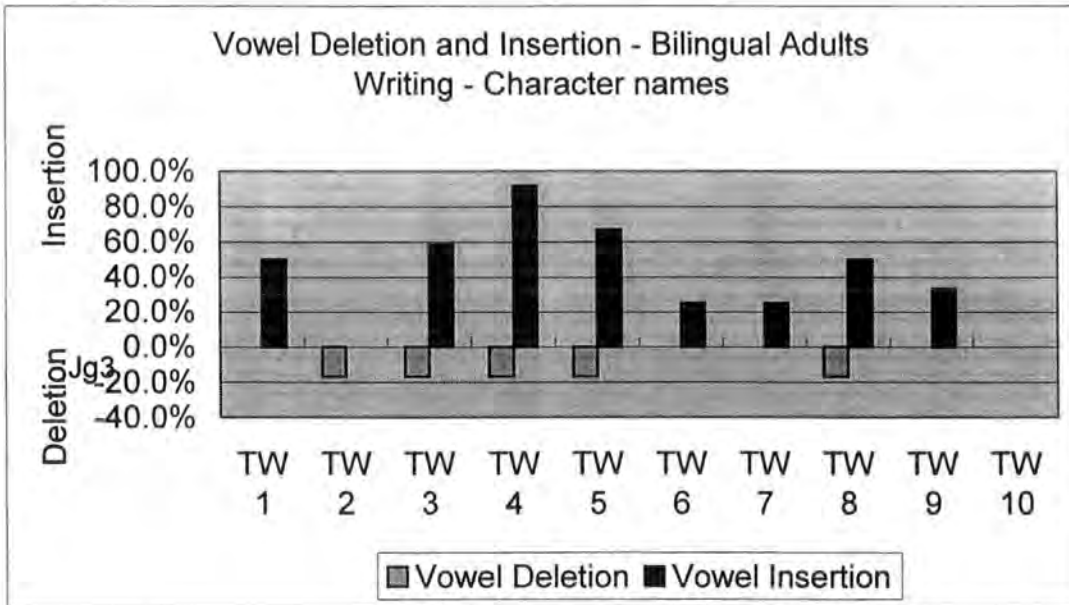

Figure 3.15 Vowel Deletion and Insertion - Writing

Again, bilingual adults showed a tendency to insert vowels rather than deleting them. There was no deletions or insertions in TW 10 (Oyayubihime), the control word. However, TW 2 (Tsuu) was subject to deletions. Recall the results from English-dominant bilingual children. They did not make any deletions or insertions in TW 10 in writing either. In TW 2, English-dominant bilingual children inserted a vowel, rather than deleting one. Overall, bilingual children showed a greater tendency to insert more and delete less vowels compared with their adult counterparts. Both bilingual adults and children made most vowel insertions in TW 4 (Ikkyuusan). Let us now compare the results of oral production and writing, as summarised in Table 3.26.

Table 3.26 Vowel Deletion and Insertion – Bilingual Adults – Character Names

TW	Deletion		Insertion	
	Oral production %	Writing %	Oral production %	Writing %
1	0.0	0.0	50.0	50.0
2	0.0	16.7	0.0	0.0
3	16.7	16.7	8.3	58.3
4	8.3	16.7	66.7	91.7
5	16.7	16.7	58.3	66.7
6	0.0	0.0	41.7	25.0
7	16.7	0.0	8.3	25.0
8	16.7	16.7	33.3	50.0
9	16.7	0.0	16.7	33.3
10	16.7	0.0	0.0	0.0
Correlation Coefficient	0.111111111		0.786181935	

In deletion, there is no correlation between oral production and writing. However, there is a strong correlation in vowel insertion.

Relative to mora count accuracy, there seem to be too many instances of deletions and insertions of vowels and consonants. Let us analyse the way bilingual adults substituted and/or compensated mora. First, the oral production data are summarised in Table 3.27.

Table 3.27 Compensatory Deletions & Insertions vs. Others – Bilingual Adults

Oral production

TW	Deletion and Insertion						Substitution and Compensation				
	Consonant Deletion		Consonant Insertion		Vowel Deletion	Vowel Insertion	Gem C with LV	LV with Gem C	Gem C with Gem C	LV with LV	MN with ON
	Gem C	MN	Gem C	ON							
1	2 16.7%	0 0.0%	0 0.0%	2 16.7%	0 0.0%	6 50.0%	2 16.7%	0 0.0%	0 0.0%	0 0.0%	0 0.0%
2	0 0.0%	0 0.0%	0 0.0%	0 0.0%	0 0.0%	0 0.0%	0 0.0%	0 0.0%	0 0.0%	0 0.0%	0 0.0%
3	0 0.0%	0 0.0%	0 0.0%	0 0.0%	2 16.7%	1 8.3%	0 0.0%	0 0.0%	0 0.0%	1 8.3%	0 0.0%
4	6 50.0%	1 8.3%	0 0.0%	3 25.0%	1 8.3%	8 66.7%	2 16.7%	0 0.0%	0 0.0%	0 0.0%	1 8.3%
5	0 0.0%	0 0.0%	1 8.3%	1 8.3%	2 16.7%	7 58.3%	0 0.0%	1 8.3%	0 0.0%	2 16.7%	0 0.0%
6	2 16.7%	0 0.0%	2 16.7%	0 0.0%	0 0.0%	5 41.7%	2 16.7%	0 0.0%	2 16.7%	0 0.0%	0 0.0%
7	0 0.0%	0 0.0%	0 0.0%	0 0.0%	2 16.7%	1 8.3%	0 0.0%	0 0.0%	0 0.0%	0 0.0%	0 0.0%
8	2 16.7%	0 0.0%	0 0.0%	0 0.0%	2 16.7%	4 33.3%	2 16.7%	0 0.0%	2 16.7%	0 0.0%	0 0.0%
9	0 0.0%	0 0.0%	0 0.0%	0 0.0%	2 16.7%	2 16.7%	0 0.0%	0 0.0%	0 0.0%	0 0.0%	0 0.0%
10	0 0.0%	0 0.0%	0 0.0%	0 0.0%	2 16.7%	0 0.0%	0 0.0%	0 0.0%	0 0.0%	0 0.0%	0 0.0%

The highlighted figures represent substitution or compensation. For example, in TW 1, there were two geminate consonants, which were replaced by two vowels. There were two onset nasal "insertions" but these were not related to any compensation, therefore, the figure is not highlighted.

The results are further presented schematically in Figures 3.16.

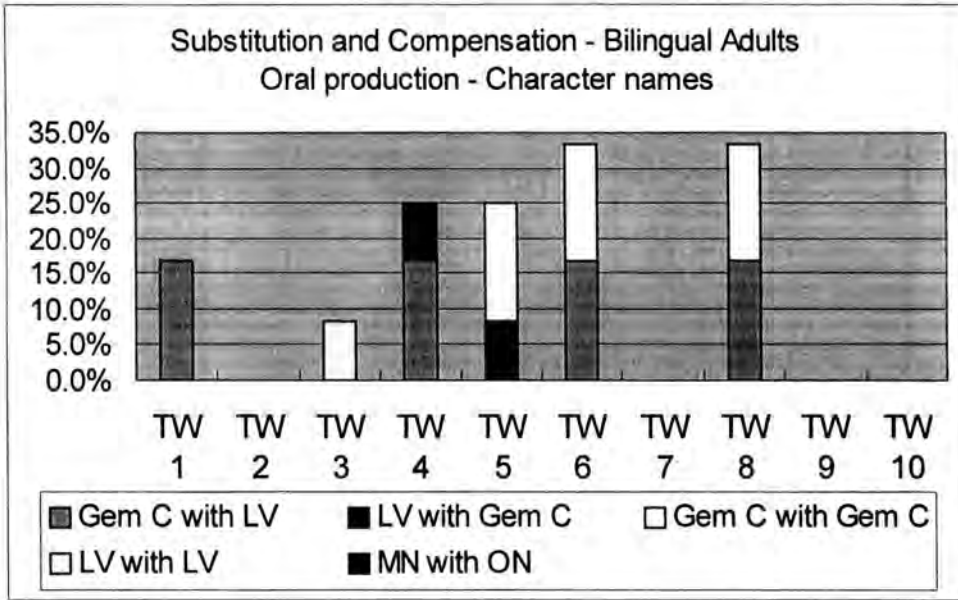

Figure 3.16 Substitution and Compensation – Oral Production

There was no substitution or compensation in TW 2, 7, 9 and 10. All test words that contained geminate consonants were subject to consonant deletion as we saw in the previous section. We now see that all four geminate consonants were indeed deleted and compensated for by vowel insertions.

Geminate consonants in TW 6 and 8 were also subject to geminate consonant substitution. For example, TW 6, 'Hyottoko' was changed into 'Hyotokko'. The same was observed in English-dominant bilingual children's data, in both TW 6 and 8, though to a lesser extent.

In TW 3 and 4, a long vowel was replaced by another long vowel. For example, TW 3 'Oshoosan' was changed into 'Oshosaan.' English-dominant bilingual children also substituted long vowels with another long vowels.

TW 5 'Genzoo Jiisan' was subject to long vowels being replaced by geminate consonants, 'Genzoo Jissan.' In all cases, it is evident that bilingual adults were trying

to preserve the mora count of the test words. This did not happen with English-dominant bilingual children.

Next, we examine the writing data, which is summarised in Table 3.28.

Table 3.28 Compensatory Deletions & Insertions vs. Others – Bilingual Adults

Writing

TW	Deletion and Insertion						Substitution and Compensation				
	Consonant Deletion		Consonant Insertion		Vowel Deletion	Vowel Insertion	Gem C with LV	LV with Gem C	Gem C with Gem C	LV with LV	MN with ON
	Gem C	MN	Gem C	ON							
1	4 33.3%	0 0.0%	0 0.0%	2 16.7%	0 0.0%	6 50.0%	4 33.3%	0 0.0%	0 0.0%	0 0.0%	0 0.0%
2	0 0.0%	0 0.0%	0 0.0%	0 0.0%	2 16.7%	0 0.0%	0 0.0%	0 0.0%	0 0.0%	0 0.0%	0 0.0%
3	0 0.0%	0 0.0%	2 16.7%	4 33.3%	2 16.7%	7 58.3%	0 0.0%	2 16.7%	0 0.0%	0 0.0%	0 0.0%
4	3 25.0%	0 0.0%	5 41.7%	2 16.7%	2 16.7%	11 91.7%	2 16.7%	2 16.7%	0 0.0%	3 25.0%	0 0.0%
5	0 0.0%	1 8.3%	2 16.7%	2 16.7%	2 16.7%	8 66.7%	0 0.0%	0 0.0%	0 0.0%	0 0.0%	0 0.0%
6	7 58.3%	0 0.0%	5 41.7%	0 0.0%	0 0.0%	3 25.0%	3 25.0%	0 0.0%	3 25.0%	0 0.0%	0 0.0%
7	0 0.0%	0 0.0%	0 0.0%	0 0.0%	0 0.0%	3 25.0%	0 0.0%	0 0.0%	0 0.0%	0 0.0%	0 0.0%
8	2 16.7%	0 0.0%	0 0.0%	2 16.7%	2 16.7%	6 50.0%	2 16.7%	0 0.0%	0 0.0%	0 0.0%	0 0.0%
9	0 0.0%	0 0.0%	0 0.0%	0 0.0%	0 0.0%	4 33.3%	0 0.0%	0 0.0%	0 0.0%	0 0.0%	0 0.0%
10	0 0.0%	0 0.0%	0 0.0%	0 0.0%	0 0.0%	0 0.0%	0 0.0%	0 0.0%	0 0.0%	0 0.0%	0 0.0%

The results are further presented schematically in Figure 3.17.

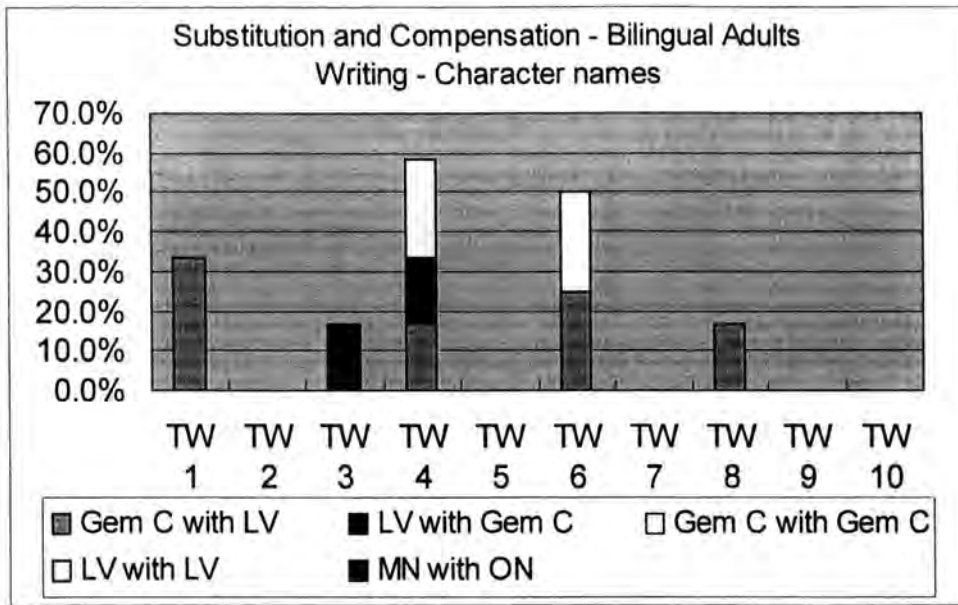

Figure 3.17 Substitution and Compensation - Writing

In writing, TW 1, 4, 6 and 8, which all contained geminate consonants were subject to substitution by long vowels. TW 3 'Oshoosan' has no geminate consonants subject to geminate consonant substitution. Thus, the long vowel 'o-o' was replaced by a geminate of 's-s' resulting in 'Oshossan.' This indicates that the bilingual adult was confused with long vowels and geminate consonants in orthographic representation, even though the same person was able to produce these orally. However, the test subject managed to preserve the total number of morae assigned to the word. English-dominant bilingual children also substituted geminate consonants with long vowels in TW 1, 4 and 8, but did not do so with TW 6. Instead, they shifted the position of geminate consonant, resulting in 'Hyottoko' becoming 'Hyotokko.'

3.3.1.4 Bilingual Children vs Bilingual Adults

Let us now compare the results from bilingual children and adults' data. As Japanese-dominant bilingual children made few errors, the data we are going to use

are English-dominant bilingual children's. The results of bilingual adults and children are compared in Table 3.29 and Figure 3.18.

Table 3.29 Mora Count Accuracy – Adults vs Children – Character Names

TW	Adults		Children (Eng-dom)	
	Oral production %	Writing %	Oral production %	Writing %
TW 1	66.7	50.0	100.0	100.0
TW 2	100.0	83.3	100.0	66.7
TW 3	91.7	41.7	50.0	50.0
TW 4	58.3	8.3	100.0	50.0
TW 5	41.7	33.3	33.3	50.0
TW 6	58.3	50.0	83.3	33.3
TW 7	75.0	75.0	33.3	66.7
TW 8	66.7	50.0	83.3	66.7
TW 9	100.0	66.7	100.0	100.0
TW 10	83.3	100.0	83.3	100.0
Correlation Coefficient	A vs C Recitation	0.306871476	A vs C Writing	0.564628276

The correlation coefficient for oral production indicates that there is little correlation between bilingual children and adults' data. In writing, however, a moderate correlation is indicated.

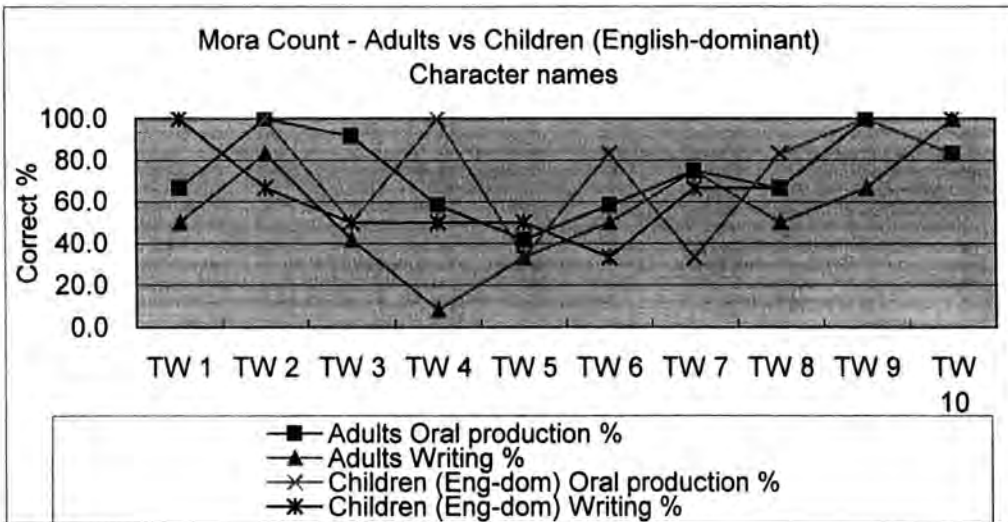

Figure 3.18 Mora Count – Adults vs Children

Figure 3.18 presents data from Table 3.30. It shows that bilingual children are more able to produce the target number of morae than their adult counterparts. As we have already established in previous sections that Japanese-dominant bilingual children were more accurate in mora count than English-dominant bilingual children, the order of competence in mora count is first Japanese-dominant bilingual children, then English-dominant bilingual children, and lastly the bilingual adults.

We now compare the results of consonant deletion, as summarised in Table 3.30.

Table 3.30 Consonant Deletion - Character Names - Adults vs Children

TW	Oral production		Writing	
	Adults %	Children %	Adults %	Children %
1	16.7	33.3	33.3	33.3
2	0.0	0.0	0.0	0.0
3	0.0	0.0	0.0	16.7
4	58.3	50.0	25.0	50.0
5	0.0	0.0	8.3	0.0
6	16.7	83.3	58.3	66.7
7	0.0	16.7	0.0	0.0
8	16.7	66.7	16.7	33.3
9	0.0	0.0	0.0	0.0
10	0.0	0.0	0.0	0.0
Mean	10.8	25.0	14.2	20.0
Correlation Coefficient	0.620736		0.912681	

There is a strong correlation in writing, but a medium correlation in oral production. These tendencies are seen in Figure 3.19.

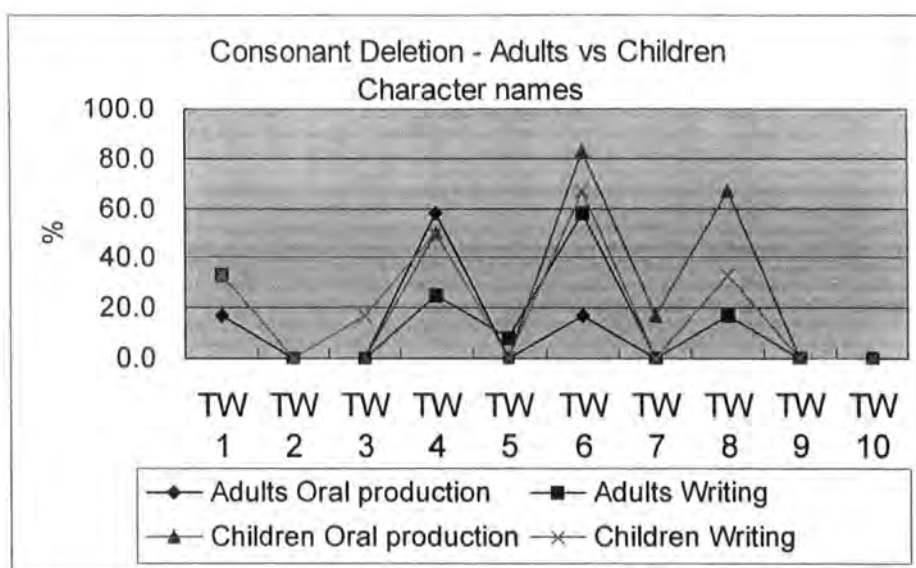

Figure 3.19 Consonant Deletion – Adults vs Children

English-dominant bilingual children on the whole deleted more consonants than their adult counterparts. Both bilingual children and adults performed better, i.e., deleted fewer consonants in writing than in oral production.

Table 3.31 compares the results of bilingual children and adults in consonant insertion.

Table 3.31 Consonant Insertion – Adults vs Children – Character Names

TW	Oral production		Writing	
	Adults %	Children %	Adults %	Children %
1	16.7	0.0	16.7	0.0
2	0.0	0.0	0.0	0.0
3	0.0	16.7	50.0	16.7
4	25.0	0.0	58.3	50.0
5	16.7	66.7	33.3	16.7
6	16.7	16.7	41.7	66.7
7	0.0	16.7	0.0	50.0
8	0.0	33.3	16.7	33.3
9	0.0	0.0	0.0	0.0
10	0.0	0.0	0.0	0.0
Mean	7.5	15.0	21.7	23.3
Correlation Coefficient	0.137046		0.505375	

As it was the case in consonant deletion, there is little correlation between English-dominant bilingual children and adults' data in oral production, while there is a medium correlation in writing.

As Figure 3.20 confirms, there seems to be little resemblance in the way bilingual children and adults insert consonants. The only common factors are 1) neither group inserted consonants in 2, 9 and 10 at all, 2) both groups tended to insert more in writing than in oral production.

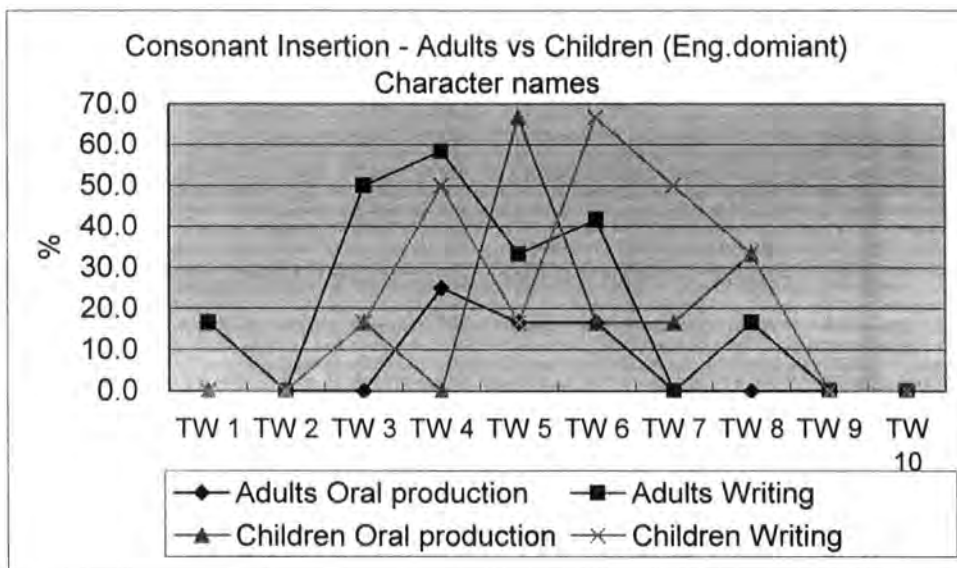

Figure 3.20 Consonant Insertion – Adults vs Children

Let us continue with the comparison with vowel deletion, which is summarised in Table 3.32.

Table 3.32 Vowel Deletion – Adults vs Children – Character Names

TW	Oral production		Writing	
	Adults %	Children %	Adults %	Children %
1	0.0	0.0	0.0	0.0
2	0.0	0.0	16.7	0.0
3	16.7	66.7	16.7	33.3
4	8.3	0.0	16.7	0.0
5	16.7	0.0	16.7	0.0
6	0.0	0.0	0.0	0.0
7	16.7	66.7	0.0	33.3
8	16.7	33.3	16.7	16.7
9	16.7	0.0	0.0	0.0
10	16.7	16.7	0.0	0.0
Mean	10.8	18.3	8.3	8.3
Correlation Coefficient	0.542186		0.124035	

There is a moderate correlation in oral production data, but there is no correlation in writing. Unlike was the case in consonant deletion and insertion, English-dominant bilingual children and adults showed a tendency to delete more vowels in oral production than in writing. Overall, English-dominant bilingual children deleted more vowels than their adult counterparts did.

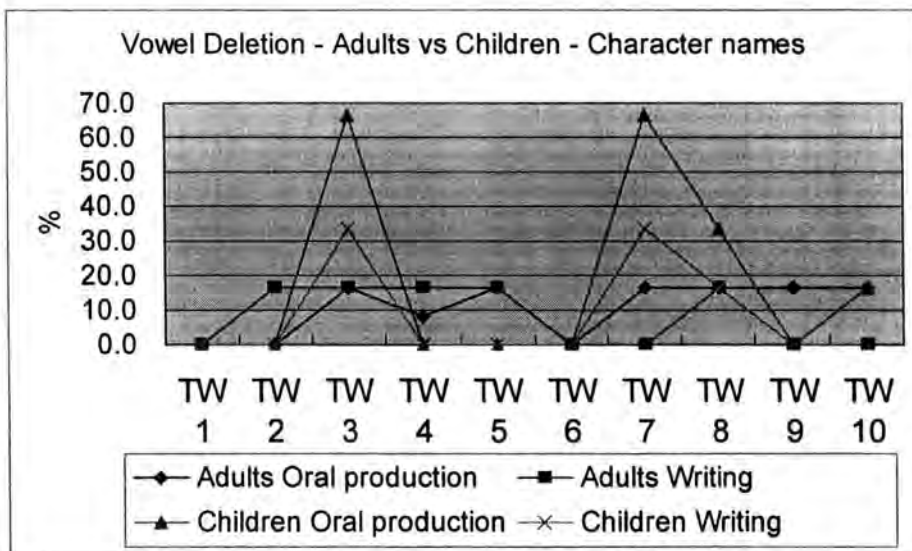

Figure 3.21 Vowel Deletion – Adults vs Children

Bilingual children deleted vowels in TW 3, 7, 8 and 10 in oral production and TW 3, 7 and 8 in writing. Neither group deleted vowels in TW 1 and 6. Apart from two factors: 1) a tendency to delete more in oral production, 2) no deletions in TW 1 and 6; there seems to be little resemblance in the way bilingual children and adults deleted vowels.

Let us now look at vowel insertion, as summarised in Table 3.33.

Table 3.33 Vowel Insertion – Adults vs Children – Character Names

TW	Oral production		Writing	
	Adults %	Children %	Adults %	Children %
1	50.0	16.7	50.0	16.7
2	0.0	0.0	0.0	16.7
3	8.3	8.3	58.3	16.7
4	66.7	25.0	91.7	50.0
5	58.3	33.3	66.7	25.0
6	41.7	33.3	25.0	33.3
7	8.3	8.3	25.0	33.3
8	33.3	41.7	50.0	41.7
9	16.7	0.0	33.3	0.0
10	0.0	0.0	0.0	0.0
Mean	28.3	16.7	40.0	23.3
Correlation Coefficient	0.749170		0.569928	

There are strong to moderate correlations in oral production and a medium to strong one in writing. As was the case in vowel deletion, the correlation in the oral production data is stronger than in writing. The results are presented in Figure 3.22.

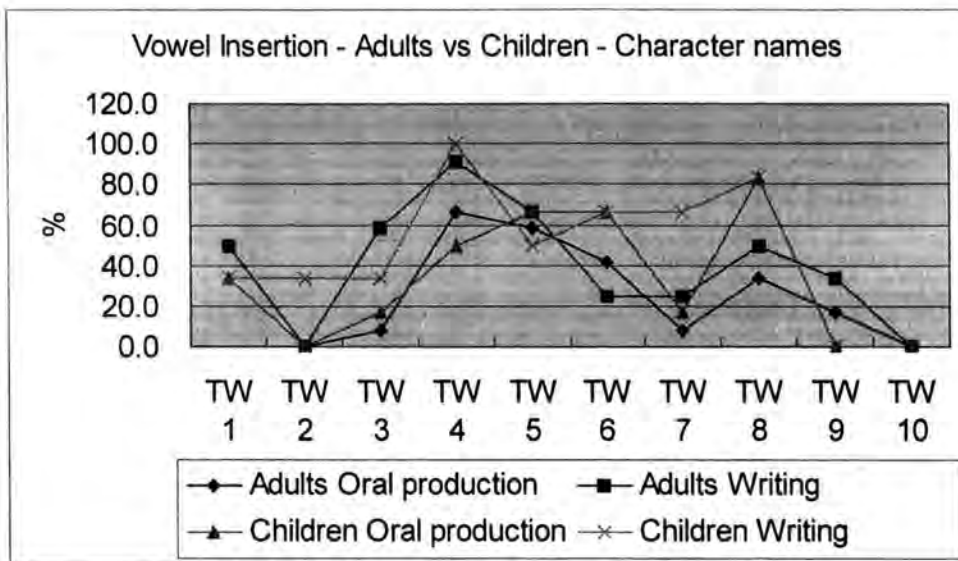

Figure 3.22 Vowel Insertion – Adults vs Children

On the whole, bilingual children inserted fewer numbers of vowels than their adult counterparts.

3.3.2 Word Familiarity and Phonological Competence

We have examined the way bilingual children and adults produced and wrote Japanese story character names in relation to the characteristics of their Japanese syllable template.

There were some patterns in their deployment of the syllable template. For example, they all showed a tendency to preserve mora count in test words. However, the strategy they employed, such as substituting geminate consonants with long vowels differed. Further more, the same syllable types do not always trigger the same strategies of deletion or insertion.

Why do bilingual children and adults failed to achieve native competence in Japanese phonology? The reason behind this may be the familiarity or associability of test words.

In the following section, we examine the familiarity of test words and their performance. All participants, including children in the control group had been asked if they had known, had heard of the test words.

3.3.2.1 Control Group

Table 3.34 summarises the results of the familiarity survey.

Table 3.34 Word Familiarity – Control Group – Character Names

TW	" I Know"		"Vaguely remember"		"Don't know"	
	Freq	%	Freq	%	Freq	%
1	6	85.7	1	14.3	0	0
2	5	71.4	2	28.6	0	0
3	7	100	0	0	0	0
4	7	100	0	0	0	0
5	5	71.4	2	28.6	0	0
6	7	100	0	0	0	0
7	7	100	0	0	0	0
8	6	85.7	1	14.3	0	0
9	6	85.7	1	14.3	0	0
10	7	100	0	0	0	0

Children who had spent the first six to seven years in Japan were familiar with all story character names used in Task 1. TW 5 ('Genzoo Jiisan') was the name that comes up in the third grade textbook of Japanese. Being second graders, not all children knew this name, but they could associate it as 'Jiisan', which means a grandfather, or an old man and a common word in story books. TW 2 ('Tsuu') was not readily recognised by all at first, but it was known as an alternative name of 'O-tsuu' and soon the remaining two children made the association. Recall the results of the oral production and writing tasks. All children in the control group produced the target number of morae, and they made no insertions or deletions. These results are

evidence to support the claim that there is a correlation between the word familiarity and the task performance.

3.3.2.2 Bilingual Children

The results of the same word familiarity survey is summarised by dominant language sub-category in Table 3.35.

Table 3.35 Word Familiarity – Bilingual Children - Character Names

TW	"I Know"		"Vaguely remember"		"Don't know"	
	English-dominant	Japanese-dominant	English-dominant	Japanese-dominant	English-dominant	Japanese-dominant
1	3 50.00%	3 50.00%	2 33.33%	3 50.00%	1 16.67%	0 0.00%
2	1 16.67%	2 33.33%	4 66.67%	4 66.67%	1 16.67%	0 0.00%
3	1 16.67%	2 33.33%	2 3.00%	4 66.67%	3 50.00%	0 0.00%
4	2 33.33%	5 83.33%	1 16.67%	1 16.67%	3 50.00%	0 0.00%
5	0 0.00%	0 0.00%	5 83.33%	5 83.33%	1 16.67%	1 16.67%
6	1 16.67%	4 66.67%	3 50.00%	2 33.33%	2 33.33%	0 0.00%
7	0 0.00%	4 66.67%	3 50.00%	2 33.33%	3 50.00%	0 0.00%
8	2 33.33%	6 100.00%	2 33.33%	0 0.00%	2 33.33%	0 0.00%
9	1 16.67%	4 66.67%	2 33.33%	2 33.33%	3 50.00%	0 0.00%
10	1 16.67%	5 83.33%	4 66.67%	1 16.67%	1 16.67%	0 0.00%

The Japanese-dominant bilingual children knew or vaguely remembered most names, with the exception of TW 5 ('Genzoo Jiisan'). English-dominant children, on the other hand, found many words unknown. These results seem to represent the amount of exposure children had to Japanese children's stories in their early years.

As the most significant difference is in the “Don’t know” numbers, these are used for comparison against the oral production and writing mora count results. Since Japanese-dominant children had produced a high percentage of correct mora count in Task 1, only English-dominant children’s data are analysed. Table 3.36 summarises the word familiarity and mora count accuracy for English-dominant children.

Table 3.36 Word Familiarity and Mora Count Accuracy – English-dominant

TW	Don't Know %	Oral production Correct %	Writing Correct %
1	16.7	100.0	100.0
2	16.7	100.0	66.7
3	50.0	50.0	50.0
4	33.3	100.0	50.0
5	83.3	33.3	50.0
6	16.7	83.3	33.3
7	33.3	33.3	66.7
8	16.7	83.3	66.7
9	16.7	100.0	100.0
10	16.7	83.3	100.0
Correlation Coefficient		-0.758585	-0.454257

Table 3.36 shows that the word familiarity in terms of “Don’t know” and the oral production results have a strong inverse correlation. However, there seem to be little to moderate correlation between “Don’t know” and the writing results. It is possible that the word familiarity is the missing factor that explains the seemingly erratic performance in mora counting for the character name test. The reason for the writing results not being strongly correlated with word familiarity may be that there is a further orthographic interference. English-dominant bilingual children were less competent in transcribing words than they could perceive or orally produce.

These results are presented in Figures 3.23 and 3.24.

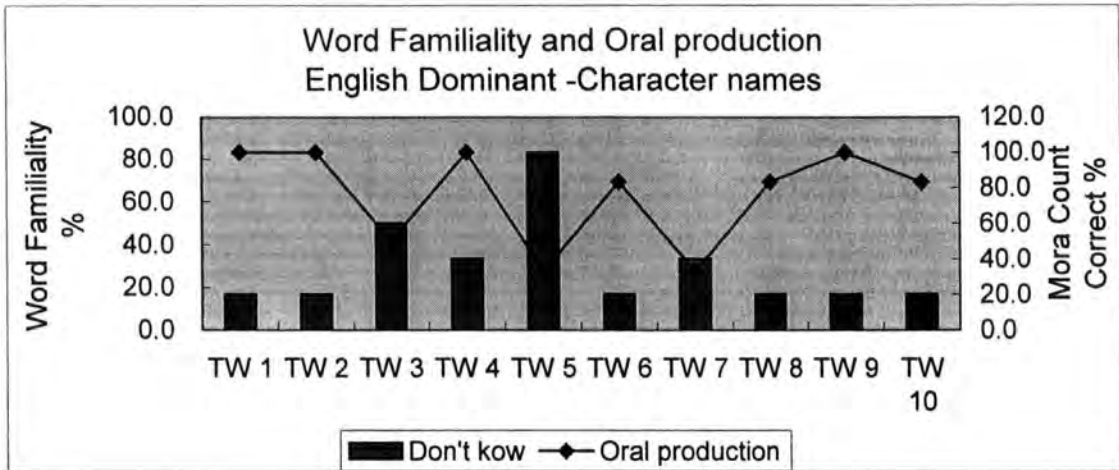

Figure 3.23 Word Familiarity and Oral Production

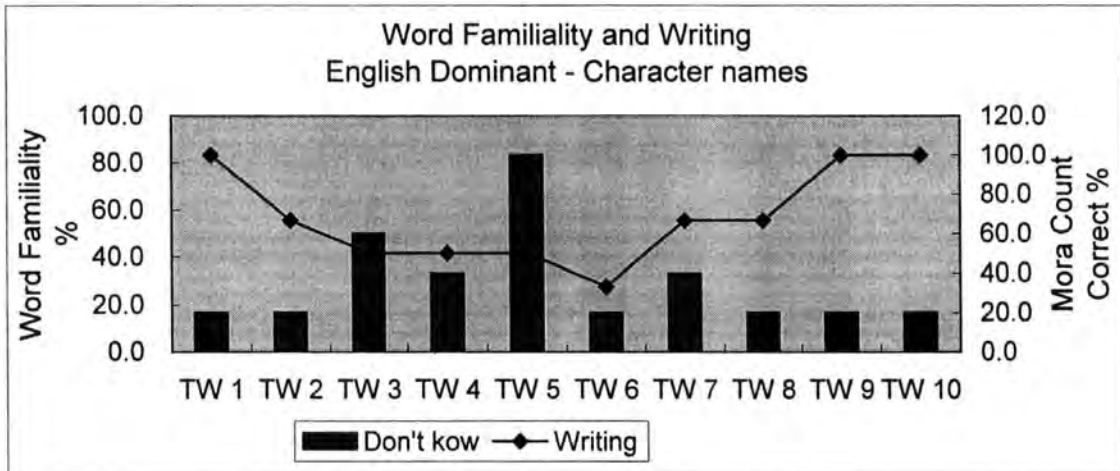

Figure 3.24 Word Familiarity and Writing

3.3.2.3 Bilingual Adults

Bilingual adults' word familiarity survey results are summarised in Table 3.37.

Table 3.37 Familiarity with the Task Words – Bilingual Adults – Character Names

TW	" I Know"	"Vaguely remember"	"Don't know"
1	2 16.67%	5 41.67%	5 41.67%
2	3 25.00%	7 58.33%	2 16.67%
3	4 33.33%	5 41.67%	3 25.00%
4	1 8.33%	6 50.00%	5 41.67%
5	0 0.00%	2 16.67%	10 83.33%
6	1 8.33%	5 41.67%	6 50.00%
7	4 33.33%	4 33.33%	4 33.33%
8	5 41.67%	4 33.33%	3 25.00%
9	2 16.67%	6 50.00%	4 33.33%
10	2 16.67%	7 58.33%	3 25.00%

Again, the column showing "Don't know" figures are taken for further analysis, which is summarised in Table 3.38.

Table 3.38 Word Familiarity and Correct Mora Count

TW	Don't Know %	Oral production Correct %	Writing Correct %
1	41.7	66.67	50.00
2	16.7	100.00	83.33
3	25.0	91.67	41.67
4	41.7	58.33	8.33
5	83.3	41.67	33.33
6	50.0	58.33	50.00
7	33.3	75.00	75.00
8	25.0	66.67	50.00

9	33.3	100.00	66.67
10	25.0	83.33	100.00
Correlation Coefficient		-0.80738	-0.51755

A strong inverse correlation is seen between the word familiarity and oral production results, while there is a moderate inverse correlation with the writing results. These results are shown in Figures 3.25 and 3.26.

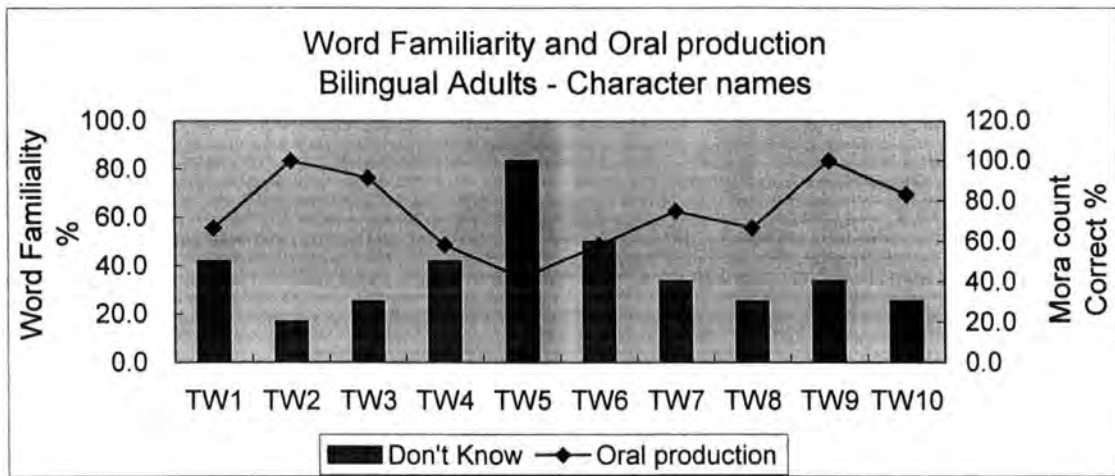

Figure 3.25 Word Familiarity and Oral Production

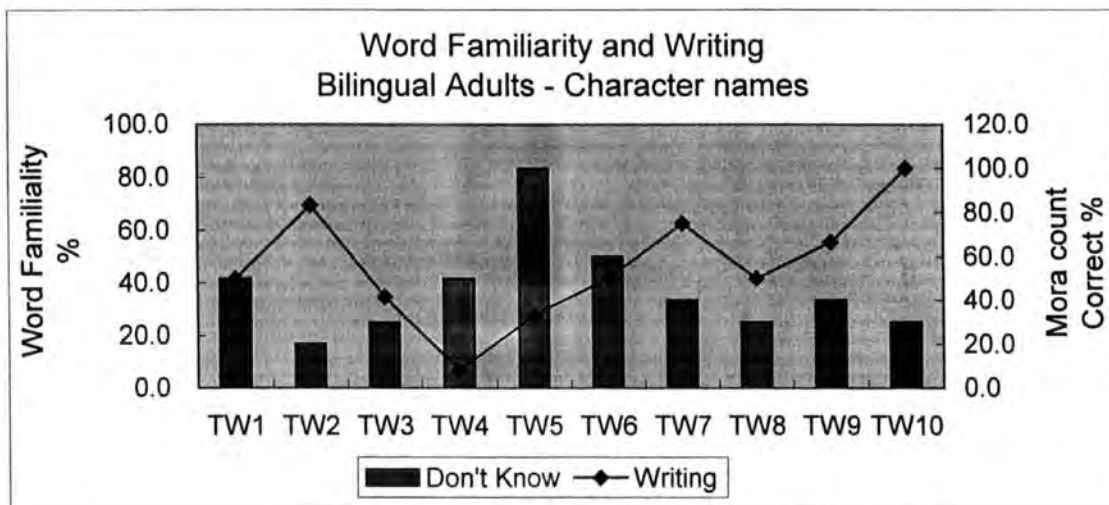

Figure 3.26 Word Familiarity and Writing

We have seen that there is a strong correlation in the word familiarity and accuracy in the oral production and writing of mora. Have they acquired the phonological rules that result in correct mora assignment? To investigate this further we can consider how learners treat borrowed words, as they have to use a system and can rely less on familiarity.

3.3.3 English Place Names as Loanwords

With data from a task that examines the way participants handle loanword formation using English place names, we attempt to analyse further their phonological competence. The phonological rules of Japanese that also govern the loanword formation generate several acceptable versions of the original words. Such varieties of output were accepted as the native target by the control subjects. However, for the purpose of this study, the most commonly produced number of mora by the control subjects was taken as the benchmark.

3.3.3.1 Control Group

The adults and children in the control group provided the benchmark versions of pronunciation and writing of English place names. There were some variations in pronunciation. For example, the latter part of “Newcastle” would be pronounced as /kjassuru/ or /kassuru/. These changes were taken into consideration when the results of Task 2 were analysed. Table 3.39 shows the possible variations in translation of English place names.

Table 3.39 Variations in Pronunciation

TW	Name	Version 1	μ	Version 2	μ	Version 3	μ
1	Newcastle	njʊ:kjassʊrʊ	6	njʊ:kɑ:sʊrʊ	6	njʊ:kassʊrʊ	6
2	Richmond	rɪttʃɪmɔndɔ	6				
3	Basingstoke	bɛɪdʒɪŋʊsʊtɔ:kʊ	9	bɛɪdʒɪnsʊtɔ:kʊ	8	bɛ:dʒɪnsʊtɔ:kʊ	8

4	Scotland	sʊkɔttɔrɔndɔ	7			
5	Tunbridge	tambʊrɪddʒɪ	6	tɔmbʊrɪddʒɪ	6	
6	Stratford	sʊtɔrɔttɔfɔ:dɔ	8	sʊtɔrɔtɔfɔ:dɔ	7	
7	Banbury	bambʊrɪ:	5	bambar:	5	
8	Darlington	dɑ:rɪŋtɔn	7	dɑ:rɪntɔn	6	
9	Oxford	ɔkkʊsʊfɔ:dɔ	7	ɔkʊsʊfɔ:dɔ	6	
10	Bristol	bʊrɪsʊtɔrʊ	5	bʊrɪsʊtʊ rʊ	5	

Differences are found not only in phones, of course, but also the total numbers of morae. For example, while the majority of native Japanese speakers interviewed produced nine and seven morae in Test Words 3 and 8, respectively, a small number of them produced eight and six morae respectively. The difference appears to be in the interpretation of /g/ or '-ing' in the English spelling. Even children who had been new comers to the UK and had little exposure to English were familiar with the pronunciation of '-ing' as [ɪŋ] form as in words like 'going.' Some common verbs in present continuous form are generally turned into Japanese as 'i-n-gu,' by shifting the coda consonant /g/ to onset position, and inserting a vowel to form a new syllable. These words are widely used in Japanese as borrowed words. For example, words such as 'going,' 'swimming,' 'shopping' and 'singing' receive this treatment. The monolingual children in the control group were able to apply their Japanese phonological rules to these non-native place names, under the influence of the English spelling.

Being residents of the North East of the UK, Darlington was a familiar name to the most participants, while none of them had heard of Basingstoke, and hence did not know how the word might be pronounced by native English speakers. Initially, all participants seemed to have influenced by the English spelling. Children seemed to be influenced by their parents (both parents and their children were in the respective control groups). For both TW 3 and 8, children of the parents who produced one lesser

mora did so themselves. In the case of TW 6 and TW 9, two participants deleted geminate consonants resulting in a fewer number of morae than the norm. They were produced by two intermediate level English speakers, showing the influence of their L2 on their native language loanword formation. Overall, new arrivals to the UK and those who had a lower proficiency level in English tend to rely purely on the English spelling for Japanese pronunciation.

The summary of number of morae produced by the control group is shown in Table 3.40.

Table 3.40 Percentage of Standard Numbers of Morae Produced

TW	Name	Adults (16 subjects)				Children (7 subjects)			
		No of μ	Freq	No of μ	Freq	No of μ	Freq	No of μ	Freq
1	Newcastle	6	16			6	7		
2	Richmond	6	16			6	7		
3	Basingstoke	9	14	8	2	9	6	8	1
4	Scotland	7	16			7	7		
5	Tunbridge	6	16			6	7		
6	Stratford	8	14	7	2	8	7		
7	Banbury	5	16			5	7		
8	Darlington	7	12	6	4	7	6	6	1
9	Oxford	7	14	6	2	7	7		
10	Bristol	5	16			5	7		
		93.75%		6.25%		97.14%		2.86%	

3.3.3.2 Bilingual Children

The results of mora count by the bilingual children are summarised in Table 3.41. The table shows the number of children hitting the target number of morae in test words and corresponding percentages. Bilingual children are, as before, grouped into 'English-dominant' and 'Japanese-dominant.'

Table 3.41 Mora Count Accuracy - Bilingual Children – Place Names

TW	English-dominant				Japanese-dominant			
	Reading		Writing		Reading		Writing	
	Freq	%	Freq	%	Freq	%	Freq	%
1	5	83.3	5	83.3	6	100	6	100
2	6	100	5	83.3	6	100	6	100
3	2	33.3	3	50	2	33.3	0	0
4	5	83.3	4	66.7	6	100	6	100
5	5	83.3	5	83.3	6	100	6	100
6	6	100	5	83.3	6	100	6	100
7	5	83.3	6	100	6	100	6	100
8	1	16.7	4	66.7	5	83.3	4	66.7
9	3	50	5	83.3	6	100	6	100
10	6	100	5	83.3	6	100	6	100
Mean	4.4	73.33	4.7	78.33	5.5	91.67	5.2	86.67
Correlation Coefficient	0.623002465				0.996710517			

As it was the case with Character Names, overall Japanese-dominant children were more accurate in counting mora than their English-dominant counterparts. With respect to TW3 (Basingstoke) and TW 8 (Darlington), Japanese-dominant bilingual children did not score 100%. Japanese-dominant bilingual children treated these words in the way some monolingual people in the control group did; less influenced by the English spelling but interpreting the English pronunciation more accurately. The result indicates two things; 1) the Japanese loanword formation rules depend on the convention of using the spelling of the original words, 2) children brought up bilingually lack some of these information, use their knowledge in English in applying the Japanese loanword formation rules.

There was a strong correlation between reading and writing results in both subcategories of bilingual children, but particularly so in those of Japanese-dominant children.

The results of bilingual children are presented schematically in Figure 3.27 and 3.28.

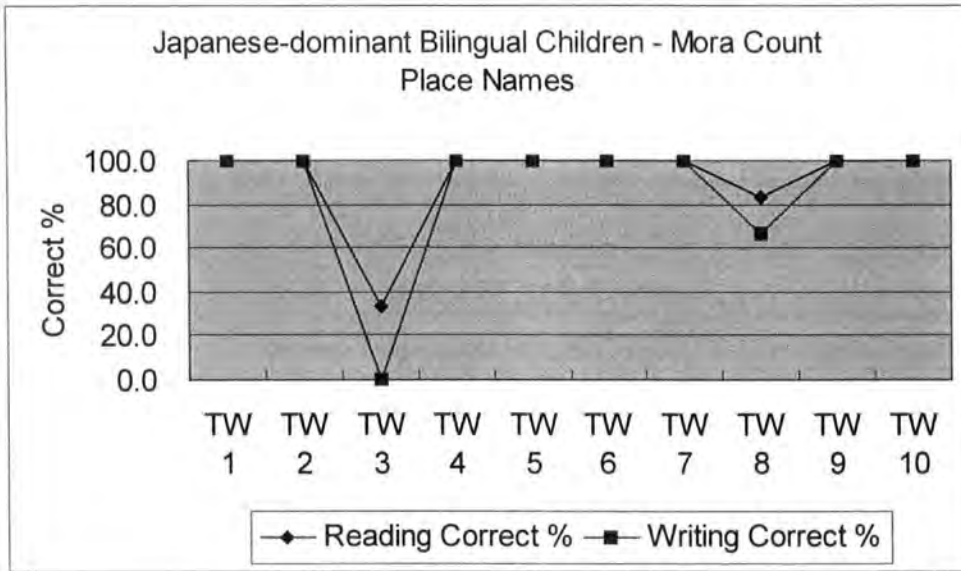

Figure 3.27 Mora Count - JCBC

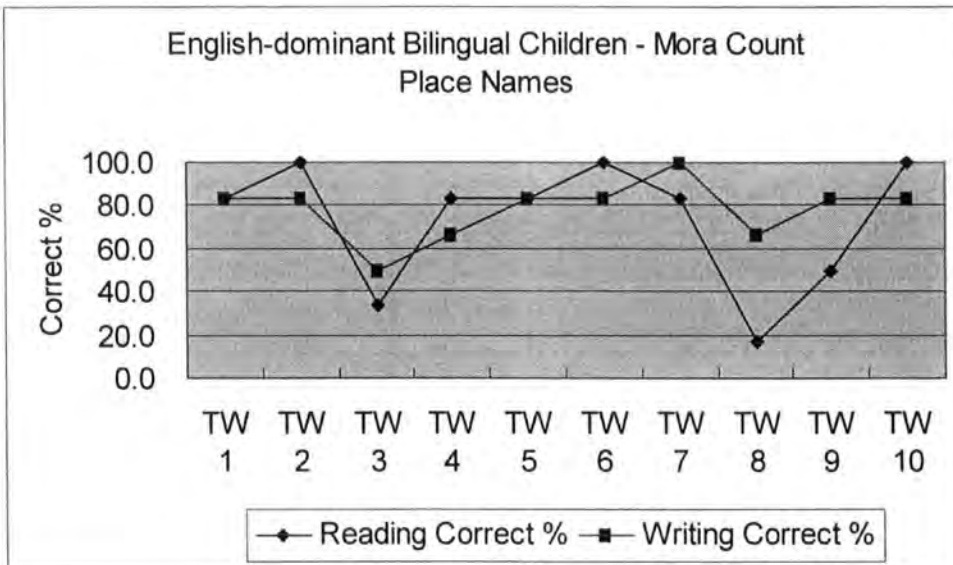

Figure 3.28 Mora Count - EDBC

While TW 2, 4, 5, 6 and 7 were most accurately produced in terms of mora count, TW 3 (Basingstoke) and TW 8 (Darlington) caused a great difficulty in both reading and writing with both Japanese-dominant and English-dominant bilingual children.

We next examine the mora count deviation as summarised in Table 3.42.

Table 3.42 Mora Count Deviation – Bilingual Children – Place Names

TW	English-dominant		Japanese-dominant	
	Reading	Writing	Reading	Writing
1	-0.17	-0.17	0	0
2	0	-0.17	0	0
3	-0.67	-0.83	-0.67	-1
4	-0.17	-0.33	0	0
5	0.17	-0.17	0	0
6	0	-0.17	0	0
7	0.17	0	0	0
8	-0.83	-0.33	-0.17	-0.33
9	-0.5	-0.17	0	0
10	0	0.17	0	0
Correlation coefficient	0.655779747		0.996710517	

Correlation coefficients indicate that there is a high correlation between reading and writing results. The results are presented in Figures 3.29.

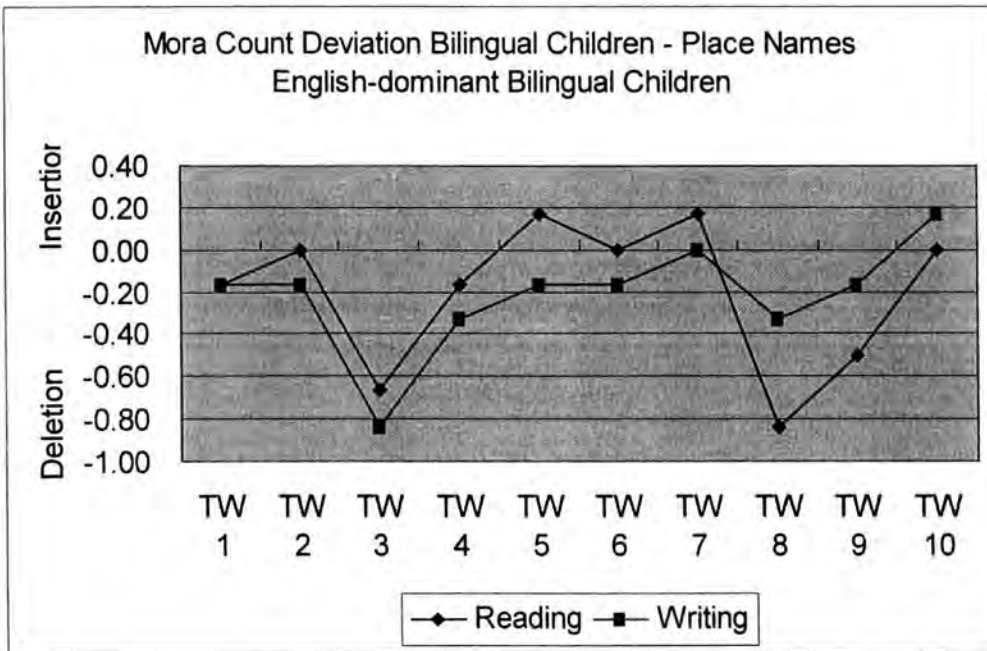

Figure 3.29 Mora Count Deviation – Place Names

From Figure 3.29, we observe that bilingual children showed a tendency to delete morae in TW 3 (Basingstoke) and TW 8 (Darlington).

Darlington was a familiar place name to all bilingual children but Basingstoke was not. While the majority of the control group opted for the longer version of mora sequence for these words reflecting the orthographic influence, bilingual children seemed to be more influenced by the original English pronunciation where the /g/ sounds are softer than Japanese version of /ngu/.

Let us now examine what constitutes such mora count deviation. First, we look at consonant deletion and insertion. The results are summarised in Table 3.43.

Table 3.43 Consonant Deletion and Insertion – Bilingual Children – Place Names

TW	English-dominant				Japanese-dominant			
	Deletion		Insertion		Deletion		Insertion	
	Read %	Write %	Read %	Write %	Read %	Write %	Read %	Write %
1	50.0	33.3	0.0	0.0	0.0	0.0	0.0	0.0
2	16.7	16.7	0.0	0.0	0.0	0.0	0.0	0.0
3	0.0	33.3	0.0	0.0	50.0	66.7	0.0	0.0
4	16.7	33.3	0.0	0.0	0.0	0.0	16.7	0.0
5	0.0	16.7	16.7	0.0	0.0	0.0	0.0	0.0
6	16.7	16.7	0.0	0.0	0.0	0.0	0.0	0.0
7	0.0	0.0	16.7	0.0	0.0	0.0	0.0	0.0
8	16.7	83.3	0.0	0.0	0.0	33.3	0.0	0.0
9	50.0	66.7	16.7	0.0	0.0	0.0	0.0	0.0
10	0.0	0.0	0.0	0.0	0.0	0.0	0.0	0.0
Mean	16.7	30.0	5.0	0.0	5.0	10.0	1.7	0.0
Correlation Coefficient	0.53480552		N/A		0.88498465		N/A	

No bilingual child inserted any consonants in writing. None made any deletions or insertions in TW 10 (Bristol), the control word.

Japanese-dominant bilingual children deleted consonants in high percentage, 50.0% in reading and 66.7% in writing in TW 3. In TW 8, 33.3% of them deleted

consonants. Both TW 3 (Basingstoke) and TW 8 (Darlington) contained '-ing' in them. TW 3, Basingstoke is a relatively unfamiliar name to all bilingual children and therefore, on hearing the native pronunciation, they decoded information with the influence of their English. TW 8, Darlington, on the other hand, was a familiar name to all bilingual children being the place name in the North East of England. Most English-dominant children (83.3%) deleted the consonant in writing. The large difference in the results of 16.7 % in reading and 83.3% in writing by English-dominant children indicates that there is a mismatch in oral and orthographic production. The disparity between the Japanese-dominant and English-dominant children with reference to TW 3 and TW 8 may be due to the influence of their L2 rather than L1. Japanese-dominant children seem to be applying their English syllable template to TW 3, which is an unfamiliar English name, but applying their Japanese syllable template to TW 8, which is a familiar English name and they have heard adult Japanese speakers mention them. English-dominant children seem to be more cautious with the unfamiliar English name that is to be translated into Japanese, and over generalised Japanese phonological rules by inserting vowels after all consonants.

On the whole, bilingual children made more consonant deletions than consonant insertions.

The results are presented schematically in Figures 3.30 and 3.31.

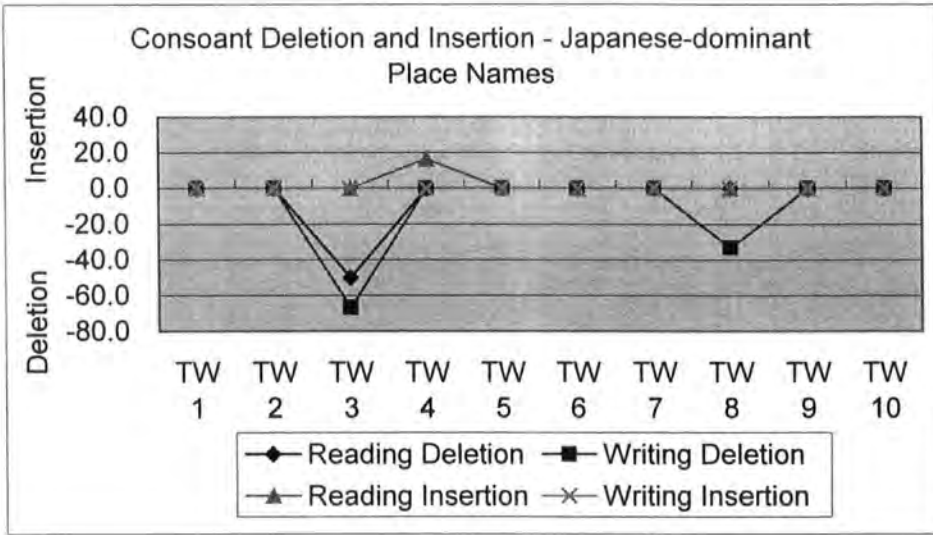

Figure 3.30 Consonant Deletion and Insertion JDBC

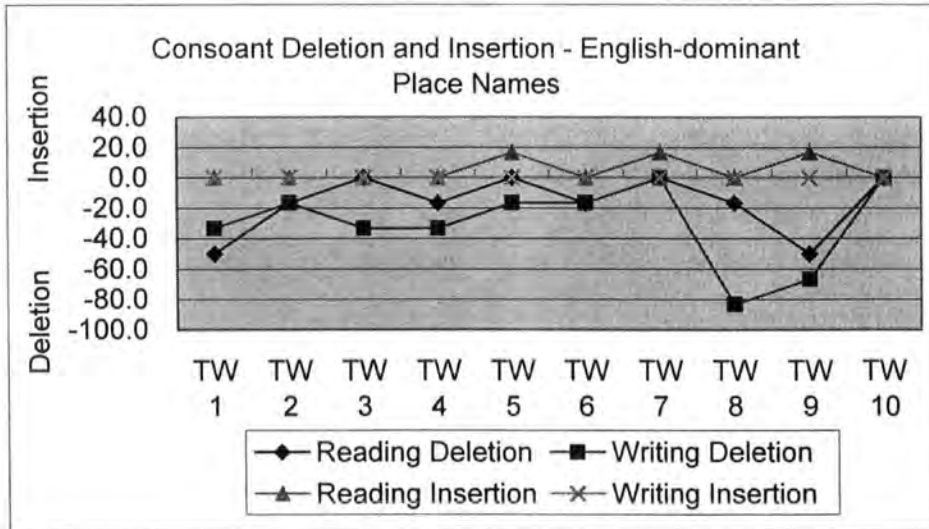

Figure 3.31 Consonant Deletion and Insertion - EDBC

Next, we look at the way bilingual children deleted and inserted vowels. The results are summarised in Table 3.44.

Table 3.44 Vowel Deletion and Insertion – Bilingual Children – Place Names

TW	English-dominant				Japanese-dominant			
	Deletion		Insertion		Deletion		Insertion	
	Read %	Write %	Read %	Write %	Read %	Write %	Read %	Write %
1	0.0	0.0	33.3	16.7	0.0	0.0	0.0	0.0
2	0.0	0.0	16.7	0.0	0.0	0.0	0.0	0.0
3	66.7	50.0	0.0	16.7	83.3	66.7	0.0	0.0
4	0.0	0.0	0.0	0.0	0.0	0.0	0.0	0.0
5	0.0	0.0	0.0	0.0	0.0	0.0	0.0	0.0
6	0.0	0.0	16.7	0.0	0.0	0.0	0.0	0.0
7	0.0	0.0	0.0	0.0	0.0	0.0	0.0	0.0
8	66.7	83.3	0.0	0.0	16.7	33.3	0.0	0.0
9	50.0	0.0	33.3	0.0	0.0	0.0	0.0	0.0
10	50.0	0.0	0.0	16.7	0.0	0.0	0.0	0.0
Mean	23.3	13.3	10.0	5.0	10.0	10.0	0.0	0.0
Correlation Coefficient	0.71807863		0.05455447		0.96000145		N/A	

There were no insertions made by Japanese-dominant bilingual children, but they deleted vowels in TW3 and TW8. While there was a strong correlation between the reading and writing results in vowel deletion, there was no correlation in vowel insertion results. Correlation coefficients indicate that there are strong correlation between reading and writing data in deletion, but no correlation in insertion.

The results are presented schematically in Figure 3.32 and 3.33.

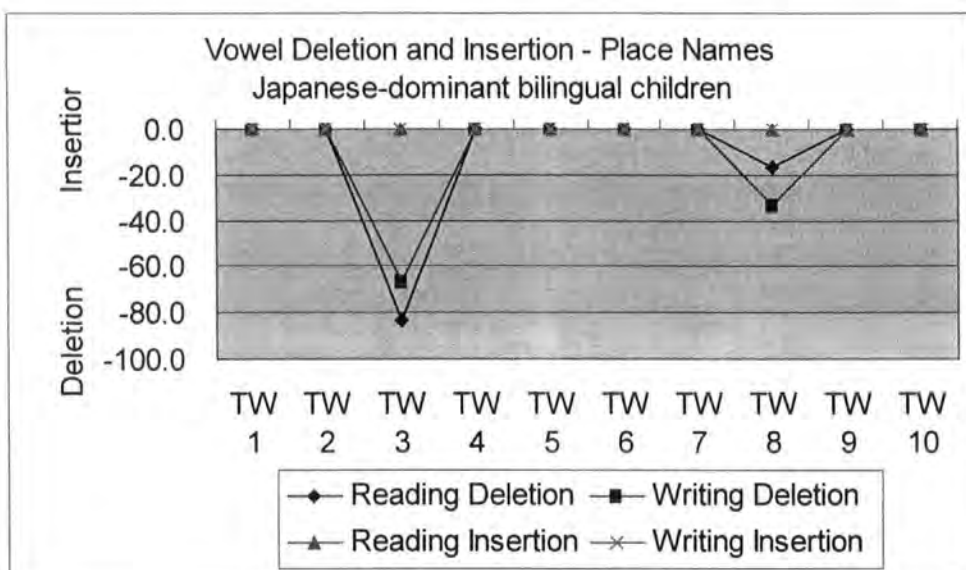

Figure 3.32 Vowel Deletion and Insertion - JDBC

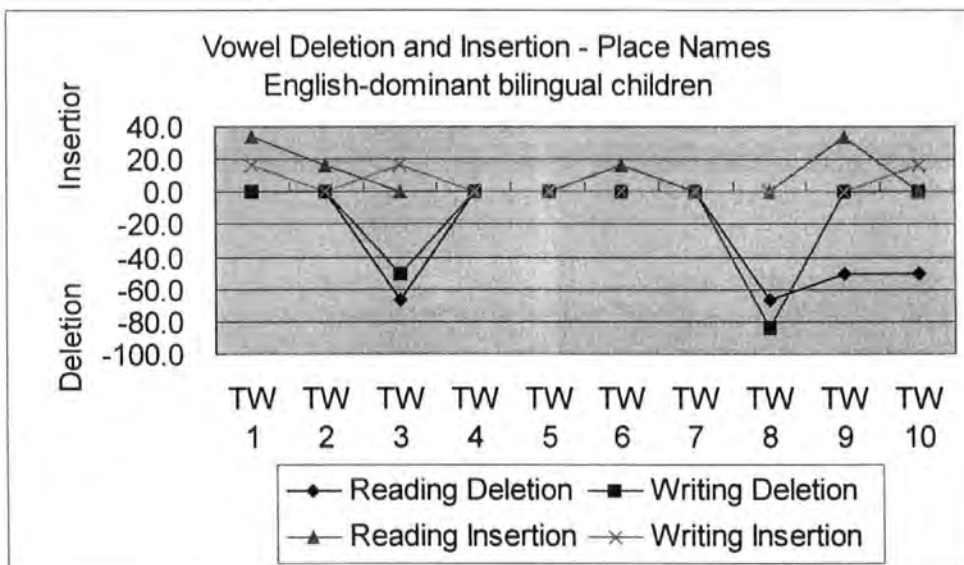

Figure 3.33 Vowel Deletion and Insertion - EDBC

On the whole, bilingual children made more vowel deletions than vowel insertions.

They inserted most vowels in TW 3 (Basingstoke) and TW 8 (Darlington).

We now compare substitution and compensation data, as summarised in Table

3.45.

Table 3.45 Substitution and Compensation – Bilingual Children – Place Names

TW	Reading		Writing		Reading		Writing	
	Freq	%	Freq	%	Freq	%	Freq	%
1	1	8.3	1	8.3	0	0.0	0	0.0
2	1	8.3	0	0.0	0	0.0	0	0.0
3	0	0.0	0	0.0	0	0.0	0	0.0
4	0	0.0	0	0.0	0	0.0	0	0.0
5	0	0.0	0	0.0	0	0.0	0	0.0
6	1	8.3	0	0.0	0	0.0	0	0.0
7	0	0.0	0	0.0	0	0.0	0	0.0
8	0	0.0	0	0.0	0	0.0	0	0.0
9	2	16.7	0	0.0	0	0.0	0	0.0
10	0	0.0	0	0.0	0	0.0	0	0.0
Mean	0.5	4.2	0.1	0.0	0.0	0.0	0.0	0.0
Correlation Coefficient	0.248451997				N/A			

Correlation coefficients indicate that there is no correlation between reading and writing. English-dominant children made some substitutions in reading and one in writing. Japanese-dominant children did not make any substitutions of any lost morae with another.

In TW 1, 2, 6 and 9, as listed in Tale 3,46, all contain geminate consonants, and these were the ones replaced by long vowels.

Table 3.46 Substitution and Compensation – English-dominant – Reading

TW	Name	IPA	Target Word	No of σ	No of μ	Gem C	MN	LV
1	Newcastle	nju:kɑ:sl	Nju-u ka-s-su-ru	4	6	s-s	-	u-u
2	Richmond	ri:tʃmænd	Ri-c-chi-mo-N-do	4	6	c-c	✓	-
6	Stratford	stratfɔ:d	Su-to-ra-t-to-fo-o-do	6	8	t-t	-	o-o
9	Oxford	ɒksfɔ:d	O-k-ku-su-fo-o-do	5	6	k-k	-	o-o

Unlike in Task 1, in Task 2, there were no instances of substitution in moraic and onset nasals. While there were no orthographic cues in Task 1, in Task 2, participants

were asked to read place names written in English and translate them into Japanese. The presence of such orthographic data, and the lack of phonetic cues and recalling of words they were familiar with, seems to have eliminated the allophonic substitutions.

We have seen in this section that Japanese-dominant bilingual children did better in applying Japanese phonological rules to English place names than English-dominant children. We now look at the results of bilingual adults.

3.3.3.3 Bilingual Adults

Table 3.47 summarises the mora count for bilingual adults.

Table 3.47 Mora Count Accuracy – Bilingual Adults – Place Names

TW	Reading		Writing	
	Freq	%	Freq	%
1	11	91.7	10	83.3
2	7	58.3	6	50.0
3	0	0.0	0	0.0
4	9	75.0	9	75.0
5	12	100.0	8	66.7
6	7	58.3	7	58.3
7	12	100.0	10	83.3
8	1	8.3	8	66.7
9	7	58.3	9	75.0
10	12	100.0	10	83.3
Mean	7.8	65.0	7.7	64.2
Correlation Coefficient	0.740467201			

Bilingual adults' mean scores in mora counting accuracy were 65.0% in reading and 64.2% in writing. Their mean scores were lower than those of English-dominant bilingual children (73.33% in reading and 78.35% in writing). With the exception of TW 8 and TW 9, they were as accurate or more accurate in reading than in writing. In TW 8 (Darlington), adult bilinguals tended to insert a vowel after 'g' in the English spelling and in TW 9 (Oxford) they tended to delete the word final vowel. In TW 3

(Basingstoke) no bilingual adult counted the correct number of morae. Again, the interpretation of the nasals and 'g'. As the correlation coefficient indicates, there is a strong correlation between reading and writing data. No one produced the target number of morae for TW 3, Basingstoke. The correlation coefficient of 0.740467201 for reading and writing, indicating a high correlation between the two sets of figures was higher than that of English-dominant bilingual children (0.623002465) but lower than that of Japanese-dominant bilingual children (0.996710517).

These results are presented in Figure 3.34.

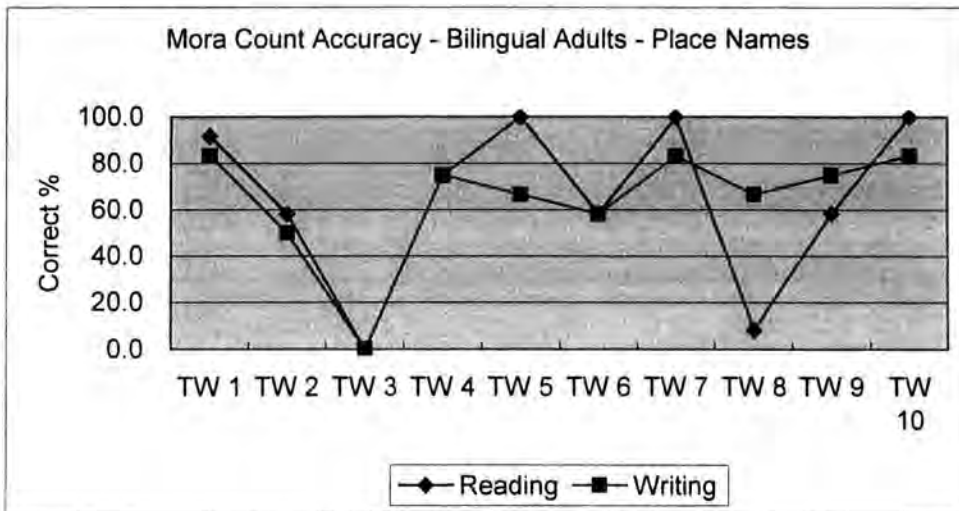

Figure 3.34 Mora Count Accuracy – Bilingual Adults

Table 3.48 summarises the way bilingual adults deleted or inserted mora. Minus numbers indicate deletions and positive numbers insertion, while zero indicates that the outcome matched the target number of morae for the word.

Table 3.48 Mora Count Deviation – Bilingual Adults – Place Names

TW	Reading	Writing
1	0.333	0.500
2	0.000	0.167
3	-0.083	0.583
4	0.583	0.917

5	0.667	0.667
6	-0.083	0.083
7	-0.083	0.250
8	0.000	0.500
9	0.000	0.333
10	-0.167	0.000
Deviation Mean (abs.)	0.097	0.153
Correlation coefficient	0.782908983	

The correlation coefficient indicates that there is a strong correlation between the two sets of data, as was the case with English-dominant bilingual children (0.655779747). With the exception of TW 8 and TW 10 in writing to a lesser degree bilingual adults tended to delete than insert morae. They deleted most morae in TW 2, 6 in both reading and writing, and TW 9 in reading. This was not the case with English-dominant bilingual children who deleted morae in TW 3 and TW 8, while they deleted few in all other test words. It is also notable that bilingual adults inserted morae in TW 8 in writing, while English-dominant bilingual children only deleted morae in TW 8. Clearly, bilingual adults and children use different strategies in processing English place names as Japanese loanwords. Figure 3.35 presents these results schematically.

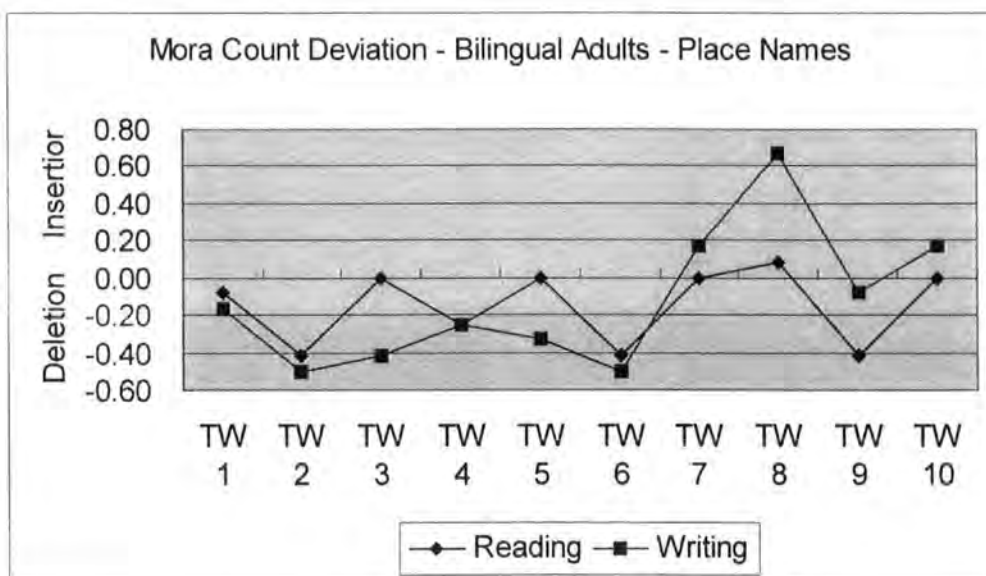

Figure 3.35 Mora Count Deviation

Next, we examine the way bilingual adults deleted and inserted consonants and vowels, starting with consonants.

Table 3.49 Consonant Deletion and Insertion – Bilingual Adults – Place Names

TW	Consonant Deletion		Consonant Insertion	
	Reading %	Writing %	Reading %	Writing %
1	41.7	50.0	8.3	0.0
2	75.0	75.0	0.0	8.3
3	50.0	41.7	0.0	8.3
4	25.0	50.0	0.0	16.7
5	8.3	83.3	0.0	0.0
6	58.3	41.7	0.0	0.0
7	0.0	0.0	0.0	0.0
8	0.0	33.3	0.0	66.7
9	33.3	83.3	0.0	16.7
10	0.0	0.0	0.0	0.0
Mean	29.2	45.8	0.8	11.7
Correlation Coefficient	0.490826906		-0.200081683	

Bilingual adults deleted more consonants than inserted them. Bilingual adults deleted more in both reading and writing than English-dominant bilingual children

(16.7% and 30.0%). Both groups deleted more in writing than in reading. While both bilingual adults and English-dominant bilingual children deleted more in writing than in reading, the consonant insertion did not show any similar tendency. Bilingual adults inserted more in writing and hardly any in reading, but English-dominant bilingual children inserted none in writing and a few in reading.

The correlation coefficient indicates that there is a moderate correlation between reading and writing results in reading. However, there is no correlation in writing data. Bilingual adults' correlation coefficient for deletion was similar to that of English-dominant bilingual children (0.53480552), which showed a moderate correlation.

Figure 3.35 confirms, there were more deletions than insertions made by the bilingual adults.

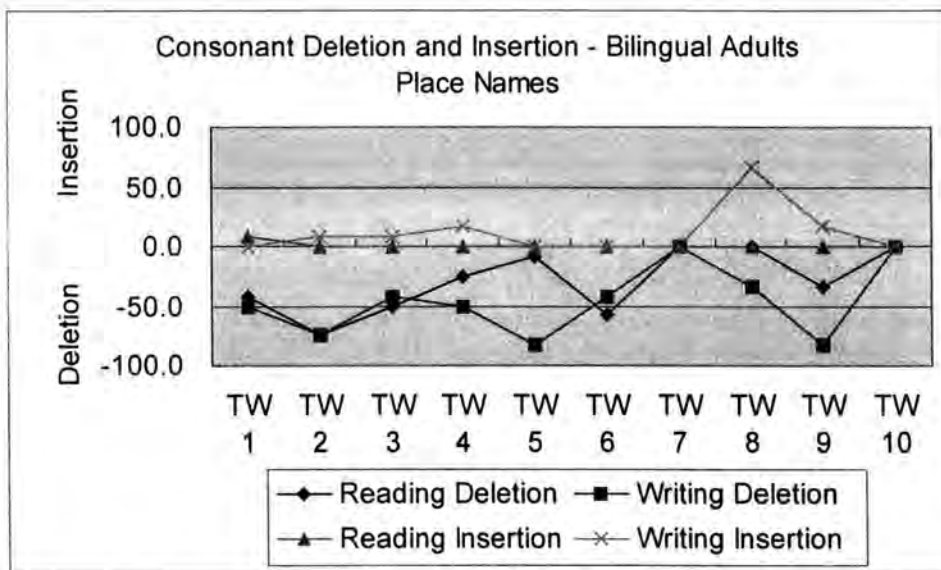

Figure 3.36 Consonant Deletion and Insertion

Let us now look at vowel deletion and insertion data, as summarised in Table 3.50.

Table 3.50 Vowel Deletion and Insertion - Bilingual Adults – Place Names

TW	Vowel Deletion		Vowel Insertion	
	Reading %	Writing %	Reading %	Writing %
1	33.3	0.0	25.0	33.3
2	0.0	0.0	33.3	25.0
3	66.7	83.3	0.0	16.7
4	8.3	0.0	0.0	8.3
5	0.0	0.0	8.3	50.0
6	16.7	8.3	16.7	0.0
7	25.0	0.0	0.0	16.7
8	25.0	16.7	8.3	66.7
9	33.3	0.0	0.0	8.3
10	0.0	0.0	0.0	16.7
Mean	20.8	10.8	9.2	24.2
Correlation Coefficient	0.786648656		0.18937069	

Bilingual adults deleted more vowels in reading than in writing, and inserted more in writing than in reading. While there was a similar tendency of more deletion in reading shown in English-dominant bilingual children's (mean for reading 23.3%, writing 13.3%) the opposite results were observed in insertion data (mean for reading 10.0%, writing 5.0%).

While there is a strong correlation between the reading and writing results in vowel deletion, there is none in vowel insertion. This was also the case with English-dominant bilingual children, showing a strong correlation between reading and writing in deletion (0.71807863) and no correlation (0.05455447) in insertion. Let us now look at the results shown in Figure 3.37.

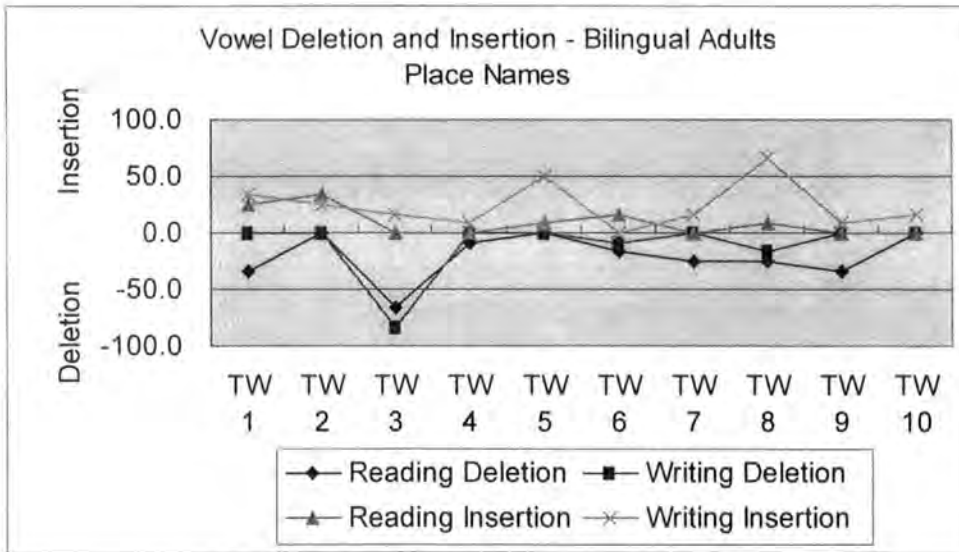

Figure 3.37 Vowel Deletion and Insertion

From Figure 3.37, we observe that bilingual adults inserted little in reading. They deleted vowels in TW 3 (Basingstoke) most in both reading and writing.

Finally, let us look at substitution and compensation data, as summarised in Table 3.51.

Table 3.51 Substitution and Compensation – Bilingual Adults – Place Names

TW	Reading		Writing	
	Freq	%	Freq	%
1	4	33.3	4	33.3
2	4	33.3	2	16.7
3	0	0.0	1	8.3
4	0	0.0	2	16.7
5	1	8.3	6	50.0
6	2	16.7	0	0.0
7	0	0.0	0	0.0
8	0	0.0	0	0.0
9	0	0.0	2	16.7
10	0	0.0	0	0.0
Mean	1.1	9.2	1.7	14.2
Correlation Coefficient	0.37689916			

Bilingual adults substituted more in writing than in reading, while the reverse was the case with English-dominant bilingual children. They did not make any substitution or compensation in TW 7, TW 8 and TW 10 in both reading and writing. English-dominant bilingual children did not make any substitution or compensation in these three, as well as TW 3, TW 4 and TW 5. All test words that were subject to substitution and compensation had geminate consonants. Indeed, in all cases, geminate consonants were replaced by long vowels. These words are shown in Table 3.52.

Table 3.52 Substitution and Compensation – Bilingual Adults – Place Names

TW	Name	IPA	Target Word	No of σ	No of μ	Gem C	MN	LV
1	Newcastle	nju:kɑ:sl	Nju-u ka-s-su-ru	4	6	s-s		u-u
2	Richmond	ri:tʃmænd	Ri-c-chi-mo-N-do	4	6	c-c	N	
4	Scotland	skɒtlənd	Su-ko-t-to-ra-N-do	5	7	t-t	N	
5	Tunbridge	tʌnbrɪdʒ	To-N-bu-ri-j-ji	4	6	j-j	N	
6	Stratford	stratfɔ:d	Su-to-ra-t-to-fo-o-do	6	8	t-t		o-o
9	Oxford	ɒksfɔ:d	O-k-ku-su-fo-o-do	5	6	k-k		o-o

Comparing the results of bilingual adults and English-dominant bilingual children, it is noticeable that bilingual adults are less able to deal with geminate consonants than their younger counterparts. However, they are still maintaining the mora slots by filling them with vowels.

3.3.3.4 Bilingual Children vs Bilingual Adults

Let us now compare the results of bilingual children and bilingual adults.

Table 3.53 shows the comparison summary of reading and writing results by bilingual adults and children, followed by Figure 3.38, which presents the results schematically.

Table 3.53 Mora Count Accuracy – Children vs Adults – Place Names

TW	Adults		Eng-dominant B.Children	
	Reading Correct %	Writing Correct %	Reading Correct %	Writing Correct %
1	91.7	83.3	83.3	83.3
2	58.3	50.0	100.0	83.3
3	0.0	0.0	33.3	50.0
4	75.0	75.0	83.3	66.7
5	100.0	66.7	83.3	83.3
6	58.3	58.3	100.0	83.3
7	100.0	83.3	83.3	100.0
8	8.3	66.7	16.7	66.7
9	58.3	75.0	50.0	83.3
10	100.0	83.3	100.0	83.3
Correlation Coefficient	A vs C Reading	0.780452593	A vs C Writing	0.719431385

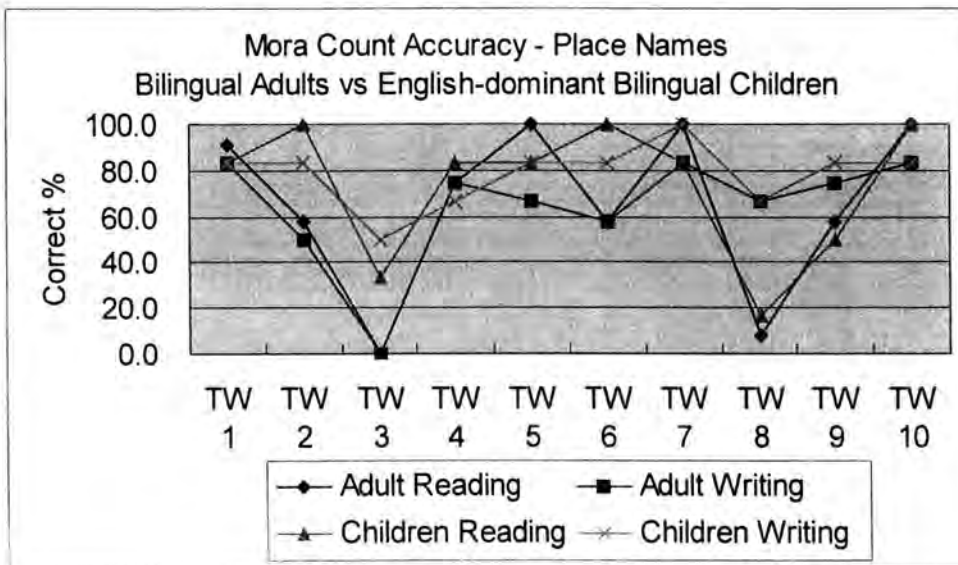

Figure 3.38 Mora Count Accuracy – Adults vs Children

There is a strong correlation between bilingual adults and children's data in both reading and writing. Both bilingual children and adults found TW 3 and TW 8 problematic.

Compared with the results from the task involving story character names, the performance difference between adults and children is small. This could be the result of word familiarity. Bilingual adults who have spent most of their lives in the UK are naturally more exposed to place names in English, and they are likely to have had at least the same, but quite possibly more exposure to Japanese ways of pronouncing English place names. On the other hand, while bilingual children appear to be systematic in their application of phonological rules, bilingual adults do not.

The way bilingual children and adults deleted consonants is summarised in Figure 3.54.

Table 3.54 Consonant Deletion and Insertion – Adults vs Children – Place Names

TW	Consonant Deletion				Consonant Insertion			
	Reading		Writing		Reading		Writing	
	Adults %	Children %	Adults %	Children %	Adults %	Children %	Adults %	Children %
1	41.7	50.0	50.0	33.3	8.3	0.0	0.0	0.0
2	75.0	16.7	75.0	16.7	0.0	0.0	8.3	0.0
3	50.0	0.0	41.7	33.3	0.0	0.0	8.3	0.0
4	25.0	16.7	50.0	33.3	0.0	0.0	16.7	0.0
5	8.3	0.0	83.3	16.7	0.0	16.7	0.0	0.0
6	58.3	16.7	41.7	16.7	0.0	0.0	0.0	0.0
7	0.0	0.0	0.0	0.0	0.0	16.7	0.0	0.0
8	0.0	16.7	33.3	83.3	0.0	0.0	66.7	0.0
9	33.3	50.0	83.3	66.7	0.0	16.7	16.7	0.0
10	0.0	0.0	0.0	0.0	0.0	0.0	0.0	0.0
Mean	29.2	16.7	45.8	30.0	0.8	5.0	11.7	0.0
Correlation Coefficient	0.326653		0.362355		-0.218218		N/A	

Both English-dominant bilingual children and bilingual adults deleted more consonants in reading than in writing. There are, however, no similarities in the insertion data between the two groups. Overall, adult bilinguals deleted more consonants than English-dominant bilingual children. However, bilingual adults

inserted less in reading than their younger counterparts. English-dominant bilingual children did not insert any consonants in writing but bilingual adults did. As the correlation coefficients show, there is hardly any correlation between adults' and children's data.

The results of consonant deletion and insertion comparison are presented in Figures 3.39 and 3.40.

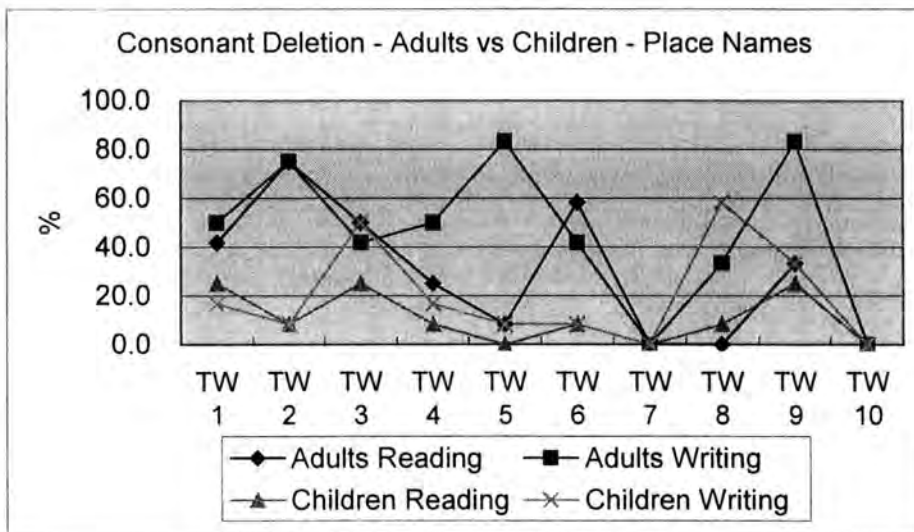

Figure 3.39 Consonant Deletion – Adults vs Children

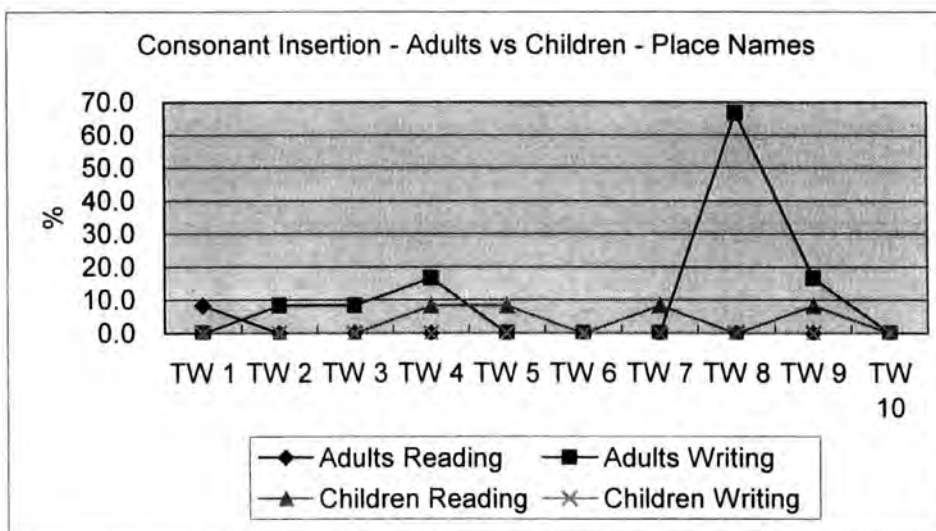

Figure 3.40 Consonant Insertion – Adults vs Children

On the whole, bilingual children deleted fewer consonants than their adult counterparts. No one deleted consonants from TW 3 and TW 7, neither of which had geminate consonants. Both bilingual adults and children showed a tendency to delete more in writing than in reading.

Overall, bilingual adults inserted more consonants than their younger counterparts.

Let us now compare vowel deletion and insertion data from English-dominant bilingual children and bilingual adults, as summarised in Table 3.55.

Table 3.55 Vowel Deletion and Insertion – Adults vs Children – Place Names

TW	Vowel Deletion				Vowel Insertion			
	Reading		Writing		Reading		Writing	
	Adults %	Children %	Adults %	Children %	Adults %	Children %	Adults %	Children %
1	33.3	0.0	0.0	0.0	25.0	16.7	33.3	8.3
2	0.0	0.0	0.0	0.0	33.3	8.3	25.0	0.0
3	66.7	75.0	83.3	58.3	0.0	0.0	16.7	8.3
4	8.3	0.0	0.0	0.0	0.0	0.0	8.3	0.0
5	0.0	0.0	0.0	0.0	8.3	0.0	50.0	0.0
6	16.7	0.0	8.3	0.0	16.7	8.3	0.0	0.0
7	25.0	0.0	0.0	0.0	0.0	0.0	16.7	0.0
8	25.0	41.7	16.7	58.3	8.3	0.0	66.7	0.0
9	33.3	25.0	0.0	0.0	0.0	16.7	8.3	0.0
10	0.0	25.0	0.0	0.0	0.0	0.0	16.7	8.3
Mean	20.8	16.7	10.8	11.7	9.2	5.0	24.2	2.5
Correlation Coefficient	0.711266		0.791735		0.490990		-0.065193	

Neither group deleted vowels in TW 2 and TW 5 in reading and writing. In writing, neither group deleted vowels in TW1, TW 7, TW 9 and TW 10. Bilingual adults deleted more vowels in reading than children. On the other hand, English-dominant bilingual children deleted vowel slightly more than their adult counterparts in writing.

Bilingual adults inserted more vowels than English-dominant bilingual children, in both reading and writing. While bilingual adults tended to insert more in writing, English-dominant bilingual children inserted more in reading.

There are strong correlations between bilingual adults and children's data in vowel deletion, and a moderate one in the reading in vowel insertion. There is no correlation in the writing data in vowel insertion.

These results are presented in Figures 3.41 and 3.42.

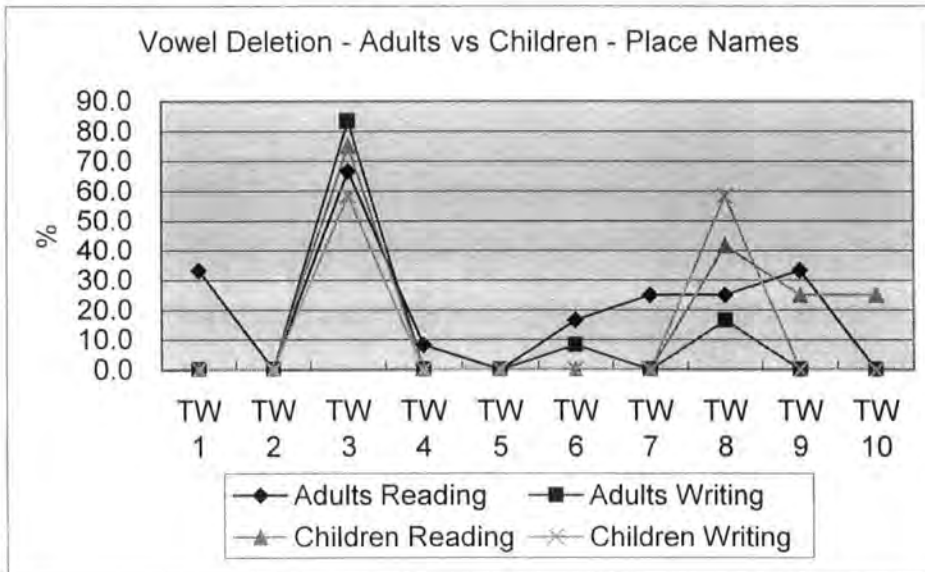

Figure 3.41 Vowel Deletion – Adults vs Children

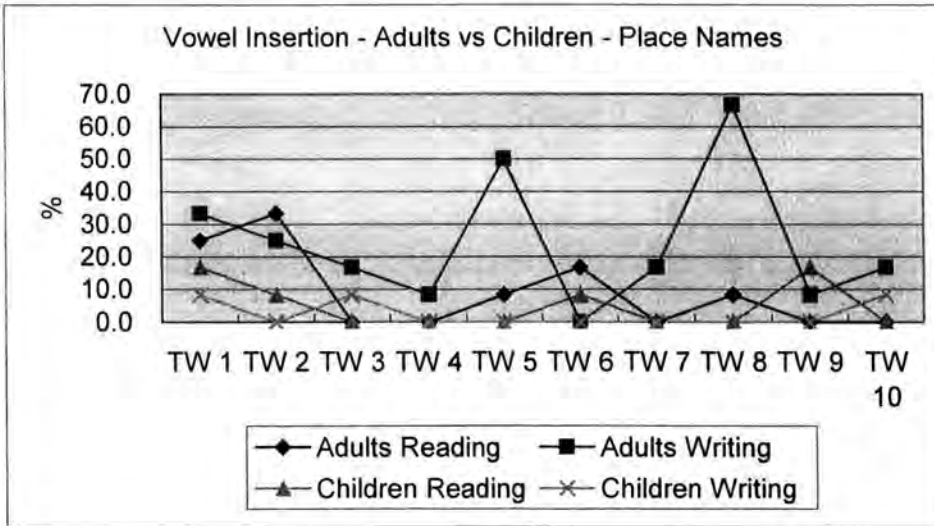

Figure 3.42 Vowel Insertion – Adults vs Children

Finally, let us compare the results of substitution and compensation, as summarised in Table 3.56. As we have noted in the previous section concerning bilingual children's substitution data, there was only one kind of substitution: geminate consonants being replaced by long vowels.

Table 3.56 Substitution and Compensation – Adults vs Children – Place Names

TW	Substitution and Compensation			
	Reading		Writing	
	Adults %	Children %	Adults %	Children %
1	33.3	16.7	33.3	16.7
2	33.3	16.7	16.7	0.0
3	0.0	0.0	8.3	0.0
4	0.0	0.0	16.7	0.0
5	8.3	0.0	50.0	0.0
6	16.7	16.7	0.0	0.0
7	0.0	0.0	0.0	0.0
8	0.0	0.0	0.0	0.0
9	0.0	33.3	16.7	0.0
10	0.0	0.0	0.0	0.0
Mean	9.2	8.3	14.2	1.7
Correlation Coefficient	0.425115		0.403509	

Overall, bilingual adults used substitution and/or compensation strategies more often than English-dominant bilingual children. Unlike the story character name task, there was no nasal substitution involved in the English place name task. Both English-dominant bilingual children and bilingual adults substituted geminate consonants with long vowels.

There are little to moderate correlation between bilingual adults and children's data, as Figure 3.43 also attests.

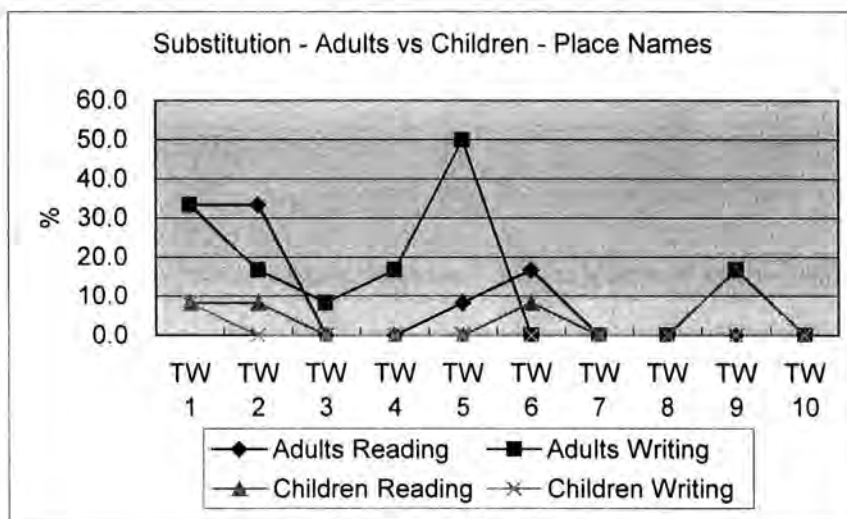

Figure 3.43 Substitution – Adults vs Children

3.3.4 Exposure to Japanese and Phonological Competence

Now that we have considered the results of Task 1, story character name task and Task 2, English place name task, let us consider further factors that might affect performance by bilinguals.

The bilingual adults were exposed to Japanese in various ways. Some spent their early childhood in Japan, some attended Japanese Saturday School for several years and for some Japanese was the main language they used at home. In this

section, we will examine the relationship between their nature and amount of exposure to Japanese and the frequency of deletion and insertion of consonants and vowels on the two tasks.

3.3.4.1 Subject Profile

The Table 3.57 is a revised version of Table 3.2, giving total number of years participating bilingual adults spent in Japan in age groups of zero to two years, two to six years, six to 12 years and 12 to 18 years.

Table 3.57 Exposure to Japanese Indexes – Bilingual Adults

Subject	Years in Japan (decimal)				Saturday School	Index A	Index B	Index C	Index D	Index E
	0 to 2	2 to 6	6 to 12	12 to 18		a+b	b+c	a+b+c	c+d+e	a+b+c+d+e
	a	b	c	d		e				
1	0	0	0	0	3	0	0	3	3	3
2	1.5	0	0	0	3	1.5	0	4.5	3	4.5
3	0	0	0	2	2	0	0	2	4	4
4	0.5	0.5	2	1	5	1	2.5	6	8	9
5	1.5	0	0	0	6	1.5	0	7.5	6	7.5
6	0.5	0	0	1	5	0.5	0	5.5	6	6.5
7	2	1	3	0	5	3	4	8	8	11
8	1	1.5	0	1	3	2.5	1.5	5.5	4	6.5
9	1	0.5	0	0	4	1.5	0.5	5.5	4	5.5
10	0	0	0	1	1	0	0	1	2	2
11	1	1	0	2	6	2	1	8	8	10
12	1	2	0	1	9	3	2	12	10	13

To take account of the effect of the language used at home, which may have contributed towards their competence in Japanese, a conversion formula has been proposed as shown in Table 3.58.

Table 3.58 Language at Home Factor

Language at Home	Factor
Japanese only	10
Japanese and English	5
English only	0

Using the factor in Table 3.58, Index F is created as shown in Table 3.59.

Table 3.59 Index F incorporating Home Language Factor

Subject (SB)	Index E (sum of a to e)	Home Language Factor	Index F
AB	3.0	0	3.0
KR	4.5	0	4.5
CC	4.0	5	9.0
CK	9.0	5	14.0
EH	7.5	5	12.5
KA	6.5	0	6.5
MK	11.0	5	16.0
AS	6.5	5	11.5
DS	5.5	10	15.5
TS	2.0	10	12.0
DB	10.0	10	20.0
AB	13.0	5	18.0

The subject AB had the total of three years exposure to Japanese, and at home she used English. Index F is therefore 3.0. The subject DB had been exposed to Japanese for ten years and also, he used only Japanese at home. His index F is therefore 20.0.

3.3.4.2 Measure of Competence

The number of deletions and insertions made by bilingual adults in two tasks: Task 1 using the Japanese story character names and Task 2 using English place

names as borrowed words are used to measure competence. These are summarised in Tables 3.60 and 3.61.

Table 3.60 Task 1 Deletions and Insertions – Bilingual Adults – Character Names

SB	Oral production					Writing				
	V Del	C Del	V Ins	C Ins	Total	V Del	C Del	V Ins	C Ins	Total
AB	1	3	5	1	10	3	4	2	0	9
KR	2	3	3	1	9	3	4	1	1	9
CC	2	2	5	5	14	2	4	1	1	8
CK	0	2	2	0	4	0	1	0	0	1
EH	3	2	1	0	6	3	4	1	0	8
KA	2	2	2	0	6	3	4	2	0	9
MK	1	0	0	0	1	3	2	0	0	5
AS	0	4	3	0	7	2	3	1	0	6
DS	1	3	1	0	5	2	3	0	0	5
TS	2	4	3	1	10	2	2	2	1	7
DB	0	1	1	0	2	2	3	0	0	5
AB	1	2	2	0	5	1	4	1	1	7

The subject CC deleted and inserted most (14) and subjects AB and TS deleted and inserted 10 each in oral production. In writing, subjects AB, KR and KA deleted and inserted most (9). The correlation coefficient of total numbers of deletions and insertions in oral production and writing is 0.587086, showing a moderate correlation.

Table 3.61 Task 2 Deletions and Insertions – Bilingual Adults – Place Names

SB	Reading					Writing				
	V Del	C Del	V Ins	C Ins	Total	V Del	C Del	V Ins	C Ins	Total
AB	6	4	0	0	10	1	7	5	5	18
KR	4	4	2	0	10	2	6	4	3	15
CC	4	4	1	0	9	3	7	4	0	14
CK	2	4	1	0	7	2	2	0	0	4
EH	3	4	0	1	8	1	6	2	1	10
KA	3	4	2	0	9	2	6	4	2	14
MK	1	0	0	0	1	0	3	1	0	4
AS	1	4	2	0	7	1	4	3	0	8
DS	0	2	1	0	3	1	2	2	1	6
TS	0	2	1	0	3	0	4	1	0	5

DB	0	1	1	0	2	0	4	1	0	5
AB	1	2	0	0	3	0	4	2	2	8

Subjects AB and KR deleted and inserted most (10) in reading. Also in writing, AB and KR showed the highest deletion and insertion rate (18 and 15 respectively). The subject MK deleted and inserted the least (1) in reading, and the same MK and CK deleted and inserted the least (4 each) in writing.

The correlation coefficient of total numbers of deletions and insertions in reading and writing is 0.840564, showing a high correlation.

3.3.4.3 Correlations between Exposure and Competence

Correlation coefficients of exposure indexes A to F and consonant and vowel deletions and insertions as competence indicators are summarised in Figures 3.43 to 3.46.

Negative correlation coefficients indicate that there is an inverse correlation between two sets of data. 'Total' indicates the sum of consonant and vowel deletions and insertions.

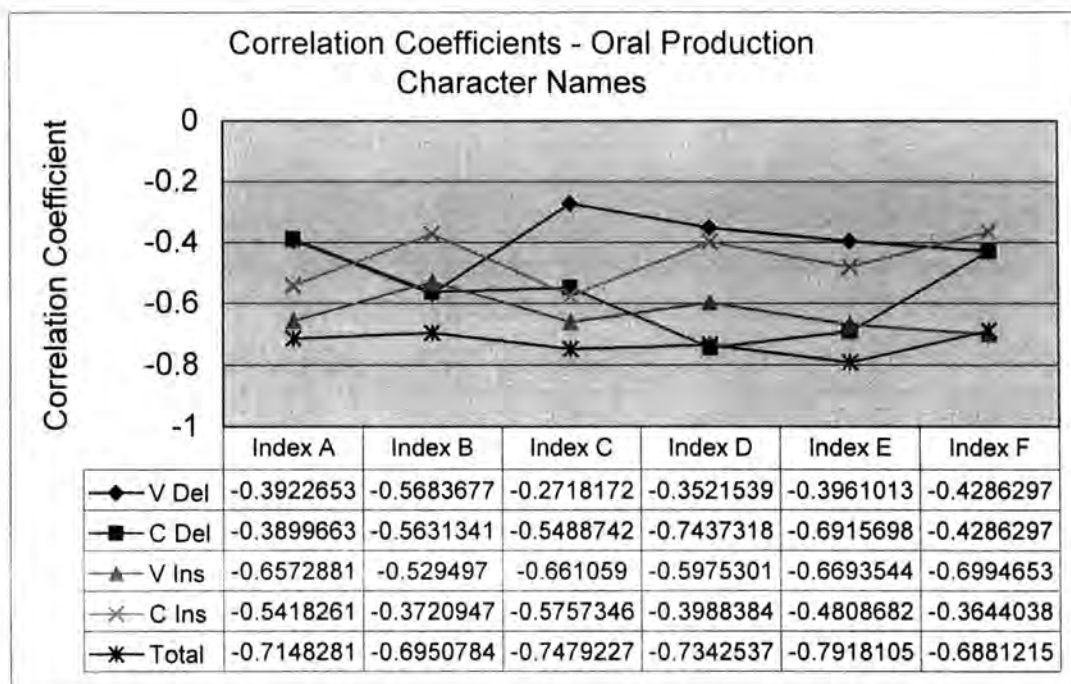

Figure 3.44 Correlation Coefficients – Oral Production

In the oral production of character names, the strongest correlation is seen between Index E (the total number of years spent in Japan from the age of 0 to 18 plus the number of years spent at a Japanese Saturday school) and 'Total,' followed by the Index C (early exposure: between age 0 and 6, plus the Japanese Saturday school exposure) with 'Total.' These results indicate that the early exposure in age and the Saturday school attendance are closely linked with the overall performance of the bilingual adults.

The high correlation coefficient in between Index D and consonant deletion suggests that the exposure to later years (resident in Japan between the age of 6 and 18, plus Japanese Saturday School while they were in the UK), while the length of exposure to Japanese under six years of age (Index A) seems to have little consequences in vowel and consonant deletion. Considering that Japanese-dominant bilingual children, at the age of eight, outperform both English-dominant bilingual

children and bilingual adults, the results must be treated as an evidence to support the claim that the critical age of phonological acquisition may be around six. This result may also be considered as an evidence that a lack of a full exposure to Japanese before the age of six may result in the bilinguals' performance resembling more closely to those of proficient L2 learners, particularly to those in the late emersion programme of the bilingual education.

There is a strong correlation between Index F, the total of exposure years in Japan, Japanese Saturday school attendance and the home language factor, and 'Total.'

Next, we look at the writing data.

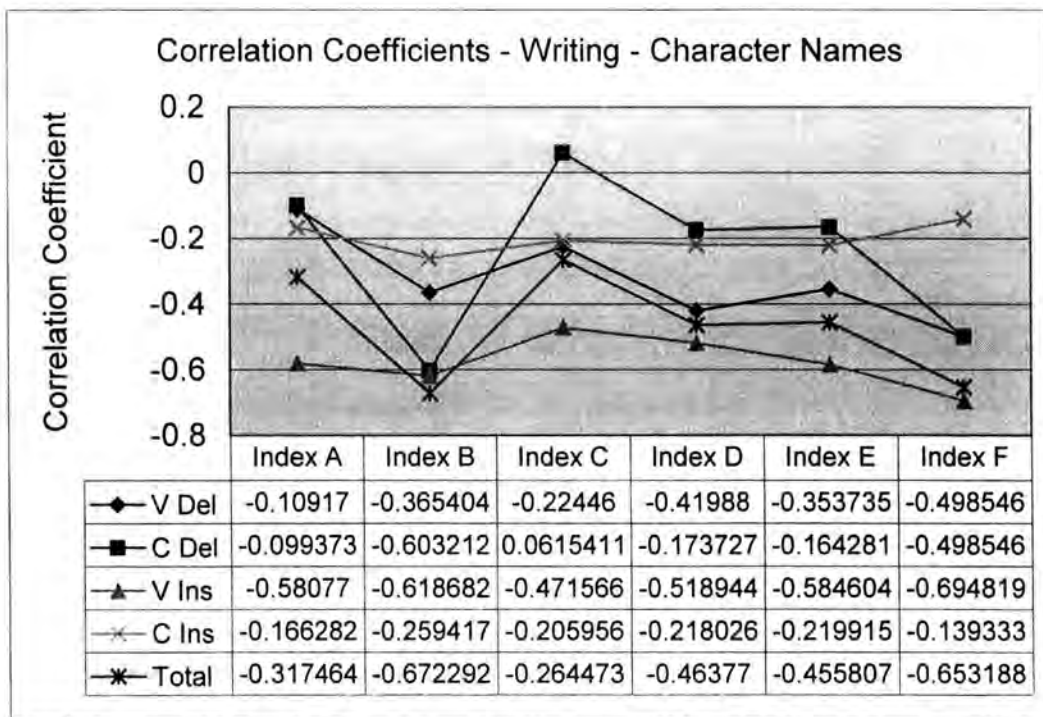

Figure 3.45 Correlation Coefficients - Writing

In writing, the strongest correlation is found between Index F and vowel insertions, followed by Index F and 'Total.' The results indicate that the length and timing of exposure to Japanese including the language used at home have influence in the way

they delete or insert vowels and consonants. In writing, the exposure to Japanese through schools either in the UK (Japanese Saturday schools) or in Japan is an important factor, as high correlation coefficient for Index B (years in Japan between the age of 2 and 12) and the 'Total' indicates.

Next we look at the reading results in Place Names.

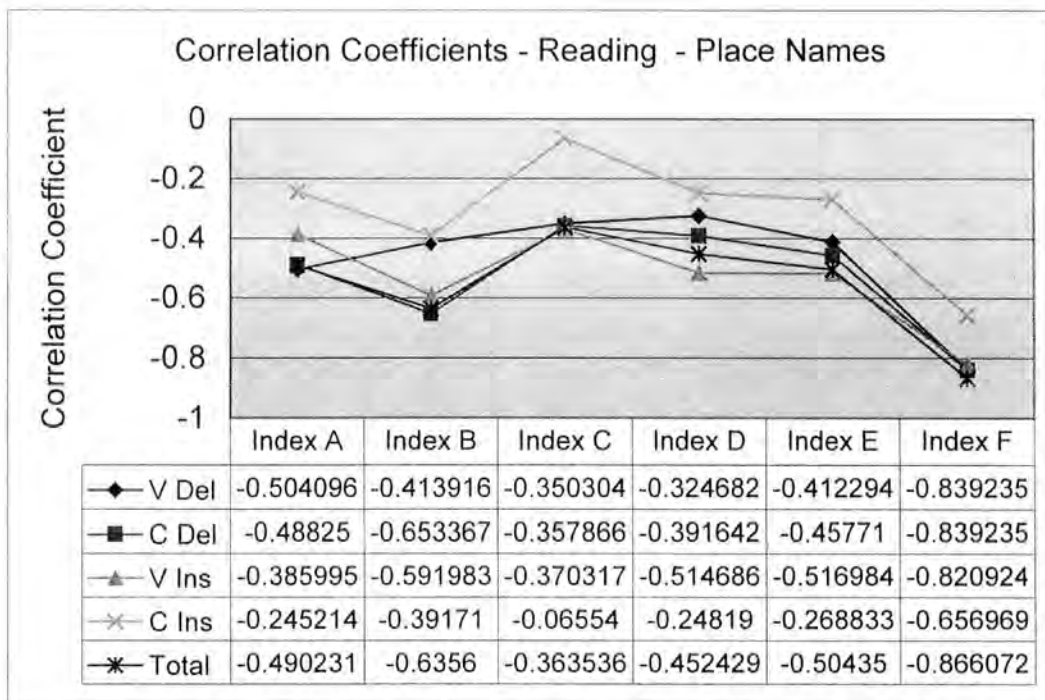

Figure 3.46 Correlation Coefficients - Reading

Again, by far the strongest correlation is found between Index F and 'Total,' followed by Index F and vowel deletion, and consonant deletion jointly.

The results indicate that applying phonological rules to leanwords is heavily dependent on the amount of exposure, including the language used at home.

Finally, we look at the results of writing in Place Names.

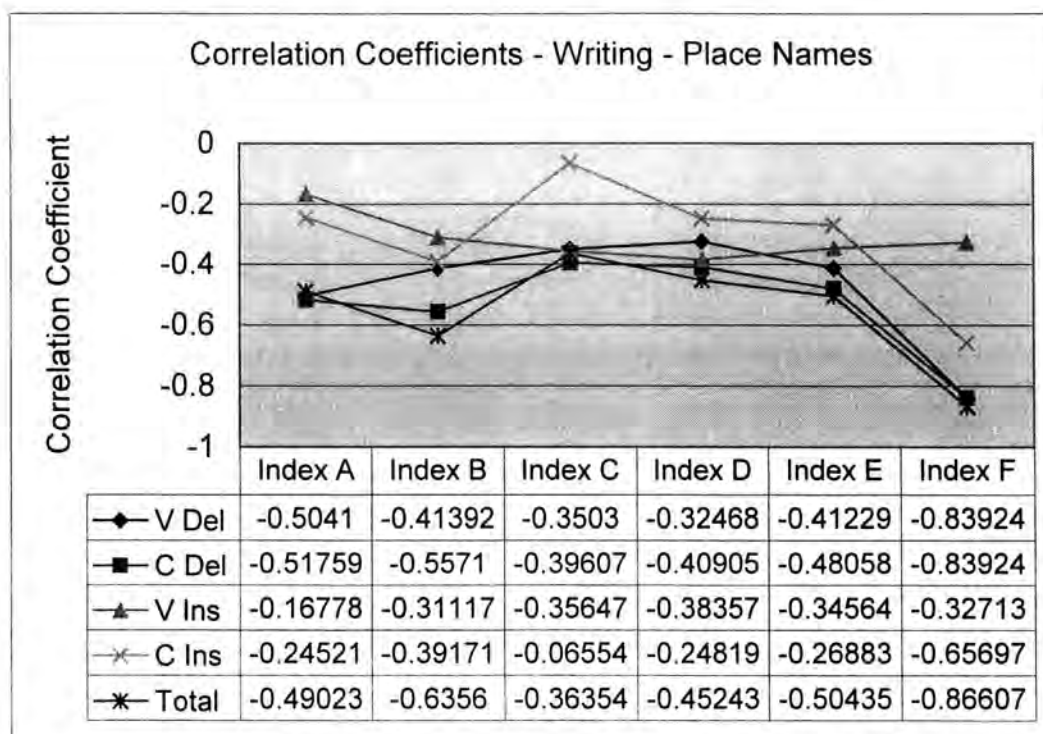

Figure 3.47 Correlation Coefficients - Writing

Again, the strongest correlation is found between Index F and 'Total,' followed by Index F and vowel deletions and consonant deletions jointly. These results enforce the argument that the development of phonological rules is heavily dependent upon the input.

3.4 Discussion

Bilingual children, whose performance suggests native competence were shown to exhibit some difficulties in dealing with both familiar and unfamiliar words.

We have seen bilingual children applying an interlanguage Japanese syllable template to unfamiliar words, managing to preserve the mora count, but not always managing to select the correct slots. It is notable that the learners are conserving the mora count of the TL, rather than their L1, like the Korean subjects in Broselow and

Park (1995: 157). The results indicate that in the development of the syllable template, mora count is fixed first. The specifics are acquired later, and thus, there are confusions of geminate consonants and long vowels, both requiring two mora slots.

English-dominant bilingual children are aware of the difference between moraic nasals and onset nasals. However, their mora timing control is immature, and overgeneralisation or compensation occurs.

We must note that both bilingual children and adults suffered from lack of competence in Kana literacy but more so with adults than children. This was because children were exposed to Kana transcription more frequently than adults, who tend to rely more heavily on Kanji (Chinese characters) than Kana. Meta-moraic awareness in terms of Kana literacy seems to lag behind linguistic competence.

Bilingual adults are the older version of English-dominant bilingual children in this study. Phonological competence as measured by the limited number of Japanese story character names and English place names as loanwords seems to be inferior to that of English-dominant bilingual children. However, we have also noted that the results of Task 2 using English place names as test words were comparable to that of English-dominant bilingual children. This suggests that unfamiliarity is a factor in preventing bilingual adults deciphering information correctly. We must also note that bilingual adults have far wider vocabulary and in general sense, they were just as competent as English-dominant bilingual children.

Apart from the word familiarity, we have also noted the importance of L2 input. This is particularly noticeable in Task 2, where we examined the way participants applied phonological rules to loanword formation. We have seen that both bilingual children and adults were significantly influenced by what they are exposed to. For

example, 'Basingstoke' and 'Darlington' were subject to two opposite interpretation depending on their dominant language and/or family environment.

Having gained some insight into the linguistic competence of English-dominant bilinguals with respect to Japanese syllables, let us now turn to the study of development of syllable structure by adult L2 learners of Japanese in the next chapter.

Chapter 4

The Acquisition of Japanese Phonology by Adult English Speakers

4.1 Introduction

In the previous chapter, the study focused on the knowledge of Japanese syllable structure by proficient speakers of Japanese, i.e., bilingual children and adults. In this chapter we will examine the process of Japanese syllable structure acquisition by native speakers of English language, from beginners to advanced-level learners. The aim of this chapter is to test the research hypotheses with cross-sectional data from L2 learners of Japanese at beginner, intermediate and advanced-levels. First we will test one of the three research hypotheses; the Mora Assignment Hypothesis, which predicts that L2 learners whose L1 does treat morae distinctively must acquire the fact that mora slots for vowels and consonants must be specified in lexical entries. Until such time their L1 parameters are reset to reflect the stage of their IL, learners rely on their L1 prosody with null mora parameter values. These parameters include the CVC syllable structure in English, and the CV structure in Japanese. The process of the acquisition of syllable structure with a specified mora tier associated with it must involve progressive parameter resetting sequences that capture the characteristics of the acquisition process. Second, we will test another research hypothesis that looks at the effectiveness of instruction focused on syllable structure to a subset of beginner-

level learners. The study is cross-sectional involving three different proficiency levels of Japanese. It is also a partially longitudinal study, as we will be examining the stages of acquisition for all learner groups twice over a nine-months period. Let us next look at the methodology we employ for the study.

In order to examine the process of Japanese syllable structure acquisition by the L2 learners several oral production and writing tasks were devised.

In this section, first I outline the participants' profiles. Next, we discuss the treatment given to a subset of this group. Then, the selection of test words is discussed. Finally, I discuss procedures of a preliminary task together with the main oral production and writing tasks.

4.1.1 Participants' Profiles

Ninety-four adult English native speakers who were at various stages of acquiring Japanese language took part in the study. They were either university students or employees of Japanese companies and other institutions in the North East of England. The collection of data was carried out at universities and company premises.

As a control group, six Japanese native speakers participated in all tasks.

4.1.1.1 Learner Category

All participants had started learning Japanese in their adulthood. The mode age onset was 18, and the mean of age onset was 21.49. Some participants had spent one to three years in Japan, working and/or studying Japanese prior to the start of the study.

All learners were receiving instruction and there were three modes of study: non-intensive, intensive and a hybrid of the two. Their teachers were either native Japanese speakers or near-native English speakers. Learners on non-intensive language programmes typically receive 44 to 45 hours of instruction in an academic

year (nine months) in a UK university setting. Those on the intensive programmes receive 200 to 260 hours of instruction. Some company employees received intensive 10 weeks' instruction prior to their placement in Japan, followed by non-intensive instruction both in Japan and back in the UK, and therefore their mode of study is a hybrid of intensive and non-intensive.

Participants were split into three learner categories based on hours of exposure: Beginner, Intermediate and Advanced. Their profiles are summarised in Table 4.1.

Table 4.1 Participant Profile by Proficiency in Japanese

Proficiency Level	Profile	Age	Study Mode	Instruction (hours)		In Japan (years)	No of Subjects	
				Month 1	Month 9			
Beginner	Company Employees	22-36	Non-Intensive	0	45	0	15	37
Beginner	University students	18-26	Non-Intensive	0	44	0	5	
Beginner	University students	18-26	Intensive	0	260	0	17	
Intermediate	Company Employees	22-36	Hybrid	200	245	2	9	34
Intermediate	University students	18-26	Intensive	600	800	1	25	
Advanced	University students	18-26	Intensive	800	1000	1-2	7	23
Advanced	Company Employees	22-36	Hybrid	300	345	2-3	12	
Advanced	Others	22-36	Hybrid	300	n/a	2-3	4	
Total number of participants							94	

The numbers of participants in three categories vary due to fluctuation in intake of learners with English mother tongue in a given academic year.

The division into - beginners, intermediate and advanced - is based on the following criteria.

- 1) Beginners - Complete beginners with no prior knowledge of Japanese at the start of this study.
- 2) Intermediate-level learners – Those who had had approximately 600 hours of instruction and had passed or deemed to have reached Level 2 in the Japanese Proficiency Test, run by a quasi-governmental body in Japan, and therefore

competent in everyday Japanese both in written and spoken form. The majority of participants in this category have spent one to two years in Japan.

3) Advanced-level learners – Those who had reached beyond the standard required by Level 1 in the Japanese Proficiency Test and therefore fluent in Japanese both in written and spoken form. The majority of participants in this category had spent two to five years in Japan.

Learners at Intermediate and Advanced-levels were not split into subcategories of Non-intensive and Intensive, as this information was not relevant beyond beginner-level.

4.1.1.2 Extra Treatment for Beginners

A subset of the group of Beginners - seven from Intensive, and 10 from the Non-intensive group – received extra treatment on Japanese syllable structure in addition to their normal instruction, as discussed in the following section. This was given by the researcher. The breakdown of these participants is shown in Table 4.2.

Table 4.2 Beginners – Extra treatment vs. No extra treatment

Intensive		Non-intensive		Total
Extra Treatment	No Extra Treatment	Extra Treatment	No Extra Treatment	
7	10	10	10	37

The detailed information on participants who were offered extra instruction is summarised in the following section. The breakdown of formal language instruction hours and extra instruction sessions are given in Table 4.3.

Table 4.3 Beginners – Formal Instruction and Extra Treatment

Test Time	Intensive		Non-intensive	
	Formal Instruction (hours)	Treatment (sessions)	Formal Instruction (hours)	Treatment (sessions)
Month 1	0	0	0	0
Month 2	52	5	10	5
Month 9	260	10	45	10

(Number of instruction hours is approximate)

4.1.1.3 Control Group

Six native Japanese speakers formed the control group for the study. They were in their 20s and 30s, graduates of Japanese universities, living in the North East England at the time of this study.

4.1.2 Extra Instruction - Treatment

The researcher developed a programme focussing on Japanese syllable structure in the form of short simple listening and pronunciation exercises combined with introductory explanation on syllable structure.

Instruction lasted 15 to 45 minutes on a weekly basis for ten consecutive weeks, starting in Month 1. Some sessions were offered as a group, and some individually due to timetabling constraints. Depending on the number of participants, the duration of the particular session varied so that equal amount of attention was given to each participant. All participants attended all ten sessions.

Participants were first introduced to the concept of English and Japanese syllable structure. Learners received information on the concept of mora, which was not made explicit during their regular Japanese courses, as their language programs at various

institutions followed the direct method of teaching, and any theoretical explanation in English did not form part of their curriculum.

Subsequent sessions dealt with phonetic and phonological aspects of Japanese syllable structure and prosody only, with exercises restricted to the written production and production of sound segments or words that appeared early on in beginner-level textbooks, such as numbers. Words in the Word Lists A and B were avoided.

To assist instruction on the timing property of the mora, a PC program (Creative Wave Studio by Creative Technology Ltd) was used during the relevant sessions. By comparing and contrasting sound wave patterns of words on the PC monitor, learners were coaxed to visualise characteristics of Japanese syllable structure and its mora-timing.

4.1.3 Test Words

Three sets of test words: Word Lists P (preliminary), A and B were devised for various tasks.

4.1.3.1 Word List P

A list of words consisting of ten numbers and their noun counters were selected for their assumed familiarity to test subjects. The word familiarity was required to contrast with the main test words, which were assumed to be unfamiliar. The basis for this choice of familiarity is the assumption that learners are able to perceive and produce known lexical items. Words included are at beginner-level and are frequently used, hence very familiar to all intermediate and advance level learners, even out of context. Test words are given in Table 4.4.

Table 4.4 Pre-Assessment Test Words

No	Type	Target	IPA	Meaning	No of Eng σ	No of Jap σ	No of Jap μ
1	CVC,VV	jissai	jɪssɑɪ	ten years old	2	2	3
2	VV	kyuuko	kjɯ:kɔ	9 pieces	2	2	3
3	CVC	hakkai	hakkɑɪ	8th floor	2	2	3
4	CV	shichi-ji	ʃitʃidʒɪ	7 o'clock	3	3	3
5	CVC	rokken	rɔkken	6 houses	2	2	4
6	VV	gotoo	gotɔ:	5 (horses)	2	2	3
7	CVN	yon-ban	jɔmban	4th	2	2	4
8	CVC	mikka	mɪkka	three days	2	2	3
9	CV	futatsu	ɸɯtatsu	two items	3	3	3
10	CVC,VV	ikkyuu	ɪkkjɯ:	1st level	2	2	4

4.1.3.2 Word List A

Words containing 1) standard CV syllable type, 2) vowel clusters, 3) geminate consonants and 4) moraic nasals were selected. Each word contained three or four morae, the typical number of morae in Japanese vocabulary (see Chapter 1), and one to four syllables. These words were selected for their unfamiliarity. These were authentic but not usually found in Japanese language textbooks at any level, as they were specialised, formal or academic vocabulary. Words of assumed familiarity were chosen based on the findings in Chapter 3, where bilinguals were better able to carry out mora assignment when they were familiar with the given word.

Table 4.5 Word List A

No	Type	Word	IPA	Meaning	No of Eng σ	No of Jap σ	No of Jap μ
1	CV	kugiri	kʉgiri	an end, a stop	3	3	3
2	CV	zugara	zʉgara	pattern	3	3	3
3	CV	shijimi	ʃʉdʒimi	a shijimi clam	3	3	3
4	CV	aramaki	aɾamaki	lightly salted salmon	4	4	4
5	CV	tsukinami	tʃʉkinami	conventional	4	4	4
6	VV	kooki	kʉ:ki	a sweet smell	2	2	3
7	VV	baai	baai	situation	2	2	3
8	VV	noori	no:ri	an able official	2	2	3
9	VV	kuiiki	kʉuiki	air space	2	3	4
10	VV	nigaoe	niɡaoe	a portrait	3	2	4
11	CVC	toppi	tʉppi	extraordinary	2	2	3
12	CVC	kakke	kakke	beriberi	2	3	3
13	CVC	setta	setta	snow sandal	2	2	3
14	CVC	zecchoo	zettʃʉ:	the peak	2	2	4
15	CVC	bassoku	bassʉkʉ	penal regulations	3	2	4
16	CVN	yoshin	jʉʃin	an aftershock	2	2	3
17	CVN	bokin	bʉkin	fund raising	2	3	3
18	CVN	seken	seken	the world, society	2	2	3
19	CVN	hensen	hensen	changes	2	2	4
20	CVN	kangan	kaŋan	a eunuch	2	2	4

4.1.3.3 Word List B

Another list, Word List B was prepared using the same criteria as Word List A.

Word List B was used as a repeat in order to confirm the initial findings and also to eliminate the learning effects resulting from the use of Word List A in several sessions.

Table 4.6 Word List B

No	Type	Word	IPA	Meaning	No of Eng σ	No of Jap σ	No of Jap μ
1	CV	mokume	mɔkɯme	the grain of wood	3	3	3
2	CV	honoka	hɔnɔka	dim, faint	3	3	3
3	CV	komono	kɔmɔnɔ	small items	3	3	3
4	CV	shitajiki	ʃɪtɔʒɪkɪ	a celluloid sheet	4	4	4
5	CV	kamidana	kamidana	Shinto altar	4	4	4
6	VV	toishi	tɔɪʃɪ	a grindstone	2	2	3
7	VV	moyoo	mɔjɔ:	design, pattern	2	2	3
8	VV	kiai	kɪɔɪ	fighting spirit	2	2	3
9	VV	kooei	kɔ:ɛɪ	gracious	2	2	4
10	VV	hoouo	hɔ:ɔ:	the Pope	2	2	4
11	CVC	shikke	ʃikke	dampness	2	2	3
12	CVC	maccha	mattʃa	powdered green tea	2	2	3
13	CVC	shokki	ʃɔkki	weaving machine	2	2	3
14	CVC	kappatsu	kappatsɯ	lively, brisk	3	3	4
15	CVC	nattoku	nattɔkɯ	a national anthem	3	3	4
16	CVN	yoshin	jɔʃɪn	an aftershock	2	2	3
17	CVN	inkyō	ɪŋkjɔ	to retire	2	2	3
18	CVN	shinka	ʃŋka	evolution	2	2	3
19	CVN	hensen	hensen	changes	2	2	4
20	CVN	senpan	senpan	some time ago	2	2	4

4.1.4 Test Procedures

To test the hypotheses discussed in Chapter 2, one preliminary assessment and two tasks were devised and administered twice¹¹ over a 9-month period. Before the main tasks took place, a preliminary assessment was carried out with the Intermediate

¹¹ Only beginners were given the twice, in order to assess the influence of using Roman alphabet in written production at the beginning. By Month 2, all beginners were able to write in Kana. The task carried out in Month 2 was necessary to assess the extent of orthographic influence on the written production data. Since intermediate and advanced level learners used Kana from the beginning on the tasks, they did not take part in tasks in Month 2.

and Advanced-level learners in order to ascertain their competence with Japanese syllable structure, at least when dealing with familiar the words from Word List P.

A mora-counting task took place at Month 1 and Month 9, using Word Lists A and B, respectively. Second, written and oral production tasks were carried out at Month 1 and 9 using Word List A, to examine interlanguage syllable template development and using Word List B, the written production and production task was carried out at Month 9.

The task schedule is summarised in Table 4.7, showing the participating learner groups. At Month 1, both non-intensive and intensive beginner groups had not been further split into two categories of instructed and not instructed, as extra instruction sessions had not yet started.

Table 4.7 Task Schedule

Month	Task	Word List	Beginner				Intermediate	Advanced
			Non-Intensive		Intensive			
			Treat	No Treat	Treat	No Treat		
1	Pre-assessment	P	x	x	x	x	✓	✓
	Mora Counting	A	✓		✓		✓	✓
	Perception and Production	A	✓		✓		✓	✓
2	Perception and Production	A	✓	✓	✓	✓	x	x
9	Perception and Production	A	✓	✓	✓	✓	x	x
	Mora Counting	B	✓	✓	✓	✓	x	x
	Perception and Production	B	✓	✓	✓	✓	x	x

The task in Month 2 was given only to beginners who had by then learned to write in Kana. The results from Month 2 compliment those from Month 1, when all beginners used Roman letter.

4.1.4.1 Preliminary Assessment of Intermediate and Advanced Learners

In order to look at the inter interlanguage of the intermediate and advanced-level learners with respect to words on their active vocabulary, two simple tests were devised. These tasks were carried out prior to the commencement of the main tasks described in the subsequent section. The results of these tasks were compared with those of the main tasks described in the subsequent section. The comparison was intended to uncover to what extent learners were dependent on purely lexical knowledge vs. rules governing Japanese syllable/mora structure.

Both intermediate and advanced level learners listened to a tape containing ten numbers and their counters (Word List P), repeated twice, and were asked to write down the entire word in Kana on the blank sheet of paper provided. The process of testing was intended to illustrate the way learners perceive the test words, process this information and produce syllables Japanese script. This assessment also provided confirmation that learners had been grouped correctly.

Intermediate and advanced-level learners were shown two phrases in English typed on a card and asked to translate them into Japanese orally.

Sentence 1 Please wait a moment.

Sentence 2 Would you please repeat it?

Both phrases can be translated into Japanese in various ways. Some of the most common ones are *Chotto matte kudasai* for sentence 1 and *Moo ichido itte kudasai* for sentence 2, both of which contain CVC and VV syllables. Both phrases are

used frequently and practiced repeatedly in beginner classes. There was no recording made for responses to this test, but the researcher assessed their competence on the spot and made notes. Assessment was given in five numeric scales of 5 to 1: 5 being the maximum score indicating near-native performance, 3 indicating average performance expected from competent intermediate-level learners, and there was no potential for misunderstanding, and 1 being the level below beginner-level and miscommunication was probable. The proficiency rating of 3 or above means that the learners are able to perceive and produce Japanese words containing CVC, CVN or VV syllables in comprehensible manner to the native speakers. This, in turn, indicates that they perform at near-native level at least when they are faced with words they know.

4.1.4.2 Mora Counting with Word List A

All learner groups: Beginners, intermediate and advanced-level learners, were given the mora counting task at Month 1, at the beginning of an academic year. Word List A was used for this task.

Data were obtained by using test words which were authentic Japanese nouns but uncommon in everyday conversation, hence it was highly unlikely that participants would recognise any of them, particularly out of context. Each word was repeated three times in the recording; the entire test lasted three minutes including pauses, with word order scrambled so that words were not grouped together by their syllable type. Recorded material was used to ensure that participants did not get cues from facial expressions. The word order was scrambled so that words were not grouped together by their syllable type.

Participants were given a sheet of paper with examples of what was expected of them and blank spaces against numbers 1 to 20. First, an explanation of the

procedure was given. The participants were expected to count the number of “sound segments” they could distinguish. As an example, two English and two Japanese words were given to the participants as shown in Table 4.8.

Table 4.8 Sample Words

Target Language	Word	Meaning	No of Sound Segments
English	desk	desk	1
	sake	rice wine	2
Japanese	desuku	desk	3
	sake	rice wine	2

The word *sake* was pronounced in English and Japanese, respectively. For each example, the number of sound segments, i.e., number of syllables, but without using the term *syllable*, was confirmed. By contrasting two sets of words of the same meaning in two languages, attention was drawn to the difference in the syllable and moraic structure in English and Japanese, illustrating what was required of learners. The control group underwent a similar procedure but instructions were given in Japanese.

The same procedure of presenting examples took place with the intermediate and advanced-level learners, even though participants had been exposed implicitly to the characteristics of Japanese syllable structure during the course of normal instruction over the previous two to six years. It was emphasised to them, without resorting to the terms *syllable* and *mora*, that they were expected to count sound segments in Japanese. This was to ensure that the results would clearly indicate the way they segmented syllables and enable us to detect any L1 influence.

Next, all participants were given a writing task. Participants listened to a tape and wrote down the words from Word List A. The sequence of words was scrambled after the mora counting task. Each word was repeated three times in the recording,

which lasted a total of four minutes including pauses in between words. Participants were asked to write down in Kana on the back of the answer sheet the words used in the mora counting task. Beginners without prior knowledge of Japanese orthography wrote these down in the Roman alphabet, while other participants were asked to use Hiragana or Katakana, whichever they felt more comfortable with.

Next, participants were asked to repeat words after listening to them twice on tape. The entire session took about three minutes. The session was tape-recorded using a Sony TCM3592. These sessions took place individually, mainly on the same day but otherwise within seven days of the date of the written production task.

In Month 2, only beginners were given written and oral production tasks, using the Word List A at Month 2, with the sequence of Word List A altered from Month 1. As explained earlier in this chapter, Month 2 data are treated as control, to assess the level of influence from orthography used in writing. Since all learners after the initial month in the academic year learnt to read and write in Kana, all written tasks were carried out using Kana. Though a choice of using Kana or Roman letters was given to all learners so as to reassure that they were not tested simply in literacy, nobody took up the offer.

At Month 9, only the beginners were given mora-counting task again using the Word List A, the sequence of which was scrambled for the third time in order to enable analysis of phonological development. All participants including beginners were given another mora-counting task using Word List B. The second mora counting task was intended to provide additional data from another set of unfamiliar words to examine whether the assumption of a correlation between the word familiarity and the phonological performance was supported independently, to assess any learning effects

from use of the same word list, and finally to provide evidence to strengthen the case for any claims that may be made based on these data.

Following the mora-counting tasks, all participants were given written production and production tasks using Word List B. Again, the purpose of the use of the Word List B was to provide additional data for scrutiny.

4.2 Results

Let us now look at the results from tasks carried out over a 9-month period. First, let us review the results of pre-assessment tests by the intermediate and advanced level learners. We will then turn to the data from the main cross-sectional and longitudinal tasks. Recall we have three tasks: 1) mora counting, 2) oral production and 3) written production. In the mora-counting task, we assess the way learners segment utterances and see if they can identify all morae in the test words they had just heard. In written production task, learners were asked to write the test words they had listened to. In the oral production task, learners were asked to repeat test words they had just heard. In both tasks, their data were analysed to see evidence for the learners identifying morae in the VV, CVC and CVN syllables, and look for any deletions and insertions. Let us now start with the preliminary assessment result.

4.2.1 Preliminary Assessment

All intermediate and advanced level learners were able to perceive and produce all test words correctly in terms of morae number. The results, as shown in Table 4.9, attest that they are behaving in a native-like manner, at least in the limited area of known and familiar vocabulary.

Table 4.9 Preliminary – Written Production – Month 1

	TW1	TW2	TW3	TW4	TW5	TW6	TW7	TW8	TW9	TW10	Mean
Intermediate	100.00% 34	97.10% 33	100.00% 34	100.00% 34	100.00% 34	97.10% 33	100.00% 34	100.00% 34	100.00% 34	100.00% 34	99.40% 33.8
Advanced	100.00% 23	100.00% 23	100.00% 23	100.00% 23	100.00% 23	95.65% 22	100.00% 23	100.00% 23	100.00% 23	100.00% 23	99.60% 22.9

In the preliminary written production task, two in intermediate and one in the advanced-level group deleted a geminate in the test word 1, 'jissai.' It was noted that subjects realised half way through the test that words contained numbers and associated counting nouns, and they had altered some of the earlier entries, though extra time for correction was not included in the task and such corrections were made in a hurry. The results suggest that all subjects in the intermediate and advanced-level groups were able to hear and write VV, CVC and CVN syllables in the familiar words accurately in a native-like manner, even when such words were given out of context.

In the second part of the task, intermediate and advanced-level learners were asked to translate English phrases into Japanese. English phrases were chosen for their predictability to elicit Japanese phrases that contain VV, CVC and CVN syllables. Their utterances were assessed by a native speaker (the author) using the scale of 1 to 5; 5 being the maximum, representing a native-like performance and 1 being the minimum given for performance that does not result in a successful communication in Japanese. The results are given in Table 4.10

Table 4.10 Preliminary – Oral Production

	5	4	>=3	Total
Intermediate N = 34	52.94% 18	47.06% 16	0.00% 0	100.00% 34
Advanced N = 23	70.83% 17	29.17% 6	0.00% 0	100.00% 23

The results shown in Table 4.10 suggest that all intermediate and advanced-level subjects demonstrated that they were able to control mora duration in sentence level in such a way that over 50% of utterances were judged as native-like, when they are dealing with familiar phrases.

We now look at their competence when they are faced with unknown vocabularies together with those of beginners in the following sections.

4.2.2 Mora Counting

Participants in all learner groups and control group counted the number of sound segments in the Word List A. Numerical data from the mora-counting task were entered into computer and analysed and using Microsoft Excel 2000.

4.2.2.1 Month 1

The results in terms of correct answers in percentages by participant groups are summarised in Table 4.11.

Table 4.11 Mora Counting – Word List A – Month 1

Test Words		Beginner Non-Intensive		Beginner Intensive		Intermediate		Advanced		Control Group	
		%	N	%	N	%	N	%	N	%	N
CV	1	95.0%	19	94.1%	16	97.1%	33	95.7%	22	100.0%	6
	2	90.0%	18	94.1%	16	97.1%	33	91.3%	21	100.0%	6
	3	95.0%	19	94.1%	16	94.1%	32	100.0%	23	100.0%	6
	4	95.0%	19	94.1%	16	94.1%	32	95.7%	22	100.0%	6
	5	90.0%	18	88.2%	15	97.1%	33	95.7%	22	100.0%	6
VV	6	10.0%	2	11.8%	2	64.7%	22	82.6%	19	100.0%	6
	7	0.0%	0	0.0%	0	58.8%	20	87.0%	20	100.0%	6
	8	5.0%	1	5.9%	1	67.6%	23	87.0%	20	100.0%	6
	9	0.0%	0	0.0%	0	52.9%	18	82.6%	19	100.0%	6
	10	0.0%	0	0.0%	0	55.9%	19	91.3%	21	100.0%	6
CVC	11	5.0%	1	5.9%	1	47.1%	16	69.6%	16	100.0%	6
	12	5.0%	1	0.0%	0	44.1%	15	60.9%	14	100.0%	6
	13	5.0%	1	0.0%	0	44.1%	15	65.2%	15	100.0%	6
	14	0.0%	0	0.0%	0	44.1%	15	73.9%	17	100.0%	6

	15	0.0%	0	0.0%	0	38.2%	13	69.6%	16	100.0%	6
CVN	16	0.0%	0	0.0%	0	50.0%	17	82.6%	19	100.0%	6
	17	5.0%	1	5.9%	1	50.0%	17	91.3%	21	100.0%	6
	18	10.0%	2	11.8%	2	47.1%	16	95.7%	22	100.0%	6
	19	0.0%	0	0.0%	0	41.2%	14	87.0%	20	100.0%	6
	20	0.0%	0	0.0%	0	47.1%	16	91.3%	21	100.0%	6
Mean	25.5%	5.1	25.3%	4.3	61.6%	21.0	84.8%	19.5	100.0%	6.0	
No of subjects	20		17		34		23		6		

Apart from the control group, who scored 100% in all test words, Advanced-level learners have scored the highest in all five categories. The overall mean score for the Advanced-level learners was 84.7%. The Intermediate-level learners scored second highest among learner groups. The overall mean score was 56.9%. Both beginners groups, Intensive and Non-intensive course participants, showed very similar results to one another. The overall mean scores were 25.3% and 25.5% respectively. All learner groups scored high for the first five words containing only CV syllables. While the rest of learner groups have shown difficulties, only the Advanced-level learners scored high in the last five words, containing CVN syllables.

In the next step of the analysis, the mora-counting data were sorted by syllable type. The results are given in Table 4.12.

Table 4.12 Mora-counting Accuracy by Syllable Type – Word List A – Month 1

TW	Beginner Non-Int	Beginner Intensive	Intermediate	Advanced	Control Group
	N = 20	N = 17	N = 34	N = 23	N = 6
CV	93/100 93.00%	79/85 92.90%	163/170 95.90%	110/115 95.70%	30/30 100.00%
VV	3/100 3.00%	3/85 3.50%	102/170 60.00%	99/115 86.10%	30/30 100.00%
CVC	3/100 3.00%	1/85 1.20%	74/170 43.50%	78/115 67.80%	30/30 100.00%
CVN	3/100 3.00%	3/85 3.50%	80/170 47.10%	103/115 89.60%	30/30 100.00%

The number of test items in each syllable type category was five. So, for example, beginner in the non-intensive group produced 100 tokens in each of the syllable type category. In CV syllables, beginners in the non-intensive group, 93 tokens attracted the target mora-count.

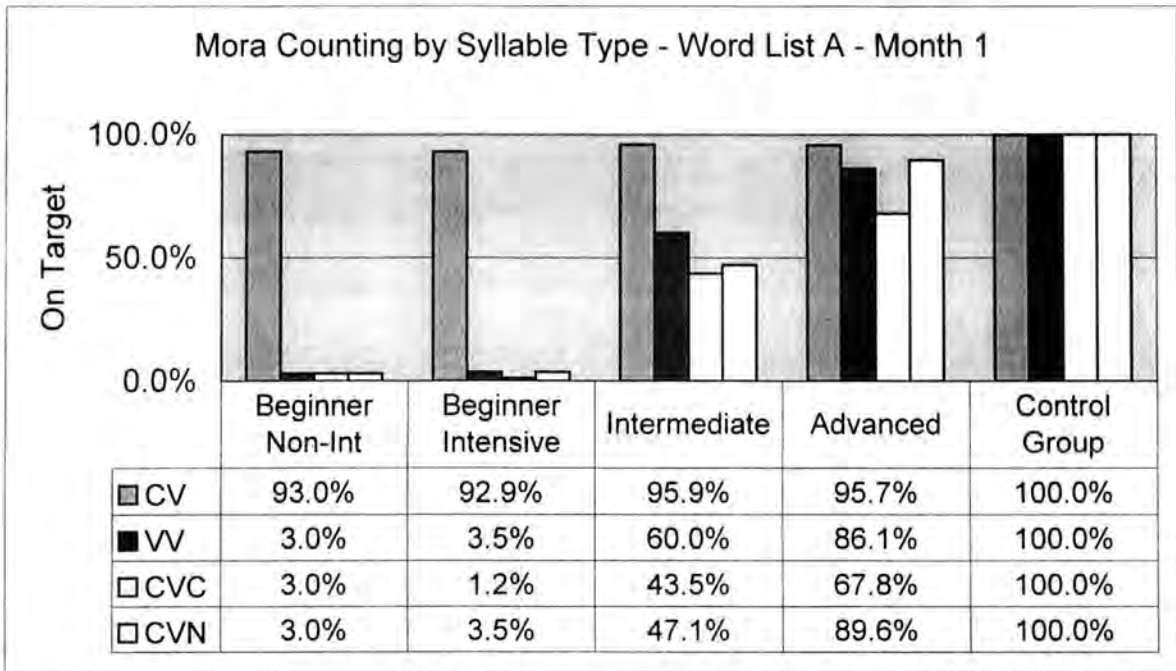

Figure 4.1 Mora Counting by Syllable Type – Word List A – Month 1

Category CV, the syllable type that is universally unmarked and also exists in English, presented little problem to all levels of learners, as was predicted in Chapter 2.

Category VV, long vowels, are counted as one syllable in both English and Japanese, but represented by multiple morae in Japanese. Most beginner-level learners of Japanese counted sound segments of such vowel sequences in terms of syllables and not in morae, indicating L1 influence. On the other hand, the intermediate and advanced-level learners show some sensitivity to morae although their scores are lower than the control groups'. Category CVC, the geminate consonants, presented the biggest problem to learners at all levels.

Moraic nasals, category CVN, were found to be the second least problematic for advanced-level learners, while all others found these just as difficult as other syllable types, as predicted in Chapter 2. However, moraic nasals are coda consonants and therefore, they are not counted as segments unless one is counting morae rather than syllables. This is more evidence that beginners are counting syllables rather than morae. Advanced-level learners, on the other hand, are more aware of mora than other learner groups, showing greater accuracy in counting number of morae.

The results suggest that participants with no prior knowledge of Japanese are segmenting words using their English syllable template. The results from more experienced learners of Japanese, however, suggest they segment words using Japanese morae. The ability to deploy the Japanese syllable template incorporating mora timing instead of the English syllable template depends on the level of proficiency in their Japanese. Advanced-level learners as predicted, seem to have identified morae most successfully in test words across the syllable categories of CV, VV, CVC and CVN. The most problematic syllable category out of four tested was the CVC, i.e., geminate consonants, type for all groups. Even the advanced-level learners have only managed to count just over 68% of geminate consonants. This evidence suggests that the advanced-level learners are still using a syllable template that is not yet fully Japanese.

Table 4.13 summarises the correlation between the results of mora counting by learner groups. As the highlighted figures show, there is a very strong correlation between the results of beginner non-intensive and intensive groups, beginner non-intensive and intermediate groups and beginner intensive and intermediate groups. There are also strong correlation between the results of the advanced-level learners and each of the remaining groups.

Table 4.13 Correlation Coefficients – Mora Counting – Word List A

	Beg Non-Int	Beg Intensive	Intermediate	Advanced
Beg Non-Int	1			
Beg Intensive	0.99969768	1		
Intermediate	0.95516674	0.959724527	1	
Advanced	0.605094559	0.624268799	0.706954362	1

The results from beginners in the non-intensive and intensive program show a high level of correlation. The results from intermediate group are also strongly correlated with those of beginners in both programme types. These correlation coefficients indicate that learners in these groups use similar strategies in mora counting.

4.2.2.2 Month 9

At Month 9, all participant groups were given the same mora counting task using Word List B. By then, non-intensive and intensive beginner groups had been split into two further sub-categories: treatment and non-treatment groups. The results are summarised in Table 4.14.

Table 4.14 Mora Counting – Word List B – Month 9

Test Words	Beginner Non Intensive				Beginner Intensive				Intermediate	Advanced	Control Group				
	No Inst		Inst		No Inst		Inst								
CV	1	80.0%	8	90.0%	9	90.0%	9	85.7%	6	94.1%	32	100.0%	23	100.0%	6
	2	90.0%	9	90.0%	9	90.0%	9	100.0%	7	97.1%	33	95.7%	22	100.0%	6
	3	80.0%	8	80.0%	8	80.0%	8	85.7%	6	97.1%	33	100.0%	23	100.0%	6
	4	90.0%	9	90.0%	9	90.0%	9	100.0%	7	91.2%	31	95.7%	22	100.0%	6
	5	90.0%	9	90.0%	9	90.0%	9	100.0%	7	100.0%	34	100.0%	23	100.0%	6
VV	6	10.0%	1	30.0%	3	40.0%	4	57.1%	4	76.5%	26	78.3%	18	100.0%	6
	7	10.0%	1	20.0%	2	30.0%	3	28.6%	2	79.4%	27	82.6%	19	100.0%	6
	8	0.0%	0	20.0%	2	30.0%	3	42.9%	3	85.3%	29	91.3%	21	100.0%	6
	9	0.0%	0	20.0%	2	20.0%	2	28.6%	2	76.5%	26	78.3%	18	100.0%	6
	10	10.0%	1	10.0%	1	30.0%	3	28.6%	2	88.2%	30	91.3%	21	100.0%	6
CVC	11	0.0%	0	10.0%	1	20.0%	2	28.6%	2	70.6%	24	65.2%	15	100.0%	6
	12	10.0%	1	10.0%	1	10.0%	1	28.6%	2	61.8%	21	60.9%	14	100.0%	6

	13	0.0%	0	10.0%	1	20.0%	2	42.9%	3	55.9%	19	60.9%	14	100.0%	6
	14	0.0%	0	20.0%	2	10.0%	1	28.6%	2	55.9%	19	56.5%	13	100.0%	6
	15	0.0%	0	20.0%	2	10.0%	1	28.6%	2	61.8%	21	60.9%	14	100.0%	6
CVN	16	10.0%	1	20.0%	2	20.0%	2	28.6%	2	76.5%	26	87.0%	20	100.0%	6
	17	10.0%	1	10.0%	1	10.0%	1	42.9%	3	91.2%	31	91.3%	21	100.0%	6
	18	0.0%	0	20.0%	2	20.0%	2	28.6%	2	88.2%	30	91.3%	21	100.0%	6
	19	10.0%	1	20.0%	2	10.0%	1	42.9%	3	91.2%	31	95.7%	22	100.0%	6
	20	10.0%	1	10.0%	1	20.0%	2	57.1%	4	97.1%	33	95.7%	22	100.0%	6
Mean		25.5%	2.6	34.5%	3.5	37.0%	3.7	50.7%	3.6	81.8%	27.8	83.9%	19.3	100.0%	6.0
No of subjects		10		10		10		7		34		23		6	

From Table 4.14, we observe two points: 1) Intermediate and advanced-level learners' results are very similar, 2) beginner groups who received treatment on Japanese syllable structure scored higher than those who did not.

Now let us analyse the data by syllable type, shown in Table 4.15 and Figure 4.4.

Table 4.15 Mora Counting Accuracy – Word List B – Month 9

TW	Beginner Non-Int No-Treatment	Beginner Non-Int Treatment	Beginner Intensive No Treatment	Beginner Intensive Treatment	Intermediate	Advanced	Control Group
	N = 50	N = 50	N = 50	N = 35	N = 170	N = 115	N = 30
CV	43 86.0%	44 88.0%	44 88.0%	33 94.3%	163 95.9%	113 98.3%	30 100.0%
VV	3 6.0%	10 20.0%	15 30.0%	13 37.1%	138 81.2%	97 84.3%	30 100.0%
CVC	1 2.0%	7 14.0%	7 14.0%	11 31.4%	104 61.2%	70 60.9%	30 100.0%
CVN	4 8.0%	8 16.0%	8 16.0%	14 40.0%	151 88.8%	106 92.2%	30 100.0%

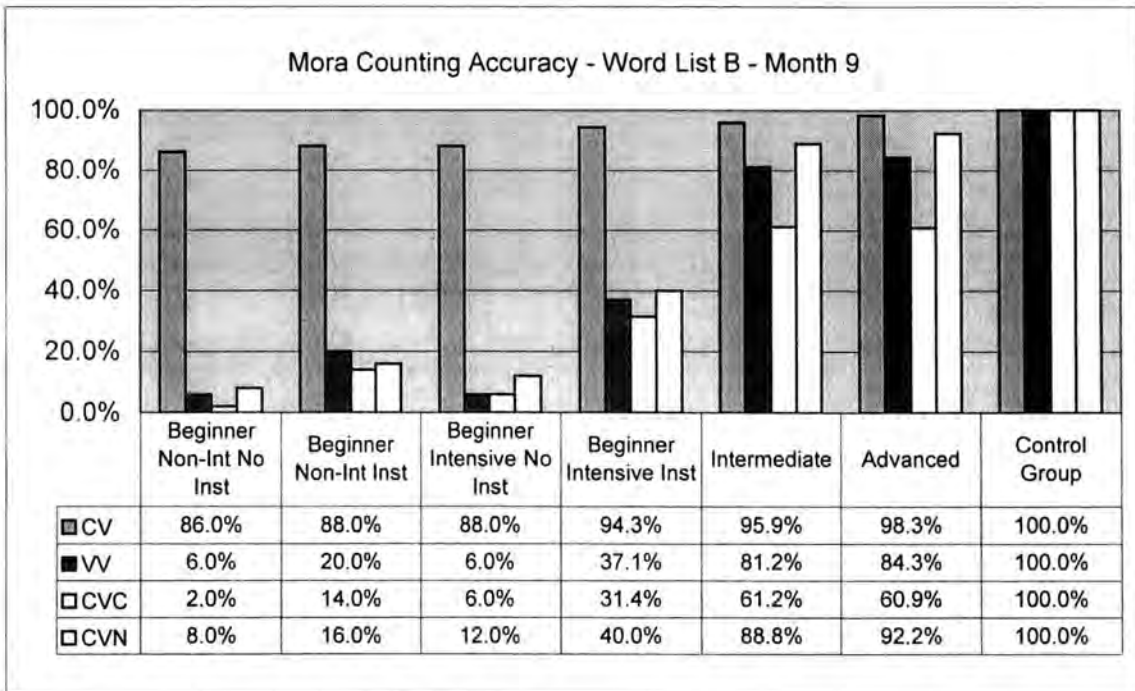

Figure 4.2 Mora Counting Accuracy – Word List B – Month 9

Figure 4.2 shows that all learner groups found CV syllables by far the easiest and CVC syllables the most difficult.

Table 4.16 summarises the correlation between each learner group results.

Table 4.16 Correlation Coefficients – Mora Counting – Word List B

	Beg NI NT	Beg NI T	Beg Int NT	Beg Int T	Intermediate	Advanced
Beg NI NT	1					
Beg NI T	0.99781426	1				
Beg Int NT	0.98071326	0.99035158	1			
Beg Int T	0.99818248	0.99438804	0.97899198	1		
Intermediate	0.67495152	0.656702	0.67215456	0.71809521	1	
Advanced	0.63261476	0.61505456	0.63560235	0.67792553	0.99818387	1

Key: NI = non-intensive, Int = intensive, NT = no treatment, T = with treatment

The highlighted figures indicate very strong correlations between all beginner groups, and between intermediate and advanced level learners. The results also show

that both advanced and intermediate-level learners show a strong correlation with each of the beginner groups. These results suggest that all beginner groups share a similar mora counting strategies, even though they had been receiving different amount of exposure to Japanese depending on the courses they were taking. The results also suggest that intermediate level learners have become more like advanced level learners after 9 months and they share similar mora counting strategies with the advanced level learners rather than with the beginners.

4.2.2.3 Month 1 to Month 9 – Mora Counting

Now let us compare these results with those of Word List A at Month 1. First, we look at the results of beginners.

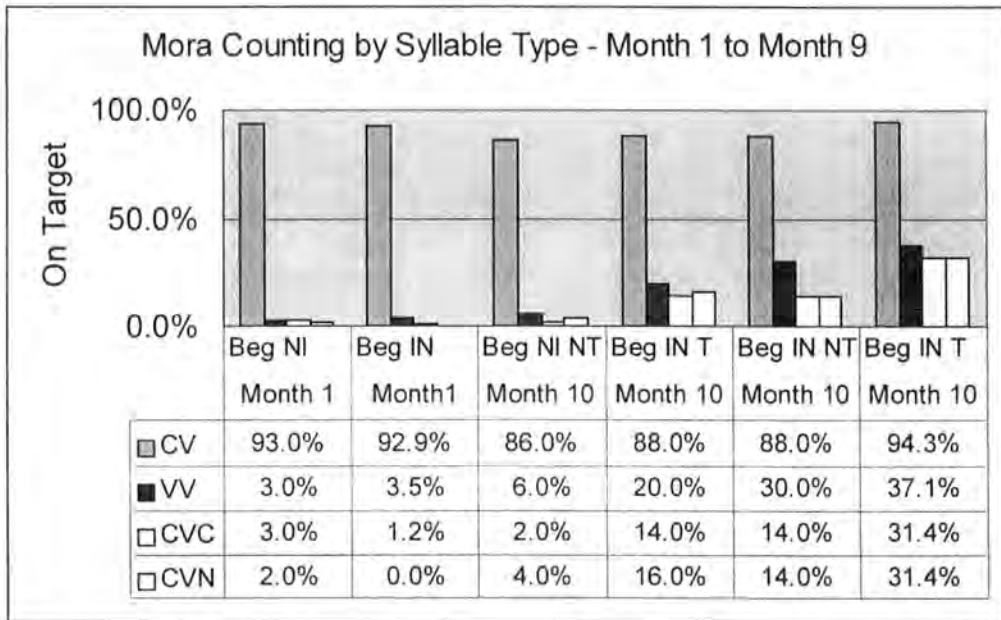

Figure 4.3 Mora Counting by Syllable Type – Month 1 to Month 9

Amongst beginner groups, those on the intensive programme with treatment scored the highest, followed by those on the non-intensive course with treatment. The remaining two sub-groups showed little difference in their scores. These results indicate that beginners who received treatment on Japanese syllable structure became

more sensitive to Japanese mora. Even beginners on non-intensive programmes, where a fraction of formal instruction offered by the intensive programmes was given, were better able to identify morae when they had received specific instruction in Japanese syllable structure.

Neither intermediate nor advanced-level learners received treatment with regard to Japanese syllable structure. However, they had been exposed to Japanese input for a further nine months by the time they were given the mora counting task using Word List B.

Let us now have a look at the results of intermediate and advanced level learners over the 9 months.

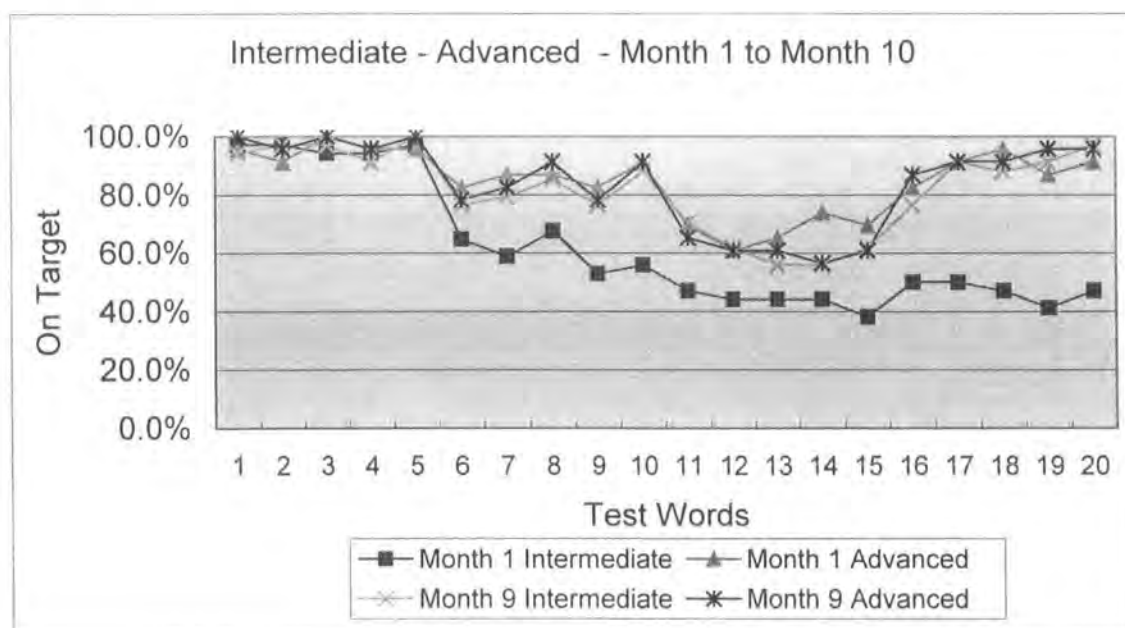

Figure 4.4 Intermediate – Advanced – Month 1 to Month 10

Figure 4.4 shows that, while there is very little difference in advanced-level learners performance in tasks using Word List A at Month 1 or B at Month 9, intermediate-level learners have improved markedly to the point of being on par with

advanced-level learners. This analysis is supported by the correlation coefficient of 0.97295 as shown in Table 4.17.

Table 4.17 Correlation Coefficients – Intermediate and Advanced Level Learners

	Month 1 Intermediate	Month 1 Advanced	Month 9 Intermediate	Month 9 Advanced
Month 1 Intermediate	1			
Month 1 Advanced	0.648923975	1		
Month 9 Intermediate	0.643570083	0.920181661	1	
Month 9 Advanced	0.640796105	0.938368025	0.972950024	1

We have seen that, while intermediate-level learners have reached advanced-level proficiency in identifying morae in unfamiliar words after 9 months, beginners, even those who were on an intensive programme and had received extra instruction had not yet reached the level of the intermediate-level learners at Month 9. This seeming anomaly may be explained by the fact that those beginners had not yet been classified as intermediate-level learners after ten months' intensive instruction by the definition used for this study. Indeed, most beginners, even those on intensive programmes need to spend at least another year of intensive study before they can be classified as intermediate-level learners for the purpose of this study. Extra treatment given to a subset of beginners was effective, but not enough to bridge the gap represented by one to two years work/study living in Japan.

Two groups whose scores showed few change in tasks using Word List A and Word List B are the non-intensive beginners and advanced-level learners. Beginners on the non-intensive courses had received only 44 to 45 hours instruction, less than a fifth of those on the intensive courses. Lack of input in terms of quantity and quality as measured by their relevance to their learning need and promote acquisition either in the form of targeted instruction or rich naturalistic environment affording variety of comprehensible input, seem to be the sole cause of their slow development. The fact

that there was no further improvement for advanced learners over the ten months indicates that perhaps there is a limit to what adult learners can achieve in terms of native-like competence, i.e. their interlanguage was now stable.

4.2.3 Written Production and Oral Production Tasks at Month 1

Following the mora counting task, participants were asked to write down the words they heard in either the Roman alphabet or in Kana. All in intermediate and advanced subjects used Kana, supplemented by the Roman alphabet when they were not sure, and the beginner-level learners used the Roman alphabet. Written production errors in the choice of consonants, e.g., “ta” instead of “sa” or ill-formed letters were not counted as errors for the purpose of this study, as our main concern here was the ability to write the correct number of sound segments, i.e., mora, or syllable. The phonemic inaccuracy was given secondary consideration while length of segment was studied closely for signs of substitution of segments and compensation for mora deletion.

Recorded materials were then analysed in terms of mora awareness and syllable template usage by the researcher and two Japanese language teacher.

The way participants deleted or inserted sound segments, i.e., vowels or consonants, is summarised by syllable type in the tables. I take the deletion of sound segments as an indication that the subject did not perceive them. Insertion, on the other hand may indicate that the subject is merely applying their L1 syllable template and ignoring the sound segment or not noticing the timing element of mora, or being over sensitive and over generalising.

Let us now look at the results of the written production and oral production tasks by each learner group.

4.2.3.1 Beginner Level Learners

In this section, we look at the results of only beginners first in written production, then in production.

First, Figure 4.5 shows the results of the two beginner groups: those who were on non-intensive courses and those who were on an intensive Japanese language courses.

Deletions in percentages are shown on the left two columns, and insertions on the right two columns. Minus 1 and minus 2 indicate that one mora or two morae were deleted, while plus 1 and 2 indicate one mora and two morae were inserted. The zero columns show the percentage of subjects who gave the same number of morae as the control group did.

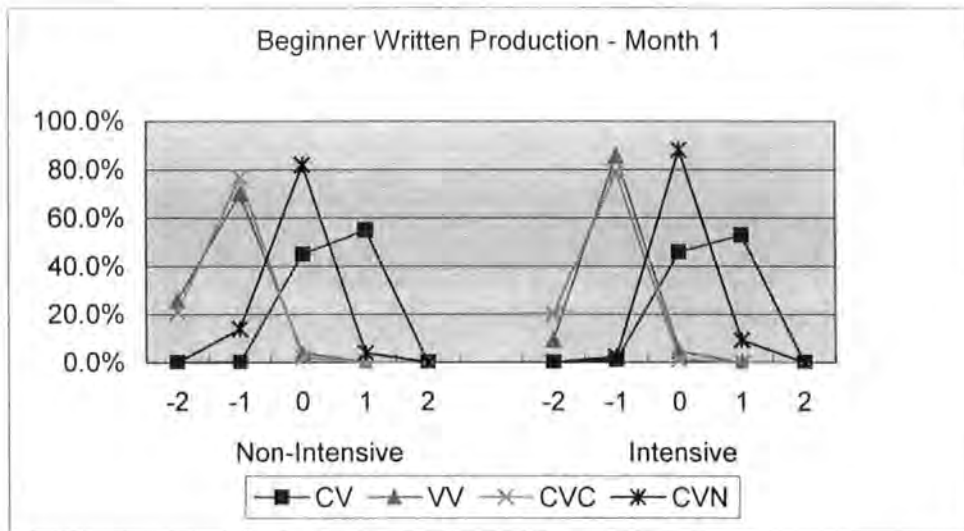

Figure 4.5 Beginner Written Production – Month 1

From Figure 4.5, we observe that both non-intensive and intensive groups tended to delete a mora in VV and CVC syllables, both of which are not apparent in orthography in their L1. Neither group deleted or inserted morae in CVN syllables. We

can see another evidence of L1 influence here, as nasals are always orthographically apparent in English.

Table 4.18 gives full details.

Table 4.18 Beginner – Written Production – Month 1

No of μ	Non-Intensive (N = 20)				Intensive (N = 17)			
	CV	VV	CVC	CVN	CV	VV	CVC	CVN
-2	0.0% 0	26.0% 26	21.0% 21	0.0% 0	0.0% 0	9.4% 8	20.0% 17	0.0% 0
-1	0.0% 0	70.0% 70	77.0% 77	14.0% 14	11.8% 1	85.9% 73	78.8% 67	2.4% 2
0	45.0% 45	4.0% 4	2.0% 2	82.0% 82	45.9% 39	4.7% 4	1.2% 1	88.2% 75
1	55.0% 55	0.0% 0	0.0% 0	4.0% 4	52.9% 45	0.0% 0	0.0% 0	9.4% 8
2	0.0% 0	0.0% 0	0.0% 0	0.0% 0	0.0% 0	0.0% 0	0.0% 0	0.0% 0

(Total number of tokens for each syllable category: Non-intensive = 100, Intensive = 85)

As beginners from both groups had only just started learning Japanese, at this stage there was very little difference across group in the pattern of their deletions and insertions. Both learner groups have inserted extra vowels in over 50% of CV words. On the other hand, many (85.9% and 70.0% of beginners on both intensive and non-intensive courses respectively) deleted vowels in VV words. A large majority of participants failed to write geminate consonants.

Though neither learner group recognised moraic nasals as independent sound segments, thus providing evidence to support the hypothesis that beginners are using their English syllable template to process Japanese words, they indeed perceived the existence of nasals as over 80% of beginners wrote them correctly.

Tables 4.19 and 4.20 show the breakdown of deletions and insertions together with substitutions.

Table 4.19 Written Production of Mora by Beginners – Non-Intensive – Month 1

Type	C-insertion	C-deletion	V-insertion	V-deletion	Substitution
CV	0.0% 0	0.0% 0	57.0% 57	2.0% 2	2.0% 2
VV	0.0% 0	0.0% 0	3.0% 3	99.0% 99	3.0% 3
CVC	0.0% 0	98.0% 98	0.0% 0	0.0% 0	0.0% 0
CVN	0.0% 0	14.0% 14	4.0% 4	0.0% 0	0.0% 0

N = 20

Table 4.20 Written Production of Mora by Beginners – Intensive – Month 1

Type	C-insertion	C-deletion	V-insertion	V-deletion	Substitution
CV	0.0% 0	0.0% 0	54.1% 46	2.4% 2	1.2% 1
VV	0.0% 0	0.0% 0	3.5% 3	98.8% 84	3.5% 3
CVC	0.0% 0	98.8% 84	0.0% 0	0.0% 0	0.0% 0
CVN	0.0% 0	2.4% 2	9.4% 8	0.0% 0	0.0% 0

N = 17

A small number of participants (3.0% and 3.5% of non-intensive and intensive learners respectively) altered vowel quantity within the word, i.e., made short vowels long and long vowels short, but on the whole, they showed a tendency to delete the latter of consecutive vowels.

We next look at the oral production results at Month 1, for which the learners were asked to repeat orally a list of target words from Word List A. The results are summarised in Figure 4.6 and Table 4.21.

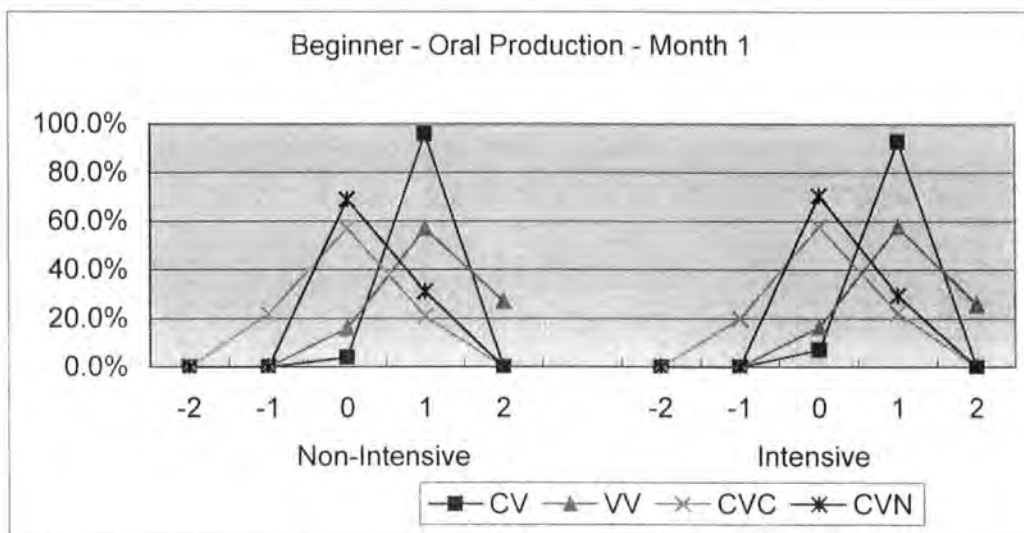

Figure 4.6 Beginner – Oral Production – Month 1

Table 4.21 Beginner – Oral Production – Month 1

No of μ	Non-Intensive (N = 20)				Intensive (N= 17)			
	CV	VV	CVC	CVN	CV	VV	CVC	CVN
-2	0.00% 0	0.00% 0	0.00% 0	0.00% 0	0.00% 0	0.00% 0	0.00% 0	0.00% 0
-1	0.00% 0	0.00% 0	22.00% 22	0.00% 0	0.00% 0	0.00% 0	20.00% 17	0.00% 0
0	4.00% 4	16.00% 16	57.00% 57	69.00% 69	7.10% 6	16.50% 14	57.60% 49	70.60% 60
1	96.00% 96	57.00% 57	21.00% 21	31.00% 31	92.90% 79	57.60% 49	22.40% 19	29.40% 25
2	0.00% 0	27.00% 27	0.00% 0	0.00% 0	0.00% 0	25.90% 22	0.00% 0	0.00% 0

Unlike the mora counting results in Task 1, most participants had difficulty in reciting CV words without inserting extra vowels, i.e., lengthening short vowels.

Upon closer examination of the consonant and vowel deletion and insertion shown in Tables 4.22 and 4.23, we observe that some learners in both learner groups have substituted geminate consonants in the CVC words with long vowels. For example, *kakke* was replaced by *kaake*. Indeed, 46.0% (the Non-Intensive) and 43.5% (the Intensive) of what appeared to be correct answers actually constituted of substitution of this kind.

Table 4.22 Beginner – Non-Intensive – Oral Production – Month 1

Type	C-insertion	C-deletion	V-insertion	V-deletion	Substitution
CV	0.0% 0	0.0% 0	98.0% 98	2.0% 2	2.0% 2
VV	0.0% 0	0.0% 0	84.0% 84	0.0% 0	0.0% 0
CVC	0.0% 0	68.0% 68	67.0% 67	0.0% 0	46.0% 46
CVN	0.0% 0	0.0% 0	31.0% 31	0.0% 0	0.0% 0

N = 20

Table 4.23 Beginner – Intensive – Oral Production – Month 1

Type	C-insertion	C-deletion	V-insertion	V-deletion	Substitution
CV	0.0% 0	0.0% 0	92.9% 79	0.0% 0	0.0% 0
VV	0.0% 0	0.0% 0	83.5% 71	0.0% 0	0.0% 0
CVC	0.0% 0	63.5% 54	65.9% 56	0.0% 0	43.5% 37
CVN	0.0% 0	0.0% 0	29.4% 25	0.0% 0	0.0% 0

N = 17

From these results, we postulate that neither learner group detect the presence of geminate consonants, but on repetition, they unconsciously insert vowels to make the syllable bi-moraic. We may further postulate that there is a mora conservation rule at work here as discussed in Chapter 1.

4.2.3.2 Intermediate Level Learners

We next look at the results of intermediate learners.

Intermediate-level learners underwent the same procedure as the beginners and the results are shown in Figure 4.7 and Table 4.24.

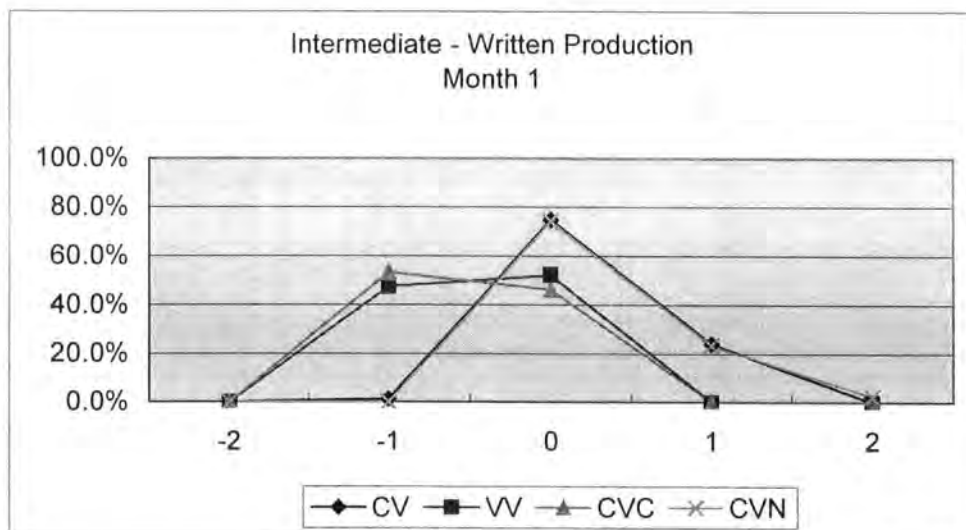

Figure 4.7 Intermediate – Written Production – Month 1

Table 4.24 Intermediate – Written Production – Month 1

No of μ	Intermediate (N = 34)			
	CV	VV	CVC	CVN
-2	0.00% 0	0.00% 0	0.00% 0	0.00% 0
-1	1.20% 2	47.60% 81	53.50% 91	0.00% 0
0	74.70% 127	52.40% 89	46.50% 79	74.10% 126
1	24.10% 41	0.00% 0	0.00% 0	23.50% 40
2	0.00% 0	0.00% 0	0.00% 0	2.40% 4

Compared with beginners, it is noticeable that the intermediate-level learners did less well in writing moraic nasals. There is also a distinct difference in repetition of moraic nasals compared with the other syllable types: only in the CVN syllable type did participants insert sound segments, in this case, vowels. By inserting vowels, participants were transforming moraic nasals into onset consonants. For example, *bokin* (TW17, Word List A) became *bokinu*, while *hensen* (TW19, Word List A) became *henusenu*. A small number of participants (5%) inserted a CV in addition to the moraic nasal. An example of this was *hensen* (TW19, Word List A) becoming *hennusen*.

As we have established in Chapter 2, the phonetic difference between moraic nasals and onset nasals is in their length; onset being much shorter, and phonologically there is no moraic value given to it. Intermediate-level learners are becoming aware of this timing property of Japanese mora, but not yet are they proficient enough to distinguish moraic nasals and onset nasals accurately. Their sensitivity to moraic nasals may have resulted in overcompensation. This indicates that their IL is unstable during the process of learning.

The breakdown of consonant insertions and deletions, vowel insertions and deletions, and substitutions and compensation is summarised in Table 4.25.

Table 4.25 Intermediate – Written Production – Month 1

Type	C-insertion	C-deletion	V-insertion	V-deletion	Substitution
CV	0.0% 0	0.0% 0	25.9% 44	2.9% 5	1.8% 3
VV	3.5% 6	0.0% 0	6.5% 11	57.6% 98	10.0% 17
CVC	0.0% 0	62.4% 106	8.8% 15	0.0% 0	8.8% 15
CVN	5.3% 9	8.2% 14	28.8% 49	0.0% 0	8.2% 14

N = 34

From Table 4.25 we can ascertain that those who have inserted vowels in CVN words have in fact substituted moraic nasals with onset nasals. A small number (5%) of participants repeated nasals in such a way that a moraic nasal was followed by a CV with a nasal as onset. This suggests that participants were not able to perceive the timing element of the moraic nasal.

We next examine oral production data from 34 intermediate-level participants, as summarised in Figure 4.8 and Table 4.26.

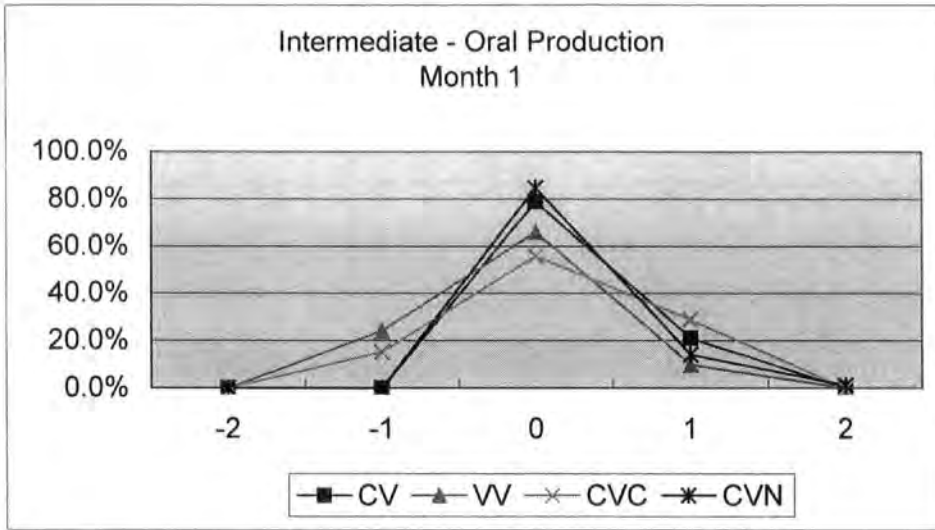

Figure 4.8 Intermediate – Oral Production – Month 1

Table 4.26 Intermediate – Oral Production – Month 1

No of μ	Intermediate (N = 34)			
	CV	VV	CVC	CVN
-2	0.00% 0	0.00% 0	0.00% 0	0.00% 0
-1	0.00% 0	24.10% 41	15.30% 26	0.00% 0
0	78.80% 134	65.90% 112	55.90% 95	84.70% 144
1	21.20% 36	10.00% 17	28.80% 49	14.10% 24
2	0.00% 0	0.00% 0	0.00% 0	1.20% 2

Compared with the written production results, intermediate-level participants show a tendency to insert morae on the oral production task. The breakdown of consonants and vowel insertions and deletions, together with substitutions is summarised in Table 4.27.

Table 4.27 Intermediate – Oral Production – Month 1

Type	Intermediate (N = 34)				
	C-insertion	C-deletion	V-insertion	V-deletion	Substitution
CV	0.00% 0/170	0.00% 0/170	27.06% 46/170	5.88% 10/170	5.88% 10/170
VV	3.53% 6/170	0.00% 0/170	10.59% 18/170	28.24% 48/170	4.12% 7/170
CVC	0.00% 0/170	42.94% 73/170	56.47% 96/170	0.00% 0/170	27.65% 47/170
CVN	7.65% 13/170	6.47% 11/170	14.12% 24/170	0.00% 0/170	6.47% 11/170

Intermediate-level learners not only deleted but also inserted vowels in the VV syllables. Words such as *noori* (TW8, Word List A) became *norii*, and *kuuiki* (TW9, Word List A) became *kuikii*. Also, they substituted geminate consonants with long vowels. For example, *kakke* (TW 12, Word List A) became *kaake* or *kaakee*, and *setta* (TW13, WLA) became *seeta*.

Where CVC and CVN syllables are concerned, intermediate-level learners were more accurate in getting the number of morae right in oral production than in written production. For CV and VV syllables, however, they were more accurate in written production than in production. The patterns of their performance are dissimilar to those of beginners.

4.2.3.3 Advanced Level Learners

Advanced-level learners have, as expected, managed to write words more accurately than all other learner groups. The results of written production task are summarised in Figure 4.9 and Table 4.28.

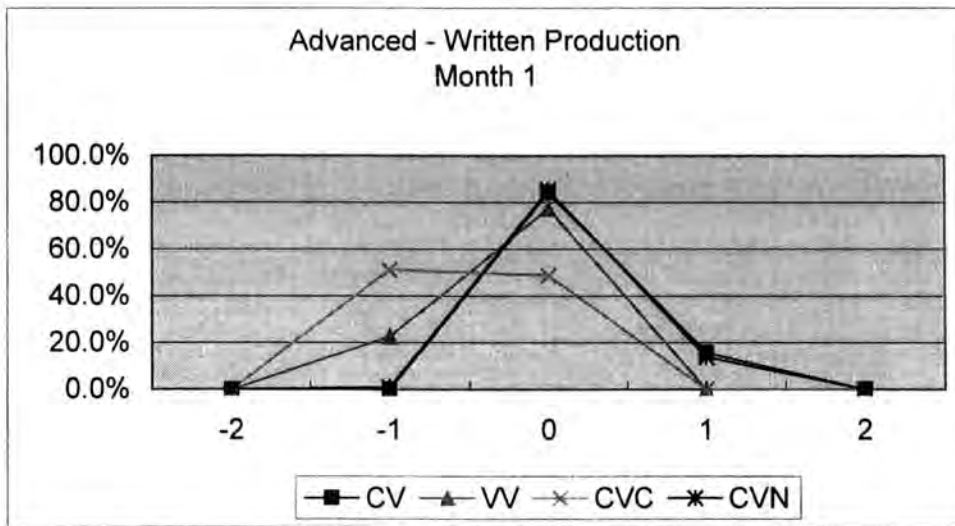

Figure 4.9 Advanced – Written Production – Month 1

Table 4.28 Advanced – Written Production – Month 1

No of μ	Advanced (N = 23)			
	CV	VV	CVC	CVN
-2	0.00% 0	0.00% 0	0.00% 0	0.00% 0
-1	0.00% 0	22.60% 26	51.30% 59	0.90% 1
0	84.30% 97	77.40% 89	48.70% 56	85.20% 98
1	15.70% 18	0.00% 0	0.00% 0	13.90% 16
2	0.00% 0	0.00% 0	0.00% 0	0.00% 0

(Total number of tokens per syllable category = 115)

Advanced-level learners had little difficulty in writing accurately CV and CVN syllable types. There were, however, some occasions (12%) where they inserted extra segments in words containing CVN. Words containing VV and CVC on the other hand showed a general tendency towards deletions. Though to a lesser extent compared with intermediate-level learners, advanced-level learners' interlanguage syllable

template does not account for all morae in VV and CVC syllables. The breakdown of consonants and vowel deletions and insertions are summarised in Table 4.29.

Table 4.29 Advanced – Written Production - Month 1

Type	C-insertion	C-deletion	V-insertion	V-deletion	Substitution
CV	0.0% 0	0.0% 0	15.7% 18	0.0% 0	0.0% 0
VV	3.5% 4	0.0% 0	7.0% 8	33.0% 38	10.4% 12
CVC	0.0% 0	60.0% 69	8.7% 10	0.0% 0	8.7% 10
CVN	5.2% 6	6.1% 7	13.9% 16	0.0% 0	5.2% 6

In syllable type CVN, as was the case with other learner groups, some advanced-level learners not only substituted moraic nasals with onset nasals but inserted additional onset consonants and associating vowels.

Figure 4.10 and Table 4.30 attest advanced-level participants have scored a high percentage of correct number of morae in production.

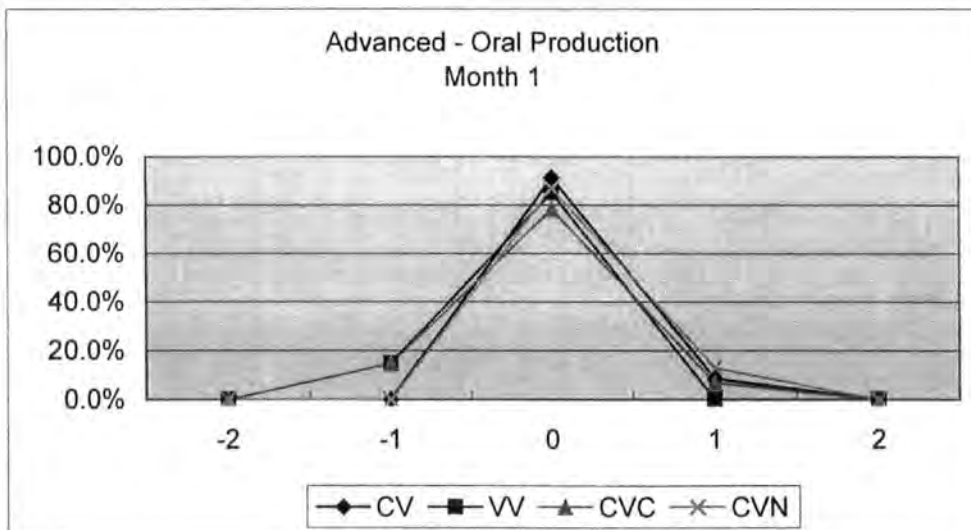

Figure 4.10 Advanced – Oral Production – Month 1

Table 4.30 Advanced – Oral Production – Month 1

No of μ	Advanced (N = 23)			
	CV	VV	CVC	CVN
-2	0.00% 0	0.00% 0	0.00% 0	0.00% 0
-1	0.00% 0	14.80% 17	14.80% 17	0.00% 0
0	91.30% 105	85.20% 98	78.30% 90	87.00% 100
1	8.70% 10	0.00% 0	7.00% 8	13.00% 15
2	0.00% 0	0.00% 0	0.00% 0	0.00% 0

(Total number of tokens per syllable type = 115)

However, as Table 4.31 shows, the correct numbers of morae were achieved by combination of deletions and insertions.

Table 4.31 Advanced – Oral Production – Month 1

Type	Advanced (N = 23)				
	C-insertion	C-deletion	V-insertion	V-deletion	Substitution
CV	0.00% 0/115	0.00% 0/115	15.70% 18/115	7.00% 8/115	7.00% 8/115
VV	5.20% 6/115	0.00% 0/115	7.00% 8/115	27.00% 31/115	12.20% 14/115
CVC	0.00% 0/115	72.20% 83/115	64.30% 74/115	0.00% 0/115	57.40% 66/115
CVN	3.50% 4/115	5.20% 6/115	14.80% 17/115	0.00% 0/115	5.20% 6/115

It is particularly noticeable that CVC syllable type attracted 49.2% of substitutions and compensation of geminate consonants with long vowels. Also, in the VV category, some advanced-level learners inserted geminate consonants in place of vowel clusters.

This indicates that advanced learners are sensitive to morae as a timing units, but have not yet achieved native Japanese phonological competence to recognise where the morae are to be assigned: rime as vowels or coda as geminate consonants. This indicates that participants were sensitive to morae in geminate consonants, but cannot realise them as such in production.

4.2.3.4 Cross-sectional Comparison: Development

Now we compare the performance of each learner group in terms of the written production task.

Figure 4.11 summarises the written production accuracy by all learner groups at Month 1.

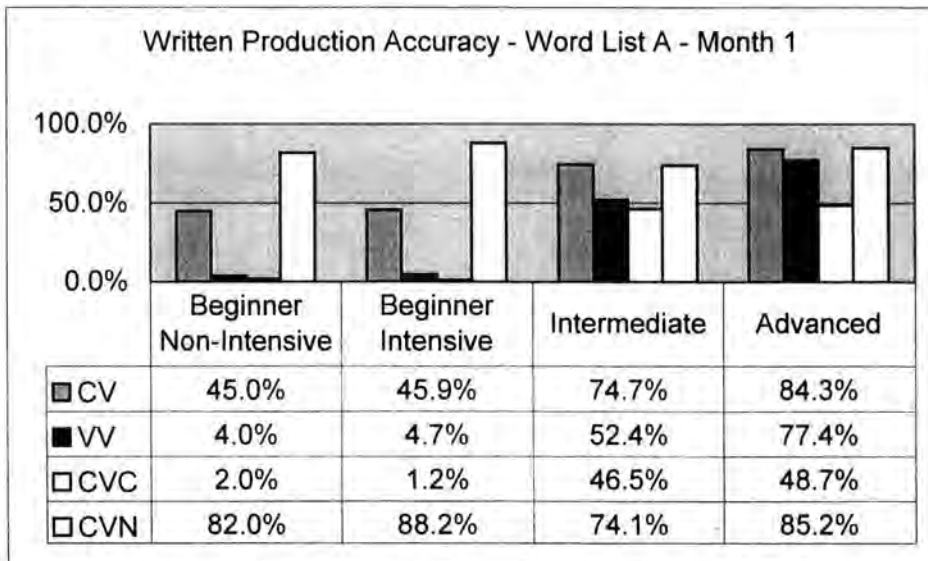

Figure 4.11 Written Production Accuracy – Word List A – Month 1

In the writing of words in the Word List A, advanced-level participants scored the highest over all, closely followed by the intermediate-level participants. The patterns of scores by syllable type resemble one another: the first acquired being the CV type, followed by CVN, then VV, and the most difficult being the CVC. Beginners performed

less well than their intermediate and advanced-level counterparts in all syllable types except CVN. While advanced and intermediate-level participants showed a minor tendency to substitute moraic nasals with onset nasals, none of the beginner-level participants did. We may infer that those who have no prior knowledge that Japanese has a distinctive moraic nasal are not likely to make substitutions of this kind.

Furthermore, Kana scripts that distinguish moraic nasals and onset nasals were disadvantageous to intermediate and advanced level learners. For example, an onset nasal manifests itself in one of five possibilities in Japanese: な na, に ni, ぬ nu, ね ne, の no, as discussed in Chapter 2. A moraic nasal, on the other hand, is written as ん n. While beginners who write words in the Roman alphabet have to identify only one grapheme, the intermediate and advanced level learners have to choose one of the six graphemes to represent a nasal. This can lead to added difficulties to the intermediate and advanced-level learners, hence there are more possibilities for confusions in case of CVN syllable type in case of the intermediate and advanced level learners.

As we have seen in previous sections, the advanced level and intermediate-level participants were more prone to use substitutions. Consequently, though written production may have been correct in the number of morae, it may not necessarily represent target answers. Taking these substitutions and alterations into consideration, and omitting double-counting and counter-balancing effects from the previous assessment, adjusted written production data is summarised as Figure 4.12.

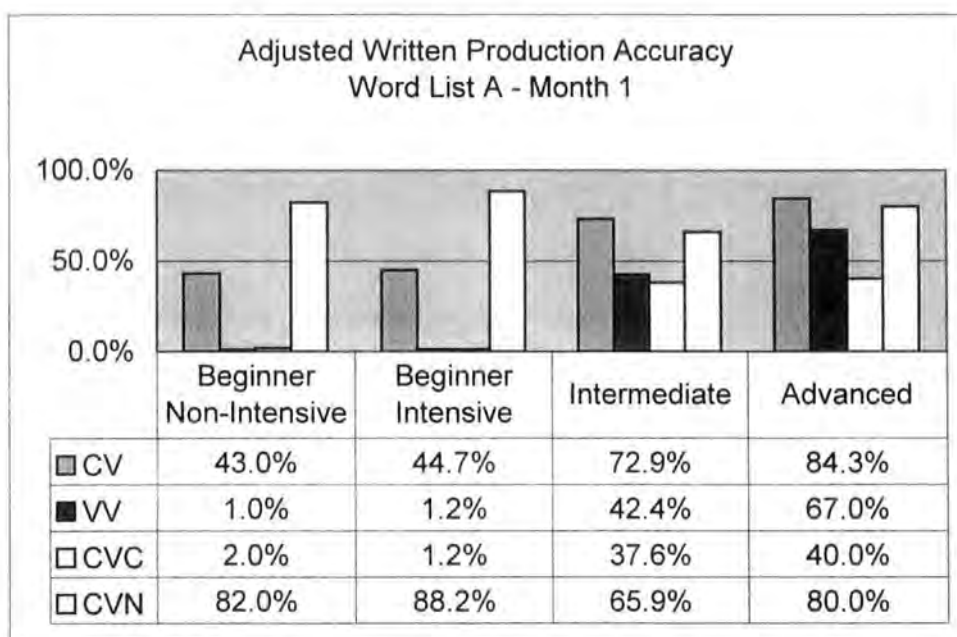

Figure 4.12 Adjusted Written Production Accuracy – Word List A – Month 1

We can now see that advanced-level learners have managed to score 40.0% in recognising and writing geminate consonants, while intermediate-level participants scored 37.6 %, beginners on intensive and non-intensive programmes 1.2% and 2.0% respectively. Both learner groups substitute geminate consonants with long vowels.

Next, we compare results from the oral production task.

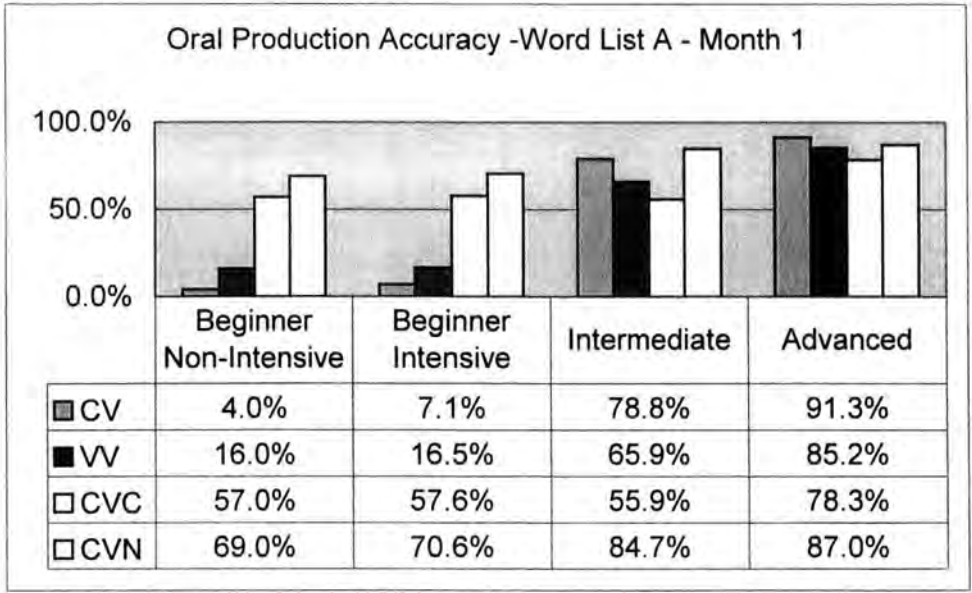

Figure 4.13 Oral Production Accuracy – Word List A – Month 1

Taking substitution and compensation into consideration, adjusted data is summarised in Figure 4.14.

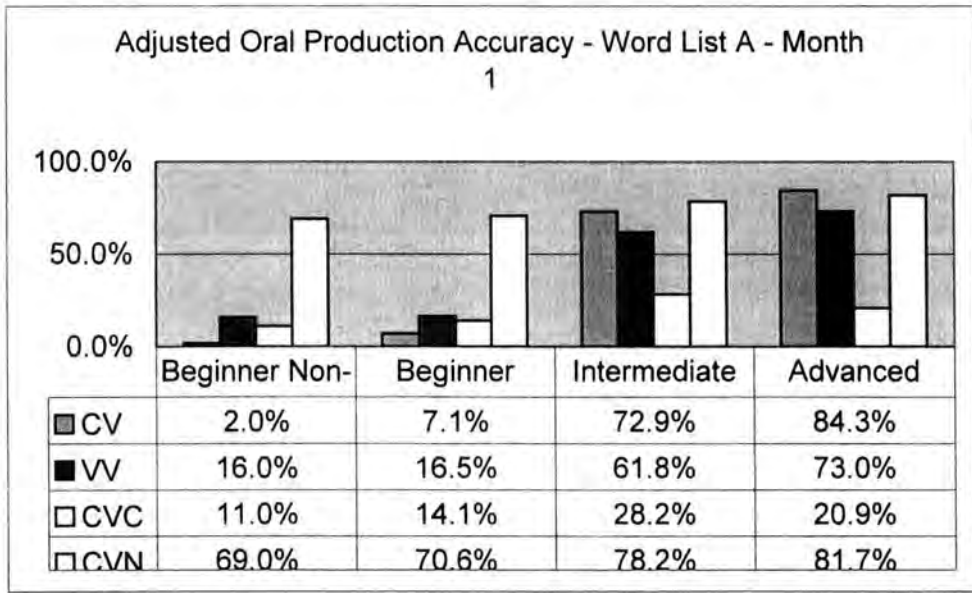

Figure 4.14 Adjusted Oral Production Accuracy – Word List A – Month 1

After adjustments, the oral production performance patterns of advanced and intermediate-level learners are now very similar to that of written production data.

Beginner-level learners, however, are still showing very low scores in the CV syllable type, as almost all of them produced lengthened vowels.

The CVC syllable results for beginners are markedly higher than those of the intermediate and advanced level learners. This may be explained by the tendency of beginners to lengthen all short vowels. Beginners were not conscious of geminate consonants or indeed the mora timing. It was incidental that they mistook the geminate consonants as stressed vowels (see Chapter 1), and the results showed either lengthened vowels or indeed geminate consonants. This analysis is supported by the fact that all beginners had difficulty in the writing of geminate consonants and they also did not write geminate consonants.

From these data, we postulate that more experienced level learners are better able to control vowel length, even though they are not very able to control the length of morae assigned to geminate consonants.

4.2.4 Development of Mora Awareness: Month 1 to Month 9

Beginner-level participants, who had been sub-categorised into treated and not-treated groups with the former groups receiving extra instruction on an on-going basis, took written production and oral production tasks in Month 2 and Month 9. At Month 9, all beginners were given mora-counting task.

In this section, we compare and contrast the results of written and oral production tasks at Month 1 to Month 9 and examine the way beginners progressed in terms of Japanese syllable template acquisition.

4.2.4.1 Written Production

We first look at written production data by syllable type as shown by written production and then production data.

Figure 4.15 presents the learners' development shown by written production over 9 months. The first column shows Month 1 data, the second column Month 2, the third Month 9 all using Word List A, and the last column shows the results of written production and production tasks using Word List B at Month 9.

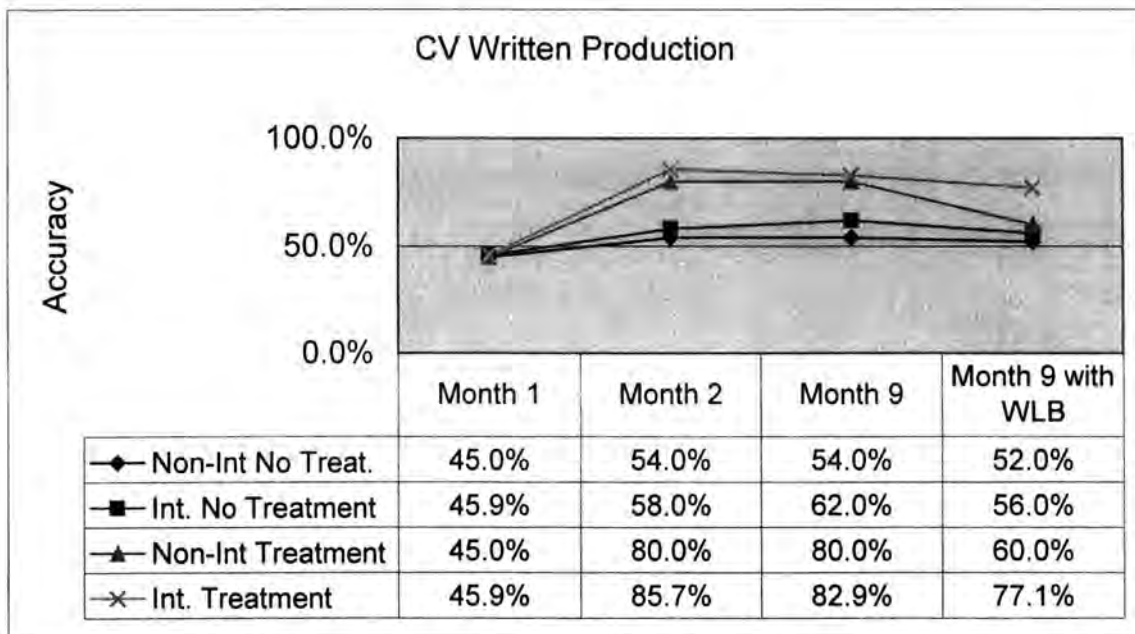

Figure 4.15 CV Written Production

Figure 4.15 shows that the learners on the intensive programme with extra instruction have improved the most. Overall, however, all learner groups performed better at Month 2 and Month 9 using Word List A than Month 9 using Word List B. This is to be expected considering all learners have studied Japanese for 9 months by the time they were faced with Word List B. Even though words on Word List B were just as unfamiliar as Word List A at Month 1, learners' general awareness of Japanese syllables has increased over the period. None of learner groups performed better in Word List B than in Word List A, because by then, the level of unfamiliarity with Word List A was not as big problem as was with Word List B.

Next, we will have a look at the VV syllable type results as summarised in Figure 4.16.

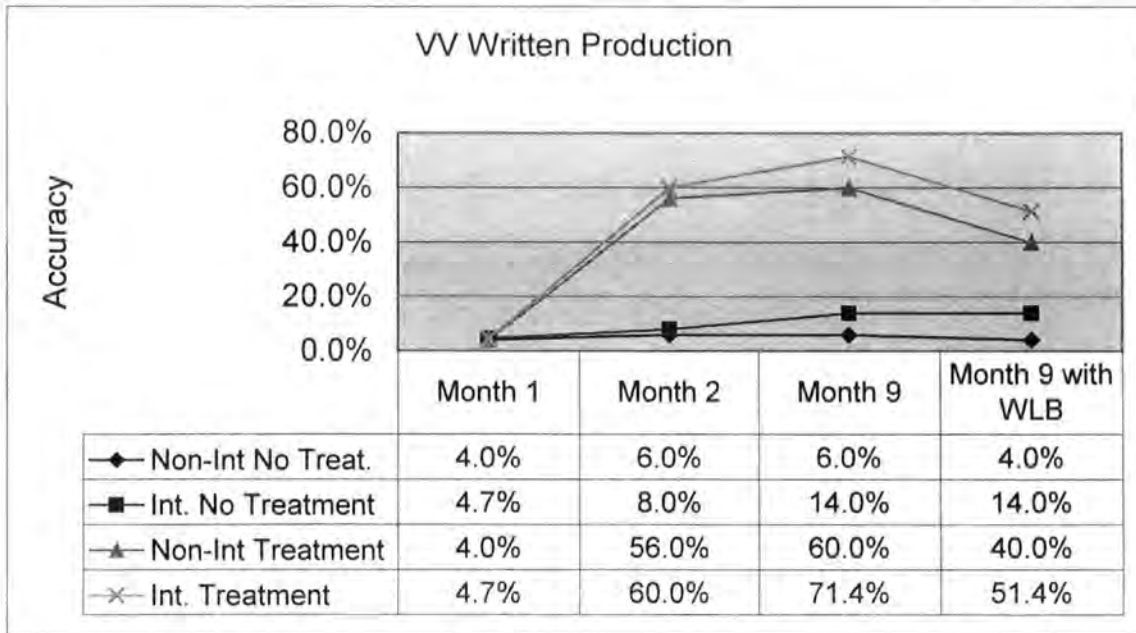

Figure 4.16 VV Written Production

Figure 4.16 shows that again, instructed groups performed better than non-instructed groups even at Month 9 with Word List B. Scores of each group, however, went down with Word List B. As was the case with CV syllables, the reason for this was Word List B, which contained completely new unknown words to all learners. It would appear that, compared with CV syllables, which were unmarked, recognising and writing vowel clusters were more difficult.

Next, we look at the CVC syllable data, as presented in Figure 4.17.

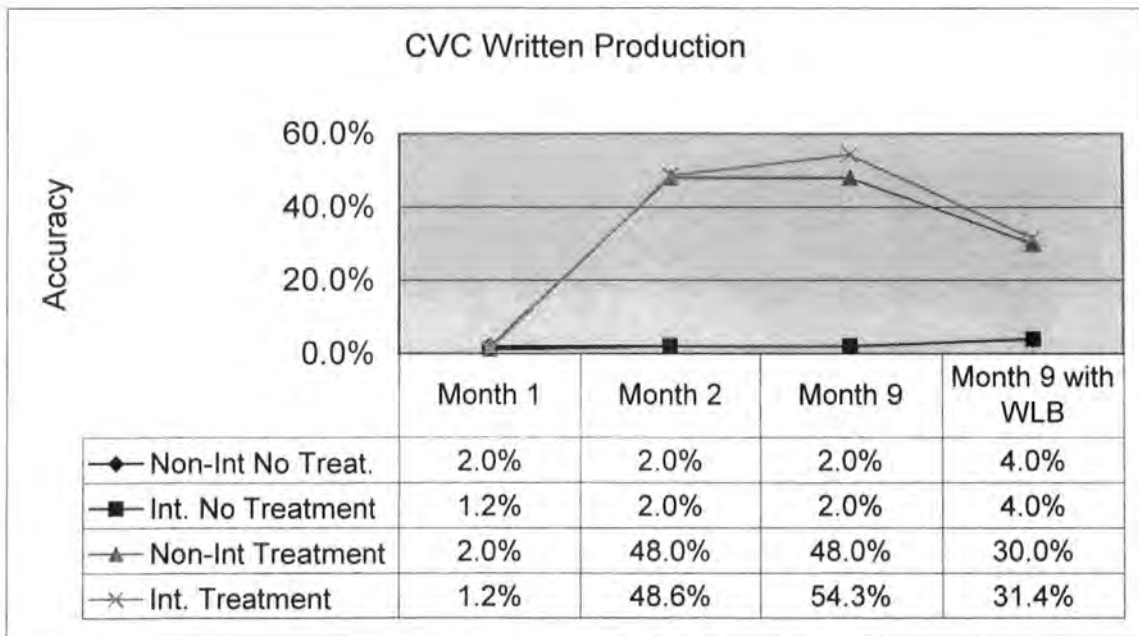

Figure 4.17 CVC Written Production

Scores for writing CVC syllables improved dramatically where extra instruction was offered. Even with Word List B, containing a new set of unknown words, participants who received instructed managed to score over 30% in month 9. However, learners who did not receive treatment found geminate consonants nearly as difficult as they did at Month 1.

Finally, let us look at the CVN syllable data shown in Figure 4.18.

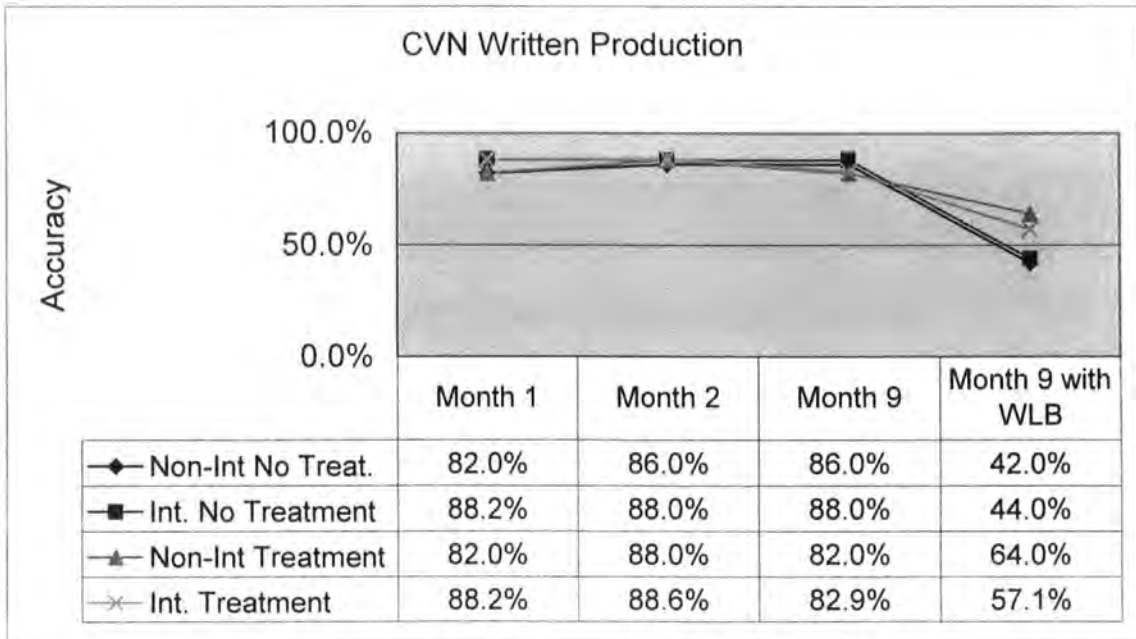

Figure 4.18 CVN Written Production

The results for Month 9 with Word List B are unexpected in the sense that learners' score went down even from Month 1. This was explained in previous sections as the orthographic influence of using Kana when Roman alphabet was used.

Next, we look at the oral production data.

4.2.4.2 Oral Production

Figure 4.19 summarises oral production data by non-intensive instructed and not instructed groups.

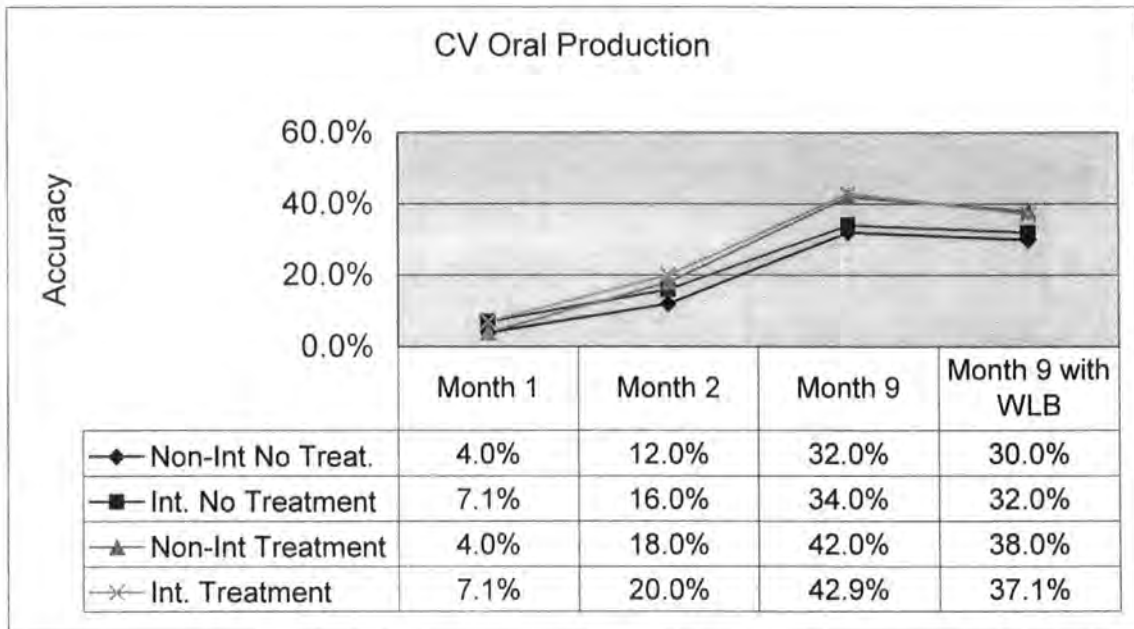

Figure 4.19 CV Oral Production

All learners improved their oral production scores over ten months but when they were faced with unknown words in Word List B, they were less able to produce them than those in Word List A, even at Month 9. Though there is a slight (less than 1%) anomaly, the general trend is that the more exposure to Japanese, whether in the form of just formal instruction or formal instruction with extra instruction, the better they were at producing unknown words accurately.

Next, we look at the results from the VV syllable type, as shown in Figure 4.20.

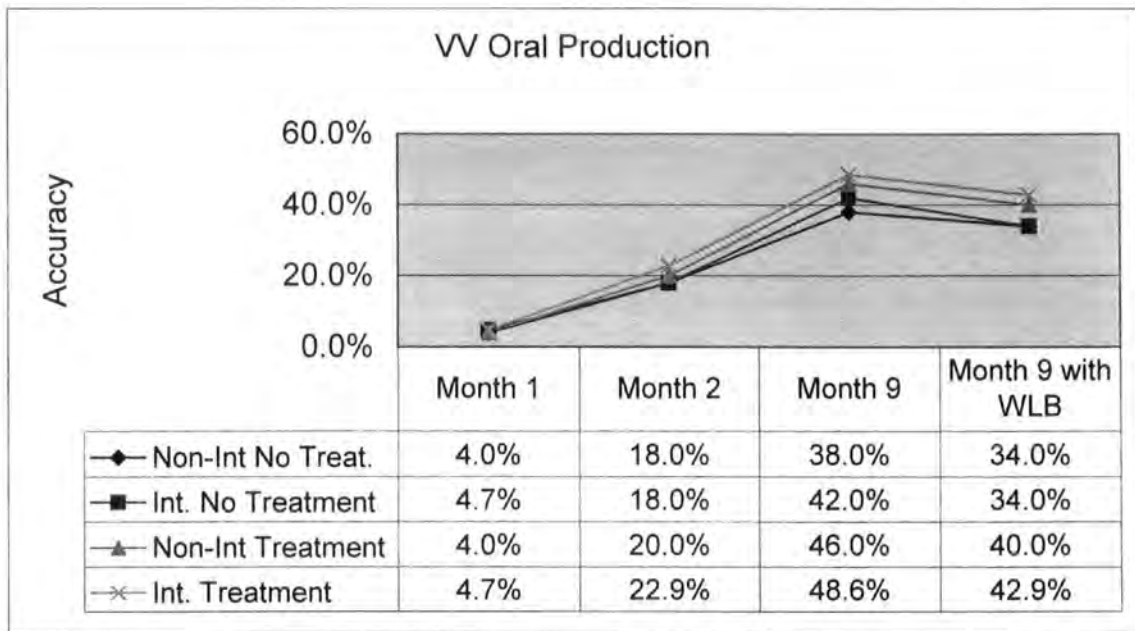

Figure 4.20 VV Oral Production

Again, those who had received treatment performed better than those who did not. Even learners on non-intensive courses who received less than a third of the instruction exposure than those on intensive courses performed better when they were given treatment on Japanese syllable structure.

Next, let us look at the CVC syllables, scores for which are summarised in Figure 4.21.

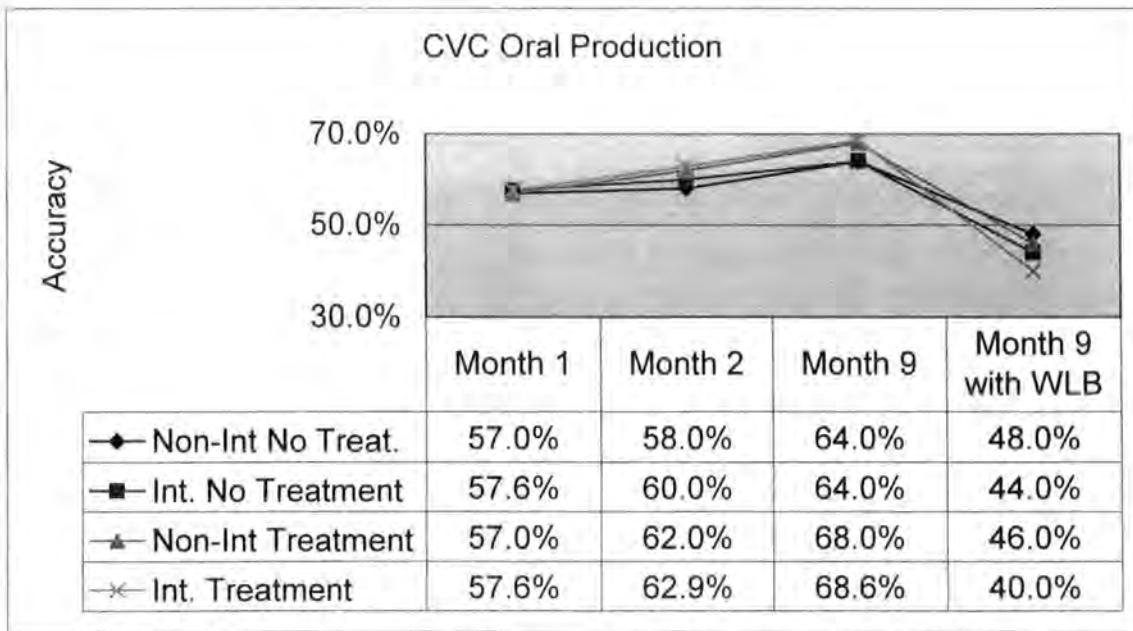

Figure 4.21 CVC Oral Production

Apart from the general trend of very minor improvement over the ten months, and then, faced with a new set of unfamiliar words in Word List B, scoring even lower than they did at Month 1, there seems to be no logical pattern to the spread of their scores. For example, at Month 9 using Word List B, the learners on non-intensive courses without extra instruction scored the highest 48% among all beginner groups. However, this may be explained as a developmental process. While it was clear from their written production data that they largely ignored the existence of morae in geminate consonants, in oral production, without being conscious many learners were mimicking the mora timing as dictated by the bi-moraic syllable structure in their L1. In the case of the CVC syllables, learners with treatment do not seem to be as advantaged as in other syllable types. Indeed, when they were faced with Word List B, extra instruction seemed to have worked against them. This may be interpreted that learners can orally produce word more accurately when they were less conscious of the Japanese syllable structure but directed by that of their L1.

Finally, let us look at the CVN syllable data, as shown in Figure 4.22.

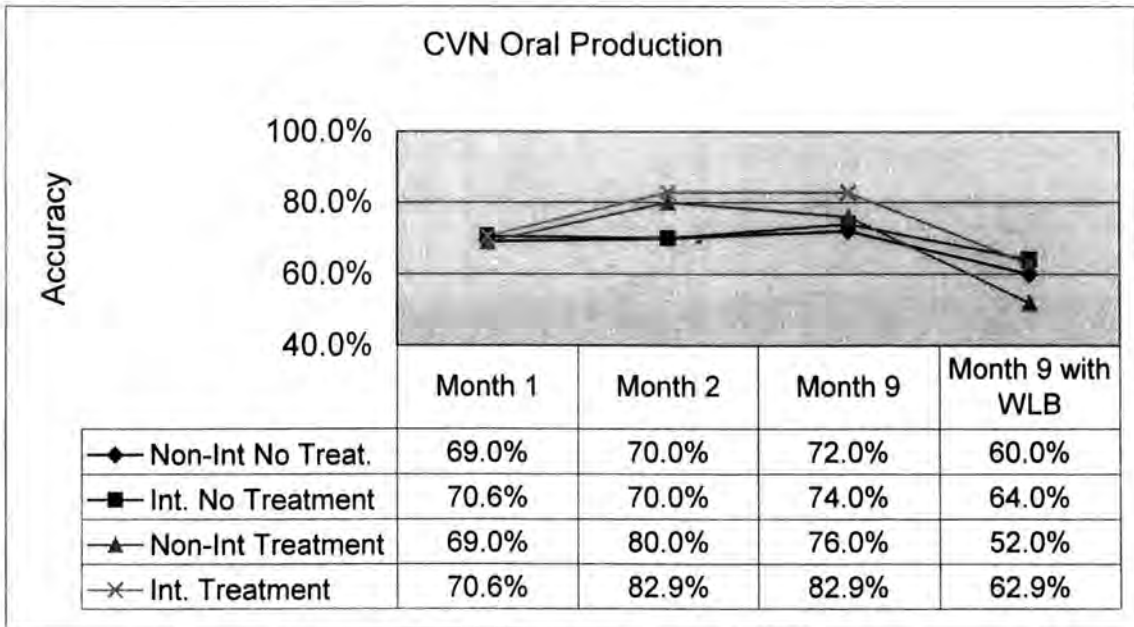

Figure 4.22 CVN Oral Production

The CVN syllable type data are similar to those of the CVC syllable type: there is little progression (or regression) over the period of Month 1 to Month 9. However, in Month 9, with Word List B, the accuracy level goes down in every learner group but more so in the case of instructed groups. One of the possible explanations for this is that, by Month 9, they have acquired the notion of moraic nasals sufficiently to start over generalising them. Another is that in Month 9, they all used Kana and the same disadvantage intermediate and advanced-level learners experienced may be now shared by the beginners.

4.3 Discussion

From the mora counting tasks using Word List A and B at Month 1 and Month 9, we have evidence that learners of Japanese initially apply their L1 syllable template, and then develop an interlanguage syllable structure of varying levels of sophistication according to their proficiency in Japanese. Beginners do not have the distinct mora tier in their syllable structure, thus the smallest sound segment for them is syllable. Some accidental production of target number of morae in the mora counting tasks was due to mora preservation rule. For example, though beginners did not register long vowels or geminate consonants as an extra mora, in production, they often compensated for the missing mora by lengthening preceding vowel or inserting a pause, hence achieving the correct number of morae.

The results of the written production and production tasks show that beginners were sometimes better able to write words with moraic nasals correctly than the intermediate and advanced level learners. This was explained as an orthographic influence. While beginners used the Roman alphabet in writing at Month 1, where all nasals were wrote as 'n', intermediate and advanced level learners were having to distinguish onset and moraic nasals in Hiragana. As we have established in Chapter 1, as far as Japanese is concerned, the essential phonetic difference in onset and moraic nasals are in the length. Not all intermediate and advanced-level learners, and certainly not all of the time, were able to distinguish onset and moraic nasals, hence their relatively lower scores in written production compared with the beginners.

Intermediate and advanced level learners were better able to identify mora than the beginners. However, they were not always successful in identifying the morae and assign them to correct mora slots. For example, the results of written production and oral production show that both intermediate and advanced level learners were

substituting geminate consonants with long vowels, preserving mora count. This suggests that while their interlanguage syllable templates have mora slots under the rime and the coda, they cannot, however, always identify the position the particular mora should be slotted into. The control of mora timing is still not target-like, and this leads to the further confusion over moraic nasals and onset nasals.

The developmental stages of the IL syllable template are, therefore, first L1 syllable template, without mora slots, then with development of mora sensitivity, the mora slots are generated. The placement of the correct segments into the right mora slot requires further time for development. The results of written production and oral production tasks at Month 9 suggest that the target-like segmentation and mora placement rely heavily on the amount of input received. The resetting of the mora assignment parameters is triggered by such input. When the learner is familiar with the word, the mora placement may be target-like. However, when they have to segment and place the mora without the ability to resort to a lexical entry, unlike native controls they are not always accurate. There seems to be a threshold of phonological competence: it is possible to reach the stage of having a syllable template with mora slots, and being able to place vowels, moraic nasals and geminate consonants in mora slots within the syllable, identification of which slot seems to be beyond the reach of many learners. However, as the preliminary assessment indicated, both intermediate and advanced level learners are phonologically competent so long as they are familiar with the vocabularies or phrases. A similar tendency is seen in native speakers' data (see Sakamoto, Suzuki, Amano, Ozawa, Kondo and Sone (1998)). Native speakers, however, seem to deploy their meta-linguistic awareness and fill any information gap.

A subset of beginners was given extra instruction on Japanese phonology. This treatment helped accelerate the acquisition of Japanese phonology, and by Month 9, those on the non-intensive programme who had received less than a fifth of the

instruction than those on the intensive programme without the treatment. By Month 9, however, beginners with treatment were still not par with intermediate-level learners. This suggests that the IL syllable templates are ready to receive mora information, but in order to process the input, more exposure to Japanese is.

The longitudinal data for Month 1 to Month 9 show that all beginners made steady progress, forming the IL syllable templates with more defined mora slots. The reasons for the apparent drop in scores in the written production and production of the CVN syllables in Month 9 are, first they were no longer relying on the Roman alphabet which did not prompt distinguishing onset and moraic nasals, and second, because of the sensitivity to the two types of nasals, they were confused and sometimes over-generated morae, in terms of insertion of extra syllables consisting of onset nasals and vowels. This tendency was seen in the results of both intermediate and advanced-level learners. Thus, we have seen another characteristic of the IL syllable template where learners go through the stages of over generation of mora syllable internally and externally.

Chapter 5

Summary and Conclusion

The study was carried out to examine the process of syllable structure acquisition by English-dominant child and adult English-Japanese bilinguals, Japanese-dominant bilingual children, and English adult learners of Japanese.

In Chapter 1, a theoretical framework was established for the study. First, we established what was meant by syllable, and then mora. We then examined the characteristics of mora as weight-bearing unit which led us to conclude that mora is an essential category for analysis of Japanese syllable structure. We further explored the characteristics of Japanese with respect to the syllable structure, and examined rules governing the rime and onset. The licensing of paths clarified how geminate consonants and moraic nasals were defined. Noting the durational property of mora as a timing unit, which is a concept beginner level learners are known to have difficulty in acquiring, English syllables' durational properties were explored. The findings in Chapter 1 led us to conclude that the durational control of and sensitivity to mora was the key to a successful acquisition of Japanese syllable structure.

In Chapter 2, we first reviewed recent research findings in the field of language acquisition, with particular focus on the acquisition of syllable structure. We concluded that the UG-principles and parameter approach, which seemed most able to capture various aspects of L2 acquisition of phonology as reported by researchers of the field, was to be adopted for the purpose of this study. Based on the review of these research papers as well as on the theoretical framework we had established in Chapter 1, the UG model, three research hypotheses were formulated based on the theoretical

framework developed in Chapter 2. These were: 1) the Mora Assignment Hypothesis that explains the process of the syllable structure acquisition as progressive resetting of parameters, and facilitate Japanese morae to be allocated to the dictated mora slots, 2) L2 phonological acquisition and age onset hypothesis that postulate that early age of onset enables the learner to acquire near-native competence in phonology, and 3) Quantity and quality of input hypothesis that argues for what the name stands for; the sufficient and appropriate input are essential for the acquisition.

The first of the two parts of the study, the acquisition of the syllable structure by bilingual children and adults was discussed in Chapter 3. First, I looked at how bilinguals deal with familiar words, in this case traditional Japanese story character names. Second, I looked at how subjects dealt with Japanese versions of English place names. These two tasks provided evidence to support that English-dominant bilinguals resort to their English syllable structure when they are dealing with unfamiliar words. English-dominant bilinguals were less sensitive to morae and their oral and written production were subject to deletions. However, they also inserted vowels and consonants to preserve the overall mora count. Since English is not a mora sensitive language, the mora conservation applied here is from Japanese. These findings support the research hypothesis, the Mora Assignment Hypothesis. Overall, with the exception of the Japanese-dominant bilinguals, there was no evidence to support that they had native competence in Japanese phonology.

The difference in performance between English-dominant bilinguals and Japanese-dominant bilinguals was startling. Even at the age of seven to eight, those who had spent more years in Japan demonstrate a native-like phonological performance. The age of onset was similar in the case of English-dominant and Japanese-dominant bilinguals. The only other variable was the amount of exposure to Japanese. English-dominant bilingual adults showed even less sensitivity to the mora

than English-dominant bilingual children. Since the age of onset was identical, and adults on average had longer exposure to Japanese, the results were baffling. The possible explanation may be sought in the area of word familiarity and lexical based acquisition of phonology. We have seen the evidence to support a claim that longer, more intense and naturalistic exposure to Japanese result in higher level of attainment in phonology. They all showed near-native competence. However, the fact that they showed weaknesses in dealing with unfamiliar words indicate that their reliance on the Japanese lexicon. Indeed, though it was outside the scope of this thesis, Japanese accent system is lexically based and every item of vocabulary must be acquired as individual lexical item. Since the mora information also fall in this category, bilinguals with less exposure to Japanese than native speakers themselves are at disadvantage. We have also seen the evidence of the influence of literacy. As discussed in Chapter 2, there has been a number of research investigating the relationship between Japanese orthography and the L1 acquisition of Japanese. The exposure to Kana system during the course of Japanese acquisition seems to enhance the sensitivity to the mora. In writing, we saw fewer cases on vowel deletions, as the Kana system does not permit this. The comparison between oral production and writing gives a mixed message. Taking geminate consonants for example, all bilinguals were more accurate in oral production than in transcription. On the other hand, they were more prone to dropping vowels in oral production than in writing. The influence of orthography was also seen in the substitution of onset nasals with moraic nasals or moraic nasals with onset nasals. This is an indication of the bilinguals not controlling the duration of morae.

In Chapter 4, we looked at adult L2 acquisition of Japanese. A total of 94 learners of Japanese took part in cross-sectional and longitudinal study programme. A subset of beginners were given extra instruction on the Japanese syllable structure focusing on segmental and suprasegmental exercises. Thus, the profiles of

participants included beginners on an intensive L2 Japanese programme with or without the extra treatment on the Japanese syllable structure, beginners on non-intensive Japanese programme with or without the extra instruction, intermediate level learners and advanced level learners. Each group of participants represented different stages of the acquisition of Japanese.

Tasks designed to examine their acquisition process and level of competence in performance, involving sets of words that were unfamiliar to all levels of learners. They were asked count the number of morae in test words, produce orally and transcribe them. Such tasks were administered over a 9-month period. There was a subset of tasks taking place in Month 2 to account for the anomaly of the complete beginners using Roman alphabets to transcribe Japanese words in the initial task. The results of the first task showed, as expected, advanced level learners were most sensitive to the mora, and the complete beginners were processing Japanese with their L1 syllable template. In Month 1, since beginners used the Roman alphabet, which did not demand learners to distinguish onset nasals and moraic nasals, the cross-sectional analysis showed there was little difference between beginners and the intermediate level learners. On closer examination, intermediate learners and to a lesser extent advanced learners were shown to be misidentifying moraic nasals and onset nasals. In some cases, overzealous attempts resulted in insertion of syllables with onset nasals.

All learners showed a tendency to delete geminate consonants and second mora in long vowels, showing the lack of sensitivity to duration, and indeed to the mora. Intermediate and advanced level learners showed more established mora tier in their representation of Japanese syllable structure. However, they were not always accurate in assigning mora. Intermediate and advanced level learners, and to a lesser extent, later beginners displayed a mora substitution. They inserted geminate consonants when the syllable required a vowel, and substituted vowels with geminate

consonants. This is another evidence that their development of sensitivity to the mora is gradual, supporting the Mora Assignment Hypothesis, and they first identify the mora tier, followed by the identification of mora slots. Though segmental acquisition is not an important issue here, bearing in mind that a majority of syllables in Japanese are in fact subset of English syllables, associating the segment with mora position proved to be most problematic. The syllable types that cause these difficulties are CVV, CVN and CVC. As discussed in Chapter 1, CVV, CVN and CVC syllables have one thing in common, which is associated with the mora. While learners have not yet reset the parameters regarding the mora, and have not yet acquired the durational control of such morae, the confusions over CVV and CVC, or CV and CVN are predictable.

At the beginning of the study, beginners showed a greater tendency of epenthesis than other learners. Their preference of bimoraic syllables over monomoraic syllables was evident in the results. This may be promoted by the underlying bimoraic structure of English and used as a temporal strategy, resulting in the transfer of their L1 stress-timing. Beginners rapidly lose this, however, and use deletion as their strategy in processing Japanese syllables than epenthesis.

The role of instruction, particularly form-focused suprasegmental instruction was explored by implementing the extra instruction programme on a subset of beginners. The effectiveness of such approach was evident in the results. Considering relatively how little time was needed for such instruction, this is an area Japanese language teachers may explore further. Those with the treatment of extra instruction performed better than those without. In some cases, their scores almost matched those of the intermediate level learners with lots more exposure. Since there was a huge difference in the total amount of exposure to Japanese beginners and the intermediate level learners had received before this task, this is encouraging.

At the end of the 9-month period, learners of all level had improved their performance level further. This was evident when the initial tasks were duplicated in Month 9 using a new set of test words. Though in many cases, the scores were not quite on par with those from the tasks using the original set of test words, the progression was evident. The reason for the results from tasks using the original test words improving over time may be linked to the word familiarity. Though each time the sequence of test words were scrambled, learners may have become more used to these words over time. As discussed in Chapter 3, the word familiarity may be responsible for this result.

Through these studies, we have gained insight into the process of the acquisition of the syllable structure. We have seen that the vital role the mora play in such a process, and the acquisition of the mora tier in the syllable structure precedes the durational control of the mora and also the identification of segmental duration. Learners, including English-dominant bilinguals, first become sensitive to mora and identify the mora tier in the syllable structure. The assignment of mora to the correct mora slot is the secondary stage, linked with the segmental acquisition. While learners may have “acquired” the part of the properties associated with the segment, they have not yet acquired the durational control associated with the segment. At the final stage, the learner is able to identify the segment including its durational property, and assign mora to it correctly. The acquisition of the syllable structure of Japanese may be seen as a continual process, involving parameter resetting triggered by the input.

In this thesis I have focused only on the fundamental role the mora plays in the acquisition of Japanese syllable structure. Clearly, further study is needed incorporating, for example, in the area of accent assignment. Such a study will complement the findings from this thesis, and contribute further in understanding of the acquisition in phonology.

Bibliography

- Abe, Y. (1987). Metrical Structure and Compounds in Japanese. Issues in Japanese Linguistics, Studies in Generative Grammar viii. Eds. T. Imai, M. Saito and K. Inoue. Dordrecht, Foris. viii: 5-52.
- Abercrombie, D. (1967). Elements of General Phonetics. Chicago, Aldine-Atherton.
- Beckman, M. (1982). "Segment Duration and the 'Mora' in Japanese." Phonetica 39: 113-135.
- Bergman, C. (1976). Interference vs. Independent development in infant bilingualism. Bilingualism in the Bicentennial and Beyond. Ed. G. Keller. New York, Bilingual Press.
- Birdsong, D. (1991). On the Notion of "Critical Period" in UG/L2 Theory: A Response to Flynn and Manuel. Point Counterpoint: Universal Grammar in the Second Language. Ed. L. Eubank. Amsterdam, Benjamins: 147-165.
- Bley-Vroman, R. (1986). "Hypothesis Testing in Second-Language Acquisition Theory." Language Learning: A Journal of Applied Linguistics 36(No. 3, 1986 Sept.): 353-376.
- Bley-Vroman, R. W., S. W. Felix and G. L. Ioup (1988). "The Accessibility of Universal Grammar in Adult Language Learning." Second Language Research 4(1): 1-32.
- Broselow, E., S.-i. Chen and M. Huffman (1997). "Syllable Weight: Convergence of Phonology and Phonetics." Phonology 14(No. 1, 1997): 47-82.
- Broselow, E. and H.-B. Park (1995). Mora Conservation in Second Language Prosody. Phonology Acquisition and Phonological Theory. Ed. J. Archibald. Hillsdale, Laurenc Erlbaum Associates, Inc.: 151-168.

- Byrne, B. and J. Ledez (1983). "Phonological Awareness in Reading-disabled Adults." Australian Journal of Psychology **35**: 185-197.
- Carlyle, K. A. (1985). "Sonority Scales and the Syllable Template." Proceeding of N.E. Linguistic Society **15**: 34-48.
- Catford, J. C. (1977). Fundamental Problems in Phonetics. Bloomington, Indiana University Press.
- Chomsky, N. (1959). "Review of Verbal Behaviour by B. F. Skinner." Language **35**: 26-58.
- Chomsky, N. (1965). Aspects of the Theory of Syntax. Cambridge, Mass., MIT Press.
- Chomsky, N. (1980a). On cognitive structures and their development: a reply to Piaget. Language and Learning: The Debate between Jean Piaget and Noam Chomsky. Ed. M. Piatelli-Palmarini. London, Routledge and Kegan Paul.
- Chomsky, N. (1980b). Rules and Representations. New York, Columbia University Press.
- Chomsky, N. and M. Halle (1968/1991). The Sound Pattern of English. London, MIT Press.
- Clahsen, H. (1990). "Constraints on Parameter Setting: A Grammatical Analysis of Some Acquisition Stages in German Child Language." Language Acquisition: A Journal of Developmental Linguistics **1**(4): 361-391.
- Clahsen, H. and P. Muysken (1989). "The UG Paradox in L2 Acquisition." Second Language Research **5**(no. 1): 1-29.
- Clements, G. N. and S. J. Keyser (1983). CV Phonology: A Generative Theory of the Syllable. Cambridge, MA, MIT Press.

- Cook, V. (1993). Linguistics and Second Language Acquisition. London, The Macmillan Press Limited.
- Corder, S. P. (1971). "Idiosyncratic dialects and error analysis." International Review of Applied Linguistics 9: 147-159.
- Cross, N. (1997). The L2 Acquisition of Japanese Special 'Haku'. 10th International Conference on Japanese Language Teaching, Frankfurt.
- Curtiss, S. (1982). Developmental Dissociations of Language and Cognition. Exceptional Language and Linguistics. Eds. L. Obler and L. Menn. New York, Academic Press: 285-312.
- Curtiss, S. (1989). The Effect of Age on First Language Acquisition. Paper presented at the 14th Boston University Language Development Conference.
- Cutler, A., J. Mehler, D. G. Norris and J. Segui (1986). "The syllable's differing role in the segmentation of French and English." Journal of Memory and Language 25: 385-400.
- De Houwer, A. (1990). The acquisition of two languages from birth: a case study. Cambridge, Cambridge University Press.
- Doyle, A. B., M. Champagne and N. Segalowitz (1978). Some issues in the assessment of the consequences of early bilingualism. Aspect of Bilingualism. Ed. M. Paradis. Columbia SC, Hornbeam Press: 13-20.
- Eckman, F. R. (1987). On the Naturalness of Interlanguage Phonological Rules. Interlanguage Phonology. Eds. G. Ioup and S. H. Weinberger. Cambridge, MA, Newbury House Publishers: 125-144.
- Ellis, R. (1985). Understanding Second Language Acquisition. Oxford, Oxford University Press.

- Fathman, A. (1975). "The Relationship Between Age and Second Language Productive Ability." Language Learning 25: 245-253.
- Fikkert, J. P. M. (1994). On the Acquisition of Prosodic Structure. The Hague, Holland Academic Graphics.
- Flynn, S. (1993). Interactions between L2 Acquisition and Linguistic Theory. Confluence: Linguistics, L2 Acquisition and Speech Pathology. Ed. F. R. Eckman. Amsterdam, Benjamins: 15-35.
- Flynn, S. and S. Manuel (1991). Age-Dependent Effects in language Acquisition: An Evaluation of 'Critical Period' Hypotheses. Point Counterpoint: Universal Grammar in the Second Language. Ed. L. Eubank. Amsterdam, Benjamins: 117-145.
- Friederici, A. (1984). Neuropsychologie der Sprache. Stuttgart, Kohlhammer.
- Geva, E. and L. S. Siegel (2000). "Orthographic and cognitive factors in the concurrent development of basic reading skills in two languages." Reading and Writing: An Interdisciplinary Journal 12: 1-30.
- Giegerich, H. J. (1992). English phonology : an introduction. Cmbridge, Cambridge University Press.
- Golato, P. S. (1998). Speech segmentation strategies of adult bilingual speakers of French and English: A second look at the limits on bilingualism. PhD, The University of Texas at Austin.
- Goldsmith, J. A. (1976). "An Overview of Autosegmental Phonology." Linguistic Analysis 2: 23-68.
- Halle, M. and J.-R. Vergnaud (1980). "Three Dimensional Phonology." Journal of Linguistic Research 1, no. 1: 83-105.

- Ham, W. H. (1998). Phonetic and phonological aspects of geminate timing(Bernese, Hungarian, Levantine Arabic, Madurese). PhD, Cornell University.
- Hamayan, E., F. Genesee and G. R. Tucker (1977). "Affective factors and language experience in second language learning." Language Learning: A Journal of Applied Linguistics 27: 225-241.
- Han, M. S. (1962). "The Feature of Duration in Japanese." Onsei no Kenkyu 10: 65-80.
- Han, M. S. (1994). "Acoustic Manifestations of Mora Timing in Japanese." Journal of the Acoustical Society of America 96(No. 1, 1994 July): 73-82.
- Hankamer, J. and J. Aissen (1974). The Sonority Hierarchy. Papers from the Parasession on Natual Phonology, April 18, 1974. Eds. A. Bruck, R. A. Fox, M. W. La Galy and B. J. Darden. Chicago, Chicago Linguistic Society: 131-145.
- Harada, T. (2000). The Acquisition of Geminates by Children in a Japanese Immersion Program. AAAL 2000 Conference, Vancouver.
- Haraguchi, S. (1991). A Theory of Stress and Accent. Dordrecht, Holland, Foris Publications.
- Haraguchi, S. (1994). On-in-ron (Phonology). Tokyo, Kaitakusha.
- Hayashi, O. (1957). Goj. Tokyo, Chikuma Shobo.
- Hayes, B. (1980/1985). A Metrical Theory of Stress Rules. New York, Garland.
- Hayes, B. (1989). "Compensatory Lengthening in Moraic Phonology." Linguistic Inquiry 20(No. 2,, 1989 Spring): 23-307.
- Hockett, C. F. (1955). A manual of phonology : memoir 11. Baltimore, Waverly Press.
- Hoffmann, C. (1991). An Introduction to Bilingualism. London, Longman.

- Homma, Y. (1981). "Durational Relationships between Japanese Stops and Vowels." Journal of Phonetics 9: 273-281.
- Hooper, J. B. (1972). "The Syllable in Phonological Theory." Language: Journal of the Linguistics Society of America 48: 525-540.
- Hyman, L. M. (1985). A Theory of Phonological Weight. Dordrecht, Foris Publications.
- Inagaki, K., G. Hatano and T. Otake (2000). "The Effect of Kana Literacy Acquisition on the Speech Segmentation Unit Used by Japanese Young Children." Journal of Experimental Child Psychology 75: 70-91.
- Ito, J. (1986). Syllable Theory in Prosodic Phonology. Doctor of Philosophy, University of Massachusetts.
- Ito, J. (1989). "A Prosodic Theory of Epenthesis." Natural Language and Linguistic Theory 7: 217-259.
- Ito, J. and R. A. Mester (1993). "Licensed Segments and Safe Paths." Canadian Journal of Linguistics 38(2): 197-214.
- Ito, J. and R.-A. Mester (1986). "The Phonology of Voicing in Japanese: Theoretical Consequences for Morphological Accessibility." Linguistic Inquiry 17: 49-73.
- Jaeger, J. J. (1986). Concept formulation as a tool for linguistic research. Experimental Phonology. Eds. J. J. Ohala and J. J. Jaeger. Orland, Academic Press: 211-235.
- Jakobson, R. (1931). Die Betonung und ihre Rolle in der Word- und Syntagmaphonologie. Travaux du Cercle Linguistique de Prague IV. Reprinted in Roman Jakobson, Selected Writings I. The Hague, Mouton: 117-136.
- Jakobson, R. (1937). Über die Beschaffenheit der prosodischen Gegensätze. Roman Jakobson, Selected Writings I. The Hague, Mouton: 254-261.

- Kahn, D. (1976/1980). Syllable-based Generalizations in English Phonology. Ph.D., M.I.T.
- Kahn, D. (1980). Syllable-Structure Specifications in Phonological Rules. Juncture: A Collection of Original Papers. Eds. M. Aronoff and M.-L. Kean. Saratoga, CA, Anma Libri: 91-105.
- Takehi, K. and Y. Hirose (1997). "Contrastive Study on Mora Identification." Journal of the Phonetic Society of Japan 1(No. 3): 23-28.
- Kawai, G. and K. Hirose (1999). "Teaching the pronunciation of Japanese double-mora phonemes using speech recognition technology." Speech Communication 30: 131-143.
- Kawakami, S. (1977). Nihongo Onsei Gaisetsu (Japanese Phonetics). Tokyo, Ohfu-sha.
- Kaye, J., J. Lowenstamm and J.-R. Vergnaud (1985). "The Internal Structure of Phonological Elements: A Theory of Charm and Government." Phonology Yearbook 2: 305-328.
- Kaye, J., J. Lowenstamm and J.-R. Vergnaud (1990). "Constituent Structure and Government in Phonology." Phonology 7(no. 2, 1990): 193-231.
- Kellerman, E. (1977). "Towards a characterization of the strategies of transfer in second language learning." Interlanguage Studies Bulletin 2: 58-145.
- Kindaichi, H. (1972). Nihongo On'in no Kenkyu (Study of Japanese Phonology). Tokyo, Tokyodo.
- Kiparsky, P. (1981). Remarks on the Metrical Structure of the Syllable. Phonologica 1980. Innsbruck, Institut für Sprachwissenschaft der Universität Innsbruck.
- Krashen, S. (1979). "A Response to McLaughlin, 'The Monitor Model: Some Methodological Considerations.'" Language Learning 29: 151-167.

- Kubozono, H. (1989). "The Mora and Syllable Structure in Japanese: Evidence from Speech Errors." Language and Speech **32 (3)**: 249-278.
- Kubozono, H. (1993). The Organisation of Japanese Prosody. Tokyo, Kuroshio.
- Kubozono, H. (1999). Mora and Syllable. Japanese Linguistics. Ed. N. Tsujimura. Oxford, Blackwell Publishers Ltd: 31-61.
- Ladefoged, P. (1982). A Course in Phonetics. New York, Harcourt Brace Jovanovich.
- Ladefoged, P. (1992). The Many Interfaces between Phonetics and Phonology. Phonologica 1988, Cambridge, England, Cambridge University Press.
- Lambert, W. E., J. Havelka and R. C. Gardner (1959). "Linguistic manifestations of bilingualism." American Journal of Psychology **72**: 77-82.
- Lenneberg, E. H. (1967). Biological Foundations of Language. New York, Wiley.
- Liberman, M. and A. Prince (1977). "On Stress and Linguistic Rhythm." Linguistic Inquiry **8**: 249-336.
- Long, M. H. (1993). Second language acquisition as a function of age: research findings and methodological issues. Progression and Regression in Language Acquisition. Eds. K. Hyltenstam and A. Viberg. Cambridge, Cambridge University Press: 196-221.
- Mann, V. A. (1986). "Phonological Awareness: The Role of Reading Experience." Cognition **24**: 65-92.
- McCarthy, J. and A. Prince (1993). Prosodic Morphology I: Constraint Interaction and Satisfaction. New Brunswick, NJ, Rutgers Center for Cognitive Science, Rutgers, the State University of New Jersey.

- McCarthy, J. J. (1982). Prosodic Templates, Morphemic Templates, and Morphemic Tiers. The Structure of Phonological Representations I. Eds. H. v. d. Hulst and N. Smith. Dordrecht, Foris Publications: 191-223.
- McCarthy, J. J. (1985/1979). Formal Problems in Semitic Phonology and Morphology. New York, Garland.
- McCawley, J. D. (1968). The Phonological Component of a Grammar of Japanese. The Hague, Paris, Mouton.
- McLaughlin, B. (1984). Second-language Acquisition in Childhood I. Hillsdale, NJ, Lawrence Erlbaum.
- McLaughlin, B. (1985). Second-language Acquisition in Childhood II. Hillsdale, NJ, Lawrence Erlbaum.
- Meisel, J. (1986). "Word order and case making in early child language: evidence from simultaneous acquisition of two first languages (French and German)." Linguistics 24: 123-183.
- Meisel, J. M. (1991). Principles of Universal Grammar and Strategies of Language Use: On some Similarities and Differences between First and Second Language Acquisition. Point Counterpoint: Universal Grammar in the Second Language. Ed. L. Eubank. Amsterdam, Benjamins: 231-276.
- Moskowitz, B. A. (1973). On the status of vowel shift in English. Cognitive Development and the Acquisition of Language. Ed. T. E. Moore. New York, Academic Press: 223-260.
- Moyer, A. (1999). "Ultimate Attainment in L2 Phonology : The Critical Factors of Age, Motivation, and Instruction." Studies in Second Language Acquisition 21: 81-108.

- Nagano-Madsen, Y. (1989). "Mora and Temporal-Tonal Interaction in Japanese." Lund University Working Papers **35**: 121-131.
- Ohala, J. J. (1974). Experimental historical phonology. Historical Linguistics II. Theory and Description in Phonology. Eds. J. M. Anderson and C. Jones. Amsterdam, North Holland: 353-389.
- Ono, K. (1991). "Gairaigo toshiteno Eigono Sokuonka nitsuite (Geminate Consonants in English Loan-words in Japanese)." Gengo Kenkyu: Journal of the Linguistic Society of Japan **100**: 67-88.
- Otake, T. (1989). "Counter Evidence for Mora Timing." LACUS (Linguistic Association of Canada and the United States) FORUM 1989 **16**: 313-322.
- Otake, T. and K. Yoneyama (1994). A Moraic Nasal and a Syllable Structure in Japanese. ICSLP 94, Yokohama, International Conference for Spoken Language Processing.
- Padilla, A. M. and E. Liebman (1975). "Language acquisition in the bilingual child." Bilingual Review **2**: 34-55.
- Parrondo Rodoriguez, A. E. (1999). The L2 Acquisition of Syllable Structure and Stress in Spanish. Ph.D, University of Durham.
- Pennington, M. C. (1998). "The teachability of phonology in adulthood: A re-examination." Internatioal Review of Applied Linguistics **36**: 323-341.
- Pennington, M. C. and N. C. Ellis (2000). "Cantonese Speakers' Memory for English Setences with Prosodic Cues." The Modern Language Journal **84**: 372-389.
- Pica, T. (1983). "Adult acquisition of English as a second language under different conditions of exposure." Language Learning: A Journal of Applied Linguistics **33**: 465-497.

- Port, R. F., J. Dalby and M. O'Dell (1987). "Evidence for Mora Timing in Japanese." Journal of the Acoustical Society of America **81**(No. 5 May 1987): 1574-1585.
- Poser, W. J. (1990). "Evidence for Foot Structure in Japanese." Language **66**(Number 1): 78-105.
- Prince, A. and Smolensky (1993). "Optimality Theory." unpublished manuscript.
- Pulleyblank, D. (1994). "Underlying Mora Structure." Linguistic Inquiry **25**(2): 344-353.
- Sakamoto, S., Y. Suzuki, S. Amano, K. Ozawa, K. Kondo and T. Sone (1998). "Shinmitsudo to On-in Balance o Koryo shita Tnago-Ryokai-do-Shiken-yo Tango-list no Kochiku (Constructing Word List for the Word Perception Test based on the Word Familiarity and the Phonological Balance)." Nihon Onkyo Gakkai-shi (Japane Acoustic Society) **54**: 842-849.
- Sato, Y. (1993). "The Duration of Syllable-Final Nasals and the Mora Hypothesis in Japanese." Phonetica(50): 44-67.
- Schwartz, B. D. (1991). Conceptual and Empirical Evidence: A Response to Meisel. Point Counterpoint: Universal Grammar in the Second Language. Ed. L. Eubank. Amsterdam, Benjamins: 277-304.
- Schwartz, B. D. (1998). "The Second Language Instinct." Lingua **106**: 133-160.
- Schwartz, B. D. and R. A. Sprouse (1996). "L2 Cognitive States and the Full Transfer/Full Access Model." Second Language Research **12**(no. 1): 40-72.
- Selinker, L. (1972). "Interlanguage." International Review of Applied Linguistics **10**: 209-231.
- Selkirk, E. (1984a). On the Major Class Features and Syllable Theory. Language, Sound, Structure: Studies in Phonology Presented to Morris Halle by His teacher

- and Students. Eds. M. Arnoff and R. T. Oehrle. Cambridge, Mass, MIT Press: 107-136.
- Selkirk, E. O. (1980). "The Role of Prosodic Categories in English Word Stress." Linguistic Inquiry **11**: 563-605.
- Selkirk, E. O. (1984b). On the major class features and syllable theory. Language Sound Structure. Eds. M. Arnoff and R. T. Oehrle. Cambridge, MA, MIT Press: 107-136.
- Skutnabb-Kangas, T. (1984). Bilingualism or Not. Clevedon, Multilingual Matters.
- Slobin, D. (1973). Cognitive prerequisites for the development of grammar. Studies of Child Language Development. Eds. C. Ferguson and D. Slobin. New York, Holt Rinehart and Winston.
- Steriade, D. (1982). Greek Prosodies and the Nature of Syllabification. Ph.D., Massachusetts Institute of Technology.
- Strozer, J. R. (1994). Language Acquisition after Puberty. Washington, D.C., Georgetown University Press.
- Suzuki, H. (1995). Minimal Words in Japanese. CLS 31 Papers from the 31st Regional Meeting of the Chicago Linguistic Society. Eds. A. Dainora, R. Hemphill, B. Luka, B. Need and S. Pargman. Chicago, Chicago Linguistic Society. **1**: 448-463.
- Tabata, T. (1989). "Syllable Structure in Japanese: Head-Modifier Dependencies." Gengo Kenkyu: Journal of the Linguistic Society of Japan **95**(1989 Mar.): 144-175.
- Tarone, E. E. (1978). The Phonology of Interlanguage. Understanding Second & Foreign Language Learning: Issues & Approaches. Ed. J. C. Richards. Rowley, MA, Newbury House: 15-33.

- Trubetzkoy, N. S., kniaz (1939/1969). Principles of Phonology (Grundzuge der Phonolgoie, Translated by Christiane A. M. Baltaxe). Berkeley and Los Angeles, University of California Press.
- Vainikka, A. and M. Young-Scholten (1996). "Gradual Development of L2 Phrase Structure." Second Language Research 12(No. 1, 1996 Jan.): 7-39.
- Vance, T. J. (1987). An Introduction to Japanese Phonology. Albany, N. Y., State university of New York Press.
- Vennemann, T. (1972). "On the Theory of Syllabic Phonology." Linguistische Berichte 18: 1-18.
- Vennemann, T. (1974). Words and Syllables in Natural Generative Grammar. Papers from the Parasession on Natural Phonology, April 18, 1974. Eds. A. Bruck, R. A. Fox, M. W. La Galy and B. J. Darden. Chicago, Chicago Linguistic Society: 346-374.
- Volterra, V. and T. Taeschner (1978). "The acquisition of language by bilingual children." Journal of Child Language 5(2): 311-326.
- Walsh, T. and K. Diller (1981). Neurolinguistic considerations on the optimum age for second language learning. Individual differences and universals in language learning aptitude. Ed. K. Diller. Rowley, MA, Newbury House: 3-21.
- Wells, S. (1995). A Speech Error Investigation of the Impact of Orthography on Japanese Speech Production. CLS 31 Papers from the 31st Regional Meeting of the Chicago Linguistic Society. Eds. A. Dainora, R. Hemphill, B. Luka, B. Need and S. Pargman. Chicago, Chicago Linguistic Society. 1: 478-489.
- White, L. (1989). Universal Grammar and Second Language Acquisition. Amsterdam, Benjamins.

Wode, H. (1989). Maturational changes of language acquisitional abilities. Variation in second language acquisition. Eds. S. Gass, C. Madden, D. Preston and L. Selinker. Clevedon, UK, Multilingual Matters. II: 176-188.

Wode, H. (1992). Categorical perception and segmental coding in the ontogeny of sound systems. Phonological development: Models, research, implications. Eds. C. Ferguson, L. Menn and C. Stoehl-Gammon. Timonium, MD, York Press: 605-631.

Yoshida, H. (1983). "Moric Phonology: Toward the Establishment of a New Phonological Unit." Dissertation Abstracts International 44(No. 1, 1983 July): 159A.

Yoshida, S. (1990a). "Government in Phonology." Gengo Kenkyu: Journal of the Linguistic Society of Japan 97(1990 March): 95-123.

Yoshida, S. (1990b). "A Government-based Analysis of the 'Mora' in Japanese." Phonology 7: 331-351.

Young-Scholten, M. (1994). "On Positive Evidence and Ultimate Attainment in L2 Phonology." Second Language Research 10(No. 3, 1994 Oct.): 193-214.

Young-Scholten, M. (1995). The Negative Effects of 'Positive' Evidence on L2 Phonology. Studies in Honor of William E. Rutherford. The Current State of Interlanguage. Eds. L. Eubank, L. Selinker and M. S. Smith. Amsterdam, Benjamins: 107-121.

