

## Durham E-Theses

---

# *Insecticidal Fusion Proteins For The Control of Coleopteran Pests*

EMMA JANE BACK

### How to cite:

---

BACK, EMMA JANE (2011) Insecticidal Fusion Proteins For The Control of Coleopteran Pests. Doctoral thesis, Durham University.

### Use policy

---

The full-text may be used and/or reproduced, and given to third parties in any format or medium, without prior permission or charge, for personal research or study, educational, or not-for-profit purposes provided that:

- a full bibliographic reference is made to the original source
- a <https://etheses.durham.ac.uk/id/eprint/3283/> is made to the metadata record in Durham E-Theses
- the full-text is not changed in any way

The full-text must not be sold in any format or medium without the formal permission of the copyright holders.

Please consult the [full Durham E-Theses policy](#) for further details.

# **Insecticidal Fusion Proteins For The Control of Coleopteran Pests**

A thesis submitted by Emma Jane Back B.Sc in accordance with the requirements of  
Durham University for the degree of Doctor of Philosophy

Department of Biological and Biomedical Sciences  
Durham University  
May 2011

## Abstract

Fusion proteins containing a toxin fused to a carrier domain which directs transport across the insect gut epithelium have been shown to be effective orally active insecticides. Expression of functional recombinant fusion proteins comprising of snowdrop lectin (*Galanthus nivalis* agglutinin; GNA) fused to toxins from Indian red scorpion (*Mesobuthus tamulus* toxin; ButaIT) and Blue Mountains funnel-web spider (*Hadronyche versuta* toxins;  $\omega$ -ACTX-Hv1a ( $\omega$ -ACTX);  $\kappa$ -ACTX-Hv1c ( $\kappa$ -ACTX)) was carried out in both yeast (*Pichia pastoris*) and plant (*Arabidopsis thaliana*) expression systems. Addition of purification tags, altering the design of assembly of the fusion protein and point mutation of toxin sequence were all investigated to improve yield and reduce proteolytic cleavage during expression and purification.

Recombinant proteins were assayed for oral toxicity against *T. castaneum* as a model coleopteran species. Fusion proteins incorporating ButaIT and  $\omega$ -ACTX toxins showed toxicity ranging from complete mortality when fed at  $1\text{ mg g}^{-1}$  ((his)<sub>6</sub>-GNA- $\omega$ -ACTX and  $\omega$ -ACTX-GNA-(his)<sub>6</sub>) to 65% mortality when fed at  $2\text{ mg g}^{-1}$  (ButaIT-GNA-(his)<sub>6</sub>). Fusion proteins incorporating  $\kappa$ -ACTX and GNA were shown to be non-toxic despite individual components being functional. Lack of toxicity was due to high proteolytic cleavage in the insect gut environment. Data was obtained to support the use of *Tribolium* as a model for wireworm (*Agriotes* spp.), serious pests of potatoes in the UK.

Selected fusion proteins were expressed in transgenic *Arabidopsis*. Expression for ButaIT-GNA as a fusion polypeptide was readily detectable in transformants with estimated levels of expression of approx. 0.15% total soluble protein in leaf tissue. When plants expressing ButaIT-GNA fusion protein were fed to larvae of the tomato moth (*Lacanobia oleracea*) the fusion protein was shown to be fully functional with levels of toxicity comparable to that seen in previous artificial diet bioassays.  $\omega$ -ACTX based constructs expressed in *Arabidopsis* were subject to high levels of proteolytic cleavage *in planta* and so were not assayed for toxicity.

## Table of Contents

|  |           |
|--|-----------|
| Declaration, statement of copyright and list of publications   | 1         |
| Acknowledgements   | 2         |
| List of figures  | 3         |
| Abbreviations  | 7         |
| <br>   |           |
| <b><u>Chapter 1 Introduction</u></b>   | <b>11</b> |
| 1.1 Costs of herbivorous pests to agriculture  | 11        |
| 1.2 Alternative methods of insect control: insecticidal proteins   | 12        |
| 1.2.1 Protease inhibitors (PIs)  | 12        |
| 1.2.2. <i>Bacillus thuringiensis</i> (Bt)  | 15        |
| 1.2.2.(i) Expression of Bt toxins in transgenic plants   | 18        |
| 1.2.2.(ii) Development and methods for delay of resistance to cry toxins                                 | 20        |
| 1.2.3 Plant lectins  | 22        |
| 1.2.3.(i) Plant endogenous response and use as insecticidal agent  | 22        |
| 1.2.3.(ii) Expression of lectins   | 24        |
| 1.3 Multi-domain proteins or ‘fusion proteins’ in nature   | 25        |
| 1.3.1 Chitin binding lectins   | 25        |
| 1.3.2 Ribosome inactivating proteins   | 26        |
| 1.4 Synthetic fusion proteins  | 27        |
| 1.4.1 Neurotoxins and their use in fusion proteins   | 28        |
| 1.4.1.(i) Toxin from Indian red scorpion ( <i>Mesobuthus tamulus</i> ) and its use<br>in fusion proteins | 30        |
| 1.4.1.(ii) Toxins isolated from Blue Mountains funnel-web<br>spider ( <i>Hadronyche versuta</i> )        | 34        |
| 1.4.1.(ii)A $\omega$ -atracotoxin-Hv1a   | 34        |
| 1.4.1.(ii)B $\kappa$ -atracotoxin-Hv1c   | 35        |
| 1.4.1.(iii) Expression of neurotoxins  | 36        |
| 1.4.2 Expression of fusion proteins: The yeast expression system   | 38        |
| 1.5 Coleopteran pests targeted by fusion proteins  | 39        |
| 1.6 Using <i>T. castaneum</i> as a model to infer toxicity to other coleopterans                         | 42        |
| 1.6.1 Life cycle of wireworms  | 42        |
| 1.6.2 Control of <i>Agriotes</i> spp. and need for alternative methods                                   | 43        |
| 1.6.3 Cultural and biological control  | 44        |
| 1.6.4 Chemical control   | 44        |

## Table of Contents

---

|  |    |
|--|----|
| 1.7 Application of fusion protein technology for control for coleopteran pests | 45 |
| 1.8 Aims and Objectives  | 47 |
| <b><u>Chapter 2 Materials and Methods</u></b>                                  | 48 |
| 2.1 Biological and chemical reagents   | 48 |
| 2.2 Statistical analysis   | 48 |
| 2.3 Standard molecular biological techniques                                   | 48 |
| 2.3.1 Oligonucleotides   | 48 |
| 2.3.2 5' Phosphorylation of oligonucleotide primers                            | 48 |
| 2.3.3 Bacterial culture  | 49 |
| 2.3.4 Plasmid DNA mini-preparations  | 49 |
| 2.3.5 Restriction endonuclease digestions                                      | 49 |
| 2.3.6 Polymerase chain reactions (PCR)   | 49 |
| 2.3.7 Agarose gel electrophoresis of DNA                                       | 50 |
| 2.3.8 Purification of DNA from agarose gel                                     | 50 |
| 2.3.9 Quantification of isolated DNA   | 50 |
| 2.3.10 Ligation of DNA   | 50 |
| 2.3.11 Ethanol precipitation   | 51 |
| 2.3.12 Chloroform extraction for DNA clean up                                  | 51 |
| 2.3.13 Generation of competent cells   | 51 |
| 2.3.13.(i) Electrocompetent <i>E. coli</i>                                     | 51 |
| 2.3.13.(ii) <i>Agrobacterium tumefaciens</i> (strain C58C1)                    | 52 |
| 2.3.14 Transformation of competent cells                                       | 52 |
| 2.3.14.(i) Transformation of TOP 10 electrocompetent <i>E. coli</i> .          | 52 |
| 2.3.14.(ii) Transformation of competent <i>Agrobacterium tumefaciens</i>       | 52 |
| 2.3.15 Colony PCR reactions  | 53 |
| 2.3.16 DNA sequencing and analysis   | 53 |
| 2.3.17 Bacterial glycerol stocks   | 53 |
| 2.3.18 Sub-cloning of PCR products   | 53 |
| 2.3.19 Purification of total RNA   | 54 |
| 2.3.20 Reverse transcription-PCR (RT-PCR)                                      | 54 |
| 2.4 Standard biochemical techniques  | 55 |
| 2.4.1 Estimation of protein concentration                                      | 55 |
| 2.4.2 SDS-PAGE gel electrophoresis   | 55 |
| 2.4.3 Staining SDS-PAGE gels with Coomassie Brilliant Blue                     | 56 |
| 2.4.4 Western blot analysis  | 56 |
| 2.4.5 <i>In vitro</i> haemagglutination of recombinant proteins                | 57 |

## Table of Contents

---

|  |    |
|--|----|
| 2.5 Production of recombinant insecticidal proteins in <i>Pichia pastoris</i>                            | 57 |
| 2.5.1 Synthesis of fusion protein constructs for expression in <i>Pichia pastoris</i>                    | 58 |
| 2.5.1(i) Recombinant GNA protein   | 58 |
| 2.5.1(ii) fusion proteins incorporating $\kappa$ -Atracotoxin-Hv1c ( $\kappa$ -ACTX) and GNA             | 58 |
| 2.5.1(ii)A $\kappa$ -ACTX-GNA  | 58 |
| 2.5.1(ii)B (His) <sub>6</sub> – GNA - $\kappa$ -ACTX   | 59 |
| 2.5.1(iii) Fusion proteins incorporating $\omega$ -atracotoxin-Hv1a ( $\omega$ -ACTX) and GNA            | 60 |
| 2.5.1(iii)A (His) <sub>6</sub> – GNA – $\omega$ -ACTX  | 60 |
| 2.5.1(iii)B $\omega$ -ACTX–GNA–(his) <sub>6</sub>  | 60 |
| 2.5.1(iii)C K34Q $\omega$ -ACTX-GNA  | 60 |
| 2.5.2 Transformation of expression constructs in <i>P. pastoris</i>                                      | 61 |
| 2.5.3 Expression screening of transformed <i>P. pastoris</i> colonies                                    | 61 |
| 2.5.4 Overexpression of recombinant proteins in <i>P. pastoris</i>                                       | 62 |
| 2.5.6 Recovery of protein  | 62 |
| 2.5.7 Purification of recombinant proteins   | 62 |
| 2.5.7(i) Purification of recombinant proteins by hydrophobic-interaction chromatography                  | 62 |
| 2.5.7(ii) Purification of recombinant proteins by nickel affinity chromatography                         | 63 |
| 2.5.7(iii) Purification of recombinant proteins by gel filtration chromatography                         | 63 |
| 2.5.8 Dialysis and freeze-drying of recombinant proteins   | 63 |
| 2.6 Insect Cultures  | 64 |
| 2.6.1 Cabbage moth ( <i>Mamestra brassicae</i> ) and Tomato moth ( <i>Lacanobia oleracea</i> )           | 64 |
| 2.6.2 Wireworms ( <i>Agriotes</i> spp.)  | 64 |
| 2.6.3 Red flour beetle ( <i>Tribolium castaneum</i> )  | 64 |
| 2.6.4 Insect bioassays   | 64 |
| 2.6.4(i) <i>T. castaneum</i> bioassays   | 64 |
| 2.6.4(ii) <i>Mamestra brassicae</i> injection bioassays  | 65 |
| 2.6.5 Total protein extraction from insect guts and estimation   | 65 |
| 2.6.6 <i>In vivo</i> determination of fusion protein stability in gut extracts                           | 65 |
| 2.6.7 Cloning of degenerate cathepsin L fragment from whole insect wireworm ( <i>Agriotes</i> spp.) cDNA | 66 |

## Table of Contents

---

|   |           |
|---|-----------|
| 2.6.7.(i) Analysis of degenerate PCR fragment   | 66        |
| 2.6.8 Assay of general proteolytic activity of wireworm ( <i>Agriotes</i> spp.) gut extract   | 67        |
| 2.6.9 Inhibition of wireworm gut cysteine protease activity by E-64   | 67        |
| 2.7 Construction of plasmids and generation of transgenic plant lines   | 68        |
| 2.7.1 Generation of constructs for expression of insecticidal proteins in plants  | 68        |
| 2.7.1.(i) ButaIT and GNA based expression constructs  | 68        |
| 2.7.1.(i)A GNA leader – GNA   | 68        |
| 2.7.1.(i)B GNA leader – GNA – ButaIT  | 68        |
| 2.7.1.(i)C GNA leader – ButaIT - GNA  | 68        |
| 2.7.1.(ii) $\omega$ -ACTX-Hv1a and GNA based expression constructs  | 69        |
| 2.7.1.(ii)A GNA leader– $\omega$ -ACTX–GNA and GNA leader–modified $\omega$ -ACTX–GNA   | 69        |
| 2.7.1.(ii)B GNA leader– $\omega$ -ACTX and GNA leader K34Q $\omega$ -ACTX   | 70        |
| 2.7.2 Cloning constructs into plant expression vectors using the Gateway cloning system   | 70        |
| 2.7.2.(i) Subcloning constructs into entry vector pENTR1A   | 70        |
| 2.7.2.(ii) Generation of an expression vector   | 71        |
| 2.8 Generation of transgenic plant lines  | 71        |
| 2.8.1 <i>Agrobacterium tumefaciens</i> culture and transformation   | 71        |
| 2.8.2 Plant material and growth conditions  | 72        |
| 2.8.3 Transformation by floral dipping  | 72        |
| 2.8.4 Seed collection   | 72        |
| 2.8.5 Seed sterilisation  | 72        |
| 2.8.6 Selection of transformed plants   | 73        |
| 2.9 Analysis of transformed plants  | 73        |
| 2.9.1 Analysis of protein expression by reverse-transcription PCR   | 73        |
| 2.9.2 Extraction of total protein from leaf tissue  | 73        |
| 2.9.3 Analysis of protein expression by western blotting  | 73        |
| 2.9.4 Demonstration of biological activity of transgene product: transgenic plant bioassays – <i>Lacanobia oleracea</i>   | 74        |
| <b><u>Chapter 3 Expression, purification and biological activity of fusion proteins incorporating Blue Mountains funnel-web spider toxin (<math>\kappa</math>-ACTX-Hv1c) and snowdrop lectin (<i>Galanthus nivalis</i> agglutinin; GNA)</u></b> | <b>76</b> |
| <b>Introduction</b>   | <b>76</b> |

## Table of Contents

---

|   |     |
|---|-----|
| 3.1 Production and purification of fusion proteins incorporating $\kappa$ -ACTX and GNA   | 77  |
| 3.1.1 $\kappa$ -ACTX-Hv1c-GNA: Design of expression construct   | 77  |
| 3.1.2. Transformation and scale up  | 77  |
| 3.1.3 Recovery of recombinant protein   | 81  |
| 3.2 Addition of a polyhistidine tag and variation of toxin/carrier assembly –<br>(His) <sub>6</sub> -GNA- $\kappa$ -ACTX  | 85  |
| 3.2.1 Design of expression construct  | 85  |
| 3.2.2 Transformation and scale up   | 87  |
| 3.2.3 Recovery of recombinant protein   | 89  |
| 3.3 Comparison of $\kappa$ -ACTX–GNA vs. (his) <sub>6</sub> -GNA- $\kappa$ -ACTX post purification  | 89  |
| 3.4 Biological activity of expressed fusion proteins incorporating $\kappa$ -ACTX and GNA   | 93  |
| 3.4.1 Functionality of fusion protein components  | 93  |
| 3.4.1.(i) <i>In vitro</i> haemagglutination activity of recombinant GNA<br>in $\kappa$ -ACTX–GNA fusions  | 93  |
| 3.4.1.(ii) Injection bioassays to demonstrate biological activity<br>of neurotoxin component  | 95  |
| 3.4.2 Oral activity of fusion proteins incorporating $\kappa$ -ACTX and GNA against<br><i>Tribolium castaneum</i>   | 98  |
| 3.5 Stability of fusion proteins incorporating $\kappa$ -ACTX and GNA <i>in vivo</i>  | 100 |
| 3.5.1 $\kappa$ -ACTX-GNA and GNA  | 100 |
| 3.5.2 (His) <sub>6</sub> -GNA- $\kappa$ -ACTX   | 100 |
| <b>Discussion</b>   | 104 |
| <br>  |     |
| <b><u>Chapter 4 Expression, purification and biological activity of fusion proteins<br/>incorporating Blue Mountains funnel-web spider toxin (<math>\omega</math>-ACTX-Hv1a)<br/>and snowdrop lectin (<i>Galanthus nivalis</i> agglutinin; GNA)</u></b> | 114 |
| <b>Introduction</b>   | 114 |
| 4.1 Design of expression constructs   | 116 |
| 4.1.1 Addition of a (his) <sub>6</sub> tag and variation of component sequence  | 116 |
| 4.1.2 Mutation of toxin sequence to remove a signal cleavage site   | 116 |
| 4.2 Comparison of protein expression during small-scale screening in rich media   | 117 |
| 4.3 Comparison of stability during bench-top fermentation of expression constructs  | 121 |
| 4.4 Comparison of stability of expression constructs during and post purification process   | 121 |
| 4.4.1 $\omega$ -ACTX–GNA vs. K34Q $\omega$ -ACTX–GNA  | 121 |
| 4.4.2 (His) <sub>6</sub> -GNA- $\omega$ -ACTX and $\omega$ -ACTX–GNA-(his) <sub>6</sub>   | 123 |

## Table of Contents

---

|  |     |
|--|-----|
| 4.5 Demonstration of biological activity of fusion protein components  | 127 |
| 4.5.1 <i>Mamestra brassicae</i> injection bioassays to demonstrate biological activity of neurotoxin component   | 127 |
| 4.6 Oral toxicity of fusion proteins incorporating $\omega$ -ACTX and GNA against <i>T. castaneum</i>  | 130 |
| 4.6.1 $\omega$ -ACTX-GNA and K34Q $\omega$ -ACTX-GNA   | 130 |
| 4.6.2 $\omega$ -ACTX-GNA-(his) <sub>6</sub> and (his) <sub>6</sub> -GNA- $\omega$ -ACTX  | 134 |
| 4.6.3 (His) <sub>6</sub> -GNA-K34Q $\omega$ -ACTX  | 137 |
| 4.7 Expression of $\omega$ -ACTX-Hv1a and fusion proteins based on $\omega$ -ACTX-Hv1a and GNA in <i>Arabidopsis thaliana</i>  | 140 |
| 4.7.1 Design of expression constructs  | 140 |
| 4.7.2 Transformation and selection of primary transformants  | 142 |
| 4.7.2.(i) Determination of transgene expression  | 142 |
| 4.7.2.(i)A RT-PCR for detection of positive K34Q $\omega$ -ACTX and $\omega$ -ACTX expressing <i>Arabidopsis</i>   | 142 |
| 4.7.2.(i)B Western blot analysis   | 143 |
| <b>Discussion</b>  | 146 |
| <br>   |     |
| <b><u>Chapter 5 Biological activity of fusion proteins incorporating Indian red scorpion toxin (ButaIT) and snowdrop lectin (<i>Galanthus nivalis</i> agglutinin; GNA) expressed using both <i>Pichia pastoris</i> and <i>Arabidopsis thaliana</i></u></b> |     |
| <b>Introduction</b>  | 153 |
| 5.1 Oral toxicity of fusion proteins incorporating ButaIT and GNA against <i>Tribolium castaneum</i>   | 154 |
| 5.1.1 ButaIT – GNA $\pm$ (his) <sub>6</sub> (protein provided by Dr. Fitches, FERA (York))   | 154 |
| 5.1.2 5' Strep-tagged ButaIT–GNA Variants (protein provided by Dr. Fitches, FERA, (York))  | 158 |
| 5.2 Expression of fusion proteins incorporating ButaIT and GNA in <i>Arabidopsis thaliana</i>  | 161 |
| 5.2.1 Design of expression constructs  | 161 |
| 5.2.2 Transformation and selection of GNA, ButaIT-GNA and GNA-ButaIT constructs  | 166 |
| 5.2.3 Detection and segregation of homozygous transgenic <i>Arabidopsis</i>  | 166 |
| 5.2.4 Detection of expression  | 167 |
| 5.2.4.(i) Western blot analysis of leaf tissue expression  | 167 |
| 5.2.4.(ii) Western blot analysis of root expression  | 168 |

## Table of Contents

---

|  |     |
|--|-----|
| 5.3 Demonstration on functionality of fusion proteins expressed <i>in planta</i>   | 173 |
| 5.3.1 Effect of transgenic <i>Arabidopsis</i> expressing fusion proteins<br>incorporating ButaIT and GNA when fed to <i>Lacanobia oleracea</i> | 173 |
| <b>Discussion</b>  | 178 |
| <b><u>Chapter 6 General discussion and conclusions</u></b>   | 183 |
| <b><u>References</u></b>   | 193 |
| <b><u>Appendix</u></b>   |     |

## Declaration and Statement of Copyright

### Declaration

No material contained herein has been previously submitted for any other degree. Except where acknowledged, all material is the work of the author

### Statement of Copyright

The copyright of the thesis rests with the author. No quotation from it should be published without prior written consent and information derived from it should be acknowledged.

**Date:** .....

**Signed:** .....

### List of Publications

Fitches E.C., Bell H.A., Powell M.E., **Back E.**, Sargiotti C., Weaver R.J., Gatehouse J.A., (2010). Insecticidal activity of scorpion toxin (ButaIT) and snowdrop lectin (GNA) containing fusion proteins towards pest species of different orders. *Pest Management Science* **66** (1), 74-83.

## Acknowledgements

I am incredibly thankful to Prof. John Gatehouse (School of Biological and Biomedical Sciences, Durham University) for his support and guidance throughout the course of my PhD. I would also like to thank Dr. Elaine Fitches (FERA, York) for her support and help throughout the project as well as the use of purified proteins and some of her gels for use in this thesis. I am also very grateful for the funding provided by BBSRC as part of a CASE studentship together with Branston Ltd.

Thanks to all members of lab 1 both past and present for creating such a warm and friendly atmosphere to be in. Particular thanks extended to Dr. Catherine Bruce, Dr. Prashant Pyati, Gareth and Dominic for their advice, guidance and friendship.

My appreciation is also extended to Dr. Howard Bell (FERA, York) for helping me dig up wireworms during the project, Drs. Jennifer Topping and Bekir Ulker for help with plant transformation techniques. Also, thanks to Prof. Glenn King for providing toxins  $\kappa$ -ACTX-Hv1c and  $\omega$ -ACTX-Hv1a for insect assays in this thesis and Dr. de Jong for providing a starter culture of *Phyllotreta nemorum*.

I am indebted to my friends, family and extended family, who have provided limitless love and support over the years – you all know who you are. Particularly to Fran, Dave, Stephen and Rich who have made my time in Durham unforgettable.

Last but not means least my heartfelt thanks to Dan who has put up with me throughout this process! I would have been lost without your love and support.

Emma Back

## List of figures

### Chapter 1 Introduction

**Figure 1.1** The three-dimensional structure of ButaIT (Wudayagiri *et al.* (2001)).

**Figure 1.2** Schematic of  $\kappa$ -ACTX-Hv1c (Wang *et al.*, 2000).

**Figure 1.3** Stereo view of the structure of  $\omega$ -ACTX-Hv1a (Fletcher *et al.*, 1997; Tedford *et al.*, 2004)

### Chapter 2 Materials and Methods

**Figure 2.1** Bioassay area used to show biological activity of fusion protein expressing leaves of *Arabidopsis thaliana*

### Chapter 3 Expression, purification and biological activity of fusion proteins incorporating Blue Mountains funnel-web spider toxin ( $\kappa$ -ACTX-Hv1c) and snowdrop lectin (*Galanthus nivalis* agglutinin; GNA)

**Figure 3.1** Full  $\kappa$ -ACTX-GNA fusion construct in yeast expression vector pGAPZ $\alpha$ B.

**Figure 3.2** Western blots (probed with anti-GNA ab): Small scale  $\kappa$ -ACTX-GNA expression screens of *P. pastoris* colonies positive by antibiotic (zeocin) selection grown in 10ml YGP media

**Figure 3.3** Purification of recombinant  $\kappa$ -ACTX-GNA produced in *Pichia pastoris* (strain SMD1168).

**Figure 3.4** Quantification of recombinant  $\kappa$ -ACTX-GNA produced in *Pichia pastoris* (strain SMD1168).

**Figure 3.5** Full (his)<sub>6</sub>- $\kappa$ -ACTX-GNA fusion construct in yeast expression vector pGAPZ $\alpha$ B

**Figure 3.6** Western blot (probed with anti-GNA ab): small-scale expression screen of (his)<sub>6</sub>-GNA- $\kappa$ -ACTX fusion protein in 10ml YPG media

**Figure 3.7** Purification of (his)<sub>6</sub>-GNA- $\kappa$ -ACTX expressed in *Pichia pastoris* (strain SMD1168).

**Figure 3.8** Quantitation of (his)<sub>6</sub>-GNA- $\kappa$ -ACTX.

**Figure 3.9** *In vitro* haemagglutination of fresh rabbit erythrocytes by recombinant GNA and  $\kappa$ -ACTX-GNA expressed in *P. pastoris*

**Figure 3.10** The survival of *Mamestra brassicae* larvae 5 days post injection with  $\kappa$ -ACTX-GNA and (his)<sub>6</sub>-GNA- $\kappa$ -ACTX at 10, 20 and 40 $\mu$ g

**Figure 3.11** Survival and mean weight of surviving *Tribolium castaneum* larvae fed recombinant GNA,  $\kappa$ -ACTX-GNA and (his)<sub>6</sub>-GNA- $\kappa$ -ACTX at 2 mg g<sup>-1</sup>.

**Figure 3.12** *In vivo* stability of  $\kappa$ -ACTX-GNA orally ingested by *T. castaneum* (Western blot probed with anti-GNA antibodies).

**Figure 3.13** Western blot (probed with anti-GNA antibodies) showing *in vivo* stability of (his)<sub>6</sub>-GNA- $\kappa$ -ACTX ingested by *T. castaneum* after 2, 4 and 6 hours.

**Figure 3.14** Survival rate and mean weight of surviving *T. castaneum* larvae fed wheat cysteine protease inhibitor (WCPI) and subtilisin/chymotrypsin inhibitor (WSCI) (provided by Dr. Pyati) at 2 mg g<sup>-1</sup>.

**Chapter 4 Expression, purification and biological activity of fusion proteins incorporating Blue Mountains funnel-web spider toxin ( $\omega$ -ACTX-Hv1a) and snowdrop lectin (*Galanthus nivalis* agglutinin; GNA)**

**Figure 4.1** Original  $\omega$ -ACTX-GNA fusion protein designed and expressed in *P. pastoris* by Dr. Fitches, FERA (York).

**Figure 4.2** Schematic representations of  $\omega$ -ACTX and GNA based fusion protein construct designs in pGAPZ $\alpha$ B.

**Figure 4.3** Western blots (probed with anti-GNA antibody): Comparison of fusion protein expression during small-scale expression in rich media (YPG).

**Figure 4.4** Western blots (probed with anti-GNA ab): Stability of  $\omega$ -ACTX-GNA compared to K34Q  $\omega$ -ACTX-GNA fusion protein through bench-top fermentation of *P. pastoris* using basal salt media

**Figure 4.5** Stability of  $\omega$ -ACTX-GNA compared to K34Q $\omega$ -ACTX-GNA fusion protein through purification.

**Figure 4.6** SDS-PAGE gels showing fusion proteins incorporating  $\omega$ -ACTX and GNA after purification steps.

**Figure 4.7** The survival of 5<sup>th</sup> instar *Mamestra brassicae* larvae 4 days post injection with  $\omega$ -ACTX-GNA and K34Q $\omega$ -ACTX-GNA at doses of 5, 10 and 20 $\mu$ g.

**Figure 4.8** Survival rate and mean weight of surviving *T. castaneum* larvae fed recombinant  $\omega$ -ACTX-GNA and K34Q  $\omega$ -ACTX-GNA at 1 mg g<sup>-1</sup> and 2 mg g<sup>-1</sup>.

**Figure 4.9** Survival and mean weight of surviving *Tribolium castaneum* larvae fed recombinant GNA at 1 mg g<sup>-1</sup>,  $\omega$ -ACTX-GNA-(his)<sub>6</sub> and (his)<sub>6</sub>-GNA- $\omega$ -ACTX at 0.5, 0.75 and 1 mg g<sup>-1</sup>.

**Figure 4.10** Survival and mean weight of surviving *Tribolium castaneum* larvae fed recombinant GNA at 1, 2 mg g<sup>-1</sup> and (his)<sub>6</sub>-GNA-k34Q $\omega$ -ACTX at 0.5, 0.75, 1 and 2 mg g<sup>-1</sup>.

**Figure 4.11** Schematic representations of  $\omega$ -ACTX-Hv1a and GNA based expression constructs for transformation into *Arabidopsis thaliana*.

**Figure 4.12** Western blot (probed with anti-GNA antibodies). Analysis of *Arabidopsis thaliana* transformants (T<sub>0</sub>) for expression of ω-ACTX-GNA.

**Figure 4.13** Western blot (probed with anti-GNA antibodies). Analysis of T<sub>0</sub> *Arabidopsis thaliana* transformants expressing K34Qω-ACTX-GNA.

**Chapter 5 Biological activity of fusion proteins incorporating Indian red scorpion toxin (ButaIT) and snowdrop lectin (*Galanthus nivalis* agglutinin; GNA) expressed using both *Pichia pastoris* and *Arabidopsis thaliana***

**Figure 5.1** Survival and mean weight of surviving *Tribolium castaneum* larvae fed recombinant GNA, ButaIT-GNA-(his)<sub>6</sub> and ButaIT-GNA at 1 and 2 mg g<sup>-1</sup> and ButaIT at 2 mg g<sup>-1</sup>.

**Figure 5.2** Survival and mean weight of surviving *Tribolium castaneum* larvae fed recombinant GNA, ButaIT, and 5' Strep-tagged ButaIT, GNA variants at 2 mg g<sup>-1</sup>.

**Figure 5.3** GNA construct in pK2WG7 for expression *in planta*.

**Figure 5.4** GNA-ButaIT construct in pK2WG7 for expression *in planta*.

**Figure 5.5** ButaIT-GNA construct in pK2WG7 for expression *in planta*.

**Figure 5.6** Western blot (probed with anti-GNA antibodies) to show representative expression of GNA in leaves of transformed *Arabidopsis thaliana* used for feeding bioassays.

**Figure 5.7** Western blot (probed with anti-GNA antibodies) to show representative expression of GNA-ButaIT in leaves of transformed *Arabidopsis thaliana* used in feeding bioassays.

**Figure 5.8** Western blot (probed with anti-GNA antibodies) to show representative expression of ButaIT-GNA in leaves of transformed *Arabidopsis thaliana* used in feeding bioassays.

**Figure 5.9** Expression of GNA, GNA-ButaIT and ButaIT-GNA in roots of T<sub>3</sub> transformed *Arabidopsis thaliana*.

**Figure 5.10** Kaplan-Meier survival curves of *Lacanobia oleracea* fed *Arabidopsis thaliana* expressing recombinant GNA at 0.15-0.2% total soluble protein (TSP), GNA-ButaIT at 0.1-0.15% TSP and ButaIT-GNA lines 40 and 45 at approx 0.15% TSP each.

**Figure 5.11** Mean weight of surviving *Lacanobia oleracea* larvae fed transgenic *Arabidopsis* expressing recombinant proteins in separate assays after 11 and 14 days.

**Appendix**

**Appendix 1** Purification of recombinant GNA produced in *Pichia pastoris* (strain X-33).

## List of Figures and Tables

---

- Appendix 2** ‘Clean up’ of GNA by gel filtration column purification and quantitation of purified protein.
- Appendix 3** Agarose gel of PCR fragments generated from degenerate PCR reaction.
- Appendix 4** Presumed amino acid sequence of degenerate PCR fragment cloned from whole insect wireworm cDNA.
- Appendix 5** ClustalW alignment of the presumed amino acid sequence of the degenerate PCR fragment from Wireworm (*Agriotes* spp.) and amino acid sequence of the corresponding section of the *Tribolium castaneum* cathepsin L pre-cursor sequence (NP\_00164088.1).
- Appendix 6** Hydrolysis of the cysteine specific substrate Z-Phe-Arg-AMC by 6, 12, 18 $\mu$ g *Agriotes* spp. gut extract.
- Appendix 7** Inhibition of protease activity with 5 $\mu$ M of an irreversible cysteine protease inhibitor (E64; (2S,3S)-3-(N-((S)-1-[N-(4-guanidinobutyl)-carbamoyl]3-methylbutyl) carbamoyl) oxirane-2-carboxylic acid)) using the cysteine specific substrate Z-Phe-Arg-AMC.
- Appendix 8** Full  $\omega$ -ACTX-GNA-(his)<sub>6</sub> fusion construct in yeast expression vector pGAPZ $\alpha$ B.
- Appendix 9** Full (his)<sub>6</sub>- $\omega$ -ACTX-GNA fusion construct in yeast expression vector pGAPZ $\alpha$ B.
- Appendix 10** Full K34Q- $\omega$ -ACTX-GNA fusion construct in yeast expression vector pGAPZ $\alpha$ B.
- Appendix 11** GNA leader-K34Q $\omega$ -ACTX-GNA fusion protein construct in expression vector pK2GW7.
- Appendix 12** GNA leader- $\omega$ -ACTX-GNA fusion protein construct in expression vector pK2GW7.
- Appendix 13** GNA leader- $\omega$ -ACTX fusion protein construct in expression vector pK2GW7.
- Appendix 14** GNA leader-K34Q $\omega$ -ACTX fusion protein construct in expression vector pK2GW7.

## Abbreviations

---

### Abbreviations

#### Nucleic acid abbreviations:

A: Adenine

T: Thymine

G: Guanine

C: Cytosine

#### Amino acid abbreviations:

| Amino Acid    | Single letter code | Three letter code | Name          | Single letter code | Three letter code |
|---------------|--------------------|-------------------|---------------|--------------------|-------------------|
| Alanine       | A                  | Ala               | Isoleucine    | I                  | Ile               |
| Arginine      | R                  | Arg               | Leucine       | L                  | Leu               |
| Asparagine    | N                  | Asn               | Lysine        | K                  | Lys               |
| Aspartic acid | D                  | Asp               | Methionine    | M                  | Met               |
| Cystiene      | C                  | Cys               | Phenylalanine | F                  | Phe               |
| Glutamic acid | E                  | Glu               | Proline       | P                  | Pro               |
| Glutamine     | Q                  | Gln               | Serine        | S                  | Ser               |
| Glycine       | G                  | Gly               | Threonine     | T                  | Thr               |
| Histidine     | H                  | His               | Tryptophan    | W                  | Trp               |
| Valine        | V                  | Val               | Tyrosine      | Y                  | Tyr               |

#### Degenerate nucleic acid abbreviations:

B: C/G/T

D: A/G/T

H: A/C/T

K: G/T

M: A/C

N: A/T/C/G

R: A/G

## Abbreviations

---

S: G/C

V: A/C/G

W: A/T

Y: C/T

### **Other abbreviations:**

AOX1: Alcohol oxidase 1

BSA: Bovine Serum Albumin

ECL: Enhanced Chemiluminescence

PBS: Phosphate buffered saline

PCR: Polymerase chain reaction

RT-PCR: Reverse transcription polymerase chain reaction

RACE: Rapid Amplification of cDNA ends

GSP: Gene specific primer

SDS-PAGE: Sodium dodecyl sulphate polyacrylamide gel electrophoresis

TEMED: Tetramethylethylenediamine

TAE: Tris acetate EDTA buffer

CBB: Coomassie brilliant blue stain

dNTPs: deoxyribonucleotide triphosphate

dATP: deoxyadenosine triphosphate

dTTP: deoxythymine triphosphate

dGTP: deoxyguanine triphosphate

dCTP: deoxycytosine triphosphate

DTT: Dithiothreitol

M-MLV RT: Moloney Murine Leukemia virus reverse transcriptase

rpm: revolutions per minute

BCA: Bicinchonic acid

OD: Optical density

HRP: Horseradish Peroxidase

FPLC: Fast Protein Liquid Chromatography

IMAC: Immobilised Metal Ion Chromatography

MWCO: Molecular weight cut off

GSH: reduced Glutathione

## Abbreviations

---

bp: base pairs

kD / kDa: KiloDalton

PIs: Protease inhibitors

$\kappa$ -ACTX:  $\kappa$ -atracotoxin-Hv1c

$\omega$ -ACTX:  $\omega$ -atracotoxin-Hv1a

ButaIT: Indian red scorpion (*Mesobuthus tamulus*) toxin

SFI1: *Segestria florentina* toxin 1

GNA: *Galanthus nivalis* agglutinin

ASAI: Garlic (*Allium Sativum*) Agglutinin I

Man: Mannose

PHA: *Phaseolus vulgaris* agglutinin

Col-1: Columbia 1 ecotype (wild type) *Arabidopsis thaliana*

WSCI Wheat subtilisin/chymotrypsin protease inhibitor

WCPI: Wheat cysteine protease inhibitor

SKTI: Kunitz trypsin inhibitor

EST: Expressed sequence tag

TSP: Total soluble protein

LB: Luria-Bertani broth

LSLB: Low salt Luria-Bertani broth

YPG: Yeast peptone glucose media

CBB: Coomassie brilliant blue

PD<sub>50</sub>: the amount of a toxin that causes the paralysis of 50% of test animals.

LD<sub>50</sub>: amount of a toxin that causes the death of 50% of test animals

ST<sub>50</sub>: The median survival time index of test animals infected with a virus

ED<sub>50</sub>: the amount of a toxin, which produces an effect on 50% of test animals

VGCC: Voltage gated calcium channels

LVA Ca<sub>V</sub>: Low voltage activated voltage gated calcium channels

HVA Ca<sub>V</sub>: High voltage activated voltage gated calcium channels

K<sub>Ca</sub>: Calcium-activated potassium channels

BK<sub>Ca</sub>: Large conductance calcium activated potassium channels

*Slo*: *Slowpoke* gene

ChTx: Charybdotoxin

IbTx: Iberiotoxin

## Abbreviations

---

$\alpha$  KTx 1: Potassium channel specific  $\alpha$  scorpion toxin family 1

nAChRs : Nicotinic acetylcholine receptor

GABA:  $\gamma$ -aminobutyric acid receptor

GluCls : glutamate-gated chloride channel

RNAi: RNA interference

## Chapter 1

### Introduction

#### 1.1 Costs of herbivorous pests to agriculture

In a world where the population is expected to grow to 10 billion over the next 10 decades (United Nations, 2004) there is a substantial pressure on the agricultural sector to boost its productivity to meet the demand for food. However, insect pests and disease are major constraints upon any attempt to increase food production. Yield losses of up to forty percent are still seen due to crop diseases, and despite worldwide spending of \$20 billion on insecticides, 10-20% yield loss of major agricultural crops is due to herbivorous insect pests (Ferry *et al.*, 2006; McKinney *et al.*, 2007).

Increasing concern over the effects of agricultural practices, such as application of insecticides, on ecological diversity and environmental integrity has led to many of the older broad-spectrum pesticides being withdrawn from commercial usage. This is particularly the case within the EU where Directive 91/414 that acts to restrict the use of insecticides as plant protection products has been implemented. New legislation to update this Directive will potentially add to the loss of chemicals available for plant protection (EU communication to the Council, 2006).

Along with the reduction in available pesticides, the development of resistance to commercial pesticides by insect pest species has been a concern for farmers. Pest resistance to chemical compounds has been apparent since 1914, and has been steadily increasing, with over 500 arthropods to date showing resistance to one or more classes of chemical insecticides (Chrispeels and Sadava, 2002).

Part of the reason suggested for the increased rate of development of pesticide resistance in insects is that chemical compounds targeting the central nervous system of pests aim to block or inhibit just one of a limited number of target sites: the voltage-gated sodium channel, the nicotinic acetylcholine receptor (nAChRs), the  $\gamma$ -aminobutyric acid (GABA) receptor, glutamate-gated chloride channel (GluCl), and acetylcholinesterase (Tedford *et al.*, 2004; Raymond-Delpech *et al.*, 2005). This

single point approach to crop protection has promoted the development of cross-resistance to different families of insecticides as well as the development of detoxification-based resistance (Brogdon and McAllister, 1998).

## **1.2 Alternative methods of insect control: insecticidal proteins**

Given the withdrawal, or potential withdrawal, of some of the most effective but also the most environmentally destructive compounds for insecticidal use, the need for new sustainable methods of control is apparent. Investigations into alternative approaches to chemical control of insect pests has led to the isolation of endogenous bacterial and plant toxic proteins that show insecticidal effects, through targeting a range of sites and processes. Examples of these are described below.

### **1.2.1 Protease inhibitors (PIs)**

Targeting insect digestion for crop protection has been a method employed by plants and humans alike. Protease inhibitors (PIs) are generally small proteins that can range in size from 4 to 25 kDa and act to block the active site of their target enzyme(s), by forming a tight-binding complex, and in some cases also by forming a covalent bond with the active site residue responsible for catalytic activity. PIs inhibiting any one of four main types of digestive protease activity (serine, cysteine, aspartic or metallo-proteases) are known. These protease inhibitors also form part of a plants endogenous defence system. Involvement of PIs in plant defence was illustrated using antisense RNA to block the normal wounding response in transgenic tobacco. Suppression of the prosystemin gene stopped expression of systemin, a peptide hormone that acts as the signal to induce synthesis and accumulation of PIs. The resulting plants were subsequently unable to synthesize wound-induced PIs and were significantly more vulnerable to herbivory from lepidopteran larvae (Orozco-Cardenas *et al.*, 1993).

Protease inhibitors reduce the activity of digestive enzymes, and therefore affect the quantity of proteins that can be digested. Hyper-production of digestive enzymes can be obtained as a response to the inhibition effect. This compounds the effects of protease inhibitors by increasing the loss of sulfur amino acids (Shukle and Murdock, 1983). The major effect of PIs is thought to be on nitrogen nutrition; the activity of PIs prevent digestive enzymes from reducing ingested proteins to free amino acids,

which can be taken up from the gut. Their action also prevents nitrogen recycling in the gut by blocking self-degradation of gut proteases, and degradation of other secreted gut proteins. These effects leave insects weak, stunted in growth and eventually cause death.

Knowledge of digestive enzymes expressed by insect pests and their inhibition by PIs has been suggested as a method to help to bring about targeted control methods. For this reason, many plant PIs have been purified and sequenced, or expressed as recombinant proteins, to characterize their interactions with digestive proteases of insects of all orders. Research into protease inhibitors has also been of interest to scientists for many years, as foods that accumulate high levels of protease inhibitors could potentially have harmful effects to both humans and animals if the food was not processed properly (Liener *et al.*, 1980).

The potential role of protease inhibitors (PIs) as an endogenous plant defence against insects was first investigated as early as 1947. Mickel and Standish found that certain insect larvae did not develop normally when fed on soybean products. Lipke *et al.* in 1954 later discovered that trypsin inhibitors within soybean were toxic when fed to the larvae of the flour beetle, *Tribolium confusum*. Since then many other protease inhibitors from plants have been isolated such as cowpea (Gatehouse *et al.*, 1980), apples (Ryan *et al.*, 1998) and potato (Rowen *et al.*, 1990).

Protease inhibitor genes can be exploited for plant protection much easier than attempting to manipulate multiple genes encoding the enzymes catalyzing the synthesis of defensive compounds in complex pathways making them an attractive option for scientists. By transferring just one defensive gene from one plant species to another whilst using their own wound inducible or constitutive promoter for plant expression, resistance to insect pests can be obtained (Boulter, 1993). For this reason, expression of protease inhibitors in transgenic plants was first demonstrated as early as 1987 when Hilder *et al.* engineered tobacco to express the cowpea trypsin inhibitor (CpTI). The PI contains two active sites for inhibition of bovine trypsin and expressed at high levels (2.5-9.6  $\mu\text{g}$  of CpTI  $\text{mg}^{-1}$  of soluble leaf protein) in transgenic tobacco leaves, causing up to 50% mortality when tobacco budworm larvae (*Heliothis*

*Virescens*) were fed on the plants. Surviving larvae that continued to feed were observed to have stunted growth (Hilder *et al.*, 1987). This success has not always been ubiquitous amongst protease inhibitors expressed in plants however. Kunitz trypsin inhibitor (SKTI) gene from soybean expressed in transgenic tobacco plants by Nandi *et al.* (1999) failed to produce any reduction in survival or retardation in growth of the cotton bollworm (*Helicoverpa armigera*). The leaves accumulated high levels of the inhibitor; however larvae grew normally despite *H. armigera* gut proteolytic activity being inhibited by SKTI.

Although protease inhibitors undoubtedly help to protect plants from insect attack, the protection is only partial due to adaptive processes within pest insects that enable them to overcome antimetabolic effects. In some cases the use of PIs can cause insects to actually increase in weight. This is shown when Colorado potato beetle larvae were fed oryzacystatin I expressing potatoes (Cloutier *et al.*, 1999). This may be explained by the fact that many protease inhibitors are rich in cysteine and lysine contributing to enhanced nutritional quality (Ryan, 1989). Insect pests have evolved highly efficient strategies to counteract the effects of plant protease inhibitors by simply up regulating expression of alternative classes of protease. This is known to happen in the model coleopteran *Tribolium castaneum* whereby the main type of digestive proteases it relies upon are cysteine proteases. Upon encountering inhibitors for this class however, it can express serine proteases as an alternative by-passing the attempts to inhibit its digestive processes (Oppert *et al.*, 2005). Colorado potato beetles are also well known to switch digestive protease expression (Bolter and Jongsma, 1995).

Despite attempts to circumvent insect adaptive mechanisms seen when expressing PIs, the use of alternative inhibitors that insects might not be preadapted to have still not afforded the transgenic plants complete protection. Synthetic multi-domain cysteine protease inhibitors based on domains found within animals and plants (i.e., kininogen, stefin, cystatin C, potato cystatin, and equistatin) have been constructed and subsequently expressed in transgenic potato. The plants were shown to have deterrent properties to thrips and within glasshouse trials gave partial resistance. However complete protection was not obtained (Outchkourov *et al.*, 2004a, 2004b).

### 1.2.2 *Bacillus thuringiensis* (Bt)

*Bacillus thuringiensis* (Bt) is a gram-positive soil dwelling bacterium that possesses entomopathogenic properties. It was first discovered in 1902 by Shigetane Ishiwatari, whilst investigating the cause of sotto disease (sudden-collapse disease) that was responsible for killing large populations of silkworms. Bt was later isolated as the bacterium that killed Mediterranean flour moths and subsequently was rediscovered by Ernst Berliner in 1915. It wasn't until 1956 however that crystal toxins were fully identified and found to be the cause of its toxicity (Angus, 1956).

The bacterium exerts its insecticidal effects by producing proteinaceous inclusions or crystal (Cry and Cyt) proteins during sporulation. These toxins are encoded by genes which are present on plasmids. It is the presence of these plasmids that distinguishes Bt from other spore-forming bacilli (Aronson and Shai, 2001). As the targets of its toxic proteins spend little time within the soil, the species has been described as an opportunistic pathogen. The process of sporulation has been suggested to have evolved as a “backup” system in order to ensure the bacterium's survival during unfavorable conditions (de Maagd *et al.*, 2001). The presence of the plasmids is obviously beneficial to the bacterium as they are ubiquitous among Bt populations despite the metabolic cost of plasmid production.

There are four types of toxic proteins produced from Bt and they have been named based upon their amino acid sequence similarity (Crickmore *et al.*, 1998). Three are usually found as crystalline deposits (named Cry or Cyt toxins) and include binary toxins, single toxins with three-domain structure (also truncated versions) and cytolytic, single domain structured toxins. The fourth set of toxin proteins include single and binary toxins that are expressed vegetatively by the bacterium (Vip).

The Cry toxins fall into one of three groups: the three domain, the mosquitocidal-like and the binary-like Cry toxins. The three domain crystal toxins are the biggest group of toxins classified into 40 different groups and subgroups based again on sequence similarity. All Bt toxins are characterized in this way into families, first with a number where the same number denotes >45% sequence identity. Toxins are then subdivided using capital letters where the same letter denotes >78% sequence identity. Small

letters follow with the same letter denoting >95% sequence identity. Numbers follow successively to generate toxins represented as Cry1, Cry2 and Cry1Aa Cry1Ab etc. (Crickmore *et al.*, 1998).

These three domain (3d-Cry) crystal proteins are the most widely used for crop protection although all Bt toxins are used. Structural identification of six different Cry toxins [Cry1Aa (Grochulski *et al.*, 1995), Cry2Aa (Morse *et al.*, 2001), Cry3Aa (Li *et al.*, 1991), Cry3Bb (Galitsky *et al.*, 2001), Cry4Aa (Boonserm *et al.*, 2006), and Cry4Ba (Boonserm *et al.*, 2005)] all showing conserved structure and sequence allowed for the general three domain model of the proteins to be developed. Domain I is approx. 260 aa and positioned at the N-terminus. The domain contains seven  $\alpha$ -helical domains with 6 being amphipathic and one hydrophobic. These are arranged in three pairs around a central helix. Domain II is approx. 170 aa and created from three symmetrically folded  $\beta$ -sheets. At the C-terminal domain III consists of 160 aa forming 2 sandwiched  $\beta$ -sheets similar to carbohydrate-binding domains in other proteins (Schnepf *et al.*, 1998; de Maagd *et al.*, 2001). Domain I is considered to have a role in cell insertion, domain II in receptor binding and recognition while domain III is involved in formation of pores and channel specificity.

The Cry  $\delta$ -endotoxins are widely considered to cause death to insects through a mechanism involving formation of pores in the membranes of gut epithelial cells. The primary step in the mechanism of action is a solubilisation step, in which the toxins become soluble from crystal inclusions in the bacterial spores when inside the insect gut. The protoxin then undergoes interaction with digestive proteases that cleave the C and N terminal ends and activate the toxin. The essential point in the activation process is the proteolytic cleavage of the N-terminal extension that can vary in size from 25-60 aa between Cry toxins. It has been suggested that the N terminal extension acts to shield a portion of the toxin that has direct involvement in binding to cellular receptors (Morse *et al.*, 2001). Once active the toxin remains relatively resistant to cleavage and thus has enough time to reach the target site of the gut epithelial cells.

The active toxin binds to receptors on the gut epithelium and inserts itself into the membrane. It is the Cry toxins themselves that determine specificity of interaction and

ligand binding. In order to identify receptors to which Cry proteins bind, immunoblotting of proteins that have been prepared from brush border membrane vesicles (BBMV) has been employed. This is not always accurate as illustrated by the identification of potential receptors for Cry1A. A membrane-anchored aminopeptidase and a cadherin-like protein (Bt-R1) were first identified as receptors for lepidopteran gut binding (Knight *et al.*, 1994; Vadlamudi *et al.*, 1995). A 270 kDa glycoprotein along with a membrane anchored alkaline phosphatase followed (Valaitis *et al.*, 2001; Jurat-Fuentes *et al.*, 2004). However Krishnamoorthy *et al.* (2007) showed V-ATP synthase subunit 1 which showed binding to actin could act as a receptor for the Cry toxin. This is unlikely as actin could not be present at the cellular surface for binding to occur.

The toxins go through a process of oligomerization promoted by the binding mechanism. Examples can be seen from Cry1 and Cry3 families which have been seen to form oligomeric structures (probably tetramers). Cry1Ab binds to the cadherin Bt-R1 receptor which involves truncating the N-terminal end of the protein in domain I (Gómez *et al.*, 2002). The role of cadherin in this process has been illustrated by Chen *et al.* (2007) where a region of cadherin acts as a synergist that increases the toxicity of Cry1A toward lepidopteran larvae. Binding between the peptide and Cry1A has been suggested as a reason for this, promoting oligomerization of the toxin prior to interaction with the gut epithelium. Cadherin is widely seen as the primary receptor for Cry toxins, with other molecules taking the role of “secondary receptors” (Soberón *et al.*, 2007).

The oligomeric Cry protein partially unfolds allowing the pore-forming domain to insert into the membrane. This denaturing is thought to occur due to a pH change near the cellular membrane within guts that is also known to occur within mammalian cells (Parker and Feil, 2005). The Cry toxin then binds to a secondary receptor (aminopeptidase N) and toxin insertion into the membrane follows (Bravo *et al.*, 2004, 2007). This forms pores in the membrane that cause osmotic lysis and eventual death. Cell leakage caused from pore formation allows proliferation of gut microflora. Dying insects therefore show massive bacterial infection of collapsing gut tissue (Grochulski *et al.*, 1995; Schnepf *et al.*, 1998).

An alternative mode of action differing from the pore forming theory has recently been proposed which uses the same primary cadherin receptor but the cause of death is by activation of  $Mg^{2+}$ -dependant signal cascade pathway. This theory suggests death does not involve the oligomeric structures that form pores of Cry toxin or receptors such as glycosylphosphatidylinositol (GPI)-anchored proteins (Zhang *et al.*, 2006).

The Cry toxins are known to be harmless to plants, humans, other vertebrates and are also biodegradable, which make these toxins highly advantageous when compared to chemical pesticides (Bravo *et al.*, 2005). For this reason, Bt has been used since 1920 as a biopesticide in spray formulations providing resistance to many insect pest species. Currently, biopesticides make up approximately 1% of all pesticides sold worldwide. Bt derived products make up approximately 80% of this figure (Whalon and Wingerd, 2003). Bt sprays however can be easily washed off by rain and are rapidly broken down in the presence of UV light. This, although an advantage over long lasting broad spectrum pesticides, may be seen as disadvantageous to farmers and pesticide managers as carefully planned repeated spraying is required to provide full protection against insect pests.

#### 1.2.2.(i) Expression of Bt toxins in transgenic plants

Almost all transgenic Bt toxin crops express three domain Cry toxins. Cry1 for plant protection against lepidopteran pests was primarily the focus for laboratory trials of transgenic crops. This research has led to a minimal expression level of Cry toxins in leaf tissue for high levels of toxicity to lepidopteran pests set at 0.05% of total protein. Preferred levels of expression in order to provide protection against other, not so sensitive, insect pests is approx. 0.5% of total protein (Sanahuja *et al.*, 2011).

Protein coding sequence for expression in plants has been the first major hurdle in development of Bt expression in transgenic crops. The C-terminal portion of the protoxin has been shown to not be required for activation and its signaling function is not required when expressed in plants. In fact, it was shown that expression of Cry toxins were 10-50 fold less when the protoxin was expressed with the C-terminal sequence opposed to without (Vaeck *et al.*, 1987). The N-terminal portion is retained

when expressed due to it being essential for toxin activation within insect gut. High levels of Cry genes in crop plants have been obtained; however, it is necessary to modify the coding sequence. Optimization of sequence codon usage (particularly for monocots where %GC in coding sequences of Bt is 36% compared to rice genes at 55%) has shown to be important for expression levels. Expression of modified sequences of Cry toxins based on plant codon usage lead to expression levels of 1% total protein in leaf tissues (Perlak *et al.*, 1991). Removal of potential RNA processing and polyadenylation signals is also important, perhaps more important than codon usage as it is the instability of RNA transcripts as a causation for poor toxin expression (de Rocher *et al.*, 1998; Murray *et al.*, 1991)

Choice of promoter for driving expression of Cry toxins has also been an important consideration. Promoters from the Ti plasmid of *Agrobacterium tumefaciens* resulted in relatively low expression and soon were eclipsed by the use of strong constitutive promoters such as the Cauliflower Mosaic Virus 35S RNA promoter (CaMV 35S). The use of a constitutive promoter does not seem to affect the plant through protein accumulation and penalties in the form of protein yield are not observed. The promoter was thought to be specific for dicots however with slight modifications, Cry toxins have been expressed in monocots using the CaMV 35S promoter (Wunn *et al.*, 1996). The use of tissue specific promoters such as those for green-tissue have been investigated for many insect species for example promoters for pith tissue and pep-carboxylase (PEPC) for green tissue from maize were introduced into rice and afforded plants high levels of protection against the yellow stem borer (*Scirpophaga incertulas*) (Datta *et al.*, 1998). The use of inducible promoters been investigated however the protection afforded was lower than when the toxin was expressed under constitutive expression in field conditions (Breitler *et al.*, 2004).

The expression of Cry toxins in transgenic plants has been one of the most successful genetically modified crop stories. Approved safe in 1995 by the Environmental Protection Agency of the United States, Bt potato was the first commercially grown pesticide-producing crop in the US. A year later Bt expressing maize and corn followed (Brookes and Barfoot, 2006).

Bt expressed in corn and cotton plants have since been embraced in 22 countries to control lepidopteran pests such as corn borers (*Ostrinia nubilalis*) cotton budworm, cotton bollworm and pink bollworm (*Heliothis virescens*, *Helicoverpa* spp., *Pectinophora gossypiella*) (Shelton *et al.*, 2002). In the case of cotton production there is clearly documented benefits to farmers for using Bt expressing plants by way of reduction in application of pesticides. A 70% reduction in pesticide use in India has been seen in areas where Bt cotton is grown. This relates to a monetary saving of \$30 per hectare and more importantly an 80-87% increase in harvested cotton (Qaim and Zilberman, 2003). In China, a major producer of cotton and one of the highest users of chemical pesticides, the use of Bt expressing crops has had major benefits. Pesticide use between 1999 and 2000 was reduced to just under 30% (from 55kg to 16kg product ha<sup>-1</sup>) while the health benefits are dramatic with farmers reporting pesticide poisoning reduced from 22% to 4.7% (Huang *et al.*, 2002).

By 2008 approximately 10% of all cropland planted was genetically modified crops (James, 2008). Transgenic crops, of which the main species were cotton, maize, soybean and canola, covered 300 million acres across 25 countries with 13 million farmers growing them. Transgenic crop production, including insect resistant Bt plants, is growing with crops currently being grown expanding to include sugar beet, tomato and sweet pepper (James, 2008).

It is also still worth noting however despite the toxicity to many insect species some of the most destructive pests such as aphids and white flies belonging to the hemipteran insect order are not protected by Bt cry toxins. A clear explanation for this has not been found to date. These sap sucking insects contain receptors which are similar to those in other insect orders affected by Bt toxins (Cristofolletti *et al.*, 2006) however they carry out very low levels of digestive proteolysis due to obtaining nitrogen from amino acids opposed to as protein. As Bt toxins require activation by proteolysis, the lack of proteolytic activity may prevent high enough levels of active toxin accumulating within the gut to cause the effects seen in other insect orders.

#### 1.2.2.(ii) Development and methods for delay of resistance to cry toxins

Despite the promising levels of plant protection afforded by Cry toxin expression in GM crops, the main problem with these new crop plants, as with many conventional chemical insecticides, is resistance by insect pests. Once insects develop resistance, the toxins become less effective and new approaches are required for pest control. Methods for slowing potential rates of resistance have been employed since development of the crops. One such method is the use of refuges, small areas within fields containing non-GM plants. This idea works on the principle that keeping an area of non GM crops will allow feeding by insect pests and so discourage strong selection pressure in favor of resistant individuals.

In spite of attempts at reducing resistance, at least 7 populations of insect pests have shown to be resistance in laboratory trials. The diamond back moth (*Plutella xylostella*) was the first insect species to develop in-field resistance due to exposure to repeated sprays containing Bt toxic proteins (Tabashnik, 1994). Development of resistance to Bt has been reported by three main mechanisms. Insects may evolve to reduce the number of binding sites of Bt Cry toxins or there may be reduced binding affinity of the toxins to the insect gut receptors. The second involves altered proteolytic processing of the protoxin resulting in reduced solubilisation and toxin activation while increasing degradation of toxins. The third resistance method suggested insects undergo rapid regeneration of midgut cells that have been damaged by toxin insertion. This subsequently prevents septicemia and insect death (Ferre and Van Rie, 2002).

In order to delay or reduce potential for resistance, alternative strategies for control of insect pests through transgenic crops have been investigated in recent years. One such approach involves pyramiding (or stacking) two or more Cry toxins produced by Bt in plants in order to increase the range of insect orders reached by one transgenic crop and to delay development of resistance by insect pests. Targeting different receptors within the insect should be more effective than expressing singular toxins as multiple mutations would be required in order to develop full resistance to the transgenic crop. Even this approach isn't without problems however as resistance has still found to be a problem. Downes (2010) reported an increase in alleles conferring resistance to

Cry2Ab in Australian field populations of *Helicoverpa punctigera* exposed to a second generation, two Bt-toxin expressing, transgenic cotton.

Other approaches involve the use of hybrid toxins to increase toxicity. Modifications of the Bt toxins to create a hybrid toxin have shown to be successful in protecting plants from insect attack. Naimov *et al.* (2003) expressed a *Cry1Ba/CryIIa* hybrid gene (SN19) that encoded a protein consisting of domains I and III of Cry1Ba and domain II of Cry1Ia in potato. The resulting transgenic potato leaves were afforded complete protection, at an expression level of 0.25% total soluble protein, against adult and larval Colorado potato beetle (*Leptinotarsa decemlineata*), potato tuber moth (*Phthorimaea operculella*) larvae and European corn borer (*Ostrinia nubilalis*) larvae.

### 1.2.3 Plant lectins

#### 1.2.3.(i) Plant endogenous response and use as insecticidal agent

Lectins are a large class of proteins that have been shown to act as storage proteins (Peunmans and Van Damme, 1995) and plant defensive compounds. They accumulate in vital tissues that require protection and have documented anti-nutritional and insecticidal effect to insects (especially to hemipteran pests currently not controlled by Bt) (Powell *et al.*, 1995; Gatehouse *et al.*, 1999; Wang *et al.*, 2003; Habibi *et al.*, 2000). These proteins contain at least one noncatalytic domain that binds reversibly to specific mono- or oligosaccharides (Peumans and Van Damme, 1995). There are 4 main lectin families (legume, chitin binding, type 2 RIPs and monocot mannose binding proteins) and 3 minor families.

Snowdrop lectin (*Galanthus nivalis* agglutinin; GNA) is one of the most widely studied lectin proteins. It is present in bulbs and other tissues of the snowdrop and it was first described as a mannose binding lectin by Van Damme *et al.* (1987). Like most plant lectins, it is synthesised as a precursor containing a signal peptide, which is removed co-translationally. The mature protein is formed after removal of a C-terminal peptide sequence, although the C-terminal region does not seem to be involved in lectin function, since further small truncations do not affect lectin activity.

Like other lectins GNA appears to be highly resistant to *in vivo* breakdown by proteolytic enzymes. Pusztai (1991) demonstrated this by feeding rats a known amount of PHA, ConA, and GNA and subsequently detecting over 90% of the lectins in feces that still had full reactivity to anti-lectin antibodies. As lectins are not prone to degradation through the digestive tract, they have the ability to bind to cells expressing recognized carbohydrate moieties.

The mannose-binding activity of GNA results in binding to many different glycoconjugates, although the biological significance of these interactions has not been established. Binding to gut glycoproteins after oral ingestion has been demonstrated in several insect species; Powell *et al.* (1998) first showed that GNA could bind to the gut of rice brown plant hopper, *Nilaparvata lugens*. It later was shown that GNA binds to a 26kDa subunit of a ferritin-like glycoprotein in the midgut of the hemipteran pest (Du *et al.*, 2000).

Fitches *et al.* (2001) also showed that GNA bound to tomato moth (*Lacanobia oleracea*) larvae gut epithelium when the lectin was orally fed, but also demonstrated that the lectin was present in the insect haemolymph. Fitches *et al.* (2008) also showed another lectin, ASAI, from garlic bulbs was able to cross the gut epithelium of the cabbage moth (*Mamestra brassicae*) and subsequently be detected in the haemolymph.

Some lectins however have been shown to have toxic properties towards mammals due to their carbohydrate binding. Common bean (*Phaseolus vulgaris*) agglutinin (PHA) is known to recognize and subsequently bind to carbohydrate structures in the brush border membrane of the intestines of rats (Pusztai *et al.*, 1995). This binding causes a disruption in the mechanisms of absorption of carbohydrate and ions as well as bacterial overgrowth of the small intestine (Dobbins *et al.*, 1986, Donatucci *et al.*, 1987 and Pusztai, 1991). Snowdrop lectin has also been shown to bind to mid-gut epithelial cells in rats. However the lectin is deemed safe for higher mammals as its binding strength is much lower than that of PHA which is a factor when considering antinutritional properties of lectins. Poulsen *et al.* (2007) importantly also showed transgenic rice expressing GNA to have no acute toxic effects in long term feeding

assays in rats. Significant differences to a control group in some parameters were seen however none were deemed to be adverse.

### 1.2.3.(ii) Expression of lectins

Expression of functional recombinant lectins, such as GNA, has been met with varying success. Bacterial systems have been used since the mid-1980s (Stubbs *et al.*, 1986). Unfortunately, the pea lectin Stubbs produced in *E. coli* was expressed only in the insoluble fractions of the cell lysate. In order to get active protein, a labour-intensive process of denaturation with guanidine hydrochloride and subsequent renaturation had to occur. Even after these steps, not all the lectin recovered was active due to misfolding and continued insolubility. The agglutination activities of recombinant lectins compared to their native counterparts have been variable also. Lin *et al.* (2003) showed recombinant *Pinellia ternate* agglutinin was able to agglutinate with similar activity to that shown by the native form of the protein. However, Chao *et al.* (1994) showed lectin from *Dolichos biflorus* produced in *E. coli* to be less active than the native lectin. One possible explanation for this is that *D. biflorus* lectin is a glycoprotein, and *E. coli* does not glycosylate proteins produced in the cytoplasm by recombinant expression. The absence of a carbohydrate side chain may have resulted in the reduced activity.

Raemaekers *et al.* (1999) first successfully functionally expressed phytohemagglutinin (PHA) and GNA in the yeast expression system using the methanotrophic yeast strain *Pichia pastoris*. The eukaryote system is capable of the post-translational steps required to generate fully functional soluble lectin proteins. The expression level was relatively low when initially expressed by Raemaekers *et al.* however later, Baumgartner *et al.* (2003) isolated higher expressing clones and refined production to express GNA at approximately 80 mg l<sup>-1</sup>.

Lectins can also be expressed as recombinant proteins in transgenic plants. This has been successful for snowdrop lectin, with GNA being expressed in tobacco, potatoes, rice and wheat. Expression of GNA in these transgenic plants has been shown to confer resistance to the hemipteran pests rice brown plant hopper (*Nilaparvata lugens*) and peach potato aphid (*Myzus persicae*) (Gatehouse *et al.*, 1996; Hilder *et*

*al.*, 1995; Rao *et al.*, 1998; Stoger *et al.*, 1999; Sudhakar *et al.*, 1998). GNA also shows an anti-feeding effect to *Lacanobia oleracea* when fed in artificial diet (2% (w/w) dietary protein) and on detached transgenic potato leaves (expressing at 0.07% total soluble protein). Significant reduction in survival is only seen when larvae are fed transgenic potato plants expressing GNA at 0.6% in glasshouse trials (Fitches *et al.*, 1997).

### **1.3 Multi-domain proteins or ‘fusion proteins’ in nature**

Like Bt which has a binding domains and domains responsible for toxic function, there are also many other multi domain proteins present in nature that have been linked to plant defensive mechanisms. Examples of which are described below.

#### **1.3.1 Chitin binding lectins**

Chitin is a polymer of 1,4-N-acetylglucosamine and is found in some nematodes and the cell walls of many fungi. A dynamic and protective structural polysaccharide in insects, it is a vital component of the cuticle and peritrophic matrix (PM). Given this, it is not surprising that although both monocots and dicots contain no chitin, they express a family of chitin-binding proteins, presumably for defence against herbivorous insect attack.

Chitin-binding lectins have been isolated from many plant species including from the rhizomes of stinging nettle (*Urtica dioica*) where it is found to accumulate in high levels (1g kg<sup>-1</sup>) (Peumans *et al.*, 1984; Shibuya *et al.*, 1986). Nettle lectin (*U. dioica* agglutinin; UDA) is a small, 8.5-kDa protein made up of two 43-amino acid glycine- and cysteine-rich domains. It has also been shown to have several isoforms (Van Damme *et al.*, 1988) with homology to the chitin-binding domains of other proteins (Chapot *et al.*, 1986). The lectin possesses both antifungal and insecticidal activities (Broekaert *et al.*, 1989; Huesing *et al.*, 1991).

Lerner and Raikhel (1992) isolated a cDNA clone encoding a stinging nettle lectin using a synthetic gene as the probe. The clone was shown to encode a putative signal sequence at the N terminus of the deduced amino sequence that was next to two nettle lectin chitin-binding domains. A C-terminal domain was also found and shown to

have partial identity to a chitinase catalytic domain. This was the first type of lectin to be created by both a domain duplication along with fusion to an unrelated domain. The function of this additional domain is unknown however Class I chitinases, which show strongest similarity to this domain, are not known to go through a posttranslational event releasing the chitin-binding domain from the chitinase catalytic domain. It was suggested that the protein might undergo this kind of event when expressed in plants due to its small size. Broekaert *et al.* (1989) showed that stinging nettle lectin and chitinase have different modes of action for inhibition of fungal growth *in vitro* and therefore could prove promising for improved fungicidal and potentially insecticidal activity.

### 1.3.2 Ribosome inactivating proteins

Another group of proteins that have been linked to plant defence and also have been investigated for their insecticidal activity are ribosome inactivating proteins (RIPs). These proteins are found both in plants and bacteria and are present in two types. Type 1 RIPs exist as single polypeptide chains around 30,000 Mr, and type 2 RIPs which comprise of two disulphide-linked polypeptides at around 60,000 Mr. (Stirpe and Barbieri, 1986). Type 2 ribosomal inactivating proteins such as ricin have for many years known to be highly potent cytotoxic proteins. First identified from the castor bean (*Ricinus communis*) ricin forms part of a group of chimerolectins. These proteins are comprised of two chains, a toxic enzymatic A chain and a sugar binding B chain. Glycoconjugate receptors on cell surfaces are the binding target for the B chains that, once bound, act to transport the A chain component into the cell. Once inside, the A chain cleaves the *N*-glycosidic bond of a single adenosine residue of the large rRNA causing inactivation of the ribosome.

Whilst these RIPs are deadly to higher eukaryotes, some insects have been shown to tolerate their toxic effects. Gatehouse *et al.* (1990) fed ricin to lepidopteran pests *Spodoptera littoralis* and *Heliothis virescens* without effect on survival. In the same study, ricin was shown to be very highly toxic when fed to coleopteran pests *Callosobruchus maculatus* and *Anthonomus grandis*. Differences in proteolytic activity or binding domains were suggested for the difference in toxicity between the insect species.

Expression of RIPs in transgenic plants has resulted in poor protection against insect pests. Maize RIP expressed in transgenic tobacco by Dowd *et al.* (2003) afforded the plants little protection against the corn earworm (*Helicoverpa zea*). In fact, the reduction in survival was barely significant. Given the fact that RIPs show insecticidal activity to some insect orders, their potent toxicity to higher animals, specifically to humans, makes these plant defence proteins unsuitable for commercial protection of plants from insect pests.

#### **1.4 Synthetic fusion proteins**

Reducing resistance to insecticidal proteins by combining different proteins, or protein domains, has been of interest to researchers for some time. This approach aims to combine two or more components that create a multi-domain protein where the components act synergistically to cause an insecticidal effect that is not seen when independent of each other.

Mehlo *et al.* (2005) for example used a fusion protein approach combining a delta endotoxin, Cry1Ac, to the galactose-binding domain of the non-toxic ricin B-chain (RB) in order to increase toxicity of Bt toxins to a range of insect pests. The addition of the ricin B-chain allowed the toxic fusion protein to have additional binding sites and therefore reach a wider range of targets than just the Cry1Ac toxin alone. The construct was expressed in transgenic rice and maize plants and showed to enhance the toxicity of the Cry1Ac to the striped stem borer (*Chilo suppressalis*) and also to species not usually affected by the toxin (the cotton leaf worm; *Spodoptera littoralis* and leafhopper; *Cicadulina mbila*).

This same approach had previously been used when creating insecticidal fusion proteins for expression in the yeast *Pichia pastoris*. This technology has been used to create novel insecticidal proteins by fusion of genes encoding plant lectins with proteins and/or peptides that are toxic when delivered to the insect haemolymph. The plant lectin acts as a “carrier” which binds and subsequently crosses the insect gut epithelium delivering insect-specific neurotoxins and other peptides to the haemolymph where the toxins can exert insecticidal effects.

Fusion proteins in their multi-domain nature are similar to 3d-Cry toxins and RIPs in that there are binding domains and domains responsible for toxic function. However, unlike domain II of the Bt cry toxins that is responsible for binding of the multi-domain protein to cells or the non-toxic B chain of ricin which binds to receptors on cells to transport the A chain into the cell, lectins both bind to the gut epithelium and are transported across the membrane. This ability to cross into the haemolymph and successfully transport fused peptides allows for a much broader range of insecticidal toxins to be considered for a targeted approach to pest management and therefore furthering research into insecticidal multifunctional domain proteins.

The absence of toxic effects of GNA to higher mammals, together with the ability of GNA, and other lectins such as ASaII, to transport across the gut epithelium in insects, whilst remaining resistant to gut proteolysis, has shown potential to act as a carrier for other peptides, such as neurotoxins, that would otherwise not be able to cross the insect gut barrier. The relative ease of expression of GNA both in yeast and plant expression systems also adds to the attractiveness of plant lectins for the use as carriers in insecticidal fusion proteins.

Recombinant fusion proteins of this type were first shown to be successful when Tobacco hornworm *Manduca sexta* allatostatin (Manse-AS) was fused to the C terminus of GNA and shown to be transported into insect haemolymph. Fed to *Lacanobia oleracea* at 1.5 or 0.5% of dietary proteins, the fusion was found to strongly inhibit feeding and therefore growth of fifth stadium larvae (Fitches *et al.*, 2002). Fusions with chitinases as well as spider and scorpion toxins have been shown previously by Fitches *et al.* (2004a, 2004b), and Trung *et al.* (2006) to be a successful and promising method of controlling a range of insect pests. They also have the potential to offer an improved, more ecologically sustainable approach to wireworm control than the current available insecticides. Examples of neurotoxins from scorpions and spiders either used in fusion proteins or candidates for incorporation into fusions with GNA are discussed below.

#### 1.4.1 Neurotoxins and their use in fusion proteins

Many eukaryotic organisms such as arthropods, molluscs, cnidarians, plants, and

numerous vertebrates such as snakes, frogs and lizards produce toxins that they use to kill or immobilize their prey. Arachnids and scorpions are predatory arthropods that produce paralyzing venoms and have been subjected to much research due to the many toxins that have been isolated from their venom. Within the venom, there is often a mixture of polypeptide toxins that exert their effects via interference with ion channel function, with the vast majority of these peptides targeting specific subtypes of voltage- or ligand-gated ion ( $K^+$ ,  $Cl^-$ ,  $Ca^{2+}$  and  $Na^+$ ) channels (Lewis and Garcia, 2003; Sollod *et al.*, 2005). Many of these toxins have been researched for their potential as useful pharmaceutical agents to modify the activity of ion channels implicated in human disease. One such toxin is the  $\omega$ -conotoxin MVIIA that was approved by the food and drug administration (under the trade name Prialt) for treatment of severe chronic pain (Miljanich, 2004).

These toxins also have considerable potential as insecticides. Many spiders feed almost exclusively on invertebrate prey and some spiders can express as many as 600–1000 different peptide toxins in their venom glands (Escoubas *et al.*, 2006). With only four groups of spider out of some 10,000 spiders potentially deadly to humans (Isbister and White, 2004), these arthropods have a vital pool of potential insecticidal compounds within their venom. Scorpions also have a range of neurotoxins within their venom affecting both vertebrate and invertebrate ion channels. However one advantage of scorpion toxins is that they often can be highly specific only affecting one species or groups of species. This allows for invertebrate specific insecticides to potentially be produced that also have the ability to be order specific creating a much more sustainable insecticide.

Unfortunately these toxins have not been fully and successfully exploited. The main problem in using these toxins in a pest control strategy is due to the chemical properties of polyamine and peptide molecules. They are unlikely to pass through the cuticle of most insects and if orally administered cannot cross the gut wall (Quistad *et al.*, 1991). Many purified toxins have been shown to be highly insecticidal by injection, but when orally administered fail to produce an insecticidal effect. Fusion proteins containing these insect specific neurotoxins linked to lectins that can

transport them across the gut have the potential to be tailored to specific insect orders reducing the environmental impact of their use.

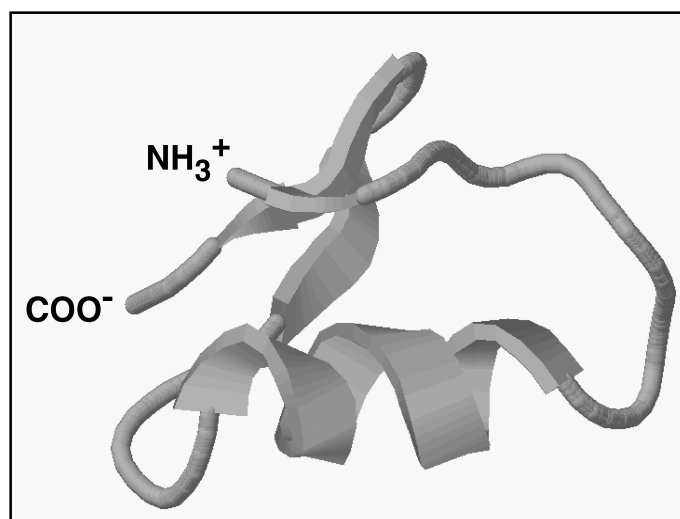
#### 1.4.1.(i) Toxin from Indian red scorpion (*Mesobuthus tamulus*) and its use in fusion proteins

Wudayagiri *et al.* (2001) isolated an insecticidal toxin from venom of the Indian red scorpion (*Mesobuthus tamulus*). The mature form of ButaIT is polypeptide consisting of 37 amino acids comprised of one  $\alpha$ -helix and three  $\beta$ -strands with four disulfide bridges (figure 1.1). This toxin belongs to the first group of short scorpion toxins that primarily affect voltage-dependent potassium channels and conductance calcium-activated potassium channels (Charbone *et al.*, 1982).

It was first thought by Wudayagiri *et al.* (2001) that the ButaIT toxin was a lepidopteran-specific neurotoxin. It was highly toxic when injected into tobacco budworm (*Heliothis virescens*) causing progressive, irreversible, flaccid paralysis at a dose of 1  $\mu\text{g}$  100  $\text{mg}^{-1}$ . However it was shown to be non-toxic to blowfly larvae at the same dose, or mice at a dose of 3  $\mu\text{g}$   $\text{g}^{-1}$  body weight. Expressed as a recombinant protein in *P. pastoris* by Trung *et al.* (2006), toxicity of ButaIT could not be compared with that isolated previously by HPLC due to incomplete purification.

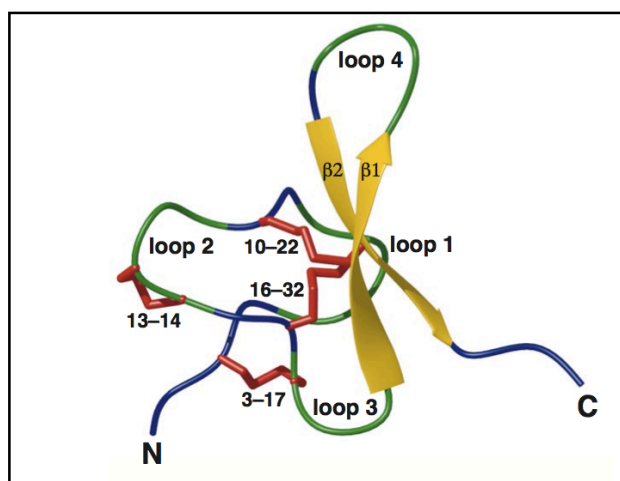
When the toxin was incorporated into a fusion protein containing ButaIT joined N-terminally to GNA however, the resulting recombinant protein remained toxic to lepidopteran larvae. Injection of ButaIT-GNA at 3 – 13  $\mu\text{g}$  100  $\text{mg}^{-1}$  insect in *L. oleracea* larvae caused mortalities of 40–60%. Fusion protein fed orally (at 4.5% dietary protein) resulted in 75% survival after 12 days compared to 100% survival in controls. Surprisingly in the same study when fed to the hemipteran pest *Nilaparvata lugens* (rice brown plant hopper), ButaIT-GNA was significantly more toxic than GNA, suggesting the ButaIT toxin had a wider range of biological activity than was first thought by Wudayagiri *et al.* (Trung *et al.*, 2006). ButaIT-GNA has additionally been shown to be highly toxic to the coleopteran pest species Colorado potato beetle (*Leptinotarsa decemlineata*) (Unpublished).

Fitches *et al.* (2010) compared toxicity of this fusion protein to a variety of insect pests and also against the fusion protein previously expressed by Fitches *et al.* (2004a) which incorporates GNA with a toxin from the European spider [*Segestria florentina* (Rossi) toxin: SFI1]. In the study it was demonstrated that delivered orally and via injection, the fusion protein showed toxicity to lepidopteran larvae, dipteran adults, coleopteran adults and larvae and dictyopteran nymphs. The effects were varied; however, ButaIT-GNA showed higher general toxicity than SFI1-GNA across the insects assayed.

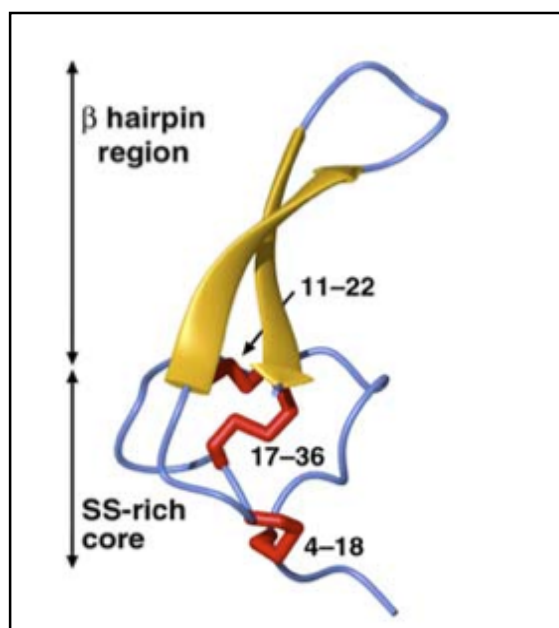


**Figure 1.1**

**The three-dimensional structure of ButaIT** (derived by Swiss-Model Protein Modeling Server using the NMR coordinates of chlorotoxin and insectoxin I5A). The RasMol program is used to visualize the 3-D structure of the molecule. The carbon backbone trace of the molecule displays a basic scaffold composed of an  $\alpha$ -helix and three  $\beta$ -strands similar to other short toxins (Wudayagiri *et al.*, (2001).



**Figure 1.2**  
**Schematic of  $\kappa$ -ACTX-Hv1c.** Location of the  $\beta$ -strands (gold),  $\beta$ -turns (green), and disulfide bridges (red). The molecule can be conveniently pictured as a series of loops (numbered 1–4 from the N-terminus to the C-terminus) bounded by half-cystine residues (Wang *et al.*, 2000).



**Figure 1.3**  
**Stereo view of the structure of  $\omega$ -ACTX-Hv1a** (Fletcher *et al.*, 1997).  $\beta$  strands are represented by orange arrows while the red tubes indicate the location of the three disulfide bonds. The toxin structure can be conveniently divided into a disulfide (SS)-rich core and a  $\beta$ -hairpin region. (Tedford *et al.*, 2004)

#### 1.4.1.(ii) Toxins isolated from Blue Mountains funnel-web spider (*Hadronyche versuta*)

Atkinson *et al.* (1998) first demonstrated the potent toxicity of the crude venom from the Blue Mountains funnel-web spider (*Hadronyche versuta*) along with purified (from high performance liquid chromatography; HPLC) toxic fractions. Injected into a range of insects belonging to different orders (e.g. Lepidoptera, Coleoptera, Diptera, Orthoptera and Hemiptera), larvae were seen to stop feeding and start to purposelessly writhe within 3 days. Once writhing started, normal pupation did not occur and recovery was never seen. This pattern of feeding and developmental arrest along with rapid death makes toxins from this spider attractive for development of insecticides.

##### 1.4.1.(ii)A $\omega$ -atracotoxin-Hv1a

The  $\omega$ -atracotoxin-Hv1a toxin was isolated from the venom of *H. versuta* and shows potent toxicity to a range of insects whilst being non-toxic to mice at doses up to 2.5 mg kg<sup>-1</sup> (Atkinson *et al.*, 1998). Fletcher *et al.* (1997) revealed the tertiary structure of the 37-residue protein to be a globular hydrophobic core that packs around two of the three intramolecular disulphide bonds and a buried Ile residue. A  $\beta$ -hairpin region protrudes from the core with the three disulphide bonds forming a cysteine knot motif (figure 1.2). Fletcher *et al.* (1997) also showed the toxin to block ganglionic neural transmission of cockroaches and demonstrated it to be an insect specific voltage-gated calcium channel agonist. Tedford *et al.* (2001) showed the  $\beta$ -hairpin region was vital for insecticidal action with amino acid residues Pro<sup>10</sup>, Asn<sup>27</sup>, and Arg<sup>35</sup> responsible for the specific interaction of this toxin with insect calcium channels (Tedford *et al.*, 2004).

A possible explanation for its apparent potency against insects is the intended ion channel target for this toxin; voltage gated calcium channels. If the *Drosophila melanogaster* genome is used as guide to insect channels, the role for neural transmission that these channels play is vital. The genome appears to encode three pore forming  $\alpha_1$ -subunits (Dmca1D, Dmca1A, and Ca- $\alpha_{1T}$ ), one  $\beta$  subunit, three  $\alpha_2$ - $\delta$  complexes, and possibly one  $\gamma$  subunit (Littleton and Ganetzky, 2000; Rieckhof *et al.*, 2003). Encoding only a small number of  $\alpha_1$  and  $\beta$  subunit isoforms may limit the

number of possible combinations and therefore the diversity of heteromeric HVA  $Ca_v$  channel complexes. However, alternative splicing and RNA editing may play a role in expanding the range of expressed function channels in insects.

The importance of these genes is clear when loss-of-function mutations in either  $\alpha_1$ -subunits of  $Ca_v$  genes (Dmca1D or Dmca1A) have been shown to be lethal (Eberl *et al.*, 1998; Smith *et al.*, 1998; Kawasaki *et al.*, 2002). The apparent essential role of these channels shows a promising target for plant protection and is even more attractive given that insect and vertebrate calcium channels are pharmacologically distinct. The channels have been shown to have different susceptibilities to chemical compounds and peptide toxins (Wicher and Penzlin, 1997).

#### 1.4.1.(ii)B $\kappa$ -atracotoxin-Hv1c

The Janus-faced atracotoxins were first isolated and characterized from the Blue Mountains funnel-web spider (*Hadronyche versuta*) by Wang *et al.* (2000). A cysteine knot motif and a rare vicinal disulfide bridge connecting Cys<sup>13</sup> to Cys<sup>14</sup> was discovered within the protein structure (figure 1.3). The only other proteins that have these vicinal bridges are methanol dehydrogenase (MDH) and the  $\alpha$ -subunit of the acetylcholine receptor ( $\alpha$ AChR). The vicinal disulphide bonds in these proteins are known to have critical functions as without it activity/binding is either reduced or abolished entirely (Blake *et al.*, 1994; Czajkowski *et al.*, 1995). Wang also proved this to be true with this atracotoxin as a double mutation (Cys to Ser) abolished activity when injected into crickets with doses up to 60 times the LD<sub>50</sub> of the native toxin.

The toxin was shown to be insect specific, as applied at doses up to 1  $\mu$ M to rat smooth and skeletal muscle preparations it was inactive. Also, when it was injected into newborn mice at doses up to 3.14  $\mu$ g g<sup>-1</sup> no effects were observed. However when applied to the metathoracic ganglion of the cockroach *Periplaneta americana* at 0.5-1.0 nmol, it elicited an excitatory response causing spontaneous, uncoordinated movement of all legs within 60 seconds (Wang *et al.*, 2000).

Maggio and King (2002b) later discovered the toxin pharmacore, which is formed by just five residues (Arg<sup>8</sup>, Pro<sup>9</sup>, Tyr<sup>31</sup>, and the Cys<sup>13</sup>-Cys<sup>14</sup> vicinal disulfide). The Arg<sup>8</sup>-Tyr<sup>31</sup> diad in J-ACTX-Hv1c matches closely with the spatially conserved Lys-(Tyr/Phe) diad seen across other K<sup>+</sup> channel blockers. This led the authors to suggest J-ACTXs might target an invertebrate K<sup>+</sup> channel and subsequently rename the toxins  $\kappa$ -atracotoxins.

The  $\kappa$ -atracotoxins are the only family of invertebrate-specific potassium channel blockers so far discovered in spiders (Tedford *et al.*, 2004). The representative family member  $\kappa$ -ACTX-Hv1c, ( $\kappa$ -ACTX) was later shown by Gunning *et al.* (2007) to be effective in blocking calcium activated potassium channels. Their insect specificity and toxicity to a range of arthropod pests, including coleopterans, have shown them to be ideal toxins to investigate for control against coleopteran pests.

#### 1.4.1.(iii) Expression of neurotoxins

Neurotoxins such as those isolated from scorpion and spider venoms have received much interest in recent years for their potential as potent insecticidal compounds. Many of these toxins are rich in cysteine residues and so require correct disulphide bridge formation for their biological activity. Expression of recombinant toxins has been limited mainly to bacterial expression systems using *E. coli*. For example, toxins from the Blue Mountains funnel-web spider (*Hadronyche versuta*)  $\kappa$ -ACTX-Hv1c and  $\omega$ -ACTX-Hv1a have both been expressed functionally in *E. coli* as GST fusion proteins (Tedford *et al.*, 2001; Maggio and King, 2002a, 2002b).

Expression of these toxins, as with other proteins in bacterial expression systems, although successful, often yield little functional product. Purification of these proteins usually includes a lengthy process with only protein expressed in soluble fractions able to be recovered with any ease. In fact, many proteins expressed in bacterial system may be expressed as insoluble aggregates or inclusion bodies that often need a process of *in vitro* refolding to be functional. Added to the costly purification of on column cleavage of the GST tag fused to many of these expressed proteins, make producing these toxins in this system commercially unfeasible.

The use of these recombinant toxins as a successful crop protection method would also depend on their ability to reach their target site of the insect central nervous system. Two methods of delivery to the haemolymph (and therefore central nervous system) have been investigated previously; one such approach is the use of insect viruses that are engineered to produce functional recombinant toxins. This approach is especially useful for crops with little tolerance to feeding damage and where speed-of-kill is an important characteristic.

This method has been successful for many insect specific neurotoxins. One toxin isolated from the venom of the Indian red scorpion (*Mesobuthus tamulus*) that has been functionally expressed by an insect virus is ButaIT (Wudayagiri *et al.*, 2006). ButaIT expressing *Autographa californica* nuclear polyhedrosis virus reduced the ST<sub>50</sub> by 42.8% and the LD<sub>50</sub> by 28.1% compared to the wild type virus when infecting the tobacco budworm, *Heliothus virescens*. This reduction in survival time and lethal dose therefore reduces feeding time and so damage to crops. The baculovirus approach is commercially available though currently, only with products containing wild type baculoviruses as active ingredients. However, due to the short survival time of hosts, low cost production of recombinant baculoviruses is problematic.

Neurotoxins from scorpions and spiders have also been independently been expressed in transgenic plants conferring resistance to insect pests. Wu *et al.* (2008) transformed cotton plants to express a synthetic scorpion toxin gene from *Androctonus australis* Hector (*AaHIT*). The resulting transgenic plants expressed in a range of 0.02 – 0.43% total soluble protein and conferred resistance to the cotton bollworm by reducing survival by between 44-98%. Magi 6, a neurotoxic peptide from the spider *Macrothele gigas*, has been expressed in tobacco at an expression level of 4-6% total soluble protein. The transgenic plants are shown to confer resistance to *Spodoptera frugiperda* (Hernández-Campuzano *et al.*, 2009).

The  $\omega$ -ACTX-Hv1a neurotoxin from the funnel web spider (*H. versuta*) has also been transformed into plants with success. Khan *et al.* (2006) expressed  $\omega$ -ACTX-Hv1a ( $\omega$ -ACTX) in transgenic tobacco. Inclusion of the gene resulted in protection of the

plants from *H. armigera* and *S. littoralis* larvae. The plants caused complete mortality of bioassay insects within 48 hours of first introduction.

#### 1.4.2 Expression of fusion proteins: The yeast expression system

*Pichia pastoris* is a commonly used expression system for the production of eukaryote proteins. Secretion via the *Saccharomyces cerevisiae* alpha-factor prepropeptide contained within the expression vector pGAP allows secretion of heterologous protein into the culture medium. This protein secretion process allows for an intrinsic purification step even before recovery of protein. This is because the yeast does not secrete many of its own endogenous proteins and the culture medium contains no added protein, so the recombinant protein is a major component of the total protein in the culture. The system also allows for more complex post-translational processing than that capable from bacterial expression. Glycosylation and proteolytic cleavage, both necessary for active lectin, are examples of such processes (Higgins and Creggs, 1998).

Many proteins that have been previously expressed as insoluble inclusion bodies in *E. coli* have been successfully expressed in yeast. However, endogenous protease activity (by secreted aspartic proteases) in the culture supernatant has caused unwanted cleavage of recombinant proteins in wild type strains (such as X-33). For this reason, *pepA* protease deficient strains e.g. SMD1168 have been utilized as expression hosts.

Fusion proteins comprising insect hormone peptides, lectins and neurotoxins from both spiders and scorpions bound to GNA have been successfully expressed using this system with varying levels of success. The GNA-chitinase fusion protein produced in *P. pastoris* was shown by Fitches *et al.* (2004b) to be biologically active upon feeding however the protein was fully degraded by gut proteolysis and so GNA was unable to act as a “carrier” preventing the activity of chitinase being increased. However, a toxin from the European spider (*Segestria florentina*, toxin: SFI1) was expressed in *P. pastoris* both alone and fused to GNA, with expression levels at 0.5–5 mg l<sup>-1</sup> culture medium.

The choice of yeast strain and its impact on proteolytic cleavage of recombinant fusion proteins are illustrated by the SFI1-GNA toxic fusion. Expressed in the wild type X33 strain, proteolytic cleavage resulted in recombinant protein with 1:1 ratio of intact fusion protein to cleaved GNA product. Expression in the protease deficient strain, SMD168, reduced cleavage of the recombinant protein markedly. Expression levels as well as cleavage of recombinant proteins during fermentation and purification are limiting factors for industrial scale-up of insecticidal proteins.

In order to recover the maximum yield of fusion proteins, several strategies have been previously investigated. Additions of tagging sequences in order to aid purification have been widely used during protein production. These tags allow for rapid affinity purification of specific proteins, which not only produces protein that is pure of other yeast proteins but also allows for quicker purification. This also reduces the time in which the protein is exposed to proteases within the culture supernatant and so reduces opportunity for cleavage. Variations in construct sequence and linker regions in fusion proteins containing ButaIT and GNA have been shown to affect yield of intact product without significant effects to biological activity (Fitches *et al.*, 2010).

### **1.5 Coleopteran pests targeted by fusion proteins**

Coleopterans are some of the most important and destructive pests to both crop plants and storage grains. The red flour beetle *Tribolium castaneum* is viewed as a model organism and is important for the study of genetics, developmental biology, toxicology and comparative genomics (colour plate 1). Factors including uncomplicated culturing, a relatively short generation time, prolific breeding capacity and efficient genetic manipulation possibilities have resulted in the genome of *T. castaneum* being sequenced by the *Tribolium* Genome Sequencing Consortium (2008). *T. castaneum* feeds primarily on stored flour and has developed the ability to interact with a diverse chemical environment as well as an absence of dietary water. Large gene expansions in odorant and gustatory receptors, and in detoxification enzymes, have been observed by genome sequencing. The availability of the genome makes analysis of potential insecticidal targets such as digestive proteases and ion channels possible. These proteins have homologues in other, less well characterised,

coleopteran species, which can be characterised as targets for control strategies using sequence similarity.

It has been shown *Tribolium* use mainly cysteine proteases for their digestion; however when digestion is reduced due to inhibition by plant defence, increased levels of serine proteases are expressed (Oppert *et al.*, 1993, 2003, 2005). Morris *et al.* (2009) completed a full transcriptome and proteome study of the larval gut of *T. castaneum* that further strengthened this idea. This revealed what enzyme studies had shown previously, that protein digestion in the mid-gut is carried out using mainly cysteine proteases. Of the 25 C1 cysteine peptidase family genes identified, seven cathepsin B and five cathepsin L encoding transcripts were found to be highly expressed (with a gut ranking >3). Five of the seven cathepsin B-like proteases are inactive enzymes as they lacked critical residues necessary for an active peptidase. Only one of five cathepsin L-like sequences was an inactive enzyme suggesting this is the primary digestive class of protease present. Serine proteases were also found with 26 and 21 of the 75 transcripts encoding presumed chymotrypsin and trypsin genes respectively. The other sequences correspond to inactive serine protease-like homologues. The lack of active gene transcripts was suggestive of low-level expression of serine proteases in the gut tissue.

Insecticidal targets isolated from the sequenced genome also include proteins that are involved in detoxification, such as cytochrome P450 proteins, as well as ion channels. 24 Cys-loop Ligand Gated Ion Channel superfamily genes were found in *Tribolium* and they not only are the largest set found in insects but also are the first complete set of genes encoding molecular targets of several insecticides (imidacloprid and other neonicotinoids (nAChRs), fipronil (GABARs) and avermectins (GluCl)). A number of subunits for voltage gated Na<sup>+</sup>, Ca<sup>2+</sup> and K<sup>+</sup> have also been observed within the genome of *Tribolium*.

**Colour Plate 1<sup>1</sup>**



Wireworm (*Agriotes* Spp.)<sup>a</sup>



Superficial damage caused by wireworm<sup>b</sup>



Model coleopteran *Tribolium castaneum* (red flour beetle) adult



*T. castaneum* larvae

---

**Image Courtesy<sup>1</sup> – Wireworm images**

<sup>a</sup><http://www.omafr.gov.on.ca/english/crops/hort/news/hortmatt/2009/08hrt09a5.htm>

<sup>b</sup><http://keys.lucidcentral.org/keys/sweetpotato/key/Sweetpotato%20Diagnoses/Media/Html/TheProblems/Pest-Root&StemInsects/Wireworm/wireworm.htm>

### **1.6 Using *T. castaneum* as a model to infer toxicity to other coleopterans**

*Tribolium castaneum* may be used as a model organism to infer toxicity of potential insecticides to other coleopterans. One group of such target species are wireworms (colour plate 1). In the United Kingdom and worldwide the larvae of click beetles, wireworm (Coleoptera: Elateridae) are an important pest. Wireworms are highly polyphagous, consuming seeds and seedlings of agriculturally important crops such as corn, sunflower and potato tubers. Unlike other crop plants, economic damage caused by wireworms is in the quality and therefore marketability of potato tubers, rather than the yield. Superficial damage brought about by the tunneling of wireworms into the tuber flesh can make the crop virtually unmarketable even at relatively low populations (<100 000/ha) (Parker and Howard, 2001). The small holes produced not only reduce the quality of the product but also can provide access to the tubers for other soil organisms that may cause further reduction in crop marketability (Gratwick, 1989, Colour plate 1).

The genus of click beetle that is responsible for most crop damage, particularly in Europe, is *Agriotes*. Within this genus, there are three species which are major pests in terms of crop damage: *Agriotes lineatus* (L.), *Agriotes obscurus* (L.), and *Agriotes sputator*. It is only in the adult stage that these species can be easily differentiated, although within the larval stage these species all cause similar damage to crops, so strategies for control of *Agriotes* should not be species specific.

#### 1.6.1 Life cycle of wireworms

The life cycle of these coleopterans is only poorly known. Adult female beetles lay their eggs in May or June, just below the soil surface. Typically they will lay their eggs in areas that are protected by grasses and weeds. Within the UK, hatching rate of the eggs is dependent upon temperature and can occur within 4 to 6 weeks (Parker and Howard, 2001). Young wireworms are approximately 1.5mm long and white. It is not until they start to grow that they develop the orange colouration typical of wireworms. While the wireworms are young they do not often cause significant economic damage, however from about a year old they are large enough to be significantly destructive (Miles, 1942, cited by Parker and Howard, 2001). The total larval period can vary between species and also site position. In the UK however, the

time spent in the soil before pupation can be as much as 4 to 5 years (Miles, 1942, cited by Parker and Howard, 2001). Pupation usually occurs in the period between July and September. Mature larvae will pupate about 5-30cm below the soil surface. Adult beetles emerge after 3-4 weeks and will undergo hibernation over winter until they emerge between March and June, when they mate and females subsequently lay their eggs (Gratwick, 1989).

Their long larval lifecycle makes culturing in laboratories very difficult. Coupled with their sporadic feeding nature (they may only feed for approximately 20% of their lifecycle (Parker and Howard, 2001) it makes assaying this insect for toxicity of proteins as insecticides unfeasible.

#### 1.6.2 Control of *Agriotes* spp. and need for alternative methods

Wireworms are usually found in areas of long-term grassland. However, recently there has been an increase in damage found by wireworms within agro-ecosystems, leading to an increased need for effective management strategies. It is thought that this may be due to a number of reasons, including increased quality demands from retailers and use of old pasture claiming to be free of some pests and soil diseases (Parker and Howard, 2001).

Risk assessments and surveys for detection of possible wireworm infestation pre-planting are almost always required to determine if methods of control need to be implemented at a particular planting site. Those carried out using baiting traps are subject to sampling error and therefore are not entirely reliable. This causes farmers to treat the fields with insecticide in anticipation of wireworm damage, even if there is not a real risk (Parker and Howard, 2001). Soil sampling can and is also used for the detection of wireworms. 1 wireworm per 20 samples taken will represent 63,635 larvae per hectare. However, not finding any wireworms within the samples will not mean the field is infestation free as populations up to 60,000 per hectare can be present without detection (Kennedy, 2007). Control methods, which are typically chemical, are generally put into place at the limit of 1 wireworm per 20 samples taken. This method is labor intensive, unlike the baiting trap method. Both methods of

trapping suffer the problem of not detecting low, but still damaging populations, mainly due to the sporadic distribution of wireworms in the soil.

### 1.6.3 Cultural and biological control

In order to avoid damage to crop plants the ideal way would be not to grow potatoes within fields containing known wireworm infestations. This however requires substantial risk assessments being carried out, and also knowledge of the previous cropping history of the field, which is not always possible. Rotational cropping methods, alternating susceptible crops with known resistant species such as linseed, peas and beans also have been shown to keep the infestations in fields down. Repeated disturbance of the soil is frequently used, as it increases the risk of predation by birds, desiccation and injury from machinery.

Using biological control methods for wireworms is likely not to be efficient enough to fully avoid damage to crop plants. Natural predators for wireworms include birds (Gratwick, 1989). Studies using nematodes and entomorphagous fungi have shown these can offer some degree of control, although they are not nearly as effective as chemical control methods (Ansari *et al.*, 2009)

### 1.6.4 Chemical control

There are three main strategies for control of wireworms using chemical methods reported by Chaton *et al.* (2008). One is to treat the upper layer of the soil with the insecticide. This although the most effective, it requires persistent compounds, which, as they are at the soil surface, can also affect non-target species. The second is a treatment directly around the crop seeds. This has the advantage of reducing the overall amount of insecticides incorporated into the soil; however, if the dose applied is not sufficient to kill the pests, it proves to be ineffective. The third, which also suffers the same disadvantage as the in-furrow treatment, involves coating the seed crop with insecticide so only those insects that attack the crop will be killed. This may work for crops such as corn, however application to potato crops would be ineffective. This is because although the wireworms can attack the seed potatoes, it is the daughter tubers that are also subject to damage. As these develop below ground application of insecticides though seed coating is impossible.

The organochlorine based insecticide aldrin was used for control of wireworms within the U.K. until 1989 when the insecticide was subsequently banned amid concerns for the environmental impact of these persistent compounds. The major reason for the long-term use was the lack of an effective alternative. After a search for effective new compounds, some organophosphates were found to be partially effective in controlling wireworms, although complete control was not attained.

Currently the organophosphate ethoprophos (Mocap) is used to control wireworm populations. This is viewed as the best available chemical control compound giving effective control up to a point. However this product does not give complete control, and even in treated soils that are heavily infested there can be still be substantial damage to potato crops (Kennedy, 2007). Ethoprophos is still a broad-spectrum insecticide and is known to be highly toxic to mammals. Over application of this insecticide may increase selection pressure on the insects and drive evolution of resistance. The use of this insecticide is not an environmentally sustainable approach for the control of wireworm, however effective the compound is. Tighter regulations, together with withdrawal of insecticide use due to detrimental effects to non-target organisms and the environment is encouraging the production of alternative strategies for control.

### **1.7 Application of fusion protein technology for control for coleopteran pests**

Fusion proteins containing ButaIT and GNA have been shown to be toxic against coleopterans, and the neurotoxins isolated from the funnel web spider have been shown to be highly attractive compounds for the use in fusion proteins. Expressed in *P. pastoris* through the yeast expression system these proteins could be used in a variety of ways for the control of wireworm populations within agricultural crop fields. As the preferred method of delivery of fusion proteins to *Agriotes* would be via the gut, the wireworms would need to ingest the protein through some means. Bait traps have been used in order to sample a field for the presence of wireworms (Parker, 1994). If the fusion proteins were shown to be suitably toxic towards the insect pest, these bait traps could be adapted to contain the protein as well as the bait. Incorporation of the protein could either be as a coating to the bait or within the trap as pellets.

Another option for the use of the fusion proteins for the control of wireworms would be, as with Bt, expression in transgenic plants. This could be either within the crop plant itself or within plants that would be sowed in crop fields in order to act as diversion crops. The use of transgenic plants is discussed as an option for many of the newly discovered insect specific toxins. The success of biotechnology-derived crops is clear both in the increase of crop yield and in the reduction in pesticide use. In 2003, six GM crops planted were planted in the US (canola, corn, cotton, papaya, squash and soybean). These plants not only produced an additional 2.4 million tones of food and fiber, increasing farm income by US\$1.9 billion but also reduced the use of pesticides by 21,000 tones (Sankula *et al.*, 2005)

The successful use for the oral delivery of any insecticide for control of wireworm is constrained by the feeding behavior of wireworms. Since the larvae only feed for perhaps only 20% of their life cycle (Parker and Howard, 2001), any toxin would have to be effective when delivered intermittently, in small doses. This would need to be considered when designing strategies involving fusion proteins, and the neurotoxins incorporated within them, for the control of wireworms on potato.

**1.8 Aims and objectives:**

The aims of this project were to explore the use of fusion proteins (as multi-domain proteins) for the protection of plants against coleopteran pests: specifically wireworm (*Agriotes* spp.) via the model coleopteran *T. castaneum*. Yeast and plant expression systems were used to produce fusion proteins for this aim in order to investigate the applications of fusion proteins via bait traps and/or genetically modified plants.

The objectives were:

- 1) To clone and express fusion proteins based on snowdrop lectin (GNA) and toxins from the Blue Mountains funnel-web spider (*H. versuta*).
- 2) To investigate methods of increasing stability of current and newly developed GNA based fusion proteins to proteolysis during production in order to increase intact protein yield and on delivery to the insect gut to increase potential toxicity.
- 3) To establish oral toxicity of recombinant fusion proteins against the model coleopteran *Tribolium castaneum* within diet formulations, and to compare toxicity of GNA based fusions containing scorpion and spider toxins.
- 4) To produce transgenic *Arabidopsis thaliana* expressing insecticidal fusion proteins and test the resulting plants for enhanced resistance against an appropriate insect pest, in order to show proof of concept.

## Chapter 2

### Materials and Methods

#### 2.1 Biological and chemical reagents

All chemicals and reagents were supplied from Sigma, BDH (from VWR) or unless otherwise stated. All chemicals and reagents were of analytical grade unless otherwise stated.

#### 2.2 Statistical analysis

All data analysis was conducted using the statistical functions of Prism 5.0 software (GraphPad Software Inc.). Kaplan–Meier insect survival curves were compared using Mantel–Cox log-rank tests. Insect weights were analysed using either Student’s t-tests or one-way analysis of variance (ANOVA), followed by Turkey–Kramer post hoc means separation. The accepted level of significance was  $P < 0.05$  in all cases.

#### 2.3 Standard molecular biological techniques

All standard molecular biological techniques carried out were based upon protocols that can be found in Molecular Cloning: A Laboratory Manual (Sambrook and Russell, 2001).

##### 2.3.1 Oligonucleotides

Oligonucleotides used to synthesize all constructs were generated and obtained from Sigma Genosys. These were resuspended in nuclease free water to a final concentration of 100mM according to the manufacturers quality control information.

##### 2.3.2 5' Phosphorylation of oligonucleotide primers

Phosphorylation of oligonucleotides was carried out in 20µl reactions made up of 10µl of the oligonucleotide (1nmol), 2µl 10 X reaction buffer A (Fermentas), 2µl 10mM ATP, 5µl sterile distilled water and 1µl T4 polynucleotide kinase (Fermentas). This was placed in a heat block set at 37°C for 20 minutes. The reaction was then placed in a water bath set at 75°C for 10 minutes to inactive the kinase.

### 2.3.3 Bacterial culture

For small-scale bacterial culturing, colonies picked from bacteriological agar plates or 5µl of glycerol stock were grown in autoclave sterilized 5ml Luria-Bertani (LB) (1% (w/v) Trypticase Peptone, 0.5% (w/v) Yeast Extract, 1% (w/v) Sodium chloride) liquid cultures. Antibiotics such as kanamycin and spectinomycin, were added where necessary at the recommended working concentration. Low salt Luria-Bertani (LSLB) (0.5% (w/v) sodium chloride) was used in place of LB where zeocin (Invitrogen) was used. Cultures were grown overnight at 37°C on an orbital shaker set at approximately 200rpm. Appropriate antibiotics were added to autoclave sterilized bacteriological agar (LB as above with 1.5% (w/v) difico agar) when the agar was approximately 50°C in order to avoid antibiotic breakdown. Sterile microbiological technique was used in all cases.

### 2.3.4 Plasmid DNA mini-preparations

Isolation of plasmid DNA was carried out based upon the alkaline lysis method (Bimboim and Doly, 1979) using the Wizard *plus* SV minipreps DNA purification obtained from Promega. In all cases, the protocol supplied by the manufacturer was followed to obtain plasmid DNA.

### 2.3.5 Restriction endonuclease digestions

All restriction endonuclease enzymes were obtained from a number of suppliers (Promega, Fermentas, Roche, New England Biolabs). Typically, the reactions were 30µl in volume using 10µl of isolated plasmid DNA, 1X appropriate enzyme buffer, 1 to 10 units of enzyme with the addition of sterile distilled water up to the required volume. Reactions were incubated in a heat block set at 37°C for 2 hours or, when complete digestion was required, overnight.

### 2.3.6 Polymerase chain reactions (PCR)

Reactions were carried out in an Applied Biosystems GeneAmp PCR system 2400 under standard conditions. Reaction volumes were typically 50 µl (1 x PCR buffer containing 1.5 mM MgCl<sub>2</sub>, 0.2 M each of dATP, dCTP, dGTP and dTTP, 2.5 ml each of 5' and 3' appropriate oligonucleotide primers at 10µM, 1µl DNA template. For amplification to be used in cloning of expression constructs 0.5µl Phusion polymerase

(supplied by Finnzymes) was used and *Taq* polymerase was used for PCR-screening and colony PCR. Typically PCR reactions consisted of an initial denaturation step of 30 seconds at 98°C, 20 cycles of denaturation at 98°C for 10 seconds, annealing at 50-60°C (appropriate temperature for oligonucleotides used) for 10 seconds, extension at 72°C for 30-60 seconds and a final extension step of 5 minutes at 72°C.

### 2.3.7 Agarose gel eletrophoresis of DNA

Submarine gel electrophoresis for the separation of DNA fragments is described in Molecular cloning (Sambrook and Russell, 2001). Gels contained between 1 and 2% (w/v) agarose with 1X TAE buffer (made by diluting 50X TAE stock buffer (2M Tris-HCl, 2M Glacial Acetic acid, 50mM EDTA pH 8.0)). Agar was dissolved in TAE buffer by heating in a microwave. Ethidium Bromide was added when the agar was cooled to a final concentration of 0.5  $\mu\text{g } \mu\text{l}^{-1}$ . All samples were combined with 1 X DNA loading dye (10 mM Tris/HCl pH 8.0, 10 mM EDTA, 30% (w/v) glycerol, 0.1% (v/v) Fast Orange G).  $\lambda$ /Eco471 (Fermentas) was run alongside samples as a size marker. Gels were run at 100V and maximum current (A) in 1X TAE buffer supplemented with ethidium bromide at the same concentration as the gels. DNA was visualised and photographed using a Geneflash Syngene UV cabinet with Pulnix camera. Images were obtained by using a Sony Video Graphic UP-895MD printer.

### 2.3.8 Purification of DNA from agarose gel

The relevant bands visualised on gel were excised using a single edged blade. The DNA was subsequently purified using a QIAquick gel extraction kit (Qiagen) according to the manufactures instructions. All DNA was eluted in 30 $\mu\text{l}$  of supplied elution buffer.

### 2.3.9 Quantification of isolated DNA

DNA was quantified using a Thermo Scientific NanoDrop<sup>TM</sup> 1000 Spectrophotometer under highly accurate UV/Vis analyses of 1 $\mu\text{l}$  samples. Sterile distilled water was used as a blank measurement.

### 2.3.10 Ligation of DNA

Ligations were carried out using 0.5 $\mu$ l T4 DNA ligase and 1 $\mu$ l 10X ligase buffer (Promega) in a 10 $\mu$ l reaction. The ratio of plasmid DNA to insert DNA was typically 1:3 and amounts used based upon concentration and size of DNA vector and insert fragments. Reactions were left overnight at 4°C to ensure complete ligation.

#### 2.3.11 Ethanol precipitation

0.1 volumes of 3 M NaAc were added to isolated DNA samples. 2 volumes of ice-cold ethanol were added and mixed thoroughly by vortexing. Samples were incubated overnight at -20 °C and then centrifuged at 12,000 x g for 30 minutes at 4 °C. The supernatant was carefully removed and 750 ml of 70% ethanol added to the sample. This was vortexed again and centrifuged as previously described for 5 minutes. The supernatant was again removed and the pellet placed in a dessicator to dry. Once fully dry, the pellet of DNA was resuspended in the required volume of sterile distilled water.

#### 2.3.12 Chloroform extraction for DNA clean up

The same volume of chloroform as sample was added to the sample. The mixture was briefly vortexed and subjected to centrifugation at 12,000 x g for 5 mins. The aqueous phase was then removed for use in further reactions.

#### 2.3.13 Generation of competent cells

##### 2.3.13.(i) Electrocompetent *E. coli*

One Shot TOP10 Electrocomp *Escherichia coli* cells of the genotype F- *mcrA*  $\Delta$ (*mrr-hsdRMS-mcrBC*)  $\phi$ 80*lacZ* $\Delta$ M15  $\Delta$ *lacX74* *recA1* *araD139*  $\Delta$ (*araleu*)7697 *galU* *galK* *rpsL* (Str<sup>R</sup>) *endA1* *nupG* were first obtained from Invitrogen. Subsequent competent cells were produced using the following method. Two 2 litre baffled flasks containing 500 ml each of LB broth were inoculated with bacterial culture grown overnight. Cells were grown with shaking (220 rpm) at 37°C until exponential growth phase was reached (OD<sub>600nm</sub> = 0.4-0.6). Flasks were then chilled for 1 hour on ice. Cells were subsequently decanted into two sterile centrifugation tubes and pelleted by centrifugation (5000 x g for 10 minutes, 4°C). Supernatant was discarded and cells were resuspended in a total volume of 1 litre ice-cold sterile water and pelleted by

centrifugation again. Cells were washed with sterile water twice more. Cells were then resuspended in 50ml of ice-cold 50% glycerol and pelleted (7000 x g for 10mins, 4°C). Finally cells were resuspended in a total volume of 3.5ml ice cold 50% glycerol divided into aliquots of 55µl that were then snap frozen in liquid nitrogen and stored at -80°C.

#### 2.3.13.(ii) *Agrobacterium tumefaciens* (strain C58C1)

Competent *Agrobacterium* were originally obtained from Dr Bekir Ülker (Durham University). 10µl of these cells were used to inoculate 5ml of LB (plus rifampicin 100mg l<sup>-1</sup>) and grown at 30°C overnight with shaking (220 rpm). 0.5ml of overnight culture was then used to inoculate 50ml of LB + 100mg l<sup>-1</sup> rifampicin. Cells were grown for 4-6 hours at 30°C with shaking (220 rpm) or until the OD<sub>600</sub> was between 0.5-0.6. The bacterial suspension was then centrifuged at 3500 rpm for 15min, 4°C. The cells were then suspended gently with 1ml of CaCl<sub>2</sub> and divided into 100µl aliquots and flash frozen in liquid nitrogen before storing at -80°C.

#### 2.3.14 Transformation of competent cells

##### 2.3.14.(i) Transformation of TOP 10 electrocompetent *E. coli*.

One Shot TOP10 Electrocomp *Escherichia coli* cells were removed from -80°C storage and thawed on ice. 0.5µl of the appropriate ligation reaction was gently mixed with 50µl of the thawed cells. Electroporation was carried out using a Biorad Gene Pulser system following the manufacturer's *Escherichia coli* electroporation protocol. Cells were then placed on an orbital shaker at 37°C for one hour to allow for generation of antibiotic resistance. Cells were subsequently plated out onto appropriate selection media plates.

##### 2.3.14.(ii) Transformation of competent *Agrobacterium tumefaciens*

Competent *Agrobacterium* (strain C58C1) were removed from -80°C storage and allowed to thaw on ice. 0.5-1µg of isolated plasmid DNA was added to the thawed cells and mixed thoroughly. Cells were then immediately placed in liquid nitrogen for 5 minutes. They were then removed and placed onto a heat block at 37°C for a further 5 minutes before adding 1ml of LB media. Cells were then placed onto an orbital

shaker at 30°C at approximately 200rpm for 2 hours before being plated out onto LB media plates containing 100mg l<sup>-1</sup> rifampicin and 50mg l<sup>-1</sup> streptomycin.

#### 2.3.15 Colony PCR reactions

Typically, 10 to 15 transformed colonies were picked off the bacterial plates. Each colony was resuspended in 10µl sterile distilled water subject to boiling for 3-5 minutes before centrifugation at top speed for 1 min. 5µl of the supernatant was used in the standard PCR reaction as described previously in section 2.3.6.

#### 2.3.16 DNA sequencing and analysis

Vector and gene specific primers, as appropriate, were used to sequence constructs. Sequencing reactions were carried out using Applied Biosystems ABI Prism 3730 automated DNA sequencers, performed by the DNA sequencing service (DBS Genomics), School of Biological and Biomedical Sciences, University of Durham. The sequence data obtained was viewed and analysed using Sequencher software (version 4.5).

#### 2.3.17 Bacterial glycerol stocks

*E.coli* clones were grown overnight in LSLB broth with appropriate antibiotic at the specified concentration for the bacterial strain/plasmid combination. 750µl of overnight culture was added to 250µl sterile 60% (v/v) glycerol in sterile cryovials and mixed. Cryovials were snap frozen in liquid nitrogen and then transferred to -80°C for long-term storage.

#### 2.3.18 Sub-cloning of PCR products

PCR products which were amplified using proofreading polymerases e.g. Phusion (Finnzymes) were purified from agarose gels using QiAquick Gel Extraction Kit, Qiagen) and cloned into pJET 1.2 cloning vector (Fermentas) according to manufacturers instructions. PCR products amplified using *Taq* Polymerase (products with sticky ends) were blunted using blunting enzyme provided with kit, before ligation into pJET 1.2 vector. Ligation reactions were subject to chloroform extraction and then transformed into electrocompetent TOP10 cells. Colonies seen as positive after selection using LSLB agar plates containing carbenicillin (50 µg ml<sup>-1</sup>) were

subject to colony PCR using appropriate primers and DNA sequencing using pJET M13 forward and reverse primers.

### 2.3.19 Purification of total RNA

Prior to RNA isolation, tissue samples were weighed and then either flash frozen in liquid nitrogen then homogenised or homogenised fresh in Tri-reagent (1ml per 50-10mg of tissue). For leaf tissue homogenisation occurred with plastic pestles (soaked in 3% H<sub>2</sub>O<sub>2</sub> the rinses in sterile water in order to sterilise them) or in a 2 ml glass tube with a PTFE pestle at 1,000 rpm. Samples were allowed to stand for 5 minutes at room temperature to allow for complete dissociation of nucleoprotein complexes. 0.2ml (per ml of tri-reagent) of chloroform was then added and the samples were shaken vigorously for 15 seconds. Samples were allowed to stand again for 15 minutes before centrifugation 12,000 x g for 15 minutes at 4 °C. RNA in the aqueous phase was removed and added to a sterile 1.5ml tube containing 0.5ml (per 1ml Tri-Reagent) and mixed. Again the sample was allowed to stand for 10 minutes before centrifugation at 12,000 x g for 10 minutes at 4°C. Supernatant was removed and the pellet was washed with 1ml (per 1ml of Tri-reagent) 75% ethanol. Samples were vortexed before centrifugation for 5min at 4°C at 7,500 x g. Pellets were dried under a vacuum and resuspended in 50µl sterile RNase free water. RNA was quantified using spectrophotometric methods. Resuspended RNA was either snap frozen in liquid nitrogen and stored at -80°C or used as a starting material for cDNA synthesis.

### 2.3.20 Reverse transcription-PCR (RT-PCR)

In a standard procedure total RNA was reverse transcribed into first strand cDNA using Moloney Murine Leukemia Virus Reverse Transcriptase (M-MLV RT, Promega). 2 µg of total RNA was mixed with 0.5 µg of poly-T<sub>(24)</sub> primer in a 15 µl volume. RNA was heated to 70°C for 5 minutes in order to melt the secondary structure. It was then placed on ice in order to prevent secondary structure reforming. 5 µl of 5X reaction buffer (250 mM Tris-HCl, pH 8.3, 375 mM KCl, 15 mM MgCl<sub>2</sub>, 50 mM DTT); dNTPs (final concentration, 0.5 mM) and 200 Units of M-MLV RT were all added to the reaction on ice plus additional nuclease free water up to a volume of 25 µl. Reactions were then incubated at 42°C for 60 minutes to produce

first strand cDNA. Reaction products were diluted 10-fold and 5 µl aliquots were used as template in standard 50µl PCR amplifications.

## **2.4 Standard biochemical techniques**

### **2.4.1 Estimation of protein concentration**

The protein content of solutions was determined using the BCA Protein Assay Kit (supplied by Pierce) and BSA (Bovine serum albumin; 0.125-2mg ml<sup>-1</sup>) as a standard protein. Concentrations of unknown protein were predicted using the standard curve. BCA reagent was prepared by mixing Solution B with A (1:50) freshly before use. In microtitre plates 10 µl of each standard or unknown sample was added to separate wells (in duplicate) and then mixed with 200µl of BCA Reagent. The plate was incubated for 30 minutes at 37°C. Absorbance was then read measured at 562 nm using VERA max microplate reader (Molecular Devices).

For some protein samples, protein estimation was carried out by coomassie stained SDS-PAGE gels. Protein samples were loaded onto SDS-PAGE gel in different concentrations along with standard GNA amounts (GNA previously shown to be >95% homogeneous). Gels were stained as per standard staining procedure and concentration of unknown protein sample was determined from GNA standard protein bands.

### **2.4.2 SDS-PAGE gel electrophoresis**

Protein samples were analysed by sodium dodecyl sulphate polyacrylamide gel electrophoresis (SDS-PAGE) using, typically, 15% or 17.5% resolving gel (15% or 17.5% (w/v) Protogel (37.5:1 acrylamide:bisacrylamide) (National Diagnostics), 0.375 M Tris/HCl (pH 8.8), 0.1% (w/v) SDS, 0.02% (w/v) ammonium persulphate, 0.05% (v/v) TEMED (*N, N, N', N'*-tetramethylethylenediamine) and 2.5% stacking gel (2.5% Protogel, 0.125 M Tris/HCl (pH 6.8), 0.1% (w/v) SDS, 0.1% (w/v) ammonium persulphate and 0.075% (v/v) TEMED as previously described by Låemmlí (Låemmlí, 1970). Gels were prepared and run in 1 x reservoir buffer (0.25M Tris-HCl, 1.92M Glycine, 1% (w/v) SDS) at 100 V (max A) through the stacking gel and 200 V (max A) through the resolving gel using an ATTO AE-6450 gel tank

apparatus. Samples were prepared by addition of 5 X SDS sample buffer (312.5mM Tris-HCl pH 6.8, 50% (v/v) Glycerol, 10% (w/v) SDS, 0.01% (w/v) Bromophenol blue, 25% (v/v)  $\beta$ -mercaptoethanol) to a 1 X final concentration and heated in boiling water for 10 minutes before loading onto gel. SDS 7 (Invitrogen) molecular weight marker was used to determine protein sizes on gel.

#### 2.4.3 Staining SDS-PAGE gels with Coomassie Brilliant Blue

After polyacrylamide electrophoresis proteins in the  $\mu$ g range were visualised by staining with 0.04% (w/v) Coomassie Brilliant Blue G250 (CBB), in 7% (v/v) glacial acetic acid, 40% (v/v) methanol, followed by destaining with 7% (v/v) glacial acetic acid, 40% (v/v) methanol prepared in distilled water. Gels were stained for up to 3 hours, both staining and destaining were carried out at room temperature with gentle agitation.

#### 2.4.4 Western blot analysis

Proteins were subjected to SDS-PAGE electrophoresis and transferred from the polyacrylamide gel to Optitran BA-S 85 nitrocellulose membrane, (Whatman Ltd.) by semi-dry blotting. Six sheets of 3MM paper and one sheet of nitrocellulose membrane were cut to the same size as the gel and soaked for 10 minutes in semi-dry transfer buffer (48mM Tris-HCL, 39mM Glycine, 20% (v/v) Methanol). It was then prepared in an ATTO blotting apparatus (Genetic Research Instrumentation Ltd.). Three sheets of 3MM paper were placed on the blotter followed by the nitrocellulose then the polyacrylamide gel with 3 additional sheets of 3MM paper on top. Bubbles were forced out by rolling a glass rod over the paper. Electroblothing was carried out at 0.15A, max V for 1 hour.

For confirmation of transfer and visualisation of the protein standard marker the nitrocellulose membrane was soaked in Ponceau S stain (10% (v/v) Glacial acetic acid, 0.5% (w/v) Ponceau S prepared in distilled water) for 1 minute and thoroughly rinsed in distilled water marking the standard protein bands as they appeared.

For immunodetection, the nitrocellulose membrane was blocked for 1 hour at room temperature in blocking buffer (1 X PBS, 0.05% (v/v) Tween-20, 5% (w/v) Milk

powder). Proteins on the nitrocellulose membrane were probed using anti-GNA antibodies (1:3000 dilution) (supplied by Cell Signalling Technology) and allowed to incubate overnight at 4°C. 3 x 5 minute washes at room temperature in blocking buffer were used to wash off the primary antibodies. Goat anti-rabbit (for anti-GNA antibodies) was used as a secondary antibody in 10 ml blocking buffer at a 1:5000 dilution and incubated with the membrane at room temperature for 1 hour. This was followed by 3 x 5 minute washed in rinse solution (1x PBS, 0.05% (v/v) Tween-20)

Enhanced chemoluminescence (ECL) substrate (1M Tris-HCl pH 8.5, 0.2mM Coumaric acid, 1.25mM luminol and 3% (v/v) hydrogen peroxide) was used for detection according to the manufacturer's instructions and proteins were visualized by exposure to X-ray film (Fuji SuperRX, Fuji Photo. Film Ltd.) The film was then developed using a Xograph Imaging Systems Compact X4 automatic developer.

#### 2.4.5 *In vitro* haemagglutination of recombinant proteins

Fresh rabbit blood was obtained from LSSU, Durham University and diluted 1:1 with Alsever's solution (Consists of 2.05 % D-Glucose, 0.42 % sodium chloride, 0.8 % tri-sodium citrate, 0.055 % citric acid in distilled H<sub>2</sub>O) to prevent coagulation. Erythrocytes were diluted 25 fold in ice-cold 1 x PBS solution (pH7.4) and centrifuged at 300 x g to wash the cells. The pellet was then resuspended in 1ml 1 x PBS (pH7.4) to a final concentration of 4% erythrocytes. Assays were carried out in round-bottomed 96 well plates with each test well receiving 50µl PBS. PBS was used as a negative control while commercially available vector GNA was used as a positive control. 100µl of a 0.1mg ml<sup>-1</sup> stock of commercial GNA (Vector Labs) was serially diluted along the test wells. 100µl of 0.1mg g<sup>-1</sup> recombinant GNA and 100µl of 0.4mg g<sup>-1</sup> recombinant fusion protein was serially diluted to test for their ability to agglutinate the erythrocytes. The assay was carried out for 3 hours at room temperature or 4°C overnight. Agglutination was visualised by cross-linking of erythrocyte cells within each test well. Negative results were visualised by the presence of cell pellet formation at the bottom of the test wells.

#### 2.5 Production of recombinant insecticidal proteins in *Pichia pastoris*

### 2.5.1 Synthesis of fusion protein constructs for expression in *Pichia pastoris*

#### 2.5.1.(i) Recombinant GNA protein

A highly expressing yeast colony containing the mature GNA nucleotide sequence was previously generated, selected and streaked out for reference from previous expression of recombinant GNA protein (Raemakers *et al.*, 1999).

#### 2.5.1.(ii) Fusion proteins incorporating $\kappa$ -atratoxin-Hv1c ( $\kappa$ -ACTX) and GNA

##### 2.5.1.(ii)A $\kappa$ -ACTX-GNA

The full-length nucleotide  $\kappa$ -ACTX toxin sequence was synthesised by using 5 overlapping oligomers:

#### **Coding strand:**

$\kappa$ -ACTX 1

5' GCTATTTG TACTGGT GCTGATAG ACCATGTGCTGCTTGT TGTCCATGTTG  
TCCAGGT

$\kappa$ -ACTX 2

5' ACTTCTTG TAAAGCTGAATCTAATGGTGTTTCTTATTGTAGAAAAGATGA  
ACCAGC

#### **Complementary strand:**

$\kappa$ -ACTX 3 - 5' ACGTCGATAA ACATGACCACGACTATCTGGTACACGACGA

$\kappa$ -ACTX 4 - 5'

ACAACAGGTACAACAGGTCCATGAAGAACATTTCTGACTTAGA

$\kappa$ -ACTX 5 - 5' TTACCACAAAGAATAACATCTTTTCTACTTGGTCGCCGG

Oligomers were phosphorylated and subsequently annealed. The annealed oligos were then ligated together to form the double stranded toxin sequence. oligonucleotide primers containing a 5' *Pst*I (5' TAA CTGCA GCT ATT TGT ACT GGT GCT GAT AG) and 3' *Not*I restriction sites (5' TTA GC GGCC GC TGG TTC ATC TTT TCT

ACA ATA AG) were used to amplify the toxin by PCR. The PCR product was cloned into the N-terminus of the sequence encoding GNA, already present in pGAPZ $\alpha$ B, using restriction/ligation. The ligation reaction was transformed into TOP electrocompetent *E. coli* and positive colonies by colony PCR were subject to DNA sequencing to confirm correct expression construct.

DNA sequencing revealed that a nucleotide sequence, which encodes 5 amino acids within the toxin, was missing. Subsequent amplification around the expression vector containing the construct was required in order to insert this sequence. Phosphorylated oligonucleotides were used (insert is underlined); Forward  $\kappa$ -ACTX *correction* 5' CCA TGT TGT CCA GGT ACT TCT TGT AAA; Reverse  $\kappa$ -ACTX *correction* 5' ACA CAC AGC AGC ACA TGG TCT to amplify the construct and around the vector. The PCR product was subject to blunt end ligation and transformation into Top 10 electrocompetent *E. coli*. DNA sequencing was employed to ensure no PCR errors. The correct construct sequence was subsequently cloned into linearised empty pGAPZ $\alpha$ B DNA by restriction/ligation using *Pst*I and *Xba*I endonucleases. Positive colonies from transformation were subject to DNA sequencing to ensure no PCR errors had occurred and also generation of a correct working expression vector.

#### 2.5.1.(ii)B (His)<sub>6</sub>-GNA- $\kappa$ -ACTX

The  $\kappa$ -ACTX toxin sequence was PCR amplified using the following primer sequences:

Fwd  $\kappa$ -ACTX *Not*I

5' TAAGCGGCCGCAGCTATTTGTACTGGTGCTGAT

Rev  $\kappa$ -ACTX *Sal*I (+ *Stop*)

5' TAAGTCGACTCATGGTTCATCTTTTCTACAATA

The resulting PCR fragment was cloned onto the C-terminus of GNA by incorporation into linearised pGAPZ $\alpha$ B already containing (his)<sub>6</sub>-GNA by restriction/ligation. Transformed *E. coli* colonies were subject to colony PCR to select for positives and then DNA sequencing to ensure generation of a correct working expression vector.

2.5.1.(iii) Fusion proteins incorporating  $\omega$ -atractoxin-Hv1a ( $\omega$ -ACTX) and GNA2.5.1.(iii)A (His)<sub>6</sub>-GNA- $\omega$ -ACTX

The sequence encoding the  $\omega$ -ACTX fragment was PCR amplified to contain *NotI* and *SalI* sites using the following primers:

Fwd  $\omega$ -ACTX *NotI*

5' - TAAGCGGCCGCATCTCCAACCTTGTATTCCATCTGGT

Rev  $\omega$ -ACTX *SalI* (+ stop)

5' - TAAGTCGACTCAATCACATCTTTTAACAGTATTACC

The resulting PCR fragment was incorporated into linearised pGAPZ $\alpha$ B vector containing (his)<sub>6</sub>-GNA by restriction/ligation. Positive transformed *E. coli* colonies were subject to colony PCR and DNA sequencing to ensure a correct working expression construct.

2.5.1.(iii)B  $\omega$ -ACTX-GNA-(his)<sub>6</sub>

The nucleotide sequence corresponding to mature GNA was PCR amplified to include *NotI* and *SalI* sites using the following PCR primers:

Fwd GNA *NotI*

5' TAGCGGCCGCAGACAATATTTTGTACTCC

Rev GNA *SalI*

5' TAGTCGACTCCAGTGGCCCAACGATC

GNA was excised from the original  $\omega$ -ACTX-GNA construct using *NotI* and *SalI* endonucleases. The PCR fragment was subsequently ligated into the linearised plasmid. Positive transformed colonies were sent for DNA sequencing to ensure the correct removal of the stop codon in the original construct and therefore presence of a working construct with polyhistidine tag.

2.5.1.(iii)C K34Q  $\omega$ -ACTX-GNA

The  $\omega$ -ACTX toxin fragment was PCR amplified with the following primers using the original  $\omega$ -ACTX–GNA sequence as a template:

Fwd  $\omega$ -ACTX *Pst*I

5' TAACTGCAGCATCTCCAACCTTGTATTCC

Rev *mod*  $\omega$ -ACTX *Not*I

5' TTAGCGGCCGCATCACATCTTTGAACAGT

pGAPZ $\alpha$ B containing the original  $\omega$ -ACTX–GNA construct was linearised with *Pst*I and *Not*I endonucleases to release the original  $\omega$ -ACTX fragment. K34Q $\omega$ -ACTX was then ligated into the linearised plasmid. Positive colonies were subject to DNA sequencing to confirm the mutation.

### 2.5.2 Transformation of expression constructs in *P. pastoris*

Transformation of the SMD1168H strain of *P. pastoris* was carried out by isolating transformed pGAPzaB plasmid DNA, containing the correct construct, from 40 ml of overnight bacterial culture. Plasmid DNA was eluted into 200 ml of nuclease free water. 160 ml of the DNA was digested with *Bln*I restriction enzyme (Roche). The fully digested DNA was purified from agarose gel and then ethanol precipitated overnight. It was then resuspended in 5ml sterile distilled water that was used in the transformation. Transformations were carried out using an Easycomp *Pichia pastoris* Kit (Invitrogen). The protocol used was according to the manufacturer's instructions. Transformed cells were plated out on YPG agar containing 100 mg ml<sup>-1</sup> Zeocin and incubated for 3-5 days at 30 °C. Colonies were then streaked out onto freshly made selective media plates, allowed to grow.

### 2.5.3 Expression screening of transformed *P. pastoris* colonies

McCartney bottles containing 10ml of YPG media supplemented with 100mg ml<sup>-1</sup> zeocin were inoculated with the positive colonies. These were allowed to grow at 30°C on an orbital shaker at 200 rpm for 3 days. The cultures were then subjected to centrifugation at room temperature at 3000 x g for 10 minutes. 25  $\mu$ l of culture supernatant was then subject to western blotting.

#### 2.5.4 Overexpression of recombinant proteins in *P. pastoris*

For overexpression of all recombinant fusion proteins stated, three 100ml starter cultures of YPG media, containing 100 $\mu\text{g ml}^{-1}$  zeocin, inoculated with transformed *P. pastoris* cells were grown at 30°C for 3 days on an orbital shaker at 200 rpm. These cultures were then used to inoculate 3 litres of basal salt medium (Higgins and Creggs, 1998) in a 5-litre benchtop fermenter (New Brunswick Scientific Bioflo 110). Fermentation was carried out over a period of 3 days at 30°C, 30% dissolved oxygen, pH 4.0, continuous agitation and a glycerol feed of 5-10 ml h<sup>-1</sup>.

#### 2.5.6 Recovery of protein

Protein was recovered from the *P. pastoris* cell suspension generated from the benchtop fermenter by centrifugation. This was carried out at 9000 x *g* at a temperature of 4°C for 30 minutes using a Beckman J-lite rotor and a Beckman Coulter centrifuge. This recovery process can occur due to the secretary sequence (yeast  $\alpha$ -factor) in pGAPZ $\alpha$ B that dictates extracellular secretion of the specific protein.

#### 2.5.7 Purification of recombinant proteins

##### 2.5.7.(i) Purification of recombinant proteins by hydrophobic-interaction chromatography

NaCl was added to the supernatant to a final concentration of 2M. This was then filtered through 2.7  $\mu\text{M}$ , followed by 0.7 $\mu\text{M}$  glass microfiber filters (Whatman, UK) using a vacuum manifold in order to prepare the sample for loading. A phenyl-sepharose matrix (Amersham Biosciences) column was prepared and equilibrated in 2M NaCl. The supernatant was loaded at 4 °C until saturated and subsequently eluted at room temperature across a 2M to 0M NaCl gradient. A flow rate of 2 ml min<sup>-1</sup> was used when eluting the column, collecting 5 ml fractions. The gradient was typically carried out over 120 ml. Fractions were visualised by SDS-PAGE gel electrophoresis to establish which fractions contained the recombinant protein. An example purification trace and corresponding SDS-PAGE gel for purification of GNA can be seen in appendix 1.

#### 2.5.7.(ii) Purification of recombinant proteins by nickel affinity chromatography

5 ml Ni-NTA columns (Amersham Biosciences) were used for purification of polyhistidine tagged fusion proteins. Recovered supernatant was equilibrated in a binding buffer (50mM sodium acetate, 0.5M NaCl (pH4.0)). It was then filtered through 2.7  $\mu$ M, followed by 0.7 $\mu$ M glass microfiber filters (Whatman, UK) using a vacuum manifold in order to prepare the sample for loading. Supernatant was loaded onto the nickel column pre-equilibrated with binding buffer at the rate of 3ml min<sup>-1</sup> at room temperature. The loaded column was washed with 10 column volumes of binding buffer until the OD reached a baseline on the FPLC recorder. Elution of bound proteins occurred by washing the column with elution buffer containing 100mM sodium acetate, 0.5M NaCl and 300mM imidazole (pH7.4). Fractions from load, wash, and elution stages were checked by SDS-PAGE followed by coomassie stain. Columns were stripped with buffer containing 20mM sodium phosphate, 500mM NaCl and 50mM EDTA (pH7.4) and then recharged with 0.1M NiSO<sub>4</sub> after every three load and elution cycles.

#### 2.5.7.(iii) Purification of recombinant proteins by gel filtration chromatography

After dialysis and freeze-drying of protein samples from peak fractions from the first purification, typically 100 mg protein was resuspended in 1ml Diaminopropane and 3ml PBS. This protein solution was loaded onto a Sephacryl S-200 (Amersham) column equilibrated in 1 X PBS. Gel filtration purification trace and corresponding SDS-PAGE gel of recombinantly expressed GNA can be seen in appendix 2.

#### 2.5.8 Dialysis and freeze-drying of recombinant proteins

Dialysis was carried out using dialysis tubing with a molecular weight cut off of 12-14kDa (Medicell International Ltd.). This was prepared by boiling for ten minutes in purified water containing 5mM ammonium hydrogen carbonate and a trace of EDTA. Fractions pooled from chromatograph peaks were dialysed in distilled water with gentle stirring overnight at 4°C and subjected to a further two changes.

Dialysed protein solutions were snap-frozen in liquid nitrogen. They were then subjected to vacuum freeze-drying using a Flexi-Dry microprocessor control

corrosion resistant freeze-dryer until the samples had lyophilized. Samples were subsequently stored at 4°C.

## 2.6 Insect cultures

### 2.6.1 Cabbage moth (*Mamestra brassicae*) and Tomato moth (*Lacanobia oleracea*)

*M. brassicae* and *L. oleracea* were originally obtained from The Food and Environmental Research Agency (FERA), York. Insects were reared as described in Chougule *et al.* (2008) on a standard diet prepared as described in Bown *et al.* (1997). Insects were maintained at 23°C ± 1°C, 40% relative humidity and 16h:8h light:dark regime. Larval stage insects were fed continuously with artificial diet (per litre of diet: 13.3g bacto-agar, 3.57 g ascorbic acid, 1.77 g sorbic acid, 2.93 g methyl-4-hydroxybenzoate, 6.33 g Vitmix (Vanderzant modification vitamin mixture for insects, ICN Biomedicals Ltd, Thame, Oxon., U.K.), 0.123 g ampicillin or 1.00 g aureomycin (Cyanamid Ltd, Gosport, Hants., U.K.), 3.67 ml formaldehyde solution (37%), 6.67 g Wesson salts (salt mix W, ICN Biomedicals Ltd.), 74.0 g haricot bean meal, 59.0 g wheat germ, 30.0 g soyabean meal, 20.0 g casein, 33.3 g yeast, distilled water to 1000 ml).

### 2.6.2 Wireworms (*Agriotes* spp.)

A small number of wireworms were obtained from Branston Holdings Ltd, Somerset. These were kept in individual plastic containers containing compost in reduced light conditions and at approximately 23°C ± 1°C.

### 2.6.3 Red flour beetle (*Tribolium castaneum*)

*T. castaneum* cultures were obtained from FERA (York), and were sustained on a diet of brewers yeast and organic wheat flour (heat treated for 5 hours at 90°C) at a ratio of 1:20 respectively. The beetles were kept on a light:dark regime of 16:8 and a temperature of 23°C ± 1°C.

### 2.6.4 Insect bioassays

#### 2.6.4.(i) *T. castaneum* bioassays

10 adult beetles were placed on 2mg of diet for approximately 10 days. At this point newly hatched larvae were picked off and placed into 2ml tubes containing 100mg diet. For control treatments the diet only was used. When feeding fusion protein, the lyophilised protein was weighed out at the correct dose (e.g. 2mg g<sup>-1</sup>) and added to the insect diet. To allow even distribution the mixture was vortexed and large pieces of fusion protein broken up with a spatula if necessary.

A total of 20 larvae were tested per treatment in all bioassays with 5 larvae per 2ml tube. Diet was changed once every 2 weeks and total larval weight per tube was taken every 7 days after a period of 14 days had elapsed when larvae were large enough to be weighed. All bioassays were carried out until the control larvae had begun to pupate.

#### 2.6.4.(ii) *Mamestra brassicae* injection bioassays

Fifth instar larval stage *M. brassicae* were identified based on size and moulting stage of larva. Those deemed at the correct stage larvae were selected for injections. Larvae were anesthetized with carbon dioxide and injected with 5µl of filter sterilized 1xPBS solution as a control or fusion protein dissolved in PBS to the required dose using a 10µl Hamilton syringe. Larvae were allowed to eat artificial diet continuously after injection and checked for survival every 24 hours for the length of the bioassay.

#### 2.6.5 Total protein extraction from insect guts and estimation

Insect guts were dissected under dissecting microscope in 0.9% saline and were washed with protein extraction buffer (50mM HEPES (4-(2-hydroxyethyl)-1-piperazineethanesulfonic acid), 0.1% Triton-X100 pH 6.4). Guts were then homogenised in extraction buffer (10µl of extraction buffer per mg tissue) with micropestle. The homogenate was incubated at 4°C for 30 minutes and then centrifuged at 14,000 rpm at 4°C for 10 minutes. Total protein in the supernatant was quantified as stated previously

#### 2.6.6 *In vivo* determination of fusion protein stability in gut extracts

*Tribolium castaneum* larvae were allowed to feed on diet containing fusion proteins at 2mg g<sup>-1</sup> for between 2 and 6 hours. Guts and their contents were dissected out in ice

cold 0.9% saline. 10 guts were pooled and protein extracted as described elsewhere and concentration estimated as described previously. 50µg of gut extract was then loaded onto SDS-PAGE gels alongside gut extract of larvae fed diet only and subjected to western blotting probed with appropriate antibody for detection of fusion proteins in the gut extracts.

#### 2.6.7 Cloning of degenerate cathepsin L fragment from whole insect wireworm (*Agriotes* spp.) cDNA

Total RNA was extracted as previously mentioned. First strand cDNA synthesis was carried out using superscript cDNA synthesis (Invitrogen) according to the manufacturers instructions. In order to identify cathepsin like proteases within the cDNA pool the following degenerate primers (based on wheat blub fly and flesh fly cathepsin sequences) were used:

Sc/Deg Fwd

5' GGHTCHTGYTGGKCHTTY

Sc/Deg Rev

5' YTTVAYBARCCARTARTC

A Standard 50µl Taq PCR reaction was carried out using 30 cycles, 5µl of each degenerate primer and 5µl of the first strand cDNA. The resulting band that appeared to be the correct size (approx. 700bp) was extracted from agarose gel and subcloned into pJET 2.1 as previously described. Positive colonies were sequenced and analysed using Sequencher.

##### 2.6.7.(i) Analysis of degenerate PCR fragment

The protein sequence obtained from the cloned and sequenced cDNA PCR product was compared against the global database using BlastP software running on the NCBI Blast server ([www.ncbi.nlm.nih.gov/blast](http://www.ncbi.nlm.nih.gov/blast)) in pairwise comparisons to identify similar sequences. Sequence alignments were carried out using the Clustal algorithm running under ClustalX software (Thompson *et al.*, 1997).

### 2.6.8 Assay of general proteolytic activity of wireworm (*Agriotes* spp.) gut extract

Whole insect guts were dissected and protein extracted as previously described. Quantification of protein concentration was carried out by BCA assay as also described earlier.

The synthetic substrate Z-Phe-Arg-AMC (Z = carbobenzoxy, AMC = 7-amino-4-methyl Coumarin; Bachem) a substrate for the fluorimetric assay of cathepsin B, L as well as papain was purchased from Bachem and 1mM stock was prepared in dimethylformamide.

A standard activity assay of 100  $\mu$ l consisted of 10  $\mu$ l glutathione stock (10 mM in assay buffer), enzyme extract, 10 $\mu$ l substrate stock and assay buffer (30 mM sodium-acetate, pH 5.5) up to 100  $\mu$ l,. Assays were performed in black 96 well plates (Greiner, Bio-one) at 25°C, and read using Fluoroskan Ascent microtiter plate fluorimeter (Labsystems) with excitation and emission filters set to 355 and 460 nm respectively. The plate was shaken for 5 seconds and fluorescence was read immediately for every 15 seconds for the first 5 minutes of reaction. The average reaction rate (AR) for each assay was measured; all assays were performed in duplicate unless otherwise specified.

### 2.6.9 Inhibition of wireworm gut cysteine protease activity by E-64

In order to demonstrate cysteine protease activity of wireworm (*Agriotes spp.*) gut extracts an irreversible inhibitor of cysteine proteases E-64: (2S, 3S)-3-(N-((S)-1-[N-(4-guanidinobutyl) carbamoyl]3-methylbutyl) carbamoyl) oxirane-2-carboxylic acid) (Sigma Chemical Co.) was incubated with gut extract. An optimal concentration of E-64 (0.1mM stock conc., 5 $\mu$ M working concentration) was prepared in assay buffer. The inhibitor was added to the premix of gut extract and glutathione in assay buffer (concentrations described previously) and allowed to form enzyme-inhibitor complex by incubating for 5 minutes at room temperature. The mixture was then added to substrate and the resulting activity read as described before. A positive control of cysteine protease papain at a protein concentration for equivalent enzyme activity was also included.

## 2.7 Construction of plasmids and generation of transgenic plant lines

### 2.7.1 Generation of constructs for expression of insecticidal proteins in plants

All previously made constructs for use as templates were supplied as glycerol stocks by Dr Elaine Fitches, FERA (York). Ligation reactions were all transformed into TOP 10 electrocompetent *E. coli* cells and positive colonies were determined by either colony PCR or diagnostic restriction reactions. Selected positive colonies were then subject to DNA sequencing.

#### 2.7.1.(i) ButaIT and GNA based expression constructs

##### 2.7.1.(i)A GNA leader-GNA

The GNA leader signal sequence followed by the mature GNA sequence was amplified by PCR using oligonucleotides to contain 5' *Pst*I (5' TATCTGCAGATGGCTAAGGCAAGTCTCCTC) and 3' *Not*I (5' TAAGCGGCCGCTCCAGTAGCCCAACGA) restriction sites using the GNA - Chitinase construct (Fitches *et al.*, 2004b) as a template. Isolated PCR product was cloned into linearised empty pGAPZ $\alpha$ B DNA by restriction/ligation.

##### 2.7.1.(i)B GNA leader–GNA-ButaIT

The 105 amino acid mature polypeptide sequence of GNA was restricted from the GNA–ButaIT construct in pGAPZ $\alpha$ B using *Pst*I and *Not*I restriction endonucleases. PCR product was ligated overnight with the vector DNA and transformed into electrocompetent TOP 10 *E. coli* cells. Selected positive transformants were subjected to DNA sequencing.

##### 2.7.1.(i)C GNA leader–ButaIT-GNA

The GNA leader sequence was reconstructed using overlapping oligonucleotides designed with *Xho*I and *Pst*I restriction sites (underlined).

#### **Coding strand:**

GNA L Fwd 5' -

TCGAGAAAAGAGAGGCTGAAGCTATGGCTAAGGCAAGTCTCCTCATTTTG  
GCCGCCATCTTCCTTGGTGTTCATCACACCATCTTGCCTGAGTGCTGCA

**Complementary strand:**

GNA L Rev 5' -

GACTCAGGCAAGAGGTTGTGATGACACCAAGAAGGATGGCGGCCAAAAT  
 GAGGAGACTTGCCTTAGCCATAGCTTCAGCCTCTCTTTTC

Oligonucleotides were phosphorylated and annealed to form the signal sequence. The GNA leader fragment was then cloned into the ButaIT-GNA construct (Trung *et al.*, 2006), within pGAPZ $\alpha$ B, using restriction/ligation.

2.7.1.(ii)  $\omega$ -ACTX-Hv1a and GNA based expression constructs

2.7.1.(ii)A GNA leader- $\omega$ -ACTX-GNA and GNA leader-K34Q $\omega$ -ACTX-GNA

For the GNA leader-K34Q $\omega$ -ACTX-GNA construct the nucleotide sequence encoding K34Q $\omega$ -ACTX-GNA was PCR amplified using the same primers used to create the K34Q $\omega$ -ACTX-GNA construct for expression in *P. pastoris* ( $\omega$ -ACTX fwd *Pst*I, K34Q $\omega$ -ACTX rev *Not*I; section 2.5.1.iiiC).

For the GNA leader- $\omega$ -ACTX-GNA construct the same forward primer was used but the following reverse primer was used instead. The original  $\omega$ -ACTX-GNA construct in pGAPZ $\alpha$ B was used as a template for both versions.

Rev  $\omega$ -ACTX *Not*I

5' TTAGCGGCCGCATCACATCTTTTAACAGT

pGAPZ $\alpha$ B containing GNA leader-ButaIT-GNA was restricted using *Pst*I and *Not*I restriction endonucleases releasing the ButaIT coding sequence. The PCR products were then ligated into the linearised plasmid and transformed into electro-competent *E. coli* cells. Positive colonies were subject to DNA sequencing to confirm a correct working expression construct.

2.7.1.(ii) B GNA leader- $\omega$ -ACTX and GNA leader K34Q $\omega$ -ACTX

Nucleotide sequences encoding  $\omega$ -ACTX and K34Q $\omega$ -ACTX toxins were PCR amplified to include *Pst*I and *Xba*I sites at the 5' and 3' ends respectively. The forward  $\omega$ -ACTX *Pst*I primer was used for both constructs with the following primers used to prime in the reverse direction.  $\omega$ -ACTX-GNA in pGAPZ $\alpha$ B was used as a template.

Rev  $\omega$ -ACTX *Xba*I

5' TTCTAGAAATCAATCACATCTTTTAACAGTATTACC

Rev K34Q $\omega$ -ACTX *Xba*I

5' TTCTAGAAATCAATCACATCTTTGAACAGTATTACC

pGAPZ $\alpha$ B containing GNA leader-ButaIT-GNA was restricted using *Pst*I and *Not*I endonucleases releasing the ButaIT-GNA coding sequence. PCR products were then ligated into the linearised vector. Positive transformed *E. coli* colonies were subject to colony PCR and DNA sequencing to ensure correct working expression construct.

2.7.2 Cloning constructs into plant expression vectors using the Gateway<sup>TM</sup> cloning system2.7.2.(i) Subcloning constructs into entry vector pENTR1A

To generate an entry clone by which the constructs could enter the GATEWAY<sup>TM</sup> system (Invitrogen) each ButaIT based construct and the GNA construct was PCR amplified (as section 2.3.6) using oligonucleotides with 5' *Sal*I and 3' *Xho*I restriction sites:

5' GNA L *Sal*I

TTAGTCGACATGGCTAAGGCAAGTCTCCTCATT

3' GNA *Xho*I

TAACTCGAGTCATCCAGTAGCCCAACGATC

3' RST *XhoI*

TAACTCGAGTCATTGTATACCACAGATACATTGTGG

For the  $\omega$ -ACTX based fusion protein constructs the forward GNA L *SalI* oligonucleotide was used along with the following oligonucleotide primers:

Rev GNA *EcoRV* (for GNA leader- $\omega$ -ACTX /K34Q $\omega$ -ACTX-GNA)

5' TAGATATCTTCATCCAGTAGCCCAACGATCAGT

Rev  $\omega$ -ACTX *EcoRV* (for GNA leader- $\omega$ -ACTX)

5' TAGATATCTTCAATCACATCTTTTAACAGTATTACC

Rev K34Q $\omega$ -ACTX *EcoRV* (for GNA leader-K34Q  $\omega$ -ACTX)

5' TAGATATCTTCAATCACATCTTTGAACAGTATTACC

Pentr1A vector DNA was obtained from Invitrogen. This DNA was linearised with the same restriction enzymes (*SalI/XhoI* for ButaIT fusion proteins, *SalI/EcoRV* for  $\omega$ -ACTX based fusion proteins) releasing the *ccdB* gene sequence. Ligation of the purified PCR product and cut vector occurred as in section 2.3.10. Transformed colonies were analysed by colony PCR and the subsequently sequenced.

### 2.7.2.(ii) Generation of an expression vector

The LR recombination reaction of the Gateway cloning system was used to generate an expression vector. The destination vectors pK2WG7 (for the ButaIT fusions) and pK2GW7 (for the  $\omega$ -ACTX fusions) (obtained from Michael Seymour in -80 storage) (Karimi *et al.*, 2002) were used in this reaction along with the entry vector pENTR1A containing the appropriate construct. The reaction was carried out according to the manufacturer's instructions. Successful transformed colonies were checked by colony PCR and again subsequently sequenced.

## **2.8 Generation of transgenic plant lines**

### 2.8.1 *Agrobacterium tumefaciens* culture and transformation

Transformed *Agrobacterium tumefaciens* strain C58C1 were grown to the stationary phase and then centrifuged for 20 minutes at 4000 x g. The pellet was then resuspended in 500 ml 5% sucrose and 0.05% Silwett-L77 (Lehle Seeds) to form the infiltration medium.

### 2.8.2 Plant material and growth conditions

*Arabidopsis thaliana* seeds of the ecotype Columbia-1 (obtained from Michael Seymour) were sown in 4'' plastic pots and covered for a 2-day period to break dormancy. Plants were grown in a growth room under a 16-hour photoperiod (16 hours light, 8 hours darkness) until flowering. First bolts were cut to reduce apical dominance and promote internodal growth.

### 2.8.3 Transformation by floral dipping

Above soil inflorescences were fully immersed in infiltration media and gently agitated for 10-15 seconds. 5 pots containing 3 to 5 plants per pot were dipped per transformation. Dipped plants were covered in cling film and placed in a shaded position within the growth room overnight. The cling film was removed the following day. Plants were subject to the dipping procedure 7 days later. The plants were then allowed to grow, set seed and dry out (Cough and Bent; Modified from Bechold *et al.* 1993)

### 2.8.4 Seed collection

Seeds were hand threshed and harvested. They were allowed to dry out for up to 2 weeks at room temperature before storing at 4°C.

### 2.8.5 Seed sterilisation

Seeds were subject to an initial wash for 1 minute in 1 ml 70% ethanol followed by centrifugation at 8000 x g for 1 minute to spin the seeds down. The supernatant was removed and 1 ml of sterilisation solution added before then tubes being vortexed for 10 minutes. Tubes containing the seeds were then centrifuged again, supernatant removed and replaced with 1ml of sterilised distilled water. The seeds were vortexed for 1 minute and centrifuged. This wash step was repeated 5 times to ensure all the bleach was removed.

### 2.8.6 Selection of transformed plants

To test for transformants, sterilised seeds were plated out onto 0.5 x Murashige and Skoog (MS) media (1962) plates containing (unless otherwise stated either 50 $\mu\text{g ml}^{-1}$  kanamycin for selection. Plates were placed at 4 degrees for 48 hours and then transferred to a growth chamber under a 16-hour photoperiod for 10 days. Plantlets with dark green cotyledons and long shoots were assumed to be successfully transformed. These plants were removed from plates and sown into soil and allowed to grow normally.

## **2.9 Analysis of transformed plants**

### 2.9.1 Analysis of protein expression by reverse-transcription PCR

Total RNA from leaves was extracted and first strand cDNA was synthesised. Reverse transcription using gene specific primers appropriate for the construct was carried out as described previously.

### 2.9.2 Extraction of total protein from leaf tissue

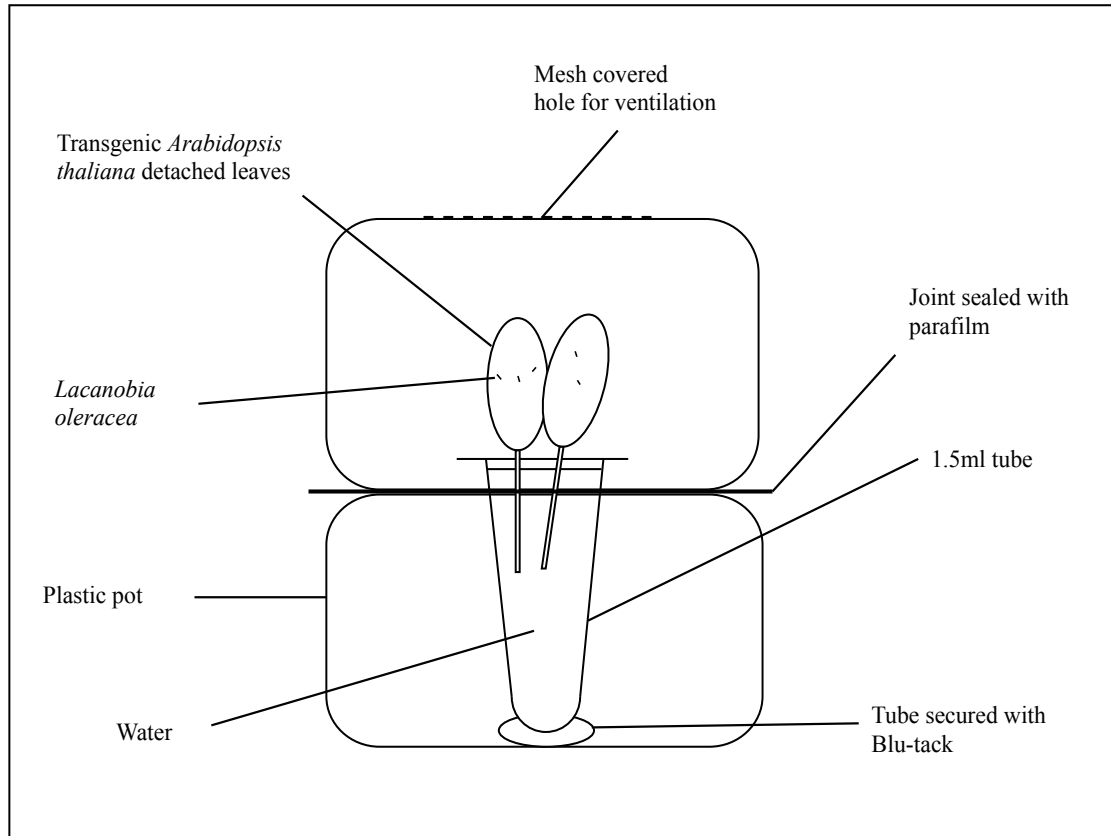
Single leaves were placed in 1.5ml tubes and flash frozen in liquid nitrogen before being ground to a fine powder. Protein extraction was carried out at 3ml g<sup>-1</sup> wet weight in 50mM Tris-HCL, pH 9.5. 1.5ml tubes containing the tissue samples and extraction buffer were placed onto an orbital shaker at approximately 600 rpm for 4 hours. Samples were then subjected to centrifugation for 10 minutes at 12 000 x g in order to spin down the solid matter. The supernatant was then removed and subject to protein concentration determination as described earlier.

### 2.9.3 Analysis of protein expression by western blotting

Functional expression of fusion proteins in the plants was confirmed by immunoblotting using anti-GNA antibodies (as described in section 2.3.2). Recombinant GNA protein was used as a standard at 25ng and 50ng concentrations. All samples unless otherwise stated were loaded on the basis of 25 or 50 $\mu\text{g}$  total solution protein. A negative control was also included using protein extracted from untransformed wild type *Arabidopsis* plants.

#### 2.9.4 Demonstration of biological activity of transgene product: transgenic plant bioassays – *Lacania oleracea*

The bioassay arena was set up as in figure 2.1. Neonate larvae of *L. oleracea* were placed using a small paintbrush onto detached *Arabidopsis* leaves expressing fusion protein. 5 larvae were used per arena and the total number of larvae per treatment was 20. Leaves were changed as required (typically every 48 hours for the first 8 days and every day for the next 6 days). Survival was measured from day 2 and larval weights were taken at day 11 and day 14.



**Figure 2.1**

**Bioassay area used to show biological activity of fusion protein expressing leaves of *Arabidopsis thaliana*.** Detached leaves were placed in a 1.5ml tube containing water and the tube secured to a plastic pot with adhesive. Neonate larvae of *L. oleracea* were placed onto the leaves and the arena was covered with another plastic pot and sealed with parafilm.

## Chapter 3

### Expression, purification and biological activity of fusion proteins incorporating Blue Mountains funnel-web spider toxin ( $\kappa$ -ACTX-Hv1c) and snowdrop lectin (*Galanthus nivalis* agglutinin; GNA)

#### Introduction

$\kappa$ -ACTX-Hv1c ( $\kappa$ -ACTX) was isolated from the Blue Mountains funnel-web spider (*H. versuta*) by Wang *et al.* (2000) and shown to be potent against a range of orthopteran, coleopteran, dipteran and lepidopteran insects (ArachnoServer; Wood *et al.*, 2009). However, it is inactive when injected into newborn mice at up to five times the LD<sub>50</sub> seen in cockroaches (Wang *et al.*, 2000; Maggio and King, 2002a, 2002b). It is the only confirmed insect specific potassium channel blocker to date, blocking calcium-activated K<sup>+</sup> (K<sub>Ca</sub>) channels (Tedford *et al.*, 2004; Gunning *et al.*, 2007). The insect specific, potent nature of the toxin highlighted it as an insecticidal peptide that was a prime candidate for fusion to a protein that would carry the peptide across the insect gut epithelium. This would therefore allow delivery of the toxin to its target site in the central nervous system. As GNA has been shown to be able to cross the insect gut epithelium and successfully deliver insecticidal peptides (Fitches *et al.*, 2001, 2002, 2004a, 2004b, 2010; Trung *et al.*, 2006), it was chosen to be the fusion partner of  $\kappa$ -ACTX.

*Pichia pastoris* has previously been used to successfully express lectin, toxin fusion proteins (Fitches *et al.*, 2004, 2010; Trung *et al.*, 2006) and therefore the expression host was utilized in this chapter for production of fusion proteins incorporating  $\kappa$ -ACTX and GNA. Biological activity of the components is demonstrated by *in vitro* haemagglutination of rabbit erythrocytes as well as insect injection bioassays. As injection into lepidopteran larvae is the standard assay for toxicity of  $\kappa$ -ACTX (Atkinson *et al.*, 1998; ArachnoServer, Wood *et al.*, 2009), this order was used for injection bioassays. Oral activity and *in vivo* gut stability of the expressed proteins is carried out against the model coleopteran pest *Tribolium castaneum*.

### **3.1 Production and purification of fusion proteins incorporating $\kappa$ -ACTX and GNA**

#### 3.1.1 $\kappa$ -ACTX-Hv1c-GNA: Design of expression construct

A nucleotide sequence encoding  $\kappa$ -atractotoxin-Hv1c ( $\kappa$ -ACTX) was assembled from five overlapping oligonucleotides, two forming the coding strand and three forming the complementary strand (see materials and methods for sequences). The fragment was subsequently amplified by PCR and attached to the N-terminus of a sequence encoding GNA already present within the expression vector pGAPZ $\alpha$ B by restriction/ligation. Upon sequencing of colonies containing the  $\kappa$ -ACTX-GNA construct, determined by colony PCR, a sequence encoding 5 amino acids within the  $\kappa$ -ACTX toxin was missing. This was probably due to misannealing of the oligonucleotides.

In order to correct this, amplification of the construct and the expression vector was carried out using a phosphorylated 5' primer to insert the missing nucleotide sequence and a phosphorylated 3' primer starting at the point in the toxin sequence where nucleotides were missing (see materials and methods for sequences). The PCR product was subjected to blunt end ligation and transformation into *E. coli*. Sequencing of several positive bacterial colonies resulted in a corrected  $\kappa$ -ACTX-GNA construct.

To ensure no PCR errors had occurred when amplification around the pGAPZ $\alpha$ B vector was carried out, the  $\kappa$ -ACTX-GNA construct was cloned into empty pGAPZ $\alpha$ B vector by restriction/ligation. Sequencing of selected colonies, positive by colony PCR analysis, confirmed generation of a correct working expression vector. A schematic diagram of the expression construct, determined nucleotide and predicted protein sequences for the introduced coding strand is shown in figure 3.1.

#### 3.1.2. Transformation and scale up

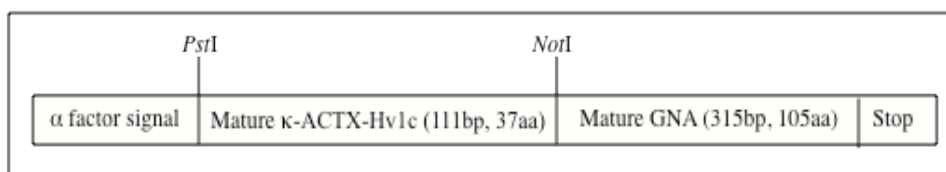
After transformation into *P. pastoris*, 10ml YPG cultures were grown up from zeocin resistant colonies. To establish levels of protein expression, culture supernatant was analyzed by SDS-PAGE gel electrophoresis and by western blotting (probed with anti GNA antibodies) (figure 3.2).

5 colonies were tested in a primary colony screen for expression of the fusion protein (figure 3.2; A). A further 3 colonies were additionally tested for expression (figure 3.2; B). There is a band of immunoreactivity seen at the top of the gel to approx. 45kDa in all samples. This is due to the presence of yeast proteins cross-reacting with the GNA antibody, as it is seen with expressing and non-expressing yeast colonies, but not when media alone is probed by western blot using GNA antibodies (Data not shown).

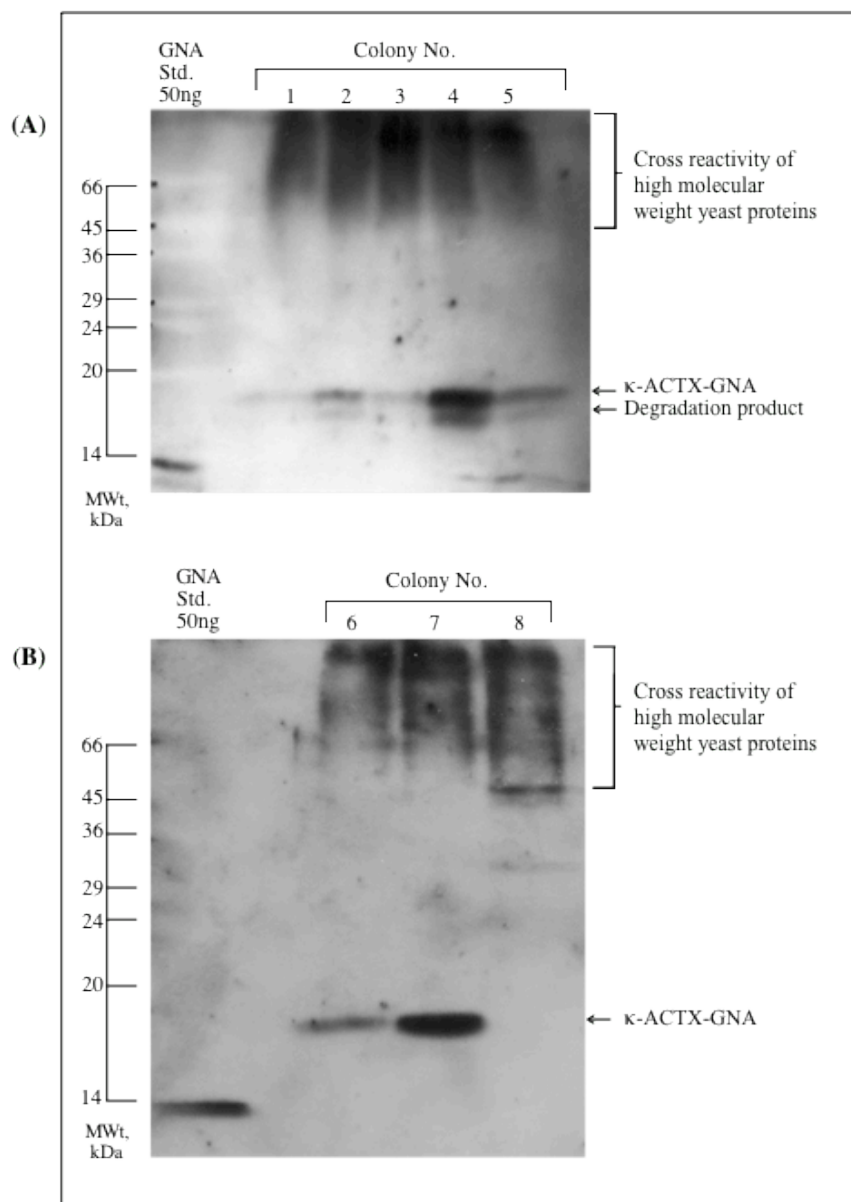
Colonies 1-7 all show a band that corresponds to a protein of approximately 17.5kDa with immunoreactivity to GNA antibodies. This is slightly higher than the predicted molecular weight of  $\kappa$ -ACTX-GNA (15.6kDa). Colonies 2, 4 and 5 all show a band at approx. 16kDa that is immunoreactive to GNA antibodies. It is thought that this band represents degradation of the expressed fusion protein by yeast proteases. A defined cleavage point has not been established, though it is hypothesized to be due to cleavage within the toxin region due to its reactivity to anti-GNA antibodies. It has therefore been annotated as a degradation product (figure 3.2; A). Colonies 4 and 6 both show expression levels of approx.  $4\mu\text{g ml}^{-1}$ . Colony 6 however was chosen for further scale-up as the expressed protein is intact.

Over expression of the recombinant protein in *P. pastoris* was carried out using a 7.5liter bench-top fermentation system. Three 100ml YPG starter cultures were used to inoculate 3litres basal salt culture media. Yeast was fermented for 3 days with protein being secreted into the culture medium. Protein was subsequently purified from the culture supernatant.

|   |              |
|---|--------------|
| ATGAGATTCCTTCAATTACTGCTGTTTTATTTCGCAGCATCC                                  | -267         |
| TCCGCATTAGCTGCTCCAGTCAACACTACAACAGAAGATGAAACGGCACAAATCCGGCTGAAGCTGTCATCGGT  | -225         |
| TACTCAGATTTAGAAGGGGATTCGATGTTGCTGTTTTGCCATTTTCCAACAGCACAAATAACGGGTATTGTTT   | -150         |
| ATAAATACTACTATTGCCAGCATTGCTGCTAAAGAAGAAGGGGTATCTCTCGAGAAAAGAGAGGCTGAAGCTGCA | - 75         |
|   | <i>Pst</i> I |
| GCTATTTGTACTGGTGTGATAGACCATGTGCTGCTTGTGTCCATGTTGTCCAGGTACTTCTTGTAAAGCTGAA   | 75           |
| <u>A I C T G A D R P C A A C C P C C P G T S C K A E</u>                    | 25           |
| TCTAATGGTGTTCCTTATTGTAGAAAAGATGAACCAGCGGCCGCCGACAAATATTTGTACTCCGGTGAGACTCTC | 150          |
| <u>S N G V S Y C R K D E P A A A D N I L Y S G E T L</u>                    | 50           |
|   | <i>Not</i> I |
| TCTACAGGGGAATTTCTCAACTACGGAAGTTTCGTTTTTATCATGCAAGAGGACTGCAATCTGGTCTTGTACGAC | 225          |
| <b>S T G E F L N Y G S F V F I M Q E D C N L V L Y D</b>                    | 75           |
| GTGGACAAGCCAATCTGGGCAACAAACACAGGTGGTCTCTCCCGTAGCTGCTTCTCAGCATGCAGACTGATGGG  | 300          |
| <b>V D K P I W A T N T G G L S R S C F L S M Q T D G</b>                    | 100          |
| AACCTCGTGGTGTACAACCCATCGAACAAACCGATTTGGGCAAGCAACTGGAGGCCAAAATGGGAATTACGTG   | 375          |
| <b>N L V V Y N P S N K P I W A S N T G G Q N G N Y V</b>                    | 125          |
| TGCATCCTACAGAAGGATAGGAATGTTGTGATCTACGGAAGTATCGTTGGGCTACTGGATGA              | 435          |
| <b>C I L Q K D R N V V I Y G T D R W A T G *</b>                            | 145          |



**Figure 3.1**  
**Full  $\kappa$ -ACTX-GNA fusion construct in yeast expression vector pGAPZ $\alpha$ B.** Full determined nucleotide sequence, presumed amino acid sequence and schematic representation of fusion protein construct. Yeast  $\alpha$ -factor signal sequence is shown highlighted, linker regions are shown in italic, mature  $\kappa$ -ACTX toxin sequence is underlined and mature GNA sequence is shown in bold.



**Figure 3.2**  
**Western blots (probed with anti-GNA ab): Small scale  $\kappa$ -ACTX-GNA expression screens of *P. pastoris* colonies positive by antibiotic (zeocin) selection grown in 10ml YGP media. (A) primary screen of transformed colonies. (B) additional screen of further positive colonies. 25 $\mu$ l supernatant was loaded onto the gel for each positive colony. Recombinant GNA (50ng) was used as a positive standard. Colonies 1-7 were deemed positive for expression of  $\kappa$ -ACTX-GNA. Colonies 1-5 show some proteolytic degradation of expressed protein while 6 and 7 appear intact. Immunoreactivity the GNA antibody was seen at the top of the gel to 45kDa has shown to be cross reactivity with the antibody to yeast proteins expressed in rich media (data not shown). Colony 7 was chosen for scaling up protein expression to bench-top fermentation.**

### 3.1.3 Recovery of recombinant protein

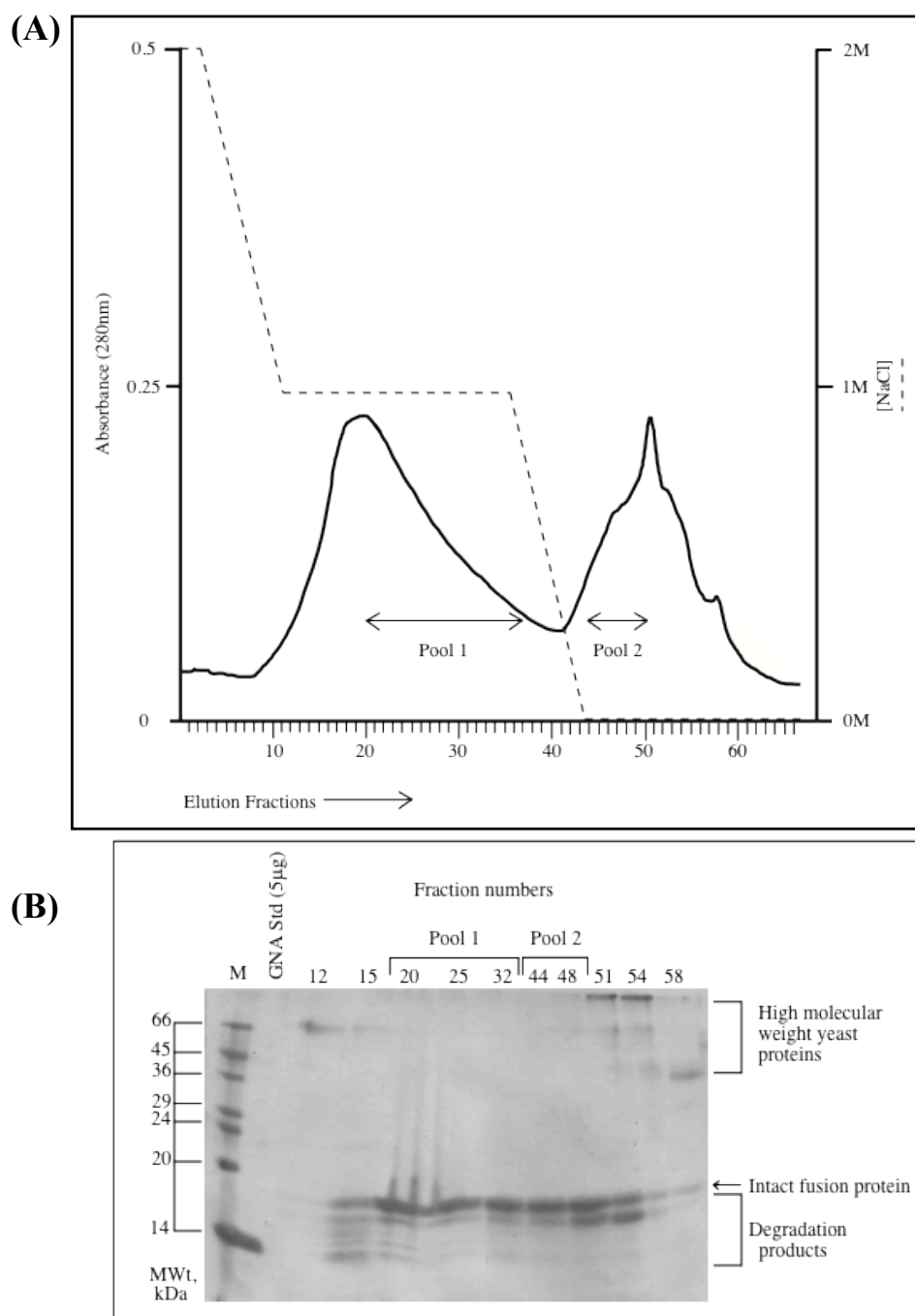
Purification of the recombinant  $\kappa$ -ACTX-GNA protein was carried out using hydrophobic-interaction chromatography. Crude culture supernatant was loaded onto Phenyl-Sepharose columns at 2M NaCl and eluted using a decreasing salt gradient (2M-0M NaCl). The salt gradient was held during peaks in absorbance (measured at 280nm). Peaks in absorbance can result from non-protein components in the culture supernatant that absorb UV light at 280nm (Layne *et al.*, 1957; Stoscheck *et al.*, 1990). SDS-PAGE however allows for analysis of protein in the fractions. Elution fractions were therefore analyzed for protein content by this technique.

Analysis of elution fractions revealed  $\kappa$ -ACTX-GNA was present in fractions 13-32 (1M NaCl) and fractions 44-58 (0M NaCl; water wash). A typical purification trace and corresponding SDS-PAGE gel can be seen in figure 3.3 (A) and (B). The fusion protein was subjected to high levels of proteolytic degradation with a number of bands seen on the gel between 16kDa and 14kDa. Again as exact cleavage points causing these products were not established, they are annotated as degradation products (figure 3.3; B).

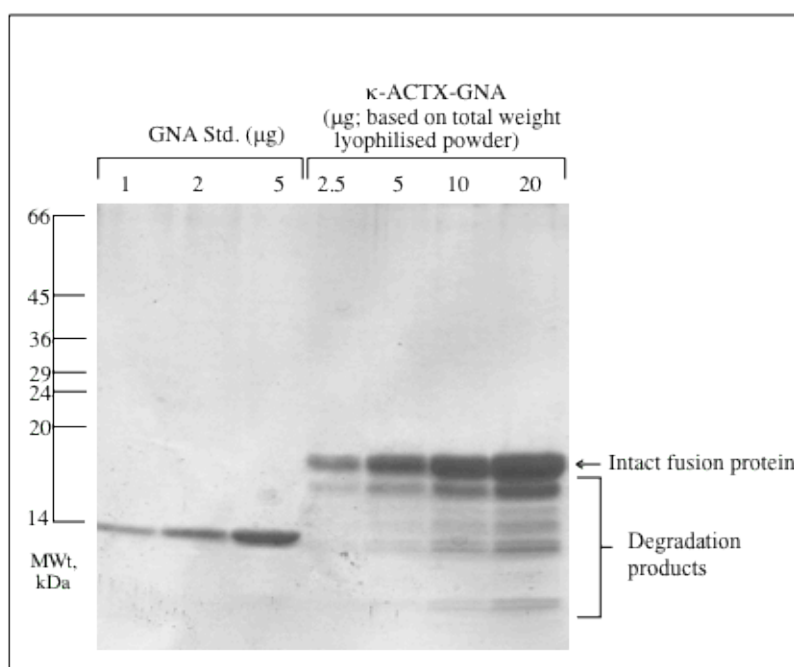
Samples containing  $\kappa$ -ACTX-GNA, free from high molecular yeast proteins, (i.e. fractions 20-37 and fractions 44-50) were pooled separately and then dialyzed with 12kDa molecular weight cut off (MWCO) dialysis tubing to remove all free toxin, salt and pigmented components from the samples. These samples were subsequently freeze-dried and quantified by SDS-PAGE analysis. A standard BCA (bicinchoninic acid) assay would show total protein in the samples however as protein may be degraded during purification, levels of intact fusion protein only can not be established by this method. Lyophilised protein was therefore resuspended in water to 1mg g<sup>-1</sup> and loaded onto SDS-PAGE gels, stained with coomassie brilliant blue (CBB) at 2.5, 5, 10, 20 $\mu$ g. Intact fusion protein was compared on gel to recombinant GNA previously shown to be >95% homogeneous GNA.

A typical quantification gel can be seen in figure 3.4 where percentage intact fusion protein in the sample is estimated to be approximately 60%. The remaining 40%

being presumed bound yeast carbohydrate and degradation products. Percentage fusion protein in the freeze-dried samples ranged from approximately 15-60% intact fusion protein when compared to GNA standards. Total dry weight of the recovered fusion protein was approximately 70 mg l<sup>-1</sup> culture supernatant.



**Figure 3.3**  
**Purification of recombinant  $\kappa$ -ATCX-GNA expressed in *Pichia pastoris* (strain SMD1168).** Filtered *P. pastoris* culture supernatant was equilibrated to 2M NaCl and loaded onto a Phenyl-Sepharose column overnight. Protein was eluted using a decreasing salt gradient (2M-0M NaCl). NaCl gradient was held while protein was eluted. **(A)** Typical purification trace. NaCl gradient shown as a dashed line, absorbance trace shown as a solid line. **(B)** 25 $\mu$ l samples of 5 ml fractions were analysed on 17.5% SDS-PAGE gel and stained with coomassie brilliant blue. M=Molecular weight marker. Fractions free from high molecular weight yeast proteins (i.e. fractions 20-37 and fractions 44-50) were pooled separately, dialysed with 12kDa MWCO tubing and lyophilized.



**Figure 3.4**  
**Quantification of recombinant  $\kappa$ -ACTX-GNA expressed in *Pichia pastoris* (strain SMD1168).** Lyophilized protein samples purified by hydrophobic interaction chromatography were resuspended in water to  $1\text{ mg ml}^{-1}$  and loaded on to 17.5% SDS-PAGE gels at 2.5, 5, 10 and  $20\mu\text{g}$  based on total weight of lyophilized protein. Samples were quantified by comparison to 1,2 and  $5\mu\text{g}$  recombinant GNA previously shown to be >95% homogeneous. The sample is deemed to be 60% fusion protein (40% bound carbohydrate and degradation products).

### **3.2 Addition of a polyhistidine tag and variation of toxin/carrier assembly - (His)<sub>6</sub>-GNA- $\kappa$ -ACTX**

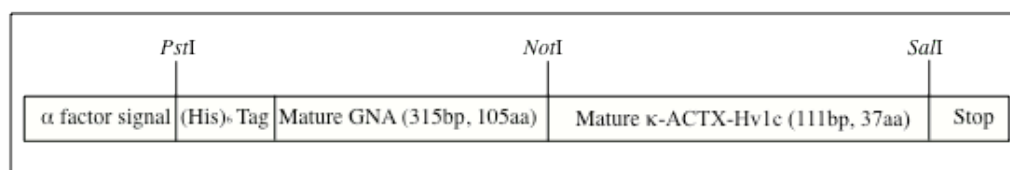
Stability of fusion proteins through production and purification is important when attempting to recover maximum yields of intact fusion protein. Variation in assembly of toxin and carrier elements in fusion proteins has been shown by Fitches *et al.* (2010) to be successful in increasing stability of expressed proteins. Fitches *et al.* (2010) found Indian red scorpion (*Mesobuthus tamulus*) toxin (ButaIT) fused to the C-terminus of GNA shows higher stability during production than ButaIT fused to the N-terminus of GNA. For this reason, the same approach is adopted here to fuse  $\kappa$ -ACTX to the C-terminus of GNA in order to potentially increase stability.

In addition, a polyhistidine tag was added to the N-terminus of the mature GNA sequence creating (his)<sub>6</sub>-GNA- $\kappa$ -ACTX. The purification tag would allow immobilized metal affinity chromatography (IMAC) to be employed. The purification technique exploits the ability of histidine to bind chelated transition metal ions, in this case nickel (Ni<sup>2+</sup>). Faster recovery of expressed proteins is achieved. Therefore reducing the time in which proteins are exposed to proteases within the culture supernatant and therefore potentially increasing recovery of intact fusion protein.

#### **3.2.1 Design of expression construct**

The nucleotide sequence encoding  $\kappa$ -ACTX fragment was amplified by PCR and attached to the C-terminus of the (his)<sub>6</sub>-GNA sequence, already contained within the expression vector pGAPZ $\alpha$ B, by restriction/ligation. Sequencing of selected positive colonies, determined by colony PCR, was used to confirm generation of a correct working expression vector, and to ensure no PCR errors had occurred. A schematic diagram of the expression construct, determined nucleotide and predicted amino acid sequences for the introduced coding strand is shown in figure 3.5.

|   |      |
|---|------|
| ATGAGATTTCCTTCAATTACTGCTGTTTTATTTCGCAGCATCCTCC                              | -270 |
| GCATTAGCTGCTCCAGTCAACACTACAACAGAAGATGAAACGGCACAAATCCGGCTGAAGCTGCATCGGTTAC   | -225 |
| TCAGATTTAGAAGGGGATTTTCGATGTTGCTGTTTTGCCATTTTCCAACAGCACAAATAACGGGTATTGTTTATA | -150 |
| AATACTACTATTGCCAGCATTGCTGCTAAAGAAGAAGGGGTATCTCTCGAGAAAAGAGAGGCTGAAGCTGCAGCA | - 75 |
| <i>Pst</i> I  |      |
| CATCATCATCATCATCATGACAATATTTTGTACTCCGGTGAGACTCTCTCTACAGGGGAATTTCTCAACTACGGA | 75   |
| <b><u>H H H H H H D N I L Y S G E T L S T G E F L N Y G</u></b>             | 25   |
| His Tag   |      |
| AGTTTCGTTTTTATCATGCAAGAGGACTGCAATCTGGTCTTGACGACGTGGACAAGCCAATCTGGGCAACAAAC  | 150  |
| <b><u>S F V F I M Q E D C N L V L Y D V D K P I W A T N</u></b>             | 50   |
| ACAGGTGGTCTCTCCCGTAGCTGCTTCCTCAGCATGCAGACTGATGGGAACCTCGTGGTGACACCCATCGAAC   | 225  |
| <b><u>T G G L S R S C F L S M Q T D G N L V V Y N P S N</u></b>             | 75   |
| AAACCGATTTGGGCAAGCAACACTGGAGGCCAAAATGGGAATTACGTGTGCATCCTACAGAAGGATAGGAATGTT | 300  |
| <b><u>K P I W A S N T G G Q N G N Y V C I L Q K D R N V</u></b>             | 100  |
| GTGATCTACGGAAGTATCGTTGGGCTACTGGAGCGGCCGAGCTATTTGACTGGTGTGATAGACCATGTGCT     | 375  |
| <b><u>V I Y G T D R W A T G A A A A I C T G A D R P C A</u></b>             | 125  |
| <i>Not</i> I  |      |
| GCTTGTGTCATGTTGTCAGGTAAGTCTTCTTGTAAAGTGAATCTAATGGTGTTCCTTATTGTAGAAAAGATGAA  | 435  |
| <b><u>A C C P C C P G T S C K A E S N G V S Y C R K D E</u></b>             | 145  |
| CCATGA  | 438  |
| <b><u>P *</u></b>   | 146  |



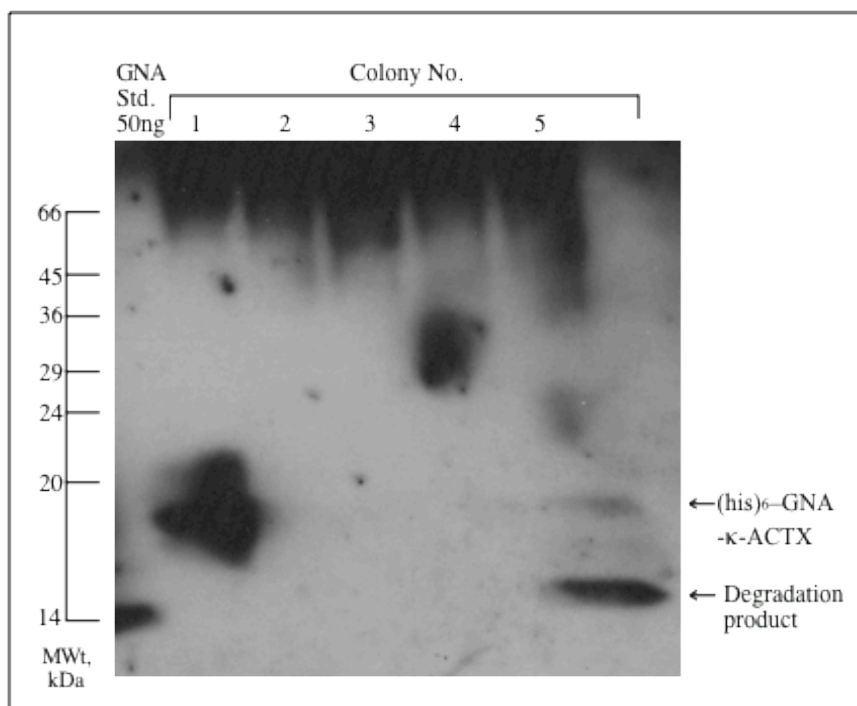
**Figure 3.5**  
**Full (his)<sub>6</sub>- $\kappa$ -ACTX-GNA fusion construct in yeast expression vector pGAPZ $\alpha$ B.**  
 Schematic representation with determined nucleotide sequence and presumes amino acid sequence of fusion protein construct. Yeast  $\alpha$ -factor signal sequence is shown highlighted, linker regions are shown in italic, mature  $\kappa$ -ACTX toxin sequence is underlined, mature GNA sequence is shown in bold and (his)<sub>6</sub> tag is bold and underlined.

### 3.2.2 Transformation and scale up

After transformation into *P. pastoris*, 10ml YPG cultures were grown up from zeocin resistant colonies. Culture supernatant was analyzed by SDS-PAGE gel electrophoresis and western blotting (probed with anti-GNA antibodies) to establish levels of expression (figure 3.6). In all samples there is a band of immunoreactivity seen at the top of the gel to approx. 45kDa. This is due to the presence of yeast proteins cross-reacting with the GNA antibody as it is seen with expressing and non-expressing yeast colonies, but not when media alone is probed by western blot using GNA antibodies (data not shown).

Of the 5 colonies picked for expression screen, only colonies 1 and 5 show presence of bands that have immunoreactivity to anti-GNA antibodies. Colony 1 is showing expression of a band on the western blot corresponding to a protein approximately 18.5kDa and at an approximate level of  $6\mu\text{g ml}^{-1}$ . This again is slightly higher than the predicted molecular weight of 16.4kDa. Colony 5 however shows a very weak band at the same molecular weight and an additional band slightly higher than recombinant GNA standard at approximately 15kDa. This is presumed to be a proteolytic degradation product that may be caused by a loss of the toxin portion of the fusion protein as it still shows immunoreactivity to anti-GNA antibodies.

Colony 1 was therefore chosen for scale-up as it shows expression of a single intact protein at approximately the correct size for (his)<sub>6</sub>-GNA- $\kappa$ -ACTX. Over expression of the recombinant protein in *P. pastoris* was carried out using a 7.5liter bench-top fermentation system. The protein was secreted into the culture medium and subsequently purified from the culture supernatant.



**Figure 3.6**  
**Western blot (probed with anti-GNA ab): small-scale expression screen of (his)<sub>6</sub>-GNA- $\kappa$ -ACTX fusion protein in 10ml YPG media.** 25 $\mu$ l sample of 10ml culture supernatant was loaded onto gel, 50ng recombinant GNA used as a positive standard. Colonies 1 and 5 show expression of bands with immunoreactivity to anti-GNA antibodies. Colony 1 shows intact band at approximately the correct size for (his)<sub>6</sub>-GNA- $\kappa$ -ACTX while colony 5 shows weak band at the same size and an additional band presumed to be degradation product at 15kDa. Immunoreactivity seen at the top of the gel to 45kDa has been shown to be yeast proteins expressed in rich media cross reacting with the GNA antibody (data not shown). Colony 1 was chosen for scale-up of expression in 7.5litre bench-top fermentation system.

### 3.2.3 Recovery of recombinant protein

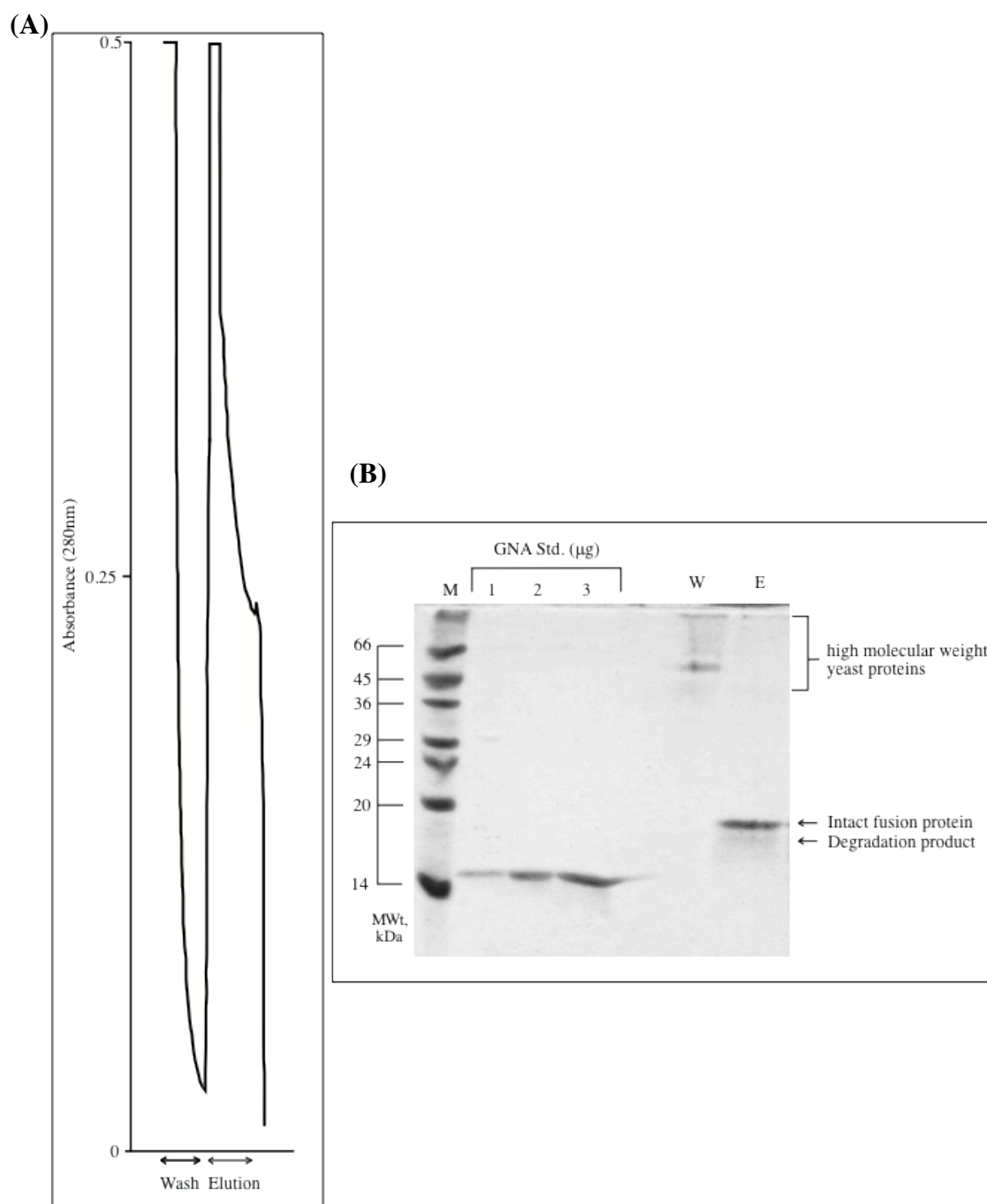
Purification of recombinant (his)<sub>6</sub>-GNA- $\kappa$ -ACTX was carried out by immobilized metal (Ni<sup>2+</sup>) affinity chromatography. Yeast culture supernatant was diluted with binding buffer and loaded on a 5ml Ni Sepharose™ 6 Fast Flow column (GE healthcare) overnight. Recombinant protein was eluted by first washing the column with binding buffer to elute any non-specific, unbound proteins, followed by washing the column with elution buffer (containing 300mM imidazole) to elute proteins bound to the column. Peak fractions were collected and analyzed on SDS-PAGE gels (figure 3.7; A, B). Elution fractions were then dialyzed using tubing with a 12kDa molecular weight cut off (MWCO) to remove all imidazole, free toxin and salt from the samples. The solutions were then flash frozen in liquid nitrogen and lyophilised by freeze-drying.

A standard BCA (bicinchoninic acid) assay would show total protein in the samples however as protein may be degraded during purification, levels of intact fusion protein only can not be established by this method. Lyophilised protein was therefore resuspended in water to 1mg ml<sup>-1</sup> and quantified on SDS-PAGE gel stained with coomassie brilliant blue (CBB) against recombinant GNA previously shown to be >95% homogeneous GNA (figure 3.8). Samples were deemed between 20 – 60% intact fusion protein. The remainder of the lyophilised power is presumed to be bound yeast carbohydrate, degradation products and some high molecular weight yeast proteins carried over from purification. Total recovery of intact fusion protein was 25mg l<sup>-1</sup>. This is lower than observed for  $\kappa$ -ACTX-GNA but figures are not directly comparable due to the loss of purified sample during dialysis.

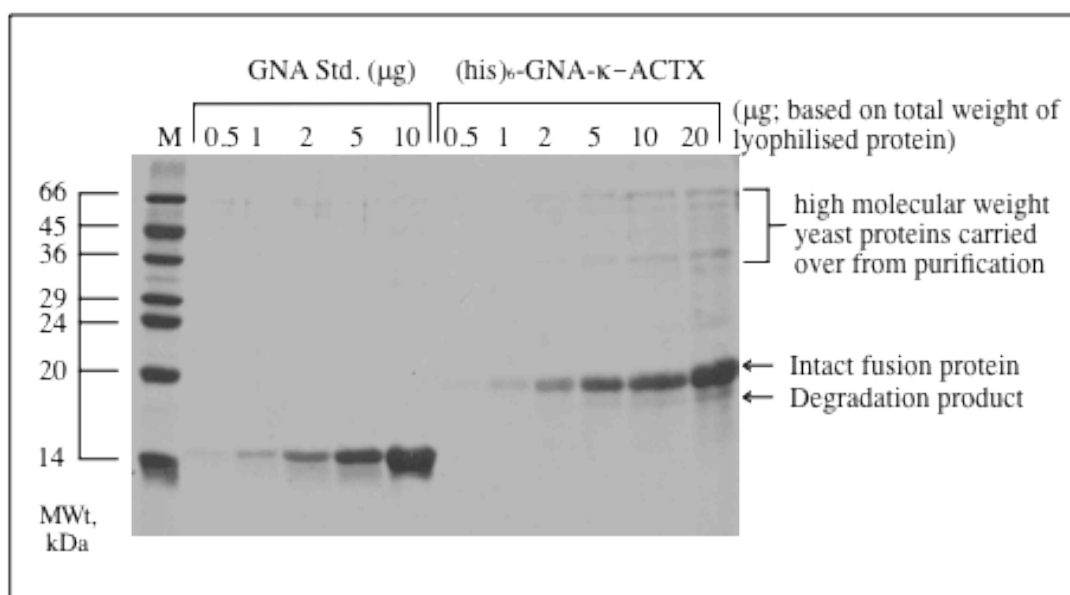
### **3.3 Comparison of $\kappa$ -ACTX-GNA vs. (his)<sub>6</sub>-GNA- $\kappa$ -ACTX post purification**

Analysis on SDS-PAGE post purification steps shows the modification in component sequence resulted in decreased protein cleavage. Comparing quantitation of samples of recombinant  $\kappa$ -ACTX-GNA (figure 3.4) to (his)<sub>6</sub>-GNA- $\kappa$ -ACTX (figure 3.8), having the toxin on the N-terminus of GNA allows the protein to be subjected to heavy degradation by proteases within the culture media during purification.  $\kappa$ -ACTX on the C-terminus of GNA however results in a seemingly more stable product. The

(his)<sub>6</sub>-GNA- $\kappa$ -ACTX fusion protein does however show slight degradation with just one cleavage product visible of a slightly smaller molecular weight. This is presumed to be the protein minus the polyhistidine tag.



**Figure 3.7**  
**Purification of (his)<sub>6</sub>-GNA- $\kappa$ -ATCX expressed in *Pichia pastoris* (strain SMD1168) by Immobilised metal ion (Ni<sup>2+</sup>) affinity chromatography.** Filtered *P. pastoris* culture supernatant was diluted with binding buffer and loaded onto 5ml Ni Sepharose™ 6 Fast Flow columns. Columns were washed with 1 X binding buffer to elute any non-specific, unbound proteins. A wash with buffer containing 300mM imidazole was then used to elute the bound recombinant protein. (A) A typical purification trace. (B) 25 $\mu$ l samples of wash (W) and elution (E) fractions were then analyzed on 17.5% SDS-PAGE gels, stained with CBB, against recombinant GNA at 1, 2 and 3 $\mu$ g. Elution fractions were dialyzed using 12kDa MWCO tubing and lyophilized.



**Figure 3.8**

**Quantitation of  $(\text{his})_6\text{-GNA-}\kappa\text{-ATCX}$ .** Lyophilised samples were resuspended in water to  $1\text{mg ml}^{-1}$  and loaded onto a 17.5% SDS-PAGE gel at 0.5, 1, 2, 5, 10 and  $20\mu\text{g}$  based on total weight of lyophilized protein powder. Gels were stained with CBB and intact fusion protein was compared against 0.5, 1, 2, 5,  $10\mu\text{g}$  recombinant GNA shown previously to be  $>95\%$ . M = Molecular weight marker. A small amount of high molecular weight yeast proteins has been carried over with the purified protein and the degradation product approx is presumed to be expressed  $(\text{his})_6\text{-GNA-}\kappa\text{-ATCX}$  which has had its polyhistidine tag cleaved by yeast proteases within the culture supernatant.

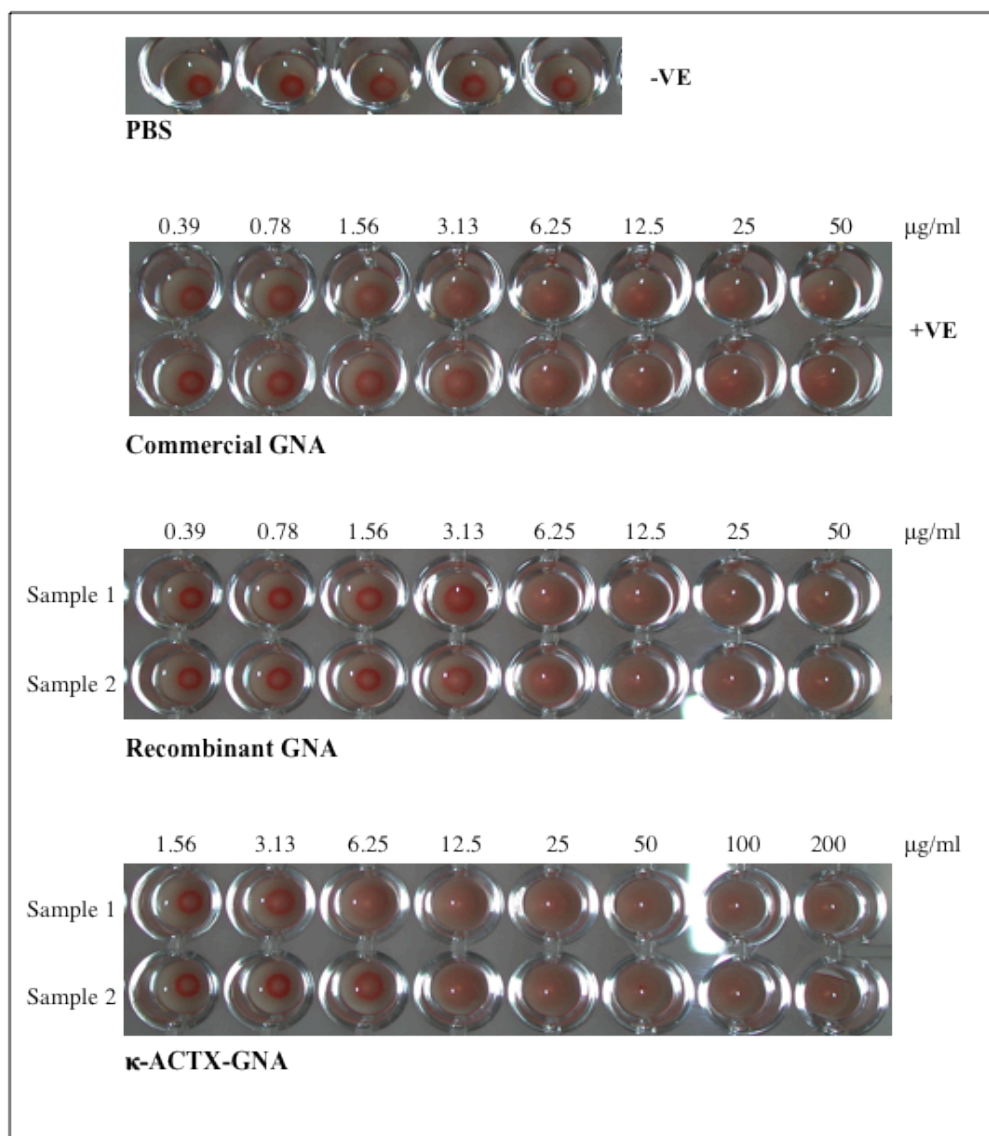
### **3.4 Biological activity of expressed fusion proteins incorporating $\kappa$ -ACTX and GNA**

#### 3.4.1 Functionality of fusion protein components

##### 3.4.1.(i) *In vitro* haemagglutination activity of recombinant GNA in $\kappa$ -ACTX–GNA fusions

*In vitro* haemagglutination of rabbit erythrocytes is a common activity assay undertaken to assess functionality of different lectins. If active, the lectin will cause the erythrocytes to cross-link and stay in suspension whereas if inactive the erythrocytes form a pellet at the bottom of the test wells. The  $\kappa$ -ACTX–GNA fusion protein and recombinant GNA were both able to agglutinate fresh rabbit erythrocytes (figure 3.9). The commercially available GNA agglutinated the erythrocytes up to  $3.13 \mu\text{g ml}^{-1}$  while the recombinant GNA showed a slightly reduced activity, being able to agglutinate up to a minimum value of  $6.25 \mu\text{g ml}^{-1}$ . This is comparable to the  $7 \mu\text{g ml}^{-1}$  minimum concentration for agglutination reported by Raemakers *et al.* (1999) and Baumgartner *et al.* (2003) when GNA was previously expressed and tested for functionality.

Complete agglutination occurred up to between  $6.25$  and  $12.5 \mu\text{g ml}^{-1}$  for the recombinant GNA in the  $\kappa$ -ATCX-GNA fusion protein. Comparable results were also seen for  $(\text{his})_6$ -GNA- $\kappa$ -ATCX (data not shown). This slightly reduced ability to agglutinate compared to recombinant GNA alone is also seen with other fusion proteins like that incorporating *Segestria florentina* toxin 1, (SF11) and GNA (SF11–GNA) which required a 2-4 fold increase in concentration to agglutinate rabbit erythrocytes (Fitches *et al.*, 2004a). This shows the GNA in the fusion protein is fully functional but not necessarily as active as recombinant GNA produced alone. This could be due to steric interference caused by the N-terminally fused  $\kappa$ -ACTX toxin in the recombinant protein.



**Figure 3.9**

***In vitro* haemagglutination of fresh rabbit erythrocytes by recombinant GNA and  $\kappa$ -ACTX-GNA expressed in *P. pastoris*.** Commercially available GNA was used as a positive control, 1X PBS was used a negative control. 100 $\mu$ l 0.1mg ml<sup>-1</sup> serially diluted along the test wells for commercial and recombinant GNA and 100 $\mu$ l 0.4mg ml<sup>-1</sup> for recombinant fusion protein; each well received 50 $\mu$ l. Agglutination was visualized by cross linking or erythrocyte cells within the wells. Commercial GNA was able to agglutinate cells up to 3.13 $\mu$ g ml<sup>-1</sup> while recombinant GNA agglutinated up to 6.25 $\mu$ g ml<sup>-1</sup>. Recombinant  $\kappa$ -ACTX-GNA agglutinated erythrocytes up to between 6.25 and 12.5 $\mu$ g ml<sup>-1</sup>.

3.4.1.(ii) Injection bioassays to demonstrate biological activity of neurotoxin component

Direct injection assays allow for the toxin to reach the active site of the insect central nervous system without the need of the lectin carrier. The standard assay of toxicity for  $\kappa$ -ACTX-Hv1c is injection into lepidopteran larvae (*Heliothis virescens*) (ArachnoServer; Wood *et al.*, 2009). Cultures of cabbage moth (*Mamestra brassicae*) were available and a method for injection has previously been established (Fitches *et al.*, 2002) therefore they were used for establishing functionality of the toxin component of the fusion protein.

10-40 $\mu$ g of  $\kappa$ -ACTX, GNA based fusion proteins were injected into fifth instar *Mamestra brassicae* (approx. 30-70mg). Injections of comparable amounts, based on molar ratios (2.5-10 $\mu$ g), of recombinant  $\kappa$ -ACTX toxin expressed in *E. coli* (obtained from Prof. Glenn King, University of Queensland; Maggio and King, 2002b) were also injected. Data in figure 3.10 is shown as end point survival for clarity, however statistical analysis of survival is conducted by analysis of Kaplan-Meier survival curves.

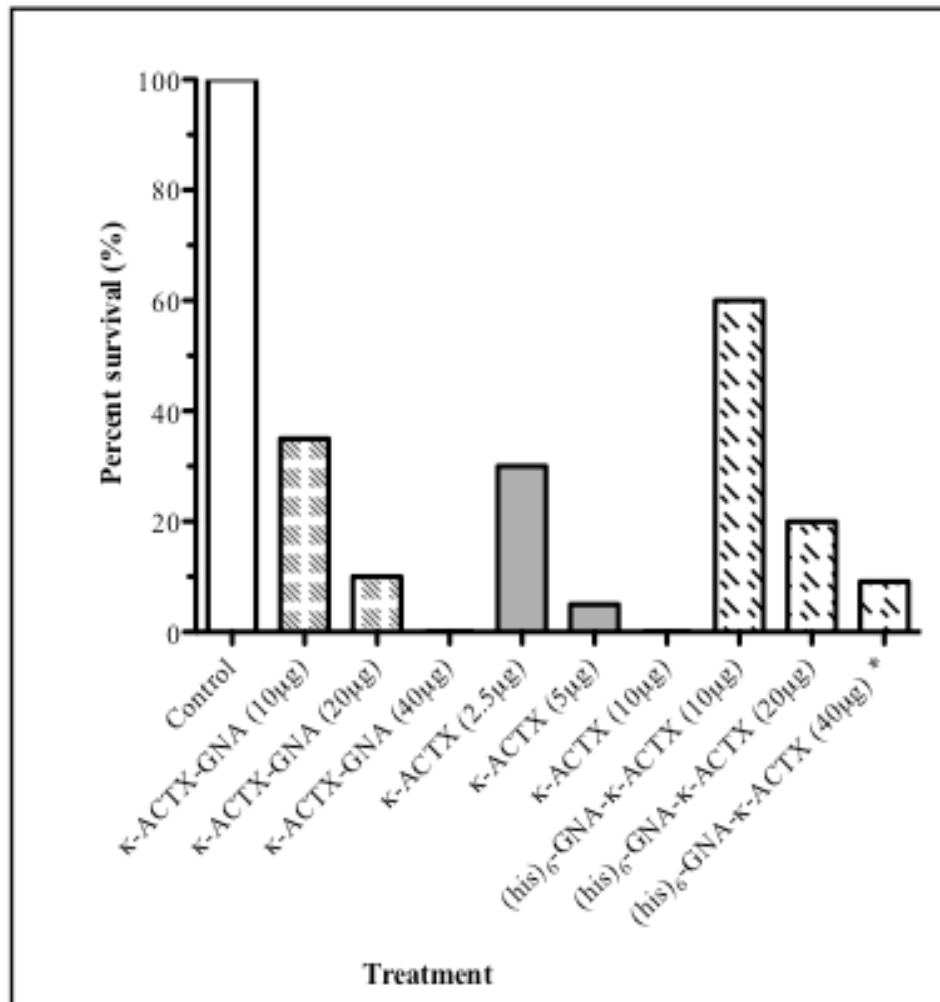
Larval morality occurred across the assay period (5 days) although the majority of deaths occurred within 24 hours. At all dose levels, survival of larvae injected with either  $\kappa$ -ACTX,  $\kappa$ -ACTX-GNA or (his)<sub>6</sub>-GNA- $\kappa$ -ACTX is significantly reduced when compared to control injected larvae (Kaplan–Meier survival curves; Mantel–Cox log-rank tests;  $P < 0.05$ ; data obtained from 20 individuals).

Analysis of Kaplan–Meier survival curves reveal no significant difference between survival of toxin-injected insects and survival of insects injected with  $\kappa$ -ACTX-GNA at all doses. For example 35% survival for larvae injected with 10 $\mu$ g fusion protein equivalent to 50 $\mu$ g toxin g<sup>-1</sup> insect compared to 30% survival of larvae injected with 2.5 $\mu$ g toxin equivalent to 50 $\mu$ g toxin g<sup>-1</sup> insect.

Comparison of survival of toxin injected larvae with (his)<sub>6</sub>-GNA- $\kappa$ -ACTX injected larvae shows no significant difference up to and including 20 $\mu$ g (Mantel–Cox log-

rank tests;  $P < 0.05$ , data obtained from 20 individuals). This is also the case when survival of larvae injected with fusion protein variants is compared. Up to and including 20 $\mu$ g, there is no difference in survival curves. At 40 $\mu$ g although survival is seen at 9% for (his)<sub>6</sub>-GNA- $\kappa$ -ACTX injected larvae and complete mortality is caused by  $\kappa$ -ACTX-GNA 5 days post injection, the Kaplan–Meier survival curves show significant difference.

Although GNA was not included as a control in this experiment, it has previously been injected into larvae of a closely related lepidopteran pest, *Lacanobia oleracea*. It was found to show 95% survival 5 days after injection with a 20 $\mu$ g dose (Trung *et al.*, 2006).



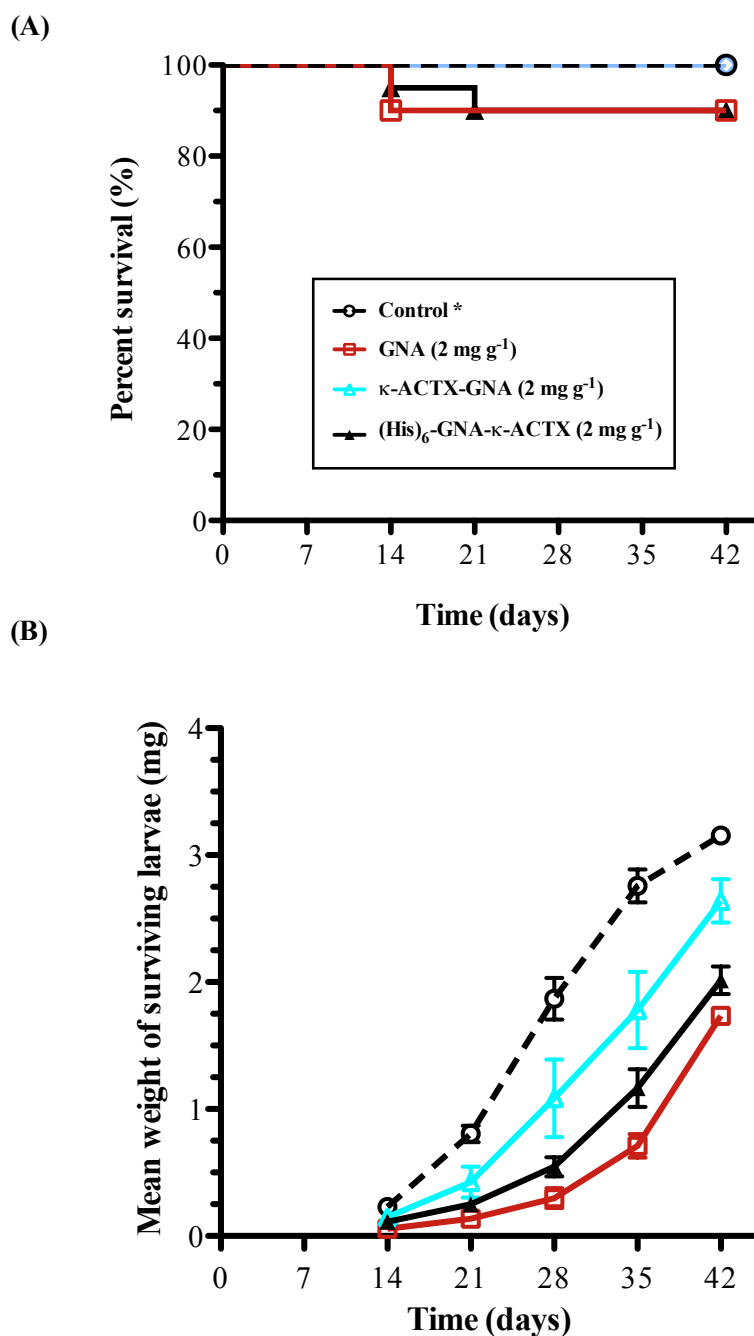
**Figure 3.10**  
The survival of *Mamestra brassicae* larvae 5 days post injection with  $\kappa$ -ACTX-GNA and (his)<sub>6</sub>-GNA- $\kappa$ -ACTX at 10, 20 and 40 $\mu$ g. Recombinant  $\kappa$ -ACTX expressed in *E. coli* (obtained from Prof. Glenn King, University of Queensland) was also injected at comparable amounts (based on molar ratio; 2.5, 5 and 10 $\mu$ g). Controls were injected with buffer (1xPBS) only. Data obtained from 20 individuals.

### 3.4.2 Oral activity of fusion proteins incorporating $\kappa$ -ACTX and GNA against *Tribolium castaneum*

$\kappa$ -ACTX–GNA and (his)<sub>6</sub>–GNA– $\kappa$ -ACTX were incorporated into wheat flour diet at 2 mg g<sup>-1</sup> with diet only was used for control treatments. *Tribolium* larvae were transferred to assay diets as neonates. Larval weights and survival were taken every 7 days after a period of 14 days (after which larvae were large enough to be weighed accurately). Diets were changed every 14 days for the length of the assay (the length of time for control larvae to start to pupate).

Both control and  $\kappa$ -ACTX–GNA treatments showed 100% survival over the assay period (42 days). (His)<sub>6</sub>–GNA– $\kappa$ -ACTX and GNA fed at 2mg g<sup>-1</sup> showed a decrease in survival of 10% after 42 days. However this was not significantly different from control survival (95% C.I., Log-Rank (Mantel-Cox) test,  $P = 0.753$ , data obtained from 20 individuals) (figure 3.11; A).

Analysis of weight data shows a significant difference in weight of surviving larvae across the assay when treatments were compared to control larval weight (Tukey-Kramer tests,  $P > 0.05$ ). Any retardation in growth from the fusion proteins is likely to be a product of the presence of GNA as the  $\kappa$ -ACTX fusion proteins showed no significant difference in weight of surviving larvae fed GNA.  $\kappa$ -ACTX variants showed no significant difference in weights between each other for all time points apart from at the very end of the assay (figure 3.11; B).



**Figure 3.11** Survival and mean weight of surviving *Tribolium castaneum* larvae fed recombinant GNA,  $\kappa$ -ACTX-GNA and (his)<sub>6</sub>-GNA- $\kappa$ -ACTX at 2 mg g<sup>-1</sup>. (A) Kaplan–Meier survival curves. (B) Mean weight of surviving larvae (mg) fed proteins at 2 mg g<sup>-1</sup>. Error bars denote  $\pm$  standard error of the mean (SEM). Diet only fed larvae are used as controls. Data is taken from 20 individuals total, control\* = 75 individuals.

### **3.5 Stability of fusion proteins incorporating $\kappa$ -ACTX and GNA *in vivo***

Since fusion proteins containing  $\kappa$ -ACTX have been shown to be toxic to insects when injected, the absence of toxicity of  $\kappa$ -ACTX fusion proteins when fed to *Tribolium* larvae was unexpected. The lack of activity was hypothesised to be a result of instability of the proteins in the *Tribolium* gut environment. If the proteins were subjected to significant proteolysis and GNA was cleaved from the toxin,  $\kappa$ -ACTX would therefore not be able to cross the gut epithelium into the haemolymph. This would therefore result in the toxin unable to access its target site of calcium activated potassium channels. The stability of the fusion proteins to digestion in *T. castaneum* gut environments was therefore assayed.

#### **3.5.1 $\kappa$ -ACTX-GNA and GNA**

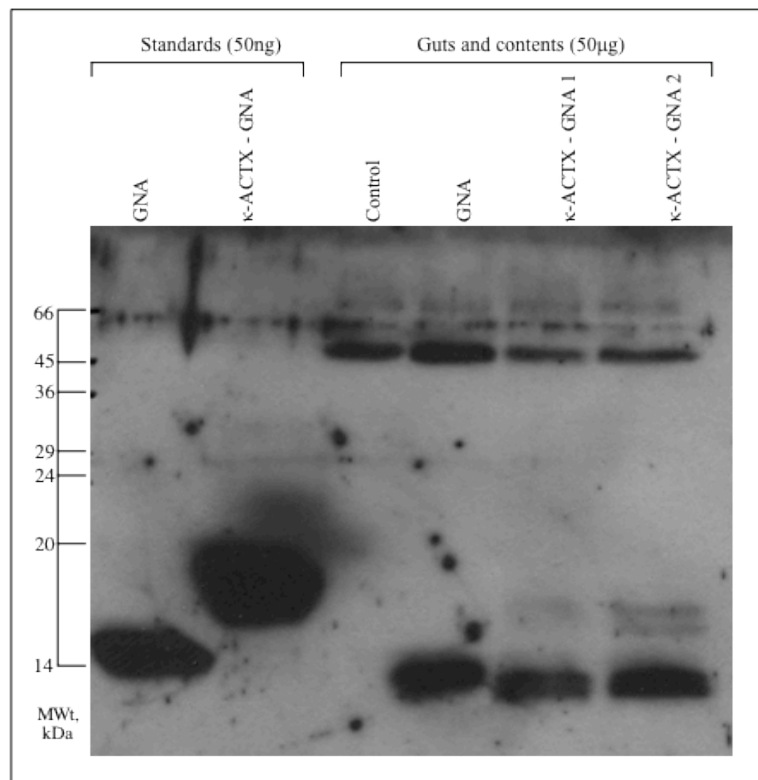
Diets containing recombinant  $\kappa$ -ACTX-GNA and GNA ( $2 \text{ mg g}^{-1}$ ) were fed to mid-instar *T. castaneum* larvae. Larvae were allowed to feed for a period of 4 hours, after which guts were dissected from 10 larvae per sample. Protein extracts were prepared and quantified as described previously. Protein extracts were analysed by SDS-PAGE, and GNA and fusion proteins were detected by western blotting.

Guts and contents from GNA fed larvae after 4 hours show a band slightly smaller in size than the recombinant GNA; however there is still quite a lot of GNA detected (approx. 50ng in 50 $\mu$ g total protein) (figure 3.12).  $\kappa$ -ACTX-GNA however is shown by western blot analysis to be completely broken down *in vivo* in both samples. The cleavage product is immunoreactive when probed with anti-GNA antibodies and is about 1kDa smaller than that detected from GNA fed larvae (figure 3.12).

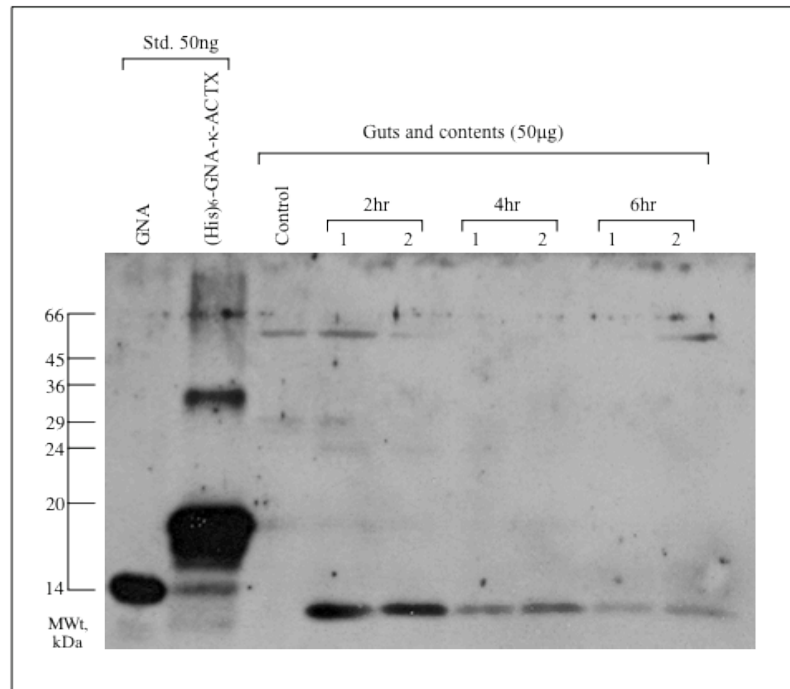
#### **3.5.2 (His)<sub>6</sub>-GNA- $\kappa$ -ACTX**

Mid instar larvae were starved for 2 hours and (his)<sub>6</sub>-GNA- $\kappa$ -ACTX was then fed at  $2 \text{ mg g}^{-1}$  diet. After 2, 4 and 6 hours 10 larval guts and contents per sample were dissected from larvae. Total protein was extracted and quantified as described previously. 50 $\mu$ g protein was run on SDS-PAGE gel and subject to western blotting.

At all time points the fusion protein showed complete break down to a protein that reacts with the anti-GNA antibodies used and has a similar size to native GNA (12.5kDa). Levels of the protein decreased over time with levels of the cleaved protein at 6 hours being approximately a third of that found after 2 hours (figure 3.13).



**Figure 3.12** Western blot (probed with anti-GNA antibodies) showing *in vivo* stability of  $\kappa$ -ACTX-GNA orally ingested by *T. castaneum* after 4 hours. 50µg of protein extracted from guts of *Tribolium* larvae fed diet only (control), and diet containing GNA and  $\kappa$ -ACTX-GNA recombinant proteins (2 mg ml<sup>-1</sup>). Positive controls of GNA and  $\kappa$ -ACTX-GNA at 50ng were also included.



**Figure 3.13** Western blot (probed with anti-GNA antibodies) showing *in vivo* stability of (his)<sub>6</sub>-GNA- $\kappa$ -ACTX ingested by *T. castaneum* after 2, 4 and 6 hours. Protein extracts (50μg) from guts and contents of insects fed (his)<sub>6</sub>-GNA- $\kappa$ -ACTX were separated by SDS-PAGE. Diet-only fed insects were used as a negative control and recombinant GNA and (his)<sub>6</sub>-GNA- $\kappa$ -ACTX at 50ng were included as positive controls.

## **Discussion**

### *large conductance calcium-activated potassium channels (BK<sub>Ca</sub>) as insecticidal targets*

$\kappa$ -ACTX-Hv1c ( $\kappa$ -ACTX), isolated from the funnel web spider (*H. versuta*), is an insect specific blocker of large conductance calcium-activated potassium channels (BK<sub>Ca</sub>). The channels exist as a complex of two different kinds of subunits, the pore-forming  $\alpha$  subunit and a regulatory  $\beta$  subunit. The  $\alpha$  subunit contains seven transmembrane domains (S0-S6) with a pore forming loop between S5 and S6. Gating of the channels is achieved by an increase in intracellular Ca<sup>2+</sup> and by membrane depolarization (Vergara *et al.*, 1998). They control calcium by preventing excessive entry into neurons by playing a role in membrane hyperpolarization as well as action potential repolarization (Grolleau *et al.*, 2000; Wickenden, 2002). BK<sub>Ca</sub> channels are involved in many important processes such as excitability of insect neurons and muscles, especially through inhibition of neurotransmitter release (Singh and Wu, 1990; Mallart, 1993; Warbington *et al.*, 1996). Despite their obvious important role in the insect nervous system, they were not considered an insecticidal target for development due to the lack of an insect-specific ligand, until the isolation of  $\kappa$ -ACTX.

The potential of this ion channel to be used as an insecticidal target is clear when considering another BK<sub>Ca</sub> channel blocker, paxilline, (McMillan *et al.*, 2003) which targets mammalian ion channels. This compound and structurally-related indole diterpenes have been shown to be lethal to a range of insects (Belofsky *et al.*, 1995; Li *et al.*, 2002, 2005).  $\kappa$ -ACTX, however, is specific to insect (dipteran, coleopteran, dictyopteran, orthopteran, and lepidopteran) channels whilst remaining inactive against mammalian channels (Wang *et al.*, 2000; Maggio and King 2002; Gunning *et al.*, 2007; Tedford *et al.*, 2007).

In *Drosophila melanogaster* the *slowpoke* (*Slo*) gene appears to be responsible for the production of BK-type channels in all tissue types (Atkinson *et al.*, 1991). Alternative splicing of *slowpoke* transcripts and in many other ion channel types can lead to

expression of many different polypeptides, thus increasing the repertoire of channels available (Lagrutta *et al.*, 1994). The conservation in the coding region of the gene between vertebrates and invertebrates shows approx. 60% sequence identity (over 900 amino acids) (Butler *et al.*, 1993; Dworetzky *et al.*, 1994; Pallanck and Ganetzky, 1994). Using Blast analysis to compare sequence identity of the *Slowpoke* gene with other insect orders, it appears to be very highly conserved with sequence identities of orthologs in other insect orders seen at 90% for Hemiptera (*A. pisum*), 94% with other Diptera (*A. gambiae*), 94% with Lepidoptera (*M. sexta*) and 95% with Coleoptera (*T. castaneum*). The human ortholog of the gene shows only 68% similarity.

The *Slo* channels in invertebrates and mammals display important differences in the pore region between the S5 and S6 helices that are believed to be the primary site of interaction with other BK<sub>Ca</sub> ‘Short-chain’ scorpion  $\alpha$ -KTx 1 family toxins, such as charybdotoxin (ChTx) and iberiotoxin (IbTx) and is also the most likely site of interaction for  $\kappa$ -ACTX-Hv1c (Gao and Garcia, 2003; Gunning *et al.*, 2007). These differences and the insect selectivity of  $\kappa$ -ACTX-Hv1c allows for the toxin to be inactive against mammals and therefore a safe toxin to be utilizing in crop protection strategies.

The high conservation of these ion channels across insect orders agrees with the findings that  $\kappa$ -ACTX is active against many different insect orders (ArachnoServer, Wood *et al.*, 2009). However, if the aim of creating an insecticide with  $\kappa$ -ACTX were to be able to target specific insect orders, this particular toxin would be not suitable. For example, Sodium channels have been shown to be as highly conserved across insect orders and the pesticides which target those channels, like DDT, are found to be broad spectrum in their control (King, 2007).

#### Expression and delivery of $\kappa$ -ACTX

Due to increased insect resistance to pesticides, it is still necessary to investigate new approaches to insect control (Chrispeels and Sadava, 2002). If  $\kappa$ -ACTX is to be used as a pesticide, methods for producing it and giving it oral toxicity are necessary.  $\kappa$ -ACTX contains eight cysteine residues and four disulphide bonds including a rare

vicinal disulphide bond critical for toxin function (Wang *et al.*, 2000; Maggio and King, 2002b).  $\kappa$ -ACTX has been expressed in soluble form, correctly folded using *E. coli* (Maggio and King, 2002b). However, toxicity of the peptide is dependent upon successful delivery into insect haemolymph where it can gain access to the central nervous system.

Snowdrop lectin (*Galanthus nivalis* agglutinin; GNA) has been detected to be in the blood of orally exposed insects in previous studies (Powell *et al.*, 1998; Fitches and Gatehouse, 1998; Fitches *et al.*, 2001, 2002). It has also been shown to co-transport fused polypeptides into the insect haemolymph (Fitches *et al.*, 2002, 2004a, 2004b, 2010; Trung *et al.*, 2006). The exact mechanism of GNA transport across insect gut epithelia is not known. However, it is thought to result from endocytosis of GNA bound to gut epithelia glycoproteins. It is also possible that passive transport via “leaky” junctions allows GNA to be transported (Fitches *et al.*, 2004b).

Constructs were therefore created to fuse  $\kappa$ -ACTX to GNA in order to deliver  $\kappa$ -ACTX into the insect haemolymph. Expression of two variants; one with the toxin fused to the C-terminus of GNA ( $\kappa$ -ACTX-GNA) and one with an N-terminal polyhistidine tag followed by the toxin fused to the N-terminus of GNA ((his)<sub>6</sub>-GNA- $\kappa$ -ACTX) is reported in this chapter. Fusion of the toxin to the N-terminus of GNA is shown to increase stability during production. This is also seen when the Indian red scorpion toxin (ButaIT) is fused to GNA and was the rationale behind the modification (Fitches *et al.*, 2010). Successful expression in *P. pastoris* and subsequent purification resulted in recovered expression levels of >25 mg l<sup>-1</sup>. Recovered yields of other fusion proteins using the same protease deficient strain of *P. pastoris* (SMD1168) have been shown to be as low as < 10mg l<sup>-1</sup> (SF11-GNA; Fitches *et al.*, 2004a) and also > 25mg l<sup>-1</sup> seen for ButaIT-GNA and GNA-ButaIT (Trung *et al.*, 2006; Fitches *et al.*, 2010).

Using *P. pastoris* for production of fusion proteins of this type can cause problems for purification due to oligosaccharides solely composed of mannose (Man) residues created by this yeast species. As GNA is mannose binding, fusion proteins and GNA

expressed in *P. pastoris* can carry over additional high molecular weight yeast proteins and bound carbohydrate through purification. Purification of  $\kappa$ -ACTX-GNA resulted in high molecular weight proteins present in purified fractions however clean samples were chosen so none could be detected in quantified samples (figure 3.3 and 3.4). High molecular weight yeast proteins were also carried over during the purification of (his)<sub>6</sub>-GNA- $\kappa$ -ACTX (figure 3.8). However, these carbohydrates and proteins have previously shown to be inert when both injected and fed into a wide range of insects including coleopterans (data not shown).

*Biological activity of lectin and toxin components in fusion proteins incorporating  $\kappa$ -ACTX and GNA*

GNA was shown to be active at levels expected for fusion proteins (6 - 12.5mg ml<sup>-1</sup>) by haemagglutination assays (Fitches *et al.*, 2004a, 2010; Trung *et al.*, 2006). Along with GNA, toxins expressed in *P. pastoris* are assumed to be correctly folded. Correct toxin folding depends on the yeast's ability to complete post-translational modification such as disulphide bond formation (Cregg *et al.*, 2000). The evidence presented suggests that correct toxin folding occurs with high efficiency, even though a vicinal disulphide bond is present in the toxin.

Injected into larvae of *M. brassicae*, the expressed fusion proteins showed significant reduction in survival compared to control indicating the toxin component in both variants was active (figure 3.10). Injection of  $\kappa$ -ACTX, expressed in *E. coli* allowed a comparison of the biological activity of expressed fusion proteins to  $\kappa$ -ACTX that had been shown to be correctly folded by NMR spectroscopy (Maggio and King, 2002b). At comparable doses up to 20 $\mu$ g (toxin equivalent 5 $\mu$ g; 100 $\mu$ g g<sup>-1</sup> insect) there is no significant difference between the variants and the toxin alone indicating that fusion to GNA and expression in *P. pastoris* did not hinder correct folding of  $\kappa$ -ACTX. There is also no difference seen when the toxin is fused to either terminus of GNA suggesting that toxin position has no effect on correct folding. This is further proof that invertebrate toxins can be produced utilizing *P. pastoris*.

Direct injection allows for a rapid indication of the biological activity of the toxin within the recombinant protein. Also, it can negate issues such as repellency or avoidance that can sometimes occur when orally administering protein through artificial diet. However, small differences in survival may be due to the difficulty assessing toxin fusion quantification. Also, however carefully it is carried out, by the nature of injection, it may be the case that bleeding back out occurs from the site of injection. This may mean not all of the dose of toxin or toxin, GNA fusion protein is delivered.

Oral delivery of fusion proteins incorporating  $\kappa$ -ACTX and GNA to *Tribolium castaneum*

Upon oral delivery of the expressed fusion proteins, neither variant was shown to significantly reduce survival when compared to control or GNA fed *T. castaneum* larvae (figure 3.11). This was hypothesized to be as a result of degradation by gut proteases as occurred when an insect chitinase was fused to GNA and fed to *Lacanobia oleracea* (Fitches *et al.*, 2004b). *In vivo* gut stability studies revealed no detectable intact protein of either variant suggesting that cleavage had occurred resulting in removal of GNA from toxic peptide.

Coleopterans are known to utilise cysteine proteases for digestion and switch to serine when cysteine protease inhibitors are encountered (Murdock *et al.*, 1987; Oppert *et al.*, 1993). Murdock *et al.* (1987) showed that 10 out of 11 beetles, (representing 10 different families) all used cysteine proteases for digestion suggesting that it is highly likely that the compliment of digestive proteases amongst Coleoptera are similar. Transcriptomics has allowed for further analysis of expression of genes within colepterans and other insects. Morris *et al.* (2009) completed a full gut transcriptome study of *T. castaneum* and found seven cathepsin B and five cathepsin L encoding transcripts to be highly expressed (with a gut ranking >3). Five of the seven cathepsin B-like proteases are inactive enzymes as they lacked critical residues necessary for an active peptidase. Only one of five cathepsin L-like sequences was an inactive enzyme suggesting this is the primary digestive class of protease present. Serine proteases were also found with 26 and 21 of the 75 transcripts encoding presumed

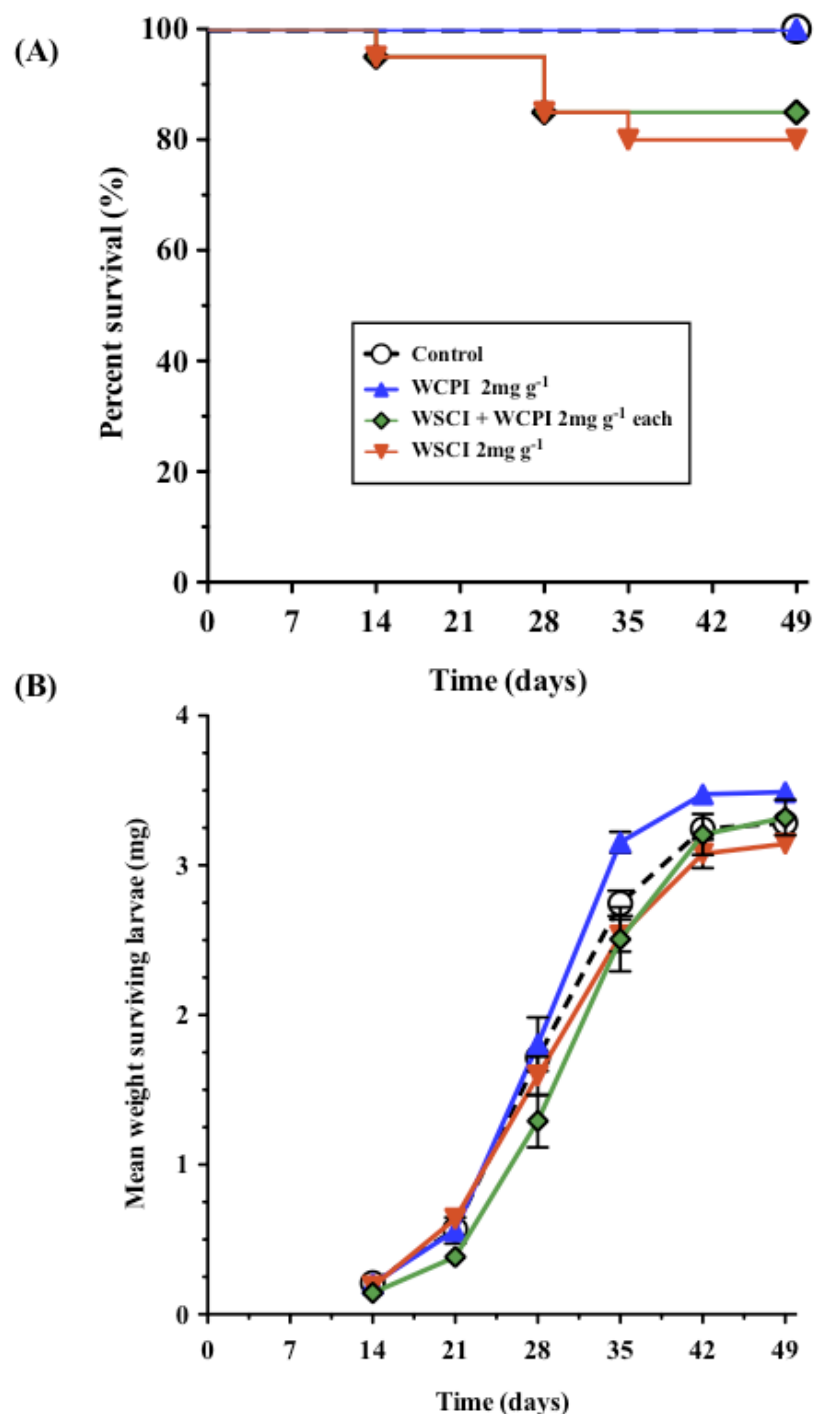
chymotrypsin and trypsin genes respectively. The lack of active gene transcripts was suggestive of low-level expression of serine proteases in the gut tissue.

In order to provide further evidence for the similarity of coleopteran digestive enzymes supplementary experiments were carried out to investigate the protease activity of wireworm (*Agriotes* spp.). A partial gene cathepsin L gene was cloned from whole insect cDNA and upon blast cathepsin L-like precursor (NP\_001164088.1). This sequence corresponds to gene locus LOC663234, and is expressed in larval stages as a moderately abundant EST (data from BeetleBase, <http://beetlebase.org>) (appendix 3 and 4). ClustalX was used to align the two sequences and over the 162 matching amino acid residues in the wireworm cathepsin L-like fragment, 138 (85%) are identical, and 152 (94%) are similar, showing that the two proteins are probably true homologues (appendix 5). Biochemical analysis using 5 $\mu$ M of an irreversible, potent and highly selective inhibitor of cysteine proteases; E64 [trans-epoxysuccinyl-L-leucylamido-(4-guanidino)butane] to inhibit wireworm gut extract and the cysteine protease papain at protein levels showing comparable levels of activity were also carried out. 5 $\mu$ M E64 inhibited the activity of 250ng of papain by 99%, showing that the concentration of inhibitor was enough to almost completely inhibit activity of commercially available cysteine protease. E64 at the same concentration inhibited wireworm extract by 80% showing that most of the protease activity in the gut extract was due to cysteine proteases (appendices 6-7).

#### Increasing stability in gut environments

Increasing stability of fusion proteins within coleopteran gut environments could involve co-expression or co-feeding of fusion proteins with protease inhibitors. This may help to reduce proteolysis to a level where sufficient toxin can be delivered to the haemolymph to have a toxic effect. However, coleopterans and other insect species are known to up-regulate alternative protease transcripts when protease inhibitors are present limiting their effect (Bolter and Jongsma, 1995; Oppert *et al.*, 2005). In an experiment not directly related to the main topic of this chapter, the oral activity of two wheat protease inhibitors (a cysteine protease inhibitor; WCPI and a subtilisin/chymotrypsin inhibitor; WSCI), which were isolated, cloned and

recombinantly expressed in *P. pastoris* by Dr. Prashant Pyati (2010), were assayed for oral toxicity against *T. castaneum* larvae (figure 3.14). The assay showed minimal effects on growth and survival of larvae; by the end of the assay period larvae from all treatments pupated within the same time period and no significant difference in mean weight of surviving larvae was seen compared to controls at the end of the assay period. Fed at 2mg g<sup>-1</sup> only WSCI reduced survival significantly when compared to control survival (Log-rank (Mantel-Cox) Test, 95% C.I.,  $P = 0.0373$ , data taken from 20 individuals). This confirms other reports that *Tribolium* are capable of counteracting effects of PIs (Oppert *et al.*, 2005) and suggests if protease inhibitors were co-fed it might not result in significantly improved stability. However, just because the PIs tested here have minimal effect, others such as soybean trypsin inhibitor (Kunitz), potato cysteine proteinase inhibitor and Job's tears cysteine proteinase inhibitor) have shown to be detrimental to growth and survival (Oppert *et al.*, 1993, 2003) and so co-feeding PIs for increased stability cannot be ruled out and should be considered for further work.



**Figure 3.14** Survival rate and mean weight of surviving *T. castaneum* larvae fed wheat cysteine protease inhibitor (WCPI) and subtilisin/chymotrypsin inhibitor (WSCI) (provided by Dr. Pyati) at 2 mg g<sup>-1</sup>. (A) Kaplan-Meier survival curves. (B) Mean weight of surviving larvae (mg), error bars denote  $\pm$  standard error of the mean (SEM) Diet only fed larvae are used as controls. Data is taken from 20 individuals total.

An alternative method of increasing stability is variation in linker regions. It has been shown with other fusion proteins of this type that linker regions are particularly susceptible to cleavage (Trung *et al.*, 2006). Studies like those carried out by Gustavsson *et al.* (2001) into size of linker regions between fusion proteins have seen that longer linker regions can result in more stable proteins. A 13 amino acid linker region containing prolines and threonines, linker types that are commonly found in bacterial cellulases (Gilkes *et al.*, 1991), proved to be more stable than other linker regions when expressed in *P. pastoris* (Gustavsson *et al.*, 2001). These linker regions have been suggested as good linker candidates for general gene fusions (Argos, 1990). Another linker region that has proved promising as a linker in fusion proteins is the IgG hinge region. Airene and Kulomaa (1995) demonstrated successful use of the IgG hinge as a flexible spacer in peptide fusions. However, as shown in this chapter those proteins stable through production in *Pichia pastoris* are not necessarily as stable in insect gut environments and therefore would still need to be investigated.

Ideally, the oral toxicity of the peptide would have been assessed along with the fusion protein equivalent however expression in *E. coli* (Maggio and King, 2002b) resulted in levels of expression insufficient to complete oral toxicity studies in *Tribolium*. This could form a basis of further work. However, it is unlikely that the toxin alone could cross the gut epithelium as demonstrated within the chapter, fusion proteins were degraded in the gut environment and therefore it would be reasonable to suggest free toxin would therefore have been present. Although further degradation of the toxin cannot be ruled out without efficient antibodies for the toxin, there was still no significant reduction in survival of either toxic fusion protein suggesting that no part of the fusion protein was successfully delivered.

### Summary

In this chapter, functional  $\kappa$ -ACTX, GNA based fusion proteins have been expressed utilising the yeast *P. pastoris*. Injection data showed the toxin components within the fusion proteins were directly comparable to correctly folded  $\kappa$ -ACTX expressed in *E. coli* however comparisons with LD<sub>50</sub> data with other lepidopteran pests was not achieved due to insufficient data sets. Further work would be required to create a

LD<sub>50</sub> for the fusion proteins presented in this chapter. Oral activity against *T. castaneum* was not established due to the high levels of proteolytic cleavage sustained *in vivo*. If the toxin were to be delivered in a fusion protein approach considerations such as linker regions, potential proteolytic cleavage sites and purification strategies should all be taken into account.

## Chapter 4

### **Expression, purification and biological activity of fusion proteins incorporating Blue Mountains funnel-web spider toxin ( $\omega$ -ACTX-Hv1a) and snowdrop lectin (*Galanthus nivalis* agglutinin; GNA)**

#### **Introduction**

$\omega$ -atracotoxin-Hv1a ( $\omega$ -ACTX) is a second atracotoxin isolated from the Blue Mountains funnel-web spider (*H. versta*) (Atkinson *et al.*, 1998; Fletcher *et al.*, 1997). It blocks insect specific voltage gated calcium channels (VGCC) and has been described as one of the most potent peptide toxins discovered to date with a PD<sub>50</sub> (i.e. the dose that paralyzes 50% of test insects) of  $<0.25 \text{ nmol g}^{-1}$  in tobacco budworm (*Heliothis virescens*) (Bloomquist, 2003). In comparison, other toxins such as those from the agelenid spider (*T. agrestis*) show a PD<sub>50</sub> of 0.89 – 2.6  $\text{nmol g}^{-1}$  (Johnson *et al.*, 1998). This potency has brought about huge interest in  $\omega$ -ACTX for insecticide use and also makes it an excellent candidate for fusion to a lectin carrier and delivery via the fusion protein approach.

An  $\omega$ -ACTX-GNA fusion protein has previously been expressed in *P. pastoris* and shown to be fully functional by Dr Elaine Fitches, FERA (York) (figure 4.1 and 4.7). However, the main disadvantage with the expressed protein was the level of proteolytic cleavage during fermentation and purification. The purified fusion protein when visualized on SDS-PAGE gel has, in the best samples, a ratio of approximately 50:50 and in some samples as little as 30:70 (intact fusion protein:cleavage product) (figure 4.1).

In order to increase stability, variation in toxin and lectin assembly was carried out. Also, in order to potentially increase yields of recovered intact fusion protein a polyhistidine purification tag was included into constructs to aid faster purification times, limiting exposure to proteases within the yeast culture supernatant. These approaches have previously been shown to result in more intact lectin-toxin fusion



#### **4.1 Design of expression constructs**

##### 4.1.1 Addition of a (his)<sub>6</sub> tag and variation of component sequence

The first construct was the addition of a polyhistidine tag at the C-terminus of GNA in the original  $\omega$ -ACTX–GNA construct. GNA was PCR amplified to create a *NotI* / *SalI* fragment. This fragment was then cloned into the pGAPZ $\alpha$ B vector that already contained the  $\omega$ -ACTX fragment (schematic figure 4.2; A, amino acid/nucleotide sequences appendix 8).

The second construct involved  $\omega$ -ACTX being fused to the C-terminus of GNA and the addition of a polyhistidine tag to the N-terminus of GNA (i.e. (his)<sub>6</sub>–GNA– $\omega$ -ACTX). To generate this construct  $\omega$ -ACTX was PCR amplified to form a *NotI* / *SalI* fragment with a stop codon after the *SalI* restriction site. This fragment was subsequently cloned into pGAPZ $\alpha$ B that already contained GNA and a N-terminal (his)<sub>6</sub> tag (schematics; figure 4.2; D, amino acid/nucleotide sequences appendix 9).

##### 4.1.2 Mutation of toxin sequence to remove a signal cleavage site

Sequence analysis of the toxin resulted in a potential proteolytic cleavage site identified at amino acid residues Lys<sup>34</sup> and Arg<sup>35</sup>. The presence of paired basic amino acids are common signals for cleavage by proprotein processing proteases such as Kex2 (Fuller *et al.*, 1989) which is responsible for processing of the yeast alpha factor. This could therefore explain the proteolysis seen with the original  $\omega$ -ACTX-GNA fusion protein. As Arg<sup>35</sup> was shown to be critical for insecticidal action while Lys<sup>34</sup> probably had a role in stability of the  $\beta$ -hairpin rather than the functionality of the toxin (Tedford *et al.*, 2001), nucleotide mutagenesis was employed to change the lysine residue for a glutamine residue. Glutamine was chosen due to its similarity on the hydrophobicity index (Gln -3.5, Lys -3.9) with the hope that the change would cause little effect on protein folding and therefore toxicity.

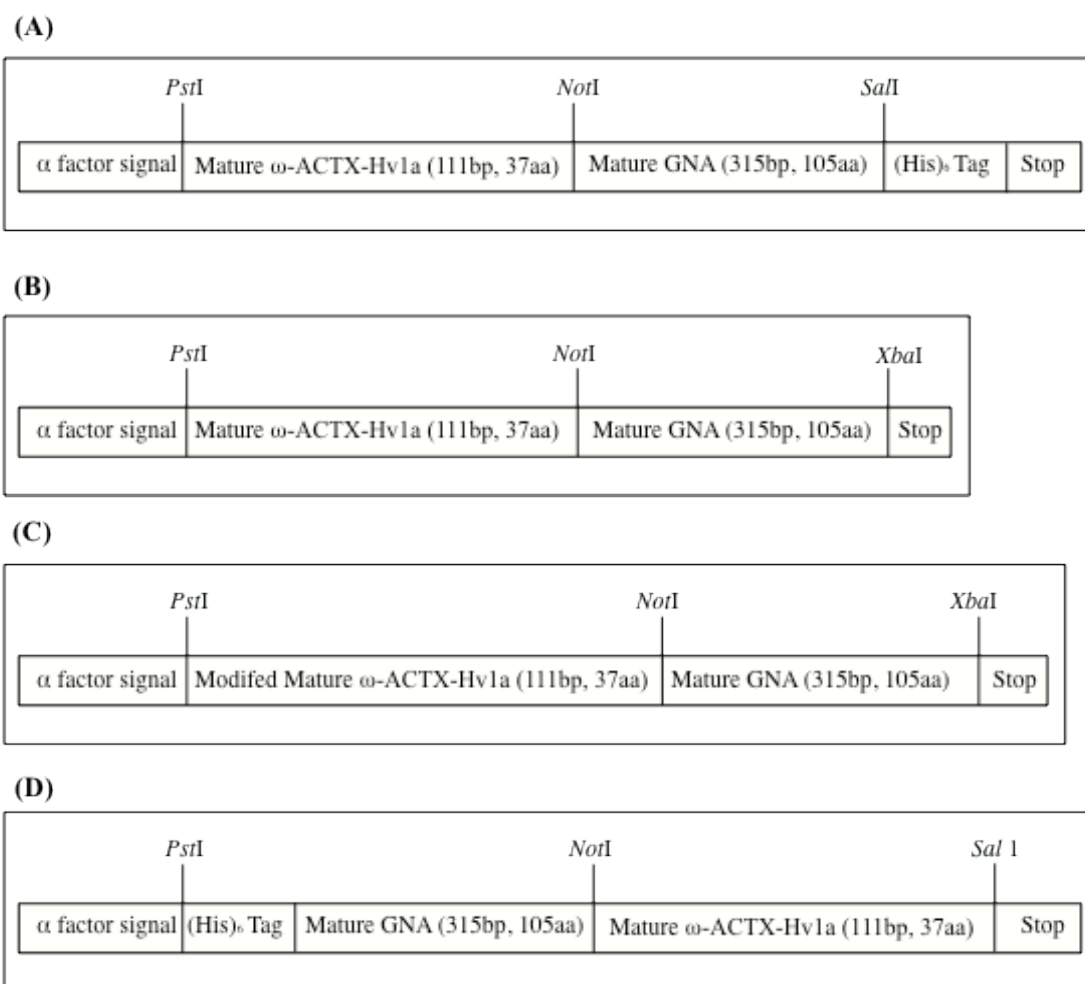
A reverse primer with the single base change (A to C) which altered the codon from AAA (encoding Lys; K) to CAA (encoding Gln; Q) was designed and used to amplify the  $\omega$ -ACTX fragment in order to create the modification. This fragment was then

cloned into the expression vector pGAPZ $\alpha$ B containing already containing GNA by restriction/ligation. Positive colonies were sequenced to determine the base and codon change had occurred successfully. (Schematic; figure 4.2; C, amino acid/nucleotide sequence appendix 10.)

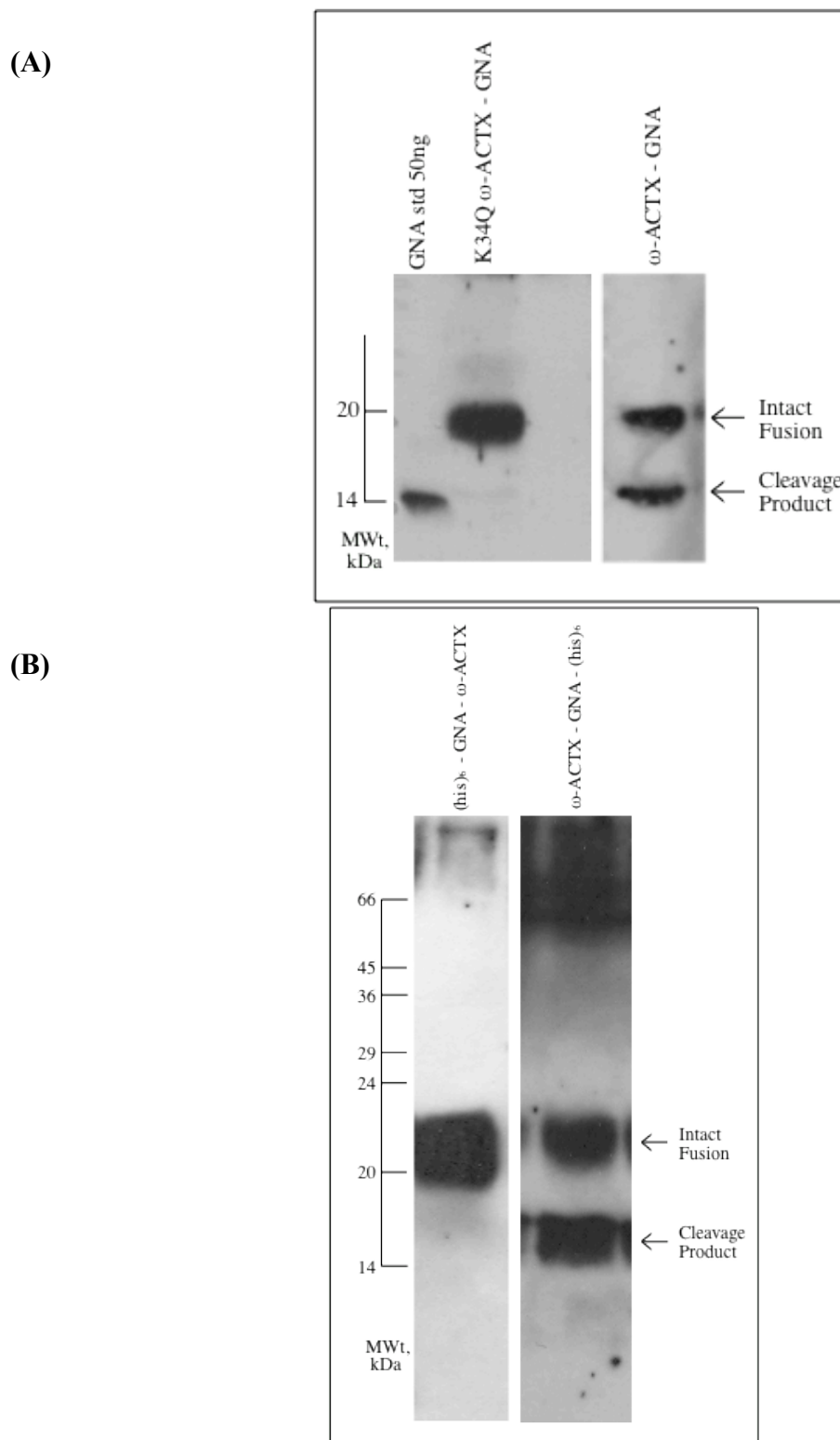
#### **4.2 Comparison of protein expression during small-scale screening in rich media**

After transformation into *P. pastoris*, 10ml YPG cultures were grown up from positive colonies. Culture supernatant was analyzed by SDS-PAGE gel electrophoresis and western blotting (probed with anti-GNA antibodies) to establish level of expression and therefore which colony would be used to carry out scale-up to bench top fermentation. Figure 4.3 (A) shows the highest expressing colony of  $\omega$ -ACTX-GNA compared with the K34Q  $\omega$ -ACTX-GNA construct. It also shows the original construct with an additional C-terminal polyhistidine tag ( $\omega$ -ACTX-GNA-(his)<sub>6</sub>) compared with  $\omega$ -ACTX on the C-terminus of GNA along with a N-terminal polyhistidine tag ((his)<sub>6</sub>-GNA- $\omega$ -ACTX) (figure 4.3; B).

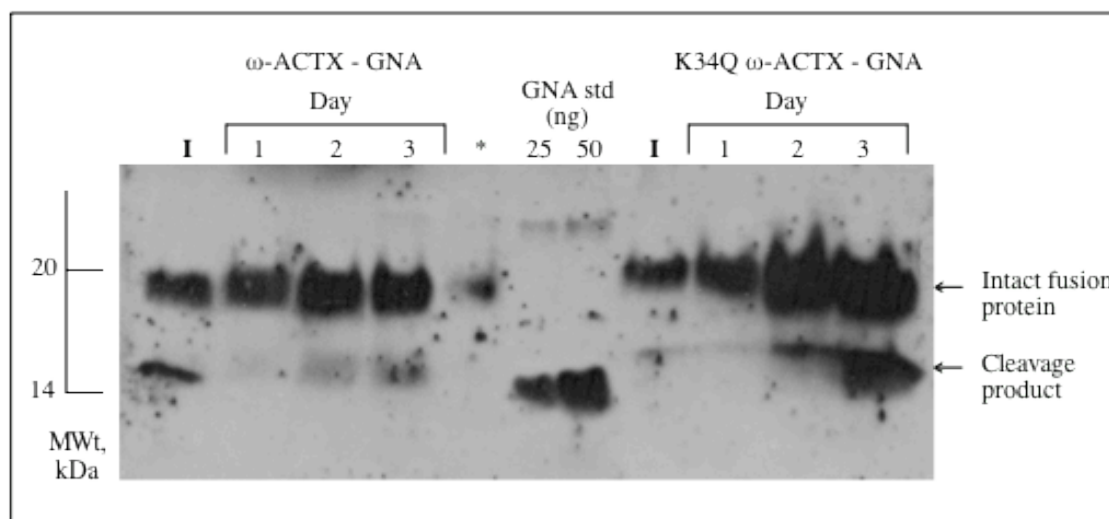
Upon comparison with the original highest  $\omega$ -ACTX-GNA expressing *P. pastoris* colony (figure 4.3; A), the modification shows a marked improvement in cleavage in rich media (YPG). K34Q  $\omega$ -ACTX-GNA after 3 days growth shows nearly all protein expressed was intact fusion whereas  $\omega$ -ACTX-GNA shows nearly half is cleaved to GNA. The addition of a C-terminal polyhistidine tag does not reduce cleavage of the fusion protein. Fusing  $\omega$ -ACTX to the C-terminus of GNA does however. Figure 4.3; B shows the (his)<sub>6</sub>-GNA- $\omega$ -ACTX construct expressed in *P. pastoris* gives a band that is intact.



**Figure 4.2**  
**Schematic representations of  $\omega$ -ACTX and GNA based fusion protein construct designs in pGAPZ $\alpha$ B.** (A)  $\omega$ -ACTX-GNA-(his)<sub>6</sub>, (B) Original  $\omega$ -ACTX-GNA construct (C) K34Q $\omega$ -ACTX-GNA construct, (D) (his)<sub>6</sub>-GNA- $\omega$ -ACTX. Nucleotide and amino acid sequences are shown in appendices 8-10.



**Figure 4.3**  
**Western blots (probed with anti-GNA antibody): Comparison of fusion protein expression during small-scale expression in rich media (YPG). (A)**  $\omega$ -ACTX-GNA compared to K34Q $\omega$  -ACTX-GNA. **(B)** (His)<sub>6</sub>-GNA- $\omega$ -ACTX compared to  $\omega$ -ACTX-GNA-(his)<sub>6</sub>. 25 $\mu$ l culture supernatant loaded onto 17.5% SDS-PAGE gel in each case.



**Figure 4.4**

**Western blots (probed with anti-GNA ab): Stability of  $\omega$ -ACTX-GNA compared to K34Q  $\omega$ -ACTX-GNA fusion protein through bench-top fermentation of *P. pastoris* using basal salt media. I: Inoculation sample (grown in YPG). *P. pastoris* expressing  $\omega$ -ACTX-GNA and K34Q  $\omega$ -ACTX-GNA fusion were grown in basal salt media for 3 days. Samples of culture were taken 1, 2 and 3 days after inoculation. Recombinant GNA (25, 50ng) used as a positive control. Lane designated \*: spillover from  $\omega$ -ACTX-GNA day 3 sample lane. (Gel courtesy of Dr. Fiches.)**

### **4.3 Comparison of stability during bench-top fermentation of expression constructs**

Three 100ml YPG cultures of *P. pastoris* expressing fusion protein were used to inoculate 3litres of basal salt media within the 7.5litre fermentation system. At the point of inoculation there is significant cleavage of the  $\omega$ -ACTX–GNA fusion which is seen in the small-scale expression screen. As the inoculum is diluted 10 fold, and more intact fusion protein is produced, the proteolytic degradation product seen in the inoculation sample (grown in YPG) is much less apparent on the western blot. The protein does not undergo significant degradation during the fermentation process (figure 4.4; courtesy of Dr. Fitches, FERA (York)). The band showing the cleavage product of similar molecular weight to GNA does increase slightly in intensity but by the third day of fermentation the cleaved product is approximately 10% of the total intact fusion protein. The level of expression is seen at approximately  $2.4\text{ng } \mu\text{l}^{-1}$ .

K34Q $\omega$ -ACTX–GNA expressed protein showed increased stability in rich media as the expression in inoculation media shows only very slight cleavage. This level of proteolysis is also found 1 day after inoculation. By 3 days post inoculation expression levels are approximately  $4\text{ng } \mu\text{l}^{-1}$  with 50ng showing as cleavage product. This shows although K34Q  $\omega$ -ACTX–GNA is more stable when fermentation occurred in rich media,  $\omega$ -ACTX–GNA appears to be much more stable during the fermentation process in basal salt media. Addition of a N-terminal polyhistidine tag showed a similar pattern of degradation as  $\omega$ -ACTX–GNA while (his)<sub>6</sub>-GNA- $\omega$ -ACTX however appeared to be stable through fermentation (data not shown; fermentation of  $\omega$ -ACTX–GNA and (his)<sub>6</sub>-GNA- $\omega$ -ACTX carried out in collaboration with Dr. Fitches, FERA, (York))

### **4.4 Comparison of stability of expression constructs during purification and post purification processes**

#### **4.4.1 $\omega$ -ACTX–GNA vs. K34Q $\omega$ -ACTX–GNA**

Purification of recombinant  $\omega$ -ACTX–GNA and K34Q $\omega$ -ACTX–GNA was carried out using hydrophobic-interaction chromatography. Crude supernatant was loaded

onto Phenyl-Sepharose columns at 2M NaCl and eluted using a decreasing salt gradient (2M-0M NaCl). The salt gradient was held during peaks in absorbance (measured at 280nm). Peaks in absorbance can result from non-protein components in the culture supernatant that absorb UV light at 280nm (Layne *et al.*, 1957; Stoscheck *et al.*, 1990). SDS-PAGE however allows for analysis of only protein in the fractions. Elution fractions were therefore analyzed for protein content by this technique. Peaks in absorbance (measured at 280nm) were seen at 2M, 0.6M and 0M NaCl when  $\omega$ -ACTX-GNA and K34Q $\omega$ -ACTX-GNA were eluted.

SDS-PAGE analysis revealed a small amount of the  $\omega$ -ACTX-GNA protein present in the wash fraction that is not present in the fractions of K34Q $\omega$ -ACTX-GNA suggesting the  $\omega$ -ACTX-GNA binds with slightly less affinity to the Phenyl-Sepharose matrix. The majority of intact  $\omega$ -ACTX-GNA fusion protein is eluted in fractions at 2M NaCl. The K34Q $\omega$ -ACTX-GNA fusion protein is eluted mainly in fractions at 0.6M NaCl.

The  $\omega$ -ACTX-GNA fusion protein in the early fractions (denoted pool 1) (figure 4.5; B, courtesy of Dr. Fitches) shows the pattern of cleavage seen both in small-scale expression in rich media (YPG) and also through fermentation in basal salt media. The amount of cleavage product does however increase in the later fractions and throughout further purification. This suggests that the original construct is being degraded by proteases present in the culture media and the amount of cleavage increases with time. The K34Q $\omega$ -ACTX-GNA fusion protein however remains more stable than the original construct showing an overall improved level of proteolytic cleavage through purification processes (figure 4.5; C).

Protein from the fractions eluted during water wash does show contaminating high molecular weight yeast proteins, particularly in the later fractions (denoted pool 3) of the K34Q $\omega$ -ACTX-GNA purification. These fractions would need a further gel filtration step in order to ‘clean-up’ the protein samples if they were to be used in further experiments.

Fractions that showed samples of protein, free of high molecular weight yeast proteins, were pooled separately based on the concentration of salt they were eluted at. Samples were then dialysed using 12 kDa molecular weight cut off (MWCO) tubing to remove salt and other small proteins, lyophilised by freeze drying and quantified by SDS-PAGE analysis. A standard BCA assay would show total protein in the samples and discount any bound yeast carbohydrate carried over from purification. However, if there were any carry over of high molecular weight yeast proteins or degradation products within the sample estimated of intact fusion proteins cannot be established by this method.

Lyophilized samples were therefore run on 17.5% SDS-PAGE gels, stained with coomassie brilliant blue (CBB) and quantified (based on total weight of lyophilized protein powder) against GNA previously shown to be >95% homogeneous GNA. K34Q $\omega$ -ACTX-GNA shows a higher level of intact fusion post purification compared to  $\omega$ -ACTX-GNA or  $\omega$ -ACTX-GNA-(his)<sub>6</sub> (figure 4.6).

#### 4.4.2 (His)<sub>6</sub>-GNA- $\omega$ -ACTX and $\omega$ -ACTX-GNA-(his)<sub>6</sub>

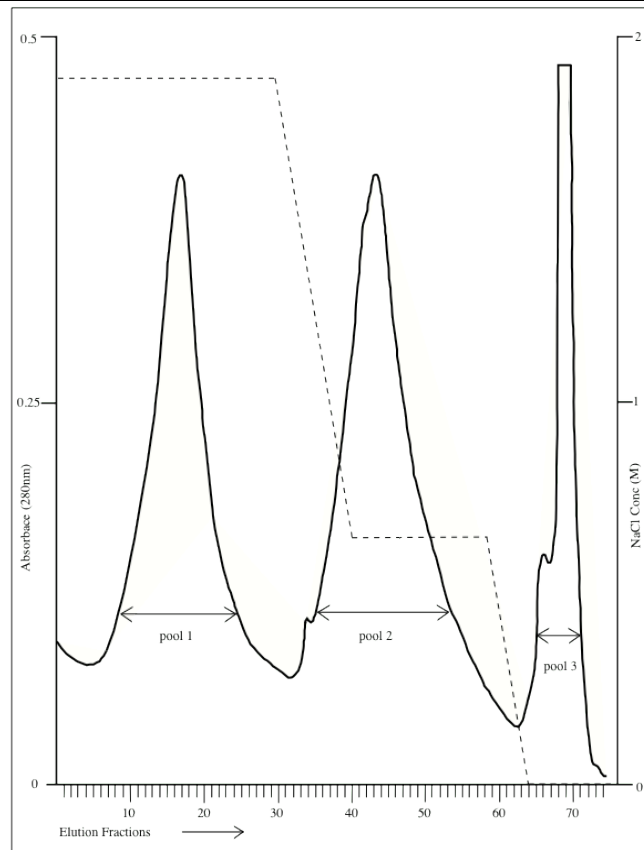
Addition of a N-terminal polyhistidine tag showed a similar pattern of degradation as  $\omega$ -ACTX-GNA through purification by immobilized metal (Ni<sup>2+</sup>) affinity chromatography (Data not shown; carried out in collaboration with Dr. Fitches, FERA (York)). (His)<sub>6</sub>-GNA- $\omega$ -ACTX appeared to show some degradation with the cleavage product presumed to be the fusion protein minus the N-terminal polyhistidine tag.

Quantitation of proteins after purification was carried out by SDS-PAGE gel analysis (figure 4.6; Courtesy of Dr. Fitches, FERA (York)).

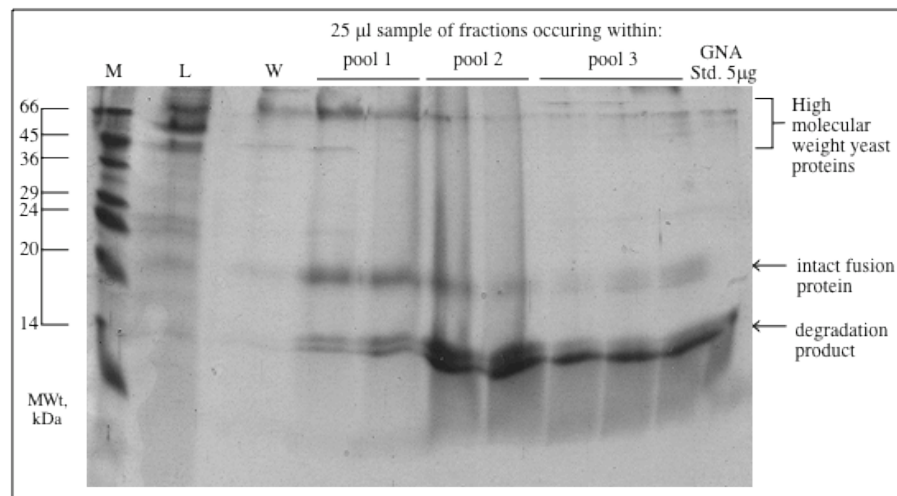
**Figure 4.5**

**Stability of  $\omega$ -ACTX-GNA compared to K34Q $\omega$ -ACTX-GNA fusion protein through purification.** Both fusion proteins were purified from *P. pastoris* by hydrophobic interaction chromatography. Filtered *P. pastoris* culture supernatant was equilibrated to 2M NaCl and loaded onto a Phenyl-Sepharose column overnight. Protein was eluted using a decreasing salt gradient (2M-0M NaCl). NaCl gradient was held while protein was eluted. **(A)** Typical purification trace. NaCl gradient shown as a dashed line, absorbance trace shown as a solid line. 25 $\mu$ l samples of 5ml fractions from the corresponding major peaks were analyzed on SDS-PAGE gels, L - Load, W - Wash; M = Molecular weight marker; **(B)**  $\omega$ -ACTX-GNA; **(C)** K34Q $\omega$ -ACTX-GNA. ( $\omega$ -ACTX-GNA purification gel courtesy of Dr. Fitches, FERA (York))

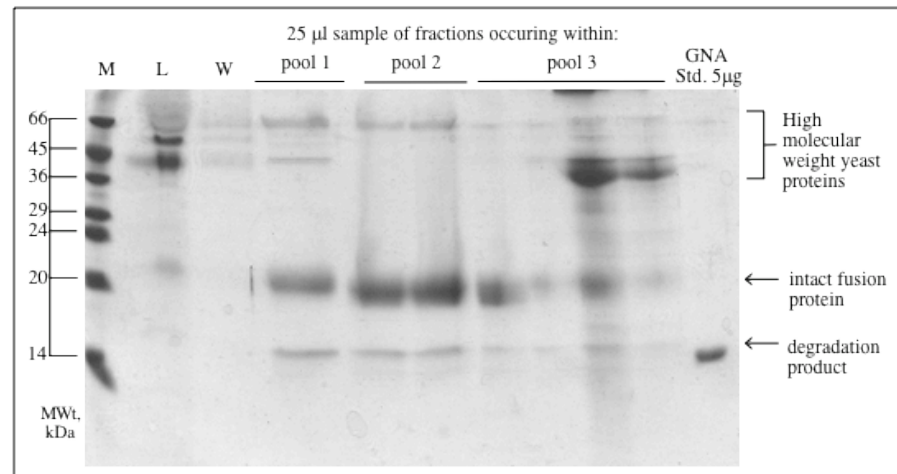
(A)

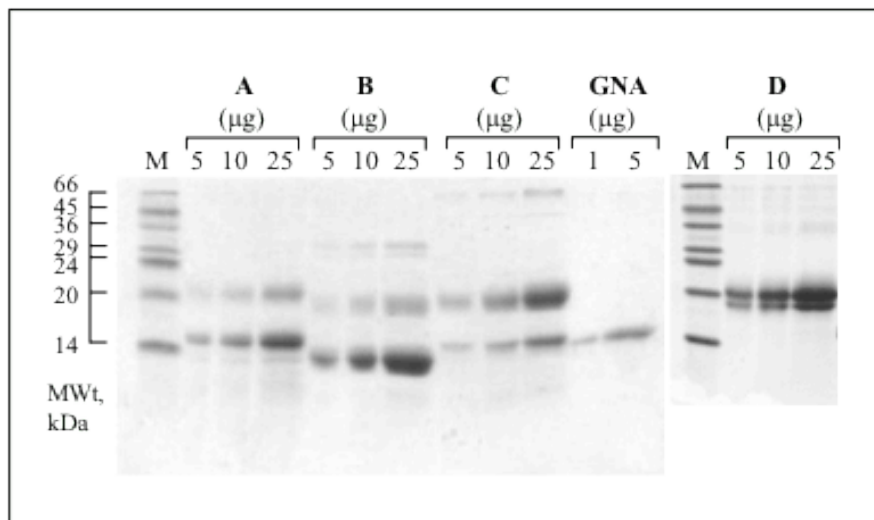


(B)



(C)





**Figure 4.6**  
**SDS-PAGE gels showing fusion proteins incorporating  $\omega$ -ACTX and GNA after purification steps.** (A)  $\omega$ -ACTX-GNA-(his)<sub>6</sub>, (B)  $\omega$ -ACTX-GNA (C) K34Q $\omega$ -ACTX-GNA, (D) (his)<sub>6</sub>-GNA- $\omega$ -ACTX. Proteins loaded on 17.5% SDS-PAGE gel, stained with CBB, at 5, 10, 25 $\mu$ g (based on total weight of lyophilized protein) and previously expressed recombinant GNA shown to be >95% homogeneous GNA at 1 and 5 $\mu$ g. M = molecular weight marker. (Gels courtesy of Dr. Fitches, FERA, (York))

#### **4.5 Demonstration of biological activity of fusion protein components**

GNA has been shown previously to remain active when peptides are fused to either terminus of the lectin, as was seen in the previous chapter when  $\kappa$ -ACTX was fused C- and N-terminally to GNA and retained agglutination activity comparable to other fusion proteins (figure 3.9). GNA in previous fusion proteins incorporating GNA and toxins, enzymes, insect hormones and fusion to purification tags has shown a reduced ability to agglutinate rabbit erythrocytes (by 2-4 fold) compared to native or recombinant free GNA however transport activity still remains (Fitches *et al.*, 2002, 2004a, 2004b, 2010; Trung *et al.*, 2006). It is therefore not likely that  $\omega$ -ACTX will affect GNA activity in the fusion proteins presented in this chapter.

##### **4.5.1 *Mamestra brassicae* injection bioassays to demonstrate biological activity of neurotoxin component**

Direct injection assays allow for the toxin to reach the active site of the insect central nervous system without the need for the lectin carrier. The standard assay of toxicity for  $\omega$ -ACTX is injection into lepidopteran larvae (Atkinson *et al.*, 1998; Arachnoserver, Wood *et al.*, 2009). Cultures of cabbage moth (*Mamestra brassicae*) were available and a method for injection has previously been established (Fitches *et al.*, 2002) therefore they were used for establishing functionality of the toxin component of the fusion proteins.

5-20 $\mu$ g of the  $\omega$ -ACTX, GNA based fusion proteins were injected into fifth instar *Mamestra brassicae* (approx. 30-70mg). Injections of comparable amounts, based on molar ratios, of recombinant  $\omega$ -ACTX toxin produced in *E. coli* (2.3-9.2 $\mu$ g) were also injected. This protein was obtained from Prof. Glenn King, University of Queensland (Tedford *et al.*, 2001). Data presented in figure 4.7 is shown as end point survival for clarity, however statistical analysis of survival is conducted by analysis of Kaplan-Meier survival curves.

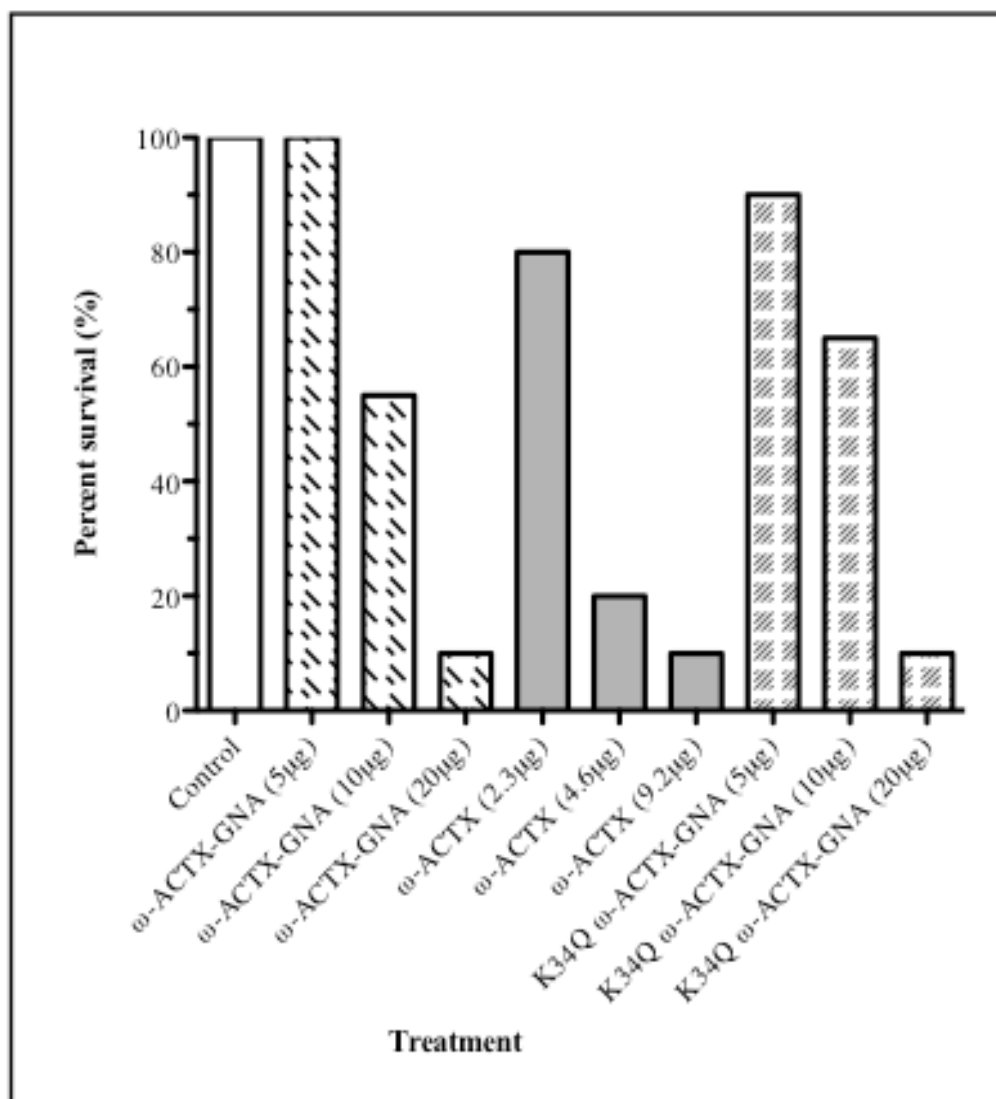
Larval mortality occurred across the assay period (4 days) although the majority of deaths occurred within 24 hours. At higher dose levels, survival of larvae injected

with either  $\omega$ -ACTX toxin (4.6 $\mu$ g and above) or fusion proteins  $\omega$ -ACTX-GNA, K34Q $\omega$ -ACTX-GNA (10 $\mu$ g and above) are significantly reduced when compared to control injected larvae (Kaplan–Meier survival curves; Mantel–Cox log-rank tests;  $P < 0.05$ ; data taken from 20 individuals).

Levels of mortality were comparable between fusion protein injected and toxin injected treatments. For instance, 90% mortality is observed for larvae injected with 20 $\mu$ g fusion protein (equivalent to 100  $\mu$ g toxin  $g^{-1}$  insect) compared to 80% mortality for larvae injected with 4.6  $\mu$ g toxin (equivalent to 92  $\mu$ g toxin  $g^{-1}$  insect) (figure 4.7; injection data for  $\omega$ -ACTX and  $\omega$ -ACTX-GNA courtesy of Dr. Fitches, FERA (York)). Addition of a C-terminal polyhistidine tag and fusion of the toxin to the N-terminal of GNA did not have any detrimental effects on toxicity; comparable mortality data was observed for constructs when compared to  $\omega$ -ACTX–GNA (data not shown; personal communication, Dr. Fitches, FERA (York)).

Comparing the survival curves over the assay period, there is no significant difference between K34Q $\omega$ -ACTX–GNA and  $\omega$ -ACTX–GNA injected larvae (Log-rank (Mantel-Cox) Test, data obtained from 20 individuals,  $P > 0.05$ ). The other protein variants produced also showed comparable levels of toxicity with  $\omega$ -ACTX-GNA and K34Q  $\omega$ -ACTX-GNA (data not shown; personal communication, Dr. Fitches, FERA (York))

Although not shown, GNA has previously been injected into larvae of a closely related lepidopteran pest the Tomato moth (*Lacanobia oleracea*) and found to show 95% survival 5 days after injection with a 20 $\mu$ g dose (Trung *et al.*, 2006).

**Figure 4.7**

The survival of 5<sup>th</sup> instar *Mamestra brassicae* larvae 4 days post injection with  $\omega$ -ACTX-GNA and K34Q $\omega$ -ACTX-GNA at doses of 5, 10 and 20 $\mu$ g. Comparable amounts of recombinant  $\omega$ -ACTX expressed in *E. coli* (obtained from Prof. Glenn King, University of Queensland), based on molar ratios, 2.3, 4.6 and 9.2 $\mu$ g were also included. Controls were injected with buffer (1x PBS) only. Data taken from 20 individuals. (Injection data for  $\omega$ -ACTX and  $\omega$ -ACTX-GNA courtesy of Dr. Fitches, FERA (York)).

#### **4.6 Oral toxicity of fusion proteins incorporating $\omega$ -ACTX and GNA against *T. castaneum***

Proteins were incorporated into wheat flour diet at between  $0.5 \text{ mg g}^{-1}$  –  $2 \text{ mg g}^{-1}$  with diet only was used for control treatments. *Tribolium* larvae were transferred to assay diets as neonates. Larval weights and survival were taken every 7 days after a period of 14 days (after which larvae were large enough to be weighed accurately). Diets were changed every 14 days for the length of the assay (the length of time for control larvae to start to pupate).

Attempts were made to express  $\omega$ -ACTX alone in *P. pastoris* in order due to limited yields obtained from *E. coli* expression (Tedford *et al.*, 2001). However this was unsuccessful so toxin alone controls were not included in the following assays. The bioassays presented here investigate the orally toxicity of GNA and  $\omega$ -ACTX based fusion protein variants against *T. castaneum*.

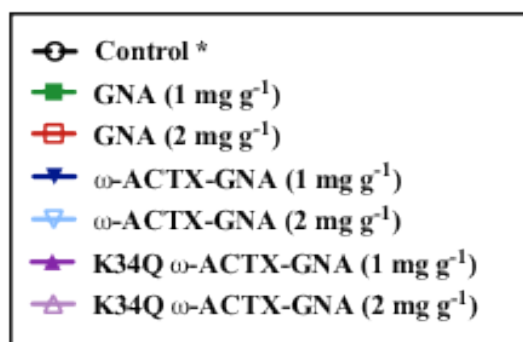
##### **4.6.1 $\omega$ -ACTX-GNA and K34Q $\omega$ -ACTX-GNA**

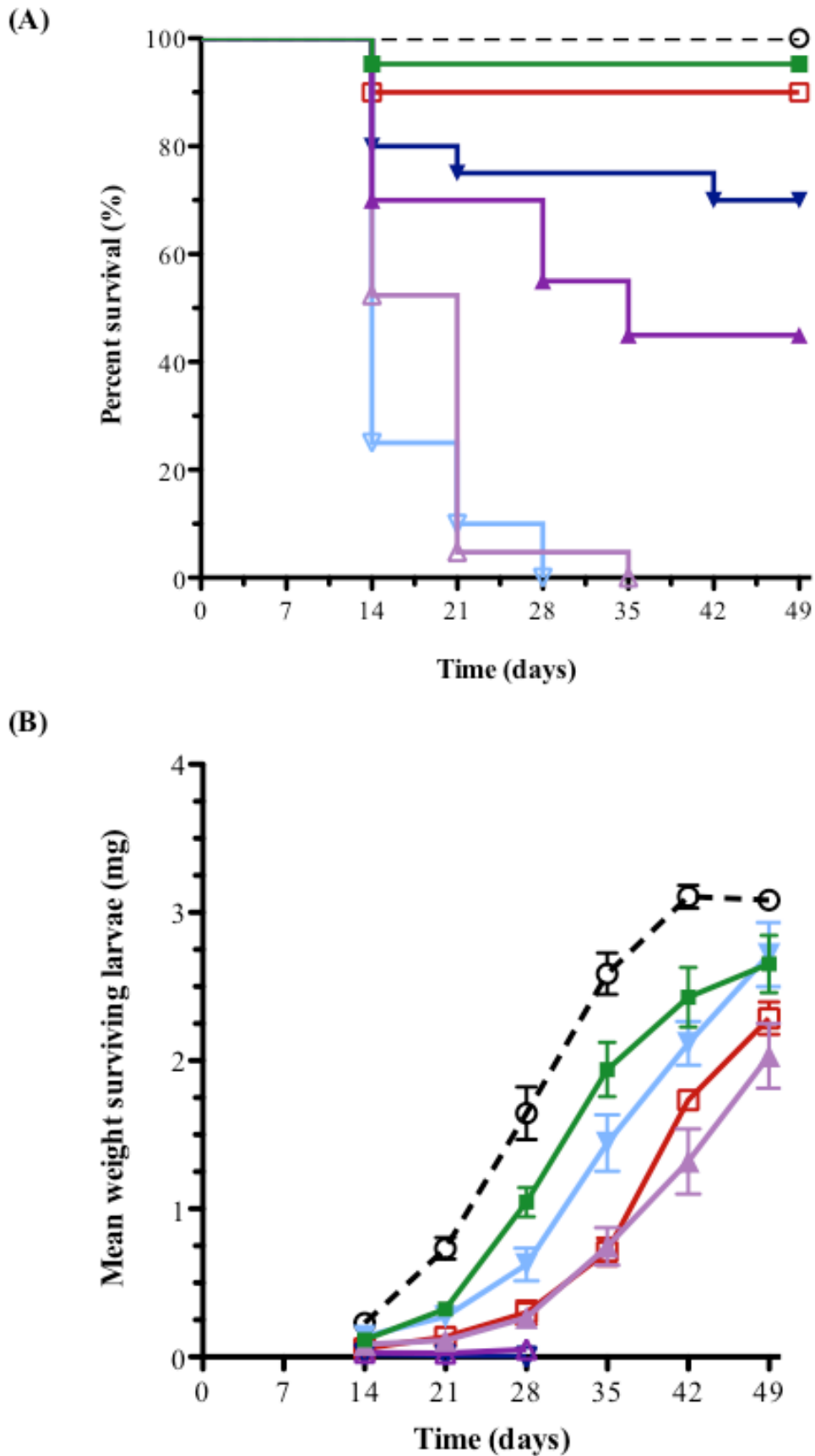
Control survival of 100% during the entire assay period was observed in these experiments. Insects fed GNA at both  $1 \text{ mg g}^{-1}$  and  $2 \text{ mg g}^{-1}$  showed no significant difference from control survival when curves were analyzed ( $P = 0.3291$ ,  $P = 0.0753$  respectively, 95% C.I, Log – rank (Mantel-Cox) test, data taken from 20 individuals). GNA at both doses is significantly less toxic than both K34Q  $\omega$ -ACTX–GNA and  $\omega$ -ACTX–GNA ( $P < 0.05$ ) (figure 4.8; A).

K34Q  $\omega$ -ACTX–GNA and  $\omega$ -ACTX–GNA both show a dose response, in that increasing the dose leads to a reduction in survival. At both doses, survival for both fusion proteins is significantly reduced compared to controls ( $P < 0.05$ ). At  $1 \text{ mg g}^{-1}$   $\omega$ -ACTX –GNA reduces survival to 70% and shows complete mortality after 28 days at  $2 \text{ mg g}^{-1}$ . K34Q  $\omega$ -ACTX–GNA shows reduction in survival to 45% at  $1 \text{ mg g}^{-1}$  and complete mortality (after 35 days) at  $2 \text{ mg g}^{-1}$ . The survival curves of the two variants at both doses are shown to be not significant ( $P > 0.05$ ) (figure 4.8; B).

GNA at 2mg g<sup>-1</sup> decreased the mean weight of larvae compared to controls, showing significant differences over the assay period (49 days). Insects fed fusion protein variants at 2mg g<sup>-1</sup> showed complete mortality, but the weight data collected over days 14-28 showed no significant difference from each other or from GNA. At 1 mg g<sup>-1</sup> K34Q $\omega$ -ACTX-GNA caused significant difference in weights compared to controls, while  $\omega$ -ACTX-GNA showed difference up to day 42 (Tukey-Kramer tests,  $P < 0.05$ ). When compared to GNA weight data at 1 mg g<sup>-1</sup> both K34Q $\omega$ -ACTX-GNA and  $\omega$ -ACTX-GNA shows no significant difference in mean weight of surviving larvae (Tukey-Kramer tests,  $P > 0.05$ ).

**Figure 4.8**  
**Survival rate and mean weight of surviving *T. castaneum* larvae fed recombinant  $\omega$ -ACTX-GNA and K34Q  $\omega$ -ACTX-GNA at 1 mg g<sup>-1</sup> and 2 mg g<sup>-1</sup>.** (A) Kaplan–Meier survival curves. (B) Mean weight of surviving larvae (mg). Error bars denote  $\pm$  standard error of the mean (SEM). Diet only fed larvae are used as controls. Data is taken from 20 individuals total, control\* = 55 individuals. Treatments are depicted in figure as follows:





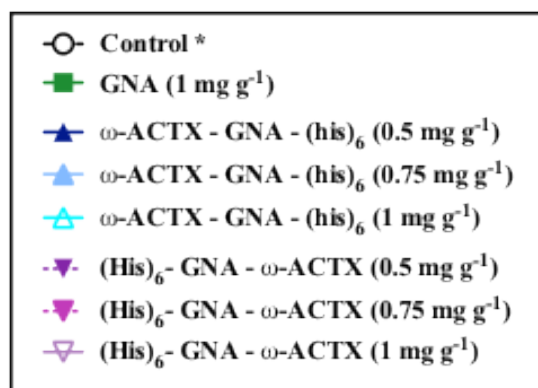
#### 4.6.2 $\omega$ -ACTX-GNA-(his)<sub>6</sub> and (his)<sub>6</sub>-GNA- $\omega$ -ACTX

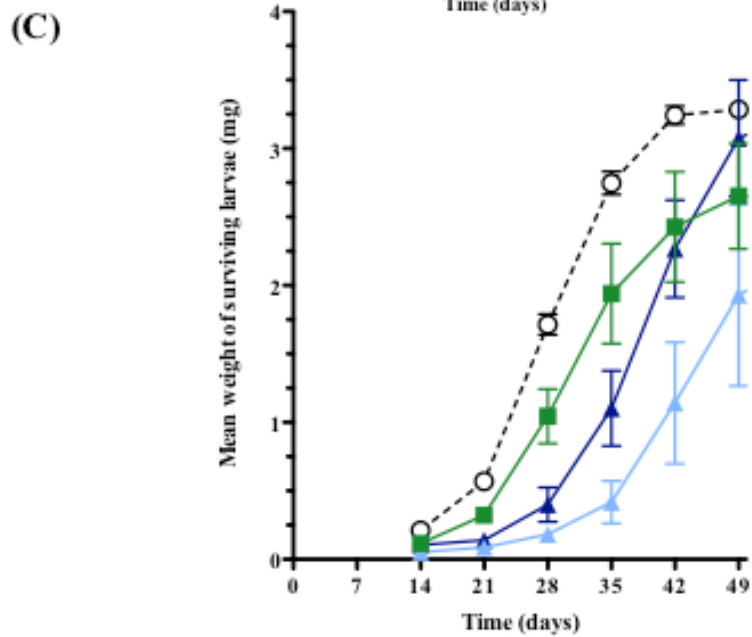
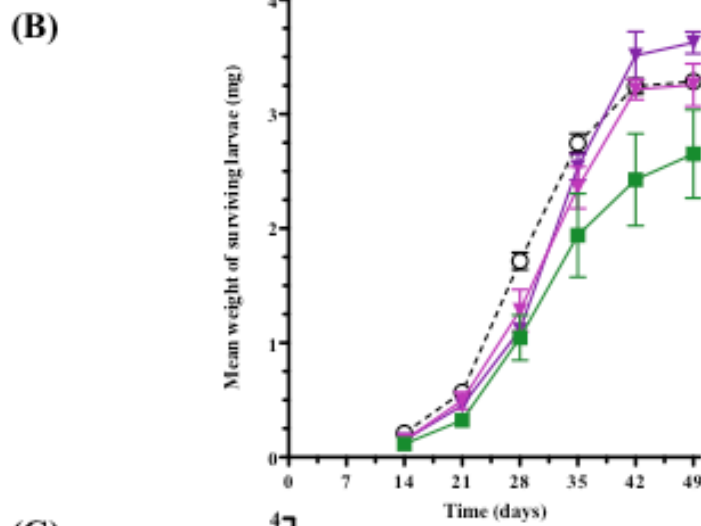
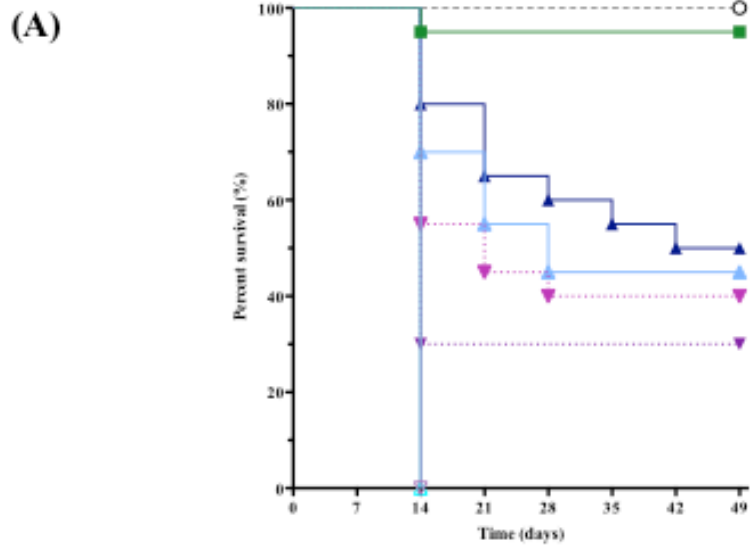
Proteins were fed at 0.5, 0.75 and 1 mg g<sup>-1</sup>.  $\omega$ -ACTX-GNA-(his)<sub>6</sub> showed a simple dose response in that at the lowest dose (0.5 mg g<sup>-1</sup>) the fusion protein reduced survival to 50%, at intermediate dose (0.75 mg g<sup>-1</sup>) survival was 45%, and at the highest dose (1mg g<sup>-1</sup>) complete mortality was observed. (his)<sub>6</sub>-GNA- $\omega$ -ACTX also showed dependence of survival on dose, but not in a simple manner; at 0.5mg g<sup>-1</sup> it reduced survival to 30%, but at 0.75mg g<sup>-1</sup> it only reduced survival to 40%. At 1 mg g<sup>-1</sup> however, the protein caused complete mortality (figure 4.9; A).

At all doses of both variants survival rates are significantly different to control survival (100%) (95% C.I, Log – rank (Mantel-Cox) test,  $P < 0.05$ , data taken from 20 individuals). GNA at a comparable dose to both the fusion protein variants had a negligible effect on survival (95% over the course of the assay vs. 100% for control). The order of components in the fusion protein had no effect on survival of insects; there is no significant difference between fusion protein variants at any dose ( $P > 0.05$ ).

Larvae fed (his)<sub>6</sub>-GNA- $\omega$ -ACTX at both 0.5 and 0.75 mg g<sup>-1</sup> show no significant difference in weights across the assay when compared to control data (Tukey-Kramer,  $P > 0.05$ ). In contrast,  $\omega$ -ACTX-GNA-(his)<sub>6</sub> fed at 0.75 mg g<sup>-1</sup> shows a significant decrease in mean weight of surviving larvae when compared to control. At 0.5 mg g<sup>-1</sup>, significance is seen when compared to control weights until the end of the assay (day 49). Between the variants at both doses there is significant difference in weight of surviving larvae (figure 4.9; B), with  $\omega$ -ACTX-GNA-(his)<sub>6</sub> causing significantly greater weight decrease than (his)<sub>6</sub>-GNA- $\omega$ -ACTX. Comparing to GNA at 1 mg ml<sup>-1</sup>, the weight decrease caused by  $\omega$ -ACTX-GNA-(his)<sub>6</sub> is significantly greater, whereas (his)<sub>6</sub>-GNA- $\omega$ -ACTX causes no significant weight decrease.

**Figure 4.9**  
Survival and mean weight of surviving *Tribolium castaneum* larvae fed recombinant GNA at  $1 \text{ mg g}^{-1}$ ,  $\omega$ -ACTX-GNA-(his)<sub>6</sub> and (his)<sub>6</sub>-GNA- $\omega$ -ACTX at 0.5, 0.75 and  $1 \text{ mg g}^{-1}$ . (A) Kaplan–Meier survival curves. Mean weight of surviving larvae (mg) fed (B)  $\omega$ -ACTX-GNA-(his)<sub>6</sub> ; (C) (his)<sub>6</sub>-GNA- $\omega$ -ACTX. Error bars denote  $\pm$  standard error of the mean (SEM). Diet only fed larvae are used as controls. Data is taken from 20 individuals total, control\* = 75 individuals. Treatments are depicted in figure as follows:





#### 4.6.3 (His)<sub>6</sub>-GNA-K34Q $\omega$ -ACTX

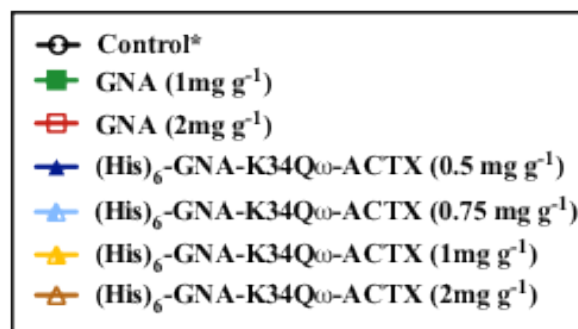
(His)<sub>6</sub>-GNA-K34Q $\omega$ -ACTX was expressed in *P. pastoris* and purified by Dr Prashant Pyati to investigate the toxicity of the modified toxin fused to the C-terminus of GNA. Injection assays showed comparable toxicity to other variants presented in this chapter (data not shown).

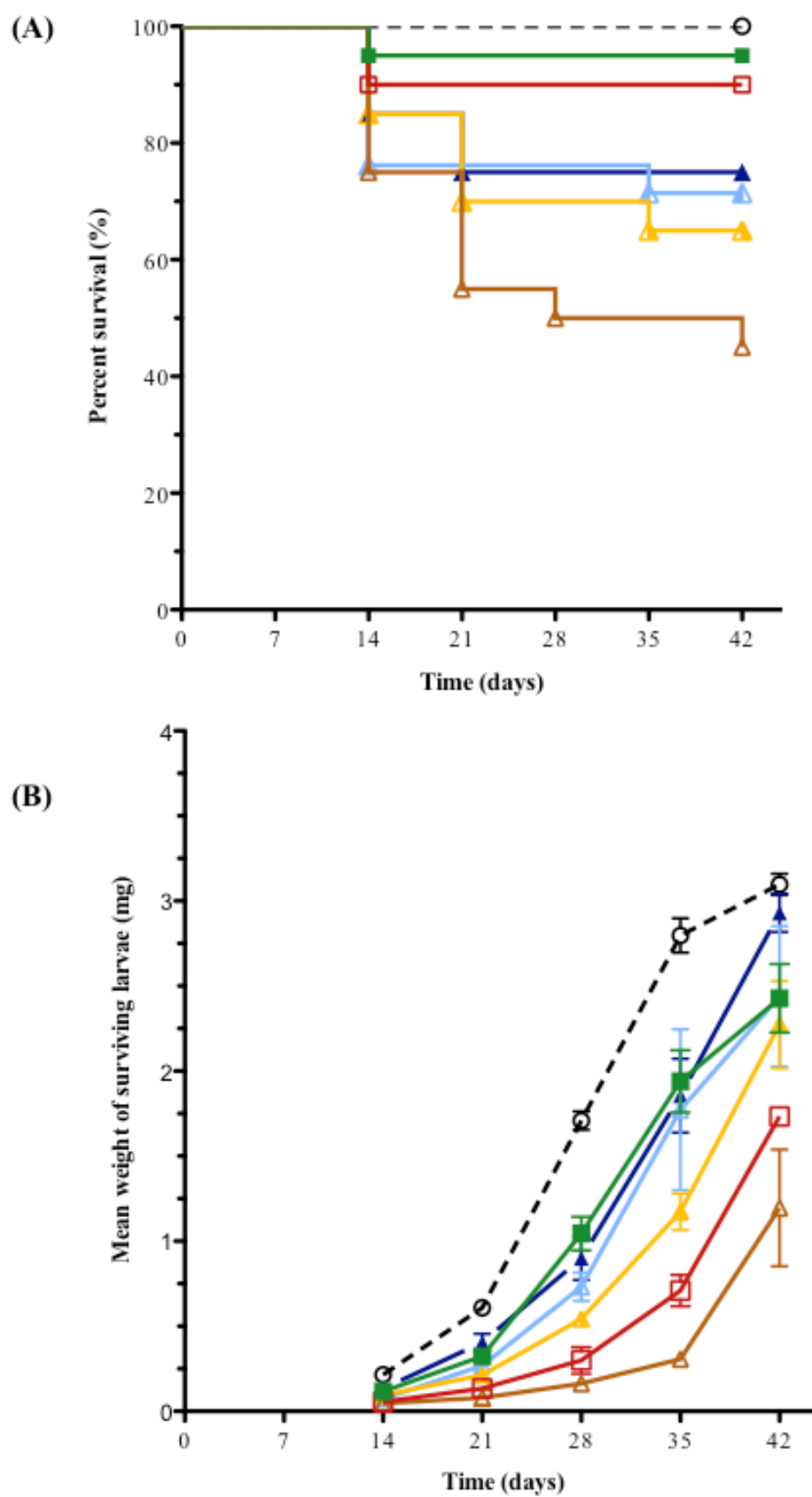
Protein was subsequently fed to *Tribolium* at 0.5, 0.75, 1 and 2 mg g<sup>-1</sup>. The rates of survival showed a dose response with the highest dose (2 mg g<sup>-1</sup>) showing the highest reduction in survival (to 45%) and the lowest dose showed the lowest reduction in survival (to 75%). At all doses the recombinant protein shows significantly reduced survival (Mantel-Cox,  $P < 0.5$ , data taken from 20 individuals). When GNA survival is analyzed against the corresponding dose (1 and 2 mg g<sup>-1</sup>) of recombinant protein, survival curves show significant difference (Mantel-Cox,  $P < 0.5$ , data taken from 20 individuals) (figure 4.10; A).

At 2mg g<sup>-1</sup>, (his)<sub>6</sub>-GNA-K34Q  $\omega$ -ACTX shows significant difference in mean weight of surviving larvae compared to control data. Across the rest of the doses, all show significant difference compared to survival weights apart from at the end of the assay. Across the assay (42 days), at comparable doses GNA and (his)<sub>6</sub>-GNA- $\omega$ -ACTX are not significantly different in mean larval weight (figure 4.10; B).

**Figure 4.10**

Survival and mean weight of surviving *Tribolium castaneum* larvae fed recombinant GNA at 1, 2 mg g<sup>-1</sup> and (his)<sub>6</sub>-GNA-k34Q $\omega$ -ACTX at 0.5, 0.75, 1 and 2 mg g<sup>-1</sup>. (A) Kaplan–Meier survival curves. (B) Mean weight of surviving larvae (mg). Error bars denote  $\pm$  standard error of the mean (SEM). Diet only fed larvae are used as controls. Data is taken from 20 individuals total, control\* = 75 individuals. Treatments are depicted in figure as follows:





#### **4.7 Expression of $\omega$ -ACTX and fusion proteins incorporating $\omega$ -ACTX and GNA in *Arabidopsis thaliana***

As  $\omega$ -ACTX has been described as one of the most potent insect specific neurotoxins (Bloomquist, 2003). Khan *et al.* (2006) expressed  $\omega$ -ACTX successfully in tobacco and when fed to lepidopteran larvae *H. armigera* and *S. littoralis*, the toxin caused 100% mortality. Therefore expression and delivery of fusion proteins incorporating this toxin in transgenic plants has been investigated within this study.

##### 4.7.1 Design of expression constructs

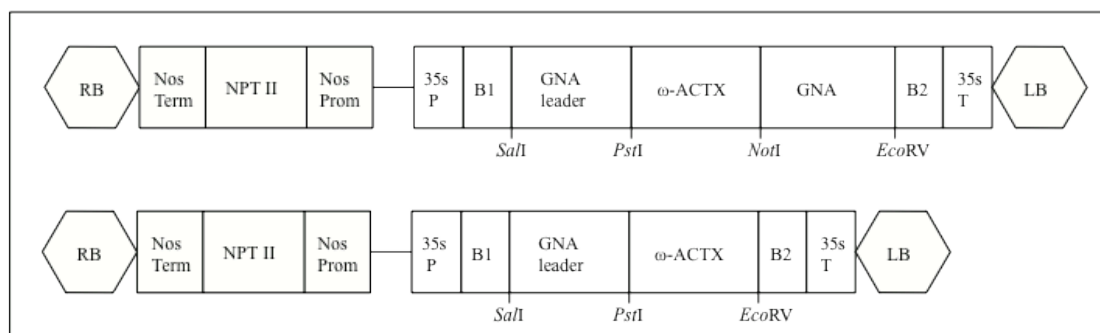
The Gateway vector system was again used to clone the constructs containing the  $\omega$ -ACTX toxin into the destination vector. For these constructs pK2GW7 was chosen as the destination vector directing expression in the sense direction. Like the vector used for the previous constructs it has kanamycin for positive selection in plants and a CAM35S promoter to allow for strong constitutive expression.

GNA is normally a secreted protein, whose coding sequence contains a signal peptide, and previous work has shown that whereas expression of GNA with its native signal peptide results in accumulation to expected levels in transgenic plants, attempts to express GNA without a signal peptide result in low or no detectable accumulation of protein (unpublished results). The GNA leader sequence was therefore included in all constructs. Codons were again not optimised as the yeast-optimised codons present in previous expression systems were deemed close enough to *Arabidopsis* codon preference.

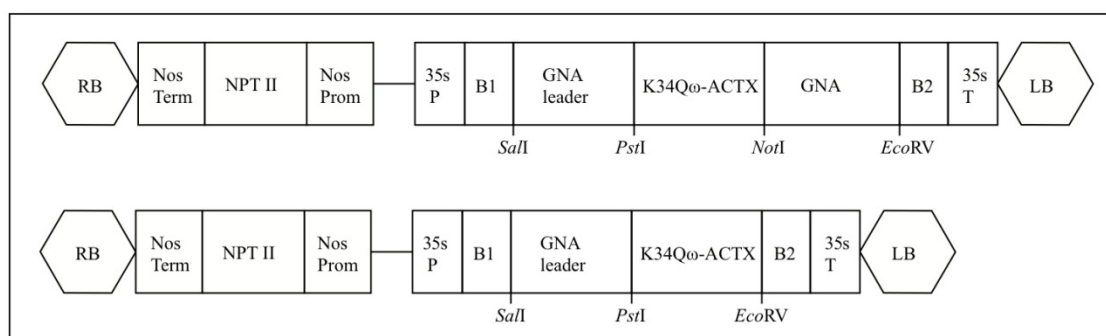
K34Q $\omega$ -ACTX-GNA and  $\omega$ -ACTX-GNA constructs together with K34Q $\omega$ -ACTX and  $\omega$ -ACTX expressed as controls were assembled first into pGAPZ $\alpha$ B using the GNA leader-ButaIT-GNA expression construct previously made as a cloning vector. Once sequencing confirmed correct insertions, constructs were PCR amplified to contain *SalI* and *EcoRV* restriction sites. PCR fragments were cloned into the entry vector pENTR1A by restriction/ligation. Entry vectors showing correct working expression constructs by DNA sequencing were used in the LR reaction using pK2GW7 as the destination vector. Colony PCR was used to confirm insertion and

creation of the expression vector. Schematic representations of the working expression vectors can be seen in figure 4.11 (determined nucleotide and presumed amino acid sequences; appendices 11-14).

(A)



(B)



**Figure 4.11**

**Schematic representations of  $\omega$ -ACTX-Hv1a and GNA based expression constructs in pK2GW7 for transformation into *Arabidopsis thaliana*.** (A) Representation of the T-DNA region of the expression vector pK2GW7 containing the GNA leader-K34Q $\omega$ -ACTX and GNA leader-K34Q $\omega$ -ACTX-GNA constructs. (B) Representation of the T-DNA region of the expression vector pK2GW7 containing the GNA leader- $\omega$ -ACTX and GNA leader- $\omega$ -ACTX-GNA constructs. LB, RB = left and right borders of T-DNA; Nos Prom., NPTII, Nos Term. = construct for expressing neomycin phosphotransferase, giving resistance to kanamycin (selectable marker); 35S = Cauliflower mosaic virus (CaMV) 35S RNA promoter; 35S Term. = 35S gene terminator; B1, B2 = enhancer sequences from CaMV 35S promoter. Determined nucleotide and presumed amino acid sequences; appendices 11-14.

#### 4.7.2 Transformation and selection of primary transformants

Expression constructs were directly transformed into *Agrobacterium tumefaciens* (strain C58C1), and antibiotic resistance was used to select transformed colonies. Selected clones were used for plant transformation and grown in suspension culture to prepare infiltration medium. Wild type (Col-1) *Arabidopsis thaliana* were transformed by the floral dipping method described by Cough and Bent (1998); modified from Bechold *et al.* (1993). Seeds were hand harvested from the plants dipped in the infiltration medium. They were then surface sterilised and grown on 0.5 X MS10 media plates supplemented with 40  $\mu\text{g } \mu\text{l}^{-1}$  kanamycin for selection. Plants that were dark green in colour with long roots were assumed to be positive transformants. These plantlets were subsequently transferred onto soil, isolated and allowed to grow normally in the growth facility

#### 4.7.2.(i) Determination of transgene expression

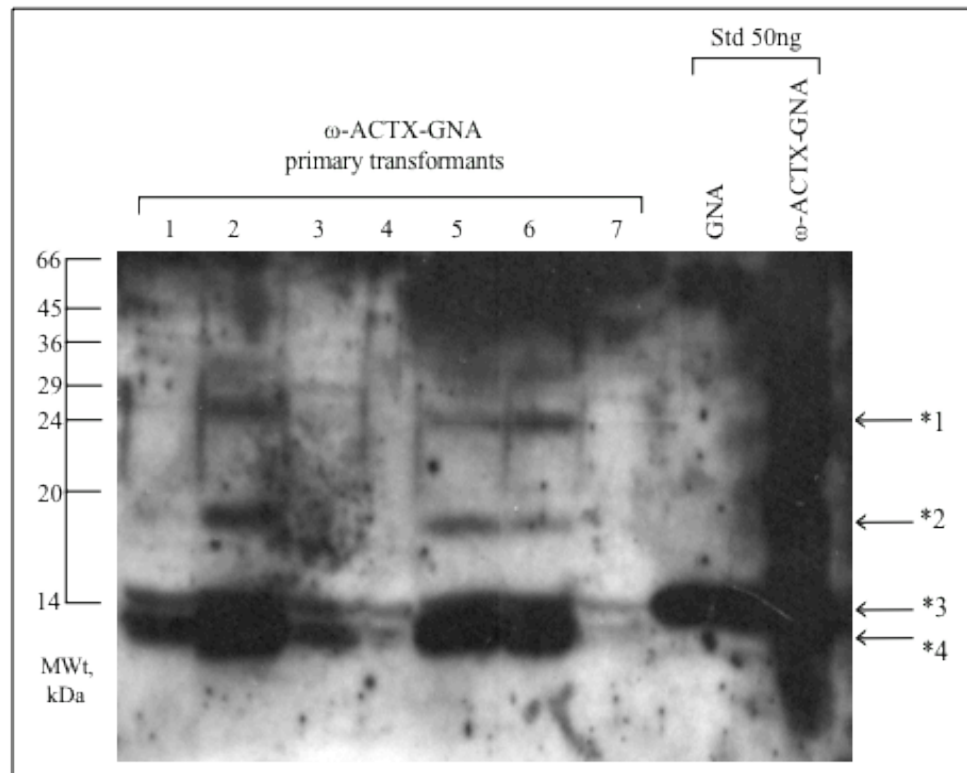
##### 4.7.2.(i)A RT-PCR for detection of positive K34Q $\omega$ -ACTX and $\omega$ -ACTX expressing *Arabidopsis*

Reverse transcription PCR was employed to show expression of the neurotoxin control constructs in transformed *Arabidopsis* plants. This is due to inefficient antibodies for detection by western blot analysis.

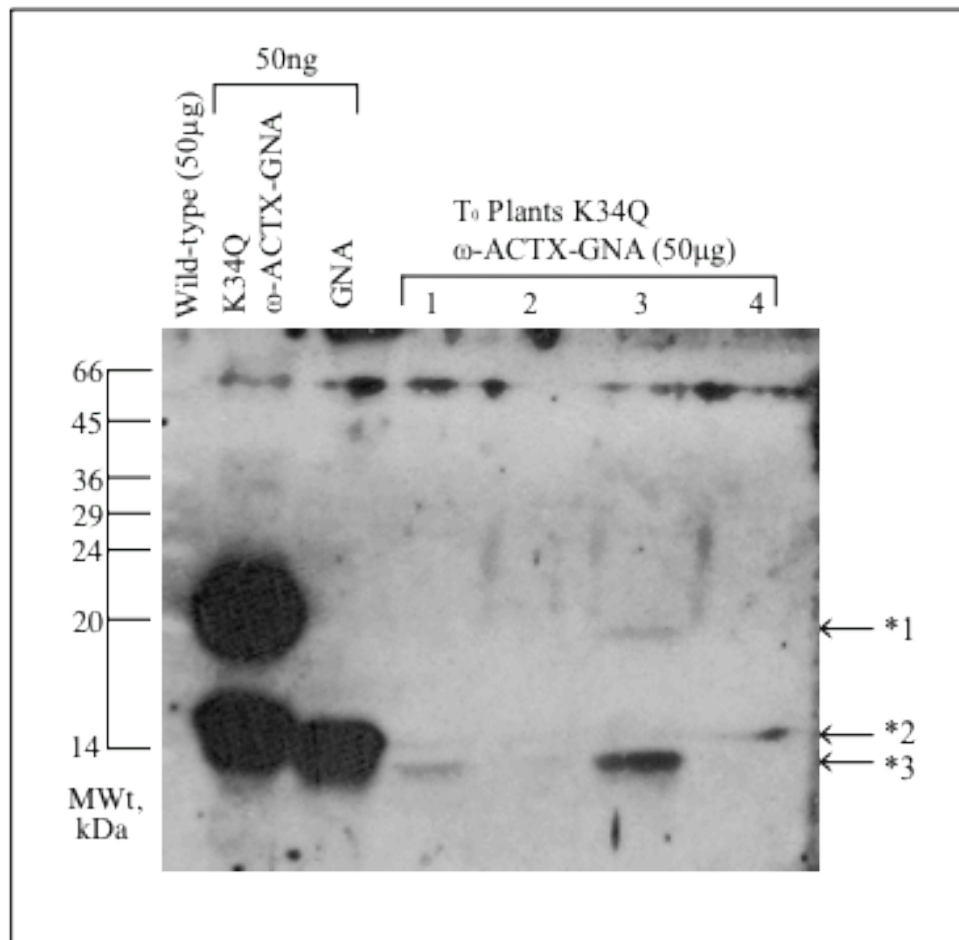
Total RNA was isolated from leaf tissues of plants that were shown to be positively transformed by kanamycin selection. RNA was quantified by nanodrop spectrophotometry and first strand cDNA was transcribed using MMLV-reverse transcriptase as described previously. 1 $\mu\text{l}$  of cDNA was used in a standard 50 $\mu\text{l}$  taq PCR reaction using gene specific primer pairs. Untransformed wild-type *Arabidopsis* plants were used as a negative control and the relevant construct in the destination vector was used as a positive control.  $\beta$ -Actin 2 was used as an internal control to check the quality of cDNA. Despite  $\beta$ -Actin 2 successfully amplified in most cDNA samples, expression of both GNA leader- $\omega$ -ACTX and GNA leader-K34Q $\omega$ -ACTX was not observed (data not shown).

4.7.2.(i)B Western blot analysis

Detection by GNA antibodies showed weak expression for both K34Q  $\omega$ -ACTX-GNA and  $\omega$ -ACTX-GNA constructs. For the  $\omega$ -ACTX-GNA, western blot analysis showed primary transformed plants expressing the protein at between 0 - 0.01% TSP with some plants expressing at only 0.001% intact fusion protein but cleavage products at approx. 15kDa and one band at a product with a similar molecular weight to GNA showing at 0.1% TSP (figure 4.12). This expression level is much lower than seen with the ButaIT-GNA transformed plants. High levels of protease cleavage *in planta* were observed with both constructs. This cleavage is similar to that seen when expressed with the *P. pastoris* yeast expression system. Intact fusion protein expression was detected in primary transformants of K34Q $\omega$ -ACTX-GNA at between 0.01 – 0.05% total soluble protein (TSP) with high levels of cleavage to bands at approx 15kDa and one band at a product with a similar molecular weight to GNA observed (figure 4.13).



**Figure 4.12**  
**Western blot (probed with anti-GNA antibodies). Analysis of *Arabidopsis thaliana* transformants ( $T_0$ ) for expression of  $\omega$ -ACTX-GNA.** Positive controls of recombinant  $\omega$ -ACTX-GNA and GNA were loaded onto a 17.5% SDS-PAGE gel at 50ng. Untransformed wild-type *Arabidopsis* was not included however leaf protein samples were shown previously not to show reactivity to GNA antibodies; figure 5.7, 5.8.  $T_0$  plants 1 – 7 show bands with immunoreactivity to GNA antibodies. Only 2, 5 and 6 showing expression of intact fusion protein (denoted by \*2). Several bands appear on gel - 1\*: thought to be incomplete dissociation in the presence of SDS and \*3, \*4 degradation products. Expressed protein has been subject to high cleavage *in planta*



**Figure 4.13**  
**Western blot (probed with anti-GNA antibodies). Analysis of T<sub>0</sub> *Arabidopsis thaliana* transformants expressing K34Q $\omega$ -ACTX-GNA.** Positive controls of recombinant K34Q $\omega$ -ACTX-GNA and GNA were loaded onto a 17.5% SDS-PAGE gel at 50ng. Untransformed wild-type *Arabidopsis* was not included however leaf protein samples were shown previously not to show reactivity to GNA antibodies; figure 5.5, 5.6. T<sub>0</sub> plants 1, 3 and 4 show bands with immunoreactivity to GNA antibodies: \*1; intact K34Q  $\omega$ -ACTX-GNA, \*2 and \*3; degradation products. Only line 3 shows expression of intact fusion protein. Expressed protein has been subject to high cleavage *in planta*.

## **Discussion**

### *Voltage gated calcium channels as insecticidal targets*

$\omega$ -ACTX-Hv1a ( $\omega$ -ACTX), isolated from the Blue Mountains funnel-web spider (*H. versuta*) is an insect specific blocker of voltage gated calcium channels (VGCC) (Fletcher *et al.*, 1997). These channels form pores within membranes that open in response to depolarization of membranes, allowing influx of extra-cellular calcium ions. Depending upon their voltage dependence of activation  $Ca_v$  channels can be arranged into two broad superfamilies: low-voltage-activated (LVA)  $Ca_v$  channels and high-voltage-activated (HVA)  $Ca_v$  channels. HVA  $Ca_v$  have a more complex tertiary structure than LVA  $Ca_v$  with multiple ( $\alpha_2$ - $\delta$ ,  $\beta$ , and  $\gamma$ ) subunits modulating activation/inactivation kinetics of the  $\alpha_1$  subunit (Doering and Zamponi, 2003) while LVA appear to have just the pore forming  $\alpha_1$  subunit (Perez-Reyes, 2003; Bourinet and Zamponi, 2005; Catterall *et al.*, 2005).

As with other channels, VGCC play critical function in intracellular processes such as hormone and neurotransmitter release as well as muscle contraction and regulation of enzymatic activities (Catterall, 2000). In insects however, there is a smaller repertoire of these channels than vertebrates. If the  $\alpha_1$  subunit is considered, in *Drosophila melanogaster*, there are only three encoded in the genome; Dmca1D, Dmca1A, and Ca- $\alpha$ 1T that represent  $Ca_v1$ ,  $Ca_v2$  and  $Ca_v3$ -type channels, respectively (King, 2007). Other sequenced insect genomes also only encode one ortholog of each of the  $\alpha_1$  subunits encoded in the *D. melanogaster* genome (King *et al.*, 2008). This may explain why loss of function gene mutations in Dmca1D ( $Ca_v1$ ) and Dmca1A ( $Ca_v2$ ) are embryonic lethal and the channels appear critical making them an ideal target for development for insecticidal use (Eberl *et al.*, 1998; Kawasaki *et al.*, 2002; King, 2007).

In addition, voltage gated calcium channels are less well conserved than voltage gated  $Na^+$  or  $BK_{Ca}$  channels across insect orders. The  $Ca_v1$ , 2 and 3 subtypes show 74-82%, 79-90%, 76-89% sequence identity respectively when gene sequences are compared across 5 taxonomic orders (King *et al.*, 2008). The fact they are less well conserved

over different orders may prove useful when aiming to create order specific insecticides. However, the toxin is reported to have a potent effect across taxonomic orders (ArachnoServer, Wood *et al.*, 2009) suggesting that this may not be totally achievable.

Most commonly used insecticides target insect voltage-gated sodium channels (e.g. DDT, pyrethroids), acetylcholinesterase (e.g. organophosphates, carbamates), or GABA receptors (e.g. the arylheterocycles endosulfan and fipronil) however, VGCC are nonconventional targets. This may serve to increase the time before resistance emerges however, their critical functions in insects may prove a selection pressure for modifications in the ion channels.

*Modification, expression and biological activity of lectin/toxin components of fusion proteins incorporating  $\omega$ -ACTX and GNA*

The aim of this chapter was to create variants of the  $\omega$ -ACTX-GNA fusion protein created by Dr. Fitches, FERA (York). Point mutation at Lys<sup>34</sup> of the toxin to remove paired dibasic amino acid residues which are signals for protease cleavage (Fuller *et al.*, 1989) and N-terminal fusion to GNA (K34Q $\omega$ -ACTX-GNA) resulted in a fusion protein that was more stable through purification but not fermentation when compared to  $\omega$ -ACTX-GNA (figure 4.4 and 4.5). Modification of toxin residues is routinely carried out in peptide chemistry and for toxins such as those from cone snails (conotoxins) during drug development, substituting selected L-amino acids for D-amino acids to improve stability by reducing susceptibility to proteolytic breakdown (Craik and Adams, 2007). It is also common when investigating structure/function relationships and has been carried out by Tedford *et al.* (2001) to show that residues Pro<sup>10</sup>, Asn<sup>27</sup> and Arg<sup>35</sup> are critical for toxin function while Lys<sup>34</sup> is responsible for stabilizing the  $\beta$  hairpin structure. In the study by Tedford *et al.* (2001) a 3 fold reduction in the LD<sub>50</sub> of their K34E mutated toxin is reported. This is not seen in this study as both  $\omega$ -ACTX-GNA and K34Q $\omega$ -ACTX-GNA show comparable activity when injected into *M. brassicae* larvae (figure 4.7). Fusion to GNA and expression in *P. pastoris* did not alter toxicity as at comparable levels, both fusion proteins and  $\omega$ -ACTX, produced in *E. coli* and shown to be correctly folded by NMR spectroscopy

(Tedford *et al.*, 2001), show levels of mortality not significant different from each other showing the toxin component is correctly folded (figure 4.7).

Variation of lectin/toxin assembly is seen to result in differences in stability during expression and purification. Fusion of the toxin to the C-terminus of GNA shows higher stability both in rich media (YPG) and after purification steps (figures 4.3; B and 4.6) than fused to the C terminus of GNA ( $\omega$ -ACTX-GNA or K34Q $\omega$ -ACTX-GNA) (figures 4.3; A and 4.6). This has also been reported with other toxin/lectin fusion proteins such as ButaIT, without a loss in biological activity when injected into *M. domestica* (Fitches *et al.*, 2010). Injected into *M. brassicae* all  $\omega$ -ACTX, GNA based fusion protein variants documented in this chapter have comparable activity to correctly folded toxin suggesting that toxins are correctly folded when expressed in *P. pastoris* and provides further evidence of the use of *P. pastoris* as a host for expression of invertebrate toxins for the use in insecticides.

As discussed previously, carry over of high molecular weight yeast proteins is a problem when using the mannose binding lectin, GNA, as a carrier due to oligosaccharides solely comprised of mannose residues. These proteins have however been shown to be inert when injected and fed into insects including coleopterans (data not shown). Investigation into alternative carriers for toxins such as  $\omega$ -ACTX has yielded little success as although other lectins such as the garlic lectin, ASaII, have been shown to transport fused scorpion toxin ButaIT into the haemolymph of *M. brassicae*, insecticidal activity was not reported (Fitches *et al.*, 2008). This was suggested to be due to misfolding of the toxin or alternatively stability issues of the created fusion protein. It is not known why GNA has been so successful as a carrier for invertebrate toxins however further work would be required to ascertain if other peptides would be suitable carriers for invertebrate neurotoxins.

*Activity of fusion proteins incorporating  $\omega$ -ACTX and GNA when orally fed to T. castaneum*

Modification of the toxin and fusion to the N-terminus of GNA (K34Q $\omega$ -ACTX-GNA) did not alter biological activity when fed to *T. castaneum* as when Kaplan-

Meier survival curves are analysed for both doses (1 and 2 mg g<sup>-1</sup>) assayed, no significant difference is seen. Addition of a C-terminal polyhistidine tag appears to increase the toxicity of the protein towards *T. castaneum*. This is unexpected as has not been reported with other fusion proteins such as Indian red scorpion toxin, ButaIT fused to GNA (Fitches *et al.*, 2010). However, it might be speculated that as addition of the polyhistidine tag increases the protein isoelectric point (4.46 to 5.34) that it may help to facilitate transport function.  $\omega$ -ACTX fused to the C-terminus of GNA appears to also enhance toxicity as (his)<sub>6</sub>-GNA- $\omega$ -ACTX shows complete mortality at 1mg g<sup>-1</sup> while  $\omega$ -ACTX-GNA shows only 30% reduction in survival at the same dose. This may be due to differences in stability in the gut environment or upon transportation and within the insect haemolymph.

When fed to *T. castaneum* at 1mg g<sup>-1</sup>, (his)<sub>6</sub>-GNA-K34Q $\omega$ -ACTX shows mortality only at 35% while (his)<sub>6</sub>-GNA- $\omega$ -ACTX shows complete mortality at the same dose. This is a surprising result and it might be speculated that GNA has a stabilizing effect of the  $\beta$  hairpin when the toxin is fused to the C-terminus of GNA and when the toxin is fused to the N-terminus of the lectin this effect is not replicated. However, all variants have comparable toxicity when injected into *M. brassicae* larvae suggesting this is not the case. Alternatively modification of the C-terminus of the toxin Lys to Gln at position 34 and fusion to the C-terminus of GNA leaving the modified terminus free may render the toxin more prone to proteolytic cleavage in the gut and or the haemolymph and thus result in a difference in stability when fed to *T. castaneum*.

*In vitro* assays to investigate the stability of variants was unsuccessful due to lack of detection of the proteins in gut samples suggesting larvae were not consuming the protein in enough quantity to be detected. Further work to investigate the differences in toxicity between these variants is required.

Small variations in toxicity between the variants may result from differences in quantification of proteins. Currently this is carried out analysis of SDS-PAGE gel, stained with coomassie brilliant blue and compared to GNA shown to be >95%

homogeneous. As levels of intact protein are compared, a standard BCA or Bradford assay is not suitable as these assays measure levels of total protein and do not distinguish between intact fusion protein and degradation products. In future, this method of quantification of proteins may need to be improved to avoid any potential differences that may occur.

#### Expression in planta

Due to the highly potent nature of this toxin, it is not surprising that investigation into delivery via fusion proteins expressed *in planta* has been carried out. Recently,  $\omega$ -ACTX has been expressed in tobacco plants (*Nicotiana tabacum*) and when fed to *Helicoverpa armigera* and *Spodoptera littoralis*, it was shown to cause 100% mortality by 48 hours (Khan *et al.*, 2006). In the same study, recombinant thioredoxin- $\omega$ -ACTX fusion protein was shown to be lethal to *H. armigera* and *S. littoralis* larvae when applied topically (Khan *et al.*, 2006). This result is surprising as  $\omega$ -ACTX expressed in *E. coli* by Tedford *et al.* (2001) showed no oral activity when droplet fed to *Lacanobia oleracea* (E. Fitches, unpublished data). However, the toxin has also been shown to be orally active against ticks (Mukherjee *et al.*, 2006) and mosquitoes (Tedford *et al.*, 2004; Huang J., King G., Wikel S., unpublished data).

Other spider toxins have also been investigated for *in planta* expression, Magi 6, from *Macrothele gigas* has been expressed in tobacco and shown to be toxic to *Spodoptera frugiperda* larvae (Hernández-Campuzano *et al.*, 2009). Expression levels of the toxin in leaf tissue were 4-6% total soluble protein and fed to late 3-4 and 4-5 instar larvae fed on transgenic plants, demonstrated a mortality of 75% and 86%, respectively. This was significantly lower than survival when fed wild-type plants. The exact mode of action for Magi 6 was not established by the authors however death was noted to be caused by rapid paralysis.

In this chapter, expression in *Arabidopsis thaliana* of  $\omega$ -ACTX, GNA based proteins has resulted in poor expression and high levels of cleavage. Expression of  $\omega$ -ACTX or K34Q $\omega$ -ACTX alone was not established. Unsurprisingly there is little reported in the literature for foreign protein expression highly cleaved *in planta* however, it is not

uncommon. However, unstable RNA transcripts have been shown to be a more important factor than codon usage when considering transgene expression (de Rocher *et al.*, 1998; Murray *et al.*, 1991).

Co-expression of protease inhibitors could help to limit proteolysis of the expressed fusion protein as has been established with expression of multiple protease inhibitors in potato (Outchkourov *et al.*, 2004). Proteolysis occurs more readily in the cell apoplast rather than the endoplasmic reticulum (ER) (Doran, 2006). Therefore an approach to retain protein in the ER using signal peptides such as KDEL or HDEL may limit foreign protein degradation (Doran, 2006). This is because the plant cell ER contains a smaller complement of proteases and also provides molecular chaperones and stabilizing agents that interact with foreign proteins to enhance proper folding and assembly providing a protective environment (Nuttall *et al.*, 2002). ER retention has resulted in foreign protein yields 10–100-times greater than those obtained when the protein is allowed to enter the secretory pathway (Hellwig *et al.*, 2004). However, not all proteins may be suitable as some may require further processing in the golgi body.

The proteins expressed in this chapter do not contain the GNA C-terminal peptide shown to properly signal GNA to the secretory pathway and have been shown by localization assays to remain in the nuclear envelope and ER (Fouquaert *et al.*, 2007). However, it was suggested that proteins may aggregate with GNA due to mannose glycans in the ER and exposed binding sites on the C-terminus of the lectin. If this was to occur, proteases may be secreted to degrade the proteins. Further work including expression with the C-terminal peptide of GNA would be required to potentially increase stability and expression levels in order to fully exploit expression in plants for delivery of these toxins.

### Summary

This chapter provides evidence for  $\omega$ -ACTX, GNA based fusion proteins.  $\omega$ -ACTX, GNA based fusion proteins are potent insecticidal proteins active against *T. castaneum*, in some cases, as low as 0.5mg g<sup>-1</sup>. This is not surprising as  $\omega$ -ACTX has previously been described by Bloomquist (2003) as one of the most potent insect

specific toxins to date. Further assays would be required to elucidate the biological activity to *T. castaneum* by the toxin alone due to reports of orally toxicity to ticks, mosquitoes and surprisingly lepidopteran pests (Khan *et al.*, 2006; Mukherjee *et al.*, 2006). Although expression *in planta* showed low expression and high cleavage of expressed protein, delivery of the toxin and fusion proteins via genetically modified plants show potential as methods for control of insect pests. Further work would need to be carried out to investigate possible methods for increasing stability, expression and delivery of these insect specific potent neurotoxins *in planta*.

## Chapter 5

### **Biological activity of fusion proteins incorporating Indian red scorpion toxin (ButaIT) and snowdrop lectin (*Galanthus nivalis* agglutinin; GNA) expressed using both *Pichia pastoris* and *Arabidopsis thaliana***

#### **Introduction**

ButaIT was first isolated from the Indian red scorpion (*Mesobuthus tamulus*) by Wudaygiri *et al.* (2001) and belongs to a group of “short” scorpion toxins that are typically 30-40 amino acids in length. It adopts the core structure of one  $\alpha$  helix and three  $\beta$  sheets with 4 disulphide bridges seen with other scorpion toxins (Bontems *et al.*, 1991; Johnson and Sugg, 1992; Johnson *et al.*, 1994; Lippens *et al.*, 1995). Based on sequence homology to these toxins, ButaIT was suggested to affect voltage gated potassium channels and high conductance calcium activated potassium channels (Charbone *et al.*, 1982; Miller *et al.*, 1985). These channels as insecticidal targets have been discussed in chapter 3.

ButaIT has previously been expressed as a recombinant protein in *P. pastoris* as well as in a polyhedrin positive *Autographa californica* nuclear polyhedrosis virus (AcMNPV) and shown to be toxic to lepidopteran pests when introduced into the haemolymph either by infection with the virus or direct injection (Trung *et al.*, 2006; Wudaygiri *et al.*, 2006). Fusion to GNA resulted in the creation of a protein that was orally active against both lepidopteran and hemipteran insect pests (Trung *et al.*, 2006). ButaIT was first described as a lepidopteran specific toxin (Wudaygiri *et al.*, 2001) but showed wider insecticidal activity when produced as a recombinant protein in *P. pastoris* (Trung *et al.*, 2006; Fitches *et al.*, 2010). Further analysis has shown it to be potent against a range of economically important insect pests including representative species from dipteran and coleopteran orders (Fitches *et al.*, 2010; ISAGRO, Personal communication). Variants of the ButaIT-GNA fusion protein, incorporating a strep tag for faster purification and easier quantification, as well as changes in the linker

region for increased protein stability have also been expressed in *P. pastoris* and shown to be active against a range of insect species (Fitches *et al.*, 2010).

In this chapter, ButaIT-GNA fusion protein variants will be evaluated for oral toxicity towards the model coleopteran *Tribolium castaneum*. The most active fusion protein variant will then be expressed in a transgenic plant (*Arabidopsis thaliana*) using a re-engineered expression construct modified for *in planta* protein production. Transgenic plants will be evaluated for biological effects to larvae of *Lacanobia oleracea*. Although not the ideal target pest, bioassays using this insect would enable functionality to be tested. It would also enable direct comparison of biological activity with *P. pastoris* expressed fusion protein fed within artificial diet assays.

### **5.1 Oral toxicity of fusion proteins incorporating ButaIT and GNA against *Tribolium castaneum***

Proteins were incorporated into wheat flour diet at between 1 - 2 mg g<sup>-1</sup>, with diet only used for control treatments. *T. castaneum* larvae were transferred to assay tubes as neonates. Larval weights and survival were taken every 7 days after a period of 14 days (after which larvae were large enough to be weighed accurately). Diets were changed every 14 days for the length of the assay (the length of time for control larvae to start to pupate).

#### **5.1.1 ButaIT – GNA ± (his)<sub>6</sub> (protein provided by Dr. Fitches, FERA (York))**

Two variants of ButaIT fused to GNA were tested at 1 and 2 mg g<sup>-1</sup> (1000 and 2000ppm). ButaIT was fused to the C-terminus of GNA in both constructs. A C-terminal extension containing myc and histidine tag was only present however, in the treatment shown as ButaIT-GNA-(his)<sub>6</sub>. Controls used were diet only, GNA only and ButaIT only, at 1 and 2 mg g<sup>-1</sup>.

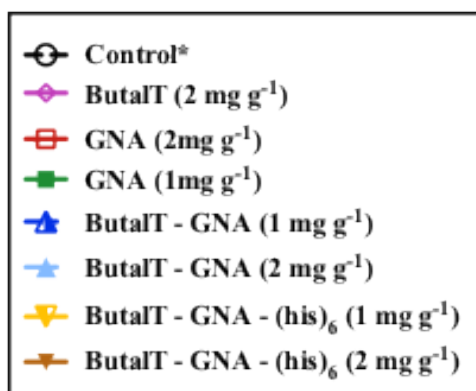
Control survival was 100% over the assay (to pupation). Recombinant ButaIT had no effect at all on survival. GNA reduced survival to 95% at 1mg g<sup>-1</sup> and 90% at 2mg g<sup>-1</sup>; neither reduction in survival was shown to be significant when compared against controls. The fusion proteins reduced survival significantly compared to controls. At

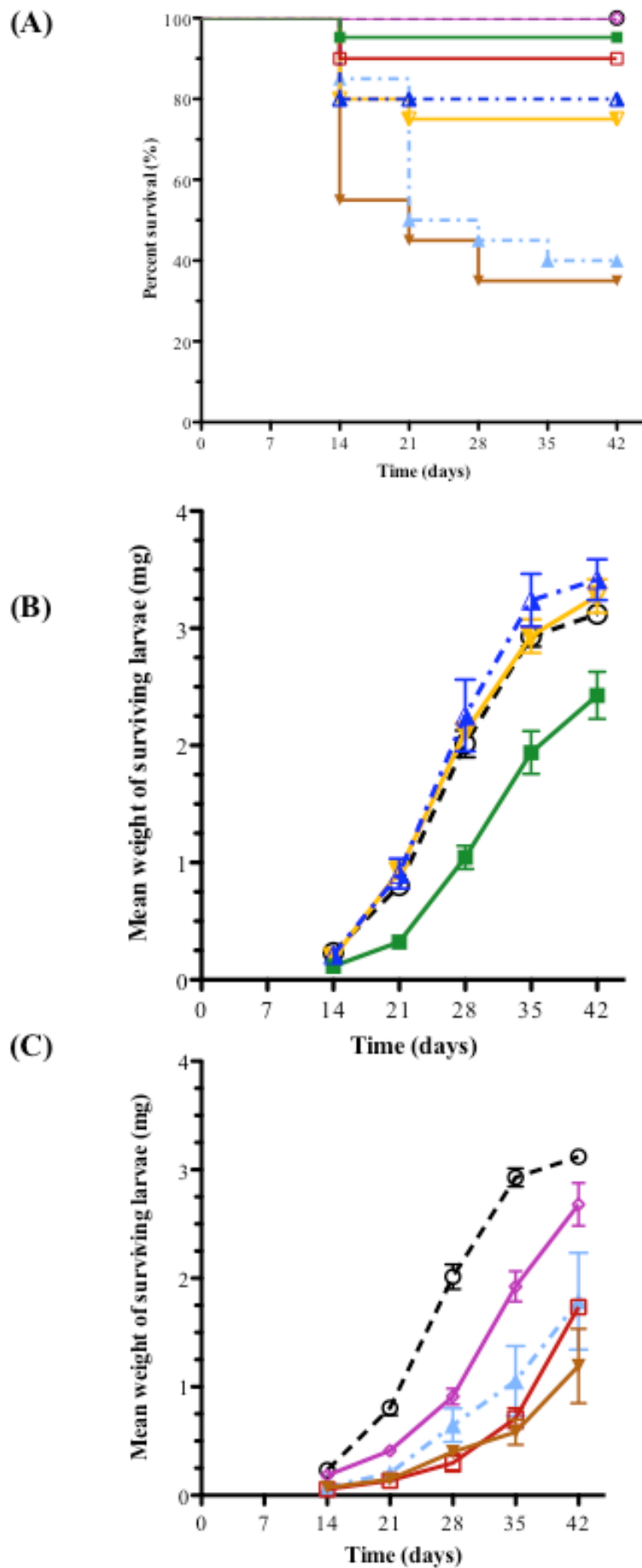
1mg g<sup>-1</sup> ButaIT-GNA showed a survival rate of 80% after 49 days and ButaIT-GNA-(his)<sub>6</sub> showed 75% survival. However, when the fusion proteins were compared against GNA, only at 2mg g<sup>-1</sup> were the fusion proteins significantly different ( $P < 0.05$ ) with ButaIT-GNA showing survival at 40% and ButaIT-GNA-(his)<sub>6</sub> showing 35% survival. Comparing the constructs, there was no significant difference in survival between them seen at either dose (1mg g<sup>-1</sup>  $P = 0.7162$ ; 2 mg g<sup>-1</sup>  $P = 0.4528$ ). Larval survival decreased most rapidly in the first 14 days of the assay, although mortality continued throughout the assay (figure 5.1; A).

At all time points at 1mg g<sup>-1</sup> both fusion proteins showed no significant differences in weight of surviving larvae when compared to each other or control mean weights (Tukey-Kramer tests,  $P > 0.05$ ). However, from 21 days onwards GNA-fed insects showed significantly lower weights than control and other treatments (Tukey-Kramer tests,  $P < 0.05$ ). At the higher dose, the added proteins had more marked effects on weight gain. ButaIT fed insects appeared to show some reduction in weight compared to control fed insects (15% reduction at the end of the assay), while insects fed GNA and ButaIT-GNA fusion proteins showed decreased weights by up to 60% at the end of the assay when compared to control insects. The mean weight of insects fed GNA, ButaIT-GNA, ButaIT-GNA-(his)<sub>6</sub> at 2 mg g<sup>-1</sup> showed significant difference from control weight at all time points in the assay. After 21 days the fusion protein treatments showed no significant difference from each other or GNA fed insects at the same dose. ButaIT shows significant reduction in weight of surviving larvae from control fed insects after 21 days. Up to 28 days ButaIT showed no significant difference when compared to GNA at the same dose. However at 35 and 42 days surviving larvae fed ButaIT showed significantly higher weight from those fed both variants and GNA (figure 5.1; B).

Recombinant ButaIT-GNA±(his)<sub>6</sub> proteins were previously fed to *T. castaneum* larvae at 2 mg g<sup>-1</sup>; results are published in Fitches *et al.* (2010). The study showed the proteins significantly reduce survival both with and without the myc/(his)<sub>6</sub> tag. The reductions in survival, 24% for fusion protein without the tag and 40% for fusion protein with the tag, are comparable to the data presented here.

**Figure 5.1**  
Survival and mean weight of surviving *Tribolium castaneum* larvae fed recombinant GNA, ButaIT-GNA-(his)<sub>6</sub> and ButaIT-GNA at 1 and 2 mg g<sup>-1</sup> and ButaIT at 2 mg g<sup>-1</sup>. (A) Kaplan–Meier survival curves. (B) Mean weight of surviving larvae (mg) fed proteins at 1 mg g<sup>-1</sup> (C) Mean weight of surviving larvae (mg) fed at 2 mg g<sup>-1</sup>. Error bars denote ± standard error of the mean (SEM). Diet only fed larvae are used as controls. Data is taken from 20 individuals total, control\* = 75 individuals. Treatments are depicted in figure as follows:





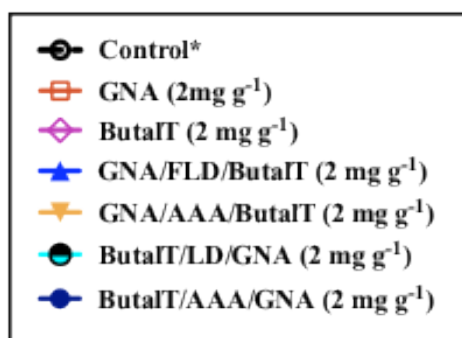
5.1.2 5' Strep-tagged ButaIT–GNA variants (protein provided by Dr. Fitches, FERA (York))

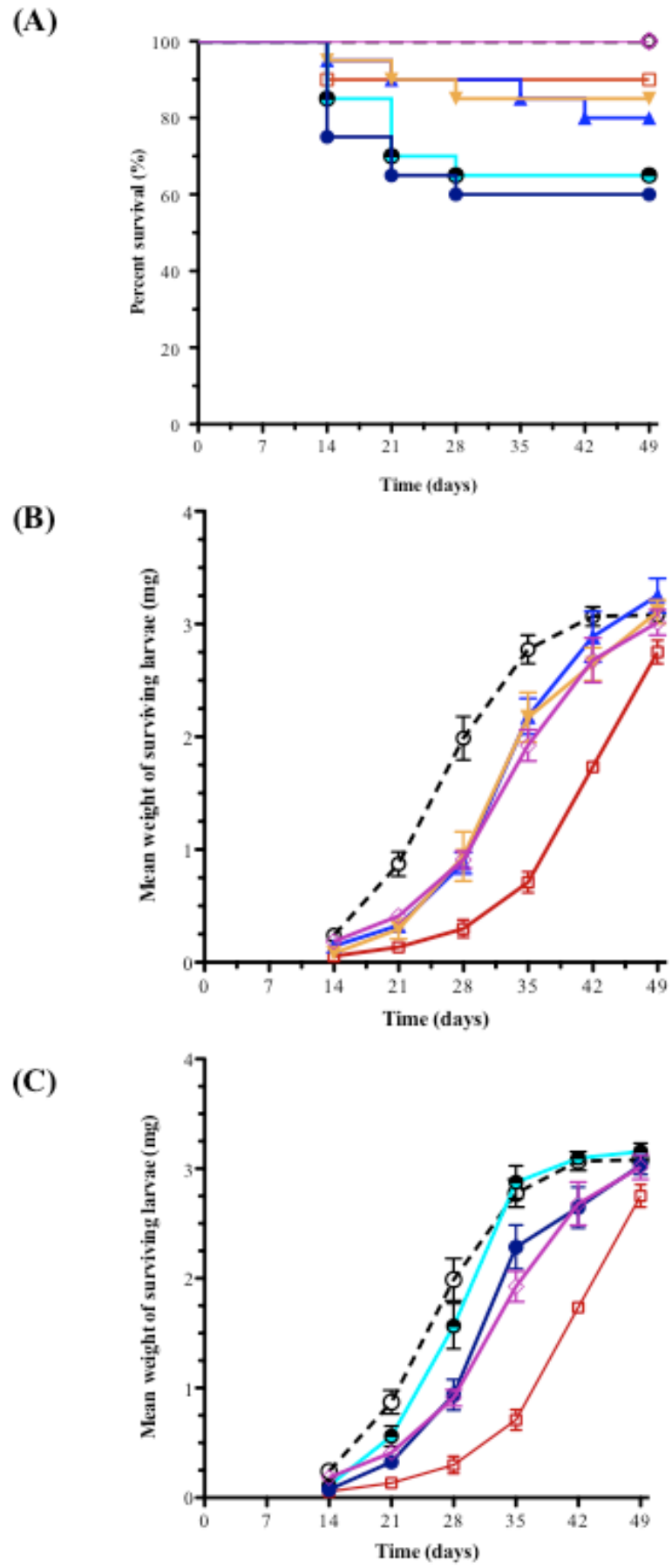
5' strep-tagged ButaIT–GNA based fusion proteins with variations in linker region and in the order of the two components of the fusion were expressed and purified by Dr. Fitches. Purified proteins were fed at 2 mg g<sup>-1</sup> to *Tribolium* larvae to test for oral toxicity. All the fusion protein variants showed significant difference in survival over the assay (49 days) from control ( $P < 0.05$ ), with reductions in survival from 15-40%, whereas GNA at 2 mg g<sup>-1</sup> (10% reduction) showed no significant difference from control. Survival rates differed between fusion proteins in which the toxin ButaIT was N-terminal to GNA, and those where the toxin was C-terminal, with the former being more effective, and the latter only marginally more effective than GNA. However, only ButaIT-AAA-GNA showed significant difference to GNA in reducing survival (to 60%;  $P = 0.0327$ ). There is no significant difference in survival between variants with the same sequence but different linker regions i.e. ButaIT-AAA-GNA (60%) and ButaIT-LD-GNA (65%) ( $P = 0.699$ ), and GNA-AAA-ButaIT (85%) and GNA-FLD-ButaIT (80%) (figure 5.2; A).

Over the assay period GNA was the only protein fed which resulted in significant difference in weight when compared to controls for all time points. The fusion proteins showed much less effect on weight of surviving larvae; for example, only at 14 days is the mean weight of larvae fed ButaIT-LD-GNA significantly different from control data. The other variants showed significant difference up to and including 28 days (Tukey-Kramer tests,  $P < 0.05$ ). There was no significant difference between the variants in either linker sequence or construct sequence (Tukey-Kramer tests,  $P > 0.05$ ). ButaIT-AAA-GNA and GNA-AAA-ButaIT only showed significantly higher mean weight of surviving larvae when compared with GNA on days 35 and 42. GNA-FLD-ButaIT showed difference from GNA that was significant at day 14, then after 28 days. ButaIT-LD-GNA showed no significance compared to GNA at the start and the end; however between 21-42 days weights were significantly different (figure 5.2; B).

**Figure 5.2**

**Survival and mean weight of surviving *Tribolium castaneum* larvae fed recombinant GNA, ButaIT, and 5' Strep-tagged ButaIT, GNA variants at 2 mg g<sup>-1</sup>. (A) Kaplan–Meier survival curves. (B) GNA-ButaIT variants; (C) ButaIT-GNA variants. Mean weight of surviving larvae (mg), error bars denote ± standard error of the mean (SEM). Diet only fed larvae are used as controls. Data is taken from 20 individuals total, control\* = 25 individuals. Treatments are depicted in figure as follows:**





## **5.2 Expression of fusion proteins incorporating ButaIT and GNA in *Arabidopsis thaliana***

Based on oral activity of variants against *T. castaneum*, the position of GNA and purification tags in relation to the toxin alters toxicity. ButaIT-GNA±(his)<sub>6</sub> shows highest toxicity (35-40% survival of larvae) towards *Tribolium* while the presence or absence of a C-terminal purification tag does not significantly alter toxicity. Therefore, ButaIT fused to the N-terminus of GNA was used to investigate whether insecticidal proteins based on arthropod toxins fused to GNA could be produced in transgenic plants, and whether fusion proteins produced *in planta* retained insecticidal activity. A GNA-ButaIT construct was also assembled to further investigate if N-terminal extensions of the ButaIT affect biological activity of the toxin.

The Gateway™ entry vector system was used to generate constructs for expression of potentially insecticidal proteins in transgenic plants. The destination plasmid, pK2WG7, is a binary vector containing *Agrobacterium tumefaciens* T-DNA borders enclosing an *nptII* gene construct that enables selection for transformation *in planta* using kanamycin (Karimi *et al.*, 2002). The T-DNA region also contains an enhanced CaMV 35S promoter and a cloning site for introducing coding sequences.

The coding sequences for expression *in planta* required a signal peptide to direct the resulting polypeptides into a secretory route. GNA is normally a secreted protein, whose coding sequence contains a signal peptide, and previous work has shown that whereas expression of GNA with its native signal peptide results in accumulation to expected levels in transgenic plants, attempts to express GNA without a signal peptide result in low or no detectable accumulation of protein (unpublished results). The GNA leader sequence was therefore included in all constructs.

### **5.2.1 Design of expression constructs**

To produce GNA in transgenic plants as a control for fusion proteins, a new GNA expression construct was prepared. The GNA coding sequence used included the signal peptide, and extended to amino acid 105 of the mature protein, omitting the C-terminal region which is removed *in planta* by post-translational proteolysis. The

required sequence was amplified by PCR from a full-length cDNA encoding GNA. This fragment was introduced into the entry vector pENTR1A (Invitrogen) by restriction/ligation, and checked by DNA sequencing.

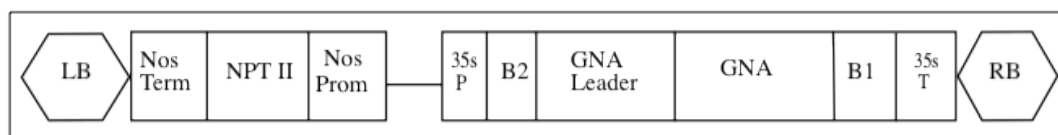
To produce fusion protein constructs, the GNA leader sequence was synthesised as a pair of complementary oligonucleotides, and introduced into pre-existing ButaIT-GNA and GNA-ButaIT fusion protein expression constructs in the vector pGAPZ $\alpha$ B by restriction/ligation. After checking the resulting constructs, the complete fusion protein coding sequences, including the GNA leader sequences were transferred to the entry vector pENTR1A by restriction/ligation, and checked by DNA sequencing. This process generated coding sequences in a reverse orientation relative to the restriction sites of the Gateway vectors, necessitating the use of the destination vector employed (which is designed for expression of antisense RNA).

The resulting constructs were transferred into the destination vector by homologous recombination. Sequencing of selected positive colonies after transformation was used to confirm the homologous recombination reaction had yielded the correct working expression vectors. Schematic diagrams of the expression constructs, and DNA and predicted protein sequences for the introduced coding strands are shown in figures 5.3, 5.4 and 5.5.

(A)

|   |                         |
|---|-------------------------|
| <u>ACCAC</u> TTTTGTACAAGAAAGCTGGGTCTAGATATCTCGACATGGCTAAGGCAAGTCTCCTCATT    | 75                      |
| attB2   | M A K A S L L I L A A I |
| TTCTTGGTGTGCATCACACCATCTGCCTGAGTGACAATATTTGTACTCCGGTGAGACTCTCTTACAGGGGAA    | 150                     |
| <b>F L G V I T P S C L S D N I L Y S G E T L S T G E</b>                    | 37                      |
| TTTCTCAACTACGGAAGTTTCGTTTTTATCATGCAAGAGGACTGCAATCTGGTCTTGTACGACGTGGACAAGCCA | 225                     |
| <b>F L N Y G S F V F I M Q E D C N L V L Y D V D K P</b>                    | 62                      |
| ATCTGGGCAACAAACACAGGTGGTCTCTCCGTAGCTGCTTCTCAGCATGCAGACTGATGGGAACCTCGTGGTG   | 300                     |
| <b>I W A T N T G G L S R S C F L S M Q T D G N L V V</b>                    | 87                      |
| TACAACCCATCGAACAACCGATTTGGGCAAGCAACACTGGAGGCCAAAATGGGAATTACGTGTGCATCCTACAG  | 375                     |
| <b>Y N P S N K P I W A S N T G G Q N G N Y V C I L Q</b>                    | 112                     |
| AAGGATAGGAATGTTGTGATCTACGGAAGTATCGTTGGGCTACTGGATGACTCGACTGAATTGGTTCCTTTAAA  | 450                     |
| <b>K D R N V V I Y G T D R W A T G *</b>                                    | attB1                   |
| GCCTGCTTTTTTGTACAAACTTGT  | 424                     |

(B)



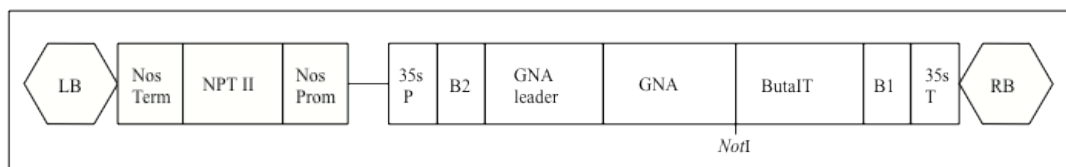
**Figure 5.3**

**GNA construct in pK2WG7 for expression *in planta*.** (A) Full derived nucleotide and presumed amino acid sequences, of the GNA construct, within the recombination sites of the expression vector. GNA leader (signal sequence) is shown in bold and italic, the mature GNA sequence is shown in bold. Recombination sequences are underlined. (B) Schematic representation of the T-DNA region of the expression vector pK2WG7 containing the GNA construct. LB, RB = left and right borders of T-DNA; Nos Prom., NPTII, Nos Term. = construct for expressing neomycin phosphotransferase, giving resistance to kanamycin (selectable marker); 35S = Cauliflower mosaic virus (CaMV) 35S RNA promoter; 35S Term. = 35S gene terminator; B1, B2 = enhancer sequences from CaMV 35S promoter.

(A)

|   |             |
|---|-------------|
| <u>ACCAC</u> TTTGTACAAGAAAGCTGGGTCTAGATATCTCGACATGGCTAAGGCAAGTCTCCTCATT     | 75          |
| <i>attB2</i> M A K A S L L I L A A I  | 12          |
| TTCCTTGGTGTCAACACCATCTGCCTGAGTGACAATATTTTGTACTCCGGTGAGACTCTCTTACAGGGGAA     | 150         |
| <b><i>F L G V I T P S C L S D N I L Y S G E T L S T G E</i></b>             | 37          |
| TTTCTCAACTACGGAAGTTTCGTTTTTATCATGCAAGAGGACTGCAATCTGGTCTTGTACGACGTGGACAAGCCA | 225         |
| <b><i>F L N Y G S F V F I M Q E D C N L V L Y D V D K P</i></b>             | 62          |
| ATCTGGGCAACAAACACAGGTGGTCTCTCCCGTAGCTGCTTCTCAGCATGCAGACTGATGGGAACCTCGTGGTG  | 300         |
| <b><i>I W A T N T G G L S R S C F L S M Q T D G N L V V</i></b>             | 87          |
| TACAACCCATCGAACAACCGATTGGGCAAGCAACACTGGAGGCCAAAATGGGAATTACGTGTGCATCCTACAG   | 375         |
| <b><i>Y N P S N K P I W A S N T G G Q N G N Y V C I L Q</i></b>             | 112         |
| AAGGATAGGAATGTTGTGATCTACGGAACGATCGTTGGGCTACTGGAGCGGCCGCAAGGTGTGGTCTTGCTTTT  | 450         |
| <b><i>K D R N V V I Y G T D R W A T G A A A R C G P C F</i></b>             | 137         |
|   | <i>NotI</i> |
| ACAACCTGATCCTCAAACACAAGCCAAGTGTAGTGAGTGTGTGGGCGAAAAGGGTGGAGTATGCAAGGGCCACAA | 525         |
| <b><i>T T D P Q T Q A K C S E C C G R K G G V C K G P Q</i></b>             | 162         |
| TGTATCTGTGGTATACAATGACTCGACTGAATTGGTTCCTTTAAAGCCTGCTTTTTTTGTACAAACTTGT      | 594         |
| <u>C I C G I Q .</u> <i>attB1</i>   | 168         |

(B)



**Figure 5.4**

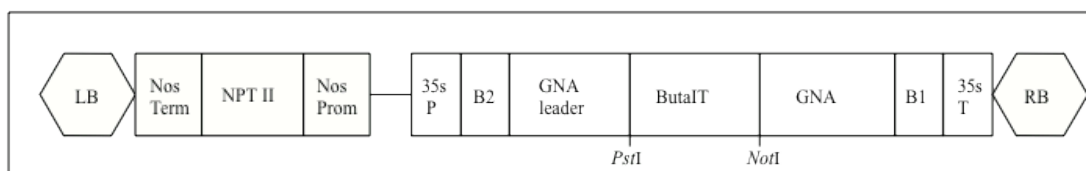
**GNA-ButaIT construct in pK2WG7 for expression *in planta*.** (A) Full derived nucleotide and presumed amino acid sequences of the GNA-ButaIT construct shown within the recombination sites of the expression vector pK2WG7. GNA leader (signal sequence) is shown in bold and italic, the mature GNA sequence is shown in bold and ButaIT is shown in regular font. Recombination sequences are underlined and restriction enzymes are shown in italic. (B) Schematic representation of the T-DNA region of the expression vector pK2WG7 containing the GNA-ButaIT construct. LB, RB = left and right borders of T-DNA; Nos Prom., NPTII, Nos Term. = construct for expressing neomycin phosphotransferase, giving resistance to kanamycin (selectable marker); 35S = Cauliflower mosaic virus (CaMV) 35S RNA promoter; 35S Term. = 35S gene terminator; B1, B2 = enhancer sequences from CaMV 35S promoter.

Chapter 5 Biological activity of fusion proteins incorporating Indian red scorpion toxin (ButaIT) and snowdrop lectin (*Galanthus nivalis* agglutinin; GNA) expressed using both *Pichia pastoris* and *Arabidopsis thaliana*

(A)

|   |     |
|---|-----|
| ACCAC <b>TTTTGTACAAGAAAGCTGGGTCTAGATATCTCGACATGGCTAAGGCAAGTCTCCTC</b> ATTTTGGCCGCCATC | 75  |
| <i>attB2</i> <b>M A K A S L L I L A A I</b>   | 12  |
| TTCCTTGGTGT <b>CATCACACCATCTTGCCTGAGTGTGCAGCAAGGTGTGGTCCTTGCTTTACA</b> ACTGATCCTCAA   | 150 |
| <b>F L G V I T P S C L S A A A R C G P C F T T D P Q</b>                              | 37  |
| <i>PstI</i>   |     |
| ACACAAGCCAAGTGTAGT <b>GAGTGTGTGGGGCAAAGGGTGGAGTATGCAAGGGCCACAATGTATCTGTGGTATA</b>     | 125 |
| T Q A K C S E C C G R K G G V C K G P Q C I C G I                                     | 62  |
| CAAGCGCCCGCCGACAATATTTTGTACTCGGTGAGACTCTCTCTACAGGGGAATTCTCAACTACGGAAGTTTC             | 300 |
| Q A A A D N I L Y S G E T L S T G E F L N Y G S F                                     | 87  |
| <i>NotI</i>   |     |
| GTTTTATCATGCAAGAGGACTGCAATCTGGTCTTGTACGACGTGGACAAGCCAATCTGGGCAACAAACACAGGT            | 375 |
| V F I M Q E D C N L V L Y D V D K P I W A T N T G                                     | 112 |
| GGTCTCTCCCGTAGCTGCTTCCTCAGCATGCAGACTGATGGAACTCGTGGTGTACAACCCATCGAACAAACCG             | 450 |
| G L S R S C F L S M Q T D G N L V V Y N P S N K P                                     | 137 |
| ATTTGGGCAAGCAACACTGGAGGCCAAAATGGGAATTACGTGTGCATCCTACAGAAGGATAGGAATGTTGTGATC           | 525 |
| I W A S N T G G Q N G N Y V C I L Q K D R N V V I                                     | 162 |
| TACGGA <b>ACTGATCGTTGGGCTACTGGATGACTCGACTGAATTGGTTCCTTTAAAGCCTGC</b> TTTTTGTACAAACT   | 600 |
| Y G T D R W A T G . <i>attB1</i>  | 171 |
| <u>TGT</u>  | 603 |

(B)



**Figure 5.5**

**ButaIT-GNA construct in pK2WG7 for expression *in planta*.** (A) Full derived nucleotide and presumed amino acid sequences of the ButaIT-GNA construct, within the recombination sites of the expression vector pK2WG7. GNA leader (signal sequence) is shown in bold and italic, the mature GNA sequence is shown in bold and ButaIT is shown in regular font. Recombination sequences are underlined and restriction enzymes are shown in italic. (B) Schematic representation of the T-DNA region of the expression vector pK2WG7 containing the ButaIT-GNA construct. LB, RB = left and right borders of T-DNA; Nos Prom., NPTII, Nos Term. = construct for expressing neomycin phosphotransferase, giving resistance to kanamycin (selectable marker); 35S = Cauliflower mosaic virus (CaMV) 35S RNA promoter; 35S Term. = 35S gene terminator; B1, B2 = enhancer sequences from CaMV 35S promoter.

### 5.2.2 Transformation and selection of GNA, ButaIT-GNA and GNA-ButaIT constructs

Expression constructs were directly transformed into *Agrobacterium tumefaciens* (strain C58C1), and antibiotic resistance was used to select transformed colonies. Selected clones were used for plant transformation and grown in suspension culture to prepare infiltration medium. Wild type (Col-1) *Arabidopsis thaliana* were transformed by the floral dipping method described by Cough and Bent (1998); modified from Bechold *et al.* (1993). Seeds were hand harvested from the plants dipped in the infiltration medium. They were then surface sterilised and grown on 0.5 X MS10 media plates supplemented with 50  $\mu\text{g } \mu\text{l}^{-1}$  kanamycin for selection. Plants that were dark green in colour with long roots were assumed to be positive transformants. These plantlets were subsequently transferred onto soil, isolated and allowed to grow normally in the growth facility.

### 5.2.3 Detection and segregation of homozygous transgenic *Arabidopsis*

Selection of transformants on 0.5 X MS10 plates containing kanamycin resulted in 16 seedlings derived from seed dipping with *Agrobacterium* containing the GNA expression construct. 45 GNA-ButaIT transformants and 48 ButaIT-GNA transformants were also obtained. These figures represent transformation efficiency of approx. 0.2%, 0.4% and 0.4% for GNA, ButaIT-GNA and GNA-ButaIT respectively.

Transformed plants were then isolated and allowed to self fertilise. Progeny were selected again on kanamycin containing 0.5 X MS10 plates to segregate for homozygous lines. Expression was analysed by western blot and plant lines with high expression levels were taken to T<sub>3</sub> for further experiments. Multiple lines of transformants were examined for each construct.

#### 5.2.4 Detection of expression

Extracted protein was subjected to protein quantification by BCA (bicinchoninic acid) assay. Ponceau S staining of the blotted nitrocellulose membrane was used to ensure equal levels of protein loading and also a good transfer during the blotting process.

##### 5.2.4.(i) Western blot analysis of leaf tissue expression

From the positively transformed plants determined by antibiotic selection, western blot analysis determined protein expression in leaf tissue in 4 of the 10 plant lines transformed with the GNA construct, 10 of 48 the lines of plants transformed with the ButaIT-GNA construct and 9 lines of the 45 plants transformed with the GNA-ButaIT construct.

At the T<sub>2</sub> stage, lines that appeared to be expressing highly were taken through to the T<sub>3</sub> stage to be used for bioassays. These plants were from the original; GNA line 3, ButaIT-GNA lines 40 and 45 and GNA-ButaIT line 5. In bioassays each line was represented by at least 50 genetically uniform plants homozygous for the transgene. Levels of protein expression for representative plants used in bioassays are shown in figures 5.6, 5.7, and 5.8.

GNA (line 3) (figure 5.6) is seen at approx. 0.15 – 0.2% total soluble protein. Several other bands appear on the gel besides that representing natively expressed GNA at approx 12.5kDa. High molecular weight (approx. 66kDa) cross reactivity is seen across all samples suggesting this is either artifacts on the gel or cross reactivity with an endogenous *Arabidopsis* protein. A slightly larger band than native GNA also appears at approx. 15kDa band which is presumed to be due to a small amount of GNA for which incomplete processing of signal peptide has occurred.

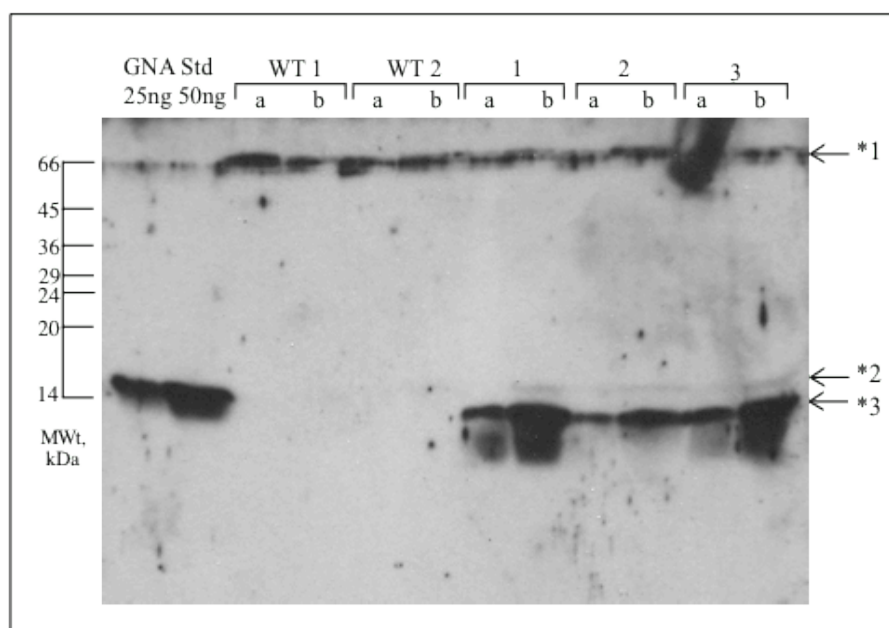
Expression of GNA-ButaIT in line 5 (figure 5.7) is approx. 0.1 – 0.15% total soluble protein. A degradation product with a similar molecular weight to that of native GNA is also seen as well as a barely visible band at approx. 32kDa that may represent incomplete dissociation in the presence of SDS.

ButaIT-GNA line 40 (figure 5.8; A) has an expression level of approx. 0.15% total soluble protein while line 45 (figure 5.8; B) has an expression level also of approx 0.15% total soluble protein. Several other bands also appear on the western blots of these proteins two proteolytic degradation products are present in the samples. One approx. 1kDa smaller than intact ButaIT-GNA and one at similar molecular weight to native GNA suggesting that the protein is cleaved within the linker region as well as being cleaved within the toxin sequence. A larger band is also seen at approx 32kDa which may represent incomplete dissociation in the presence of SDS. The cross reactivity at approx 66kDa seems less apparent in these western blots however a band does appear in plant 1 sample (a) (figure 5.8; B) this is not apparent in any other samples of the same line or within the same plant sample loaded on at 50µg so is presumed to be a gel artifact.

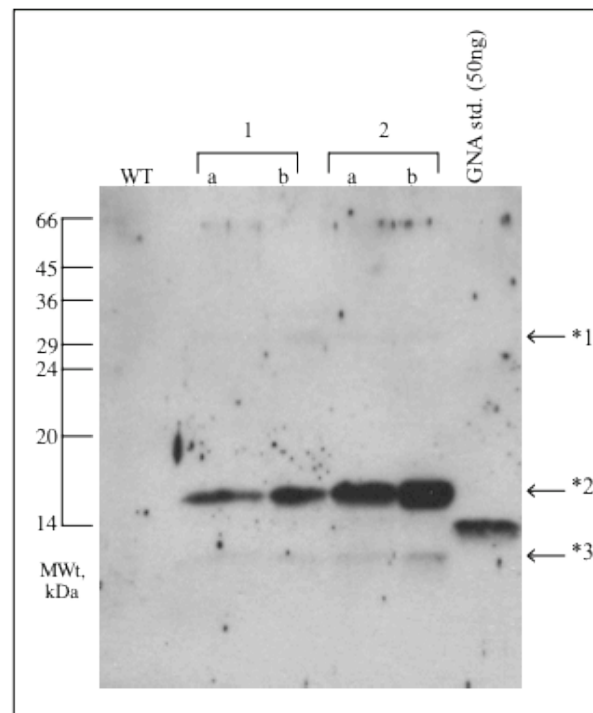
#### 5.2.4.(ii) Western blot analysis of root expression

Analysis of levels of expression of recombinant proteins within root tissues was carried out for plants selected by western blot for high expression in leaf tissue (used in further bioassays). This was carried out to see if there was a difference in expression between roots and leaves. 25µg total soluble protein (TSP) was loaded onto SDS-PAGE gel and probed with anti-GNA antibodies.

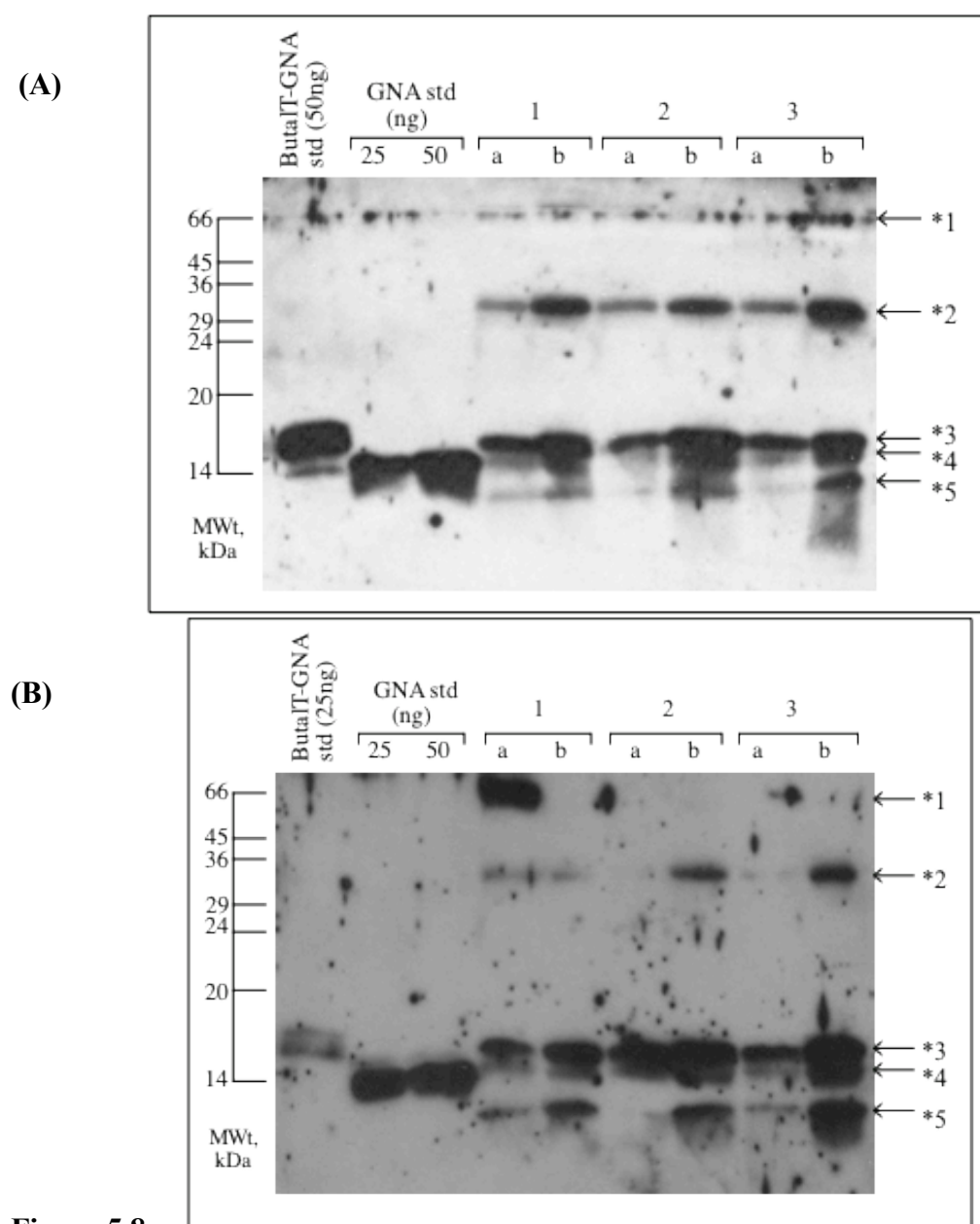
The two independent plants expressing GNA well in leaves showed expression of a band representing native GNA approx. 0.1% TSP. Independent lines of GNA-ButaIT expressing plants (line 5) showed expression of protein at approx 0.1% TSP also with significant cleavage, to a band at the same molecular weight to GNA, which was observed much less in leaf tissue. The lines for ButaIT-GNA however showed weak (0.01% TSP), and for line 45 barely detectable expression of intact protein along with proteolytic cleavage to a band of the same molecular weight as GNA (which is also seen for leaf tissue) (figure 5.9).



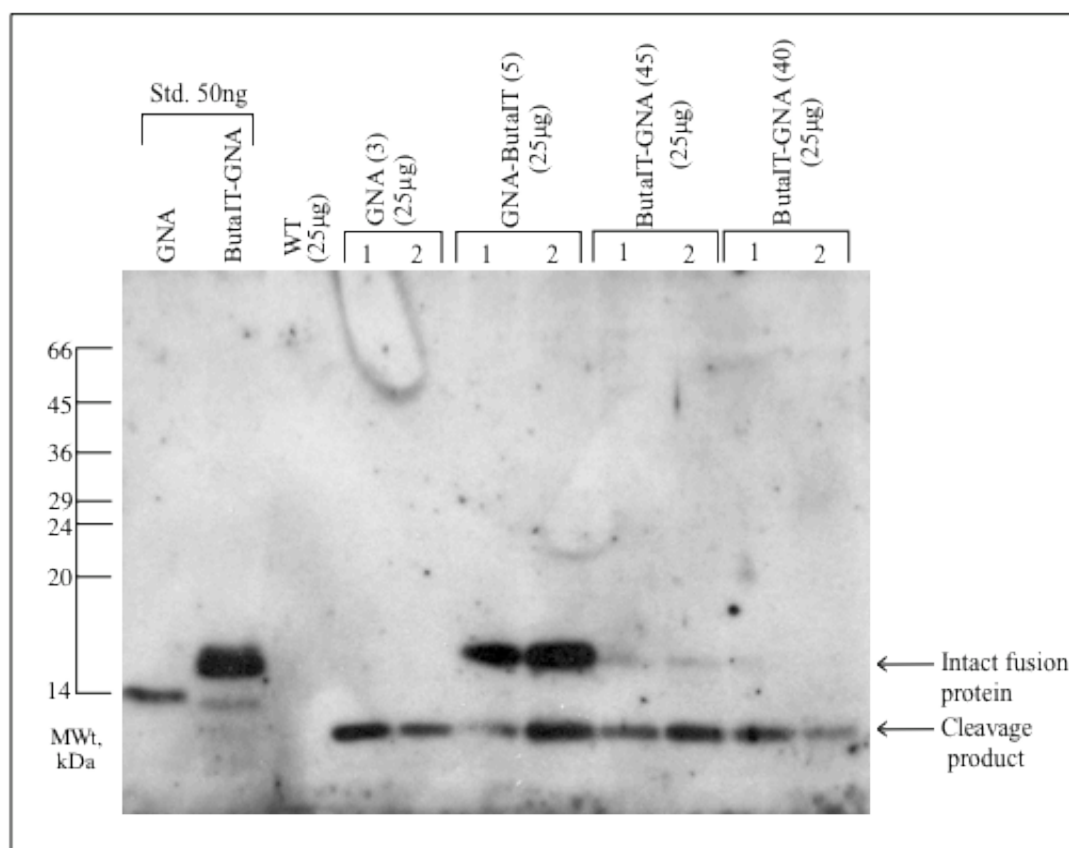
**Figure 5.6**  
**Western blot (probed with anti-GNA antibodies) to show representative expression of GNA in leaves of transformed *Arabidopsis thaliana* used for feeding bioassays.** Total soluble protein (TSP) from three independent T<sub>3</sub> plants (1, 2, 3) of the same line (3) loaded onto a 17.5% SDS-PAGE gel at 25 $\mu$ g (a) and 50 $\mu$ g (b) (quantified by BCA assay). Recombinant GNA produced in *P. pastoris* was loaded onto the gel as positive controls at 25 and 50 ng. Two independent lines of untransformed wild type (WT; col-1) at 25 $\mu$ g (a) and 50 $\mu$ g (b) TSP were included as negative controls. Several bands appear on the gel - \*1: 66kDa band of cross reactivity with endogenous protein as present in all samples, \*2 : kDa band presumed to be due to a small amount of GNA for which incomplete processing of signal peptide has occurred \*3: approx. 12.5kDa band native GNA.



**Figure 5.7** Western blot (probed with anti-GNA antibodies) to show representative expression of GNA-ButaIT in leaves of transformed *Arabidopsis thaliana* used in feeding bioassays. Two independent T<sub>3</sub> plants of the same original line (5) loaded onto a 17.5% SDS-PAGE gel at 25 $\mu$ g (a) and 50 $\mu$ g (b) total soluble protein (TSP). Recombinant GNA produced in *P. pastoris* was loaded onto the gel as positive controls at 50 ng. A negative control of untransformed wild-type (WT; Col-1) was also included. Several bands appear on the gel - \*1: 30 kDa band thought to show incomplete dissociation in the presence of SDS, \*2: intact GNA-ButaIT, \*3: approx. 12.5kDa kDa band degradation product at the same molecular weight as native GNA.



**Figure 5.8** Western blot (probed with anti-GNA antibodies) to show representative expression of ButaIT-GNA in leaves of transformed *Arabidopsis thaliana* used in feeding bioassays. Three independent T<sub>3</sub> transgenic plants (1, 2, 3) expressing (A) ButaIT-GNA (line 40); (B) ButaIT-GNA (line 45) loaded onto 17.5% SDS-PAGE gel at 25µg (a) and 50µg (b) total soluble protein (TSP). Recombinant GNA standards of 25ng and 50ng and recombinant ButaIT-GNA at 25ng are included as positive controls. Wild type negative control was not included however previous western blots have shown no reactivity with GNA antibodies (figure 5.4, 5.5). Similar band patterns are observed in both lines - \*1: (B) plant 1, sample a band at 66kDa does not appear in previous samples with this line or within same plant loaded on at 50µg so presumed to be a gel artifact, \*2: 30 kDa band thought to show incomplete dissociation in the presence of SDS, \*3: intact ButaIT-GNA \*4: Degradation product \*5: band approx 12 kDa degradation product similar in molecular weight to native GNA.



**Figure 5.9**  
**Expression of GNA, GNA-ButaIT and ButaIT-GNA in roots of T<sub>3</sub> transformed *Arabidopsis thaliana* plants.** Two independent T<sub>3</sub> stage transgenic plants (1, 2) expressing GNA (line 3), GNA-ButaIT (line 5) and ButaIT-GNA (lines 45 and 40) loaded onto 17.5% SDS-PAGE gel at 25µg total soluble protein (TSP). Recombinant GNA and ButaIT-GNA standards of 25ng were loaded on as positive controls. Wild type (WT; Col-1) 25µg TSP loaded on as negative control. GNA plants show expression of a single band at approx. 12.5kDa which represents native GNA at approx. 0.1% TSP. GNA-ButaIT show expression of two bands; a degradation product at the same molecular weight as native GNA and intact GNA-ButaIT at approx. 0.1% TSP. Both lines 45 and 40 of ButaIT-GNA show a band representing degradation product at the same molecular weight as native GNA. Line 45 shows a band representing intact fusion protein at approx 0.01% TSP while line 40 shows barely detectable expression of intact fusion protein.

### **5.3 Demonstration on functionality of fusion proteins expressed *in planta***

In order to assess the functionality of the expressed fusion proteins, the plants needed to be fed to an insect pest that would feed on *Arabidopsis*. Ideally, as this study is targeting coleopteran insect pests, a coleopteran pest would have been assayed. A small starter culture of yellow striped flea beetle (*Phyllotreta nemorum*) was obtained from Dr. de Jong, Wageningen, Denmark. However, despite many efforts, a substantial population required for insect bioassay could not be established.

However, toxicity of ButaIT, GNA based fusion proteins have previously been shown against larvae of the tomato moth (*Lacanobia oleraceae*) (Trung *et al.*, 2006). Although not the ideal target pest, bioassays using this insect would enable functionality to be tested. It would also enable direct comparison of biological activity with *P. pastoris* expressed fusion protein fed within artificial diet assays.

#### **5.3.1 Effect of transgenic *Arabidopsis* expressing fusion proteins incorporating ButaIT and GNA when fed to *Lacanobia oleracea***

20 neonate *Lacanobia oleracea* larvae were placed in pots (5 per pot) and allowed to feed on detached leaves from T<sub>3</sub> replicate homozygous transgenic *Arabidopsis* plants expressing GNA at 0.15-0.2% total soluble protein (TSP) (line 3), GNA-ButaIT at 0.1-0.15% TSP (line 5) and two independent lines (40 and 45) of ButaIT-GNA *Arabidopsis* expressing at 0.15% TSP. Survival was measured over the course of a 14-day period and weights were measured at days 11 and 14. Assays were repeated under the same conditions once giving a total number of individuals per treatment of 40.

Survival is shown to be significantly different between control insects (93% survival) and the ButaIT-GNA line 40 (65% survival) which has an expression level in leaves of approx. 0.15% total soluble protein (TSP) (Kaplan–Meier survival curves; Mantel–Cox log-rank tests;  $P = 0.0002$ ). The same line of ButaIT-GNA also shows significantly different survival when compared to larvae fed GNA (line 3) expressing at approx. 0.15-0.2% TSP which shows larval survival of 90% (Kaplan–Meier survival curves; Mantel–Cox log-rank tests;  $P = 0.0074$ ) (figure 5.10).

Larvae fed leaves expressing ButaIT-GNA (line 45) at approx. 0.15% TSP show a survival rate of 70%. This is significantly different from larvae fed untransformed wild type leaves as control (Kaplan–Meier survival curves; Mantel–Cox log-rank tests;  $P = 0.0004$ ) (figure 5.10). The level of survival is also significantly different from larvae fed GNA (line 3) expressing leaves at approx. 0.15-0.2% TSP in leaves (Kaplan–Meier survival curves; Mantel–Cox log-rank tests,  $P = 0.0295$ ) (figure 5.10). Between the two lines of ButaIT-GNA there is no significant difference in survival ( $P = 0.5468$ ).

The transgenic plant bioassays suggest a difference in toxicity between the two versions of the fusion protein containing GNA and ButaIT. ButaIT fused onto the C-terminus of GNA caused significantly less mortality compared to both lines when the toxin is fused to the N-terminal of GNA (line 40  $P = 0.0148$ ; line 45  $P = 0.0470$ ). Also, the difference in survival seen between larvae fed GNA-ButaIT (85% survival) expressing leaves at approx 0.1-0.15% TSP and control fed larvae is not significant (Kaplan–Meier survival curves; Mantel–Cox log-rank tests,  $P = 0.2889$ ). There is also no significant difference seen in the level of surviving larvae fed leaves expressing GNA at 0.15-0.2% TSP and leaves expressing GNA-ButaIT fed at 0.1-0.15% TSP (Kaplan–Meier survival curves; Mantel–Cox log-rank tests,  $P = 0.6153$ ). Insects fed leaves expressing GNA had no significant difference in survival when compared to insects fed control leaves (Kaplan–Meier survival curves; Mantel–Cox log-rank tests,  $P = 0.5552$ ) (figure 5.10).

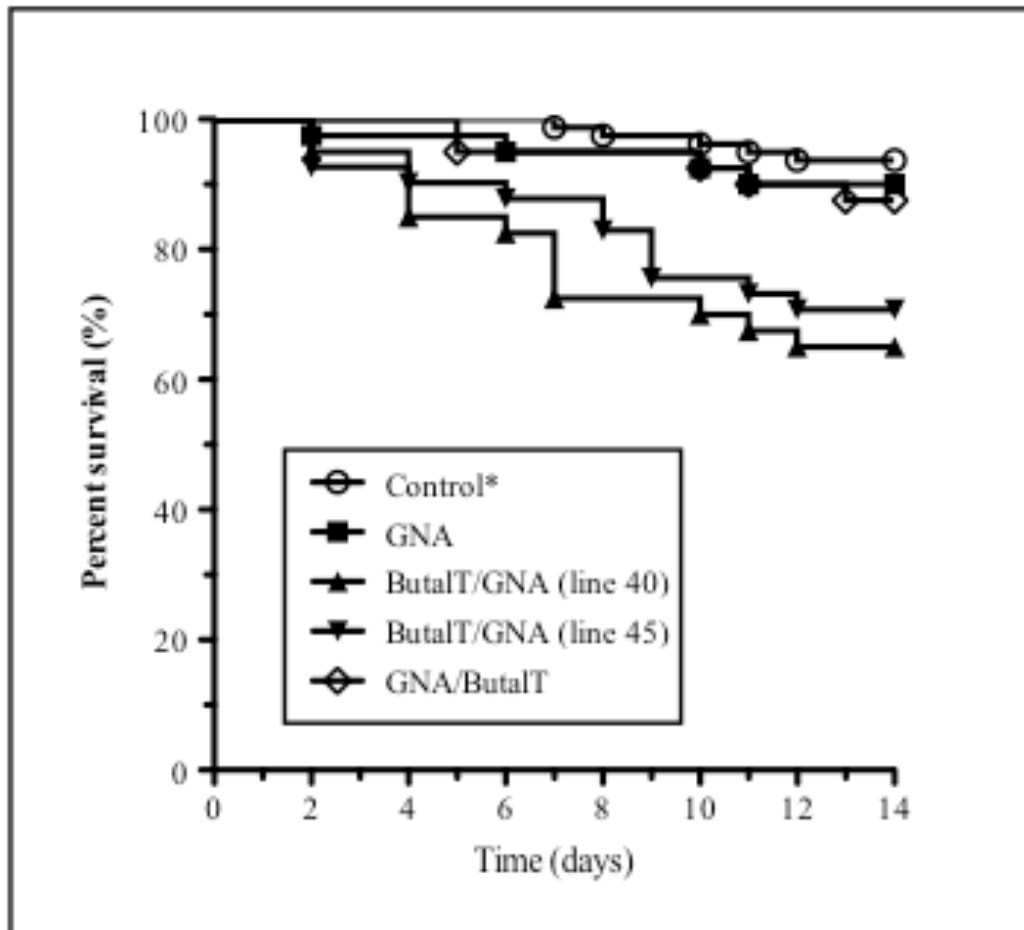
Feeding assays were repeated twice however larvae grew more slowly in some experiments. For this reason not all weight data could be combined together (figure 5.11). Although it would appear from statistical analysis that the ButaIT-GNA expressing plants have a negative effect on survival, there is no similar effect on growth of surviving larvae.

Comparing weight data for ButaIT-GNA (line 45) expressing at approx 0.15% TSP, GNA expressing at approx. 0.15-0.2% TSP and GNA-ButaIT expressing at approx 0.1-0.15% TSP (figure 5.11; A), for both days 11 and 14 there is a significant

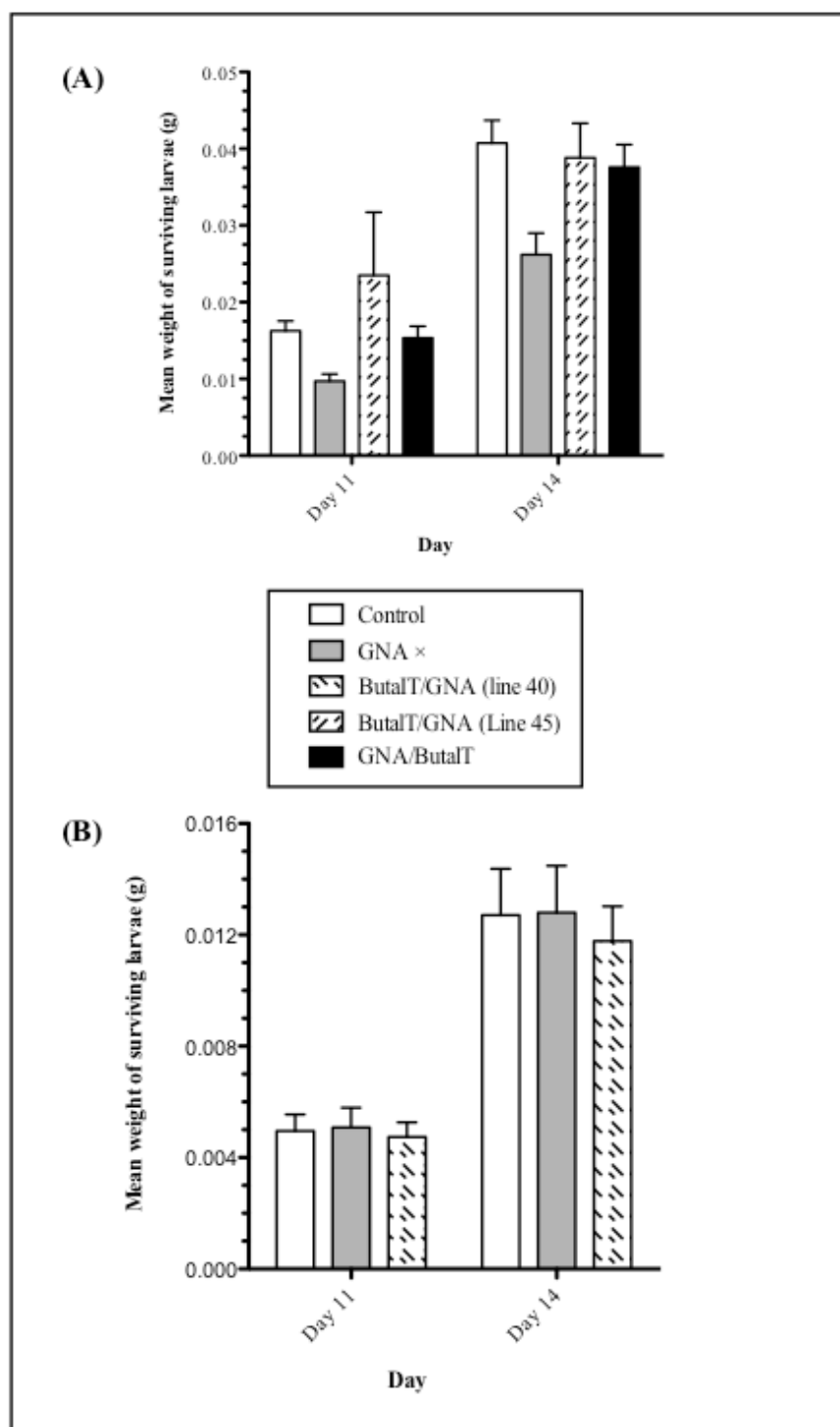
difference seen in mean weight between control and GNA, with larvae feeding on plants expressing GNA showing retarded growth. (Student's T-test,  $P < 0.05$ ). At day 11 surviving larvae fed ButaIT-GNA (line 45) show increased growth when compared to controls however this is shown not to be significant (Student's T-test,  $P < 0.05$ ). By day 14 however the control larvae have caught up in weight and the difference is not significant (Student's T-test,  $P > 0.05$ ). There is a slight growth reduction effect by plant material expressing GNA-ButaIT, however is not significant compared to control larval weights at either day 11 or day 14 ( $P > 0.05$ ).

Despite ButaIT-GNA (line 45) showing higher larval weight when compared to GNA insects, statistical analysis shows no significant difference on day 11 ( $P > 0.05$ ). On day 14 however there is a statistical difference ( $P < 0.05$ ). Weight of surviving larvae fed GNA leaves expressing at 0.15-0.2% TSP compared with GNA-ButaIT at 0.1-0.15% show significance at both day 11 and 14 ( $P < 0.05$ ). Between GNA-ButaIT (45) and ButaIT-GNA (5) the difference in weight is not significant for both days ( $P > 0.05$ ).

Comparing weights of data for GNA expressing at approx 0.15-0.2% TSP and ButaIT-GNA (line 40) expressing at approx 0.15% TSP (figure 5.11; B), there is interestingly no significant difference between control fed larvae and either treatment (Student's T-test,  $P > 0.05$ ). There is also no significant difference seen when weight of surviving GNA fed larvae are compared to weights of ButaIT-GNA (line 40) fed larvae (Student's T-test,  $P > 0.05$ ).



**Figure 5.10**  
**Kaplan-Meier survival curves of *Lacanobia oleracea* fed *Arabidopsis thaliana* expressing recombinant GNA at 0.15-0.2% total soluble protein (TSP), GNA-ButaIT at 0.1-0.15% TSP and ButaIT-GNA lines 40 and 45 at approx 0.15% TSP each.** Data is obtained from 40 individuals and 80 control individuals. Both lines of ButaIT-GNA show significant reduction in survival when compared to GNA and control survival (Mantel-Cox log-rank tests,  $P < 0.05$ ). GNA-ButaIT survival is not significant when compared to either control or GNA survival (Mantel-Cox log-rank tests,  $P < 0.05$ ).



**Figure 5.11**

Mean weight of surviving *Lacanobia oleracea* larvae fed transgenic *Arabidopsis* expressing recombinant proteins in separate assays after 11 and 14 days. **(A)** Weight of surviving larvae fed leaves expressing GNA at approx. 0.15-0.2% total soluble protein (TSP), ButaIT-GNA (line 45) at approx. 0.15% TSP and GNA-ButaIT at approx. 0.1-0.15% TSP. **(B)** weight of surviving larvae fed leaves expressing GNA (line 3) at approx. 0.15-0.2% TSP and ButaIT-GNA (line 40) at approx. 0.15% TSP. Control larvae were fed untransformed wild type *Arabidopsis* leaves. Mean weight in (g), data obtained from 40 individuals, GNAX data obtained from 20 individuals.

## **Discussion**

### Oral toxicity of fusion protein incorporating ButaIT and GNA against *T. castaneum*

Contrary to earlier claims of lepidopteran specificity of Indian red scorpion (*Mesobuthus tamulus*) toxin (ButaIT), it has been shown to be toxic to dipteran, coleopteran and dictyopteran insects (Trung *et al.*, 2006; Fitches *et al.*, 2010). Wudayagiri *et al.* (2001) reported no effects upon injection of blowfly larvae at 1  $\mu\text{g}$  100  $\text{mg}^{-1}$  purified ButaIT. However, Fitches *et al.* (2010) demonstrated significant effects both by injection and in feeding assays against *M. domestica*. This could however be as a result differences in injection doses as Fitches *et al.* reported little mortality was recorded at an injection dose equivalent to 2.5  $\mu\text{g}$  ButaIT 100  $\text{mg}^{-1}$  of *M. domestica* flies. This work also shows further evidence of the toxicity of ButaIT to a wider range of insect orders than first described by Wudayagiri *et al.*

Fitches *et al.* (2010) found that linking ButaIT to the C-terminus of GNA (GNA-ButaIT) appeared to improve stability during expression and purification, as cleavage of the C-terminus, evident in both versions of ButaIT-GNA, did not occur. Similarly, alteration of the toxin location relative to GNA and changes to the linker region did not negate biological activity in feeding assays against *M. domestica*. In this study, using *Tribolium* larvae as a test organism, addition of a C-terminal polyhistidine tag to ButaIT-GNA constructs did not alter the toxicity of the fusion proteins (figure 5.1; A). However, addition of a N-terminal strep-tag did seem to alter toxicity. ButaIT fused to the N-terminal of GNA with an AAA linker region and N-terminal strep-tag (Strep-ButaIT-(AAA)-GNA) resulted in a reduction in survival of 40% (figure 5.2; A) compared to reduction in survival by 65% for the same assembly but instead of the N-terminal strep-tag, a C-terminal extension of myc and polyhistidine tags are present (ButaIT-(AAA)-GNA-(his)<sub>6</sub>) (figure 5.1; A).

Fed at the same dose (2mg  $\text{g}^{-1}$ ), Strep-GNA-(AAA)-ButaIT is less toxic than Strep-ButaIT-(AAA)-GNA which in turn is less toxic than ButaIT-(AAA)-GNA $\pm$ (his)<sub>6</sub> (reductions in survival of 15-20%, 40% and 65-70% respectively). This difference in toxicity may reflect the structure of the toxin and conserved residues. ButaIT and

other 'short' scorpion toxins have higher sequence variability at the C-terminus than the N-terminus where at amino acid 2 there is always a completely conserved cysteine residue which in ButaIT forms a disulphide bond with Cys<sup>19</sup> which cross-links the  $\alpha$ -helix to the N-terminal strand of the  $\beta$ -sheet (Wudayagiri *et al.* 2001, Trung *et al.*, 2006). The C-terminus of the toxin may play less of a role in biological activity and therefore extension in this terminus does not alter toxicity while a free N-terminus is important to maintain correct structural formation. Alternatively, altering assembly causes differences in stability in the *T. castaneum* gut environment, which is a factor known to alter toxicity (Fitches *et al.*, 2004a; chapter 3) Stability studies were attempted to elucidate this (data not shown), however fusion protein could not be detected within gut or contents which might indicate that the larvae are not eating enough of the toxin to be detected.

The data for weight gain by larvae in the *Tribolium* bioassays are complicated by the effects of GNA itself. Whereas GNA has little or no effect on survival, the protein causes a consistent decrease in growth rates, as measured by weight gain. GNA was shown to cause most of the retardation in growth of larvae fed fusion proteins containing ButaIT and GNA (figures 5.1; B and 5.2; B). The reduction in weight is not unexpected as GNA and other lectins are known to have anti-metabolic effects to coleopteran insect pests (Murdock *et al.*, 1990; Hogervorst *et al.*, 2006).

ButaIT, fed to *T. castaneum* larvae resulted in no reduction in survival but significant reduction in larval weight over the assay period (figures 5.1; B and 5.2; B). ButaIT fed to larvae of the lepidopteran pest *Spodoptera littoralis* also resulted in no impact on survival but a small reduction in growth when compared with control insects was observed (Fitches *et al.*, 2010). This may indicate that the toxin shows mildly repellent activity causing an anti-feeding effect or that the toxin alone exhibits a weak oral toxicity.

*Expression and biological activity of fusion proteins incorporating ButaIT, GNA in planta*

These constructs were created and successfully expressed in *Arabidopsis*; GNA and ButaIT fused to both C and N-terminals of GNA. Transformation rates were seen at approx 0.2% and 0.4% respectively. Cough and Bent (1998) claim using their method, modified from Bechtold *et al.* (1993), that transformation efficiencies of above 1% can be obtained. The transformation rates seen in this study are much lower than expected. Plant health and the developmental state of the flowers have been shown to be the most important factors of high transformation rates (Desfeux *et al.*, 2002). Although recommendations of plant size and developmental stage were adhered to, it cannot be ruled out that plant health affected transformation together with the combination of *Arabidopsis* ecotype and strain of *Agrobacterium* which are also known to have an effect on transformation rates (Dehestani *et al.*, 2010).

Constructs for fusion protein expression contained the signal peptide but did not contain the C-terminal signal peptide of GNA. Fouquaert *et al.* (2007) created several variants omitting the C and N terminal signal peptides and fusions with GFP for localization to investigate the function of the C-terminal extension. The study found that expressed without the C-terminal peptide, the protein was held within the ER/nuclear envelope. Although partial secretion could not be ruled out, it was suggested that carbohydrate-binding sites of GNA are fully accessible when expressed without the CTP and as a result, the protein can interact with high mannose N-glycans in the lumen of the ER. This would result in formation of aggregates that are excluded from the secretory pathway (Fouquaert *et al.*, 2007).

Proteins not secreted properly may result in degradation by proteases within the endoplasmic reticulum (ER) and Golgi apparatus pathway (Sharp and Doran, 2001). If the protein were held within the ER when expressed, degradation witnessed in this chapter would therefore be explained. Further work to evaluate this would include expression of the fusion proteins with the CTP to investigate the level of cleavage. However, it could be that as in *P. pastoris*, that the fusion proteins are just liable to proteolytic cleavage during expression. ButaIT fused to the C-terminus of GNA is shown to be more stable than fused to the N-terminus of GNA when expressed in *P. pastoris* and a similar level when expressed in *Arabidopsis*. If this was the case,

multiple protease inhibitors could be co-expressed. Representative classes of inhibitors of cysteine and aspartic proteases [kininogen domain 3 (K), stefin A (A), cystatin C (C), potato cystatin (P) and equistatin (EIM)] have been fused together to form multi-domain proteins comprising of four (K-A-C-P) to five (EIM-K-A-C-P) individual domains and expressed in potato, have been shown to be less susceptible to plant proteases than the single domain protease inhibitors (Outchkourov *et al.*, 2004).

In order to show that fusion proteins could be expressed in plants and retain biological activity, neonate larvae of *L. oleracea* were placed on detached leaves of T<sub>3</sub> homozygous *Arabidopsis* plants for 14 days. Leaves were changed every 2 days or as required. Larvae fed leaves expressing ButaIT fused to the C-terminus of GNA at 0.1-0.15% total soluble protein (TSP) showed no significant difference from control fed insects. This marginal reduction in survival is also seen when Strep-GNA-(AAA)-ButaIT is fed to *Tribolium* providing further evidence that ButaIT fused to the N-terminus of GNA reduces activity of the toxin.

*L. oleracea* larvae fed leaves expressing ButaIT fused to the N-terminus of GNA in two plant lines at 0.15% TSP showed approx. 30-35% reduction in survival (figure 5.10). Trung *et al.* (2006) found third instar *L. oleracea* larvae fed ButaIT-GNA in artificial diet at 4.5% w/w showed 25% reduction in survival over a period of 12 days. Survival between insects fed artificial diet containing ButaIT-GNA expressed in *P. pastoris* and protein expressed *in planta* is comparable suggesting that recombinant ButaIT-GNA expressed in *Arabidopsis* has retained biological activity. GNA fed at 5% w/w in artificial diet shows no significant effect on survival in the study by Trung *et al.* which is also the case when GNA expressed in *Arabidopsis* at 0.15-0.2% TSP is fed to *L. oleracea*.

The weight data presented however, shows variability between the repeated assays. This is most clear when comparing GNA (figure 5.11). In one set of assays all larvae grew much slower throughout the assay period than in the other. Trung *et al.* (2006) found ButaIT-GNA expressed in *P. pastoris* and fed to third instar *L. oleracea* larvae in artificial diet at 4.5% w/w reduced weight after 12 days by 40% and GNA fed at

5% w/w minimally reduced weight gain. The same level of reduction in weight gain is seen when proteins are expressed *in planta* in this chapter. This difference in weight could be due to the background that the proteins are fed to the larvae in. The artificial diet fed to *L. oleracea* by Trung *et al.* was based on freeze-dried potato leaf diet (Fitches *et al.*, 1997) and shown to be sub-optimal for later instar insects. Differences in weight effects of *L. oleracea* fed proteins in freeze dried potato based artificial diet opposed to expressed in *Arabidopsis* have also been reported by Fitches *et al.* 2001 when *Phaseolus vulgaris* erythro- and leucoagglutinating isolectins caused no effect on development and growth of larvae but actually caused weight gain when fed in transgenic plant bioassays.

These assays show evidence that fulfills the objective of showing fusion proteins can be functionally expressed *in planta* however, additional replicates would be required to fully provide a scientifically rigorous proof of concept. Although testing two independent lines expressing ButaIT-GNA and showing similar survival reductions, which may indicate that it is not effects of the transformation that resulted in reduced survival of *L. oleracea* larvae, unexpected effects of transformation cannot be totally ruled out. Further assays that could be carried out to strengthen the transgenic plant assay findings would be including testing lines which show low or no expression but contain the transgene. This would ensure that it was the expressed fusion protein and not an effect of transformation that was causing reduction in survival of *L. oleracea* larvae.

### Summary

This chapter provides further evidence for the toxicity of ButaIT, GNA based fusion proteins against a wider range of insect pests than first reported (Wudayagiri *et al.*, 2001). Expression of fusion proteins, for the first time, in *Arabidopsis* resulted in intact protein expression of GNA, GNA-ButaIT and ButaIT-GNA at expression levels of 0.15-0.2%, 0.1-0.15% and 0.15% TSP respectively. Primary data for the toxicity of expressed ButaIT-GNA within *Arabidopsis* against *L. oleracea* larvae have shown reduction in survival of between 30-35% comparable with artificial diet assays against the same insect pest at 4.5% w/w.

## Chapter 6

### General discussion and conclusions

#### *New sources of insecticides for crop protection*

Within the EU where Directive 91/414 that acts to restrict the use of insecticides as plant protection products has been implemented. New legislation to update this Directive will potentially add to the loss of chemicals available for plant protection (EU communication to the Council, 2006). Given this withdrawal, or potential withdrawal, of some of the most effective but also the most environmentally destructive compounds for insecticidal use such as DDT and Aldrin, the need for new sustainable methods of control is apparent.

As a result, a vast quantity of proteins that originate from insect predators, pathogens and also from plant defensive systems have been identified as potential lead insecticidal peptides (Copping and Menn, 2000). Of these, protein or peptide toxins which target sites in the central nervous system of the pest form a major class of potential new insecticides.

Although proteins derived from plants, like lectins, have an advantage over other proteins such as venom-derived toxins or microbial agents in their bioavailability, and in acceptability to the public, they lack the potency seen with neurotoxic peptides (Fitches *et al.*, 1997; Atkinson *et al.*, 1998), and thus have proved difficult to introduce into commercial agriculture and horticulture. Venom-derived peptides like those from scorpions (Wugargiri *et al.*, 2001), wasps (Gould and Jeanne, 1984), cone snails (Olivera, 2002; Bruce *et al.*, 2001), predatory mites (Tomalski *et al.*, 1988) and spiders (Lipkin *et al.*, 2002; Tedford *et al.*, 2004) are highly insecticidal toxins, effective at small doses, and suitable examples from all these sources could be utilized for pest control. In the case of arachnid derived venom toxins, there are at 0.5 to 1.5 million peptides that are active against insects showing the large potential catalogue of new toxins available for crop protection strategies (Quistad and Skinner, 1994; Wang *et al.*, 2000; Tedford *et al.*, 2004). However, it is important to ascertain the insect specificity of the toxins, as some are specifically active against just

invertebrates, or have toxicity towards both vertebrates and invertebrates (Wang *et al.*, 2000; Miljanich, 2004).

Many of these insecticidal toxins derived from invertebrates are active against neuronal voltage dependent  $\text{Na}^+$ ,  $\text{K}^+$ ,  $\text{Ca}^{2+}$  or  $\text{Cl}^-$  channels; however toxins for unusual targets such as intracellular calcium activated ryanodine channels have also been found (Fajloun *et al.*, 2000). The target on which toxins act is important as the current chemical compounds targeting the central nervous system of pests aim to block or inhibit just one of a limited number of target sites: the voltage-gated sodium channel, the nicotinic acetylcholine receptor (nAChRs), the  $\gamma$ -aminobutyric acid (GABA) receptor, glutamate-gated chloride channel (GluCl), and acetylcholinesterase (Tedford *et al.*, 2004; Raymond-Delpech *et al.*, 2005). The use of toxins that target currently underused ion channels such as voltage gated calcium channels (VGCC), targets for  $\omega$ -ACTX-Hv1a used in this study, complements existing pesticides and may prove to slow the development of resistance or prove to be potent due to their essential role in insects and other organisms (Eberl *et al.*, 1998; Kawasaki *et al.*, 2002).

#### Delivery of venom derived insect neuropeptides

Toxins with sites of action in the central nervous system need to reach their target in order to be effective. When toxins are used as insecticides in nature, a sting is normally used to introduce the toxin into the haemolymph and thus gain access to neuronal ion channels. However, if used as crop protection agents, most venom peptides would be unlikely to pass through the insect cuticle if applied topically, or cross the insect gut epithelium if administered orally (Quistad *et al.*, 1991). There are a number of options available in order to exploit these highly potent toxins that include vectored delivery or fusion to a lectin carrier, as was investigated in this study.

#### 1. Fusion with a protein 'carrier'

There have been a number of different successful fusion proteins incorporating neurotoxins with snowdrop lectin, GNA (*Galanthus nivalis* agglutinin), as the carrier protein (Fitches *et al.*, 2002, 2004a, 2004b, 2010; Trung *et al.*, 2006). However,

although this method has been established as a successful technique for making toxins orally effective, a number of questions about the underlying mechanisms remain. First, although evidence for transport of GNA across the gut epithelium involving binding to the gut surface and subsequent endocytosis has been presented (Fitches *et al.*, 2001), the mechanism of transport of this protein across the gut is not fully understood. A range of other proteins, including bovine serum albumin, are transported across lepidopteran guts (Casartelli *et al.*, 2005; Jeffers *et al.*, 2005), and a megalin-like receptor mechanism has been implicated in this process (Casartelli *et al.*, 2008). Similarly, peptides derived from the storage protein vicilin are transported to the haemolymph of bruchid seed weevils feeding on seeds containing the protein (Souza *et al.*, 2010). The effectiveness of GNA as a "carrier" in fusion proteins has been assumed to be due to binding to gut surfaces through its carbohydrate binding activity. This has been investigated and transport was not observed when GNA is subjected to boiling or is inhibited when incubated with mannose suggesting in the case of GNA that transport is directly due to its lectin activity (Fitches, 1998). In addition, stability to digestion in the gut may be another factor that affects transport.

A second factor in the success of GNA as a carrier protein in recombinant fusion proteins may be due to its activity during protein translation and post-translational folding and modification. When compared to the similar garlic lectins, GNA was able to form fully functional recombinant fusion proteins, whereas toxins fused to garlic lectin had no biological activity (Fitches *et al.*, 2008). This result suggested that toxins fused to garlic lectin were not correctly folded, or had scrambled disulphide bonds. Arthropod neurotoxins are also rich in disulphide bonds while GNA has 3 three cysteins at positions 29, 52 and 86 per subunit and has one intrachain disulfide bond between Cys<sup>29</sup> and Cys<sup>52</sup> (Hester *et al.*, 1995; Tedford *et al.*, 2004); it is possible that recruitment of protein folding aids and disulphide isomerases to assist GNA folding in the ER when expressed as a recombinant protein in yeast or plants enhances the folding of the toxin part of the fusion. The insecticidal activity of GNA-based fusion proteins is comparable to synthetic toxins (on a molar basis), providing evidence that toxin folding has been completed successfully (figures 3.10 and 4.7).

The possibility of using other suitable proteins fused to arthropod neurotoxins to produce orally effective insecticides remains open, but unproven. Further research in this area is in progress. In this study GNA was used as the carrier domain for fusion proteins, and linkage of scorpion toxins (ButaIT) and spider toxins ( $\omega$ -ACTX and  $\kappa$ -ACTX) to GNA was carried out in order to investigate their toxicity to coleopteran pests.

The results from this study show that fusion proteins, with spider and scorpion toxic elements are likely to show high levels of insecticidal activity towards coleopterans. (His)<sub>6</sub>-GNA- $\omega$ -ACTX and  $\omega$ -ACTX-GNA-(his)<sub>6</sub> show the highest toxicity to *Tribolium* causing complete mortality when fed in diet at 1 mg g<sup>-1</sup>. Scorpion toxin (ButaIT) and GNA fusions show a reasonable reduction in survival with the highest toxicity shown by ButaIT-GNA-(his)<sub>6</sub> fed at 2mg g<sup>-1</sup> (35% survival after 42 days).

Stability within the insect gut environment is a key factor when considering fusion protein toxicity as was seen for the  $\kappa$ -ACTX, GNA based fusion proteins in chapter 3 where complete breakdown was seen in gut environments and no oral toxicity was observed. It is however also important to consider the stability of fusion proteins within the insect hemolymph. To be successfully toxic the proteins need to be able to withstand gut proteolysis however when transported across into the hemolymph they may need to be able to breakdown to release free toxin. If fusion proteins are too stable when transported into the haemolymph, free toxin cannot interact with their targets on the central nervous system. It has been observed in lepidopteran larvae that the breakdown of ButaIT-GNA within the haemolymph is directly comparable with insecticidal activity (Fitches E., Personal communication).

## 2. Baculoviruses and other insect viruses

An alternative method of delivery of insecticidal arthropod toxins would be vectored delivery within insect viruses such as baculoviruses. These arthropod-specific viruses cannot infect vertebrates or plants (Gröner, 1986; Black *et al.*, 1997; Herniou *et al.*, 2003). Although mammalian cells can uptake these viruses, they are incapable of replicating in vertebrate hosts (Kost and Condreay, 2002).

Spider toxins used within this study  $\omega$ -ACTX-Hv1a or  $\kappa$ -ACTX-Hv1c have been expressed within these viruses and shown in preliminary data to kill *H. virescens* more quickly than wild-type virus. Importantly, potency can be significantly improved by expressing both toxins simultaneously (Tedford *et al.*, 2004; Maggio, Mukherjee, and King, unpublished data). This was also seen when synergistic expression of excitatory and depressant scorpion neurotoxins was expressed in baculoviruses and reduced the  $ET_{50}$  in *H. virescens* by 18-22% compared to larvae infected with recombinant viruses that express only one of the toxins (Regev *et al.*, 2003).

However, the only well-documented hosts are Diptera, Hymenoptera, and Lepidoptera (Erlandson, 2008). Strategies to counteract some of the limitations of baculoviruses, especially their slow killing activity, have been shown to be successful like those for co-expression of toxins. However, with some exceptions such as viral control of the soybean caterpillar (*A. gemmatilis*) in Brazil (Moscardi, 1999), viral pesticides have not been successfully commercialized. Along with this, there is little evidence of baculoviruses that are active against coleopteran insect pests. *Oryctes rhinoceros* virus (OrV) shown to suppress coconut rhinoceros beetle, (*Oryctes rhinoceros* L.) (Zelazny *et al.*, 1992; Prasad *et al.*, 2008) was thought to belong to nonoccluded baculovirus based on structural similarities however it was later described as a different virus type (Huger, 2005).

Another insect virus that has been isolated exclusively from Coleoptera is Alphaentomopoxvirus. It was thought that they were too similar to vertebrate poxviruses however, from genome data, it can be seen that entomopoxviruses have a set of collinear core genes that distinguish them from vertebrate poxviruses (Erlandson, 2008). Also, the evidence for host restriction of entomopoxviruses to insects is strong suggesting that these viruses could be a potential vector for delivery of toxins (Erlandson, 2008). However, given the success of baculoviruses for control of lepidopteran pests and the lack of commercialization together with the lack of evidence for the use of insect viruses for the control of coleopteran pests, it is unlikely that this method of delivery would be more suitable than other methods such as fusion to a lectin carrier.

### 3. Delivery of neurotoxins and fusion proteins in planta

Methods of delivery described previously have been considered under the assumption that the neurotoxins show no toxicity upon oral administration. This is not the case with all neurotoxins as both  $\omega$ -ACTX from *H. versuta* and another toxin from *Macrothele gigas* spider, Magi 6, have been shown to be orally active when expressed *in planta* and fed to *H. armigera*, *S. littoralis* and *S. frugiperda* (Khan *et al.*, 2006; Hernández-Campuzano *et al.*, 2009). Interestingly  $\omega$ -ACTX was also shown to be toxic by topical application (Khan *et al.*, 2006). However oral activity was not observed upon droplet feeding to *L. oleracea* (Fitches E., Personal communication). Further investigation would be required to ascertain the level of oral toxicity, if any, which was caused by the toxin alone when fed to *T. castaneum* in this study.

If it were the case that neurotoxins show oral activity, delivery via *in planta* expression would need to be explored as the expression of invertebrate toxins has previously been shown to be successful (Khan *et al.*, 2006; Hernández-Campuzano *et al.*, 2009) In the study, the toxin sequence was introduced with codons optimized for tobacco expression but without a plant signal peptide. In contrast in the work carried out within this thesis the GNA signal peptide was fused to the N-terminus of the toxin and the construct transformed into *A. thaliana*. Upon investigating expression by RT-PCR of presumed transformed plants by antibiotic selection, no expression was observed (data not shown). This suggests that either a failure in antibiotic selection occurred or alternatively an error during transformation.

However, in this study the *Arabidopsis* plant expression system was, for the first time, used successfully to express lectin-toxin fusion proteins *in planta*. Although expression in *P. pastoris* yields relatively high levels of recombinant proteins which can be used in artificial diet bioassays of target insect pests, or produced on a large scale as an exogenously applied insecticide, expression of fusion proteins or indeed neurotoxins alone *in planta* offers the possibility of producing endogenous resistance to insect pests in crops. Expression *in planta* allows for a more direct approach to control coleopteran pest species, and particularly wireworm, where expression of insecticidal proteins can offer direct protection to parts of crop plants, such as potato tubers, which are difficult to treat with exogenous insecticides (Chaton *et al.*, 2008).

The potential for endogenously expressing fusion proteins in plants will be an avenue to be explored for some time due to their toxicity to a range of insect species (Fitches *et al.*, 2004a, 2010). Although the level of mortality observed in this study is 30-35% when *L. oleracea* larvae were fed *Arabidopsis* expressing ButaIT-GNA at 0.15% total soluble protein (figure 5.10), which is nowhere near the level of mortality seen for Bt toxins, it is important to note that survival levels are similar to artificial diet assays at 4.5% w/w dietary protein as part of artificial diet studies (Trung *et al.*, 2006). This shows that fusion proteins can be functionally expressed within transgenic plants. However, the choice of toxin to express within plants together with to the insect available to bioassay was not the ideal combination to achieve maximal mortality rates.

ButaIT-GNA had previously been shown to be highly toxic to larvae of the Colorado potato beetle, and was also the most insecticidal fusion protein towards other insect orders previous to the work carried out within this thesis (ISAGRO, Personal communication; Trung *et al.*, 2006).  $\omega$ -ACTX based fusion proteins were shown in *T. castaneum* bioassays to be the more toxic than ButaIT constructs (figures 4.8-4.10 and 5.1-5.2); however, expressed in *Arabidopsis* they showed a high level of cleavage by proteolysis *in planta* (figures 4.12-4.13 and 5.7-5.9). Based on recombinant fusion protein bioassay data against *T. castaneum*, (his)<sub>6</sub>-GNA- $\omega$ -ACTX, which is the most toxic to this species, would be worth pursuing in further work for expression in transgenic plants in order to provide protection against coleopteran pests. Given the expression and cleavage problems observed with the  $\omega$ -ACTX and GNA based constructs, investigation into improving stability *in planta* could form the basis of further work as discussed previously.

However, despite success within some important crops, single transgene expression (including Bt-modified crops), may not provide sustainable crop protection within many standard cultivars as single gene products often lack broad enough activity to work effectively against all major pests species within such systems (Sharma *et al.*, 2004). This has been addressed by stacking different genes together for example Bt toxins were stacked with GNA and shown to increase toxicity as well as increase the range of resistance against pest species to include hemipteran pests (Maqbool *et al.*,

2001; Ramesh *et al.*, 2004), on which Bt products have no effect alone (Bernal *et al.*, 2002). However, if the purpose is to target just one insect order, although toxins identified and used within the fusion protein system to date have not shown this ability (Fitches *et al.*, 2004b, 2010), there is still a large catalogue of potential toxins that have the potential to be order specific (Escoubas *et al.*, 2006).

If expressed *in planta*, fusion proteins would have to show a competitive level of potency when compared to the current most successful, and the only sanctioned gene to be used within transgenic crops; Bt toxins (Sanahuja *et al.*, 2011). Bt genes have been given the highest level of interest mainly due to the fact that other transgenes do not confer the same degree of insecticidal activity. For example plant derived insecticidal proteins such as PI and lectin genes expressed *in planta* largely affect insect growth and development and, in most instances, do not result in insect mortality (Fitches *et al.*, 1997; Outchkourov *et al.*, 2004a, 2004b). They also require much higher effective concentrations of these proteins than required for the Bt toxin proteins. For example, transgenic tobacco plants carrying a baculovirus *enhancin* gene have been demonstrated to slow the development, and increase the mortality, of *Trichoplusia ni* larvae, but with comparatively less efficiency than Bt toxins (Hayakawa *et al.*, 2000; Cao *et al.*, 2002). Although Bt toxins are successful, accounts of insect resistance have been reported and so there is a constant need for new and alternative approaches to current methods of crop protection such as fusion protein technology and the use of venom-derived peptides (Tabashnik, 1994; Downes *et al.*, 2010).

#### Alternative approaches to crop protection

Other alternative strategies that may be useful in conjunction with fusion proteins to reduce the development of insect resistance or strategies that have previously proved themselves successful at controlling coleopteran pests are pyramiding toxins, RNA interference (RNAi) and expression of semiochemicals in transgenic plants.

As with Bt toxins, pyramiding different genes for control of insect pests may prove to be successful either in increasing the potency of the insecticide or reducing development of resistance. An example of a successful product is SmartStax™

transgenic corn which contains six insect resistance genes active against corn rootworm and lepidopteran pests (rootworm; Cry34Ab1 + Cry35Ab1, modified Cry3Bb1: lepidoptera; Cry1F, Cry1A.105, Cry2Ab2) and two genes giving tolerance to herbicides (glyphosate and glufosinate-ammonium) (Grainnet, 2007)

Protease inhibitors, may be an example of crop protection proteins which by themselves may appear as a less attractive alternative to chemical control on their own but may prove useful in conjunction with fusion proteins to potentially increase the level of intact protein reaching the target site.

The use of semiochemicals in order to attract or repel coleopteran insect pests from plants is well known (Guerrero *et al.*, 1997). These chemicals could be used to attract coleopterans, specifically wireworm, to bait traps or within transgenic plants where fusion proteins were incorporated is an attractive method for ensuring wireworms are in contact with insecticidal fusion protein.

RNA interference has also proved to be a highly successful strategy against *T. castaneum* as well as other insect pests (Baum *et al.*, 2007) and could also be an interesting option for the control of wireworm. This technology involves double stranded RNA which, when either ingested through expression in transgenic plants or in artificial diet. The double stranded RNA interferes with expression of its target genes and therefore 'knocks out' the target gene. This is a highly targeted approach and can be tailored to specific insects that would avoid the problem of effects to non-target insect species. The technology although targeted would also involve the use of transgenic crops and a comprehensive review of this technology can be seen in Price and Gatehouse (2008).

In order to fully control coleopteran pests including wireworm however, more must be known about the insects themselves. Potential genetic targets are needed in the future for use in technologies such as RNAi and toxin choices for fusion protein technology. The investigation process would ideally include next generation sequencing. The technology was expensive and in its infancy at the start of this study. However, due to lowering costs this technology it would be an attractive approach for

further investigation into insect gene expression. Insecticidal targets could be identified from specific gene expression at certain points i.e. feeding. Therefore generation of an expressed sequence tag (EST) library would be more advantageous than sequencing the whole genome. As wireworm only feed for such a limited time during their life cycle (approximately 20%), insecticidal approaches need to be targeted with a high LD<sub>50</sub> to ensure rapid death. EST libraries from nervous tissues would therefore aid this by better understanding of neurological targets; aiding the identification of potential toxins within fusion proteins to control the insect pest. EST data from digestive tissues would also aid a full understanding of insect digestion and therefore facilitate the development of approaches to disrupt it.

### Conclusions

Biopesticides represent only about 1% of the world pesticide market, with Bt products constituting nearly 80% of this amount (Whalon and Wingerd, 2003). However, The organization for Economic Cooperation and Development predict an increase in sales to 20% of the market by 2020 suggesting a potential for a flourishing market for pesticides such as those derived from invertebrate venoms.  $\omega$ -ACTX,  $\kappa$ -ACTX and ButaIT have been shown to be functionally expressed as fusion proteins with GNA in *P. pastoris* and ButaIT and  $\omega$ -ACTX based proteins shown to significantly reduce survival of *T. castaneum* larvae. Expression of these lectin-toxin multi domain proteins in *Arabidopsis* has shown the ability of these proteins to be functionally expressed *in planta* and highlighted the need for future development of fusion proteins in transgenic plants. The results presented here show fusion proteins incorporating venom-derived neurotoxins as an attractive sustainable alternative to broad-spectrum pesticides either by themselves or in conjunction with other successful pest control methods.

---

**References**

- Airenne K.J. and Kulomaa M.S. (1995) Rapid Purification of recombinant proteins fused to chicken avidin. *Gene* **167** (1-2), 63-68.
- Angus T.A., (1956). Association of toxicity with protein- crystalline inclusions of *Bacillus sotto* Ishiwata. *Canadian Journal of Microbiology* **2**, 122-131.
- Ansari M.A., Evans M., Butt T.M., (2009). Identification of pathogenic strains of entomopathogenic nematodes and fungi for wireworm control. *Crop Protection* **28** (3), 269-272.
- Argos P., (1990). An investigation of oligopeptides linking domains in protein tertiary structures and possible candidates for general gene fusion. *Journal of Molecular Biology* **211** (4), 943-958.
- Aronson A.I., Shai Y., (2001). Why *Bacillus thuringiensis* insecticidal toxins are so effective: unique features of their mode of action. *FEMS Microbiology letters* **195** (1), 1–8.
- Atkinson N.S., Robertson G.A., Ganetzky B., (1991). A component of calcium-activated potassium channels encoded by the *Drosophila slo* locus. *Science* **253** (5019), 551-555.
- Atkinson R.K., Vonurx E.J., and Howden M.E.H., (1996). Effects of Whole Venom and Venom Fractions From Several Australian Spiders, Including *Atrux* (*Hadronyche*) Species, When Injected Into Insects. *Comparative Biochemistry and Physiology* **114C** (2), 113-117.
- Baum J.A., Bogaert T., Clinton W., Heck G.R., Feldmann P., Ilagan O., Johnson S., Plaetinck G., Munyikwa T., Pleau M., Vaughn T., Roberts J., (2007). Control of coleopteran insect pests through RNA interference. *Nature Biotechnology* **25**, 1322 – 1326.
- Baumgartner P., Harper K., Raemaekers R.J.M., Durieux A., Gatehouse A.M.R., Davies H.V., Taylor M.A., (2003). Large-scale production and purification of recombinant *Galanthus nivalis* agglutinin (GNA) expressed in the methylotrophic yeast *Pichia pastoris*. *Biotechnology letters* **25** (15), 1281-1285.
- Bechtold N., Ellis J., Pelletier G., (1993). *In planta Agrobacterium*-mediated gene transfer by infiltration of adult *Arabidopsis thaliana* plants. *Les Comptes Rendus de l'Académie des sciences, Life Sciences* **316**, 1194-1199.
- Belofsky G.N., Gloer J.B., Wicklow D.T., Dowd P.F., (1995). Anti insect alkaloids: Shearinines A-C and a new paxilline derivative from the ascomycota of *Eupenicillium shearii*. *Tetrahedron* **51**, 3959-3968.
- Bernal C.C., Aguda R.M., Cohen M.B., (2002). Effect of rice lines transformed with *Bacillus thuringiensis* toxin genes on the brown planthopper and its predator *Cyrtorhinus lividipennis*. *Entomologia Experimentalis Et Applicata* **102** (1) 21-28.
- Bimboim H.C., and Doly J., (1979) A rapid alkaline extraction procedure for screening recombinant plasmid DNA. *Nucleic Acids Research* **7** (6), 1513-1523.
- Black B.C., Brennan L.A., Dierks P.M., Gard I.E., (1997). Commercialization of baculoviral insecticides. Miller L.K., (eds.). Plenum Press, New York, 341-457.
- Blake C.C.F., Ghosh M., Harlos K., Avezoux A. Anthony C., (1994). The active site of methanol dehydrogenase contains a disulphide bridge between adjacent cysteine residues. *Nature Structural Biology* **1**, 103–105.
- Bloomquist J.R., (2003). Mode of action of atracotoxin at central and peripheral synapses of insects. *Invertebrate Neuroscience* **5**, 45–50.
- Bolter C.J., Jongsma M.A., (1995). Colorado potato beetles adapt to proteinase inhibitors induced in potato leaves by methyl jasmonate. *Journal of Insect Physiology* **41**, 1071–1078.
- Bontems F., Roumestand C., Gilquin B., Menez A., Toma F., (1991). Refined structure of charybdotoxin: common motifs in scorpion toxins and insect defensins. *Science* **254** (5037), 1521-152.

## References

---

- Boonserm P., Davis P., Ellar DJ., Li J., (2005). Crystal structure of the mosquito-larvicidal toxin Cry4Ba and its biological implications. *Journal of Molecular Biology* **348**, 363–382.
- Boonserm P., Mo M., Angsuthanasombat C., Lescar J., (2006). Structure of the functional form of the mosquito larvicidal Cry4Aa toxin from *Bacillus thuringiensis* at a 2.8-Angstrom resolution. *Journal of Bacteriology* **188**, 3391–3401.
- Boulter D., (1993). Insect pest control by copying nature using genetically engineered crops. *Phytochemistry* **34** (6), 1453-1466.
- Bourinet E. and Zamponi G.W., (2005). Voltage Gated Calcium Channels as Targets for Analgesics. *Current Topics in Medicinal Chemistry* **5** (6), 539-546.
- Bown D.P., Wilkinson H.S., Gatehouse J.A., (1997). Differentially regulated inhibitor sensitive and insensitive protease genes from the phytophagous insect pest *Helicoverpa armigera*, are members of complex multi-gene families. *Insect Biochemistry and Molecular Biology* **27** (7), 625–638.
- Bravo A., Gómez I., Conde J., Munõz-Garay C., Sánchez J., Zhuang M., Gill S.S., Soberón M., (2004). Oligomerization triggers differential binding of a pore-forming toxin to a different receptor leading to efficient interaction with membrane microdomains. *Biochimica et Biophysica Acta* **1667**, 38–46.
- Bravo A., Gill S.S., Soberón M., (2005). *Bacillus thuringiensis* Mechanisms and Use. *Comprehensive Molecular Insect Science*. Elsevier BV, Amsterdam, 175–206.
- Bravo A, Gill S.S., Soberón M., (2007). Mode of action of *Bacillus thuringiensis* Cry and Cyt toxins and their potential for insect control. *Toxicon* **49**, 423–435.
- Breitler J.C., Vassal J.M., Catala M.D., Meynard D., Marfa V., Mele E., Royer M., Murillo I., San Segundo B., Guiderdoni E., Messeguer J., (2004). Bt rice harbouring Cry genes controlled by a constitutive or wound-inducible promoter: protection and transgene expression under Mediterranean field conditions. *Plant Biotechnology Journal* **2**, 417–430.
- Broekaert W.F., Van Parijs J., Leyns F., Joos H., Peumans W.J., (1989). A chitin-binding lectin from stinging nettle rhizomes with antifungal properties. *Science* **245** (4922), 1100-1102.
- Brogdon W.G., and McAllister J.C., (1998). Insecticide resistance and vector control. *Emerging Infectious Diseases* **4** (4), 605-613.
- Brookes G., and Barfoot P., (2006). GM Crops: The First Ten Years - Global Socio-Economic and Environmental Impacts. ISAAA Brief No. 36. ISAAA: Ithaca, NY.
- Bruce C., Fitches E.C., Chougule N., Bell H.A., Gatehouse J.A., (2011). Recombinant conotoxin, TxVIA, produced in yeast has insecticidal activity. *Toxicon* **58** (1), 93-100.
- Butler A., Tsunoda S., McCobb D.P., Wei A., Salkoff L., (1993). *mSlo*, a complex mouse gene encoding “maxi” calcium-activated potassium channels. *Science* **261**, 221–224.
- Cao J., Ibrahim H., Garcia J., Mason H., Granados R., Earle E., (2002). Transgenic tobacco plants carrying a baculovirus *enhancin* gene slow the development and increase the mortality of *Trichoplusia ni* larvae. *Plant Cell Reports* **21** (3) 244-250.
- Casartelli M., Corti P., Leonardi M.G., Fiandra L., Burlini N., Pennacchio F., Giordana B., (2005). Absorption of albumin by the midgut of a lepidopteran larva. *Journal of Insect Physiology* **51** (8), 933-940.
- Casartelli M., Cermenati G., Rodighiero S., Pennacchio F., Giordana B., (2008). A megalin-like receptor is involved in protein endocytosis in the midgut of an insect (*Bombyx mori*, Lepidoptera). *American Journal of Physiology-Regulatory Integrative and Comparative Physiology* **295** (4), 1290-1300.
- Catterall W.A., Perez-Reyes E., Snutch T.P., Striessnig J., (2005). International Union of Pharmacology. XLVIII. Nomenclature and structure-function relationships of voltage-gated calcium channels. *Pharmacology Review* **57**, 411–425.
- Chao Q., Casalongue C., Quinn J.M. Etzler M.E., (1994). Expression and partial characterization of *Dolichos biflorus* seed lectin in *Escherichia coli*. *Archives of Biochemistry and Biophysics* **313**, 346-50.

## References

---

- Chapot M.P., Paumans W.J., Strosberg A.D., (1986). Extensive homologies between lectins from non-leguminous plants. *FEBS Letters* **195** (1-2) 231-234.
- Charbone E., Wanke E., Prestipino G., Possani L.D., Maelicke (1982). Selective blockage of voltage-dependent K<sup>+</sup> channels by a novel scorpion toxin. *Nature*. **296**, 90-91.
- Chaton P.F., Liégeois M.H., Meyran J.C., Ravanel P., Tissut M., (2003). Feeding behaviour as a limiting step in insecticide absorption for the wireworm *Agriotes* sp. (Coleoptera: Elateridae), *Pesticide Biochemistry and Physiology* **77** (3), 106–114.
- Chaton P.F., Lemperiere, M., Tissut P., Ravanel P., (2008). Biological traits and feeding capacity of *Ariotes* larvae (Coleoptera: Elateridae): A trial of seed coating to control larval populations with the insecticide fipronil. *Pesticide Biochemistry and Physiology*. **90**, 97-105.
- Chen J., Hua G., Jurat-Fuentes J.L., Abdullah M.A., Adang M.J., (2007). Synergism of *Bacillus thuringiensis* toxins by a fragment of a toxin-binding cadherin. *Proceedings of the National Academy of Science USA* **104**, 13901–13906.
- Chrispeels M.J., and Sadava D.E, (2002) *Plants, genes and crop biotechnology*. Jones and Bartlett, Sudbury; (MA), USA.
- Clough S.J., and Bent A.F., (1998). Floral dip: a simplified method for *Agrobacterium*-mediated transformation of *Arabidopsis thaliana*. *The Plant journal* **16**, 735-43.
- Chougule N.P., Doyle E., Fitches E., Gatehouse J.A., (2008). Biochemical characterization of midgut digestive proteases from *Mamestra brassicae* (cabbage moth; Lepidoptera: Noctuidae) and effect of soybean Kunitz inhibitor (SKTI) in feeding assays. *Journal of Insect Physiology* **54** (3), 563-572.
- Cloutier C., Fournier M., Jean C., Yelle S., Michaud D., (1999). Growth compensation and faster development of Colorado potato beetle (Coleoptera: Chrysomelidae) feeding on potato foliage expressing oryzacystatin I. *Archives of Insect Biochemistry and Physiology* **40**, 69-79.
- Copping L.G. and Menn J.J., (2000). Biopesticides: a review of their action, applications and efficacy. *Pest Management Science* **56** (8), 651-676.
- Craik D.J. and Adams D.J., (2007). Chemical Modification of Conotoxins to Improve Stability and Activity. *ACS Chemical Biology* **2** (7), 457–468.
- Cregg J.M., Cereghino J.L., Jianying S., Higgins D.R., (2000). Recombinant protein expression in *Pichia pastoris*. *Molecular Biotechnology* **16** (1), 23-52.
- Crickmore N., Zeigler D.R., Feitelson J., Schnepf E., Van Rie J., Lereclus D., Baum J., Dean D.H., (1998). Revision of the nomenclature for the *Bacillus thuringiensis* pesticidal crystal proteins. *Microbiology and Molecular Biology Reviews* **62**, 807-813.
- Cristofolletti P.T., de Sousa F.A.M., Rahbe Y., Terra W.R., (2006). Characterization of a membrane-bound aminopeptidase purified from *Acyrtosiphon pisum* midgut cells. *FEBS Journal* **273**, 5574–5588.
- Czajkowski C., and Karlin A., (1995) Structure of the nicotinic receptor acetylcholine-binding site: identification of acidic residues in the d subunit within 0.9 nm of the  $\alpha$  subunit-binding site disulfide. *Journal of Biological Chemistry* **270**, 3160–3164.
- Datta K., Vasquez A., Tu J., Torrizo L., Alam M.F., Oliva N., Abrigo E., Khush G.S., Datta S.K., (1998). Constitutive and tissue-specific differential expression of the cryIA(b) gene in transgenic rice plants conferring resistance to rice insect pest. *Theoretical and Applied Genetics* **97** (1-2), 20-30.
- Dehestani A., Ahmadian G., Salmanian A.H., Jelodar N.B., Kazemitabar K., (2010). Transformation efficiency enhancement of *Arabidopsis* vacuum infiltration by surfactant application and apical inflorescence removal. *Trakia Journal of Sciences* **8** (1), 19-26.
- de Maagd R.A., Bravo A., Crickmore N., (2001). How *Bacillus thuringiensis* has evolved specific toxins to colonize the insectworld. *Trends in Genetics* **17**, 193–199.
- de Rocher E.J., Vargo-Gogola T.C., Diehn S.H., Green P.J., (1998). Direct evidence for rapid degradation of *Bacillus thuringiensis* toxin mRNA as a cause of poor expression in plants. *Plant Physiology* **117**, 1445–1461.
- Desfeux C., Clough S.J., Bent A.F., (2000). Female reproductive tissues are the primary

## References

---

- target of *Agrobacterium*-mediated transformation by the *Arabidopsis* floral-dip method. *Plant Physiology* **123**, 895–904.
- Doering C.J. and Zamponi G.W., (2003). Molecular Pharmacology of High Voltage-Activated Calcium Channels. *Journal of Bioenergetics and Biomembranes* **35** (6) 491-505.
- Dobbins J.W., Laurenson J.P., Gorelick F.S. Banwell J.G., (1986). Phytohemagglutinin from red kidney bean (*Phaseolus vulgaris*) inhibits sodium and chloride absorption in the rabbit ileum. *Gastroenterology* **90** (6), 1907-1913.
- Donatucci D.A., Liener I.E., Gross C.J., (1987). Binding of navy bean (*Phaseolus vulgaris*) lectin to the intestinal cells of the rat and its effect on the absorption of glucose. *Journal of Nutrition* **117** (12), 2154-2160.
- Doran P.M., (2006). Foreign protein degradation and instability in plants and plant tissue cultures. *Trends in Biotechnology* **24** (9), 426-432.
- Dowd P.F., Zuo W.N., Gillikin J.W., Johnson E.T., Boston R.S., (2003). Enhanced resistance to *Helicoverpa zea* in tobacco expressing an activated form of maize ribosome-inactivating protein. *Journal of Agricultural Food Chemistry* **51**, 3568–3574.
- Downes S., Mahon R. J., Rossiter L., Kauter G., Leven T., Fitt G., Baker G., (2010). Adaptive management of pest resistance by *Helicoverpa* species (Noctuidae) in Australia to the Cry2Ab Bt toxin in Bollgard II<sup>®</sup> cotton. *Evolutionary Applications* **3**, 574–584.
- Du J., Foissac X., Carss A., Gatehouse A.M.R., Gatehouse J.A., (2000). Ferritin acts as the most abundant binding protein for snowdrop lectin in the midgut of rice brown planthoppers (*Nilaparvata lugens*). *Insect Biochemistry and Molecular Biology*. **30**, 297-305.
- Dworetzky S.I., Trojnacki J.T., Gribkoff V.K., (1994). Cloning and expression of a human large-conductance calcium-activatedpotassiumchannel. *Brain Research. Molecular Brain Research* **27** (1),189-93.
- Eberl D.F., Ren D., Feng G., Lorenz L.J., Vactor D.V., Hall L.M., (1998). Genetic and developmental characterization of Dmca1D, a calcium channel alpha1 subunit gene in *Drosophila melanogaster*. *Genetics* **148**, 1159–1169.
- Erlanson M., (2008). Insect Pest Control by Viruses. *Encyclopedia of Virology (Third Edition)*, 125-133.
- Escoubas P., Sollod B., King G.F., (2006). Venom landscapes: Mining the complexity of spider venoms via a combined cDNA and mass spectrometric approach. *Toxicon* **47** (6), 650-663.
- European Union, Communication from the Commission to the Council, A thematic strategy on the sustainable use of pesticides. The European Parliament, the European Economic and Social Committee and the Committee of the Regions, pp. 1–13 (2006).
- Fajloun Z., Carlier E., Lecomte C., Geib S., Di Luccio E., Bichet D., Mabrouk K., Rochat H., De Waard M., Sabatier J.M., (2000). Chemical synthesis and characterization of Pi1, a scorpion toxin from *Pandinus imperator* active on K<sup>+</sup> channels. *European Journal of Biochemistry* **267** (16), 5149-55.
- Ferre J., and Van Rie J., (2002) Biochemistry and genetics of insect resistance to *Bacillus thuringiensis*. *Annual Review of Entomology* **47**, 501-533.
- Ferry N., Edwards M.G., Gatehouse J., Capell T., Christou P., and Gatehouse A.M.R., (2006). Transgenic Plants for Insect Pest Control: A Forward Looking Scientific Perspective. *Transgenic Research*. **15** (1), 13-19.
- Fitches E., Gatehouse A.M.R, Gatehouse J.A., (1997). Effects of snowdrop lectin (GNA) delivered via artificial diet and transgenic plants on the development of tomato moth (*Lacanobia oleracea*) larvae in laboratory and glasshouse trials. *Journal of Insect Physiology* **43** (8), 727-739.
- Fitches E.C. and Gatehouse J.A. (1998). A comparison of the short and long term effects of insecticidal lectins on the activities of soluble and brush border enzymes of tomato moth larvae (*Lacanobia oleracea*). *Journal of Insect Physiology* **44** (12), 1213-1224.
- Fitches E., Woodhouse S., Edwards J.P., Gatehouse J.A., (2001) In vitro and in vivo binding of snowdrop (*Galanthus nivalis* agglutinin; GNA) and jackbean (*Canavalia*

## References

- ensifformis*; Con A) lectins within tomato moth (*Lacanobia oleracea*) larvae; mechanisms of insecticidal action. *Journal of Insect Physiology*. **47**, 777–787.
- Fitches E., Audsley N., Gatehouse J.A., Edwards J.P., (2002). Fusion proteins containing neuropeptides as novel insect control agents: snowdrop lectin delivers fused allatostatin to insect haemolymph following oral ingestion. *Insect Biochemistry and Molecular Biology*. **32**, 1653–1661.
- Fitches E., Edwards M.G., Mee C., Grishin E., Gatehouse A.M.R., Edwards J.P., Gatehouse J.A. (2004a). Fusion proteins containing insect-specific toxins as pest control agents: snowdrop lectin delivers fused insecticidal spider venom toxin to insect haemolymph following oral ingestion. *Journal of Insect Physiology*, **50**, 61-71.
- Fitches E., Wilkinson H., Bell H., Bown D.P., Gatehouse J.A., Edwards J.P., (2004b). Cloning, expression and functional characterisation of chitinase from larvae of tomato moth (*Lacanobia oleracea*): a demonstration of the insecticidal activity of insect chitinase. *Insect Biochemistry and Molecular Biology*, **34**, 1037-1050.
- Fitches E.C. Philip J., Hinchliffe G., Vercruyse L., Chougule N., Gatehouse J.A., (2008a). An evaluation of garlic lectin as an alternative carrier domain for insecticidal fusion proteins. *Insect Science* **15** (6), 483–495.
- Fitches E.C., Wiles D., Douglas A.E., Hinchliffe G., Audsley N., Gatehouse J.A., (2008b). The insecticidal activity of recombinant garlic lectins towards aphids. *Insect Biochemistry and Molecular Biology* **38** (10), 905-915.
- Fitches E.C., Bell H.A., Powell M.E., Back E., Sargiotti C., Weaver R.J., Gatehouse J.A., (2010). Insecticidal activity of scorpion toxin (ButaIT) and snowdrop lectin (GNA) containing fusion proteins towards pest species of different orders. *Pest Management Science* **66** (1), 74-83.
- Fletcher J.I., Smith R., O'Donoghue S.I., Nilges M., Connor M., Howden M.E.H., Christie M.J., King G.F., (1997). The structure of a novel insecticidal neurotoxin,  $\omega$ -atracotoxin-Hv1, from the venom of an Australian funnel web spider. *Nature Structural Biology* **4**, 559–566.
- Fouquaert E., Hanton S.L., Brandizzi F., Peumans W.J., Van Damme E.J.M., (2007). Localization and Topogenesis Studies of Cytoplasmic and Vacuolar Homologs of the *Galanthus nivalis* Agglutinin. *Plant Cell Physiology* **48** (7), 1010-1021.
- Fuller R.S., Brake A., Thorner J., (1989). Yeast prohormone processing enzyme (KEX2 gene product) is a Ca<sup>2+</sup>-dependent serine protease. *Proceedings of the National Academy of Sciences of the United States of America* **86** (5), 1434-1438.
- Galitsky N., Cody V., Wojtczak A., Ghosh D., Luft J.R., Pangborn W., English L., (2001). Structure of the insecticidal bacterial d-endotoxin CryBb1 of *Bacillus thuringiensis*. *Acta Crystallographica Section D* **57**, 1101–1109.
- Gao Y.D., and Garcia M.L., (2003). Interaction of agitoxin2, charybdotoxin, and iberiotoxin with potassium channels: Selectivity between voltage-gated and Maxi-K channels. *Proteins: Structure, Function, and Bioinformatics* **52** (2), 146–154.
- Gatehouse A.M.R., Gatehouse J.A., Boulter D., (1980). Isolation and characterization of trypsin inhibitors from cowpea (*Vigna unguiculata*). *Phytochemistry* **19** (5), 751-756.
- Gatehouse A.M.R., Barbieri L., Stirpe F., Croy R.R.D., (1990). Effects of ribosome inactivating proteins on insect development - differences between Lepidoptera and Coleoptera. *Entomologia Experimentalis et Applicata* **54**, 43-51.
- Gatehouse A.M.R., Down R.E., Powell K.S., Sauvion N., Rahbé Y., Newell C.A., Merryweather A., W.D.O., Gatehouse J.A., (1996). Transgenic potato plants with enhanced resistance to the peach-potato aphid *Myzus persicae*. *Entomologia Experimentalis et Applicata* **79** (3), 295-307.
- Gatehouse A.M.R., Davison G.M., Stewart J.N., Gatehouse L.N., Kumar A., Geoghegan I.E., Birch A.N.E., Gatehouse J.A., (1999). Concanavalin A inhibits development of tomato moth (*Lacanobia oleracea*) and peach-potato aphid (*Myzus persicae*) when expressed in transgenic potato plants. *Molecular Breeding* **5** (2), 153-165.

## References

---

- Gilkes N.R., Henrissat B., Kilburn D.G., Miller Jr R.C., Warren R.A., (1991). Domains in microbial beta-1, 4-glycanases: sequence conservation, function, and enzyme families. *Microbiology and Molecular Biology Reviews* **55** (2), 303-315.
- Gómez I., Sánchez J., Miranda R., Bravo A., Soberón M., (2002). Cadherin-like receptor binding facilitates proteolytic cleavage of helix  $\alpha$ -1 in domain I and oligomer pre-pore formation of *Bacillus thuringiensis* Cry1Ab toxin. *FEBS Letters* **513**, 242–246.
- Gould W.P. and Jeanne R.L., (1984). Polistes Wasps (Hymenoptera: Vespidae) as Control Agents for Lepidopterous Cabbage Pests. *Environmental Entomology* **13** (1), 150-156.
- Grainnet (2007). Monsanto and Dow Agrosiences launch "SmartStax", industry's first-ever eight-gene stacked combination in corn. Grainnet. <http://www.grainnet.com/> (September 14, 2007).
- Gratwick M., ed. (1989). *Potato Pests*. MAFF Reference Book 187. HMSO. London.
- Grochulski, P., Masson, L., Borisova, S., Pusztai-Carey, M., Schwartz, J.L., Brousseau, R., Cygler, M., (1995). *Bacillus thuringiensis* CryIA (a) Insecticidal Toxin: Crystal Structure and Channel Formation. *Journal of Molecular Biology* **254** (5) p. 447-464.
- Grolleau F., and Lapiéd B., (2000). Dorsal unpaired median neurones in the insect central nervous system: towards a better understanding of the ionic mechanisms underlying spontaneous electrical activity. *Journal of Experimental Biology* **203**, 1633–1648.
- Gröner A., (1986). Specificity and safety of baculoviruses. Granados R.R., Federici B.A. (eds.). Boca Raton, Fla. (USA): CRC Press, v. 1, 177-202.
- Guerrero A., Feixas J., Pajares J., Wadhams L.J., Pickett J.A., Woodcock C.M., (1997). Semiochemically Induced Inhibition of Behaviour of *Tomicus destruens* (Woll.) (Coleoptera: Scolytidae). *Naturwissenschaften* **84** (4), 155-157.
- Gunning S.J., Maggio F.J., Valenzuela S.M., King G.F., Nicholson G.M., (2007). Identification of a novel insecticide target using an insect-specific spider toxin.
- Gustavsson M., Lehtiö J., Denman S., Teeri T.T., Hult K., Martinelle M., (2001). Stable linker peptides for a cellulose-binding domain–lipase fusion protein expressed in *Pichia pastoris*. *Protein Engineering* **14** (9), 711-715.
- Habibi J., Backus E.A., Huesing J., (2000). Effects of phytohemagglutinin (PHA) on the structure of midgut epithelial cells and localization of its binding sites in western tarnished plant bug, *Lygus hesperus* Knight. *Journal of Insect Physiology* **46** (5), 611-619.
- Hayakawa T., Shimojo E., Mori M., Kaido M., Furusawa I., Miyata S., Sano Y., Matsumoto T., Hasimoto Y., Granados R.R., (2000). Enhancement of baculovirus infection in *Spodoptera exigua* (Lepidoptera: Noctuidae) larvae with *Autographa californica* nucleopolyhedrovirus or *Nicotiana tabacum* engineered with a granulovirus enhancin gene. *Applied Entomology and Zoology* **35** (1), 163-170.
- Hellwig S., Drossard J., Twyman R.M., Fischer R., (2004) Plant cell cultures for the production of recombinant proteins. *Nature Biotechnology* **22**, 1415–1422.
- Hernández-Campuzano B., Suárez R., Lina L., Hernández V., Villegas E., Corzo G., Iturriaga G., (2009). Expression of a spider venom peptide in transgenic tobacco confers insect resistance. *Toxicon* **53**, 122–128.
- Herniou E.A., Olszewski J.A., Cory J.S., O'Reilly D.R., (2003). The genome sequence and evolution of baculoviruses. *Annual Review of Entomology* **48**, 211-234.
- Hester G., Kaku H., Goldstein I.J., Wright C.S., (1995). Structure of mannose-specific snowdrop (*Galanthus nivalis*) lectin is representative of a new plant lectin family. *Nature Structural Biology* **2**, 472-479
- Huesing J.E., Murdock L.L., Shade R.E., (1991). Rice and stinging nettle lectins: Insecticidal activity similar to wheat germ agglutinin. *Phytochemistry* **30** (1), 3565-3568.
- Higgins D.R., and Creggs J.M., (1998), *Pichia* Protocols *Methods in Molecular Biology*, **103**, Humana Press, Totowa, NJ, USA.
- Hilder V.A., Gatehouse A.M.R., Sheerman S.S., Barker R.S., Boulter, D.A., (1987). Novel mechanism of insect resistance engineered into tobacco. *Nature* **330**, 160-163.
- Hilder V.A., Powell K.S., Gatehouse A.M.R., Gatehouse J.A., Gatehouse L.N., Shi Y.,

## References

---

- Hamilton W.D.O., Merryweather A., Newell C.A. and J. C. Timans J.C., Peumans W.J., Van Damme E., Boulter D., (1995). Expression of snowdrop lectin in transgenic tobacco plants results in added protection against aphids. *Transgenic Research* **4**, 18–25.
- Hogervorst P.A.M., Ferry N., Gatehouse A.M.R., Wäckers F.L., Romels J., (2006). Direct effects of snowdrop lectin (GNA) on larvae of three aphid predators and fate of GNA after ingestion. *Journal of Insect Physiology* **52** (6), 614-624.
- Huang J., Rozelle S., Pray C., Wang Q., (2002). Plant Biotechnology in China. *Science* **295** (5555), 674-679.
- Huger A.M., (2005). The *Oryctes* virus: Its detection, identification, and implementation in biological control of the coconut palm rhinoceros beetle, *Oryctes rhinoceros* (Coleoptera: Scarabaeidae) *Journal of Invertebrate Pathology* **89** (1), 78-84.
- Isbister G.K., and White J., (2006). Clinical consequences of spider bites: recent advances in our understanding. *Toxicon* **43** (5), 477-492.
- James C., (2008). Global Status of Commercialized Biotech/GM Crops: 2008. ISAAA Brief No. 39. ISAAA: Ithaca, New York.
- Jeffers L.A., Thompson D.M., Ben-Yakir D., Roe R.M., (2005). Movement of proteins across the digestive system of the tobacco budworm, *Heliothis virescens*. *Entomologia Experimentalis et Applicata* **117** (2), 135-146.
- Johnson J.H., Bloomquist J.R., Krapcho K.J., Kral R.M., Trovalto R., Eppler K.G., Morgan T.K., DelMar E.G., (1998). Novel insecticidal peptides from *Tegenaria agrestis* spider venom may have a direct effect on the insect central nervous system. *Archives of Insect Biochemistry and Physiology* **38**, 19–31.
- Johnson B.A., Stevens S.P., Williamson J.M., (1994). Determination of the Three-Dimensional Structure of Margatoxin by <sup>1</sup>H, <sup>13</sup>C, <sup>15</sup>N Triple-Resonance Nuclear Magnetic Resonance Spectroscopy. *Biochemistry* **33** (50), 15061–15070.
- Johnson B.A. and Sugg E.E., (1992). Determination of the three-dimensional structure of iberiotoxin in solution by proton nuclear magnetic resonance spectroscopy. *Biochemistry* **31** (35), pp 8151–8159.
- Jurat-Fuentes J.L., Adang M.J., (2004). Characterization of a Cry1Ac-receptor alkaline phosphatase in susceptible and resistant *Heliothis virescens* larvae. *European Journal of Biochemistry* **271**, 3127–3135.
- Karimi M., Inze D., Depicker A., (2002). Gateway vectors for Agrobacterium-mediated plant transformation. *Trends in Plant Science* **7** (5), 193-195.
- Katunuma N., and Kominami E., (1995). Structure, properties, mechanisms, and assays of cysteine protease inhibitors: cystatins and E-64 derivatives *Methods in Enzymology* **251**, 382-97.
- Kawasaki F., Collins S.C., Ordway R.W., (2002). Synaptic Calcium-Channel Function in *Drosophila*: Analysis and Transformation Rescue of Temperature-Sensitive Paralytic and Lethal Mutations of *Cacophony*. *Journal of Neuroscience* **22**, 5856–5864.
- Kennedy T., (2007). Aphid and wireworm problems in potatoes. *Proceedings of the national potato conference and trade show*, 17-21.
- Khan S.A., Zafar Y., Briddon R.W., Malik K.A., Mukhtar Z., (2006). Spider venom toxin protects plants from insect attack. *Transgenic Research* **15**, 349–357.
- King G.F., (2007). Modulation of insect Ca<sub>v</sub> channels by peptidic spider toxins. *Toxicon* **49** (4), 513-530.
- King G.F., Escoubas P., Nicholson G.M., (2008). Peptide toxins that selectively target insect Na(V) and Ca(V) channels. *Channels* **2** (2), 100-116.
- Knight P., Crickmore N., Ellar D.J., (1994). The receptor for *Bacillus thuringiensis* CryIA(c) delta-endotoxin in the brush border membrane of the lepidopteran *Manduca sexta* is aminopeptidase N. *Molecular Microbiology* **11**, 429–436.
- Kost T.A. and Condreay J.P., (2002). Recombinant baculoviruses as mammalian cell gene-delivery vectors. *Trends in Biotechnology* **20** (4), 173-180.
- Krishnamoorthy M., Jurat-Fuentes J.L., McNall R.J., Andacht T., Adang M.J., (2007). Identification of novel Cry1Ac binding proteins in midgut membranes from *Heliothis*

## References

---

- virescens* using proteomic analyses. *Insect Biochemistry and Molecular Biology* **37** (3), 189-201.
- Läemmler U.K., (1970). Cleavage of structural proteins during the assembly of the head of Bacteriophage T4. *Nature* **227**, 680–685.
- Lagrutta A., Shen K.Z., North R.A., Adelman J.P., (1994). Functional differences among alternatively spliced variants of *slowpoke*, a *Drosophila* calcium-activated potassium channel. *Journal of Biological Chemistry* **269**, 20347–20355.
- Layne E., (1957). Spectrophotometric and Turbidimetric Methods for Measuring Proteins. *Methods in Enzymology* **3**, 447-455.
- Lerner D.R., and Raikher N.V., (1992). The gene for stinging nettle lectin (*Urtica dioica* agglutinin) encoded both a lectin and a chitinase. *Journal of Biological Chemistry* **267**. 11085-11091.
- Lewis R.J., and Garcia M.L., (2003). Therapeutic potential of venom peptides. *Nature Reviews Drug Discovery* **2**, 790-802.
- Li C., Gloer J.B., Wicklow D.T., Dowd P.F., (2002). Thiersinines A and B: Novel Antiinsectan Indole Diterpenoids from a New Fungicolous *Penicillium* Species *Organic Letters* **4** (18), 3095-3098.
- Li C., Gloer J.B., Wicklow D.T., Dowd P.F., (2005). Antiinsectan Decaturin and Oxalicine Analogues from *Penicillium thiersii*. *Journal of Natural Products* **68** (3), 319-322.
- Li J., Carrol J., Ellar D.J., (1991). Crystal structure of insecticidal d-endotoxin from *Bacillus thuringiensis* at 2.5 Å resolution. *Nature* **353**:815–821.
- Liener I.E., Kakade M.L., Protease inhibitors. In *Toxic Constituents of Plant Foodstuffs*; Liener, I. E., Ed.; Academic Press: New York, 1980; pp 7-71.
- Lin J., Yao J., Zhou X., Sun X., Tang K., (2003). Expression and purification of a novel mannose-binding lectin from *Pinellia ternate*. *Molecular Biotechnology* **25** (3), 215-221.
- Lipke H., Liener I.E., Fraenkel G., (1954). Effects of soybean inhibitors on growth of *Tribolium confusum*. *Journal of Agricultural Food Chemistry* **2**, 410-414.
- Lipkin A., Kozlov S., Nosyreva E., Blake A., Windass J.D., Grishin E., (2002). Novel insecticidal toxins from the venom of the spider *Segestria florentina*. *Toxicon* **40** (2), 125-130.
- Lippens G., Najib J., Wodak S.J., Tartar A., (1995). NMR Sequential Assignments and Solution Structure of Chlorotoxin, a Small Scorpion Toxin That Blocks Chloride Channel. *Biochemistry* **34** (1), 13–21.
- Littleton J.T., Ganetzky B., (2000). Ion Channels and Synaptic Organization: Analysis of the *Drosophila* Genome. *Neuron* **26**, 35-43.
- Maggio F., and King G.F., (2002a). Role of the structurally disordered N- and C-terminal residues in the Janus-faced atracotoxins. *Toxicon* **40** (9), 1355-1361.
- Maggio F., and King G.F., (2002b). Scanning Mutagenesis of a Janus-faced Atracotoxin Reveals a Bipartite Surface Patch That Is Essential for Neurotoxic Function. *Journal of Biological Chemistry* **277** (25), 22806–22813.
- Mallart A., (1993). Calcium-dependent modulation of the facilitation of transmitter release at neuromuscular junctions of *Drosophila*. *Journal of Physiology (Paris)* **87** (2), 83–88.
- Maqbool S.B., Riazuddin S., Loc N.T., Gatehouse A.M.R., Christou P., (2001). Expression of multiple insecticidal genes confers broad resistance against a range of different rice pests. *Molecular Breeding* **7** (1), 85-93.
- Mehlo L., Gahakwa D., Nghia P.T., Loc N.T., Capell T., Gatehouse J.A., Gatehouse A.M.R., Christou P., (2005). An alternative strategy for sustainable pest resistance in genetically enhanced crops. *Proceedings of the National Academy of Science* **102**, 7812–7816.
- McKinney M.L., Schoch R.M., Yonavja L., (2007) *Environmental science: systems and solutions*. 4th edition, Jones and Bartlett, Sudbury, USA.
- McMillan L.K., Carr R.L., Young C. A., Astin J.W., Lowe R.G., Parker E.J., Jameson G.B., Finch S.C., Miles C.O., McManus O.B., Schmalhofer W.A., Garcia M.L., Kaczorowski G.J., Goetz M., Tkacz J.S., Scott B., (2003). Molecular analysis of two

## References

---

- cytochrome P450 monooxygenase genes required for paxilline biosynthesis in *Penicillium paxilli*, and effects of paxilline intermediates on mammalian maxi-K ion channels. *Molecular Genetics and Genomics* **270** (1), 9-23.
- Mickel, C.E. and Standish, J., (1947). Susceptibility of processed soy flour and soy grits in storage to attack by *Tribolium castaneum*. *University of Minnesota Agricultural Experimental Station Technical Bulletin* **178**, 1-20
- Miljanich G.P., (2004) Ziconotide: Neuronal Calcium Channel Blocker for Treating Severe Chronic Pain. *Current Medicinal Chemistry* **11** (23), 3029-3040.
- Miller C., Moczydlowski E., Latore R., Philips M., (1985). Charybdotoxin, a potent inhibitor of single Ca<sup>2+</sup>-activated K<sup>+</sup> channels from mammalian skeletal muscle. *Nature* **313**, 316-318.
- Morris K., Lorenzen M.D., Hiromasa Y., Tomich J.M., Oppert C., Elpidina E.N., Vinokurov K., Jurat-Fuentes J.L., Fabrick J., Oppert B., (2009). *Tribolium castaneum* Larval Gut Transcriptome and Proteome: A Resource for the Study of the Coleopteran Gut. *Journal of Proteome Research* **8** (8), 3889-3898.
- Morse R.J., Yamamoto T., Stroud R.M., (2001). Structure of Cry2Aa suggests an unexpected receptor binding epitope. *Structure* **9**, 409-417.
- Moscardi F., (1999) Assessment of the application of baculoviruses for the control of lepidoptera. *Annual Review of Entomology* **44**, 257-289.
- Mukherjee A.K., Sollod B.L., Wikel S.K., King G.F., (2006). Orally active acaricidal peptide toxins from spider venom. *Toxicon* **47**, 182-187.
- Murashige T., Skoog F., (1962). A revised medium for rapid growth and bioassays with tobacco tissue culture. *Physiologia Plantarum* **15**, 473-497.
- Murdock L.L., Brookhart G., Dunn P.E., Foard D.E., Kelley S., Kitch L., Shade R.E., Shukle R.H., Wolfson J.L., (1987). Cysteine digestive proteinases in Coleoptera. *Comparative Biochemistry and Physiology Part B: Comparative Biochemistry* **87** (4), 783-787.
- Murdock L.L., Huesing J.E., Nielsen S.S., Pratt R.C., Shade R.E., (1990). Biological effects of plant lectins on the cowpea weevil. *Phytochemistry* **29** (1) 85-89.
- Murray E.E., Rocheleau T., Eberle M., Stock C., Sekar V., Adang M., (1991). Analysis of unstable RNA transcripts of insecticidal crystal protein genes of *Bacillus thuringiensis* in transgenic 2548 plant and electroporated protoplasts. *Plant Molecular Biology* **16**, 1035-1050.
- Naimov S., Dukiandjiev S., de Maagd R.A., (2003). A hybrid *Bacillus thuringiensis* delta-endotoxin gives resistance against a coleopteran and a lepidopteran pest in transgenic potato. *Plant Biotechnology Journal* **1**, 51-57.
- Nandi A.K., Basu D., Das S., Sen, S.K., (1999). High level expression of soybean trypsin inhibitor gene in transgenic tobacco plants failed to confer resistance against damage caused by *Helicoverpa armigera*. *Journal of Bioscience* **24**, 445-452.
- Nuttall J., Vine N., Hadlington J.L., Drake P., Frigerio L., Ma J.K.C., (2002). ER-resident chaperone interactions with recombinant antibodies in transgenic plants. *European Journal of Biochemistry* **269**, 6042-6051.
- Olivera B.M., (2002). "Conus" Venom Peptides: Reflections from the Biology of Clades and Species. *Annual Review of Ecology and Systematics* **33**, 25-47.
- Oppert B., Morgan T.D., Christina Culbertson C., Kramer K.J., (1993). Dietary mixtures of cysteine and serine proteinase inhibitors exhibit synergistic toxicity toward the red flour beetle, *Tribolium castaneum*, *Comparative Biochemistry and Physiology* **105C**, 379-385.
- Oppert B., Morgan T.D., Hartzler K., Lenarcic B., Galesa K., Brzin J., Turk V., Yoza K., Ohtsubo K., Kramer K.J., (2003). Effects of proteinase inhibitors on digestive proteinases and growth of the red flour beetle, *Tribolium castaneum* (Herbst) (Coleoptera: Tenebrionidae). *Comparative Biochemistry and Physiology Part C: Toxicology & Pharmacology* **134** (4), 481-490.
- Oppert B., Morgan T.D., Kramer K.J., (2004). Inhibitor strategies to control coleopteran pests. *International Congress Series* **1275**, Animals and Environments. Proceedings

## References

---

- of the Third International Conference of Comparative Physiology and Biochemistry, 149-156.
- Oppert B., Morgan T.D., Hartzler K., Kramer K.J., (2005). Compensatory proteolytic responses to dietary proteinase inhibitors in the red flour beetle, *Tribolium castaneum* (Coleoptera: Tenebrionidae). *Comparative Biochemistry and Physiology Part C: Toxicology & Pharmacology* **140** (1), 53-58.
- Orozco-Cardenas M., McGurl B., Ryan C.A., (1993). Expression of an antisense prosystemin gene in tomato plants reduces resistance toward *Manduca sexta* larvae. *Proceedings of the National Academy of Sciences USA* **90**, 8273–8276.
- Outchkourov N.S., de Kogel W.J., Schuurman-de Bruin A., Abrahamson M., Jongsma M.A., (2004a). Specific cysteine protease inhibitors act as deterrents of western flower thrips, *Frankliniella occidentalis* (Pergande), in transgenic potato. *Plant Biotechnology Journal* **2**, 439–448.
- Outchkourov N.S., de Kogel W.J., Wieggers G.L., Abrahamson M., Jongsma M.A., (2004b). Engineered multidomain cysteine protease inhibitors yield resistance against western flower thrips (*Frankliniella occidentalis*) in greenhouse trials. *Plant Biotechnology Journal* **2**, 449–458.
- Pallanck L. and Ganetzky B., (1994). Cloning and characterization of human and mouse homologs of the *Drosophila* calcium-activated potassium channel gene, *slowpoke*. *Human Molecular Genetics* **3**, 1239–124.
- Parker W.E., Howard J.J., (2001). The Biology and management of wireworms (*Agriotes* spp.) on potato with particular reference to the U.K. *Agriculture and Forest Entomology* **3**, 85-98.
- Parker W.E., (1994). Evaluation of the use of food baits for detecting wireworms (*Agriotes* spp., Coleoptera: Elateridae) in fields intended for arable crop production. *Crop Protection* **13**, 271–276.
- Parker M.W., Feil S.C., (2005). Pore-forming protein toxins: from structure to function. *Progress in Biophysics and Molecular Biology* **88**, 91–142.
- Perlak F.J., Fuchs R.L., Dean D.A., McPherson S.L., Fischhoff D.A., (1991). Modification of the coding sequence enhances plant expression of insect controlling protein genes. *Proceedings of the National Academy of Sciences USA* **88**, 3324–3328.
- Perez-Reyes E., (2003). Molecular Physiology of Low-Voltage-Activated T-type Calcium Channels. *American Physiological Society* **83** (1), 117-161.
- Peuman W.J., De Lay M., Broekaert W.F., (1984) An unusual lectin from stinging nettle (*Urtica dioica*) rhizomes. *FEBS letters* **177** (1), 99-103.
- Peumans W.J., and Van Damme E.J., (1995). Lectins as plant defense proteins. *Plant Physiology* **109** (2), 347-352.
- Poulsen M., Kroghsbo S., Schröder M., Wilcks A., Jacobsen H., Miller A., Frenzel T., Danier J., Rychlik M., Shu Q., Emami K., Sudhakar D., Gatehouse A.M.R., Engel K.H., Knudsen I.B. (2007). A 90-day safety study in Wistar rats fed genetically modified rice expressing snowdrop lectin *Galanthus nivalis* (GNA). *Food and Chemical Technology* **45** (3) 350-363.
- Powell K.S., Gatehouse A.M.R., Hilder V.A., Gatehouse, J.A., (1995). Antifeedant effects of plant lectins and an enzyme on the adult stage of the rice brown planthopper *Nilaparvata lugens*. *Entomologia experimentalis et applicata* **75**, 51-59.
- Powell K.S., Spence J., Bharathi M., Gatehouse J.A., Gatehouse A.M.R., (1998). Immunohistochemical and developmental studies to elucidate the mechanism of action of the snowdrop lectin on the rice brown planthopper, *Nilaparvata lugens*. *Journal of Insect Physiology* **44**, 529-539.
- Prasad G.S., Jayakumar V., Ranganath H.R., Bhagwat V.R., (2008). Bio-suppression of coconut rhinoceros beetle, *Oryctes rhinoceros* L. (Coleoptera: Scarabaeidae) by *Oryctes* baculovirus (Kerala isolate) in South Andaman, India. *Crop Protection* **27** (6), 959-964.
- Price D.R. and Gatehouse J.A., (2008). RNAi-mediated crop protection against insects. *Trends in Biotechnology* **26** (7), 393-400.

## References

---

- Pusztai A., (1991). General effects on animal cells. In: Pusztai A., (Ed.), *Plant Lectins*, Cambridge University Press, Cambridge, 105–205.
- Pusztai A., Ewen S.W.B., Grant G., Peumans W.J., Van Damme E.J.M., Coates M.E., Bardocz S., (1995). Lectins and also bacteria modify the glycosylation of gut surface receptors in the rat. *Glycoconjugate Journal* **12**, 22-35.
- Pyati P., (2010). Molecular approaches to increasing resistance of wheat (*Triticum aestivum* L.) towards two insect pests; Cereal aphid (*Sitobion avenae* F.) and Wheat bulb fly (*Delia coarctata* Fallen). PhD thesis, Durham University.
- Qaim M., Zilberman D., (2002). Yield effects of genetically modified crops in developing countries. *Science* **299**, 900–902.
- Quistad G.B., Reuter C.C., Skinner W.S., Dennis P.A., Suwanrumpha S., Fu E.W., (1991). Paralytic and insecticidal toxins from the funnel web spider, *Hololena curta*. *Toxicon* **29**, 329- 336.
- Quistad G.B. and Skinner W.S., (1994). Isolation and sequencing of insecticidal peptides from the primitive hunting spider, *Plectreuryx tristis* (Simon). *Journal of Biological Chemistry* **269** (15), 11098-11101.
- Raemaekers R.J., De Muro L., Gatehouse J.A., Fordham-Skelton A.P., (1999). Functional phytohemagglutinin (PHA) and *Galanthus nivalis* agglutinin (GNA) expressed in *Pichia pastoris* correct N-terminal processing and secretion of heterologous proteins expressed using the PHA-E signal peptide. *European Journal of Biochemistry* **265**, 394-403.
- Ramesh S., Nagadhara D., Pasalu I.C., Kumari A.P., Sarma N.P., Reddy V.D., Rao., K.V., (2004). Development of stem borer resistant transgenic parental lines involved in the production of hybrid rice. *Journal of Biotechnology* **111** (2), 131-141.
- Rao K.V., Rathore K.S., Hodges T.K., Fu X., Stoger E., Sudhakar D., Williams S., Christou P., Bharathi M., Bown D.P., Powell K.S., Spence J., Gatehouse A.M., Gatehouse J.A., (1998). Expression of snowdrop lectin (GNA) in transgenic rice plants confers resistance to rice brown planthopper. *The Plant Journal*, **15** (4), 469-77.
- Regev A., Rivkin H., Gurevitz M., Chejanovsky N., (2006). New measures of insecticidal efficacy and safety obtained with the 39K promoter of a recombinant baculovirus. *FEBS Letters* **580** (30), 6777-6782.
- Rowan A.D., Brzin J., Buttle D.J., Barrett A.J., (1990). Inhibition of cysteine proteinases by a protein inhibitor from potato. *FEBS letters* **269** (2), 328-330.
- Raymond-Delpech V., Matsuda K., Sattelle B.M., Rauh J.J., Sattelle D.B., (2005). Ion channels: molecular targets of neuroactive insecticides. *Invertebrate Neuroscience* **5** (3-4), 119-33.
- Rieckhof G.E., Yoshihara M., Guan Z., Littleton J.T., (2003). Presynaptic N-type Calcium Channels Regulate Synaptic Growth. *Journal of Biological Chemistry* **278**, 41099-41108.
- Ryan C.A., (1989). Protease Inhibitors in Plants: Genes for Improving Defenses Against Insects and Pathogens. *Annual Review of Phytopathology* **28**, 425-449.
- Ryan S.N., Laing W.A., McManus M.T., (1998). A cysteine proteinase inhibitor purified from apple fruit. *Phytochemistry* **49** (4), 957-963.
- Sambrook J., Russell D.W., (2001). *Molecular Cloning: A laboratory manual.*, 4rd ed, Cold Harbour Laboratory Press, New York.
- Sanahuja G., Banakar R., Twyman R.M., Capell T., Christou P., (2011). *Bacillus thuringiensis*: a century of research, development and commercial applications. *Plant Biotechnology Journal* **9** (3), 283-300.
- Sankula S., Marmon G., Blumenthal E., (2005). Biotechnology-derived crops planted in 2004 – impacts on US agriculture. *National Center for Food and Agricultural Policy* (<http://www.ncfap.org/whatwedo/pdf/2004biotechimpacts.pdf>).
- Schnepf H.E., Cricmore N., Vanrie J., Lereclus D., Baum J., Feitelson J., Zfider D.R., Dean D.H., (1998). *Bacillus thuringiensis* and its pesticidal crystal proteins. *Microbiology and Molecular Biology Reviews* **62** (3), 775-806.
- Sharp J.M. and Doran P.M., (2001). Characterization of monoclonal antibody fragments

## References

---

- produced by plant cells. *Biotechnology and Bioengineering* **73** (5), 338-346.
- Shelton A.M., Zhao J.Z., Roush R.T., (2002). Economic, ecological, food safety, and social consequences of the development of Bt transgenic plants. *Annual Review of Entomology* **47**, 845-881.
- Shibuya N., Goldstein I.J., Shafer J.A., Peumans W.J., Broekaert W.K., (1986). Carbohydrate binding properties of the stinging nettle (*Urtica dioica*) rhizome lectin. *Archives of Biochemistry and Biophysics* **249** (1), 215-224.
- Shukle R.H., and Murdock L.L., (1983). Lipoxxygenase Trypsin Inhibitor, and Lectin from Soybeans: Effects on Larval Growth of *Manduca sexta* (Lepidoptera: Sphingidae). *Environmental Entomology* **12** (3), 787-791.
- Singh S., and Wu C.F., (1990). Properties of potassium currents and their role in membrane excitability in *Drosophila* larval muscle fibers. *Journal of Experimental Biology* **152**, 59-76.
- Smith L.A., Peixoto A.A., Kramer E.M., Vilella A., Hall J.C., (1998). Courtship and visual defects of cacophony mutants reveal functional complexity of a calcium-channel alpha1 subunit in *Drosophila*. *Genetics* **149**, 1407-1426.
- Soberón M., Pardo-López L., López I., Gómez I., Tabashnik B.E., Bravo A., (2007). Engineering modified Bt toxins to counter insect resistance. *Science* **318**, 1640-1642.
- Sollod B.L., Wilson D., Zhaxybayeva O., Gogarten J.P., Drinkwater R., King G.F., (2005). Were arachnids the first to use combinatorial peptide libraries? *Peptides* **26** (1), 131-139.
- Sreedharan S.K., Verma C., Caves L.S., Brocklehurst S.M., Gharbia S.E., Shah H.N., Brocklehurst, K., (1996). Demonstration that 1-trans-epoxysuccinyl-L-leucylamido-(4-guanidino) butane (E-64) is one of the most effective low Mr inhibitors of trypsin-catalysed hydrolysis. Characterization by kinetic analysis and by energy minimization and molecular dynamics simulation of the E-64-beta-trypsin complex. *Biochemical Journal* **316**, 777-786.
- Stirpe F., and Barbieri L., (1986). Ribosomal-inactivating protein up to date. *FEBS letters* **195** (1-2), 1-8.
- Stoger E., Williams S., Christou P., Down, R. E., Gatehouse J.A., (1999). Expression of the insecticidal lectin from snowdrop (*Galanthus nivalis* agglutinin, GNA) in transgenic wheat plants: effects on predation by the grain aphid *Sitobion avenae*. *Molecular Breeding* **5** 65-73.
- Stoscheck C.M., (1990). Quantitation of Protein. *Methods in Enzymology* **182**, 50-69.
- Stubbs M.E., Carver J.P., Dunn R.J. (1986). Production of pea lectin in *Escherichia coli*. *Journal of Biological Chemistry*, **261** (14), 6141-4.
- Sudhakar D., Fu X., Stoger E., Williams S., Spence J., Brown D.P., Bharathi M., Gatehouse J.A., Christou P., (1998). Expression and Immunolocalisation of the Snowdrop Lectin, GNA in Transgenic Rice Plants. *Transgenic Research* **7** (5), 371-378.
- Souza S.M., Uchoa A.F., Silva J.R., Samuels R.I., Oliveira A.E.A., Oliveira E.M., Linhares R.T., Alexandre D., Silva C.P., (2010). The fate of vicilins, 7S storage globulins, in larvae and adult *Callosobruchus maculatus* (Coleoptera: Chrysomelidae: Bruchinae). *Journal of Insect Physiology* **56** (9), 1130-1138.
- Tabashnik B.E. (1994). Evolution of resistance to *Bacillus thuringiensis*. *Annual Review of Entomology* **39**, 47-79.
- Tedford H.W., Fletcher J.I., King G.F., (2001). Functional significance of the beta hairpin in the insecticidal neurotoxin omega-*atractoxin*-Hv1a. *Journal of Biological Chemistry* **276** (28), 26568-76.
- Tedford H.W., Sollod B.L., Maggio F., and King G.F., (2004). Australian funnel web spiders: master insecticidal chemists. *Toxicon* **43**, 601-618.
- Tomalski M.D., Bruce W.A., Travis J., Blum M.S., (1988). Preliminary characterization of toxins from the straw itch mite, *Pyemotes tritici*, which induce paralysis in the larvae of a moth. *Toxicon* **26** (2) 127-132.
- Tribolium* Genome Sequencing Consortium (2008). The genome of the model beetle and pest *Tribolium castaneum*. *Nature* **452**, 949-955.

## References

---

- Trung N.P., Fitches E., and Gatehouse J.A., (2006). A fusion protein containing a lepidopteran-specific toxin from the South Indian red scorpion (*Mesobuthus tamulus*) and snowdrop lectin shows oral toxicity to target insects. *BMC Biotechnology* **6** (18).
- United Nations, Department of Economic and Social Affairs; Population Division (2004), World population prospects: The 2004 revision analytical report.
- Vadlamudi R.K., Weber E., Ji I., Ji T.H., Bulla L.A. Jr., (1995). Cloning and expression of a receptor for an insecticidal toxin of *Bacillus thuringiensis*. *Journal of Biological Chemistry* **270**, 5490–5494.
- Vaeck M., Reynaerts A., Hofte H., Jansens S., De Beuckeleer M., Dean C., Zabeau M., Van Montagu M., Leemans J., (1987). Transgenic plants protected from insect attack. *Nature* **328**, 33–37.
- Valaitis A.P., Jenkins J.L., Lee M.K., Dean D.H., Garner K.J., (2001). Isolation and partial characterization of Gypsy moth BTR-270, an anionic brush border membrane glycoconjugate that binds *Bacillus thuringiensis* Cry1A toxins with high affinity. *Archives of Insect Biochemical Physiology* **46**, 186–200.
- Van Damme, E.J.M., Allen, A.K. and Peumans, W.J., (1987). Isolation and characterization of a lectin with exclusive specificity towards mannose from snowdrop (*Galanthus nivalis*) bulbs. *FEBS Letters* **215**, 140–144.
- Van Damme E.J.M., Broekaert W.F., Peumans W.J., (1988). The *Urtica dioica* Agglutinin is a complex mixture of isolectins. *Plant Physiology* **86**, 598-601.
- Vergara C., Latorre R., Marrion N.V., Adelman J.P., (1998). Calcium-activated potassium channels. *Current Opinions in Neurobiology* **8** (3), 321–329.
- Wang W., Peumans W.J., Rougé P., Rossi C., Proost P., Chen J., Van Damm E.J.M., (2003). Leaves of the Lamiaceae species *Glechoma hederacea* (ground ivy) contain a lectin that is structurally and evolutionary related to the legume lectins. *The Plant Journal* **33** (2), 293-304.
- Wang H.W., Connor M., Smith R., Maciejewski M.W., Howden M.E, Nicholson G.M., Christie M.J., King G.F., (2000). Discovery and characterization of a family of insecticidal neurotoxins with a rare vicinal disulfide bridge. *Nature Structural Biology*. **7** (6), 505-513.
- Warbington L., Hillman T., Adams C., Stern M., (1996). Reduced transmitter release conferred by mutations in the *slowpoke*-encoded  $Ca^{2+}$ -activated  $K^{+}$  channel gene of *Drosophila*. *Invertebrate Neuroscience* **2** (1), 51–60.
- Whalon M.E., and Wingerd B.A., (2003). Bt: Mode of action and use. *Archives of Insect Biochemistry and Physiology* **54**, 200-211.
- Wickenden A., (2002).  $K^{+}$  channels as therapeutic drug targets. *Pharmacology and Therapeutics* **94** (1-2), 157–182.
- Wicher D., and Penzlin H. (1997).  $Ca^{2+}$  currents in central insect neurons: electrophysiological and pharmacological properties. *Journal of Neurophysiology* **77**, 186–199.
- Wood D.L.A., Miljenovic T., Cai S., Raven R., Kaas Q., Escoubas P., Herzig V., Wilson D., King G.F., (2009). ArachnoServer: a database of protein toxins from spiders. *BMC Genomics* **10**, 375.
- Wudayagiri R., Inceolglu B., Herrmann R., Derbel M., Choudary P.R., Hammock B.D., (2001). Isolation and characterization of a novel lepidopteran-specific toxin from the venom of South Indian red scorpion, *Mesobuthus tamulus*. *BMC Biotechnology* **2** (16).
- Wudayagiri R., Hackett K.J., Buckley E., Hammock B.D., (2006). Functional expression of lepidopteran-selective neurotoxin in baculovirus: potential for effective pest management. *Biochimica et Biophysica Acta* **1760** (2), 158-63.
- Wu J., Luo X., Wang Z., Tian Y., Liang A., Sun Y., (2008). Transgenic cotton expressing synthesized scorpion insect toxin *AaHIT* gene confers enhanced resistance to cotton bollworm (*Heliothis armigera*) larva. *Biotechnology Letters* **30** (3), 547-554.
- Wunn J., Kloti A., Burkhardt P.K., Biswas G.C.G., Launis K., Iglesias V.A., Potrykus I., (1996). Transgenic Indica rice breeding line IR58 expressing a synthetic cryIA(b)

## References

---

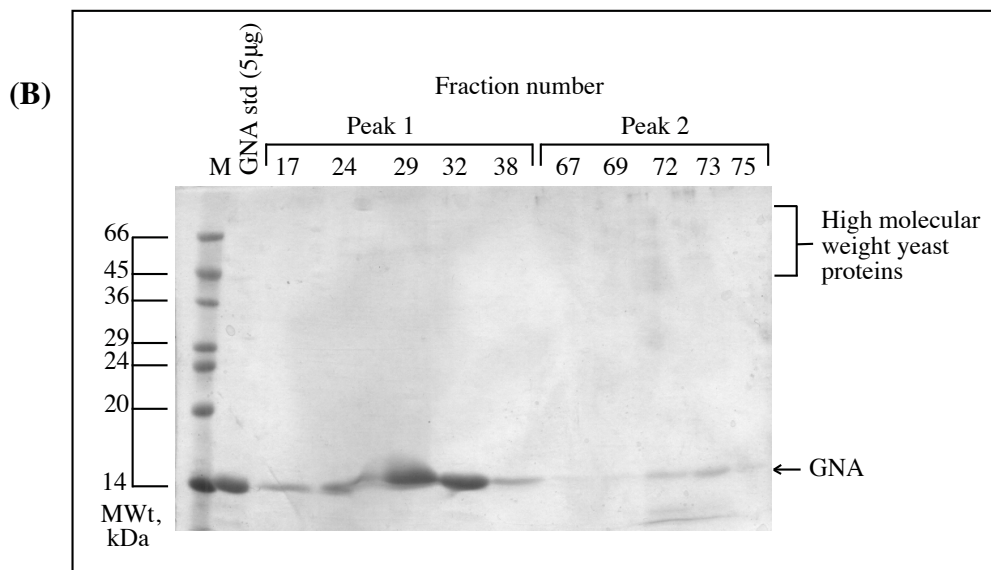
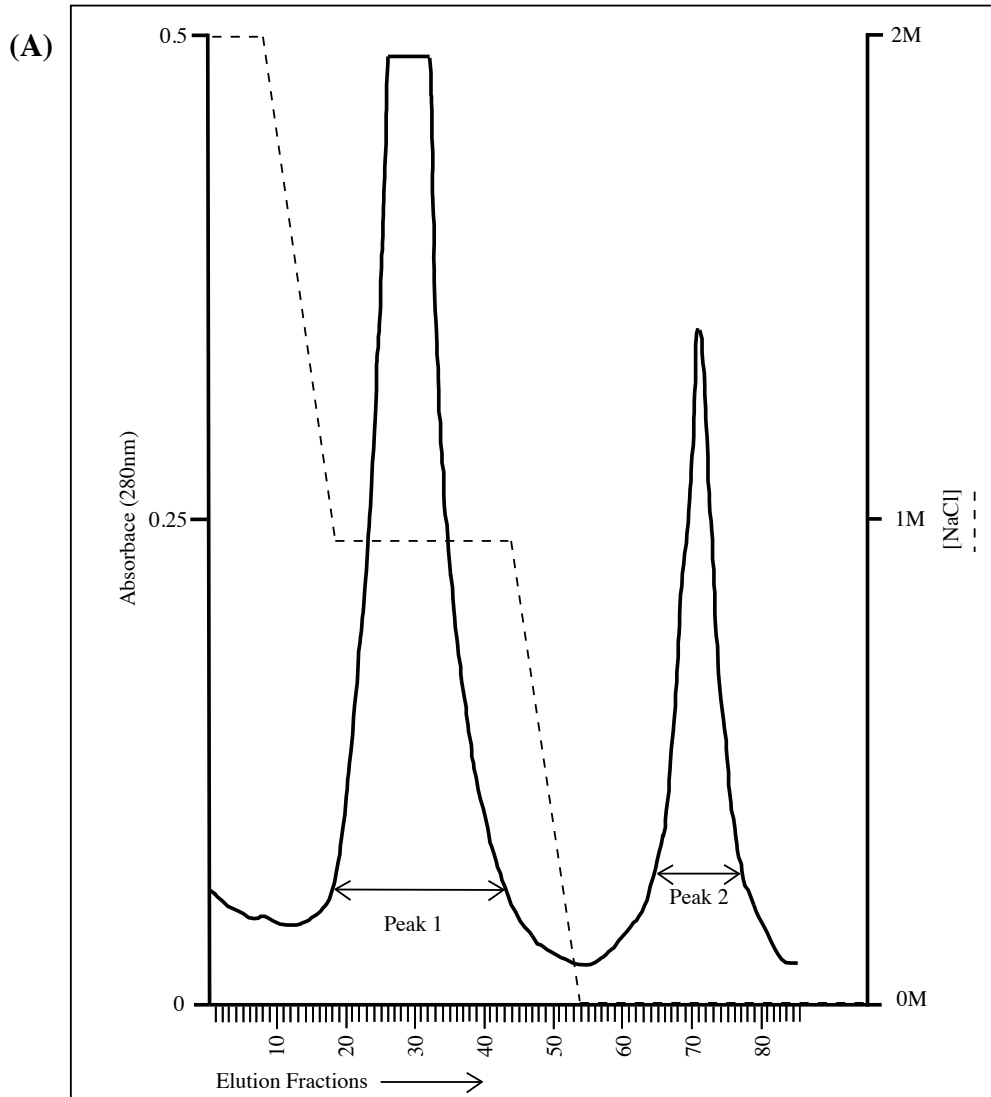
- gene from *Bacillus thuringiensis* provides effective insect pest control. *Biotechnology* **14**, 171–176.
- Zelazny B., Lolong A., Pattang B., (1992) *Oryctes rhinoceros* (Coleoptera: Scarabaeidae) populations suppressed by a baculovirus. *Journal of Invertebrate Pathology* **59** (1), 61-68.
- Zhang X., Candas M., Griko N.B., Taussig R., Bulla L.A. Jr., (2006). A mechanism of cell death involving an adenylyl cyclase/PKA signaling pathway is induced by the Cry1Ab toxin of *Bacillus thuringiensis*. *Proceedings of the National Academy of Sciences* **103**, 9897–9902.

## Appendix

### Appendix 1

**Purification of recombinant GNA produced in *Pichia pastoris* (strain X-33).** Filtered *P. pastoris* culture supernatant was equilibrated to 2M NaCl and loaded onto a Phenyl-Sepharose column overnight. Protein was eluted using a decreasing salt gradient (2M-0M NaCl). NaCl gradient was held while protein was eluted. **(A)** Typical purification trace. NaCl gradient shown as a dashed line, absorbance trace shown as a solid line. Peaks in absorbance can result from non-protein components in the culture supernatant that absorb UV light at 280nm (Layne *et al.*, 1957; Stoscheck *et al.*, 1990) so fractions were analysed by SDS-PAGE **(B)** 25µl samples of 5 ml fractions were analysed on 17.5% SDS-PAGE gel and stained with CBB. 5µg recombinant GNA previously expressed was used as a standard; M=Molecular weight marker. Fractions from peak 1 were pooled, dialysed with 12kDa MWCO tubing and lyophilysed for further clean up.

Appendix

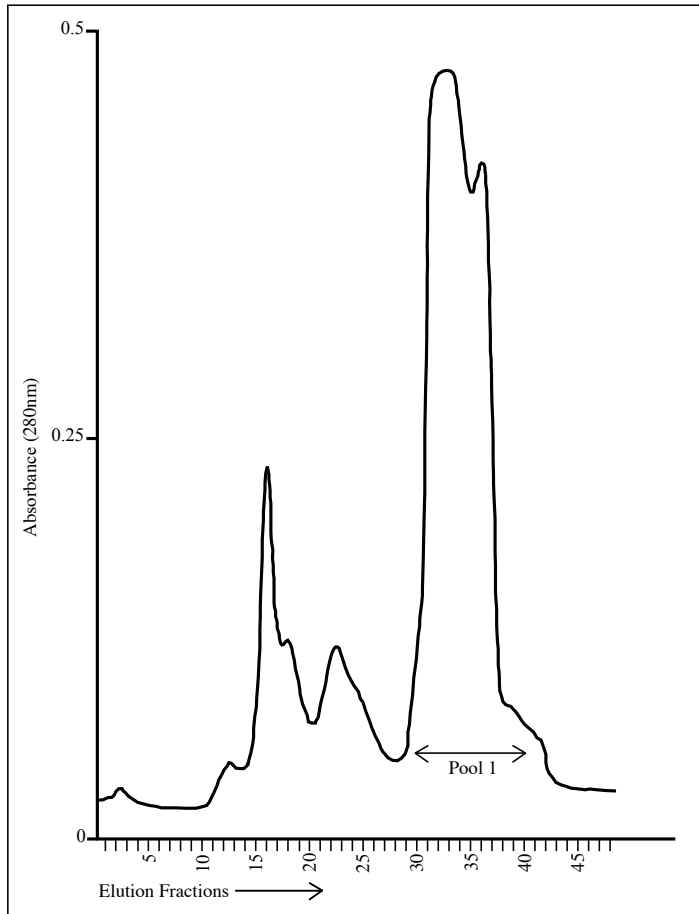


## Appendix 2

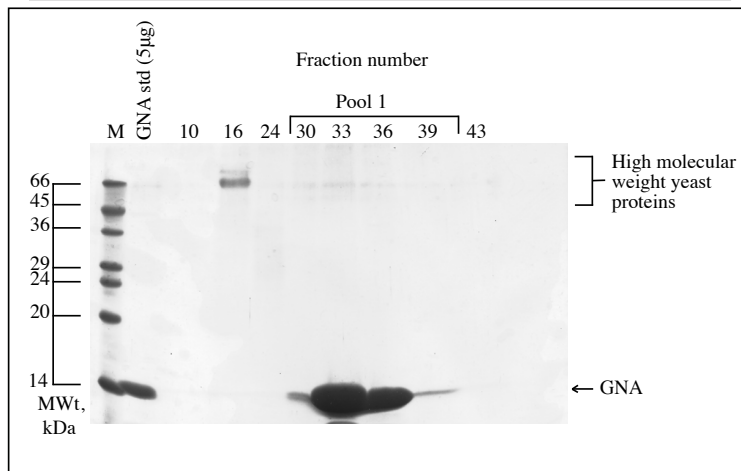
**'Clean up' of GNA by gel filtration column purification and quantitation of purified protein.** Pooled lyophilized protein from Phenyl-Sepharose purification was resuspended in 1 x PBS and loaded onto a gel filtration column. Proteins were eluted in 1 X PBS. **(A)** Standard purification trace. Fractions containing GNA (pool 1). **(B)** 25 $\mu$ l samples of 10ml peak fractions were analyzed on 17.5% SDS PAGE gels. Fractions 15-26 typically contained high molecular weight yeast proteins and fractions 30-40 contained GNA. Fractions containing GNA were pooled, dialysed with 12kDa MWCO tubing and subsequently lyophilized. Lyophilized protein was resuspended in water at 1mg ml<sup>-1</sup>. **(C)** 2 and 5 $\mu$ g of samples (1-4) were quantified against recombinant 2 and 5 $\mu$ g GNA previously shown to be >95% homogeneous GNA on 17.5% SDS PAGE gel stained with CBB. M = Molecular weight marker. No high molecular weight yeast proteins could be detected in quantified samples. Recovered protein yield was approx. 90mg l<sup>-1</sup>.

Appendix

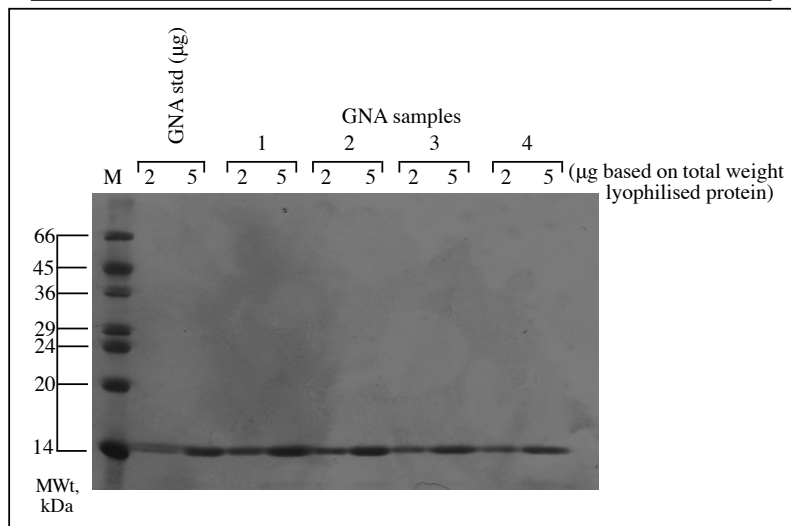
(A)

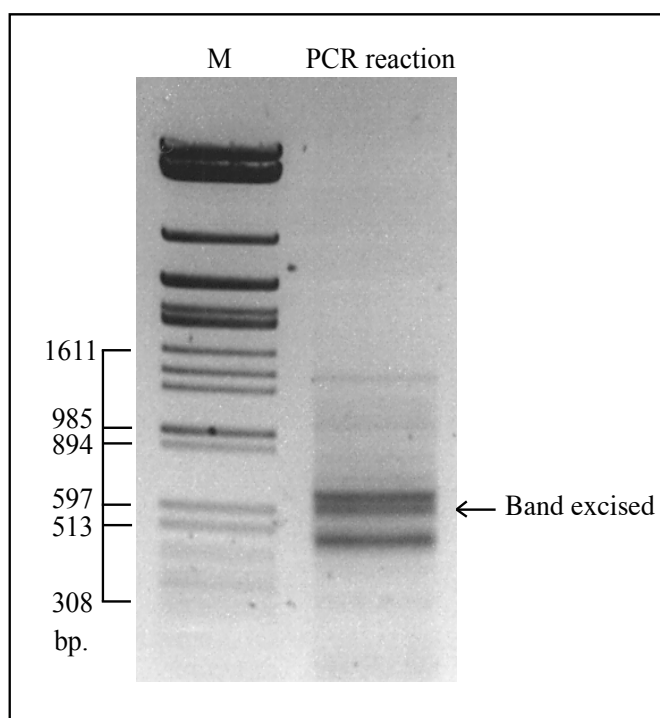


(B)



(C)





### Appendix 3

**Agarose gel of PCR fragments generated from degenerate PCR reaction.** Several bands appear on the gel at approx. 480, 600 and 650bp. Band at approximately 600bp was deemed to be the correct product. It was carefully excised and cloned into pJET2.1 for sequencing.

|  |     |
|--|-----|
| WSFGTVGAIEGAFFLSNGNQLVRLSQQALIDCSWGYGNNGCDGGEDFRAY   | 50  |
| QWMLKHGGIPTEDEYGPYLGQDGYCHINNVTLTAKITGYVNVTSGVEDAL   | 100 |
| RLAIVKHGPI SVAIDASHRTFSFY SNGVYYEPKCGNKIDELDHAVLAVGY | 150 |
| GSINGNDYWLVK   | 162 |

### Appendix 4

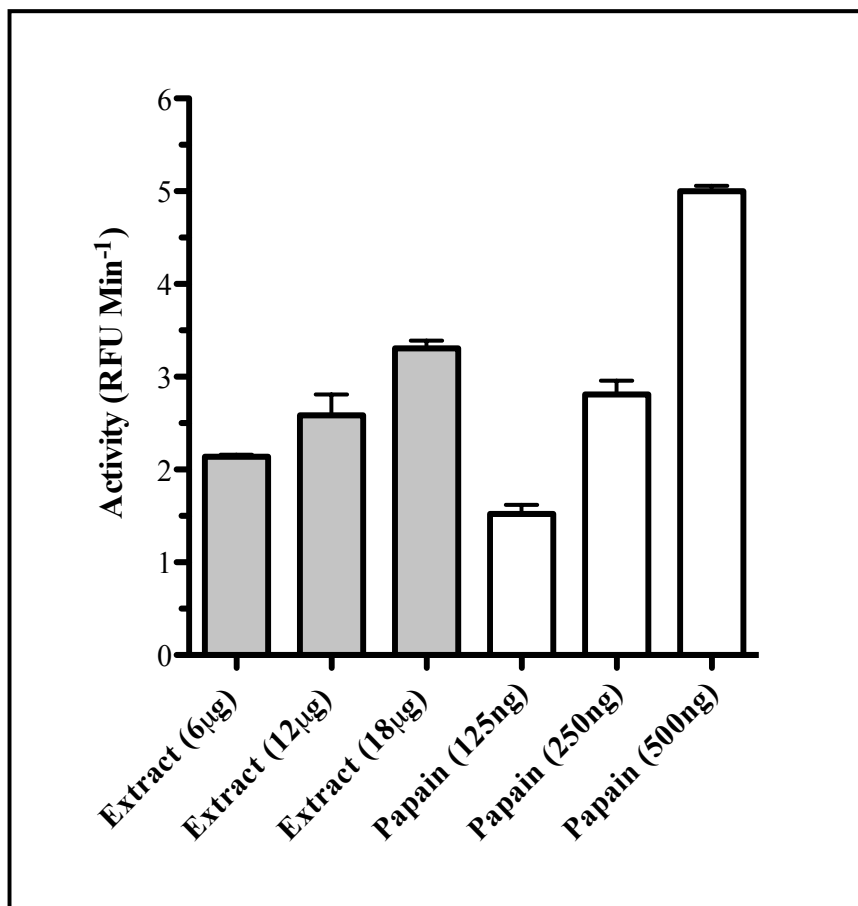
**Presumed amino acid sequence of degenerate PCR fragment cloned from whole insect wireworm cDNA.** Highlighted eukaryote thiol (cysteine) proteases histidine active site (ExpASy; ScanProsite tool).

## Appendix

|           |   |     |
|-----------|---|-----|
| Wireworm  | WSFGTVGAIEGAFFLSNGNQLVRLSQQALIDCSWGYGNNCGDGEDFRAYQWMLKHGGIP | 60  |
| Tribolium | WSFGTVGTVEGALFLHNGGRLFRLSQQALVDCSWGYGNNCGDGEDFRAYQWMLKHGGIP | 60  |
|           | *****:***:* *.:*.*****:*****:*****:*****:*****:*****        |     |
| Wireworm  | TEDEYGPYLGQDGYCHINNVTLAKITGYVNVTSQVEDALRLAIVKHGPISVAIDASHRT | 120 |
| Tribolium | TEEAYGPYLGQDGYCHADKVQKVAKITGYVNVTTDENALRLALFKHGPISVAIDASQRT | 120 |
|           | **.:*****:*.*****:.*:*****:.*:*****:.*:*****:.*:*****:.*    |     |
| Wireworm  | FSFYNSGVYYEPKCGNKIDELDHAVLAVGYGSINGNDYWLVK                  | 162 |
| Tribolium | FSFYNSGVYYEPKCGNKIDELDHAVLAVGYGTINGENYWLVK                  | 162 |
|           | *****:*****:*****:*****:*****:*****:*****:*****:*****:***** |     |

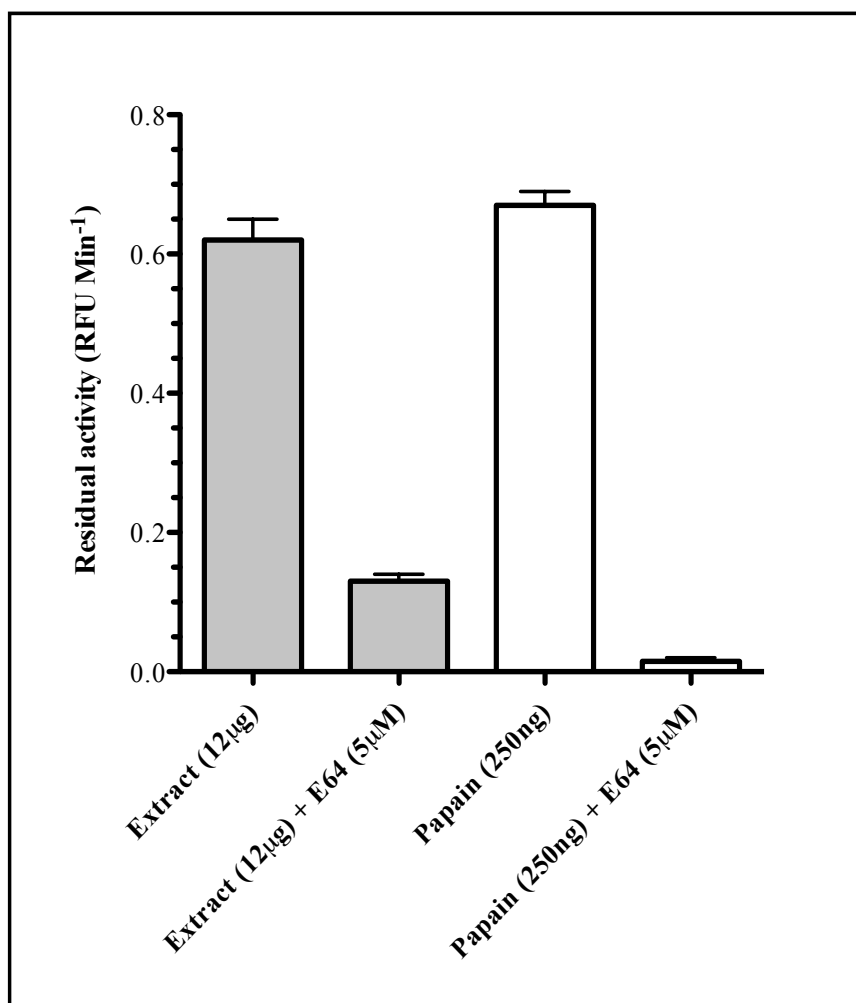
### Appendix 5

ClustalW alignment of the presumed amino acid sequence of the degenerate PCR fragment from Wireworm (*Agriotes* spp.) and amino acid sequence of the corresponding section of the *Tribolium castaneum* cathepsin L pre-cursor sequence (NP\_00164088.1). Colours denote different residues; matching colours represent conserved residues.



### Appendix 6

Hydrolysis of the cysteine specific substrate Z-Phe-Arg-AMC by 6, 12, 18µg *Agriotes* spp. gut extract. 125, 250, 500ng of the cysteine protease, papain was used as a positive control. All assays were carried out in the presence of 1µM glutathione. Error bars denote standard error of the mean (SEM).



#### Appendix 7

**Inhibition of protease activity with 5µM of an irreversible cysteine protease inhibitor (E64; (2S,3S)-3-(N-((S)-1-[N-(4-guanidinobutyl)-carbamoyl]3-methylbutyl) carbamoyl) oxirane-2-carboxylic acid)) using the cysteine specific substrate Z-Phe-Arg-AMC.** Based on activity profiles (appendix 4) comparable levels of activity were seen with 12µg gut extract and 250ng papain. These concentrations were used for inhibition by E64. All assays were carried out in the presence of 1µM glutathione. Error bars denote standard error of the mean (SEM).

## Appendix

|   |      |
|---|------|
| ATGAGATTCCTTCAATTACTGCTGTTTTATTTCGCAGCATCTCC  | -270 |
| <u>GCATTAGCTGCTCCAGTCAACACTACAACAGAAGATGAAACGGCACAAATTCGGCTGAAGCTGTCATCGGTTAC</u>           | -225 |
| <u>TCAGATTTAGAAGGGGATTCGATGTTGCTGTTTTGCCATTTTCCAACAGCACAAATAACGGGTATTGTTTATA</u>            | -150 |
| <u>AAATACTACTATTGCCAGCATTGCTGCTAAAGAAGAAGGGGTATCTCTCGAGAAAAGAGAGGCTGAA</u> <i>GCTGCAGCA</i> | - 75 |
| <i>PstI</i>   |      |
| TCTCCAACCTGTATTCCATCTGGTCAACCATGTCCATATAATGAAAATTGTTGTTCTCAATCTTGACTTTTAAA                  | 75   |
| <u>S P T C I P S G Q P C P Y N E N C C S Q S C T F K</u>                                    | 25   |
| GAAAATGAAAATGGTAATACTGTAAAAGATGTGATGCGGCCCGCACAAATTTTGTACTCCGGTGAGACTCTC                    | 150  |
| <u>E N E N G N T V K R C D</u> A A A D N I L Y S G E T L                                    | 50   |
| <i>NotI</i>   |      |
| TCTACAGGGGAATTTCTCAACTACGGAAGTTTCGTTTTTATCATGCAAGAGGACTGCAATCTGGTCTTGACGAC                  | 225  |
| <u>S T G E F L N Y G S F V F I M Q E D C N L V L Y D</u>                                    | 75   |
| GTGGACAAGCCAATCTGGGCAACAAACACAGGTGGTCTCTCCCGTAGCTGCTTCTCAGCATGCAGACTGATGGG                  | 300  |
| <u>V D K P I W A T N T G G L S R S C F L S M Q T D G</u>                                    | 100  |
| AACCTCGTGGTGTACAACCCATCGAACAACCGATTTGGGCAAGCAACACTGGAGGCCAAAATGGGAATTACGTG                  | 375  |
| <u>N L V V Y N P S N K P I W A S N T G G Q N G N Y V</u>                                    | 125  |
| TGCATCCTACAGAAGGATAGGAATGTTGTGATCTACGGAAGTATCGTTGGGCTACTGGAGTCGACCATCATCAT                  | 435  |
| <u>C I L Q K D R N V V I Y G T D R W A T G V D</u> <b><u>H H H</u></b>                      | 145  |
| <i>SalI His tag</i>   |      |
| CATCATCATTGA  | 444  |
| <u><b>H H H</b></u> *   | 148  |

### Appendix 8

#### Full $\omega$ -ACTX-GNA-(his)<sub>6</sub> fusion construct in yeast expression vector pGAPZ $\alpha$ B.

Nucleotide and amino acid sequence of fusion protein construct. Yeast  $\alpha$ -factor signal sequence is shown highlighted, linker regions are shown in italic, mature  $\omega$ -ACTX toxin sequence is underlined, mature GNA sequence is shown in bold and (his)<sub>6</sub> tag is bold and underlined

## Appendix

|  |      |
|--|------|
| ATGAGATTTCCTTCAATTACTGCTGTTTTATTTCGACGATCCTCC                                      | -270 |
| <u>GCATTAGCTGCTCCAGTCAACACTACAACAGAAGATGAAACGGCACAAAATCCGGCTGAAGCTGTCATCGGTTAC</u> | -225 |
| <u>TCAGATTTAGAAGGGGATTCGATGTTGCTGTTTTGCCATTTTCCAACAGCACAAATAACGGGTATTGTTTATA</u>   | -150 |
| <u>AATACTACTATTGCCAGCATTGCTGCTAAAGAAGAAGGGGTATCTCTCGAGAAAAGAGAGGCTGAAGCTGCAGCA</u> | - 75 |
| <i>PstI</i>  |      |
| CATCATCATCATCATCATGACAATATTTTGTACTCCGGTGAGACTCTCTCTACAGGGGAATTTCTCAACTACGGA        | 75   |
| <u>H H H H H H</u> D N I L Y S G E T L S T G E F L N Y G                           | 25   |
| His Tag  |      |
| AGTTTCGTTTTTATCATGCAAGAGGACTGCAATCTGGTCTTGTACGACGTGGACAAGCCAATCTGGGCAACAAAC        | 150  |
| <b>S F V F I M Q E D C N L V L Y D V D K P I W A T N</b>                           | 50   |
| ACAGGTGGTCTCTCCCGTAGCTGCTTCCCTCAGCATGCAGACTGATGGGAACCTCGTGGTGTACAACCCATCGAAC       | 225  |
| <b>T G G L S R S C F L S M Q T D G N L V V Y N P S N</b>                           | 75   |
| AAACCGATTTGGGCAAGCAACACTGGAGGCCAAAATGGGAATTACGTGTGCATCCTACAGAAGGATAGGAATGTT        | 300  |
| <b>K P I W A S N T G G Q N G N Y V C I L Q K D R N V</b>                           | 100  |
| GTGATCTACGAACTGATCGTTGGGCTACTGGAGCGGCCCATCTCCAACCTTGTATTCCATCTGGTCAACCATGT         | 375  |
| <b>V I Y G T D R W A T G A A A S P T C I P S G Q P C</b>                           | 125  |
| <i>NotI</i>  |      |
| CCATATAATGAAAATTGTGTTCTCAATCTTGTACTTTTAAAGAAAATGAAAATGGTAATACTGTAAAAGATGT          | 435  |
| <b>P Y N E N C C S Q S C T F K E N E N G N T V K R C</b>                           | 145  |
| GATTGA   | 438  |
| D *  | 146  |

### Appendix 9

#### Full (his)<sub>6</sub>- $\omega$ -ACTX-GNA fusion construct in yeast expression vector pGAPZ $\alpha$ B.

Nucleotide and amino acid sequence of fusion protein construct. Yeast  $\alpha$ -factor signal sequence is shown highlighted, linker regions are shown in italic, mature  $\omega$ -ACTX toxin sequence is underlined, mature GNA sequence is shown in bold and (his)<sub>6</sub> tag is bold and underlined.

## Appendix

|  |      |
|--|------|
| ATGAGATTCCTTCAATTACTGCTGTTTTATTTCGCAGCATCCTCC  | -270 |
| GCATTAGCTGCTCCAGTCAACACTACAACAGAAGATGAAACGGCACAAATTCGGGCTGAAGCTGTCATCGGTTAC  | -225 |
| TCAGATTTAGAAGGGGATTCGATGTTGCTGTTTTGCCATTTTCCAACAGCACAAATAACGGGTATTGTTTATA  | -150 |
| AATACTACTATTGCCAGCATTGCTGCTAAAGAAGAAGGGTATCTCTCGAGAAAAGAGAGGCTGAA  | - 75 |
| <i>Pst</i> I   |      |
| TCTCCAACCTTGTTATCCATCTGGTCAACCATGTCCATATAATGAAAATGTTGTTCTCAATCTTGACTTTTAAA   | 75   |
| <u>S P T C I P S G Q P C P Y N E N C C S Q S C T F K</u>   | 25   |
| GAAAATGAAAATGGTAATACTGTTCAAAGATGTGATGCGGCCCGACAATATTTGTACTCCGGTGAGACTCTC   | 150  |
| <u>E N E N G N T V <span style="border: 1px solid black; padding: 0 2px;">Q</span> R C D A A A D N I L Y S G E T L</u> | 50   |
| <i>Not</i> I   |      |
| TCTACAGGGGAATTTCTCAACTACGGAAGTTTCGTTTTTATCATGCAAGAGGACTGCAATCTGGTCTTGTACGAC  | 225  |
| <b>S T G E F L N Y G S F V F I M Q E D C N L V L Y D</b>   | 75   |
| GTGGACAAGCCAATCTGGGCAACAAACACAGGTGGTCTCTCCCGTAGCTGCTTCTCAGCATGCAGACTGATGGG   | 300  |
| <b>V D K P I W A T N T G G L S R S C F L S M Q T D G</b>   | 100  |
| AACCTCGTGGTGTACAACCCATCGAACAACCGATTGGGCAAGCAACACTGGAGGCCAAAATGGGAATTACGTG  | 375  |
| <b>N L V V Y N P S N K P I W A S N T G G Q N G N Y V</b>   | 125  |
| TGCATCTACAGAAGGATAGGAATGTTGTGATCTACGGAAGTATCGTTGGGCTACTGGATGA  | 435  |
| <b>C I L Q K D R N V V I Y G T D R W A T G *</b>   | 145  |

### Appendix 10

#### **K34Q- $\omega$ -ACTX-GNA fusion construct in yeast expression vector pGAPZ $\alpha$ B.**

Nucleotide and amino acid sequence of fusion protein construct. Yeast  $\alpha$ -factor signal sequence is shown highlighted, linker regions are shown in italic, mature  $\omega$ -ATCX toxin sequence is underlined (amino acid modification boxed) boxed, mature GNA sequence is shown in bold.

## Appendix

|   |     |
|---|-----|
| <b><u>ACAAGTTTGTACAAAAAGCAGGCT</u></b> TAAAGGAACCAATTCAGTCGACATGGCTAAGGCAAGTCTCCTCATTTG       | 75  |
| <b>attB1</b> <span style="margin-left: 150px;"><i>salI</i></span> <b>M A K A S L L I L</b>    | 9   |
| GCCGCCATCTTCCTGGTGTGCATCACACCATCTTGCTGAGTGCTGCAGCATCTCCAACCTGTATCCATCTGGT                     | 150 |
| <b>A A I F L G V I T P S C L S A A A</b> <u>S P T C I P S G</u>                               | 34  |
| <i>PstI</i>   |     |
| CAACCATGTCCATATAATGAAAAATGTTGTTCTCAATCTGTACTTTTAAAGAAAATGAAAATGGTAATACTGTT                    | 225 |
| <u>Q P C P Y N E N C C S Q S C T F K E N E N G N T V</u>                                      | 59  |
| CAAAGATGTGATGCGGCCCGACAATATTTTGTACTCCGGTGAGACTCTCTCTACAGGGGAATTTCTCAACTAC                     | 300 |
| <b>Q</b> <u>R C D</u> A A A D N I L Y S G E T L S T G E F L N Y                               | 84  |
| <i>NotI</i>   |     |
| GGAAGTTTCGTTTTTATCATGCAAGAGGACTGCAATCTGGTCTTGTACGACGTGGACAAGCCAATCTGGGCAACA                   | 375 |
| <b>G S F V F I M Q E D C N L V L Y D V D K P I W A T</b>                                      | 109 |
| AACACAGGTGGTCTCTCCCGTAGCTGCTTCCTCAGCATGCAGACTGATGGGAACCTCGTGGTGTACAACCCATCG                   | 450 |
| <b>N T G G L S R S C F L S M Q T D G N L V V Y N P S</b>                                      | 134 |
| AACAAACCGATTTGGGCAAGCAACACTGGAGGCCAAAATGGGAATTACGTGTGCATCCTACAGAAGGATAGGAAT                   | 525 |
| <b>N K P I W A S N T G G Q N G N Y V C I L Q K D R N</b>                                      | 159 |
| GTTGTGATCTACGGAACCTGATCGTTGGGCTACTGGATGAAGATATCTAG <u>ACCCAGCTTTCTTGTACAAAGTGGT</u>           | 599 |
| <b>V V I Y G T D R W A T G *</b> <i>EcoRV</i> <span style="float: right;"><b>AttB2</b></span> | 171 |

### Appendix 11

**GNA leader-K34Q $\omega$ -ACTX-GNA fusion protein construct in plant expression vector pK2GW7.** Full nucleotide and derived amino acid sequence of the construct shown within the recombination sites of the expression vector pK2GW7. GNA leader is shown in bold italics,  $\omega$ -ACTX is underlined (amino acid modification boxed) and GNA is shown in bold.

## Appendix

|   |     |
|---|-----|
| <b><u>ACAAGTTTGTACAAAAAGCAGGCT</u></b> TTAAAGGAACCAATTCAGTCGACATGGCTAAGGCAAGTCTCTCATTTTG  | 75  |
| <b><i>attB1</i></b> <span style="margin-left: 150px;"><i>salI</i></span> <b><i>M A K A S L L I L</i></b>  | 9   |
| GCCGCCATCTTCCTTGGTGCATCACACCATCTTGCTGAGTGCCTGAGCATCTCCAACCTGTATTCCATCTGGT   | 150 |
| <b><i>A A I F L G V I T P S C L S A A A S P T C I P S G</i></b>   | 34  |
| <i>PstI</i>   |     |
| CAACCATGTCCATATAATGAAAATGTTGTTCTCAATCTTGTACTTTTAAAGAAAATGAAAATGGTAATACTGTT  | 225 |
| <b><u>Q P C P Y N E N C C S Q S C T F K E N E N G N T V</u></b>   | 59  |
| AAAAGATGTGATGCGGCCGCCGACAATATTTTGTACTCCGGTGAGACTCTCTCTACAGGGGAATTTCTCAACTAC   | 300 |
| <b><u>K R C D A A A D N I L Y S G E T L S T G E F L N Y</u></b>   | 84  |
| <i>NotI</i>   |     |
| GGAAGTTTCGTTTTTATCATGCAAGAGGACTGCAATCTGGTCTTGTACGACGTGGACAAGCCAATCTGGGCAACA   | 375 |
| <b><i>G S F V F I M Q E D C N L V L Y D V D K P I W A T</i></b>   | 109 |
| AACACAGGTGGTCTCTCCCGTAGCTGCTTCCTCAGCATGCAGACTGATGGGAACCTCGTGGTGTACAACCCATCG   | 450 |
| <b><i>N T G G L S R S C F L S M Q T D G N L V V Y N P S</i></b>   | 134 |
| AACAAACCGATTTGGGCAAGCAACACTGGAGGCCAAAATGGGAATTACGTGTGCATCCTACAGAAGGATAGGAAT   | 525 |
| <b><i>N K P I W A S N T G G Q N G N Y V C I L Q K D R N</i></b>   | 159 |
| GTTGTGATCTACGGAAGTATCGTTGGGCTACTGGATGAAGATATCTAG <b><u>ACCAGCTTTCTGTACAAAGTGGT</u></b>  | 599 |
| <b><i>V V I Y G T D R W A T G *</i></b> <span style="margin-left: 50px;"><i>EcoRV</i></span> <span style="margin-left: 100px;"><b><i>AttB2</i></b></span> | 171 |

### Appendix 12

**GNA leader- $\omega$ -ACTX-GNA fusion protein construct in plant expression vector pK2GW7.** Full nucleotide and derived amino acid sequence of the construct shown within the recombination sites of the expression vector pK2GW7. GNA leader is shown in bold italics,  $\omega$ -ACTX is underlined and GNA is shown in bold.

## Appendix

|  |     |
|--|-----|
| <b><u>ACAAGTTTGTACAAAAAGCAGGCT</u></b> TTAAAGGAACCAATTCAGTCGACATGGCTAAGGCAAGTCTCCTCATTTTG  | 75  |
| <b>attB1</b> <span style="margin-left: 150px;"><i>salI</i></span> <b>M A K A S L L I L</b> | 9   |
| GCCGCCATCTTCCTTGGTGTGCATCACACCATCTTGCCTGAGTGCAGCATCTCCAAGTGTATTCCATCTGGT                   | 150 |
| <b>A A I F L G V I T P S C L S A A A</b> <u>S P T C I P S G</u>                            | 34  |
| <i>PstI</i>  |     |
| CAACCATGTCCATATAATGAAAATGTTGTTCTCAATCTTGTACTTTTAAAGAAAATGAAAATGGTAATACTGTT                 | 225 |
| <u>Q P C P Y N E N C C S Q S C T F K E N E N G N T V</u>                                   | 59  |
| AAAAGATGTGATTGAAGATATCTAG <b><u>ACCCAGCTTTCTTGTACAAAGTGGT</u></b>                          | 275 |
| <u>K R C D</u> * <i>EcoRV</i> <span style="margin-left: 150px;"><b>AttB2</b></span>        | 63  |

### Appendix 13

**GNA leader- $\omega$ -ACTX fusion protein construct in plant expression vector pK2GW7.** Full nucleotide and derived amino acid sequence of the construct shown within the recombination sites of the expression vector pK2GW7. GNA leader is shown in bold italics,  $\omega$ -ACTX is underlined.

|   |     |
|---|-----|
| <b><u>ACAAGTTTGTACAAAAAGCAGGCT</u></b> TTAAAGGAACCAATTCAGTCGACATGGCTAAGGCAAGTCTCCTCATTTTG   | 75  |
| <b>attB1</b> <span style="margin-left: 150px;"><i>salI</i></span> <b>M A K A S L L I L</b>  | 9   |
| GCCGCCATCTTCCTTGGTGTGCATCACACCATCTTGCCTGAGTGCAGCATCTCCAAGTGTATTCCATCTGGT  | 150 |
| <b>A A I F L G V I T P S C L S A A A</b> <u>S P T C I P S G</u>   | 34  |
| <i>PstI</i>   |     |
| CAACCATGTCCATATAATGAAAATGTTGTTCTCAATCTTGTACTTTTAAAGAAAATGAAAATGGTAATACTGTT  | 225 |
| <u>Q P C P Y N E N C C S Q S C T F K E N E N G N T V</u>  | 59  |
| CAAAGATGTGATTGAAGATATCTAG <b><u>ACCCAGCTTTCTTGTACAAAGTGGT</u></b>   | 275 |
| <span style="border: 1px solid black; padding: 0 2px;">Q</span> <u>R C D</u> * <i>EcoRV</i> <span style="margin-left: 150px;"><b>AttB2</b></span> | 63  |

### Appendix 14

**GNA leader-K34Q $\omega$ -ACTX fusion protein construct in plant expression vector pK2GW7.** Full nucleotide and derived amino acid sequence of the construct shown within the recombination sites of the expression vector pK2GW7. GNA leader is shown in bold italics,  $\omega$ -ACTX is underlined (amino acid modification boxed).