

Durham E-Theses

*The evaluation of Corona and Ikonos satellite
imagery for archaeological applications in a semi-arid
environment*

Anthony Richard Beck

How to cite:

Beck, Anthony Richard (2004) The evaluation of Corona and Ikonos satellite imagery for archaeological applications in a semi-arid environment. Doctoral thesis, Durham University.

Use policy

The full-text may be used and/or reproduced, and given to third parties in any format or medium, without prior permission or charge, for personal research or study, educational, or not-for-profit purposes provided that:

- a full bibliographic reference is made to the original source
- a <https://etheses.durham.ac.uk/id/eprint/3120/> is made to the metadata record in Durham E-Theses
- the full-text is not changed in any way

The full-text must not be sold in any format or medium without the formal permission of the copyright holders.

Please consult the [full Durham E-Theses policy](#) for further details.

THE EVALUATION OF CORONA AND
IKONOS SATELLITE IMAGERY FOR
ARCHAEOLOGICAL APPLICATIONS IN A
SEMI-ARID ENVIRONMENT.

Volume 1 of 1

Thesis submitted for the degree of

Doctor of Philosophy

at the University of Durham

**A copyright of this thesis rests
with the author. No quotation
from it should be published
without his prior written consent
and information derived from it
should be acknowledged.**

By

Anthony Richard Beck BA (Newcastle upon Tyne)

Department of Archaeology

University of Durham

2004



21 JUN 2005

THE EVALUATION OF CORONA AND
IKONOS SATELLITE IMAGERY FOR
ARCHAEOLOGICAL APPLICATIONS IN A
SEMI-ARID ENVIRONMENT.

Volume 1 of 1

Thesis submitted for the degree of

Doctor of Philosophy

at the University of Durham

By

Anthony Richard Beck BA (Newcastle upon Tyne)

Department of Archaeology

University of Durham

2004

THE EVALUATION OF CORONA AND
IKONOS SATELLITE IMAGERY FOR
ARCHAEOLOGICAL APPLICATIONS IN A
SEMI-ARID ENVIRONMENT.

Volume 1 of 1

Thesis submitted for the degree of

Doctor of Philosophy

at the University of Durham

By

Anthony Richard Beck BA (Newcastle upon Tyne)

Department of Archaeology

University of Durham

2004

ABSTRACT

'The evaluation of Corona and Ikonos satellite imagery for archaeological applications in a semi-arid environment' by Anthony Richard Beck

Archaeologists have been aware of the potential of satellite imagery as a tool almost since the first Earth remote sensing satellite. Initially sensors such as Landsat had a ground resolution which was too coarse for thorough archaeological prospection although the imagery was used for geo-archaeological and enviro-archaeological analyses. In the intervening years the spatial and spectral resolution of these sensing devices has improved. In recent years two important occurrences enhanced the archaeological applicability of imagery from satellite platforms: The declassification of high resolution photography by the American and Russian governments and the deregulation of commercial remote sensing systems allowing the collection of sub metre resolution imagery.

This thesis aims to evaluate the archaeological application of three potentially important resources: Corona space photography and Ikonos panchromatic and multispectral imagery. These resources are evaluated in conjunction with Landsat Thematic Mapper (TM) imagery over a 600 square km study area in the semi-arid environment around Homs, Syria. The archaeological resource in this area is poorly understood, mapped and documented.

The images are evaluated for their ability to create thematic layers and to locate archaeological residues in different environmental zones. Further consideration is given to the physical factors that allow archaeological residues to be identified and how satellite imagery and modern technology may impact on Cultural Resource Management.

This research demonstrates that modern high resolution and historic satellite imagery can be important tools for archaeologists studying in semi-arid environments. The imagery has allowed a representative range of archaeological features and landscape themes to be identified. The research shows that the use of satellite imagery can have significant impact on the design of the archaeological survey in the middle-east and perhaps in other environments.

Key words: archaeology, Corona, CRM, GIS, Ikonos, Landsat, landscape, prospection, remote sensing, satellite, semi-arid, soil, Syria

TABLE OF CONTENTS

TABLE OF CONTENTS	I
LIST OF FIGURES	VI
LIST OF TABLES	XII
ACKNOWLEDGMENTS	XIII
GLOSSARY	XV
SECTION 1 INTRODUCTION	1
CHAPTER 1 RESEARCH INTRODUCTION AND SUMMARY	2
1.1 INTRODUCTION	2
1.2 THESIS STRUCTURE	3
1.3 RESEARCH SUMMARY	3
1.3.1 <i>Traditional approaches to landscape survey</i>	4
1.3.2 <i>Settlement and landscape development in the Homs region</i>	6
1.3.3 <i>Introduction to the data sources</i>	6
1.3.4 <i>Remote sensing</i>	8
1.3.5 <i>Image interpretation</i>	9
1.3.6 <i>Archaeological data</i>	11
1.3.7 <i>Remote sensing and archaeology</i>	13
1.4 METHOD SUMMARY	14
1.4.1 <i>Aims and objectives for the evaluation of satellite imagery</i>	17
1.5 OTHER RESEARCH INTO THE ARCHAEOLOGICAL APPLICATION OF HIGH RESOLUTION SATELLITE IMAGERY	18
CHAPTER 2 CONCEPTS OF REMOTE SENSING FOR ARCHAEOLOGY	26
2.1 REMOTE SENSING – INTRODUCTION AND DEFINITION	26
2.1.1 <i>Electromagnetic energy</i>	27
2.1.2 <i>Interactions with the atmosphere</i>	32
2.1.3 <i>Interactions with an object</i>	36
2.1.4 <i>Discussion</i>	36
2.2 THE COMPONENTS OF REMOTE SENSING SYSTEMS	38
2.2.1 <i>Hardware: Platforms</i>	38
2.2.2 <i>Hardware: Sensor systems</i>	40
2.2.3 <i>Hardware: Sensor characteristics</i>	40
2.2.4 <i>Software: Image processing systems</i>	46
2.2.5 <i>Processing: Image pre-processing</i>	47
2.2.6 <i>Processing: Image display and visualisation</i>	52
2.2.7 <i>Processing: Image classification</i>	62
2.3 IMAGE INTEGRATION AND PROBLEMS OF SCALE	68
2.4 ARCHAEOLOGICAL INTERPRETATION	69
CHAPTER 3 CONCEPTS OF LANDSCAPE FOR ARCHAEOLOGY	73
3.1 LANDSCAPE ARCHAEOLOGY: INTRODUCTION AND DEFINITION.....	73
3.2 THE COMPONENTS OF ARCHAEOLOGICAL LANDSCAPES.....	74
3.2.1 <i>Natural landscapes</i>	75
3.2.2 <i>Landscapes and space</i>	76
3.2.3 <i>Landscapes and scale</i>	77
3.2.4 <i>Cultural landscapes</i>	77
3.2.5 <i>Discussion</i>	78
3.3 TRANSFORMATION OF ARCHAEOLOGICAL LANDSCAPES.....	79
3.3.1 <i>Cultural transforms</i>	79
3.3.2 <i>Natural transforms</i>	81
3.3.3 <i>Discussion</i>	83

3.4	PRACTICE AND ARCHAEOLOGICAL LANDSCAPES	85
3.4.1	<i>Survey objectives</i>	85
3.4.2	<i>Desk based assessment</i>	87
3.4.3	<i>Ground reconnaissance</i>	90
3.4.4	<i>Summary</i>	94
3.5	LANDSCAPE MODELLING	95
3.5.1	<i>Modelling archaeological landscapes</i>	96
3.5.2	<i>'Sites' as interpretative units</i>	101
3.6	DISCUSSION	102
3.6.1	<i>Research implications of landscape archaeology</i>	103
SECTION 2: METHODOLOGY AND ANALYSIS.....		105
CHAPTER 4 SETTLEMENT AND LANDSCAPE DEVELOPMENT IN THE HOMS REGION, SYRIA: AIMS, SETTING, RESEARCH QUESTIONS AND FIELDWORK (1999-2003).....		106
4.1	THE SHR PROJECT	106
4.2	ENVIRONMENTAL ZONES, LAND USE AND ARCHAEOLOGICAL SUMMARY	109
4.2.1	<i>The marl zone (units 1 and 4)</i>	109
4.2.2	<i>The basalt zone (units 3 and 7)</i>	112
4.2.3	<i>The alluvial zone (units 2, 5 and 8)</i>	113
4.2.4	<i>Lake Qatina (unit 8)</i>	115
4.3	SURVEY METHODOLOGY	117
4.3.1	<i>SHR project DBA</i>	117
4.3.2	<i>Ground observation</i>	118
4.4	FIELDWORK PROGRAMME	120
4.5	SHR RESEARCH GOALS	123
CHAPTER 5 IMAGE PREPARATION.....		125
5.1	DATA SOURCES	125
5.1.1	<i>Landsat</i>	125
5.1.2	<i>Ikonos</i>	131
5.1.3	<i>Corona</i>	134
5.1.4	<i>Ancillary data sets</i>	138
5.2	IMAGE SELECTION	141
5.2.1	<i>Atmospheric ramifications</i>	143
5.2.2	<i>Land management ramifications</i>	144
5.2.3	<i>Field observations</i>	146
5.2.4	<i>Determining acquisition times</i>	146
5.2.5	<i>Data sets acquired</i>	149
5.3	IMAGE PRE-PROCESSING	153
5.3.1	<i>Digitising Corona</i>	153
5.3.2	<i>Atmospheric calibration</i>	156
5.3.3	<i>Correction of topographic effects</i>	157
5.4	GEO-RECTIFICATION	158
5.4.1	<i>Co-registration</i>	163
5.5	IMAGE RESCALING	165
5.6	IMAGE FUSION	166
5.6.1	<i>Pan-sharpening</i>	167
5.7	DISCUSSION	170
CHAPTER 6 SATELLITE IMAGERY FOR THEMATIC INFORMATION EXTRACTION.....		171
6.1	LANDSCAPE THEMES	171
6.2	LAND COVER MAPPING	172
6.2.1	<i>Land cover classification systems</i>	173
6.2.2	<i>Land cover mapping methodology</i>	175
6.2.3	<i>Vector digitising methodology</i>	177
6.3	HYDROLOGY NETWORKS	179
6.4	COMMUNICATION NETWORKS	184

6.5	LAND COVER PARCELS.....	184
6.6	GEOLOGY/SOIL MAPPING.....	188
6.7	DIGITAL TERRAIN MODELLING	192
	6.7.1 DTM from contour data.....	193
	6.7.2 DTM generation from remotely sensed data.....	194
	6.7.3 DTM evaluation	197
6.8	DISCUSSION	197
CHAPTER 7 SATELLITE IMAGERY AS A PROSPECTION TOOL.....		199
7.1	ARCHAEOLOGICAL PROSPECTION.....	199
7.2	IMPACT OF THE ENVIRONMENTAL ZONES ON PROSPECTION.....	201
7.3	METHODOLOGICAL BACKGROUND.....	202
	7.3.1 Qualitative methodologies.....	203
	7.3.2 Quantitative methodologies.....	204
	7.3.3 Digitising methodology.....	205
7.4	PROSPECTION IN THE BASALT ZONE	210
	7.4.1 Image selection in the basalt zone.....	214
	7.4.2 Qualitative techniques in the basalt zone.....	214
	7.4.3 Quantitative techniques in the basalt zone.....	216
	7.4.4 Case study in the basalt zone.....	216
	7.4.5 Evaluation of sensors in the basalt zone	220
	7.4.6 Russian aerial photographs in the basalt zone	224
7.5	PROSPECTION IN THE MARL ZONE.....	226
	7.5.1 Image selection in the marl zone.....	231
	7.5.2 Spectral nature of the residues in the marl zone.....	233
	7.5.3 Qualitative techniques in the marl zone.....	238
	7.5.4 Quantitative techniques in the marl zone.....	250
	7.5.5 Evaluation of sensors in the marl zone.....	253
7.6	PROSPECTION IN THE ALLUVIAL ZONE (AND FLOODPLAIN).....	256
7.7	DISCUSSION	259
CHAPTER 8 ANALYSIS OF MARL SOILS.....		261
8.1	INTRODUCTION	261
8.2	PEDOLOGY	263
	8.2.1 Soil biochemistry.....	265
	8.2.2 Organic matter.....	265
	8.2.3 Soil particle size.....	266
8.3	SOIL SPECTRAL REFLECTANCE.....	268
	8.3.1 Organic matter response	270
	8.3.2 Moisture response.....	271
	8.3.3 Iron and Iron-Oxide response	272
	8.3.4 Particle size response	272
	8.3.5 Theoretical reasons for changes in reflectance	273
8.4	SOIL TEXTURE ANALYSIS.....	274
	8.4.1 The 2001 soil sampling programme.....	276
	8.4.2 The 2003 soil sampling programme.....	293
	8.4.3 Interpretation of the analysis.....	296
8.5	DISCUSSION	304
	8.5.1 Non-organic imports.....	305
	8.5.2 Organic matter imports	306
	8.5.3 Reflectance implications of the soil analysis: summary and conclusions	307
	8.5.4 Recommendations for field collection and analysis.....	308
CHAPTER 9 SATELLITE IMAGERY AS A CRM TOOL.....		309
9.1	INTRODUCTION	309
9.2	SATELLITE IMAGERY AS A CONTEXTUAL BACKDROP.....	309
	9.2.1 The comparison of satellite imagery against digital map bases.....	310
	9.2.2 Satellite imagery as a presentation and visualisation tool	313

9.3	SATELLITE IMAGERY AND MOBILE APPLICATIONS	315
9.3.1	<i>Site navigation</i>	316
9.3.2	<i>Spatial data collection</i>	317
9.4	TIME CHANGE ANALYSIS	317
9.4.1	<i>Data preparation</i>	318
9.4.2	<i>Impact of changes over time</i>	319
9.4.3	<i>Site monitoring</i>	326
9.5	DISCUSSION	328
SECTION 3 SUMMARY, RECOMMENDATIONS AND CONCLUSIONS.....		330
CHAPTER 10 DISCUSSION OF THE RESULTS.....		331
10.1	ARCHAEOLOGICAL PROSPECTION SUMMARY	331
10.1.1	<i>Positive evidence</i>	337
10.1.2	<i>Negative evidence</i>	337
10.1.3	<i>Masked evidence</i>	338
10.1.4	<i>Image interpretation key</i>	342
10.1.5	<i>Quantitative summary</i>	342
10.1.6	<i>Effects of resolution on archaeological detection</i>	343
10.2	THEMATIC EXTRACTION SUMMARY	347
10.3	CRM APPLICATION SUMMARY	347
10.3.1	<i>Impact of landscape change on archaeological residues and site monitoring</i>	347
10.4	LIMITATIONS OF ARCHAEOLOGICAL INTERPRETATION FROM SATELLITE IMAGERY	348
10.4.1	<i>Crop mark identification</i>	348
10.5	RECOMMENDATIONS	349
10.5.1	<i>Issues of implementation</i>	351
10.5.2	<i>Impact of the recommendations on the application area</i>	355
10.6	FUTURE SYSTEMS.....	358
CHAPTER 11 CONCLUSIONS.....		360
11.1	GENERAL DISCUSSION	360
11.2	SATELLITE IMAGERY AS A COMPLEMENT TO LANDSCAPE ARCHAEOLOGICAL SURVEY	361
11.2.1	<i>Satellite imagery comparison against aerial photography</i>	363
11.2.2	<i>Satellite imagery comparison against other landscape survey techniques</i>	364
11.3	SOME LIMITATIONS OF ARCHAEOLOGICAL REMOTE SENSING	365
11.4	CLASSIFICATION, CLASSIFICATION, CLASSIFICATION.....	366
11.5	SUMMARY.....	367
APPENDIX I : THE ARCHAEOLOGICAL DATA MODEL AND ENVIRONMENT		369
1.1	INTRODUCTION	369
1.1.1	<i>Project requirements of the data model</i>	371
1.1.2	<i>Model brief</i>	374
1.2	MODEL ENVIRONMENT	376
1.2.1	<i>Software environment</i>	376
1.2.2	<i>Hardware environment</i>	381
1.3	SHR PROJECT DATA MODEL	382
1.3.1	<i>Data flowline</i>	382
1.3.2	<i>A-spatial model</i>	383
1.3.3	<i>Spatial model</i>	389
1.3.4	<i>Data validation</i>	391
1.3.5	<i>Audit trail</i>	393
1.3.6	<i>Data generalisation</i>	393
1.4	DOCUMENTATION	395
1.4.1	<i>Metadata</i>	396
1.5	ARCHIVING AND RE-USE	397
1.6	FUTURE REQUIREMENTS	399
1.7	USING THE DATA MODEL AND RECORDING SYSTEM.....	400

APPENDIX II : COULTER SAMPLE PROCESSING METHODOLOGY	401
APPENDIX III PARTICLE SIZE ANALYSIS RESULTS FROM SITES 97, 218, 221, 238, 271, 279, 339, 478, 496 AND 508.....	402
III.1 PARTICLE SIZE ANALYSIS AT SITE 97	402
III.2 PARTICLE SIZE ANALYSIS AT SITE 218.....	405
III.3 PARTICLE SIZE ANALYSIS AT SITE 221	405
III.4 PARTICLE SIZE ANALYSIS AT SITE 238.....	408
III.5 PARTICLE SIZE ANALYSIS AT SITE 271	408
III.6 PARTICLE SIZE ANALYSIS AT SITE 279	411
III.7 PARTICLE SIZE ANALYSIS AT SITE 339.....	411
III.8 PARTICLE SIZE ANALYSIS AT SITE 478.....	414
III.9 PARTICLE SIZE ANALYSIS AT SITE 496.....	414
III.10 PARTICLE SIZE ANALYSIS AT SITE 508.....	417
REFERENCES CITED.....	418

LIST OF FIGURES

Number	Page
FIGURE 1 EXAMPLES OF THE ARCHAEOLOGICAL RESIDUES IN THE APPLICATION AREA.....	5
FIGURE 2 COMPARISON OF THE 3 PRIMARY SATELLITE SENSORS USED IN THE RESEARCH.....	7
FIGURE 3 OVERVIEW OF REMOTELY SENSED IMAGE ACQUISITION (AFTER CAMPBELL 2002).....	8
FIGURE 4 SCHEMATIC SEQUENCE FOR DIGITAL ANALYSIS (AFTER CAMPBELL 2002).....	10
FIGURE 5 A SCHEMATIC REPRESENTATION OF CATEGORIES OF INFORMATION ABOUT THE REAL WORLD (AFTER CLARK 1987 P. 57).....	16
FIGURE 6 SCHEMATIC ARCHAEOLOGICAL INTERPRETATION PROCESS.....	17
FIGURE 7 SOIL RELATED ARCHAEOLOGICAL APPLICATIONS AT DIFFERENT PORTIONS OF THE EM SPECTRUM (AFTER LUCAS 2001 P. 156).....	26
FIGURE 8 DIAGRAMMATIC REPRESENTATION OF A PHOTON.....	27
FIGURE 9 THE ELECTROMAGNETIC SPECTRUM AND ATMOSPHERIC ABSORPTION CURVE.....	28
FIGURE 10 ELECTROMAGNETIC ENERGY INTERACTIONS WITH A TARGET.....	29
FIGURE 11 THE SPECTRAL DISTRIBUTION OF ENERGY EMITTED BY A BLACKBODY AS A FUNCTION OF ITS TEMPERATURE (AFTER LILLESAND AND KIEFER 1999).....	30
FIGURE 12 DIURNAL TEMPERATURE VARIATIONS (AFTER LILLESAND AND KIEFER 1999).....	31
FIGURE 13 SOLAR RADIATION INTERACTIONS WITH THE ATMOSPHERE FOR SHORT WAVELENGTHS (AFTER CAMPBELL 2002).....	32
FIGURE 14 FIVE TYPES OF RADIATIVE INTERACTION WITH THE ATMOSPHERE AND HOW THEY IMPACT THE INSTANTANEOUS FIELD OF VIEW (IFOV: AFTER TSO AND MATHER 2001 P. 15).....	33
FIGURE 15 CHANGES IN REFLECTED, DIFFUSE, SCATTERED AND OBSERVED RADIATION OVER WAVELENGTH (AFTER CAMPBELL 2002).....	34
FIGURE 16 REFRACTION: HOW THE PATH OF RADIATION IS AFFECTED BY CHANGES IN THE DENSITY OF THE MEDIUM.....	34
FIGURE 17 ATMOSPHERIC PARTICULATES AND THEIR SCATTERING EFFECTS (AFTER CAMPBELL 2002).....	35
FIGURE 18 SPECULAR AND PERFECTLY DIFFUSE (LAMBERTIAN) REFLECTANCE.....	36
FIGURE 19 REMOTE SENSING FROM DIFFERENT PLATFORMS.....	37
FIGURE 20 SUN-SYNCHRONOUS ORBIT.....	39
FIGURE 21 COMMON DIGITAL IMAGING SYSTEMS.....	40
FIGURE 22 CONTRASTING SPECTRAL RESOLUTIONS OF AVIRIS, LANDSAT AND PANCHROMATIC IMAGERY. NOTE HOW CLOSELY THE 4 BANDS IN LANDSAT FOLLOW THE 100 AVIRIS BANDS.....	42
FIGURE 23 DECREASING SPATIAL RESOLUTION.....	42
FIGURE 24 THE CREATION, RECORDING AND ANALYSIS OF MIXED AND PURE PIXELS.....	43
FIGURE 25 THE BENEFITS OF INCREASED RADIOMETRIC RESOLUTION. THE 8 BIT IMAGERY IS OVEREXPOSED WHEREAS STRUCTURES ARE IDENTIFIABLE IN THE 11 BIT IMAGERY (IMAGE COURTESY OF DIGITALGLOBE AND DR. AMR AL-AZM).....	44
FIGURE 26 DECREASING RADIOMETRIC RESOLUTION (NOTE THIS IS NOT JUST IMPROVING CONTRAST).....	45
FIGURE 27 TEMPORAL RESOLUTION: LOOKING AT CHANGES OVER TIME. THE NEGATIVE CORONA IMAGE OF 1970 IS COMPARED TO A POSITIVE IKONOS IMAGE FROM 2002. THE MAJOR CHANGES ARE NOTED ON THE IKONOS IMAGE.....	46
FIGURE 28 ROLL, PITCH AND YAW EFFECTS ON THE NADIR POINT.....	47
FIGURE 29 COMMON PIXEL RESAMPLING TECHNIQUES.....	48
FIGURE 30 EXAMPLES OF CAMERA LENS AND OBLIQUE DISTORTIONS (AFTER SCOLLAR 1990 P. 83; TENG 1997 P. 82).....	49
FIGURE 31 UNIT GRID DISTORTIONS OF THE CORONA KH-4B PANORAMIC CAMERA (AFTER GALIATSATOS IN PREP P. 93).....	50
FIGURE 32 IMAGE DISPLACEMENT DUE TO VARIATIONS IN RELIEF (AFTER DIAL AND GRODECKI 2003).....	51
FIGURE 33 CORRECTION FOR RELIEF DISPLACEMENT IN A MONOSCOPIC IMAGE BY ORTHORECTIFICATION (AFTER DIAL AND GRODECKI 2003).....	52
FIGURE 34 LANDSAT BANDS 1, 2, 3, 4, 5, 6 AND 7 IN A LAYER STACK.....	53
FIGURE 35 INCREASED MAGNIFICATION ON 15 METER LANDSAT PANCHROMATIC IMAGERY.....	55
FIGURE 36 COMPARISON OF A TRUE AND FALSE COLOUR COMPOSITE MADE UP FROM THE VISUAL BANDS.....	56
FIGURE 37 HISTOGRAM OF LANDSAT TM BAND 4.....	56

FIGURE 38 HISTOGRAM EQUALISATION OF LANDSAT TM BAND 4.	57
FIGURE 39 6 COMPONENTS OF A PCA ON LANDSAT TM SCENE (EXCLUDING BAND 6).	60
FIGURE 40 A MOVING 'SHARPENING' 3X3 KERNEL.	61
FIGURE 41 THE CONCEPT OF CLASSIFICATION (AFTER TSO AND MATHER 2001 P. 4).	62
FIGURE 42 FEATURE SPACE REPRESENTATION (AFTER TSO AND MATHER 2001 P. 57).	63
FIGURE 43 SPECTRAL SIGNATURES OF HAEMATITE AND FIR TREE.	64
FIGURE 44 IMPROVING CLASSIFICATION ACCURACY BY REMOVING PIXEL MIXING EFFECTS THROUGH INCREASING SPATIAL RESOLUTION.	65
FIGURE 45 IKONOS IMAGERY WITH ARCHAEOLOGICAL SITES OUTLINED IN WHITE (NOTICE THE INCREASE IN REFLECTANCE AT THE 'SITES').	66
FIGURE 46 UNSUPERVISED CLASSIFICATION OF A LANDSAT TM SCENE.	67
FIGURE 47 AERIAL IDENTIFICATION: CROP, SHADOW AND SOIL MARKS (AFTER GREENE 1990).	69
FIGURE 48 CROPMARKS OBSERVED OVER A SEVEN YEAR PERIOD FROM AERIAL SORTIES FROM THE YORK OFFICE OF ENGLISH HERITAGE.	71
FIGURE 49 SCHEMATIC OF INTERACTIONS IN A HUMAN ECOSYSTEM HIGHLIGHTING THE RELATIONSHIPS BETWEEN THE CULTURAL AND NON-CULTURAL ENVIRONMENT (MODIFIED FROM CLARKE 1978 P. 133; MODIFIED FROM WATERS 1992 P. 5)	76
FIGURE 50 FORMATION AND DEFORMATION PROCESS IN THE MARL.	84
FIGURE 51 NATURAL AND CULTURAL FORMATION AND DEFORMATION PROCESSES ON TELL NEBI MEND.	84
FIGURE 52 HYPOTHETICAL SITE DISTRIBUTION AS PERTURBATIONS IN A DISTRIBUTION OF ARTEFACTS. THE SITE LEVEL IS CALCULATED AT A DENSITY OF 2.5 ARTEFACTS PER M ²	97
FIGURE 53 EXAMPLE OF ASSEMBLAGE OVERLAP TO ERRONEOUSLY PRODUCE A SITE (AFTER BANNING 2002 P. 19).	99
FIGURE 54 LOCATION MAP OF THE STUDY AREA.	107
FIGURE 55 THE ENVIRONMENTAL ZONES IN THE APPLICATION AREA (LABELLED BY UNIT AND THEIR RESPECTIVE AREAS) ON A 4,3,2 LANDSAT IMAGE (28TH OCTOBER 2000).	108
FIGURE 56 ELEMENTS OF THE MARL LANDSCAPE	109
FIGURE 57 ARCHAEOLOGICAL RESIDUES IN THE MARL.	110
FIGURE 58 ELEMENTS OF THE BASALT LANDSCAPE.	111
FIGURE 59 ARCHAEOLOGICAL RESIDUES IN THE BASALT.	112
FIGURE 60 ARCHAEOLOGICAL RESIDUES IN THE ALLUVIUM.	112
FIGURE 61 ELEMENTS OF THE ALLUVIAL LANDSCAPE.	113
FIGURE 62 ELEMENTS OF THE LANDSCAPE AROUND LAKE QATINA.	114
FIGURE 63 ARCHAEOLOGICAL RESIDUES ERODED AT LAKE QATINA.	115
FIGURE 64 TELL SITES IN THE LACUSTRINE DEPOSITS AT THE SOUTH WESTERN END OF LAKE QATINA (SCALE 1:20,000).	116
FIGURE 65 SUMMARY OF FIELDWORK FROM 1999 TO 2003.	122
FIGURE 66 RELATIVE SPECTRAL RESPONSE CURVES FOR LANDSAT 7, 5 AND 4.	127
FIGURE 67 DIAGRAM OF THE VISIBLE AND IR REGION OF THE EM SPECTRUM AND LANDSAT TM BANDS. GASES RESPONSIBLE FOR ATMOSPHERIC ABSORPTION ARE INDICATED (AFTER SABINS 1997 P. 5).	128
FIGURE 68 RELATIVE SPECTRAL RESPONSE CURVE FOR THE IKONOS MULTISPECTRAL AND PANCHROMATIC BANDS (COURTESY SPACE IMAGING).	131
FIGURE 69 THE LOCATION OF SPACE IMAGING REGIONAL AFFILIATES AND THEIR DIRECT SPHERES OF INFLUENCE (COURTESY SPACE IMAGING).	133
FIGURE 70 CORONA MODULE PHOTOGRAPHED AT THE AIR AND SPACE MUSEUM (WASHINGTON D.C., USA). NOTE THE FILM SPOOLS AND STEREO PANORAMIC CAMERAS. COURTESY OF KEITH CHALLIS.	136
FIGURE 71 SPECTRAL RESPONSE OF THE KODAK EK 3404 FILM (AFTER KODAK 2003).	137
FIGURE 72 DIGITISED VECTOR BASEMAP. NOTE THE POOR QUALITY CONTOUR DATA IN THE NORTHERN SEGMENT OF THE NORTHERN STUDY AREA.	140
FIGURE 73 COMPARISON OF THE RUSSIAN AERIAL PHOTOGRAPHY, IKONOS AND CORONA IMAGERY (SCALE 1:5,000).	142
FIGURE 74 SENSOR COMPARISON OVER DIFFERENT FEATURE TYPES.	143
FIGURE 75 RAMS AND RESERVOIR IN THE BASALT.	144
FIGURE 76 ELEVATION AND ANNUAL PRECIPITATION (AFTER HIRATA <i>ET AL.</i> 2001 P. 509) IN SYRIA.	145
FIGURE 77 MONTHLY RAINFALL AVERAGE FOR THE HOMS REGION (DATA KINDLY SUPPLIED BY ICARDA). TOTAL RAINFALL IS 480MM FOR FAO AND 442.6MM FOR GRUZGIPROVDKHOZ.	148
FIGURE 78 COMPARISON OF THE SPATIAL CLARITY AND GEOMETRIC ACCURACY OF RAW IKONOS PANCHROMATIC IMAGERY FROM DIFFERENT DATES AND ACQUISITION ORIENTATIONS.	151

FIGURE 79 COMPARISON OF THE DIFFERENT RECTIFIED CORONA MISSIONS.	152
FIGURE 80 CORONA IMAGERY SCANNED AT DIFFERENT RESOLUTIONS	154
FIGURE 81 SUBTRACTING A CONSTANT FROM A BAND IS EQUIVALENT TO TRANSLATING THE ORIGIN AND HAS NO EFFECT ON THE VARIANCE-COVARIANCE MATRIX. HENCE DARK OBJECT SUBTRACTION HAS NO EFFECT ON CLASSIFICATION RESULTS (AFTER SONG <i>ET AL.</i> 2000 P. 232).	155
FIGURE 82 ISOMETRIC VIEW OF THE APPLICATION AREA AND CONTOUR LINES.....	158
FIGURE 83 RAW GPS READINGS OVERLYING RAW IKONOS DATA (AFTER BECK <i>ET AL.</i> IN PRESS).	160
FIGURE 84 COMPARISON OF CORONA RECTIFICATION USING GCPS DERIVED FROM GPS AND IKONOS (AFTER BECK <i>ET AL.</i> IN PRESS).....	162
FIGURE 85 THE LOCATION OF TWO GCPS, RAW IKONOS AND CORRECTED IKONOS.	163
FIGURE 86 GEO-REFERENCING ERRORS. THE IKONOS IMAGE ON THE RIGHT IS OFFSET FROM THE LEFT IMAGE BY 7.3M EAST AND 9.9M NORTH.	164
FIGURE 87 COMPARISON OF RESCALING TECHNIQUES. ALTHOUGH THE 4,3,2 FCC LOOK SIMILAR THE HISTOGRAM OF THE IMAGE USING SD RESCALING IS SIGNIFICANTLY ALTERED FROM THE ORIGINAL...	165
FIGURE 88 THE RESCALE PARAMETERS USED IN ERDAS IMAGINE TO CONVERT 11 BIT IKONOS TO 8 BIT.	166
FIGURE 89 IKONOS PAN AND MS IMAGERY WITH A PCT AND SFIM RESOLUTION MERGE DERIVATIVE.....	168
FIGURE 90 LAND USE DIGITISING SCHEMA (AFTER CAMPBELL 2002 P. 559).....	176
FIGURE 91 DIGITISING TOPOLOGICALLY INTACT POLYGONS AND NETWORKS FOR GIS ANALYSIS.....	178
FIGURE 92 HYDROLOGY NETWORK IMAGE INTERPRETATION KEY.	180
FIGURE 93 THE DIGITISED HYDROLOGICAL AND COMMUNICATION NETWORKS.....	182
FIGURE 94 COMMUNICATION NETWORK IMAGE INTERPRETATION KEY.....	183
FIGURE 95 THE DIGITISED LAND COVER PARCELS FROM THE IKONOS 2002 IMAGERY.	186
FIGURE 96 LAND COVER PARCELS IMAGE INTERPRETATION KEY.	187
FIGURE 97 THE UNSUPERVISED CLASSIFICATION ALGORITHM FOR GEOLOGY/SOIL CLASSIFICATION	189
FIGURE 98 THE SOIL/GEOLOGY/URBAN CLASSIFICATION.....	191
FIGURE 99 THE EFFECTS OF INCREASED RAINFALL. NOTE THE LEFT HAND IMAGES ARE ALL SUMMER IMAGES WHERE THERE HAS BEEN NORMAL RAINFALL (HENCE THE IRRIGATION CHANNELS ARE EMPTY).	192
FIGURE 100 DEM, ASPECT AND SLOPE DERIVED FROM CONTOUR DATA.....	194
FIGURE 101 GRAPH HIGHLIGHTING THE RELATIONSHIP BETWEEN PHOTOGRAMMETRIC DERIVED DTM HEIGHTS FROM CORONA AND DGPS CHECK HEIGHTS (AFTER GALIATSATOS IN PREP).....	196
FIGURE 102 CHANGES IN CROP COVER AT SITE 339 AT DIFFERENT TIMES OF THE YEAR.	202
FIGURE 103 'SITE' 358 IN THE BASALT LANDSCAPE AND ITS SURFACE COLLECTION SUBSIDIARIES.	206
FIGURE 104 DIGITISED CAIRNS AND WALLS IN THE BASALT AREA (SCALE 1:11,000).	207
FIGURE 105 SCHEMATIC EXAMPLE OF THE A-SPATIAL AND SPATIAL LINKAGES FOR THE ARCHAEOLOGICAL DATA.	208
FIGURE 106 EXAMPLE OF THE HIERARCHICAL STRUCTURING SYSTEM AT SITE 173.	209
FIGURE 107 THE BASALT LANDSCAPE. MODERN DESTRUCTION IS CONTRASTED BETWEEN THE IKONOS AND CORONA IMAGERY (IN ITALICS). POINTS A, B, C AND D IN THE IKONOS AND CORONA IMAGES REFER TO THE LOCATIONS OF THE PHOTOGRAPHS (BUILDING FOUNDATIONS, OLIVE-PRESS, WALL, ROAD AND BIRKA RESPECTIVELY).	211
FIGURE 108 COMPARISON OF THE DIFFERENT SPATIAL RESOLUTIONS OF THE IMAGERY AND THEIR EFFECTS ON IDENTIFICATION IN THE BASALT (SCALE 1:5,000).	212
FIGURE 109 COMPARISON OF THE DIFFERENT SPATIAL RESOLUTIONS OF THE IMAGERY AND THEIR EFFECTS ON IDENTIFICATION IN THE BASALT (SCALE 1:1,000).	213
FIGURE 110 KERNEL FILTERS APPLIED IN THE BASALT ZONE (SCALE 1:5,000). IT SHOULD BE NOTED THAT AS DEMONSTRATED IN FIGURE 108 AND FIGURE 109 THAT INTERPRETATIVE CLARITY IS RELATED TO IMAGE SCALE.	215
FIGURE 111 HINTERLAND ZONES AT THE SE OF KRAD AD-DĀSINIYA (DIGITISED WALLS ARE DERIVED FROM IKONOS IMAGERY). THE PARALLEL WALLS REPRESENT ACCESS TRACKS.	217
FIGURE 112 COMPARISON OF THE OBSERVABLE DETAIL BETWEEN CORONA AND IKONOS IMAGERY AND THEIR RESULTANT DIGITISED INTERPRETATIONS (SCALE 1:2,000). THE LACK OF PARALLEL WALLS ON THE CORONA COULD BE DUE TO ITS LOWER RESOLUTION. ALTERNATIVELY THE TRACKS COULD HAVE BEEN CREATED TO ALLOW TRACTOR ACCESS.	218
FIGURE 113 COMPARISON OF THE CORONA AND IKONOS IMAGERY IN A BULLDOZED AREA OF THE BASALT (SCALE 1:3000). EVEN THOUGH BULLDOZED THE IKONOS RESOLUTION MERGE IMAGE EXHIBITS SOME OF THE RESIDUES SEEN ON THE CORONA IMAGE.	219
FIGURE 114 COMPARISON OF DIGITISING USING THE CORONA AND IKONOS IMAGERY AS BACKDROPS (SCALE 1:3,000).....	221

FIGURE 115 THE EXTENT OF THE RUSSIAN AERIAL PHOTOGRAPHS AND CORONA IMAGERY IN THE NORTHERN APPLICATION AREA.	223
FIGURE 116 COMPARISON OF THE RUSSIAN AERIAL PHOTOGRAPHY, CORONA AND IKONOS IMAGERY.	224
FIGURE 117 COMPARISON OF THE RUSSIAN AERIAL PHOTOGRAPHY, IKONOS AND CORONA IMAGERY OVER AN UNKNOWN SITE AND A COMPARATIVE EVALUATION OVER A DIFFERENT AREA USING THE MISSION 1108 CORONA.	225
FIGURE 118 THE MARL LANDSCAPE AND 'SITES'. MODERN DEVELOPMENT IS CONTRASTED BETWEEN THE IKONOS AND CORONA IMAGERY (IN ITALICS).	227
FIGURE 119 COMPARISON OF THE DIFFERENT SPATIAL RESOLUTIONS OF THE IMAGERY AND THEIR EFFECTS ON IDENTIFICATION IN THE MARL (SCALE 1:12,500). SITES ARE HIGHLIGHTED IN IMAGE A.	228
FIGURE 120 COMPARISON OF THE DIFFERENT SPATIAL RESOLUTIONS OF THE IMAGERY AND THEIR EFFECTS ON IDENTIFICATION IN THE MARL (SCALE 1:5,000).	229
FIGURE 121 DIFFERENT VISUALISATIONS OF RAW AND PROCESSED LANDSAT IMAGERY OVERLAID BY 'SITES'. YELLOW SITES ARE FLAT, BLACK SITES ARE TELLS.	230
FIGURE 122 SPECTRAL PROFILE OF ON AND OFF-SITE POINT LOCATIONS DERIVED FROM IKONOS MS IMAGERY.	232
FIGURE 123 THE DISTRIBUTION OF ARCHAEOLOGICAL RESIDUES WHERE TRANSECT SPECTRAL PROFILES AND SURFACE PROFILES WERE CONDUCTED.	234
FIGURE 124 TRANSECT SPECTRAL PROFILE AND SURFACE PROFILE OF SITES 97-256. THE LINE AND RECTANGLE IN THE LOCATION REPRESENT THE TRANSECT AND SURFACE PROFILE RESPECTIVELY.	235
FIGURE 125 TRANSECT SPECTRAL PROFILE AND SURFACE PROFILE OF SITES 259-339. THE LINE AND RECTANGLE IN THE LOCATION REPRESENT THE TRANSECT AND SURFACE PROFILE RESPECTIVELY.	236
FIGURE 126 TRANSECT SPECTRAL PROFILE AND SURFACE PROFILE OF SITES 454-602. THE LINE AND RECTANGLE IN THE LOCATION REPRESENT THE TRANSECT AND SURFACE PROFILE RESPECTIVELY.	237
FIGURE 127 COMPARISON OF ZONAL AND NORMAL IKONOS MS IMAGERY (3,2,1 FCC), WITH A CLOSE UP OF SITE 238.	240
FIGURE 128 STATISTICAL DISTRIBUTION OF THE RED BAND AFTER 200M AVERAGING KERNEL.	242
FIGURE 129 COMPARISON OF 200M KERNEL AVERAGE AND NORMAL IKONOS MS IMAGERY (3,2,1 FCC), WITH A CLOSE UP OF CLUSTER OF SITES.	243
FIGURE 130 TRANSECT SPECTRAL PROFILES FOR 200M MEAN CORONA 1111 AND IKONOS MS IMAGERY AT SITES 256, 279 AND 339. NOTE THE USE OF NEGATIVES FOR CORONA RESULTING IN A LOWER DN VALUE FOR SITES.	244
FIGURE 131 COMPARISON OF THE 200 AND 400M RADIUS AVERAGING KERNEL ON AN IKONOS MS IMAGE.	247
FIGURE 132 COMPONENTS OF TASSELLED CAP AND PCA ANALYSIS IN THE MARL.	249
FIGURE 133 CLASSIFICATION OF THE MARL AND THICK MARL ZONES (RESIDUES IN BLUE AND GREEN AND SITES OUTLINED IN WHITE).	250
FIGURE 134 IKONOS MS 200M MEAN IMAGE SEGMENTATION (100 BLOCK SIZE, 60 SPECTRAL THRESHOLD AND 250 REGION SIZE)	251
FIGURE 135 STRIP FIELDS OFF WADI AL-RABAYA ARE EASIER TO IDENTIFY IN THE WINTER (MISSION 1108) AS OPPOSED TO THE SPRING (MISSION 1111) IMAGE. ALSO NOTE THE DIFFERENT ILLUMINATION OF THE FOOTHILLS IN THE SE.	254
FIGURE 136 PROBLEMS OF CLOUD AND CROP COVER.	255
FIGURE 137 COMPARISON OF CORONA AND IKONOS IN THE ALLUVIAL ZONE.	257
FIGURE 138 EVIDENCE FROM SITE 494 INCLUDING A TENUOUS LINEAR FEATURE IN THE FOUNDATIONS OF A RESERVOIR.	258
FIGURE 139 IKONOS IMAGE (VERTICAL VIEW) AND PHOTOGRAPH (HORIZONTAL VIEW) OF A TELL (SITE 191). NOTE THE INCREASED AND DECREASED REFLECTANCE OF THE SE AND NW PART OF THE RAMPARTS DUE TO DIFFERENTIAL ILLUMINATION FROM THE SUN AND SITE TOPOGRAPHY.	261
FIGURE 140 SOIL PROFILE (AFTER IRONS <i>ET AL.</i> 1989 P. 77).	264
FIGURE 141 SOIL DESCRIPTION MATRIX (AFTER ASRAR 1989 P. 75) AND ARCHAEOLOGICAL FIELD SOIL DESCRIPTION CHART (AFTER MIDDLETON 2000).	267
FIGURE 142 BIDIRECTIONAL REFLECTANCE OF SOILS (AFTER ASRAR 1989 P. 89).	269
FIGURE 143 SOIL REFLECTANCE FOR A SILT LOAM SOIL WITH VARYING MOISTURE CONTENT (AFTER ASRAR 1989 P. 90)	271
FIGURE 144 LOCATION OF SITES WHERE SOIL SAMPLES WERE TAKEN BY WILKINSON.	277
FIGURE 145 LOCATIONS OF SOIL SAMPLES COLLECTED BY WILKINSON OVER SITE 259 AND RESULTS OF PARTICLE SIZE ANALYSIS (GENERALISED TO THE BRITISH SOIL SURVEY CLASSIFICATION).	278

FIGURE 146 AVERAGED SPECTRAL CURVE AND SIMULATED IKONOS MS READINGS FROM THE SPECTRO-RADIOMETER READINGS OF THE SOIL SAMPLES FROM SITE 259.	279
FIGURE 147 ANALYSIS OF THE SOIL SAMPLES FROM SITE 259 AND THE DN VALUE FROM THE CORONA AND IKONOS MS SATELLITE SENSORS FOR THE CORRESPONDING GPS POINT.....	281
FIGURE 148 ANALYSIS OF THE SOIL SAMPLES FROM SITE 279 AND THE DN VALUE FROM THE CORONA AND IKONOS MS SATELLITE SENSORS FOR THE CORRESPONDING GPS POINT.....	282
FIGURE 149 LOCATIONS OF SOIL SAMPLES COLLECTED BY WILKINSON OVER SITE 279 AND RESULTS OF PARTICLE SIZE ANALYSIS (GENERALISED TO THE BRITISH SOIL SURVEY CLASSIFICATION) ON THESE SAMPLES.....	283
FIGURE 150 AVERAGED SPECTRAL CURVE AND SIMULATED IKONOS MS READINGS FROM THE SPECTRO-RADIOMETER READINGS OF THE SOIL SAMPLES FROM SITE 259.	284
FIGURE 151 LOCATIONS OF SOIL SAMPLES COLLECTED BY WILKINSON OVER SITE 339 AND RESULTS OF PARTICLE SIZE ANALYSIS (GENERALISED TO THE BRITISH SOIL SURVEY CLASSIFICATION) ON THESE SAMPLES.....	286
FIGURE 152 AVERAGED SPECTRAL CURVE AND SIMULATED IKONOS MS READINGS FROM THE SPECTRO-RADIOMETER READINGS OF THE SOIL SAMPLES FROM SITE 339.	287
FIGURE 153 ANALYSIS OF THE SOIL SAMPLES FROM SITE 339 AND THE DN VALUE FROM THE CORONA AND IKONOS MS SATELLITE SENSORS FOR THE CORRESPONDING GPS POINT.....	288
FIGURE 154 ANALYSIS OF THE SOIL SAMPLES FROM SITE 602 AND THE DN VALUE FROM THE CORONA AND IKONOS MS SATELLITE SENSORS FOR THE CORRESPONDING GPS POINT.....	289
FIGURE 155 LOCATIONS OF SOIL SAMPLES COLLECTED BY WILKINSON OVER SITE 602 AND RESULTS OF PARTICLE SIZE ANALYSIS (GENERALISED TO THE BRITISH SOIL SURVEY CLASSIFICATION) ON THESE SAMPLES.....	290
FIGURE 156 AVERAGED SPECTRAL CURVE AND SIMULATED IKONOS MS READINGS FROM THE SPECTRO-RADIOMETER READINGS OF THE SOIL SAMPLES FROM SITE 602.	291
FIGURE 157 COMBINED SPECTRAL CURVE FROM SITES 259 AND 339 BY SAMPLE LOCATION.....	292
FIGURE 158 COMPARISON OF MARL SOIL CURVE (FROM SPECTRO-RADIOMETRY) AGAINST STANDARD SAMPLES OF HEMATITE AND GOETHITE.	294
FIGURE 159 LOCATION OF SITES SAMPLED IN THE 2003 SEASON.....	295
FIGURE 160 COMPARISON OF THE DIFFERENT COULTER 'RUNS' ON SELECTED 2001 AND 2003 SAMPLES AT SITES 279 AND 339.....	297
FIGURE 161 MUD-BRICK STRUCTURES IN VARYING DEGREES OF COLLAPSE.....	299
FIGURE 162 GRAPH OF PARTICLE SIZE DISTRIBUTIONS FROM MUD-BRICK AND SOIL. THE SAMPLE NUMBERS RELATE TO TABLE 21.....	300
FIGURE 163 COMPARISON OF CURVE PROFILES FOR A NUMBER OF ATTRIBUTES FOR SITE 339.	303
FIGURE 164 VARIATIONS IN ORGANIC MATTER CONTENT ACROSS SITES 279, 259, 602 AND 339.....	304
FIGURE 165 IMAGE INTERPRETATION KEY FOR THE SYRIAN TOPOGRAPHIC MAP.....	311
FIGURE 166 ISOMETRIC VISUALISATION (WITH 15 TIME EXAGGERATION) OF DIFFERENT IMAGERY DRAPED OVER A TERRAIN MODEL.....	314
FIGURE 167 PROBLEMS OF SITE LOCATION (SITE 308).....	315
FIGURE 168 COMPARISON OF CORRECTED AND UNCORRECTED IKONOS IMAGERY WITH GPS OVERLAY.....	316
FIGURE 169 COMPARISON OF OCTOBER LANDSAT SCENES FROM 1987 AND 2000. NOTE THE INCREASE IN VEGETATION IN THE 2000 SCENE (DENOTED BY THE RED COLOURATION) AND SHRINKAGE OF LAKE QATINA DUE TO IRRIGATION.....	321
FIGURE 170 DEPTHS OF THE WATER TABLE IN TEL HADYA (1983 – 1997 (RODRIGUEZ <i>ET AL.</i> 1999 P. 9)).....	322
FIGURE 171 URBAN EXPANSION IN THE MARL ZONE.....	323
FIGURE 172 SEASONAL EFFECTS ON THE SATELLITE IMAGERY.....	324
FIGURE 173 COMPARISON OF CORONA MISSIONS OF THE SAME AREAS IN THE BASALT AND MARL ZONES. NOTE THE MUCH BETTER RELATIVE IMAGE QUALITY OF THE WINTER SCENE.....	325
FIGURE 174 MONITORING OF TELL (SITE 173) ON THE LAKE EDGE.....	326
FIGURE 175 COMPARISON OF SITE EXTENTS OVER TIME FOR SITES 251, 319, 339, 471 AND 477.....	327
FIGURE 176 RESIDUE IMAGE INTERPRETATION KEY: POSITIVE FEATURES IN THE MARL.....	339
FIGURE 177 RESIDUE IMAGE INTERPRETATION KEY: NEGATIVE AND MASKING FEATURES IN THE MARL.....	340
FIGURE 178 RESIDUE IMAGE INTERPRETATION KEY: BASALT ZONE.....	341
FIGURE 179 REVISED SEQUENCE FOR THE INCORPORATION OF SATELLITE IMAGERY INTO AN ARCHAEOLOGICAL LANDSCAPE PROJECT.....	357
FIGURE 180 SCHEMATIC OF AN ARCHAEOLOGICAL DATA MODEL (AFTER MARTIN 1991 P. 55). NOTE ALL ARROWS PERFORM SOME TRANSFORMATION.....	369

FIGURE 181 HERMENEUTIC LOOP OF ARCHAEOLOGICAL ENQUIRY.....	370
FIGURE 182 CONCEPTUAL MODELLING SCHEMA.	375
FIGURE 183 PROJECT DIRECTORY STRUCTURE.....	379
FIGURE 184 HARDWARE SCHEMA FOR THE PROJECT DATA MODEL.	381
FIGURE 185 SCHEMATIC DATA FLOWLINE.....	382
FIGURE 186 DATABASE SCHEMA.....	383
FIGURE 187 PDADB.MDB ENTITY RELATIONSHIP MODEL. . NOTE THE FIELDS IN BOLD TEXT ARE THE PRIMARY (OR COMPOUND PRIMARY) KEYS.	385
FIGURE 188 DskTOPDB.MDB ENTITY RELATIONSHIP MODEL. NOTE THE FIELDS IN BOLD TEXT ARE THE PRIMARY (OR COMPOUND PRIMARY) KEYS.....	386
FIGURE 189 THE MAIN SWITCHBOARD FOR FORMS.MDB.	386
FIGURE 190 FULLY INTEGRATED DATABASE ENTITY RELATIONSHIP MODEL.	387
FIGURE 191 THE METADATA SWITCHBOARD FOR FORMS.MDB.....	388
FIGURE 192 AN EXAMPLE OF A SITE FORM (AFTER CLICKING ADD/VIEW DATA ON THE MAIN SWITCHBOARD). NOTE THE TABS TO ACCESS OTHER DATA ABOUT THE SITE.	388
FIGURE 193 COMPARISON OF VECTOR VERSUS HIGH AND MEDIUM RESOLUTION RASTER REPRESENTATIONS (COURTESY NERC, GETMAPPING AND ENGLISH NATURE).	389
FIGURE 194 DATA SCHEMA FOR MULTI SCALAR DATA INTEGRATION	394
FIGURE 195 EXAMPLE OF DUBLIN CORE RESOURCE DISCOVERY METADATA MAINTAINED IN TABLE META.T.	395
FIGURE 196 EXAMPLE OF TABLE LEVEL METADATA STORED IN TABLE METATDB.....	396
FIGURE 197 EXAMPLE OF BIBLIOGRAPHIC METADATA HELD IN TABLE DOCUT.....	397
FIGURE 198 LOCATIONS OF SOIL SAMPLES COLLECTED OVER SITE 97 AND RESULTS OF PARTICLE SIZE ANALYSIS ON THESE SAMPLES.	403
FIGURE 199 LOCATIONS OF SOIL SAMPLES COLLECTED OVER SITE 218 AND RESULTS OF PARTICLE SIZE ANALYSIS ON THESE SAMPLES.	404
FIGURE 200 LOCATIONS OF SOIL SAMPLES COLLECTED OVER SITE 221 AND RESULTS OF PARTICLE SIZE ANALYSIS ON THESE SAMPLES.	406
FIGURE 201 LOCATIONS OF SOIL SAMPLES COLLECTED OVER SITE 238 AND RESULTS OF PARTICLE SIZE ANALYSIS ON THESE SAMPLES.	407
FIGURE 202 LOCATIONS OF SOIL SAMPLES COLLECTED OVER SITE 271 AND RESULTS OF PARTICLE SIZE ANALYSIS ON THESE SAMPLES.	409
FIGURE 203 LOCATIONS OF SOIL SAMPLES COLLECTED OVER SITE 279 AND RESULTS OF PARTICLE SIZE ANALYSIS ON THESE SAMPLES.	410
FIGURE 204 LOCATIONS OF SOIL SAMPLES COLLECTED OVER SITE 339 AND RESULTS OF PARTICLE SIZE ANALYSIS ON THESE SAMPLES.	412
FIGURE 205 LOCATIONS OF SOIL SAMPLES COLLECTED OVER SITE 478 AND RESULTS OF PARTICLE SIZE ANALYSIS ON THESE SAMPLES.	413
FIGURE 206 LOCATIONS OF SOIL SAMPLES COLLECTED OVER SITE 496 AND RESULTS OF PARTICLE SIZE ANALYSIS ON THESE SAMPLES.	415
FIGURE 207 LOCATIONS OF SOIL SAMPLES COLLECTED OVER SITE 508 AND RESULTS OF PARTICLE SIZE ANALYSIS ON THESE SAMPLES.	416

LIST OF TABLES

Number	Page
TABLE 1 RADIOMETRIC ENHANCEMENT TECHNIQUES	58
TABLE 2 SPECTRAL ENHANCEMENT TECHNIQUES.....	59
TABLE 3 EXAMPLES OF DIFFERENT KERNEL FILTERS	62
TABLE 4 FIELDWORK SUMMARY.	120
TABLE 5 LANDSAT TM TECHNICAL SPECIFICATION (AFTER TOWNSHEND <i>ET AL.</i> 1988).....	126
TABLE 6 TM AND ETM+ SPECTRAL BAND WIDTHS AND SPATIAL RESOLUTION.....	127
TABLE 7 LANDSAT TM INTERPRETATIVE SENSOR CHARACTERISTICS (AFTER SABINS 1997 P. 74; CAMPBELL 2002 P. 173).	129
TABLE 8 USER DEFINABLE PROCESSING PARAMETERS FOR LANDSAT IMAGERY.....	130
TABLE 9 IKONOS TECHNICAL SPECIFICATION (AFTER SPACE IMAGING 2003 P. 1).....	132
TABLE 10 IKONOS PRODUCT LEVELS (AFTER SPACE IMAGING 2003 P. 2: CE90 = CIRCULAR ERROR AT 90% CONFIDENCE, RMS = ROOT MEAN SQUARE ERROR AND NMAS = US NATIONAL MAP ACCURACY STANDARDS). NOTE THE COSTINGS ARE BASED UPON THE MAY 2003 PRICING LEVELS AND THE PRICING FOR GEO REPRESENTS BESPOKE AND ARCHIVE IMAGERY.	132
TABLE 11 USER DEFINABLE PROCESSING PARAMETERS FOR IKONOS IMAGERY.	134
TABLE 12 CORONA KEY-HOLE CAMERA MISSION CHARACTERISTICS (AFTER GALIATSATOS IN PREP).	135
TABLE 13 SUMMARY OF HISTORIC AND MODERN MAPPING USED IN THE RESEARCH.	138
TABLE 14 LAYERS AND SUMMARY INFORMATION FOR THE DIGITISING OF THE MAP-BASE.....	139
TABLE 15 CORONA ACQUISITION SUMMARY.....	153
TABLE 16 CORONA CO-REGISTRATION RMSE ACCURACY.....	164
TABLE 17 COMBINED USGS AND SHR LAND USE CODES.	174
TABLE 18 PCA (SOUTHERN MARL ONLY) AND TASSELLED CAP COMPONENT MATRIX AND PERCENTAGE VARIATION FOR IKONOS MS (THE TASSELLED CAP STATISTICS ARE AFTER HORNE 2003).....	248
TABLE 19 COMPARISON OF ON AND OFF SITE SOIL COLOURS WHEN WET AND DRY. NOTE THIS REQUIRES THE COLOUR CHIPS DESCRIBED BY MIDDLETON (2000).	270
TABLE 20 BRITISH SOIL SURVEY PARTICLE SIZE CLASSIFICATION	275
TABLE 21 PARTICLE SIZE ANALYSIS OF MUD BRICK AND SOIL. NON SHR SAMPLES ARE TAKEN FROM SAUVAGE (1998 P. 19, TABLES 2 AND 3).	298
TABLE 22 PIVOT TABLE DISPLAYING A SUMMARY OF THE AVERAGE PERCENTAGE CHANGE OF SOIL FRACTIONS BETWEEN OFF-SITE AND SITE.	301
TABLE 23 VARIATIONS IN SOIL TEXTURE CALCULATED FROM THE AVERAGE OF THE COULTER RESULTS FOR EACH LOCATION.....	302
TABLE 24 SUMMARY OF SITES IN THE WHOLE APPLICATION AREA.....	332
TABLE 25 SUMMARY OF EVIDENCE FOR INDETERMINATE (POTENTIAL) SITES IN THE SOUTHERN MARL.....	332
TABLE 26 SUMMARY OF EVIDENCE FOR NON-SITES IN THE SOUTHERN MARL.	333
TABLE 27 SUMMARY OF EVIDENCE FOR TELL SITES IN THE SOUTHERN MARL.	333
TABLE 28 SUMMARY OF EVIDENCE FOR SCATTER SITES IN THE SOUTHERN MARL.	334
TABLE 29 SUMMARY OF RESULTS IN THE SOUTHERN MARL BY METHOD.	335
TABLE 30 SENSOR SUMMARY BY ZONE.	349
TABLE 31 TYPES OF DIGITAL RESOURCE.....	378
TABLE 32 ACTIVE AND ARCHIVE FILE FORMATS	378
TABLE 33 DEFINITION OF THE FEATURE DATA SETS AND THEIR CLASSES WITHIN SHR_GEOBASE.MDB.	390
TABLE 34 GENUS LOOKUP TABLE WITH 'VALUE ADDED' INFORMATION (LGENUS IS THE PRIMARY KEY): COURTESY OF DR. PHILIP PIPER.	391

ACKNOWLEDGMENTS

Any work such as this is impossible without the support of a whole range of people and organisations. I would like to thank them for their support throughout the duration of this research. Initially I'd like to thank Mr. Fraser Brown for helping me with my first faltering steps on the road to archaeology. Dr. Philip Piper and Mr. Tim Allen were great companions on this road and taught me much. To my wife Maria: words are not enough to express my gratitude, all I can do is provide a paltry thanks. At least you'll be happy that my sentence structure has improved. To my supervisors Drs. Graham Philip and Danny Donoghue: this work would have been impossible without their unstinting support and friendship (even during my ranting phases). Furthermore, thanks to the students and staff of the Departments of Archaeology and Geography at the University of Durham (particularly Dr. Kay McManus, Dr. Paul Newson, Nikolaous Galiatsatos and Terry Harrison).

I am indebted to the Council for British Research in the Levant and the Department of Archaeology, University of Durham for their financial, logistical and moral support. Furthermore, the advice and companionship of many Middle Eastern archaeologists, particularly Drs. Bill Finlayson, Alex Wasse and Amr al-Azm, was indispensable. I am also indebted for all the hard work by those at the Director General of Antiquities and Museums (Syria) particularly Dr. Michel Maqudassi, Dr. Mamoun Abdulkareem and Eng. Farid Jabour. Further thanks are due to Dr. Abdulkareem for providing the Russian aerial photographs and his permission to use them in this research. I would especially like to thank Eng. Maryam Bshesh not only for her assistance during the fieldwork but her great friendship. ICARDA very kindly provided articles on Syrian soils and agriculture and data on regional rainfall. Dr. Keith Wilkinson of King Alfred's College, Winchester also provided invaluable help in the interpretation of Syrian soils. Keith Challis of York Archaeological Trust provided me with a wealth of information on Corona. Dr. Bob Bewley, Peter Horne, Dave MacLeod and all others at the Aerial division of English Heritage who provide me with support and data. Dr. Meredith Williams (Department of Geomatics, University of Newcastle-upon-Tyne) provided me with invaluable information concerning the nature of the projection of the Syrian mapping. Valerie Hood and Mary Foussier at EuriSy who provided me with the opportunity of seeing things with my eyes wide open. Final thanks go to NERC (grant award GT0499TS53): without whom none of this research would have been possible. Dr. Stuart

White's support was particularly welcome when there were problems in the acquisition of the Ikonos satellite imagery.

I would like to express my appreciation to all the local people of the Homs region for their cooperation and hospitality. Particular thanks go to the Bshesh family, Hannan, Hassan, Salam Wakim, Abdullah Khan and the irrepressible Mimo. Just so you all know I'll always be happy to be Homsy.

This thesis is dedicated to the people and the cultural heritage of Syria, my friends and my family. Salam.

This thesis was prepared in Microsoft Word (XP) with bibliographic referencing supplied by Endnote (v. 5.0.2). Supporting information was prepared in Microsoft Access (XP), Microsoft Excel (XP), Adobe Illustrator (v. 9), Adobe Photoshop (v. 6.5), ArcGIS 8.3 and AutoCAD MAP 2000.

The copyright of this thesis text and other original content rests solely with the author. No quotation from it should be published without the authors' prior written consent and information derived from it should be duly acknowledged.

GLOSSARY

Active Sensor	Sensor that supplies its own energy source
ADMS	Archaeological Data Management System (see AIS)
ADS	Archaeological Data Service
AHDS	Arts and Humanities Data Service
AHRB	Arts and Humanities Research Board
AIS	Archaeological Information System (see ADMS)
Albedo	The percentage of incoming radiation that is reflected by a natural surface such as the ground, ice, snow, water, clouds, or particulates in the atmosphere.
AP	Aerial Photography
ArcCatalog	Data management component of ArcGIS software suite
ArcGIS	Scalable system of software for geographic data creation, management, integration, analysis and dissemination; framework for articulating inter-site, intra-site and landscape relationships using both spatial and attribute data. Released by ESRI.
ArcMAP	Visualisation component of ArcGIS software suite.
ArcPAD	Mobile GIS application
Attitude	The angular orientation of a remote sensing system with respect to a geographical reference system. The orientation of the sensor along with information about the accuracy and precision with which this orientation is known.
AutoCAD	A Computer Aided Design software package.
AVHRR	Advanced Very High Resolution Radiometer
Band	A portion of the electromagnetic spectrum recorded by a sensor
Breaklines	Lines that delineate a break of slope.
CAD	Computer Aided Design
CAM	Computer Aided Mapping
Cluster	A homogeneous group of units based upon how 'alike' an object is to its neighbours. 'Likeness' is usually determined by the association, similarity, or distance among the measurement patterns associated with the units.
Co-register	Placing two or more images into the same co-ordinate scheme
Corona	American 'Spy' satellite program. The results are now available commercially
CRM	Cultural Resource Management
DEM	Digital Elevation Model. A raster method of creating a DTM
DGAM	Directorate General of Antiquities and Museums
DGPS	Differential Global Positioning Systems
DSM	Digital Surface Model
DTM	Digital Terrain Model. A computerised representation of the Earth's surface
Dublin Core	MetaData standard
Dynamic Range	The range between the maximum and minimum amount of input radiant energy that an instrument can measure.
EH	English Heritage

ENVI	Image Processing Software
Ephemeris	A table of predicted satellite orbital locations for specific time intervals. The ephemeris data help to characterize the conditions under which remotely sensed data are collected and are commonly used to correct the sensor data prior to analysis.
Erdas IMAGINE	Image Processing Software
EROS	Earth Resources Observations Systems: The EROS program was established in the early 1970s, under the Department of the Interior's U.S. Geological Survey, to receive, process, and distribute data from United States Landsat satellite sensors and from airborne sensors
ERSC	Environmental Remote Sensing Centre
ES	Electromagnetic Spectrum
ESRI	Environmental Systems Research Institute. Purveyors of GIS software systems ArcVIEW, Arc/Info and ArcGIS.
ETM+	Enhanced Thematic Mapper +: a sensor on the Landsat program
Extrapolate	To infer (values of a variable in an unobserved interval) from values within an already observed interval.
Fiducial Marks	A set of four marks located in the corners or edge-centred, or both, of a photographic image. These marks are exposed within the camera onto the original film and are used to define the frame of reference for spatial measurements on aerial photographs.
Fusion	Combining the spatial or spectral characteristics of two or more sensors
GCP	Ground Control Point
Geodatabase	A GIS data format (designed by ESRI) that stores both spatial and attribute data within a single RDBMS architecture
Georegistered	An image that has been geographically referenced or rectified to an Earth model, usually to a map projection. Sometimes referred to as geocoded or geometric registration.
GeoTIFF	A TIFF file with geo-referencing information contained within the header.
GIS	Geographical Information System. A mechanism of linking geographic entities to associated database information
GPS	Global Positioning Systems
Ground Observation	Testing desk based hypothesis by field observation
Ground Truthing	Testing desk based hypothesis by field observation (superseded by Ground Observation)
GRS	Ground Receiving Station
Handspring	PDA running the PALM Operating System
Heads Up Digitising	A method of creating a vector drawing using a raster backdrop rather than a digitising tablet
HRS	Homs Regional Survey
HSSF	Hellenic State Scholarship Fund
Hyperspectral	Imagery with multiple bands. Normally greater than 20
IFA	Institute of Field Archaeologists
IFOV	Instantaneous Field-of-View
Ikonos	High resolution commercial satellite program managed by SpaceImaging

Interpolate	To insert a value between known values by using a procedure or algorithm specifically related to the known values.
IP	Image Processing
iPAQ	PDA running Pocket PC Operating System
Isopleth	A line on a map connecting points at which a given variable has a specified constant value.
JADIS	Jordan Archaeological Database
KH	Key Hole
KVR	Russian 'Spy' satellite program. The results are now available commercially
Landsat	Commercial satellite program
Lookup Table	Data dictionary used in RDBMS
MetaData	Data ABOUT data. For example creation date, creator, copyright etc.
MIR	Middle Infra Red
MSS	MultiSpectral Scanner: a sensor on the Landsat program
Multispectral	Imagery with multiple bands. Normally less than 20
Nadir	Point on the ground vertically beneath the centre of a remote sensing platform.
NASA	National Aeronautics Space Administration
NDVI	Normalized Difference Vegetation Index: NDVI is computed by calculating the ratio of the VI (vegetation index, i.e., the difference between Channel 2 and 1) and the sum of Channels 2 and 1. Thus $NDVI = (channel\ 2 - channel\ 1) / (channel\ 2 + channel\ 1)$.
NERC	Natural Environment Research Council
NIR	Near Infra Red
Orbit	The path of a body acted upon by the force of gravity.
Orbital period	The time it takes a satellite to complete one revolution (orbit) around the Earth. The orbital period of Landsat 7 is about 1.5 hours.
Ortho-correction	Correction applied to satellite imagery to account for terrain-induced distortion.
Panchromatic	Sensor sensitive to all or most of the visible spectrum, between 0.4 and 0.7 micrometers.
Passive Sensor	Sensor that records reflected or emitted radiation
PCI	Image Processing Software
PCMCIA card	Personal Computer Memory Card International Association card. Credit card hardware used in laptops to add functionality (Modem, GPS, hard disk, etc.)
PDA	Personal Digital Assistant. Handheld computer. For examples see Handspring and iPAQ
Pixel	An abbreviation of picture element. The minimum size area on the ground detectable by a remote sensing device. The size varies depending on the type of sensor.
Primary Key	Mechanism to uniquely identify records in a RDBMS table. A primary key can be based on a single field or multiple fields (referred to as compound primary key)
Radiance	Measure of the energy radiated by an object. In general, radiance is a function of viewing angle and spectral wavelength and is expressed as energy per solid angle.

Raster	The generic term for a grid based spatial data storage mechanism. E.g. GeoTIFF
RDBMS	Relational Database Management System
Reflectance	Reflectance is the fraction of the total radiant flux incident upon a surface that is reflected and that varies according to the wavelength distribution of the incident radiation.
RMSE	Root Mean Square Error: The RMSE statistic is used to describe accuracy encompassing both random and systematic errors. The square of the difference between a true test point and an interpolated test point divided by the total number of test points.
SA	Selective Availability: The reduction in the accuracy of GPS controlled by the American Military
SHR	Settlement and Landscape Development in the Homs Region, Syria
SMR	Sites and Monuments Record
Spectral signature	The unique spectral response that a feature displays over a range of wavelengths
Spin-2	Commercial satellite program
SWIR	Short Wave Infra Red
Theme	Group of related geographical data
TIFF	Tagged Image File Format, a common raster file format also referred to as TIF
TIN	Triangular Irregular Network. A vector method of creating a DTM
TM	Thematic Mapper: a sensor on the Landsat program
Unique Identifier	GIS link between Spatial and A-spatial databases
USGS	United States Geological Survey
UTM	Universal Transverse Mercator. Worldwide projection system
Vector	The generic term for a point, line and polygon spatial data storage mechanism. For example AutoCAD .dwg or ESRI .shp files.
WGS-84	World Geodetic System 1984: GPS reference ellipsoid

SECTION 1 INTRODUCTION

CHAPTER 1 RESEARCH INTRODUCTION AND SUMMARY

1.1 Introduction

This PhD research project originated from fieldwork undertaken in 1996 by Dr. Graham Philip (Department of Archaeology, University of Durham) and Mr. Stephen Holmes, (Department of Archaeology, University of Edinburgh) a doctoral student studying 'The application of Remote Sensing and GIS to the Location of Prehistoric Settlement in part of Anatolia'. At the time, Dr. Philip was evaluating a potential project in an area of known archaeological and historical significance around Homs, Syria. Although a few large sites had been excavated very little was known about the chronological and spatial distribution of less obvious settlements and other archaeological residues across the landscape. In the semi-arid environment of the application area Dr. Philip recognised that satellite applications had the potential to, amongst other things, pinpoint areas of archaeological activity. After conversations with Dr. Daniel Donoghue (Department of Geography, University of Durham), who informed Dr. Phillip of the declassified Corona programme and the proposed Ikonos satellite, a research proposal was submitted to the Natural Environmental Research Council (NERC) to study the archaeological applications of high resolution satellite imagery within this semi-arid environment.

This application was successful and secured a post-graduate student, Anthony Beck (NERC grant award GT0499TS53), to undertake a three year research PhD. NERC also generously agreed to cover the acquisition costs of Ikonos imagery within the grant application. In addition another post-graduate student, Nikolaous Galiatsatos, approached Dr. Donoghue with an application to undertake research into satellite applications and archaeology. This student had already secured funding towards a doctoral research programme through the Hellenic State Scholarship Foundation (speciality T1327.06, contract 368 (NG)). Galiatsatos' thesis is provisionally entitled 'Assessment of satellite imagery in landscape archaeology applications: case study from Orontes valley, Syria'. Hence, two PhD students were engaged to research different aspects of satellite imagery applications to archaeology, both based in the University of Durham: Beck primarily affiliated to the Department of Archaeology and Galiatsatos primarily affiliated to the Department of Geography.

1.2 Thesis structure

This thesis has been structured to incorporate stand alone sections. This approach has been used due to the different conceptual and methodological approaches employed by landscape archaeologists and remote sensing specialists. Therefore, archaeologists who are familiar with the concepts of archaeological landscapes but are unfamiliar with remote sensing can review the chapters appropriate to their research. Broadly the thesis has been sub-divided into three sections:

1. Introduction (Chapters 1-3): These chapters introduce physical, methodological and interpretative processes in remote sensing and landscape archaeology.
2. Methodology and Analysis (Chapters 4-9): These chapters outline the physical environment, methodology and analysis conducted on the satellite imagery. Chapter 8 specifically examines what physical variations make archaeological residues visible in satellite imagery.
3. Summary, recommendations and conclusions (Chapters 10-11): These chapters evaluate the methodology in relation to other archaeological techniques and provide recommendations for future research.

Each section addresses archaeological and remote sensing aspects of the data. This culminates in a breakdown of the cost benefit analysis of the data sets and recommendations for future projects that may want to adapt the methodologies employed. Further pertinent, but not directly relevant, material is contained in the appendix. Overall this is a science based programme of research which is evaluating new archaeological data sources. Hence, the outcomes are predominantly methodological and although the imagery is interpreted for its archaeological content there is little archaeological interpretation.

1.3 Research summary

The use of satellite imagery for archaeological investigations seems to be increasing. The spatial, spectral, radiometric and temporal resolutions of satellite imagery have developed to such an extent that satellite imagery shares many of the physical properties of aerial imagery at a vastly reduced acquisition cost. However, it is not clear that the full capabilities of the data are being exploited. This research will attempt to address some of the potentials and methodological issues surrounding the use of satellite imagery within archaeology with particular reference to the semi-arid landscape around Homs, Syria. Corona and Ikonos high

resolution satellite image data have been evaluated for a range of archaeological activities including cultural resource management, data visualisation and thematic data extraction. The main thrust of the research has been the application of these data to site prospection and their impact on landscape survey. A suite of medium resolution Landsat imagery was also incorporated into the research in order to evaluate the effect of larger spatial and spectral resolution on the information that can be obtained.

1.3.1 Traditional approaches to landscape survey

Many landscape surveys initially start with a *Desk Based Assessment* (DBA). A DBA will normally look at data derived from the *Sites and Monuments Record* (SMR, or its equivalent), aerial photography, geophysics and historical document searches. This information is normally synthesised into a document that outlines the archaeological potential within the application area and provides a framework for subsequent fieldwork programmes and analysis. This archaeological information can be augmented with additional data sets. These secondary data sets tend to include topographic and environmental data (such as soils, hydrology and elevation). However, there are many countries where the archaeological resource is not managed in this way.

Syria is one example of a country, typical of many parts of the developing world, where there is no systematic regional database of archaeological remains, no ready access to topographic mapping at scales greater than 1:25,000, nor is aerial-photography available (Donoghue *et al.* 2000; Philip *et al.* 2002a). Thematic data (for example soil and land use maps) in this region are normally highly generalised. Furthermore, due to military restrictions, the national map projection remains secret and the opportunity to conduct any aerial photographic survey is limited.

When faced with this situation most projects would embark on an archaeological survey. The tradition in Mediterranean environments is to employ a *systematic surface survey* strategy (Cherry *et al.* 1991; Alcock *et al.* 1994; Bintliff 2000; Banning 2002). These techniques are extremely well developed, but have the disadvantage of being expensive and time consuming. Given the consolidation of funding within a few large projects, a re-evaluation of satellite applications as a complementary survey strategy is timely.

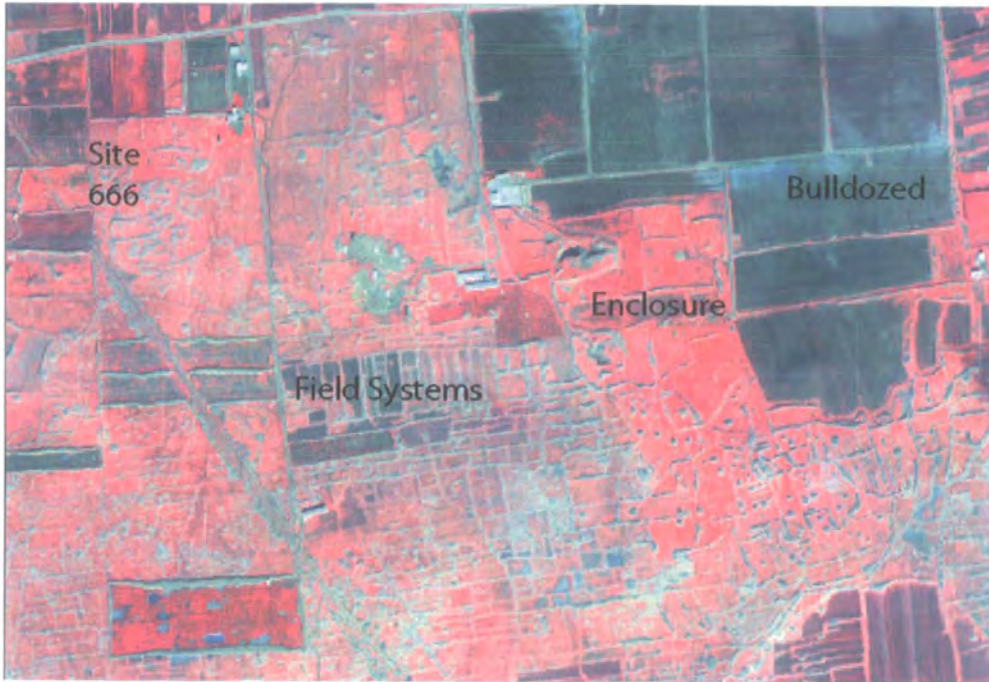

Ikonos 4,3,2 False Colour Composite of the Northern Basalt area.
Please note the field systems, enclosures, cairns and bulldozed areas.

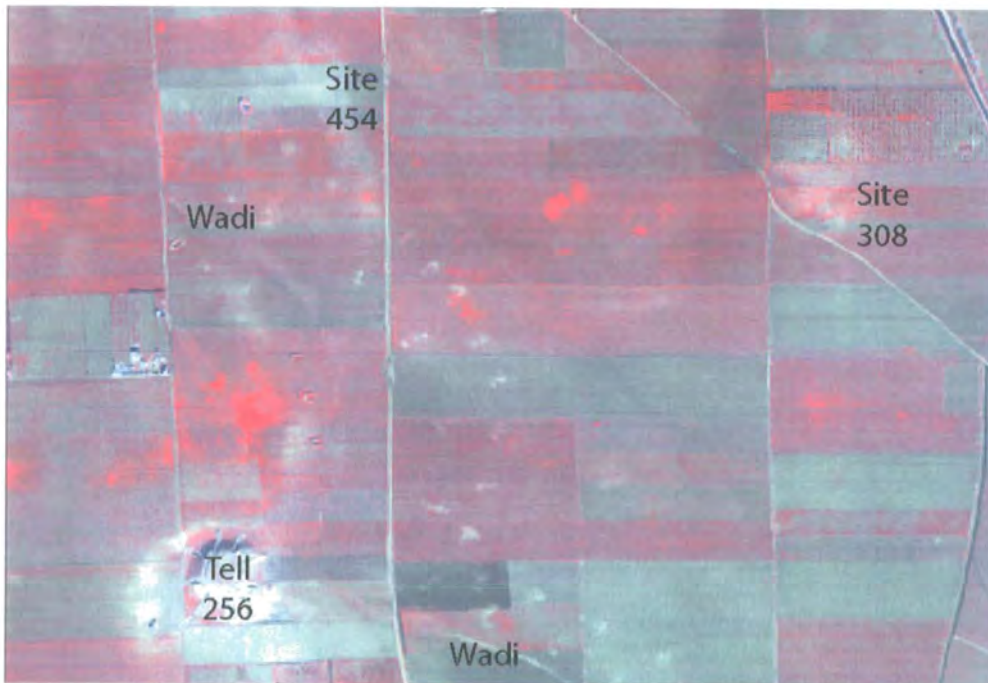

Ikonos 4,3,2 False Colour Composite of the Southern Marl area.
Please note the tell, wadi and flat sites.

Figure 1 Examples of the archaeological residues in the application area.

1.3.2 Settlement and landscape development in the Homs region

In this data poor environment the project brief is to improve the understanding of *Settlement and Landscape Development in the Homs Region* (the SHR project). The project team is required to rapidly evaluate the archaeological resource and to create a variety of integrated *thematic* data sets to provide an interpretative context. The vast majority of these data sets were and still are unavailable from traditional sources. Satellite imagery with different resolutions has therefore been evaluated to determine their efficacy in bridging this significant data gap. This imagery has different spatial, spectral, radiometric and temporal resolution. The research postulates that individual satellite imagery or the integration of imagery with different resolving characteristics can significantly enhance the understanding of the archaeological resource.

The SHR project application area is particularly suitable for this evaluation as it contains three distinct environmental zones: basaltic plateau, alluvium and marl. Each of these zones employs distinctive urban and rural land management strategies. Furthermore, the archaeological record has been subjected to different formation and de-formation events in each zone. In the basaltic zone the archaeology takes the form of abandoned villages, isolated villas, roads, tombs and agricultural systems all preserved as a *palimpsest* of stone walls and concentrations of rubble. By contrast, the marl zone contains a few mounded tell sites and many ploughed out artefact scatters (see Figure 1).

1.3.3 Introduction to the data sources

Landsat has already proved useful in providing landscape environmental data, and has been applied to map soil, vegetation and geology for archaeological purposes (Cox 1992; Gaffney *et al.* 1996; Ostir *et al.* 1999; Rothaus and De Morett 1999). However, Landsat's 30m cell resolution limits its application for site prospection (Allan and Richards 1983).

The last decade has, however, seen the declassification of high-resolution (sub 2-3 metre) panchromatic military photography such as the American Corona and Russian KVR missions (Comfort 1997; Day *et al.* 1998; Fowler 2001; Campbell 2002). Furthermore, this period has seen the deregulation of high spatial resolution commercial sensors that have recently resulted in the Ikonos and Quickbird satellites which provide geo-corrected panchromatic (at 1 and 0.61m respectively) and 4 band multispectral imagery (at 4 and 2.44m respectively).



Corona KH-4B photography (1967 - 1972)

1.83 - 2.5 m panchromatic

Photogrammetrically scanned
to 8 bit raster imagery



Ikonos 11 bit digital imagery (1999 - present)

1 m panchromatic 0.45-0.9 μm
4 m Multispectral: 0.45-0.52 μm Blue
0.52-0.60 μm Green
0.63-0.69 μm Red
0.76-0.90 μm Near IR



Landsat 8 bit 7 band TM (and ETM+) digital imagery (1974 - present)

0.45-0.52 μm , 30 m Blue
0.52-0.60 μm , 30 m Green
0.63-0.69 μm , 30 m Red
0.76-0.90 μm , 30 m Near IR
1.55-1.75 μm , 30 m Mid IR
10.40-12.50 μm , 120 μm Far (thermal) IR
2.08-2.35 μm , 30 m Mid IR
15 m panchromatic ETM+ only

Figure 2 Comparison of the 3 primary satellite sensors used in the research.

This research uses a combination of Corona, Ikonos and Landsat imagery (see Figure 2), although other data sources may be integrated in the future for evaluation purposes. All of these data sets are well documented (Colwell *et al.* 1983; Day *et al.* 1998; Space Imaging 2003; USGS 2003e).

1.3.4 Remote sensing

Remote sensing systems rely on collecting energy that is either emitted by or reflected from an object under study. The energy source for all passive remote sensing of the Earth is the Sun (even for emitted radiation where the Sun's energy is transformed and re-emitted). Active sensors, such as RADAR and LiDAR, provide their own (artificial) source of energy.

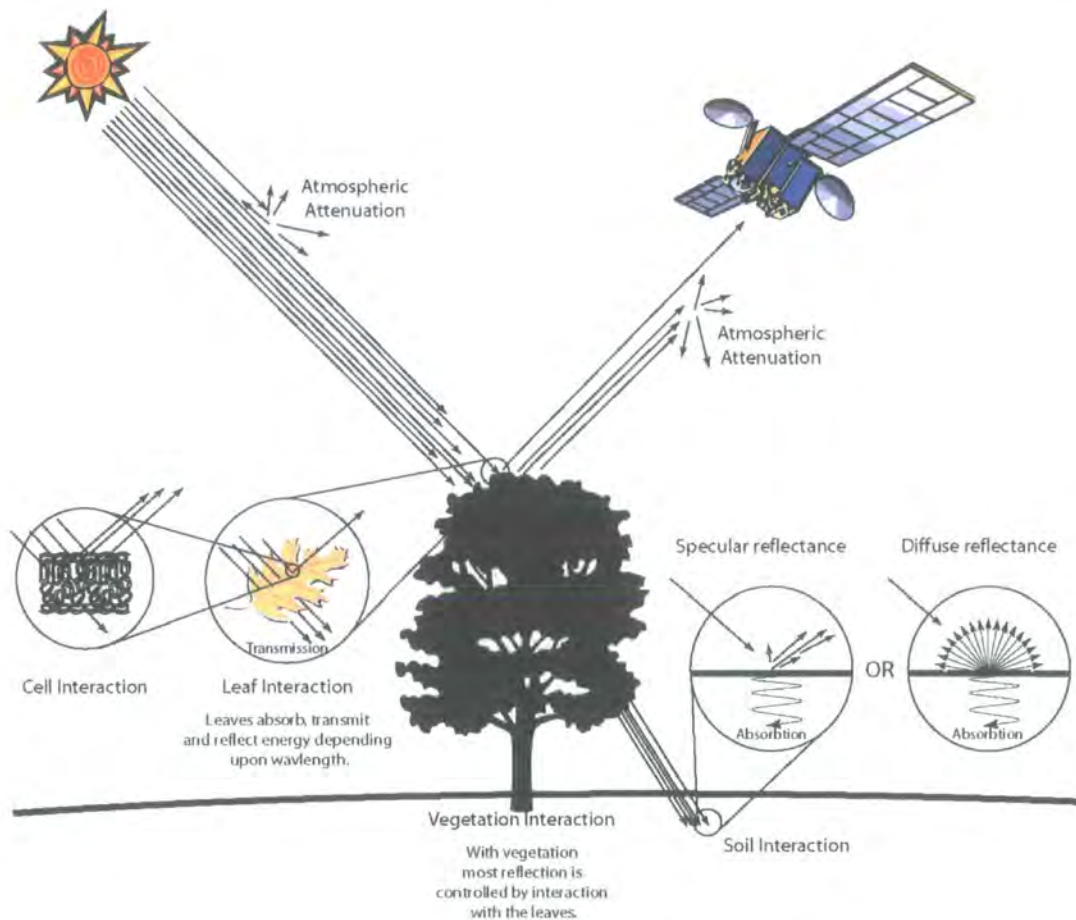

Figure 3 Overview of remotely sensed image acquisition (after Campbell 2002).

The Sun, with a temperature of 6000 Kelvin, emits a spectrum of radiation which is transmitted through space without undergoing major attenuation (see Figure 3). This radiation then passes through the Earth's atmosphere prior to interaction with an object. After interaction energy travels through another portion of the Earth's atmosphere to reach the sensor. During this process the energy may be altered in intensity and wavelength (*attenuated*) by particles and gases within the atmosphere itself (Nunnally 1973).

Every object with a temperature above absolute zero (0°Kelvin) emits electromagnetic radiation. Objects also reflect radiation that has been emitted by other objects. An object's ability to reflect radiation is dependent upon its physical, chemical and surface characteristics. The radiation that is not reflected by the object is *transmitted* or *absorbed* and then reradiated as thermal (emitted) energy. Remote sensing systems record this reflected and/or emitted radiation.

The underlying premise of remote sensing is that interpreters can extract information about objects and features on the Earth's surface by studying the radiation measured by a sensor system. Interpreting remotely sensed imagery depends upon being able to differentiate features of interest from reflected or emitted energy on the basis of variations in the signal strength and spectral response. The basis for interpretation of *multispectral* images is the *spectral signature* (see Figure 22) i.e. the unique spectral response that a feature displays over a range of wavelengths (Campbell 2002 p. 15). However, every sensor has limitations: most limitations revolve around the resolving characteristics, or *resolution*, of the sensor. The most important axes of resolution are spatial, spectral, radiometric and temporal. For sensor platforms there is normally a negative relationship between a sensor's spatial and spectral resolution (i.e. the higher the spatial resolution the lower the spectral resolution and vice-versa).

1.3.5 Image interpretation

Once data has been collected it is then interpreted using a combination of manual and digital procedures. Figure 4 suggests a schematic for the flowline of image processing.

Pre-processing is where the data is prepared for subsequent analysis. Analogue data (non-digital information such as photographs) will require *digitising* using an appropriate *scanning* methodology. *Radiometric* pre-processing is designed to compensate for errors introduced by defective sensors, atmospheric attenuation, system noise, and variations in illumination and scan angle. *Geo-metric* pre-processing is designed to place the raw image in a known geographic co-ordinate system and projection. This is to compensate for errors introduced by variations in orientation of the platform and the curvature of the Earth.

Feature Extraction is the process of reducing data complexity by selecting only the appropriate data sources for the problem in hand. Therefore, the degree of feature extraction is dependent upon the interpreters' knowledge of which bands are appropriate for the objects

under study. The reduction in data complexity reduces the number of variables that can be examined and hence the time and costs of interpretation (Campbell 2002 p. 119). It is not essential to discard any information at this stage.

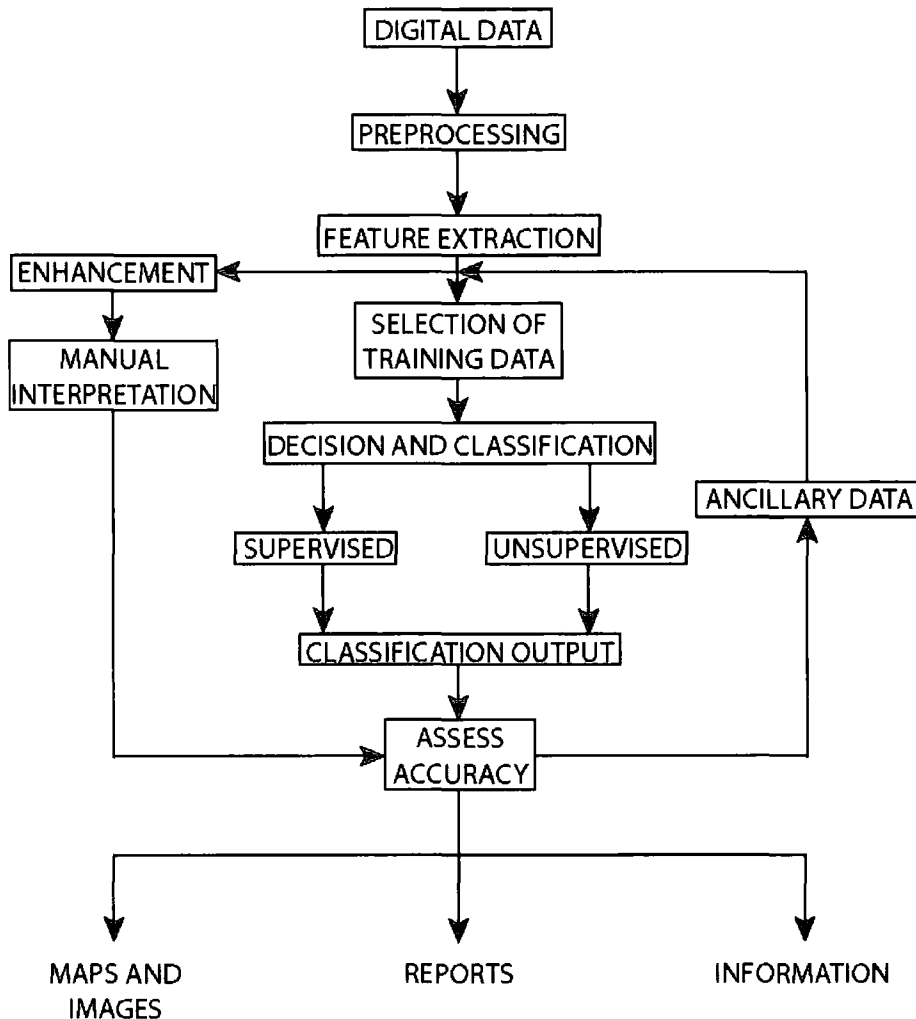

Figure 4 Schematic sequence for digital analysis (after Campbell 2002).

For manual interpretation the image can undergo a variety of enhancements that allow the interpreter to extract more information from the image visually. These enhancement techniques can drastically disrupt the structure of the original or post-processed data; hence, enhanced images are rarely, if ever, used for any statistical classification.

Decision and Classification by either manual or computerised methods is the assignment of specific information classes based upon their visual or numerical appearance in the image.

Computerised classification is the quantitative extraction of information using one of two main techniques: *supervised* and *unsupervised* classification techniques.

Each classification should have an associated level of confidence. It is beneficial to subdivide this confidence rating into three areas: *Detection* is the determination of the *presence* of a feature (note that the concomitant absence of a feature does not necessarily mean that it *is* absent), for example, vegetation. *Recognition* is the further characterisation of the feature into a class, category or genus, for example, pulse crop. *Identification* places the feature into a specific class, category or sub-genus, for example, pea (Campbell 2002 p. 124). This hierarchically structured knowledge base is an intrinsic element of many classification programmes, for example, the CORINE international land cover map derived from Landsat (Gerard 2002).

The final stage of all processing is that of *accuracy assessment*. This should occur for all image interpretations and normally requires a continuing programme of ground observation. Accuracy assessment also includes *post-classification* evaluation. Both supervised and unsupervised classifications produce *confusion matrices* which statistically define the degree of uncertainty when placing a pixel into a category. Confused classes should be highlighted during this process.

The final results of this procedure is a series of classified, synthetic and attribute information which is commonly presented within maps or reports. The preparation, articulation and analysis of these final data sets are augmented by the analytical functionality of Geographical Information Systems (GIS).

1.3.6 Archaeological data

Archaeological data are some of the most complex and diverse information sets studied within any discipline (Ryan 1991). Data of archaeological relevance encompasses virtually all areas of nature and culture. Furthermore, archaeological data is inherently spatial: all past actions happened somewhere in space (Aldenderfer 1998).

The increased use of computerised storage and analysis systems such as Relational DataBase Management Systems (RDBMS), Computer Aided Design (CAD), GIS, Image Processing (IP) systems and more traditional 'office' applications means that the vast majority of archaeological data is now stored in a digital format. A survey of users' needs (Condrón *et al.* 1999) highlights the increased production of and demand for digital data by archaeologists.

This use of digital data has important ramifications: more sophisticated forms of analysis can be entertained and raw and synthetic data from multiple archaeological projects can be relatively easily integrated and re-analysed by other researchers.

The ability to perform multi-criteria and other complex analyses upon spatial data can only realistically occur in a computerised environment. Indeed it can be argued that the reconstruction of past environments and society within a spatial context can only be fully articulated and analysed using GIS and associated software.

Although GIS allows the integration and analysis of multiple data sets collected at different scales, archaeological GIS applications are still relatively immature. There are standardised GIS ready archaeological data sets (such as the Sites and Monuments Record (SMR)), though these are normally transpositions of synthetic paper catalogues. Thus, the complexity of the archaeological record is not articulated through any of these commonly available data sets. This lack of data has limited the way in which archaeological studies are analysed within computerised systems, as the collection of ancillary information becomes very time consuming or difficult. Therefore, each landscape study sets its own criteria and goals for its analysis and collects its own regional information accordingly.

These analyses can vary drastically in their methods of execution which are, in part, defined by research goals. Six main approaches can be recognised:

1. Archaeological prospection.
2. Archaeological evaluation/data collection.
3. Thematic analyses.
4. Holistic analyses.
5. Archaeological prediction.
6. Archaeological interpretation.

Each approach endeavours to understand aspects of past human ecology or to manage such landscape resources (Scudder *et al.* 1996). Models of the organisation of human systems are used to understand the mechanisms behind mobility, the placement of archaeological activities in space, and discard strategies. Human organisation at a systems level responds not simply to the unique placement of specific resources at a single time and place, but also to the

regional, spatial and temporal patterning of all resources – that is, to the organisation of the ecosystem as a whole (Ebert 1989). GIS can be used to articulate these complex and subtle relationships.

1.3.7 Remote sensing and archaeology

Aerial photography is the most widely used and oldest form of remote sensing in archaeology. Archaeologists are expert at re-using information from other organisations and have made great use of vertical and stereo aerial photographic surveys conducted by national mapping agencies and the military. Historically, bespoke archaeological remote sensing has been based on low altitude aerial survey using handheld cameras with films sensitive to the optical and near infra-red (Wilson 2000). The techniques were introduced in the first half of the 20th century by such pioneers as Antoine Poidebard (in the Middle East), Charles Lindbergh (in the United States) and Osbert Crawford and Major George Allen (in the United Kingdom). The improvement in aircraft and camera technology after the second World War led to changes in technique spearheaded by Derrick Riley, Irwin Scollar, Keith St. Joseph and David Wilson amongst others (Crawford 1953; Parrington 1983; Bewley 2000; Wilson 2000; Donoghue 2001).

Archaeologists were quick to spot the potential of Earth observation satellites in the 1970's. Lyons and Avery (1977) rapidly produced 'Remote sensing: a handbook for archaeologists and cultural resource managers' which discussed satellite imagery. Lyons became the series editor for the influential 'Cultural resources remote sensing' book and supplements (Lyons and Mathien 1980). These supplements provided best practice methodology for the analysis of satellite imagery and the expanding airborne multi and hyperspectral imaging systems. Furthermore, this series introduced more formal remote sensing quantitative and qualitative analytical techniques.

Until satellite imagery has much higher spatial resolution than is currently available its role must be limited in archaeological studies. However, there is one area in which the satellite perspective can provide very useful information, namely in the provision of a preliminary overview of a large study area where detailed study or sampling is proposed.

(Allan and Richards 1983 p. 4)

The above quote encompasses how many archaeologists have viewed satellite applications within archaeological research. In general archaeologists have only considered satellite imagery useful for enviro-archaeological applications (see for example Cox 1992). However, it is timely to re-evaluate this stance in light of the high spatial resolution imagery that is available from modern sensors and declassified sources.

Most archaeologists are familiar with aerial photography and its interpretative requirements. However, most applications focus primarily on the identification of archaeological residues in a European context. The majority of sites are identified through variations in crop vigour influenced by subsurface archaeological features. It has yet to be demonstrated if this form of identification is actually appropriate in Middle Eastern environments. Hence, wholesale incorporation of aerial interpretation techniques in this area may be unwise.

Unfortunately most archaeologists are unfamiliar with the more formal remote sensing interpretation techniques described by Lyons. Although over twenty years old this series of handbooks outlines many of the techniques used in this research. The difference between the European and American traditions is possibly explained by access to data. In the USA access to satellite imagery and aerial multi and hyperspectral scanning systems was much easier than in Europe. Furthermore, the USA consists of a number of starkly contrasting environmental zones that do not occur within any single European country.

1.4 Method summary

Classification is one of the major technical goals of archaeology. Archaeological entities from artefacts through to landscapes are classified in order to generalise the complexity of archaeological data so that synthetic analysis is simplified.

From a remote sensing basis archaeological classification of imagery requires the use of different analytical techniques. Archaeological features vary in permanence and construction. They are commonly constructed using locally available building material or by creating 'negative' features in the landscape which are subsequently filled in by local material. Where archaeological features are transitory their deformation sometimes results in subtle changes to the underlying soil matrix which can be identified as a localised change in soil colour or crop vigour. However, some archaeological residues are more permanent in nature (such as upstanding monuments) and vestiges of past anthropogenic action can be easily identified.

Where this does occur many different phases of archaeological occupation can be superimposed on one another to create a palimpsest. Disentangling this information can also be extremely complex. Hence, the nature of archaeological residue creation means that the identification and interpretation of archaeological phenomena is potentially very difficult. Unlike other Earth observation techniques there is no standard archaeological 'spectral signature' to aid classification.

Archaeological remote sensing techniques, from any platform, are based on the measurement of contrast between the physical properties of materials that constitute discrete activity loci and those of their environment. Most remote sensing techniques aimed at archaeological prospection involve identifying contrasts in the surface or near surface attributes of soils, topography and the vegetation canopy. One of the benefits of remote sensing imagery as a resource is that it has a large synchronic footprint. The co-registered bands are multiple layers of numeric information that have spatial and spectral structure. Some of this structure relates to archaeological phenomena. Interpretation is the process of extracting the pertinent elements of the data structure. The creative act of 'interpretation' itself requires that the interpreter has an understanding of the data and its structures so that there is more self awareness of the processes in play during the act of archaeological 'discovery' (Aldenderfer 1987 p. 92).

This ability to identify or detect archaeological residues is based on the conceptual premise that a portion of the data available in the present comprises aspects of past human behaviour which can be isolated and studied. A problem can be addressed by subdividing aspects of the real world that are relevant to a particular problem (referred to as the problem domain or *Total Data Structure* (see Figure 5: from a remote sensing perspective the problem domain exists in n dimensional feature space)). The *Relevant Data Structure* is a subset of the problem domain that *is* relevant to the phenomena of interest. The *Expected Data Structure* is a subset of the problem domain that *is expected* to be relevant to the phenomena of interest. The expected data structure may correspond well, poorly or not at all with the relevant data structure. These data structures are articulated through deductive or inductive reasoning and are extrapolated from remotely sensed data through quantitative or qualitative techniques. The relationship between these categories of information progressively isolates portions of a relevant data structure and its relationship with the real world (Carr 1985 cited in; Clark 1987 p. 58).

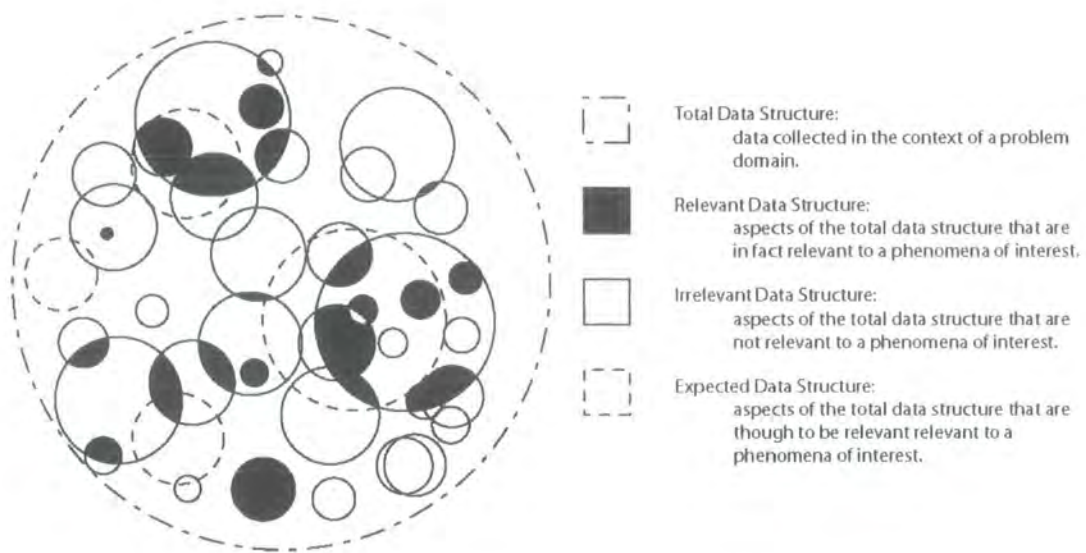

Figure 5 A schematic representation of categories of information about the real world (after Clark 1987 p. 57)

The simplicity of this conceptual model belies a great deal of complexity and, in reality, it is difficult to ascertain how to define each component and, once defined, how to access its accuracy. More recent theoretical stances (for example reflexivity: Hodder 1999; Lucas 2001) demand a more iterative and pluralistic model to address this problem.

Figure 6 outlines a schema for the collection, analysis and interpretation of satellite imagery. The 'image interpretation and classification' stage is where the *relevant data* is extracted from the *total data*. However, this is an iterative approach such that detection and interpretative procedures are part of a feedback loop and can be continually refined in light of new information.

However, there are a number of formal stages through which the data will be processed:

- Data pre-processing (Chapter 5).
- Thematic data extraction (Chapter 6).
- Archaeological prospection (Chapters 7 and 8).
- Imagery as a Cultural Resource Management (CRM) tool (Chapter 9).
- Archaeological evaluation (Chapter 10).

These processing stages will be used to create a range of archaeological resources that can be used to address different archaeological problems as described in section 1.3.6. The primary focus will be to address practical issues such as archaeological prospection and thematic data extraction which will build capacity and add value to the overall programme of enquiry. These are the core issues which should be addressed by the research programme. These datasets can also be used to address some of the other mechanisms of articulation (for example virtual reality). Furthermore, satellite imagery itself can provide novel frameworks for re-addressing methodology, particularly holistic and predictive analyses.

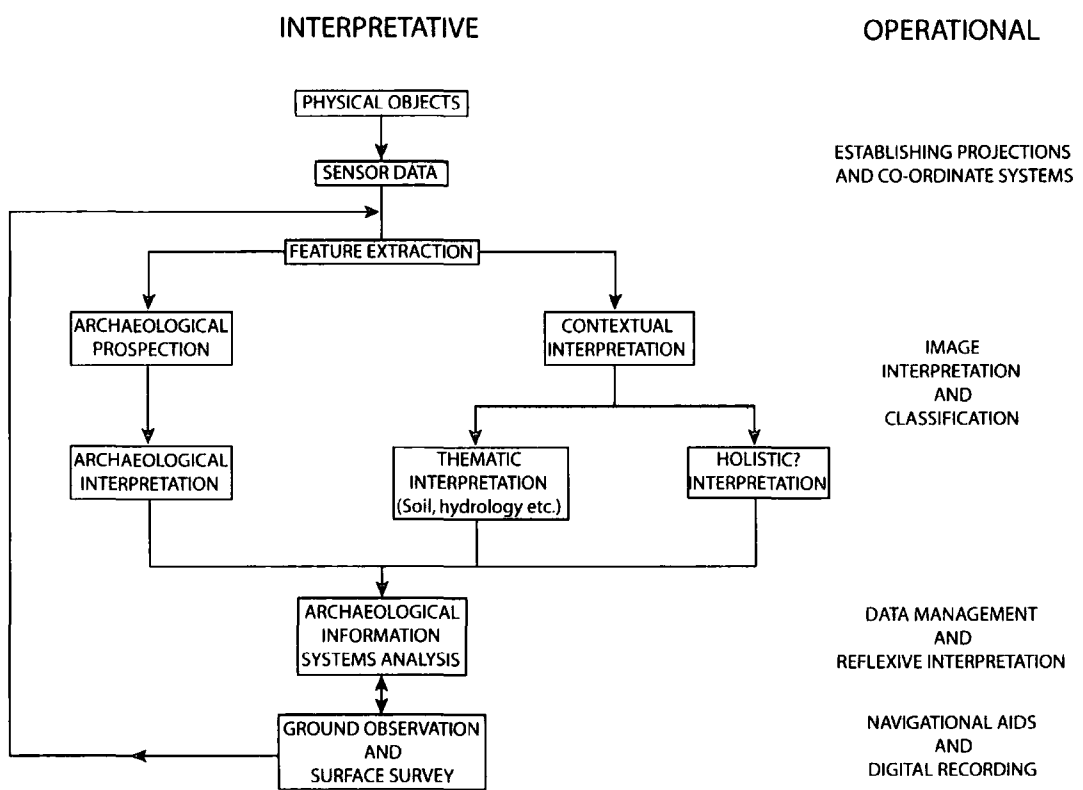

Figure 6 Schematic Archaeological Interpretation process.

1.4.1 Aims and objectives for the evaluation of satellite imagery

The primary thrust of the research is to address issues of archaeological detection and interpretation and to evaluate satellite imagery against other landscape archaeological data sources. Furthermore, as there is an approximate thirty year gap between the collection of the Corona imagery and the Ikonos imagery critical CRM issues relating to landscape change can also be addressed. In comparison to mapping, satellite imagery can be viewed as a more

objective data resource (i.e. it has not been subject to generalisation or synthesis beyond the limitations of the sensor itself). This could offer alternative mechanisms for visualising and classifying archaeological landscapes. In the same vein satellite imagery could be used to reproduce landscape thematic data to contextualise the archaeological resource. Satellite imagery may even be able to improve on traditional thematic resources on the basis of content, scale and utility. As new data sources are employed in this research a best-practice methodological overview is essential for future practitioners.

Given the above the thesis formally proposes to address the following aims and objective:

- To evaluate whether satellite imagery can detect previously unrecognised archaeological residues in different environmental zones. If residues are recognised to attempt to understand the physical processes which allow their detection.
- The level of interpretation that is possible following residue detection.
- To establish how the landscape has changed over time (multi-temporal analysis).
- To identify if satellite imagery allows alternative mechanisms of visualising and analysing archaeological landscapes.
- The comparison of high resolution satellite imagery with other desk based assessment tools.
- The impact of high-resolution imagery for landscape survey in arid environments.
- Establishing the strengths and weaknesses of satellite imagery for archaeological research.
- The ability to produce other archaeologically pertinent thematic information.
- Methodological best practice in employing satellite imagery.

1.5 Other research into the archaeological application of high resolution satellite imagery

This research will evaluate the utility of high resolution satellite imagery for archaeological enquiry in the semi-arid environment around Homs, Syria. However, this work has not been conducted in isolation. Other researchers have also examined the implications of satellite

imagery for archaeological applications. This section places this research into the broader worldwide analysis of high resolution satellite archaeological applications.

Gaffney *et al.* (1996) summarises archaeological GIS applications involving satellite imagery just prior to the introduction and declassification of hi-resolution satellite sensors. Hence, for the purposes of this research it acts as a benchmark summary. They employed Landsat imagery to define a range physiographic and soil zones in a region around Hvar, Yugoslavia. Daels and Al Saadi (1990) applied both Landsat TM and SPOT sensors for a geoarchaeological investigation of relict channels in Mesopotamia. They also identified the utility of the multispectral nature of Landsat particularly, band 5. A less rigorous and potentially spurious Landsat prospection scheme was undertaken by Mumford and Parcak (2002) in Sinai.

In general medium spatial resolution satellite sensors, predominantly Landsat, have only been employed to classify the landscape into different themes as a precursor to other archaeological analyses. Although most of these researchers dismiss the utility of satellite imagery as a prospection tool due to the perceived problem of limited spatial resolution, this research has demonstrated that satellite imagery can be a significant tool for archaeological prospection. However, the resolving characteristics of the sensor and the environmental conditions do dictate what residues will be detected. Sever and Wagner (1991) were fortunate enough to analyse airborne sensors that simulated satellite sensors but had a spatial resolution of between 5 and 10 metres. Thematic Mapper Simulator (TMS: with similar spectral characteristics to Landsat) and day and night-time Thermal Infrared Multispectral Simulator (TIMS: with narrow spectral bandwidths in the thermal) detected a number of surface and subsurface phenomena such as prehistoric walls, buildings, agricultural fields and roadways. The application area was the semi-arid environment at Chaco Canyon in north-western New Mexico, USA. TIMS imagery was found to be a superior interpretative medium than the TMS imagery. By exploiting the thermal inertia properties between the day and night-time images, the thermal channels were analysed independently or as false colour composites to identify roadways, structures and other archaeological residues. The authors also took a distinctly statistical stance on interpretation and developed a number of different filtering techniques to improve interpretation. Finally, they recognised that the analytical methodology could be employed in other semi-arid environments throughout the world, including North Africa and the Middle East. This highlights the utility of non-visual wavelengths, particularly

thermal, which have yet to be fully evaluated for archaeological purposes (although see Bendor *et al.* (1999b) and Donoghue (2001) for localised examples) and that it is the spatial resolution, and not the spectral resolution, of sensors such as Landsat that limit their archaeological application.

Fowler and El-Baz have produced a number of articles that have raised the awareness of high and medium resolution satellite resources within the archaeological community. These have tended to focus on such high profile landscapes as Danebury, Giza, the Great Wall of China and Stonehenge (Fowler 1993; 1994; 1996; El-Baz 1997; Fowler 2001; 2002) employing sensors such as Landsat, SPOT, Corona, KVR and Ikonos. El-Baz (1997) discusses a range of sensors (including RADAR) used in different projects throughout the world outlining the potential of satellite remote sensing in different environments. Furthermore, this article discusses a range of complementary ground-based remote sensing techniques. Fowler's work is generally in environments where the archaeological resource is well understood and these enquiries have added little new archaeological information. However, they have been very useful in providing examples of an alternative viewpoint from which to contextualise a landscape. Although Fowler does identify the scale-dependent benefits of different sensors. This is exemplified in his paper concerning the landscape environs of Figsbury Ring, Wiltshire (Fowler 2002).

Of more import has been the work of Comfort (1997; 1999; 2000), Kennedy (1998), Kouchoukos (2001), Stone (1995; 2003), Wilkinson *et al.* (2001) and Ur (2002; 2003) with Corona imagery. These studies have focused on archaeological residue detection (Comfort, Kennedy and Ur), geoarchaeological investigations (Stone and Wilkinson *et al.*) and human/environmental interactions (Kouchoukos). Each project has tended to use Corona in conjunction with other satellite imagery (mainly Landsat, SPOT and KVR) and in general SPOT has been employed as the geo-referencing medium (see Ur 2003 for a methodological discussion). Comfort's reports outlined possibly the first large-scale archaeological survey to employ Corona photography. Although the analytical techniques employed were not sophisticated, the results demonstrated the utility of the recently declassified resource (particularly for road and aqueduct networks). Kennedy, Kouchoukos and Ur each made the significant point that Corona could provide a useful substitute to aerial photography where it is difficult to access and that the antiquity of the imagery is important. Stone (2003) applied Corona photography and SPOT imagery to locate palaeochannels in the unstable Tigris

floodplain and any associated settlement activity. Wilkinson *et al.* (2001) employed Corona for geoarchaeological and landscape studies around Tell Brak, Syria. Once again the antiquity of the photography meant that identification of some features was easier than with present day imagery. The authors identified possible sites, hollow ways, wadis and the extent of the alluvial fan surrounding Tell Brak. At the tell itself they were able to identify different post-deposition alluvial fans and colluvial slopes.

Ur employed Corona imagery on a comparative scale to this research project, although in Ur's research area there are no structural remains as observed in the basalt zone. He also recognised the limitations of Landsat and SPOT imagery for the large scale identification of archaeological residues and in response applied high resolution Corona photography to study ancient road networks in Northern Mesopotamia. Ur (2003 p. 105) also recognised that anthropogenic modification of the soils at archaeological sites led to changes in reflectance and accords this to improved drainage (and hence reduced moisture content) at these sites. However, he has yet to undertake physical characterisation of these soils to demonstrate this hypothesis (as discussed in Chapter 8). In summary, although different methodological techniques are employed in Ur's research the overall implications of the Corona photography for archaeological interpretation are similar.

Hence, Corona has been employed by a number of different research projects in a number of different, but mainly semi-arid, application areas. Less archaeological work has been conducted on the use of high resolution commercial satellite sensors. Campana and Francovich (2003) have integrated high resolution satellite remote sensing techniques into the high quality GIS driven CRM system of Tuscany. The Department of Medieval Archaeology at the University of Siena, Italy has been conducting landscape surveys and analysis for over 25 years. In addition, over the past 10 years they have been employing innovative GIS techniques. The result is an exemplary archive within which archaeological data from any scale can be fully integrated and articulated.

Like Ur (2002; 2003) they recognised the benefits of large area synoptic collection and the multispectral capacity that satellite sensors offered, but also recognised that the predominantly low spatial resolution of the sensors limited their archaeological utility. In early 2001 they first integrated Ikonos high resolution satellite imagery into their data model, quickly followed by Quickbird imagery. In contrast to this research project they were able to

evaluate these data in a well studied landscape. This provided benchmarks (mature methodological and theoretical hypotheses) against which the archaeological interpretation of the imagery could be evaluated. They used a number of different visual and statistical techniques for image interpretation including false colour composites, stretching, PCA and Tasseled Cap. Analysis of the imagery identified a significant number (84) of potential archaeological features which were not observed on any other dataset. Ground observation was conducted on a 40% sample; 59% of this sample proved to be archaeological. For their environment they concluded that the NIR band proved the most useful. The positive results of this study are particularly interesting as the landscape has been intensively studied with a range of different archaeological techniques and therefore it would be expected that the imagery would only locate previously identified residues. However, until recently bespoke archaeological aerial photography has been restricted by the Italian military.

Little work has been conducted on satellite imagery and its application in recording and monitoring field-systems. However, Romano and Tolba (1996) identified centuriation patterns in Corinthia, Greece using SPOT imagery. However, although they were able to identify the larger frameworks, they were not able to locate smaller divisions.

Although Brivio *et al.* (2000) did not explicitly employ high resolution satellite imagery, they did define an integrated analytical model which explicitly examined aspects of scale changes in archaeological interpretation. This is another area where satellite imagery will help in archaeological enquiries to determine empirical scale thresholds through which different prospection and interpretation mechanisms are required. Such analyses can be very fine grained. Buck *et al.* (2003) examined the applicability of distinguishing pottery and obsidian artefacts from background soils using spectral signatures. High resolution spectro-radiometry data was collected in-situ and compared with laboratory samples. Further research can be conducted into the scale implications of generalising these studies. Understanding the scale implications of these different research projects will elucidate a range of archaeological problems.

Clark *et al.* (1998 p. 1475), although employing slightly lower resolution sensors, do highlight the impact that satellite images have on fieldwork design. They specifically discuss the fact that satellite imagery can be used to determine which areas are more likely to contain

archaeological residues. They agree that this has a significant positive cost implications for archaeological fieldwork.

In contrast to these other studies this research was established with the formal aim of evaluating high resolution satellite sensors. The application area was chosen because it comprised of different environmental zones which provided a more representative context for evaluation. Furthermore, although this research is framed within the broader goals of the SHR project this component had strictly defined methodological aims. As such the research has allowed the full potential of the sensors to be explored.

Like Comfort (1997; 1999; 2000), Kennedy (1998), Kouchoukos (2001), Stone (2003), Wilkinson *et al.* (2001) and Ur (2002; 2003) this research has further demonstrated that Corona imagery is a significant tool for residue prospection. In addition this research has compared the utility of Corona against the modern Ikonos satellite imagery and found this to be an equally useful resource (more so in the basalt zone). Rather than just visually analysing the raw data a number of quantitative techniques were produced which improved the likelihood of detecting residues, particularly in the marl zone. This was augmented with the laboratory analysis of soil samples from the marl. Even though the results of these analyses were not conclusive they provided a promising platform with which to understand the formation and deformation processes which produce reflectance increases which make sites visible. Furthermore, the work in the basalt zone has extended the scope of these sensors for recording fieldsystems, which was previously unrecognised. The ability to record such systems with a high degree of spatial accuracy will be of value to archaeologists facing similar problems.

The ability to conduct time change analysis on the Corona and Ikonos imagery provided a number of critical CRM insights. Not only was it possible to identify which residues had been destroyed in the intervening period, it was also possible to determine what caused their destruction. This information is essential in order to frame a realistic management strategy for the archaeological resource.

The integration of imagery with different spectral and spatial resolutions allowed the creation of spatially and a-spatially accurate thematic layers which provide context for archaeological interpretations. It is likely that the integration of multi-resolution data collected at different

scales for highly accurate thematic analysis will become the norm in remote sensing applications. Irrespective of the multi-scalar integration this thematic information was not previously available to the SHR project.

Due to the different environmental conditions it is difficult to compare the results of this research with the work conducted by Campana and Francovich (2003) although it is interesting to note that Ikonos imagery produced positive results in a European and Mediterranean context (although see below). Campana and Francovich also conducted their research in a well studied environment and were therefore able to provide benchmark figures concerning the utility of high resolution satellite imagery for landscape prospection. Unfortunately, this was not possible within the application area and hence the levels of interpretation are still limited and are likely to remain so until further ground observation is conducted.

However, this lack of information has allowed the SHR project to methodologically and theoretically review its ground survey procedures from first principles. In this context both the Corona and Ikonos satellite imagery has proven invaluable in providing a structure for ground survey. This has saved a considerable amount of time and money and has meant that after only five field seasons that SHR project has a mature grasp of the archaeological problem within the application area.

In well researched environments, such as most of Europe, it is unlikely that high resolution sensors will provide much benefit. In general these countries have mature CRM systems and access to a range of aerial imagery. However, the larger footprint of satellite sensors may make them useful for some enviro-archaeological applications (see for example Cox 1992), although in these instances increased spectral, rather than spatial, resolution is likely to be important. Mosaiced high spatial resolution aerial imagery, such as GetMapping, is also becoming available, further reducing the likelihood that satellite imagery would be employed. However, even in Europe some archaeologists have had difficulty in accessing and employing aerial imagery, such as those in Italy (where until recently aerial photography was subject to restrictions (Jones 2000 p. 53)). In these environments satellite imagery still has utility as a prospection tools (see for example Campana and Francovich 2003).

However, the majority of the applications discussed in this section have been conducted in semi-arid or arid environments. It appears that archaeological satellite applications are ideally suited to these environments where many of the residues exist as upstanding architectural monuments or as soil marks. Corona, Ikonos and other high resolution commercial sensors will continue to have a huge impact on site and landscape studies in these areas.

CHAPTER 2 CONCEPTS OF REMOTE SENSING FOR ARCHAEOLOGY

2.1 Remote sensing – Introduction and definition

This chapter is a selective introduction of remote sensing concepts and techniques which are likely to be of relevance for understanding the analytical techniques employed in the research.

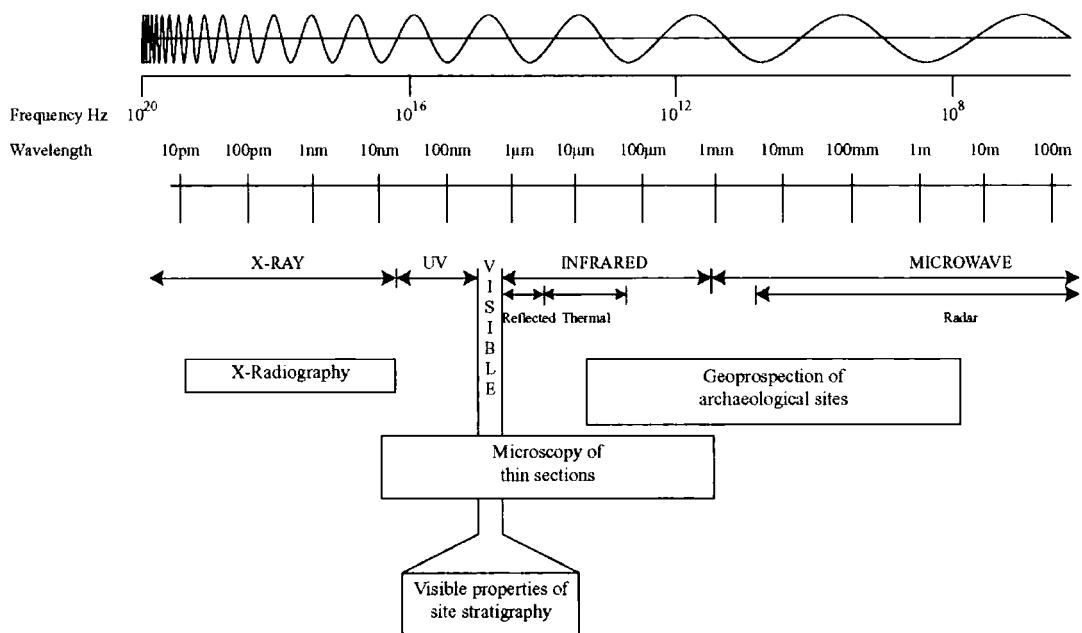

Figure 7 Soil related archaeological applications at different portions of the EM spectrum (after Lucas 2001 p. 156).

Remote sensing has been generically defined as:

..... the acquisition of information about an object without being in physical contact with it.

(Elachi 1987)

However, a more stringent definition is required in order to discuss the elucidation of archaeologically related information on the Earth's surface from space, which is the thrust of this research. A more appropriate definition comes from the United Nations in their annex 'Principles Relating to Remote Sensing of the Earth from Space' (United Nations 1985):

The term Remote Sensing means the sensing of the Earth's surface from space by making use of the properties of electromagnetic waves emitted, reflected or diffracted by the sensed objects, for the purpose of improving natural resources management, land use and the protection of the environment.

Visible light of wavelengths from 0.4 to 0.7 μm (micrometers) is a small section of the EM energy spectrum. The vast majority of archaeological remote sensing applications have relied on this small portion of the spectrum (see Figure 7). Extending beyond these wavelengths allow archaeologists to explore potentially significant information. Archaeologists do employ non-visual wavelengths: x-rays of archaeological objects, thin section analysis and geophysical prospection (Sever 1988; Lucas 2001 pp. 154-156). However, there has been little research into how archaeological sites respond to different wavelengths.

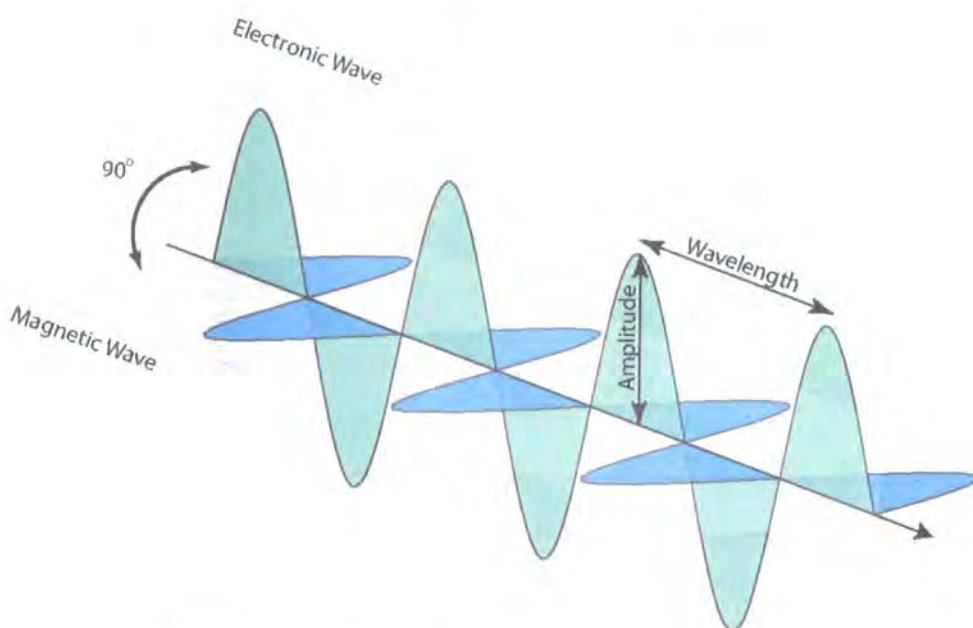

Note: Frequency is the number of crests of waves, that have the same wavelength, that pass a single point in 1 second.

Figure 8 Diagrammatic representation of a photon.

2.1.1 Electromagnetic energy

The underlying basis for most remote sensing systems is that of measuring the varying energy levels of a *photon*. A photon travels as an electromagnetic (EM) wave having two

components, oscillating as sine waves at right angles, one consisting of a varying electric field, the other a varying magnetic field. Both have the same amplitudes (strengths) which reach their maxima and minima at the same time (see Figure 8). Variations in photon energies are tied to the *wavelength* (or its inverse, *frequency*). EM radiation that varies from high to low energy levels comprises the *electromagnetic spectrum* (see Figure 9). Radiation from specific parts of the EM spectrum contain photons of different wavelengths whose energy levels fall within a discrete range of values (Nunnally 1973). When any target material is excited by internal processes or by interaction with incoming EM radiation, it will emit photons of varying wavelengths whose radiometric quantities differ in a way that is diagnostic of the material. The plot of variation of power with wavelength gives rise to a specific pattern or curve that is the *spectral signature* for the object being sensed (see Figure 22 and Figure 43).

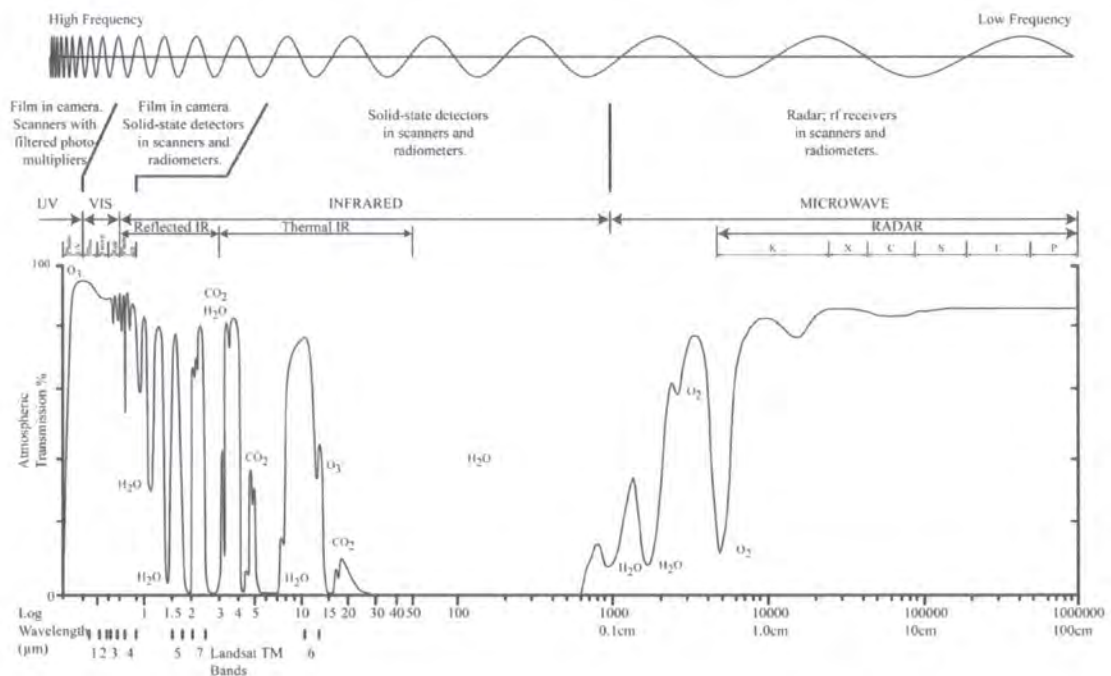

Figure 9 The electromagnetic spectrum and atmospheric absorption curve.

The majority of EM remote sensing instruments, including the human visual cortex, passively monitor the Earth, detecting the *reflected* Sun's energy at selected wavelength groupings (*bands*) from different elevations (*platforms*). The images produced depend directly on the efficiency with which the ground and vegetation reflect the measured wavelengths, how the atmosphere affects (*attenuates*) this signal (see Figure 10) and the resolution of the sensing devices. The

wavelength determines some physical properties. For example, there is an inverse relationship between wavelength and the degree of atmospheric scattering. For example, the shortest visible wavelength (blue) is affected by atmospheric particulates and scattered (referred to as *Rayleigh* scattering). Most wavelengths only interact with the surface microns of the Earth, which for the vast majority of the Earth's surface is composed of vegetation, soil or water. Wavelength penetration is dependent upon the characteristics of both the material and the wavelength. For example shorter wavelengths have increased penetration in water and longer wavelengths have increased penetration in dry sand.

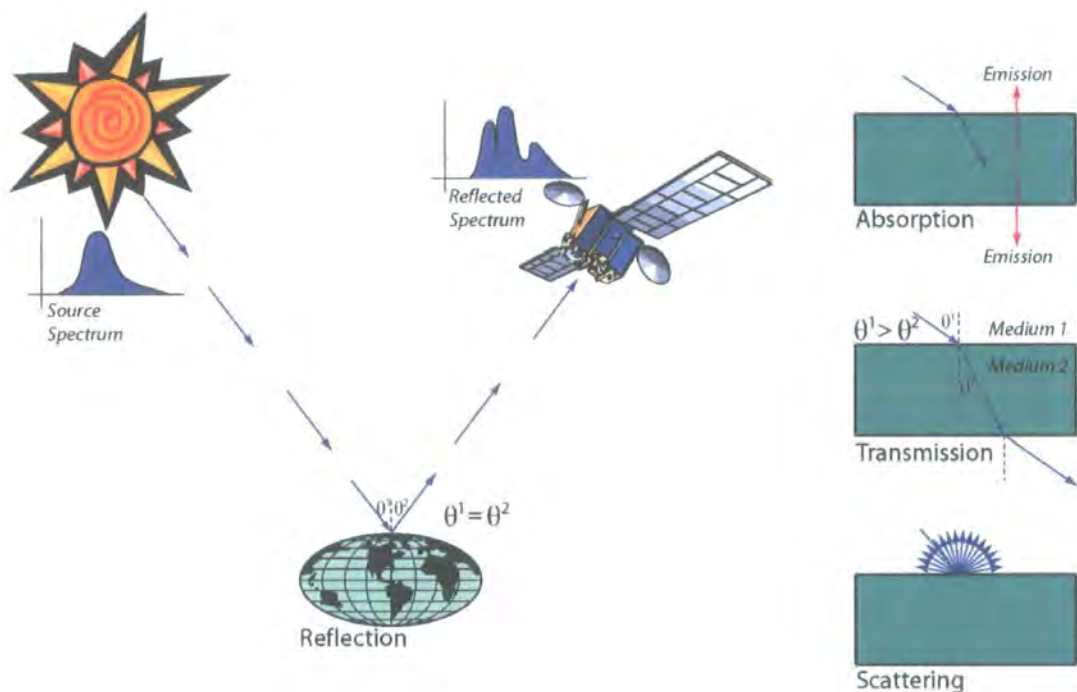

Figure 10 Electromagnetic energy interactions with a target.

However, not all EM radiation is reflected: the Earth also emits its own radiation. A *body* emits radiation as a function of its temperature. The peak of the Sun's emitted energy is in the visible energy band ($0.55 \mu\text{m}$), whilst the Earth itself at an ambient temperature of 300K radiates energy in the mid infrared range ($3\text{-}50 \mu\text{m}$ see Figure 11). Therefore, in contrast to the visible and near to mid infrared ($0.4\text{-}5.0 \mu\text{m}$), where the reflection characteristics determine the structure of an image, thermal infrared sensors principally detect the intensity of *emitted* thermal energy (Shell 2000).

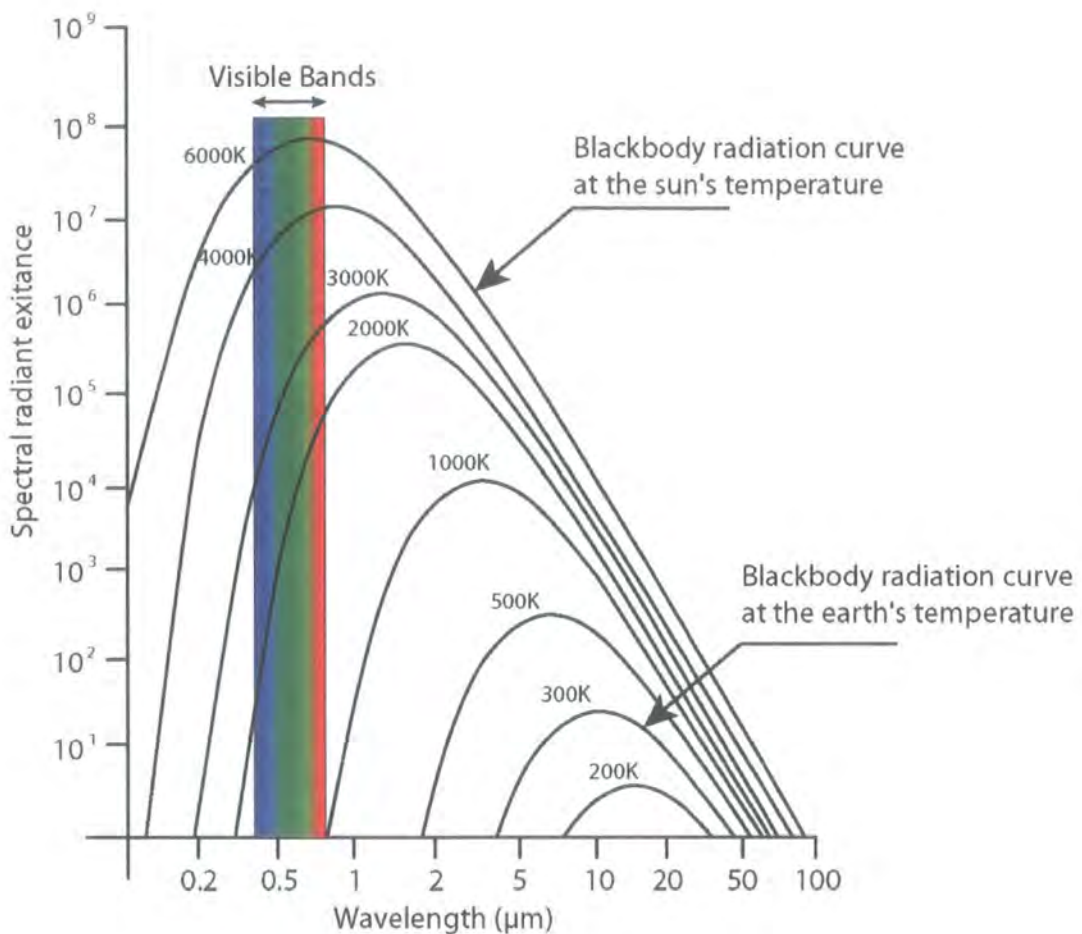

Figure 11 The spectral distribution of energy emitted by a blackbody as a function of its temperature (after Lillesand and Kiefer 1999).

During the day the Sun's contribution to thermal imaging is not negligible. All materials absorb the Sun's energy to differing extents, depending on their absorption/reflection characteristics at these wavelengths. This will change their temperature as a function of their thermal conductivity and thermal capacity characteristics. The topographical effect of ground slope and aspect on the angle of incidence of the Sunlight is also a significant factor in the Sun's ability to heat the ground, and thermal shadowing occurs in daytime thermal imaging. At night, in the absence of the Sun's influence, objects cool at a rate determined by the same factors influenced by the local environment. This leads to a situation where, for example, dry soil and rocks heat up more rapidly during the day than water, and cool more rapidly at night (see Figure 12). The diurnal variation in temperature leads to a phenomenon where, sometime after both dawn and Sunset, respectively heating and cooling objects transiently

have the same radiant temperature, and cannot be distinguished in the thermal infrared image (Shell 2000).

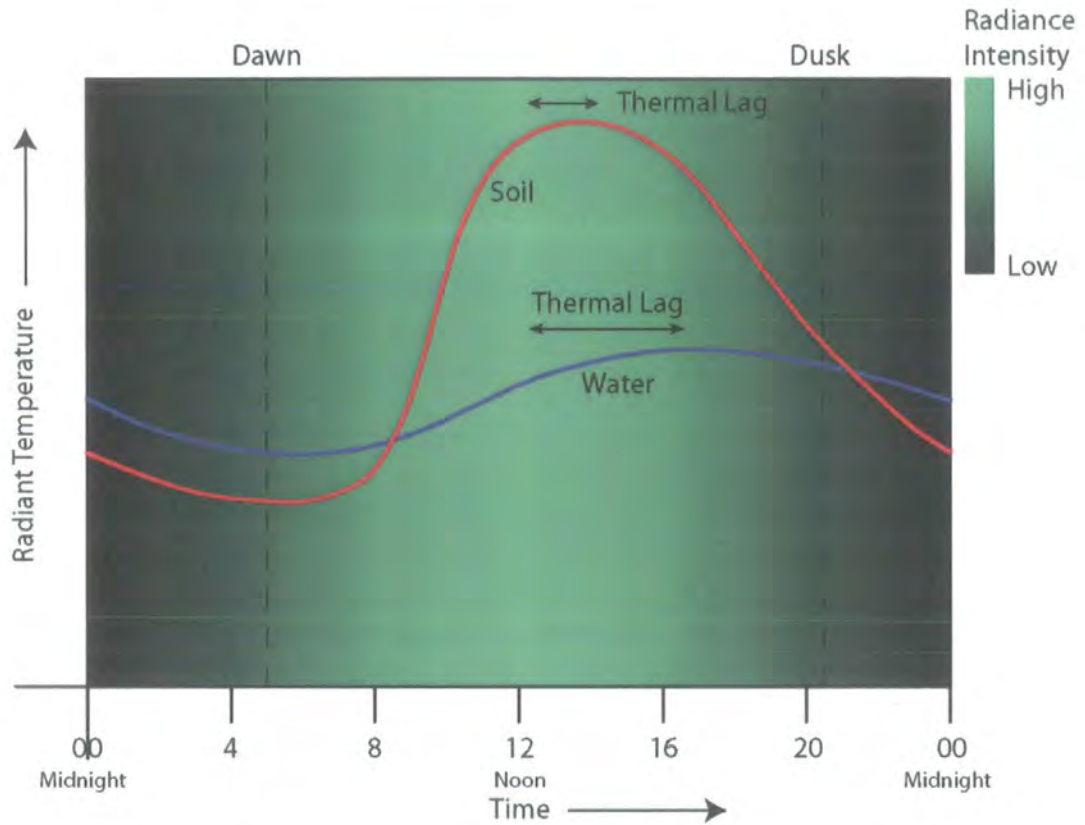

Figure 12 Diurnal temperature variations (after Lillesand and Kiefer 1999).

Sensors can be established to analyse different portions (*bands*) of the EM spectrum with differing degrees of resolution (Kruckman 1987; Holden *et al.* 2002). These bands can be combined to display what the eye would see in the red, green and blue portions of the spectrum (as with colour aerial photography), but also other spectral bands that the eye cannot discriminate (see Figure 34).

2.1.1.1 Visible region

The visible region of the EM spectrum (0.4-0.7 μm) is nominally delimited on the basis of human vision. This region coincides with an atmospheric window (see Figure 9) which makes the atmosphere almost transparent and with the peak emittance of the Sun (see Figure 11).

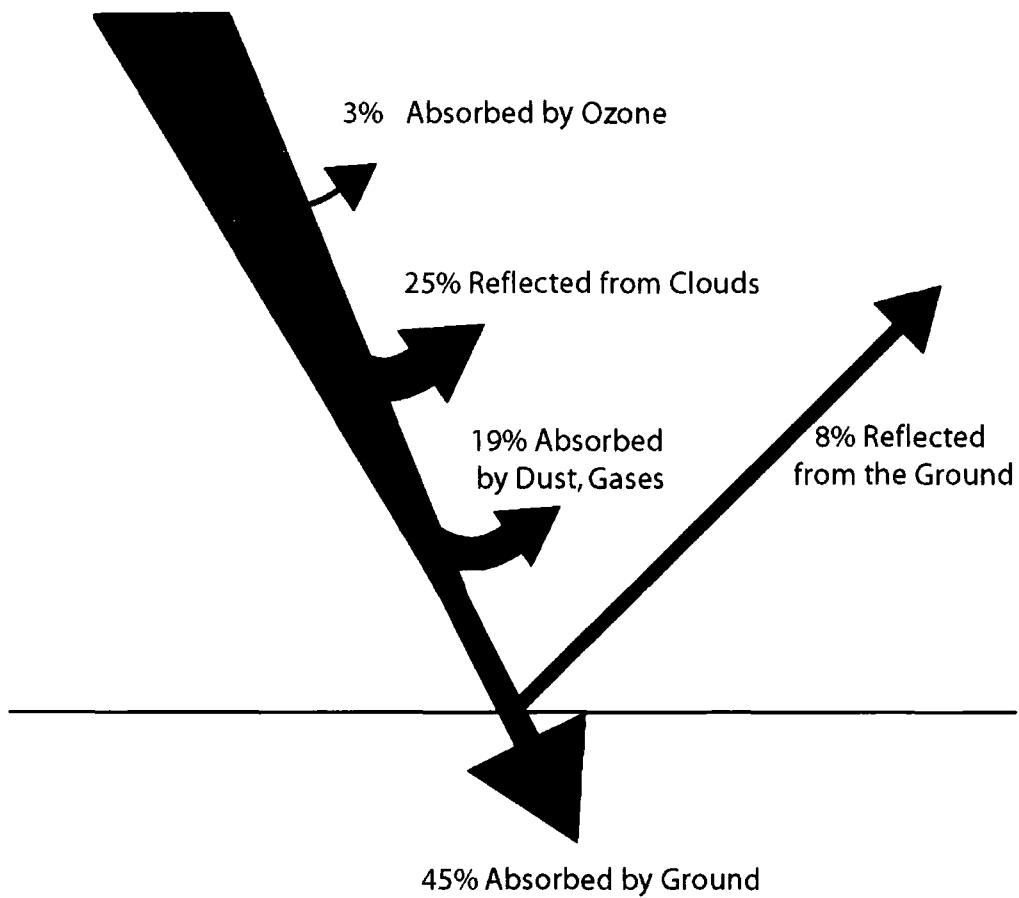

Figure 13 Solar radiation interactions with the atmosphere for short wavelengths (after Campbell 2002).

2.1.2 Interactions with the atmosphere

All radiation collected by remote sensors passes through the Earth's atmosphere, to varying degrees. However, radiation that reaches satellite sensors must pass through the entire atmosphere at least once which substantially attenuates the radiation (see Figure 14 and Figure 15). Atmospheric effects can be divided into three categories: *scattering*, *absorption* and *refraction*. At the shorter wavelengths approximately 90% of the incoming energy is affected (see Figure 13).

2.1.2.1 Scattering

Scattering, as the name suggests, is the scattering of energy as it interacts with particles or atmospheric molecules. The amount of scattering is dependent upon the ratio of the particle size to the wavelength: the higher this ratio value the less the likelihood that scattering will occur. Radiation is scattered towards space, the Earth and, importantly, the sensor.

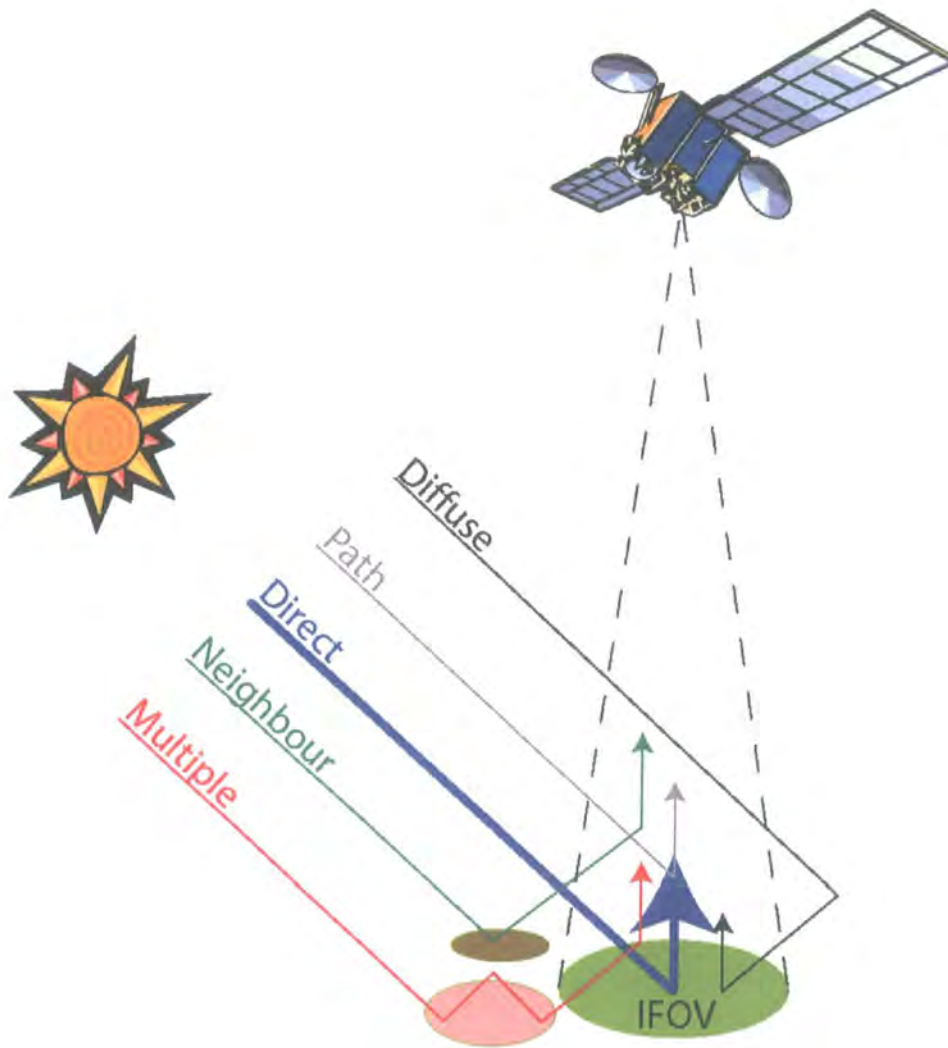

Figure 14 Five types of radiative interaction with the atmosphere and how they impact the Instantaneous Field of View (IFOV: after Tso and Mather 2001 p. 15)

Scattering is predominantly wavelength dependent. When there is a very low particle size to wavelength ratio *Rayleigh* scattering occurs. Tiny particles and some of the smaller molecules (such as N_2 and O_2) affect radiation with shorter wavelengths. Its effects start to become negligible in the NIR. When the particle size to wavelength ratio approaches 1 *Mie* scattering occurs (i.e. particulate diameter and wavelength are approximately the same: see Figure 15 and Figure 17). When particulate size is much larger than the wavelength then *Nonselective* scattering occurs.

Scattering affects sensor readings in a variety of ways. Many interpreters do not consider the blue and ultraviolet regions as useful, when collected from a satellite platform, due to the large amount of Rayleigh scattering. Furthermore, the preponderance of forward scattering effects can reduce spatial detail by scattering radiation from adjacent pixels into the 'observed' pixel (see Figure 14).

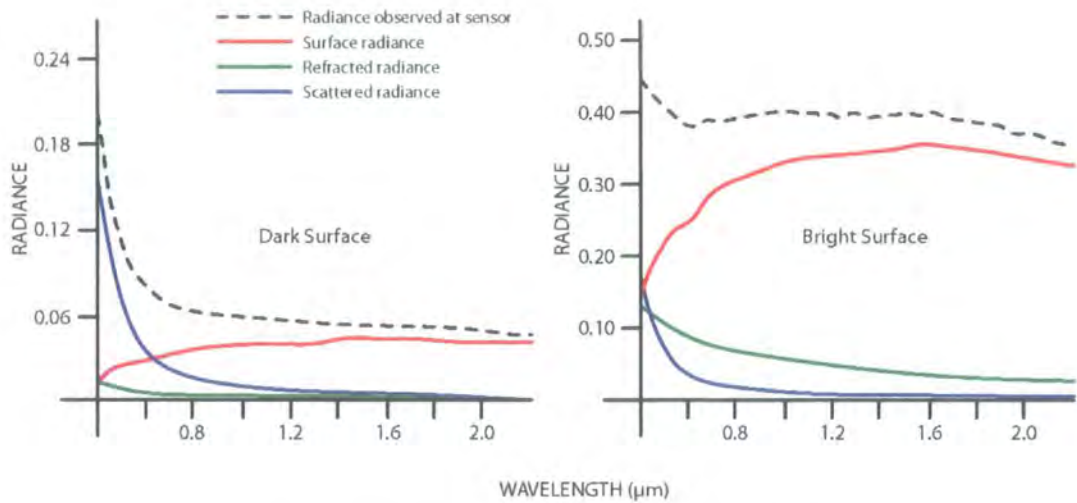

Figure 15 Changes in reflected, diffuse, scattered and observed radiation over wavelength (after Campbell 2002).

2.1.2.2 Refraction

Refraction (see Figure 16) is the change of direction caused by radiation striking a transparent material with a different density. The atmosphere is composed of different 'layers' characterised by variations in clarity, humidity and temperature. Each of these variables affects the density of the layer and in turn the amount of attenuation that occurs.

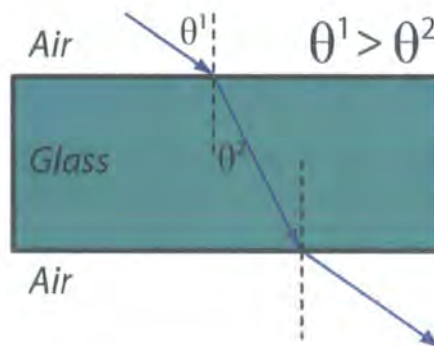

Figure 16 Refraction: How the path of radiation is affected by changes in the density of the medium.

2.1.2.3 Absorption

Atmospheric absorption is the prevention or severe attenuation of energy transmission through the atmosphere. Energy which is absorbed by the atmosphere is re-radiated at longer wavelengths. Absorption is mainly caused by three gases: Ozone (O_3), carbon dioxide (CO_2) and water vapour (H_2O). The parts of the spectrum through which EM energy passes relatively unhindered are called *atmospheric windows*. Obviously, satellite systems focussed on remote sensing of the Earth's surface have sensor systems that are configured to coincide with an atmospheric window (see Figure 9).

IRREGULAR PARTICULATES

Strong, irregular forward scattering.

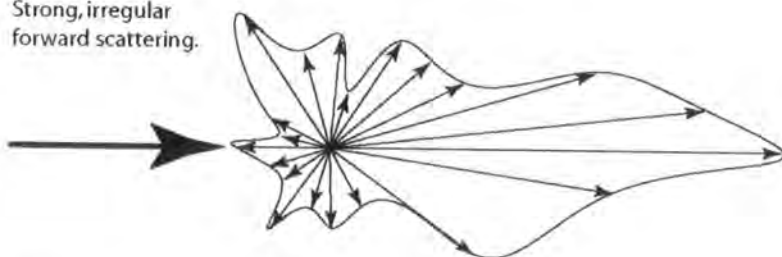

REGULAR PARTICULATES

Strong, regular fore and back scattering.

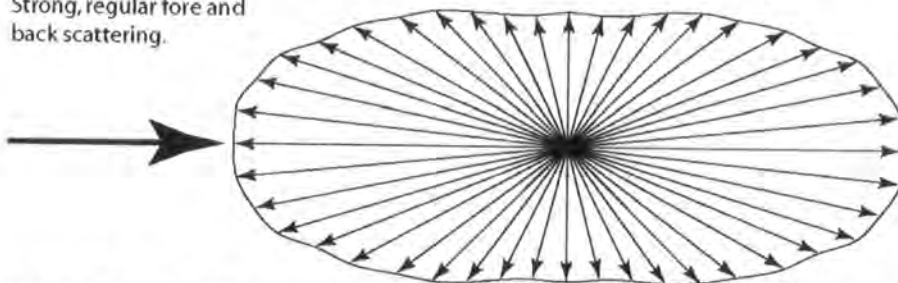

WATER DROPLETS

Pronounced forward scattering with some backscatter effects.

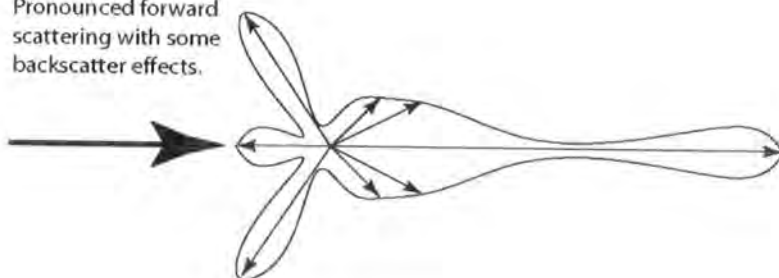

Figure 17 Atmospheric particulates and their scattering effects (after Campbell 2002).

2.1.3 Interactions with an object

As electromagnetic energy reaches the object on the Earth's surface it must be reflected, absorbed or transmitted. The proportions of each process are dependent upon the surface characteristics of the object, the wavelength of the energy and the angle of illumination.

2.1.3.1 Reflection

Energy is reflected when it interacts with a non-transparent surface. The type of reflection that occurs is dependent upon the relationship of the wavelength of the energy and the relative roughness of the surface on the object. If, for example, the surface of the object appears smooth at a certain wavelength (i.e. the irregularities on the surface are much smaller than the wavelength) then *specular* reflection occurs. For visible wavelengths specular reflection occurs on the surface of mirrors and water (Campbell 2002 p. 42). Conversely, if the surface of the object appears rough at a certain wavelength then *diffuse* reflection occurs. A perfectly diffuse surface is known as a *Lambertian* surface (see Figure 18). Most surfaces behave in between these two extremes. It is important to note that the view angle of the sensor will effect the amount of radiation that is received. Archaeologists have exploited non-lambertian reflectance in the use of oblique photography of crop marks.

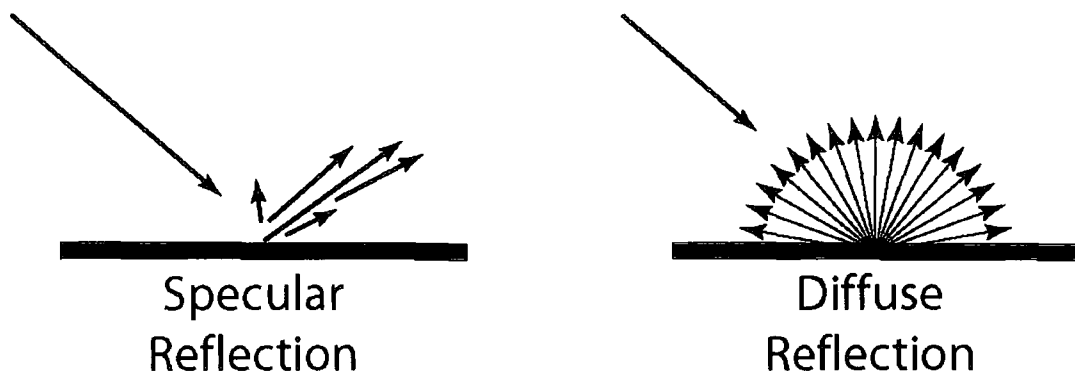
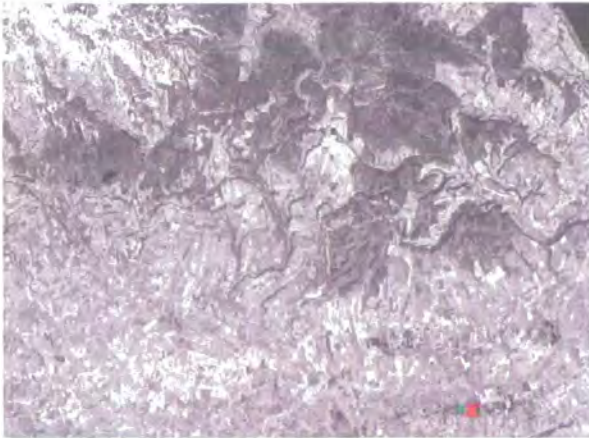

Figure 18 Specular and perfectly diffuse (Lambertian) reflectance.

2.1.4 Discussion

A satellite sensor records the intensity of EM radiation over portions of the EM spectrum. However, as explained above, the values recorded by the sensor do not reflect the actual values observed at the object. On the path from the object to the sensor radiation is removed by scattering, refraction and absorption. Furthermore, radiation is also added by scattering and refraction from adjacent objects.



SATELLITE

Multispectral imaging devices.
 Located through ephemeris data.
 High atmospheric attenuation.
 High spectral and medium
 to low spatial resolution.
 Large ground footprint.

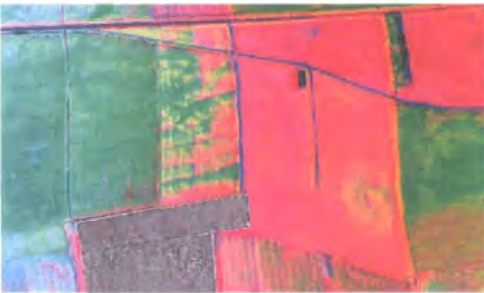

AERIAL

Multi/hyperspectral imaging devices and LiDAR.
 Located through hand correction or inertial DGPS
 post-processing.
 Atmospheric attenuation.
 Very high spectral and medium spatial resolution.
 Medium ground footprint.

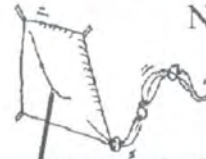

NEAR GROUND

Photography from kites, blimps and
 microlights.
 Located through ground survey.
 Slight atmospheric attenuation.
 Low spectral and high spatial
 resolution.
 Small ground footprint.



GROUND

Traditional geophysics and handheld
 photography.
 Located through ground survey.
 Attenuated by soil and vegetation masking.
 Low spectral and high spatial resolution.
 Small ground footprint although can have
 contiguous surveys.

Figure 19 Remote sensing from different platforms.

2.2 The components of remote sensing systems

2.2.1 Hardware: Platforms

The distance between a sensor and the object under study is important not only for its relationship to spatial resolution. The closer the sensor the lower the impact of attenuation by the 'masking' medium be this soil, vegetation or the atmosphere. All remotely sensed imagery is attenuated by the medium through which it passes. The effect of this attenuation is a function of the distance between the sensor, the object and the energy source, the characteristics of the medium and the characteristics of the specific wavelength.

The choice of platform also has a significant impact on the ability to *geo-register* the imagery. Geo-registering, in this context, provides locational information to a digital file. The process of geo-registration will be dealt with in more detail in later chapters. Suffice it to say that it is more desirable to obtain imagery which is either pre-registered or easy to geo-register. This is particularly relevant to airborne multispectral imagery where the pitch, tilt and yaw of the aircraft makes registration a particularly time-consuming process.

Archaeologists use four platforms for remote sensing (Figure 19):

Ground Level: Traditional terrestrial geophysics and handheld photography. Imagery is normally located through terrestrial survey techniques, if at all.

Near Ground Level: Remote photography from a kite, blimp or tower. Normally located through terrestrial survey techniques, if at all.

Aerial: Bespoke oblique archaeological imagery or vertical landscape survey. Resolution from this platform is variable and dependent upon the elevation and resolving characteristics of the sensor. The majority of sensors are based upon cameras employing different film types, although archaeologists are researching the application of airborne multispectral systems (Donoghue 1999). Correcting scanned airborne imagery used to be a very time-consuming process (Teng 1997 p. 76). However, integrated Differential Global Positioning Systems (DGPS) and inertial navigation systems have improved the ease and cost of geo-referencing.

Satellite: Normally multispectral electromagnetic scanners. Spatial resolution is dependent upon the sensor set-up and varies between less than 1m to many hundreds of metres. The footprint of a satellite image is much larger than other RS

platforms, consequently increasing the land area that can be explored efficiently. Satellite imagery suffers from relatively severe atmospheric effects. Most imagery is automatically geo-located by referring to the orbital (*ephemeris*) and sensor characteristics at the time of data capture.

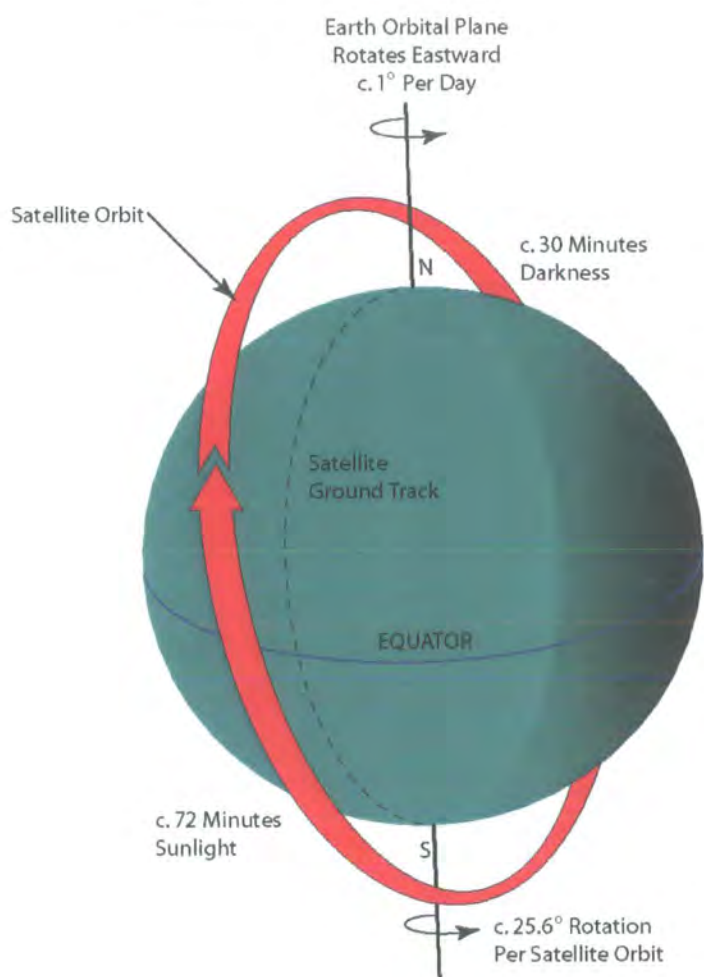

Figure 20 Sun-synchronous orbit.

Satellites used for archaeological purposes require relatively high spatial resolution. High spatial resolution satellites tend to follow a low Sun-synchronous orbit (see Figure 20). As the vast majority contain passive sensors, Earth related information is normally only collected during daylight. However, when the satellite is orbiting the dark side of the Earth sensors will pick up emitted and artificial radiation primarily from the Earth's emitted thermal energy (this has been used to great effect for mapping sea surface temperature and plotting geo-thermal anomalies) and artificial light sources (i.e. major conurbations).

2.2.2 Hardware: Sensor systems

Most analogue camera systems collect on a frame by frame basis. Each frame has a relatively large synoptic footprint. Although there are some analogue camera scanning systems, such as Corona KH4-B, the majority have been replaced by digital scanning systems (see Figure 21). Digital systems use a variety of techniques to collect information mainly employing *pushbroom*, *whiskbroom* or *area array* configurations. These systems collect data along the line of flight with a certain degree of pixel overlap. Consequently, the stability and attitude of the collection platform plays an important role in how easily the data can be corrected and geo-referenced.

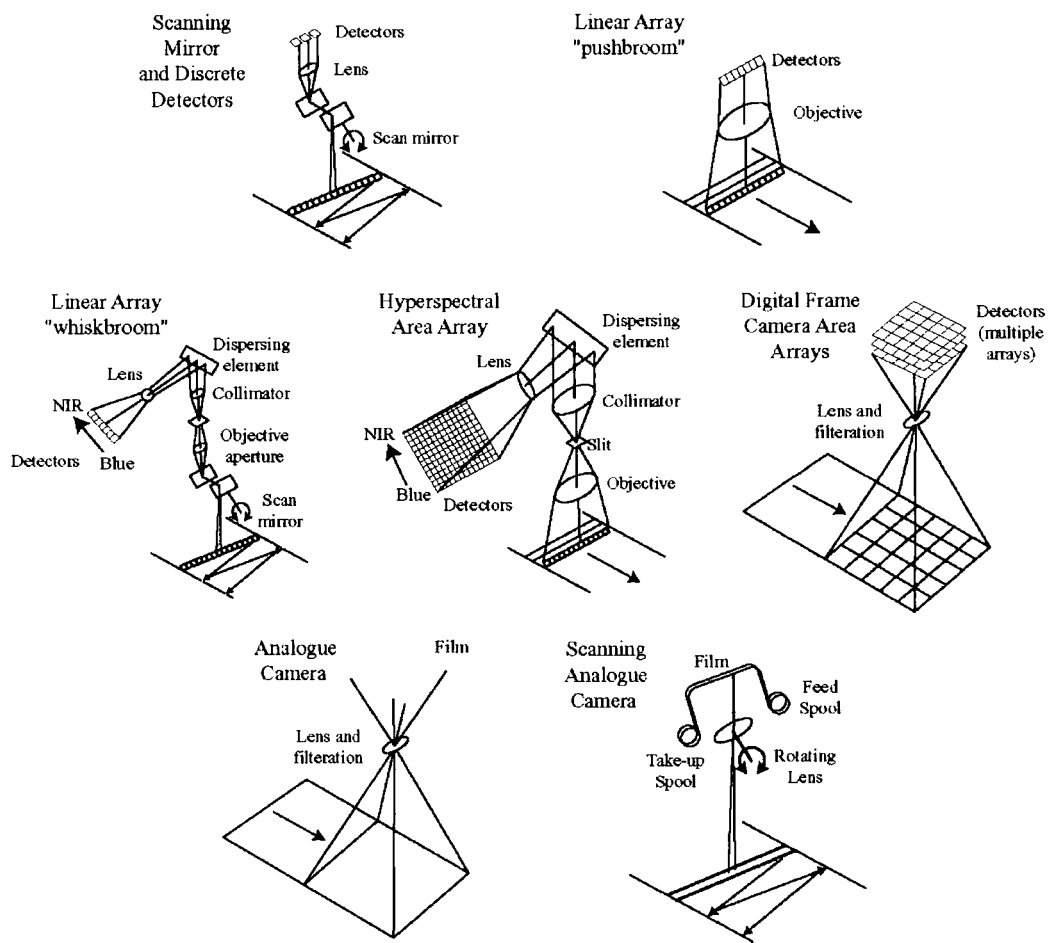

Figure 21 Common digital imaging systems.

2.2.3 Hardware: Sensor characteristics

Due to the complexities of sensor systems only the aspects pertinent to this research will be highlighted. For a broader discussion see the standard remote sensing texts (Elachi 1987;

Cracknell and Hayes 1991; Jensen 1996; Sabins 1997; Lillesand and Kiefer 1999; Mather 1999; Campbell 2002). Sensors fall into two main categories: *passive* and *active*. Passive sensors are the most common form of sensor, and record naturally occurring electromagnetic radiation that is reflected or emitted from the Earth. Active sensors (such as RADAR and LiDAR) bathe the terrain in artificial energy and then record the amount of radiant flux scattered back to the sensor. No active sensors will be evaluated in this research.

Other, non-instrumental, aspects of sensors are related to their ability to resolve data. Each remote sensing system has four major axes of resolution:

1. Spatial resolution.
2. Spectral resolution.
3. Radiometric resolution.
4. Temporal resolution.

2.2.3.1 Spectral resolution

Spectral resolution (see Figure 22) refers to the dimensions and number of specific wavelengths for which a sensor is sensitive. Black and white (or more correctly grey scale) imagery is normally sensitive to a broad spectral range normally in the visible and NIR wavelengths. This is often referred to as *panchromatic* imagery. In comparison, the multispectral scanner of Landsat Thematic Mapper contains 7 bands covering discrete wavelength ranges over different parts of the spectrum. For example between 0.5 and 0.7 μm (the visible wavelengths) the Landsat TM sensor has 3 bands that broadly relate to the blue/green, green and red parts of the spectrum.

Hyperspectral scanners can collect data in many very narrow band passes. For example, the AVIRIS sensor can collect approximately 224 bands between 0.4 and 2.5 μm at 10 nm intervals. Therefore, between 0.5 and 0.7 μm AVIRIS collects data in 20 bands. Thus, spectral resolution can be seen to increase from a 'broad band' panchromatic to the very narrow bands of hyperspectral. Increasing spectral resolution at the appropriate areas of the electromagnetic spectrum may help to improve image interpretation and classification. However, this is dependent upon how easy it is to discriminate between the different spectral signatures of the components in the image.

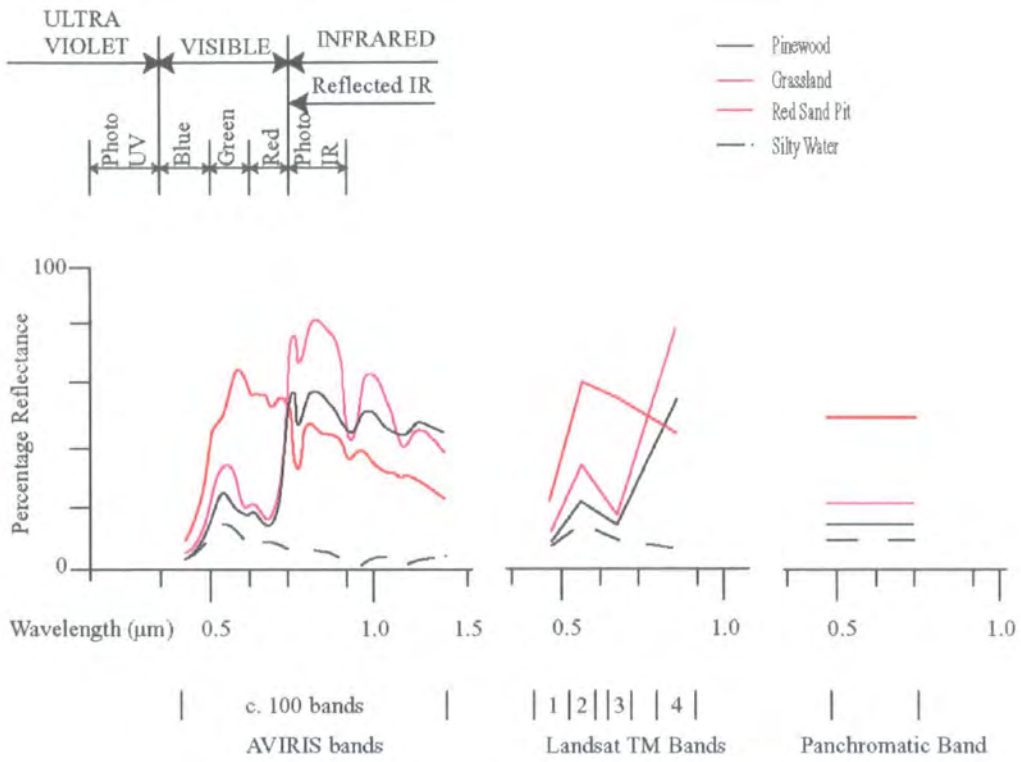

Figure 22 Contrasting spectral resolutions of AVIRIS, Landsat and Panchromatic imagery. Note how closely the 4 bands in Landsat follow the 100 AVIRIS bands.

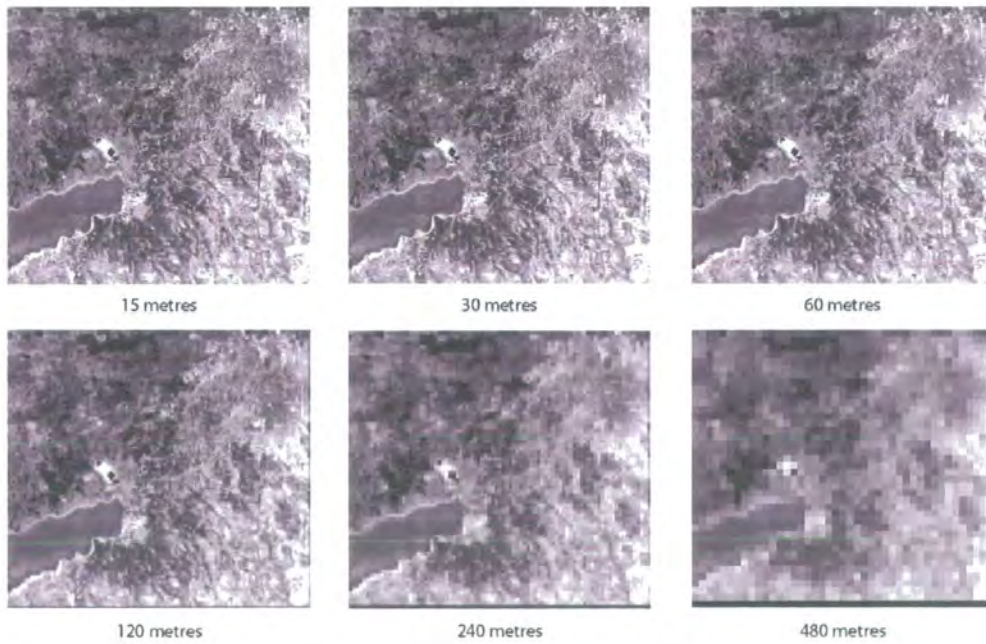

Figure 23 Decreasing spatial resolution.

2.2.3.2 Spatial resolution

Spatial resolution (see Figure 23) is dependent upon the resolving power of the sensor, the distance from the object and the size of the object to be identified. Fortunately, many systems now represent this relationship as simply the ground dimension in metres for each pixel. As a general rule, when using the same sensor system, spatial resolution will decrease as distance from the object increases (a negative relationship). This is particularly important for aerial platforms where aircraft elevation can change dramatically. However, the current generation of commercial satellite sensors (such as Ikonos) have very powerful resolving characteristics (approximately 1m ground resolution) which are comparable to many aerial surveys. A useful rule of thumb is that in order to detect a feature the spatial resolution of the sensor should be one half of the feature's smallest dimension (Jensen 2000).

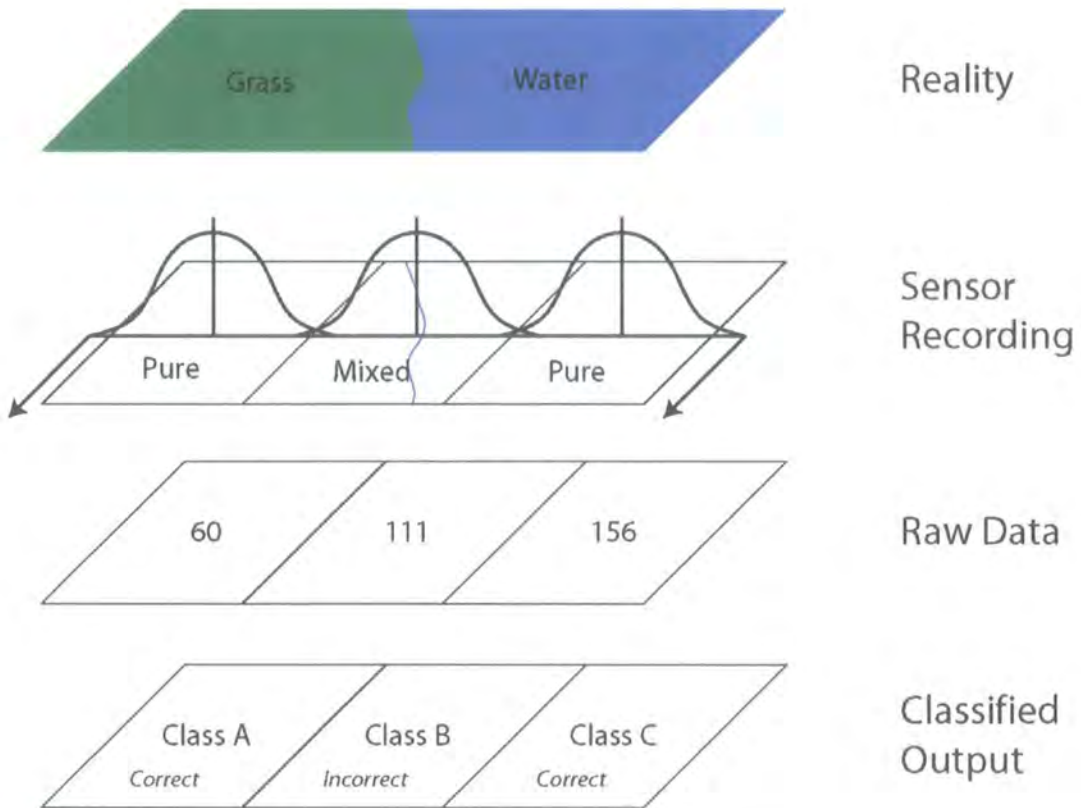

Figure 24 The creation, recording and analysis of mixed and pure pixels.

An important function related to pixel size is that of mixed pixels. In reality it is rare for a single pixel to contain homogenous information (see Figure 24). Even areas which look

homogenous to the eye contain a mixture of information. For example, a Landsat pixel collected over a field containing wheat will also contain information about the soil and weeds. This means that the spectral values of any particular pixel are really composite values for each of the objects present. However, if the reflectance curves of the objects are known and their scattering properties are identical, then the pixel's reflectance can be mathematically decomposed into the reflectance of its constituent objects.

2.2.3.3 Radiometric resolution

Radiometric resolution (see Figure 26) determines the sensitivity of the sensor to differences in received signal strength. The data are normally quantised into *bits* (power of 2). For example, Landsat Thematic Mapper (TM) data is quantised as 8 bits (8 to the power of 2: 256 different values or Digital Numbers (DNs)). Ikonos data is quantised in 11 bits (2048 DN values). Consequently this can have a significant impact on the ability to measure and discriminate objects. For example, in 8 bit imagery bright areas may be overexposed and dark areas in shadow whereas with 11 bit data it is possible to distinguish objects within these bright and dark areas (see Figure 25). Some researchers do not use Landsat imagery in arid and semi-arid environments as they consider it to be too overexposed (Stone 2003).



Figure 25 The benefits of increased radiometric resolution. The 8 bit imagery is overexposed whereas structures are identifiable in the 11 bit imagery (image courtesy of DigitalGlobe and Dr. Amr Al-Azm).

Sensors with high radiometric resolution require image manipulation to appreciate the increase in data quality (as exemplified by Figure 25 and Figure 26). The Ikonos multispectral imagery has the following approximate standard deviations for each band: Blue (30DN),

green and red (60DN) and near infra-red (110DN). This means that, with the exception of the near infra-red band, all bands could have been recorded in 8 bit and maintained at least two standard deviations from the mean. So why is the Ikonos imagery 11 bit rather than 8 bit? In reality sensors are configured to record the full range of values expected across the whole Earth. Although a sensor has the potential to record in 8 bit within each scene it only requires a subset of its full range. Therefore, to ensure full 8 bit resolution a sensor must have the ability to record a much higher range of values.



16 values (4 bit)



8 values (3 bit)



4 values (2 bit)

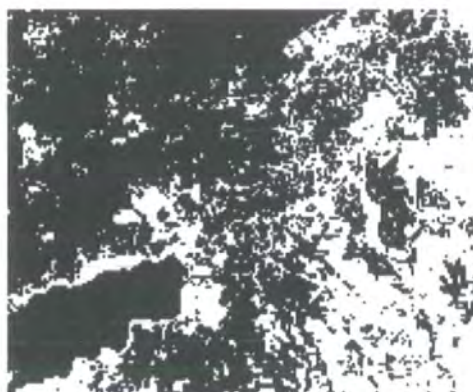

2 values (1 bit)

Figure 26 Decreasing radiometric resolution (Note this is not just improving contrast).

2.2.3.4 Temporal resolution

Temporal resolution (see Figure 27) refers to how often a sensor system records a particular area. For all platforms except satellite this value is likely to be infrequent. All satellites, except

those in geo-stationary orbits, have a temporal resolution dependent upon their orbital characteristics, their ability to record off-nadir (see Figure 28) and the number of satellites containing the same or similar sensor system. For example, a single SPOT satellite has a repeat rate of 26 days at-nadir and 5 – 10 days for off-nadir. Furthermore, the current constellation of 3 satellites with similar sensor characteristics (SPOT 2, 4 and 5) has a much lower repeat rate as each satellite is placed in a complementary orbit. Temporal resolution is particularly important for undertaking time change analysis. The choice of sensor is dependent upon the rate of change of the object under study.

2.2.4 Software: Image processing systems

The vast majority of remotely sensed data are now captured in raster digital format. These digital *images* can be processed with computerised image processing software. Raster processing systems vary greatly in functionality and price, ranging from a simple image-editing suite such as Adobe Photoshop to complex hyperspectral image processing systems such as ENVI, PCI or Erdas IMAGINE.

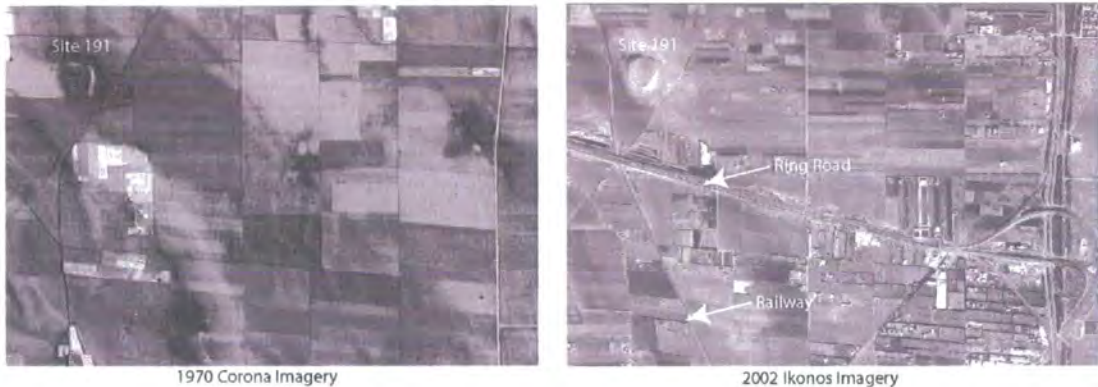

Figure 27 Temporal Resolution: Looking at changes over time. The negative Corona image of 1970 is compared to a positive Ikonos image from 2002. The major changes are noted on the Ikonos image.

Image enhancement is the process of making an image more interpretable for a particular application. A dedicated image-processing package has the capability to perform varied digital manipulation. The most important are:

- Image pre-processing.
- Histogram manipulations.

- Band ratioing and other Boolean algebraic techniques.
- Multivariate analyses (including Principal Components Analysis).
- Kernel filtering.
- Image classification.
- Colour composite combinations from different raw or processed bands.

Landsat Thematic Mapper (TM) imagery is primarily used for illustrative purposes throughout this section, although the techniques described can be used for data from any platform (ground, near ground, aerial and satellite) and any image depth (the image processing term for radiometric resolution).

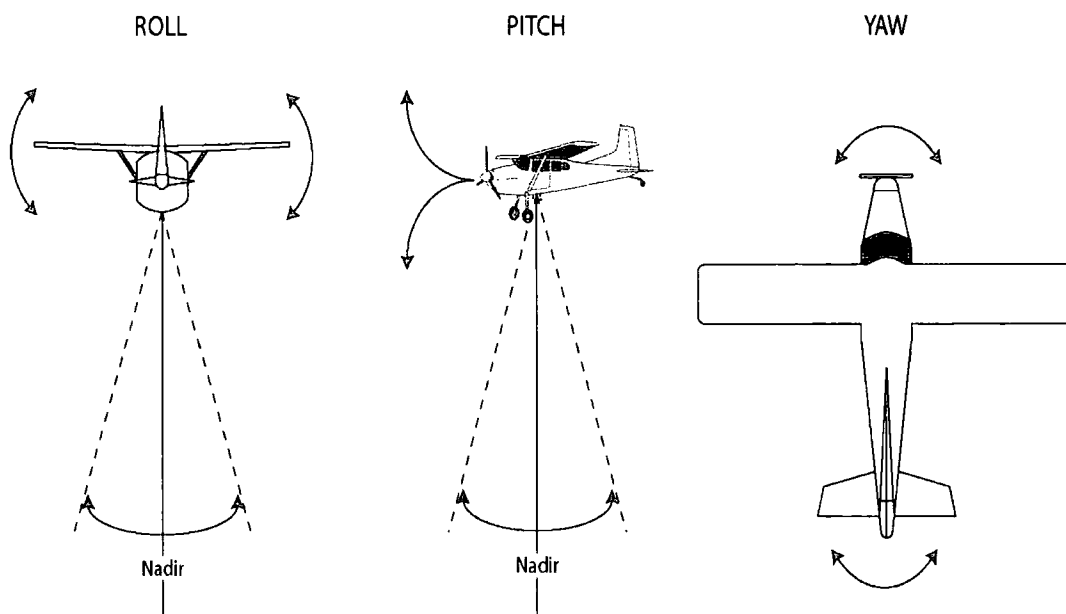

Figure 28 Roll, pitch and yaw effects on the nadir point.

2.2.5 Processing: Image pre-processing

The data from aerial or orbiting sensors are initially uncorrected for radiometric and geometric discrepancies; they are considered 'raw' (if one wanted to apply bespoke correction one can purchase imagery in this state). However, most users prefer to have errors corrected by the supplier. The subject of correction is tied to the procedures called pre-processing or image restoration.

Pre-processing is an important stage where *models* are used to artificially correct for problems that attenuate the EM signal between the object and the sensor (in the case of active sensors this also includes the passage of energy from the sensor to the object: as discussed in 2.1). Pre-processing can be subdivided into radiometric and geometric corrections.

Geometric correction includes correcting for skew (the effect owing to rotation of the Earth) and platform movements (roll and pitch) that cause the straight-down line of sight (nadir) to deviate from the vertical (off-nadir, see Figure 28). The pixels acquired off nadir are progressively elongated depending on the look angle and the natural curvature of the surface of the Earth. Some projection compensation is needed: normally through registering the image to a known coordinate system. The most commonly applied projection is Universal Transverse Mercator (UTM). Once the various corrections are made, the result is usually a shift in position of any given pixel into its new projection system, such that it does not necessarily have the same DN values that it had in the original (distorted) position (Shennan and Donoghue 1992). A new set of values can be calculated by re-sampling, a mathematical process involving interpolation of values using an algorithm such as Nearest-Neighbour, Bilinear, or Cubic Convolution (see Figure 29). These re-sampling techniques give an estimation of the new brightness value (as a DN) that is closer to the new condition (A).

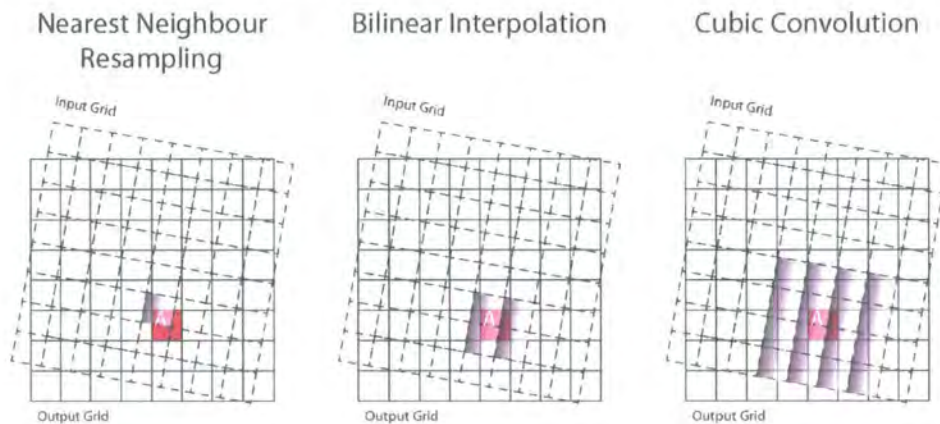

Figure 29 Common pixel resampling techniques.

In the Nearest Neighbour technique, the transformed pixel takes the value of the closest pixel in the pre-shifted array. In the Bilinear Interpolation approach, the average of the DN's for the 4 pixels surrounding the transformed output pixel is used. The Cubic Convolution technique averages the 16 closest input pixels.

Corrections can be made that affect undue radiometric variations, i.e. changes in the measured radiances owing to a variety of factors. These are divided into natural and instrumental variations. One natural condition relates to temporal and spatial differences in atmospheric conditions. For example, presence of atmospheric water vapour influences the radiance, such that the reflectance from the same object varies over space because of differences in atmospheric conditions. Another correction takes into account the changes in Sun angle (seasonal elevation; time of day) as reflection values from the same object vary according to the angle and intensity of incoming radiation.

Instrument corrections involve variations in detector response and electronic anomalies. Most common are systematic differences in one or more detectors. This can induce such effects as variable line darkening (one detector may produce a line that is brighter or darker than its neighbours), line drop out (a fluctuation may cause all or part of a line to be missing), and random noise (speckling). Procedures are available to apply computer-generated corrections for any of these based upon localised assumptions, improving overall image quality. Furthermore, sensors are periodically calibrated against objects on the ground with known reflectance characteristics.

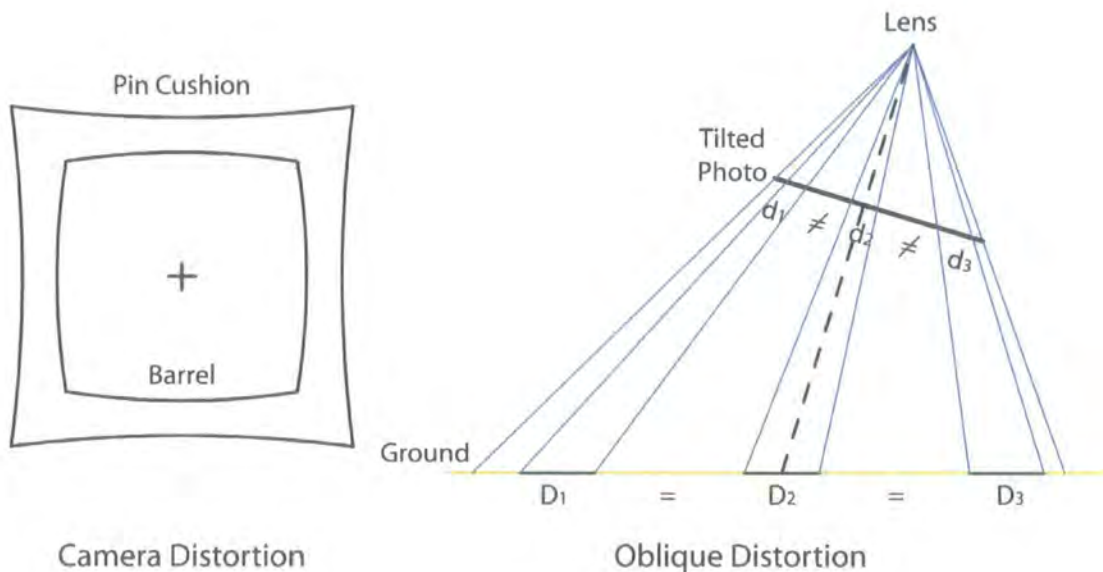

Figure 30 Examples of camera lens and oblique distortions (after Scollar 1990 p. 83; Teng 1997 p. 82).

2.2.5.1 A short note on image geometry

Many satellite platforms now allow programmable view angles which can result in scenes taken from multiple view angles. Platforms that can collect multiple view angles provide a number of advantages including revisit frequency, stereoscopy, sun-spot avoidance and angular reflectance analysis.

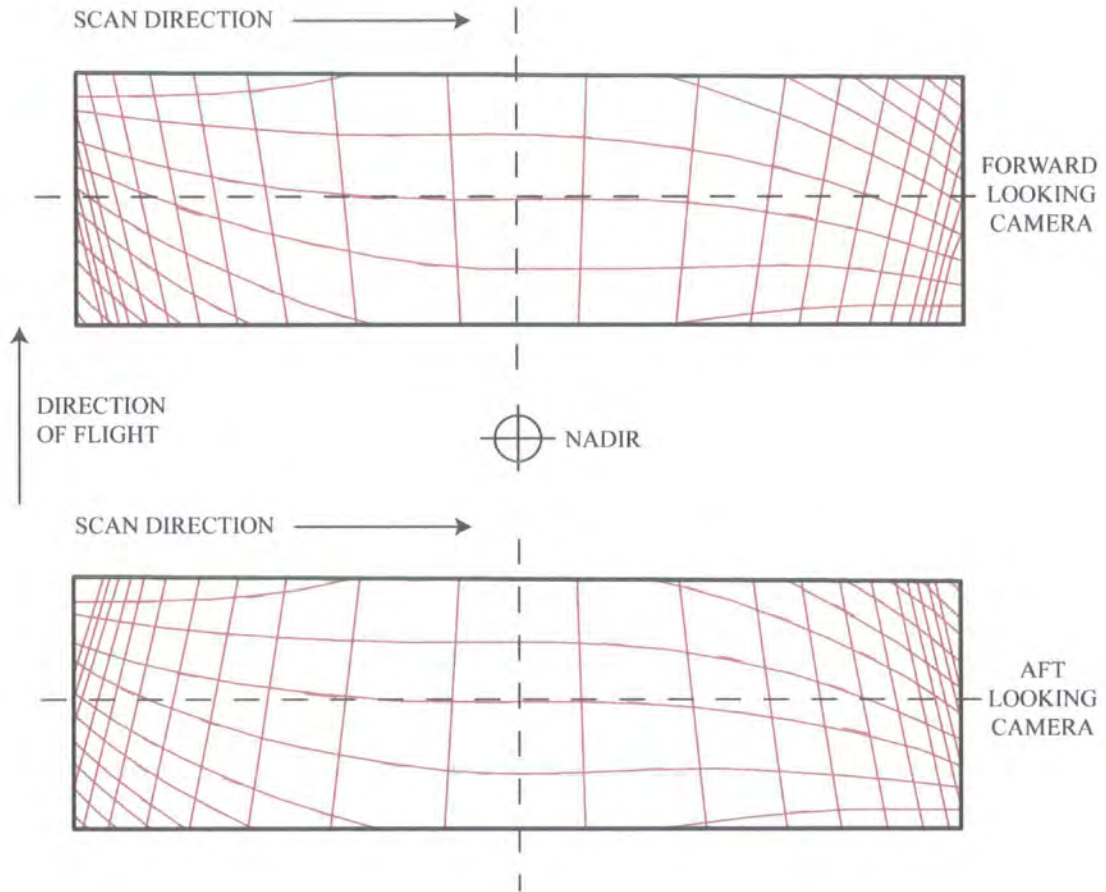

Figure 31 Unit grid distortions of the Corona KH-4B panoramic camera (after Galiatsatos in prep p. 93).

Variable view angles are essential for the generation of stereo pairs which use differences in relative image orientation to deduce depth. Hotspots effects can be reduced with non-vertical view angles. Hotspots occur when the instantaneous field of view, sensor and Sun are in a direct line resulting in a strongly illuminated shadow free area. So called sunspots are where the Sun's energy is reflected directly into the sensor by a specular reflector (i.e. water) resulting in glare. This effect is view angle dependant. Galiatsatos (in prep) recognised that variations in view angle altered the archaeological interpretability of the Corona KH-4B fore and aft

cameras for the same area in Syria. Changes in feature contrast is a function of both directional reflectance properties and the absolute reflectance of the ground features. View angle can be considered important as different features can produce different responses under different view angles (Barnsley *et al.* 1997). Hence, an increased understanding in view angle effects could be increasingly important for archaeological interpretation in the future, however, it is not a major focus of this work.

Oblique images have a number of important geometric properties, the understanding of which are germane to their interpretation. All collection platforms introduce geometric distortions. A number of these are inherent to the device itself. For example, pin and barrel distortions in camera systems are dependent on the lenses employed and commonly increase away from the nadir point (see Figure 30). A schematic diagram of the panoramic distortions in Corona can be seen in Figure 31. Oblique imagery causes variation in scale. The more the principal point moves away from the nadir the greater the scale variation in the image (as demonstrated in Figure 30). This is further exacerbated when there are variations in terrain which can result in displacement in the imagery.

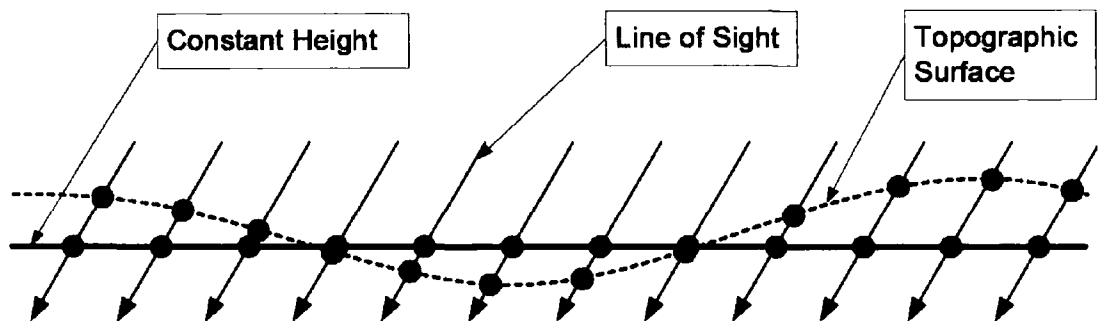

Figure 32 Image displacement due to variations in relief (after Dial and Grodecki 2003).

Many satellite images can be projected to a map projection at a constant height. Terrain distortions are not corrected. Hence, objects above the reference elevation are displaced away from the sensor while objects below the reference elevation are displaced towards the sensor (see Figure 32). These terrain displacements affect the spatial accuracy of the imagery.

To mitigate against increasingly complex geometric errors a range of rectification techniques have been developed (ERDAS 1999). The majority involve one or more of the following: an

increase in the number of ground control points, sensor construction information or a Digital Terrain Model (DTM) and are either monoscopic or stereoscopic in approach.

Orthorectification is a means of correcting monoscopic images for relief displacement by using a DEM. The DEM is collected from an alternative source (such as a basemap). As illustrated in Figure 33 the DEM is used to adjust terrain displacement so that the resultant image has correct planimetric coordinates.

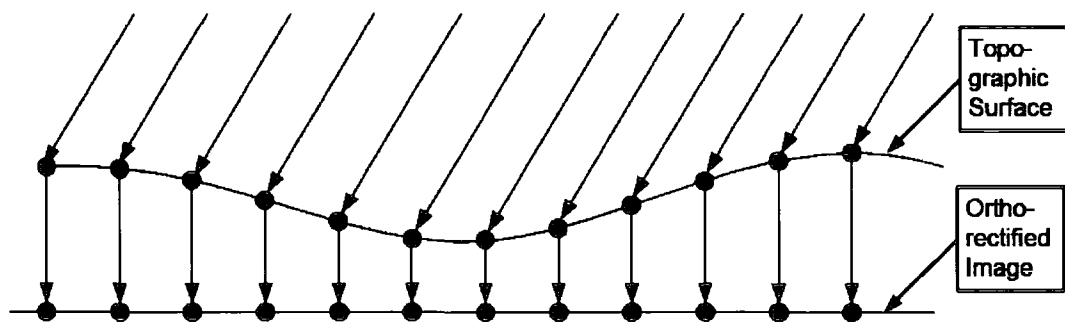

Figure 33 Correction for relief displacement in a monoscopic image by orthorectification (after Dial and Grodecki 2003).

Stereoscopic techniques also adjust for terrain displacement. However, stereo techniques have the added benefit that they use the input stereo pair to create the DEM. The DEM generated from the stereo pair produces better accuracy as the DEM is at a comparable scale to the input image and it reflects the height differences at the time of image collection. For example, if contours from a basemap are used they will not take into account buildings and the landscape may have changed. Further, stereoscopic techniques can allow digitisation to occur directly in 3d as opposed to 2d in monoscopic imagery.

Due to the minimum amount of terrain distortion in the application area neither stereo nor orthorectification was necessary for the interpretative techniques employed.

2.2.6 Processing: Image display and visualisation

Image processing software considers remotely sensed data as a stack of spatially co-registered layers over n bands, where n refers to the number of discrete bands collected by the sensor (see Figure 34). Multichannel analysis is based on the premise that each pixel in each layer is perfectly (or near-perfectly) co-registered (Sever 1988). Thus, any pixel in a scene can be

considered as a stack, each layer corresponding to one wavelength. Image processing systems allow raster imagery to be manipulated in a variety of ways, by comparing and combining the different data 'layers' without disrupting the basic structure of the image. The results of mathematical operations can be used to create a new 'layer' in the stack. Hence, the integrity of the original data sources is not compromised. These layers can also be used in the production of a variety of false colour composites for human visualisation (Harris *et al.* 1999).

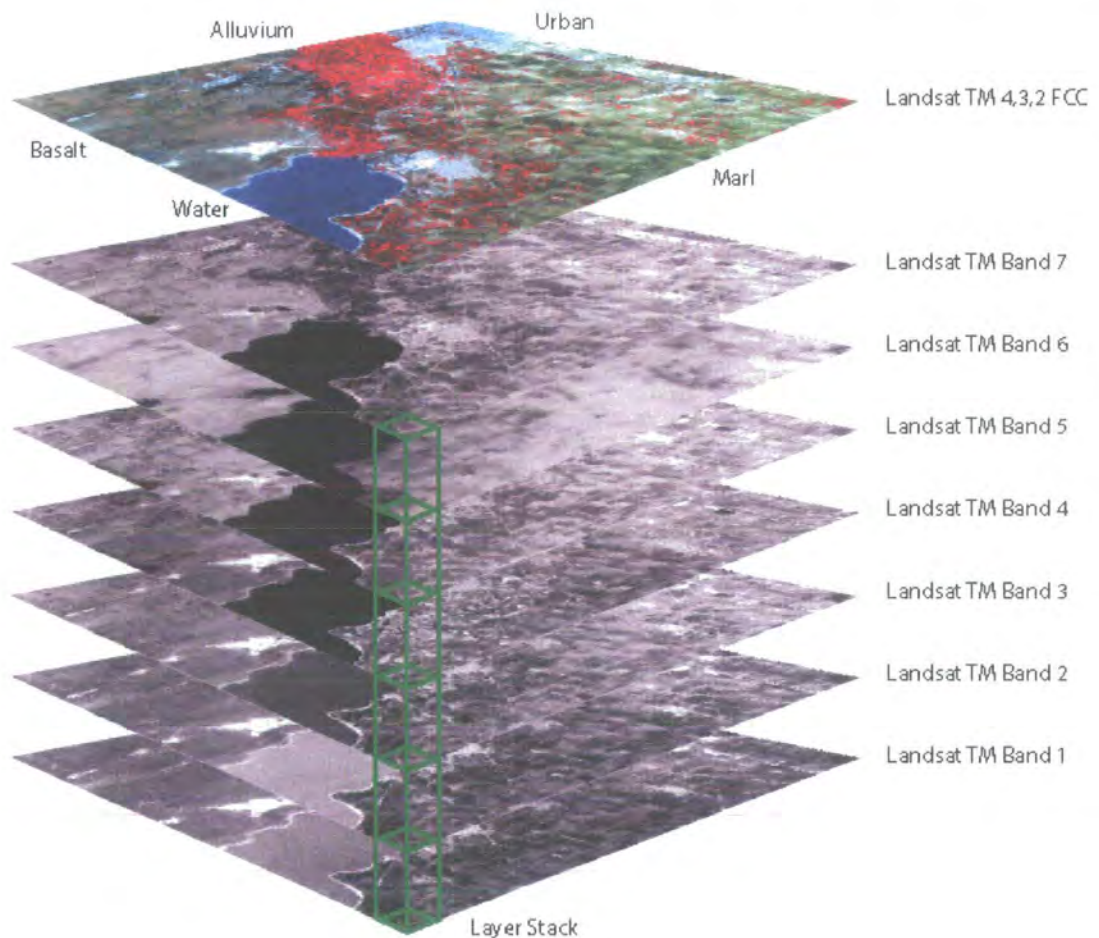

Figure 34 Landsat bands 1, 2, 3, 4, 5, 6 and 7 in a layer stack.

For visual analysis bands are commonly viewed as colour scales or colour composites. Individual bands are commonly viewed as grey scale (which is a ramped colour scale between white and black). The combination of three bands substituted for red, green and blue can produce a colour composite image. For raw TM imagery this provides 120 (6x5x4) possible colour combinations without band duplication (Landsat TM Band 6 is rarely used due to its

relatively low spatial resolution) and even more new layers are created through quantitative techniques. Projecting band 3 as red, band 2 as green, and band 1 as blue yields a result close to what humans perceive as 'true colour'. All other types of RGB combination are referred to as false colour composites (for example the Landsat 4, 3, 2 band false colour composite in Figure 34).

It should be noted that each image (or image stack) consists of purely digital data. Although the visualisation approaches employed mimic how the human brain handles visual imagery, (hence a reliance on systems that provide variations in tone, texture, colour, pattern, shape and size) other mathematical systems can be employed to extract meaning from imagery that at first sight are not as visually intuitive as RGB or greyscale visualisation.

2.2.6.1 Human perception

Human perception of imagery is a complex procedure. People instinctively interpret qualities such as tone, texture, colour, pattern, shape and size. Tone is a measure of the relative amount of light reflected by an object on the ground and is fundamental to all other recognition elements except colour. On a black and white photograph, tones range from black to white and the spacing of variation in tone determines the texture of a portion of the image. Texture can be used, for example, to separate disturbed soils from undisturbed surfaces, to discriminate differences in vegetation cover that might signal the presence of buried materials, or to discern areas of disturbed topography. Pattern refers to the arrangement of features seen in an image (Ebert 1984 pp. 313-315; Teng 1997).

Pattern, shape and size are relative cultural interpretation flags. The spatial resolution of the image is important for visual interpretation; this is a scale-dependent parameter. Some parts of the scene are identifiable at all resolutions, whilst others only become apparent with increased detail. Increasing magnification will eventually result in the component pixels interfering with image clarity. However prior to this point smaller resolution features can become clearer (see Figure 35).

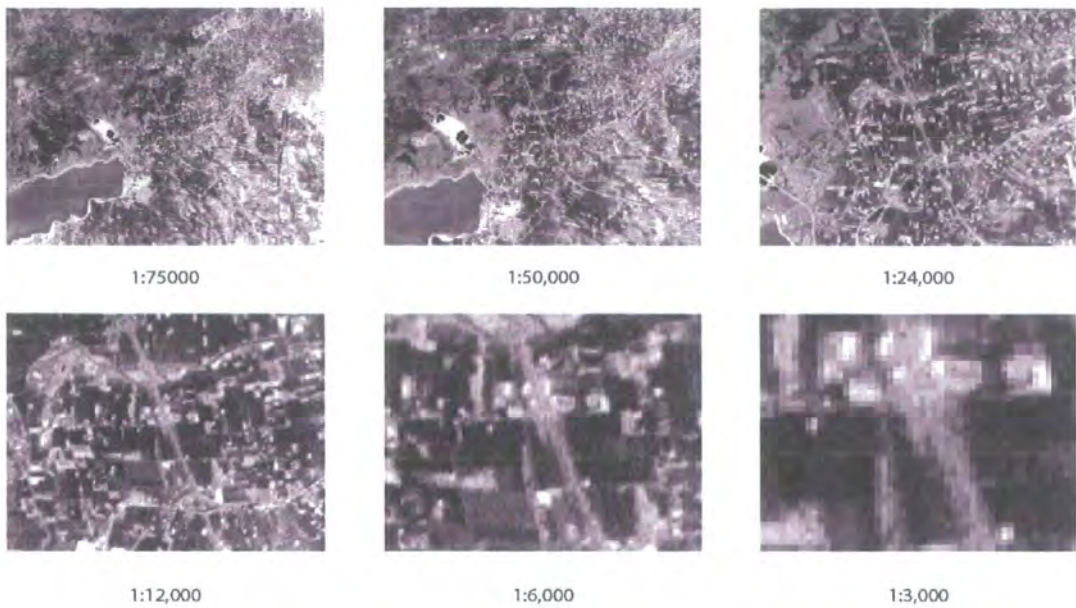

Figure 35 Increased magnification on 15 meter Landsat panchromatic imagery.

The human eye can discriminate between 20 to 30 shades of grey under normal viewing situations (see Figure 26). Under the same conditions, it can discriminate a much larger number of colours. A Landsat sensor can gather up to 256 shades of grey (8 bit) for each band in its detection array: literally thousands of pieces of grey scale information are available for analysis. The same numeric data from a scanner system can be combined to produce millions of colours. An understanding of the perception of colour is, however, one of the most important aspects for image interpretation. The human brain is very adept at interpreting the visual spectrum when each band corresponds with its own colour (a Landsat 3, 2, 1, true colour composite). However, projecting Green as Red, Blue as Green and Red as Blue gives an unfamiliar image (a Landsat 2, 1, 3 false colour composite, see Figure 36). The same electromagnetic bands are used although they are presented in a different way. Although this is a simple example, as the image structure is still recognisable, this is an important concept for multispectral image interpretation. Colours produced in a false colour composite correspond to variations in an objects reflectance for the projected wavelengths.



Landsat 3, 2, 1
True Colour Composite



Landsat 2, 1, 3
False Colour Composite

Figure 36 Comparison of a true and false colour composite made up from the visual bands.

2.2.6.2 Histograms (radiometric enhancement)

Information about the possible range of Digital Number (DN) values within each band is commonly represented in a histogram. For example, a histogram of a single band of data is a representation of how the EM radiation energy at the collected wavelength is distributed in two dimensions: the *x-axis* is the *integer* radiometric value and the *y-axis* is the *frequency*.

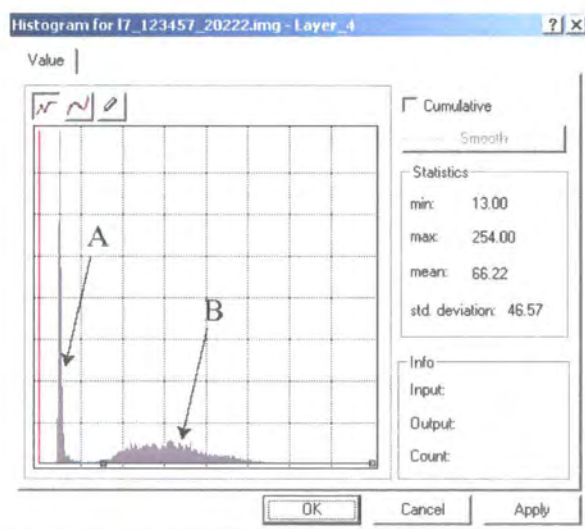

Figure 37 Histogram of Landsat TM Band 4.

Its shape indicates the *contrast* and *homogeneity* (or modality) of a scene. For example, a scene with an homogenous surface with a low contrast will produce a histogram with a single sharp peak. Conversely, images containing several distinct types of surface cover may show multiple peaks. For example, Figure 37 is a multimodal example of Landsat TM Band 4 from North Yorkshire. A = Water, B = Land. There is not enough spectral difference in Band 4 of this scene to distinguish between the broad categories of *urban* and *rural* landuse. The distribution of brightness values, in the lower quartiles, indicates the data is low in contrast as highlighted by the summary band statistics.

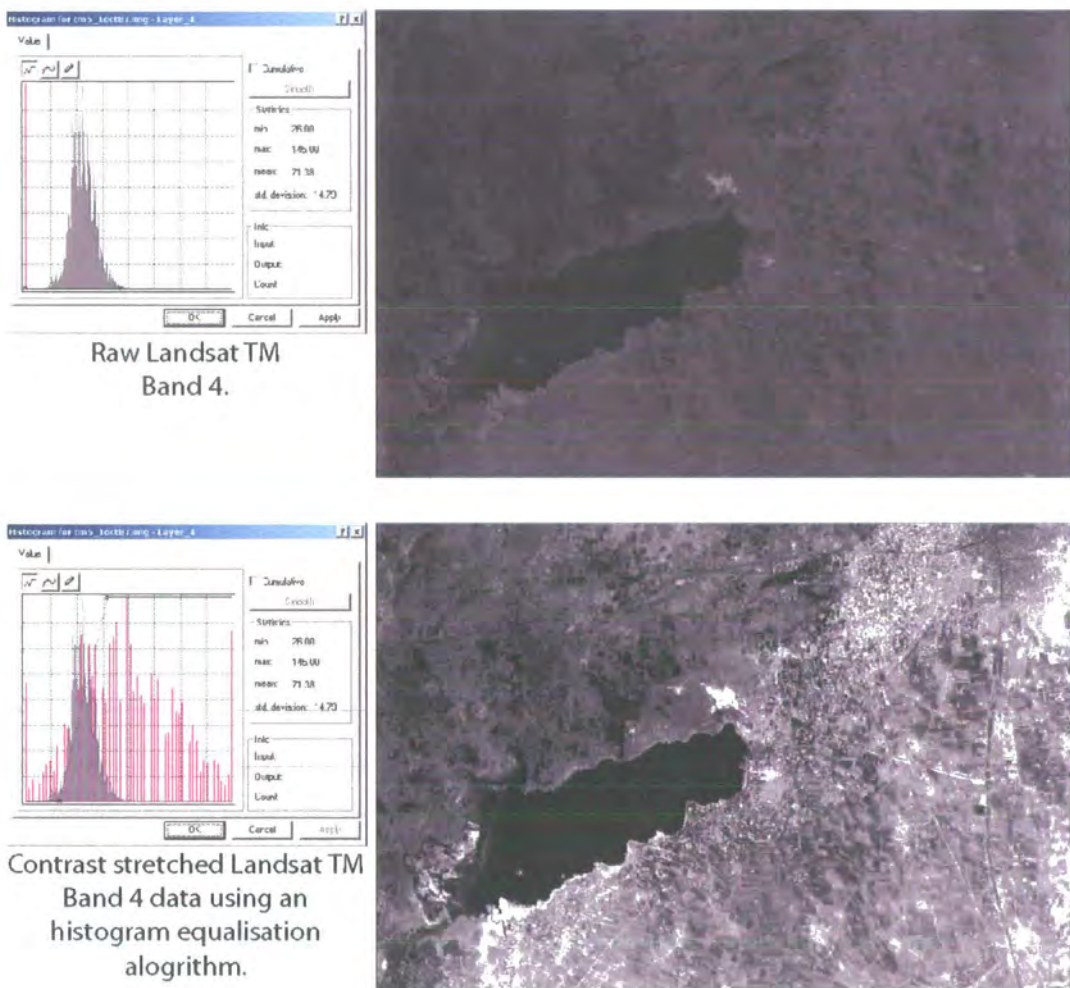

Figure 38 | Histogram equalisation of Landsat TM band 4.

The distribution of the histogram can be mathematically manipulated in a variety of ways to improve image visualisation (and hence interpretation) or to focus in on certain areas in the

distribution. More complex analyses (such as Principal Components) use multiple histograms from different bands (producing multi-dimensional distributions) to examine degrees of correlation.

2.2.6.2.1 Histogram manipulation

Histogram manipulation techniques are used to increase or decrease image contrast across the histogram. These manipulations can occur across the whole range of values or only in specific areas. Contrast stretching expands a measured range of values (DNs) in an image to a larger range to improve the contrast of the image and its component parts. The simple algorithms in contrast stretching are very important for image visualisation and hence human interpretation. An image rarely uses the full range of radiometric values available to it; in fact they are normally clustered over a small range of values. Thus, an unstretched image can appear to have low contrast to the human eye (Figure 38).

These enhanced images, as single bands or in false colour composites (see Figure 34), can be interpreted with greater confidence as the increased contrast displays information which would otherwise have been hidden. Common stretching methods are described in Table 1.

Stretch	Use
Piecewise Stretch	A linear stretch involving two or more lines of differing gradient to enhance contrast in specific areas of the histogram
Gaussian Stretch	Transforms the original histogram to a gaussian curve (or normal distribution) with the arithmetic mean, median and mode at 127 (for an 8 bit image)
Ramp Stretch	A ramp stretch forces the cumulative frequency curve into a straight line. This has the effect of increasing the contrast in the most populated regions of the histogram
Logarithmic Stretch	A logarithmic stretch expands the contrast of the dark component while still maintaining contrast in the light range
Exponential Stretch	Is the inverse of the logarithmic stretch
Histogram Equalising	Applies the greatest contrast to the image by reducing the contrast in very light or dark areas (at the tails of a normal distribution)

Table 1 Radiometric enhancement techniques

2.2.6.3 Spectral enhancements

Spectral enhancement techniques require more than 1 band of data. They can be used to:

- Compress bands of data that are similar.

- Extract new bands of data that are more interpretable to the eye.
- Apply mathematical transformations and algorithms.

Table 2 outlines some common spectral enhancements:

2.2.6.3.1 Ratioing

Ratioing multispectral channels consists of dividing the radiance value in one channel by the corresponding radiance value in another channel. Amongst other things ratioing is used to improve the identification of materials. For example in Figure 22 the spectral response of vegetation is at a maximum in band 4 and minimum in bands 1, 2 and 3. However the geological spectra have a similar correlation to the vegetation wavelength in band 1, less in band 2 and very little in band 3. In this instance the ratio of band 3 over band 4 should give a low (c. 0.25) ratio for vegetation and a high (c. 1) ratio for geology (Rothaus and De Morett 1999).

Spectral Enhancement	Description
Principal Components Analysis	Statistically compresses redundant data values into fewer bands, which are often more interpretable than the source data.
Inverse Principal Components	Performs an inverse Principal Components Analysis
Decorrelation Stretch	Applies a contrast stretch to the principal components of an image
Tasseled Cap	Rotates the data structure axes to optimise data viewing for vegetational studies
RGB to IHS	Transforms red, green, blue values to intensity, hue, saturation values
IHS to RGB	Transforms intensity, hue, saturation values to red, green, blue values
Indices (ratio)	Performs band ratios commonly used in vegetation and mineral studies

Table 2 Spectral enhancement techniques

An important consideration when using ratioing is how it will affect image storage. All optical sensor systems normally collect integer values. However, ratioing an image will produce non integer values which will need to be stored at a higher level of precision. This will dramatically increase file size, particularly if incorporated into a layer stack.

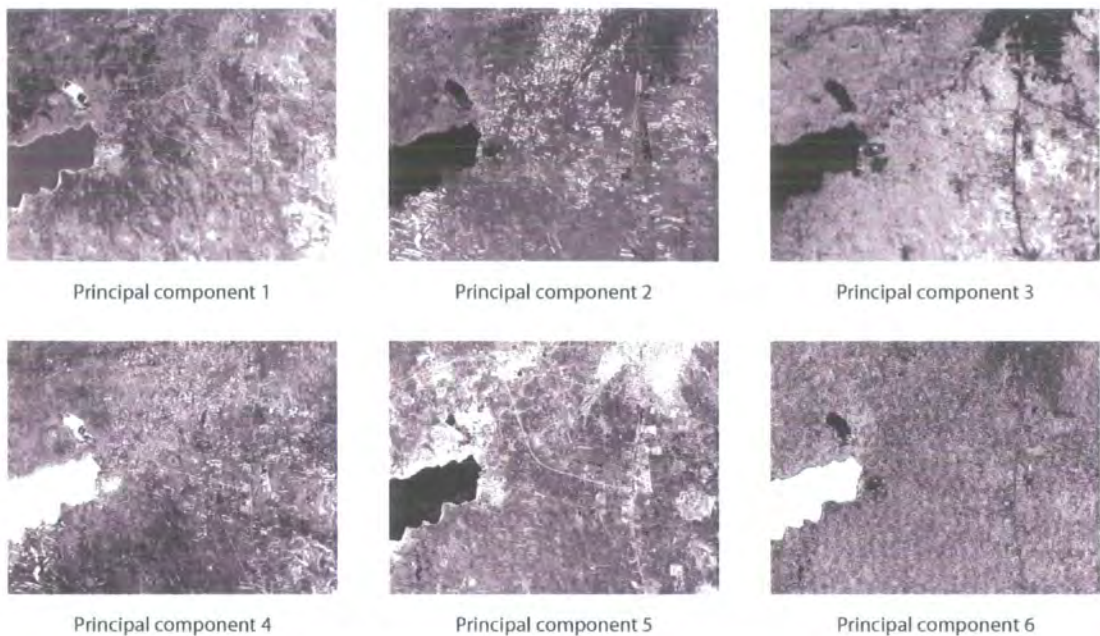

Landsat	Component 1	Component 2	Component 3	Component 4	Component 5	Component 6
Band 1	0.178	-0.268	-0.244	0.414	0.641	-0.505
Band 2	0.329	-0.338	-0.256	0.389	0.009	0.749
Band 3	0.517	-0.517	0.083	-0.101	-0.557	-0.373
Band 4	0.580	0.722	0.051	0.340	-0.128	-0.086
Band 5	0.488	-0.029	0.350	-0.583	0.512	0.189
Band 7	-0.134	-0.158	0.862	0.459	0.037	0.043
Percentage variation	80.504	9.551	6.640	2.343	0.769	0.194

Figure 39 6 Components of a PCA on Landsat TM scene (excluding band 6).

2.2.6.3.2 Principal components analysis (multivariate spectral enhancement)

Multispectral imagery bands are often highly correlated (i.e. they are visually and numerically similar (see Figure 34)). Principal Components Analysis (PCA) is a tool used to remove this redundancy and has proven invaluable in the analysis of multispectral data. A PCA transformation can create new images that may be more interpretable than the original data (Jensen 2000). It can also be used to reduce the number of bands used to describe the whole image (used as part of the feature extraction process (see Chapter 5)). PCA uses multivariate correlation statistics as its input data. It then calculates what components within the scene determine the greatest and least variation. For example, Figure 39 shows the correlation for a Landsat scene. Nearly 99% of the variance within the image can be described in the first four components. Principal component 1 is usually a brightness component. This has high loadings for bands 3, 4 and 5 suggesting this to be a near infrared dominated component. Component 2 has high values for bands 3 and 4 suggesting a vegetation component.

Multivariate statistics characterise the underlying factors that define a scene by combining the different bands statistically. A correlation matrix is calculated based upon the statistical distributions of the bands and expressed as a ratio. All values are expressed between ± 1 . +1 indicates a perfect positive relationship. Conversely -1 indicates a perfect negative relationship. A high correlation suggests there is a substantial amount of redundancy in the image among the correlated bands. Conversely, a low correlation indicates no relationship and uniqueness in the data. This technique is particularly useful for extracting key information from hyperspectral data.

2.2.6.4 Kernel filtering (spatial enhancement)

Spatial enhancement techniques modify pixel values based on the values of surrounding pixels. This technique uses a kernel: a moving matrix normally of dimensions 3x3, 5x5 or 7x7. This matrix mathematically alters the central pixel based upon the values of its surrounding pixels. These filtering techniques are used with great effect in image editing software, such as Photoshop. They are usually used within image processing applications to enhance local variation (the extent is determined by the size of the kernel and pixels, see Figure 40).

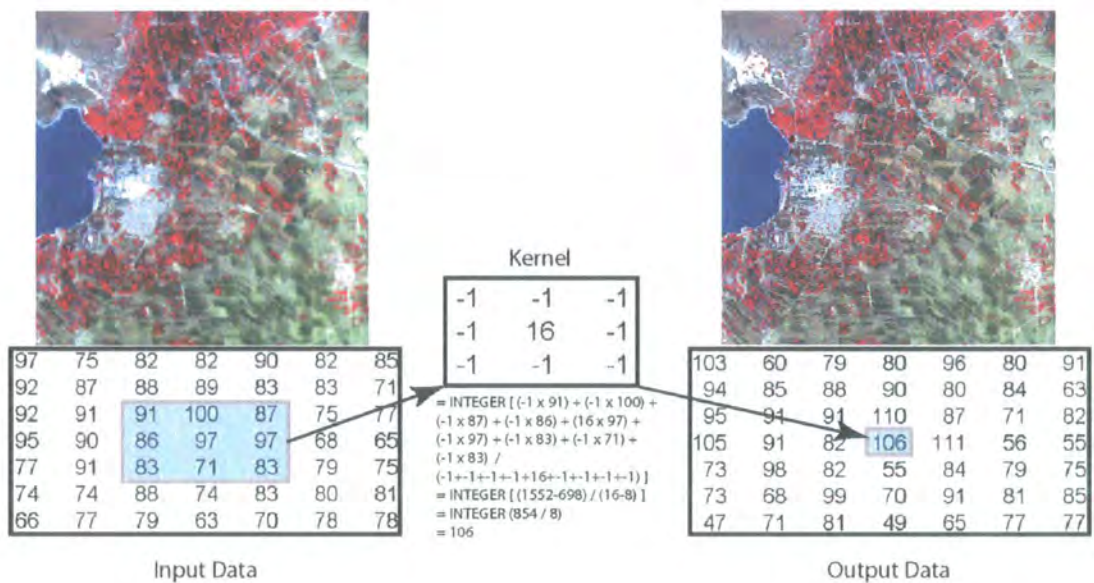

Figure 40 A moving 'sharpening' 3x3 kernel.

Table 3 describes a number of commonly used kernel filters.

Spatial Enhancement	Description
Convolution	Uses a matrix to average a small set of pixels across an image
Non-directional Edge	Averages the results from two orthogonal 1st derivative edge detectors
Texture	Defines texture as a quantitative characteristic in an image
Adaptive Filter	Varies the contrast stretch for each pixel depending upon the DN values in the surrounding window
Statistical Filter	Averages pixels within a moving window that fall within a statistical range
Resolution Merge (Fusion)	Merges imagery of different spatial resolutions

Table 3 Examples of different kernel filters

2.2.7 Processing: Image classification

Image classification is the process of sorting pixels into a finite number of individual classes or categories of information based upon their spectral characteristics (see Figure 42). If a pixel satisfies a certain set of criteria for a class then it is assigned to that class (see Figure 41). However, pixel mixing can significantly compromise the accuracy of the classification procedure (see Figure 24).

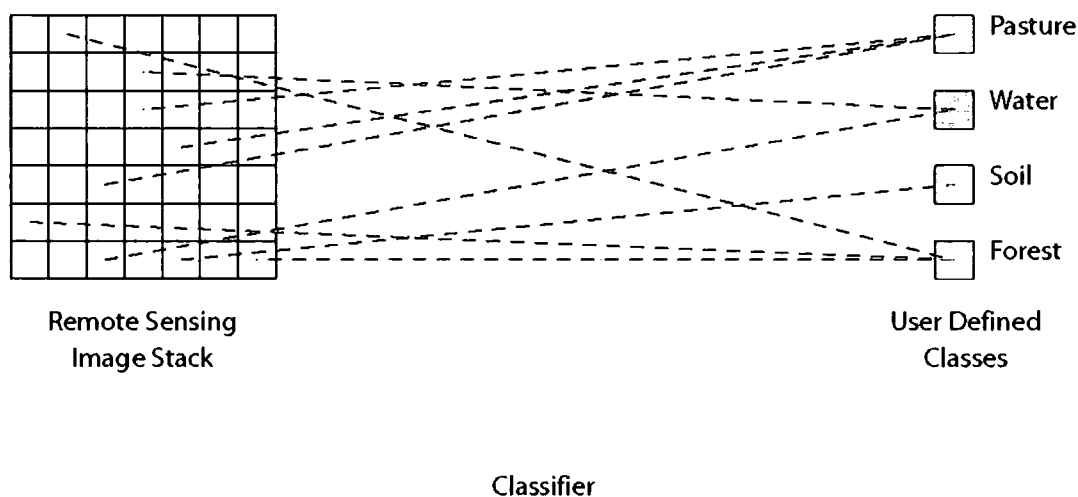

Figure 41 The concept of classification (after Tso and Mather 2001 p. 4).

Increasing resolution does not always improve classification accuracy. Obviously classification using six bands of Landsat imagery (excluding the thermal band) will produce

more accurate results than classification based upon a single band. More important is that the bands are located over discriminatory areas of the object's spectral signature. Researchers who use hyperspectral imagery often find improved classification accuracy, but the computational cost is expensive. To reduce these computational requirements irrelevant bands should be discarded during the image extraction stage.

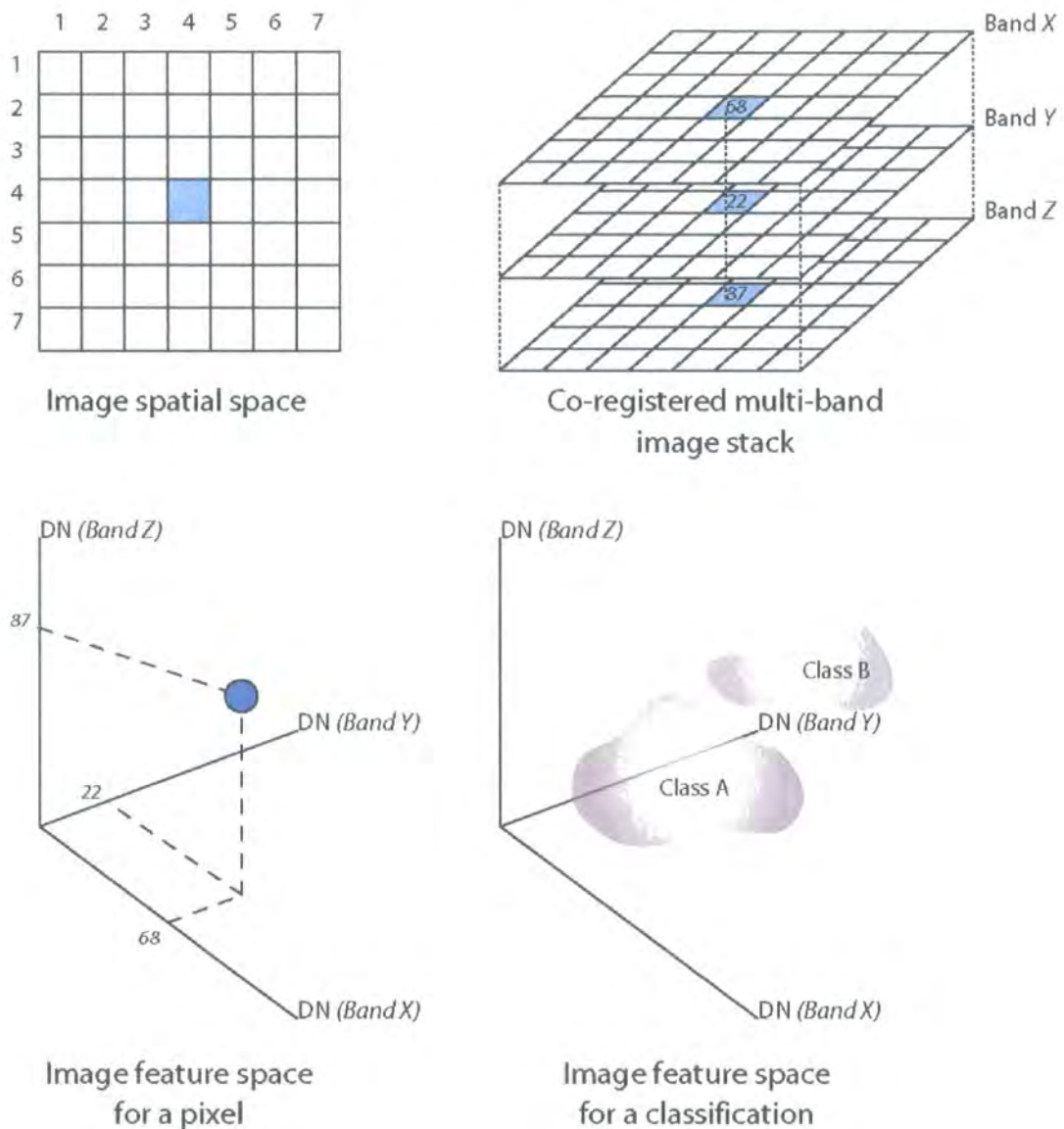

Figure 42 Feature space representation (after Tso and Mather 2001 p. 57).

From an intuitive basis one would assume that improving spatial resolution would improve classification accuracy (see Figure 44). However, increasing spatial resolution means that

smaller objects can be identified thus increasing image heterogeneity which can decrease classification accuracy. In essence increasing spatial resolution increases image complexity requiring more complex classifiers for accurate analysis.

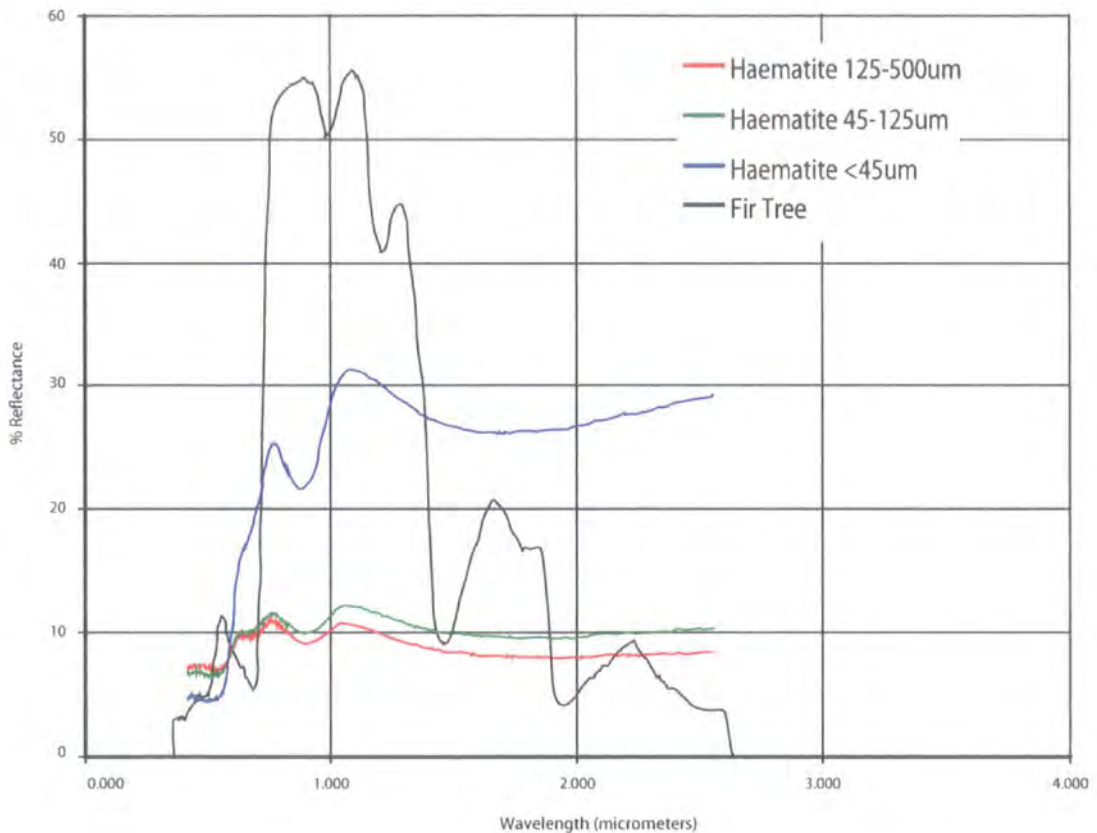

Figure 43 Spectral signatures of Haematite and Fir tree.

2.2.7.1 Spectral signatures

The ability to analyse and interpret remotely sensed imagery is due, in part, to the unique spectral responses of objects during interaction with the EM spectrum. For any given material, the amount of solar radiation that is reflected, absorbed or transmitted varies with wavelength. This important property of matter makes it possible to identify different substances or classes and separate them from their spectral signature. However, this signature can fluctuate depending upon local environmental conditions, vegetation health and physical properties (such as particle size which affects the percentage of energy reflected), although the basic characteristics of the curve remain the same (Figure 43). Accurate identification occurs by comparing standard reflectance responses against observed responses. Thus, the

resolution of the sensor becomes very important. A high spectral resolution (hyperspectral) sensor will provide an abundance of sampling intervals allowing accurate identification of the material (and for vegetation its current state of health). The lower spectral resolution Landsat TM sensor only collects data over seven broad wavelengths. However, these wavelengths are placed in the best locations to detect signature variation for geological and vegetation applications.

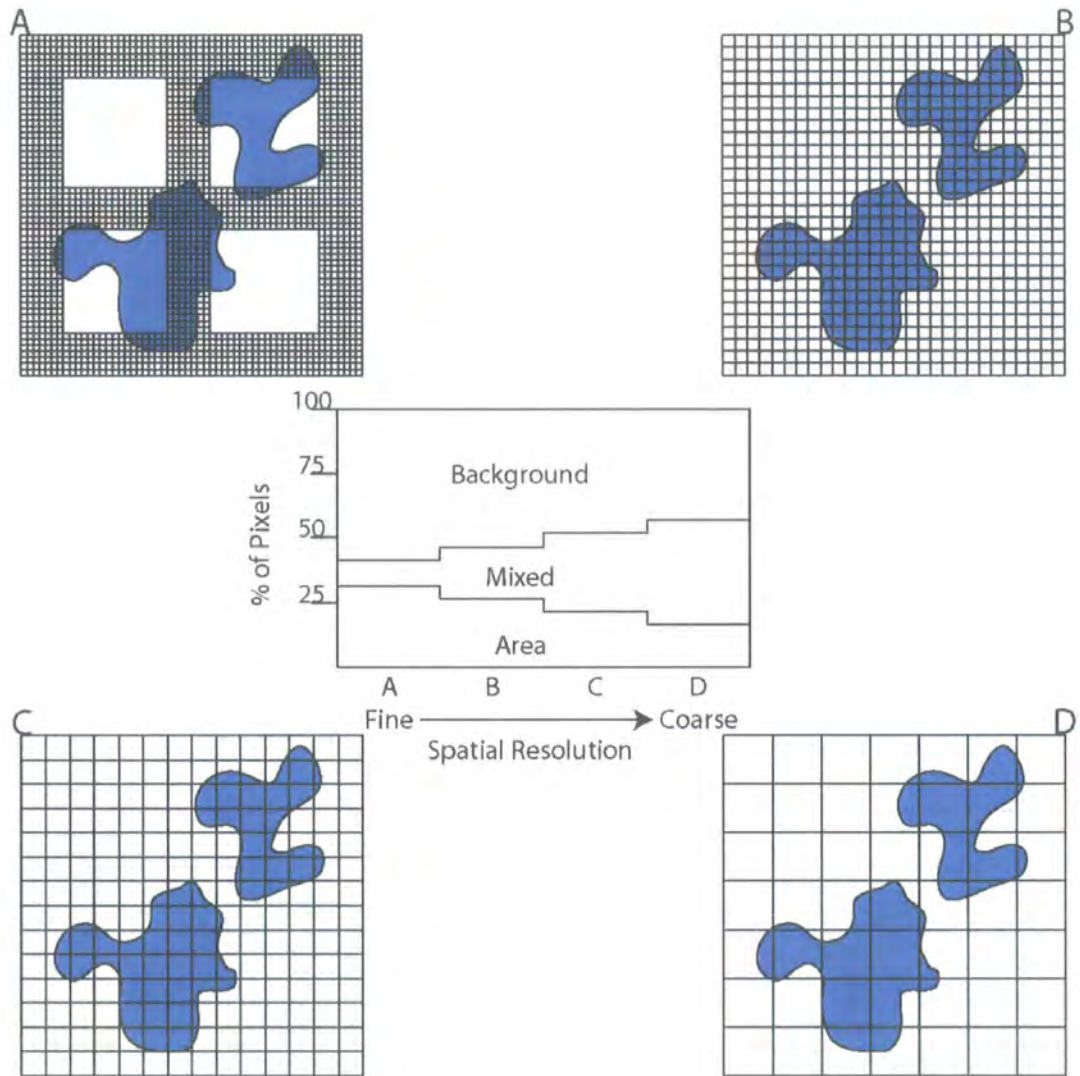

Figure 44 Improving classification accuracy by removing pixel mixing effects through increasing spatial resolution.

However, in practice, identification is rarely as simple as this. Laboratory spectra rarely match with field measurements, as in reality each pixel will contain mixed responses for a variety of

different material types and is attenuated by the atmosphere. This is exacerbated by archaeological features which provide a subtle variation to the background soil or vegetation response (see Figure 45).

There are two main classification techniques:

- Supervised classification.
- Unsupervised classification.

2.2.7.2 Supervised classification

Supervised classification extrapolates information from a few 'known' areas (referred to as *training areas*) derived from *ancillary data* (normally from *ground-observation*) to classify the whole image. These areas are chosen carefully, as they need to fully represent the objects of interest throughout the whole image for the best possible classification. The classification procedure then evaluates the image on a pixel by pixel basis and assigns each pixel to a *category* defined by its 'goodness of fit' to the training areas.

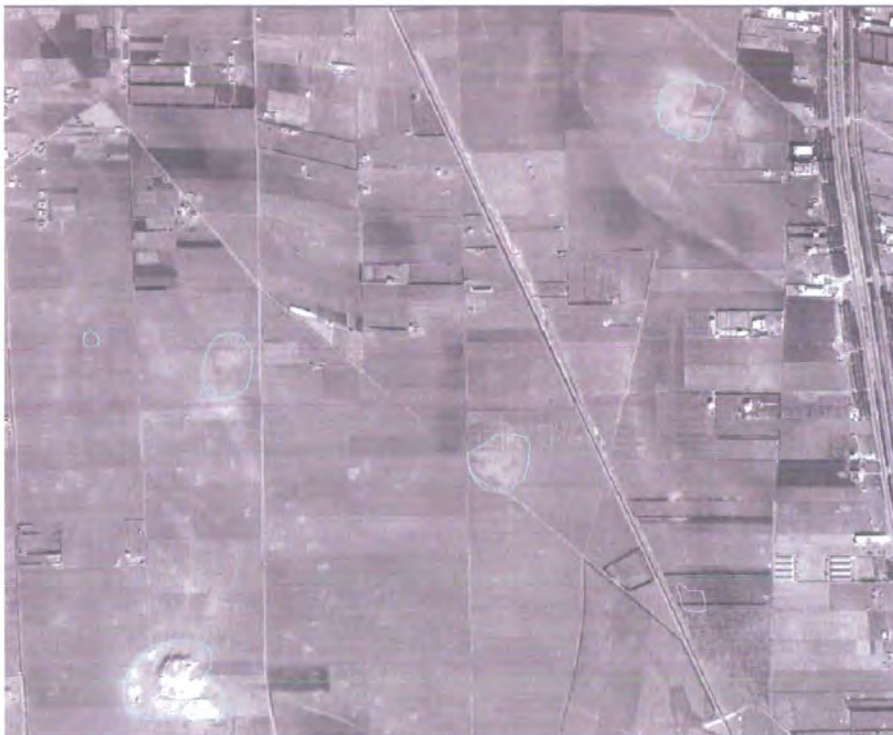

Figure 45 Ikonos imagery with archaeological sites outlined in white (notice the increase in reflectance at the 'sites').

The success of supervised classifications is based upon the accuracy of the training areas and the ability to discriminate among different classes of training area. If there is any feature space overlap of the classes then there is likely to be ‘confusion’ during the classification process. As already discussed in reality there should be confusion as most pixels contain a mixture of objects. Pixel unmixing techniques and fuzzy classification systems are designed to cope with these ambiguities.

2.2.7.3 Unsupervised classification

Unsupervised classification techniques assign pixels to categories based upon ‘natural’ groupings of data within the image (see Figure 46). The interpreters’ task is then to assign these ‘natural’ clusters to a category. User input for unsupervised classification is limited to the classification technique and the number of categories to be assigned. However, ‘cropping’ an image (reducing the image footprint) can significantly change unsupervised classifications as the global statistics across the image are changed.

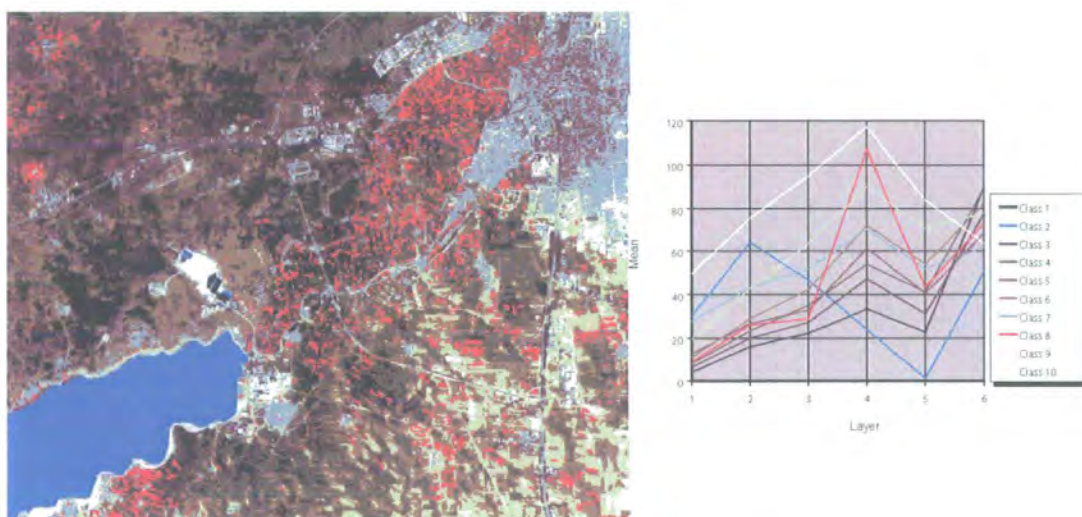

Figure 46 Unsupervised classification of a Landsat TM scene.

2.2.7.4 Image segmentation

Image segmentation is much like unsupervised classification. However, image segmentation also utilises a spatial component. This technique groups neighbouring pixels which have the same or similar spectral properties. This means that rogue classifications (i.e. lone pixel) which commonly occur on boundary classes in supervised and unsupervised classifications can be avoided. This technique can be particularly beneficial where objects in the scene do

cluster into discreet areas. There are a number of image segmentation techniques that require different user input parameters, the most common of which are pixel-based region growing algorithms (Beauchemin and Thomson 1997; Kartikeyan *et al.* 1998)

2.3 Image integration and problems of scale

Earth focused remote sensing applications collect synchronic and diachronic data about the surface of the Earth. In this context, scale is related to resolution and most closely to spatial resolution (or more accurately the instantaneous field of view). Spatial resolution refers to the ability of a sensor to record and display spatial detail that can be distinguished from its surroundings. The paradox of scale, in relation to remote sensing, is that by increasing resolution the object becomes more detailed i.e. the closer we look at the world the more detail we see (Goodchild and Quattrochi 1997 p. 1). This paradox was examined by Mandelbrot (1967; cited in Pecknold *et al.* 1997 p. 364) when measuring the length of the British coastline and led to the conclusions that measurements of an object depend upon the scale at which it was examined. This led to the definition of a new field of research: Fractal geometry.

These problems of representation are observed when changing map scales: a 1:25,000 map is much more complex and detailed than the same area mapped at 1:250,000. However, both representations are correct. The 1:250,000 map is generalised, at the cartographer's discretion, to improve interpretability. Indeed it is argued, justifiably, that the generalisation process 'adds' information as larger scale processes become more obvious. However, the process of generalisation adds uncertainty to the data set (Goodchild and Quattrochi 1997 p. 4). Hence, remotely sensed imagery are a much more flexible resource. If users have the tools and techniques to operate with multiscale data then they can aggregate or disaggregate in ways that suit their own decision making and presentation process.

The Corona and Ikonos imagery have a spatial resolution approximately an order of magnitude less than Landsat. The scale implications in the movement from medium resolution to high resolution imagery could highlight a number of important issues for archaeological detection and spatial patterning (Lang 1992).

2.4 Archaeological interpretation

Pictures, in the form of aerial photography and, more recently, multispectral imagery have played a significant role in the development of archaeology and its management (referred to as Cultural Resource Management (CRM)). These pictures convey information pertaining to the size, positions and relationships of objects. Archaeologists trained in the collection and interpretation of, predominantly, aerial photography possess a high level of proficiency in deriving archaeological information from such images, even though they appear visually complex. The human brain and visual systems are extremely good at extracting information from imagery, particularly when it is derived from visual wavelengths. A large component of this interpretation relies on the acquired knowledge of the interpreter (Bewley 2000; Bewley and Raczkowski 2000; Wilson 2000). However, when images are formed using data from outside the visual components of the electromagnetic spectrum our experience is not adequate to interpret this data without understanding the fundamentals of how EM energy interacted with the objects in the image.

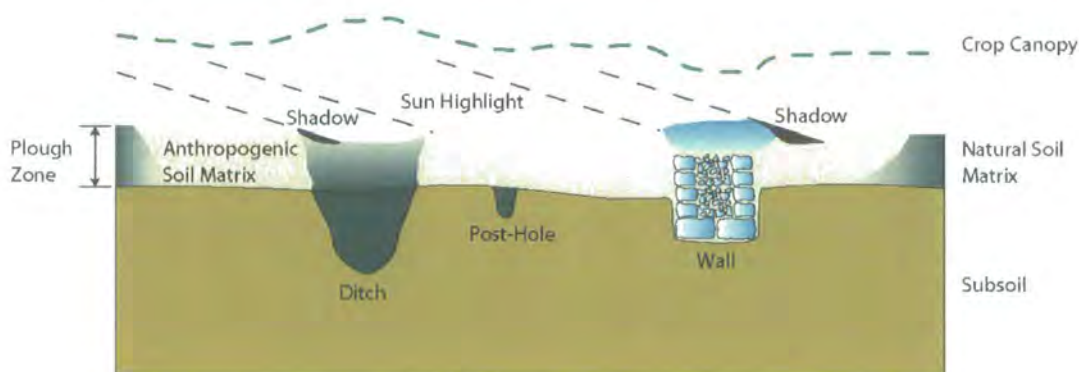

Figure 47 Aerial Identification: Crop, shadow and soil marks (after Greene 1990).

Aerial photography is a long-established means of assessing archaeological data in a landscape context. Aerial reconnaissance may highlight crop marks, soil marks, parch marks or shadow sites, each of which are formed by different natural and cultural processes and each of which may only be recognised under specific environmental circumstances (see Figure 47). This is one of the major difficulties with this form of evidence for landscape survey. The visibility of any site depends not only upon the type of photography used (oblique or vertical), but also upon environmental conditions and the type and level of natural light available at the moment that the photograph was taken. For example, parch

marks may only be visible in the driest summer, at least in the visual wavelengths. Therefore, an aerial photographic survey cannot be considered comprehensive. In European contexts this problem is resolved by analysing archived photography taken over many years encompassing a range of environmental conditions (Bewley 2000). However, where sites are already known to exist, aerial photography can be used to highlight plan form or structure that is essentially invisible on the ground.

However, the probability of spotting archaeological sites in existing vertical aerial photographs depends very much on whether or not the imagery was acquired at a propitious time of day and year or not. When aerial photographs are made specifically for archaeology, the probability of detection can be raised by many orders of magnitude

(Scollar 1990 p. 26)

Aerial photographs intended for mapping purposes are normally taken with the camera lens axis vertical using a highly accurate camera system. Conversely, hand-held aerial photographs are normally oblique to illustrate vegetation pattern or shadow (Ebert 1984 p. 307). It is essential to make a distinction between the application of vertical and oblique images as the different perspectives provide very different results and interpretations.

Vertical or near vertical imagery, collected with the appropriate camera system, have very good geometric properties. These allow the images to be used in quantitative programmes for reconnaissance, desktop mapping or contour creation (from stereo pairs). The high geometric accuracy allows many individual images to be accurately *mosaiced* together. Hence, a whole application area can be viewed as a single pseudo image. However, obtaining bespoke vertical imagery (particularly aerial imagery) can be an expensive process. When using existing imagery (satellite or aerial) not collected expressly for archaeological purposes, the selection process is much more restricted, as the observer has little control over the appearance of the image. Furthermore, optimal conditions for archaeological discovery occur within a few relatively small daily and seasonal time frames (see Figure 48) and it is unlikely that vertical cover will occur during these timeframes (Scollar 1990 p. 28).

Cropmarks observed per month

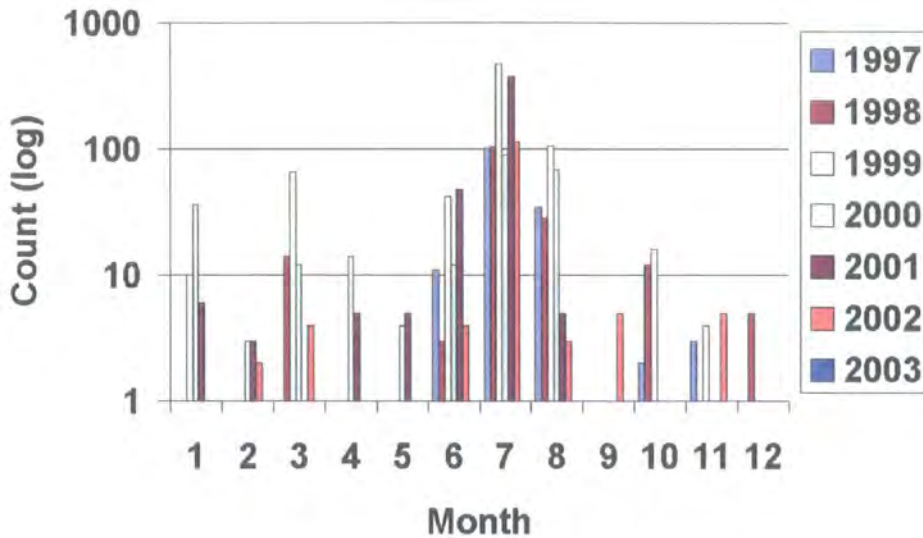

Figure 48 Cropmarks observed over a seven year period from aerial sorties from the York office of English Heritage.

However, this premise is resolution and wavelength dependent. The majority of aerial photographic applications have not focussed solely on the *detection* of archaeological phenomena but rather at *recognition* or *interpretation*. Hence, the applications are focused at the feature rather than site level. For example, Scollar (1990 pp. 37-46) discusses sites detected as soil marks with reference to the response of negative features rather than the soil 'halo' that surrounds them. However, if one focuses solely on the *detection* of archaeological activity at the site level then the use of large-scale vertical photography (either from satellite imagery or mosaiced aerial photography) is appropriate. Therefore, the window of opportunity where imagery is pertinent for archaeological discovery expands, particularly for soil mark sites. However, in well studied, European, contexts vertical imagery provides fewer new discoveries.

Although vertical photographs are geometrically accurate, many archaeologists prefer to trade geometric precision against archaeological interpretability by using oblique images. Oblique images (especially those collected during optimum conditions) can highlight particularly subtle changes in topography that are not immediately visible in vertical photography. This trade off between precision and interpretability is of most import to archaeologists when the

photographic reconnaissance is part of a Cultural Resource Management (CRM) programme (such as the National Mapping Programme: Bewley 1993). In an area with a known archaeological background the geometric errors are acceptable, as the increased archaeological interpretation is of more import (Scollar 1990 p. 28).

However, recent satellite platforms can allow collection on demand to specific days. This is of particular import in areas where aerial photographic evidence is minimal and flights are restricted. Although current satellite resolution does not equate with the spatial resolution of a handheld SLR camera used at low elevation, they are able to determine areas of archaeological activity, particularly those evident as soil marks. As demonstrated in Figure 48 soil mark evidence accounts for a small proportion of sites identified. However, this may be linked with the desire to provide a high level of interpretation by archaeological aerial photographers and interpreters. Soil marks do not produce the crisp, easily interpretable imagery seen in crop mark evidence, thus soil marks may be overlooked in favour of more responsive sites. Non soil mark sites are normally identified by the geometric properties which distinguish archaeological features from the surrounding natural landscape. This is further exacerbated by intensive agricultural regimes where the landscape is almost permanently under crop. A similar point is made by Donoghue (2001 p. 558).

Given this information satellite imagery is likely to be an important resource for the detection of archaeological residues in a Middle Eastern context for the following reasons:

- The archaeological resource has not been studied in as much detail in the Middle East as in Europe. Hence, vertical imagery is still likely to reveal many previously undetected sites.
- Archaeological residues do not arise from the same architectural traditions as in Europe. Given the reduction in negative residues (fewer ditches, postholes and palisades) European aerial photographic techniques may not be as responsive in this environment.
- Traditional land management techniques between temperate and semi-arid environments are very different. For a large proportion of the year much of the Earth's surface in semi-arid environments will comprise of soil rather than crop cover.

CHAPTER 3 CONCEPTS OF LANDSCAPE FOR ARCHAEOLOGY

3.1 Landscape archaeology: Introduction and definition

The landscape is a palimpsest on to which each generation inscribes its own impressions and removes some of the marks of earlier generations. Constructions of one age are often overlain, modified or erased by the work of another. The present patchwork of settlement has evolved as a result of thousands of years of human endeavour, producing a landscape which possesses not only a beauty associated with long and slow development, but an inexhaustible store of information about the many kinds of human activities in the past.

(Aston and Rowley 1974 p. 14)

Our cultural heritage lies scattered all around us. It is an intrinsic element of the landscapes which we inhabit and is transformed over successive generations of inhabitation by both cultural (anthropogenic) and natural processes. Thus, the present landscape represents the manifestations of past and present decision making by individuals, groups and institutions in society and the long term variable effects of natural processes. Understanding the inter-relationships between cultural and natural systems and how they are transformed is necessary to re-construct a theoretical understanding of archaeological landscape processes and how they impact interpretation. Such an understanding can be gained by modelling the present landscape and incorporating data from the historical, archaeological and environmental record. One of the main difficulties of archaeological interpretation is to extend cultural values to these models of physical residues and processes.

We suggest that a landscape approach is relevant to archaeology's goal to explain humanity's past through its ability to facilitate the recognition and evaluation of the dynamic, interdependent relationships that people maintain with the physical, social and cultural dimensions of their environments across space and over time.

(Anschuetz *et al.* 2001 p. 159)

Landscapes have always played a fundamental role in archaeological enquiries. Initially they provided a backdrop onto which archaeological data and interpretations were plotted and evaluated. More recently, archaeologists have shifted their attention from single sites to problems of regional change and variation. Employing landscape theories requires archaeologists to reconsider how they evaluate the archaeological problem. For example, non-site and off-site landscape approaches arose to combat the limitations of forcing important archaeological residues into systems that consider the 'site' as the primary analytical unit (Knapp and Ashmore 1999).

Archaeologists are placing increased importance on its multi-disciplinary nature. Therefore, by inference, multiple researchers can produce different, but complementary, data sets for the interpretative melting pot. A landscape approach provides a framework whereby these data can be used collectively to form a more comprehensive understanding of the past.

3.2 The components of archaeological landscapes

.... what was once theorised as a passive backdrop or forcible determinant of culture is now seen as an active and far more complex entity in relation to human lives.

(Knapp and Ashmore 1999 p. 2)

All landscape approaches address the fundamental nature of the relationship(s) between people and the spaces they occupy (Anschuetz *et al.* 2001 p. 158). Researchers employ a variety of classified variables to describe natural (e.g. ecological, geomorphological and hydrological) and cultural (e.g. organisational, ritual, technological and ideological) features of the landscape. Different interpretative or theoretical models use different variables in their analysis.

The systemic frameworks of analysis are complicated by changes in cultural systems. It is assumed that the adaptive strategies of each community leave separate but distinct traces in the archaeological record and, furthermore, that these communities are constrained by their local and regional ecology and topography (Rossignol 1992). For example, the framework of analysis and theory underpinning hunter-gatherer communities is different to that of sedentary communities and how and what they exploit are defined by their regional ecology.

3.2.1 Natural landscapes

Natural landscapes, in an archaeological context, encompass all elements of the landscape which are crudely believed to be non-cultural. Hence the lithosphere, biosphere, hydrosphere and atmosphere are all aspects of the natural landscape. However, culture can impact on each of these systems so natural landscapes are, therefore, not completely independent from cultural systems (Clarke 1978; Butzer 1982; Waters 1992).

The natural landscape cannot be viewed as a passive entity. It guided movement, offered resources and formed backdrops for the human presence. Furthermore, the form of the landscape in each period itself influenced the processes of inhabitation (Barrett 1995). Hence, many archaeologists consider it important to model aspects of the natural environment to improve their understanding of the archaeological context. From the point of view of landscape survey it is difficult to model both the biosphere and atmosphere at the local or regional level through time without significant supporting material from environmentalists. However, some changes in both the lithosphere and hydrosphere are evident on the surface of the Earth in the form of floodplains, terraces, relict channels and other topographic features. Furthermore, although drift geology may have changed significantly since the Pleistocene the solid geology has not. Hence, it is theoretically possible to retrogressively model aspects of past natural landscapes.

3.2.1.1 Ecology

Ecology is the holistic study of living organisms and their environment. Ecology has many sub-disciplines including those of landscape, historical and human ecology (Winterhalder 1994). Human ecology, particularly the contextual archaeology of Butzer (1982), applies specifically to how human agents interact with other agents and ecological systems (see Figure 49). Human-environment interaction thus covers all relationships between people and the environment, whilst also encompassing the reciprocal influences of human behaviour on the ecosystem and how this maintains stability or causes change. The use of human ecological analysis has led to the deductive process of settlement ecology where models are used to predict where human agents will settle in a landscape based upon ecological indicators and assumptions about what they will exploit. Ebert (1988) discusses the applications of satellite techniques for ecosystemic analysis by looking at variations in environmental diversity.

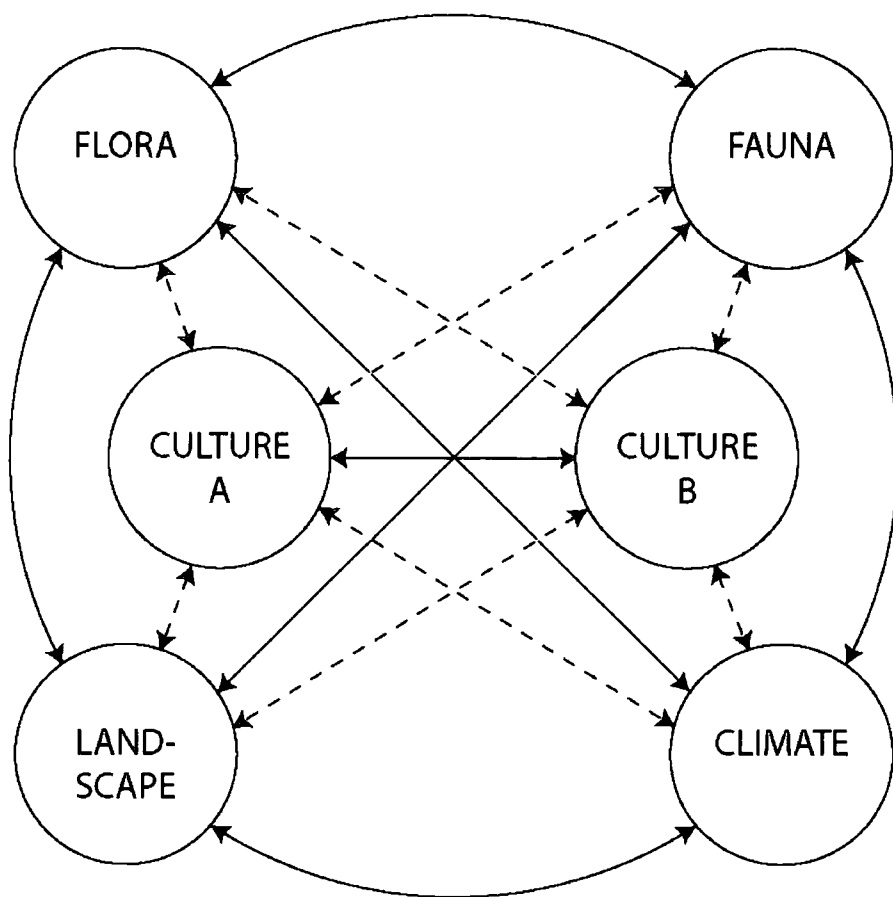

Figure 49 Schematic of interactions in a human ecosystem highlighting the relationships between the cultural and non-cultural environment (modified from Clarke 1978 p. 133; modified from Waters 1992 p. 5)

3.2.2 Landscapes and space

All archaeological sites were once areas of human activity that took place within a landscape context. Archaeologists attempt to describe and understand the nature of these activities through their relationships with the landscape and each other. This is to observe and understand the delineation of the formal variability, temporal loci and spatial loci of sites, activity areas and communication networks (Golledge and Stimson 1987 pp. 5-6).

3.2.2.1 Distribution and settlement patterns

If a sampling strategy has been employed that will identify spatial patterning within a temporal framework (see section 3.4.3) then the next task is to understand why the patterning occurred as it did. Patterning in the landscape is seen as a reflection of the ways that people respond to the agents of ecology, economy or society. Archaeologists should not only

attempt to understand these agents but also the interaction between them over space, time and within the context of society (Knapp 1997 p. 14). Ethno-archaeological sources predict that spatial patterning within a landscape is rarely the product of actors within a single cultural system. Rather, there are spheres of multiple interactions between localised actors through the aforementioned agents. Furthermore, these systems operate at a variety of differing spatial and temporal scales (Wandsnider 1992b). Hence, the analysis of settlement patterns requires the integration of different landscape data collected at different scales.

3.2.3 Landscapes and scale

The impact of scale on spatial analyses has been recognised by the social and natural sciences for more than forty years (Marceau 1999). In archaeological research there is, however, no real consensus on what spatial scales are appropriate for specific archaeological analyses beyond the broad terminology of ‘micro’, ‘meso’ and ‘macro’. These terms, with differing emphasis in their interpretations, are used to broadly differentiate patterning from the local to the landscape level (Allen 2000 p. 101). However, each of these terms tends to be used during interpretative stages and is thus a product of a theoretical stance. Conversely many data sets are now being collected with a more thorough understanding of how they should be integrated with other data (for examples see Shennan 1985; Francovich *et al.* 2000). Hence, archaeology has formed both empirical and synthetic appreciation of scalar interactions.

Traditionally, scale has been utilised as a convenient tool to partition the landscape (i.e. site – micro, inter-site – meso and regional – macro) in order to help facilitate the production of syntheses or narratives. More recently research has focussed on the relationships between scales of synthesis, data scales and data resolutions (Crumley and Marquardt 1987; Rossignol and Wandsnider 1992; Ramenofsky and Steffen 1998; Allen 2000).

3.2.4 Cultural landscapes

The cultural landscape is fashioned from a landscape by a culture group. Culture is the agent, the natural area is the medium, the cultural landscape is the result.

(Sauer 1938 p. 46; cited in Anschuetz *et al.* 2001 p. 164)

Understanding the inhabited landscape requires more than the description of the form of that landscape’s organisation. Inhabitation concerns perception, practice, and experience. It

addresses the history of the formation of the communities who moved through and who worked the land in its different aspects. The context, which included all the material aspects of the contemporary landscape, natural as well as cultural, framed human actions and provided foci for them. Hence, the physical context was built up and changed; elements endured and embodied different values and meanings for those who moved through it at different times. For example in the Homs area, the seasonal 'rams' (depressions which collect water) have a different value to farmers and pastoralists.

If the actions of actors within a landscape are studied with regard to the physical, material and cognitive way in which people manage their natural and cultural environment, then social organisation may be extrapolated in terms of the material and ideological landscapes in which people acted (Barrett 1995; Knapp 1997).

Sauer's definition of cultural landscapes is important in this context as it highlights the transformative power of culture upon the landscape itself. Although culture can be identified as a mechanism for landscape transformation, archaeologists consider landscapes as constructs that embed information on the structure and organization of societies. Therefore, the physical landscapes themselves offer insights into social and communal structures and practices. The difficulty is how to access past cultural actions from data embedded in the present landscape. The difficulties in applying many of these concepts become self-evident when reading, as a landscape archaeologist, Chatwin's (1987) fictional(?) traveller's narrative of Australian Aborigines and their relationships with their landscapes. Multiple interpretations are particularly evident when he is exploring the conflicting cultural tensions within and between native and non-native Australians.

3.2.5 Discussion

The literature shows that by using the same data sources a variety of different landscape interpretations could be constructed depending upon the theoretical, analytical and interpretive approach taken. Fisher and Thurston (1999 p. 631) noted that some of the most productive landscape research employs different theoretical models to juxtapose different research goals, hence producing complementary interpretations with multiple interpretative strands (Hodder 1993; 1999). Within the context of this research it is essential that many of the themes and interpretations fulfil these diverse theoretical, analytical and interpretative criteria. Satellite imagery is an important resource for the evaluation and interpretation of the

cultural and natural components of archaeological landscapes. However, it is only when satellite-derived themes are integrated with other information sources structured by a theoretical research agenda that their full potential will be realised.

3.3 Transformation of archaeological landscapes

Regrettably, neither the historic record nor the archaeological record gives up its secrets about the past easily. Each must be handled with great care by the investigator seeking to infer past behaviors, for the evidence that survives has been changed in many ways by a variety of processes. To make justifiable inferences the investigator must consider and take into account the factors that have introduced variability into the historical and archaeological record. The factors that create the historic and archaeological record are known as formation processes.

(Schiffer 1987 p. 7)

The study of formation and deformation targets the interaction between cultural and natural processes, which thus determine the preservation of the archaeological record (Butzer 1982; Schiffer 1987; Waters 1992). This leads to an understanding of the dynamics of the formation process that in turn influence how the archaeological record is perceived and understood (Rossignol 1992).

As Wandsnider states (1992a p. 96) 'we understand that if the cultural deposition rate is faster than the natural deposition rate a palimpsest deposit will result...Conversely, if the natural deposition rate exceeds the rate of cultural deposition, then burial results'. However, these rates of natural and cultural aggradation and degradation are not homogenous; rather, they are spatially discrete and temporally variable. Furthermore, their causation may be traced to other anthropogenic actions in the region.

3.3.1 Cultural transforms

Cultural transforms involve the deliberate or accidental activities of human beings as they conduct their daily activities. Over time, a variety of factors change the way that societies interact and structure their environment. Settlements are abandoned as, for example, regional resources are exhausted, internal political organisations change or are supplanted. Such actions can leave 'snapshots' of past systems (as is observed in the so-called 'Dead Cities'

near Aleppo in Northern Syria). However, these examples are rare; the majority of archaeological residues are transformed by the more pervasive acts of inhabitation over time. Each successive generation alters the fabric of the archaeological record: structures can be dismantled and the material re-used. The hinterland can undergo various re-structuring regimes as systems of land tenure develop or new systems are imposed (such as Roman land cadastration or the English enclosure awards). The hinterland itself has been subject to a range of destructive (and preserving) agricultural activity for millennia. At a finer scale artefact reuse modifies the original functional context and can subsequently cause erroneous interpretation. For example, broken pottery is not just 'discarded' locally but can be re-used during land fertilisation (night soiling), leading to a potential misinterpretation of a pottery scatter as a site. The scale and impact of the resultant transforms can vary greatly.

Extensive cultural modification has occurred over the past century. Social and technological changes have significantly impacted on the fabric of urban and rural landscapes. Urban expansion and the use of more destructive agricultural techniques (deep ploughing, boundary re-organisation and increased drainage), have caused immense destruction of archaeological residues. Although these recent modifications have, arguably, destroyed more archaeological residues than at any other time they are still part of a larger scale process of change. The archaeological resource has been subject to a range of cultural modifications (for example ploughing, settlement abandonment, land tenure re-organisations and re-use of structural material) for as long as human activity has occurred. It is the responsibility of archaeologists and cultural resource managers to ensure that appropriate mitigation or preservation systems are in place prior to any destruction.

Although specific will be discussed in greater detail later in the research cultural transforms in the study area include:

- Past obliteration of early sites through changes in landscape management and agricultural practices (i.e. roman cadastration).
- Mudbrick quarrying (shallow scoops associated with tells).
- Modern agricultural practices (bulldozers, ploughing and irrigation).
- The modern transport of archaeological soil horizons for topsoil.
- Cairn creation and clearances in the basalt.

3.3.2 Natural transforms

The archaeological record affects and is affected by its immediate surroundings: its environment or matrix (Stein 1992; Schiffer 1996). The immediate environmental matrix determines the medium of preservation, and the attributes of the material determine if the material will survive within this matrix. Thus, understanding the immediate matrix leads to increased appreciation of material bias governed by artefact-environment interactions. There are three main agents of deterioration:

Chemical Agents: Chemical agents are pervasive in both systemic and archaeological contexts. The atmosphere and the soil contain water and oxygen, which are sufficient to propagate many chemical reactions, the most common of which are oxidation and reduction. Irradiation of materials by Sunlight induces photochemical degradation, particularly within organic compounds. Furthermore, increase in heat increases reaction rates. Acids and Bases react chemically with a variety of material types and occur naturally both in the atmosphere (for example, CO_2 reacts with water to form the weak Carbonic Acid H_2CO_3) and within soils.

Physical Agents: Physical agents of deterioration are ubiquitous. Volcanoes, hurricanes, earthquakes, landslides, floods and other natural disasters affect artefacts and structures over large geographical extents. Water is a particularly pervasive deteriorating agent: streams, rivers and the sea erode the physical matrix, reworking and abrading any archaeological material, drainage leads to erosion and moisture is the normal medium of decay. Wind can erode the most labile elements of a soil structure which causes formation patterns to combine and collapse while the re-depositing material may obscure some other residues. Temperature changes have a significant impact on soil expansion and contraction providing fissures through which residues can fall. Even the action of gravity on a steep slope can displace or bury archaeological residues.

Biological Agents: Living organisms are the principal agents of long term biological decay. Bacteria and fungi initiate the process of decay or rot and can survive within a variety of extreme environmental conditions. Animals ranging from insects to mammals can cause a variety of pre and post-depositional disturbance. Plant roots and burrowing animals cause particular damage to the local matrix, disturbing artefact sequences.

The rate at which these processes operate is dependent upon local conditions. As the local matrix is modified the conditions change to promote or inhibit particular agents (Schiffer 1987). These effects are variable over different environmental, ecological and temporal scales. For example, a criticism of using 'soil-type' as a variable within any historical modelling exercise is that the current soil-type may not be representative of any past conditions as the interaction of biological, physical and chemical agents in conjunction with anthropogenic actions have changed the nature of the soil. Furthermore, there is a more philosophical issue on the nature of classification: do modern soil science classifications have any relationship with how archaeological agents classified soil (if, indeed, they did).

The micro-environmental conditions determine the differential preservation of the archaeological record. However, further modification and masking can occur through meso and macro environmental effects. The primary areas of interaction are:

1. Site mesoenvironment: the topographic setting and landforms of the area utilised for subsistence.
2. Site modification: pre and post-depositional disturbance through the actions of running water, frost, expansion and contraction, deflation, animals (including humans), plants and gravity.
3. Site destruction and dispersal: through the same agents.

Geoarchaeology is the study of the effect of these natural processes (Scudder *et al.* 1996). One aim of geoarchaeology is to understand how natural processes have transformed the archaeological record and how this impacts upon interpretation. For example, a multi-period pottery scatter makes much more sense when one is informed that significant deflation has occurred in the landscape. Alternatively, an area that is considered to be sterile during surface survey does not actually provide negative evidence when one is informed that it is part of an aggrading floodplain.

Many anthropogenic actions can have a significant impact upon the natural environment. Prehistoric woodland clearances have been demonstrated to cause massive soil erosion events that substantially affect the hydrological system and the topography of a regional river catchment (Macklin and Needham 1992; Macklin *et al.* 1992). Thus, the inter-relationships of natural and cultural processes can modify the landscape in many complex ways.

3.3.3 Discussion

Landscapes are the manifestation of tensions between Cultural and Natural (C and N) transformations working at various spatial and temporal scales and with varying degrees of positive or negative interaction. The development of landscapes is complex, and it is difficult to extract the specific impact of either cultural or natural events on this development (Layton and Ucko 1999 p. 2). However, the relationships between natural and anthropogenic agents, although complex, have been hypothetically modelled (see particularly the works of Butzer 1982; Crumley and Marquardt 1987; Waters 1992; Crumley 1994). Cultural formation and deformation influence the structure of the archaeological record, ranging from larger scale site and hinterland modifications (or even destruction) down to micro scale discard strategies. It is also possible for 'sites' to go through a cyclical process of birth (inception), life (use), death (disuse) and then re-birth (re-use) (Langran 1992) creating a palimpsest of discontinuous occupations that may be difficult to disentangle (see Figure 53). Natural formation processes in such forms as erosion, mixing and burial interact with cultural processes and further modify them. Furthermore, the nature of the archaeological material undergoes long-term degradation based upon physical, chemical and biological agents that is a function of the localised environmental matrix (Rossignol 1992). The long term modification and even destruction of archaeological residues has a profound impact on their interpretation. Settlement patterns become increasingly fragmentary and those from some periods may have lost so much of their original structure that coherent and valid interpretation is now impossible (Taylor 1972).

In some environments disentangling and interpreting these natural and cultural formation and deformation sequences is extremely complex (for example see Figure 50 and Figure 51). Ebert (1988) compares a number of projects that have determined depositional and post-depositional processes from satellite imagery. The study area (see Chapter 4) has undergone a range of natural and cultural processes that have occurred over numerous millennia including; deflation, fluvial burial, modern and past anthropogenic practices (examples include irrigation, topsoil movement, bulldozing, land reorganisation and mudbrick extraction pits).



Tip lines through the rampart
at site 14 (Tell Nebi Noah)



Recent mud-brick collapse
at site 315 (Tell Nebi Mend)



Mud brick collapse in section
at site 256 (Tell Ahmad)

Figure 50 Formation and deformation process in the marl.



Occupied Tell (Tell Nebi Mend Site 315).
Note the range of building materials and that
current occupation occurs in conjunction with
seemingly abandoned structures.



Occupied Tell (Tell Nebi Mend Site 315).
Juxtaposing modern development against collapse.

Figure 51 Natural and cultural formation and deformation
processes on Tell Nebi Mend.

3.4 Practice and archaeological landscapes

The vast majority of archaeological residues are buried and essentially invisible to the human eye. However, traces can be identified through such evidence as upstanding monuments, relict fieldsystems, clusters of artefacts, chemical and physical residues and variations in surface relief. Archaeologists employ two main approaches to identify and understand archaeological residues: *Survey* (with no or limited destruction) and *excavation* (destructive). Each approach uses a variety of different techniques that sample different attributes of a landscape in progressively increasing detail.

Survey itself comes in many different forms each providing different results. It is often the first stage of a long-term archaeological project providing an overview of the range and nature of the archaeological residues. However, survey is not just the preliminary stage for future intrusive excavations; a well designed survey strategy will address questions that excavation can never answer. Realistically only regional survey provides the opportunity to study and interpret related archaeological residues dispersed over space (Banning 2002 p. 1).

In *landscape survey* a block of land is examined with the purpose of *detecting* 'sites' or loci of past activity. Background information is collated through a desk-based assessment. The areas are then examined during *site survey* where intensive fieldwalking, geophysical prospection and sub-surface sampling techniques can be used to further characterise (or *recognise*) the residues or reveal areas that may have been missed. Survey of this nature is widely used throughout the world. Many archaeological investigations only use the two broad techniques of landscape and site survey as they provide the archaeologist with a wealth of data for interpretation. However, for more detailed understanding (or *identification*) then the many techniques of *excavation* are required (Roskams 2001). For the requirements of this research excavations will not be discussed in detail.

3.4.1 Survey objectives

The results of archaeological survey depend on the objectives it was designed to achieve. The survey design or *methodology* inherently biases any data collected. For example, a methodology that focuses on identifying areas of past settlement will identify few, if any, temporary or nomadic sites. Therefore, it is important to record the survey objectives in any metadata descriptor of the data set. Recording such information will reduce erroneous application of the survey data by other researchers. For example using the previous case of surveying past

settlements, these data should not be used to determine the range of site types within a landscape as there may be significant bias in the collection methodology.

All surveys do not aim to achieve the same ends. There are many different survey objectives, but the majority can be generalised into the following groups:

Reconnaissance survey: (Detection) Primarily designed to detect all the positive and negative archaeological evidence within a study area.

Evaluation survey: (Recognition) To assess the archaeological content of a landscape using survey techniques that allow either field-prospection, statistical hypothesis building or the identification of spatial structure to occur.

Landscape research: (Identification) To form theoretical understanding of the relationships between settlement dynamics, hinterlands and the landscape itself.

Cultural Resource Management (CRM): (Protection) Primarily designed for management of the available resources. CRM applications are not necessarily distinct from other survey objectives although they may be conducted as part of a more general information capture system.

The aim of landscape survey is to detect areas of past human activity. Two principal data collection techniques are employed:

- Desk based assessment.
- Ground reconnaissance.

Desk Based Assessment (DBA) is the collation, integration and analysis of all archaeologically pertinent material for the study area. Ground reconnaissance is the process of field data capture. Most ground reconnaissance techniques employ solely surface collection. This is ideal where post-depositional process actually leave an assemblage on the surface. However, this is rarely the case and many surface assemblages are the result of modification from ploughing or exposure by erosion. Only experimental work will help to understand the relationships and transforms from sub-surface assemblages to surface assemblages. However, for residues revealed by ploughing there is a strong correlation between surface and subsurface remains (Lambrick 1977). In some situations sub-surface collection will occur by test-pitting or shovelling to access buried residues.

3.4.2 Desk based assessment

Desk based assessment involves the thorough researching of all existing information. The Institute of Field Archaeologists (IFA) defines it as:

... a programme of assessment of the known or potential archaeological resource within a specified area or site on land, inter-tidal zone or underwater. It consists of a collation of existing written, graphic, photographic and electronic information in order to identify the likely character, extent, quality and worth of the known or potential archaeological resource in a local, regional, national or international context as appropriate.

(IFA 2001)

Sources that are normally considered for reference during a DBA are:

- Regional and national site inventories.
- Public and private collections of artefacts and ecofacts.
- Modern and historical mapping.
- Aerial photography and other remote sensing.
- Historic documents.
- Geo-technical information (such as soil maps and borehole data).

Desktop studies allow a broad understanding of the landscape and thus aid the implementation of the project design, saving valuable time and money.

It is within this framework that satellite imagery plays an important role. Medium spatial and spectral resolution satellite imagery (such as Landsat) allows the determination of geo-technical information in scales that are more useful for archaeological enquiry than many available map sources. High spatial resolution satellite imagery can supplant modern mapping sources by providing a mapping base which has not been subjected to generalisation, and hence loss of detail. This imagery also shares many of the characteristics of aerial photographic imagery but with a much larger synoptic footprint.

3.4.2.1 Prospection

Prospection techniques optimise the probability of detecting archaeological residues. As opposed to statistical surveys (see section 3.4.3.1), which use more elaborate and time-consuming techniques, prospection takes advantage of any available information which will improve the chances of discovering archaeological material. Historical and geo-technical documentation are a valuable resource for prospection as they can indicate areas to exclude from a survey. For example it is a waste of resources to intensively survey for prehistoric remains on a terrace that was formed in the 12th Century AD. However, rarely do these sources provide accurate spatial referencing for specific events. To address this issue, data collated and created during the DBA are modelled from manual interpretation or computer classification in a geo-referenced format.

Manual interpretation correlates the information layers (and possibly enhances them using computer techniques) and, after reference to an image interpretation key, is used to describe and interpret as many potential archaeological residues as possible.

Computer classification employs a variety of different digital classification techniques to provide archaeological information. The approach used is determined by the methodology employed by the user. If, for example, the user believes there is an identifiable archaeological spectral signature, then one might create training areas and classify the information accordingly. Alternatively, if it is believed that the archaeological residues exhibit a higher or lower statistical distribution relative to a 'background' reading then a variety of regional or local statistical modelling exercises could be undertaken. It may also be necessary to combine multiple themes using, for example, multivariate techniques. Whatever the approach archaeologists tend to refer to these mechanisms of classification as predictive modelling. More formally they can be called Exploratory Data Analysis.

Whatever technique is used ground observation is required to check the validity of the detection exercise and to collect more data to further characterise the residues under investigation. Prospection is used to provide maximum archaeological return for minimum investment of time and resources and is applied in a structured way that intersects with areas of high archaeological probability.

This technique by its very nature creates biases in the collected data as areas of high archaeological probability are examined in preference to other areas. Hence, the results of prospection should only be generalised with care. If the assumptions used in prospection have not been statistically ground tested then erroneous landscape generalisations could occur. However, generalisation and interpretation is not the primary goal of prospection; rather, prospection is used to characterise particular archaeological residues within the landscape.

3.4.2.2 Predictive modelling

Predictive modelling is based on determining the correlation between known sites and environmental features in a particular region and projecting the knowledge to environmentally similar areas (Warren and Asch 2000 p. 6).

Predictive models attempt to propose a:

...simplified set of testable hypotheses based on either behavioural assumptions or on empirical correlations which at a minimum attempts to predict a loci of past human activities resulting in the deposition of artefacts or the alteration of the landscape.

(Judge and Sebastian 1988 p. 33)

Archaeological predictive modelling has its basis in the settlement studies carried out by archaeologists in the 1950s and 1960s. In the mid 1960s locational concepts were borrowed from geography and provided a supporting body of theory. It was also at this time that archaeologists began to appreciate the importance of ecological and environmental variables in understanding settlement variability. Since then these variables have been used to great effect (Dalla Bona 1994).

Predictive models are either inductively or deductively derived. Inductively derived models test hypotheses against a database usually using multivariate classifiers. Hence these models are subject to any bias existing in the database. Deductively derived models begin with theories predicting human behaviour (for example, all settlements will be close to water). While deductive models better encompass the range of human behaviour they suffer from changing interpretations and theoretical viewpoints (Dalla Bona 1994).

Those models that focus on the physical environment and its effects on settlement have been referred to as man-land relationships (Kvamme 1988 p. 332). The examination of site-catchments, topography, vegetation and other environmental features are major elements of this approach. On the other hand man-man relationships refer to analyses that assess the importance of the human or social environment in structuring patterns of settlement. These analyses focus on such themes as central place theory, rank size theory and population distributions over the landscape (Banning 2002).

Finally, all predictive modelling exercises can be broken down into three primary stages (after Dalla Bona 1994):

1. Hypothesis development, organisation and data collection.
2. Initial model development and testing.
3. Continued application of the model and on-going refinement.

Most predictive models stop at the secondary stage. However the tertiary stage can be viewed as the most important and is ideally a never ending process whereby the predictive robustness of the model is increased. Ebert (1988) compares a number of American predictive modelling exercises employing satellite imagery as an analytical layer.

The analysis of landscape information has traditionally occurred in a case by case fashion. However, GIS applications allow archaeologists the ability to reproduce their methodologies over a discontinuous area and, furthermore, re-evaluate analyses after more information has been collected. The use of such a toolkit will allow the continual development of hypotheses to occur.

3.4.3 Ground reconnaissance

Fieldwork programmes that collect landscape-orientated information are not focused on excavation techniques; rather they are focused upon large scale sampling strategies that collect physical and artefactual data and place extant residues into a contextual framework (Plog *et al.* 1978; Ammerman 1981). The developmental history of the application areas needs to be researched, not only to integrate any other archaeological works, but to understand the extent to which surface material may have been disturbed by natural or cultural transformations. This information aids the identification of areas where the methodology employed will not work (for example fieldwalking on an aggrading alluvial floodplain). Many

regions contain a variety of landscape types and a single methodology may not be appropriate. Therefore, flexible methodologies are employed that can respond to the unique developmental histories of different landscape zones. However, such flexibility has an impact on the Archaeological Information System (AIS), the associated recording system and the interpretative frameworks as these data sources will need to be interpreted as a single co-ordinated information set.

3.4.3.1 Statistical survey

Sampling techniques are used because it would be extremely expensive and time consuming to apply the same strategy across the whole landscape. Landscape surveys employ various sampling methodologies during data collection (i.e. random, non-probabilistic, cluster, multistage and total (Judge *et al.* 1975; Schiffer *et al.* 1978; Banning 2002)). These are predominantly determined by the research goals of the project, the accessibility of sites in the landscape, the types of analysis which will be performed upon the data and cost. A sample is a subset of a population; if the sample is representative of the population under study then the characteristics of the population can be estimated using attributes of the sample. If this assumption holds for archaeological survey then it is not necessary to detect all archaeological residues as processes that affect the whole population can be extrapolated from the sample. The problems of sampling in an archaeological context are clear, primarily concentrating on the bias of different strategies and the fact that any sample, however well defined, remains just a sample. Its results may be broadly applicable to the rest of the area, but will never be entirely so. Furthermore, no sampling technique is total, even the misnomer of 'total' survey rarely samples everything.

In total survey the whole landscape may be evaluated by transects or quadrats, but only a small sample of each transect is actually surveyed (Banning 2002 p. 167). The *intensity* of the survey reveals a level of probability that the survey has adequately characterised the required residues. Intensity does not just refer to increased coverage but also to re-surveying in different environmental conditions, times of day and with different crew members (Schiffer *et al.* 1978; Shennan 1985 p. 10; Banning 2002 pp. 224 - 225). The results are compounded by the problem of *detectability* which is the possibility that an observer may fail to notice a target even though the survey intersects with the target (Shennan 1997). This could be due to the target being completely obscured, for example, by alluvium, transparently obscured, for example, by vegetation or that the observer does not have the skills to recognise the target.

The visibility of sites and artefacts can vary widely predominantly due to factors such as seasonal weather patterns, vegetation cover and land use regimes. Results tend to be more reliable from long-term projects where the region is covered repeatedly. However, it is financially untenable to conduct a total survey *and* be statistically confident that all of the archaeological residues have been characterised, never mind understood.

Even with these statistical limitations, landscape sampling provides a data resource which not only complements excavation data but, for certain types of enquiry, transcends it. It is a particularly effective means of analysing spatial organisation. Hence, a clearly defined sampling strategy with a robust research design will facilitate landscape interpretations which are used to develop more refined fieldwork approaches.

Sampling reduces the costs of both fieldwork and analysis. As sampling is selective in its approach to the landscape, areas that are unsampled remain undisturbed for future researchers. However, in order to define what form of sampling is appropriate one needs to understand the general spatial and temporal attributes of the population, which, in the initial phases of an unsurveyed landscape is difficult.

Unlike prospection, statistical surveys are commonly used to directly infer the following information (after Banning 2002):

- Site densities (by type and/or period).
- Artefact densities (by classification and/or period).
- Spatial patterning of residues.
- Material diversity.

This information is then used within other theoretical systems to indirectly estimate population change, ecological preference, settlement systems and many of the other cultural products already discussed. Equally importantly the data can be used to refine the hypotheses and assumptions defined during the prospection phase.

To address the statistical limitations of sampling, surveys are often undertaken at varying resolutions and intensities. Rapid low resolution surveys can be conducted to infer large scale patterning, these are then refined by conducting higher intensity surveys around areas of

interest. In such a situation it is implicit that the information system can manage the data effectively to ensure consistency in interpretation and generalisation. Surveys with multiple goals can thus be realised using different survey techniques.

3.4.3.1.1 Consistency

Consistency within the survey is essential in order to confidently interpret survey results across the landscape. However, researchers are increasingly combining the results of different surveys in order to look at archaeological variations at even larger scales (this is an emerging body of work referred to as *meta* landscapes (Raczkowski 2000)). It is inevitable that different techniques will be used by different surveys. Hence the integration of multiple surveys into a single body may well be significantly undermined by differences in survey technique.

Although ensuring consistency for other future researchers may not be a high priority for the survey team it is possible to build in levels of consistency for the longer term:

- The local or national CRM body may insist on core information to facilitate other enquiries.
- Document all aspects of the survey strategy and methodology and include them during data deposition.
- Where practicable, if inter-project goals have been identified, incorporate them into the survey methodology.

3.4.3.1.2 Artefacts

Artefacts provide the major chronological frameworks for the archaeological record and insights into the social, political, artistic and economic backdrop. Differential preservation of artefacts is dependent upon the local matrix, temperature and material of the object. Rarely do conditions prevail which are conducive to the retrieval of all the materials originally present. This differential preservation will normally give large biases in the collection of artefacts, usually in the favour of inorganic materials.

However, in the context of detection, the mere clustering of artefacts is as important as the attributes each artefact contains. From the spatial patterning of artefact distributions within the landscape, sites are ascribed. The types of artefact may indicate the date, duration, form,

function and variability of the site. Further, relationships between sites are extrapolated to produce thematic understanding of past societies.

3.4.3.1.3 Ecofacts

Only recently have archaeologists attempted to place archaeological sites into their contemporary environment and view the human action as an inherent part of a broader ecological system. A reliable date for a site allows coarse interpretations of the local climate by reference to environmental indicators contained within secure deposits (such as sediment or ice cores). Finer grade questions follow; local flora and fauna can be reconstructed by their archaeological remains. Some of these plants, insects and animals live in specific environmental conditions and therefore their presence is a good indication of the local habitat at that time. Further, analysis gives indications of subsistence and diet, which can be extrapolated to gain an understanding of how the ecology was exploited.

3.4.3.1.4 Other techniques

With the emphasis on cost and time, excavation is a tool that is rarely used in landscape studies due to its inherent expense. However, a battery of remote sensing techniques can detect sub-surface features quickly and cheaply. The results of these geophysical surveys, particularly on single-period sites, complement surface survey by improving spatial control.

3.4.4 Summary

It is a truism that the survey design and methodology constrain the results that the survey can be expected to yield. Consequently, surveys are designed to produce the results that are required for interpretation and analysis. This design process may take many years as most surveys start with an imperfect knowledge of the problem and the resource. Increased understanding occurs over successive seasons of fieldwork and interpretation. Hence, the relationship between goals, data and methodology is hermeneutic.

Commonly, surveys are designed to optimise the discovery of archaeological residues (prospection), to use statistics to extrapolate attributes of a population from a sample or to detect spatial patterning. One aspect of this research is to address how high resolution satellite imagery can impact upon survey design. It should be expected that high spatial resolution imagery with a large synoptic footprint, within which archaeological residues can be easily identified, will frame how survey is undertaken. This has occurred for the SHR

project where residue identification from satellite imagery is the first stage of a battery of survey techniques which also includes:

- Rapid recording and grab samples focussed on diagnostic material for all sites.
- Gridded sieved collections on a sample of sites
- Off-site field-walked transects.
- Artefact fall off by distance from site.

The survey design and methodology provides the archaeologist with data. It is then the archaeologist's goal to transform this data into information which corresponds with the research hypotheses. However, it must be remembered that these data are not intrinsically meaningful: archaeologists have spent many years defining mechanisms to classify archaeological residues to facilitate meaningful interpretation. All of these classification schemas are cultural products of archaeologists rather than true cultural reflections of past societies.

3.5 Landscape modelling

In order to address questions of organisational change and stability, interpretation of the archaeological record requires one to make certain inferences regarding:

1. How the material record reflects the role that people and place played in the organisation of the past.
2. How the pre and post-depositional formation processes have affected the material record.
3. How these factors vary over space and time.

Given a robust collection strategy and understanding of landscape formation, archaeologists need to take a theoretically informed 'leap of faith' from perceived variations in a regional archaeological record to interpretations about past cultural systems (Wandsnider 1992a). These interpretations are constrained by any assumptions implicit in the way the landscape is analytically modelled.

3.5.1 Modelling archaeological landscapes

All landscape applications model their data in unique ways dictated by their survey methodology, research goals and the established regional classification systems. Although it would be impossible to explicitly define all the modelling techniques used, it is possible to outline the theoretical development of the main approaches.

3.5.1.1 The 'site' model

This is the oldest model of archaeological residue dispersion and relies on the simple premise that the archaeological population consists of a set of discrete activity areas (nominally referred to as sites). Originally 'site' was only applied to residues that had a monumental component such as those containing upstanding architectural remains (of stone, brick or mud-brick), earthen mounds (tells) or substantial fortifications (Iron Age hillforts). Subsequently, after methodological and interpretative techniques improved, surface artefact concentrations were also recognised as sites.

These sites can be classified upon a number of criteria. The following themes are commonly used:

- Size.
- Material diversity.
- Function.
- Morphology.

Although simplistic, this model is a convenient interpretative tool in environments where the archaeological residues are actually discrete.

Associated with the site model is the concept of networks between (i.e. communication) or surrounding (i.e. hinterland) sites. Early aerial archaeologists were quick to exploit the fact that many large scale landscape features survived intact or as earthworks. Many such features could easily be overlooked during ground survey but are obvious on aerial photographs. In fact these 'off-site' traces were being recorded by aerial archaeologists long before the concept of landscape archaeology existed (Banning 2002 p. 13).

3.5.1.2 Sites as perturbations in a distribution

The inclusion of surface residues (particularly artefact scatters) into the site model marked a subtle shift in the appreciation of site definition. Residue attributes are measured to establish if they have a higher or lower concentration than a 'background' value. This variation is based on the simple assumption that the background (which can also be referred to as off-site or non-site, both of which will be defined later) values represent predominantly natural transforms and site values represent cultural transforms, and that these distributions can be distinguished mathematically. This assumption can be used in the interpretation of many data collection techniques including artefact distributions, chemical residues, soil differences and magnetic or resistance variations. In the hypothetical example illustrated in Figure 52 the landscape was sampled in 2 metre square units, a 'site' being defined as having at least 2.5 artefacts per m². This technique can be extended across a landscape. Two common methods employ fixing a set value for the background level (i.e. assuming it is an isotropic plain) or by calculating a moving average for the background level.

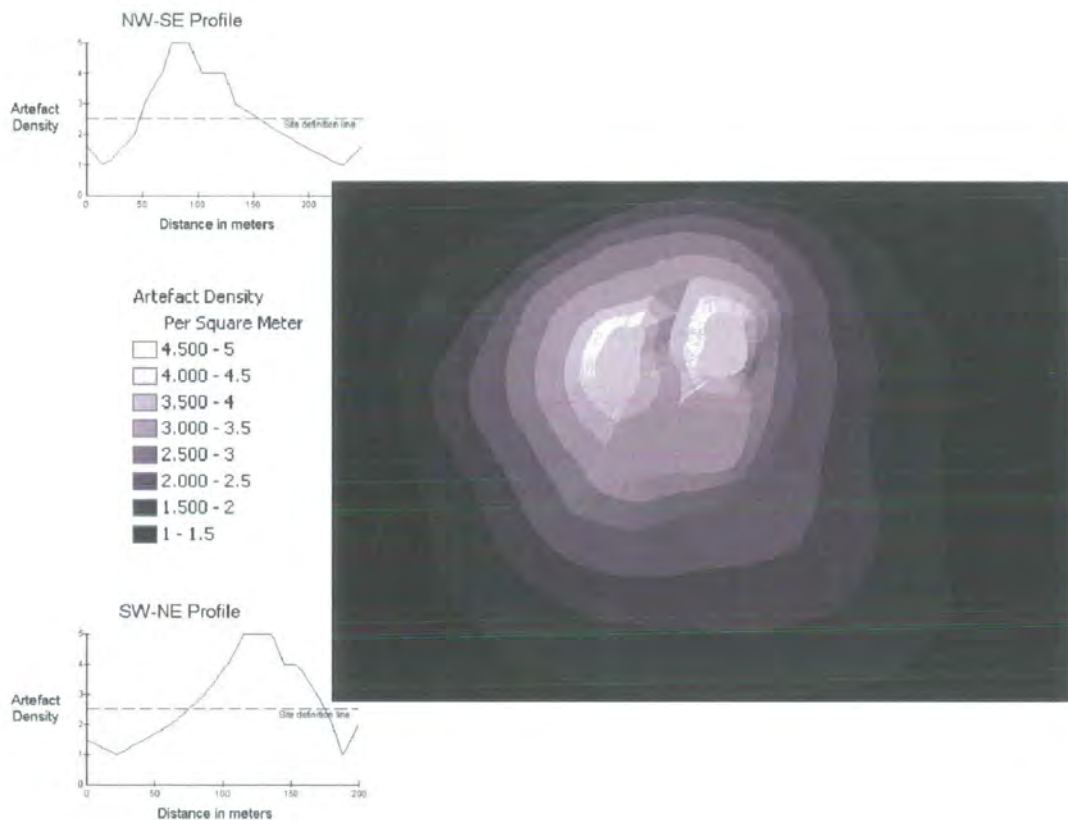

Figure 52 Hypothetical site distribution as perturbations in a distribution of artefacts. The site level is calculated at a density of 2.5 artefacts per m².

This simplistic analysis can be improved by more robust statistical techniques. For example the uniform distribution approach assumes that both 'sites' and 'non-sites' have attributes that are normally distributed around a mean. The mean value for the 'sites' is relatively higher or lower than that of the 'non-sites'. This property, therefore, allows sites to be distinguished (Buck *et al.* 1996).

These techniques primarily model the landscape as a binary entity (site or non-site). However, many surveys now postulate that the landscape is a blanket of recognisable archaeological residues with varying intensities (Cherry *et al.* 1991; Robinson and Zubrow 1999; Bintliff 2000; Francovich *et al.* 2000; Wilkinson 2000; 2001) Therefore, the values of a particular archaeological residue (such as phosphate value or artefact count) vary continuously over the landscape and can be modelled in much more subtle ways. One approach, referred to as the 'fried egg' model, interpolates isopleths of equal attribute values (analogous to contours). This technique highlights the gradual variations between the boundaries of sites and non-sites. There are many such statistical approaches that allow more refined (and fuzzier) interpretations. However, a criticism of many of these approaches is that the temporal classification of sites can be under-represented.

3.5.1.3 Sites as palimpsests

Archaeological residues can reflect prolonged cultural activity. Hence, a settlement site may represent continued occupation from the Neolithic, as is the case with many tell sites. These sites may have seen variable cultural systems in their lifespan and may have been disused for prolonged periods.

Therefore, the clustering of artefacts upon such a site does not represent a single cultural event but many overlapping cultural sequences that form a palimpsest. It is assumed that data collection represents the mathematical union of these activities. These data are normally classified to highlight overlapping distributions, each distribution representing, for example, a different set of activities or time-frames. The palimpsest model requires attribute classification and is therefore only used on such data where the attribute collection is adequate for the modelling goal (for example, pottery assemblages to define spatio-temporal divisions in an area with a robust pottery sequence).

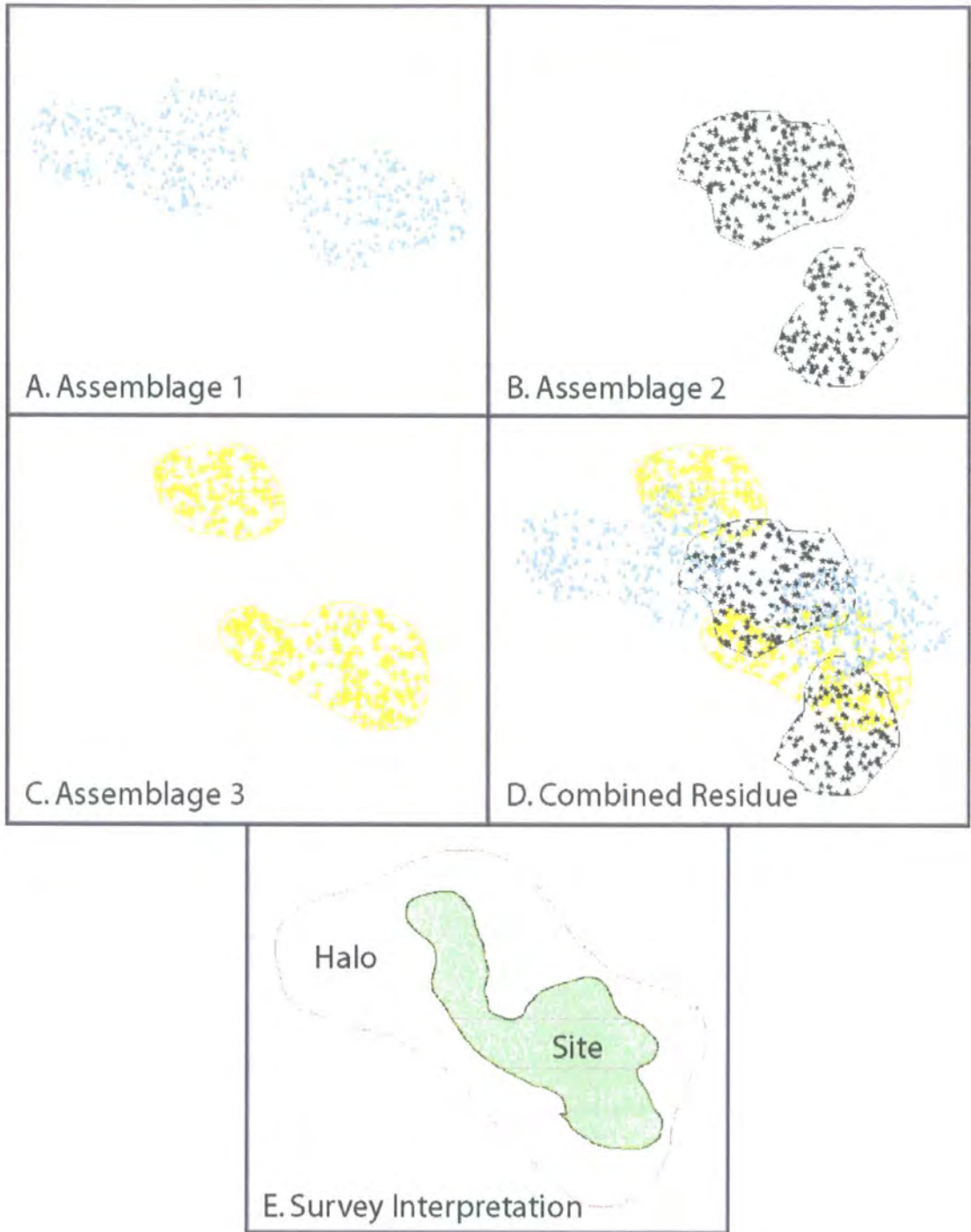

Figure 53 Example of assemblage overlap to erroneously produce a site (after Banning 2002 p. 19)

A criticism of this technique is that cultural, natural and post-depositional processes can transform the relationships between the original and modern distributions. Hence, these data may not be representative of any original cultural/temporal variations: i.e. the Neolithic phases may be obscured by later phases (particularly in an aggrading environment) or modern ploughing may have destroyed all structure. However, Rossignol and Wandsnider (1992) amongst others have applied mechanisms to mitigate against some post-deposition processes during modelling.

The logical extension of the palimpsest approach, as demonstrated by Foley (1981), is that non-palimpsest approaches would identify an area as a site through artefact density even though it actually represents the overlap of several distinct cultural assemblages (see Figure 53).

3.5.1.3.1 Systemic contexts

In order to reconstruct past human activity it is important to be aware of the *context* of an artefact, feature or site. Its context relates to the analytical unit's immediate matrix, its date (or ability to provide a date) and its association with other analytical units. The selection of an analytical unit, in some respect, dictates the scale of the analysis to be performed (Shennan 1985; Renfrew and Bahn 1991 p. 42; Banning 2002). However, artefacts and features recovered from an archaeological context may be in different systemic contexts. A systemic context refers to residues when they are participating in the same behavioural system. Thus, due to the multi-faceted interpretation and classification of artefacts, features and settlements each may exist in multiple archaeological and systemic contexts depending upon the viewpoint of the observer (Schiffer 1987 p. 3). The palimpsest model was one of the first models that could properly account for changes in systemic context.

3.5.1.4 The off-site (or hinterland) model

The off-site model is a complementary technique to a site model because it focuses on modelling cultural activity between and around sites. Off-site collection was a reaction in the late 1970s and early 1980s to the site-centric view of landscape survey. Binford (1982; 1992; 1996) argued that increased understanding of settlements and settlement patterning could be achieved by understanding how the landscape between sites was exploited and managed. This led to a re-appraisal of survey techniques that explicitly included collection and interpretation of off-site residues. In landscapes where persistent settlement evidence is the norm (such as

many areas of the Middle East (Wilkinson 2000)), the off-site model is regularly used to incorporate other aspects of human occupation that occur away from a settlement. These approaches are primarily focussed on subsistence activities such as agriculture, pastoralism and other resource procurement and management strategies. Furthermore, off-site modelling is complementary to more modern landscape theories of perception and phenomenology (for examples see Barrett 1994; Tilley 1994) which consider that the landscape is much more complex than categories of sites and empty spaces. The off-site model should not be confused with the non-site model which uses different assumptions and techniques for collection and interpretation.

3.5.1.5 The non-site model

The non-site model is a development of the off-site model which applies a distinctly statistical approach to residue variation within the landscape (Ebert 1991; Dunnell 1992). The methodology is not designed to detect sites *per se*, rather, it is designed to focus upon residue (and attribute) variations. It is postulated that spatial analysis of these variations in conjunction with ecological parameters (i.e. soil type, hydrology and landform) leads to better archaeological understanding.

3.5.2 'Sites' as interpretative units

The term 'site' has already been referred to extensively, but what is a 'site'? What constitutes its existence and what, as an analytical unit, does 'site' mean? The notion of 'site' is ubiquitous as an archaeological tool for conceptualising the archaeological record. It is expressed as a recognised unit, which, in itself, brings credence to the definition, although it is rarely defined. The problem of site, within the context of approaches to landscape archaeology, lies in the definition of form, function, duration, variability and spatial boundedness.

Initially sites were any prominent areas in the landscape, as determined by topography or monumental architecture, of any antiquity. Surveys initially focused on the prospection and characterisation of these sites. However, as archaeologists became more interested in reconstructing human impact over the whole landscape, it was recognised that this approach severely biased any archaeological collection programme. Smaller settlements, transitory camps, fields and other activity loci can produce clusters of artefacts and other less obvious residues. Hence it was postulated (at least for artefacts) that the landscape contains a variable, but continuous, distribution on or near the surface (see section 3.5.1.5). How does the



quantitative or qualitative variation of attributes reflect human dynamics and thus upon what basis can we extrapolate the notion of site (Dunnell 1992)? Surveying the whole landscape to discover such residues gave the theoretical and terminological paradox of 'when does a site become a site'? Off-site and non-site methodologies were developed as an attempt to resolve this paradox. These methodologies require a significant shift in techniques that can only be achieved by applying systematic statistical survey, as comparative analysis with other areas is necessary during interpretation.

So is the term 'site' still a useful term in synthetic applications? Amongst others, Binford (1992) criticises many uses of the term site. He argues that without supporting evidence from morphological sources and extrapolation into the social (and spatial) dynamics of the landscape one cannot define a site. In short, simple aggregation of artefacts does not lead to the discovery of a site. There is a movement away from 'site' studies at the landscape level into a more profound consideration of artefacts and morphological factors. In fact, Binford has argued that aggregating landscape information within sites, during collection and in subsequent interpretation, can mask the underlying patterns and processes. These philosophical problems extend beyond the remits of this research. However, they are important in relation to the exploitation of remote sensing resources for archaeological purposes and offer important new avenues for visualising and evaluating landscapes.

3.6 Discussion

The improvement of reconnaissance techniques and the integration of information from different sources have developed surface survey from a preliminary stage for fieldwork into an area of inquiry in its own right, forming the framework for Cultural Resource Management. The integration of information from a number of neighbouring surveys can lead to a large scale information resource, although the quality, accuracy and consistency of projects with different goals and methodologies can vary widely.

A well-developed and implemented surface survey methodology can produce a great deal of archaeological information. However, survey does not give the same quality of information as excavation. This is particularly important during the assessment of artefacts. Artefacts provide the chronological, functional and economic frameworks for the survey; yet how can we be sure that surface traces reflect the same distributions below ground. This argument has been countered by the assertion that most artefacts were originally surface assemblages and if

one can understand the transformation processes that affected artefacts then biases can be modelled (Camilli and Ebert, 1992). Furthermore, the chronological frameworks of pottery sequences, for example, are subject to change at both a local and regional level. This causes a problem when dating, derived from such sequences, enters a site record. How can a revised pottery sequence be propagated back into the archaeological record so that it reflects the revised sequence?

Artefacts from single period or shallow sites would be expected to give the most reliable information. Conversely, multi-period sites, particularly tells, could show little evidence on the surface of the earliest and deepest levels. In addition, natural transformation agents may effectively mask an area of archaeological interest (for example, the burial of sites beneath alluvial or aeolian deposits) or alternatively they may mix a group of stratigraphically distinct artefacts by a process of deflation. Although this is problematic, if the methodology and analytical components state the assumptions and biases in survey strategy then interpretation should not be unduly affected. After interpretation it could be possible to test the hypothesis by further empirical collection, for example, by test pitting and excavation.

Some archaeologists denigrate the usefulness of archaeological surveys. They point out the fact that many have failed, and still continue to fail, to detect sites of significance or that surveys introduce undue bias when estimating a site's date or relative import. However, surveys do collect information that is regularly overlooked during excavation and other higher resolution data collection. Furthermore, most failures are due to poor survey design and lack of focus for the survey objectives.

3.6.1 Research implications of landscape archaeology

Approaches to landscape archaeology are becoming increasingly multi-disciplinary. The SHR project (see Chapter 4) is in its early stages and is in a state of imperfect knowledge. The only traditional DBA resources are modern and historic mapping at different scales. These only provide a limited indication of the range of archaeological residues in the application with a significant bias towards monumental remains. Satellite imagery is viewed as a potentially cost-effective medium to improve on this state of knowledge. It is hoped that information derived from the satellite imagery will frame the theoretical and methodological techniques employed in the short to medium term. These improvements are not just related to the detection and interpretation of archaeological residues. Allied colleagues (geomorphologists,

environmentalists and historical geographers) require a range of thematic information in order to contextualise their data. Satellite imagery also has the potential to aid in their research enquiries. The integration of satellite imagery into landscape archaeological approaches has the potential to bridge the gap between processual and post-processual theoretical stances by generalizing the digital imagery into a variety of theoretically driven archaeological themes (Anschuetz *et al.* 2001 p. 159). Aerial photography and satellite imagery have not only aided landscape collection by the inherent information they contain, they can be used as analytical tools. It is not unreasonable to collect satellite imagery for the whole application area, and through a process of 'ground-observation' and image manipulation it is possible to extend the correlation of the ground-observed (or CRM) data through the whole application area in conjunction with other thematic data sets (geology, hydrology etc.).

Irrespective of the above, the impact of satellite imagery on landscape archaeology should be evaluated as to whether it can improve method and analysis or whether it can reduce costs in general.

SECTION 2: METHODOLOGY AND ANALYSIS

CHAPTER 4 SETTLEMENT AND LANDSCAPE DEVELOPMENT IN THE HOMS REGION, SYRIA: AIMS, SETTING, RESEARCH QUESTIONS AND FIELDWORK (1999-2003)

4.1 The SHR project

Settlement and Landscape Development in the Homs Region, Syria (abbreviated to SHR) is a multidisciplinary, multi-period regional survey project with both archaeological and palaeo-environmental dimensions. The project was formally initiated in 1999 and is jointly directed by Dr. Graham Philip (University of Durham, UK) and Drs. Michelle Maqudassi and Mamoun Abdulkareem (Directorate General of Antiquities and Museums, Damascus, Syria). This chapter draws upon the results of several project publications (Donoghue *et al.* 2000; Beck 2002; Philip *et al.* 2002a; Philip *et al.* 2002b; Beck 2003; Bridgland *et al.* 2003; Philip *et al.* in press), unpublished project documentation and various discussions with colleagues both in Durham and in Syria. As such this chapter outlines many of the overarching agendas of the SHR project of which this research forms a part.

The project area itself consists of two distinct study areas (see Figure 54): one located to the north-west of Homs covering some 195 km² and the other located south-west of Homs covering some 385 km². Each of these areas contains elements of the three principal environmental zones characteristic of this region of the Orontes valley: marl, alluvium and basalt plateau (see Figure 55). In part these contrasting zones were deliberately chosen with a view to evaluate the methods for their applicability in a broad range of environment types. The study area was designed to be large enough to permit the analysis of overall settlement structure while remaining small enough to permit representative high intensity survey. The extents of each environmental zone are referred to as landscape units, and form the basic analytical units for sampling.

The project aims to understand the ecological context of human activity and the complex interplay between natural and anthropogenic factors in structuring long term trends in regional landscape development in western Syria.

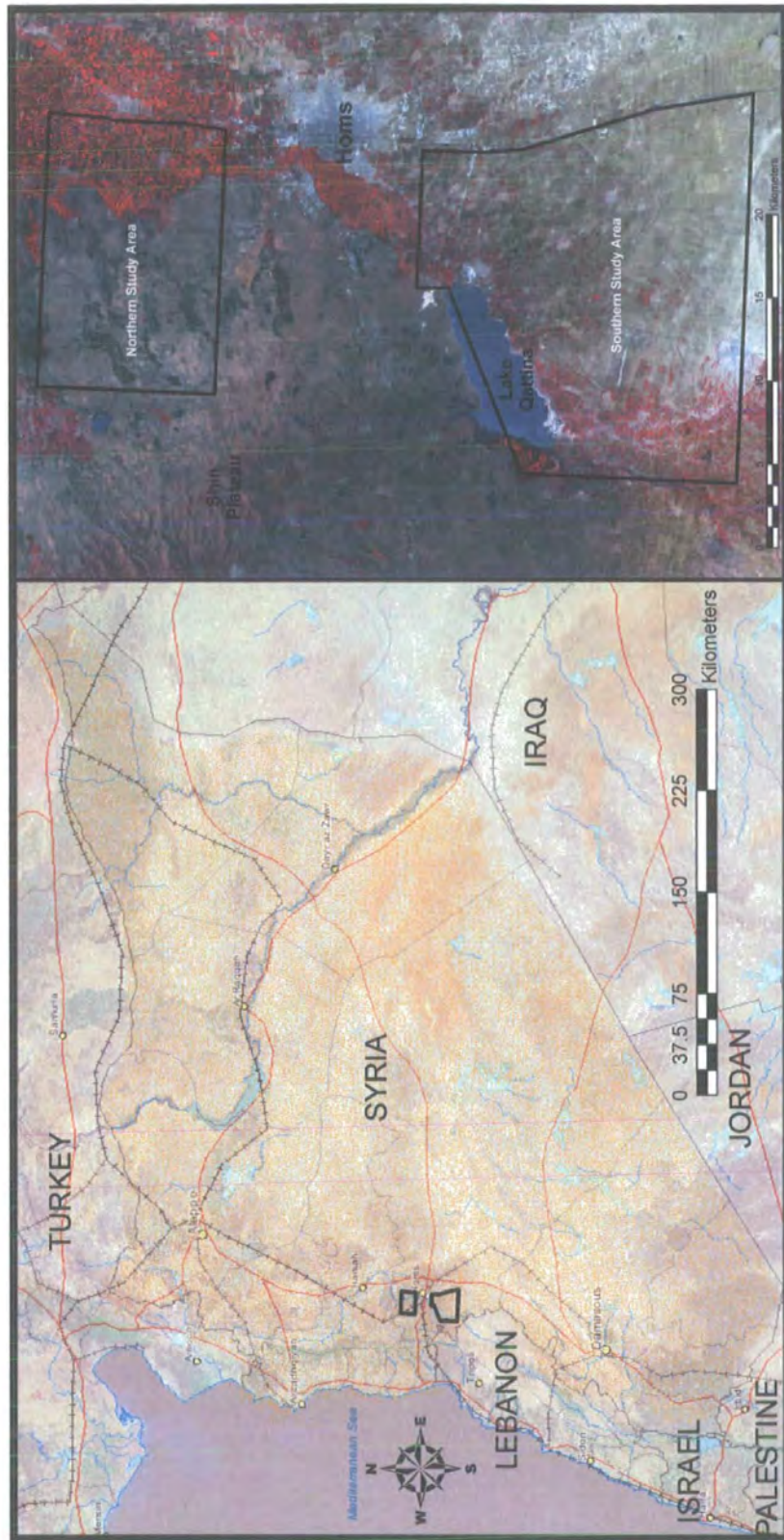

Figure 54 Location map of the study area.

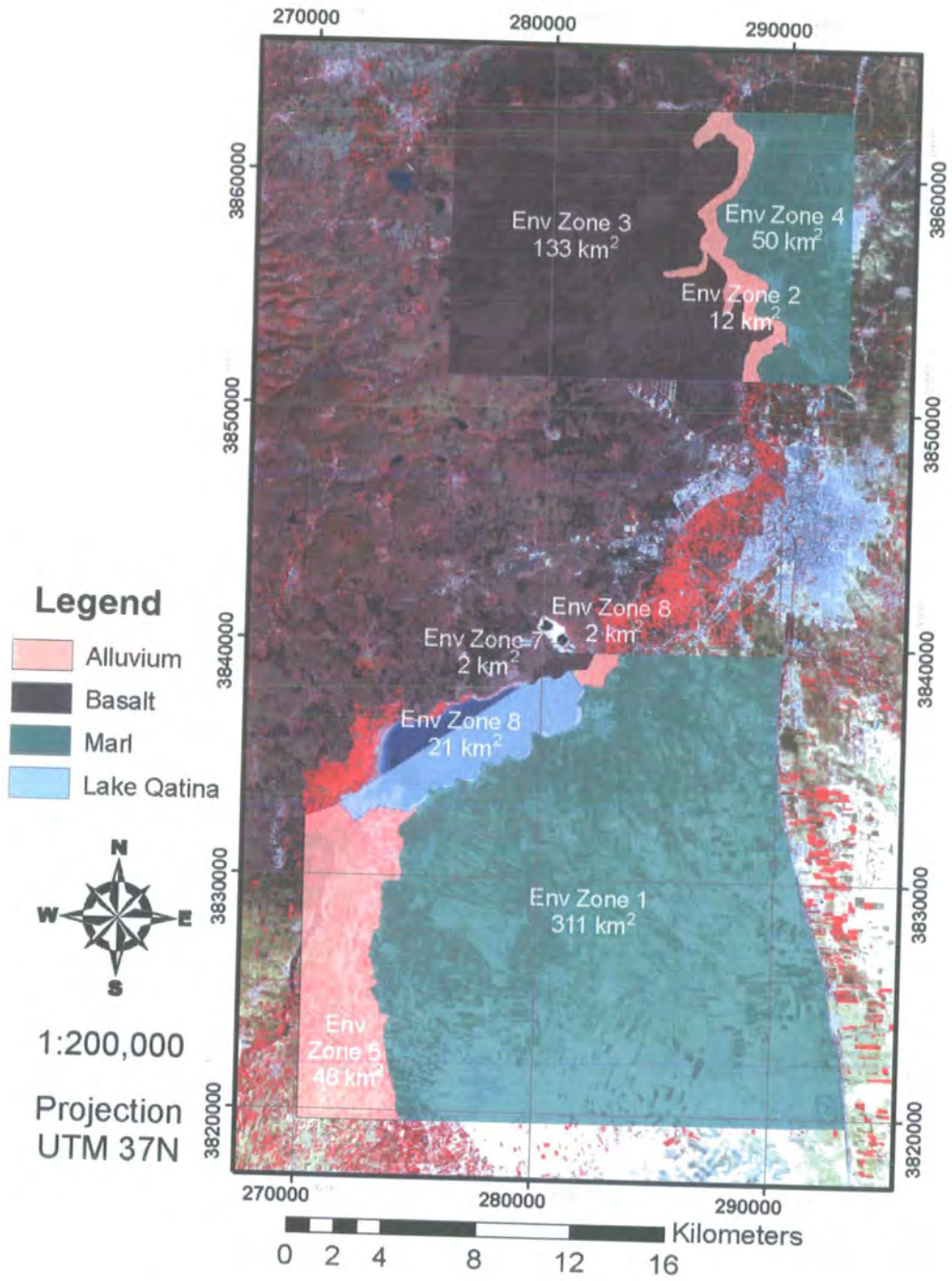
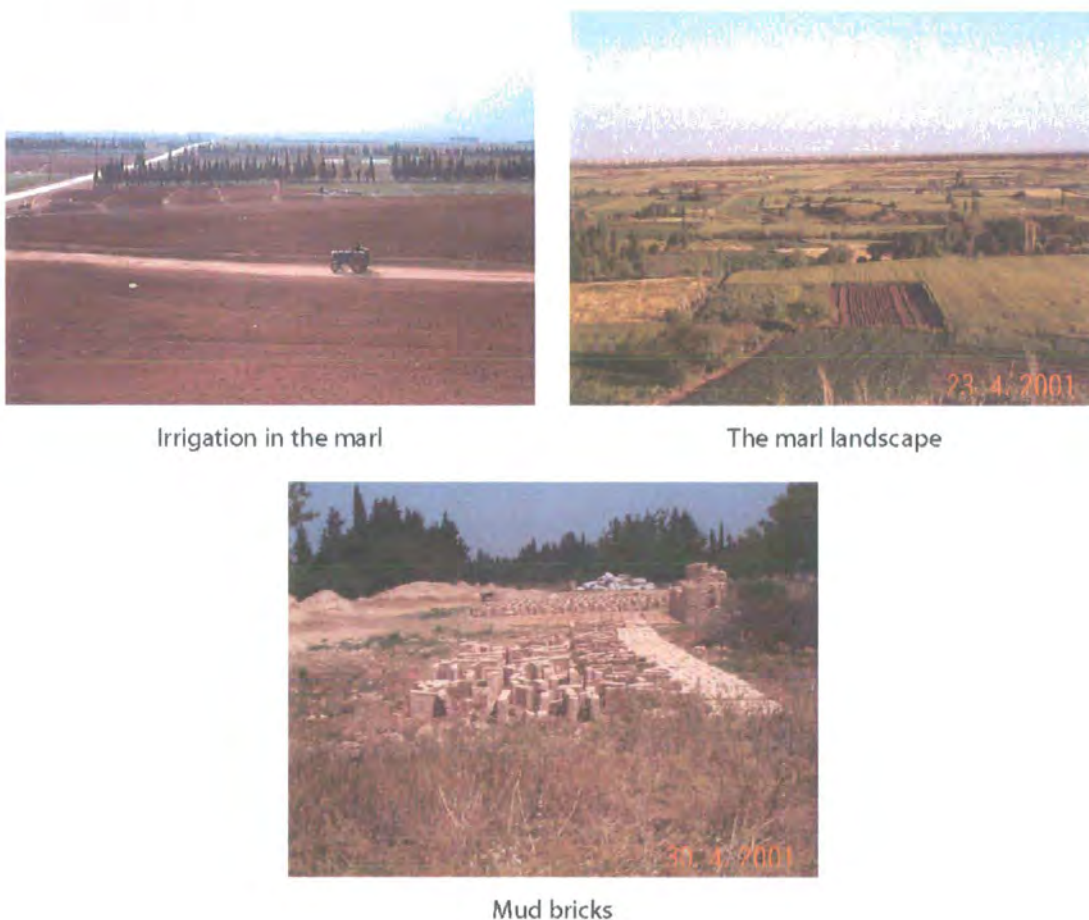

Figure 55 The environmental zones in the application area (labelled by unit and their respective areas) on a 4,3,2 Landsat image (28th October 2000).

4.2 Environmental zones, land use and archaeological summary

There is little recent literature on the geological and geomorphological characteristics of the region. Hence, the acquisition of such data is fundamental to the success of the project (see for example Bridgland *et al.* 2003). The following summaries of the main environmental zones is reliant upon a limited range of older publications (Voûte 1955; Ponikarov *et al.* 1967), the summary statements of Wirth (1971) and Wolfart (1967) and field observations by the project teams.



Irrigation in the marl

The marl landscape

Mud bricks

Figure 56 Elements of the marl landscape

4.2.1 The marl zone (units 1 and 4)

The area consists of Upper Miocene lacustrine marls, overlain by thin irregular sheets of Pleistocene pebbles and gravels. These are covered by a layer of reddish brown loam, which is derived in part from the weathering of the marls, but also through colluviation from the Eocene limestone hills to the south-east. This soil depth ranges from 0.2 to 0.4 m but can

reach up to 0.7 m in wadi beds. These soils are undergoing aeolian deflation. With the exception of the active river terraces, where extensive irrigation means that crop cover is virtually continuous throughout the year, agriculture relies on rainfall. The rainfall within the study area varies between 200mm and 1000mm per annum (see Figure 76). This variation demonstrates that some of the area is marginal. However, in recent years further crops have been realised by pumping water from the underlying water table. The area is crossed by several very shallow wadi systems which run in a north-westerly direction from the course of the large wadi al-Rabaya that hugs the lower slopes of the Anti-Lebanon range. These are shown on recent maps as seasonal watercourses, although field investigation indicates that they are scarcely perceptible in some places, and there is no indication that they are still actively connected to wadi al-Rabaya. Rather, it appears, that they now remove surface runoff (Bshesh, pers. comm.). Thus, for large parts of the growing season the area can be considered to be bare soil in a semi-arid environment (Philip *et al.* 2002a). However, the interim fieldwork season conducted during April and May 2001, after the rainfall, has demonstrated that the application area is far from agriculturally marginal. Although a reducing water table over the past two decades has led to increased cultivation of olive groves, almond groves and fruit orchards within the rainfed areas (Bshesh, pers. comm.), at least one harvest of wheat and other crops is possible within the application area. This significant shift from bare soil to intensive vegetation has a significant impact on the prospection techniques used.



Tell site 256 in the marl (notice the compacted bedouin settlement in the foreground)

Flat site 308 in the marl

Figure 57 Archaeological residues in the marl.

In Unit 4, the marl in the northern study area, the agricultural practices were significantly modified after the introduction of concrete irrigation infrastructure in the 1930s. Although this has impacted on the archaeological residues in the area, it is useful from a CRM perspective to attempt to quantify this archaeological impact.

Archaeologically this zone is characterised by a number of distinctive tell sites and far less obvious smaller sites that appear as either low mounds or flat areas (sometimes associated with a depression) marked by artefact scatters and soil colour differences (see Figure 57). There are also a number of obvious industrial and architectural fragments (such as columns, olive presses and rotary mills) distributed through the landscape.



Pumping in the basalt.



The basalt landscape



Basalt architecture

Figure 58 Elements of the basalt landscape.



Cobble wall in the basalt



Greek inscription

Figure 59 Archaeological residues in the basalt.

4.2.2 The basalt zone (units 3 and 7)

Units 3 and 7 are located on the eastern edge of the Shin plateau, a large expanse of Pleistocene basalt originating some 40 km west of Homs. This zone consists of large areas of thin boulder strewn basaltic soils. Soil and water are transported downslope by surface run off either towards the Orontes or into small internal depressions (rams). Sediment is deposited during this process creating distinct areas with deeper soils (referred to as 'well drained basalt' in section 6.6). The rams may be inundated in winter and, as some have no external drainage, can retain water well into the summer. It is assumed that these natural reservoirs would have been significant for past human populations. While the rainfall is sufficient for dry-farming of cereals, water for humans and livestock has generally to be collected by artificial means (see Figure 58).



Low rise (site 496) in the alluvium



Site 483 in the alluvium

Figure 60 Archaeological residues in the alluvium.

Archaeologically this zone is characterised by structural remains in the form of abandoned villages, isolated villas, roads, tombs, cairns and agricultural systems. These are all preserved as a palimpsest of stone walls and concentrations of rubble. In contrast to the other zones the basalt should potentially provide rapid insights into how hinterlands were managed and exploited.

4.2.3 The alluvial zone (units 2, 5 and 8)

Units 2 and 8 north of Lake Qatina and the eastern portion of unit 5 encompass the most recent incision of the Orontes and its active floodplain zone. In units 2 and 8 the Orontes is at its western extent as it cannot migrate further west due to the basalt blocking further movement. The terrace formations associated with migration of the Orontes and other broader scale fluvial events are poorly understood at present. However, Bridgland *et al.* (2003) have tentatively suggested that the application area resides within a previously unidentified Quaternary terrace sequence.



Pumping in the alluvium



The alluvial landscape



The Orontes

Figure 61 Elements of the alluvial landscape.

Due to the proximity of the river these areas are constantly irrigated and under virtually continuous crop cover. West of the river terraces in zone 5 is an area of land that was initially identified as alluvial floodplain (see section 7.6 for a re-interpretation). The formation sequences that created this environment are extremely complex and hence detailed geomorphological investigations are required prior to any archaeological investigations.



Irrigation channels from Qatina



Southern view of the lake



Marl and conglomerate
at the lake edge

Figure 62 Elements of the landscape around Lake Qatina.

Archaeologically, the alluvial zone is difficult to characterise: the intensive cropping and complex geomorphology mean that archaeological residues can vary dramatically. However, most archaeological residues within the active river incision consist of flat sites which are very difficult to locate under crop. The lacustrine margins between the Orontes and the south-western end of Lake Qatina contain the same residue range as observed in the marl. On the

floodplain to the west of the Orontes in the south archaeological residues appear to be very sparse with only a handful of low mounds and tells.

4.2.4 Lake Qatina (unit 8)

Lake Qatina is one of the few bodies of long term standing water in western Syria, having probably originated as a natural depression adjacent to the basalt. This natural feature was exploited by an ancient dam which raised the water level to c. 497 m. The completion of a larger dam and associated irrigation system in the late 1930s raised the lake level by a further 2-3 m. However, capping the spring at 'Ain at-Tannur (to divert the water to Homs), a reduction in the yearly rainfall average and extensive irrigation has led to the shrinkage of lake Qatina (see Figure 64 and Figure 169). The lake itself offers great potential for obtaining data suited to palaeo-environmental reconstruction. Cores in the sediments have yielded radiocarbon dates that indicate that the sediments in lake Qatina have been accumulating for at least 4000 years (Philip *et al.* 2002b p. 14).

The original damming of Lake Qatina has produced many interesting ramifications. From a geomorphological perspective, erosion at the lake margins has revealed different geological layers that elucidate the formation sequence in the surrounding environments (see Figure 62). Archaeologically, the damming has helped preserve sites in the centre of the lake from further anthropogenic modification. However, there have been obvious erosional consequences. Those tells on the lake margins have been significantly eroded and in some case destroyed by the lake (see Figure 63).



Tell site 275 eroded by lake Qatina



Tell site 173 eroded by lake Qatina

Figure 63 Archaeological residues eroded at Lake Qatina.

At the western edge of Lake Qatina there is an area of low lying land covered in lacustrine deposits. After the modern (1930s) dam was built this area is very susceptible to flooding if the lake is high enough. Figure 64 displays how water level changes in the lake have affected these residues. When the lake was at peak capacity in the late 1960s none of the tells were accessible. Even at its lowest level (prior to the winter rain (Corona 1108) most of the tells are still surrounded by water. However, in the 2002 Ikonos image the lake has fallen to such a level that all of these tells are now on reclaimed 'lacustrine' land and are now subject to intensive cropping.

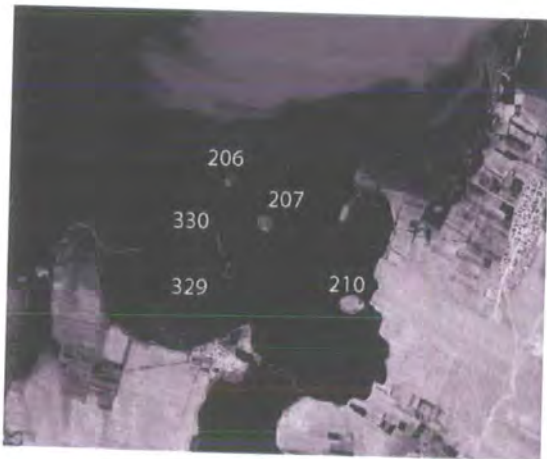

Corona 1111 June 1970 (full lake)

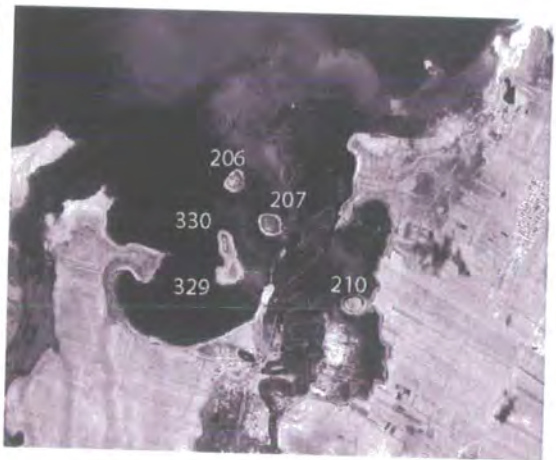

Corona 1108 December 1969 (medium lake)

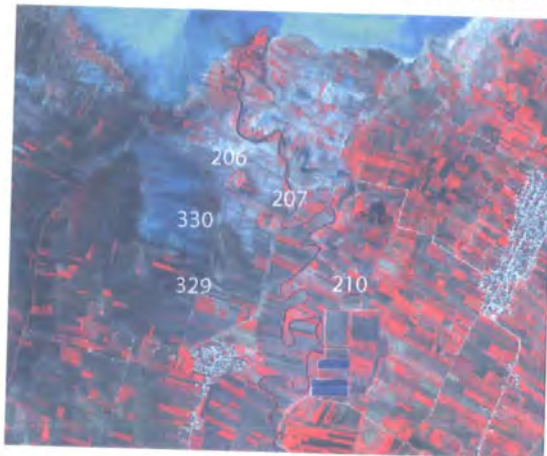

Ikonos MS February 2002 (low lake)

Figure 64 Tell sites in the lacustrine deposits at the south western end of Lake Qatina (scale 1:20,000).

4.3 Survey methodology

Philip *et al.* (2002b pp. 7-14) define the survey methodology for the application area in detail. Only the specific components of the methodologies which affect this research will be discussed in depth. The satellite imagery is employed for a number of different purposes (prospection, archaeological evaluation and thematic analysis). Of particular import is the relationship that satellite imagery may have in the determination of survey methodologies.

Wherever possible all survey data is collected digitally. Where data is not collected digitally it is digitised after collection. These data are stored, manipulated and analysed in the project information system primarily employing relational database and Geographical Information Systems (GIS) technology (see Appendix I). This information system is pivotal for the rapid assessment and analysis of the full range of data. Results of these analyses aid the structuring, programming and management of fieldwork.

As Alcock *et al.* (1994 p. 138) recommend, the available evidence was assessed to help provide a framework for field survey. This formed the Desk Based Assessment.

4.3.1 SHR project DBA

As discussed in section 3.4.2 a Desk Based Assessment is an analysis of the known or potential resources within a study area. The initial DBA was focussed on the topographic and thematic map sources and is hence discussed first.

4.3.1.1 Non-satellite data sources

Prior to incorporating satellite imagery into the research programme the only available information sources were topographic and thematic maps. Of these resources the Syrian 1:25,000 mapping proved to be the most useful for any initial archaeological DBA in the application area. Approximately 90 'sites' were positively identified from the mapping, referred to as 'known sites', from specific legend symbols or identified place names such as *tell* or *kbirbah* (ruin). Approximately 80 additional 'sites', referred to as 'potential sites', were located through less obvious indicators that might be associated with archaeological residues. These included nameless contour features and suggestive toponyms with no obvious associated settlement. In the basalt zone field systems, settlements and clusters of ovoid structures (tentatively interpreted as animal pens) were mapped. It was only after the acquisition of the satellite imagery that it became apparent how generalised this mapping was.

All of these sites were entered into the GIS and given their own unique site number. Associated attribute information was entered into the database.

A digital elevation model was created for the application area from digitised contours derived from the 1:25,000 mapping. This is discussed in greater detail in sections 5.1.4.1 and 6.6.

Thematic maps of the application area are available at a variety of small scales ranging from 1:500,000 to 1:1,000,000. These proved to be inadequate for most purposes apart from the definition of broad environmental zones. Therefore, satellite imagery is used to create these themes in more detail. Landsat TM data has a proven track record in the creation of such mapping.

4.3.1.2 Satellite data sources

Although the topographic and thematic mapping provided an initial framework for evaluation of the survey methodology, preliminary fieldwork identified numerous 'flat' surface concentrations in the marl zone and a palimpsest of field systems and structural evidence in the basalt that were not apparent on the mapping. After geo-rectifying the imagery (section 5.4) a variety of prospection techniques were used to locate areas of 'potential' archaeological residues (Chapter 7). In summary, the satellite imagery revealed over 400 'potential sites' which were plotted in the GIS. In order to evaluate the accuracy of these 'potential sites' they had to be evaluated on the ground.

4.3.2 Ground observation

Various forms of fieldwork were designed to:

- Ground observe potential sites identified from the satellite imagery – Site visits.
- Locate sites which were not identified on the satellite imagery, in order to clarify the weaknesses of satellite prospection – intensive surface collection of sample areas.
- Record information about sites visited (extent, morphology, soil and vegetation cover) in order to elucidate the relationship between the satellite images and the archaeology visible on the ground.
- Collect a small sample of diagnostic surface material to allow a provisional identification of the main periods of activity represented on each site.

- Record information about the different environmental zones to aid thematic map production.
- Collect samples for analytical determination of site visibility and geomorphological analysis.

4.3.2.1 Attribute recording

A range of attributes were recorded during site visits, including: extent, morphology, post-depositional erosion, masking, soil colour (both off and on-site), artefacts (types and ranges), land use, vegetation cover and land setting. The artefacts were washed, labelled and their attributes entered into the object database. This data was augmented by digital photography to provide a rapid and cheap aide-memoir of the site. Other, more innovative, techniques were also employed including 360 degree photography which allows individuals to immerse themselves in a digital landscape.

These same attributes were recorded for 'potential sites' which revealed no unambiguous archaeological residues. This was in order to gain further understanding of the physical conditions that actually caused 'sites' to be located and to improve the image interpretation key (see Chapter 8).

4.3.2.2 Spatial recording

There are a variety of ways in which the spatial record can be collected. In the basalt zone spatial data is normally derived from the Ikonos imagery as it is the most accurate record. However, where this data is found lacking then additional information observed on the ground can be added using GPS or by digitising directly into ArcPAD.

In all other zones the spatial component becomes more complex. It is possible to get a spatial extent for archaeological residues from the Landsat, Ikonos and Corona imagery and by defining the extent of the artefact residues or soil colour differences on the ground. For the sake of consistency it was decided to use the extent derived from handheld GPS as the definitive version. However, analysis of the extents from the other imagery should not be neglected as it is likely that the spatial extent of the residues has changed over time. This could give some insight into how modern post-depositional processes have impacted on the residues.

4.4 Fieldwork programme

Six visits were made to the application area to conduct fieldwork (see Table 4 and Figure 65). The financial and logistical assistance of the CBRL, DGAM and NERC are duly acknowledged.

The initial fieldwork season, conducted during December 1999 and January 2000, was focussed on evaluating surface collection procedures at a number of key sites in the southern marl. Three dimensional CAD models were produced at each site using a total station. This season also gave an insight into the nature of the archaeological residues across the environmental zones.

Season	Date	Goals
1	December 1999 - January 2000	Familiarisation with the project zones, the evaluation of surface collection procedures and 3 dimensional modelling of some key sites.
2	August - September 2000	To evaluate the efficacy of satellite prospection: A 20%, by area, sample was rapidly surveyed using a combination of vehicle and pedestrian survey techniques.
3	April - May 2001	To determine the benefits and problems of surveying in late spring when crop cover is at its peak and to evaluate the 7 x 7 km Ikonos panchromatic imagery.
4	August - September 2001	To focus on site and off-site ground observation in all zones. Soil samples were taken to attempt to determine the physical basis for the increased reflectance of archaeological residues in the marl area.
5	August - October 2002	To continue the goals of season 4 and to evaluate the full Ikonos panchromatic and multi-spectral imagery. GPS co-ordinates were taken as rectification points to improve the spatial accuracy of the Ikonos imagery.
6	August - September 2003	A study season to address methodological issues of recording and analysis. Further sites were ground observed in the basalt and a further group of soil samples were taken in the marl zone.

Table 4 Fieldwork summary.

The second season, conducted during August and September 2000, was aimed at locating and identifying residues identified from the satellite imagery. The study area was broken up

into 2 x 2 km squares from which a 20% sample (across environmental zones) was selected for intensive vehicle and pedestrian survey. It was intended that this survey should provide rapid feedback on which sites the imagery helped to identify, which sites were misidentified and which sites were missed. Unfortunately, at the time, the geo-referencing of the Corona imagery was quite poor. To compound matters the Syrian Grid projection was employed which meant that the hand held GPS was difficult to use (see section 5.4 for a discussion of the Syrian Grid). Therefore, navigation to the residues became very problematic: so much so that no residues could be confidently located in the basalt zone. Hence, although traversed, residues identified in this zone could not be mapped with confidence. In total 138 potential sites were visited of which 121 were positively identified.

A third season was conducted during April and May 2001. The aim was primarily to evaluate the landscape under different environmental conditions (i.e. crop). 36 new sites were visited of which 31 were positively identified. Soil characteristics (colour, compaction and composition) were also taken at these sites. A GPS map of roads and road intersections was created to aid the geo-rectification of the Corona imagery. This also provided an opportunity to evaluate the spatial accuracy of an archive 6 x 7 km panchromatic Ikonos imagery located in the southern Marl (see section 5.4). This was the first season in which the whole recording process was digital.

During the fourth season, conducted during August and September 2001, this programme of ground observation was continued (a further 55 sites). On and off-site soil samples were taken for physical and chemical analysis in order to investigate what determined the distinctive reflectance properties associated with archaeological residues in the marl. 'Off-site' sample units, referred to as transects, were surveyed to determine the level and range of 'background material' and to attempt to locate sites not identified from the imagery.

A fifth season was conducted during August and October 2002. This season had the same overall goals as the previous season (a further 70 sites and c. 5 sq. km of transects). This was the first season where the Ikonos panchromatic and multispectral imagery for the full application area was available. Further rectification points were taken with hand held GPS to improve the geo-rectification of the Ikonos imagery to facilitate desk-based mapping of the residues in the basalt.

A sixth season was conducted during August and September 2003. This was primarily a study season to analyse the pottery and flint artefacts and address artefact data recording issues. Intensive survey was also carried out in the basalt zone to establish the range of evidence and the accuracy of the desk based interpretation of the archaeological residues (a further 50 sites). Further samples were taken for particle size analysis.

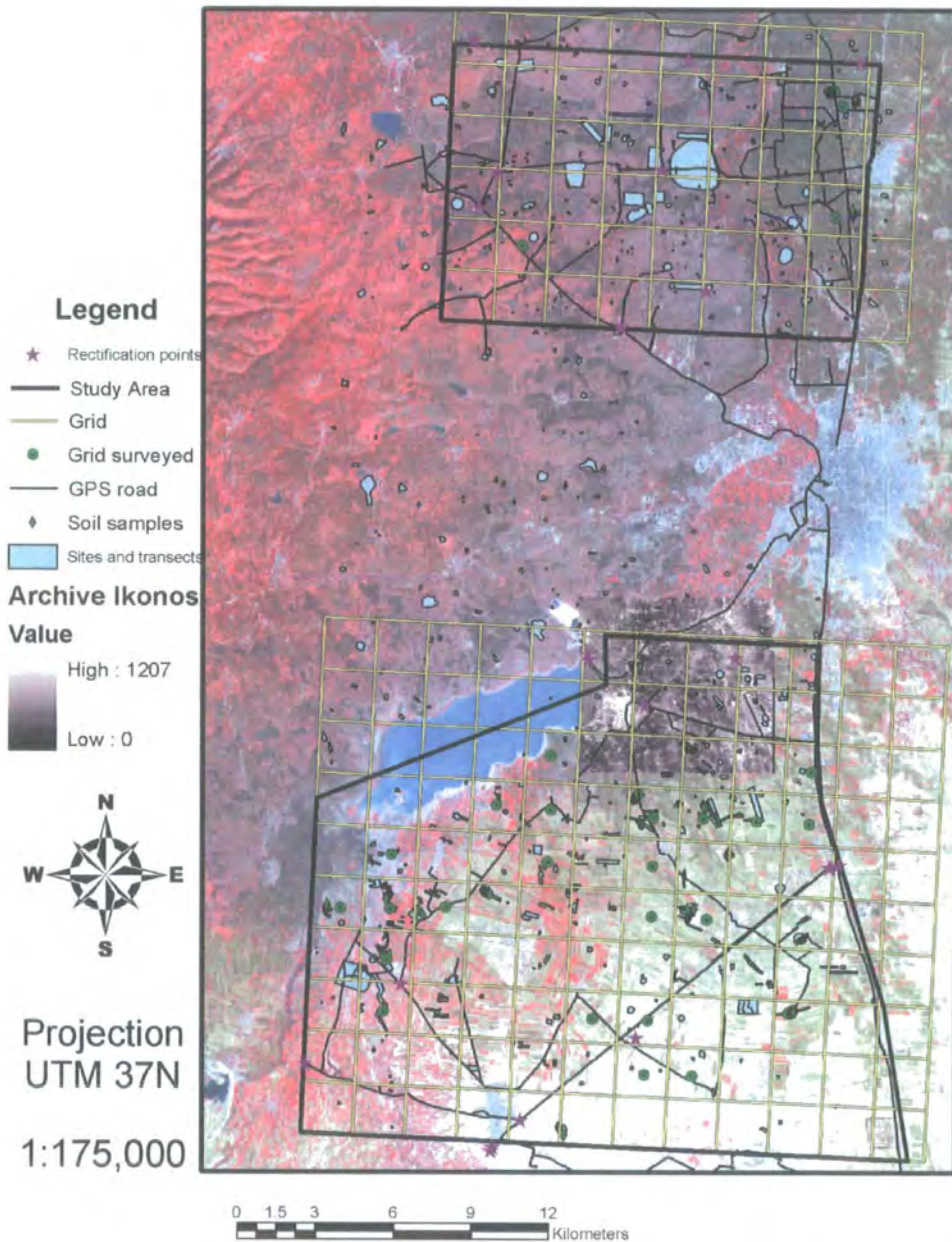

Figure 65 Summary of fieldwork from 1999 to 2003

4.5 SHR research goals

The SHR project has been designed to address the following research issues (Philip *et al.* 2002b):

- Collection of survey data for inter-regional comparative analysis.
- Monitoring inter-regional interactions.
- Region specific themes.
- Methodological issues.

These research issues are discussed in more depth by Philip *et al.* (2002b). However, there are issues that directly impact upon this research programme.

The increased availability of survey data for the Near East has begun to make inter-regional analysis possible (Wilkinson 2000). However, different surveys vary in technique, quality and coverage. As highlighted in pan-regional reviews of settlement evidence (Alcock 1994 p. 181) Western Syria is virtually devoid of any systematic archaeological survey. Where these surveys have been conducted they have focussed upon the more obvious archaeological residues (such as tells). This bias, inherent in such archaeological surveys, has been discussed by Wilkinson (1998). The methodological techniques employed by these surveys would, in all likelihood, have failed to detect many of the archaeological residues extant in the SHR project study area. This is particularly pertinent when one considers that Alcock *et al.* (1994 p. 138) recommend that sampling (and hence survey) should be guided by the known distribution of archaeological residues and a detailed knowledge of the local landscape types. Although sensible, this recommendation presupposes that such data is actually available. For this study area it was not.

The initial fieldwork seasons demonstrated that there was a positive correlation between areas of lighter soil and archaeological residues in the marl zone and that the basalt zone contained an extensive, but unmapped, palimpsest of ancient field walls, cairns and structures. However, given the size of the application area, a high-intensity ground-based survey and mapping programme would have proven to be prohibitively expensive. Furthermore, some mechanism was required to rapidly collate the distribution of archaeological residues and provide a framework for determining the local landscape types as suggested by Alcock *et al.* (1994 p. 138). Satellite sensors offer the potential to rapidly image

large areas in different bands of the electromagnetic spectrum. Some sensors have a spatial resolution approaching that of vertical aerial photography. This potentially makes satellite imagery a more cost-effective resource than aerial photography and the large ground footprint also makes it a more appropriate medium for large scale metric survey (Kouchoukos 2001). Hence, it was proposed to examine how satellite imagery can aid archaeological prospection, what impact it may have on survey methodology and how it can help in providing a framework for contextualising the archaeological residues within their environment and landscape.

The application area itself intersects a range of different environmental zones, all located with easy access to the Homs-Tripoli gap. It covers an area of transition between mobile pastoral and sedentary agricultural groups. In part these zones will have structured the social, economic and political dynamics in this landscape. The survey will produce results which will help elucidate the nature of contemporary human activity within and between these zones. Hence, it is proposed that satellite imagery can aid archaeological interpretation by providing thematic contextual backdrops.

In agricultural and industrial terms the Homs region is economically significant. As a consequence the archaeological resource is under severe threat from development, in particular residential construction, industrial expansion and intensified agricultural practices. The frequency of lower visibility 'flat' sites within the study area means that these sites are under even greater threat as they are less likely to be recognised and protected than tell sites. The documentation of the archaeological residues is intended as the first step in preparing a cultural resource mitigation and management programme to preserve permanently the character of the archaeological landscape.

CHAPTER 5 IMAGE PREPARATION

5.1 Data Sources

The research uses a combination of Landsat TM, Landsat ETM+, Ikonos and Corona imagery. Each of these sensors has different spatial and spectral characteristics and mechanisms of image acquisition. A variety of other information sources have been integrated into the project, including present day and historic mapping. Prior to integration into the data model and analysis, each of the data sets needed a certain degree of pre-processing. This is discussed in this chapter.

5.1.1 Landsat

The Landsat ('Land Satellite') programme (originally entitled Earth Resources Technology Satellite) was first publicly proposed by Dr. Robert Alexander in 1964 and the first satellite was launched in 1972 (Morain 1998). It was the first repetitive worldwide surface focussed satellite imaging system with a relatively high instantaneous field of view. The Landsat family of seven satellites (Landsat 6 was destroyed at launch) have not only seen technical changes in their sensor arrays but also changes in their ownership and management. Throughout these changes, the United States Geological Societies (USGS) Earth Resources Observation Systems (EROS) data centre retained primary responsibility for the maintenance of the Landsat archive (Campbell 2002).

The programme consists of three distinct generations of satellites (at the time of writing Landsats 5 and 7 are the only working satellites):

1. Landsats 1, 2 and 3: contained a MultiSpectral Scanner (MSS) and Return Beam Vidicom (RBV).
2. Landsats 4 and 5: contained MSS and Thematic Mapper (TM).
3. Landsat 7: contains Enhanced Thematic Mapper plus (ETM+) with approximately the same frequencies as TM with increased (60m) resolution for band 6 and an additional Panchromatic channel (0.52 – 0.90 μm , at 15m resolution).

The consistency of the Landsat data over the past three decades offers opportunities to compare land cover change over significant periods of time. This archive provides a rich collection of information about the Earth's surface. Major characteristics and changes to the surface of the planet can be detected, measured, and analysed. Thus, the effects of desertification, deforestation, pollution, volcanic activity and other natural and anthropogenic events can be examined. The information obtained from the historical and current Landsat data play a key role in analysing local environmental changes through time. Recognition of the significance of this body of data led to the 1992 Land Remote Sensing Policy Act which called for continuity beyond Landsat 7 (Morain 1998 p. 44).

For more information on the history, sensor characteristics, pre-processing and analysis of Landsat imagery please consult the following references: Morain (1998), Townshend *et al.* (1988) and USGS (2003c; 2003d; 2003e).

5.1.1.1 Thematic mapper

The TM sensor array achieved orbit in 1982 on the Landsat 4 platform. Table 5 describes the technical characteristics of the Landsat TM sensor.

Altitude	705 km
Equatorial Crossing	approx 9:45 am
Field of View	15.4°
Image overlap at Equator	7.60%
Inclination	Sun-synchronos
Number of Bands	7
Orbit cycle	233
Orbits per day	14.5
Programmable	Yes
Quantisation	8 bit
Size of image	185 x 172 km
Spatial Resolution	30-120m
Spectral Range	0.45-12.5 μm
Stereo	No
Swath	185 km
Temporal Resolution (Repeat cycle)	16 days
Sensor Type	opto-mechanical sensor

Table 5 Landsat TM technical specification (after Townshend *et al.* 1988)

Landsat TM 5 has a similar sensor array to Landsat TM 4, but Landsat 7 has the ETM+ sensor array. This sensor has the same basic characteristics of the TM sensor except that band 8 (15m panchromatic) has been added, band 6 (thermal) now has a 60m resolution and it is collected in both high and low gain (see Figure 66 and Table 6).

Range of Measure: Bandwidth (μ)								
Sensor	Band 1	Band 2	Band 3	Band 4	Band 5	Band 6	Band 7	Band 8
TM	0.45 - 0.52	0.52 - 0.60	0.63 - 0.69	0.76 - 0.90	1.55 - 1.75	10.4 - 12.5	2.08 - 2.35	N/A
ETM+	0.45 - 0.52	0.53 - 0.61	0.63 - 0.69	0.78 - 0.90	1.55 - 1.75	10.4 - 12.5	2.09 - 2.35	52 - 90
	30m	30m	30m	30m	30m	120/60m	30m	15m

Table 6 TM and ETM+ spectral band widths and spatial resolution.

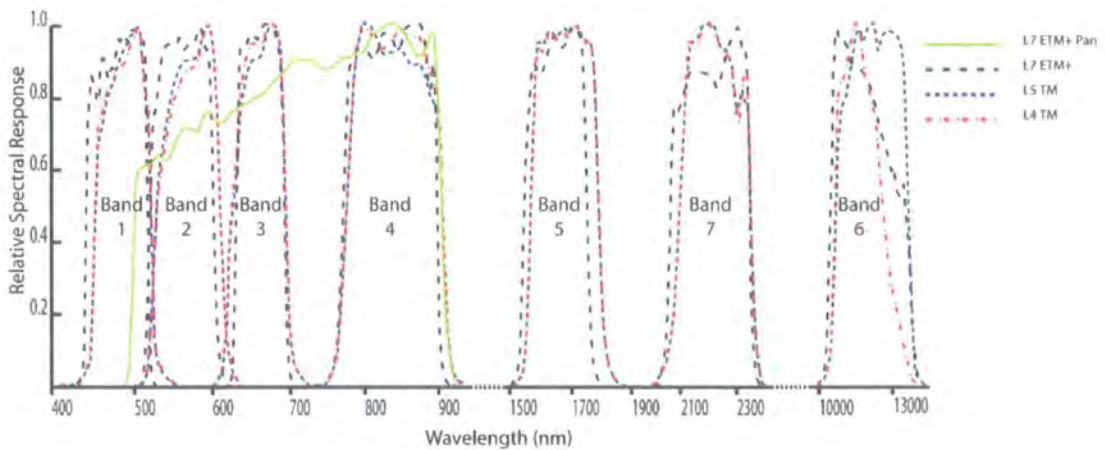

Figure 66 Relative spectral response curves for Landsat 7, 5 and 4.

The original choice of the spectral bands sensed by TM was primarily related to the spectral reflectance of vegetation and the available atmospheric windows (see Figure 67 and Table 7). Band 7 was the final band to be included due to its ability to discriminate geology and is the reason why the band sequence is not in numerical order (see Figure 66).

5.1.1.2 Landsat acquisition

Landsat imagery is available through a variety of academic sources (NERC funded researchers have free access to a variety of remotely sensed imagery including Landsat at the NERC Earth Observation Data Centre) and third party vendors (such as Infoterra Ltd.: <http://www.infoterra-global.com>). The whole Landsat archive is also available from the United States Geological Survey (USGS) through the EROS data centre

(<http://edc.usgs.gov/>). 19,662 free Landsat images of the majority of the Earth's surface are available from the Global Landcover Facility (<http://glcf.umiacs.umd.edu/index.shtml>).

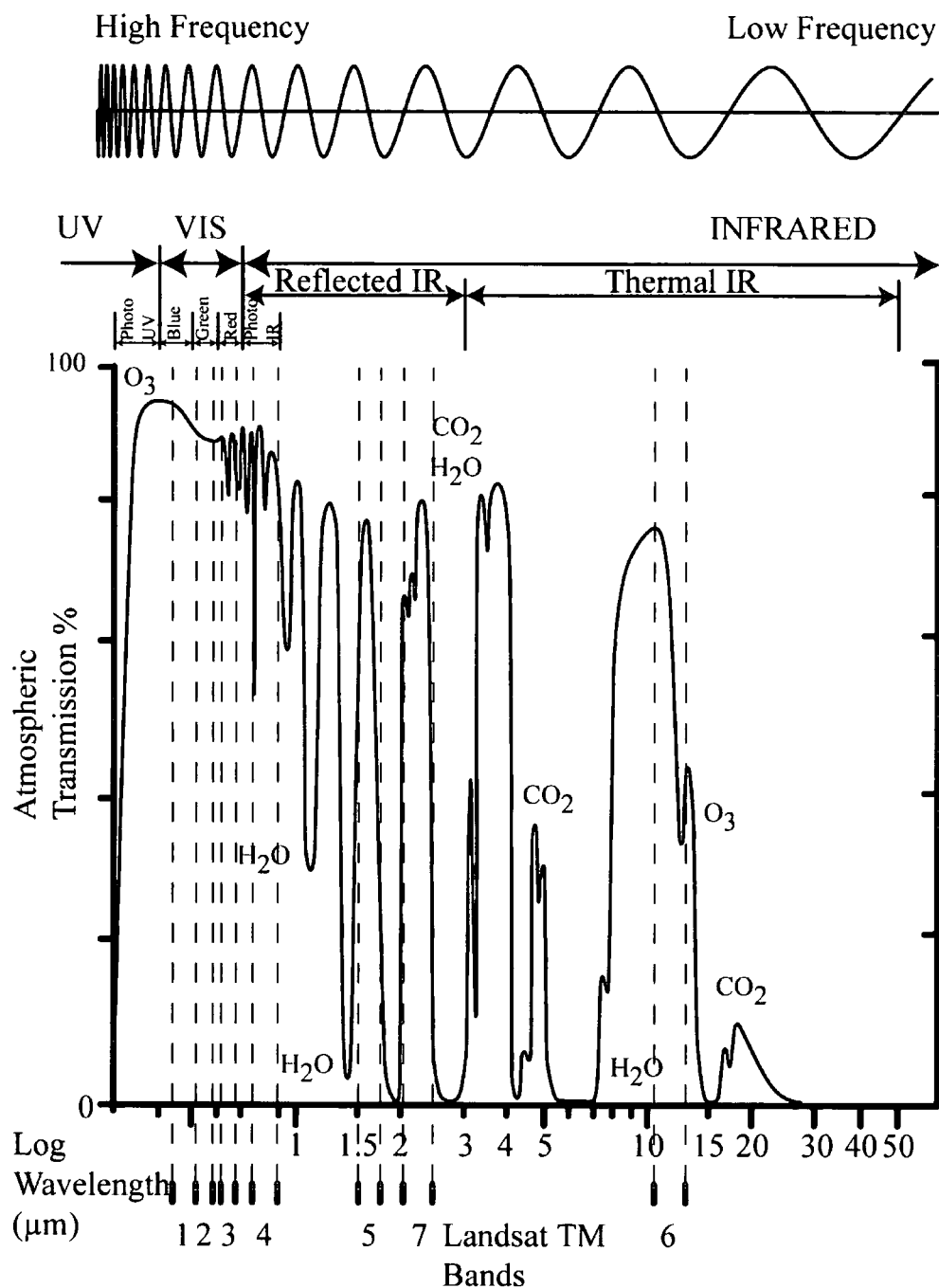

Figure 67 Diagram of the visible and IR region of the EM spectrum and Landsat TM bands. Gases responsible for atmospheric absorption are indicated (after Sabins 1997 p. 5)

Band	Wavelength, μm		Sensors	Resolution (m)	Characteristics
	Lower	Upper			
1	0.45	0.52	16	30	Blue-green. Maximum penetration of water. Useful for distinguishing soil from vegetation, deciduous from coniferous plants, bathymetry, study of water laden sediments and surface properties of snow/ice.
2	0.52	0.60	16	30	Green. Matches green reflectance peak of vegetation (chlorophyll). Useful for assessing plant vigour, distinguishing forest types, soil toxicity and pedology.
3	0.63	0.69	16	30	Red. Matches a chlorophyll absorption band that is important for discriminating vegetation types.
4	0.76	0.90	16	30	Near Reflected IR. Vegetation survey through reflection of mesophyll layer. Useful for determining biomass content, healthy vegetation and for mapping shorelines.
5	1.55	1.75	16	30	Mid Reflected IR. Indicates moisture content of soil and vegetation. Penetrates thin clouds. Provides good contrast between vegetation types.
6	10.40	12.50	4	120	Thermal IR. Night time images are useful for thermal mapping and estimating soil moisture.
7	2.08	2.35	16	30	Mid Reflected IR. Coincides with an absorption band caused by hydroxyl ions in minerals. Useful as a lithological discriminant.

Table 7 Landsat TM interpretative sensor characteristics (after Sabins 1997 p. 74; Campbell 2002 p. 173).

Landsat 5 imagery can be purchased with up to 3 levels of processing (however, precision and terrain corrected imagery can only be purchased by approved United States government and affiliated users):

1. Systematic correction: is both radiometrically and geometrically corrected. Ephemeris data is used to geometrically correct the imagery.
2. Precision correction: is the same as systematic correction product with improved geometric accuracy though the incorporation of Ground Control Points (GCPs).
3. Terrain correction: is the same as precision correction product but corrected for topographic relief using a digital elevation model.

Landsat 5 imagery can be purchased from EROS at \$425 per scene (c. 170 x 183 km) for systematic correction processing, \$550 per scene for precision correction processing and \$625 per scene for terrain correction processing. There is a significant discount for bulk purchases.

Landsat 7 imagery can be purchased with up to 5 levels of processing. Levels 1P and 1T can only be purchased by USGS approved researchers:

1. Level 0R: is the raw downloaded data with all the metadata required to conduct radiometric and geometric correction.

2. Level 1R: is the Level 0R product radiometrically corrected.
3. Level 1G: is the Level 0R product that is both radiometrically and geometrically corrected. Ephemeris data is used to geometrically correct the imagery. Residual positional error is approximately 250 metres (1 sigma).
4. Level 1P: is the Level 1G product with improved geometric accuracy though the incorporation of GCPs.
5. Level 1T: is the Level 1P product corrected for topographic relief using a digital elevation model.

Further information about the processing of Landsat imagery can be found at the USGS (2003d) website. Landsat 7 imagery can be purchased from EROS at \$475 per scene for Level 0R processing, \$600 per scene for Level 1R or Level 1G processing, \$725 per scene for Level 1P processing and \$800 per scene for Level 1T processing. There is a significant discount for bulk purchases.

Furthermore, users can define aspects of the processing parameters for Landsat imagery as outlined in Table 8.

Processing Parameters	Available options
Map projection	UTM Space Oblique Mercator Albers Equal-Area other
Horizontal datum	WGS84 NAD83 NAD27 other
Resampling method	cubic convolution (CC) nearest neighbor (NN) other
Image orientation	Map (north up) Path (satellite; not recommended for UTM projection)
Pixel size	30 metre (30m/120m) 28.5 meter (28.5m/114m) other
Multi-scene	available for up to 3 scenes
Scene shift	available in 10% increments (north-to-south only)

Table 8 User definable processing parameters for Landsat imagery.

5.1.2 Ikonos

In 1994 the US approved the development of commercial satellite sensors with a ground resolution of up to 1 metre. The first of these new generation of high resolution commercial satellite sensors to attain orbit was the Ikonos satellite owned by Space Imaging. It successfully achieved orbit on 24th September 1999 (Space Imaging 2003).

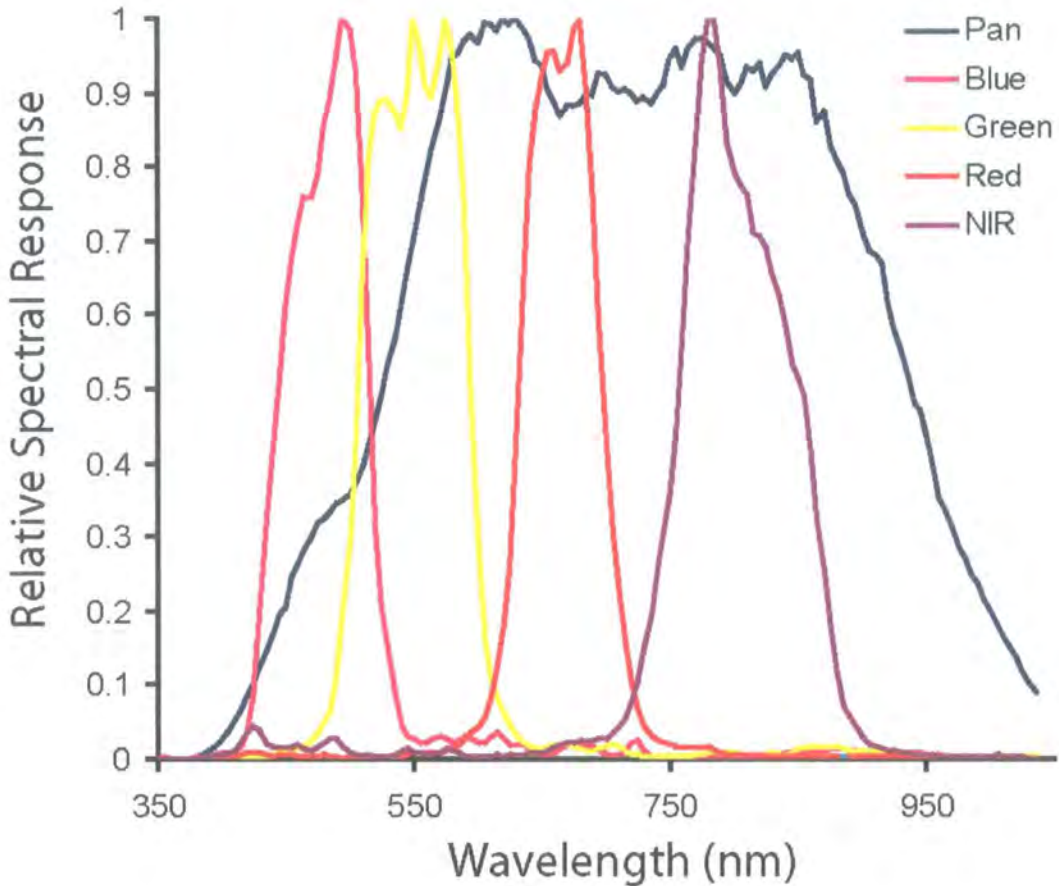

Figure 68 Relative spectral response curve for the Ikonos Multispectral and Panchromatic bands (courtesy Space Imaging).

The Ikonos satellite provides 0.82m resolution imagery in panchromatic mode and 3.26m resolution imagery in multispectral mode (4 bands: blue, green, red and near infrared with similar spectral characteristics to bands 1, 2, 3 and 4 of Landsat (see Figure 67)). This spatial resolution is resampled to 1m and 4m respectively. All the imagery has a radiometric dynamic range of 11 bits (see Table 9 and Figure 68). The sensor can be pointed off-nadir to an angle of 60° (i.e. acquisition from forward and reverse positions (Gerlach 2000)) and can hence collect stereo imagery.

Altitude	681 km
Equatorial Crossing	approx 10:30 am
Inclination	Sun-synchronos
Number of Bands	5
Orbits per day	14.7
Programmable	Yes
Quantisation	11 bit
Size of image	programmable
Spatial Resolution	Nadir: 0.82 - 3.2m
	26° off nadir: 1 - 4m
Spectral Range	MS Band 1: 0.45-0.52 µm (blue)
	MS Band 2: 0.52-0.60 µm (green)
	MS Band 3: 0.63-0.69 µm (red)
	MS Band 4: 0.76-0.90 µm (near infrared)
	Panchromatic: 0.45-0.90 µm
Stereo	Yes
Swath	Nadir: 11.3 km
	26° off nadir: 13.8 km
Temporal Resolution (Repeat cycle)	c. 3 days at 1 m resolution, 40° latitude
Cloud Cover	<20%
Sensor Type	pushbroom and whiskbroom

Table 9 Ikonos technical specification (after Space Imaging 2003 p. 1).

There are six levels of Ikonos product determined by the level of positional accuracy and pre-processing (see Table 10). Some of these products require GCPs from the client.

	Positional Accuracy			Ortho Corrected	Target Elevation	Mosaiced	Stereo option	Cost (US \$) per km ²			Applications
	CE90 (m)	RMS (m)	NMAS					Pan	MS	Bundle	
Geo	15	N/A	N/A	No	60° to 90°	No	No	28/20	28/20	32/22	Visual and interpretative applications.
Standard Ortho	50	25	1:100,000	Yes	60° to 90°	No	No	35	35	39	Basic mapping projects
Reference	25.4	11.8	1:50,000	Yes	60° to 90°	Yes	Yes	Bespoke	Bespoke	Bespoke	Regional large area mapping and general GIS applications.
Pro	10.2	4.8	1:12,000	Yes	66° to 90°	Yes	Yes	Bespoke	Bespoke	Bespoke	Transportation, infrastructure, utilities planning and economic development.
Precision	4.1	1.9	1:4,800	Yes	72° to 90°	Yes	Yes	100	100	110	High positional accuracy for urban applications.
Precision Plus	2	0.9	1:2,400	Yes	75° to 90°	Yes	Yes	120	n/a	n/a	Detailed urban analysis, cadastral and infrastructure mapping.

Table 10 Ikonos product levels (after Space Imaging 2003 p. 2: CE90 = Circular Error at 90% confidence, RMS = Root Mean Square error and NMAS = US National Map Accuracy Standards). Note the costings are based upon the May 2003 pricing levels and the pricing for Geo represents bespoke and archive imagery.

The Geo Ikonos image is used in this research. It is the cheapest option in the range of Ikonos products with the lowest level of geometric processing and has not been corrected for terrain effects (Fraser *et al.* 2002).

Other satellite sensors are also available with comparable resolutions including Quickbird (DigitalGlobe; 0.61m Pan, 2.44 MS) and EROA-A1 (ImageSat; 1.5m Pan). In 2001, the approved ground resolution for commercial satellites was further reduced from 1m to 0.5m. Satellites with improved spatial and spectral sensor systems are expected.

5.1.2.1 Ikonos acquisition

Space Imaging is a commercial, non-research venture. All company costs are recouped through the sale of the imagery. It is expected that the majority of funds will accrue through the seven year lifespan of the satellite with a further, diminishing, income stream from the sale of archive imagery after the satellite is decommissioned. As Ikonos is a commercial proposition the products come with stringent copyright and licensing terms (as detailed in Space Imaging 2003). This has implications for the future re-use and archiving of the imagery.

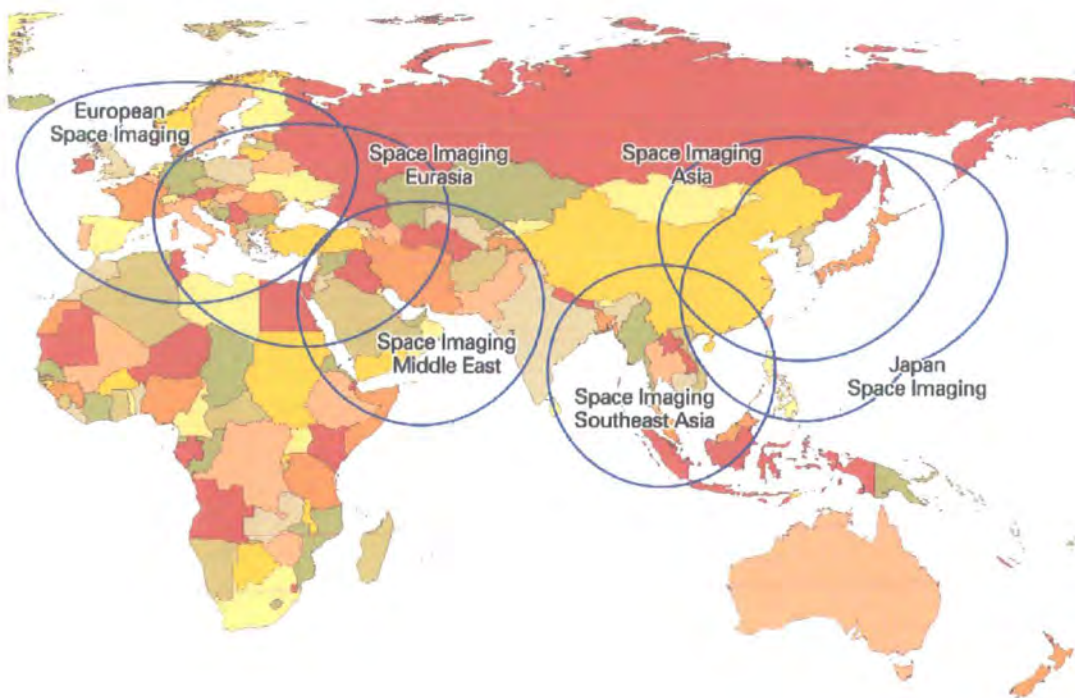

Figure 69 The location of Space Imaging regional affiliates and their direct spheres of influence (courtesy Space Imaging).

Imagery can be purchased directly from Space Imaging (USA), from one of its regional affiliates (see Figure 69) or from third party vendors (such as Infoterra Ltd). Space Imaging's home web-site (<http://www.spaceimaging.com>) and those of its regional affiliates have sophisticated viewers which allow the viewing and ordering of archive imagery on-line. The

price of the imagery is detailed in Table 10. This is subject to change and discounts are offered on a regular basis. Furthermore, products can be ordered as bespoke imagery (by defining the Area Of Interest (AOI) and the time-frame for collection) or as archive imagery (imagery is archived 4 months after collection). There is a significant discount of c. 30% for archived imagery. A minimum order size of 100 square km is necessary for new collections and 49 square km for archive products.

Every Ikonos image comes with supporting metadata, licence and AOI shape files. However, the Rational Polynomial Coefficient (RPC) camera model files are only supplied when stereo imagery is purchased. Users can also define aspects of the processing and collection parameters as outlined in Table 11.

Processing Parameters	Available options
Map projection	UTM State Plane Albers Equal-Area Lambert Conformal Conic Transverse Mercator
Horizontal datum	WGS84 NAD83 NAD27
Resampling method	cubic convolution (CC default) nearest neighbor (NN)
File Format	GeoTIFF Uncompressed NITF 2.0
Radiometric Resolution	8 bit (unknown reclass) 11 bit
Dynamic Range Adjust	On Off
Tonal Balance Mosaic	On Off
Off-Nadir angle	Definable

Table 11 User definable processing parameters for Ikonos imagery.

5.1.3 Corona

The Corona programme was endorsed by President Eisenhower in the late 1950s as a system to improve the intelligence gathering efforts of denied areas (Brugioni 1996). The Corona satellite system employed a high acuity panoramic camera for the collection of panchromatic photographic images called Key Hole (KH). Unlike modern satellites, the Corona system was placed in a decaying Earth orbit for 'missions' that lasted from 1 to 19 days. This allowed the

mission controllers to change the spatial resolution of the resultant photographic image by changing the orbital characteristics of the capsule (see Table 12). Furthermore, the orbital parameters could be adjusted for each mission. Although most launches coincided with an image acquisition time of between 10:00 to 14:00 (to optimise lighting conditions), some missions collected imagery at different times of the day (for example mission 1111 at c. 18:30).

There were a total of 134 launches between 1959 and 1972. Of these 134 launches, 102 were considered successful, acquiring over 800,000 frames of photographs covering some 650 – 750 square nautical miles (Hall 1997). In 1995 President Clinton declassified the Corona project and released the information to the public as it was no longer considered to be militarily sensitive (Campbell 2002 p. 197).

	KH-1	KH-2	KH-3	KH-4	KH-4A	KH-4B
Period of operation	27/6/59-13/9/60	26/10/60-23/10/61	30/8/61-13/1/62	27/2/62-24/3/64	24/8/63-22/9/69	15/9/67-25/5/72
Amount of frames	1432	7246	9918	101743	517688	188526
Mission life (days)	1	2-3	1-4	6-7	4-15	19
Lower Altitude (estimated in km)	192	252	217	211	180	150
Higher Altitude (estimated in km)	817	704	232	415	n/a	n/a
Successful missions	1	3	5	20	49	16
Targets	USSR	Emphasis on USSR		World-wide/emphasis on denied areas		
Aperture width	5.265°	5.265°	5.265°	5.265°	5.265°	5.265°
Pan angle	71.16°	71.16°	71.16°	71.16°	71.16°	71.16°
Stereo angle				30°	30°	30°
Lens	F/5.0 Tessar	F/5.0 Tessar	F/3.5 Petzval	F/3.5 Petzval	F/3.5 Petzval	F/3.5 Petzval
Focal length (cm)	61	61	61	61	61	61
Ground Resolution (ft)	40	25	12-25	10-25	9-25	6-25
Film (lp/mm)	50-100	50-100	50-100	50-100	120	160
Nominal ground coverage image frame	15.3x209 to 42x579 (km)	15.3x209 to 42x579 (km)	15.3x209 to 42x579 (km)	15.3x209 to 42x579 (km)	17x232 (km)	13.8x188 (km)
Nominal photoscale in film	1:275,000 to 1:760,000	1:275,000 to 1:760,000	1:275,000 to 1:760,000	1:300,000	1:305,000	1:247,500

Table 12 Corona Key-Hole camera mission characteristics (after Galiatsatos in prep).

Throughout the lifetime of the Corona project a succession of Key Hole camera systems were employed (KH-1, KH-2, KH-3, KH-4, KH-4A and KH-4B). Each camera improved the resolving characteristics of the sensor system, predominantly through increasing image resolution and decreasing platform vibration (see Table 12).

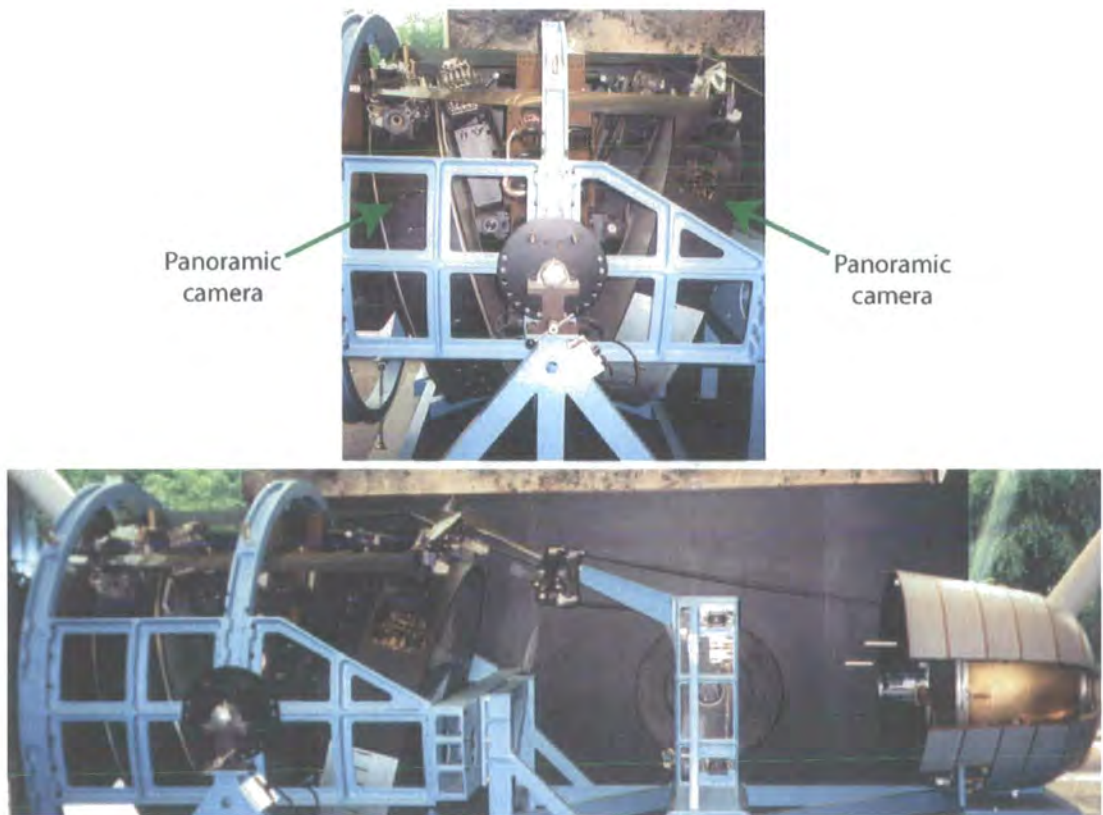

Figure 70 Corona module photographed at the Air and Space Museum (Washington D.C., USA). Note the film spools and stereo panoramic cameras. Courtesy of Keith Challis.

The film employed by the Corona mission was also improved during the lifetime of the system. The KH-1 missions originally employed 3mm thick acetate film. Unfortunately this film became brittle in a vacuum and had a tendency to break. To overcome this problem Kodak developed a 2.75mm thick Estar (polyester) film. There is some dispute about the actual film types and their specific spectral responses although Day *et al.* (1998) states that the KH-4B camera employed the Kodak EK-3404 film format (see Figure 71 for its spectral response).

Further information on the specific technical characteristics of Corona missions are available in the following references: Campbell (2002), Day *et al.* (1998), Galiatsatos (in prep) and McDonald (1997).

5.1.3.1 Corona archivation

There is very little information on the quality of storage between image capture in the 1960s and 1970s and declassification and archivation in the late 1990s. Although it is known that duplicates were made of the original photographic film, the relationship of the archived 'original' to the true 'original' is unknown. As discussed by Donoghue (2001 p. 556) photographic film is a complex material that degrades with time, depending upon how it is stored.

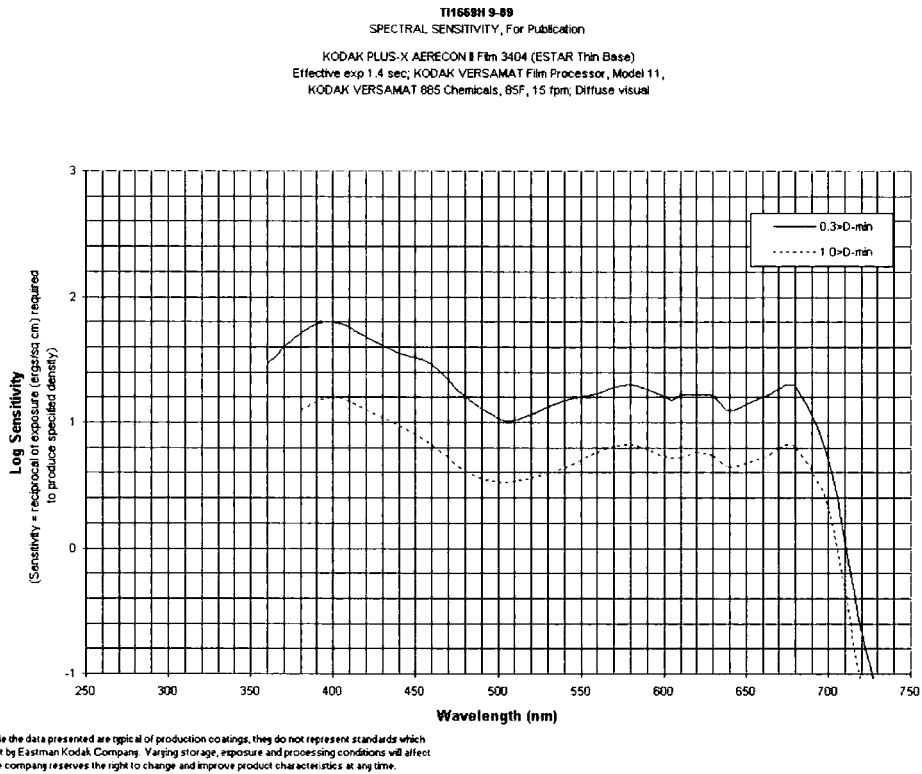

Figure 71 Spectral response of the Kodak EK 3404 film (after Kodak 2003).

After declassification, copies of the original photographic film were duplicated by Eastman Kodak and sent to USGS for metadata digitisation, archivation and re-sale. The original photographic films (and a duplicate positive copy) were sent for long-term archivation at the National Archives Record Administration (NARA) in Maryland, USA. NARA also possess a full set of all the paper catalogues, mission summaries, camera manuals, mission evaluations, technical review reports and other materials generated by the CIA during the life of Corona.

5.1.3.2 Corona acquisition

Corona can be acquired through the USGS website via the sophisticated EarthExplorer web interface (<http://edcsns17.cr.usgs.gov/EarthExplorer/>). This interface allows a variety of textual and spatial searches of multiple image archives including Corona. The interface allows access to some supporting metadata and provides the user with a preview image. Previewing Corona imagery is essential as it is the most effective way to determine the amount of cloud cover on the imagery and if that cover affects the AOI. However, as the imagery is only crudely located it is advisable to expand the AOI during any image searches.

Corona imagery can be purchased as a black and white print (\$14), film positive (\$18) and film negative (\$18) exclusive of a small handling charge and postage. The KH-4B media is 2.25" by 29.9" (USGS 2003b; 2003a).

Alternatively, one can duplicate the archived copies of the Corona photography held in NARA. Although this is a more time consuming process it has been argued by Vick (1999 cited in Galiatsatos in prep) that this will produce a higher quality product. It is advisable to retrieve all the AOI and metadata information from EarthExplorer before visiting NARA.

5.1.4 Ancillary data sets

In addition to the satellite imagery a number of historic and modern maps were procured. Historic mapping was available from the Royal Geographical Society (see Table 13). This mapping was pre-scanned by the Royal Geographic Society in TIF format.

These scans were geo-referenced using the corrected Syrian mapping. The techniques used are described in section 5.3.3. As the original scans were of unknown quality and are only for visual and comparative purposes a RMSE of 10 pixels or less was deemed acceptable.

Country of Origin	Sheet Nos.	Scale	Year	Map_Type
England		1:100,000	1920	Demographic
England		1:10,000	1952	Topographic
England		1:50,000	1952	Topographic
French	NI-37-XII-4a,	1:50,000	1933	Topographic
German	Blatt Nr. 27	1:50,000	1941	Topographic
Ottoman		1:100,000	1932	Topographic
Syrian		1:25,000	1980s	Topographic

Table 13 Summary of historic and modern mapping used in the research.

Photocopies of eight modern (1980s) 1:25,000 Syrian maps of the Homs region were also available. These photocopies were of poor quality in some places. These maps were scanned on a Contex A0 greyscale roller scanner in 8 bit and converted into a 1 bit tiff. The existing 1 km grid was used to calibrate the images for scanning and photocopying errors and geo-reference the images in the Syrian Grid (see section 5.4 for a discussion of the Syrian Grid). Once geo-referenced they were merged into one image file.

5.1.4.1 Digitising the Syrian mapping

Digitising of the modern Syrian mapping was undertaken in AutoCAD MAP CADOVERLAY using the conventions described in Table 14. The CADOVERLAY extension has a line following algorithm that simplifies digitising of complex basemaps. All 3-dimensional information had its elevation incorporated during the digitising process so that they could be used for creating a DTM (see section 6.6). Unfortunately the photocopying errors are particularly significant at the northern boundary of the Northern application area (see Figure 72). This also has ramifications for any derived terrain model created using the digitised contour data. Subsequently contour data was integrated from the 1:50,000 mapping for these areas. However, this does pose some potential problems as the data is derived from different scales.

Theme	Layer	Topology	Description	Objects	Segments
Archaeology	Fieldboundary	Network/Polygon	Field boundaries identified from the mapping	6308	13144
Archaeology	Structureamorphous	Polygon	Amorphous structures identified from the mapping	1035	2003
DTM	Contour	None	3D Contour lines	535	102014
DTM	Spotheight	None	3D Spot height	470	470
DTM	Trigpoint	None	3D Triangulated trig. points	27	27
DTM	Contourpoint	None	3D points 'weeded' from the contour lines	58701	58701
Hydrology	Lakeedge	TBC	Lake edge	1	1227
Hydrology	Marsh	TBC	Marsh edge	2	491
Hydrology	Riveredge	TBC	River banks	5	1929
Hydrology Network	Canal	Network	Network of canals	37	182
Hydrology Network	Irrigationchannel	Network	Network of irrigation channels	117	259
Hydrology Network	Rivercent	Network	Network of rivers	144	1441
Hydrology Network	Seasonalwater	Network	Network of seasonal water courses	403	4277
Mapping	Bridge	None	Bridges	2	6
Mapping	Unidentified	None	Unidentified features	4	9
Rail Network	Traintrack	Network	Rail network	3	53
Road Network	A-road	Network	Network of major roads	608	2109
Road Network	B-road	Network	Network of minor roads	1437	10409
Road Network	Track	Network	Network of tracks	425	3719
Site Polygons	Sitecent	Point/Polygon	Centroid for 'sites' polygon (seed) containing identifier	282	282
Site Polygons	Sites	Polygon	Boundary for 'sites' polygon	282	3643
Study Area	Studyarea	None	Boundary of study area	2	23
Total				70830	206418

Table 14 Layers and summary information for the digitising of the map-base

Once the digitising was completed each layer was cleaned and topology was created within MAP (see Table 14). These files were exported as shapefiles and incorporated into the project GeoDatabase (SHR_GeoBASE.mdb see Figure 72).

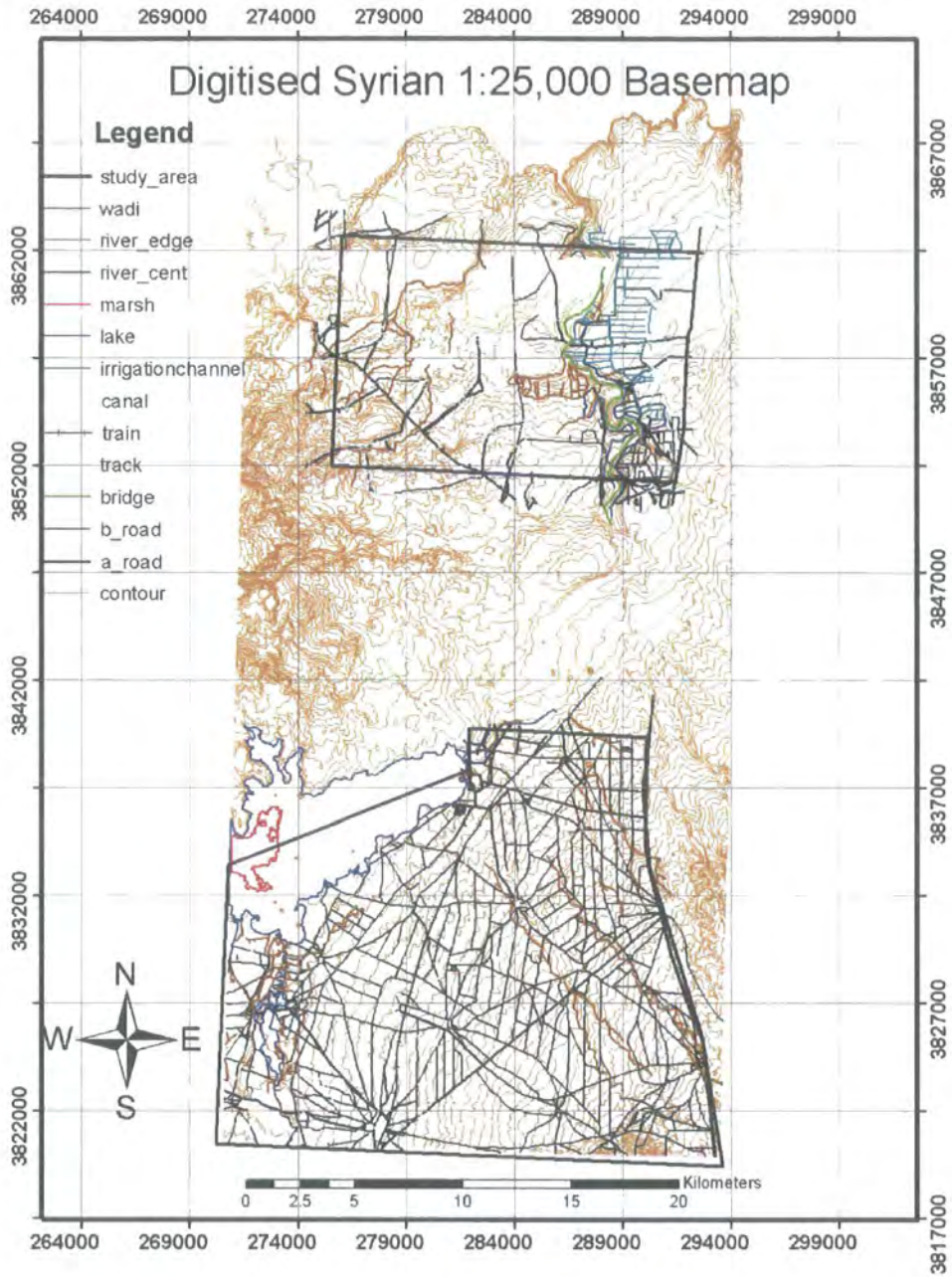

Figure 72 Digitised vector basemap. Note the poor quality contour data in the northern segment of the northern study area.

5.1.4.2 Aerial photography

During the August 2003 fieldwork season Russian vertical photography (taken in 1958) was made available through Dr. Mamoun Abdulkareem (Head of Museums, DGAM). Five

frames intersected with the northern application area. These were scanned using the resources available in Syria. Each photograph was scanned on a Canoscan GDE 20 flatbed scanner as an 8 bit greyscale tiff file at 600 dpi (the maximum physical resolution of the scanner) providing a ground resolution of 1 metre. These images were then geo-corrected within Erdas Imagine 8.4 (using a first order polynomial with an RMSE error of less than 1 pixel) with GCPs supplied from both the geo referenced Ikonos and Corona (mission 1110, 1970) imagery (discussed in section 5.4). The Corona data was required because the photographs extended beyond the range of the Ikonos imagery available, therefore control points had to be established from alternative sources. This was not an ideal geo-referencing procedure, particularly when one considers the quality of mission 1110 Corona imagery (see Figure 73). Unfortunately the higher quality mission 1108 Corona imagery did not extend into this region.

The receipt, scanning and rectification of this imagery took under 4 hours to achieve. Such speed was only possible because of the pre-registered Ikonos imagery. It is important to recognise that collection of further ground control for these images would have taken a long time: the requirements for these photographs are much more rigorous than that of Corona. A large Corona strip could be coarsely referenced using handheld GPS but it would have a footprint of many kilometres. However, the individual Russian photographs have a footprint of some 4 x 4 km, and finding appropriate hard-detail, in the absence of Ikonos and/or Corona, is difficult. The success of this initial conversion procedure will hopefully result in the procurement of more imagery under the direction of Dr. Abdulkareem. This photography is evaluated against the Ikonos and Corona imagery in section 7.4.6.

5.2 Image selection

Image selection is either the collection of new imagery at propriorious times, the selection of specific image sources from an archive of imagery or the reduction of the corpus of imagery by the selection of specific sub-sets. Prior to starting the research project Dr. Philip and Dr. Donoghue had already acquired a batch of satellite imagery. They had decided to focus on the Corona missions which employed the KH-4B lens as these missions provided both stereoscopic coverage and the highest spatial resolution. A sub-set of the mission data which intersected the application area was selected and purchased. This sub-set was based upon appropriate spatial resolution, good ground cover, a low cloud cover index and different seasonality so that the imagery could be effectively compared and evaluated (see Figure 74).

Mission 1111 was added due to the anomalous collection time of c. 18:30 hours. All missions (1108, 1110 and 111) had imagery collected from the aft camera and mission 1110 also had stereo imagery from the forward camera. For consistency the aft camera photography for each mission has been employed unless stereo analysis has been conducted.



Russian aerial photograph



Corona 1970 (mission 1110)



Ikonos panchromatic

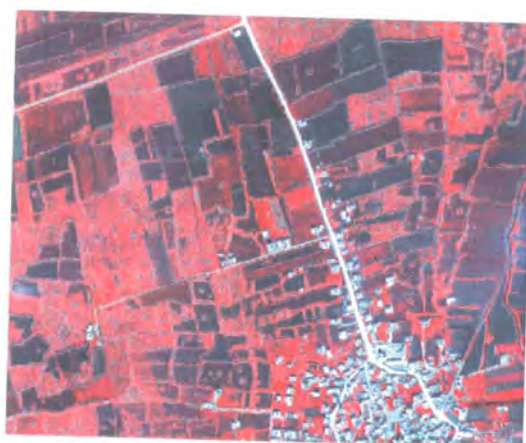

Ikonos 4,3,2 resolution merge

Figure 73 Comparison of the Russian aerial photography, Ikonos and Corona imagery (scale 1:5,000).

The Landsat sensors have a large archive of imagery. It was initially assumed that the Landsat imagery would provide important information pertaining to drift geology and vegetation. Hence images were selected that covered different environmental regimes in the application area. Two scenes were selected from 1987 (26th May and 1st October respectively) which display the maximum difference between crop cover in the landscape. May is just prior to

harvesting when the crops are at their peak and October is prior to the winter rains, at peak aridity, where crop cover is minimal (see Figure 102).

The Corona and Landsat imagery provided the benchmark from which to evaluate the most appropriate timing to collect the Ikonos imagery. Initial analysis of these Landsat and Corona images gave great insights into the operation of environmental processes and recent landscape changes in the application area.

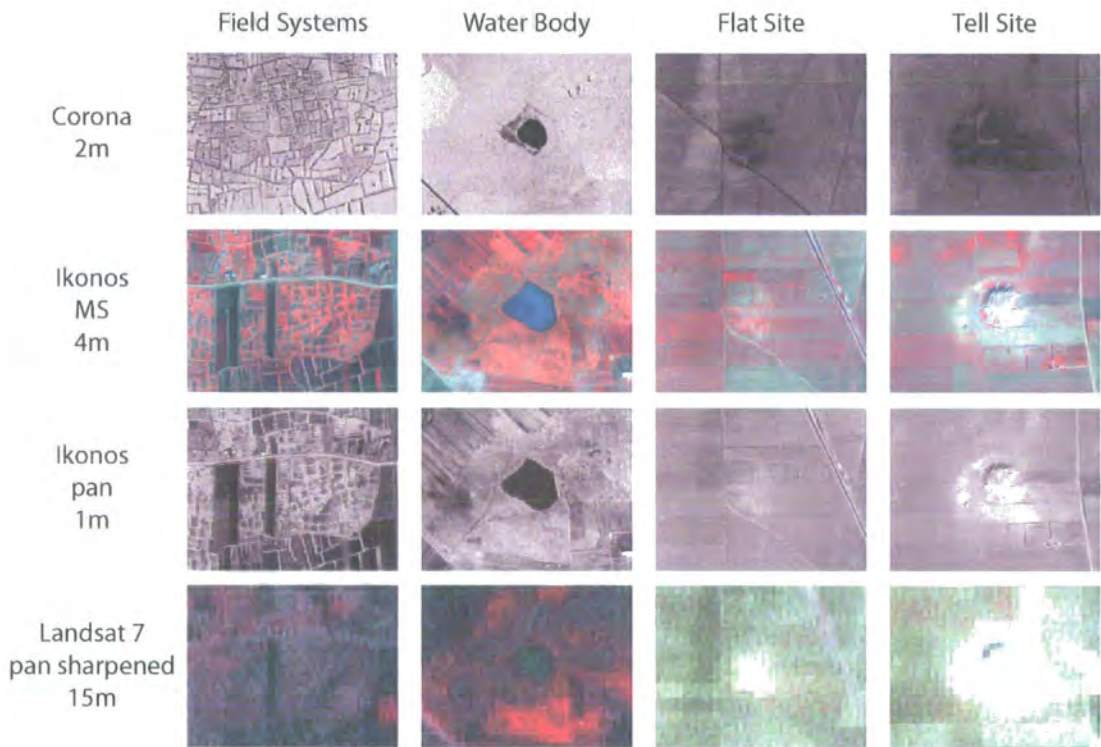

Figure 74 Sensor comparison over different feature types.

5.2.1 Atmospheric ramifications

Although it is difficult to compare the Corona imagery on a like-for-like basis as each mission had different orbital characteristics, it was rapidly deduced that increased atmospheric particulates in the spring and summer vastly reduce image quality (Donoghue *et al.* 2000). Particulates are reduced in the winter months when the wind channelled through the Homs-Tripoli gap is reduced and the atmosphere is cleansed with the first winter precipitation (see Figure 173).

5.2.2 Land management ramifications

Agricultural practices in the majority of the basalt and marl zones are based upon rain-fed agriculture. Most rainfall occurs between December and April (see Figure 77). Increased river levels are observed for a few months after this period as recharged aquifers feed local springs and snow melt (from the anti-Lebanon range) adds to the surface and subsurface hydrological regime.



Natural water holding depression (ram)



Reservoir in the basalt



Water marks on basalt rubble in the ram indicating the peak capacity



The same reservoir when empty

Figure 75 Rams and reservoir in the basalt.

During this period, in the marl zone, the water table temporarily rises and coupled with the increased surface run-off some of the inactive wadi channels become active again. In the basalt zone, natural depressions (ram) and purpose built reservoirs hold standing water (birka, see Figure 75). This hydrological system provides enough water for one main season of winter crop (between December and May see Figure 76) in all zones. According to Rodriguez

et al. (1999) encroaching desertification means that this area may soon be on the margins of sustainable agriculture. However, in exceptional years two crops may be realised (Bshesh, pers. comm.). This cropping cycle can be extended by irrigation. The alluvial zones and their margins are heavily irrigated and hence these areas are under nearly continuous crop cover. The same is true in the northern marls where, if enough water is in reserve in Lake Qatina, the French irrigation canals allow multiple cropping regimes. The image selection process (see section 5.2) determined that imagery collected during the months of September or October would be most appropriate for archaeological detection. The surface cover at this time predominantly consists of crop (alluvium), bare soil/scrub (marl) and grazing/scrub (basalt). However, where extensive irrigation does intersect with the area of interest it may be more appropriate, although logistically difficult, to collect imagery between different crop rotations to ensure that the major component of reflectance is soil.

Elevation and Annual Precipitation

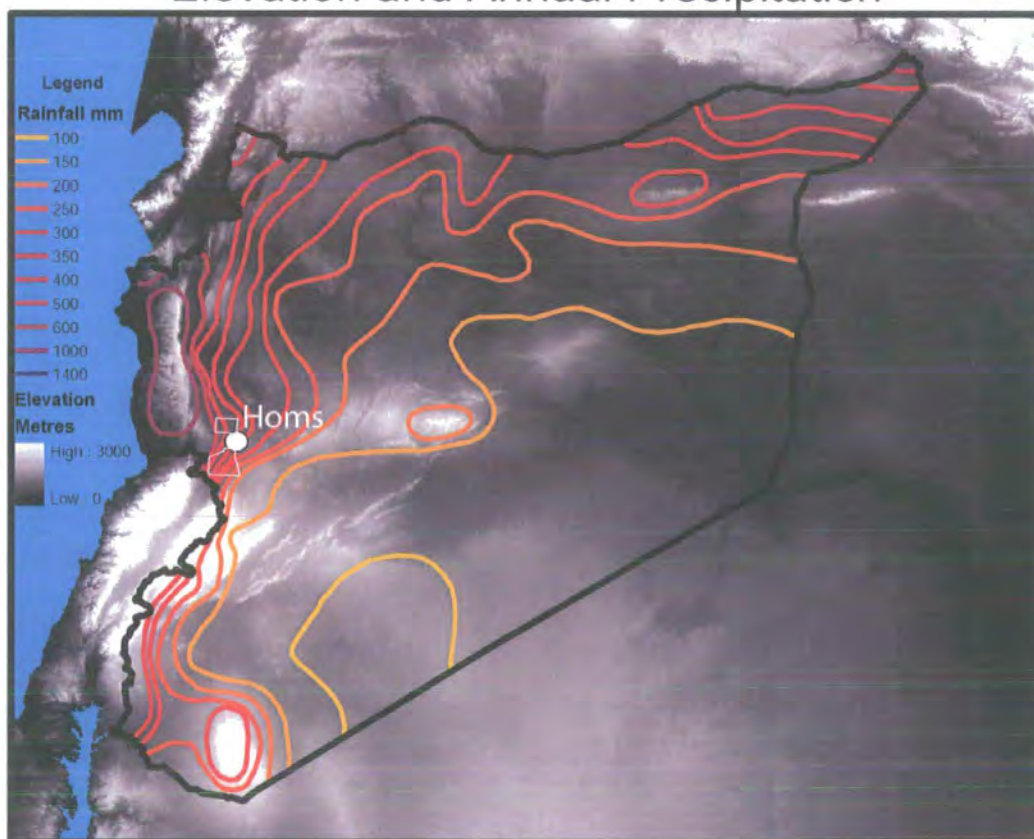

Figure 76 Elevation and annual precipitation (after Hirata *et al.* 2001 p. 509) in Syria.

This general increase in irrigation has extended the amount of time during which bare soil is masked by vegetation. Concomitantly this decreases the window of opportunity to collect appropriate imagery that contains predominantly bare soil to prospect for soil marks. Furthermore, it can be argued, that the use of deeper ploughing techniques damages the underlying archaeological residues and moves them to the surface (Lambrick 1977). Although destructive this could make the surface identification of archaeological residues much easier.

5.2.3 Field observations

The first phase of fieldwork (October 1999 to January 2000) was undertaken to refine some of the methodological field techniques which would be employed by the SHR project in subsequent field seasons. It also allowed an initial understanding of the landscape under study and the nature of the archaeological residues. This initial fieldwork led to the following conclusions:

- Except for fluvial margins the landscape could be considered as either completely bare soil or a combination of bare soil and crop throughout the year.
- Site soil colour in the marl zones was significantly different to off-site soil colour when dry and similar when wet.
- Areas of high artefact density had a positive relationship with areas of light soil colour in the marl.
- Establishing sites from crop marks would be difficult due to the perceived lack of negative features (i.e. 'positive' mud-brick construction as opposed to 'negative' postholes and ditches). The main agricultural season was between October (seeding) and May (harvesting).
- The majority of walls in the basalt zone have a width of between 0.5 and 2m.

5.2.4 Determining acquisition times

To determine when would be the most appropriate time of year to purchase Ikonos imagery the data collected from the fieldwork and through studying the Landsat and Corona imagery was combined. The rationale was to ensure that the collected imagery provides the maximum observable information for the phenomena of interest (Teng 1997).

For the mapping of small features, such as field walls, image fidelity needs to be high. Hence, the summer months (May to September) where increased airborne particulates increase specular reflection and therefore decrease spatial resolution were to be avoided. Furthermore, collecting lithological information is better after a rainfall as the surfaces under study are clean of dust. This could improve the reflectance of the basalt walls.

In the marl and alluvial zone it was considered important to collect imagery when there was little or no crop cover. This is primarily related to the nature of the archaeological residues and the difficulty in targeting crop marks. European models of crop mark formation are based upon the theory that crop vigour or crop stress is a function of sub-surface archaeological residues such as walls and ditches, and their effect upon soil moisture (see Figure 47). However, it has yet to be demonstrated if this is an appropriate system for the Homs area of Syria (or the Middle East generally) where the formation and deformation systems are strikingly different. For example, walls have limited footings and ditches rarely form part of the archaeological repertoire.

The majority of settlements were built of mud-brick and incorporated a variety of organic material that did not transform the landscape in the manner observed in Europe. Hence, European models of crop mark detection would need fully re-evaluating for this environment. Crop mark formation is a function of the environmental conditions which are different between Europe and the Middle East. Furthermore, the visible effects of crop marks have a short time span (see, for example, Figure 48) and the interpretation of crop mark evidence as a systematic prospection tool is subject to bias (Cowley 2002). Hence, even if crop marks were susceptible in the application area, the likelihood of intersecting the period of peak crop mark formation would require extensive determination. Even if these times were determined it would still be difficult to capture them with current sensors (even though Ikonos is a bespoke platform the ordering process is time consuming and the exact time of the collection can not be guaranteed (see section 5.2.5)). Finally, would the sensors have the spatial resolution to detect crop marks? The 1m resolution Ikonos panchromatic may display crop marks, but, the NIR band in the 4m multispectral is likely to improve detection. It is unlikely that linear crop marks can be adequately detected with a 4m sensor. Using Jensen's approximation the crop mark would have to be 8m in diameter! However, it can be hoped that future sensor systems with increased spectral and spatial resolution will allow the earlier and later identification of differential crop stress and vigour characteristics,

allowing the window of opportunity for identification to be extended (Hanson, pers. comm.). Therefore, as the likelihood of detecting crop marks was very low the months of intense crop cover (February-May) were avoided.

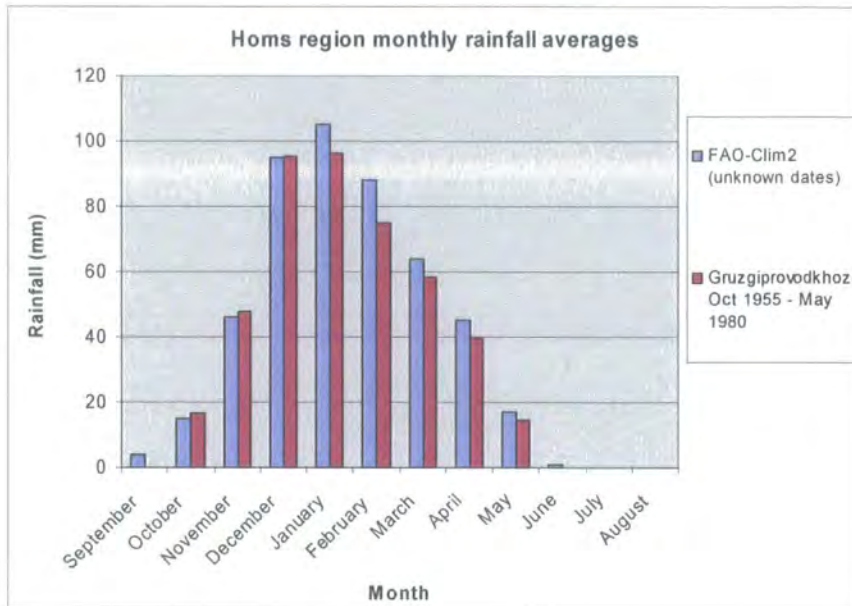

Figure 77 Monthly rainfall average for the Homs region (data kindly supplied by ICARDA). Total rainfall is 480mm for FAO and 442.6mm for Gruzgiprovodkhoz.

Fieldwork had demonstrated that sites could be readily identified from soil colour differences alone. Representative samples were taken for both on and off-site soils. Amongst other measurements, the soil colour values were taken in both ambient (dry) and wet conditions. Colour was calculated by reference to a standard colour matrix reference sheet. Originally the archaeological soils recording chart produced by Artacorn (Middleton 2000) was used, but it did not prove to be adequate for recording soils in arid environments. Hence the Munsell colour charts (Munsell Colour Company 1975) were employed. The results showed that the colour difference between wet and dry off-site soils is very close. However, there is a large difference between wet and dry on-site soils (wet soils are significantly browner (Munsell 1981 pp. 55-57)). Furthermore, the on-site wet colour is very close to both the wet and dry off-site soil colour (possibly highlighting the shared relationships with parent material or improved drainage on sites). From this information it was deduced that the lower the soil moisture (or the higher the aridity) then the greater the colour difference between on and off-

site soils and hence the easier it is to discriminate archaeological residues. After talking to local farmers (Bshesh, pers. comm.) and evaluating the rainfall data provided by ICARDA (see Figure 77) it was determined that peak aridity would occur between the months of September to December (this includes a time lag for the evaporation of moisture).

Hence the months of February to September were to be avoided due to inclement crop cover or environmental factors. The ideal months for acquiring satellite imagery for archaeological prospection are during the months of November and December. Although some fields are sometimes under crop at this time the crop is usually immature, the initial rains would still not unduly affect the overall soil colour but would remove dust from surfaces in the basalt area.

5.2.5 Data sets acquired

With this in mind, Ikonos imagery for the application area was ordered from Infoterra Ltd. to be collected between November and December 2000. However, due to communication problems between the various agencies in the supply chain this collection programme was not successful. Although a small sample of Ikonos data was retrieved from Space Imaging's archival data, the lack of Ikonos imagery necessitated a six month suspension of the research programme between July and December 2001. Another application for imagery was requested for November 2001. Unfortunately, this collection period coincided with the military action in Afghanistan and hence the Ikonos satellite was in heavy demand.

Syria currently is part of one of the "area of high contention" for obvious global political reasons and, as such, our acceptance of new collections in these regions have been impacted. We can certainly accept the order but will note that the backlog is such that the order will not receive any priority for approximately 30 to 45 days and, even at that point, standard collection times cannot be guaranteed. Also, due to the severity of the situation, we cannot accommodate rush tasking requests for the same reasons.

(Key 2001)

The Ikonos imagery was finally collected on 26th January 2002 and 3rd February 2002. The total cost of the imagery was £21,770.26 excluding VAT and delivery (1m and 4m Geo

bundle for the Northern area @ 195 sq. km £7,512.63 and 1m and 4m Geo bundle for the Southern area @ 370 sq. km £14,256.63). The imagery was delivered on 4 CD-ROMs to Dr. Donoghue on the 20th February 2002. Unfortunately, one set of multispectral data for the southern area (Order ID: 87554_0010000 MS) was corrupt. All disks were returned to Space Imaging and replacement data was received by Dr. Donoghue on the 26th April 2002. Due to an administrative error by Space Imaging the second set of disks did not contain the Panchromatic or Multispectral imagery for the Northern area. This completed data set was finally received by Dr. Donoghue on 27th June 2002.

An initial inspection revealed that the quality of the data sets was very good. The supporting metadata is excellent. Cloud cover is low (the largest obscured image has < 5% cloud). Of the 2048 DN values possible for 11bit data each scene, on average, has a dynamic range of approximately 400-600. Image clarity is very good (individual olive stands can be resolved in panchromatic and inferred from MS). Image geometry is good (within Space Imaging's specification and closely correlated with handheld GPS readings) with a maximum displacement between overlapping images of 25m in the South and 15m in the North. This good correlation is in part due to the limited relief.

Due to the size of acquisition each application area was collected in two blocks (a western and eastern block). Unfortunately, the southern blocks did not overlap which necessitated the collection of a third block of data. This data will be useful for examining the photogrammetric potential of the geo product. Although the images were not collect in the stipulated time frame and final delivery was some 7 months after the closure of the collection window it was recognised that this would not significantly affect the research. A combination of good radiometric resolution and a less dusty atmosphere (working on the assumption that the atmosphere has reduced particulate matter after the rains) has provided higher quality data than would have been expected during our stipulated time frame even though the environmental characteristics are not ideal (see Figure 78). Some equalisation of surface soil colour must be expected in the area due to an increase in soil moisture but it is difficult to quantify such a problem. This is exemplified in Figure 78 where haze effects are visible in the September image but not in the February images. This haze effect has reduced the effective spatial resolution of the September imagery. For example, the markings in the open ground and detail on the rooftops are blurred in the September image.



Ikonos (6th September 2000)
and GPS overlay.

Ikonos (3rd February 2002)
forward acquisition
and GPS overlay.



Open ground



Ikonos (3rd February 2002)
reverse acquisition
and GPS overlay.

Figure 78 Comparison of the spatial clarity and geometric accuracy of raw Ikonos panchromatic imagery from different dates and acquisition orientations.



Corona mission 1108
(17th December 1969)
and GPS overlay.

Corona mission 1110
(28th May 1970)
and GPS overlay.

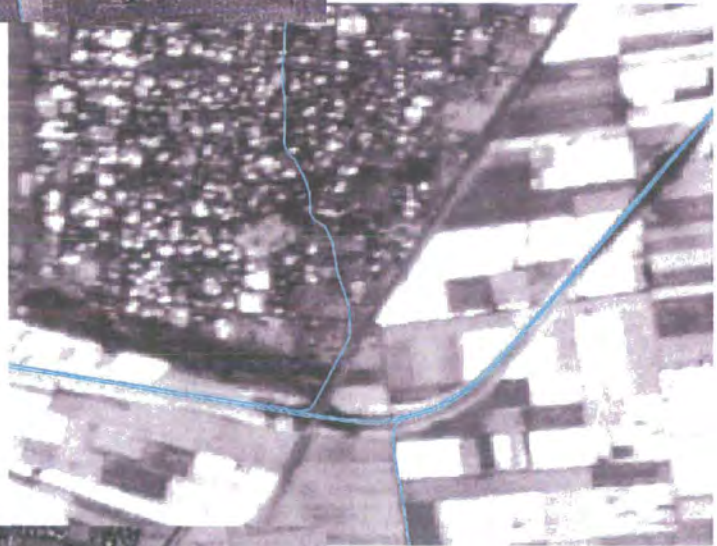

Corona mission 1111
(31st June 1970)
and GPS overlay.

Figure 79 Comparison of the different rectified Corona missions.

Three missions of Corona imagery were purchased as detailed in Table 15. Crop cover in mission 1108 and 1111 imagery should be minimal in most areas as these images were taken pre and post the growing season. Furthermore, mission 1111 imagery was collected at c. 18:30 hours instead of in the morning, which may exacerbate shadow marks. Mission 1110 was collected during peak crop cover. The imagery quality of this mission was quite poor in comparison to the other Corona images.

Mission No.	1108	1110	1111
Date	17/12/1969	28/05/1970	31/6/1970
Time	c. 10:30	c. 10:30	c. 18:30
Season	pre-crop	pre-harvest	post-harvest
Image fidelity	Good	Poor	Good
No. of frames	3	6	2
	D203043-5	D106007-9 D106013-5	D135001-2
Stereo	N	Y	N

Table 15 Corona acquisition summary.

Two full scenes of Landsat 5 were purchased for the 26th May 1987 and 1st October 1987 with a processing level of systematic correction. Both images were in UTM map projection, with the WGS84 datum, used a nearest neighbour resampling method and a 28.5m pixel size.

Two full scenes of Landsat 7 were purchased for the 14th January 2000 and the 28th October 2000 with a processing level of 1G. Both images were in UTM map projection, with the WGS84 datum, used a nearest neighbour resampling method and a 28.5m pixel size.

5.3 Image pre-processing

As discussed in section 2.2.5, image pre-processing is a preparatory step to remove radiometric and geometric discrepancies in imagery. The Corona imagery also requires converting from an analogue to a digital medium.

5.3.1 Digitising Corona

In order to convert the Corona photographic negative into a digital image it requires scanning. The film strips cover a large ground footprint. The first task is to locate and mark out the extent of the areas of interest on the negatives, so that only these areas are scanned.

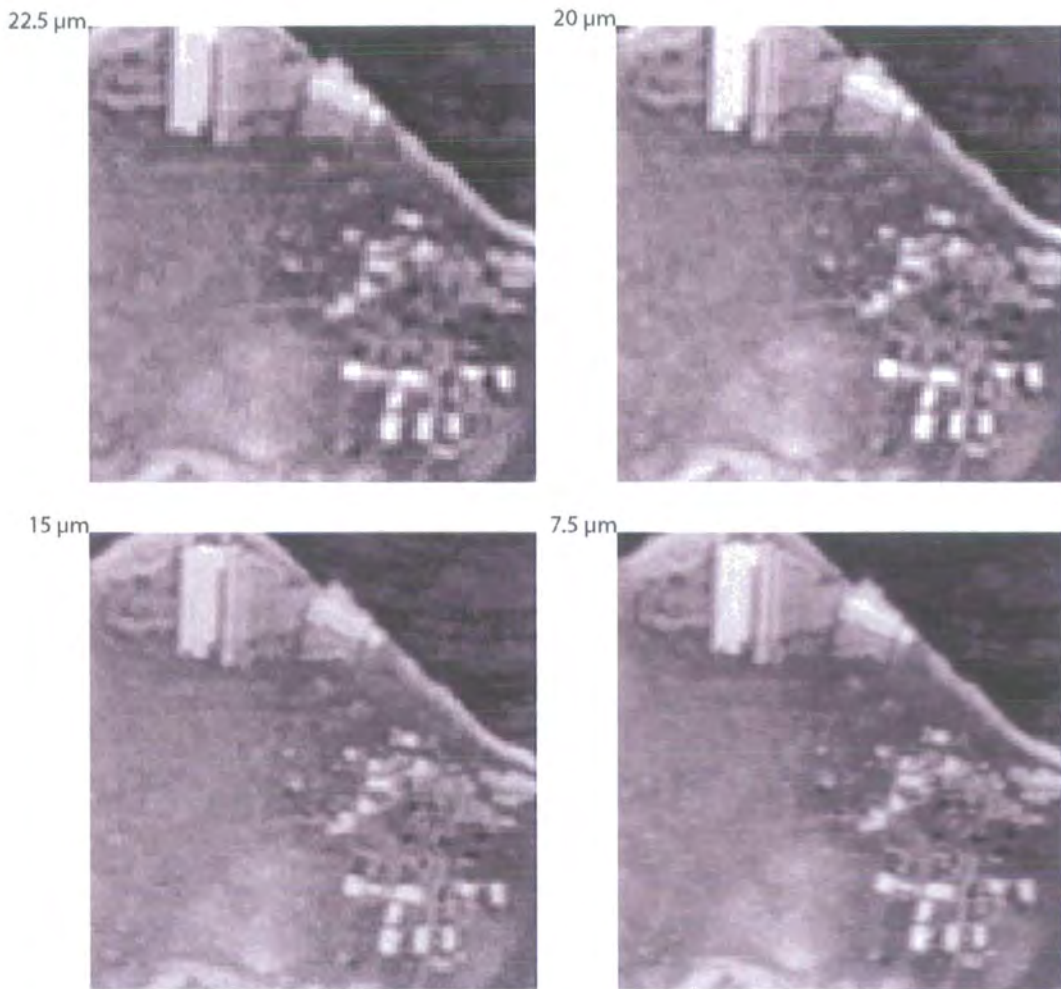

Figure 80 Corona imagery scanned at different resolutions

As the resultant digital facsimile will be employed in a variety of quantitative processes the spatial and radiometric fidelity of the scanning process is of paramount importance. For this reason, desktop scanning solutions were discounted due to their low spatial and radiometric fidelity (Coburn *et al.* 2001). The Corona photography has a nominal resolution of 160 lp/mm (see Table 12). Full resolution scanning would require a scanner with $3\mu\text{m}$ (c. 8000 dpi) resolution which are not available in a desktop range. Other researchers (Ur 2003, Challis pers. comm.) have used desktop scanners for digitising Corona photographic prints with adequate results. However, it has yet to be demonstrated if these less rigorous approaches facilitate a broad range of quantitative techniques (for example DTM creation see section 6.6).

A high resolution photogrammetric scanner (a Vexcel VX4000) was employed to scan the imagery. This scanner has a high resolution scan head without interpolation, a geometric accuracy of 1/3 pixel RMSE and a radiometric accuracy (in 8 bit) of 2 DN's RMSE.

For evaluation purposes the same segment was scanned at four different resolutions (22.5, 20, 15 and 7.5 μm (see Figure 80)). The 7.5 μm resolution produced the best results and was used for all the other Corona negatives. The cost of each scan at 7.5 μm was £18.

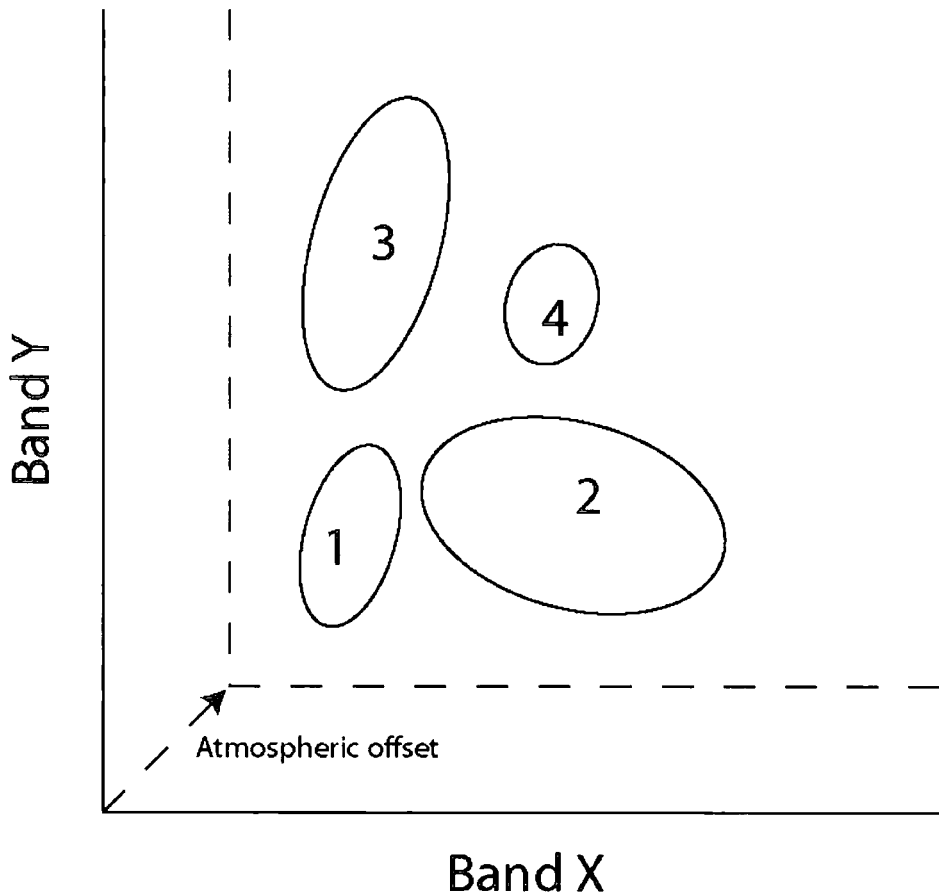

Figure 81 Subtracting a constant from a band is equivalent to translating the origin and has no effect on the variance-covariance matrix. Hence dark object subtraction has no effect on classification results (after Song *et al.* 2000 p. 232).

Galiatsatos (in prep) discusses the radiometric and geometric effects of the scanning process and the geometric distortions inherent in panoramic cameras in detail.

5.3.2 Atmospheric calibration

As discussed in Chapter 2, electromagnetic energy detected by a satellite sensor, particularly those in the optical region of the spectrum, consist of a mixture of energy reflected from or emitted by the ground surface. This energy is modified by a variety of mechanisms while travelling through the atmosphere (see Figure 9, Figure 13, Figure 14, and Figure 15). Hence, energy recorded at the satellite sensor is not a true measurement of surface reflectance (Franklin and Giles 1995; Song *et al.* 2000).

Atmospheric effects can mask the subtle differences in reflectance or emittance. For optical satellite sensors absorption is less important. As described in Figure 67 the bands are located in regions with low absorption characteristics (Song *et al.* 2000 p. 232). Hence, scattering is the main effect which, in a scene with an homogenous atmosphere, normally produces a linear (additive) offset and does not affect either variance or covariance (see Figure 81).

When, then, does one correct for atmospheric effects? Tso and Mather (2001 p. 12) and Song *et al.* (2000 p. 232) recommend that if only single date images are used for land cover identification then it can be assumed that all pixels are equally affected by atmospheric processes and atmospheric correction need not occur.

However, correction may prove desirable when one intends to conduct time change analysis, requiring comparison of images taken at different times. There are four main methods of correction:

1. Dark object subtraction (Histogram adjustment): This method is based upon the assumption that some objects in a scene should have zero reflection. Hence, any DN value recorded in these pixels is derived solely from atmospheric scattering. This value is offset against all values in the band. Shadows are commonly used as dark objects in the visible bands and deep clear water in the Near Infrared (Tso and Mather 2001 pp. 13-14). Multiple image normalisation improves this technique for multi-temporal image sets (Jensen 1996 p. 116). Although dark object subtraction is easy to apply it provides only an approximation and can fail in some areas (Liang *et al.* 2002).
2. Histogram Equalisation: If images are collected at similar times and on similar dates then many of the environmental factors can be assumed to be the same

(solar illumination, crop cover, rainfall etc.). It is further assumed that matching the histograms of each image will suppress atmospheric effects.

3. Use of a model atmosphere: An assumed atmosphere is calculated using the time of year, altitude, latitude and longitude of the application area and environmental variables. This model is used to determine what corrections are required for each band. However, determining the ambient variables for this technique can be difficult.
4. Correction using contemporaneous ground readings: If ground reflectance readings have been taken in the AOI with a spectro-radiometer during the satellite collection phase then these readings can be used to accurately correct for atmospheric effects at the sample points. This correction can then be extrapolated across the whole scene using, for example, the empirical line method (Karpouzli and Malthus 2003). However, the large spatial resolution of most satellite imagery means that this technique is rarely used.

Other researchers have attempted to remove atmospheric noise by using multi-temporal Principal Components Analysis (PCA) with some success (Song *et al.* 2000).

For time change analysis only comparable sensors will be analysed together. The Landsat imagery was corrected for atmospheric, haze and solar elevation effects using the Erdas module produced by Skirvin (2003). This module applies the correction methodology outlined by Chavez (1996) based on dark object subtraction. Furthermore, this algorithm produces 6 band data (by removing both the panchromatic (for ETM only) and the thermal bands). Due to the complex differences in geometric fidelity and spectral content between the Corona and Ikonos and the lack of atmospheric data for the Corona imagery, histogram matching was decided as the most appropriate mechanism for the Ikonos and Corona imagery. However, this process disrupts the structure of the image histogram and will only be applied when necessary.

5.3.3 Correction of topographic effects

Most remote sensing classifications assume that the terrain under study is flat with Lambertian reflectance behaviour. However, topographic slope and aspect may introduce radiometric distortion (Franklin and Giles 1995; Tso and Mather 2001 p. 21). In some instances the area may be in complete shadow, dramatically affecting the brightness value.

The goal of topographic correction is to remove all topographically induced illumination so that two objects having the same reflectance properties show the same brightness no matter what their orientation to the Sun's position. Topographic correction has been shown to improve some classifications (Jensen 1996 p. 122) and reduce the visual impression of terrain ruggedness. Most topographic correction procedures require a digital elevation model (DEM) as a basis for modelling, although others use ratioing procedures (for example Holben and Justice 1981).

Fortunately, the application area is relatively flat (see Figure 82). With the exception of the basalt walls and tells, few archaeological residues demonstrated a significant topographic component. No topographic correction was applied for the majority of analyses. However, Galiatsatos (in prep) has conducted extensive research into digital topographic modelling in the area.

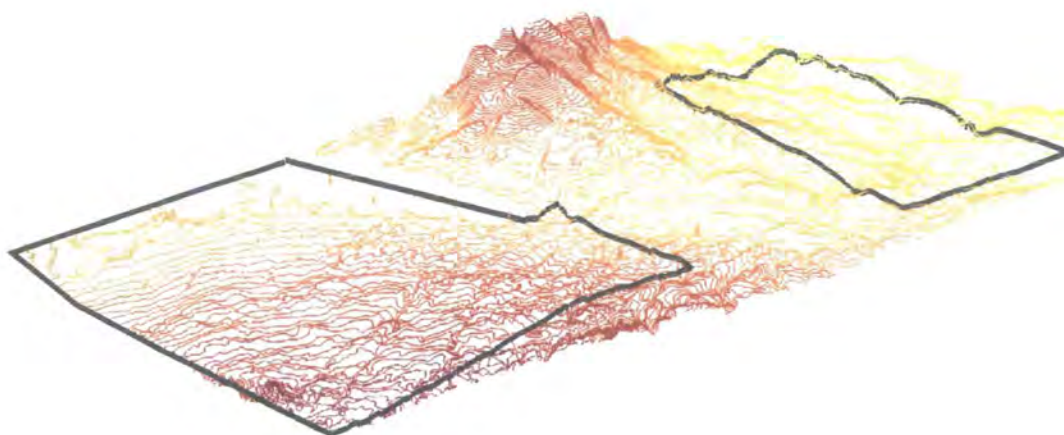

Figure 82 Isometric view of the application area and contour lines.

5.4 Geo-rectification

Archaeology is a spatial discipline: every archaeological residue has a spatial component. It is therefore important that archaeological residues are located somewhere in space. Rectification is the process of correcting systematic and random errors in imagery. Rectification procedures can either be spatial or non-spatial. Non-spatial rectification is commonly used to correct camera lens and scanning aberrations (or other errors in a collection device). Spatial rectification is used to locate imagery somewhere in space. Image rectification places a data set with a spatial component into a spatial framework. Amongst

other things, this will allow accurate measurements to be taken from the imagery, and integration with other spatial data sets and spatial data collection devices.

Prior to any rectification or data collection procedure, a projection system needed to be determined. In most areas with institutionalised CRM bodies, the regional or national projection system is easily accessible. It is advisable (and in some instances mandatory) that this projection is used. This will ensure that any results will integrate seamlessly with the national CRM data and other data sets enabling subsequent data re-use and integration (Bewley *et al.* 1999).

Where such a system does not exist, it is advisable to use one of the standard worldwide referencing systems such as Universal Transverse Mercator (UTM) or Lat/long projections (both standard worldwide reference projections) and an appropriate datum (if in doubt use WGS84). All systems must support the projection used. Pre-registered satellite imagery will normally come in a worldwide referencing system. If the registered imagery needs re-projecting by one of the many available algorithms, then some data loss is likely due to the pixel resampling technique employed (see Figure 29). However, many current GIS and image processing systems allow on-the-fly rectification of imagery in different projections.

During the first two fieldwork seasons the only rectification medium available to the project was the 1:25,000 Syrian mapping (in a projection that was referred to as the Syrian Grid) and handheld GPS. At the time (late 1999) the use of handheld GPS was discounted as Selective Availability (SA: the deliberate degradation of GPS accuracy) had only just been removed and there was no reference material to determine the accuracy of handheld GPS (Rees 2001). The use of Differential GPS (DGPS) was impossible due to military restrictions. Hence, the Syrian mapping was the only available resource. This was also the grid system employed by the Homs regional office of the Directorate General of Antiquities and Museums. Using GCPs identified from the maps both the Corona and Landsat imagery were corrected to the Syrian Grid.

When overlying this information with data collected by handheld GPS (in UTM 37N) it was obvious that the Syrian Grid and UTM, although similar, were not the same. The only indication the Syrian maps gave for their coordinate system was a reference to a '4th spheroid UTM'. The Syrian Grid required offsetting, rotating and scaling to fit the UTM grid

(Galiatsatos in prep). In order to re-project the Syrian Grid into UTM an understanding of the parameters of the projection system were required. Contacts at the Directorates of Museums (including the Al-Bassal centre), Agriculture, Remote Sensing and Survey were approached to see if they could provide any further information on the technical characteristics of the projection. Unfortunately, for bureaucratic or sensitivity reasons this information was unavailable. However, it was determined that the majority of mapping created within the directorates (including the Al-Bassal centre which is in the process of creating a national archaeological inventory) was projected in UTM.

During the third field season (17th April to 10th May 2001) a comparison (see Figure 83) was made between GPS readings and the recently received 6 x 7 km archived Ikonos 'geo' panchromatic image (collected on 6th September 2000). A very high spatial correlation was observed between the Ikonos imagery and handheld GPS readings. The excellent geometry and clarity of the Ikonos panchromatic meant that this imagery could be used to supplant the Syrian 1:25,000 map series or GPS co-ordinates for rectification purposes. Furthermore, the accuracy of the handheld GPS appeared to be about 4-5 m in this region (Rees 2001).

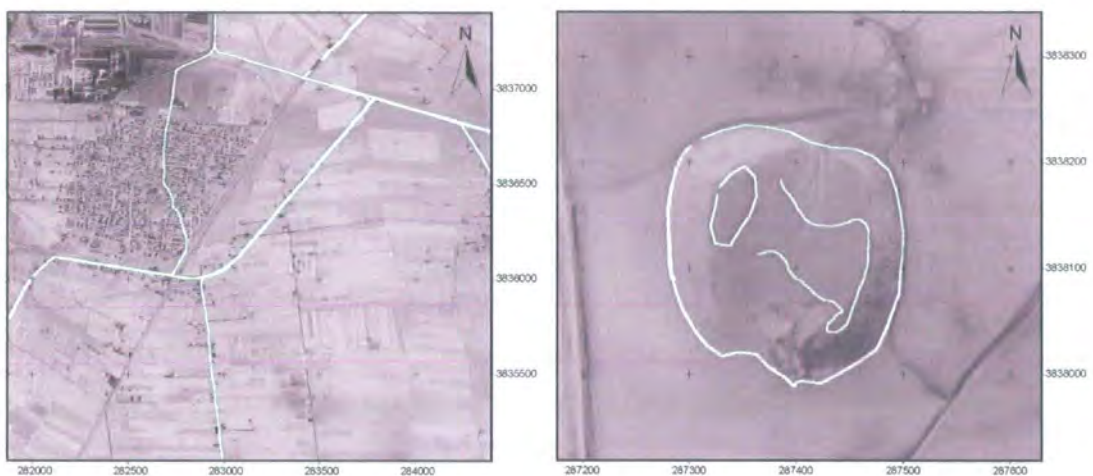

Figure 83 Raw GPS readings overlying raw Ikonos data (after Beck *et al.* in press).

On the basis that UTM was used by many of the Syrian directorates and it fulfilled many of the other criteria previously outlined the Syrian Grid was abandoned in favour of UTM. Similar problems were encountered by Harrower *et al.* (2002) in their projection and datum definition. It was subsequently ascertained after conversations with Dr. Meredith Williams

(Department of Geomatics, University of Newcastle-upon-Tyne) that the Syrian mapping was probably based upon Russian military mapping. Russian mapping of this nature employs the Gauss-Kruger projection.

UTM is more intuitive for in-field work than Lat/Long (units are metres as opposed to seconds of arc). It is also widely supported (e.g. by Landsat, Ikonos and most GPS systems) and is already used by Cultural Resource Management databases elsewhere in the region (Palumbo 1992). World Geodetic System (WGS) 84 is used for the datum.

Beck *et al.* (in press) discuss a comparative rectification methodology using GPS and the 6 x 7 km archived Ikonos as sources for Ground Control Points (GCPs) to reference the Corona imagery. They determined that Ikonos imagery provides the best reference source (see Figure 84) due to its ability to provide a substantially greater number of concurrent GCPs. It should also be noted that locating GCPs by GPS for Corona imagery is very difficult: the landscape has changed significantly in the intervening 30 years. This situation was also noted by Altmaier and Kany (2002 p. 227).

Upon receipt of the whole Ikonos data set it was possible to expand the results from the small scale 6 x 7 km area to the whole application area. After examining the different Ikonos images and comparing them to GPS readings (see for example Figure 78) it was obvious that geometric accuracy of the imagery was not consistent. For some reason the ephemeris characteristics of the September 2000 Ikonos imagery allowed a particularly accurate rectification. In light of this information the results of the rectification process undertaken by Beck *et al.* (in press) were re-evaluated.

The geometric errors associated with the Ikonos imagery still provide a good level of accuracy for rectification across the application area. Any image rectified using the Ikonos imagery as a GCP source will have the combined error of the rectification process and the original error of the Ikonos basemap. The accuracy of the 'geo' imagery (> 25m RMSE) is still appropriate for the mapping and location of archaeological residues in the marl where absolute accuracy is not as important. However, in the basaltic landscape some discrete elements are less than 10 m in width. Hence, the accuracy of the Ikonos imagery is too coarse to enable accurate desk based mapping in this zone. In such instances, field checking based upon GPS navigation of the digitised segment would require one to make a choice between a

number of wall segments. Fraser *et al.* (2002) had improved the accuracy of the Ikonos geoproduct to sub-meter levels by using Differential GPS to re-geo-correct the imagery. They noted that the internal geometries of the Ikonos imagery were very accurate and hence only a few GCPs were required for the correction. They found that a configuration of 3 good GCPs gave similar accuracies to 6 or 8. It was recommended that the centre of roundabouts provided some of the best GCPs.

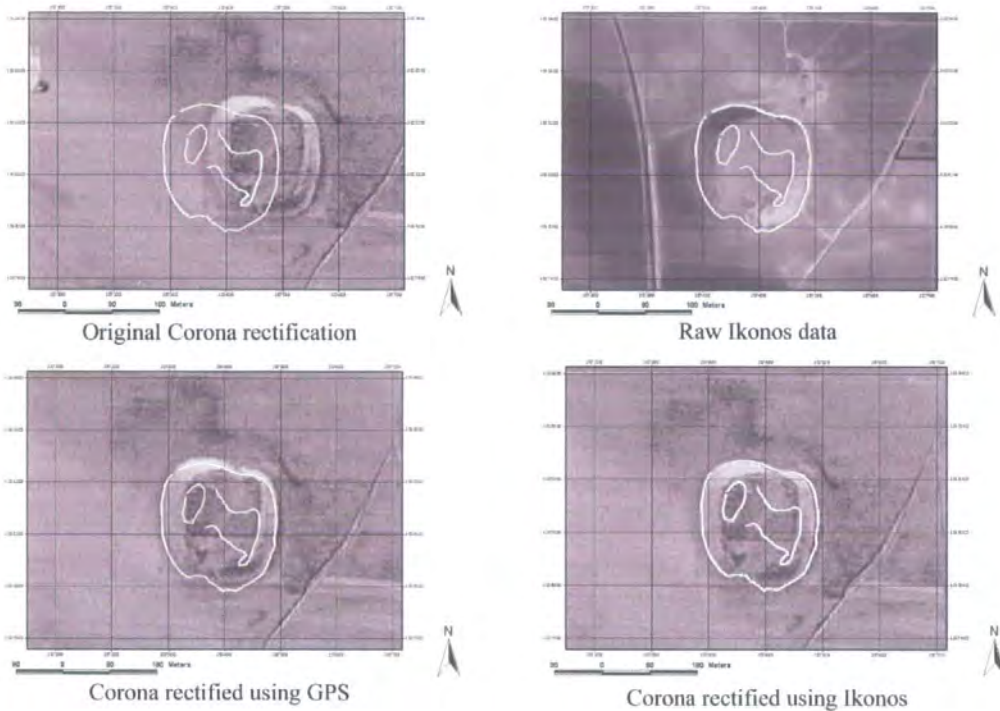

Figure 84 Comparison of Corona rectification using GCPs derived from GPS and Ikonos (after Beck *et al.* in press).

Applying the methodology of Fraser *et al.* (2002), 15 GCPs were taken with hand-held GPS throughout the application areas. At each piece of detail an average of 100 GPS readings was taken to produce 1 point. This was repeated so each location had 2 GCP points (in retrospect it would have been more appropriate to take 200 individual readings and then perform a more rigorous averaging technique). A photograph of each GCP point was taken to aid the subsequent rectification procedure (see Figure 85). Three GCPs were used to correct each of the five Ikonos pan images using Erdas Imagine with a first polynomial nearest neighbour rectification. The panchromatic images were used first as the higher spatial resolution enabled

a more accurate location of the tie point. These same GCPs and tie points were used to correct the 5 Ikonos MS images.

The re-geo-correction of the Ikonos imagery using GCPs from handheld GPS (with an estimated positional error of c. 4-5 m) provides 5-8 m RMSE. This accuracy allows desk based mapping and subsequent field navigation to be undertaken with improved confidence. It cannot be overstated how much time and money this simple technique will save in comparison to traditional Total Station survey (Newson 2002). This re-geo-corrected Ikonos imagery became the basemap upon which all subsequent co-registration of Corona and Landsat was undertaken.

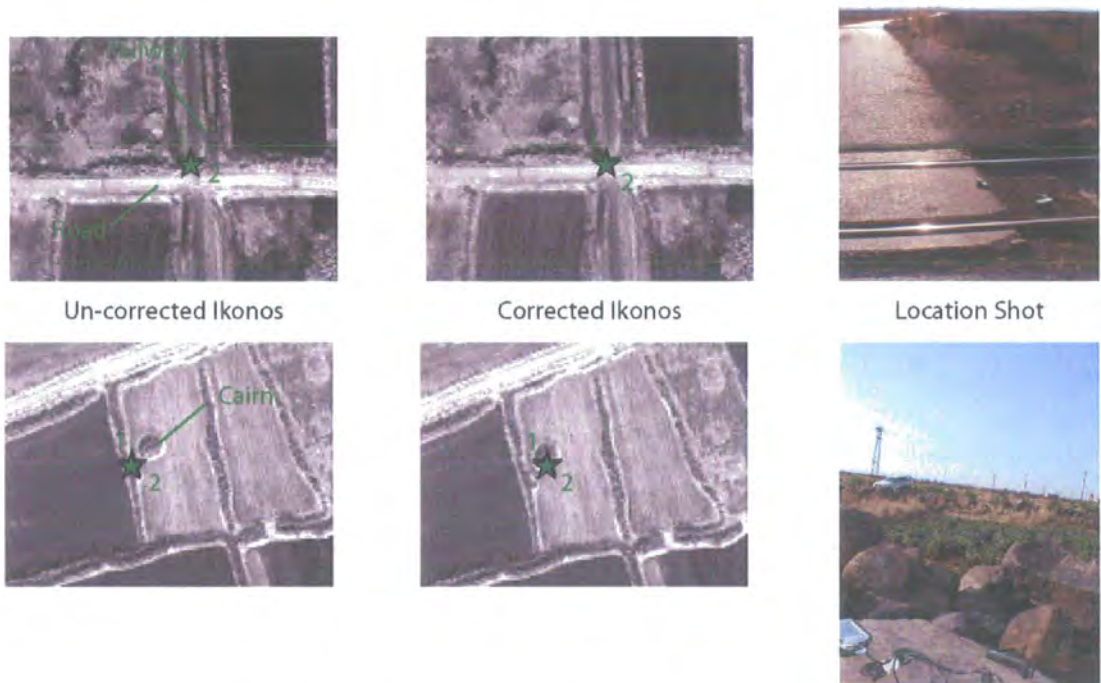

Figure 85 The location of two GCPs, raw Ikonos and corrected Ikonos.

5.4.1 Co-registration

Most modern satellite imagery is delivered to the user as geo-referenced data. All such data has an error associated with its spatial location. This means that it is extremely rare that two images collected by the same satellite at different times will have the same location in the same space. Figure 86 shows this for two different panchromatic Ikonos images. There is an

offset of 7.3m East and 9.9m North between the images. For most applications this is an insignificant difference. However, for image fusion techniques, such as pan sharpening (see section 5.6.1) or time change analysis (see section 9.4), it is important that the pixels in the layer stacks all represent the same object. This process is referred to as co-registration.

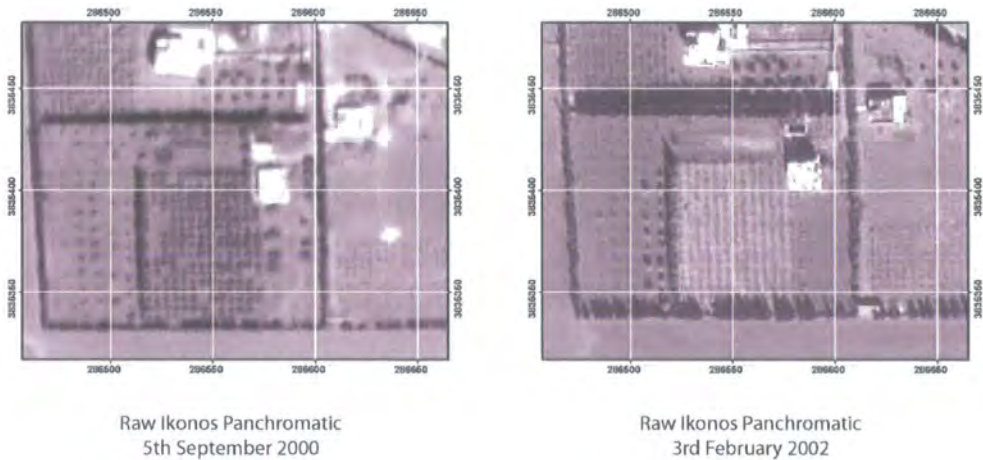

Figure 86 Geo-referencing errors. The Ikonos image on the right is offset from the left image by 7.3m East and 9.9m North.

As the Corona imagery was scanned from photographic negatives they have no spatial component. These images were co-registered to the re-geo-corrected Ikonos imagery using concurrent GCPs. It should be noted that the Corona imagery used non-metric cameras. This means that there can be a significant non-linear displacement of features in the negative. Therefore higher order polynomial functions were required to warp the imagery in order to ensure low error margins at the GCP points (see Table 16).

Image	No. of GCPs	Correction Method	RMSE (1m Pixels)
Corona 1108 North	34	3rd order polynomial	1.90
Corona 1108 mid	25	3rd order polynomial	2.63
Corona 1108 South	20	3rd order polynomial	1.79
Corona 1110 North	21	3rd order polynomial	1.93
Corona 1110 mid	12	2nd order polynomial	2.15
Corona 1110 South	26	3rd order polynomial	2.63
Corona 1111 mid	27	3rd order polynomial	2.66
Corona 1111 South	8	2nd order polynomial	13.40

Table 16 Corona co-registration RMSE accuracy.

The anomalous 13.40 RMSE for the Corona 1111 South image is due to the lack of concurrent control between the Corona and Ikonos. It should also be noted that the area of intersection between the two images is very small in relation to the full extent of the Corona image.

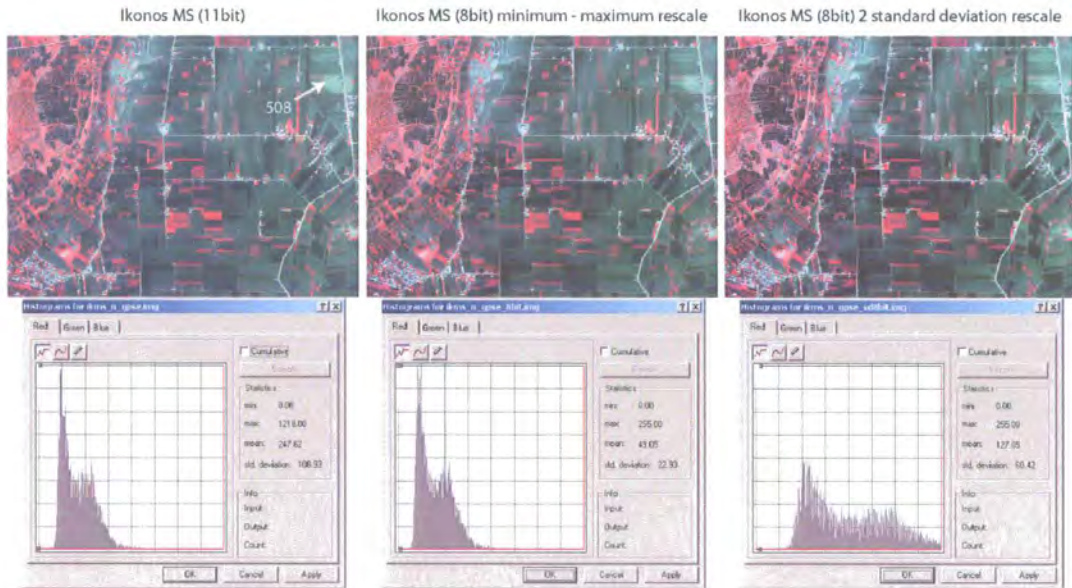

Figure 87 Comparison of rescaling techniques. Although the 4,3,2 FCC look similar the histogram of the image using SD rescaling is significantly altered from the original.

The Landsat imagery was co-registered to the re-referenced Ikonos imagery by selecting concurrent tie points. However, the difference in scale between 1m and 30m spatial resolutions made the choice of points very difficult. This situation was somewhat ameliorated with Landsat 7 imagery. The panchromatic band has a ground resolution of 15m. This band allows the collection of tie points with greater confidence. After the Landsat 7 images were co-registered the panchromatic bands were used as basemaps for the Landsat 5 imagery.

5.5 Image rescaling

In order to evaluate whether the 11 bit radiometric depth was of significant value, the Ikonos imagery was re-scaled to 8 bit image depth. This procedure was undertaken in Erdas Imagine 8.4 using the re-scale command and the parameters outlined in Figure 88. Each new Ikonos file was provided with the suffix '*_8bit*'.

A minimum-maximum rescale was used as this simulates the 11 bit sensor recording in 8 bits (the nature of the histogram is preserved). However, from an image compression perspective a standard deviation rescale was also conducted (see Figure 87). The standard deviation rescale uses more of the DN bins than the minimum-maximum rescale and therefore maintains more of the original data. If processing time or disk space is an issue this technique could be used in order to reduce file size with minimal loss of content. It is also interesting to note that the standard deviation rescale makes some archaeological residues more obvious (see site 508 in Figure 87).

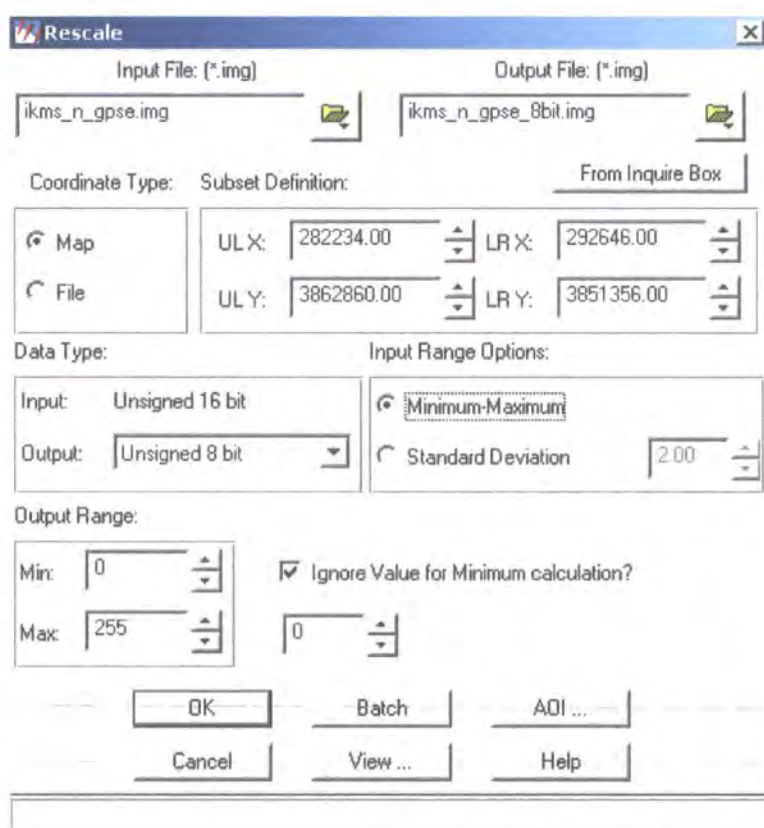

Figure 88 The rescale parameters used in Erdas Imagine to convert 11 bit Ikonos to 8 bit.

5.6 Image fusion

Image fusion is the process of analysing more than one image source. Image fusion techniques are valuable because of their ability to integrate the various characteristics of different imagery into a single image stack. Imagery is fused in order to exploit the spectral and spatial characteristics of different sensors (pan-sharpening see section 5.6.1) or to

evaluate changes in image structure over time (time change analysis see section 9.4). As such, fusion is not normally an end in itself but an interim process for different analytical goals (Pohl and Van Genderen 1998). Image fusion can only occur if the images to be analysed are co-registered.

5.6.1 Pan-sharpening

Remote sensing systems usually exhibit high spatial resolution and low spectral resolution or low spatial resolution and high spectral resolution. High spatial resolution is necessary for the definition of shape and structure, whereas improved identification (as opposed to detection) comes from high spectral resolution (Ranchin *et al.* 2003). Panchromatic sharpening is a generic term for the process of merging any high spatial resolution image with a low spatial but higher spectral resolution image. The resultant imagery combines both the high spatial and spectral resolution of the input products (see Figure 89). These images can improve visual interpretation by integrating the texture of the higher resolution imagery with the colour composition of the multispectral bands (Dare and Fraser 2001).

Successful pan-sharpening requires that the images are co-registered (see section 5.4.1) and are collected on or around the same date. The specifics of the pan-sharpening algorithms are beyond the scope of this research but are discussed in detail by Chavez *et al.* (1991), Wald *et al.* (1997), Pohl and Van Genderen (1998) and Ranchin *et al.* (2003). Campbell (2002 pp. 313-315) summarises the most common pan-sharpening techniques. Given the spatial, spectral and temporal variations in the imagery only co-collected imagery was pan-sharpened: the 4m Ikonos MS bands with the 1m Ikonos pan band and the 30m Landsat ETM+ MS bands with the 15m Landsat ETM+ pan band. This will allow further evaluation of a 1m resolution MS Ikonos image (potentially useful in the basalt) and a 15m resolution MS Landsat ETM+ image (potentially useful in the marl).

Most image fusion techniques employ information from different sensors (for example Sunar and Musaoglu 1998). Increasingly, sensors are developed that have the capability to co-collect co-registered multispectral and higher resolution panchromatic imagery. Both the Ikonos and Landsat ETM+ imagery sets have these characteristics. These data sets have limited or no error in their co-registration and because they are co-collected they have the same solar illumination (Liu 2000a).

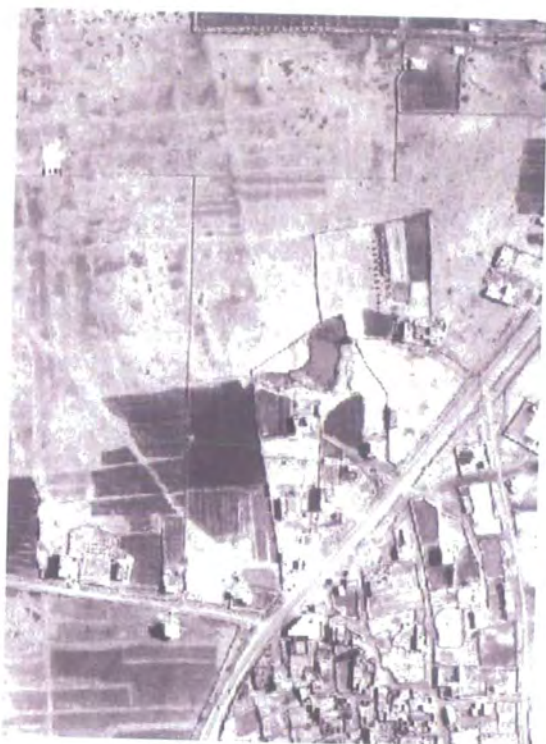

Ikonos Panchromatic



Ikonos Multispectral



Ikonos PCT resolution merge



Ikonos SFIM resolution merge

Figure 89 Ikonos pan and MS imagery with a PCT and SFIM resolution merge derivative.

Liu (2000a) compared the Smoothing Filter-based Intensity Modulation (SFIM: Liu 2000b), Intensity, Hue and Saturation (IHS) and Brovey image sharpening techniques on an image stack of Landsat 7 ETM+ data. The panchromatic band was used as the high resolution image. SFIM was determined as the most robust technique primarily due to the sensitivity of the technique to co-registration accuracy. Furthermore, the quality of the Landsat merge for all techniques was better with the 15m panchromatic than with a higher resolution SPOT 10m panchromatic image. Again this is due to the imperfect co-registration of the SPOT to the Landsat. Liu (2000b) also states that SFIM retains the majority of the spectral component of the imagery. However, this assertion is refuted by Wald and Ranchin (2002). Frank (2001) compared automated classification techniques on raw TM imagery and SFIM and IHS sharpened Landsat TM using 5m IRS panchromatic imagery. Considering the 6 fold improvement in spatial resolution the classification accuracies of 96.87% SFIM and 93.45% IHS are very good against the 98.51% of Landsat TM.

Given the relatively robust nature of the SFIM technique with co-located imagery it was the method chosen for pan-sharpening in this research. A Principal Components Transformation (PCT) was also used. The PCT method calculates principal components from the multispectral image and then substitutes the high resolution image into the first principal component (brightness). An inverse principal component transformation is then applied resulting in an image with the spectral resolution of the multispectral image and the spatial resolution of the panchromatic image. This method assumes that PC-1 corresponds to image brightness (the same assumption as the Intensity (brightness), Hue and Saturation method).

The Principal Component method is best used in applications that require the original scene radiometry (colour balance) of the input multispectral image to be maintained. As this method rescales the high spatial resolution data set to the same data range as Principal Component 1, before the Inverse Principal Component calculation is applied, the band histograms of the output file closely resemble those of the input multispectral image.

The PCT transformation is a built-in function within ERDAS imagine and was run directly for each data set. The SFIM transformation was built by the author in the Model Maker component of Erdas Imagine. Figure 89 compares the results of these transformations on the Ikonos imagery.

5.7 Discussion

The image preparation stage is an essential component of any modelling exercise. It necessitates a clear understanding of the nature of the problem in hand. Sensors are selected on their ability to provide appropriate imagery to answer the problem. Local factors, such as geology, agricultural regime and rainfall must also be assessed in order to collect imagery from an appropriate time frame. The acquisition of imagery for this research has highlighted that this can be a time consuming and difficult process. It is essential that enough time is programmed into image acquisition as unforeseen difficulties inevitably arise.

The image pre-processing stage is where the different data sets are co-ordinated to facilitate interpretation and analysis. An appropriate projection scheme is chosen and where necessary imagery is co-registered and fused. In particular fused imagery (with different spatial, spectral and temporal characteristics) can potentially produce a significant improvement in interpretative techniques.

CHAPTER 6 SATELLITE IMAGERY FOR THEMATIC INFORMATION EXTRACTION

6.1 Landscape themes

Landscape archaeology is a geographical approach whereby a region is investigated in an integrated manner, studying sites and artefacts not in isolation, but as aspects of living societies that once occupied the landscape. To do this it is necessary to collect and analyse archaeological and environmental data over large areas. Satellite imagery can be utilised to derive information about the contemporary landscape, and under certain circumstances it is possible to make inferences regarding former changes in the environment.

(Clark *et al.* 1998 p. 1461)

Thematic variables such as soil type, hydrology, topography and elevation may be used to either contextualise archaeological data during Exploratory Data Analysis, as data layers in predictive modelling exercises or as a backdrop for CRM applications (see section 3.1). From a landscape survey perspective these themes can be extremely useful, providing information on such diverse themes as land management (will archaeological residues be masked by vegetation?) and geomorphology (was this terrace formed before or after a certain date?). The thematic approach analyses different landscape components in an integrated manner. These landscape components commonly include the following themes:

- Land use and cover (topography).
 - Communication networks.
 - Hydrology networks.
 - Settlements (discussed in Chapter 7).
 - Field Systems (discussed in Chapter 7).
 - Soil/geology maps.
- Elevation (Digital Terrain Modelling).

The resultant thematic maps can be analysed independently or in conjunction with other data sets. Many different techniques are available for the production and analysis of these themes. The components can be analysed with standard GIS techniques such as network analysis, shape analysis and image overlay. Synthesis is achieved by composite mapping or multivariate statistical techniques between layers or individual layer analysis. Overlay techniques are frequently used to look for spatial associations and relationships between the different themes (e.g. between settlement distribution and soil types).

For many areas of the world thematic data is already available from the national mapping agency (such as the Ordnance Survey). Although this information is available in Syria, it is at too coarse a scale, poor or difficult to access. Thematic information is only available at small scales (greater than 1:500,000, such as the Russian geology maps (Ponikarov *et al.* 1967)). Furthermore, cartography generalises the real world (Morehouse 1995; Müller *et al.* 1995; Lee 1996): the generalisation process is normally undertaken for economic or asset management purposes and therefore can have limited archaeological content. Satellite and aerial imagery can be used to improve information extraction by allowing user-defined generalisation and interpretation.

The use of remote sensing in this context is dependent upon the type of 'theme' desired and the scale of interpretation. For example, in the absence of geological maps multispectral imagery can be used to identify different surficial soils and geologies. Landsat TM imagery is regularly used for this type of identification (Ebert 1989). Geological themes can be extracted from Landsat data which has a large ground footprint, a relatively high spatial resolution for the application (a 30m cell size is much smaller than any geological unit) and an appropriate spectral resolution. Ikonos imagery can supply information related to modern topography and can be used akin to aerial photography to update digital mapping. Corona imagery can supply information on broadly the same scale as Ikonos but it relates to a relict landscape and hence information can be elucidated regarding landscape change. Furthermore, the Ikonos and Corona data sets are available as stereo pairs, which allow the production of digital terrain models using photogrammetric techniques.

6.2 Land cover mapping

The analysis of land use patterning is used to infer the relationship between people and their environment. As a result the delineation of modern land use patterns is fundamental to the

work of geographers and economists amongst others. Landscape archaeologists are interested in land use patterns for curatorial reasons and as a means to reconstruct past systems of inhabitation. Reconstructing these 'past' variables can be difficult. For example, surface vegetation changes on a yearly basis and has a positive correlation to ambient environmental factors. On the other hand soils change over a much longer time-frame and modern soil characteristics may not be positively related to many past soil conditions. Finally, the parent regolith changes slowly over time and for archaeological purposes can normally be assumed as constant.

The delineation of land use information can involve a complex integration of data from a variety of sources. The choice of these sources is in part determined by the scale of land use and the analytical requirements of the end product. For example, the requirements of a regional planner, where regional generalisation may be important, are very different from those of a social geographer, for whom high resolution geodemographic data may be important. Remote sensing sources, particularly aerial photography, are commonly integrated with map bases for mapping purposes. The benefit of imagery in this process is the lack of cartographic generalisation. High spatial resolution imagery can be used to identify parcels at large scales. At correspondingly smaller scales, which normally increase the footprint of the area to be studied, lower spatial and higher spectral resolutions become more important. Whatever the scale of analysis collateral information from ground observation is always required.

6.2.1 Land cover classification systems

Creating land use maps from imagery is essentially a process of segmenting the imagery into contiguous parcels with different characteristics. If specific archaeological themes have not been identified (see Chapter 3) it is advised that a standard classification system is employed so that other land use identification programmes can be easily integrated (Campbell 2002 p. 559). The classification schema should also be tallied with the requirements of the analytical problem. For example although 'suburban area' may seem like a natural choice for analytical purposes it is inappropriate if the end user needs to identify sub categories such as 'residential', 'commercial' and 'industrial'.

Many classification systems, including the USGS system (Anderson *et al.* 1976 cited in; Campbell 2002), use a nested hierarchy of levels which allow the identification and

subsequent generalisation of data between different levels. Levels I and II in the USGS system are defined in the framework with Level III (high resolution identification) defined by the user (see Table 17). The USGS system has many benefits; not the least being that it was designed with remotely sensed imagery in mind. This allows the allocation of different land use categories based upon the scale of information available. For example Level I is designed for broad scale imagery such as Landsat. Levels II and III are more detailed classifications that can be attributed to finer resolution (both spatial and spectral) imagery. The CORINE programme has employed a similar approach in creating an integrated European Union-wide land cover data set using satellite imagery (Gerard 2002).

ClassID	USGSLevel_I	USGSLevel_IIcode	USGSLevel_II	SHRLevel_III	SHR Geol
55	Agricultural land	21	Croplands and pasture	Cropland: well drained basalt	Basalt: Well drained
65	Agricultural land	21	Croplands and pasture	Cropland: wadi silts/Marl	Marl/Wadi silts
8	Agricultural land	21	Croplands and pasture	Croplands and pasture	N/A
54	Agricultural land	21	Croplands and pasture	Cropland: alluvial	Alluvium
56	Agricultural land	21	Croplands and pasture	Cropland: poorly drained basalt	Basalt: Poorly drained
57	Agricultural land	21	Croplands and pasture	Cropland: thick southern marl	Marl: Thick southern
58	Agricultural land	21	Croplands and pasture	Cropland: lacustrine deposits	Lacustrine
59	Agricultural land	21	Croplands and pasture	Cropland: alluvial fan	Alluvial fan
60	Agricultural land	21	Croplands and pasture	Cropland: wadi silts	Wadi silts
61	Agricultural land	21	Croplands and pasture	Cropland: southern marl	Marl: Southern
62	Agricultural land	21	Croplands and pasture	Cropland: thin southern marl	Marl: Thin southern
64	Agricultural land	21	Croplands and pasture	Cropland: irrigated southern marl	Marl: Irrigated southern
53	Agricultural land	21	Croplands and pasture	Cropland: irrigated northern marl	Marl: Irrigated northern
9	Agricultural land	22	Orchards, groves, vineyards, nurseries and ornamental horticultural areas	Orchards/Groves	N/A
38	Agricultural land	22	Orchards, groves, vineyards, nurseries and ornamental horticultural areas	Orchards, groves, vineyards, nurseries and ornamental horticultural areas	N/A
63	Barren land	74	Bare exposed rock	Bedrock slope	Bedrock slope
17	Forest land	43	Mixed forest land	Mixed forest land	N/A
1	Urban or built up land	11	Residential	Residential	Urban
2	Urban or built up land	12	Commercial and services	Commercial and services	Urban
3	Urban or built up land	13	Industrial	Industrial	Urban
45	Urban or built up land	14	Transportation, communications and utilities	Road (tarmac)	Urban
4	Urban or built up land	14	Transportation, communications and utilities	Transportation, communications	Urban
48	Urban or built up land	14	Transportation, communications and utilities	Water pipe	Urban
46	Urban or built up land	14	Transportation, communications and utilities	Main Road	Urban
49	Urban or built up land	14	Transportation, communications and utilities	Airport	Urban
43	Urban or built up land	14	Transportation, communications and utilities	Railway (disused)	Urban
44	Urban or built up land	14	Transportation, communications and utilities	Railway	Urban
50	Urban or built up land	15	Industrial and commercial complexes	Military zone	Urban
5	Urban or built up land	15	Industrial and commercial complexes	Industrial and commercial	Urban
6	Urban or built up land	16	Mixed urban or built up land	Mixed urban or built up land	Urban
7	Urban or built up land	17	Other urban or built up land	Other urban or built up land	Urban
18	Water	51	Streams and canals	Streams and canals	Water
39	Water	51	Streams and canals	Channel (wadi)	Water
40	Water	51	Streams and canals	Channel (palaeo)	Water
41	Water	51	Streams and canals	River	Water
42	Water	51	Streams and canals	Channel (concrete canal)	Water
47	Water	51	Streams and canals	Channel (anthropogenic)	Water
19	Water	52	Lakes	Lakes	Water
51	Water	52	Lakes	Seasonal lakes	Water
20	Water	53	Reservoirs	Reservoirs	Water
52	Water	53	Reservoirs	Birka	Water
21	Water	54	Bays and estuaries	Bays and estuaries	Water

Table 17 Combined USGS and SHR land use codes.

The USGS system maintains flexibility for specific projects and allows wider scale generalisation and incorporation of the data within other programmes of collection and analysis. However, the classification system must also correspond to the data used to compile

the land use map. It is obviously inappropriate to expect a high level of identification when one is employing imagery collected at a coarse scale.

The classification system employed in this research will be based upon the USGS system (see Table 17). Other SHR project specific levels have been built into the hierarchy to enable the allocation of land use classes specific to the application area and the project goals. Over time this classification schema can be extended to not only produce traditional classifications but also archaeologically specific classifications (i.e. land-segmentation that might have had currency in the past). However, each of these classes can be generalised through the USGS system. The flexibility of this system allowed the production of a joint land use and land cover classifications system to identify economic, landform and surface sedimentary zones.

6.2.2 Land cover mapping methodology

As discussed in section 2.2 imagery can be classified by either qualitative or quantitative methods. For the purposes of this research the majority of thematic classification has occurred through qualitative rather than quantitative classification as this is the easiest system to implement. This is primarily due to the fact that thematic data, although useful for analysis and synthesis, are not archaeological in nature. Furthermore, quantitative image classification techniques are highly skilled: it is difficult for an interpreter who is not trained in the specifics of multispectral analysis of different land cover types to incorporate these skills. Some specific image classification did occur. Where quantitative techniques have been used to elucidate land use information they are explained in the text. Great use, however, was made of image enhancement techniques during the visual interpretation component (particularly histogram stretches, false colour composites and band ratios).

The best practice methodological guidelines outlined by Campbell (2002 pp 559-576) were followed (as summarised in Figure 90). All the metadata information concerning the image quality (sensor type, cloud cover index and collection date) were recorded within the metadata for each data set. The classifications schema is defined in Table 17 where the field 'SHRlevel_III' delineates the bespoke classification values for the application area. The 2000 Landsat imagery and 2002 Ikonos imagery were the primary image sources for the classification.

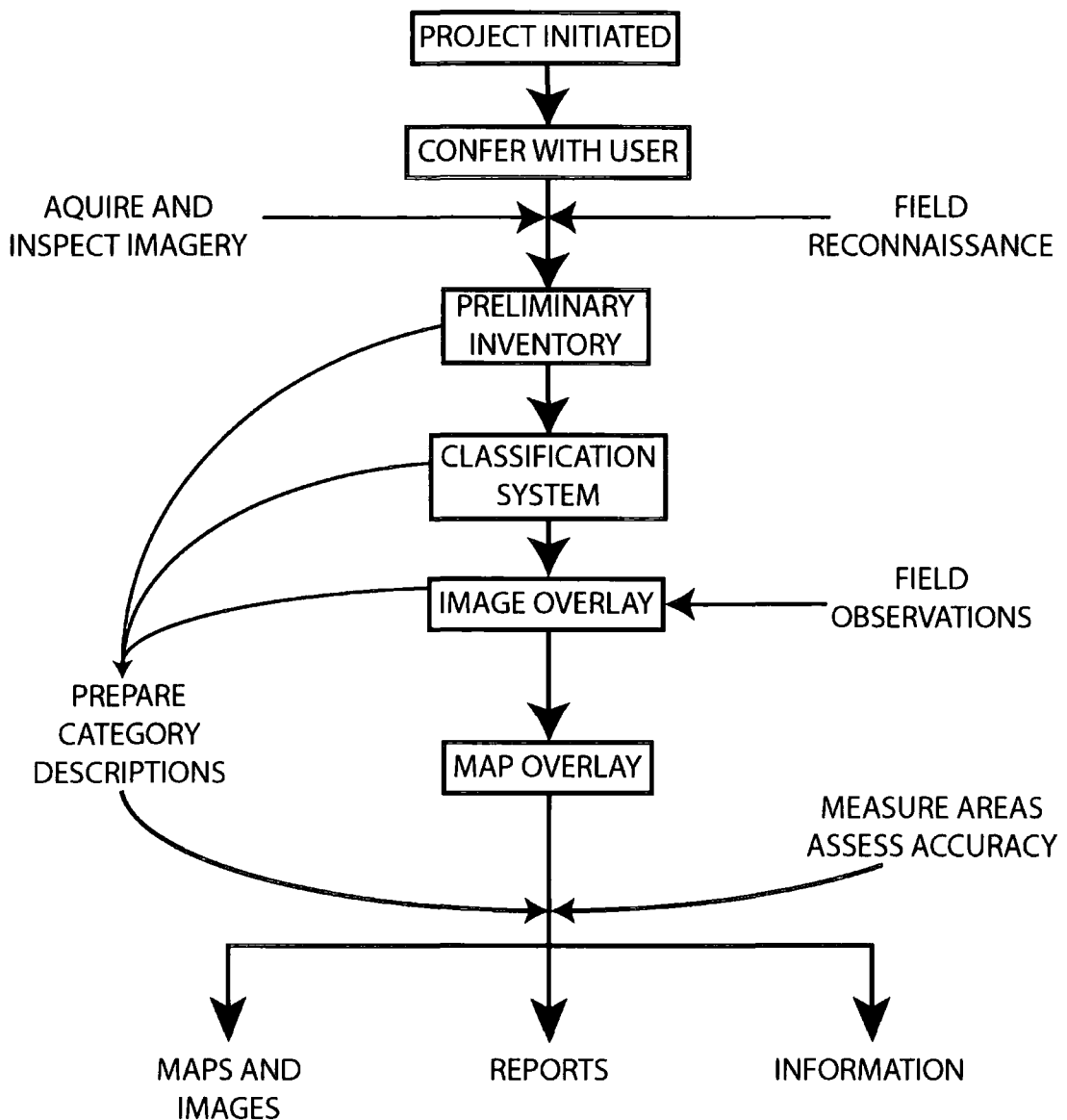

Figure 90 Land use digitising schema (after Campbell 2002 p. 559).

The basic approach to digitising the land cover themes was to digitise linear and land parcel elements directly from the satellite imagery within ArcGIS. Ikonos imagery would provide the primary resource for landcover mapping in the northern and southern application areas and Landsat imagery would provide the primary resource for the soil, geology and urban mapping. The Corona imagery, Syrian map and Russian geology map were also used as ancillary data sets. Ground observation during previous fieldwork seasons had provided a general understanding of most of the region. This was augmented by the geomorphological work undertaken by Drs Bridgland and Westaway (Bridgland *et al.* 2003).

Finally, decisions need to be made about the form of the thematic output. Manual interpretation techniques traditionally delineate parcels or linear features using vector techniques. On the other hand, image classification techniques produce a raster output. As both techniques are used in the production of thematic information it was decided to produce all themes, with the exception of the DTM, as vector layers. Vector delineation of this information also removes misclassification artefacts commonly associated with pixel mixing and natural heterogeneity in class composition (Tso and Mather 2001; Campbell 2002; Harrower *et al.* 2002).

6.2.3 Vector digitising methodology

Whereas Campbell (2002 p. 560) advocates working on translucent overlays the digitising process was conducted directly using ArcGIS. The imagery, or its derivatives, provided the digitising backdrop. Land use and cover was separated into polygon features and polyline networks. Polyline networks were employed so that direction of flow and other attributes could be appended for the appropriate feature types. Polyline networks include transportation systems and hydrology. Polygon layers were created for land cover and surficial geology/soil types. Each polyline network and land cover polygon was attributed an identifier from the classification schema based upon the most refined 'SHRlevel_III' field and linked through the primary key field 'CodeID' (see Table 17). This allowed the generalisation of the themes to the USGS levels I and II. To reflect this, three new vector layers were created within the Geodatabase (see Appendix I) within the theme 'satellite_themes': a polyline network layer called 'Line_landcover' and two polygon coverages called 'Polygon_landcover' and 'Soils_geology_urban'.

6.2.3.1 Polyline networks

Linear elements digitised for land cover are best represented as polylines. These are vector lines that represent linear units such as road and river networks (based on centre lines). GIS systems can enhance the utility of connected polylines by analysing them as polyline networks. These networks can be embedded with information determining how the line segment can be used. For example, in a road network a line segment could be a one way street with a specific speed limit. These attributes can be embedded into the polyline. When a network is analysed for the shortest or quickest route from place A to place B these attributes can form part of the analysis. Figure 91 defines the creation of a polyline network for digitising the hydrology in the application area. In this model water is only allowed to flow

downhill (i.e. from node X to node W). When digitising in ArcGIS polyline networks are created dynamically, however, attribute data (ClassID and flow direction) needs to be added for each individual polyline. The attribute 'ClassID' is the linking field between the drawing and the USGS code database described in Table 17.

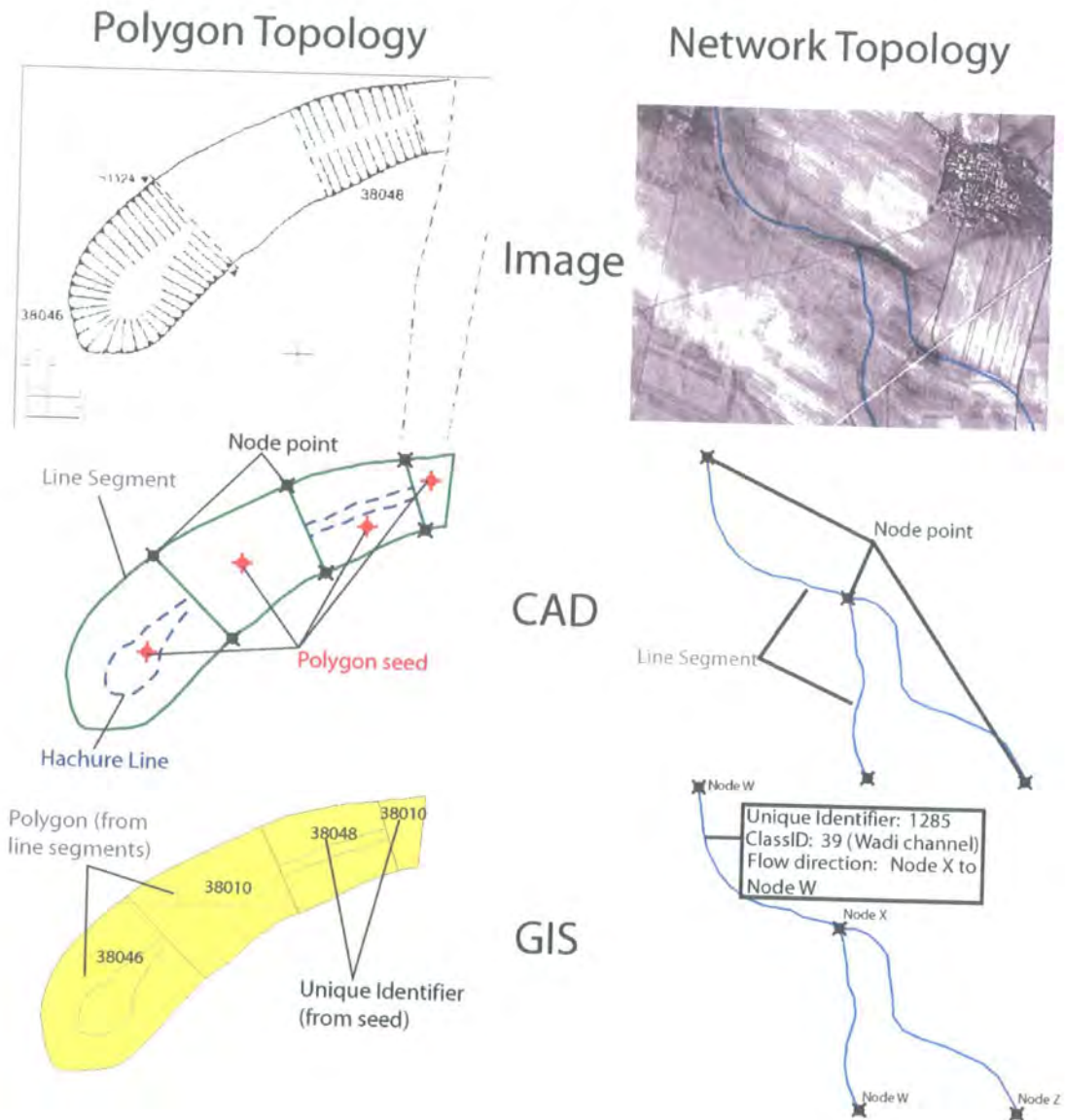

Figure 91 Digitising topologically intact polygons and networks for GIS analysis.

6.2.3.2 Polygon layers

Enclosed areas digitised for land cover are best represented as polygons. These are closed vector lines that represent land parcels such as a geological unit or an urban area. It is

possible to just describe a polygon by digitising its outline (for example the technique which is applied for digitising site extents). However, in land cover applications many of the polygons are contiguous (i.e. they share adjacent borders) or are contained within other polygons. Digitising topology (the spatial relationships which make up a polygon) can substantially reduce the work involved in the digitising process and ensure that polygons actually share common boundaries. Figure 91 defines the creation of a polygon topology using archaeological excavation data. Burroughs (1986) discusses extensively the formal process of polygon topology creation.

When digitising in ArcGIS polygon topology is created dynamically, but attribute data (ClassID) needs to be added for each individual polygon. The attribute 'ClassID' is the linking field between the drawing and the USGS code database described in Table 17.

6.3 Hydrology networks

The hydrology network consists of rivers, seasonal wadis, anthropogenic canals and channels (see Figure 92 and Figure 93). These were digitised directly from the pan-sharpened Ikonos imagery. However, use was also made of the panchromatic Ikonos imagery overlaid by the multispectral imagery with a 60% transparency setting. This provided a combination of high resolution imagery and colour contextual information without the need for pan-sharpening. Any co-registered resource can be used in this fashion (for example panchromatic aerial imagery and SPOT multispectral imagery). A few specific enhancements were used to aid in the identification of water bodies. Particularly important were differences between the visual bands and near-infrared. The value of the near-infrared lies in the fact that the contrast between water, vegetation and other surface phenomena, which are not obvious in the visible spectrum, are more enhanced. All wet areas tend to absorb infrared radiation, and this leads to a lower reflectance value (Ebert and Lyons 1983 p. 1256; Campbell 2002 p. 525).

$$NDI = \frac{Infra\ Red - Blue}{Infra\ Red + Blue}$$

Equation 1 NDI equation

Image Interpretation Key: Land-Cover

HYDROLOGY

Version 1: Anthony Beck, October 2003







EVIDENCE TYPE	EVIDENCE CHIP	EVIDENCE DISCUSSION	
Birka, Seasonal water	 <p>Ikonos 2002 NDI</p>	 <p>Ikonos 2002 4,4,1 FCC</p>	Area of standing water either natural or managed. Highlighted through NDI and 4,4,1 FCC. Check against an Ikonos 3,2,1 FCC for verification.
Channel	 <p>Corona 1970</p>	 <p>Ikonos 2002 pan</p>	Anthropogenic channel. Is normally indistinguishable on the Ikonos imagery due to more intensive land use in recent years. They are visible in the Corona and look a little like wadis. In order to identify these as channels the contours must be loaded. These features run adjacent to contours.
Irrigation Canal	 <p>Corona 1970</p>	 <p>Ikonos 2002 3,2,1 pan sharpened</p>	Irrigation canals. These are normally empty concrete canals. They are identified through their morphology (sinuous features associated with roads (but narrower)). The system is visible in both Corona and Ikonos. Both image sources should be employed for identification.
River	 <p>Ikonos 2002 NDI</p>	 <p>Ikonos 2002 4,4,1 FCC</p>	Rivers. Highlighted through NDI and 4,4,1 FCC. Check against an Ikonos 3,2,1 TCC Only use the Ikonos imagery for river mapping as it is the most up-to-date source. The Orontes exhibits a characteristic sinuous form.
Wadi	 <p>Corona 1970</p>	 <p>Ikonos 2002 3,2,1 pan overlay</p>	Wadis. Much like the channels wadis are sometimes difficult to identify on the Ikonos. Where possible use the Corona and correlate against the modern Ikonos. Wadis run nearly perpendicular to contours.

Figure 92 Hydrology network image interpretation key.

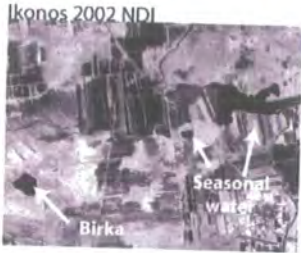
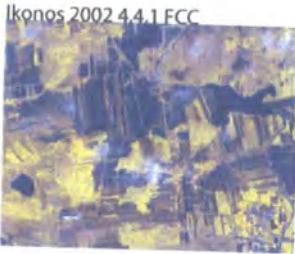
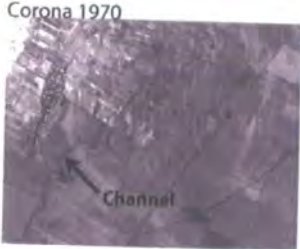
To further illuminate these differences between the visible and NIR a ratio of the pan-sharpened Ikonos bands 1 and 4 was also calculated. This was augmented with a 4, 4, 1 false colour composite. Finally a Normalised Difference Index (NDI) between the NIR band and the blue band (see Equation 1) was also conducted. In this technique water bodies are dark areas.

The Corona imagery was also used to provide extra contextual information, particularly for the location of wadi channels. These are seasonal channels that for the majority of the year exist as soil marks with a higher reflectance than the surrounding soil matrix (presumably from wadi silts and gravels). Modern agricultural practices (including deep ploughing, bulldozing, and increased vegetation cover due to irrigation) have masked or blurred many of these features in more recent imagery. These agricultural practices had limited impact on the older Corona imagery. The same situation applies for the features identified as 'channels (anthropogenic)' (see Figure 92). These features have the same reflectance characteristics as the wadi channels however they differ in one significant aspect: instead of flowing directly through the contours on a path of least resistance they hug contours observed on the digitised Syrian 1:25,000 maps. This led to the interpretation that these channels were anthropogenic in origin. One of these wadi channels appears to run into the ditch surrounding Tell as-Safinat Nebi Noah (site 14), giving the impression that this fortified site may have been moated. For the same reasons Corona imagery has been exploited by Stone (2003) for her research into the course of the ancient Tigris.

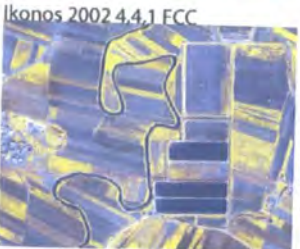
In the northern marl zone extensive concrete irrigation channels fed from Lake Qatina were constructed under the French mandate during the 1930s. Since the late 1980s the combined effects of capping the spring at 'Ain at-Tannur (to divert the water to the expanding city of Homs) and a reduction in rainfall has led to shrinkage of Lake Qatina (see Figure 64 and Figure 169). This has effectively meant that during periods of low rainfall (such as the winter of 2001/2002) these irrigation channels are redundant. Consequently these hydrological features can not always be identified on the basis of the reflection characteristics of water. However, these linear features have a distinct morphological signature. They run in straight lines with distinct periodic curves and roads have regularly been built on their margins. They can be distinguished from normal roads due to their curvature and where necessary can be interpreted by proxy.

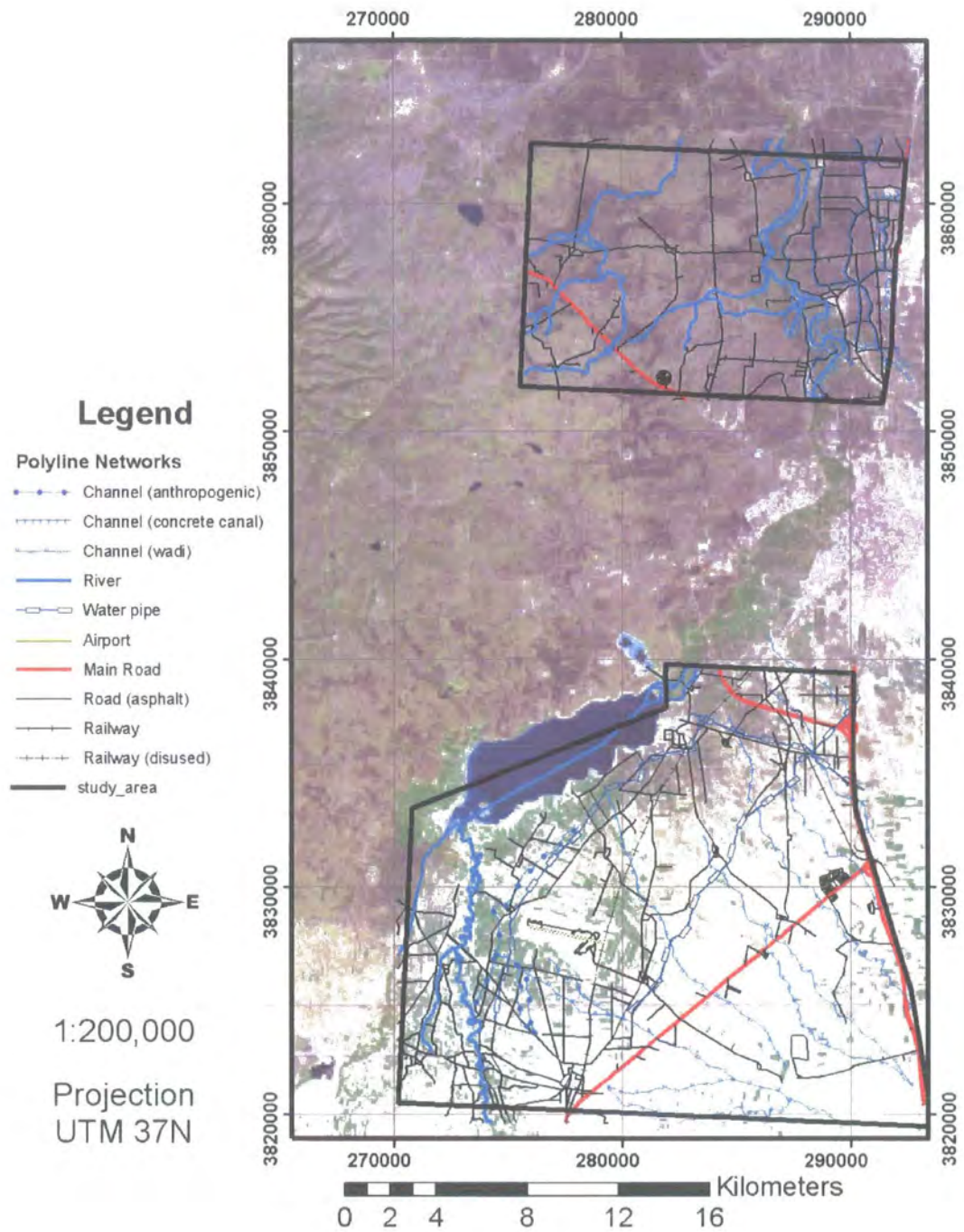

Figure 93 The digitised hydrological and communication networks.

Image Interpretation Key: Land-Cover

COMMUNICATION

Version 1: Anthony Beck, October 2003

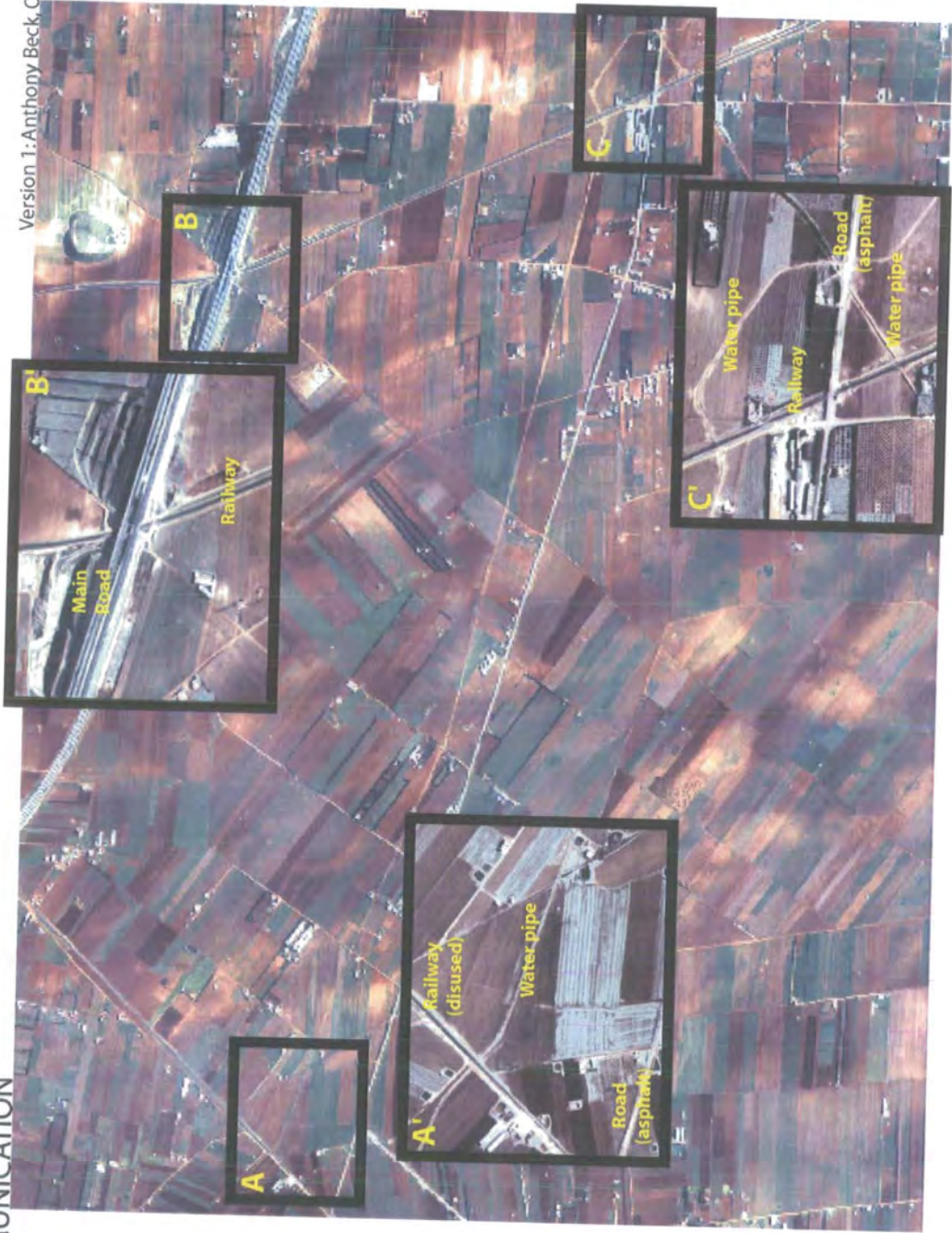

Figure 94 Communication network image interpretation key.

The digitised components were compared with the 1:25,000 Syrian maps and driving surveys and showed a high degree of correlation. For many of the features there was, in fact, an improved level of detection.

6.4 Communication networks

A similar methodology was used for digitising the communication networks. However, in this instance only the panchromatic and multispectral Ikonos imagery were employed. Main roads, asphalt roads, water pipes, railways (both used and disused) and an airport runway were all digitised (see Figure 93 and Figure 94). Due to time constraints tracks were not digitised, however, they were easily identifiable on the imagery. There was very little interpretative difference between the pan and MS Ikonos for this theme. No specific enhancements were required to detect these features. The result were correlated against the Syrian 1:25,000 maps and compared during driving surveys and showed a much improved product in comparison to the mapping.

6.5 Land cover parcels

The land cover parcels contained a greater range of variation than either the communication or hydrology networks (see Figure 95 and Figure 96). This was predicated on the basis that discrimination of the different land cover elements should be as refined as possible. All the land cover parcels for this theme were identified using the Ikonos imagery so that this theme could provide a benchmark for the state of the landscape in 2002. It is a future intention to digitise a set of Corona imagery in the same way. Comparison of these data sets would be particularly useful for time change analysis based solely on interpretative data (see section 9.4). The benefit of this technique is that instead of quantifying the change between pixel DN values, one can evaluate the changes in specific land use categories (i.e. from cropland to orchard) and hence extrapolate changes in agricultural, economic or political factors.

Water features (lakes, seasonal lakes, reservoirs and birka) were identified using the same techniques and enhancements as described in section 6.2.3.2. Where seasonal lakes were identified the surrounding corona which delineated the full extent of the lake when full was also included in the parcel. Reservoirs were defined as any dam like structure. The only exception to this rule is lake Qatina, which although dammed is referred to as a lake. Birka are small reservoirs associated with settlements in the basalt. Sometimes these features are delineated by surrounding basalt walls.

Olive groves and orchards were identified by textural variation in the imagery. Areas with mature plants were easier to identify on the Ikonos multispectral imagery (particularly when using the near infrared (band 4)) whereas areas with younger plants were easier to identify on the Ikonos panchromatic imagery. Hence, the most effective way to locate groves and orchards was to overlay a 4, 3, 2 false colour composite of the Ikonos multispectral with a 60% transparency setting over the Ikonos panchromatic. Forested areas were detected in the same way. Differentiation between grove and forest was based upon differences in location (forests occur in the basalt zone only), texture and shadow length (see Figure 96).

The high reflectance observed at urban and other concreted areas was very easy to identify. The separation of each of these into the different classes of military, residential, industrial, commercial and industrial complexes was based upon morphological differences and by proxy along major communication networks. The default designation was residential; these areas are identified by their distinctive tone and texture. Military zones were extremely easy to identify due to their distinctive morphology. Virtually everything else would be classed as industrial. Most small scale industry is confined to long buildings (chicken farms). Industrial complexes were attributed on the basis of scale and include the fertiliser factory and oil refinery. Where there was a combination of urban usage the parcel was allocated to the 'mixed urban or built up land' zone. No specific enhancement techniques were required to identify these features.

Cropland accounted for the vast majority of the land surface. The bespoke level III schema for cropland took into account the formation processes and parent regolith unique to each environmental zone. Hence, the marl was split into Northern marl, thick marl, irrigated marl, thin marl and wadi silts/marl (see Figure 95) to aid the delineation of different marl types. The basalt was split into poorly drained and well drained units (the well drained deposits are probably areas of stable floodplain). Alluvial cropland is related to areas of overbank flooding or modern river terraces. In the area SW of lake Qatina the alluvial area blends into an area where lacustrine deposits have been revealed (and exploited as agricultural land) by the shrinking of the lake. Wadi silts are areas of high reflectance associated with migrating and alluviating seasonal wadi channels. At the south end of lake Qatina west of the current course of the Orontes there is an alluvial fan extending from the Anti-Lebanon range. Finally there is an area of exposed bedrock slope in the south of the area.

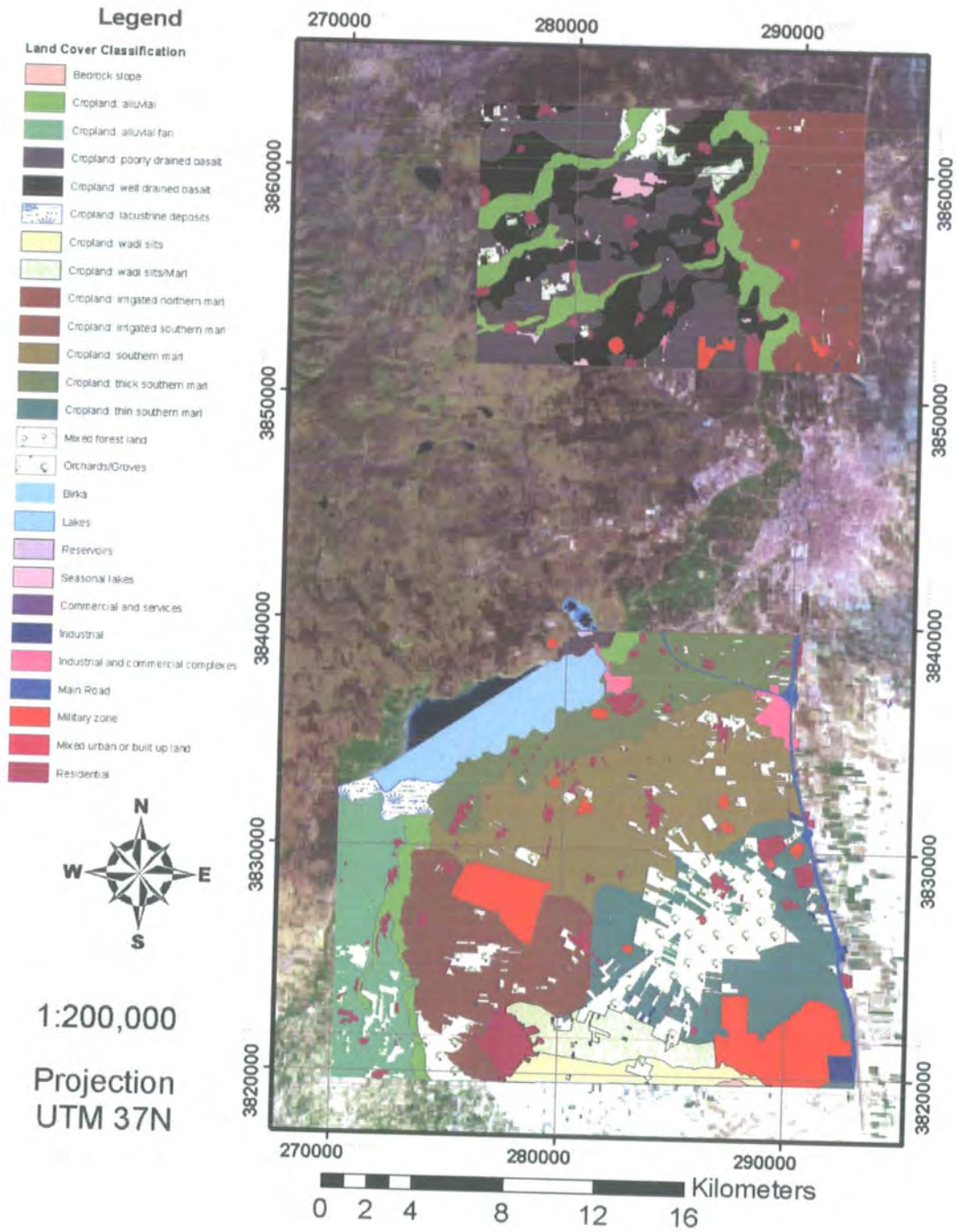

Figure 95 The digitised land cover parcels from the Ikonos 2002 imagery.

Image Interpretation Key: Land-Cover

LAND COVER PARCELS

Version 1: Anthony Beck, October 2003











EVIDENCE TYPE	EVIDENCE CHIP		EVIDENCE DISCUSSION
	Ikonos Pan	Ikonos Pan/MS overlay	
Forest			Forest area, usually conifers, have a distinct texture and spacing which allows them to be differentiated from groves.
Grove			As for forests, groves, usually olive or almond, have a distinct texture and spacing.
Large Industrial			Large industrial areas have distinct, complex arrangements consisting of long rectangular buildings and towers. Shadow effects can be useful for determining these features.
Industrial			Individual battery farms are located with regularity through the landscape. These consist of a single or group of long rectangular buildings.
Military			The internal layout of military sites makes them particularly easy to identify.
Residential			Residential areas consist of a nucleation of small buildings with associated roads networks.

Figure 96 Land cover parcels image interpretation key.

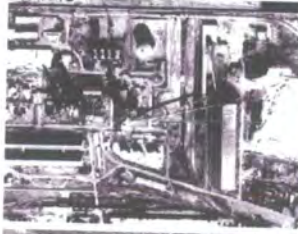
6.6 Geology/soil mapping

Remote sensing imagery can be used to classify geology and soil attributes (Siegal and Gillespie 1980; Williams 1983; Irons *et al.* 1989; Drury 1993; Mattikalli 1997; Way and Everett 1997). The scale of information captured means that high spatial resolution data is not necessarily required. The use of high spatial resolution imagery can increase heterogeneity and hence makes the classification/identification process more difficult by producing a classification schema with many different variables rather than landscape groups. Rather, improved spectral resolution imagery can be more important for defining geological attributes as different units are easier to discriminate when spectral resolution is increased.

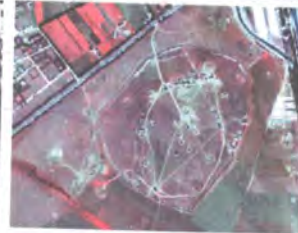
The Landsat imagery was used for the majority of the soil/geology mapping. One of the major benefits of Landsat in this instance is the size of footprint. This imagery extended well beyond the application area. This substantially increased the overall context of the imagery, improving interpretation by having access to broader scale environmental systems. Arid and semi-arid environments, such as the landscape around Homs, offer better potential for the characterisation and identification of surficial soil and rocks due to the limited vegetation cover. It is advisable to select an image that has minimal vegetation cover to conduct this process or to conduct comparable analyses on multiple scenes and generalise the results accordingly.

Computerised classification and image enhancement techniques were used to help determine soil and geology units. Classification involves the categorisation of the multispectral image using statistical procedures. As discussed in section 2.2.7 supervised classification procedures involve user intervention to define training areas which are then statistically extrapolated to the rest of the imagery. Alternatively unsupervised classifications define their own clusters by employing a statistical algorithm on the data. These techniques produce spectral signatures that respond to each cluster or training area. These spectral signatures vary due to a number of factors including sensor attitude, wavelength, ground cover, vegetation cover, moisture content, atmospheric conditions, slope and aspect (Campbell 2002). Multi-band visualisation, density slicing and band ratioing (particularly bands 7 and 5) can help distinguish specific geological units. False colour composites using band combinations 7, 5, 1 and 3, 5, 1 were used to help discriminate different geology types. In areas of high reflectance, such as the wadi silts, it is appropriate to enhance the histogram (by using a minimum-maximum stretch or density slicing) to improve contrast and hence interpretation. Tasselled cap

transformations were also employed to assess whether feature space transformations improved residue detection.

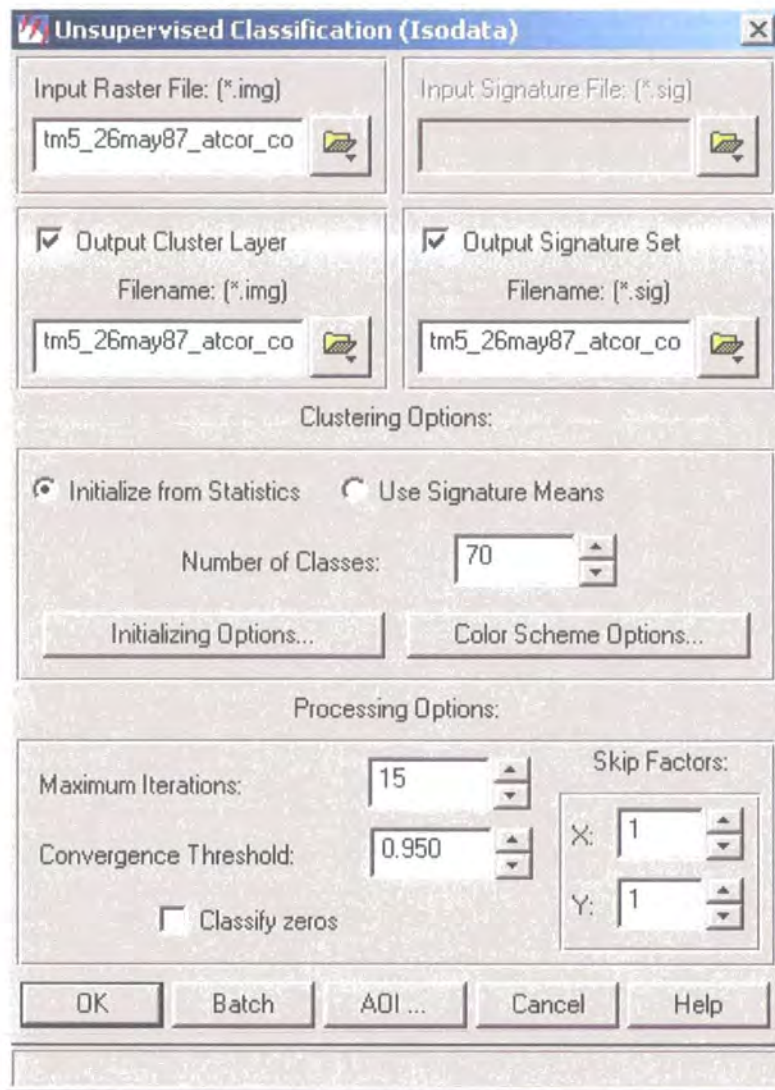

Figure 97 The unsupervised classification algorithm for geology/soil classification

Using the methodology outlined by Harrower *et al.* (2002) an unsupervised classification was conducted on all the co-registered and atmospherically corrected Landsat imagery (see Chapter 5 for details on this pre-processing). 70 classifications were produced, for each Landsat scene, using an Isodata unsupervised algorithm (see Figure 97). This algorithm produced an output image with colour determined by the red, green and blue bands and a spectral signature file for each cluster.

One of these classified images was chosen as the primary scene. It was initially assumed that the October 1987 imagery would be the most appropriate imagery to conduct lithological analysis based upon the assumption that in the summer of 1987 less surface vegetation would be visible as the irrigation techniques were not as extensive in 2000. While classifying the imagery and viewing the tasselled cap transformation it became apparent that the northern marls were heavily vegetated. This is due to the high rainfall in 1987 and successful irrigation through the network of concrete canals (discussed in section 6.2.3.2). Therefore the October 2000 scene was employed as the primary scene as it contained the least amount of vegetation as determined from the greenness index of the tasselled cap images.

Using the ancillary data, including the land cover map techniques, each of the 70 classifications were attributed to a different landuse type in the USGS schema (see Table 17). Wherever possible geology and soil zones were subdivided based on the classification results and ground observations (i.e. the number of different marl zones in Figure 98). The digitising of these data sets into vector files meant that rogue, misclassified, pixels (see section 6.2.2) did not occur.

The Ikonos-based land cover mapping (see section 6.5) was used in the geology map. The SHR_LevelIII agricultural classification contained the geological zone of the cropland. An extra field was added into the USGS schema to generalise the classification to the parent materials. This allowed the original schema to be expanded so that it incorporated both land cover components and surficial deposits. This simple application reduces data complexity as one single data set can be used to answer a range of different questions from land cover to surficial geology. Furthermore, the higher spatial resolution of the Ikonos imagery allowed more accurate spatial referencing of features.

In summary, the following data and visualisation methods were used for the creation of the geology/soil map (see Figure 98):

- False colour composite of Landsat imagery.
- Unsupervised classifications.
- The land cover mapping.

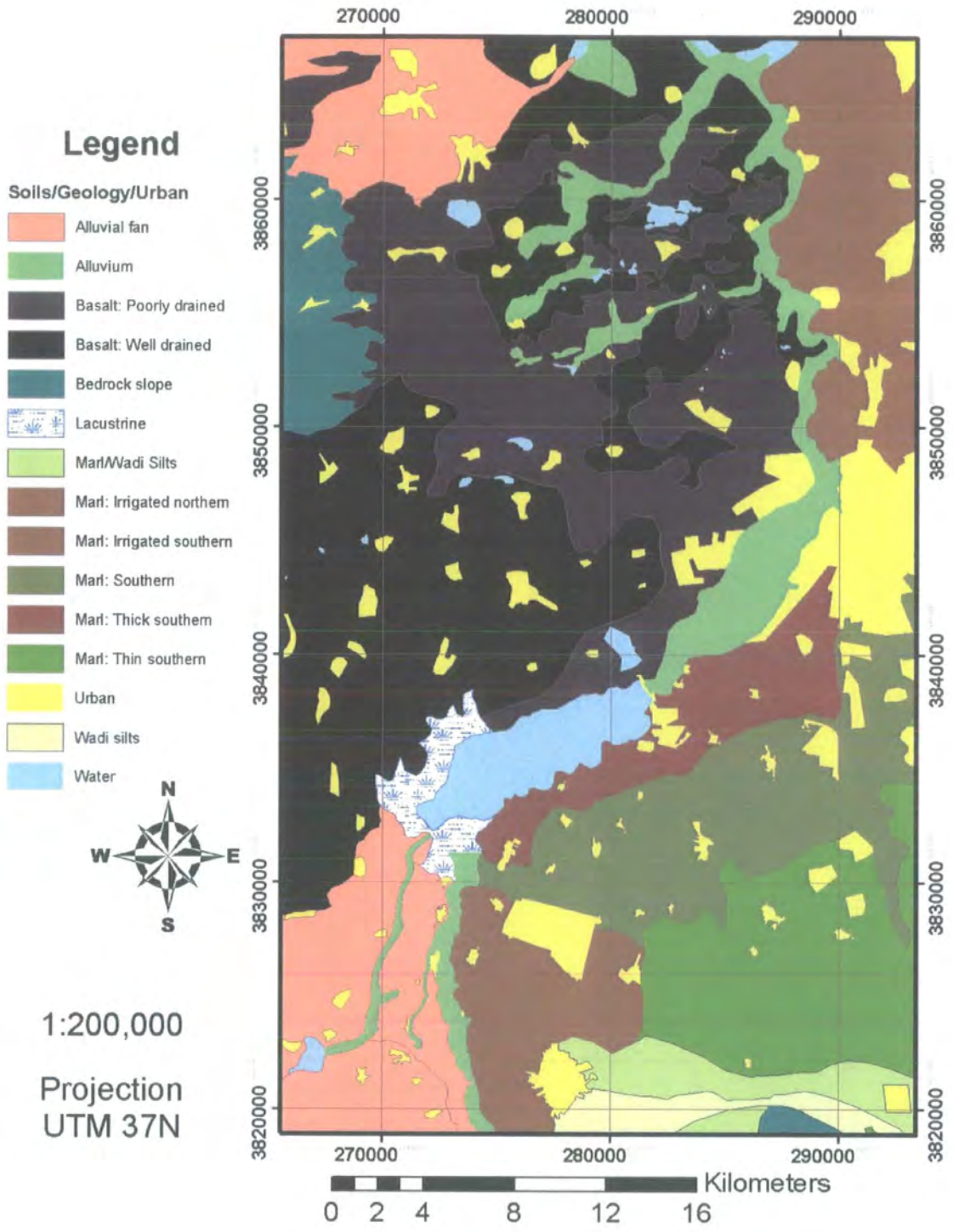

Figure 98 The soil/geology/urban classification



Summer
vegetation
in the Northern
Marl



Irrigation in
the Northern
Marl



View from
Nebi Mend



Qatina
Dam

Figure 99 The effects of increased rainfall. Note the left hand images are all summer images where there has been normal rainfall (hence the irrigation channels are empty).

6.7 Digital terrain modelling

Digital Terrain Models (DTMs) are an essential component of many archaeological modelling exercises. Elevation data can aid in solving a wide range of spatial problems (Toutin 2001). Terrain models are important within archaeology for studying individual monuments as well as their larger scale topographic context (Redfern *et al.* 1999).

Furthermore, terrain models offer a range of thematic information from a primary elevation model to the secondary slope and aspect models. For a discussion of DTMs and their raster and vector derivatives (digital surface models, digital elevation models, triangular irregular networks, slope derivatives and aspect derivatives) consult Burroughs (1986), Fujimura and Kuo (1999), Hageman and Bennett (2000) and Wheatley and Gillings (2002).

Many archaeological predictive modelling and visualisation exercises place significant emphasis on DTMs and their derivative layers (Gaffney and Stancic 1991; Hageman and Bennett 2000; Wescott and Brandon 2000). Wheatley (1995), in particular, has argued for the use of cumulative viewshed analysis to elucidate aspects of site and network locations in respect to their visibility from prominent points in the landscape. Furthermore, DTMs are used within remote sensing to model and correct for reflectance from different illumination angles (Campbell 2002).

Most DTMs used in archaeology are created by digitising the contours of an available base map. However, there has been some criticism of DTMs derived in this manner (Kvamme 1995; Redfern *et al.* 1999). Hageman and Bennet (2000) produced a best-practice guideline for contour digitising. One of the major criticisms of DTMs created from digitised contours is that they require interpolation of non-primary data. Contours themselves are produced by interpolating primary elevation data (collected either from photogrammetry or land survey), hence contours are secondary data. The process of digitisation introduces further errors into the data set.

6.7.1 DTM from contour data

Although the inaccuracy of creating Digital Terrain Models (DTM) from contour data is recognised (Redfern *et al.* 1999 p. 212), if the mapping data is available at an appropriate scale it is the easiest source for creating a DTM.

The digital contours created from the 1:25,000 basemap were used to create a Triangular Irregular Network (TIN). Best practice guidelines for the contour digitising were followed to improve the DTM accuracy (Burroughs 1986; Hageman and Bennett 2000). Contours were derived from the TIN and compared to the original basemap contours to evaluate the accuracy of the TIN. The TIN was converted into a raster Digital Elevation Model (DEM) with a 20m cell resolution. Slope and aspect models were derived from the DEM (see Figure

100). It is interesting to note that artefacts from the original contour data itself are obvious in the slope model.

These models were used throughout the research project for a variety of archaeological and visualisation procedures already discussed. In this context they also provide an important information resource from which to evaluate the DTM generation by photogrammetric techniques from Corona and Ikonos imagery.

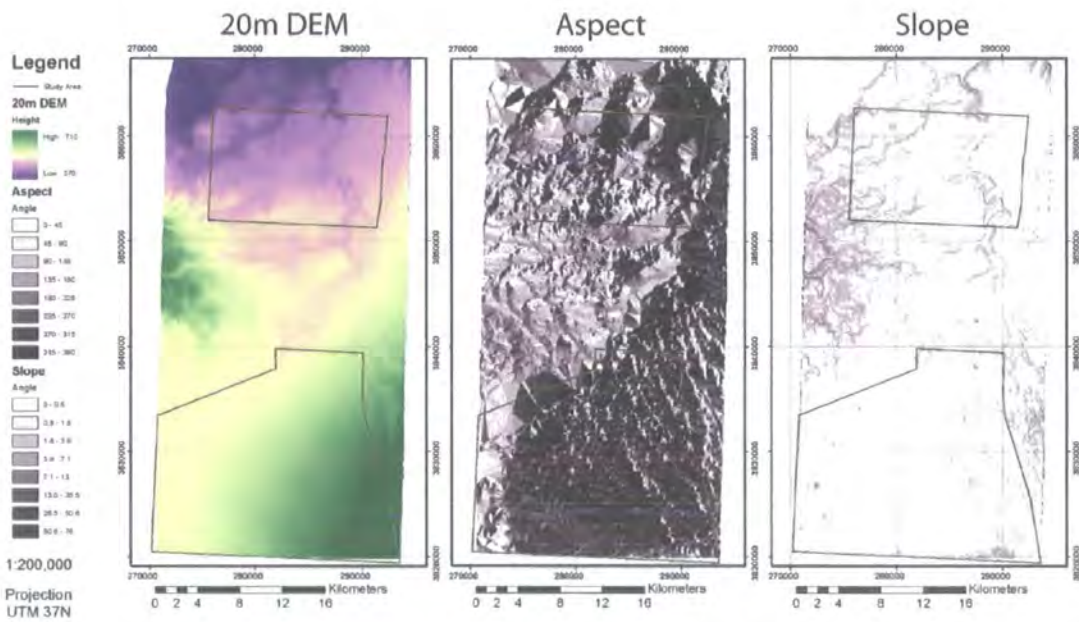

Figure 100 DEM, aspect and slope derived from contour data.

6.7.2 DTM generation from remotely sensed data

Remote sensing provides two primary solutions to the creation of DTMs. One solution encompasses the variable wavelength detection and ranging techniques such as RADAR and LiDAR (respectively, RAdio and LIght Detection And Ranging). These active sensors record the duration of travel. As the wavelength is known distance can therefore be calculated (Holden *et al.* 2002).

The other solution, which is more familiar to archaeologists, is that of Photogrammetry: More specifically the exploitation of the differences in stereoscopic parallax between two images taken from slightly different perspectives. Stereo photography was exploited by archaeologists as early as 1975 (Astorqui 1999). Photogrammetry is defined as:

The art or science of obtaining reliable measurements by means of photography.

(Colwell 1997 p. 3)

If two images are taken of an object from slightly different perspectives (a stereo pair) then a displacement in the object can be observed in the images. This phenomenon is referred to as *stereoscopic parallax*. If these images are placed side by side and viewed through a stereoscope a 3-d effect is observed. These phenomena can be exploited for measuring distances or heights. This technique is called photogrammetry, or more specifically for those who work on digital imagery, soft-copy photogrammetry. In order to extract a DTM from a stereo pair a sophisticated work-station is required that runs specific photogrammetric software (such as SocetSET or Erdas Imagine Stereo Analyst) and a camera model is required. The camera model refers to the interior geometry of the camera and its orientation (Teng 1997 pp. 82-102; Campbell 2002 pp. 77-84).

Any overlapping satellite imagery taken from different perspectives can be used to create a stereo pair (for example Toutin 2001; Li *et al.* 2002; Toutin 2002; Zomer *et al.* 2002). Furthermore, these images can come from different platforms and sensor devices. However, better results are obtained with imagery from the same sensor taken with a limited time differential. High resolution satellite sensors such as Ikonos and Quickbird recognise the fact that users would want to extract DTMs using stereo images and provide Rational Polynomial Coefficients (RPCs) with their metadata to facilitate DTM extraction. RPCs contain all the necessary metadata about the camera model and orientation required for the interpolation algorithms (ERDAS 2001).

Galiatsatos (in prep) extensively discusses the creation of DTMs by soft-copy photogrammetry using SocetSET and Erdas Imagine Stereo Analyst for the application area. Galiatsatos employs Corona-Corona (mission 1110 stereo pair), Ikonos-Ikonos and Corona-Ikonos stereo pairs. It is important to note that the Ikonos-Ikonos imagery was not purchased as a stereo pair and hence the RPC files were not supplied. Therefore, Galiatsatos extracted the DTM using traditional photogrammetric techniques. Furthermore, the camera model and ephemeris data for the Corona imagery are difficult to obtain (it requires a visit to NARA). This necessitated the use of an empirical non-metric camera model to determine the

terrain model. Altmaier and Kany (2002) also had difficulties when attempting to create a DEM from Corona stereo pairs.

Galiatsatos (in prep) proposes that the Corona – Ikonos stereo model can be used for time change analysis. He postulates that if one were to analyse the error surface associated with the DTM then locations with large errors will be due to changes (such as house construction).

Heights comparison

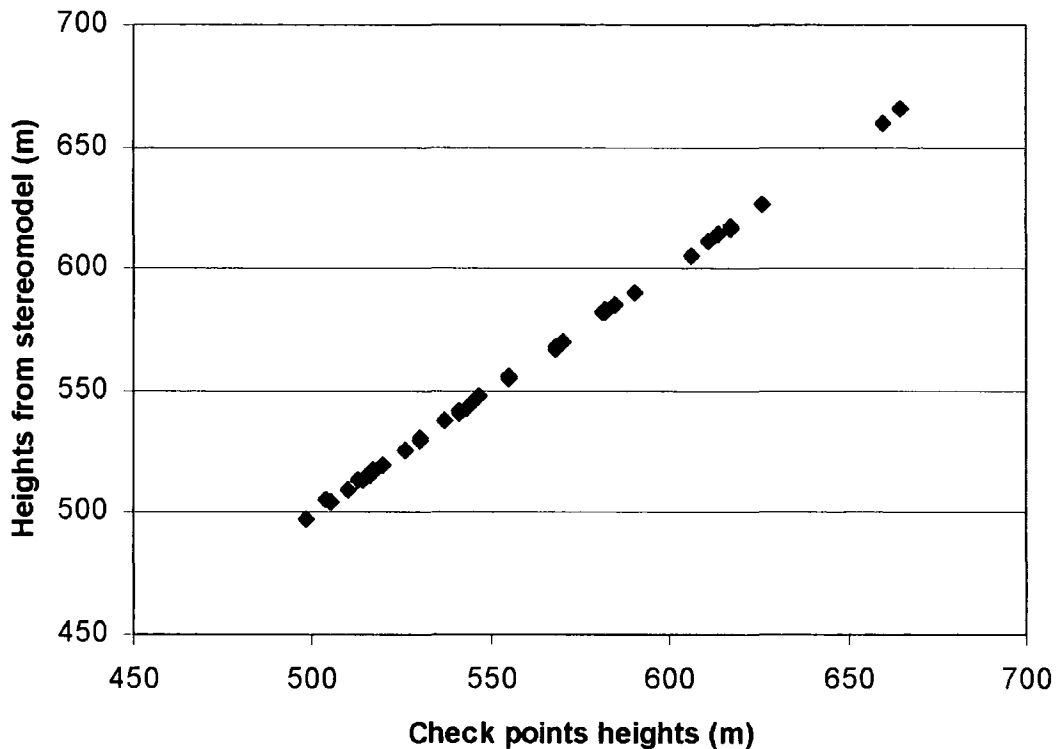

Figure 101 Graph highlighting the relationship between photogrammetric derived DTM heights from Corona and DGPS check heights (after Galiatsatos in prep).

During the 2002 season a DGPS was permitted for the collection of geomorphological features (mainly terraces) in the application area. Unfortunately it was not permitted to record areas of 'hard' detail which could have been used as GCPs for any of the rectification procedures. However, these points did provide an effective control from which to independently assess the accuracy of the DTMs. The mean height difference was 0.46m with

a maximum difference of 1.35m and a minimum of 0.01m. Figure 101 shows the correlation between these check heights and the photogrammetrically derived DTM. The correlation coefficient (r) is 0.999.

6.7.3 DTM evaluation

Photogrammetric DTM creation when using a metric measuring device with an appropriate camera model produces accurate results while at the same time being highly efficient in terms of labour (Redfern *et al.* 1999). This contrasts sharply with traditional archaeological DTM generation techniques such as contour digitising (which is an inefficient use of labour and relatively inaccurate) and ground survey using Total Stations or DGPS (which is a highly inefficient use of labour and very accurate). However, LiDAR technology does provide highly accurate and labour effective terrain models relatively cheaply, although its application is currently limited due to sensor costs. Photogrammetric software is rarely used by archaeologists, predominantly due to the expense of the software, the need for accurate camera information, a lack of skilled users and lack of awareness (Redfern *et al.* 1999). Gillings and Goodrick (1998) have used the low cost PhotoModeller software for 3-d reconstruction of standing buildings in archaeology but it has yet to be ascertained how this software would work with aerial and satellite imagery.

High resolution elevation data is an important interpretative data source within archaeological analyses. Many archaeological features produce a topographic effect, this effect is exploited in oblique aerial imagery, or occur within specific areas identifiable through elevation analyses, such as river terraces (Holden *et al.* 2002).

6.8 Discussion

This chapter has discussed the creation of thematic layers from satellite imagery. These layers are relevant for a number of archaeological management and analysis needs and can help to frame further research. A combination of medium and high spatial resolution imagery has been integrated to produce a number of thematic layers which were not previously available at this scale. The ability to produce bespoke thematic generalisations from satellite imagery is one of its major benefits. This is even more significant in an area which has limited alternative mapping and little published data on soils, hydrology, etc.

In general terms the spatial resolution of the imagery dictates the type of classification technique. The medium-resolution Landsat imagery was successfully employed for quantitative classification. However, classification becomes increasingly more complex when spatial resolution is increased. Even classification techniques used by experienced interpreters do not produce the same kind of results commonly seen in the classification of medium spatial resolution data (Palumbo and Powlesland 1996 p. 126). This is due to increased heterogeneity in the imagery and the inclusion of artefacts not necessarily relevant to the scale of analysis (e.g. groves in the Ikonos when one is classifying for surficial geology). However, the differences in spatial resolution are complementary in that high spatial resolution imagery can be used to 'truth' classified results from lower resolution sensors.

High spatial resolution imagery, from any platform, can be used in conjunction with any contemporaneous coarser spatial resolution imagery (such as Landsat) to aid any interpretation or classification of the imagery. For example, it is possible to identify crop types or genus directly from the high resolution imagery and use this to directly interpret the Landsat imagery.

With the techniques employed and the lack of alternative resources at appropriate scales it is difficult to evaluate the accuracy of the classifications. This is particularly important for the more qualitative themes (such as geology and soil, see section 8.2) which tend to change gradually over the landscape and do not occur in discrete parcels. However, this classification is not seen as the finished product. It is envisaged that further fieldwork, ground observation and consultation with the project geomorphologists will continue to refine its accuracy.

As a mechanism to improve engagement with the landscape it is recommended that a land cover and soil classification is undertaken at a very early stage in the interpretation process. This engages the investigator with the landscape and provides important information on its structure and morphology. The outlined techniques provide a broader and more representative understanding of the landscape than, for example, a driving survey.

CHAPTER 7 SATELLITE IMAGERY AS A PROSPECTION TOOL

7.1 Archaeological prospection

This chapter addresses the issues of extrapolating elements of the relevant archaeological data structure from satellite imagery. The complex theoretical issues in the delineation and interpretation of archaeological phenomena (as discussed in Chapter 3) are somewhat simplified when one is employing satellite imagery for archaeological prospection: the level of interpretation will normally only occur at the detection or recognition levels rather than the much more complex identification level. Hence, there are two primary issues when using satellite imagery for prospection:

- Can aspects of the relevant data structure actually be identified?
- If so, how much of the data structure can be identified?

The answer to both of these questions requires ground observation. The first question can be addressed by visiting the potential areas identified from the imagery as part of a more rigorous recording exercise (recognition or identification of the residues). The second question can be addressed by visiting 'blank' areas of the landscape in search of archaeological residues. The second question is much more difficult as the extent of the total relevant data structure is unknown and locating other 'undetected' archaeological residues is a difficult task. Effective quantification requires an appropriate sampling methodology (see section 0).

In a macroscopic landscape context, the archaeological record can be thought of as a more or less continuous spatial distribution of artefacts, structures, organic remains, chemical residues and other less obvious modifications. Microscopically, the distribution is far from even, with large areas where archaeological remains are widely and infrequently dispersed. There are other areas, however, where materials and other remains are abundant and clustered. It is these peaks of abundance that are commonly referred to as sites. In areas where there is limited understanding of the archaeological resource, particularly with reference to the distribution of 'sites', then some form of archaeological residue discovery is required. As discussed in section 3.5.2 the term site can be a misleading. In this context site refers to any archaeological residue (including field systems, hinterlands and settlements).

Discovery requires the detection of one or more site constituents. These are sufficient to suggest that the site might be present (McManamon 1984). Many archaeological projects detect archaeological residues through an intensive process of ground survey (Shennan 1985; Shennan 1997; Gillings *et al.* 1999; Francovich *et al.* 2000; Banning 2002). However, such approaches are costly in terms of time and human resource allocation. It is proposed that satellite remote sensing techniques can be incorporated into archaeological landscape evaluations, at an early stage, to help determine the strategic deployment of the ground survey teams.

Analysis of remotely sensed data involves identifying features and correlating ground-based measurements with recorded reflectance or emittance values. The co-registered bands are multiple layers of numeric information that have spatial and spectral structure. Some of this structure relates to archaeological phenomena. Analysis of this data is a creative synthetic process that transforms data into information. The creative act of 'interpretation' itself requires that the interpreter has an understanding of the data and its structure. This means that the interpreter is aware of underlying processes during the act of archaeological 'discovery' (Aldenderfer 1987 p. 92). It is hoped that this chapter will apply these processes and outline an appropriate methodology for this and other environmentally similar application areas.

The important points for archaeological residue detection (after McManamon 1984) are that:

1. Archaeological sites are physical and chemical phenomena.
2. There are different kinds of site constituents.
3. The abundance and spatial distribution of different constituents vary both between sites and within individual sites.
4. These attributes may be masked or accentuated by a variety of other phenomena.

Archaeological prospection applies a series of principals aimed at the detection, localisation and identification of previously unknown archaeological sites or features. For purposes of definition this section is focussed on site *discovery* using satellite imagery. Thus, the primary focus of archaeological prospection is to *detect* locations that have a high potential of containing archaeological residues. The *recognition* or even *identification* (see section 1.3.5) of archaeological residues is desirable at this stage but not essential. It is envisaged that residue

detection using satellite imagery is quicker, more cost effective and may provide a more representative sample than surface survey. However, for successful archaeological 'interpretation' to occur, increased resolution, or more likely ground observation data may also be required to provide adequate interpretative definition. Site discovery, on the other hand, focuses on a study area with the goal of locating as high a proportion as possible of sites and potential factors which may account for bias in their discovery. In this context, satellite imagery can be used as part of a Desk Based Assessment to provide a rapid overview of the archaeological potential within different environmental areas. Thus, satellite imagery provides a platform from which to perform landscape identification at a scale hitherto unprecedented.

However, this physical approach to site definition is not well documented. Most archaeological site analysis aims mainly to interpret sites and structure them culturally or behaviourally, rather than physically or chemically. There is, therefore, a limited consolidated body of reference data. Yet this sort of information would be extremely useful for determining the effectiveness of different identification techniques (however, notable exception include: McManamon 1984; Scollar 1990; Bintliff *et al.* 1992; Spoerry 1992; Pollard and Heron 1996; Taylor 2000; Heron 2001). These authors employ different techniques including, satellite and aerial imagery, soil geochemistry, artefact variations and geophysics. Sites can be identified by the variation in frequency and distributions of various physical, chemical and biological constituents. Chapter 8 addresses some of these issues analysing the physical and chemical nature of samples collected in the marl zone of the application area.

7.2 Impact of the environmental zones on prospection

Ground observation has shown that the three different environmental zones produce contrasting and complementary types of archaeological residue. In each zone the archaeological record has also been subjected to different formation and de-formation events. The basaltic zone contains a well preserved combination of sites and hinterlands as a *palimpsest* of stone walls and concentrations of rubble. By contrast, the marl zone, where a mud-brick architectural tradition dominated, contains a few mounded tell sites and many ploughed out artefact scatters. The marl zone only contains site loci as the hinterland has been masked, or eradicated, by subsequent anthropogenic activity. The alluvial zone contains a proportion of each type, depending upon the location of the alluvium, with a preponderance of artefact scatters. Each of these zones employs distinctive urban and rural

management strategies that impact upon the visibility of the archaeological residues. Some strategies can effectively destroy, or severely mask, archaeological residues (such as land clearance through bulldozing or urban expansion). This chapter will focus on each of the environmental zones separately as each zone requires different methodological techniques.



Figure 102 Changes in crop cover at site 339 at different times of the year.

The visibility of most of the archaeological residues is primarily influenced by the type of surface cover. Surface cover is positively related to the environmental conditions and the agricultural regime (see Figure 102). For this research ground observation at different times of the year indicated that crop cover is the most debilitating factor in the detection of archaeological residues from satellite imagery (see section 5.2.4):

- Unless crop marks are produced the crop canopy effectively masks any underlying archaeological residues (see Figure 102).
- It has yet to be determined if negative archaeological features produce the same kind of crop mark evidence in the region as observed in Europe (i.e. the construction techniques, materials and deformation are different).
- Even if crop marks do occur, demonstrating that the spatial or temporal resolution of the satellite images are adequate to detect crop vigour or stress is inappropriate with the imagery available.

7.3 Methodological background

When an image is available in digital form, the interpreter can use several approaches to extract information. Campbell (2002) distinguished two complementary approaches (see

Figure 4): photointerpretation (or qualitative image interpretation), where an analyst extracts information according to their experience and understanding of the phenomena under study; and quantitative analysis, where classification schemes are used to examine the image and assign classifications according to their pixel attributes. Each approach has its own strengths and weaknesses and the final combination depends upon the scope of the application.

Identifying the physical or chemical contrast between archaeological residues and the natural landscape can be undertaken using either quantitative or qualitative techniques. Qualitative prospection is the norm for archaeological image interpreters (see Donoghue 2001 for a general discussion of archaeological remote sensing interpretation techniques). Qualitative interpretation requires an experienced interpreter and imagery of the appropriate resolution for the interpretative task. This process can be improved by having access to contextual information to enable rapid verification. Quantitative interpretations in their purest form rely on digital manipulation of the imagery to extract the relevant data from feature space. Quantitative approaches are rarely used for archaeological prospection using satellite or aerial imagery. This is in all likelihood a legacy trait due to two important issues: the fact that most remote sensing techniques are 'site' rather than landscape focused (such as geophysical surveys or site focused aerial photography) and the perception that spatial variations in the physical and chemical residues at different sites would make quantitative techniques difficult, if not impossible to apply. Furthermore, the human visual system and brain is much more adept at interpreting and classifying complex information than a computer system (Ebert 1984 p. 348). This is particularly pertinent for archaeological residues which tend to exhibit complex tonal, textural and spatial patterning which are difficult to classify by automated techniques.

7.3.1 Qualitative methodologies

Archaeological residues can be distinguished on the basis of a number of image qualities including tone, texture, colour, pattern, shape and size (Ebert 1984 pp. 313-315). Most interpreters apply these techniques manually, relying solely on visual inspection of images collected, predominantly from the visual wavelengths. False colour composites produced from bands outside the visual wavelengths create representations which are unfamiliar to the inexperienced analyst. When applying qualitative techniques to digital satellite data an interpreter is provided not only with the potential to analyse information from other wavelengths but also with a number of sophisticated tools to enhance these data (Scollar

1990 pp. 126-204; Philipson 1997; Campana and Pranzini 1999; Campbell 2002). Digital image interpretation can improve on analogue interpretation by providing the interpreter with geometric and radiometric enhancement techniques. Radiometric enhancement techniques include contrast enhancement, histogram equalisation and histogram matching. Geometric enhancement techniques include filtering, edge detection, spatial derivatives and shape detection.

Multispectral images can also be transformed to generate new sets of image components or bands, which represent an alternative, feature space, description of the data. Image transformations include principal components analysis, image arithmetic, vegetation indices, and the tasselled cap transformation.

Qualitative interpretation can be difficult to reproduce, though, many interpreters produce *image interpretation keys*. These keys highlight the salient aspects used during image interpretation and can be considered as a form of interpretative metadata (see appendix I.4).

7.3.2 Quantitative methodologies

When we think of the structure of archaeological data, most of us consider the sets of cases and observations on the cases we may have collected from a site or series of sites. Data in this sense are “things” or objects and their attendant descriptors. We can easily think of other structural attributes of data, such as the three “dimensions” of archaeological data postulated by Spaulding – time, space and culture – or of somewhat less general categories of data such as “settlement” data or “spatial” data. Those of us with some mathematical or statistical training may think of data in reference to some scale or measurement, such as the now familiar quartet of nominal, ordinal, interval and ratio data. Some others may think of data as swarms of points in Euclidean hyperspace and be concerned with the degree to which these point swarms resemble standard models of statistical distributions.

(Aldenderfer 1987 p. 89)

The quantitative approach uses classification techniques for image analysis. It is hoped that the numerical structure of the relevant archaeological residue data embedded in satellite imagery can be extrapolated using these techniques. These include supervised classifications like maximum likelihood, Mahalanobis, minimum distance, parallelepiped and unsupervised classification techniques based on various algorithms.

Objects distributed in space have a relationship with one another. This relationship can be expressed in a variety of ways but does tend to conform to the assumption that objects that are close to one another are more related than distant objects. This phenomena is referred to as spatial autocorrelation (Wheatley and Gillings 2002 pp. 131-134, 183). Hence, spatial data does not conform to the traditional assumptions of statistics as levels of spatial dependence and heterogeneity deviate from the norm. This body of statistics is referred to as spatial statistics or geo-statistics.

Only a few researchers have applied quantitative remote sensing techniques for archaeological prospection using imagery with a large footprint (for example see Gaffney *et al.* 1996; Clark *et al.* 1998; Sever 1998; for example see Campana and Pranzini 1999; Harrower *et al.* 2002). Other quantitative prospection applications, such as predictive modelling, tend to occur within CRM bodies (Wheatley 1996; Wescott and Brandon 2000). One of the difficulties of quantitative analyses is that it can be difficult to ascertain if clustering within the data is relevant or irrelevant. Further, one needs to question whether the observed relationship is a reflection of clustering in the data or is a residue of the quantitative process (Aldenderfer 1987 p. 105). One of the major criticisms of predictive modelling is the amount of irrelevant data that is produced. The decision of relevance is based upon the knowledge and experience of the interpreter.

7.3.3 Digitising methodology

From a GIS perspective the archaeological residues identified during the prospection phase can be broken down into point, linear and polygonal residues. There is a broad division between the basalt zone and all other zones in respect of these feature types. The vast majority of the residues identified in the basalt are cairns (currently identified as point features) and wall segments (belonging to either field systems or structures and digitised as polyline features). Where there is a complex of structures then these are agglomerated, digitised as a polygon and issued a site number (see Figure 103). In all the other areas the

archaeological residues predominantly consist of polygonal features. However, some possible linear features have also been identified. As discussed in section 6.2.3 all the digitising occurred within ArcGIS.

One of the most important aspects of digital image interpretation is that the images are normally already geo-referenced. Therefore, if an appropriate digitising methodology is employed, the vector or raster derivatives defining residue location will also be geo-referenced.

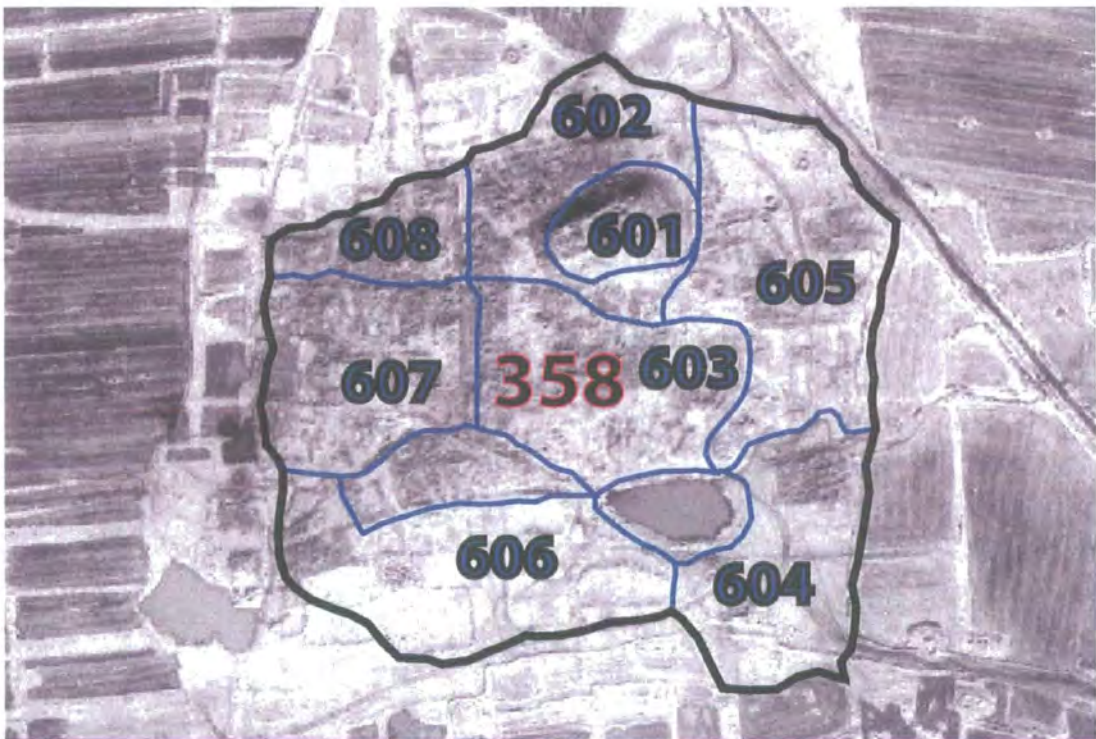

Figure 103 'Site' 358 in the basalt landscape and its surface collection subsidiaries.

7.3.3.1 Data sources

Digitised data is primarily derived from two sources: digitised from the satellite imagery (see Figure 104) or collected by GPS. The satellite imagery provides snapshots of the landscape under different environmental conditions. The measured extent of residues from different imagery and GPS may have subtle spatial differences. These differences will in part be caused by spatial errors, but more significantly, they will also be caused by different environmental conditions and post-depositional processes (such as bulldozing). Although these different

extents are potentially difficult to model, having a record of them will be useful for determining the impact of cultural and natural modifications over time (see section 9.4). Due to problems of co-registering satellite imagery, GPS data is considered as the primary resource and, where appropriate, supplants all other data. However, GPS data can only be collected for areas which have been ground observed, and in some cases use of GPS would be inappropriate. For example, recording basalt walls by GPS would be extremely time consuming and reflects the contemporary 'modified' landscape of the 21st century and not necessarily the more intact archaeological landscape as described by, for example, Corona in the late 1960s.

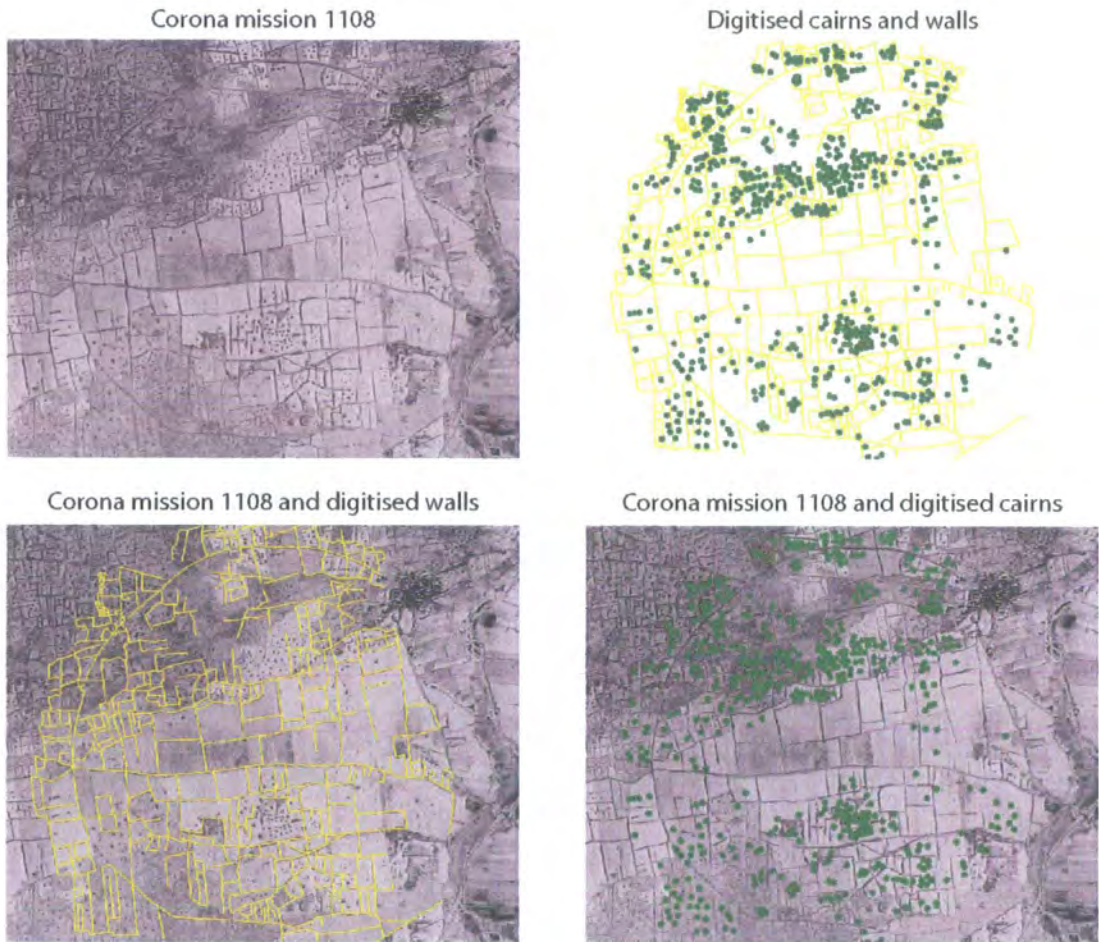

Figure 104 Digitised cairns and walls in the basalt area (scale 1:11,000).

7.3.3.2 Digitising 'point' features

Data represented as points are derived from two sources: points collected by GPS (the location of sample points (e.g. the soil samples discussed in Chapter 8), archaeological 'installations' (such as oil-presses, discussed in section 1.1.2)), and points digitised for the location of cairns (see Figure 104). The research into the basalt area is still in a preliminary phase and specific attributes for the cairns have not yet been finalised. Those attributes which have been defined are currently held within the structure of the geodatabase.

7.3.3.3 Digitising 'linear' features

The same basic technique is used for digitising polyline networks as described in section 6.2.3.1. Polyline network digitising was employed as this reduces each line segment into a feature type which can have attributes associated with it (e.g. from a site visit: see Figure 104). Attributes for the wall segments have also not been finalised. Those attributes which have been defined are currently held within the structure of the geodatabase. The same is true for all other linear features identified in other areas.

7.3.3.4 Digitising 'site' polygons

The same basic technique is used for digitising 'site' polygons as described in section 6.2.3.2. However, the unique referencing systems employed are different. The archaeology feature data set contains a simple three tier hierarchy for the linking of all spatial and attribute data (see Figure 105).

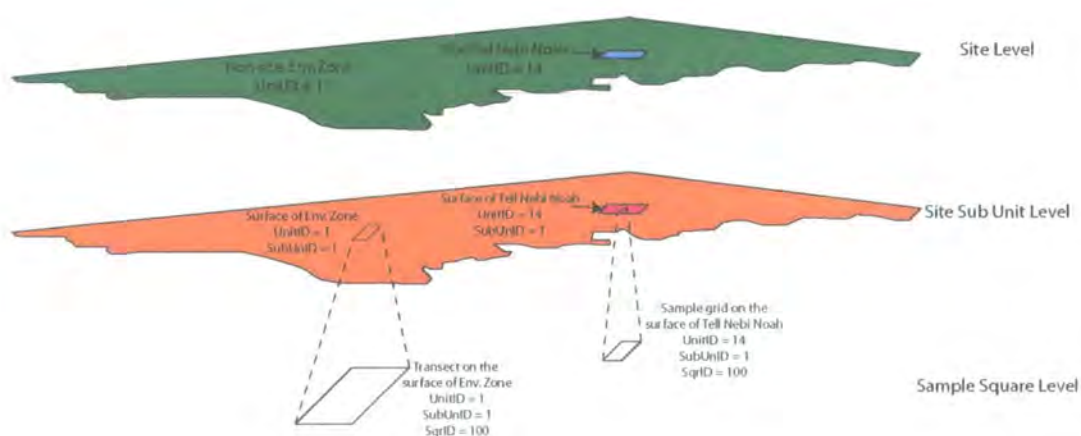

Figure 105 Schematic example of the a-spatial and spatial linkages for the archaeological data.

The most generalised element is referred to as the *Site Level*. This contains a polygon outline for the extent of the site, non-site or background landscape. This is the level where most of the satellite imagery is digitised.

The next element is referred to as the *Site Sub Unit Level*. This contains a polygon outline for any sub-units within the site. This allows large and complex sites to be broken down into sub-units (see Figure 106). Although this layer may appear to be unnecessary it is employed so that if any future excavations occur this can be used to reflect any feature or group numbers assigned during excavation. For example, when conducting surface survey all artefacts are collected from the 'surface plough soil' layer. For simplicity the ploughsoil layer across the whole landscape is given a default value of 1. However, each of these layers is spatially unique as they belong to a 'Site' with known spatial extent. For example any non gridded surface collections at Tell Nebi Noah would belong to *UnitID* = 14 and *SubUnID* = 1 as this is the most refined level of spatial control (see Figure 105).



Figure 106 Example of the hierarchical structuring system at site 173.

The most refined element in the hierarchy is the *Sample Square Level* (note that these are not always squares and could be excavated contexts). This contains the identifier for each sample unit. Hence, artefacts collected from a 2m square on the surface of Tell Nebi Noah would belong to *UnitID* = 14, *SubUnitID* = 1 and *SqrID* = 100 (where 100 is the unique square identifier for that site).

This simple hierarchical system has proven to be relatively robust. For example site 173 (Tell Qatina) has been heavily eroded on its western side by Lake Qatina and a portion of its surface levelled by bulldozing. The hierarchical structuring employed (see Figure 106) allows each of these post-depositional events to be individually modelled. This structuring will not only facilitate landscape analyses at virtually all scales but will also allow hinterlands and other off-site related artefacts to be articulated within a single model. This is exemplified by site sub-unit 173-3 which falls outside the modern extent of site 173. From a CRM perspective this information is essential as it delineates areas of destruction outside of what could be argued as the 'scheduled' area.

7.4 Prospection in the basalt zone

The basalt zone is distinct from all the other zones in that the majority of the archaeological residues exist as extant physical features in the form of cairns, field walls and other structural features. This in its own right has ramifications for the nature of the formation and deformation processes that have occurred in this environmental zone (i.e. a stable matrix with minimum deflation or aggradation in the landscape). This has resulted in a complex multi-period palimpsest of field boundaries, structures and tracks.

Unfortunately this is now a landscape which is under significant threat. In the past 30 years, enhancements to the road and rail networks (and the concomitant increase in associated settlement activity (cf Sever 1998)) have removed some archaeological residues. Even more significance is the clearance of fields, walls and cairns by bulldozing. Hence, in this environmental zone, historical imagery should provide a more representative view of the archaeological landscape than present day imagery (see Figure 107). However, this will only be the case if the historical Corona imagery can be used to detect the same range of residues as the present day Ikonos imagery.

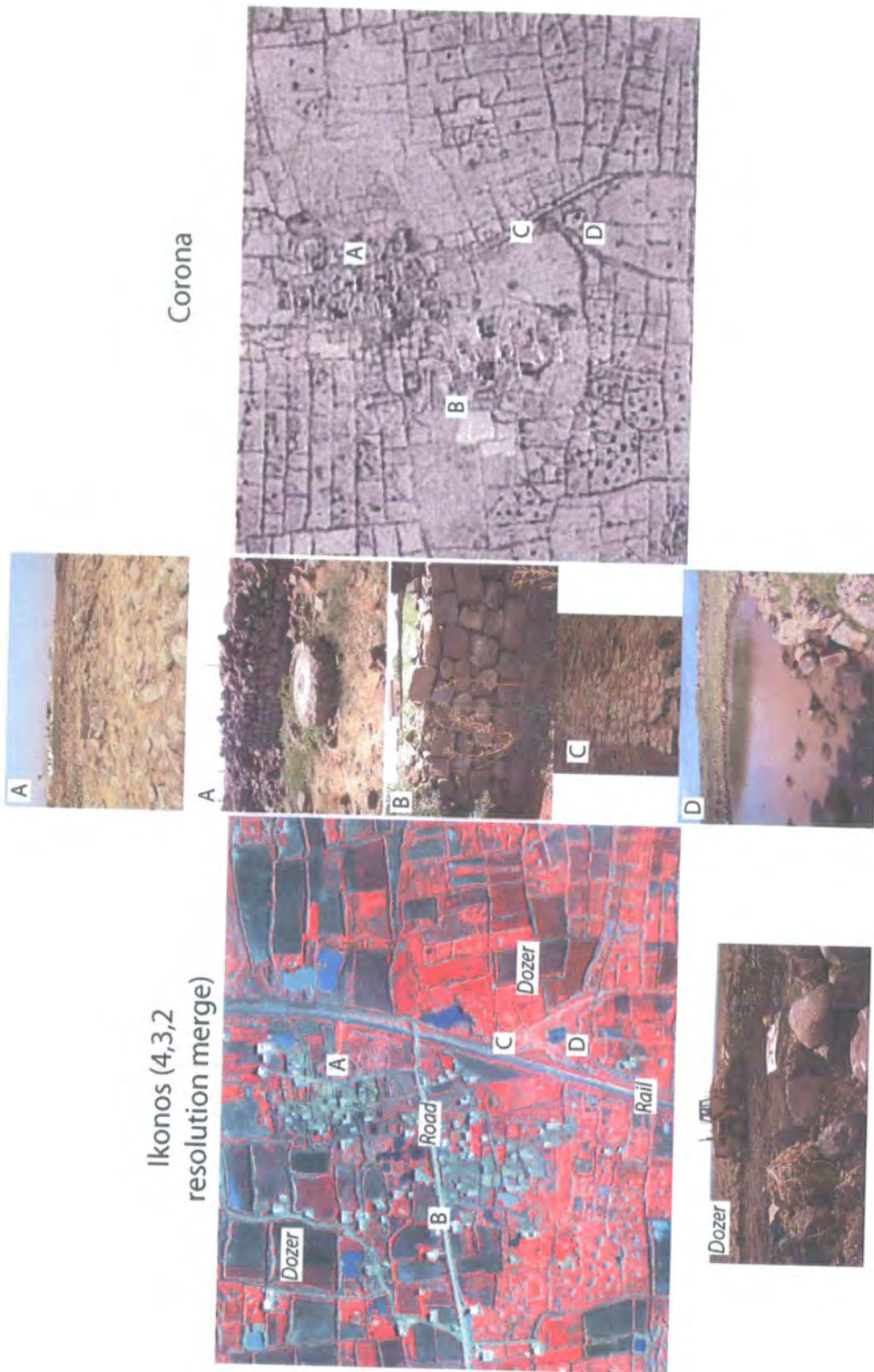

Figure 107 The basalt landscape. Modern destruction is contrasted between the Ikonos and Corona imagery (in italics). Points A, B, C and D in the Ikonos and Corona images refer to the locations of the photographs (building foundations, olive-press, wall, road and birka respectively).

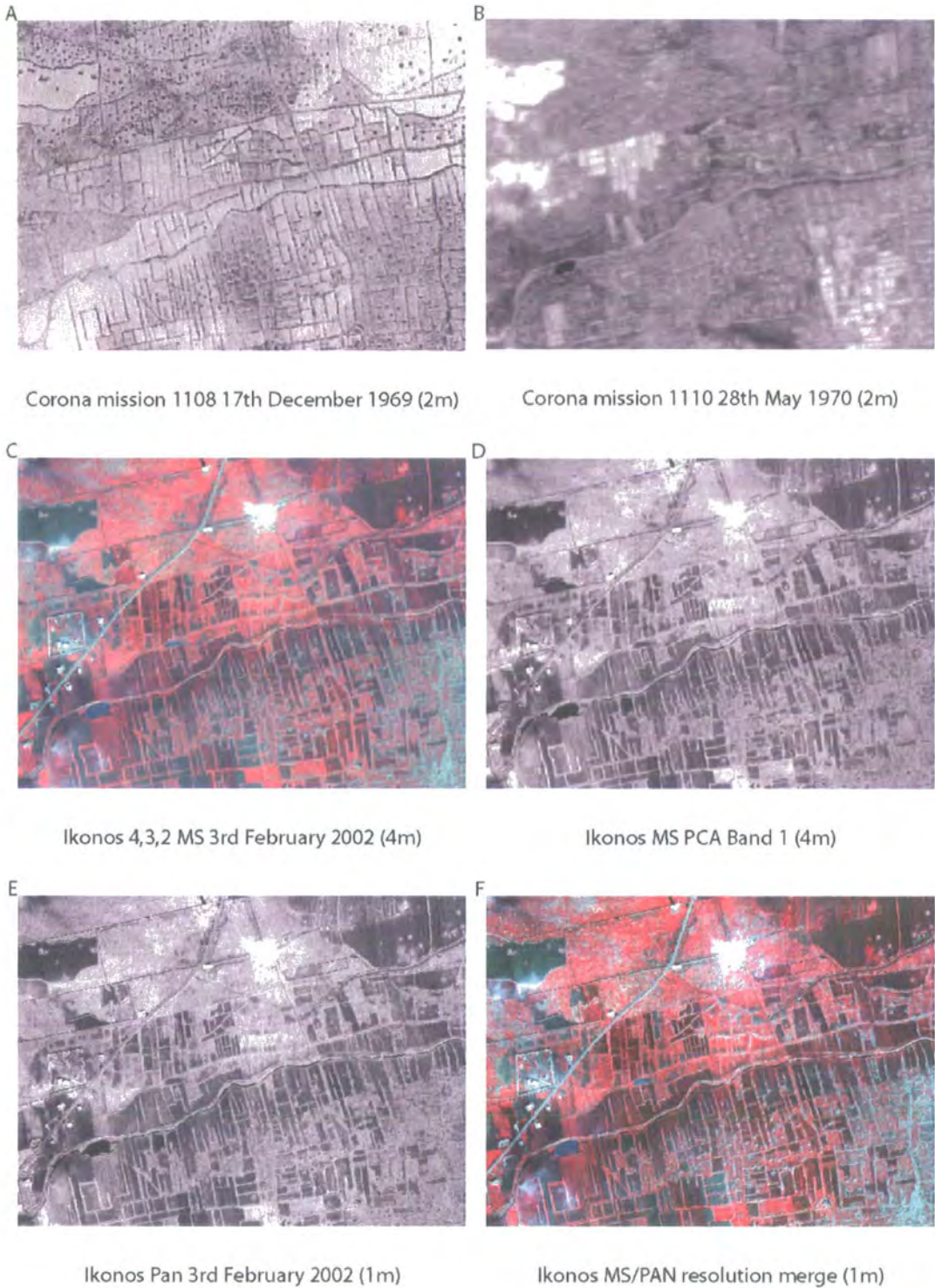
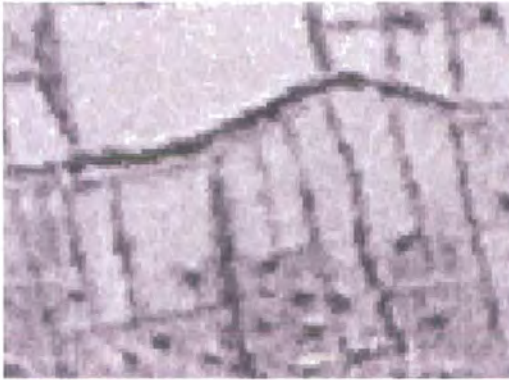

Figure 108 Comparison of the different spatial resolutions of the imagery and their effects on identification in the basalt (scale 1:5,000).

A'



Corona mission 1108 17th December 1969 (2m)

B'



Corona mission 1110 28th May 1970 (2m)

C'

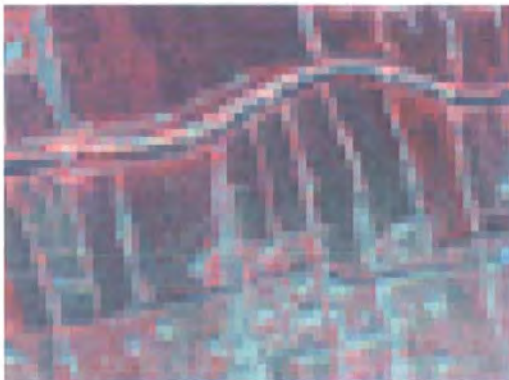

Ikonos 4,3,2 MS 3rd February 2002 (4m)

D'



Ikonos MS PCA Band 1 (4m)

E'



Ikonos Pan 3rd February 2002 (1m)

F'

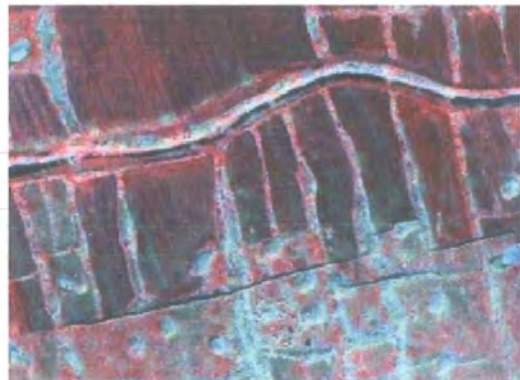

Ikonos MS/PAN resolution merge (1m)

Figure 109 Comparison of the different spatial resolutions of the imagery and their effects on identification in the basalt (scale 1:1,000).

7.4.1 Image selection in the basalt zone

There is a positive relationship between the size of the objects under study and the resolution of the imagery required to identify them. In the case of the basalt zone, where the smallest wall width is c. 0.5-1m, (see Figure 108 and Figure 109) Jensen's (2000) approximation that the spatial resolution of the sensor should be one half of the feature's smallest dimension appears to hold.

At a scale of 1:5,000 (see Figure 108) all the images, with the exception of image B (due to atmospheric haze and vegetation), clearly delineate the field-systems and clearance cairns. However, in order to digitally map these features, increased magnification is required. At a scale of 1:1,000 (see Figure 109) it becomes obvious that the lower (4 m) resolution of the Ikonos MS imagery (images C' and D') is too coarse to provide an accurate backdrop.

It is interesting to note that both the cairns and field-systems are identifiable in these images, but producing an accurate digital plan is out of the question. Image A' at 2m resolution still provides enough detail for mapping, although this is in part due to the shadow cast by the walls. The panchromatic and pan-sharpened (resolution merged) Ikonos imagery provide the best backdrop for digitising. Pan-sharpened false colour composites provide a better interpretative medium than the panchromatic imagery due to the increased spectral resolution (contrast E' and F' in Figure 109). Given the specific reliance on spatial resolution in this environmental zone, the Landsat imagery is obviously of nominal value for prospection purposes.

7.4.2 Qualitative techniques in the basalt zone

Qualitative techniques are the main mechanism for archaeological residue detection in the basalt zone. The procedure effectively involves the visual interpretation of walls, structures and cairns and digitising them directly within ArcGIS.

Images were enhanced through the normal histogram manipulations of standard deviation stretch and histogram equalisation. Minimum-maximum and linear stretches tended to reduce image contrast and hence were not used.

Kernel filters were also applied to the images to help enhance the visualisation of archaeological residues. As the majority of residues are linear, edge detection algorithms were

employed. Both the Sobel and Prewitt non-directional kernel filters were applied within

Corona mission 1108

Pan sharpened ikonos

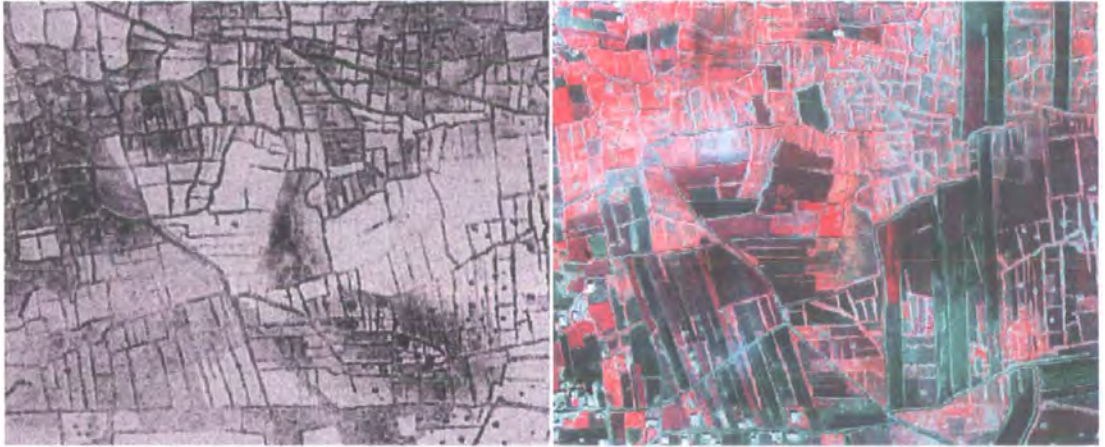

'Crisp' algorithm



Sobel edge detection algorithm

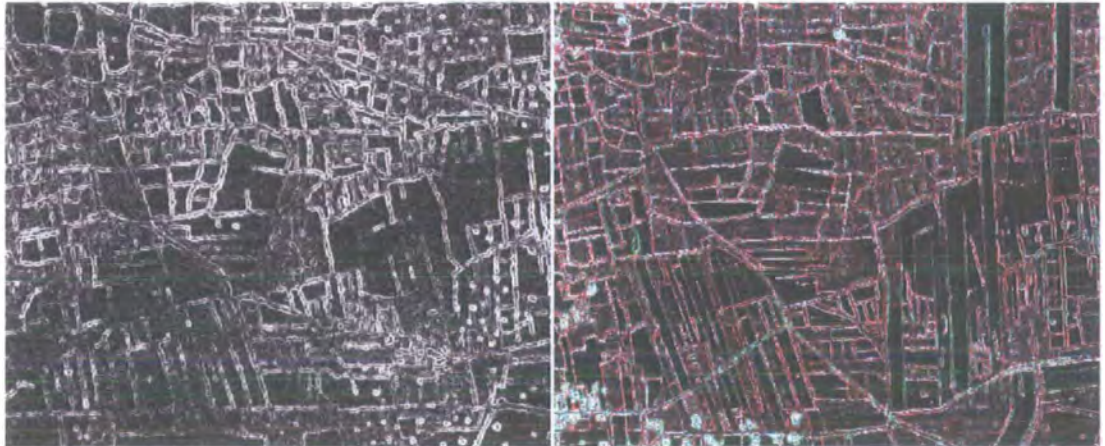

Figure 110 Kernel filters applied in the basalt zone (scale 1:5,000). It should be noted that as demonstrated in Figure 108 and Figure 109 that interpretative clarity is related to image scale.

Erdas Imagine (see Figure 110). However, these did not add any value to the other analytical techniques. Of more interest were the 'crisp' filters. This filter did allow the detection of features that were more ephemeral. Unfortunately, due to temporal fieldwork constraints, it was impossible to verify if these were actual artefacts or anomalies inherent in the data structure. However, from the general alignment of features one is inclined to place them with the former.

7.4.3 Quantitative techniques in the basalt zone

Quantitative techniques were applied within the basalt zone with limited success. Unsupervised classifications were conducted on both the Corona and Ikonos imagery. The results of these analyses were, unsurprisingly, disappointing. Image segmentation did produce slightly more worthwhile results. However, segmentation values needed recalculating for each zone. Furthermore, no new information was extracted using these techniques and the vector information still required digitising. Quantitative techniques were not pursued further.

7.4.4 Case study in the basalt zone

Initially it was decided to select a 4 km² area around the village of Borg el-Qaí. The primary reason for this choice was that it has just been placed under the protection of the Directorate General of Antiquities and Museums (Damascus). This represents one of the last remaining intact palimpsests of archaeological residues in any basalt area in Syria (Abdulkareem, pers. comm.). Unfortunately this area is at the extreme north of the application area and is only covered by the poor quality Corona mission 1110 imagery.

As an alternative a 4 km² area around the village of Krad ad-Dâsiniya (Akrad) was selected. Akrad lies on the edge of a plateau overlooking a gentle slope down towards Râm Sheikh Hanifa in the poorly drained basalt zone (see Figure 98). The original village nucleus (site 866) is a low tell-like structure, comprising small rectangular houses and narrow interconnecting alleyways, all constructed in roughly-dressed basalt. Much of the construction material is re-used. The Corona imagery indicates that by the late 1960s the village had expanded to the south and west (following the main road routes) from its original nucleated core.

The hinterland for the village appears to be split into a number of zones (see Figure 111). The immediate environs are used for market gardening (vines, vegetables and orchards) in a

dense pattern of small walled plots. Beyond these plots are larger fields which would traditionally have been used for dry-farming cereal cultivation. Sheep and possibly cattle are grazed in the more marginal ground.



Figure 111 Hinterland zones at the SE of Krad ad-Dāsiniya (digitised walls are derived from Ikonos imagery). The parallel walls represent access tracks.

Within the hinterland zone it is possible to extract at least four different systems of land management from the geometry and stratigraphy of the walls and the form of the enclosed areas (see Figure 178):

1. Large fields cleared with a bulldozer (modern): these are demarcated by large piles of boulders up to 5m wide. These bulldozed areas do not tend to appear on the Corona imagery.

2. Long straight dry stone walls (modern: < 30 years old): Built of regular basalt blocks these walls line access routes and surround groups of smaller fields. These walls do not tend to appear on the Corona imagery.
3. Traces of multiple parallel, low linear walls probably related to the past Mouchaa farming system (pre 20th century land reform): Large fields (probably from Centuriation) evenly divided into smaller units.
4. Centuriation: extensive field system with large fields instituted (mainly Roman). Not easy to detect across the whole area.

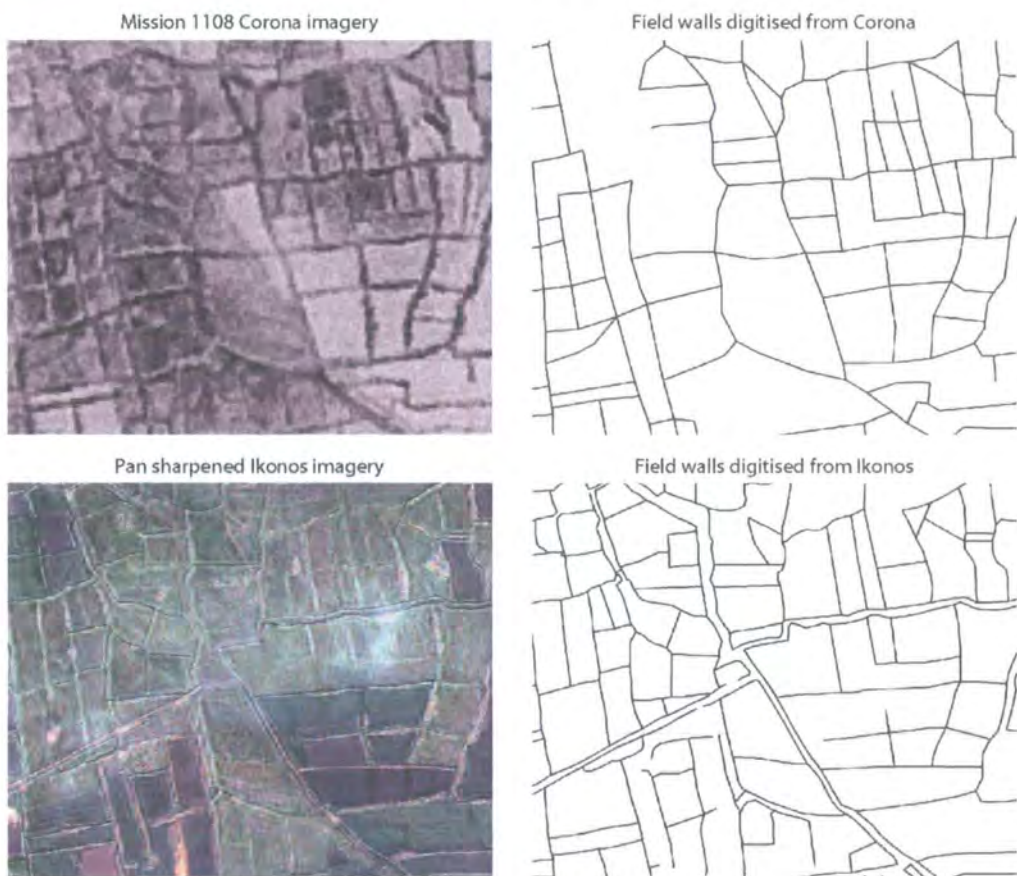

Figure 112 Comparison of the observable detail between Corona and Ikonos imagery and their resultant digitised interpretations (scale 1:2,000). The lack of parallel walls on the Corona could be due to its lower resolution. Alternatively the tracks could have been created to allow tractor access.

Across the study area these systems maintain the same broad field orientation of 352° (Newson, pers. comm.). Vestiges of the centuriation, as the earliest identified form of land division, are still incorporated into many of the later systems.

Figure 111 and Figure 112 display digitising from the south eastern quadrant centred on Akrad. The higher spatial resolution in the Ikonos imagery is translated into a much more detailed vector output. Even though there are differences in the digitised outputs the core structure of the systems are very similar (see Figure 114).

A broader scale evaluation of the settlement and hinterland systems in the basalt zone is currently being undertaken by Dr. Paul Newson (Department of Archaeology, University of Durham) as part of an AHRB post-doctoral research project.



Corona 1969

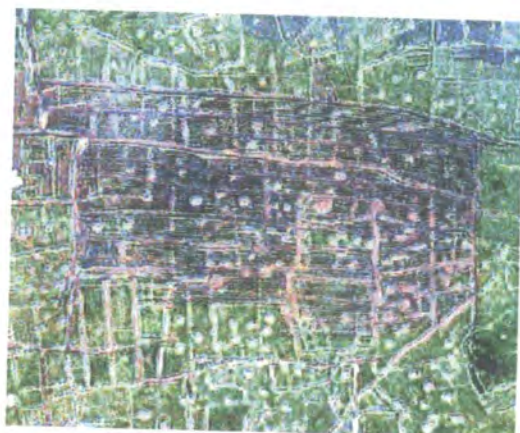

Ikonos 3,2,1
resolution merge



Ikonos panchromatic



Ikonos 3,2,1 multi spectral

Figure 113 Comparison of the Corona and Ikonos imagery in a bulldozed area of the basalt (scale 1:3000). Even though bulldozed the Ikonos resolution merge image exhibits some of the residues seen on the Corona image.

7.4.5 Evaluation of sensors in the basalt zone

In this application area the Corona imagery predates the significant use of bulldozing and has recorded an effectively intact landscape with minimal destruction, disturbance or masking of archaeological residues by present day agricultural or settlement expansion. This is a potentially fortuitous set of circumstances: the application area was, and still is, considered militarily sensitive therefore a relatively large number of Corona missions intersected the application area.

Of the relatively cloud free missions only 1108 and 1111 provided the appropriate spatial resolution and contrast for digital mapping in the basalt (compare image A against image B in Figure 108). Unfortunately the 1108 imagery does not cover the whole basalt zone and mission 1111 does not intersect it at all (see Figure 115). The mission 1111 collection time (c. 18:30 hours) would have recorded shadows which could have improved interpretation. Although the spatial resolution of the Corona imagery is high enough for mapping purposes it is not as refined as the Ikonos imagery. Hence a more generalised mapping product is generated (see Figure 113 and Figure 114). Furthermore, Corona imagery does not display the full range of residues as seen on the Ikonos imagery and noted during ground observation (see Figure 116). The cause of this is unknown although it may have something to do with the time the imagery was collected, the radiometric resolution of the film or the scanning process. Most importantly, the Corona imagery requires extensive geo-referencing (see section 5.4). As experienced in the first field season, without the Ikonos imagery as a geo-referencing base (as at the time differential GPS was impossible and handheld GPS correction was too time consuming) the Corona imagery would have highlighted many residues but locating them in this complex landscape would have been difficult if not impossible.

The Ikonos imagery records the landscape under the environmental conditions determined during the collection window (see section 5.2). Therefore, in comparison to Corona, there is much more flexibility in obtaining an image where archaeological residues are easier to distinguish. Much like any source of evidence the Ikonos imagery may not fully represent the archaeological resource due to recent landscape modification (examine the wooded area, centre right, in Figure 117). In comparison to the Corona the spatial resolution of the panchromatic Ikonos imagery allows detection with a higher degree of confidence. Consequently, the accuracy of the digitising is improved.

Ikonos pan sharpened and Ikonos walls

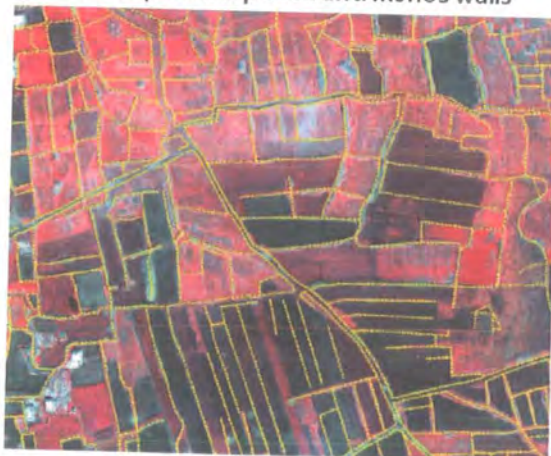

Corona Mission 1108 and Ikonos walls



Ikonos pan sharpened and Corona walls

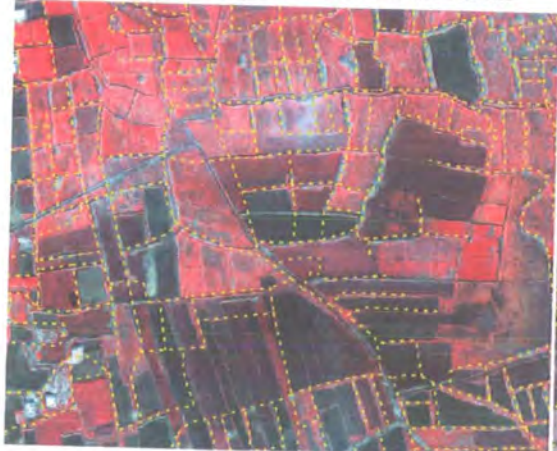

Corona Mission 1108 and Corona walls



Ikonos walls and Corona walls (black)



Figure 114 Comparison of digitising using the Corona and Ikonos imagery as backdrops (scale 1:3,000).

The multispectral Ikonos imagery should not be used for digitising purposes as the spatial resolution is too coarse. However, the increased spectral resolution of the pan-sharpened MS Ikonos imagery improves the detection of residues that are difficult to distinguish in the panchromatic (see Figure 112 and Figure 114). Alternatively placing the Ikonos multispectral over the panchromatic with a 40-60% transparency produced a similar result. This technique has the advantage of reducing storage requirements. For example, where an Ikonos pan and MS image have file sizes of 235MB and 60MB respectively the resolution merged image has a file size of 940MB. Furthermore, the pan-sharpened Ikonos imagery has allowed the identification and mapping of wall elements where the above ground component has been removed by bulldozing (see the Ikonos 3,2,1 resolution merge in Figure 113).

In summary, both Corona and Ikonos imagery are appropriate sensors for the prospection and mapping of archaeological residues in the basalt zone. The Corona imagery provides a synoptic view of the landscape prior to recent destructive modifications. Thus the Corona imagery is potentially a more representative snapshot of the archaeological resource than the Ikonos. However, the Ikonos imagery produces a less generalised view of the archaeological residues. When the Ikonos and Corona imagery are used in conjunction with one another further benefits are realised. From a CRM perspective the analysis of both data sources provides an overview of the archaeological residues and the range and number of destructive modifications over the past thirty years. The Ikonos imagery provides a present day snapshot of a landscape under destruction and is therefore useful as a CRM tool to determine the level of threat to the landscape. This form of information is essential when determining the management strategy for this environment (this is discussed in more detail in Chapter 9).

From a methodological perspective the most productive approach would be to ensure that the imagery is geo-referenced and co-registered to a high degree of ground precision. The archaeological residues should then be digitised from the Ikonos imagery (either 1m pan or 1m pan-sharpened (see Figure 112)). This would produce a present day 'benchmark' of the potential archaeological residues essential for constructing a CRM strategy. The Corona imagery can then be digitised or alternatively evaluated against the Ikonos digitising. Residues that have been masked or eradicated in the intervening period can be mapped, integrated into the data model and evaluated. As regards user interpretation of the imagery, qualitative techniques for residue detection are more appropriate than quantitative techniques. However, some image enhancement algorithms, particularly sharpening and edge enhancement kernels,

can help improve detection. Specific quantitative techniques and classification algorithms do not appear to produce adequate results. Although it could be argued that automated archaeological residue detection techniques are desirable, from an archaeological interpretative viewpoint, at least in this zone, this means that the interpreter is less likely to immerse themselves in the data and hence subtle relevant nuances may be overlooked

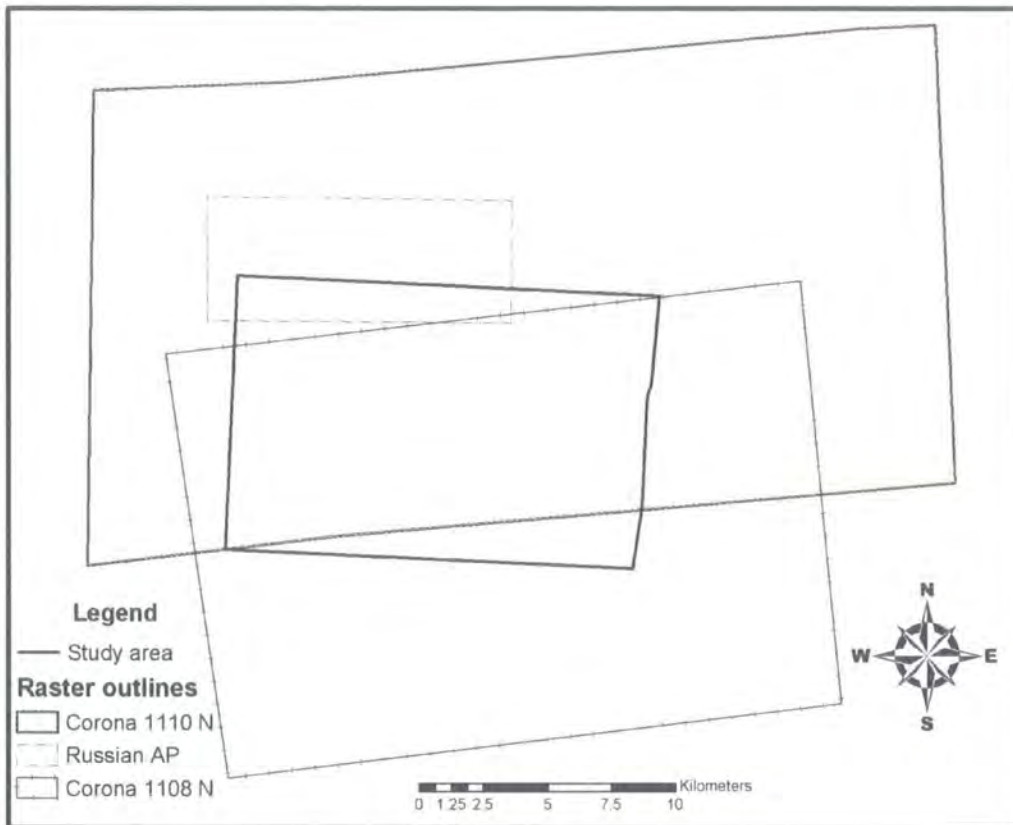

Figure 115 The extent of the Russian aerial photographs and Corona imagery in the northern application area.

Using such a technique it is possible to record the extent and impact of landscape modifications that have occurred in the intervening years. The resultant vector map when used in conjunction with ArcPAD and a GPS facilitates the navigation to specific residue elements with confidence (see section 9.3.1). The accurate co-registration between desk based digitising and field reconnaissance is a significant methodological advance that has resulted in substantial financial savings. For example, digitising these field systems using traditional total station technology, apart from being extremely difficult and time consuming, would have been very expensive (cf. Newson 2002 pp. 166-172).

7.4.6 Russian aerial photographs in the basalt zone

In addition to the Corona and Ikonos imagery, Russian vertical aerial photography was made available by Dr. Abdulkareem in 2003 (see section 5.1.4.2). The five overlapping aerial photographs covered a small portion of the Northern study area. Unfortunately these photographs did not correspond with the extent of the Corona 1108 imagery (see Figure 115). Therefore, only the Ikonos imagery was directly comparable with the aerial photography. Comparisons between the Corona 1108 imagery and the aerial photography are extrapolated (see Figure 117).

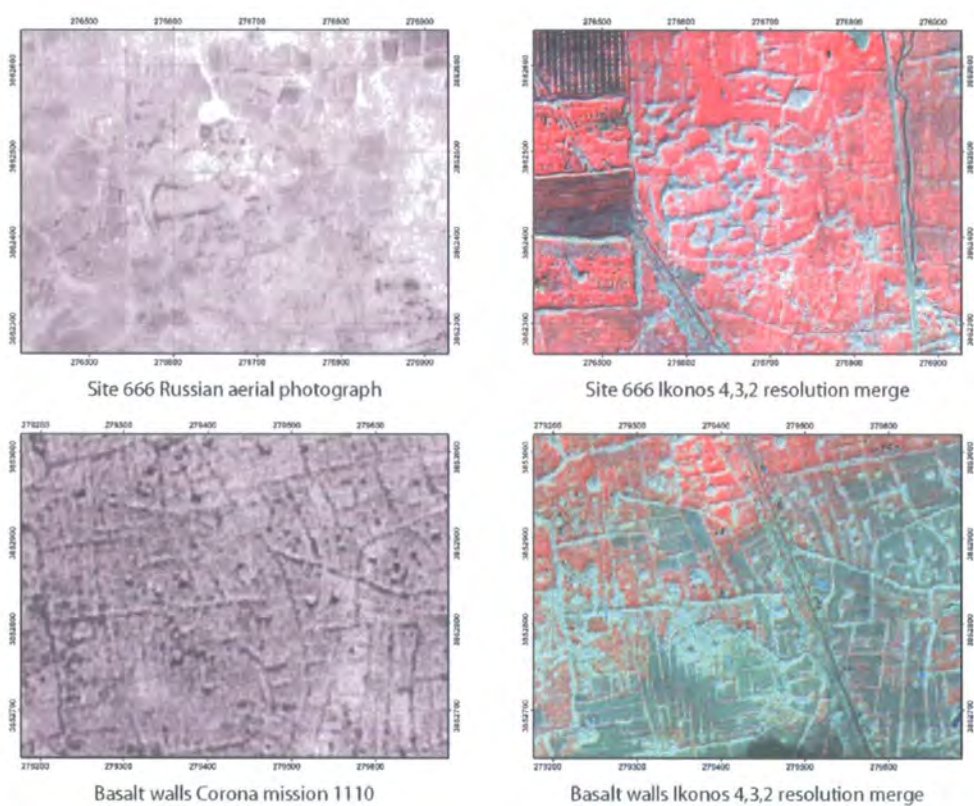

Figure 116 Comparison of the Russian aerial photography, Corona and Ikonos imagery.

Using the analogue to digital conversion technique described in section 5.1.4.2 the Russian aerial photographs have similar spatial resolution to the Ikonos panchromatic and spectral characteristics of the Corona imagery. Furthermore, it was assumed that this aerial imagery was collected for mapping purposes. If correct, this imagery would have been taken with a metric camera at a relatively stable (low) platform with a relatively low cloud cover index.

Russian Aerial Photography



Corona 1969 (mission 1108)



Ikonos 4,3,2 resolution merge

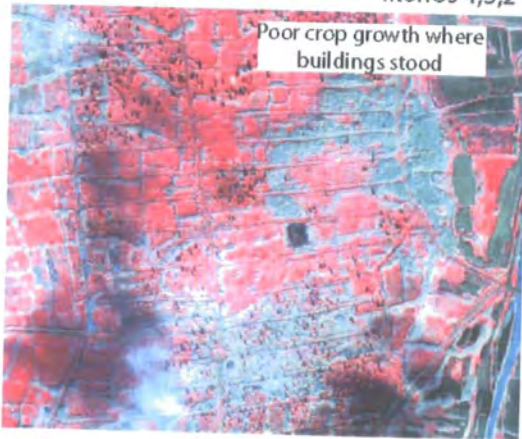

Corona 1970 (mission 1110)

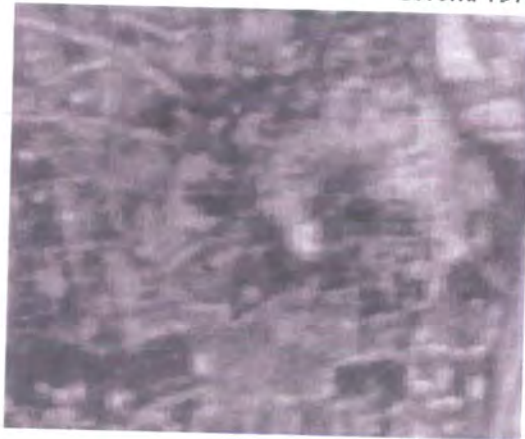

Figure 117 Comparison of the Russian aerial photography, Ikonos and Corona imagery over an unknown site and a comparative evaluation over a different area using the mission 1108 Corona.

This combination of factors has produced crisp imagery with good geometric properties. Although it is not possible to directly contrast the Corona 1108 and Russian aerial photography, extrapolation from the 1970 Corona 1110 gives the impression that the landscape was not significantly modified between 1958 and 1970. This adds further credence to the assumption that the Corona imagery is a representative snapshot of a preserved archaeological palimpsest. However, like the Corona imagery the contrast of the photography does not highlight all the archaeological residues (see Figure 116). This could be a result of poor storage or the scanning process. It is hoped that a more appropriate scanner with better spatial, radiometric and geometric fidelity would produce even more detail and compensate for any potential inadequacies in the original scanning process.

On a point of methodology it is important to stress that without the Ikonos imagery accurate rectification of these photographs would have been extremely time consuming (see section 5.1.4.2). Furthermore, it is interesting to note that although Dr. Abdulkareem stated that these photographs are Russian in origin they are labelled in Roman rather than Cyrillic script.

7.5 Prospection in the marl zone

The marl zone contains archaeological residues that contrast strongly with those found in the basalt zone. The majority of these residues do not exist as hard wearing structural material (such as basalt blocks); rather it appears they are remnants of the ongoing formation and deformation processes associated with settlement and the creation and decay of mud-brick architecture. The residues can be broadly considered as anthropogenically induced physical and chemical variations of the localised soil matrix. Settlement evidence consists of mounded tells and other 'flatter' sites producing a distribution of discrete 'site loci' across the zone. These residues are at least an order of magnitude larger than those in the basalt. The smallest radius attributed to a site is 23m (site 478).

At a very early stage in the research it was observed that these sites showed a distinct soil colouration in comparison with the background soil matrix (see Figure 118). This phenomenon, which is investigated in detail in Chapter 8, is the basis for residue prospection in this zone. Hinterland evidence in the form of field systems associated with these settlements has not been recognised either on the satellite imagery or during ground survey.

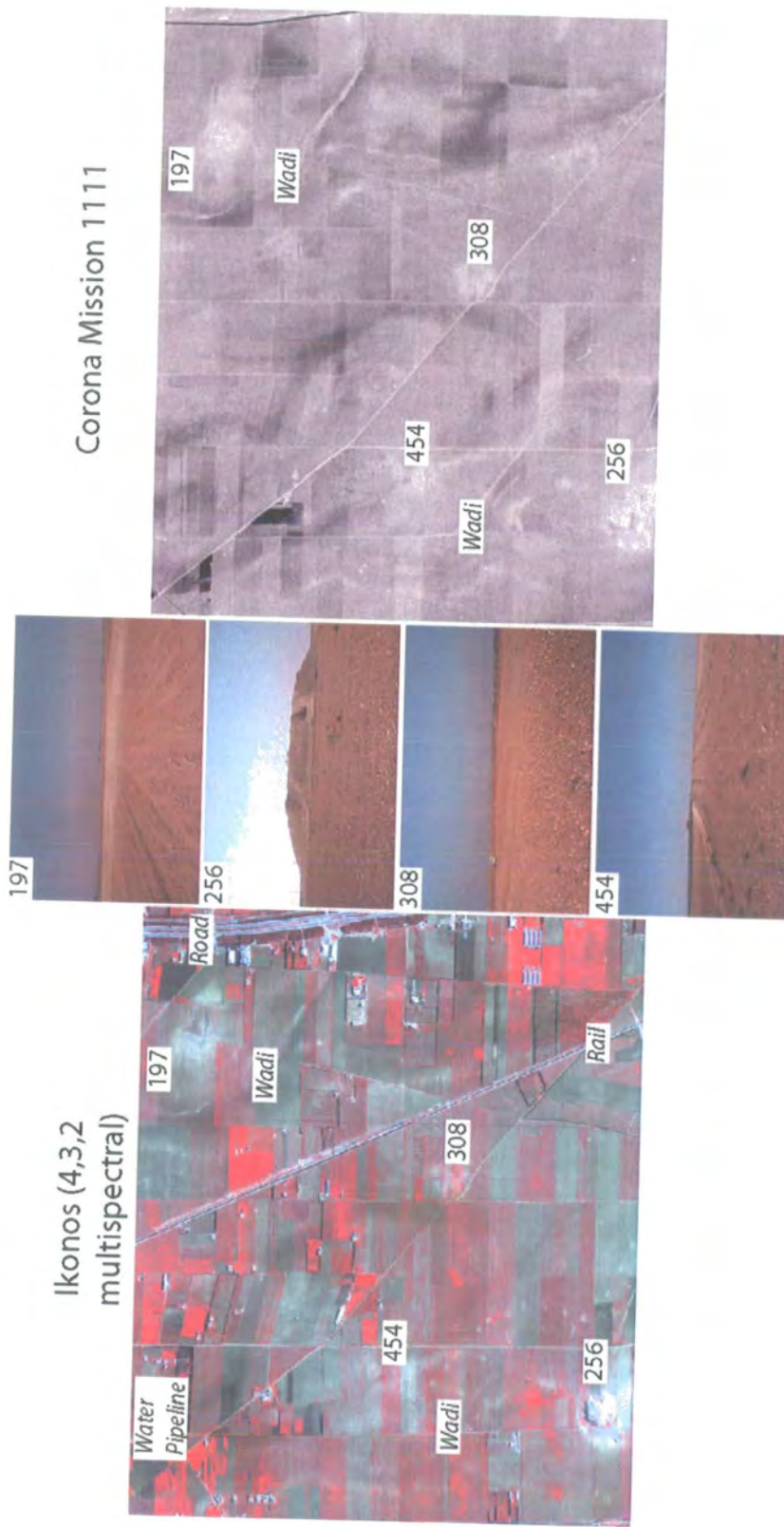

Corona Mission 1111

Ikonos (4,3,2 multispectral)

Figure 118 The marl landscape and 'sites'. Modern development is contrasted between the Ikonos and Corona imagery (in italics).

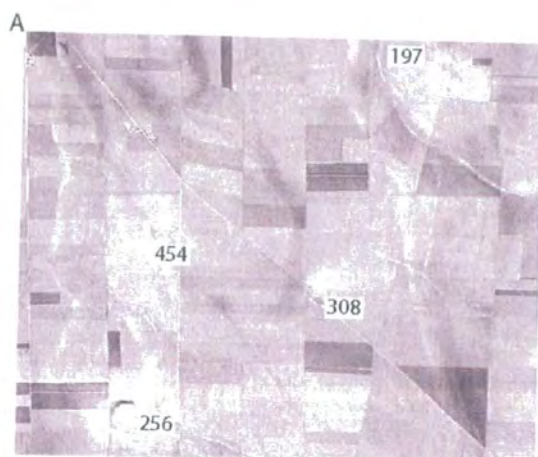

Corona mission 1108 17th December 1969 (2m)

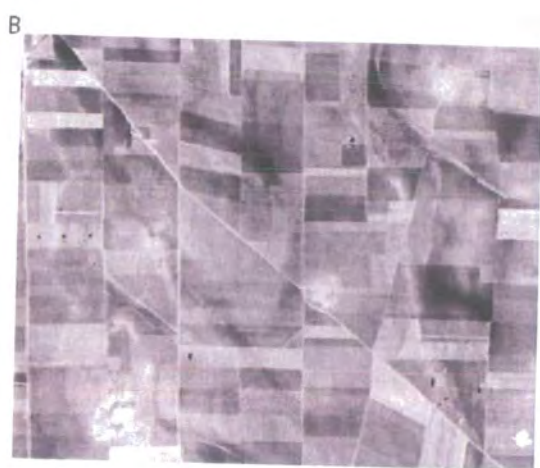

Corona mission 1110 28th May 1970 (2m)



Ikonos Pan 3rd February 2002 (1m)

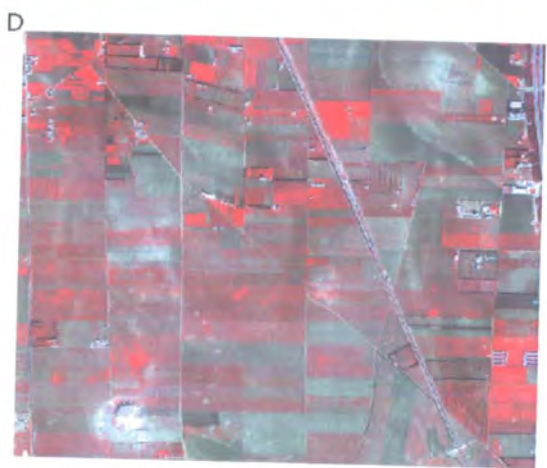

Ikonos 4,3,2 MS 3rd February 2002 (4m)



Landsat 7, 5, 3 MS/PAN resolution merge (15m)

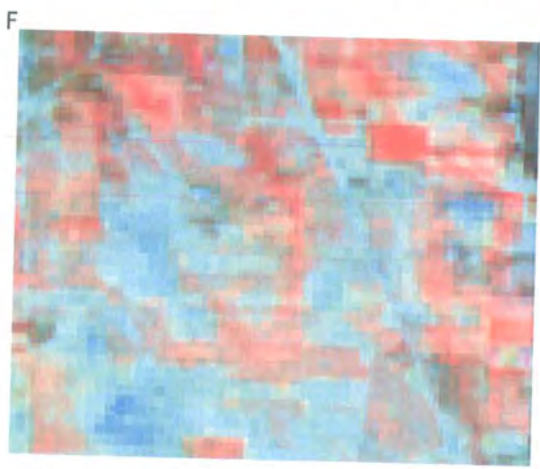

Landsat 7, 5, 3 MS 14th January 2000 (30m)

Figure 119 Comparison of the different spatial resolutions of the imagery and their effects on identification in the marl (scale 1:12,500). Sites are highlighted in image A.

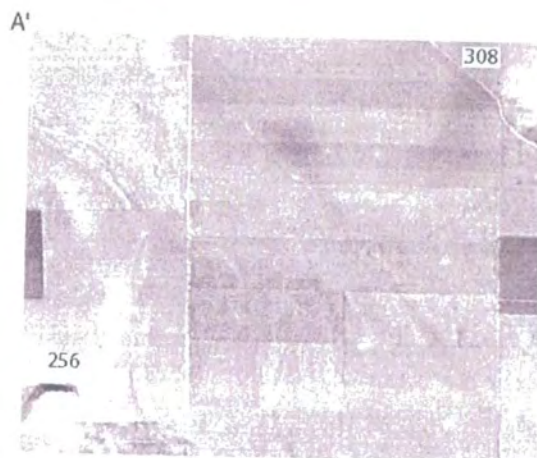

Corona mission 1108 17th December 1969 (2m)



Corona mission 1110 28th May 1970 (2m)



Ikonos Pan 3rd February 2002 (1m)

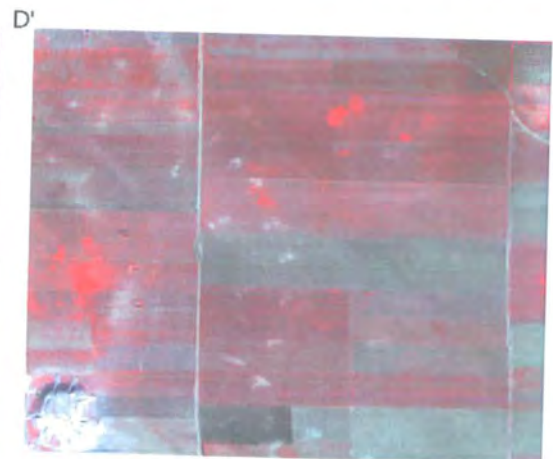

Ikonos 4,3,2 MS 3rd February 2002 (4m)



Landsat 7, 5, 3 MS/PAN resolution merge (15m)

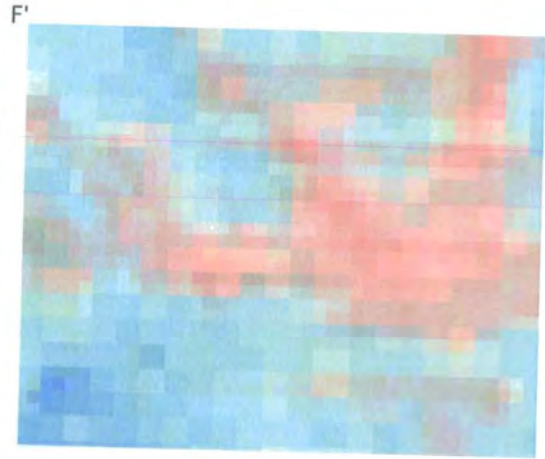

Landsat 7, 5, 3 MS 14th January 2000 (30m)

Figure 120 Comparison of the different spatial resolutions of the imagery and their effects on identification in the marl (scale 1:5,000).

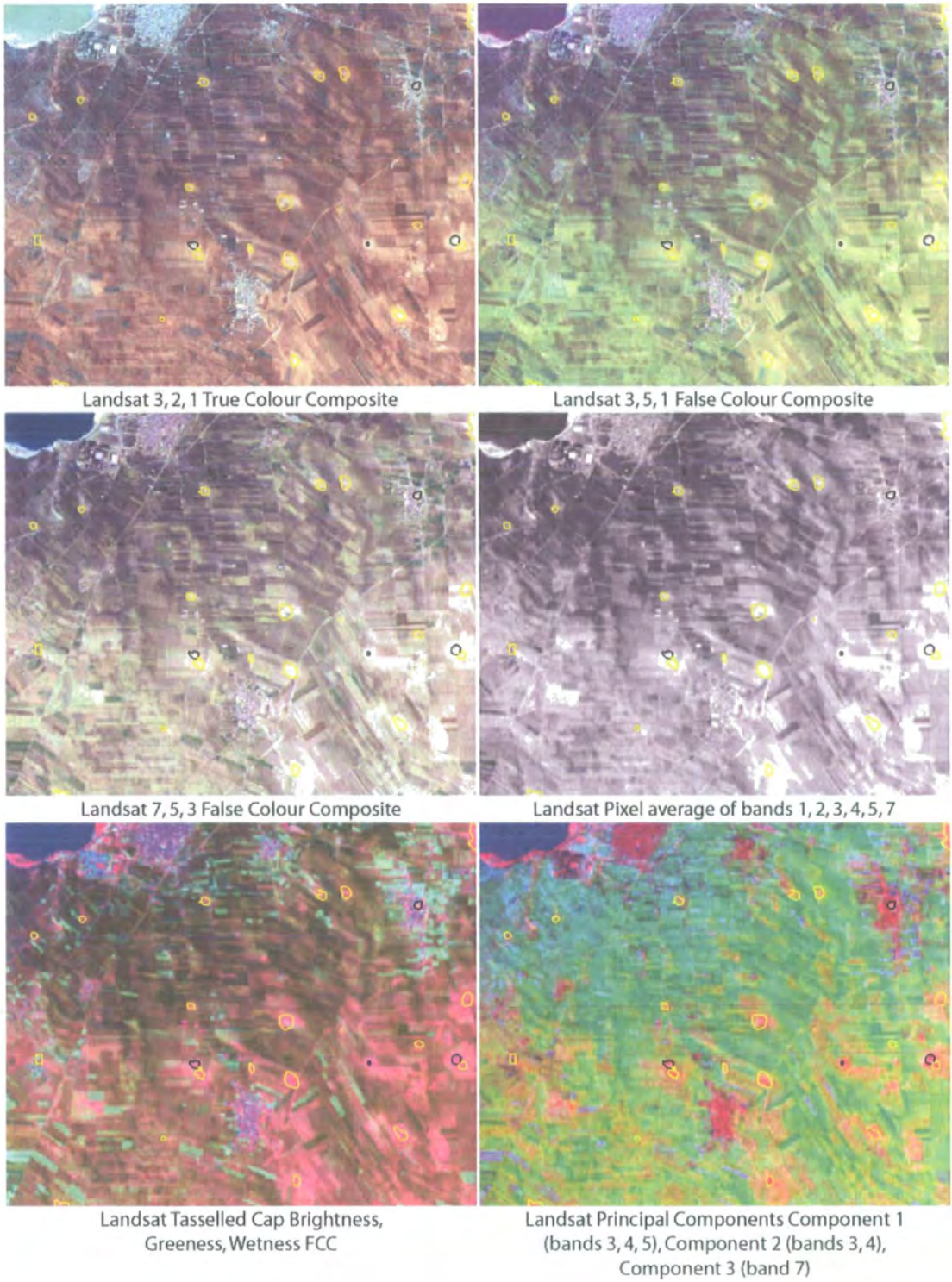

Figure 121 Different visualisations of raw and processed Landsat imagery overlaid by 'sites'. Yellow sites are flat, black sites are tells.

The archaeological residues in this area fulfil many of the expected norms for the Middle East. This is reflected in the tell focused archaeological studies that have been conducted in Syria for many years and which have, in part, been criticised by Wilkinson (2000).

In common with the basalt zone the marl zone is also experiencing residue modification through landscape clearance, urban expansion and changes in agricultural technique (particularly deep ploughing, see for example Lambrick (1977)). The contrast in construction technique between the zones is most striking. The basalt environment exhibits extensive structural evidence which are not evident in the marl. At present only areas of settlement have been located in the marl and associated hinterland systems appear to have been eradicated. Continuous ploughing has not yet eradicated the settlement residues in the marl.

However, current survey evidence indicates that over time the marl landscape was more intensively settled and exploited than the basalt landscape. While recognising that this is a simplified comparison this does imply that there is an increased likelihood of cultural transforms in the marl landscape. This landscape will have seen a number of profound variations in landscape structure over time. Both cadastration and musha'a farming would have impacted on previous landscape structures. For example, Van Liere (1959) identified centuriation in the marl landscape East of Homs and one would expect this system to extend into all the Homs hinterlands. However, no trace of this land management structure has been identified in our marl areas.

7.5.1 Image selection in the marl zone

The larger size of residues in the marl zone increases the range of imagery which is effective for prospection. Obviously the Ikonos (4m multispectral and 1m panchromatic) and Corona imagery are appropriate. Theoretically the 15m panchromatic band on the Landsat ETM sensor should detect all residues and the other 30m resolution bands on the Landsat platform should detect most residues. The increased size meant that pan-sharpened Ikonos imagery was not employed. However, the transparent overlay technique of MS over pan Ikonos imagery was used.

Figure 119 compares the resolution of the primary sensors within the marl zone. Without any major image manipulation most of the residues are relatively easy to distinguish in the Corona and Ikonos panchromatic imagery (compare images A or B with C). However,

present day modifications (i.e. infrastructure building, settlement expansion and deeper ploughing) have increased complexity in the Ikonos imagery. It is interesting to note that the reduced image fidelity of the mission 1110 Corona image, which made it an inappropriate resource for prospection in the basalt, is not so significant for the marl zone. The increased spectral resolution of the Ikonos multispectral allows the creation of colour composites improving visual detection (compare image C with image D). The pan-sharpened Landsat imagery still allows the identification of the sites. However, the decreasing spatial resolution means that more 'potential', but negative, sites are identified. This would necessitate increased time for ground observation. This is further exacerbated in the 30m Landsat imagery. However, the increased spectral resolution of the Landsat imagery allows greater flexibility in image processing and visualisation. Different bands can be combined to produce false colour composites and alternative visual representations such as tasselled cap and principal components (see Figure 121). These same techniques can be applied to the Ikonos multispectral imagery. Of particular relevance are Landsat bands 5 and 7 in the infrared which provide useful information about soil and surficial geology.

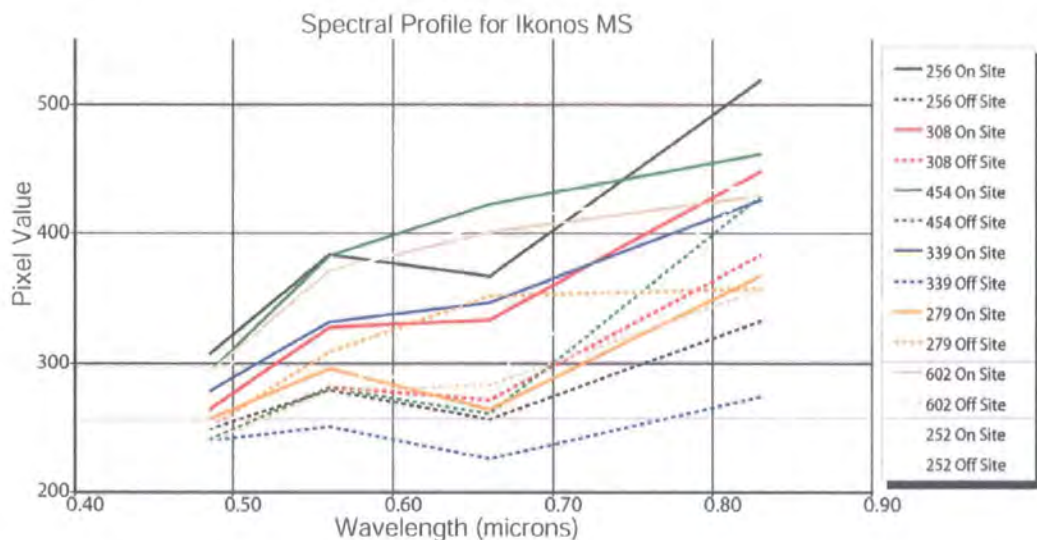

Figure 122 Spectral profile of on and off-site point locations derived from Ikonos MS imagery.

As the scale is decreased (see Figure 120) other interpretative artefacts become clearer. The Corona imagery appears to display the greatest contrast between archaeological residues and the background soil and vegetation. The Ikonos imagery provides the best backdrop for digitising features (such as the military entrenchments on site 256 (compare C' against all

other images). It also interesting to note that the 4m multispectral Ikonos provides better clarity for mapping purposes than the Corona (compare image D' against A' and B'). At these scales the spatial resolution of the Landsat imagery makes the scenes relatively unintelligible (compare E' and F' with E and F in Figure 119).

7.5.2 Spectral nature of the residues in the marl zone

As previously discussed, the main mechanism for detection in the marl is through differences in soil colour associated with archaeological sites. This necessitates a change in reflectance within, at least, the visual portion of the EM spectrum. This phenomenon will be discussed in more detail in this section. For simplicity, throughout this section the Ikonos MS imagery is used for illustrative purposes, as it has a relatively high spatial resolution (useful for examining transects and surfaces) and a medium spectral resolution (useful to examine changes across the EM spectrum).

Figure 122 displays the spectral profile from a single on and off-site point for a number of different site types in the marl. In all instances, with the exception on site 279 (discussed at length in Chapter 8), there is a significant increase in DN values for 'site' pixels of between 20 and 30%. The graph also reveals that there is not a single spectral signature for archaeological residues. However, most sites do show a general increase for bands 2 (c. 0.55 microns) and 3 (c. 0.65 microns) against bands 1 (c. 0.5 microns), which may be useful for band ratioing.

A closer examination of the spectral content of the archaeological residues was deemed necessary. Using ERDAS Imagine, transects and surface spectral profiles were taken from the Ikonos MS imagery for a number of sites within the marl zone (see Figure 123). These sites were of a range of different types (tells to flat sites), chronological periods and in different soil zones (as defined in section 6.6).

Most sites displayed an increase in each band in comparison to the off-site readings. Sites 218 and 279 were the exceptions. Site 218 exhibits very strong reflectance in the NIR and consistent readings in all other bands. It is likely that this site was largely masked by crop at the time of image collection. For detection purposes the NIR is the least reliable band of all. Vegetation makes it difficult to detect sites in the NIR band in a number of profiles (218,

221, 259, 339, 454, 478 and 602). Although, this band is not valuable for detecting residues it does allow one to simply plot the location of vegetation.

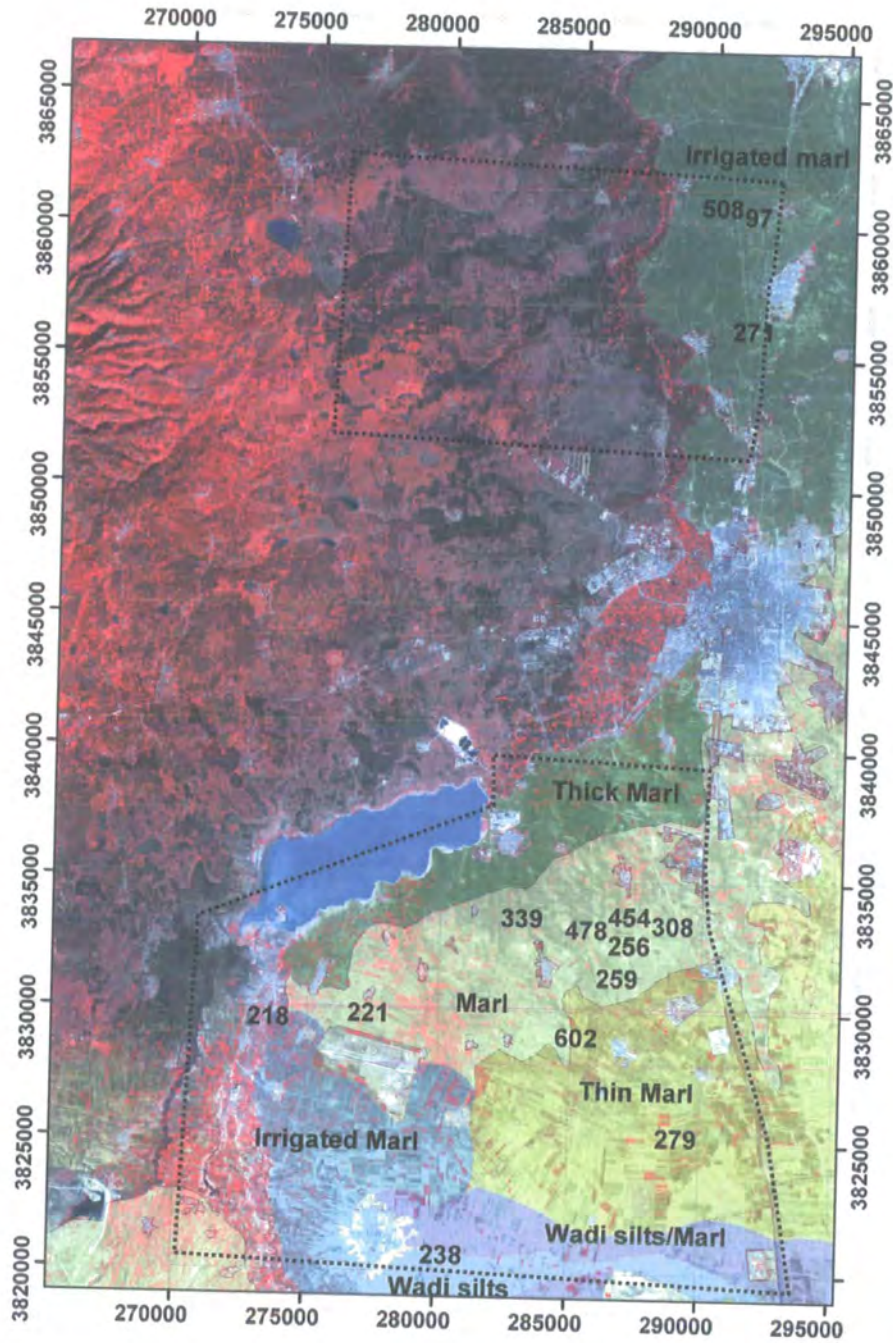

Figure 123 The distribution of archaeological residues where transect spectral profiles and surface profiles were conducted.

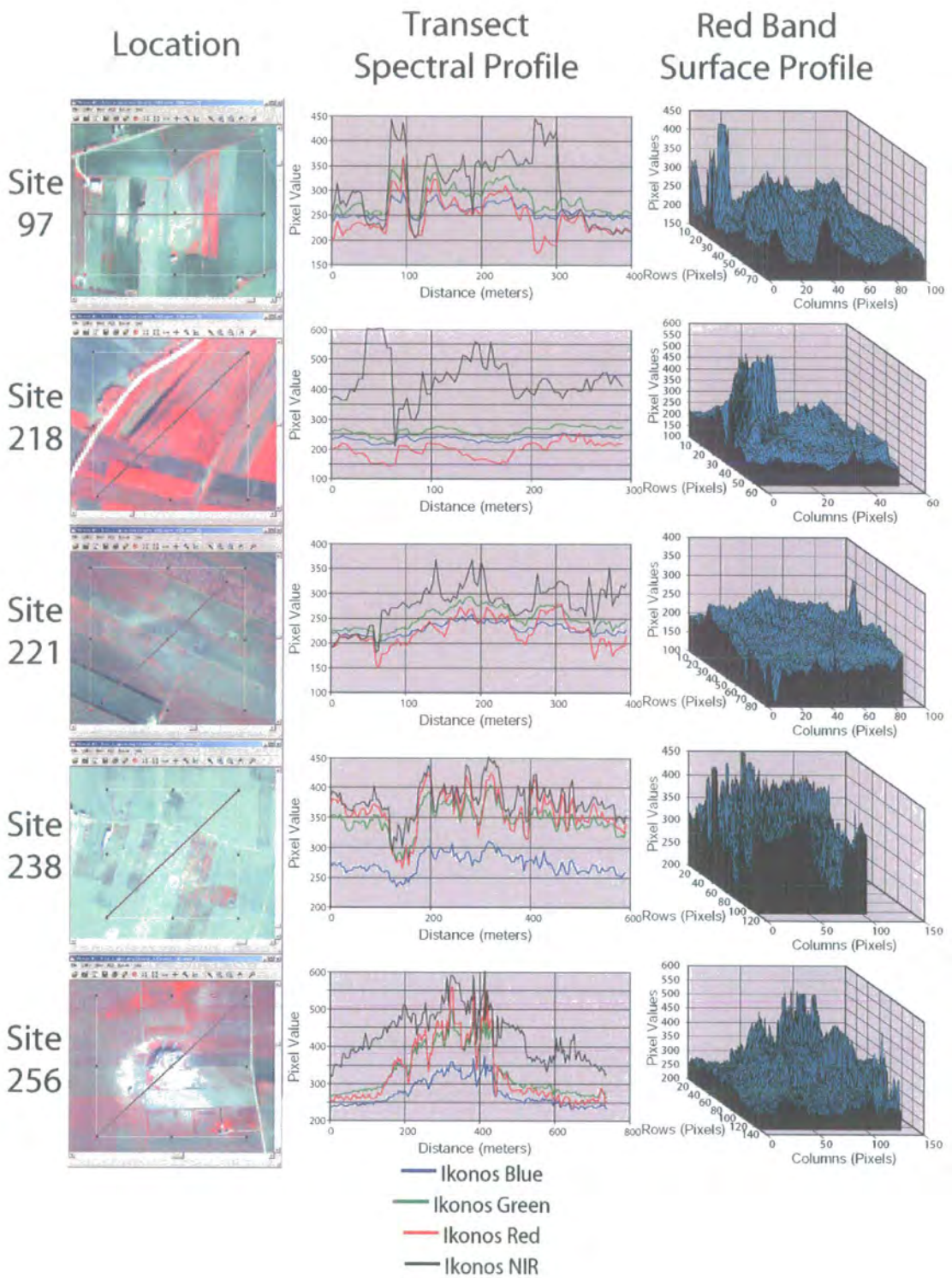

Figure 124 Transect spectral profile and surface profile of sites 97-256. The line and rectangle in the location represent the transect and surface profile respectively.

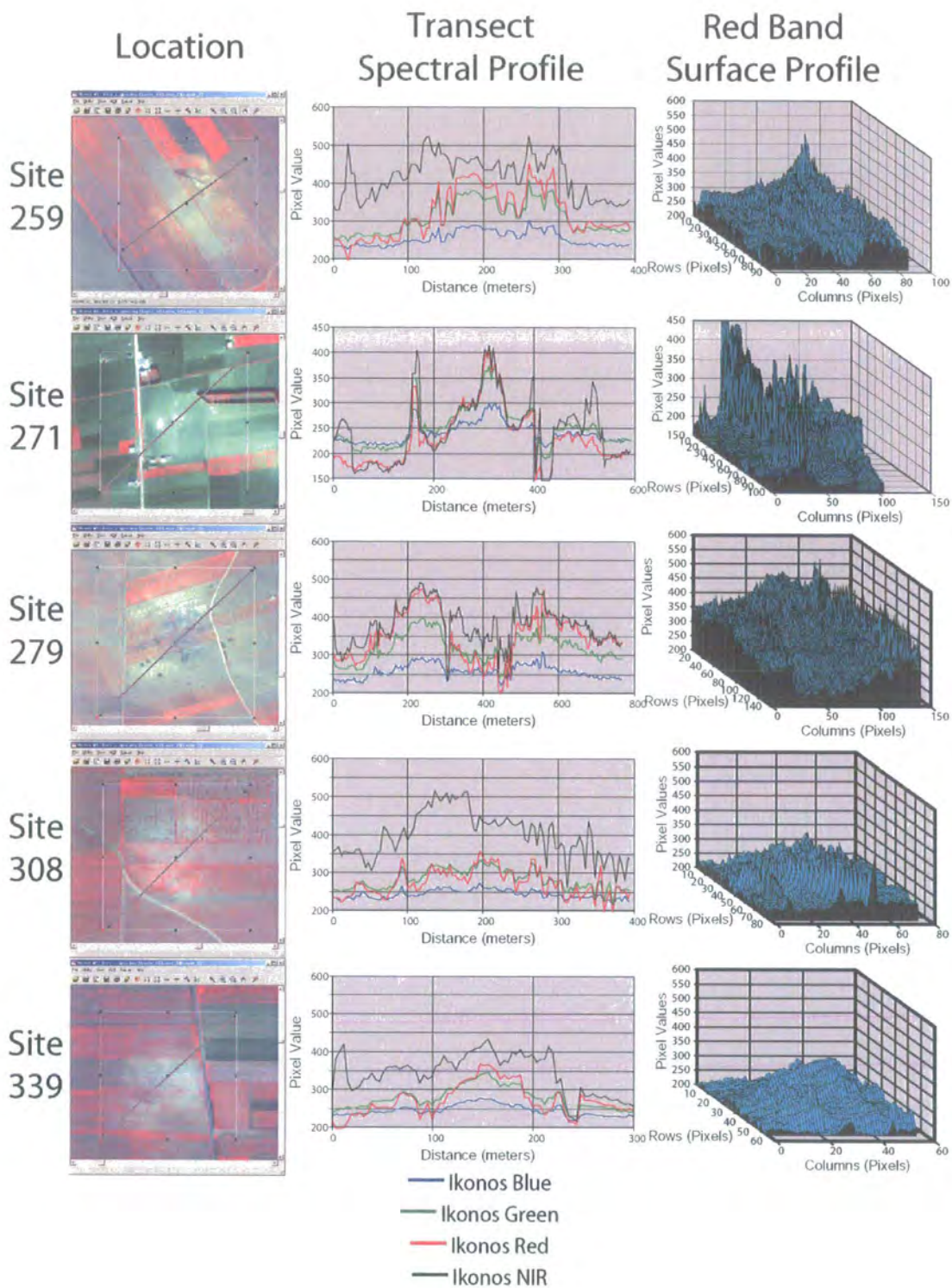

Figure 125 Transect spectral profile and surface profile of sites 259-339. The line and rectangle in the location represent the transect and surface profile respectively.

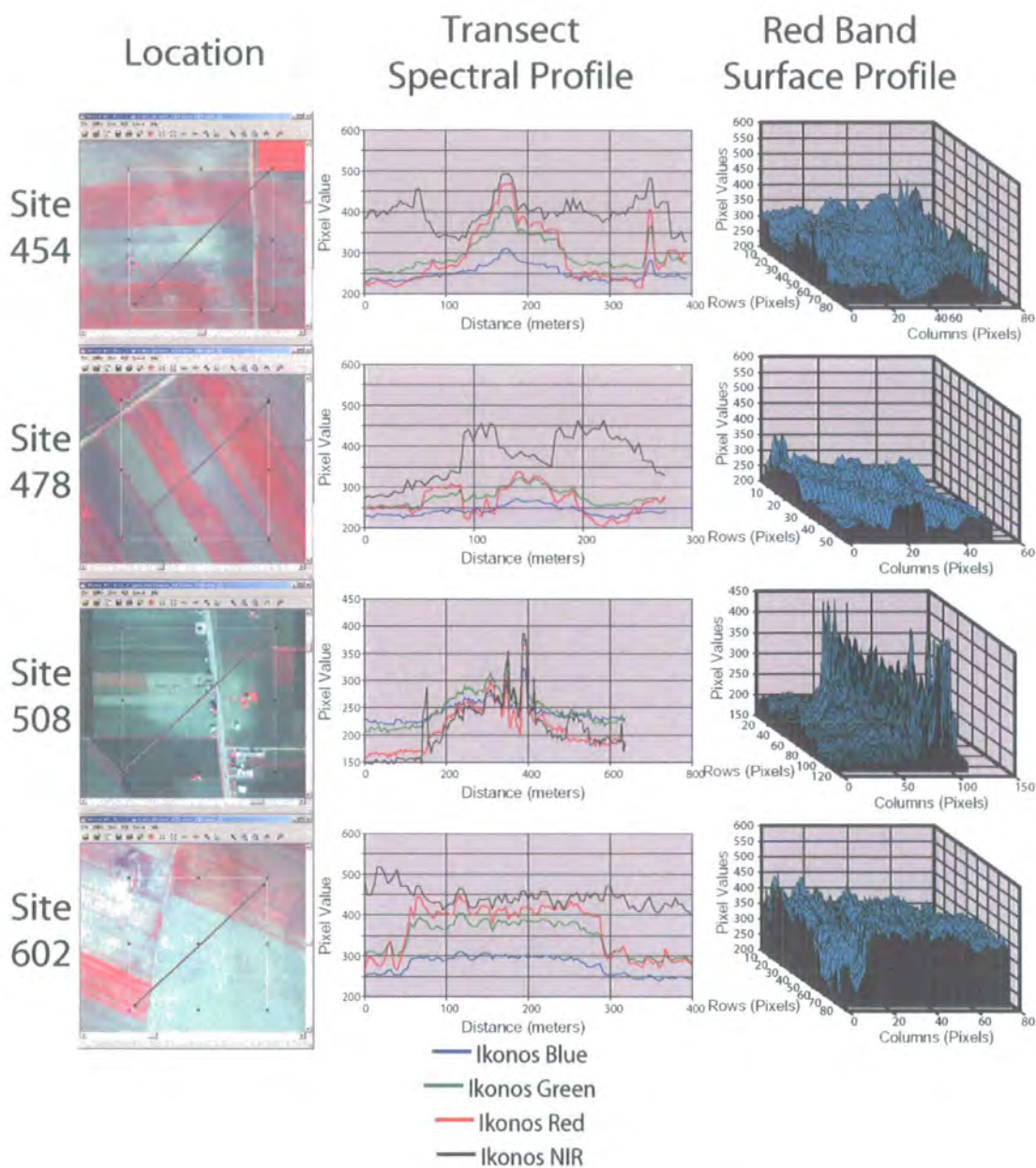

Figure 126 Transect spectral profile and surface profile of sites 454-602. The line and rectangle in the location represent the transect and surface profile respectively.

Where there is limited vegetation cover the blue, green and red bands appear to provide the most accurate reflection of the site extents. There is generally a 20-40% increase in DN value between off and on-site values. Most off-site reflectance values were in the range of 200-250. These values were seen to increase the further south one moved through the marl zone (possibly due to a decrease in soil organic matter content, a decrease in moisture content or

thinner soils). Site 238, which lay in an area of silts deposited by an active seasonal wadi, exhibited the lowest percentage change (c. 10%), also had the highest general reflectance values (an average of c. 350). Sites 238 and 279 do not exhibit the same consistent change in reflectance as seen on the other sites. Rather, these sites exhibit high frequency sinusoidal variations in reflectance which are possibly related to changes in texture.

The red and green bands in particular show the greatest percentage increase between off-site and site soils. Hence, the red band was used to display the surface profile. Although the surface profiles are difficult to interpret they work in a similar way to a digital elevation model, but the DN value is plotted in the z axis. In general these plots display the gradually increasing reflectance between off-site and site soils. Roads (i.e. the peaks in 271, 454 and 508 and the trough in 339) and buildings (site 97, 271 and 508) are in a number of the plots.

There is generally quite a close correlation in the shape of the red, green and blue bands along transects. The red and green bands tend to have approximately the same DN values while those of the blue band tend to be lower. These curves also indicate that a ratio between the red or green bands and the blue band may be useful (off-site it would approach unity). Once again the plots reinforce the fact that there is no single spectral signature for archaeological residues. However, each site does express quantifiable changes that can be identified from the background soil and vegetation responses.

7.5.3 Qualitative techniques in the marl zone

Qualitative techniques are the main mechanism for archaeological residue detection in the marl zone. The procedure effectively involves the visual interpretation of sites and delineating their extent by digitising the area of distinctive reflectance in ArcGIS. As has already been discussed many of the archaeological residues are relatively easy to detect as they display a marked increase in reflectance. However, initial supervised and unsupervised clustering algorithms covering the whole marl area did not produce specific spectral signatures that responded to archaeological residues (discussed in section 7.5.4). This led to the hypothesis that archaeological sites in the marl area change the physical and chemical properties of the soil to such an extent that the 'site' exhibits a localised quantifiable increase in reflectance. This hypothesis was the basis for the majority of image manipulations to improve residue detection.

Although no specific spectral signature can be defined that describes archaeological residues across all areas one can apply a variety of different techniques to improve detectability. Five major avenues were chosen (note that the word zone in this context refers to any defined geographical extent with some level of similarity):

- Traditional histogram manipulation and false colour composites.
- Histogram enhancements within spatial zones.
- Archaeological residues as background soil variations.
- Band indices in the Ikonos MS.
- Image visualisation using alternative feature space transformation.

7.5.3.1 Traditional histogram manipulation and false colour composites

Both the Corona and Ikonos responded well to the normal histogram enhancements (standard deviation stretch, minimum-maximum stretch and histogram equalisation). The application of stretches depended primarily on where the imagery was located. For example the minimum-maximum stretch did not work well with the Ikonos imagery as it tended to reduce contrast. However, in certain Corona scenes (such as Cor_1108_mid) the minimum-maximum stretch was the most effective. For the Ikonos MS images false colour composites provided better residue visualisation than individual band stretches. All combinations worked well although a 3, 2, 1 band combination provided the best contrast particularly when applied in conjunction with a histogram equalisation stretch (it also produces a familiar colour scheme). As discussed in section 7.5.2 the red, green and blue bands provide the best response for archaeological residues in this environment.

In the southern part of the Southern marl zone the Ikonos imagery is relatively bright with a low contrast making residue detection quite difficult. As was discussed in section 7.5.2, this is because the soils in this area have a higher reflectance than those in other areas. However, this phenomenon was not evident in the Corona imagery that intersected the same region. This could, in part, be due to the increased radiometric resolution of the Ikonos imagery or recent landscape modifications. It is, however, more likely that it is due to changes in the nature of the surface soil as a consequence of present day land management practices (a decrease in soil organic matter content, a decrease in moisture content or thinner soils).

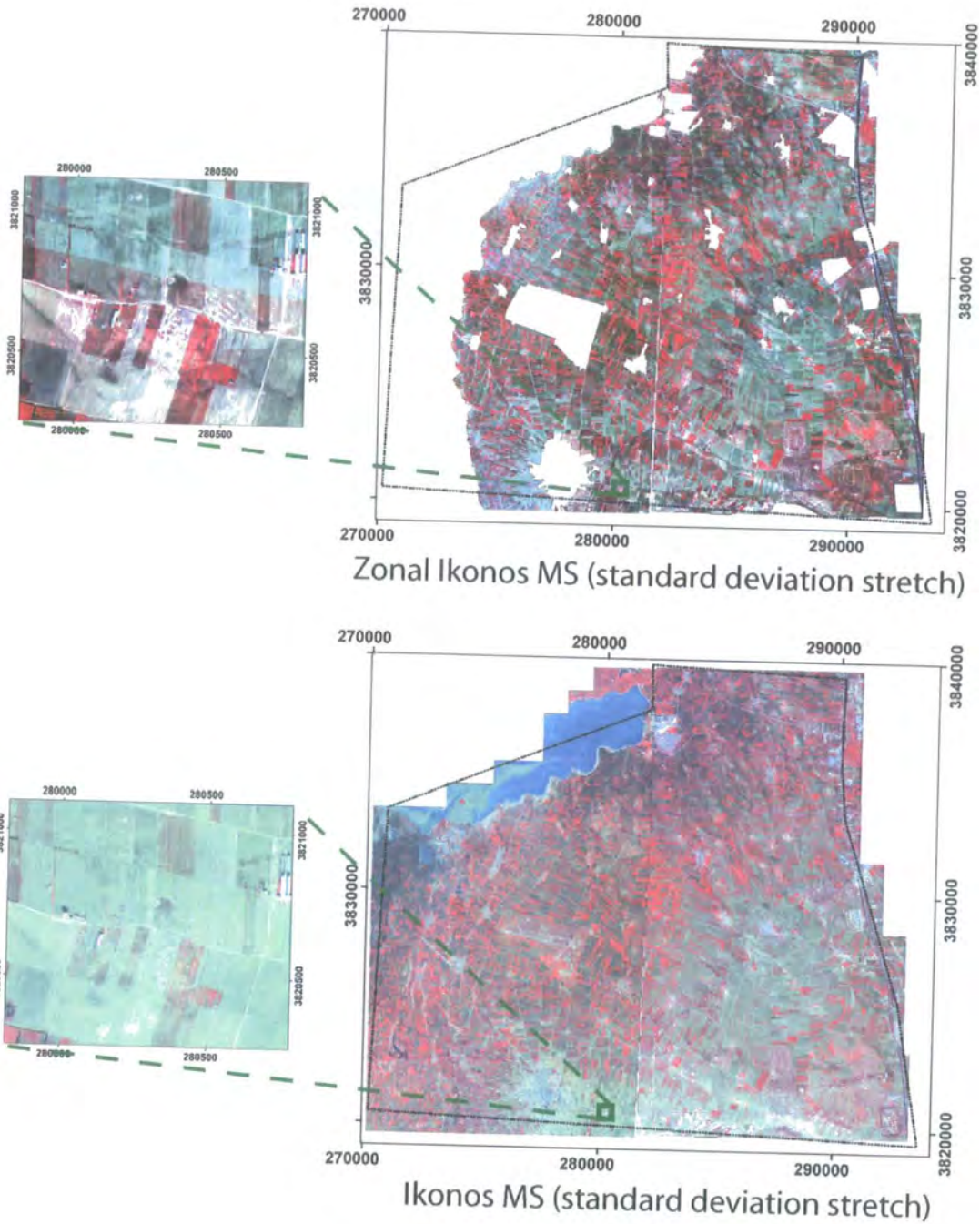

Figure 127 Comparison of zonal and normal Ikonos MS imagery (3,2,1 FCC), with a close up of site 238.

7.5.3.2 Histogram enhancements within spatial zones

Histogram enhancements are based upon manipulating the statistical distribution of pixels (O'Brien *et al.* 1982). If an image contains many contrasting zones then the enhancement of variations within each zone is likely to be reduced. Detecting residues in zones where the

contrast has been reduced is much more difficult. In order to maximise contrast in each zone it was decided to subdivide the Corona and Ikonos imagery based upon zonal data derived in section 6.6 (see Figure 123). These new images correspond to areas with similar soil characteristics. These should show improved contrast when histogram enhancements are applied, hopefully improving detection. The soil/geology/urban image was chosen because it corresponds with changes in reflectance in the soil zones which appear to impact on the visual detection of archaeological residues. Urban areas have been removed, as they tend to have very high reflectance and therefore skew the histogram's distribution.

Figure 127 compares the original Ikonos MS imagery with a set of zonal Ikonos images with a standard deviation histogram stretch. As expected, the zonal imagery exhibits much improved contrast across the whole marl zone. Therefore archaeological residues were much easier to detect visually. This is particularly well demonstrated in the inset image of site 238, from the wadi silts, where the original Ikonos image had very low contrast. All the standard histogram stretches proved useful for identifying residues in the zonal data sets.

The subdivision of a large image into areas of similarity (or ecologically these could be viewed as large scale patches) is an interesting technique that could produce further dividends for qualitative interpretation. The subdivision in the imagery improves contrast manipulation in each zone allowing a greater range of values to be expressed, which improves visual detection. Trimming each image into the different zones does not affect the numerical structure of the data, therefore it can still be considered as raw data. Hence, a range of quantitative manipulations can still be conducted on the data, such as band ratios and classifications.

7.5.3.3 Archaeological residues as background soil variations

Before the 20th century the major building material in the marl zone was mud-brick. The destructional debris of these structures exacerbated by incorporation with other anthropogenic refuse (particularly ash) has resulted in 'tells' which dominate the landscape. Even though mud-brick is normally of local origin, it is postulated that the incorporation of these archaeological residues into the soil matrix would reduce the average but increase the range of particle sizes and increase the organic content (discussed in detail in Chapter 8). Archaeological sites reflect the complex interaction between the sub-surface characteristics and surface characteristics of the soil and the vegetation growing on it. This interaction

disguises the nature of the archaeological residues by distorting the underlying geometry of the feature or masking it completely. These variations in the nature of the soil matrix are exploited in many archaeological prospection techniques including geophysical, geochemical and aerial survey techniques (Kouchoukos 2001).

As has been demonstrated in section 7.5.2, the archaeological residues tend to exhibit a distinct increase in reflectance in comparison to the background soil matrix. This change in reflectance is not consistent and it is, therefore, difficult to define a distinct archaeology spectral curve that will detect residues across the marl zones. However, subtracting an averaged background soil DN value from an on-site pixel DN value will generally produce a positive value. It was decided to apply a moving average kernel (see section 2.2.6.4) to the Corona and Ikonos imagery in order to evaluate whether residues were easier to locate in the resultant statistical surface. In theory, after processing, areas of unmodified soil should have an average approaching zero. Features that significantly deviate from these background values, such as archaeological residues, roads, buildings, crops and water, should exhibit positive or negative values. It is likely that this kernel would create a statistical surface which approximates to a normal distribution with a mean value of zero.

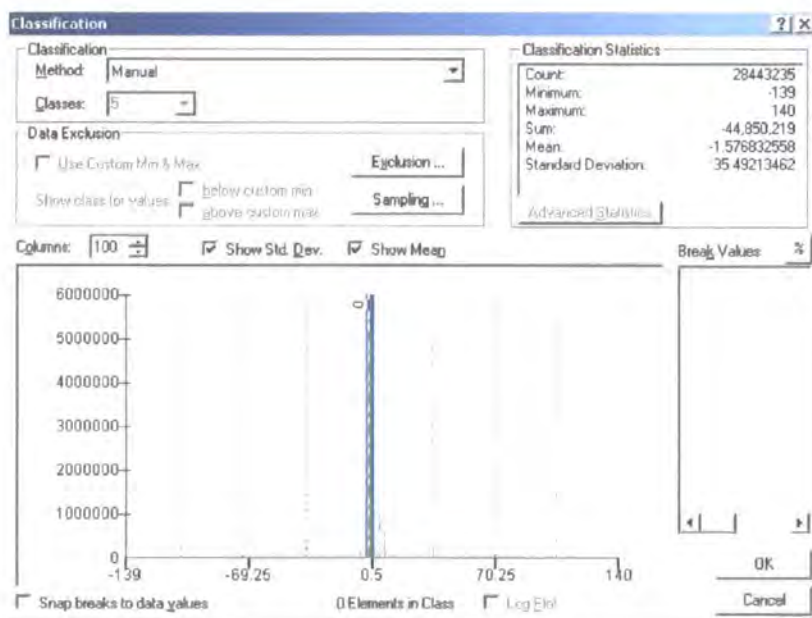

Statistical distribution of values in the Red band of Ikonos MS after a 200m averaging kernel

Figure 128 Statistical distribution of the Red band after 200m averaging kernel.

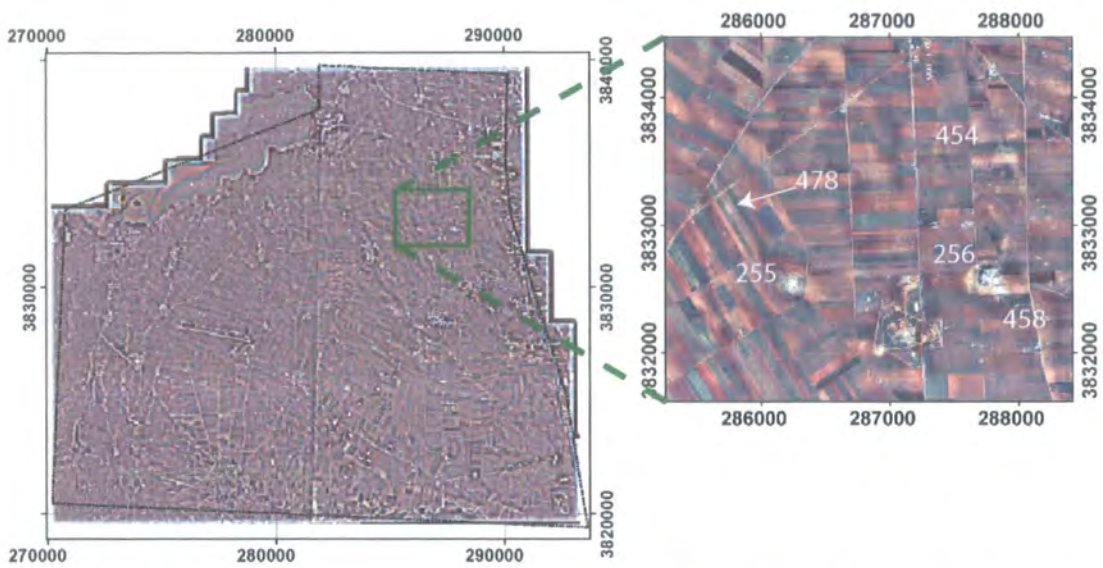

200m radius kernel average Ikonos MS (3,2,1 standard deviation stretch)

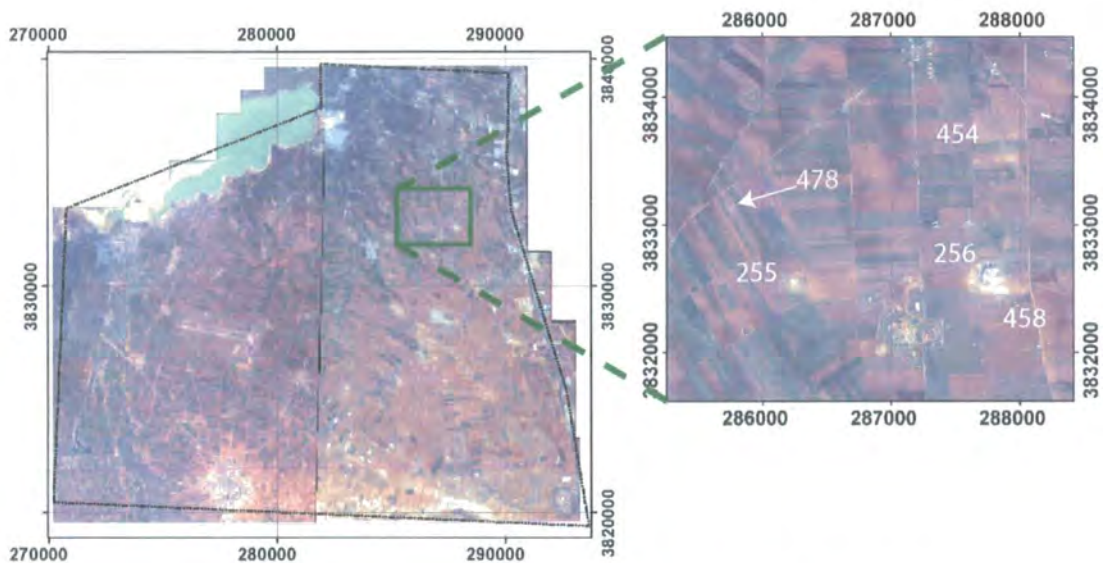

Ikonos MS (3,2,1 standard deviation stretch)

Figure 129 Comparison of 200m kernel average and normal Ikonos MS imagery (3,2,1 FCC), with a close up of cluster of sites.

After empirical trial and error approaches to define an appropriate radius for the averaging kernel, a compromise of 200m was reached. This provides a large enough area that extends beyond the outlines of most sites and can be processed in a reasonable time frame. However, even this relatively conservative figure demands a large amount of processing power. For

example the Ikonos panchromatic imagery, at 1m resolution, requires a 400 by 400 kernel (note that most kernels employ 3 by 3, 5 by 5 or 7 by 7 matrix). Thus each new pixel value is the average of the 160,000 surrounding pixels, however, only 125,664 pixels are used (as this is a radius kernel), all external pixels have a weight of 0. Therefore, for the eastern marl panchromatic Ikonos image a total of 2×10^{13} calculations is required. To overcome these significant processing problems the 1m resolution data was degraded to 4m and a 200m radius was calculated from this derivative. This significantly reduced the number of calculations to 3×10^{11} . Although this reduces the accuracy of the kernel algorithm, spatial autocorrelation means that this should not significantly skew the results. For comparative purposes the same technique was used to degrade the Ikonos MS imagery to 8m for the calculation of a 400m radius kernel algorithm. The results of the processing are real numbers which has a concomitant increase in storage size for each image.

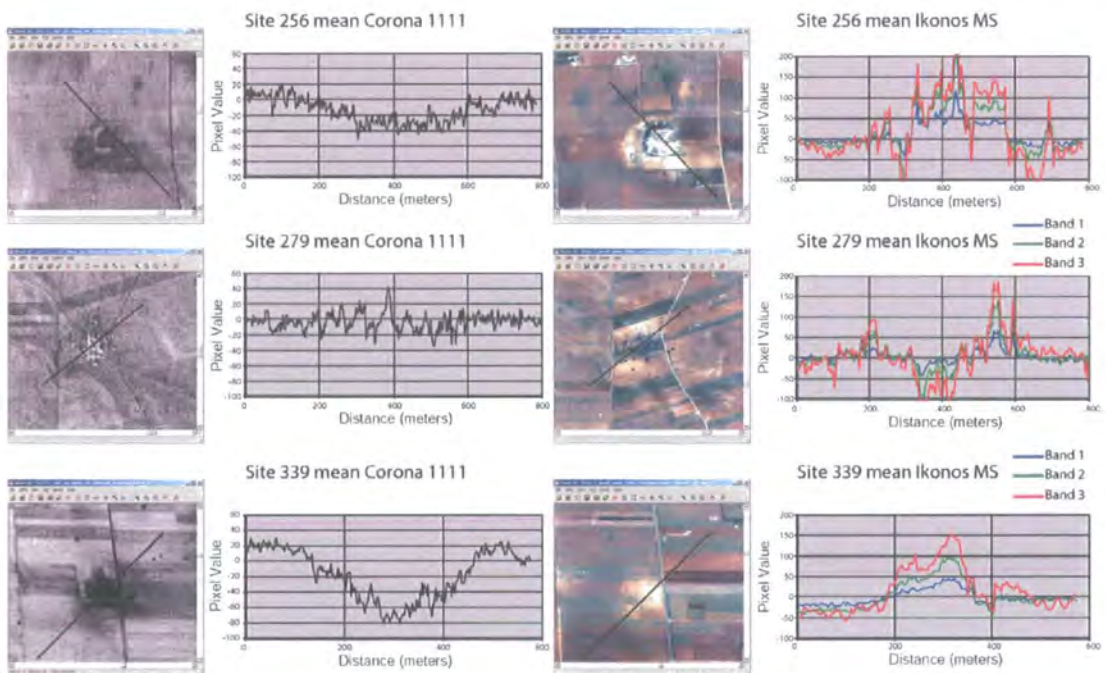

Figure 130 Transect spectral profiles for 200m mean Corona 1111 and Ikonos MS imagery at sites 256, 279 and 339. Note the use of negatives for Corona resulting in a lower DN value for sites.

The results of the averaging kernel on all the imagery were excellent. Figure 129 compares a 3,2,1 false colour composite of the 200m kernel average and unprocessed Ikonos MS imagery. Although from the small scale image it looks like this technique provides no benefit, the close up of the cluster of sites displays how the processed imagery aids visual detection:

site 478 (the prehistoric site (see the profile in Figure 126)) is significantly enhanced as is site 458 (an Islamic settlement in the lee of tell site 256). The small scale imagery appears effectively in grey scale as most off-site values are close to zero in all bands. When these are combined in a colour composite shades of grey are produced (see the off-site vales in Figure 130). As expected, this algorithm did produce a near normal distribution with a mean approaching zero (see Figure 128).

Figure 130 shows spectral profiles of the averaging kernel for sites 256 (tell), 279 (flat site) and 339 (flat site). For reasons of clarity the NIR band was not displayed in this figure (see Figure 124 and Figure 125 for comparative profiles). As expected site 256 and 339 have a higher value than the local mean (this is inverted for the Corona negative). It is also possible to identify site 458 to the SW of 256. The site 279 Ikonos profile does produce the same decrease as displayed in Figure 125. Of particular interest is the blue band which exhibits minimum variation from the mean. On the other hand the Corona profile for site 279 neither exhibits a consistent increase or decrease. The mean across the whole length of the transect appears to approximate to zero. However, the frequency of peaks decrease and their amplitude increase when over the site. This probably reflects the variations in texture at this site (as discussed in section III.6).

For comparative purposes, a 400m radius averaging kernel was applied to the Ikonos MS image. Figure 131 shows an example area of the 200 and 400m kernels. The residues exhibit an increased difference from the mean in the 400m radius kernel. This is to be expected as a larger radius should move the kernel average closer to the scene mean. The 400m radius kernel has the distinct advantage of improving the contrast for larger sites (such as 256). On larger sites a 200m radius kernel may contain a majority of site pixels. Hence, the contrast against background soil values is reduced. Theoretically there should be a distance limit beyond which the benefits of an averaging kernel would be reduced. It is recommended that further research is conducted into defining these limits.

This technique provided a number of significant benefits: not only does the averaging kernel improve contrast across the whole image without the need to subdivide it (see section 0) it also corresponds to theoretical expectations. In order to detect archaeological residues then there needs to be a local contrast between a variable on the site and off the site. This technique examines those local variations. Furthermore, there could be a whole range of

quite simple statistical kernels that improve on this relatively simple tool. Unfortunately this technique significantly disrupts the structure of the original data. The results of this analysis should, therefore only be incorporated into further quantitative calculations with care.

7.5.3.4 Band indices in the Ikonos MS.

As previously discussed (see section 7.5.2), ratioing bands 2 or 3 over band 1 may highlight areas that contain archaeological residues. The same techniques used to derive vegetation indices were employed for two reasons:

1. The difference between Band 1 and Band 2 or Band 1 and Band 3 for contrasting on and off-site reflectance is similar to the red-NIR shift exploited in vegetation indices (see Figure 122).
2. A large amount of research has been conducted on differentiating vegetative from non-vegetative material.

The following analogous indices were produced:

- NIR/R (near infra-red/red).
- SQRT (NIR/R).
- Vegetation Index = NIR-R.
- Normalized Difference Vegetation Index (NDVI).

When producing these indices the NIR band was replaced by band 2 or 3 and the red band was replaced by Band 1. All of these indices did highlight archaeological residues to some degree. However, none of them provided any more information than was already available from a 3,2,1 false colour composite. Substituting Band 2 for NIR proved to be slightly better for visual detection than substituting Band 3.

7.5.3.5 Image visualisation using alternative feature space transformation

Tasselled cap and Principal Component Analyses (PCA, see section 2.2.6.3.2) were conducted on the Ikonos MS imagery. The tasselled cap transformation has been developed specifically by Space Imaging (SI) for its Ikonos satellite (Horne 2003). This transformation has been devised to maximise the separation between different surface types. The PCA algorithm was instructed to produce four principal components.

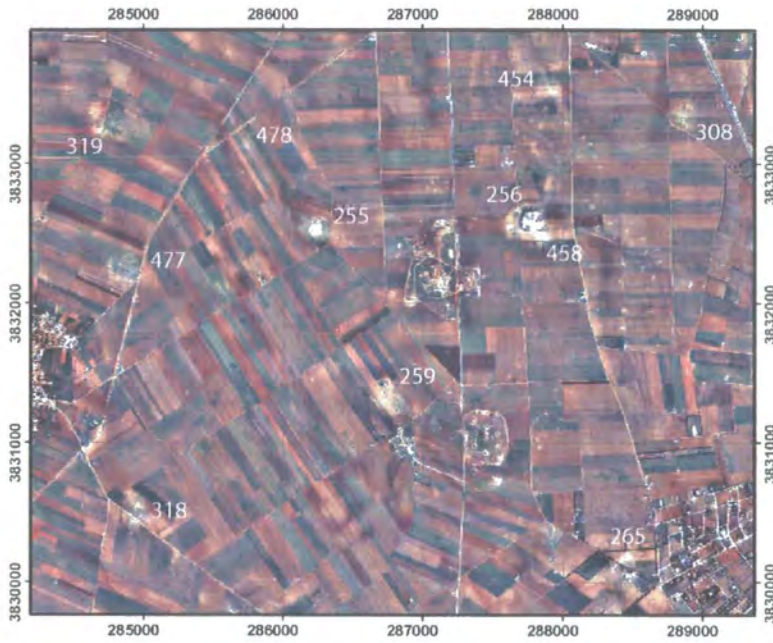

200m radius kernel average
Ikonos MS (3,2,1 standard deviation stretch)

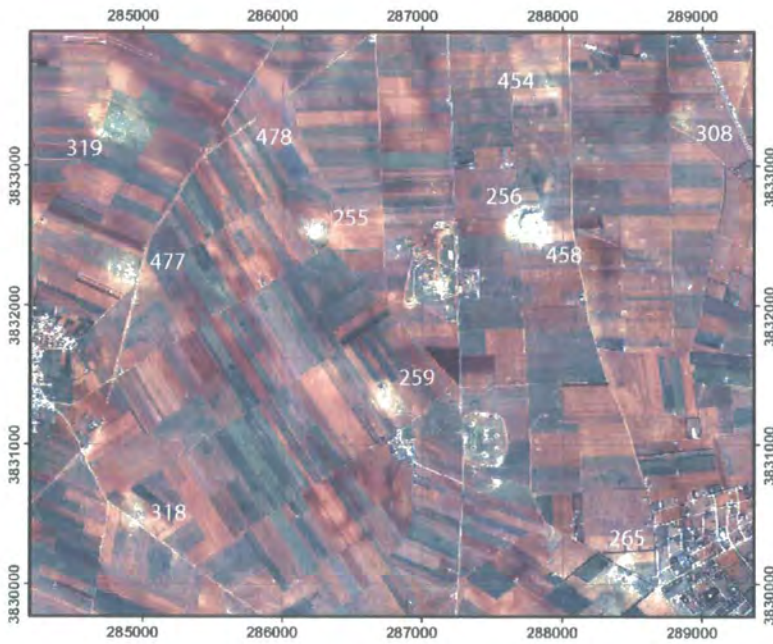

400m radius kernel average
Ikonos MS (3,2,1 standard deviation stretch)

Figure 131 Comparison of the 200 and 400m radius averaging kernel on an Ikonos MS image.

Ikonos MS SW	Component 1	Component 2	Component 3	Component 4
Band 1	0.419	0.278	-0.496	-0.708
Band 2	0.491	0.452	-0.303	0.680
Band 3	0.433	0.344	0.814	-0.179
Band 4	0.629	-0.775	0.007	0.064
Percentage variation	83.916	14.383	1.391	0.311

Ikonos MS SE	Component 1	Component 2	Component 3	Component 4
Band 1	0.376	0.142	0.750	0.525
Band 2	0.476	0.270	0.265	-0.794
Band 3	0.497	0.578	-0.571	0.304
Band 4	0.620	-0.757	-0.201	0.047
Percentage variation	91.481	6.950	1.485	0.083

SI TasCap	Component 1	Component 2	Component 3	Component 4
Band 1	0.326	-0.311	-0.612	-0.650
Band 2	0.509	-0.356	-0.312	0.719
Band 3	0.560	-0.325	0.722	-0.243
Band 4	0.567	0.819	-0.081	-0.031
Percentage variation	73.240	25.060	1.530	0.160

Table 18 PCA (Southern Marl only) and Tasseled Cap component matrix and percentage variation for Ikonos MS (the tasseled cap statistics are after Horne 2003).

Table 18 displays the component matrix and the percentage variation contained within each component. The first two components in all the transformations account for c. 98% of the total scene variance. Component 1 in all the transformation is approximately the average of all the bands and corresponds very well with the Ikonos pan image (albeit at 4m resolution: see Figure 132). Component 2 approximates to NIR minus the visible bands for the tasseled cap transformation and visible minus the NIR for the PCA transformations. This component will primarily indicate vegetation and water. Component 3 approximates to Red minus Blue for the tasseled cap and the south western (SW) PCA transformation and Blue minus Red for the south eastern (SE) PCA transformation. This should also indicate some archaeological residues due to the predominance of bands which have been identified as useful for ratioing. Component 4 approximates to Green minus Blue for the tasseled cap and the SW PCA transformation and Blue minus Green for the SE PCA transformation. This should indicate some archaeological residues due to the predominance of bands which have been identified as useful for ratioing. However, this component has low variance and is too noisy for detection purposes. The correlation between the components in the SI tasseled cap transformation and the SW Ikonos PCA transformation is probably due to the presence

of Lake Qatina in the western image and the lack of a significant water body in the eastern image.

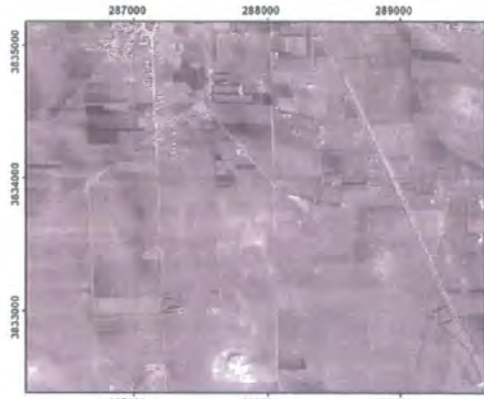

Ikonos MS East PCA component 1

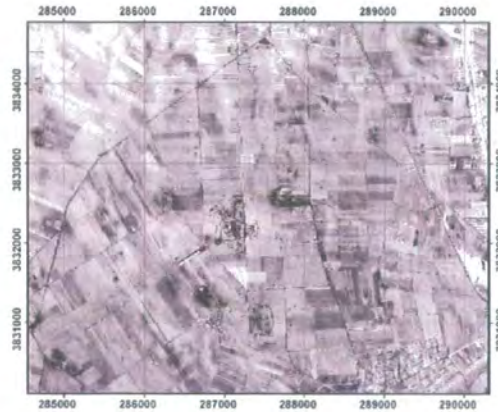

Ikonos MS East PCA component 3



Ikonos MS East Tasseled Cap component 1

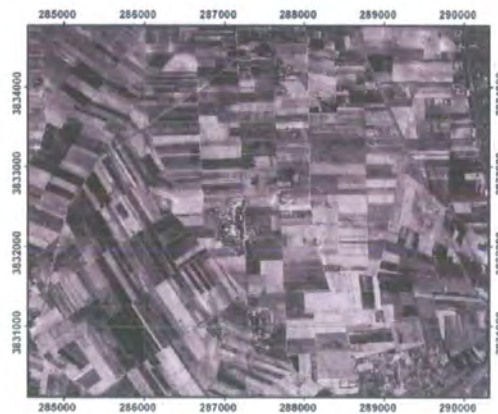

Ikonos MS East Tasseled Cap component 3



Ikonos Panchromatic

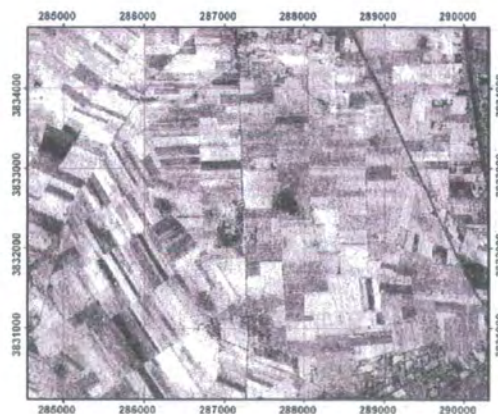

Ikonos MS East PCA component 4

Figure 132 Components of Tasseled Cap and PCA analysis in the marl.

Figure 132 shows examples of the transformations in the marl zone. There is no significant improvement for residue detection in these transformations although component 3 in the PCA did provide some improvements in the southern marl. However, these transforms should prove quite beneficial for any future re-interpretation of the land cover classifications.

7.5.4 Quantitative techniques in the marl zone

In general the application of quantitative techniques in the marl zone was of limited success. Image classification and segmentation techniques were evaluated.

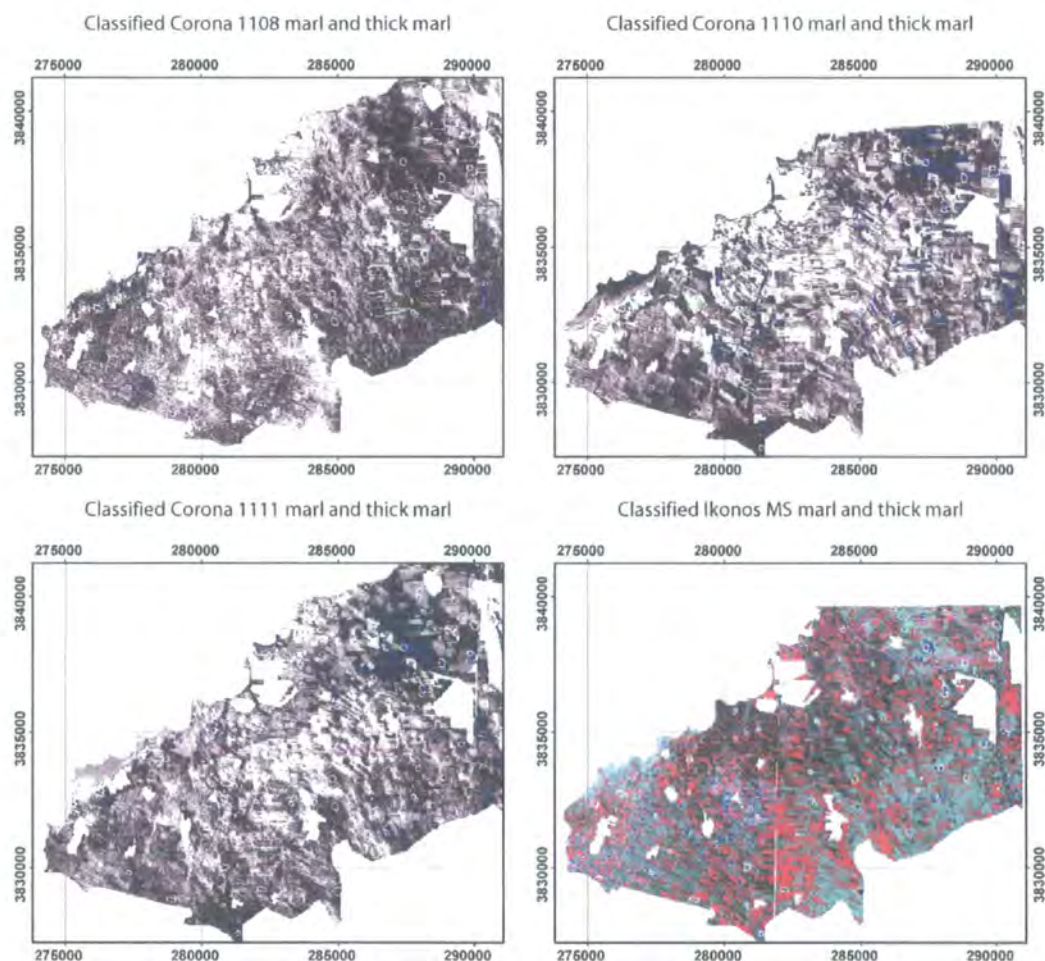

Figure 133 Classification of the marl and thick marl zones (residues in Blue and Green and sites outlined in white).

Supervised and unsupervised classifications were applied to the Corona and Ikonos imagery. The results of these classifications were generally disappointing. The unsupervised classifications produced a better correlation than the supervised classification. Some

archaeological residues were identified with each technique although there was no consistency. The problems of pixel mixing, the coarse sampling of the electromagnetic wavelengths and the non-standardised residue response meant that spectral classifications grouped different features as the same entity.

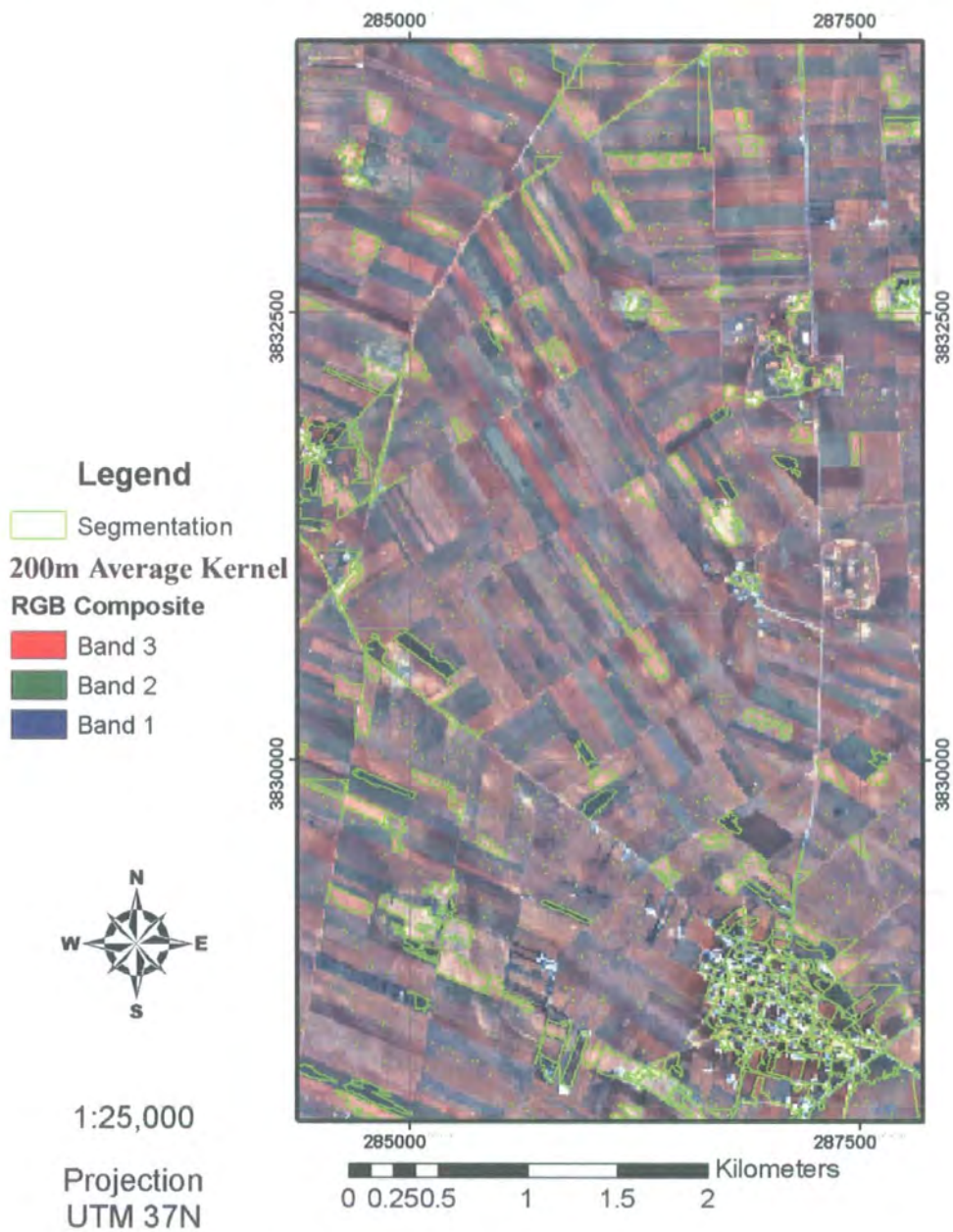

Figure 134 Ikonos MS 200m mean image segmentation (100 block size, 60 spectral threshold and 250 region size)

It was felt that subdividing the image into spectrally similar areas might improve the accuracy of the image classification. Twenty class unsupervised classifications were undertaken in each of the individual soil zones for all the sensors. Again, in general these did not produce favourable results. However, the marl and thick marl zones (see Figure 123 and Figure 133) did produce some worthwhile results where the classification groups correlated relatively well with the known archaeological residues. Even with this correlation the classifications do not indicate any previously unknown residues.

Image segmentation examines the spatial variation in changes in reflectance. It was hoped that this technique would produce better results as the archaeological residues actually exhibit these spatial variations (see the surface plots from Figure 124 to Figure 126). Separate block sizes, spectral thresholds and region sizes were produced by trial and error for the Ikonos MS, pan and Corona. Different parameters were required as each image has a different spatial resolution (impacting block size) and radiometric resolution (impacting spectral threshold). Region size was based upon the size of archaeological residues (a minimum area of 200m² was applied). These parameters represent a trade-off between complex and generalised segmented images. The spectral threshold value is particularly important for delineating the break points from which a new polygonal area is produced: a lower threshold will produce many more polygons. The region size determines the minimum size of the resultant polygons. Prior to conducting the segmentation the NIR band was removed from the Ikonos MS imagery. This band was removed as it responds to vegetation rather than archaeological residues.

The results of image segmentation were somewhat more encouraging than spectral (supervised or unsupervised) classification. Although the results are quite complex to interpret there was a relatively good correlation with archaeological residues. Unfortunately, it appears that different segmentation parameters are required for each sub-zone in the marl. Rather than establishing these parameters for each individual zonal image for each satellite (a very time consuming process) it was decided to apply image segmentation to the 200m radius mean image (see section 7.5.3.3). It was hoped that the effective 'normalisation' of this image would negate the variable effects introduced by the different zones. A 100 block size, 60 spectral threshold and 250 region size were used for image segmentation on the Ikonos MS 200m mean image.

Figure 134 displays the results of this segmentation process. The correlation between residues and segmented areas is very good. However, image segmentation gives no indication of which discontinuous polygons may share levels of similarity. Therefore, each polygon needs verifying individually (it is easiest to do this by selecting a 'no colour' fill and overlying the polygons over the appropriate satellite image). Some areas can be removed automatically (for example very large polygons that relate to the general background soil).

7.5.5 Evaluation of sensors in the marl zone

Both the Corona and Ikonos imagery are very effective mediums for residue detection in the marl zone. Once again qualitative interpretation proved the best mechanism for detection. A number of statistical and zonal approaches were tested which aided visual detection.

In general the Corona images provide a very good backdrop. The imagery is distinctly less complex than the Ikonos. The lack of modifying processes in the landscape aids the detection of residues (compare images A and B against C and D in Figure 119) as the associated changes in reflectance are much easier to locate. All of the Corona missions were useful for detection, though Corona mission 1110 produced the fewest potential residues. As has already been discussed in section 0 the 1110 mission has poor image quality. In this case it is the timing of the imagery which is more important. The Corona 1110 was collected on 28th May 1970 when cereal crop would have been at its most vigorous. Therefore, a proportion of the landscape is masked by vegetation. Without a NIR band it is impossible to quantify how much of the landscape this affects. Missions 1108 and 1111 were equally good at detecting residues. At the time of collection (17th December 1969 and 31st June 1970 respectively) the marl area would have been effectively soil only. It is interesting to note that the strip fields coming off wadi al-Rabaya have a higher reflectance in the December image (probably due to ploughing or to the c. 18:30 collection time of the June image: see Figure 135). In the southern part of the southern marl zone archaeological residues were much easier to detect using Corona than the Ikonos due to the clear textural component obvious in the Corona imagery. This may have been lost to deeper ploughing in the intervening period or alternatively irrigation may have reduced the contrast by equalising the soil moisture content (see section 9.4.2). It must be remembered that the high quality Corona imagery available for this area may not be available elsewhere.

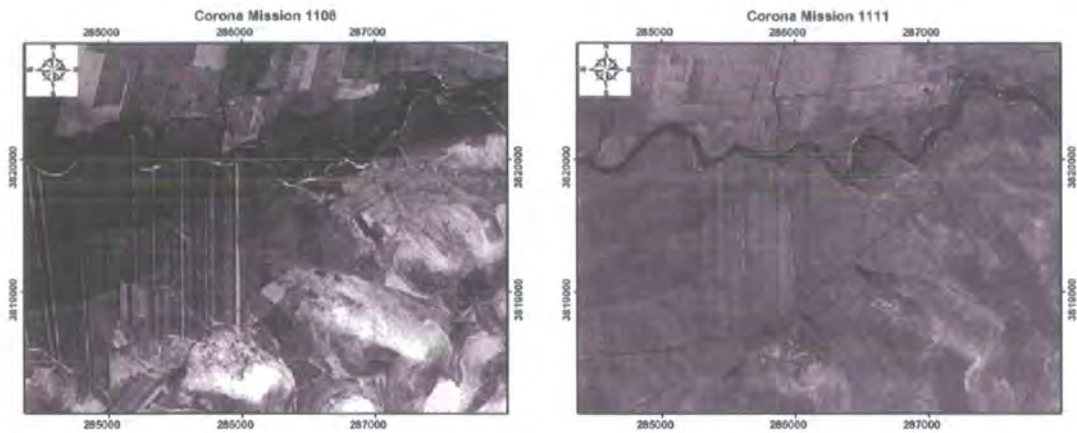

Figure 135 Strip fields off wadi al-Rabaya are easier to identify in the winter (mission 1108) as opposed to the spring (mission 1111) image. Also note the different illumination of the foothills in the SE.

The Ikonos pan and MS imagery are also good media for residue detection. However, the MS imagery is a better resource for detection as the increased spectral resolution allowed more confident interpretation. It was hoped that the high resolution Ikonos pan imagery would aid in enhanced residue recognition or interpretation (such as the mapping of internal structures) but this was not the case. Although it did allow the improved mapping of post-depositional modifications (such as bulldozing events or military entrenchments on the tells).

The red, green and blue bands tended to show an increase in DN values over archaeological residues in the Ikonos MS. It was expected that the NIR band would be a significant advantage for detection purposes. However, due to the delay in image collection, which took place further into the growing season than planned, there was a significant amount of vegetation across the landscape: this made this band very difficult to interpret. The NIR band may still prove to be beneficial if the imagery is collected when there is minimum vegetation cover. However, the NIR is important for detecting areas of vegetation masking. The MS imagery is much better for identifying cloud cover than the panchromatic (see Figure 136). Over the past 30 years landscape modifiers have affected micro and macro-sopic reflectance characteristics making the Ikonos imagery more complex to interpret than Corona. This has resulted in a greater number of potential sites identified from Ikonos imagery. Some of these are negative sites that are artefacts of landscape processes (see Figure 177).

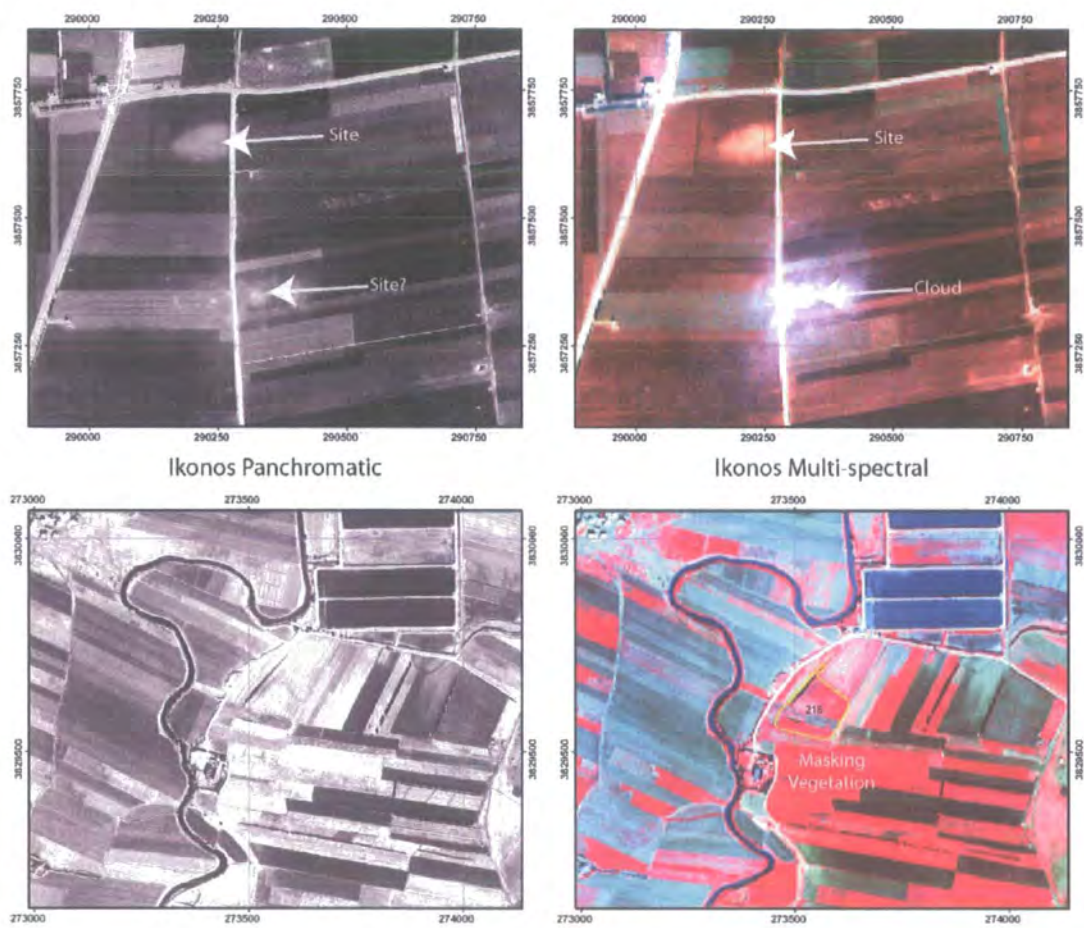

Figure 136 Problems of cloud and crop cover.

On both the Ikonos and Corona images most residues could be detected by employing standard histogram techniques. Subdividing the imagery into different zones substantially improved visualisation. Of more significance was the moving average kernel. This effectively treated the image as a statistical surface and improved the contrast of the residues across the whole image. Although this did not add many new residues it did improve the interpreter's confidence during detection. Quantitative classification techniques did not improve on visual detection. However, image segmentation on the moving average kernel did correlate quite well with the residues.

From a methodological viewpoint each image should be processed with the moving 200m radius average kernel. The resultant images should then be visually interpreted. It is more appropriate to examine the Corona imagery first as the residues are more prominent. The

Ikonos MS imagery can then be compared and analysed. Where 'sites' correlate there is a strong likelihood that they are archaeological. Where they do not correlate the Ikonos response may be due to some recent landscape modification. This will produce a number of 'high potential' and 'potential' archaeological residues.

7.6 Prospection in the alluvial zone (and floodplain)

The alluvial zone contains a range of archaeological residues and has been a continual focus for anthropogenic activity. Of the 35 tells (including low tells) identified in the application area 20 are located adjacent to the current course of the Orontes or Lake Qatina. Not only does this indicate the importance of water for settlement location it also infers that the current course of the Orontes has not significantly migrated in the past 8-10 millennia. Consequently, this area has a complex natural and cultural formation and deformation sequence.

The obvious proximity of the alluvial zone to the Orontes creates a number of significant problems in the applications of satellite imagery for residue detection. With the exception of tell sites, where most can be readily located due to their topographic component, the identification of discrete areas of activity is complicated by near consistent crop cover. In Figure 137 it is much easier to discriminate between the different zones in Corona (the new road and the extension of irrigation have blurred the zonal boundaries in the Ikonos image). The Corona image also indicates the preferential use of the floodplain for agriculture use prior to extensive irrigation. In the Ikonos imagery the crop cover (denoted as a redder colouration) and to a lesser extent the road, make it impossible to locate site 483 (Arjoune), whereas it is an obvious feature in the Corona imagery. Furthermore, alluviation (overbank silting) is likely to mask any deposits on the lower terraces.

With the exception of the larger sites (such as Arjoune), no potential sites were detected from the satellite imagery even though a range of quantitative and qualitative approaches were applied. At best only broad areas of potential activity could be inferred. In this situation the Corona imagery proved to be a more useful resource as there was less landscape modification than in the Ikonos imagery. Small scale fieldwalking and driving survey identified a range of residues. However, given the importance of this zone for agricultural purposes and the complexity of the landscape modifiers it was difficult to define many of these residues as sites. Therefore, it is recommended that due to the somewhat arbitrary nature of the

detection process (the problems associated with masking from alluviation, irrigation and crop) and that as the alluvial zone only accounts for c. 20 km² that a programme of intensive fieldwalking is conducted in this area. These results can then be reviewed in conjunction with the satellite imagery to ascertain, retrospectively, if there is a correlation between sites and reflectance.

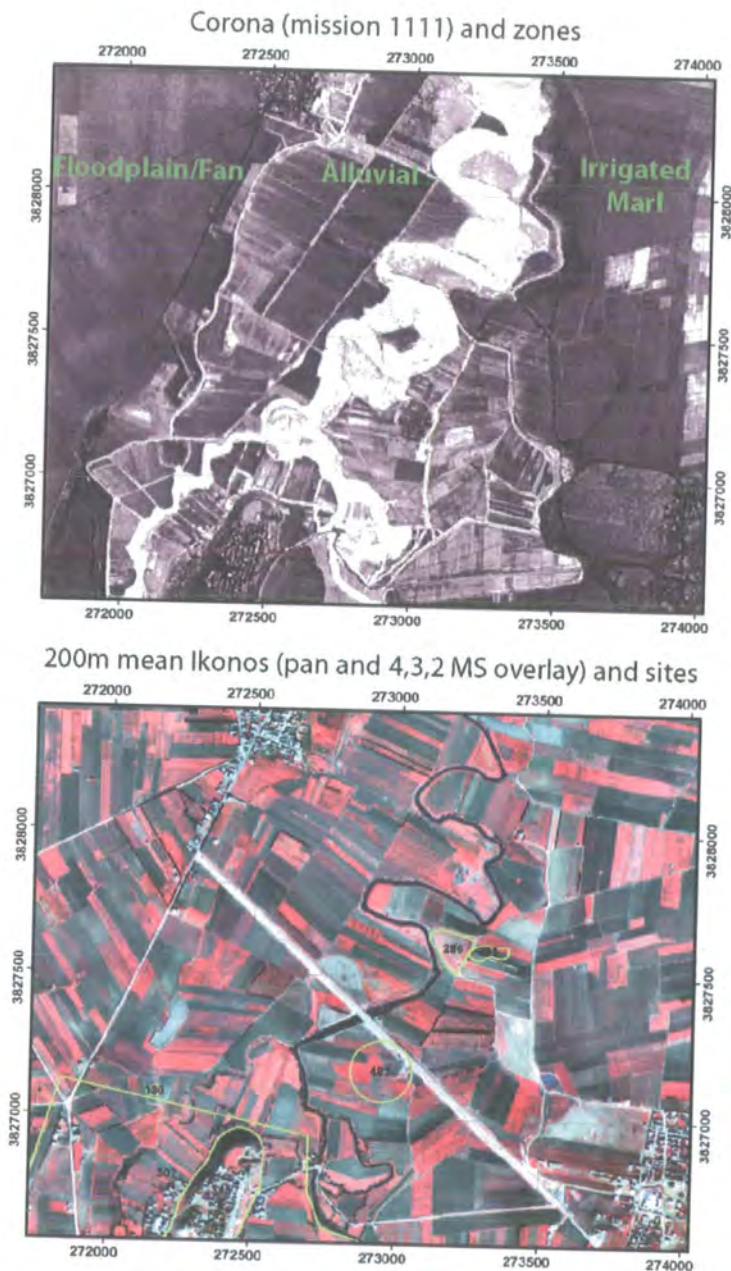

Figure 137 Comparison of Corona and Ikonos in the alluvial zone.



Figure 138 Evidence from site 494 including a tenuous linear feature in the foundations of a reservoir.

The area west of the Orontes and south west of Lake Qatina was originally interpreted as a floodplain created during river migration. Again a range of quantitative and qualitative detection techniques were applied in this area with limited success. Overall it demonstrated a negative response for archaeological residues as only 8 sites have been identified (only 3 of these with any high degree of certainty and each was impacted by bulldozing). Fieldwork in this area did produce material. However, due to the paucity of residues and surface material, any part of the landscape displaying only a small number (<10) of clustered artefacts was identified as a potential site. Coins and a gaming piece were handed over by a farmer who discovered them while excavating the foundations for a reservoir (site 494). These objects were provisionally dated as Hellenistic. Further fieldwalking produced a handful of sherds. Hence, it was assumed that, unless these are stray artefacts, any associated settlement is masked beneath an unknown depth of alluvium. The possible identification of a ditch (see Figure 138) supports this assumption. From this evidence it was extrapolated that the floodplain was prone to extensive alluviation over the past millennia masking the majority of archaeological residues in the area.

However, if this was the case then all the archaeological residues in the alluvial zone and those west of Orontes would be masked by the same sediments. This is not the case, as sites displaying prehistoric activity (such as Arjoune) are still surficial. After extensive consultation with the geomorphologists Drs David Bridgland and Rob Westaway (University of Durham and the Open University respectively) it is felt more likely that the sediments in this zone are related to sheet wash or an alluvial fan extending from the foothills of the Anti-Lebanon mountain range. The exact geomorphological origin of this zone is still under investigation.

Although this zone has a diverse range of local resources and would therefore be attractive for settlement, it is likely that residues are masked by a significant depth of sediments. Successful detection with satellite imagery is therefore highly unlikely. However, if there are appropriate negative archaeological features it may be possible to detect them as crop marks.

7.7 Discussion

Multi-resolution satellite imagery has been employed as an archaeological residue detection tool in three contrasting environments. With the exception of the alluvial zone the application of satellite imagery was an unqualified success. However, different sensor

resolving characteristics and interpretative techniques are required for the each environmental zone. These are discussed in this chapter and summarised in Chapter 10.

To date with the exception of extrapolated morphological evidence from extensive monumental sites the imagery gives little indication of the form (the current workable classification covers *large site (possibly tell)* to *small site (probably flat)*), function and dates of an archaeological site. It is also unlikely that the site constituents identified from satellite imagery will allow a high degree of temporal identification. Therefore, satellite imagery should only be used in conjunction with other Cultural Resource Management (CRM) techniques.

The use of other techniques (such as surface survey or even basic ground observation) are essential to enhance the resource. Thus, the data sets can be used to analyse and hypothesise about the archaeological resource and to produce a feedback loop allowing increased accuracy of the identification procedure. This will allow improved interpretation, particularly for sites not initially identified from the imagery, and an understanding of the scale threshold with which the imagery can be confidently interpreted.

CHAPTER 8 ANALYSIS OF MARL SOILS

8.1 Introduction

Low mounds with phosphate-rich, artefact-rich or ashy sediments will often appear quite different in colour than their surroundings.

(Banning 2002 p. 42)

Chapter 7 demonstrated that archaeological residues can be identified from satellite imagery. It was proposed that the soil in the marl area be examined in an initial attempt to determine the physical cause for the localised increases in reflectance associated with 'sites'. This should provide a platform for future research and analyses in similar environments. The sites that have been recognised fall into two main categories: flat sites and tells. Tells are artificial mounds that have developed through long-term re-building employing degradable building material (Rosen 1986; Stevanovic 1997). The distinct topography of tells makes them easy to identify both from the ground and from a vertical perspective (see Figure 139).



Figure 139 Ikonos image (vertical view) and photograph (horizontal view) of a tell (site 191). Note the increased and decreased reflectance of the SE and NW part of the ramparts due to differential illumination from the Sun and site topography.

As has been demonstrated in Chapter 7, flat sites do not exhibit such extreme topographic variations and are located by the detection of anthropogenically formed sediments and other physical residues (Schuldenrein 1995). Here, it is assumed that anthropogenic action has

caused the colour change and not that lighter coloured soils were preferentially chosen for settlement locations. The question is what are the anthropogenically introduced physical or chemical constituents that have produced the observable variations in the colour of the soil matrix?

Soil colour is one of the most obvious and easily determined attributes of soil, and is a primary element widely used by soil scientists in the identification, field description, characterisation and classification of soils (White 1997). Soil colour is almost entirely an indirect measure of other more important characteristics or qualities that are not so easily observed. Surface colour that differs from that of the parent material is usually an indication of the processes involved in soil formation and may also be indicative of anthropogenic actions which have disturbed a localised soil matrix. Myers (1983) and Horvath *et al.* (1984) state that the most important factors influencing soil colour are mineralogy and chemical constituents, soil moisture, soil structure, particle size and organic matter content.

In the field, a pedologist determines soil colour by a direct comparison between a soil sample and Munsell colour chips (as discussed in section 5.2). The Munsell colour system utilises the descriptive system of hue, value and chroma (Munsell 1981). Hue is the dominant spectral colour and corresponds to the wavelength regions used in optical remote sensing. Value refers to the relative brightness of the colour and is a function of the total amount of light reflected. Chroma is the relative purity or strength of the spectral colour. The solar radiation reflected from the surface microns of soils can also be observed by remote sensing instruments that offer measurement capabilities beyond those of the naked eye. Obukhov and Orlov (1964, cited in Ben-Dor *et al.* 1999a) concluded that the red region and the near infrared region are the most favourable for a qualitative and quantitative description of soils. Fernandez *et al.* (1988) calculated soil colour from DN values and reported increased accuracy and precision from satellite sensors in comparison to visual interpretation, thus making it possible to quantify small differences in soil colour that would otherwise be difficult to assess. An understanding of how reflectance changes as soil properties alter is required to infer soil properties and processes from the observed reflectance (Irons *et al.* 1989; Mattikalli 1997).

In order to reduce complexity during interpretation it was assumed that the soils were stable during periods of occupation and that subsequent post depositional soil formation or

deformation has not significantly impacted on the original sediments (Wilkinson, pers. comm.). Further, it was hypothesised on the basis of known patterns of human settlement loci that the increase in soil reflectance observed at flat sites was due to either one or a combination of the following reasons:

- Variation in soil moisture between on and off-site soils.
- Changes in soil particle size distribution between on and off site soils (see section 8.2.3).
- Different levels of organic matter content.
- Different levels of trace elements or chemical compounds on sites.
- Increased ash content on sites.

An understanding of soil formation processes and how the above changes may affect the reflectance of electromagnetic energy was required.

8.2 Pedology

Pedology is a study of soils as three dimensional natural bodies resulting from weathering processes. The processes are conditioned by climate, biota and topography, acting on parent material over time. Pedology includes the description, quantitative characterisation, classification and mapping of soils (White 1997). Since the characteristics of radiation reflected from a material are a function of material properties, observations of soil reflectance can provide information on the properties and state of soils. These properties can be quantified using a variety of laboratory techniques (Olson 1984; Goldberg 1992). The most familiar application of this concept is the observation of soil colour to describe and help classify soils (Irons *et al.* 1989; Curran 1990).

Soil maps typically divide the landscape into discrete units with distinct boundaries. Although the delineation of mapping units is useful for descriptive purposes, abrupt soil boundaries are rare, due to the nature of the soil-forming processes (as observed when producing the soil/geology map as described in section 6.6). More often, a gradual transition in soil properties and profiles occurs over the landscape. This variation is best observed from remote platforms, which can afford a synoptic perspective of a geographic area. Remotely

acquired images show variations in surface reflectance, which can indicate corresponding variations in underlying soil profiles.

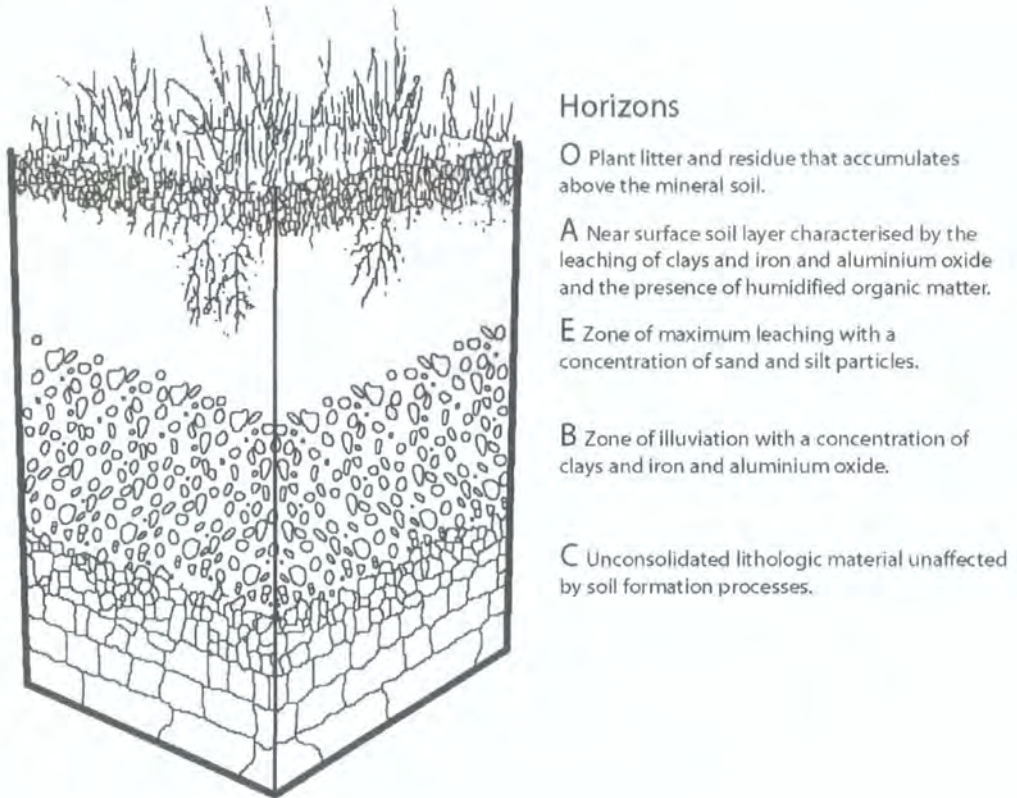

Figure 140 Soil profile (after Irons *et al.* 1989 p. 77).

Soil profiles continue to develop and change over the years, but the changes are generally gradual. The sequence and character of horizons in a profile (see Figure 140) often persist for decades or even centuries. This variation in the nature of soils is a common criticism of predictive modelling techniques that assume that present day soil variables adequately represent past values. Soil surface roughness, structure, moisture content and other properties are readily altered by weather, cultivation, erosion, plant growth and other surface phenomena. These temporal variations affect the surface reflectance properties. Changes in reflectance properties can complicate the use of remote sensing for soil mapping and characterisation. Alternatively, observations of reflectance variation over time can also indicate characteristics of the underlying soil properties. Thus, for certain applications an appreciation of spatial and temporal soil variability is needed to understand soil reflectance and the application of remote sensing to pedology (Irons *et al.* 1989).

8.2.1 Soil biochemistry

Soil may be thought of as a chemical mixture formed en route from rock to infinitely diluted ions. Inevitably its composition is variable, representing various stages of weathering in different environments. Furthermore, microbiological action takes place within the chemical system altering its chemistry by modifying the inorganic balance and generating complex organic components. More advanced life forms, by their growth and decay and the circulation of air and water, further modify the soil structure. It should be noted that at the surface layer the amount of carbon and hydrogen increase significantly due to the presence of organic matter. Soil water within this medium is the solute for a variety of ions, some of which are essential for plant growth.

8.2.2 Organic matter

From the moment death occurs organic matter begins to decompose. Almost instantaneously microbial organisms attack tissues. The majority of the initial decomposition of large objects is carried out by mammals, termites and earthworms (Stein 1992). Many plants and organisms obtain their energy from this partially decomposed matter and in turn reduce the organic compounds into residues and humus. As organic matter becomes more finely divided the size of the decomposing organisms decrease. All decomposition is affected by environmental factors, especially variations in temperature, moisture and available oxygen.

Organic soil matter consists of decomposing plant material, animal material and substances derived from the products of decomposition by micro-organisms and small animals in the soil. The elements of organic matter are joined in various compounds such as proteins, glucose, carbohydrates, fats, tannins and lignin. These are readily decomposed by soil micro-organisms. The products of decomposition form complex mixtures of brown or dark brown amorphous and colloidal substances called humus (Brady 1984). Humus, composed of humin, humic acid and fulvic acid, constitutes approximately 65 to 75 per cent of the organic matter in mineral soils and can occur as a discreet substance in soil or as coatings on mineral particles. It can also act as a binder between particles in aggregates. Those elements of organic matter not degraded to humus are referred to as non-humic. Some non-humic substances are still recognisable as physical or chemical components of plant or animal tissue and include proteins, peptides, amino acids, fats, waxes and organic acids (Schnitzer 1982).

At every stage of this reduction, carbon dioxide gas is released and escapes from the soil. Moulds and spore-forming bacteria are especially active in consuming the proteins, starches and cellulose of fresh organic matter and they release carbon dioxide, water, ammonia, hydrogen sulphide, sulphur dioxide and organic acids as by-products. Further reduction by other micro-organisms results in the creation of humus and the further release of carbon dioxide. Carbon, released as carbon dioxide, is transferred from the soil to the atmosphere or dissolved in soil water to produce carbonic acid which lowers ambient pH. In temperate regions half of the organic carbon produced during soil genesis is lost to the atmosphere in the first 3-4 months and in the tropics half is lost in only 3-4 weeks. Thus, the organic carbon content of the soil organic matter, or organic sediment, is lowered through decomposition.

In the context of sediments, deposition of organic matter is a single event. The organic matter will support a micro-organism population that is related to the amount of organic matter originally deposited. Lacking a continuing source of organic matter, a steady state is not reached. The micro-organism population will be supported until the original organic sediments decompose (i.e. until all the carbon dioxide is lost to the atmosphere and the other by-products reduced to humus). As decomposition occurs, the micro-organism population will change. If the process occurs for millennia the organic matter will be reduced to only the most resistant humus. On the other hand, if the organic sediment is augmented by repeated deposition, then the rate of decay and the size of the micro-organism population will depend on the conditions within the buried deposits. Decomposition is slowed when oxygen or water is not available (or available in excess), or in places experiencing extreme acidity or cold. In these circumstances animal and plant material can survive for millennia and in certain cases (i.e. desert, bog and frozen sites) can be almost perfectly preserved (Stein 1992).

8.2.3 Soil particle size

Soil is an extremely complex physical and biological medium. Soils consist of material in the three common physical phases: solid, liquid (water) and gas (mostly air). The solid particles are of different sizes. The grain size distribution is the principal factor which governs the majority of the physical and mechanical properties with the exception of magnetic anomalies (Scollar 1990 p. 9).

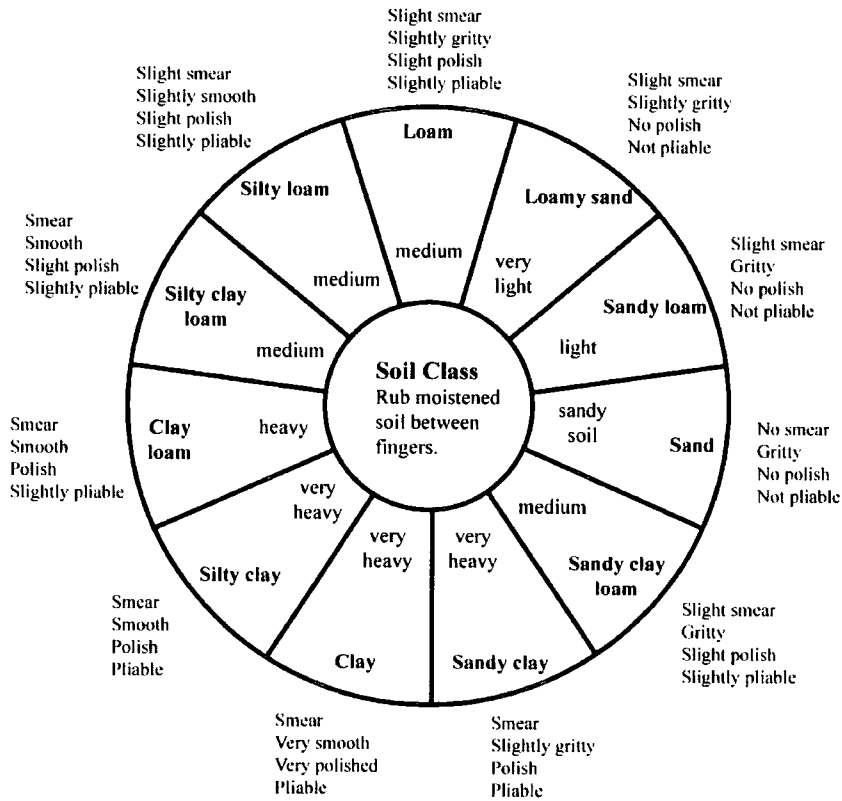
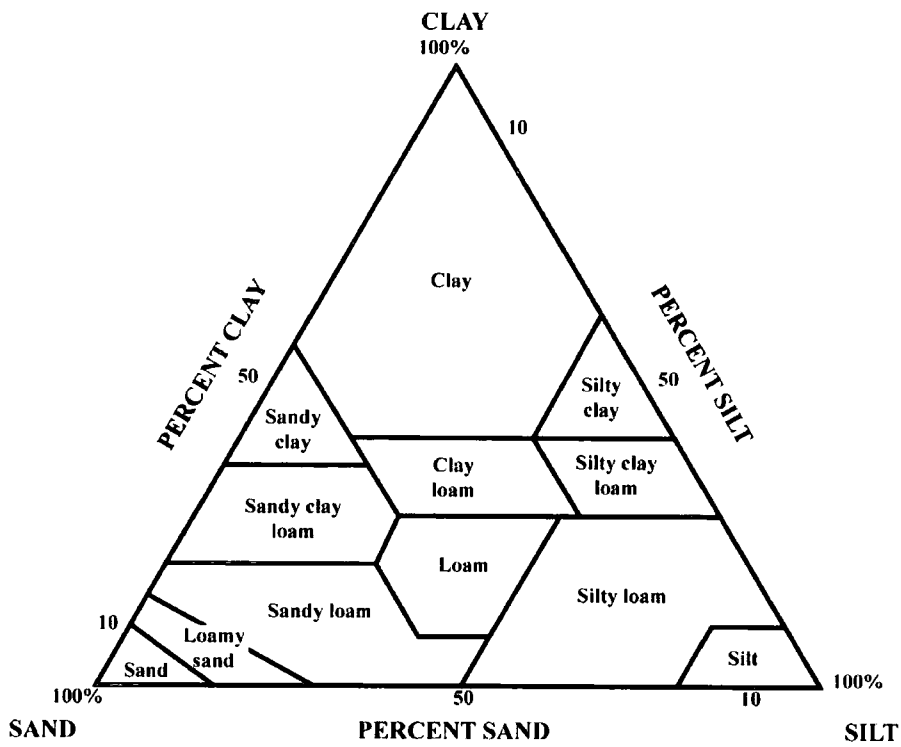

Figure 141 Soil description matrix (after Asrar 1989 p. 75) and archaeological field soil description chart (after Middleton 2000).

The solid phase consists of irregular particles. Particle size is determined by the minimum size of sieve through which the particle will pass or by the diffraction of light through a suspension of material when using laser granulometry (i.e. Coulter). The combinations of these fractions give the general soil classification. Archaeologists coarsely gauge soil fractions during fieldwork by rubbing damp soil between a thumb and forefinger. The rubbing breaks down aggregates into primary particles and the feel, or texture of the broken-down soil is determined to a large degree by the particle size distribution of the soil minerals (see Figure 141).

The continuum of particle size in a soil sample can range over three to four orders of magnitude. For ease of interpretation this large range is divided into different particle size fractions. Different soil classification schemas use different ranges for grouping particle size fractions (such as the British Soil Survey and Wentworth/Udden classifications). Texture descriptions are further facilitated by the definition of texture classes on the basis of relative portions of sand, silt and clay sized particles (Olson 1984; Asrar 1989; White 1997). However, this classification technique does not take into account any organic material that may exist in the soil.

8.3 Soil spectral reflectance

Analysis of remotely sensed data involves identifying features and correlating ground-based measurements with recorded reflectance or emittance values. In the case of soils, these ground-based measurements include several properties such as texture, composition, grain size, soil moisture and colour. Earlier studies have identified significant relationships between some of these properties and spectral reflectance of soil in the visible and infra-red portions of the electromagnetic spectrum (Irons *et al.* 1989; Ben-Dor *et al.* 1999a).

The observation and mapping of soil conditions through optical remote sensing is restricted to reflectance of the surface microns (Leone and Escadafal 2001). Because the characteristics of radiation reflected from a material are a function of its physical and chemical properties, the observation of surface reflectance principally carries information on the properties and the state of the topsoil. This means that only effects which cause significant changes to surface characteristics can be observed and mapped. The spectral reflectance of soils is a cumulative property which derives from the inherent spectral behaviour of heterogeneous

combinations of minerals (and their textural components), organic matter and soil water (Baumgardner *et al.* 1985; Irons *et al.* 1989; Sommer *et al.* 1998 p. 198).

A substantial number of researchers have measured spectral reflectance factors from soil samples in the laboratory and from soil surfaces in the field. Perhaps the most comprehensive study of soil reflectance in different regimes was conducted by Stoner and Baumgardner (1981) in the United States. Using laboratory techniques they measured spectral bidirectional reflectance factors, over the 0.52 - 2.32 μm wavelength region, from samples of over 240 soil series. The samples were selected by a stratified sampling strategy of soil series within 17 temperature and moisture regimes across the United States. Several samples of tropical soils from Brazil were included.

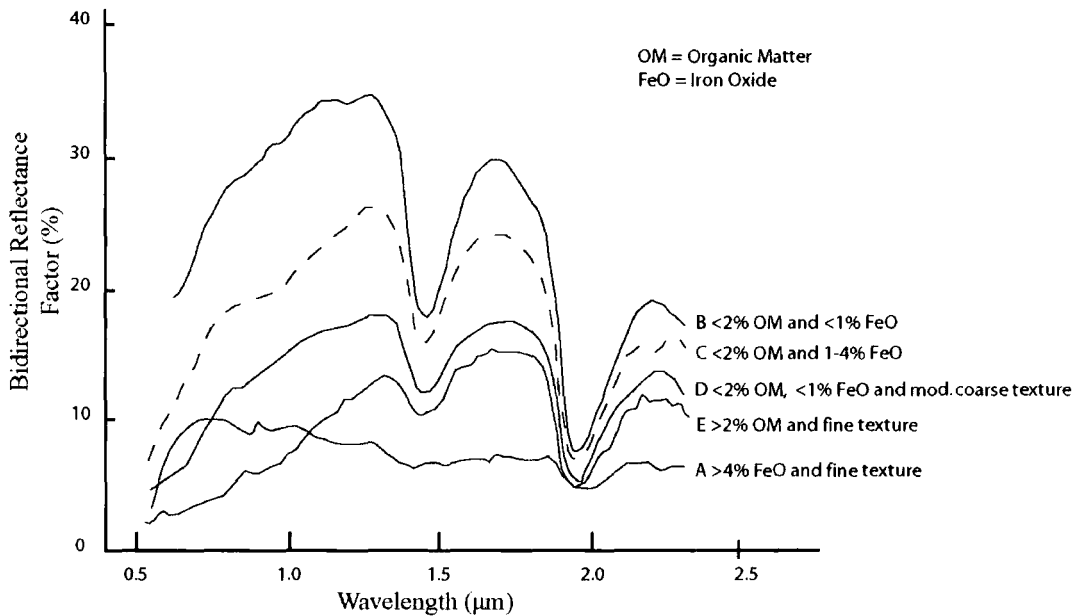

Figure 142 Bidirectional reflectance of soils (after Asrar 1989 p. 89).

Stoner and Baumgardner (1981) defined five spectral curves that were characteristic of the observed soil reflectance spectra. In other words, they believed each of the observed spectra resembled one of the five curves shown in Figure 142, the resemblance being determined by soil properties, especially organic matter and iron-oxide content. The discriminating features of the five curves are shape and the presence or absence of spectral absorption bands.

8.3.1 Organic matter response

Despite the generally low content of organic matter in most soils it exerts a profound influence on soil properties such as structure, fertility, water holding capacity and, in particular, reflectance. The influence is highly dependent on climate and environment (Irons *et al.* 1989). Under different climatic conditions the organic matter constituents will vary significantly. Soils developed in semi-arid grassland environments contain abundant humus, which imparts a very dark pigmentation to the soils. That pigmentation is less intense in soils of humid temperate regions and is least apparent in the soils of the tropics and semi-tropics.

UnitID	Unit Type	Solid Geology	Soil Colour Wet	Soil Colour Dry	Off-Soil Colour Wet	Off-Soil Colour Dry
6	Structures	Basalt	L2	N13	K2	N14
14	Tell	Marl	I19	G12	K18	L14
83	Tell	Limestone	N14	B11	L19	L19
90	Tell	Limestone	N13	C11	M19	N14
97	Tell	Limestone	N13	C11	N13	N13
184	Scatter	Marl	M14	K13	M15	M14
191	Tell	Marl	N13	C11	M14	L14
208	Tell	Marl	K2	C11	L19	G14
210	Tell	Marl	M13	C11	A10	B10
222	Scatter	Marl	N13	B11	M14	G13
245	Tell	Marl	A11	C11	K19	J18
252	Scatter	Marl	M13	L13	K18	J15
253	Scatter	Marl	M14	L13	L14	K13
268	Tell	Limestone	L19	B11	N13	M14
279	Scatter	Marl	L14	G13	M14	L14
280	Scatter	Marl	M14	L13	K14	L13
283	Scatter	Marl	M14	G13	M14	G13
318	Scatter	Marl	L13	G12	M14	L14
348	Indeterminate	Marl	M14	L13	M15	M14
351	Indeterminate	Marl	M14	K13	L17	K15
496	Scatter	Marl	N13	M13	K19	A11
498	Scatter	Marl	M13	G12	A10	B10
508	Scatter	Limestone	M14	L13	M14	L13
521	Scatter	Marl	M13	C11	J19	L14

Table 19 Comparison of on and off site soil colours when wet and dry. Note this requires the colour chips described by Middleton (2000).

Kristof and Zachary (1971, cited in Myers 1983) and Baumgardner (1970, cited in Myers 1983) classified multispectral data to delineate organic matter content in soil classes (see Figure 142). They generated five different ranges of organic matter content for mineral soils containing from 1.5 to 7 per cent organic matter. Da Costa (1979, cited in Ben-Dor *et al.* 1999a), showed that colour values can be used to estimate organic matter content from soil, but that this correlation is more pronounced in some soils than in others (Myers 1983). The strongest correlations between organic matter and reflectance are usually observed in the visible spectral region (see spectra E in Figure 142), whereas the relationships between reflectance and the clay fraction is better observed in the short wave infrared ((SWIR) Ben-

Dor and Banin 1995; Ben-Dor *et al.* 1997; Galvao *et al.* 2001). Spectral reflectance generally decreases over the entire SWIR region as organic matter content increases. At organic matter contents greater than 2%, the reflectance decrease may mask other absorption features in soil spectra. The spectra of soils with organic matter content greater than 5% often have a concave shape between 0.5 and 1.3 μm (see Figure 142, curve E) as compared to the convex shape of spectra for soils with lower organic matter content (Stoner and Baumgardner 1981).

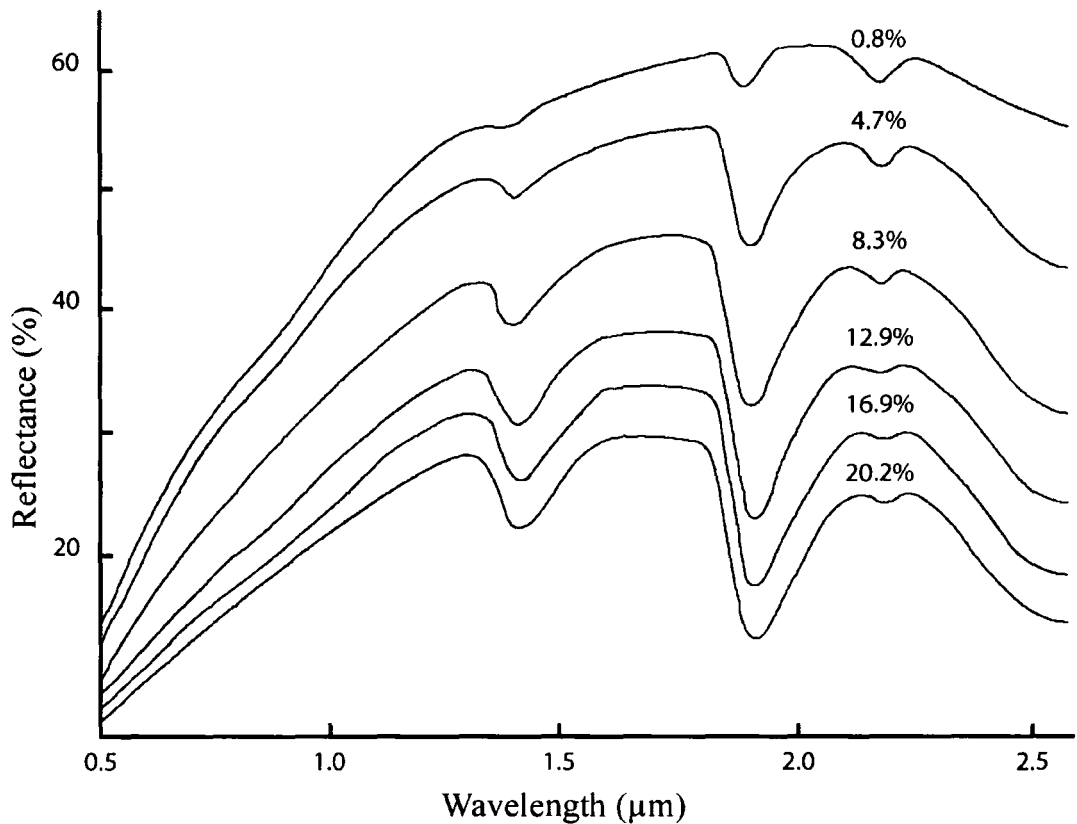

Figure 143 Soil reflectance for a silt loam soil with varying moisture content (after Asrar 1989 p. 90)

8.3.2 Moisture response

Increasing moisture content generally decreases soil reflectance across the entire visible and SWIR spectrum (Asrar 1989). Wet soils usually appear darker to the eye than dry soils for this reason. The decrease in reflectance in the visible spectrum has been attributed to internal reflections within the film of water covering soil surfaces and particles (see Figure 143). For this reason colours were taken from both ambient and wet site and off-site soils to help determine image acquisition times (as discussed in section 5.2.4: see Table 19).

8.3.3 Iron and Iron-Oxide response

Iron commonly occurs as a principal constituent of some soil minerals and as ions in soil water. Many of the absorption features in soil reflectance spectra are due to the presence of iron in some form. The absorption features are caused by either crystal field effects or charge transfers involving Fe^{2+} or Fe^{3+} ions. For example, the steep decrease in reflectance toward the blue and ultraviolet wavelengths is a characteristic of almost all soil reflectance spectra (Figure 142). Increasing the proportion of iron content results in increased levels of energy absorption in the visible wavelengths and decreases in the reflectance curve (compare curves B and C in Figure 142). Curve A represents the spectra of soils with a high iron-oxide content and display generally low reflectance (Stoner and Baumgardner 1981).

8.3.4 Particle size response

Soil reflectance is not only influenced by the chemical composition of the soil constituents, but also by the size and arrangement of the soil particles. Soil texture refers to the size distribution of soil mineral particles. The physical arrangement and aggregation of these particles provide a soil with structure. Texture and structure determine the amount of pore space available in a soil for occupation by water and air. Soils of similar mineral composition and texture can have distinctly different structures and hence porosity.

Bidirectional reflectance generally increases and absorption features decrease as particle size decreases. This behaviour is characteristic of transparent materials, and most silicate minerals behave transparently in the shortwave region. In contrast, the bidirectional reflectance of opaque materials decrease as particle size decreases (Ben-Dor *et al.* 1999a).

Soil texture is fundamental to understanding the characteristics of a soil. The mineralogy of the inorganic solids, for example, is related to particle size. Sandy soils contain a high proportion of quartz and other primary minerals, whereas clay rich soils contain a higher proportion of secondary minerals. In particular, sandy soils tend to be brighter than clay rich soils. The difference may be explained in part by the different mineralogies, and hence reflectance properties, of clay and sand particles, but it may also be due to the tendency of clay particles to aggregate. This aggregation into colloids larger than sand grains can contribute to the darker appearance of clay soils. Additionally the presence of rock fragments (i.e. particles greater than 2 mm in size) modifies texture and hence affects the physical properties and reflectance of soils. Since the size distribution of the mineral particles is not

generally subject to rapid alterations in topsoils, texture is considered a relatively constant soil property and its determination is a basic requirement for any soil description (Irons *et al.* 1989).

Decrease in particle size has been seen to increase soil reflectance among sandy textured soils, possibly by forming a smoother surface with fewer voids to trap incoming light. However, the inverse appears to be true with medium to fine textured soils. This is possibly because the increased moisture and organic matter content associated with clay rich soils leads to lower reflectance.

8.3.5 Theoretical reasons for changes in reflectance

The relationships between soil constituents and in-situ or laboratory spectral reflectance has been discussed by several researchers who have studied the spectral effects of soil parameters such as moisture, organic matter, iron oxide and particle size.

Moisture reduces overall soil reflectance and produces strong and broad absorption bands at 1.4 and 1.9 μm that affect the shape of a soil spectrum (see Figure 143). Soil colour can provide extremely valuable insights into the hydrological regime or drainage status of the soil. Bright (high chroma) colours throughout the profile are typical of well-drained soils through which water easily passes, and in which air is generally plentiful. The presence of grey, low chroma colours, either alone or mixed in a mottled pattern with brighter colours, is indicative of waterlogged conditions during at least a major part of the plant growing season. Colour can also provide qualitative information about the current moisture status of the soil, dry soils generally having lighter (higher value) colours than moist soils.

Organic matter has a profound influence on soil colour. In general, decreases in organic matter produce an increase in reflectance. Increases in iron oxides tend to decrease soil reflectance. In the optical region a reduction in particle size tends to increase reflectance.

The archaeological residues produce a distinctly higher reflectance than the background soil colour. Therefore, theoretically this increased reflectance is related to one or a combination of the following phenomena:

- Low organic matter content.

- Low iron oxide content.
- Relatively finer textured particles or differences in soil structure.
- Improved drainage reducing soil moisture.

8.4 Soil texture analysis

In the 2001 fieldwork season, Dr. Keith Wilkinson (King Alfred's College, Winchester) collected 68 soil samples from various locations in the marl zone in order to examine variations in present day soil properties from on and off-site locations (Wilkinson, pers. comm.). These samples were taken from consolidated material below the ploughsoil (c. 10-15cm below topsoil) and the location of each sample was recorded using handheld GPS. These samples were analysed for trace metals (copper, iron, manganese, potassium and sodium), magnetic susceptibility and moisture using standard methodologies within King Alfred's College (Wilkinson, pers. comm.). Digital number (DN) values were taken from the pixels surrounding each sample location on the Ikonos multispectral and Corona mission 1111 imagery. As there may be errors associated with the spatial location of the imagery the values for the Ikonos imagery were an average of the four closest pixels and for the Corona imagery the nine closest pixels were used. It should be noted that there may be difficulty in the quantitative analysis of the Corona imagery due to variations in view angle and that different filters were employed on different missions.

On completion of the analysis outlined above the soil samples were returned to Durham where particle size analysis and reflectance measurements were undertaken within the Department of Geography. Particle size was determined using a Coulter LS230 by Galiatsatos. The raw particle size readings could be generalised into the British Soil Survey classification through the use of a look-up table (see Table 20). It should be recognised that the determination of particle size using laboratory techniques requires the disaggregation of the particles (i.e. the reduction of aggregated lumps to their constituent particles). Furthermore, Coulter analysis is only conducted on particles with sizes of less than 2mm. Therefore this does not measure in-situ particle size which is the component that directly affects reflectance. However, it is assumed that there is a positive relationship between the laboratory measurements and field sample behaviour. Laboratory based reflectance measurements were undertaken by Galiatsatos using a GER 1500 handheld spectroradiometer. This instrument measures reflectance between 0.3 and 1.1 μm which means that

the moisture absorption bands at 1.4 and 1.9 μm could not be examined. Four measurements were taken as follows:

- A sample in a Petrie dish.
- A sample in an aluminium tin.
- A sample dried overnight at 100° in a Petrie dish.
- A sample dried overnight at 100° in an aluminium tin.

These measurements correspond to ambient and dry conditions. Different containers were used to see if they impacted on the reflectance measurements.

Organic matter and moisture readings were not taken as the timeframe between collecting the samples and their arrival in the UK meant that this component would be severely compromised. It is recommended that field based recording of organic matter, particle size and moisture values are conducted in the future. However, for future research it may be possible to evaluate organic matter and soil moisture by reference to the satellite imagery and the spectro-radiometry profiles.

Fraction Size	BSS Particle Classification	Generalised Classification
<2 μm	Clay	Clay
>2 and <6 μm	Fine Silt	Silt
>6 and <20 μm	Medium Silt	Silt
>20 and <60 μm	Coarse Silt	Silt
>60 and <200 μm	Fine Sand	Sand
>200 and <600 μm	Medium Sand	Sand
>600 and <2000 μm (2mm)	Coarse Sand	Sand
>2000 and <6000 μm	Fine Gravel	Stone

Table 20 British Soil Survey particle size classification

Hence a range of different analytical results were collected for each soil sample. The fact that these samples have their transect location plotted by GPS means that the results can be analysed in conjunction with the satellite imagery. This allows a number of comparisons to occur:

- The spectro-radiometry results can be compared directly with sensor reflectance.
- Sensor reflectance can be simulated directly from the spectro-radiometry.

- Trace metals can be analysed to see if chemical variations impact upon spectro-radiometry and reflectance readings.
- Grain size distributions can be analysed to see if they impact upon spectro-radiometry and reflectance readings.

There are further scale implications in this analysis: the samples represent results from a 3 dimensional point, whereas the satellite pixel represents a generalised average of a 2 dimensional surface.

The results of these analyses (discussed in section 8.4.1) were very encouraging. During the 2003 season a further 122 soil samples were taken across representative features in the marl zone (and one further in the alluvial zone) for particle size analysis.

8.4.1 The 2001 soil sampling programme

Of the samples collected by Wilkinson, four groups formed transects across sites (259, 279, 339 and 602: see Figure 144). Each of these transects was analysed individually to determine if any of the variables showed a correlation with reflectance variations from the background soil to the site. Each of the samples was given a locational value depending on where they were in relation to the site (pre-site (off-site at the start of the transect), pre-transition (the boundary between pre-site and site), site, post-transition and post-site). Even though these samples were collected from below the topsoil layer it was felt that the results would correlate well with topsoil samples due to the shallow topsoil. If the results showed promise then further samples could be collected from the topsoil.

The data for each site is presented in three figures denoting:

- Site location, transect position and particle size response.
- Grouped (site, transition and off-site) spectro-radiometry curves and simulated Ikonos MS readings across the transect.
- A summary of sensor reflectance and the laboratory analyses conducted by Wilkinson.

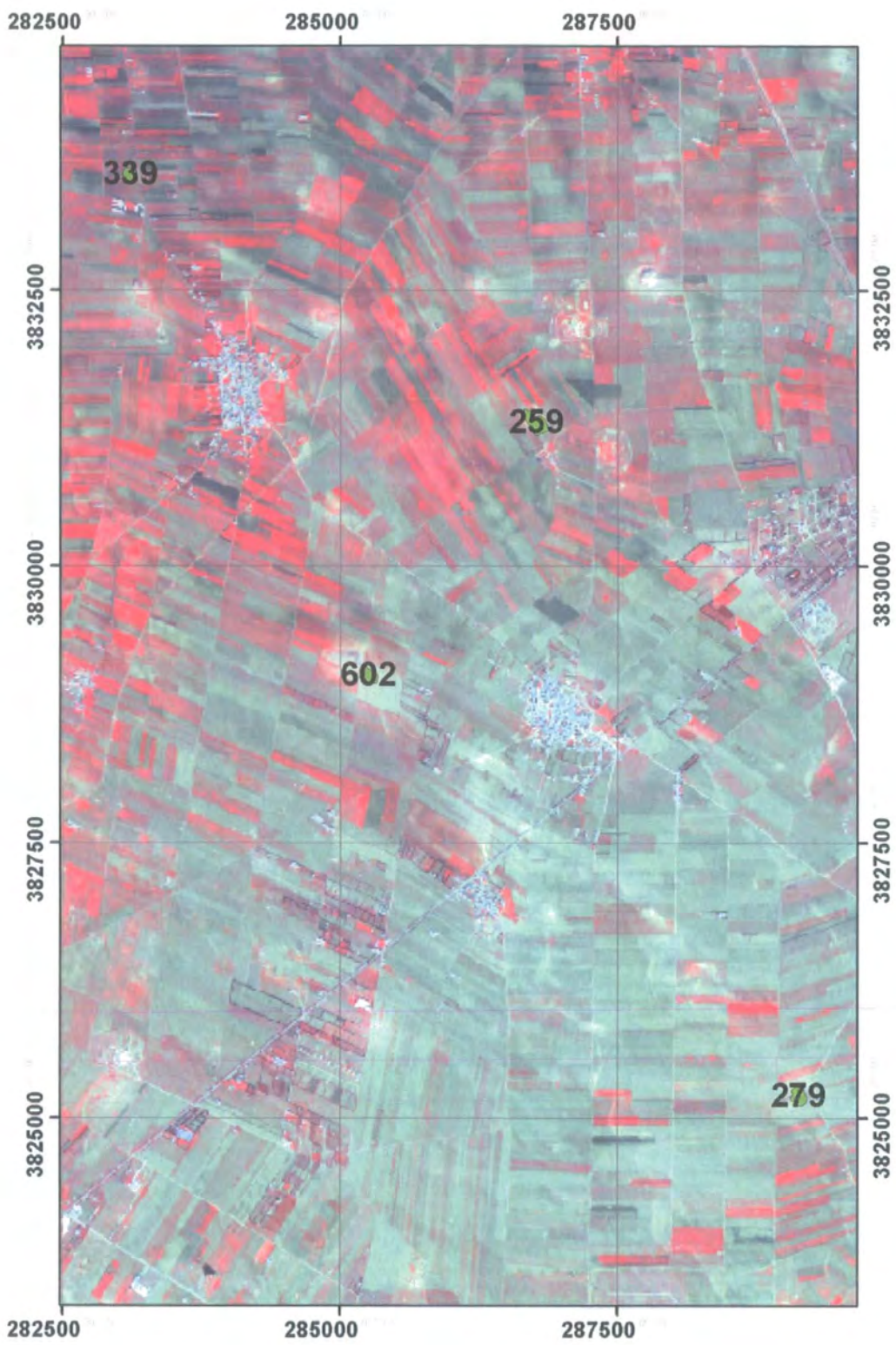

Figure 144 Location of sites where soil samples were taken by Wilkinson.

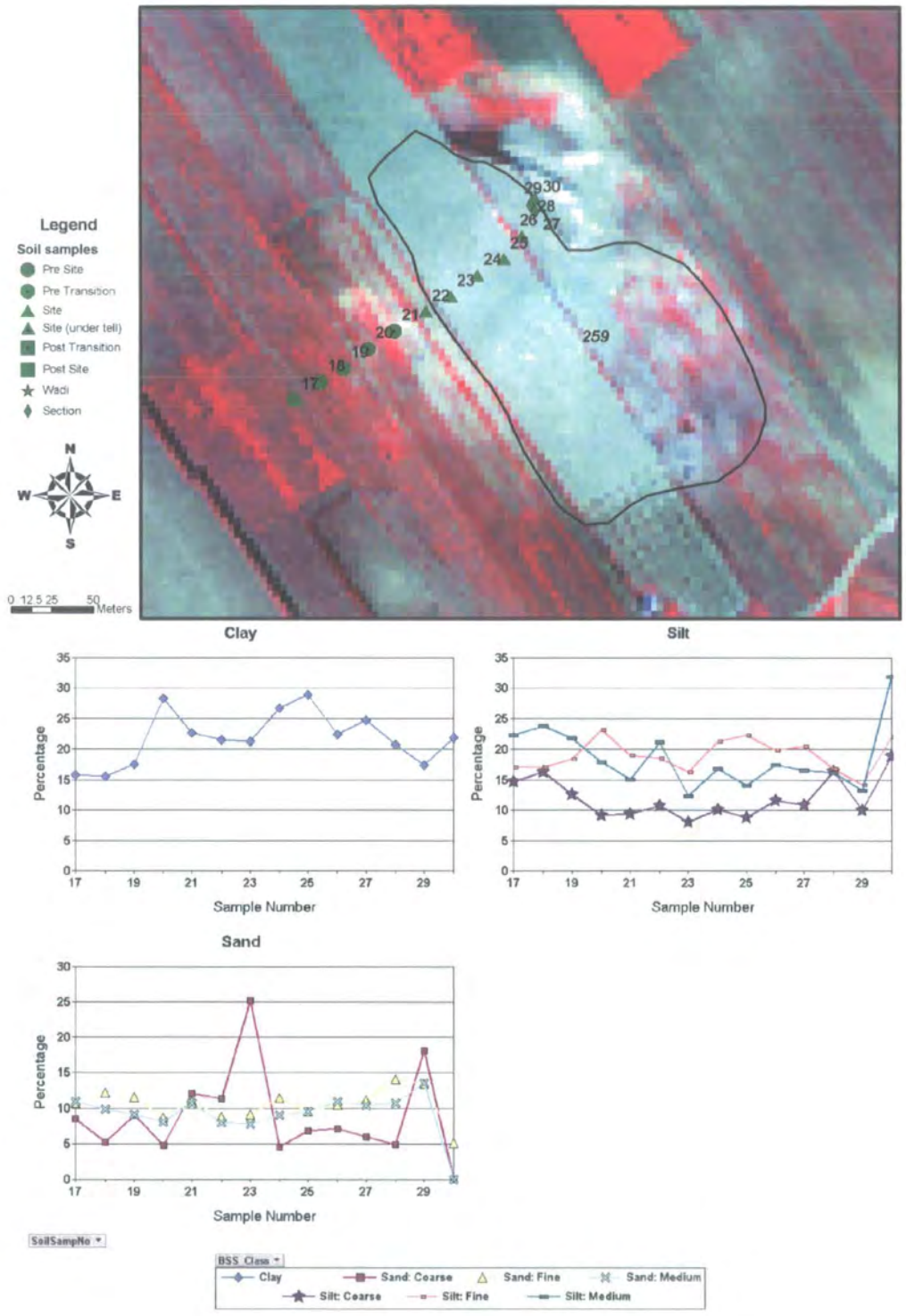
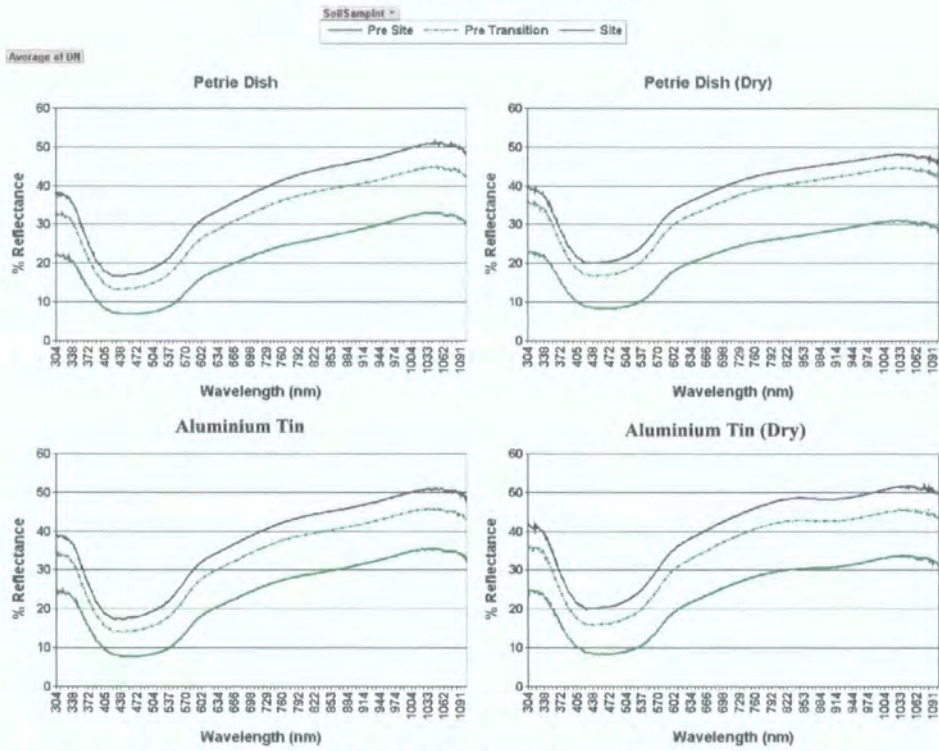

Figure 145 Locations of soil samples collected by Wilkinson over site 259 and results of particle size analysis (generalised to the British Soil Survey classification).

Spectral curve across the transect



Simulated Ikonos MS readings from the spectro-radiometer

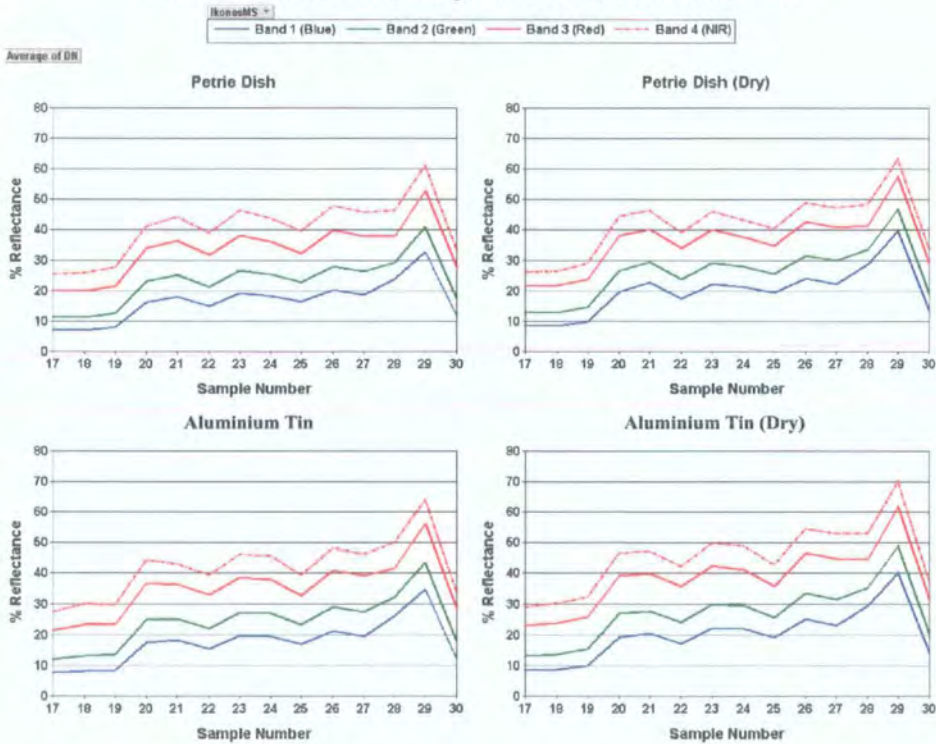

Figure 146 Averaged spectral curve and simulated Ikonos MS readings from the spectro-radiometer readings of the soil samples from site 259.

8.4.1.1 Analysis at site 259

Site 259 is a flat site west of a wadi in the marl zone (as defined in section 6.6) with a local place name of 'Um Al-Sakhr. During the last visit the site was under olive plantation and various cereals. Surface material included pottery and architectural fragments. A significant portion of the eastern edge of the site has been bulldozed revealing interleaved conglomerate and marl sediments. The sample transect was located across the site in a WSW-ENE direction and sampling took place at approximately 20 metre intervals (see Figure 145). Unfortunately the transect does not exit the site on the eastern edge due to the bulldozing, thus the transect is considered completed at sample point 26. Sample points 19 to 20 highlight the transition between off-site and site respectively. The site boundary has been recorded from satellite imagery and not from field observation.

As shown in Figure 145, Figure 146 and Figure 147, there is an increase in DN values and reflectance readings from the MS Ikonos sensor between off-site and site soils and a corresponding decrease on the Corona imagery (note that the Corona is digitised from a negative so the decrease is actually an increase. Hence the Corona and Ikonos sensors represent the same pattern). This curve is also seen in the simulated Ikonos MS using the lab-based radiometry data. The general trends between the simulated and real Ikonos readings compare favourably, including the dip between samples 21 and 23.

Both the low and high frequency magnetic susceptibility readings show a reduction in value at the site boundary. These data should indicate that on-site soils show less anthropogenic activity than off-site soils. This is an unexpected result requiring more research. Moisture contents shows a broad correlation with the site. Trace copper and sodium do not correlate. There is a possible correlation with trace manganese, potassium and iron and a large increase in the percentage of clay on the site and a large decrease in coarse and medium silt. There is also a slight, but observable, increase in fine silt.

The spectral data show an increase in reflectance from pre, through transition to site soils. After comparison with Figure 142 it can be extrapolated that the soil has low organic matter content (< 2%; see curves B, C and D). In conclusion the increase in the spectral response is most likely to have occurred through changes in particle size, although moisture may play some part.

8.4.1.2 Analysis at site 279

Site 279 is a flat site east of a wadi in the thin marl zone (as defined in section 6.6) with a local place name of Khirba (ruin) Al-Qatisiyya. When last visited the site was under a combination of wheat and potato cultivation. Surface material included pottery, basalt and numerous architectural fragments (which provide a large textural change across the site). A small amount of bulldozing has occurred on this site. The transect was located across the site in an ENE-WSW direction. Samples were taken at c. 20 metre intervals (see Figure 149). Sample points 3 to 5 and 11 to 13 highlight the transition between off-site and site. This is one of the few sites in the whole application area where the satellite imagery actually shows a decrease in DN values (however, in dry conditions on the ground the site soil appears lighter). The site boundary has been recorded from the satellite imagery.

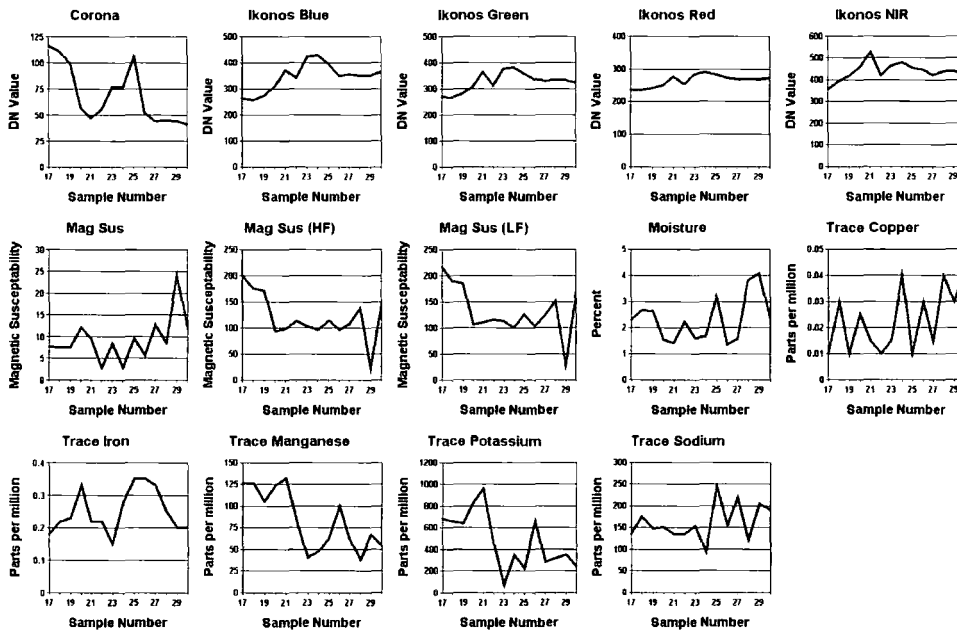

Figure 147 Analysis of the soil samples from site 259 and the DN value from the Corona and Ikonos MS satellite sensors for the corresponding GPS point.

As shown in Figure 148, Figure 149 and Figure 150 there is a decrease in DN values and reflectance readings from the Ikonos sensor on site (which are more pronounced in the blue and near infrared bands) and a corresponding increase on the Corona imagery. Although slight, this is reflected in the simulated Ikonos MS in the red and near infrared bands. The

simulated Ikonos displays an increase in the blue and green bands (which tallies with the ground observation).

Both the low and high frequency magnetic susceptibility data produce an increase in value over the site, indicating anthropogenic activity. Moisture values decrease strongly within the site. This is a particularly interesting result considering that there is no concomitant increase in reflectance. None of the trace metals indicate any correlation with the site extent. There is a large decrease in the percentage of clay and fine silt and a large increase in coarse sand.

The spectral curves show a complex pattern across the different parts of the transect. The site shows the highest reflectance between 400 and 600 nm (blue and green). The site shows the lowest reflectance value between 600 and 800 nm (red and near infrared). The transition soils are particularly difficult to classify and indicates soil complexity at the site boundary. After comparison with Figure 142 it can be extrapolated that the soil has low organic matter content (< 2%; see curves B, C and D). In conclusion, the increase in reflectivity is most likely to have occurred through changes in particle size. The heterogeneous frequency of massive clasts (architectural fragments) must play some part in the variation in texture across the site, further emphasising the lack of clarity at the site boundary.

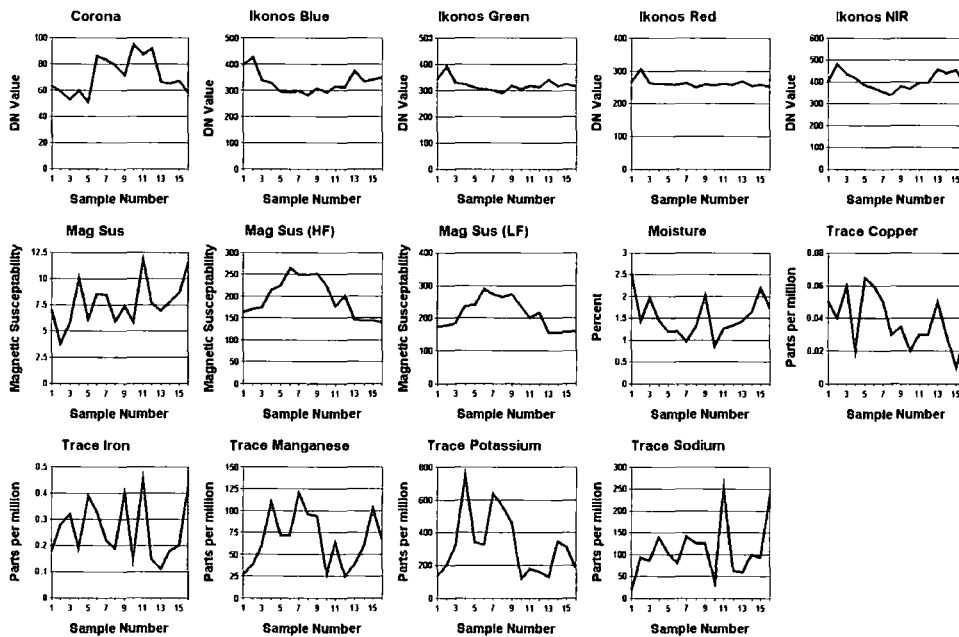

Figure 148 Analysis of the soil samples from site 279 and the DN value from the Corona and Ikonos MS satellite sensors for the corresponding GPS point.

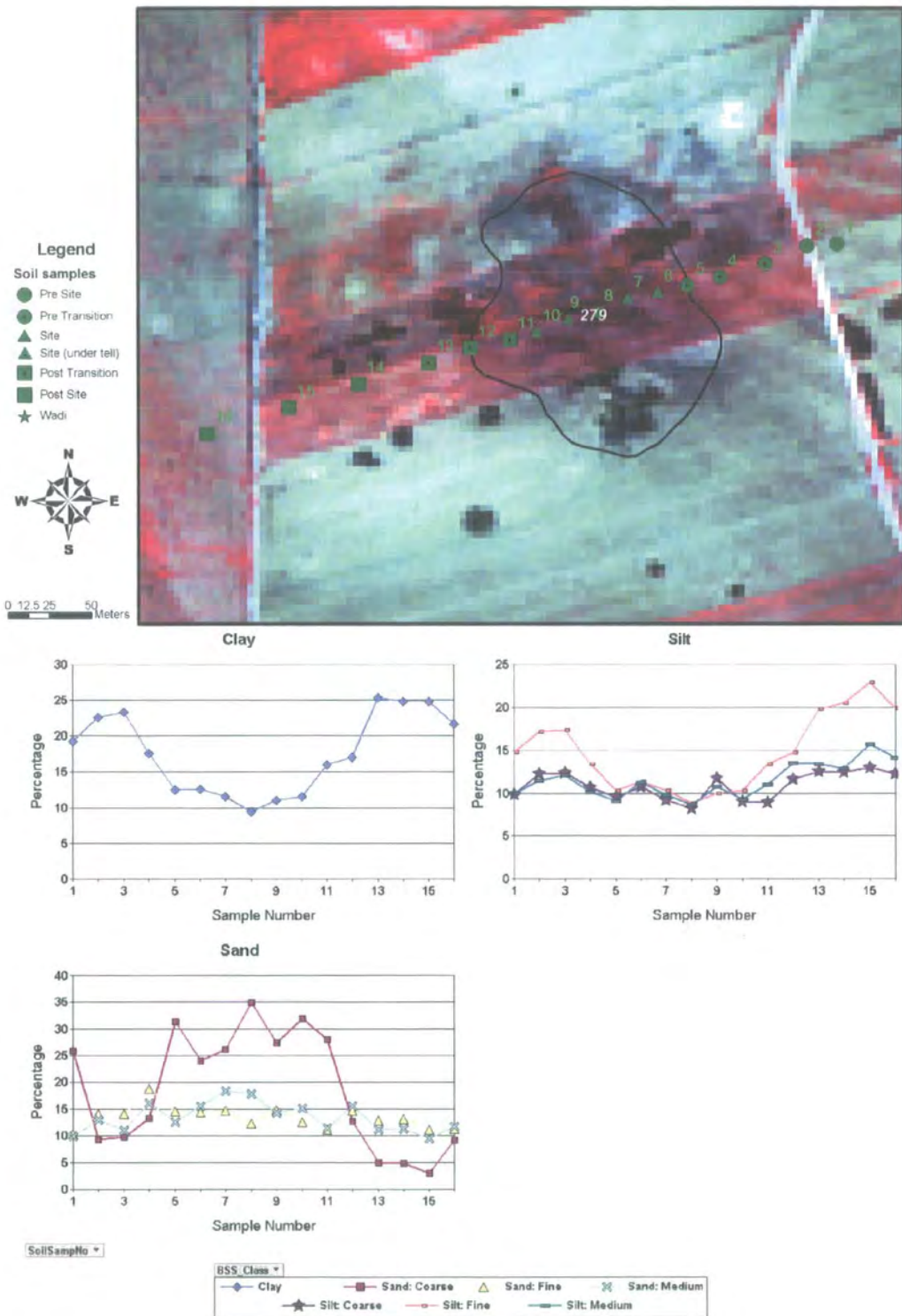
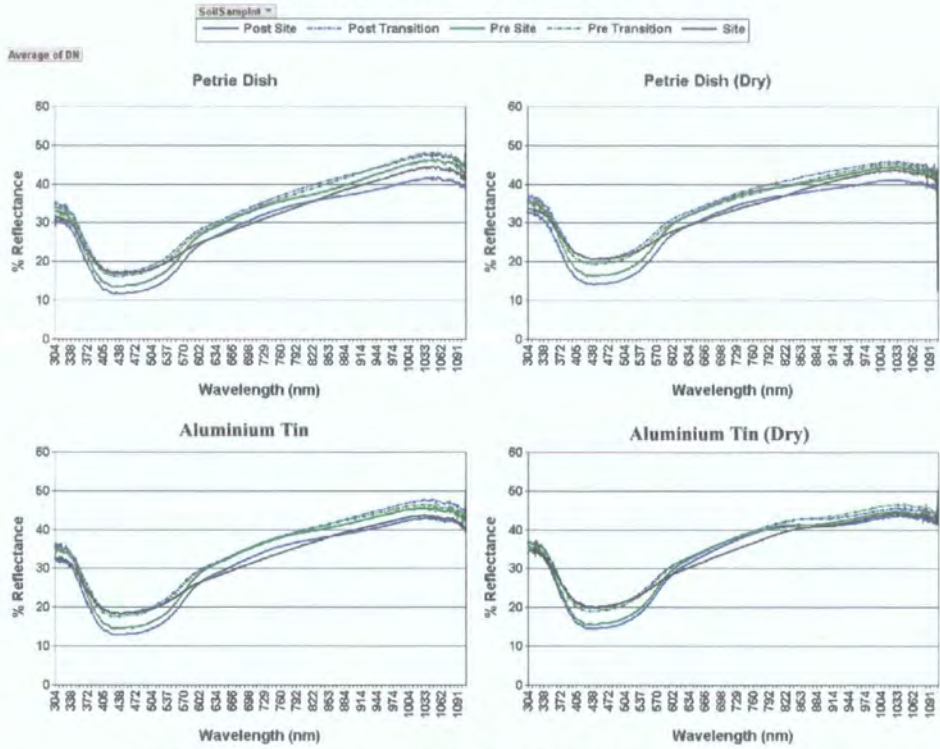

Figure 149 Locations of soil samples collected by Wilkinson over site 279 and results of particle size analysis (generalised to the British Soil Survey classification) on these samples.

Spectral curve across the transect



Simulated Ikonos MS readings from the spectro-radiometer

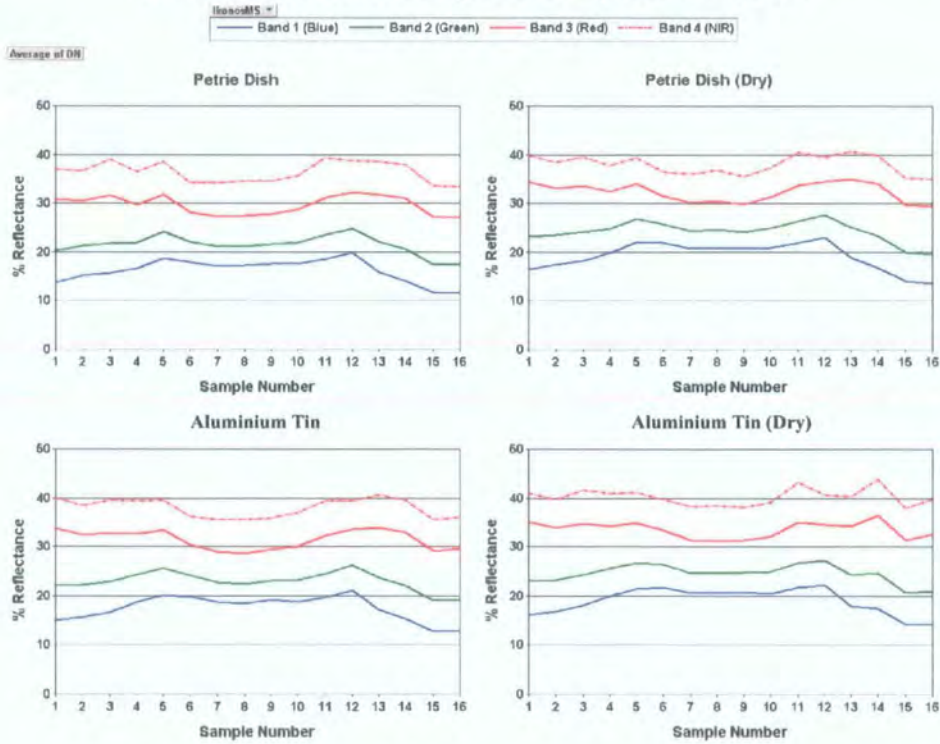

Figure 150 Averaged spectral curve and simulated Ikonos MS readings from the spectro-radiometer readings of the soil samples from site 259.

8.4.1.3 Analysis at site 339

Site 339 is a flat site in the marl zone (as defined in section 6.6) with a local place name of Khirba (ruin) Al-Tahisah. This is one of a number of sites which is associated with a large topographic depression. In this instance the depression is located in the centre of the site. When last visited the site was under cereal cultivation. Surface material included pottery and architectural fragments (including tile). The transect was located across the site in a SW-NE direction with samples taken at approximately 20 metre intervals (see Figure 151). Sample points 57 to 59 and 63 to 64 highlight the transition between off-site and site. The site boundary has been recorded from satellite imagery.

As shown in Figure 151, Figure 152 and Figure 153 there is an increase in DN values and reflectance readings from the Ikonos sensor on site (note the peak in all the bands between samples 61 and 62). There is also a corresponding decrease on the Corona imagery (the peak at sample 64 on the Corona is possibly due to interference from the road). These results are also seen in the simulated Ikonos MS.

Both low and high frequency magnetic susceptibility data produce an observable decrease in value over the site. Moisture values decrease strongly within the site. In this instance a reflectance increase is associated with the moisture decrease. None of the trace metals indicate any correlation with the site extent. There is a large increase in the percentage of clay (with the exception of the initial anomaly) and sand and a decrease in silt.

As seen at site 259, the spectral data for this site show an increase in reflectance from off-site, through transition to site soils. After comparison with Figure 142 it can be extrapolated that the soil has low organic matter content (< 2%; see curves B, C and D). In conclusion the increase in spectral response is most likely to have occurred through changes in particle size and decrease in moisture content.

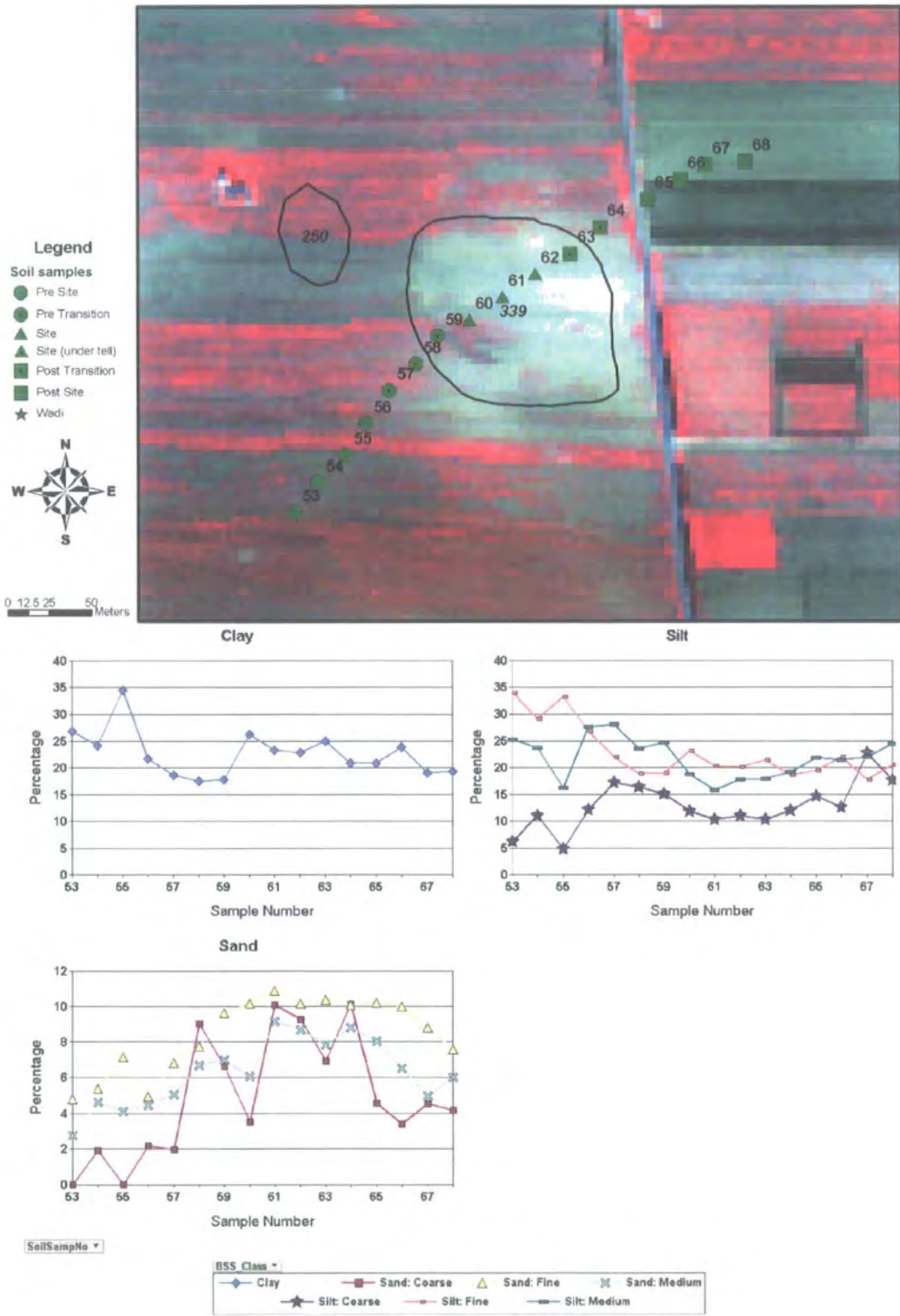
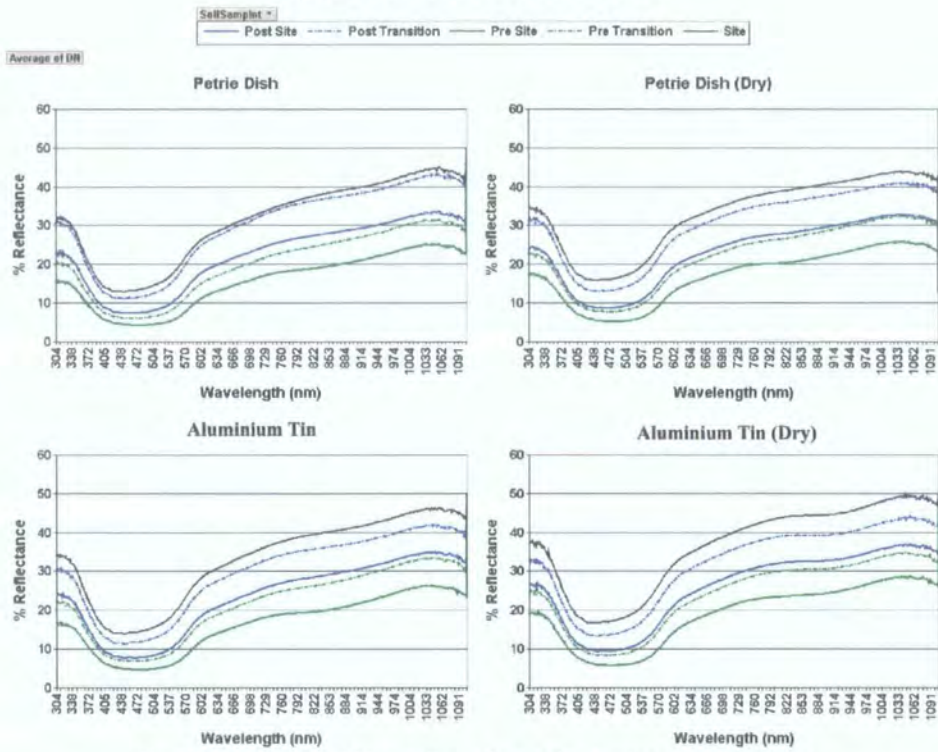

Figure 151 Locations of soil samples collected by Wilkinson over site 339 and results of particle size analysis (generalised to the British Soil Survey classification) on these samples.

Spectral curve across the transect



Simulated Ikonos MS readings from the spectro-radiometer

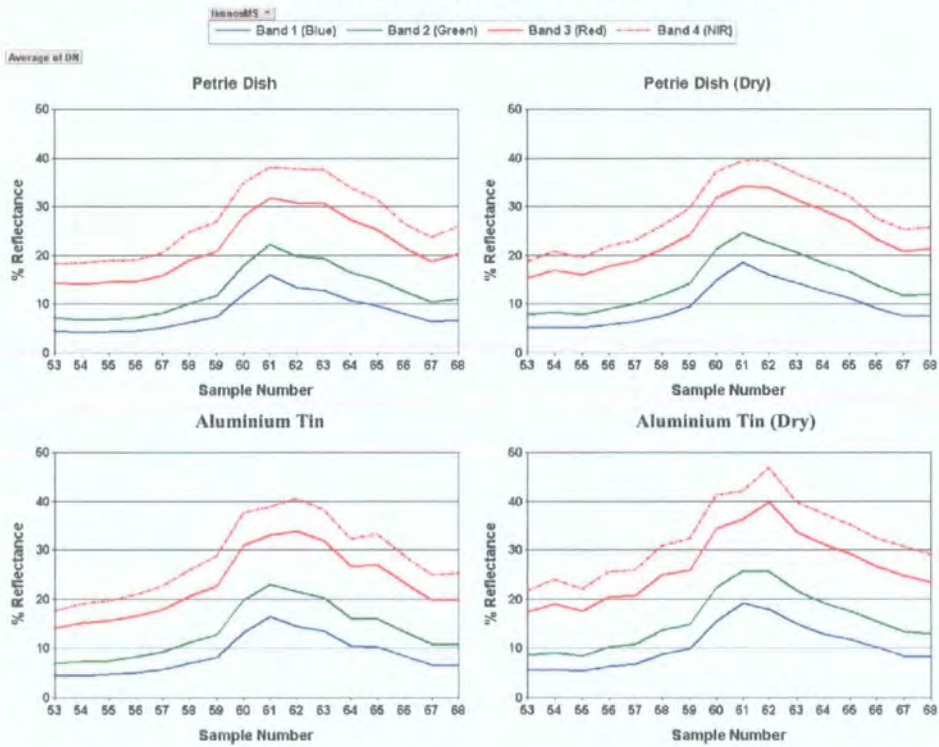

Figure 152 Averaged spectral curve and simulated Ikonos MS readings from the spectro-radiometer readings of the soil samples from site 339.

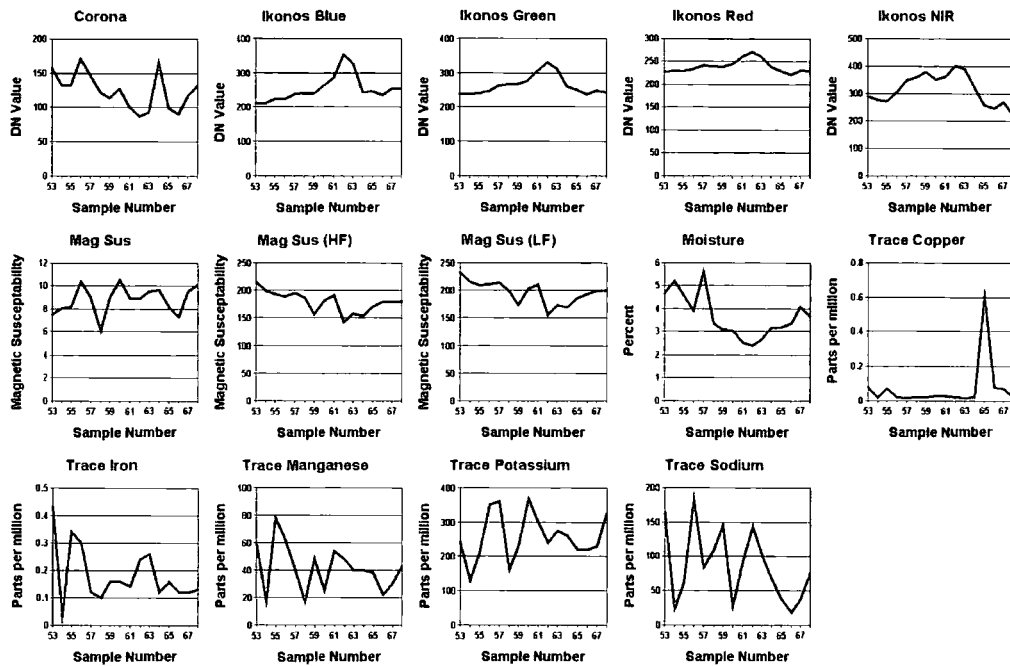

Figure 153 Analysis of the soil samples from site 339 and the DN value from the Corona and Ikonos MS satellite sensors for the corresponding GPS point.

8.4.1.4 Analysis at site 602

Site 602 is a flat site in the lee of tell 254 in the thin marl zone (as defined in section 6.6) to the west of a wadi. When last visited the site was under an olive plantation and various cereals. Surface material included pottery (mostly Islamic), basalt and architectural fragments (including tile). A trench (area 601 see Figure 155) has been cut into the western part of the site. The transect was located across the site in a SW-NE direction with samples taken at approximately 30 metre intervals (see Figure 155). Due to its proximity to tell 254 it is difficult to define the exact limits of this site, the current boundary is extremely arbitrary. Hence the transect was extended to ensure off-site coverage. From the satellite imagery it has been extrapolated that the transition between off-site and site starts between samples 39 and 42 and finishes between samples 46 and 49. It should also be noted that sample 50 is taken from the wadi margins.

As shown in Figure 154, Figure 155 and Figure 156 there is an increase in DN values and reflectance readings from the Ikonos sensor on site and a corresponding decrease on the Corona imagery. This, however, is unsurprising in this context given that the imagery was used to define the site limits. The fact that this trend is reflected in the simulated Ikonos MS

is encouraging and it is recommended that intensive surface survey is conducted at this site to determine the site extent by artefact fall-off.

Both low and high frequency magnetic susceptibility data produce an observable decrease in value over the site. Moisture values do not seem to correlate with the site although there is an increase in moisture content as the samples approach the wadi. None of the trace metals indicate any correlation with the site extent. The SW edge of the site can be seen through the increase in the clay component between samples 39 and 40. It is difficult to isolate trends in the particle sizes and to locate the NE edge of the site, although there could be interference at the NE edge due to the proximity of the wadi and its associated deposits (see Figure 155).

The spectral curves for this site show an increase in reflectance from off-site, through transition to site soils. The on and off-site soils do appear to correlate well, although defining a site edge in the transitional samples is difficult. This should be re-examined after the site extent is re-surveyed. After comparison with Figure 142 it can be extrapolated that the soil has low organic matter content (< 2%; see curves B, C and D). In conclusion, the increase in spectral response is most likely to have occurred through changes in particle size.

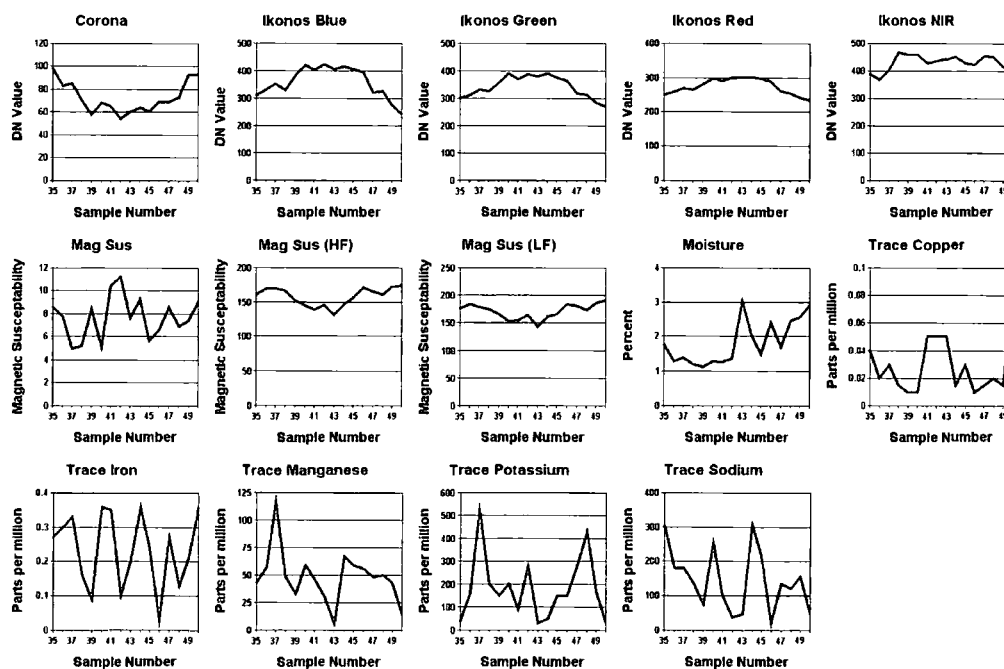

Figure 154 Analysis of the soil samples from site 602 and the DN value from the Corona and Ikonos MS satellite sensors for the corresponding GPS point.

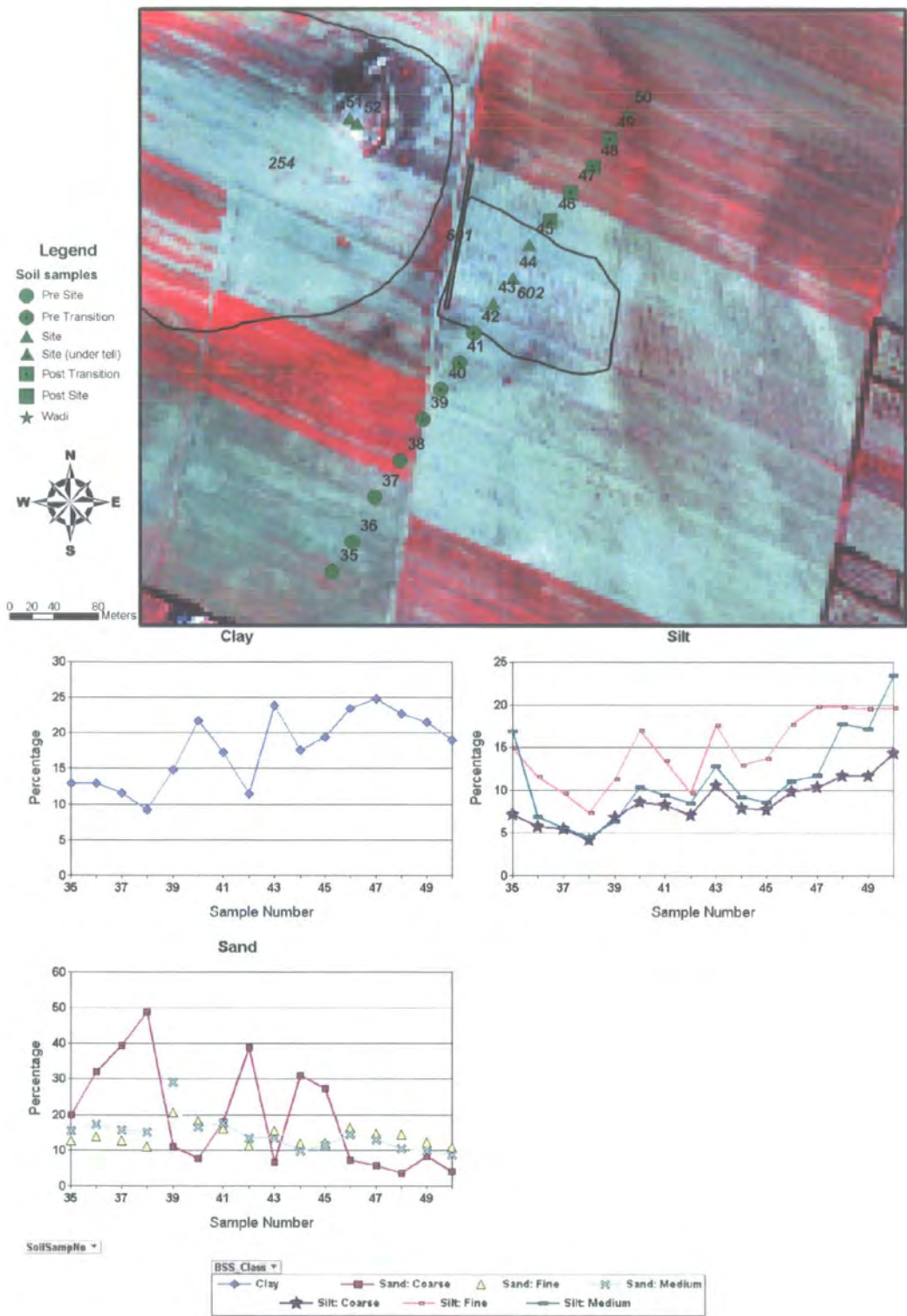
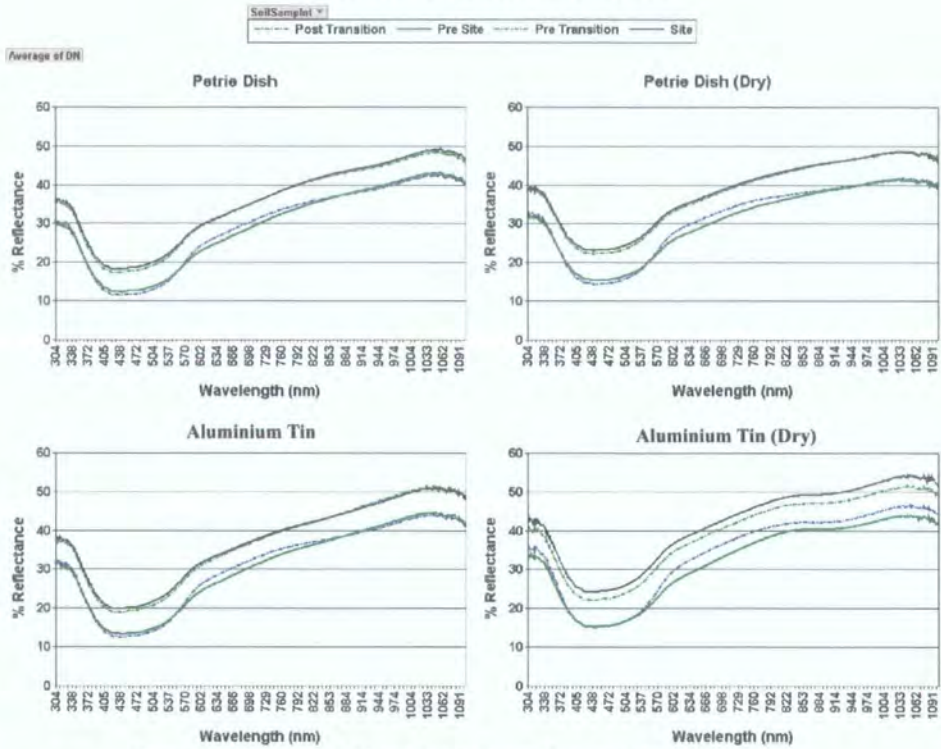

Figure 155 Locations of soil samples collected by Wilkinson over site 602 and results of particle size analysis (generalised to the British Soil Survey classification) on these samples.

Spectral curve across the transect



Simulated Ikonos MS readings from the spectro-radiometer

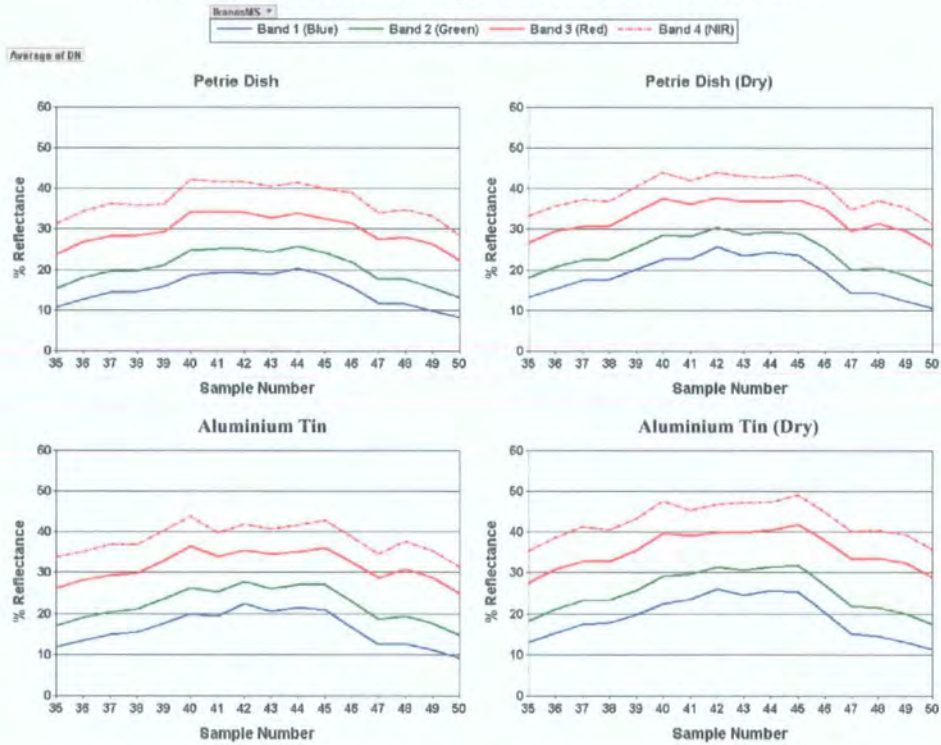

Figure 156 Averaged spectral curve and simulated Ikonos MS readings from the spectro-radiometer readings of the soil samples from site 602.

8.4.1.5 Summary of the analysis of Wilkinson's 2001 soil samples

After evaluation of the soil samples collected by Wilkinson the following results were interpreted. Anthropogenic action may have altered the quantities of trace metals on sites (see in particular site 259). However, in respect to their impact on reflectance the results are inconclusive. However, lead, zinc and Al_2O_3 , which produced positive results for Rimmington (2000) in Greece were not analysed by Wilkinson. On sites 259, 279 and 339 moisture content does appear to decrease. However, these results may be skewed by changes in moisture content between sampling in the field, transit from Syria and laboratory analysis. This is supported by the similarity of the ambient and dry spectral curves at each site. Both low and high frequency magnetic susceptibility data appear to be related to archaeological residues. There is a very strong correlation between these readings and sites 259 and 279 and weak correlations on sites 339 and 602. It is interesting to note that only site 279 exhibits an increase in magnetic susceptibility. These changes in magnetic susceptibility should be related to ash content (as should the potassium measurements). However, magnetic susceptibility is not related to changes in reflectance.

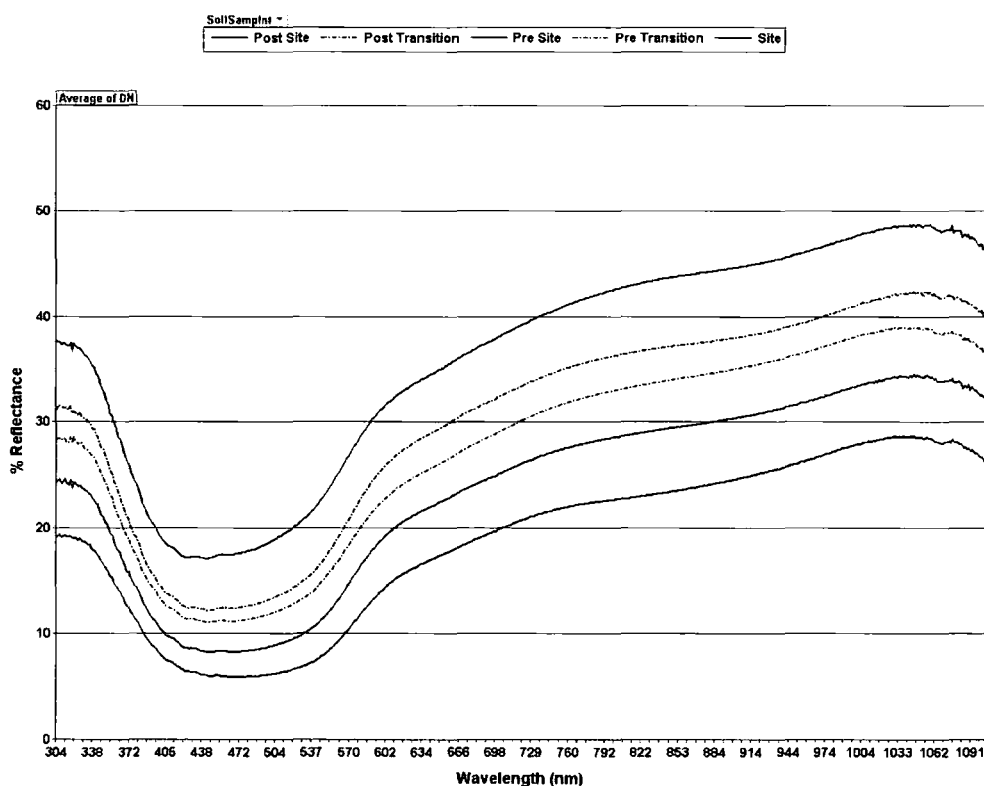

Figure 157 Combined spectral curve from sites 259 and 339 by sample location.

Figure 157 shows the combined spectral curves by sample location from the most representative sites (259 and 339: site 602 is ephemeral on the ground and 279 exhibits a DN value decrease). All the curves have a similar shape (dominated by Fe^{3+} absorption), but the site curve has a 15-20% increase in reflectance in comparison to the off-site (pre and post site) curves. A similar increase in DN value is also observed in the satellite imagery itself. Analysis of these curves in ENVI against NASA standards (Grove *et al.* 1992) revealed that the marl soil appears to be a closely related to hematite (Fe_2O_3) and goethite ($\text{Fe}^{3+}\text{O}(\text{OH})$). The marl soil displays the characteristic iron absorption curves of these minerals. As expected, the transitional samples describe curves somewhere in between the site and off-site curves. In comparison to Figure 142, the off-site curve appears to correlate quite closely with curve C (< 2% organic matter and 1-4% iron oxide (FeO)). The site soils appear to correlate quite closely with curve B (< 2% organic matter and <1% FeO). However, analysis of the trace iron content in the samples does not correspond with this identification. Alternatively, curves B and D are chemically and biologically the same soils with a different arrangement of particle sizes. Hence, this change in texture and/or structure produces a 15% increase in reflectance from curve D to curve B over the 0.3 to 1.1 μm range (the same range as the GER 1500 spectro-radiometer). Therefore, if one assumes that there is a close physical and chemical relationship between on and off-site soils then a change in particle size distribution and a reduction in moisture content is the most likely cause for the increase in DN value. This hypothesis is supported by the correlation across all the sites between changes in DN value and corresponding changes in particle size distribution.

8.4.2 The 2003 soil sampling programme

After the encouraging results from Wilkinson's samples a further 122 samples were collected for particle size analysis from 10 sites (and located with GPS) during the 2003 study season. As optical reflectance is based on the surface microns of soil these samples were collected from the topsoil. Unfortunately 8 of these samples were misplaced during collection and transit resulting in 114 samples being available for analysis. Sites were carefully chosen so that a range of site types of different dates and in different soil environments were sampled (see Figure 159 and Table 22). For control purposes sites 279 and 339, where Wilkinson placed transects in the 2001 season, were re-sampled. Transects were located so that they started and finished off-site and traversed the site itself. Sample intervals were variable, although

nominally between 20 and 30 metres. However, emphasis was placed on collecting more samples at site boundaries.

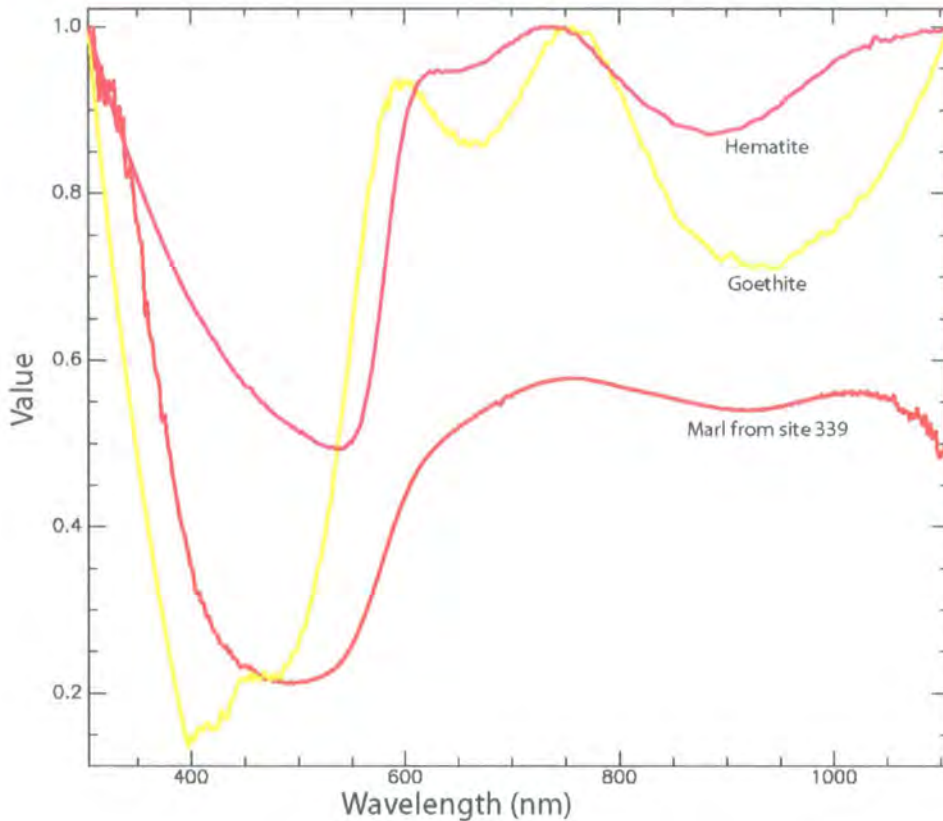

Figure 158 Comparison of marl soil curve (from spectroradiometry) against standard samples of hematite and goethite.

These samples were processed and analysed for particle size using the methodology described in Appendix II. The results of these analyses are contained in Appendix III. However, there were differences between the particle size analyses from the 2001 and 2003 collection on the control samples at sites 279 and 339. In contrast to the 2001 samples the 2003 samples did not contain particles greater than 1mm. Only two reasons were immediately obvious for these results: either there was human error during the preparation of the 2001 or 2003 samples or the Coulter LS230 was out of calibration during one of the processing runs.

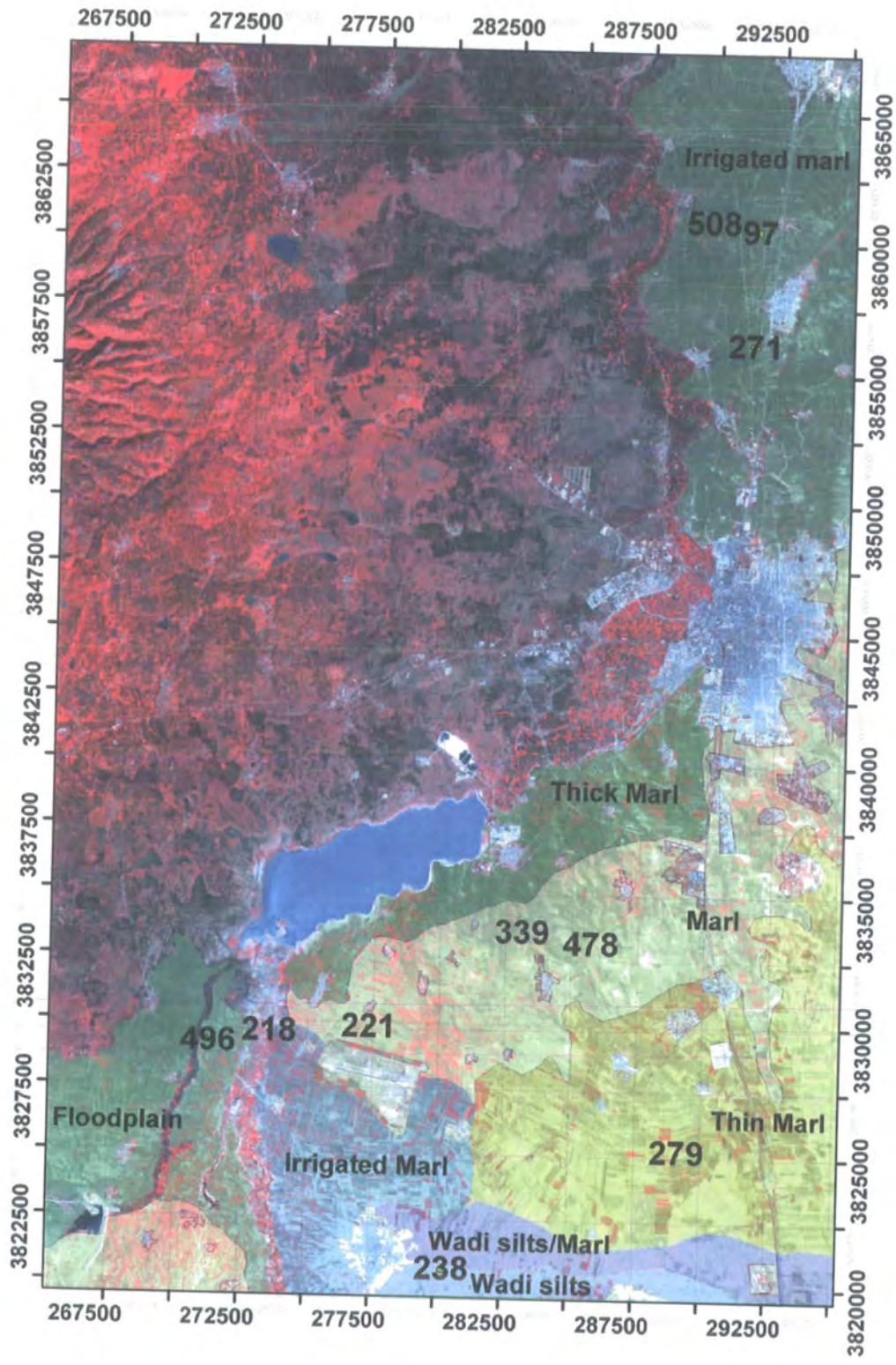

Figure 159 Location of sites sampled in the 2003 season.

It was determined that there were subtle differences in the processing techniques employed by Galiatsatos and myself. Galiatsatos did not riffle the samples and therefore increased the likelihood that the Coulter sample was unrepresentative. However, this is highly unlikely to produce the observed variations. The Coulter LS230 was checked for calibration by running a range of standard samples and was determined to be in specification. It was subsequently ascertained that Wilkinson's samples were collected from consolidated material below the ploughsoil (c. 10-15cm below topsoil: Wilkinson, pers. comm.). Hence, variations in particle size were to be expected, but once again such extreme results are unlikely.

To ensure reliability 6 comparable samples collected from the control sites (279 and 339) during 2001 and 2003 were re-analysed (resulting in a total of thirteen samples). Minor variations were observed between the two runs of the 2003 samples. Significant variation was observed between the first and second runs of the 2001 samples (samples 4, 8, 13, 58, 61 and 64: see Figure 160). Like the 2003 samples the second run of the 2001 samples contained no particles greater than 1 mm. The second run 2001 samples produced comparable particle size distributions with the 2003 samples.

The causation of these variations in particle size results is still unclear. It is recommended that the methods employed in Coulter sample preparation and analysis are reviewed so that multi-temporal sample results can be integrated with confidence.

8.4.3 Interpretation of the analysis

As discussed in section 8.4.1.5, the 2001 samples and their analysis provided a promising basis for explaining the increase in satellite DN value over archaeological residues in the marl zone. However, the results of the particle size analysis on the 2003 samples are generally disappointing. With the reliability of the grain size analyses still in question any interpretations are, at the best, tentative. In 2001 the surface scatter sites 259, 279 and 339 produced very clear differences in particle size at the predicted site boundaries. This clarity is only exhibited in the tell and low tell sites (97 and 218 respectively) for the 2003 samples. However, less clear, but identifiable correlations occur at the scatter sites 221, 271, 279, 339 and 508.

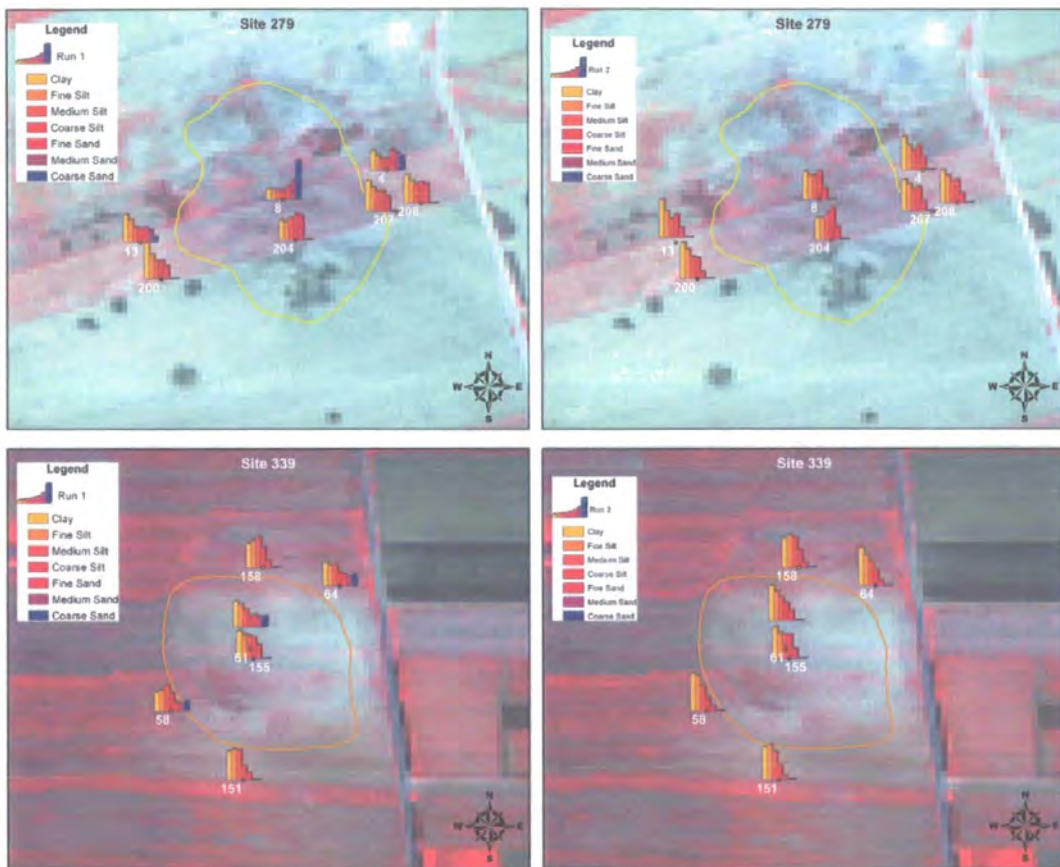

Figure 160 Comparison of the different Coulter 'runs' on selected 2001 and 2003 samples at sites 279 and 339.

This difference in results could be due to a number of issues:

- Particle size modification in the intervening two years.
- The reliance on the satellite imagery to define the sample location (i.e. pre, post, transitional or site samples).
- Unresolved problems in the Coulter analysis.
- Laboratory analysis of particle size does not adequately reflect in-situ particle size.
- Particle size variation has no relationship with archaeological residues.

Whatever the cause, variation in particle size still has a positive relationship with DN value across many of the sites studied. However, these variations are not consistent across the range of sites. Table 21 and Table 22 outline a summary of the results of the particle size analysis.

Source	Site	Place of extraction or number of the sample	Gravel %	Sand %	Silt %	Clay %	Sample No
Sauvage	Tureng Tépé	Building stucco	2.00	46.00	43.00	9.00	1
		Edge E4		9.00	27.00	14.00	2
	Nush-i-Jan		15.00	34.00	47.00	15.00	3
	Samarra	Brick no. 3B		61.90	12.30	25.80	4
	Ur	Brick no. 2		16.60	68.20	15.20	5
		Brick no. 2		7.60	53.20	39.20	6
	Choche	Brick no. 5		7.00	59.10	33.90	7
		Brick no. 8		5.20	20.00	39.80	8
	Aqar Quf			13.70	58.50	27.80	9
	Tell Umar			31.60	49.10	19.30	10
	Upland Mesopotamian soil			2.40	71.10	26.50	11
	Lowland Mesopotamian soil			4.10	45.75	50.15	12
SHR	Tell Nebi Mend (SHR site 315)	Sample 69: Rampart red brick		4.10	61.70	34.20	13
		Sample 70: Rampart grey brick		13.00	65.30	21.70	14
		Sample 71: Rampart white brick		1.90	61.20	36.90	15
		Sample 72: TrVIII yellow brick		6.40	73.60	20.00	16
		Sample 73: Modern mudbrick		7.80	65.70	26.50	17
		Sample 74: Modern surface		8.30	65.80	25.90	18
	SHR wadi	Average across the marl zone		22.00	57.50	20.50	19
	Irrigated Northern Marl	Off site average		2.38	70.27	27.35	20
		SHR tell 97		6.24	59.53	34.23	21
		SHR scatter 271		6.59	62.24	31.17	22
		SHR scatter 508		5.74	73.18	21.09	23
	Irrigated Southern Marl	Off site average		4.57	60.85	34.59	24
		SHR low tell 218		9.74	63.59	26.67	25
	Southern Marl	Off site average		6.71	62.57	30.73	26
		SHR scatter 221		6.04	61.07	32.89	27
		SHR scatter 339		7.47	61.93	30.60	28
		SHR scatter 478		5.47	66.50	28.03	29
	Thin Southern Marl	Off site average		11.88	55.26	32.86	30
		SHR scatter 279		18.24	62.41	19.35	31
	Wadi silts/Thin Marl	Off site average		16.99	58.94	24.07	32
SHR scatter 238			26.11	54.50	19.39	33	

Table 21 Particle size analysis of mud brick and soil. Non SHR samples are taken from Sauvage (1998 p. 19, Tables 2 and 3).

If the hypothesis that the change in particle size and hence reflectance is primarily caused by the incorporation of degraded mud-brick into the soil matrix, one would expect to see an increase in clay particulates. This is based on the assumption that mud-brick is created with local material and that manufacture increases the clay component. However, this may be complicated by the amount of re-used material used in the construction of mud-bricks. For example, it is fair to assume that, mud-bricks on flat sites do not contain much re-used material. Conversely, mud-bricks on tell sites are likely to be made with material quarried from the tell itself (i.e. the residues of collapsed mud-brick structures are used as a source for creating new mud-bricks). In such a situation re-used tell mud-bricks are likely to contain a range of anthropogenic and natural material that will alter the particle size distribution (see Figure 161).

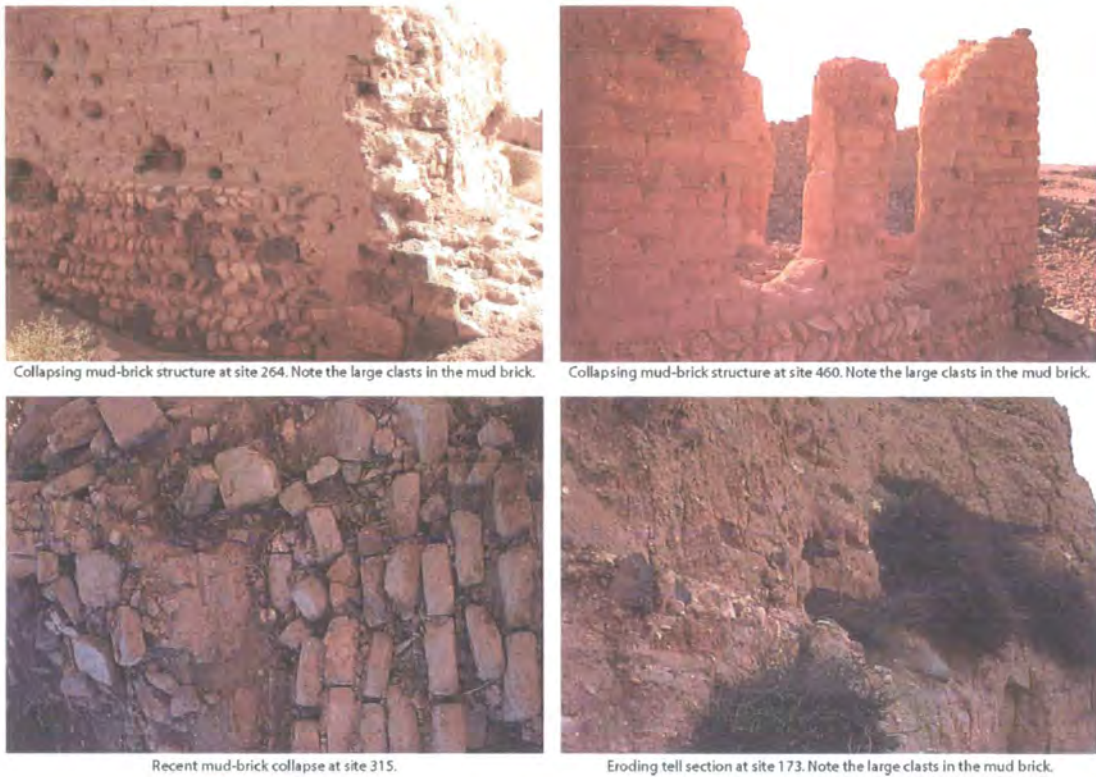

Figure 161 Mud-brick structures in varying degrees of collapse.

In addition, Table 21 and Figure 162 (displaying a range of particle sizes for mud-brick samples and on and off-site soils) shows that particle sizes can vary irrespective of local or regional soil conditions. The range of components in mud-brick is extremely variable (sand: 1.9%-61.9%, silt: 12.3%-73.6% and clay 9%-39.8%). Therefore, the impact of degraded mud-brick on soil particle size is much more complex than originally postulated.

This observation is confirmed in Table 22 which summaries the percentage change of each soil fraction between off and on site soils. The sites fall into four categories, those that exhibit an:

- Increase in clay and silt and a decrease in the sand fraction (site 602).
- Increase in clay and sand and a decrease in the silt fraction (site 97, 259 and 339 (2001 and 2003 samples)).
- Increase in sand and a decrease in the clay and silt fraction (site 238, 271, 279 (2001 sample), and 508).

- Increase in sand and silt and a decrease in the clay fraction (site 218, 279 (2003 sample) and 478).

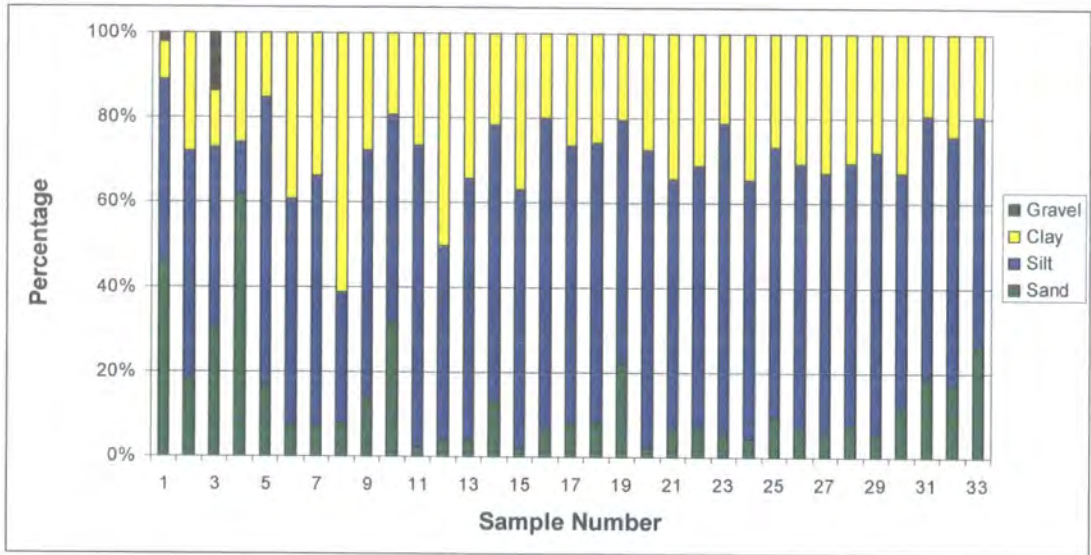

Figure 162 Graph of particle size distributions from mud-brick and soil. The sample numbers relate to Table 21.

The only possible permutations not encountered are:

- Increase in the clay and a decrease in the sand and silt fraction.
- Increase in the silt and a decrease in the sand and clay fraction.

Table 22 also subdivides the results on a number of other criteria (the period of the site, the zone the site is located in, if a depression occurs on the site, the year of collection and the type of site) in an attempt to allow the visual extrapolation of relationships between these criteria and soil changes. There seems to be no correlation between any of the four categories of sample and any of the other site criteria.

The raw Coulter results expressed in Table 22 have been further generalised to display soil texture in Table 23 (see Figure 141 for cross referencing purposes). Unsurprisingly no real correlation is expressed. However, the anomalous Coulter readings, between different seasons, at sites 279 and 339 are displayed in sharp contrast.

Sum of Size			Zone	UnitID	Year	Site Type												
			Floodplain/Alluvial fan	Irrigated Northern Marl	Irrigated Southern Marl	Southern Marl				Thin Southern Marl				Wadi Silts/Thin Marl				
			486	97	271	508	218	221	269	339	478	279	602	238				
			2003	2003	2003	2003	2003	2003	2001	2001	2003	2003	2001	2003				
Period	Depressions	BSS Class	Scatter	Tell	Scatter	Scatter	Low Tell	Scatter	Scatter	Scatter	Scatter	Scatter	Scatter	Scatter				
Islamic?	N	Clay					-7.92							8.69				
		Sand: Coarse												-13.35				
		Sand: Fine					5.17							0.51				
		Sand: Medium												-4.38				
		Silt: Coarse					5.22							3.06				
		Silt: Fine					-3.56							3.83				
		Silt: Medium					1.09							1.74				
	Y	Clay				-3.37				0.36	1.71							
		Sand: Coarse								5.05								
		Sand: Fine				4.98				3.04	3.84							
		Sand: Medium								2.78								
		Silt: Coarse				3.75				-1.69	4.21							
		Silt: Fine				-3.90				-4.19	-6.68							
		Silt: Medium				-1.43				-5.35	-4.18							
Multi-Period	N	Clay		10.24														
		Sand: Fine		3.46														
		Silt: Coarse		-3.60														
		Silt: Fine		0.06														
		Silt: Medium		-10.16														
Pre-historic	N	Clay										-2.52						
		Sand: Fine										0.63						
		Silt: Coarse										2.75						
		Silt: Fine										-1.66						
		Silt: Medium										0.80						
Unknown	N	Clay	0.11			-2.42			8.42				-11.42	-13.51				
		Sand: Coarse							4.21				18.45					
		Sand: Fine	0.28			2.99			-1.58				1.76	6.36				
		Sand: Medium							-1.33				5.15					
		Silt: Coarse	-0.69			-0.42			-5.70				-2.21	7.24				
		Silt: Fine	0.55			-0.86			2.62				-8.88	-4.22				
		Silt: Medium	-0.24			0.70			-6.64				-2.87	4.12				
	Y	Clay							0.15						-4.68			
		Sand: Fine							-5.62						9.07			
		Sand: Medium													0.04			
		Silt: Coarse							-0.45						1.56			
		Silt: Fine							1.94						-3.89			
		Silt: Medium							3.97						-2.01			

Table 22 Pivot table displaying a summary of the average percentage change of soil fractions between off-site and site.

UnitID	Year	Location	loam	sandy loam	silt loam	silty clay loam
97	2003	Off site			1	
		Site				1
218	2003	Off site				1
		Site			1	
221	2003	Off site				1
		Site				1
238	2003	Off site			1	
		Site			1	
259	2001	Off site			1	
		Site	1			
271	2003	Off site				1
		Site				1
279	2001	Off site	1			
		Site		1		
	2003	Off site				1
339	2001	Off site			1	
		Site	1			
	2003	Off site				1
478	2003	Off site				1
		Site				1
496	2003	Off site				1
		Site				1
508	2003	Off site			1	
		Site			1	
602	2001	Off site		1		
		Site	1			

Table 23 Variations in soil texture calculated from the average of the Coulter results for each location.

Scatter sites 238, 478 and 496 did not display a clear correlation between the site boundaries and changes in particle size. Site 496 is a site located in the alluvial floodplain/fan zone where post-depositional mixing of alluvium or alluvial fan deposits may have caused variations in the particle size distribution. This is reinforced by the results where the average percentage change between off and on-site soils is less than 1% for all components. Site 478 is a small prehistoric site where the assumptions about mud-brick construction may not hold. Furthermore this site was extremely difficult to locate using satellite imagery. It is also difficult to accurately define the site extent for site 238, therefore the samples may have been given wrong locations in relation to the site (i.e. off, transition and site). Site 339, gave positive results in the 2001 sample programme but less clear results in the 2003 programme. As yet no convincing reason has been established as to why this site did not produce comparable results during the 2003 sampling programme. However, this is one of the four

sites which contain a depression. In this instance the depression lies effectively in the centre of the site (see Figure 102). Therefore these depressions could very easily skew transect interpretations of particle size distributions by becoming repositories for different particle sizes (an aeolian or water trap or an area of increased colluviation). These are issues which should be addressed in a continuing programme of more refined analyses.

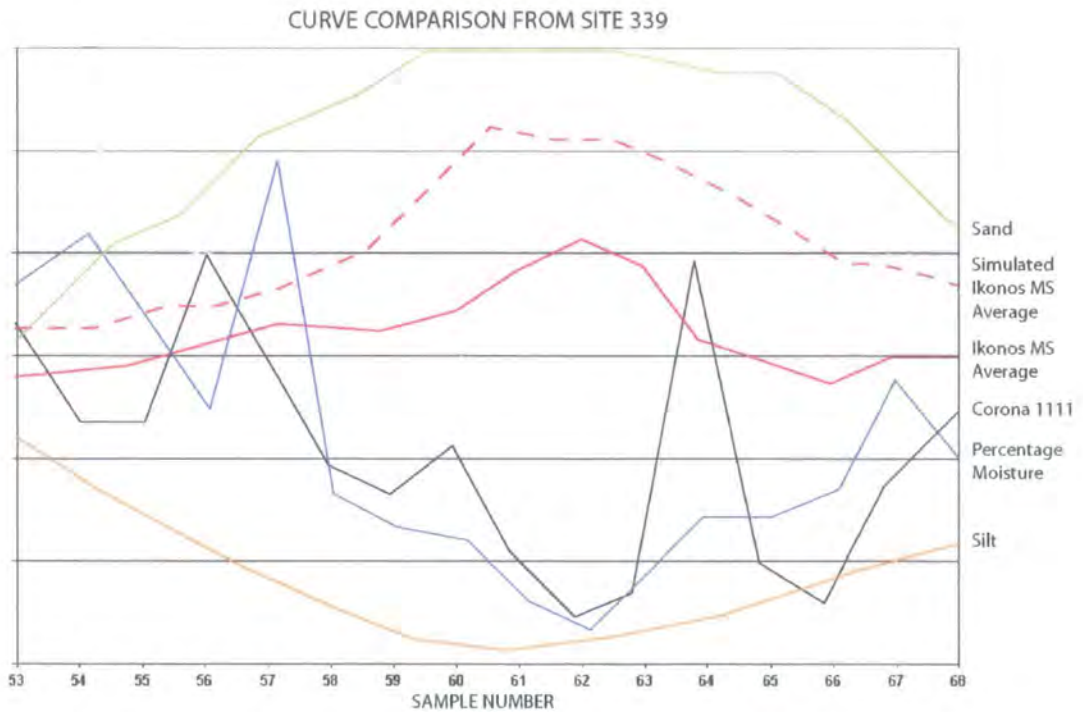

Figure 163 Comparison of curve profiles for a number of attributes for site 339.

Irrespective of the particle size analysis this research has produced a number of empirical observations that require explanation. Archaeological site soils do demonstrate an increase in reflectance in comparison to off site soils. This increase in reflectance is observed in both the satellite sensors and the spectro-radiometry readings. The similarity of the spectral curves (see Figure 157) demonstrate that no new absorption features were introduced, indicating that the soils are chemically similar. Hence, the structure of the soil has changed resulting in an increase in reflectance. This research has demonstrated that whatever changes have occurred will be complex, possibly involving combined changes in particle size, moisture content and organic matter (see Figure 163).

Subsequently, Galiatsatos (in prep) conducted loss on ignition on the 2001 samples to determine the percentage organic content of the soils. Galiatsatos found a slight negative correlation between variations in organic matter and variations in laboratory reflectance (see Figure 164). This decrease in organic matter content associated with sites would theoretically increase reflectance

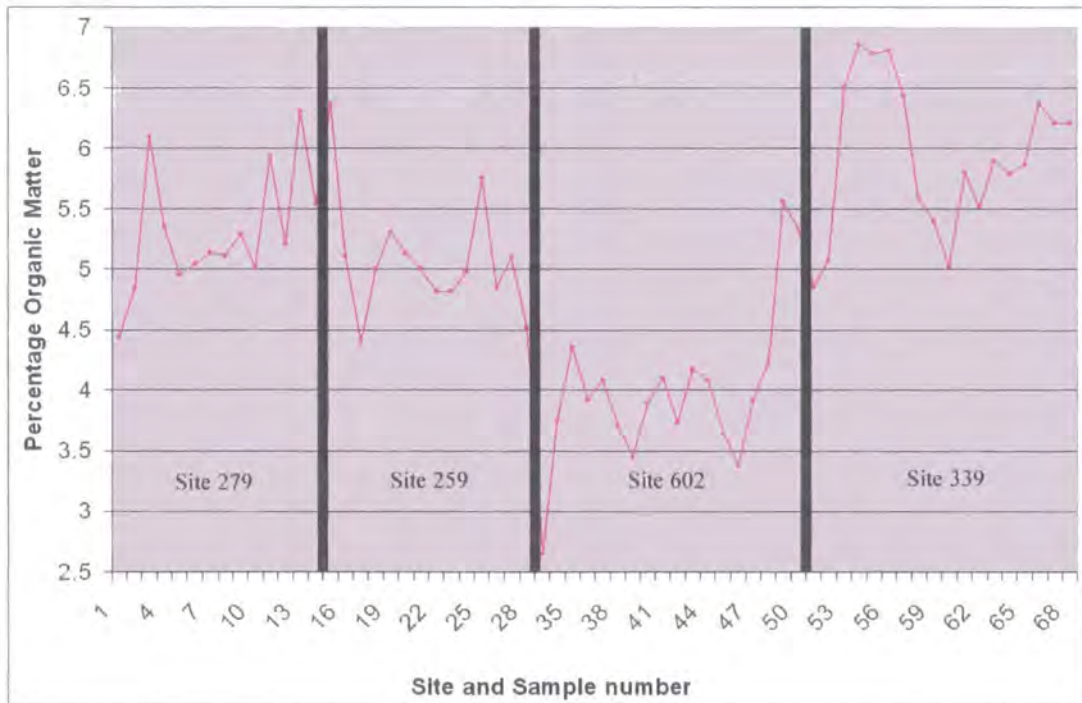

Figure 164 Variations in organic matter content across sites 279, 259, 602 and 339.

8.5 Discussion

The laboratory analysis of the soil samples produced a number of interesting results. Changes in particle size do seem to correlate with areas of increased DN value. However, these changes in particle size are not consistent between different size fractions and do not highlight any correlation with other site attributes except moisture content. Furthermore, there is some ambiguity regarding the accuracy of the Coulter particle size readings. The changes in particle size will be discussed, including their implications for changes to soil structure and drainage.

On a point of methodology, samples should be collected perpendicular to the normal ploughing direction. For example at site 221 (see Figure 200) the imagery displays a diffuse

spread in the NE-SW direction which corresponds with the direction of ploughing. This spread is less intense in the NW-SE direction. Samples taken in a transect perpendicular to the ploughing direction should show a more distinct boundary change.

8.5.1 Non-organic imports

For the purposes of this discussion non-organic imports to an archaeological site fall into two categories on the basis of their size: micro imports (those with a particle size of less than 2mm) and macro imports (those with a particle size greater than 2mm)

Micro imports have been the major focus of this chapter. It has been assumed that degraded building material, particularly mud-brick, and pottery is the major cause for the change in particle sizes between on and off-site soils. However, mud-brick itself has been recognised as a complex medium, and although degraded mud-brick will change the particle size distribution of a soil it does not do so in a predictable way. For example, one cannot say that there is always an increase in the clay component. Therefore the increase in DN value is a product of the different mineralogies, the different particle size and their structure. The ability of clay to aggregate should not be completely discounted in this process. Therefore other factors, related to particle size, which produce a consistent increase in soil reflectance must be sought. It is likely that, associated with the change in the particle size distribution, there is also a change in structure and porosity which has a profound impact on reflectance. This is seen when examining curves B and D in Figure 142; these are chemically and biologically similar soils with a different arrangement of particle sizes. The laboratory analysis undertaken does not give an indication of these important components. The changes in structure and porosity could also indirectly impact on reflectance by changing the nature of drainage. If the soil has a loose structure (as at site 221) then there is improved drainage and an increase in reflectance. However, the spectro-radiometry readings of the ambient and dried samples did not display any moisture variations. In-situ spectro-radiometry readings are under analysis by Galiatsatos (in prep).

Imported material such as stone, brick and tile (even after robbing) may be incorporated into the site matrix. These have a massive grain size in comparison to the local matrix. Material may also be masked by the dumping of other material over them. Field-walking is used to identify clusters of these macroscopic artefacts. However, the sizes of these surface artefacts are massive in comparison to the soil matrix and will affect its texture and porosity.

Subsurface layers and masonry have a large impact on the surface qualities of the soil and soil moisture characteristics. Whatever formation and de-formation processes are associated with the arrival of massive material they do have an impact on site reflectance. This is highlighted on site 279 which has the largest number of artefacts with massive grain size and exhibits a decrease in reflectance. In this context the particle size analysis has ignored massive particles as they were sieved prior to Coulter analysis.

8.5.2 Organic matter imports

Organic matter has frequently been used to define some aspect of an archaeological site, especially the boundaries of occupation (horizontally and vertically), the presence of features, the source of the deposits, or the presence of post-depositional alterations. However, archaeological residue prospection employing surficial organic matter should be approached with care. A salutary lesson on organic matter analysis is discussed by Stein (1992), where Heidenreich and Narratil expected organic matter to rise within site confines. In fact organic matter did not change significantly. Their expectations were based on the assumption that greater amounts of organic matter were deposited within the village boundaries and that, consequently, the level of organic matter within village samples would be higher than those in the surrounding soils. They failed to recognise that decomposition of the organic material by micro-organism activity would re-establish the equilibrium. However, another study conducted by Goffer *et al.* (1983) at the tell site of Beer-Sheba, Israel showed a different response in a more regionally representative environment. Two large pits were discovered that were filled with very dark sediment. The large size and organic-rich content of the pits led the authors to suggest that the pits were used for making compost. The percentages of organic carbon, nitrogen, and phosphorus were determined for samples from the pit fill, the nearby tell, an off-site location and from compost found in an adjacent modern town. The largest percentages of carbon were found in the sample from the modern compost, with decreasing values found in the pit fill, the tell sediment, and the lowest percentages in the off-site soil. Decomposition had resulted in the loss of organic matter in the tell sediments. The percentages of organic matter in the pit fill were elevated above those expected by occupation or pedogenesis alone. However, these pit deposits were not surficial and hence underwent different post-depositional processes.

Aeolian erosion in the application area has led to the removal of the majority of the 'O' horizon. This means that the background soils may have their humic content exposed. This

degraded organic matter, which has a red colour, might provide a good contrast against sites which do not express such colouration. The laboratory analysis of the 2001 samples also indicated that there is a slight negative correlation between site organic content and reflectance. It is recommended that further organic matter analyses are undertaken in the future to confirm these results over a more representative sample.

8.5.3 Reflectance implications of the soil analysis: summary and conclusions

In section 8.3.5 the following reasons were postulated for the increased reflectance observed at sites in the marl zone:

- Low organic matter content.
- Low iron oxide content.
- Relatively finer textured particles or differences in soil structure.
- Improved drainage reducing soil moisture.

The loss on ignition analysis on the 2001 soil samples (Galiatsatos in prep) did show that there was a slight decrease in organic matter content associated with sites. In order to more rigorously verify this further samples should be analysed.

With the possible exception of site 259, trace element analysis of the 2001 samples effectively discounted iron as an important factor. However, this analysis was conducted on iron and not its oxides (as discussed in section 8.4.1.5). In fact the lack of any significant correlation with trace element analysis implies that the site soils still share many chemical characteristics with the background soil and parent material.

Particle size does display a correlation with the boundaries of sites as defined by the satellite imagery. However, it is unclear whether this is a direct result of changes in reflectance due to changes in particle size or a change in reflectance due to some other factor such as structure or porosity (and hence drainage). Further analyses, such as bulk density (Stanjek and Fabbinder 1995; Scudder *et al.* 1996) and in-situ moisture and organic matter readings, would be beneficial to define these causative factors rigorously. Further benefits may be derived if the results are analysed in conjunction with micro and macro scale formation models (see for example Ward and Larcombe 2003).

Even though no specific reason for the increase in reflectance associated with archaeological sites has been explicitly defined, the analysis has empirically identified a number of promising areas for further enquiry:

- Reflectance differences are observed at sites in the visible and NIR wavelengths by all sensors.
- Ground and laboratory radiometry correlates with these sensor readings and with soil moisture differences at key sites.
- Ground and laboratory radiometry relationships with grain size are unclear. However, there is evidence to show positive relationships.
- Reflectance data from soil samples matches with theoretical expectations (i.e. no major absorption features other than Fe^{3+} and Fe^{2+} transitions (see section 8.3.3 and Figure 146)).

This analysis has provided a platform from which to conduct further research to explain the increase in soil reflectance associated with archaeological sites. The relationships between grain size, organic matter, moisture and soil structure on archaeological sites requires further work as there is surprisingly little literature available on this topic. Further, radiometry is an objective way of observing reflectivity in the field and has thus allowed spatial and spectral scale issues to be addressed between a point and a pixel. It is hoped this phase of the research will have significant impact in this and other environmental similar areas.

8.5.4 Recommendations for field collection and analysis

In addition to the collection and analysis of in-situ bulk density, moisture and organic matter readings (discussed above), it is recommended that further grain size analysis is undertaken. Samples can be coarsely analysed in the field by sieving the major fractions (clay, silt, sand and gravel) on site. Furthermore, a handheld radiometer should be used to collect reflectance values of these samples.

CHAPTER 9 SATELLITE IMAGERY AS A CRM TOOL

9.1 Introduction

The previous chapters have been concerned with the prospection and documentation of the archaeological record within the project area. As Syria does not currently have an accessible national archaeological inventory, the SHR data set can be used by the DGAM for the purposes of management and monitoring to ensure long term stability. This is critical as the archaeological resource is under considerable stress as a result of population growth and developments in both industry and agriculture. However, CRM applications do not solely concern themselves with management and preservation; they also cover a range of associated activities including research and aspects of public participation.

All of the data has been integrated into a GIS framework which allows the data sets to be analysed in many complementary ways. Satellite imagery can provide an alternative mechanism for visualising the landscape in a digital environment. It can be used as an alternative basemap or as a different layer for computerised landscape visualisation. Not only are these useful for research purposes, particularly for phenomenological approaches to interpretation; they are also a powerful tool for public engagement in the archaeological resource. For example, 3-dimensional fly-overs are employed in a number of successful museum applications (Forte and Williams 2003). The application of multi-temporal imagery provides valuable insights into how the landscape has changed over time and how these changes have impacted on archaeological residues. When coupled with digital in-field recording devices, satellite imagery provides another layer of information that can improve in-situ interpretations and aid in field navigation.

9.2 Satellite imagery as a contextual backdrop

Air photographs are not maps, but mirrors: they are not selective: they simply show what happens to be visible at the time; they are indiscriminating and should be valued with this in mind.

(Johnson, 1982, 6 in Maxwell)

The context of archaeological residues is an important aspect for their interpretation. However, 'context' can mean a number of different things to a number of different people depending on their analytical goals. For example an environmentally determinist archaeologist may be interested in environmental variables that determine site placement (as discussed in Chapter 6); a CRM archaeologist will also be interested in localised developments that may impact on the archaeological residues, and archaeologists researching settlement dynamics will be interested in the spatial relationships of contemporaneous sites and infrastructure networks. As has been discussed in earlier chapters, satellite images are flexible resources that can be applied to a wide range of spatial problems providing different mechanisms of contextualisation. With this in mind two areas of visualisation are discussed: the comparison of satellite against digital base maps and the use of satellite imagery as a visualisation tool.

9.2.1 The comparison of satellite imagery against digital map bases

Remotely sensed imagery and maps are both representations of the Earth. However, there are profound differences between the two data sources. Maps are generalisations of reality and reflect the mapmaker's selection of what is important to represent (Müller *et al.* 1995). Hence, information of low import is discarded to improve interpretative clarity. Unfortunately this normally includes the majority of non-monumental archaeological residues. Remotely sensed imagery, on the other hand, are an 'objective' data source. The interpretable content of the imagery is subject to different biases relating to the resolution of the sensors and the ambient environmental conditions during collection (Liverman *et al.* 1998). As the spatial resolution of satellite sensors continues to improve they are more regularly being used as alternative sources for updating map bases (Armenakis *et al.* 2003)

As has already been discussed in Chapter 5, the availability of base mapping in the application area was generally poor, although a 1:25,000 topographic map was acquired. Comparisons will be drawn between this mapping and the satellite imagery (primarily the Ikonos). From a European perspective, this may be viewed as a biased comparison in favour of satellite imagery. However, in the Middle East and other areas of the world it is difficult to access high quality topographic and thematic mapping at appropriate scales.

From the 1:25,000 topographic mapping 16 sites were identified from antiquity symbols, 187 potential sites from contours, 33 pen sites (see Hinterland System 1 in Figure 165) and 106

sites from possible place name evidence. An image interpretation key was produced for this process of identification (see Figure 165). As has already been demonstrated in Chapter 7 the satellite imagery allowed the detection of many more residues. From a prospection basis satellite imagery is a much more useful product, providing more accurate interpretation and spatial referencing (particularly in the basalt zone).

Image Interpretation Key

Page 1

BASE MAP INTERPRETATION

Version 1: Anthony Beck, December 2003



Figure 165 Image interpretation key for the Syrian topographic map.

This is further reinforced by the improved contextualisation of archaeological residues from satellite imagery. As is demonstrated in Figure 165 the satellite image provides improved insights into local conditions. For example, the imagery provides information about residue

type, residue extent and vegetation cover. However, experience is required to interpret these indicators.

Satellite imagery was a much improved resource for compiling thematic data. Thematic mapping for the area was only available at inappropriate scales. Therefore, landscape themes were produced directly from the satellite imagery (see Chapter 6). Thematic variables such as soil, vegetation, hydrology, topography and elevation are used to either contextualise the archaeological data or in predictive modelling exercises. Many projects have employed Landsat imagery to classify soil and vegetation themes (Gaffney and Stancic 1991; Gaffney *et al.* 1996; Rothaus and De Morett 1999; Harrower *et al.* 2002). Ikonos and Corona imagery can immediately supply information related to present day and relict topography and hydrology and can be used akin to vertical aerial photography to update digital mapping. Furthermore, the Ikonos and Corona data sets are available as stereo pairs which can be used to create digital elevation models. However, environmental thematic variable production is not just an issue of reproducing maps:

The real issue is that the variables are not usually chosen because of some theoretical model or even based on a hypothesis about the past. Rather, they are most often selected because they are the only data available. This is not good science.

(Maschner 1996).

This quote highlights one of the most fundamental problems facing archaeological thematic data analysis through its use of readily available yet potentially inappropriate data sets. Satellite imagery has uses beyond the accurate collection of information reflected in present day mapping it also has the capacity to model more archaeologically pertinent information. However, very limited research has been conducted into the production of specific landscape archaeological themes. This lack of research is in stark contrast when one compares the research into this area by landscape ecologists (Griffiths *et al.* 2000; Griffiths and Mather 2000; Luque 2000; Wu and Qi 2000). Much of the archaeological research has been focussed on terrain based viewshed analysis (Wheatley 1995; Lake *et al.* 1998). However, Duncan and Beckman's (2000 pp. 41-42) site location model created a theme to represent solar insolation gain on the shortest day of the year using DEM derived variables. This theme was created on

the assumption that, in their application area at least, warmer areas are preferable to colder areas during the colder parts of the year. Gaffney *et al.* (1996) employed Landsat TM to define soil types. However, their criteria only classified agricultural value from poor to good. Ebert (1988) gives an overview of holistic or ecosystemic approaches employing satellite imagery.

Mapping does have some benefits over satellite imagery. Map generalisation allows the presentation of complex spatial entities and relationships in a digestible format. However, as has been demonstrated by many of the illustrations in this thesis these elements can be replicated by satellite imagery derivatives to produce equivalent resources. More importantly, mapping can have more stable spatial accuracy than satellite imagery. Due to the problem of projection encountered with the Syrian mapping in this research this was not the case. However, neighbouring countries (such as Jordan and Lebanon (Seif, pers. comm.)) do have accessible, regularly updated mapping. These resources are particularly useful as a reference source when co-registering satellite imagery. This impact has, however, been reduced by the accuracy of handheld and differential GPS.

Remotely sensed data provide an alternative representation of geographical context to that given by maps. The 'objectivity' of a satellite image in most instances provides an improved archaeological backdrop. Furthermore, satellite imagery may allow the creation of more archaeologically specific thematic data. In the study area the high spatial resolution effectively made the available topographic and thematic mapping redundant. However, given that other projects may not have comparable access to the quality and quantity of high resolution satellite imagery, mapping sources should still be included in any project.

Finally, it is important to identify the fact that neither remotely sensed imagery nor map data provide insights into how landscapes were perceived by the people who inhabited them.

9.2.2 Satellite imagery as a presentation and visualisation tool

The last decade has seen the archaeological community embrace computerised virtual visualisation and reconstruction tools (Gillings *et al.* 1999; Goodrick and Gillings 2000; Forte and Williams 2003). Forte in particular has championed the integration of multiple data sources, including satellite imagery, for landscape analysis, reconstruction and visualisation purposes (Forte 1995; 1999; 2000; 2003b; 2003a; Forte and Kay 2003). Forte (2003a)

employs the term ‘mindscape’ for an immersive computer generated ecosystem that facilitates multi-scalar archaeological cognition, contextualisation and re-interpretation. He also provides a series of protocols for the integration of such data. Although most of this work is beyond the scope of this research it provides a useful template for the presentation and visualisation requirements of satellite imagery within landscape archaeological applications.

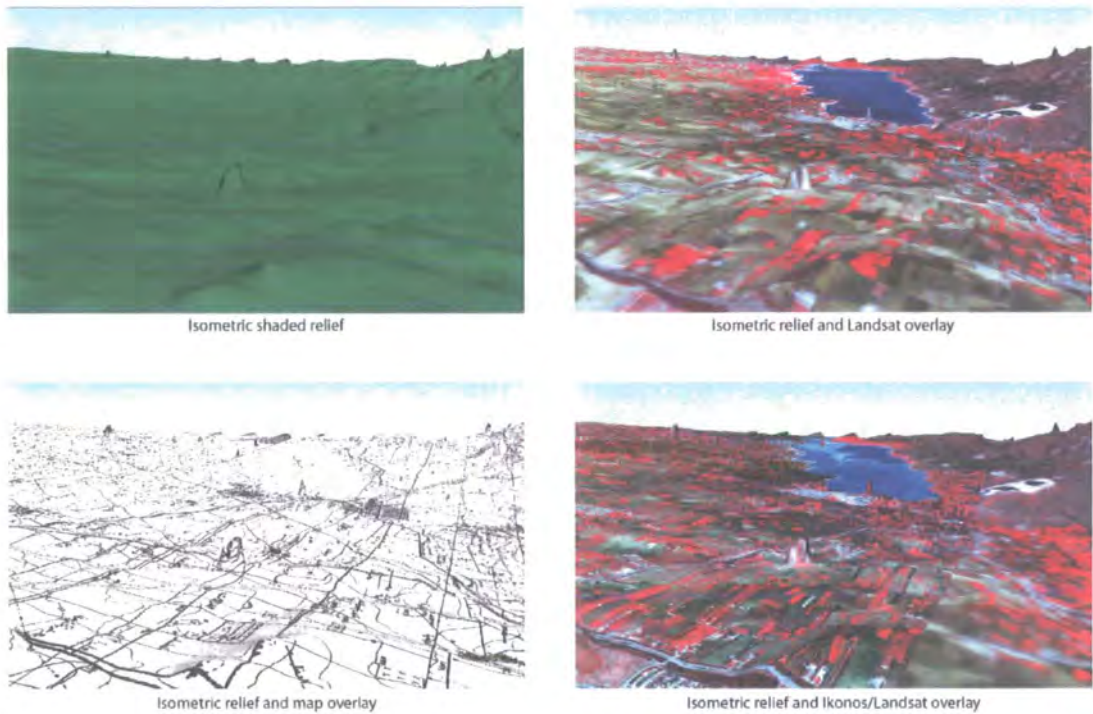
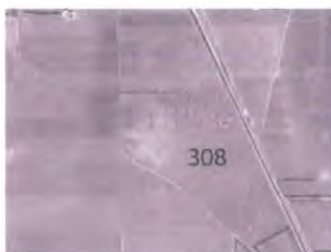

Figure 166 Isometric visualisation (with 15 time exaggeration) of different imagery draped over a terrain model.

At a basic level satellite imagery provides a geo-referenced backdrop for the articulation and visualisation of landscape data. As discussed in section 9.2.1 satellite imagery provides a more ‘objective’ representation of space which is comparatively realistic to the end user. Visualisation is significantly enhanced by ‘draping’ satellite imagery over a terrain model to produce a 2.5 dimensional representation (see Figure 166). The inclusion of higher spatial resolution imagery, extracted derivatives and archaeological data means that a user can visualise a range of information in pseudo 3-d. This facilitates the articulation of a range of landscape data for the researcher and can provide an engaging presentation medium for museums. These static presentations can be further enhanced by producing ‘fly’ or ‘walk-through’ movies or alternatively a fully interactive virtual environment.

From a presentation perspective, the integration of satellite imagery within a GIS facilitates the rapid production of publication quality mapping (see, for example, Figure 54 and Figure 65). The benefit of GIS applications in this instance is that a variety of bespoke maps can be produced whereby the user controls the content and degree of generalisation.

Once again, however, the vast majority of these presentations are prepared in Cartesian space and do not represent how the mental or cognitive maps of the landscape are perceived by actors (Kvamme 1999 p. 182). These actors may have used different, and at times, non-linear representations of space.



Ikonos Pan

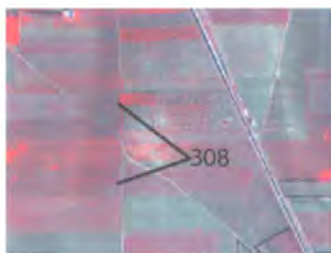

Ikonos MS
showing camera location



Site 308

Figure 167 Problems of site location (Site 308).

9.3 Satellite imagery and mobile applications

The benefits of field-based GIS for spatial sciences are outlined by Pundt and Brinkkotter-Runde (2000). The future for field archaeology will inevitably see increased usage of computerised techniques. Global Positioning Systems (GPS) and total stations are supplanting traditional approaches in many applications (particularly landscape survey) and cheap handheld Personal Digital Assistants (PDAs) are already used to record 'digital' context sheets in a relational database (Ryan *et al.* 1998; Beck and Beck 2001; Beck 2002).

There are many layers of data which an archaeologist can access while using mobile computer applications. Amongst other things satellite imagery will be of value for site navigation and field interpretation applications.

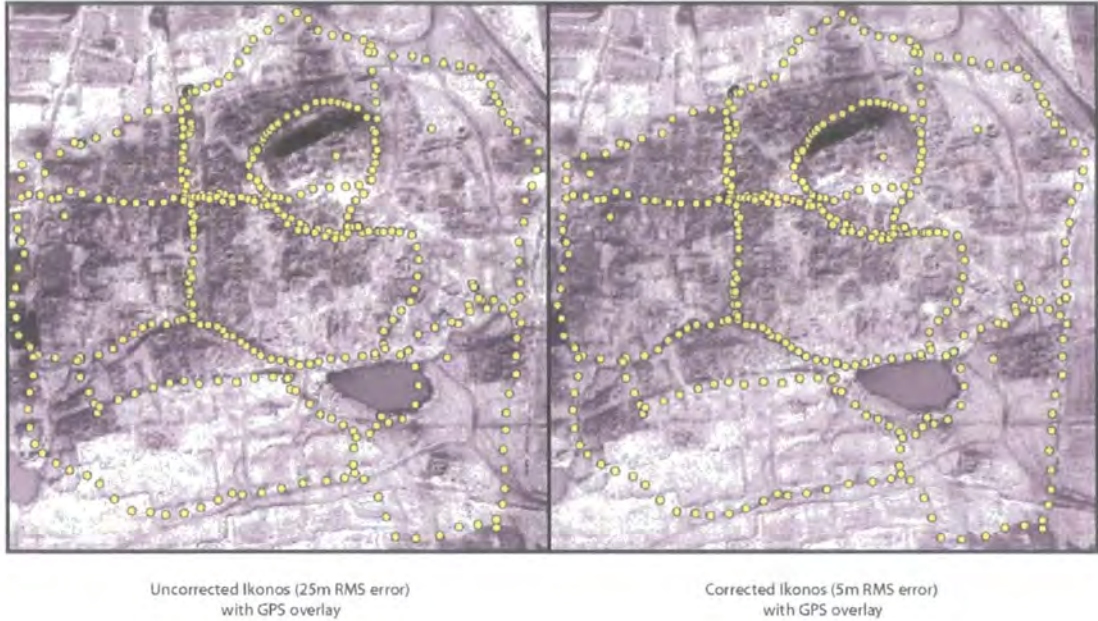

Figure 168 Comparison of corrected and uncorrected Ikonos imagery with GPS overlay

9.3.1 Site navigation

The 1999 to 2000 fieldwork seasons highlighted how difficult it was to locate sites even after they had been identified on the satellite imagery. Figure 167 shows the physical colour difference that led to the identification of site 308. However, the inset photograph indicates the difficulty in actually locating this scatter on the ground. After correction of the satellite imagery to the UTM 37N projection system (see discussion in section 5.4) it was possible to use GPS to locate the sites. This simple procedure saved a considerable amount of time as locating sites from out of date maps or imagery in a non-standard projection was very time consuming. This underlines the importance of selecting an appropriate projection. Furthermore, incorporating the Ikonos and Corona satellite images into ArcPAD (in MrSID file format) allowed the use of this significant data resource in the field to aid interpretation. This is particularly important for the field systems in the basalt landscape (see Figure 168).

9.3.2 Spatial data collection

From analysis of the satellite imagery it was possible to map the extent of sites within the project GIS (see Chapter 7). However, in order to ensure that what was seen in the imagery was comparable to what was observed on the ground the survey teams also mapped the extent of surface scatters/soil discolourations in the field. Each 'site' was mapped as a simple polygon within ArcPAD by walking around the extent of the archaeological residues and logging GPS readings directly. Upon completion of a circuit the polygon was closed and its unique GIS identifier was added.

The techniques used for site navigation and mapping proved essential for the recording of the basalt field systems. Using the derived vector interpretations of the archaeological residues (as discussed in Chapter 7) in ArcPAD the survey team can accurately navigate to each individual wall segment. However, the survey team was faced with a recording paradox. Figure 168 shows an uncorrected and corrected Ikonos satellite image overlaid by GPS points. These GPS points were taken by handheld GPS without reference to an ArcPAD image backdrop. The corrected image (on the right) demonstrates that basalt walls have a high correlation with many of the GPS tracks collected. However, the imagery contains more information than was recorded by GPS alone. On the ground some features may appear ephemeral or insignificant but when viewed on the satellite imagery a whole wealth of information can be revealed. Hence, a more rounded interpretation can be produced in the field by exploiting the synergy of field observations with supporting vertical imagery and other GIS data.

9.4 Time change analysis

Change detection is a technique used to extract and analyse differences in imagery acquired at different times. These differences can be a result of anthropogenic modifications (for example, new construction and de-forestation) or natural/environmental changes (for example variation in crop vigour). Analysis of image change involves a relatively simple group of procedures. The challenge is to develop techniques that highlight change in the phenomena of interest. For example an urban planner, who is interested in monitoring urban sprawl, would find changes related to crop health a distraction.

Change detection techniques can be broken down into the following areas:

- Visual comparison: when change is obvious, visual comparison can be the simplest technique. No processing is required beyond image rectification.
- Layer stacking: changes in co-registered imagery can be highlighted by assigning the different imagery to different colour guns (red, green and blue). Changes in reflectance values are observed as colour variations.
- Image algebra: Changes can be quantified by the mathematical manipulation of two images using, for example, subtraction, regression and ratioing.
- Post-classification comparison: Independently classified images from different dates are compared. This is the only method in which 'from' and 'to' classes can be evaluated (forest zone to urban zone).

9.4.1 Data preparation

Image selection and preparation are important for successful change detection analysis. If comparing imagery from different sensors it is important that the spatial, radiometric and spectral resolutions are actually comparable (Song *et al.* 2000; Furby and Campbell 2001).

9.4.1.1 Atmospheric effects

Consideration should also be given to ambient atmospheric effects which can produce erroneous artefacts for time change analysis. Haze, smoke and clouds can produce undesired areas of change. Clouds should be masked out of any analysis. Haze and smoke can be more difficult to mitigate. Both atmospheric correction and histogram matching techniques can be used to improve analysis. However, Song *et al.* (2000) discuss a variety of temporal analysis techniques which do not require atmospheric calibration.

9.4.1.2 Seasonal effects

Vegetation differences are the over-riding cause for most change in imagery over time. Unless one wants to detect seasonal changes then it is advisable to minimise their impact by selecting imagery that has been collected at approximately the same month and day. Hence, seasonal effects and Sun angle differences can be assumed to be constant.

9.4.1.3 Soil moisture

Moisture content affects the reflectance values of both soil and vegetation. Hence, change detection techniques can highlight reflectance changes due solely to differences in moisture content. Although this may have some useful applications for agronomists it can mask other

more subtle effects. It is therefore not advisable to employ imagery that has been taken after heavy rainfall. Historical climatological data, if available, can be used to determine the effects of rainfall.

9.4.1.4 Image preparation

The amount of image preparation to ameliorate for atmospheric, Sun-angle, vegetation and moisture effects are dependent on the type of analysis to be performed. Visual comparison was deemed the most appropriate analytical method for the high spatial resolution Ikonos and Corona imagery for the following reasons:

- Sub-pixel co-registration could not be guaranteed.
- The imagery is taken at different times of the year, predominantly highlighting vegetation changes.
- Concurrent atmospheric information is not available for the Corona imagery.
- The radiometric depth between the Corona and Ikonos imagery was different.

As the Landsat imagery was only used for providing information on the effects of changes in land management over time this was also analysed visually. This meant that no specific preparation techniques were used prior to conducting the analysis.

9.4.2 Impact of changes over time

The temporal component of the imagery was of profound significance in relation to residue detection. There is approximately 30 years difference between the Corona and Ikonos data sets. In the intervening periods the landscape has been significantly modified, directly and indirectly impacting on the archaeological residues.

Bulldozing is the most significant modification in the basalt zone, so much so that the DGAM is preserving a 2x2 km area. Bulldozing has also impacted on the marl landscape, although to a lesser extent. The residues in this zone are also harder to eradicate completely as they are fine grained deposits. Site 97 demonstrates that bulldozing (or some other heavy earth moving equipment) was in use prior to 1970 (see Figure 176). Consequently, bulldozing cannot be discounted as a residue modifier in the Corona imagery. Other infrastructure modifications have also occurred. The road network has been extensively upgraded (a north-south dual carriageway, ring road around Homs and surface metalling for b-roads). An

underground water pipe has been laid between the spring at 'Ain at-Tannur and Homs cutting across the southern marl. The rail network has also been extended.

These changes to infrastructure have also had an impact on settlement locations and land management practices. Settlement expansion in particular is closely linked to high quality infrastructure networks such as roads (cf Sever 1998). However, urban expansion itself has not heavily impacted on residues. Although, a number of sites are enclosed within military areas and the cutting of trenches into tells has compromised their archaeological integrity.

In this time frame agricultural practices have changed. Deeper ploughing techniques have been introduced to the area. In the marl zone the Ikonos imagery contains many more high reflectance areas (potential archaeological residues) than the Corona. It is likely that this is either underlying marl being brought to the surface by the plough or possibly increased erosion due to the aridity of the past decade. A number of these areas were examined in the 2003 season: no obvious archaeological residues were encountered. Higher quality agricultural soil has been moved and re-deposited in the landscape. This has been reported from both tell sites and lacustrine deposits (Bshesh, pers. comm.).

Irrigation has extended across all the zones allowing an increased number of crop rotations in a year. The increased amount of surface vegetation could potentially mask many archaeological sites if the time of image collection is not chosen carefully. A combination of these factors probably accounts for the eradication of subtle features such as some wadi channels (see section 6.3).

The Landsat imagery (see Figure 169) highlights the effects of irrigation over a thirteen year period. As late as the 1980s the majority of the application area was reliant on rain-fed agriculture with one cropping season (except in the fluvial margins). However, irrigation and other pumping has meant that more crop rotations can occur in a single season. This has had a significant impact on the local water table. 25 years ago the water table was c. 2 – 5 metres below the surface, but now some pumps have depths of between 20 and 40 metres (Bshesh, pers. comm.).

The ramifications of this pumping are seen in the extent of Lake Qatīna which has shrunk dramatically (see Figure 64 and Figure 169). A study of ground water use (Rodriguez *et al.* 1999) has been undertaken by the International Centre for Agricultural Research in the Dry

Areas at Atareb, northwest Syria. A 15 year study of the water-table at Tel Hadya determined that the water table was shrinking by, on average, 1.44 m per year (see Figure 170).

Landsat 4,3,2 FCC 1st October 1987



Landsat 4,3,2 FCC 28th October 2000

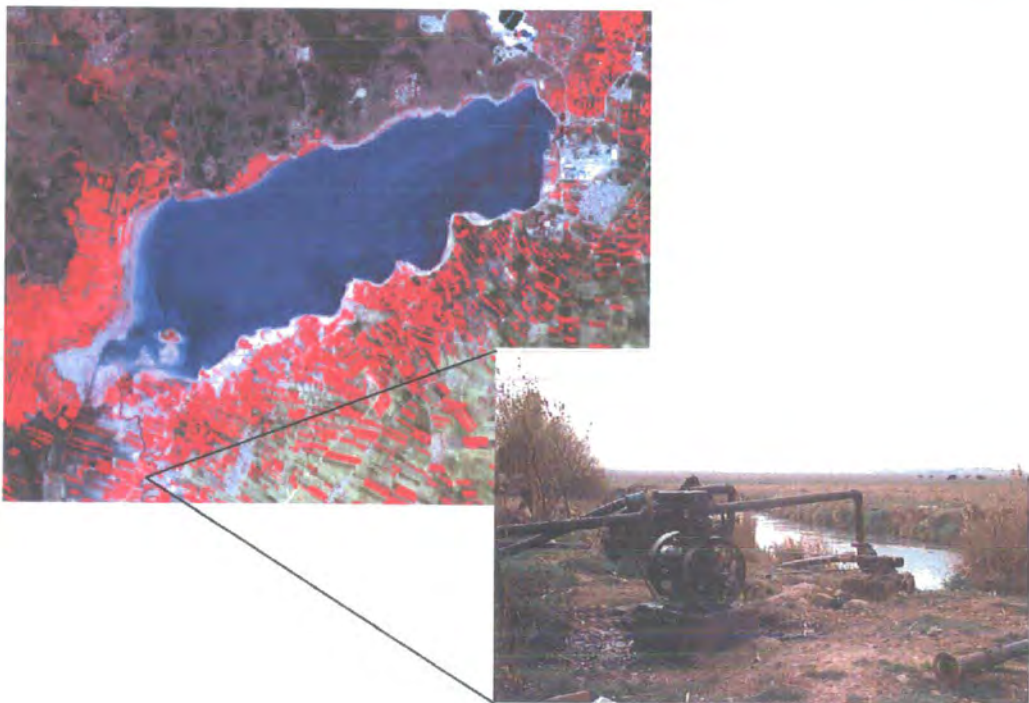

Figure 169 Comparison of October Landsat scenes from 1987 and 2000. Note the increase in vegetation in the 2000 scene (denoted by the red colouration) and shrinkage of Lake Qatina due to irrigation.

This could explain why reflectance has increased between 1987 and 2000 in the Landsat imagery in the southern marl zone. As the water table has dropped there is less soil moisture and hence reflectance is increased. Furthermore, the culmination of the effects of the different landscape modifiers has effectively eradicated some features from the imagery. As discussed in Chapters 6 and 7 some natural and cultural features, particularly wadis, appeared on the Corona imagery but not on the Ikonos.

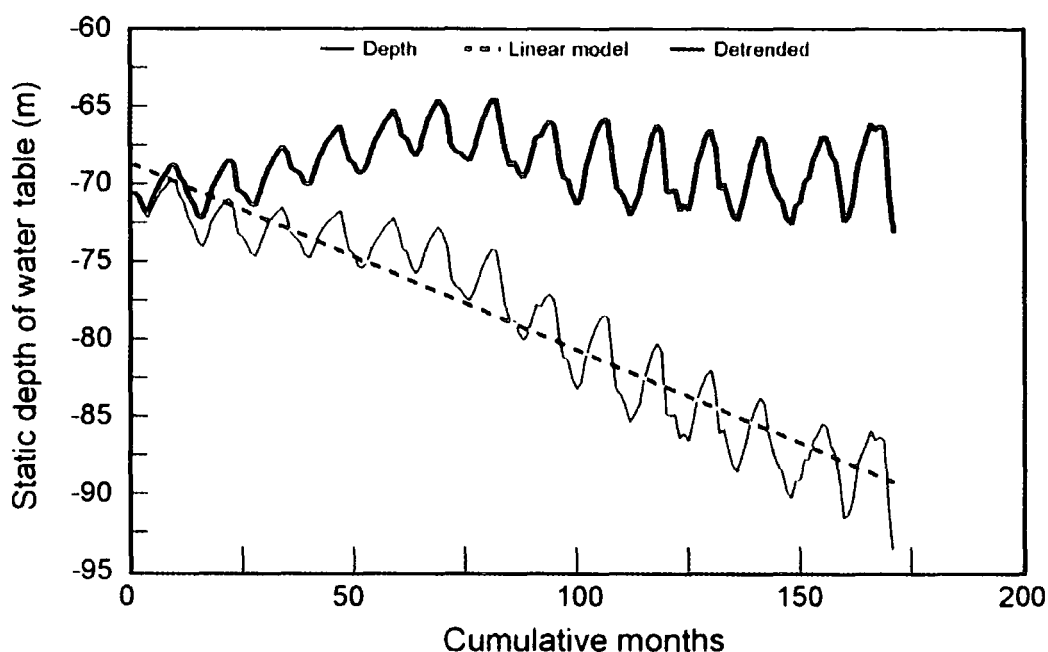

Figure 170 Depths of the water table in Tel Hadya (1983 – 1997)
(Rodriguez *et al.* 1999 p. 9)

Although some landscape features have disappeared on the Ikonos imagery underlying artefacts can sometimes be inferred. For example, Figure 171 displays a Corona image with an indistinct geological feature which, from its morphology, looks hydrological. The comparable Ikonos image shows that modern house construction respects the geological feature (which is now not visible) rather than the NE-SW road which appears in both images.

In summary changes in landscape management techniques have had a profound impact on this landscape in the past 30 years. Improvements in infrastructure and urban expansion have impacted on a small number of archaeological residues. Of greater concern, however, are the changes in agricultural practices and bulldozing. Extensive irrigation has helped to lower the water table which has significantly altered reflectance characteristics in the marl zone. Deeper

ploughing has eradicated or partially destroyed some features and produced many more negative but 'potential' features (see Figure 177). Finally bulldozing in the basalt zone has reached such a level that the DGAM has had to protect a portion of the landscape.

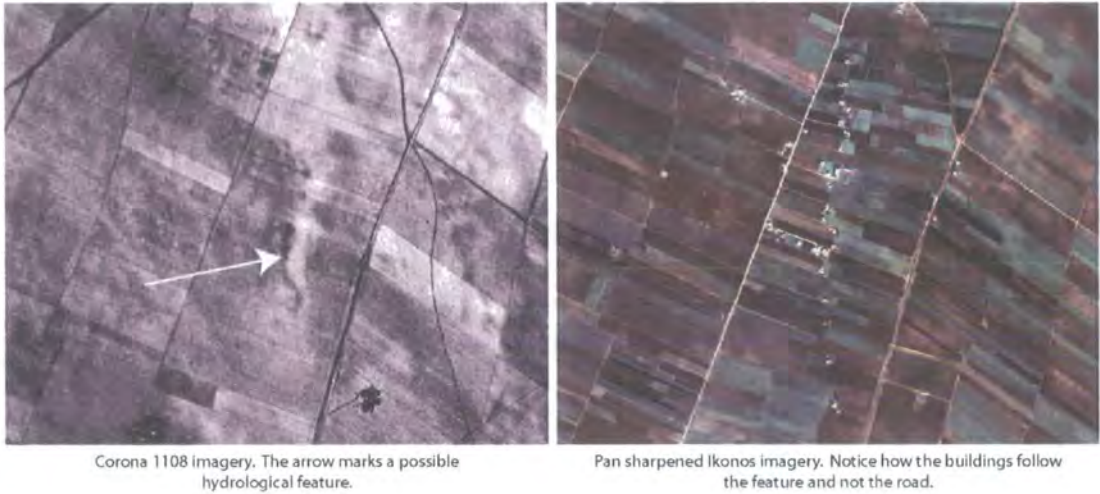

Figure 171 Urban expansion in the marl zone.

At a more refined level, images can be studied on a seasonal basis to evaluate changes in landscape pattern. From a detection perspective, this allows the evaluation of archaeological residue visibility under different environmental regimes. As part of the purchasing arrangement for the Ikonos imagery it was attempted to get repeat coverage of a small area of known archaeological residues at monthly interval. Amongst other things this study would allow one to explicitly define the environmental conditions for optimal residue detection using empirical, rather than theoretical, reasoning. However, the cost implications for such a study were prohibitive. It is hoped that closer academic relationships will be forged with the current and future providers of high resolution commercial imagery to facilitate such studies.

The three different Corona missions were originally collected over a six month period (December 1969 – June 1970) and intersected pre-harvest, harvest and post-harvest (see Figure 172 and Figure 173). Mission 1108 was taken prior to the heavy rainfall (Lake Qatina is not full). Although some rain has occurred there is still a good contrast between sites and soil across the landscape. Mission 1110 was taken just prior to harvest. The vegetation means that with the exception of tells many sites are masked (particularly those near the Orontes and Lake Qatina). This mission had the lowest image quality, probably due to atmospheric

dust (see Figure 173). Mission 1111 was taken after the harvest. Although some patches of vegetation can still be identified, there is a good contrast between sites and soil across the landscape. It should be noted that the atmospheric problem that probably affected the Mission 1110 imagery is not exhibited in the 1111 imagery. Mission 1111 was collected at c. 18:30: at this time the wind driven through the Homs-Tripoli gap has generally subsided.

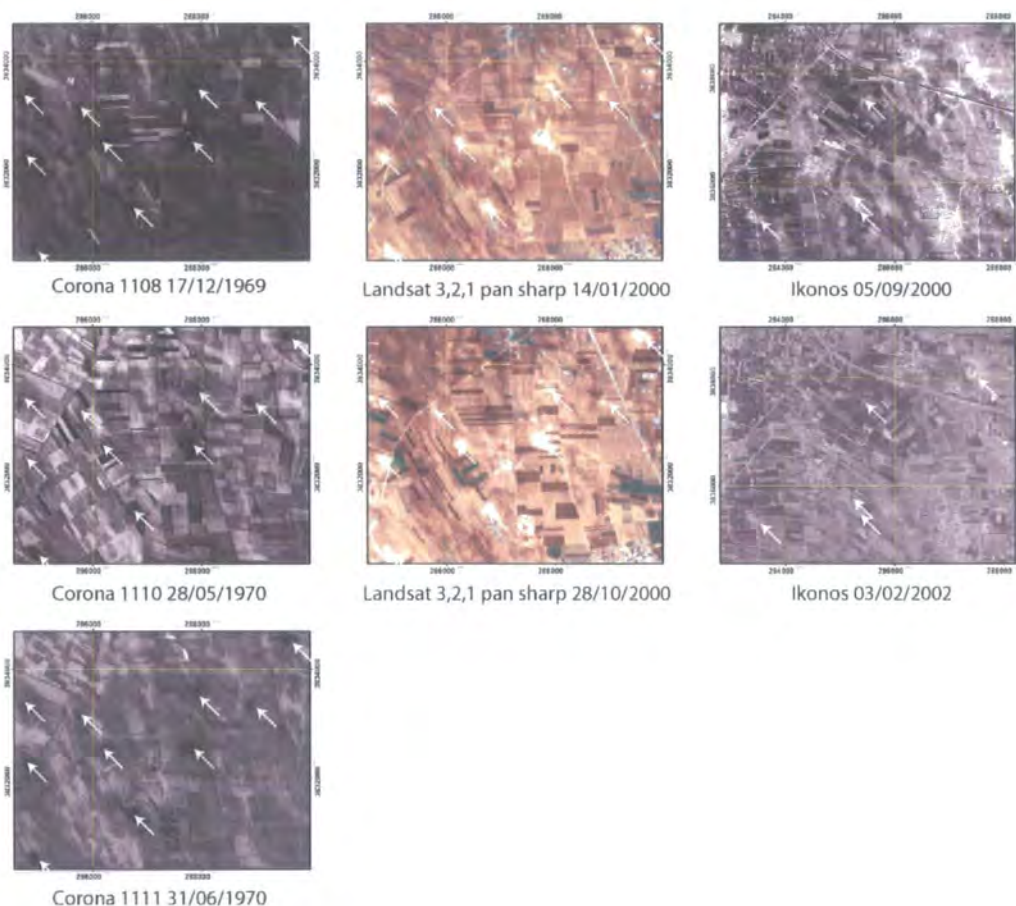

Figure 172 Seasonal effects on the satellite imagery.

Two Landsat images were collected on 14th January 2000 and 28th October 2000 (the 1987 images had approximately the same time difference but can not be pan-sharpened; see Figure 172). The January image was taken during heavy rainfall and with immature vegetation. Sites are still quite obvious in this landscape, although the full range can not be detected due to the spatial resolution of the sensor. Comparatively, the October scene exhibits a much brighter residue response resulting in improved detection. This demonstrates that increased aridity increases the visibility of archaeological residues.

Two Ikonos images were collected on 5th September 1999 and 3rd February 2002. Much like the October Landsat image, the residues in the September Ikonos appear much brighter. However, the spatial resolution has been somewhat degraded due to atmospheric dust. In the wet February image, all of the residues are still visible although contrast between site and soil has been reduced. This is paralleled by the results of soil colours from on and off site soil samples when wet and dry. However, rain has removed atmospheric dust and the image is comparatively sharp.



Figure 173 Comparison of Corona missions of the same areas in the basalt and marl zones. Note the much better relative image quality of the winter scene.

Hence, seasonal environmental conditions have a significant effect on the ability to detect archaeological residues. Periods of intense vegetation should be avoided as sites are masked, whereas increased aridity increases the relative reflectance. Even during the periods of heavy rain residues can still be detected, although their contrast with the background soil is likely to be reduced. The results of this study compare quite closely with the theoretically defined acquisition time variables defined in section 5.2.4.

9.4.3 Site monitoring

In order to evaluate if seasonality or changes in landscape management impacted on archaeological residues, site extents from different satellite imagery were mapped and compared. An area in the marl zone was chosen as this zone is subject to a wider range of landscape modifications. Figure 175 displays these different extents in the Corona missions and the Ikonos MS. The results of this comparison are not conclusive. Some of the sites show quite subtle changes (sites 251, 339, 475) which could be due to geo-referencing errors. Sites 319 and 477 show quite different extents and it is difficult to explain the cause for this change. Other sites, such as 221, do exhibit much larger extents in the Ikonos imagery probably due to the spread of surface material during ploughing or bulldozing.

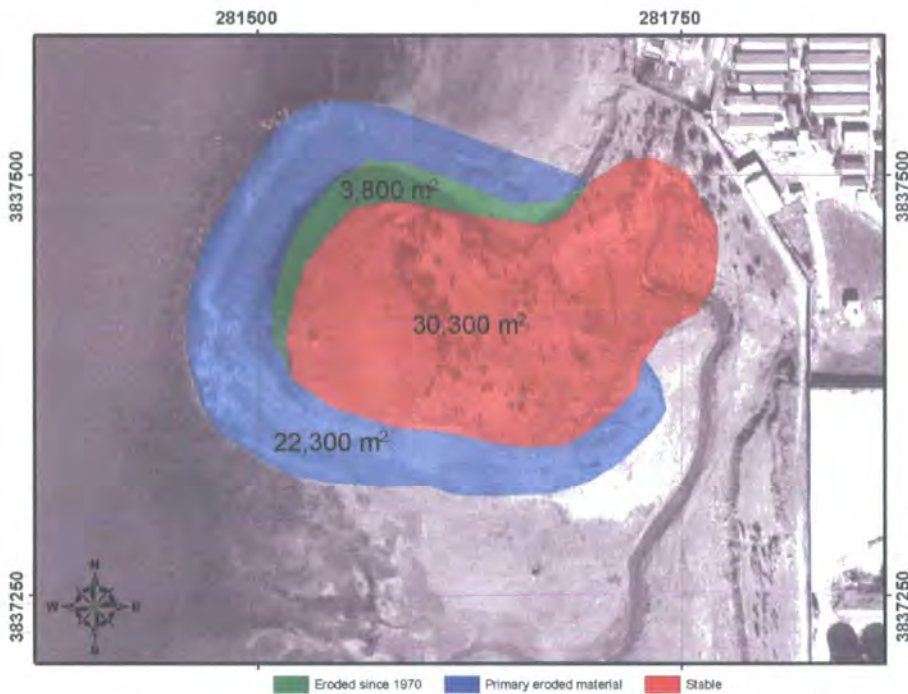

Figure 174 Monitoring of tell (site 173) on the lake edge.

However, it was possible to record other more specific impacts on archaeological residues. In addition to the destruction of the basalt landscape by bulldozing (as discussed in section 7.4) sites at the lake margins are subject to the longer term destructive effects of water. Figure 174 displays the extent of tell erosion between 1970 and 2002 taken directly from the Corona and Ikonos satellite imagery. In the intervening timeframe 3,800m² (approximately 10%) of the stable tell platform has been eroded.

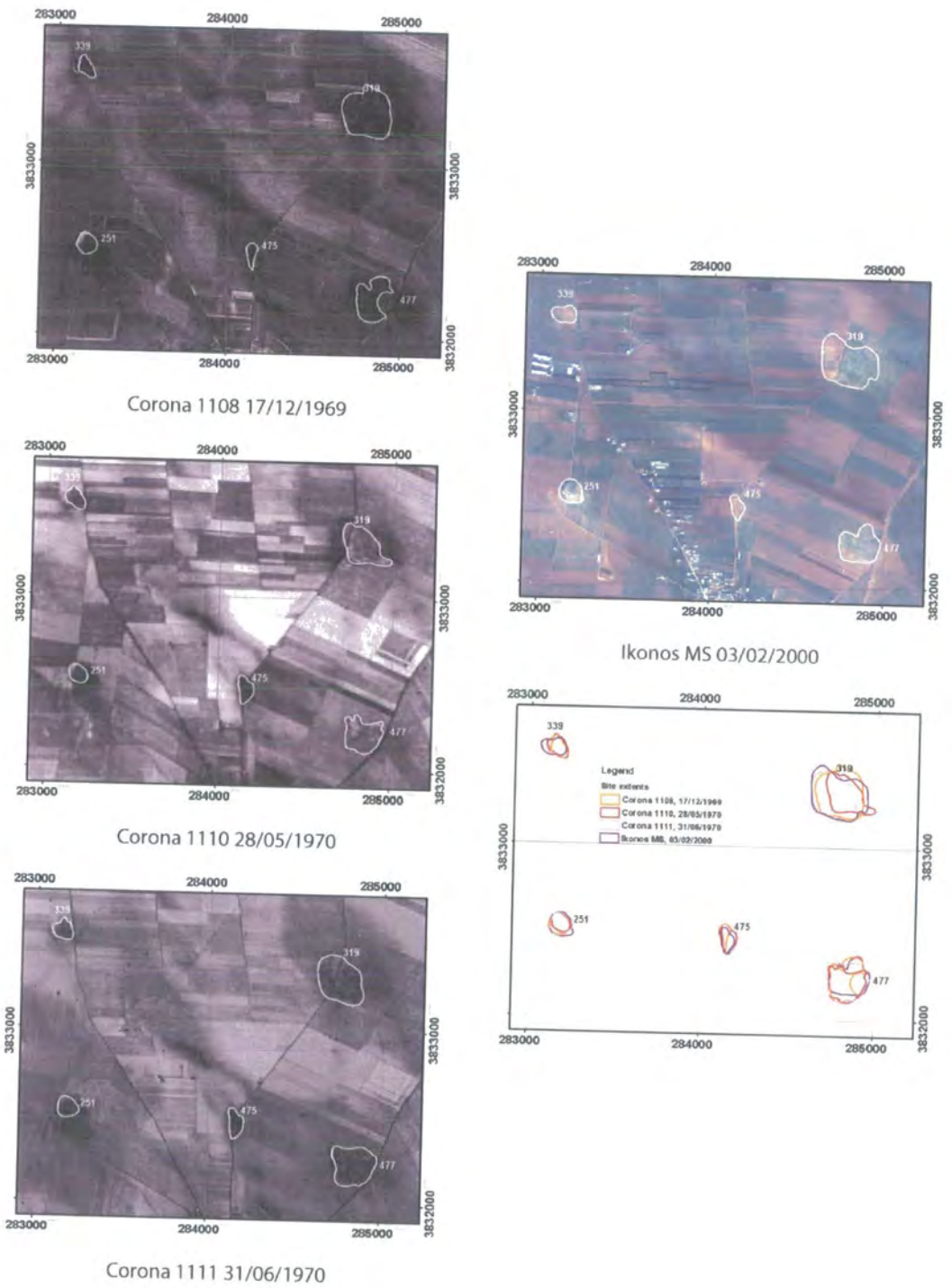

Figure 175 Comparison of site extents over time for sites 251, 319, 339, 471 and 477.

Hence, multi-temporal imagery can be used to monitor archaeological sites. However, ground observation data is required to provide a context for any interpretation. From a monitoring perspective it may be financially untenable to buy imagery regularly. However, an increasing amount of archive imagery is made available at discount or at nominal cost.

Many archaeological sites have been subject to unforeseen catastrophic disasters. In recent years floods, earthquakes and military action have destroyed a number of world class sites. Although the application of satellite imagery cannot stop such disasters from occurring it can help to rapidly evaluate their impact. High resolution commercial sensors can easily collect imagery in these potentially dangerous areas. This would be a significant resource in any mitigation scheme.

Satellite imagery may also aid in the curation of world heritage sites. At present the spatial component of the world heritage site database is not complete and many developing countries find it difficult to provide appropriate spatial data (Stott, pers. comm.). This could be ameliorated by including medium to high spatial resolution data (such as Landsat ETM+) with every regional application. It is, however, understood that satellite imagery will not resolve such issues in its own right and some degree of supportive capacity building is also required.

Although not observed in this environment a particularly novel time change application was employed by Palumbo and Powlesland (1996 pp. 126-127) at Pueblo Buenito and Chentro Kedi. By integrating aerial and satellite imagery from over a thirty year period they were able demonstrate how the management infrastructure (footpaths, roads, car-parks etc.) had changed and developed and how this knowledge would be useful in the future management of the archaeological parks. However, it does strike a cautionary note: in some instances these management strategies had had a significant negative impact on the archaeological resource (Powlesland, pers. comm.).

9.5 Discussion

Satellite imagery can play an important role within CRM activities. This role is increased in areas where mapping is poor and the curatorial authorities do not have a full inventory of their archaeological resource. From an inventory basis satellite imagery has already demonstrated its utility and, in this application area, is a more useful medium than

topographic mapping. Furthermore, satellite imagery can be a very flexible resource in the presentation of data to both academic peers and the public. Although it can be argued that aerial photographs provide imagery with a higher level of interpretable content, satellite imagery provides a much larger synoptic footprint (Schmidt 2004). Satellite imagery are, therefore, much more appropriate for landscape survey and archaeological inventory applications. Furthermore, from a cost-benefit perspective it is cheaper to incorporate satellite imagery at an early stage rather than relying on long term coverage from aerial photography. This is even more important where GIS management techniques are used, as rectification of small footprint vertical and oblique photographs can be time consuming and expensive.

From a practical viewpoint the incorporation of satellite imagery within digital mobile applications provides a number of benefits. Although quite simplistic, the ability to navigate directly to potential residues saves significant amounts of time. Of more import is the use of the imagery in the field as an interpretative tool. The different perspective offered by vertical imagery can improve the detection and interpretation of features that look ephemeral on the ground.

Time change analysis provided some valuable insights into how the landscape has changed since 1969. This analysis highlights the important utility of historical satellite imagery in any study such as this. The Corona imagery provides a snapshot of a landscape prior to significant urban and rural modification. Furthermore, many of the most archaeologically destructive heavy machinery (i.e. bulldozers and tractors with deep ploughs) were not in common use. The imagery was unable to provide any significant monitoring information for sites in an agricultural setting (see Figure 175). However, it was possible to monitor the destruction of sites on the lake edge and those subject to large scale destructive modification through bulldozing or infrastructure expansion.

SECTION 3 SUMMARY, RECOMMENDATIONS AND CONCLUSIONS

CHAPTER 10 DISCUSSION OF THE RESULTS

Chapters 6-9 have described a number of different techniques for preparing satellite imagery and extracting archaeologically pertinent information. This information has been particularly beneficial for the goals of the SHR project. Prior to the incorporation of the satellite imagery the Desk Based Assessment revealed that, with the exception of tell sites, little was known about the range and location of archaeological residues in the environmental zones and, for that matter, about variations within the environmental zones themselves. What follows in this chapter is a summary of the salient points of the interpretation process across all environmental zones. The main focus is on archaeological prospection.

10.1 Archaeological prospection summary

In comparison to traditional ground survey aerial photography can be a very economical way of getting an initial overall perspective of objects, phenomenon and their spatial relationships; furthermore, as a reconnaissance tool, it can prove to be highly cost-effective efficient way of exploring a large area for discovery purposes.

(Ebert and Lyons 1983 p. 1246)

The use of satellite imagery for archaeological prospection has been the main thrust of this research. In general, the application of Corona and Ikonos satellite imagery to archaeological prospection in the application area has been an unqualified success. The techniques employed have a high correlation with archaeological residues observed during surface survey and have the benefit of being rapid, spatially accurate and cost-effective. Furthermore, they allow the prospection phase to occur as part of the Desk Based Assessment, which not only reduces costs but enables the contextualisation of the resources with other geographical data sets, enhancing the research framework at an early stage. Within this context the re-rectification of the satellite imagery using GPS derived GCPs is of particular significance. This allows each of the spatial datasets to be overlaid with a higher degree of spatial precision.

High resolution satellite imagery has enhanced the understanding of the archaeological resource within the application area. Prior to the analysis of the imagery only 63 sites were known (i.e. place name (tell, khirbet) or antiquity symbol). After the analysis a total of 189 archaeological sites have been positively identified on the ground (tells, scatters and structures) and 271 potential sites have been located but not visited (see Table 24). It should also be noted that this does not include the 133 km² of field systems have been mapped in the basalt zone. This significant amount of work has only been one facet of the SHR project over the previous 5 years.

Unit Type	Count
Field System	3
Indeterminate	271
Installation	4
Non-site	60
Scatter	91
Structures	66
Tell	32
TOTAL	527

Table 24 Summary of sites in the whole application area.

UnitType		Evidence										Grand Total		
UnitID	Count	Corona 1108		Corona 1110		Corona 1111		Ikonos MS		Ikonos Pan			Lyrian 1:25,000	
		Soil Colour	Soil Colour	Soil Colour	Soil Colour	Soil Colour	Soil Colour	Antiquity	Contour	Khirbet	Place Name		Quarry	
130			1				1				1			3
132							1				1			1
133							1				1			1
135							1				1			1
170	1						1				1			2
171							1				1			1
198							1				1			1
199							1				1			1
200							1				1			1
201							1				1			1
202							1				1			1
203							1				1			1
205							1				1			1
219								1			1			3
225							1				1			2
244	1			1							1			3
258											1			1
260											1			1
261											1			1
263							1							1
277	1			1							1			3
278	1						1				1			3
281												1		1
322											1			1
326			1					1						2
327			1					1						2
329	1			1				1						3
350			1											1
355			1		1			1						3
364	1		1		1			1						5
408			1							1				2
483			1		1							1		3
950				1				1						2
951				1				1						2
952				1										1
954	1			1				1						3
955	1			1										3
Grand Total		8	8	11	12	1	1	19	6	1	1			68

Table 25 Summary of evidence for indeterminate (potential) sites in the southern marl.

UnitType	Non-site
----------	----------

Count	Evidence source		Evidence				Syrian 1:25,000		Grand Total
	Corona 1108	Corona 1110	Corona 1111	Ikonos MS	Ikonos Pan	Contour	Khirbet		
UnitID	Soil Colour	Soil Colour	Soil Colour	Soil Colour	Soil Colour				
174						1		1	
185	1					1		2	
208	1				1			2	
215						1		1	
226						1		1	
227						1		1	
228						1		1	
230						1		1	
231						1		1	
232						1		1	
233						1		1	
234						1		1	
235						1		1	
236						1		1	
239							1	1	
241							1	1	
242						1		1	
245						1		1	
247						1		1	
248							1	1	
316						1		1	
330	1		1	1				3	
331		1						1	
335		1						1	
341		1		1				2	
342		1						1	
343		1						1	
346			1					1	
348	1		1					2	
349		1						1	
352		1						1	
353		1	1					2	
354		1						1	
Grand Total	4	9	4	2	1	17	3	40	

Table 26 Summary of evidence for non-sites in the southern marl.

UnitType	Tell
----------	------

Count	Evidence source		Evidence				Syrian 1:25,000			Grand Total
	Corona 1108	Corona 1110	Corona 1111	Ikonos MS	Ikonos Pan	Antiquity	Contour	Khirbet	Tell	
UnitID	Soil Colour	Soil Colour	Soil Colour	Soil Colour	Soil Colour					
14	1	1	1	1	1		1		1	7
173	1	1	1	1	1		1		1	7
179	1	1	1						1	4
191	1	1	1	1	1		1		1	7
206	1		1	1	1		1		1	6
207	1		1	1	1		1		1	6
210	1	1	1	1	1		1		1	7
212	1	1	1	1	1		1		1	7
216	1	1	1				1		1	5
218		1		1			1	1		4
229				1			1		1	2
251	1	1	1	1	1		1		1	7
254	1	1	1	1	1		1		1	7
255	1	1	1	1	1		1		1	7
256	1	1	1	1	1		1		1	7
264									1	1
265	1	1								2
315	1	1	1	1	1	1	1		1	8
484	1		1	1	1					4
Grand Total	16	14	15	14	13	1	15	1	16	105

Table 27 Summary of evidence for tell sites in the southern marl.

UnitType	Scatter
----------	---------

Count	Evidence source		Evidence			Syrian 1:25,000						Grand Total
	Corona 1108	Corona 1110	Corona 1111	Ikonos MS	Ikonos Pan	Antiquity	Contour	Khirbet	Place Name	Tell	Um	
UnitID	Soil Colour	Soil Colour	Soil Colour	Soil Colour	Soil Colour							
127	1		1	1	1							4
172	1		1	1	1		1					5
177	1	1	1	1	1	1						6
178			1			1		1				3
181	1	1	1			1	1					5
184		1	1	1	1	1		1	1			7
193	1	1	1	1	1	1		1		1		7
194		1	1	1	1	1		1		1		5
196		1	1	1	1	1	1	1		1		6
197		1	1	1	1	1		1		1		7
204	1			1	1	1						3
211		1	1	1			1					4
213								1				1
217	1								1			2
221	1	1	1	1	1		1					6
222									1			1
224	1	1	1	1	1				1			5
238			1	1	1		1			1		3
249	1			1	1				1			3
252	1			1	1			1				3
257											1	1
259	1	1	1	1	1						1	6
266	1	1	1	1	1				1			5
267		1										1
275				1						1		2
279	1	1	1	1	1				1			6
280			1	1	1							4
308	1	1	1	1	1				1			6
317	1		1	1	1		1					4
318	1	1	1	1	1		1	1				7
319	1		1	1	1			1				5
320	1	1	1	1	1			1				5
328	1			1	1							2
332	1			1	1				1			3
334	1	1	1	1	1							4
336	1	1	1	1	1							4
339	1	1	1	1	1			1				6
344	1	1	1	1	1							4
345	1		1	1	1			1				5
351		1	1	1	1							2
454	1	1	1	1	1							5
459									1			1
461	1		1	1	1			1				4
475	1	1	1	1	1							4
477	1		1	1	1							3
478		1	1	1	1							2
480			1	1	1							2
486			1	1	1							2
487			1	1	1							2
496		1		1	1				1			3
498				1	1							1
521				1	1							1
523			1	1	1		1					3
524		1	1	1	1							4
734	1	1	1	1	1							4
737	1			1	1							2
Grand Total	33	28	37	48	20	8	8	21	5	1	2	211

Table 28 Summary of evidence for scatter sites in the southern marl.

Tables 25 to 28 describe the Desk Based Assessment (DBA) evidence that was used to identify tells, scatters, non-sites and indeterminate (potential sites) in the southern marl only. Given the continuous nature of the residues in the basalt zone the same quantitative approach cannot be undertaken. In each of the tables sites are cross-tabulated against evidence. This allows the comparative evaluation of different evidence types at each site. Table 29 summarises these tables into evidence types. From the sites visited to date the satellite imagery produces by far the most accurate results.

Table 27 describes the evidence for tell sites. There is a good correlation between all the satellite imagery and tells and as would be expected there is a good correlation between place name and contour evidence. Table 28 describes the evidence for scatter sites, which are less obvious on the ground than tell sites. In this instance there is a reasonable relationship between mapping evidence and sites visited (62.5%). However, there is a very high correlation between satellite evidence and sites visited (92.9%).

It should also be noted that most of the non-sites from the Syrian mapping are derived from contour features (see Table 26). Of the 56 scatter sites positively identified contours have only been evidence for 8 sites (see Table 28). If one assumes that all tell sites have been identified during the course of the survey (they are, after all, the easiest residue to detect) then the remaining contours can only refer to scatters. Therefore, extrapolating from Table 26 and Table 28 then statistically only 25% of these contours will be scatters. From the indeterminate (potential sites) evidence (see Table 25) 19 of these are based on contour evidence. This means that only 4 of these are likely to actually be sites. To make matters worse in Table 28, with the exception of 1 site, every site with contour evidence has supporting evidence from satellite imagery. Of the remaining 19 only 4 are supported by satellite evidence. As would be expected the place name evidence and antiquity symbols were very good indicators of residues. However, it should be noted that for place name evidence in particular, the spatial accuracy on the maps is very poor. For example place name evidence can be up to 5km away from the actual location of a site. 8 indeterminate (potential sites) have associated place name or antiquity symbol evidence. Unfortunately only 2 of these are associated with contours. Therefore, when the southern marl has been fully surveyed one can expect the accuracy of the mapping resource in Table 29 to decrease dramatically.

Evidence	Satellite imagery	1:25,000 mapping	Combined Satellite and Mapping
Not Visited (potential)	20	25	37
Not Sites	14	20	33
Scatters	52	35	56
Tells	17	16	19
Total Sites	103	96	145
Total Sites Visited	83	71	108
% Accuracy from sites visited	83.13%	71.83%	69.44%

Table 29 Summary of results in the southern marl by method.

From the satellite imagery the Corona mission 1110 has produced the most non-sites. In many respects this is to be expected as this is the poorest quality imagery. Of all the sensors the Ikonos multispectral correctly highlights the largest number of residues. In general, however, the scatters and tells are well represented by all sensors.

However, this should not be taken solely at face value: it is also important to establish if the results are representative of the full range of expected archaeological residue types. Given that the total data structure is unknown this is a difficult task. However, it can be appraised theoretically and empirically. From an empirical standpoint the landscape has had a programme of 'off-site' sample transects (see sections 3.5.1.4 and 3.5.1.5) located across all zones. Amongst other things, it is hypothesised that some of these transects should locate archaeological residues that have not been identified from the satellite imagery. From these transects, not including the alluvial zone, only three sites were identified that were not observed on the satellite imagery. Of these two were subsequently identified on the imagery after ground location. Hence, there is an excellent correlation between the number of extant physical surficial residues and the residues identified by satellite imagery.

Theoretically, however, the techniques do exhibit some serious bias. With a few exceptions, the vast majority of sites have both sedentary architectural and pottery traditions. Hence, the vast majority of the residues are post-Neolithic. Therefore, the majority of pre-sedentary human inhabitation has not been identified, although this does assume that inhabitation actually occurred at this time. Furthermore, no evidence has been identified for transitory sites (such as non-modern Bedouin camps). As discussed by Wilkinson (2001 p. 531) archaeological residues derived from sedentary occupation are easier to detect than those of nomadic pastoralists. The impact of nomadic communities on the landscape is slight and any residues are easily eradicated or masked by post-depositional processes (especially ploughing and deflation). Hence, it is not surprising that neither of these residue types have been identified. Furthermore, the fact that they have not been identified during surface survey makes it very unlikely that they would be identified from satellite imagery.

Given these limitations the evidence in the application area falls into three categories: positive, negative and masked.

10.1.1 Positive evidence

Positive evidence is the identification of an actual archaeological residue, or the interpretation, by proxy, of objects that would lead one to assume that archaeological residues exist. Figure 176 and Figure 178 display the range of positive evidence within the marl and basalt zones respectively.

In the basalt zone the archaeological residues take the form of site and hinterland structural evidence (field walls, enclosures and buildings). These are relatively easy to identify on both the Corona and Ikonos panchromatic imagery. The Ikonos pan and particularly the Ikonos pan-sharpened imagery provide the best level of interpretation in this environment due to the higher spatial resolution of the sensor (see Figure 112). However, the Ikonos imagery, although representative of the present day conditions, does not encompass the same range of residues as observed in the Corona imagery. This is due to destructive modifications that have occurred over the past 30 years. Hence, the Ikonos and Corona imagery are complementary resources that provide a greater understanding of the archaeological resource and its destructive modifications.

Archaeological residues in the marl zone take the form of discrete settlement sites that are easy to identify as colour or textural variations in soil. These residues are an order of magnitude larger than those found in the basalt zone. Hence, there is not such a reliance on high spatial resolution data. The Ikonos MS and the Corona imagery provide the best interpretative sources for this zone. The Ikonos MS is a particularly useful resource for displaying changes in soil colour. Furthermore, there is more scope for interpretation by proxy in this zone. Sites 279 and 308 in Figure 176 show kinks in the road network where the road respects the archaeological site. These are useful indicators when interpreting the satellite imagery. Once again this zone has been subject to a range of landscape modifications, but due to the nature of the residues few sites have been eradicated. Rather, deeper ploughing has removed some of the surface textural components in the Ikonos and brought sub-surface marl deposits to the surface creating a number of potential but negative features.

10.1.2 Negative evidence

Negative evidence is the identification of features that appear to be archaeological but are in fact natural features or residues of other processes (see Figure 177 and Figure 178).

In the basalt zone no negative features have been identified *per se*. However, modern field boundaries have been created in the past 30 years (see Wall type 1 and Wall type 2 in Figure 178) and could, therefore, be classed as negative features.

In the marl zone a range of negative evidence occurs (see Figure 177). The vast majority of these appear to be military in origin. This can normally be attested to by the regularity of the features. Recent Bedouin encampments are also observed in the imagery as rectangular areas (such as around sites 191 and 256 and see Figure 177). This is due to localised compaction of the soil in the areas where the tents were pitched changing reflectance characteristics. Finally, it is important to be aware of irrigation marks. These are by-products of the irrigation systems used in the zone and either form darker areas (through water leakage) or brighter areas in the NIR (due to localised increased crop vigour). These should not be confused with archaeological crop marks (cf. GORS 2002 p. 28). In general the vast majority of the negative evidence is exhibited in the Ikonos imagery. Therefore, once again, the Corona imagery is a complementary resource for evaluating and understanding these effects.

10.1.3 Masked evidence

While it is useful to consider whether the perceived archaeological anomalies are positive or negative evidence it is also necessary to delineate areas that are masked and may not respond to satellite prospection. Masking can take two primary forms:

- Temporary masking, such as vegetation cover or contrast equalisation after rainfall
- Permanent masking, such as burial by sediments or eradication by bulldozing

Temporary masking effects can be resolved by acquiring satellite imagery at a more appropriate timeframe (i.e. when crop has been harvested or during periods of peak aridity). However, it is essential that the environmental regime is thoroughly understood prior to purchasing any satellite imagery where temporary masking may be a factor.

Image Interpretation Key

MARL - positive evidence

Version 1: Anthony Beck, October 2003





EVIDENCE TYPE	EVIDENCE CHIP		EVIDENCE GROUND TRUTH	EVIDENCE DISCUSSION
	Ikonos MS	Corona		
Tell				Tell site 256, marl (S). This site exhibits the classic tell high reflectance properties. Please note that topographic shadow is also present.
Tell				Tell site 97, irrigated marl (N). This site exhibits the classic tell high reflectance properties. This tell has been bulldozed in both Ikonos and Corona imagery. Note the spread of deposit.
Flat site				Flat site 734, irrigated marl (S). This is a large flat site exhibiting high reflectance. The Corona imagery has more texture than the Ikonos.
Flat site				Flat site 308, marl (S). This is a flat site exhibiting medium-high reflectance. Note how the road respects the site.
Flat site				Flat site 478, marl (S). This is a small prehistoric flat site (dot in the centre) exhibiting a slight reflectance increase. It is difficult to detect on the Corona.
Flat site				Flat site 279, thin marl (S). This is a large flat site exhibiting variable reflectance. The Corona imagery has more texture than the Ikonos.
Flat site				Flat site 952, thin marl (S). This is a flat site exhibiting variable reflectance. The Corona imagery has more texture than the Ikonos. This site is now in a military zone.

Figure 176 Residue image interpretation key: positive features in the marl.

Image Interpretation Key

MARL - negative evidence/masking

Version 1: Anthony Beck, October 2003























EVIDENCE TYPE	EVIDENCE CHIP		EVIDENCE GROUND TRUTH	EVIDENCE DISCUSSION
	Ikonos	Corona		
Bedouin Camp				Bedouin Camp. Soil compaction in the area where the tent was pitched alters soil reflectance characteristics. These features do not tend to occur on both the Corona and Ikonos.
Military Feature				Bermed depression. This is a military feature.
Military? Soil Mark				Sub-circular feature with evidence of internal features. This does not appear on the Corona imagery. It is assumed that this feature is military in origin.
Military? Soil Mark				The parallel lines of soil marks are not visible on the Corona. It is assumed that this feature is military in origin.
Military? Soil Mark				Right angled soil mark. This does not appear on the Corona imagery. It is assumed that this feature is military in origin.
Soil Mark				In the Ikonos imagery many small areas produce higher reflectance areas similar to archaeological residues. These are areas where marl has been ploughed to the surface.
Irrigation Mark				Irrigation marks. These marks form in the location of the pipes. Escaping water decreases reflectance. In some areas these form a herringbone pattern across fields.
Vegetation Masking				Vegetation masking. Vegetation is starting to mask the NW portion of this site. Prior to harvesting the crop will significantly mask the site.

Figure 177 Residue image interpretation key: negative and masking features in the marl.

Image Interpretation Key

BASALT

Version 1: Anthony Beck, October 2003

EVIDENCE TYPE	EVIDENCE CHIP		EVIDENCE GROUND TRUTH	EVIDENCE DISCUSSION
	Ikonos pan sharpened	Corona		
Tell				Tell site 49. Even in the basalt zone tells display a reflectance increase. Note that topographic shadow is present and that the clouds are easy to see on Ikonos.
Structure				Structure site 64. This site contains structures (possibly animal pens). The Ikonos imagery provides the best resolution for digitising.
Wall 1				Wall type 1. Bulldozed walls up to 5m in width. These tend not to show up on the Corona imagery (see Bulldozer Masking).
Wall 2				Wall type 2. Long straight walls enclosing narrow fields. These do not tend to show on the Corona.
Wall 3				Wall type 3. Moucha farming. Large fields subdivided into much smaller units. The outer field possibly relates to centuriation.
Centuriation				Centuriation. Centuriation is clearly evident in Corona. A new railroad and bulldozing have severely impacted the structure of the field systems in Ikonos.
Road				Ancient Road Network. It can be very difficult to distinguish these from walls. However, the form of these features are more irregular.
Bulldozer Mask				Masking by bulldozer. The field systems evident in the Corona imagery have been bulldozed. It is possible to extrapolate the original field systems in Ikonos.
Forest Mask				Masking by forest. The field systems evident in the Corona imagery have been overlaid by forest. The Ikonos imagery shows no residues.

Figure 178 Residue image interpretation key: basalt zone.

Temporary masking is more prevalent in the Ikonos imagery in the marl zone. This is predominantly due to the increase in irrigation between 1970 and the present day. Since the Corona imagery was collected extensive irrigation has had two effects: crop cover has been increased across the zone and increased water content after irrigation has reduced the contrast between background soil and archaeological residues. This potentially masks more residues over a longer time frame than observed in the Corona imagery

Permanent masking is a much more serious barrier for interpretation. Where residues have been eradicated (e.g. through bulldozing in the basalt zone) it may be possible to infer some elements of the archaeological residues (see Figure 178). However, where they have been buried or subject to extensive post-depositional processes (such as in the alluvium and alluvial fan zones) satellite imagery may be of little value for prospection purposes. Optical sensors only reflect the surface microns of an object, therefore unless a buried residue expresses some surface anomaly (such as a crop mark) it is unlikely to be detected. Even RADAR imagery, which can penetrate arid soils (Holcomb 2001), would require high spatial resolution to detect most archaeological residues.

10.1.4 Image interpretation key

Given the qualitative nature of archaeological residue detection it is unlikely that two different interpreters will classify a landscape in the same way. Image interpretation keys have been developed in order to maintain a semblance of consistency (see Figure 176 to Figure 178). They are valuable aids for organising and presenting the knowledge of expert interpreters. As such, they can be used for training novice personnel or as a general reference aid (Colwell 1997 pp. 19-27; Campbell 2002 p. 133). The image interpretation keys cover all aspects of evidence (positive, negative and masked). It is hoped that further collaboration with the DGAM and other CRM bodies in the region will extend this image interpretation key to cover different areas throughout Syria. This will be a significant resource for any future research employing remotely sensed imagery.

10.1.5 Quantitative summary

Although the vast majority of the residues were interpreted qualitatively, quantitative analysis was undertaken on soil samples in the marl zone. This had the aim of establishing the physical properties that accounted for increased reflectance in this zone. Although these analyses are in their early phase, initial results indicate that increased soil reflectance

associated with archaeological residues is related to variations in particle size distribution and soil structure (see Chapter 8).

Changes in particle size impact on a variety of soil properties such as texture, structure and drainage. However, due to differences in the materials of mud-brick construction and post-depositional deformation processes no single variant has been identified for increased reflectance. Further research into these variations is recommended, including further analysis of a number of other soil properties (e.g. in-situ water content and bulk density).

In general, however, no specific spectral signature that responds to archaeological residues has been recognised during the course of this research. Rather, archaeological residues produce a localised positive or negative variation in the DN values when compared to the background reading. This has been demonstrated during the recognition of soil marks in the marl zone and should be equally true for the application of aerial imagery for crop mark identification (Powlesland *et al.* 1997). In essence when prospecting for residues in crop or soil they can only be identified if they exhibit sufficient contrast against the 'natural' background level.

10.1.6 Effects of resolution on archaeological detection

Remote sensing instrumentation provides archaeologists with a range of imagery with different spatial, spectral and temporal resolutions consisting of numeric data (with different radiometric resolution). Changes in any of the axes of resolution can lead to different classifications and interpretations.

The benefit of increasing any axis of resolution is that more objects can be confidently resolved and classified (Tso and Mather 2001 p. 9). However, increasing any axis of resolution produces a concomitant increase in complexity, storage size and analysis costs. This is recognised in hyperspectral imaging systems which produce an extremely large amount of data within which, for any specific problem, there is a large amount of data redundancy.

10.1.6.1 Spatial resolution and archaeological detection

Spatial resolution is particularly important for the visual detection of objects. In order to detect a feature, the spatial resolution of the sensor should be roughly one half of the feature's smallest dimension (Jensen 2000). There is, therefore, a positive relationship

between the size of the objects under study and the resolution of the imagery required to identify them. In the case of the basalt zone, where the smallest wall width is c. 1m (see Figure 108 and Figure 109), a pixel size of 0.5m should be required. However, features were accurately detected by Corona with a 2m spatial resolution, although the higher resolution Ikonos imagery gave a much more informative digital product. In part this can be explained by shadows cast by the wall increasing its perceived ground footprint. Further, the combination of shadow and wall may produce a significant increase or decrease in local contrast which predominates in the reflectance recorded by the sensor. Even so, only the highest spatial resolution sensors are appropriate (i.e. with a ground pixel size $\leq 2\text{m}$) within this zone. It will be very interesting to evaluate panchromatic Quickbird imagery in this environment as a 0.6m pixel size is very close to the postulated 0.5m required.

In comparison to the basalt zone the residues in the marl are much larger. Thus lower resolution sensors are suitable for detection. In this context pan-sharpened Landsat imagery (15m) did appear to highlight archaeological residues more accurately than 30m Landsat (see Figure 119). Therefore, sensors with a spatial resolution of 3-15m would seem to be most appropriate for prospection in the marl zone. Obviously, higher resolution sensors would make visual interpretation much easier. However, at certain scales higher resolution sensors appear to increase heterogeneity which makes quantitative detection more difficult. Furthermore, unlike some European examples, increased spatial resolution has not led to a higher level of understanding (i.e. internal artefacts have not been identified leading to feature recognition or interpretation). The decreased spatial resolution required for this zone means that a number of cheaper satellite sensors are appropriate for detection (e.g. SPOT).

10.1.6.2 Spectral resolution and archaeological detection

The benefit of increasing spectral resolution is that from the comparison of two or more images, from different parts of the spectrum, we may learn more than studying tonal variations of just one image (Parker and Wolff 1973 p. 31). Images from different bands can also be combined to produce false colour composites. These make identification easier by focussing on aspects of the EM spectrum that exhibit greater contrast for the objects under study.

The Ikonos MS imagery is the only data set with a multispectral component that has been fully evaluated. Although this imagery only provided four bands (blue, green, red and NIR) it

was a significant resource in all zones. In the basalt zone it was most effective as pan-sharpened high spatial resolution imagery and as a transparent overlay with the panchromatic imagery. True and false colour composites improved detection. However, given the requirement for high spatial resolution in this zone, it is unlikely that new high spatial resolution sensors will be developed that extend much beyond the near infra-red.

In the marl zone, colour composite combinations were also exploited to great effect. In particular the red, green and blue bands showed a high correlation with archaeological residues. The DN variations within these bands at archaeological sites permits a range of statistical manipulations to improve detection. In both zones increasing spectral resolution will improve detection. Although not yet available, the use of bands in the short wave infrared chosen for distinguishing geology or soil (such as Landsat bands 5 and 7) would be of particular benefit as the ability to discriminate different soil types and conditions could significantly improve archaeological interpretation.

The NIR band was disappointing for this study. However, this is probably due to the time of image collection. The Ikonos imagery was collected after the winter rains and while the crops were growing. The NIR band is sensitive to soil moisture and vegetation vigour. Given the window of collection the soil moisture contrast, which would be correlated to a difference in soil structure (discussed in Chapter 8) and hence archaeological residues in the marl, is reduced. Hence the NIR band has not been fully evaluated in this region. Data collected under different environmental conditions would be needed to fully evaluate this band. This was attempted in this programme of work but was found to be too expensive.

Another benefit of the MS imagery is that it is much easier to identify clouds. It is very easy to misinterpret small areas of cloud cover as potential sites in the Ikonos panchromatic (see Figure 136). Furthermore, the near infra-red band is very useful for determining areas of masking vegetation (which is difficult to identify in panchromatic imagery). For example site 218 is identifiable in some of the Corona imagery. However, it is difficult to detect it in the Ikonos imagery. As Figure 136 illustrates, site 218 is masked by surface vegetation (the NIR band is displayed in red).

10.1.6.3 Radiometric resolution and archaeological detection

Increasing radiometric resolution improves the recording sensitivity of the sensor. The benefit of increasing radiometric resolution is that subtle diagnostic variations within an image, which would otherwise have been grouped with other values, can be differentiated (see Figure 25 and section 5.5).

In this region no significant benefit has been observed by the increased radiometric resolution of the Ikonos imagery. A summary qualitative interpretation of the Ikonos imagery degraded to 8 bit (with a minimum-maximum rescale) displayed the same residues as the 11 bit imagery. In the marl zone there is no improvement in detection (see Figure 87). In the basalt zone the improved radiometric quality of the Ikonos may aid in the detection of wall components. However, it is likely that the improved spatial resolution is more important. In this context it would be interesting to compare Quickbird and Ikonos imagery in the basalt zone. Quickbird imagery has higher spatial resolution (0.6m pan and 2.4m MS) but a lower radiometric resolution (8 bit). Evaluation of Quickbird imagery in a different environmental context (Beck *et al.* in prep) has shown that it may be susceptible to saturation.

Given that the 11 bit radiometric depth of the Ikonos imagery is of limited value for archaeological interpretation in the application area the raw imagery can be rescaled to reduce file size with little loss of interpretative detail. This would reduce the storage requirements for the Ikonos imagery by a factor of 2. As discussed in section 5.5, a standard deviation rescale would maintain most of the dynamic range present in the original 11 bit imagery. Space Imaging offer 14 different combinations of Ikonos imagery (panchromatic, multispectral and merged) with different radiometric image depths, although the documentation is unclear about the rescaling technique used. The lower radiometric imagery does not, at present, come with a cost reduction. In the future it would be hoped that this degraded imagery would be retailed at a premium discount.

It is difficult to discuss radiometric resolution in the context of Corona but, as outlined in section 7.4, the Corona imagery does not highlight all the residues in the basalt zone that were observed in the Ikonos imagery. This may be due to variations in the radiometric resolution between the two sensors or unidentified modifications in the intervening years. However, given that the film may have deteriorated over thirty years, that it is scanned and that the images were collected at different times of day and year this is impossible to verify.

10.2 Thematic extraction summary

The analysis of co-registered Landsat and Ikonos imagery allowed a number of thematic layers to be extrapolated at different scales. The Ikonos imagery was essential for creating a number of high resolution land cover themes. In this context the MS imagery was important for the recognition of different vegetation and hydrological components.

At a broader scale the Landsat imagery provided a range of information pertaining to larger scale soil, geological and other environmental components. Of particular import was the United States Geological Society (USGS)-based interpretation schema which provided a common framework for both analytical systems. Furthermore this allows the incorporation of contiguous data collected by other researchers. It is strongly recommended that any future researchers use this, or another, co-ordinated approach for environmental identification.

Both the land cover and soil mapping provided essential contextual data which was unavailable at this scale from any other source.

10.3 CRM application summary

In addition to the utility of satellite imagery for residue prospection it provides a number of benefits for other CRM applications. The imagery itself is a complementary resource to traditional mapping. It can provide important contextual information which, through the process of generalisation, has been removed from cartography. Satellite imagery also lends itself to a number of practical field applications. The convergence of technological tools (such as handheld computers and GPS) facilitates the use of satellite imagery for navigational, mapping and interpretative purposes in the field. Satellite imagery is also a useful presentation tool. Not only does it provide a different representation to traditional cartography; it can also be incorporated easily into more immersive digital presentation environments. Finally multi-temporal imagery can have a significant monitoring component.

10.3.1 Impact of landscape change on archaeological residues and site monitoring

Changes in agricultural techniques, infrastructure expansion and urban sprawl have all had substantial impacts on the landscape over the past 30 years. More profound landscape changes have probably occurred during this period than at any other time. Analysis of the Landsat, Corona and Ikonos imagery has produced a much greater understanding of the

types and extent of these modifications. These types of change are rarely recorded and it is difficult to ascertain if this important information would have been available from any other source.

High resolution Corona and Ikonos imagery allows archaeological residues themselves to be monitored. Natural processes have impacted on a number of sites (such as erosion and burial of sites by Lake Qatina) and the imagery has allowed a coarse quantification of this rate of change. This information may help in protecting sites which are at significant risk. Cultural processes have had an extensive impact in the landscape, particularly bulldozing in the basalt zone. The satellite imagery has helped identify the extent of this destruction and was pivotal in defining a zone which was placed under protection by the DGAM.

10.4 Limitations of archaeological interpretation from satellite imagery

Although satellite imagery has provided significant benefits for the evaluation of the study area there are limitations to its application. From an archaeological perspective in this environment satellite imagery only allows the ability to confidently *detect* residues. Recognition and interpretation of residues is complicated (with the exception of tell sites). Hence, archaeological residues in the marl zone have been interpreted as tell or flat sites and residues in the basalt zone as structures, enclosures and walls. However, in the basalt zone it is possible to examine the stratigraphic relationships of the field systems to establish a relative chronology (i.e. the use of the t-junction rule). Therefore, although areas of high archaeological potential are located, without ground observation the analytical and research value is limited.

10.4.1 Crop mark identification

Considering the reliance on crop mark identification in European contexts, there has been very little comment on the use of crop marks for the detection of archaeological residues in this application area. As discussed in section 5.2.4, it is unclear whether crop marks actually occur. Furthermore, the likelihood of being able to programme a collection sequence which intersects with crop mark appearance is low. This is further exacerbated when one considers the large footprint of satellite imagery and variations in crop ripening within that footprint. There is a much greater window of opportunity to collect imagery which will show soil marks, and soil marks appear to be representative of the bulk of archaeological residues.

Therefore, unless specific research questions are to be addressed then satellite imagery should not be purchased with the sole aim of crop mark detection in similar environments.

Sensor	Resolution		Zone		
	Spatial (m)	Spectral (bands)	Basalt	Marl	Alluvium
Corona	2	1	Medium-Good	Good-Excellent	Medium-Poor
Ikonos Pan	1	1	Good	Good	Poor-Medium
Ikonos MS	4	4	Medium-Poor	Good-Excellent	Poor-Medium
Ikonos Pan-sharpened	1	4	Excellent	Good-Excellent	Poor-Medium
Landsat TM	30	7	N/A	Poor	Poor
Landsat ETM+	15	9	N/A	Poor-Medium	Poor

Table 30 Sensor summary by zone.

10.5 Recommendations

This research programme has successfully applied a number of satellite sensors for landscape archaeological prospection and analysis. Table 30 summaries the utility of each sensor within each environmental zone.

What follows are recommendations for researchers wishing to apply satellite imagery to their own projects in similar environments.

Prior to purchasing any imagery it is essential that the nature of the environmental zones and the archaeological residues are understood and that a Desk Based Assessment is undertaken. This information can be contextualised by one of the number of free satellite images available over the internet (for example Landsat imagery at the Global Land Cover Facility in Maryland: <http://glcf.umiacs.umd.edu/index.shtml>). A preliminary field visit is required to record the following environmental, archaeological and background information:

- The type and extent of different environmental zones.
- Surface cover in each zone.
- Agricultural seasons in each zone.
- Extent of irrigation.
- Rainfall average per month.
- Atmospheric variations over the year.
- The nature and extent of archaeological residues in each zone.

- Establish a range of rectification points by GPS on features that are likely to be identifiable on present day and historic imagery.

Regarding archaeological residues, it is particularly important to understand how their contrast changes against any 'background' readings during different environmental conditions. For example, in the marl zone residues exhibit greater contrast during periods of peak aridity (i.e. the soil colour difference between sites and soils is at its maximum). After rainfall and when under crop this contrast is reduced or eradicated.

This information can then be integrated within a GIS with the DBA data (including geology, present day, historic and archaeological CRM mapping and aerial photographic archives). This allows the project team to evaluate if satellite imagery is required and if so of what type and within which time frame.

When deciding upon the spatial, spectral and temporal resolution of the sensor for archaeological residue detection and landscape evaluation one should understand the nature of the residues to be encountered and the level of identification that one is hoping to achieve. Inevitably this will mean that a range of different sensors are appropriate for a survey: for example the following sensors could be employed in this study area:

1. Low spatial (>100m) and high spectral (>10 bands) resolution imagery for coarse landscape identification (particularly soils and geology).
2. Medium spatial (10-60m) and medium spectral (> 6 bands) resolution imagery for refined landscape identification e.g. Landsat ETM+ or equivalent.
3. High to medium spatial (2-15m) and low to medium spectral (>3 bands) resolution to detect larger features (ploughed out sites, tells etc.) e.g. Quickbird MS, Ikonos MS or SPOT 5.
4. High spatial (<1m) and low spectral (pan) resolution imagery to detect very small features (walls, linear soil marks, pits, postholes etc.) e.g. Quickbird pan or Ikonos pan.

Wherever it exists historic satellite imagery should be purchased, even if it turns out to be of nominal value. The purchase and evaluation costs are minimal and it has the benefit of being collected prior to many countries adopting deep (tractor) ploughing, extensive irrigation and other heavy earth moving equipment, each of which has profoundly altered the present day

landscape. Archive high resolution commercial image sets should also be consulted. However, if the commercial archives fall outside the required time frame for image collection they should be discounted as this imagery is only available at a small discount.

If bespoke or archive high resolution imagery is to be purchased then an evaluation sub-set of imagery could be procured prior to collecting the whole application area. This will allow the full utility of the imagery to be evaluated without committing to costly imagery that may not provide the desired results. However, this could have the disadvantage that it may take over one year to acquire the full data set. For this research, the purchase of £21,770.26 (excluding VAT) worth of inappropriate Ikonos imagery would have been disastrous. Finally, other avenues of acquisition should also be pursued. For example purchase costs can be shared between a number of projects or institutions working in the same geographical locale.

Furthermore, none of these data sets need to cover the whole application area. If the environmental conditions and the reflectance characteristics of the objects of interest are well understood then one can discriminate where imagery should be purchased. Significant economies can then ensue (see section 10.5.2).

From a detection viewpoint this research has defined a number of different quantitative and qualitative techniques. However, the techniques used in this region may be inappropriate in other areas. Fortunately, the majority of the techniques used rely on the detection of residues in the visual wavelengths. Hence, it should be relatively easy to create bespoke analytical systems in similar environments. To ensure long-term utility of the imagery, it is recommended that image interpretation keys are produced for each environmental zone and disseminated to the regional and national CRM bodies.

10.5.1 Issues of implementation

As with any development the cost benefit of the application needs to be justified. The organisational issues of implementation should also be addressed as there can be significant barriers to success if key stakeholders are excluded during any phase of implementation. This phase should also cover appropriate software purchase and training. Any benefits should be articulated through the project information systems. The techniques employed in this application area may require re-appraisal for individuals wishing to test the methods in other environments. Finally, copyright requires addressing: archaeologists have a long history of

sharing information. However, the stringent copyright attached to satellite imagery may reduce its full research potential.

10.5.1.1 Cost

As with any project the cost of purchase is of over-riding import. From a cost basis the Corona photography is the cheapest satellite source to purchase. However, it does have processing costs. Landsat is reasonably cheap for archive imagery and is becoming increasingly available at no cost through certain websites, although the environmental suitability of this imagery is generally reduced. High resolution imagery is the most significant financial investment. The launch of the Quickbird satellite increased competition within the market which has generally reduced image acquisition costs.

In general, existing imagery is of course the least expensive to use; the costs of acquisition have been met by others and copies of the results can be obtained at a discount. However, re-using imagery collected by a partner may have copyright limitations. The most cost-effective mechanism for imagery collection is through a strategic partnership purchase with other bodies.

Costs can only be fully evaluated against any benefits that ensue. The costs of purchase for the satellite imagery in this research at c. £30,000 (including VAT) equate to approximately three seasons of fieldwork funding. Most projects would consider this an extreme expense and it could be argued that only the most visionary funding bodies would support such a proposal. However, without the purchase of this imagery at an early stage, it would take many seasons of fieldwork to produce a commensurate archive. Therefore on a pound for pound research value the satellite imagery has proven to be extremely cost effective. If the recommendations outlined in section 10.5.2 are followed then the purchase cost is only c. £15,000 (including VAT) providing more significant returns on investment.

10.5.1.2 Copyright

The last ten years has seen a revolution in remote sensing technology and management. Advances in sensor resolving characteristics have occurred, the industry is deregulated (particularly from the dominance of NASA) and the majority of hard and software analysis systems have matured (Slonecker *et al.* 1998). Furthermore, the internet has facilitated the rapid dissemination of data (raw and classified), method and synthesis. The shift from

research led to commercially driven Earth observation has had a significant impact on the industry: particularly in the area of copyright. Commercial data is generally subject to more stringent copyright than research data. The nature of this copyright varies between the different commercial organisations, the sensors and the age of the imagery.

Onerous copyright may become the major inhibiting factor in the application of satellite imagery for archaeology. Archaeologists are great borrowers and the discipline has benefited from techniques and data imported from other researchers and related fields of study. It is essential that mechanisms are sought whereby archaeologists, and other researchers, can share remote sensing data without breaching copyright.

One such method is to purchase data for an organisation rather than a sub-division (in this instance I am considering an academic framework, whereby the data is licensed to a University rather than to a Department). However, this does not make the data available to peers in other establishments. It is recommended that umbrella organisations (such as NERC) could be a central conduit for data purchase, making the data available to national or even international researchers. Whatever mechanism is chosen it is essential that archaeological researchers have affordable access to appropriate remote sensing resources.

10.5.1.3 Rectification and Co-registration

Image rectification and co-registration are vital stages in image preparation. For this research Ground Control Points recorded by handheld GPS were used to re-rectify the Ikonos imagery which in turn was used as a basemap for the co-registration of all the other satellite sensors. It is likely that differential GPS will be employed for the collection of GCPs in most other areas due to its improved positional accuracy. Whichever GPS technique is used points should be collected so as to satisfy statistical rigour and future satellite systems or declassifications. From a statistical viewpoint many individual readings and their metadata should be recorded at each control point (as opposed to the averaging technique discussed in section 5.4). This will allow more rigorous statistical procedures to deduce the most accurate position using, for example, least squares techniques. Further, these points should be as accurate as possible: there is very little point in conducting a GCP survey with only one image product in mind as the GCPs will have utility for the correction of future images with different spatial and spectral characteristics.

10.5.1.4 Use in other geographical locations

The re-application of the techniques described in this research in other geographical locales is particularly important. Changes in environmental conditions will change how residues are observed by sensors but will also structure the natural and cultural formation and deformation of the residues themselves. In this instance it is advised that the recommendations outlined in sections 10.5.1 and 10.5.2 are followed.

10.5.1.5 Archaeological information systems and data management

In the wider context multispectral data can be integrated with any other form of spatially referenced information, particularly within a Geographic Information System, and many of the image enhancements methods applied to multispectral data can be used with suitably transformed, i.e., digitised, conventional aerial photography. Therefore multispectral remote sensing has the potential to become a fully integrated and routine technique in archaeological research. At present it is neither.

(Shennan and Donoghue 1992 p. 224)

As discussed by Parrington (1983 p. 107), Shennan and Donoghue (1992 p. 231) and Palumbo and Powlesland (1996 p. 127) satellite imagery and other remote sensing resources will play an increasingly significant role in the management of cultural resources. However, in isolation these resources will have limited capacity. It is much more beneficial for archaeologists to integrate remote sensing data with other resources, such as ground survey and other 'monuments' records, through an information system. GIS and image processing technology will be essential as will the collection and, more importantly, the database structuring of attribute data so that it can be used to address research problems. The web will have an important part to play for the future of archaeological data analysis and management. It is proposed that a full web-GIS data entry, visualisation and analysis system is created for this archive. Researchers could articulate the full archive within a web browser from anywhere in the world. Furthermore, it would mean that all users are querying the most up-to-date data at any one time. Developments such as this should significantly improve the mechanisms archaeologists employ to analyse the landscape and should thus impact upon theory and practice.

10.5.1.5.1 Software and training

However, these benefits come at a cost: they can only be realised if the appropriate software packages have been purchased and effectively integrated and if the project personnel have been taught how to use them. In a research project such as this it is difficult to advise on specific software packages as the situation changes very rapidly. Furthermore, some packages are better than others at certain tasks. However, one thing can be guaranteed and that is the continued functionality convergence between GIS, image processing software and database systems. In this environment it is more important that the data formats employed are interoperable (i.e. they can be used in any software package and on any platform without loss of data content). Appendix I defines the structures used in this project and although the data structures are not fully interoperable they are one processing step away from such a position. Furthermore, the system has been designed so that it can be easily archived within the Archaeology Data Service.

Training is a separate issue and once again it is difficult to determine where the responsibility for training should lie (the individual, the project, a teaching institution or the professional body (through continuing professional development)). The Institute for Field Archaeologists has highlighted that computer skills, geophysics and remote sensing will play an increasingly important role in the future of archaeological practice and are currently under-resourced (Aitchison and Edwards 2003). It is hoped that the professional archaeological body can increase pressure to improve training in this sphere.

10.5.2 Impact of the recommendations on the application area

The following section re-evaluates theoretically the decision-making process of the SHR project in light of the above recommendations. After the preliminary field study it would have been established that:

- The application area consists of three environmental zones (basalt, marl and alluvium).
- Aerial photographic, geological and land-use mapping resources were minimal or at inappropriate scales.
- The 1:25,000 mapping, although appropriate, was in an undefined projection.

- The CRM dataset only contained monumental archaeological residues with a bias towards the marl zone.
- The residues in the basalt zone are a palimpsest of complex structural components and would require high resolution (< 1m) imagery.
- The residues in the marl zone are discrete tells or ploughed out sites. Ploughed out sites exhibit a distinct soil colour change in comparison to the background soil. This soil colour varies with moisture content.
- The alluvial zone contains a range of archaeological residues. It is difficult to establish the extent of residues in this area due to a range of post-depositional processes.
- The main agricultural season is between December and May, although a second crop may be realised in irrigated areas (mainly in the marl).
- The majority of rainfall occurs between December and April.

This background information provides the framework from which the application of the remote sensing programme must be structured (see Figure 179).

From a thematic perspective multiple sensor systems can be used to establish a range of layers that define the different environmental zones, geology, soil types and land use. Soil variations in particular appeared to be important for the detection of archaeological residues. In this context a sensor with high spectral resolution and coarse spatial resolution to define broad geological, soil, vegetation and urban zones. Two images should be acquired encompassing low crop and peak aridity (October-December) and high crop (April-May). This low spatial resolution resource can be augmented by the incorporation of higher spatial resolution Landsat imagery. Further time change analysis should be conducted employing imagery from different seasons and years. This will elucidate the impact of cropping, rainfall and other landscape modifications over time. Higher spatial resolution imagery can be integrated into this framework to provide even greater recognition or identification. This is the exact form of framework employed when integrating the Ikonos imagery with the Landsat imagery for the land cover classification (see section 6.2). It should also be advised that one of the Landsat images should be an October Landsat 7 scene so that the 15m band can be evaluated for residue prospection. The cost implication of this phase (2 low cost high spectral and low spatial resolution scenes (for example ASTER) and 4 Landsat (2 at January-

May and 2 at July-November with a 10+ year gap) would be c. £100 for ASTER and £1350 for Landsat.

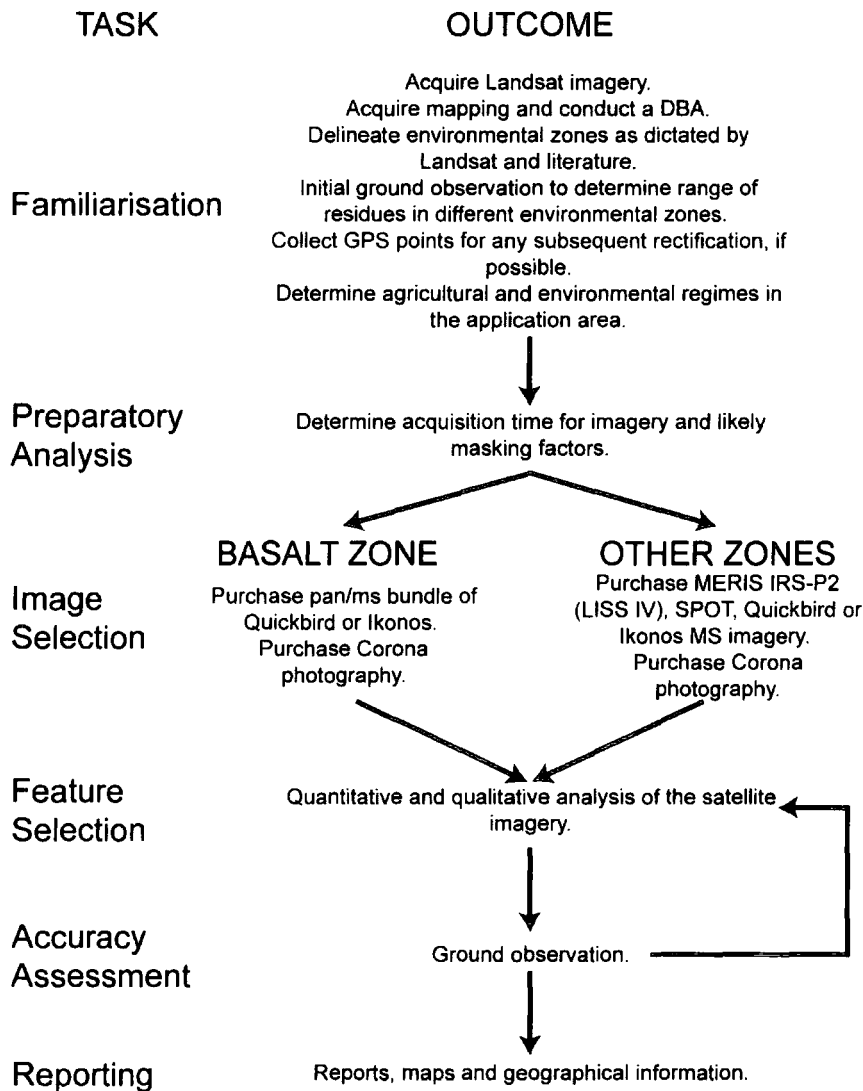

Figure 179 Revised sequence for the incorporation of satellite imagery into an archaeological landscape project.

From a residue prospection viewpoint, different sensors would be required for the different environmental zones. The marl zone requires high but not the highest spatial resolution sensors. A multispectral image focused on the visual wavelengths is much more appropriate for detection in this zone. Appropriate sensors include SPOT 5 (5m panchromatic and 10m MS), Ikonos MS and Quickbird MS. This imagery should be collected between October and December. The cost implication for this imagery, excluding VAT, would be £5700, £6000

and £8333 (for SPOT (Orthorectified, 3600 km²), Ikonos (Geo, 500 km²) and Quickbird (Standard, 500 km²) respectively). In this instance SPOT 5 imagery would appear to be most appropriate. Not only is it the cheapest, it also has the largest ground footprint, greatest geo-referencing accuracy and would improve land-cover identification.

The basalt zone would require the highest spatial resolution imagery. As multispectral imagery would also be useful in this zone then either co-collected Ikonos or Quickbird pan and MS imagery should be purchased for the whole 133 km² basalt zone. This imagery should be taken in December or January to coincide with minimal crop cover and maximum visibility of the basalt structures after the first rains. For Ikonos or Quickbird imagery this would have a cost implication of £2660 (excluding VAT).

In addition, archive satellite photography would be incorporated. All scenes with a high spatial resolution sensor and low cloud cover index should be purchased. Since the inception of this research programme the KH-7 missions have been declassified (with ground resolution of between 0.6 and 1.2m).

Hence a range of complementary satellite imagery has been purchased and processed that fulfils the diverse goals of the landscape survey (see Figure 179). The full cost of the imagery would be c. £15,000 (including VAT). This compares very favourably against the c. £30,000 spent during the current research programme.

10.6 Future systems

Inevitably sensor systems will improve in the future. In the short to medium term there will be improvements on spatial resolution and possibly on spectral resolution. It can be hoped that multispectral satellite sensors will be produced that have more bands located in the infra-red so that differences in crop vigour and soil can be analysed in more detail leading to improved archaeological detection and interpretation.

Hyperspectral systems and LiDAR have been referred to in passing throughout this research. These sensors are discussed here in more detail as they have immense potential for the future of archaeological remote sensing.

As has been discussed, electromagnetic remote sensing techniques in archaeology take advantage of differential responses of vegetation or soil which are affected by chemical,

physical and topographic traces of archaeological activity. These traces produce different responses in different portions of the electromagnetic spectrum. This research has exploited the different characteristics of satellite imagery by analysing the components of each spectral band through radiometric, spatial and spectral manipulation. The benefit of hyperspectral systems is that more finer spectral resolution bands are recorded (see Figure 22). Under certain environmental conditions cropmarks (stressed or vigorous vegetation), thermal anomalies (expressing different emissivity characteristics) and soil variations may be analysed in much more detail than with multispectral and panchromatic systems. The benefit of hyperspectral systems is that the small window of opportunity which is used to detect these residues in the visual part of the spectrum can theoretically be substantially enhanced in other parts of the spectrum. Computer enhancement of this data places less reliance on specific environmental conditions to reveal archaeological anomalies (Donoghue 1999; 2001). Hence environmentally extreme conditions are not required to detect archaeological anomalies.

Amongst other things, aerial LiDAR sensors are used to create high resolution digital terrain models. Holden *et al.* (2002) have demonstrated the utility of LiDAR DEMs for archaeological detection and recognition. One of the major benefits of LiDAR is that the high resolution DEM can be manipulated in a number of ways within image processing and GIS software. For example, many aerial photographic techniques rely on discriminating shadows cast by subtle archaeological topographic disturbances. The light source for these observations is fixed by the position of the Sun. This means that only objects perpendicular to the Sun's direction will be in full shadow. Virtual reconstructions allow the Sun to be placed anywhere in the sky allowing non-natural illumination conditions to occur. Holden *et al.* (2002) exploited this virtual technique to improve archaeological detection and interpretation.

Specialised sensors and techniques could be focussed on specific topographic, soil and vegetation responses during the appropriate environmental conditions. This may start to structure future archaeological research agendas by discriminating between topographic, soil and vegetation response variations. As a trivial example hyperspectral bands that correlate with crop stress or crop vigour could identify a range of 'new' crop marks in environments which are currently marginal for aerial photographic prospection.

CHAPTER 11 CONCLUSIONS

Remote sensing has broad multidisciplinary applications to geology, geomorphology, biology, pedology, hydrology and climatology, as well as to anthropology...The remote sensing perspective provides not only the synoptic overview otherwise unobtainable, but more importantly, a synergistic grasp of obscured physical and cultural phenomena.

(Lyons and Avery 1977 p. 53)

11.1 General discussion

Satellite imagery offers immense possibilities in terms of its deployment in the context of archaeological survey and Cultural Resource Management (CRM) applications. This is particularly the case in areas where the traditional desk based resources of archaeological catalogues, cartographic and air-photographic data are sparse or difficult to access. The experience, of working in western Syria, suggests that the critical element is 'fitness for purpose', that is, the employment of satellite imagery at appropriate scales and in appropriate environments.

Imagery has the potential to provide critical information on both present and past environments, the ability to assist in the location of concentrations of human activity and to provide bespoke thematic mapping. When integrated within a Geographical Information System, which contains other appropriate data, satellite imagery provides a multifunctional analytical tool.

In environments such as Syria it is inevitable that aerial photography will be available for most if not all areas. This photography is normally collected for topographic or military reconnaissance purposes. However, it is rare for this resource to become available as it is normally classed as militarily sensitive. It was only after 6 seasons of fieldwork that samples of the 1958 Russian photographs were made available. If these had been made available at the initiation of the research then a significant amount of fieldwork would have been required in order to accurately geo-correct these images. This is due to the small footprint of

the photography and the lack of any appropriate geo-referencing base. Hence, the utility of these images is increased by the ability to rapidly co-register them against a satellite backdrop.

11.2 Satellite imagery as a complement to landscape archaeological survey

High resolution satellite imagery has immense potential as a complementary tool to frame landscape survey. Traditional applications tend to employ a battery of ground focussed survey techniques such as fieldwalking and geophysical survey (Banning 2002). Larger scale interpretations only accrue after many years of intensive fieldwork. Many of these are aligned to the theoretical premise that the landscape is a blanket of archaeological residues of varying intensity (see section 3.5.1.2). Alternatively, some landscape surveys tailor their fieldwalking based upon assumptions about human settlement. Many of these surveys use proximity to water as their main criterion for site location (for example Adams 1981 p. 28). Satellite imagery provides an effective tool with which to evaluate rapidly these assumptions prior to entering into the field.

Ground survey has demonstrated that the residues in the marl zone are islands of discrete settlement loci with very little archaeological material in between. This equates to the settlement class 'nucleated 1a' as discussed by Wilkinson *et al.* (2004 p. 191). In this environment the satellite imagery has framed the survey programme by locating these 'peaks' of archaeological activity. Hence, resources can be efficiently deployed during field seasons resulting in improved modes of data collection and analysis.

By contrast the basalt zone does exhibit off-site scatters. However, the complex relationships between the structural palimpsest and the artefact scatters currently makes interpretation difficult. The satellite imagery has also helped frame the survey of the basalt zone by allowing the rapid recording of the nature and extent of the structural evidence. The stable internal geometry of the Ikonos imagery allowed its re-rectification providing high ground precision. Due to this accuracy individual structural components can be digitised with confidence and subsequently visited, using GPS, when further attributes could be recorded. The significance of this simple rectification procedure to the accuracy of the subsequent mapping should not be underestimated. If differential GPS were permitted for the collection of ground control points the positional accuracy could be improved to the sub meter or decimetre level. Traditional ground survey using a total station or differential GPS would have produced a more spatially precise representation of this landscape. However, the costs involved in

conducting such a survey would have been prohibitive. Equally, aerial reconnaissance would have been costly in terms of the flight and the extensive rectification required.

The contrast in the environmental zones, the nature of inhabitation in these zones and the consequence for the structure of the archaeological residues provides a good framework for evaluating the satellite imagery. The satellite imagery has framed interpretative approaches and survey methodology across the study area. This is in part due to selecting imagery from seasons which make the identification of archaeological residues easier. If residue location occurred only through fieldwalking then only a small portion of the 600 km² area would have been covered in any detail and the project would still be in its preliminary stages. Many surveys still use this approach based upon assumptions about archaeological residue dispersal. One should not assume that continuous patterns of artefact scatters are always present, as is sometimes assumed in Mediterranean survey (Cherry *et al.* 1991; Alcock *et al.* 1994; Knapp 1997; Bintliff 2000; Francovich *et al.* 2000). However, it must be stressed that this can only occur in environments where the archaeological resource is distributed in this manner: the satellite imagery provide a resource where the project team could question this assumption at an early stage.

The most fundamental impact is that satellite imagery is an important tool for visualising and evaluating landscapes. For example, the change in perspective, large footprint and pseudo-objective nature of the imagery can make satellite imagery a more powerful contextual and interpretative medium than a map. The ability to articulate all the data directly within the GIS (see Appendix I) has enabled the project team to rapidly redefine survey objects at a micro and macro-scopic level in light of new data.

Furthermore, the vast majority of landscape survey models discussed are primarily focussed on detecting and interpreting archaeological residues on the basis of statistical variations in artefact concentrations over large areas. The scale and scope of such operations correspond closely with many applications of satellite imagery. Archaeological aerial photography, on the other hand, is normally an unsystematic tool that locates archaeological residues over small areas.

However, in order to define what form of sampling is appropriate one needs to understand the general spatial and temporal attributes of the population. This application area was

unsurveyed, hence, little was known about the nature of the archaeological population. Satellite imagery has the inherent property of being able to provide synoptic observations with high sampling density of relatively large areas. This in itself is an improvement on traditional aerial photographic techniques. This also means that satellite imagery can be classed as total survey with high intensity. In this respect the scales of analysis between satellite imagery and landscape archaeology are complementary. Thus, satellite imagery can be considered as a landscape sample. This assumes the remotely sensed measurements may be less accurate at a given point, but, because of the great number of observations, may produce greater accuracy over large areas (Salomonson 1983 p. 1497). This allows the imagery to be analysed statistically in order to extract information of interest. Hence, the detection and interpretation systems employed by landscape survey archaeologists and aerial archaeologists have relevance when interpreting satellite imagery. Natural and cultural formation and deformation processes are contained in the structure of the satellite imagery (i.e. the *total data structure* see section 1.4). The challenge for the image interpreter is to extract the relevant components. Logically this will employ variations on the methodologies employed in *site* and *non-site* modelling, as satellite imagery does not immediately define the temporal dimension during interpretation.

In conclusion, in this environment satellite imagery provides a reasonably high level of residue detection and thematic content which, due to the relatively large footprint of the imagery, can be used to frame subsequent research enquiries and field techniques. It must be stressed that the full benefits of satellite imagery can only be realised if it is an integral component of a field observation programme. This may appear self evident, however even after 100 years of use aerial photographic techniques are still not routinely employed in conjunction with excavation (Aerial Archaeology Committee 1983; Palmer 2000).

As a prospection tool satellite imagery has proven to be accurate and cost effective. However, as was discussed in Chapter 3, there are a number of other techniques that could have produced the same form of data.

11.2.1 Satellite imagery comparison against aerial photography

Satellite imagery and aerial photography share a common heritage. It is likely that aerial photography will remain the preferred resource for archaeological applications due its flexibility of collection (oblique, vertical and at different times of day), large archive, generally

higher spatial resolution and enhanced archive duration. However, satellite imagery does provide some significant benefits over aerial photography. Most satellite imagery is already geo-referenced, meaning that it can be immediately integrated within a GIS project. However, it should not be forgotten that improving the rectification accuracy can significantly enhance this resource. Once orbit is achieved satellite imagery is cheaper than bespoke photography on an area by area basis (contra Schmidt 2004). Satellite sensors also exploit more of the electromagnetic spectrum which may yield other archaeologically pertinent information (aerial hyperspectral systems have yet to be fully evaluated for archaeological purposes). Satellite imagery can also be acquired for areas where aerial surveys and archives are restricted. Finally the large footprint of the imagery means that it is a more representative snapshot of a survey area (Schmidt 2004). Most archaeological aerial photography is non-systematic: the results from aerial photographic surveys are biased (Cowley 2002). This is due to selective flight lines, a focus on sites and not on the surrounding landscape and a reliance on visual applications. Consequently, areas that look blank from AP interpretation are not necessarily archaeologically sterile. Although satellite imagery is subject to the same criticisms, the larger sampling footprint can improve quantitative and qualitative analysis. Importantly, the nature of the environmental and land use regime dictates if a response will be observed from aerial or satellite sensors.

In reality, however, it is not an either / or situation. Satellite imagery and aerial photography are complementary resources. Both can provide valuable archaeological insights. The discriminatory application of both sources allows archaeological problems to be framed in a number of different ways.

11.2.2 Satellite imagery comparison against other landscape survey techniques

Ground reconnaissance and particularly survey (such as driving survey, village to village survey and fieldwalking) are the traditional techniques for locating archaeological residues in Mediterranean environments. These approaches have many elements to recommend them, not the least being that archaeological interpretations are often significantly enhanced, artefactual data can be collected or analysed *in-situ* (providing information relating to site form, function, date and duration) and formation and deformation processes can be understood in greater detail. However, these are expensive strategies in terms of resource deployment and unless total survey is being conducted (the most expensive option) then

inevitably much of the landscape will not be surveyed. Furthermore, it can take many seasons of survey before it is possible to contextualise the whole landscape over time with these techniques.

However, remote sensing approaches have very little meaning unless they are augmented with ground reconnaissance data. The techniques employed by the SHR project means that most of the field teams are directed to areas that are likely to be archaeologically productive. This means that the teams themselves spend proportionally more time evaluating archaeological residues than 'blank' areas. The other field teams have been conducting control survey to assess if the satellite imagery has located the full range of archaeological residues. Hence, these techniques are complementary and in the semi-arid landscape around Homs, where the archaeological resource is poorly understood, they are an effective tool.

11.3 Some limitations of archaeological remote sensing

The limitations of satellite based archaeological remote sensing techniques, as discussed by several researchers (for example Ebert 1988; Gaffney and Stancic 1991), require reappraisal in light of technological developments. The recent generation of high resolution sensors allow a number of new archaeological applications to be realised as discussed above. However, even though technological developments have increased the utility of satellite imagery there are still limitations.

Some limitations are inherent in the sensor itself: the spatial, spectral, radiometric and temporal resolutions may impose limits on what can be analysed. Of particular import are spatial and spectral resolutions. While the spatial resolution of Ikonos and Quickbird imagery is approaching that of aerial photography they also offer greater flexibility in spectral resolution. However, as yet these sensors are limited to the visible and near infra-red component of the spectrum. Airborne hyperspectral systems will allow different wavebands across the electromagnetic spectrum to be compared for archaeological value.

Human limitations (such as the ability to perceive colours, experience in remote sensing and archaeological knowledge) can affect any remote sensing applications. Training is essential to address some of these limitations. Furthermore, the research questions must be unambiguously stated and the relationship of remote sensing data to this problem must be defined.

Environmental factors impose further limitations on the interpretative capacity of imagery. Clouds, mist and haze can obscure or degrade the phenomena of interest in any scene. However, these atmospheric effects affect different sensors in different ways depending upon the wavelength of collection (for example RADAR is not affected by cloud or vegetation cover). The ability to detect different archaeological residues is based upon the ambient environmental conditions: some sites are easier to distinguish as crop marks, others as soil marks. Identifying the optimal environmental conditions for the research problem may take many years of experimentation.

The most important point is that any measuring device is dependent upon the conditions under which it is employed. The failure of a sensor to reach its full interpretative potential in one situation does not mean that they will always be less than useful. In essence, the environmental conditions are of paramount importance in order to appropriately interpret any image set. The optimum environmental conditions for archaeological interpretation will vary in each geographical locale.

11.4 Classification, classification, classification

Why such prominence on the term 'classification'. If nothing else, this programme of research has demonstrated the importance of classification techniques within archaeology and remote sensing. The development of classification techniques for archaeology and remote sensing are very different and respond to the needs, aims and goals of each discipline. Generally, remote sensing applications can successfully classify their material due to a-priori knowledge of the materials under study. There is a large body of reference material that aids the remote interpreter to classify materials. The ability of an interpreter to adequately identify materials is based upon the amount of information required and the resolution of the data available to them. Conversely archaeologists do not have this a-priori luxury. Objects and sites are classified in artificial ways that do not necessarily represent how they were physically or chemically constructed or how they were observed, understood and incorporated into past societies and life-styles. Theoretically, archaeological entities can be validly classified into a variety of different groups for the purpose of attempting to understand them from a different contextual viewpoint (Hodder 1991; Hodder 1999; Lucas 2001).

From a technical perspective there are a wide range of techniques that can be used to model and classify data. The 'great borrowing' of statistical and mathematical techniques from

associated hard and soft sciences (Aldenderfer 1987 p. 90) has been given greater validity by the use of GIS and associated computer technology. However, it is rare for these techniques to have a methodological or theoretical consistency (Doran 1987 p. 74). However, many archaeologists see the need for methodological transparency in their modelling exercises (for example the papers in Wescott and Brandon 2000). It is hoped that this research programme adds to this body of methodology which will enable flexible and theoretically sound application of statistical and interpretative technique.

11.5 Summary

Even in the early 21st century many non-archaeologists believe that archaeological enquiry is predicated by excavation. On the other hand archaeologists are increasingly contextualising their sites within landscapes. Landscape analysis at or beyond the regional scale provide an appropriate backdrop to study many archaeological problems and cultural processes (Wilkinson 2001).

Survey techniques, as discussed by Banning (2002) and Wilkinson (2001), sample the landscape to evaluate surface and sub-surface archaeological residues employing a range of techniques. The use of high resolution satellite imagery in this semi-arid environment has enabled the detection of productive areas for archaeological survey. Furthermore the imagery itself provides an interpretative backdrop that is easy to integrate and analyse. Top-down intensive survey has also been demonstrated to be very expensive as each part of an application area is analysed with the same techniques. This technique is very useful when one has no prior understanding of the landscape, the distribution of residues and any important landscape modifications. However, satellite imagery provide a large scale synoptic coverage of an application area allowing one to focus survey resources effectively saving both time and money. This is particularly appropriate when one considers that Alcock *et al.* (1994 p. 138) recommend that field survey should be guided by the known distribution of archaeological residues. In environments where the distribution of archaeological residues is unknown, poorly understood or subject to significant biases then high resolution satellite imagery can be considered an essential resource for evaluating the landscape prior to conducting surface survey.

It is expected that the cost of satellite imagery will continue to decrease as the market expands and as the general utility of archive imagery decreases. Initiatives such as the Global

Land Cover Facility website at Maryland where one has access to a vast range of free satellite imagery (this site includes Landsat imagery for virtually the entire land surface) will promote the uptake of satellite imagery within a variety of industries. It is not difficult to imagine that other sites like this will emerge containing more archaeologically pertinent data.

Theoretical agendas now require archaeologists to evaluate the archaeological resource at a number of different scales and interpret it from different perspectives. Within this framework high resolution satellite imagery is a significant tool, particularly in environments which are poorly understood.

The archaeological potential of remotely sensed satellite data is about to grow rapidly.With these (higher) resolutions it will be possible to not only conduct within-site investigations from space that will be able to identify individual surface or near-surface features but also undertake such things as the periodic monitoring of sites for the effects of erosion or vandalism.

(Kvamme 1999 p. 184)

This prescient quote from Kvamme neatly encapsulates many of the conclusions from this research. Present day and historic high resolution satellite imagery are now part of the archaeologists arsenal that offer new insights into our cultural heritage. The next generation of satellite sensors will, inevitably, offer the archaeologist even greater benefits.

APPENDIX I : THE ARCHAEOLOGICAL DATA MODEL AND ENVIRONMENT

I.1 Introduction

Data modelling is the process of defining the structure, vocabulary, content and environment to represent information in a digital system. The structure defines the relationships between individual elements, or objects, in the system; the vocabulary defines the terminology to be used to describe individual elements; the content defines what is and what is not included in the system; and the environment defines the specific hardware and software required to store and manipulate the content.

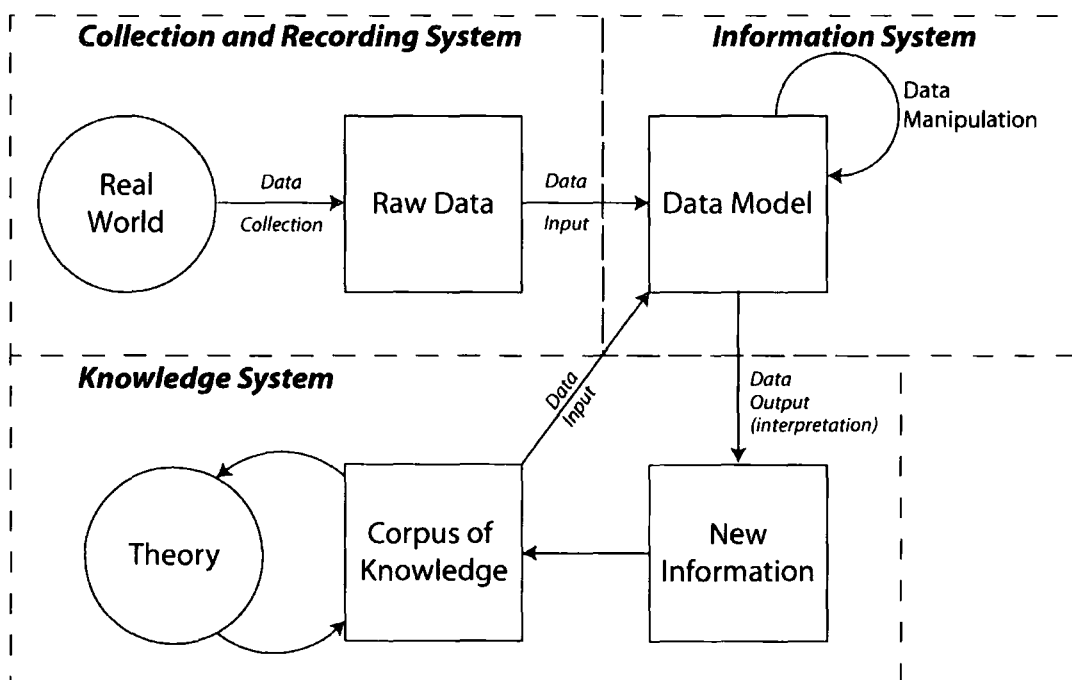

Figure 180 Schematic of an Archaeological Data Model (after Martin 1991 p. 55) . Note all arrows perform some transformation.

Figure 180 outlines a schematic for the processes of archaeological enquiry employing a digital analytical system. The real world is observed and transformed by the process of recording (or data collection). Where a non-digital collection system is employed this raw data is then further transformed during the process of data input into the data model. In an archaeological scenario the raw data is augmented by our current knowledge (this could

include theories, syntheses and other data). These data are manipulated (and further transformed) within the model to create new information. This information is added to our current knowledge and used to reappraise any theoretical models. This is used to create a hermeneutic loop between theory, data and synthesis (see Figure 181).

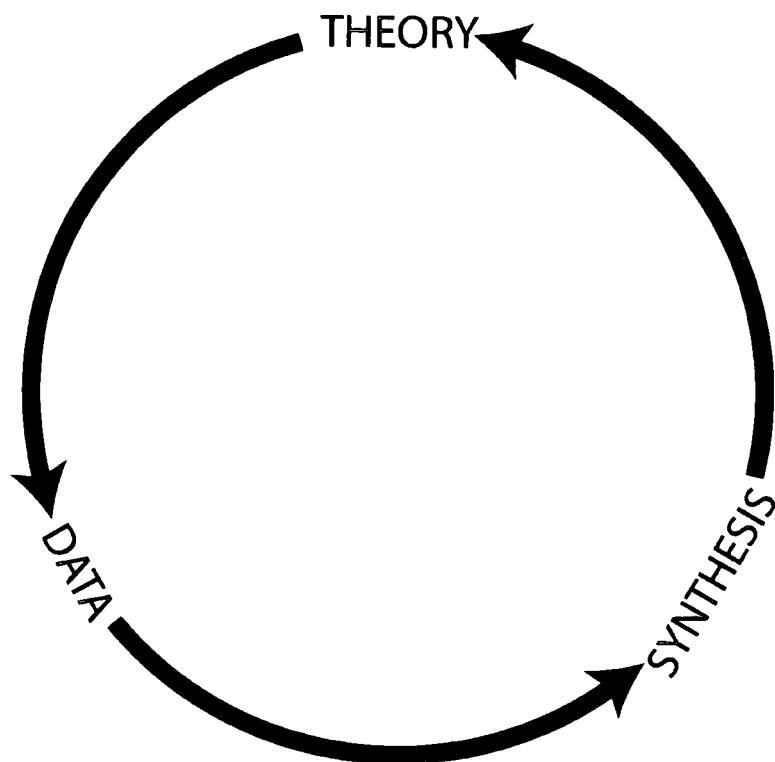

Figure 181 Hermeneutic loop of archaeological enquiry.

The model concept is to provide a single set of co-ordinated digital spatial and a-spatial data for use in all aspects of the project process: from concept design through collection, interpretation and eventually on to synthetic analysis, dissemination, archivation and CRM. Therefore, the data model will outline a framework which will ensure successful data collection, analysis, management, curation and dissemination. The environment should allow the following to occur:

- Data re-use throughout the duration of the project.
- Access to an up to date model at all times.
- Creation of a collaborative environment to allow the sharing of data.

- Robust data management and back-up regime.

In comparison to only 10 or 15 years ago, computers are now an accepted part of archaeological life. The use of integrated 'office' products is now ubiquitous in the discipline. Archaeological data management, analysis and visualisation applications using software such as Geographical Information Systems (GIS), Relational DataBase Management Systems (RDBMS), Virtual Reality Mark-up Language (VRML) viewers and statistical analysis packages have proliferated over the past decade. The use of technology has led to the phenomena of information explosion. Hence, defining the modelling environment becomes even more important in order to manage this important and potentially volatile resource.

The use of GIS and database applications, in particular, has allowed archaeologists to not only rapidly analyse their data sets but to employ a variety of different analytical mechanisms (Kvamme 1999). GIS and other computerised analysis software should take us beyond the simplistic, but useful, production of distribution maps into the realms of multi-criteria and other statistical analysis. This can only occur if the data model has been defined with analysis in mind and the data that is recorded is of consistent quality. The accumulated benefits of running sophisticated statistical analyses at a variety of generalisations should transform current analytical frameworks. The key to understanding these information resources is to find appropriate mechanisms to collect, integrate, analyse, generalise and synthesise the archaeological record.

1.1.1 Project requirements of the data model

The thrust of this research is to evaluate the effective integration of three important sources of satellite imagery as aids to archaeological analyses;

- Recently declassified military photography (Corona).
- Multispectral imagery (Landsat TM).
- New sub-metre imagery (Ikonos).

To facilitate analysis and interpretation the processed and co-registered satellite imagery had to be integrated with ground-observation information captured as part of the SHR project. These data, predominantly morphological, artefactual and geo-archaeological, will provide the basis for understanding the history of human inhabitation of the application area. The integrated study will consist of data sets from the following sources:

1. Present day and historic mapping.
2. Multi-resolution satellite imagery.
3. Ground survey (e.g. total station and GPS survey, field walking and geophysical survey).
4. Site, artefact and environmental attribute recording.

The comparative study of these data sets will allow the following to occur:

1. Identification of features/anomalies from past archaeological landscapes.
2. Recognition of additional features based upon spectral and spatial characteristics determined from (1).
3. Assessment of the different environmental zones and their impact on archaeological visibility and preservation during different seasonal and agricultural regimes.
4. The creation of thematic data sets as an analytical and predictive framework (e.g. geomorphology, hydrology and relict-hydrology).
5. The delineation of relationships between archaeological landscapes and the environment.
6. Long term evaluation and management of the regional cultural resources.

In essence the research entails the elucidation of as many of the archaeological components of the landscape as possible from the satellite resource. However, to realise the full CRM potential of the application area and the long-term potential of the SHR project the information system must be able to respond to archaeological investigation at any scale (including excavation) and have the ability to synthesise this information for different scales of analyses.

A major requirement of the SHR project is to investigate the feasibility of applying wholly digital recording and analysis techniques throughout the project from inception to deposition. Integrated digital applications are rarely applied during the process of data collection itself. The vast majority of digital techniques are used during the creation of synthetic information (report preparation) or, potentially more dangerously, to generalise the fieldwork record to perform landscape analyses (for example the English Sites and Monuments Record). Generalisation in this way can severely inhibit analytical enquiries as the

raw data is separated from the analytical data i.e. scalar generalisation occurs through a synthetic intermediary rather than directly on the raw data. As the research employs data sets with different spatial resolutions, one goal is to develop analytical and management models that enable the raw data sets to be analysed at a variety of scales (from landscape down to intrasite analysis).

1.1.1.1 The archaeological evidence

The archaeological evidence within the study area falls into the following categories and sub-categories:

1. Sites and their sample units.
 - a. Tells (sites of sustained, intensive duration, usually identified through contour interpretation).
 - b. Other sites (artefact scatters, soil features and structures).
2. Non-sites (or background).
3. Hinterlands.
4. Field systems.
 - a. Those identified through 'hard' physical features (walls).
 - b. Those identified through 'soft' physical features (vegetation and ditches).
 - c. Those identified as 'relict' or 'out of use' systems (soil marks etc.).
5. Communication networks.
6. Seasonal systems.
7. Contextual environments.

1.1.1.2 The project environment

This data set will primarily be used by researchers within the departments of Archaeology and Geography at the University of Durham. However, many different specialists (particularly environmental and artefact specialists) will need to contribute to and have access to the data set. Many of these specialists (mainly university affiliates) will be in different locations and countries. For periods of the year, the fieldwork programme requires a significant proportion of the data set to be 'off-line'. Furthermore, the project has Syrian

partners within the Directorate General of Antiquities and Museums (DGAM), who in the longer term, will need easy access to this information resource.

The most obvious practical problem is the distributed nature of users and work environments. The traditional solution to this problem provides each individual with their own copy of the archive. Each researcher inputs their data, these multiple data sets are then collated and then re-integration to a single model is attempted. This approach creates a significant data management problem which is further exacerbated in an archive which is predominantly digital in nature.

I.1.2 Model brief

The model data set will consist of 2-d and 3-d graphical data and attribute data. These data will be in raster, vector and RDBMS format. The model will be used to provide spatial and attribute information to the user in the required format by querying the data model. This set of data will be geographically and spatially correct (projected in Universal Transverse Mercator (UTM) 37N).

Attribute data will be linked through to vector data via the use of unique identifiers and other compound keys. These links will allow spatial and attribute queries to occur at any level of abstraction. For example, the whole landscape can be spatially queried for the distribution of artefact attributes based upon their most refined spatial location, alternatively, the same query could be performed at the level of 'site' where the artefact attributes would be grouped by a 'containing' site which generalises their spatial location.

Some data sets will be 'stand alone' that is. they will have limited or no direct links to other data sets and will be used for visualisation and resource purposes only (e.g. raster digital mapping). Although satellite imagery and TIN models will be used to derive other thematic products (such as land use maps, archaeological sensitivity maps and slope and aspect models), where such a situation occurs all processing metadata will be maintained to allow subsequent recreation of these data sets.

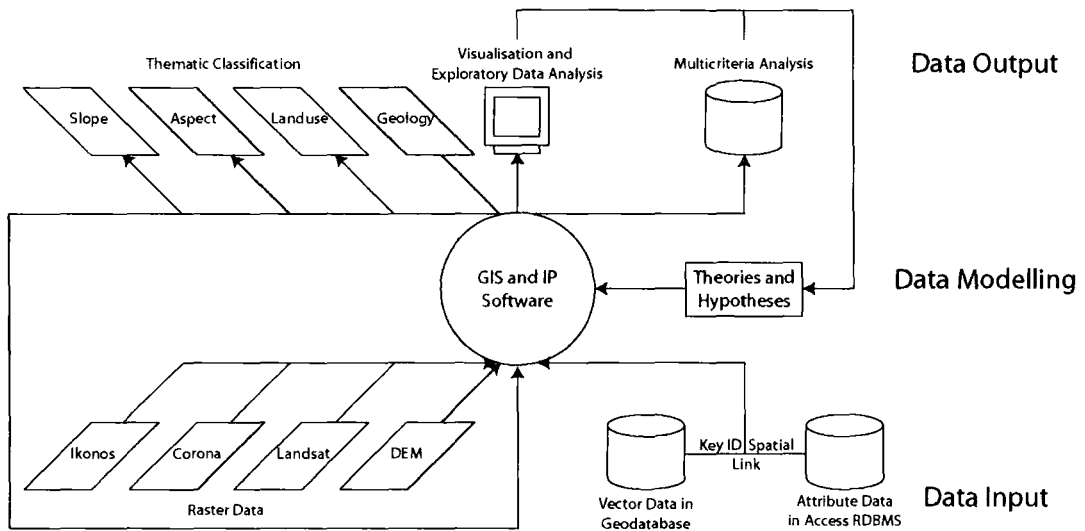

Figure 182 Conceptual modelling schema.

The data model will be structured predominantly to produce results from satellite processing techniques and archaeological surface survey. However, the data model must allow future invasive excavation episodes to be adequately incorporated and queried. Furthermore, isolated architectural evidence (for example olive presses or milestones), referred to as *installations*, must also be able to be recorded and queried without the attribution of any 'site' details.

Where appropriate the model will conform to the following requirements:

1. The adherence to cultural collection standards to ensure data conformity and longevity.
2. Where possible all data will be captured by digital means.
3. All database tables will be *normalised* (Date 2000).
4. *Referential integrity* will be maintained in the database.
5. Files will be maintained in *interoperable* data formats (but not at the expense of data management and integrity).
6. Metadata will be created and maintained in appropriate formats.
7. Where possible an audit trail for all information conversion and analytical reasoning will be maintained.

8. There will be a strict regime for backup.

To summarise, the data model aims to produce a flexible environment where high quality data can be collected, integrated, generalised and disseminated for analysis at any scale. The environment outlined will provide a research framework that will allow the integration and generalisation of ALL archaeological data whatever the scale and mechanism of collection. The ability to access multiple high quality data sets should unify some of the disparate agendas of archaeological theory and practice by re-establishing the causal links between practice, data, analysis, synthesis and theory. Current interest in the complex relationships between theory versus practice, particularly on the point of reflexivity, have re-opened many discussions on the application of technology (Beck and Beck 2001; Lucas 2001; Chadwick in press). Reflexive approaches to field recording, by their very nature, require rapid feedback of complex information in a digestible format (synthesis on the fly), a process which is best conducted through a robust data model. Technology itself is a facilitator; however, the implementation and use of this technology is subject to organisational pressures (for example see Campbell and Masser 1993).

Finally, a data model is not rationalised by what data it can store (that is the domain of a catalogue), rather upon what information can be extracted from it. Hence, information extraction is the primary driving force in the model design.

I.2 Model environment

I.2.1 Software environment

The backbone of the software environment will be provided by the functionality of Environmental Systems Research Institute's (ESRI) ArcGIS suite of GIS software, Research System's ENVI and ERDAS's Imagine Image Processing (IP) software. MicroSoft (MS) Access will be the Relation DataBase Management System (RDBMS).

ArcGIS is an industry standard Geographical Information Software (GIS) suite with advanced 'object orientated' raster and vector modelling capabilities. It allows users to access separate project files as if they were a single model and at the same time allows multiple users to work on individual files simultaneously. All vector files are stored within the co-ordinated ESRI personal Geodatabase format (an MS Access file). All raster files will employ the interoperable formats determined by the Image Processing (IP) systems. ArcPAD is used in conjunction with ArcGIS. ArcPAD is a mobile GIS data collection application designed to

run on the Pocket PC O/S. ArcPAD is designed as a seamless interface for multiple users wishing to collect and update spatial and attribute data within a collaborative work environment.

ENVI and Imagine are both dedicated image processing packages with advanced raster modelling capabilities (including dedicated hyperspectral analysis programs) and GIS functionality. All raster files are stored as GeoTiff or multi-band Imagine files. All vector files will be shared in interoperable formats determined by the GIS.

Microsoft Access is a popular and inexpensive RDBMS which is widely supported within many GIS packages. Files are stored in native MS Access format. ThinkDB will be used in conjunction with MS Access. ThinkDB is a mobile relational database application designed to run on the Palm OS. ThinkDB is a multi-user system which allows users to bi-directionally synchronise records with the central database (see Figure 184). This allows users to have the most up-to-date records with them at all times.

Other software systems will also be included in the data model. However, these will be predominantly intermediary software for the conversion of data from a collection device into the required formats for the data model (i.e. digital camera, total station or GPS downloading and conversion software) and are hence subject to rapid change.

1.2.1.1 File Formats

The software environment employs a suite of different applications, each of which has specific strengths, weaknesses and their own preferred, and in some instances proprietary, file format. These applications will access the same data in the data model. In order for this to occur seamlessly, wherever possible, the data should be interoperable. Interoperability is the ability of a system or a product to work with other systems or products without special effort on the part of the user (whatis.com). Although interoperability is normally used in a hardware and software context, it also pertains to data itself. With the increase in volume of data being produced and stored digitally, data interoperability is a topic of concern in all collaborative projects and programmes. Table 31 and Table 32 outline the major file format groupings the choice of file formats for active usage and archive formats.

Type	Comments	Format
Structured Texts	Documents produced using word-processing, desk top publishing and text mark-up applications.	MS Word (.doc), MS Excel (.xls), Adobe Portable Document Format (.pdf) and Adobe PageMaker (.pmd)
Raster Graphics	Bitonal, greyscale and colour raster images. Produced for recording and illustration purposes.	TIF, JPEG, BMP and Adobe Photoshop (.psd)
Vector Graphics	Vector images, including 3d models. Produced for recording and illustration purposes.	WMF, AutoCAD (.dwg), ESRI Shape (.shp) and Adobe Illustrator (.ai)
GIS	Although this comprises a combination of other datasets it is grouped separately due to its integrated nature. The arbitrary focus for GIS datasets are vector files.	ESRI Geodatabase (.mdb), Erdas Imagine (.img) and GeoTIFF (.tif)
Image Processing	Although this comprises a combination of other datasets it is grouped separately due to its integrated nature. The arbitrary focus for IP datasets are multiband raster files.	ESRI Shapefile (.shp), Erdas Imagine (.img), MrSID (.sid) and GeoTIFF (.tif)
Database	Integrated raw data and analysis systems. No spreadsheets will be created for raw data; rather they will be included as database tables.	MS Access (.mdb)

Table 31 Types of Digital Resource

Over the medium to long time frame software and file convergence between GIS, IP and RDBMS will continue, which will ultimately provide the full functionality of these diverse software packages within one framework. From a file format perspective this has already been achieved within ESRI's Geodatabase, a single RDBMS containing raster, vector and attribute data. However, this file format has yet to demonstrate its interoperability.

Data Type	Use Format	Archive Format
Structured Text:	Microsoft Word	DOC
Word Processed	Adobe Portable Document Format	PDF
Structured Text: DTP	Adobe Pagemaker	PDF
Raster Graphics: Publication	TIFF	TIF
	JPEG	JPEG
	Adobe Photoshop	TIF
Raster Graphic: Geo Single Band	GeoTIFF	GeoTIFF
	Erdas Imagine	GeoTIFF
Raster Graphics: Multi Band	Erdas Imagine	GeoTIFF (one per band)
	MrSID	No archive
Vector Graphics: Publication	Adobe Illustrator	AI
	Windows Metafile	WMF
	AutoCAD Drawing Web Format	DWF
Vector Graphics: Geo	ESRI GeoDatabase	ESRI shape
Data Sets: Database	Microsoft Access	ASCII text (comma separated with text in quotes) or MDB
Data Sets: Spreadsheets	Microsoft Excell	XLS (these files should be integrated into the database)

Table 32 Active and archive file formats

1.2.1.2 Naming conventions and file structures

For deposition and re-use purposes an 8 character-naming convention is preferred (based on DOS). All directories are currently in this format with the exception of directories

automatically generated through theme creation in ArcGIS. However, in order to make some filenames intelligible (particularly when working with processed raster imagery) long filenames are used. No names shall include the following characters <spaces> / \ < > * % \$ £ “ ! + - .

Figure 183 outlines the project directory structure. Each directory and sub-directory contains an *ascii* text file called ‘Readme.txt’ which provides more information about the directory and any subdirectories. The directories called *unknown* contain information created during the project which have been misfiled and consequently need integrating or deleting.

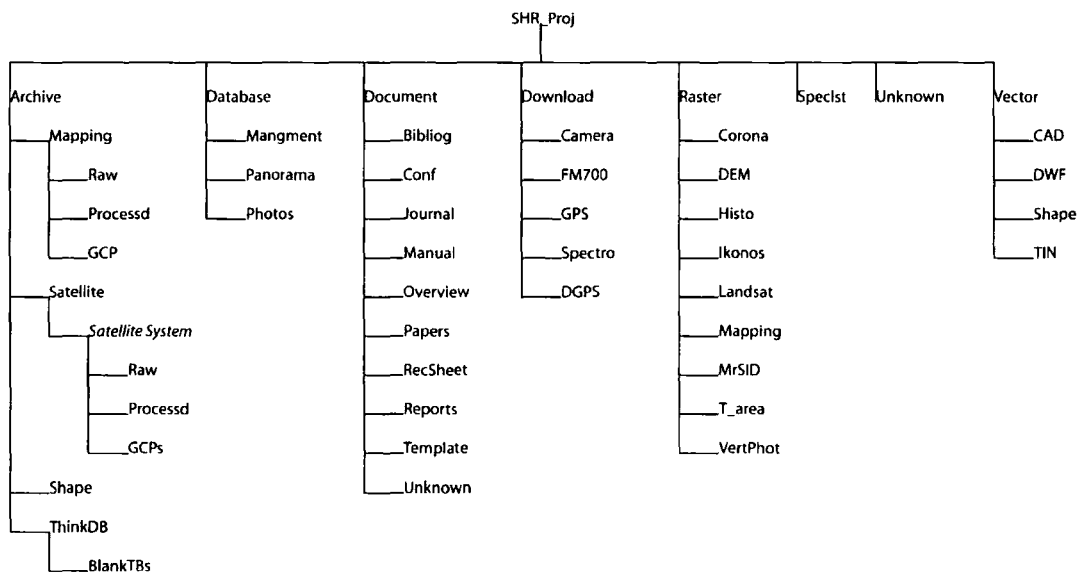

Note: Italics represent a generic structure where the italics are replaced by the appropriate data source name.

Figure 183 Project Directory Structure.

1.2.1.2.1 Archive directory

The *archive* directory contains all archived and legacy data sets. These will normally reside solely on the Geography server at the University of Durham.

1.2.1.2.2 Database directory

The *database* directory contains all RDBMS files and their derivatives. The subdirectories *Panorama* and *photos* contain the project panoramic (360 degree) and digital photographs. The *mangment* subdirectory contains any database management files.

1.2.1.2.3 Document directory

The *document* directory contains all validated project (and related) documentation. Each document in this directory has an associated metadata database record. This also means that all documentation can be accessed directly through the information system. For publication purposes some documentation files contain separate textual and graphical components. For simplicity of data management each graphic is prefixed by the filename of the linking document and suffixed by *fig* and the appropriate figure number. For example the document *sienna2001.doc* has three images stored as *tiff* files called *sienna2001fig1.tif*, *sienna2001fig2.tif* and *sienna2001fig3.tif*. Note that ALL unvalidated documentation is stored in the *unknown* directory.

1.2.1.2.4 Download directory

The *download* directory contains all the *raw* downloaded data sets. The subdirectories refer to the nature and type of device. These data sets are maintained to ensure that if a critical system failure or malicious deletion occurs then the archive can be recreated from proprietary data.

1.2.1.2.5 Raster directory

The *raster* directory contains all the geo-referenced raster data sets. This does not include digital photography unless it has been geo-registered. Each sub-directory contains data set groupings which are mainly self explanatory.

1.2.1.2.6 Speclst directory

The *speclst* directory contains all interim information supplied by the project specialists and is therefore a holding directory until all the primary data can be integrated into the model.

1.2.1.2.7 Unknown directory

The *unknown* directory contains all unvalidated information of unknown purpose that has arrived into the project data structure but may be important. These files will be integrated into the main project structure as appropriate.

1.2.1.2.8 Vector directory

The *vector* directory contains all the geo-referenced data sets held in the vector format. As the project has moved to a geodatabase model (held in MS Access database format in the *database* directory) for the primary vector data this directory contains commonly used vector data sets exported from the geodatabase. Hence all files in the directory are *secondary* files.

I.2.2 Hardware environment

The modelling environment has been established on the principal of a co-ordinated yet distributed situation. This design is to reflect the stable data management and back-up facilities available at the University of Durham and the less stable fieldworking environment. A worst-case data scenario would involve multiple field collection teams in Syria and multiple users accessing and altering the on-line information content in Durham.

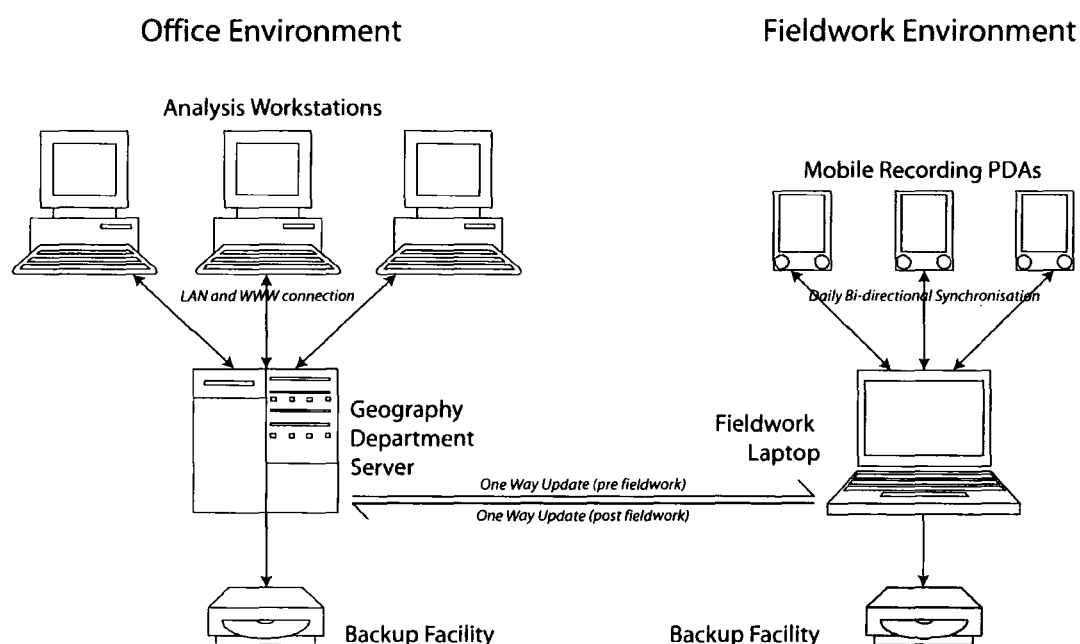

Figure 184 Hardware schema for the project data model.

Figure 184 outlines the basic hardware schema for the project. This currently entails making the server effectively 'offline' during fieldwork to ensure that there is no duplication of data or data loss at either end. However, it is the long-term goal to define a global data model where the fieldwork data is bi-directionally synchronised with the stable data set stored on the Geography Server. This would ensure that local and remote users can work simultaneously on the same up-to-date data set.

In addition to the basic hardware schema defined by Figure 184 the project also employs digital cameras, handheld GPS devices and PDAs for digital mobile data collection.

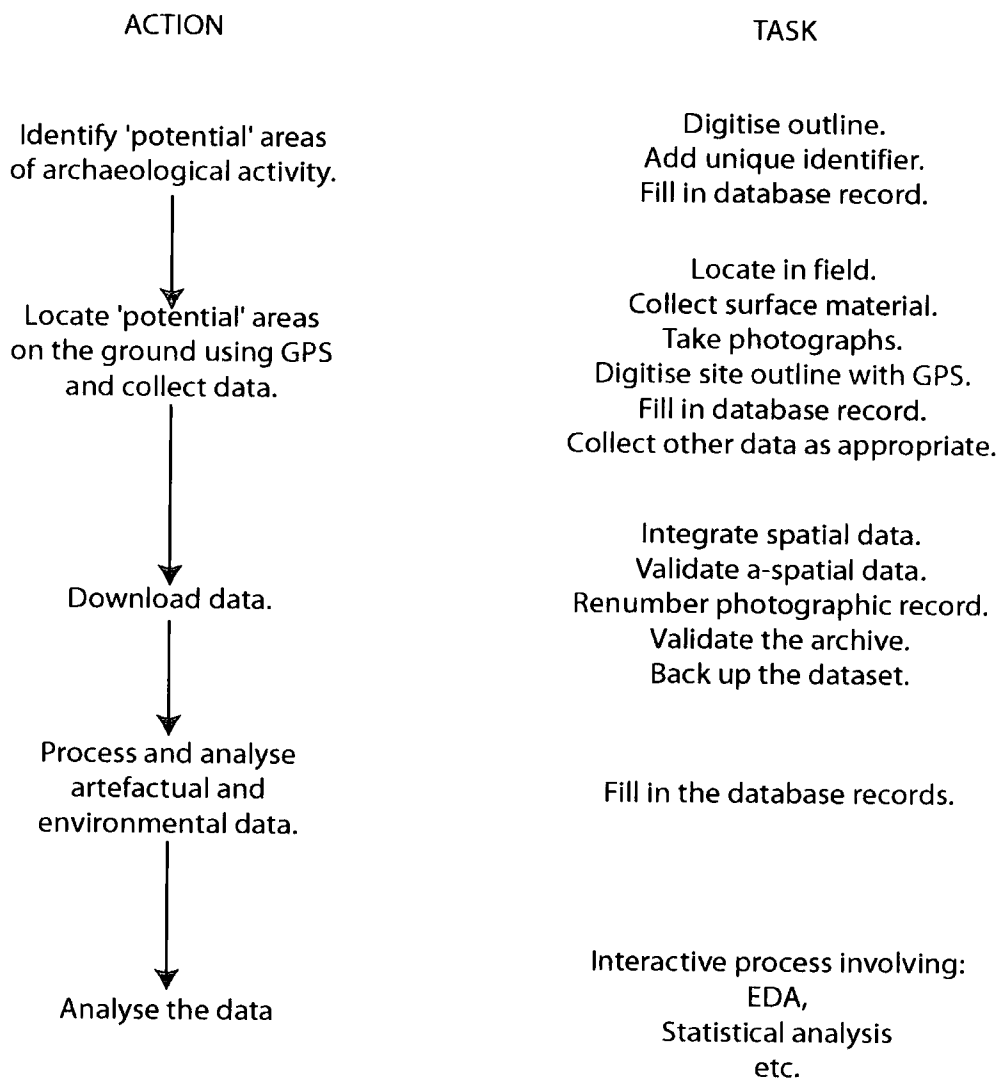

Figure 185 Schematic data flowline

1.3 SHR project data model

1.3.1 Data flowline

Figure 185 defines the project data flowline. Formal delineation of this flowline is essential for the data model as it provides information on how data enters into the model and how it is transformed by the modelling process. This information is then used to help determine the nature of the data structure. For example, artefactual evidence, with the exception of installations, all come from somewhere within a geo-referenced site or off-site collection unit. It is essential that when an artefact's attributes are entered into the database that at least the

basic information for this unit exists. Otherwise, particularly in an environment where referential integrity is applied, the user will be unable to add any data about the artefact.

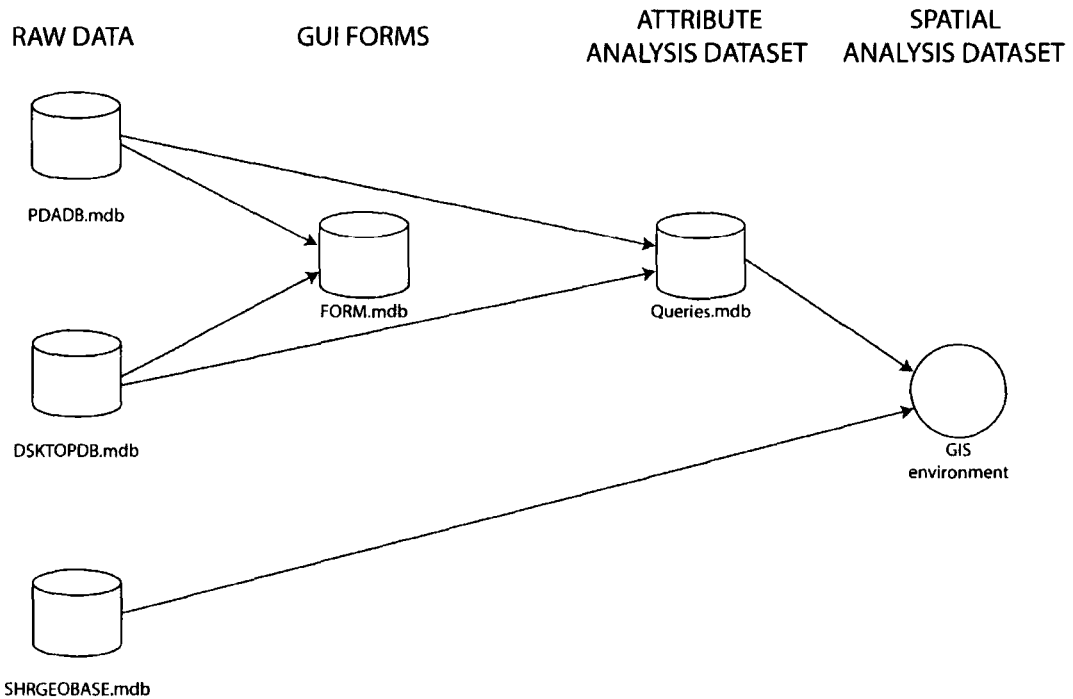

Figure 186 Database schema.

I.3.2 A-spatial model

There are many GIS data sets within the project yet only a few of these will have the need for a complicated attribute data set. It should be possible to store most information within the spatial data set itself. For example, the hydrology network can contain the river network dendritic hierarchy weighting within the drawing. Where external information is stored separately from the drawing it will initially be maintained within the Access2000 environment, however, migration to AccessXP may occur if this database format is utilised within the university.

Complex a-spatial information will be maintained for the ground based reconnaissance and the interpretative elements of the landscape. This data set will include information about finds, site sub-divisions, sites, morphology and interpretation.

The use of the geodatabase will allow the seamless integration of all spatial and attribute data within one data environment. However, until this storage model has been rigorously tested in the distributed work environment it will not be fully implemented.

1.3.2.1 Database architecture

For data management purposes the Access data sets have been separated into five Access databases, including the geodatabase *SHR_GeoBase.mdb* (see Figure 186). All referential integrity has been turned off for the database *PDADB.mdb* as this is essential for the synchronisation process between the PDAs and Access. Referential integrity ensures that a 'parent' table must have a record with the appropriate primary key before any 'child' table can refer to this record. For example, with referential integrity turned on you can not add any sub-table attributes about site 454 if site 454 does not already exist in the parent table. Referential integrity is now enforced through the Graphical User Interface (GUI) rather than at the table level. When the software and hardware architecture change it is hoped that referential integrity will be enforced at the table level.

1.3.2.2 PDADB.mdb

PDADB.mdb holds the raw data and data management queries for the tables which are synchronised with the PDAs (see Figure 187).

1.3.2.3 DskTopDB.mdb

DskTopDB.mdb (Desk Top Database) holds the raw data and data management queries for the tables which are not synchronised with the PDAs (see Figure 188).

1.3.2.4 Analysis and visualisation databases

PDADB.mdb and *DskTopDB.mdb* contain the raw database tables and management queries for the a-spatial data model. These databases have been physically separated for ease of data management and maintenance when, for example, implementing the mobile collection database on the PDAs. However, when users need to access or analyse the full data set then both *PDADB.mdb* and *DskTopDB.mdb* need incorporating into one conceptual model. This has occurred by *linking* all the tables from the two databases into any number of new databases. This provides a flexible mechanism to create as many user-definable databases as required which all have direct access to the raw data contained in *PDADB.mdb* and *DskTopDB.mdb*.

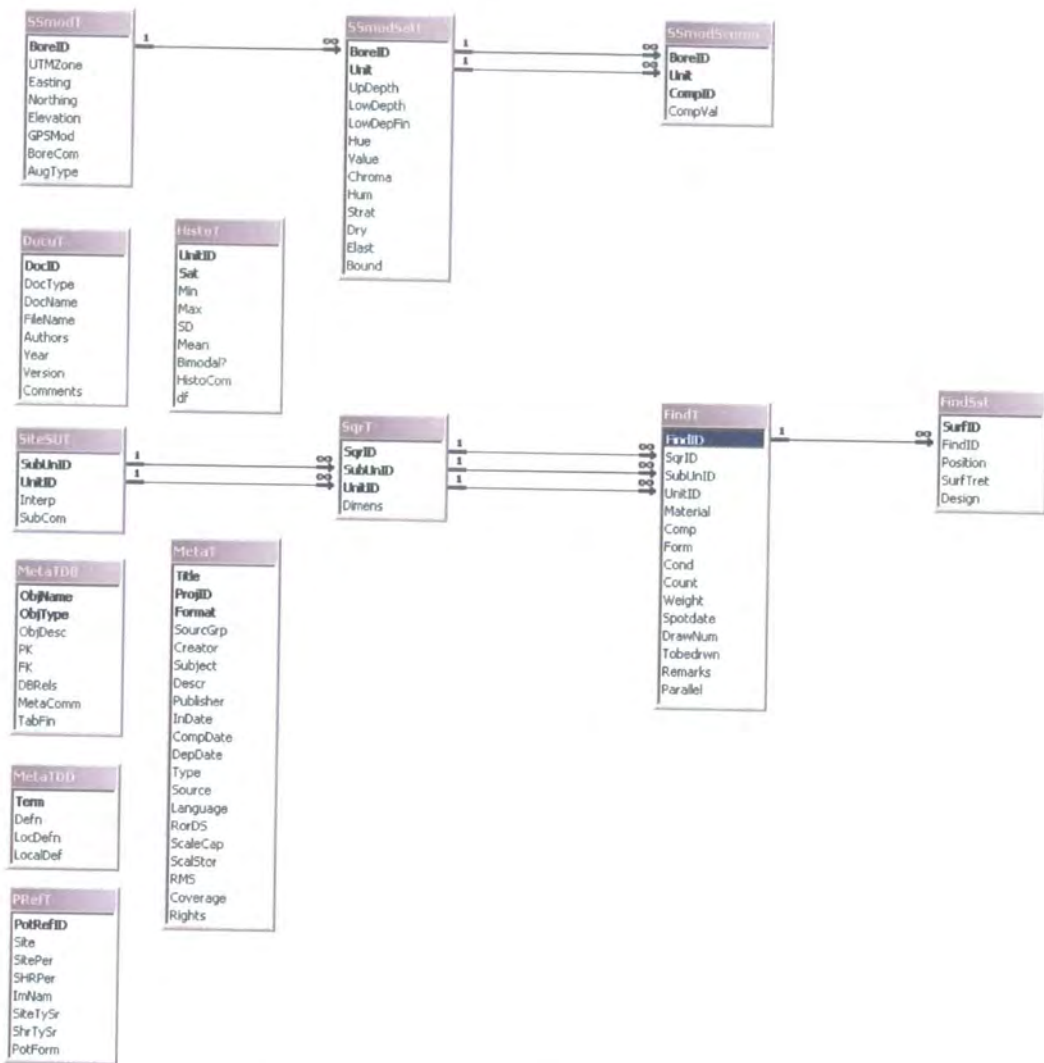

Figure 188 DskTopDB.mdb entity relationship model. Note the fields in bold text are the primary (or compound primary) keys.

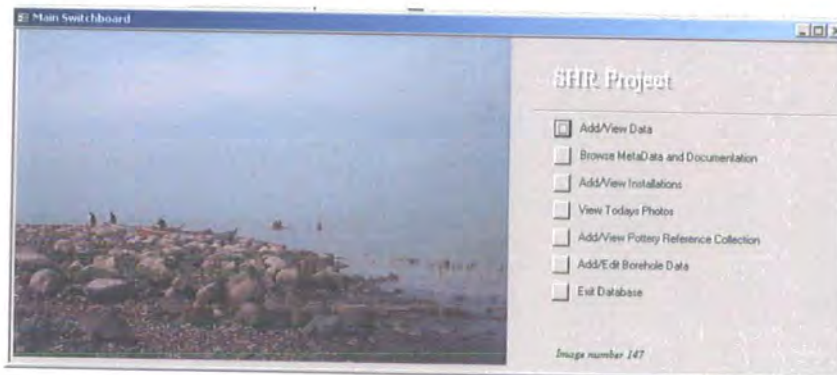

Figure 189 The main switchboard for Forms.mdb.

means that all changes in design can be easily distributed over any number of computers on the network.

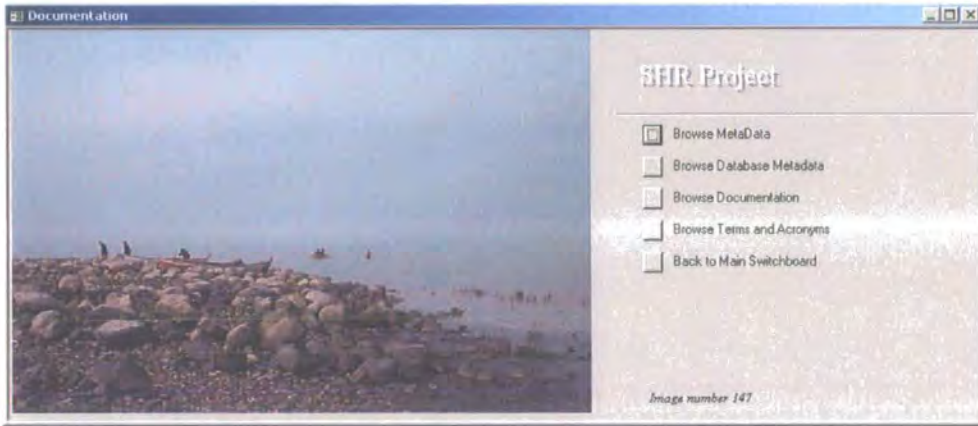

Figure 191 The metadata switchboard for Forms.mdb.

1.3.2.4.2 Queries.mdb

Query.mdb contains user defined queries, reports and linked tables from *DskTopDB.mdb* and *PDADB.mdb* (see Figure 186). This database should be used as a link for any pivot-table querying in MS Excel and as a basis for any GIS attribute queries. If the project upgrades to Office XP pivot table analysis will occur directly in MS Access.

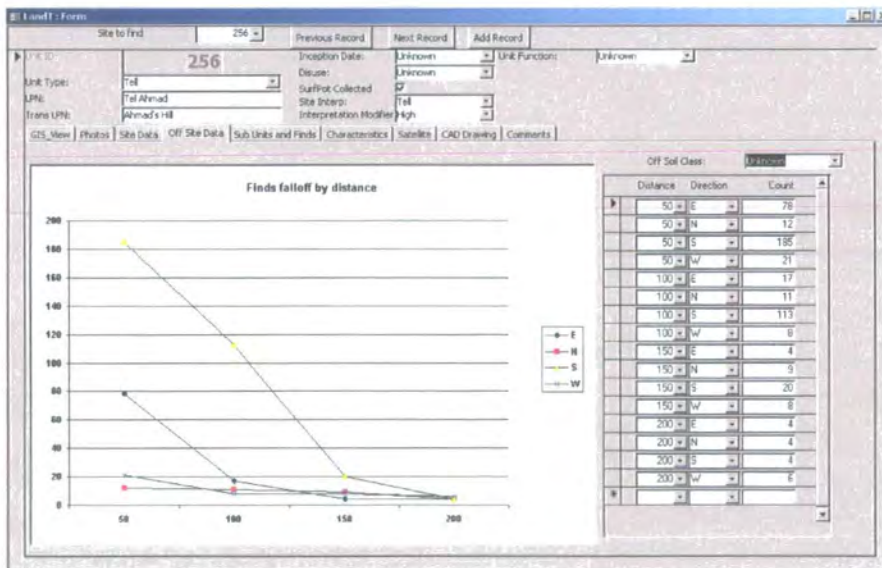

Figure 192 An example of a site form (after clicking Add/View data on the main switchboard). Note the tabs to access other data about the site.

1.3.3 Spatial model

Spatial data refers to any data set that has an implicit spatial component. Archaeological examples include maps, aerial photographs, satellite imagery, site plans, geophysical surveys and terrain models. Unfortunately, spatial data standards are not as robust as RDBMS standards although organisations such as the Open GIS consortium (www.opengis.org) are facilitating interoperable data formats. This project is employing both raster and vector formats to store its data.

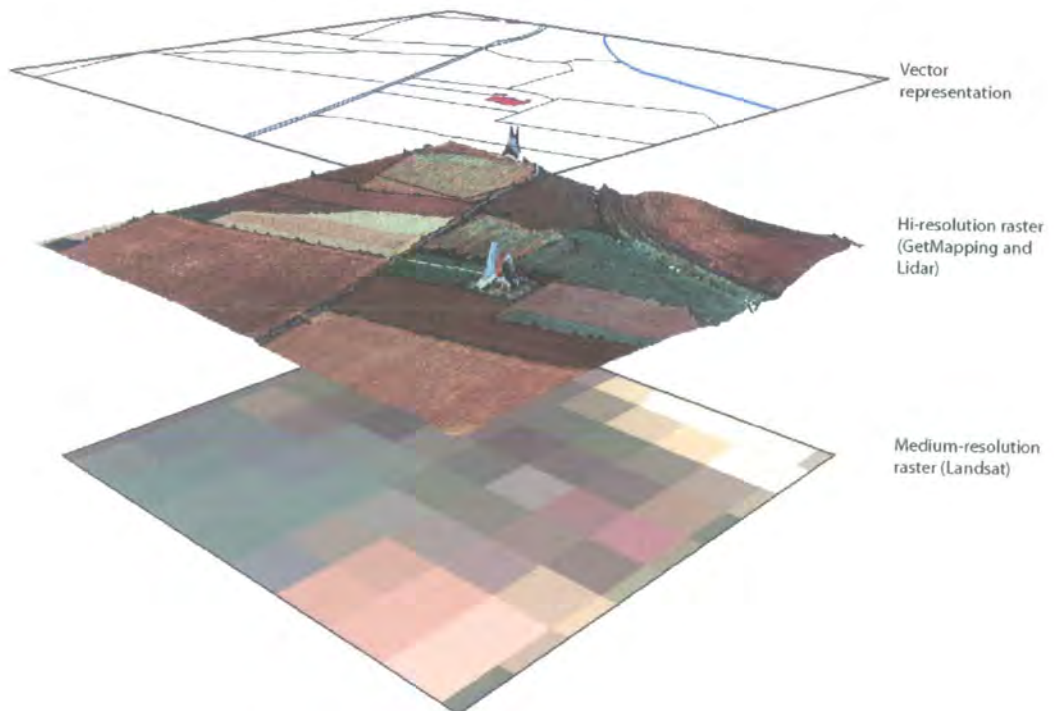

Figure 193 Comparison of vector versus high and medium resolution raster representations (Courtesy NERC, GetMapping and English Nature).

1.3.3.1 Raster model

The raster model employs a simple array of cells located in space. Each cell contains a value that represents a real world object. The cells can be of any shape which can form a tessellation although rectangles are the most common examples. Due to the regular nature of the data structure raster models are easily manipulated within computers. Raster models are spatially less precise than vector models as the representational scale is governed by the size

of the cell (see Figure 193). However, many spatial data sets (satellite imagery, aerial imagery and geophysical surveys) are collected in raster format.

The raster model is maintained through the interoperable file formats described earlier. These formats are used so that seamless analysis can occur in all the software environments.

I.3.3.2 Vector model

Vector representations use points, lines and polygons to represent reality. Vector GIS have more accurate spatial referencing and are thus commonly used in environments where spatial precision is essential (such as cartography). Hence, there has been a long standing relationship between Computer Aided Design (CAD) and vector GIS (Burroughs 1986). The vector model is maintained within a single ESRI Geodatabase called SHR_GeoBase.mdb. The geodatabase is hierarchically structured into many *feature data sets* which contain many related *feature classes* (see Table 33).

Feature Dataset	Feature Class	Topology	Description
3d Mapping	Contour	Network	3D Contour lines
3d Mapping	Contour_point	Point	3D points 'weeded' from the contour lines
3d Mapping	GPS Breaklines	Network	3D and 2D breakline data collected from GPS
3d Mapping	Spotheight	Point	3D Spot height
3d Mapping	Trigheight	Point	3D Triangulated trig. points
Archaeology	Depressions	Polygon	Depressions associated with sites
Archaeology	Non_Arch_Soil_marks	Polygon	Soil marks of non-archaeological origin
Archaeology	Poss_Linears	Network	Possible linear features
Archaeology	Site_Sub_units	Polygon	Outlines of site sub units
Archaeology	Sites	Polygon	Outlines of sites
Boundary	Grid	Network/Polygon	2km sampling grid
Boundary	Grid_done	Point	Sampled 2km sampling grid
Boundary	Study_Area	Network/Polygon	Extent of the study area
Communication	A_Road	Network	Network of major roads
Communication	B_road	Network	Network of minor roads
Communication	Bridge	Network	Bridges
Communication	Track	Network	Network of tracks
Communication	Train	Network	Train network
HistoricMapping	Fields_Syrian1to50	Network/Polygon	Field boundaries identified from the mapping
HistoricMapping	Structure_Syrian1to50	Polygon	Amorphous structures identified from the mapping
Hydrology	Canal	Network	Concrete irrigation canals
Hydrology	Irrigationchannel	Network	Irrigation canals
Hydrology	Lake	Network	Lake edge
Hydrology	Marsh	Network	Marsh edge
Hydrology	River_cent	Network	River centerline
Hydrology	River_edge	Network	River network
Hydrology	Wadi	Network	Wadis and other seasonal water courses
Soil	Soil Mapping	Polygon	Soil polygons

Table 33 Definition of the feature data sets and their classes within SHR_GeoBase.mdb.

The specific methodologies for converting any raster-derived themes or classifications into vector themes are discussed in the appropriate sections of the methodology. The majority of attribute data is contained directly within the geodatabase itself except for the *archaeology* feature data sets.

I.3.3.3 Legacy information

The spatial modelling environment has already gone through many incarnations as the core spatial software environment has changed. Initially ESRI's ArcView GIS was the main vector modelling environment. Unfortunately the vector data management capabilities of ArcView were quite poor. To address this issue AutoDesk's AutoCAD MAP software was employed to manage the vector data as AutoCAD is one of the most widely supported packages for surveying instrumentation; furthermore, the functionality of MAP enabled high-end GIS data cleaning, topology management and export to occur.

LatinGenus	Common Name	Genus	Family	Suborder	Order	Vertebrate Code
Accipiter nisus	Sparrowhawk	Accipiter sp.	Accipitridae	Accipitridae	Accipitriformes	Avian
Alauda arvensis	Skylark	Alauda sp.	Alaudidae	Alaudidae	Passeriformes	Avian
Anas crecca	Teal	Anas sp.	Anatidae	Anatidae	Anseriformes	Avian
Anas platyrhynchos	Mallard/ Domestic Duck	Anas sp.	Anatidae	Anatidae	Anseriformes	Avian
Anguis fragilis	Slow Worm	Anguis sp.	Anguidae	Anguidae	Sauria	Reptilian
Anura sp.	Frog/ Toad sp.	Anura sp.	Anura	Anura	Anura	Amphibian
Apodemus cf. Sylvaticus	Wood Mouse	Apodemus sp.	Muridae	Myomorpha	Rodentia	Mammalian
Apodemus flavicollis	Yellow Necked Field Mouse	Apodemus sp.	Muridae	Myomorpha	Rodentia	Mammalian
Apodemus sp.	N/A	Apodemus sp.	Muridae	Myomorpha	Rodentia	Mammalian
Apodemus sylvaticus	N/A	Apodemus sp.	Muridae	Myomorpha	Rodentia	Mammalian
Apodemus/ Mus sp.	Wood Mouse/ House Mouse	Apodemus sp.	Muridae	Myomorpha	Rodentia	Mammalian
Ardea cinerea	Grey Heron	Ardea sp.	Ardeidae	Ardeidae	Ciconiformes	Avian
Arvicola terrestris	Water Vole	Arvicola sp.	Cricetidae	Myomorpha	Rodentia	Mammalian
Asio flammeus	Short-Eared Owl	Asio sp.	Strigidae	Strigidae	Strigiformes	Avian
Asio otus	Long-Eared Owl	Asio sp.	Strigidae	Strigidae	Strigiformes	Avian
Athene noctua	Little Owl	Athene sp.	Strigidae	Strigidae	Strigiformes	Avian
Bird sp.	Bird sp.	Bird sp.	Other	Other	Other	Avian
Bufo bufo	Common Toad	Bufo sp.	Bufo	Bufo	Anura	Amphibian
Bufo calamita	Natterjack Toad	Bufo sp.	Bufo	Bufo	Anura	Amphibian
Bufo sp.	Toad sp.	Bufo sp.	Bufo	Bufo	Anura	Amphibian
Buteo buteo	Common Buzzard	Buteo sp.	Accipitridae	Accipitridae	Accipitriformes	Avian
Buteo cf. Buteo	Buzzard sp.	Buteo sp.	Accipitridae	Accipitridae	Accipitriformes	Avian

Table 34 Genus lookup table with 'Value Added' information (LGenus is the primary key): Courtesy of Dr. Philip Piper.

I.3.4 Data validation

Many analyses are limited by attempting to query information in a model which is incomplete or inconsistent. Data validation is the process of ensuring that all data is complete and consistent and where there are problems these are flagged. Many of the validation procedures are transparent to the user by the use of digital recording. The databases on the PDAs require that all their fields contain a value, even if this value is 'unknown' thus enforcing validity. Furthermore, many management queries have been developed in the databases to test for

logical consistency within the data itself. However, the most prevalent form of data validation is in the use of *lookup tables*.

Lookup tables (attribute table or data dictionaries) are commonly employed to standardise data entry. They contain a list of pre-defined terms that can be entered into a field without the user introducing typographical errors. However, lookup tables can also be used to extend meaning from the 'value laden' terms used in recording by incorporating a powerful generalisation and analytical functionality. Table 34 is a genus table for an animal bone specialist. The field 'LatinGenus' is the primary key (a field that contains only unique values) and is all that is required for a look-up table. However, the other fields 'add value' to the table by including information implicitly contained within the 'Latin Genus'. As a trivial example 'Common Name' can be used to replace the Latin name for popular publications, or more importantly 'Order' can be used to generalise data into taxonomic order groupings. This technique could also be extended to include other 'indicator' attributes such as habitat. This will allow more sophisticated and generalised querying to occur while maintaining the primacy of the raw data (i.e. show the distribution of all bones grouped in their taxonomic 'Order' that occur in enclosure ditches and are of animals that do not prefer moist habitats).

1.3.4.1 Confidence

It is important to be aware of the level of error associated with data sets before they are modelled. Most of the raster data sets will have their locational and classification errors embedded directly into their meta-data. It is more difficult to describe confidence for attribute data: error is introduced from a variety of sources and is closely correlated to the subjective experience and goals of the individual recorder (Richards 1998 pp. 65, 224-225; Banning 2002 p. 40). Attempting to create wholly objective field records is viewed by many archaeologists as a fruitless goal (Shennan 1985; Banning 2002). Hence, a subjective system has been adopted whereby a recorder can evaluate their own confidence in their interpretation by use of a modifier. For example the 'Unit Interpretation' field *UnitInt* has an associated modifier field *IntMod* (see Figure 187) whereby the recorder can add one of the following values to represent their own confidence in the interpretation: low, medium or high. These fields are used extensively throughout the database. Although not ideal, the system does provide greater awareness to an end-user of the vagaries of field recording. Future developments may include a landscape version of the innovative excavation recording systems used by the Archaeology Services at the University of Durham (Adams 2001).

I.3.5 Audit trail

Currently only a few stages of auditing have been implemented into the data model. The maintenance of raw data and the processing methodology allows the re-creation of data sets from first principals, if, for example, new information is incorporated into the model which requires global data model changes (i.e. a change in the geoid model). From an intellectual perspective an extensive audit trail is maintained in the comments table *LandScom* (see Figure 187). This table has been designed to provide a date-stamped list of comments relating to all forms of data collection, processing and analysis for each 'site'. This means that any future researcher can examine the formal and intellectual processes that occurred in the interpretation of a site. This design also has significant CRM benefits as it delineates every visit to a site and its purpose. Upon achieving long-term stability for the data model a final audit system will be invoked which will involve a separate database within which any physical changes to a field value will be maintained. This system, which will also provide a robust backup resource, will also highlight any changes in the intellectual process not documented in the current approach.

I.3.6 Data generalisation

Data generalisation is an essential component of archaeological analysis. Archaeological processes and mechanisms of collection are scale-dependent and require changing degrees of detail when analysis occurs. Hence, there is a need for variable levels of abstraction for different modelling and analytical purposes (Adams 2001 p. 3). Excavation data are normally synthesised for inter-site and landscape analysis. However, the general rule has been to synthesise these data sets with limited long-term reference to their raw information sets. Hence, over time, these data sets can lose their precise analytical value. Data are collected at different scales which, in turn, are integrated in a variety of ways for analytical purposes. Ideally these data should be integrated into a single spatial and related attribute data set that can be automatically generalised rather than multiple data sets that need maintenance and refreshing.

Database generalisation has been a long overlooked area within all the spatial disciplines. The cartographers' challenge is to create meaningful maps at different scales (the ratio between the size of an object on a map and its real size) and resolutions (the smallest object that can be represented). This same analogy is being applied within the GIS and Computer Aided Mapping (CAM) industries to manage automated and semi-automated generalisation of

spatial data (Müller *et al.* 1995). Until recently the software to enable cost-effective spatial data generalisation has been either non-existent or prohibitively expensive. However, modern software can, at least theoretically, automatically generalise spatial and a-spatial data sets. Encoding a generalisation index or algorithm which is applied to the spatial component and its a-spatial attribute information is, potentially, one technique of successful generalisation (Morehouse 1995). The use of object-orientated data models such as ESRI's geodatabase could be pivotal (Müller *et al.* 1995 pp. 3-5 gives an overview of proposed generalisation functions for ESRI; Lee 1996). Ideally this information should be encoded within metadata (MacDonald 2001). These metadata indices should be created for all potential scales of analysis (both spatially and a-spatially). For example, for inter-site analysis the metadata index would automatically generalise raw data (spatial and a-spatial) to its context groupings (e.g. enclosures and structures).

In order to integrate information from multiple scales into the data model, metadata recording is essential. Figure 194 details a possible data schema for this integration process. This data model conforms to this general schema, however, it must be emphasised that incorporating other project data structures into this approach would be extremely difficult for exactly the same reasons defined by CIDOC (see section I.5 (Wise and Miller 1997)).

An approach of this type could still retain any level of complexity and could be employed at a variety of information levels automatically reducing the data to fit into any scale of analysis without influencing the primacy of the raw data.

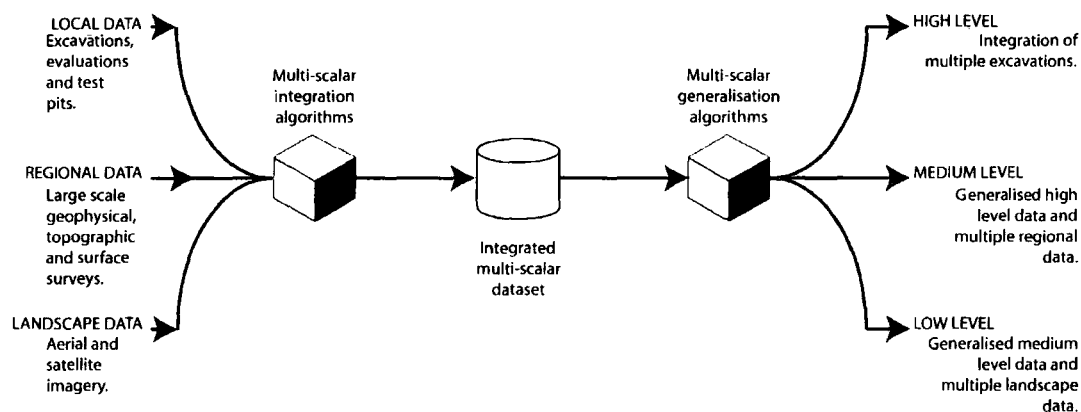

Figure 194 Data schema for multi scalar data integration

I.4 Documentation

The range of documentation includes reporting (in the form of academic and popular syntheses in a variety of media formats) down to basic file and structure documentation created as part of data creation itself. Metadata will be created for every piece of documentation. It is expected that this high level of metadata will be useful for reconstruction (and hence re-use) of the raw archaeological data and as an audit trail for both the processing of data and the creation of any project syntheses or narrative. Therefore, all documentation is accessible through the project information system.

MetaT				
Title	ProjID			
ikms_w	SHR			
Creator	Anthony Beck			
Subject	IkonosMS satellite imagery of the western half of the southern area for use with mobile applications			
Description	Ikonos MS satellite imagery bands 4,3,2 degraded to MrSID format			
Publisher	Inception Date	Completion Date	Deposition Date	Type
Space Imaging and NERC	26/01/2002	26/01/2002		Image
Format	MrSID			
Source	Source Group:	Satellite		
ikms_s_26012002w.img				
Language	English			
Relation or Data Source	Raster GIS data set			
Scale Res capture	Scale Res storage	RMS		
4m	4m	c. 25m		
Coverage	Rights			
Homs, Syria	Space Imaging			
Record: 14 23 of 34				

Figure 195 Example of Dublin Core resource discovery metadata maintained in table MetaT.

I.4.1 Metadata

Metadata is data about data (Wise and Miller 1997; Crofts *et al.* 2003). It is a specific subset of documentation that systematically catalogues information about data that is not normally available or obvious. For example, information pertaining to the creation, content, accuracy, use, ownership and geographic coverage are all included in metadata.

DB Name	Open Type	Description	Primary Key	Foreign Key	DB Relationship	Comments	Table Related
DocuT	Lookup	Document Lookup Type	DocType	N/A	Many-1 with DocuT		
DocuT	Main Table	Documents Table	DocID	N/A		Character or less names. These names should correspond with documents stored in both Word and PDF	
DocuT	Sub Table	Special Response Photogram Table	SRN, UnitID and Cat	N/A	Many-1 with LandT	This table was deleted as it is currently temporary	
Land_Chr	Lookup	Lookup Landuse Unit Characteristics	UnitChar	N/A	Many-1 with LandT		
Land_Dr	Lookup	Lookup Landuse Drif Tracking	DrifType	N/A	Many-1 with LandT		
Land_Ev	Lookup	Lookup Landuse Evidence Archaeological evidence categories	Evidence	N/A	Many-1 with LandT		
Land_Fun	Lookup	Landuse Lookup Function	UnitFunc	N/A	Many-1 with LandT	A single choice of most common function for a site	
Land_In	Lookup	Landuse Lookup Investigation	Invest	N/A	Many-1 with LandT	A single choice of most common investigation for a site	
Land_Map	Lookup	Landuse Lookup Mapping	Map	N/A	Many-1 with LandT		
Land_Pd	Lookup	Landuse Lookup Postgeological processes	PostProc	N/A	Many-1 with LandT		
Land_Sol	Lookup	Landuse Lookup Soil Class	SoilClass	N/A	Many-1 with LandT		
Land_Son	Lookup	Landuse Lookup Soil Composition	SoilComp	N/A	Many-1 with LandT		
Land_Sit	Lookup	Landuse Lookup Site Geology	SiteGeo	N/A	Many-1 with LandT		

Figure 196 Example of table level metadata stored in table MetaTDB.

The project has extensive metadata information stored throughout the data model. The vast majority are stored in tables: *MetaTDB*, *MetaTDD* and *DocuT* within *DskTopdb.mdb* and *MetaT* within *PDADB.mdb*. *MetaT* (see Figure 195) contains an ADS compatible Dublin Core based metadata architecture (ESRI 1995; Gillings and Wise 1998; Bewley *et al.* 1999). This table is used to describe all the data sets and/or data set groups for subsequent resource discovery in, for example, the ADS *ArchSearch* catalogue. *MetaTDB* (see Figure 196) contains metadata for the Access databases at the *table* level with descriptions about each table and how they relate to one another (note that field metadata is maintained within the raw table design). *MetaTDD* contains the project Data Dictionary (glossary or thesaurus). *DocuT* (see Figure 197) contains bibliographic information about all the documentation held in the *document* directory.

I.5 Archiving and re-use

Archiving is becoming an increasingly important issue within archaeology and other cultural heritage sectors. This is reflected in the emergence or participation of many bodies over the past decade dedicated to providing best practice guidelines for preparing, preserving and warehousing digital resources (for example; the Arts and Humanities Data Service, The Centre for the Study of Archaeology (CSA), Electronic Resource Preservation and Access NETWORK (ERPANET) and English Heritage).

Document Type	FileName	Authors	Year	Version	Comments:
Report	Corona_Sudan	Goossens, R., De Man, J. r.	2000	1	Research to possibilities of Corona-Satellite-data to replace Conventional Aerial Photographs in Geo-archaeological Studies, Practised on Sai (Sudan) Open Word Doc
Conf	Sat_Dronit	Beck, A. R.	2001	1	Conference Presentation at the Duham Dronites Session in 2001. There is an associated powerpoint presentation Open Word Doc
Conf	Sienna2001	Beck, A.R.	2001	1	Conference presentation at Sienna 2001. Presentation extended into an article. There is also an associated powerpoint presentation Open Word Doc
Papers	Getting_your_Hand_dirty	Beck, A. R.	2002	1	Paper published in Archaeological Computing Newsletter Getting your Hand dirty In the field with the Handspring PDA and thinkDB. Open Word Doc
Reports	DamRep11_4_2001	Beck, A. r., Jabour, F. B. shes	2001	1	Fieldwork Report for the Spring season 2001 Homs Regional Survey (HRS) 2001 Report for DGAM. 10th May. 2001 Open Word Doc

Record: 14 of 14

Figure 197 Example of bibliographic metadata held in table DocuT.

Many researchers are being encouraged to subscribe to these facilitators either through internal best practice mechanisms or as stipulations from a funding body (i.e. NERC, AHRB and EH). This NERC funded research is no exception. However, there are intrinsic storage and copyright difficulties with the deposition of this archive. The archive is currently 35GB, of which the vast majority is satellite imagery and derived thematic information. Hence, the curation of an archive of this magnitude would be very expensive. Many of the data sets have been purchased through funding bodies (e.g. NERC for the Ikonos satellite imagery). These bodies and the original data providers have their own licensing systems which may conflict with the open copyright policies of warehousing organisations, such as the ADS, making deposition of this data difficult or impossible.

Furthermore, the breadth of the data model and the requirement of other users to access and develop this resource make it possible that this data set will not have a clear termination date. Hence, it is difficult to assign a clear time-frame to archive a 'live' data resource. However, as the data model, and particularly cutting edge software formats change, high priority will be given to ensure backward compatibility with standard deposition formats or the prioritised use of standard deposition formats. Fortunately the use of, for example, the ESRI geodatabase storage architecture allows the integration of diverse data sets within one file, providing significant data management advantages (Richards and Robinson 2000; ESRI 2002). Furthermore, the project already employs many standard formats which by their very nature are interoperable between many software systems with limited or no data loss (MacDonald 2001).

Comité International pour la DOcumentation du Conseil international des musées (CIDOC) (Brown 2000) have acknowledged that many cultural resources suffer these problems of archivation. Their original concept recommended the integration of data sets through a single data model. Although it is possible to produce a framework which will directly integrate with other CRM systems this approach has many drawbacks; not the least being that the specific challenges faced in the SHR project would be under-represented using a standardised CRM data model. The difficulties in extending the original CIDOC data model to cater for all structuring eventualities led to its abandonment. CIDOC now advocate the use of mediation systems capable of managing data from heterogeneous sources. Mediation systems allow access to multiple information sources facilitating distributed queries without the need to aggregate the data within a single data model. Integration of this data set within such a model will require re-modelling to ensure concept conformity, but the benefits of the proposed system will allow access to multiple data source at multiple levels of generalisation.

Once an integrated data set has been produced a coherent dissemination structure is required. Other geographical science industries have consolidated their provision of spatial information through a few web-based geographic data portals (e.g. ESRI's geography network www.geographynetwork.com). These portals tend to be collaborative, multi-participant systems allowing discriminatory access to geographical data. The majority of leading GIS and remote sensing software vendors include functionality to access data sets over such distributed networks. Higher speed communication systems (such as broadband) and improved compression algorithms mean that larger file sizes can be easily accessed. For

example, the use of Enhanced Compressed Wavelet (ECW) technology by ER Mapper Inc. has facilitated the deployment of terabytes of data over the web (e.g. a single 25cm resolution mosaiced aerial photograph of the whole of Denmark is available at www.kortal.dk). It is acknowledged that this technology is predominantly available in Europe and America, although it is hoped that improvements in communication technology will alleviate this problem in the near future. However, given the size and nature of modern digital data sets the ability to adequately archive and provide access to information outweighs short-term problems in user access.

I.6 Future requirements

A requirement of the model design has been to provide scope for future developments of the data model. Hence this data model does not stand in isolation. Rather it outlines current best practice guidelines and is expected to evolve to meet the requirements of changing research and management needs and the general computing environment.

Considering the scope of the project, the range of specialists involved and the distributed nature of their working environments it would seem appropriate to enable online updating and querying of the data set. This will ensure that all participants conform to the data model and are always working on up-to-date information. It was impossible to incorporate this approach into the initial data models as until quite recently the use of the internet was illegal in Syria. Although, in such a scenario, the deployment of many of the large satellite imagery files might be restricted, access to the other geographical and attribute data resources should be easily facilitated through the use of dedicated internet mapping software (such as ESRI's ArcIMS). This will also have an impact upon the attribute recording system which currently employs two different mobile platforms running two different operating systems (Handspring PDAs running Palm O/S and Compaq iPAQ running Pocket PC O/S). These handhelds are used off-line and synchronised with the local data management system at the end of each day. However, the development of multi-platform mobile application synchronisation systems (such as the Freedom! Platform developed by ThinkingBytes Technology) will enable the bi-directional synchronisation of these data sources between the field, the fieldwork laptop and the server in Durham.

I.7 Using the data model and recording system

Once the data sets are downloaded only minimal post-processing is needed. The a-spatial data is already in MS Access format and available through the desktop database. The digital photographs need their numbers converting followed by a cursory check. The only difficult issue is the integration of the GPS data. This is primarily due to the limited functionality of handheld GPS. Other mechanisms to capture spatial data directly within a GIS are being researched. However, the approach used provides the project team with a fully accessible GIS ready archive at the end of each day. Consequently, hypotheses can be quickly re-evaluated and amended. Furthermore, summary statistical information can be quickly and easily generated to support any reports. The ability to dynamically engage with a project archive in this way has far reaching consequences for the feedback between hypothesis development and hypothesis testing. Furthermore, it provides valuable insights into the quality of the record, the validity of the recording system and how these impact on analysis.

APPENDIX II : COULTER SAMPLE PROCESSING METHODOLOGY

The LS230 measures particle size distribution using the principle of laser diffraction. A sample placed in the fluid module is circulated through a sample cell at a constant speed. A beam of laser light shone through the cell is diffracted by particles within the sample, and the forward scattered (or diffracted) light is collected by a series of detectors. The distribution of light falling on the sensors enables the size distribution of the sample to be calculated. This method enables the measurement of particles from $0.4\mu\text{m}$ to $2000\mu\text{m}$ (0.0004mm to 2mm).

Preparation of a solution for Coulter analysis requires a representative sample of 0.5 ± 0.2 g (all less than 2mm) in solution with the organic component removed. In order to achieve the appropriate sample weight each sample was sieved through a 2mm sieve into a blank. The residue was subdivided in a riffle so that the resultant sample was representative of the range of particle sizes. 87.5% (i.e. three 50% boxes) of the sample was retained and re bagged. The remaining sample was subdivided in the riffle until a weight of 0.5 ± 0.2 g was achieved. The sample was placed into a test tube marked with the sample number.

The organic material was removed by the addition of 20 ml of 10% Hydrogen Peroxide (H_2O_2) to each sample. The sample was left in a water bath for 3 hours to allow the complete oxidation of the organic material. Distilled water was added to each sample and any other coarse organic material was removed. The sample was placed in a centrifuge for 6 minutes at 4000rpm. The excess liquid was decanted and 20 ml of distilled water was added. 2ml of Sodium Hexameta Phosphate was added and mixed vigorously with the sample. This agent reduces the likelihood of particles re-agglomerating. The sample is now ready for analysis in the Coulter LS230.

APPENDIX III PARTICLE SIZE ANALYSIS RESULTS FROM SITES 97, 218,
221, 238, 271, 279, 339, 478, 496 AND 508.

III.1 Particle size analysis at site 97

Site 97 is a tell site in the northern irrigated marl zone (as defined in section 6.6) with a local place name of Khirba Al-Ramadi. When last visited the site was under olive plantation and various cereals. Surface material included pottery and basalt. A deep N-S bulldozed cut (down to soil level) has removed all the site soil in the centre of the site. Sample 270 was taken from the base of this bulldozed area and should therefore correspond to the underlying soil or the earliest deposits. It appears that some of this has been re-deposited to the south of the site (see Figure 198). The transect was located across the site in a S-N direction. Sample points 276 to 277 and 282 to 283 highlight the transition between off-site and site. The site boundary has been recorded from satellite imagery.

The particle size analysis displays a 10% increase in clay, a 5% decrease in fine silt, a 10% decrease in medium silt, a 5% decrease in coarse silt and a c. 5% increase in fine sand between off and on-site soils. Medium and coarse sand do not occur on the site. The transitional boundaries defined by the satellite imagery correlate with the boundary changes from the particle size analysis. Sample 270 has approximately the same particle size response as the off-site soils.

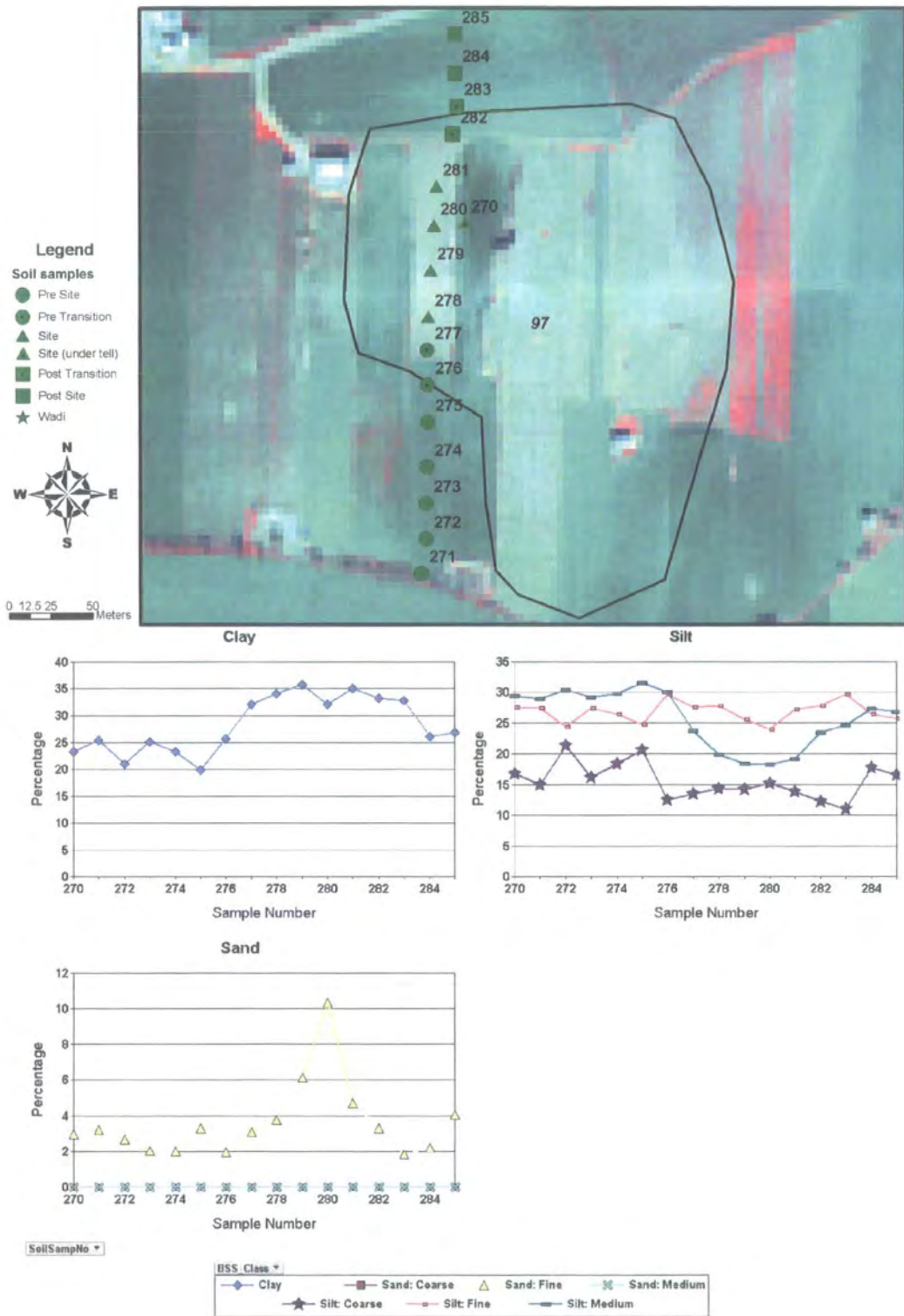

Figure 198 Locations of soil samples collected over site 97 and results of particle size analysis on these samples.

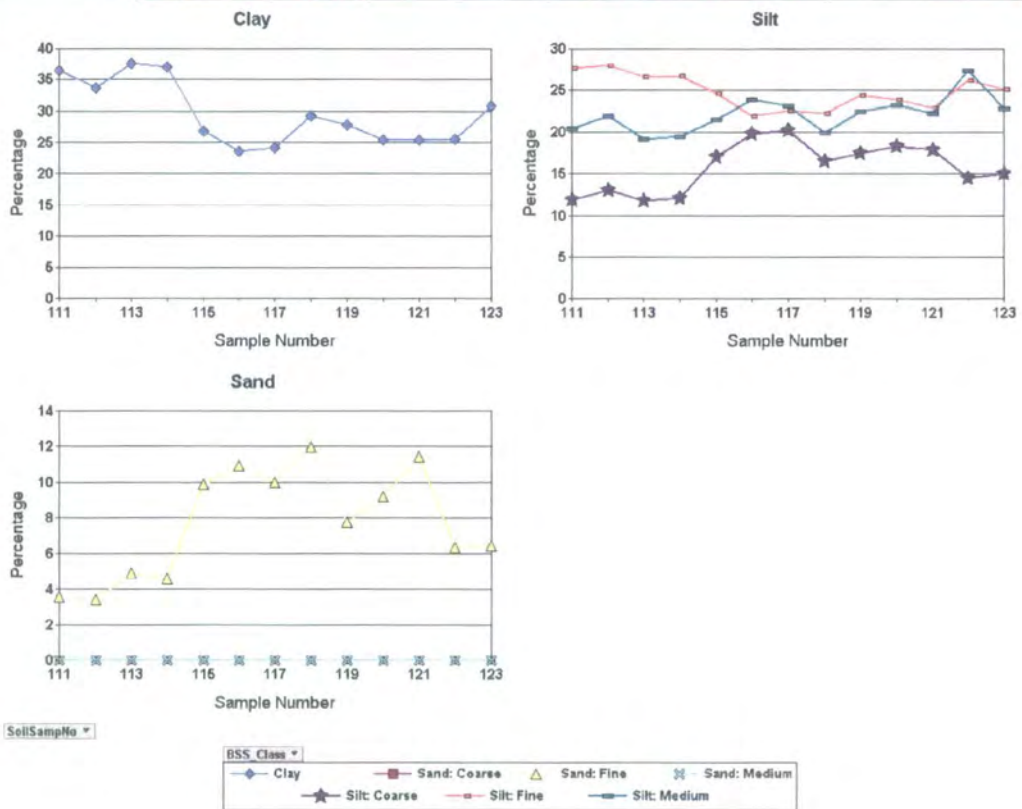
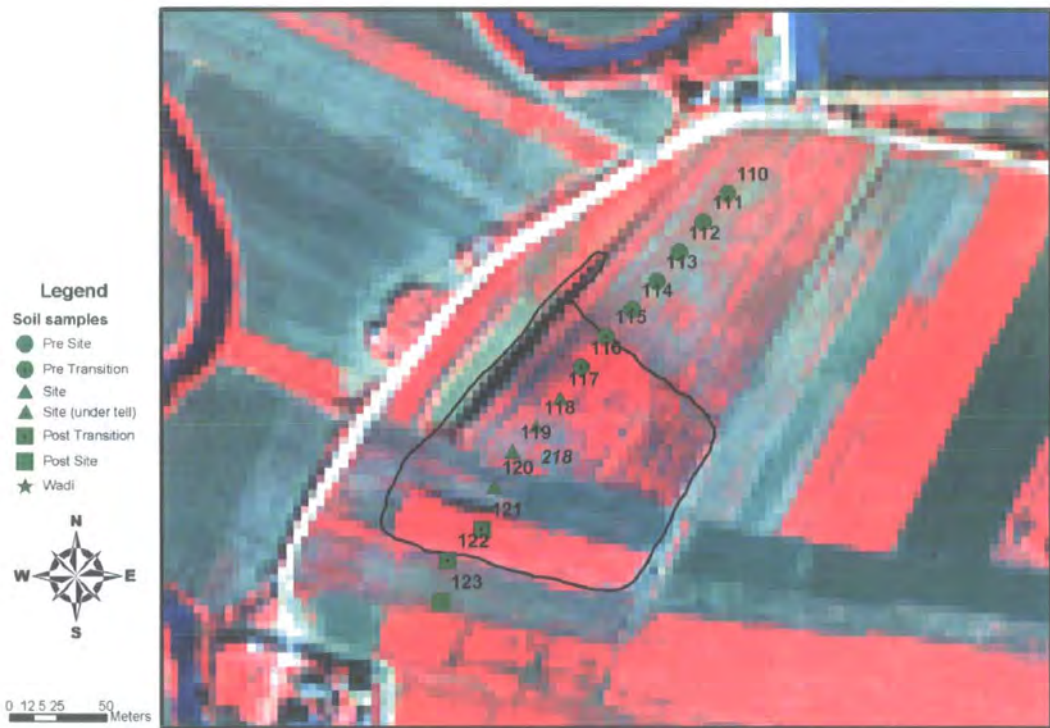

Figure 199 Locations of soil samples collected over site 218 and results of particle size analysis on these samples.

III.2 Particle size analysis at site 218

Site 218 is a low tell site in the southern irrigated marl zone (as defined in section 6.6) close to the Orontes with a local place name of Khirba Kafr Musa. The site was fallow when last visited. Surface material included pottery, glass, basalt, tile and architectural remains. A deep SW-NE bulldozed cut is on the NW edge of the site and a shallower NW-SE cut is on the SW edge of the site. The transect was located across the site in a NE-SW direction (see Figure 199). Sample points 114 to 116 and 121 to 122 highlight the transition between off-site and site. Sample 110 was misplaced from this site. The site boundary was recorded from field collection.

The particle size analysis displays a 10% decrease in clay, a 5% decrease in fine silt, a <5% increase in medium silt, a 5% increase in coarse silt and a c. 5% increase in fine sand between off and on-site soils. Medium and coarse sand do not occur on the site. The transitional boundaries defined by the satellite imagery do not correlate with the boundary changes from the particle size analysis. The site extent should probably be moved to near sample 115. If possible, this should be verified during the next fieldwork season.

III.3 Particle size analysis at site 221

Site 221 is a scatter in the southern marl zone (as defined in section 6.6). Like site 339 this site is associated with topographic depressions (three in total). The site was fallow when last visited. Surface material included pottery, basalt, tile and architectural remains. The transect was located across the site in a NW-SE direction (see Figure 200). Sample points 131 to 133 and 137 to 139 highlight the transition between off-site and site. Samples 132, 133 and 138 were misplaced. The site boundary has been recorded from satellite imagery.

The particle size analysis displays a small 5% decrease in clay, no discernable difference in fine silt, a 5% increase in medium silt and a tenuous <5% increase in coarse silt between off and on-site soils. Fine sand produces a 10% increase on the post-transition and post-site soils. Medium and coarse sand do not occur on the site. The transitional boundaries defined by the satellite imagery correlate with the boundary changes from the particle size analysis for the post site change. However, this correlation does not occur for pre-site. This indicates that the transect for pre-site should have been extended further to the NW. During sample collection it was noticed that the site soil had a noticeably looser structure (so much so that walking the site was difficult).

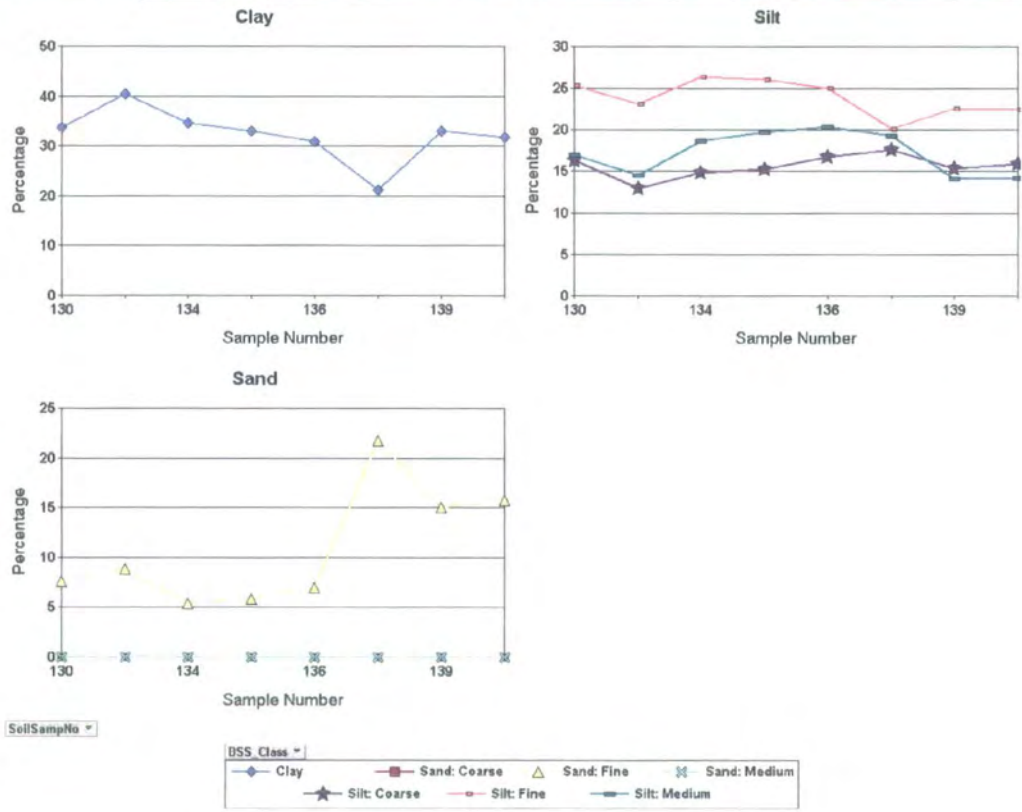
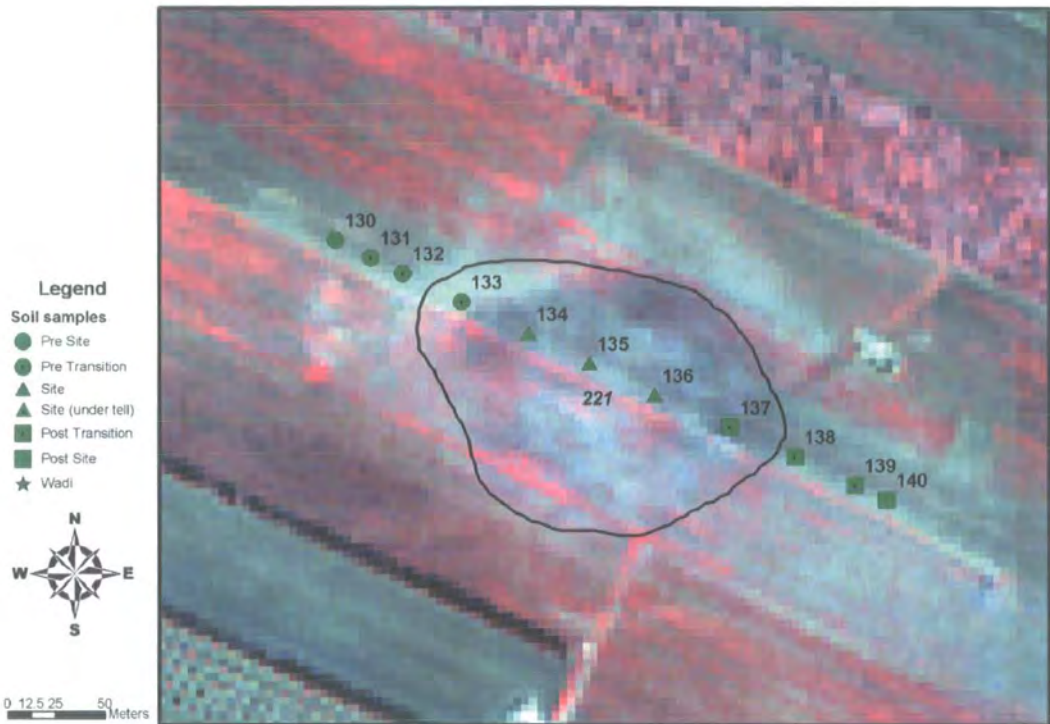

Figure 200 Locations of soil samples collected over site 221 and results of particle size analysis on these samples.

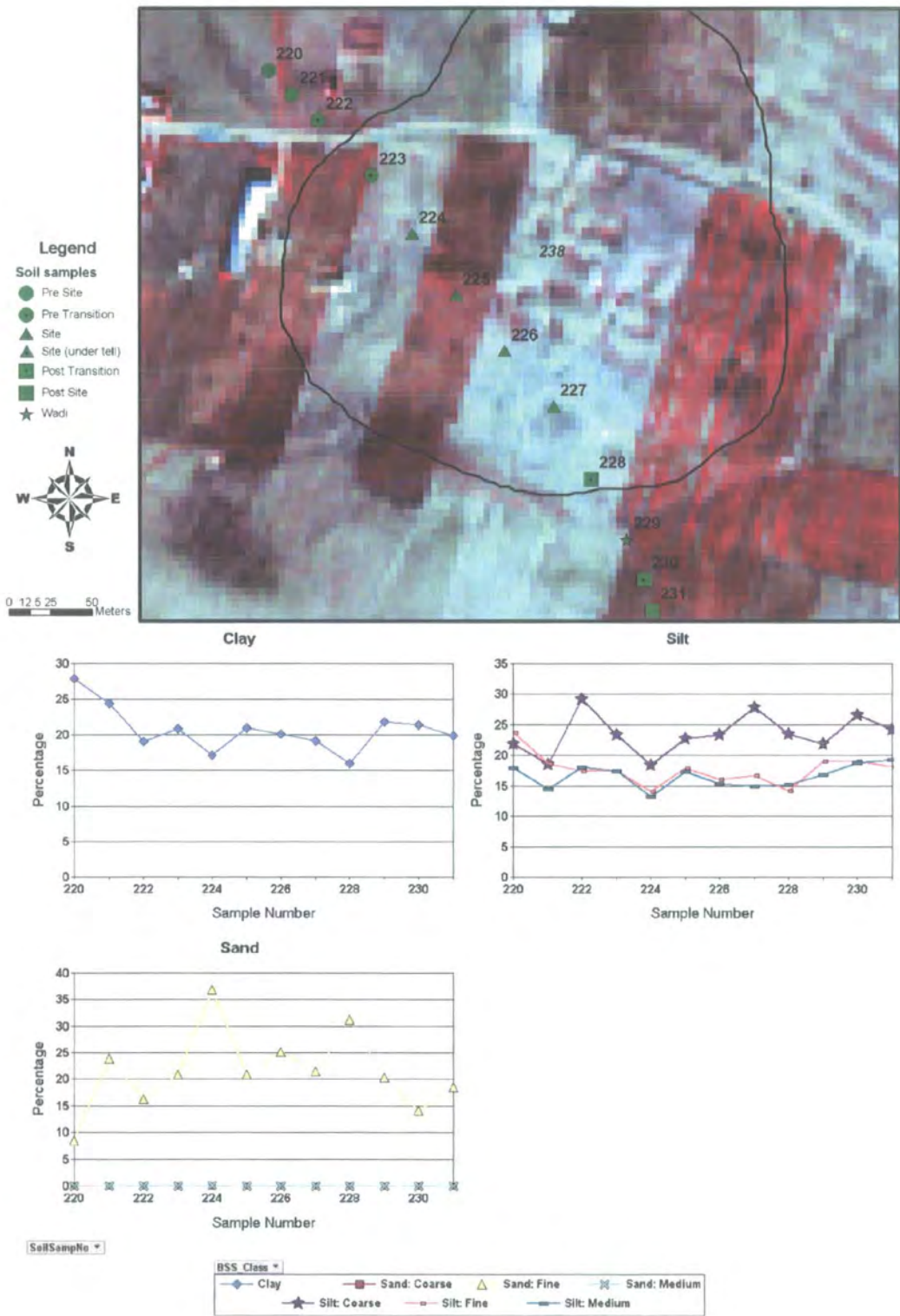

Figure 201 Locations of soil samples collected over site 238 and results of particle size analysis on these samples.

III.4 Particle size analysis at site 238

Site 238 is a scatter on the margins of thin marl and wadi silts (as defined in section 6.6), just north of a wadi with a local place name of Khirba Ramzoun. This site is also associated with a topographic depression. When last visited the site was under fruit and olive plantation. Surface material included pottery, basalt, tile, glass and a coin (undated). The transect was located across the site in a NW-SE direction (see Figure 201). Sample points 222 to 223 and 228 to 230 highlight the transition between off-site and site. Please also note that samples 229 and possibly 230 are in a wadi. The site boundary has been recorded from satellite imagery.

The results of the particle size analysis are unclear and interpretations are difficult. There is a decrease in clay, fine silt and medium silt and an increase in coarse silt and fine sand between off and on-site soils. Medium and coarse sand do not occur on the site.

III.5 Particle size analysis at site 271

Site 271 is a scatter in the northern irrigated marl zone (as defined in section 6.6) with a local place name of Khirba Khair Jamali. This site is also associated with a topographic depression. The site was fallow when last visited. Surface material included pottery (possibly Islamic), basalt, tile and architectural remains. The transect was located in a S-N direction (see Figure 202). Sample points 252 to 254 and 258 to 259 highlight the transition between off-site and site. The site boundary has been recorded from satellite imagery.

The particle size analysis displays no discernable change in clay, a 5% decrease in fine silt, a 10% decrease in medium silt, a 5% increase in coarse silt and a 5% increase in fine sand between off and on-site soils. Medium and coarse sand do not occur on the site. The transitional boundaries defined by the satellite imagery correlate with the boundary changes from the particle size analysis with the exception of medium silt.

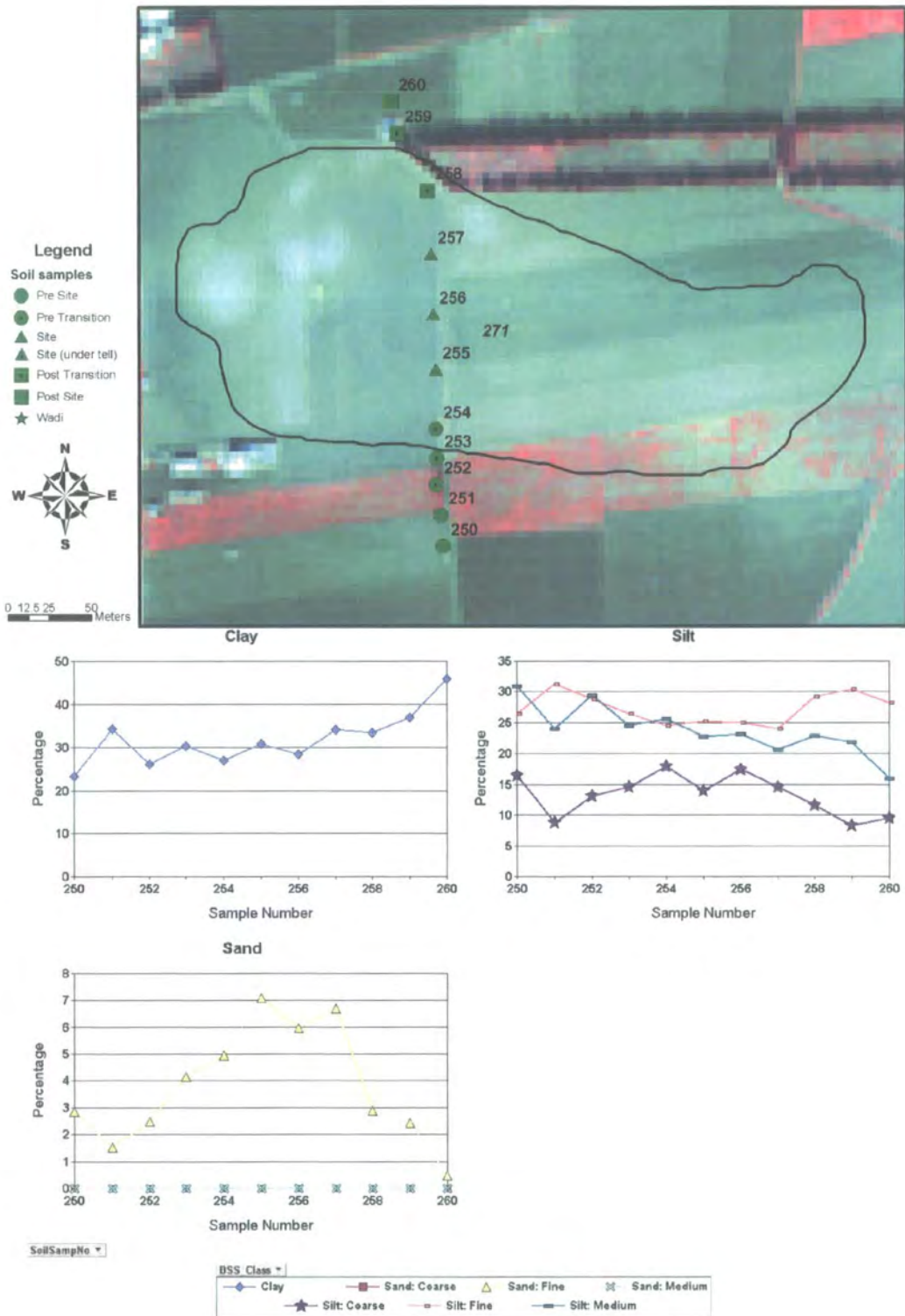

Figure 202 Locations of soil samples collected over site 271 and results of particle size analysis on these samples.

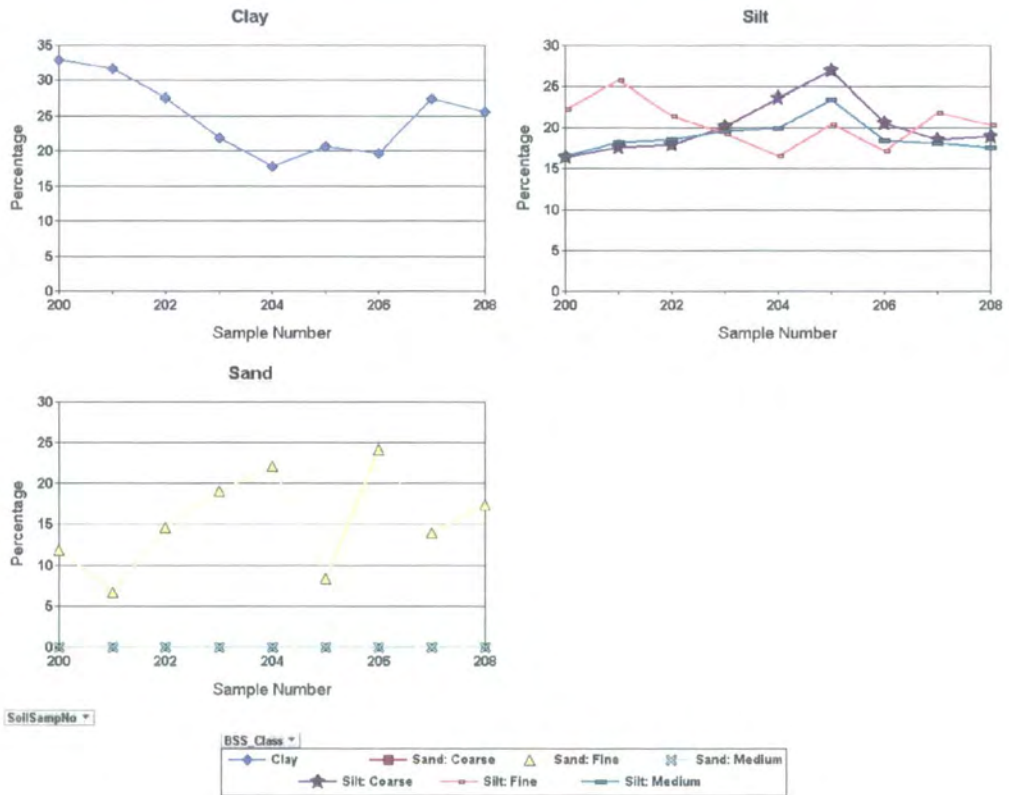
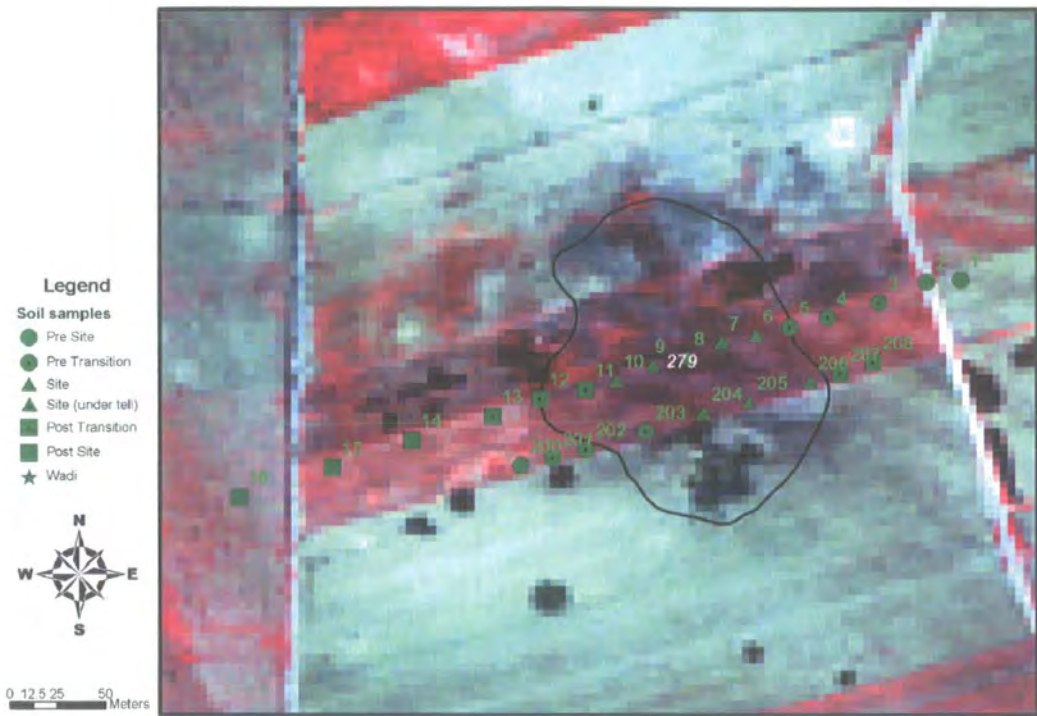

Figure 203 Locations of soil samples collected over site 279 and results of particle size analysis on these samples.

III.6 Particle size analysis at site 279

Site 279 is discussed in section 8.4.1.2. The second transect was located across the site in a SW-NE direction (see Figure 203). Unfortunately the transect was not long enough and sample 208 remains in the transition zone. Sample points 201 to 203 and 207 to 208 highlight the transition between off-site and site. The site boundary has been recorded from satellite imagery.

The particle size analysis displays a 10-15% decrease in clay, a 5% decrease in fine silt, a 5% increase in medium silt, a 10% increase in coarse silt and a c. 10% increase in fine sand between off and on-site soils. Medium and coarse sand do not occur on the site. The transitional boundaries defined by the satellite imagery correlate with the boundary changes from the particle size analysis. This is an extremely interesting result as the correlation between the two particle size analyses is poor (see Figure 149). Particle size analysis on the 2001 samples gave very clear results from this site (see section 8.4.1.2).

III.7 Particle size analysis at site 339

Site 339 is discussed in section 8.4.1.3. The second transect was located across the site in a S-N direction (see Figure 204). Sample points 151 to 153 and 157 to 158 highlight the transition between off-site and site. Sample 152 and 159 were misplaced from this site. The site boundary has been recorded from satellite imagery.

The particle size analysis displays an uncorrelated change in clay, a 5% decrease in fine silt, a 5% decrease in medium silt, a 5% increase in coarse silt and a c. 7% increase in fine sand between off and on-site soils. Medium and coarse sand do not occur on the site. The transitional boundaries defined by the satellite imagery correlate with the boundary changes from the particle size analysis. In comparison to the original transect (see Figure 151), the results from the second transect are less clear. However, this change in clarity could be a more representative reflection of how particle size varies through a site with a central depression.

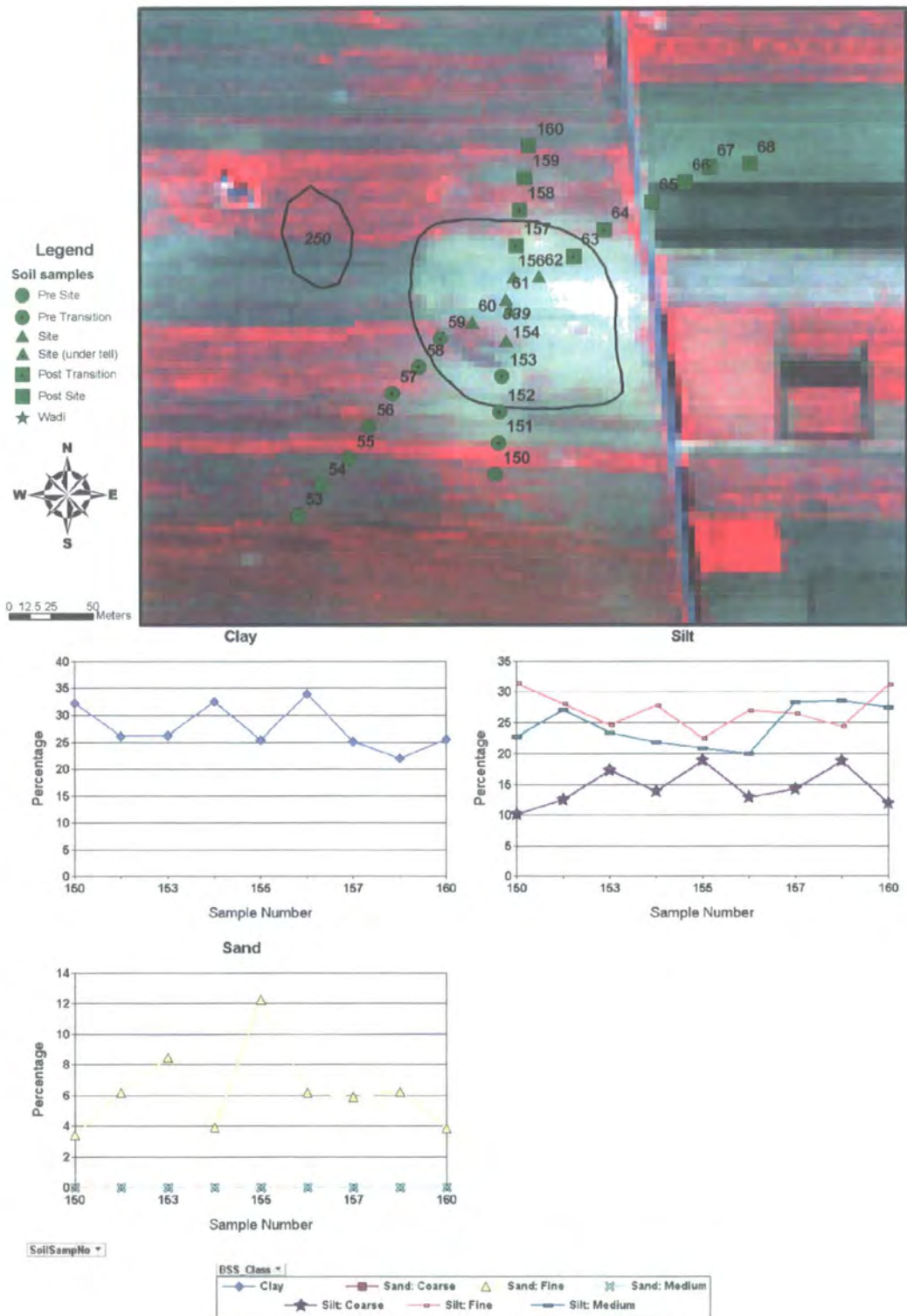

Figure 204 Locations of soil samples collected over site 339 and results of particle size analysis on these samples.

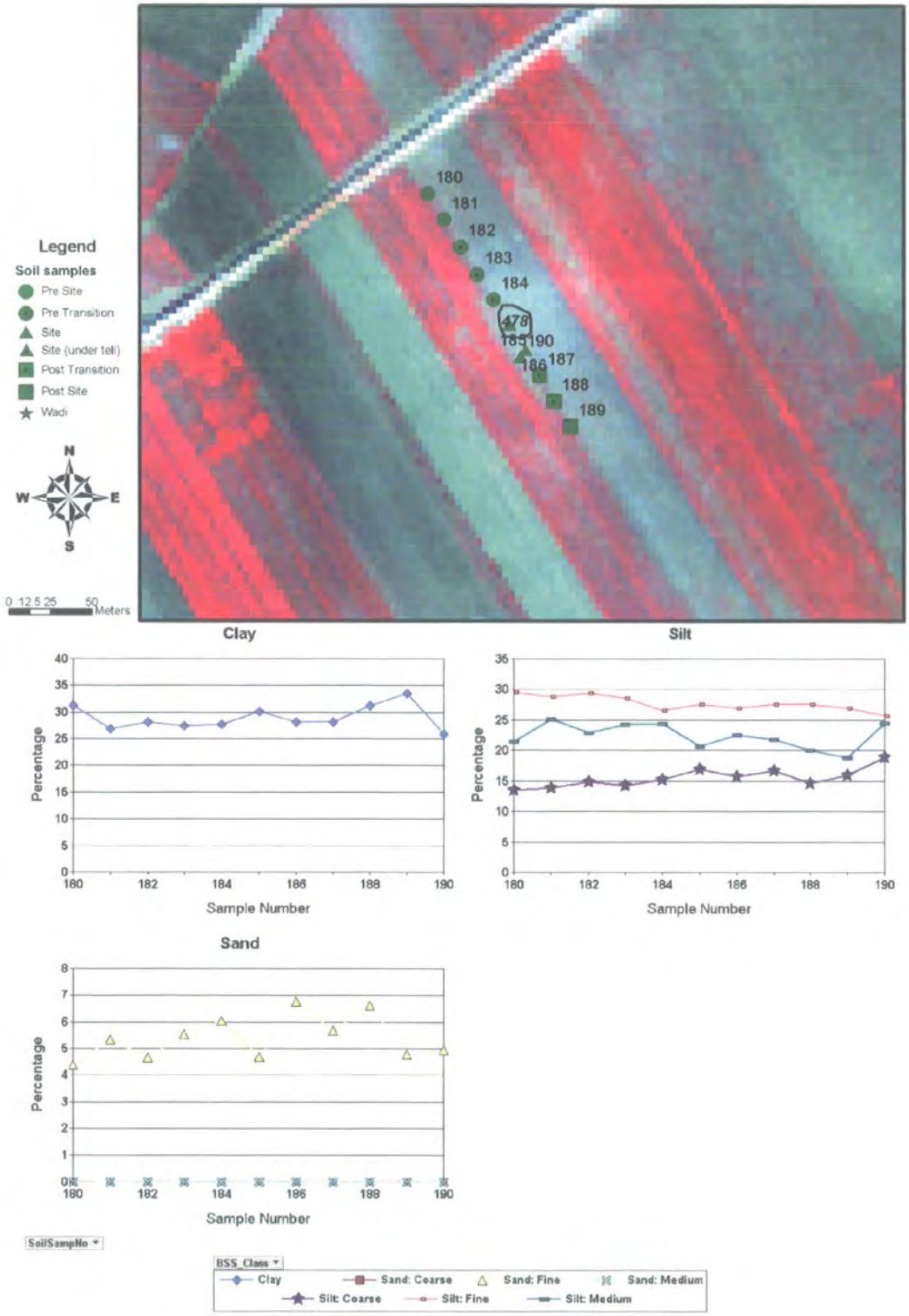

Figure 205 Locations of soil samples collected over site 478 and results of particle size analysis on these samples.

III.8 Particle size analysis at site 478

Site 478 is a scatter in the southern marl zone (as defined in section 6.6) and is one of the few distinct single period prehistoric sites in the application area. The site was fallow when last visited. Surface material included pottery (coarse tempered) and flint. The transect was located across the site in a NE-SW direction (see Figure 202). Sample points 182 to 184 and 187 to 188 highlight the transition between off-site and site. An extra sample (190) was taken next to an animal burrow where the majority of pottery was located. The site boundary has been recorded from satellite imagery.

The particle size analysis displays no discernable change in any of the particle sizes with the exception of a small (2-3%) increase in fine sand. This reflects the general difficulty in detecting the site from the imagery and locating the site on the ground. In all probability this difficulty is due to a different construction tradition in this period.

III.9 Particle size analysis at site 496

Site 496 is a scatter in the alluvial fan to the west of the Orontes (as defined in section 6.6). When last visited the site was under scrub, beans and wheat. Surface material included pottery, basalt, tile and architectural fragments. This site has been bulldozed creating a distinct line of cleared basalt blocks (see Figure 206). Sample points 102 to 103 and 105 to 106 highlight the transition between off-site and site. Samples 100 and 102 were misplaced. The transect was located across the site in an E-W direction. The site boundary has been recorded from satellite imagery.

The particle size analysis displays no discernable change in any of the particle sizes. However, there is a 10% increase in clay and a 10% decrease in medium sand across the transect. Although this site is not in the marl zone it was included for comparative purposes in the belief that it employed a similar construction tradition. The post-depositional processes in this zone mean that many of the archaeological residues are likely to be buried. Hence, any surviving surficial deposits will be impacted by mixing with alluvial wash deposits making identification using this technique rather difficult.

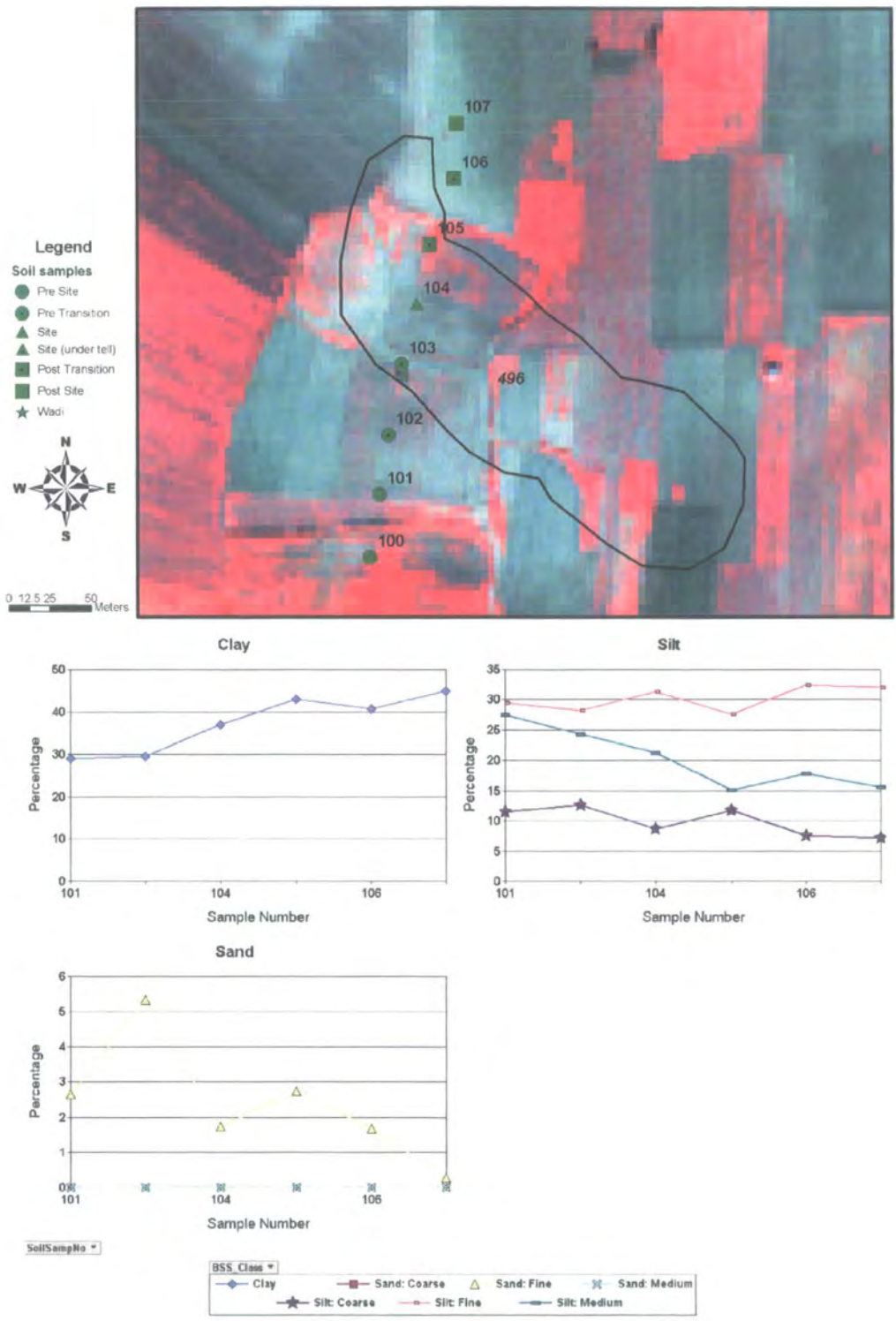

Figure 206 Locations of soil samples collected over site 496 and results of particle size analysis on these samples.

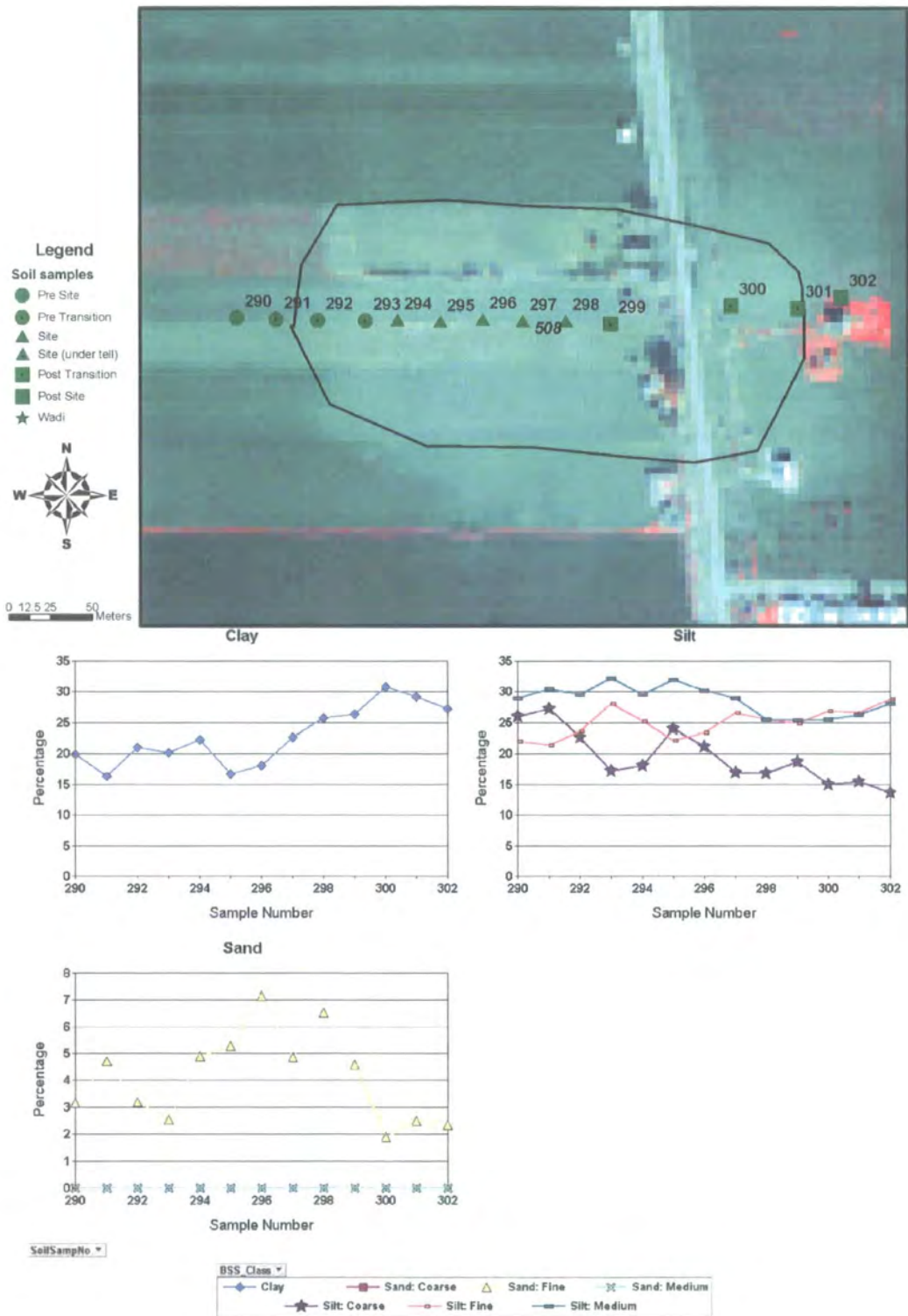

Figure 207 Locations of soil samples collected over site 508 and results of particle size analysis on these samples.

III.10 Particle size analysis at site 508

Site 508 is a scatter in the northern irrigated marl zone (as defined in section 6.6). The site was fallow when last visited. Surface material included pottery, basalt, glass, tile and architectural remains. A shallow bulldozed cut ran E-W across the centre of the site. The transect was located across the site in an E-W direction (see Figure 207). Sample points 291 to 293 and 299 to 301 highlight the transition between off-site and site. The site boundary has been recorded from satellite imagery.

The particle size analysis displays an uncorrelated change in clay, a tenuous 5% increase in fine silt, a tenuous 5% increase in medium silt, a 10% decrease in coarse silt across the transect and a <5% increase in fine sand between off and on-site soils. Medium and coarse sand do not occur on the site.

REFERENCES CITED

- Adams, M. (2001). The Optician's Trick: an approach to recording excavation using an Iconic Formation Process Recognition System. Interpreting Stratigraphy Site evaluation, recording procedures and stratigraphic analysis. S. Roskams, (Ed.), Tempus Reparatum. **910**: 91-102.
- Adams, R. M. (1981). Heartland of cities: Survey of Ancient Settlements and Land Use of the Central Floodplains of the Euphrates. Chicago, University of Chicago press.
- Aerial Archaeology Committee (1983). Research objectives in aerial archaeology. Research objectives in British archaeology. C. Thomas, (Ed.). London, CBA: 1-6.
- Aitchison, K. and R. Edwards (2003). Archaeology Labour Market intelligence: Profiling the Profession 2002/03. Bradford, Institute of Field Archaeologists: 129.
- Alcock, S. E. (1994). Breaking up the hellenistic world: survey and society. Classical Greece. Ancient histories and modern archaeologies. I. Morris, (Ed.). Cambridge, Cambridge University Press: 171-190.
- Alcock, S. E., J. F. Cherry and J. L. Davis (1994). Intensive survey, agricultural practice and the classical landscape of Greece. Classical Greece. Ancient histories and modern archaeologies. I. Morris, (Ed.). Cambridge, Cambridge University Press: 137-170.
- Aldenderfer, M. S. (1987). On the Structure of Archaeological Data. Quantitative Research in Archaeology: Progress and Prospects. M. S. Aldenderfer, (Ed.). London, London: 89-113.
- Aldenderfer, M. S. (1998). "Quantitative Methods in Archaeology: A review of recent trends and developments." Journal of Archaeological Research **6**(2): 1998.
- Allan, J. A. and T. S. Richards (1983). "Use of Satellite Imagery in Archaeological Surveys." Libyan Studies **14**: 4-8.
- Allen, K. (2000). Consideration of Scale in Modelling Settlement Patterns Using GIS. Practical Applications of GIS for Archaeologists: A predictive modelling toolkit. K. L. Wescott and R. J. Brandon, (Eds.). London, Taylor and Francis.
- Altmair, A. and C. Kany (2002). "Digital surface model generation from CORONA satellite imagery." ISPRS Journal of Photogrammetry and Remote Sensing **56**: 221-235.
- Ammerman, A. (1981). "Surveys and Archaeological Research." Annual Review of Anthropology **10**: 68-88.
- Anderson, J. R., E. E. Hardy, J. T. Roac and R. E. Witmer (1976). A land use and land cover classification for use with remote sensing data. Washington, US Government printing office: 18.

Anschuetz, K. F., R. H. Wilshusen and C. L. Scheick (2001). "An Archaeology of Landscapes: Perspectives and Directions." Journal of Archaeological Research **9**(2): 157-207.

Armenakis, C., F. Ledue, I. Cyr, F. Savopol and F. Cavayas (2003). "A comparative analysis of scanned maps and imagery for mapping applications." ISPRS Journal of Photogrammetry and Remote Sensing **57**: 304-314.

Asrar, G. (1989). Theory and applications of optical remote sensing. New York, Wiley.

Aston, M. and T. Rowley, (Eds.) (1974). Landscape archaeology: an introduction to fieldwork techniques on post-Roman landscapes. Newton Abbot, David & Charles.

Astorqui, A. (1999). Studying the archaeological record from photogrammetry. New techniques for old times: CAA 98, computer applications and quantitative methods in archaeology. J. A. Barceló, I. Briz and A. Vila, (Eds.). Oxford, Archaeopress.

Banning, E. (2002). Archaeological Survey. New York, Kluwer Academic.

Barnsley, M. J., D. Allison and P. Lewis (1997). "On the information content of multiple view angle (MVA) images." International Journal of Remote Sensing **18**(9): 1937 - 1960.

Barrett, J. C. (1994). Fragments from antiquity: An archaeology of social life in Britain, 2900-1200BC. Oxford, Blackwell Publishers.

Barrett, J. C. (1995). Some Challenges in Contemporary Archaeology. IFA conference, Oxbow.

Baumgardner, M. F., L. F. Silva, L. L. Biehl and E. R. Stoner (1985). "Reflectance properties of soils." Advances in agronomy **38**: 1-44.

Beauchemin, M. and K. P. B. Thomson (1997). "The evaluation of segmentation results and the overlapping area matrix." International Journal of Remote Sensing **18**(18): 3895-3899.

Beck, A., G. Philip and D. Donoghue (in prep). "The preliminary evaluation of high resolution satellite imagery for landscape applications in Syria and India."

Beck, A. R. (2002). "Getting your Hand dirty: In the field with the Handspring PDA and ThinkDB." Archaeological Computing Newsletter(59): 11-15.

Beck, A. R. (2003). Integrated mobile applications: A case study from the SHR project, Syria. WAC, Washington.

Beck, A. R. and M. Beck (2001). Computing, Theory and Practice: establishing the agenda in contract archaeology. Interpreting Stratigraphy Site evaluation, recording procedures and stratigraphic analysis. S. Roskams, (Ed.), Tempus Reparatum. **910**: 173-182.

Beck, A. R., G. Philip, D. N. M. Donoghue and N. Galliatsatos (in press). Geo-locating declassified CORONA satellite photography for archaeological surveys and cultural resource

management applications: an interim paper. Workshop on Aerial Archaeology and Remote Sensing, Siena.

Ben-Dor, E. and A. Banin (1995). "Near Infrared Analysis as a rapid method to simultaneously evaluate several soil properties." Soil Science Society of America **59**: 364-372.

Ben-Dor, E., Y. Inbar and Y. Chen (1997). "The Reflectance Spectra of Organic Matter in the Visible Near-Infrared and Short Wave Infrared Region (400-2500 nm) during a Controlled Decomposition Process." Remote Sensing of Environment **61**(1): 1-15.

Ben-Dor, E., J. R. Irons and G. F. Epema (1999a). Soil Reflectance. Remote Sensing for the Earth Sciences. A. N. Rencz, (Ed.). London, John Wiley and Sons. **3**.

Ben-Dor, E., J. Portugali, Kochavi, M. Shimoni and V. Lipaz (1999b). "Airborne thermal video radiometry and excavation planning at Tel viehah, Golan Heights, Israel." Journal of Field Archaeology **26**.

Bewley, R. (1993). Aerial photography for archaeology. Archaeological Resource Management in the UK: An Introduction. J. Hunter and I. Ralston, (Eds.). Stroud, Sutton Publishing Limited.

Bewley, R. (2000). Aerial Survey: Learning from a Hundred Years of Experience? Aerial archaeology - developing future practice, Leszno, Poland, IOS Press.

Bewley, R., D. Donoghue, V. Gaffney, M. Van Leusen and A. Wise (1999). Archiving Aerial Photography and Remote Sensing Data: A Guide to Good Practice. Oxford, Oxbow.

Bewley, R. and W. Raczkowski (2000). Past Achievements and Prospects for the Future Development of Aerial Archaeology: An Introduction. Aerial archaeology - developing future practice, Leszno, Poland, IOS Press.

Binford, L. R. (1982). "The archaeology of place." Journal of anthropological archaeology(1): 5-31.

Binford, L. R. (1992). Seeing the Present and Interpreting the Past - and keeping things straight. Space, time, and archaeological landscapes. J. Rossignol and L. Wandsnider, (Eds.). New York, Plenum Press.

Binford, L. R. (1996). Willow Smoke and Dogs' Tails: Hunter-Gatherer Settlement Systems and Archaeological Site Formation. Contemporary Archaeology in Theory: a reader. R. W. Preucel and I. Hodder, (Eds.). Oxford, Blackwell: 39-60.

Bintliff, J. (2000). The concepts of 'site' and 'off-site' archaeology in surface artefact survey. Non-destructive techniques applied to landscape archaeology. M. Pasquinucci and F. Trement, (Eds.). Oxford, Oxbow.

Bintliff, J., B. Davies, C. Gaffney, A. Snodgrass and A. Waters (1992). Trace metal accumulations in soils on and around ancient settlements in Greece. Geoprospection in the Archaeological Landscape. P. Spoerry, (Ed.). Oxford, Oxbow.

- Brady, N. C. (1984). The nature and properties of soils. New York, Macmillan.
- Bridgland, D. R., G. Philip, R. Westaway and M. White (2003). "A long Quaternary terrace sequence in the Orontes River valley, Syria: A record of uplift and occupation." Current Science **84**(5): 1080-1089.
- Brivio, P. A., M. Pepe and R. Tomasoni (2000). "Multispectral and multiscale remote sensing data for archaeological prospecting in an alpine alluvial plain." Journal of Cultural Heritage **1**(2): 155 - 164.
- Brown, A. (2000). "Centre for Archaeology Digital Archiving Strategy." 1.0. Retrieved 3rd March, 2003, from <http://www.english-heritage.org.uk>.
- Brugioni, D. A. (1996). "The Art and Science of Photoreconnaissance." Scientific American(March): 78-85.
- Buck, C. E., W. G. Cavanagh and C. D. Litton (1996). Bayesian Approach to Interpreting Archaeological Data. New York, John Wiley and Sons.
- Buck, P. E., D. E. Sabol and A. R. Gillespie (2003). "Sub-pixel artifact detection using remote sensing." Journal of Archaeological Science **30**: 973-989.
- Burroughs, P. A. (1986). Principles of GIS for Land Based Assessment. Oxford, Clarendon Press.
- Butzer, K. W. (1982). Archaeology as human ecology: method and theory for a contextual approach. Cambridge, Cambridge University Press.
- Campana, S. and R. Francovich (2003). Landscape Archaeology in Tuscany: Cultural resource management, remotely sensed techniques, GIS based data integration and interpretation. The reconstruction of archaeological landscapes through digital technologies: proceedings of the 1st Italy-United States workshop, Boston, Massachusetts, USA, November 1-3, 2001. M. Forte and P. R. Williams, (Eds.). Oxford, BAR: 15 - 29.
- Campana, S. and E. Pranzini (1999). Il telerilevamento in Archeologia. Ciclo di Lezioni sulla ricerca applicata in archeologia; Remote sensing in archaeology, Siena, Italy, Edizioni All'Insegna del Giglio.
- Campbell, H. and I. Masser (1993). Implementing GIS: the organisational dimension. Association of Geographic Information, AGI.
- Campbell, J. B. (2002). Introduction to remote sensing. New York, Guilford Press.
- Carr, C. (1985). Perspective and basic definitions. For concordance in archaeological analysis. C. Carr, (Ed.). Kansas City, Westport: 1-17.
- Chadwick, A. (in press). What have the post-processualists ever done for us? Towards an integration of theory and practice, and a radical field archaeology. Proceedings of the 2001

Interpreting Stratigraphy Conference. S. Roskams and C. M. Beck, (Eds.). Oxford, Tempus Reparatum.

Chatwin, B. (1987). The Songlines. London, Cape 1987.

Chavez, P. S. (1996). "Image based atmospheric corrections - revisited and revised." Photogrammetric Engineering and Remote Sensing **62**(9): 1025-1036.

Chavez, P. S., S. C. Sides and J. A. Anderson (1991). "Comparison of three different methods to merge multiresolution and multispectral data: Landsat TM and Spot panchromatic." Photogrammetric Engineering and Remote Sensing **57**: 265-303.

Cherry, J. F., J. L. Davis and E. Mantzourani (1991). Landscape archaeology as long-term history: northern Keos in the Cycladic Islands from earliest settlement until modern times. Los Angeles, Institute of Archaeology University of California Los Angeles.

Clark, C. D., S. M. Garrod and M. M. Parker Person (1998). "Landscape archaeology and remote sensing in southern Madagascar." International Journal of Remote Sensing **19**(8): 1461-1477.

Clark, G. A. (1987). Paradigms and Paradoxes in Contemporary Archaeology. Quantitative Research in Archaeology: Progress and Prospects. M. S. Aldenderfer, (Ed.). London, London: 30-60.

Clarke, D. L. (1978). Analytical Archaeology. London, Methuen.

Coburn, C., A. Roberts and K. Bach (2001). "Spectral and spatial artifacts from the use of desktop scanners for remote sensing." International Journal of Remote Sensing **22**(18): 3863-3870.

Colwell, R. N. (1997). History and place of photographic interpretation. Manual of Photographic Interpretation. W. R. Philipson, (Ed.). Bethesda, American Society of Photogrammetry and Remote Sensing: 3-48.

Colwell, R. N., J. E. Estes and G. A. Thorley (1983). Manual of remote sensing. Falls Church, Va., American Society of Photogrammetry.

Comfort, A. (1997). Remote sensing and archaeological survey on the Euphrates: 1997 Report: 19.

Comfort, A. (1999). Remote sensing and archaeological survey on the Euphrates: 1998 Report: 19.

Comfort, A. (2000). Satellite remote sensing and archaeological survey on the Euphrates: 1999 Report: 25.

Condron, F., J. Richards, D. Robinson and A. Wise (1999). Strategies for digital data: findings and recommendations from Digital Data in Archaeology: a survey of user needs. York, Archaeology Data Service University of York 1999.

Cowley, D. C. (2002). "A case study in the analysis of patterns of aerial reconnaissance in a lowland area of Southwest Scotland." Archaeological Prospection **9**: 255-265.

Cox, C. (1992). "Satellite Imagery, aerial photography and wetland archaeology." World Archaeology **24**(2): 249-267.

Cracknell, A. P. and L. Hayes (1991). Introduction to remote sensing. New York, Taylor & Francis.

Crawford, O. G. S. (1953). Archaeology in the field.

Crofts, N., M. Doerr and T. Gill. (2003, February 2003). "The CIDOC Conceptual Reference Model: A standard for Communicating Cultural Content." Retrieved 2nd March, 2003, from http://cidoc.ics.forth.gr/docs/martin_a_2003_comm_cul_cont.htm.

Crumley, C. L. (1994). Historical Ecology: A Multidimensional Ecological Orientation. C. L. Crumley, (Ed.). Sante Fe, School of American Research Press.

Crumley, C. L. and W. H. Marquardt, (Eds.) (1987). Regional dynamics: Burgundian landscapes in historical perspective. London, Academic Press.

Curran, P. J. (1990). Remote sensing of soils and vegetation in the USSR. London, Taylor & Francis.

Daels, L. and K. M. Al Saadi (1990). The detection of old irrigation patterns in Mesopotamia based upon the interpretation of aerial photographs and satellite images. Aerial photography and geophysical prospection in archaeology. C. Léva, (Ed.). Brussels, CIRA - ICL: 83-86.

Dalla Bona, L. (1994). "Predictive Modelling Methodology." Retrieved 3 January, 2003, from <http://modelling.pictographics.com/method.htm>.

Dare, P. M. and C. S. Fraser (2001). "Mapping informal settlements using high resolution satellite imagery." International Journal of Remote Sensing **22**(8): 1399-1401.

Date, C. J. (2000). An introduction to database systems. Reading, Mass., Addison-Wesley.

Day, D., A., J. Logsdon, M. and B. Latell (1998). Eye in the sky: the story of the CORONA spy satellites. Washington, Smithsonian Institution Press.

Dial, G. and J. Grodecki (2003). Applications of Ikonos imagery. ASPRS. Anchorage, Alaska.

Donoghue, D. N. M. (1999). Multispectral Remote Sensing for archaeology. Ciclo di Lezioni sulla ricerca applicata in archeologia; Remote sensing in archaeology, Siena, Italy, Edizioni All' Insegna del Giglio.

Donoghue, D. N. M. (2001). Remote Sensing. Handbook of archaeological sciences. D. R. Brothwell and A. M. Pollard, (Eds.). Chichester, Wiley.

- Donoghue, D. N. M., N. Galiatsatos, G. Philip and A. R. Beck (2000). Satellite Imagery for Archaeological Applications: A Case Study from the Orontes Valley, Syria. Aerial archaeology - developing future practice. R. H. Bewley and W. Raczkowski, (Eds.). Leszno, Poland, IOS Press: 211-223.
- Doran, J. (1987). Modelling and Expert Systems. Quantitative Research in Archaeology: Progress and Prospects. M. S. Aldenderfer, (Ed.). London, Sage.
- Drury, S. A. (1993). Image interpretation in geology. London; New York, Chapman & Hall.
- Duncan, R. B. and K. A. Beckman (2000). Site Location in Pennsylvania and West Virginia. Practical Applications of GIS for Archaeologists: A predictive modelling toolkit. K. L. Wescott and R. J. Brandon, (Eds.). London, Taylor and Francis.
- Dunnell, R. C. (1992). The Notion of Site. Space, time, and archaeological landscapes. J. Rossignol and L. Wandsnider, (Eds.). New York, Plenum Press.
- Ebert, I. (1988). Remote sensing in archaeological projection and prediction. Quantifying the present and predicting the past: theory, method, and application of archaeological predictive modelling. W. J. Judge and L. Sebastian, (Eds.). Denver, U.S. Department of the Interior Bureau of Land Management: 429-492.
- Ebert, I. (1991). Distributional Archaeology. Albuquerque, University of New Mexico Press.
- Ebert, J. I. (1984). "Remote Sensing Applications in Archaeology." Advances in Archaeological Method and Theory 7.
- Ebert, J. I. (1989). Techniques, methods and theoretical goals in American archaeological remote sensing: 'Predictive Modelling' as an example. Into the sun: essays in air photography in archaeology in honour of Derrick Riley. D. L. Kennedy, (Ed.). Sheffield [England], Dept. of Archaeology and Prehistory University of Sheffield.
- Ebert, J. I. and T. R. Lyons (1983). Archaeology, anthropology, and cultural resources management. Manual of Remote Sensing. R. N. Colwell, J. E. Estes and G. A. Thorley, (Eds.). Falls Church, Va., American Society of Photogrammetry.
- El-Baz, F. (1997). "Space Age Archaeology." Scientific American(August): 60-65.
- Elachi, C. (1987). Introduction to the physics and techniques of remote sensing. New York; Chichester, John Wiley.
- ERDAS (1999). ERDAS Field Guide. Atlanta, ERDAS.
- ERDAS (2001). IKONOS sensor model support. Atlanta, ERDAS: 62.
- ESRI (1995). Metadata Management in GIS. Redlands, ESRI.
- ESRI (2002). Working with the Geodatabase. Redlands, ESRI.

- Fernandez, R. N., D. G. Schulze, D. L. Coffin and G. E. Van Scoyoc (1988). "Color, organic matter and pesticide adsorption relationships in a soil landscape." Soil Science Society of America **52**: 1023-1026.
- Fisher, C. T. and T. L. Thurston (1999). "Forward to Dynamic Landscapes and Sociopolitical Process: The Topography of Anthropogenic Environments in Global Perspective." Antiquity **73**(281): 630-632.
- Foley, R. A. (1981). Off-site archaeology: An alternative approach for the short-sited. Patterns of the Past: Studies in honour of David Clarke. I. Hodder, G. Isaac and N. Hammond, (Eds.). Cambridge, Cambridge University Press: 157-183.
- Forte, M. (1995). Scientific visualization and archaeological landscape: the case study of a terramara, Italy. Archaeology and Geographical Information Systems: a European perspective. G. Lock and Z. Stancic, (Eds.). London, Taylor & Francis.
- Forte, M. (1999). Telerilevamento e paesaggi archeologici tridimensionali. Ciclo di Lezioni sulla ricerca applicata in archeologia; Remote sensing in archaeology, Siena, Italy, Edizioni All' Insegna del Giglio.
- Forte, M. (2000). GIS, Aerial Photographs and Microtopography in Archaeology: Methods and Applications. Aerial archaeology - developing future practice, Leszno, Poland, IOS Press.
- Forte, M. (2003a). Mindscape: ecological thinking, cyber-anthropology and virtual archaeological landscapes. The reconstruction of archaeological landscapes through digital technologies: proceedings of the 1st Italy-United States workshop, Boston, Massachusetts, USA, November 1-3, 2001. M. Forte and P. R. Williams, (Eds.). Oxford, BAR: 81-93.
- Forte, M. (2003b). The remote sensing project for the archaeological landscape of Askum (Ethiopia). The reconstruction of archaeological landscapes through digital technologies: proceedings of the 1st Italy-United States workshop, Boston, Massachusetts, USA, November 1-3, 2001. M. Forte and P. R. Williams, (Eds.). Oxford, BAR: 81-93.
- Forte, M. and S. Kay (2003). Remote sensing, GIS and virtual reconstruction of archaeological landscapes. The reconstruction of archaeological landscapes through digital technologies: proceedings of the 1st Italy-United States workshop, Boston, Massachusetts, USA, November 1-3, 2001. M. Forte and P. R. Williams, (Eds.). Oxford: 109-115.
- Forte, M. and P. R. Williams (2003). The reconstruction of archaeological landscapes through digital technologies: proceedings of the 1st Italy-United States workshop, Boston, Massachusetts, USA, November 1-3, 2001. Oxford, Archaeopress: for British Archaeological Reports.
- Fowler, M. J. F. (1993). "Satellite archaeology. Stonehenge from space." Spaceflight **35**: 130-132.
- Fowler, M. J. F. (1994). "Satellite image processing for the archaeologist." Archaeological Computing Newsletter **39**: 2-7.

Fowler, M. J. F. (1996). "High-resolution satellite imagery in archaeological application: a Russian satellite photograph of the Stonehenge region." Antiquity **269**: 667-671.

Fowler, M. J. F. (2001). "A high resolution satellite image of archaeological features to the south of Stonehenge." International Journal of Remote Sensing **22**(7): 1197-1171.

Fowler, M. J. F. (2002). "Satellite remote sensing and archeology: a comparative study of satellite imagery of the environs of Figsbury Ring, Wiltshire." Archaeological Prospection **9**: 55-69.

Francovich, R., H. Patterson and G. Barker, (Eds.) (2000). Extracting meaning from ploughsoil assemblages. The POPULOUS project. Oxford, Oxbow.

Frank, S. (2001). "Comparison of classification of intensity-Hue-Saturation and Smoothing Filter based Modulation (SFIM) image fusion techniques." Retrieved 11th June, 2003, from <http://www.geo.vvu.edu/geog655/spring2001/03/project.htm>.

Franklin, S. E. and P. T. Giles (1995). "Radiometric processing of aerial and satellite remote sensing imagery." Computers and Geosciences **21**(3): 413-423.

Fraser, C. S., E. Baltsavias and A. Gruen (2002). "Processing of Ikonos imagery for submetre 3D positioning and building extraction." ISPRS Journal of Photogrammetry and Remote Sensing **56**: 177-194.

Fujimura, K. and E. Kuo (1999). "Shape reconstruction from contours using isotopic deformation." Graphical Models and Image Processing **67**: 127-147.

Furby, S. L. and N. A. Campbell (2001). "Calibrating images from different dates to 'like-value' digital counts." Remote Sensing of Environment **77**(2001): 186-196.

Gaffney, V., K. Ostir, T. Podobnikar and Z. Stancic (1996). Satellite imagery and GIS applications in mediteranean landscapes. Interfacing the past: CAA95. H. Kamermans and K. Fennema, (Eds.). Leiden, Institute of Prehistory University of Leiden: 337-342.

Gaffney, V. and Z. Stancic (1991). GIS approaches to regional analysis: a case study of the island of Hvar. Ljubljana, Research Institute Faculty of Arts and Science University of Ljubljana.

Galiatsatos, N. (in prep). Assessment of satellite imagery in Landscape Archaeology applications: Case study from Orontes valley, Syria. Department of Geography. Durham, UK, University of Durham.

Galvao, L. S., A. P. Marco and N. E. José Carlos (2001). "Variations in Reflectance of Tropical Soils: Spectral-chemical composition relationships from AVIRIS data." Remote Sensing of Environment **75**: 245-255.

Gerard, F. (2002). "A CORINE map of Great Britain by semi-automated means." Retrieved 8th December, 2002, from <http://www.ceh.ac.uk/subsites/CORINE/index.html>.

Gerlach, F. (2000). "Characteristics of space imaging's one-meter resolution satellite imagery products." International archives of Photogrammetry and Remote Sensing **33 (B1)**: 128-135.

Gillings, M. and G. Goodrick (1998). "Sensuous and Reflexive GIS: Exploring visualisation and VRML." Internet Archaeology.

Gillings, M., D. J. Mattingly and J. v. Dalen, (Eds.) (1999). Geographical information systems and landscape archaeology. The archaeology of Mediterranean landscapes. Oxford, Oxbow.

Gillings, M. and A. Wise (1998). GIS Guide to Good Practice. Oxford, Oxbow.

Goffer, Z., M. Molcho and I. Geit-Arich (1983). "The disposal of wastes in ancient Beer-Sheba." Journal of Field Archaeology **10**: 231-235.

Goldberg, P. (1992). Micromorphology, Soils and archaeological sites. Soils in archaeology: landscape evolution and human occupation. V. T. Holliday, (Ed.). Washington, D.C, Smithsonian Institution Press.

Golledge, R. G. and R. J. Stimson (1987). Analytical behavioural geography. London; New York, Croom Helm.

Goodchild, M. F. and D. A. Quattrochi (1997). Scale, Multiscaling, Remote Sensing, and GIS. Scale in Remote Sensing and GIS. D. A. Quattrochi and M. F. Goodchild, (Eds.). London, Lewis Publishers: 1-11.

Goodrick, G. and M. Gillings (2000). Constructs, simulations and hyperreal worlds: the role of Virtual Reality (VR) in archaeological research. On the Theory and Practice of Archaeological Computing. G. Lock and K. Brown, (Eds.). Oxford, Oxbow.

GORS (2002). Syria: Archaeology from Space. Damascus, General Organisation of Remote Sensing.

Greene, K. (1990). Archaeology: an introduction. London, Batsford.

Griffiths, G. H., J. Lee and B. C. Eversham (2000). "Landscape pattern and species richness; regional scale analysis from remote sensing." International Journal of Remote Sensing **21(13&14)**: 2685-2704.

Griffiths, G. H. and P. M. Mather (2000). "Remote sensing and landscape ecology: landscape patterns and landscape change." International Journal of Remote Sensing **21(13&14)**: 2537-2539.

Grove, C. I., S. J. Hook and E. D. Paylor II (1992). Laboratory Reflectance Spectra of 160 minerals, 0.4 to 2.5 Micrometers. Jet Propulsion Laboratory, Pasadena, California.

Hageman, J. B. and D. A. Bennett (2000). Construction of Digital Elevation Models for Archaeological Applications. Practical Applications of GIS for Archaeologists: A predictive modelling toolkit. K. L. Wescott and R. J. Brandon, (Eds.). London, Taylor and Francis: 113 - 127.

Hall, R. C. (1997). Post War Strategic Reconnaissance and the Genesis of the project Corona. Corona between the Sun and the Earth the first NRO reconnaissance eye in space. R. A. McDonald, (Ed.). Bethesda, American Society for Photogrammetry and Remote Sensing.

Harris, J. R., D. W. Viljoen and A. N. Rencz (1999). Integration and Visualization of Geoscience Data. Remote Sensing for the Earth Sciences. A. N. Rencz, (Ed.). London, John Wiley and Sons. 3.

Harrower, M., J. McCorrison and E. A. Ocher (2002). "Mapping the results of agriculture in Southern Arabia: the application of satellite remote sensing, global positioning system and geographic information system technologies." Archaeological Prospection 9(1): 35-42.

Heron, C. (2001). Geochemical Prospecting. Handbook of Archaeological Sciences. D. R. Brothwell and A. M. Pollard, (Eds.). Chichester, Wiley.

Hirata, M., N. Koga, H. Shinjo, H. Fujita, G. Gintzburger and A. Miyazaki (2001). "Vegetation classification by satellite image processing in a dry area of North-Eastern Syria." International Journal of Remote Sensing 22(4): 507-516.

Hodder, I. (1991). Reading the past: current approaches to interpretation in archaeology. Cambridge, Cambridge University Press.

Hodder, I. (1993). Changing Configurations: the relationships between theory and practice. Archaeological Resource Management in the UK: An Introduction. J. Hunter and I. Ralston, (Eds.). Stroud, Sutton Publishing Limited.

Hodder, I. (1999). The Archaeological Process: an introduction. Oxford, Blackwell.

Holben, B. and C. Justice (1981). "An examination of spectral band ratioing to reduce the topographic effect of remotely sensed data." International Journal of Remote Sensing 2: 115-133.

Holcomb, D. W. (2001). "Imaging Radar and Archaeological Survey: An Example from the Gobi Desert of Southern Mongolia." Journal of Field Archaeology 28: 131 - 141.

Holden, N., P. Horne and R. Bewley (2002). High-Resolution Digital Airborne Mapping and Archaeology. Aerial Archaeology: Developing Future Practice. R. H. Bewley and W. Raczkowski, (Eds.). Oxford, IOS press: 173-180.

Horne, J. H. (2003). A Tasseled Cap transformation for Ikonos images. ASPRS, Anchorage, Alaska.

Horvath, E. H., D. F. Post and J. B. Kelsey (1984). "Relationship among Landsat digital data and the properties of Arizona rangelands." Soil Science Society of America 56: 865-872.

IFA. (2001, September 2001). "Standard and guidance for archaeological desk-based assessment." 2nd. Retrieved 6 January, 2003, from <http://www.archaeologists.net/docs/codes/dba2.pdf>.

- Irons, J. R., R. Weismiller and G. W. Petersen (1989). Soil Reflectance. Theory and applications of optical remote sensing. G. Asrar, (Ed.). New York (N.Y.); Chichester, Wiley.
- Jensen, J. R. (1996). Introductory digital image processing: a remote sensing perspective. Upper Saddle River, N.J., Prentice-Hall.
- Jensen, J. R. (2000). Remote sensing of the environment: an earth resource perspective. Upper Saddle River, N.J., Prentice Hall.
- Jones, B. (2000). Aerial archaeology around the Mediterranean. Non-destructive techniques applied to landscape archaeology. M. Pasquinucci and F. Trement, (Eds.). Oxford, Oxbow: 49-60.
- Judge, W. J., J. I. Ebert and R. K. Hitchcock (1975). Sampling in Regional Archaeological Survey. Sampling in Archaeology. J. W. Mueller, (Ed.). Tucson, The University of Arizona Press.
- Judge, W. J. and L. Sebastian, (Eds.) (1988). Quantifying the present and predicting the past: theory, method, and application of archaeological predictive modelling. Denver, U.S. Department of the Interior Bureau of Land Management.
- Karpouzli, E. and T. Malthus (2003). "The empiracle line method for the atmospheric correction of IKONOS imagery." International Journal of Remote Sensing **24**(5): 1143-1150.
- Kartikayan, B., A. Sarkar and K. L. Majumder (1998). "A segmentation approach to classification of remotely sensed imagery." International Journal of Remote Sensing **19**(9): 1695-1709.
- Kennedy, D. L. (1998). "Declassified satellite photographs and archaeology in the Middle East: case studies from Turkey." Antiquity **72**: 553-561.
- Key, J. (2001). "FW: Syrian - Ikonos." Retrieved 12th November, 2001.
- Knapp, A. B. (1997). The archaeology of late Bronze Age Cypriot society: the study of settlement, survey and landscape. Glasgow, Department of Archaeology.
- Knapp, A. B. and W. Ashmore (1999). Archaeological landscapes: Constructed, conceptualised, ideational. Archaeologies of landscape: contemporary perspectives. W. Ashmore and A. B. Knapp, (Eds.). Oxford, Blackwell Publishers: 1-30.
- Kodak. (2003, 6th February 2003). "KODAK PLUS-X AERECON II Film 3404." Retrieved 2nd June, 2003, from <http://www.kodak.com/US/en/government/aerial/technicalPubs/tiDocs/ti1669/ti1669.shtml#specsens>.
- Kouchoukos, N. (2001). "Satellite Images and Near Eastern Landscapes." Near Eastern Archaeology **64**(1-2): pp. 80 - 91.

Kruckman, L. (1987). "The role of remote sensing in Ethnohistorical research." Journal of Field Archaeology **14**.

Kvamme, K. L. (1988). Development and testing of quantitative models. Quantifying the present and predicting the past: theory, method, and application of archaeological predictive modelling. W. J. Judge and L. Sebastian, (Eds.). Denver, U.S. Department of the Interior Bureau of Land Management.

Kvamme, K. L. (1995). A view from across the water: the North American experience in archaeological GIS. Archaeology and Geographical Information Systems: a European perspective. G. Lock and Z. Stancic, (Eds.). London, Taylor and Francis: pp. 1-14.

Kvamme, K. L. (1999). "Recent Directions and Developments in Geographical Information Systems." Journal of Archaeological Research **7**(2): 153-201.

Lake, M. W., P. E. Woodman and S. J. Mithen (1998). "Tailoring GIS software for archaeological applications: An example concerning multiple viewshed analysis." Journal of Archaeological Science **25**: 27-38.

Lambrick, G. (1977). Archaeology and agriculture: a survey of modern cultivation methods and the problems of assessing plough damage to archaeological sites. Oxford, Council for British Archaeology and the Oxfordshire Archaeological Unit.

Lang, S. A. (1992). An investigation of image processing techniques at Pincevent habitation No. 1, a late Magdalenian site in Northern France, Arizona State University.

Langran, G. (1992). Time in geographic information systems. London; Washington, Taylor and Francis 1992.

Layton, P. and P. J. Ucko (1999). Introduction: gazing on the landscape and encountering the environment. The archaeology and anthropology of landscape: shaping your landscape. P. J. Ucko and R. Layton, (Eds.). London, Routledge.

Lee, D. (1996). "Automation of Map Generalization." Retrieved 6th April, 2002, from http://arconline.esri.com/arconline/whitepapers/ao_/mapgen.pdf.

Leone, A. P. and R. Escadafal (2001). "Statistical analysis of soil colour and spectroradiometric data for hyperspectral remote sensing of soil properties (example in a southern Italy Mediterranean ecosystem)." International Journal of Remote Sensing **22**(12): 2311-2328.

Li, R., G. Zhou, N. J. Schmidt, C. Fowler and G. Tuell (2002). "Photogrammetric processing of high-resolution airborne and satellite linear array stereo images for mapping applications." International Journal of Remote Sensing **23**(20): 4451-4473.

Liang, S., H. Fang, J. Morissette, M. Chen, C. Shuey, C. Walthall and C. Caughtry (2002). "Atmospheric Correction of Landsat ETM+ Land Surface Imagery: II. Validation and Applications." IEEE Transactions on Geoscience and Remote Sensing: 1-10.

Lillesand, T. M. and R. W. Kiefer (1999). Remote sensing and image interpretation. New York, John Wiley & Sons.

Liu, J. G. (2000a). "Evaluation of Landsat-7 ETM+ Panchromatic Band for image fusion with Multispectral Bands." Natural Resources Research 9(4): 269-276.

Liu, J. G. (2000b). "Smoothing Filter-based intensity modulation: a spectral preserve image fusion technique for improving spatial details." International Journal of Remote Sensing 21(18): 3461-3472.

Liverman, D., E. F. Moran, R. R. Rinfus and P. C. Stern (1998). People and pixels: Linking Remote Sensing and Social Science. Washington, National Academy Press.

Lucas, G. (2001). Critical approaches to fieldwork: contemporary and historical archaeological practice. London, Routledge.

Luque, S. S. (2000). "Evaluating temporal changes using Multi-Spectral Scanner and Thematic Mapper data on the landscape of a natural reserve: the New Jersey Pine Barrens, a case study." International Journal of Remote Sensing 21(13&14): 2589-2611.

Lyons, T. R. and T. E. Avery (1977). Remote sensing: a handbook for archaeologists and cultural resource managers. Washington, D.C., Cultural Resources Management Division National Park Service U.S. Dept. of the Interior.

Lyons, T. R. and F. J. Mathien (1980). Cultural resources remote sensing. Washington, D.C., Cultural Resources Management Division National Park Service.

MacDonald, A. (2001). Building a geodatabase: GIS by ESRI. Redlands, CA, Environmental Systems Research Institute c1999-2001.

Macklin, M. G. and S. Needham, (Eds.) (1992). Alluvial archaeology in Britain. Oxbow monograph; 27. Oxford, Oxbow Books.

Macklin, M. G., D. Passmore and B. Rumsby (1992). Climatic and cultural signals in Holocene alluvial sequences: the Tyne basin, northern England. Alluvial archaeology in Britain. G. Macklin Mark and S. Needham, (Eds.). Oxford, Oxbow Books.

Mandelbrot, B. B. (1967). "How long is the coastline of Britain? Statistical self-similarity and fractal dimension." Science 155(636).

Marceau, D. J. (1999). "The scale issue in social and natural sciences." Canadian Journal of Remote Sensing 25(4): 347-356.

Martin, D. (1991). Geographic Information Systems and their Socioeconomic Implications. London, Routledge.

Maschner, H. D. G. (1996). Theory, Technology, and the Future of Geographic Information Systems in Archaeology. New methods, old problems: geographic information systems in

modern archaeological research. H. D. G. Maschner, (Ed.). Carbondale, Southern Illinois University: 301-308.

Mather, P. M. (1999). Computer processing of remotely sensed images: an introduction. New York, John Wiley.

Mattikalli, N. M. (1997). "Soil colour modelling for the visible and near infrared bands of Landsat sensors using laboratory spectral measurements." Remote Sensing of Environment **59**: 14-28.

McDonald, R. A. (1997). Corona between the Sun and the Earth the first NRO reconnaissance eye in space. Bethesda, American Society for Photogrammetry and Remote Sensing.

McManamon, F. P. (1984). "Discovering Sites Unseen." Advances in Archaeological Method and Theory **7**.

Middleton, M. (2000). The Archaeological Soils Recording Chart. Fife, Artacorn.

Morain, S. A. (1998). A Brief History of Remote Sensing Applications with Emphasis on Landsat. People and pixels: Linking Remote Sensing and Social Science. D. Liverman, E. F. Moran, R. R. Rinfus and P. C. Stern, (Eds.). Washington, National Academy Press: 28-50.

Morehouse, S. (1995). GIS-based map compilation and generalization. GIS and generalization: methodology and practice. J. C. Muller, J. P. Lagrange and R. Weibel, (Eds.). Compiegne, France, Taylor & Francis: 21-30.

Müller, J. C., J. P. Lagrange and R. Weibel, (Eds.) (1995). GIS and generalization: methodology and practice. Gisdata. 1. London, Taylor & Francis.

Mumford, G. and S. Parcak (2002). "Satellite image analysis and archaeological fieldwork in El-Markha Plain (South Sinai)." Antiquity **76**: 953-954.

Munsell, A. H. (1981). A Color Notation. Baltimore, Macbeth.

Munsell Colour Company (1975). Munsell Soil Colour Charts. Baltimore, Macbeth Division of Kollmorgen.

Myers, V. (1983). Remote sensing applications in agriculture. Manual of remote sensing. R. N. Colwell, J. E. Estes and G. A. Thorley, (Eds.). Falls Church, Va., American Society of Photogrammetry.

Newson, P. G. (2002). Settlement, land use and water management systems in Roman Arabia: an integrated archaeological approach. School of archaeology and ancient history. Leicester, University of Leicester: 266.

Nunnally, N. R. (1973). Introduction to Remote Sensing: The physics of electromagnetic radiation. The Surveillance Science: Remote Sensing of the Environment. R. K. Holz, (Ed.). Boston, Houghton Mifflin Company: 18-26.

O'Brien, M. J., J. L. Beets, R. E. Warren, T. Hotrabhavananda, T. W. Barney and E. E. Voight (1982). "Digital enhancement and grey-level slicing of aerial photographs: techniques for archaeological analysis of intrasite variability." World Archaeology **14**(2): 173-190.

Olson, G. W. (1984). Field guide to soils and the environment: applications of soil surveys. New York; London, Chapman and Hall.

Ostir, K., Z. Stancic and M. Trusnovec (1999). Multispectral classification of satellite images. Geographical information systems and landscape archaeology. M. Gillings, D. J. Mattingly and J. v. Dalen, (Eds.). Oxford, Oxbow.

Palmer, R. (2000). Air Photo Interpretation and Mapping to Guide Fieldwork in Commercial Archaeology in England. Aerial archaeology - developing future practice, Leszno, Poland, IOS Press.

Palumbo, G. (1992). JADIS (Jordan Antiquities Database and Information System): An example of national archaeological inventory and GIS applications. Computing the past: computer applications and quantitative methods in archaeology. J. Andresen, T. Madsen and I. Scollar, (Eds.). Aarhus; Denmark, Aarhus Denmark: 183-188.

Palumbo, G. and D. Powlesland (1996). Remote sensing and geographic database management systems applications for the protection and conservation of cultural heritage. Remote Sensing for Geography, Geology, Land Planning and Cultural Heritage. D. Arroyo-Bishop, R. Carla, J. B. Lurie, C. M. Marino, A. Panunzi, J. J. Pearson and E. Zilioli, (Eds.). Washington, SPIE. **2960**: 124-129.

Parker, D. C. and M. F. Wolff (1973). Remote Sensing. The Surveillance Science: Remote Sensing of the Environment. R. K. Holz, (Ed.). Boston, Houghton Mifflin Company: 29-37.

Parrington, M. (1983). "Remote Sensing." Annual Review of Anthropology(12): 105-124.

Pecknold, S., S. Lovejoy, D. Schertzer and C. Hooge (1997). Multifractals and Resolution Dependence of Remotely Sensed Data: GSI to GIS. Scale in Remote Sensing and GIS. D. A. Quattrochi and M. F. Goodchild, (Eds.). London, Lewis Publishers: 361-394.

Philip, G., A. R. Beck and D. N. M. Donoghue (in press). The contribution of satellite imagery to archaeological survey: an example from Western Syria. Workshop on Aerial Archaeology and Remote Sensing, Siena.

Philip, G., D. N. M. Donoghue, A. R. Beck and N. Galiatsatos (2002a). "CORONA satellite photography: an archaeological application from the Middle East." Antiquity **76**(291): 109-118.

Philip, G., F. Jabour, A. R. Beck, M. Bshesh, J. Grove, A. Kirk and A. R. Millard (2002b). "Settlement and Landscape Development in the Homs Region, Syria: Research Questions, Preliminary Results 1999-2000 and Future Potential." Levant **34**.

Philipson, W. R. (1997). Manual of Photographic Interpretation. Bethesda, Md., American Society of Photogrammetry and Remote Sensing.

Plog, S., F. Plog and W. Wait (1978). Decision making in modern surveys. Advances in Archaeological Method and Theory. M. Schiffer, B., (Ed.). London, Academic Press. **1**: 383-421.

Pohl, C. and J. L. Van Genderen (1998). "Multisensor image fusion in remote sensing: concepts methods and applications." International Journal of Remote Sensing **19**(5): 823-854.

Pollard, A. M. and C. Heron (1996). Archaeological Chemistry. Cambridge, Royal Society of Chemistry.

Ponikarov, V. P., V. G. Kazmin, I. A. Mikhailov, A. V. Razvaliyev, V. A. Krasheninnikov, V. V. Kozlov, E. D. Soulidi-Kondratyev, K. Y. Mikhailov, V. V. Kolakov, V. A. Faradzhev and K. M. Mirzayev (1967). The Geology of Syria: Explanatory notes on the 1:500,000 geological map of Syria: Part I. Stratigraphy, igneous rocks and tectonics. Moscow.

Powlesland, D., J. Lyall and D. Donoghue (1997). "Enhancing the record through remote sensing: the application and integration of multi-sensor, non-invasive remote sensing techniques for the enhancement of the Sites and Monuments Record." Internet Archaeology(2).

Pundt, H. and K. Brinkkotter-Runde (2000). "Visualization of spatial data for field based GIS." Computers and Geosciences **26**: 51-56.

Raczkowski, W. (2000). Beyond the Technology: Do we need 'Meta-Aerial Archaeology'? Aerial archaeology - developing future practice, Leszno, Poland, IOS Press.

Ramenofsky, A. F. and A. Steffen, (Eds.) (1998). Unit issues in archaeology: measuring time, space, and material. Foundations of archaeological inquiry. Salt Lake City, University of Utah Press.

Ranchin, T., B. Aiazzi, L. Alparone, S. Baronti and L. Wald (2003). "Image-fusion- the ARSIS concept and some successful implementation schemes." ISPRS Journal of Photogrammetry and Remote Sensing **58**: 4-18.

Redfern, S., G. Lyons and R. M. Redfern (1999). "Digital Elevation Modelling of individual monuments from Aerial Photographs." **6**: 211-224.

Rees, W. G. (2001). "Improving the accuracy of low-cost GPS measurements for remote sensing applications." International Journal of Remote Sensing **22**(5): 871-881.

Renfrew, C. and P. G. Bahn (1991). Archaeology: theories, methods, and practice. New York., Thames and Hudson.

Richards, J. (1998). "Recent trends in Computer Applications in Archaeology." Journal of Archaeological Research **6**(4): 331-382.

Richards, J. D. and D. Robinson (2000). Digital archives from excavation and fieldwork: a guide to good practice. Oxford, Oxbow.

Rimington, J. N. (2000). Soil geochemistry and artefact scatters in Boeotia, Greece. Non-destructive techniques applied to landscape archaeology. M. Pasquinucci and F. Tremont, (Eds.). Oxford, Oxbow.

Robinson, J. M. and E. Zubrow (1999). Between Spaces: Interpolation in Archaeology. Geographical information systems and landscape archaeology. M. Gillings, D. J. Mattingly and J. v. Dalen, (Eds.). Oxford, Oxbow.

Rodriguez, A., H. Salahieh, R. Badwan and H. Khawam (1999). Groundwater Use and Supplemental Irrigation in Atareb, northwest Syria. Aleppo, Syria, ICARDA.

Romano, D. G. and O. Tolba (1996). Remote sensing and GIS in the study of Roman Centuriation in the Corinthia, Greece. Interfacing the past: CAA95. H. Kamermans and K. Fennema, (Eds.). Leiden, Institute of Prehistory University of Leiden: 457-463.

Rosen, A. M. (1986). Cities of clay: the geoarchaeology of tells. Chicago, University of Chicago Press.

Roskams, S. (2001). Excavation. Cambridge, Cambridge University Press.

Rossignol, J. (1992). Concepts, Methods and Theory Building: A Landscape Approach. Space, time, and archaeological landscapes. J. Rossignol and L. Wandsnider, (Eds.). New York, Plenum Press.

Rossignol, J. and L. Wandsnider, (Eds.) (1992). Space, time, and archaeological landscapes. Interdisciplinary contributions to archaeology. New York, Plenum Press.

Rothaus, R. M. and A. A. De Morett (1999). Landsat TM imagery in landscape archaeology: Detection and modelling. Ciclo di Lezioni sulla ricerca applicata in archeologia; Remote sensing in archaeology, Siena, Italy, Edizioni All' Insegna del Giglio.

Ryan, N. (1991). Beyond the relational database: Managing the variety and complexity in archaeological data. Computer applications and quantitative methods in archaeology, 1991. G. Lock, J. Moffett and J. Castleford, (Eds.). Oxford, BAR.

Ryan, N. S., D. R. More and J. Pascoe (1998). Enhanced Reality Fieldwork: the Context Aware Archaeological Assistant. Computer Applications in Archaeology, 1997. V. Gaffney, S. Exon and M. van Leusen, (Eds.). Oxford, BAR.

Sabins, F. F. (1997). Remote sensing: principles and interpretation. New York, W.H. Freeman & Co.

Salomonson, V. V. (1983). Water resources assessment. Manual of remote sensing. R. N. Colwell, J. E. Estes and G. A. Thorley, (Eds.). Falls Church, Va., American Society of Photogrammetry.

Sauer, C. O. (1938). The morphology of landscape. Berkeley, Calif., University of California Press.

Sauvage, M. (1998). La brique et sa mise en œuvre en Mésopotamie: des origines à l'époque achéménide. Paris, Centre de recherche d'Archéologie Orientale, Université de Paris.

Schiffer, M., B. (1987). Formation processes of the archaeological record. Albuquerque, University of New Mexico Press.

Schiffer, M. B. (1996). Formation processes of the archaeological record. Salt Lake City, University of New Mexico Press.

Schiffer, M. B., A. P. Sullivan and T. C. Kilinger (1978). "The design of archaeological surveys." World Archaeology **10**(1): 1-28.

Schmidt, A. (2004). "Remote Sensing and Geophysical Prospection." Internet Archaeology **25**.

Schnitzer, M. (1982). Organic matter characterisation. Methods of soil analysis. A. L. Page, R. H. Miller and R. Keeney Dennis, (Eds.). Madison, Wis., American Society of Agronomy: Soil Science Society of America.

Schuldenrein, J. (1995). Geochemistry, Phosphate Fractionation, and the Detection of Activity Areas at Prehistoric North American Sites. Pedological Perspectives in Archaeological Research. M. E. Collins, B. J. Carter, B. G. Gladfelter and R. J. Southard, (Eds.). Madison, Soil Science Society of America.

Scollar, I. (1990). Archaeological prospecting and remote sensing. Cambridge, Cambridge University Press.

Scudder, S. J., J. E. Foss and M. E. Collins (1996). "Soil Science and Archaeology." Advances in agronomy **57**: 1-76.

Sever, T. L. (1988). Remote Sensing. Benchmarks in time and culture: an introduction to the history and methodology of Syro-Palestinian archaeology. J. F. Drinkard, G. L. Mattingly and J. M. Miller, (Eds.). Atlanta, Scholars Press.

Sever, T. L. (1998). Validating prehistoric and current social phenomena upon the landscape of eten, Guatemala. People and pixels: Linking Remote Sensing and Social Science. D. Liverman, E. F. Moran, R. R. Rinfus and P. C. Stern, (Eds.). Washington, National Academy Press: 145-163.

Sever, T. L. and D. W. Wagner (1991). Analysis of prehistoric roadways in Chaco Canyon using remotely sensed digital data. Ancient road networks and settlement hierarchies in the New World. C. D. Trombold, (Ed.). Cambridge, University of Cambridge: 42-52.

Shell, C. (2000). Airborne High-Resolution Digital, Visible, Infra-Red and Thermal Sensing for Archaeology. Aerial archaeology - developing future practice, Leszno, Poland, IOS Press.

- Shennan, I. (1997). Quantifying Archaeology. Edinburgh, Edinburgh University Press.
- Shennan, I. and D. N. M. Donoghue (1992). "Remote sensing in archaeological research." Proceedings of the British Academy **77**: 223-232.
- Shennan, S. (1985). Experiments in the Collection and Analysis of Archaeological Survey Data: The East Hampshire survey. Sheffield, Department of Archaeology and Prehistory.
- Siegal, B. S. and A. R. Gillespie (1980). Remote sensing in geology. Chichester, Wiley.
- Skirvin, S. (2003). "Atmospheric and radiometric correction of Landsat Thematic Mapper data using the COST model of Chavez, 1996." Retrieved 10th June, 2003, from http://www2.erdas.com/supportsite/downloads/models/user_models/user_model_2.html.
- Slonecker, E. T., D. M. Shaw and T. M. Lillesand (1998). "Emerging legal and ethical issues in advanced remote sensing technology." Photogrammetric Engineering and Remote Sensing **64**: 589-595.
- Sommer, S., J. Hill and J. Mégier (1998). "The potential of remote sensing for monitoring rural land use changes and their effects on soil conditions." Agriculture Ecosystems and Environment **67**: 197-209.
- Song, C., C. E. Woodcock, K. C. Seto, M. P. Lenney and S. A. Macomber (2000). "Classification and change detection using Landsat TM data: When and how to correct atmospheric effects?" Remote Sensing of Environment **75**: 230-244.
- Space Imaging. (2003). "Ikonos Product Guide." Retrieved 30th May, 2003, from www.spaceimaging.com/whitepapers_pdfs/IKONOS_Product_Guide.pdf.
- Spoerry, P., (Ed.) (1992). Geoprospection in the Archaeological Landscape. Oxford, Oxbow.
- Stanjek, H. and J. W. E. Fabbinder (1995). "Soil aspects affecting archaeological details in aerial photographs." Archaeological Prospection **2**: 91-101.
- Stein, J. K. (1992). Organic Matter in Archaeological Contexts. Soils in archaeology: landscape evolution and human occupation. V. T. Holliday, (Ed.). Washington, D.C, Smithsonian Institution Press.
- Stevanovic, M. (1997). "The Age of Clay: The Social Dynamics of House Destruction." Journal of anthropological archaeology(16): 334-395.
- Stone, E. (2003). Remote sensing and the location of the ancient Tigris. The reconstruction of archaeological landscapes through digital technologies: proceedings of the 1st Italy-United States workshop, Boston, Massachusetts, USA, November 1-3, 2001. M. Forte and P. R. Williams, (Eds.). Oxford, 157-162: 81-93.
- Stone, E. and P. Zimansky (1995). "The Tapestry of Power in a Mesopotamian City." Scientific American(April): 118-123.

Stoner, E. R. and M. F. Baumgardner (1981). "Characteristic variation in the reflectance of surface soils." Soil Science Society of America **45**: 1161-1165.

Sunar, F. and N. Musaoglu (1998). "Merging multiresolution SPOT P and Landsat TM data: the effects and advantages." International Journal of Remote Sensing **19**(2): 219-224.

Taylor, C. C. (1972). The study of settlement patterns in pre-Saxon Britain. Man, Settlement and Urbanism. P. J. Ucko, R. Tringham and G. W. Dimbleby, (Eds.). London, Duckworth.

Taylor, J. (2000). Soil phosphate survey. Non-destructive techniques applied to landscape archaeology. M. Pasquinucci and F. Trement, (Eds.). Oxford, Oxbow.

Teng, W. L. (1997). Fundamentals of Photographic Interpretation. Manual of Photographic Interpretation. W. R. Philipson, (Ed.). Bethesda, American Society of Photogrammetry and Remote Sensing: 49-116.

Tilley, C. (1994). A Phenomenology of Landscape. London, Routledge.

Toutin, T. (2001). "Elevation modelling from satellite visible and infrared (VIR) data." International Journal of Remote Sensing **22**(6): 1097-1125.

Toutin, T. (2002). "DEM from stereo Landsat 7 ETM+ data over high relief areas." International Journal of Remote Sensing **23**(10): 2133-2139.

Townshend, J. R. G., J. R. Hardy, J. Cushnie and A. Wilson (1988). Thematic mapper data: characteristics and use, NERC/SERC reprographics.

Tso, B. and P. M. Mather (2001). Classification methods for remotely sensed data. London, Taylor & Francis.

United Nations. (1985). "Principles Relating to Remote Sensing of the Earth from Outer Space." Retrieved 24 January, 2003, from <http://www.oosa.unvienna.org/SpaceLaw/rstxt.htm>.

Ur, J. (2002). "Settlement and landscape in Northern Mesopotamia: The Tell Hamoukar Survey 2000-2001." Akkadica **123**: 57-88.

Ur, J. (2003). "CORONA satellite photography and ancient road networks: A Northern Mesopotamian case study." Antiquity **77**(295): 102-115.

USGS. (2003a). "Declassified Satellite Imagery - 1." Retrieved 2nd June, 2003, from <http://edc.usgs.gov/products/satellite/declass1.html>.

USGS. (2003b). "Declassified Satellite Imagery - 1 (1996)." Retrieved 2nd June, 2003, from <http://edc.usgs.gov/guides/disp1.html>.

USGS. (2003c, Friday, May 09, 2003). "EROS Data Center, Sioux Falls, SD." Retrieved 28th May, 2003, from <http://edc.usgs.gov/products/satellite/tm.html>.

USGS. (2003d, October 9, 2002). "LANDSAT-7 LEVEL-0 AND LEVEL-1 DATA SET DOCUMENT." Retrieved 28th May, 2003, from http://eosims.cr.usgs.gov:5725/DATASET_DOCS/landsat7_dataset.html.

USGS. (2003e, Monday, April 14, 2003). "USGS Landsat Project - Landsat 7 Home page." Retrieved 28th May, 2003, from <http://landsat7.usgs.gov/index.php>.

Van Liere, W. J. (1959). "Ager centuriatus of the roman colonia of Emesa." Les annales archaeologiques de Syries **8-9**: 55-58.

Voûte, C. (1955). "Climate or tectonics? Some remarks on the evolution of the valley of the Orontes (Nahr el-Aassi) between Homs and the marshy plains of the Ghab (Syria)." Geologie en Mijnbouw **17**: 197-206.

Wald, L. and T. Ranchin (2002). "Comment: Liu "Smoothing Filter-based intensity modulation: a spectral preserve image fusion technique for improving spatial details"." International Journal of Remote Sensing **23**(3): 593-597.

Wald, L., T. Ranchin and M. Mangolini (1997). "Fusion of satellite images of different spatial resolutions: Assessing the quality of resulting images." Photogrammetric Engineering and Remote Sensing **63**: 691-699.

Wandsnider, L. (1992a). Archaeological Landscape Studies. Space, time, and archaeological landscapes. J. Rossignol and L. Wandsnider, (Eds.). New York, Plenum Press.

Wandsnider, L. (1992b). The Spatial Dimension of Time. Space, time, and archaeological landscapes. J. Rossignol and L. Wandsnider, (Eds.). New York, Plenum Press.

Ward, I. and P. Larcombe (2003). "A process-orientated approach to archaeological site formation: application to semi-arid Northern Australia." Journal of Archaeological Science(30): 1223-1236.

Warren, R. E. and D. L. Asch (2000). A Predictive Model of Archaeological Site Location in the Eastern Prairie Peninsula. Practical Applications of GIS for Archaeologists: A predictive modelling toolkit. K. L. Wescott and R. J. Brandon, (Eds.). London, Taylor and Francis.

Waters, M. R. (1992). Principles of geoarchaeology: a North American perspective. Tucson, University of Arizona Press.

Way, D. S. and J. R. Everett (1997). Landforms and geology. Manual of Photographic Interpretation. W. R. Philipson, (Ed.). Bethesda, American Society of Photogrammetry and Remote Sensing: 117-166.

Wescott, K. L. and R. J. Brandon (2000). Practical Applications of GIS for Archaeologists: A predictive modelling toolkit. London, Taylor and Francis.

Wheatley, D. (1995). Cumulative viewshed analysis: a GIS-based method for investigating intervisibility, and its archaeological application. Archaeology and Geographical Information

Systems: a European perspective. G. Lock and Z. Stancic, (Eds.). London, Taylor and Francis: 171 - 186.

Wheatley, D. (1996). Between the lines: the role of GIS-based predictive modelling in the interpretation of extensive survey data. Interfacing the past: CAA95. H. Kamermans and K. Fennema, (Eds.). Leiden, Institute of Prehistory University of Leiden: 275-291.

Wheatley, D. and M. Gillings (2002). Spatial technology and archaeology: the archeological applications of GIS. New York, Taylor & Francis.

White, R. E. (1997). Principles and practice of soil science: the soil as a natural resource. Oxford, Blackwell Science.

Wilkinson, T. J. (1998). "Water and human settlement in the Balikh Valley, Syria: investigations from 1992 - 1995." Journal of Field Archaeology **25**: 63-87.

Wilkinson, T. J. (2000). "Regional Approaches to Mesopotamian Archaeology: The Contribution of Archaeological Surveys." Journal of Archaeological Research **8**(3): 219 - 267.

Wilkinson, T. J. (2001). Surface collection techniques in field archaeology: Theory and Practice. Handbook of archaeological sciences. D. R. Brothwell and A. M. Pollard, (Eds.). London, John Wiley and Sons Ltd.

Wilkinson, T. J., C. A. I. French, W. Matthews and J. Oates (2001). Geoarchaeology, Landscape and the Region. Excavations at Tell Brak Vol. 2: Nagar in the third millennium BC. D. Oates, J. Oates and H. McDonald, (Eds.). Cambridge, McDonald Institute for Archaeological Research. **2**: 1-14.

Wilkinson, T. J., J. Ur and J. Casana (2004). From Nucleation to Dispersal: Trends in Settlement Pattern in the Northern Fertile Crescent. Side by Side Survey: Comparative regional studies in the Mediterranean World. S. E. Alcock and J. F. Cherry, (Eds.). Oxford, Oxbow: 251.

Williams, R. S. (1983). Geological Applications. Manual of remote sensing. R. N. Colwell, J. E. Estes and G. A. Thorley, (Eds.). Falls Church, Va., American Society of Photogrammetry.

Wilson, D. R. (2000). Air photo interpretation for archaeologists. Stroud, Tempus.

Winterhalder, B. (1994). Concepts in Historical Ecology: The view from evolutionary ecology. Historical Ecology. C. L. Crumley, (Ed.). Sante Fe, School of American Research Press.

Wirth, E. (1971). Syrien eine geographische Landeskunde. Darmstadt, Wissenschaftliche Buchgesellschaft.

Wise, A. and P. Miller (1997). "Why metadata matters." Internet Archaeology(1).

Wolfart, R. (1967). Syria und Lebanon: Beiträge zur regionalen geologie der erde. Berlin, Gebrüder Borntraeger.

Wu, J. and Y. Qi (2000). "Dealing with scale in landscape analysis: An overview." Geographic Information Sciences 6(1): 1-5.

Zomer, R., S. Ustin and J. Ives (2002). "Using satellite remote sensing for DEM extraction in complex mountainous terrain: landscape analysis of the Makalu Barun National Park of eastern Nepal." International Journal of Remote Sensing 23(1): 125-143.

