

Durham E-Theses

Genetic engineering of rice for improved agronomic characteristics

Nghia Pham Trung

How to cite:

Trung, Nghia Pham (2004) Genetic engineering of rice for improved agronomic characteristics. Masters thesis, Durham University.

Use policy

The full-text may be used and/or reproduced, and given to third parties in any format or medium, without prior permission or charge, for personal research or study, educational, or not-for-profit purposes provided that:

- a full bibliographic reference is made to the original source
- a <https://etheses.durham.ac.uk/id/eprint/3015/> is made to the metadata record in Durham E-Theses
- the full-text is not changed in any way

The full-text must not be sold in any format or medium without the formal permission of the copyright holders.

Please consult the [full Durham E-Theses policy](#) for further details.

GENETIC ENGINEERING OF RICE FOR IMPROVED AGRONOMIC CHARACTERISTICS

A Thesis Submitted By Nghia Pham Trung, M.Sc (Genetics And Plant Breeding) In
Accordance With The Requirements Of The University Of Durham For The Degree Of
Doctor Of Philosophy.

**A copyright of this thesis rests
with the author. No quotation
from it should be published
without his prior written consent
and information derived from it
should be acknowledged.**

Department Of Biological And Biomedical Sciences,

University Of Durham, UK,

2004



20 APR 2005

**GENETIC ENGINEERING OF RICE FOR IMPROVED AGRONOMIC
CHARACTERISTICS***ABSTRACT*

This thesis describes the production of three populations of transgenic rice plants using particle bombardment method altered in two main traits: (1) polyamine content and (2) insect pest resistance. The expression of antisense heterologous oat arginine decarboxylase (ADC) cDNA in transgenic rice plants suppressed endogenous ADC enzyme activity, and decreased putrescine and spermidine levels in a tissue/organ dependent manner, with no concomitant changes in the expression of other polyamine biosynthetic genes. The second population of transgenic rice plants engineered with a homologous spermidine synthase (SpdSyn) transgene, and observed through two generations, showed increased expression of both endogenous and transgene mRNAs. However, no significant accumulation of spermidine level in transgenic rice plants when compared to wild type control plants was observed. Putrescine levels were significantly increased in these transgenic plants. The study suggested the possible presence of an inter-conversion process from spermidine to putrescine in transgenic plants, triggered by over-expression of SpdSyn mRNAs. Novel insect resistance gene constructs encoding fusion proteins, including (1) rice thioredoxin h fused with snowdrop lectin-GNA (TRX-GNA), (2) the first domain of Bt toxin gene-Cry1Ac fused with GNA (Ac-GNA) and (3) Cry1Ac fused with ricin B chain-RTB (Ac-RTB) were assembled. When expressed in transgenic plant, these fusion proteins displayed an additive effect as insect toxins by maintaining the functional properties of the individual proteins. Artificial diet bioassays against insect pests showed that using these fusion proteins could enhance toxicity, insecticidal spectrum and possibly durability of resistance to insect pests. Our results clearly showed that transgenic rice plants expressing these fusion protein genes are resistant to brown planthopper, an important insect pest in tropical rice growing areas. These rice plants behave as horizontally resistant cultivars that are suitable for integrated pest management (IPM) networks.



DECLARATION

No part of this thesis has been previously submitted for a degree in this or any other University. I declare that, unless otherwise stated, the work herein is entirely my own.

The copyright of this thesis rests with the author. No quotation from it should be published without her written consent and information derived from it should be acknowledged.

ACKNOWLEDGEMENTS

I gratefully acknowledge the fellowship and financial support provided by the Rockefeller Foundation, and the John Innes Centre, the Department of Biological Sciences (Durham University) for the use of their facilities.

I would like to thank my supervisor Dr. John A. Gatehouse for his guidance, enthusiasm, and support throughout the project, and for critically reading this manuscript. Especially, I am indebted to John for his generosity in helping me to deal with day-to-day problems during my time in Durham. I would like to thank my previous supervisors, Drs Paul Christou and Teresa Capell for their guidance, support and enthusiasm during my time at the John Innes Centre. I would also like to thank Drs. Nicola Harbberd, Ed Hitchin, Elaine Fitches, Dave Bown, Jinping Du, Romaan Raemaekers and Miss Hillary Wilkinson for their advice and technical know-how. Many thanks extend to all my friends Ludo, Rose, Hang, Fu, Olivia, Dan, Du, Hillary, Kevin, Li, Ajay, Duncan and Mike for their friendship and for making the atmosphere the laboratories in which I have worked, both warm and welcoming.

Finally, I would like to thank my former boss, Dr Bui Ba Bong for his kind help in searching the scholarship from the Rockefeller Foundation. I dedicate this work to my parents who endured a hard life for my education, and to my family for being with me always.

LIST OF FIGURES AND TABLES

Figure 1.1: Evolutionary pathway of two cultivated species of rice.	15
Figure 1.2: Chemical structure of the three main polyamines and common Polyamine-conjugates	29
Figure 1.3: Pathway for biosynthesis and inter-conversion of Polyamines.	32
Figure 1.4: The structure of <i>Bacillus thuringiensis</i> delta-endotoxin.	35
Figure 2.1: Map of plant expression plasmid vector pJIT60.	60
Figure 2.2: Map of plant expression plasmid vector pal 76.	61
Figure 2.3: Maps of gene constructs used in rice transformation.	62
Figure 3.1: Southern blot analysis of R0 oat antisense ADC transgenic rice plants.	72
Figure 3.2: PCR analysis of R1 oat ADC transgenic rice plants, clone No. 92.	73
Figure 3.3: Southern blot analysis of R1 oat antisense transgenic rice plants.	74
Figure 3.4: RT-PCR analysis for the expression of oat antisense ADC cDNA in selected R1 PCR positive transgenic rice plants.	75
Figure 3.5: Relative quantitative RT-PCR analysis of oat antisense ADC transcripts expressed in R1 transgenic rice plants	76
Figure 3.6: Northern blot analysis of total RNAs of R1 oat antisense ADC transgenic rice plants.	77
Figure 3.7: ADC enzyme activity measurement in leaf and root tissues of R1 oat antisense ADC transgenic rice plants.	78
Figure 3.8: Polyamine levels in leaves of R1 oat antisense ADC transgenic rice plants.	79

Figure 3.9: Polyamine levels in roots of R1 oat antisense ADC transgenic rice plants.	80
Figure 3.10: Polyamine levels in seeds of R1 oat antisense ADC transgenic rice plants.	81
Figure 3.11: Northern blot analysis of total RNAs of R1 oat antisense ADC transgenic rice plants, hybridized with rice ADC, ODC, SAMDC and SpdSyn probes.	82
Figure 3.12: Southern blot analysis of EcoRI and HindIII-digested genomic rice and oat DNAs	83
Figure 4.1: Southern blot analysis of R0 rSpdSyn transgenic rices DNAs.	91
Figure 4.2: Northern bolt analysis of leaf total RNA samples from six primary rSpdSyn transgenic rice plants.	92
Figure 4.3: Polyamine analyses in leaves and seeds on six primary transgenic rice plants.	93
Figure 4.4: Southern blot analyses of R1 rSpdSyn transgenic rice plants, digested with EcoR1.	94
Figure 4.5: Southern blot analyses of R1 rSpdSyn transgenic rice plants, double digested with EcoRI and HindIII.	95
Figure 4.6: Northern blot analysis of leaf total RNA samples from six R1 rSpdSyn transgenic rice lines.	96
Figure 4.7: Polyamine analysis in leaves of six R1 rSpdSyn transgenic rice lines.	97
Figure 4.8: ADC enzyme activity measurement in leaf tissues of R1 Spd.Syn	98

transgenic rice lines.

Figure 5.1: Expression of the first domain Ac-GNA fusion protein in <i>E. coli</i> and protein purification.	114
Figure 5.2: Expression of TRX-GNA fusion protein in <i>E. coli</i> and protein purification.	115
Figure 5.3: Expression of Ac-RTB fusion protein in <i>E. coli</i> and protein purification.	116
Figure 5.4: An artificial diet bioassay of the purified first domain Ac-GNA fusion protein and GNA.	117
Figure 5.5: An artificial bioassay of the first domain Ac-GNA against <i>Lacanobia oleracea</i> .	118
Figure 5.6: Artificial diet bioassay of the purified TRX-GNA fusion protein at the concentration of 0.05 in diet medium.	118
Figure 5.7: Artificial bioassay of Ac-RTB against <i>Lacanobia oleracea</i> .	120
Figure 5.8: Southern blot analysis of genomic DNAs from leaves of R0 first domain Ac-GNA transgenic rice plants.	121
Figure 5.9: Southern blot analysis of genomic DNAs from leaves of R0 TRX-GNA transgenic rice plants.	122
Figure 5.10: Southern blot analysis of genomic DNAs from leaves of R0 Ac-RTB transgenic rice plants.	123
Figure 5.11: RT-PCR analysis of R0 first domain Ac-GNA transgenic rice plants.	124
Figure 5.12: Western blot analysis of R0 first domain Ac-GNA transgenic rice	125

plants.	
Figure 5.13: RT-PCR analysis of R0 TRX-GNA transgenic rice plants.	126
Figure 5.14: Western blot analysis of R0 TRX-GNA transgenic rice plants.	127
Figure 5.15: RT-PCR analysis of R0 Ac-RTB transgenic rice plants.	128
Figure 5.16: Western blot analysis of R0 Ac-RTB transgenic rice plants.	129
Figure 5.17: Selection of hygromycin-resistant plants of R1 progenies of TRX-GNA and first domain Ac-GNA transgenic rice lines.	130
Figure 5.18: PCR analysis for the presence of TRXGNA and AcGNA genes in R1 transgenic rice plants	132
Figure 5.19: Bioassay of R1 first domain Ac-GNA transgenic rice plants against brown planthopper.	133
Figure 5.20: Bioassay of R1 TRX-GNA transgenic rice plants against brown planthopper.	134
Figure 5.21: Screening R1 TRXGNA transgenic plants against BHP insect	135
Table 2.1: General solutions.	55
Table 2.2: Experimental plasmid vectors.	57
Table 2.3: Plant tissue culture media.	58
Table 2.4:List of primers.	59
Table 3.1: Inheritance analysis of R1 plants of oat antisense ADC transgenic rice plants.	73
Table 5.1: Inheritance analysis of R1 transgenic rice progenies for hygromycin resistance gene.	131

ABBREVIATIONS

ADC: Arginine decarboxylase

BPH: Rice brown plant hopper

Bt: *Bacillus thuringiensis*

GNA: *Galanthus nivalis* agglutinin

kb: Kilobase pair

kD: Kilo Dalton

M: molecular weight marker

ODC: Ornithine decarboxylase

R1: The first generation derived from transformant plants

RTB: Ricin B chain

SAMDC: S-adenosylmethionine decarboxylase

SDS gel: Sodium dodecyl sulphate protein gel

SPD: Spermidine

SpdSyn: Spermidine synthase

SPM: Spermine

SpmSyn: Spermine synthase

wt: Wild type control plant

GLOSSARY OF PLANT LATIN AND COMMON NAMES

<u>Common Name</u>	<u>Latin Name</u>
Banana	<i>Musa acuminata</i>
Barley	<i>Hordeum vulgare</i>
Cassava	<i>Manihot esculenta</i> Crantz
Caston bean	<i>Ricinus communis</i>
Cauliflower	<i>Brassica oleracea</i> botrytis
Cotton	<i>Gossypium hirsutum</i> L.
Maize	<i>Zea mays</i>
Oat	<i>Avena sativa</i>
Oil seed rape	<i>Brassica napus</i>
Potato	<i>Solanum tuberosum</i>
Rice	<i>Oriza sativa</i> L.
Rye	<i>Secale cereale</i>
Snowdrop	<i>Galathus nivalis</i>
Sorghum	<i>Sorghum bicolour</i>
Soybean	<i>Glycine max</i>
Sugarcane	<i>Saccharum esculentum</i>
Sweet potato	<i>Ipomoea batalas</i>
Thorn apple	<i>Datura stramonium</i>
Tobacco	<i>Nicotiana tabaccum</i> cv Burley
Tomato	<i>Lycopersicon esculentum</i>
Wheat	<i>Triticum aestivum</i> cv.

TABLE OF CONTENTS

Abstract.	1
Statement.	2
Acknowledgements.	3
Lists of figures and tables.	4
Abbreviations.	8
Glossary of plant latin and common name	9
Tables of contents.	10
I. Chapter 1: General Introduction.	14
1. <i>Rice (Oryza sativa L) as a crop.</i>	14
1.1 Origin, dispersal, variation and cultivation.	14
1.2 Economic importance.	15
1.3 Need for genetic engineering to accelerate rice improvement.	16
2. <i>Rice transformation technology.</i>	18
2.1 Marker genes used in cereal transformation.	18
2.2 Promoter controlling foreign genes in transgenic cereals.	19
2.3 Nuclear gene transfer methods.	20
2.4 Transgene expression in host plants.	23
2.5 Plastid transformation.	26
2.6 Marker-free transgenic plants.	27
3. <i>Polyamines.</i>	28
3.1 Chemical structure and functional.	28
3.2 polyamine metabonic pathway.	30
3.3 Manipulation of the polyamine pathway through genetic engineering.	31
4. <i>Genetic engineering of insect resistance gene.</i>	33
4.1 <i>Bacillus thuringenies</i> toxin.	33
4.2 GNA- a plant derived insect resistance gene.	34
5. <i>Other goals for rice genetic engineering: Golden rice.</i>	36
6. <i>The production of antibodies in transgenic plants: plantibody approach.</i>	37
7. <i>Genetically modified crops and public perception</i>	38

8. <i>The aims and objectives of the present study.</i>	40
II. Chapter 2: Materials and Methods.	41
a. <i>Plants materials.</i>	41
b. <i>Chemical reagents, molecular biology kits and enzymes.</i>	41
c. <i>Bacterial strains, vector constructs and PCR primers.</i>	42
1. Polyamine gene constructs.	42
1.1 Oat ADC construct.	42
1.2 Rice Spd.Syn construct.	42
2. Insect resistance gene construct.	42
2.1 The first domain of Cry1Ac fused with GNA construct.	42
2.2 Cry1Ac fused with ricin B chain (RTB) construct.	43
2.3 Rice thioredoxin h fused with GNA construct.	44
d. <i>Rice transformation.</i>	45
1. Preparation of DNA and gold particle coating.	45
2. Plant materials and tissue preparation.	45
3. Particle bombardment.	46
4. Selection and generation of putatively transgenic tissues.	46
e. <i>DNA analysis.</i>	47
1. Plasmid DNA extraction (miniprep).	47
2. Plant genomic DNA extraction.	47
3. Polymerase chain reaction (PCR).	47
4. Southern blot hybridisation.	48
f. <i>RNA analysis.</i>	49
1. Total RNA extraction.	49
2. Reverse transcription PCR (RT-PCR).	50
3. Northern blot hybridisation.	50
g. <i>Western blot analysis.</i>	51
h. <i>Expression and purification of recombinant proteins in E.coli.</i>	51
i. <i>Enzyme activity measurements.</i>	52
j. <i>Polyamine analysis.</i>	53
1. Crude extraction.	53

2. Dansylation.	53
3. Thin layer chromatography.	53
k. <i>Insect bioassay analysis.</i>	54
1. <i>Statistical analysis.</i>	56
III. Chapter 3: Reduction in the endogenous arginine decarboxylase transcript levels leads to depletion of the free polyamine pools in a tissue/organ dependent manner, with no concomitant changes in the expression of other polyamine biosynthetic genes.	63
3.1 <i>Results</i>	64
3.1.1 Molecular characterization of the transgenic population.	64
3.1.2 Expression of the oat ADC transgene in R1 plants.	65
3.1.3 Expression of oat antisense ADC transcript results in reduction of ADC activity in transgenic plants.	66
3.1.4 Levels of polyamine accumulation in R1 transgenic rice plants vary in a tissue/organ dependent manner.	66
3.1.5 Expression of the oat ADC antisense transcript in rice only affects expression of its rice homologue.	67
3.2 <i>Discussion</i>	68
3.2.1 Integration of the oat antisense ADC cDNA in rice genome results in a reduction of the steady state ADC mRNA with no concomitant changes in the expression of other polyamine genes.	68
3.2.2 Levels of ADC activity and free polyamines in the transgenic population vary in a tissue/organ- dependent manner.	70
IV. Chapter 4: Reduction of spermidine level in transgenic rice by introduction of a homologous gene construct.	84
4.1 <i>Results</i>	85
4.1.1 Generation and molecular analysis of primary transgenic rice plants	85
4.1.2 Expression of Spd.Syn and other polyamine biosynthesis genes in transgenic rice plants.	85
4.1.3 Polyamine levels in transgenic rice plants.	86
4.1.4 Molecular analysis of R1 transgenic rice population.	87

4.2 <i>Discussion.</i>	88
V. Chapter 5: Production of transgenic rice plants with wide-spectrum resistance to insect pests.	99
5.1 <i>Results</i>	100
5.1.1 Expression of fusion proteins in E.coli and protein purification.	100
5.1.2 Bioassays of fusion proteins against insect pests.	102
5.1.3 Generation and molecular analysis of R0 transgenic plants.	104
5.1.4 Expression of fusion genes in transgenic rice plants.	105
5.1.5 Insect bioassays of R1 transgenic plants.	106
5.2 <i>Discussion.</i>	109
5.2.1 Enhancing toxicity and insecticidal spectrum of toxin proteins by protein fusion.	109
5.2.2 Transgenic rice plants expressing low level of GNA fusion proteins display “horizontal resistance” to brown planthopper.	112
VI. General conclusions	136
References	140
Appendix	161
Artificial diet composition.	161
Published research paper in Planta.	162

Chapter 1**GENERAL INTRODUCTION*****1. Rice (Oryza sativa L) as a crop******1.1 Origin, dispersal, variation and cultivation.***

Like wheat, maize, rye, oat and barley, rice belongs to the Poaceae (formerly Gramineae) or grass family. The genus *Oryza*, to which cultivated rice belongs, probably originated at least 130 million years ago and spread as a wild grass in Gondwana land, the super continent that eventually broke up and drifted apart to become Asia, Africa, the Americas, Australia and Antarctica (Chang, 1976). There are two cultivated species of rice: *O. sativa* (Asian rice) and *O. glaberrima* (African rice); and twenty-one wild species in the genus *Oryza*. Most rice species, including the cultivated ones, are diploid ($2n=24$), but nine of the wild species are tetraploid. The Asian cultivated rice, *O. sativa*, is grown all over the world, whereas the African cultivated rice; *O. glaberrima* is grown only on a small scale in West Africa. These two cultivated species are thought to be an example of parallel evolution in crop plants. The wild progenitor of *O. sativa* is *O. rufipogon*, which shows a range of variation from perennial to annual types. In a parallel evolution path, *O. glaberrima* was domesticated from annual *O. breviligulata*, which in turn evolved from *O. longistaminata* (Figure 1.1, Khush, 1997)

O. sativa is a tremendously variable species and has worldwide distribution. Through long-term domestication, two subspecies termed japonica and indica were formed. The indica rices were probably domesticated in the foothills of Himalayas in Eastern India, and dispersed throughout the tropics and subtropics from India. The japonica rices, domesticated somewhere in Southern China, moved northward and became the temperate ecotype. They also moved southward to Southeast Asia, and from there to West Africa and Brazil and became tropical japonica (javanica). The Africa cultivars, *O. glaberrima*, originated in Niger river-delta, are cultivated only in Africa (Khush, 1997). Domesticated rice now grows under diverse growing conditions such as

irrigated, rainfed lowland, rainfed upland and flood-prone ecosystems. The extreme variability and adaptability of rice to different geographic locations, soil types, and environments make it the world's most versatile crop.

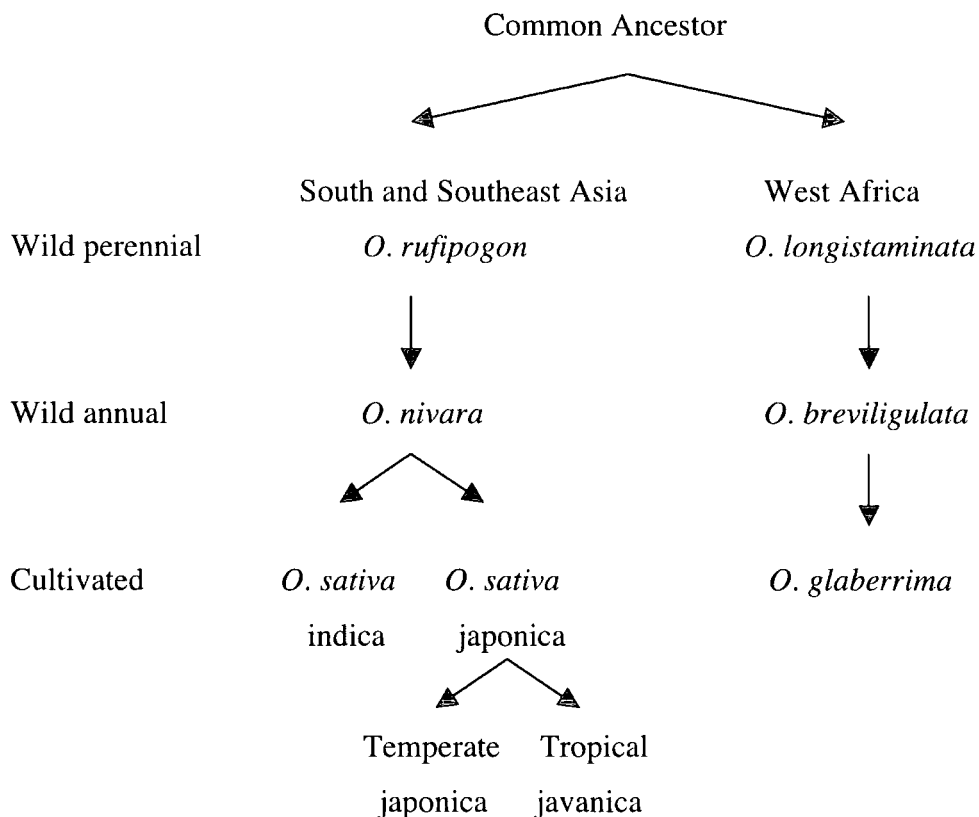

Figure 1.1: Evolutionary pathway of two cultivated species of rice. (Khush, 1997)

1.2 Economic importance

Rice is one of the most important crops for mankind. It is the basic food of more than 3 billion people and it accounts for 50 to 80% of their daily calorie intake. More than 90% of all rice is grown and consumed in Asia where 60% of the world's population lives. Rice is also a staple food in Latin America, parts of Middle East and Africa. In Europe and North America, rice is developing a new market as both a staple and gourmet food. Over 150 million hectares are planted annually and the world production is close to 600 million tons. In Asia, on average, the demand for rice should increase by 25% by 2010 which means the current average yield of 5 tons per hectare will have to increase to 8 tons per hectare under cultivation conditions which are far

from optimal, if food shortages are to be avoided. Moreover, these changes will need to take place against a reduction in agricultural land as a result of urban growth (Fisher *et al.*, 2000). Globally, rice provides 23% per capita energy and 16% per capita protein in human diets. Rice protein ranks high in nutritional quality among the cereals, though the protein content is modest. Unmilled rice (brown rice) provides 4.3-18.2 % protein, averaging 9.5%, based on 17,587 cultivars in the International Rice Research Institute germplasm bank (Datta, 1999). It contains all of the amino acids essential for human nutrition, but is limiting in lysine, which is present in low content. Rice also provides minerals, vitamins and fibre. Even though rice is low in proteins, minerals and vitamins, it has distinct nutritional advantages: its carbohydrates are easily digested, and this improves protein efficiency; the net protein values for rice, maize and wheat are 63, 36 and 49, respectively (Chandler, 1979).

1.3 Need for genetic engineering to accelerate rice improvement.

Major increases in rice production have occurred during the last 25 years because of the large-scale adoption of high-yielding semi-dwarf varieties and improved management practices. World rice production doubled in a 25-year period, from 256 million tons in 1966 to 520 million tons in 1990. During this period, rice production increased at a slightly higher rate than the population. However, the rate of increase of rice production is now lower (1.5% per year) than the rate of increase in population (1.8% per year). If this trend is not reversed, severe food shortages will occur in the next century. It is estimated that the demand for rice will exceed production by the early part of the 21st century (Pinstrup-Anderson *et al.*, 1999). In addition, there are no additional lands available for rice cultivation. In fact, the area planted to rice is going down in several countries due to pressures of urbanization. To address this issue, researchers in China and at the International Rice Research Institute (IRRI) have adopted hybrid rice technology. Using hybrids will theoretically raise the yield by about 15 to 20 percent more than the best of the semi-dwarf inbred varieties upon which the rice crop of tropical Asia depends. However, the commercial viability of hybrid rice relies totally upon a technically complex process for producing fresh hybrid seed stocks each year. This is a major obstacle to the adoption of hybrid genotypes by rice growing

communities worldwide, except China. However, the recent success of a conventional breeding program to produce a new plant type with improved architecture and fewer tillers (the result of work at IRRI during the last 20 years) could potentially increase rice yields of conventional varieties under optimum conditions, by at least 20% and as much as 30% (to nearly 15 tonnes per hectare) if it is combined with hybrid-variety development. These new rice types are expected to be ready for farmers by 2005 (Khush, 1995). However, a lack of novel genetic variation in breeding populations and the inaccuracy in selecting plants by their appearance are probably the reasons for slow progress in breaking the rice yield ceiling. Furthermore, many scientists believe that pests are becoming increasingly difficult to control, and water and other resources are becoming scarce. Recent breakthroughs in plant biotechnology research, which include genetic engineering and the transfer of genes from unrelated plants and microorganisms, have offered powerful tools for rice improvement. Transformation techniques allow us to generate the genetically modified pro-vitamin A-enriched “golden rice” (Ye *et al.*, 2000), enhanced pest resistant rice plants e.g. introduction of Bt gene (Datta *et al.*, 1998), GNA gene (Rao *et al.*, 1998), Xa21 gene (Song *et al.*, 1995), salt tolerant genotypes (Sajio *et al.*, 2000) and genes conferring water, cold and salt stress responses (Liming Xiong *et al.*, 2002). It might be possible to redesign the rice plant’s inefficient C₃ photosynthetic pathway to that of the more efficient C₄ pathway that exists in maize and sorghum (Sheehy *et al.*, 2000). Achieving this would allow the rice plant reach a yield potential unattainable by even the new plant type. Ku *et al.* (1999) introduced maize phosphoenolpyruvate carboxylase (PEPC) - which catalyses the initial fixation of atmosphere CO₂ in C₄ plants - into rice plants. Most transgenic rice plants exhibited reduced O₂ inhibition of photosynthesis. The results demonstrated a successful strategy for installing the key biochemical component of the C₄ pathway of photosynthesis into rice. As up to one-half of the world’s population lives in a water-scarce environment, it is now realistic to think of developing high-yielding “aerobic” rice plants, which will not need standing water in order to grow and produce high yield. It will mark a fundamental change to rice cultivation and create huge additional productivity in the coming decades. Importantly, achieving this will

have an impact on the livelihoods of the poorest rice farmers and consumers in developing countries worldwide.

2. Rice transformation technology.

Among the four major cereals, rice has so far been the easiest to manipulate in terms of initiation and establishment of dedifferentiated callus and suspension cultures from many different explants. Such plasticity enabled many laboratories to launch extensive programmes focusing on gene transfer in rice

2.1 Marker genes used in cereal transformation.

A prerequisite for the recovery of transgenic plants is a method for the effective selection of transformed cells. Selectable markers such as antibiotic or herbicide resistance genes increase the chance of recovering the rare transformed cells from the non-transformed cells. The *nptII* gene was used in many of the early cereal transformation experiments to confer resistance to the antibiotic kanamycin or geneticin (G418) (Fromm *et al.*, 1986). However, cell cultures of many cereal and grass species possess natural tolerance to kanamycin and effective selection of transformed cells is not always achieved (Hauptmann *et al.*, 1988). An alternative selectable marker gene is hygromycin phosphotransferase (*hpt*), which confers resistance to the aminoglycoside antibiotic hygromycin B, allows good discrimination between transformed and non-transformed cells and does not cause abnormalities in regenerated plants. Herbicide resistance genes such as phosphinothricin acetyltransferase (PAT) encoded by the *bar* gene from *Streptomyces hygroscopicus* (De Block *et al.*, 1987), have also been widely used for rice transformation. Transgenic rice expressing the *bar* gene are tolerant or completely resistant to the herbicide BASTA (glufosinate ammonia, bialaphos), a useful trait for weed control (Vasil, 1994).

In transient or stable transgene expression experiments, the *E. coli* gene encoding β -glucuronidase (GUS) is definitely the most frequently used reporter gene. Its expression is easily detected by histochemical methods or fluorimetric enzyme assay (Jefferson *et al.*, 1987). However, *gusA* gene expression assays are destructive. The luciferase gene of the firefly (*Photinus pyralis*) that can be assayed non-destructively is

limited by expensive detection equipment and low penetration of the luciferin substrate in whole plant material (Wilmink & Dons, 1993). More recently, the gene for green fluorescent protein (GFP) from the jellyfish *Aequorea victoria* has become an important reporter gene in plant transformation (Chalfie *et al.*, 1994). When expressed in cells and illuminated with blue or ultraviolet (UV) light, GFP yields stable bright-green fluorescence, allowing direct imaging of the fluorescent gene product in living cells without the need for prolonged and lethal histochemical staining procedures. GFP has been used to monitor protein targeting to nucleus, cytoplasm, and plastids from nuclear genes (Sheen *et al.*, 1995; Chiu *et al.*, 1996; Kohler *et al.*, 1997), to follow virus movement in plants (Epel *et al.*, 1996) and to detect transient gene expression in plastids (Khan & Maliga, 1999).

Ebinuma *et al.* (1997) used an agrobacterium transformation vector containing isopentenyl pyrophosphate transferase (*ipt*) gene that permits identification of transgenic plants in the absence of a selective agent in tobacco transformation. The *ipt* gene affects cytokinin metabolism, enhancing the regeneration ability of the transformed cells, so transformed plants are recognized by a shooty phenotype. However, the *ipt*-shooty transformation system is not suitable for plant species that depend on embryogenesis for regeneration, like rice. Recently, they developed a successful single-step transformation for generating transgenic rice using the *ipt*-type MAT vector system. This technique allows generation of transgenic rice plants through embryogenic tissues without forming the *ipt*-shooty phenotype (Endo *et al.*, 2002).

2.2 Promoters for expression of foreign genes in transgenic cereals.

Promoter strength is critical to allow high-level transcription of the selected coding sequences in plant cells. Some promoters confer constitutive expression, such as the cauliflower mosaic virus (CaMV 35S) (Rhodes *et al.*, 1988), maize alcohol dehydrogenase (1-Emu) (Last *et al.*, 1991), rice actin (Act1) (McElroy *et al.*, 1990), maize ubiquitin (Ubi1) (Christensen *et al.*, 1992), while others may be tissue specific like rice glutelin and globulin - endosperm-specific promoters (Hwang *et al.*, 2002), the rice sucrose synthase1 (Rss1), phloem cell expression promoter (Wang *et al.*, 1992), maize pepcarboxylase (PEPCP), the green tissue specific promoter (Datta *et al.*, 1998).

Other promoters confer environmentally inducible expression, e.g. the tobacco PR1-1 promoter (Beilmann *et al.*, 1991), which is inducible by tetracycline. The CaMV 35S promoter has been used extensively in plant transformation, showing relatively low levels of transient expression in cereals (Hauptmann *et al.*, 1987). Li *et al.* (1997) compared expression of GUS under the control of Ubi1, Emu and CaMV35S promoters in rice transformation. They reported that the Ubi1 promoter gave the strongest expression of the transgene, followed by Emu and CaMV35S, respectively. Park *et al.* (1996) transformed rice with the *bar* gene under the control of CaMV35S and Act1 promoters. They obtained only transgenic rice with Act-*bar* construct. No plants were selected after CaMV35S-*bar* transformation. The possible explanation was that the expression driven by CaMV35S was not sufficient to give a viable level of herbicide resistance. Huang *et al.* (2001) reported the use of a rice beta-glucanase promoter (Gns9) to target the expression of the *hpt* gene to rice callus, but not in leaves, roots or seeds. Therefore, the Gns9 promoter can be effectively used to eliminate the accumulation of the product of the antibiotic marker gene in leaf or seed of transgenic rice plants, making the crop safer for consumption by people and animals.

2.3 Nuclear gene transfer methods.

Rice transformation technology has seen remarkable progress in the past few years. The transformation of the rice genome was first demonstrated by electroporation of protoplasts (Zhang *et al.*, 1988) and polyethylene glycol (PEG)-mediated transformation (Zhang & Wu, 1988). Subsequently, many attempts have been made to improve important agronomic traits in rice by genetic engineering. Presently, the introduction of foreign genes into rice cells can be achieved routinely, either by the direct gene transfer method using bombardment (Christou *et al.*, 1991) or by *Agrobacterium* mediated transformation (Hiei *et al.*, 1994).

Agrobacterium-mediated transformation offers the potential to generate transgenic plants at high efficiency in dicotyledonous plants. It is based on the ability of *Agrobacterium* to infect plant cells and transfer its T-DNA into the genome of plant cells by conjugation. The T-DNA is a discrete section of the Ti plasmid bounded by 25 bp imperfect repeats termed the right (RB) and the left borders (LB). The processing of

the T-DNA and its transfer to the host plant cell nucleus is achieved primarily by the concerted action of about 20 virulence (*vir*) gene products that are encoded within the *vir* region of the Ti-plasmid (reviewed in Christie, 1997 & Das, 1998). T-DNA integration can occur in any chromosome (Robin *et al.*, 1995) and involves illegitimate recombination (Matsumoto *et al.*, 1990) In binary Ti- vector systems, the T-DNA and the *vir* region reside on separate plasmids. The *vir* gene functions are normally provided by the disarmed Ti-plasmids resident in the *Agrobacterium* strain. The T-DNA, within which are the gene(s) to be transferred, is provided on a smaller binary vector, which has a broad host range and can be engineered in *E. coli* prior to transfer to *Agrobacterium tumefaciens*. Early attempts to generate transgenic rice plants by *Agrobacterium*-mediated transformation were less successful (Raineri *et al.*, 1990; Chan *et al.*, 1992). Recently, the development of improved strains with modified virulence, wider host range, and new effective binary Ti-vectors has expanded the use of *Agrobacterium* in rice transformation. Strain A281 (or its modified strains like EHA101, EHA105, AGL1) is a super-virulent strain, with transformation efficiency higher than that of ordinary strains. This characteristic is due to the Ti plasmid pTiBo542, which has a *virG* region that acts as a super-activator of the transcription of all of the *vir* genes (Hood *et al.*, 1986). The DNA fragment included *virB*, *virC*, and *virG* from the virulent region of pTiBo542 has been introduced into a small T-DNA plasmid, creating a new vector system: the super-binary vector (Komari, 1990). Hiei *et al.* (1994) compared two commonly used strains of *Agrobacterium*: LBA4404 (ordinary strain) and EHA 101 and two systems of vectors: binary (pIG121Hm) and super-binary vectors (pTOK233) in establishing the ability of *Agrobacterium* to transform rice. They found that all bacteria/vector combinations were successful in transformation experiments, however the most effective was LBA4404 /pTOK233. They also set out several requirements for successful transformation, such as the use of acetosyringone at 100 μ M and a temperature of 22-28°C during co-cultivation. Following this report, several laboratories have reported similar results in rice transformation (Datta *et al.*, 1996; Toki, 1997; Cheng *et al.*, 1998). Ke *et al.* (2001) reported a significant increase in the efficiency of *Agrobacterium*-mediated transformation in rice using a double-mutant plasmid that contained a *vir* gene constitutive mutant *virGN54D* and a mutant gene that

increased plasmid copy number in *A. tumefaciens*. This double- mutant plasmid allowed a constitutive, very high level of *vir* gene expression in the infecting bacteria, which led to very high level of rice transformation. Hamilton (1997) reported the development of a binary bacterial artificial chromosome (BIBAC) vector system for *Agrobacterium* mediated transformation of large DNA fragments (up to at least of 150kb) into plants.

Microprojectile-mediated transformation or particle bombardment is currently one of the most effective approaches to produce transgenic plants. The method is based on high velocity bombardment of plant cells with DNA-coated microprojectiles (tungsten or gold) accelerated by either pressurised helium or an electric current. An advantage of the particle gun is that it can be used on almost any tissue, including immature embryos (Christou *et al.*, 1991), embryo slices (Cao *et al.*, 1991), mature seed-derived callus (Sudhakar *et al.*, 1998) and even any tissue or organ that can be made accessible to the gene gun (Elina Helenius *et al.*, 2000). It is a versatile technique that can be used both for transient expression studies e.g. promoter analysis, and for creating stable transformants (Christou, 1994). Due to the physical nature of the process, there is no biological limitation to the actual DNA delivery process, thus genotype is not a limiting factor. All major cereals and many other plant species have been transformed using particle bombardment (Dubey *et al.*, 1997). The routine generation of transgenic plants using particle bombardment involves delivery of metal particles coated with supercoiled plasmid DNA, and causes integration of vector backbone sequences into the genome along with the transgene(s). It has been observed that vector backbone sequences may exert undesirable negative effects in transgene expression level due to transgene rearrangement and multiple copies integration (Kohli *et al.*, 1998; Salomon and Puchta, 1998). Recently, an improved technique that employs “clean DNA” has been reported in rice transformation (Fu *et al.*, 2000; Breitler *et al.*, 2002; Loc *et al.*, 2002). Rice tissue was bombarded with minimal transgene expression cassettes comprising promoter, target gene coding sequence and terminator, but lacking vector backbone sequence. Transformation with such constructs resulted in the production of transgenic plants with low copy numbers for foreign genes (frequently a single copy only), and a low frequency of transgene rearrangement (Fu *et al.*, 2000).

The process was claimed to lead to higher transgene expression levels (Loc *et al.*, 2002).

As most agronomic traits are polygenic, that is, they result from the action of several genes; the modification of such traits requires the introduction of multiple genes into plant genome. Integrating multiple genes by repetitive insertion of single genes is impractical, due to the time and effort required for the recovery of transgenic plants, and also the need to utilise new selectable markers for each new gene. The transfer of multiple genes via *Agrobacterium* becomes problematic as the size of the T-DNA increases. It was found that particle bombardment allowed the selectable marker gene and the desired gene to be co-transformed into plant genomes with high efficiency, even when the two genes were not present on the same plasmid. This strategy has been extended, and particle bombardment is the method of choice to co-transform a mixture of multiple genes, which may be carried on separate plasmids, each containing a single gene construct for expression in plants, into the target tissue. In this manner, many genes can be transferred simultaneously using a single selectable marker (Chen *et al.*, 1998; Maqbool and Christou, 1999).

2.4 Transgene expression in host plants

With the successful development of procedures for transformation, transgenic plants and their progeny have been studied for continued expression of the foreign gene through several generations. These studies have revealed that how strongly a transgene is expressed in a transformed plant resulting from a single transformation event is characteristically unpredictable, and depends on many factors. These include the position of integration; the location at which a gene is inserted on a chromosome, and on which chromosome (Topping *et al.*, 1991); the number of transgene copies (Martzke *et al.*, 1994); methylation of promoter and/or coding regions of the target genes (Ingelbrecht *et al.*, 1994); the structural integrity of transgene and interactions between the transgene and endogenous genes (reviewed by Flavell, 1994; Martzke *et al.*, 1994; Stam *et al.*, 1997). Some of these effects involve epigenetic changes to DNA, which result in the expression of transgenes changing in progeny of primary transformants.

Kohli *et al.*, (1998) showed that transgene integration in plants using particle bombardment involves a two-phase mechanism. In the pre-integration phase, transforming plasmid molecules, either intact or fragmented, are spliced together and give rise to rearranged transgenic sequences, which upon integration do not contain any interspersed plant genomic sequences. Subsequently, integration of transgenic DNA into the host genome is initiated. Their results suggested that the original site of integration acts as a “hot spot” facilitating subsequent integration of successive transgenic molecules at the same locus.

The introduction into plants of heterologous genes from other plant species, which determine a specific phenotype, usually results in that phenotype is being enhanced in transformants (Zhu *et al.*, 1997; Sakamoto *et al.*, 1998; Fu *et al.*, 2001). However, in some instances, introduction of a transgene into plants drastically reduces or abolishes expression of both endogenous and introduced gene(s). This is termed gene silencing. There are several causes of gene silencing and these seem to reply on homology either between different transgenes or between transgenes and endogenous genes (homology-dependent gene silencing). Currently, there are two models to explain gene silencing (reviewed by Stam *et al.*, 1997). Firstly, transcriptional gene silencing results from promoter inactivation by DNA methylation and/or heterochromatinization (Matzke & Matzke, 1995). Secondly, post-transcriptional gene silencing occurs when promoter is active but the mRNA fails to translate into protein. Many examples of gene silencing in plants by re-introducing homologous sequences into the host have been reported (Jorgensen *et al.*, 1996; Stam *et al.*, 1998; Klahre *et al.*, 2002). This type of gene silencing has been termed co- or sense-suppression. A number of hypotheses have been proposed to explain the mechanism behind the post-transcriptional gene-silencing phenomenon. Most of the hypotheses invoke the possible involvement of antisense RNA, which forms a duplex with target RNA and leads to its degradation by double strand specific ribonuclease (Baulcombe *et al.*, 1996; Wassenegger & Pelissier, 1998). Fire *et al.*, (1998) suggested that double stranded RNA (dsRNA) might be the key trigger of gene silencing. Indeed, they show that dsRNA was a much more potent silencing trigger than either sense or antisense single stranded RNA alone. Direct introduction of dsRNA into single epidermal cells of cereal by particle bombardment

has been shown to be effective in interference with gene functions (Schweizer *et al.*, 2000). This phenomenon was named RNA interference (RNAi), distinguishing it mechanistically from classical antisense-mediated suppression. Denli & Hannon (2003) reviewed the current model for mRNA degradation mediated through RNAi. Long dsRNAs are cleaved by anti-parallel dicer dimmers—an enzyme of RNase III family—to form small interfering RNAs (siRNAs). The siRNA, normally observed as 21-25 nucleotide sequences, is incorporated into a nuclease complex, called the RNA-induced silencing complex (RISC) and functions as a specificity subunit to direct a multi-component nuclease towards destruction of homologous mRNA.

The involvement of dsRNA in “gene silencing” effects in transgenic plants may result from transgene loci containing inverted repeats that can form hairpin RNAs on read-through transcription to produce dsRNA. An alternative origin of dsRNAs could lie in the production of copy RNA (cRNA) in which RNA directed RNA polymerases use sense “aberrant” RNAs from transgene(s) as templates for the synthesis of antisense cRNAs (Wassenegger & Pelissier, 1998).

As a result of increased knowledge of the causes of transgene variable expression and silencing, recent efforts have been made to control factors that influence transgene expression. The use of matrix attachment regions (MARs) to minimize transgene silencing and increase transgene expression has been reported as an effective approach in controlling gene expression in transgenic plants (Vain *et al.*, 1999; Ulker *et al.*, 1999; Allen *et al.*, 2000). Matrix attachment regions are chromosomal DNA regions that attach to the nuclear matrix and often flank actively expressed genes. A MAR flanking a transgene can ensure transgene expression, perhaps by maintaining the chromosomal region in an open configuration to facilitate communication between an enhancer and a promoter and, as a result, increase transgene expression levels in proportion to copy number. Alternative proposed approaches, which still remain to be fully achieved, are: (1) to control transgene integration into a predetermined site in plant genome by homologous recombination to avoid position effects; (2) increase the number of single-copy integration events to eliminate gene silencing caused by transgene loci containing inverted repeats (reviewed by Kumar & Fladung, 2001).

2.5 *Plastid transformation*

In nuclear gene transformation, the expression level of an introduced gene can vary greatly from one transformed plant to another. Consequently, many transformants with the same gene usually need to be produced and tested to identify a strongly expressing transformed line suitable for further research or for commercialization. The consequences of variable expression are compounded if more than one gene needs to be introduced. Besides these challenges in nuclear gene transformation, there are negative perceptions and environmental concerns about genetically modified crops. Gene flow from nuclear transgenic plants to related weeds or crops through pollen or seed dispersal has been a major concern (Daniell, 1999). The introduction of genes through chloroplast genetic engineering was recently advanced as a potential solution to this problem. Plastid transformation is an environmentally and friendly approach to plant genetic engineering that minimizes out-crossing of transgenes to related weeds or crops (Daniell *et al.*, 1998). Because the plastid genome is highly polyploid, plastid transformation permits the presence of thousands of copies of transgenes in plant cell, and generates extraordinarily high levels of transgene protein. Exceptionally high accumulation (upto 46% of total soluble protein) of Bt Cry2Aa2 protein, the distal gene of a three-gene operon, has been reported for transgenic tobacco chloroplasts. This study was also the first demonstration of bacterial operon expression in transgenic plants (De Cosa *et al.*, 2001). Chloroplast transformation vectors use two targeting sequences that flank the foreign genes and insert them, through homologous recombination, at a precise, predetermined location in chloroplast genome. This results in uniform transgene expression among transgenic lines and eliminates the position effect often observed in nuclear transgenic plants. Interestingly, gene silencing has not been observed in genetically engineered chloroplasts (Reviewed by Daniell *et al.*, 2002). Furthermore, foreign proteins observed to be toxic in the cytosol are non-toxic when accumulated within the transgenic chloroplast (Daniell *et al.*, 2001). Although plastid transformation has been successful in: tobacco (Svab *et al.*, 1990), potato (Sidorov *et al.*, 1999), and tomato (Ruf *et al.*, 2001), plastid transformation for cereal crops is still a great challenge. Khan and Maliga (1999) could recover transplastomic rice plants from embryogenic cells using particle bombardment method. Unfortunately,

regenerated plants were heteroplastomic and sterile. The current approach to obtaining homoplasmic plants is repeated selection from transformed tissues in culture, followed by regenerating plants when homoplasmy state is reached. However, repeated cell culture puts a further restraint on the kinds of plant material that can be used for regeneration.

2.6 Marker-free transgenic plants.

A major challenge in the generation of transgenic plants is to distinguish rare transformation events against a background of a large number of non-transformed cells. Therefore, most transformation techniques co-introduce a gene that confers antibiotic resistance (or sometimes herbicide tolerance), along with the gene of interest and regenerate transformed cells in antibiotic or herbicide containing growth media to permit selection of only those cells expressing the marker gene. Such antibiotic-based selection is known to inhibit growth and regeneration of transformed cells, and thereby decreases transformation frequency. In addition, there are public concerns over the use of such marker genes, particularly in the medical implications of consuming genetically modified food and in environmental safety (Daniell, 1999). Considering these issues, several approaches have been developed to remove selectable marker genes from transgenic plants. These include: (1) excision of selectable marker genes via Cre/lox recombination; (2) Ac/Ds transposable element system; and (3) co-transformation of plants with 2 T-DNA vectors through the *Agrobacterium*-mediated method (reviewed by Ebinuma *et al.*, 2001). Besides these “marker removal” methods, recent studies have demonstrated that plant regeneration-promoting factors or genes are not only useful for explant regeneration, but can also be used for generating marker-free transgenic plants without using a selectable marker gene. By appropriate manipulation of a regeneration-promoting gene, only transformed cells can regenerate in the absence of key growth regulators. Under the same conditions, non-transformed cells will be unable to regenerate (reviewed by Zuo *et al.*, 2002). One example for marker-free transformation method is the development of a successful single-step transformation to generate transgenic rice using the *ipt*-type MAT vector system (Endo *et al.*, 2002).

3. Polyamines.

Polyamines and their biosynthetic enzymes are probably ubiquitous in plant cells. Recent studies have shown the existence of links between polyamines and abiotic stress responses in plants (Richards *et al.*, 1952; Capell *et al.*, 2004), polyamines and plant morphogenesis (reviewed in Kakkar *et al.*, 2000), and even between polyamine content in food and tumour growth (Bachrach and Wang, 2002). These studies suggest that polyamines could do something interesting and important in crop improvement and cancer therapy. With this in mind, manipulation of the polyamine biosynthetic pathway may deserve closer attention from a biotechnological point of view. The study of plants transformed carrying genes involved in polyamine biosynthesis with low or high polyamine levels may shed light on how the polyamine pathways are regulated at the transcription level, translational and post-transcriptional levels. The outcome from these studies could help the development of transgenic crops or foods with increased their tolerance to environmental stress or nutrient and health values.

3.1 Chemical structure and cellular function.

Polyamines represent a group of low molecular mass, polycationic compounds. The most common polyamines are the diamine putrescine, the triamine spermidine and the tetramine spermine (Figure 1.2). A variety of other related compounds have been found in plants, including cadaverine. In plants, polyamines localize in the vacuole, mitochondria, chloroplasts (Slocum, 1991), and in thylakoid membranes (Kotzabasis *et al.*, 1993). Polyamines often occur as free bases, but can be associated with phenolic acids and various macromolecules including proteins (Martin-Tanguy, 1997). Polyamines are involved in many cellular functions including the cell cycle, cell division, tissue growth and differentiation. Polyamines have also been implicated in a wide range of biochemical processes including DNA replication, transcription, protein synthesis, membrane stabilization and RNA and protein turnover (Evans & Malmberg, 1989).

In higher plants, polyamines play an important role in a variety of growth and development. Polyamines have been reported to retard leaf senescence and chlorophyll

loss (Sawhney & Galtson, 1979), and have been linked with a wide range of stress response, plant hormone response, ethylene biosynthesis (Sawhney & Galtson, 1990)

Figure 1.1: Chemical struture of the three main polyamines

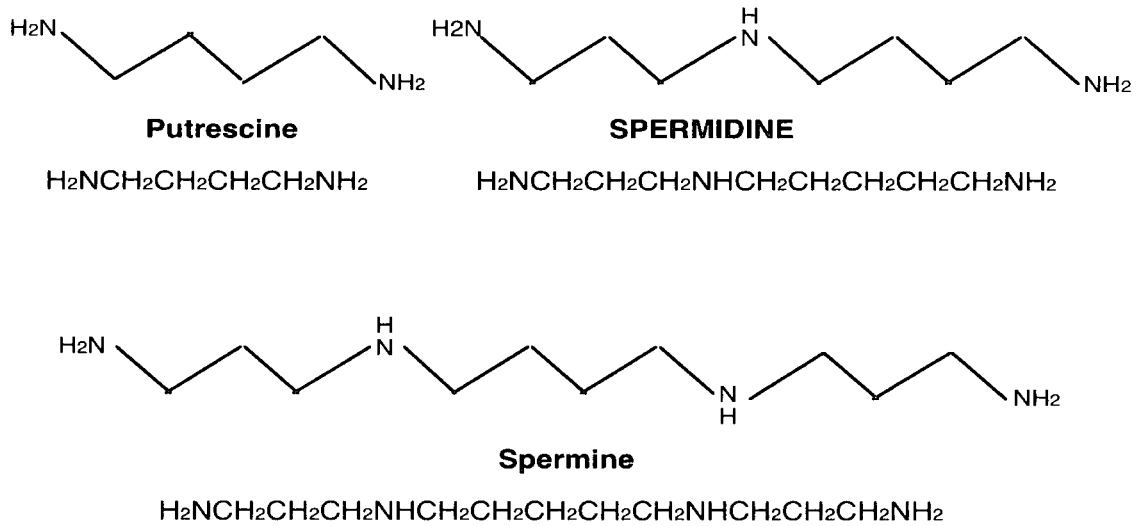

Common polyamine-conjugates

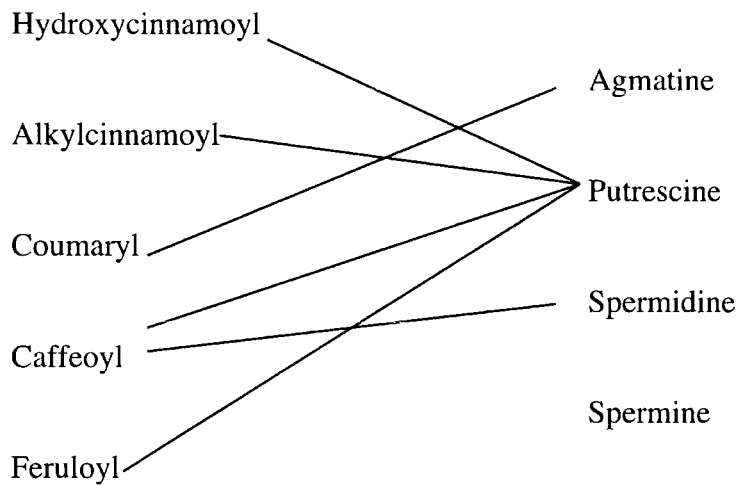

3.2 *The polyamine metabolic pathway.*

The polyamine pathway in mammals and fungi has only one route via ornithine decarboxylase (ODC) leading to putrescine formation, whereas in bacteria and plants, the polyamine biosynthesis pathway consists of two different branches (Figure 1.3). One branch starts from ornithine, which is decarboxylated by ornithine decarboxylase to yield putrescine. The other branch starts from the amino acid arginine using arginine decarboxylase (ADC) to yield agmatine. Agmatine is then further converted to putrescine by agmatine iminohydrolase and N-carbamoylputrescine amidohydrolase. The biosynthesis of spermidine (SPD) and spermine (SPM) involve the addition of an aminopropyl moiety from decarboxylated S-adenosylmethionine (dcSAM), which is produced by the action of S-adenosylmethionine decarboxylase (SAMDC) on S-adenosylmethionine (SAM), to one or both primary amino groups of putrescine, by the enzymes spermidine synthase (Spd Syn) and spermine synthase (Spm Syn), respectively (Smith, 1985). Polyamines and ethylene synthesis are linked through a common precursor (SAM) (Figure 1.3). Two further enzymes, diamine oxidase (DAO) and polyamine oxidase (PAO), play a key part in polyamine oxidation and degradation.

It has been known for a long time that a conversion of spermine into spermidine and of spermidine into putrescine can occur in mammals. The polyamine inter-conversion pathway consists of two steps; first an acetylation of the aminopropyl group of Spermidine and spermine and then an oxidation giving rise to 3-acetamidopropanal, together with putrescine or spermidine, respectively, by the combined actions of two enzymes: spermidine/spermine-N¹-acetyltransferase (SAT) and polyamine oxidase (PAO) (Tiburcio *et al.*, 1997). Spermidine/spermine N¹-acetyltransferase catalyses the conversion of spermine into N¹-acetylspermine which is then degraded by PAO to form spermidine and 3-acetamidopropanal. Similarly, spermidine is a substrate for SAT which forms N¹-acetylspermidine and this is split by PAO to form putrescine and 3-acetamidopropanal (figure 1.3). SAT is highly induced in response to a wide range of hormones and toxic stimuli, by administration of polyamines and their synthetic analogues. One possible hypothesis would be that SAT is induced whenever the concentration of free polyamines in the cell exceeds a certain critical level, and that its function is to reduce this level by acetylation of the excess. In higher plants, recent data

have shown the existence of inter-conversion pathways for putrescine from spermidine (Caffaro *et al.*, 1993; De Agazio *et al.*, 1995).

3.3 Manipulation of the polyamine pathway through genetic engineering.

With the availability of key genes involved in the polyamine biosynthetic pathway, it has become possible to manipulate polyamine metabolism using a transgenic approach. This technique has several advantages over approaches using metabolic inhibitors, since results are highly specific to the targeted gene(s), providing a means of relating changes in the biosynthetic flux to changes in gene expression. This is not generally possible in inhibitor-based experiments.

Studies in transgenic expression of heterologous genes for polyamine biosynthetic enzymes have shown that flux through the polyamine pathway can be manipulated. For example, the yeast ODC has been expressed in *Nicotiana rustica* to demonstrate that the levels of putrescine and nicotine could be increased in transgenic lines (Hamill *et al.*, 1990). The mouse ODC gene was over-expressed in transgenic carrot, leading to an increased putrescine level, and this was correlated with the induction of a high degree of somatic embryogenesis under *in vitro* conditions (Noh & Minocha, 1994). Masgrau *et al.*, (1997) generated transgenic tobacco plants carrying the oat *adc* cDNA under the control of a tetracycline-inducible promoter. Inducible-overexpression of oat ADC led to increased ADC activity, and changes in polyamine levels. However, transformed plants displayed aberrant phenotypes associated with growth inhibition, such as inter-veinal necrosis and chlorosis, wrinkled young leaves and shortened roots. Kumar *et al.*, (1996) generated transgenic potatoes with either sense or antisense homologous SAMDC constructs, using both the 35S constitutive promoter and the tetracycline-inducible promoter. A reduction in the level of SAMDC transcript in the antisense plants was observed. Additionally, modulation of the expression of the SAMDC gene affects not only the biosynthesis of polyamines, but also the biosynthesis of the plant growth regulator ethylene. Recent studies also showed the existence of links between polyamine content in foods and tumour growth (Bachrach & Wang, 2002). Therefore, the development of transgenic food plants with high or low polyamine levels might increase their nutritional and health values.

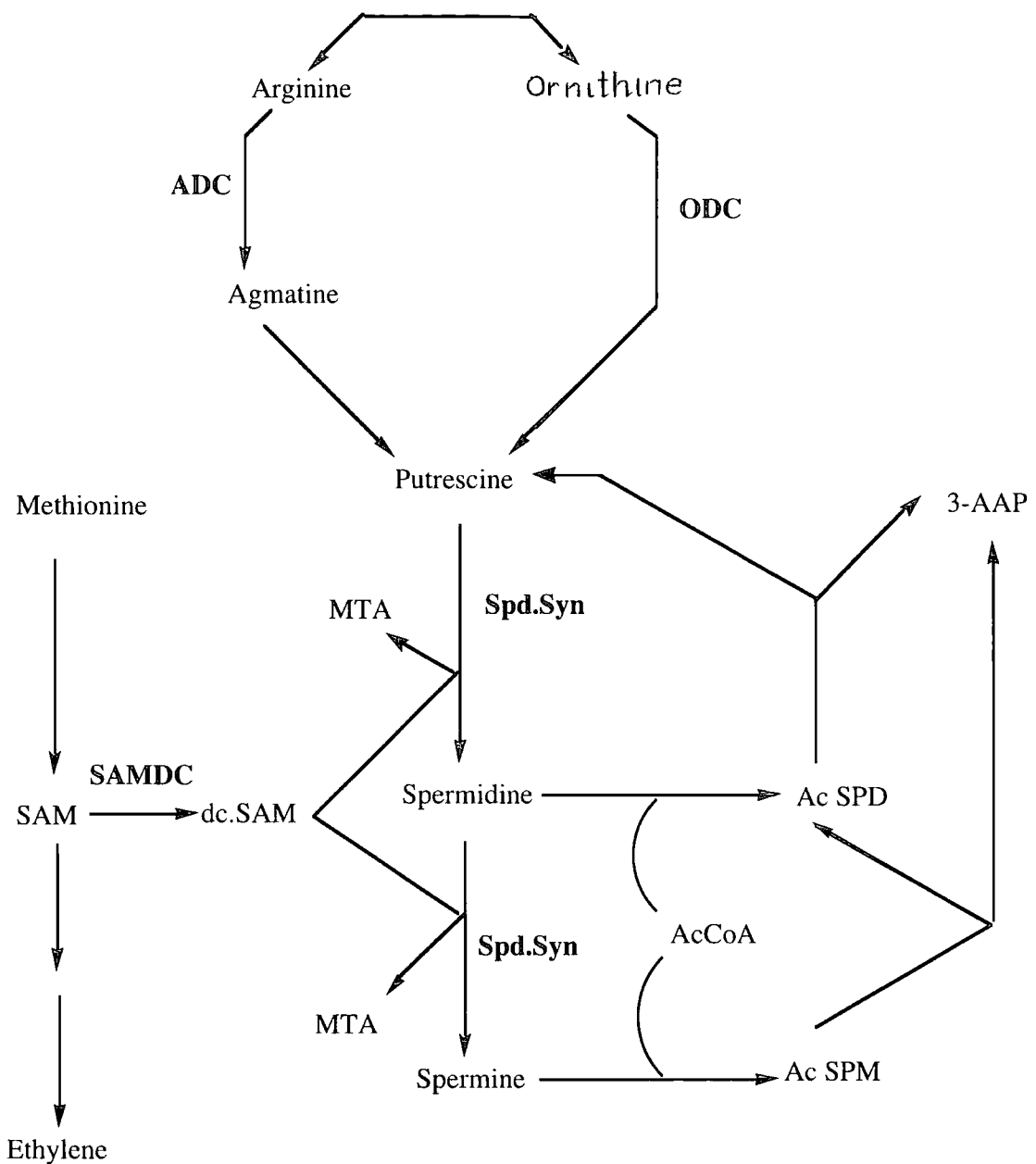

ADC: Arginine decarboxylase; ODC: Ornithine decarboxylase; Spd.Syn: Spermidine synthase; Spm.Syn: Spermene synthase; SAM: S-adenosylmethionine; SAMDC: S-adenosylmethionine decarboxylase; dc.ADC: decarboxylated SAM; MTA: 5'-methylthioadenosine; AcCoA: acetyl coenzyme A, AcSPD: acetyl spermidine; AcSPM: acetyl spermene; 3-APP: 3-acetamidopropanal.

Figure 1.3: Pathway for biosynthesis and inter-conversion of polyamines

4. Genetic engineering of insect resistance genes.

4.1 Bacillus thuringiensis toxins

Bacillus thuringiensis (known as “Bt”) is a soil bacterium used for more than 50 years as a biological insecticide. *B. thuringiensis* strains produce two types of toxin. The main types are the Cry (crystal) toxins, encoded by different *cry* genes. The second types are the Cyt (cyolytic) toxins. The insecticidal activity resides in crystalline inclusion bodies that are produced during sporulation of the bacteria. In the case of Bt toxins specific for lepidopteran insects, the crystal protein (protoxin) is a large protein (usually about 130-140kDa) and highly insoluble in normal conditions, so it is entirely safe to humans, higher animals and most insects. However, it is solubilised in reducing conditions of high pH (above about pH 9.5); the conditions commonly found in the mid-gut of lepidopteran larvae. Once it has been solubilised in the insect gut, the protoxin is cleaved by a gut protease to produce an active toxin of about 60-70 kD (Hofte and White, 1989). This toxin is termed delta-endotoxin. Under natural conditions, it binds to the midgut epithelial cells, creating pores in the cell membranes and leading to equilibration of ions. As a result, the gut is rapidly immobilised, the epithelial cells lyse, the larva stops feeding, and the gut pH is lowered by equilibration with the blood pH. This lower pH enables the bacterial spores to germinate, and the bacteria can then invade the host, causing a lethal septicaemia (Gill *et al.*, 1992). Studies on the delta-endotoxin structure show that it has three domains. Domain I (N-terminal) is a bundle of 7 alpha helices, some or all of which can insert into the gut cell membrane, creating a pore. Domain II consists of three anti-parallel beta-sheets and is responsible for binding to the “receptor” glycoprotein(s) on the gut surface, appearing to be necessary for effective pore formation to take place. Domain III is a tightly packed beta-sandwich which is thought to protect the exposed end (C-terminal) of the active toxin, preventing further cleavage by gut proteases (Figure 1.4) (Li *et al.*, 1991; Grochulski *et al.*, 1995). The *cry* genes have been transferred into some crop plants to make them insect-resistant. Expression of Bt toxin genes containing complete protoxin coding sequences *in planta* was very low, but modified genes encoding the truncated

delta endotoxins could be expressed at insecticidal levels (>0.1% of total soluble protein). Fujimoto *et al.*, (1993) reported that a modified *cry1Ab* gene was highly expressed in transgenic japonica rice plants and their progeny for at least two generations, and that resultant transgenic plants were resistant to two lepidopteran rice insects; the rice leaf folder and the rice stem borer. Maqbool *et al.*, (1998) reported that two indica rice varieties (Basmati370 and M7) carrying the *cry2A* gene, were resistant to yellow stem borer and leaf folder. Cheng *et al.*, (1998) transformed rice plants with fully modified (plant codon optimized) versions of two synthetic of *cry1Ab* and *cry1Ac* genes. They observed high accumulation of *cry1Ab* and *cry1Ac*, up to 3% of soluble proteins in Ro plants. Bioassay with R1 transgenic plants indicated that the transgenic plants were highly toxic to striped stem borer and yellow stem borer, with mortalities of 97-100% within 5 days after infection.

4.2 GNA - a plant-derived insect resistance gene.

Most transgenic insect-resistant rice plants produced to date rely on the expression of insecticidal Bt endotoxins. However, this strategy has not been successful to date against Homoptera (sap-sucking insects), as Bt toxins with high levels of activity against these insects are not available. However, certain plant lectins, including snowdrop lectin (*Galathus nivalis* agglutinin; GNA), are toxic to homopteran insects (Powell *et al.*, 1995) as well as lepidopteran and coleopteran larvae (Gatehouse *et al.*, 1995). GNA is member of a family of monocot mannose-binding lectins. It is a homotetramer composed of four identical subunits, each containing a polypeptide of 109 residues (12 kDa) with three potential carbohydrate-binding sites. The insecticidal activity of GNA has been demonstrated by bioassays in which the protein has been fed to insects in artificial diets. Under these conditions, it has shown activity against Homoptera such as aphids (Stoger *et al.*, 1999) and rice brown plant hopper (Sudhakar *et al.*, 1998), Coleoptera such as bruchid beetles, and also Lepidoptera such as tomato moth (Gatehouse *et al.*, 1997). The mechanism of lectin toxicity is not clear, although GNA has been shown to bind to the gut surface in rice brown plant hopper (Powell *et al.*, 1995) and to the peritrophic membrane (Eisemann *et al.*, 1994). The gene encoding snowdrop lectin (*gna*) has been introduced into different crops including tobacco,

potato, rice, oilseed rape, wheat, sweet potato, producing resistance against different target insects (Gatehouse, 1999). Rao *et al.* (1998) firstly reported transgenic indica rice plants carrying the *gna* gene in constructs where its expression was driven by a phloem-specific promoter (from the rice sucrose synthase gene RSs1) and by a

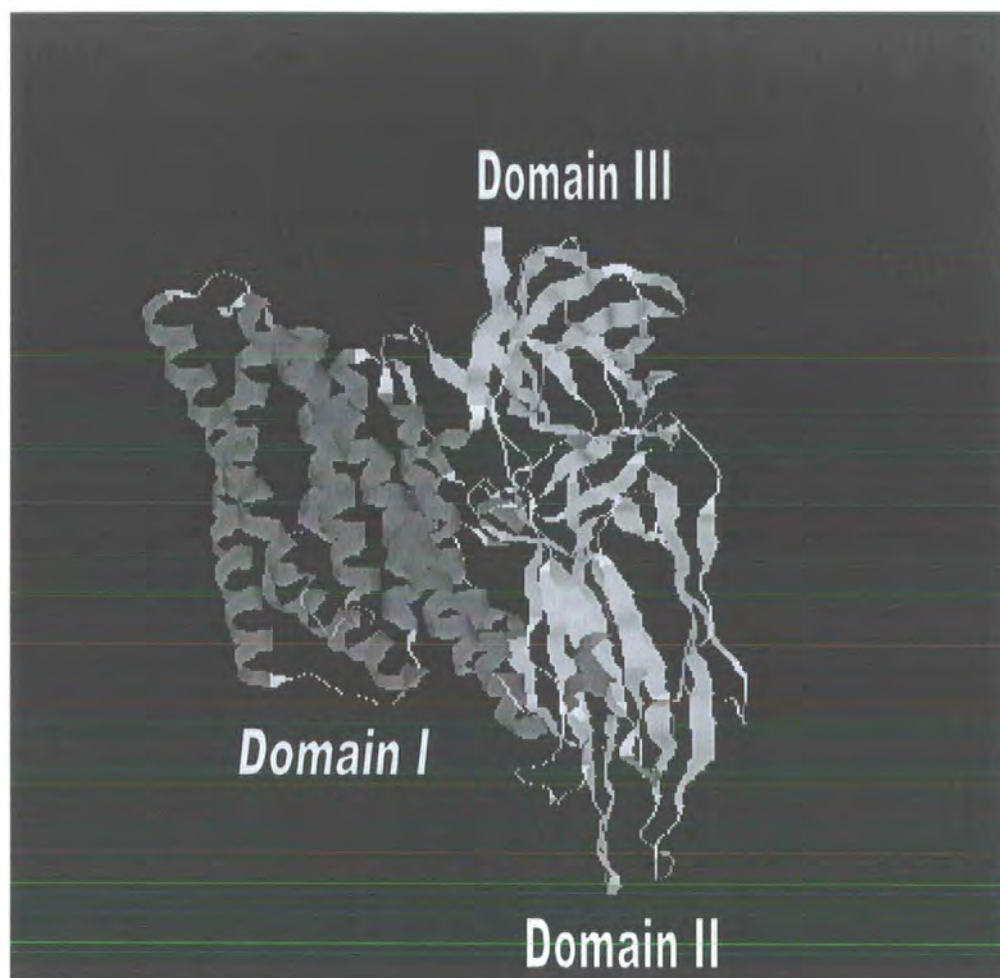

Figure 1.4. The structure of *Bacillus thuringiensis* delta- endotoxin

constitutive promoter (from the maize ubiquitin *ubi1* gene). Transgenic rice containing an RSs1-GNA construct accumulated GNA in vascular and epidermal tissue, and decreased survival of rice brown plant hoppers by up to 60%. Expression of GNA from some transgenic rice plants harbouring an *ubi1*-GNA construct resulted in upto 2% total protein, and led to retarded insect development and a deterrent effect on feeding.

Similar results were also obtained by Tinjuangjun *et al.* (2000). The expression of GNA in transgenic rice plants was also found to confer resistance to rice green leafhopper (Foissac *et al.*, 2000), and to rice small brown plant hopper (Wu *et al.*, 2002).

5. Other Goal for Rice Genetic Engineering: Golden Rice

Rice feeds nearly one-half of the world's population, but it is a poor source of many essential micronutrients. As a consequence, and due to poverty and limited access to more diversified foods, deficiencies of iron, zinc, iodine and vitamin A are common among the populations in rice-consuming developing countries. Naturally occurring vitamin A derives entirely from carotenoids with provitamin A activity, with beta-carotene the most important provitamin A for mammals. Recently, engineering high levels of beta-carotene in the endosperm of "golden rice" is a major breakthrough in the intention of combating vitamin A deficiency (Ye *et al.*, 2000). *Agrobacterium*-mediated transformation was used to introduce genes encoding the entire beta-carotene biosynthesis pathway into rice endosperm, based on the finding that rice endosperm is capable of synthesizing geranylgeranyldiphosphate, a precursor in carotenoid metabolism. Therefore, theoretically four novel enzymes are required for beta-carotene synthesis in this tissue: phytoene synthase (*psy*), phytoene desaturase, carotene desaturase and lycopene beta-cyclase (*lcy*) (for review, see Giuliano *et al.*, 2000). However, in the "Golden rice" experiment, they used only 3 genes: two of these genes were *psy* and *lcy*, both originating from daffodil and driven by the rice endosperm-specific glutelin promoter. The third gene was the bacterial phytoene desaturase (*crtI*) from *Erwinia uredovora*, which is able to substitute for the two plant desaturases. The resulting "Golden rice" grains contain up to 200 μ g beta-carotene per 100 g of rice. Further experiments showed that the use of only two transgenes, *psy* and *crtI* was able to reconstitute the entire carotenoid pathway, including the formation of alpha- and beta-carotene and derived xanthophylls (Ye *et al.*, 2000; Hoa *et al.*, 2003). These novel lines are highly valuable because they are expected to receive approval for follow-up studies such as nutritional and risk assessments more readily and to be more amenable to breeding approaches leading to development of local-adapted varieties.

6. The production of antibodies in transgenic plants: the plantibody approach.

Transgenic plants can be generated for a multitude of reasons, including using the plants as bioreactors for the production of foreign proteins, mammalian hormones, oils, specialized carbohydrates and biodegradable plastics (Godijin and Pen, 1995; Miele, 1997; Fischer and Emans, 2000). Of all the proteins that have been produced in plants, perhaps the most intriguing are complete recombinant antibodies (rAbs) and antibody fragments such as one antigen-binding fragment (Fab), two antigen-binding fragment (F(ab')₂) and single-chain variable fragment (scFv). One scFv antibody consists of variable light chain and variable heavy chain domains of an antibody molecule fused by a flexible peptide linker so it retains full antigen-binding activity but lacks specific assembly requirements. Antibodies were first expressed in transgenic plants in 1989 (Hiatt *et al.*, 1989). Since then, many different antibodies have been produced in different plant species, in different tissues and different sub-cellular compartments for different purposes (Fischer and Emans, 2000; Stoger *et al.*, 2002). Enzymes and antibodies produced in seed exhibit remarkable stability if they are properly stored at refrigerator temperature. Recently, success was reported using tropical plants, such as cassava (*Manihot esculenta* Crantz) (Zhang *et al.*, 2000) and banana (Schenk *et al.*, 1999). This opens up the possibility of delivering oral vaccines and recombinant pharmaceuticals directly to consumers in developing countries. Antibodies or antibody fragments produced in plants are often referred to as “plantibodies” and they can be exploited for *ex-* and *in-planta* applications. Many of the antibodies currently produced in plant-based expression systems for pharmaceutical use, in particular antibodies directed against an antigen from *Streptococcus* mutants, the bacteria that causes tooth decay, thereby reducing cavities. These antibodies are now in clinical trials (Larrick *et al.*, 1998). Another plantibody that is likely to result in a product for human medical applications is a humanised antibody against herpes simplex virus (HSV) glycoprotein B. this antibody was expressed in soybean and shown to be effective in a model study using mice (Zeitlin *et al.*, 1998). Recently, agroinfiltration of tobacco was used to produce a diabody against carcinoembryonic antigen (CEA) expressed in colon cancer (Vaquero *et al.*, 2002). In addition, there is also a growing

interest for *in planta* applications. A technique called immunomodulation, in which antibodies or antibody fragments are produced in plants to modulate the function of a corresponding antigen, offers the opportunity to study the function of the antigen in plants, to alter plant metabolism or to immunize the plant against pathogen infection (De Jaeger *et al.*, 2000). Transgenic tobacco that accumulated high levels of an anti-gibberellin A19/24 scFv fragment in the endoplasmid reticulum showed a dwarf phenotype and lower gibberellin A1 levels than wild type (Shimada *et al.*, 1999). The results suggest that scFv antibodies reduced the concentration of bioactive gibberellins by trapping and inhibiting the metabolism of the bioactive gibberellin precursors A19 and A24. Artsaenko *et al* (1999) point out an important advantage of immunomodulation versus the use of existing mutants or antisense technology to study hormone action namely that antibody binding can inactivate an end product of a hormone biosynthetic pathway without affecting the function of any precursors. Antibody-mediated virus resistance has been demonstrated by the production of transgenic tobacco plants that produce antibodies directed against a viral coat protein. These plants exhibit resistance to artichoke mottled crinkle virus (Tavladoraki *et al.*, 1993) and tobacco mosaic virus (Voss *et al.*, 1995). Plantibody-mediated resistance against complex eukaryotic, multicellular pathogens, such as nematodes, fungi and insects, remains a major challenge (De Jaeger *et al.*, 2000). Attempts to make tobacco resistant against root-knot nematodes has been tested upon the accumulation of the IgM antibody 6D4 in transgenic plants (Baum *et al.*, 1996; Rosso *et al.*, 1996). For insects, preliminary results suggest that plantibody approach would also work against insects (East *et al.*, 1993; Ben-Yakir & Shochat, 1996).

7. Genetically modified crops and public perception.

There are certain limitations on the commercialisation of genetically modified (GM) crops. One important constraint that should be dealt with carefully is the public perception of GM food and environmental risk assessment of products derived from recombinant DNA technology. There is yet no substantial evidence that GM products of plant biotechnology are inherently more dangerous than products derived from

conventional breeding just because they have been produced using novel techniques. However, several environmental concerns have led to wariness and a lack of public acceptance of GM crops around the world including: (1) the presence of antibiotic marker in transgenic plants/food, (2) transgenic plants becoming weeds themselves, (3) conduits for transfer of new genes to the wild, (4) a source of new viruses or toxic substances for consumer and (5) a risk to ecosystem (Daniell, 1999). These problems can be minimised or avoided by using some novel strategies such as plastid transformation, elimination of antibiotic genes, tissue specific expression of the transgenes, and follow the standard bio-safety guidelines in producing transgenic plants. In addition, because risk is a quantifiable measure and virtually everything we do has a risk, the risk of GM crops should be considered in this way and compared to the risks posed by conventional practices. Anti- GM biotechnology activists argue that genetic engineering is so new that its effects on the environment cannot be predicted. This could be misleading. In fact, for hundreds of years virtually all food has been improved genetically by natural mutation, hybridization and selection or by the work of plant breeders. Therefore, almost all our crops under cultivation today are the result of mutation and shuffled genes. Presently, 80% of the world's population live in the developing countries and this will represent between 8 and 10 billion persons by the year 2050 (Fedoroff *et al.*, 1999). It is estimated that global food production must increase by 40% in the next 20 years to meet the goal of a better and more varied diet for a world population of some 8 billion people (Bailey, 2001). Traditionally, increased crop production has been achieved by bringing more land under cultivation. Such activity is unsustainable, as the practice is already resulting in severe depletion of the world's natural ecosystems. It is clearly that significant increases in production from the agricultural systems employed in developing countries can be obtained, largely from the land already under cultivation and by applying agro-biotechnology along with conventional methods. GM cotton, corn and soybean seeds became available in the USA in 1996, and by the year of 1999, more than one-third of all US-grown soybean and one-fourth corn were genetically modified. The number of acres devoted to GM crops in Argentina, Canada, Mexico and Australia increased tenfold between 1996 and 1997 (Carter, 1998). To date, over 30 million hectares of transgenic crops have been

grown with no human health problems associated with the ingestion of transgenic crops or their products yet identified (Bailey, 2001).

8. Aims and Objectives of the Present Study.

The research described in this thesis was made possible by the award of a PhD Fellowship funded by the Rockefeller Foundation as part of their Rice Biotechnology programme. The primary aim of the work was to develop expertise in rice transformation technology in order to be able to develop the production of transgenic rice with characteristics valuable to local agriculture in Vietnam. Within this overall aim two specific objectives were defined to allow research suitable for a PhD programme to be carried out.

The first objective of the work was to unravel the fundamental mechanisms and principles associated with the regulation of the polyamine biosynthetic pathway in rice using a transgenic approach. By expression of antisense or sense gene constructs, the programme aimed to study how the suppression or over-expression of endogenous enzyme activity in the polyamine biosynthetic pathway affected free polyamine content, and expression of the natural existing polyamine biosynthesis genes. Furthermore, the generation of these transgenic rice plants offered an opportunity to investigate how metabolite flux through the polyamine pathway is controlled and regulated.

The second objective of my present study was to produce and test the efficacy of transgenic rice plants expressing fusion protein(s) conferring resistance to insect pests. The design of these fusions aimed to enhance insecticidal activity of an insect resistant gene product by directing the transport of its product to its site of action (GNA) or to broaden the toxicity (Bt) by adding additional domains with binding or potential pesticidal properties. The resulting insect resistant transgenic rice lines could be used as a valuable source for breeding efforts to develop locally adapted insect-resistant rice varieties in Viet Nam.

Chapter 2

MATERIALS AND METHODS

This chapter describes the general materials, reagents and protocols applicable to this thesis. General molecular biological techniques, unless stated, follow Sambrook and Russel (2001).

a. Plant materials.

Two rice cultivars: EYI 105 and ITA 212 (Japonica type) have been used for transformation. Transgenic rice plants were grown in peat-based compost, either in glasshouses maintained at 25°C (\pm 5 °C) with supplementary lighting using 400W sodium lamps to give a 16-h photoperiod/day, or in plant growth chambers maintained at 28°C, with a 12h photoperiod.

b. Chemical reagents, molecular biology kits and enzymes.

All chemicals were of analytical grade and purchased from Sigma or Merck (BDH) Ltd. unless otherwise stated. Restriction enzymes, molecular markers, enzymes and biochemical reagents were purchased from Roche, Promega, Amersham Pharmacia Biotech, Gibco BRL, New England Biolabs, Kramel Biotech, NBL Gene Sciences and Cambio companies. All primers for specific sequences were purchased from Sigma-Genosys Ltd. All chemicals and kits for Southern and Northern blot analyses were purchased from Roche. Plasmid extraction kits (miniprep), Reverse transcription (RT) kits, RT-PCR kits and RQ1 RNase-free DNase kits were purchased from Promega. Plasmid extraction kits, gel and PCR product purification kits were purchased from Promega and QIAGEN.

Agarose; Gibco BRL Life Technologies Ltd, Paisley, Scotland.

Bacto Agar; Difco Laboratories, Detroit, Michigan, U.S.A.

Yeast extract; Umpath Ltd, Basingstoke, UK.

3MM paper and glass fibre; Whatman Ltd, Maidstone, Kent, U.K.

Reagents for SDS-PAGE were obtained from Gibco BRL, UK.

X-ray film (Fuji-RX); Fuji Photo Film Ltd, UK.

Sephadex G-50, Ficoll-400, Hitrap-Q 1ml ion exchange columns; Pharmacia Fine Chemicals, Uppsala, Sweden

α 32 P-dCTP was obtained from Amersham.

All general stock solutions used in this thesis are listed in Table 2.1.

c. Bacterial strains, vector constructs and PCR primers.

Bacterial strains, Dh 5a, Topo10 (Invitrogen) and BL21 DE3 (Novagen), were used in bacterial transformation of the target gene construct vectors. Plasmid vectors used for cloning and transformation are listed in Table 2.2. Specific plasmids were constructed following protocols in Promega (1996) or Sambrook and Russel (2001) and will be described below.

1. Polyamine gene constructs.

1.1. Oat ADC construct.

The 2124bp oat arginine decarboxylase (ADC) cDNA (gene bank X56820, Bell and Malberg 1990) was excised as an EcoR I fragment and subcloned in the EcoR I site of vector pJIT 60 (Gurineau et al. 1992), which contains a CAMV 35S promoter with duplicated enhancer sequences and a CAMV transcriptional terminator (figure 2.1). The antisense orientation of the oat ADC cDNA in the plasmid vector pJIT 60 was confirmed using the restriction enzyme SalI and DNA sequencing. This plasmid was referred to as p35SOADC.

1.2. Rice Spd.Syn construct.

The 1.308kb full-length rice Spd.Syn.(spermidine synthase) cDNA (gene bank AJ251298) was excised as a SalI/Not I fragment from pBlueScript vector (Stratagene) background, blunt ended and subcloned into the EcoRV site of pAL 76 (Christensen, 1992). The pAL76 contains the maize Ubi-1 promoter fused with the first intron and a CAMV transcriptional terminator (figure 2.2). This plasmid was then referred to as pUbiRSpd.Syn.

2. Insect resistance gene constructs.

2.1. The 1st domain of CryI_{Ac} fused with GNA construct.

A 762-bp fragment coding for the first domain of the CryI_{Ac} protein that begins with the start codon was amplified by PCR from the plasmid pWJK20 (a gift from Prof. David Ellar, University of Cambridge) using a pair of primers with restriction site sequences of NdeI and NcoI incorporated respectively: (1) forward primer; 5'-cgc gcg cgc cat atg gat aac aat ccg aac atc-3';(2) reverse primer; 5'-cgc gcc atg gct cct cct ggt ctt cta cta tca taa ttc gg-3' (underline indicates the restriction enzyme

sites). The amplified products were cloned into plasmid pCR2.1 (TA cloning method, TOPO cloning kit- Invitrogen). For GNA, a coding sequence of 109 amino acids was amplified by PCR using a pair of primers harbouring restriction sites NcoI and BamHI respectively: (1) forward primer; 5'-ttg ccc cat ggacaa tat ttt gta ctc cgg tga ga-3'; (2) reverse primer; 5'-ctg agg atc ctc agt ggt gat ggt gat gtc cgg tgt gag ttc cag-3' (the reverse primer contains a short sequence coding for six histidine before a stop codon). The amplified products were cloned into plasmid PCR 2.1 using TA cloning method. These two cloned sequences, the first domain of Cry1Ac and GNA, were then excised from PCR 2.1 vector by digestion with NdeI / NcoI for Cry1Ac domain I, and with NcoI/BamHI for GNA, and subsequently ligated into vector pET 11a (Novagen) to create a fusion gene of Cry1Ac domain I and GNA (Du J., unpublished data).

To express this fusion gene in transgenic plants, it was excised from pET 11a as a blunt-ended NdeI / HindIII fragment and subcloned into the EcoRV/HindIII site of the plasmid pAL76, which contains the maize 1 ubiquitin (Ubi1) promoter and a nopaline synthase transcriptional terminator. This plasmid was then referred to as pUbi1st AcGNA.

2.2. *Cry1Ac fused with ricin B chain (RTB) construct.*

The full-length open reading frame of Cry1Ac beginning from the start codon (not including stop codon) was amplified from plasmid carrying Cry1Ac gene with plant codon optimised sequence by PCR using a pair of primers with added restriction sites of Nde I and Nhe I, respectively: (1) forward primer; 5'-gga cat atg gac aac aac cca aac-3'; (2) reverse primer; 5'-gga gct agc tgt tgc agt aac tgg-3' (underline indicates the restriction enzyme sites). To obtain a DNA sequence encoding RTB, we used a pair of primers with added restriction sites for Nhe I and Sal I respectively: (1) forward primer: 5'-gca gct agc aat gct gat gtt tgt-3'; (2) reverse primer: 5'-gca gtc gac aaa taa tgg taa cca-3'. The amplified products were then cloned into plasmid pCR2.1 (TA cloning method, TOPO cloning kit- Invitrogen). A characterised clone of the plasmid containing the RTB sequence was digested with Nhe I and SalI, and the insert was isolated by agarose gel electrophoresis, purified, and ligated into the plasmid that carried Cry1Ac gene, which had also been restricted with NheI and SalI. The resulting recombinant plasmid contained a fusion gene Cry1Ac-RTB. The fusion gene was then excised from the cloning plasmid by restriction digestion with NdeI and Sal I, and subsequently cloned into plasmid pET24b vector for expression in bacteria E.coli.

To produce plants expressing this gene construct, the fusion gene was excised from pCR2.1 vector by digestion with restriction enzymes EcoR I (blunt-ended with T4 polymerase) and Hind III and subcloned into the SmaI/HindIII site of the plasmid pAL76 (which contains the maize 1 ubiquitin (Ubi1) promoter and a nopaline synthase transcriptional terminator. This plasmid was then referred to as pUbi AcGNA.

2.3. Rice Thioredoxin h fused with GNA construct.

A 366bp of coding sequence of rice thiorexin h (rTRX h) open reading frame (not containing stop codon) was amplified from its cDNA by PCR using a pair of primers: (1) forward primer; 5'-att aca tat ggc cgc cga gga ggg-3'; (2) reverse primer; 5'-att agg atc cgc aga agc aga tca-3' (underlines indicate restriction enzyme sites NdeI and BamHI, respectively). The rTRX h fragment was then subcloned into pET 24b plasmid vector (Novagen) by digestion of both insert DNA and vector with restriction enzymes NdeI and BamHI. For GNA, a coding sequence of 109 amino acids was amplified by PCR using a pair of primers harbouring restriction sites BamHI and EcoR I respectively: (1) forward primer; 5'-tct gcg gat ccg gac aat att ttg tac-3'; (2) reverse primer; 5'-at tag aat tca tcc ggt gtg agt tcc-3'. The amplified GNA sequence was then subcloned into the pET24b vector carrying rice Thioredoxin h by digestion of both the insert and vector with BamHI and EcoR I to make the fusion gene "rTRX h-GNA" (Raemaekers R., unpublished data)

To express this fusion gene in transgenic plants, it was excised from pET 24b as a blunt-ended NdeI / EcoRI fragment and subcloned into the SmaI/EcoRI site of the plasmid pAL76, which contains the maize 1 ubiquitin (Ubi1) promoter and a nopaline synthase transcriptional terminator. This plasmid was then referred to as pUbiRTRXGNA.

To confirm the presence of target genes inside plasmid vectors, DNA sequencing was carried out after each step of subcloning using the ABI Prism® BigDye™ Terminator Cycle Sequencing Ready Reaction Kit according to manufacturer's recommendations (PE Applied Biosystems). Maps of gene constructs used for rice transformation are shown in figure 2.3. A list of primers that were used in transgenic rice analyses was presented in table 2.4.

d. Rice transformation.

Rice transformation, selection and plant regeneration procedures were carried out as described previously in Sudhaka et al., (1998); Valdez et al., (1998).

1. Preparation of DNA and gold particle coating.

Large and small-scale plasmid DNA extractions were performed using the QIAGEN plasmid maxi, midi or mini prep kits according to manufacturer's instructions (QIAGEN).

DNA-coated gold particles were prepared as described by Christou *et al.* (1991). Five mg of 0.71 μm gold particles was mixed with 10 μg DNA solution in 100 μl Xho buffer (150 mM NaCl, 10 mM Tris-HCl, pH 8.0). The solution was vortexed gently for 10 seconds (sec), then 100 μl 0.1M spermidine and 100 μl 25 % PEG were added with continuous vortexing. Finally, 100 μl 2.5 M CaCl_2 was added drop by drop while vortexing. The mixture was vortexed at room temperature (RT) for 10 minutes (min) then centrifuged at 13,000 g for 1 min. The supernatant was subsequently removed. This step was repeated to remove the excess chemicals. The DNA-coated gold pellet was re-suspended in 1 ml 100% v/v ethanol contained in a scintillation vial (10 ml total volume). After sonication, the resulting suspension was transferred to the scintillation vial containing 9 ml 100 % v/v ethanol and sonicated briefly once again before storing at -20°C .

Just before bombardment, 163 μl of DNA-coated gold suspension was placed onto an 18x18 mm carrier sheet to give 0.05 mg of gold cm^{-2} and excess ethanol was removed by air-drying. For co-transformation experiments, a molar ratio 1:3 of selectable marker gene (*hpt*) to non-selectable genes (genes of interested) was used, as this has been shown to provide the greatest likelihood of co-transformation and non-selectable transgene expression.

2. Plant materials and tissue preparation.

Rice varieties EYI 105 and ITA212 (japonica) were used for transformation experiments. Mature seed-derived callus was used as target material for particle bombardment. Matured rice seeds were sterilised and cultured as described by Sudhakar *et al.* (1998) and Valdez *et al.* (1998): De-husked seeds were sterilised in 70 % v/v ethanol for a few seconds and then in 50 % v/v sodium hypochloride for 30 min with agitation. They were rinsed three times with sterile distilled water and then plated

in 90 mm-petri dishes containing MSCI medium (Table 2.3). Seeds were incubated at 27°C in the dark for 5-7 days. Expanding mature embryos were separated from the endosperm and formed the mature seed-derived callus. The isolated callus was placed on fresh MSCI medium.

3. Particle bombardment.

Target tissues were centred on 50 mm-petri dishes containing induction medium with osmoticum (MSCIO; Table 2.3) for 4 hours prior to bombardment.

Bombardment using the Accell™ gun was performed according to Christou *et al.* (1991). The carrier sheet with the gold beads and the DNA was loaded onto the particle accelerator, which uses the discharge of a high voltage capacitor through a small water droplet as the motive force. A 100 µm-mesh retaining screen was placed between the sheet and the target tissue suspended above the accelerator. The assembly was then evacuated to 500 mm Hg to reduce aerodynamic drag. A discharge of 15 kV from a 0.2 µF capacitor through a 10 µl water droplet inside the expansion chamber then accelerated the carrier sheet against the retaining screen, permitting the DNA-coated gold particles to continue onward to impact the target tissues.

4. Selection and generation of putatively transgenic tissues.

Sixteen hours after bombardment, bombarded tissues were transferred to fresh callus induction medium (MSCI; Table 2.3) without selection and incubated in the dark at 27°C for 48 hours. Mature seed-derived callus was then transferred to selection medium (MSCIHg; Table 2.3) supplemented with 30 mg l⁻¹ hygromycin B. After 2 weeks selection, the surviving callus was separated into small pieces and subcultured on the same selection medium for another two weeks. All cultures were incubated at 27°C in the dark for 4 weeks in total. Proliferating callus was then transferred to regeneration medium (MSR; Table 2.3) supplemented with 30 mg l⁻¹ hygromycin B. All cultures were incubated at 27°C with a 16-h photoperiod (photosynthetic photon flux of 55µmol M⁻²s⁻¹ cool white fluorescent tubes) and the regenerating callus was sub-cultured on the same medium every two weeks. Once plantlets were regenerated, they were transferred to rooting medium (MSRR; Table 2.3) and cultured under the same conditions as the regeneration step until plants were 8-10 cm in height. Plants were first transferred to soil and grown for a month in controlled environment rooms before transfer to larger pots, and growth to maturity in the greenhouse.

e. DNA analysis.

1. Plasmid DNA extraction (miniprep).

Plasmid DNAs were extracted from overnight cultures in accordance with the protocol supplied with the Wizard miniprep plasmid isolation kit (Promega). This consisted of a lysis step followed by alkaline neutralisation. The cell debris was then separated from the DNA by centrifugation. The plasmid DNAs were isolated on the matrix of the spin columns, washed with an ethanol + salt solution and eluted using 100 µl of nuclease free water.

2. Plant genomic DNA extraction.

DNA extraction was carried out essentially as described earlier. However certain modifications were required for rice as detailed below. For a large amount of genomic DNA, 1g of leaf sample were ground in liquid nitrogen to a fine powder. The sample was then homogenized with 20 ml of CTAB buffer (Table 2.1) and incubated at 65°C for 2 hours. Twenty milliliters of chloroform was added into the sample and shaken vigorously for 1 min. The supernatant was collected after centrifuging the sample at 1,600x g for 10 min at 4°C. The chloroform extraction step was repeated twice. DNA was precipitated by adding 20 ml of pre-chilled isopropanol to the supernatant and kept at -20°C for 30 min. After centrifugation at 1,600 g for 10 min at 4°C, the DNA pellet was washed with 70 % ethanol, dried and dissolved in 200 µl of distilled water.

For a small amount of genomic DNA, 100 mg leaf sample was ground in liquid nitrogen. The sample was then homogenized with 400 µl of DNA extraction buffer (Table 2.1) and incubated at 65°C for 20 min. Four hundred µl of bio-phenol was added to the sample and mixed well for 5 min. Following centrifugation of the sample at 13,000 g for 10 min, the supernatant was collected. DNA was precipitated by adding 400 µl of pre-chilled isopropanol to the supernatant and kept at -20°C for 10 min. After centrifuging at 13,000 g for 5 min at 4°C, the DNA pellet was washed with 70 % v/v ethanol, dried and dissolved in 50 µl of distilled water.

3. Polymerase chain reaction (PCR).

PCR amplifications were carried out in a total volume of 50 µl containing 100 ng genomic DNA or 100 pg of plasmids, 1x PCR buffer (10 mM Tris-HCl, 1.5 mM

MgCl₂, 50 mM KCl, pH 8.3), 200 mM each dNTP, 50 nM each primer and 2.5 units of Taq DNA Polymerase (Roche). The PCR cycling conditions were optimised for each template and primer pair as discussed for each gene in subsequent chapters. Primer sequences used in the thesis are listed in Table 2.4. PCR products were separated by 0.8-1.2 % TBE agarose gel electrophoresis depending on product size. The gel was stained for 10 min with 0.5mg ml⁻¹ ethidium bromide before visualising on a UV transilluminator and photographed using a Mitsubishi Video Copy Processor with Quantity One Software (Bio-Rad).

4. Southern blot hybridisation.

Ten to fifteen micrograms of plant genomic DNA was digested with 10-20 units of appropriate restriction endonuclease(s) along with its 1x buffer in a final volume of 50-100 µl. The reaction was then incubated at 37°C for 10-16 hs. Digested DNA was fractionated by 0.8 % TBE agarose gel electrophoresis. The gel was washed with denaturation solution (Table 2.1) for 20 min and then with a neutralisation solution (Table 2.1) for 10 min, 3 times at RT with agitation. DNA was transferred to positively charged nylon (N⁺) membranes using 20xSSC buffer (Table 2.1) overnight before UV cross-linking. The membrane was then washed with 2xSSC buffer and allowed to air-dry.

Two detection methods were used for DNA blots; with non-radioactive labelling and radioactive labelling. In the non-radioactive labelling method, the probe DNA was labelled with digoxigenin (DIG)-dUTP using the PCR DIG Probe Synthesis kit (Roche). Alkali-labile DIG-11-dUTP was incorporated into the probe in a final volume of 50 µl containing 4 mM dATP, 4 mM dCTP, 4 mM dGTP, 3.2 mM dTTP, 0.8 mM DIG-11-dUTP, 1 x Roche PCR buffer (50 mM KCl, 10 mM Tris-HCl pH 9.0, 0.1% Triton X-100), 2.5 units of Taq DNA Polymerase, 0.1 mM each of the forward and reverse sequence primers and 100 pg of the plasmids. The reaction conditions were the same as for PCR conditions depending on specific primers and DNA sequences. The labelled probe was fractionated by agarose gel electrophoresis and purified using the QIA quick Gel Extraction Kit (QIAGEN). The probe was denatured at 68°C for 10 min prior to use. The membrane was pre-hybridized with DIG Easy Hyb solution (Roche) for 1-2 hours and hybridized overnight at 42°C with DIG-labelled probe. The membrane was washed twice for 5 min in 2x SSC, 0.1% SDS at RT, and then twice for 15 min in 0.5x SSC, 0.1 % SDS at 68°C with shaking. Detection was carried out

according to the manufacturer's instructions using the DIG Luminescent Detection Kit (Roche). After washing, the membrane was incubated with CSPD^(R) Chemiluminescent Substrate (Roche) and subsequently exposed to X-ray film (Fuji Photofilm) for 30 min at 37°C.

For the radioactive detection method, the DNA probe was labelled using the random hexamer method (Feinberg and Vogenstein, 1983). DNA in a volume of 31 µl (25-50 ng) was denatured by boiling for 7 minutes and cooled on ice for three minutes. It was then labelled in a volume of 50 µl containing: 10 µl OLB buffer; 2 µl of 10 mg/ml BSA, 2 µl of 2U/µl Klenow polymerase and 5 µl of 32p-dCTP, 50 µCi. This reaction mix was left for one hour or overnight at room temperature. The unincorporated dNTPs were removed by gel filtration in a 10 ml glass pipette filled with Sephadex G50. For prehybridization, the filter was incubated at 65°C for 3 hours in 50 ml of prehybridization solution (20 ml distilled water, 25 ml of 10x SSC, 5 ml of 50x Denhardt's solution and 1 ml of 10 mg/ml denatured salmon sperm DNA, added after the solution had been heated to 65°C). The prehybridisation solution was then replaced with a further 50 ml of solution, and the DNA probe added. Hybridization was performed for 20-24 hs at 65°C. The filter was then washed twice for 15 minutes with 2xSSC, 0.5% SDS. This was followed by two washes of 15 minutes each with 0.2xSSC, 0.5% SDS. The filter was blotted dry with Whatman paper and sealed in cling film. Hybridization signals were visualised by exposure to X ray film (Fuji RX) at -70°C for overnight, or longer as required.

When membranes were to be re-hybridised with different probes, they were stripped as described by manufacturer's instructions (Roche). The membrane was washed in water for 1 min, and then incubated twice for 10 min at 37°C in alkaline probe-stripping solution (Table 2.1). The membrane was rinsed thoroughly in 2xSSC. Reprobing procedures commenced with the pre-hybridisation step.

f. RNA analysis

1. Total RNA extraction.

For large amounts of total RNA, 1 g young leaf tissue sample was used for extraction using TRIZOL reagent according to the manufacturer's instructions (Gibco BRL). Plant tissue samples were ground in liquid nitrogen, then homogenized with 10 ml of TRIZOL reagent and incubated at RT for 5 min. Two millilitres of chloroform was added and the mixture was shaken vigorously for 1 min. After centrifuging the sample at

12,000 *g* for 30 min at 4°C, the aqueous phase was transferred to a fresh tube. To precipitate RNA, 5 ml isopropanol was added, mixed well and incubated at RT for 20 min. The RNA pellet was collected by centrifugation at 12,000 *g* for 20 min at 4°C, and then washed with 75 % v/v ethanol. After air-drying, the RNA pellet was dissolved in 200 µl RNase-free water.

For small amounts, total RNA was extracted from 100 mg young leaf tissue samples using TRIZOL reagent. Plant tissue sample was ground in liquid nitrogen, homogenized with 1 ml of TRIZOL reagent and incubated at RT for 5 min. 200 µl of chloroform was added and the mixture was shaken vigorously. The sample was centrifuged at 12,000 *g* for 15 min at 4°C. The aqueous phase was transferred to a fresh tube, 500 µl isopropanol was added and incubated at RT for 15 min to precipitate the RNA. The RNA pellet was collected by centrifuging the sample at 12,000 *g* for 10 min at 4°C. The pellet was then washed with 75 % ethanol, air-dried, and dissolved in 50 µl RNase-free water.

To ensure that the RNA was free of DNA contamination, DNase treatment was carried using RQ1 RNase-Free DNase (Promega). DNA digestion was carried out for 30 min at 37°C, in 10 µl final volume containing 5 µg total RNA, 1 unit of RQ1 DNase I and 1x reaction buffer (40 mM Tris-HCl, pH 8.0, 10 mM MgSO₄, 1 mM CaCl₂). The reaction was terminated by adding 1 µl of stop solution (20 mM EGTA, pH 8.0) and incubated at 65°C for 10 min.

2. Reverse transcription PCR (RT-PCR).

RT-PCR was carried out using the Access RT-PCR system (Promega) in 50 µl reaction volumes containing 100 ng of total RNA, 1x AMV/*Tfl* reaction buffer, 0.2 mM each dNTP, 1 mM MgSO₄, 1 µM each primer, 5 units of *Tfl* DNA Polymerase and 5 units of AMV Reverse Transcriptase.

RT-PCR was carried out under the following conditions: reverse transcription at 48°C for 45 min, denaturation at 94°C for 2 min, 40 amplification cycles with annealing temperature depending on specific primer pairs, and final extension at 68°C for 7 min. RT-PCR products were visualized by 1.0 % TBE agarose gel electrophoresis.

3. Northern blot hybridisation.

Thirty mg of total rice RNA was used for each lane on northern blots. All solutions and equipment used for RNA were autoclaved or treated with RBS35 to ensure they were free of RNase. RNA was denatured by formamide and formaldehyde

at 65°C for 15 min, and then fractionated on 1.2 % agarose-formaldehyde gel using 1x MOPS buffer (Table 2.1). RNA on the gel was transferred onto an N⁺ membrane (Roche) and then fixed by UV cross-linking. All subsequent steps were carried out as described previously for Southern blots.

When the membrane was to be re-hybridised with a different probe, it was stripped soon after the initial detection as described by Hloch *et al.* (2001). The membrane was rinsed briefly in RNase-free water, and then incubated in northern stripping solution (Table 2.1) twice for 30-60 min at 80°C in a sealed bag in a pre-heated shaking water bath. The membrane was briefly rinsed in 2xSSC and stored wet in 4°C for subsequent experiments.

g. Western blot analysis.

Protein samples for western blot analysis were extracted from small leaf sections ground to a fine powder under liquid nitrogen. When the nitrogen had evaporated, 1 ml of protein extraction buffer (table 2.1) was added to the powder. The extract was incubated for 5 hours at 4°C followed by centrifugation at 12,000 g for 10 minutes at 4°C. Protein concentration was estimated using Bradford Reagent (Bio-Rad) by the dye binding method (Bradford, 1976). Proteins were electrophoresed on SDS-PAGE gels according to Laemmli (1971), and transferred onto nitro-cellulose membranes by semi-dry electro-blotting (Towbin *et al.*, 1979). Membranes were blocked by incubation in blocking buffer for 1 hour at room temperature. For proteins extracted from potentially insect resistant transgenic rice, either rabbit anti-Cry1A antiserum (Cry1Ac proteins) or polyclonal rabbit anti-GNA antiserum (GNA proteins) was used as a primary antibody, with goat anti rabbit IgG (horseradish peroxidase-conjugated; Bio-Rad) as a second antibody at 1:10,000 dilution. Proteins were visualised by enhanced chemiluminescence (ECL; Amersham), processing and washing the membranes according to the instructions supplied with the ECL reagents.

h. Expression and purification of recombinant proteins in *E. coli*.

Total proteins were extracted from bacterial cells followed protocols described in pET system manual (Novagen). The following procedure was used for the expression of target proteins in 1000 ml culture. This can be scaled up as required. A single colony was picked, and grown up as a culture in 50 ml LB media with appropriate antibiotics added. The culture was shaken at 37°C for 4 hours. The bacteria

were harvested by centrifugation at 3,000 g for 30 minutes and then re-suspended in 2 ml of LB media. Bacteria from the “starter” culture were then transferred to 1000 ml LB media with appropriate antibiotics, and grown at 37°C with shaking, monitoring the OD at 600 nm by spectrophotometry until it reached 0.6-0.7 (approximately 3 hours). When this value had been reached, IPTG was added at 0.4 mM final concentration. The culture was then shaken at 37°C for approximately 4 hours. After that, the culture was placed on ice for 5 minutes, and the cells were harvested by centrifugation at 9,000 g for 30 minutes. The cell pellet was resuspended in 0.25 culture volume of cold 50 mM Tris HCl pH 8.0; 2 mM EDTA. The centrifugation step was repeated and pellet was then resuspended in 1/10 culture volume of cold 50 mM Tris HCl pH 8.0; 2 mM EDTA or stored at -20°C until purification. To prepare soluble and insoluble fractions, the cell culture in 1/10 culture volume of cold 50 mM Tris HCl pH 8.0 was incubated with lysozyme at a concentration of 100 µg/ml and 1/10 volume of 1% Triton X-100. The sample was incubated at 30°C for 15 minutes, sonicated and then centrifuged at 12,000 g for 15 minutes at 4°C. The supernatant that contained soluble proteins was collected for further analysis. The pellet that contained insoluble proteins was subjected to a denaturing and refolding step if required. The method of refolding of insoluble proteins employed urea or CAPS buffer in combination with N-lauroylsarcosine as denaturants (described in Protein refolding kit manual, Novagen). The proteins were then dialyzed in 10 mM Tris HCl for 3 to 4 times, at least 3 hours/each time at 4°C. The purification of target proteins was performed using a Ni affinity or Q-Sepharose column (QIAGEN) following the manufacturer’s instructions.

i. Enzyme activity measurements.

Leaf and root tissues were used for enzyme activity measurements. Samples were ground in enzyme extraction buffer (Table 2.1) at a ratio of 1 g leaf per 3 ml buffer. Polyvinylpyrrolidone (PVP; 100 mg) was added during grinding. Following centrifugation at 12,000 g for 20 min, the supernatant was used directly in enzyme activity assays. Tissue was processed immediately after harvest and all assays were performed using fresh extracts on ice. Enzyme assays were carried out as described in Lepri *et al.*, (2001).

Enzyme assays were carried out in 1.5 ml microcentrifuge tubes. A 6-mm diameter filter paper disc impregnated with 50 µl of 2N KOH and transfixed with a 3 cm needle was used to trap the ¹⁴CO₂ liberated during the reaction.

The reaction mixture for ADC activity contained 20 μl of enzyme extraction buffer (pH 8.0), 160 μl of crude enzyme and 20 μl of the substrate mix [20 μl of L-(U- ^{14}C) arginine (specific activity 297 mCi mmol^{-1} , Amersham International plc) diluted with 20 μl non-radioactive arginine (500 mM) and 60 μl of distilled water] to give a final concentration of 10 mM arginine.

Assays were carried out at 37°C for 45 min. Two hundred μl of 10% (v/v) perchloric acid (PCA) has added to stop the reaction. After a further 45 min incubation, the filter paper was placed in scintillation mini-vials with 2 ml scintillation liquid (OptiPhase Hisafe II, Fisons Chemicals) and radioactivity was measured in a Wallac 1219 Rackbeta liquid scintillation counter. One nKat of ADC activity was defined as the amount (μmol) of $^{14}\text{CO}_2$ released per min and per mg (nKat mg^{-1}) of protein. The protein was measured using a standard Bradford assay (Bradford, 1976).

j. Polyamine analysis.

Crude extracts from leaves, roots and seeds were dansylated and separated by thin layer chromatography as described in Capell *et al.*, (1998).

1. Crude extraction

Plant tissues (leaves, roots and seeds) were homogenized in 5% chilled perchloric acid (PCA) at a ratio of 1 g tissue per 3 ml buffer. The homogenates has centrifuged at 27,000 g for 20 min at 4°C and the supernatants were collected for dansylation.

2. Dansylation

Saturated sodium carbonate (100 μl) was added to all samples and polyamine standards (100 μl). 200 μl of dansylchloride (5 mg ml^{-1}) in acetone was then added to the mixture. Dansylation was carried out overnight at RT in the dark. The reaction was stopped by adding 50 μl of proline (100 mg/ml) and incubating 30 min in the dark. Dansyl-polyamines were extracted using 250 μl of toluene and vortexed for 30 sec. The supernatants were collected for thin layer chromatography (TLC).

3. Thin Layer Chromatography

The dansyl-polyamines were separated on high-resolution silica gel TLC plates (Whatman LK6DF) for 90 min and developed using chloroform:triethylamine (4:1 v/v).

The dansyl-polyamine bands were identified on the basis of their Rf values after visualisation under UV light (312 nm) and comparison to the dansylated polyamine standards. The image of the chromatogram was captured and analysed by Quantity One (Quantification Software; Bio-Rad). The relative amount of dansyl-polyamines in each sample was determined by calculating the integrated optical density of the bands compared to the integrated optical density of the appropriate dilution of the dansylated control samples. Results were expressed as nmol g⁻¹ fwt (nmol per gram of fresh weight).

k. Insect bioassay analysis.

The toxicity of recombinant proteins towards rice brown planthopper (*Nilaparvata lugens*) was assayed by feeding in a liquid artificial diet, as described by Powell *et al.*, (1993). Briefly, recombinant proteins were incorporated into MMD1 liquid diet at a concentration of 1 mg ml⁻¹, and filter-sterilised. Insect feeding chambers were set up containing 10 third instar hoppers, and 100 ml of diet separated by a parafilm membrane; diet was changed every second day. Insect survival, in comparison to controls, containing diet with no added protein, was recorded daily.

For BPH insect bioassay analysis on transgenic plants, insects were released onto 20-day-old rice plants (10 neonates per plant), individually confined within insect-proof fine-mesh nylon cages to prevent migration of insects between plants. Ten replicates were set up for each transgenic line and the non-transformed control plants. The number of live insects was monitored for 2 days after release onto the plants (recorded as day 0) and thereafter every two days throughout the trial period.

l. Statistical analysis.

For polyamine and enzyme analyses, all measurements were based on three replicate samples from six independent control plants (wild type, n=6) and six *hpt*-transformed transgenic plants (n=6). Hygromycin-resistant transformants and wild-type controls were not significantly different ($P > 0.05$) in terms of enzyme activity and polyamine levels in any of the tissues analyzed (Lepri *et al.* 2002). The data were analyzed by one way analysis of variance followed by t-test using the Residual Mean Square in the ANOVA as the estimate of variability. Toxicity of recombinant proteins in the insect bioassay and insect survival on rice plants were examined by survival analysis, using the Kaplan-Meier (logrank) method (Statview software).

Table 2.1: General solutions

Stock	Components
20X SSC	3 M NaCl, 0.3 M sodium citrate, pH 7.0
20%SDS	20 g sodium dodecyl sulphate (SDS) in 100 ml water.
10X TBE	0.9 M Tris, 0.9 M boric acid, 0.02 M EDTA, pH 8,0
5M MOPS	0.2 M 3-[N-morpholino]-2-hydroxypropanesulfonic acid (MOPS), 50 mM sodium acetate, 10 mM EDTA, pH 8.0
CTAB buffer	20 g cetyltrimethyl-ammonium bromide (CTAB), 82 g NaCl, 20 mM EDTA, 0.1 M Tris-HCl, pH 8.0 in 1 litre.
DNA extraction buffer	20% SDS, 0.5 M NaCl, 50 mM EDTA, 0.1 M Tris-HCl, pH 8.0
Denaturation solution	0.5 N NaOH, 1.5 M NaCl
Neutralization sol.	0.5 M Tris-HCl (pH 7.5), 3 M NaCl
Alkaline probe-stripping solution	0.2 N NaOH, 0.1% SDS
Northern stripping solution	50% formamide, 5% SDS, and 50 mM Tris-HCl, pH 7.5
Enzyme extraction buffer	0.1 M Tris pH 7.5, 2 mM DTT
6X DNA loading dye	0.25% bromophenol blue, 0.25% xylen cyanol FF, 30% glycerol in water.
Protein extraction buffer	50 mM Tris HCl, pH 9.5+ 1% PMSF
2X protein loading buffer	100 mM Tris HCl pH 6.8, 200 mM DTT, 4% SDS, 0.2% bromophenol blue
SDS-PAGE buffer	25 mM Tris HCl, 250 mM Glycine, 0.1% SDS
Semi-dry transfer buffer	25 mM Tris base, 150 mM glycine, 10% (v/v) methanol
TBS-Tween buffer	20 mM Tris HCl, 500 mM NaCl, 0.05% (v/v) Tween 20 pH 7.5
Blocking buffer	5% non-fat dry milk in TBS-Tween buffer
Coomassie staining solution	0.05% (w/v) Coomassie Brilliant Blue, 40% (v/v) ethanol, 10%(v/v) glacial acetic acid, 50% (v/v) water
Destaining solution	40% v/v ethanol, 10% (v/v) glacial acetic acid, 50% water
Ponceau S staining solution	0.5% (w/v) Ponceau S, 1% (v/v) glacial acetic acid

Table 2.1 (cont)

OLB buffer	Solution O: 1.25 M Tris HCl, 0.125 M MgCl ₂ Solution A: 1 ml of solution O + 18 µl 2-mercaptoethanol + 5 µl of 0.1M dATP + 5 µl 0.1 M dGTP + 5 µl of 0.1 M dTTP Solution B: 2M HEPES Solution C: Hexadeoxyribonucleotides in TE at 90 OD units/ml Mix A:B:C in the ratio of 100:250:150 to make OLB buffer
1X Denhardt's solution	0.02% Ficoll 400, 0.02% PVP, 0.02% BSA

Table 2.2: Experimental plasmid vectors

Experimental vector	Discription
PJIT 60	Cloning vector for plant transformation containing double 35S promoters and the CaMV terminator.
PAL 76	Cloning vector for plant transformation containing the maize ubiquitin-1 promoter and the noaline synthase (nos) terminator
PCR 2.1	Commercial cloning vector containing Lac Z, Ampicillin and Kanamycin resistant genes
PET 11a	Commercial cloning vector containing ampicillin resistant gene, product of Novagen.
PET 24b	Commercial cloning vector containing kanamycin resistant gene, product of Novagen.
PBlueScript(+/-)	Commercial cloning vector containing ampicillin resistant gene, product of Stratagene.
PWRG1515	Plant transformation vector carrying the hygromycin gene driven by the CaMV 35S promoter and terminated bythe nos sequence.
p35SOADC	pJIT60 based-plant transformation vector carries antisense oat ADCcDNA.
PubiRSpdSyn	pAL76 based-plant transformation vector carries rice Spd.Syn cDNA.
pUbi1stAcGNA	pAL76 based-plant transformation vector carries fusion gene of the first domain Cry1Ac and GNA.
PUBiAcRTB	pAL76 based-plant transformation vector carries fusion gene of Cry1Ac and ricin B chain.
PUBiRTRXGNA	pAL76 based-plant transformation vector carries fusion gene of rice thioredoxin h and GNA.

Table 2.3: Plant tissue culture media

Medium	Components (per litre)	Usage
MSCI	Msbasal medium, 30 g sucrose, 2.5 mg 2,4-D, 10 ml vitamin B5, 5 mg phytigel	Callus induction medium
MSCIO	MSCI added with 0.4 M mannitol and 0.4 M sorbitol	Osmotic medium
MSCIHg	MSCI with 50 mg hygromycin-B	Selection medium
MSR	MS basal medium, 30 g maltose, 10 ml vitamin B5, 2 mg BAP, 0.5 mg NAA, 50 mg hygromycin, 5 g phytigel	Regeneration medium
MSRR	1/2 MS basal medium, 10 g sucrose, 10 ml vitamin B5, 50 mg hygromycin, 2 g phytigel	Rooting medium
Vitamin B5 (100X)	1 g thiamin HCl, 0.1 g pyridoxine HCl, 0.1 g nicotinic acid, 10 g myo-inositol, 0.2 g glycine, pH 5.8	Modified from Gamborg et al.(1968)

All media were adjusted to pH 5.8 using potassium hydroxide. MS basal and phytigel were added prior to autoclaving, but the vitamin B5, phytohormones and hygromycin were added when the medium was cool down after autoclave using sterile filters in sterilised tissue culture hood.

Table 2.4: list of primers

Gene /gene fusion	Primer direction	Primer sequence (5' to 3')
Rice actin 1	Forward	ATGGCTGACGCAGAGGACAT
	Reverse	AGGAGTGGTGA CTGAGTAAC
Oat ADC	Forward	CGGCGATGTGTACCATGTTCGAGGG
	Reverse	GCGGGTGCAGCGGCATCGTCTCGG
Rice ADC	Forward	AGCGCGCTGGTGTGCGCACCA
	Reverse	TGTCGCAGGTGAGGTCGGAG
Rice ODC	Forward	GCGTTTTATGCGATTTGCGAACGG
	Reverse	CCCAGTCTAAACAAGCCGGAACCG
Rice Spd.Syn	Forward	GGATGGTTCTCCGAGATTAG
	Reverse	GATCTAGTTGGCCTTGGATC
Rice SAMDC	Forward	GGAGATCCAGCAAAGCCTGGCC
	Reverse	CCCAGGGGAGAAGATTGCCAG
Maize ubiquitin1	Forward	GATTCCCCAAAGAGAAACAC
	Reverse	TTGACAACAGGACTCTACAG
The 1 st AcGNA	Forward	ATCCGAACATCAATGAATGC
	Reverse	TTCCGTAGTTGAGAAATTCC
AcRTB	Forward	TGTTTGTATGGATCCTGAGC
	Reverse	TCTTGAACATCCATCGTTGG
TRXGNA	Forward	GCAAAGTGGTCATAATTGAC
	Reverse	TTCCGTAGTTGAGAAATTCC

Figure 2.1 : Map of plant expression plasmid vector pJIT60

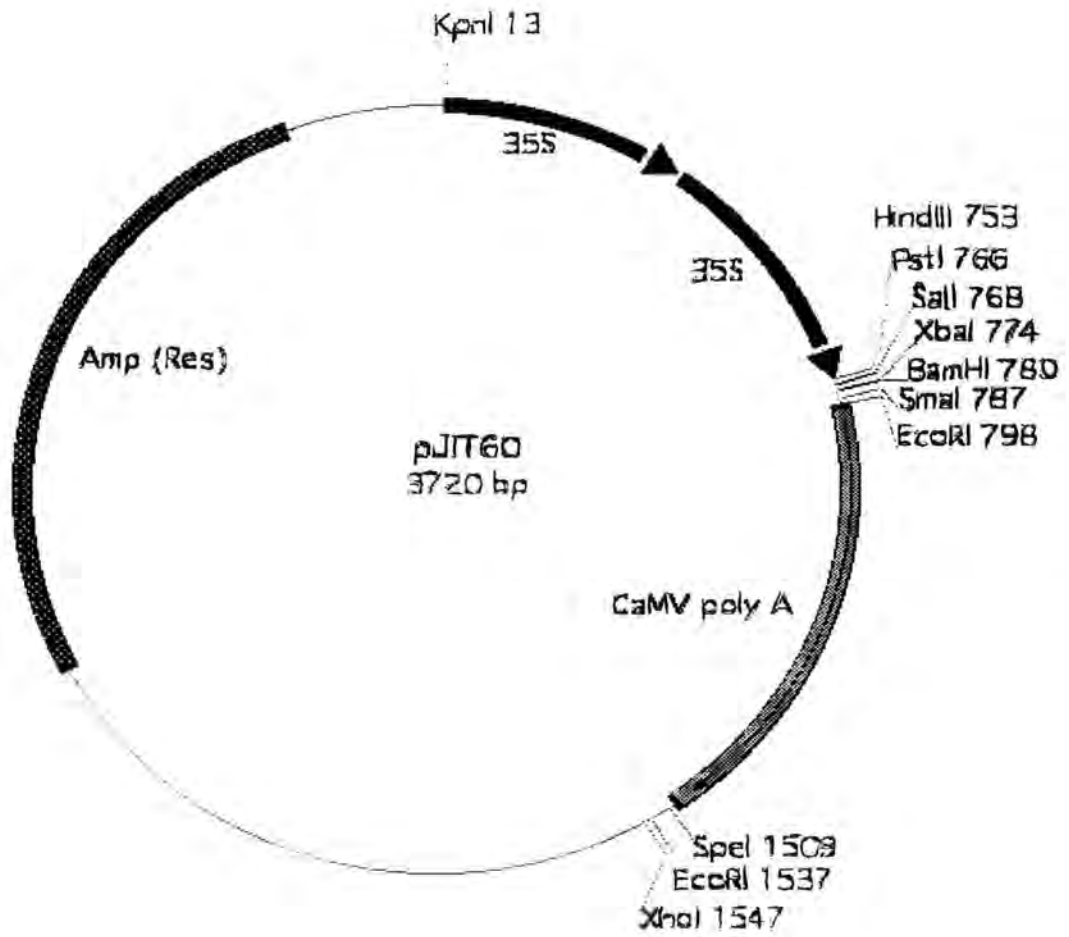

Figure 2.2: Map of plant expression plasmid vector pal 76

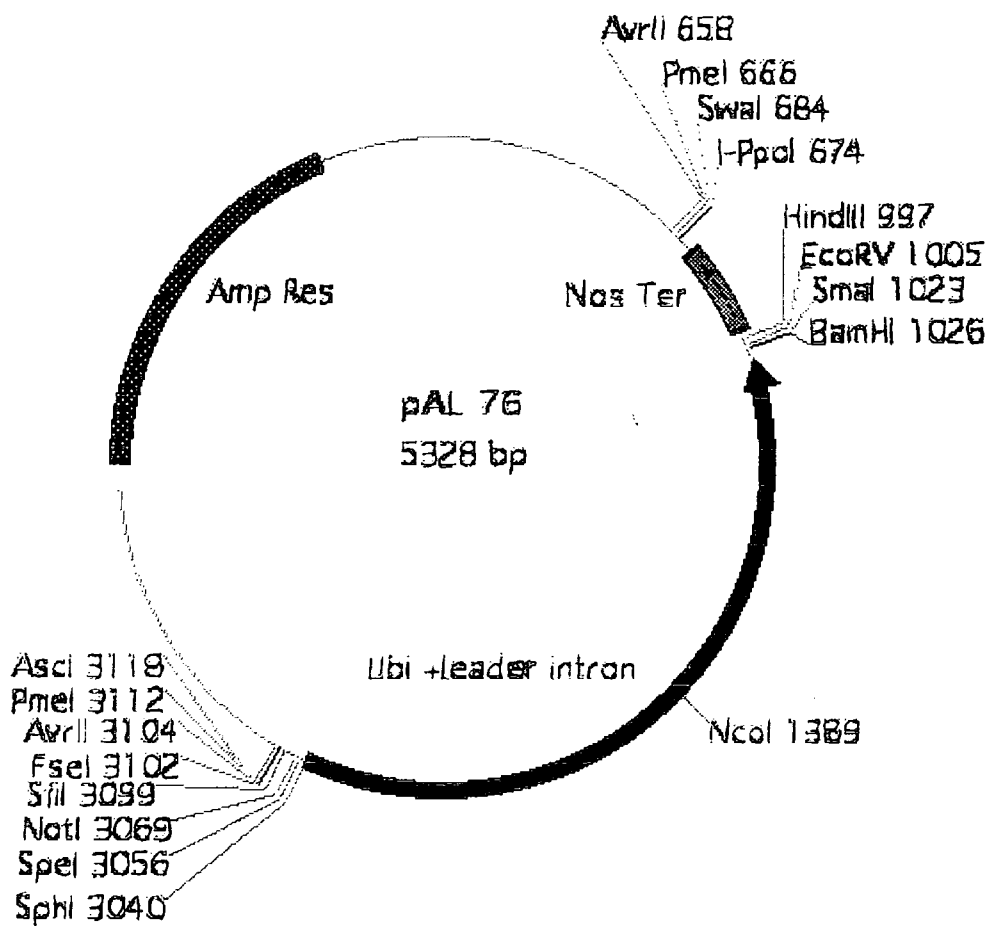
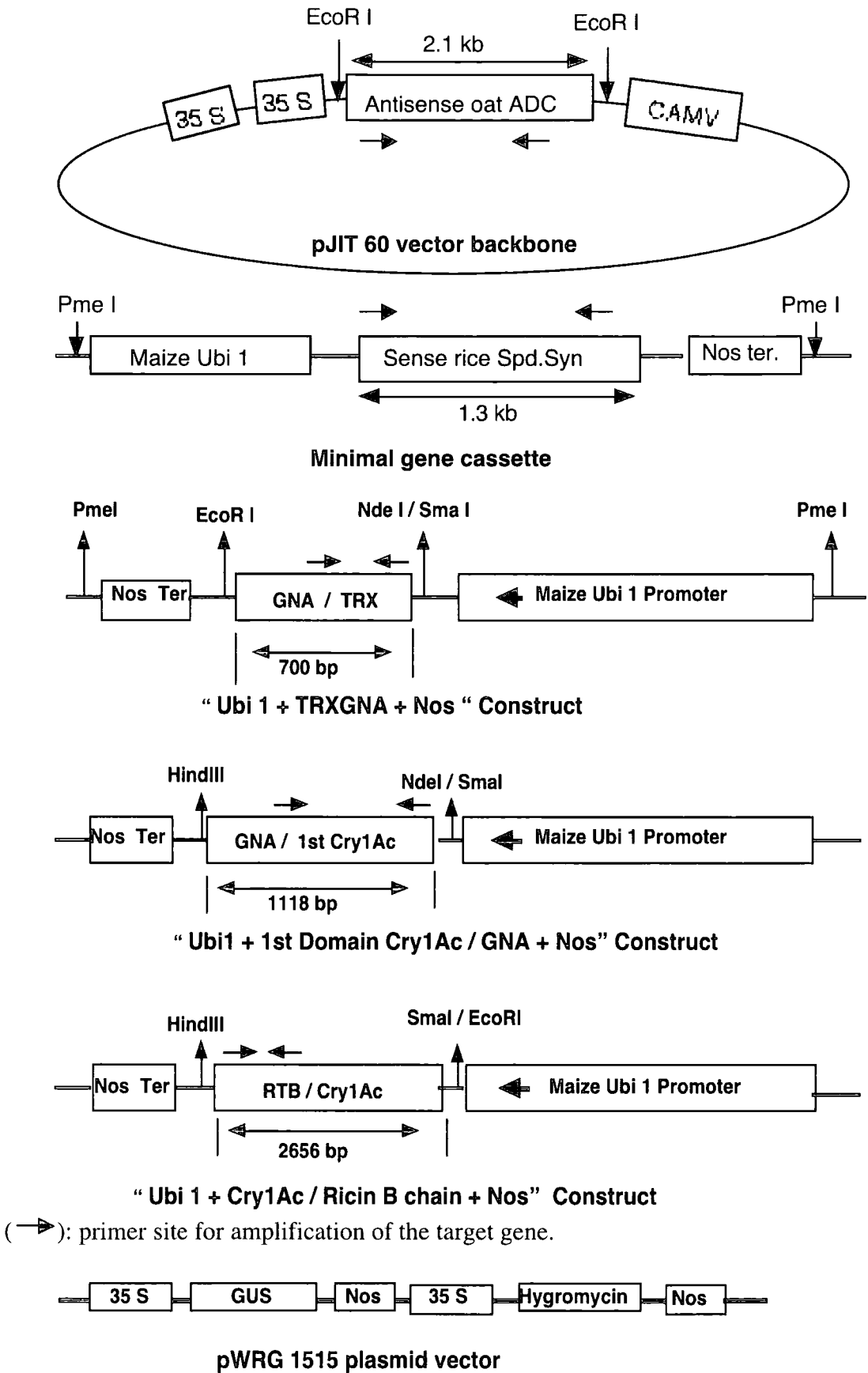

Figure 2.3: Maps of gene constructs used in rice transformation



Chapter 3**REDUCTION IN ENDOGENOUS ARGININE DECARBOXYLASE TRANSCRIPT LEVELS LEADS TO DEPLETION OF THE FREE POLYAMINE POOLS IN A TISSUE/ORGAN DEPENDENT MANNER, WITH NO CONCOMITANT CHANGES IN THE EXPRESSION OF OTHER POLYAMINE BIOSYNTHETIC GENES**

Recent progress in transgenic expression of heterologous genes for polyamine biosynthetic enzymes has provided a novel approach to confirm their developmental role in animal (Kauppinen and Alhonen, 1995). Parallel studies with transgenic plants have now been conducted in several laboratories. These studies aided in establishing specific roles for polyamines in plant development and stress responses, and also shed some light on the mechanisms of their action (Kumar and Minocha, 1998). A number of attempts have been made to manipulate the polyamine biosynthetic pathway in plants using the oat ADC cDNA. Burtin and Michael (1997) generated transgenic tobacco plants that constitutively expressed the oat ADC cDNA. These plants had 10 to 20-fold increases in ADC activity, 20 to 65-fold increases in agmatine level. However, there was no significant change in polyamine levels. Masgrau *et al.* (1997) generated transgenic tobacco plants carrying the oat ADC cDNA under the control of a tetracycline-inducible promoter. Inducible over-expression of oat ADC in transgenic tobacco led to an accumulation of ADC mRNA, increased ADC activity and changes in polyamine levels. Transformed plants displayed aberrant phenotypes whose severity was roughly proportional to the putrescine content. This suggested that over-production of putrescine might be toxic to plant development. Bassie *et al.* (2000) and Noury *et al.* (2000) observed similar results of over-production of putrescine in transgenic rice plants that transformed with the oat ADC cDNA. Those above studies likely suggested that high ADC expression could lead to higher-level production of putrescine in transgenic plants and sometimes resulted in an increase in the concentration of spermidine. With this in mind, we wonder how down regulation of ADC enzyme by an antisense ADC cDNA could affect the endogenous ADC enzyme and other polyamine biosynthetic genes? And how flux through the polyamine pathway is controlled and regulated.

This chapter describes work in which a transgenic rice population engineered to express an oat arginine decarboxylase (ADC) cDNA in the antisense orientation was produced. It also describes biochemical assays to determine whether arginine decarboxylase activity was suppressed by expression of the antisense construct, and whether effects on this first committed step of polyamine metabolism were reflected in polyamine content, and expression of other polyamine biosynthesis genes.

3.1. RESULTS

3.1.1 Molecular characterization of the transgenic population

Mature rice embryos (var. ITA212) were co-bombarded with plasmid p35SOADC, containing the oat arginine decarboxylase cDNA in an antisense orientation with respect to the CaMV 35S promoter, and plasmid pWRG 1515 containing the hygromycin phosphotransferase (*hpt*) gene as a selectable marker. Following tissue culture, selection and regeneration, 12 independent primary transformant rice plants (R0) were obtained. DNA was extracted from each of these plants and subjected to Southern blotting, using diagnostic restriction enzymes. Genomic DNAs were digested with Hind III that cut one site in the vector p35SOADC. This gave an estimated numbers of oat ADC integration sites in transgenic rice genome. Blots were probed with coding sequence for ADC, and the resulting band patterns showed that each of the primary transformants had a distinct integration pattern for the transgene (Figure 3.1). DNA samples from all transgenic plants contained a 1.5 kb Hind III fragment derived from the endogenous *adc* gene (Figure 3.1 and 3.12), but in no case was this the only fragment observed. All plants contained multiple fragments hybridising to the probe, some of which appeared to be present in multiple copies on the basis of hybridisation intensity. DNA from control wild type plants, and plants transformed with *hpt* only, showed no hybridisation under the conditions used (high stringency wash).

R1 seeds from 8 fertile R0 transgenic plants were collected for further analysis. 20 progeny plants from each of 8 R0 transgenic plants were analysed for the segregation pattern of the transgene(s) using a PCR method. Amplification of a fragment using primers specific for oat ADC was taken as evidence for transgene presence, whereas failure to amplify a band was indicative of no transgene present. In all lines, the transgene segregated

in a ratio of approximately 3:1, indicating a single transgene locus (table 3.1 and figure 3.2). Three lines, 82; 88 and 97, had an extra PCR band of smaller size when amplified with the set of primers oat ADC1 and ADC2. This lower molecular weight PCR band was purified from gel and subjected to Tag I and BamHI enzyme digestions, which cut at several different sites inside the amplified fragment of oat ADC cDNA. This analysis showed that a deletion of approximately 400bp had taken place at the 5' end of oat ADC cDNA in the integrated transgene from which this smaller PCR band had been amplified (data not shown). However, all three lines contained the expected "correct" PCR fragment, and must also have contained inserted *adc* transgenes with no deletion.

A genomic DNA gel blot analysis of 4 R1 siblings from each lineage is shown in figure 3.3. Enzyme digestions were performed using EcoRI that released a 2.1kb fragment comprising the entire coding sequence of the oat ADC cDNA. The EcoRI digest demonstrated that 6 out of the 8 lines contained an intact 2.1kb oat ADC cDNA fragment. Some lines showed lower molecular weight hybridizing bands, suggesting some kinds of internal rearrangement. Four of the lines showed extensive and complex patterns of hybridising bands, suggesting multiple insertions of the transgene, which had undergone extensive rearrangements.

3.1.2 Expression of the oat ADC transgene in R1 plants

The presence of the antisense oat ADC RNA in total RNA from transgenic rice plants was analysed by RT-PCR using the set of primers ADC1 and ADC2 (figure 3.4). The antisense RNA could be detected in all the R1 lines but two. These two lines, 93 and 95, either did not express the construct, or had very low expression levels of the antisense oat ADC RNA, since no bands could be detected on RT-PCR (figure 3.4). Three lines, 82; 88 and 97, expressed a second transcript with a lower molecular weight resulting from a truncated copy of the integrated transgene (see above). To quantitatively compare the expression level of the antisense oat ADC RNA between R1 transgenic rice lines, we performed RT-PCR reactions containing 2 sets of primers, one set for the oat ADC gene (primers ADC1 and ADC2) and other set of primers to amplify rice actin 1 mRNA, which is constitutively expressed (Actin1 and Actin2). The amplification reaction was done for 10 cycles. Amplified samples were then run on 0.8% agarose gel, blotted and hybridized with corresponding probes. Oat ADC transcripts could now be detected in lines 93 and 95,

albeit at low level. Three lines, 82, 88 and 96 showed relatively high expression levels of the antisense oat ADC RNA in the transgenic plants (figure 3.5). A northern blot analysis of total RNAs from R1 oat ADC transgenic plants showed detectable bands of antisense oat ADC transcript in only 3 lines: 82, 88 and 96 (figure 3.6). This was consistent with the result obtained from the quantitative RT-PCR analysis, as these 3 lines showed relatively high oat ADC transcript expression.

3.1.3. Expression of oat antisense ADC transcript results in reduction of ADC activity in transgenic plants.

Four R1 plants expressing the antisense oat ADC RNA were selected from each line for ADC activity measurements. A single tiller from each plant was separated and grown hydroponically in Yoshida's solution (Yoshida *et al.* 1976) to induce root growth after leaf samples had been taken for assay. Roots were harvested 2 weeks later to measure ADC activity.

The assays showed that, in leaf tissues, 50% of the lines (4 out of 8) showed up to about 30% reduction in ADC activity as compared to controls (Figure 3.7). Unexpectedly, lines 95, 97 and 93, which had low levels of expression of the antisense transgene, exhibited the most reduction in ADC activity (0.0241 ± 0.003 nKat, 0.243 ± 0.005 nKat and 0.0254 ± 0.002 nKat, $P < 0.005$, respectively). On the other hand, lines 82 and 88, that showed ADC transcript bands in northern blot analysis, exhibited less reduction of ADC activity in leaves. When ADC activity was measured in roots, a significant reduction ($P < 0.001$) was detected in all of the lines analyzed (Figure 3.7). Approximately 50% reduction in ADC activity was detected in lines 82, 88, 93 and 96 (0.016 ± 0.0004 nKat, 0.015 ± 0.0009 nKat, 0.014 ± 0.0006 nKat, 0.014 ± 0.0001 nKat respectively). We also measured ornithine decarboxylase activity simultaneously with ADC and no significant variation in this activity was detected in any of the lines, compared to appropriate controls (data was not shown).

3.1.4. Levels of polyamine accumulation in R1 transgenic rice plants vary in a tissue/organ dependent manner

Determination of free polyamines in leaves and roots was carried out at the same time on the same 4 selected plants as ADC activity measurements in leaves and roots. For

seeds, polyamine measurement was carried out after drying of mature seeds for three days. Free polyamines levels were found to be variable within different lines and different tissues/organs. In leaves, we observed only 4 lines (93, 95, 96 and 97) that showed a reduction in putrescine content as compared to wild type plant, with reductions up to 30% observed (284.62 ± 38.03 nmol g⁻¹fwt; 314.33 ± 28.48 nmol g⁻¹fwt; 346.09 ± 45.11 nmol g⁻¹ fwt and 322.31 ± 25.67 nmol g⁻¹fgw, $P < 0.001$ as compared to wild-type plant 423.38 ± 18.43 nmol g⁻¹fwt). The reduction of putrescine level also affected spermidine accumulation in leaves, with a reduction of upto 60% observed in line 93 (138.59 ± 7.77 nmol g⁻¹fwt) as compared to wild-type plant (372.12 ± 12.88 nmol g⁻¹fwt). However, there was no significant variation in spermine levels observed in these transgenic rice lines (Figure 3.8).

In roots, putrescine level was reduced in all the transgenic rice lines, with up to approx. 55% reduction in line 93 (133.67 ± 12.55 nmol g⁻¹fwt, $P < 0.001$) as compared to wild-type control (301.58 ± 3.10 nmol g⁻¹fwt). Five lines, 88; 93; 95, 96 and 97, showed reduction in spermidine and spermine levels. A maximum reduction in spermidine (approx. 70%) was observed in line 93 (53.44 ± 0.98 nmol g⁻¹fwt, $P < 0.001$) and a minimum reduction (approx. 35%) in line 84 (120.36 ± 9.22 nmol g⁻¹fwt, $P < 0.001$) compared to wild-type plants (185.25 ± 5.40 nmol g⁻¹fwt). Line 93 showed maximum reduction (approx. 55%) in spermine (64.11 ± 1.56 nmol g⁻¹fwt, $P < 0.001$) as compared to wild-type plant (138.08 ± 7.06 nmol g⁻¹fwt) (Figure 3.9).

In seeds, we observed 5 lines having reduced putrescine contents, with up to 50% reduction in putrescine levels in lines 96 and 93 (57.37 ± 2.81 nmol g⁻¹fwt and 64.51 ± 2.85 nmol g⁻¹fwt, $P < 0.001$ respectively as compared to wild-type plant, 109.47 ± 5.33 nmol g⁻¹fwt) (Figure 3.10). Four lines, 92, 93, 95 and 96: showed reduction in spermidine levels. However, no significant reduction in spermine levels between oat ADC transgenic rice and wild-type plants was observed.

3.1.5. Expression of the oat ADC antisense transcript in rice only affects expression of its rice homologue

The expression of endogenous rice genes involved in polyamine biosynthesis in transgenic rice plants containing the antisense oat ADC construct was assayed by northern blotting. A rice ADC sequence of 200 bp (accession no. C99671) was used as a probe to

investigate expression of the endogenous rice ADC gene. Similarly, expression of ornithine decarboxylase (ODC) was assayed using a 288 bp rice ODC probe based on the published rice ODC EST sequence (BE040058), and probes derived from the rice spermidine synthase (Spd. Syn; AJ251298) and rice S-adenosylmethionine decarboxylase (SAMDC; Y07766) were used to detect corresponding rice mRNAs expressed in transgenic and wild-type plants. An equal amount of 50 µg of total RNAs for all samples was loaded on each RNA gel and the membranes were re-probed one time with different probes. Levels of rice ADC transcripts were reduced in all transgenic rice lines relative to wild type plant (Figure 3.11). Significant reduction was seen in lines 93, 96 and 95. The levels of rice ODC, SAMDC and Spd.Syn transcripts in oat ADC transgenic plants remained unchanged as compared to wild-type plants (Figure 3.11).

To confirm that the antisense effect that down-regulated the endogenous ADC transcript levels in rice was due to the homology between oat and rice ADC sequences, genomic DNAs from oat and non-transformed rice were digested with EcoR I and Hind III, and hybridised at moderate stringency to the 1.5 Kb DIG-labelled oat ADC probe (section 3.1.1). The blot showed visible hybridizing bands in EcoR I and Hind III digested rice genomes, showing that the oat ADC probe had hybridised to the endogenous rice gene(s) under these conditions (Figure 3.12).

3.2. DISCUSSION

3.2.1. *Integration of the oat antisense ADC cDNA in rice genome results in a reduction of the steady state rice ADC mRNA with no concomitant changes in the expression of other polyamine genes*

Molecular analysis of the transformed plants (Figure 3.1 and 3.3) showed that the oat ADC was stably integrated into the rice genome and was transmitted to progeny as a dominant Mendelian trait, consistent with its integration in a single genetic locus. RT-PCR analysis showed oat antisense mRNA expression in all the eight lines we analyzed (Figure 3.5). A considerable variation in the degree of oat ADC expression was observed among lines. We could only visualize oat ADC mRNA bands in lines 93 and 95 by quantitative RT-PCR (Figure 3.4 and 3.5). Three lines 82, 88 and 97 that contained a truncated oat ADC copy expressed two mRNA transcripts, one of which was shorter than the expected size. This RNA profile was detected in roots and tillers as well (data not shown). In plants,

gene silencing by antisense and sense methods have been widely used to elucidate gene function, to enhance the quality of plant products, alter flower colour, create new novel traits, viral disease resistance (reviewed by Senior and Dale, 1996). Kumar *et al.*, (1996) modulated enzymes involved in the polyamine pathway by down-regulating a potato S-adenosylmethionine decarboxylase (SAMDC) gene using a homologous transgene in antisense orientation. Engineered potato plants exhibited an abnormal phenotype that was correlated with altered levels of the SAMDC transcript, SAMDC activity and polyamine content. However, the authors did not measure whether or not transgene expression could affect the expression of other genes involving in polyamine pathways. In the current investigation, we down-regulated the expression of rice ADC gene by using its full-length oat ortholog in antisense orientation (Figure 3.11). The alignment of the oat ADC sequence (X56820) to the rice putative ADC (C99671), rice ODC EST (BE040058), rice Spd.Syn (AJ251298), rice SAMDC (Y07766) sequences showed that the oat and rice ADCs share a high sequence homology of 71% identity, but not to the other polyamine genes (<http://www2.ebi.ac.uk/clustalW>, data not shown) as confirmed by the southern blot analysis (Figure 3.12). Genomic DNAs of two different genotypes: EYI and ITA, when probed with oat ADC probe and washed with less stringency (65°C), showed up the hybridized band of about 1.5 kb. This provides adequate levels of homology between the two species for the antisense effect to occur in the antisense oat ADC transgenic rices. In general, we found that all the transgenic rice plants had a reduction in the rice ADC mRNA levels in leaves as compared to wild type control plants (Figure 3.11). However, there is no tight negative correlation between the expression levels of oat antisense mRNAs and the steady state levels of rice ADC mRNAs. Lines 93 and 95, that showed very low levels of oat ADC antisense RNA, had a large reduction in rice ADC transcripts, whereas line 82, which had a high level of oat ADC antisense RNA, showed only a small reduction in rice ADC levels (Figures 3.5 and 3.11). The reduction in ADC enzyme activity (Figure 3.7) showed a better correlation with the levels of rice ADC mRNAs (Figure 3.11).

A goal of this investigation was to evaluate whether rice ODC, SAMDC or Spd.Syn transcripts were influenced by the size of the free polyamine pool in transgenic rice plants. The results showed that the steady-state mRNAs for the other endogenous polyamine genes remained unaffected by the presence of the oat ADC antisense RNA (Figure 3.11). This suggests that feedback regulation of the expression of the genes by

polyamines is not a major regulatory mechanism. Thu Hang *et al.* (2002) observed no changes in the endogenous SAMDC and Spd.Syn mRNAs in the transgenic rice plants with a 2.5-fold increase in foliar spermidine as a result of expression of the *Datura* SAMDC transgene. These results indicate that tight regulation at the level of mRNA expression of the genes involved in the polyamine pathway is not overcome by alteration of the size of the free polyamine pool.

3.2.2. Levels of ADC activity and free polyamines in the transgenic population vary in a tissue/organ-dependent manner.

The cauliflower mosaic virus (CaMV) 35S promoter has been shown to be highly active in most plant organs and during most stages of development when integrated into the genome of transgenic plants (Odell *et al.*, 1985; Jefferson *et al.*, 1987). Battra and Hall (1990) measured GUS activity driven by CaMV 35S promoter in rice transgenic plants. They detected GUS activity in the embryo and endosperm of seed, in leaf epidermis, mesophyll and vascular bundle, and in the cortex and vascular cylinder of the root. To our knowledge, there is no study has been reported on the degree of tissue specific activity of CaMV 35S promoter in various tissues/organs of plant due to limitations caused by differences in cell size, metabolic activity and substrate accessibility to various cell types between different plant tissues/organs. Therefore, we assumed the use of constitutive CaMV 35S promoter did not target expression of antisense ADC gene in any specific tissues/organs, leading to biased interpretations on transgene expression and regulation.

In leaf tissues only four out of eight transgenic lines showed reduction in ADC activity greater than 30% relative to control untransformed plants. However, a significant reduction in ADC activity in roots was detected in all eight lines (Figure 3.7). Reduction in ADC activity resulted in lower levels of free polyamine pool in leaves, roots and seeds of R1 transgenic rice population. Levels of putrescine and spermidine were reduced only in four lines but no variation in spermine level was observed (Figure 3.8). Levels of putrescine and spermidine in roots were reduced in all eight lines (Figure 3.9). Lines 93 and 97 had also a significant reduction in spermine levels in roots. In seeds, reduction of putrescine, spermidine and spermine levels were also detectable (Figure 3.10). Chattopadhyay *et al.*, (1997), who investigated the role of polyamines in abiotic-stress tolerance in plants, showed that the regulation of ADC in root tissue is not as tight as in

leaves. Watson *et al.*, (1998) described an *Arabidopsis thaliana* mutant that exhibited lower ADC activity in leaves and roots, with putrescine concentration decreased only in roots. Lepri *et al.*, (2001) transformed human ODC cDNA that was under the control of maize ubiquitin promoter into rice plant. They reported a hierarchical accumulation of ODC enzyme activity and polyamines in different tissues/organs in transgenic rices, and suggested that the pathway is regulated in a tissue- specific manner. As a different constitutive promoter has been used and similar results observed, we strongly believed that a tissue-specific regulation of ADC enzyme activity and polyamine levels in transgenic plants is not biased by the use of CaMV 35S, a constitutive promoter, that controlling antisense ADC gene. Therefore, the data presented here, and also the studies of Chattopadhyay *et al.*, (1997), Watson *et al.*, (1998) and Lepri *et al.* (2001) strongly suggest that regulation of ADC activity and the free polyamine pool differs between different tissues/organs. This means root and seed tissues showed a lot more plasticity in terms of polyamine changes as a result of altered expression of polyamine genes in transgenic plants. It is interesting that spermine levels remained unchanged in leaves of all transgenic plants, despite declines in the levels of putrescine and spermidine. Two possible explanations for this result are: (1) a highly metabolically active tissue (eg leaf tissue) requires tighter regulation of cellular spermine metabolism; or (2) the depletion of putrescine or particularly of spermidine is not serious enough to cause a decrease in spermine level, which is low in leaf tissues as compared to putrescine or spermidine levels. This finding is consistent with the results obtained by Bassie *et al.*, (2000) and Noury *et al.*, (2000).

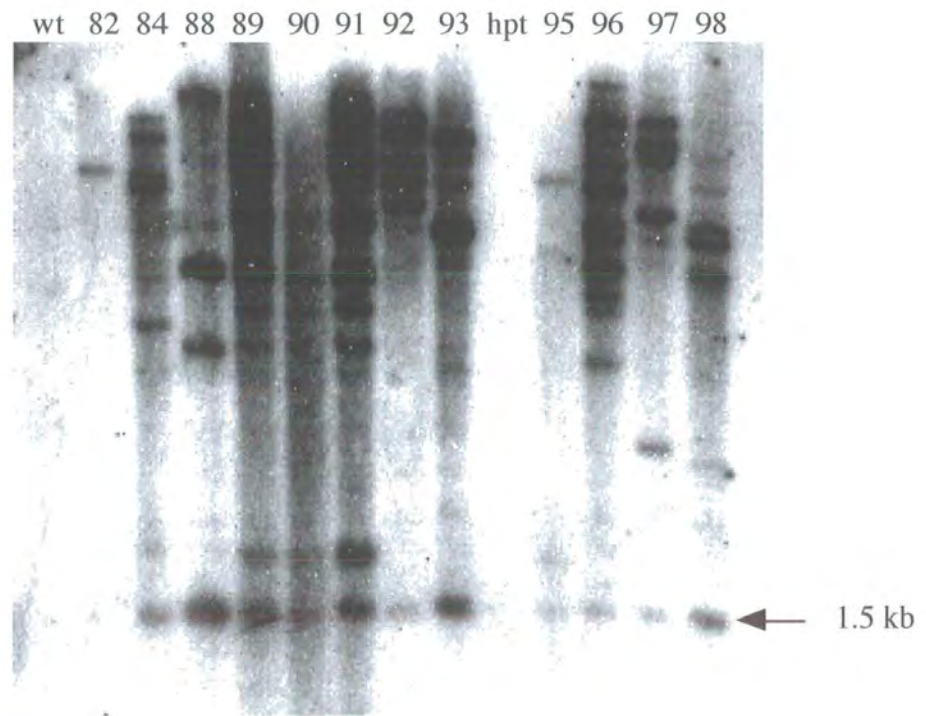

Figure 3.1: Southern blot analysis of R0 oat antisense ADC transgenic rice plants, digested with HindIII, and blot was hybridized with oat ADC probe (DIG labelled probe). Bands at 1.5kb are endogenous rice ADC gene that cross-hybridized with the oat ADC probe..

Table 3.1: Inheritance analysis of R1 plants of oat antisense ADC transgenic rices using PCR method.

<u>No.</u>	<u>Clone</u>	<u>PCR positive/total</u>	<u>expected ratio</u>	<u>PCR band</u>
1	82	11/20	3 :1	2
2	84	12/18	3 :1	1
3	88	11/15	3 :1	2
4	92	14/20	3 :1	1
5	93	12/19	3 :1	1
6	95	14/20	3 :1	1
7	96	13/20	3 :1	1
8	97	14/20	3 :1	2



Figure 3.2: PCR analysis of R1 oat antisense ADC transgenic rice plants, clone No. 92.

M: 1Kb DNA ladder marker

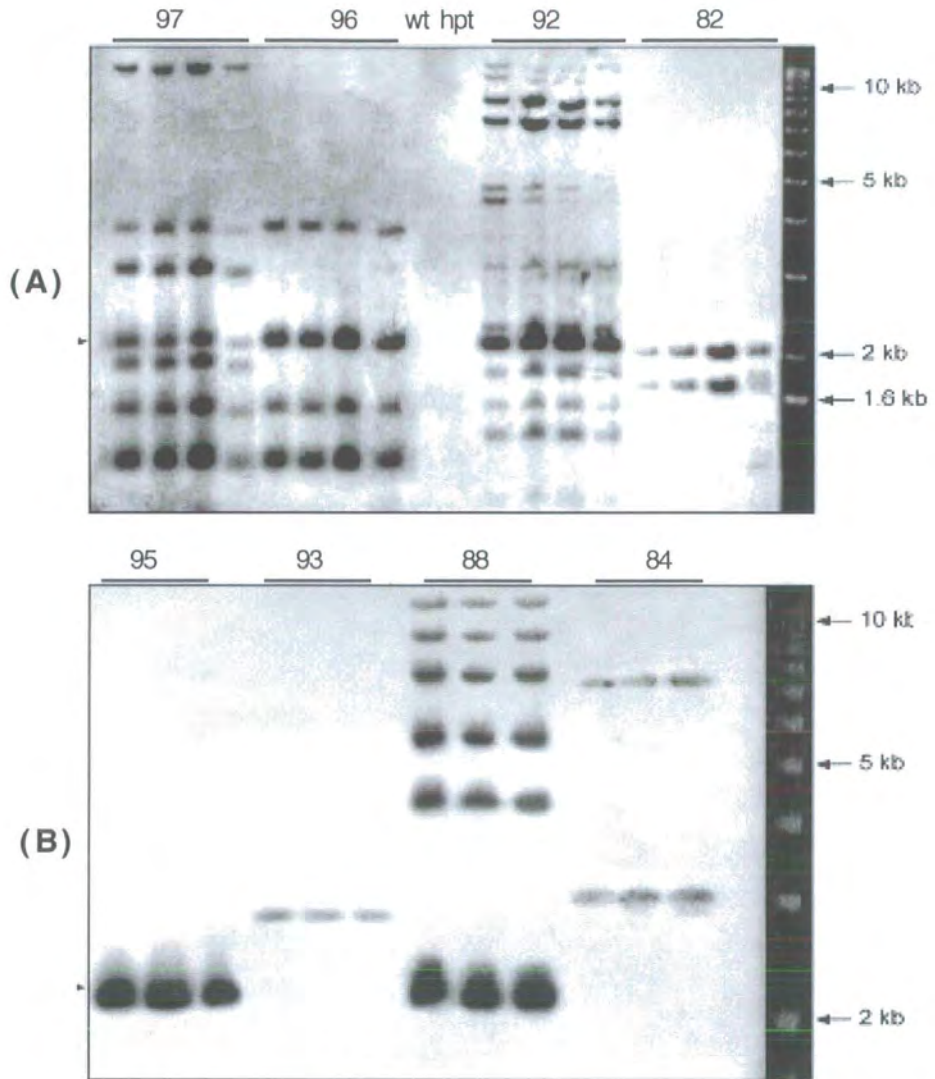

Figure 3.3 : Southern blot analysis of R1 oat antisense transgenic rice plants, digested with *EcoRI* and hybridized with oat ADC probe. (A): siblings of lines 82, 92, 96, 97, hpt (hygromycin resistant plant) and wt (wild type plant). (B) : siblings of lines 84, 88, 93 and 95

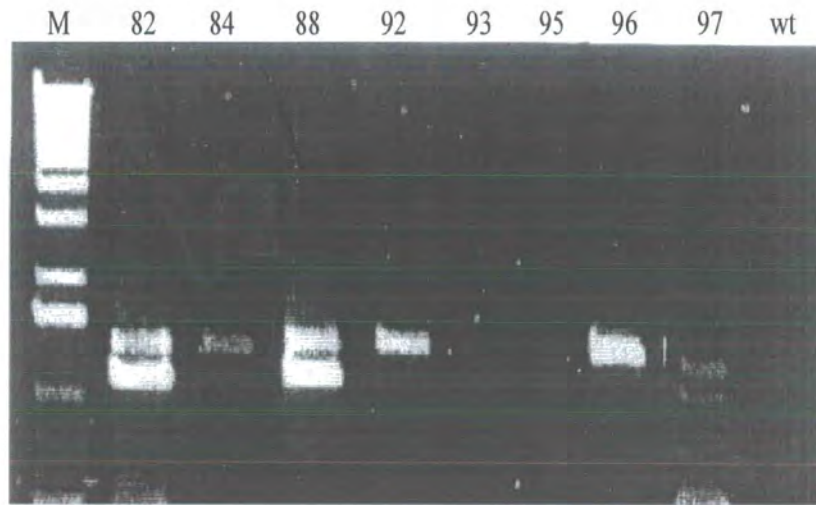

Figure 3.4: RT-PCR analysis for the expression of oat antisense ADC cDNA in selected R1 PCR positive transgenic rice plants.

(M) : 1 kb DNA ladder marker

(wt) : wild type control plant

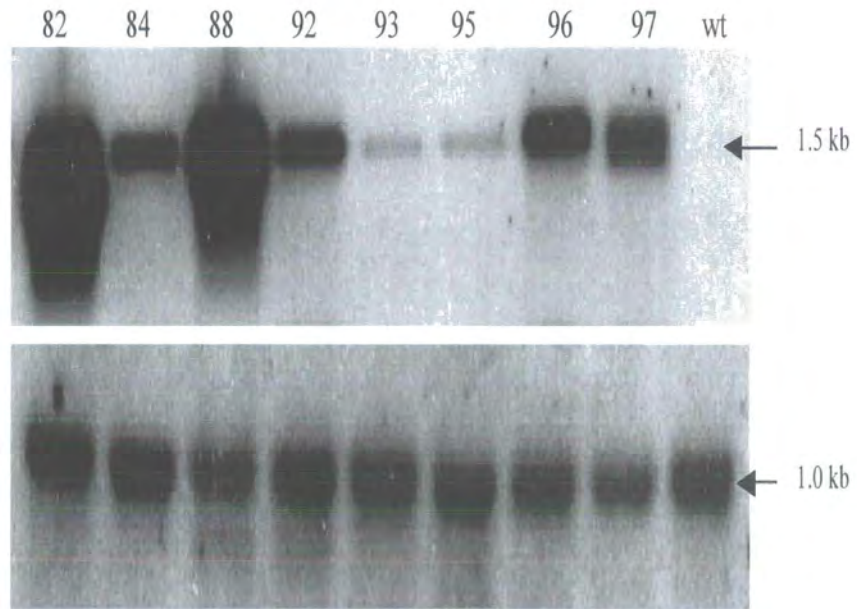

Figure 3.5: Relative quantitative RT-PCR analysis of oat antisense ADC transcripts expressed in R1 transgenic rice plants. The upper panel showed oat ADC expression. The lower panel showed constitutive expression of rice actin 1 transcript as a positive control

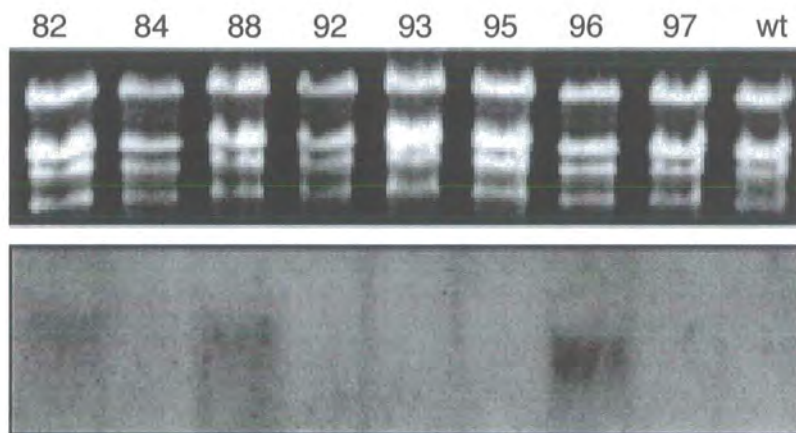

Figure 3.6 : Northern blot analysis of total RNAs of R1 oat antisense ADC transgenic rice plants. The upper panel was rRNAs bands. . The lower panel was RNA blot hybridized with oat ADC probe

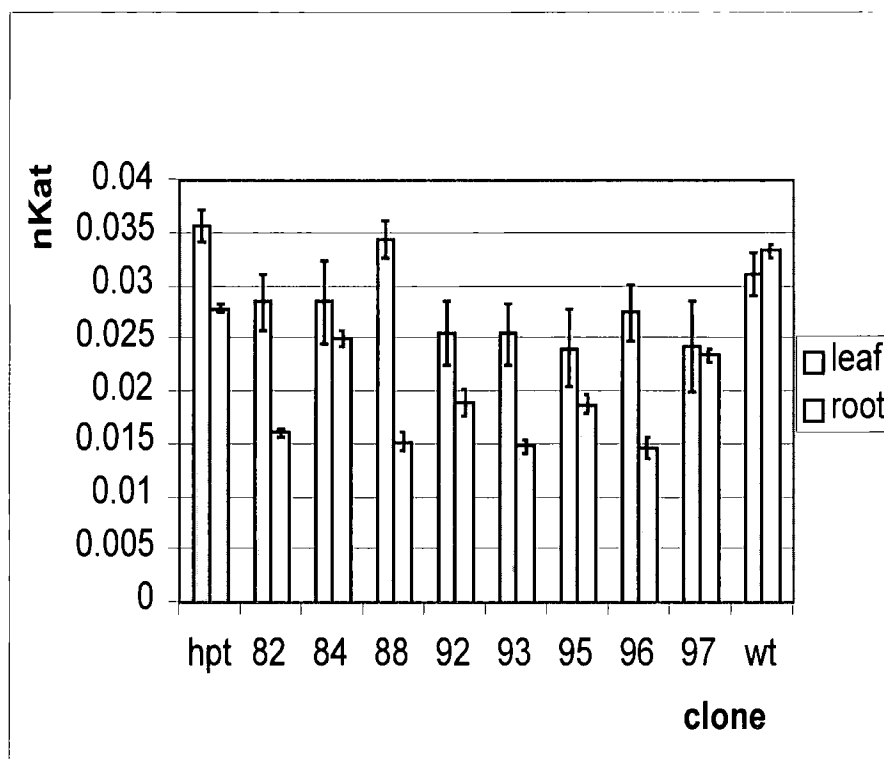

Figure 3.7: ADC enzyme activity measurement in leaf and root tissues of R1 oat antisense ADC transgenic rice plants.

hpt: hygromycin resistant plant

wt : wild type plant

1 nKat = $1 \text{ nmol s}^{-1} \text{ g}^{-1} \text{ fwt}$

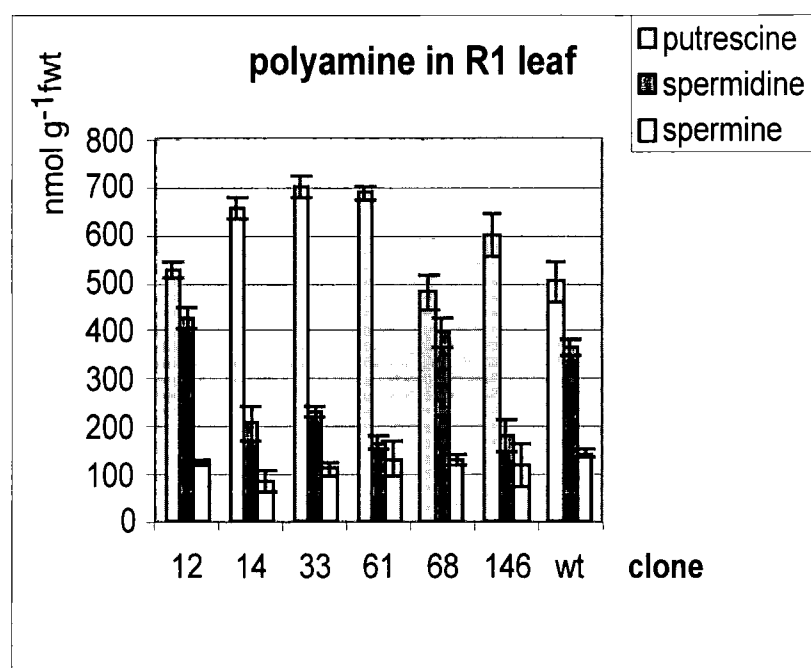

Figure 3.8: Polyamine levels in leaves of R1 oat antisense ADC transgenic rice plants.

(wt) : wild type plant.

nmol g⁻¹ fwt : nmol per gram of fresh weight

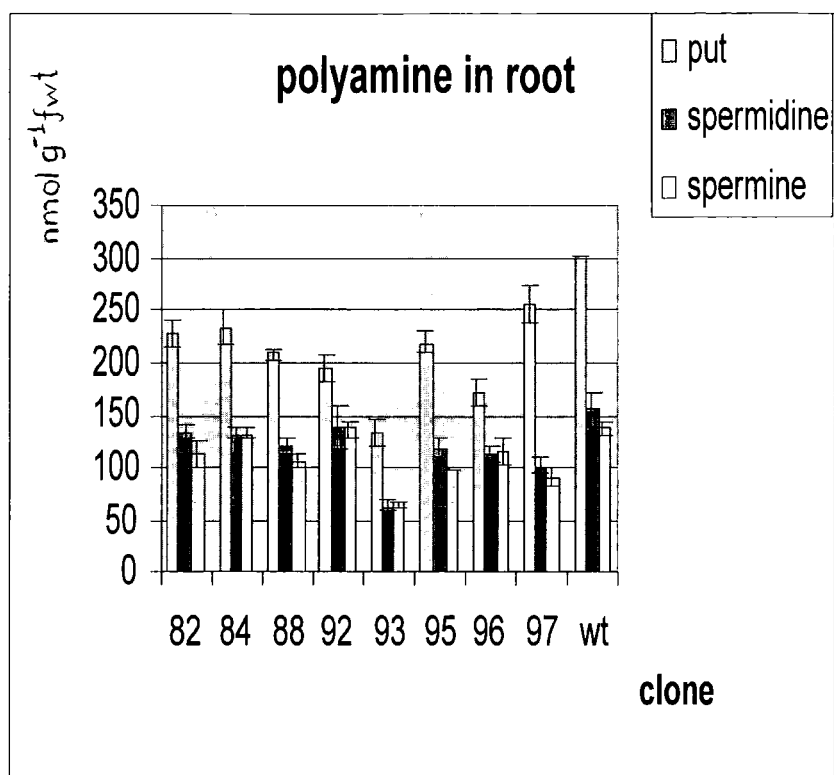

Figure 3.9: Polyamine levels in roots of R1 oat antisense ADC transgenic rice plants.

(wt) : wild type plant.

nmol g⁻¹fwt : nmol per gram of fresh weight

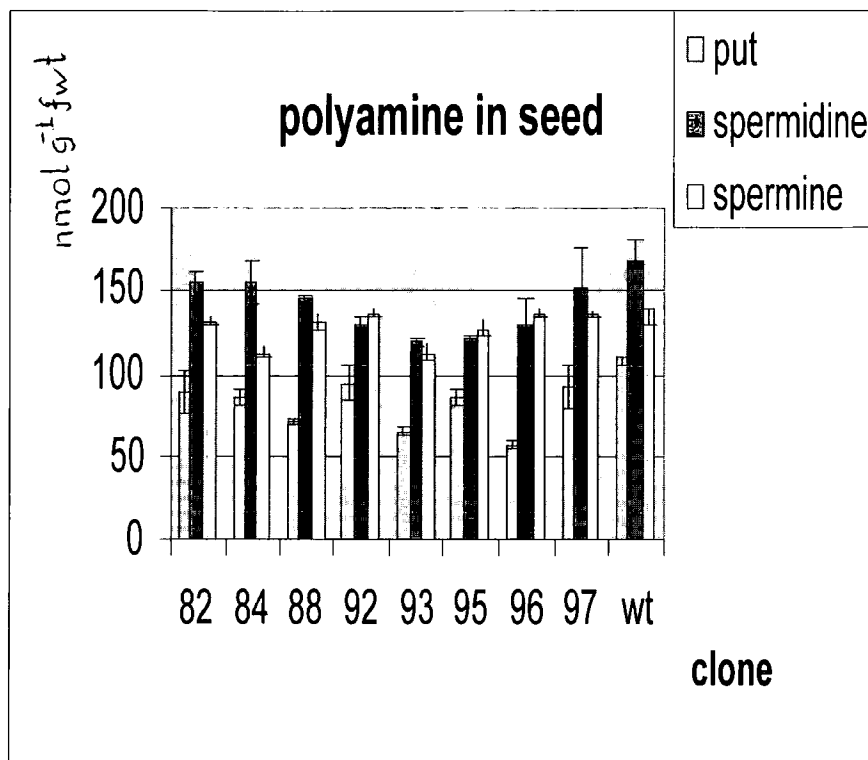

Figure 3.10: Polyamine levels in seeds of R1 oat antisense ADC transgenic rice plants.

(wt) : wild type plant.

nmol g⁻¹fwt= nmol per gram of fresh weight

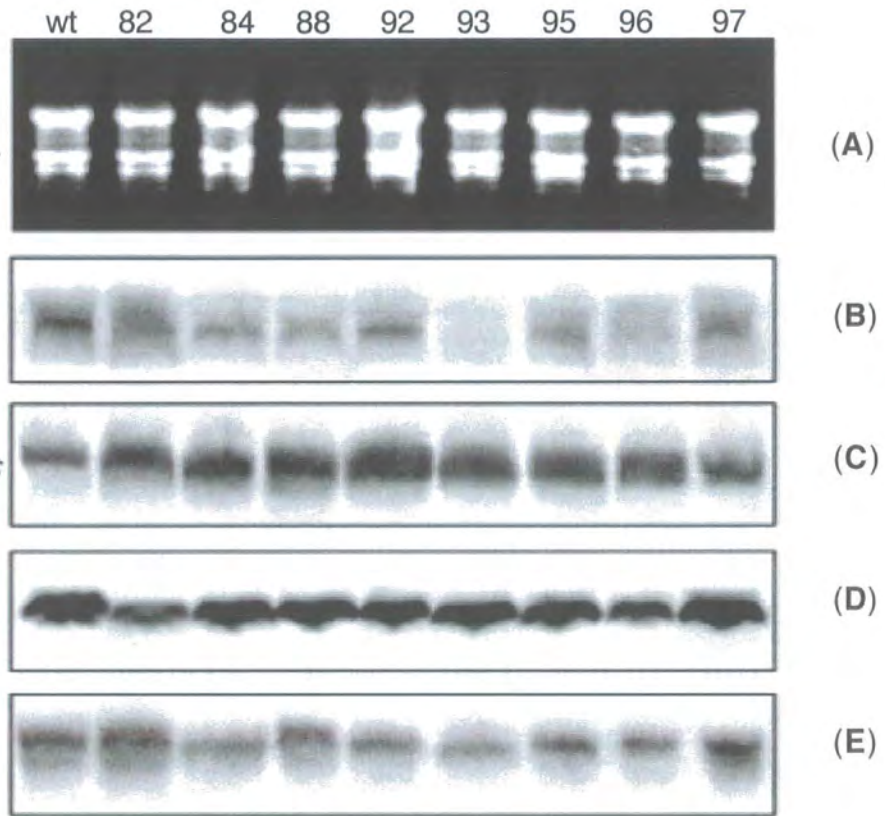

Figure 3.11: Northern blot analysis for total RNAs of R1 oat antisense ADC transgenic rice plants, hybridized with : (B) rice ADC probe; (C) rice ODC probe; (D) rice SAMDC probe and (E) rice SpdSyn probe. The panel (A) showed bands of rRNAs

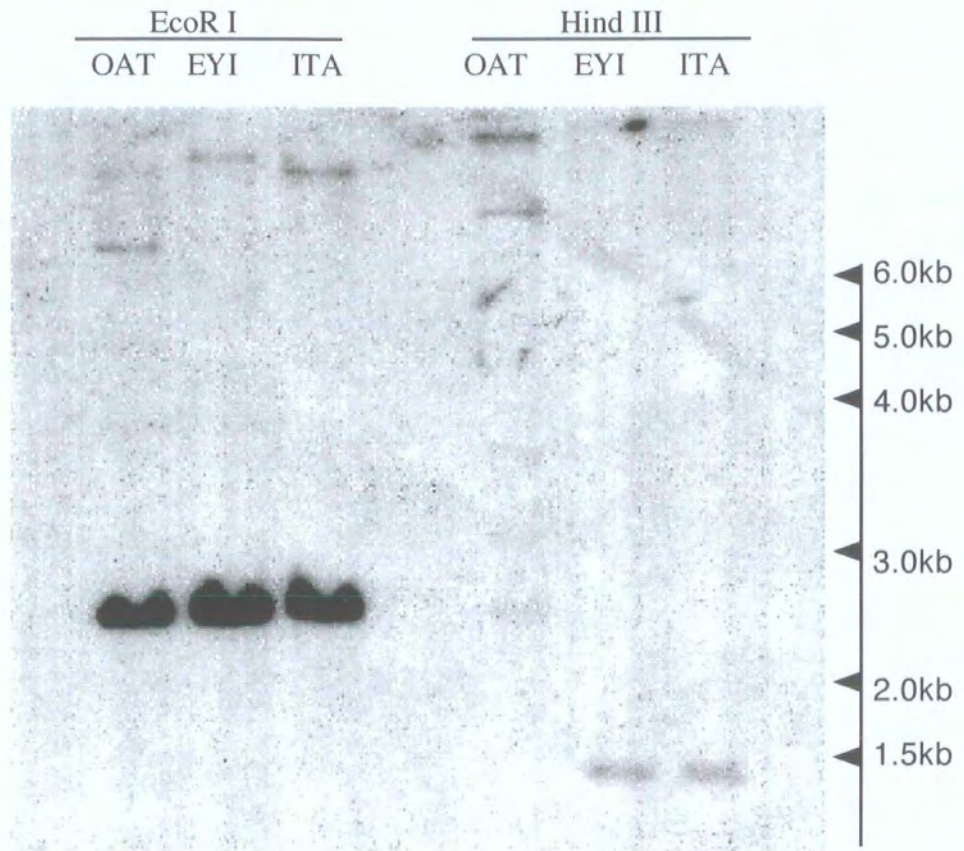

Figure 3.12: Southern blot analysis of EcoR I and Hind III - digested genomic rice (*Oryza sativa*, genotypes ITA and EYI) and oat (*Avena sativa*) DNAs. The blot was probed with 1.5 kb oat ADC probe.

Chapter 4

REDUCTION OF SPERMIDINE LEVEL IN TRANSGENIC RICE BY INTRODUCTION OF A HOMOLOGOUS GENE CONSTRUCT.

Our experiment in the chapter three and results from some other publications (Himill, *et al.* 1990; Descenzo and Minocha, 1993; Burtin and Michael, 1997; Masgrau *et al.* 1997; Capell *et al.* 1998; Noury *et al.* 2000; Bhatnager *et al.* 2001; Lepri *et al.* 2001) collectively demonstrate that the tight regulation of the polyamine pathway at putrescine biosynthetic step can be manipulated by over-expressing or down-regulating key enzymes involved in the ADC and/or ODC pathways. In some cases, this is accompanied by a relatively small increase in spermidine concentration (Bassie *et al.* 2000; Lepri *et al.* 2001). Such findings suggest that the levels of spermidine and spermine are under strict homeostatic regulation (Bhatnager *et al.* 2001). Noh and Minocha (1994) generated transgenic containing the human SAMDC cDNA under the control of the CaMV35S promoter. Transgenic plants showed a 2-4-fold increase in SAMDC activity and 2-3 times of spermidine content higher than in control plants. Kumar *et al.* (1996) generated transgenic potato plants that constitutively expressed homologous SAMDC gene in either sense or antisense orientations. They observed reduction in the level of free polyamines, SAMDC transcript and enzyme activity in the antisense transgenic plants. However, all attempts to produce transgenic plants with sense constructs were unsuccessful. Using the above results as a stepping stone, we wished to elucidate the role of enzymes involved in later parts of the pathway, particularly that of spermidine synthase (Spd. Syn). This chapter describes experiments in which the rice genome was transformed by introduction of the homologous rice Spermidine Synthase (Spd.Syn) gene. The generation of this germplasm offers an opportunity to study how over-expression or down-regulation of a homologous Spd.Syn transgene affects the expression of the already existing polyamine genes, free polyamine levels, and how the change in spermidine level could affect to the accumulation of spermine which is very rarely change as the result of over-expression of ADC or ODC transgenes in transgenic plants.

4.1 Results

4.1.1 Generation and molecular analysis of primary transgenic rice plants

A mini-gene cassette (linear DNA fragment) containing the maize Ubiquitin1 promoter, rice Spd.Syn cDNA and *nos* terminator was excised as a Xho I/Not I fragment from the plasmid pUbiRSpdSyn and used for rice transformation by the particle bombardment method, as described by Fu *et al.*, (2000). After tissue culture, selection and regeneration, seven independent transgenic rice plants (R0) were obtained. Southern blot analysis of DNA extracted from these primary transformants confirmed the presence of additional rice Spd.Syn genes, besides the endogenous gene present in the parental line, in all of the transgenic plants except one (Figure 4.1). The plant containing no introduced Spd.Syn gene was not analysed further. The enzyme used for restriction digestion (*EcoR* I) cut only once in the mini-gene cassette, permitting an estimation of the number of integrated transgene copies. The majority of transgene integration patterns were simple, corresponding to one additional copy of the Spd.Syn gene per haploid genome in four plants (i.e. one extra hybridising band of equal intensity to the endogenous gene). Transformants 14 and 61 contains four or five additional copies of the transgene, as estimated by additional hybridising DNA fragments.

4.1.2 Expression of Spd.Syn and other polyamine biosynthesis genes in transgenic rice plants

Since the introduced Spd.Syn gene(s) were identical to the endogenous rice Spd.Syn gene, analysis of RNA transcribed from transgenes would also detect RNA transcribed from the endogenous gene. Total RNA was extracted from leaves of the transgenic rice plants, separated by agarose gel electrophoresis and analysed by northern blotting, using the rice Spd.Syn cDNA as a probe (Figure 4.2). When the strength of the hybridisation signal was compared with that of RNA from wild type and transgenic hygromycin only (i.e. transformed only with the *hyg^R* gene) control plants, 4 plants (14, 33, 61 and 146) showed increased levels of Spd.Syn steady state accumulated transcripts. Estimates from exposures of the blots suggested that mRNA levels were increased by at least 5-fold, and were >10-fold for plants 14, 61 and 146. The other two plants, 12 and 68, showed hybridization signals of similar intensity to that exhibited by control plants. The

northern blot analysis also showed that both the control and transgenic rice plants produced 2 Spd.Syn transcripts of different sizes, with both bands of approximately equal intensity. The reason for this is not known, but the two products may result from different processing of a primary transcript. To evaluate whether the introduction of the homologous Spd.Syn transgene into the rice genome affected expression of other genes involved in the polyamine pathway, northern blots of total RNA from leaves of the primary transformants were hybridized or re-hybridized with rice ADC, ODC and SAMDC probes. These blots showed that steady-state accumulated levels of rice ADC, ODC and SAMDC transcripts were little changed (estimated less than 2-fold change) in transgenic plants when compared to control plants (Figure 4.2).

4.1.3. Polyamine levels in transgenic rice plants

Free polyamine concentrations in leaves from six primary transgenic rice plants were measured using the assay techniques described in “method section”. Two plants, 12 and 68, had putrescine, spermidine and spermine levels not significantly different from control plants (Figure. 4.3). The other four plants, 14, 33, 61 and 146, exhibited a maximum of 45% reduction (plant 33; 246.59 ± 24.73 nmol g⁻¹fw, $P < 0.005$) and a minimum of 15% reduction (plant 61; 317.04 ± 15.10 nmol g⁻¹fw, $P < 0.005$) in spermidine when compared to the average of wild type and hygromycin control plants (372 nmol g⁻¹fw). Interestingly, these plants showed an increased accumulation of putrescine levels (up to 37% increase of putrescine in plant 61: 727.51 ± 21.97 nmol g⁻¹fw). No significant variation was observed in the levels of spermine in any of these plants in leaves or seed as compared with wild type plants (Figure 4.3). Levels of putrescine, spermidine and spermine accumulations observed in R1 seeds had the same tendency as in leaf tissues. Two plants, 12 and 68, showed no significant variation in putrescine, spermidine and spermine levels compared to control plants. Four plants 14, 33, 61 and 146 had significant reduction in spermidine levels, a maximum of 50% reduction observed in plant 146 and 61 (48.29 nmol g⁻¹fw ± 3.7 , $P < 0.005$ and 48.88 ± 10.3 nmol g⁻¹fw, $P < 0.005$, respectively). Putrescine accumulation in seeds of these four plants was 1.4 - 2.2 fold-increased as compared to a wild type plant (plant 14: 200.0 ± 23.65 nmol g⁻¹fw; plant 61: 311.94 ± 23.91

nmol g⁻¹fwt, wild type plant: 132.98 ±14.06 nmol g⁻¹fwt). Spermine levels in seeds of all transgenic rice remained unchanged.

4.1.4 Molecular analysis of R1 transgenic rice population

Seeds derived from self-fertilisation of the R0 transgenic rice plants containing extra copies of the Spd.Syn gene were germinated, and screened against hygromycin antibiotic. Two hygromycin resistant R1 plants for each line were chosen randomly for further analysis. In search of an explanation why primary transgenic rice plants 12 and 68 appeared not to express the transgene at all, DNA extracted from these R1 plants was restricted and separated by agarose gel electrophoresis, and used to prepare Southern blots. The blots were probed with both labelled Spd.Syn coding sequence, and Ubi promoter sequence probes. Randomly selected R1 transgenic plants had the band pattern on Southern blots as their respective primary transformants when genomic DNAs were digested with EcoRI enzyme and the blot was hybridized with Spd Syn probe (Figure 4.4). This indicates that transgene copies were stably inherited to the R1 generation. When this blot was reprobated with labelled Ubi promoter sequence, we did not detect hybridization signals in transgenic lines 12 and 68, indicating that these two lines contained a truncated mini-gene cassette with a deletion at the promoter end. Figure 4.5 shows the result of a Southern blotting experiment which confirmed the presence of intact transgene coding sequence in all transgenic lines; in this blot genomic DNAs were digested with both EcoRI and Hind III that released the full length of Spd.Syn cDNA from its mini-gene cassette (about 1.3kb in size). In both these Southern blots bands due to endogenous genes were visualised by both probes (these bands are not present in Figure. 4.4 B due to “trimming” the gel image),

A northern blot of total RNAs extracted from leaves of R1 plants showed an increased level of Spd Syn transcript expression in 4 transgenic lines 14, 33, 61 and 146 (Figure 4.6). This was consistent with the result we obtained in the primary transgenic rice generation, although the increase in mRNA level did not appear to be as great. Free polyamine contents in leaves of R1 plants were also analysed. Four transgenic lines, 14, 33, 61 and 168, exhibited significant reductions ($P < 0.001$) in spermidine levels, up to about 50% reduction in line 61 as compared to control wild type (line 61: 166.76±13.55

nmol g⁻¹fwt, wild type plant: 365,72±14.50 nmol g⁻¹fwt) These four lines exhibited significantly higher accumulation of putrescine in leaf tissues. Spermine levels remained unchanged in all the transgenic lines as compared to control plants. ADC enzyme activity in leaf tissues of R1 transgenic plants was also assayed, but no significant variation was observed between transgenic and control plants (Figure 4.8).

4.2 Discussion

In particle bombardment-mediated transformation, plasmids are often used to deliver the target gene in its expression cassette into plant genomes. When integrated into plant DNA, excess bacterial vector backbone sequences often spontaneously acquire dense methylation (Jakowitsch *et al.*, 1999), and contribute to de-stabilising gene expression resulting in gene silencing (Iglesias *et al.*, 1997; Kumpatla *et al.*, 1997). Transgene rearrangement can also take place as a result of the presence of multiple copies of plasmid backbones. Fu *et al.*, (2000) and Breitler *et al.*, (2002) have recently investigated the use of isolated minimal gene cassettes for successfully transforming rice. They both agreed that transformation of rice using gene cassettes is possible without significantly reducing transformation efficiency, potentially leading to less gene silencing events. However, they obtained contrasting results regarding transgene integration pattern and inheritance. In our experiment, we obtained a simple transgene integration pattern in five out of seven primary transgenic rice plants (Figure 4.1), stable inheritance to the next generation (Figure 4.4) and stability of expression of the combination of transgene and endogenous Spd Syn gene in R1 transgenic plants (Figure 4.6). Two lines, 12 and 68 did not express mRNA of the transgene, this was not due to a transgene silencing event, but due to the loss of ubiquitin promoter sequence that completely abolished the expression of Spd Syn gene in the mini-gene cassette. The success of using linear DNA fragments for transforming plant cells is unexpected; it was anticipated that the wound created by micro-projectile penetration in the cell would lead not only to activation of the DNA repair mechanism, but also to activation of exogenous DNA degradation system (Hunold *et al.*, 1994). Consequently, linear DNA as minimal gene cassette introduced into the cell nucleus would be rapidly degraded from its ends by nucleases before integration into plant genome. This might be the case in our

rice transformation since minimal gene cassettes gave rise to integrated transgenes lacking the ubiquitin promoter sequence.

Initial studies in plant transformation concentrated on seeking to enhance the phenotype or to create novel traits by introduction of a heterologous gene (reviewed by Christou, 1994). However, the introduction of additional copies of an endogenous gene as a transgene, in some instances, did not lead to over-expression of the combination of introduced and endogenous genes, but drastically reduced expression of both the endogenous and the introduced genes (Van Der Krol *et al.*, 1990). The phenomenon of coordinate silencing of a transgene and a homologous endogenous gene is often referred to as co-suppression. In most cases, co-suppression was due to the overproduction of transgene and homologous endogenous RNAs above a putative threshold level that triggers the irreversible degradation of RNA (reviewed by Depicker and Van Montagu, 1997; Stam *et al.*, 1997). In the experiments described in this chapter, the maize ubiquitin promoter, a strong constitutive promoter, was used to drive the expression of rice Spd Syn cDNA as a transgene in rice genome. The transgenic rice plants, which were obtained and were analyzed through two generations, did not show co-suppression, but a coordinate elevation of the steady state pool of Spd.Syn mRNAs resulting from the expression of the transgene(s) and, presumably, the endogenous gene (Figure 4.2 and 4.6). Paradoxically, transgenic plants with increased Spd.Syn transcript levels displayed reduction in free spermidine level in leaf tissues (Figure 4.3 and 4.7), coupled with an increased accumulation of putrescine. The increased putrescine level could not be explained by an increase in ADC and ODC enzyme activity, as mRNA levels of these two enzymes remained essentially unchanged. Analysis of the activity of ADC enzyme confirmed that increased synthesis of the enzyme could not explain the increased putrescine levels (Figure 4.2). Additionally, as putrescine level contributes a major portion of the free polyamine pool in rice leaf tissues, and spermidine levels are relatively low, the maximum of 2-fold reduction in spermidine could not account for a 2-fold increase in putrescine accumulation. To date, there are only a few published papers on the regulation of spermidine biosynthesis in plants. De Agazio *et al.*, (1995) treated maize roots with spermidine, and observed putrescine accumulation as a consequence. The authors showed evidence of an interconversion from spermidine to putrescine in plants. Tassoni *et al.*, (2000) showed that

Arabidopsis plants, when treated with both free spermidine and N-acetyl spermidine, had successive increases of putrescine, predominantly in the free form, and suggested the presence of an interconversion of acetylspermidine to putrescine via a putative polyamine oxidase. They also found that spermidine-treated plants showed an increased ODC activity, but no significant changes in ADC activity could be observed in response to spermidine treatment. However, Hanfrey *et al.*, (2001) reported that ODC enzyme was not present, and that the synthesis of putrescine is solely reliant on ADC activity in *Arabidopsis* plants. Kumar *et al.*, (1996) studied the expression of a homologous sense SAMDC transgene under the control of a tetracycline-inducible promoter in transgenic potato plants. They obtained transgenic plants with an increase in both the steady state transcript level of SAMDC and polyamine (putrescine and spermidine) levels after tetracycline induction. However, attempts to generate transgenic plants that constitutively over-expressed the homologous sense SAMDC were unsuccessful. They explained that constitutive expression of SAMDC might cause death to transformed cells because too much spermidine might be cytotoxic. As the results with transgenic rice plants could not be explained by a co-suppression event, we suggest the presence of an inter-conversion from spermidine to putrescine in rice plant. It is possible that the introduction of rice sense Spd.Syn cDNA as a transgene into the rice genome leads to high expression level of Spd.Syn mRNAs, and consequently this event triggers an elevated inter-conversion process from spermidine to putrescine in transgenic rice plants. Unfortunately, Spd.Syn enzyme activity analysis or further confirmatory studies could not be carried out. Therefore, it is not possible to give a definitive answer to the question why free spermidine levels in these transgenic rice plants were lower compared to control wild type plants. As the previous transgenic rice experiment with antisense oat ADC indicated the likelihood of a tight regulation that controls spermidine and spermine levels in leaves, and since too much spermidine accumulation might be cytotoxic to transformed plant cells (Kumar *et al.*, 1996), it is possible that the recovery of viable plants from the transformation experiments is a limiting factor. When transformation of rice cells with homologous sense Spd.Syn gene occurs, only transgenic plants with small (or no) changes in spermidine level can be recovered, because large changes are lethal.

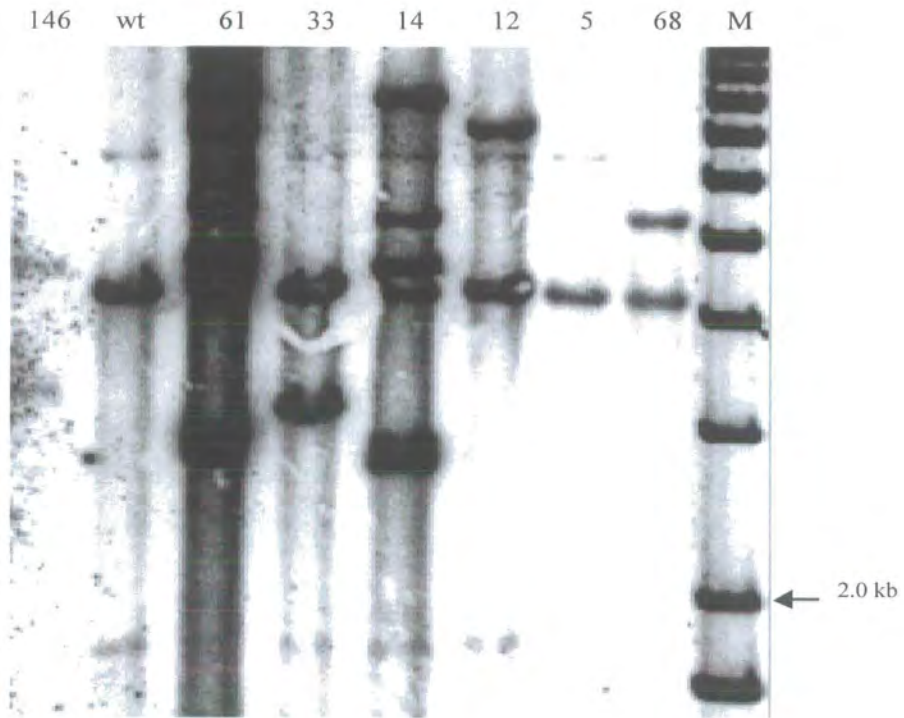

Figure 4.1: Southern blot analysis of R0 rSpd.Syn transgenic rice DNAs digested with EcoR I, hybridized with rice Spd.Syn probe. (M): 1kb DNA ladder marker, (wt): wild type control plant.

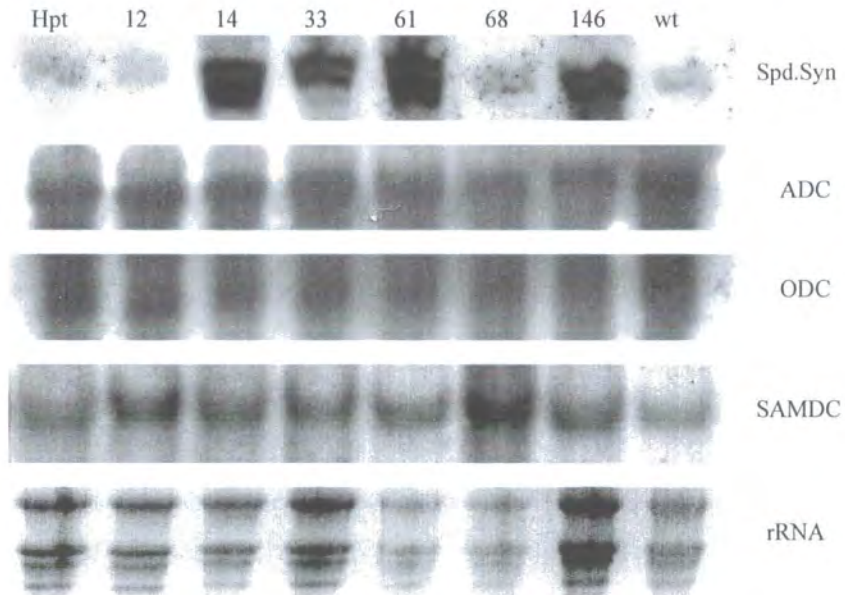

Figure 4.2: Northern blot analysis of leaf total RNA samples from six primary rSpd.Syn transgenic rice plants, hybridized with rice Spd.Syn, rice ADC, rice ODC and rice SAMDC probes, (wt): wild type plant and (hpt): transgenic plant contained only hygromycin transgene.

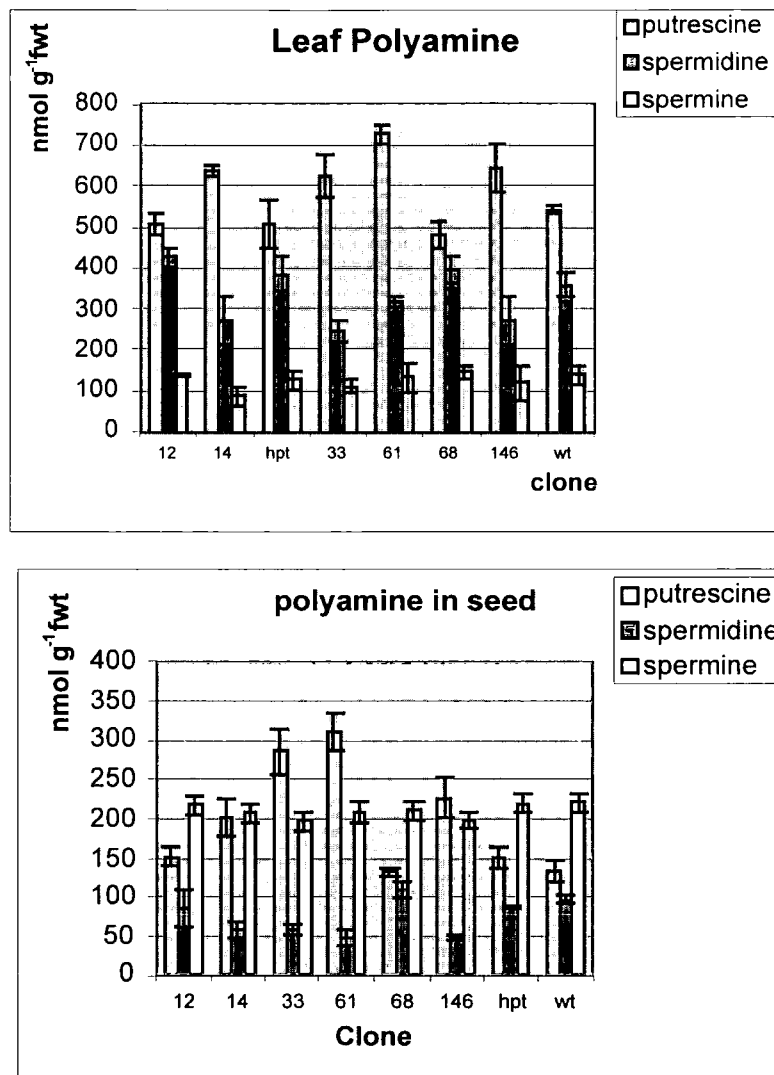

Figure 4.3: Polyamine analyses in leaves and seeds of six primary transgenic rice plants. (hpt): transgenic plant contains only hygromycin transgene, (wt): wild type plant. nmolg⁻¹ fwt= nmol per gram of fresh weight..

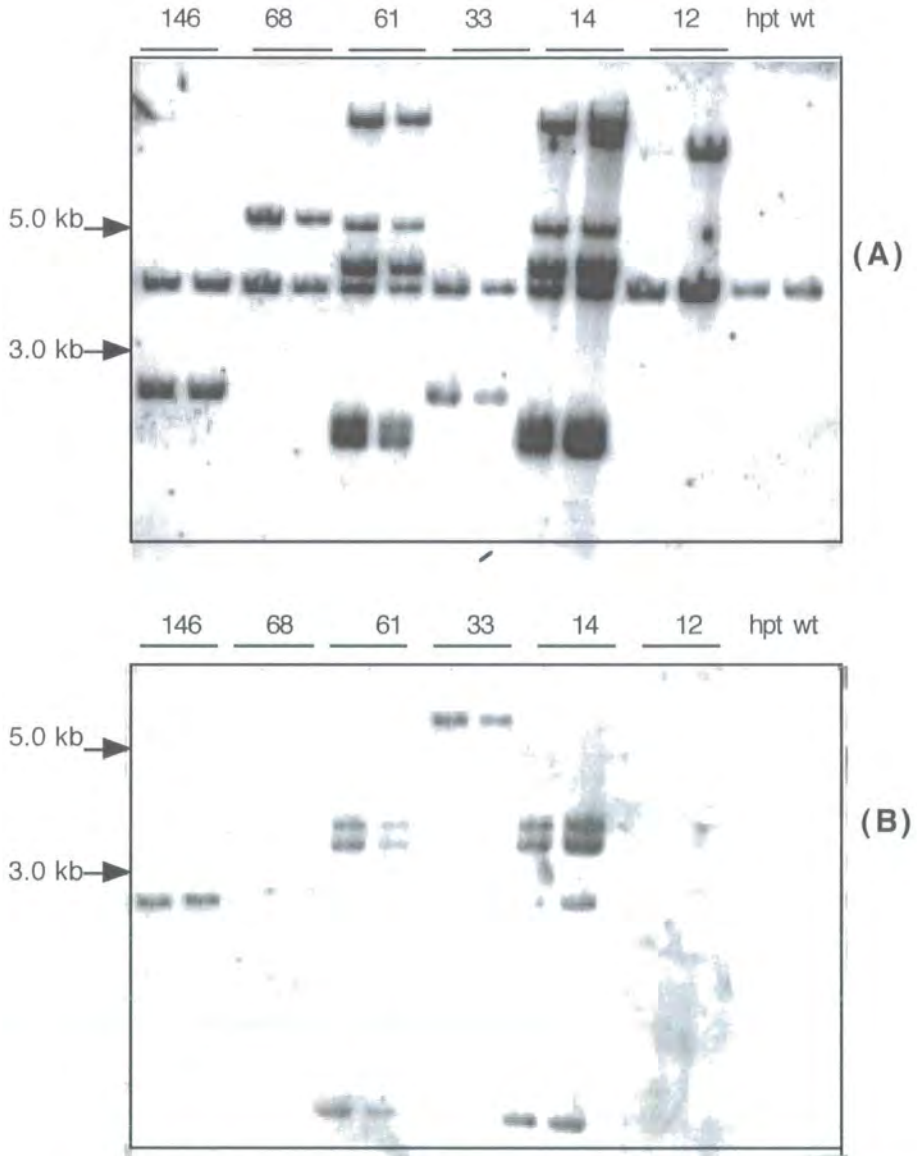

Figure 4.4: Southern blot analyses of R1 rSpd.Syn transgenic rice plants. The genomic DNAs were digested with EcoR I, (A): the blot was hybridized with rice Spd.Syn probe, (B): the blot was re-hybridized with Ubi promoter probe, (wt): wild type plant and (hpt): transgenic plant contained only hygromycin transgene.

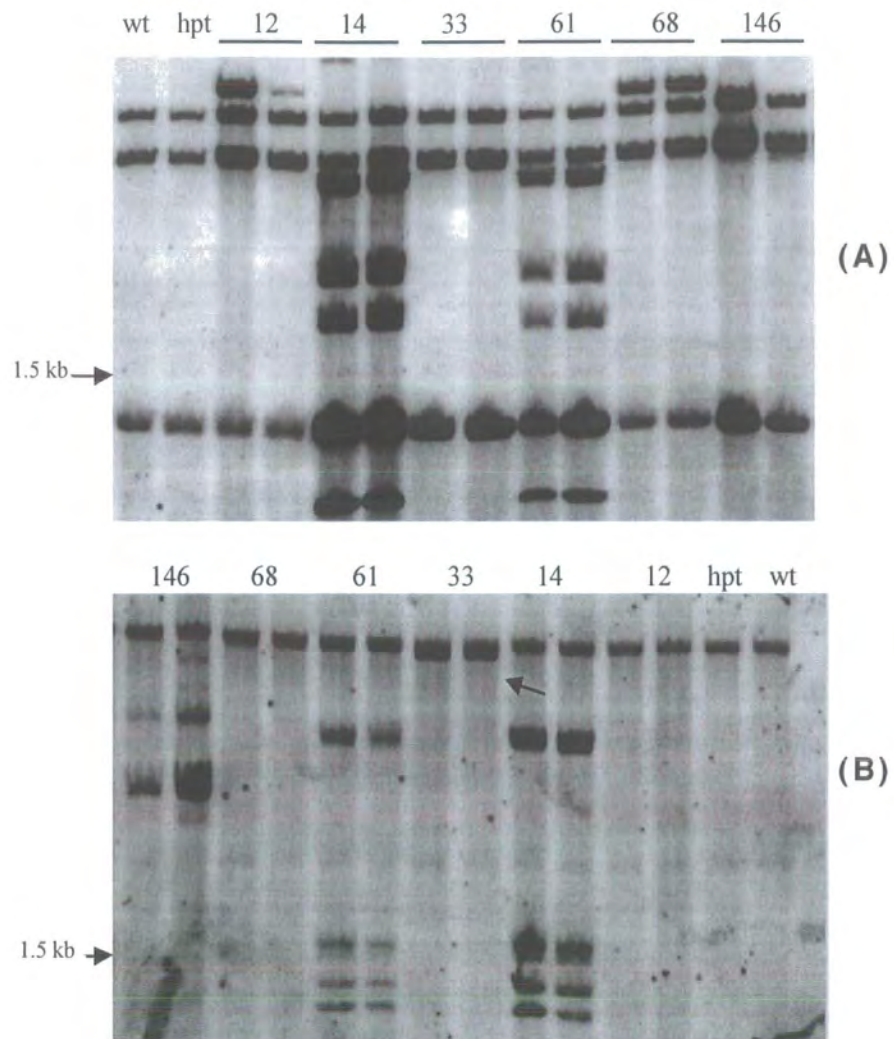

Figure 4.5: Southern blot analyses of R1 rSpd.Syn transgenic rice plants. The genomic DNAs were digested with EcoR I and Hind III, (A): the blot was hybridized with rice Spd.Syn probe, (B): the blot was rehybridized with Ubi promoter probe, (wt): wild type plant and (hpt): transgenic plant contained only hygromycin transgene.

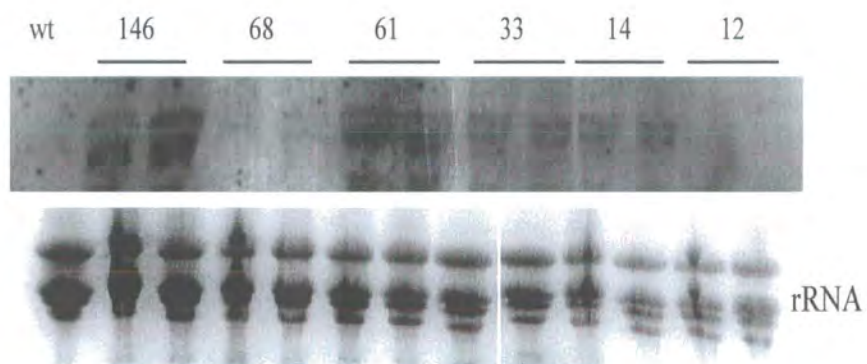

Figure 4.6: Northern blot analysis of leaf total RNA samples from six R1 rSpd.Syn transgenic rice lines (2 plants/each line), the blot was hybridized with rice Spd.Syn probe, (wt): wild type plant

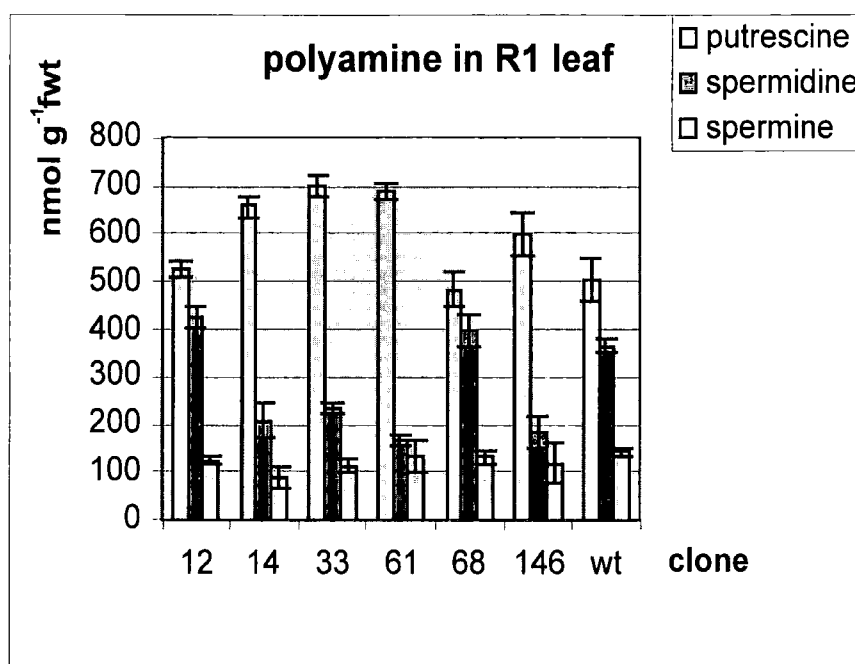

Figure 4.7: Polyamine analysis in leaves of six R1 rSpd.Syn transgenic rice lines, (wt): wild type plant.

nmol g⁻¹fwf= nmol per gram of fresh weight.

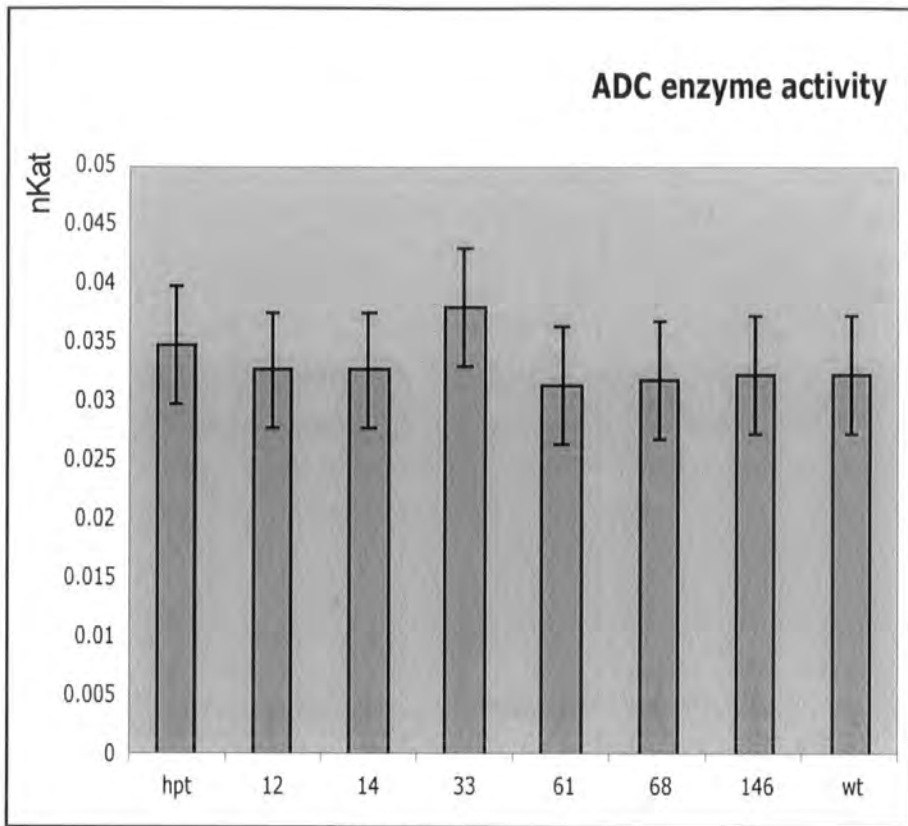

Figure 4.8: ADC enzyme activity measurement in leaf tissues of R1 Spd.Syn transgenic rice lines. Four positive PCR transgenic plants for the transgene were used as replicates for each transgenic lines

hpt: hygromycin resistant plant

wt : wild type plant

1 nKat = $1\text{nmol s}^{-1}\text{g}^{-1}$ of fresh weight

Error bars: =+/_ 1 Standard errors

PRODUCTION OF TRANSGENIC RICE PLANTS WITH WIDE-SPECTRUM RESISTANCE TO INSECT PESTS.

The use of gene transfer technology to introduce insect-resistance genes into crop plants provides an economical and environmentally sustainable alternative to the extensive use of chemicals for the control of insect pests. For example, commercial cultivation of Bt crops (potato, cotton and corn) has created direct environmental benefits by reducing the amount of insecticide used to control pests and by reducing the use of highly toxic and non-specific insecticides. However, the success of insect-resistance crops will depend on whether target pests develop resistance to them. Insects have developed resistance to almost all control measures that have so far been applied. A number of resistance management strategies have been used or proposed to delay or prevent such an outcome, including the use of tissue-specific or inducible promoter, the simultaneous introduction into the same plant of several resistance genes with different action against the same pest (de Maagd *et al.*, 1999; Maqbool *et al.*, 2001), and the artificial broadening of toxin activity by producing recombinant toxins with additional binding domains. Bohorova *et al.*, (2001) reported the development of transgenic tropical maize carrying the cry1B-cry1Ab translational fusion that confers resistance to southwestern corn borer (*Diatraea grandiosella*), sugarcane borer (*Diatraea sacchralis*) and fall armyworm (*Spodoptera frugiperda*). The success of this strategy to broaden insect resistance of transgenic plants requires determination of binding domains in both toxins and target insects. Recently, certain neurotoxin polypeptides, like *Manduca sexta* allatostatin (Manse-AS) and *Segestria florentina* toxin 1 (SFI 1), have been known as potential insecticides and have no toxin effects to mammal (Masler *et al.*, 1993; Lipkin *et al.*, 2002). However, insect neurotoxin polypeptides are unlikely to be rapid absorbed through the insect cuticle and would be prone to proteolysis and rapid degradation in the environment and within the insect gut. Attempts to exploit new pesticidal genes for tackling the imminent problem of insect resistance have been investigated (Fitches *et al.*, 2002; Fitches *et al.*, 2004 (a) and (b)). Their study based on the ability of snowdrop

lectin GNA to resist gut proteolysis and to act as a carrier to deliver fused peptides to the circulatory system of target insects (Raemaekers, 2000; Fitches *et al.*, 2001). They demonstrated that GNA delivers fused insect neuropeptide, Manse-AS and SFI 1, to the haemolymph of lepidopteran larvae following oral administration and the fusion proteins toxic to target insects.

This chapter describes experiments in which genes encoding fusion proteins were constructed and expressed in *E. coli*, and introduced into transgenic rice plants using the particle bombardment method. The design of these fusions aimed to enhance insecticidal activity of insect resistance gene(s) by directing the transport of its product to the site of action (thioredoxin-GNA fusion) or to broaden the toxicity by adding a binding domain (Bt toxin – lectin fusions).

5.1 Results:

5.1.1. Expression of fusion proteins in *E. coli* and protein purification.

Constructs to express three fusion proteins as recombinant proteins in *E. coli* were assembled in the pET expression vector system. Expression of sequences cloned in the pET vector is under control of the strong T7 bacteriophage promoter when induced in *E. coli* host strain BL21 (DE3) pLysS cells. Expression of the system is strongly repressed unless induced by adding IPTG. The fusion protein expression constructs were assembled by joining DNA fragments encoding the required protein domains. DNA fragments were prepared by PCR, using primers incorporating suitable restriction sites to allow construct assembly, and checked by DNA sequencing to confirm absence of PCR errors. The fusion protein constructs were as follows:

- (i) Cry 1Ac domain 1 + GNA (Ac-GNA); this construct encoded the pore forming domain from the Cry1 Ac Bt toxin joined to the N-terminus of the snowdrop lectin (GNA) mature polypeptide;
- (ii) Thioredoxin-GNA (TRX-GNA); this construct encoded the entire coding sequence of rice thioredoxin joined N-terminally to the snowdrop lectin (GNA) mature polypeptide;

- (iii) Cry 1Ac + RTB (Ac-RTB); this construct encoded the entire active Bt toxin Cry 1Ac joined N-terminally to the carbohydrate binding domain from the castor bean ribosome inactivating protein ricin.

The fusions incorporated C-terminal (his)₆ tags to allow the recombinant proteins to be affinity-purified. Constructs were transformed into the *E. coli* host strain for expression, grown and induced.

Expression of the Ac-GNA fusion polypeptide is shown in Figure 5.1(A). When a Western blot of proteins extracted from bacteria after varying times of induction with IPTG was probed with polyclonal rabbit anti-GNA antiserum, a band reacting with the antibody was observed, confirming the presence of the fusion protein, of approximate molecular weight 41.15 kDa. No expression of the Ac-GNA fusion was observed in an uninduced bacterial sample. However, most of the first domain Ac-GNA fusion was expressed in the form of insoluble inclusion bodies in the host cells, when soluble and insoluble fractions were analysed by SDS-PAGE (figure not shown). To isolate soluble and functional recombinant protein, the inclusion bodies were solubilized by treatment with 6 M urea solubilization buffer. The solubilized protein was then affinity-purified on an NTA immobilised nickel column (QIAGEN). Fractions eluted in high imidazole concentration, after washing the column, contained purified Ac-GNA fusion protein. They were pooled and dialysed against refolding buffer, and concentrated to approx. 1mg/ml using an ultracentrifugation tube (Centrepip, Vivascience). The purified fusion protein was estimated to be >90% pure as assessed by SDS-PAGE gel (Figure 5.1(B)).

Expression of the TRX-GNA fusion polypeptide in *E. coli* is shown in Figure 5.2. Western blotting of proteins extracted from cells after induction of expression showed that more than 90% of TRX-GNA protein was expressed in the form of insoluble inclusion bodies (Figure 5.2(A)). When the blot was probed with anti-GNA antibody the expected band for TRX-GNA, migrating at molecular weight of approx. 25.9 kDa, was present in both soluble and insoluble fractions, but was present in much greater amount in the insoluble fraction. Some binding to bands of other molecular weights was present in the insoluble fraction, possibly due to incomplete denaturation of the fusion polypeptide. Soluble TRX-GNA fusion was recovered from the inclusion bodies using a protein refolding method using CAPS buffer in combination with N-



lauroylsarcosine as denaturants (described in protein refolding kit manual, Novagen). The solubilised proteins were then dialyzed against 10 mM Tris HCl at 4°C for refolding. The refolded protein was purified by ion exchange chromatography on a Q-Sepharose column. The eluted fractions were pooled and assessed by SDS-PAGE using a 12% acrylamide gel. An estimated purity of more than 90% TRX-GNA protein in eluted sample was obtained (Figure 5.2 (B)). The TRX-GNA protein sample was concentrated to 1 mg/ml using an ultracentrifugal concentrator.

Expression of the Ac-RTB fusion protein in *E. coli* is shown in figure 5.3 (A). After induction of expression, soluble and insoluble protein fractions from the cells were analysed by SDS-PAGE and Western blotting. When the blot was probed with with an anti-Cry1Ab antibody, a band migrating at the expected molecular weight of 98 kDa was present. The protein was mainly expressed in the form of insoluble inclusion bodies. The aggregates were solubilized in a buffer containing 6M urea, filtered through a 0.2 µm membrane, and affinity-purified on a Ni-Agarose column. The fractions eluted at high imidazole concentration after washing the column were pooled and refolded by dialysis with gradual dilution, to final dialysis buffer of 10 mM Tris-HCl. The refolded Ac-RTB protein sample was run on SDS-PAGE 12% acrylamide gel. The Ac-RTB protein was estimated to be >80% pure as assessed by staining of the SDS-PAGE gel (Figure 5.3(B)). The protein sample was concentrated to 1 mg/ml using an ultracentrifugation tube.

5.1.2. Bioassays of fusion proteins against insect pests.

The purified Ac-GNA fusion protein was tested for toxicity towards the homopteran pest *Nilaparvata lugens* (rice brown planthopper) and the lepidopteran *Lacanobia oleracea* (tomato moth, a noctuid lepidopteran herbivore) in artificial diet bioassays. Figure 5.4 shows a BPH diet bioassay of the Ac-GNA fusion protein compared to GNA, each at two different concentrations of 0.05 and 0.1 mg/ml. Survival on control diet was higher than 80% over 8 days in this assay. Survival curves for both Ac-GNA fusion protein and GNA treatments at both concentrations used were significantly different from the control diet after feeding for five days. GNA treatments showed a greater effect on survival of *N. lugens* nymphs when compared to first domain

Ac-GNA treatments. By day 9, there was less than 10% BPH survival on diets containing GNA, whereas BPH survival on diets containing the Ac-GNA fusion protein was approx. 40%. The survival curves of BPH nymphs at two concentrations, 0.05 and 0.1 mg/ml, did not differ significantly for either GNA or Ac-GNA fusion protein. To investigate the possibility that this fusion protein could be toxic to a wider spectrum of insect pests, an artificial diet bioassay was carried out against larvae of tomato moth (*L. oleracea*). Figure 5.5 illustrates the impact of first domain Ac-GNA upon the survival and development of tomato moth larvae. By day 9, about 50% larva mortality was recorded for first domain Ac-GNA feeding treatment, significantly different from both parental toxic proteins and diet control. The survival was not much affected by feeding larvae artificial diet containing Cry1Ab, Cry1Ac or GNA as compared with the diet control. Larvae fed on first domain Ac-GNA diet did not show a significant lower mean weight as compared with larvae that fed on Bt parental toxins or on diet control measured at day 9. However, first domain Ac-GNA showed a significant lower mean larval weight as compared to GNA feeding control.

Recombinant TRX-GNA, at added protein level of 0.05%, was tested for toxicity towards third instar BPH nymphs in an artificial diet bioassay (Figure 5.6). The TRX-GNA fusion protein started showing a significant reduction in BPH nymph from day 3 onwards when compared to control diet. By day 8, survival of BPH nymphs on diet containing TRX-GNA is about 20-30% whereas 70-80% nymphs survived on control diet, indicating a substantial toxic effect of TRX-GNA against BPH. This protein is comparable to GNA in toxicity towards *N. lugens* when compared on a molar basis (data not presented).

Recombinant Ac-RTB protein was tested for toxicity towards *Lacanobia oleracea* (tomato moth, in an artificial diet bioassay.). Figure 5.7 illustrates the impact of Ac-RTB upon the survival and development of tomato moth larvae. By day 9, about 30-40% larva mortality was recorded for recombinant Ac-RTB feeding treatment, slightly different from Bt toxic proteins (10-20% mortality) and significantly different from diet control (less than 10% mortality). However, larvae fed on Ac-RTB diet did not show a significant lower mean weight as compared with larvae that fed on Bt parental toxins or on diet control measured at day 9.

5.1.3. Generation and molecular analysis of R0 transgenic plants

Plasmids containing fusion gene constructs encoding Ac-GNA, TRX-GNA and Ac-RTB were delivered separately into rice by bombardment of mature embryos. The gene constructs contained the coding sequences expressed in *E. coli* (section 5.1.1) under the control of the maize ubiquitin promoter *Ubi1* that has been shown to give high-level expression of transgene(s) in monocotyledonous plants (Christensen & Quail, 1996). Rice transformation and regeneration was carried out as described previously (Method section).

A southern blot analysis of 5 regenerated Ac-GNA primary transgenic rice plants is shown in Figure 5.8. This blot showed that each of the selected plants contained integrated DNA from the transforming plasmid, and that transgene integration patterns differed between plants, with the exception of plant 5, which gave a transgene integration pattern similar to that of plant 2. These two individuals must come from an identical transformation event. Therefore, plant numbered 5 was discarded from subsequent analyses. The enzyme used for restriction, EcoRI, was expected to cut once inside the transforming vector, permitting an estimation of the number of integrated transgene copies. The complexity of integration ranged from three to nine estimated copies of the gene per haploid genome.

Southern blot analysis of TRX-GNA primary transformants (R0) confirmed the presence of the target gene in 6 regenerated rice plants (Figure 5.9). Rice genomic DNA was digested with EcoR that cuts the plasmid once. Hybridization with random probe(s) for the coding TRX-GNA sequence revealed complex integration patterns of the gene in the genomes of three rice plants numbered 2, 4 and 5. Plants numbered 1, 3 and 6 have an estimated transgene copies ranging from two to four per haploid genome.

A Southern blot analysis of eight regenerated R0 rice plants from the transformation with the Ac-RTB gene construct are shown in Figure 5.10. Genomic DNA was digested with restriction enzyme EcoRI, which was expected to release a hybridizing fragment of about 2.2 kb when hybridized with random probe(s) for the coding sequence of Ac-RTB fusion gene. The blot revealed the presence of the target gene in four out of eight plants. The transgene integration patterns were clearly unique

for each Ac-RTB transgenic line. Two plants, numbered 3 and 4, contained truncated versions of the transgene copies as they showed some hybridizing bands smaller than 2.2 kb in size.

5.1.4. Expression of fusion genes in transgenic rice plants.

Expression of the gene constructs introduced into transgenic rice plants was studied both at the level of mRNA, and in terms of protein accumulated in leaf tissue. Unless stated otherwise, all assays were carried out on leaf tissue from R0 plants. Total RNAs samples were treated with RQ 1 Rnase-free Dnase (promega) before carrying out RT-PCR reaction (see Method section).

mRNA encoding the Ac-GNA fusion protein was detected in total RNA extracted from transgenic plants by RT-PCR. RT-PCR was carried out using a pair of primers that spanned both the Cry and GNA domains, and amplified a product of 820 bp in size. Results are shown in Figure 5.11. All four independent R0 transgenic plants showed steady-state Ac-GNA mRNA expression in leaf tissues. Subsequently, 50 mg of total soluble protein extracted from leaf tissue of these transgenic plants was subjected to SDS-PAGE and western blotting (Figure 5.12). When probed with anti-GNA antibodies, the blot showed a band at approximately 39 kDa (expected size is 41.15 kDa), which is more intense than background binding bands observed from hygromycin and wild type control plants. The background binding bands could be a result of cross-reaction between anti GNA antibody with rice lectin proteins. On the basis of band intensity, the level of the Ac-GNA fusion protein accumulated in transgenic rice plants was low (less than 0.01% of total soluble protein). This is apparent in Figure 5.12 if the intensity of the band due to the Ac-GNA fusion protein is compared to the band produced by 50 ng of GNA.

RT-PCR analysis of total RNA from leaf tissues of TRX-GNA transgenic plants is shown in Figure 5.13. The expected RT-PCR product (350 bp in size) was detected in all six TRX-GNA plants. Total protein, extracted from young leaves of these plants, were fractionated by 12% SDS-PAGE and then subjected to immunoblotting against anti-GNA antibodies (Figure 5.14). A faint band that migrated at approx. 25 kDa appeared in all transgenic plants, but not in hygromycin and wild type control lanes.

This faint band is expected to be TRX-GNA fusion protein with predicted size of 25.9 kDa. Expression of TRX-GNA fusion proteins in transgenic plants was somewhat variable, with relatively more fusion protein present in TRX-GNA transgenic plants numbered 1, 2 and 3 compared to TRX-GNA plants 4, 5, and 6. However, the level of TRX-GNA fusion protein expressed in all transgenic plants was very low, and was estimated at less than 0.01% of total soluble protein. A background-binding band that migrated slightly slower than that of stained GNA band was observed in both transgenic and control plants.

The presence of Ac-RTB mRNA in all four transgenic plants was confirmed by RT-PCR analysis using a pair of primers that amplifies a 654 bp product from the coding sequence of RTB gene (Figure 5.15). Initial analysis of leaf extracts by SDS-PAGE followed by immunoblotting with anti-Cry1Ab antibody (that cross-reacts with Cry1Ac protein), using 50 mg of total protein for each transgenic plant, failed to reveal a detectable band of Ac-RTB fusion protein (expected size is 97 kDa). When 100 mg of total protein for each transgenic plant was loaded, two plants numbered 2 and 4 displayed a detectable band (Figure 5.16). This band migrated at approximately 95 kDa (indicated from sizes of protein marker standards), as expected for Ac-RTB fusion protein. Two remaining plants, 1 and 3, did not show any detectable band at the expected size of the Ac-RTB protein indicating the possibility of very low expression at mRNA transcription or translation of Ac-RTB fusion protein in these transgenic plants.

5.1.5. Insect bioassays of R1 transgenic plants

All R0 transgenic rice plants developed normally until the point of setting seed, when they proved to show a high level of self-sterility. The four Ac-RTB transgenic plants did not produce any seeds, and thus could not be subjected to insect bioassays. For those transformants that did produce seeds, insect bioassays were carried out on R1 plants.

It has been shown that multiple genes of various transforming plasmids being delivered into rice genome by bombardment method preferentially integrate at a single locus, so that they function as, and are inherited as, a single genetic unit (Register *et al.*, 1994; Kohli *et al.*, 1998; Kexuan Tang *et al.*, 1999). We assumed that co-transferred

plasmids containing hygromycin and insect resistance genes in our experiment, delivered into the rice genome by bombardment transformation method, should integrate together at one locus and pass down to the R1 generation as linked genes. Therefore, to select R1 rice plants for insect bioassays, hygromycin screening experiments were carried out to identify R1 hygromycin-resistance plants instead of testing for insect resistance genes. Figure 5.17 shows representative photos of R1 rice seedlings of Ac-GNA4, TRX-GNA1 and wild type plants germinated in 1/10 MS medium solution containing 50mg/l Hygromycin. We observed that hygromycin gene segregated in a ratio of approximately 3:1, indicating a single transgene locus in transgenic rice genome (Table 5.1). Genomic DNAs of some randomly selected hygromycin-resistance plants were subjected to PCR to confirm the presence of the insect resistance genes (Figure 5.18).

For bioassay of transgenic rice plants against brown plant hopper, ten first- or second-instar BPH nymphs per plant were set up for ten 20 days-old rice seedlings of Ac-GNA or TRX-GNA transgenic plant lines. Insects were able to move over individual plants, but were confined with fine-mesh nylon cages to prevent movement between plants.

Bioassay results for R1 Ac-GNA plants against brown plant hopper are shown in Figure 5.19. The variation between different R1 Ac-GNA transgenic rice lines in term of toxicity against BPH nymphs is presented in Figure 5.19 (A). Survival on control plants was > 80% up to day 16, but declined rapidly thereafter due to the plants becoming desiccated and moribund. From day 6 to day 16, survival on the plants expressing Ac-GNA was consistently poorer than on control plants, By day 8, percentage of BPH survival on Ac-GNA transgenic rice lines ranged from 70% (Ac-GNA4) to 80% (AC-GNA3). By day 16, it is from 40% (Ac-GNA4) to 60% (Ac-GNA3) and by day 24, a variation between 20 to 25% of BPH survival observed on different AC-GNA transgenic rice lines. This small difference in toxicity against BPH insect displayed by different Ac-GNA transgenic progenies was consistent with the western blot analysis of R0 transgenic plants showing similar expression level of Ac-GNA fusion proteins. Figure 5.19 (B) presents pooled data of Ac-GNA transgenic rice and wild type plants. At day 4 insect survival was nearly the same on both transgenic

and control plants, but from day 6 onwards, insect survival on transgenic rice started declined compared to control. By day 16 it was significantly reduced (55% BPH survival) compared to that on wild type control (80% BPH survival; $p < 0.01$). From day 18, wild type control plants began to wilt or die and the number was increasing to 100% dead by day 24. This led to the survival of insects recorded on control plants reduced rapidly from day 16 to day 24. The survival of BPH insects on transgenic plants was steadily reducing and by day 24, about only 25% insect survival was recorded on transgenic rice. All Ac-GNA transgenic rice plants survived to the end of the trial.

Insect bioassay results for R1 TRX-GNA transgenic plants against brown plant hopper are summarised in Figure 5.20. Once again, survival of insects on control plants was $> 80\%$ until day 16 of the trial. The variation between different R1 TRX-GNA transgenic rice lines in term of toxicity against BPH insects is presented in Figure 5.20 (A). By day 8, the range of insect survival on TRX-GNA transgenic rice lines was from 65% (TRX-GNA2) to 75% (TRX-GNA5). However, differences between lines increased with time, and by day 16, percentage of insect survival on transgenic rice plants ranged from 30% (TRX-GNA1) to 55% (TRX-GNA5). By day 24, BPH survival was 5% on TRX-GNA1, about 25% on TRX-GNA2 and TRX-GNA3 and 40% BPH survival observed on TRX-GNA4, TRX-GNA5 and TRX-GNA6 plants. Therefore, the level of toxicity displayed by different TRX-GNA R1 transgenic plants seemed to be consistent with the western blot analysis of R0 TRX-GNA transgenic plants, that showed a relatively higher expression level of fusion proteins in TRX-GNA plants numbered 1, 2 and 3 as compared to that of TRX-GNA plants numbered 4, 5 and 6. This also indicates that expression of fusion protein in transgenic plant was stably transmitted to the next generation. Figure 5.20 (B) presents pooled data of TRX-GNA transgenic rice and wild type plants. As expected, the transgenic rice lines expressing TRX-GNA fusion showed toxicity to BPH nymphs as early as by day 4 (85% insect survival on TRX-GNA transgenic plants, compared to 95% survival on control plants). By day 16, only 40% insect survival was recorded on transgenic plants, significantly different as compared to that on wild type control plants (about 80% BPH survival; $p < 0.01$). As was observed in the insect bioassay of Ac-GNA R1 transgenic rice plants, wild type control plants began to wilt or die from day 16 and all the control plants had

died by day 24. This led to the survival of insects recorded on control plants reducing rapidly from day 16 to day 24. The survival of BPH insects on transgenic plants declined steadily and by day 24, only 30% insect survival was recorded. All the TRX-GNA transgenic rice plants remained alive by the end of experiment.

5.2. Discussion

5.2.1. Enhancing toxicity and insecticidal spectrum of toxin proteins by protein fusion.

Transgenic crops expressing individual *Bacillus thuringiensis* (Bt) endotoxin genes to enhance the resistance of the plant to insect pests have been in commercial use for several years. Other insecticidal genes, such as the gene encoding the snowdrop lectin GNA (Gatehouse *et al.*, 1997; Rao *et al.*, 1998; Xavier Foissac *et al.*, 2000; Wu *et al.*, 2002; Loc *et al.*, 2002) have been shown to be effective in small-scale trials, and are currently awaiting commercial development. However, the unrestricted and commercial use of insect-resistance transgenic crops is likely to lead to the emergence of resistance in target insect pests unless measures are used to delay or halt its development. Besides the use of different field management strategies to delay the onset of resistance (Mallet *et al.*, 1992; Liu *et al.*, 1997; Cohen, 2000) several molecular approaches have been tested including the restricted expression of toxin products in certain plant tissues (Rao *et al.*, 1998), simultaneous expression of multiple insecticidal genes in the same transgenic plants (Maqbool *et al.*, 2001) and the production of hybrid toxins (Naimov, S. *et al.*, 2003).

The goal of this study was to determine whether our novel fusion proteins, based on insecticidal Bt and GNA genes, could combine the functional properties of the individual proteins and therefore acquire a wider insecticidal spectrum. The lectin-based chimeric protein Ac-GNA, consisting of peptide sequence of the domain I of Cry1Ac toxin fused to the N-terminus of GNA protein, was expressed successfully in *E. coli* and tissues of transgenic rice plants as an uncleaved protein of 41.15 kDa (Figures 5.1 and 5.12). Artificial diet bioassays of purified *E. coli*-expressed Ac-GNA fusion proteins against BPH and tomato moth (*L. oleracea*) insects showed “additive insecticidal effects” attributable to the individual property of each linked protein

(Figures 5.4 and 5.5). An earlier study by Fitches *et al.*, (1997) in which larvae were fed artificial diet containing GNA, showed that GNA has little effect on larval survival in tomato moth. A similar result was obtained in this work. However, the Ac-GNA fusion caused 50% larvae mortality, that was significantly higher than that caused by the parental toxins (GNA and Cry1Ac) or diet control. The Ac-GNA fusion protein therefore showed evidence of enhanced toxicity in tomato moth. In contrast to the insecticidal effect on the survival of tomato moth, the presence of fusion protein in artificial diet showed less reduction in BPH survival than that displayed by GNA protein, although survival was decreased compared to control diet. Similarly, when BPH insects were feeding directly on Ac-GNA-expressing transgenic plants (Figure 5.19), the survival of BPH insects was decreased on transgenic plants compared to controls. This is in broad agreement with previous studies on transgenic rice expressing GNA that reduced insect survival by 40 – 50% by day 20 (Rao *et al.*, 1998; Tinjuangjun *et al.*, 2000, Loc *et al.*, 2002), but the effects on this insect caused by the fusion are similar to, or less than the effects of GNA alone. Comparison of the effect of Ac-GNA against BPH insects between artificial diet and transgenic plant bioassays with that of GNA itself suggests that the lower activity of the fusion protein is due to the Cry 1Ac domain having no effect on BPH, even when fused to GNA. There is then a dosage effect due to the presence of the first domain Cry1Ac in the fusion protein that increases the protein size up to 3-fold. On a weight for weight basis the fusion protein contains less GNA than the pure protein. It is also possible that the protein produced in *E. coli* is not fully functional, especially as the refolding of GNA itself produced in *E. coli* is inefficient. In this case the fusion has not produced a novel toxicity towards BPH.

The second lectin-based chimeric gene, encoding the TRX-GNA fusion that consists of rice thioredoxin protein fused to N-terminus of GNA, expressed as an uncleaved protein in *E. coli* and tissues of transgenic rice plants (Figures 5.2 and 5.14). Bioassays against BPH nymphs in artificial diet confirmed the insecticidal activity of TRX-GNA fusion protein towards this insect (Figure 5.6), but did not show that it was more toxic than GNA itself (compare Figures 5.4 and 5.6). Given the very low levels of accumulation of this protein in transgenic rice plants (Figure 5.14), the enhanced resistance of the plants towards BPH (Figure 5.20) is surprising. As thioredoxin h has

been identified as a major protein in rice phloem sap (Ishiwatari *et al.*, 1995) and it has the capacity to move itself around the plant via the translocation stream through plasmodesmata (Ishiwatari *et al.*, 1998), fusing with the gene encoding thioredoxin h could increase the accumulation of GNA-based fusion protein in the rice phloem sap and therefore increasing the resistance of transgenic rice plants to BPH, a homopteran insect that feeds on phloem sap to obtain necessary nutrients for survival. There is an early and significant reduction of BPH survival on TRX-GNA transgenic plants, by day 4 of testing, when compared to Ac-GNA plants. This is possibly due to TRX-GNA being more available in rice phloem sap than Ac-GNA, even though the level of TRX-GNA protein expressed in transgenic plants, as shown by western blots, was lower than that of Ac-GNA protein (Figures 5.12 and 5.14). However, this hypothesis remains to be established in further studies.

The aim of making the chimeric Ac-RTB gene was simply to make more potential receptor binding sites for Bt toxins available in the target insect. The non-toxin B chain of Ricin toxin (RTB) was found to bind strongly to galactose and acetylgalactosamine terminated residues on the cell surface of insect midgut (Frigerio and Roberts, 1998). Transgenic rice plants expressing Ac-RTB fusion protein might possess enhanced toxicity towards different insect pests or merely function to prevent development of resistance to Bt toxins by the insect. This is because development of resistance to the resulting transgenic plants may require several mutations to occur simultaneously in the same insect or at least the combination of several independent mutations through sexual crossing in the susceptible insect population (Maqbool *et al.*, 2001). We obtained preliminary results indicating that Ac-RTB fusion gene expressed in transgenic rice as an uncleaved 97kDa fusion protein. Artificial bioassay against tomato moth (Figure 5.7) showed a slightly reduced survival of tomato moth larva fed on Ac-RTB transgenic rice plants as compared to the survival of larvae that fed on a diet containing the parental Bt toxin. This could imply that the RTB protein domain is only playing a role in increasing receptor-binding sites, and is not as a result increasing the toxicity of the fusion protein. However, further confirmatory experiments including artificial bioassays and a trial of transgenic plants expressing this fusion protein against different insect pests need to be done to fully assess the biological activity of Ac-RTB

fusion protein.

In summary, our results demonstrated that it is possible to increase toxicity, insecticidal spectrum and probably the durability of insect resistance genes against insect pests by the chimeric gene approach, and that individual proteins in fusions remain functional in an “additive effect” manner.

5.2.2. Transgenic rice plants expressing low level of GNA fusion proteins display “horizontal resistance” to brown plant hopper.

Although development of strongly pest-resistant rice cultivars is always a high priority, these cultivars are threatened by “resistance breakdowns”, notable examples including loss of resistance to the brown planthopper (Heinrichs, 1986) and the Asian rice gall midge (Bennett *et al.*, 2000). The implementation of integrated pest management (IPM) in irrigated rice areas for the past few decades has proved it as a significant pest management strategy for preventing insect pest problems (Matteson, 2000). This strategy employs the use rice cultivars with “moderate resistance” (also termed as “horizontal” or “field resistance”). These moderate-resistance rice plants do not necessarily kill all insects, but render a tolerant trait to rice plants to survive under the attack of insect pest. Cohen (2000) described the “high-dose/refuge” resistance management strategy for the sustainable use of Bt transgenic rice, in which the author recommended the use of transgenic rice with high level of Bt expression (up to 0.2% of soluble leaf protein) in combination with non-Bt plants (refuge plants) serve to maintain susceptible insects in the population. However none of the transgenic rices produced so far meet this requirement for resistance to BPH, and Bt-rice shows no resistance at all to this pest. Therefore, in our view, horizontal resistance rice cultivars still prove their benefit for rice farmers for some coming years.

In our bioassays, transgenic rice plants expressing GNA-based fusion proteins gave a significant reduction in survival of brown planthoppers that fed on them. By day 24, only 20-30% of insects survived on these transgenic plants (Figures 5.19 and 5.20). Further, although wild type control plants began to die from day 18 of these bioassays and reached 100% dead by day 24, all transgenic plants survived with little damage. To confirm the resistance of these transgenic plants against BPH, a feeding preference

experiment was carried out. The R1 seeds of transgenic plants expressing Ac-GNA and TRX-GNA fusion proteins were germinated in hygromycin 1/10 MS solution and then transplanting in seed trays, along with wild type control and TN1 plants (BPH susceptible rice cultivar, often used as susceptible check) following the procedure of the International Rice Testing Programme (IRRI, 1985). After seven days of transplanting, BPH nymphs of 1st instar were released on to rice plants to be tested at an estimated density of about 10 insects per plant. By day 6 after BPH infestation, all wild type control plants were recorded as dead. By day 9, all TN1 plants were dead but all transgenic lines of Ac-GNA and TRX-GNA were scored between 5 and 7 (between moderate resistant to susceptible, in scale of 0 to 9) (figure 5.21). Interestingly, we also observed that BPH nymphs preferred feeding on susceptible (wild type and TN1) plants rather than transgenic plants, and continued to show this preference until the control plants showed severe damage and became stunted, forcing more insects to feed on transgenic plants. Xavier Foissac *et al.*, (2000) suggested that GNA expression in rice plant tissues could interfere with plant physiology in such a way that reduces the quality or quantity of sap nutrients, making it a suboptimal or unbalanced diet for the hoppers. This could explain why hoppers avoided feeding on transgenic plants expressing GNA fusions as their first choice.

Our data demonstrated that transgenic rice plants expressing low level of GNA fusion proteins show moderate resistance to BPH and could tolerate the attack of insect pests, a character that is displayed by horizontal resistance rice cultivars. In conclusion we believe that, until researchers could find the way to produce transgenic rice plants with a high level of resistance to this pest, which is likely to require high expression levels of insect resistance genes, up to 0.2% of total soluble protein or more, these GNA-fusion genes would be good candidates for insect resistance breeding programs in developing elite rice plants suitable for local demands.

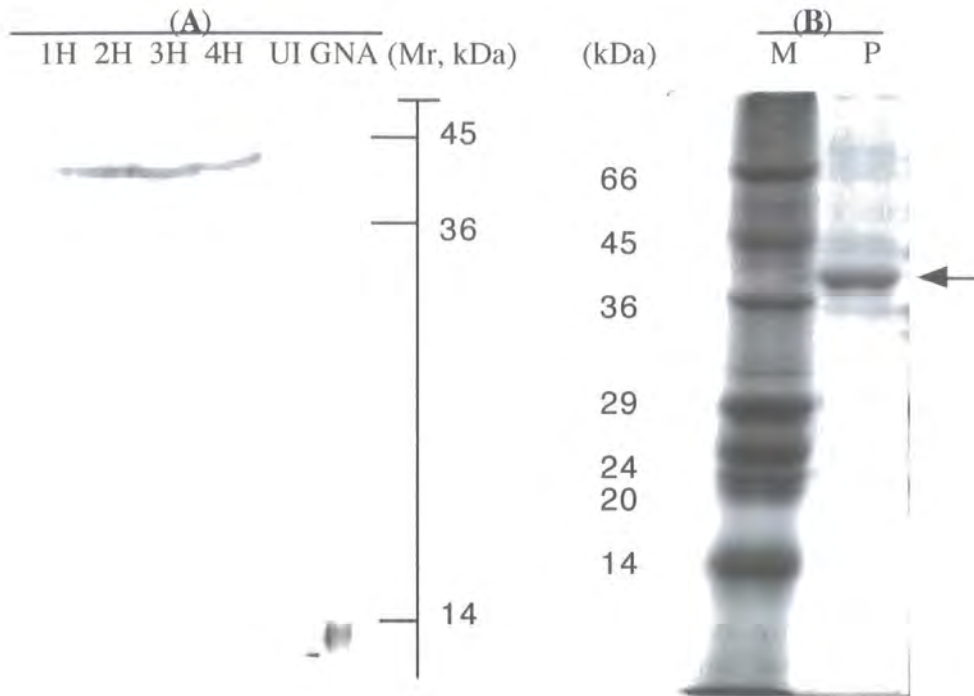

Figure 5.1: Expression of the first domain Ac-GNA fusion protein in E.Coli and protein purification.

(A): western blot of total protein samples (1H: sample taken at 1 hour after induction; 2H, 3H, 4H: 2, 3, 4 hours after induction) run on SDS-PAGE protein gel (12% acrylamide), probed with anti-GNA antibody. UI: Un-induced sample, GNA: Purified GNA standard.

(B): SDS-PAGE protein gel of purified (P) sample using an affinity Ni-column. Proteins were detected by Coomassie blue staining.

(→): the first domain Ac-GNA fusion protein, approximately 41,15 kDa.

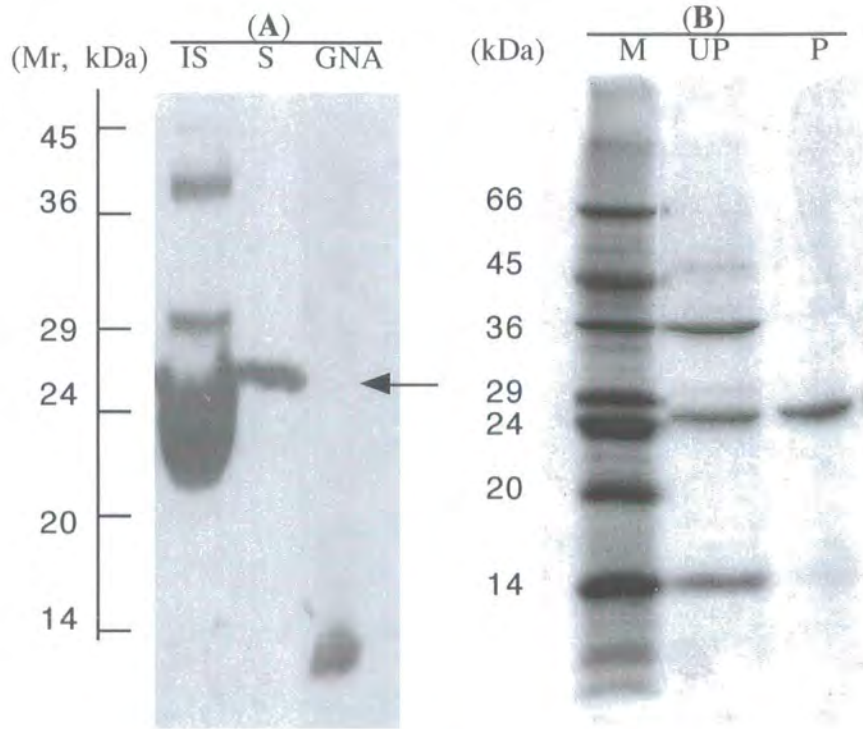

Figure 5.2. : Expression of TRX-GNA fusion protein in *E.coli* and protein purification.

(A): western blot of insoluble (IS) and soluble (S) fractions run on SDS-PAGE protein gel (12% acrylamide), probed with anti-GNA antibody, GNA: Purified GNA standard.

(B): SDS-PAGE protein gel of unpurified (UP) sample from solubilised IS fraction and purified (P) sample using Q-sepharose column. Proteins were detected by Coomassie blue staining.

(→): TRX-GNA fusion protein, approximately 25,9 kDa

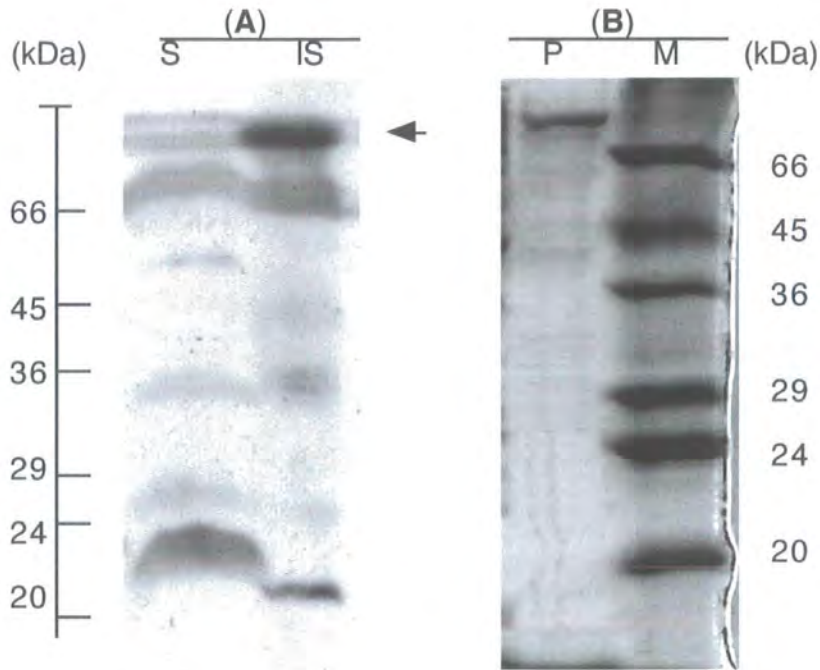

Figure 5.3: Expression of Ac-RTB fusion protein in *E.coli* and protein purification.

(A): western blot of soluble (S) and insoluble (IS) samples of Ac-RTB fusion proteins run on SDS-PAGE protein gel (12% acrylamide), probed with anti-Cry1Ab antibody which cross-reacts with the Cry1Ac protein

(B): SDS-PAGE protein gel (12% acrylamide gel) of purified Ac-RTB protein sample eluted from Ni-affinity column. Proteins were detected by Coomassie blue staining.

(→): Ac-RTB fusion protein, expected size is about 97 kDa

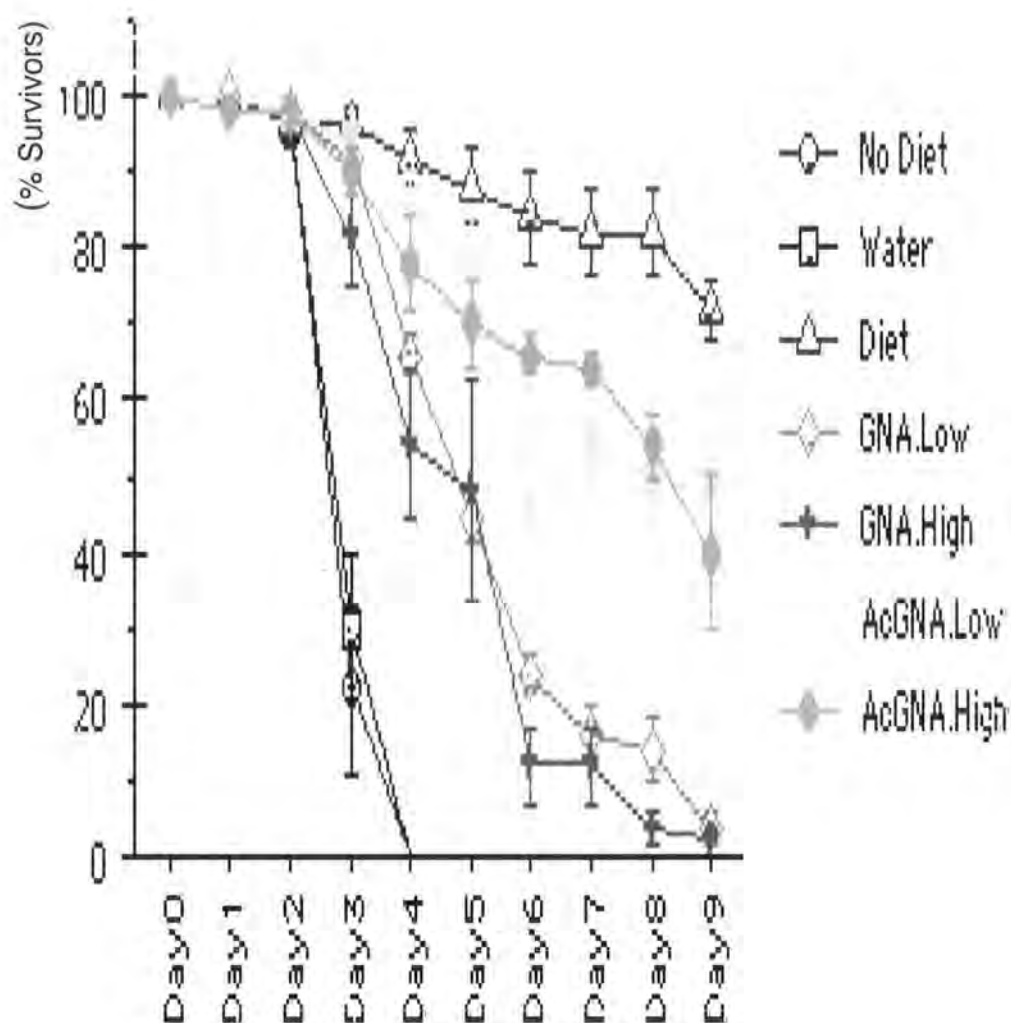

Figure 5.4 : An artificial diet bioassay of the purified first domain Ac-GNA fusion protein and GNA, each at concentrations of 0.05 mg/ml and 0.1 mg/ml in diet medium. Controls include (1) no diet, (2) water and (3) diet medium without added purified first domain Ac-GNA protein. Five of second or third instar BPH nymphs were used in each dish, ten replicates for each treatment. Error bars: ± 1 standard errors.

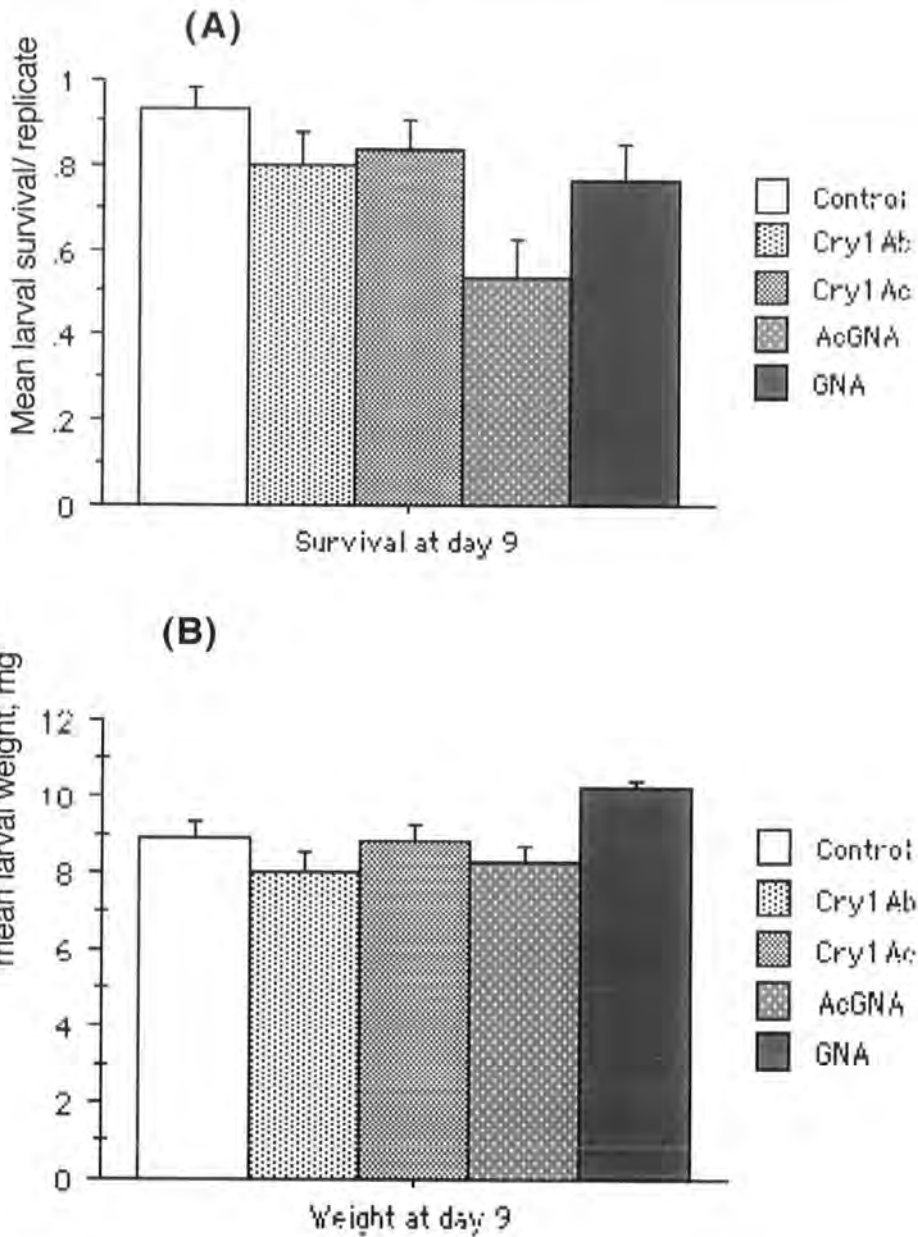

Figure 5.5: An artificial bioassay of the first domain Ac-GNA against *Lacanobia oleracea*. (A): Larval survival analysis. Neonate first instar larvae were placed individually on diet treatments containing toxin proteins (either Cry1Ab, Cry1Ac, first domain Ac-GNA or GNA) or adding only casein instead (control treatment) at the concentration of 2% (w/w). Each treatment was replicated for 30 times. (B): Larval development; individual wet weights (± 0.1 mg) were recorded.

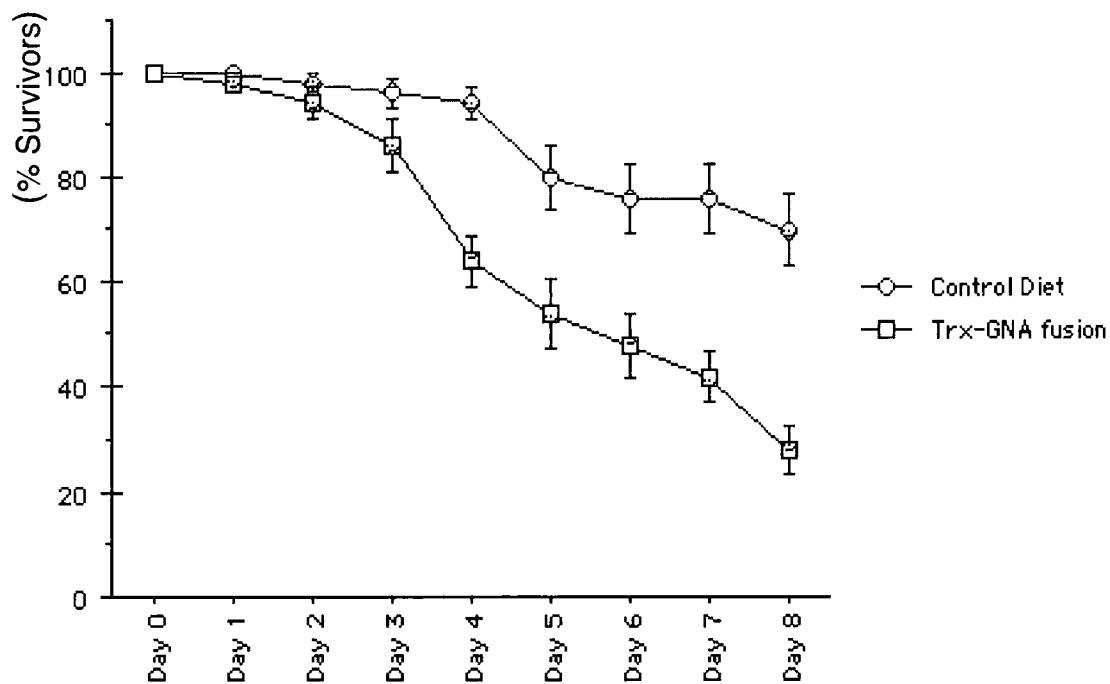

Figure 5.6: Artificial diet bioassay of the purified TRX-GNA fusion protein at the concentration of 0.05 mg/ml in diet medium. Control diet is without added purified TRX-GNA protein. Five of second or third instar BPH nymphs were used in each dish, ten replications for each treatment. Error bars : ± 1 standard errors.

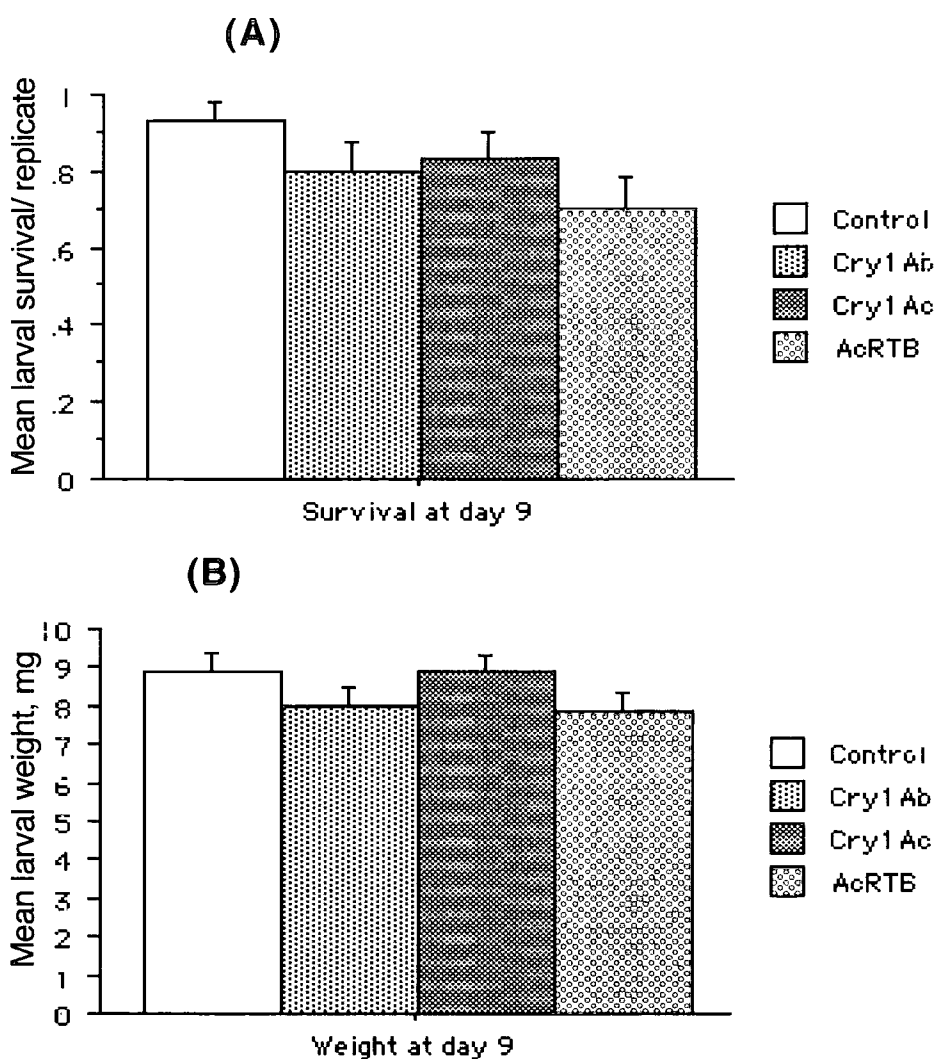

Figure 5.7: Artificial bioassay of Ac-RTB against *Lacania oleracea*. (A): Larval survival analysis. Neonate first instar larvae were placed individually on diet treatments containing toxin proteins (either Cry1Ab, Cry1Ac or Ac-RTB) or adding only casein instead (control treatment) at the concentration of 2% (w/w). Each treatment was replicated for 30 times. (B): Larval development; individual wet weights (± 0.1 mg) were recorded.

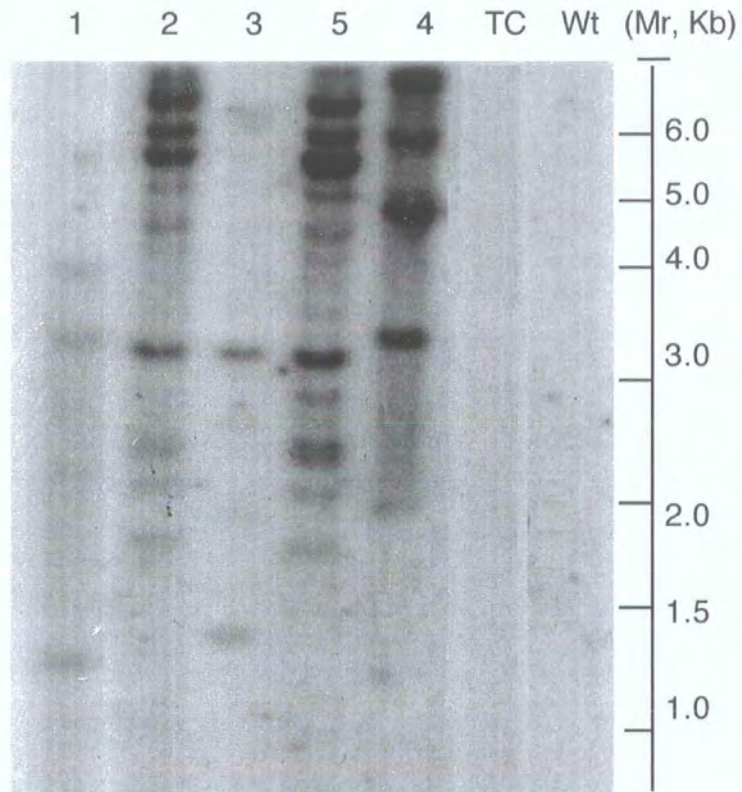

Figure 5.8 : Southern blot analysis of genomic DNAs from leaves of R0 first domain Ac-GNA transgenic rice plants. The DNAs were digested with EcoR1, which cut the transforming plasmid once, and hybridised with random labelled probes from the coding sequence of first domain Ac-GNA fusion. (TC): Hygromycin transgenic plant. (WT): Wild type EY1105. (Mr): 1kb molecular marker.

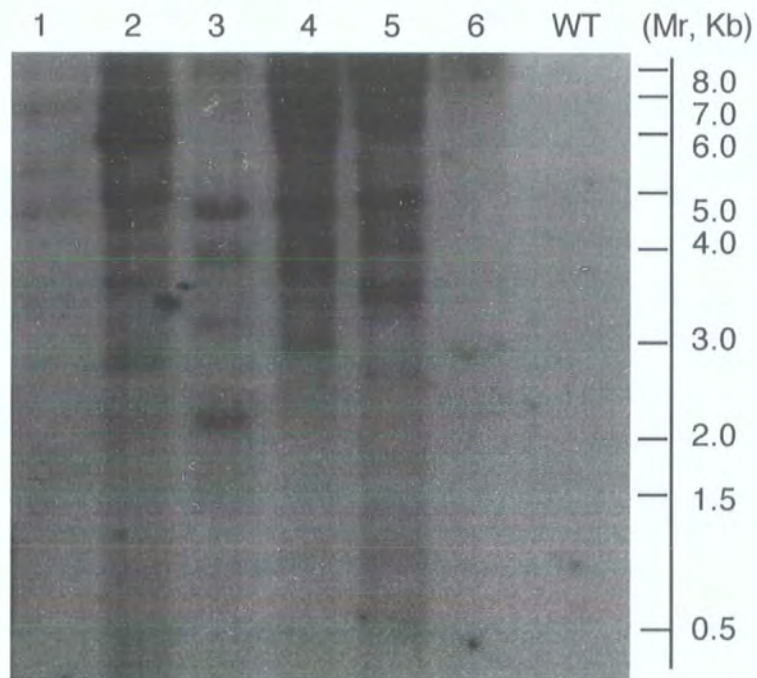

Figure 5.9 : Southern blot analysis of genomic DNA from leaves of R0 TRX-GNA transgenic rice plants. The DNAs were digested with EcoRI, which cut the transforming plasmid once, and hybridised with random labelled probes from the coding sequence of TRX-GNA.

WT: Wild type EYI105

Mr: 1kb molecular marker

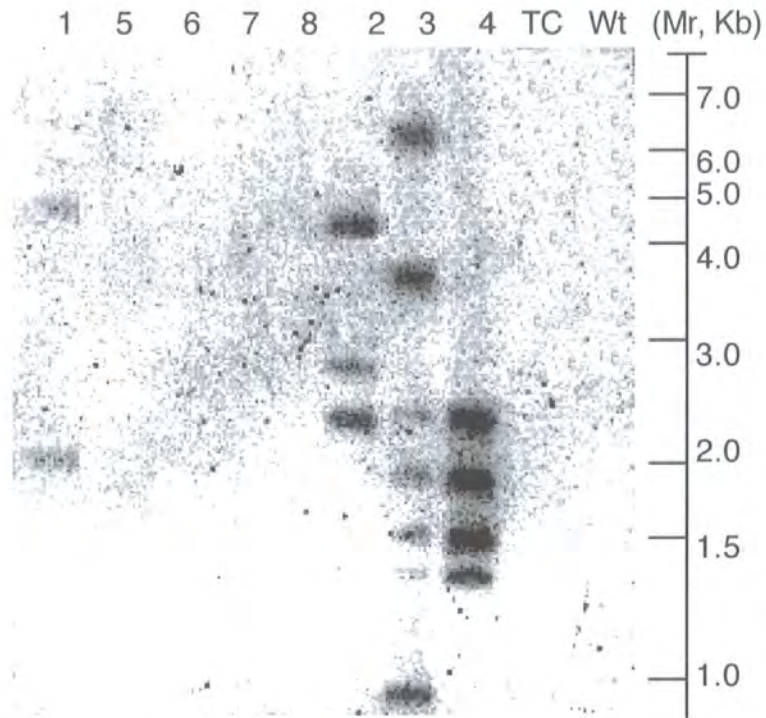

Figure 5.10: Southern blot analysis of genomic DNA from leaves of R0 Ac-RTB transgenic rice plants. The DNAs were digested with EcoR1, which cut the transforming plasmid twice (one inside the Ac-RTB gene and the other at the cloning site of pAL 76 vector), and hybridised with random labelled probes from the coding sequence of Ac-RTB. (TC): Hygromycin transgenic plant. (WT): Wild type EY1105. (Mr): 1kb molecular marker.

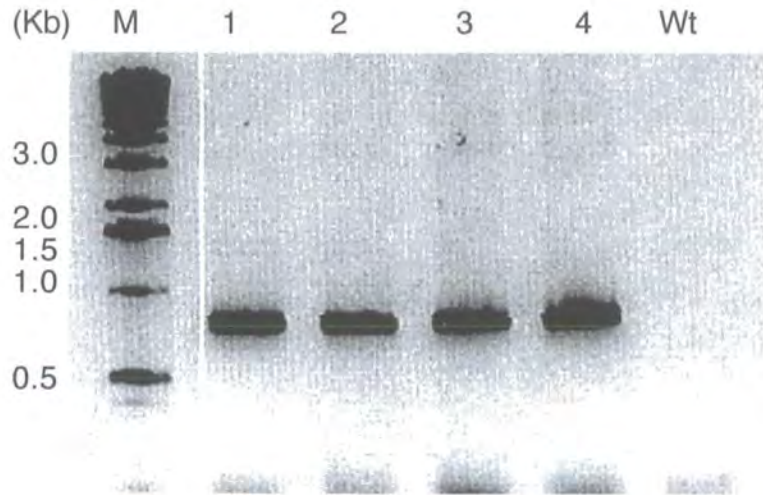

Figure 5.11: RT-PCR analysis of R0 first domain Ac-GNA transgenic rice plants. The amplified product is 820 bp in size. Total RNAs were treated with DNase before RT-PCR analysis. Lane 1-4: R0 first domain Ac-GNA transgenic plants . WT: wild type EYI105. M: 1kb DNA ladder marker

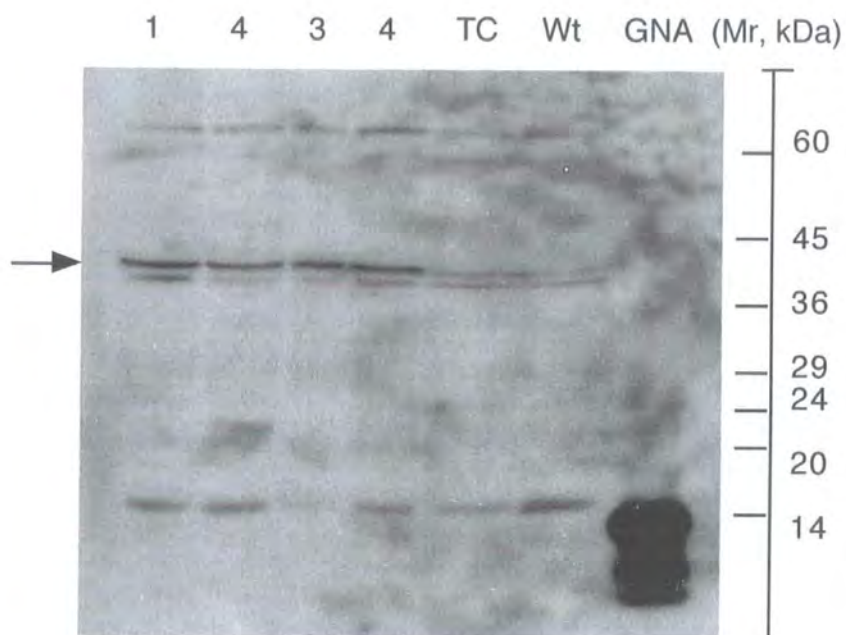

Figure 5.12: Western blot analysis of R0 first domain Ac-GNA rice transgenic plants. An amount of 50ug of total protein was loaded on SDS-PAGE protein gel (12% acrylamide), probed with anti-GNA antibody.

Lane 1-4: R0 first domain Ac-GNA transgenic plants

Wt: wild type EY1105

GNA: purified GNA protein, 50ng loaded per lane.

(→): first domain Ac-GNA fusion protein, expected size is 41,15 kDa.

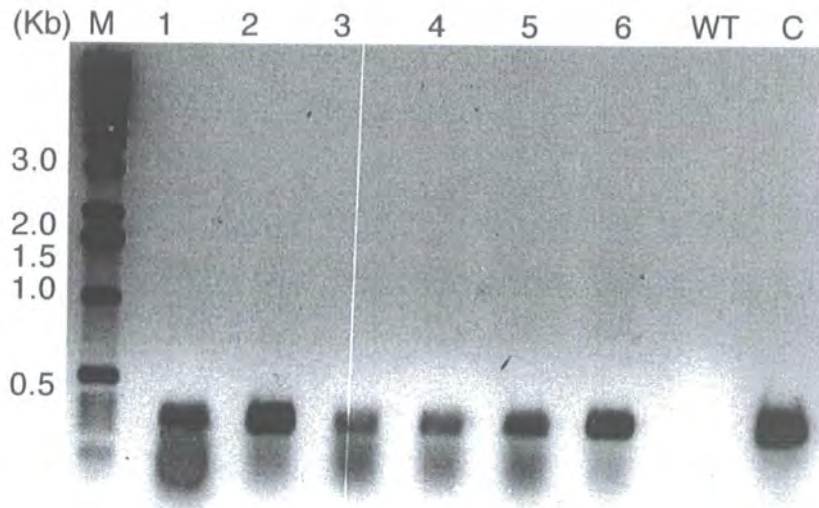

Figure 5.13: RT-PCR analysis of R0 TRX-GNA transgenic rice plants. The amplified product is 350 bp in size. Total RNAs were treated with DNase before RT-PCR analysis..
WT: wild type EYI105
C: control transforming plasmid of TRX-GNA construct.
M: 1kb DNA ladder marker

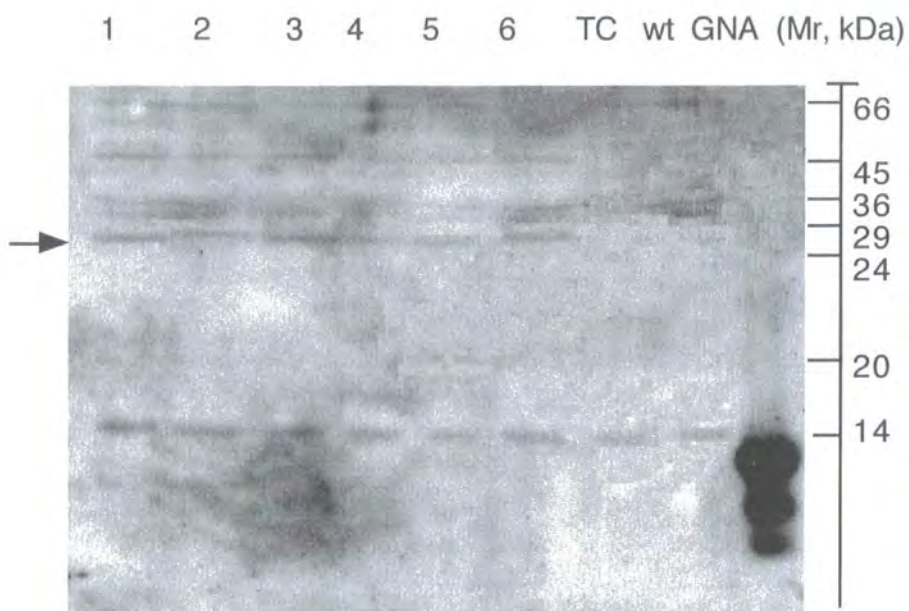

Figure 5.14: Western blot analysis of R0 TRX-GNA rice transgenic plants. 50ug of total protein was loaded on SDS-PAGE protein gel (12% acrylamide), probed with anti-GNA antibody.

Lane 1-6: R0 TRX-GNA transgenic plants

wt: wild type EYI105

GNA: purified GNA protein, 50ng loaded per lane.

(→): TRX-GNA protein , expected size is 25.9 kDa.

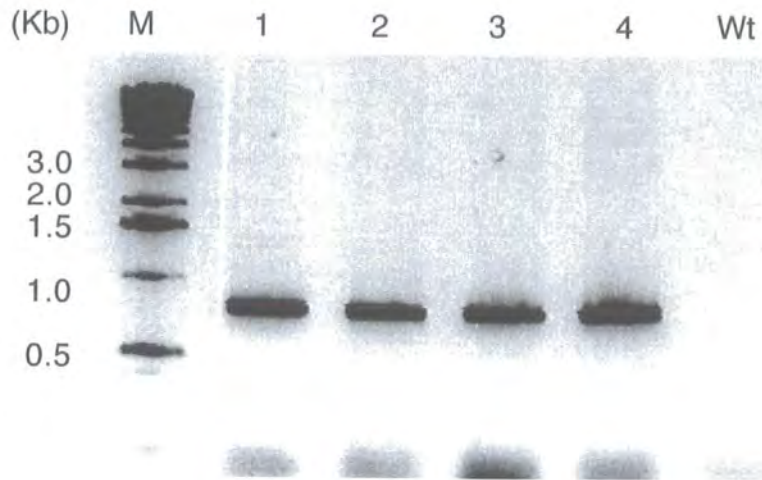

Figure 5.15: RT-PCR analysis of R0 Ac-RTB transgenic rice plants. The amplified product is 654 bp in size. Total RNAs were treated with DNase before RT-PCR analysis.

Lane 1-4: R0 Ac-RTB transgenic plants .

WT: wild type EY1105.

M: 1kb DNA ladder marker

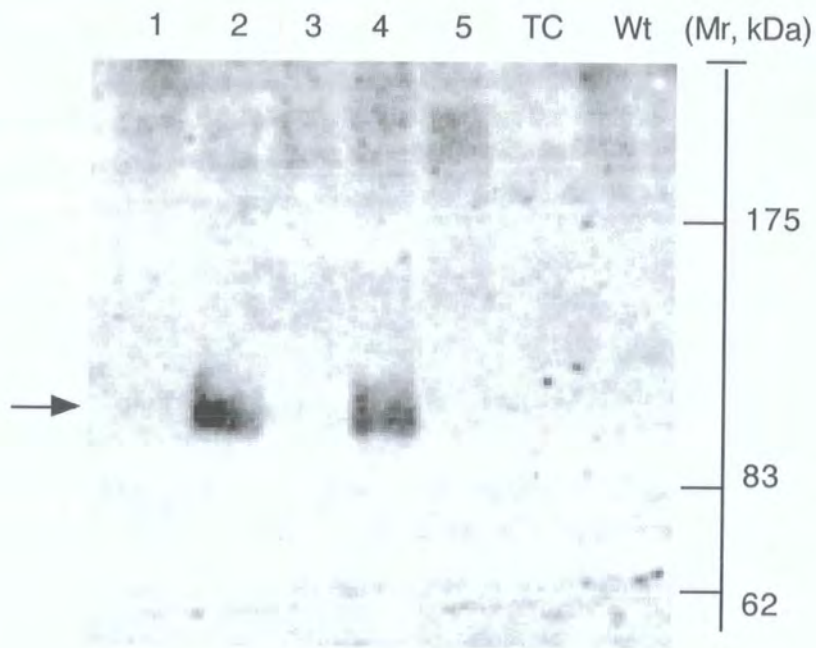

Figure 5.16: Western blot of R0 transgenic rice plants expressing Ac-RTB fusion protein; blot probed with anti-cryIAb antibody, which cross-linked with CryIAc protein. Wt : non-transformed control; TC : transformed control, negative for Ac-RTB transgene by PCR. Mol. wt. scale from NEB prestained protein marker standards (P7708). SDS-PAGE carried out on 5% acrylamide gel. (\blackrightarrow): Ac-RTB fusion protein, expected size is 97kDa.

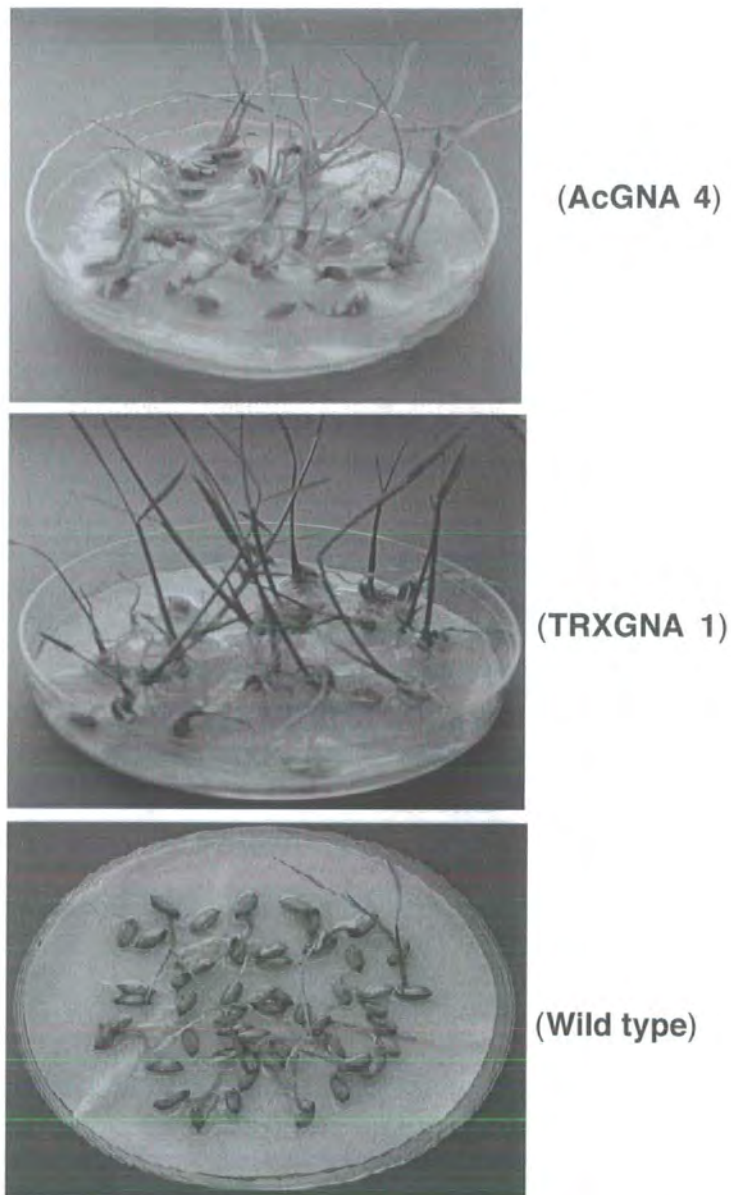

Figure 5.17: Selection of hygromycin-resistant plants of R1 progenies of TRX-GNA and first domain Ac-GNA transgenic rice lines. Seeds obtained from R0 transgenic and wild type plants were germinated in 1/10 MS medium nutrient solution containing 50mg/l hygromycin. Representative photos of screened AcGNA4 , TRXGNA1 and wild type seeds were shown (1 week after germination).

Table 5.1 : Inheritance analysis of R1 transgenic rice progenies for hygromycin resistance gene.

Construct	Clone	total seeds germinated	resistant seedlings	susceptible germinated seeds	Expected Ratio
First domain Ac-GNA	1	50	39	11	3 : 1
	2	36	25	11	3 : 1
	3	33	24	9	3 : 1
	4	50	37	13	3 : 1
TRX-GNA	1	50	39	11	3 : 1
	2	50	38	12	3 : 1
	3	13	10	3	3 : 1
	4	20	16	4	3 : 1
	5	14	9	4	3 : 1
	6	15	10	5	3 : 1

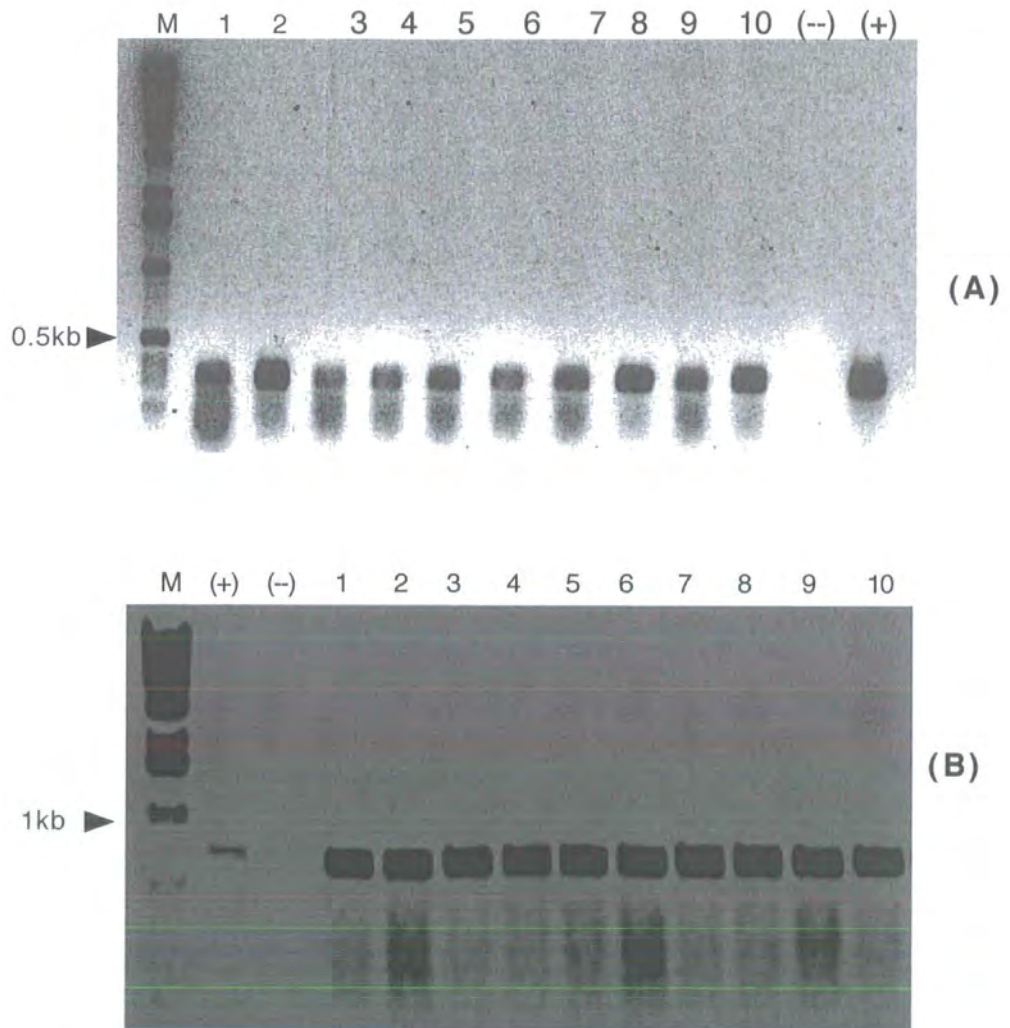

Figure 5.18: PCR analysis for the presence of TRX-GNA (A) and Ac-GNA genes (B) in R1 transgenic rice plants.

(--) : negative control (water).

(+) : positive control (plasmids containing target genes)

M : Marker, 1kb marker

lane 1 - 10: R1 transgenic rice plants

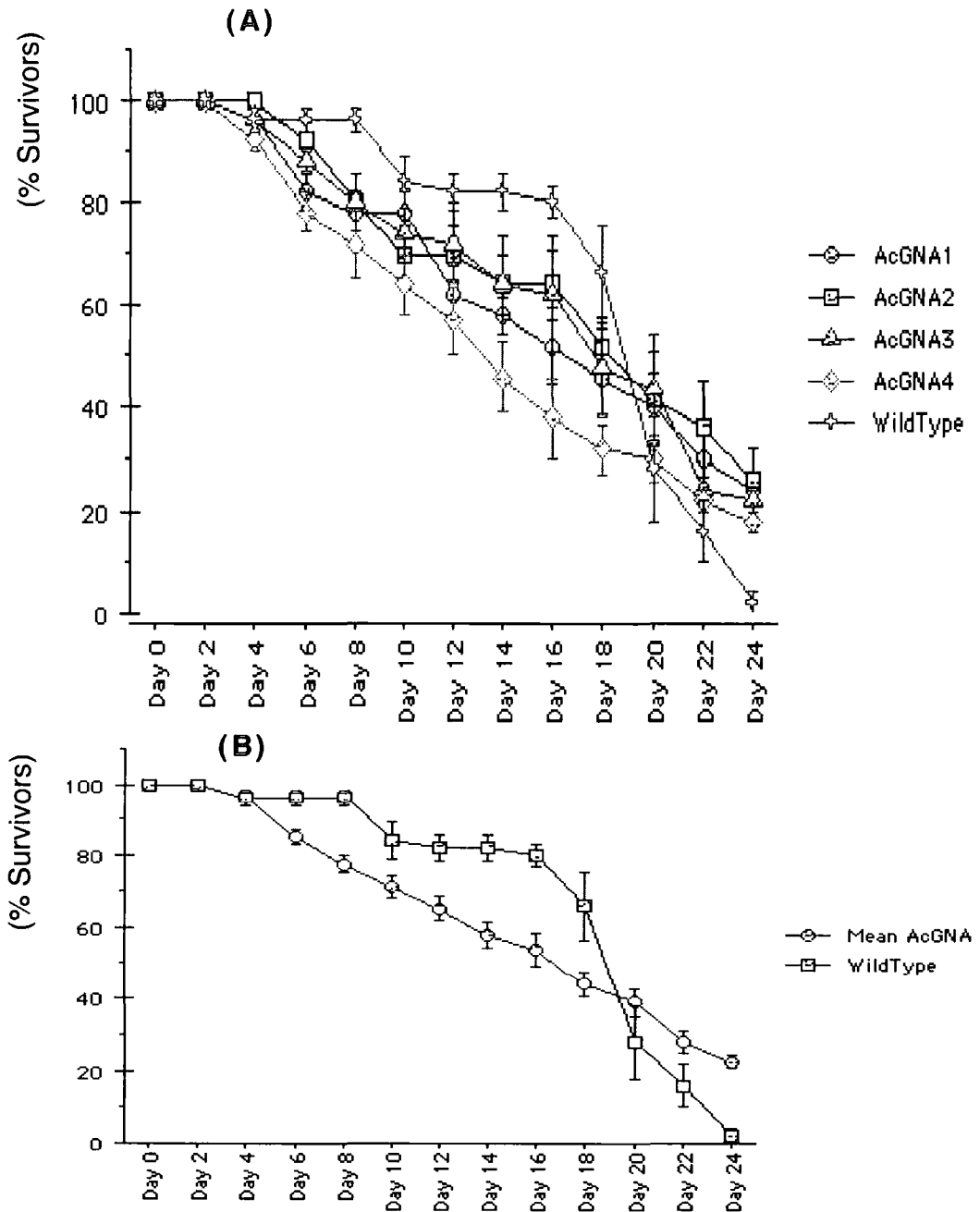

Figure 5.19: Bioassay of R1 first domain Ac-GNA transgenic rice plants against brown plant hopper. (A): Assays were carried out with first- or second-instar nymphs, Ten nymphs were inoculated onto 20 days-old rice seedling plants and were set up for 10 replicates of each transgenic line. Wild type EY1105 plants were used as controls. Error bars: ± 1 standard errors. (B): Mean value (% survivors) of survival BPH nymphs from pooled R1 Ac-GNA transgenic and wild type data during the time course of bioassay.

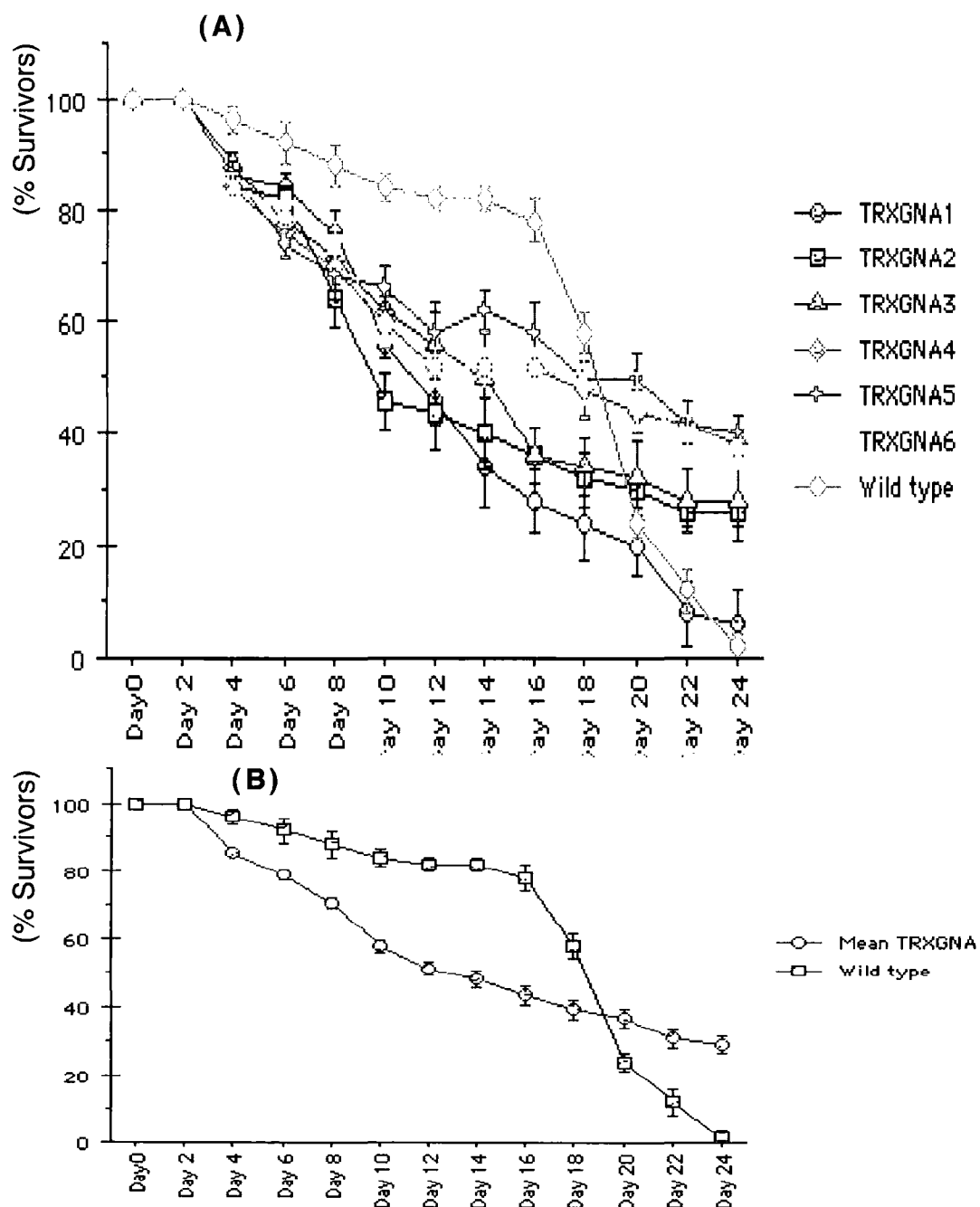

Figure 5.20: Bioassay of R1 TRX-GNA transgenic rice plants against brown plant hopper. (A): Assays were carried out with first- or second-instar nymphs, Ten nymphs were inoculated onto 20days-old rice seedling plants and were set up for 10 replicates of each transgenic line. Wild type EYI105 was used as a control. Error bars: ± 1 standard errors (B): Mean value (% survivors) of survival BPH nymphs from pooled R1 TRX-GNA transgenic and wild type data during the time course of bioassay.

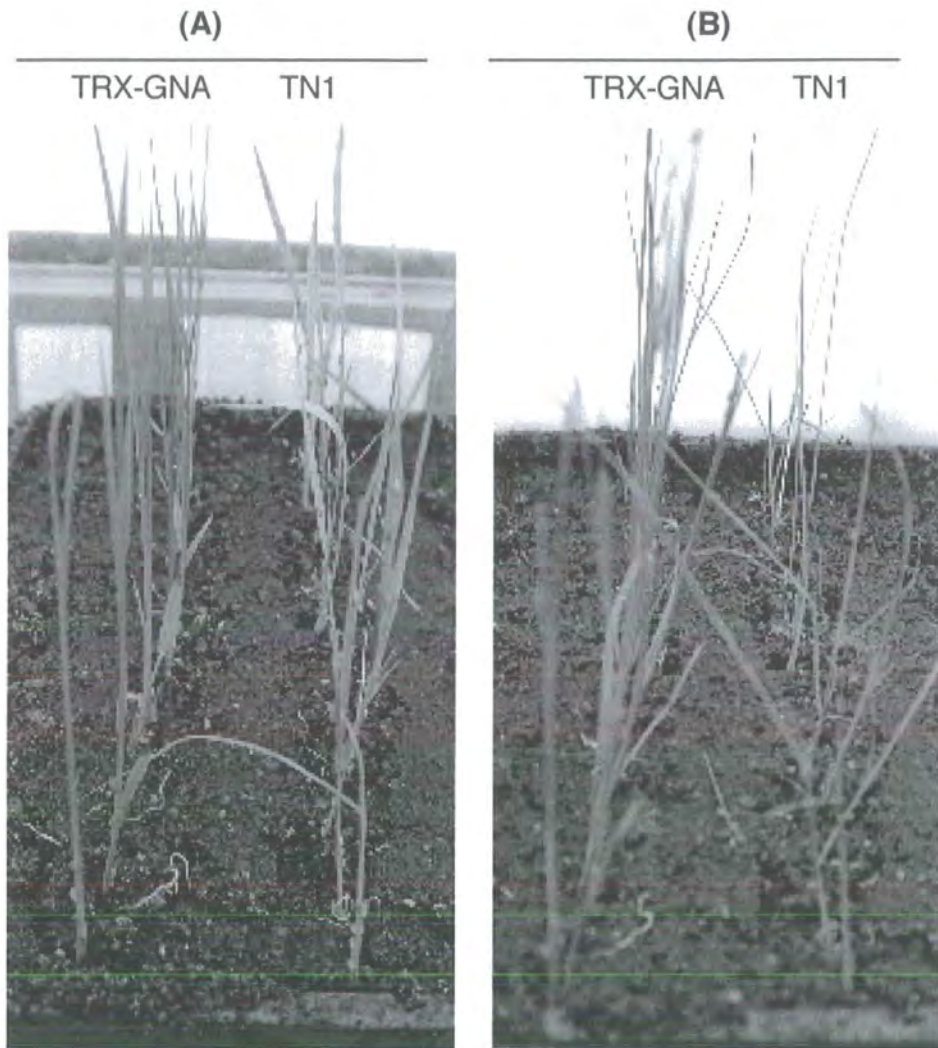

Figure 5.21: screening R1 TRX-GNA transgenic plants against brown planthopper (BPH) insect . **(A)**: two days after BPH infection. **(B)**: nine days after BPH infection.

TN1 : BPH susceptible control plants

TRXGNA : R1 transgenic rice plants

Chapter 6

GENERAL CONCLUSIONS

This work has aimed at applying plant genetic engineering methods to understand the bases of, and to improve, some agronomic characteristics of rice. Recent advances in molecular genetics and biology have greatly increased our understanding and capacity to modify and produce crop plants with desirable characteristics that would be impossible to achieve with conventional, non-molecular-based breeding alone. The success of this study would have an impact, at least, on the sustainability of rice production in Viet Nam where rice production has been a remarkable achievement in term of productivity and export recently.

This thesis describes the production of transgenic rice plants with alterations to two main traits:

(1) Polyamine content in the rice plant, as an agronomic-related physiological trait that affects the ability of rice to tolerate environmental stresses (Sawhney and Galtson, 1979). An understanding of how the polyamine pathway is controlled and regulated will benefit our planning for the production of polyamine modified rice cultivars for environmental stress areas.

(2) Resistance of the rice plant to attack by insect pests plays an important in sustaining food productivity. The rice crop is vulnerable to a wide range of insect herbivores which both feed on the plant and act as vectors for transmission of viral pathogens. Therefore the continuing enhancement of insect resistance traits in rice, in terms of toxicity, insecticidal spectrum and durability, is a priority for rice researchers.

I have demonstrated that the level of putrescine in rice plants can be modified according to need by using transgenic approaches. The expression of antisense heterologous oat arginine decarboxylase cDNA in rice plants can suppress endogenous enzyme activity, and decrease end product level in a tissue dependent manner. The expression level of oat antisense ADC vs endogenous rice ADC transcripts, rice ADC transcript vs ADC enzyme activity in transgenic rice plant did not tighly correlated. Malmberg *et al.* (1992) and Watson and Malmberg (1996) reported that precursor ADC polypeptide was post-translationally processed in oat and Arabidopsis species to give

rise two active polypeptides. Therefore, the less- or un-correlation between oat ADC and rice ADC transcripts, between rice ADC transcript and ADC enzyme activity indicated that the activity of ADC enzyme is post-transcriptional regulated. For a hierarchical accumulation of polyamines in different tissues/organs, it is reasonable to assume that in highly metabolically active tissues/organs such as leaf, plant employs some kinds of regulation mechanism to maintain steady-state pools of key vital metabolites. Therefore, it is possibly that the differentiate accumulation of polyamines in leaf (metabolically active) and in seed or root (less metabolically tissues) is due to the translocation of polyamines from one to another parts of the plant. Thus the translocation of polyamines might be one of regulatory mechanisms that plant cells use to control polyamine pathway and its products. Our results also showed that the steady-state mRNAs for the other endogenous polyamine genes remained unaffected by the presence of the oat ADC antisense ADC. This indicated that the tight regulation at the level of mRNA expression of the genes involved in the polyamine pathway is not overcome by the alteration of the size of the free polyamine pool.

To extend the results obtained with putrescine synthesis, I have demonstrated that the over-expression of a homologous spermidine synthase transgene in rice plants increases the expression of both endogenous and transgene mRNAs. Transgenic rice plants were observed over-expressed spermidin synthase mRNAs and possibly resulted in higher level of spermidine synthase enzyme. Paradoxically, the accumulation of spermidine was not significantly changed when compared to that of non-transformed wild type plants. It was noted, however, that putrescine levels in these transgenic rice plants were significantly higher accumulated without changes in ADC and ODC at mRNAs levels. The phenomenon suggests the possible presence of an inter-conversion process from spermidine to putrescine in transgenic plants. This may be one of regulatory mechanisms through which plants adjust their metabolism to maintain steady-state pools of key metabolites. David *et al.* (1992) have proposed that animal cells, although able to tolerate high concentrations of putrescine, are unable to tolerate high concentrations of spermidine and spermine. Woon-Noh *et al.*, (1994) generated transgenic tobacco plants which over-expressed a human SAMDC gene under the control of 35S promoter. They obtained abnormal morphological transgenic plants with

significantly increased level of SAMDC activity, putrescine level was significant reduced, spermidine was 2-3 times higher than the control, while spermidine content was either increased or remained unchanged. Kumar *et al.* (1996) generated transgenic potato plants with either sense or antisense SAMDC. They observed that transgenic plants with constitutively expressing sense SAMDC failed to survive after the micro callus stage and suggested that large increase in the level of spermidine could be cytotoxic to transformed cells. In our study, transgenic plants that over-expressed spermidine synthase mRNAs displayed normal phenotype development as similar as that of control wild type and hygromycin transformed plants. It is possible that the process of selection of transformed cells might have recovered only transgenic plants with small or moderately changes in spermidine synthase enzyme activity and with an elevated inter-conversion process as indicated by normal phenotype development of the transgenic rice plants. Those transformed cells with over-expressed spermidine synthase enzyme that caused large increase in spermidine became lethal. Furthermore, this study also suggests that the step from putrescine to spermidine which catalysed by spermidine synthase enzyme is regulated at post-transcriptional levels.

In summary, our results along with other publications clearly showed that: (1) although putrescine levels in plant cells can fluctuate widely, little or no changes in either spermidine or spermine was observed. (2) The likelihood of a tight metabolic regulation that controls polyamine levels in leaf (or stem) is probably achieved by some regulatory mechanisms likely (a) transcription, translational and post translational modifications, (b) translocation of polyamines from one to other parts of the plant, (c) inter-conversion process. It is possible that some of these regulatory mechanisms may be important in controlling minor fluctuations in polyamine levels, while others only become involved under large changes of polyamine pools. Our results also imply that attempts to alter polyamine metabolism might be nullified by regulatory mechanisms present in the plant that are not fully understood at present.

I have demonstrated that toxicity, insecticidal spectrum and possibly durability of toxins resistant to insect pests can be enhanced by using gene constructs encoding fusion proteins. The fusion between the first domain of cry1Ac with GNA (AcGNA) showed toxic to both tomato moth (*Lacanobia oleracea*; Lepidoptera) and brown

planthopper (*Nilaparvata lugens*; homoptera) insect pests as demonstrated by artificial insect bioassays of purified proteins and plant-insect bioassay (Fig. 5.4; 5.5; and 5.19). The fusion between cry1Ac with ricin B chain (RTB) showed a slightly reduced survival of tomato moth larva fed on Ac-RTB transgenic rice plants as compared to the survival of larvae that fed on a diet containing the parental Bt toxins: cry1Ac or cry1Ab (Fig. 5.7). This could imply that the RTB protein domain is only playing a role in increasing receptor-binding sites, and is not as a result increasing the toxicity of the fusion protein. However, further confirmatory experiments including artificial bioassays and a trial of transgenic plants expressing this fusion protein against different insect pests need to be done to fully assess the biological activity of Ac-RTB fusion protein. The level of resistance seen in plants containing the TRX-GNA fusion gene (Fig. 5.20 and 5.21), despite very low levels of expression of the protein (Fig. 5.14) suggested that the fusion of TRX gene with GNA might help targeting GNA present in phloem cells much efficiency than plants that expressed GNA alone. In summary, these fusion proteins have been shown to display an additive effect as insect toxins by maintaining the functional properties of the individual proteins. Our study along with the results published by Fitches *et al.* (1997; 2002; 2004 (a) and (b)) demonstrated that fusion between different translational peptides could generate novel insecticidal toxin genes possessing novel traits according to our needs.

Our results clearly showed that transgenic rice plants expressing these fusion protein genes are moderately resistant to brown planthopper, an important insect pest in tropical rice growing areas. We suggest that optimisation of expression of Ac-GNA and TRX-GNA constructs could result in rice plants that were highly resistant to the pest. I have developed transgenic rice plants that could be used as valuable breeding resources for an insect-resistance breeding program. These rice plants behave as horizontally resistant cultivars that are suitable for integrated pest management (IPM) networks.

References

- Allen, G.C., Spiker, S., Thompson, W.F. (2000). Use of matrix attachment region (MARs) to minimize transgene silencing. *Plant Mol. Biol.* 43: 361-376.
- Artsaenko, O., Phillips, J., Fiedler, U., Peisker, M. and Conrad, U. (1999). Intracellular immunomodulation in plants – a new tool for the investigation of phytohormones. In: Harper, K. and Ziegler, A. (Eds), *Recombinant antibodies: Applications in plant science and plant pathology*, Taylor & Francis, London, pp 145-156.
- Bachrach, U. and Wang, Y.C. (2002). Cancer therapy and prevention by green tea: role of *Ornithine decarboxylase*. *Amino Acids* 22: 1-13.
- Bailey, R. (2001). Why we should learn to stop worrying and love genetically modified food. *Reason Magazine* in www.agbioworld.org/biotech_info/topics/agbiotech/strangelunch.html.
- Bassie, L., Noury, M., Lepry, O., Lahaye, T., Christou, P. and Capell, T. (2000). Promoter strength influences polyamine metabolism and morphogenic capacity in transgenic rice tissues expressing the oat *Arginine decarboxylase* cDNA constitutively. *Trans. Res* 9:33-42.
- Baulcombe, D.C. (1996). Mechanisms of pathogen-derived resistance to viruses in transgenic plants. *Plant Cell* 8: 1833-1844.
- Baum, T.J., Hiatti, A., Parrott, W.A., Pratt, L.H. and Hussey, R.S. (1996). Expression in tobacco of a functional monoclonal antibody specific to stylet secretions of the root-knot nematode. *Mol. Plant-Microbe Interact.* 9: 382-387.
- Beilmann, A., Pfitzner, A.J.P., Goodman, H.M. and Pfitzner, U.M. (1991). Functional analysis of the pathogenesis-related 1a protein gene minimal promoter region: Comparison of reporter gene expression in transient and in stable transfections. *Eu J Biochem* 196: 415-421.
- Ben-Yakir, D. and Shochat, D. (1996). The fate of immunoglobulin G fed to larvae of *Ostrinia nubilalis*. *Entomol. Exp. Appl.* 81: 1-5.

References

- Bennett, J., Bentur, J.S., Pasalu, I.C. and Krishnaiah, K., editors (2000). New approaches to gall midge resistance in rice. Makati city (Philippines): International Rice research institute.
- Bhatnager, P., Glasheen, R.L., Bains S.K., Long, S.T., Minocha, R., Walter, C. and Minocha, S.C. (2001). Transgenic manipulation of the metabolism of polyamines in polar cells. *Plant Physiol.* 125: 2139-2153.
- Bohorova, N., Frutos, R., Royer, M., Estanol, P., Pacheco, M., Rascon, Q., McLean, S., and Hoisington, D. (2001). Novel synthetic *Bacillus thuringiensis* cry 1B gene and the cry1B-cry1Ab translational fusion confer resistance to southwestern corn borer, sugarcane borer and fall armyworm in transgenic tropical maize. *Theor. Appl. Genet.*, 103: 817-826.
- Bradford, M.M. (1976). A rapid and sensitive method for the quantitation of microgram quantities of protein utilizing the principle of protein dye binding. *Annal. Biochem.* 723: 248-254.
- Breitler, J.C., Labeyrie, A., Meynard, D., Legavre, T. and Guiderdoni, E. (2002). Efficient microprojectile bombardment-mediated transformation of rice using gene cassettes. *Theor. Appl. Genet.* 104:709-719.
- Burtin, D. and Michael, T. (1997). Over-expression of arginine decarboxylase in transgenic plants. *Biochem. J.* 325: 331-337.
- Cao, J., Zhang, W., McElroy, D. and Wu, R. (1991). Assessment of rice genetic transformation techniques. In *Rice biotechnology; Biotechnology in agriculture* No. 6. Khush, G.S. and Toenniessen, G.H. (eds). CAB international, Wallingford, UK, pp. 175-198.
- Capell, T., Bassie, L. and Christou, P. (2004). Modulation of the polyamine biosynthetic pathway in transgenic rice confers tolerance to drought stress. *Pro. Natl. Acad. Sci. USA*, 101 (26): 9909-9914.
- Capell, T., Escobar, C., Lui, H., Burtin, D., Lepri, O. and Christou, P. (1998). Over-expression of the oat *arginine decarboxylase* cDNA in transgenic rice (*Oryza sativa* L) affects normal development patterns in vitro and results in putrescine accumulation in transgenic plants. *Theor. Appl. Genet.* 97: 246-254.

References

- Carter, J. (1998). Who's afraid of genetic engineering? The New York Times in [www. Agbioworld.org/biotech_info/topics/agbiotech/carter.html](http://www.Agbioworld.org/biotech_info/topics/agbiotech/carter.html).
- Chalfie, M., Tu, Y., Euskirchen, G., Ward, W.W. and Prasher, D.C. (1994). Green Fluorescent Protein as a marker for gene expression. *Science* 236: 802-807.
- Chan, M.T., Lee, T.M. and Chang, H.H. (1992). Transformation of indica rice (*Oryza sativa*) mediated by *Agrobacterium tumefaciens*. *Plant cell Physiol.* 33: 577-583.
- Chandler, R.F. Jr. (1979). Rice in the tropics. Westview Press, Boulder, Colorado.
- Chang, T.T. (1976). The origin, evolution, cultivation dissemination and diversification of Asian and African rices. *Euphytica* 25: 435-444.
- Chattopadhyay, M.K., Gupta, S., Sengupta, D.N. and Ghosh, B. (1997). Expression of *Arginine decarboxylase* in seedlings of indica rice (*Oryza sativa* L) cultivars as affected by salinity stress. *Plant Mol. Biol.* 34:422-425.
- Chen, L., Marmey, P., Taylor, N.J., Espinoza, C., D'Cruz, P., Huet, H., Zhang, S., de Kochko, A., Beachy, R.N. and Fauquet, C.M. (1998). Expression and inheritance of multiple transgenes in rice plants. *Nat. Biotech.* 16: 1060-1064.
- Cheng, X., Sardana, R., Kaplan, H. and Altosaar, I. (1998). *Agrobacterium*-mediated transformation rice plants expressing synthetic Cry1Ab and Cry1Ac, genes are highly toxic to striped stem borer. *Proc. Natl. Acad. Sci. USA*, 95: 2767-2772.
- Chiu, W.L., Niwa, Y., Zeng, W., Hirano, T., Kobayashi, H. and Sheen, J. (1996). Engineered GFP as a vital reporter in plants. *Curr. Biol.* 6: 325-330.
- Christensen, A.H. and Quail, P.H. (1996). Ubiquitin promoter-based vectors for high-level expression of selectable and /or screenable marker genes in monocotyledonous plants. *Trans. Res.* 5: 213-218.
- Christensen, A.H., Sharrock, R.A. and Quail, P.H. (1992). Maize polyubiquitin gene: structure, thermal perturbation of expression and transcript splicing, and promoter activity following transfer to protoplasts by electroporation. *Plant. Mol. Biol.* 18: 675-689.

References

- Christie, P. (1997). *Agrobacterium tumefaciens* T-complex transport apparatus: a paradigm for a new family of multifunctional transporters in eubacteria. *J Bacteria* 179: 3085-3094.
- Christou, P. (1994). Rice biotechnology and genetic engineering. Technomic Publishing Co.Inc. USA p.211.
- Christou, P., Ford, T.L. and Kofron, M. (1991). Production of transgenic rice plants from agronomically important indica and japonica via electric discharge particle acceleration of exogenous DNA into immature zygotic embryos. *Biotechnology* 9: 957-962.
- Cohen, M.B. (2000). Bt rice: practical steps to sustainable use. *IRRN* 25.2: 4-10.
- Daniell, H. (1999). Environmentally friendly approaches to genetic engineering. *In Vitro Cell Dev. Biol. Plant* 35: 361-368.
- Daniell, H., Datta, R., Varma, S., Gray, S. and Lee, S.B. (1998). Containment of herbicide resistance through genetic engineering of the chloroplast genome. *Nat. Biotechnol.* 16: 345-348.
- Daniell, H., Khan, M.S. and Allison, L. (2002). Milestones in chloroplast genetic engineering: an environmentally friendly era in biotechnology. *Trends Plant Sci.* 7: 84-91.
- Das, A. (1998). DNA transfer from *Agrobacterium* to plant cells in crown gall tumor disease. In: Biswas, B.B. and Das, H.K. (eds) *Subcellular biochemistry: plant microbe interactions*. Plenum, London, pp 343-363.
- Datta, K., Oliva, N., Torrizo, L., Abrigo, E., Khush, G.S. and Datta, S.K. (1996). Genetic transformation of indica and japonica rice by *Agrobacterium tumefaciens*. *Rice Genet. Newsletter* 13: 136-139
- Datta, K., Vasquez, A., Tu, J., Torrizo, L., Alam, M.F., Oliva, N., Abrigo, E., Khush, G.S. and Datta, S.K. (1998). Constitutive and tissue specific differential expression of cry1 A(b) gene in transgenic rice plants conferring resistance to rice insect pest. *Theor. Appl. Genet.* 97: 20-30.
- Datta, S.K. (1999). Transgenic cereals: *Oryza sativa* (rice). In: *Molecular improvement of cereal crop*. Vasil IK (ed). Kluwer Academic Publishers, Dordrecht, The Netherlands. Pp 149-186.

References

- David, R.H., Morris, D.R., and Coffino, P. (1992). Sequestered end products and enzyme regulation: the case of ornithine decarboxylase. *Microbiol. Rev.* 56:280-290.
- De Agazio, M., Zacchini, M., Federico, R., Grego, S. (1995). Putrescine accumulation in maize roots treated with spermidine: evidence for spermidine to putrescine conversion. *Plant Sci.* 111: 181-185.
- De Block, M., Botterman, J., Vandewiele, M., Dock, J., Thoen, C., Gossele, V., Rao Movva, N., Van Montagu, M. and Leemans, J. (1987). Engineering herbicide resistance in plants by expression of a detoxifying enzyme. *EMBO J.* 6:2513-2518.
- De Cosa, B., Moar, W., Lee, S.B., Miller, M. and Daniell, H. (2001). Overexpression of the Bt cry2Aa2 operon in chloroplasts leads to formation of insecticidal crystals. *Nat. Biotechnol.* 19: 71-74.
- De Jaeger, G., De Wilde, C., Eekhout, D. and Depicker, P.H. (2000). The plantibody approach: expression of antibody genes in plants modulate plant metabolism or to obtain pathogen resistance. *Plant Mol. Biol.* 43: 419-428.
- Denli, A.M. and Hannon, G.J. (2003). RNAi: an ever-growing puzzle. *Trends Biochem. Sci.* 28: 196-201.
- De Maagd, R.A., Bosch, D., and Stiekema, W. (1999). *Bacillus thuringiensis* toxin-mediated insect resistance in plants. *Trends Plant Sci.*, 4(1): 9-13.
- Depicker, A. and Van Montagu, M. (1997). Posttranscriptional gene silencing in plants. *Curr. Opin. Cell. Biol.* 9: 373-382.
- Descenzo, R.A. and Minocha, S.C. (1993). Modulation of cellular polyamines in tobacco by transfer and expression of mouse ornithine decarboxylase cDNA. *Plant Mol. Biol.* 22: 113-127.
- East, I.J., Fitzgerald, C.J., Pearson, R.D., Donaldson, R.A., Vuocolo, T., Cadogan, L.C., Tellam, R.L. and Eisemann, C.H. (1993). *Lucilla cuprina*: inhibition of larval growth induced by immunization of host sheep with extracts of larval peritrophic membrane. *Int. J. Parasitol.* 23: 221-229.
- Ebinuma, H., Sugita, K., Matsunaga, E., Endo, S., Yamada, K. and Komamine, S.K. (2001). System for the removal of a selection marker and their combination with a positive marker. *Plant Cell Rep.* 20: 383-392.

References

- Ebinuma, H., Sugita, K., Matsunaga, E. and Yamakodo, M. (1997). Selection of marker-free transgenic plants using the isopentenyl transferase gene. *Proc. Natl. Acad. Sci. USA*, 94: 2117-2121.
- Eisemann, C.H., Donaldson, R.A., Pearson, R.D., Cadagon, L.C., Vuocolo, T. and Tellam, R.L. (1994). Larvicidal action of lectins on *Lucilia cuprina*; mechanism of action. *Entomol. Exp. Appl.* 72: 1-11.
- Elina, H., Boije, M., Niklander-Teeri, V., Palva, T.E. and Teeri, T.H. (2000). Gene delivery into intact plants using the Helios™ gene gun. *Plant Mol. Biol. Rep.* 18: 287a-2871.
- Endo, S., Sugita, K., Sakai, M., Tanaka, H. and Ebinuma, H. (2002). Single-step transformation for generating marker-free transgenic rice using the ipt-type MAT vector system. *Plant J.* 30(1): 115-122.
- Epel, G.L., Padgell, H.S., Heinlein, M. and Beachy, R.N. (1996). Plant virus movement protein dynamics probed with a movement protein fused to GFP. *Gene* 173: 75-79.
- Evans, P.T. and Malmberg, R. (1989). Do polyamines have roles in plant development? *Annu. Rev. Plant Physiol. Plant Mol. Biol.* 40: 235-269.
- Fedoroff, N.V. and Cohen, J.E. (1999). Plants and population: is there time? *Proc. Nat. Acad. Sci. USA*, 96: 5903-5907.
- Feinberg, A.P. and Vogelsten, B. (1994). A technique for radio-labelling DNA restriction endonuclease fragments to high specific activity. *Annal. Biochem.* 137: 266-267.
- Fire, A., Xu, S., Montgomery, M.K., Kostas, S.A., Driver, S.E. and Mello, C.C. (1998). Potential and specific interference by double-stranded RNA in *Caenorhabditis elegans*. *Nature* 391: 806-811.
- Fischer, K.S. (2000). Collaboration in rice. *Science*, 290,279-280.
- Fischer, R. and Emans, N. (2000). Molecular farming of pharmaceutical proteins. *Trans. Res.* 9: 279-299.
- Fitches, E., Audsley, N., Gatehouse, J.A., and Edwards, J.P. (2002). Fusion proteins containing neuropeptides as novel insect control agents: snowdrop lectin delivers

References

- fused allatostatin to insect haemolymph following oral ingestion. *Insect Biochem. Mol. Biol.*, 32: 1653- 16661.
- Fitches, E., Edwards, M.J., Mee, C., Grishan, E., Gatehouse, A.M.R., Edwards, J.P., and Gatehouse, J.A. (2004) (a). Fusion proteins containing neurotoxins as insect control agents: snowdrop lectin delivers fused insecticidal spider venom neurotoxin to insect haemolymph following oral ingestion. *J. Insect Physiol.* 50: 61-71.
 - Fitches, E., Gatehouse, A.M.R. and Gatehouse, J.A. (1997). Effect of Snowdrop lectin (GNA) delivered via artificial diet and transgenic plants on the development of tomato moth (*Lacanobia oleracea*) larvae in laboratory and glasshouse trials. *J. Insect Physiol.* 43(8): 727-739.
 - Fitches, E., Wilkinson, H., Bell, H., Bown, D.P., Gatehouse, J.A. and Edwards, J.P. (2004) (b). Cloning, expression and functional characterisation of chitinase from larvae of tomato moth (*Lacanobia oleracea*): a demonstration of the insecticidal activity of insect chitinase. *Insect Biochem. Mol. Biol.* 34: 1037-1050.
 - Fitches, E., Woodhouse, S., Edwards, J.P., and Gatehouse, J.A. (2001). In vitro and in vivo binding of snowdrop (*Galanthus nivalis* agglutinin; GNA) and jackbean (*Canavalia ensiformis*; Con A) lectins with tomato moth (*Lacanobia oleracea*) larvae; mechanisms of insecticidal action. *J. Insect Physiol.* 47, 777-787.
 - Flavell, R.B. (1994). Inactivation of gene expression in plants as a consequence of novel sequence duplications. *Proc. Natl. Acad. Sci. USA*, 91: 3490-3498.
 - Fromm, M., Taylor, L.P. and Walbot, V. (1986). Stable transformation of maize after gene transfer by electroporation. *Nature* 317:791-793.
 - Fu, X., Duc, L.T., Bong, B.B., Tinjuangjun, P., Sudhakar, D., Twyman, R.M., Christou, P. and Kohli, A. (2000). Linear transgene constructs lacking vector backbone sequences generate low-copy-number transgenic plants with simple integration patterns. *Trans. Res.* 9: 11-19.
 - Fu, X., Sudhakar, D., Peng, J., Richards, D.E., Christou, P. and Harberd, N.P. (2001). Expression of Arabidopsis GAI in transgenic rice represses gibberellin response. *Plant Cell*, 13: 1791-1802.

References

- Fujimoto, H., Itoh, K., Yamamoto, M., Kyozuka, J. and Shimamoto, K. (1993). Insect-resistant rice generated by introduction of a modified delta-endotoxin gene of *Bacillus thuringiensis*. *Bio/Technol.* 11: 1151-1155.
- Gatehouse, A.M.R., Davison, G.M., Newell, C.A., Merryweather, A., Hamilton, W.D.O., Burgess, E.P.J., Gilbert, R.J.C. and Gatehouse, J.A. (1997). Transgenic potato plants with enhanced resistance to the tomato moth, *Lacanobia oleracae*: growth room trials, *Mol. Breed.* 3: 49-63.
- Gatehouse, A.M.R., Dewey, F.M., Dove, J., Fenton, K.A. and Pusztai, A. (1984). Effect of seed lectin from *Phaseolus vulgaris* on the development of larvae of *Callosobruchus maculatus*; mechanism of toxicity. *J. Sci. Food Agric.* 35: 373-380.
- Gatehouse, A.M.R., Powell, K.S., Peumans, W.J., Van Damme, E.J.M. and Gatehouse, J.A. (1995). Insecticidal properties of lectins; their potential in plant protection. In: *Lectins Biomedical perspectives.* (eds: Pusztai A & Bardocz S), pp 35-58, Taylor and Francis, Hants, UK.
- Gill, S.S., Cowels, E.A. and Pietrantonio, P.V. (1992). The mode of action of *Bacillus thuringiensis* endotoxins. *Annu. Rev. Ento.* 37: 615-636.
- Giuliano, G., Aquilani, R. and Dharmapuri, S. (2000). Metabolic engineering of plant carotenoids. *Trends Plant Sci.* 5(10): 406-409.
- Godijn, O.J.M. and Pen, J. (1995). Plants as bioreactors. *Trends Biotech.* 13: 379-387.
- Grochulski, P., Mason, L., Borisova, S., Pusztai-Carey, M., Schwatz, J.L., Brousseau, R. and Cygler, M. (1995). *Bacillus thuringiensis* Cry1A(a) insecticidal toxin: Crystal structure and channel formation. *Mol. Biol. J.* 254: 447-464.
- Gurineau, F., Lucy, A. and Mullineaux, P. (1992). Effect of two consensus sequences preceding the translation initial codon on gene expression in plant protoplasts. *Plant Mol. Biol.* 18: 815-818.
- Hamill, J.D., Robins, R.J., Parr, A.J., Evans, D.M., Furze, J.M. and Rhodes, M.J.C. (1990). Over-expressing a yeast ornithine decarboxylase gene in transgenic roots of *Nicotiana rustica* can lead to enhanced nicotine accumulation. *Plant Mol. Biol.* 15: 27-38.

References

- Hamilton, C.M. (1997). A binary-BAC system for plant transformation with high-molecular-weight DNA. *Gene* 200,107-116.
- Hanfrey, C., Sommer, S., Mayer, M.J., Burtin, D. and Michael, A.J. (2001). *Arabidopsis* polyamine biosynthesis: absence of ornithine decarboxylase and the mechanism of arginine decarboxylase activity. *Plant J.* 27(6): 551-560.
- Hauptmann, R.M., Ozias-Akins, P., Vasil, V., Tabaeizadeh, Z., Rogers, S.G., Horsch, R.B., Vasil, I.K. and Fraley, R.T. (1987). Transient expression of electroporated DNA in monocotyledonous and dicotyledonous species. *Plant Cell Rep.* 6: 265-270.
- Hauptmann, R.M., Vasil, V., Ozias-Akins, P., Tabaeizadeh, Z., Rodgers, S.G., Fraley, R.T., Hosch, R.B. and Vasil, I.K. (1988). Evaluation of selectable markers for obtaining stable transformants in graminiae. *Plant Physiol.* 86: 602-606.
- Heinrichs, E.A. (1986). Perspectives and directions for the continued development of insect-resistant rice varieties. *Agric. Ecosyst. Environ.* 18: 9-36.
- Hiatt, A., Cafferkey, R. and Bowdish, K. (1989). Production of antibodies in transgenic plants. *Nature* 342: 76-78.
- Hiei, Y., Ohta, S., Komari, T. and Kumashiro, T. (1994). Efficient transformation of rice (*Oryza sativa* L) mediated by agrobacterium and sequence analysis of the boundaries of the T-DNA. *Plant J.* 6:271-282.
- Hloch, P., Hoffmann, K., Kruchen, B. and Rueger, B. (2001). The DIG system- a high sensitive substitute of radioactivity in northern blot analysis. *Biochemica.* 2: 24-25.
- Hoa, T.T.C., Al-Babili, S., Schaub, P., Potrykus, I. and Beyer, P. (2003). Golden indica and japonica rice lines amenable to deregulation. *Plant Physiol.* 133: 161-169.
- Hofte, H. and Hite, H.R. (1989). Insecticidal crystal proteins of *Bacillus thuringiensis* delta-endotoxins. *Appl. Environ.* 53: 242-255.
- Hood, E.E., Helmer, G.L., Fraley, R.T. and Chilton, M.D. (1986). The hypervirulence of *Agrobacterium tumefaciens* A281 is encoded in the region of pTiBo542 outside of T-DNA. *Bacteriol. J.* 168: 1291-1301.

References

- Huang, N., Wu, L., Nandi, S., Bowman, E., Huang, J., Sutliff, T. and Rodriguez, R.L. (2001). The tissue specific activity of a rice beta-glucanase promoter (Gns9) is used to select rice transformations. *Plant Sci.* 161: 5589-595.
- Hunold, R., Bronner, R. and Hahne, G. (1994). Early event in microprojectile bombardment, cell viability and particle location. *Plant J.* 5: 593-604.
- Hwang, Y.S., Yang, D., McCullar, C., Wu, L., Chen, L., Pham, P., Nandi, S. and Huang, N. (2002). Analysis of the rice endosperm-specific globulin promoter in transformed rice cells. *Plant Cell Rep.* 20: 842-847.
- Iglesias VA, Moscone EA, Papp I, Neuhuber F, Michalowski S, Phelan T, Spiker S, Matzke M, Matzke AJM (1997). Molecular and cytogenetic analyses of stably and unstably expressed transgene loci in tobacco. *Plant Cell* 9: 1251-1264.
- Ingelbrecht, I., Van Montagu, M. and Depicker, A. (1994). Posttranscriptional of reporter transgenes in tobacco correlates with DNA methylation. *Proc. Natl. Acad. Sci. USA*, 91: 10502-10506.
- Ishiwatari, Y., Fujiwara, T., McFarland, K.C., Nemoto, K., Hayashi, H., Chino, M. and Lucas, W.J. (1998). Rice ploem thioredoxin h has the capacity to mediate its own cell-to-cell transport through plasmodesmata. *Planta* 205: 12-22.
- Ishiwatari, Y., Honda, C., Kawashima, I., Nakamura, S., Hirano, H., Mori, S., Fujiwara, T., Hayashi, H. and Chino, M. (1995). Thioredoxin h is one of the major proteins in rice phloem sap. *Planta* 195: 456-463.
- Jackowitsch, J., Papp, I., Moscone, E.A., Van Der Winder, J., Matzke, M. and Matzke, A.J.M. (1999). Molecular and cytogenetic characterization of a transgene locus that induces silencing and methylation of homologous promoters in trans. *Plant J.* 17:131-140.
- Jefferson, R.A. (1987). Assaying chimeric genes in plants: the GUS fusion system. *Plant Mol. Biol. Rep.* 5: 387-405.
- Jorgensen, R., Cluster, P., Que, Q., English, J. and Napoli, C. (1996). Chacoal synthase cosuppression phenotypes in petunia flowers: comparison of sense vs antisense constructs and single copy vs complex T-DNA sequences. *Plant Mol. Biol.* 31: 957-973.

References

- Kakkar, R.K., Najar, P.K., Ahuja, P.S. (2000). Polyamines and Plant morphogenesis. *Biologia Plantarum* 43 (1): 1-11.
- Kauppinen, R.A. and Alhonen, L.I. (1995). Transgenic animals as models in the study of the neurobiological role of polyamines. *Progress Neurobiol.* 47(6): 545-563.
- Ke, J., Khan, R., Johnson, T., Somers, D.A. and Das, A. (2001). High-efficiency gene transfer to recalcitrant plants by *Agrobacterium tumefaciens*. *Plant Cell Rep.* 20: 150-156.
- Kexuan Tang, Tinjuangjun, P., Xu, Y., Sun, X., Gatehouse, J.A., Ronald, P.C., Qi, H., Lu, X., Christou, P. and Kohli, A. (1999). Particle-bombardment-mediated-co-transformation of elite Chinese rice cultivars with genes conferring resistance to bacterial blight and sap-sucking insect pests. *Planta* 208:552-563.
- Khan, M.S. and Maliga, P. (1999). Fluorescent antibiotic resistance marker for tracking plastid transformation in higher plants. *Nat. Biotechnol.* 17: 910-915.
- Khush, G.S. (1995). Modern varieties: their real contribution for food supply and equity. *Geo. J.* 35: 275-284.
- Khush, G.S. (1997). Origin, dispersal, cultivation and variation of rice. In: *Oryza: from molecule to plant*. Sasaki, T. and Moore, G. (eds). Kluwer Academic Publishers, Dordrecht, The Netherlands, pp. 25-34.
- Klahre, U., Crete, P., Leuenberger, S.A., Iglesias, V.A. and Meins, Jr. F. (2002). High molecular weight RNAs and small interfering RNAs induce systematic posttranscriptional gene silencing in plants. *Proc. Natl. Acad. Sci. USA*, 99: 11981-11986.
- Kohli, A., Leech, M., Vain, P., Laurie, D.A. and Christou, P. (1998). Transgene organization in rice engineered through direct DNA transfer supports a two-phase integration mechanism mediated by the establishment of integration host-spots. *Proc. Natl. Acad. Sci. USA*, 95: 7203-7207.
- Komari, T. (1990). Transformation of callus cells of *Chenopodium quinoa* by binary factors that carry a fragment of DNA from the virulence region of pTiBo 542. *Plant Cell Rep.* 9: 303-306.

References

- Kotzabasis, K. (1993). Polyamines in photosynthetic apparatus: Photosystem II highly resolved sub-complexes are enriched in spermine. *Photo. Res.* 38: 83-88.
- Ku, M.S., Agarie, S., Nomura, M., Fukayama, H., Tsuchida, H., Ono, K., Hirose, S., Toki, S., Miyao, M. and Matsuoka, M. (1999). High level expression of maize phosphoenolpyruvate carboxylase in transgenic rice plants. *Nat. Biotech.* 17(1): 76-80.
- Kumar, A. and Minocha, S.C. (1998). Transgenic manipulation of polyamine metabolism. In: Lindsey, K. (ed). *Transgenic research in plants*. Harwood Academic Publishers, U.K., p.p. 187-199.
- Kumar, A., Taylor, M.A., Mad Arif, S.A. and Davies, H. (1996). Potato plants expressing antisense and sense *S-adenosylmethionine decarboxylase* (SAMDC) transgenes showed altered levels of polyamine and ethylene: antisense plants display abnormal phenotypes. *Plant J.* 9(2): 147-158.
- Kumar, S. and Fladung, M. (2001). Colling transgene integration in plants. *Trends Plant Sci.* 6(4): 155- 159.
- Kumpatla, S.P., Teng, W.M., Buchholz, W.G., Hall, T.C. (1997). Epigenetic transcriptional silencing and 5-azacytidine- mediated reactivation of a complex transgene in rice. *Plant Physiol.* 115: 361-375.
- Laemmli, U.K. (1971). Cleavage of structural proteins during the assembly of the head of bacteriophage T4. *Nature* 227: 680-685.
- Larrick, J.W., Yu, L., Chen, J., Jaiswal, S., Wycoff, K. (1998). Production of antibodies in transgenic plants. *Res. Immunol.* 149: 603-608.
- Last, D.I., Bretell, R.I.S., Chamberlain, D.A., Chaudhury, A.M., Larkin, P.J., Marsh, E.L., Peacock, W.J. and Dennis, E.S. (1991). pEmu: an improved promoter for gene expression in cereal cells. *Theor. Appl. Genet.* 81: 581-588.
- Lepri, O., Bassie, L., Safwat, G., Thu-Hang, P., Trung-Nghia, P., Holta, E., Christou, P. and Capell, T. (2001). Over-expression of the human *ornithine decarboxylase* cDNA in transgenic rice plants alters the polyamine pool in a tissue specific manner. *Mol Genet. Gen.* 266: 303-312.
- Li, J., Carroll, J. and Ellar, D.J. (1991). Crystal structure of insecticidal δ -endotoxin from *Bacillus thuringiensis* at 2.5Å^o Resolution. *Nature* 353:815-821.

References

- Li, Z., Upadhyaya, N.M., Meena, S., Adrian, J.G. and Waterhouse, P.M. (1997). Comparison of promoter and selectable marker genes for use in Indica rice transformation. *Mol. Breed.* 3: 1-14.
- Lipkin, A., Kozlov, S., Nosyreva, E., Blake, A., Windass, J.D., and Grishan, E. (2002). Novel insecticidal toxins from the venom of the spider *Segestria florentina*. *Toxicon*, 40: 125-130.
- Liu, Y.B. and Tabashnik, B.E. (1997). Experimental evidence that refuges delay insect adaptation to *Bacillus thuringiensis*. *Proc. R. Soc. Lond. Ser. B* 264: 605-610.
- Loc, N.T., Porntip, T., Gatehouse, A.M.R., Christou, P. and Gatehouse, J.A. (2002). Linear transgene constructs lacking vector backbone sequences generate transgenic rice plants with accumulate higher levels of proteins conferring insect resistance. *Mol. Breed.* 9: 231-244.
- Mallet, J. and Porter, P. (1992). Preventing insect adaptation to insect-resistant crops: are seed mixtures or refugia the best strategy? *Proc. R. Soc. Lond. Ser. B* 250: 165-169.
- Malmberg, R.L., Smith, K.E., Bell, E., and Cellino, M.L. (1992). Arginine decarboxylase of oats is clipped from a precursor into 2-polypeptides found in the soluble enzyme. *Plant Physiol.* 100: 146-152.
- Maqbool, S.B. and Christou, P. (1999). Multiple traits of agronomic importance in transgenic indica rice plants: Analysis of transgene integration patterns, expression levels and stability. *Mol. Breed.* 5: 471-480.
- Maqbool, S.B., Husnain, T., Riazuddin, S., Masson, L. and Christou, P. (1998). Effective control of yellow stem borer and rice leaf folder in transgenic rice indica varieties Basmati 370 and M7 using the novel endotoxin Cry2A *Bacillus thuringiensis* gene. *Mol. Breed.* 4: 501-507.
- Maqbool, S.B., Riazuddin, S., Loc, N.T., Gatehouse, A.M.R., Gatehouse, J.A. and Christou, P. (2001). Expression of multiple insecticidal genes confers broad resistance against a range of different rice pests. *Mol. Breed.* 7: 85-93.
- Martin-Tanguy, J. (1997). Conjugated polyamines and reproductive development: biochemical and physiological approaches. *Physiologia Plantarum.* 100: 675-688.

References

- Masgrau, C., Altabella, T., Farras, R., Flores, D., Thompson, A.J., Besford, R.T. and Tiburcio, A. (1997). Inducible over-expression of oat arginine decarboxylase in transgenic tobacco plants. *Plant J.* 11: 465-473.
- Masler, E.P., Kelly, T.J. and Menn, J.J. (1993). Insect neuropeptides: discovery and application in insect management. *Arch. Insect Biochem. Physiol.* 22, 87-111.
- Matteson, P.C. (2000). Insect pest management in tropical asian irrigated rice. *Annu. Rev. Entomol.* 45: 549-574.
- Matzke, A.J.M., Neuhuber, F., Park, Y.D., Ambros, P.F., and Watzke, M.A. (1994). Homology-dependent gene silencing in transgenic plants: epistatic silencing loci contain multiple copies of methylated transgenes. *Mol. Gen. Genet.* 244: 219-229.
- Matzke, M.A. and Matzke, A.J.M. (1995). How and why do plants inactivate homologous transgene(s)? *Plant Physiol.* 107: 679-689.
- McElroy, D., Zhang, W., Cao, J. and Wu, R. (1990). Isolation of an efficient actin promoter for use in rice transformation. *Plant Cell* 2: 163-171.
- Miele, J.L (1997). Plant as bioreactors: regulatory considerations. *Trends Biotechnol* 15: 45-50.
- Naimov, S., Dukiandjiev, S. and de Maagd, R.A. (2003). A hybrid *Bacillus thuringiensis* delta-endotoxin gives resistance against a coleopteran and a lepidopteran pest in transgenic potato. *Plant Biotechnol. J.* 1:51-57.
- Noh, E.W. and Minocha, S.C. (1994). Expression of a human S-adenosylmethionine decarboxylase cDNA in transgenic tobacco and its effects on polyamine biosynthesis. *Trans. Res.* 3: 25-53.
- Noury, M., Bassie, L., Lepri, O., Kurek, I., Christou, P. and Capell, T. (2000). A transgenic cell lineage expressing the oat *Arginine decarboxylase* (*adc*) cDNA constitutively accumulates putrescine in callus and seeds but not in vegetative tissues. *Plant Mol. Biol.* 43: 357-544.
- Park, S.H., Pinson, S.R.M. and Smith, R.H. (1996). T-DNA integration into genomic DNA of rice following *Agrobacterium* inoculation of isolated shoot apices. *Plant Mol. Biol.* 32:1135-1148.

References

- Pinstrup-Anderson, P., Pandya-Lorch, R. and Rosegrant, M.W. (1999). World food prospects: Critical issues for the early twenty-first century. 2002 vision food policy report. International Food Policy Research Institute, Washington DC.
- Powell, K.S., Gatehouse, A.M.R., Hilder, V.A. and Gatehouse, J.A. (1993). Antimetabolic effects of plant lectins and plant and fungal enzymes on the nymphal stages of two important rice pests, *Nilaparvata lugens* and *Nephotettix nigropituita*. Entomol. Exp. Appl. 66: 119-126.
- Powell, K.S., Gatehouse, A.M.R., Hilder, V.A., Van Damme, E.J.M., Peumans, W.J., Boonjawat, J., Horsham, K. and Gatehouse, J.A. (1995). Different antimetabolic effects of related lectins toward nymphal stages of *Nilaparvata Lugens*. Entomol. Exp. Appl. 75: 61-65.
- Promega (1996). The source for discovery: Protocol and application guide. Third edition.
- Raemaekers, R.J. (2000). Expression of functional plant lectins in heterologous systems. PhD thesis, University of Durham, UK, 173-207.
- Raineri, D.M., Bottino, P., Gordon, M.P. and Nester, E.W. (1990). *Agrobacterium* mediated transformation of rice (*Oryza sativa* L). Bio/Technol. 8:33-38.
- Rao, K.V., Rathore, K.S., Hodges, T.K., Fu, X., Stoger, E., Sudhakar, D., Williams, S., Christou, P., Bharathi, M., Bown D.P., Powell, K.S., Spence, J., Gatehouse, A.M.R. and Gatehouse, J.A. (1998). Expression of, snowdrop lectin (GNA) in transgenic rice plants confers resistant to rice brown plant hopper. Plant J. 15: 469-477.
- Register, J.C., Peterson, D.J., Bell, P.J., Bullock, W.P., Evans, I.J., Frame, B., Greenland, A.J., Higgs, N.S., Jepson, I., Jiao, S.P., Lewnau, C.J., Sillick, J.M. and Wilson, H.M. (1994). Structure and function of selectable and non-selectable transgenes in maize after introduction by particle bombardment. Plant Mol. Biol. 25: 951-961.
- Rhodes, C.A., Pierce, D.A., Mettler, I.J., Mascarenhas, D. and Detmer, J.J. (1988). Genetically transformed maize plants from protoplasts. Science 240: 204-207.
- Richards, F.J. and Coleman, E.G. (1952). Occurrence of putrescine in potassium deficient barley. Nature 170: 460-461.

References

- Roin potassium desso, M.N., Schouten, A., Roosien, J., Borst-Vrenszen, T., Hussey, R.S., Gommers, F.J., Bakker, J., Schots, A. and Abad, P. (1996). Expression and functional characterization of a single chain Fv antibody directed against secretions involved in plant nematode infection process. *Biochem. Biophys. Res. Commun.* 220: 255-263.
- Ruf, S., Hermann, M., Berger, I.J., Carrer, H. and Bock, R. (2001). Stable genetic transformation of tomato plastids: foreign protein expression in fruit. *Nat. Biotechnol.* 19: 870-875.
- Sajio, Y., Hata, S., Kyojuka, J., Shimamoto, K. and Izui, K. (2000). Over-expression of a single Ca²⁺- dependent protein kinase confers both chilled and salt/drought tolerance on rice plants. *Plant J.* 23(3): 319-327.
- Sakamot, A., Alia and Murata, N. (1998). Metabolic engineering of rice leading to biosynthesis of glycine betaine and tolerance to salt and cold. *Plant Mol. Biol.* 38:1011-1019.
- Salomon, S. and Puchta, H. (1998). Capture of genomic and T-DNA sequences during double-strand break repair in somatic plant cells. *EMBO J.* 17: 6086-6095.
- Sambrook, J. and Russell, D.W. (2001), *Molecular cloning: a laboratory manual*, 3rd edition. New York: Cold Spring Harbour Press.
- Sawhey, R.K. and Galston, A.W. (1979). Interaction of polyamine and light on biochemical process involved in leaf senescence. *Plant Cell Environ.* 2: 189-196.
- Schenk, P.M., Sagi, L., Remans, T., Dietzgen, K.G., Bernard, M.T., Graham, M.W. and Manners, J.M. (1999). A promoter from sugarcane bacilliform badnavirus drives transgene expression in banana and other monocot and dicot plants. *Plant Mol. Biol.* 39: 1221-1230.
- Schweizer, P., Pokorny, J., Schulze-Lefert, P. and Dudler, R. (2000). Double-stranded RNA interferes with gene function at the single-cell level in cereals. *Plant J.* 24: 895-903.
- Senior, J.I. and Dale, J.P. (1996). Plant transgene silencing – Gremlin or gift? *Chem. Ind.* 19:604-609.
- Sheehy, J.E. (2000). Redesigning rice photosynthesis to increase yield. Elsevier Science and International Rice Research Institute, Philippines.

References

- Sheen, J., Hwang, S.B., Niwa, Y., Kobayashi, H. and Galbraith, D.W. (1995). Green fluorescent protein as a new vital marker in plant cells *Plant J.* 8: 777-784.
- Shimada, N., Suzuki, Y., Nakajima, M., Conrad, U., Murofushi, N. and Yamaguchi, I. (1999). Expression of a functional single chain antibody against GA24/19 in transgenic tobacco. *Biosci. Biotechnol. Biochem.* 63: 779-783.
- Sidorov, V.A., Kasten, D., Pang, S.Z., Hajdukiewicz, P., Staub, J.M. and Nehra, N.S. (1999). Stable chloroplast transformation in potato: use of green fluorescent protein as a plastid marker. *Plant J.* 19: 209-216.
- Slocum, R.D. (1991). Tissue and subcellular localisation of polyamines and enzymes of polyamine metabolism. In: *The biochemistry and physiology of polyamines in plants*, (Slocum RD, Flores HE eds) CRC press. 93-103.
- Smith, T.A. (1985). Polyamines. *Annu. Rev. Plant Physiol.* 36: 117-143.
- Song, W.Y., Wang, G.L., Chen, L.L., Kim, H.S., Pi, L.Y., Holsten, T., Gardner, J., Wang, B., Zhai, W.X., Zhu, L.H., Fauquet, C. and Ronald, P. (1995). A receptor kinase-like protein encoded by the rice disease resistance gene, Xa21. *Science* 270: 1804-1806.
- Stam, M., Joseph, N.M. and Kooter, J.M. (1997). The silence of gene in transgenic plants. *Annals Bot.* 79: 3-12.
- Stam, M., Viterbo, A., Mol, J.N.M. and Kooter, J.M. (1998). Position-dependent methylation and transcriptional silencing of transgenes in inverted T-DNA repeats: implications for posttranscriptional silencing of homologous host genes in plants. *Mol. Cell Biol.* 18: 6165-6177.
- Stoger, E., Sack, M., Fischer, R. and Christou, P. (2002). Plantibodies: applications, advantages and bottlenecks. *Curr. Opin. Biotech.* 13: 161-166.
- Stoger, E., Williams, S., Christou, P., Down, R.E. and Gatehouse, J.A. (1999). Expression of the insecticidal lectin from snowdrop (*Galanthus nivalis* agglutinin; GNA) in transgenic wheat plants: effect on predation by the grain aphid *Sitobion avenae*. *Mol. Breed.* 5: 65-73.
- Sudhakar, D., Duc, L.T., Bong, B.B., Tinjuangjun, P., Maqbool, S.B., Valdez, M., Jefferson, R. and Christou, P. (1998). An efficient rice transformation system

References

- utilizing mature seed-derived explants and a portable, inexpensive particle bombardment device. *Trans. Res.* 7: 289-294.
- Sudhakar, D., Fu, X., Stoger, E., Williams, S., Spence, J., Brown, D.P., Bharathi, M., Gatehouse, J.A. and Christou, P. (1998). Expression and immunolocalisation of the snowdrop lectin GNA in transgenic rice plants. *Trans. Res.* 7: 1-8.
 - Svab, Z., Hajdukiewicz, P. and Maliga, P. (1990). Stable transformation of plastids in higher plants. *Proc. Natl. Acad. Sci. USA*, 87: 8526-8530.
 - Tassoni, A., van Buuren, M., Franceschetti, M., Fornale, S. and Bagni, N. (2000). Polyamine content and metabolism in *Arabidopsis thaliana* L. and effect of spermidine on plant development. *Plant Physiol. Biochem.* 38: 1-11.
 - Tavladoraki, P., Benvenuto, E., Trinca, S., De Martinis, D., Cattaneo, A. and Galeffi, P. (1993). Transgenic plants expressing a functional single chain Fv antibody are specifically protected from virus attack. *Nature* 366: 469-472.
 - Thu-Hang, P., Bassie, L., Safwat, G., Trung-Nghia, P., Christou, P. and Capell, T. (2002). Expression of heterologous *S-adenosylmethionine decarboxylase* cDNA in plants demonstrates that changes in SAMDC activity determine levels of the higher polyamine and spermine. *Plant Physiol.* 129: 1744-1754.
 - Tiburcio, A.F., Altabella, T., Borrel, A. and Masgrau, C. (1997). Polyamine metabolism and its regulation. *Physiol. Planta.* 100: 664-674.
 - Tinjuangjun, P., Loc, N.T., Gatehouse, A.M.R., Gatehouse, J.A. and Christou, P. (2000). Enhanced insect resistance in Thai rice varieties generated by particle bombardment. *Mol. Breed.* 6: 391-399.
 - Toki, S. (1997). Rapid and efficient *Agrobacterium*-mediated transformation in rice. *Plant Mol. Biol. Rep.* 15: 16-21.
 - Topping, J.F., Wei, W. and Lindsay, K. (1991). Functional tagging of regulatory in plant genome. *Development* 112:1009-1019.
 - Towbin, H., Staehelin, T. and Gordon, J. (1979). Electrophoretic transfer of proteins from polyacrylamide gels to nitrocellulose sheets: procedure and some applications. *Proc. Natl. Acad. Sci. USA*, 76: 4350-4354.

References

- Ulker, B., Allen, G.C., Thompson, W.F., Spiker, S. and Weissinger, A.K. (1999). A tobacco MRA increases transgene expression and protects against gene silencing in the progeny of transgenic tobacco plants. *Plant J.* 18: 253-263.
- Vain, P., Worland, B., Kohli, A., Snape, J.W., Christou, P., Allen, G.C. and Thompson, W.F. (1999). Matrix attachment regions increase transgene expression levels and stability in transgenic rice plants and their progeny. *Plant J.* 18: 233-242.
- Valdez, M., Cabrera-Ponce, J.L., Sudhakar, D., Herrera-Estrella, L. and Christou, P. (1998). Transgenic Central American, West African and Asian elite rice varieties resulting from particle bombardment of foreign DNA into mature seed-derived explants utilizing three different bombardment devices. *Annals Bot.* 82: 795-801.
- Van der Krol, A.R., Mur, L.A., Beld, M., Mol, J.N. and Stuitje, A.R. (1990). Flavonoid genes in petunia: addition of limited number of gene copies may lead to a suppression of gene expression. *Plant Cell.* 2: 291-299.
- Vaquero, C., Sack, M., Schuster, F., Finnern, R., Drossard, J., Schumann, D., Reimann, A. and Fischer, R. (2002). A carcinoembryonic antigen-specific diabody produced in tobacco. *FASEB J.* 16: 408-410.
- Vasil, I.K. (1994). Molecular improvement of cereals. *Plant Mol. Biol.* 25: 925-937.
- Voss, A., Niersbach, M., Hain, R., Hirsch, H.J., Liao, Y.C., Kreuzaler, F. and Fischer, R. (1995). Reduced virus infectivity in *N. tabacum* secreting a TMV-specific full size antibody. *Mol. Breed.* 1: 39-50.
- Wang, M.B., Boulter, D. and Gatehouse, J.A. (1992). A complete sequence of the rice sucrose synthase-1 (RSs1) gene. *Plant Mol. Biol.* 19: 881-885.
- Wassenegger, M. and Pelissier, T. (1998). A model for RNA-mediated gene silencing in higher plants. *Plant Mol. Biol.* 37: 349-362.
- Watson, M.B., Emory, K.K., Piatak, R.M. and Malmberg, R.L. (1998). *Arginine decarboxylase* (Polyamine biosynthesis) mutants of *Arabidopsis thaliana* with altered root growth. *Plant J.* 13:231-239.
- Watson, M.B., and Malmberg, R.L. (1996) Regulation of *Arabidopsis thaliana* L. arginine decarboxylase by potassium-deficiency stress. *Plant Physiol.* 111:1077-1083.

References

- Wilmink, A. and Dons, J.J.M. (1991). Selective agents and marker genes for use in transformation of monocotyledonous plants. *Plant Mol. Biol. Rep.* 11: 165-185.
- Woon Noh, E., and Minocha, S.C. (1994). Expression of a human S-adenosylmethionine decarboxylase in transgenic tobacco and its effects on polyamine biosynthesis. *Transgenic Res.* 3:113-127.
- Wu, A., Sun, X., Pang, Y. and Tang, K. (2002). Homozygous transgenic rice lines expressing GNA with enhanced resistance to the rice sap-sucking pest *Laodelphax striatellus*. *Plant Breed.* 121: 93-95.
- Wu, L., Nandi, S., Chen, L., Rodriguez, R.L. and Huang, N. (2002). Expression and inheritance of nine transgenes in rice. *Trans. Res.* 11(5): 533-541.
- Xavier, F., Loc, N.T., Christou, P., Gatehouse, A.M.R. and Gatehouse, J.A. (2000). Resistance to green leafhopper (*Nephotettix virescens*) and brown plant hopper (*Nilaparvata lugens*) in transgenic rice expressing snowdrop lectin (*Galanthus nivalis agglutinin; GNA*). *Insect Physiol. J.* 46: 573-583.
- Xiong, L., Schumaker, K.S. and Zhu, J.K. (2002). Cell signalling during cold, drought and salt stress. *Plant Cell*, 5165-5183.
- Ye, X., Al-Babili, S., Kloti, A., Zhang, J., Lucca, P., Beyer, P. and Potrykus, I. (2000). Engineering the provitamin A (β -carotene) biosynthetic pathway into (carotenoid free) rice endosperm. *Science* 287: 303-305.
- Yoshida, S., Forno, O.A., Cock, J.H. and Gomez, K.A. (1976). Laboratory manual for physiological studies of rice. International Rice Research Institute, Manila, Philippine.
- Zhang, P., Potrykus, I. and Pounti-Karlas, J. (2000). Efficient production of transgenic cassava using negative and positive selection. *Trans. Res.* 9: 405-415.
- Zhang, S., Song, W.Y., Chen, L., Ruan, D., Taylor, N., Ronald, P., Beachy, R. and Fuaquet, C. (1998). Transgenic elite indica rice varieties, resistant to *Xanthomonas oryzae* pv. *Oryzae*. *Mol. Breed.* 4: 551-558.
- Zhang, W. and Wu, R. (1988). Efficient regeneration of transgenic plants from rice protoplasts and correctly regulated expression of the foreign gene in the plants. *Theor. Appl. Genet.* 76: 835-840.

References

- Zeitlin, L., Olmsted, S.S., Moench, T.C., Co, M.S., Martinell, B.J., Paradkar, V.M., Russell, D.R., Queen, C., Cone, R.A. and Whaley, K. (1998). A humanized monoclonal antibody produced in transgenic plants for immunoprotection of the vagina against genital herpes. *Nat. Biotechnol.* 16: 1361-1364.
- Zhu, J.K., Hasegawa, P.M. and Bressan, R.A. (1997). Molecular aspects of osmotic stress in plants. *Cri. Rev. Plant Sci.* 16: 253-277.
- Zuo, J., Niu, Q.W., Ikeda, Y. and Nam-Hai-Chua (2002). Marker-free transformation: increasing transformation frequency by the use of regeneration –promoting genes. *Curr. Opin. Biotechnol.* 13: 173-180.

APPENDIX

ARTIFICIAL DIET COMPOSITION

<i>Ingredient</i>	<i>mg/l</i>
K_2HPO_4	7500
$MgSO_4 \cdot 7H_2O$	1230
Sucrose	50000
L-alanine	1000
L-arginine hydrochloride	2700
L-asparagine	5500
L-aspartic acid	1400
L-cysteine	400
L-glutamic acid	1400
L-glutamine	1500
Glycine	800
L-histidine	800
L-isoleucine	800
L-leucine	800
L-lysine hydrochloride	1200
L-methionine	800
L-phenylalanine	400
L-proline	800
DL-serine	800
L-threonine	1400
L-tryptophan	800
L-tyrosine	400
L-valine	800
Thiamine hydrochloride	25
Riboflavin	5
Nicotinic acid	100
Pyridoxine hydrochloride	25
Folic acid	5
Calcium pantothenate	50
Meso-inositol	500
Choline chloride	500
Biotin	1
Sodium ascorbate	1000
$FeCl_3 \cdot 6H_2O$	22.28
$CuCl_2 \cdot 2H_2O$	2.68
$MnCl_2 \cdot 4H_2O$	7.93
$ZnCl_2$	11.88
$CaCl_2 \cdot 2H_2O$	31.15
pH (with KOH)	6.5

Store below $-20^\circ C$

Dissolve tyrosine in small volume 1N HCl

Dissolve riboflavin by gentle heating in distilled water prior to adding to stock

(ref: Mitsuhashi (1975))

Pham Trung-Nghia · Ludovic Bassie · Gehan Safwat
Pham Thu-Hang · Olivia Lepri · Pedro Rocha
Paul Christou · Teresa Capell

Reduction in the endogenous *arginine decarboxylase* transcript levels in rice leads to depletion of the putrescine and spermidine pools with no concomitant changes in the expression of downstream genes in the polyamine biosynthetic pathway

Received: 27 March 2003 / Accepted: 14 June 2003 / Published online: 24 July 2003
© Springer-Verlag 2003

Abstract We investigated whether down-regulation of arginine decarboxylase (ADC) activity and concomitant changes in polyamine levels result in changes in the expression of downstream genes in the polyamine pathway. We generated transgenic rice (*Oryza sativa* L.) plants in which the rice *adc* gene was down-regulated by expression of its antisense oat (*Avena sativa* L.) ortholog. Plants expressed the oat mRNA *adc* transcript at different levels. The endogenous transcript was down-regulated in five out of eight plant lineages we studied in detail. Reduction in the steady-state rice *adc* mRNA levels resulted in a concomitant decrease in ADC activity. The putrescine and spermidine pool was significantly reduced in plants with lower ADC activity. Expression of the rice *ornithine decarboxylase* (*odc*),

S-adenosylmethionine decarboxylase (*samdc*) and *spermidine synthase* (*spd syn*) transcripts was not affected. We demonstrate that even though levels of the key metabolites in the pathway were compromised, this did not influence steady-state transcription levels of the other genes involved in the pathway. Our results provide an insight into the different regulatory mechanisms that control gene expression in the polyamine biosynthetic pathway in plants by demonstrating that the endogenous pathway is uncoupled from manipulations that modulate polyamine levels by expression of orthologous transgenes.

Keywords Antisense · Arginine decarboxylase · *Oryza* · Polyamine

Abbreviations ADC (*adc*): arginine decarboxylase protein (gene) · DIG: digoxigenin · ODC (*odc*): ornithine decarboxylase protein (gene) · SAMDC (*samdc*): adenosylmethionine decarboxylase protein (gene) · SPD SYN (*spd syn*): spermidine synthase protein (gene) · RT-PCR: reverse transcription-polymerase chain reaction

P. Trung-Nghia · L. Bassie · G. Safwat
P. Thu-Hang · O. Lepri · P. Rocha · P. Christou · T. Capell (✉)
Department of Crop Genetics and Biotechnology,
Fraunhofer IME, Auf dem Aberg 1,
57392 Schmallenberg, Germany
E-mail: teresa.capell@ime.fraunhofer.de
Fax: +49-2972-302328

Present address: P. Trung-Nghia
Department of Biological Sciences,
University of Durham, South Road,
Durham, DH1 3LE, UK

Present address: G. Safwat
John Innes Centre, Norwich Research Park,
Norwich, NR4 7UH, UK

Present address: O. Lepri
John Innes Centre, Norwich Research Park,
Norwich, NR4 7UH, UK

Present address: P. Thu-Hang
Department of Agricultural and Environmental Sciences,
University of Newcastle upon Tyne,
Newcastle upon Tyne, NE1 7RU, UK

Present address: P. Rocha
CENIPALMA, Calle 21 No 42C-47,
Bogotá, Colombia

Introduction

Manipulation of metabolic pathways in plants through molecular genetic approaches is now possible as a result of a significant increase in our knowledge base in terms of how such, often complex, networks are controlled and regulated. An important step forward in our ability to understand and modulate plant biosynthetic pathways is the availability of cloned genes encoding key enzymes involved in the pathway. This, together with the identification of useful mutant phenotypes and advances in gene transfer technology make it possible to pose important biochemical questions that need to be addressed before we embark on useful strategies to

engineer complex pathways in plants. Sophisticated genomic tools, availability of transcription factors that influence metabolism in a holistic manner and a better understanding of how the biochemistry of a given pathway may be controlled spatially and/or temporally provide additional means of manipulating plant metabolism.

Transgenic manipulation of polyamine metabolism has become a valuable tool for studying their physiological roles in plants (for review, see Kumar and Minocha 1998; Bhatnagar et al. 2002). Cellular content of polyamines has been modulated by over-expression or down-regulation of *arginine decarboxylase (adc)*, *ornithine decarboxylase (odc)* and *S-adenosylmethionine decarboxylase (samdc)*; for review, see Kumar and Minocha 1998; Bhatnagar et al. 2002). Over-expression of heterologous *adc* or *odc* cDNA generally causes the production of high levels of putrescine (DeScenzo and Minocha 1993; Bastola and Minocha 1995; Burtin and Michael 1997; Capell et al. 1998). In most cases, a relatively small increase in spermidine and spermine has been observed despite significantly large increases in putrescine levels in transgenic cells (Bassie et al. 2000; Lepri et al. 2001; Sivamani et al. 2001). This observation, combined with the fact that under stress conditions mostly putrescine levels appear to fluctuate without major changes in spermidine or spermine levels, suggests that the levels of spermidine and spermine are under a tight homeostatic regulation (Bhatnagar et al. 2002).

Among the regulatory mechanisms controlling ADC, ODC and SAMDC activities, feedback control by polyamines has been described in different systems. In osmotically stressed oat leaves, spermidine inhibits post-translational processing of the ADC precursor with a subsequent decrease in mature ADC (Borrell et al. 1995). Exogenously added polyamines suppressed ADC activity in tobacco cell cultures, also suggesting the existence of a feedback regulatory mechanism for ADC (Hiatt et al. 1986). With regard to the feedback control of plant ODC by polyamines, the sensitivity of ODC activity to these molecules suggests that polyamine synthesis via ODC may be regulated, at least in part, by simple end-product accumulation (Slocum and Richardson 1991). However, the data obtained by Hiatt et al. (1986) suggest that this may not be a general mechanism since exogenously added polyamines did not suppress ODC activity in tobacco cell cultures. In contrast to the mammalian or yeast enzymes, the plant SAMDC enzyme is not stimulated by putrescine, and it appears that the accumulation of cellular polyamines inhibits SAMDC activity (Hiatt et al. 1986). In tobacco cell cultures, treatment with 1 mM spermidine resulted in a rapid decrease in SAMDC activity by blocking the synthesis of the enzyme (Hiatt et al. 1986). This suggested that there might be different mechanisms involved in regulating ADC, ODC and SAMDC activities (Tiburcio et al. 1997).

For the past several years we have been investigating molecular and biochemical aspects of the polyamine

biosynthetic pathway in plants, using rice as a model. In the course of these studies we generated transgenic plants expressing different polyamine biosynthetic genes, including *adc*, *odc* and *samdc* (Capell et al. 1998; Noury et al. 2000; Lepri et al. 2001; Thu-Hang et al. 2002). We have demonstrated that by over-expressing the *Datura samdc* cDNA, rice leaf tissue can accumulate 2-fold higher putrescine and 2.5-fold higher spermidine levels when compared to wild type, with a concomitant increase in ADC and ODC activity. No changes in *samdc* and *spermidine synthase (spd syn)* transcripts were observed (Thu-Hang et al. 2002). We subsequently wished to investigate whether down-regulation of the rice *adc* gene would result in depletion of the polyamine pool and whether this would influence expression of other genes in the pathway. We used transgenic rice plants in which the rice *adc* gene was down-regulated by expression of its antisense oat ortholog. Transcript accumulation of the rice *odc*, *samdc* and *spd syn* was not affected. Reduction in the steady-state rice *adc* mRNA levels resulted in a concomitant decrease in ADC activity. We demonstrated that even though levels of the key metabolites in the pathway were compromised, this did not influence steady-state transcript levels of the other genes involved in the pathway. Our results indicate that even though the endogenous polyamine pool in these plants is altered substantially, this does not have any effect on the steady-state mRNA of the other downstream genes in the polyamine pathway.

Materials and methods

Plasmids, transformation and plant regeneration

The 2.124-kb oat *adc* cDNA (Bell and Malberg 1990) was excised as an *EcoRI* fragment from pAMC2 (Burtin and Michael 1997) and subcloned into the *EcoRI* site of pJIT60 (Gurineau et al. 1992) which contains a 35S CaMV promoter with duplicated enhancer sequences and a *nos* termination region. Using the restriction enzyme *Sall*, we confirmed the antisense orientation of the oat *adc* cDNA. This plasmid was subsequently referred to as 35S:*adc*. Bombardment, selection and regeneration of transgenic material were as described previously (Sudhakar et al. 1998; Capell et al. 2000).

Polymerase chain reaction (PCR) and reverse transcription-polymerase chain reaction (RT-PCR)

Genomic DNA was extracted from leaf tissue according to the method of Edwards et al. (1991). Genomic PCR amplifications were carried out in a total volume of 50 µl, comprising 100 ng genomic DNA, 1× Roche PCR buffer [50 mM KCl, 10 mM Tris-HCl (pH 9.0), 1.5 mM MgCl₂, 0.1% Triton X-100], 400 µM each deoxynucleoside triphosphate, 100 nM of each primer and 2.5 units of *Taq* DNA polymerase (Roche). The accession number for the oat *adc* sequence, primer sequences and the predicted amplification product size are indicated in Table 1. For the oat *adc* cDNA we carried out 35 amplification cycles: denaturation (96 °C, 40 s), annealing (70 °C, 30 s) and extension (72 °C, 2 min 30 s). The product was visualized on a 1% Tris-borate buffer (TBE) agarose gel.

Total RNA was extracted from 2-month-old leaves and tillers of transgenic plants and wild type using the RNeasy Plant Mini Kit

Table 1 Primers used in PCR, RT-PCR analysis and probes. PCR product sizes: pRadc-3, pRadc-4 = 400 bp; pOatadc-1, pOatadc-5 = 1.5 kb; pRodc-1, pRodc-2 = 700 bp; pRsamdc-1, pRsamdc-2 = 700 bp; pRspdsyn-1, pRspdsyn-2 = 900 bp; pAct-1, pAct-2 = 600 bp. *EST* Expressed sequence tag, *ORF* open reading frame

Accession number	Primer name	Nucleotide position in the EST (E) or ORF (O)	Sequence
C99671 (rice <i>adc</i>)	pRadc-3 ^a pRadc-4 ^b	1 (E)	5'-AGCGCGCTGGTGTGCGCACCA-3' 5'-TGTCGCAGGTGAGGTCCGGAG-3'
X56820 (oat <i>adc</i>)	pOatadc-1 ^a pOatadc-5 ^b	1 (O)	5'-CGGCGATGTGTACCATGTCGAGGG-3' 5'-GCGGGTGCAGCGGCATCGTCTCGG-3'
BE040058 (rice <i>odc</i>)	pRodc-3 ^a pRodc-4 ^b	60 (E)	5'-GCGTTTTATGCGATTTCGAACGG-3' 5'-CCCAGTCTAAACAAGCCGGAACCG-3'
Y07766 (rice <i>samdc</i>)	pRsamdc-1 ^a pRsamdc-2 ^b	1023 (O)	5'-GGAGATCCAGCAAAGCCTGGCC-3' 5'-CCCAGGGGAGAAGATTGCCAG-3'
AJ251298 (rice <i>spd syn</i>)	pRspdsyn-1 ^a pRspdsyn-2 ^b	196 (O)	5'-GGATGGTTCTCCGAGATTAG-3' 5'-GATCTAGTTGGCCTTGGATC-3'
X16280 (rice <i>actin-1</i>)	pAct-1 ^a pAct-2 ^b	1 (O)	5'-ATGGCTGACGCCGAGGATAT-3' 5'-AGGAGTGGTACTGAGTAAC-3'

^aForward primer

^bReverse primer

(Qiagen). A single tiller from each plant was separated and grown hydroponically in Yoshida's solution (Yoshida et al. 1972) to induce root growth. Roots were harvested 2 weeks later and RNA analyses were carried out using the same kit as before. Aliquots of 200 ng total RNA were used in each RT-PCR reaction. Reverse transcription was performed using the Access RT-PCR System (Promega). The resulting oat *adc* cDNA was amplified as described above, using the same primers and cycling conditions. As a negative control, particular RNAs without RT were also subjected to RT-PCR. Products from 25 cycles after separation in a 1% TBE agarose gel were capillary-blotted on positively charged nitrocellulose membranes (Roche). Blots were hybridized with the oat *adc* probe (Table 1) under the same conditions used for DNA gel blot analysis (as described subsequently). Exposure time was 10 min. For each plant, rice *actin-1* transcripts also were amplified as constitutive expression controls as described in Fu et al. (2001). Re-hybridization of the blot with the rice *actin-1* probe (Table 1) was carried out as described in Hloch et al. (2001). Exposure time was 20 min.

DNA and RNA gel blot analysis

Rice (*Oryza sativa* L.) DNA, RNA and oat (*Avena sativa* L.) DNA was isolated from leaf and root tissue according to the procedure of Creissen and Mullineaux (1995). Tissue from plants grown exactly under the same conditions as described for PCR analysis was used. Following *Hind*III or *Eco*RI digestion and electrophoresis on a 1% TBE agarose gel (Sambrook et al. 1989), DNA (15 µg) was transferred to a positively charged nylon membrane (Roche). Nucleic acids were fixed by baking at 80 °C for 2 h. Filters were washed in 2×SSC for 30 min and then pre-hybridized at 42 °C for 2 h using the digoxigenin (DIG)-easy hybridization solution (Roche). The primer sequences used to make the oat *adc* probe and the predicted amplification product size are indicated in Table 1. The probe was labeled using the PCR DIG probe synthesis kit (Roche). Alkalilabile DIG-11-dUTP was incorporated into the probe in a final volume of 50 µl comprising 4 µM dATP, 4 µM dCTP, 4 µM dGTP, 3.2 µM dTTP, 0.8 µM DIG-11-dUTP, 1× Roche PCR buffer [50 mM KCl, 10 mM Tris-HCl (pH 9.0), 0.1% Triton X-100], 2.5 units of *Taq* DNA polymerase (Roche), 0.1 mM each of the forward and reverse sequence primers and 200 pg of the plasmid. We carried out 35 amplification cycles: denaturation (96 °C, 10 s), annealing (70 °C, 10 s), and extension (72 °C, 1 min 30 s). Labeled oat *adc* probe was purified using the QIAquick Gel Extraction Kit (Qiagen) and denatured at 68 °C for 10 min prior to use. Hybridization was performed at 42 °C overnight. The membranes were washed twice for 5 min in 2×SSC, 0.1% SDS at room temperature, and then twice (15 min) in 0.5×SSC, 0.1% SDS at 68 °C. Genomic *Eco*RI-digested rice and oat DNA (5 µg) from wild-type plants was probed with the oat *adc* DIG-labeled probe and washed twice (15 min) in 2×SSC, 0.1% SDS at 68 °C. Chemiluminescence detection was carried out according to the manufacturer's instructions using the DIG Luminescence

Detection Kit. After washing, the membranes were incubated with CSPD^(R) Chemiluminescent Substrate (Roche) and subsequently exposed to X-ray film (Fuji Photofilm Co., Kanawa, Japan) for 30 min at 37 °C.

Denatured RNA (30 µg) from leaf tissue and roots was subjected to electrophoresis on a 1.2% agarose-formaldehyde gel using 1×Mops buffer (Sambrook et al. 1989). Hybridization of the RNA gel blots from leaf tissue and roots with the oat *adc* probe was as described above for DNA procedures. Membranes were exposed to X-ray film for 10 min at 37 °C. Hybridization of the RNA gel blot with the rice probes was carried out as described subsequently. Accession numbers, primer sequences used to make the rice *adc*, rice *odc*, rice *samdc* and rice *spd syn* probes and the predicted amplification product sizes are indicated in Table 1. Probes were labeled using the PCR DIG probe synthesis kit (Roche). We carried out 35 amplification cycles: denaturation (96 °C, 10 s), annealing [64 °C (rice *adc*), 65 °C (rice *odc*), 65 °C (rice *samdc*), 60 °C (rice *spd syn*), 10 s], and extension (72 °C, 1 min). Labeled probes were purified using the QIAquick Gel Extraction Kit (Qiagen) and denatured at 68 °C for 10 min prior to use. Transfer and hybridization were carried out as described above for DNA procedures. Re-probing of the membranes was performed as described in Hloch et al. (2001). Membranes were exposed at 37 °C to X-ray film for 30 min for *adc*, 50 min for *odc*, 30 min for *samdc*, and 1 h for *spd syn*.

All RNA experiments were repeated at least twice from independent RNA isolations. Oat and rice *adc* steady-state mRNA hybridization signals were quantified using Quantity One (Quantification Software; Bio-Rad) and the resulting values were normalized using values obtained from RNA loading levels.

Determination of ADC activity

Leaf tissue from 2 month-old plants at the same stage as described for molecular analysis were used for ADC activity measurements. Tissue was extracted in buffer (0.1 M Tris, pH 7.6, and 2 mM DTT) at a ratio of 300 mg ml⁻¹ buffer. Polyvinylpyrrolidone (100 mg) was added during grinding. Following centrifugation at 12,000 g for 20 min, the supernatant was used directly in enzyme activity assays. Tissue was always processed immediately after harvest and all assays were performed using fresh extracts. Enzyme assays were carried out in 1.5-ml Eppendorf tubes. A 6-mm-diameter filter paper disc impregnated with 50 µl of 2 N KOH and transfixed with a 3-cm needle was used to trap the ¹⁴CO₂ liberated during the reaction. The reaction mixture for ADC activity contained 20 µl of extraction buffer (pH 7.6), 160 µl of crude enzyme and 20 µl of the substrate mix [20 µl of L-[U-¹⁴C]-arginine (specific activity 11 GBq mmol⁻¹, radioactive concentration 1,850 kBq ml⁻¹; Amersham International) diluted with 20 µl non-radioactive arginine (500 mM) and 60 µl of distilled water] to give a final concentration of 10 mM arginine. Two hundred microliters of 10% (v/v) perchloric acid was added to stop the reaction. After further

incubation for 45 min the filter paper was placed in scintillation minivials with 2 ml scintillation liquid (OptiPhase Hisafe II; Fisons Chemicals) and radioactivity was measured in a Wallac 1219 Rackbeta liquid scintillation counter. Protein determination was carried out as described in Bradford (1976), using bovine serum albumin as a standard. One nkat of ADC activity was defined as the amount (μmol) of $^{14}\text{CO}_2$ released per min and per mg protein.

Polyamine analysis

Crude extracts from leaves from 2-month-old plants and seeds were dansylated and separated by TLC (thin-layer chromatography) as described earlier (Bassie et al. 2000). The dansyl-polyamine bands were identified on the basis of their R_f values after visualisation under UV light (312 nm) and comparison to dansylated polyamine standards. The image of the chromatogram was captured and analysed by Quantity One (Quantification Software; Bio-Rad). The relative amount of dansyl-polyamines in each sample was determined by calculating the integrated optical density of the bands compared to the integrated optical density of the appropriate dilution of the dansylated control samples. Results were expressed as nmol g^{-1} fresh weight (fw).

Statistical analysis

As control values for biochemical analyses (enzyme activity and polyamine content) we used *hpt*-transformed plants in addition to wild-type controls (average of three samples each from six independent lines; $n=36$). Hygromycin-resistant transformants and wild-type control values were not significantly different ($P>0.05$) in terms of enzyme activity and polyamine levels (Lepri et al. 2002). For biochemical analyses of transgenic material (enzyme activity and polyamine content) we used the average value of three samples from each sibling ($n=3$) and each measurement was repeated twice. The data were analyzed by two-way analysis of variance followed by a *t*-test using the Residual Mean Square in the ANOVA as the estimate of variability.

Results

The 1.5-kb oat *adc* probe, detects the rice *adc* gene

To confirm that the antisense effect was due to the homology between sequences, we digested rice and oat genomic DNA with *EcoRI* and hybridised at low stringency to the 1.5-kb DIG-labelled region of the oat *adc* cDNA. *EcoRI* digests of rice and oat DNA yielded one fragment at ≈ 12 kb that hybridised strongly to the *adc* probe in both species. In oat, a second genomic fragment of ≈ 7 kb was also detected (Fig. 1).

Molecular characterization of the transgenic population

The transformation vector containing the oat antisense *adc* cDNA was constructed as described in Materials and methods. Gene transfer and recovery of primary transformants were carried out as described in Capell et al. (2000). We analyzed 12 independent transgenic rice plant lineages and we confirmed integration of the

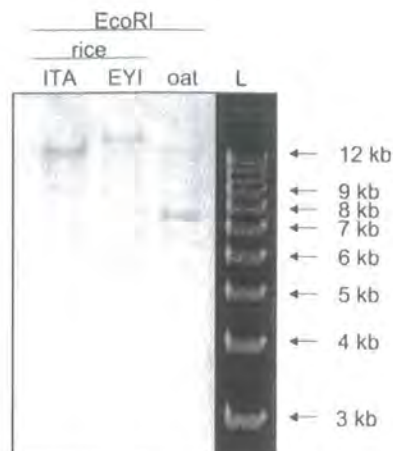

Fig. 1 Gel blot analysis of *EcoRI*-digested genomic rice (*Oryza sativa*, genotypes ITA and EYI) and oat (*Avena sativa*) DNA. The blot was probed with the 1.5-kb DIG-labelled PCR product from *35S:adca* at low stringency. Exposure time 30 min. L Molecular size marker (1-kb DNA ladder; Invitrogen)

35S:adca by genomic DNA gel blot analyses (Capell et al. 2000). Twenty fertile phenotypically normal plants (R1) from each of eight randomly selected primary transformants (R0) were analysed for the presence of the transgene. Segregation analysis was performed by PCR using the set of primers pOatadc-1 and pOatadc-5 (Table 1). We observed that in all lines the *35S:adca* transgene segregated in a ratio of approximately 3:1 (results not shown) and confirm that single or multiple copies of the transgene was/were integrated in a single genetic locus. These results are consistent with previous reports describing the genomic organisation of multiple integrated transgenes in rice (Kohli et al. 1998; Fu et al. 2000). Genomic DNA gel blot analysis of representative samples from each lineage (up to four siblings) is shown in Fig. 2 (*adc* DIG-labelled probe). Digests were carried out using either *HindIII*, which cuts once within the transgene (Fig. 2a) or with *EcoRI*, which releases a 2.1-kb diagnostic fragment comprising the entire coding sequence of the oat *adc* cDNA (Fig. 2b, c). In the *HindIII* digest, each line showed a unique integration pattern, confirming that plants originated from independent transformation events (Fig. 2a). R1 progeny had rather simple integration patterns and these were identical with those of the corresponding primary transformant(s). The *EcoRI* digest demonstrated that six out of the eight lines contained an intact 2.1-kb fragment corresponding to the oat *adc* cDNA coding sequence (lines N82, N84, N92, N93, N96 and N97; Fig. 2b, c). In several lineages, additional fragments were seen, indicating the existence of multiple rearranged copies of the *35S:adca* and also lower molecular weight species representing integration of truncated copies of the transgene. Lineages N88 and N95 showed hybridization signals higher than the expected 2.1 kb (Fig. 2c), most likely resulting from the loss of one *EcoRI* site during the integration process.

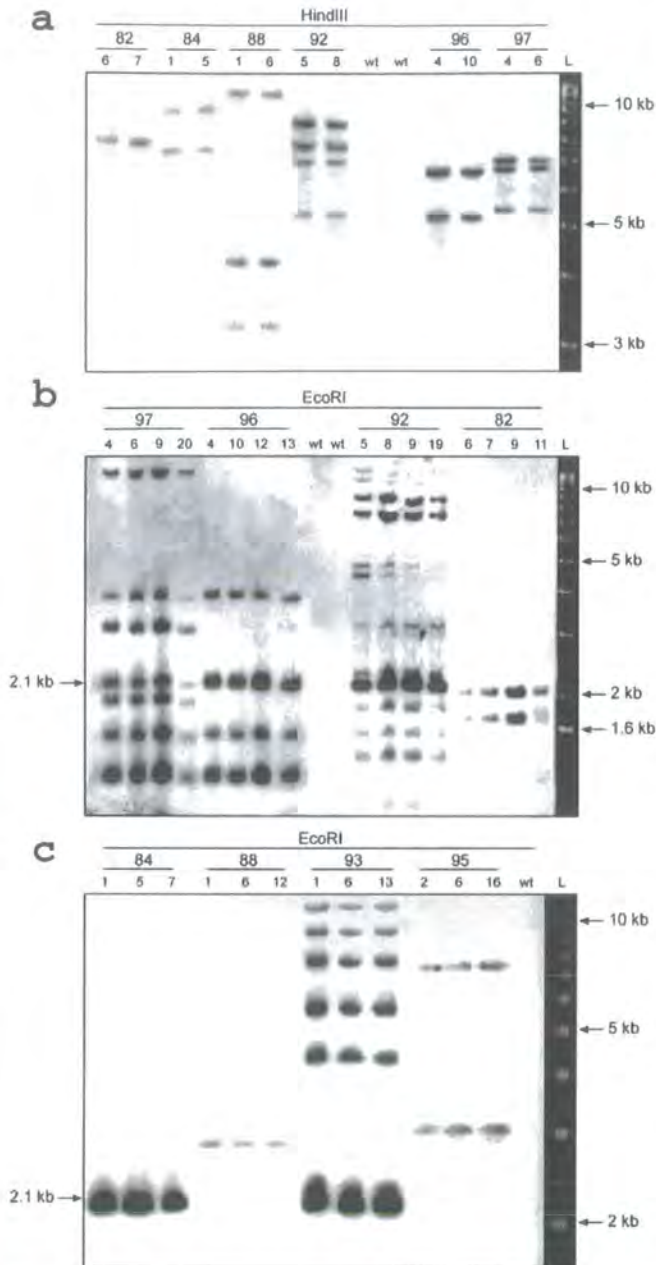

Fig. 2a-c DNA gel blot analysis of R1 progeny from wild-type (*wt*) rice and plants harbouring *35S:adc*. Fifteen micrograms of genomic DNA was digested with *Hind*III (a) or *Eco*RI (b, c) and blots were probed with the 1.5-kb DIG-labelled PCR product from *35S:adca* at high stringency. Exposure time 30 min. Expected size of cDNA fragment, ≈ 2.1 kb is shown on the left-hand side of the panel (arrow in b and c). *L* Molecular size marker (1-kb DNA ladder; Invitrogen). Numbers above gels represent siblings (*lower number*) from the same parental line (*upper number*)

The oat *adc* transcript is expressed in all primary transgenic plants and progeny

We extracted total RNA from leaves, tillers and roots from all 32 plants representing the 8 lineages and we analysed oat *adc* antisense expression by RT-PCR (Fig. 3a, b and c, respectively). Out of the eight lines analysed, six showed mRNA expression in all four

siblings in leaves (Fig. 3a), tillers (Fig. 3b) and roots (Fig. 3c; N84-1, 5, 7, 8; N88-1, 6, 12, 13; N92-5, 8, 9, 19; and N96-4, 10, 12, 13). When RNA samples were subjected to RT-PCR analysis in the absence of reverse transcriptase, no amplification products were obtained. Thirty micrograms of total RNA from leaves and roots was used for RNA gel blot analysis. Leaves and roots from lines N82-7, N88-1 and N96-4 accumulated the oat *adc* transcript, with roots showing substantially higher levels of expression compared to leaves (Fig. 4b, d). The remaining two lineages (N93-1 and N95-16) which appeared not to express the transcript were subsequently shown to contain low but detectable levels of the oat *adc* mRNA following blotting and probing the RT-PCR product from leaf tissue with the oat *adc* DIG-labelled probe (Fig. 4e). When RT was not included in the reaction mixture no amplification bands were obtained (data not shown). All RT-PCR experiments were repeated at least twice from independent RNA isolations and produced the same results.

This three-stage analysis confirmed constitutive expression of the antisense oat *adc* transcript in all lineages, albeit at varying levels. Two lineages (N82 and N97) expressed a second transcript with a lower molecular weight, most likely resulting from expression of an additional truncated copy of the integrated transgene (Fig. 3a-c).

Expression of the oat antisense *adc* transcript only affects expression of its rice ortholog

A rice *adc* 400-bp sequence (Table 1) was used as a probe to investigate expression of the rice *adc* in plants shown to express the introduced *35S:adca*. Levels of rice *adc* steady-state transcript were reduced in five of the eight lines analysed. Representative siblings from each line (N88-1, N92-9, N95-16, N96-4 and N97-20) are shown (Fig. 5b). Line N95 hardly exhibited any expression of the rice *adc* (Fig. 5b). Levels of the endogenous rice *adc* gene remained unaffected in three lines (representative siblings, e.g. N82-7, N84-8 and N93-1 are shown in Fig. 5b). The membranes were re-probed sequentially with a 700-bp DIG-labelled probe from the rice *odc* sequence, a 700-bp probe from the rice *samdc* sequence and a 900-bp probe from the rice *spd syn* sequence (Table 1). Rice *odc*, *samdc* and *spd syn* steady-state transcript accumulation remained unchanged compared to wild type (Fig. 5c, d and e, respectively).

Transgenic rice plants with reduced levels of the *adc* transcript also show reduction in ADC activity

Multiple tissue segments (3–4 cm in length) from the central section of leaves from R1 progeny were harvested from greenhouse-grown plants at the same developmental stage. ADC activity was measured in

Fig. 3a–c RT-PCR analysis of *35S:adc* transcript levels from R1 progeny of rice. Samples were prepared from total RNA extracted from leaf (a), tillers (b) and roots (c). Specific primers amplifying a 1.5-kb fragment from the oat *adc* cDNA were used as described in Materials and methods and Table 1. wt Wild type, L molecular size marker (1-kb DNA ladder; Invitrogen). In b and c, '-' indicates the negative control (water). Numbers above gels represent siblings (lower number) from the same parental line (upper number)

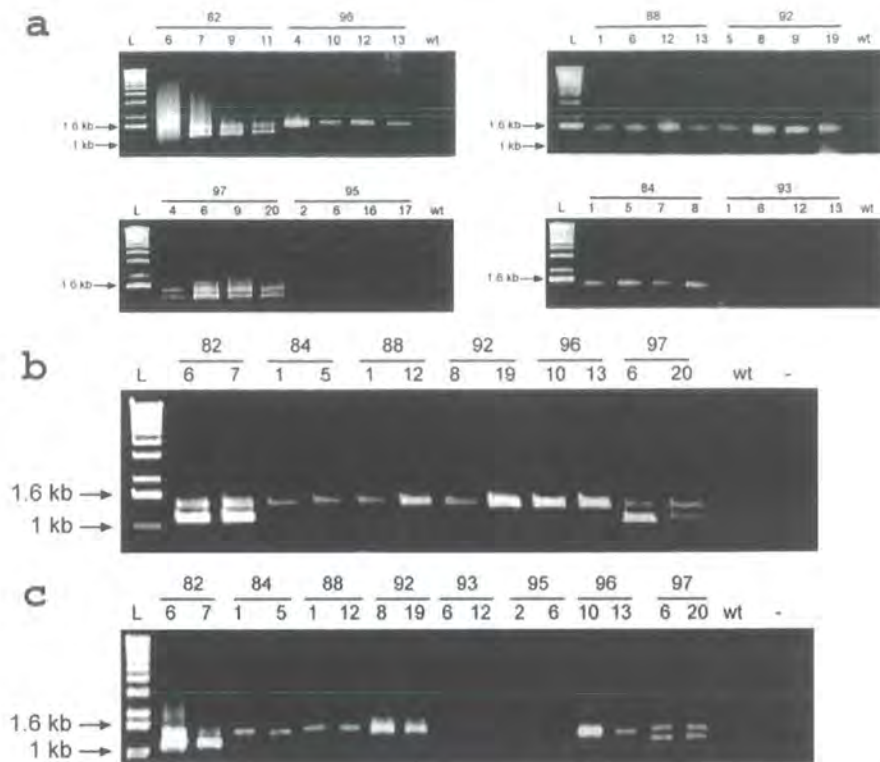

randomly selected siblings from all eight lineages. We also included samples from negative segregants, wild type and *hpt* controls. We measured significant reductions in ADC activity in leaves in three of the eight lineages (N92, N95 and N97). A 60% reduction in ADC activity was measured in leaves from these plants (1.11 ± 0.32 nkat mg^{-1} protein; $P < 0.01$) while the remaining plants exhibited no significant variation in ADC activity (2.82 ± 0.5 nkat mg^{-1} protein, $P > 0.05$) when compared to the control population (3.5 ± 0.72 nkat mg^{-1} protein; Fig. 6a).

A single tiller from each plant was separated and grown hydroponically in Yoshida's solution (Yoshida et al. 1972) to induce root growth after leaf samples were taken, as described earlier for molecular analyses. Roots were harvested 2 weeks later and ADC activity and polyamine content were determined. The three lines (N92, N95 and N97) that had shown significant reductions in activity in leaves (Fig. 6a) also showed significant reduction in ADC activity in roots (Fig. 6c). The minimum and maximum statistically significant reductions in activities were detected in plants N97-20 (2.5 ± 0.09 nkat mg^{-1} protein, $P < 0.05$) and N82-7 (1.46 ± 0.02 nkat mg^{-1} protein, $P < 0.01$) representing a 10 and 50% reduction, respectively compared to controls (2.77 ± 0.08 nkat mg^{-1} protein, Fig. 6c).

Putrescine and spermidine pools are reduced in transgenic plants in which the *adc* transcript and ADC activity are reduced

To determine whether down-regulation of ADC enzyme activity had a quantitative effect on the titers

of putrescine, spermidine, and spermine, we measured free-polyamine concentrations in leaf tissue in progeny from the eight different lineages. Determination of free polyamines was carried out at the same time as ADC activity measurements for all tissues. Plants N92-9, N95-16 and N97-20 exhibited a maximum of 50% (N97-20, 217.50 ± 21 nmol g^{-1} fw, $P < 0.01$) and a minimum of 30% (N95-16, 284.22 ± 14 nmol g^{-1} fw, $P < 0.05$) reduction in putrescine concentration when compared to controls (426.74 ± 32 nmol g^{-1} fw; representative examples are shown in Fig. 6b). All the above plants also had a significant reduction in spermidine levels in leaves. Up to 60% reduction in spermidine content was measured in plant N92-9 (159.11 ± 28 nmol g^{-1} fw, $P < 0.001$) when compared to control levels (408.28 ± 42 nmol g^{-1} fw). No significant variation ($P > 0.05$) was observed in the levels of spermine in any of these lines in leaf tissues (representative examples are shown in Fig. 6b).

All eight lines had a significant reduction in putrescine levels in roots. A maximum 64% reduction in plant N95-16 (137.4 ± 13 nmol g^{-1} fw, $P < 0.01$) was measured compared to control levels (385.8 ± 36 nmol g^{-1} fw). Spermidine levels were reduced significantly in all lines that had exhibited significant reduction in putrescine levels. A maximum of 71% reduction in spermidine levels was measured in plant N95-16 (51.65 ± 9 nmol g^{-1} fw, $P < 0.001$) when compared to control levels (180.12 ± 8 nmol g^{-1} fw). Out of the eight lines that had a concomitant reduction in putrescine and spermidine levels in roots, only two lines had a significant reduction in spermine. Plant N95-16 had a 60% reduction (63.21 ± 19 nmol g^{-1} fw, $P < 0.01$) and

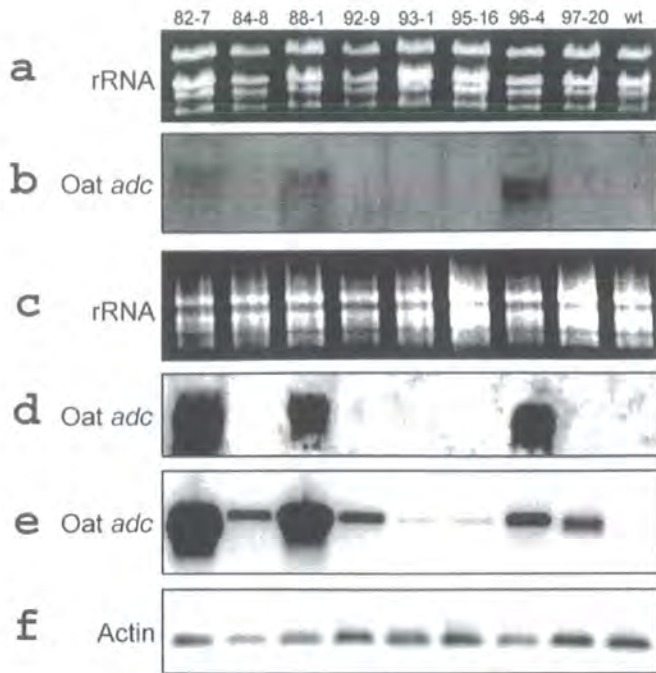

Fig. 4a-f RNA gel blots of total RNA extracted from wild-type (*wt*) rice and R1 progeny containing *35S:adca*. Numbers above gels represent one sibling from each line. **a** Ethidium bromide gel demonstrating equal loading of total RNA extracted from leaves. **b** Membrane probed with the rice *adc* 200 bp DIG-labelled PCR product. Exposure time 30 min. **c** Membrane re-probed with the rice *odc* 289 bp DIG-labelled PCR product. Exposure time 50 min. **d** Membrane re-probed with the rice *samdc* 0.7-kb DIG-labelled PCR product. Exposure time 30 min. **e** Membrane re-probed with the rice *spd syn* 0.9-kb DIG-labelled PCR product. Exposure time 1 h. Re-probing of the membrane, cycling conditions for DIG-labelling of the probes, primers used and sequences are described in Materials and methods

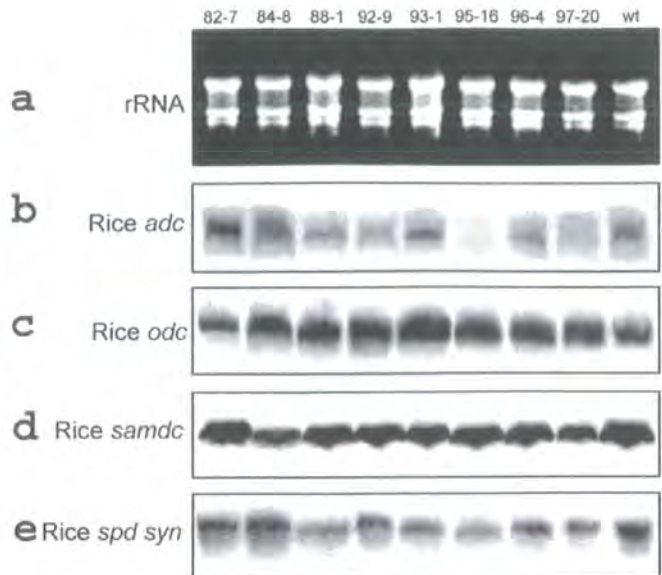

Fig. 5a-e RNA gel blots of total RNA extracted from wild-type (*wt*) rice and R1 progeny containing *35S:adca*. Numbers above gels represent one sibling from each line. **a** Ethidium bromide gel demonstrating equal loading of RNA extracted from leaves. **b** Membrane probed with the rice *adc* 200 bp DIG-labelled PCR product. Exposure time 30 min. **c** Membrane re-probed with the rice *odc* 289 bp DIG-labelled PCR product. Exposure time 50 min. **d** Membrane re-probed with the rice *samdc* 0.7-kb DIG-labelled PCR product. Exposure time 30 min. **e** Membrane re-probed with the rice *spd syn* 0.9-kb DIG-labelled PCR product. Exposure time 1 h. Re-probing of the membrane, cycling conditions for DIG-labelling of the probes, primers used and sequences are described in Materials and methods

plant N97-20 a 50% reduction ($89.98 \pm 18 \text{ nmol g}^{-1} \text{ fw}$, $P < 0.05$) when compared to control levels ($162.15 \pm 10 \text{ nmol g}^{-1} \text{ fw}$, representative examples are shown in Fig. 6d).

Discussion

In plants, co-suppression and antisense inhibition have been widely used to elucidate gene function, to enhance the quality of essential oils through metabolic engineering, to alter flower color, etc. (Wang and Wagner 2003). One goal of expressing constitutively the oat *adc* cDNA in antisense orientation in rice was to determine whether this could influence the cellular free polyamine content through down-regulating the rice ADC enzyme. Prior to this investigation only one report on the modulation of enzymes involved in the polyamine pathway by down-regulating a potato *samdc* gene using a homologous transgene in antisense orientation was described. Engineered potato plants exhibited an abnormal phenotype that was correlated with altered levels of the

samdc transcript, SAMDC activity and polyamine content (Kumar et al. 1996). In the current investigation, we down-regulated the rice *adc* gene by using its full-length oat ortholog in antisense orientation. The oat and the rice *adc* cDNAs share a high sequence homology (Fig. 1). The alignment of the oat *adc* cDNA sequence (X56820) to the rice putative *adc* cDNA (GI6006369 from GI6006355) indicates a 71% identity, reflecting a close evolutionary relationship between them (<http://www2.ebi.ac.uk/clustalw>). This provides adequate levels of homology between the two species for the antisense effect to occur and results from genomic DNA gel blot analysis between the two orthologous genes confirm this (Fig. 1).

Molecular analysis of the transformed plants (Fig. 2) showed that the oat transgene was stably integrated into the rice genome and was transmitted to progeny as a Mendelian trait, consistent with its integration in a single genetic locus (Kohli et al. 1998; Fu et al. 2000). RT-PCR analysis showed mRNA expression in six of the eight lines we analyzed (Fig. 3). Five of these contained an intact copy of the transgene, whereas the remaining expressing line, N88 contained a rearranged copy (Fig. 2b, c). Interestingly, lines N82 and N97 that contained the intact coding region of the transgene expressed two mRNA species, one of which was shorter than the expected size. The aberrant RNAs in these lines

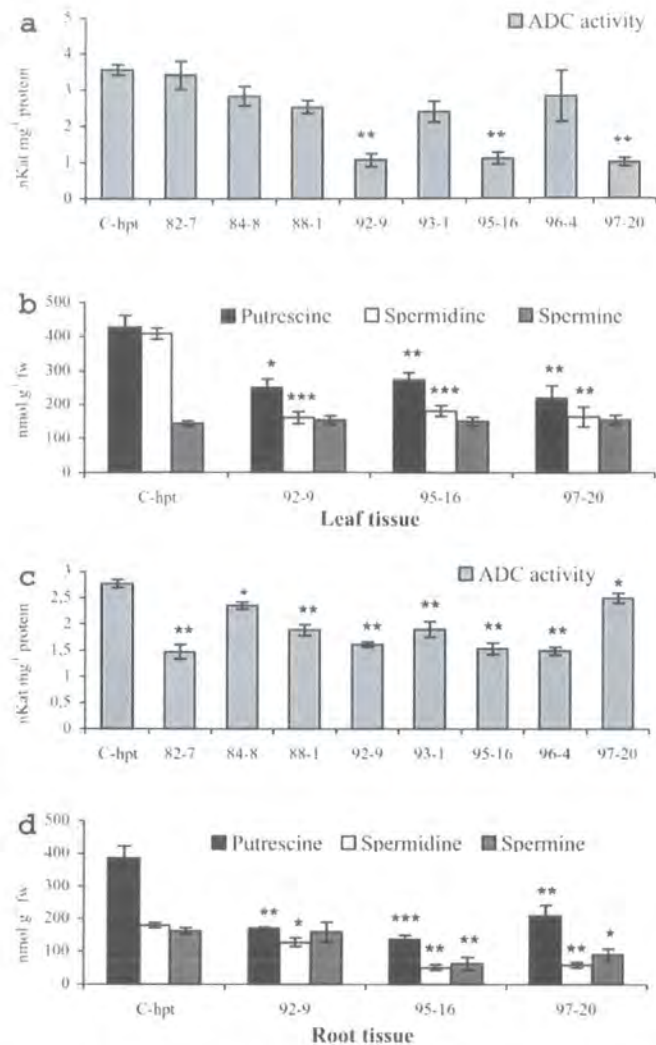

Fig. 6a–d Biochemical characterisation of R1 progeny of rice expressing *35S:adca*. Values are mean \pm SE for control lines ($n=36$) and mean \pm SE in transgenic lines ($n=3$). Significance of data is as follows: ***, $P < 0.001$; **, $0.01 > P > 0.001$; *, $0.05 > P > 0.01$. *C-hpt* Control harboring the *hpt* selectable marker gene. **a** ADC enzyme activity in leaves from different transgenic lines and wild type. **b** Cellular polyamine content in leaf tissue. **c** ADC enzyme activity in roots. **d** Cellular polyamine content in roots.

presumably resulted from a truncated copy (inside the open reading frame) of the transgene. This RNA profile was detected in leaves, roots and tillers in both lines (Fig. 3).

After comparing the normalized hybridization signals from the RNA gel blots for leaves and roots we observed that the intensity of the transcript signal from the transgene in root tissue was higher compared to leaves (Fig. 4b, d). Transgene expression resulted in a reduction of the steady-state rice *adc* mRNA in leaves (Fig. 5b). In one of these lines (N95), steady-state rice *adc* mRNA was not detectable. Some of the down-regulated antisense plants had a significant reduction in ADC activity in leaves. A maximum of 60% reduction in

activity was detected in plant N95-16 (Fig. 6a). Interestingly a significant reduction in ADC activity in roots was detected in all eight lines (Fig. 6c). Plants with reduced levels of ADC activity were indistinguishable from wild type at all stages of development. Even plant N95-16, which had a 60% reduction in ADC activity in leaves and a 50% reduction in roots, was indistinguishable from the rest of the plants, exhibiting normal phenotype and fertility (Fig. 6a, c). Watson et al. (1998) isolated mutants of *Arabidopsis thaliana* that were deficient in ADC activity. From a population of 15,000 EMS M2 plants they identified 9 independently isolated alleles with low ADC activity. The most striking phenotypes of the individual mutants were in root development, where decreased ADC activity was correlated with increased lateral root branching and growth. None of the individual mutant alleles (*spe1-1* and *spe2-1*) abolished ADC activity completely, and even the strongest double mutant (*spe1-1 spe2-1*) decreased polyamine levels by only 10–20%. Chattopadhyay et al. (1997) investigated the role of polyamines in abiotic-stress tolerance in plants. Firstly, they measured ADC activity in shoots and roots from salt-sensitive and salt-tolerant rice. When salinity stress was applied, a significant increase in ADC activity was observed in shoots and roots, but roots showed a much higher induction, with most dramatic increases observed in the salt-sensitive cultivar. Our data and also the studies of Watson et al. (1998) and Chattopadhyay et al. (1997), indicate that the regulation of ADC in root tissue is not as tight as it is in leaves. Feirer et al. (1984), by using α -difluoromethylarginine (DFMA, a specific inhibitor of ADC activity), reported an 88% reduction in ADC activity in wild-type carrot cells. This resulted in a significant reduction in putrescine and spermidine content. Embryogenic capacity of these cells was compromised by 50%. Thus, it is apparent that none of the three strategies, mutants, inhibitors or molecular approaches involving transgenic plants, designed to shut down ADC enzyme activity completely resulted in null plants for the ADC phenotype. It is likely that a null mutation in ADC activity may be lethal. This suggests that ADC may play a role in plant development.

Reduction in ADC activity (Fig. 6a) resulted in lower levels of putrescine and spermidine in leaves (Fig. 6b). Levels of putrescine and spermidine in roots were reduced in all eight lines (Fig. 6d). Two of these lines had also a significant reduction in spermine levels in roots (Fig. 6d). When polyamine levels were measured in mutants that had the lowest enzyme activity (*spe1-1* and *spe2-1*) or in double mutants (*spe1-1 spe2-1*) no significant variation was found in the aerial parts of the plant (Watson et al. 1998). Putrescine levels were only reduced in roots of the double mutants (*spe1-1 spe2-1*). Roots in these mutants had an altered morphology. Thus results from *Arabidopsis* and rice indicate that polyamine pools are altered more dramatically in roots than in leaves. It is interesting, however, that *Arabidopsis* and rice behave very differently in terms of phenotype when polyamine

levels are decreased. This may reflect evolutionary differences between the two species; however, it is not clear why *Arabidopsis* with two different *adc* genes (Watson et al. 1997) will behave in this manner compared to rice which only has one copy of the gene (Chattopadhyay et al. 1997).

A second goal of this investigation was to evaluate whether the rice *odc*, *samdc* or *spd syn* steady-state transcripts were influenced by the size of the free polyamine pool in the plants we generated. Our results indicate that steady-state mRNAs for the endogenous genes remain unaffected in the *adc* antisense transformants. This suggests that feedback regulation of the expression of the genes by polyamines is not a major regulatory mechanism. Thu-Hang et al. (2002) studied expression of the rice *samdc* and *spd syn* genes in rice plants transformed with a *Datura samdc* cDNA. Plants with a 2.5-fold increase in foliar spermidine as a result of expression of the introduced *samdc* transgene showed no variation in the rice *samdc* and the *spd syn* (Thu-Hang et al. 2002). White et al. (1990) reported an 18.8-fold increase in SAMDC activity in Swiss 3T3 cells that had depleted cellular polyamines by using the ODC inhibitor difluoromethylornithine (DFMO). The magnitude of the increase in SAMDC activity in these cells could not be accounted for by either the elevation of mRNA level or an increase in enzyme stability, suggesting increased efficiency of translation of the *samdc* message. These results indicate that the tight regulation at the level of mRNA expression of the genes involved in the polyamine pathway is not overcome by alteration of the size of the free polyamine pool.

Conclusions

By studying transgenic rice plants expressing the 35S:*adca*, we have demonstrated that significant reduction in enzyme activity results in reduction in putrescine and spermidine content in leaf tissue, and putrescine, spermidine and spermine in roots. Expression of the transgene affected expression of its rice ortholog; however, expression of other endogenous genes involved in the pathway was not affected even though the size of the pool of the free polyamines was significantly reduced. By investigating all components in the polyamine pathway biosynthetic machinery, i.e. transgene integration, transcription and translation, and also how these affect end-product profiles in a range of lineages, we show that the pathway is tightly regulated. It appears that alteration of the size of the endogenous free polyamine pool does not act as a signal to induce changes in the transcription of other genes in the pathway. Such studies can now be extended to more complex pathways to unravel additional elements that control accumulation of end products in plants.

Acknowledgements We thank R. Malmberg, T. Michael, H. Bohnert and T. Sasaki for the kind gift of the cDNAs, J. Dix for

graphic design and E. Aguado for maintaining plants. Pham Trung-Nghia and Pham Thu-Hang were supported by Rockefeller Foundation Fellowships.

References

- Bassie L, Noury M, Lepri O, Lahaye T, Christou P, Capell T (2000) Promoter strength influences polyamine metabolism and morphogenic capacity in transgenic rice tissues expressing the oat arginine decarboxylase cDNA constitutively. *Transgenic Res* 9:33–42
- Bastola DR, Minocha SC (1995) Increased putrescine biosynthesis through transfer of mouse ornithine decarboxylase cDNA in carrot promotes somatic embryogenesis. *Plant Physiol* 109:63–71
- Bell E, Malmberg RL (1990) Analysis of a cDNA encoding arginine decarboxylase from oat, reveals similarity to the *Escherichia coli* arginine decarboxylase and evidence of protein processing. *Mol Gen Genet* 224:431–436
- Bhatnagar P, Minocha R, Minocha SC (2002) Genetic manipulation of the metabolism of polyamines in poplar cells. The regulation of putrescine catabolism. *Plant Physiol* 128:1455–1469
- Borrell A, Culiñez-Macia FA, Altabella T, Besford RT, Flores D, Tiburcio AF (1995) Arginine decarboxylase is localized in chloroplasts. *Plant Physiol* 109:771–776
- Bradford MM (1976) A rapid and sensitive method for the quantification of microgram quantities of protein utilizing the principle of dye-binding. *Anal Biochem* 72:248–254
- Burtin D, Michael T (1997) Over-expression of arginine decarboxylase in transgenic plants. *Biochem J* 325:331–337
- Capell T, Escobar C, Lui H, Burtin D, Lepri O, Christou P (1998) Over-expression of the oat arginine decarboxylase cDNA in transgenic rice (*Oryza sativa* L.) affects normal development patterns in vitro and results in putrescine accumulation in transgenic plants. *Theor Appl Genet* 97:246–254
- Capell T, Bassie L, Topsom L, Hitchin E, Christou P (2000) Simultaneous down-regulation of two related enzymes in early steps of the polyamine biosynthetic pathway in transgenic rice by a single antisense mRNA species. *Mol Gen Genet* 264:470–476
- Chattopadhyay MK, Gupta S, Sengupta DN, Ghosh B (1997) Expression of arginine decarboxylase in seedlings of indica rice (*Oryza sativa* L.) cultivars as affected by salinity stress. *Plant Mol Biol* 34:477–483
- Creissen GP, Mullineaux PM (1995) Cloning and characterisation of glutathione reductase cDNAs and identification of two genes encoding the tobacco enzyme. *Planta* 197:422–425
- DeScenzo RA, Minocha SC (1993) Modulation of cellular polyamines in tobacco by transfer and expression of mouse ornithine decarboxylase cDNA. *Plant Mol Biol* 22:113–127
- Edwards K, Johnstone C, Thompson C (1991) A simple and rapid method for the preparation of plant genomic DNA for PCR. *Nucleic Acids Res* 19:1349
- Feirer RP, Mignon G, Litvay JD (1984) Arginine decarboxylase and polyamines required for embryogenesis in wild carrot. *Science* 223:1433–1444
- Fu X, Kohli A, Twyman RM, Christou P (2000) Alternative silencing effects involve distinct types of non-spreading cytosine methylation at a three-gene, single-copy transgenic locus in rice. *Mol Gen Genet* 263:106–118
- Fu X, Sudhakar D, Peng J, Richards DE, Christou P, Harberd NP (2001) Expression of *Arabidopsis* GAI in transgenic rice represses multiple gibberellin responses. *Plant Cell* 13:1791–1802
- Gurineau F, Lucy A, Mullineaux P (1992) Effect of two consensus sequences preceding the translation initial codon on gene expression in plant protoplasts. *Plant Mol Biol* 18:815–818
- Hiatt AC, McIndoo J, Malmberg R (1986) Regulation of polyamine biosynthesis in tobacco. Effects of inhibitors and exogenous polyamines on arginine decarboxylase, ornithine

- decarboxylase, and S-adenosylmethionine decarboxylase. *J Biol Chem* 261:1293–1298
- Hloch P, Hoffmann K, Kruchen B, Rueger B (2001) The DIG System — a high sensitive substitute of radioactivity in northern blot analysis. *Biochemica No.* 24–25
- Kohli A, Leech M, Vain P, Laurie DA, Christou P (1998) Transgene organisation in rice engineered through direct DNA transfer supports a two-phase integration mechanism mediated by the establishment of integration hot-spots. *Proc Natl Acad Sci* 95:7203–7208
- Kumar A, Minocha SC (1998) Transgenic manipulation of polyamine metabolism. In: Lindsey K (ed) *Transgenic research in plants*. Harwood Academic Publishers, London, pp 187–199
- Kumar A, Taylor MA, Mad-Arif SA, Davies H (1996) Potato plants expressing antisense and sense S-adenosylmethionine decarboxylase (SAMDC) transgenes show altered levels of polyamine and ethylene: antisense plants display abnormal phenotypes. *Plant J* 9:147–158
- Lepri O, Bassie L, Safwat G, Thu-Hang P, Trung-Nghia P, Hölttä E, Christou P, Capell T (2001) Over-expression of the human *ornithine decarboxylase* cDNA in transgenic rice plants alters the polyamine pool in a tissue-specific manner. *Mol Gen Genet* 266:303–312
- Lepri O, Bassie L, Thu-Hang P, Christou P, Capell T (2002) Endogenous enzyme activities and polyamine levels in diverse rice cultivars depend on genetic background and are not affected by the presence of the hygromycin phosphotransferase selectable marker. *Theor Appl Genet* 105:594–603
- Noury M, Bassie L, Lepri O, Kurek I, Christou P, Capell T (2000) A transgenic rice cell lineage expressing the oat arginine decarboxylase (*adc*) cDNA constitutively accumulates putrescine in callus and seeds but not in vegetative tissues. *Plant Mol Biol* 43:537–544
- Sambrook J, Fritsch EF, Maniatis T (1989) *Molecular cloning. A laboratory manual*, 2nd edn. Cold Spring Harbor Laboratory Press, New York
- Sivamani E, Bassie L, Christou P, Capell T (2001) Development of a novel gene transfer system for *Cajanus cajan* and expression of a monocot arginine decarboxylase cDNA in transformed cell lines. *Plant Physiol Biochem* 39:575–582
- Slocum RD, Richardson DP (1991) Purification and characterization of ornithine transcarbamylase from pea (*Pisum sativum* L.). *Plant Physiol* 96:262–268
- Sudhakar D, Duc LT, Bong BB, Tinjuangjun P, Maqbool SB, Valdez M, Jefferson R, Christou P (1998) An efficient rice transformation system utilizing mature seed-derived explants and a portable, inexpensive particle bombardment device. *Transgenic Res* 7:289–294
- Thu-Hang P, Bassie L, Sawfat G, Trung-Nghia P, Christou P, Capell T (2002) Expression of a heterologous S-adenosylmethionine decarboxylase cDNA in plants demonstrates that changes in SAMDC activity determine level of the higher polyamines spermidine and spermine. *Plant Physiol* 129:1744–1754
- Tiburcio AF, Altabella T, Borrel A, Masgrau C (1997) Polyamine metabolism and its regulation. *Physiol Plant* 100:664–674
- Wang E, Wagner G (2003) Elucidation of the function of genes central to diterpene metabolism in tobacco trichomes using posttranscriptional gene silencing. *Planta* 216:686–691
- Watson MB, Yu W, Galloway G, Malmberg RL (1997) Isolation and characterisation of a second arginine decarboxylase cDNA from *Arabidopsis* (Accession No. AF009647) (PG97114). *Plant Physiol* 114:1569
- Watson MB, Emory KK, Piatak RM, Malmberg RL (1998) Arginine decarboxylase (polyamine synthesis) mutants of *Arabidopsis thaliana* with altered root growth. *Plant J* 13:231–239
- White MW, Degen C, Hill J, Morris DR (1990) Specific regulation by endogenous polyamines of translational initiation of S-adenosylmethionine decarboxylase mRNA in Swiss 3T3 fibroblasts. *Biochem J* 268:657–660
- Yoshida S, Forno DA, Cock JH, Gomez KA (1972) *Laboratory manual for physiological studies of rice*. International Rice Research Institute, Los Baños, Philippines, pp 70

