

Durham E-Theses

Methodologies for selective electrophilic fluorination

Takashi Nakano

How to cite:

Nakano, Takashi (2004) Methodologies for selective electrophilic fluorination. Doctoral thesis, Durham University.

Use policy

The full-text may be used and/or reproduced, and given to third parties in any format or medium, without prior permission or charge, for personal research or study, educational, or not-for-profit purposes provided that:

- a full bibliographic reference is made to the original source
- a <https://etheses.durham.ac.uk/id/eprint/2989/> is made to the metadata record in Durham E-Theses
- the full-text is not changed in any way

The full-text must not be sold in any format or medium without the formal permission of the copyright holders.

Please consult the [full Durham E-Theses policy](#) for further details.

University of Durham

A Thesis Entitled

Methodologies for Selective Electrophilic Fluorination

A copyright of this thesis rests with the author. No quotation from it should be published without his prior written consent and information derived from it should be acknowledged.

submitted by

Takashi Nakano

(Ustinov College)

Department of Chemistry

A Candidate for the Degree of Doctor of Philosophy

2004



25 AUG 2004

To Miyuki, Shiori and Nozomi

Acknowledgements

I would like to express my cordial thanks to Dr. Graham Sandford and Professor Richard D. Chambers for their invaluable advice and encouragement throughout this project.

I also thank all of the other members of the research group past and present, namely: Dr Ian Wilson, Dr Paul Richmond, Dr Darren Holling, Dr Elodie Copin, Dr Emmanuelle Thomas, Dr Christopher B. Murray, Dr Jamal Bousbaa, Dr Cam N. Tat, Dr Mark A. Fox, Miss Jelena Trmčić, Mr Chris A. Hargreaves, Miss Rachel Slater and Mr Matthew W. Cartwright.

This thesis could not have been completed without the help of Dr Alan Kenwright, Mr Ian McKeag and Mrs Catherine Heffernan (NMR); Dr Michael Jones and Miss Lara Turner (Mass Spectrometry); Mr Lennox Lauchlan (Chromatography); Mrs Jaroslava Dostal (Elemental analysis); Dr Andrés Goeta, Dr Andrei Batsanov and Mr Raju Mondal (X-ray crystallography); Mr Peter Coyne and Mr Malcolm Richardson (Glassblowing); Mr James Hodgson and Mr Neil Holmes (Mechanical Workshop); Mr James Lincoln, Mrs Elizabeth Wood, Mr Anthony Baxter and Mr Joe Peel (Stores); Mr Barry Barker and Kelvin Appleby (Electronic Workshop); Dr Euan Ross (Administration), and Mr David Hunter.

I also thank all the other people who worked and studied in the chemistry department who have not been mentioned.

Great thanks also go to Asahi Glass Co., Ltd. for financial support throughout this period of study.

Memorandum

The work described in this thesis was carried out at the University of Durham between October 2001 and February 2004. This thesis is the work of the author, except where acknowledged by reference and has not been submitted for any other degree.

Nomenclature and Abbreviations

Ac	acetyl
AIBN	2,2'-azobisisobutyronitrile
BINAP	2,2'-bis(diphenylphosphino)-1,1'-binaphtyl
bmim	butylmethylimidazolium
bmp	butylmethylpyridinium
BOC	<i>t</i> -butoxycarbonyl
CBZ	benzyloxycarbonyl
CFC	chlorofluorocarbon
ch	channel
COSY	correlated spectroscopy
DABCO	1,4-diazabicyclo[2.2.2]octane
DAST	(diethylamino)sulfer trifluoride
DEAD	diethyl azodicarboxylate
DEPT	Distortionless Enhancement by Polarisation Transfer
DIPHOS	1,2-bis(diphenylphosphino)ethane
DMAP	4-(dimethylamino)pyridine
DPPA	Diphenylphosphoryl azide
ee	enantiomeric excess
eq.	equivalent
FEP	fluorinated ethylene propylene
FFMR	Falling Film Microreactor
GC	Gas Chromatography
HFC	Hydrofluorocarbon
hfc	(1 <i>S</i>)-3-heptafluorobutyrylcamphorato
hmim	hexylmethylimidazolium
HSQC	Heteronuclear Single-Quantum Correlation
IR	Infrared

KHMDS	potassium bis(trimethylsilyl)amide
LDA	lithium diisopropylamide
LHMDS	lithium bis(trimethylsilyl)amide
MM	Molecular Mechanics
MO	Molecular Orbital
MOM	methoxymethyl
MS	Mass spectrometry
NFSI	<i>N</i> -fluorobenzenesulfonimide
NFOBS	<i>N</i> -fluoro- <i>o</i> -benzenedisulfonimide
NMR	Nuclear Magnetic Resonance
PET	Positron Emission Tomography
Ph	phthaloyl
PMHS	polymethylhydrosiloxane
PMP	1,2,2,6,6-pentamethylpiperidine
PNB	<i>p</i> -nitrobenzyl
PTFCE	polytrifluorochloroethylene
PTFE	polytetrafluoroethylene
<i>rac</i>	racemic
R _f	perfluoroalkyl
rt	room temperature
SET	Single Electron Transfer
TBDMS	<i>t</i> -butyldimethylsilyl
Tf	trifluoromethanesulfonyl
THF	tetrahydrofuran
THP	tetrahydropyranyl
TIPS	triisopropylsilyl
TMS	trimethylsilyl
TMSCl	trimethylsilyl chloride
Tr	trityl
Trp	tryptophan
Ts	<i>p</i> -toluenesulfonyl

Numbering of Steroid Systems

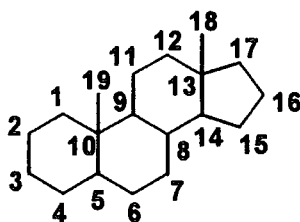

Statement of Copyright

No part of this thesis may be reproduced by any means, nor transmitted, nor translated into any machine language without the written permission of the author.

Abstract

Methodologies for Selective Electrophilic Fluorination

Takashi Nakano, University of Durham, 2004

Chapter 1 Chapter 1 contains a discussion of the effects of the introduction of fluorine atoms into organic molecules. A review of electrophilic fluorination reactions which have been reported recently, from the viewpoint of selectivity is given.

Chapter 2 As a new methodology for selective fluorination of unactivated C-H sites, geometrically directed remote fluorination of steroid derivatives was investigated. Steroid derivatives bearing a variety of tethers which possess an ability to interact with elemental fluorine were prepared. Direct fluorination of 3 α -(3-cyanobenzoyloxy)-5 α -androstan-17-one showed an increased selectivity for the 9-position compared with the control reactions.

Chapter 3 A feasibility study of the use of elemental fluorine for catalytic enantioselective fluorination reaction of 1,3-ketoesters was conducted. A range of metal compounds were examined in the fluorination of a 1,3-ketoester and some of them were applied for further investigation involving attempts at catalytic enantioselective direct fluorination.

Chapter 4 The capability of the Durham-type multi-channel microreactor for direct fluorination of carbonyl compounds was demonstrated. Effects of various parameters on the conversion and the selectivity in the direct fluorination of ethyl 3-oxobutanoate using a 9-channel microreactor were investigated systematically and results were helpful for determining the conditions of fluorination of other substrates.

Chapter 5 Some miscellaneous reactions were collected in this chapter.

Chapter 6–9 Experimental details of the work discussed in Chapter 2–5.

Contents

Chapter 1. General Introduction	1
1.1 Organofluorine chemistry	1
1.1.1 Introduction	1
1.1.2 Brief history	1
1.1.3 Properties of the fluorine atom	2
1.1.4 Effects of fluorine in organic compounds	4
1.2 Electrophilic fluorinating agents	9
1.2.1 Introduction	9
1.2.2 Elemental fluorine	9
1.2.2.1 Physical properties of elemental fluorine	9
1.2.2.2 Preparation of elemental fluorine	10
1.2.2.3 Selective direct fluorination	10
1.2.3 Xenon difluoride	18
1.2.4 O-F reagents	20
1.2.4.1 Hypofluorites (ROF)	20
1.2.4.2 Perchloryl fluoride (ClO ₃ F)	22
1.2.4.3 Cesium fluoroxy sulfate (CsSO ₄ F)	22
1.2.5 N-F reagents	23
1.2.5.1 Neutral compounds (R ₂ NF)	23
1.2.5.1.1 Sulfonyl derivatives	23
1.2.5.1.2 Other neutral compounds	30
1.2.5.2 Quaternary compounds (R ₃ N ⁺ F X ⁻)	31
1.2.5.2.1 <i>N</i> -fluoropyridinium salts	31
1.2.5.2.2 Saturated derivatives	36
1.2.5.2.3 Other quaternary compounds	41
1.2.5.3 Reaction mechanism	42
1.2.6 Conclusions	42
Chapter 2. Remote Fluorination of Steroids Directed by Tethers	45
2.1 Introduction	45
2.2 Fluorination of steroids	47
2.2.1 Fluorination of steroids using electrophilic fluorinating agents	47

2.2.1.1	Fluorination at unactivated C-H position	47
2.2.1.2	Fluorination of alkenes	50
2.2.1.3	Fluorination of derivatives of carbonyl compounds	52
2.2.2	Fluorination of steroids using nucleophilic fluorinating agents	55
2.3	Remote functionalizations directed by tethered reagents	57
2.4	Remote fluorination of steroids directed by tethered N-F reagents	65
2.4.1	Introduction	65
2.4.2	Model study	66
2.4.2.1	Introduction	66
2.4.2.2	Preparation of model compounds	66
2.4.2.2.1	Pyridine derivatives	67
2.4.2.2.2	Quinuclidine derivatives	68
2.4.2.2.3	1,4-diazabicyclo[2.2.2]octane (DABCO) derivatives	68
2.4.2.3	Evaluation of the fluorinating ability of model compounds	70
2.4.2.3.1	Pyridine derivatives	71
2.4.2.3.2	Quinuclidine derivatives	76
2.4.2.3.3	1,4-diazabicyclo[2.2.2]octane (DABCO) derivatives	79
2.4.2.4	Conclusion	81
2.4.3	Preparation of the steroid derivatives bearing DABCO moiety	83
2.4.3.1	Introduction	83
2.4.3.2	Synthesis of steroids connected to the DABCO moiety by an ester linkage	84
2.4.4	Remote fluorination of steroids directed by tethered N-F reagents	88
2.4.4.1	Fluorination of steroids using Selectfluor TM	88
2.4.4.2	Remote fluorination of steroids directed by tethered N-F reagents	93
2.4.5	Conclusion	117
2.5	Direct remote fluorination of steroids with tethered functional groups	119
2.5.1	Introduction	119
2.5.2	Preparation of steroid derivatives with tethered functional groups	120
2.5.2.1	Synthesis of steroids connected to nitrile group	120
2.5.2.2	Synthesis of steroids connected to carboxyl group	121
2.5.2.3	Synthesis of steroids connected to pyridine group	121
2.5.3	Direct remote fluorination of steroids with tethered functional groups	122
2.5.3.1	Control reactions	122
2.5.3.2	Direct remote fluorination of steroids with tethered functional groups	124
2.5.3.2.1	Direct remote fluorination of steroids with tethered DABCO moiety	124

2.5.3.2.2	Direct remote fluorination of steroids with tethered nitrile group	127
2.5.3.2.3	Direct remote fluorination of steroids with tethered carboxyl group	131
2.5.3.2.4	Direct remote fluorination of steroids with tethered pyridine group	132
2.5.3.2.5	Summary of results	133
2.5.4	Conclusion	136
2.6	Chapter 2. Summary	136

Chapter 3. Attempts at Catalytic Enantioselective Fluorination of 1,3-Ketoesters using Elemental Fluorine **138**

3.1	Introduction	138
3.1.1	Enantioselective fluorination	138
3.1.1.1	Reagent-controlled reaction	138
3.1.1.2	Catalyst-controlled reaction	144
3.1.2	Diastereoselective fluorination using elemental fluorine	151
3.2	Titanium catalysed direct fluorination of 1,3-ketoesters	153
3.2.1	Screening of catalysts (1)	153
3.2.2	Screening of additives	155
3.2.3	Effect of ancillary ligand of titanium complex	157
3.2.4	Effect of intermittent introduction of fluorine	161
3.2.5	Conclusion	162
3.3	Nickel catalysed direct fluorination of 1,3-ketoesters	163
3.3.1	Screening of catalysts (2)	163
3.3.2	Effect of auxiliaries and ligands	165
3.3.3	Effect of intermittent introduction of fluorine	167
3.3.4	Preparation of cyclic 1,3-ketoesters	169
3.3.5	Catalytic direct fluorination of 1,3-ketoesters using a racemic catalyst	171
3.3.6	Attempted catalytic enantioselective direct fluorination of 1,3-ketoesters	173
3.4	Conclusions	176

Chapter 4. Selective Direct Fluorination using Microreactor Technology **178**

4.1	Introduction	178
4.1.1	Gas-liquid two-phase reactions using microreactor technology	179
4.1.1.1	Direct fluorination using microreactors	179

4.1.1.2	Other gas / liquid reactions using microreactors	186
4.2	Device used to perform direct fluorination	188
4.3	Direct fluorination of carbonyl compounds using microreactor technology	193
4.3.1	Fluorination of 1,3-ketoesters using multi-channel microreactor	193
4.3.1.1	Fluorination of ethyl 3-oxobutanoate using multi-channel microreactor – A systematic study	194
4.3.1.1.1	Effect of the concentration of the substrate solution	196
4.3.1.1.2	Effect of reaction temperature	197
4.3.1.1.3	Effect of the flow rate of the substrate solution	198
4.3.1.1.4	Effect of the flow rate of fluorine	200
4.3.1.1.5	Effect of the solvent	200
4.3.1.1.6	Effect of the catalyst	205
4.3.1.1.7	Effect of the reactor alignment	207
4.3.1.1.8	Effect of cleaning the reactor	208
4.3.1.1.9	Effect of work up	209
4.3.1.1.10	Summary of results	212
4.3.1.2	Fluorination of other 1,3-ketoesters using multi-channel microreactor	213
4.3.2	Fluorination of 1,3-diesters using multi-channel microreactor	215
4.3.2.1	Diethyl malonate	215
4.3.2.2	Dimethyl malonate	217
4.3.2.3	2,2-Dimethyl-1,3-dioxane-4,6-dione (Meldrum's acid)	218
4.3.3	Fluorination of other carbonyl compounds using multi-channel microreactor	222
4.3.3.1	1-Cyclohexen-1-yl acetate	222
4.4	Conclusions	222
Chapter 5. Miscellaneous Reactions		224
5.1	Introduction	224
5.2	Direct fluorination in ionic liquids	224
5.2.1	Introduction	224
5.2.2	Preparation of ionic liquids	224
5.2.3	Direct fluorination of carbonyl compounds in ionic liquids	227
5.2.4	Conclusion	230
5.3	Direct fluorination of thioanisole using microreactor technology	231

5.3.1	Introduction	231
5.3.2	Direct fluorination of thioanisole using microreactor technology	233
5.3.3	Conclusion	235
Chapter 6. Experimental to Chapter 2		236
6.1	Instrumentation	236
6.2	The use of elemental fluorine in the laboratory	237
6.3	Preparation of model compounds	241
6.4	Evaluation of the fluorinating ability of model compounds	244
6.5	Preparation of the steroid derivatives bearing DABCO moiety	248
6.6	Fluorination of steroids using Selectfluor™	256
6.7	Remote fluorination of steroids directed by tethered N-F reagents	258
6.8	Preparation of the steroid derivatives with tethered functional groups	266
6.9	Direct remote fluorination of steroids with tethered functional groups	271
Chapter 7. Experimental to Chapter 3		277
7.1	Titanium catalyzed direct fluorination of 1,3-ketoesters	277
7.2	Nickel catalyzed direct fluorination of 1,3-ketoesters	283
Chapter 8. Experimental to Chapter 4		299
8.1	Fluorination of ethyl 3-oxobutanoate using multi-channel microreactor	299
8.2	Fluorination of other 1,3-ketoesters using multi-channel microreactor	314
8.3	Fluorination of 1,3-diester using multi-channel microreactor	315
8.4	Fluorination of 1-cyclohexen-1-yl acetate using multi-channel microreactor	320
Chapter 9. Experimental to Chapter 5		322
9.1	Preparation of ionic liquids	322
9.2	Direct fluorination of carbonyl compounds in ionic liquids	324
9.3	Direct fluorination of thioanisole using microreactor technology	325

Appendix	327
References	328

Accompanying Compact Disc

Full infra red spectra, mass spectrometry spectra and X-ray crystal structure data are supplied on the CD.

Chapter 1.

General Introduction

1.1 Organofluorine chemistry

1.1.1 Introduction

Organofluorine chemistry is one of the most fascinating fields in organic chemistry today. Although only 12 naturally occurring organofluorine compounds have been found,^{1,2} quite a few perfluorinated or partly fluorinated organic compounds are produced and used in our daily life throughout the world because of the remarkable properties derived from the introduction of fluorine atoms into organic compounds.³

1.1.2 Brief history

Fluorine exists in nature mostly as fluorides in minerals, such as fluorite (CaF_2), cryolite ($\text{Na}_3[\text{AlF}_6]$), and phosphorite ($\text{Ca}_5[\text{F, Cl}][\text{PO}_4]_3$). The abundance of fluorine in the Earth's crust is 625wt/ppm, which is about five times larger than that of chlorine. Fluorite has traditionally been the main source of hydrofluoric acid, but now cryolite has gradually replaced it due to short supply.

In the 17th century, it was known that an acid generated by exposure of fluorite to sulfuric acid corroded glass. This acid was used for glass etching, yet not well characterised. The first synthesis of an organofluorine compound is thought to be a synthesis of fluoromethane, prepared by heating a mixture of dimethyl sulfate and potassium fluoride, reported by Dumas and Pélignot.⁴ Isolation of fluorine was successfully achieved in 1886 by Moissan in France.⁵ He electrolyzed anhydrous hydrogen fluoride in the presence of small amounts of potassium fluoride. However, elemental fluorine did not play an important role in organofluorine chemistry until the 1930s because of its violent reactivity.

Remarkable progress in the development of synthetic methods for the preparation of organofluorine compounds was made during the 20th century. Swarts discovered an important method for fluorination of organic halides which utilised antimony (III) fluoride.⁶ This reaction enabled him to synthesise a variety of fluorinated aliphatic compounds which included chlorofluorocarbons (CFCs). Development of CFCs progressed quickly afterwards due to excellent performance as refrigerants, the



injection agent of sprays, the foaming agent of polymers, washing agent of electronic products, and so on. Large-scale industrial production was performed with increasing demand in the second half of the 20th century, but it became the cause of inducing global environment problems in the 1980s. CFCs are now replaced with hydrofluorocarbons (HFCs).

Another important finding was the Balz-Schiemann reaction.⁷ Aromatic amines were converted into diazonium salts, followed by decomposition to the fluorinated aromatic compounds. This reaction was continuously improved and is still very important for the manufacture of fluoroaromatics.

The discovery of poly(tetrafluoroethene) (1938) made a great impact on the chemical industry on account of its high heat and chemical resistance. This discovery resulted in remarkable progress in fluorine-containing materials and chemicals, which are now applied in a wide variety of fields.

One of the important applications of organofluorine compounds is in medical science and pharmacy. Even a single fluorine atom may bring a dramatic increase of biological activity, a reduction of side effects, or an improvement in stability to an organic molecule owing to its unique effects. Since Fried and Sabo (1953) synthesised a fluorinated steroid⁸ which showed a considerable enhancement of bioactivity, the introduction of fluorine into bioactive molecules has become a powerful tool in the development of new drugs. In the meantime, the development of new fluorinating agents and techniques for site selective introduction of fluorine into organic molecules has advanced swiftly, and contributed greatly to the present rapid progress in this field. In addition to the natural and stable isotope ^{19}F , radioisotopes ^{17}F and ^{18}F have been prepared. ^{18}F has the longest half-life (110 min) of the four common positron emitting isotopes (^{11}C , ^{15}O , ^{13}N , and ^{18}F), and ^{18}F labeled compounds have been utilised for positron emission tomography (PET), which is a medical imaging method for studying biochemical transformations and distribution in living human and animal bodies.⁹

1.1.3 Properties of the fluorine atom

Although fluorine belongs to halogen group, organofluorine compounds have quite distinct chemical and physical properties from organochlorine or organobromine compounds. Properties of hydrogen, fluorine and several other elements, from an organic chemical point of view, are summarised in the Table 1.1.

TABLE 1.1 Comparison of several properties of elements

Element	EN (Pauling)	IP (kJ/mol)	EA (kJ/mol)	r_v (nm) (Pauling)	r_v (nm) (Bondi)	CH ₃ -X (nm)	BE of CH ₃ -X (kJ/mol)
H	2.1	1311	72	0.120	0.120	0.109	412
F	4.0	1680	333	0.135	0.147	0.139	440
Cl	3.0	1255	348	0.180	0.175	0.177	328
Br	2.8	1142	324	0.195	0.185	0.193	275
I	2.5	1008	295	0.215	0.198	0.214	240
O (OH)	3.5	1298	141	0.140	0.150	0.143	356
S (SH)	2.5	999	201	0.185	0.180	0.182	272

EN: Electronegativity, IP: Ionization potential, EA: Electron affinity, r_v : van der Waals radius, BE: Bond energy.

The most important characteristic of fluorine is that it has the largest electronegativity of all elements. This fact causes significant influences on the properties of C-F bonds, and on the entire properties of organic molecules in turn. The C-F bond length is the shortest except for a C-H bond and the bond energy is greater than those of C-H or other carbon-halogen bonds. This fact causes some perfluorinated compounds to be thermally and chemically quite stable. Another important property is the small atomic size. Fluorine has a very compact van der Waals radius (0.135 nm, [Pauling]), that is not significantly different from that of hydrogen (0.120 nm), although according to Bondi's estimation, fluorine is closer to oxygen rather than hydrogen.¹⁰ Therefore, it is possible to replace an arbitrary number of C-H bonds with C-F bonds unlike other halogen atoms. Fluorine's ionization potential is the largest with the exception of helium and neon, which means it is more difficult to form 'F⁺' than to form 'Cl⁺', 'Br⁺', and 'I⁺'.

1.1.4 Effects of fluorine in organic compounds

Due to its large electronegativity, fluorine has various effects on organic molecules. The electronic effects of a C-F bond are generally understood in terms of inductive and resonance effects¹¹ (Figure 1.1). Fluorine bonded to sp^3 -carbon induces a $-I_\sigma$ effect to reduce the electron density at the carbon of a C-F bond. When fluorine bonds to an sp^2 -carbon, it pushes the π -electrons to a β carbon due to the repulsion between the unshared electron pairs of fluorine and the π -electrons ($+I_\pi$ effect), whereas fluorine can resonate with the π -electron system ($+R$ effect) like other halogen atoms. As a specific example, α -fluorocarocations are stabilised by resonance effects owing to the empty p-orbital. On the other hand, β -fluorocarocations are difficult to generate because they are destabilised by $-I_\sigma$ effect and, besides, there is no contribution of a stabilizing effect due to the formation of halonium ions unlike the case of bromine and chlorine. In the case of anions, α -fluorocarbanions can be stabilised and destabilised depending on the geometry, and β -fluorocarbanions are stabilised by $-I_\sigma$ effect, although elimination of fluoride competes. In addition, fluorobenzene gives *para*-substituted products preferentially in electrophilic substitution reaction, which can be understood as a result of a $+R$ effect and especially from a $+I_\pi$ effect.

FIGURE 1.1

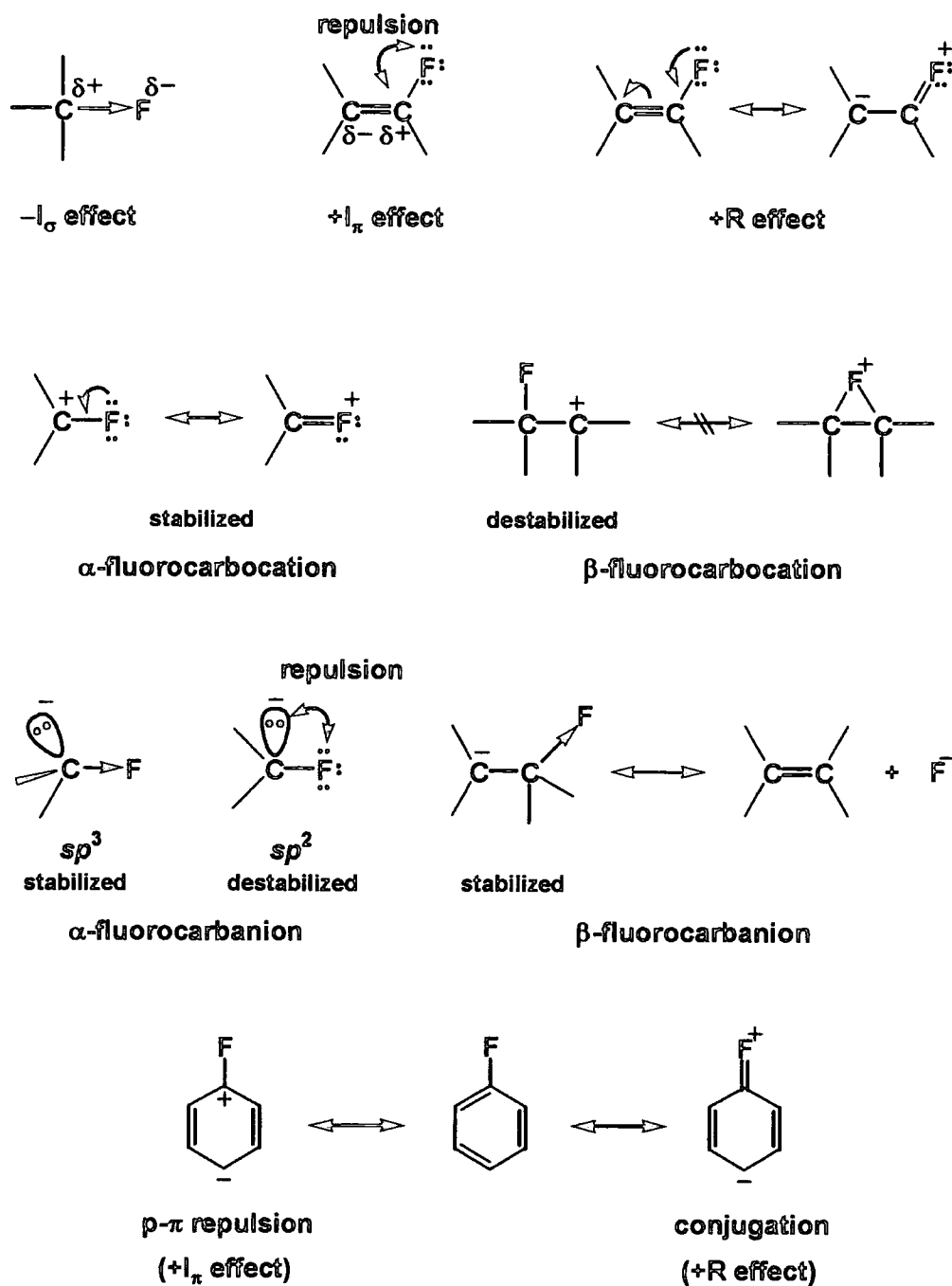

A perfluoroalkyl group, such as CF_3 , or C_2F_5 group always acts as an electron-withdrawing group at sp^3 - and sp^2 -carbon (Figure 1.2). In particular, the inductive effect of CF_3 at sp^2 -carbon may be enhanced by negative hyperconjugation.

FIGURE 1.2

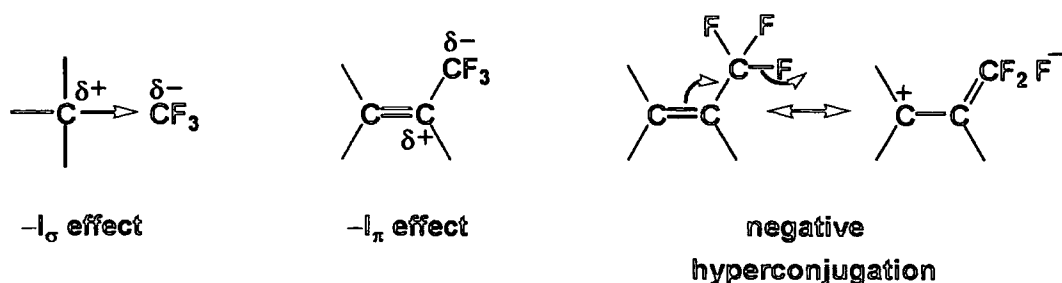

It is well known that a significant difference of reactivity is observed between alkenes and fluoroalkenes. In hydrocarbon systems, electron rich alkenes react with positively charged electrophiles. In contrast, fluoroalkenes have electrophilic carbons, and undergo nucleophilic addition by reaction with negatively charged nucleophiles (Scheme 1.1).

SCHEME 1.1

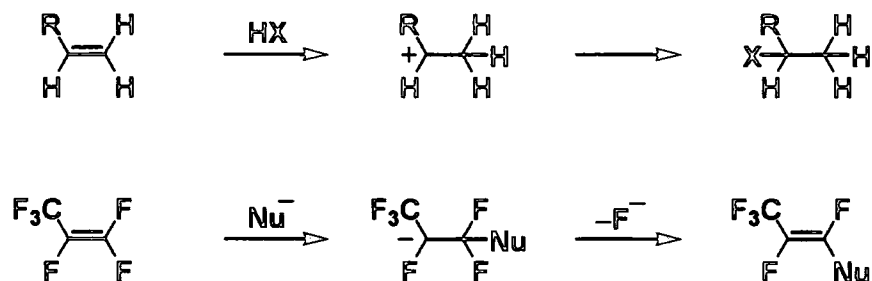

Because of the electron-withdrawing effect of fluorine, organic compounds become more acidic upon substitution of hydrogen with fluorine. Table 1.2 shows a comparison of $\text{p}K_a$ of various halogenated- or non-halogenated organic compounds.¹² The $\text{p}K_a$ of fluorinated acetic acid decreases as the number of fluorines increase. The acidity of trifluoroacetic acid is stronger than trichloroacetic acid. On the other hand, pentafluorophenol is less acidic than pentachlorophenol. The fact is attributed to competing $-I_{\sigma}$ and $+I_{\pi}$ effects.

TABLE 1.2 Acidities of organic acids and carbon acids (pK_a)

Acid	pK_a	Acid	pK_a	Acid	pK_a
$\text{CH}_3\text{CO}_2\text{H}$	4.8				
		$\text{CH}_2\text{FCO}_2\text{H}$	2.6	$\text{CH}_2\text{ClCO}_2\text{H}$	2.9
		$\text{CHF}_2\text{CO}_2\text{H}$	1.2	$\text{CHCl}_2\text{CO}_2\text{H}$	1.3
		$\text{CF}_3\text{CO}_2\text{H}$	0.2	$\text{CCl}_3\text{CO}_2\text{H}$	0.6
$\text{CH}_3\text{SO}_3\text{H}$	-1.9				
		$\text{CF}_3\text{SO}_3\text{H}$	-5.1		
$\text{C}_6\text{H}_5\text{OH}$	9.9				
		$\text{C}_6\text{F}_5\text{OH}$	5.5	$\text{C}_6\text{Cl}_5\text{OH}$	5.3
$(\text{CH}_3)_3\text{COH}$	19.0				
		$(\text{CF}_3)_3\text{COH}$	5.4		
		CHF_3	30.5	CHCl_3	24.4
$\text{CH}_3\text{CO}_2\text{C}_2\text{H}_5$	24.0				
		$\text{CH}_2\text{FCO}_2\text{C}_2\text{H}_5$	21.0		
		$\text{CHF}_2\text{CO}_2\text{C}_2\text{H}_5$	25.0		
CH_3NO_2	10.21				
		CH_2FNO_2	9.5		
		CHF_2NO_2	12.40		

H is the acidic proton

Introduction of fluorine also affects the acidity of carbon acids. As shown in table 1.2, fluoroform is less acidic than chloroform because, when the acidic proton and fluorine are bonded to the same carbon, the conjugate base is destabilised by $+I_\pi$ effects. For a similar reason, difluorinated ethyl acetate and nitromethane are less acidic than the parent compounds.

Obviously, the effect of fluorine substitution is more remarkable in perfluoroorganic compounds. A C-F bond has not only a strong bond energy but also a

quite small polarisability, which brings a variety of unique properties such as a low refractive index, a low permittivity, and small intermolecular forces, which cause small surface tension, non-tackiness, and so on to perfluoro compounds.

As mentioned in section 1.1.2, partially fluorinated (1-3 hydrogen atoms substituted with fluorine atoms) compounds are widely accepted to be very useful in pharmaceutical fields.¹³ Because of the small atomic size, there is not a significant change in the geometry of molecules upon substitution of a C-H bond by a C-F bond. Consequently, the compound is taken in the living body in a similar way to the parent compound (mimic effect). Also, introduction of a fluorine atom, especially in a CF₃ group, increases lipid solubility, enhancing rates of absorption and transport of drugs *in vivo*. In addition, fluorine has an isoelectronic structure to oxygen in a hydroxy group and was considered to be a hydrogen bond acceptor in some cases.¹⁴ Similarly, a fluoroalkene is thought to be isoelectronic to an amide moiety as shown in Figure 1.3. In fact, many protease inhibitors which contain such structural moieties have appeared recently.^{15,16}

FIGURE 1.3 Fluorine-containing isosteres

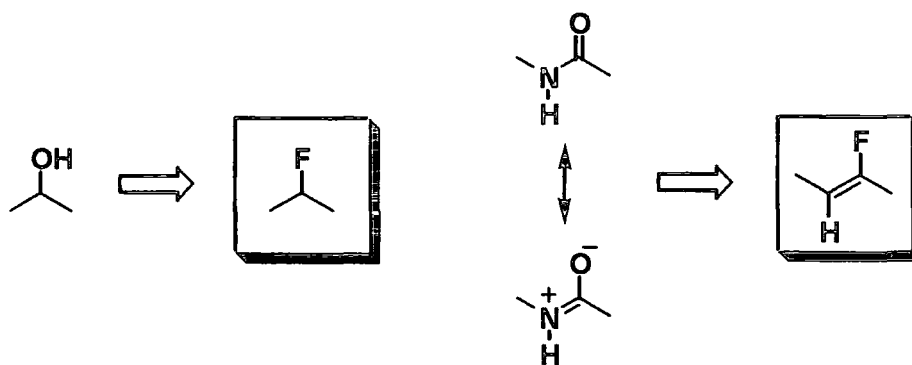

As seen above, the effects of introducing of a fluorine atom into organic compounds covers wide chemical and life science fields and, accordingly, the importance of developing new methodology for regio- and stereoselective fluorination of organic molecules is still increasing. This thesis is concerned with the development of new fluorination methodology and so a brief introduction into the current progress for introduction of fluorine into an organic system follows below.

1.2 Electrophilic fluorinating agents

1.2.1 Introduction

As described in section 1.1.1, only a few examples of fluorine containing natural compounds have been found. This fact means that organofluorine chemistry is a wholly man-made chemistry. In other words, fluorination reactions are essential techniques for the preparation of fluorinated organic molecules, and many fluorinating agents have been developed.^{17,18} These can be roughly divided into two categories, *i.e.* nucleophilic and electrophilic fluorinating agents. Examples of nucleophilic fluorinating agents that are sources of fluoride ion (F^-) are HF and its complexes with amines (HF-pyridine etc.), alkali metal fluorides (KF, CsF etc.), ammonium fluorides (Bu_4NF etc.), SF_4 and its homologues (DAST, morpholinosulfur trifluoride, etc.), and so on. On the other hand, the fluorination of electron-rich centres, in particular, direct conversion of C-H to C-F linkages, is usually not feasible with such nucleophilic fluorinating agents. Radical or electrophilic sources of fluorine are needed for this purpose. Radical fluorination reactions are not suitable for the preparation of partially fluorinated organic compounds.

We have been interested in the development of a general methodology for production of carbon-fluorine bonds. In this thesis, we aimed at establishing new methodology for selective fluorination of saturated C-H bonds using elemental fluorine or other F^+ species generated *in situ*. Accordingly published work involving selective fluorination using electrophilic fluorinating agents, which are most important or are the most recently published (from 2000 to the present day), particularly focused on fluorination of saturated systems, will be reviewed in the following sections.

1.2.2 Elemental fluorine

1.2.2.1 Physical properties of elemental fluorine

Elemental fluorine is an extremely pale yellow-green diatomic gas at ambient temperature. The boiling point is $-188\text{ }^\circ\text{C}$ and the melting point is $-218.6\text{ }^\circ\text{C}$. The dissociation energy of elemental fluorine is much smaller (159 kJ/mol) than other diatomic gases. It makes a sharp contrast to the very strong bond energy between fluorine and other elements. As a result, fluorine gas readily reacts with other substances, even with rare gases such as xenon and krypton to give a variety of fluorinated compounds. Some physical properties of halogens and several other elements are summarised in Table 1.3.¹⁹

TABLE 1.3

Element	Melting point (°C)	Boiling point (°C)	Dissociation energy (kJ/mol)	Distance of X-X (nm)
F ₂	-219.6	-188.1	159	0.142
Cl ₂	-101.0	-34.0	240	0.199
Br ₂	-7.25	58.8	191	0.228
I ₂	113.6	184.4	149	0.267
O ₂	-218.4	-183.0	494	0.121
N ₂	-209.9	-195.8	942	0.110
H ₂	-259.1	-252.9	432	0.074

1.2.2.2 Preparation of elemental fluorine

Elemental fluorine is produced by electrolysis of a melt mixture of HF and KF, which is basically the same method as discovered by Moissan. In particular, a method termed 'medium temperature electrolysis' operating at about 90 °C has now been adopted for manufacturing fluorine.²⁰ In this method, KF·2HF (mp 70 °C) is used as an electrolytic mixture in order to make the vapour pressure of HF low.

1.2.2.3 Selective direct fluorination

Obviously elemental fluorine is the most fundamental electrophilic fluorinating agent. Besides, all other electrophilic fluorinating agents are necessarily made from elemental fluorine. Accordingly it is ideal to utilise elemental fluorine for a wide range of direct fluorination reactions. Elemental fluorine is extremely reactive to organic compounds as shown in Scheme 1.2.

SCHEME 1.2

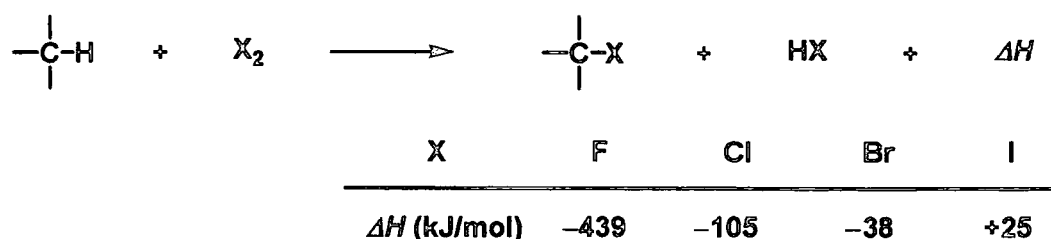

The enthalpy of formation of a C-F bond from a C-H bond is 439 kJ/mol, much higher than that of a C-Cl, C-Br or C-I bond. It is highly exothermic and even much larger than the dissociation energy of a C-C bond (368 kJ/mol). It means that fluorination of organic compounds using elemental fluorine sometimes is not easy to control. However, direct fluorination can be successfully carried out using a dilute mixture with an inert gas like helium, or molecular nitrogen, at low temperatures sometimes in the presence of F-F bond-polarising solvents or additives for trapping radical species.^{21,22}

Selective direct fluorination of saturated C-H sites has been reported. In the fluorination of *trans*-4-methylcyclohexyl *p*-nitrobenzoate, a specific tertiary C-H bond was predominantly fluorinated because the electron densities are higher than the other tertiary C-H bond and all secondary C-H bonds (Scheme 1.3).²³

SCHEME 1.3

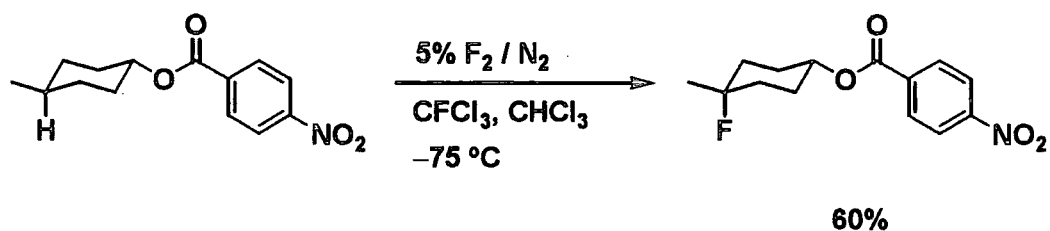

The reaction was carried out in a polar solvent, such as a 1:1 mixture of fluorotrichloromethane and chloroform at very low temperature. Tertiary carbons of adamantanes and steroid derivatives were successfully fluorinated by the same method. Direct fluorination of steroid derivatives will be discussed in section 2.2.1.1.

Fluorination of a range of hydrocarbons was reported by Chambers. The fluorination reactions were carried out in acetonitrile at more convenient temperature (Scheme 1.4).^{24,25}

SCHEME 1.4

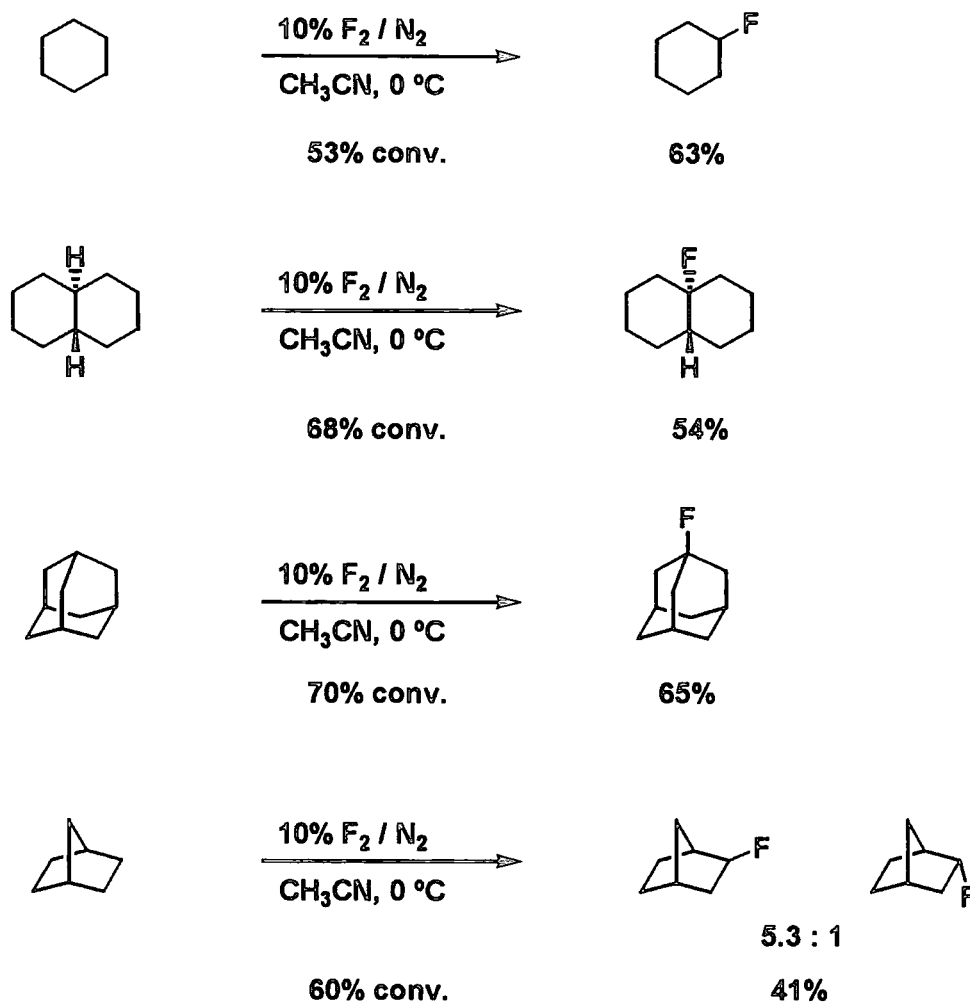

In these reactions, the reaction proceeds with full retention of configuration. A mechanism involving a non-classical three-centre two electron carbocation as the intermediate was suggested by Barton and Rozen (Scheme 1.5). The polar solvent (Solv-H) does not simply encourage polarization of the fluorine molecule but also acts as an acceptor for the fluoride ion. A result of an *ab initio* calculation supported this electrophilic mechanism.²⁶

SCHEME 1.5

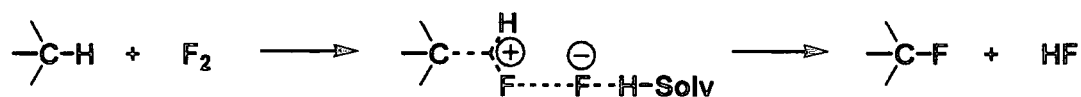

Fluorinations of *cis*-decalin in a range of solvents were also carried out at 0 °C.²⁵ The results showed that the most suitable solvent for fluorination of hydrocarbons were nitriles, especially acetonitrile. The effectiveness of nitriles is not solely attributed to the relative permittivity because nitromethane is not a suitable reaction medium. One possible explanation is that interaction between nitriles and fluorine is occurring and an electrophilic N-F species is generated *in situ* (Scheme 1.6).

SCHEME 1.6



Fluorination of 1,4-disubstituted cubanes was reported by Lagodzinskaya.²⁷ Dimethyl cubane-1,4-dicarboxylate was fluorinated in acetonitrile using 4% fluorine / nitrogen mixture at temperatures from -30 to -20 °C to give dimethyl 2-fluorocubane-1,4-dicarboxylate and small amounts of side products (Scheme 1.7).

SCHEME 1.7

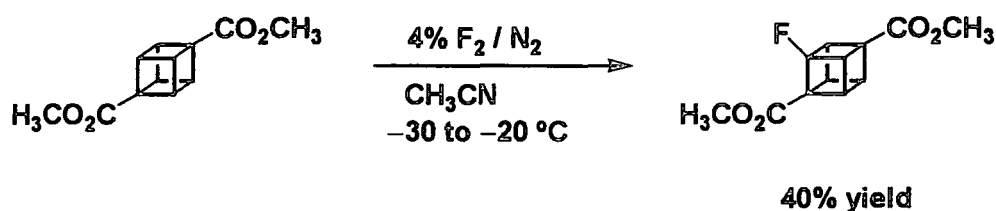

Kobayashi reported direct fluorination of 1,3-dioxolan-2-one. It was successfully carried out to give 4-fluoro-1,3-dioxolan-2-one, which was used as an additive for a lithium ion secondary battery (Scheme 1.8).²⁸ The reaction was carried out without solvent at 50 °C to give monofluorinated product in 70% isolated yield.

SCHEME 1.8

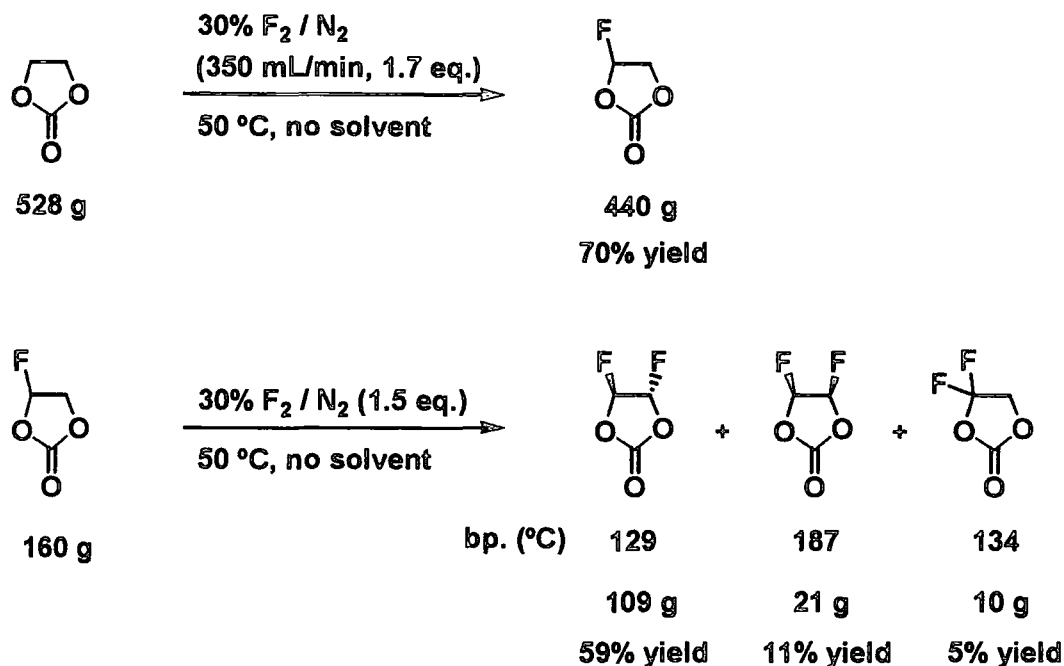

The reaction could also be carried out in hydrogen fluoride at 0 °C with good selectivity, however, the reaction had to be performed at low temperature due to the low boiling point of hydrogen fluoride, and was very slow at this temperature. 4-Fluoro-1,3-dioxolan-2-one was also further fluorinated with elemental fluorine under the same conditions to give three isomeric difluoro derivatives, *trans*-4,5-difluoro-1,3-dioxolan-2-one, *cis*-4,5-difluoro-1,3-dioxolan-2-one and 4,4-difluoro-1,3-dioxolan-2-one. Each compound was separated by distillation followed by recrystallization and obtained in 59, 11, and 5% yield, respectively.

Because fluorinated carbonyl compounds have been accepted as useful building blocks for organofluorine compounds, many studies have focused on the direct fluorination of simple carbonyl compounds.

Fluorination of pyruvic acid derivatives, which are predominantly in the enol form, gave α -fluorinated products.²⁹ On the other hand, in the case of normal ketones which exist almost completely as the keto form, after converting the corresponding silyl enol ether, fluorination was carried out to give α -fluoroketones (Scheme 1.9).³⁰

SCHEME 1.9

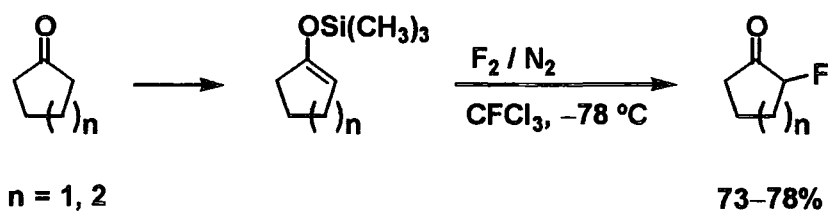
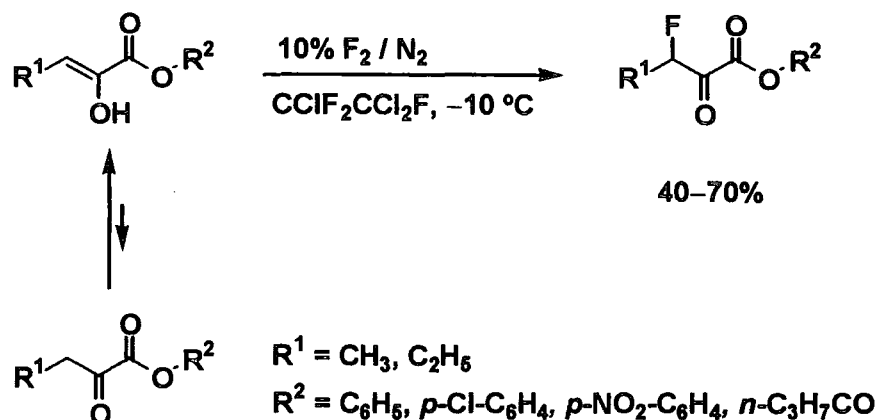

Recently, it has been shown that acetonitrile and formic acid are very useful solvents for direct fluorination of carbonyl compounds.³¹ Chambers reported that the fluorinations of a range of 1,3-dicarbonyl compounds³² and enol acetates³³ were successfully carried out at convenient temperatures (0 to 15 °C) (Scheme 1.10 to 12).

SCHEME 1.10

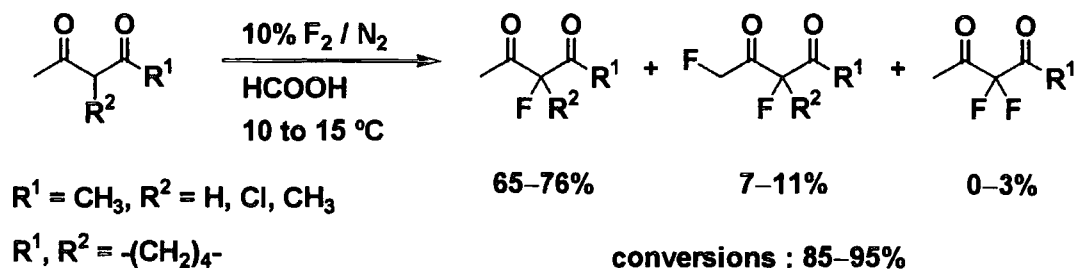

SCHEME 1.11

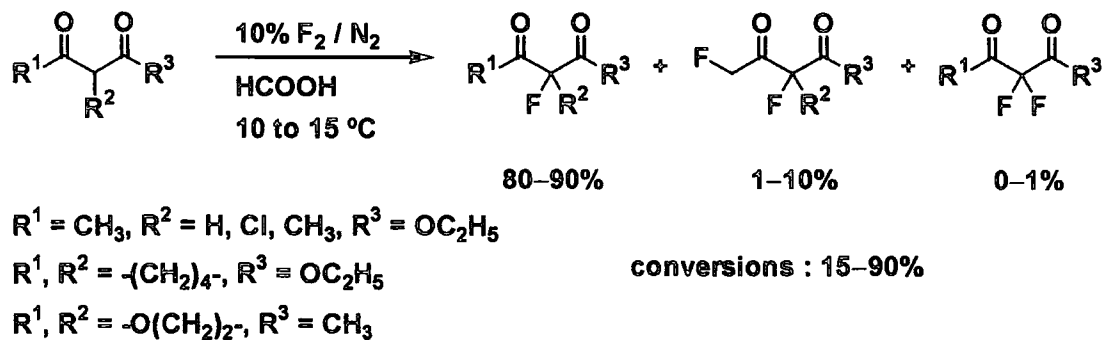

SCHEME 1.12

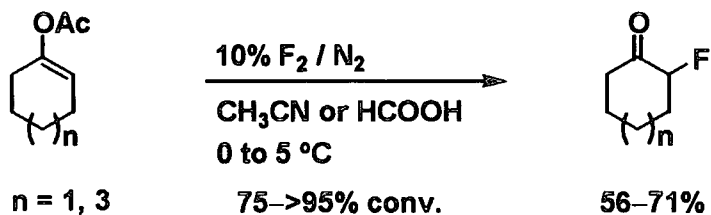

In both the cases of fluorination of 1,3-diketones and 1,3-ketoesters, a C-H bond at the 2-position was fluorinated preferentially, although 2,4- and 2,2- (only in the case of R² is H) difluoro derivatives were also obtained. In essence, these reactions are understood as an electrophilic addition of fluorine to the electron-rich double bond of the enol form of the substrate, as is the case of pyruvic acid derivatives. Consequently, a high enol content or a rapid rate of the enolisation is required for a high conversion of the substrate to the product. Fluorination of 1,3-diketones proceed more rapidly than 1,3-ketoesters. The reactivity order of a range of 1,3-dicarbonyl compounds and other carbonyl compounds was found as shown in Figure 1.4.³¹

ketones was reported by Prakash.³⁹ In model reactions, 2,2-difluoro silyl enol ethers, which could be prepared by magnesium metal mediated reductive defluorination of trifluoroketones, were fluorinated by elemental fluorine in acetonitrile at $-45\text{ }^{\circ}\text{C}$ to give initial trifluoroketones (Scheme 1.14).

SCHEME 1.14

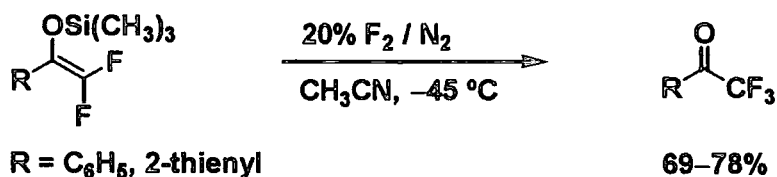

1.2.3 Xenon difluoride

Xenon difluoride is a commercially available crystalline fluorinating agent which is readily sublimed at room temperature (vapor pressure: 4.55 Torr at $25\text{ }^{\circ}\text{C}$).⁴⁰

Selective fluorination of tertiary C-H sites of hydrocarbons using XeF_2 was reported by Zupan. The heating of adamantane with XeF_2 at $105\text{ }^{\circ}\text{C}$ gave a mixture of mono-, di-, and trisubstituted products (Scheme 1.15).⁴¹

SCHEME 1.15

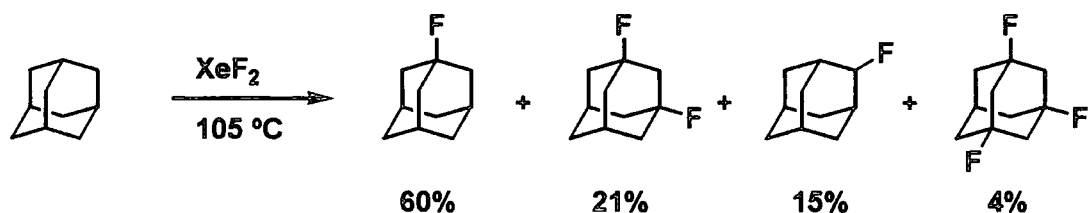

Highly enolisible ketones such as 1,3-diketones and enol acetates or silyl enol ethers were fluorinated to give α -fluoroketones⁴². Recently Ramsden investigated fluorination of silyl enol ethers with XeF_2 in detail and found that the nature of the reaction solvent and vessel was critical to the outcome of the fluorination.^{43,44} On one hand, in glass flasks and in solvents other than acetonitrile, the reactive species appears to be XeF^+ , which reacts as an electrophile. On the other hand, in nonvitreous flasks (e.g., FEP) or in glass flasks using acetonitrile, the reactive species appears to be unionised XeF_2 which reacts as a one-electron oxidizing agent. In general, the use of acetonitrile as a solvent and borosilicate glass vessels gave the best results (Scheme 1.16).⁴⁴

SCHEME 1.16

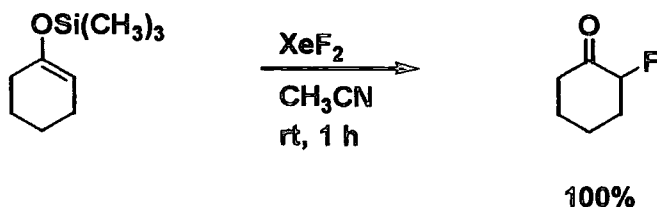

In the case of the fluorination of TMS ether of β -tetralone and norcamphor, significant amounts of parent ketones were obtained. The fact is consistent with a mechanism involving single electron transfer (SET) giving a radical cation as the key intermediate (Scheme 1.17).⁴⁴ In both cases, the radical cation species are relatively stable and do not readily react with the fluorinating agent, consequently, intramolecular hydrogen transfer predominates.

SCHEME 1.17

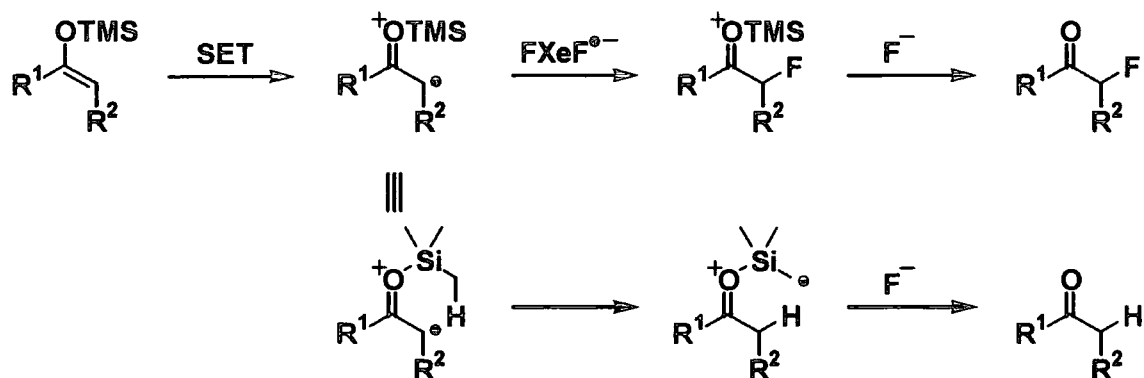

Ramsden also reported a convenient method for preparing [^{18}F]XeF₂ using fluoride exchange. XeF₂ was treated with [^{18}F]fluoride in the presence of Cs⁺-Kryptofix 222 (4,7,13,16,21,24-hexaoxa-1,10-diazabicyclo[8.8.8]hexacosane) complex to give [^{18}F]XeF₂ as the predominant radioactive component.⁴⁵ The [^{18}F]XeF₂ could be utilised for preparation of [^{18}F]2-fluorocyclohexanone.

XeF₂ readily reacts with sulfides to give α -fluorinated sulfides.⁴⁶ This reaction was called the 'fluoro-Pummerer reaction', and utilised for preparation of fluorinated methionine derivatives.⁴⁷ The fluorination exclusively occurred at the methylthio position (Scheme 1.18).

SCHEME 1.18

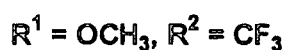
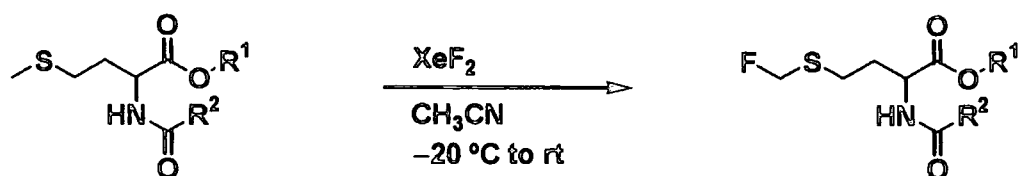

70–90%

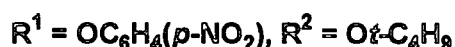

The mechanism involving 3-centre fluorine transfer shown in Scheme 1.19 was proposed for the fluorination of sulfides.⁴⁶ In this mechanism initial fluorination occurs at the sulfur atom to give sulfur (IV) difluoride 1. Hydrogen fluoride is lost *via* a 4-centre step to give intermediate 2 followed by fluorine transfer *via* 3-centre step to give α -fluorinated sulfides 3.

SCHEME 1.19

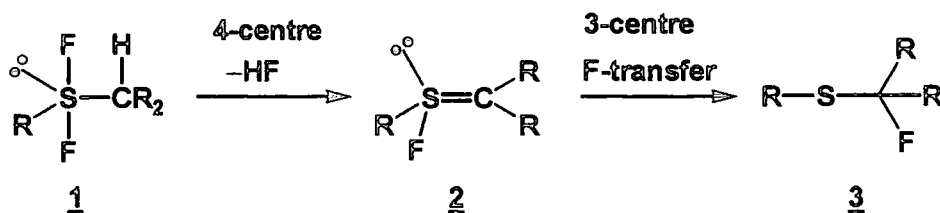

1.2.4 O-F reagents⁴⁸

1.2.4.1 Hypofluorites (ROF)

Trifluoromethyl hypofluorite (CF_3OF) is known as the oldest hypofluorite.⁴⁹ However, it is not easy handled because it is gaseous reagent (b.p. = -95 °C) and too reactive. Recent applications of CF_3OF or other R_fOF s are mainly a straightforward preparation of fluoro-monomers based on the addition to alkenes.⁵⁰ On the other hand, acetyl hypofluorite (CH_3COOF) can be easily handled and prepared from sodium acetate and elemental fluorine (Scheme 1.20).⁵¹ This reagent cannot be isolated because it thermally decomposes.

SCHEME 1.20

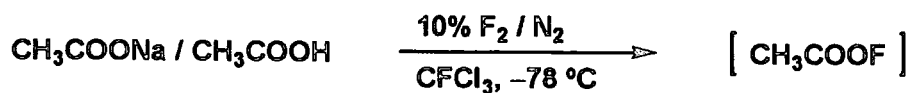

The fluorinating power is milder than other hypofluorites such as CF_3OF or $\text{CF}_3\text{CF}_2\text{OF}$. Particularly, fluorinations of 1,3-dicarbonyl compounds gave good results (Scheme 1.21).⁵²

SCHEME 1.21

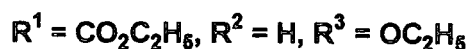
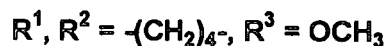
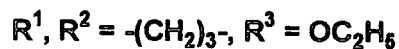
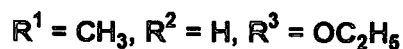
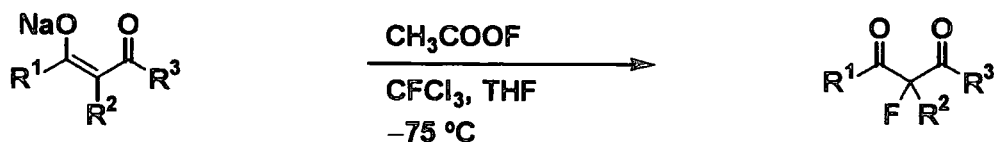

75–92%

Rozen recently reported a synthesis of α -fluorocarboxylic esters and acids using acetyl hypofluorite (Scheme 1.22)⁵³.

SCHEME 1.22

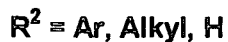
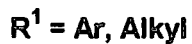
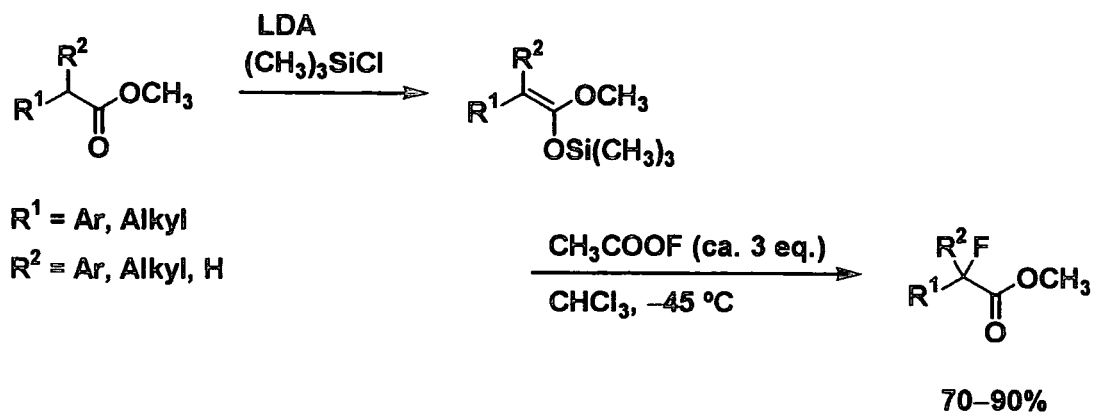

70–90%

SCHEME 1.22 (Continued)

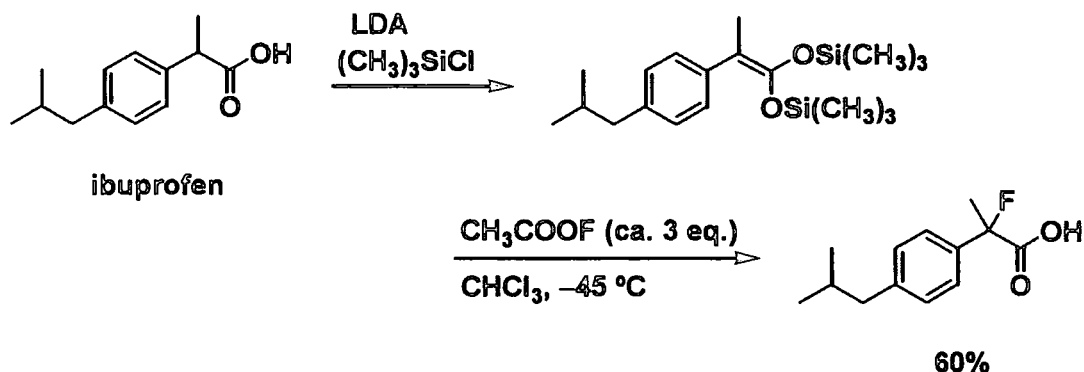

The corresponding esters were converted to their ketene silyl acetals, and these enol derivatives reacted with acetyl hypofluorite. Direct fluorination of the ketene acetals gave much worse yields (around 20%). α -Fluoroibuprofen, 2-fluoro-(4-isobutylphenyl) propionic acid, was also obtained by the same procedure from ibuprofen itself *via* its bis(trimethylsilyl acetal).

1.2.4.2 Perchloryl fluoride (ClO_3F)

Today perchloryl fluoride (ClO_3F) is not widely used because it is an explosive gaseous reagent (b.p. = $-47\text{ }^\circ\text{C}$). Reactions using this reagent with enolate anions, enol esters and enamines gave α -fluorocarbonyl compounds in relatively good yields⁵⁴⁻⁵⁶. Fluorination of ketene silyl acetals with perchloryl fluoride was reported by Takeuchi as shown in Scheme 1.23⁵⁷.

SCHEME 1.23

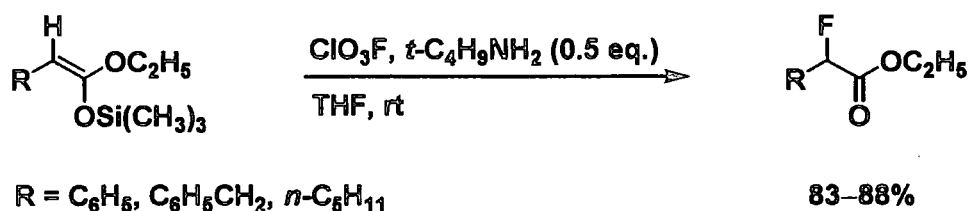

The reaction required sub-stoichiometric amounts of base as an additive to avoid decomposition of the rather unstable substrate, in particular *t*-butylamine was the most effective.

1.2.4.3 Cesium fluoroxy sulfate (CsSO_4F)

Cesium fluoroxy sulfate is a strong crystalline fluorinating agent which can be

prepared by fluorination of cesium sulfate with elemental fluorine and can be stored at 0 °C for about 2 weeks (Scheme 1.24).⁵⁸

SCHEME 1.24

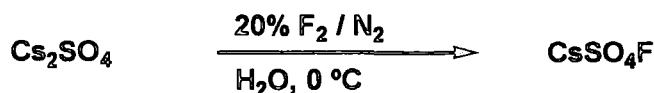

The fluorinating ability of CsSO₄F is strong enough to fluorinate unactivated C-H sites of saturated hydrocarbons. Fluorination of adamantane resulted in 1-fluoro, 2-fluoro, 1,3-difluoro substituted products.⁵⁹

CsSO₄F easily react with cyclic enol esters to give α-fluoroketones in good yields.⁶⁰ The fluorination of 1,3-dicarbonyl compounds gave not only monofluorinated products but also difluorinated systems.⁶¹

The use of CsSO₄F is restricted to a laboratory level because the use of large quantities of this reagent is dangerous since contact with a metal or mechanical pressure may cause a violent decomposition or an explosion.⁵⁸

1.2.5 N-F reagents

In the last twenty years, a number of compounds which have nitrogen-fluorine bonds have been developed as a new class of electrophilic fluorinating agents.^{17,62} These reagents are generally safe, stable and easy to handle. They are usually prepared by the fluorination of the corresponding N-H compounds which are relatively inexpensive, using elemental fluorine. Several reagents are now commercially available and widely used in synthetic organic chemistry.

1.2.5.1 Neutral compounds (R₂NF)

1.2.5.1.1 Sulfonyl derivatives

The DesMarteau reagent, *N*-fluorobis[(trifluoromethyl)sulfonyl]imide [(CF₃SO₂)₂NF]⁶³ is one of the most powerful N-F reagents.⁶⁴ This reagent is liquid at ordinary temperature (m.p. = -69.8 °C) and the preparation needs a sort of intractable procedure, that is direct fluorination of bis(trifluoromethylsulfonyl)imide with non-diluted elemental fluorine in an autoclave.⁶³ *In situ* prepared lithium enolates of esters, amides and ketones easily react with (CF₃SO₂)₂NF at low temperature to give various α-fluorocarbonyl compounds.⁶⁵

Fluorination of 1,3-dicarbonyl derivatives with (CF₃SO₂)₂NF resulted in the

selective formation of 2-fluoro- or 2,2-difluoro-1,3-dicarbonyl analogues, depending on the reaction conditions (Scheme 1.25).⁶⁶ The reaction in CH₂Cl₂ gave exclusively 2,2-difluorinated products. On the other hand, using CH₂Cl₂/H₂O (10:3) as the solvent, monofluorinated compounds were selectively obtained. In this case, the enolisation of monofluoro-compound and the subsequent fluorination to the difluoro-compound were greatly reduced because the strongly acidic by-product, (CF₃SO₂)₂NH was highly water-soluble and rapidly removed from the reaction system.

SCHEME 1.25

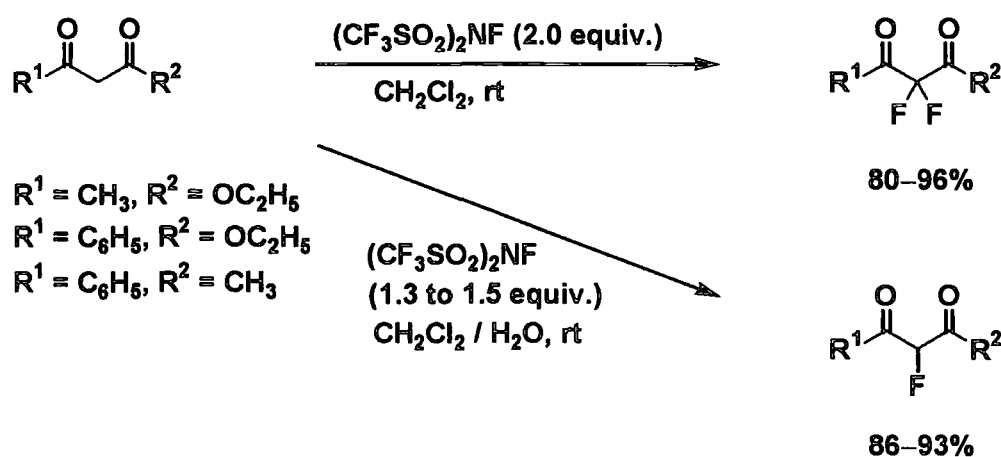

DesMarteau reported a new series of fluorinating agents of this type recently (Figure 1.5).^{67,68}

FIGURE 1.5

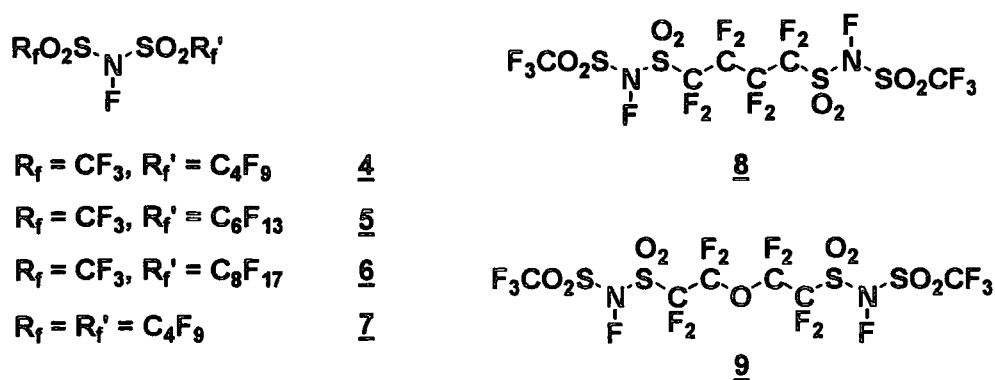

The fluorinating ability of *N*-fluorobis[(perfluoroalkyl)sulfonyl]imides 4–7 were similar to (CF₃SO₂)₂NF. Difunctional derivatives 8 and 9 also exhibited parallel

reactivity to $(\text{CF}_3\text{SO}_2)_2\text{NF}$ in the reaction with a 1,3-dicarbonyl compound utilizing both N-F functions (Scheme 1.26).⁶⁸

SCHEME 1.26

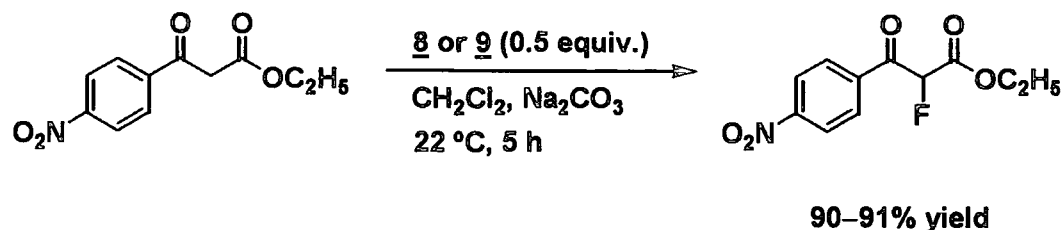

Syvret reported a potentially-viable commercial route to $(\text{CF}_3\text{SO}_2)_2\text{NF}$.⁶⁹ Direct fluorinations of the parent imide were carried out using 20% F_2 / N_2 in perfluorocarbon fluids in a flow system at 80–120 °C. Reaction using 5 to 22 g of $(\text{CF}_3\text{SO}_2)_2\text{NH}$ and up to 6 equivalents of fluorine gave the N-F product in 63 to 81% isolated yield.

N-Fluorobenzensulfonimide [$(\text{PhSO}_2)_2\text{NF} = \text{NFSI}$] and *N*-fluoro-*o*-benzenedisulfonimide (= NFOBS) are both stable, crystalline and easy to handle N-F reagents. They are easily prepared by treatment of the corresponding sulfonimide with 10% elemental fluorine in the presence of NaF (Scheme 1.27).^{70,71}

SCHEME 1.27

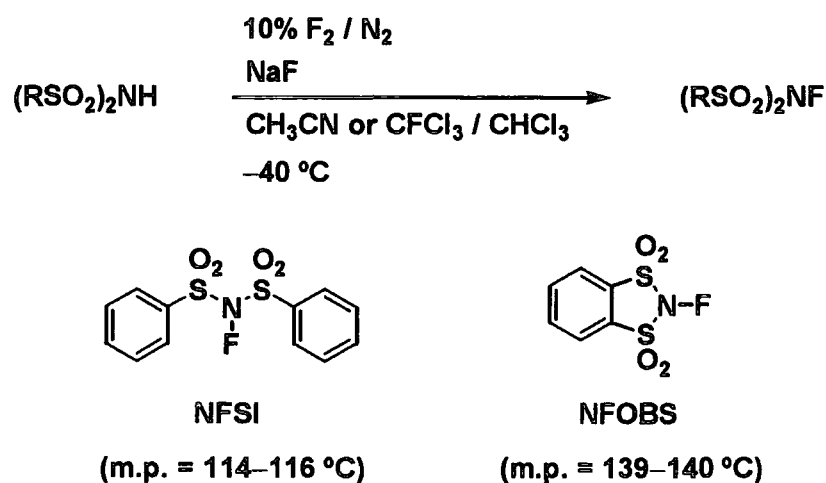

These reagents were utilised for the diastereoselective fluorination of enolates. Highly diastereoselective electrophilic fluorination of lithium imide enolates could be achieved using Evans' oxazolidinone⁷² as a chiral auxiliary and NFOBS (Scheme 1.28).⁷³ Chiral imides were metallated with LDA at –78 °C followed by reaction with

NFOBS at $-78\text{ }^{\circ}\text{C}$ to room temperature. α -Fluoro compounds were obtained in good to excellent yields and diastereoselectivities.

SCHEME 1.28

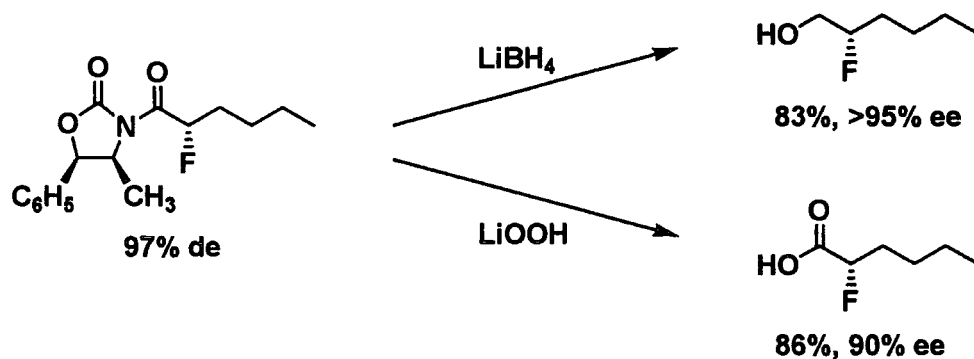
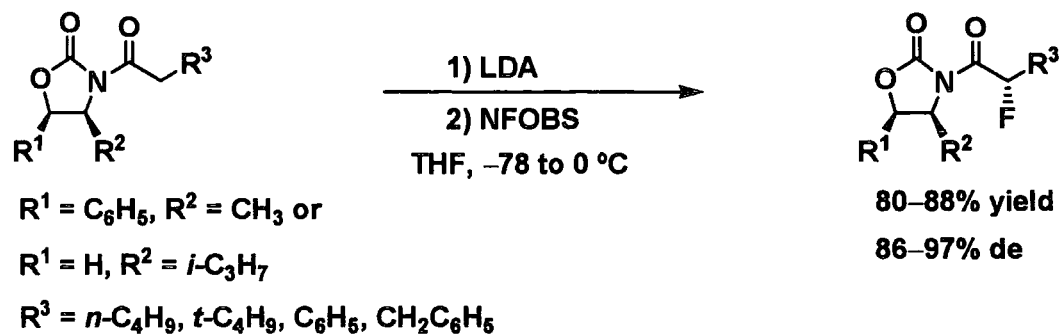

Subsequent reductive or hydrolytic removal of the chiral auxiliary gave 2-fluoroalkanol or 2-fluoroalkanoic acid with very high ee.

Fluorination of the α,β -unsaturated chiral imide enolate was performed using both NFSI and NFOBS as fluorinating agents (Scheme 1.29).^{74,75} The diastereoselectivities were better with NFSI than with NFOBS and the higher de's were attributed to the greater steric bulk of NFSI compared to NFOBS.

SCHEME 1.29

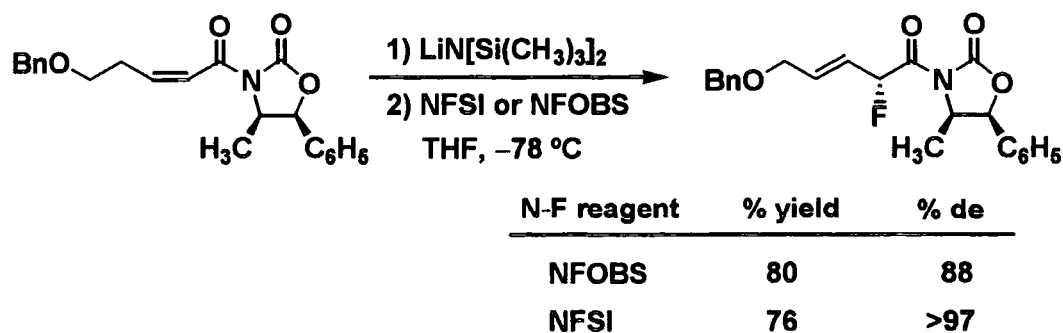

The product was used as a key intermediate in the stereoselective synthesis of 2-deoxy-2-fluoropentoses.

Diastereoselective fluorination of enantiopure α -silylketones using NFSI was reported by Enders (Scheme 1.30).⁷⁶

SCHEME 1.30

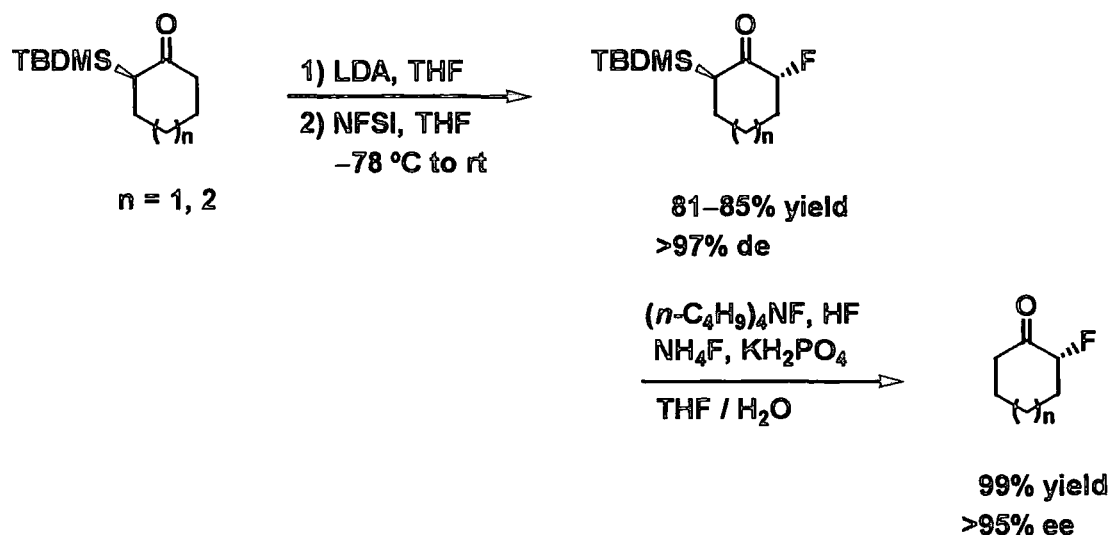

Metalation of α -silylketones with LDA, followed by fluorination with 1 equivalent of NFSI, led to α -fluoro- α' -silylketones in good yield with high diastereoselectivities, in the cases of cyclic ketones particularly. α -Fluoroketones were obtained by the desilylation of α -fluoro- α' -silylketones using a mixture of fluoride sources under buffered conditions without racemization. In the cases of acyclic derivatives and large cycles, the replacement of LDA by LHMDS for enolate formation allowed access to the other diastereomer, which meant both enantiomers were produced from the same substrate.

Coward described fluorination of enantiomerically pure 2-pyrrolidinones derived from L-glutamic acid using NFSI as a method for synthesis of single stereoisomers of 4-fluorinated glutamic acids (Scheme 1.31).^{77,78}

SCHEME 1.31

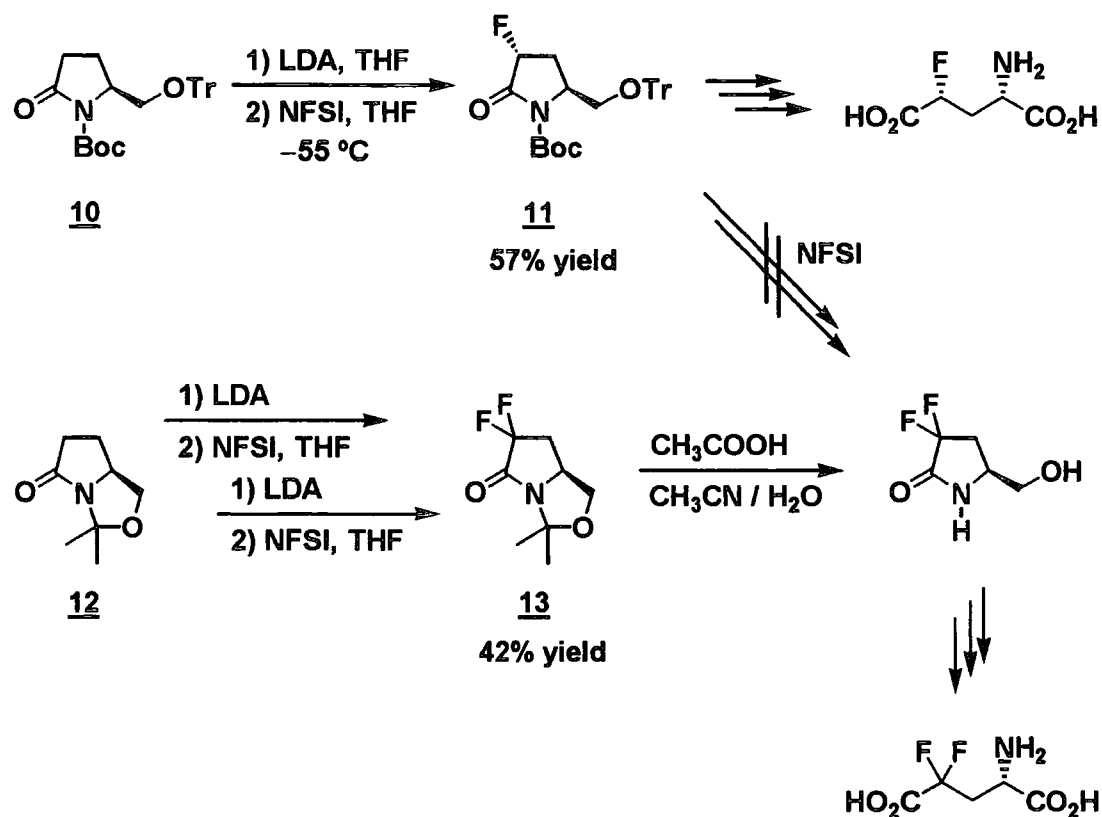

Reaction of the lactam enolate of **10** with NFSI resulted in a completely diastereoselective monofluorination to yield the *trans*-substituted α -fluorolactam **11**. The second fluorination of **11** was unsuccessful. On the other hand, a bicyclic lactam **12** was readily difluorinated using a step by step procedure to give compound **13**. This significant difference of reactivity can be attributed to both the steric effect of the protecting group in the monocyclic derivative **11** and the more kinetically acidic nature of the bicyclic derivative resulted from the distorted structure.

Recent other applications of NFSI are summarised in Figure 1.6.

FIGURE 1.6

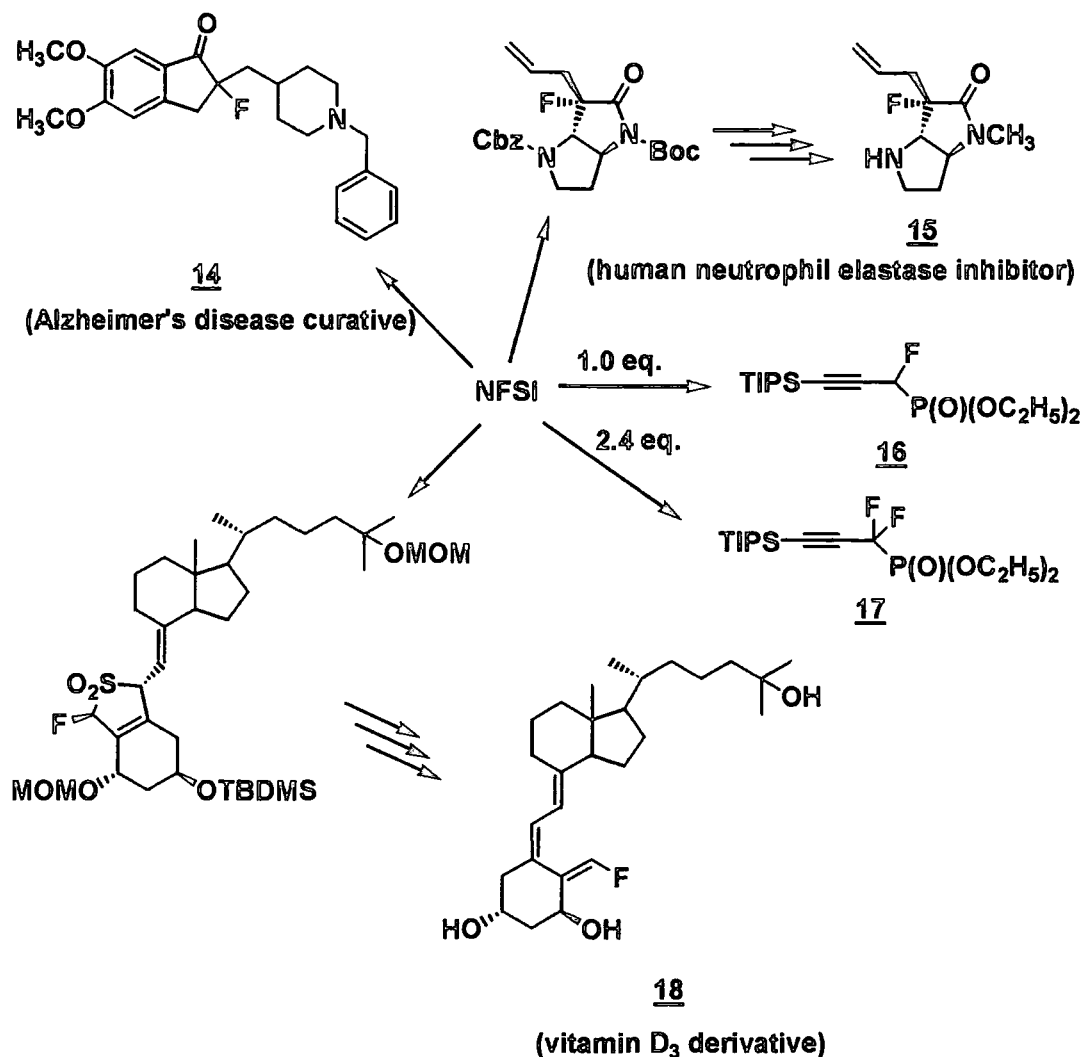

Takeushi utilised NFSI for preparation of an acetylcholine esterase inhibitor **14** which was effective for Alzheimer's disease.⁷⁹ A potent human neutrophil elastase inhibitor **15** prepared by fluorination of lithium enolate of the *trans*-lactam with NFSI was reported by Macdonald.⁸⁰ Fluorination of diethyl-3-triisopropylsilyl-1-propynephosphonate using NFSI gave mono- or difluorinated product (**16** and **17**) depending on the equivalent of the reagent.⁸¹ Fluorinated derivative of vitamin D₃, **18** was synthesised *via* fluorination of the SO₂ adduct with NFSI.⁸²

N-Fluoro *N*-alkylarenesulfonamides are also effective electrophilic fluorinating agents (Figure 1.7).⁸³⁻⁸⁶

FIGURE 1.7

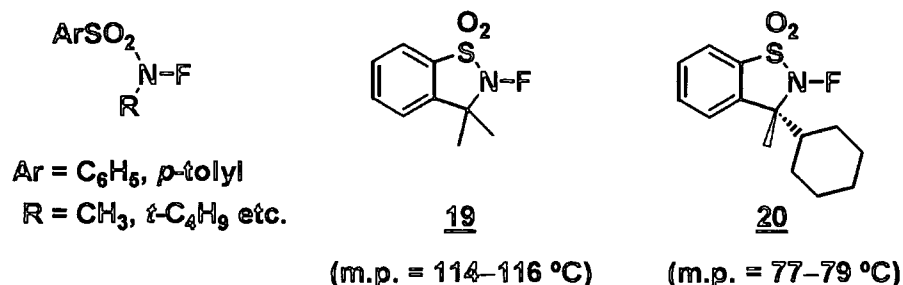

The selective transformation of enolates into mono- and difluorinated carbonyl compounds could be performed in a one-pot procedure using *N*-fluorosaccharinsultam (**19**) (Scheme 1.32).⁸⁷ When LHMDS was used as the base, the α -monofluorinated compound **21** was predominantly obtained. On the other hand, KHMDS gave α,α -difluorinated products **22** selectively.

SCHEME 1.32

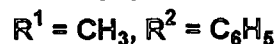
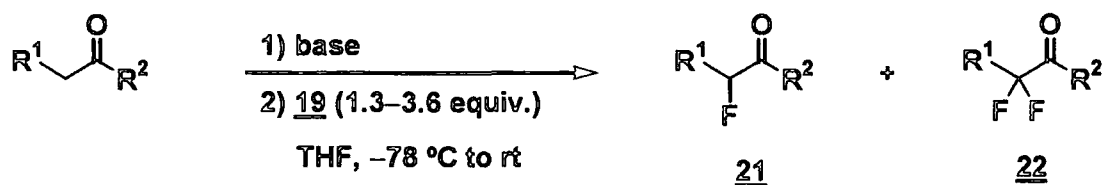

base	21 / 22	yield (%)
LHMDS	≥95 : 5	33–66
KHMDS	5 : ≥95	53–64

The 'chiral version' of *N*-fluorosaccharinsultam **20** is one of the most effective stoichiometric enantioselective fluorinating agents currently.⁸⁶ Enantioselective fluorination including compound **20** will be discussed in section 3.1.1.1.

1.2.5.1.2 Other neutral compounds

The structure of other neutral N-F reagents are summarised in figure 1.8.^{88–92}

FIGURE 1.8

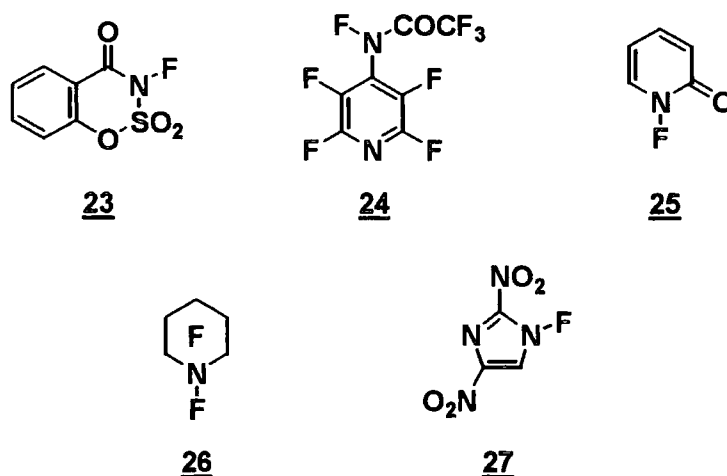

The N-F sulfam reagent **23** reported by Cabrera, was effective for fluorination of sodium salts of 1,3-carbonyl compounds, conjugated enol acetate derivatives of a steroid, and so on.⁸⁸ Banks reported the synthesis of perfluoro-[*N*-fluoro-*N*-(4-pyridyl)acetamide] (**24**) in 80% purity (contaminated with its N-H analogue).⁸⁹ The impure reagent reacted with a sodium salt of diethyl 2-phenylmalonate, 1-morpholino cyclohexene, etc. *N*-Fluoro-2-pyridone (**25**),⁹⁰ perfluoro *N*-fluoropiperidine (**26**)⁹¹ and *N*-fluoro-2,4-dinitroimidazole (**27**)⁹² are also known to be electrophilic fluorinating agents, but the reactivities are rather low compared with sulfonyl derivatives.

1.2.5.2 Quaternary compounds (R₃N⁺F X⁻)

1.2.5.2.1 *N*-Fluoropyridinium salts

Fluorination of pyridine with elemental fluorine gave *N*-fluoropyridinium fluoride **28**, which violently decomposed above -2 °C.⁹³ Umemoto and co-worker reported this unstable compound **28** could smoothly undergo counter anion displacement reaction with the nonnucleophilic triflate anion to give the stable *N*-fluoropyridinium salt **29** (Scheme 1.33).⁹⁴

SCHEME 1.33

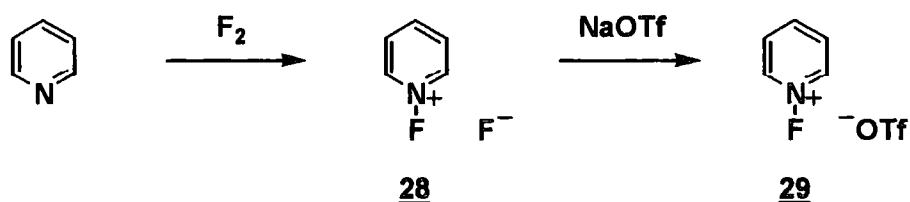

A series of *N*-fluoropyridinium salts having electron-donating or -withdrawing substituents were prepared and their fluorinating abilities were evaluated (Figure 1.9).⁹⁵ The power of fluorination increased as the electron density of the positive nitrogen site decreased (**30** < **29** < **31** < **32** < **33** < **34**). Some of these are now commercially available. Counteranion-bound salts **36** and *N*-fluoropyridinium pyridine heptafluorodiborate **37** are also on the market.

FIGURE 1.9

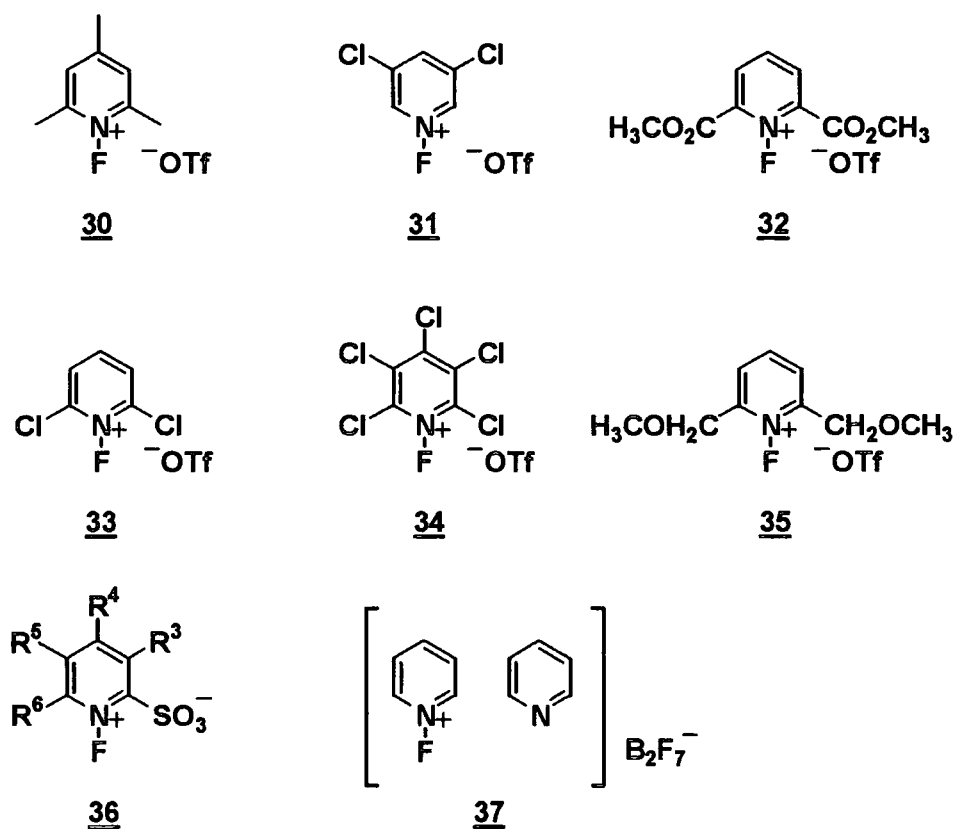

$R^{3-6} = \text{H}, \text{CH}_3, \text{CF}_3, \text{etc.}$

Lewis acids accelerate the fluorination rates of active methylene compounds with 2,4,6-trimethyl salt **30**. Fluorination of 1,3-diketones with **30** in the presence of a catalytic amount of zinc chloride gave difluoro product in 88% yield. On the other hand, a stronger Lewis acid, aluminum chloride was required to difluorinate the malonate (Scheme 1.34).

SCHEME 1.34

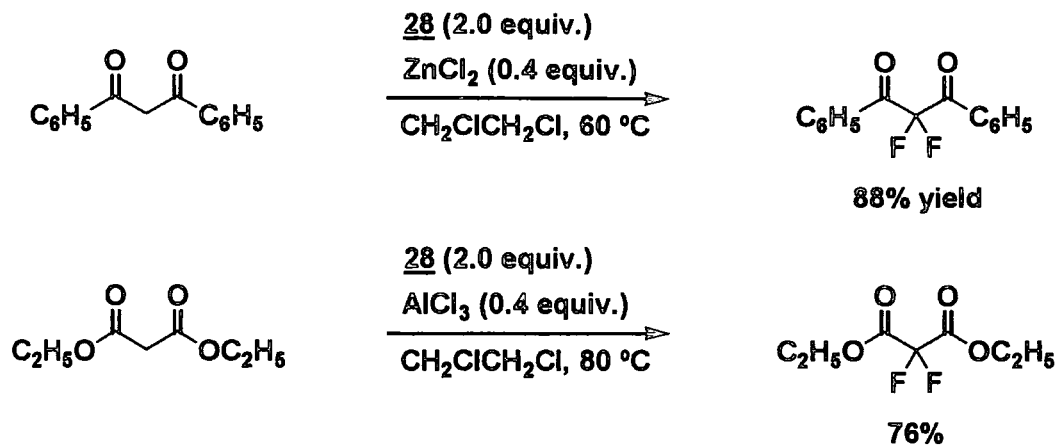

N,N-Difluorobipyridinium salts were found to be more powerful fluorinating agent than monomeric *N*-fluoropyridinium salts because each of two *N*-fluoropyridinium moieties could act not only as a fluorine source but also as an electron-withdrawing substituent.⁹⁶ 2,2'-Bipyridyl salts **38** were much stronger than the 4,4'-isomers **39** (Scheme 1.35).

SCHEME 1.35

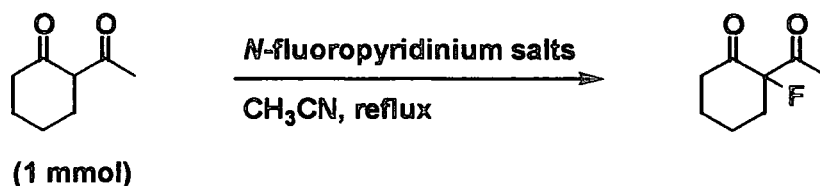

	<i>N</i> -fluoropyridinium salts (mmol)	reaction time	yield (%) ^a	
38		(0.5)	<5 min	85
39		(0.5)	5 h	87
29		(1.0)	19 h	79

^a Yields were determined by ¹⁹F NMR using an internal standard.

Recently a synthesis of 4,4-difluorobenzoazepine-5-one (**42**), which is a useful intermediate for an anti-hypertensive medicine, was achieved by Tamura *via* difluorination reaction of a 5-alkoxybenzoazepine derivative **40** with *N*-fluoropyridinium salt **29** (Scheme 1.36).⁹⁷ These reactions could be carried out in the same vessel without work up for a difluorinated hemiketal derivative **41**.

SCHEME 1.36

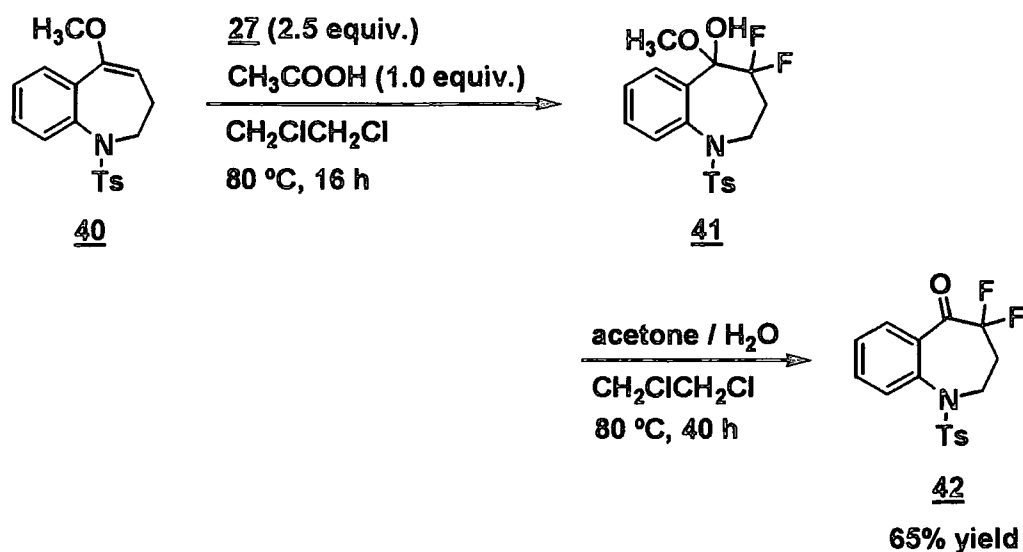

Takeda reported α,α -difluorination of α -(alkylthio)acetophenones with *N*-fluoropyridinium salts. The use of 2,4,6-trimethyl analogue **30** and zinc bromide as a additive gave the best results (Scheme 1.37).⁹⁸

SCHEME 1.37

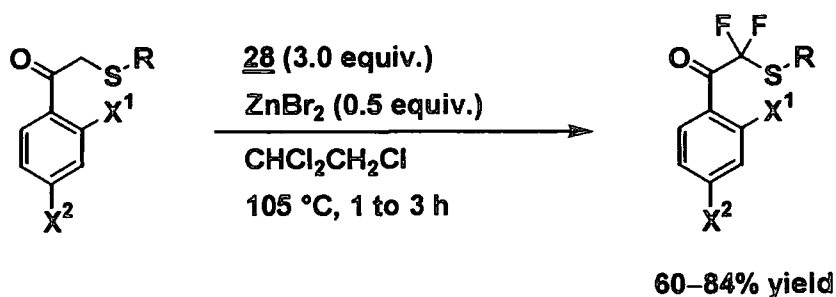

- $\text{X}^1 = \text{X}^2 = \text{F}$, $\text{R} = \text{CH}_3, \text{C}_2\text{H}_5, \text{cyclopropyl}, (\text{CH}_2)_2\text{OAc}$
- $\text{X}^1 = \text{X}^2 = \text{H}$, $\text{R} = \text{CH}_3$
- $\text{X}^1 = \text{X}^2 = \text{Cl}$, $\text{R} = \text{CH}_3$
- $\text{X}^1 = \text{H}$, $\text{X}^2 = \text{OCH}_3$, $\text{R} = \text{CH}_3$
- $\text{X}^1 = \text{H}$, $\text{X}^2 = \text{CF}_3$, $\text{R} = \text{CH}_3$

Synthesis of fluorogypsetin and fluorobrevianamide E was described by Shibata.⁹⁹ As shown in scheme 1.38, fluorination of *cyclo*-L-Trp-L-Trp **43** with **30** proceeded accompanied by cyclization to give fluorogypsetin **44** as a mixture of stereoisomers since electrophilic attack of fluorine at the 3-position of the indole ring facilitates internal nucleophilic attack at the 2-position.

SCHEME 1.38

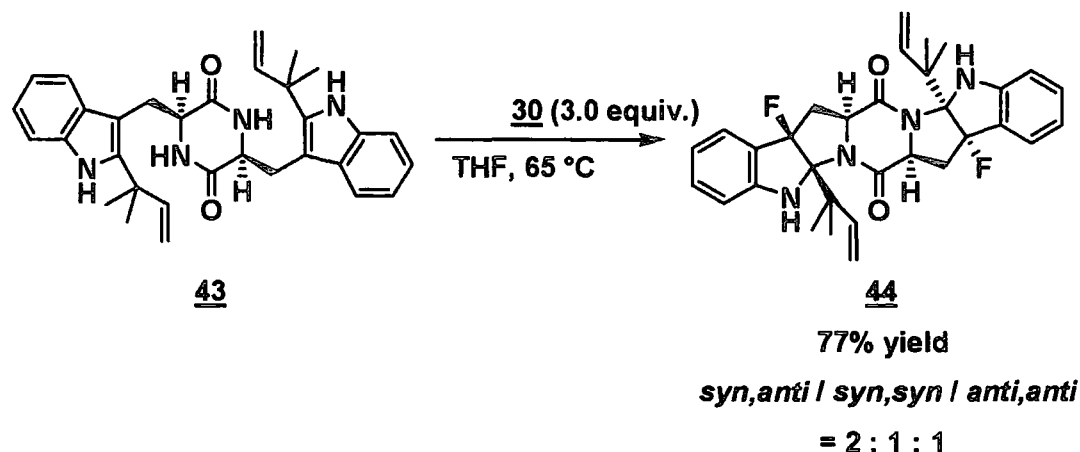

Mechanistic aspects of electrophilic fluorination of indole derivatives will be discussed in a following section.

Adachi reported that the fluorination of 2-naphthol in liquid CO₂ with *N,N*-difluorobipyridinium salts proceeded cleanly without the generation of by-products (Scheme 1.39).³⁸ The products of the fluorination were a mixture of 1-fluoronaphthol and 1,1-difluoro-1*H*-naphthalen-2-one, all of which were converted into 1-fluoronaphthol through reduction by H₂/Pd-C. When *N,N*-difluoro-2,2'-bipyridinium bis(triflate) **38** was employed, the reaction smoothly proceeded in liquid CO₂ to give 1-fluoronaphthol quantitatively. Acetonitrile as a solvent gave a comparatively low yield under normal pressure. On the other hand, fluorination with bis(tetrafluoroborate) **45** did not proceed at all owing to its quite low solubility in liquid CO₂. The addition of catalytic amounts of sodium triflate solved this problem.

SCHEME 1.39

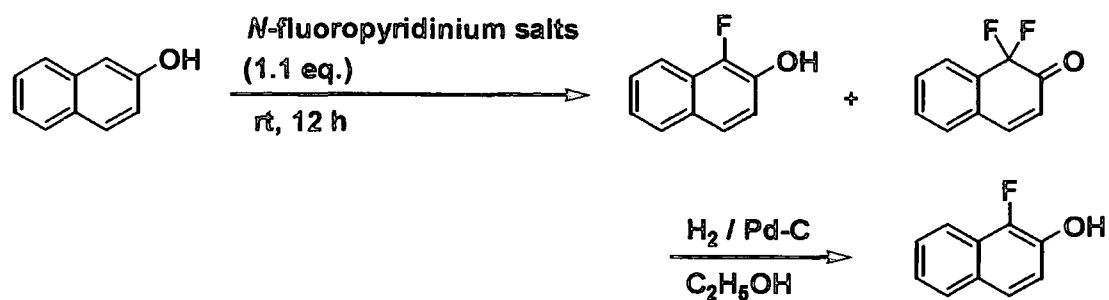

<i>N</i> -fluoropyridinium salts	solvent	additive	% yield after reduction
38	liq. CO ₂	—	99
	CH ₃ CN	—	85
45	liq. CO ₂	—	no reaction
	liq. CO ₂	NaOTf (0.2 eq.)	95

1.2.5.2.2 Saturated derivatives

Banks found *N*-fluoroammonium salts were highly effective electrophilic fluorinating agents (Figure 1.10).^{100–102} One of the series of compounds, 1-chloromethyl-4-fluoro-1,4-diazoniabicyclo[2.2.2]octane bis(tetrafluoroborate) [R = CH₂Cl, X⁻ = BF₄⁻ (Selectfluor™)] is now one of the most widely used electrophilic fluorinating agents.¹⁰³

FIGURE 1.10

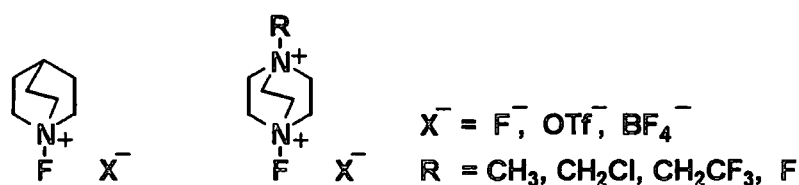

Selectfluor reacted with 1,3-dicarbonyl compounds at room temperature to give corresponding mono- or difluoro products (Scheme 1.40).¹⁰⁴

SCHEME 1.40

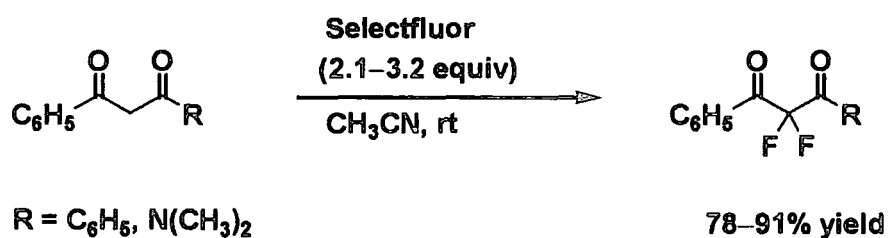
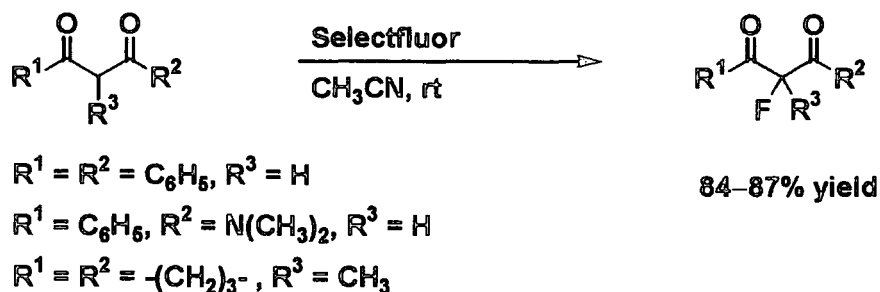

Chambers reported that Selectfluor has sufficient fluorinating power to fluorinate saturated C-H sites. Fluorination of *trans*-decalin proceeded in acetonitrile under reflux conditions to give 1- and 2-fluorodecalins (Scheme 1.41).^{24,25} In this case, two tertiary positions were not fluorinated at all. The reason for the quite contrasting results to direct fluorination (see Scheme 1.4) was attributed to the greater steric requirements of the Selectfluor reagent.

SCHEME 1.41

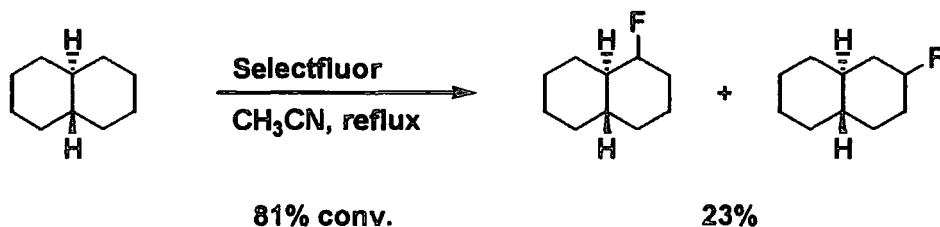

Fluorination of 3-substituted indoles, including derivatives of tryptophan and serotonin with Selectfluor was reported by Takeuchi recently.¹⁰⁵ The fluorination was carried out in a mixture of acetonitrile and water using 3 equivalents of Selectfluor and gave 3-substituted 3-fluoroindoles in good to high yields (Scheme 1.42).

SCHEME 1.42

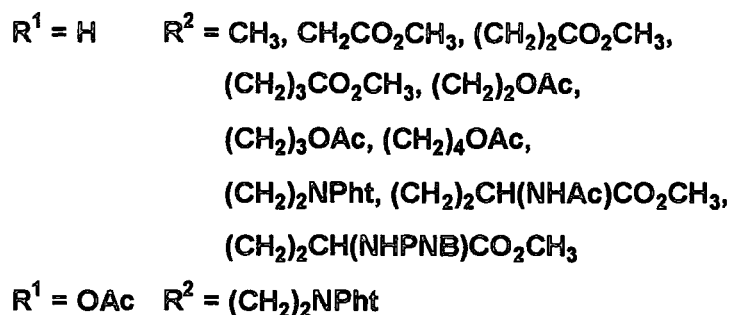
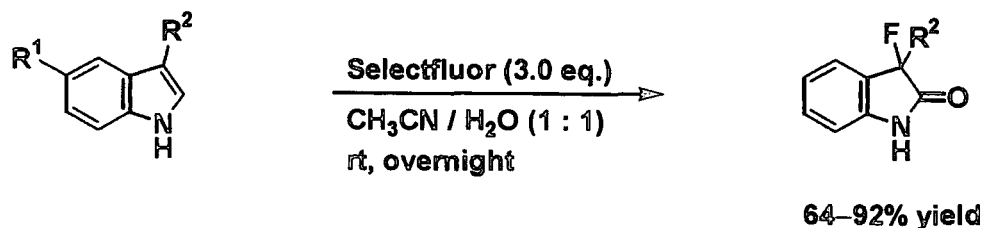

Plaquet described that this reaction could also be carried out in ionic liquids using methanol as a cosolvent with better yields (Scheme 1.43)¹⁰⁶.

SCHEME 1.43

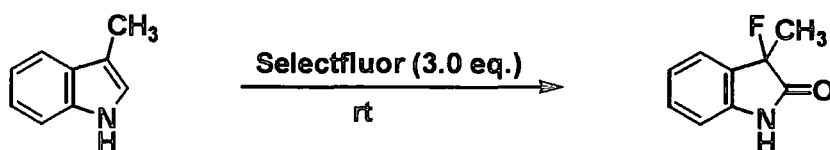

solvent	time (h)	yield (%)
$\text{CH}_3\text{CN} / \text{H}_2\text{O}$ (1 : 1)	overnight	71
$[\text{bmim}][\text{PF}_6] / \text{CH}_3\text{OH}$ (1 : 1)	3	99
$[\text{bmim}][\text{BF}_4] / \text{CH}_3\text{OH}$ (1 : 1)	3	99

Takeuchi proposed the reaction mechanism outlined in scheme 1.44. According to this proposal, Selectfluor reacts with indoles to give the unstable 3-fluoroindolenine **46**, which undergoes loss of HF by addition of water. A subsequent 1,5-prototropic shift gives the enol **47**. Finally, fluorination of **47** with additional Selectfluor yields 3-fluoroindoles. Formation of the non-fluorinated oxindole as a side product is consistent with this mechanism.

SCHEME 1.44

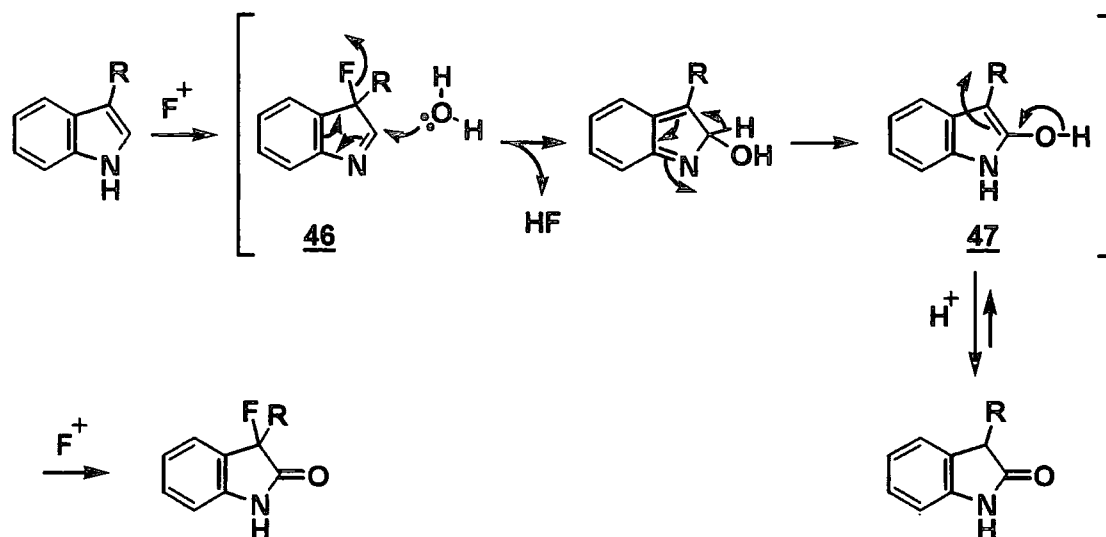

In addition formation of a 2-sulfur substituted indole derivative in the presence of benzyl mercaptan under the similar conditions, described by Plaquet, supported this mechanism (Scheme 1.45).¹⁰⁶

SCHEME 1.45

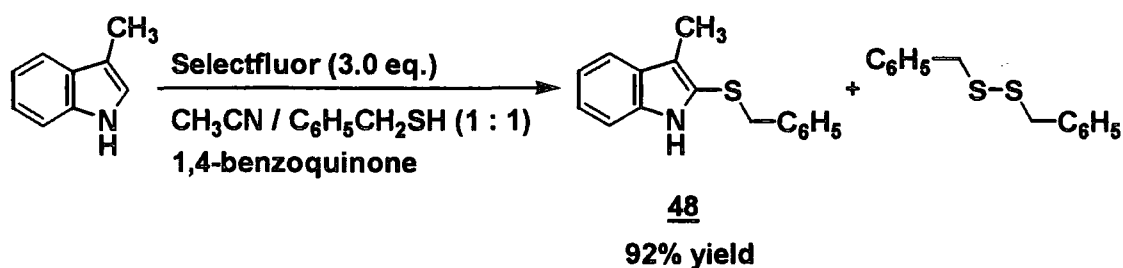

The reaction stopped at the intermediate **48** in good yield accompanied with the formation of benzyl disulfide, which reduced Selectfluor and prevented the subsequent fluorination of **48**.

Syntheses of α -fluorophosphonates using Selectfluor were reported by Wnuk (Scheme 1.46).¹⁰⁷ Treatment of the α -carbanions generated from several α -(pyrimidin-2-ylsulfonyl)alkylphosphonates with Selectfluor gave high yields of the corresponding α -fluorinated products. Following this, tin-mediated desulfonylation provided α -fluorophosphonates.

SCHEME 1.46

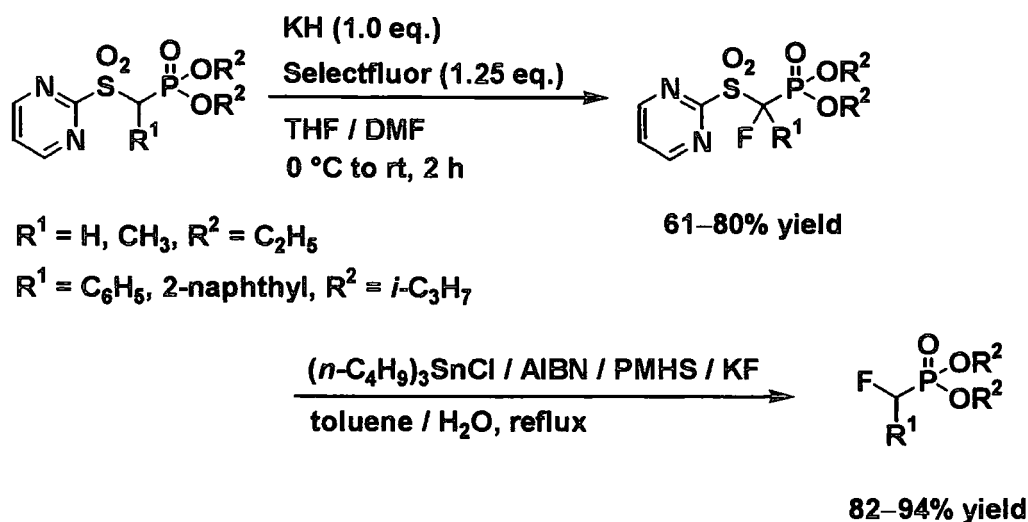

Willson reported another example of α,α -difluorination of phosphonates with Selectfluor using dibenzyl β -ketophosphonates.¹⁰⁸

Prestwich found that Selectfluor was a good reagent for preparation of tetraethyl fluoromethylenebisphosphonate, which could be utilised for the syntheses of fluorinated analogues of lysophosphatidic acid.¹⁰⁹

1-Hydroxy-4-fluoro-1,4-diazoniabicyclo[2.2.2]octane bis(tetrafluoroborate) (**49**) is another commercially available electrophilic fluorinating agent having DABCO moiety, first reported by Poss (Figure 1.11).¹¹⁰

FIGURE 1.11

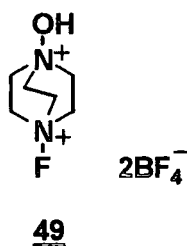

This reagent shows similar fluorinating ability to Selectfluor, but sometimes gave better results in some reactions. Zupan reported that selective α -fluorinations of ketones were enabled by the use of **49** and methanol as the solvent (Scheme 1.47).^{111,112} A variety of ketones were regiospecifically transformed to the corresponding α -fluoro derivatives without prior activation in high yield even in the presence of an activated aromatic ring, which is also an electron-rich part of the substrates. In contrast when

fluorination of such aromatic ketones possessing a strongly activated aromatic ring with **49** was carried out in acetonitrile solvent, fluorination exclusively occurred at the aromatic ring. This significant difference of the course of the reactions could be attributed to the distinct behaviour of the keto-enol tautomerism in these solvents.

SCHEME 1.47

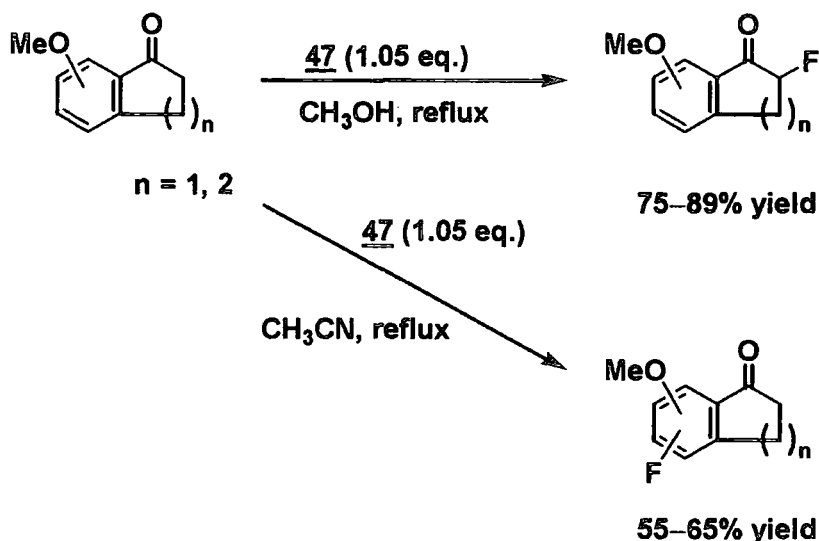

1.2.5.2.3 Other quaternary compounds

The structure of other quaternary N-F reagents are shown in figure 1.12. 1-Fluoro-2,4,6-trisubstituted 1,3,5-triazinium salts **50** were synthesised and their fluorinating ability were evaluated using aromatics by Banks.¹¹³⁻¹¹⁵ $\text{NF}_4^+\text{BF}_4^-$ **51** is one of the oldest N-F reagents. Christie reported that this reagent fluorinates hexafluorobenzene in HF to give 1,4-perfluorocyclohexadiene in 94% yield.¹¹⁶ Fluorination of 1,3-diketones and 1,3-ketoesters with gaseous trifluoroamine oxide **52** in the presence of tetrabutylammonium hydroxide to give α -mono- or α,α -difluoro products with good selectivity and yields was described by Shreeve recently.¹¹⁷

FIGURE 1.12

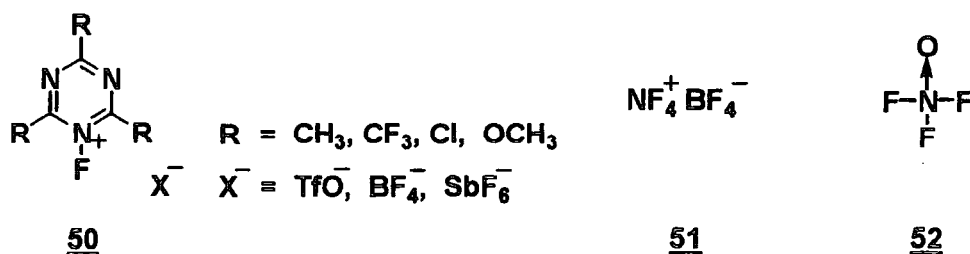

1.2.5.3 Reaction mechanism

In fluorinations with N-F reagents there are two possible reaction pathways, which are a single electron transfer mechanism (SET) and a direct nucleophilic addition to fluorine (S_N2).¹¹⁸ These mechanistic possibilities are illustrated schematically for the neutral R_2NF reagents in Scheme 1.48.

SCHEME 1.48

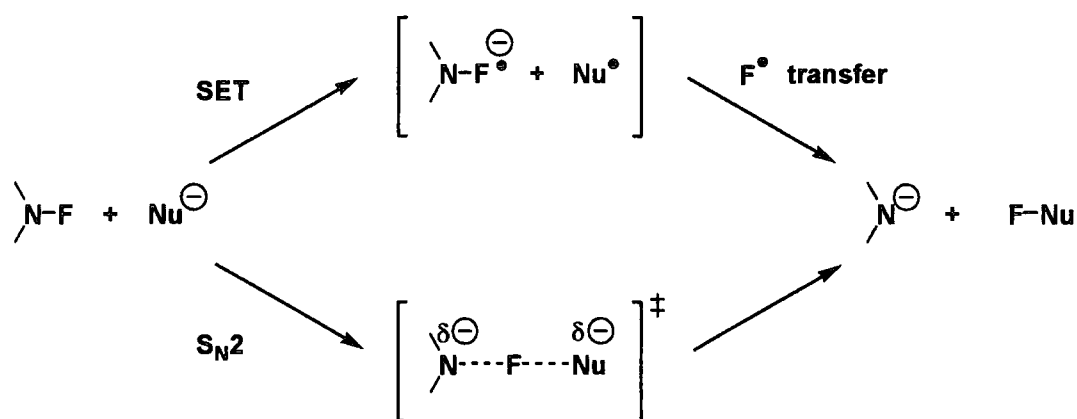

The SET mechanism involves one-electron transfer from the nucleophile to the fluorinating reagent to give free radical species (Nu^\bullet) followed by fluorine radical (F^\bullet) transfer. The fluorination of anionic and neutral substrates with *N*-fluoropyridinium salts are thought to proceed via this pathway.⁹⁵ This mechanism was supported by the fact of the greater reactivity of the reagents towards Grignard reagents, which are known to undergo SET chemistry, compared to organolithium systems. DesMarteau proposed a similar mechanism for the fluorination by *N*-fluorobis[(trifluoromethyl) sulfonyl]-imide.¹¹⁹ Another possible pathway is the classical S_N2 reaction mechanism. This mechanism was supported by the reaction of a citronellic ester with several N-F reagents.¹²⁰ The fluorination of a potential precursor to a 5-hexenyl-type radical clock gave exclusively open-chain α -fluorinated products. The complete absence of cyclic products indicated that the fluorination did not proceed *via* free radical intermediates.

1.2.6 Conclusions

Organofluorine chemistry is now an indispensable part of organic chemistry and fluorination reactions are fundamental and essential techniques for preparing organofluorine compounds. In particular electrophilic fluorinating agents are prerequisite tools for direct conversion of C-H to C-F linkages. Consequently, various

electrophilic fluorinating agents have been developed and evaluated, and in each case, optimum reagents have been selected and used from among them for each individual purpose.

Each reagent discussed in this section has not only characteristic reactivity that is an advantage, but also limitations. Xenon difluoride has a significant drawback of being extremely expensive. Trifluoromethyl hypofluorite (CF₃OF) is commercially available but it is very expensive and as reactive as elemental fluorine and thus should be handled with equal care. In the case of other O-F reagents, they are not stable enough to isolate or store for long time, or possess an explosive nature. Some N-F reagents are commercially available, and easy to handle. Above all, Selectfluor has become less expensive recently. However, it is still not inexpensive and it seems that there are not any large scale industrial applications. Comparison of effective fluorine content³⁷ and price of some of commercially available electrophilic fluorinating agents is shown in table 1.4.

TABLE 1.4 Comparison of effective fluorine content and price

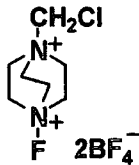
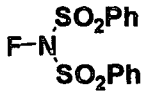
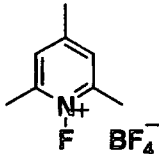
structure	F ₂	CF ₃ OF	XeF ₂	 Selectfluor TM	 NFSI	 AcF
Mol.wt	38.0	104.0	169.3	354.3	315.4	227.0
EFC ^a (g/kg)	500	183	112	54	60	84
price (£/kg)	264 ^b	35960 ^c	41160 ^d	1490 ^d	7020 ^d	13240 ^d
price/EFC (£/g)	0.53	197	368	28	117	158

^a EFC: Effective Fluorine Content. ^b price based on 20% F₂ / N₂ cylinder. ^c price based on ABCR catalogue (2001–2). ^d price based on Aldrich catalogue (2003–4).

Obviously elemental fluorine is the most inexpensive and effective positive fluorine source among all the electrophilic fluorinating agents. The use of elemental fluorine is still viewed by some as something extraordinary that should be avoided due to the

highly toxic and corrosive nature, however, direct fluorination can be safely carried out using appropriate apparatus and taking elementary precautions. Numerous reports about direct fluorination of organic molecules have emerged, but there are relatively few are concerned with the use of elemental fluorine for selective fluorination, thus new versatile methodologies are still needed.

In this thesis we aimed at exploring and establishing new methodologies for selective fluorination of saturated C-H bond with elemental fluorine or other F^+ species generated *in situ* using removable tether, catalysis, and microreactor technology.

Chapter 2

Remote Fluorination of Steroids Directed by Tethers

2.1 Introduction

The regio- or stereoselective electrophilic fluorination reactions described in the preceding chapter can be roughly divided into two categories from the standpoint of the substrate used (Figure 2.1). The first method is based on functional group interconversion. In this method, a specific position of the substrate is activated and fluorinated selectively. Fluorination of enol derivatives, such as enol silyl ethers, enol acetates, enamines, and enolate anions, is one of the representatives of this method. In other words, another functional group is exploited as a scaffold and fluorine is introduced into the neighbouring position. However, it is a considerable limitation of this method that fluorine atoms cannot be introduced into positions remote from the scaffold. The second method introduces fluorine atoms into specific unactivated C-H sites by utilizing the difference originating in the electronic character between each position. This very simple method is selective enough in the case of particular substrates, however, inevitably by-products are often formed due to fluorination at undesirable positions.

FIGURE 2.1 Access to selective electrophilic fluorination

1. Functional Group Interconversion

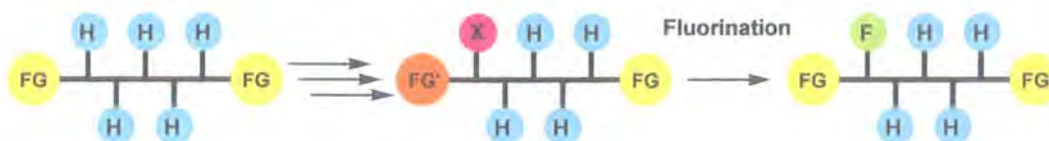

2. Direct Method

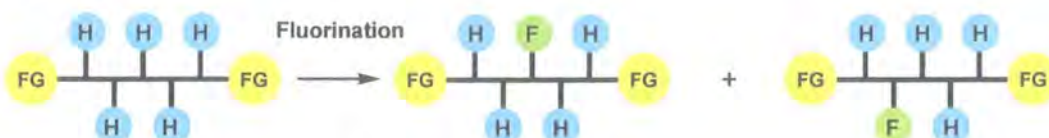

3. Geometrically Directed Remote Functionalization

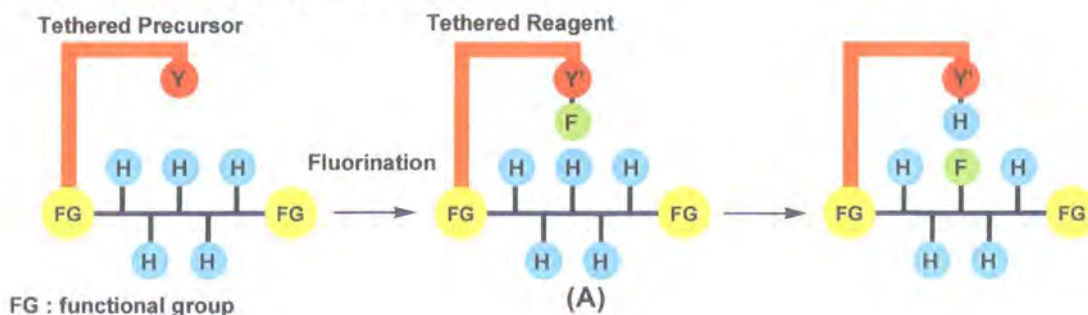

Another possible and unexplored approach is geometrically directed remote functionalisation. In this method, a precursor of a fluorinating agent is connected with the substrate itself by a tether. Fluorination of the substrate with elemental fluorine gives a tethered fluorinating agent (**A**), which reacts with a remote specific position of the substrate in an intramolecular manner. The reaction is regulated by the tethers, and consequently, it has, potentially, a key advantage that different positions can be fluorinated by introducing various tethers having different geometrical demands.

This approach was well investigated and described by Breslow and co-workers in a series of publications about selective chlorination and oxidation of steroid derivatives but not for fluorination.

We were, therefore, interested in exploring new methodology for selective fluorination of steroids using tethers. Consequently, before the current work is discussed, literature concerning the fluorination of steroid derivatives and geometrically directed remote functionalisations using tethered reagents will be reviewed in the following sections.

2.2 Fluorination of steroids

The sometimes considerable enhancement of biological activity of steroids by introducing a single fluorine atom was first reported by Fried and Sabo in 1954.⁸ They compared glucocorticoid activities of 9 α -halogeno derivatives of hydrocortisone acetate (Figure 2.2, **53a**, X = H) and established that the order of increasing potency was X = I (0.1) < Br (0.28) < Cl (4) < F (11) (values relative to H = 1).^{8,121} This early finding prompted not only syntheses of a lot of fluorinated steroids but also developments of innumerable bioactive compounds including fluorine atoms.

FIGURE 2.2

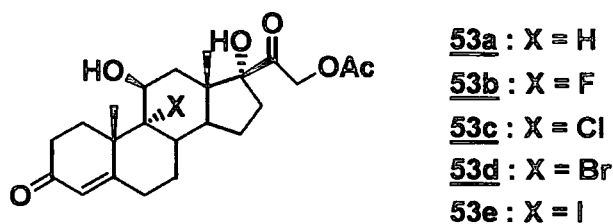

2.2.1. Fluorination of steroids using electrophilic fluorinating agents

2.2.1.1 Fluorination at unactivated C-H position

As described in section 1.2.2.3, direct fluorination of saturated hydrocarbons gave predominant displacement at tertiary positions. Steroids are fitting substrates for this method because the steroid skeleton have generally four or five unactivated tertiary C-H sites, which have subtly different geometrical and electronic properties (Figure 2.3). Rozen and co-workers made many important contributions to this area.^{122,123} They showed that by using appropriate electron-withdrawing substituents in various positions, almost any tertiary hydrogen could be fluorinated relatively selectively. The most electron rich C-H site, which means the furthest site from electron withdrawing groups, was replaced as seen in the following examples.

FIGURE 2.3

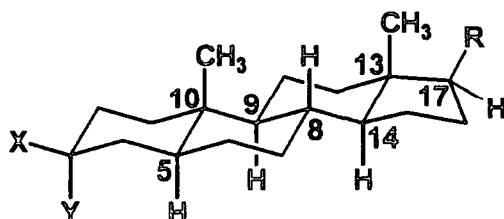

Direct fluorination of 3 β ,17 β -diacetoxy-5 α -androstan-20-one (**54**) in the presence of anhydrous sodium fluoride and/or sodium trifluoroacetate as a hydrogen fluoride scavenger gave 3 β ,17 β -diacetoxy-9 α -fluoro-5 α -androstan-20-one (**55**) in 50% yield (Scheme 2.1).¹²² In this case, the result showed that only 9 α -H, which was the remotest from the acetoxy groups, was replaced by fluorine. Reaction of 3 β -acetoxy-5 α ,6 β -dichloropregnan-20-one (**56**) with elemental fluorine resulted in the deactivation at the 9-position to give 14 α -fluoro product **57**. The product was converted to 3 β -acetoxy-14 α -fluoropregn-5-en-20-one (**58**) without isolation. In the case of 5 α ,6 β -dichloro-3 β -trifluoroacetoxycholestan-20-one (**59**), the 17 α -fluoro product **60** was obtained as the major product after reductive dechlorination, but 17 α ,25-difluoro product **61** was also obtained.

SCHEME 2.1

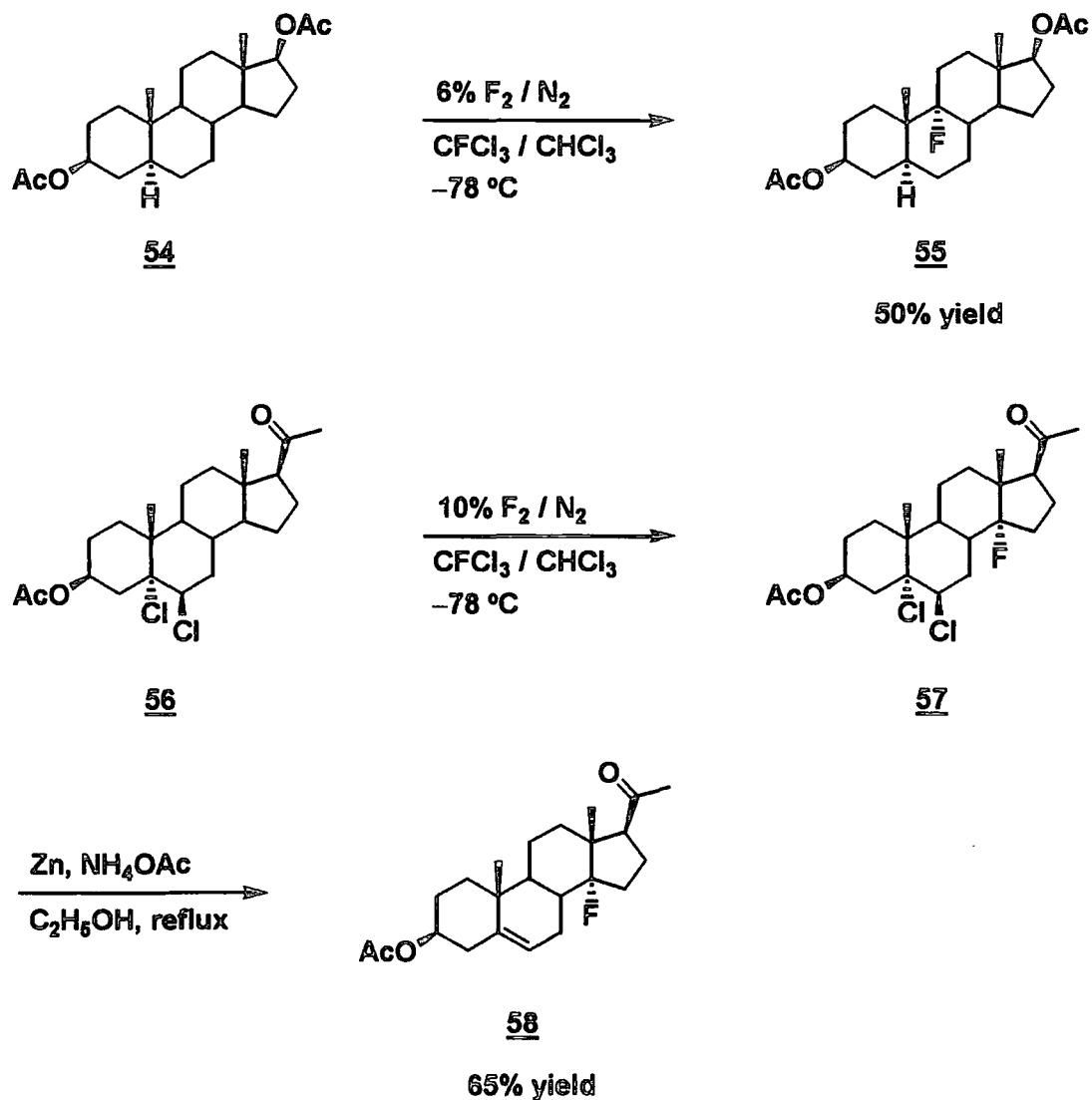

SCHEME 2.1 (Continued)

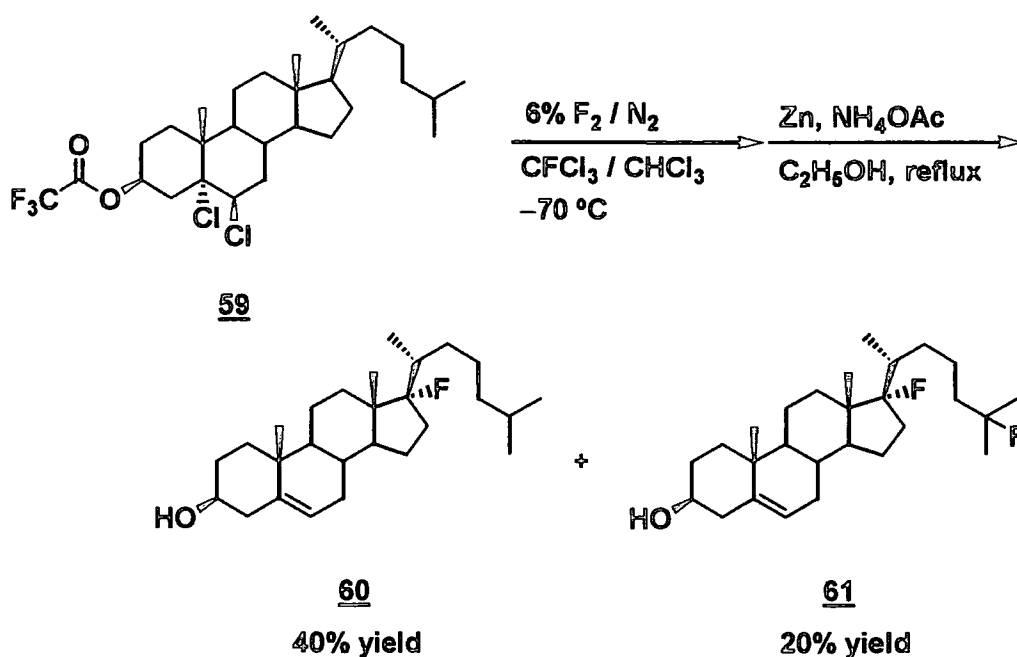

5-Fluoro products are not common in the 3β -ol and 5α series. 5α -Fluoro product **63b** was obtained in the fluorination of 3α -acetoxy- 5α -androstane-17-one (**62**) together with 9α -fluoro product **63a** (Scheme 2.2).¹²³ This phenomenon was explained to be caused by deactivation of the 9-position to some extent. In the case of 5β -steroid **64**, the fluorination resulted in a mixture of 5-fluoro and 14-fluoro product (**65a** and **65b**) because the 9-position is blocked to some extent by ring A, which is perpendicular to the steroidal plane (Scheme 2.3). The only tertiary position that was never attacked was the β -hydrogen at 8-position, which is effectively shielded by the two axial methyl groups at 10- and 13-position.

SCHEME 2.2

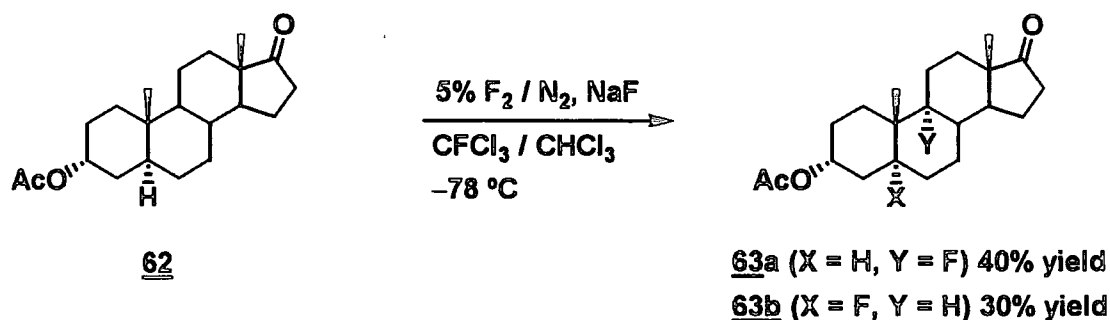

SCHEME 2.3

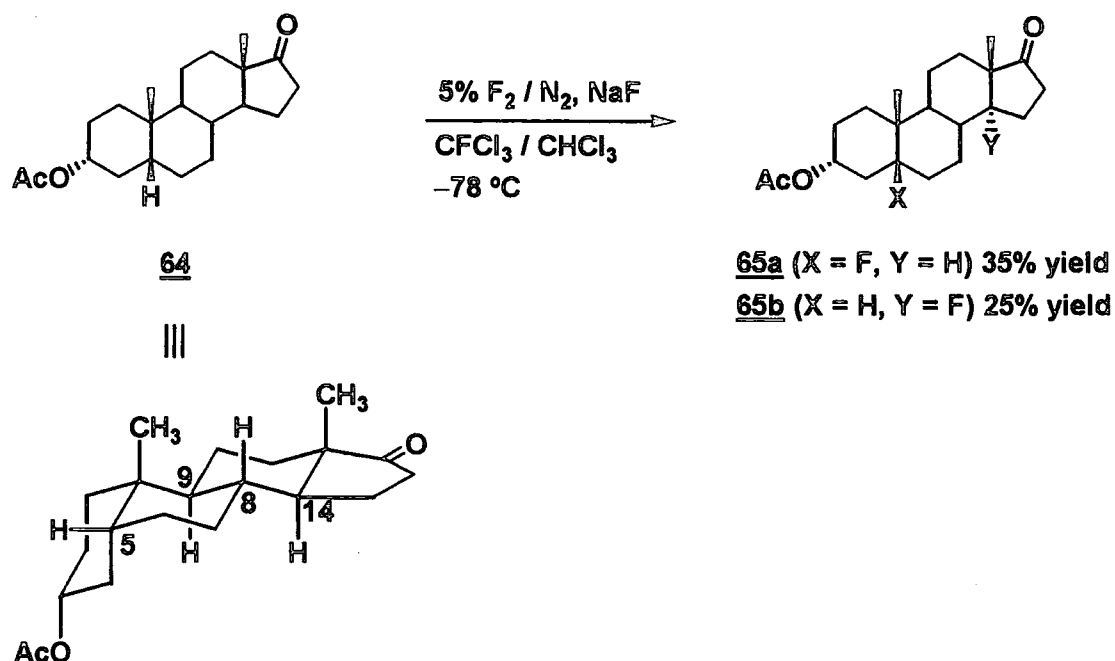

As described in the previous section, this method has a distinct disadvantage that undesired by-products often accompany the desired compound since it depends on the delicate control of the electron density of the C-H sites by the electronic character of the substituents present. Moreover, these reactions required the banned solvent (CFC₁₃), very low reaction temperature and diluted conditions, and thus can not be practically performed now.

2.2.1.2 Fluorination of alkenes

The direct fluorination of steroidal alkenes was reported for the first time by Merritt in the mid-1960s. The reaction of cholest-4-en-3-one **66** with elemental fluorine gave *cis*-4,5-difluoro product **67** in 60-70% yield (Scheme 2.4).¹²⁴

SCHEME 2.4

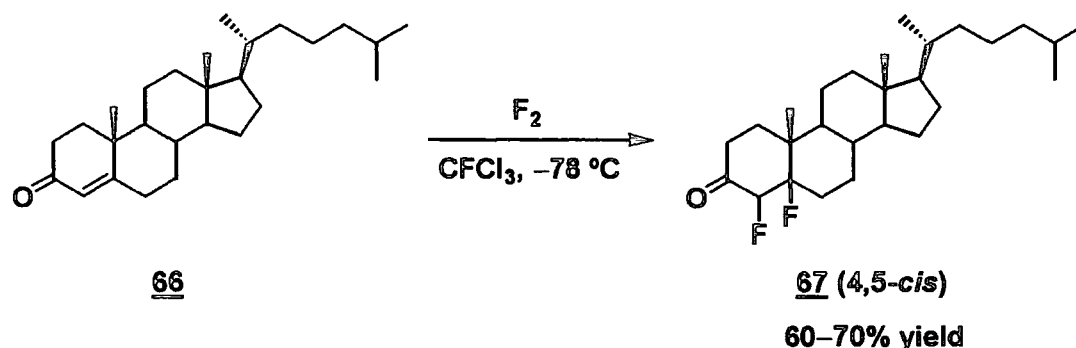

In the reaction of elemental fluorine to double bonds *syn*-addition is predominant in distinct contrast to chlorination and bromination, which prefer *anti*-addition *via* halonium ion intermediates. Rozen rationalised this stereoselectivity based on the formation of a tight ion pair as an intermediate.¹²⁵ This ion pair collapses before any rotation around the C-C bond takes place to give *cis*-adduct (Scheme 2.5).

SCHEME 2.5

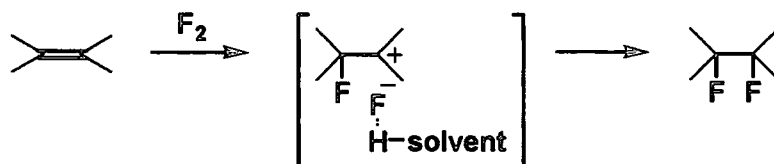

On the other hand, Yamabe carried out *ab initio* MO calculations to determine the transition state structure.¹²⁶ The results suggested the addition of fluorine to ethylene occurred *via* a four-centred transition state resulting in the *cis*-adduct rather than three membered ring-halonium ion (Scheme 2.6).

SCHEME 2.6

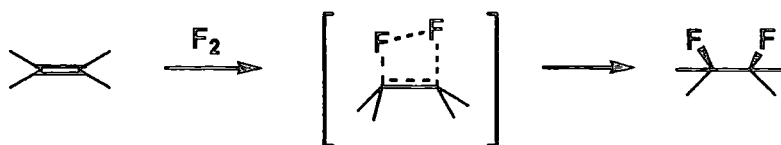

Fluorination of alkenes using hypofluorites usually proceeded in a *syn*-mode

suggesting a similar concerted mechanism as the case of elemental fluorine to give alkoxy fluorides or acetoxy fluorides. 3 β ,12 β -Diacetoxy-5 α ,20 α ,22 α ,-25*D*-spirost-9(11)-ene (**68**) reacted cleanly with acetyl hypofluorite to give 3 β ,9 α ,12 β -triacetoxy-11 α -fluoro-5 α ,20 α ,22 α ,-25*D*- spirostane (**69**) in 90% yield (Scheme 2.7).¹²⁷

SCHEME 2.7

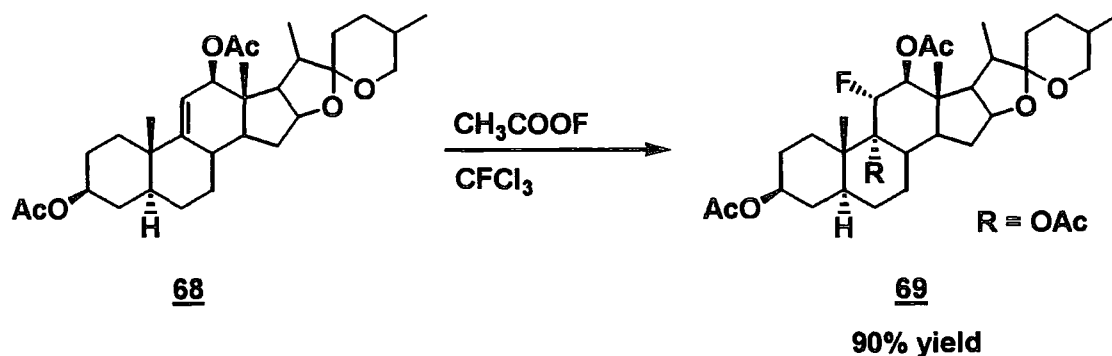

2.2.1.3 Fluorination of derivatives of carbonyl compounds

α -Fluorination of carbonyl groups is the most useful method for regio- or stereoselective introduction of fluorine atom into secondary C-H sites of steroid derivatives. Various electrophilic fluorinating agents reacted with steroidal enol acetates,¹²⁸⁻¹³⁰ enol silyl ethers¹³¹ or enamines¹³² to give α -fluoro derivatives (Scheme 2.8).

SCHEME 2.8

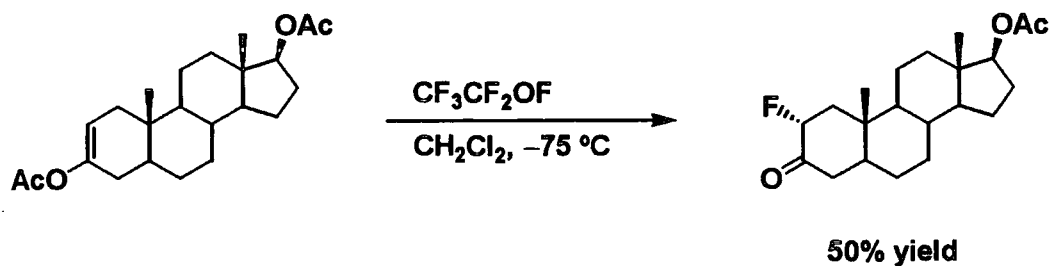

SCHEME 2.8 (Continued)

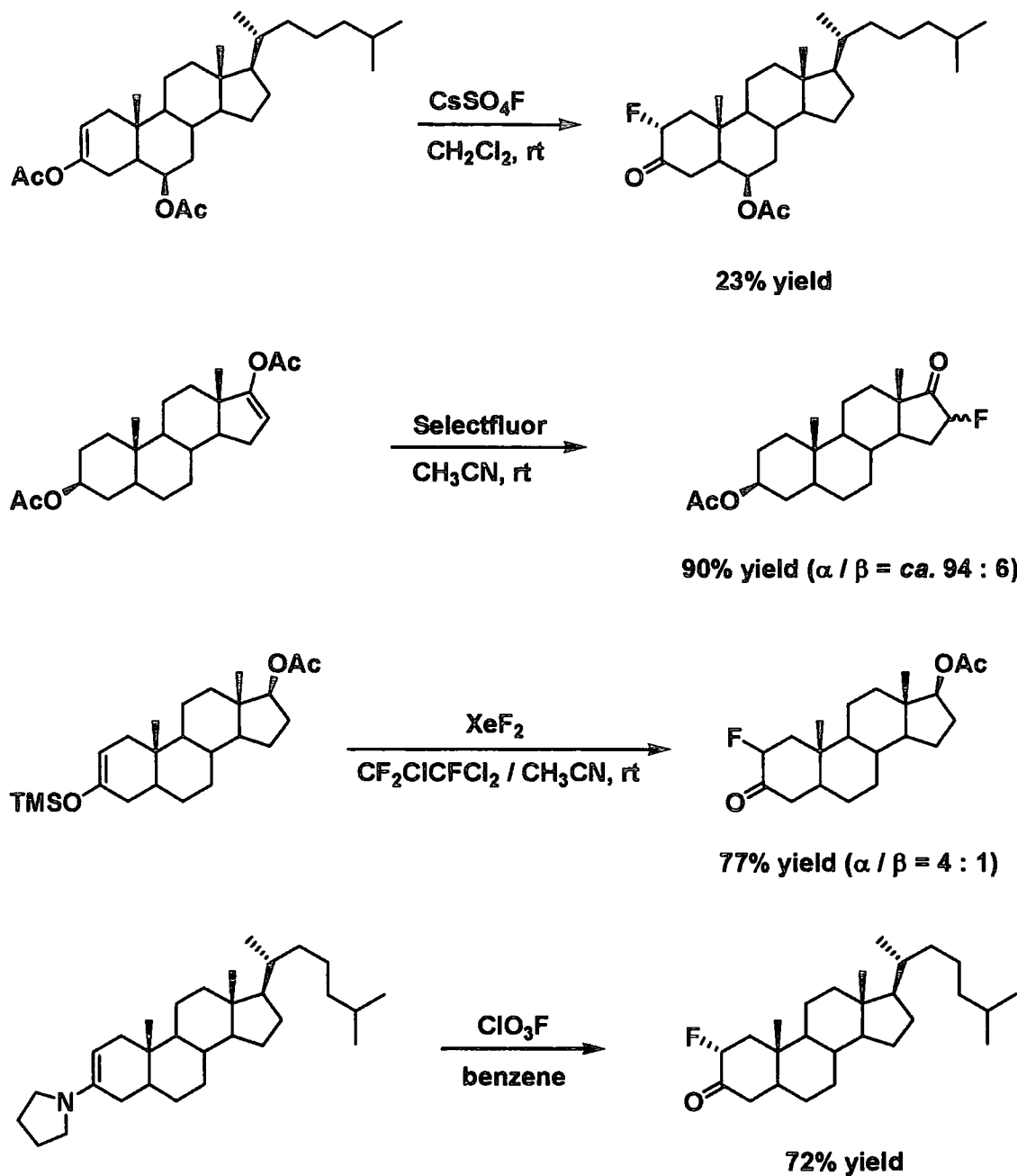

An alternative method for the introduction of fluorine atoms at the α -position of carbonyl groups is fluorination of enolate anions generated by treatment with base. The reaction of the lithium enolate of 3 β -tetrahydropyranyloxy-androst-5-en-17-one (**70**) with perchloryl fluoride gave 16 α -fluoro product **71** in 56% yield (Scheme 2.9).¹³³

SCHEME 2.9

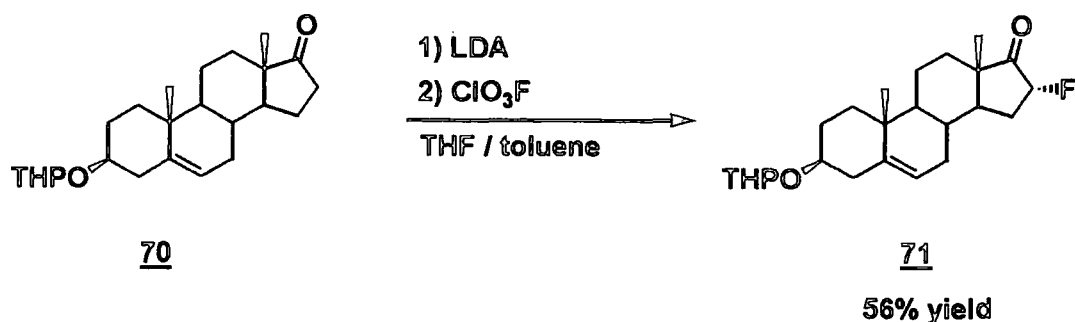

6-Fluorosteroids, which are an entry to important anti-inflammatory agents, can be synthesised by γ -fluorination of conjugated enol acetates. Fluorination of 3,17 β -diacetoxyandrost-3,5-diene (72) was carried out using several N-F reagents to give 6-fluoro derivatives (Table 2.1). Fluorination of 72 with Selectfluor proceeded smoothly at room temperature to give a 2:3 mixture of 6-fluoro products (73a and 73b) in excellent yield.¹⁰¹ *N*-Fluoropyridinium salts were also effective for this reaction. Using non-substituted *N*-fluoropyridinium triflate (29) the reaction gave a 1:2 mixture of the desired 6-fluoro adducts in 72% yield. The use of the more sterically demanding *N*-fluoro-2,4,6-trimethylpyridinium triflate (30) resulted in the increase of 6 β product 73b.⁹⁵ On the other hand, the fluorination of 72 with *N*-fluoropyridinium pyridine heptafluorodiborate 37 in acetonitrile at elevated temperatures favored formation of the α -isomer 73a.¹³⁴ The most β -selective fluorination at the 6-position was achieved by *N*-fluoro benzenesulfonimide (NFSI).¹³⁵ The reaction of 72 with NFSI gave a 1:19 ratio of 73a and 73b.

TABLE 2.1

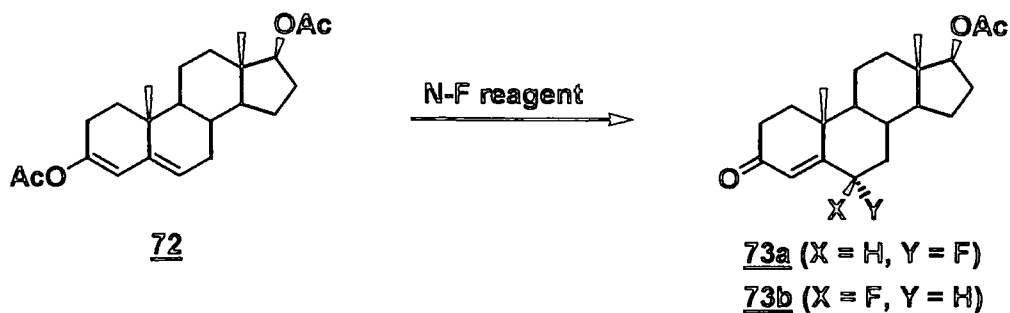

N-F reagent	solvent	temp (°C)	time (h)	yield (%)	α / β ratio (73a / 73b)
Selectfluor	MeCN	20	0.15	95	2 / 3
29	CH ₂ Cl ₂	40	16	72	1 / 2
30	CH ₂ Cl ₂	40	46	55	1 / 8.5
37	MeCN	40	48	96	1 / 1
37	MeCN	80	5	57	4 / 1
NFSI	THF	40	24	55—60	1 / 19

2.2.2 Fluorination of steroids using nucleophilic fluorinating agents

Needless to say, hydrofluoric acid is the most fundamental source of fluoride ion. Fried and Sabo synthesised the first fluorinated steroid by the ring-opening reaction of 21-acetoxy-9 β ,11 β -epoxy-17-hydroxypregn-4-en-3,20-one **74** using anhydrous HF (Scheme 2.10).⁸

SCHEME 2.10

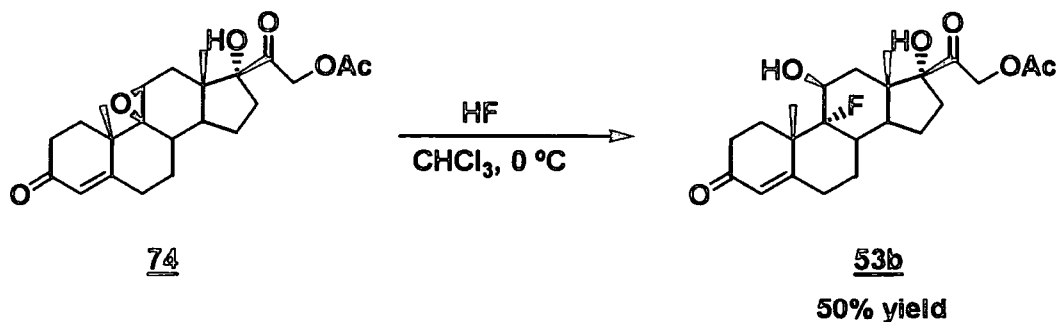

Tetrabutylammonium dihydrogen trifluoride ($\text{Bu}_4\text{N}^+\text{H}_2\text{F}_3^- = \text{TBAF}(\text{HF})_2$) is an

efficient and easy-to-handle hydrofluorination agent for the ring-opening reaction of oxiranes. The reaction of 3 β -hydroxy-5 α ,6 α -epoxycholestane **75** with TBAF(HF)₂ gave 3 β ,5 α -hydroxy-6 β -fluorocholestane **76** in 47% yield (Scheme 2.11).¹³⁶

SCHEME 2.11

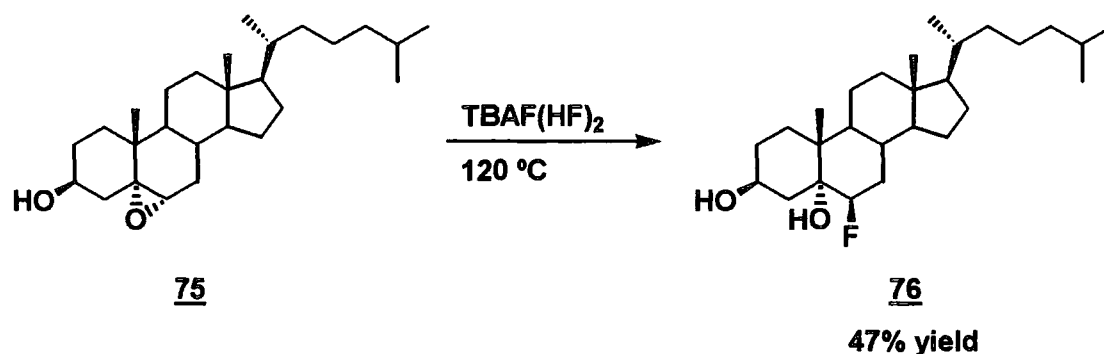

Diethylaminosulfur trifluoride (DAST) is one of the most applicable reagents for the transformation of hydroxy group into fluoride.¹³⁷ In many cases, the displacement of hydroxy groups by fluorine occurs with complete inversion of configuration, thus pointing to an S_N2 reaction. However, the 5-en-3 β -hydroxy series of steroids reacted with DAST with complete retention of the configuration to give 5-en-3 β -fluoro steroids in high yield (Scheme 2.12).¹³⁸

SCHEME 2.12

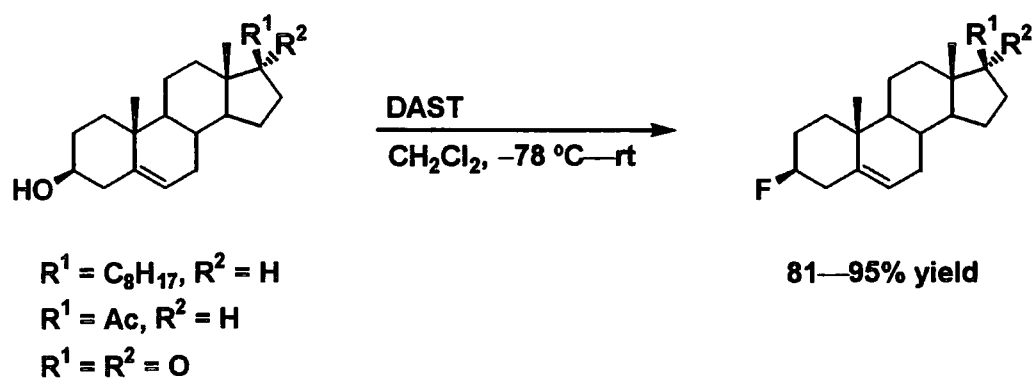

These results were explained that the reactions involved a stable carbocation **77** as intermediate, leading to the 3 β -fluoro derivatives (Scheme 2.13).

SCHEME 2.13

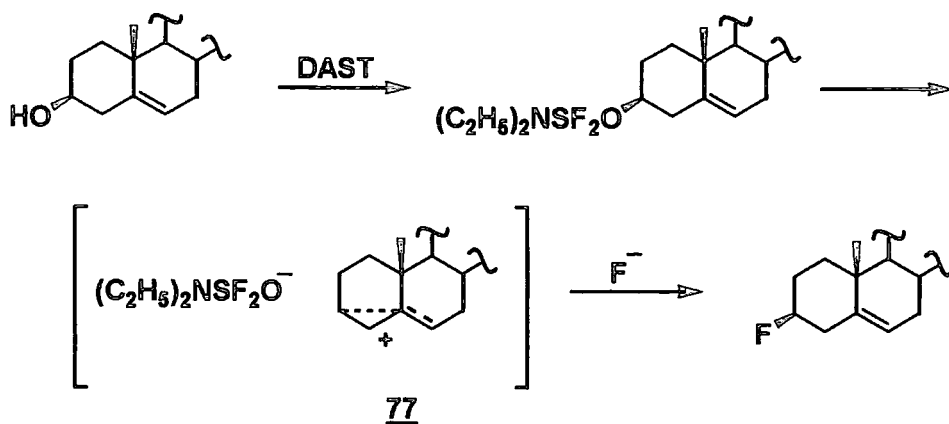

Fluoride ion displacement reaction of sulfonate derivatives is also an effective method for the nucleophilic introduction of fluorine. The reaction of 3,16 α -bis{[(trifluoromethyl)sulfonyl]oxy}estra-1,3,5(10)-trien-17-one **78** with TBAF proceeded at room temperature to give 16 β -fluoro-3-{[(trifluoromethyl)sulfonyl]oxy}estra-1,3,5(10)-trien-17-one **79** in 82% yield (Scheme 2.14).¹³⁹

SCHEME 2.14

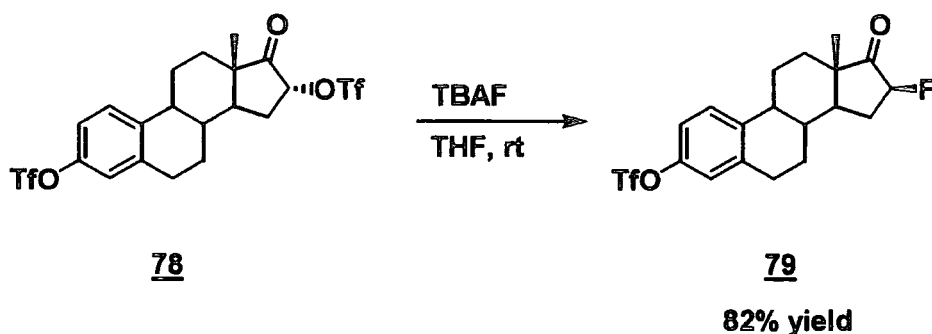

2.3 Remote functionalisations directed by tethered reagents

As mentioned above, the main contributor to this field is Breslow and co-workers.¹⁴⁰ The first example of this kind of reaction was photolysis of long alkyl esters of benzophenone-4-carboxylic acid (Scheme 2.15).¹⁴¹ Photolysis of *n*-tetradecyl ester was carried out and the resulting carbinols were derived to ketones by subsequent dehydration and oxidation. Half of the product mixture was a compound with a keto group inserted at C-12 position although the functionalisations occurred over carbons 8 to 13. Even with longer alkyl chains, significant insertions of a keto group at the same

position were observed. Obviously, the flexibility of the alkyl chains reduced the selectivity.

SCHEME 2.15

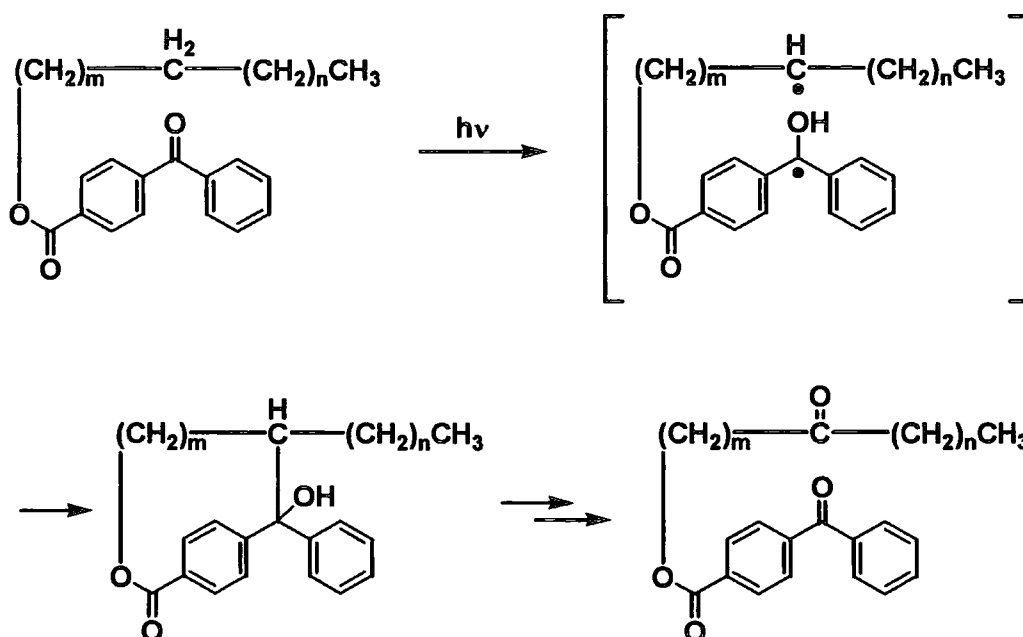

Steroids are rigid substrates and their selective functionalisations are practically interesting. Breslow applied the photochemical remote functionalisation using a benzophenone group to steroid systems. Photolysis of 3 α -cholestanyl (*p*-benzoylphenyl)acetate (**80**) gave a single alkenic product **82** (Scheme 2.16).¹⁴² An isotopic labeling study implied that the oxygen atom of benzophenone excited triplet state removed the hydrogen at C-14 position to give a diradical **81**, and the hydrogen at C-15 was transferred to the diphenylmethyl radical.¹⁴³ The selectivity was induced by the geometry of the system, specifically the match of the C-3 oxygen to C-14 hydrogen distance in the steroid skeleton with the carboxyl to ketone distance in the attached reagent. In another study, it was found that the benzophenone group need not be directly attached to the substrates.¹⁴⁴ A hydrogen-bonded complex between hemisuccinate of 3 α ,5 α -androstanol and benzophenone-4-carboxylic acid was irradiated to give 16-keto-3 α ,5 α -androstanol selectively.

SCHEME 2.16

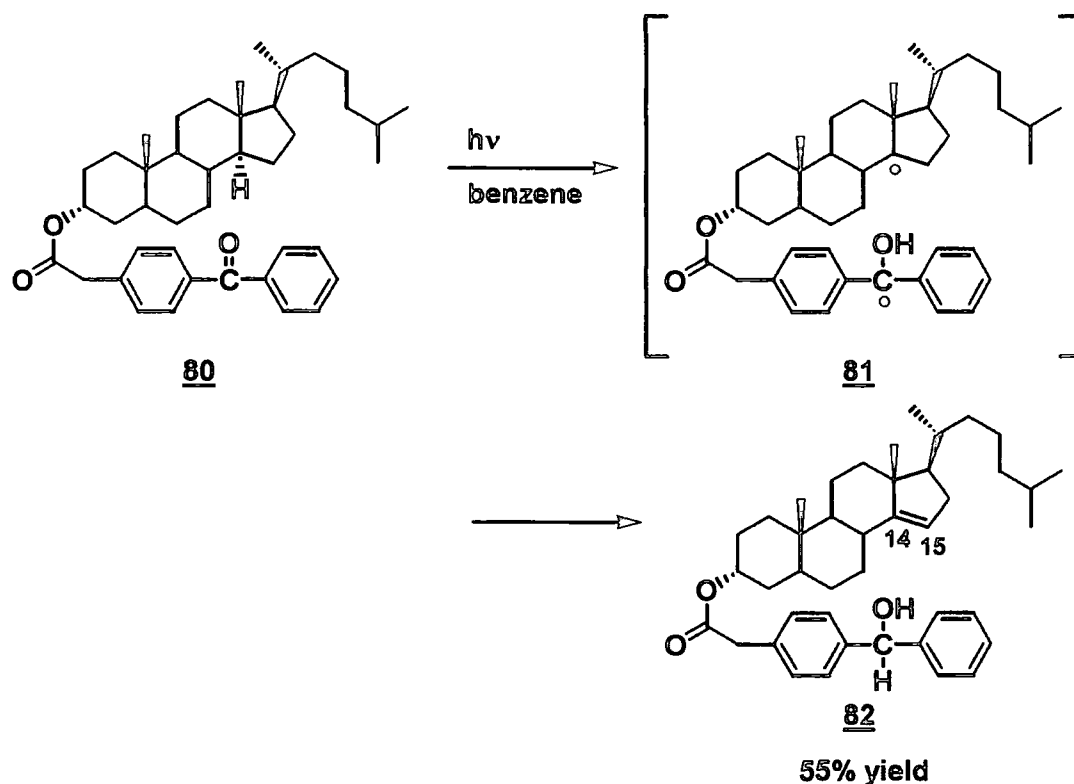

Alkenes can be converted to epoxides by alkyl peroxide in the presence of catalytic metal compounds of molybdenum, tungsten, and so on. If the substrate olefins have an allylic hydroxy group, they are particularly reactive since the metal forms a complex not only with the peroxide but also with the hydroxy group, and delivers an oxygen atom to the double bond. Breslow reasoned that it might be possible to achieve remote epoxidation of alkenes if the substrate was attached with a tether of appropriate length, with a hydroxy group to bind the metal catalyst. This was proved by the regio- and stereoselective epoxidation of a steroidal ester carbinol **85** shown in scheme 2.17.¹⁴⁵ Epoxidation of an alkenic steroid **83** with *t*-butyl hydroperoxide in the presence of catalytic amounts of $\text{Mo}(\text{CO})_6$ gave allylic epoxidation in 61% conversion and 100% yield. In contrast, treatment of the ester carbinol **85** in the same conditions led to remote epoxidation to give **86**. A similar substrate **87**, which was attached with a *meta* isomer of the tether in **85** gave no reaction.

SCHEME 2.17

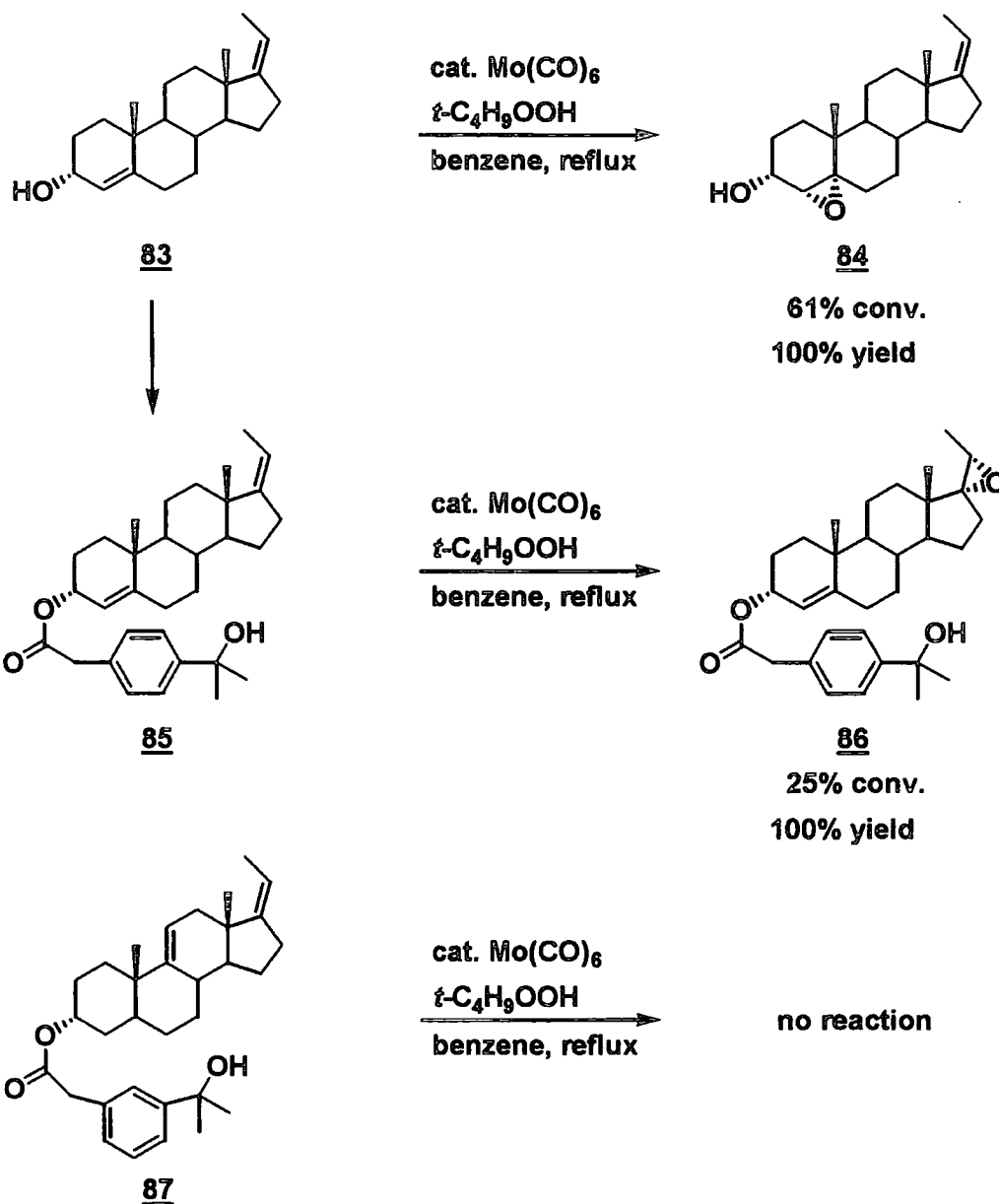

Photolysis of the compounds bearing benzophenone were not attractive for large scale synthetic work.

On the other hand, free radical chlorination is a highly practical process, commonly run on an enormous industrial scale. Besides, chlorine atoms can react with unactivated C-H bonds. Breslow directed his attention to the fact that phenyliodine dichloride can also be used in chlorinations by a free-radical chain mechanism (Scheme 2.18).^{146,147}

SCHEME 2.18

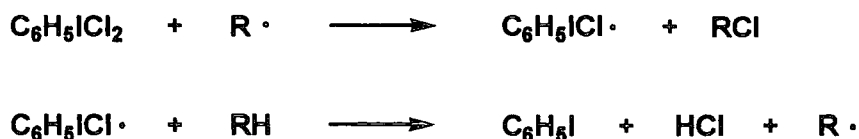

There was another feature of this reaction which was attractive. It was known that $\text{PhICl}\cdot$ attack on tertiary C-H sites occurs quite selectively (which is similar to direct fluorination). Generally, there is only one tertiary carbon along any arc generated by pivoting around the C-3 oxygen in 3α -hydroxy-steroid derivatives. Thus, steroid derivatives with a tethered chlorinating agent attached were prepared and geometrically directed remote chlorinations were investigated using them (Scheme 2.19).^{148,149}

SCHEME 2.19

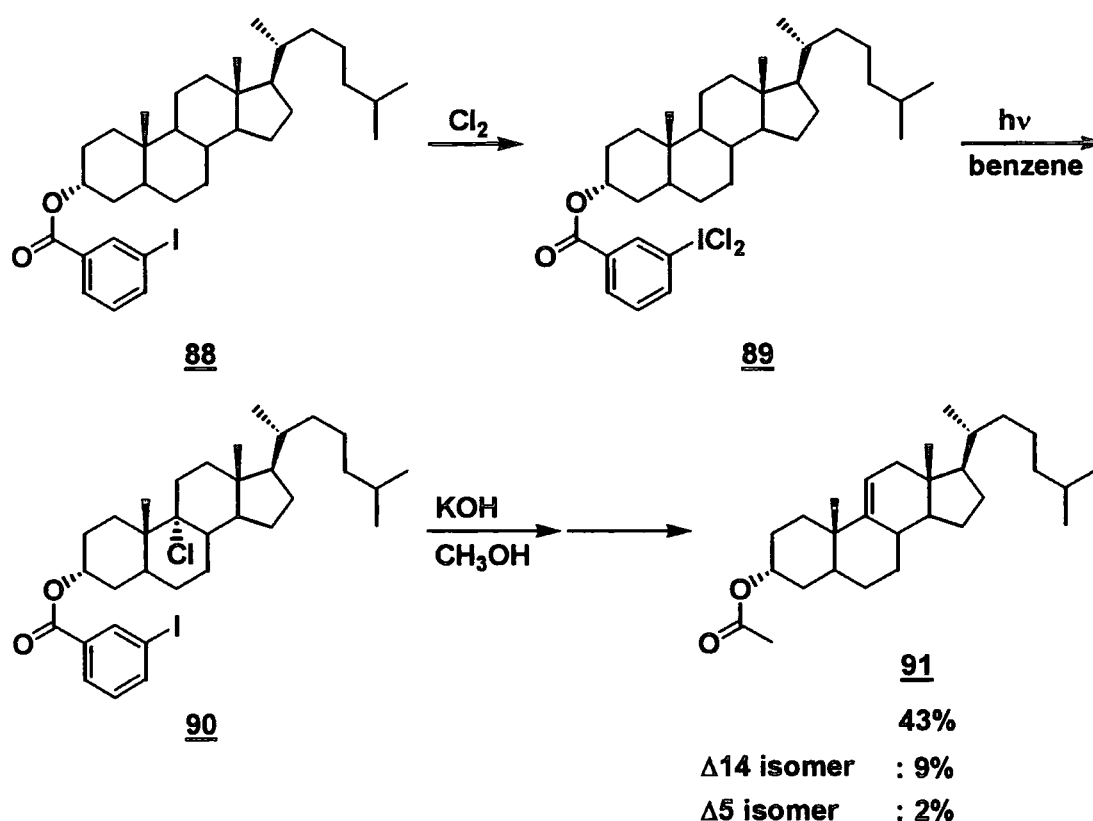

3α -Cholestanyl *m*-iodobenzoate (**88**) was converted to iododichloride **89** by treatment with Cl_2 , and then irradiated. After hydrolysis and acetylation, $\Delta^{9(11)}$ -cholestenyl 3α -acetate (**91**) was obtained in 43% yield, although Δ^{14} - and Δ^5 isomers were also

obtained in 9% and 2% yields, respectively. This geometrically controlled reaction enabled change of the selectivity by using another tether with a different length (Scheme 2.20).¹⁴⁸ Irradiation of a steroid tethered chlorinating agent **93** derived from 3 α -cholestanyl (*p*-iodophenyl)acetate (**92**) gave predominantly 14-chloro compound **94**.

SCHEME 2.20

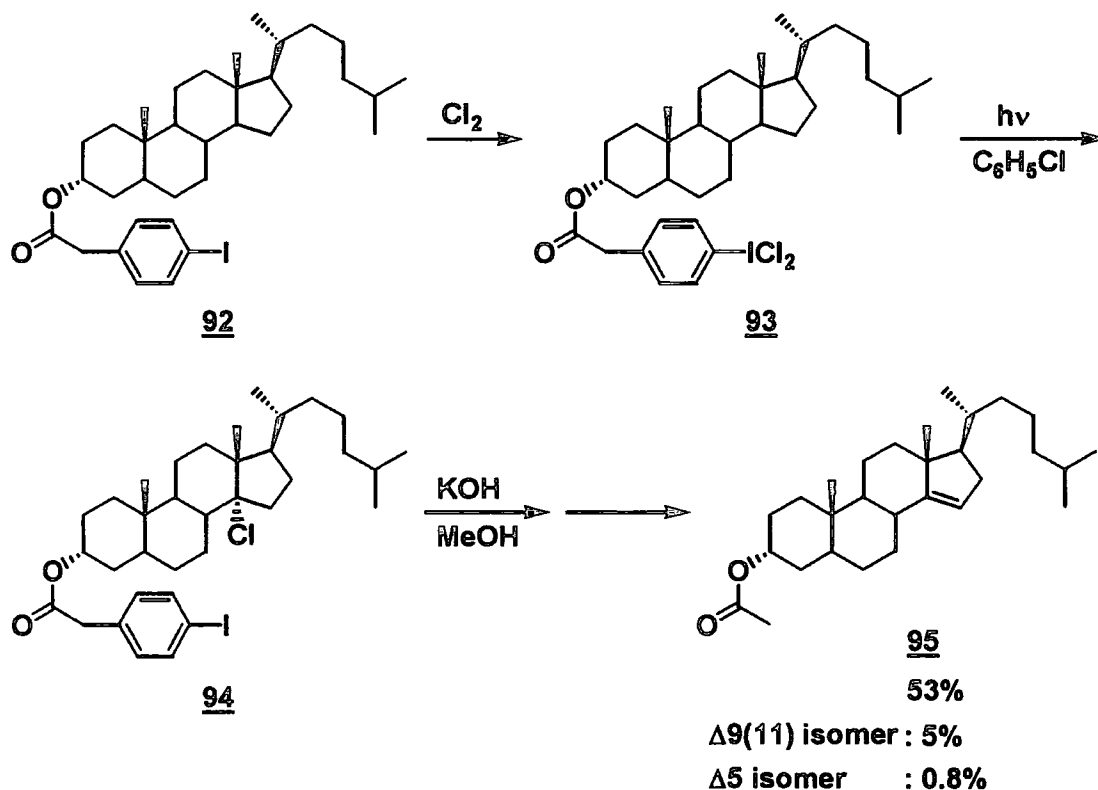

It was found that the tethered chlorinating reagents such as **93** did not have to be prepared. The reaction of 3 α -cholestanyl *m*-iodobenzoate (**88**) with phenyliodine dichloride was carried out under free radical conditions to give exclusively the 9-Cl derivative **90** (Scheme 2.21).^{149,150} The reaction process is called a radical-relay mechanism, that is, the free phenyliodine dichloride is converted on photolysis to the $\text{PhICl}\cdot$ radical, and this chlorine atom donor transfers the chlorine to the tethered *m*-iodophenyl group of **88** to generate the key intermediate **96** directly. The chlorine atom is delivered to the most geometrically accessible 9-position hydrogen of the substrate. The resulting radical **97** is chlorinated by an external reagent to give the product **90**. It was very intriguing that the two-step sequence – intermolecular chlorine atom transfer, then intramolecular hydrogen abstraction – was faster than an

intermolecular hydrogen abstraction by the free radical in solution.

SCHEME 2.21

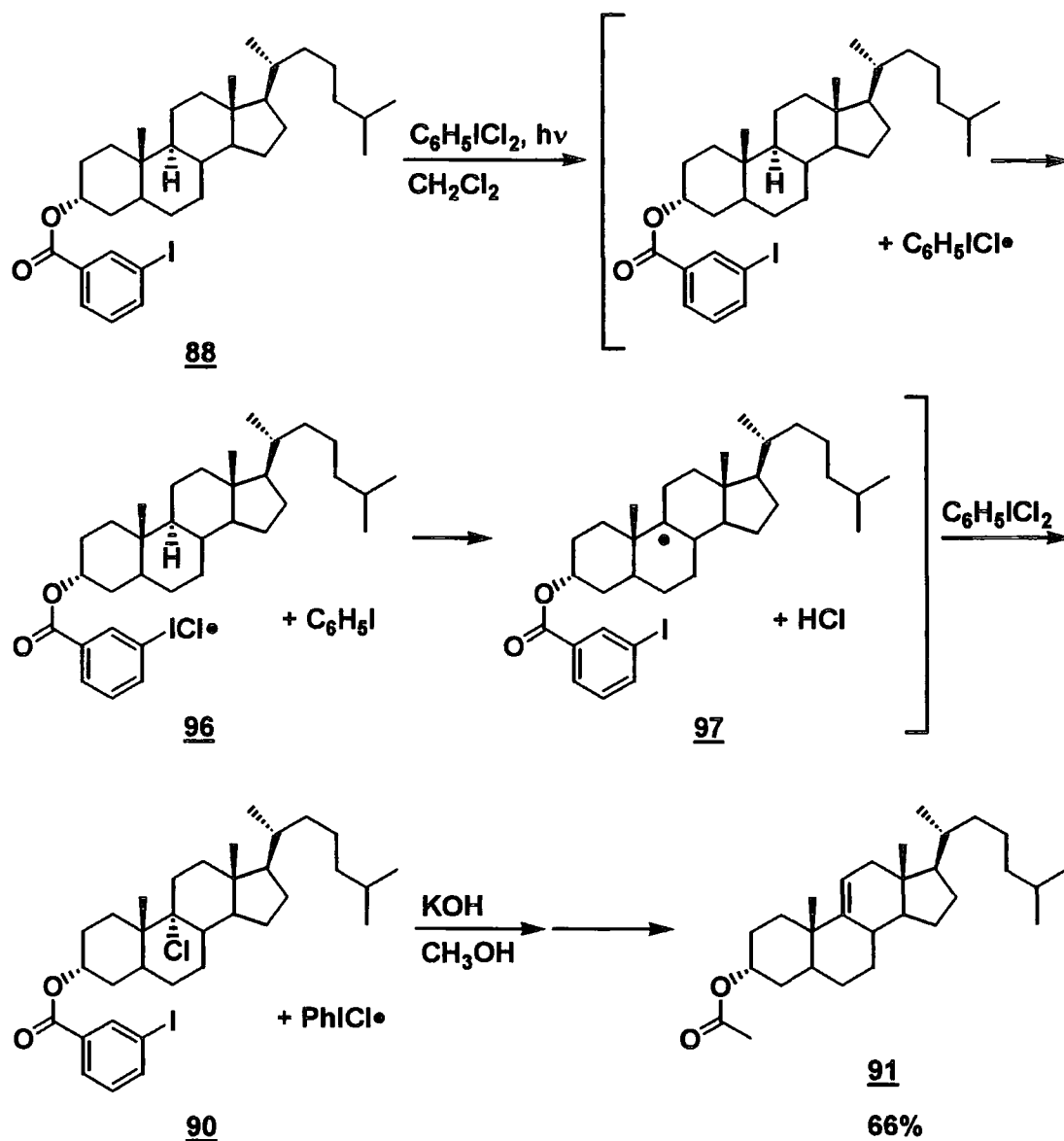

A selective formation of C-17 chlorinated system **99**, which enabled the removal of the hydrocarbon side chain in cholesterol derivatives, was achieved by using a longer tether (Scheme 2.22).^{149,151} Photolysis of 3 α -cholestanyl 4'-iodo-3-biphenyl carboxylate (**98**) with phenyliodine dichloride in carbon tetrachloride gave Δ^{16} -3 α -cholestenyl acetate (**100**) in 41% yield after derivatization. The distance from C-3 oxygen to the hydrogen at C-17 was calculated to be 8.5 Å, which was well matched up with that of the oxygen-chlorine in the intermediate radical that was

assumed 8.7 Å. The product **100** could be converted to androsterone acetate (**101**) by isomerization and ozonolysis.

SCHEME 2.22

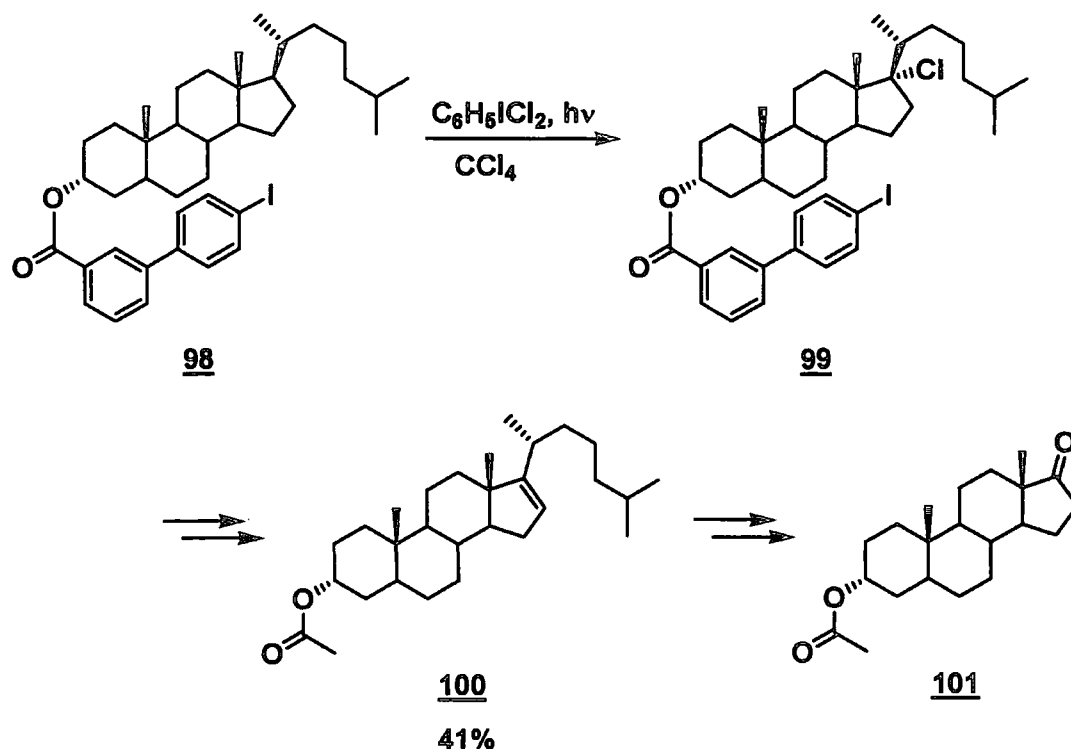

Wiedenfeld demonstrated that when the photolysis of steroids bearing an iodophenyl group was conducted in the presence of an excess amount of CBr_4 or $(\text{SCN})_2$ the products were regioselectively brominated or thiocyanated steroid derivatives respectively.¹⁵²

Further work by Breslow described pyridine-based tethers that were superior to those based on aryl iodides.¹⁵³ Irradiation of 3 α -cholestanyl nicotinate (**102**) with phenyliodine dichloride gave quantitatively 9-chloro derivative (**103**), contaminated by small amounts of the 14-chloro compound. After derivatization steps, $\Delta^{9(11)}$ -3 α -cholestenol (**104**) was obtained in 92% yield accompanied by 3% of Δ^{14} -isomer (Scheme 2.23). In this system, a photochemically generated chlorine radical is captured by the pyridine ring, and delivered to the most geometrically accessible 9-position hydrogen of the steroid. After the abstraction of hydrogen, the resulting radical is chlorinated by external reagent to give 9-chlorinated steroids.

SCHEME 2.23

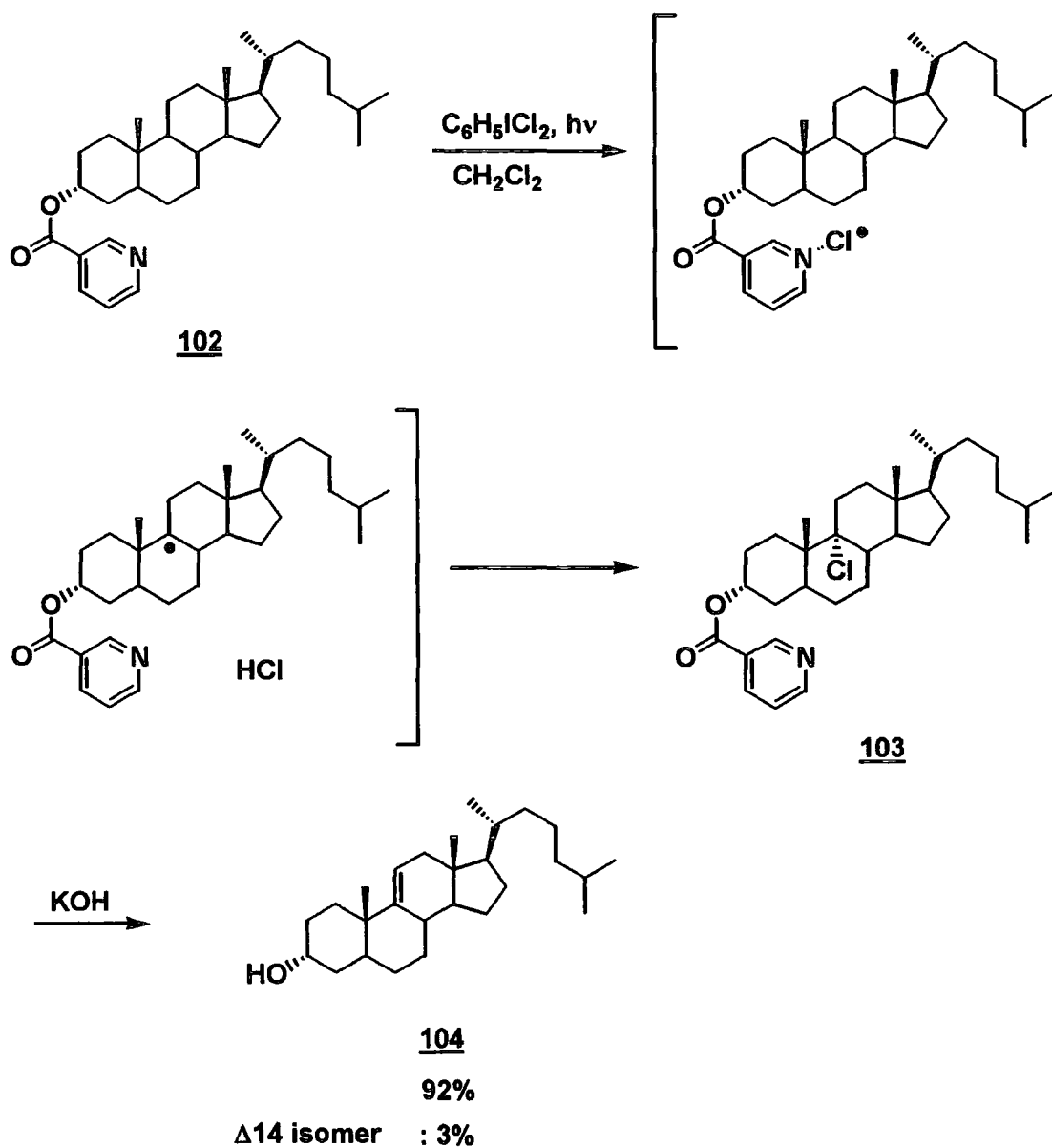

2.4 Remote fluorination of steroids directed by tethered N-F reagents

2.4.1 Introduction

As described in the last section, tethers bearing an appropriate functional group could direct particular reactions toward a geometrically favourable product. When this strategy is applied to electrophilic fluorinations, it is quite likely that nitrogen-containing functional groups would give great possibilities because N-F reagents can be relatively easily prepared and react even with unactivated C-H sites. Thus, we have investigated the geometrically directed remote fluorination of steroid derivatives using tethered N-F reagents. The concept is illustrated in Scheme 2.24.

SCHEME 2.24 Geometrically directed remote fluorination of steroids with tethered N-F reagents

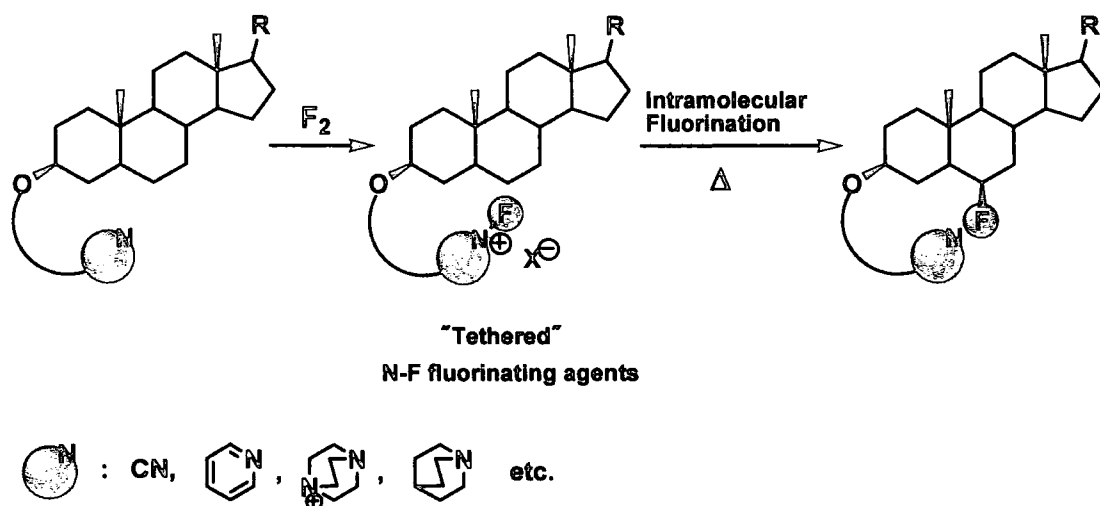

Fluorination of steroid derivatives bearing tethers containing a nitrogen atom with elemental fluorine proceeds to give 'tethered N-F reagents' *in situ*. In the second step, 'intramolecular fluorination' occurs to give regio- and stereoselectively fluorinated steroid systems because, potentially, the fluorine atom introduced on the nitrogen can fluorinate only the most geometrically accessible C-H bond.

2.4.2 Model study

2.4.2.1 Introduction

In our concept, we need tethered N-F reagents, which have enough fluorinating power to convert saturated C-H bonds into C-F bonds. Fluorination of saturated C-H sites using several electrophilic N-F reagents have already been demonstrated,¹⁵⁴ but the investigation was not sufficient for our project. Firstly, we studied the fluorinating power of various model compounds for the fluorination of saturated hydrocarbons, which could be developed to tethered reagents for selective remote fluorination.

2.4.2.2 Preparation of model compounds

In this section, we discuss the syntheses of various precursors of N-F reagents for the study of the fluorinating ability. The model compounds should possess minimised structures for the tethered reagents attached to steroids and thus, be composed of three parts, namely a nitrogen-containing functional group, a linking group and a simple alkyl group which imitates steroid skeleton (Figure 2.4).

FIGURE 2.4 Structure of model compound

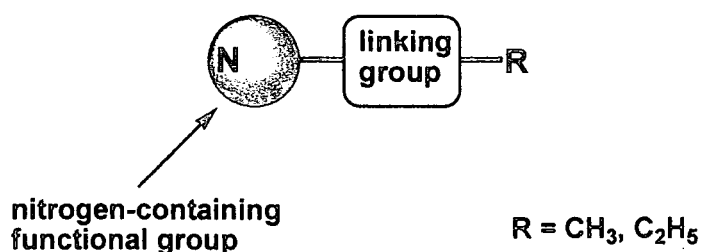

2.4.2.2.1 Pyridine derivatives

Pyridine derivatives are one of the strongest candidates for this strategy because *N*-fluoropyridinium salts are well-established N-F reagents and their fluorinating power can be controlled by introducing appropriate substituents onto the pyridine ring.

Methyl nicotinate (106) Methyl nicotinate (**106**) was prepared from nicotinoyl chloride hydrochloride (**105**) and methanol in good yield (Scheme 2.25).

SCHEME 2.25

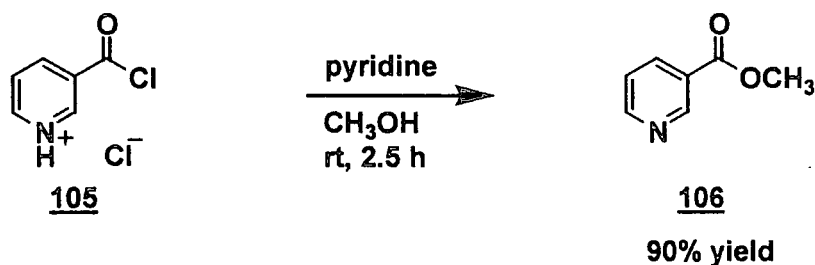

Methyl 2,6-dichloronicotinate (108) Compound **108** could be prepared from 2,6-dichloronicotinic acid (**107**) (Scheme 2.26).¹⁵⁵ Although the starting material obtained commercially was contaminated by 10% of another isomer, the ester **108** could be isolated by recrystallization from hexane/diethyl ether (2:1).

SCHEME 2.26

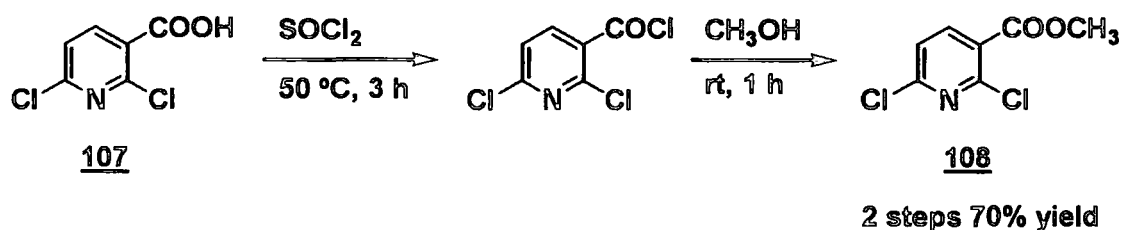

2.4.2.2.2 Quinuclidine derivatives

Quinuclidine derivatives are precursors of saturated-type quaternary N-F salts.⁹⁷ 3-Quinuclidinol is commercially available and its hydroxy group is usable for connection to a steroid skeleton.

3-Acetyloxyquinuclidine (**110**) 3-Acetyloxyquinuclidine (**110**) was prepared from 3-quinuclidinol (**109**) and acetic anhydride under reflux.¹⁵⁶ Since the desired compound was found to be unstable to silica gel from a TLC analysis, the pure compound was obtained by a combination of distillation and column chromatography on neutral aluminium oxide. Column chromatography on the neutral aluminium oxide using hexane and ethanol was carried out after Kuhgelrohr distillation to give 3-acetyloxyquinuclidine (**110**) as a colourless oil (62% yield) (Scheme 2.27).

SCHEME 2.27

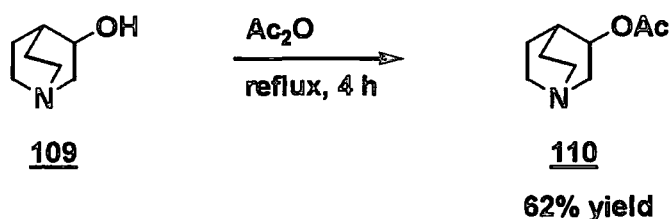

2.4.2.2.3 1,4-diazabicyclo[2.2.2]octane (DABCO) derivatives

1,4-Diazabicyclo[2.2.2]octane (DABCO, **111**) is the precursor of Selectfluor-type N-F reagents. The Selectfluor reagent is one of the strongest N-F reagents, and its power is variable by changing the electronegativity of the quarternizing group on the second nitrogen.

1-(2-Chloroethyl)-4-aza-1-azoniabicyclo[2.2.2]octane tetrafluoroborate (**112**) This compound was prepared by a similar manner to the synthesis of the precursor of Selectfluor.¹⁰¹ DABCO (**111**) was reacted with 1,2-dichloroethane in the

presence of sodium tetrafluoroborate in acetonitrile (Scheme 2.28) and the reaction proceeded slowly to give a brown oil. The crude mixture contained some oligomers and starting material and the amounts of oligomers seemed to be increased by heating. It was difficult to crystallise the product from any solvents using the oily crude mixture. The crude mixture was purified finally by removing the impurities as a precipitate. Filtration was repeated after precipitation of the impurities from acetone and dichloromethane to give desired monoquarternary salt. The resulting brown oil still contained oligomers to some extent, but the purity was adequate to carry out the model study.

SCHEME 2.28

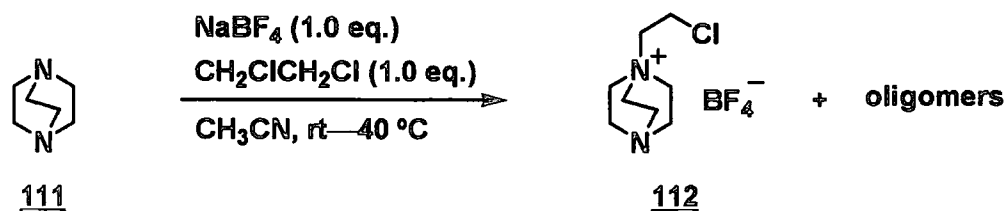

1-(2-Methoxyethyl)-4-aza-1-azoniabicyclo[2.2.2]octane tetrafluoroborate (113) This compound was prepared by the reaction of DABCO (**111**) with 2-chloroethyl methyl ether in a similar method as compound **112** (Scheme 2.29). The reaction gave the desired monoquarternary salt without forming oligomers under even reflux conditions.

SCHEME 2.29

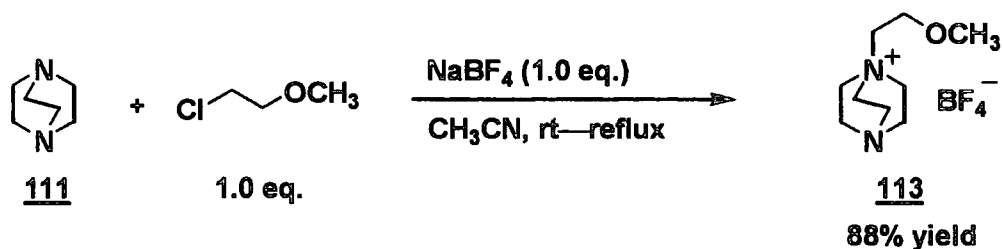

1-(Ethoxycarbonylmethyl)-4-aza-1-azoniabicyclo[2.2.2]octane tetrafluoroborate (114) This compound was also prepared by a similar manner to other precursors **112** and **113**. DABCO (**111**) was reacted with ethyl bromoacetate in the presence of sodium tetrafluoroborate in acetonitrile (Scheme 2.30). The exothermic

reaction proceeded instantly to give 1-(ethoxycarbonylmethyl)-4-aza-1-azoniabicyclo [2.2.2]octane bromide and followed by anion-exchange reaction using sodium tetrafluoroborate. The desired product **112** was obtained as white crystals. In the ^1H NMR spectrum in D_2O , two kinds of resonances corresponding to 3 methylene groups next to nitrogen were observed as triplets at 3.13 and 3.55 ppm. These chemical shifts were similar to those of the corresponding resonances of Selectfluor precursor, namely 1-chloromethyl-4-aza-1-azoniabicyclo[2.2.2]octane tetrafluoroborate (3.29 and 3.50 ppm).¹⁵⁷ The resonance derived from another methylene group at the α position to the carbonyl group was found at 4.11 ppm as a singlet.

SCHEME 2.30

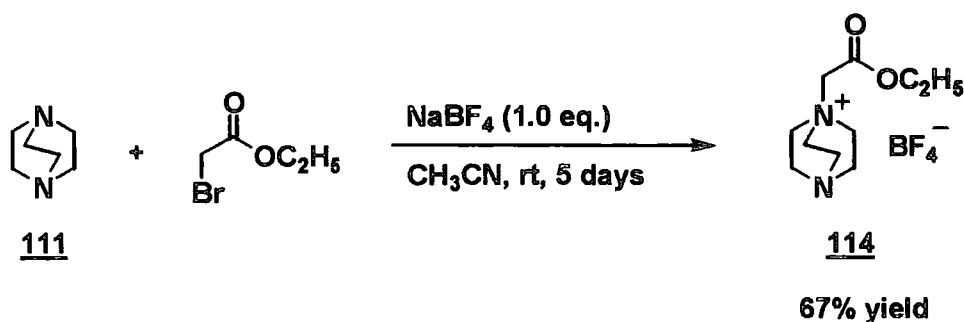

2.4.2.3 Evaluation of the fluorinating ability of model compounds

The fluorinating abilities of the N-F compounds derived from prepared model compounds were estimated using *cis*-decalin (**115**). Fluorinations of the model compounds with elemental fluorine were carried out in acetonitrile in the presence of equimolecular amounts of NaBF_4 at around $-10\text{ }^\circ\text{C}$ (Scheme 2.31). The amount of the N-F species formed was calculated by comparing the integration for the N-F resonance with the counter anion's resonance (BF_4^-) by ^{19}F NMR. The reaction mixture was added to *cis*-decalin (**115**) and refluxed for 1 to 19 hours. After work-up in the usual procedure, the crude products were analyzed by NMR, GC and GC-MS.

SCHEME 2.31

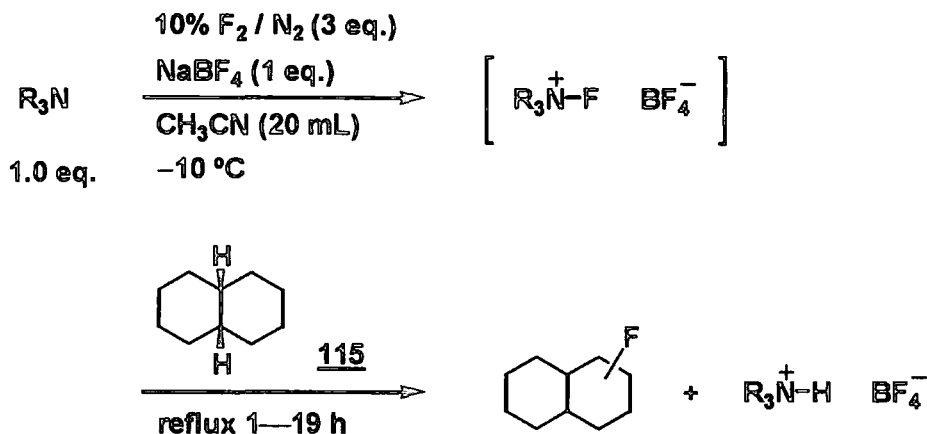

2.4.2.3.1 Pyridine derivatives

Methyl nicotinate (**106**) Direct fluorination of methyl nicotinate (**106**) gave the corresponding N-F compound in 74% conversion. The N-F resonance was observed at +50.2 ppm in ^{19}F NMR and the relative intensity was 0.74 ($\text{BF}_4^- = 4$). After refluxing with *cis*-decalin (**115**) for 1 hour, disappearance of the N-F resonance was observed. The product contained methyl 2-fluoronicotinate (**116a**) and methyl 6-fluoronicotinate (**116b**) (6:1) and unchanged *cis*-decalin (**115**) (Scheme 2.32).

SCHEME 2.32

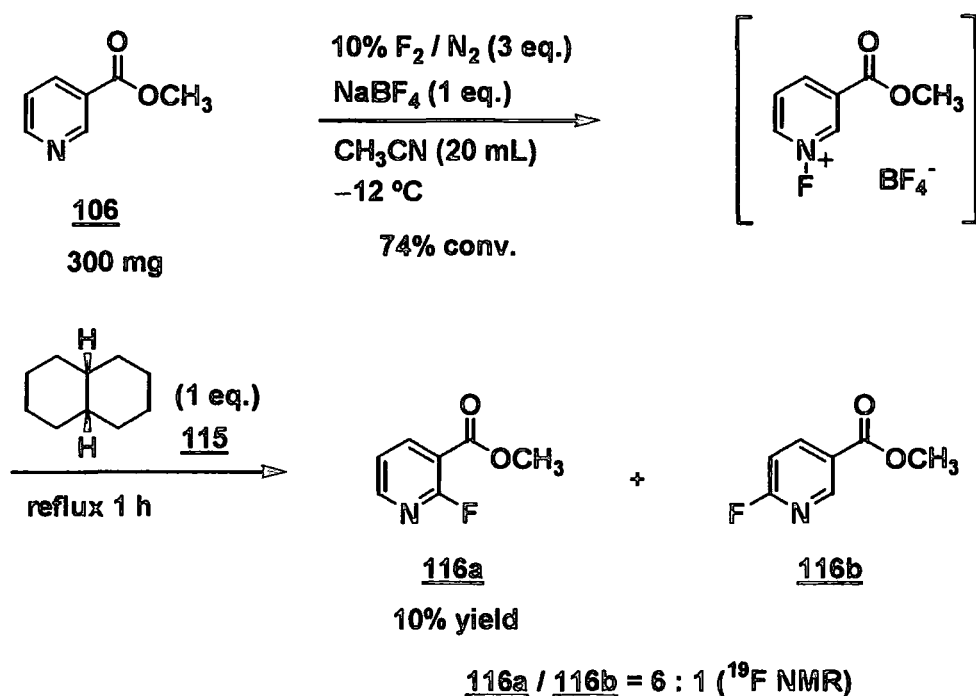

The formation of 2-fluoropyridines by direct fluorination of pyridine derivatives was reported by Puy.¹⁵⁸ He described that the fluorination of methyl nicotinate (**106**) with elemental fluorine in tetrachloromethane at 0 °C gave methyl 2-fluoronicotinate (**116a**) and methyl 6-fluoronicotinate (**116b**) in 16% and 20% yield respectively. The spectral data of both isomers were consistent with those which were observed in our product. The proposed mechanism suggested that decomposition of the *N*-fluoropyridinium fluoride, which was thought to be an intermediate, involving attacking of fluoride ion on the 2- or 6-position followed by loss of HF, led to the resulting products. In our case, the 2-position was preferentially fluorinated, which is more sterically hindered, but more electrophilic than the 6-position due to the presence of the electron withdrawing ester group at the neighbouring position (Scheme 2.33).

SCHEME 2.33

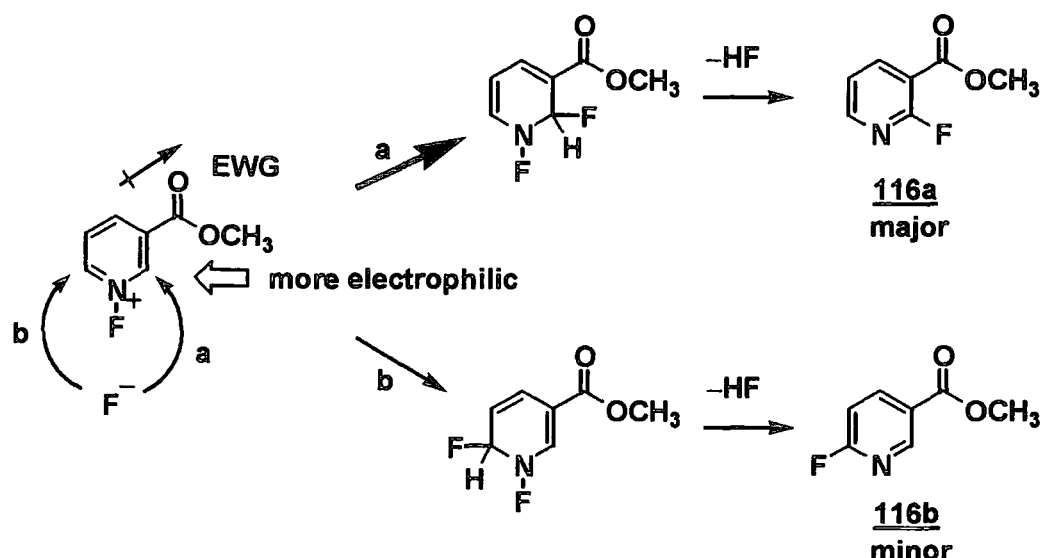

Methyl 2,6-dichloronicotinate (108**)** The fluorination of methyl 2,6-dichloronicotinate (**108**) was carried out in acetonitrile in the presence of $NaBF_4$ at -10 °C and -40 °C. In both cases, the reaction mixture included *N*-F species accompanied by a considerable amount of complicated fluorinated compounds. The *N*-F resonance was found at $+33.4$ ppm in ^{19}F NMR. This value was close to that of *N*-fluoro-2,6-dichloropyridinium salt ($+31.7$ ppm).¹⁵⁹ The crude mixture of the reaction with *cis*-decalin (**115**) was found to contain unreacted *cis*-decalin (**115**) and a complex mixture of multisubstituted pyridines (Scheme 2.34).

SCHEME 2.34

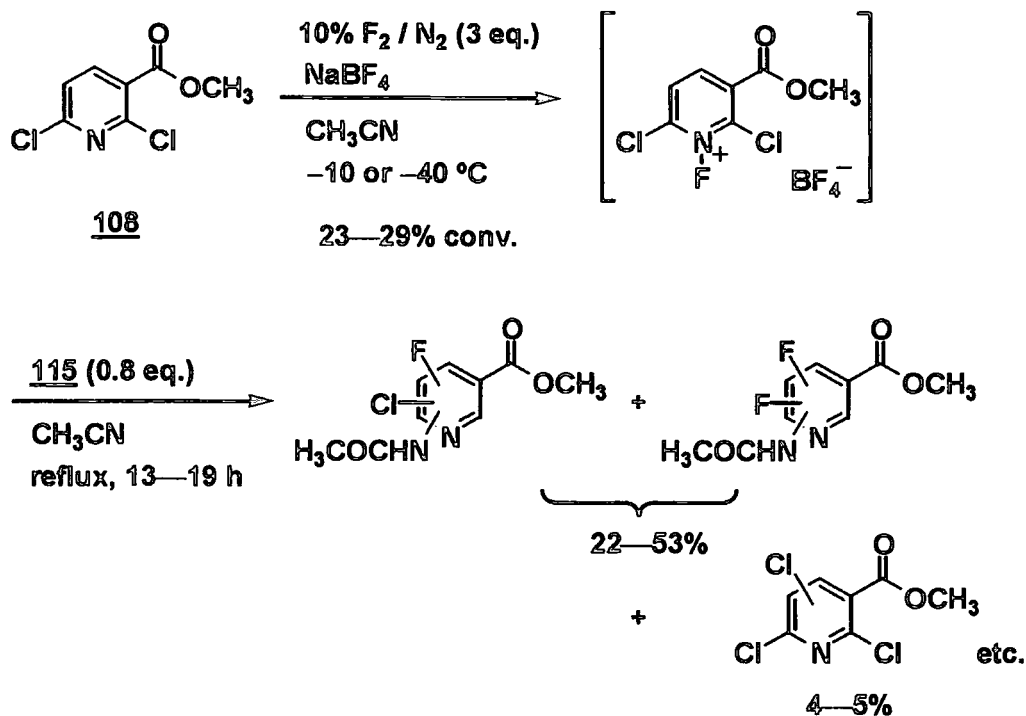

As mentioned in the preceding chapter (see section 1.2.5.2.1), fluorinating abilities and syntheses of *N*-fluoropyridinium salts were widely investigated by Umemoto and co-workers.^{95,160} They reported syntheses of various *N*-fluoropyridinium salts using several different procedures (Scheme 2.35).

SCHEME 2.35

Method A

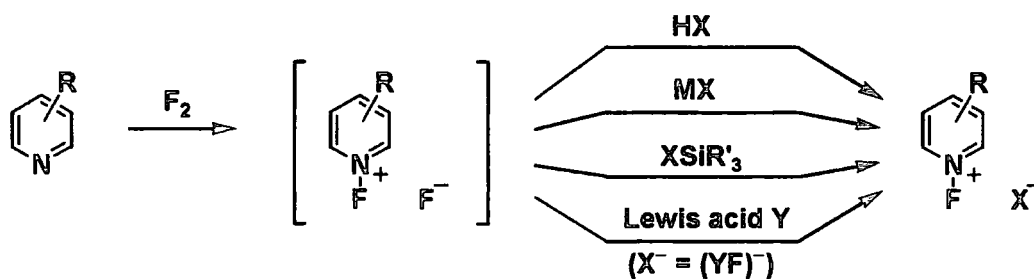

Method B

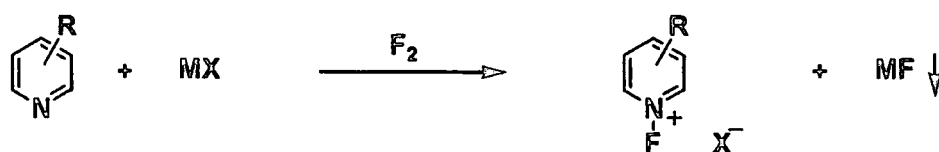

SCHEME 2.35 (Continued)

Method C

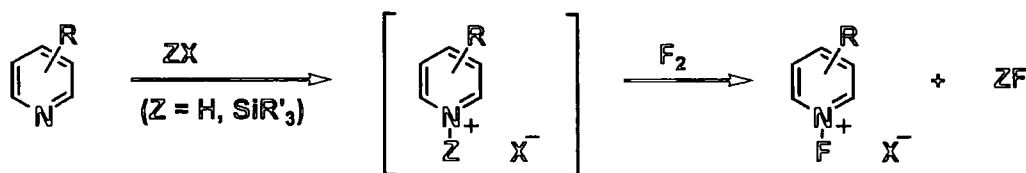

Method D



Method A is a two-step procedure *via* unstable *N*-fluoropyridinium fluoride. Method B is a one-step procedure using corresponding metal salts that have a counter anion of the desired *N*-fluoropyridinium salts. This procedure inevitably provided corresponding metal fluoride as a by-product. Method C was applied to highly substituted pyridines having electron withdrawing group substituents. In this Method, the starting materials were reacted with the corresponding protonic acids or silyl ester firstly to give pyridinium hydrogen salts or *N*-silylpyridinium salts, and then fluorinated. Method D was fluorination of pyridine-Lewis acid complexes. In the case of *N*-fluoro-2,6-dichloropyridinium salt **33**, Method C was reported to be superior to Method B (Scheme 2.36).¹⁶⁰ The main reason for these results was supposed to be the low reactivity of the nitrogen atom of the electron-deficient pyridine ring.

SCHEME 2.36

Method B

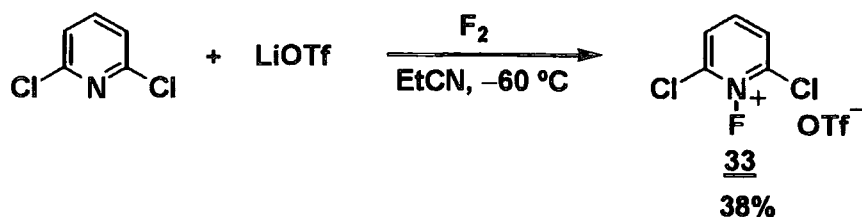

Method C

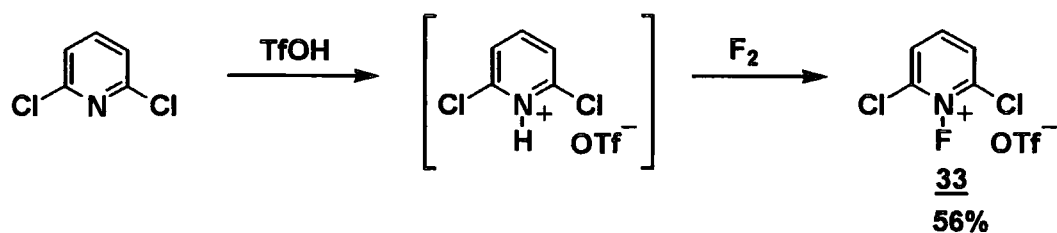

Therefore, we applied method C to the synthesis of N-F species derived from **108** (Scheme 2.37). The dichloronicotinate **108** was treated with triflic acid in acetonitrile at $-10\text{ }^\circ\text{C}$ for 30 minutes. The resulting mixture was fluorinated by 3 equivalents of elemental fluorine to give N-F species without the formation of by-products. However, the N-F species did not show enough ability to fluorinate saturated C-H sites of *cis*-decalin (**115**).

SCHEME 2.37

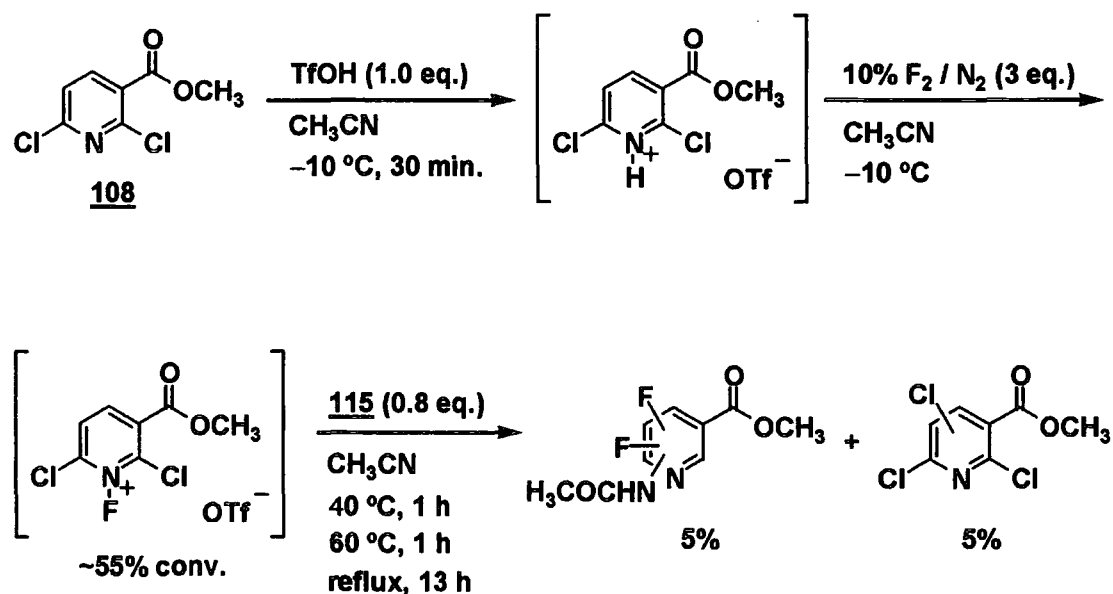

These results indicated the fluorinating power of *N*-fluoropyridinium salts was not sufficient to fluorinate saturated C-H bonds, and pyridine derivatives were not suited to be the template for remote electrophilic fluorination.

2.4.2.3.2 Quinuclidine derivatives

3-Acetyloxyquinuclidine (**110**) The reaction of 3-acetyloxyquinuclidine (**108**) with elemental fluorine in the presence of NaBF₄ gave the corresponding N-F species quantitatively. The N-F resonance appeared at +54.3 ppm. and was comparable with *N*-fluoroquinuclidinium salts reported by Banks (+51.2 ppm).¹⁶¹ Unfortunately, the fluorinating power was not sufficient to convert saturated C-H bonds into C-F bonds (Scheme 2.38).

SCHEME 2.38

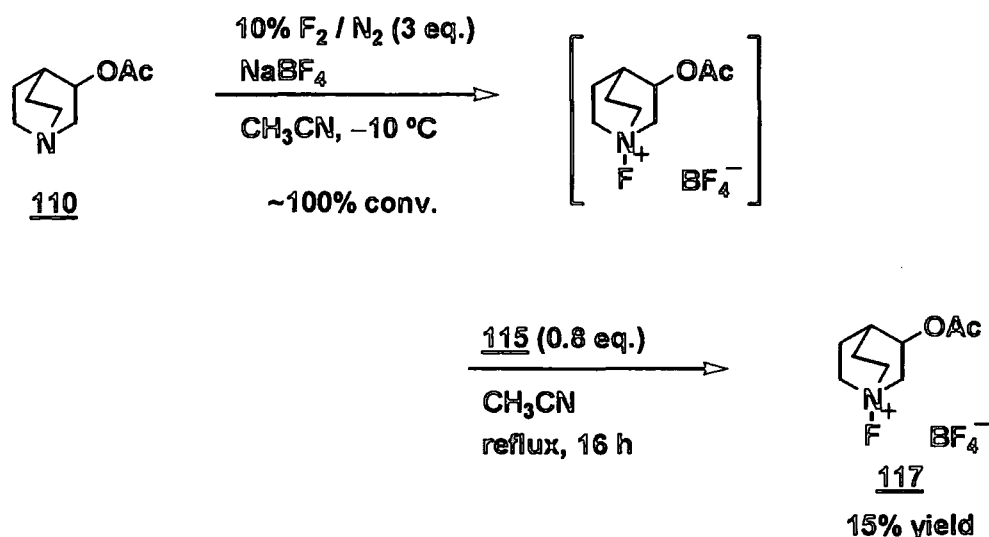

Generally, the *N*-fluoroquinuclidinium salts are known as less reactive fluorinating agents than Selectfluor-type reagents.¹⁶² For example, Banks reported that a 'transfer fluorination' of quinuclidine with Selectfluor proceeded exothermically to completion within 10 minutes at room temperature to give *N*-fluoroquinuclidinium tetrafluoroborate (Scheme 2.39).

SCHEME 2.39

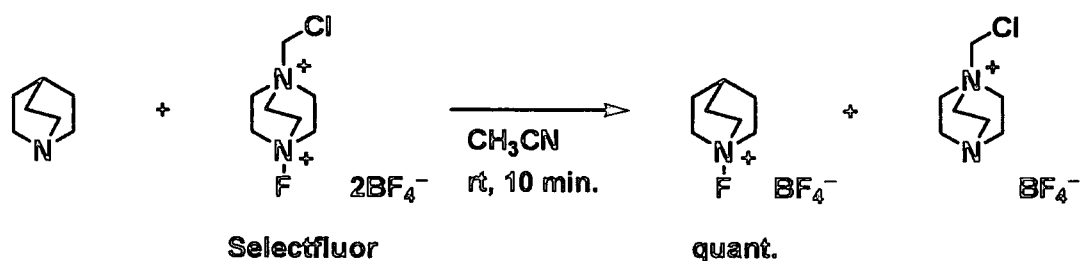

The N-F compound, *N*-fluoro-3-acetoxyquinuclidinium tetrafluoroborate (**117**) could be isolated as white crystals from the crude mixture of the evaluation study. The X-ray structure of this compound was determined (Figure 2.5). The N-F bond length of 1.413 Å is similar to that of the *N*-fluoroquinuclidinium triflate (**118**) (1.407 Å).¹⁶³

FIGURE 2.5 X-ray structure of *N*-fluoro-3-acetoxyquinuclidinium tetrafluoroborate (**117**)

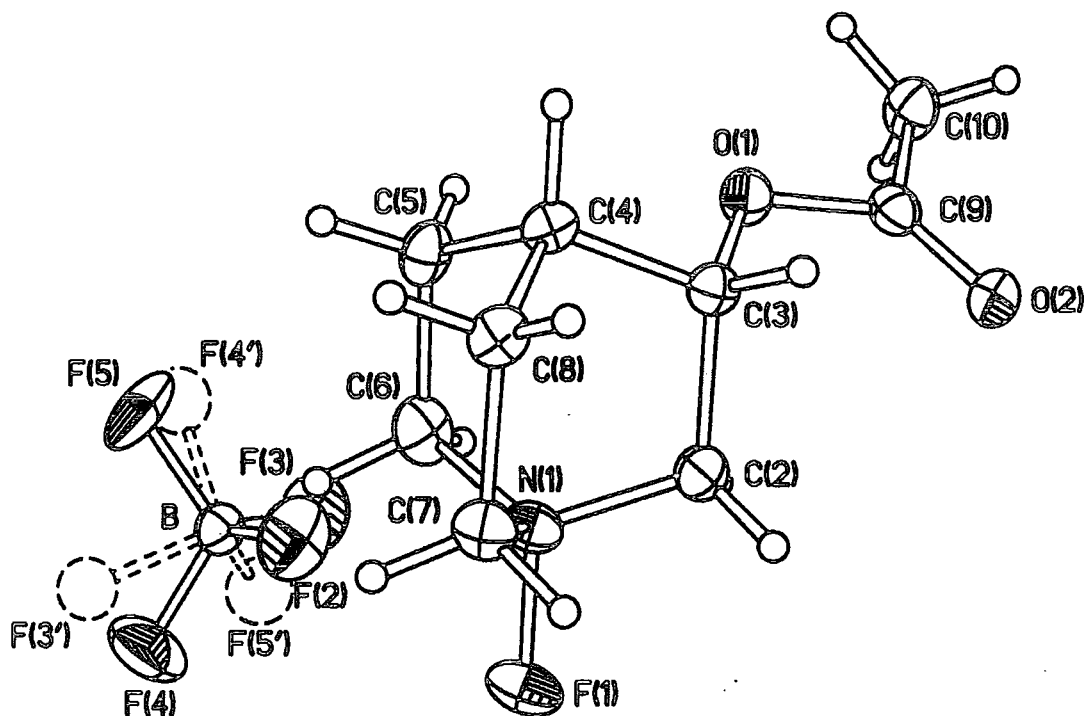

X-ray structures of N-F compounds are few in number. Figure 2.6 shows the X-ray structures of reported N-F fluorinating agents and their N-F bond lengths.

FIGURE 2.6 N-F fluorinating agents and their N-F bond lengths

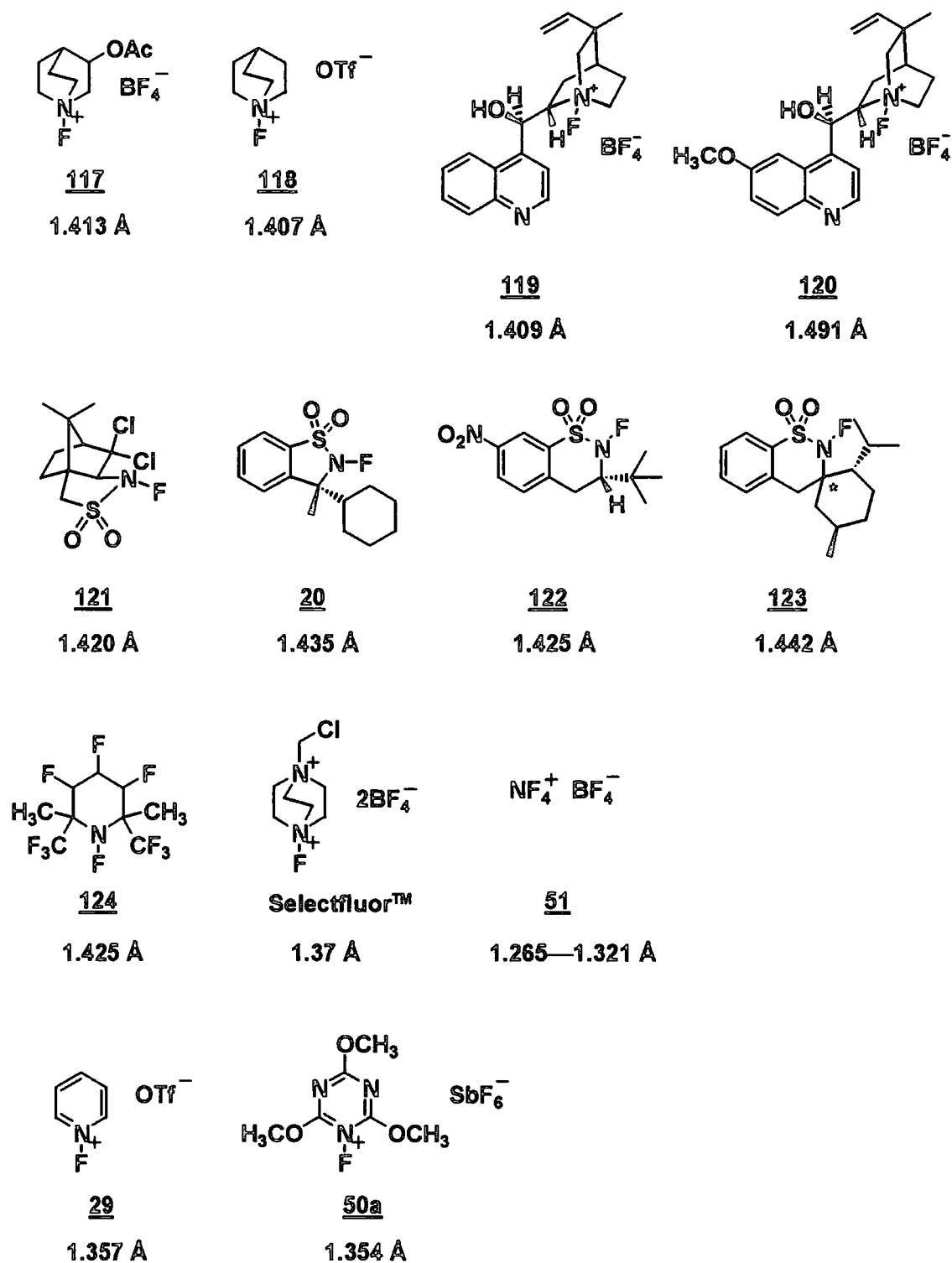

Compounds 117 to 120 are *N*-fluoroquinuclidinium salt type fluorinating agents, and in particular 119 and 120 were derived from cinchona alkaloids as chiral fluorinating

agents.¹⁶³⁻¹⁶⁵ Compounds **121** to **123** and **20** were also developed recently as enantioselective fluorinating agents which are all *N*-fluorosultam type.¹⁶⁶⁻¹⁶⁹ Compound **124** is the 2,6-dimethyl analogue of the perfluoro *N*-fluoropiperidine derivatives reported by Banks.¹⁷⁰ Except for compound **118** and unsaturated N-F compounds **29** and **50a**, the N-F bonds have very similar lengths among the same type of compounds (compounds **117** to **119** and compounds **121** to **123** and **20**). The N-F bond length of the compound **124** is comparable to *N*-fluorosultam type. On the other hands, Selectfluor has a significantly shorter N-F bond length (1.37 Å)¹⁵⁷ than those of other electrophilic fluorinating agents (**117** to **124**), although it is longer than that found in compound **51** (1.265—1.321 Å) in which four fluorine atoms are connected with the same nitrogen.¹⁷¹ Recently Banks reported the first examples of crystal structures of unsaturated N-F compounds. Both the well known pyridinium salt **29** and novel triazinium salt **50a** possess shorter N-F bond lengths (1.357 and 1.354 Å) than saturated derivatives.¹¹⁵ So far, the relation between the N-F bond length and the fluorinating ability is not clear. Determination of X-ray structures of various other N-F compounds are needed to establish if any relationship between bond length and fluorinating ability is present.

2.4.2.3.3 1,4-Diazabicyclo[2.2.2]octane (DABCO) derivatives

1-(2-Chloroethyl)-4-aza-1-azoniabicyclo[2.2.2]octane tetrafluoroborate (**112**)

Fluorination of compound **112** gave the corresponding N-F compound, which was a homologue of Selectfluor, quantitatively (Scheme 2.40). The N-F resonance was observed at +47.8 ppm by ¹⁹F NMR, and this value was similar to that of Selectfluor (+47.5 ppm).¹⁵⁷ The reaction mixture was added to *cis*-decalin (**115**) and refluxed for 4 hours. The fluorination of *cis*-decalin (**115**) proceeded in 35% conversion and monofluorinated products were selectively obtained. Interestingly the monofluorinated products included *cis*-9-fluorodecalin (**126**, 15%), which could not be obtained in the case of using Selectfluor itself.^{24,154}

SCHEME 2.40

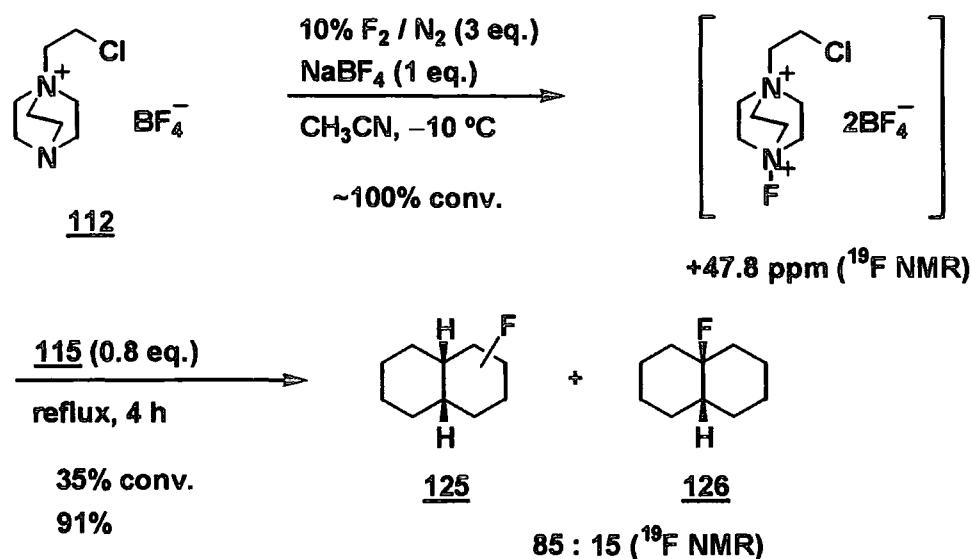

1-(2-Methoxyethyl)-4-aza-1-azoniabicyclo[2.2.2]octane tetrafluoroborate (**113**) Treatment of compound **113** with elemental fluorine gave the corresponding N-F compound quantitatively, and it showed a similar N-F resonance to the case of compound **112** (Scheme 2.41). The reaction with *cis*-decalin (**115**) was carried out for 14 hours, and the crude product included mono- and difluorinated adducts **125** and some amidated products. These results were consistent with the fact that fluorinated saturated hydrocarbons were converted into amidated compounds by prolonged reflux in acetonitrile.^{25,154}

SCHEME 2.41

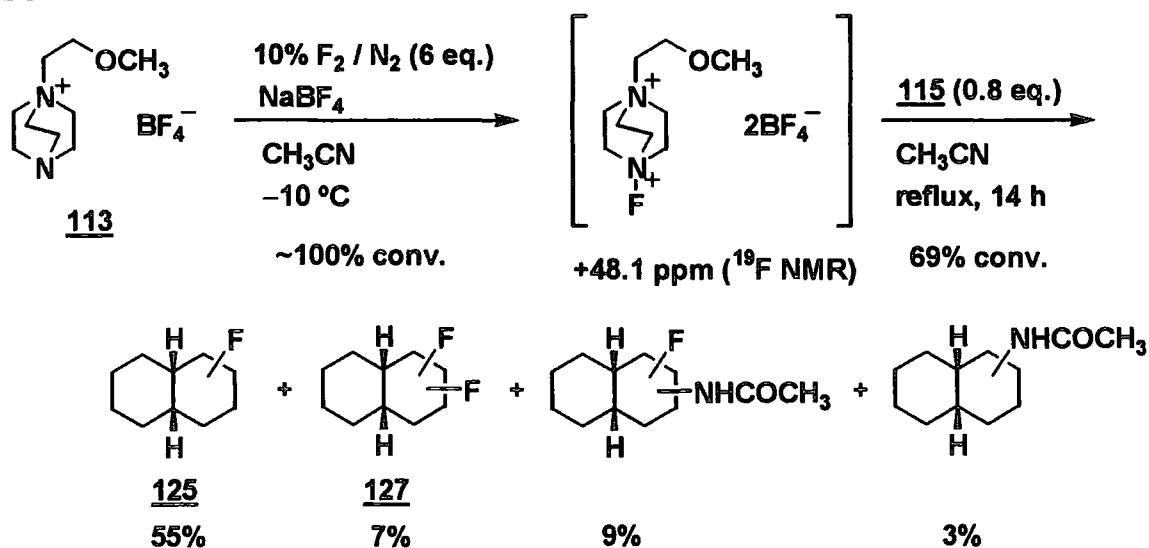

1-(Ethoxycarbonylmethyl)-4-aza-1-azoniabicyclo[2.2.2]octane tetrafluoroborate (114**)** Fluorination of compound **114** gave the N-F derivative in 57% conversion (Scheme 2.42). The N-F resonance was observed at +49.90 ppm in ^{19}F NMR. The fluorination of *cis*-decalin (**115**) proceeded in 53% conversion and the products were monofluorinated decalins **125** and small amounts of difluorinated products **127**.

SCHEME 2.42

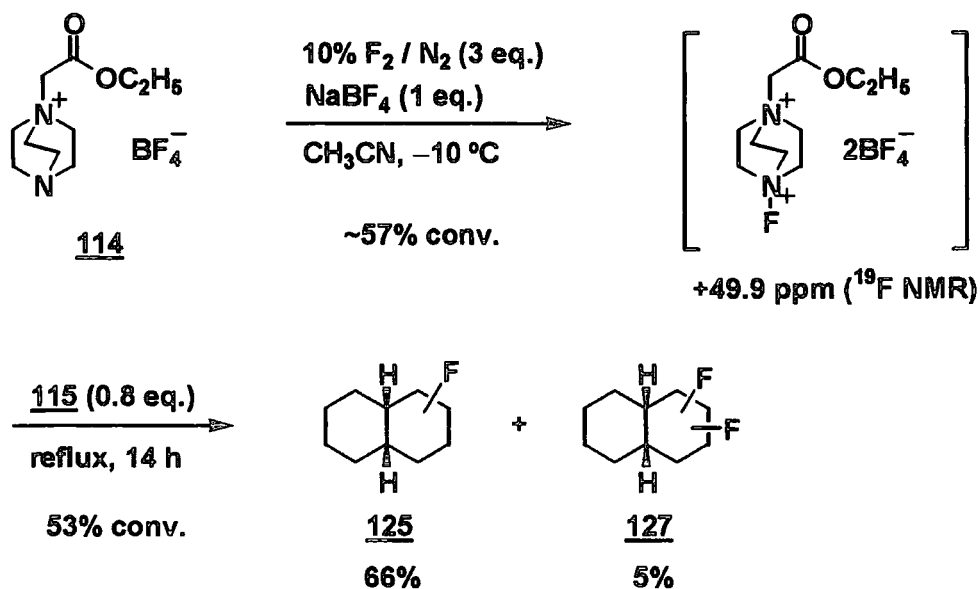

2.4.2.4 Conclusion

It is not straightforward to understand the fluorinating abilities between reported N-F reagents. The results of the fluorination of anisole reported by other workers using 'Selectfluor type' reagents and *N*-fluoropyridinium salts are shown in Table 2.2.^{95,101}

TABLE 2.2 Comparison of fluorinating ability between 'Selectfluor type' reagents and *N*-fluoropyridinium salts

Reaction scheme showing the fluorination of anisole (methoxybenzene) using a fluorinating agent. The products are a 1:1 mixture of 2-fluoroanisole and 4-fluoroanisole.

entry	fluorinating agent	solvent	temp. (°C)	time (h)	conv. (%)
1	 2OTf ⁻	CH ₃ CN	40	5	72
2	 2OTf ⁻	CH ₃ CN	40	13	ca. 70
3	 2OTf ⁻	CH ₃ CN	40	6	ca. 70
SelectfluorTM					
4	 <u>33</u> OTf ⁻	CH ₂ Cl ₂	40	7	71
5	 <u>34</u> OTf ⁻	CH ₂ Cl ₂	rt	0.25	91

From these results, the fluorinating ability towards aromatic compounds of *N*-fluoro-2,6-dichloro pyridinium triflate was nearly equal to that of Selectfluor. Nevertheless, we found that the fluorinating ability towards saturated hydrocarbons of those two agents was quite different because in the case of using *N*-fluoropyridinium salts intramolecular fluorination proceeded preferentially rather than fluorination of saturated C-H sites of *cis*-decalin (115). The series of results of the model study indicated that 1,4-diazabicyclo[2.2.2]octane (DABCO) moiety was the only suitable functional group of tethered reagents for remote fluorination of saturated C-H bonds.

2.4.3 Preparation of the steroid derivatives bearing DABCO moiety

2.4.3.1 Introduction

Because of the outcome of the model study, preparation of steroid derivatives tethered to a 1,4-diazabicyclo[2.2.2]octane (DABCO) moiety were required. Scheme 2.43 illustrates the synthetic plan for the preparation of steroid derivatives bearing a DABCO moiety.

SCHEME 2.43

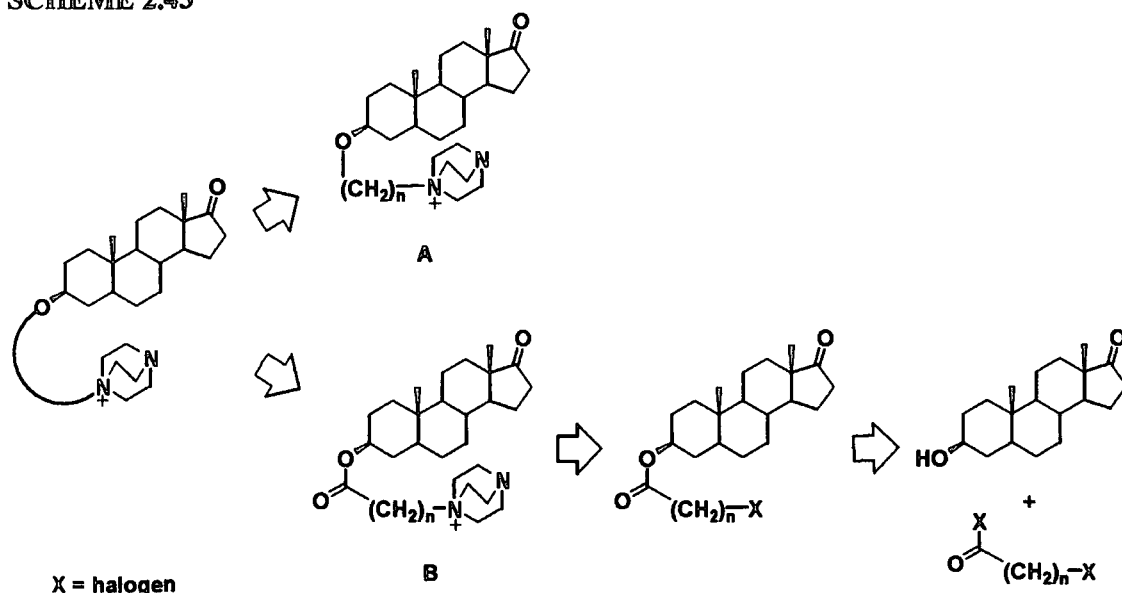

Two synthetic routes for the preparation of steroid derivatives carrying a DABCO moiety were planned and investigated. In compound **B**, however, the connection is by an ester linkage. These types of compounds were thought to be more easily prepared using acid halides and the side-chains could potentially be cleaved after fluorination.

2.4.3.2 Synthesis of steroids connected to the DABCO moiety by an ester linkage

3β -[(4-Aza-1-azoniabicyclo[2.2.2]oct-1-yl)-acetoxy]-5 α -androstan-17-one tetrafluoroborate (**131**) 3β -[(4-Aza-1-azoniabicyclo[2.2.2]oct-1-yl)-acetoxy]-5 α -androstan-17-one tetrafluoroborate [**131**, compound **B** in scheme 2.43 ($n = 1$)] was synthesised by *N*-alkylation of DABCO with 3β -(bromoacetoxy)-5 α -androstan-17-one (**129**), which was prepared from epiandrosterone (**128**) and bromoacetyl bromide (Scheme 2.44). The esterification of epiandrosterone (**128**) with bromoacetyl bromide was carried out in dichloromethane in the presence of pyridine and catalytic amounts of 4-dimethylaminopyridine at ambient temperature for 16 hours. The desired product was obtained as white crystals from hexane and ethyl acetate after column chromatography. Although the crystalline product seemingly had a narrow melting point (143—144 °C), it nevertheless contained 18% of chlorinated compound (**130**). This ratio was calculated by the integration of the areas of resonances of methylene protons connected to bromine and chlorine atoms in ^1H NMR (4.00 and 3.78 ppm, respectively). The source of the chlorine atom in the compound **130** was assumed to be the solvent or impurity of the starting material, but the mechanism of the formation is still unclear. The presence of the strong base (DMAP) in chlorinated solvent conceivably caused formation of chloride ion *in situ*. Using the mixture of compound **129** and **130**, the following *N*-alkylation was carried out stepwise. In the first step, the *N*-alkylation reaction was carried out with DABCO in dichloromethane taking into account the solubility of the substrates. The resulting bromide was converted to desired product by anion exchange using sodium tetrafluoroborate in acetonitrile. Compound **131** was obtained as a white solid from the acetonitrile solution after removal of sodium bromide by filtration. Recrystallization from acetone and water gave white, fine crystals. The structure was confirmed by several analytical methods (NMR, IR, and mass spectrum). The three resonances derived from three kinds of methylene groups next to nitrogen were observed at 3.21, 3.65, and 4.09 ppm in the ^1H NMR spectrum in CDCl_3 (relative intensities 3:3:1) which were similar to those of the corresponding resonances of 1-(ethoxycarbonylmethyl)-4-aza-1-azoniabicyclo[2.2.2]octane tetrafluoroborate (**114**) (3.13, 3.55, and 4.11 ppm in D_2O , respectively). Gradual decomposition of the crystals was observed above 200 °C. The crystals melted at around 256—258 °C with colour change when rapidly heated.

SCHEME 2.44

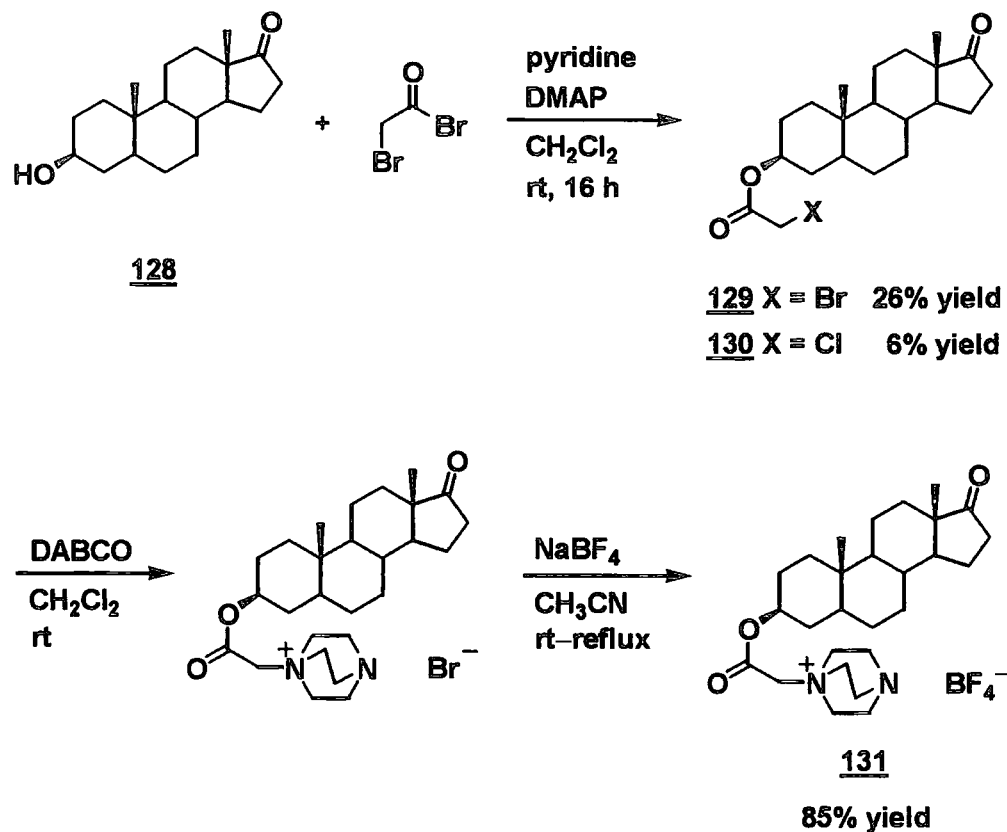

3β-[4-(4-Aza-1-azoniabicyclo[2.2.2]oct-1-yl)-butyryloxy]-5α-androstan-17-one tetrafluoroborate (**133**) 3β-[(4-Aza-1-azoniabicyclo[2.2.2]oct-1-yl)-butyryloxy]-5α-androstan-17-one tetrafluoroborate [**133**, compound **B** in scheme 2.43 (n = 3)] was synthesised by a similar procedure to compound **131**. The esterification of epiandrosterone (**128**) with 4-bromobutyryl chloride gave 3β-(4-bromobutyryloxy)-5α-androstan-17-one (**132**) in 84% yield (Scheme 2.45). This compound contained 13% of the corresponding chloride in analogy with compound **129**.

SCHEME 2.45

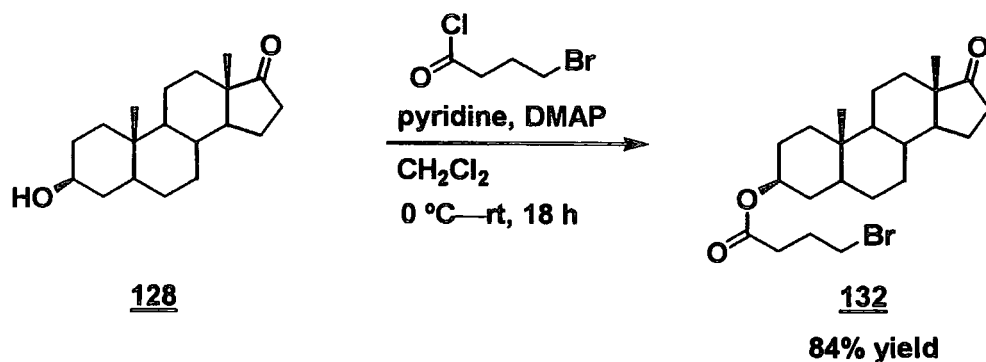

N-Alkylation of DABCO with compound **132** proceeded to give a precursor of ‘tethered N-F reagent’ **133** (Scheme 2.46). The corresponding chloride reacted with DABCO very slowly, and was removed during the purification. Compound **133** was recrystallised from ethanol to give white crystals and the ^1H NMR spectrum was similar to compound **131**.

SCHEME 2.46

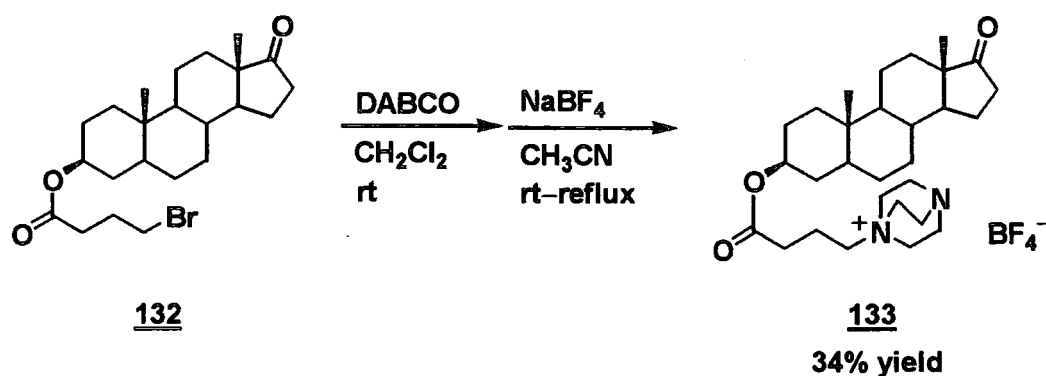

3 β -[5-(4-Aza-1-azoniabicyclo[2.2.2]oct-1-yl)-valeryloxy]-5 α -androstan-17-one tetrafluoroborate (135**)** 3 β -[5-(4-Aza-1-azoniabicyclo[2.2.2]oct-1-yl)-valeryloxy]-5 α -androstan-17-one tetrafluoroborate [**135**, compound **B** in scheme 2.43 ($n = 4$)] was synthesised by the same procedure to **133** (Scheme 2.47).

SCHEME 2.47

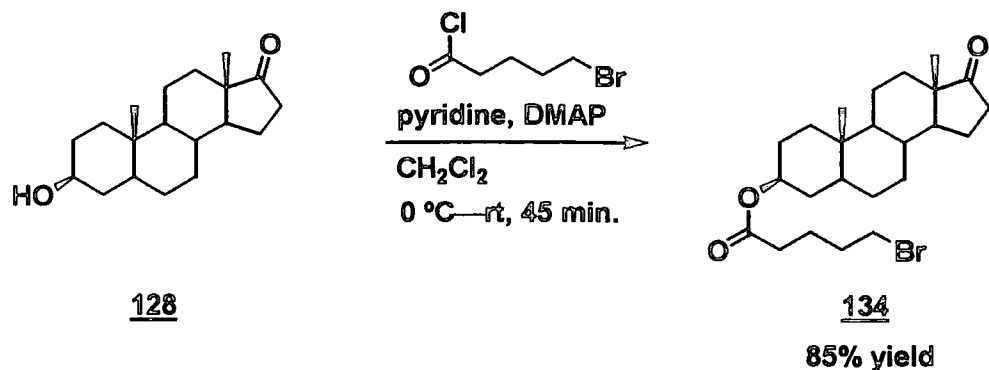

N-Alkylation of DABCO with compound **134** was carried out to give the desired product **135**, which has a 4 methylene group spacer between the carbonyl group and DABCO moiety (Scheme 2.48). Recrystallization of compound **135** from ethanol gave white crystals.

SCHEME 2.48

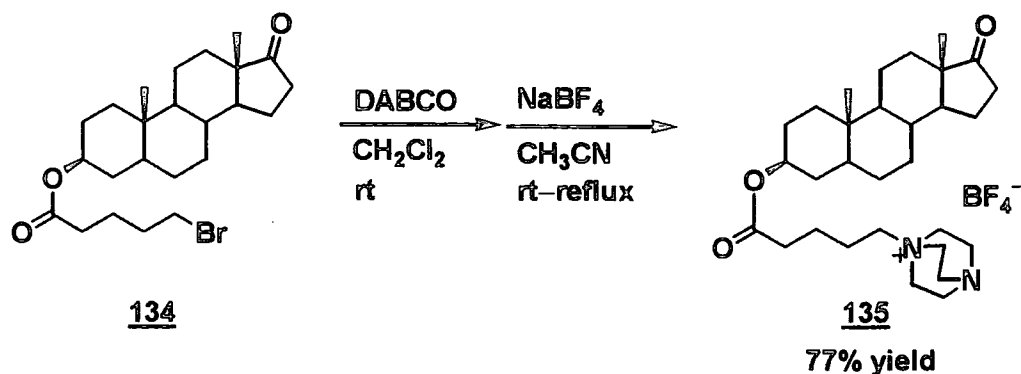

3 β -[6-(4-Aza-1-azoniabicyclo[2.2.2]oct-1-yl)-hexanoyloxy]-5 α -androstan-17-one tetrafluoroborate (137) **3 β -[6-(4-Aza-1-azoniabicyclo[2.2.2]oct-1-yl)-hexanoyloxy]-5 α -androstan-17-one tetrafluoroborate [137, compound B in scheme 2.43 (n = 5)]** was synthesised by a similar procedure to compound **133**. Epiandrosterone (**128**) was reacted with 6-bromohexanoyloxy chloride in the presence of pyridine to give **3 β -(6-bromohexanoyloxy)-5 α -androstan-17-one (136)** in 65% (Scheme 2.49). The crystals had a lower melting point (51—54 °C) than compound **134**, which is probably due to the greater flexibility of the longer alkyl side chain.

SCHEME 2.49

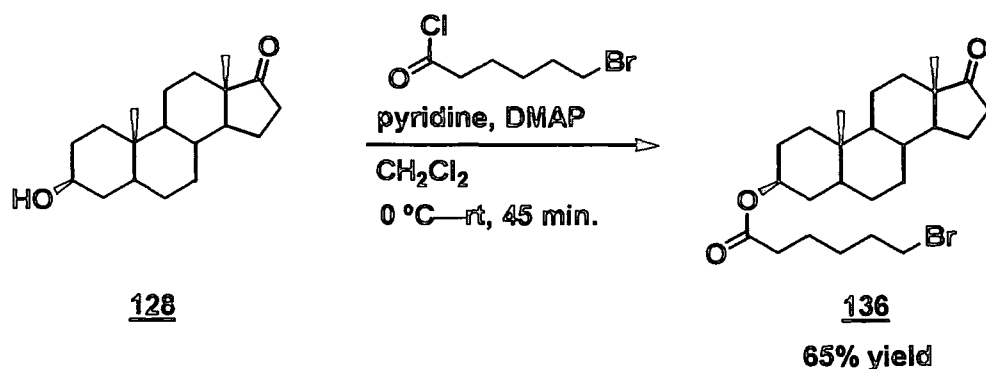

N-Alkylation of DABCO with compound **136** was carried out in diethyl ether and followed by treatment with sodium tetrafluoroborate to give compound **137** in 81% yield (Scheme 2.50).

SCHEME 2.50

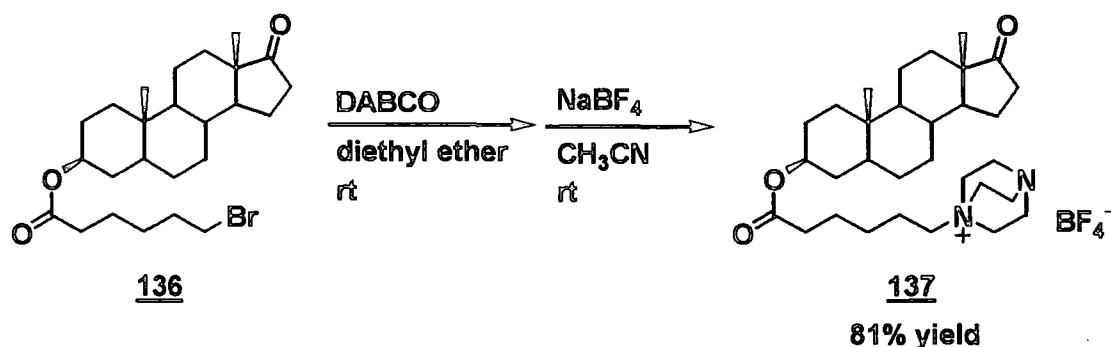

2.4.4 Remote fluorination of steroids directed by tethered N-F reagents

2.4.4.1 Fluorination of steroids using Selectfluor™

The aim of the present project is regio- and stereoselective fluorination of steroids utilizing tethered *N*-fluorinated compounds. In other words, that is 'intramolecular fluorination'. For the evaluation of the results of this 'intramolecular fluorination' it is useful to know the results of 'intermolecular fluorination' of steroids using N-F reagents. Thus, the fluorination of steroid derivatives with Selectfluor was investigated as a reference.

3 β -Acetoxy-5 α -androstane-17-one (**138**) was prepared for this purpose from epiandrosterone (**128**) in the usual method. The acetylation of epiandrosterone (**128**) using acetic anhydride was carried out in dichloromethane in the presence of 4-dimethylaminopyridine (Scheme 2.51). The desired product (**136**) was obtained

quantitatively. The melting point was 104 to 105 °C, which is consistent with the reported value.¹⁷²

SCHEME 2.51

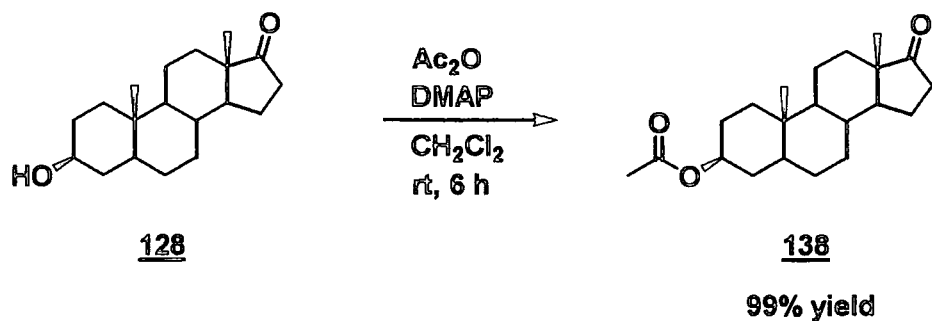

The fluorination of 3β-acetoxy-5α-androstan-17-one (**138**) using one equivalent of Selectfluor was carried out in acetonitrile under reflux condition for 16 hours (Scheme 2.52). The reaction proceeded in 28% conversion, and gave more than seven fluorinated products. The crude product was purified by silica gel column chromatography to give three main products (**139a**, **139b** and **139c**) separately (70 to 90% purity). These products were analyzed by ¹H and ¹³C NMR, 2-dimensional NMR experiments (COSY, HSQC) and DEPT to determine which C-H site was fluorinated. Compound **139a** to **139c** could be deduced to be 12α-, 12-β- and 6α-fluorinated compounds mainly by ¹³C NMR.

SCHEME 2.52

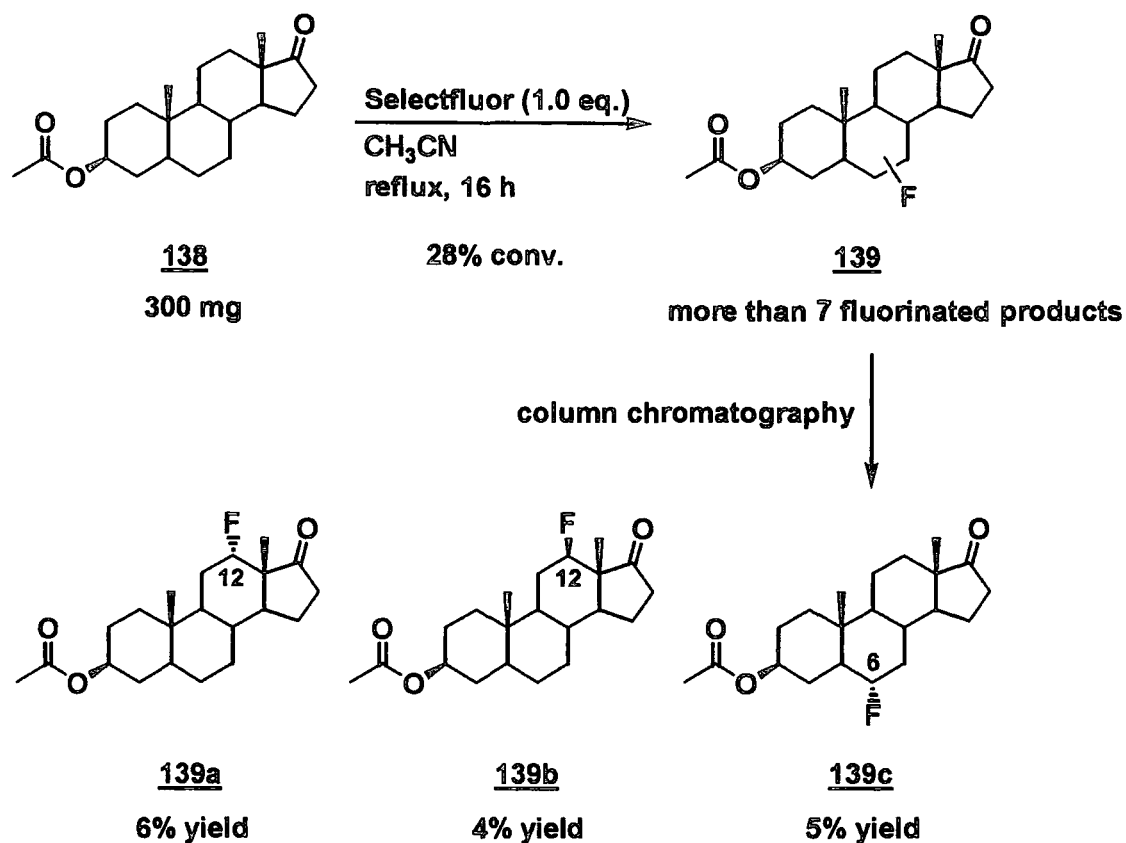

Basically the replacement of a hydrogen atom by a fluorine atom influences the chemical shifts at α , β and γ positions because the high electronegativity of a fluorine atom introduces a considerable change of the electronic environment. C-F coupling is also observed at α and β position, and the typical value is about 170 and 20 Hz, respectively, in the case of saturated cyclic hydrocarbons. Table 2.3 shows the chemical shifts and coupling constants of the isolated fluorinated products.

Table 2.3 ^{13}C NMR chemical shifts (ppm) and coupling constants (Hz) of fluorinated steroids

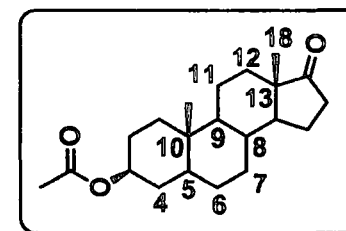

Compound		Position of the carbon relative to the fluorine atom ^a													
		α		β		γ gauche				γ antiperiplanar					
139a	δ	C-12	90.4	C-11	26.4	C-13	51.4	C-9	48.4	C-14	43.8	C-18	13.3		
	$\Delta\delta^b$		+59.0		+6.0		+3.7		-5.7		-7.4		-0.4		
	J_{CF}		173.7		22.0		20.1		—		—		7.2		
139b	δ	C-12	92.0	C-11	27.6	C-13	51.4	C-18	8.2			C-9	52.1	C-14	48.6
	$\Delta\delta$		+60.6		+7.6		+3.7		-5.5				-2.0		-2.6
	J_{CF}		183.3		19.2		16.1		4.2				9.2		5.0
139c	δ	C-6	91.2	C-5	49.6	C-7	37.0	C-4	27.9			C-8	33.6	C-10	36.6
	$\Delta\delta$		+63.0		+5.1		+6.3		-5.9				-1.3		+1.1
	J_{CF}		172.9		14.9		18.4		4.2				11.5		8.0

^a The carbons further away from the fluorine atom do not differ by more than 0.3 ppm from the corresponding carbons in the parent compound (3 β -acetoxy-5 α -androstan-17-one). ^b $\Delta\delta$ is defined as the difference between the chemical shift of the relevant carbon atoms in the corresponding unfluorinated and fluorinated steroids; + represents a deshielding effect and - a shielding effect, both induced by the fluorine atom.

All α - and β -carbons are deshielded by the fluorine atom. The differences of the chemical shifts compared to the parent compound were 59.0 to 63.0 ppm and 3.7 to 7.6 ppm respectively. The γ -carbons, however, are divided into two groups. The carbons *gauche* to the fluorine atom are all shielded by 5.5 to 5.9 ppm, whereas the γ -carbons *anti* to the fluorine are shielded to a lesser extent (-1.1 to 2.6 ppm). Moreover, the γ -carbons *gauche* to the fluorine have a relatively small coupling constant (0 to 4.2 Hz), while the *anti* γ -carbons are coupled to the fluorine by 5.0 to 11.5 Hz. These are consistent with the results of tertiary fluorinated steroids reported by Rozen.¹⁷³

As described above, fluorination of hydrocarbons using Selectfluor exclusively proceeded at the CH₂ sites.^{24,154} These results indicate that the C-H bonds at the 12-position and the 6 β -position possess not only the highest electron density but also are the least sterically hindered sites among all the CH₂ sites in compound **138**. Compound **139b** and **139c** were recrystallised to give crystals. The expected structures were confirmed by X-ray diffraction analysis (Figure 2.7).

FIGURE 2.7 X-ray structure of **139c**

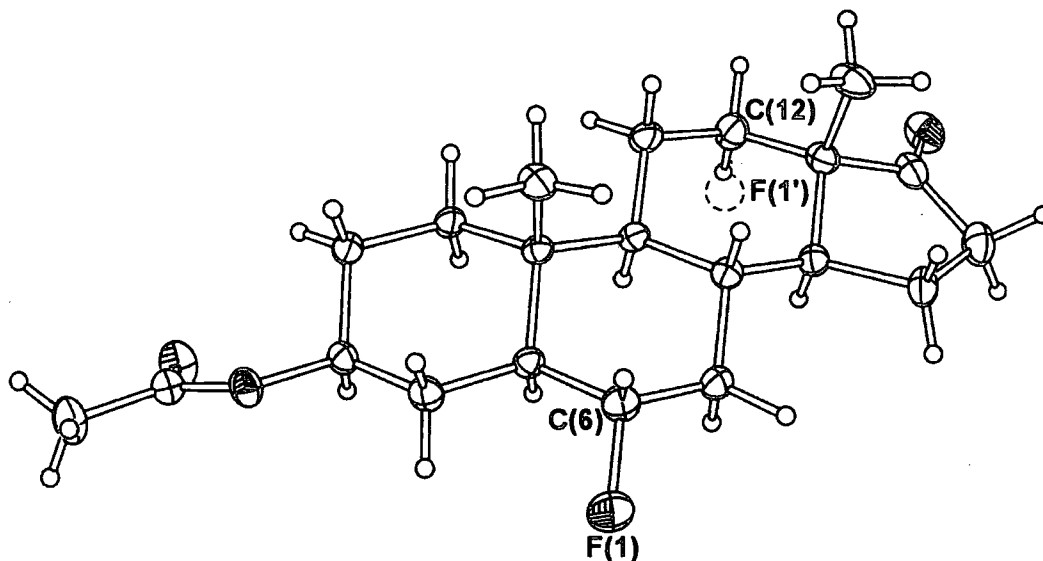

Thus, the fluorination of the steroid derivative **138**, which possesses no tethers, with Selectfluor was found to be non-selective giving many products fluorinated at secondary sites.

Direct fluorination of this substrate **138** was already investigated in a precedent project of our group, and gave three monofluorinated isomers non-selectively (Scheme 2.53).¹⁵⁴

SCHEME 2.53

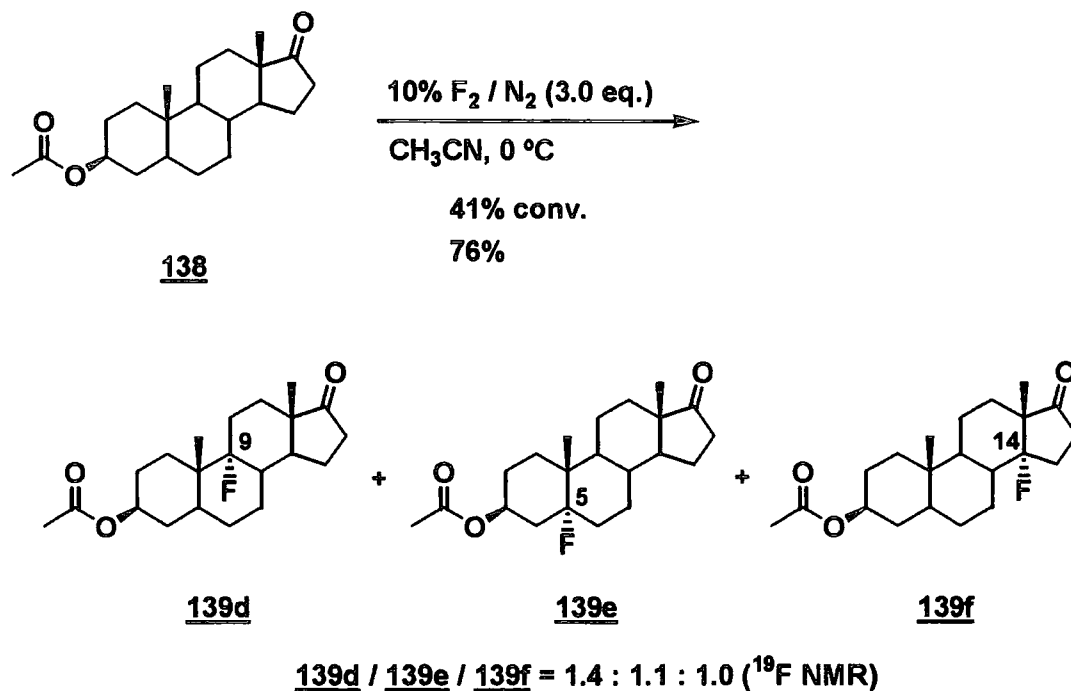

Purification of the crude product by column chromatography, recrystallisation and HPLC proved unsuccessful.

2.4.4.2 Remote fluorination of steroids directed by tethered N-F reagents

Above we discussed reactions of 3 β -acetoxy-5 α -androstan-17-one (**138**) with an N-F reagent and elemental fluorine and now we compare these results with reaction of tethered fluorinating agents to determine whether a tether affects the outcome of the fluorination reaction.

3 β -[(4-Aza-1-azoniabicyclo[2.2.2]oct-1-yl)-acetoxy]-5 α -androstan-17-one tetrafluoroborate (131**)** The fluorination of 3 β -[(4-aza-1-azoniabicyclo[2.2.2]oct-1-yl)-acetoxy]-5 α -androstan-17-one (**131**) was carried out in acetonitrile in the presence of equimolecular amounts of sodium tetrafluoroborate at -10°C using 6 equivalents of elemental fluorine (Scheme 2.54).

SCHEME 2.54

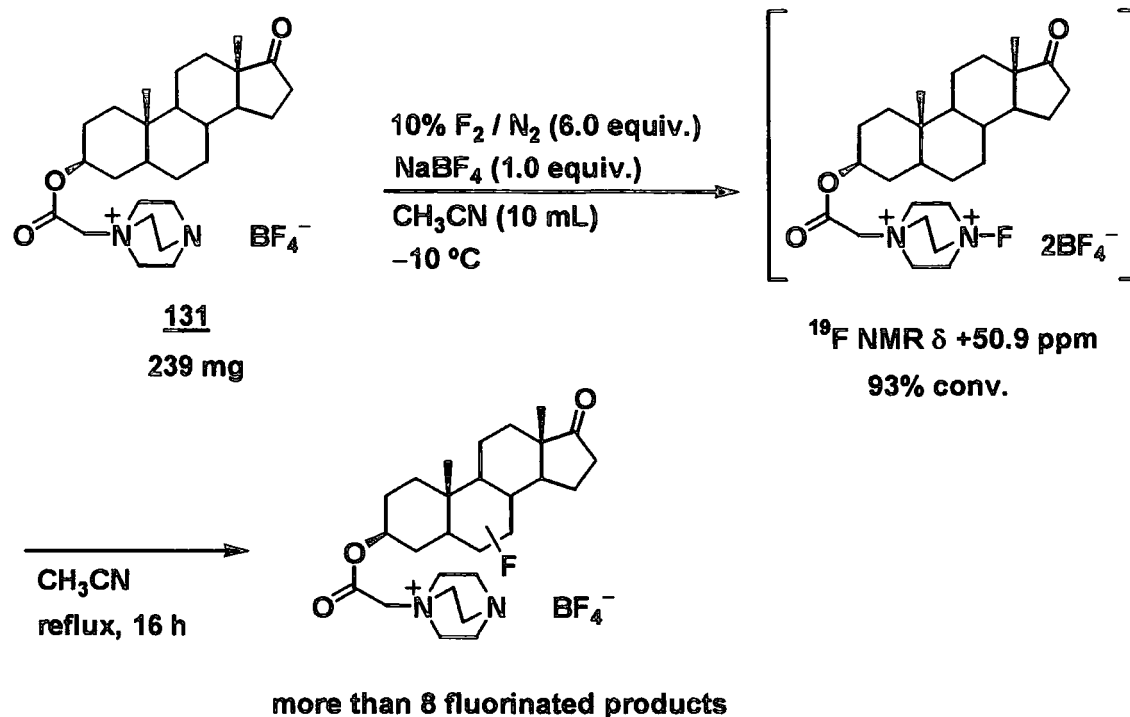

The N-F resonance was observed at +50.9 ppm in ^{19}F NMR and the conversion was estimated to be 93% by comparing the integration for the N-F resonance with that of BF_4^- (Figure 2.8). The chemical shift was similar to those of the resonances of the fluorine atom in Selectfluor or other *N*-fluorinated species derived from model compounds which have a DABCO moiety. The reaction mixture including the ‘tethered electrophilic fluorinating agent’ was refluxed overnight. The *N*-fluorinated species were consumed completely (After refluxing for 4 hours, 42% of the N-F species still remained). Fluorination proceeded to some extent, but regio- or stereoselectivity was not observed. More than 8 kinds of resonances were observed between -199 and -169 ppm in ^{19}F NMR.

FIGURE 2.8 ^{19}F NMR spectrum of the reaction mixture of the fluorination of compound **131**

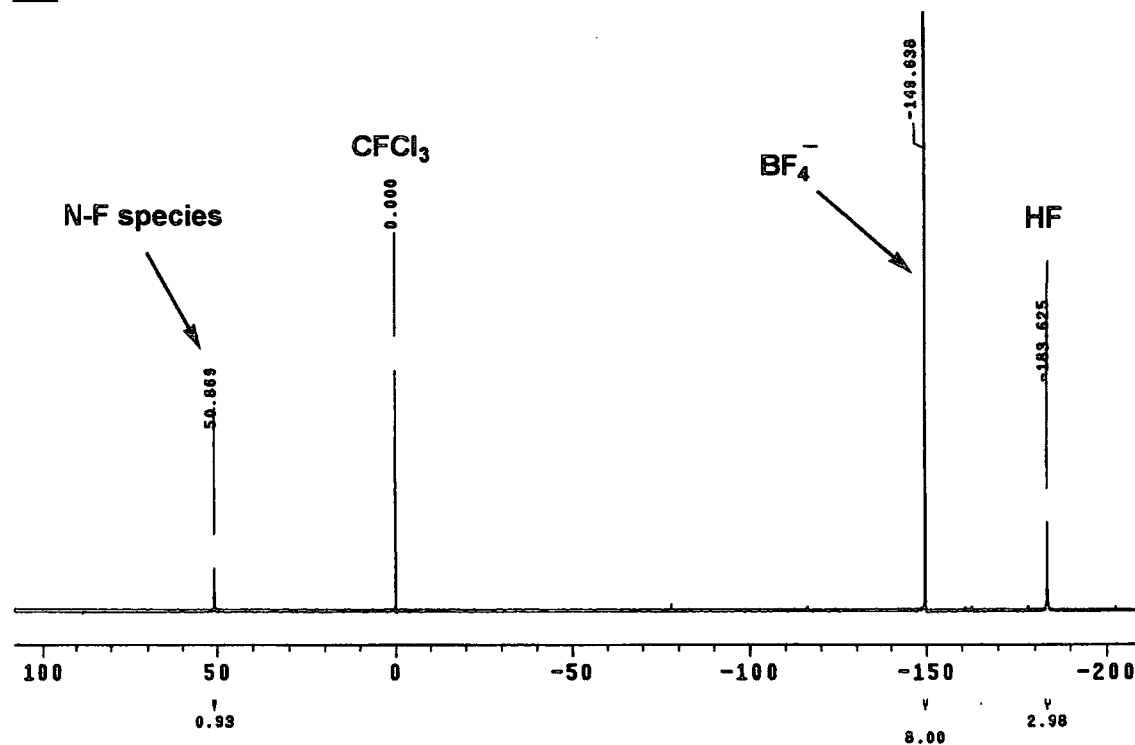

The comparison of the ^{19}F NMR spectra of the crude products between this reaction and the reference reaction, that is the fluorination of compound **138** with Selectfluor is shown in Figure 2.9.

FIGURE 2.9 ^{19}F NMR spectra of crude products of fluorination of **138** and **131**.

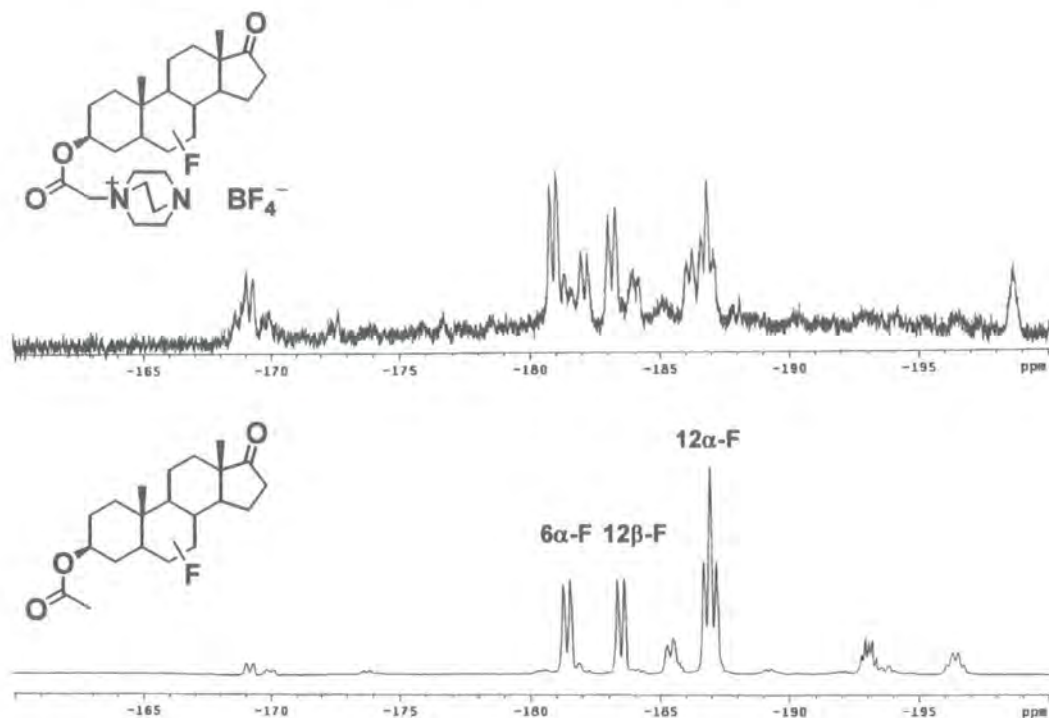

The 3 kinds of major resonances were observed in both these spectra at *ca.* -181, -183 and -187ppm. These resonances were thought to be derived from fluorines located at identical positions on the steroid skeleton. These results indicate that ‘intermolecular fluorination’ predominantly proceeded rather than ‘intramolecular fluorination’ in the fluorination of compound **131**.

The N-F bond derived from DABCO group was highly sterically hindered because of the three-dimensional structure. Therefore, it was thought that a longer alkyl chain which connects the steroid with DABCO group was required to have a longer length. Figure 2.10 shows molecular models for the consideration of the accessibility of DABCO moiety to steroid skeleton using Chem3DTM (Some atoms are replaced by other atoms for the calculations.).

FIGURE 2.10 3D models for the consideration of the accessibility of DABCO moiety to steroid skeleton using Chem3D™

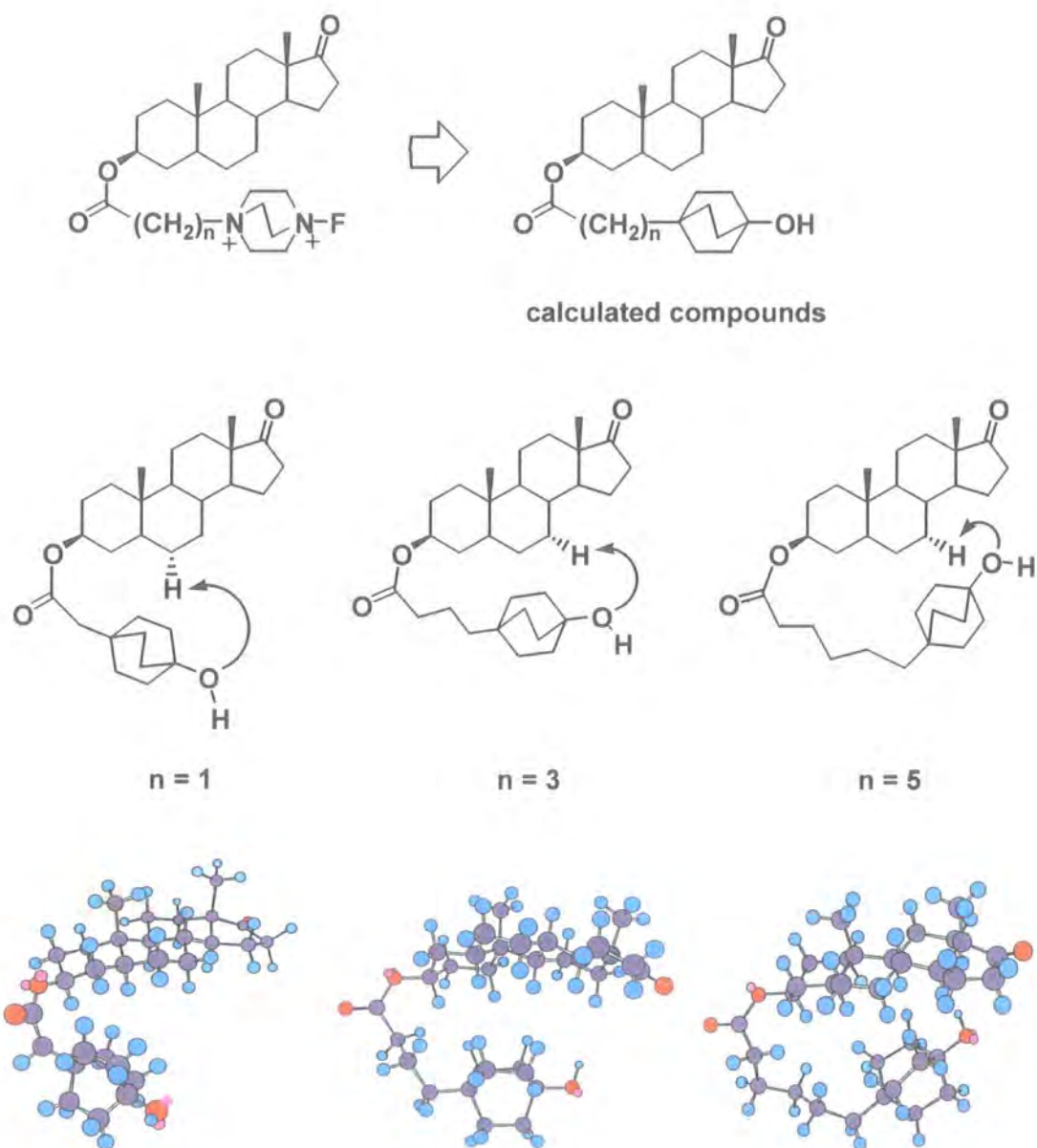

Obviously, as alkyl chain become longer, the bridgehead oxygen, which is replacement of fluorine of the tethered reagent, can possibly be closer to the steroid skeleton. The results clearly suggest longer alkyl chains are preferable for 'intramolecular fluorination'.

Therefore, we decided to investigate fluorination of molecules with longer alkyl chains, which follows below.

3β-[4-(4-Aza-1-azoniabicyclo[2.2.2]oct-1-yl)-butyryloxy]-5α-androstan-17-one tetrafluoroborate (**133**) The fluorination of 3β-[4-(4-aza-1-azoniabicyclo[2.2.2]oct-1-yl)-butyryloxy]-5α-androstan-17-one tetrafluoroborate (**133**) was carried out in the same procedure as the case of compound **131** (Scheme 2.55). The 'tethered N-F reagent' was formed in 86% conversion, and the N-F resonance was observed at +49.7 ppm, which was close to that of the N-F derivative of compound **131**. The second step aimed at 'intramolecular fluorination' was carried out under two different concentrations. The first condition was set at 45 mM in concentration, which was the same as the fluorination of 3β-acetoxy-5α-androstan-17-one (**138**) using Selectfluor. The other reaction was carried out under highly diluted condition, which was 3 mM in concentration, because more diluted conditions could potentially reduce the probability of the 'intermolecular reaction' and thus, 'intramolecular reaction' should be favoured.

SCHEME 2.55

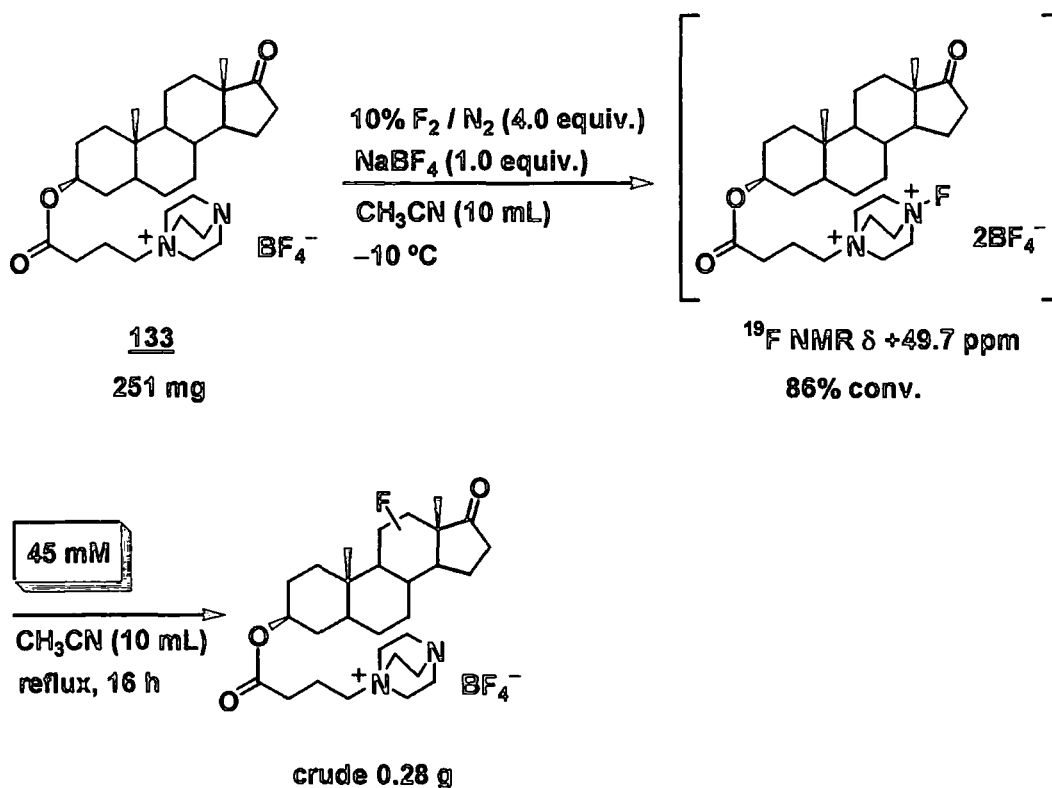

SCHEME 2.55 (continued)

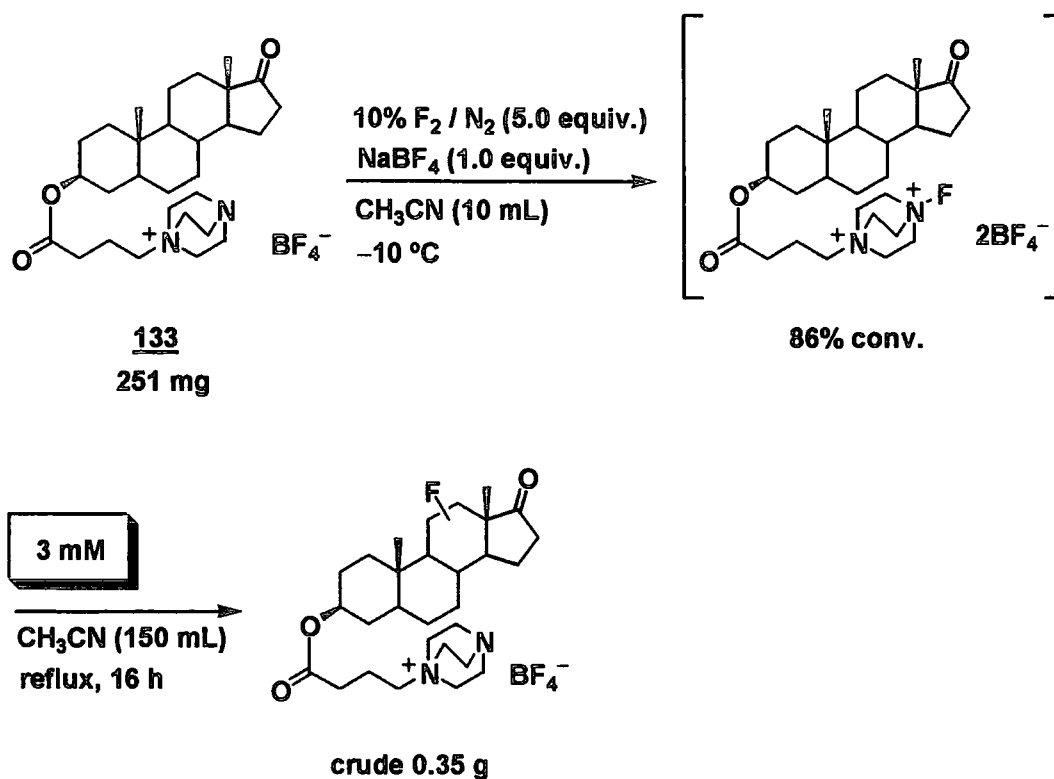
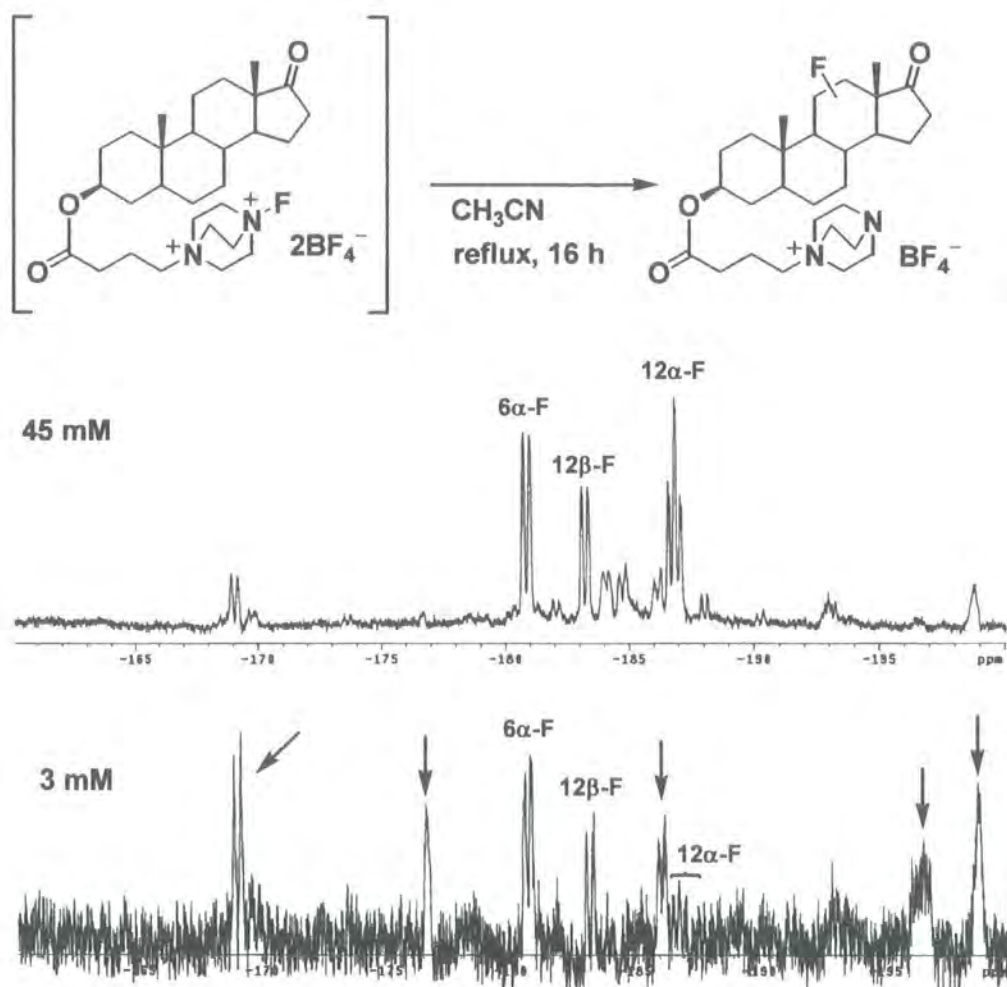

Figure 2.11 shows the ^{19}F NMR spectra of the crude products of these reactions. Obviously, the product distributions between these reactions were quite different. In the case of 45 mM, the major products were similar to those of the fluorination of 3 β -acetoxy-5 α -androstan-17-one (**138**) using Selectfluor. In contrast, the high dilution condition gave a significant decrease of 12 α -fluoro product, and alternatively some new or increased resonances were observed.

FIGURE 2.11 ^{19}F NMR spectra of crude products of fluorination of **133** under different concentrations.



These results indicate that, under the high dilution conditions, several different fluorinated products were obtained from the reaction under normal concentration, and these may have arisen from intramolecular fluorination. However, the reaction is not very selective, so no highly favoured products seem to occur.

The crude products of fluorination using tethered N-F reagent were analyzed by LC-MS, but this was unsuccessful. Both of these crude products and the starting material, compound **131** and **133**, are not applicable to LC- and GC-MS because they are non-volatile and very polar. On the other hand, the crude mixture of fluorination of 3β -acetoxy- 5α -androstane-17-one (**138**) could be applicable to GC and GC-MS analysis, and the analytical data such as the retention times in GC, the spectral data of ^1H , ^{13}C and ^{19}F NMR should be helpful. Therefore, the deprotection conditions of the acyloxy

groups, which contain an analytically difficult DABCO moiety, were investigated. Both basic and acidic conditions for the deprotection of the acyloxy groups were attempted. In a model reaction, the basic deprotection reaction of compound **131** with potassium carbonate in methanol proceeded to give epiandrosterone (**128**) (Scheme 2.56). The crude product was treated with acetic anhydride to give 3 β -acetoxy-5 α -androstan-17-one (**138**).

These conditions were used by other workers for deacetylation of 5-fluorosteroid derivatives without any considerable HF eliminations.¹⁷⁴

SCHEME 2.56

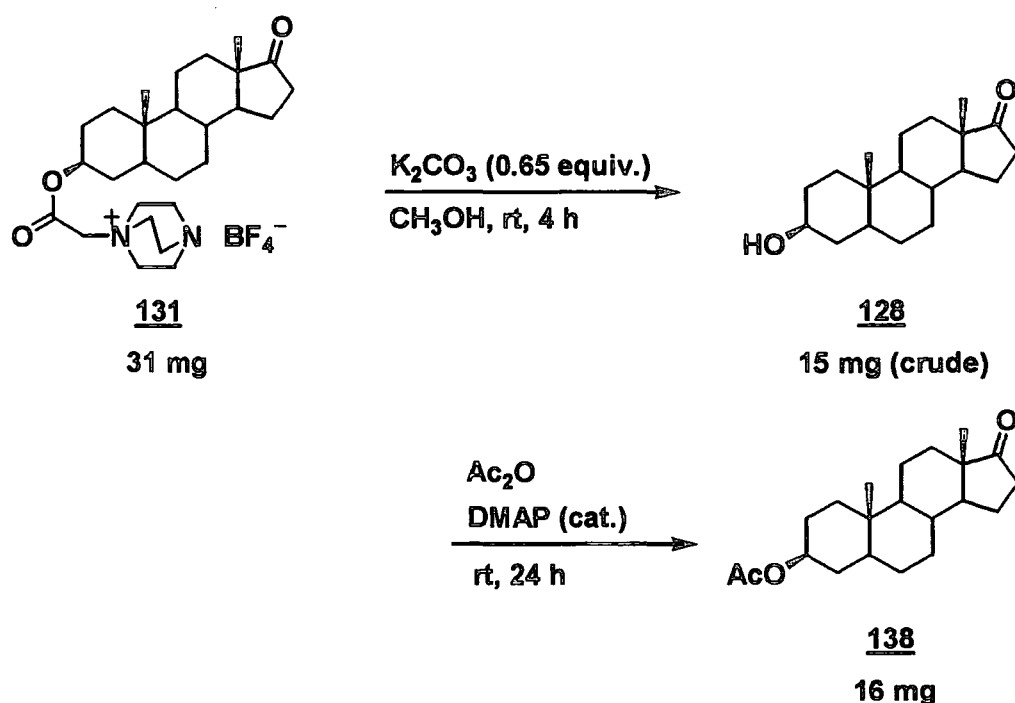

The deprotection reaction of compound **133** using concentrated hydrochloric acid and acetonitrile (1:2, v/v)¹⁷⁵ gave epiandrosterone (**128**) after stirring for 30 hours at room temperature (Scheme 2.57). The resulting alcohol was easily converted to *O*-acetylated compounds, and they were successfully analyzed by GC-MS.



SCHEME 2.57

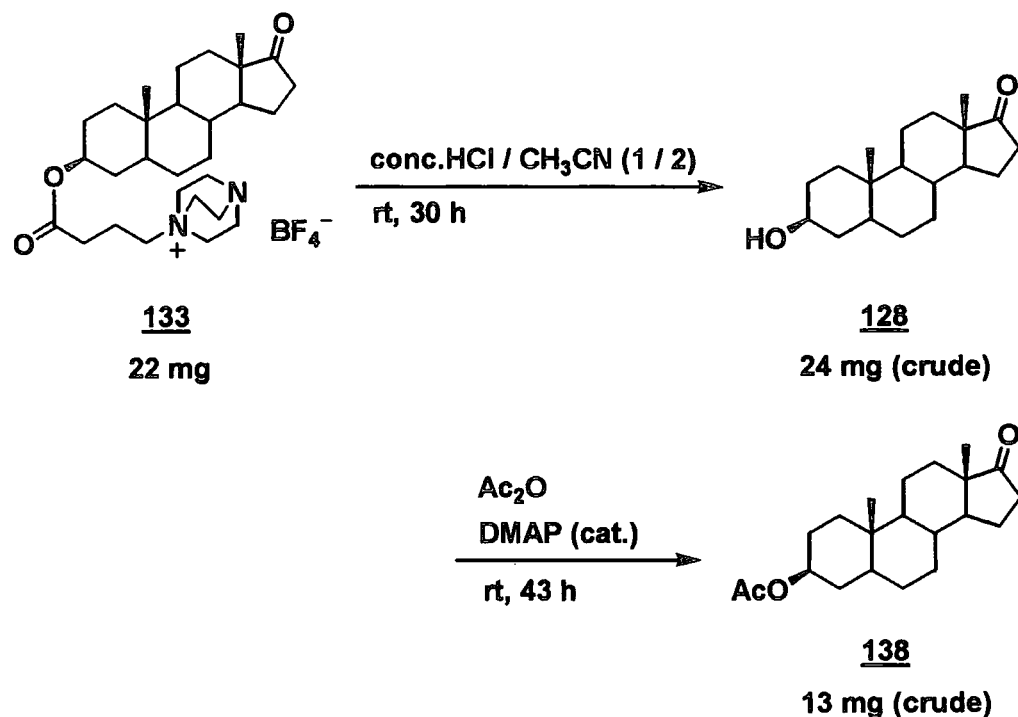

Using these conditions the derivatization of the crude products of the fluorination of compound **133** under the normal concentration (45 mM) was carried out (Scheme 2.58). The resulting crude products of the acetoxy derivatives were analyzed by GC, GC-MS and ^{19}F NMR. These results were roughly comparable. In both cases, 13 to 18% of unsaturated compounds **140** were found in GC-MS analysis. These compounds are suggested to be formed by elimination of HF from the fluorinated compounds.

In order to confirm that the elimination of HF to give unsaturated products did not occur during the derivatization processes, the deprotection of 3 β -acetoxy steroid derivatives containing C-F bonds was carried out (Scheme 2.59). A mixture of 139a, 139c and 138 was deprotected once under acidic condition, followed by acetylation to return to the acetoxy derivatives again. The ratio of the compounds by GC was not changed at all.

SCHEME 2.59

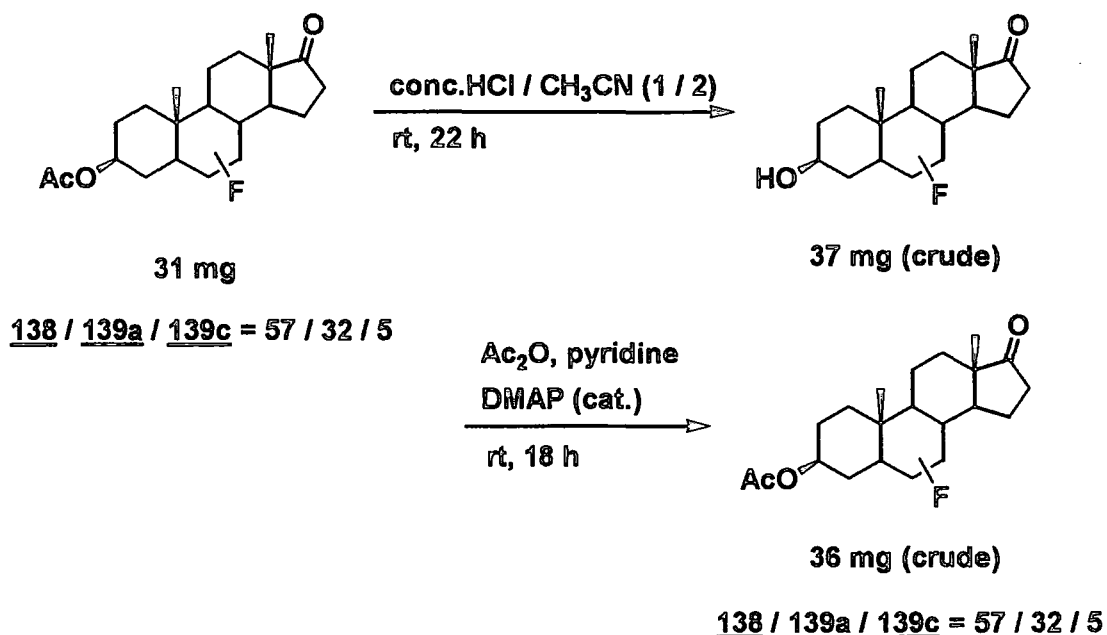

This result supported the thought that the elimination occurred during the either first or second fluorination. Further analysis of the reaction mixture after the first fluorination should provide the answer to the question of whether this elimination occurred during the first (by elemental fluorine) or second (by tethered N-F reagents) fluorination step. The control experiments to answer this question will be discussed later.

The crude product of the fluorination of compound 133 under the high-dilution condition (3 mM) was treated with hydrochloric acid in acetonitrile to deprotect the ester moiety bearing the DABCO template. The resulting 3-hydroxy derivatives were protected again by an acetyl group and were analysed by GC-MS (Scheme 2.60). The products included monofluorinated compounds 139 in which the amounts and the ratio were considerably changed, unfluorinated 138 and the much larger amounts of HF eliminated compounds 140.

SCHEME 2.60

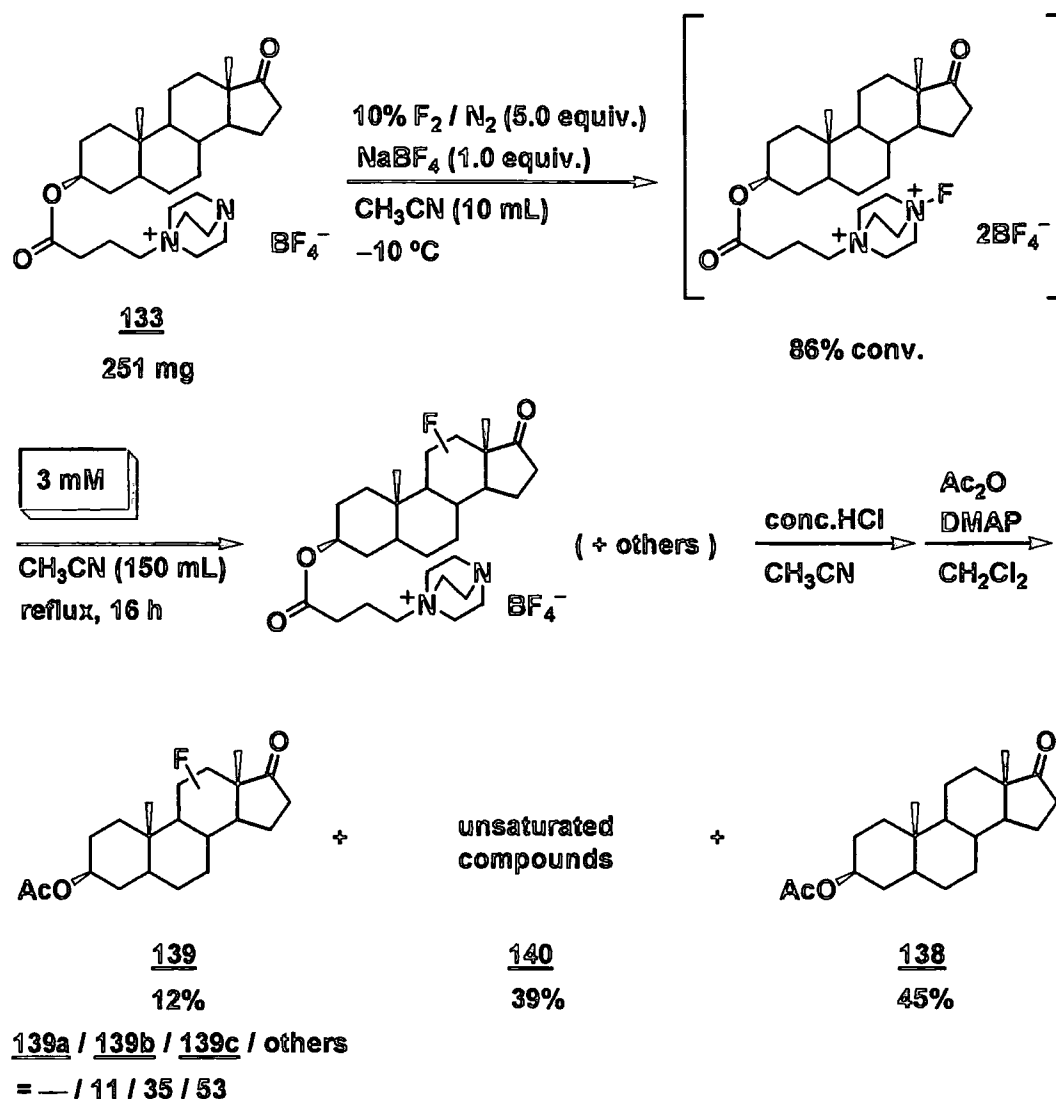

3β -[5-(4-Aza-1-azoniabicyclo[2.2.2]oct-1-yl)-valeryloxy]-5 α -androstano-17-one tetrafluoroborate (**135**) The fluorination of 3β -[5-(4-aza-1-azoniabicyclo[2.2.2]oct-1-yl)-valeryloxy]-5 α -androstano-17-one tetrafluoroborate (**135**) was carried out in the same procedure to compound **131** and **133** (Scheme 2.61). The N-F species was formed in 75 to 100% conversion, and the resonance was observed at +49.0 ppm, which was close to the case of **133**. The second step was carried out under two different concentrations, which were 45 mM and 3 mM. The crude products were converted to their 3-acetoxy derivatives, and analyzed by GC and GC-MS.

SCHEME 2.61

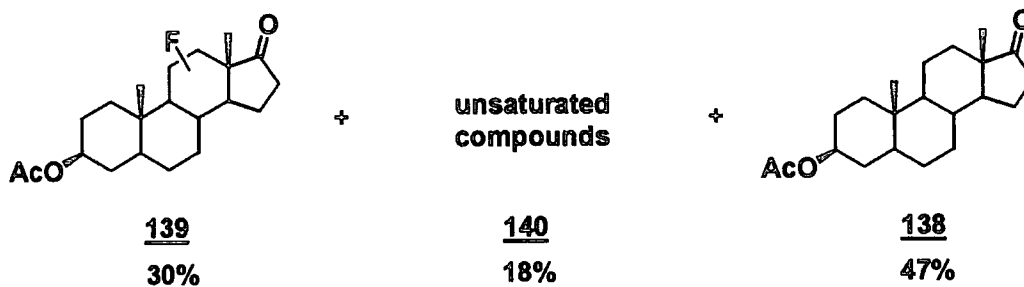
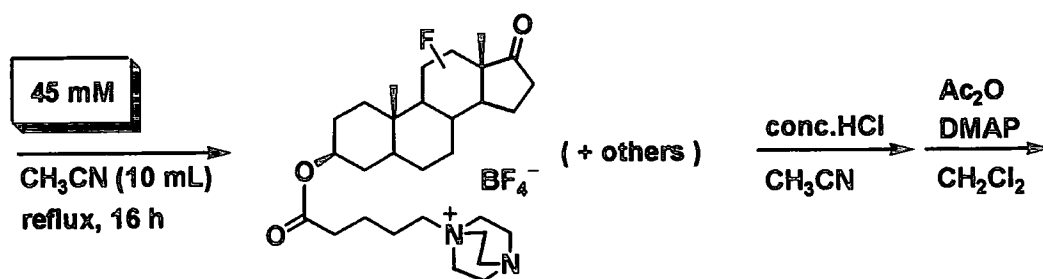
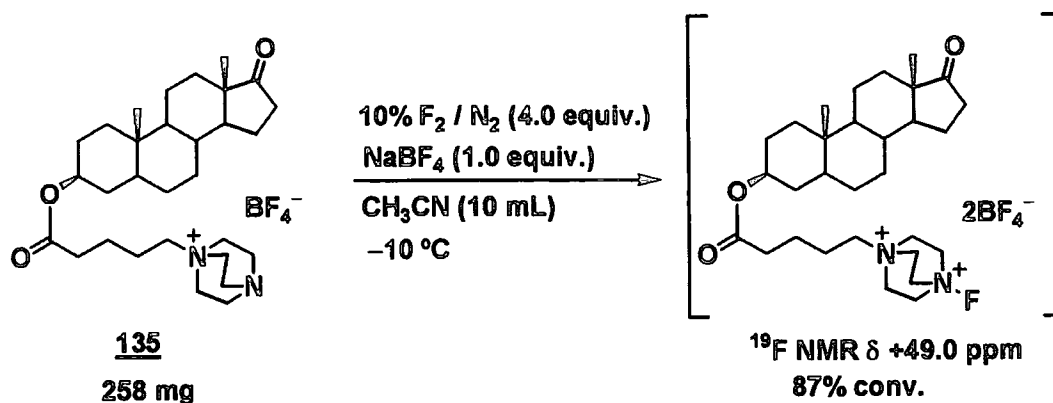

139a / 139b / 139c / others
 = 33 / 17 / 30 / 20

SCHEME 2.61 (Continued)

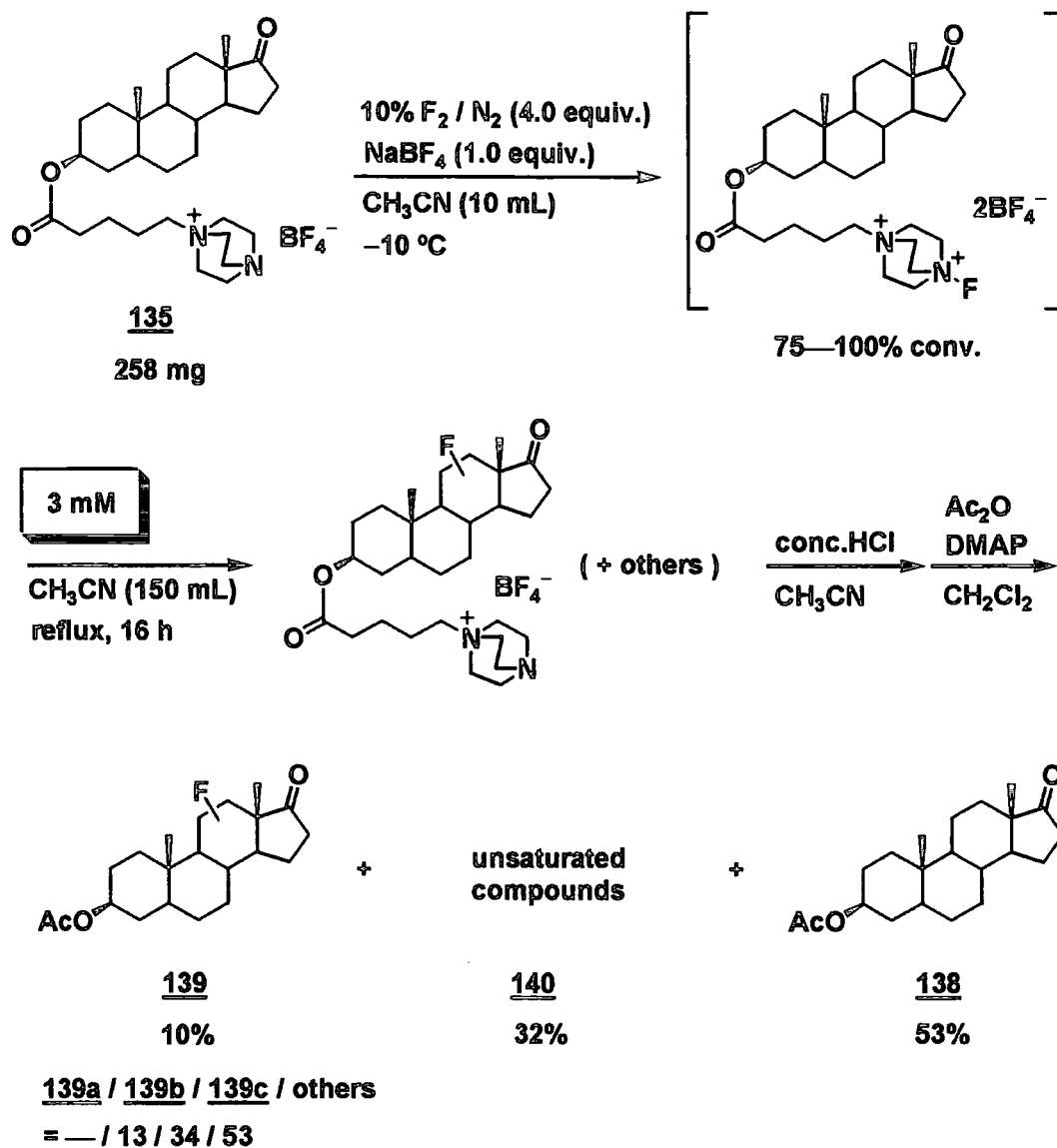
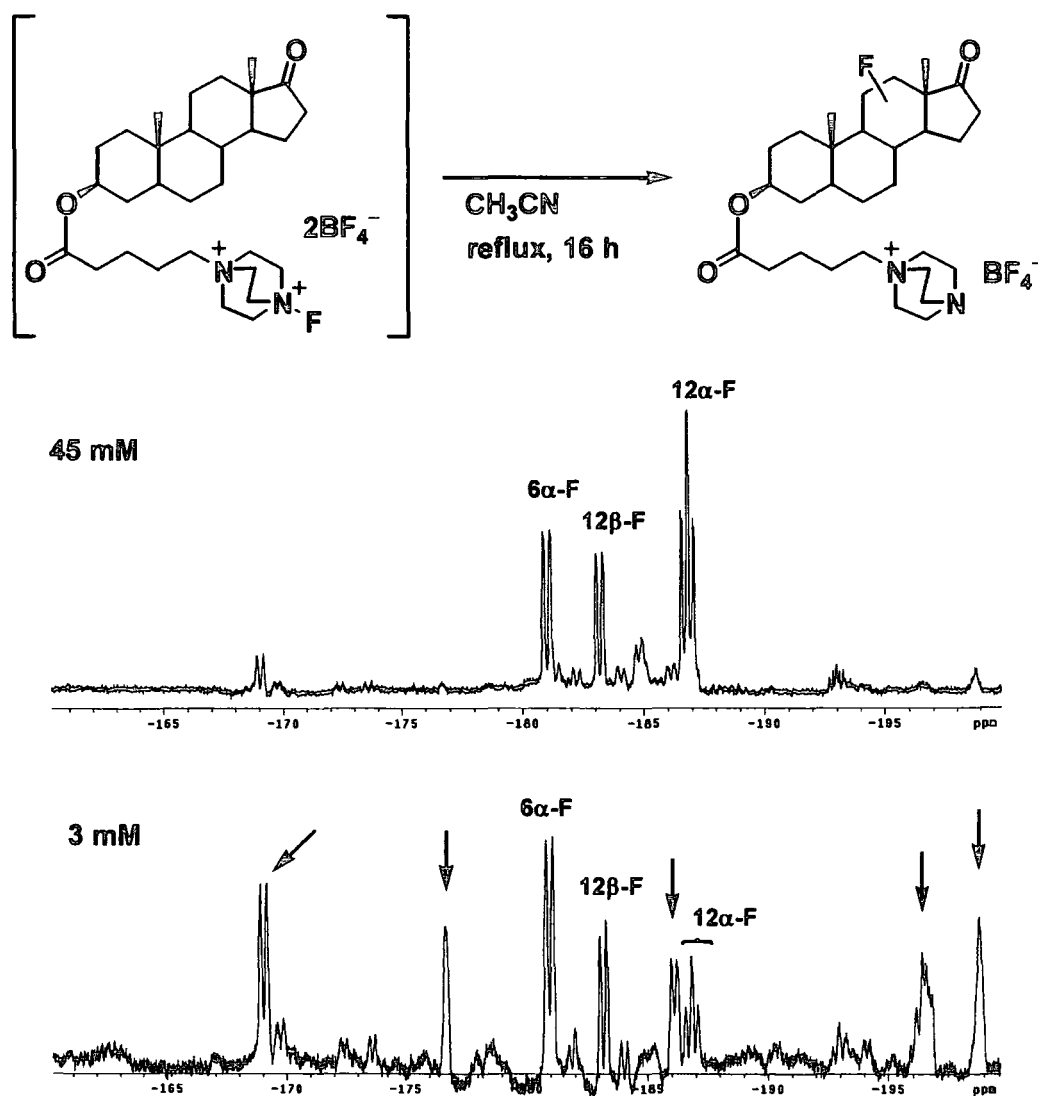

Figure 2.12 shows the ^{19}F NMR spectra of the crude products of these reactions. The product distributions were very similar to those of fluorination of compound **133**. In the case of 45 mM, the major products were similar to those of the fluorination of 3 β -acetoxy-5 α -androstane-17-one (**138**) using Selectfluor. In contrast, the high dilution condition gave a significant decrease of 12 α -fluoro product, and alternatively some new or increased resonances were observed, which may be attributed to intramolecular fluorination but this is not selective.

FIGURE 2.12 ^{19}F NMR spectra of crude products of fluorination of **135** under different concentrations.



3β-[6-(4-Aza-1-azoniabicyclo[2.2.2]oct-1-yl)-hexanoyloxy]-5α-androstan-17-one tetrafluoroborate (137**)** The fluorination of 3β-[6-(4-aza-1-azoniabicyclo[2.2.2]oct-1-yl)-hexanoyloxy]-5α-androstan-17-one tetrafluoroborate (**137**) was carried out in the same procedure to other substrates (Scheme 2.62). The N-F reagent was formed in 82–83% conversion, and the N-F resonance was observed at +49.5 ppm, which was similar to those of **133** and **135**. The second step was carried out under the two different concentrations.

SCHEME 2.62

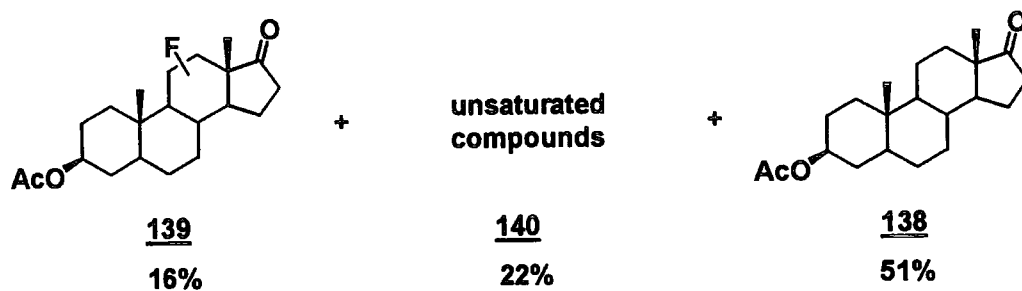
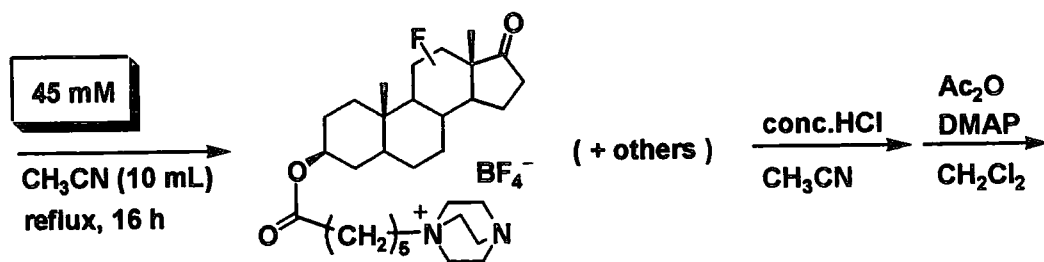
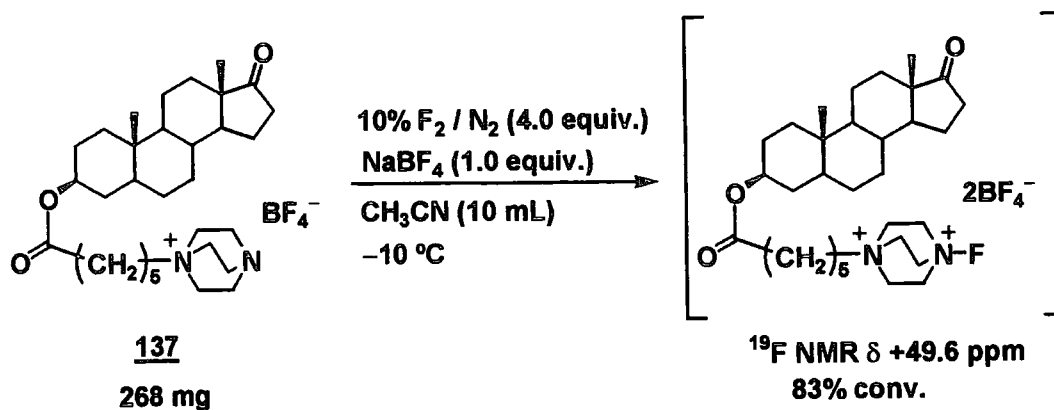

139a / 139b / 139c / others
 = 33 / 18 / 26 / 24

SCHEME 2.62 (Continued)

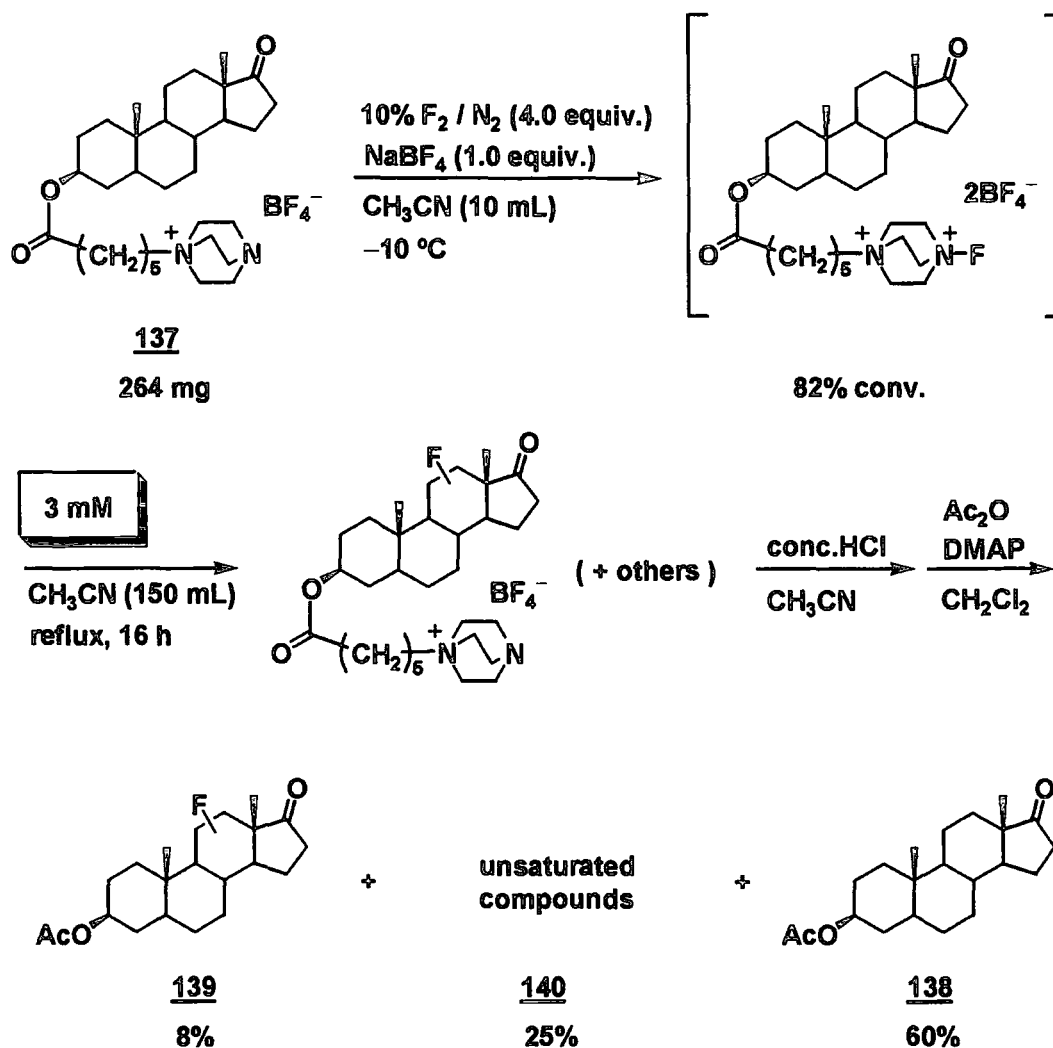

139a / 139b / 139c / others

= — / 12 / 36 / 52

The ^{19}F NMR spectra of the crude products of these reactions are shown in Figure 2.13. The product distributions were very similar to those of fluorination of 133 and 135. When the second step was carried out in normal concentration, the major products were the same as those of the fluorination of 3 β -acetoxy-5 α -androstan-17-one (138) using Selectfluor. On the other hand, a significant decrease of 12 α -fluoro product was observed in the high dilution condition, and alternatively some new or increased resonances were observed. Some of those were not observed in the cases of the fluorination of 133 and 135.

FIGURE 2.13 ^{19}F NMR spectra of crude products of fluorination of **137** under different concentrations.

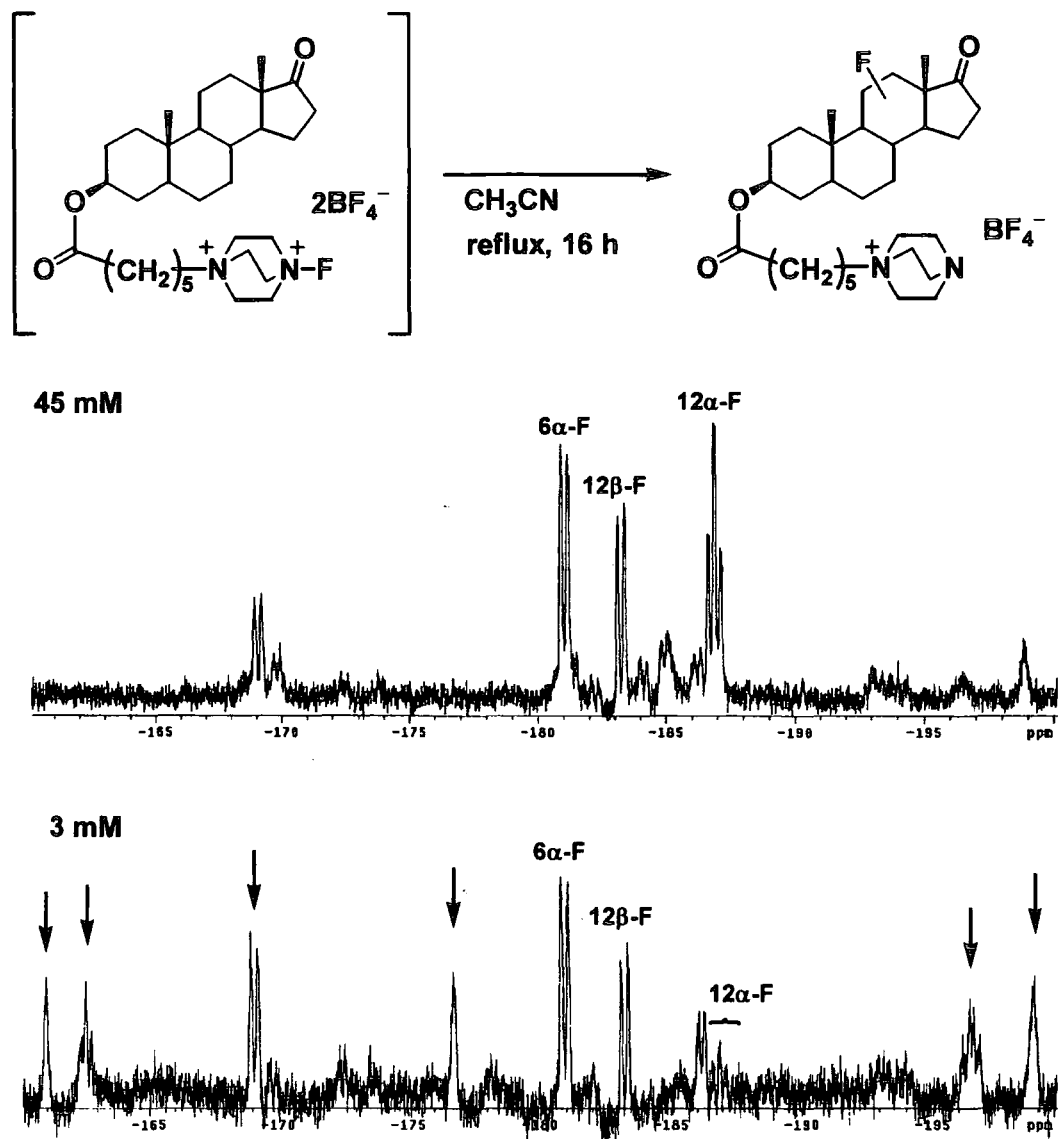

In all cases some HF eliminated compounds were found in the crude mixture after derivatization to 3-acetoxy derivatives. The high dilution condition tended to give larger amounts of the HF eliminated compounds.

Control reaction As described above the product distributions between 45 mM and 3 mM in each fluorination of **133**, **135**, and **137** were considerably different. In order to make it clear in which stage each product formed, a control reaction was carried out. The fluorination of 3 β -[5-(4-aza-1-azoniabicyclo[2.2.2]oct-1-yl)-valeryl

oxy]-5 α -androstane-17-one tetrafluoroborate (**135**) was carried out in the same method as described above, but the reaction mixture was quenched without heating in the second step (Scheme 2.63). The crude products were converted to the 3 β -acetoxy derivatives in the same procedure. The crude mixture obtained after quenching (Crude A) involved considerable amounts of compounds which were fluorinated at tertiary sites such as 5, 9, or 14 position (The ratio was 1.0:1.8:1.0, Figure 2.14). However, these compounds eliminated HF during the acidic deprotection reaction. These unsaturated compounds **140** involved mainly three kinds of systems, which showed identical retention times in GC analysis to those obtained in other experiments with the second fluorination step. Therefore the alkenic compounds **140** were assumed to be Δ^5 -, Δ^9 -, and Δ^{14} - derivatives.

SCHEME 2.63

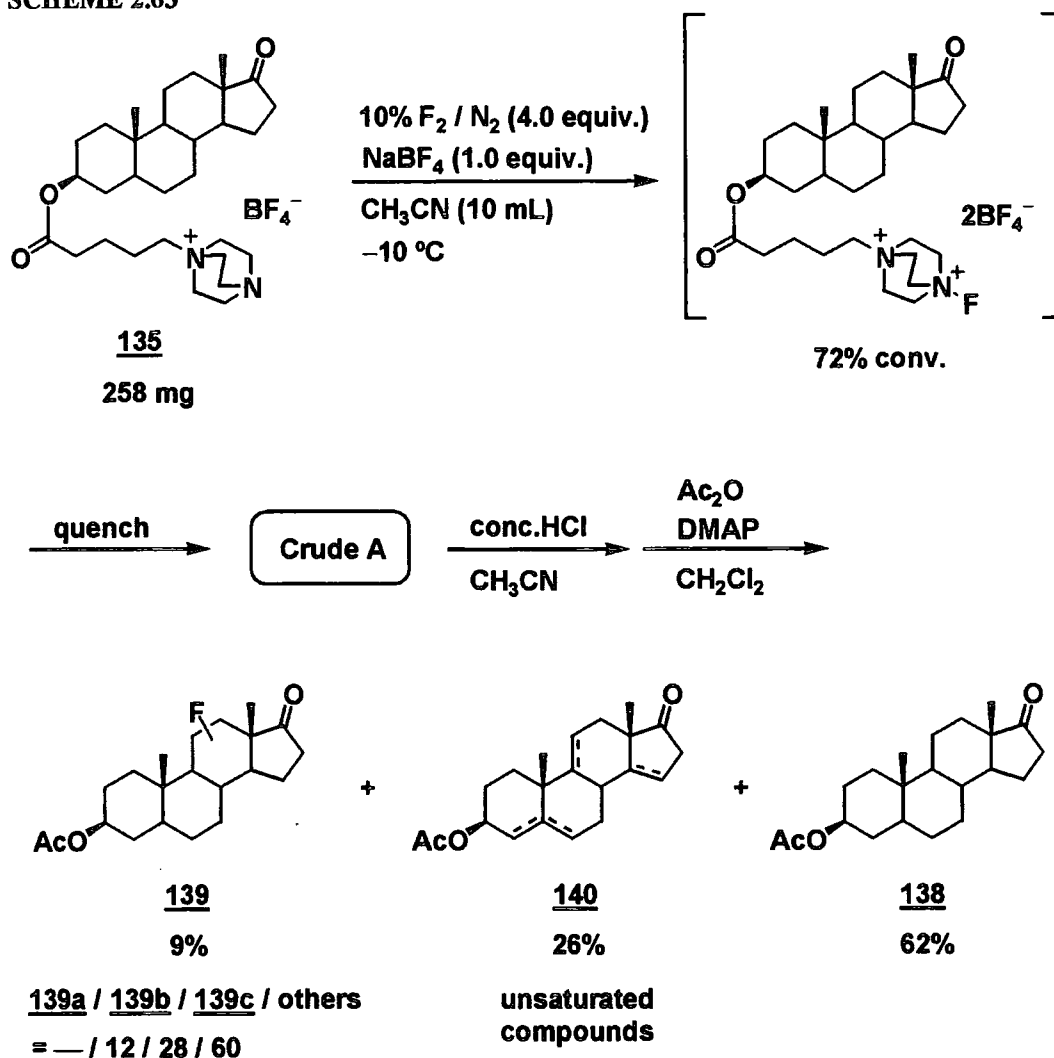

Interestingly, the acetylated crude products contained some compounds fluorinated at secondary positions.

FIGURE 2.14 ^{19}F NMR spectrum of the crude A of the fluorination of compound 135

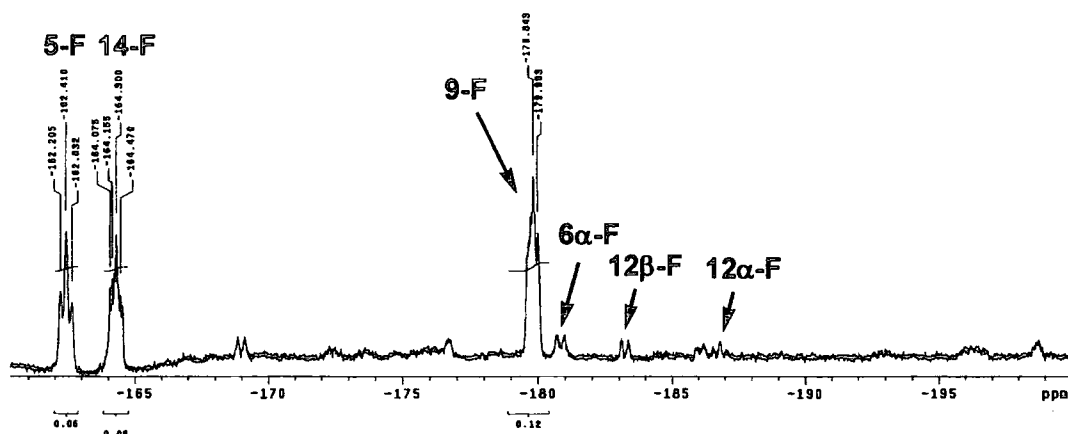

To understand all the above results more easily, the product distributions of all of the fluorination experiments using compound 133, 135, and 137 were summarised in Table 2.4.

TABLE 2.4 The Product Distribution of Remote Fluorination of Steroid Derivatives bearing DABCO moiety

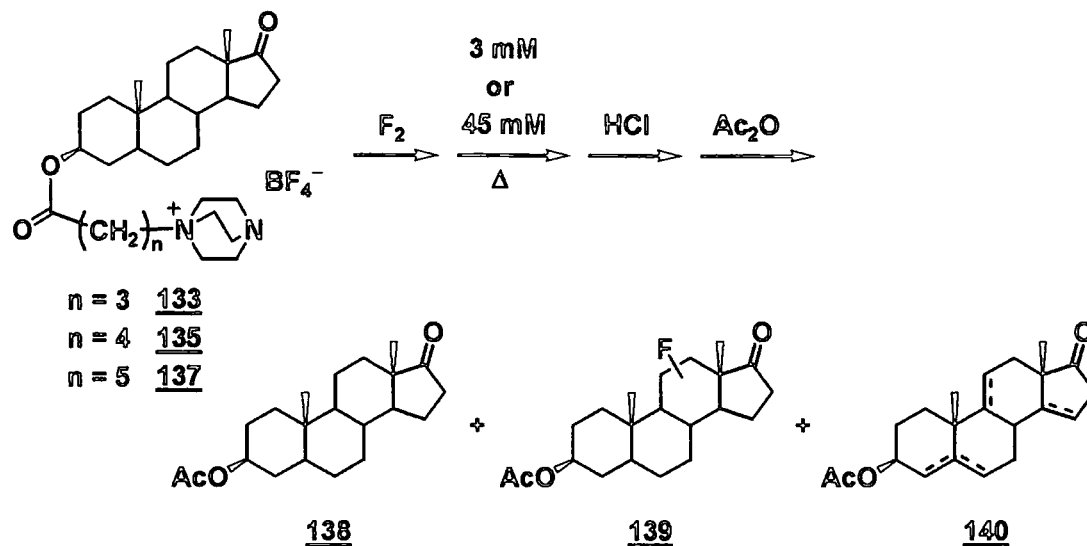

entry	n	concentration ^a (mM)	product (%) ^b						selectivity 12-F / 6-F ^c	
			mono-fluorinated products (<u>139</u>)					<u>140</u>		
			<u>138</u>	<u>139a</u>	<u>139b</u>	<u>139c</u>	others (total)			
1	3	45	64	6	3	7	7	(23)	13	1.7 : 1
2	3	3	45	—	1	4	6	(12)	39	1 : 2.1
3	4	45	47	10	5	9	6	(30)	18	2.4 : 1
4	4	3	53	—	1	3	5	(10)	32	1 : 1.4
5	5	45	51	5	3	4	4	(16)	22	1.6 : 1
6	5	3	60	—	1	3	4	(8)	25	1 : 2.0
7	4	— ^d	62	—	1	3	5	(9)	26	1 : 1.2
8 ^e	—	—	72	11	5	5	7	(28)	0	3.4 : 1

^a Concentration in which the second step was carried out. ^b Determined by GC. ^c The ratio was estimated by ¹⁹F NMR. ^d The N-F compounds was quenched without the second step. ^e The results of the fluorination of 138 with Selectfluor.

Comparing between the yields of mono-fluorinated compounds 139 in 3 mM and those of the control reaction (entry 2, 4, 6 and 7), the mono-fluorinated compounds in 3 mM were thought to form only in the first step, which was fluorination by elemental

fluorine. Therefore, the change of the product distribution between the different concentrations in the second step seemed to be not caused by the different fashion of the fluorination. On the other hand, comparison of the ratio between 12-fluoro and 6-fluoro derivatives suggested that the fluorination of the tethered steroids were less selective than the fluorination of steroids without tethers using Selectfluor. However, considering the rather preferential formation of the 6-fluoro compound in the first step (entry 7), the fluorination in the second step in 45 mM may be more 12-position selective than they appear and involve some contribution of intramolecular pathway (entry 1, 3 and 5).

Under the acidic deprotection conditions, the compounds fluorinated at tertiary positions eliminated HF to give unsaturated compounds as described above and thus alternative basic conditions were attempted for the deprotection reaction (Scheme 2.64).

SCHEME 2.64

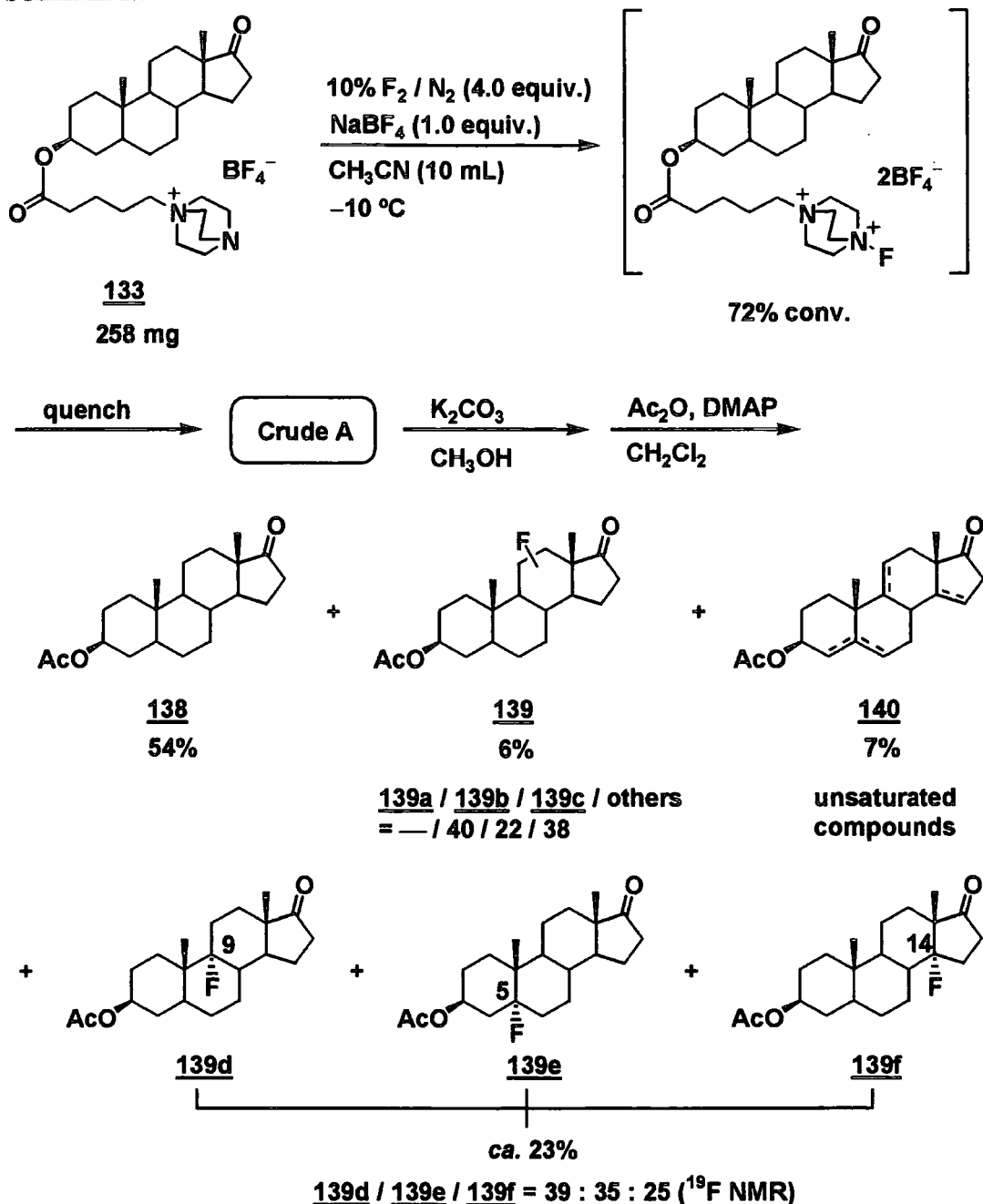

In this case, the components fluorinated at tertiary positions did not dehydrofluorinate into unsaturated compounds. Three major resonances were observed in the ^{19}F NMR of the final crude product. Those had similar chemical shifts with reported mono-fluorinated derivatives and they could be attributed to 9-fluoro (**139d**), 5-fluoro (**139e**) and 14-fluoro (**139f**) derivative (-180.0 , -162.9 and 164.5 ppm respectively). The total yield of those compounds was about 23%. These results mean that while the

fluorination on the nitrogen atom proceeding in the first step the saturated C-H sites of the steroid skeleton were fluorinated simultaneously to considerable extent. This is surprising because the basic nitrogen atom should be more nucleophilic, and therefore more reactive towards elemental fluorine, than the C-H bonds.

2.4.5 Conclusion

A series of steroid derivatives bearing a DABCO moiety were successfully fluorinated by elemental fluorine in acetonitrile to give steroids carrying an N-F reagent connected by an ester linkage. The steroidal tethered N-F reagents were heated in acetonitrile without isolation aiming at achieving intramolecular fluorination at a specific unactivated C-H position. Quite distinct product distributions between normal and highly diluted concentration were observed, however, a control reaction indicated that no fluorination proceeded in diluted solution in the second step. The fact that not only fluorination of nitrogen atom but also fluorination at unactivated C-H sites, which was mainly tertiary position, were occurred in the first step was also suggested by the control reaction. When the reaction was carried out under normal concentration the second fluorination using tethered N-F species were assumed to give 12-fluoro products preferably but the effect was not so obvious because the yields were not high and the products formed in the first step veil the true effects. The whole reaction pathway in the fluorination of compound 137 can be illustrated as shown in Scheme 2.65.

SCHEME 2.65

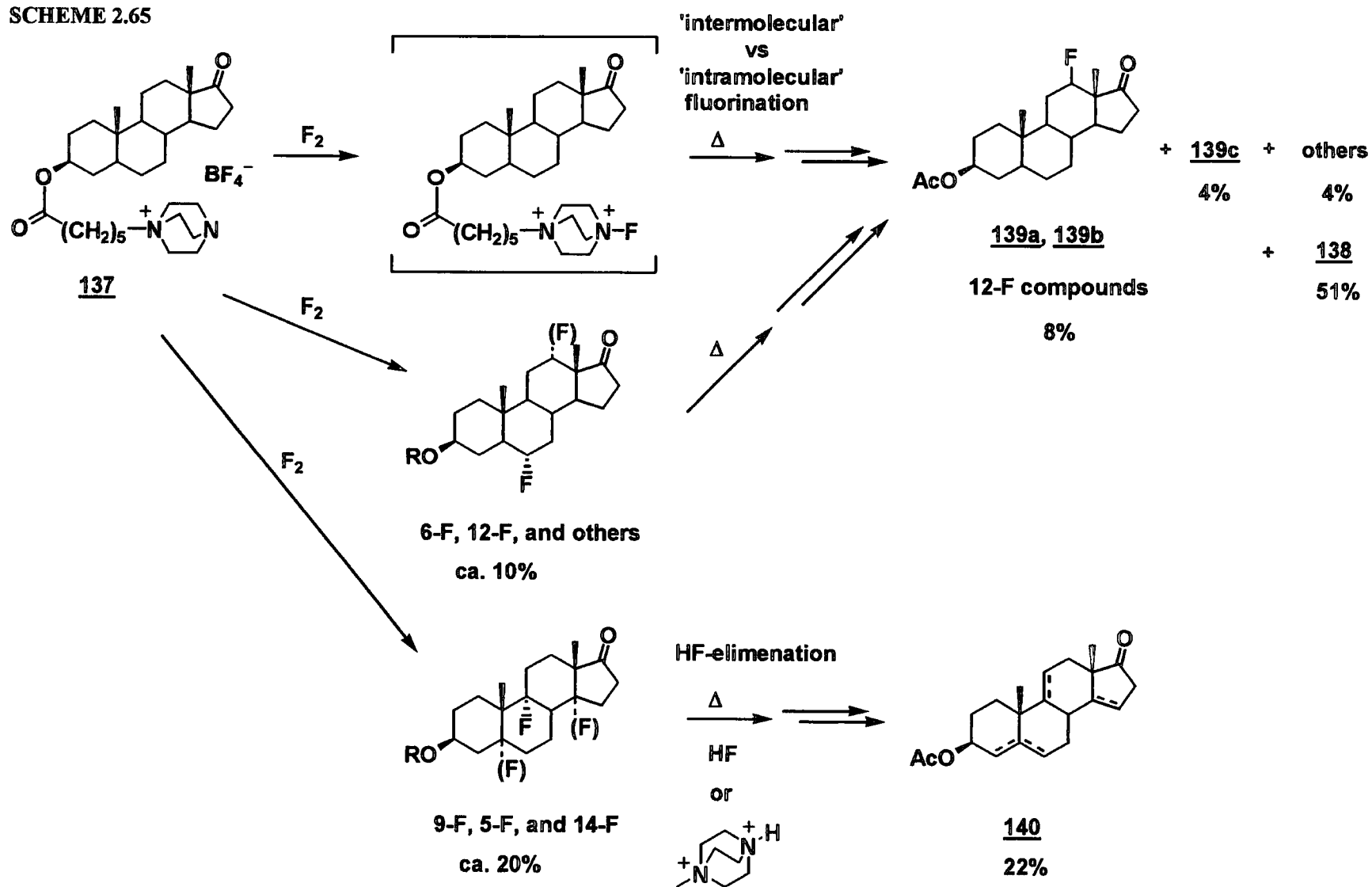

In the first step, the fluorination of **137** with elemental fluorine gives the corresponding N-fluorinated compound. However, fluorination also occurs at both the secondary and tertiary C-H sites. This fact is quite intriguing because the fluorination of electron rich nitrogen centre is much more likely to happen than that of carbon centre. Obviously the possibility of over-fluorination with the excess fluorine cannot be ruled out. The steroid skeleton is fluorinated by the tethered N-F reagent to give 12-fluoro compounds preferably, but this tendency is cancelled by the products fluorinated at the secondary position in the first step. On the other hand, 9-, 5-, and 14-fluoro derivatives are decomposed by probably acidic species, such as HF or ammonium species derived from the N-F reagent after fluorination, into unsaturated systems under reflux condition in acetonitrile. Unreacted steroid derivatives bearing the N-F reagent are quenched and lead to 3 β -acetoxy-5 α -androstan-17-one (**138**). Consequently, this two-step process, involving formation of distinct tethered N-F compound, shows no great increase in selectivity over intermolecular process.

2.5 Direct remote fluorination of steroids with tethered functional groups

2.5.1 Introduction

In the attempted remote fluorination reactions that were discussed in the last section, the tethered functional groups (= precursor) were fluorinated to N-F compounds *in situ*, and utilised for intramolecular fluorination in the second step. In other words, electrophilic 'F⁺' species were generated as stable N-F reagents.

On the other hand, in direct fluorination reaction in nitrile solvents an N-F species shown in the scheme 2.66 has not been observed by ¹⁹F NMR under the ordinary reaction conditions.

SCHEME 2.66



In any event, polar functional groups which have a high dielectric constant, such as nitrile and carboxyl group, are thought to be able to polarise elemental fluorine and promote electrophilic fluorination. When the functional group is 'tethered' to the substrate molecule without the formation of a stable N-F intermediate, the fluorine activated by the functional group would react with the most accessible C-H site. Therefore direct remote fluorination of steroid derivatives with tethered functional

groups will be discussed in the following section. The concept is illustrated in Scheme 2.67.

SCHEME 2.67

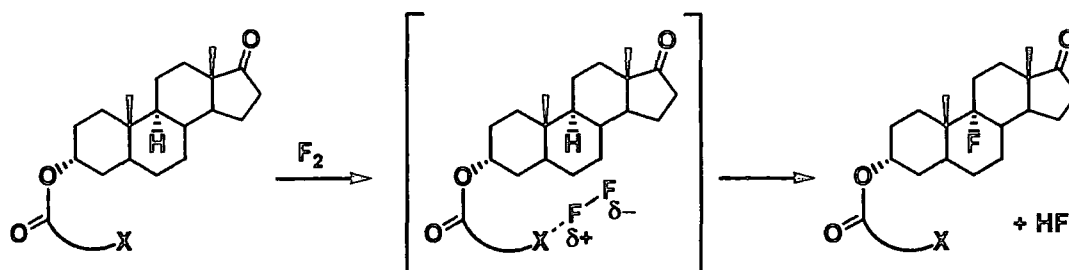

2.5.2 Preparation of steroid derivatives with tethered functional groups

Various steroids bearing functional groups, which potentially polarise elemental fluorine, were synthesised for fluorination studies and the preparations of the substrates are discussed below.

2.5.2.1 Synthesis of steroids connected to nitrile group

3 α -(3-Cyanobenzoyloxy)-5 α -androstan-17-one (142) 3 α -(3-Cyanobenzoyloxy)-5 α -androstan-17-one (142) was synthesised by esterification of androsterone (141) with 3-cyanobenzoyl chloride (Scheme 2.68). The reaction was sluggish at ambient temperature due to the electron-withdrawing cyano group and needed reflux conditions in tetrahydrofuran to proceed.

SCHEME 2.68

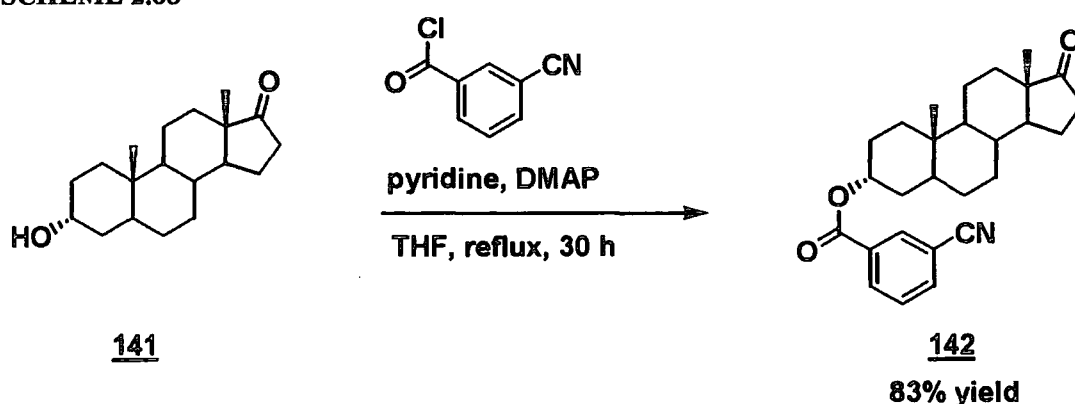

3 α -Cyanoacetoxy-5 α -androstan-17-one (143) Cyanoacetyl chloride was prepared by reaction of cyanoacetic acid with phosphorus pentachloride,¹⁷⁶ and reacted with androsterone (141) to give 3 α -cyanoacetoxy-5 α -androstan-17-one (143) in 56% yield (Scheme 2.69).

SCHEME 2.69

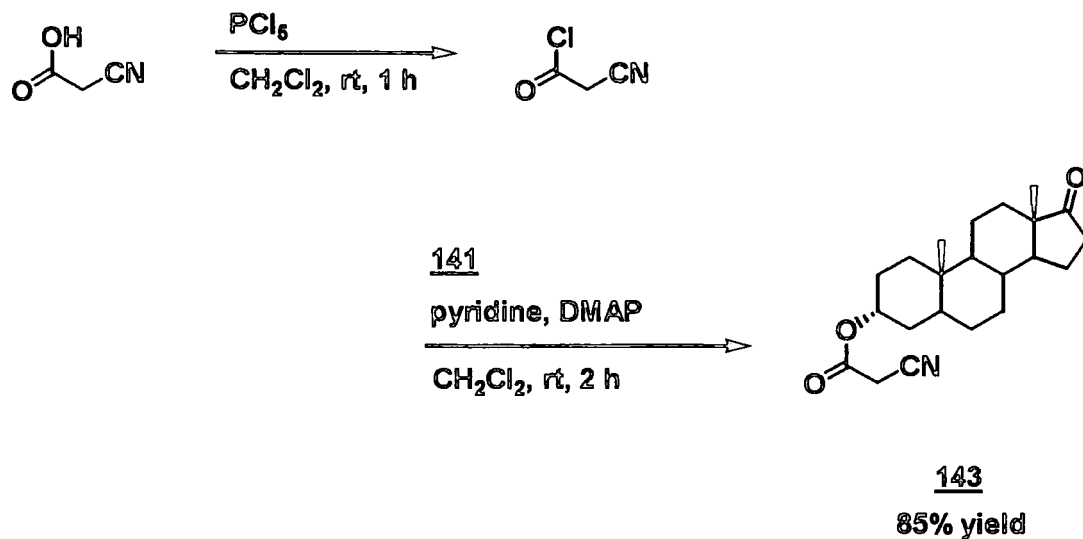

2.5.2.2 Synthesis of steroids connected to a carboxyl group

As described in chapter 1, carboxyl group is not only a possible precursor of electrophilic O-F reagent and also an effective functional group to polarise elemental fluorine. Thus, a steroid bearing a carboxyl group was prepared for the present study.

3 α -[(3-Carboxypropyl)-acetoxy]-5 α -androstan-17-one (**144**) 3 α -[(3-Carboxypropyl)-acetoxy]-5 α -androstan-17-one (**144**) was prepared by esterification of androsterone (**141**) with glutaric anhydride (Scheme 2.70).¹⁷⁷ The reaction proceeded slowly in dichloromethane at room temperature in the presence of catalytic amounts of 4-dimethylaminopyridine.

SCHEME 2.70

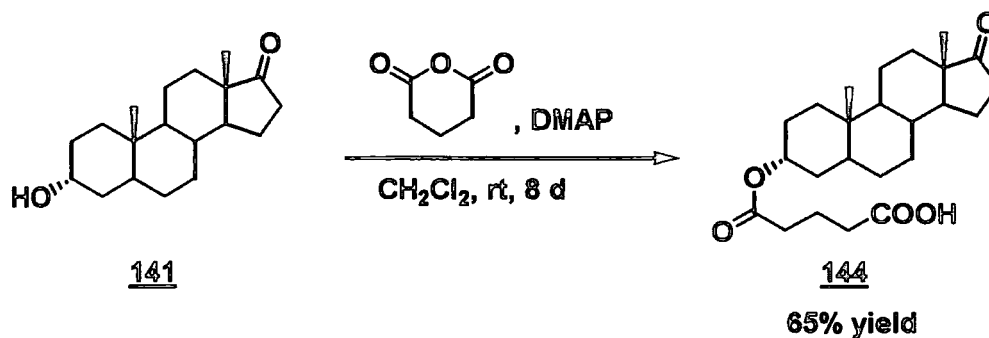

2.5.2.3 Synthesis of steroids connected to a pyridine group

Pyridine moiety was ruled out in the remote fluorination with stable tethered N-F

reagents because of the insufficient reactivity, but was still to be investigated in this one step strategy.

3 α -Nicotinoyl-5 α -androstan-17-one (145) **3 α -Nicotinoyl-5 α -androstan-17-one (145)** was prepared by esterification of epiandrosterone (**128**) with nicotinic acid under Mitsunobu conditions¹⁷⁸ (Scheme 2.71). The reaction proceeded in THF at room temperature to give the inverted ester **145** with 3 α stereochemistry in 51% yield.

SCHEME 2.71

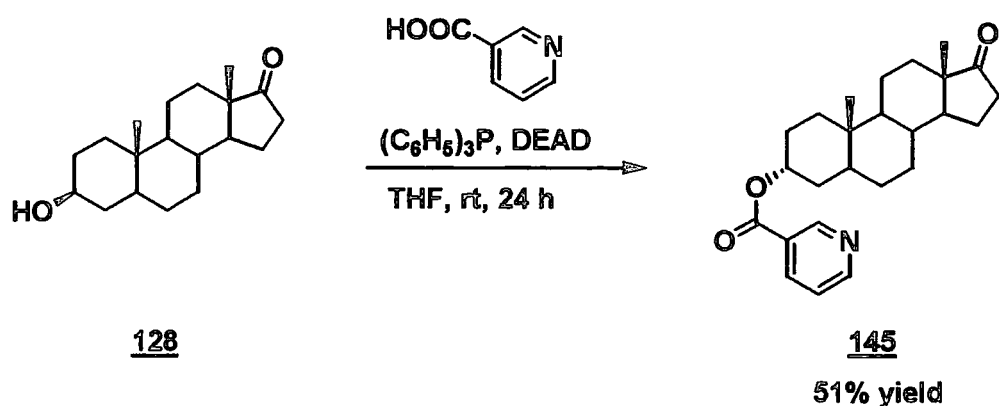

3 α -(2,6-Dichloronicotinoyl)-5 α -androstan-17-one (146) **3 α -(2,6-Dichloronicotinoyl)-5 α -androstan-17-one (146)** was prepared by the same method as 3 α -nicotinoyl-5 α -androstan-17-one (**145**) (Scheme 2.72).

SCHEME 2.72

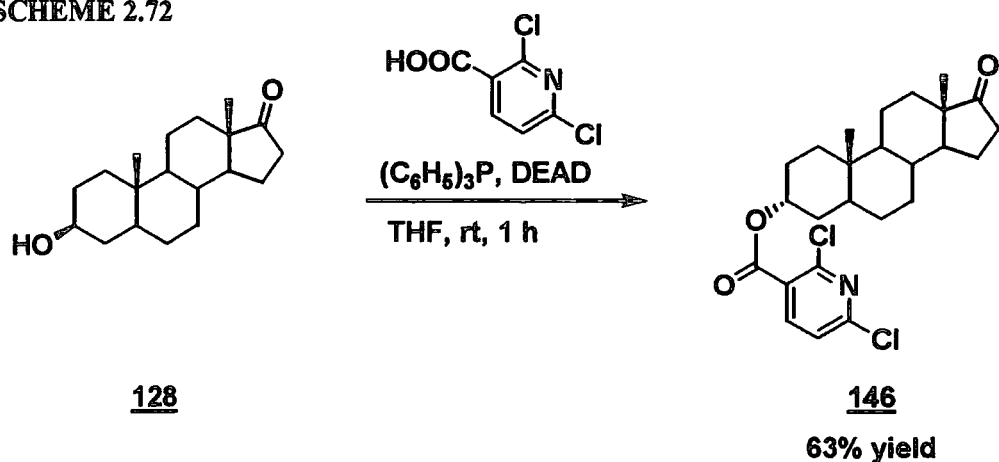

2.5.3 Direct remote fluorination of steroids with tethered functional groups

2.5.3.1 Control reactions

3 α -Acetoxy-5 α -androstan-17-one (**62**) which has no proper functional group for

activating elemental fluorine was prepared for the control reactions to evaluate the results of direct remote fluorinations. This compound was derived from androsterone (**141**) in the same method to 3 β -acetoxy derivative **138** (Scheme 2.73). The desired compound **62** was obtained in 97% yield.

SCHEME 2.73

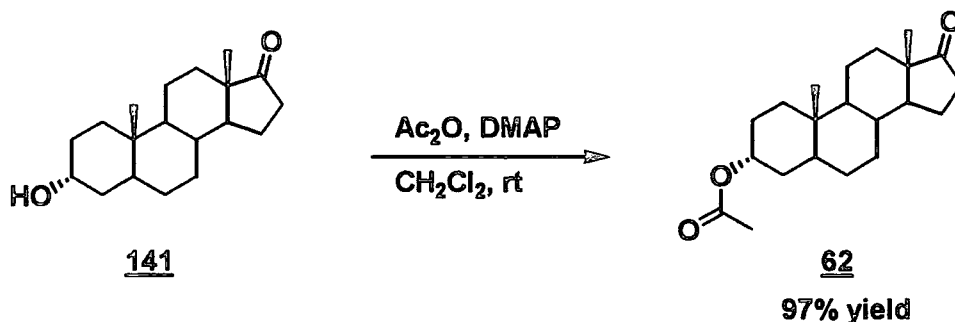

The fluorination of 3 α -acetoxy-5 α -androstan-17-one (**62**) with elemental fluorine was carried out in acetonitrile, dichloromethane and nitromethane as control reactions (Table 2.5).

TABLE 2.5 The fluorination of 3-acetoxy-5 -androstan-17-one (**62**)

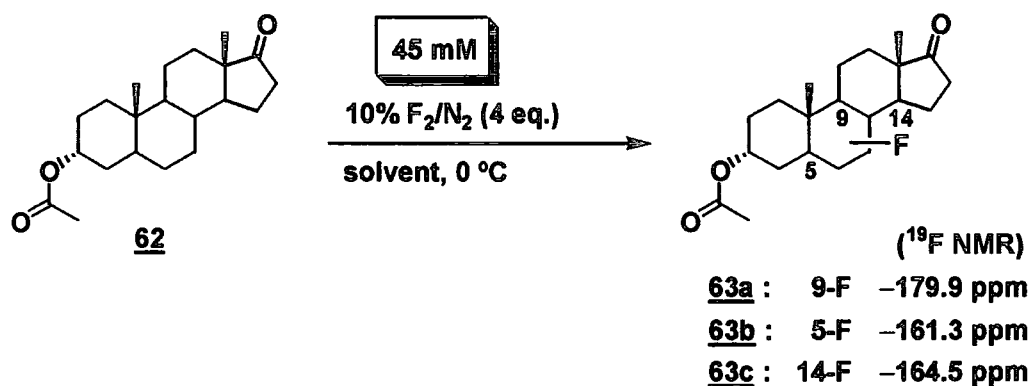

solvent	F ₂ (equiv.)	63a / 63b / 63c	% yield
CH ₃ CN	4	36 : 30 : 34	57
CH ₂ Cl ₂	8	49 : 36 : 15	0.4
CH ₃ NO ₂	4	40 : 34 : 27	40

The yields of the fluorinated compounds were estimated by ¹⁹F NMR in the presence of fluorobenzene as an internal standard. Three main resonances were observed in the

^{19}F NMR of the crude mixture. Two of those had identical chemical shifts with reported mono-fluorinated isomer, which were 9-fluoro and 5-fluoro derivative (-179.9 and -161.3 ppm respectively). The rest of the resonances (-164.5 ppm) were attributed to 14-fluoro derivative because the 8-position is known to be a completely blocked site among the tertiary carbons in the steroid skeleton. The fluorination in acetonitrile gave mono-fluorinated compounds in 57% yield and the 9-F/5-F/14-F ratio was 36:30:34. On the other hand, the reaction hardly proceeded in dichloromethane, although the 9-F/5-F/14-F ratio was slightly more selective towards the 9 position than in acetonitrile. Nitromethane, which has high relative permittivity but no contribution of N-F species, also gave a fair yield with the similar 9-F/5-F/14-F ratio to the case of the acetonitrile reaction.

These results contrasted with Rozen's studies described in section 2.2.1.1 (see scheme 2.2).¹²³ This difference was thought to be attributable to the higher reaction temperature as well as the solvent or the absence of NaF as a HF scavenger.

2.5.3.2 Direct remote fluorination of steroids with tethered functional groups

2.5.3.2.1 Direct remote fluorination of steroids with tethered DABCO moiety

3 β -[5-(4-Aza-1-azoniabicyclo[2.2.2]oct-1-yl)-valeryloxy]-5 α -androstan-17-one tetrafluoroborate (135**)** In the two-step remote fluorination strategy discussed previously, the N-F species were sufficiently stable for the second fluorination step in the presence of tetrafluoroborate ion in acetonitrile. A one step procedure was also employed for direct fluorination of compound **135**. In this case, the reaction was carried out in the absence of sodium tetrafluoroborate. The fluorine could interact with the nitrogen atom of the DABCO moiety without forming a stable N-F species, and also react in competition with the C-H bonds of the steroid skeleton (Scheme 2.74).

SCHEME 2.74

Two step procedure

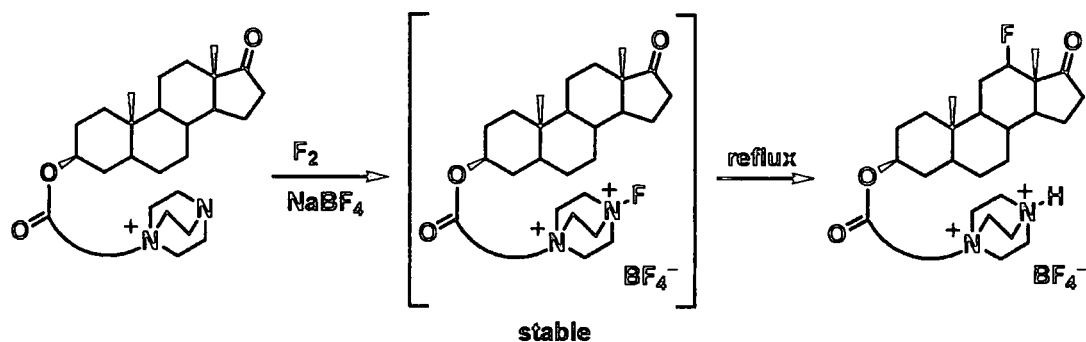

One step procedure

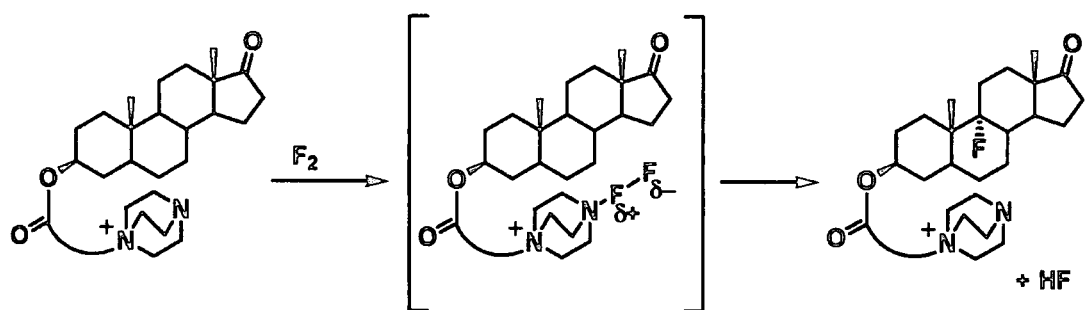

The fluorination of 3 β -[5-(4-aza-1-azoniabicyclo[2.2.2]oct-1-yl)-valeryloxy]-5 α -androstan-17-one tetrafluoroborate (**135**) was carried out in acetonitrile in the absence of sodium tetrafluoroborate under two different concentrations (Scheme 2.75). In the lower temperature, the N-F species was thought to be stable even in the absence of sodium salt, thus the reaction was carried out at 20 °C.

SCHEME 2.75

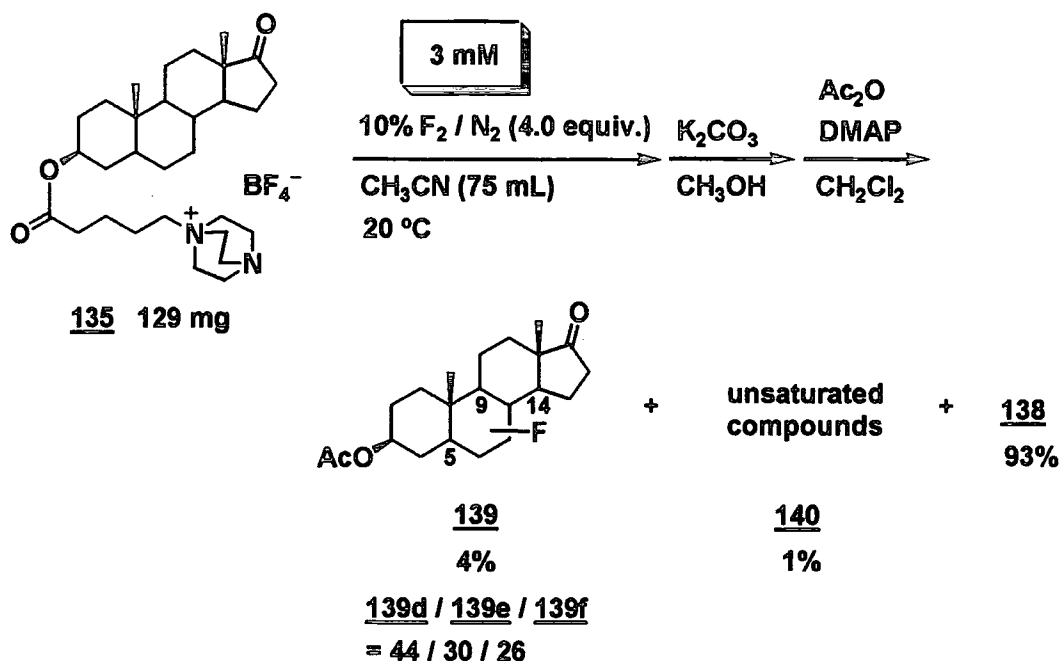
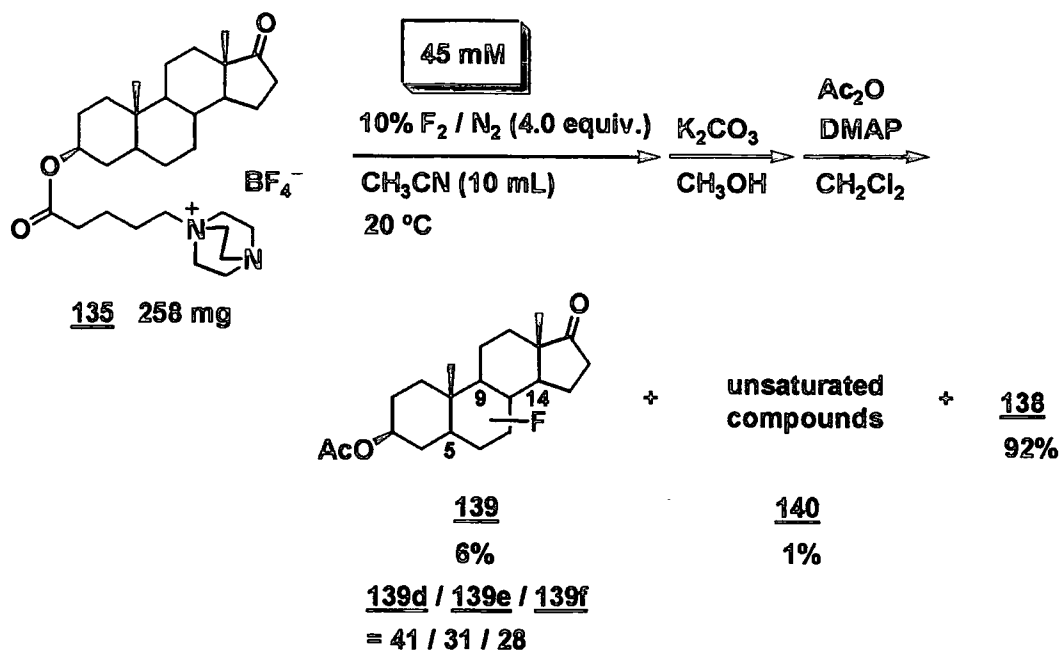

In the both cases, small amounts (4–6%) of compounds which were mono-fluorinated at tertiary positions were obtained non-selectively accompanied by only 1% of HF eliminated products. The same reaction was carried out in dichloromethane because dichloromethane was thought to be much less polar than acetonitrile and suitable for the avoidance of intermolecular fluorination. However, the fluorination of **135** in

dichloromethane gave no reaction (Scheme 2.76).

SCHEME 2.76

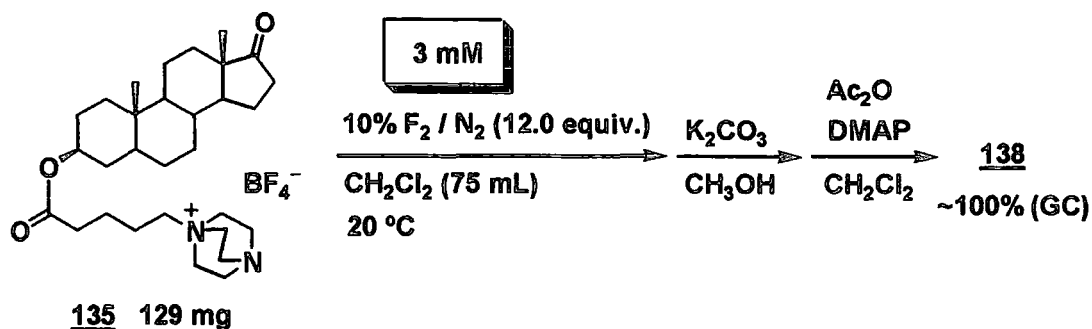

From these results, DABCO tethers are found to be not sufficiently reactive for this one-step strategy.

2.5.3.2.2 Direct remote fluorination of steroids with tethered nitrile group

3 α -(3-Cyanobenzoyloxy)-5 α -androstan-17-one (142) The direct fluorination of 3 α -(3-cyanobenzoyloxy)-5 α -androstan-17-one (**142**) was carried out in dichloromethane at 0 °C using 8 to 12 equivalents of elemental fluorine under two different concentrations to assess how a nitrile tether could direct the fluorination reaction (Scheme 2.77).

SCHEME 2.77

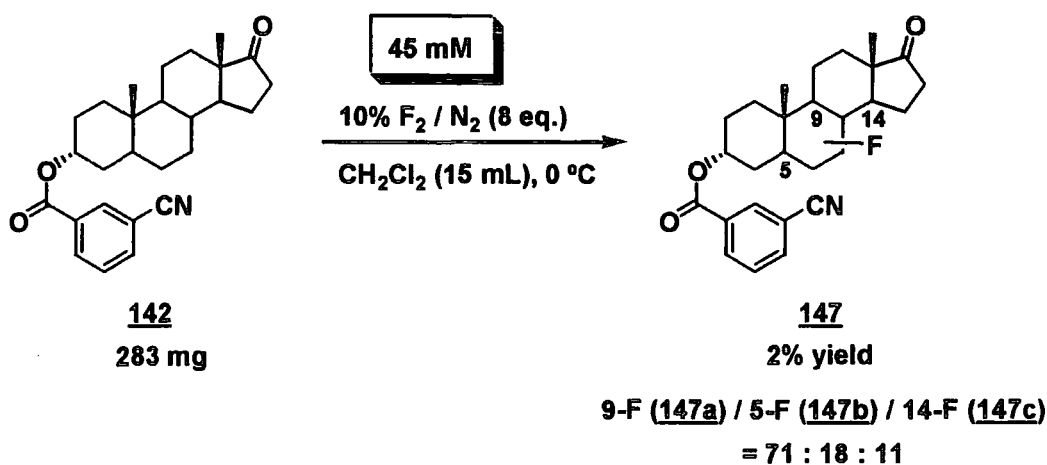

SCHEME 2.77 (Continued)

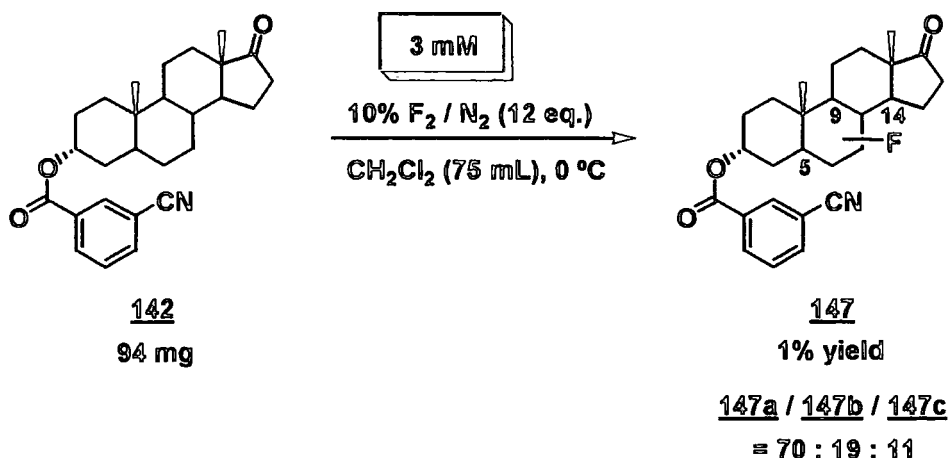

The yields were determined to be very poor (1 to 2%) by measuring ^{19}F NMR in the presence of fluorobenzene as a internal standard. In both concentrations, three resonances which can be assigned to 9- α , 5- α , and 14- α fluorinated compound (147a-c) accompanied by more than 10 of other fluorinated systems were observed. The total integration of the area between -50 to -130 ppm was 5 times larger than those of the compounds fluorinated at tertiary sites. The 9- α /5- α /14- α ratio was about 70:20:10 in the both cases which means the concentration did not affect the selectivity.

When the same reaction was carried out in nitromethane the yield was much improved. The fluorination of 142 with 4 equivalents of elemental fluorine in nitromethane gave a mixture of 147a-c in 47% yield with slight less selectivity (Table 2.6). The side products which were observed in the case of using dichloromethane were not obtained at all. The lower reaction temperature was slightly effective for improving the selectivity. ^{19}F NMR spectra of the crude products of both of the low temperature reaction and the control reaction using 62 were shown in the figure 2.15.

TABLE 2.6

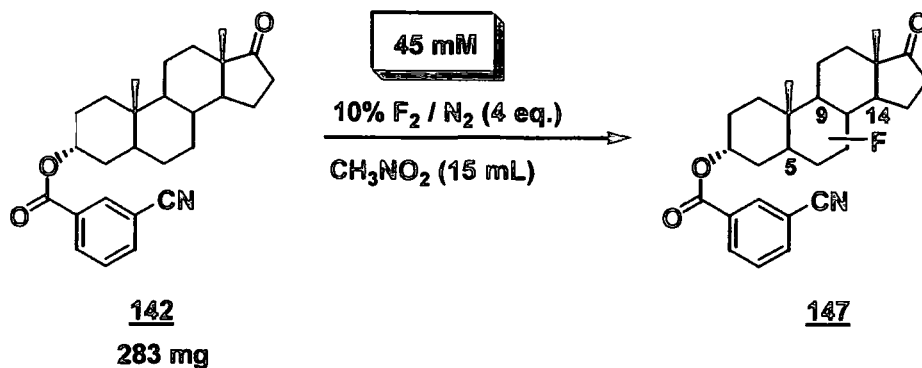

temperature (°C)	yield (%)	ratio [9-F (147a) / 5-F (147b) / 14-F (147c)]
0	47	63 : 21 : 17
-25	47	66 : 20 : 14

Control reaction (fluorination of 62)		ratio (9-F / 5-F / 14-F)
0	40	40 : 34 : 27

FIGURE 2.15 ¹⁹F NMR spectra of the crude products of the fluorination of compound **142** and **62**

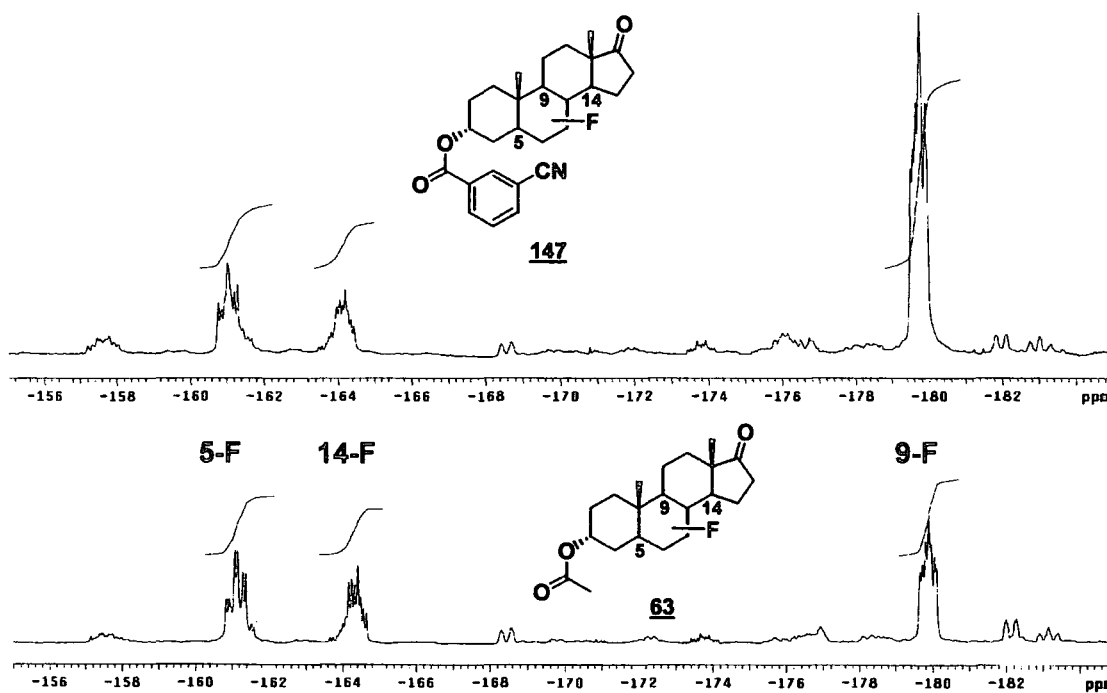

The main product, 3 α -(3-cyanobenzoyloxy)-9 α -fluoro-5 α -androstane-17-one (**147a**) was isolated by column chromatography, and recrystallised. The X-ray structure was determined as shown in figure 2.16.

FIGURE 2.16 X-ray structure of **147a**

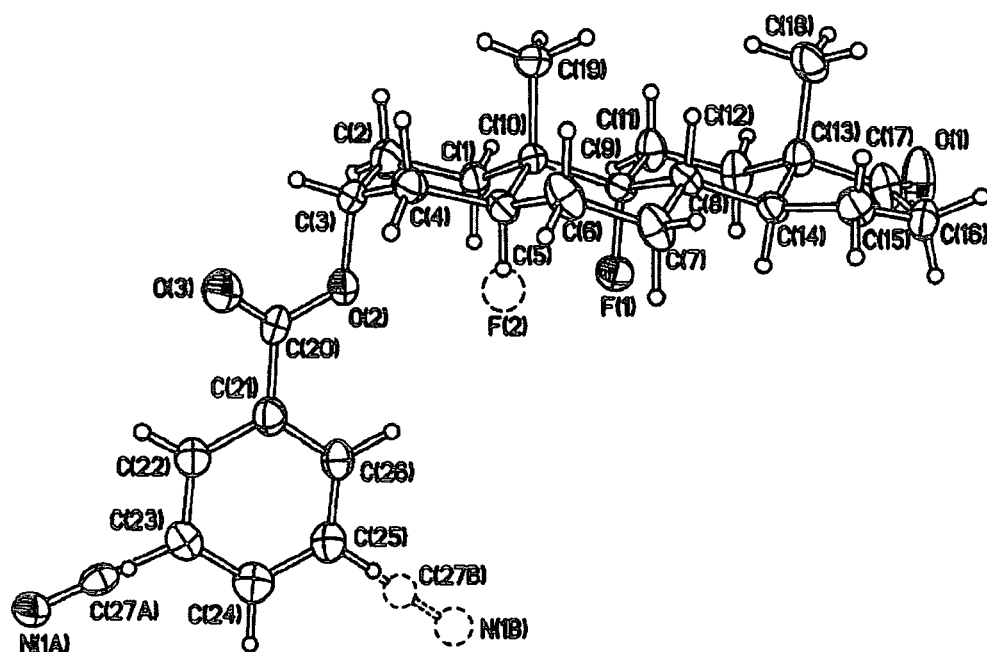

3 α -Cyanoacetoxy-5 α -androstane-17-one (143**)** The direct fluorinations of 3 β -cyanoacetoxy-5 α -androstane-17-one (**143**) were also examined using both nitromethane and dichloromethane (Table 2.7). The same tendency of yield to the benzyloxy derivative **142** was observed with much less selectivity.

TABLE 2.7

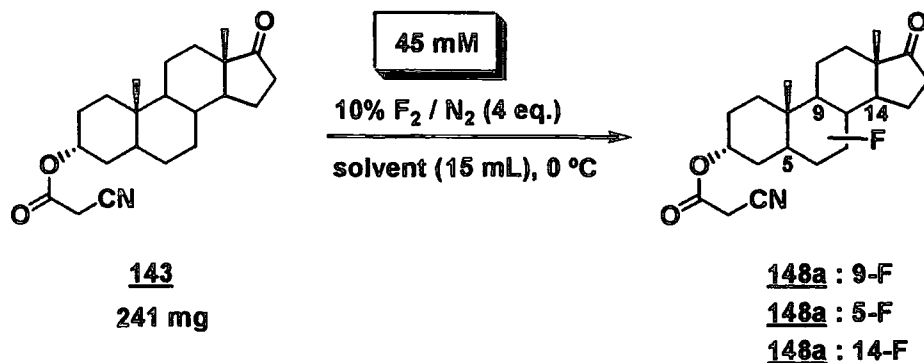

solvent	yield (%)	ratio (148a / 148b / 148c)
CH ₂ Cl ₂	0.4	43 : 35 : 22
CH ₃ NO ₂	42	40 : 29 : 31

Control reaction (fluorination of 62)		ratio (9-F / 5-F / 14-F)
CH ₃ NO ₂	40	40 : 34 : 27

Direct remote fluorination of steroids bearing tethered nitrile group were found to show some selectivity for 9-position when 3-cyanobenzoyloxy group was employed for the tether to androsterone system, whilst cyanoacetyloxy group gave no improvement of the selectivity.

2.5.3.2.3 Direct remote fluorination of steroids with tethered carboxyl group

3 α -[(3-Carboxypropyl)-acetoxy]-5 α -androstan-17-one (**144**) 3 α -[(3-Carboxypropyl)-acetoxy]-5 α -androstan-17-one (**144**) could not be dissolved in nitromethane. Consequently the fluorination of **144** was carried out in a mixture of dichloromethane and nitromethane (4:1) as shown in Scheme 2.78.

SCHEME 2.78

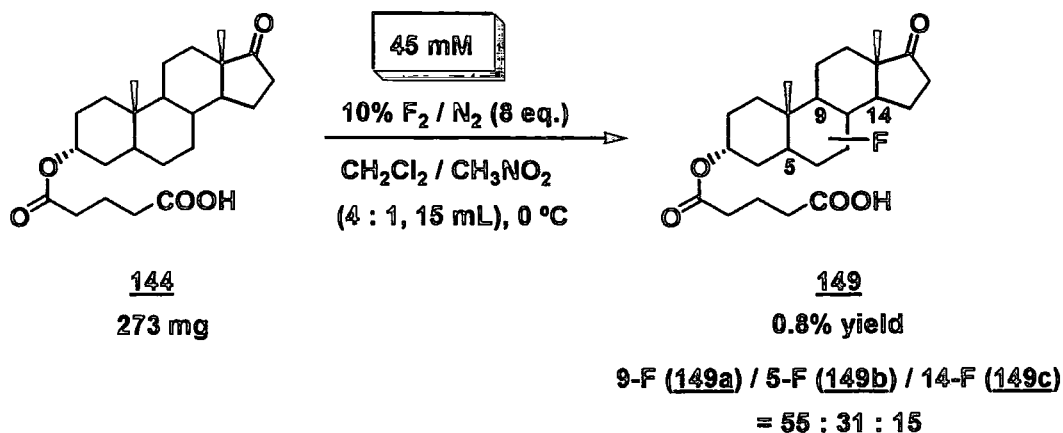

The crude mixture gave less than 1% of the mono-fluorinated compounds despite the use of 8 equivalents of elemental fluorine and so this tether was abandoned.

2.5.3.2.4 Direct remote fluorination of steroids with tethered pyridine group

3 α -Nicotinoyl-5 α -androstan-17-one (145) Direct fluorination of 3 α -nicotinoyl-5 α -androstan-17-one (145) was carried out in nitromethane in the same procedure to other substrates (Scheme 2.79).

SCHEME 2.79

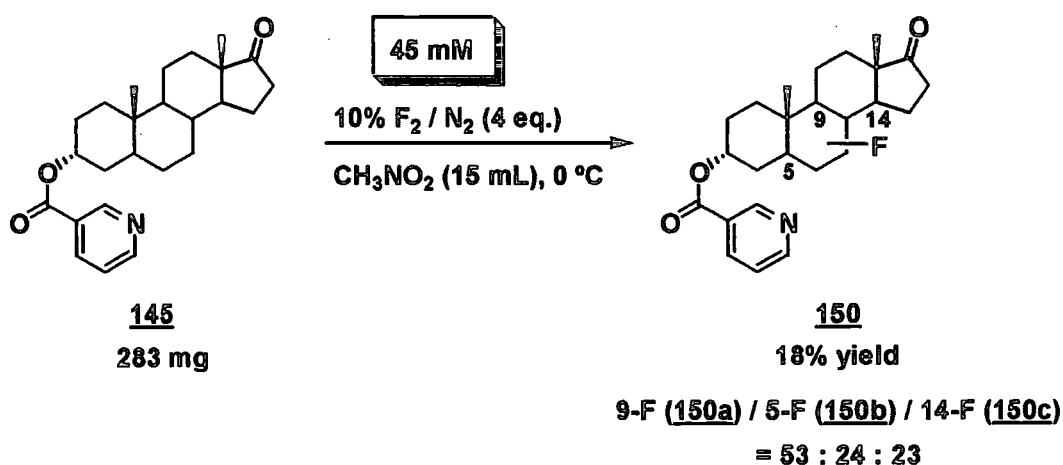

Control reaction (fluorination of 62)

solvent	% yield	ratio (9-F / 5-F / 14-F)
CH_3NO_2	40	40 : 34 : 27

Both selectivity and yield were less than the case of cyanobenzoyloxy derivative 142 although the 9-fluoro derivative 150a was obtained as the main product. Some by-products in which the C-H bonds of the pyridine ring were also fluorinated were also obtained as minor components.

3 α -(2,6-Dichloronicotinoyl)-5 α -androstan-17-one (146) Fluorination of 3 α -(2,6-dichloronicotinoyl)-5 α -androstan-17-one (146) was carried out in the same manner to compound 145, but the reaction gave a lot of by-products and the yields of the mono-fluorinated compounds could not be estimated by ^{19}F NMR.

The pyridine tethers did not show notable effect in the attempted direct remote fluorination in contrast to Breslow's remote chlorination.

2.5.3.2.5 Summary of results

The series of results of direct fluorinations of the steroid derivatives with tethered functional groups are summarised in Table 2.8.

TABLE 2.8 Direct remote fluorination of steroids with tethered functional groups

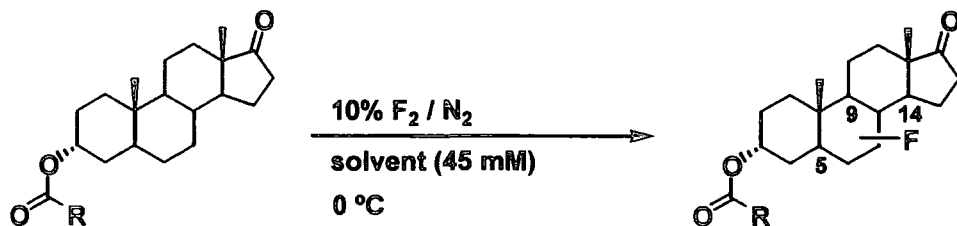

entry	R	solvent	F ₂ (equiv.)	9-F / 5-F / 14-F	% yield
1		CH ₃ CN ^a	4	1.5 / 1.1 / 1	6
2		CH ₂ Cl ₂	8	6.7 / 1.7 / 1	2
3		CH ₃ NO ₂	4	3.8 / 1.3 / 1	47
4		CH ₃ NO ₂ ^b	4	4.8 / 1.5 / 1	47
5	CH ₂ CN	CH ₂ Cl ₂	8	2.0 / 1.3 / 1	0.4
6	CH ₂ CN	CH ₃ NO ₂	4	1.3 / 0.9 / 1	42
7	(CH ₂) ₃ COOH	CH ₂ Cl ₂ / CH ₃ NO ₂ (4 / 1)	8	3.8 / 2.1 / 1	0.8
8		CH ₃ NO ₂	4	2.3 / 1.1 / 1	18

control reactions					
9	CH ₃	CH ₃ CN	4	1.1 / 0.9 / 1	57
10	CH ₃	CH ₂ Cl ₂	8	3.2 / 2.4 / 1	0.4
11	CH ₃	CH ₃ NO ₂	4	1.5 / 1.3 / 1	40

^a The reaction was carried out at 20 °C. ^b The reaction was carried out at -25 °C.

The control reactions using acetoxy derivatives (**62**), which have no tethered functional group, in acetonitrile or nitromethane gave almost non-selective fluorination at tertiary carbons (entry 9 and 11). In contrast, the direct fluorination of 3-cyanobenzoyloxy derivative (**142**) gave some 9-position selectivity (entry 3 and 4). When dichloromethane was employed as solvent, the yield was considerably decreased

although the selectivity was improved (entry 2). On the other hands, in the case of the cyanoacetoxy derivatives (143) no direction effect was observed (entry 6). This fact could imply the cyanoacetoxy group did not possess proper length and geometrical demand.

As mentioned in section 2.2.2, the distance to the reaction point from the attachment point should be related to the length of the tether in the geometrically controlled reactions¹⁴⁹. From the determined X-ray structure of 142 the distance from C-3 oxygen to the hydrogen at C-9 was 4.5 Å, which was much shorter than that between the oxygen and the nitrogen in the cyanogroup that was 6.1 to 7.1 Å (Figure 2.17). The geometry of the molecule should be changed in the transition state, nevertheless this inconsistency is quite disputable about the fashion of the fluorination.

FIGURE 2.13 X-ray structure of 142

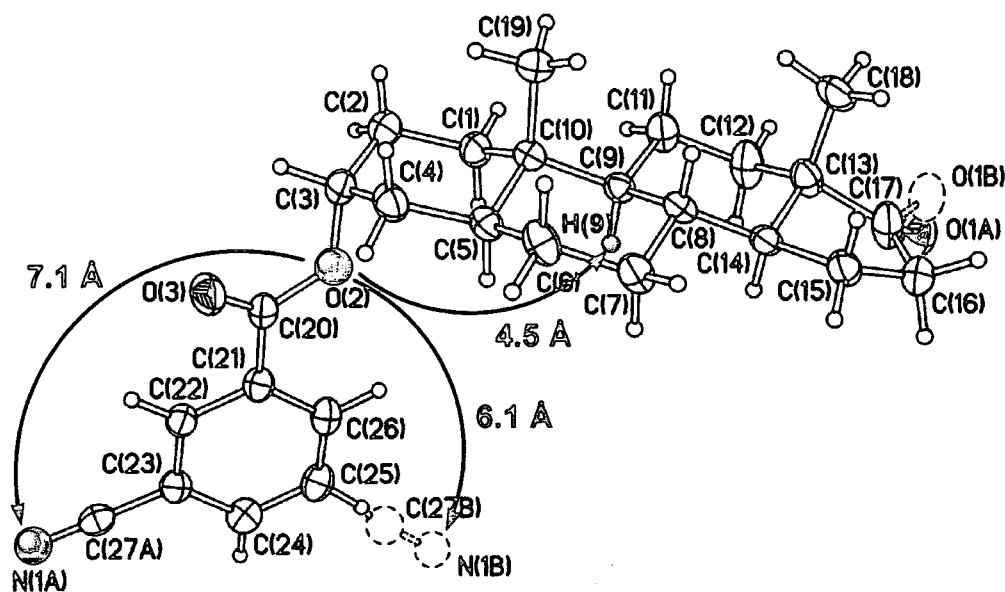

It is difficult to evaluate the results discussed above because elemental fluorine is quite reactive and it is thought to be impossible to exclude the contribution of intermolecular fluorination in the background completely. However, we believe that further investigation on the direct fluorination of more variety of tethers, which have a cyano group or other polarising functional group with different geometrical demand, would make this clearer.

2.5.4 Conclusion

A series of steroid derivatives bearing various functional groups which can interact with elemental fluorine were prepared and fluorinated. The results showed the combination of 3 α -(3-cyanobenzoyloxy) group and nitromethane gave some 9-position selective fluorination compared to the control reaction using simple acetoxy derivative. The major fluorinated product could be isolated and the X-ray structure was determined.

2.6 Chapter 2. Summary

As a new methodology for regio- and stereoselective fluorination of complex molecules, geometrically directed remote fluorination of steroid derivatives was investigated. For coping with this complicated problem, we employed two methods, which were:

- 1) Two step fluorination utilizing N-F reagents which prepared *in situ*
- 2) One step fluorination with tethered functional groups which can interact with elemental fluorine and encourage electrophilic fluorination

In the first method we found that DABCO moiety was a suitable functional group for the tethered N-F reagents, and investigated the remote fluorination of steroid derivatives bearing a DABCO moiety with tethers of different lengths. The results indicated that the tethered N-F reagents could react with some specific unactivated C-H sites of the steroid skeleton, although the selectivity and yields were not very useful. The less reactivity could be attributed to a common problem of intramolecular reaction with a macrocyclic transition state whilst the less selectivity may indicate little contribution of intramolecular fluorination. In either event, some fluorination at C-H sites occurred during the preparation of the tethered N-F reagents *in situ* caused the evaluation of the results to be difficult.

In the second attempt we prepared a series of steroid derivatives carrying various functional groups which were thought to be promoters of electrophilic fluorination with elemental fluorine. Direct fluorination of 3 α -(3-cyanobenzoyloxy)-5 α -androstane-17-one (**142**) showed fair 9-position selectivity compared with the control reactions. We could not conclude that this selectivity solely came from the intramolecular fashion of the fluorination owing to the inconsistency of the distances to the cyano group and the reaction point from the attachment point.

Geometrically directed reaction could potentially be one of the most effective approaches for the specific functionalisation of an unactivated C-H site in a complex molecule. We met many difficulties in attempting to develop this methodology for the electrophilic fluorination, however we believe that the project described in this chapter provides some important clues for the development of new methodology for selective fluorination.

Attempts at Catalytic Enantioselective Fluorination of 1,3-Ketoesters using Elemental Fluorine

3.1 Introduction

Chiral organofluorine compounds are becoming increasingly important with uses in biological and medicinal chemistry, and also in the chemistry of materials.¹⁷⁹ In particular, chiral organofluorine compounds containing a fluorine atom bonded directly to a stereogenic centre are useful for studies of enzyme mechanisms and as intermediates in asymmetric syntheses.^{180,181} Consequently, the development of effective methodologies for the preparation of chiral fluorinated systems is critical to further advances in organofluorine chemistry. Obviously, one of the most straightforward and elegant methods for the preparation of fluorine-containing stereogenic centres should be enantioselective fluorination. Since Lang introduced chiral *N*-fluorocamphorsultam, which is the first example of a chiral N-F reagent, in 1988,¹⁸² a number of reagent-controlled enantioselective electrophilic fluorination reactions have been reported, and currently the centre of interest is moving towards catalytic asymmetric introduction of fluorine. However, elemental fluorine has never been directly used for enantioselective fluorination. Therefore, we are interested in exploring the use of elemental fluorine for enantioselective fluorination, in a complementary study to directed fluorination discussed in previous chapter.

This chapter is concerned with novel attempts at catalytic enantioselective fluorination reactions of 1,3-ketoesters using elemental fluorine. Prior to discussing the current work, literature concerning enantioselective electrophilic fluorination and diastereoselective fluorination using elemental fluorine will be reviewed in the following section.

3.1.1 Enantioselective Fluorination

3.1.1.1 Reagent-controlled reaction

As mentioned above, the first example of enantioselective fluorination was reported by Lang and co-workers (Scheme 3.1).¹⁸² They synthesised chiral

N-fluorocamphorsultam **151** and carried out fluorination of ethyl 2-oxo-cyclopentanecarboxylate. The enantiomeric excess of the product was 70%.

SCHEME 3.1

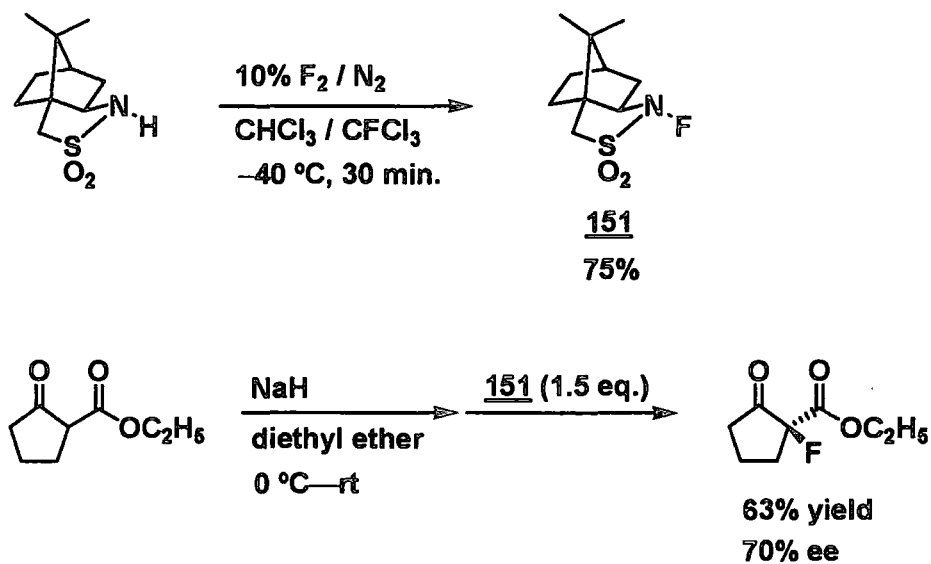

Davis modified the *N*-fluorocamphorsultam **151**. A 3,3-dichloro derivative **152** was efficient for the fluorination of 2-methyl-1-tetralone although this gave less enantioselectivity for ethyl 2-oxo-cyclopentanecarboxylate (Scheme 3.2).^{166,183}

SCHEME 3.2

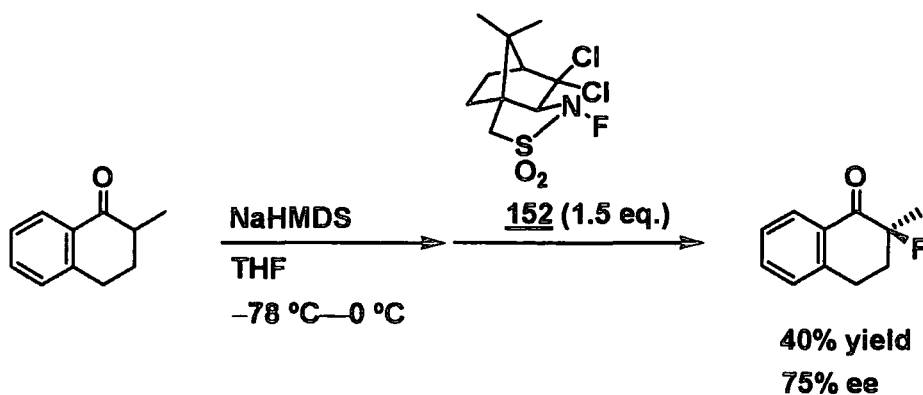

The conveniently accessible *N*-fluoro-*N*-tosyl derivative **153** prepared from (*S*)-1-phenylethylamine was employed for enantioselective fluorination by Takeuchi

(Scheme 3.3).¹⁸⁴

SCHEME 3.3

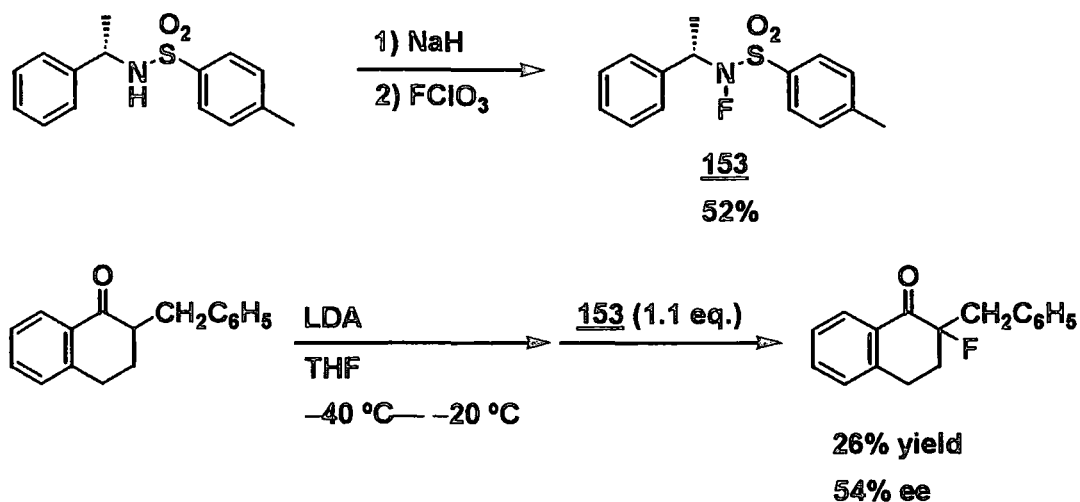

Compound **153** was obtained from fluorination of *N*-tosylated (*S*)-1-phenylethylamine using perchloryl fluoride (FClO₃) and sodium hydride. Compound **153** fluorinated the enolate of 2-benzyl-1-tetralone, although both the reactivity and enantioselectivity were not satisfactory. They also examined *N*-fluoro sultam **20** derived from saccharin, which gave up to 88% ee in the fluorination of the same substrate (Scheme 3.4).⁸⁶

SCHEME 3.4

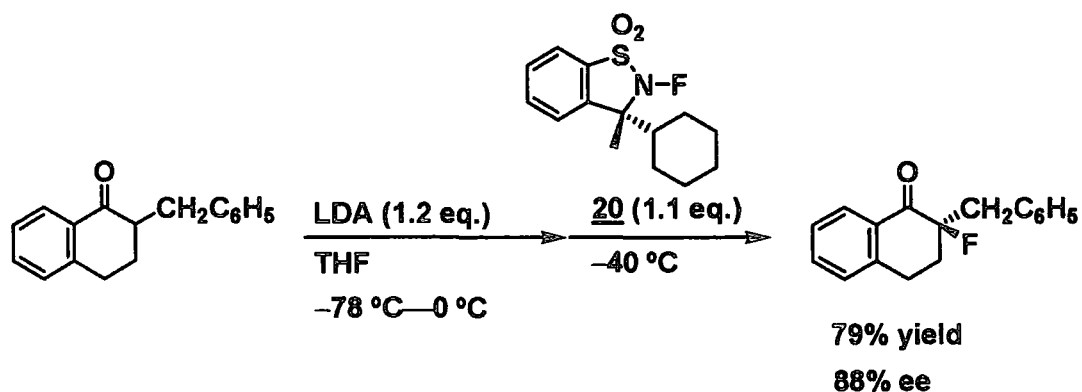

In 2000, two groups independently reported the use of cinchona alkaloid based N-F reagents (Scheme 3.5 and 3.6).^{185,186} Selectfluor was employed as a fluorinating agent for the preparation of the chiral N-F reagent in both cases. Takeuchi used a mixture of

Selectfluor and dihydroquinine 4-chlorobenzoate (**154**), and achieved up to 91% ee in the fluorination of silyl enol ether of 2-benzyl-1-indanone. On the other hand, Cahard reported fluorination of silyl enol ether of 2-methyl-1-tetralone using isolated *N*-fluorocichonidinium tetrafluoroborate, which gave fluorinated product in 61% ee.

SCHEME 3.5

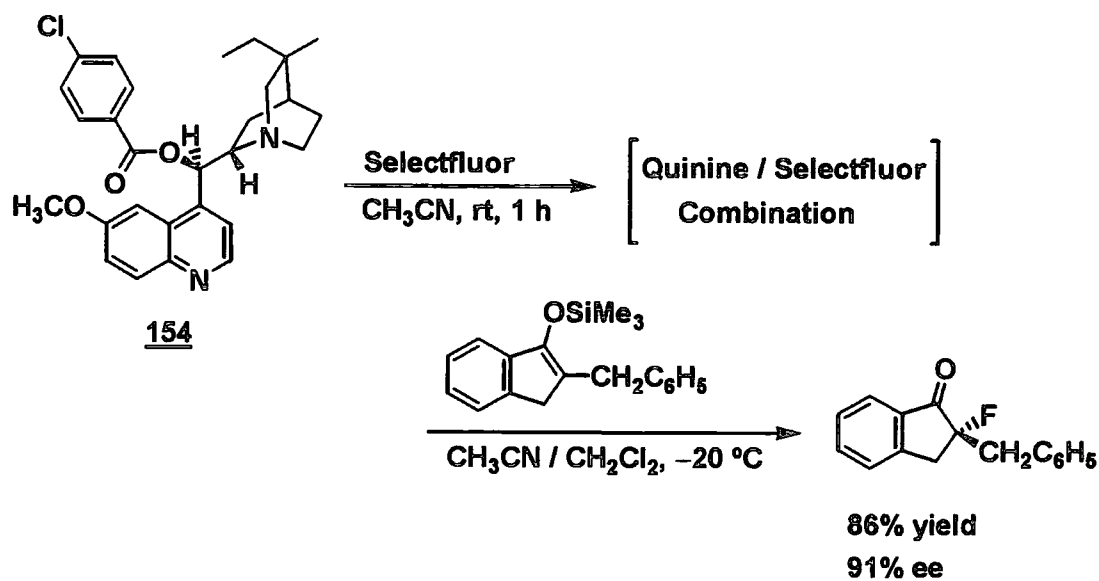

SCHEME 3.6

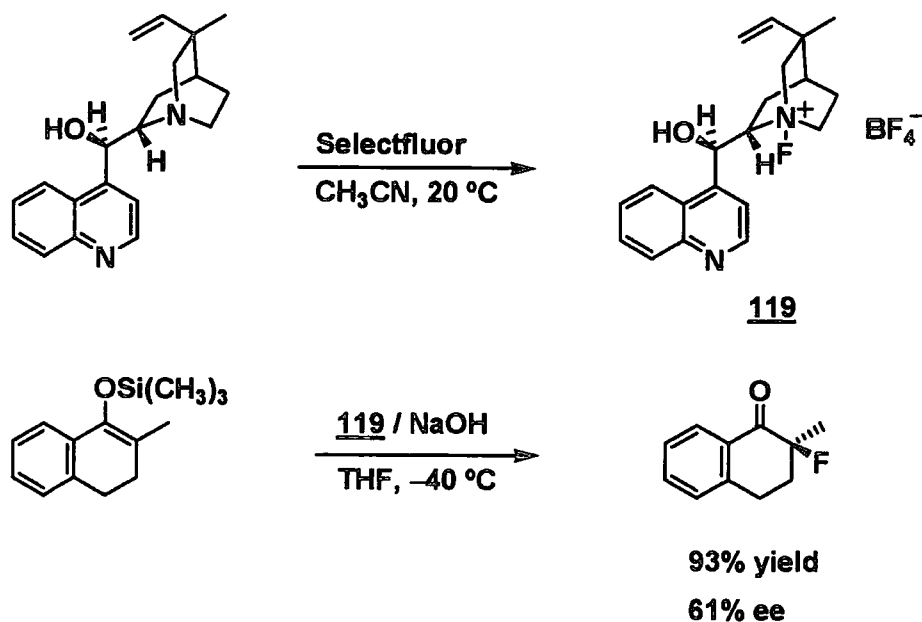

Cahard applied this type of fluorinating agent to enantioselective synthesis of α -fluoro- α -amino acid derivatives (Scheme 3.7).¹⁸⁷

SCHEME 3.7

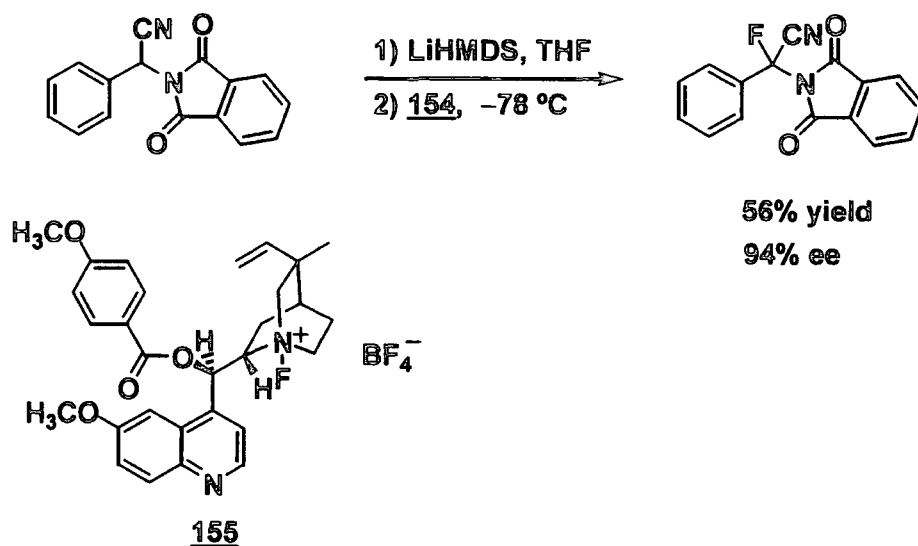

They investigated the relationship between the structure of the *N*-fluoro cinchona alkaloid derivatives and enantioselectivities, and found that quinine and quinidine-based *N*-fluoro reagents were superior to the two other cinchona alkaloids, namely cinchonine and cinchonidine. When *O*-(*p*-methoxybenzoyl)-*N*-fluoroquininium tetrafluoroborate (**155**) was employed in the fluorination of *N*-phthaloylphenyl glycinonitrile, 94% ee was achieved. The enantiomeric excess was significantly higher than in the case of using *N*-phthaloylphenylglycine ethyl ester (66% ee). This difference was explained by the postulated intermediates shown in scheme 3.8.

SCHEME 3.8

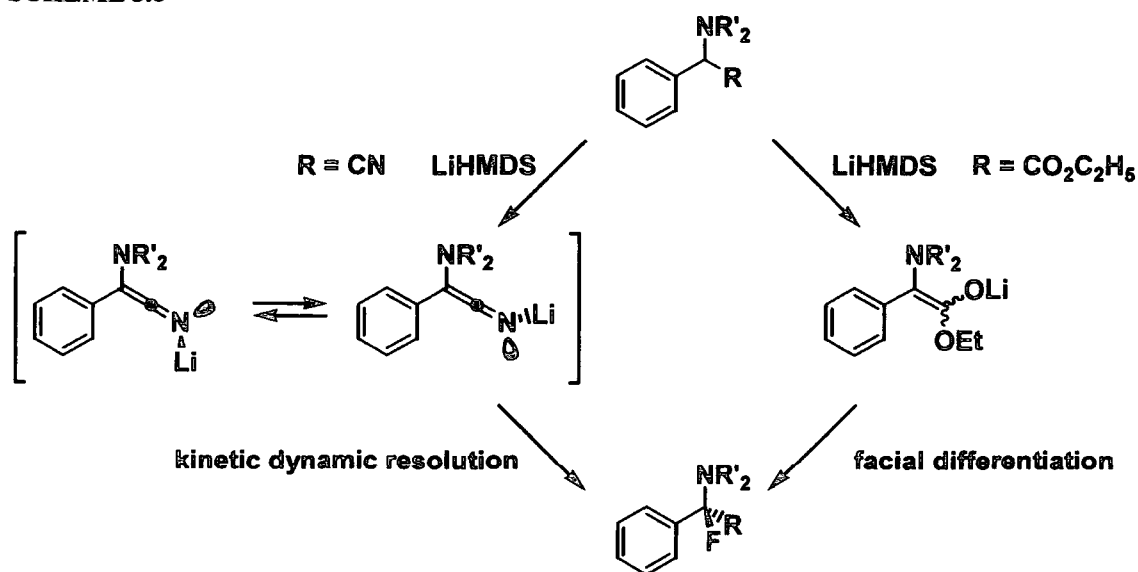

Deprotonation of the ester typically gives a *Z/E* mixture of a prochiral sp^2 enolate, and the asymmetric step consists of an enantiofacial differentiation. On the other hand, nitrile anions presumably exist as lithiated ketenimines with axial chirality. The two isomers undergo racemization rapidly and the enantioselective fluorination results from a kinetic dynamic resolution of those isomers.

Additional work by Cahard demonstrated that the enantioselective fluorination of silyl enol ethers could be carried out in ionic liquids.¹⁸⁸ The fluorination reactions successfully proceeded at 0 °C in [hmim][PF₆] (hmim = hexylmethylimidazolium), the enantioselectivity was comparable or superior to those in acetonitrile at -40 °C.

Gouverneur employed the cinchona alkaloids/Selectfluor combination for the enantioselective fluorodesilylation of allyl silanes (Scheme 3.9).¹⁸⁹

SCHEME 3.9

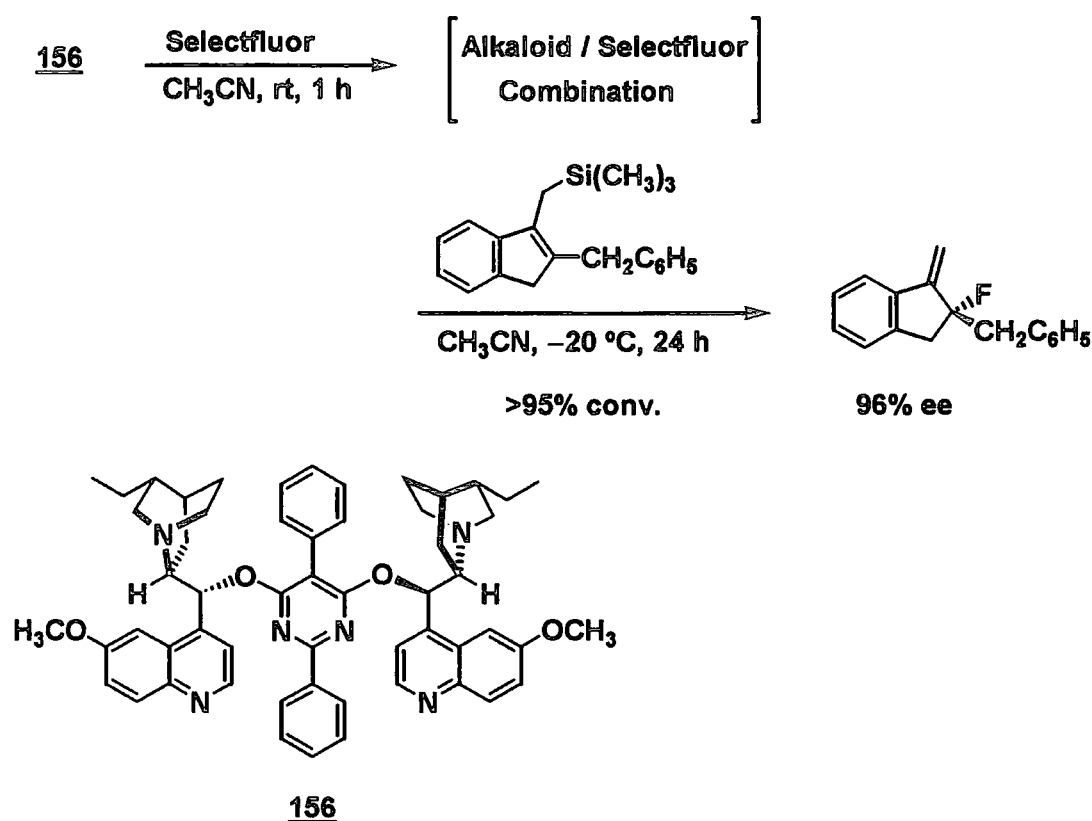

Recently, enantioselective syntheses of a biological active fluorooxindole **156** using *N*-fluoro cinchona alkaloid agents were reported by Cahard and Shibata independently (Scheme 3.10).^{190,191}

SCHEME 3.10

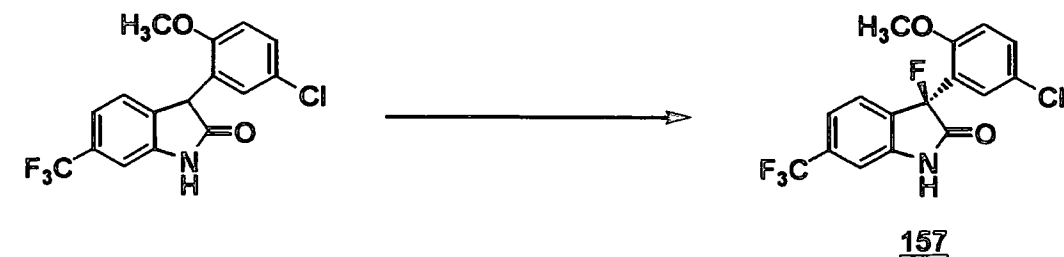

condition	% yield	% ee
[<u>158</u> / Selectfluor combination], CH ₃ CN / CH ₂ Cl ₂ , -80 °C, overnight	94	84
<u>159</u> , DABCO, THF / CH ₃ CN / CH ₂ Cl ₂ -78 to 0 °C, overnight	96	88

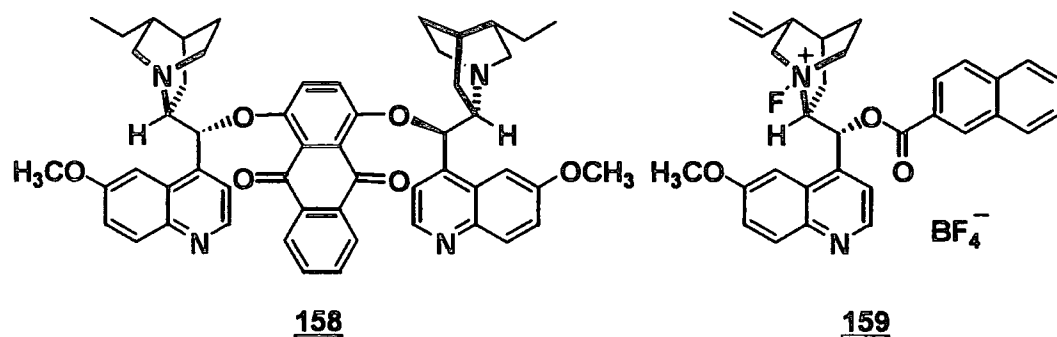

High enantioselectivities were obtained in the fluorination of the parent oxindole using both the bis-cinchona alkaloid 158/Selectfluor combination and isolated *N*-fluoro-2-naphthoyl-quininium tetrafluoroborate (159). In both cases, simple recrystallisation gave enantiomerically pure (>99% ee) crystals of the product 157.

3.1.1.2 Catalyst-controlled reaction

The first example of catalytic enantioselective fluorination was reported by Togni in 2000 (Scheme 3.11).¹⁹² He directed his attention to the fact that the fluorination of ketone systems, such as 1,3-ketoesters or 1,3-diketones, proceed *via* enol forms of the substrates, and reasoned that catalytic amounts of a Lewis acid might accelerate the reaction by catalyzing the enolisation process. A range of Lewis acids were screened for catalytic fluorination of 1,3-ketoesters using Selectfluor (Table 3.1).

The results indicated that titanium or aluminum compounds were the only possible Lewis acid catalysts which can accelerate enolisation of 1,3-ketoesters in the electrophilic fluorination.

TABLE 3.1 Qualitative ordering of catalytic activity of several Lewis acids for the fluorination of ethyl 2-methyl-3-oxo-3-phenylpropionate

Very fast (< 1 h)	Fast (< 1 d)	Slow (≤ 2 w)	Very slow or no reaction (> 2 w)
TiCl ₄	CpTiCl ₃	Cp ₂ Ti(OTf) ₂	Cp ₂ TiCl ₂
AlCl ₃	TiCl ₂ (diolato)	HBF ₄	HCl
		BF ₃	ZnCl ₂
		(CH ₃) ₃ SiOTf	Cu(ClO ₄) ₂
			Cp ₂ Zr(OTf) ₂
			TiF ₄
			TaCl ₅
			Yb(OTf) ₃

He employed chiral titanium (IV) complexes as catalysts for the enantioselective fluorination of 1,3-ketoesters and found that fluorination of 2,4,6-triisopropylbenzyl 2-methyl-3-oxopentanoate using Selectfluor in the presence of 5 mol% of **160** gave 2-fluoro adduct in 90% ee.

SCHEME 3.11

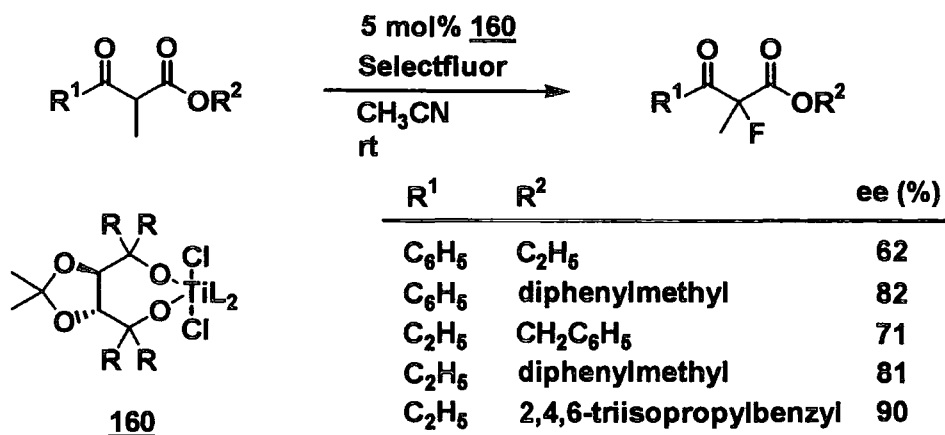

R = 1-Naphthyl, L = CH₃CN

A proposed mechanism involving a cationic titanium monochloro complex **161** as the catalyst is illustrated in scheme 3.12.^{193,194} The substrate 1,3-ketoester coordinates to the titanium complex **160** and substitutes one of the two chlorides and one of the acetonitrile molecules to give the cationic species **161**. After deprotonation, resulting neutral titanium enolato complex **162** is the reactive species and fluorinated by Selectfluor. Finally, in the complex **163**, the fluorinated product is replaced by another substrate molecule to regenerate the catalyst **161** and complete the catalytic cycle.

In additional work, Togni described that the same titanium complex **160** catalyzed a one-pot enantioselective heterodihalogenation of 1,3-ketoesters with Selectfluor and NCS to afford 2-chloro-2-fluoro-1,3-ketoesters in moderate and good yield with up to 65% ee.¹⁹⁵

SCHEME 3.12

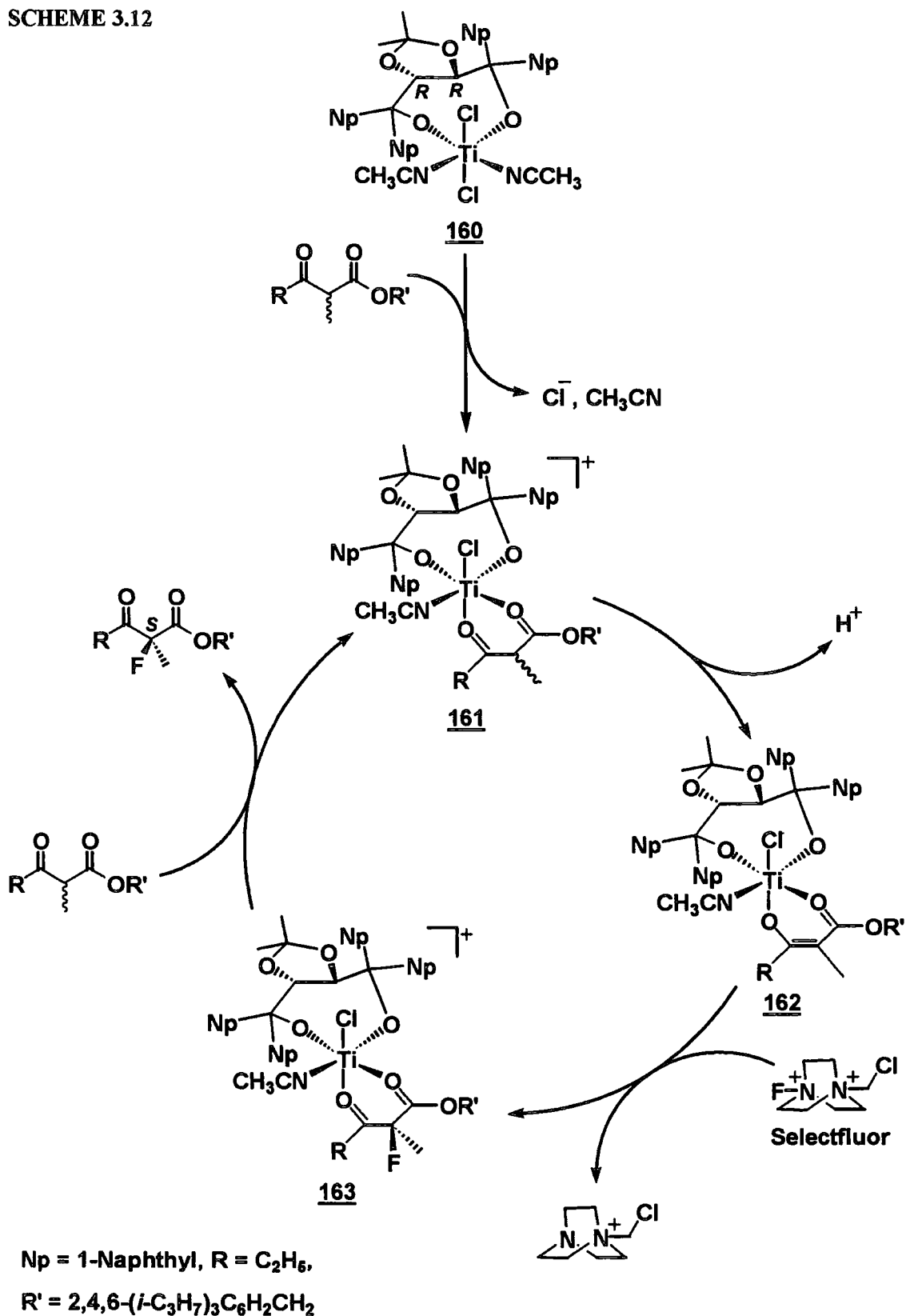

Kim did not utilise a cinchona alkaloid derivative as a chiral N-F reagent, but as a phase-transfer catalyst for enantioselective fluorination of 1,3-ketoesters (Scheme 3.13).¹⁹⁶

SCHEME 3.13

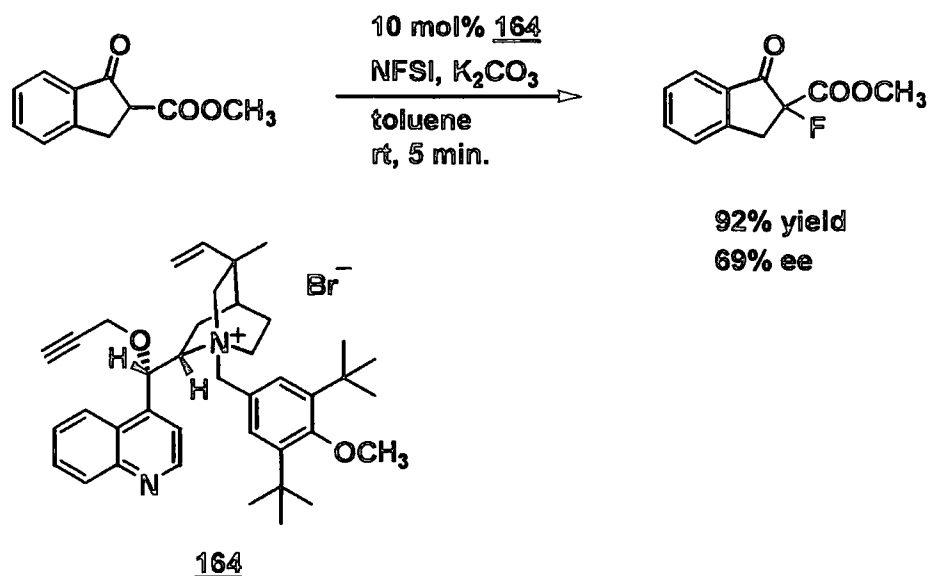

The fluorination of methyl 1-oxoindan-2-carboxylate using 10 mol% of cinchonine-derived quaternary ammonium salt **164**, which has a bulky (3,5-di-*tert*-butyl-4-methoxy)benzyl group at the bridgehead nitrogen, proceeded rapidly to give 2-fluoro product in 69% ee. In this system, the reaction was carried out using NFSI as the fluorinating agent in non-polar toluene in the presence of a solid base, such as K₂CO₃ and Cs₂CO₃, at room temperature.

On the other hand, Sodeoka developed an efficient catalytic fluorination of 1,3-ketoesters using chiral palladium complexes (Scheme 3.14).¹⁹⁷

SCHEME 3.14

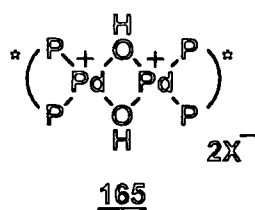
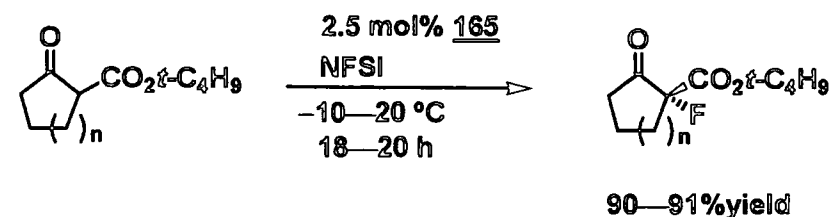

n	catalyst	solvent	ee (%)
1	165a	<i>i</i> -C ₃ H ₇ OH	92
2	165b	C ₂ H ₅ OH	94

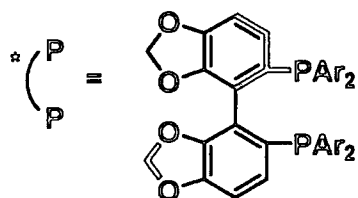

X⁻ = TfO⁻
Ar = 3,5-di(*t*-butyl)-4-methoxyphenyl

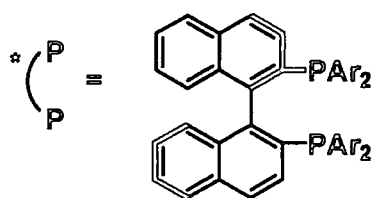

X⁻ = BF₄⁻
Ar = 3,5-dimethylphenyl

They found that the palladium hydroxo complexes **165**, which were effective for a enantioselective Michael reaction of 1,3-dicarbonyl compounds,¹⁹⁸ showed a catalytic activity in the fluorination of 1,3-ketoesters using NFSI. The fluorination of cyclic 1,3-ketoesters, which had a *tert*-butyl ester group, in alcoholic solvents gave 92 to 94% ee.¹⁹⁷ Even in the case of acyclic 1,3-ketoesters, which were generally difficult to fluorinate with high enantioselectivity, 87 to 91% ee were obtained. The mechanism of the generation of the palladium enolate was proposed as shown in scheme 3.15.¹⁹⁸

SCHEME 3.15

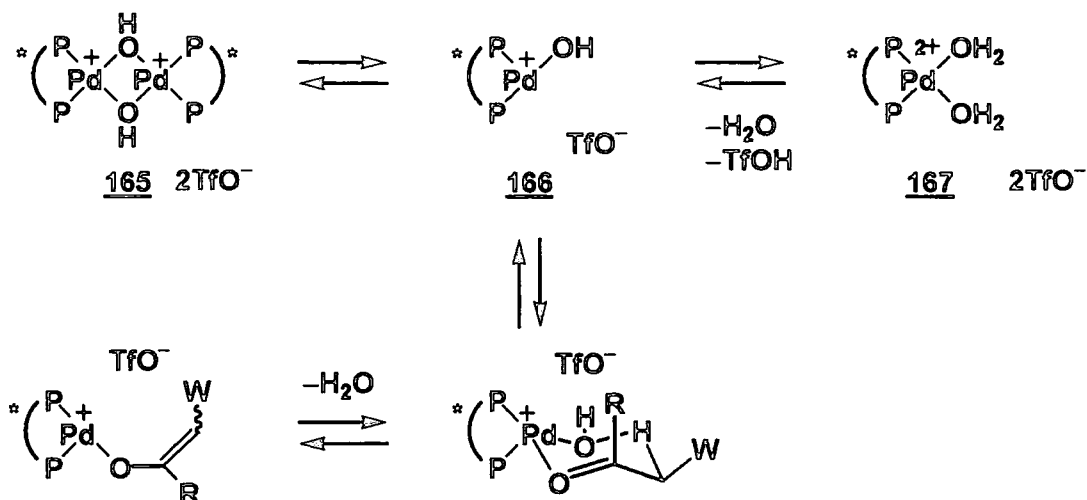

They anticipated that the palladium complexes **165** and **167** are in equilibrium with the monomeric palladium hydroxo complex **166**, which would act in two distinct roles, Lewis acid and Brønsted base. Palladium complex **166** was thought to react with carbonyl compounds to give a chiral enolate, through a favorable six-membered transition state. Sodeoka demonstrated that the products obtained in this reaction system could be utilised for the syntheses of α -fluoro β -hydroxy and β -amino esters (Scheme 3.16).

SCHEME 3.16

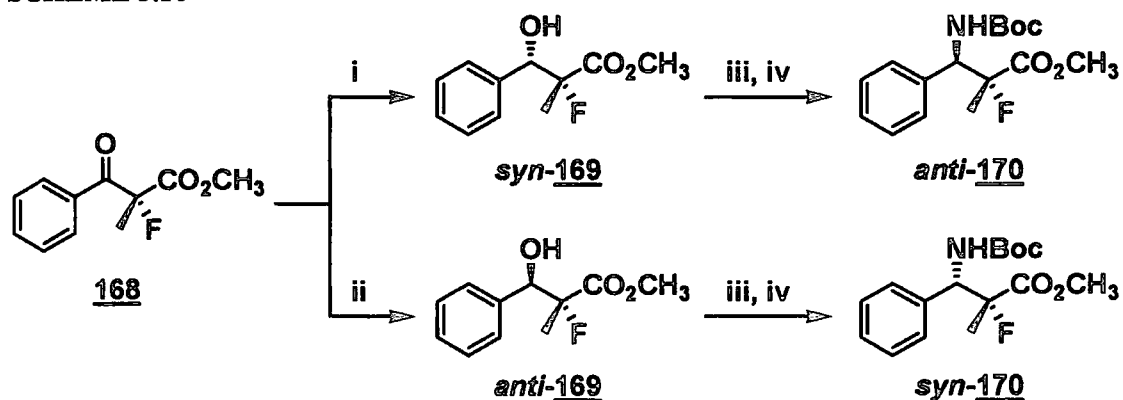

Conditions: i) $\text{C}_6\text{H}_5(\text{CH}_3)_2\text{SiH}$ (3.0 eq.), TBAF (2.0 eq.), DMF, 0°C , 10 min, 83% (dr = $>95/5$); ii) $(\text{C}_6\text{H}_5)_3\text{SiH}$ (3.0 eq.), TFA, rt, 3 h, 75% (dr = $>95/5$); iii) $(\text{C}_6\text{H}_5)_3\text{P}$ (1.5 eq.), DEAD (1.5 eq.), DPPA (1.2 eq.), THF, rt, 2 h, 79% from *syn*-**169**, 73% from *anti*-**169**; iv) Pd/C, H_2 , $(\text{Boc})_2\text{O}$, CH_3OH , 1 h, 80% for *anti*-**170**, 57% for *syn*-**170**.

The methyl ester **168**, which was derived from the corresponding *tert*-butyl ester for the determination of the absolute configuration, was converted to both diastereomers of the α -fluoro β -hydroxy ester **169** in a highly diastereoselective manner by simply changing the reducing conditions. These compounds were subjected to azidation with inversion of configuration. Reduction of the azide group, followed by protection of the amino group, afforded the α -fluoro β -amino ester **170** in good yields.

Further work by Sodeoka described that the palladium catalysts could be immobilised in ionic liquids and reused (Scheme 3.17).¹⁹⁹

SCHEME 3.17

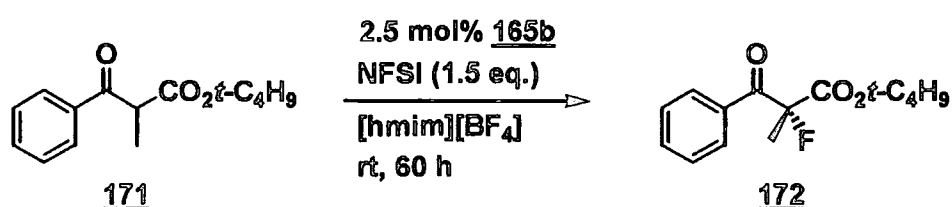

cycle	yield (%)	ee (%)	cycle	yield (%)	ee (%)
1	93	92	6	91	91
2	80	91	7	91	91
3	81	91	8	86	91
4	91	91	9	86	91
5	81	91	10	67	91

The fluorination reaction of *tert*-butyl 2-methyl-3-oxo-3-phenylpropionate (**171**) was successfully carried out using the same catalyst dissolved in the IL to give **172** no less than 9 times without loss of yield and enantioselectivity.

So far all of the enantioselective fluorinations have adopted N-F reagents as the fluorinating agent. Thus, we were interested in the direct use of elemental fluorine for enantioselective fluorination because it is the most inexpensive source of electrophilic fluorine.

3.1.2 Diastereoselective Fluorination using elemental fluorine

In general, the steric bulk of fluorinating agents could affect the stereoselectivity in fluorination reactions as described in section 1.2.5. Elemental fluorine is thought to be not an advantageous fluorinating agent from this point of view, but Kaneko reported enantioselective preparation of 2-fluoro-1,3-ketoesters using elemental fluorine

(Scheme 3.18).²⁰⁰ Direct fluorination of a 1,3-dioxin-4-one **174a** having (-)-menthone as the chiral auxiliary at the 2-position which was derived from the corresponding 1,3-ketoacid **173** and following treatment with potassium carbonate gave 2-fluoro-1,3-ketoester **175** in excellent enantioselectivity. The elemental fluorine exclusively attacked from the less hindered isopropyl-side (Figure 3.1)

SCHEME 3.18

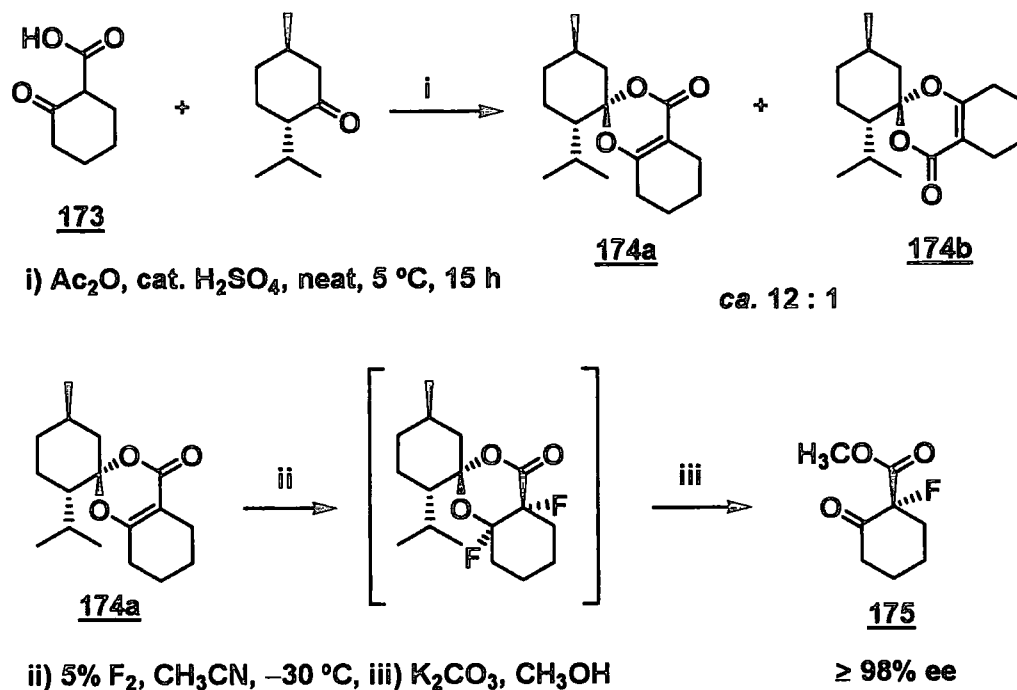
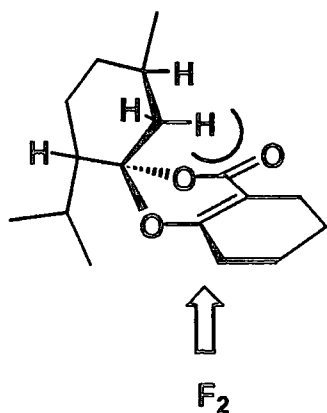

FIGURE 3.1



On the other hand, the Durham group found hydrated copper nitrate effectively catalysed direct fluorination of 2-substituted carbonyl compounds as described in

section 1.2.2.3 (see Scheme 1.13).³⁵ We reasoned that direct use of elemental fluorine for catalytic enantioselective fluorination could be possible if we establish a 'fluorine-tolerant' catalyst system which possesses an appropriate asymmetric environment.

To achieve this quite challenging goal, we conducted further screening of Lewis acid catalysts for direct fluorination of 1,3-ketoesters to find 'fluorine-tolerant' catalyst systems. Then, the effect of auxiliaries or ligands was examined for which catalytic activity was shown in the catalyst survey, to explore the feasibility of catalytic enantioselective fluorination with elemental fluorine.

3.2 Titanium catalyzed direct fluorination of 1,3-ketoesters

3.2.1 Screening of catalysts (1)

For the beginning of our investigation, we assessed whether the titanium catalyst system reported by Togni could be applied to direct fluorination of 1,3-ketoesters. We employed ethyl 2-methyl-3-oxobutanoate (**176**) as a model compound for the preliminary investigation. Direct fluorinations of **176** were carried out in the presence or absence of catalyst (Table 3.2).

TABLE 3.2 Screening of catalyst for direct fluorination of ethyl 2-methyl-3-oxo-butanoate (**176**) (1)

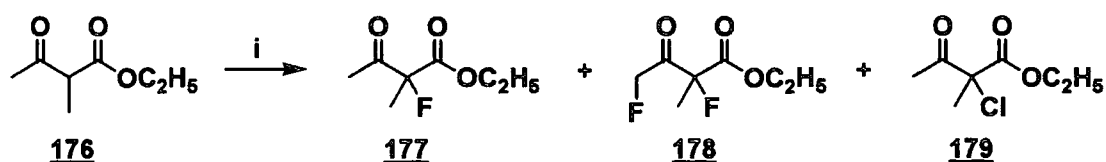

i) 10% F₂ / N₂, catalyst (0.1 eq.), CH₃CN, 0 °C

entry	catalyst	F ₂ (equiv.)	conv. (GC, %)	yield (GC, %)		
				177	178	179
1	none	2.0	6	35	—	—
2	TiCl ₄	2.0	49	13	7	77
3	TiCl ₄ ^a	1.0	63	4	—	96
4	TiCl ₂ (OR) ₂ ^b	1.2	32	5	—	78

^a 0.2 eq. of catalyst was used. ^b (OR)₂ = *trans*-

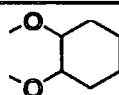

Reactions were carried out in acetonitrile at 0 °C, because it was preferable not to proceed in the absence of catalyst. In the case of using formic acid as the solvent, this reaction proceeded in 25% conversion at 10 to 15 °C.³² As expected, fluorination of 176 in the absence of catalyst in acetonitrile gave a very low conversion (entry 1).

TiCl₄, which is an effective catalyst of fluorination of 1,3-ketoesters using Selectfluor, gave interesting results (entry 2, 3). The reactions proceeded to give the chlorinated derivative 179 as the major product. Titanium (*trans*-cyclohexane-1,2-diolato) dichloride also mediated the chlorination of 176 (entry 4). It was, therefore, very important to modify this catalyst system for enantioselective fluorination. In addition, the reaction mixture showed red colour in the beginning of reaction, and the colour disappeared in the course of the reaction. The red colour was thought to be derived from titanium enolate species. A possible mechanism of the reaction can be supposed as shown in scheme 3.19.

SCHEME 3.19

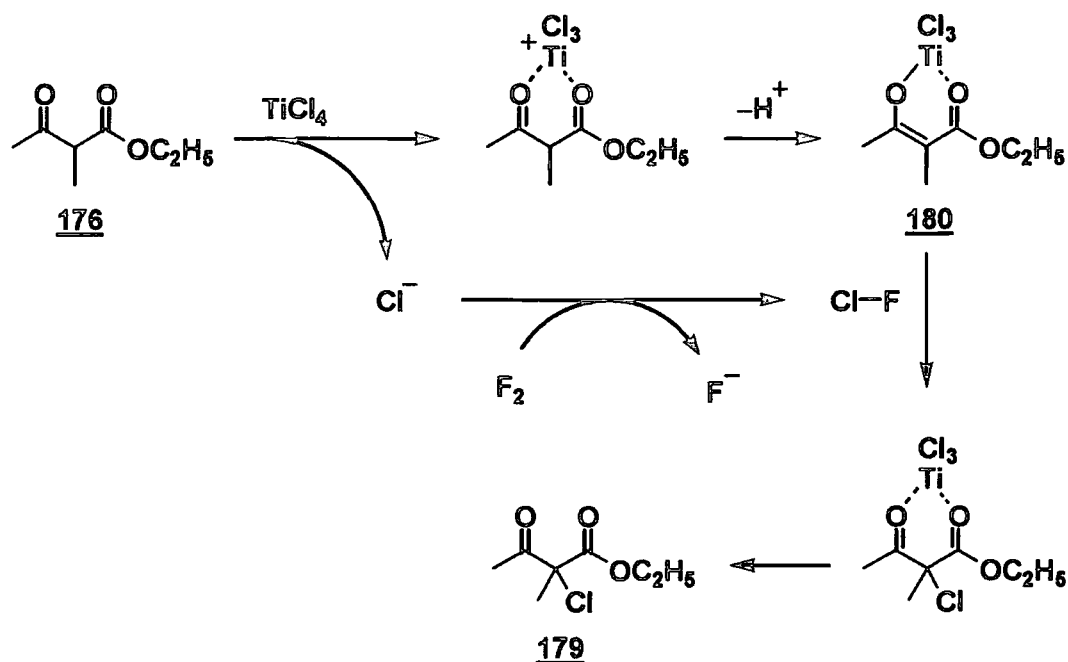

The chlorination is assumed to proceed *via* titanium enolate species (180). The chlorinating agent is supposed to be chlorine fluoride (Cl-F) generated by the reaction between chloride ion or chlorine on the titanium species and elemental fluorine. Titanium (IV) chloride was thought to finally be changed into titanium (IV) fluoride, which is inactive in enolisation process as Togni reported (see table 3.1).¹⁹²

3.2.2 Screening of additives

As described above, the change of colour of the reaction mixture indicated that titanium compounds were deactivated in the course of the reaction. This deactivation was thought to be caused by the formation of HF or fluoride ion, which possesses a strong affinity for titanium (IV) species. In order to prevent the deactivation of the catalyst, effects of various additives which were thought to be able to trap hydrogen fluoride or fluoride ion were investigated in the direct fluorination of 176 with titanium (IV) compounds (Table 3.3).

TABLE 3.3 Screening of additive

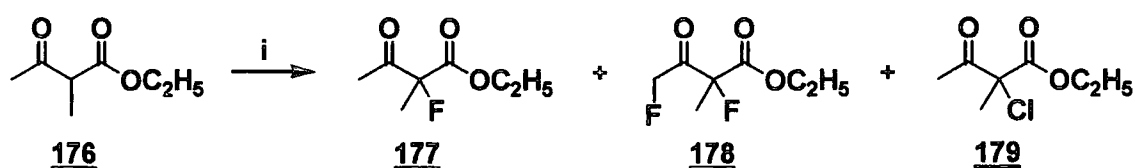

i) 10% F₂ / N₂ (1.2 eq.), TiCl₄ (0.1 eq.), additive (1.5 eq.), CH₃CN, 0 °C

entry	additive	conv. (GC, %)	yield (GC, %)		
			<u>177</u>	<u>178</u>	<u>179</u>
1	NaF	30	—	—	92
2	NaHCO ₃	9	20	—	61
3 ^a	DABCO, NaBF ₄	5	37	—	—
4 ^b	NaBF ₄	45	9	4	63
5	BF ₃ ·O(C ₂ H ₅) ₂	54	38	13	28
6	(CH ₃) ₃ SiCl	86	—	—	100

^a The reaction was carried out at 0 °C to rt. ^b Titanium (*trans*-cyclohexane-1,2-diolato) dichloride was used as the catalyst.

Sodium fluoride, which was thought to be able to react with hydrogen fluoride to give sodium hydrogen difluoride, did not act as a trapping agent (entry 1). Sodium hydrogen carbonate was added to neutralise with hydrogen fluoride, but the reaction did not proceed (entry 2). DABCO and sodium tetrafluoroborate, thought to form N-F species with elemental fluorine *in situ*, caused significant decrease of the conversion (entry 3). On the other hand, sodium tetrafluoroborate alone slightly improved the

conversion and selectivity (entry 4, see also table 3.2 entry 4). In the case of boron trifluoride, the reaction proceeded in 54% conversion and gave fluorinated derivatives as major products but accompanied by chlorinated compound (entry 5). Trimethylsilyl chloride successfully extended the life time of the catalyst. The reaction proceeded in 86% conversion, and gave chlorinated system **176** exclusively (entry 6). Trimethylsilyl chloride is supposed to react with fluoride ion to give volatile trimethylsilyl fluoride and chloride ion, which may be used as the chlorinating agent. A proposed catalyst cycle is shown in scheme 3.20.

SCHEME 3.20

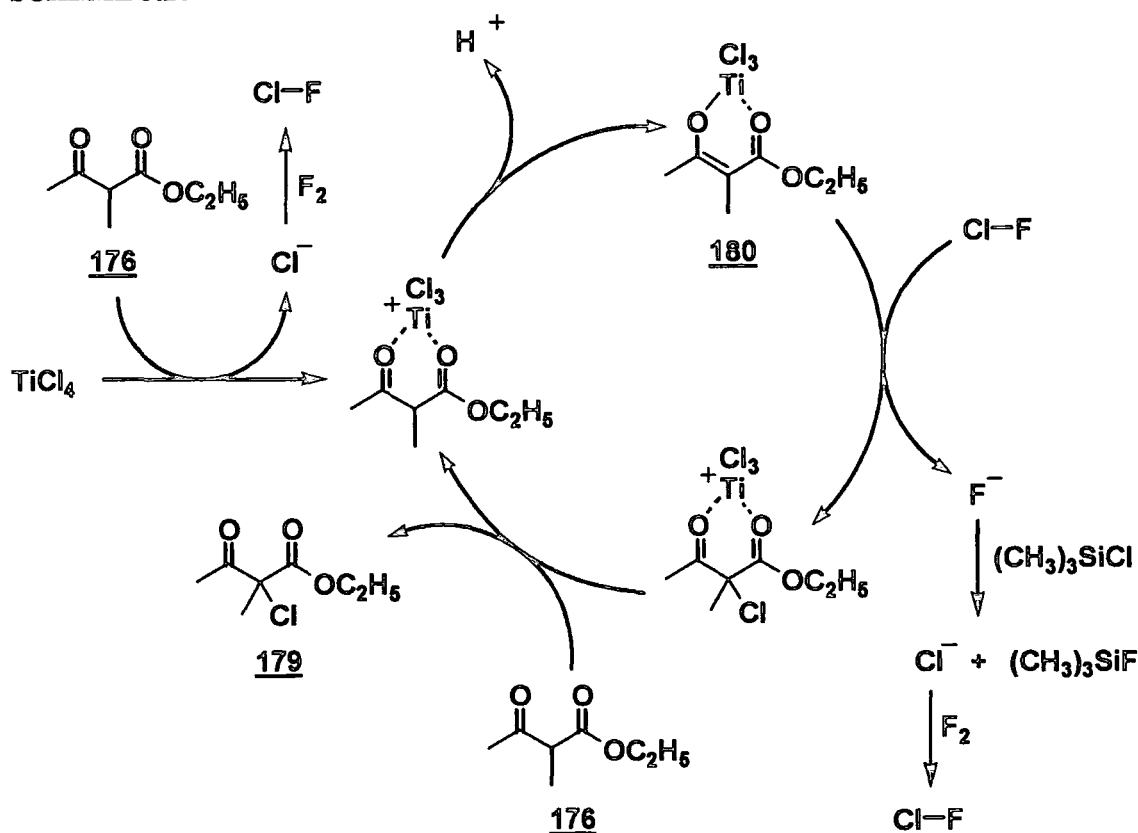

In addition, fluoride ions are formed also by the reaction between chloride ion and elemental fluorine as shown in scheme 3.19. Consequently, introduction of elemental fluorine in the presence of trimethylsilyl chloride can be efficient system for generating Cl-F , which is an electrophilic chlorinating agent (Scheme 3.21).²⁰¹

SCHEME 3.21

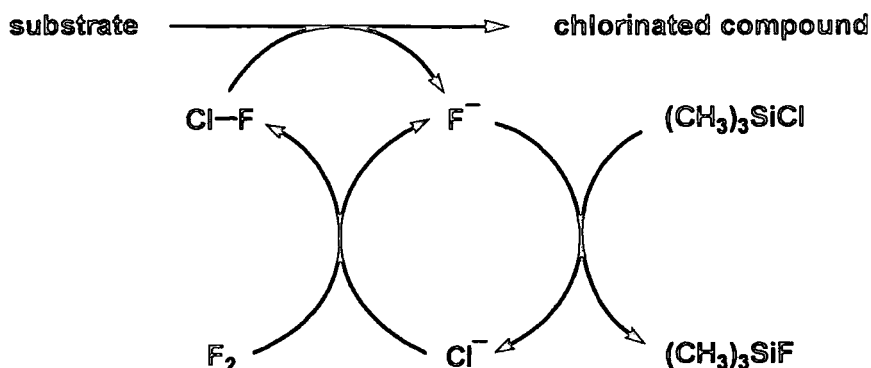

3.2.3 Effect of ancillary ligand of titanium complex

Generation of chloride ion *in situ* was found to lead to formation of Cl-F and an introduction of chlorine atom into the substrate rather than fluorine in the reaction using tetravalent titanium and elemental fluorine. Thus, ancillary ligands other than chloride were investigated.

Titanium (*trans*-cyclohexane-1,2-diolato) bis(trifluoromethanesulfonate) **181** and titanium (*trans*-cyclohexane-1,2-diolato) bis(trifluoroacetate) **182** were prepared as shown in Scheme 3.22.²⁰²

SCHEME 3.22

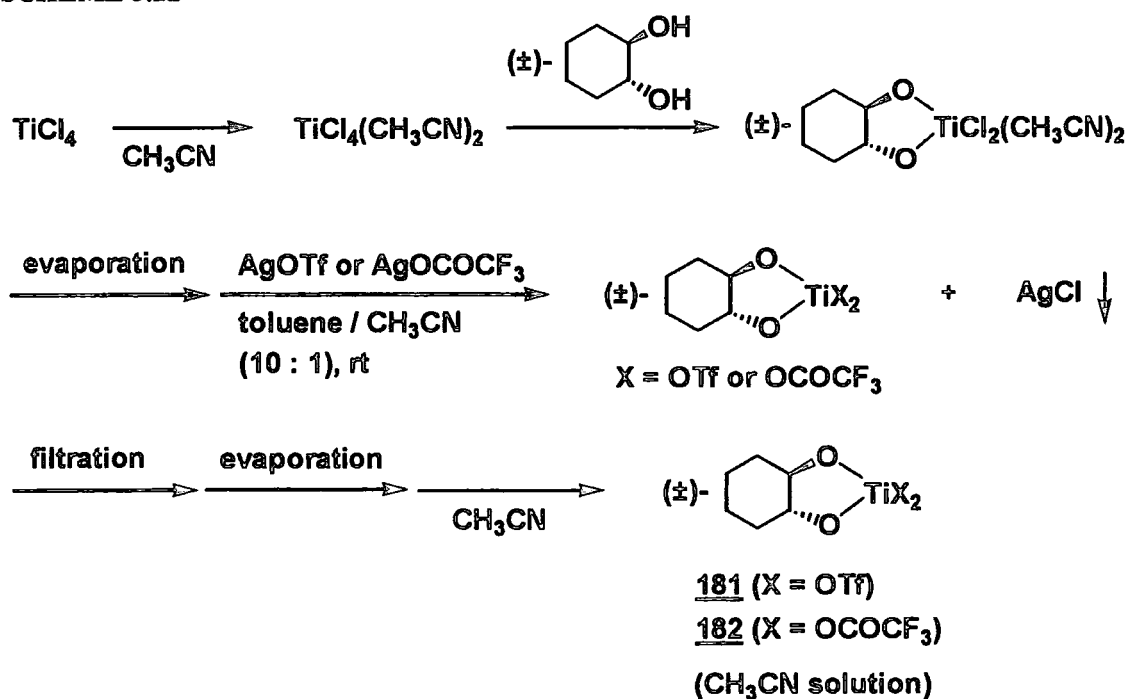

Using these titanium complexes fluorinations of **176** were carried out (Table 3.4).

TABLE 3.4 Titanium catalysed direct fluorination of ethyl 2-methyl-3-oxopropionate (**176**)

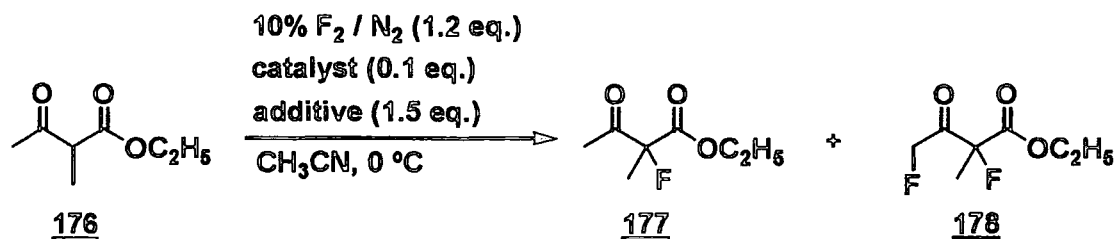

entry	catalyst	additive	conv. (GC, %)	yield (GC, %)	
				177	178
1	181	—	32	58	25
2	181	(CH ₃) ₃ SiOTf	70	47	21
3	181	(CH ₃) ₃ SiOCOCF ₃	58	59	25
4	181	(CH ₃) ₃ SiOAc	60	55	26
5	181	(CH ₃) ₃ SiCF ₃	46	55	28
6	TfOH	—	47	58	32
7	181	(CH ₃) ₃ SiOTf, proton sponge ^a	22	19	—
8	181	(CH ₃) ₃ SiOTf, PMP ^b	53	60	24
9	182	—	7	100	—
10	182	(CH ₃) ₃ SiOCOCF ₃	55	48	23
11	182 ^c	(CH ₃) ₃ SiOCOCF ₃	51	40	19
12 ^d	182	(CH ₃) ₃ SiOCOCF ₃	67	46	23
13 ^e	182	(CH ₃) ₃ SiCF ₃	26	68	32
14	—	(CH ₃) ₃ SiOCOCF ₃	4	100	—
15	CF ₃ COOH	—	5	46	—

^a proton sponge = 1,8-bis(dimethylamino)naphthalene. ^b PMP = 1,2,2,6,6-penta-methylpiperidine. ^c 20 mol % of the catalyst was used. ^d 2.4 eq. of fluorine was used. ^e The reaction was carried out at 25 °C.

The reaction of **176** with elemental fluorine using 10 mol % of **181** proceeded to give fluorinated products in 32% conversion (entry 1). The catalyst seemed to become deactivated during the reaction, similar to when titanium chloride was used. A series of the compounds which have trimethylsilyl group were effective to lengthen the life time of the catalyst (entry 2–5). The order of the efficiency was $\text{TMSOTf} > \text{TMSOAc} \approx \text{TMSOCOFCF}_3 > \text{TMSCF}_3$, which was supposed to be concerned with acidity of the corresponding acids of the counter parts. However, the reaction was found to be also accelerated by catalytic amounts of triflic acid (entry 6). When the ancillary ligand is triflate, inevitably catalytic amounts of triflic acid are formed *in situ*. Coe reported that triflic acid was an effective solvent for direct fluorination of aromatic compounds.²⁰³ Consequently, triflic acid was thought to be able to mediate not only the enolisation process but also the fluorination process due to its extremely acidic nature. The existence of a non-catalytic process is not preferable to further application to asymmetric catalysis.

In entry 7 and 8, the reactions were carried out in the presence of weak nucleophilic bases, which were thought to act as a trapping agent for triflic acid. In the case of using 1,8-bis(dimethylamino)naphthalene, the reaction was interrupted (entry 7). On the other hand, 1,2,2,6,6-pentamethylpiperidine gave comparable results to the case without base (entry 8).

The reaction using **182** as the catalyst in the absence of additive gave only 7% conversion (entry 9). Trimethylsilyl trifluoroacetate was also effective in this system (entry 10), however, the increase of the catalyst did not lead to improvement of the conversion (entry 11). On the other hand, excess amounts of fluorine slightly improved the conversion (entry 12). Trimethylsilyl trifluoromethane was less effective than trimethylsilyl trifluoroacetate at even room temperature, which was thought to be preferable to evaporating trimethylsilyl fluoride and in turn to removing fluoride ion (entry 13). Trimethylsilyl trifluoroacetate and trifluoroacetic acid did not show any catalytic activity separately (entry 14 and 15).

From these results, the reactions using **182** and trimethylsilyl trifluoroacetate seemed to proceed *via* titanium enolate. A possible catalytic cycle, which is similar to that of the chlorination described in the previous section, is shown in scheme 3.23.

SCHEME 3.23

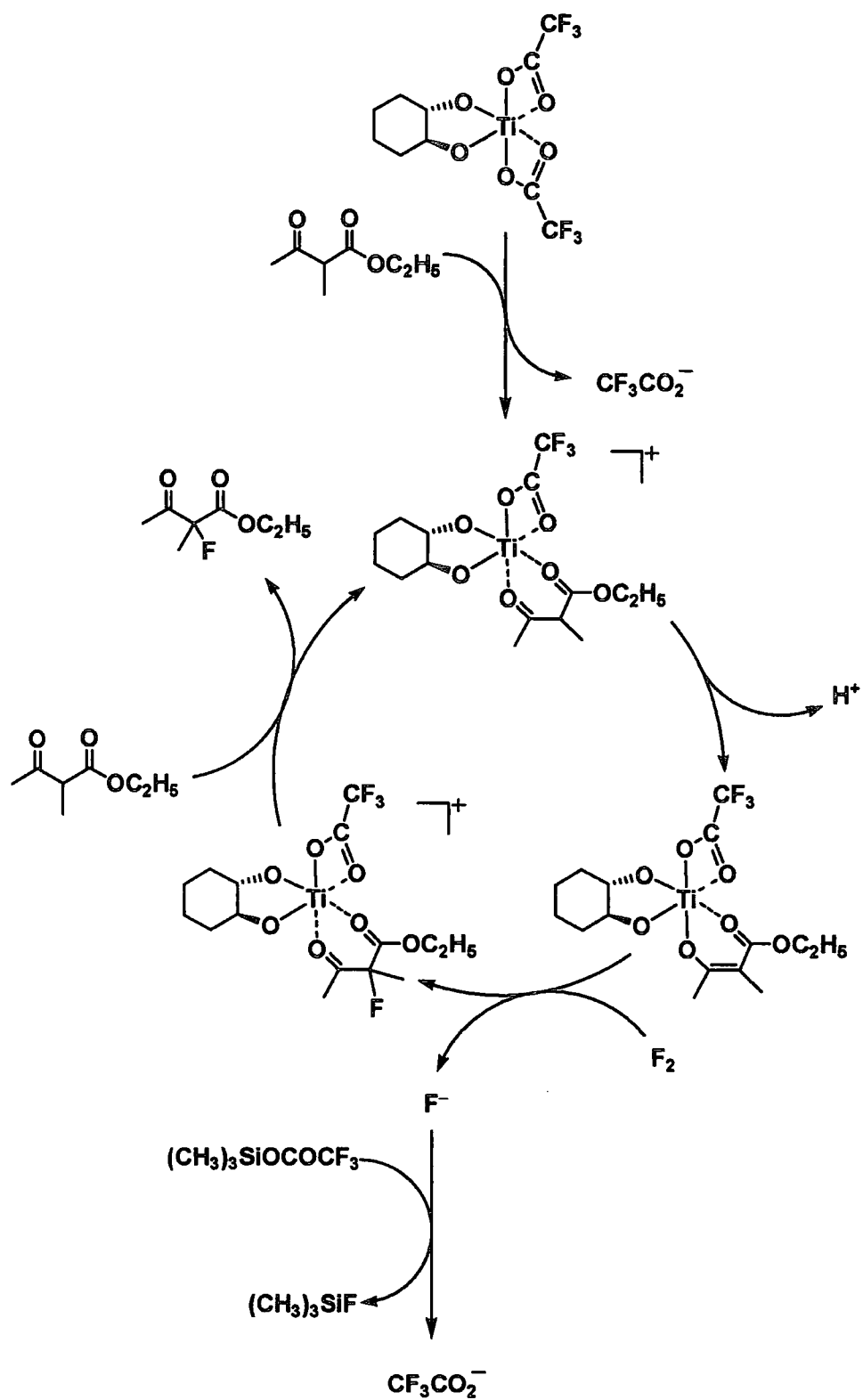

Currently, the efficiency of the catalyst system was not sufficient to complete the reaction. This was thought to be caused by the nature of the ancillary ligand, trifluoroacetate, which was not so good leaving group, and therefore the replacement of the ligand for substrate in the catalytic cycle was not rapid enough.

3.2.4 Effect of intermittent introduction of fluorine

In this reaction, removal of fluoride by removal of trimethylsilyl fluoride by distillation could be crucial to maintain the catalytic cycle. Consequently, the fluorination of **176** was carried out using **182** and trimethylsilyl trifluoroacetate with an intermittent introduction of fluorine to improve the conversion because such a procedure was thought to be effective to keep or regenerate the active species (Scheme 3.24).

SCHEME 3.24

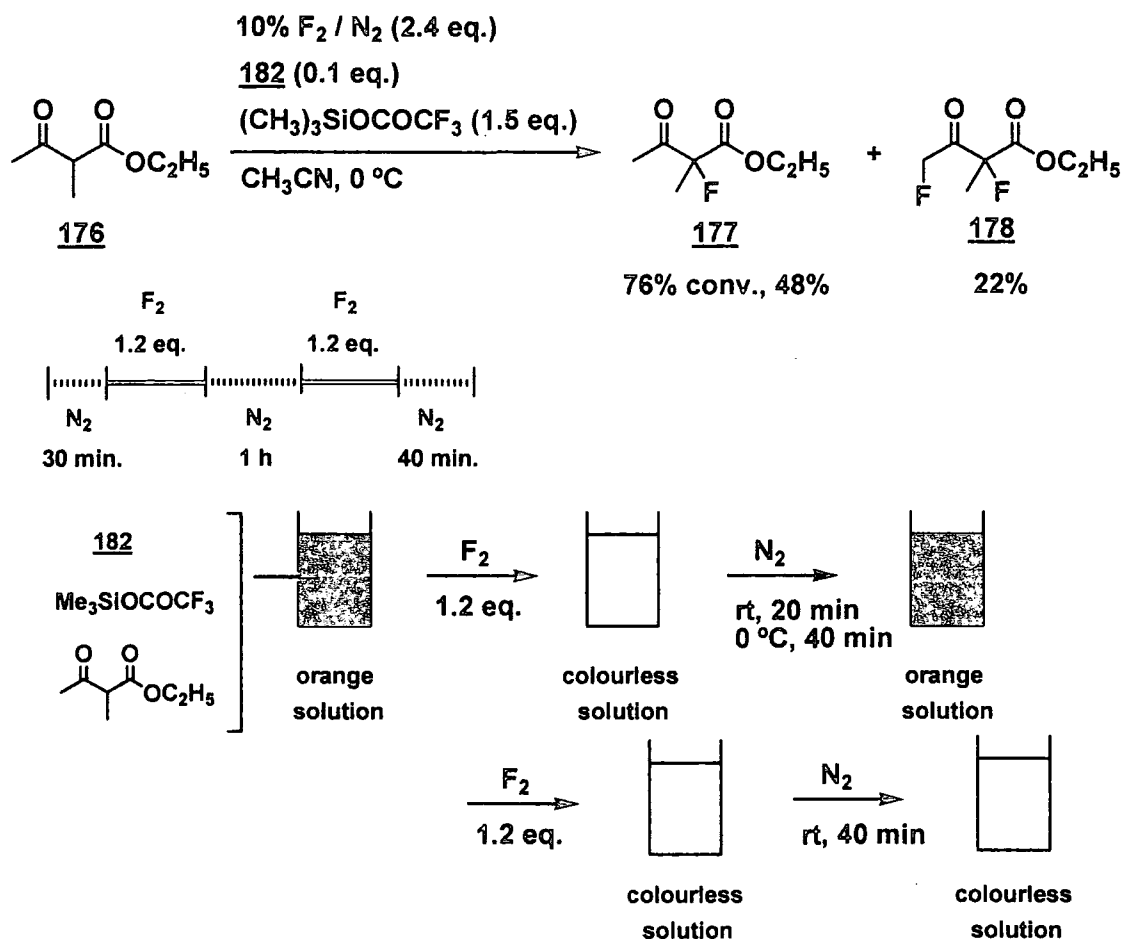

during the fluorination. In this reaction, nitrogen purge was carried out for 20 minutes at room temperature, which gave reappearance of the colour. Further fluorination proceeded with another 1.2 equivalents of fluorine to give a colourless solution which could not be regenerated by further nitrogen purge. The conversion reached to 76% which was better than the normal condition (Graph 3.1). The nitrogen purge at room temperature is assumed to be slightly effective for removing HF or trimethylsilyl fluoride formed in the reaction mixture to regenerate active titanium species.

GRAPH 3.1

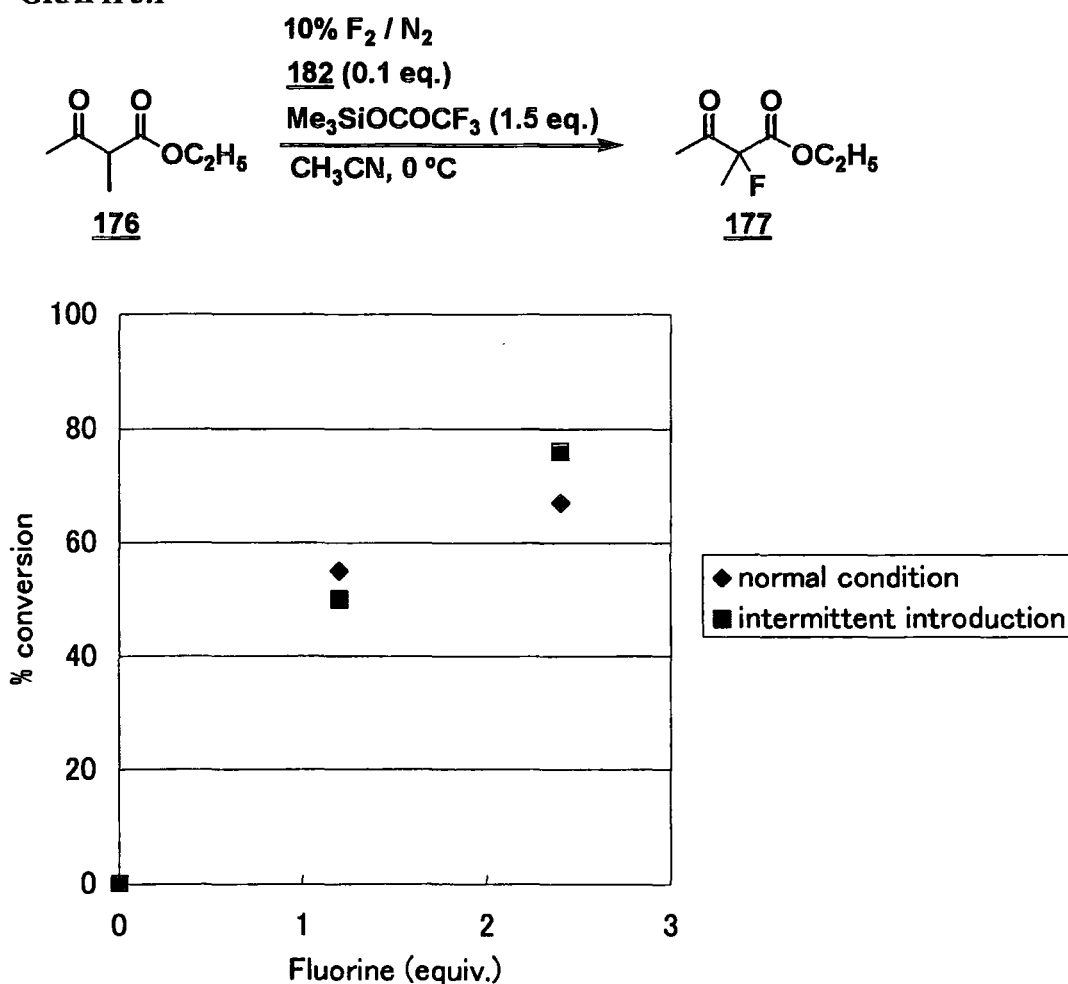

3.2.5 Conclusion

The titanium catalyst system, which was successfully utilised for enantioselective fluorination of 1,3-ketoesters using Selectfluor, was not found to be applicable to direct fluorination of ethyl 2-methyl-3-oxobutanoate (176). However, the change of the ancillary ligands and additives, which had a trimethylsilyl group, allowed catalytic

direct fluorination to proceed. Currently, the efficiency of the catalyst is not sufficient to apply the catalyst to enantioselective fluorination with elemental fluorine. Further improvement of the capability of the catalyst system is required.

3.3 Nickel catalyzed direct fluorination of 1,3-ketoesters

3.3.1 Screening of catalyst (2)

As described in the preceding section, Togni screened a range of Lewis acids for catalytic fluorination of 1,3-ketoesters using Selectfluor, which indicated that titanium or aluminium compounds were the only possible Lewis acid catalysts which can accelerate enolisation of 1,3-ketoesters in the electrophilic fluorination.¹⁹² However, it is thought that the catalyst may still be improved by adopting other unexplored metal compounds. Thus further screening of catalysts for direct fluorinations of **176** were conducted (Table 3.5).

TABLE 3.5 Screening of catalysts for direct fluorination of ethyl 2-methyl-3-oxo-butanoate (**176**) (2)

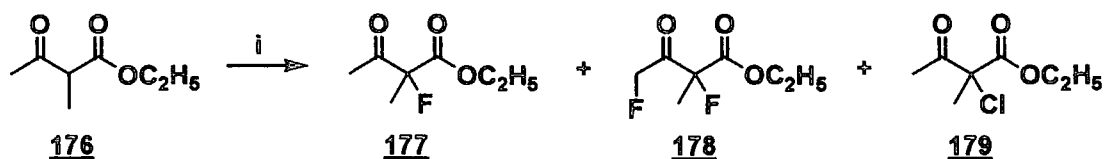

i) 10% F₂ / N₂ (1.2 eq.), catalyst (0.1 eq.), CH₃CN, 0 °C

entry	catalyst	conv. (GC, %)	yield (GC, %)		
			177	178	179
1	none ^a	6	—	—	—
2	HfCl ₄	25	trace	trace	~100
3	Sc(OTf) ₃	53	58	32	—
4	La(OTf) ₃	44	58	32	—
5	Cu(NO ₃) ₂ ·2.5H ₂ O	51	53	—	—
6	Cu(acac) ₂ ^{b, c}	4	—	—	—
7	Cu(OTf) ₂	59	16	9	—
8	Ni(NO ₃) ₂ ·6H ₂ O	32	68	—	—
9	Pd(NO ₃) ₂ ·xH ₂ O	3	~100	trace	—
10	AgOTf	<1	trace	—	—
11	In(NO ₃) ₃ ·5H ₂ O	3	~100	—	—
12	Bi(NO ₃) ₃ ·5H ₂ O	4	27	—	—

^a 2.0 eq. of fluorine was used. ^b 1.0 eq. of fluorine was used. ^c 0.05 eq. of catalyst was used.

HfCl₄, which is in the same group as titanium, gave a similar result to the cases of titanium complexes but with lower conversion (entry 2).

Lanthanide triflates accelerate the fluorination to some extent. Both scandium triflate and lanthanum triflate gave about 40 to 50% conversion. The main product was the 2-fluorinated adduct **177**, but considerable amounts of the 2,4-difluorinated system **178** was also obtained (entry 3, 4). In addition, it should be noticed that triflic acid could mediate the fluorination as described in the previous section because the quite

strong acid could be generated *in situ* during the reaction.

Hydrated copper nitrate and nickel nitrate are known to be good catalysts for fluorination of diethyl malonate.³⁵ Interestingly, in both these cases, 2,4-difluoro adduct **178** was not obtained at all (entry 5, 8). On the other hand, 5 mol % of copper (II) acetoacetate did not show any acceleration of the reaction (entry 6). Copper (I) triflate gave substantial amount of by products (entry 7).

While palladium (II) complexes were found to be excellent catalysts for enantioselective fluorination of 1,3-ketoester using NFSI,¹⁹⁷ palladium (II) nitrate showed almost no catalytic activity for the present system (entry 9).

Silver triflate, indium (III) nitrate and bismuth (III) nitrate²⁰⁴ did not show catalytic activity either (entry 10–12).

3.3.2 Effect of auxiliaries and ligands

In order to assess the applicability to enantioselective fluorination, the effect of racemic auxiliaries or ligands as substitutes for expensive enantiomerically pure ones was examined for which catalytic activity was shown in table 3.5, namely scandium, copper and nickel compounds (Table 3.6).

TABLE 3.6 Effect of auxiliaries and ligands

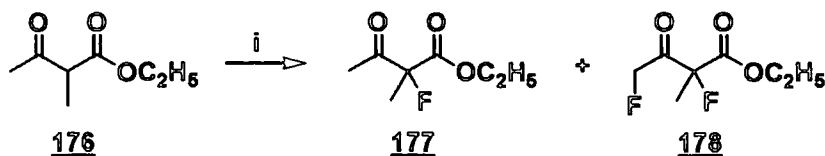

i) 10% F₂ / N₂ (1.2 eq.), catalyst (0.1 eq.), CH₃CN, 0 °C

entry	catalyst	conv. (GC, %)	yield (GC, %)	
			<u>177</u>	<u>178</u>
1 ^a	Sc(OTf) ₃ , BINOL, PMP ^b	<1	trace	trace
2	Cu(NO ₃) ₂ ·2.5H ₂ O, 2(C ₆ H ₅) ₃ P	34	29	trace
3	Cu(NO ₃) ₂ ·2.5H ₂ O, <i>rac</i> -BINAP	45	8	trace
4	CuF ₂ , <i>rac</i> -BINAP	<1	trace	trace
5	Ni(NO ₃) ₂ ·6H ₂ O, 2(C ₆ H ₅) ₃ P	15	~100	trace
6	Ni(NO ₃) ₂ ·6H ₂ O, <i>rac</i> -BINAP	36	~100	trace
7	Ni(NO ₃) ₂ ·6H ₂ O, DIPHOS ^c	20	~100	trace
8 ^d	Ni(NO ₃) ₂ ·6H ₂ O, <i>rac</i> -BINAP	73	97	3

^a CH₃CN / CH₂Cl₂ = 9 : 1 was used as a solvent. ^b PMP = 1,2,2,6,6-pentamethyl-piperidine ^c DIPHOS = 1,2-bis(diphenylphosphino)ethane ^d Fluorine: 5.0 eq.

Scandium triflate, 1,1'-bi-2-naphthol (BINOL) and a tertiary amine system was quite effective in the enantioselective Diels-Alder reactions of acyl-1,3-oxazolidin-2-ones with dienes.²⁰⁵ However, this catalyst system was not effective in the fluorination of 176 (entry 1).

For copper and nickel nitrate, phosphine ligands were chosen because a number of enantioselective reactions using copper or nickel complexes containing chiral phosphine ligands have been reported.²⁰⁶⁻²⁰⁸ Copper nitrate and phosphine ligand system gave much less desired compound than using only copper nitrate as a catalyst (entry 2, 3). This was thought to be partially caused by reduction of copper (II) species accompanied by oxidation of the phosphine ligands.²⁰⁹ Alternatively, copper (II) fluoride and racemic BINAP [= 2,2'-bis(diphenylphosphino)-1,1'-binaphthyl]²¹⁰ was employed in entry 4, which did not show any catalytic activity. In contrast, nickel nitrate and phosphine ligand system was quite effective for selective fluorination of

176. Nickel nitrate/triphenylphosphine (1:2) system gave almost 100% selectivity, although the conversion was 15% (entry 5). In the case of using racemic BINAP and nickel nitrate, the conversion was improved to 36% (entry 6). Another bidentate achiral ligand, 1,2-bis(diphenylphosphino)ethane (DIPHOS) improved the conversion to less extent compared with BINAP (entry 7). When 5 equivalents of fluorine was used for the reaction, nickel nitrate – BINAP system achieved 73% conversion and 97% selectivity (entry 8). This highly selective reaction system looks promising for application to catalytic enantioselective fluorination.

3.3.3 Effect of intermittent introduction of fluorine

In the case of using only nickel nitrate as a catalyst, the reaction mixture showed a blue colour in the beginning that disappeared during the fluorination, however, the colour reappeared after nitrogen purge (Figure 3.2).

FIGURE 3.2

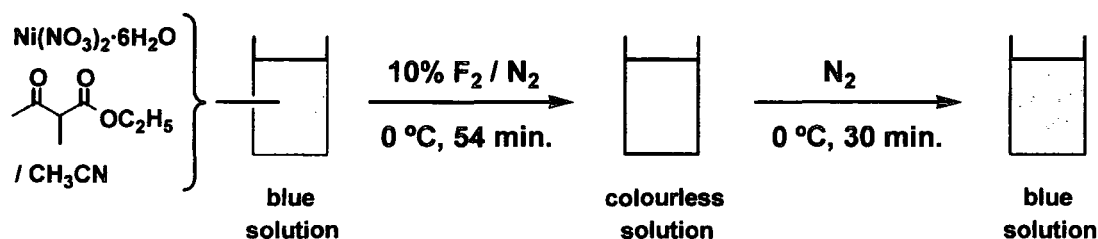

This observation was thought to imply that nitrogen purge was effective to regenerate the active catalyst species similar to the case of the titanium system. Consequently, the fluorination of **176** using nickel nitrate –BINAP system was carried out with intermittent introduction of fluorine. In this reaction, nitrogen was passed through the reaction mixture at intervals during the introduction of fluorine (Scheme 3.25).

SCHEME 3.25

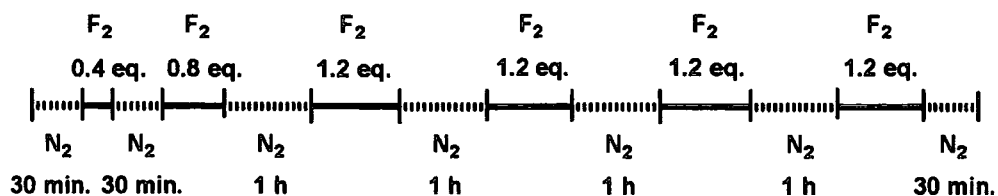
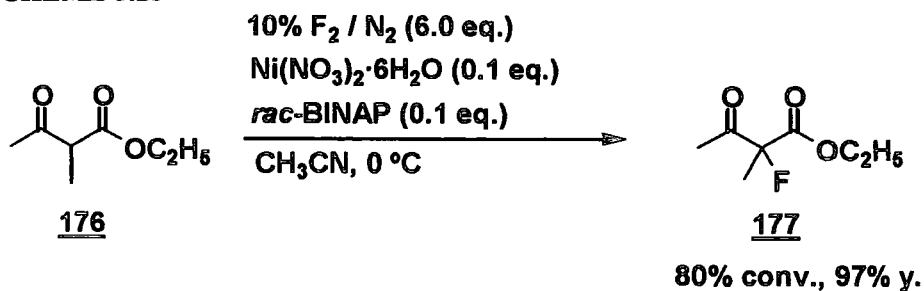

A small amount of the reaction mixture was taken from the reactor at the same intervals after introduction of fluorine and analyzed by NMR and GC. Graph 3.2 shows the relation between the conversion and equivalents of fluorine. No obvious effect of nitrogen purge was observed.

GRAPH 3.2

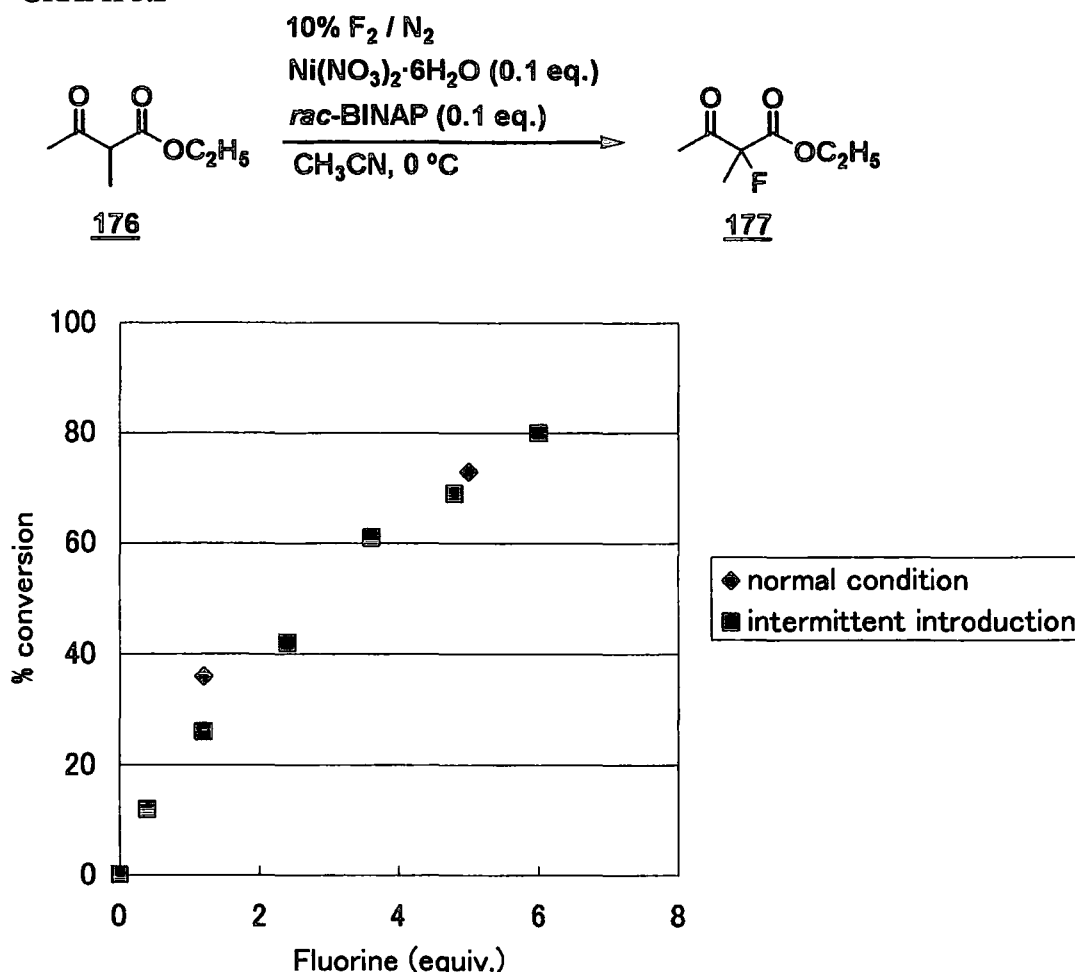

3.3.4 Preparation of cyclic 1,3-ketoesters

In asymmetric catalysis, the steric demand of the substrate is one of the most critical factors for enantioselection. The nature of the ester group clearly influenced the enantioselectivity in the titanium catalyzed fluorination reported by Togni. They obtained the best result by using 2,4,6-triisopropylbenzyl group as an ester group (Scheme 3.11).¹⁹² On the other hand Sodeoka demonstrated that *t*-butyl ester had a high enough level of steric demand for enantioselection in the palladium catalyzed fluorinations (Scheme 3.14).¹⁹⁷ Therefore, two cyclic 1,3-ketoesters bearing *t*-butyl groups, which gave quite high enantioselectivities in palladium catalyzed fluorination system, were prepared for investigation of catalytic enantioselective direct fluorination using nickel nitrate – BINAP system.

t-Butyl 2-oxocyclopentanecarboxylate (**185**) *t*-Butyl 2-oxocyclopentane carboxylate (**185**) was prepared by Dieckmann condensation of symmetrical diester

184 which was available from esterification of adipoyl chloride (**183**) by *t*-butanol as described in the literature^{211,212} (Scheme 3.26). Adipoyl chloride (**183**) was treated with *t*-butanol in the presence of *N,N*-dimethylaniline in ether at room temperature to give di-*t*-butyl adipate (**184**) in 75% yield. The diester **184** was refluxed with sodium hydride in toluene to yield the desired 1,3-ketoester (**185**) in 79%.

SCHEME 3.26

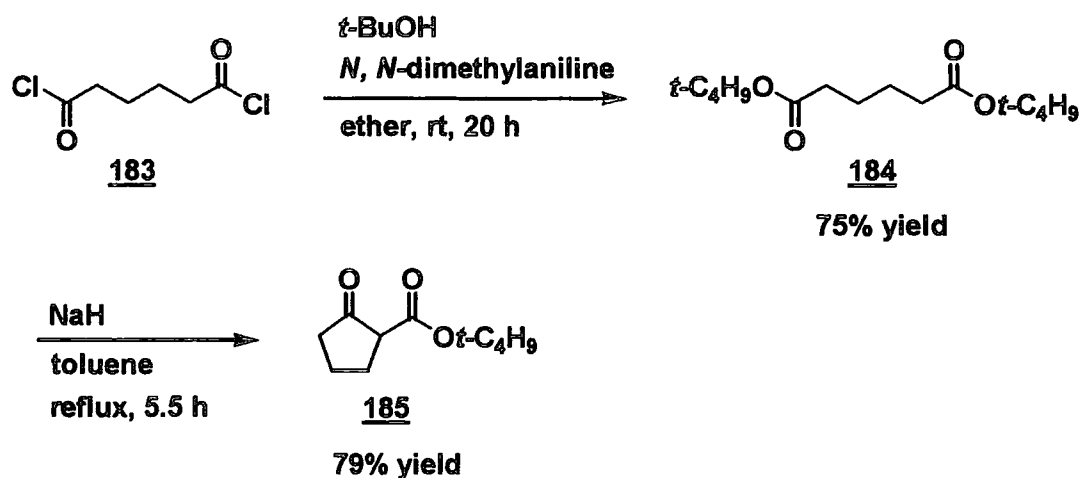

t-Butyl 2-oxocyclohexanecarboxylate (**188**) *t*-Butyl 2-oxocyclohexane carboxylate (**188**) was prepared by the same procedure to **185**. (Scheme 3.27). Pimeloyl chloride (**186**) was reacted with *t*-butanol to give diester **187** in 72% yield. The 1,3-ketoester **188** was obtained by Dieckmann condensation of **187** in 70% yield.

SCHEME 3.27

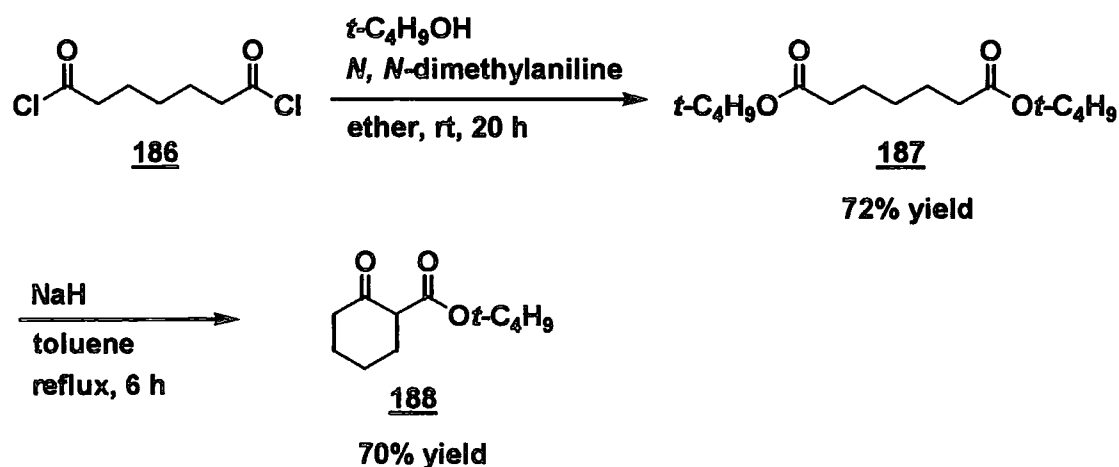

3.3.5 Catalytic direct fluorination of 1,3-ketoesters using a racemic catalyst

The catalyst system consisting of nickel nitrate and racemic BINAP was applied to cyclic 1,3-ketoesters to determine the fluorination conditions before using the corresponding chiral ligands and also to obtain racemic samples of the fluorinated products for determination of enantiomeric excess (Table 3.7).

TABLE 3.7 Nickel catalysed direct fluorination of cyclic 1,3-ketoesters

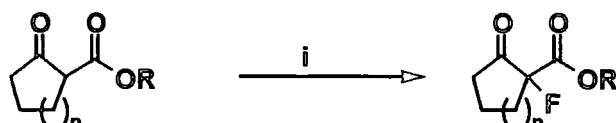

189 ($n = 1$, $R = C_2H_5$)

185 ($n = 1$, $R = t-C_4H_9$)

190 ($n = 2$, $R = C_2H_5$)

188 ($n = 2$, $R = t-C_4H_9$)

191 ($n = 1$, $R = C_2H_5$)

192 ($n = 1$, $R = t-C_4H_9$)

193 ($n = 2$, $R = C_2H_5$)

194 ($n = 2$, $R = t-C_4H_9$)

i) 10% F_2 / N_2 (3.0 eq.), $Ni(NO_3)_2 \cdot 6H_2O$ (0.1 eq.), *rac*-BINAP (0.1 eq.), CH_3CN , 0 °C

entry	n	R	conv. (GC, %)	GC yield (%)	isolated yield(%)
1	1	C_2H_5	100	100	81
2	1	$t-C_4H_9$	100	100	88
3	2	C_2H_5	100	86	60
4	2	$t-C_4H_9$	100	89	67
5 ^a	1	C_2H_5	17		
6 ^a	2	C_2H_5	87		

^a The reaction was carried out without catalyst.

Fluorination of all of the substrates, ethyl 2-oxo-cyclopentanecarboxylate (**189**), *t*-butyl 2-oxo-cyclopentanecarboxylate (**185**), ethyl 2-oxo-cyclohexanecarboxylate (**190**) and *t*-butyl 2-oxo-cyclohexanecarboxylate (**188**), proceeded smoothly, and 100% conversions were achieved using BINAP/Ni catalyst system (entry 1–4). Each product was isolated by silica gel column chromatography. In the case of using no catalyst, **189** and **190** showed dramatically different reactivity (entry 5, 6). On the one hand, **189** gave only 17% conversion, but on the other hand fluorination of **190** proceeded in 87% conversion even in the absence of the catalyst. This contrasting difference is probably caused by the difference of enol content at equilibrium of these substrates. Thus, enol

contents of 1,3-ketoesters in acetonitrile- d_3 were estimated by ^1H NMR (Table 3.8).

Table 3.8 Enol contents of 1,3-ketoesters in acetonitrile- d_3

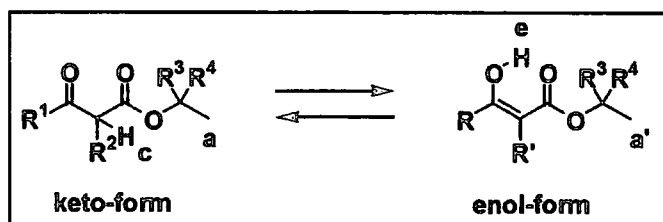

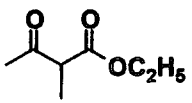
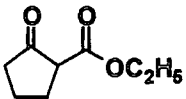
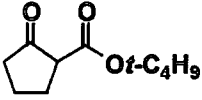
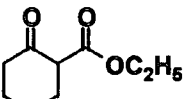
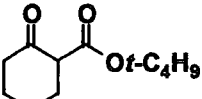
1,3-keto ester	time ^a	keto-form	enol-form	lit. (enol, %)	
		% ^b , (ppm)	% ^c , (ppm)	in CCl_4 ²¹³	in EtOH ²¹⁴
 <u>176</u>	<30 min.	92 (3.37)	2 (12.50)		
	1 month	93	—		
 <u>189</u>	<30 min.	91 (2.95)	—	11.5	6.3
	1 month	88	—		
 <u>185</u>	<30 min.	92 (2.81)	—		
	1 month	93	—		
 <u>190</u>	<30 min.	20 (3.22)	71 (12.04)	85	59
	1 month	39	50		
 <u>188</u>	<30 min.	28 (3.08)	64 (12.13)		
		31 ^d (1.24)	69 ^d (1.28)		
	1 month	67	25		
		72 ^d	28 ^d		

^a The sample solution were allowed to equilibrate for the time at room temperature before the measurement. ^b Based on integrated values of resonance of c vs (a + a').

^c Based on integrated values of resonance of e vs (a + a'). ^d Based on integrated values of resonance of a vs (a + a').

As expected, ethyl 2-methyl-3-oxobutanoate (176), ethyl 2-oxocyclopentane

carboxylate (**189**), and *t*-butyl 2-oxocyclopentanecarboxylate (**185**) have a very low enol content. On the other hand, ethyl 2-oxo-cyclohexanecarboxylate (**190**) and *t*-butyl 2-oxocyclohexanecarboxylate (**188**) showed higher enol contents, although the equilibria shifted to the keto-forms after 1 month. From these results 1,3-ketoesters of five-membered ring, **185** and **189** were thought to be preferable substrates for catalytic reaction because these compounds possess very low enol contents and slow enolisation rates, and thus, the fluorination of them should not proceed to large extent without catalyst. In Sodeoka's system, the reaction proceeded quite slowly (18-72 h)¹⁹⁷ and this fact should be related to the high enantioselectivity even in the fluorination of **188** which has a high enol content.

3.3.6 Attempted catalytic enantioselective direct fluorination of 1,3-ketoesters

Now that conditions and the best substrate have been determined, fluorination of **185** and **189** using nickel nitrate and enantiomerically pure BINAP were carried out (Table 3.9).

TABLE 3.9 Attempted nickel catalysed enantioselective direct fluorination of cyclic 1,3-ketoesters

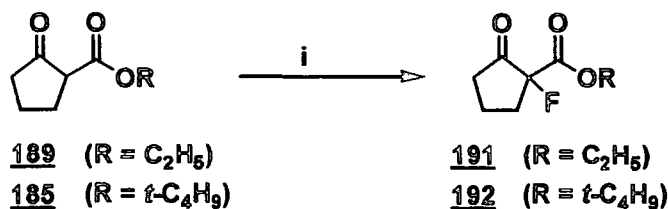

i) 10% F₂ / N₂ (5.0 eq.), Ni(NO₃)₂·6H₂O (0.1 eq.), (*R*)-BINAP (0.1 eq.), CH₃CN, 0 °C

entry	R	procedure ^a	GC analysis		isolated yield(%)	% ee ^b
			% conv.	% yield		
1	Et	A	100	100	82	<1
2	Et	B	99	100	79	<1
3	<i>t</i> -Bu	A	100	100	73	(<1) ^c
4	<i>t</i> -Bu	B	100	100	69	(1) ^c

^a Procedure A: The catalyst was simply mixed and sonicated *in situ*. Procedure B: The catalyst was treated with elemental fluorine before adding the substrates.

^b Enantiomeric excess determined by ¹H NMR shift experiments using Eu(hfc)₃.

^c Two enantiomeric resonances could not be separated completely.

Two procedures were used for the preparation of the catalyst. Procedure A was an ordinary preparation method which involved simple mixing of the nickel nitrate and BINAP *in situ*. In this procedure, the reaction mixture contained a precipitate to the middle of the reaction, and then became a clear solution eventually. Then, in the procedure B, substrate was added after passing fluorine to the solution only including the catalyst first, which resulted in a clear solution. The enantiomeric excess of the products were determined by a chiral shift reagent. Figure 3.3 shows ¹H NMR experiments using increasing amounts of europium tris[3-heptafluoropropylhydroxymethylene]-(+)-camphorate] [Eu(hfc)₃]^{166,183} with racemic ethyl 1-fluoro-2-oxo cyclopentane carboxylate (**191**). In all cases the reactions gave 99 to 100% conversion and 69 to 82% isolated yield, however, no obvious enantioselection was observed.

FIGURE 3.3 A chiral shift reagent ^1H NMR experiments using increasing amounts of $\text{Eu}(\text{hfc})_3$

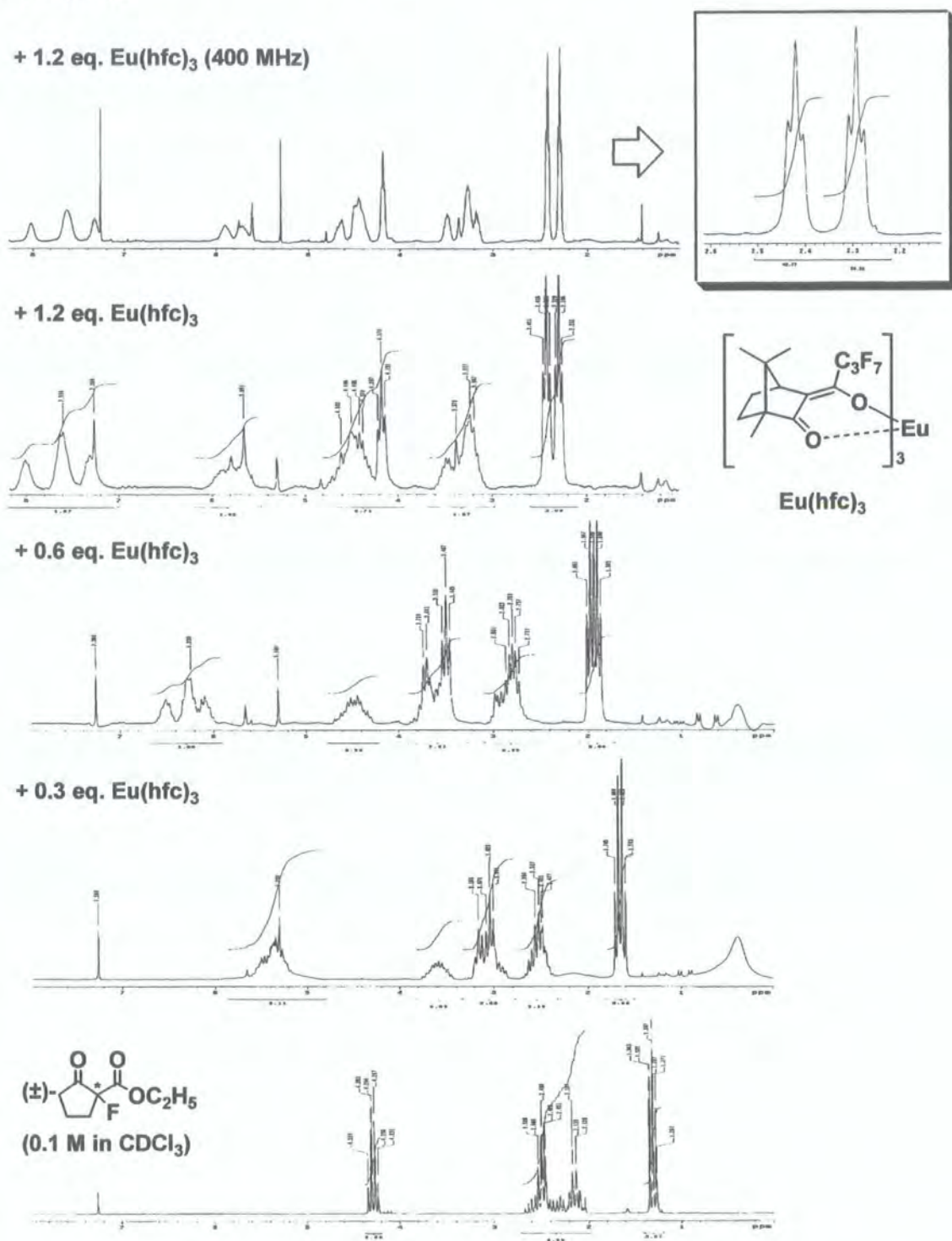

The fluorination of **189** using the same catalyst in a mixture of dichloromethane/

acetonitrile (1:1) as a solvent gave a homogeneous reaction system, and exclusively chlorinated product **195** (Scheme 3.28).

SCHEME 3.28

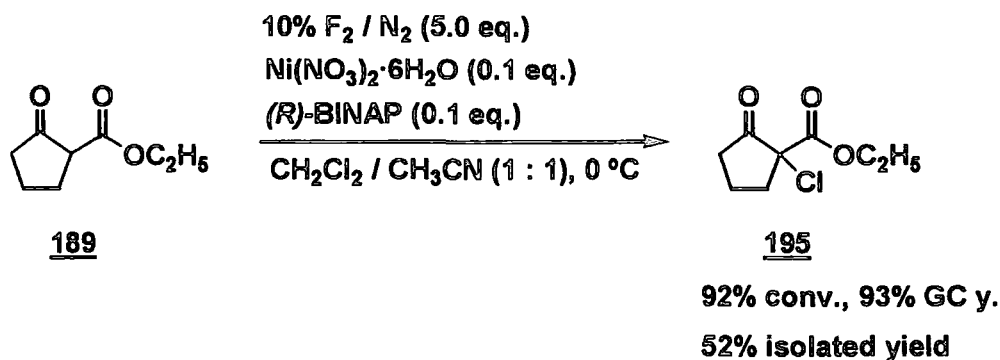

Only a trace amounts of fluorinated product **191** was found in GC-MS analysis. The reaction mixture showed a dark purple colour in the course of the fluorination, which is thought to imply a generation of a radical species. The mechanism of this anomalous chlorination is unclear although it is indisputable that the solvent is the only source of the chlorine atom and chlorine radical may be concerned in this reaction.

This reaction system using nickel nitrate – BINAP system should be applied to different solvent systems such as nitromethane, 2,2,2-trifluoroethanol, etc. because acetonitrile is one of powerful coordination solvents, which would compete against BINAP. Another possible reason for the non-enantioselectivity would be more intrinsic. In general, phosphines are less basic but more nucleophilic than corresponding amines. Thus, fluorination of the phosphorus centre may compete with the reactive enolate species.²¹⁵ In addition, the less stereo demanding nature of elemental fluorine than N-F reagents can not also be ruled out for the reason of the results.

3.4 Conclusions

The feasibility of catalytic enantioselective fluorination of 1,3-ketoesters with elemental fluorine has been assessed. A series of metal compounds were examined in the fluorination of the model compound **176**, and some of them showed an acceleration of the enolisation process.

In the titanium-catalyst system, the product could be changed depending on the ancillary ligand. When the ancillary ligand was chloride, chlorination reaction proceeded efficiently in the presence of trimethylsilyl chloride. On the other hand, catalytic fluorination was accomplished by using a combination of titanium

trifluoroacetate derivatives and trimethylsilyl trifluoroacetate. In this case, the intermittent introduction of elemental fluorine was effective for a slight improvement of the conversion.

The catalyst system using nickel nitrate and BINAP provided a very clean fluorination of 1,3-ketoesters at 2-position. This system enabled to exclude the formation of 2,4-difluoro derivative, which could be regarded as a serious side product as mentioned in the next chapter. A significant difference of the reactivity in the fluorination without catalyst between cyclic 1,3-ketoesters was found and is caused by the distinct enol contents.

Attempts at enantioselective fluorination of 1,3-ketoesters using elemental fluorine have currently been unsuccessful, but there is still some possibility for getting enantioselection in those systems.

Selective Direct Fluorination using Microreactor Technology

4.1 Introduction

New methodologies for selective fluorination have been explored using removable tethers and catalysis in the preceding chapters. In this chapter, a solution to the problem of control and scaling up fluorination reaction will be described by utilizing an efficient microreactor device.

As mentioned in section 1.2.2.3, direct fluorination reactions are highly exothermic processes. Therefore, direct fluorinations are usually carried out by batch-wise procedures involving passage of diluted fluorine through a rapidly stirred solution of a substrate at low temperatures where the reaction between fluorine and the organic species occurs mainly at the gas-liquid interface, i.e. in a heterogeneous manner.²¹⁶ This can produce local overheating which leads to side reactions and degradation of the substrate. From these viewpoints, a more selective fluorination would be possible if a more efficient interfacial reaction and heat exchange are attained.

Interest in the application of microreactor technology for synthetic organic chemistry has been increasingly developing in the last few years,²¹⁷ because of the great potential of very small reactors for providing substantial effects to the chemical reaction itself.

Microreactor technology²¹⁸ has attractive features for application to direct fluorination, as follows:

- (i) A small linear dimension – In general, microreactor devices contain microchannels with widths between 0.05 mm to 0.5 mm. The small linear dimension allows laminar flow conditions and a significant decrease of mixing time which can lead to a higher conversion.
- (ii) A large surface-to-volume ratio – As a result of the decrease in fluid layer thickness, the surface-to-volume ratio is dramatically increased. This fact brings several benefits, namely high efficiency for interfacial reaction and excellent heat transfer which means less substrate degradation and increased reaction selectivity

can be expected.

- (iii) A small reactor volume – The small inventory of reagents in the reaction zone enables the hazardous reaction to be carried out more safely.
- (iv) ‘Scale-out’ – Numbering-up theory makes the conventional laborious scale-up process much easier by simply increasing the number of the microreactors optimised for each reaction.

This chapter is concerned with the investigation into the potential of microreactor technology as a useful device for selective direct fluorination of organic compounds. Prior to discussing the current work, literature concerning reactions performed in microreactors, especially focused on gas-liquid two-phase reactions will be reviewed in the next section.

4.1.1 Gas-liquid two-phase reactions using microreactor technology

General microreactor technology has been reviewed recently,^{217–220} and hence types of microreactors and reactions other than those reviewed in this section can be found in that literature and the references cited therein.

4.1.1.1 Direct fluorination using microreactors

The majority of the examples of gas-liquid two-phase reactions using microreactors are direct fluorinations due to the substantial advantages described in the preceding section.

Chambers described a microreactor for direct fluorination, which consisted of a single channel 500 μm wide and 500 μm deep in a nickel block, as shown in figure 4.1.²²¹

FIGURE 4.1 Single channel microreactor

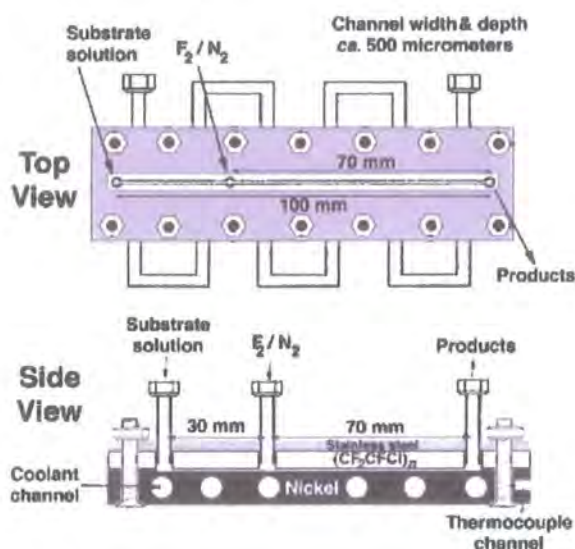

The channel was sealed by a piece of transparent PTFCE plate which is held by a stainless steel base plate and a number of screw fittings. The substrate solution was delivered into one end of the reaction chamber *via* a syringe using a syringe pump and fluorine was introduced from a cylinder by an accurate mass-flow controller. When the liquid-gas mixture flowed along the microchannel, a 'pipe flow' (similar term to 'annular flow') occurred, where the surface-to-volume ratio and, in turn, the efficiency of the contact between the liquid and the gas were maximised. Products were trapped out in a FEP tube, which was cooled with either a salt/ice bath (0 °C) or an acetone/CO₂ bath (-78 °C).

The direct fluorination of 1,3-ketoesters using this device proceeded quite efficiently (Scheme 4.1). Ethyl 3-oxobutanoate (**196**) dissolved in formic acid was fluorinated in 99% conversion to give ethyl 2-fluoro-3-oxobutanoate (**197**). On the other hand, less reactive ethyl 2-chloro-3-oxobutanoate (**200**) was also fluorinated with a lower flow rate in 90% conversion, yielding ethyl 2-chloro-2-fluoro-3-oxobutanoate (**201**).

SCHEME 4.1

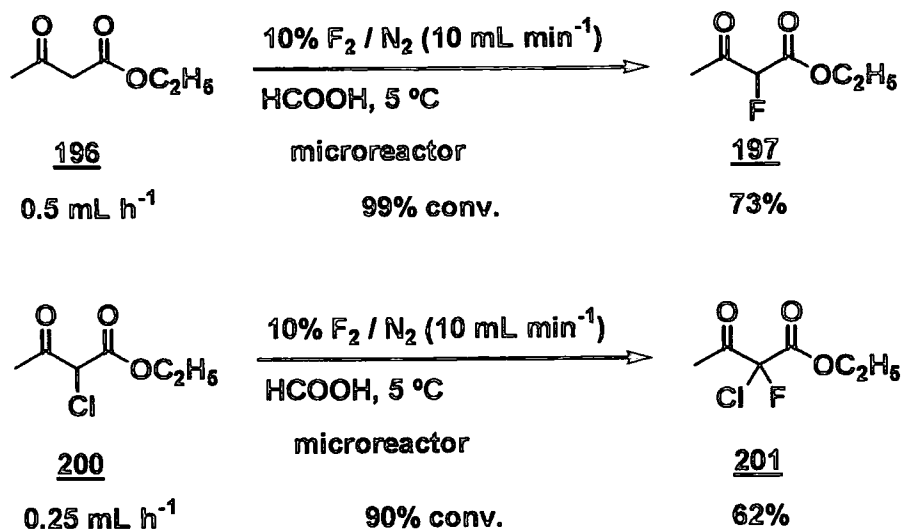

Importantly, the bulk fluorination of **200** gave only a low conversion to **201**,³² exemplifying the high efficiency of this system. It was also pointed out that a catalytic effect by the fluorinated metal surface could be occurring.

Using the same reactor system, sulfur pentafluoride derivatives were successfully prepared (Scheme 4.2).

SCHEME 4.2

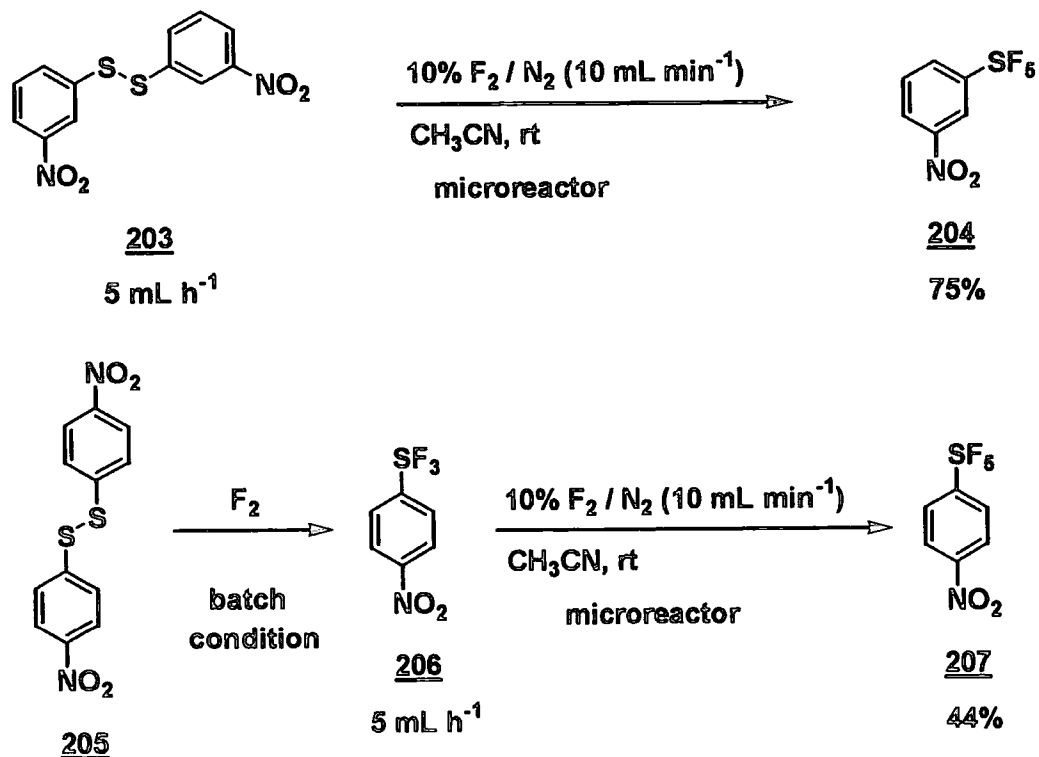

1-(Pentafluorosulfer)-3-nitrobenzene (**204**) was obtained from direct fluorination of 3-nitrophenyl disulfide (**203**) in 75% yield whilst *p*-nitro system **207** was prepared by a two step fluorination, that is, the combination of fluorination using the microreactor and conventional batch conditions, *via* the sulfur trifluoride derivative **206** due to the low solubility of disulfide **205** in acetonitrile.

Chambers also demonstrated that this device could be used for perfluorination (Scheme 4.3).²²¹ In this case, an additional heated stage was needed to complete the reaction and this was simply connected to the outlet of the reactor.

SCHEME 4.3

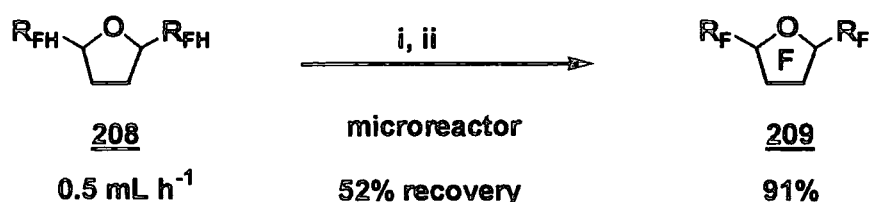

i) 50% F₂ / N₂ (15 mL min⁻¹), rt; ii) 50% F₂ / N₂ (15 mL min⁻¹), rt,
then 280 °C

The fluorination of the tetrahydrofuran derivative **208** using 50% fluorine with an additional heating step at 280 °C gave the perfluorinated compound **209** in 91% yield.

Chambers demonstrated that 'scale-out' could be achieved by simple replication of the single channel device described above.²²² A three channel microreactor was constructed (Figure 4.2) by a similar process to the single channel reactor and fluorinations of several 1,3-dicarbonyl compounds and aromatic substrates were carried out (Table 4.1, Scheme 4.4).

FIGURE 4.2 Three channel microreactor

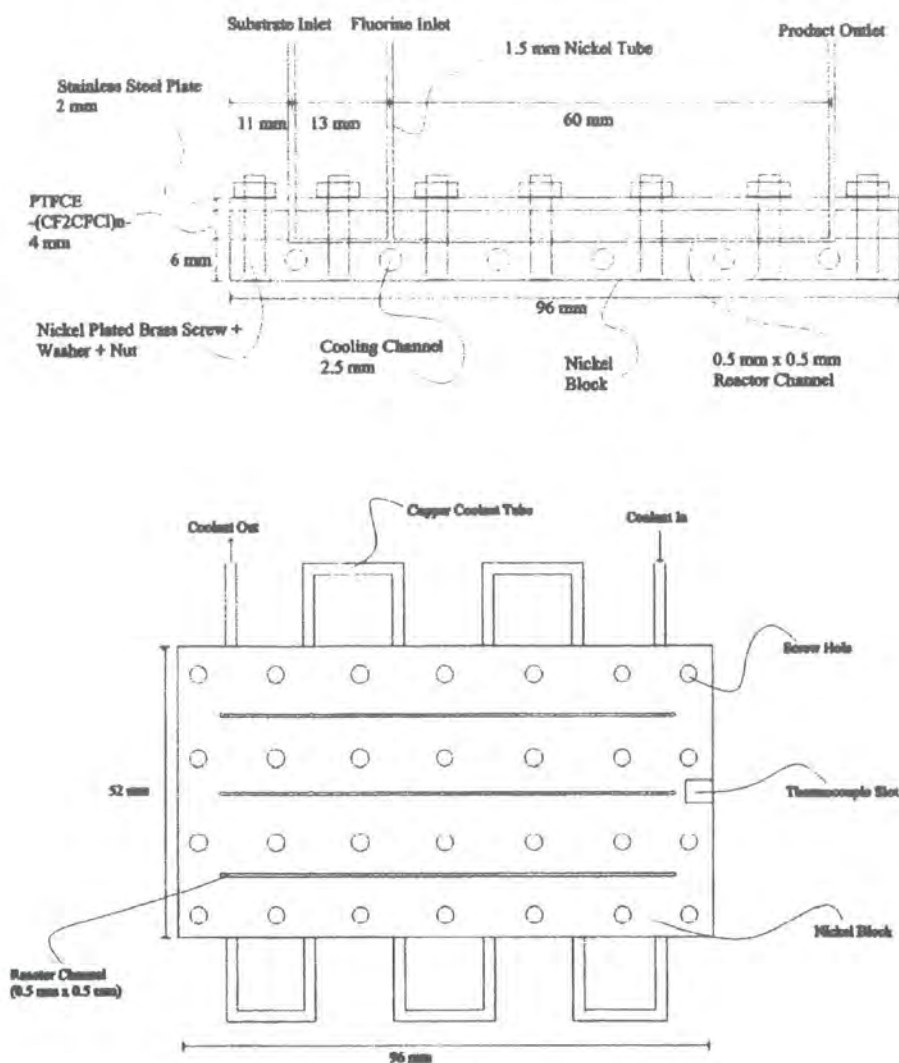

1,3-Ketoesters **176**, **196** and **200** and 1,3-diketone **210** were successfully fluorinated using this device to give the corresponding 2-fluoro derivatives although rather lower conversions than the single channel reactor were observed in the case of **196** and **200** (Table 4.1). Ethyl 2-methyl-3-oxobutanoate **176** gave a higher conversion compared with the conventional bulk fluorination.

TABLE 4.1

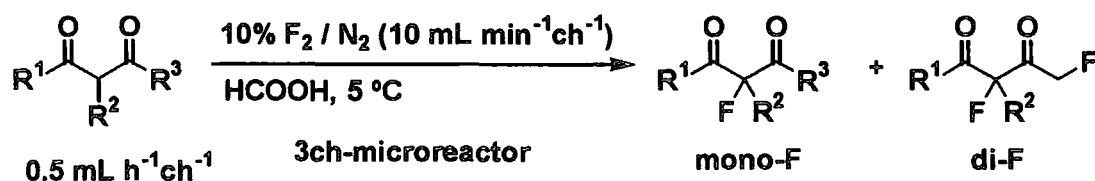

substrate	R ¹	R ²	R ³	% conv.	% yield (GC)	
					mono-F	di-F
<u>196</u>	OC ₂ H ₅	H	CH ₃	59	82 (<u>197</u>)	7 (<u>198</u>)
<u>176</u>	OC ₂ H ₅	CH ₃	CH ₃	47	38 (<u>177</u>)	— (<u>178</u>)
<u>200</u>	OC ₂ H ₅	Cl	CH ₃	59	74 (<u>201</u>)	— (<u>202</u>)
<u>210</u>	—(CH ₂) ₄ —		CH ₃	53	75 (<u>211</u>)	9 (<u>212</u>)

An attempt to fluorinate 1-methyl-4-nitrobenzene in formic acid using the microreactor led to blockage of the microreactor due to the low solubility of this substrate in formic acid. Consequently, fluorination of 1-methyl-4-nitrobenzene was carried out efficiently and selectively in a mixture of acetonitrile and formic acid [3:2 (v/v)] to give 2-fluoro-1-methyl-4-nitrobenzene in 66% yield (Scheme 4.4).

SCHEME 4.4

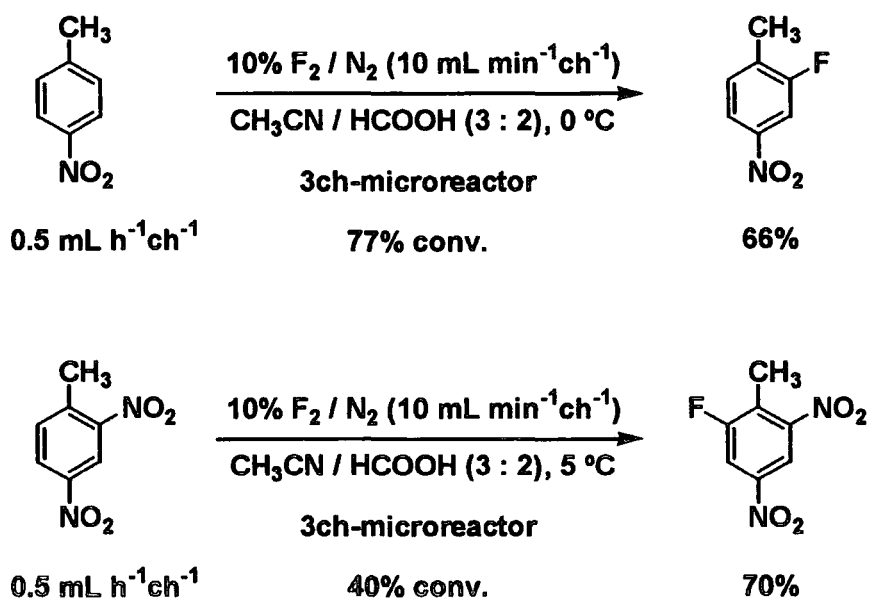

The less reactive 1-methyl-2,4-dinitrobenzene was also fluorinated in 40% conversion under the similar conditions to give 2-fluoro-1-methyl-4,6-dinitrobenzene in 70% yield.

Direct fluorination of toluene using microreactor technology was investigated by two groups independently.^{223,224} Jähnisch and Hessel build two microreaction systems for direct fluorination, namely a micro bubble column (MBC) and a falling film microreactor (FFMR).²²³

The micro bubble column consisted of a mixing and a reaction unit. The mixer was equipped with 20 μm deep gas and liquid feeding channels 7 and 20 μm wide, respectively. The reaction unit comprised an array of parallel microchannels with two different sizes, namely 50 μm by 50 μm or 300 μm by 100 μm channel cross-section. This device generated a continuous stream of small bubbles in a flow of liquid.

The falling film microreactor included a platelet comprising a large number of microchannels of 100 μm by 300 μm cross-section which enabled the generation of a thin falling film of several 10 μm thickness to flow by means of gravity forces.

Direct fluorination of toluene using these microreaction systems was investigated under a range of reaction parameters and the results were compared with those of a laboratory bubble column (LBC) as a benchmark. Both the falling film microreactor and the micro bubble column were by far superior to the laboratory bubble column, and the best result was obtained using the falling film microreactor with 50% fluorine in nitrogen (Scheme 4.5). The authors also found that the *para*-fluoro toluene was predominantly obtained when using 50% fluorine, whilst 10% fluorine typically gave *ortho*-/*meta*-/*para*- ratio of 5:1:3.

SCHEME 4.5

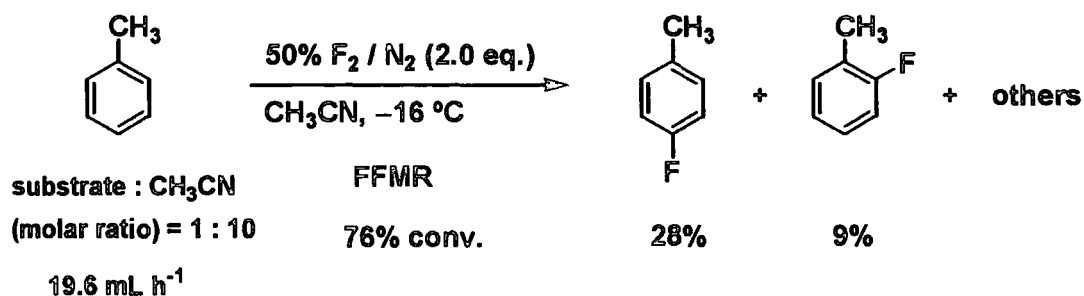

Jensen also reported direct fluorination of toluene in a microreactor fabricated from silicon wafer, onto which a thin nickel layer was deposited.²²⁴ The reactor consisted of two parallel reaction channels with a triangular cross-section, 435 μm wide, 305 μm

FIGURE 4.3

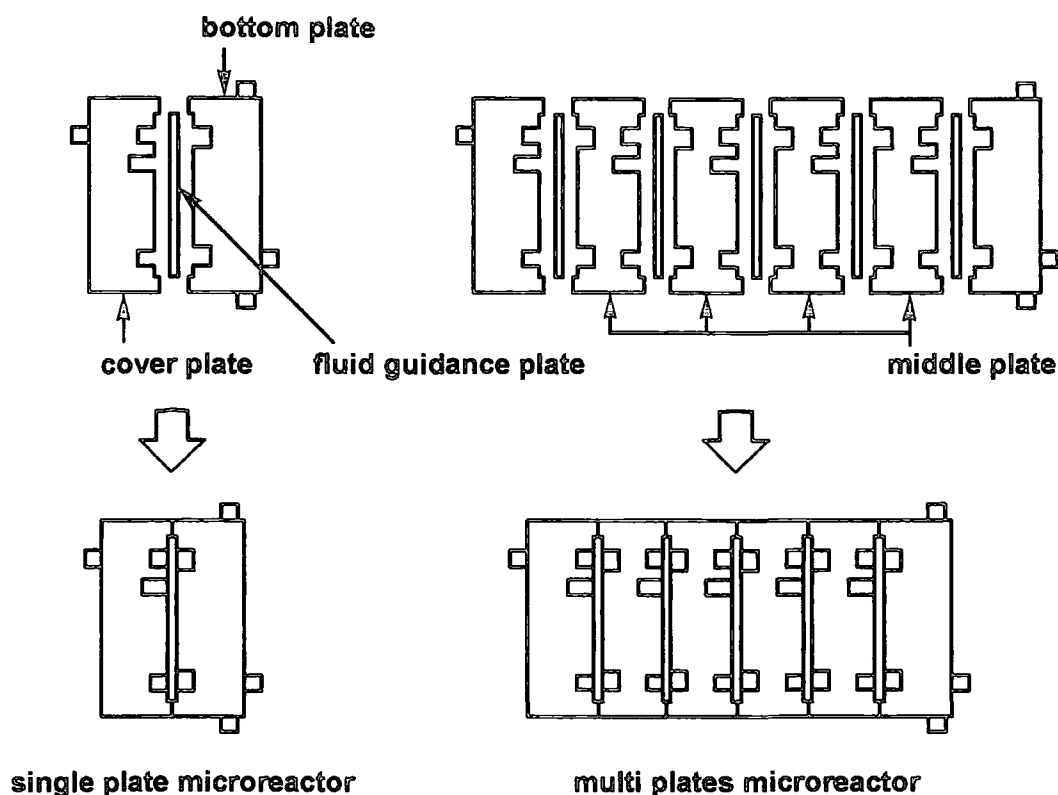

The reduction of ethyl [*N*-(4-nitro phenyl)-hydrazino]-oxo-acetate (**213**) with hydrogen using the microreactor which included 10 fluid guidance plates gave ethyl [*N*-(4-aminophenyl)-hydrazino]-oxo-acetate (**214**) quantitatively (Scheme 4.8).²²⁵ In this case, the bottom plate, cover plate and middle plates were made of graphite and the fluid guidance plates were made of graphite containing palladium.

SCHEME 4.8

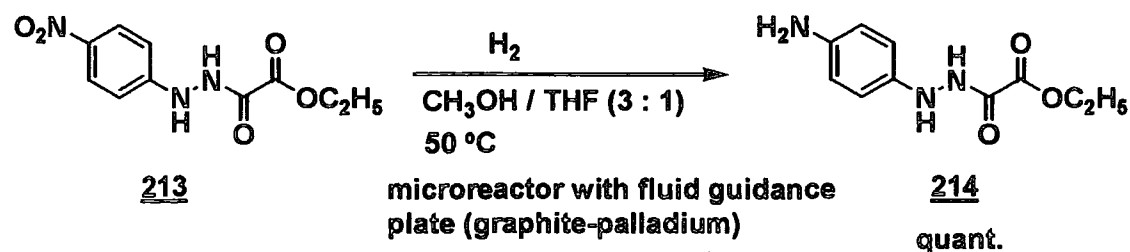

Chlorination of acetic acid was carried out in the presence of acetyl chloride at 180 °C using similar microreactor including 5 fluid guidance plates which was made of tantalum to give chloroacetic acid in an excellent selectivity (Scheme 4.9).^{225,226}

SCHEME 4.9

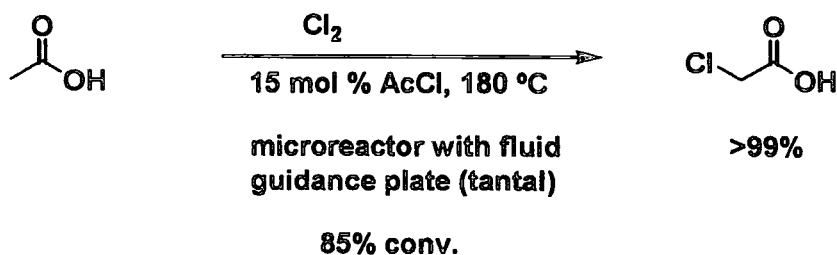

Chambers reported the oxidation of alcohols and Baeyer-Villiger oxidation of ketones using fluorine in the single channel microreactor (Scheme 4.10).²²⁷

SCHEME 4.10

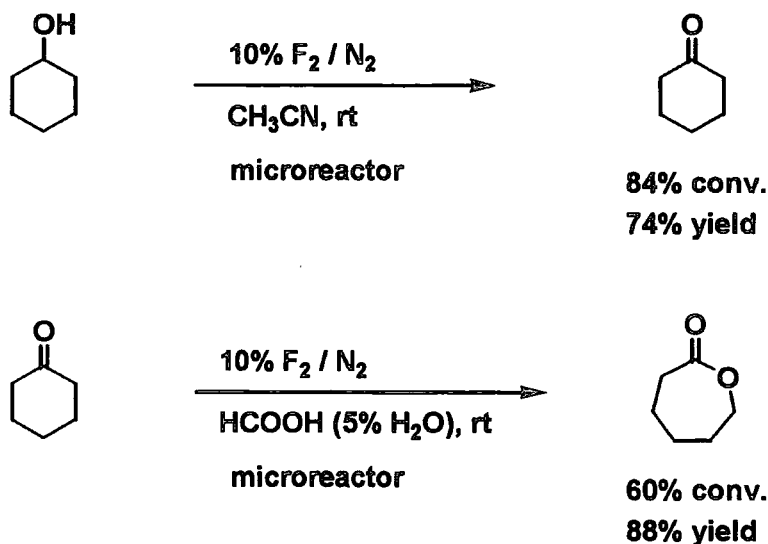

4.2 Device used to perform direct fluorination

Direct fluorination reactions were carried out using a new multi-channel microreactor (V-21) which was developed in Durham most recently (Figure 4.4, 4.5).²²⁸ This new microreactor provides a versatile and practical multi-channel microreaction system for gas/liquid two-phase reactions by virtue of the unique design features. The channels are created by three plates, namely a bottom plate, a channel plate and a PTFCE plate, which are sandwiched between a base block and a steel top plate. (Figure 4.6). The channel plate, which is made of a stainless steel sheet of 500 μm in thickness, possesses nine slits of 500 μm wide (Figure 4.7). The base block is equipped with gas and substrate reservoirs which enable fluorine and substrate delivery into each microchannel from one source at a regulated temperature. These features

allow simple maintenance and great versatility for replacing the channel plate with another which has a different number of channels.

FIGURE 4.4 Top-view of the V-21 base block

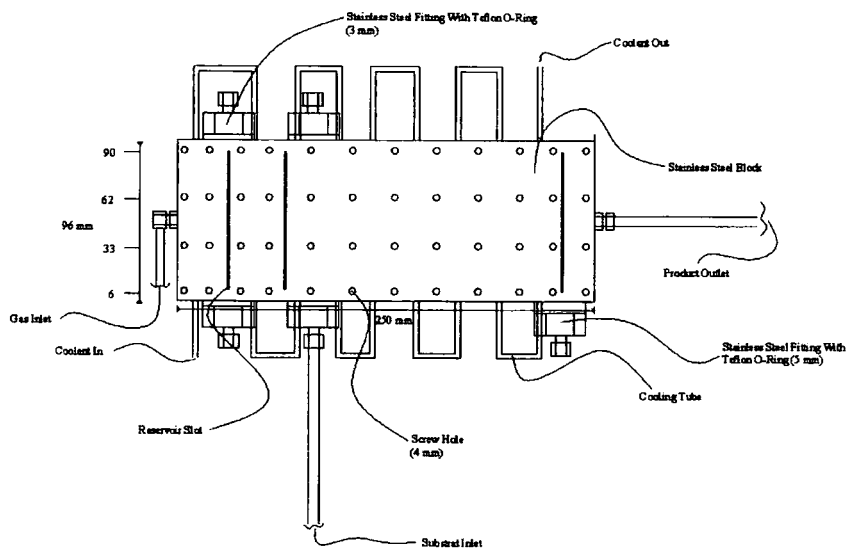

FIGURE 4.5 Side-view of the V-21 base block

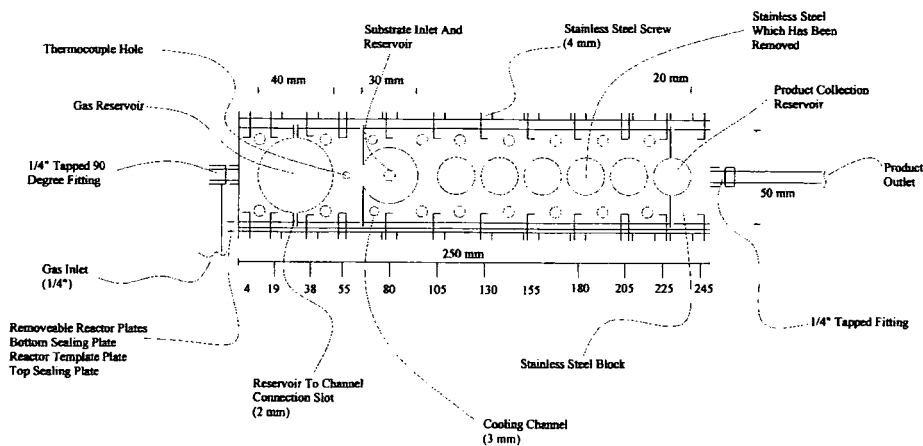

FIGURE 4.6 Plate arrangement of the V-21

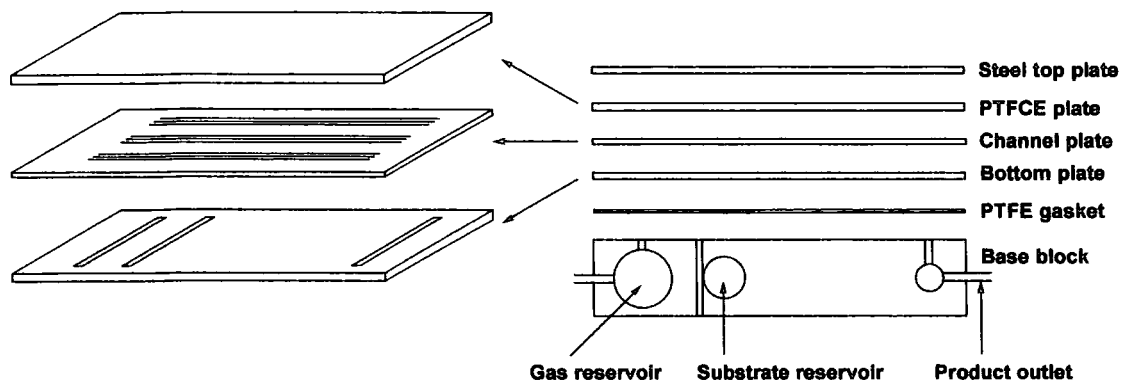
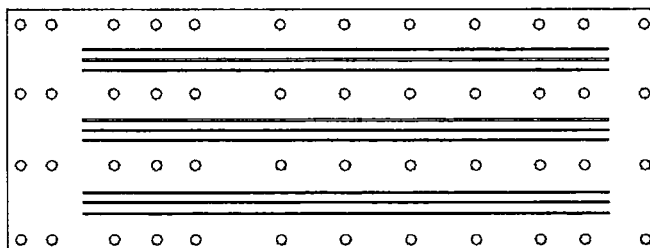

FIGURE 4.7 The 9-ch microreactor channel plate

3 x 3 0.5 mm Slots
Separated By 3.5 mm



Further details of design of this microreactor were described in the doctoral thesis of Darren Holling.²²⁸

The microreactor is operated in a vertical position, unlike the single and three channel microreactors developed earlier in Durham (Figure 4.8, 4.9).

FIGURE 4.8 Schematic diagram of apparatus used for direct fluorination reactions

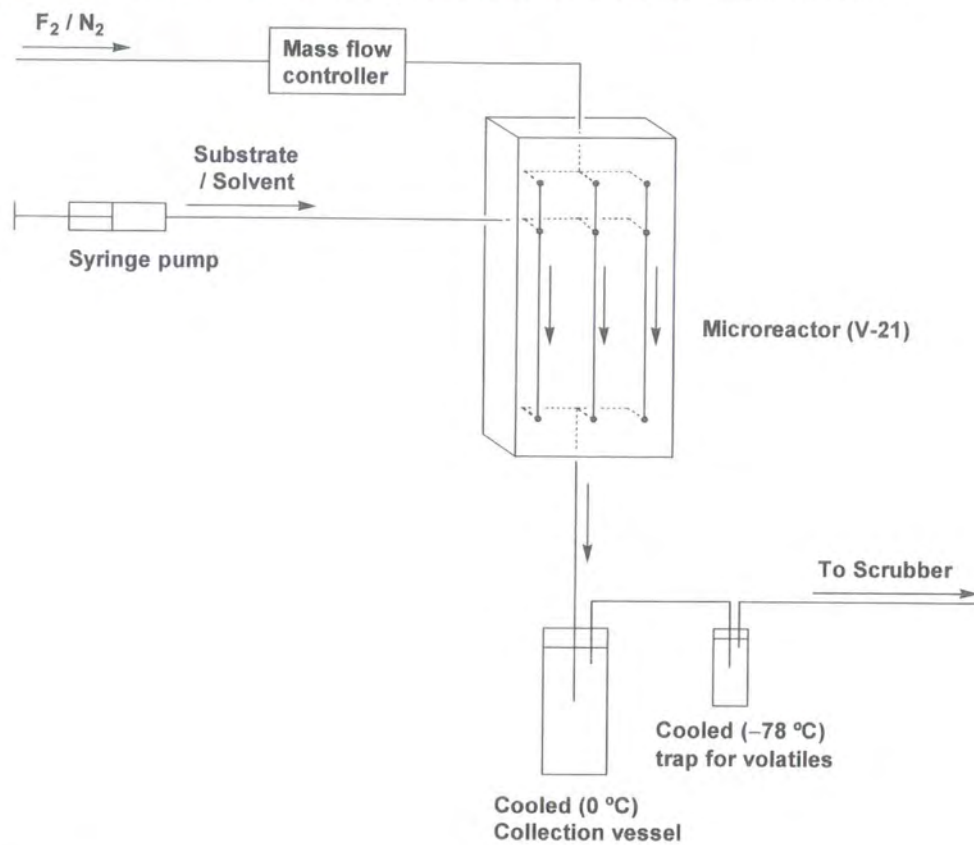
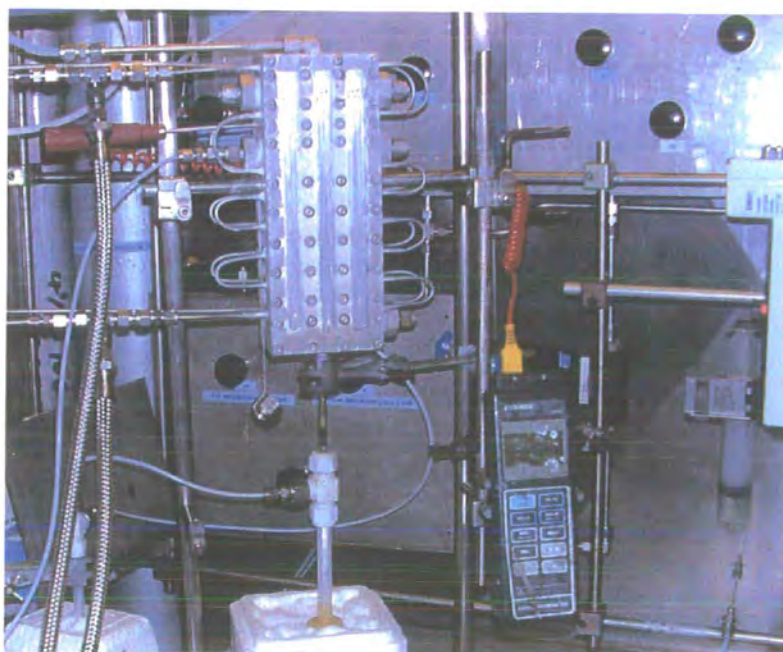

FIGURE 4.9 The V-21 in operational position



A mixture of substrate and solvent is introduced into the substrate reservoir at a continuous rate, typically 4.5 mLh^{-1} ($= 0.5 \text{ mLh}^{-1}\text{ch}^{-1}$), to distribute the solution to each channel whilst fluorine, as a 10% mixture in nitrogen, is introduced simultaneously into the channels *via* the gas reservoir, typically 90 mL min^{-1} ($= 10 \text{ mL min}^{-1} \text{ ch}^{-1}$), using a mass flow controller. During the fluorination, all of the solution and fluorine mixing proceeds by ‘pipe flow’ (*i.e.* the liquid forms an outer ‘pipe’ coating the surface of the reaction channel with the gas flowing through the centre, Figure 4.10, 4.11) rather than slug flow (*i.e.* alternate slugs of liquid and gas, Figure 4.10). Products were collected in a FEP bottle, which was cooled on ice bath and the more volatile components were trapped in another FEP bottle cooled with dry ice.

FIGURE 4.10

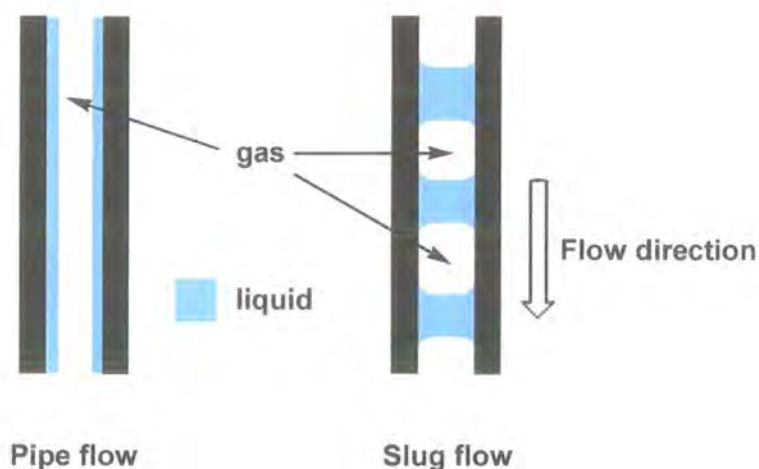
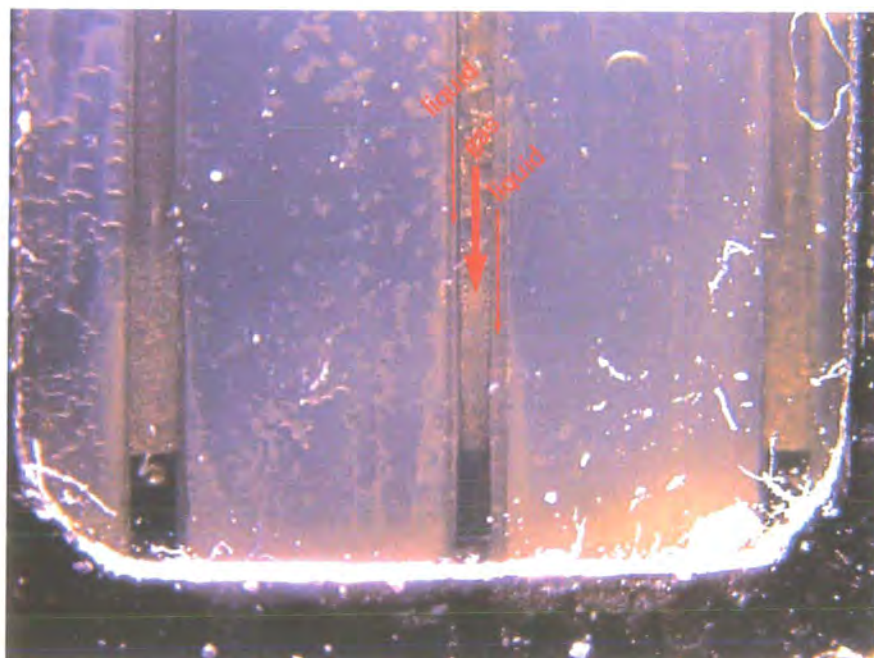

FIGURE 4.11 A close up view of the end of the channels in operation



4.3 Direct fluorination of carbonyl compounds using microreactor technology

4.3.1 Fluorination of 1,3-ketoesters using multi-channel microreactor

Direct fluorination of 1,3-ketoesters using the multi-channel microreactor (V-21) have already been tested preliminarily.²²⁸ However, the effects of changing various parameters on the conversion or the selectivity have not been investigated systematically. There are many parameters that can affect conversion and yield in operation of microreactor, i.e. as follows:

- Substrate concentration
- Reaction temperature
- Flow rate of substrate
- Flow rate of fluorine
- Solvent
- Use of catalysts
- Alignment of reactor

According to previous experiments by the Durham group, direct fluorination of ethyl 3-oxobutanoate (**196**) under batch conditions gave not only ethyl 2-fluoro-3-oxobutanoate (**197**) but also two difluoro derivatives, namely ethyl

2,4-difluoro-3-oxobutanoate (**198**) and ethyl 2,2-difluoro-3-oxobutanoate (**199**), in 10% and about 1% yield respectively (Scheme 4.11).³²

SCHEME 4.11

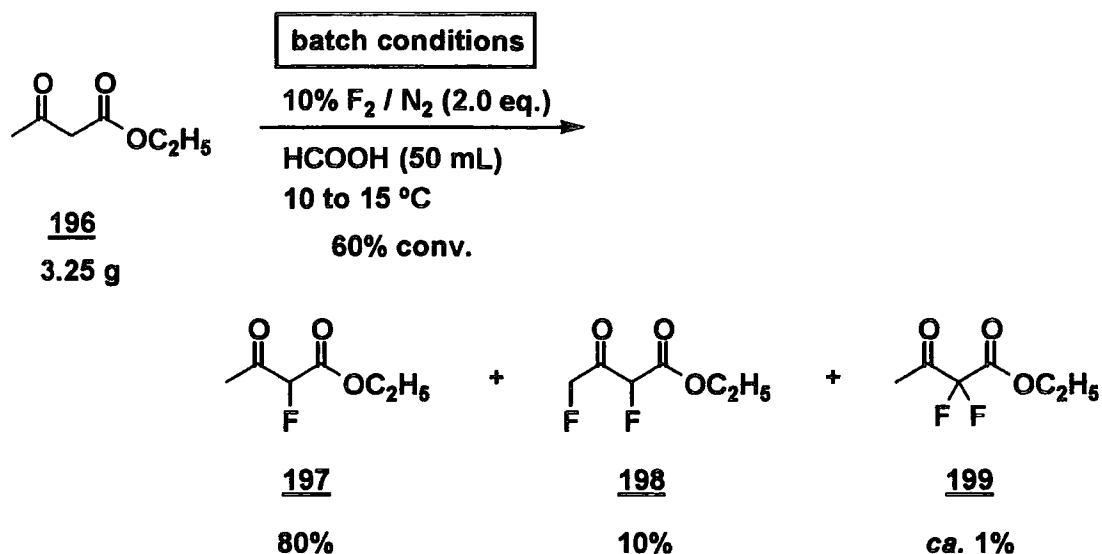

On the other hand, direct fluorination of **196** using the single channel microreactor gave rather less selectivity (**197**: 71%, **198**: 12%, **199**: 3% yield) although the fluorination proceeded in a quite high conversion (98%).²²¹ Thus we have been interested in the effects of changing various parameters on the conversion or the selectivity of this reaction in the multi-channel microreactor and thought that the results would be helpful to choose appropriate conditions for fluorinations of other substrates. Consequently, direct fluorination of ethyl 3-oxobutanoate (**196**) was investigated using 9-channel microreactor (V-21-9) under various conditions, and thereafter fluorination of other systems using these results would be carried out.

4.3.1.1 Fluorination of ethyl 3-oxobutanoate using multi-channel microreactor – A systematic study

Using 9-channel microreactor (V-21-9), direct fluorination of ethyl 3-oxobutanoate (**196**) was carried out (Table 4.2).

TABLE 4.2 Fluorination of ethyl 3-oxobutanoate (**196**) using microreactor

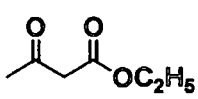

196

$\xrightarrow[\text{HCOOH}]{10\% \text{ F}_2 / \text{N}_2 (1.4 \text{ eq.})}$
 $(2.6 \text{ mmol h}^{-1}\text{ch}^{-1})$
 8 to 10 °C, 18 h

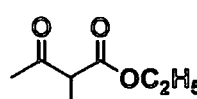

197

0.5 mL h⁻¹ch⁻¹
(1.8 mmol h⁻¹ch⁻¹)

substrate : HCOOH
= 1 : 4 (molar ratio)

9ch-microreactor
(V-21-9)

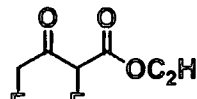

198

+

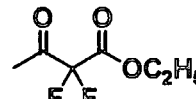

199

run	GC		NMR	
	% conv.	% yield	% conv.	ratio (197 / 198 / 199)
1 reaction mixture (before work up)				82 : 15 : 3
crude	64	84	62	92 : 5 : 3

2 reaction mixture (before work up)				83 : 14 : 3
crude	60	88	57	91 : 5 : 3

Substrate solution was prepared by mixing ethyl 3-oxobutanoate (**196**) and 4 equivalents of formic acid. The solution was passed through the microreactor at a rate of 4.5 mLh⁻¹ in total (0.5 mLh⁻¹ch⁻¹, 1.8 mmolh⁻¹ch⁻¹) while fluorine was passed through the microreactor at a rate of 90 mLmin⁻¹ (10 mLmin⁻¹ch⁻¹, 2.6 mmolh⁻¹ch⁻¹). The conversions and yields calculated by GC analyses were thought not to be always precise because the peak corresponding to ethyl 3-oxobutanoate (**196**) is very broad and unresolved from that of the monofluorinated product (**197**). Hence, the conversions were also estimated by comparing the integration between the resonances of the methyl groups of ethyl ester and methylene group of the remaining starting material in ¹H NMR. From the same reason, the ratios of the products were calculated by ¹⁹F NMR. In both experiments, the conversions were around 60%. Importantly, the reaction mixtures were analyzed by ¹⁹F NMR before work-up, and found to contain much more ethyl 2,4-difluoro-3-oxobutanoate (**198**). This fact implied that the side product **198** was removed into the aqueous phase during the work up. Consequently, in the following experiments, the selectivity were evaluated by measuring ¹⁹F NMR of the

reaction mixtures before work up.

4.3.1.1.1 Effect of the concentration of the substrate solution

The concentration of the substrate solution was thought to be related to conversion and selectivity. Direct fluorination of ethyl 3-oxobutanoate (**196**) using the microreactor (V-21-9) was carried out using substrate solutions with different substrate concentration (Table 4.3). In each case, the same flow rate of the substrate solution was used.

TABLE 4.3 The fluorination of ethyl 3-oxobutanoate (**196**) under different concentrations

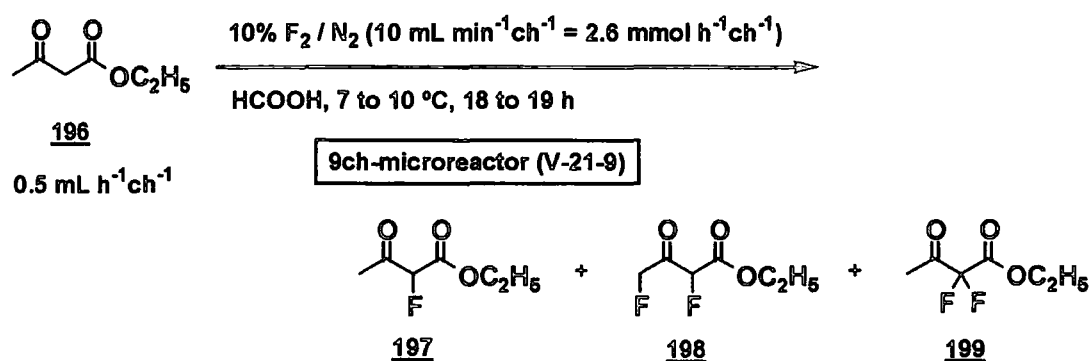

entry	substrate : HCOOH : F ₂ (molar ratio)	GC		NMR	
		% conv.	% yield	% conv.	ratio ^a (197 / 198 / 199)
1	1 : 2 : 1.2	36	91	40	74.8 : 22.1 : 3.1
2 ^b	1 : 4 : 1.4	62	86	60	82.6 : 14.7 : 2.8
3	1 : 8 : 2.4	82	87	70	85.0 : 12.1 : 2.8
4	1 : 16 : 4.1	74	88	76	86.9 : 9.7 : 3.4
5	1 : 32 : 7.4	66	90	69	88.2 : 9.5 : 2.3

^a Evaluated from analyses of the reaction mixtures. ^b The conversions, yields, and ratios are averaged from several experiments.

Results in table 4.3 show that as we used a more diluted solution of substrate the conversion tended to increase. However, a more important fact was that the selectivity was also improved with less concentrated solution, in spite of using a large excess of fluorine.

4.3.1.1.2 Effect of reaction temperature

In general, reaction temperature is one of the crucial factors for selectivity in chemical reactions. Lower temperatures often give better selectivity. The effect of reaction temperature on the fluorination process was assessed and summarised in Table 4.4.

TABLE 4.4 The fluorination of ethyl 3-oxobutanoate (**196**) at different temperatures

$10\% \text{ F}_2 / \text{N}_2 \text{ (} 10 \text{ mL min}^{-1} \text{ch}^{-1} = 2.6 \text{ mmol h}^{-1} \text{ch}^{-1} \text{)}$
 HCOOH, 18 to 19 h
9ch-microreactor (V-21-9)
 $0.5 \text{ mL h}^{-1} \text{ch}^{-1}$

entry	substrate : HCOOH : F ₂ (molar ratio)	temperature (°C)	GC		NMR	
			% conv.	% yield	% conv.	ratio ^a (197 / 198 / 199)
1	1 : 2 : 1.2	7—8	36	91	40	74.8 : 22.1 : 3.1
2	1 : 2 : 1.2	20	32	91	36	73.1 : 23.4 : 3.5
3	1 : 4 : 1.4	1—3	59	83	56	80.4 : 16.2 : 3.4
4 ^b	1 : 4 : 1.4	8—10	62	86	60	82.6 : 14.7 : 2.8
5	1 : 8 : 2.7	2—3	81	84	70	85.2 : 11.9 : 2.8
6	1 : 8 : 2.7	8	82	87	70	85.0 : 12.1 : 2.8
7	1 : 8 : 2.7	15—16	79	91	77	85.7 : 11.4 : 2.9
8	1 : 16 : 3.7	8—9	74	88	76	86.9 : 9.7 : 3.4
9	1 : 16 : 3.7	20	94	91	84	87.4 : 8.6 : 4.0
10	1 : 32 : 7.0	8—9	66	90	69	88.2 : 9.5 : 2.3
11	1 : 32 : 7.0	20	85	92	83	88.2 : 8.5 : 3.3

^a Evaluated from analyses of the reaction mixtures. ^b The conversions, yields, and ratios are averaged from plural experiments.

A sharp difference of selectivity was not observed between 1 to 20 °C. More strictly, compared between entry 3 and 4, a lower temperature seemed to give slightly poorer selectivity. In the case of 1:8 (substrate/formic acid) solution, the selectivity was essentially the same ranging from 2 to 16 °C (entry 5, 6 and 7). The faint decrease of compound **198** was observed at higher temperature in diluted conditions comparing entry 8 with 9, and entry 10 with 11. In addition, the improvement of conversion was observed at higher temperature under diluted conditions (entry 7, 9 and 11). This tendency was not observed in concentrated solution (entry 1 and 2). These results were quite meaningful because a low reaction temperature was not necessarily required in order to obtain high selectivity.

4.3.1.1.3 Effect of the flow rate of the substrate solution

The number of equivalents of fluorine to substrate is one of the possible factors for changing selectivity. There are two ways to vary the equivalents of fluorine using a fixed concentration of substrate solution. One is changing flow rate of substrate, and another is that of fluorine. Table 4.5 shows the influence of changing the flow rate of substrate whilst keeping the flow rate of fluorine constant.

TABLE 4.5 Effect of the flow rate of the substrate solution (1)

10% F₂ / N₂ (10 mL min⁻¹ch⁻¹ = 2.6 mmol h⁻¹ch⁻¹)
HCOOH, 8 to 10 °C, 18 h
9ch-microreactor (V-21-9)
substrate : HCOOH
(molar ratio) = 1 : 1

entry	flow rate of substrate		GC		NMR	
	F ₂ (eq.)	[mL h ⁻¹ ch ⁻¹ (mmol h ⁻¹ ch ⁻¹)]	% conv.	% yield	% conv.	ratio ^a (197 / 198 / 199)
1	1.0	0.42 (2.5)	55	72	52	74.5 : 20.5 : 5.0
2 ^b	1.4	0.29 (1.7)	83	77	77	70.5 : 23.5 : 6.0

^a Evaluated from analyses of the reaction mixtures. ^b The conversions, yields, and ratios are averaged from plural experiments.

The fluorination was carried out using a concentrated solution. The increase of the number of equivalents of fluorine by decreasing the flow rate of substrate was effective to lead to higher conversion but the selectivity became worse.

A change of the flow rate of the substrate solution is thought to be also related to the flow regime. In general, the flow regime depends on the relative rates of liquid and gas flow, and pipe flow requires a fast flow rate of gas relative to that of liquid. Consequently, the increase of the flow rate of substrate could lead to change of the flow regime due to the decrease of the relative flow rate of fluorine. From this point of view, the effect of more drastic changes of the flow rate was investigated using a diluted solution (Table 4.6).

TABLE 4.6 Effect of the flow rate of the substrate solution (2)

196
substrate : HCOOH
(molar ratio) = 1 : 36

9ch-microreactor (V-21-9)

197 + 198 + 199

entry	flow rate of substrate		F ₂ (eq.)	GC		NMR	
	[mL h ⁻¹ ch ⁻¹]	(mmol h ⁻¹ ch ⁻¹)		% conv.	% yield	% conv.	ratio ^a (197 / 198 / 199)
1	0.49	(0.32)	8.1	84	87	84	87.1 : 9.7 : 3.2
2	1.0	(0.64)	4.1	54	87	54	88.8 : 8.7 : 2.5
3	1.9	(1.3)	2.0	27	90	27	89.2 : 8.6 : 2.2
4	3.9	(2.6)	1.0	15	90	15	90.2 : 7.8 : 2.0

^a Evaluated from analyses of the reaction mixtures.

The fluorinations were carried out using various flow rates ranging 0.5 to 4 mLh⁻¹ch⁻¹. Pipe flow could be observed even in the very fast flow rate. Although the influence on the selectivity was rather small, the conversion decreased sharply as the flow rate

increased probably due to decreased residence time in the reactor.

4.3.1.1.4 Effect of the flow rate of fluorine

Table 4.7 shows the influence of the decrease of number of equivalents of fluorine by decreasing flow rate of fluorine.

TABLE 4.7 Effect of the flow rate of fluorine

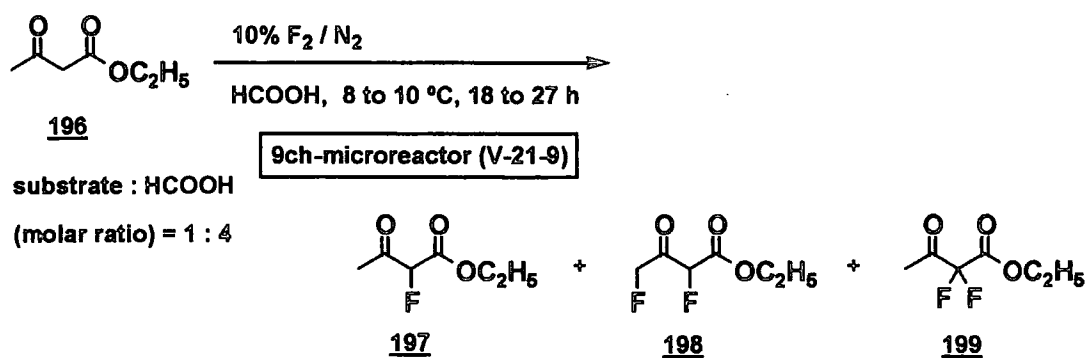

entry	flow rate of fluorine		F ₂ (eq.)	GC		NMR	
	[mL min ⁻¹ ch ⁻¹]	(mmol h ⁻¹ ch ⁻¹)		% conv.	% yield	% conv.	ratio ^a (197 / 198 / 199)
1 ^b	10	(2.6)	1.4	62	86	60	82.6 : 14.7 : 2.8
2 ^b	7	(1.8)	1.0	53	88	52	80.7 : 16.1 : 3.2

^a Evaluated from analyses of the reaction mixtures. ^b The conversions, yields, and ratios are averaged from plural experiments.

Interestingly, slightly less selectivity was obtained by the decrease of the flow rate of fluorine in spite of the decrease of the number of equivalents of fluorine. These results were in contrast to those shown in Table 4.5 and 4.6.

4.3.1.1.4 Effect of the solvent

The effect of solvents other than formic acid was evaluated and the results are summarised in table 4.8.

TABLE 4.8 Solvent effect in the fluorination of ethyl 3-oxobutanoate (**196**)

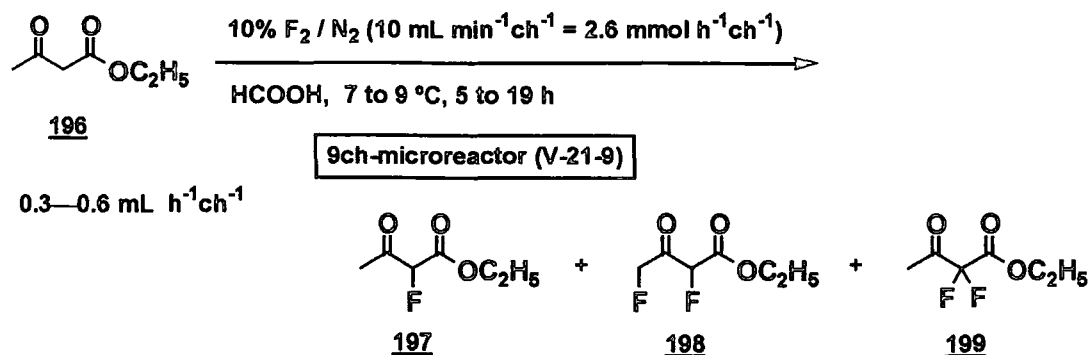

entry	solvent	substrate / solvent / F ₂ (molar ratio)	GC		NMR	
			% conv.	% yield	% conv.	ratio ^a (197 / 198 / 199)
1 ^b	HCOOH	1 : 4 : 1.4	62	86	60	82.6 : 14.7 : 2.8
2	CH ₃ CN	1 : 4 : 1.5	27	76	36	62.0 : 32.9 : 5.1
3	HCOOH / CH ₃ CN ^c	1 : 4 : 1.6	51	91	57	71.4 : 25.5 : 3.1
4 ^d	<i>t</i> -C ₄ H ₉ OH	1 : 4 : 2.4	36	67	— ^e	70.0 : 24.5 : 5.5
5	CF ₃ CH ₂ OH	1 : 4 : 2.4	66	69	79	62.6 : 34.4 : 3.0
6	—	1 : 0 : 1.0	52	75	49	68.5 : 25.3 : 6.2

^a Evaluated from analyses of the reaction mixtures. ^b The conversions, yields, and ratios are averaged from plural experiments. ^c 1 : 1 mixture (mol / mol). ^d The reaction was carried out at 20 °C. ^e The conversion could not be estimated due to the solvent's resonances.

Acetonitrile

In the direct fluorination of 1,3-dicarbonyl compounds, acetonitrile is generally inferior to formic acid^{32,35} because the substrate can be enolised to a less extent in acetonitrile. As expected the fluorination of ethyl 3-oxobutanoate in acetonitrile using microreactor gave much less conversion compared with the case in formic acid (entry 1 and 2). In respect of the selectivity, the product contained substantial amounts of 2,4-difluoro derivative **198**. A 1 to 1 mixture of acetonitrile and formic acid was a better solvent system than acetonitrile alone, but the selectivity could not be improved sufficiently.

***t*-Butanol**

As a rule, alcoholic solvents are unacceptable solvents for direct fluorination reaction because the hydroxyl group may react with elemental fluorine to give hypofluorite species, followed by decomposition to an aldehyde leading to the formation of complex by-products. However, tertiary alcohols can be applied to the direct fluorination because they can not be oxidised by elimination of HF. The fluorination using *t*-butanol in microreactor was carried out at 20 °C due to its relatively high freezing point (entry 4). Conversion was much less than the case of using only formic acid, even when using 2.4 equivalents of fluorine.

2,2,2-Trifluoroethanol

2,2,2-Trifluoroethanol was also thought to be applicable to direct fluorination because it should not be oxidised, owing to the electron withdrawing effect of the CF₃ group. The fluorination in 2,2,2-trifluoroethanol gave a comparable conversion to the reaction in formic acid (entry 5). However, significant amounts of 2,4-difluoro product (**198**) were obtained.

No solvent

As mentioned in the preceding sections, one of the striking features of the microreactor is the excellent heat removing ability. This benefit could enable the reaction to be carried out under quite concentrated conditions. In particular, the fluorination of liquid substrates without solvent in a microreactor is thought to be beneficial from the viewpoint of both industrial application and 'green chemistry'. The fluorination of ethyl 3-oxobutanoate (**196**) was carried out in the absence of solvent (entry 6). Around 50% conversion was achieved using only equimolar amounts of fluorine for this reaction although relatively less selectivity was observed.

Ethyl 2-fluoro-3-oxobutanoate (197**)**

The product itself can be utilised as a solvent if the product is stable enough towards further fluorination. The fluorination was carried out using a mixture of ethyl 3-oxobutanoate (**196**) and the fluorinated products (**197/198/199** = 97.1/1.1/1.8 in ¹⁹F NMR) (Scheme 4.12).

SCHEME 4.12 The fluorination of ethyl 3-oxobutanoate (**196**) using fluorinated products as a solvent

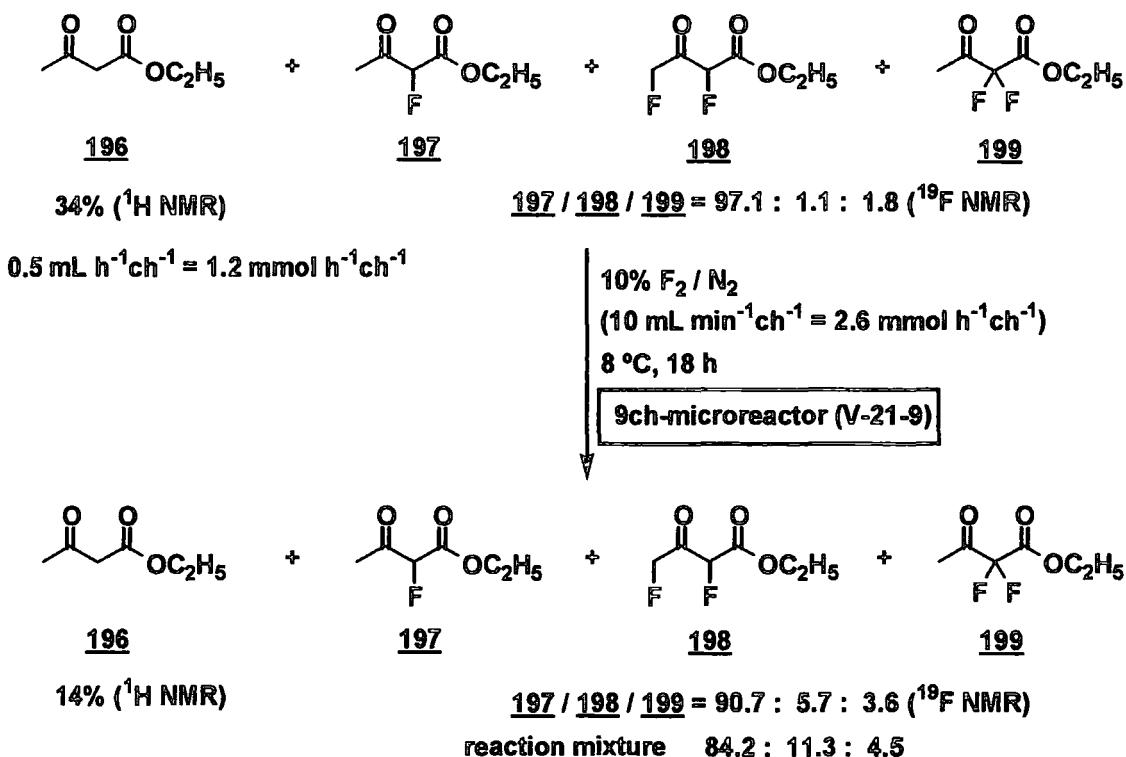

After fluorination in microreactor, 14% of ethyl 3-oxobutanoate (**196**) still remained in the crude product. The $\underline{197}/\underline{198}/\underline{199}$ ratio changed to 90.7:5.7:3.6, although the reaction mixture, before work up, contained larger amounts of 2,4-difluoro product **198** (the $\underline{197}/\underline{198}/\underline{199}$ ratio was 84.2:11.3:4.5). Assuming that no further fluorination of **197** to **198** or **199** occurred during the course of the reaction, the net conversion was 59%, and the selectivity was found to be 41.5/45.0/13.5 as a $\underline{197}/\underline{198}/\underline{199}$ ratio. The formation of large amounts of **198** suggested that the pathway from **197** to **198** could not be rejected. In order to prove the existence of this reaction pathway (**197** \rightarrow **198**) the fluorination of pure **197** was carried out (Scheme 4.13).

SCHEME 4.13 The fluorination of ethyl 2-fluoro-3-oxobutanoate (**197**)

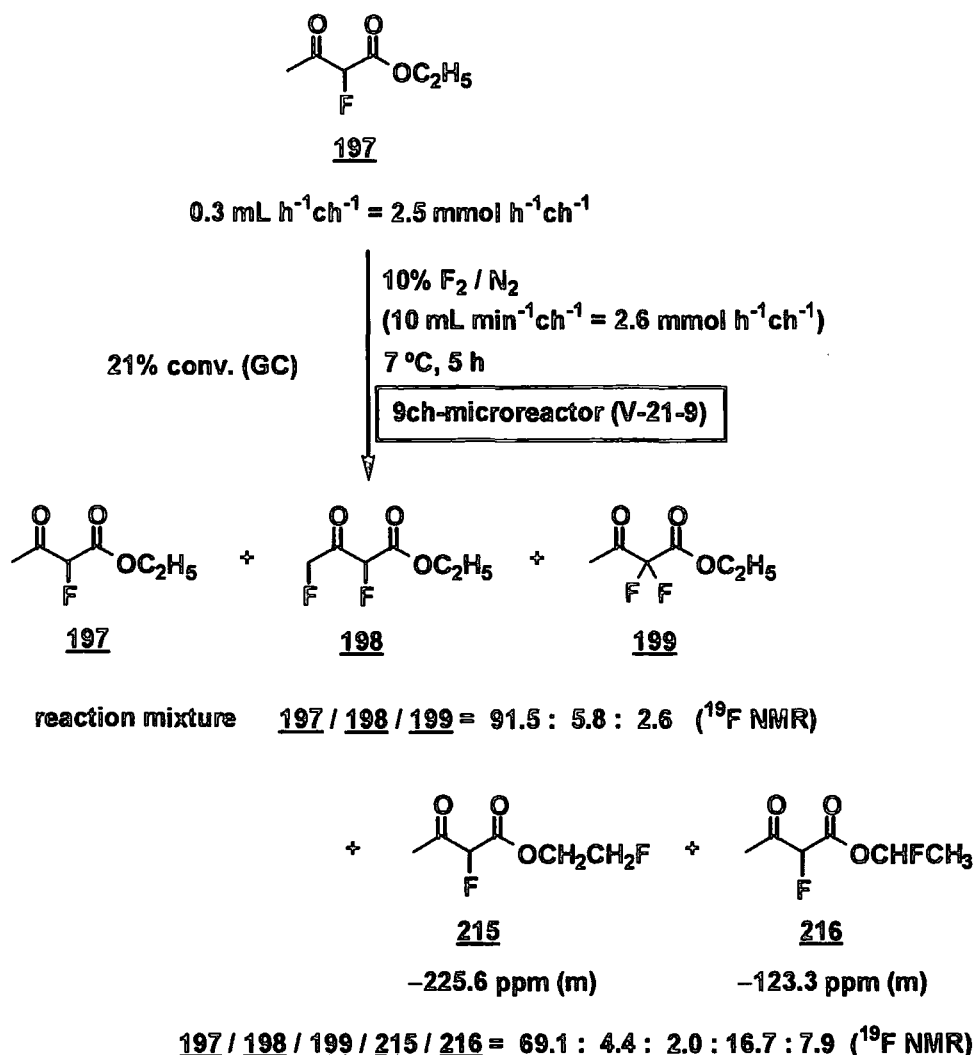

As expected, the reaction mixture of the fluorination of pure **197** using the microreactor included difluorinated products, and the **197/198/199** ratio was 91.5:5.8:2.6. However, other difluoro systems, which could be recognised as compounds fluorinated at the ethyl group, **215** and **216**, were preferentially obtained in this reaction. On the other hand, fluorination of the mixture of ethyl 3-oxobutanoate (**196**) and the fluorinated products described above gave less amounts of **215** and **216** (**197/198/199/215/216** = 75.5:9.6:4.1:7.2:3.6). This difference of the product distributions were thought to be attributed to the existence of the much more reactive non-fluorinated system. The direct fluorination of **197** was also carried out under batch condition in order to confirm whether the product distribution was peculiar to the fluorination using the microreactor or not (Table 4.9).

TABLE 4.9 The fluorination of ethyl 2-fluoro-3-oxobutanoate (**197**) under batch condition

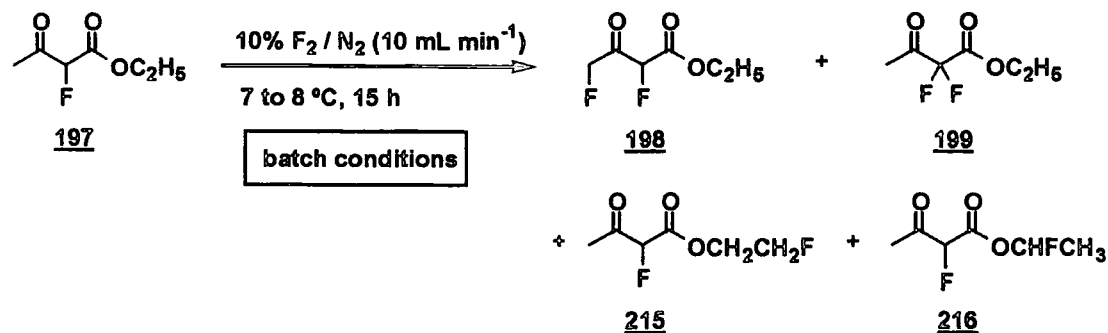

entry	substrate : HCOOH		conv. (GC, %)	197 / 198 / 199 / 215 / 216 (^{19}F NMR) ^a
	: F ₂ (molar ratio)			
1	1.0 : 0	1.0	20	69.2 : 5.1 : 2.2 : 15.5 : 8.0
2	1.0 : 0.1	1.0	10	71.3 : 5.1 : 2.1 : 15.7 : 5.8

^aEvaluated from analyses of the reaction mixtures.

The direct fluorination of **197** under batch condition without solvent gave a quite similar result to that in the microreactor (entry 1). The fluorination was thought to partially proceed *via* a radical process because catalytic amounts of formic acid, which should encourage electrophilic process, decreased the conversion (entry 2).

4.3.1.1.4 Effect of the catalyst

As mentioned repeatedly in the preceding chapters, in batch conditions, late transition metal nitrates (copper, nickel, etc.) are effective catalysts for the fluorination of 1,3-dicarbonyl compounds.³⁵ Therefore, fluorination of ethyl 3-oxobutanoate using nickel nitrate as a catalyst under batch conditions were attempted before applying this fluorination reaction to the microreactor (Table 4.10). In the absence of catalyst, the reaction gave only 44% conversion. 10 mol % Nickel nitrate accelerated the reaction to give 75% conversion. And so, this catalyst was employed for the fluorination of ethyl 3-oxobutanoate using the microreactor (Table 4.11). The fluorination was carried out using 0.5 mol% and 4 mol% of nickel nitrate (entry 2 and 4). In both cases, the conversion and selectivity were not obviously improved (compared with entry 1 and 3). These results were probably caused by a relatively short residence time of the substrate compared with the time scale of the catalytic cycle. Copper nitrate could not be employed for this system owing to the formation of precipitates which blocked the microreactor.

TABLE 4.10 Fluorination of ethyl 3-oxobutanoate (**196**) under batch conditions

196
 347 mg
 batch conditions

197 + **198** + **199**

entry	catalyst	temperature (°C)	GC		NMR
			% conv.	% conv.	ratio ^a (197 / 198 / 199)
1	—	16	44	45	90.8 : 7.9 : 1.3
2	Ni(NO ₃) ₂ ·6H ₂ O	8–9	75	73	87.8 : 6.3 : 5.9

^a Evaluated from analyses of the reaction mixtures.

TABLE 4.11 Catalyst effects in the fluorination of ethyl 3-oxobutanoate (**196**) using microreactor

196
 0.5 mL h⁻¹ ch⁻¹
 9ch-microreactor (V-21-9)

197 + **198** + **199**

entry	catalyst	substrate : solvent : F ₂ : catalyst (molar ratio)		GC		NMR
				% conv.	% yield	% conv. ratio ^a (197 / 198 / 199)
1	—	1 : 4 : 1.4 : 0	62	86	60	82.6 : 14.7 : 2.8
2	Ni(NO ₃) ₂ ·6H ₂ O	1 : 4 : 1.5 : 0.005	60	95	64	78.2 : 18.7 : 3.1
3	—	1 : 32 : 7.4 : 0	66	90	69	88.2 : 9.5 : 2.3
4	Ni(NO ₃) ₂ ·6H ₂ O	1 : 32 : 7.6 : 0.04	60	95	64	89.3 : 7.6 : 3.1

^a Evaluated from analyses of the reaction mixtures.

4.3.1.1.5 Effect of the reactor alignment

In the fluorination using V-21 type microreactor, the horizontal alignment of the reactor is quite important, which means the channels should be precisely orthogonal to the horizontal plane because it is thought that the substrate solution needs to divide and flow equally between each channel. However, the importance of the vertical angle of the reactor had not been made clear. Therefore, the effect of the vertical angle of the reactor was investigated (Table 4.12).

TABLE 4.12 The effect of the vertical angle of the reactor

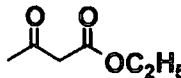

196

$\xrightarrow[10\% \text{ F}_2 / \text{N}_2 (10 \text{ mL min}^{-1} \text{ ch}^{-1} = 2.6 \text{ mmol h}^{-1} \text{ ch}^{-1})]{\text{HCOOH, 8 to 10 } ^\circ\text{C, 19 h}}$

9ch-microreactor (V-21-9)

0.5 mL h⁻¹ch⁻¹
substrate / solvent / F₂
(molar ratio) = 1 : 4 : 1.5

+

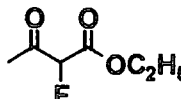

197

+

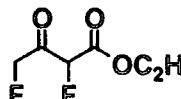

198

+

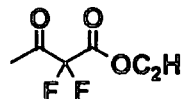

199

entry	θ	GC		NMR	
		% conv.	% yield	% conv.	ratio ^a (197 / 198 / 199)
1	0°	57	92	60	77.9 : 19.6 : 2.6
2	5°	37	93	41	78.9 : 18.6 : 2.4
3	2°	49	94	53	78.6 : 18.8 : 2.6
4	1°	56	93	59	78.5 : 19.0 : 2.5
5	0°	56	94	59	79.7 : 17.7 : 2.6
6	-1°	59	92	63	78.4 : 19.0 : 2.6

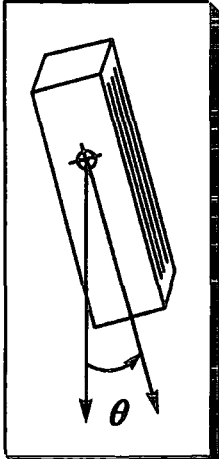

^a Evaluated from analyses of the reaction mixtures.

The fluorination of ethyl 3-oxobutanoate (**196**) was carried out with different θ angles, which is shown above, between -1° and 5° . When $|\theta|$ was 0 or 1, no obvious difference of conversion was observed (run 1, 4, 5 and 6). However, θ more than 2° caused lower conversion (run 2 and 3), although the **197/198/199** ratio were almost

same in all cases. From these results $|\theta|$ should be less than 2° to obtain the best result using this type of microreactor.

4.3.1.1.6 Effect of cleaning the reactor

The microreactor should be cleaned occasionally because the channels gradually accumulate some scaling which disturbs the reagent flow. The fluorination of ethyl 3-oxobutanoate (**196**) was carried out after cleaning to assess the effect on conversion and selectivity (Table 4.13). In this case, the cleaning involved disassembling the reactor and washing with acetone and water (see Appendix for the procedure).

TABLE 4.13 The effect of cleaning the microreactor

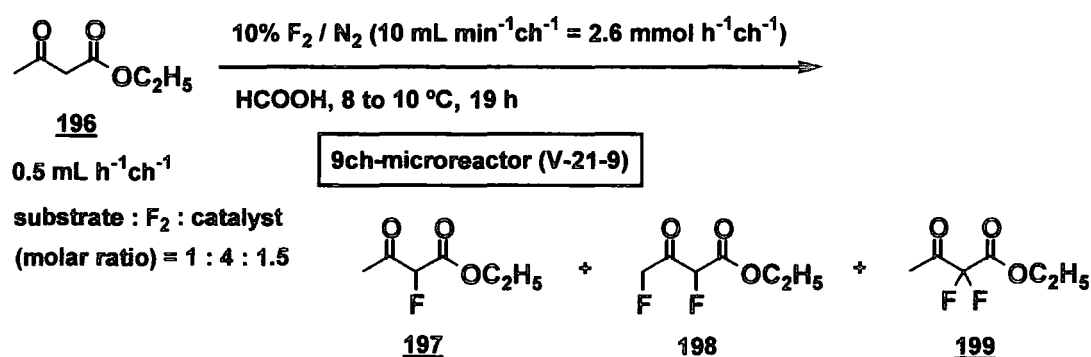

	entry	GC		NMR	
		% conv.	% yield	% conv.	ratio ^a (197 / 198 / 199)
Before cleaning	1	56	94	59	79.7 : 17.7 : 2.6
After cleaning	2	73	89	75	77.0 : 20.2 : 2.8
	3	74	93	74	78.2 : 19.1 : 2.7

^a Evaluated from analyses of the reaction mixtures.

Obviously, the conversion increased after cleaning although the selectivity slightly declined. The reactivity was thought to be closely connected to the condition of the surface of the reactor made by nickel as well as the reagent flow.²²¹ Therefore, the increase of the conversion can be construed as a result partially derived from activation of the surface of the reactor.

4.3.1.1.7 Effect of work up

As mentioned in section 4.3.1.1, ethyl 2,4-difluoro-3-oxobutanoate (**198**) was found to be removed into the aqueous phase to a considerable extent during the course of the work up. Thus, the ratio of products in each extraction during work up were analyzed by ^{19}F NMR, and summarised in Figure 4.12.

Figure 4.12 Work up procedure of fluorination of ethyl 3-oxo-butanoate (**196**)

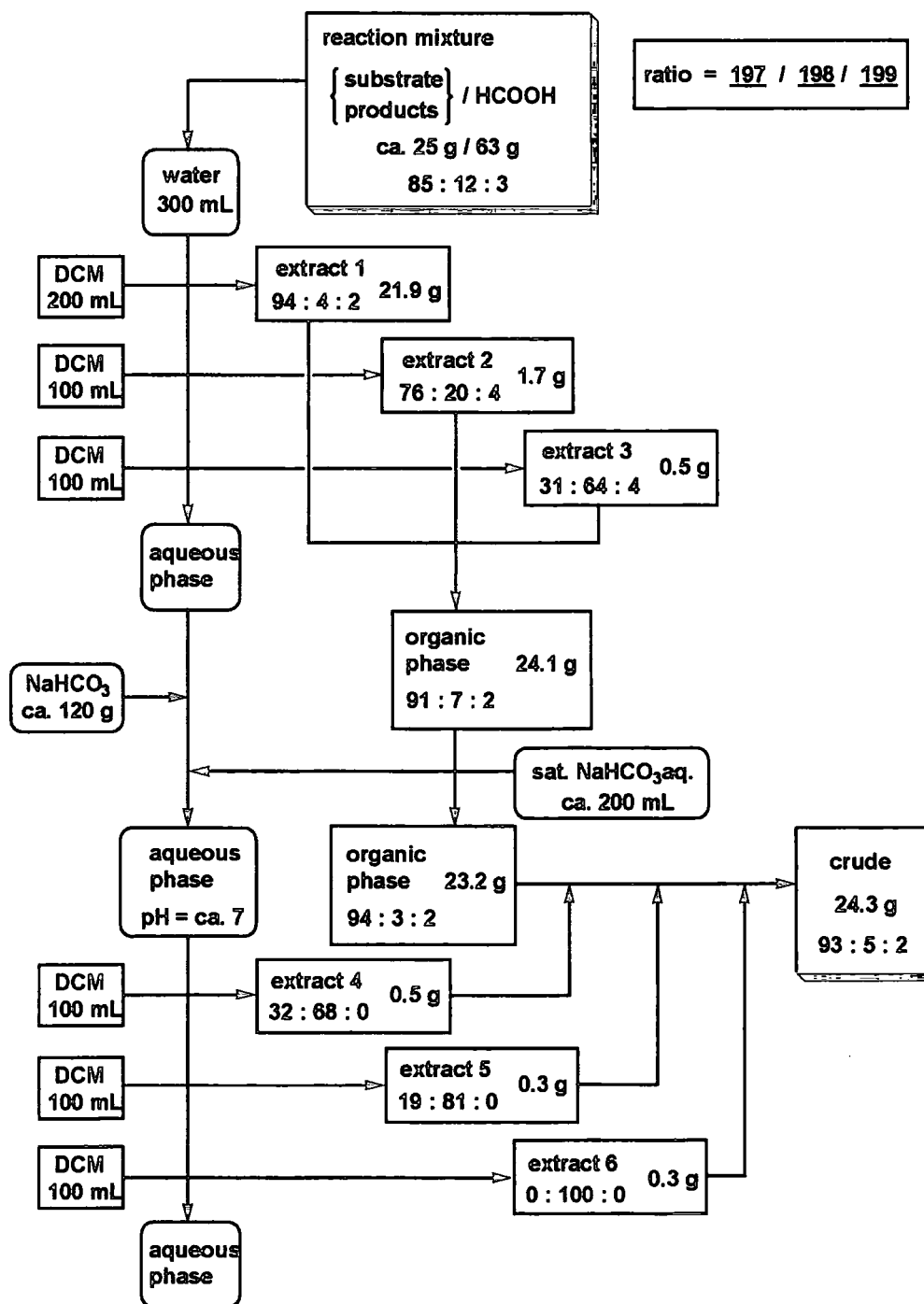

The ratio of compound 197, 198, and 199 was dramatically changed during the course of the work up. The initial ratio of products was 85/12/3, whilst the first extract contained the mixture of products in the ratio of 94/4/2 and the proportion of compound 198 sharply increased in the latter extractions. Moreover, the compound 198 was also found to be removed to some extent by washing with saturated sodium hydrogencarbonate solution. The final ratio of the crude mixture obtained from the six extracts was 93/5/2. The effect of acidity or basicity of the solution used for the washing on the ratio of products was examined as shown in Figure 4.13.

Figure 4.13

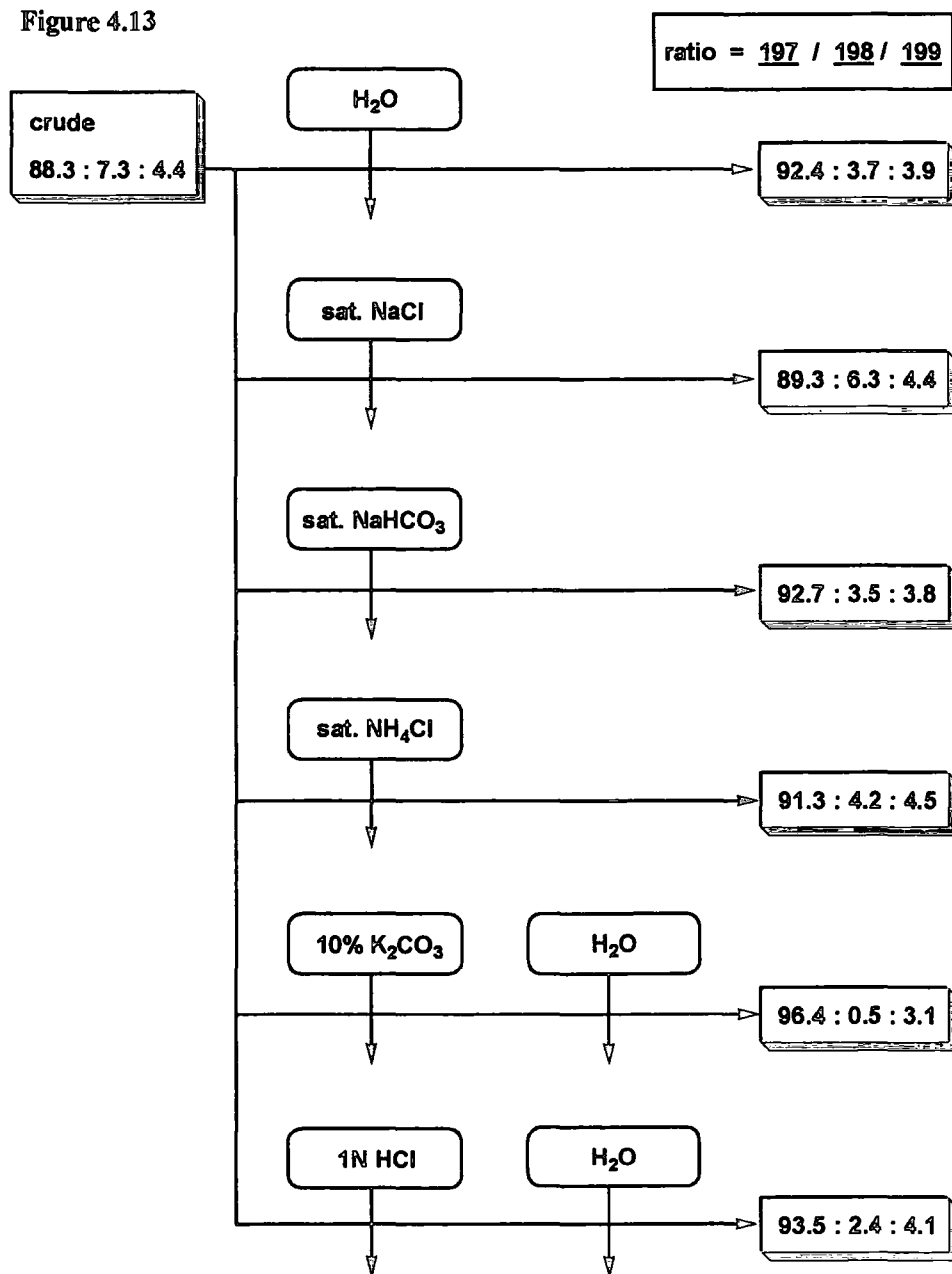

1 g of crude product was used for each test. The crude product was dissolved in 10 mL of dichloromethane and washed with 10 mL of various solutions ranging in pH from *ca.* 1 to 12. 1 mL of samples were withdrawn from the resulting organic phase, evaporated and analyzed by ^{19}F NMR. All aqueous solutions showed some effect for removing compound **198**, and, particularly, basic solutions were effective to reduce the by-product. Thus, purification of 9 g of crude product using saturated aqueous sodium hydrogencarbonate and 10% potassium carbonate was demonstrated (Figure 4.14).

FIGURE 4.14

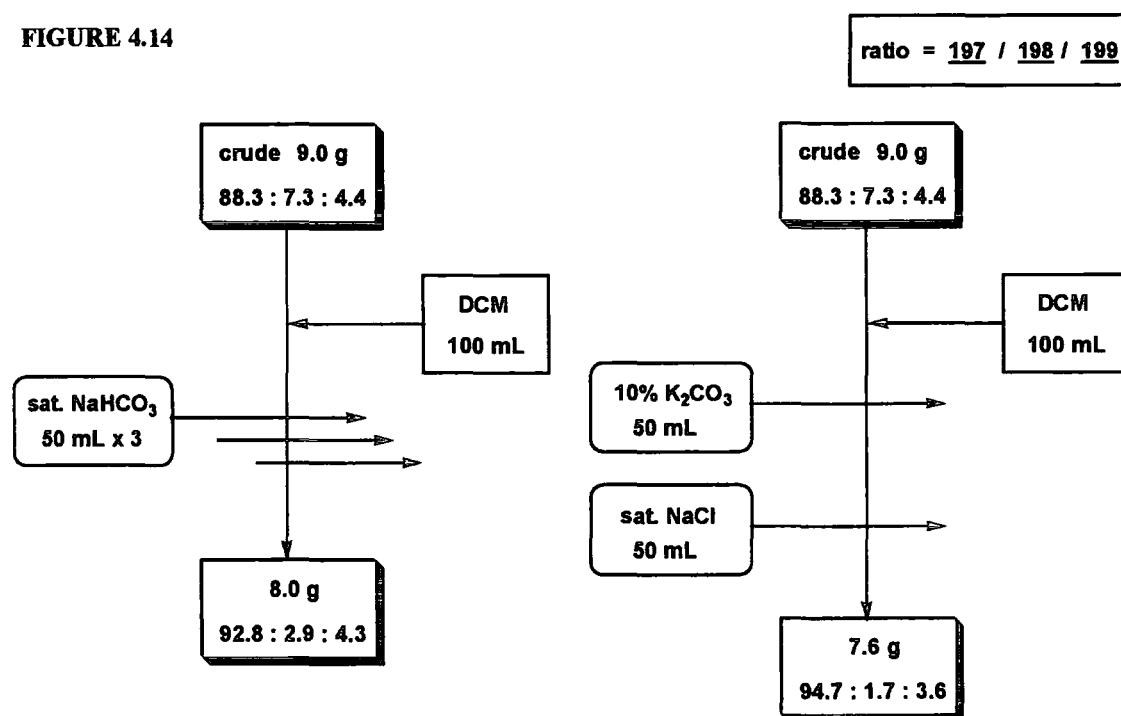

Each crude product was dissolved in 100 mL of dichloromethane, washed with saturated sodium hydrogencarbonate or 10% potassium carbonate, dried over magnesium sulfate, and evaporated. In the case of 10% potassium carbonate, the organic phase was also washed with saturated sodium chloride to neutralise. In both cases, compound **198** was significantly reduced. Washing with 10% potassium carbonate was more effective to remove compound **198** rather than washing with 3 portions of saturated sodium hydrogencarbonate.

The fact that 2,4-difluoro derivative **198** can be removed by washing with aqueous solution obviously suggests that it can be dissolved in aqueous media relatively easily compared with other fluorinated products. Although it is not easy to rationalise, a comparison of dipole moments of these compounds may be helpful to understand this phenomenon (Table 4.14). In general, dipole moment is closely related with

octanol/water partition coefficient ($\log P_{ow}$), which is an index for lipophilicity (or hydrophilicity) of organic compounds and widely used in pharmacological and environmental research.²²⁹

TABLE 4.14 Comparison of dipole moment of the fluorinated products

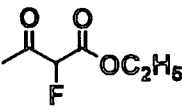
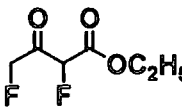
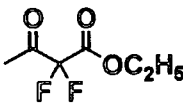
	 197	 198	 199
dipole moment (debye)^a	0.780	2.842	1.344

^a Calculated from a structure optimized by a semiempirical method [MOPAC (PM3)].

The dipole moments were calculated from structures which were optimised by a semiempirical method [MOPAC (PM3)]. The dipole moment of 2,4-difluoro system **198** was found to be much larger than the others, which implied the more hydrophilic nature of this compound.

4.3.1.1.8 Summary of results

A summary of the effects of various parameters on the conversion and the selectivity in the direct fluorination of ethyl 3-oxobutanoate (**196**) using 9-channel microreactor which are discussed above is shown in table 4.15. The results showed that the intrinsic selectivity can be improved only by diluted conditions, which is not necessarily favourable for the efficiency of the production. Considering that washing by basic aqueous solution was quite effective for removing 2,4-difluoro system which is a major by-product, the conversion should precede the selectivity in this reaction. In addition, it should be pointed out that the starting material is much more awkward to separate the desired product from the crude mixture because they possess very close boiling points. In concentrated conditions, the fluorine can be utilised more efficiently and a slow flow rate of substrate solution was effective to improve the conversion. Use of more concentrated fluorine gas should also be effective to increase the conversion without decrease of the hourly production, which has already demonstrated using the 9-channel microreactor.²²⁸ It is also notable that the fluorination under neat conditions was successfully demonstrated.

SCHEME 4.14

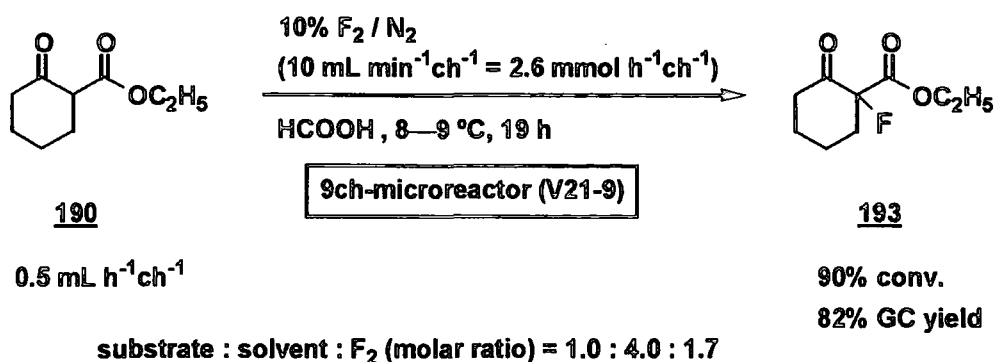

Substrate solution was prepared by mixing ethyl 2-oxocyclohexanecarboxylate (**190**) and 4 equivalents of formic acid. The substrate solution and fluorine was passed through the microreactor at a standard rate, which is 0.5 mLh⁻¹ch⁻¹, 10 mLmin⁻¹ch⁻¹ respectively. The substrate/fluorine ratio was 1.0:1.7, and 90% conversion and 82% yield was achieved.

Ethyl 2-chloro-3-oxobutanoate (200**)**

Ethyl 2-chloro-3-oxobutanoate (**200**) is much less reactive than ethyl 3-oxobutanoate (**196**).³² The direct fluorination of **200** was carried out using a 1 to 4 mixture (molar ratio) of substrate and formic acid and a rather slow flow rate (Scheme 4.15)

SCHEME 4.15

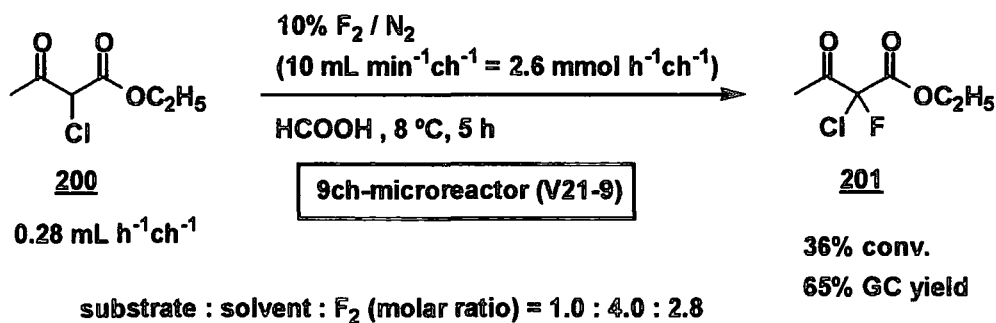

The conversion was estimated to be 36%, which was much lower than the case of using the single channel microreactor. This could be attributed to the material of the groove. The channels of multi-channel microreactor (V-21) is composed of one nickel

base, two stainless walls and one PTFCE top, whilst the channel of the single channel microreactor consists of three nickel walls and one PTFCE top. Considering that nickel was thought to accelerate the enolisation process, it was relevant that the number of nickel walls affected the conversion.

4.3.2 Fluorination of 1,3-diester using multi-channel microreactor

As described in chapter 1, the direct fluorination of 1,3-diester is more demanding to achieve under conventional batch conditions because of the lower reactivity than 1,3-ketoesters.³¹ Indeed, usually sodium salts of parent diesters or transition metal catalysts are required for the reactions with elemental fluorine.^{34,35} Therefore, the direct fluorination of malonates was investigated using the microreactor.

4.3.2.1 Diethyl malonate (**217**)

The fluorination of diethyl malonate (**217**) was carried out using formic acid as a solvent (Table 4.16).

TABLE 4.16 The fluorination of ethyl malonate (**217**) using microreactor

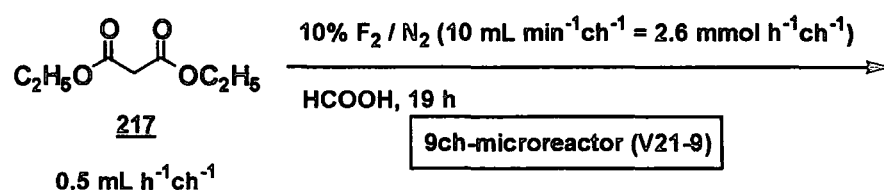

substrate : solvent : F₂ (molar ratio) = 1.0 : 16 : 4.3

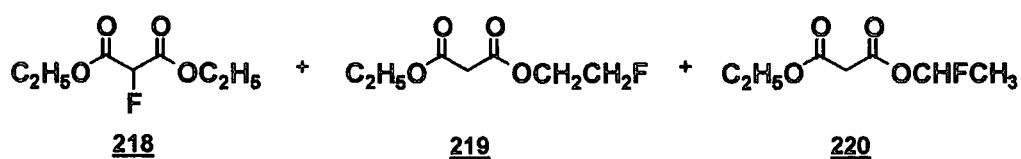

entry	Temperature (°C)	% conv. (GC)	ratio (218 / 219 / 220) (¹⁹ F NMR)
1	8–9	24	2 : 59 : 39
2	20	20	2 : 62 : 37

Although the reactions were carried out at two different temperatures, only about 20% conversion was obtained in both cases. The desired diethyl 2-fluoromalonate (**218**) was obtained as a minor product. Two major fluorinated products could be assigned to the

TABLE 4.17 The fluorination of dimethyl malonate (**221**) using microreactor

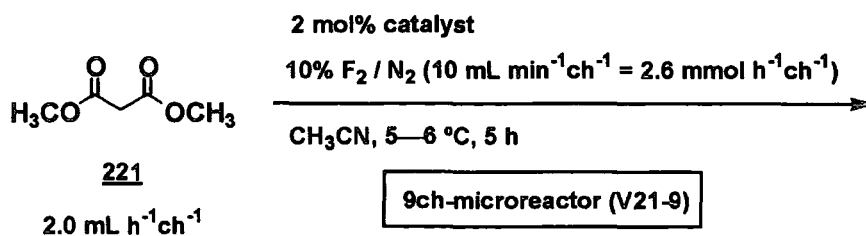

substrate : solvent : F₂ (molar ratio) = 1.0 : 64 : 4.6

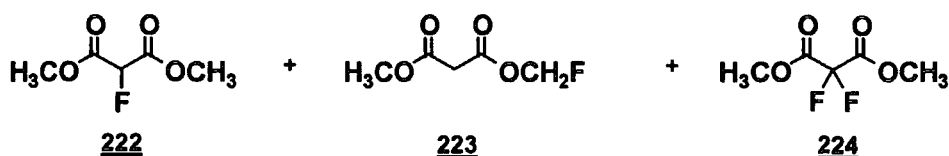

entry	catalyst	% conv. (GC)	ratio (222 / 223 / 224) (¹⁹ F NMR)
1	—	2	42 : 50 : 7
2	Ni(NO ₃) ₂ ·6H ₂ O	9	80 : 12 : 7
3	Cu(NO ₃) ₂ ·2.5H ₂ O	13	81 : 13 : 6

The fluorination in acetonitrile without catalyst gave only 2% conversion (entry 1). In the case of using catalyst, 80% of selectivity was observed (entry 2, 3), although low conversions were still obtained. Copper nitrate gave a slightly better result than nickel nitrate.

4.3.2.3 2,2-Dimethyl-1,3-dioxane-4,6-dione (Meldrum's acid)

2,2-Dimethyl-1,3-dioxane-4,6-dione (Meldrum's acid, **225**) is a well-known cyclic malonate which has a highly acidic proton, and is easily enolised. Therefore, we hoped that the substrate would be more reactive towards elemental fluorine than acyclic malonates. The fluorination of 2,2-dimethyl-1,3-dioxane-4,6-dione (**225**) using formic acid failed due to decomposition of the substrate. Therefore, acetonitrile was employed as the solvent for the fluorination, and gave 15% conversion (Scheme 4.18).

SCHEME 4.18

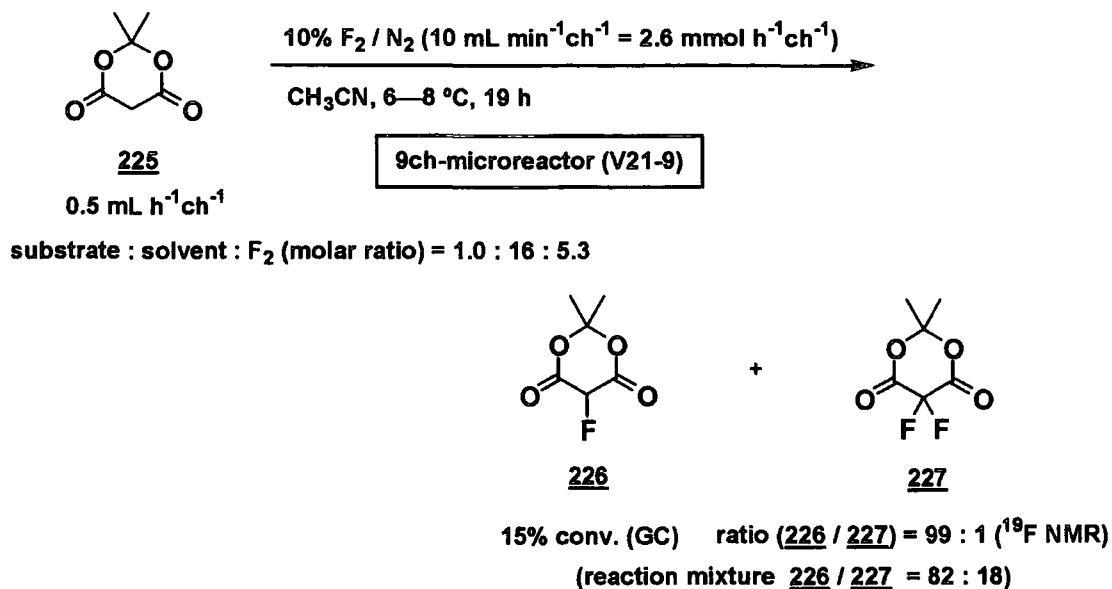

The products were monofluorinated and difluorinated compound (**226** and **227**), and the ratio was 99:1. However, the reaction mixture involved much larger amounts of difluorinated adduct. This was thought to be caused by decomposition of the products into the free carboxylic acid derivatives during the work up. The same reaction was carried out in the presence of 2 mol% of nickel nitrate (Scheme 4.19). Some precipitates formed in the substrate solution, but 4 or 5 channels were blocked by precipitates during the reaction.

SCHEME 4.19

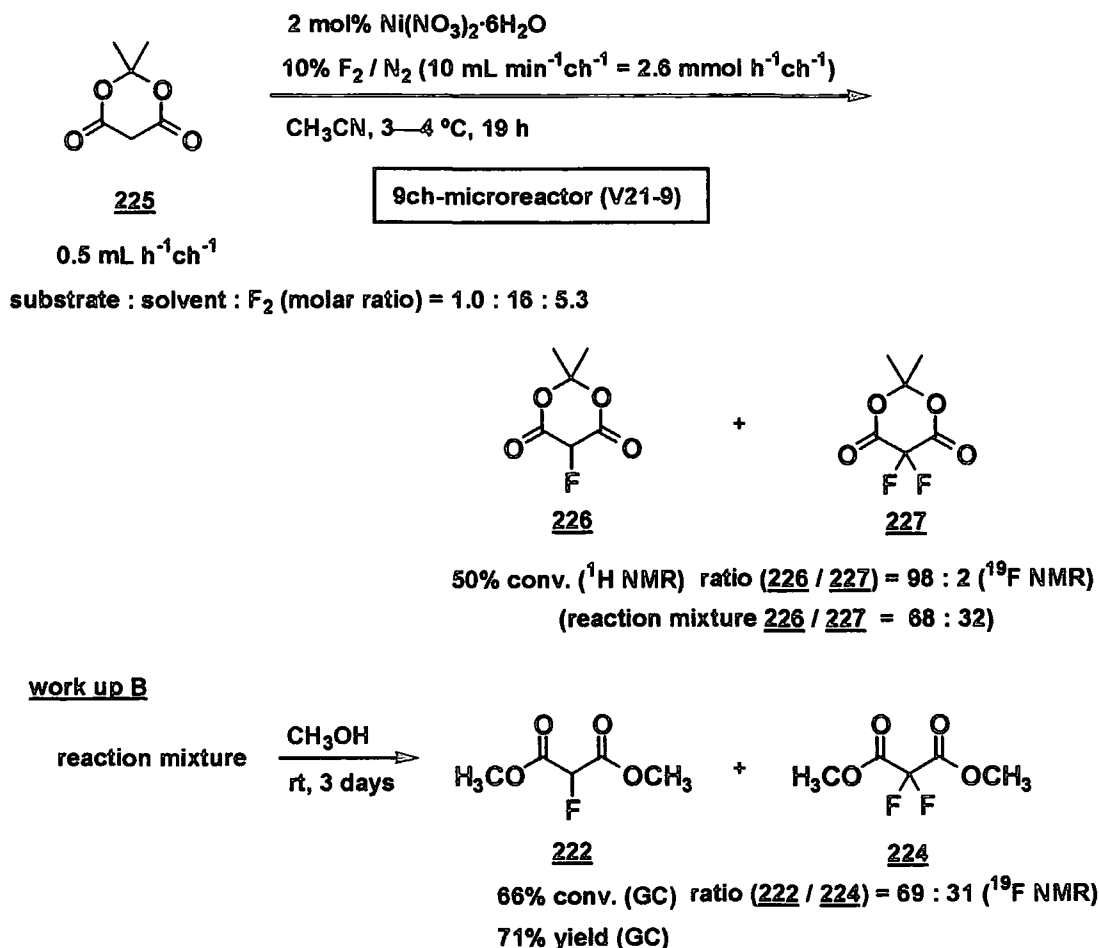

In this case, the reaction mixture was divided into two parts. One half was treated with water as usual to give the crude product, and the ratio **226/227** was 98:2. The other half was mixed with methyl alcohol and stirred for 3 days. The reaction mixture gave a mixture of fluorinated dimethyl malonates after aqueous work up. The conversion was estimated to be 66%, and the ratio **222/224** was 69:31, which was consistent with the ratio **226/227** of the reaction mixture before the treatment. The transformation of cyclic malonate to dimethyl malonate can easily be achieved by treatment with methyl alcohol and catalytic amounts of sulfuric acid under reflux condition²³⁰ (Table 4.18).

TABLE 4.18 The fluorination of 2,2-dimethyl-1,3-dioxane-4,6-dione (**225**) using microreactor

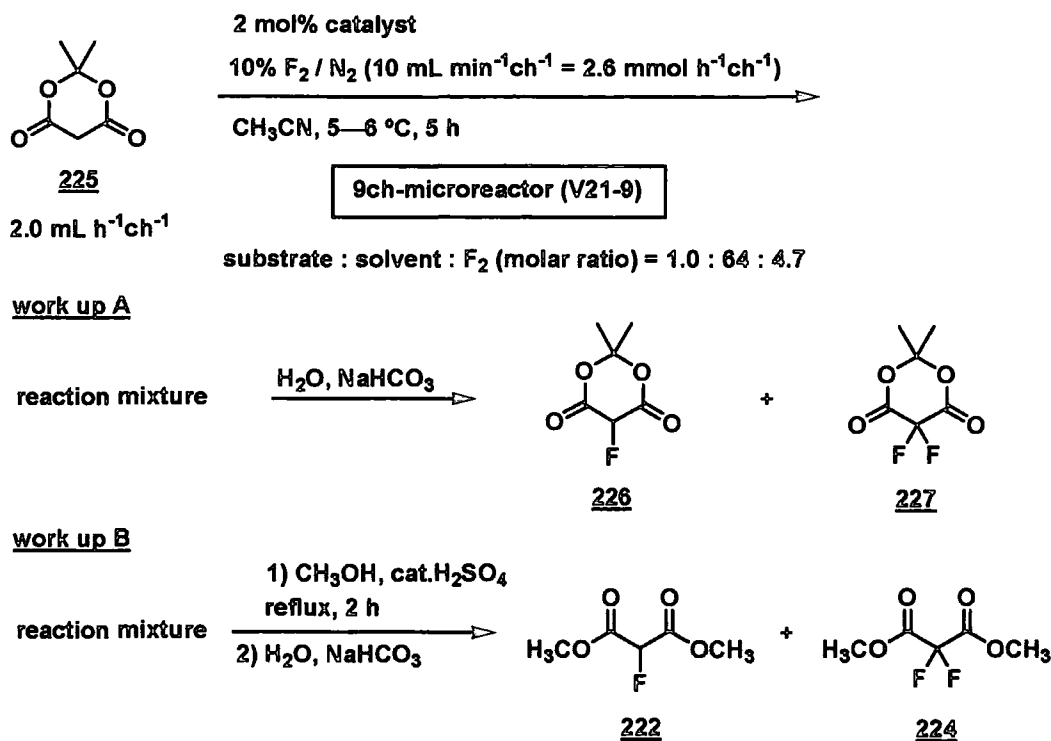

entry	catalyst	work up A		work up B		
		% conv. ^a	ratio (226 / 227) ^b	% conv. ^c	% yield (222) ^c	ratio (222 / 224) ^b
1	—	6	100 : 0	26	79	83 : 17
2	Ni(NO ₃) ₂ ·6H ₂ O	44	94 : 6	50	74	72 : 28

^a Estimated by ¹H NMR. ^b Estimated by ¹⁹F NMR. ^c Estimated by GC.

The fluorination was carried out using a diluted solution and fast flow (2.0 mL h⁻¹ ch⁻¹). This condition was effective to reduce the formation of precipitates and blockage. When the new work up method was employed (work up B), 26% conversion was observed even in no presence of the catalyst (entry 1). In the case of using 2 mol% of catalyst, the conversion increased to 50%. This acceleration was not observed in the fluorination of ethyl 3-oxobutanoate (**196**). Therefore, the rate constant of the enolisation of 2,2-dimethyl-1,3-dioxane-4,6-dione (**225**) in the presence of nickel nitrate is thought to be larger than that of ethyl 3-oxobutanoate (**196**).

To the best of our knowledge, the direct fluorination of Meldrum's acid has only been achieved by using the hydroxymethylenated derivative at very low temperature.²³¹ In addition, this is one of few examples of a homogeneous catalytic reaction in a microreactor,²³² although further optimisation was required to resolve the

problem of the precipitation.

4.3.3 Fluorination of other carbonyl compounds using multi channel microreactor

α -Fluorination of a simple ketone in the microreactor was also investigated using 1-cyclohexen-1-yl acetate (**228**) as the substrate.

4.3.3.1 1-Cyclohexen-1-yl acetate (**228**)

The direct fluorination of 1-cyclohexen-1-yl acetate (**228**) was carried out using both acetonitrile and formic acid (Table 4.19).

TABLE 4.19 The fluorination of 1-Cyclohexen-1-yl acetate (**228**) using the microreactor

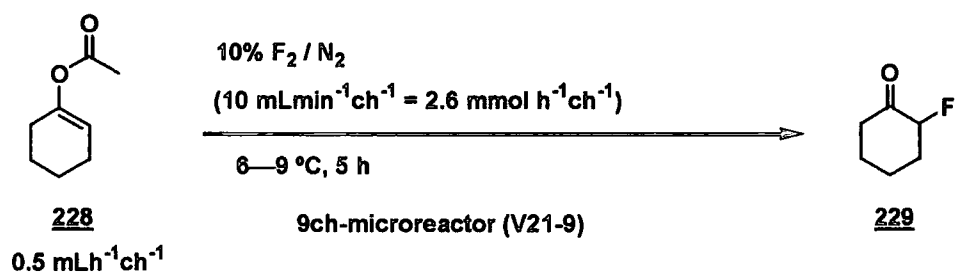

solvent	substrate : solvent : F ₂ (molar ratio)	% conv.	% yield (GC)
CH ₃ CN	1 : 6 : 2.6	98	67
HCOOH	1 : 12 : 3.2	100	65
cf. (batch condition) ³³			
CH ₃ CN	1 : 48 : 2.5	>95	56
HCOOH	1 : 66 : 3.2	75	71

The reactions of 1-cyclohexen-1-yl acetate (**228**) with the same equivalents of fluorine in the microreactor gave comparable conversions and yields to those of batch conditions.³³

4.4 Conclusions

In summary, the capacity of the Durham multi channel microreactor (V-21) for the direct fluorination of carbonyl compounds has been demonstrated.

Effects of various parameters on the conversion and the selectivity in the direct

fluorination of ethyl 3-oxobutanoate (**196**) using a 9-channel microreactor were investigated systematically. The results showed dilute concentrations of the substrate solution and higher temperatures were effective for improving both conversion and selectivity. Decrease of flow rate of the substrate was found to also be effective to increase conversion. Other 1,3-ketoesters were successfully fluorinated using conditions carefully chosen on account of the reactivity of the substrate.

The fluorination of the acyclic malonates was found to be difficult, whereas a cyclic malonate derivative (**225**) could be fluorinated by using nickel nitrate as a catalyst. Fluorinated dimethyl malonate (**222**) was obtained by simple treatment of the reaction mixture with methanol in the presence of catalytic amounts of sulfuric acid.

The direct fluorination of 1-cyclohexen-1-yl acetate (**228**) was demonstrated by using both acetonitrile and formic acid to give α -fluorinated cyclohexanone (**229**) in comparable conversions and yields to the batch conditions.

Chapter 5

Miscellaneous Reactions

5.1 Introduction

Miscellaneous reactions which are not included in other chapters and preliminary experiments are collected in this chapter in order to be kept as a record.

5.2 Direct fluorination in ionic liquids

5.2.1 Introduction

Recently, the use of ionic liquids, which are organic salts with a low melting point, as alternative solvents has attracted growing interest to meet the need for environmentally friendly and cost-effective processes.²³³ In particular, ionic liquids have intrinsically negligible vapour pressure and provide good solubility for a wide range of organic, inorganic, and organometallic compounds. Moreover, immobilisation of transition metal catalysts in ionic liquids allows not only recovery and reuse of catalysts but also simple work-up procedures and straightforward isolation protocols for products.²³⁴

As mentioned in the preceding chapters, some electrophilic fluorination reactions have already performed in ionic liquids,^{106,188,199} however, all reactions utilised N-F reagents and elemental fluorine have never been used in ionic liquids. We have been interested in the use of elemental fluorine in ionic liquids because ionic liquids with noncoordinating anions represent highly polar organic solvents that may be good solvents for direct fluorination. This section is concerned with direct fluorination using ionic liquids as replacements for conventional organic solvents.

5.2.2 Preparation of ionic liquids

Several ionic liquids which have a bis[(trifluoromethyl)sulfonyl]amide as the counter anion were prepared because:

- (i) These types of ionic liquids generally possess a highly hydrophobic nature (water washable to remove HF), low melting points ($<0\text{ }^{\circ}\text{C}$), and small viscosities.²³⁵

(ii) Bis[(trifluoromethyl)sulfonyl]amide ion can potentially react with elemental fluorine to form N-F species,⁶⁹ which may enable fluorination to proceed more selectively (Scheme 5.1).

SCHEME 5.1

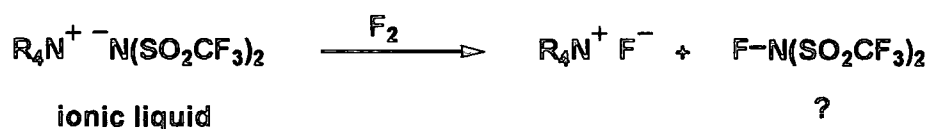

Methyltrioctylammonium bis[(trifluoromethyl)sulfonyl]amide
 ([Oc₃NMe][NTf₂], **230**) Methyltrioctylammonium bis[(trifluoromethyl)sulfonyl]amide (**230**) was prepared from Aliquat® 336 and lithium bis[(trifluoromethyl)sulfonyl]amide (Scheme 5.2).²³⁶

SCHEME 5.2

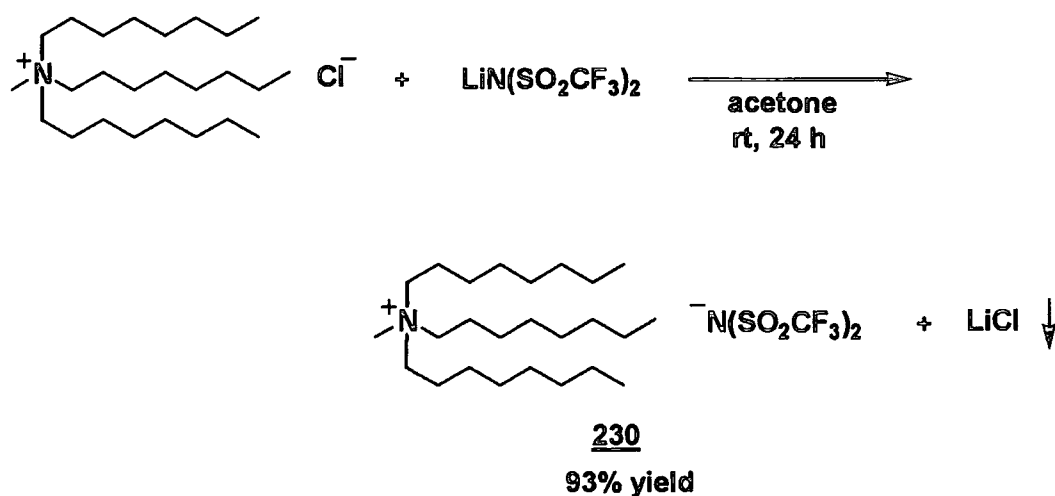

Aliquat® 336 (methyltrioctylammonium chloride) was treated with lithium bis[(trifluoromethyl)sulfonyl]amide in acetone to give [Oc₃NMe][NTf₂] (**230**) in 93% yield after filtrations to remove the precipitate (lithium chloride) and drying under reduced pressure. An orange viscous oil was obtained.

1-Butyl-3-methylimidazolium bis[(trifluoromethyl)sulfonyl]amide
 ([Bmim][NTf₂], **231**) 1-Butyl-3-methylimidazolium bis[(trifluoromethyl)sulfonyl]amide (**231**) was prepared by a similar procedure to [Oc₃NMe][NTf₂] (**230**) (Scheme 5.3).²³⁵

SCHEME 5.3

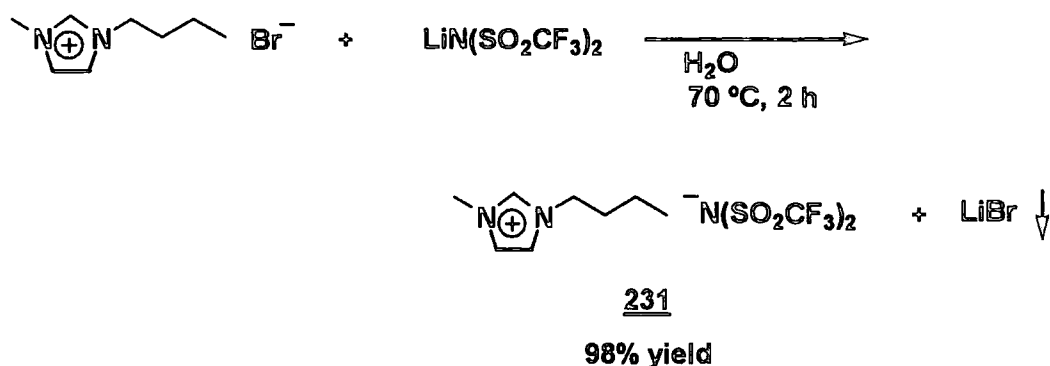

The anion exchange reaction was carried out in water using 1-butyl-3-methylimidazolium bromide and lithium bis[(trifluoromethyl)sulfonyl]amide. The desired ionic liquid [Bmim][NTf₂] (**231**) was obtained as a less viscous yellow oil than **230** in 98% yield.

1-Butyl-4-methylpyridinium bis[(trifluoromethyl)sulfonyl]amide ([Bmp][NTf₂], **232**) 1-Butyl-4-methylpyridinium bis[(trifluoromethyl)sulfonyl]amide (**232**) was prepared using a similar method to [Oc₃NMe][NTf₂] (**230**) and [Bmim][NTf₂] (**231**) (Scheme 5.4).²³⁷

SCHEME 5.4

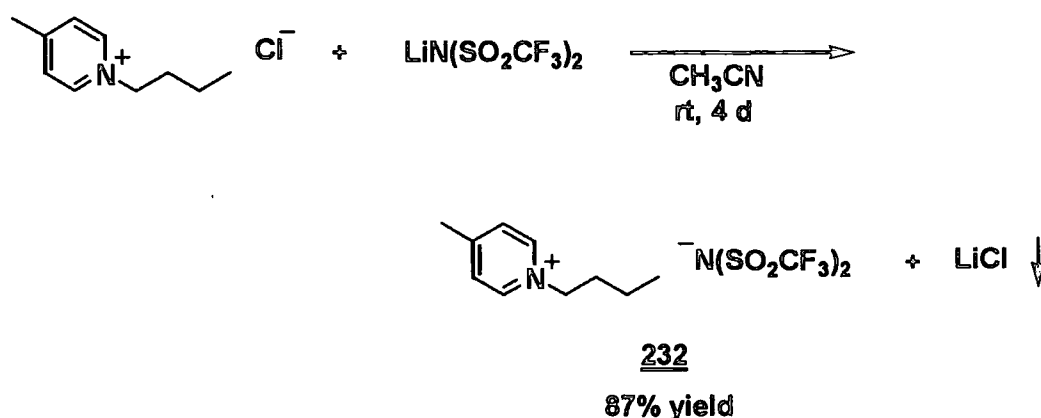

The reaction of 1-butyl-4-methylpyridinium chloride with lithium bis[(trifluoromethyl)sulfonyl]amide in acetonitrile afforded the desired ionic liquid [Bmp][NTf₂] (**231**) in 87% yield.

5.2.3 Direct fluorination of carbonyl compounds in ionic liquids

Methyltrioctylammonium bis[(trifluoromethyl)sulfonyl]amide

([OC₃NMe][NTf₂], **230**) Methyltrioctylammonium bis[(trifluoromethyl)sulfonyl]amide (**230**) seemed to be too viscous to carry out direct fluorination. Thus, alternatively, direct fluorination of this ionic liquid in acetonitrile was carried out to see whether an N-F species was formed *in situ* (Scheme 5.5). Treatment with equimolar amounts of elemental fluorine gave no obvious N-F species by analysis of the ¹⁹F NMR spectrum of the reaction mixture (reaction mixture A). Ethyl 3-oxobutanoate (**196**) was added to the reaction mixture, and fluorinated with elemental fluorine to give a mixture of fluorinated products.

SCHEME 5.5

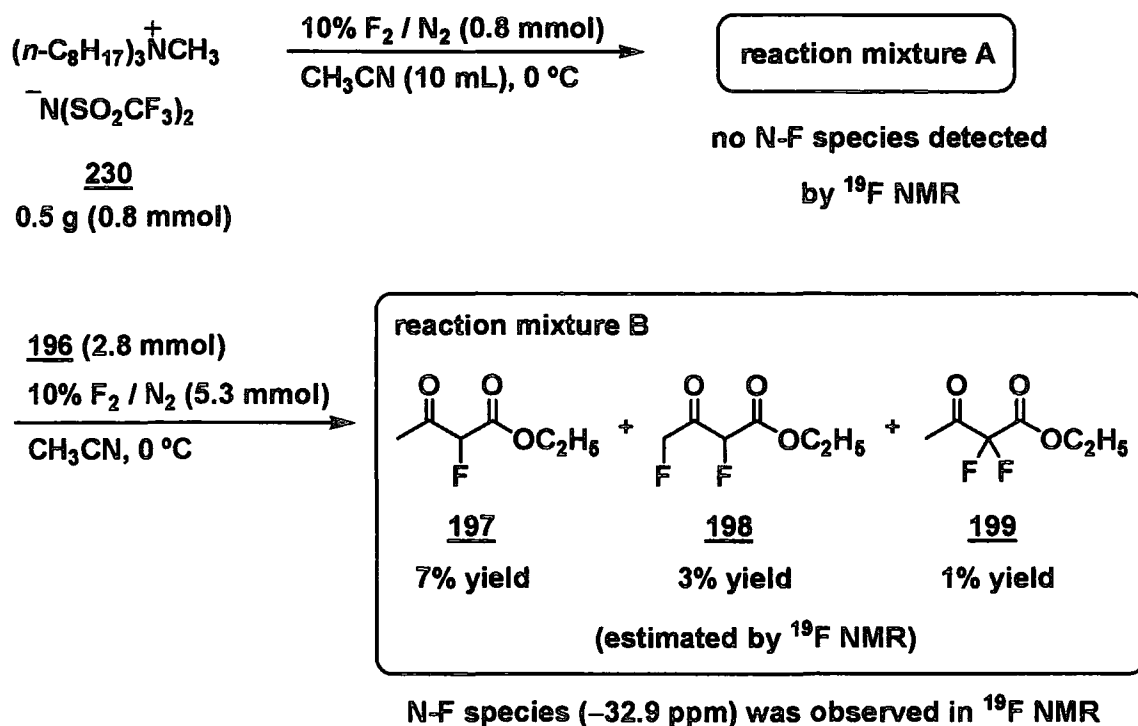

The yield was calculated by ¹⁹F NMR, comparing the integration with the resonance of the counter anion of the ionic liquid (NTf₂⁻). The low yield may be attributed to the diluted conditions with mainly acetonitrile as the solvent. A resonance which could be assigned as the N-F species was observed at -32.9 ppm (lit.⁶⁹, -33.5 ppm) in ¹⁹F NMR of the reaction mixture B, although selective formation of 2,2-difluoro derivatives was not observed unlike fluorinations of 1,3-dicarbonyl compounds with excess amounts of (CF₃SO₂)₂NF as mentioned in section 1.2.5.1.1 (See scheme 1.25).

1-Butyl-3-methylimidazolium bis[(trifluoromethyl)sulfonyl]amide

([Bmim][NTf₂], **231**) The direct fluorination of 1-cyclohexen-1-yl acetate (**228**) was carried out using 1-butyl-3-methylimidazolium bis[(trifluoromethyl)sulfonyl]amide (**231**) as a solvent (Scheme 5.6).

SCHEME 5.6

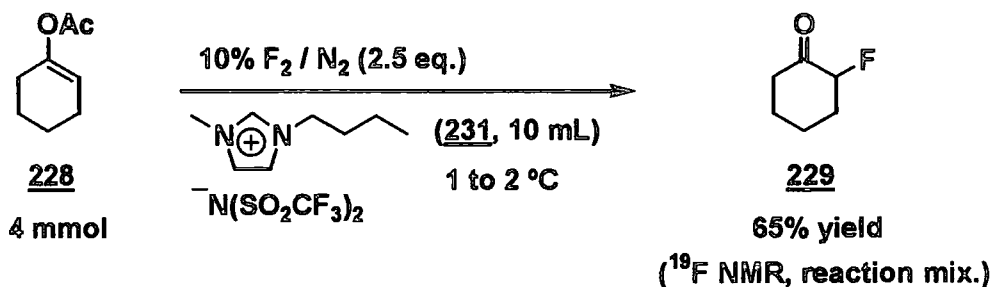

The substrate could be dissolved in the ionic liquid and the fluorination could be conducted at low temperature (1 to 2 °C). The reaction mixture contained desired 2-fluoro-cyclohexanone (**229**), but work up which involved extractions with five portions of hexane and vacuum transfer was unsuccessful. The yield was estimated to be 65% by comparing the integration for the product's resonance (-188.7 ppm) with the resonance of the counter anion of the ionic liquid (NTf₂⁻) in the ¹⁹F NMR spectrum of the reaction mixture. The residual ionic liquid became a dark brown colour after heating, and still contained some fluorinated products. The discolouration of the ionic liquid can be attributed to a decomposition which was described in a recent report of our research group²³⁸ as illustrated in scheme 5.7.

SCHEME 5.7

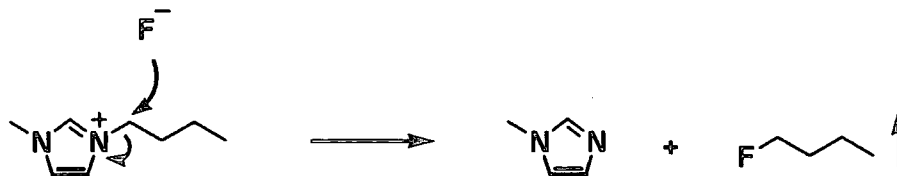

An improved work up procedure involving an appropriate method for isolating the product and removal of HF was thought to be required. Moreover, using imidazolium as the cation part of the ionic liquid may be a problem because one of the nitrogen atoms can still be quarternised. Thus, fluorine can potentially react with the nitrogen rather than substrate to give a diammonium salt as shown in scheme 5.8, although such

species may act as an electrophilic fluorinating agent. Actually, some unidentified resonances which could be ascribed to such species were observed between +25 and +52 ppm in ^{19}F NMR of the reaction mixture.

SCHEME 5.8

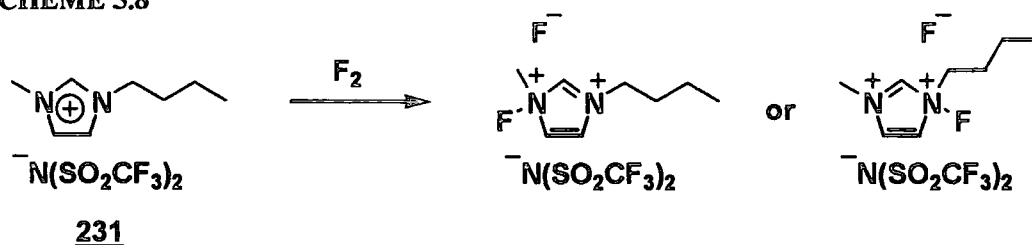

1-Butyl-4-methylpyridinium bis[(trifluoromethyl)sulfonyl]amide

([Bmp][NTf₂], 232) The direct fluorination of ethyl 2-oxocyclohexanecarboxylate (190) in 1-butyl-4-methylpyridinium bis[(trifluoromethyl)sulfonyl]amide (232) was carried out at 0 °C (Scheme 5.9).

SCHEME 5.9

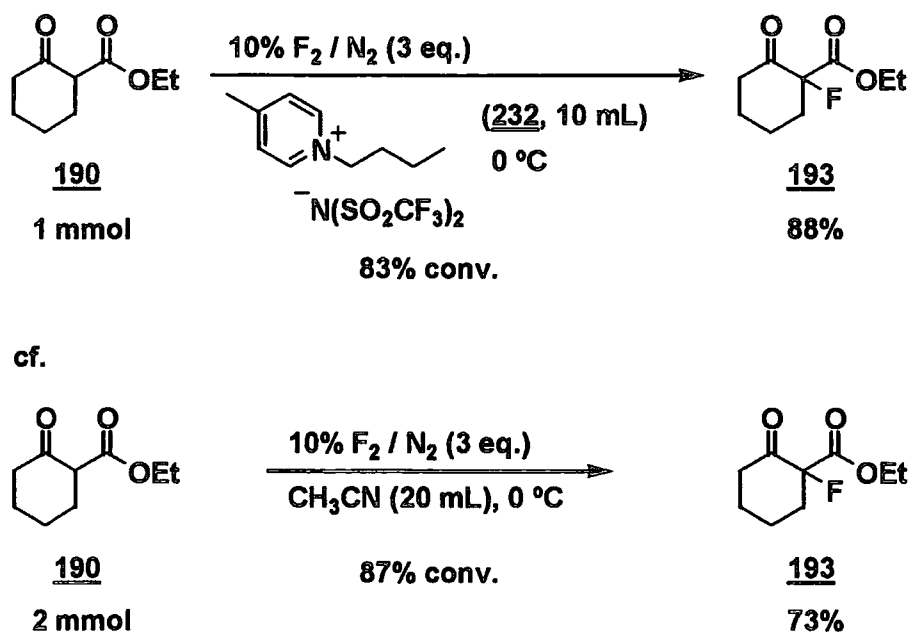

The substrate was soluble in the ionic liquid 232. The reaction mixture was diluted with dichloromethane and washed with deionised water five times to remove HF. The resulting solution was heated at 200 °C under reduced pressure (0.6 mbar) and volatile components were condensed in a cold trap which was cooled with liquid nitrogen

(-196 °C). A crude product was obtained from the cold trap and the conversion and yield were determined by GC analysis to be 83% and 88% respectively, which was comparable to that using acetonitrile as the solvent. The residual ionic liquid coloured dark brown to similar extent compared with the case of the previous experiment but no change was observed in ^1H and ^{19}F NMR analyses.

5.2.4 Conclusion

Several ionic liquids which possess a bis[(trifluoromethyl)sulfonyl]amide as anion part were prepared and evaluated as alternative solvents for direct fluorination of carbonyl compounds. Methyltrioctylammonium bis[(trifluoromethyl)sulfonyl] amide (**230**) did not show enough fluidity to be used for direct fluorination, which is a gas/liquid interfacial reaction. On the other hand, 1-butyl-3-methylimidazolium bis[(trifluoromethyl)sulfonyl]amide (**231**) and 1-butyl-4-methylpyridinium bis[(trifluoromethyl)sulfonyl]amide (**232**) were successfully used as alternative solvents for direct fluorination of carbonyl compounds. However, the current work up procedure is not practically convenient and requires improvement.

The use of ionic liquids as reaction media for direct fluorination reaction can potentially enable some unique fluorination systems. For instance, immobilisation of precursors of N-F reagents in ionic liquids can provide reusable N-F reagents (Figure 5.1).

FIGURE 5.1

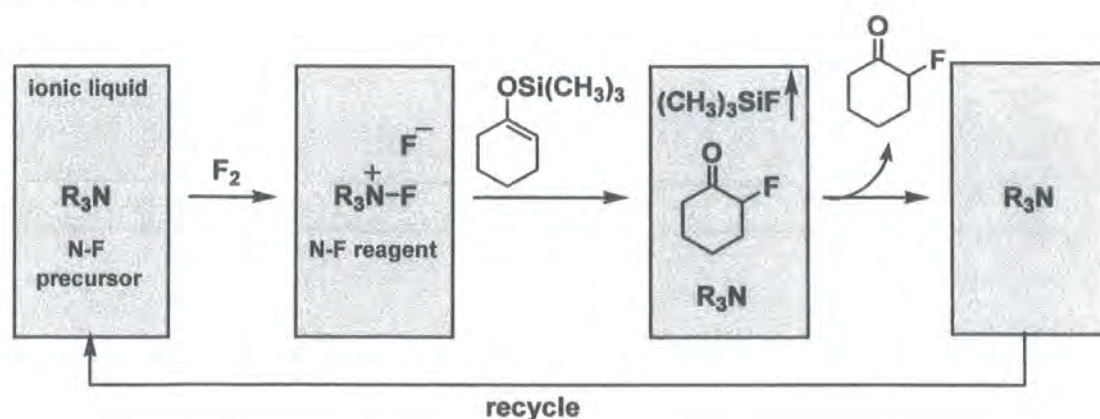

An immobilised precursor is fluorinated with elemental fluorine to give an N-F reagent, which fluorinates a substrate added to the system. After an isolation step, the ionic liquid phase involving the precursor can be reused for the next reaction cycle.

The use of trimethylsilyl enol ether as a substrate would be particularly advantageous

because formation of the troublesome HF can probably be avoided. Moreover, a reusable enantioselective fluorination reaction system can also potentially be realised when using cinchona alkaloids as the precursors. This system can be superior to the reported system¹⁸⁸ as mentioned in section 3.1.1.1 because no accumulation of the side product derived from another N-F reagent (i.e. Selectfluor or NFSI).

5.3 Direct fluorination of thioanisole using microreactor technology

5.3.1 Introduction

Trifluoromethylation is quite an important technique in organic chemistry as well as fluorination.²³⁹ A number of methods for the introduction of the trifluoromethyl group into organic molecules have been reported, in particular, (trifluoromethyl)trimethylsilane (TMS-CF₃) is one of the most versatile nucleophilic trifluoromethylating agents.²⁴⁰

Since TMS-CF₃ was first prepared by Ruppert²⁴¹ in 1984, several other preparation methods of this agent, involving both chemical and electrochemical methods, have been developed, however, all of these methods are not practically satisfactory.

Quite recently, Prakash reported a new efficient method for the preparation of TMS-CF₃ (Scheme 5.8).²⁴²

SCHEME 5.8

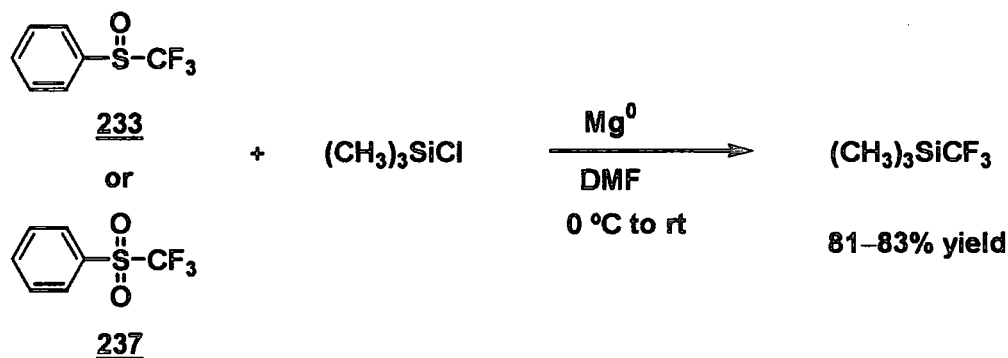

The reaction of sulfoxide 233 or sulfone 237 with trimethylsilane was mediated by magnesium metal in DMF to give TMS-CF₃ in good isolated yield. Moreover, this method allows the preparation of (difluoromethyl)trimethylsilane, which enables access to relatively less explored difluoromethylated compounds. Phenyl trifluoromethyl sulfoxide (233) or sulfone (237) are commercially available but very expensive. They can be prepared by several methods using less expensive starting material,²⁴³⁻²⁴⁵ however, they are all multi-step syntheses.

On the other hand, Kaneko reported direct fluorination of methyl phenyl sulfoxide (**234**) (Scheme 5.9).²⁴⁶

SCHEME 5.9

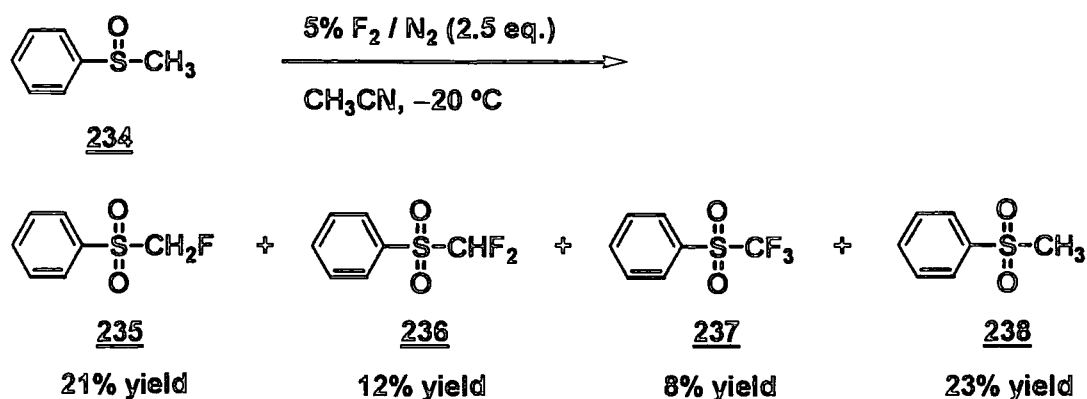

The fluorination reaction of methyl phenyl sulfoxide (**234**) with 2.5 equivalents of elemental fluorine gave a mixture of fluorinated and non-fluorinated sulfones including phenyl trifluoromethyl sulfone **237**. A mechanism of the formation of these products was proposed as scheme 5.10.

SCHEME 5.10

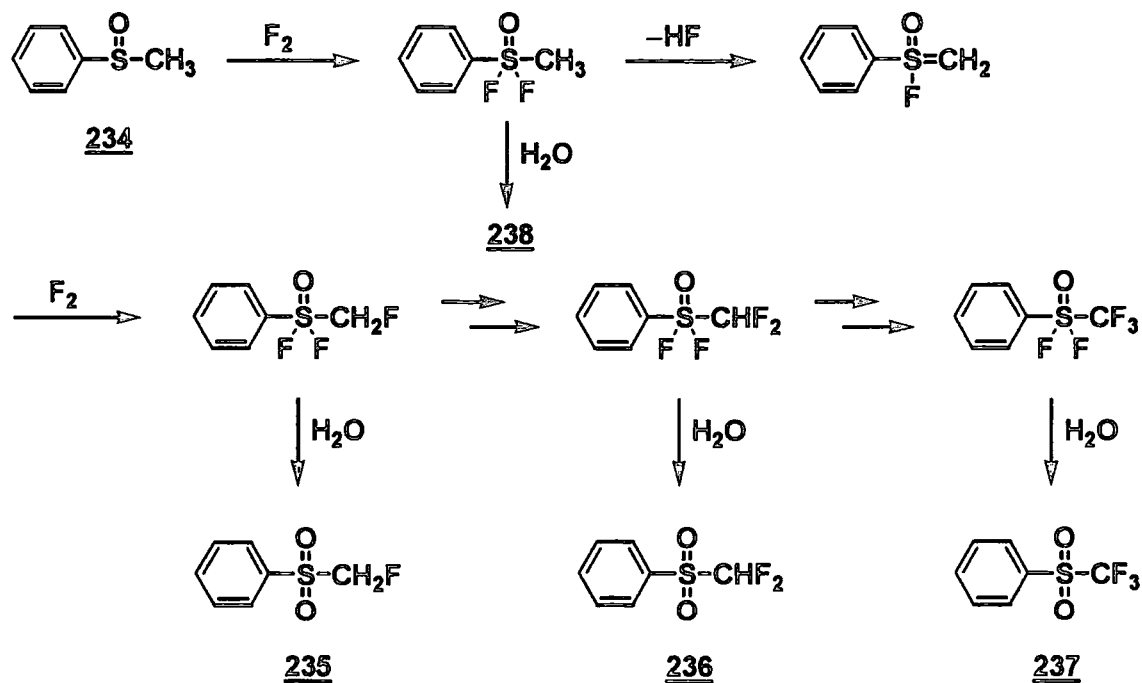

This mechanism involves oxidative fluorination of the sulfur centre, dehydrofluorination, and addition of fluorine to unsaturated intermediates. Repetition of the similar reaction sequence gives each precursor of the sulfones.

Kaneko also examined direct fluorination of thioanisole (**239**) (Scheme 5.11).²⁴⁶ Reaction of thioanisole (**239**) with 1 equivalent of elemental fluorine gave fluorinated and non-fluorinated sulfoxides and mono-fluorinated sulfone, although 34% starting material was recovered.

SCHEME 5.11

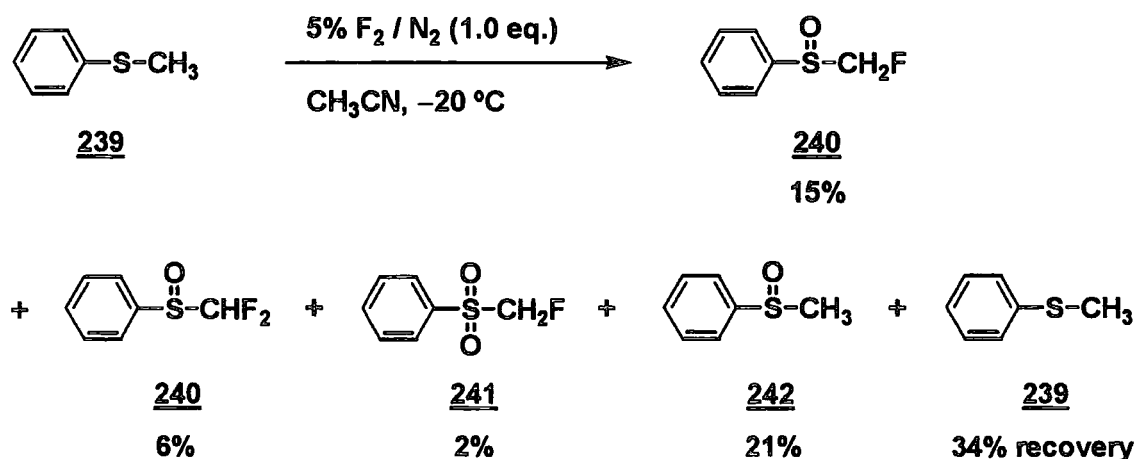

The trifluorinated product (**233**) was not obtained in this reaction, which was probably attributed to the small equivalents of fluorine used.

We reasoned that direct fluorination of thioanisole (**239**) or methyl phenyl sulfoxide (**234**) using an excess amounts of fluorine could potentially be an efficient method for preparation of trifluorinated sulfoxide **233** or sulfone **237**. In particular, thioanisole (**239**) was thought to be suitable raw material because it is much less expensive than methyl phenyl sulfoxide (**234**). Consequently, direct fluorination of thioanisole (**239**) was carried out as described in a following section.

5.3.2 Direct fluorination of thioanisole (**239**) using microreactor

Direct fluorination of thioanisole (**239**) was investigated using the microreactor (V-21) because formation of the desired trifluorinated product should require a highly efficient multi-fluorination process. Fluorination of **239** was carried out using a 1 to 20 mixture (molar ratio) of substrate and acetonitrile and a rather slow flow rate because an excess amounts of fluorine was thought to be needed (Scheme 5.12).

SCHEME 5.12

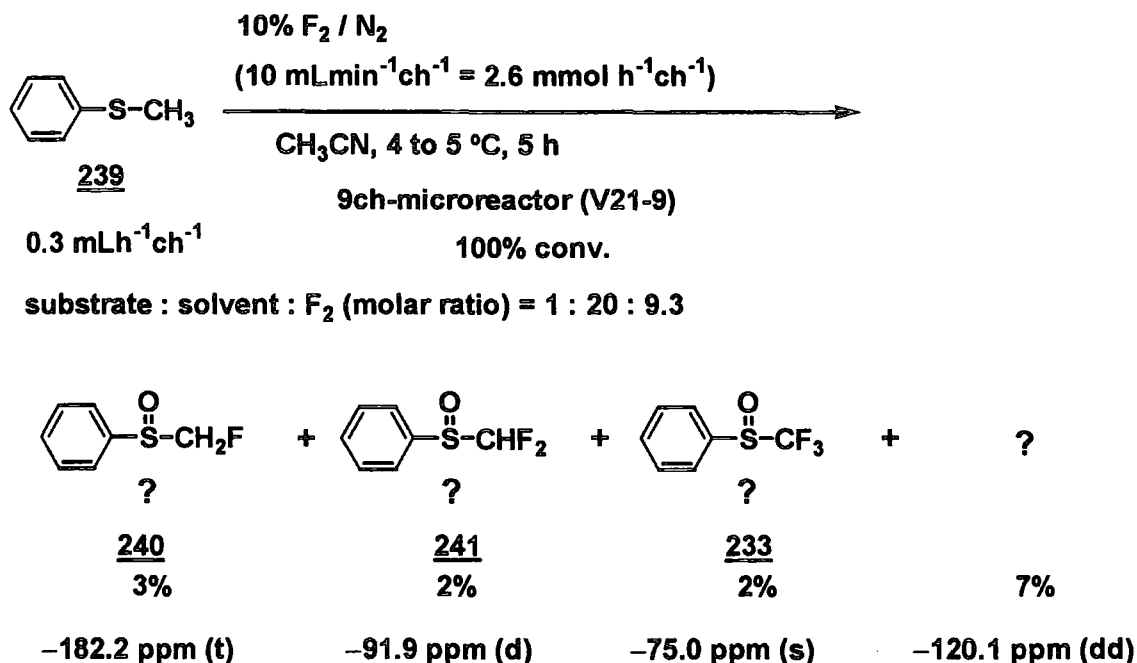

The crude mixture contained 4 major products in ¹⁹F NMR, and one of them could be assigned to trifluorinated compound **233**²⁴⁵ but the yield estimated by adding an internal standard was very low. GC analysis indicated that no starting material remained in the crude mixture, but there were significant amounts of tar, thus further analysis by GC-MS was abandoned.

Direct fluorination of **239** using formic acid as the solvent was also carried out. In this reaction, acetonitrile was used as a co-solvent owing to the poor solubility of the substrate in formic acid (Scheme 5.13).

SCHEME 5.13

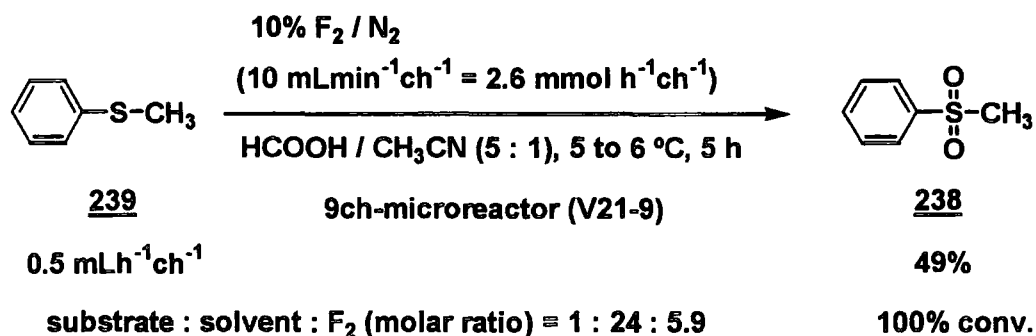

Fluorination of **239** was carried out using about 6 equivalents of fluorine. In this case, GC and GC-MS analysis indicated that methyl phenyl sulfone (**238**) was obtained as

the main product. On the other hand, trace amounts of trifluoromethylated compounds were observed by ^{19}F NMR although some resonances which could not be assigned were also seen. These results showed the use of formic acid leads predominantly oxidation reaction probably by HOF derived from the reaction between water which is contained in the formic acid and fluorine rather than fluorination.^{227,247} Interestingly, Kaneko observed a contrastive results using a mixture of acetonitrile and water (10:1) where fluorination was still preferentially occurred over oxidation by HOF.²⁴⁶ On the other hand, Rozen reported oxidation reactions of sulfides to sulfones using HOF· CH_3CN complex²⁴⁸. In addition, our group already demonstrated that reaction of fluorine with water in the presence of acids provides more effective oxidants²⁴⁷. This one step oxidation reaction could potentially be an efficient synthetic method for sulfones from sulfide.

5.3.3 Conclusion

A preliminary investigation of direct preparation of phenyl trifluoromethyl sulfoxide **233** by fluorination of thioanisole (**239**) with elemental fluorine was conducted using the multi-channel microreactor. Acetonitrile solvent and a large excess of fluorine gave considerable amounts of tar although small amounts of fluorinated products were observed by ^{19}F NMR. Less amounts of fluorine could give a better result. Formic acids was found to be not a suitable solvent due to the predominance of oxidation reaction over fluorination. Further investigation was required for concluding the feasibility of this reaction for the effective synthesis of TMS- CF_3 .

Chapter 6

Experimental to Chapter 2

6.1 Instrumentation

Reagents, Materials, and Solvents

All chemicals were used as received from the suppliers unless otherwise stated. Solvents were dried according to literature methods. Column chromatography was performed using silica gel supplied by Fluorochem.

Gas Liquid Chromatography

Chromatographic analyses were performed on a Hewlett Packard 5890 Series II gas liquid chromatograph equipped with a 25m cross-lined methyl silicone or 5% phenyl methyl silicone capillary column with a flame ionisation detector.

Elemental Analysis

Elemental analyses were carried out on an Exeter Analytical CE-440 Elemental Analyser.

NMR Spectroscopy

NMR spectra were recorded in deuteriochloroform, deuterium oxide or acetonitrile- d_3 on either a Varian Mercury 200, a Varian Unity 300, a Bruker AVANCE 400, a Varian Mercury 400 or a Unity Inova 500 NMR spectrometer using tetramethylsilane, trichlorofluoromethane and chloroform as internal references. Coupling constants are rounded to the nearest 0.5 Hz and in all NMR spectra, the shifts are reported using the "high frequency is positive" convention.

Mass Spectroscopy

Mass spectra were recorded on a Fisons VG Trio 1000 mass spectrometer coupled with a Hewlett Packard 5890 series II gas chromatograph (for Cl^+) or Micromass LCT (for ES^+). Mass spectra were also obtained from a Thermo Finnigan Trace MS mass spectrometer (for EI^+). Accurate mass measurements were determined on a Micromass Autospec Mass Spectrometer and at the EPSRC national mass spectrometry centre,

Swansea.

IR Spectra

IR spectra were recorded on a Perkin-Elmer 1600 FT-IR spectrometer using thin films between KBr plates or KBr discs.

X-ray Analysis

Diffraction data were obtained on a Bruker Smart 1K CCD diffractometer or a Bruker Smart 6K CCD diffractometer. The Structures were solved by direct methods and refined by least-squares (non-H atoms anisotropic, all H refined isotropic) against F^2 of all data using SHELX-97 software (G. M. Sheldrick, University of Göttingen, Germany, 1997).

Melting Point Analysis

Melting points were obtained from a Gallenkamp melting point apparatus and are not corrected.

6.2 The use of elemental fluorine in the laboratory

Elemental fluorine is extremely reactive and very toxic. Consequently, it is necessary to use apparatus which has been designed specifically to conduct reactions using elemental fluorine in a safe and controllable manner (Figure 6.1).

FIGURE 6.1

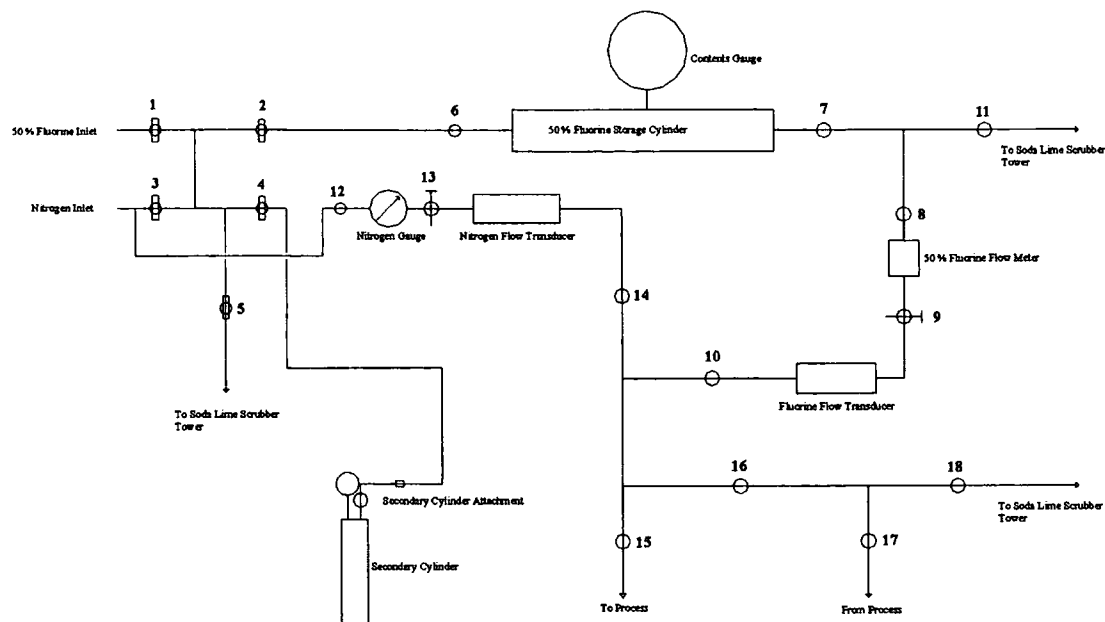

1-18: valves

Elemental fluorine is purchased as a 50% or 20% mixture with nitrogen in high-pressure cylinders (*ca.* 50 L). The fluorine is regulated from the primary cylinder pressure to 4 bar.

The fluorine cylinder is placed in a vented gas cabinet and is connected to a manifold system *via* a metal-metal connection (Figure 6.2). It should be pointed out that organic materials, such as PTFE, are not used in this connection because elemental fluorine may react with such materials due to the relatively high pressure and concentration of fluorine at this point. The manifold system is equipped with a pneumatic shut-off valve which can be operated remotely. Fluorine is supplied to two rigs, namely the microreactor rig and the right-hand rig.

The right-hand rig (Figure 6.1) is constructed from 1/4" stainless tubing, Monel® or stainless steel Swagelok® valves and stainless steel fittings and is housed in a stainless steel fumehood. Using the right hand rig, it is possible to fill secondary cylinders (3.7 L) up to a maximum pressure of 5 bar. These portable cylinders can be detached and installed into other fumehoods which house small fluorination rigs (Figure 6.3).

FIGURE 6.2

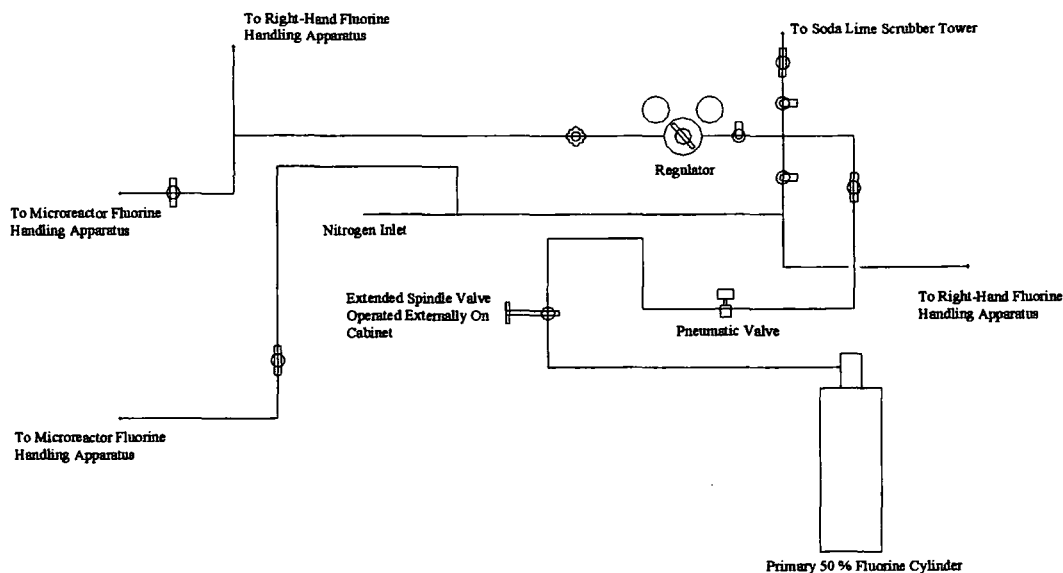
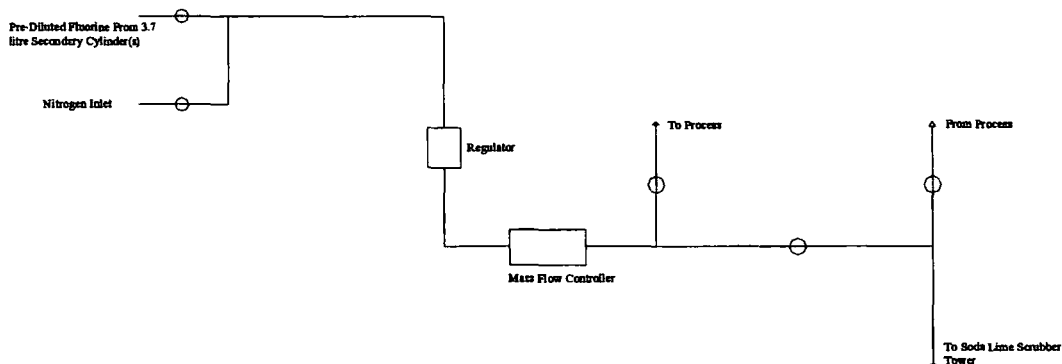

FIGURE 6.3



The small fluorination rig is constructed from stainless steel pipe work and is fitted with Monel Swagelok® valves similar to the right-hand rig.

All valves, tubings, fittings, and cylinders which are used to handle elemental fluorine are passivated using fluorine before they are used to perform fluorination reactions.

Except for microreactor reactions, all reactions which are described in this thesis were carried out using the small fluorination rig. To perform fluorinations using the rig shown in figure 6.3, the fluorine is run from the secondary cylinder(s) into a PTFE reaction vessel (Figure 6.4). The flow rate of the fluorine is controlled by a mass flow

controller (Brooks 5850S). 30 mL and 100 mL of PTFE reaction vessels were used for direct fluorination reaction under batch conditions. They are equipped with a PTFE dip pipe, which nearly reaches to the bottom of the reactor, a gas outlet that connects with a scrubber tower, and a magnetic stirrer bar.

FIGURE 6.4

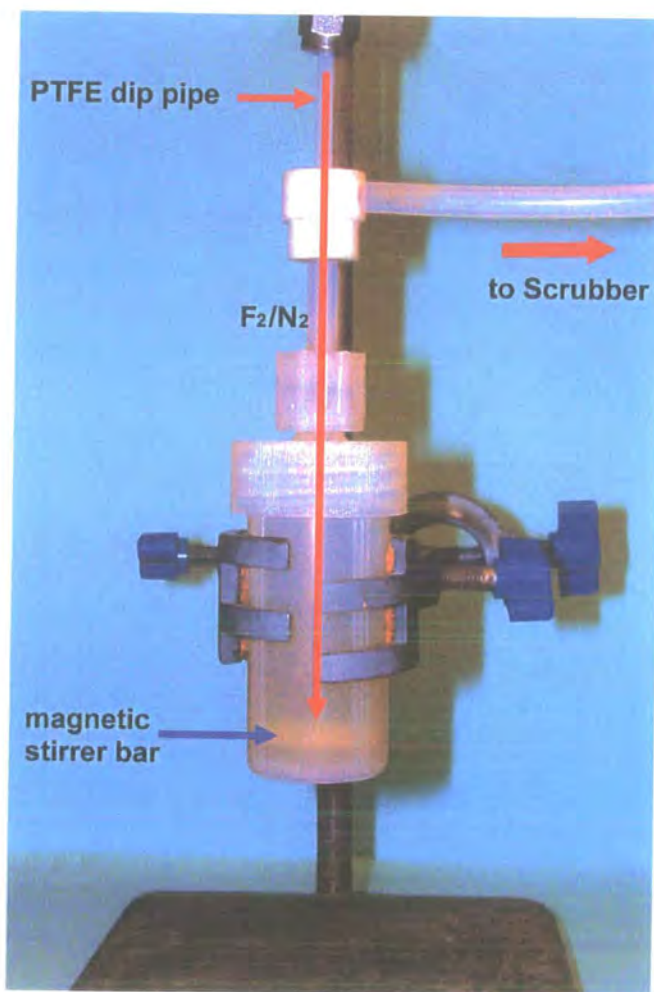

The microreactor rig (Figure 6.5) is also constructed from stainless steel pipe work and is fitted with Monel Swagelok® valves. The storage cylinders are constructed from stainless steel (5 L) and mild steel (9 L). The mass flow controller is a Brooks 5850S and controlled by a DDE computer program obtained from Flotech Solutions® linked to a PC operating in Microsoft® Excel.

FIGURE 6.5

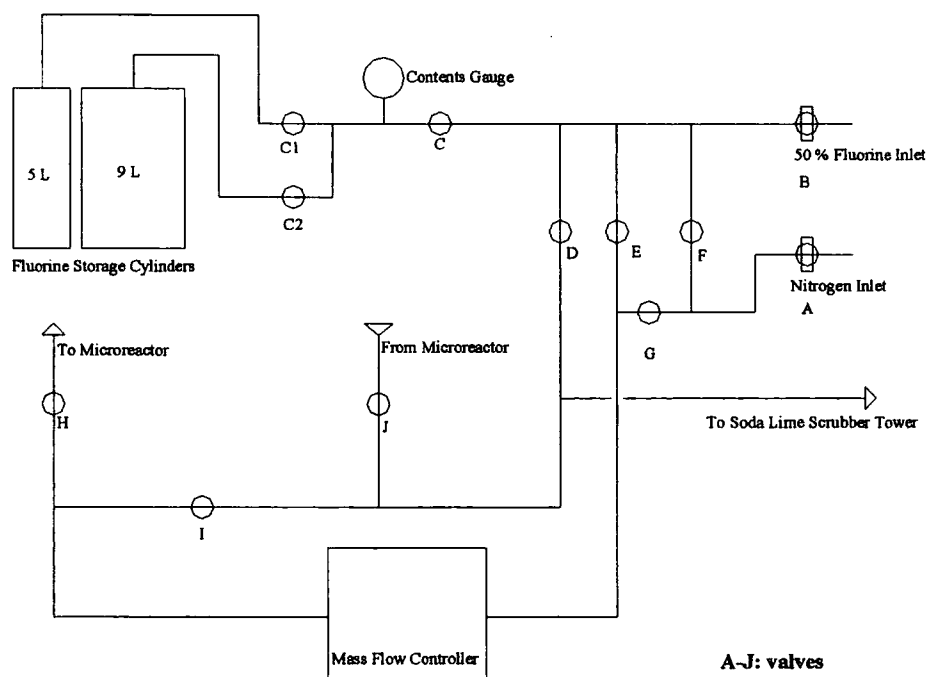

The operation of the microreactor will be described in Appendix in detail.

6.3 Preparation of model compounds

Methyl nicotinate (**106**)

Nicotinoyl chloride hydrochloride (**105**) (5.00 g, 28.1 mmol) was added to a stirred mixture of methanol (5.00 g) and pyridine (5.33 g, 67.4 mmol) at room temperature. 2.5 hours later, the resulting mixture was poured into water, and extracted with dichloromethane (2 x 20 mL). The combined organic extracts were washed with water and brine, dried over MgSO_4 and evaporated to give methyl nicotinate (**106**) (3.45 g, 90%) as a white solid; m.p. 39 °C; (Found: C, 61.12; H, 5.17; N, 10.17%. $\text{C}_7\text{H}_7\text{NO}_2$ requires C, 61.31; H, 5.14; N, 10.21%); ^1H NMR (400 MHz, CDCl_3) δ 3.93 (s, 3H, CH_3), 7.36 (ddd, $J = 1.0, 5.0$ and 8.0 Hz, 1H, 5-H), 8.26 (m, 1H, 4-H), 8.74 (dd, $J = 2.0$ and 9.0 Hz, 1H, 6-H), 9.19 (m, 1H, 2-H); ^{13}C NMR (100 MHz) δ 52.4 (s, CH_3), 123.3 (s, 5-C), 126.0 (s, 3-C), 137.0 (s, 4-C), 150.9 (s, 2-C), 153.4 (s, 6-C), 165.7 (s, C=O); IR (KBr) 1727, 1589, 1446, 1425, 1292, 742, 702 cm^{-1} . (As compared to literature data.²⁴⁹)

Methyl 2,6-dichloronicotinate (**108**)

A solution of 2,6-dichloronicotinic acid (**107**) (4.00 g, 20.8 mmol) in thionyl chloride

(19.8 g, 167 mmol) was stirred at 50 °C for 3 hours, and the solvent was evaporated. Toluene (3 x 10 mL) was added to the residue and azeotropically distilled under reduced pressure. Methyl alcohol (16 mL) and triethylamine (2.90 mL, 20.8 mmol) was added to the resulting crude acid chloride and stirred at room temperature for 1 hour. The reaction mixture was poured into water and extracted with dichloromethane. The extracts were washed by water and brine, dried over anhydrous magnesium sulfate and evaporated to give crude product (3.99 g). The crude product was recrystallised from hexane and diethyl ether (2:1) to give methyl 2,6-dichloronicotinate (**108**) (3.01 g, 70%) as cream-coloured columns; m.p. 57—58 °C (Found: C, 40.83; H, 2.47; N, 6.89%. $C_7H_3Cl_2NO_2$ requires C, 40.81; H, 2.45; N, 6.80%); 1H NMR (400 MHz, $CDCl_3$) δ 3.91 (s, 3H, CH_3), 7.32 (d, $J = 8.0$ Hz, 1H, 5-H), 8.12 (d, $J = 8.0$ Hz, 1H, 4-H); ^{13}C NMR (101 MHz, $CDCl_3$) δ 52.9 (s, OCH₃), 122.8 (s, 5-C), 125.1 (s, 3-C), 142.5 (s, 4-C), 149.7 (s, 2-C), 152.9 (s, 6-C), 163.9 (s, C=O); IR (KBr) 3096, 3079, 2957, 1741, 1734, 1572, 1543, 1417, 1272, 1152, 1133, 1054 cm^{-1} . (As compared to literature data.²⁵⁰)

3-Acetyloxyquinuclidine (**110**)

A solution of 3-quinuclidinol (**109**) (1.00 g, 7.86 mmol) in acetic anhydride (10 mL) was refluxed for 4 hours. The solution was concentrated under reduced pressure, neutralised with a saturated $NaHCO_3$ solution and extracted with chloroform (10 x 10 mL). The extracts were dried over anhydrous magnesium sulfate and evaporated to give crude product (2.78 g). The crude product was distilled under reduced pressure using Kugelrohr apparatus to give colourless oil (1.38 g). The oil was chromatographed over neutral aluminium oxide [hexane/ethyl alcohol (9:1)] to give 3-acetyloxyquinuclidine (**110**) (819 mg, 62%) as a pale yellow oil; 1H NMR (400 MHz, $CDCl_3$) δ 1.27—1.80 (m, 4H, 5-H and 6-H), 1.91 (m, 1H, 4-H), 2.00 (s, 3H, CH_3), 2.57—2.62 (m, 1H, one of 8-H), 2.64—2.86 (m, 4H, 7-H and 9-H), 3.16 (ddd, $J = 2.0, 8.5, 14.5$ Hz, 1H, one of 8-H), 4.70 (m, 1H, 3-H); ^{13}C NMR (101 MHz) δ 19.3 (s, 5-C or 6-C), 21.1 (s, CH_3), 24.4 (s, 5-C or 6-C), 25.0 (s, 4-C), 46.3 (s, 7-C or 9-C), 47.2 (s, 7-C or 9-C), 55.3 (s, 8-C), 71.2 (s, 3-H), 170.7 (s, C=O); IR (neat) 2942, 2870, 1739, 1248, 1029 cm^{-1} ; mass spectrum, m/z (EI^+) 170 ($[M+H]^+$, 15%), 169 (M^+ , 54), 126 ($[M-CH_3CO]^+$, 100). (As compared to literature data.¹⁵⁶)

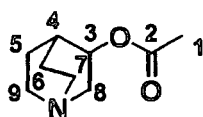

110

1-(2-Chloroethyl)-4-aza-1-azoniabicyclo[2.2.2]octane tetrafluoroborate (112**)**

A mixture of 1,4-diazabicyclo[2.2.2]octane (**111**) (4.33 g, 38.6 mmol), 1,2-dichloroethane (3.04 mL, 38.6 mmol), NaBF₄ (4.33 g, 39.4 mmol) and acetonitrile (85 mL) was stirred at room temperature for 100 hours. The reaction temperature was raised to 40 °C for 16 hours. The precipitate was removed by filtration and the filtrate was evaporated to give crude product as a brown oil (8.30 g). The crude mixture was dissolved in acetone (20 mL) and dichloromethane (40 mL) was added to the solution. White precipitate was filtered off and the filtrate was evaporated. This operation was repeated one more time to give the title compound **112** (5.63 g). The oligomers still remained in the product. Further purification was not carried out; ¹H NMR (500 MHz, D₂O) δ 3.11 (m, 6H, NCH₂), 3.40 (m, 6H, N⁺CH₂CH₂N), 3.61 (t, *J* = 6.5 Hz, 2H, NCH₂CH₂Cl), 3.92 (t, *J* = 6.5 Hz, 2H, CH₂Cl); ¹⁹F NMR (188 MHz, D₂O) δ -150.56 (s); ¹³C NMR (126 MHz, D₂O) δ 44.3 (s, NCH₂CH₂N⁺), 51.4 (s, CH₂Cl), 52.9 (s, N⁺CH₂CH₂N), 64.7 (s, NCH₂CH₂Cl).

1-(2-Methoxyethyl)-4-aza-1-azoniabicyclo[2.2.2]octane tetrafluoroborate (113**)**

A mixture of 1,4-diazabicyclo[2.2.2]octane (**111**) (3.77 g, 33.6 mmol), 2-chloroethyl methyl ether (3.18 g, 33.6 mmol), NaBF₄ (3.69 g, 33.6 mmol) and acetonitrile (75 mL) was stirred at room temperature for 71 hours. The reaction temperature was raised to 50 °C for 92 hours and then 80 °C for 65 hours. White precipitate was removed by filtration and the filtrate was evaporated to give crude product as a cream-coloured solid (7.96 g). The solid was broken up, and suspended in diethyl ether (30 mL). The suspension was refluxed for 1 hour, and the precipitate was filtered off, washed with diethyl ether, and dried *in vacuo* to give the title compound **113** (7.60 g, 88% yield) as a cream-coloured amorphous solid; ¹H NMR (400 MHz, D₂O) δ 3.08 (m, 6H, NCH₂), 3.27 (s, 3H, OCH₃), 3.35—3.40 (m, 8H, N⁺CH₂), 3.79 (m, 2H, OCH₂); ¹⁹F NMR (188 MHz, D₂O) δ -149.17 (s); ¹³C NMR (101 MHz, D₂O) δ 44.3 (s, NCH₂), 53.1 (s, N⁺CH₂CH₂N), 58.2 (s, OCH₃), 63.7 (s, NCH₂CH₂O), 64.9 (s, NCH₂CH₂O); IR (KBr) 2950, 2891, 1459, 1084, 1058 cm⁻¹; *m/z* (ES⁺) 429 ([2M-BF₄]⁺, 10%), 172 ([M+H-BF₄]⁺, 14), 171 ([M-BF₄]⁺, 100).

1-(Ethoxycarbonylmethyl)-4-aza-1-azoniabicyclo[2.2.2]octane tetrafluoroborate (114)

Ethyl bromoacetate (4.47 g, 33.6 mmol) was added to a stirred solution of 1,4-diazabicyclo[2.2.2]octane (111) (3.00 g, 26.7 mmol) in acetonitrile (60 mL). The reaction was exothermic. After stirring for 1 hour, NaBF₄ (2.94 g, 26.7 mmol) was added to the solution and the mixture was stirred at room temperature for 5 days. White precipitate was removed by filtration and the filtrate was evaporated to give crude product as a white solid (6.88 g). The solid was recrystallised from ethanol and washed with diethyl ether to give the title compound 114 (5.16 g, 67%) as white crystals; m.p. 142—144 °C (Found: C, 41.86; H, 6.73; N, 9.68%. C₁₀H₁₉BF₄N₂O₂ requires C, 41.98; H, 6.69; N, 9.79%); ¹H NMR (400 MHz, D₂O) δ 1.17 (dt, *J* = 1.0, 7.0 Hz, 3H, CH₃), 3.13 (t, *J* = 7.5 Hz, 6H, NCH₂), 3.55 (t, *J* = 7.5 Hz, 6H, N⁺CH₂CH₂), 4.11 (s, 2H, N⁺CH₂CO), 4.18 (dq, *J* = 1.0, 7.0 Hz, 2H, OCH₂); ¹⁹F NMR (188 MHz, D₂O) δ -150.38 (s); ¹³C NMR (101 MHz, D₂O) δ 13.3 (s, CH₃), 44.2 (s, NCH₂), 53.0 (s, N⁺CH₂CH₂N), 61.8 (s, NCH₂CO), 63.6 (s, OCH₂), 164.9 (s, C=O); IR (KBr) 2967, 1743, 1219, 1123, 1057, 1028 cm⁻¹; *m/z* (ES⁺) 485 ([2M-BF₄]⁺, 9%), 200 ([M+H-BF₄]⁺, 40), 199 ([M-BF₄]⁺, 100).

6.4 Evaluation of the fluorinating ability of model compounds

General procedure

A mixture containing a model compound (2.60 mmol), sodium tetrafluoroborate (285 mg, 2.60 mmol), and freshly distilled anhydrous acetonitrile (20 mL) was placed in a small PTFE reactor. The mixture was purged with N₂ and immersed in a cooling bath of -10 °C. Elemental fluorine as a 10% (v/v) mixture with nitrogen was introduced at a flow rate of 20 mL/min into the rapidly stirred mixture *via* PTFE tubing. The reaction mixture was purged with N₂ for 30 minutes. The conversions of the model compounds into N-F species were determined by analyzing the reaction mixture using ¹⁹F NMR spectroscopy. The amount of the N-F species formed was calculated by comparing the integration with the counter anion's resonances (BF₄⁻ or OTf⁻). The reaction mixture was allowed to warm to room temperature and added to *cis*-decalin (115) (300 mg) in a three neck round bottomed flask. The reaction mixture was refluxed with stirring under an argon atmosphere. The resulting mixture was poured into water (20 mL), neutralised by NaHCO₃, and extracted with dichloromethane (3 x 20 mL). The combined organic extracts were dried over anhydrous MgSO₄ and evaporated to give a crude product. The crude mixture was analyzed by ¹⁹F NMR spectroscopy, GC, and GC-MS to determine the amount of fluorinated decalin.

Methyl nicotinate (**106**)

Methyl nicotinate (**106**) (300 mg, 2.19 mmol), sodium tetrafluoroborate (240 mg, 2.19 mmol), elemental fluorine (6.61 mmol) and anhydrous acetonitrile (20 mL) gave the corresponding N-F derivatives in 74% conversion (+50.2ppm in CDCl₃/CH₃CN). The reaction mixture was added to the *cis*-decalin (**115**) (303 mg, 2.19 mmol), and refluxed for 1 hour to give a crude product (0.61 g). The *cis*-decalin (**115**) was found to be unchanged by GC-MS analysis. The crude mixture was chromatographed over silica gel to give methyl 2-fluoro nicotinate (34 mg, 10%) as a colorless liquid; ¹H NMR (200 MHz, CDCl₃) δ 3.95 (s, 3H, CH₃), 7.27 (m, 1H, 5-H), 8.35 (m, 2H, 4-H and 6-H); ¹⁹F NMR (188 MHz) δ -62.3 (m); m/z (EI⁺) 156 ([M+H]⁺, 7%), 155 (M⁺, 77), 154 ([M-H]⁺, 73), 125 ([M-CH₂O]⁺, 18), 124 ([M-CH₃O]⁺, 100) and methyl 6-fluoro nicotinate (ca. 20 mg, estimate 6%); ¹H NMR (200 MHz, CDCl₃) δ 3.89 (s, 3H, CH₃), 6.95 (m, 1H, 5-H), 8.35 (m, 1H, 4-H), 8.82 (m, 1H, 2-H); ¹⁹F NMR (188 MHz) δ -61.7 (m); m/z (EI⁺) 155 (M⁺, 21%), 154 ([M-H]⁺, 20), 125 ([M-CH₂O]⁺, 5), 124 ([M-CH₃O]⁺, 100). (As compared to literature data.¹⁵⁸)

Methyl 2,6-dichloronicotinate (**108**)

(Using general procedure)

Methyl 2,6-dichloronicotinate (**108**) (536 mg, 2.60 mmol), sodium tetrafluoroborate (285 mg, 2.60 mmol), elemental fluorine (7.80 mmol), and anhydrous acetonitrile (20 mL) gave the corresponding N-F species in 40% (33.43 ppm in CDCl₃/CH₃CN). The reaction mixture and *cis*-decalin (**115**) (300 mg, 2.17 mmol) was refluxed for 19 hours to give a crude product (0.51 g) which contained *cis*-decalin (**115**) (41%); m/z (EI⁺) 138 (M⁺, 43%), **108** (22 %); m/z (EI⁺) 209 (M⁺ (C₇H₅³⁷Cl₂NO₂), 5%), 207 (M⁺ (C₇H₅³⁷Cl³⁵CINO₂), 34%) 205 (M⁺ (C₇H₅³⁵Cl₂NO₂), 54%), methyl acetylamino-chloro-fluoronicotinate and methyl acetylamino-difluoronicotinate (11%); m/z (EI⁺) 248 [M⁺ (C₉H₈³⁷ClFN₂O₃), 1%], 246 [M⁺ (C₉H₈³⁵ClFN₂O₃), 3%] and 230 [M⁺ (C₉H₈F₂N₂O₃), 41%], another methyl acetylamino-difluoronicotinate (3%); m/z (EI⁺) 230 [M⁺ (C₉H₈F₂N₂O₃), 10%], 171 ([M-COOCH₃]⁺, 50), methyl trichloronicotinate (3%); m/z (EI⁺) 245 [M⁺ (C₇H₄³⁷Cl₃NO₂), 1%], 243 [M⁺ (C₇H₄³⁷Cl₂³⁵CINO₂), 9%], 241 [M⁺ (C₇H₄³⁷Cl³⁵Cl₂NO₂), 29%], 239 [M⁺ (C₇H₄³⁵Cl₃NO₂), 30%] and unidentified products (20 %).

(The first fluorination was carried out at -40 °C)

Methyl 2,6-dichloronicotinate (**108**) (536 mg, 2.60 mmol), sodium tetrafluoroborate

(285 mg, 2.60 mmol), elemental fluorine (7.80 mmol), and anhydrous acetonitrile (20 mL) gave the corresponding N-F species (40%). The reaction mixture and *cis*-decalin (**115**) (300 mg, 2.17 mmol) was refluxed for 13 hours to give a crude product (0.69 g) which contained *cis*-decalin (**115**) (49%); *m/z* (EI^+) 138 (M^+ , 42%), methyl acetylamino-chloro-fluoronicotinate and methyl acetylamino-difluoronicotinate (15%); *m/z* (EI^+) 248 [M^+ ($\text{C}_9\text{H}_8^{37}\text{ClFN}_2\text{O}_3$), 1%], 246 [M^+ ($\text{C}_9\text{H}_8^{35}\text{ClFN}_2\text{O}_3$), 4%] and 230 [M^+ ($\text{C}_9\text{H}_8\text{F}_2\text{N}_2\text{O}_3$), 51%], **108** (4%); *m/z* (EI^+) 209 [M^+ ($\text{C}_7\text{H}_5^{37}\text{Cl}_2\text{NO}_2$), 3%], 207 [M^+ ($\text{C}_7\text{H}_5^{37}\text{Cl}^{35}\text{ClNO}_2$), 14%] 205 [M^+ ($\text{C}_7\text{H}_5^{35}\text{Cl}_2\text{NO}_2$), 21%], methyl trichloronicotinate (2%); *m/z* (EI^+) 245 [M^+ ($\text{C}_7\text{H}_4^{37}\text{Cl}_3\text{NO}_2$), 1%], 243 [M^+ ($\text{C}_7\text{H}_4^{37}\text{Cl}_2^{35}\text{ClNO}_2$), 5%], 241 [M^+ ($\text{C}_7\text{H}_4^{37}\text{Cl}^{35}\text{Cl}_2\text{NO}_2$), 16%], 239 [M^+ ($\text{C}_7\text{H}_4^{35}\text{Cl}_3\text{NO}_2$), 17%] and unidentified products (24%).

[The first fluorination was carried out using Method C

(See section 2.4.2.3.1, scheme 2.35)]

A mixture containing methyl 2,6-dichloronicotinate (**108**) (536 mg, 2.60 mmol), sodium tetrafluoroborate (285 mg, 2.60 mmol), and freshly distilled anhydrous acetonitrile (17 mL) was placed in the small PTFE reactor. The mixture was purged with N_2 and immersed in a cooling bath of -10°C . A solution of triflic acid (390 mg, 2.60 mmol) in acetonitrile (3 mL) was added to the mixture. The resulting mixture was stirred for 30 minutes. 10% F_2/N_2 gas was introduced at a flow rate of 20 mL/min into the rapidly stirred mixture using PTFE tubing. The reaction mixture was purged with N_2 for 30 minutes. N-F species was formed in 46%. The reaction mixture was allowed to warm to room temperature and added to *cis*-decalin (**115**) (300 mg) in a three neck round bottomed flask. The resulting mixture was stirred at 40°C for 1 hour, and at 60°C for 1 hour. The reaction mixture was refluxed with stirring for 13 hours. The same work up was carried out as described above. Crude product contained *cis*-decalin (**115**) (69%); *m/z* (EI^+) 138 (M^+ , 79%), **108** (21%); *m/z* (EI^+) 209 [M^+ ($\text{C}_7\text{H}_5^{37}\text{Cl}_2\text{NO}_2$), 18%], 207 [M^+ ($\text{C}_7\text{H}_5^{37}\text{Cl}^{35}\text{ClNO}_2$), 60%] 205 [M^+ ($\text{C}_7\text{H}_5^{35}\text{Cl}_2\text{NO}_2$), 68%], methyl trichloronicotinate (2%); *m/z* (EI^+) 245 [M^+ ($\text{C}_7\text{H}_4^{37}\text{Cl}_3\text{NO}_2$), 1%], 243 [M^+ ($\text{C}_7\text{H}_4^{37}\text{Cl}_2^{35}\text{ClNO}_2$), 12%], 241 [M^+ ($\text{C}_7\text{H}_4^{37}\text{Cl}^{35}\text{Cl}_2\text{NO}_2$), 35%], 239 [M^+ ($\text{C}_7\text{H}_4^{35}\text{Cl}_3\text{NO}_2$), 34%], methyl acetylamino-chloro-fluoronicotinate and methyl acetylamino-difluoronicotinate (1%); *m/z* (EI^+) 246 [M^+ ($\text{C}_9\text{H}_8^{35}\text{ClFN}_2\text{O}_3$), 1%] and 230 [M^+ ($\text{C}_9\text{H}_8\text{F}_2\text{N}_2\text{O}_3$), 7%] and unidentified products (7%).

3-Acetyloxyquinuclidine (**110**)

3-Acetoxyquinuclidine (**110**) (440 mg, 2.60 mmol), sodium tetrafluoroborate (285 mg,

2.60 mmol), elemental fluorine (7.80 mmol), and anhydrous acetonitrile (20 mL) gave the corresponding N-F species quantitatively (55.15 ppm in CDCl₃/CH₃CN). The reaction mixture and *cis*-decalin (**115**) (300 mg, 2.17 mmol) was refluxed for 16 hours to give a crude product (0.30 g) which contained only *cis*-decalin (**115**) (100%); *m/z* (EI⁺) 138 (M⁺, 92%).

The crude mixture was recrystallised from dichloromethane to give *N*-fluoro 3-acetoxyquinuclidinium tetrafluoroborate (**117**) (107 mg, 15%) as white crystals; m.p. 105—107 °C (Found: C, 39.52; H, 5.56; N, 4.95%. C₉H₁₅BF₅NO₂ requires C, 39.30; H, 5.50; N, 5.09%); ¹H NMR (500 MHz, D₂O) δ 2.01 (s, 3H, 1-H), 2.15—2.53 (m, 5H, 5-H, 6-H and 7-H), 3.98—4.18 (m, 5H, one of 4-H, 8-H and 9-H), 4.50 (m, 1H, one of 4-H), 5.24 (m, 1H, 3-H); ¹³C NMR (126 MHz, D₂O) δ 20.2 (s, 1-C), 22.4 (d, ³J_{CF} = 4.0 Hz, 6-C or 7-C), 22.9 (d, ³J_{CF} = 5.0 Hz, 6-C or 7-C), 23.6 (d, ⁴J_{CF} = 4.5 Hz, 5-C), 60.2 (d, ²J_{CF} = 9.5 Hz, 8-C or 9-C), 60.9 (d, ²J_{CF} = 9.5 Hz, 8-C or 9-C), 66.8 (d, ²J_{CF} = 10.5 Hz, 4-C), 70.3 (d, ³J_{CF} = 5.5 Hz, 3-C), 173.1 (s, 2-C); ¹⁹F NMR (188 MHz, D₂O) δ -150.8 (s, 4F, BF₄⁻), 54.3 (s, 1F, N-F); IR (KBr) 3043, 2992, 1744, 1245, 1083, 1035 cm⁻¹.

Crystal data for **117**: C₉H₁₅BF₅NO₂, *M* = 275.03, monoclinic, *P*2₁/*c* (No. 14), *a* = 10.016(1) Å, *b* = 9.508(1) Å, *c* = 12.388(1) Å, α = 90°, β = 103.68(1)°, γ = 90°, *V* = 1146.3(2) Å³, *F*(000) = 568, *Z* = 4, *D*_c = 1.594 g/cm³, μ = 0.161 mm⁻¹ (Mo Kα, λ = 0.71073 Å), *T* = 120(2) K, crystal size 0.34 × 0.18 × 0.08 mm³.

1-(2-Chloroethyl)-4-aza-1-azoniabicyclo[2.2.2]octane tetrafluoroborate (**112**)

1-(2-Chloroethyl)-4-fluoro-1,4-diazoniabicyclo[2.2.2]octane tetrafluoroborate (**112**) (740 mg, 2.82 mmol), sodium tetrafluoroborate (310 mg, 2.82 mmol), elemental fluorine (8.46 mmol), and anhydrous acetonitrile (20 mL) gave the corresponding N-F species quantitatively (47.79 ppm in D₂O/CH₃CN). The reaction mixture and *cis*-decalin (**115**) (300 mg, 2.17 mmol) was refluxed for 4 hours to give a crude product (0.16 g) which contained *cis*-decalin (**115**) (65%); *m/z* (EI⁺) 138 (M⁺, 86%), fluorodecalins [4 peaks, 32%, including *cis*-9-fluorodecalin (**126**)]; peak A: (7%); *m/z* (EI⁺) 156 (M⁺, 100%), 136 ([M-HF]⁺, 77), peak B: (3%); *m/z* (EI⁺) 156 (M⁺, 20%), 136 ([M-HF]⁺, 57), peak C: (11%); *m/z* (EI⁺) 156 (M⁺, 26%), 136 ([M-HF]⁺, 100), peak D: (10%); *m/z* (EI⁺) 156 (M⁺, 6%), 136 ([M-HF]⁺, 100) and unidentified products (3%); ¹⁹F NMR (188 MHz, CDCl₃) δ -140.2 (m, 15%), -177.2 (m, 47%), -179.0 (m, 38%).

cis-9-Fluorodecalin (**126**) (not isolated)

¹⁹F NMR (188 MHz) δ -140.2 (m) (As compared to literature data.^{24, 154}).

1-(2-Methoxyethyl)-4-fluoro-1,4-diazoniabicyclo[2.2.2] octane tetrafluoroborate (113)

1-(2-Methoxyethyl)-4-fluoro-1,4-diazoniabicyclo[2.2.2]octane tetrafluoroborate (**113**) (671 mg, 2.60 mmol), sodium tetrafluoroborate (285 mg, 2.60 mmol), elemental fluorine (15.60 mmol), and anhydrous acetonitrile (20 mL) gave the corresponding N-F species quantitatively [48.14 ppm in D₂O/CH₃CN (48.90 ppm in CDCl₃/CH₃CN)]. The reaction mixture and *cis*-decalin (**115**) (300 mg, 2.17 mmol) was refluxed for 14 hours to give a crude product (0.37 g) which contained *cis*-decalin (**115**) (31%); m/z (EI⁺) 138 (M⁺), fluorodecalins (**125**) (2 peaks, 38%); m/z (EI⁺) 156 (M⁺), difluorodecalin (**127**) (3 peaks, 5%); m/z (EI⁺) 174 (M⁺), *N*-(fluorodecalyl)acetamide (2 peaks, 10%); peak A: m/z (EI⁺) 213 (M⁺, 3%), 193 ([M-HF]⁺, 8), 154 ([M-C₂H₅NO]⁺, 18), 134 ([M-HF-C₂H₅NO]⁺, 90), peak B: m/z (EI⁺) 213 (M⁺, 5%), 193 ([M-HF]⁺, 28), 134 ([M-HF-C₂H₅NO]⁺, 100), *N*-decalylacetamide (3%); m/z (EI⁺) 195 (M⁺, 29%), 136 ([M-C₂H₅NO]⁺, 96) and unidentified products (17%).

1-(Ethoxycarbonylmethyl)-4-aza-1-azoniabicyclo[2.2.2]octane tetrafluoroborate (114)

1-(Ethoxycarbonylmethyl)-4-aza-1-azoniabicyclo[2.2.2]octane tetrafluoroborate (**114**) (743 mg, 2.60 mmol), sodium tetrafluoroborate (285 mg, 2.60 mmol), elemental fluorine (7.80 mmol), and anhydrous acetonitrile (20 mL) gave the corresponding N-F species in 57% conversion (49.90 ppm in CDCl₃/CH₃CN). The reaction mixture and *cis*-decalin (**115**) (300 mg, 2.17 mmol) was refluxed for 14 hours to give a crude product (0.90 g) which contained *cis*-decalin (**115**) (47%); m/z (EI⁺) 138 (M⁺, 49%), fluorodecalins (**125**) (4 peaks, 35 %); m/z (EI⁺) 156 (M⁺), difluorodecalins (**127**) (2 peaks, 3%); m/z (EI⁺) 174 (M⁺) and unidentified products (15%).

6.5 Preparation of the steroid derivatives bearing DABCO moiety

3β-(Bromoacetoxy)-5α-androstan-17-one (**129**)

A solution of bromoacetyl bromide (913 mg, 4.52 mmol) in dichloromethane (6 mL) was added dropwise to a mixture of epiandrosterone (**128**) (1.30 g, 4.48 mmol), pyridine (885 mg, 11.2 mmol), 4-dimethylaminopyridine (10 mg, 0.082 mmol) and dichloromethane (20 mL) at 0 °C. The resulting mixture was stirred at ambient temperature for 16 hours. 1N HCl was added to the mixture, and the organic layer was extracted with dichloromethane (twice), washed with water and saturated aqueous NaCl, dried over anhydrous MgSO₄ and evaporated to give crude product (2.30 g). The crude mixture was chromatographed over silica gel [silica gel: 50 g, eluent:

hexane/ethyl acetate (5:1)] to give white crystals (670 mg). The recrystallization from hexane/ethyl acetate (1:1) gave white plates (582 mg). The crystals consisted of 3 β -(bromoacetoxy)-5 α -androstan-17-one (**129**) and 3 β -(chloroacetoxy)-5 α -androstan-17-one (**130**) (**129/130** = 82:18); m.p. 143—144 °C; ¹H NMR (500 MHz, CDCl₃) δ 0.70 (m, 1H, 9-H), 0.83 (s, 6H, 18-H, 19-H), 0.9—1.1 (m, 2H, one of 1-H, one of 7-H), 1.2—1.6 (m, 10H, one of 2-H, one of 4-H, 5-H, 6-H, 8-H, one of 11-H, one of 12-H, 14-H, one of 15-H), 1.63 (m, one of 4-H, one of 11-H), 1.7—1.9 (m, 5H, one of 1-H, one of 2-H, one of 7-H, one of 12-H, one of 15-H), 2.04 (m, 1H, one of 16-H), 2.41 (m, 1H, one of 16-H), 4.00 (s, 2H, 21-H), 4.76 (m, 1H, 3-H); ¹³C NMR (101 MHz) δ 12.1 (s, 18-C or 19-C), 13.7 (s, 18-C or 19-C), 20.4 (s, 11-C), 21.6 (s, 15-C), 27.1 (s, 2-C), 28.1 (s, 6-C), 30.7 (s, 7-C), 31.4 (s, 12-C), 33.6 (s, 4-C), 34.9 (s, 8-C), 35.5 (s, 10-C), 35.7 (s, 16-C), 36.5 (s, 1-C), 41.1 (s, 21-C), 44.5 (s, 5-C), 47.7 (s, 13-C), 51.2 (s, 14-C), 54.1 (s, 9-C), 75.6 (s, 3-C), 166.7 (s, 20-C), 221.1 (s, 17-C); IR (KBr) 2935, 2848, 1743 (C=O), 1412, 1308, 1191 (C-O) cm⁻¹; mass spectrum, m/z (EI⁺) 412 [M⁺ (C₂₁H₃₁⁸¹BrO₃), 15%], 410 [M⁺ (C₂₁H₃₁⁷⁹BrO₃), 15].

3 β -(Chloroacetoxy)-5 α -androstan-17-one (**130**)

¹H NMR (500 MHz, CDCl₃) δ 0.70 (m, 1H, 9-H), 0.83 (s, 6H, 18-H, 19-H), 0.9—1.1 (m, 2H, one of 1-H, one of 7-H), 1.2—1.6 (m, 10H, one of 2-H, one of 4-H, 5-H, 6-H, 8-H, one of 11-H, one of 12-H, 14-H, one of 15-H), 1.63 (m, one of 4-H, one of 11-H), 1.7-1.9 (m, 5H, one of 1-H, one of 2-H, one of 7-H, one of 12-H, one of 15-H), 2.04 (m, 1H, one of 16-H), 2.41 (m, 1H, one of 16-H), 3.78 (s, 2H, 21-H), 4.76 (m, 1H, 3-H); ¹³C NMR (101 MHz) δ 12.1 (s, 18-C or 19-C), 13.7 (s, 18-C or 19-C), 20.4 (s, 11-C), 21.6 (s, 15-C), 26.3 (s, 21-C), 27.0 (s, 2-C), 28.1 (s, 6-C), 30.7 (s, 7-C), 31.4 (s, 12-C), 33.5 (s, 4-C), 34.9 (s, 8-C), 35.5 (s, 10-C), 35.7 (s, 16-C), 36.5 (s, 1-C), 44.5 (s, 5-C), 47.7 (s, 13-C), 51.2 (s, 14-C), 54.1 (s, 9-C), 75.6 (s, 3-C), 166.7 (s, 20-C), 221.1 (s, 17-C); mass spectrum, m/z (EI⁺) 368 [M⁺ (C₂₁H₃₁³⁷ClO₃), 39%], 366 [M⁺ (C₂₁H₃₁³⁵ClO₃), 100].

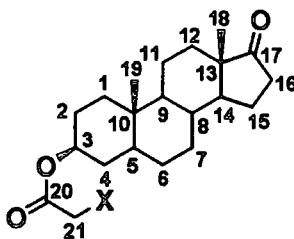

129: X = Br

130: X = Cl

3 β -[(4-Aza-1-azoniabicyclo[2.2.2]oct-1-yl)-acetoxy]-5 α -androstan-17-one tetrafluoroborate (131)

A solution of a mixture of 3 β -(bromoacetoxy)-5 α -androstan-17-one (129) and 3 β -(chloroacetoxy)-5 α -androstan-17-one (130) (129/130 = 82:18) (452 mg, 1.12 mmol) in dichloromethane (5 mL) was added to a stirred solution of 1,4-diazabicyclo[2.2.2]octane (111) (124 mg, 1.11 mmol) in dichloromethane (5 mL) at room temperature. The resulting solution was stirred for 17 hours, and evaporated to give a white amorphous solid. Dry acetonitrile (20 mL) and NaBF₄ (121 mg, 1.10 mmol) was added to the amorphous solid and the mixture was stirred at room temperature for 5 days. Additional 1,4-diazabicyclo[2.2.2]octane (111) (25 mg, 0.22 mmol) and NaBF₄ (24 mg, 0.22 mmol) was added to the reaction mixture, and the resulting mixture was refluxed for 2 hours. The reaction mixture was cooled to room temperature, and stirred for 6 days. White precipitate was removed by filtration and the filtrate was evaporated to give a crude product as a white solid (629 mg). The solid was dissolved in chloroform, and the precipitate that formed was removed by filtration. The filtrate was evaporated, and the resulting amorphous solid was treated with diethyl ether. The mixture was evaporated to give a white solid. The solid was washed by diethyl ether, and recrystallised from acetone/water and washed with water to give 3 β -[(4-Aza-1-azoniabicyclo[2.2.2]oct-1-yl)-acetoxy]-5 α -androstan-17-one tetrafluoroborate (130) (505 mg, 85%) as white crystals; m.p. 256—258 °C (decomposed); ¹H NMR (400 MHz, CDCl₃) δ 0.68 (m, 1H, 9-H), 0.82 (s, 3H, 18-H or 19-H), 0.83 (s, 3H, 18-H or 19-H), 0.9—1.0 (m, 2H, one of 1-H, one of 7-H), 1.1—1.3 (m, 6H, 5-H, 6-H, one of 11-H, one of 12-H, 14-H), 1.4—1.6 (m, 6H, one of 2-H, 4-H, 8-H, one of 11-H, one of 15-H), 1.7-1.8 (m, 4H, one of 1-H, one of 2-H, one of 7-H, one of 12-H), 1.89 (m, 1H, one of 15-H), 2.04 (m, 1H, one of 16-H), 2.41 (dd, 1H, $J = 9.0, 19.0$ Hz, one of 16-H), 3.21 (m, 6H, NCH₂), 3.65 (m, 6H, N⁺CH₂CH₂), 4.09 (s, 2H, 21-H), 4.76 (m, 1H, 3-H); ¹³C NMR (101 MHz) δ 12.1 (s, 18-C or 19-C), 13.7 (s, 18-C or 19-C), 20.4 (s, 11-C), 21.6 (s, 15-C), 27.0 (s, 2-C), 28.1 (s, 6-C), 30.6 (s, 7-C), 31.4 (s, 12-C), 33.4 (s, 4-C), 34.8 (s, 8-C), 35.5 (s, 10-C), 35.7 (s, 16-C), 36.4 (s, 1-C), 44.5 (s, 5-C), 45.0 (s, NCH₂), 47.7 (s, 13-C), 51.2 (s, 14-C), 52.5 (s, N⁺CH₂), 54.1 (s, 9-C), 60.9 (s, 21-C), 76.8 (s, 3-C), 163.5 (s, 20-C), 221.1 (s, 17-C); IR (KBr) 2941, 2855, 1741 (C=O), 1467, 1221, 1083, 1057 cm⁻¹; mass spectrum, m/z (ES⁺) 444 ([M+H-BF₄]⁺, 16%), 443 ([M-BF₄]⁺, 100%), (Found: [M-BF₄]⁺ 443.3282. C₂₇H₄₃N₂O₃ requires 443.3274).

3 β -(4-Bromobutyryloxy)-5 α -androstan-17-one (132)

A solution of 4-bromobutyl bromide (1.40 g, 6.20 mmol) in dichloromethane (8 mL)

was added dropwise to a mixture of epiandrosterone (**128**) (1.80 g, 6.20 mmol), pyridine (0.99 g, 12.5 mmol), 4-dimethylaminopyridine (40 mg, 0.33 mmol) and dichloromethane (10 mL) at 0 °C. The resulting mixture was stirred at ambient temperature for 18 hours. The mixture was added into water (35 mL), extracted with dichloromethane (3 x 25 mL), dried over anhydrous MgSO₄ and evaporated to give crude product (3.62 g). The crude mixture was chromatographed over silica gel [silica gel: 20 g, eluent: hexane/ethyl acetate (4:1)] to give white crystals (3.10 g). The recrystallization from hexane/ethyl acetate (9:1) gave 3β-(4-bromobutyryloxy)-5α-androstan-17-one (**132**) (2.28 g, 84%) as white plates; m.p. 89—90 °C; ¹H NMR (400 MHz, CDCl₃) δ 0.68 (m, 1H, 9-H), 0.81 (s, 3H, 18-H or 19-H), 0.82 (s, 3H, 18-H or 19-H), 0.9—1.0 (m, 2H, one of 1-H, one of 7-H), 1.1—1.8 (m, 16H, one of 1-H, 2-H, 4-H, 5-H, 6-H, one of 7-H, 8-H, 11-H, 12-H, 14-H, one of 15-H), 1.88 (m, one of 15-H), 2.0—2.2 (m, 3H, one of 16-H, 22-H), 2.39 (dd, 1H, *J* = 8.0, 18.0 Hz, one of 16-H), 2.42 (t, 2H, *J* = 7.0 Hz, 21-H), 3.42 (t, 2H, *J* = 6.0 Hz, 23-H), 4.67 (m, 1H, 3-H); ¹³C NMR (101 MHz) δ 12.1 (s, 19-C), 13.7 (s, 18-C), 20.3 (s, 11-C), 21.6 (s, 15-C), 27.3 (s, 2-C), 27.7 (s, 22-C), 28.1 (s, 6-C), 30.7 (s, 7-C), 31.4 (s, 12-C), 32.7 (s, 21-C, 23-C), 33.8 (s, 4-C), 34.9 (s, 8-C), 35.5 (s, 10-C), 35.7 (s, 16-C), 36.5 (s, 1-C), 44.5 (s, 5-C), 47.6 (s, 13-C), 51.2 (s, 14-C), 54.1 (s, 9-C), 73.6 (s, 3-C), 171.9 (s, 20-C), 221.1 (s, 17-C); IR (KBr) 2941, 2855, 1734 (C=O), 1193 (C-O) cm⁻¹; mass spectrum, *m/z* (EI⁺) 440 [M⁺ (C₂₃H₃₅⁸¹BrO₃), 4%], 438 [M⁺ (C₂₃H₃₅⁷⁹BrO₃), 4], 272 ([M-Br(CH₂)₃CO₂]⁺, 100).

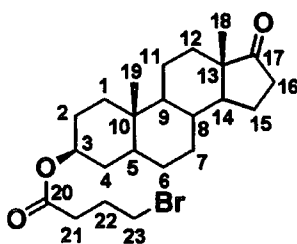

132

3β-[4-(4-Aza-1-azoniabicyclo[2.2.2]oct-1-yl)-butyryloxy]-5α-androstan-17-one tetrafluoroborate (133**)**

A solution of a mixture of 3β-(bromoacetoxy)-5α-androstan-17-one (**132**) (2.20 g, 5.00 mmol) in dichloromethane (10 mL) was added to a stirred solution of 1,4-diazabicyclo [2.2.2]octane (**111**) (562 mg, 5.01 mmol) in dichloromethane (15 mL) at room temperature. The resulting solution was stirred for 65 hours. Additional

1,4-diazabicyclo[2.2.2]octane (**111**) was added to the reaction mixture after 19 hours and 50 hours (175 mg and 121 mg, respectively, 2.64 mmol). The resulting mixture evaporated to give a white amorphous solid. Dry acetonitrile (30 mL) and NaBF₄ (840 mg, 7.65 mmol) was added to the amorphous solid and the mixture was refluxed for 3 hours. The reaction mixture was cooled to room temperature, and stirred for 90 hours. White precipitate was removed by filtration and the filtrate was evaporated to give a crude product as a white solid (4.15 g). The solid was dissolved in chloroform, and the precipitate that formed was removed by filtration. The filtrate was evaporated to give an amorphous solid. Diethyl ether was added to the amorphous solid and refluxed for 3 hours. The resulting white solid was washed by diethyl ether, and recrystallised from ethanol to give 3β-[4-(4-aza-1-azoniabicycl[2.2.2]oct-1-yl)-butyryloxy]-5α-androstan-17-one tetrafluoroborate (**133**) (1.03 g, 34%) as white crystals; m.p. 226—229 °C (decomposed); ¹H NMR (400 MHz, CDCl₃) δ 0.69 (m, 1H, 9-H), 0.82 (s, 3H, 18-H or 19-H), 0.83 (s, 3H, 18-H or 19-H), 0.9—1.0 (m, 2H, one of 1-H, one of 7-H), 1.1—1.7 (m, 12H, one of 2-H, 4-H, 5-H, 6-H, 8-H, 11-H, one of 12-H, 14-H, one of 15-H), 1.7—1.8 (m, 4H, one of 1-H, one of 2-H, one of 7-H, one of 12-H), 1.91 (m, 1H, one of 15-H), 2.01 (m, 2H, 22-H), 2.04 (m, 1H, one of 16-H), 2.38 (t, 1H, *J* = 7.0 Hz, 21-H), 2.41 (dd, 1H, *J* = 8.0, 19.0 Hz, one of 16-H), 3.20 (m, 6H, NCH₂), 3.27 (m, 2H, 23-H), 3.35 (m, 6H, N⁺CH₂), 4.64 (m, 1H, 3-H); ¹⁹F NMR (188 MHz, CDCl₃) δ -151.37 (s); ¹³C NMR (101 MHz) δ 12.1 (s, 19-C), 13.7 (s, 18-C), 17.1 (s, 22-C), 20.4 (s, 11-C), 21.7 (s, 15-C), 27.3 (s, 2-C), 28.2 (s, 6-C), 30.3 (s, 21-C), 30.7 (s, 7-C), 31.4 (s, 12-C), 33.8 (s, 4-C), 34.9 (s, 8-C), 35.5 (s, 10-C), 35.8 (s, 16-C), 36.6 (s, 1-C), 44.6 (s, 5-C), 45.1 (s, NCH₂), 47.7 (s, 13-C), 51.2 (s, 14-C), 52.4 (s, N⁺CH₂), 54.2 (s, 9-C), 63.4 (s, 23-C), 74.2 (s, 3-C), 171.4 (s, 20-C), 221.3 (s, 17-C); IR (KBr) 2939, 2843, 1734 (C=O), 1083, 1058 cm⁻¹; mass spectrum, *m/z* (ES⁺) (Found: [M-BF₄]⁺ 471.3603. C₂₉H₄₇N₂O₃ requires 471.3587).

3β-(5-Bromovaleryloxy)-5α-androstan-17-one (**134**)

A solution of 5-bromovaleryl chloride (1.65 g, 8.27 mmol) was added dropwise to a mixture of epiandrosterone (**128**) (1.60 g, 5.51 mmol), pyridine (2.18 g, 27.6 mmol), and dichloromethane (32 mL) at 0 °C. The resulting mixture was stirred at 0 °C for 30 minutes and at ambient temperature for 15 minutes. The mixture was added into water and extracted with dichloromethane (3 times). The combined organic layer was washed by 1 N HCl and water (twice), dried over anhydrous MgSO₄ and evaporated to give crude product (3.15 g). The crude mixture was chromatographed over silica gel [silica gel: 60 g, eluent: hexane/ethyl acetate (5:1 to 4:1)] to give white crystals (2.60 g). The

recrystallization from hexane/ethyl acetate gave 3 β -(5-bromovaleryloxy)-5 α -androstan-17-one (**134**) (2.11 g, 85%) as white plates; m.p. 87—89 °C; ¹H NMR (400 MHz, CDCl₃) δ 0.69 (m, 1H, 9-H), 0.82 (s, 3H, 18-H or 19-H), 0.83 (s, 3H, 18-H or 19-H), 0.90—1.05 (m, 2H, one of 1-H, one of 7-H), 1.12—1.65 (m, 12H, one of 2-H, 4-H, 5-H, 6-H, 8-H, 11-H, one of 12-H, 14-H, one of 15-H), 1.68—1.94 (m, 9H, one of 1-H, one of 2-H, one of 7-H, one of 12-H, one of 15-H, one of 16-H, 22-H, 23-H), 2.04 (dt, 1H, $J = 9.0, 19.0$ Hz, one of 16-H), 2.28 (t, 2H, $J = 7.0$ Hz, 21-H), 2.40 (dd, 1H, $J = 9.0, 19.0$ Hz, one of 16-H), 3.42 (t, 2H, $J = 7.0$ Hz, 24-H), 4.67 (m, 1H, 3-H); ¹³C NMR (101 MHz) δ 12.1 (s, 19-C), 13.7 (s, 18-C), 20.4 (s, 11-C), 21.7 (s, 15-C), 23.5 (s, 22-C), 27.3 (s, 2-C), 28.2 (s, 6-C), 30.7 (s, 7-C), 31.4 (s, 12-C), 31.9 (s, 23-C), 33.0 (s, 24-C), 33.6 (s, 21-C), 33.9 (s, 4-C), 34.9 (s, 8-C), 35.5 (s, 10-C), 35.7 (s, 16-C), 36.6 (s, 1-C), 44.5 (s, 5-C), 47.7 (s, 13-C), 51.2 (s, 14-C), 54.1 (s, 9-C), 73.4 (s, 3-C), 172.6 (s, 20-C), 221.2 (s, 17-C); IR (KBr) 2945, 2854, 1732 (C=O), 1274, 1179 cm⁻¹; mass spectrum, m/z (EI⁺) 454 [M⁺ (C₂₄H₃₇⁸¹BrO₃), 3%], 452 [M⁺ (C₂₄H₃₇⁷⁹BrO₃), 3], 272 ([M-Br(CH₂)₃CO₂]⁺, 100).

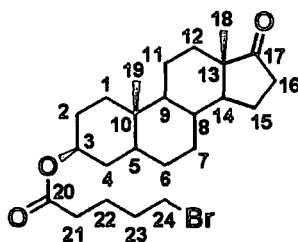

134

3 β -[5-(4-Aza-1-azoniabicyclo[2.2.2]oct-1-yl)-valeryloxy]-5 α -androstan-17-one tetrafluoroborate (135**)**

A solution of a mixture of 3 β -(5-bromovaleryloxy)-5 α -androstan-17-one (**134**) (1.90 g, 4.19 mmol) in dichloromethane (11 mL) was added to a stirred solution of 1,4-diazabicyclo[2.2.2]octane (**111**) (475 mg, 4.23 mmol) in dichloromethane (10 mL) at room temperature. The resulting solution was stirred for 20 hours. Additional 1,4-diazabicyclo[2.2.2]octane (**111**) was added to the reaction mixture after 15 hours (105 mg, 0.94 mmol). The resulting mixture was evaporated to give a white amorphous solid. Dry acetonitrile (25 mL) and NaBF₄ (570 mg, 5.19 mmol) was added to the amorphous solid and the mixture was stirred for 69 hours. Additional 1,4-diazabicyclo[2.2.2]octane (**111**) (122 mg, 1.09 mmol) and NaBF₄ (115 mg, 1.05 mmol) was added to the reaction mixture after 44 hours. The reaction mixture was refluxed for 1 hours. White precipitate was removed by filtration and the filtrate was evaporated to give a

crude product as a white solid (3.08 g). The solid was dissolved in chloroform, and the precipitate that formed was removed by filtration. The filtrate was evaporated to give an amorphous solid. Diethyl ether was added to the amorphous solid and refluxed for 2 hours. The resulting white solid was washed by diethyl ether, and recrystallised from ethanol to give 3β -[5-(4-aza-1-azoniabicyclo[2.2.2]oct-1-yl)-valeryloxy]-5 α -androstan-17-one tetrafluoroborate (**135**) (1.84 g, 77%) as white crystals; m.p. 225 °C (decomposed); ^1H NMR (400 MHz, CDCl_3) δ 0.69 (m, 1H, 9-H), 0.83 (s, 3H, 18-H or 19-H), 0.84 (s, 3H, 18-H or 19-H), 0.90—1.05 (m, 2H, one of 1-H, one of 7-H), 1.12—1.98 (m, 21H, one of 1-H, 2-H, 4-H, 5-H, 6-H, one of 7-H, 8-H, 11-H, 12-H, 14-H, 15-H, 22-H, 23-H), 2.04 (dt, 1H, $J = 9.0, 19.0$ Hz, one of 16-H), 2.34 (t, 2H, $J = 7.0$ Hz, 21-H), 2.41 (dd, 1H, $J = 8.5, 19.0$ Hz, one of 16-H), 3.19 (m, 6H, NCH_2), 3.24 (m, 2H, 24-H), 3.33 (m, 6H, N^+CH_2), 4.64 (m, 1H, 3-H); ^{19}F NMR (188 MHz, CDCl_3) δ -151.4 (s); ^{13}C NMR (101 MHz) δ 12.1 (s, 19-C), 13.8 (s, 18-C), 20.4 (s, 11-C), 21.1 (s, 22-C), 21.6 (s, 23-C), 21.7 (s, 15-C), 27.3 (s, 2-C), 28.2 (s, 6-C), 30.7 (s, 7-C), 31.4 (s, 12-C), 33.4 (s, 21-C), 33.8 (s, 4-C), 34.9 (s, 8-C), 35.6 (s, 10-C), 35.8 (s, 16-C), 36.6 (s, 1-C), 44.6 (s, 5-C), 45.1 (s, NCH_2), 47.7 (s, 13-C), 51.3 (s, 14-C), 52.4 (s, N^+CH_2), 54.2 (s, 9-C), 64.1 (s, 24-C), 73.7 (s, 3-C), 172.3 (s, 20-C), 221.3 (s, 17-C); IR (KBr) 2937, 1732 (C=O), 1059 cm^{-1} ; mass spectrum, m/z (ES^+) 486 ($[\text{M}+\text{H}-\text{BF}_4]^+$, 49), 485 ($[\text{M}-\text{BF}_4]^+$, 100%), (Found: $[\text{M}-\text{BF}_4]^+$ 485.3790. $\text{C}_{30}\text{H}_{49}\text{N}_2\text{O}_3$ requires 485.3743).

3β -(6-Bromohexanoyloxy)-5 α -androstan-17-one (136**)**

A solution of 6-bromohexanoyl bromide (1.77 g, 8.27 mmol) was added dropwise to a mixture of epiandrosterone (**128**) (1.60 g, 5.51 mmol), pyridine (2.18 g, 27.6 mmol), and dichloromethane (32 mL) at 0 °C. The resulting mixture was stirred at 0 °C for 30 minutes and at ambient temperature for 15 minutes. The mixture was added into water and extracted with dichloromethane (3 times). The combined organic layer was washed by 1 N HCl and water (twice), dried over anhydrous MgSO_4 and evaporated to give crude product (3.50 g). The crude mixture was chromatographed over silica gel [silica gel: 60 g, eluent: hexane/ethyl acetate (5:1 to 4:1)] to give white crystals (2.65 g). The recrystallization from hexane/ethyl acetate gave 3β -(6-bromohexanoyloxy)-5 α -androstan-17-one (**136**) (1.67 g, 65%) as white plates; m.p. 51—54 °C; ^1H NMR (400 MHz, CDCl_3) δ 0.70 (m, 1H, 9-H), 0.83 (s, 3H, 18-H or 19-H), 0.84 (s, 3H, 18-H or 19-H), 0.90—1.06 (m, 2H, one of 1-H, one of 7-H), 1.14—1.95 (m, 23H, one of 1-H, 2-H, 4-H, 5-H, 6-H, one of 7-H, 8-H, 11-H, 12-H, 14-H, 15-H, 22-H, 23-H, 24-H), 2.05 (dt, 1H, $J = 9.0, 19.0$ Hz, one of 16-H), 2.27 (t, 2H, $J = 7.0$ Hz, 21-H), 2.42 (dd,

^1H , $J = 8.5$, 19.0 Hz, one of 16-H), 3.39 (t, 2H, $J = 7.0$ Hz, 25-H), 4.68 (m, 1H, 3-H); ^{13}C NMR (101 MHz) δ 12.2 (s, 19-C), 13.8 (s, 18-C), 20.4 (s, 11-C), 21.7 (s, 15-C), 24.1 (s, 22-C), 27.4 (s, 2-C), 27.5 (s, 23-C), 28.2 (s, 6-C), 30.7 (s, 7-C), 31.4 (s, 12-C), 32.3 (s, 24-C), 33.5 (s, 25-C), 33.9 (s, 4-C), 34.4 (s, 21-C), 34.9 (s, 8-C), 35.6 (s, 10-C), 35.8 (s, 16-C), 36.6 (s, 1-C), 44.6 (s, 5-C), 47.7 (s, 13-C), 51.3 (s, 14-C), 54.2 (s, 9-C), 73.3 (s, 3-C), 173.0 (s, 20-C), 221.3 (s, 17-C); IR (KBr) 2939, 1736 (C=O), 1197, 1174 cm^{-1} ; mass spectrum, m/z (EI^+) 468 [M^+ ($\text{C}_{25}\text{H}_{39}^{81}\text{BrO}_3$), 2%], 466 [M^+ ($\text{C}_{25}\text{H}_{39}^{79}\text{BrO}_3$), 2], 272 ([$\text{M}-\text{Br}(\text{CH}_2)_3\text{CO}_2$] $^+$, 100).

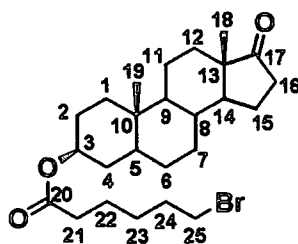

136

3 β -[6-(4-Aza-1-azoniabicyclo[2.2.2]oct-1-yl)-hexanoyloxy]-5 α -androstan-17-one tetrafluoroborate (137)

A solution of 3 β -(6-bromohexanoyloxy)-5 α -androstan-17-one (**136**) (1.50 g, 3.21 mmol) in diethyl ether (10 mL) was added to a stirred solution of 1,4-diazabicyclo[2.2.2]octane (**111**) (366 mg, 3.26 mmol) in diethyl ether (10 mL) at room temperature. The resulting solution was stirred for 84 hours. The resulting mixture was evaporated to give a white amorphous solid. Dry acetonitrile (23 mL) and NaBF_4 (360 mg, 3.28 mmol) was added to the amorphous solid and the mixture was stirred for 39 hours. White precipitate was removed by filtration and the filtrate was evaporated to give a crude product as a white solid (2.00 g). The solid was dissolved in chloroform, and the precipitate that formed was removed by filtration. The filtrate was evaporated to give an amorphous solid. Diethyl ether was added to the amorphous solid and refluxed for 2 hours. The resulting white solid could not be filtered and dissolved in chloroform and evaporated to give an amorphous solid again. The solid was dissolved in ethanol and evaporated to give 3 β -[6-(4-aza-1-azoniabicyclo[2.2.2]oct-1-yl)-hexanoyloxy]-5 α -androstan-17-one tetrafluoroborate (**137**) (1.52 g, 81%) as a mixture of white crystals and solid; ^1H NMR (400 MHz, CDCl_3) δ 0.68 (m, 1H, 9-H), 0.82 (s, 3H, 18-H or 19-H), 0.83 (s, 3H, 18-H or 19-H), 0.90—1.04 (m, 2H, one of 1-H, one of 7-H), 1.1—1.8 (m, 22H, one of 1-H, 2-H, 4-H, 5-H, 6-H, one of 7-H, 8-H, 11-H, 12-H, 14-H,

one of 15-H, 22-H, 23-H, 24-H), 1.90 (m, 1H, one of 15H), 2.03 (dt, 1H, $J = 9.0, 19.0$ Hz, one of 16-H), 2.25 (t, 2H, $J = 7.0$ Hz, 21-H), 2.40 (dd, 1H, $J = 9.0, 19.0$ Hz, one of 16-H), 3.21 (m, 6H, NCH_2), 3.30 (m, 2H, 25-H), 3.44 (m, 6H, N^+CH_2), 4.63 (m, 1H, 3-H); ^{19}F NMR (188 MHz, CDCl_3) $\delta -151.5$ (s); ^{13}C NMR (101 MHz) δ 12.1 (s, 19-C), 13.7 (s, 18-C), 20.4 (s, 11-C), 21.6 (s, 15-C or 24-C), 21.7 (s, 15-C or 24-C), 24.2 (s, 22-C), 25.7 (s, 23-C), 27.3 (s, 2-C), 28.2 (s, 6-C), 30.7 (s, 7-C), 31.4 (s, 12-C), 33.9 (s, 4-C), 34.0 (s, 21-C), 34.9 (s, 8-C), 35.5 (s, 10-C), 35.8 (s, 16-C), 36.6 (s, 1-C), 44.6 (s, 5-C), 45.2 (s, NCH_2), 47.7 (s, 13-C), 51.2 (s, 14-C), 52.4 (s, N^+CH_2), 54.2 (s, 9-C), 64.3 (s, 25-C), 73.5 (s, 3-C), 172.7 (s, 20-C), 221.3 (s, 17-C); IR (KBr) 2935, 2859, 1733 ($\text{C}=\text{O}$) cm^{-1} ; mass spectrum, m/z (ES^+) 500 ($[\text{M}+\text{H}-\text{BF}_4]^+$, 46), 499 ($[\text{M}-\text{BF}_4]^+$, 100%), (Found: $[\text{M}-\text{BF}_4]^+$ 499.3878. $\text{C}_{31}\text{H}_{51}\text{N}_2\text{O}_3$ requires 499.3900).

6.6 Fluorination of steroids using SelectfluorTM

3 β -Acetoxy-5 α -androstan-17-one (**138**)

A mixture of epiandrosterone (**128**) (0.60 g, 2.07 mmol), acetic anhydride (0.42 g, 4.11 mmol), 4-dimethylaminopyridine (84 mg, 0.69 mmol) and dichloromethane (50 mL) was stirred at ambient temperature for 6 hours. The reaction mixture was poured into water, neutralised by NaHCO_3 , and extracted with dichloromethane (3 x 20 mL). The combined organic extracts were dried over anhydrous MgSO_4 and evaporated to give a crude product (1.20 g). The crude mixture was chromatographed over silica gel [silica gel: 10 g, eluent: hexane/ethyl acetate (4:1)] to give 3 β -Acetoxy-5 α -androstan-17-one (**138**) (681 mg, 99%) as white crystals; m.p. 104—105 °C (lit.¹⁷² 103—104 °C) (Found: C, 75.88; H, 9.75. $\text{C}_{21}\text{H}_{32}\text{O}_3$ requires C, 75.86; H, 9.70%); ^1H NMR (400 MHz, CDCl_3) δ 0.68 (m, 1H, 9-H), 0.82 (2 x s, 6H, 18-H and 19-H), 0.9—1.0 (m, 2H, one of 1-H, one of 7-H), 1.1—1.4 (m, 7H, one of 4-H, 5-H, 6-H, one of 11-H, one of 12-H, 14-H), 1.4—1.5 (m, 3H, one of 2-H, 8-H, one of 15-H), 1.5—1.6 (m, 2H, one of 4-H, one of 11-H), 1.7-1.8 (m, 4H, one of 1-H, one of 2-H, one of 7-H, one of 12-H), 1.90 (m, 1H, one of 15-H), 1.99 (s, 3H, 21-H), 2.03 (m, 1H, one of 16-H), 2.40 (dd, 1H, $J = 9.0, 19.5$ Hz, one of 16-H), 4.65 (m, 1H, 3-H); ^{13}C NMR (126 MHz) δ 12.1 (s, 19-C), 13.7 (s, 18-C), 20.4 (s, 11-C), 21.4 (s, 21-C), 21.7 (s, 15-C), 27.3 (s, 2-C), 28.2 (s, 6-C), 30.7 (s, 7-C), 31.4 (s, 12-C), 33.8 (s, 4-C), 34.9 (s, 8-C), 35.5 (s, 10-C), 35.7 (s, 16-C), 36.6 (s, 1-C), 44.5 (s, 5-C), 47.7 (s, 13-C), 51.2 (s, 14-C), 54.2 (s, 9-C), 73.4 (s, 3-C), 170.6 (s, 20-C), 221.1 (s, 17-C); IR (KBr) 2920, 2855, 1735 ($\text{C}=\text{O}$), 1241, 1020 cm^{-1} ; mass spectrum, m/z (EI^+) 332 (M^+ , 21%), 272 ($[\text{M}-\text{C}_2\text{H}_4\text{O}_2]^+$, 100). [As compared to literature data (^{13}C NMR).²⁵¹]

Fluorination of 3 β -acetoxy-5 α -androstan-17-one (**138**) with Selectfluor™

A mixture of 3 β -acetoxy-5 α -androstan-17-one (**138**) (300 mg, 0.905 mmol) and freshly distilled anhydrous acetonitrile (20 mL) was placed in a round bottomed flask. Selectfluor™ (321 mg, 0.906 mmol) was added to the mixture, and the mixture was refluxed with stirring for 16 hours. The mixture was poured into water (30 mL), neutralised by NaHCO₃ and extracted with dichloromethane (3 x 20 mL). The combined organic extracts were dried over anhydrous MgSO₄ and evaporated to give a crude product (341 mg) which contained 3 β -acetoxy-5 α -androstan-17-one (**138**) (72%); m/z (EI⁺) 332 (M⁺, 13%), 272 ([M-C₂H₄O₂]⁺, 100), 3 β -acetoxy-12 α -fluoro-5 α -androstan-17-one (**139a**) (11%); m/z (EI⁺) 350 (M⁺, 3%), 290 ([M-C₂H₄O₂]⁺, 72), 3 β -acetoxy-12 β -fluoro-5 α -androstan-17-one (**139b**) (5%); m/z (EI⁺) 350 (M⁺, 5%), 290 ([M-C₂H₄O₂]⁺, 75), 3 β -acetoxy-6 α -fluoro-5 α -androstan-17-one (**139c**) (5%); m/z (EI⁺) 350 (M⁺, 8%), 290 ([M-C₂H₄O₂]⁺, 60), other isomers of monofluorinated acetoxyandrostanone (3 peaks, 7%); m/z (EI⁺) 350 (M⁺) and unidentified products (1%). The crude mixture was chromatographed over silica gel [eluent: hexane/ethyl acetate (6:1)] to give three major isomers: 3 β -acetoxy-12 α -fluoro-5 α -androstan-17-one (**139a**) (19 mg, 6%), 3 β -acetoxy-12 β -fluoro-5 α -androstan-17-one (**139b**) (13 mg, 4%), 3 β -acetoxy-6 α -fluoro-5 α -androstan-17-one (**139c**) (15 mg, 5%).

3 β -Acetoxy-12 α -fluoro-5 α -androstan-17-one (**139a**)

¹H NMR (400 MHz, CDCl₃) δ 0.81 (s, 3H, 18-H), 0.83 (s, 3H, 19-H), 1.0–2.0 (m, 18H, 1-H, 2-H, 4-H, 5-H, 6-H, 7-H, 8-H, 9-H, 11-H, 14-H, 15-H), 2.01 (s, 3H, 21-H), 2.12 (dd, 1H, $J = 9.5, 19.5$ Hz, one of 16-H), 2.41 (dd, 1H, $J = 8.0, 19.5$ Hz, one of 16-H), 4.68 (m, 1H, 3-H), 4.90 (d, 1H, $^2J_{\text{HF}} = 49.5$ Hz, 12-H); ¹³C NMR (126 MHz) δ 11.9 (s, 19-C), 13.3 (d, $^3J_{\text{CF}} = 7.0$ Hz, 18-C), 21.0 (s, 15-C), 21.4 (s, 21-C), 26.4 (d, $^2J_{\text{CF}} = 22.0$ Hz, 11-C), 27.2 (s, 2-C), 28.1 (s, 6-C), 30.5 (s, 7-C), 33.8 (s, 4-C), 34.4 (s, 8-C), 35.2 (s, 10-C), 36.3 (s, 1-C or 16-C), 36.3 (s, 1-C or 16-C), 43.8 (s, 14-C), 44.5 (s, 5-C), 48.4 (s, 9-C), 51.4 (d, $^2J_{\text{CF}} = 20.0$ Hz, 13-C), 73.3 (s, 3-C), 90.4 (d, $^1J_{\text{CF}} = 173.5$ Hz, 12-C), 170.6 (s, 20-C), 216.7 (s, 17-C); ¹⁹F NMR (188 MHz, CDCl₃) δ -187.0 (t, $^2J_{\text{HF}} = 49.5$ Hz); mass spectrum, m/z (EI⁺) 350 (M⁺, 3%), 290 ([M-C₂H₄O₂]⁺, 97).

3 β -Acetoxy-12 β -fluoro-5 α -androstan-17-one (**139b**)

¹H NMR (400 MHz, CDCl₃) δ 0.8–2.2 (m, 19H, 1-H, 2-H, 4-H, 5-H, 6-H, 7-H, 8-H, 9-H, 11-H, 14-H, 15-H, one of 16-H), 0.86 (s, 3H, 19-H), 0.99 (d, 3H, $^4J_{\text{HF}} = 1.0$ Hz, 18-H), 2.02 (s, 3H, 21-H), 2.47 (m, 1H, one of 16-H), 4.57 (ddd, 1H, $^2J_{\text{HF}} = 50.0$ Hz, $^3J_{\text{HH}} = 11.0, 5.0$ Hz, 12-H), 4.68 (m, 1H, 3-H); ¹³C NMR (101 MHz) δ 8.2 (d, $^3J_{\text{CF}} = 4.0$ Hz, 18-C), 12.0 (s, 19-C), 21.2 (d, $^4J_{\text{CF}} = 2.0$ Hz, 15-C), 21.4 (s, 21-C), 27.2 (s, 2-C), 27.6 (d, $^2J_{\text{CF}} = 19.0$ Hz, 11-C), 28.0 (s, 6-C), 29.7 (s, 7-C), 33.7 (s, 4-C and 8-C),

35.4 (s, 16-C), 35.5 (s, 10-C), 36.6 (s, 1-C), 44.4 (s, 5-C), 48.6 (d, $^3J_{CF} = 5.0$ Hz, 14-C), 51.4 (d, $^2J_{CF} = 16.0$ Hz, 13-C), 52.1 (d, $^3J_{CF} = 9.0$ Hz, 9-C), 73.2 (s, 3-C), 92.0 (d, $^1J_{CF} = 183.0$ Hz, 12-C), 170.7 (s, 20-C), 217.5 (s, 17-C); ^{19}F NMR (188 MHz, CDCl_3) δ -183.5 (d, $^2J_{HF} = 50.0$ Hz); mass spectrum, m/z (EI^+) 350 (M^+ , 8%), 290 ($[\text{M}-\text{C}_2\text{H}_4\text{O}_2]^+$, 100).

3 β -Acetoxy-6 α -fluoro-5 α -androstan-17-one (**139c**)

^1H NMR (400 MHz, CDCl_3) δ 0.7–0.8 (m, 1H, 9-H), 0.86 (s, 3H, 18-H or 19-H), 0.86 (s, 3H, 18-H or 19-H), 1.0–2.3 (m, 18H, 1-H, 2-H, 4-H, 5-H, 7-H, 8-H, 9-H, 11-H, 12-H, 14-H, 15-H, one of 16-H), 2.03 (s, 3H, 21-H), 2.44 (m, 1H, one of 16-H), 4.31 (m, 1H, $^2J_{HF} = 50.0$ Hz, 6-H), 4.68 (m, 1H, 3-H); ^{13}C NMR (101 MHz) δ 13.2 (s, 18-C or 19-C), 13.8 (s, 18-C or 19-C), 20.2 (s, 11-C), 21.4 (s, 21-C), 21.7 (s, 15-C), 27.0 (s, 2-C), 27.9 (d, $^3J_{CF} = 4.0$ Hz, 4-C), 31.2 (s, 12-C), 33.6 (d, $^3J_{CF} = 11.5$ Hz, 8-C), 35.7 (s, 16-C), 36.6 (d, $^3J_{CF} = 8.0$ Hz, 10-C), 36.9 (s, 1-C), 37.0 (d, $^2J_{CF} = 18.5$ Hz, 7-C), 47.7 (s, 13-C), 49.6 (d, $^2J_{CF} = 15.0$ Hz, 5-C), 51.0 (s, 14-C), 53.5 (d, $^4J_{CF} = 1.5$ Hz, 9-C), 72.7 (s, 3-C), 91.2 (d, $^1J_{CF} = 173.0$ Hz, 6-C), 170.5 (s, 20-C), 220.4 (s, 17-C); ^{19}F NMR (188 MHz, CDCl_3) δ -181.4 (d, $^2J_{HF} = 49.5$ Hz); mass spectrum, m/z (EI^+) 350 (M^+ , 16%), 290 ($[\text{M}-\text{C}_2\text{H}_4\text{O}_2]^+$, 100).

Crystal data for **139c**: $\text{C}_{21}\text{H}_{31}\text{FO}_3$, $M = 350.62$, monoclinic, $P2_1$ (No. 4), $a = 9.999(1)$ Å, $b = 8.082(2)$ Å, $c = 11.783(2)$ Å, $\alpha = 90^\circ$, $\beta = 90.60(1)^\circ$, $\gamma = 90^\circ$, $V = 952.2(3)$ Å³, $F(000) = 380$, $Z = 4$, $D_c = 1.222$ g/cm³, $\mu = 0.086$ mm⁻¹ (Mo $K\alpha$, $\lambda = 0.71073$ Å), $T = 120(2)$ K, crystal size $0.55 \times 0.5 \times 0.3$ mm³.

6.7 Remote fluorination of steroids directed by tethered N-F reagents

General procedure

A mixture containing the substrate, sodium tetrafluoroborate, and freshly distilled anhydrous acetonitrile was placed in the small PTFE reactor. The mixture was purged with N_2 and immersed in a cooling bath of -10°C . Elemental fluorine as a 10% (v/v) mixture with nitrogen was introduced at a flow rate of 10 mL/min into the rapidly stirred mixture *via* PTFE tubing. The reaction mixture was purged with N_2 for 30 minutes. The conversion of the substrate into N-F species was determined by analyzing the reaction mixture using ^{19}F NMR spectroscopy. The amount of the formed N-F species was calculated by comparing the integration with the BF_4^- resonance. The reaction mixture was allowed to warm to room temperature, moved to a three neck round bottomed flask and refluxed with stirring for 16 hours. The resulting mixture was poured into water, neutralised by NaHCO_3 , and extracted with chloroform (three times). The combined organic extracts were dried over anhydrous MgSO_4 and

evaporated to give a crude product. The crude product was analysed by ^{19}F NMR spectroscopy.

Fluorination of 3β -[(4-aza-1-azoniabicyclo[2.2.2]oct-1-yl)-acetoxy]- 5α -androstan-17-one (131**)**

3β -[(4-Aza-1-azoniabicyclo[2.2.2]oct-1-yl)-acetoxy]- 5α -androstan-17-one tetrafluoroborate (**131**) (239 mg, 0.451 mmol), sodium tetrafluoroborate (50 mg, 0.46 mmol), acetonitrile (10 mL), and elemental fluorine (2.70 mmol) gave an N-F species in 93%. After the heating process, a crude product (171 mg) was obtained. More than 8 kinds of fluorinated compounds were observed at -199 to -169 ppm in ^{19}F NMR (See ^{19}F NMR analysis in figure 2.9.).

Fluorination of 3β -[4-(4-aza-1-azoniabicyclo[2.2.2]oct-1-yl)-butyryloxy]- 5α -androstan-17-one tetrafluoroborate (133**)**

(Reaction concentration: 45mM)

3β -[4-(4-Aza-1-azoniabicyclo[2.2.2]oct-1-yl)-butyryloxy]- 5α -androstan-17-one tetrafluoroborate (**133**) (251 mg, 0.45 mmol), sodium tetrafluoroborate (49 mg, 0.45 mmol), acetonitrile (10 mL), and elemental fluorine (1.80 mmol) gave the corresponding N-F derivative (86%). The reaction mixture was refluxed with stirring to give crude product (0.28 g); ^{19}F NMR (188 MHz, CDCl_3) δ -169.05 (d, $^2J_{\text{HF}} = 48$ Hz, 4%), -180.85 (d, $^2J_{\text{HF}} = 50$ Hz, 22%), -183.22 (d, $^2J_{\text{HF}} = 48$ Hz, 13%), -184.07 (m, 8%), -184.74 (m, 10%), -186.13 (m, 8%), -186.83 (m, 25%), -188.04 (d, $^2J_{\text{HF}} = 39$ Hz, 3%), -192.97 (m, 4%), -198.82 (m, 3%) (See ^{19}F NMR analysis in Figure 2.11.). (See derivatization and GC-MS analysis below.)

(Reaction concentration: 3mM)

3β -[4-(4-Aza-1-azoniabicyclo[2.2.2]oct-1-yl)-butyryloxy]- 5α -androstan-17-one tetrafluoroborate (**133**) (251 mg, 0.45 mmol), sodium tetrafluoroborate (49 mg, 0.45 mmol), acetonitrile (10 mL), and elemental fluorine (2.26 mmol) gave the corresponding N-F derivative (86%). The reaction mixture was diluted with anhydrous acetonitrile (140 mL), refluxed with stirring to give crude product (0.35 g); ^{19}F NMR (188 MHz, CDCl_3) δ -169.02 (d, $^2J_{\text{HF}} = 52$ Hz, 18%), -176.63 (m, 10%), -180.71 (m, 20%), -183.21 (m, 8%), -186.08 (m, 12%), -196.55 (m, 16%), -198.68 (m, 16%) (See ^{19}F NMR analysis in Figure 2.11.). (See derivatization and GC-MS analysis below.)

Deprotection of (4-aza-1-azoniabicyclo[2.2.2]oct-1-yl)-acetoxy group from 3 β -[(4-aza-1-azoniabicyclo[2.2.2]oct-1-yl)-acetoxy]-5 α -androstan-17-one (**131**) using potassium carbonate

A mixture containing 3 β -[(4-aza-1-azoniabicyclo[2.2.2]oct-1-yl)-acetoxy]-5 α -androstan-17-one tetrafluoroborate (**131**) (31 mg, 0.058 mmol), potassium carbonate (5.5 mg, 0.040 mmol), and methanol (3 mL) was stirred for 4 hours. The mixture was added to water, extracted with dichloromethane (3 times), dried over anhydrous MgSO₄ and evaporated to give epiandrosterone (**128**) (15 mg); ¹H NMR (500 MHz, CDCl₃) δ 0.68 (m, 1H, 9-H), 0.82 (s, 3H, 19-H), 0.85 (s, 3H, 18-H), 0.9—1.0 (m, 2H, one of 1-H, one of 7-H), 1.12 (m, 1H, 5-H), 1.2—1.4 (m, 6H, one of 4-H, 6-H, one of 11-H, one of 12-H, 14-H), 1.40 (m, 1H, one of 2-H), 1.5—1.6 (m, 3H, one of 4-H, 8-H, one of 15-H), 1.65 (m, 1H, one of 11-H), 1.71 (dt, 1H, $J = 3.5, 13.5$ Hz, one of 1-H), 1.78 (m, 3H, one of 2-H, one of 7-H, one of 12-H), 1.92 (m, 1H, one of 15-H), 2.05 (dt, 1H, $J = 9.0, 19.5$ Hz, one of 16-H), 2.43 (m, 1H, one of 16-H), 3.59 (m, 1H, 3-H); ¹³C NMR (126 MHz) δ 12.3 (s, 19-C), 13.8 (s, 18-C), 20.5 (s, 11-C), 21.7 (s, 15-C), 28.4 (s, 6-C), 30.9 (s, 7-C), 31.4 (s, 12-C), 31.5 (s, 2-C), 35.0 (s, 8-C), 35.6 (s, 10-C), 35.8 (s, 16-C), 36.9 (s, 1-C), 38.0 (s, 4-C), 44.8 (s, 5-C), 47.8 (s, 13-C), 51.4 (s, 14-C), 54.4 (s, 9-C), 71.1 (s, 3-C), 221.4 (s, 17-C).

A mixture of the crude product, acetic anhydride (64 mg, 0.63 mmol), 4-dimethylaminopyridine (11 mg, 0.14 mmol) and dichloromethane (1.5 mL) was stirred at ambient temperature for 24 hours. The reaction mixture was poured into water, neutralised by NaHCO₃, and extracted with dichloromethane (3 times). The combined organic extracts were dried over anhydrous MgSO₄ and evaporated to give a crude product (25 mg). The crude mixture was chromatographed over silica gel [silica gel: 0.15 g, eluent: hexane/ethyl acetate (1:1)] to give 3 β -acetoxy-5 α -androstan-17-one (**138**) (16 mg) as a white solid; GC (97 %); mass spectrum, m/z (EI⁺) 332 (M⁺, 9%), 272 ([M-C₂H₄O₂]⁺, 75). (As compared to an authentic sample.)

Deprotection of 4-(4-aza-1-azoniabicyclo[2.2.2]oct-1-yl)-butyryloxy group from 3 β -[4-(4-aza-1-azoniabicyclo[2.2.2]oct-1-yl)-butyryloxy]-5 α -androstan-17-one tetrafluoroborate (**133**) using hydrochloric acid in acetonitrile

A mixture containing 3 β -[4-(4-aza-1-azoniabicyclo[2.2.2]oct-1-yl)-butyryloxy]-5 α -androstan-17-one tetrafluoroborate (**133**) (22 mg, 0.039 mmol), concentrated hydrochloric acid (0.2 mL), and acetonitrile (0.4 mL) was stirred for 30 hours. The reaction mixture was poured into water, neutralised by NaHCO₃, and extracted with

dichloromethane (3 times). The combined organic extracts were dried over anhydrous MgSO_4 and evaporated to give a crude product (24 mg). The crude mixture, acetic anhydride (47 mg, 0.46 mmol), 4-dimethylaminopyridine (7 mg, 0.06 mmol) and dichloromethane (3.5 mL) gave 3 β -acetoxy-5 α -androstan-17-one (**138**) (13 mg) as a white solid; GC (98%); mass spectrum, m/z (EI^+) 332 (M^+).

Derivatization and analysis of the crude product of fluorination of compound **133** under the normal concentration

The deprotections and following acetylations were carried out as described above.

(Deprotected by basic condition)

The crude product of the fluorination of compound **133** under the normal concentration (45 mM) (176 mg), potassium carbonate (25 mg, 0.18 mmol) and methanol (15 mL) gave crude product (74 mg). The impure product reacted with acetic anhydride (93 mg, 0.91 mmol) in the presence of 4-dimethylaminopyridine (7 mg, 0.06 mmol) in dichloromethane (7 mL) to give crude mixture (81 mg) which contained 3 β -acetoxy-5 α -androstan-17-one (**138**) (60%); m/z (EI^+) 332 (M^+ , 20%), 272 ($[\text{M}-\text{C}_2\text{H}_4\text{O}_2]^+$, 45), 3 β -acetoxy-6 α -fluoro-5 α -androstan-17-one (**139c**) (7%); m/z (EI^+) 350 (M^+ , 9%), 290 ($[\text{M}-\text{C}_2\text{H}_4\text{O}_2]^+$, 73), 3 β -acetoxy-12 α -fluoro-5 α -androstan-17-one (**139a**) (6%); m/z (EI^+) 350 (M^+ , 2%), 290 ($[\text{M}-\text{C}_2\text{H}_4\text{O}_2]^+$, 84), 3 β -acetoxy-12 β -fluoro-5 α -androstan-17-one (**139b**) (3%); m/z (EI^+) 350 (M^+ , 5%), 290 ($[\text{M}-\text{C}_2\text{H}_4\text{O}_2]^+$, 66), other isomers of monofluorinated 3 β -acetoxy-5 α -androstan-17-one (2 peaks, 6%); m/z (EI^+) 350 (M^+), HF eliminated compounds (**140**) (3 peaks, 18%); m/z (EI^+) 330 (M^+).

(Deprotected by acidic condition)

The crude product of the fluorination of compound **133** under the normal concentration (45 mM) (120 mg), concentrated hydrochloric acid (0.5 mL) and acetonitrile (1 mL) gave crude product (55 mg). The impure product reacted with acetic anhydride (92 mg, 0.90 mmol) in the presence of 4-dimethylaminopyridine (6 mg, 0.05 mmol) in dichloromethane (5.5 mL) to give crude mixture (66 mg) which contained 3 β -acetoxy-5 α -androstan-17-one (**138**) (64%); m/z (EI^+) 332 (M^+ , 28%), 272 ($[\text{M}-\text{C}_2\text{H}_4\text{O}_2]^+$, 75), 3 β -acetoxy-6 α -fluoro-5 α -androstan-17-one (**139c**) (7%); m/z (EI^+) 350 (M^+ , 9%), 290 ($[\text{M}-\text{C}_2\text{H}_4\text{O}_2]^+$, 75), 3 β -acetoxy-12 α -fluoro-5 α -androstan-17-one (**139a**) (6%); m/z (EI^+) 350 (M^+ , 3%), 290 ($[\text{M}-\text{C}_2\text{H}_4\text{O}_2]^+$, 99), 3 β -acetoxy-12 β -fluoro-5 α -androstan-17-one (**139b**) (3%); m/z (EI^+) 350 (M^+ , 5%), 290 ($[\text{M}-\text{C}_2\text{H}_4\text{O}_2]^+$, 64), other isomers of monofluorinated 3 β -acetoxy-5 α -androstan-17-one (4 peaks, 6%); m/z (EI^+) 350 (M^+), HF eliminated compounds (**140**) (3 peaks, 13%); m/z (EI^+) 330 (M^+).

Deprotection and reprotection of acetoxy group from a mixture containing 3 β -acetoxy-12 α -fluoro-5 α -androstan-17-one (**139a**)

A mixture of **139a**, **139c** and **138** [37:5:52, which also contained another monofluorinated 3 β -acetoxy-5 α -androstan-17-one (5%)] was treated with concentrated hydrochloric acid (0.5 mL) and acetonitrile (1 mL) gave crude product (37 mg). The impure product reacted with acetic anhydride (92 mg, 0.90 mmol) in the presence of 4-dimethylaminopyridine (3 mg, 0.02 mmol) in dichloromethane (4 mL) to give crude mixture (36 mg) which contained 3 β -acetoxy-5 α -androstan-17-one (**138**) (52%); *m/z* (EI⁺) 332 (M⁺, 18%), 272 ([M-C₂H₄O₂]⁺, 45), 3 β -acetoxy-12 α -fluoro-5 α -androstan-17-one (**139a**) (37%); *m/z* (EI⁺) 350 (M⁺, 4%), 290 ([M-C₂H₄O₂]⁺, 92), 3 β -acetoxy-6 α -fluoro-5 α -androstan-17-one (**139c**) (5%); *m/z* (EI⁺) 350 (M⁺, 34%), 290 ([M-C₂H₄O₂]⁺, 18), another isomer of monofluorinated 3 β -acetoxy-5 α -androstan-17-one (5%); *m/z* (EI⁺) 350 (M⁺).

Derivatization and analysis of the crude product of fluorination of compound **133** under high-dilution conditions

The deprotections and following acetylations were carried out as described above.

The crude product of the fluorination of compound **133** under high-dilution condition (3 mM) (350 mg), concentrated hydrochloric acid (1.5 mL) and acetonitrile (3 mL) gave crude product (130 mg). The impure product reacted with acetic anhydride (220 mg, 2.2 mmol) in the presence of 4-dimethylaminopyridine (13 mg, 0.11 mmol) in dichloromethane (14 mL) to give crude mixture (156 mg) which contained 3 β -acetoxy-5 α -androstan-17-one (**138**) (45%); *m/z* (EI⁺) 332 (M⁺, 23%), 272 ([M-C₂H₄O₂]⁺, 63), 3 β -acetoxy-6 α -fluoro-5 α -androstan-17-one (**139c**) (4%); *m/z* (EI⁺) 350 (M⁺, 5%), 290 ([M-C₂H₄O₂]⁺, 38), 3 β -acetoxy-12 β -fluoro-5 α -androstan-17-one (**139b**) (1%), other isomers of monofluorinated 3 β -acetoxy-5 α -androstan-17-one (3 peaks, 6%); *m/z* (EI⁺) 350 (M⁺), HF eliminated compounds (**140**) (3 peaks, 39%); *m/z* (EI⁺) 330 (M⁺).

Fluorination of 3 β -[5-(4-aza-1-azoniabicyclo[2.2.2]oct-1-yl)-valeryloxy]-5 α -androstan-17-one tetrafluoroborate (**135**)

(Reaction concentration: 45 mM)

3 β -[5-(4-Aza-1-azoniabicyclo[2.2.2]oct-1-yl)-valeryloxy]-5 α -androstan-17-one tetrafluoroborate (**135**) (258 mg, 0.450 mmol), sodium tetrafluoroborate (49 mg, 0.45 mmol), acetonitrile (10 mL), and elemental fluorine (1.79 mmol) gave N-F species (87%). The reaction mixture was refluxed with stirring to give a crude product (257 mg); ¹⁹F NMR (188 MHz, CDCl₃) δ -169.0 (d, ²J_{HF} = 50.0 Hz, 4%), -181.0 (d, ²J_{HF} =

55.5 Hz, 21%), -183.2 (d, $^2J_{\text{HF}} = 50.0$ Hz, 16%), -184.1 (m, 4%), -184.8 (m, 10%), -186.1 (m, 10%), -186.8 (m, 35%), -193.0 (m, 3%), -198.8 (m, 2%) (See ^{19}F NMR analysis in figure 2.12.).

(Derivatization and analysis)

The crude product (257 mg), concentrated hydrochloric acid (1 mL), and acetonitrile (2 mL) gave a crude product (105 mg). The crude product (105 mg) was reacted with acetic anhydride (230 mg, 2.3 mmol), 4-dimethylaminopyridine (7 mg, 0.06 mmol) in dichloromethane (5 mL) to give a crude mixture (122 mg) which contained 3 β -acetoxy-5 α -androstan-17-one (**138**) (47%); m/z (EI^+) 332 (M^+ , 32%), 272 ($[\text{M}-\text{C}_2\text{H}_4\text{O}_2]^+$, 76), 3 β -acetoxy-6 α -fluoro-5 α -androstan-17-one (**139c**) (9%); m/z (EI^+) 350 (M^+ , 12%), 290 ($[\text{M}-\text{C}_2\text{H}_4\text{O}_2]^+$, 92), 3 β -acetoxy-12 α -fluoro-5 α -androstan-17-one (**139a**) (10%); m/z (EI^+) 350 (M^+ , 5%), 290 ($[\text{M}-\text{C}_2\text{H}_4\text{O}_2]^+$, 92), 3 β -acetoxy-12 β -fluoro-5 α -androstan-17-one (**139b**) (5%); m/z (EI^+) 350 (M^+ , 5%), 290 ($[\text{M}-\text{C}_2\text{H}_4\text{O}_2]^+$, 82), other isomers of monofluorinated 3 β -acetoxy-5 α -androstan-17-one (2 peaks, 6%); m/z (EI^+) 350 (M^+), HF eliminated compounds (**140**) (3 peaks, 18%); m/z (EI^+) 330 (M^+).

(Reaction concentration: 3 mM)

3 β -[5-(4-Aza-1-azoniabicyclo[2.2.2]oct-1-yl)-valeryloxy]-5 α -androstan-17-one tetrafluoroborate (**135**) (258 mg, 0.450 mmol), sodium tetrafluoroborate (49 mg, 0.45 mmol), acetonitrile (10 mL), and elemental fluorine (1.79 mmol) gave the N-F species in 75–100% conversion. The reaction mixture was diluted with acetonitrile (140 mL) and refluxed with stirring to give a crude product (275 mg); ^{19}F NMR (188 MHz, CDCl_3) δ -169.0 (d, $^2J_{\text{HF}} = 48.5$ Hz, 18%), -169.7 (m, 4%), -176.7 (m, 7%), -181.0 (d, $^2J_{\text{HF}} = 51.0$ Hz, 19%), -183.2 (d, $^2J_{\text{HF}} = 46.0$ Hz, 7%), -186.1 (m, 9%), -186.8 (m, 7%), -193.0 (m, 2%), -196.4 (m, 15%), -198.8 (m, 12%) (See ^{19}F NMR analysis in figure 2.12.).

(Derivatization and analysis)

The crude product (275 mg), concentrated hydrochloric acid (1 mL), and acetonitrile (2 mL) gave a crude product (132 mg). The crude product (132 mg), acetic anhydride (230 mg, 2.3 mmol), 4-dimethylaminopyridine (6 mg, 0.05 mmol) and dichloromethane (7.5 mL) gave a crude mixture (152 mg) which contained 3 β -acetoxy-5 α -androstan-17-one (**138**) (53%); m/z (EI^+) 332 (M^+ , 36%), 272 ($[\text{M}-\text{C}_2\text{H}_4\text{O}_2]^+$, 81), 3 β -acetoxy-6 α -fluoro-5 α -androstan-17-one (**139c**) (3%); m/z (EI^+) 350 (M^+ , 6%), 290 ($[\text{M}-\text{C}_2\text{H}_4\text{O}_2]^+$, 47), 3 β -acetoxy-12 β -fluoro-5 α -androstan-17-one (**139b**) (1 %); m/z (EI^+) 350 (M^+ , 1%), 290 ($[\text{M}-\text{C}_2\text{H}_4\text{O}_2]^+$, 14), other isomers

of monofluorinated 3 β -acetoxy-5 α -androstan-17-one (3 peaks, 5 %); m/z (EI⁺) 350 (M⁺), HF eliminated compounds (140) (3 peaks, 32%); m/z (EI⁺) 330 (M⁺).

Fluorination of 3 β -[6-(4-aza-1-azoniabicyclo[2.2.2]oct-1-yl)-hexanoyloxy]-5 α -androstan-17-one tetrafluoroborate (137)

(Reaction concentration: 45 mM)

3 β -[6-(4-Aza-1-azoniabicyclo[2.2.2]oct-1-yl)-hexanoyloxy]-5 α -androstan-17-one tetrafluoroborate (137) (268 mg, 0.457 mmol), sodium tetrafluoroborate (50 mg, 0.46 mmol), acetonitrile (10 mL), and elemental fluorine (1.79 mmol) gave the corresponding N-F species (83%). The reaction mixture was refluxed with stirring to give a crude product (328 mg); ¹⁹F NMR (188 MHz, CDCl₃) δ -169.1 (d, ²J_{HF} = 53.0 Hz, 10%), -169.8 (m, 5%), -181.0 (d, ²J_{HF} = 51.0 Hz, 24%), -183.3 (d, ²J_{HF} = 46.5 Hz, 14%), -184.1 (m, 3%), -184.9 (m, 9%), -186.2 (m, 5%), -186.9 (m, 26%), -198.8 (m, 4%) (See ¹⁹F NMR analysis in figure 2.13.).

(Derivatization and analysis)

The crude product (328 mg), concentrated hydrochloric acid (1 mL), and acetonitrile (2 mL) gave a crude product (113 mg). The crude product (113 mg), acetic anhydride (230 mg, 2.3 mmol), 4-dimethylaminopyridine (6 mg, 0.05 mmol) and dichloromethane (6 mL) gave a crude mixture (71 mg) which contained 3 β -acetoxy-5 α -androstan-17-one (138) (51%), 3 β -acetoxy-6 α -fluoro-5 α -androstan-17-one (139c) (5%), 3 β -acetoxy-12 α -fluoro-5 α -androstan-17-one (139a) (4%), 3 β -acetoxy-12 β -fluoro-5 α -androstan-17-one (139b) (3%), other isomers of monofluorinated 3 β -acetoxy-5 α -androstan-17-one (2 peaks, 4%), HF eliminated compounds (140) (3 peaks, 22%).

(Reaction concentration: 3 mM)

3 β -[6-(4-Aza-1-azoniabicyclo[2.2.2]oct-1-yl)-hexanoyloxy]-5 α -androstan-17-one tetrafluoroborate (137) (264 mg, 0.450 mmol), sodium tetrafluoroborate (49 mg, 0.45 mmol), acetonitrile (10 mL), and elemental fluorine (1.79 mmol) gave the corresponding N-F species (82%). The reaction mixture was diluted with acetonitrile (140 mL), and refluxed with stirring to give a crude product (260 mg); ¹⁹F NMR (188 MHz, CDCl₃) δ -161.0 (m, 4%), -162.5 (m, 10%), -169.1 (d, ²J_{HF} = 47.5 Hz, 15%), -169.7 (m, 4%), -176.7 (m, 6%), -180.9 (d, ²J_{HF} = 55.0 Hz, 22%), -183.2 (d, ²J_{HF} = 51.0 Hz, 7%), -186.2 (m, 7%), -186.9 (m, 2%), -196.5 (m, 13%), -198.9 (m, 10%) (See ¹⁹F NMR analysis in figure 2.13.).

(Derivatization and analysis)

The crude product (260 mg), concentrated hydrochloric acid (1 mL), and acetonitrile (2 mL) gave a crude product (115 mg). The crude product (115 mg), acetic anhydride (230 mg, 2.3 mmol), 4-dimethylaminopyridine (6 mg, 0.05 mmol) and dichloro methane (6 mL) gave a crude mixture (141 mg) which contained 3 β -acetoxy-5 α -androstan-17-one (**138**) (60%), 3 β -acetoxy-6 α -fluoro-5 α -androstan-17-one (**139c**) (3%), 3 β -acetoxy-12 β -fluoro-5 α -androstan-17-one (**139b**) (1%), other isomers of monofluorinated 3 β -acetoxy-5 α -androstan-17-one (3 peaks, 4%), HF eliminated compounds (**140**) (3 peaks, 25%).

Control reaction

The reactions were carried out in a similar manner described above.

3 β -[5-(4-Aza-1-azoniabicyclo[2.2.2]oct-1-yl)-valeryloxy]-5 α -androstan-17-one tetrafluoroborate (**135**) (258 mg, 0.450 mmol), sodium tetrafluoroborate (49 mg, 0.45 mmol), acetonitrile (10 mL), and elemental fluorine (1.79 mmol) gave the corresponding N-F species (72%). The reaction mixture was poured into water (20 mL), neutralised by NaHCO₃, and extracted with chloroform (3 x 20 mL). The combined organic extracts were dried over anhydrous MgSO₄ and evaporated to give a crude product (280 mg); ¹⁹F NMR (188 MHz, CDCl₃) δ -162.7 (m, 22%), -164.6 (m, 22%), -169.3 (d, ²J_{HF} = 47.5 Hz, 4%), -177.0 (m, 2%), -180.2 (m, 38%), -181.2 (d, ²J_{HF} = 49.0 Hz, 3%), -183.6 (d, ²J_{HF} = 53.0 Hz, 1%), -186.5 (m, 1%), -187.1 (m, 2%), -196.8 (m, 3%), -199.1 (m, 2%).

(Derivatization and analysis)

(Deprotected by basic condition)

The crude product of fluorination (140 mg), concentrated hydrochloric acid (1 mL), and acetonitrile (2 mL) gave a crude product (67 mg). The crude product (67 mg), acetic anhydride (119 mg, 1.2 mmol), 4-dimethylaminopyridine (3 mg, 0.02 mmol) and dichloromethane (7 mL) gave a crude mixture (77 mg) which contained 3 β -acetoxy-5 α -androstan-17-one (**138**) (62%); m/z (EI⁺) 332 (M⁺, 39%), 272 ([M-C₂H₄O₂]⁺, 86), 3 β -acetoxy-6 α -fluoro-5 α -androstan-17-one (**139c**) (3%); m/z (EI⁺) 350 (M⁺, 10%), 290 ([M-C₂H₄O₂]⁺, 87), 3 β -acetoxy-12 β -fluoro-5 α -androstan-17-one (**139b**) (1%); m/z (EI⁺) 350 (M⁺, 4%), 290 ([M-C₂H₄O₂]⁺, 58), other isomers of monofluorinated 3 β -acetoxy-5 α -androstan-17-one (3 peaks, 6%); m/z (EI⁺) 350 (M⁺), HF eliminated compounds (**140**) (4 peaks, 26%); m/z (EI⁺) 330 (M⁺).

(Deprotected by acidic condition)

The crude product (154 mg), potassium carbonate (23 mg, 0.17 mmol), and methanol (15 mL) was stirred for 3 hours. The mixture was added to water, extracted with

dichloromethane (3 times), dried over anhydrous MgSO_4 and evaporated to give a crude product (60 mg). The crude product (23 mg), acetic anhydride (74 mg, 0.72 mmol), 4-dimethylaminopyridine (1 mg, 0.008 mmol) and dichloromethane (3 mL) gave a crude mixture (24 mg) which contained 3β -acetoxy- 5α -androstan-17-one (**138**) (54%); m/z (EI^+) 332 (M^+ , 27%), 272 ($[\text{M}-\text{C}_2\text{H}_4\text{O}_2]^+$, 89), 3β -acetoxy- 9α -fluoro- 5α -androstan-17-one (**139d**), 3β -acetoxy- 5α -fluoro- 5α -androstan-17-one (**139e**) and 3β -acetoxy- 14α -fluoro- 5α -androstan-17-one (**139f**) in the ratio of 39:35:25 (^{19}F NMR; -180.0 , -162.9 , and -164.5 ppm, respectively) (2 peaks, 23%); m/z (EI^+) 350 (M^+), 3β -acetoxy- 6α -fluoro- 5α -androstan-17-one (**139c**) (2%), 3β -acetoxy- 12β -fluoro- 5α -androstan-17-one (**139b**) (1%), other isomers of monofluorinated 3β -acetoxy- 5α -androstan-17-one (2 peaks, 2%); m/z (EI^+) 332 (M^+), HF eliminated compounds (**140**) (3 peaks, 7%); m/z (EI^+) 330 (M^+).

6.8 Preparation of the steroid derivatives with tethered functional groups

3α -(3-Cyanobenzoyloxy)- 5α -androstan-17-one (**142**)

A mixture of androsterone (**141**) (2.29 g, 7.88 mmol), 3-cyanobenzoyl chloride (1.88 g, 11.4 mmol), 4-dimethylaminopyridine (77 mg, 0.63 mmol), pyridine (5.00 g, 63.2 mmol) and tetrahydrofuran (50 mL) was refluxed for 30 hours. The reaction mixture was poured into water, and extracted with dichloromethane (3 x 100 mL). The combined organic extracts were dried over anhydrous MgSO_4 and evaporated to give a crude product (4.85 g). The crude mixture was chromatographed over silica gel [silica gel: 150 g, eluent: hexane/ethyl acetate (3:1)] to give white solid (4.05 g). Recrystallization from hexane/ethyl acetate gave 3α -(3-cyanobenzoyloxy)- 5α -androstan-17-one (**142**) (2.75 g, 83%) as white crystals; m.p. 159 — 161 °C; (Found: C, 77.32; H, 7.95; N, 3.13. $\text{C}_{27}\text{H}_{33}\text{NO}_3$ requires C, 77.29; H, 7.93; N, 3.34%); ^1H NMR (400 MHz, CDCl_3) δ 0.84—0.92 (m, 1H, 9-H), 0.87 (s, 6H, 18-H, 19-H), 1.01—1.11 (m, 1H, one of 7-H), 1.20—1.38 (m, 6H, one of 1-H or 4-H, 6-H, one of 11-H, one of 12-H, 14-H), 1.45—1.97 (m, 12H, three of 1-H and 4-H, 2-H, 5-H, one of 7-H, 8-H, one of 11-H, one of 12-H, 15-H), 2.07 (dt, 1H, $J = 9.0$, 19.0 Hz one of 16-H), 2.43 (dd, 1H, $J = 8.0$, 19.0 Hz, one of 16-H), 5.30 (m, 1H, 3-H), 7.59 (m, 1H, 25-H), 7.83 (m, 1H, 24-H), 8.27 (m, 1H, 26-H), 8.30 (m, 1H, 22-H); ^{13}C NMR (101 MHz) δ 11.3 (s, 19-C), 13.8 (s, 18-C), 20.0 (s, 11-C), 21.7 (s, 15-C), 26.1 (s, 2-C), 28.0 (s, 6-C), 30.6 (s, 7-C), 31.4 (s, 12-C), 32.8 (s, 1-C or 4-C), 33.0 (s, 1-C or 4-C), 34.9 (s, 8-C), 35.8 (s, 16-C), 36.0 (s, 10-C), 40.4 (s, 5-C), 47.7 (s, 13-C), 51.3 (s, 14-C), 54.2 (s, 9-C), 71.7 (s, 3-C), 112.8 (s, 23-C), 118.0 (s, CN), 129.4 (s, 25-C), 132.2 (s, 21-C), 133.1 (s, 22-C or 26-C), 133.7 (s, 22-C or 26-C), 135.8 (s, 24-C), 163.9 (s, COCH_3), 221.3 (s, 17-C); IR

(KBr) 3067 (Ar-H), 2934, 2858 (C-H), 2233 (CN), 1734, 1710 (C=O), 1291, 1189, 758 cm^{-1} ; m/z (ES^+) 861 ($[\text{2M}+\text{Na}]^+$, 8%), 442 ($[\text{M}+\text{Na}]^+$, 100).

Crystal data for **142**: $\text{C}_{27}\text{H}_{33}\text{NO}_3$, $M = 419.54$, monoclinic, $P2_1$ (No. 4), $a = 10.872(1) \text{ \AA}$, $b = 10.635(1) \text{ \AA}$, $c = 20.160(2) \text{ \AA}$, $\alpha = 90^\circ$, $\beta = 95.11(1)^\circ$, $\gamma = 90^\circ$, $V = 2321.8(4) \text{ \AA}^3$, $F(000) = 904$, $Z = 4$, $D_c = 1.200 \text{ g/cm}^3$, $\mu = 0.077 \text{ mm}^{-1}$ (Mo $\text{K}\alpha$, $\lambda = 0.71073 \text{ \AA}$), $T = 120(2) \text{ K}$, crystal size $0.22 \times 0.14 \times 0.10 \text{ mm}^3$.

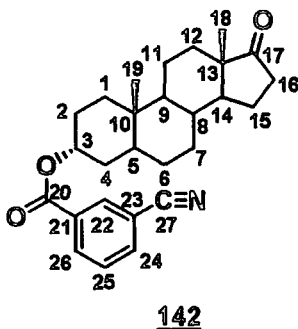

3 α -Cyanoacetoxo-5 α -androstan-17-one (**143**)

Phosphorus pentachloride (1.23 g, 5.91 mmol) was added to a solution of cyanoacetic acid (0.51 g, 6.0 mmol) in dry dichloromethane (40 mL) and the reaction mixture was stirred at ambient temperature for 1 hour. The dichloromethane and most of the phosphorus oxychloride were removed under reduced pressure. The oily residue was dissolved in dry dichloromethane (20 mL), and androsterone (**141**) (1.15 g, 3.96 mmol) was added to the solution. Pyridine (0.94 g, 12 mmol) was added dropwise to the mixture, and then 4-dimethylaminopyridine (77 mg, 0.63 mmol) was added in one portion to the mixture. The resulting mixture was stirred at room temperature for 2 hours. The reaction mixture was poured into water, and extracted with dichloromethane (3 times). The combined organic extracts were dried over anhydrous MgSO_4 and evaporated to give a crude product (1.66 g). The crude mixture was chromatographed over silica gel [silica gel: 40 g, eluent: hexane/ethyl acetate (2:1)] to give white solid (1.23 g). Recrystallization from hexane/ethyl acetate gave 3 α -cyanoacetoxo-5 α -androstan-17-one (**143**) (1.21 g, 85%) as white crystals; $m.p.$ 149–150 $^\circ\text{C}$; (Found: C, 74.11; H, 8.84; N, 3.92. $\text{C}_{22}\text{H}_{31}\text{NO}_3$ requires C, 73.92; H, 8.74; N, 3.92%); $^1\text{H NMR}$ (400 MHz, CDCl_3) δ 0.77–0.83 (m, 1H, 9-H), 0.81 (s, 3H, 19-H), 0.84 (s, 3H, 18-H), 1.00 (dq, 1H, $J = 5.0, 12.0 \text{ Hz}$, one of 7-H), 1.19–1.33 (m, 6H, one of 1-H or 4-H, 6-H, one of 11-H, one of 12-H, 14-H), 1.43–1.82 (m, 11H, three of 1-H and 4-H, 2-H, 5-H, one of 7-H, 8-H, one of 11-H, one of 12-H, one of 15-H), 1.92 (m, 1H, one of 15-H), 2.01–2.10 (m, 1H, one of 16-H), 2.42 (dd, 1H, $J =$

8.5, 19.0 Hz, one of 16-H), 3.45 (s, 2H, CH₂CN), 5.12 (m, 1H, 3-H); ¹³C NMR (101 MHz) δ 11.2 (s, 19-C), 13.7 (s, 18-C), 20.0 (s, 11-C), 21.6 (s, 15-C), 25.1 (s, CH₂CN), 25.8 (s, 2-C), 27.8 (s, 6-C), 30.6 (s, 7-C), 31.4 (s, 12-C), 32.5 (s, 1-C or 4-C), 32.5 (s, 1-C or 4-C), 34.9 (s, 8-C), 35.8 (s, 16-C), 35.8 (s, 10-C), 39.9 (s, 5-C), 47.7 (s, 13-C), 51.3 (s, 14-C), 54.0 (s, 9-C), 73.5 (s, 3-C), 113.2 (s, CN), 162.3 (s, OCOCH₂), 221.3 (s, 17-C); IR (KBr) 2928, 2914, 2855 (C-H), 2265 (CN), 1744 (C=O), 1331, 1219, 1198, 1160, 997 cm⁻¹; m/z (EI⁺) 357 ([M]⁺, 100%).

Crystal data for **143**: C₂₂H₃₁NO₃, *M* = 357.48, monoclinic, *P*2₁ (No. 4), *a* = 9.7072(9) Å, *b* = 7.7406(7) Å, *c* = 13.6019(14) Å, α = 90°, β = 105.238(4)°, γ = 90°, *V* = 986.11(16) Å³, *F*(000) = 388, *Z* = 2, *D*_c = 1.204 g/cm³, μ = 0.079 mm⁻¹ (Mo Kα, λ = 0.71073 Å), *T* = 170(2) K, crystal size 0.55 × 0.45 × 0.22 mm³.

3α-[(3-Carboxypropyl)-acetoxy]-5α-androstan-17-one (**144**)

4-Dimethylaminopyridine (105 mg, 0.859 mmol) was added to a solution of androsterone (**141**) (1.67 g, 5.75 mmol) and glutaric anhydride (789 mg, 6.91 mmol) in dichloromethane (15 mL) at 0 °C. The reaction mixture was stirred at room temperature for 7 days. Additional glutaric acid (525 mg, 4.60 mmol) was added during the reaction to allow the reaction to completion. The reaction mixture was poured into water, and extracted with dichloromethane (3 times). The combined organic extracts were washed with 0.1 M aqueous NaHCO₃, dried over anhydrous MgSO₄ and evaporated to give a crude product (2.79 g). The crude mixture was chromatographed over silica gel [silica gel: 100 g, eluent: hexane/ethyl acetate (2:1) and dichloromethane/ethyl acetate (2:1)] to give white solid (2.37 g). Recrystallization from hexane/ethyl acetate gave 3α-[(3-carboxypropyl)-acetoxy]-5α-androstan-17-one (**144**) (1.50 g, 65%) as white crystals; m.p. 173—175 °C; (Found: C, 71.16; H, 9.02. C₂₄H₃₆O₅ requires C, 71.26; H, 8.97%); ¹H NMR (500 MHz, CDCl₃) δ 0.77—0.82 (m, 1H, 9-H), 0.80 (s, 3H, 19-H), 0.85 (s, 3H, 18-H), 0.96—1.04 (m, 1H, one of 7-H), 1.15—1.31 (m, 6H, one of 1-H or 4-H, 6-H, one of 11-H, one of 12-H, 14-H), 1.42—1.82 (m, 11H, three of 1-H and 4-H, 2-H, 5-H, one of 7-H, 8-H, one of 11-H, one of 12-H, one of 15-H), 1.90—1.98 (m, 3H, one of 15-H, 22-H), 2.02—2.10 (m, 1H, one of 16-H), 2.37—2.46 (m, 5H, one of 16-H, 21-H, 23-H), 5.03 (m, 1H, 3-H); ¹³C NMR (101 MHz) δ 12.3 (s, 19-C), 13.8 (s, 18-C), 19.9 (s, 11-C or 22-C), 20.0 (s, 11-C or 22-C), 21.7 (s, 15-C), 26.0 (s, 2-C), 28.0 (s, 6-C), 30.7 (s, 7-C), 31.4 (s, 12-C), 32.8 (s, 1-C or 4-C), 32.8 (s, 1-C or 4-C), 32.9 (s, 21-C or 23-C), 33.6 (s, 21-C or 23-C), 34.9 (s, 8-C), 35.8 (s, 16-C), 35.9 (s, 10-C), 40.0 (s, 5-C), 47.8 (s, 13-C), 51.4 (s, 14-C), 54.2 (s, 9-C), 70.0 (s, 3-C), 172.3 (s, 20-C), 178.8 (s, 24-C), 221.7 (s, 17-C); IR (KBr)

3022 (COO-H), 2930 (C-H), 1743, 1715 (C=O), 1245, 1181, 1001 cm^{-1} ; m/z (ES^+) 427 ($[\text{M}+\text{Na}]^+$, 77%).

Crystal data for **144**: $\text{C}_{24}\text{H}_{36}\text{FO}_5$, $M = 404.53$, monoclinic, $P2_1$ (No. 4), $a = 11.231(2)$ Å, $b = 7.250(1)$ Å, $c = 13.360(2)$ Å, $\alpha = 90^\circ$, $\beta = 103.99(1)^\circ$, $\gamma = 90^\circ$, $V = 1055.6(3)$ Å³, $F(000) = 440$, $Z = 2$, $D_c = 1.273$ g/cm³, $\mu = 0.087$ mm⁻¹ (Mo K α , $\lambda = 0.71073$ Å), $T = 120(2)$ K, crystal size $0.40 \times 0.08 \times 0.04$ mm³.

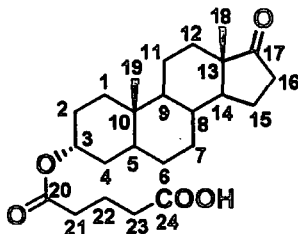

144

3 α -Nicotinoyl-5 α -androstan-17-one (**145**)

Diethyl azodicarboxylate (2.40 g, 13.8 mmol) was added to a mixture of epiandrosterone (**128**) (2.00 g, 6.89 mmol), triphenylphosphine (3.61 g, 13.8 mmol), nicotinic acid (1.70 g, 13.8 mmol), and tetrahydrofuran (100 mL) at room temperature. The resulting mixture was stirred for 24 hours. The reaction mixture was poured into water, and extracted with diethylether (3 x 100 mL). The combined organic extracts were dried over anhydrous MgSO_4 and evaporated to give a crude product (10.1 g). The crude mixture was chromatographed over silica gel [silica gel: 130 g, eluent: hexane/ethyl acetate (1:1)] to give a white solid (3.02 g), which contained 1,2-dicarbethoxyhydrazine as a by-product. The solid was dissolved in hexane/ethyl acetate (1:1), washed with 1N HCl (several times), saturated aqueous NaHCO_3 , and water. The solution was dried over MgSO_4 and evaporated to give white amorphous (1.79 g). Recrystallization from hexane/ethyl acetate gave 3 α -nicotinoyl-5 α -androstan-17-one (**145**) (1.38 g, 51%) as white crystals; m.p. 129–130 °C; (Found: C, 75.66; H, 8.43; N, 3.50. $\text{C}_{25}\text{H}_{33}\text{NO}_3$ requires C, 75.92; H, 8.41; N, 3.54%); ^1H NMR (500 MHz, CDCl_3) δ 0.83 (m, 1H, 9-H), 0.85 (s, 6H, 18-H, 19-H), 0.97–1.05 (m, 1H, one of 7-H), 1.19–1.38 (m, 6H, one of 1-H or 4-H, 6-H, one of 11-H, one of 12-H, 14-H), 1.44–1.95 (m, 12H, three of 1-H and 4-H, 2-H, 5-H, one of 7-H, 8-H, one of 11-H, one of 12-H, 15-H), 2.06 (dt, 1H, $J = 19.0, 9.5$ Hz one of 16-H), 2.42 (dd, 1H, $J = 19.0, 9.0$ Hz, one of 16-H), 5.30 (m, 1H, 3-H), 7.39 (dd, 1H, $J = 8.0, 5.0$ Hz, 24-H), 8.28 (m, 1H, 25-H), 8.75 (m, 1H, 23-H), 9.23 (m, 1H, 22-H); ^{13}C NMR (126 MHz) δ 11.3 (s, 19-C), 13.8 (s, 18-C), 20.0 (s, 11-C), 21.7 (s, 15-C), 26.1 (s, 2-C), 28.0 (s, 6-C),

30.7 (s, 7-C), 31.4 (s, 12-C), 32.8 (s, 1-C or 4-C), 33.0 (s, 1-C or 4-C), 34.9 (s, 8-C), 35.8 (s, 16-C), 36.0 (s, 10-C), 40.4 (s, 5-C), 47.7 (s, 13-C), 51.3 (s, 14-C), 54.3 (s, 9-C), 71.2 (s, 3-C), 123.3 (s, 24-C), 126.8 (s, 21-C), 137.0 (s, 25-C), 150.8 (s, 22-C), 153.2 (s, 23-C), 164.5 (s, 20-C), 221.3 (s, 17-C); IR (KBr) 2910 (C-H), 1735, 1714 (C=O), 1281, 745, 702 cm^{-1} ; m/z (ES⁺) 396 ($[M+H]^+$, 100%).

Crystal data for **145**: $\text{C}_{25}\text{H}_{33}\text{NO}_3$, $M = 395.52$, monoclinic, $P2_1$ (No. 4), $a = 11.366(2)$ Å, $b = 6.4174(8)$ Å, $c = 14.540(2)$ Å, $\alpha = 90^\circ$, $\beta = 102.76(1)^\circ$, $\gamma = 90^\circ$, $V = 1034.4(3)$ Å³, $F(000) = 428$, $Z = 2$, $D_c = 1.270$ g/cm^3 , $\mu = 0.082$ mm^{-1} (Mo $K\alpha$, $\lambda = 0.71073$ Å), $T = 120(2)$ K, crystal size $0.28 \times 0.22 \times 0.08$ mm^3 .

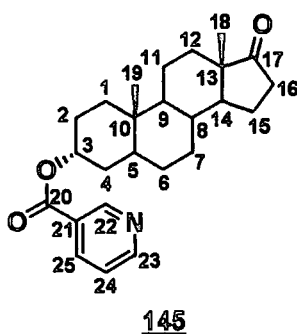

3 α -(2,6-Dichloronicotinoyl)-5 α -androstan-17-one (**146**)

Using a similar procedure to the preparation of 3 α -nicotinoyl-5 α -androstan-17-one (**145**), diethyl azodicarboxylate (1.30 g, 7.44 mmol), epiandrosterone (1.08 g, 3.72 mmol), triphenylphosphine (1.95 g, 7.44 mmol), 2,6-dichloronicotinic acid (1.43 g, 7.44 mmol), and tetrahydrofuran (50 mL) gave a crude product (6.10 g). The crude mixture was chromatographed over silica gel [silica gel: 100 g, eluent: hexane/ethyl acetate (3:1)] to give a white amorphous solid (1.37 g). Recrystallization from ethyl acetate gave 3 α -(2,6-dichloronicotinoyl)-5 α -androstan-17-one (**146**) (1.10 g, 63%) as white crystals; m.p. 169—170 °C; (Found: C, 64.47; H, 6.74; N, 2.98. $\text{C}_{25}\text{H}_{31}\text{Cl}_2\text{NO}_3$ requires C, 64.65; H, 6.73; N, 3.02%); ¹H NMR (400 MHz, CDCl_3) δ 0.76—0.82 (m, 1H, 9-H), 0.85 (2s, 6H, 18-H, 19-H), 0.94—1.05 (m, 1H, one of 7-H), 1.18—1.36 (m, 6H, one of 1-H or 4-H, 6-H, one of 11-H, one of 12-H, 14-H), 1.44—1.95 (m, 12H, three of 1-H and 4-H, 2-H, 5-H, one of 7-H, 8-H, one of 11-H, one of 12-H, 15-H), 2.05 (dt, 1H, $J = 19.0, 9.0$ Hz one of 16-H), 2.42 (dd, 1H, $J = 19.0, 8.0$ Hz, one of 16-H), 5.32 (m, 1H, 3-H), 7.36 (d, 1H, $J = 8.5$ Hz, 24-H), 8.14 (d, 1H, $J = 8.0$ Hz, 25-H); ¹³C NMR (101 MHz) δ 11.4 (s, 19-C), 13.8 (s, 18-C), 20.0 (s, 11-C), 21.7 (s, 15-C), 26.0 (s, 2-C), 27.9 (s, 6-C), 30.7 (s, 7-C), 31.4 (s, 12-C), 32.7 (s, 1-C or 4-C), 33.0 (s, 1-C or 4-C), 34.9 (s, 8-C), 35.8 (s, 16-C), 35.9 (s, 10-C), 40.3 (s, 5-C), 47.7 (s,

13-C), 51.3 (s, 14-C), 54.3 (s, 9-C), 72.9 (s, 3-C), 122.9 (s, 24-C), 126.1 (s, 21-C), 142.6 (s, 25-C), 149.4 (s, 22-C), 152.6 (s, 23-C), 163.3 (s, 20-C), 221.3 (s, 17-C); IR (KBr) 2952, 2906 (C-H), 1739, 1709 (C=O), 1571, 1353, 1281, 1159, 778 cm^{-1} ; m/z (ES^+) 467 [M^+ ($\text{C}_{25}\text{H}_{31}^{37}\text{Cl}_2\text{NO}_3$), 13%], 465 [M^+ ($\text{C}_{25}\text{H}_{31}^{35}\text{Cl}^{37}\text{ClNO}_3$), 68], 463 [M^+ ($\text{C}_{25}\text{H}_{31}^{35}\text{Cl}_2\text{NO}_3$), 100].

6.9 Direct remote fluorination of steroids with tethered functional groups

General procedure

A mixture containing the substrate and a solvent was placed in the small PTFE reactor. The mixture was purged with N_2 and immersed in a cooling bath of 0°C . Elemental fluorine as a 10% (v/v) mixture with nitrogen was introduced at a flow rate of 10 mL/min into the rapidly stirred mixture *via* PTFE tubing. The reaction mixture was purged with N_2 for 30 minutes. The resulting mixture was poured into water, neutralised by NaHCO_3 , and extracted with chloroform (three times). The combined organic extracts were dried over anhydrous MgSO_4 and evaporated to give a crude product. The crude product was analysed by ^{19}F NMR spectroscopy where known amounts of fluorobenzene was used as an internal standard apart from the case of 3β -[5-(4-aza-1-azoniabicyclo[2.2.2]oct-1-yl)-valeryloxy]- 5α -androstan-17-one tetrafluoroborate (**135**).

Control reactions

Preparation of 3α -acetoxy- 5α -androstan-17-one (**62**)

A mixture of androsterone (**141**) (400 mg, 1.38 mmol), acetic anhydride (336 mg, 3.29 mmol), 4-dimethylaminopyridine (56 mg, 0.46 mmol) and dichloromethane (35 mL) was stirred at ambient temperature for 9 days. The reaction mixture was poured into water, and extracted with dichloromethane (3 x 20 mL). The combined organic extracts were dried over anhydrous MgSO_4 and evaporated to give a crude product (700 mg). The crude mixture was chromatographed over silica gel [silica gel: 10 g, eluent: hexane/ethyl acetate (4:1)] to give 3α -acetoxy- 5α -androstan-17-one (**62**) (445 mg, 97%) as white crystals; m.p. 163 — 165°C (lit.²⁵² 164 — 165°C) (Found: C, 75.57; H, 9.70. $\text{C}_{21}\text{H}_{32}\text{O}_3$ requires C, 75.86; H, 9.70%); ^1H NMR (500 MHz, CDCl_3) δ 0.78—0.83 (m, 1H, 9-H), 0.81 (s, 3H, 19-H), 0.85 (s, 3H, 18-H), 1.00 (dq, 1H, $J = 5.0, 12.5$ Hz, one of 7-H), 1.16—1.32 (m, 6H, one of 1-H or 4-H, 6-H, one of 11-H, one of 12-H, 14-H), 1.43—1.83 (m, 11H, three of 1-H and 4-H, 2-H, 5-H, one of 7-H, 8-H, one of 11-H, one of 12-H, one of 15-H), 1.93 (m, 1H, one of 15-H), 1.99 (s, 3H, 21-H), 2.02—2.09 (m, 1H, one of 16-H), 2.04 (s, 3H, COCH_3), 2.43 (dd, 1H, $J = 9.0,$

19.5 Hz, one of 16-H), 5.00 (m, 1H, 3-H); ^{13}C NMR (126 MHz) δ 11.3 (s, 19-C), 13.8 (s, 18-C), 20.0 (s, 11-C), 21.5 (s, COCH_3), 21.7 (s, 15-C), 26.0 (s, 2-C), 28.0 (s, 6-C), 30.7 (s, 7-C), 31.5 (s, 12-C), 32.8 (2 of s, 1-C and 4-C), 34.9 (s, 8-C), 35.8 (s, 16-C), 35.9 (s, 10-C), 40.0 (s, 5-C), 47.8 (s, 13-C), 51.4 (s, 14-C), 54.2 (s, 9-C), 69.9 (s, 3-C), 170.7 (s, COCH_3), 221.4 (s, 17-C); IR (KBr) 2936, 2855 (C-H), 1735, 1726 (C=O), 1240, 1015 cm^{-1} (lit.²⁵² 1736 cm^{-1}).

Fluorination of 3 α -acetoxy-5 α -androstan-17-one (**62**)

(In acetonitrile)

3 α -Acetoxy-5 α -androstan-17-one (**62**) (224 mg, 0.675 mmol), acetonitrile (15 mL) and elemental fluorine (2.67 mmol) gave a crude product (266 mg). Fluorobenzene (35.4 mg, 0.368 mmol) was added to the crude product; ^{19}F NMR (188 MHz, CDCl_3) δ -161.3 (m, 5 α -F, 17%), -164.5 (m, 14 α -F, 19%), -179.9 (m, 9 α -F, 20%) [lit.¹²³ 5 α -F: -161.0 (m), 9 α -F: -180.0 (m)], more than 15 of other resonances were observed between -150 and -200 ppm (28% in total).

(In dichloromethane)

3 α -Acetoxy-5 α -androstan-17-one (**62**) (150 mg, 0.450 mmol), dichloromethane (10 mL) and elemental fluorine (3.62 mmol) gave a crude product (163 mg). Fluorobenzene (11.4 mg, 0.119 mmol) was added to the crude product; ^{19}F NMR (188 MHz, CDCl_3) δ -161.3 (m, 5 α -F, 0.15%), -164.5 (m, 14 α -F, 0.06%), -179.9 (m, 9 α -F, 0.21%), more than 6 traces of other resonances were observed between -150 and -200 ppm.

(In nitromethane)

3 α -Acetoxy-5 α -androstan-17-one (**62**) (224 mg, 0.675 mmol), nitromethane (15 mL) and elemental fluorine (2.68 mmol) gave a crude product (335 mg) as a yellow oil. Fluorobenzene (33.7 mg, 0.351 mmol) was added to the crude product; ^{19}F NMR (188 MHz, CDCl_3) δ -161.2 (m, 5 α -F, 13.5%), -164.4 (m, 14 α -F, 10.7%), -179.9 (m, 9 α -F, 16.0%).

Fluorination of 3 β -[5-(4-aza-1-azoniabicyclo[2.2.2]oct-1-yl)-valeryloxy]-5 α -androstan-17-one tetrafluoroborate (**135**)

(In acetonitrile: 45 mM)

The reaction was carried out at 20 °C.

3 β -[5-(4-Aza-1-azoniabicyclo[2.2.2]oct-1-yl)-valeryloxy]-5 α -androstan-17-one

tetrafluoroborate (**135**) (258 mg, 0.450 mmol), acetonitrile (10 mL), and elemental fluorine (1.79 mmol) gave a crude product (309 mg); ^{19}F NMR (188 MHz, CDCl_3) δ -162.1 (m, 1%), -162.5 (m, 3%), -164.4 (m, 6%), -168.5 (m, 6%), -169.0 (m, 1%), -179.9 (m, 6%).

(Derivatization and analysis)

The reactions were carried out in the same manner described in section 6.8.

The crude product of fluorination of **135** (300 mg), potassium carbonate (40 mg, 0.29 mmol), and methanol (30 mL) gave a crude product (117 mg). The crude product (117 mg), acetic anhydride (200 mg, 2.0 mmol), 4-dimethylaminopyridine (6 mg, 0.05 mmol) and dichloromethane (12 mL) gave a crude mixture (136 mg) which contained 3 β -acetoxy-5 α -androstan-17-one (**138**) (92%); m/z (EI^+) 332 (M^+ , 13%), 272 ($[\text{M}-\text{C}_2\text{H}_4\text{O}_2]^+$, 100), 3 β -acetoxy-9 α -fluoro-5 α -androstan-17-one (**139d**), 3 β -acetoxy-5 α -fluoro-5 α -androstan-17-one (**139e**) and 3 β -acetoxy-14 α -fluoro-5 α -androstan-17-one (**139f**) in the ratio of 41:30:29 (^{19}F NMR; -180.1, -163.0, and -164.5 ppm, respectively) (2 peaks, 6%), 3 β -acetoxy-6 α -fluoro-5 α -androstan-17-one (**139c**) (1%), an HF eliminated compound (**140**) (1%).

(In acetonitrile: 3 mM)

The reactions were carried out in a similar manner described above. The reaction was carried out at 20 °C.

3 β -[5-(4-Aza-1-azoniabicyclo[2.2.2]oct-1-yl)-valeryloxy]-5 α -androstan-17-one tetrafluoroborate (**135**) (129 mg, 0.225 mmol), acetonitrile (75 mL), and elemental fluorine (0.89 mmol) gave a crude product (139 mg); ^{19}F NMR (188 MHz, CDCl_3) δ -162.1 (m, 2%), -162.5 (m, 1%), -164.4 (m, 3%), -168.8 (m, 3%), -179.9 (m, 3%).

(Derivatization and analysis)

The reactions were carried out in the same manner described in section 6.8.

The crude product of fluorination of **135** (137 mg), potassium carbonate (20 mg, 0.14 mmol), and methanol (14 mL) gave a crude product (64 mg). The crude product (64 mg), acetic anhydride (100 mg, 1.0 mmol), 4-dimethylaminopyridine (3 mg, 0.02 mmol) and dichloromethane (6 mL) gave a crude mixture (77 mg) which contained 3 β -acetoxy-5 α -androstan-17-one (**138**) (93%); m/z (EI^+) 332 (M^+ , 19%), 272 ($[\text{M}-\text{C}_2\text{H}_4\text{O}_2]^+$, 92), 3 β -acetoxy-9 α -fluoro-5 α -androstan-17-one (**139d**), 3 β -acetoxy-5 α -fluoro-5 α -androstan-17-one (**139e**) and 3 β -acetoxy-14 α -fluoro-5 α -androstan-17-one (**139f**) in the ratio of 44:30:26 (^{19}F NMR; -180.1, -163.0, and -164.6 ppm, respectively) (2 peaks, 4%), an HF eliminated compound (**140**) (1%); m/z (EI^+) 330 (M^+).

(In dichloromethane)

The reaction was carried out at 20 °C.

3 β -[5-(4-Aza-1-azoniabicyclo[2.2.2]oct-1-yl)-valeryloxy]-5 α -androstan-17-one tetrafluoroborate (**135**) (129 mg, 0.225 mmol), anhydrous dichloromethane (75 mL) and elemental fluorine (2.67 mmol) gave a crude product (131 mg); No resonances were observed in ¹⁹F NMR (188 MHz, CDCl₃) except for the tetrafluoroborate ion (δ -151.3 ppm).

(Derivatization and analysis)

The reactions were carried out in the same manner described in section 6.8.

The crude product of fluorination of **135** (131 mg), potassium carbonate (20 mg, 0.14 mmol), and methanol (15 mL) gave a crude product (91 mg). The crude product (91 mg), acetic anhydride (100 mg, 1.0 mmol), 4-dimethylaminopyridine (3 mg, 0.02 mmol) and dichloromethane (9 mL) gave a crude mixture (120 mg) which contained 3 β -acetoxy-5 α -androstan-17-one (**138**) (100%).

Fluorination of 3 α -(3-cyanobenzoyloxy)-5 α -androstan-17-one (142**)**

(In dichloromethane: 45 mM)

3 α -(3-Cyanobenzoyloxy)-5 α -androstan-17-one (**142**) (283 mg, 0.675 mmol), dichloromethane (15 mL), and elemental fluorine (5.40 mmol) gave a crude product (328 mg). Fluorobenzene (13.5 mg, 0.140 mmol) was added to the crude product; ¹⁹F NMR (188 MHz, CDCl₃) δ -161.0 (m, 5 α -F, 0.34%), -164.3 (m, 14 α -F, 0.20%), -179.7 (m, 9 α -F, 1.33%), more than 15 resonances were observed between -47 and -132 ppm (11% in total).

(In dichloromethane: 3 mM)

3 α -(3-Cyanobenzoyloxy)-5 α -androstan-17-one (**142**) (94 mg, 0.225 mmol), dichloromethane (75 mL), and elemental fluorine (2.70 mmol) gave a crude product (118 mg). Fluorobenzene (9.1 mg, 0.095 mmol) was added to the crude product; ¹⁹F NMR (188 MHz, CDCl₃) δ -161.1 (m, 5 α -F, 0.18%), -164.3 (m, 14 α -F, 0.10%), -179.7 (m, 9 α -F, 0.65%), more than 10 resonances were observed between -47 and -132 ppm (5% in total).

(In nitromethane, 0 °C)

3 α -(3-Cyanobenzoyloxy)-5 α -androstan-17-one (**142**) (283 mg, 0.675 mmol), nitromethane (15 mL), and elemental fluorine (2.68 mmol) gave a crude product (364 mg) as an orange amorphous solid. Fluorobenzene (19.7 mg, 0.205 mmol) was added

to the crude product; ^{19}F NMR (188 MHz, CDCl_3) δ -161.0 (m, 5 α -F, 9.8%), -164.2 (m, 14 α -F, 7.8%), -179.7 (m, 9 α -F, 29.4%).

(In nitromethane, -25 °C)

The reaction was carried out at -25 °C.

3 α -(3-Cyanobenzoyloxy)-5 α -androstan-17-one (**142**) (283 mg, 0.675 mmol), nitromethane (15 mL), and elemental fluorine (2.68 mmol) gave a crude product (422 mg) as a yellow amorphous solid. Fluorobenzene (29.5 mg, 0.307 mmol) was added to the crude product; ^{19}F NMR (188 MHz, CDCl_3) δ -161.0 (m, 5 α -F, 9.6%), -164.1 (m, 14 α -F, 6.6%), -179.7 (m, 9 α -F, 31.3%). The crude product was chromatographed over silica gel [eluent: hexane/ethyl acetate (6:1)] to give a white amorphous solid (38 mg, 13%). Recrystallization from diethylether gave 3 α -(3-cyanobenzoyloxy)-9-fluoro-5 α -androstan-17-one (**147a**) (19 mg, 6%) as white crystals; m.p. 157—159 °C; (Found: C, 73.71; H, 7.34; N, 3.17. $\text{C}_{27}\text{H}_{32}\text{FNO}_3$ requires C, 74.12; H, 7.37; N, 3.20%); ^1H NMR (500 MHz, CDCl_3) δ 0.88 (s, 3H, 18-H), 0.98 (s, 3H, 19-H), 1.2—2.0 (m, 18H, 1-H, 2-H, 4-H, 6-H, 7-H, 8-H, 11-H, 12-H, 14-H, 15-H), 2.08—2.16 (m, 1H, one of 16-H), 2.22—2.27 (m, 1H, 5-H), 2.45 (dd, 1H, $J = 19.5, 8.5$ Hz, one of 16-H), 5.27 (m, 1H, 3-H), 7.58 (m, 1H, 25-H), 7.83 (m, 1H, 24-H), 8.27 (m, 1H, 26-H), 8.32 (m, 1H, 22-H); ^{13}C NMR (126 MHz) δ 12.7 (d, $^5J_{\text{CF}} = 1.5$ Hz, 18-C), 13.5 (d, $^3J_{\text{CF}} = 6.0$ Hz, 19-C), 21.5 (s, 15-C), 24.5 (d, $^2J_{\text{CF}} = 25.0$ Hz, 11-C), 24.8 (s, 7-C or 12-C), 25.9 (s, 2-C), 26.2 (d, $^3J_{\text{CF}} = 3.5$ Hz, 7-C or 12-C), 27.3 (s, 1-C or 6-C), 27.3 (s, 1-C or 6-C), 32.2 (d, $^3J_{\text{CF}} = 3.5$ Hz, 5-C), 32.7 (s, 4-C), 35.8 (s, 16-C), 37.1 (d, $^2J_{\text{CF}} = 21.0$ Hz, 8-C), 40.2 (d, $^2J_{\text{CF}} = 19.0$ Hz, 10-C), 44.6 (d, $^3J_{\text{CF}} = 2.0$ Hz, 14-C), 47.1 (s, 13-C), 71.2 (s, 3-C), 99.3 (d, $^1J_{\text{CF}} = 180.0$ Hz, 9-C), 112.9 (s, 23-C), 118.0 (s, CN), 129.4 (s, 25-C), 132.2 (s, 21-C), 133.2 (s, 22-C), 133.6 (s, 26-C), 135.8 (s, 24-C), 163.9 (s, 20-C), 220.2 (s, 17-C); ^{19}F NMR (188 MHz, CDCl_3) δ -179.8 (m); IR (KBr) 3067 (Ar-H), 2927, 2864 (C-H), 2234 (CN), 1741, 1715 (C=O), 1287, 759 cm^{-1} ; m/z (ES^+) 897 ($[\text{2M}+\text{Na}]^+$, 10%), 460 ($[\text{M}+\text{Na}]^+$, 100).

Crystal data for **147a**: $\text{C}_{27}\text{H}_{32}\text{F}_2\text{N}_2\text{O}_6$, $M = 875.07$, monoclinic, $P2_1$ (No. 4), $a = 10.847(1)$ Å, $b = 10.565(1)$ Å, $c = 20.323(2)$ Å, $\alpha = 90^\circ$, $\beta = 97.57(1)^\circ$, $\gamma = 90^\circ$, $V = 2308.7(4)$ Å³, $F(000) = 936$, $Z = 2$, $D_c = 1.259$ g/cm³, $\mu = 0.086$ mm⁻¹ (Mo K α , $\lambda = 0.71073$ Å), $T = 120(2)$ K, crystal size 0.32 × 0.24 × 0.08 mm³.

Fluorination of 3 α -cyanoacetoxy-5 α -androstan-17-one (143**)**

(In dichloromethane)

3 α -Cyanoacetoxy-5 α -androstan-17-one (**143**) (241 mg, 0.674 mmol), dichloromethane

(15 mL), and elemental fluorine (5.24 mmol) gave a crude product (264 mg) as a white amorphous solid. Fluorobenzene (21.9 mg, 0.228 mmol) was added to the crude product; ^{19}F NMR (188 MHz, CDCl_3) δ -161.1 (m, 5 α -F, 0.13%), -164.4 (m, 14 α -F, 0.082%), -179.8 (m, 9 α -F, 0.16%).

(In nitromethane)

3 α -Cyanoacetoxy-5 α -androstan-17-one (**143**) (241 mg, 0.674 mmol), anhydrous nitromethane (15 mL), and elemental fluorine (2.69 mmol) gave a crude product (322 mg) as an orange amorphous solid. Fluorobenzene (23.0 mg, 0.239 mmol) was added to the crude product; ^{19}F NMR (188 MHz, CDCl_3) δ -161.1 (m, 5 α -F, 12.1%), -164.3 (m, 14 α -F, 13.0%), -179.8 (m, 9 α -F, 16.6%).

Fluorination of 3 α -[(3-carboxypropyl)-acetoxy]-5 α -androstan-17-one (144**)**

[In dichloromethane/nitromethane (4:1)]

3 α -[(3-Carboxypropyl)-acetoxy]-5 α -androstan-17-one (**144**) (273 mg, 0.675 mmol), dichloromethane (12 mL), nitromethane (3 mL), and elemental fluorine (5.24 mmol) gave a crude product (275 mg) as a white amorphous solid. Fluorobenzene (22.9 mg, 0.238 mmol) was added to the crude product; ^{19}F NMR (188 MHz, CDCl_3) δ -161.1 (m, 5 α -F, 0.24%), -164.5 (m, 14 α -F, 0.11%), -180.0 (m, 9 α -F, 0.42%).

Fluorination of 3 α -nicotinoyl-5 α -androstan-17-one (145**)**

(In nitromethane)

3 α -Nicotinoyl-5 α -androstan-17-one (**145**) (267 mg, 0.675 mmol), nitromethane (15 mL), and elemental fluorine (2.68 mmol) gave a crude product (0.47 g) as a brown oil. Fluorobenzene (34.9 mg, 0.363 mmol) was added to the crude product; ^{19}F NMR (188 MHz, CDCl_3) δ -160.9 (m, 5 α -F, 4.4%), -164.2 (m, 14 α -F, 4.1%), -179.7 (m, 9 α -F, 9.4%).

Fluorination of 3 α -(2,6-dichloronicotinoyl)-5 α -androstan-17-one (146**)**

(In nitromethane)

3 α -(2,6-Dichloronicotinoyl)-5 α -androstan-17-one (**146**) (313 mg, 0.675 mmol), nitromethane (25 mL), and elemental fluorine (2.68 mmol) gave a crude product (0.45 g) as a yellow amorphous solid. The yield could not be determined by ^{19}F NMR due to many by-products.

Chapter 7

Experimental to Chapter 3

7.1 Titanium catalyzed direct fluorination of 1,3-ketoesters

General procedure

The reactions below follow the procedure described, unless otherwise stated. A mixture containing ethyl 2-methyl-3-oxobutanoate (**176**), catalyst, additive, and freshly distilled anhydrous acetonitrile was placed in the small PTFE reactor. The mixture was purged with N₂ and immersed in a cooling bath of 0 °C. Elemental fluorine as a 10% (v/v) mixture with nitrogen was introduced at a flow rate of 10 mL/min into the rapidly stirred mixture *via* PTFE tubing. The reaction mixture was purged with N₂ for 30 minutes. The reaction mixture was poured into water (20 mL), neutralised by NaHCO₃, and extracted with chloroform (3 x 20 mL). The combined organic extracts were dried over anhydrous MgSO₄ and evaporated to give a crude product.

Screening of catalysts (1)

Table 3.2, entry 1

No catalyst and additive were added. Ethyl 2-methyl-3-oxobutanoate (**176**) (299 mg, 2.07 mmol), acetonitrile (20 mL), and elemental fluorine (4.15 mmol) gave a colourless oil (321 mg); conversion was found to be 6%, which consisted of, 35% ethyl 2-fluoro-2-methyl-3-oxobutanoate (**177**) (GC). (As compared to literature data.³²)

Table 3.2, entry 2

No additive was added. Ethyl 2-methyl-3-oxobutanoate (**176**) (303 mg, 2.10 mmol), titanium (IV) chloride (36 mg, 0.19 mmol), acetonitrile (20 mL), and elemental fluorine (4.20 mmol) gave a colourless oil (303 mg); conversion was found to be 49%, which consisted of, 13% ethyl 2-fluoro-2-methyl-3-oxobutanoate (**177**), 7% ethyl 2,4-difluoro-2-methyl-3-oxobutanoate (**178**), and 77% ethyl 2-chloro-2-methyl-3-oxobutanoate (**179**); m/z (Cl⁺, NH₃) 198 ([M+NH₄]⁺ (C₇H₁₅³⁷CINO₃), 3%), 196 ([M+NH₄]⁺ (C₇H₁₅³⁵CINO₃), 8), 145 (100). Spectral data for ethyl 2-chloro-2-methyl-3-oxobutanoate (**179**) are also shown below (See the experimental part for table 3.3, entry 6).

Table 3.2, entry 3

No additive was added. Ethyl 2-methyl-3-oxobutanoate (**176**) (289 mg, 2.00 mmol), titanium (IV) chloride (76 mg, 0.40 mmol), acetonitrile (20 mL), and elemental fluorine (2.00 mmol) gave a colourless oil (301 mg); conversion was found to be 63%, which consisted of, 4% ethyl 2-fluoro-2-methyl-3-oxobutanoate (**177**), and 96% ethyl 2-chloro-2-methyl-3-oxobutanoate (**179**) (GC).

Table 3.2, entry 4

Titanium (*trans*-cyclohexanediolato) dichloride was prepared by the following procedure.

trans-1,2-Cyclohexanediol (116 mg, 1.00 mmol) was added to a mixture of titanium (IV) chloride (190 mg, 1.00 mmol) and anhydrous acetonitrile (5 mL). The resulting mixture was evaporated once, and dissolved in anhydrous acetonitrile (5 mL) and used directly in the following experiment.

No additive was added. Ethyl 2-methyl-3-oxobutanoate (**176**) (289 mg, 2.00 mmol), titanium (*trans*-cyclohexane-1,2-diolato) dichloride acetonitrile solution (0.2 M, 1 mL, 0.2 mmol), acetonitrile (19 mL), and elemental fluorine (2.41 mmol) gave a colourless oil (355 mg); conversion was found to be 32%, which consisted of, 5% ethyl 2-fluoro-2-methyl-3-oxobutanoate (**177**), and 78% ethyl 2-chloro-2-methyl-3-oxobutanoate (**179**) (GC).

Screening of additives

Table 3.3, entry 1

Ethyl 2-methyl-3-oxobutanoate (**176**) (280 mg, 1.94 mmol), titanium (IV) chloride (38 mg, 0.20 mmol), sodium fluoride (128 mg, 3.05 mmol), acetonitrile (20 mL), and elemental fluorine (2.32 mmol) gave a colourless oil (306 mg); conversion was found to be 30%, which consisted of, 92% ethyl 2-chloro-2-methyl-3-oxobutanoate (**179**) (GC).

Table 3.3, entry 2

Ethyl 2-methyl-3-oxobutanoate (**176**) (288 mg, 2.00 mmol), titanium (IV) chloride (38 mg, 0.20 mmol), sodium hydrogen carbonate (252 mg, 3.00 mmol), acetonitrile (20 mL), and elemental fluorine (2.41 mmol) gave a colourless oil (314 mg); conversion was found to be 9%, which consisted of, 20% ethyl 2-fluoro-2-methyl-3-oxobutanoate (**177**), and 61% ethyl 2-chloro-2-methyl-3-oxobutanoate (**179**) (GC).

Table 3.3, entry 3

Ethyl 2-methyl-3-oxobutanoate (**176**) (288 mg, 2.00 mmol), titanium (IV) chloride (38 mg, 0.20 mmol), DABCO (337 mg, 3.00 mmol), sodium tetrafluoroborate (329 mg,

3.00 mmol), and acetonitrile (20 mL), elemental fluorine (4.20 mmol) gave a colourless oil (252 mg); conversion was found to be 5%, which consisted of, 37% ethyl 2-fluoro-2-methyl-3-oxobutanoate (**177**) (GC).

Table 3.3, entry 4

Ethyl 2-methyl-3-oxobutanoate (**176**) (289 mg, 2.00 mmol), titanium (*trans*-cyclohexane-1,2-diolato) dichloride acetonitrile solution (0.2 M, 1 mL, 0.2 mmol), sodium tetrafluoroborate (329 mg, 3.00 mmol), acetonitrile (19 mL), and elemental fluorine (2.41 mmol) gave a colourless oil (634 mg); conversion was found to be 45%, which consisted of, 9% ethyl 2-fluoro-2-methyl-3-oxobutanoate (**177**), 4% ethyl 2,4-difluoro-2-methyl-3-oxobutanoate (**178**), and 63% ethyl 2-chloro-2-methyl-3-oxobutanoate (**179**) (GC).

Table 3.3, entry 5

Ethyl 2-methyl-3-oxobutanoate (**176**) (288 mg, 2.00 mmol), titanium (IV) chloride (38 mg, 0.20 mmol), boron trifluoride diethyl etherate (0.38 mL, 3.0 mmol), acetonitrile (20 mL), and elemental fluorine (2.40 mmol) gave a colourless oil (335 mg); conversion was found to be 54%, which consisted of, 38% ethyl 2-fluoro-2-methyl-3-oxobutanoate (**177**), 13% ethyl 2,4-difluoro-2-methyl-3-oxobutanoate (**178**), and 28% ethyl 2-chloro-2-methyl-3-oxobutanoate (**179**) (GC).

Table 3.3 entry 6

Ethyl 2-methyl-3-oxobutanoate (**176**) (288 mg, 2.00 mmol), titanium (IV) chloride (38 mg, 0.20 mmol), trimethylsilyl chloride (0.38 mL, 3.0 mmol), acetonitrile (20 mL), and elemental fluorine (2.40 mmol) gave a colourless oil (319 mg); conversion was found to be 86%, which consisted of, 100% ethyl 2-chloro-2-methyl-3-oxobutanoate (**179**) (GC).

Purification by flash chromatography [silica gel: 20 g, eluent: hexane/ethyl acetate (20:1)] provided ethyl 2-chloro-2-methyl-3-oxobutanoate (**179**), (174 mg, 49%) as a colourless oil.

Ethyl 2-chloro-2-methyl-3-oxobutanoate (179**)**

$^1\text{H NMR}$ (400 MHz, CDCl_3) δ 1.28 (t, $J = 7.0$ Hz, 3H, CH_2CH_3), 1.80 (s, 3H, CClCH_3), 2.35 (s, 3H, $\text{CH}_3\text{C}=\text{O}$), 4.26 (q, $J = 7.0$ Hz, 2H, CH_2); $^{13}\text{C NMR}$ (101 MHz) δ 13.8 (s, CH_2CH_3), 24.2 (s, CClCH_3 or $\text{CH}_3\text{C}=\text{O}$), 25.2 (s, CClCH_3 or $\text{CH}_3\text{C}=\text{O}$), 63.0 (s, OCH_2), 70.7 (s, CCl), 168.0 (s, CClCOO), 198.7 (s, CH_3COCCl); IR (neat) 2986, 1733, 1255, 1124 cm^{-1} ; mass spectrum, m/z (EI^+) 179 ($[\text{M}+\text{H}]^+$ ($\text{C}_7\text{H}_{12}^{35}\text{ClO}_3$), 1%), 138 ($[\text{M}-\text{C}_2\text{H}_2\text{O}]^+$ ($\text{C}_5\text{H}_9^{37}\text{ClO}_2$), 53), 136 ($[\text{M}-\text{C}_2\text{H}_2\text{O}]^+$ ($\text{C}_5\text{H}_9^{35}\text{ClO}_2$), 89), 110 (63), 108 (86).

Effect of ancillary ligand of titanium complex

Titanium (*trans*-cyclohexane-1,2-diolato) bis(trifluoromethanesulfonate) (**181**)

Anhydrous acetonitrile (10 mL) was added to titanium(IV) chloride (0.36 g, 1.9 mmol) at $-78\text{ }^{\circ}\text{C}$, and the mixture was allowed to warm up to room temperature. *trans*-1,2-Cyclohexanediol (220 mg, 1.9 mmol) was added to the resulting yellow solution, and stirred for 30 minutes. The solution was evaporated to give a slightly green solid. The solid was dissolved in a mixture of anhydrous toluene (10 mL) and anhydrous acetonitrile (1 mL). Silver trifluoromethanesulfonate (976 mg, 3.80 mmol) was added to the solution, and stirred for 1 hour at room temperature. The resulting precipitate was removed by filtration, and the filtrate was evaporated once, and dissolved in anhydrous acetonitrile (10 mL) to give 0.19M acetonitrile solution of the title compound.

Titanium (*trans*-cyclohexane-1,2-diolato) bis(trifluoroacetate) (**182**)

Titanium (*trans*-cyclohexane-1,2-diolato) bis(trifluoroacetate) (**182**) was prepared using the same method to **181** described above.

Titanium(IV) chloride (0.40 g, 2.1 mmol), *trans*-1,2-cyclohexanediol (244 mg, 2.1 mmol), and silver trifluoroacetate (979 mg, 4.43 mmol) gave 0.21M acetonitrile solution of the title compound.

Table 3.4, entry 1

No additive was added. Ethyl 2-methyl-3-oxobutanoate (**176**) (279 mg, 1.94 mmol), titanium (*trans*-cyclohexane-1,2-diolato) bis(trifluoromethanesulfonate) (**181**) acetonitrile solution (0.19 M, 1 mL, 0.19 mmol), acetonitrile (19 mL), and elemental fluorine (2.28 mmol) gave a colourless oil (374 mg); conversion was found to be 32%, which consisted of, 58% ethyl 2-fluoro-2-methyl-3-oxobutanoate (**177**), 25% ethyl 2,4-difluoro-2-methyl-3-oxobutanoate (**178**) (GC).

Table 3.4, entry 2

The additive was added to the reaction mixture at $-15\text{ }^{\circ}\text{C}$. Ethyl 2-methyl-3-oxobutanoate (**176**) (280 mg, 1.94 mmol), titanium (*trans*-cyclohexane-1,2-diolato) bis(trifluoromethanesulfonate) (**181**) acetonitrile solution (0.19 M, 1 mL, 0.19 mmol), acetonitrile (19 mL), trimethylsilyl trifluoromethanesulfonate (0.52 mL, 2.85 mmol), and elemental fluorine (2.28 mmol) gave a colourless oil (500 mg); conversion was found to be 70%, which consisted of, 47% ethyl 2-fluoro-2-methyl-3-oxobutanoate (**177**), 21% ethyl 2,4-difluoro-2-methyl-3-oxobutanoate (**178**) (GC).

Table 3.4, entry 3

Ethyl 2-methyl-3-oxobutanoate (**176**) (279 mg, 1.94 mmol), titanium (*trans*-cyclohexane-1,2-diolato) bis(trifluoromethanesulfonate) (**181**) acetonitrile solution

(0.19 M, 1 mL, 0.19 mmol), acetonitrile (19 mL), trimethylsilyl trifluoroacetate (0.49 mL, 2.84 mmol), and elemental fluorine (2.32 mmol) gave a colourless oil (432 mg); conversion was found to be 58%, which consisted of, 59% ethyl 2-fluoro-2-methyl-3-oxobutanoate (**177**), 25% ethyl 2,4-difluoro-2-methyl-3-oxobutanoate (**178**) (GC).

Table 3.4, entry 4

Ethyl 2-methyl-3-oxobutanoate (**176**) (280 mg, 1.94 mmol), titanium (*trans*-cyclohexane-1,2-diolato) bis(trifluoromethanesulfonate) (**181**) acetonitrile solution (0.19 M, 1 mL, 0.19 mmol), acetonitrile (19 mL), trimethylsilyl acetate (0.43 mL, 2.87 mmol), and elemental fluorine (2.32 mmol) gave a colourless oil (0.4 g); conversion was found to be 60%, which consisted of, 55% ethyl 2-fluoro-2-methyl-3-oxobutanoate (**177**), 26% ethyl 2,4-difluoro-2-methyl-3-oxobutanoate (**178**) (GC).

Table 3.4, entry 5

Ethyl 2-methyl-3-oxobutanoate (**176**) (280 mg, 1.94 mmol), titanium (*trans*-cyclohexane-1,2-diolato) bis(trifluoromethanesulfonate) (**181**) acetonitrile solution (0.19 M, 1 mL, 0.19 mmol), acetonitrile (19 mL), trimethylsilyl trifluoromethane (0.42 mL, 2.84 mmol), and elemental fluorine (2.32 mmol) gave a colourless oil (372 mg); conversion was found to be 46%, which consisted of, 55% ethyl 2-fluoro-2-methyl-3-oxobutanoate (**177**), 28% ethyl 2,4-difluoro-2-methyl-3-oxobutanoate (**178**) (GC).

Table 3.4, entry 6

No additive was added. Ethyl 2-methyl-3-oxobutanoate (**176**) (332 mg, 2.30 mmol), trifluoromethanesulfonic acid (35 mg, 0.23 mmol), acetonitrile (20 mL), and elemental fluorine (2.77 mmol) gave a colourless oil (394 mg); conversion was found to be 47%, which consisted of, 58% ethyl 2-fluoro-2-methyl-3-oxobutanoate (**177**), 32% ethyl 2,4-difluoro-2-methyl-3-oxobutanoate (**178**) (GC).

Table 3.4, entry 7

Ethyl 2-methyl-3-oxobutanoate (**176**) (279 mg, 1.94 mmol), 1,8-bis(dimethylamino) naphthalene (611 mg, 2.85 mmol), titanium (*trans*-cyclohexane-1,2-diolato) bis(trifluoromethanesulfonate) (**181**) acetonitrile solution (0.19 M, 1 mL, 0.19 mmol), acetonitrile (19 mL), trimethylsilyl trifluoromethanesulfonate (0.52 mL, 2.85 mmol), and elemental fluorine (2.28 mmol) gave a dark brown solid (1.31 g); conversion was found to be 22%, which consisted of, 19% ethyl 2-fluoro-2-methyl-3-oxobutanoate (**177**) (GC).

Table 3.4, entry 8

Ethyl 2-methyl-3-oxobutanoate (**176**) (279 mg, 1.94 mmol), 1,2,2,6,6-pentamethylpiperidine (443 mg, 2.85 mmol), titanium (*trans*-cyclohexane-1,2-diolato) bis(trifluoromethanesulfonate) (**181**) acetonitrile solution (0.19 M, 1 mL, 0.19 mmol),

acetonitrile (19 mL), trimethylsilyl trifluoromethanesulfonate (0.52 mL, 2.85 mmol), and elemental fluorine (2.28 mmol) gave a dark brown solid (1.39 g); conversion was found to be 53%, which consisted of, 60% ethyl 2-fluoro-2-methyl-3-oxobutanoate (177), 24% ethyl 2,4-difluoro-2-methyl-3-oxobutanoate (178) (GC).

Table 3.4, entry 9

No additive was added. Ethyl 2-methyl-3-oxobutanoate (176) (303 mg, 2.10 mmol), titanium (*trans*-cyclohexane-1,2-diolato) bis(trifluoroacetate) (182) acetonitrile solution (0.21 M, 1 mL, 0.21 mmol), acetonitrile (19 mL), and elemental fluorine (2.50 mmol) gave a colourless oil (0.53 g); conversion was found to be 7%, which consisted of, 100% ethyl 2-fluoro-2-methyl-3-oxobutanoate (177) (GC).

Table 3.4, entry 10

Ethyl 2-methyl-3-oxobutanoate (176) (303 mg, 2.10 mmol), titanium (*trans*-cyclohexane-1,2-diolato) bis(trifluoroacetate) (182) acetonitrile solution (0.21 M, 1 mL, 0.21 mmol), trimethylsilyl trifluoroacetate (0.54 mL, 3.1 mmol), acetonitrile (19 mL), and elemental fluorine (2.50 mmol) gave a colourless oil (439 mg); conversion was found to be 55%, which consisted of, 48% ethyl 2-fluoro-2-methyl-3-oxobutanoate (177), 23% ethyl 2,4-difluoro-2-methyl-3-oxobutanoate (178) (GC).

Table 3.4, entry 11

Ethyl 2-methyl-3-oxobutanoate (176) (303 mg, 2.10 mmol), titanium (*trans*-cyclohexane-1,2-diolato) bis(trifluoroacetate) (182) acetonitrile solution (0.21 M, 2 mL, 0.42 mmol), trimethylsilyl trifluoroacetate (0.54 mL, 3.1 mmol), acetonitrile (18 mL), and elemental fluorine (2.50 mmol) gave a colourless oil (412 mg); conversion was found to be 51%, which consisted of, 40% ethyl 2-fluoro-2-methyl-3-oxobutanoate (177), 19% ethyl 2,4-difluoro-2-methyl-3-oxobutanoate (178) (GC).

Table 3.4, entry 12

Ethyl 2-methyl-3-oxobutanoate (176) (303 mg, 2.10 mmol), titanium (*trans*-cyclohexane-1,2-diolato) bis(trifluoroacetate) (182) acetonitrile solution (0.21 M, 1 mL, 0.21 mmol), trimethylsilyl trifluoroacetate (0.54 mL, 3.1 mmol), acetonitrile (19 mL), and elemental fluorine (5.03 mmol) gave a colourless oil (439 mg); conversion was found to be 67%, which consisted of, 46% ethyl 2-fluoro-2-methyl-3-oxobutanoate (177), 23% ethyl 2,4-difluoro-2-methyl-3-oxobutanoate (178) (GC).

Table 3.4, entry 13

Elemental fluorine [10% (v/v) mixture with nitrogen] was passed through the reaction mixture at 25 °C at a flow rate of 5 mL/min. Ethyl 2-methyl-3-oxobutanoate (176) (303 mg, 2.10 mmol), titanium (*trans*-cyclohexane-1,2-diolato) bis(trifluoroacetate) (182) acetonitrile solution (0.21 M, 1 mL, 0.21 mmol), trimethylsilyl trifluoromethane (0.47

mL, 3.2 mmol), acetonitrile (19 mL), and elemental fluorine (2.50 mmol) gave a colourless oil (375 mg); conversion was found to be 26%, which consisted of, 68% ethyl 2-fluoro-2-methyl-3-oxobutanoate (**177**), 32% ethyl 2,4-difluoro-2-methyl-3-oxobutanoate (**178**) (GC).

Table 3.4, entry 14

No catalyst was added. Ethyl 2-methyl-3-oxobutanoate (**176**) (303 mg, 2.10 mmol), trimethylsilyl trifluoroacetate (0.54 mL, 3.1 mmol), acetonitrile (20 mL), and elemental fluorine (2.50 mmol) gave a colourless oil (354 mg); conversion was found to be 4%, which consisted of, 100% ethyl 2-fluoro-2-methyl-3-oxobutanoate (**177**) (GC).

Table 3.4, entry 15

No additive was added. Ethyl 2-methyl-3-oxobutanoate (**176**) (303 mg, 2.10 mmol), trifluoroacetic acid (24 mg, 0.21 mmol), acetonitrile (20 mL), and elemental fluorine (2.50 mmol) gave a colourless oil (387 mg); conversion was found to be 5%, which consisted of, 46% ethyl 2-fluoro-2-methyl-3-oxobutanoate (**177**) (GC).

Effect of intermittent introduction of fluorine

A mixture containing titanium (*trans*-cyclohexane-1,2-diolato) bis(trifluoroacetate) (**182**) acetonitrile solution (0.21 M, 1 mL, 0.21 mmol), ethyl 2-methyl-3-oxobutanoate (**176**) (303 mg, 2.10 mmol), trimethylsilyl trifluoroacetate (0.54 mL, 3.1 mmol) and acetonitrile (19 mL) was placed in the PTFE reactor. The mixture was immersed in a cooling bath of 0 °C and purged with N₂ for 30 minutes. Elemental fluorine [10% (v/v) mixture with nitrogen] was introduced at a flow rate of 10 mL/min into the mixture for 56 minutes. The reaction mixture was purged with N₂ for 20 minutes at room temperature and further 40 minutes at 0 °C. Further fluorine was introduced into the mixture for 56 minutes and the reaction mixture was purged with N₂ for 40 minutes at room temperature (total 2.4 equivalents of fluorine was passed through the mixture). Ordinary work-up gave a yellowish oil (450 mg); conversion was found to be 76%, which consisted of, 48% ethyl 2-fluoro-2-methyl-3-oxobutanoate (**177**), 22% ethyl 2,4-difluoro-2-methyl-3-oxobutanoate (**178**) (GC).

7.2 Nickel catalyzed direct fluorination of 1,3-ketoesters

General procedure

The reactions below follow the procedure described, unless otherwise stated. A mixture containing ethyl 2-methyl-3-oxobutanoate (**176**), catalyst, and freshly distilled anhydrous acetonitrile was placed in the small PTFE reactor. The mixture was purged

with N₂ and immersed in a cooling bath of 0 °C. Elemental fluorine as a 10% (v/v) mixture with nitrogen was introduced at a flow rate of 10 mL/min into the rapidly stirred mixture *via* PTFE tubing. The reaction mixture was purged with N₂ for 30 minutes. The reaction mixture was poured into water (20 mL), neutralised by NaHCO₃, and extracted with chloroform (3 x 20 mL). The combined organic extracts were dried over anhydrous MgSO₄ and evaporated to give a crude product.

Screening of catalyst (2)

Table 3.5, entry 1

No catalyst were added. Ethyl 2-methyl-3-oxobutanoate (**176**) (299 mg, 2.07 mmol), acetonitrile (20 mL), and elemental fluorine (4.15 mmol) gave a colourless oil (321 mg); conversion was found to be 6%, which consisted of, 35% ethyl 2-fluoro-2-methyl-3-oxobutanoate (**177**) (GC).

Table 3.5, entry 2

Ethyl 2-methyl-3-oxobutanoate (**176**) (289 mg, 2.00 mmol), hafnium (IV) chloride (65 mg, 0.20 mmol), acetonitrile (20 mL), and elemental fluorine (2.40 mmol) gave a slightly yellowish oil (400 mg); conversion was found to be 25%, which consisted of, 100% ethyl 2-chloro-2-methyl-3-oxobutanoate (**179**) (GC).

Table 3.5, entry 3

Ethyl 2-methyl-3-oxobutanoate (**176**) (289 mg, 2.00 mmol), scandium (III) triflate (99 mg, 0.20 mmol), acetonitrile (20 mL), and elemental fluorine (2.40 mmol) gave a slightly yellowish oil (517 mg); conversion was found to be 53%, which consisted of, 58% ethyl 2-fluoro-2-methyl-3-oxobutanoate (**177**), 32% ethyl 2,4-difluoro-2-methyl-3-oxobutanoate (**178**) (GC).

Table 3.5, entry 4

Ethyl 2-methyl-3-oxobutanoate (**176**) (295 mg, 2.05 mmol), lanthanum (III) triflate (117 mg, 0.205 mmol), acetonitrile (20 mL), and elemental fluorine (2.40 mmol) gave a slightly yellowish oil (347 mg); conversion was found to be 44%, which consisted of, 58% ethyl 2-fluoro-2-methyl-3-oxobutanoate (**177**), 32% ethyl 2,4-difluoro-2-methyl-3-oxobutanoate (**178**) (GC).

Table 3.5, entry 5

Ethyl 2-methyl-3-oxobutanoate (**176**) (288 mg, 2.00 mmol), copper (II) nitrate hemipentahydrate (47 mg, 0.20 mmol), acetonitrile (20 mL), and elemental fluorine (2.40 mmol) gave a slightly bluish oil (272 mg); conversion was found to be 51%, which consisted of, 53% ethyl 2-fluoro-2-methyl-3-oxobutanoate (**177**) (GC).

Table 3.5, entry 6

Ethyl 2-methyl-3-oxobutanoate (**176**) (306 mg, 2.12 mmol), copper (II) acetylacetonate (28 mg, 0.11 mmol), acetonitrile (20 mL), and elemental fluorine (2.14 mmol) gave a colourless oil (360 mg); conversion was found to be 4% (GC).

Table 3.5, entry 7

Ethyl 2-methyl-3-oxobutanoate (**176**) (288 mg, 2.00 mmol), copper (II) triflate (72 mg, 0.20 mmol), acetonitrile (20 mL), and elemental fluorine (2.40 mmol) gave a slightly bluish oil (389 mg); conversion was found to be 59%, which consisted of, 16% ethyl 2-fluoro-2-methyl-3-oxobutanoate (**177**), 9% ethyl 2,4-difluoro-2-methyl-3-oxobutanoate (**3**) (GC).

Table 3.5, entry 8

Ethyl 2-methyl-3-oxobutanoate (**176**) (288 mg, 2.00 mmol), nickel (II) nitrate hexahydrate (58 mg, 0.20 mmol), acetonitrile (20 mL), and elemental fluorine (2.40 mmol) gave a colourless oil (298 mg); conversion was found to be 32%, which consisted of, 68% ethyl 2-fluoro-2-methyl-3-oxobutanoate (**177**) (GC).

Table 3.5, entry 9

Ethyl 2-methyl-3-oxobutanoate (**176**) (288 mg, 2.00 mmol), palladium (II) nitrate hydrate (53 mg, 0.20 mmol), acetonitrile (20 mL), and elemental fluorine (2.40 mmol) gave a slightly yellowish oil (317 mg); conversion was found to be 3%, which consisted of, 100% ethyl 2-fluoro-2-methyl-3-oxobutanoate (**177**) (GC).

Table 3.5, entry 10

Ethyl 2-methyl-3-oxobutanoate (**176**) (288 mg, 2.00 mmol), silver (I) triflate (52 mg, 0.20 mmol), acetonitrile (20 mL), and elemental fluorine (2.40 mmol) gave a slightly yellowish oil (356 mg); conversion was found to be less than 1% (GC).

Table 3.5, entry 11

Ethyl 2-methyl-3-oxobutanoate (**176**) (288 mg, 2.00 mmol), indium (III) nitrate pentahydrate (78 mg, 0.20 mmol), acetonitrile (20 mL), and elemental fluorine (2.40 mmol) gave a slightly red oil (252 mg); conversion was found to be 3%, which consisted of, 100% ethyl 2-fluoro-2-methyl-3-oxobutanoate (**177**) (GC).

Table 3.5, entry 12

Ethyl 2-methyl-3-oxobutanoate (**176**) (288 mg, 2.00 mmol), bismuth (III) nitrate pentahydrate (97 mg, 0.20 mmol), acetonitrile (20 mL), and elemental fluorine (2.40 mmol) gave a colourless oil (295 mg); conversion was found to be 4%, which consisted of, 27% ethyl 2-fluoro-2-methyl-3-oxobutanoate (**177**) (GC).

Effect of auxiliaries and ligands

Table 3.6, entry 1

A mixture containing scandium (III) triflate (98 mg, 0.20 mmol), BINOL (69 mg, 0.24 mmol), 1,2,2,6,6-pentamethylpiperidine (75 mg, 0.48 mmol), and dichloromethane (2 mL) was placed in the PTFE reactor at 0 °C. The mixture was stirred for 30 minutes at this temperature, and ethyl 2-methyl-3-oxobutanoate (**176**) (288 mg, 2.00 mmol) and acetonitrile (20 mL) were added. Fluorination of this mixture was carried out using elemental fluorine (2.40 mmol) in the same manner as above, and gave a brown oil (544 mg); conversion was found to be less than 1% (GC).

Table 3.6, entry 2

Ethyl 2-methyl-3-oxobutanoate (**176**) (290 mg, 2.00 mmol), copper (II) nitrate hemipentahydrate (48 mg, 0.21 mmol), triphenylphosphine (107 mg, 0.41 mmol) acetonitrile (20 mL), and elemental fluorine (2.40 mmol) gave a pale brown oil (461 mg); conversion was found to be 34%, which consisted of, 29% ethyl 2-fluoro-2-methyl-3-oxobutanoate (**177**) (GC).

Table 3.6, entry 3

A mixture containing copper (II) nitrate hemipentahydrate (47 mg, 0.20 mmol), *racemic*-BINAP (124 mg, 0.20 mmol), and acetonitrile (15 mL) was placed in the PTFE reactor. The mixture was stirred for 30 minutes, and ethyl 2-methyl-3-oxobutanoate (**176**) (288 mg, 2.00 mmol) and acetonitrile (5 mL) was added. Fluorination of this mixture was carried out using elemental fluorine (2.40 mmol) in the same manner as above, and gave a brown oil (512 mg); conversion was found to be 45%, which consisted of, 8% ethyl 2-fluoro-2-methyl-3-oxobutanoate (**177**) (GC).

Table 3.6, entry 4

A mixture containing copper (II) fluoride (21 mg, 0.21 mmol), *racemic*-BINAP (127 mg, 0.20 mmol), and acetonitrile (15 mL) was placed in the PTFE reactor. The mixture was sonicated for 5 minutes, and stirred for 30 minutes. Ethyl 2-methyl-3-oxobutanoate (**176**) (288 mg, 2.00 mmol) and acetonitrile (5 mL) was added to the mixture. Fluorination of this mixture was carried out using elemental fluorine (2.40 mmol) in the same manner as above, and gave a brown oil (512 mg); conversion was found to be less than 1% (GC).

Table 3.6, entry 5

A mixture containing nickel (II) nitrate hexahydrate (57 mg, 0.20 mmol), triphenylphosphine (106 mg, 0.40 mmol), and acetonitrile (15 mL) was placed in the PTFE reactor. The mixture was sonicated for 5 minutes, and stirred for 30 minutes. Ethyl 2-methyl-3-oxobutanoate (**176**) (288 mg, 2.00 mmol) and acetonitrile (5 mL) was added to the mixture. Fluorination of this mixture was carried out using elemental fluorine (2.40 mmol) in the same manner as above, and gave a yellowish oil (531 mg);

conversion was found to be 15%, which consisted of, 100% ethyl 2-fluoro-2-methyl-3-oxobutanoate (**177**) (GC).

Table 3.6, entry 6

A mixture containing nickel (II) nitrate hexahydrate (58 mg, 0.20 mmol), *racemic*-BINAP (126 mg, 0.20 mmol), and acetonitrile (15 mL) was placed in the PTFE reactor. The mixture was sonicated for 5 minutes, and stirred for 30 minutes. Ethyl 2-methyl-3-oxobutanoate (**176**) (288 mg, 2.00 mmol) and acetonitrile (5 mL) was added to the mixture. Fluorination of this mixture was carried out using elemental fluorine (2.40 mmol) in the same manner as above, and gave a yellowish oil (489 mg); conversion was found to be 36%, which consisted of, 100% ethyl 2-fluoro-2-methyl-3-oxobutanoate (**177**) (GC).

Table 3.6, entry 7

A mixture containing nickel (II) nitrate hexahydrate (58 mg, 0.20 mmol), 1,2-diphenylphosphinoethane (80 mg, 0.20 mmol), and acetonitrile (15 mL) was placed in the PTFE reactor. The mixture was stirred for 30 minutes, and ethyl 2-methyl-3-oxobutanoate (**176**) (288 mg, 2.00 mmol) and acetonitrile (5 mL) was added. Fluorination of this mixture was carried out using elemental fluorine (2.40 mmol) in the same manner as above, and gave a slightly yellowish oil (385 mg); conversion was found to be 20%, which consisted of, 100% ethyl 2-fluoro-2-methyl-3-oxobutanoate (**177**) (GC).

Table 3.6, entry 8

A mixture containing nickel (II) nitrate hexahydrate (58 mg, 0.20 mmol), *racemic*-BINAP (126 mg, 0.20 mmol), and acetonitrile (15 mL) was placed in the PTFE reactor. The mixture was sonicated for 5 minutes, and stirred for 30 minutes. Ethyl 2-methyl-3-oxobutanoate (**176**) (288 mg, 2.00 mmol) and acetonitrile (5 mL) was added to the mixture. Fluorination of this mixture was carried out using elemental fluorine (10.0 mmol) in the similar manner as above, and gave a yellowish oil (550 mg); conversion was found to be 73%, which consisted of, 97% ethyl 2-fluoro-2-methyl-3-oxobutanoate (**177**), 3% ethyl 2,4-difluoro-2-methyl-3-oxobutanoate (**178**) (GC).

Purification by flash chromatography [silica gel: 20 g, eluent: hexane/ethyl acetate (8:1)] provided ethyl 2-fluoro-2-methyl-3-oxobutanoate (**177**), (72 mg, 22%) as a colourless oil.

Ethyl 2-fluoro-2-methyl-3-oxobutanoate (177**)**

¹H NMR (400 MHz, CDCl₃) δ 1.29 (t, *J* = 7.0 Hz, 3H, CH₂CH₃), 1.66 (d, ³*J*_{HF} = 22.0 Hz, 3H, CFCH₃), 2.31 (d, *J* = 4.5 Hz, 3H, CH₃C=O), 4.26 (q, *J* = 7.0 Hz, 2H, CH₂);

^{13}C NMR (101 MHz) δ 13.9 (s, CH_2CH_3), 19.7 (d, $^2J_{\text{CF}} = 23.0$ Hz, CFCH_3), 24.9 (s, $\text{CH}_3\text{C}=\text{O}$), 62.6 (s, CH_2), 97.6 (d, $^1J_{\text{CF}} = 193.0$ Hz, CF), 166.8 (d, $^2J_{\text{CF}} = 25.0$ Hz, CFCOO), 202.3 (d, $^2J_{\text{CF}} = 28.5$ Hz, CH_3COCF); IR (neat) 2987, 1756, 1736, 1374, 1361, 1280, 1141, 1108, 1019 cm^{-1} ; mass spectrum, m/z (EI^+) 163 ($[\text{M}+\text{H}]^+$, 1%), 120 ($[\text{M}-\text{C}_2\text{H}_2\text{O}]^+$, 98), 92 (100), (Found: M^+ 162.0686. $\text{C}_7\text{H}_{11}\text{FO}_3$ requires 162.0687). (As compared to the literature data.³²)

Effect of intermittent introduction of fluorine

A mixture containing nickel (II) nitrate hexahydrate (58 mg, 0.20 mmol), *racemic*-BINAP (126 mg, 0.20 mmol), and acetonitrile (15 mL) was placed in the PTFE reactor. The mixture was sonicated for 5 minutes, and stirred for 30 minutes. Ethyl 2-methyl-3-oxobutanoate (**176**) (288 mg, 2.00 mmol) and acetonitrile (5 mL) was added to the mixture. The mixture was immersed in a cooling bath of 0 °C and purged with N_2 for 30 minutes. Elemental fluorine [10% (v/v) mixture with nitrogen] was introduced at a flow rate of 10 mL/min into the mixture for 18 minutes. The reaction mixture was purged with N_2 for 30 minutes. Further fluorine was introduced into the mixture for 36 minutes and the reaction mixture was purged with N_2 for 60 minutes. Further fluorine was introduced into the mixture for 50 minutes and the reaction mixture was purged with N_2 for 60 minutes. Further fluorine was introduced into the mixture for 49 minutes and the reaction mixture was purged with N_2 for 60 minutes. Further fluorine was introduced into the mixture for 47 minutes and the reaction mixture was purged with N_2 for 60 minutes. Further fluorine was introduced into the mixture for 46 minutes and the reaction mixture was purged with N_2 for 30 minutes (total 6.0 equivalents of fluorine was passed through the mixture). Ordinary work-up gave a yellowish oil (588 mg); conversion was found to be 80%, which consisted of, 97% ethyl 2-fluoro-2-methyl-3-oxobutanoate (**177**), 3% ethyl 2,4-difluoro-2-methyl-3-oxobutanoate (**178**) (GC). 0.3 mL of the reaction mixture was taken from the reactor at the same intervals after introduction of fluorine. The reaction mixture was poured into water, neutralised by NaHCO_3 , extracted with dichloromethane, dried over MgSO_4 , and evaporated to give about 10 mg of crude product; conversions were found to be 12% (0.4 equiv.), 26% (1.2 equiv.), 42% (2.4 equiv.), 61% (3.6 equiv.) and 69% (4.8 equiv.).

Preparation of cyclic 1,3-ketoesters

Di-*t*-butyl adipate (**184**)

A solution of adipoyl chloride (**183**) (11.9 g, 65.2 mmol) in dry ether (10 mL) was

added dropwise to a stirred mixture of *t*-butanol (20 mL, 209 mmol), *N,N*-dimethylaniline (26 mL, 205 mmol), and dry ether (10 mL) at room temperature. This mixture was stirred vigorously for 17 hours, after which it was diluted with 10% aqueous sodium chloride (200 mL) and extracted with ether (200 mL and 100 mL). The organic layer was washed with 3:1 (v/v) 2 M aqueous hydrochloric acid/saturated brine (3 x 200 mL), 3:1 (v/v) 1 M aqueous sodium hydroxide/saturated brine (2 x 200 mL), and saturated brine (200 mL). The resulted organic extracts were dried over MgSO₄, and evaporated to give crude product (16.1 g). The product was purified by distillation under reduced pressure [b.p. 90—92 °C (0.5—0.8 mmHg)] to afford di-*t*-butyl adipate (**184**) (12.71 g, 75%) as a low-melting solid; ¹H NMR (400 MHz, CDCl₃) δ 1.41 (m, 18H, 2 C(CH₃)₃), 1.57 (m, 4H, 2 CH₂CH₂C=O), 2.19 (m, 4H, 2 CH₂C=O); ¹³C NMR (101 MHz) δ 24.5 (s, 2 CH₂), 28.0 (s, 6 CH₃), 35.2 (s, 2 CH₂C=O), 80.0 (s, 2 C(CH₃)₃), 172.8 (s, 2 C=O). (As compared to the literature data.²¹¹)

t-Butyl 2-oxocyclopentanecarboxylate (**185**)

Sodium hydride (60% in oil, 4.0 g, 100 mmol) was washed with dry hexane (3 x 10 mL) under argon atmosphere in the usual method to remove the oil. Dry toluene (40 mL) was added and the suspension was stirred under argon and di-*t*-butyl adipate (**184**) (0.5 g, 2 mmol) and *t*-butanol (0.2 mL) were added in one portion. The mixture was then refluxed with vigorous stirring for 30 minutes. A second portion of di-*t*-butyl adipate (12.0 g, 46.4 mmol) in dry toluene (20 mL) was added dropwise to the boiling mixture over 20 minutes and the mixture was refluxed with vigorous stirring for further 4.5 hours. The resulting thick suspension was cooled to 0 and neutralised by 10% aqueous acetic acid (90 mL). The mixture was poured into water (100 mL), extracted with ether (2 x 100 mL) and the combined extracts were washed with saturated aqueous sodium hydrogencarbonate and water, dried over magnesium sulfate, and evaporated to give crude product (9.34 g). The product was purified by distillation under reduced pressure [b.p. 86 °C (3 mmHg)] to afford *t*-butyl 2-oxocyclopentane carboxylate (**185**) (7.00 g, 79%) as a colourless liquid; (Found: C, 65.14; H, 8.85. C₁₀H₁₆O₃ requires C, 65.19; H, 8.75%); ¹H NMR (400 MHz, CDCl₃) δ 1.46 (s, 9H, C(CH₃)₃), 1.78—1.89 (m, 1H), 2.06—2.15 (m, 1H), 2.21—2.31 (m, 4H), 3.04 (t, *J* = 9.0 Hz, 1H, 1-H); ¹³C NMR (101 MHz) δ 20.8 (s, 4-C), 27.3 (s, 5-C), 27.9 (s, 8-C), 38.0 (s, 3-C), 55.6 (s, 1-C), 81.5 (s, 7-C), 168.6 (s, 6-C), 212.8 (s, 2-C); IR (neat) 2976, 1753, 1720, 1369, 1257, 1157, 1109, 844 cm⁻¹; mass spectrum, *m/z* (EI⁺) 184 (M⁺, 2%), 128 ([M-C₄H₈]⁺, 44), 111 (100). (As compared to the literature data.²¹²)

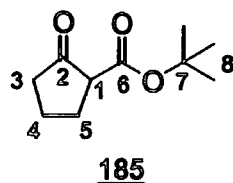

Di-*t*-butyl pimelate (187)

Di-*t*-butyl pimelate (187) was prepared by the same procedure to di-*t*-butyl adipate (184). Pimeloyl chloride (186) (10.0 g, 50.7 mmol), *t*-butanol (15.8 mL, 165 mmol), *N,N*-dimethylaniline (19.3 g, 159 mmol) gave crude product (12.9 g). The product was purified by distillation under reduced pressure [b.p. 120 °C (5 mmHg)] to afford 9.94 g (72%) of di-*t*-butyl pimelate (187) as a colourless liquid; ^1H NMR (400 MHz, CDCl_3) δ 1.27—1.38 (m, 2H), 1.43(s, 18H, 2 $\text{C}(\text{CH}_3)_3$), 1.59 (quint, $J = 7.5$ Hz, 4H, 2 $\text{CH}_2\text{CH}_2\text{C}=\text{O}$), 2.20 (t, $J = 7.5$ Hz, 4H, 2 $\text{CH}_2\text{C}=\text{O}$); ^{13}C NMR (101 MHz) δ 24.7 (s, 2 $\text{CH}_2\text{CH}_2\text{C}=\text{O}$), 28.1 (s, 6 CH_3), 28.5 (s, $\text{CH}_2\text{CH}_2\text{CH}_2\text{C}=\text{O}$), 35.4 (s, 2 $\text{CH}_2\text{C}=\text{O}$), 79.9 (s, 2 $\text{C}(\text{CH}_3)_3$), 173.0 (s, 2 $\text{C}=\text{O}$).

t-Butyl 2-oxocyclohexanecarboxylate (188)

t-Butyl 2-oxocyclohexanecarboxylate (188) was prepared by the same procedure to *t*-butyl 2-oxocyclopentanecarboxylate (185). Sodium hydride (60% in oil, 3.02 g, 75.4 mmol), di-*t*-butyl pimelate (187) (9.93 g, 36.5 mmol) and *t*-butanol (0.15 mL) gave crude product (8.79 g). The product was purified by distillation under reduced pressure [b.p. 80—82 °C (0.7—0.8 mmHg)] to afford 5.03 g (70%) of *t*-butyl 2-oxocyclohexanecarboxylate (188) as a colourless liquid; (Found: C, 66.70; H, 9.21. $\text{C}_{11}\text{H}_{18}\text{O}_3$ requires C, 66.64; H, 9.15%); ^1H NMR (400 MHz, CDCl_3) keto-enol (36%–64%) δ 1.45—1.48 (m, 9H, $\text{C}(\text{CH}_3)_3$), 1.53—2.51 (m, 8H), 2.06—2.15 (m, 1H), 2.21—2.31 (m, 4H), 3.24 (m, 0.36H), 12.38 (s, 0.64H, OH-enol); ^{13}C NMR (101 MHz) δ 22.0 (s, 4-C or 5-C or 6-C-enol), 22.5 (s, 4-C or 5-C or 6-C-enol), 22.8 (s, 4-C or 5-C or 6-C-enol), 23.1 (s, 4-C or 6-C-keto), 27.1 (s, 4-C or 6-C-keto), 28.0 (s, 9-C-keto), 28.3 (s, 9-C-enol), 29.1 (3-C-enol), 29.9 (5-C-keto), 41.5 (s, 3-C-keto), 57.8 (s, 1-C-keto), 80.6 (s, 8-C-enol), 81.5 (s, 8-C-keto), 98.9 (s, 1-C-enol), 169.2 (s, 7-C-keto), 171.2 (s, 2-C-enol), 172.6 (s, 7-C-enol), 206.8 (s, 2-C-keto); IR (neat) 2936, 1737, 1717, 1654, 1393, 1367, 1309, 1266, 1223, 1161, 1081, 843 cm^{-1} ; mass spectrum, m/z (EI^+) 198 (M^+ , 3%), 142 ($[\text{M}-\text{C}_4\text{H}_8]^+$, 51), 124 (100).

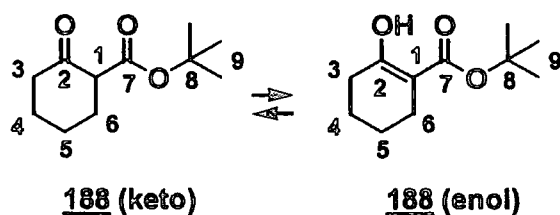

Catalytic direct fluorination of cyclic 1,3-ketoesters

General Procedure

The reactions below follow the procedure described, unless otherwise stated.

(Procedure A)

A mixture containing nickel (II) nitrate hexahydrate (58 mg, 0.20 mmol), BINAP (126 mg, 0.20 mmol), and anhydrous acetonitrile (15 mL) was placed in the PTFE reactor. The mixture was sonicated for 5 minutes, and stirred for 30 minutes. The substrate (2.00 mmol) and anhydrous acetonitrile (5 mL) was added to the mixture. The mixture was immersed in a cooling bath of 0 °C and purged with N₂ for 30 minutes. Elemental fluorine [10% (v/v) mixture with nitrogen] was introduced at a flow rate of 10 mL/min into the mixture for required time. The reaction mixture was purged with N₂ for 30 minutes. The reaction mixture was poured into water (20 mL), neutralised by NaHCO₃, and extracted with dichloromethane (3 x 20 mL). The combined organic extracts were dried over anhydrous MgSO₄ and evaporated to give a crude product.

(Procedure B)

A mixture containing nickel (II) nitrate hexahydrate (58 mg, 0.20 mmol), BINAP (126 mg, 0.20 mmol), and anhydrous acetonitrile (15 mL) was placed in the PTFE reactor. The mixture was immersed in a cooling bath of 0 °C and purged with N₂ for 30 minutes. Elemental fluorine [10% (v/v) mixture with nitrogen] was introduced at a flow rate of 10 mL/min into the mixture for 45 minutes. The substrate (2.00 mmol) and anhydrous acetonitrile (5 mL) was added to the mixture after being purged with N₂ for 30 minutes. The mixture was purged with N₂ for 30 minutes at 0 °C and elemental fluorine [10% (v/v) mixture with nitrogen] was introduced at a flow rate of 10 mL/min into the mixture for required time. The reaction mixture was purged with N₂ for 30 minutes. The remaining work up was same as procedure A.

Catalytic direct fluorination of cyclic 1,3-ketoesters using a racemic catalyst

Table 3.7 entry 1

The reaction was carried out using procedure A.

Ethyl 2-oxocyclopentanecarboxylate (189) (312 mg, 2.00 mmol), nickel (II) nitrate

hexahydrate (58 mg, 0.20 mmol), *racemic*-BINAP (126 mg, 0.20 mmol), and elemental fluorine (6.00 mmol) gave a yellowish oil (549 mg); conversion was found to be 100%, which consisted of 100% ethyl 1-fluoro-2-oxocyclopentanecarboxylate (**191**) (GC); m/z (EI^+) 174 (M^+ , 16%), 146 ($[\text{M}-\text{C}_2\text{H}_4]^+$, 25), 101 (96).

Purification by flash chromatography [silica gel: 20 g, eluent: hexane/ethyl acetate (8:1)] provided ethyl 1-fluoro-2-oxocyclopentanecarboxylate (**191**), (280 mg, 81%) as a colourless oil.

Ethyl 1-fluoro-2-oxocyclopentanecarboxylate (191)

^1H NMR (400 MHz, CDCl_3) δ 1.28 (t, $J = 7.0$ Hz, 3H, CH_3), 2.07—2.15 (m, 2H), 2.23—2.34 (m, 1H), 2.44—2.58 (m, 3H), 4.26 (q, $J = 7.0$ Hz, 2H, OCH_2); ^{13}C NMR (101 MHz) δ 13.9 (s, CH_3), 17.9 (d, $^3J_{\text{CF}} = 3.5$ Hz), 33.8 (d, $^2J_{\text{CF}} = 21.0$ Hz, CH_2CF), 35.6 (s), 94.5 (d, $^1J_{\text{CF}} = 200.0$ Hz, CF), 167.3 (d, $^2J_{\text{CF}} = 27.0$ Hz, CFCOO), 207.5 (d, $^2J_{\text{CF}} = 17.0$ Hz, CH_2COCF); ^{19}F NMR (188 MHz, CDCl_3) δ -164.5 (m); IR (neat) 2984, 1771, 1752, 1729, 1294, 1165, 1022 cm^{-1} ; mass spectrum, m/z (EI^+) 174 (M^+ , 21%), 146 ($[\text{M}-\text{C}_2\text{H}_4]^+$, 27), 117 (71), 91 (100), (ES^+) (Found: $[\text{M}+\text{NH}_4]^+$ 192.1032. $\text{C}_8\text{H}_{15}\text{FNO}_3$ requires 192.1030). (As compared to the literature data.⁵²)

Table 3.7 entry 2

The reaction was carried out using procedure A.

t-Butyl 2-oxocyclopentanecarboxylate (**185**) (368 mg, 2.00 mmol), nickel (II) nitrate hexahydrate (58 mg, 0.20 mmol), *racemic*-BINAP (126 mg, 0.20 mmol), and elemental fluorine (6.00 mmol) gave a yellowish oil (360 mg); conversion was found to be 100%, which consisted of 100% *t*-butyl 1-fluoro-2-oxocyclopentanecarboxylate (**192**) (GC); m/z (EI^+) 202 (M^+ , 13%), 187 ($[\text{M}-\text{CH}_3]^+$, 53), 146 ($[\text{M}-\text{C}_4\text{H}_8]^+$, 65), 129 ($[\text{M}-\text{C}_4\text{H}_9\text{O}]^+$, 59), 101 ($[\text{M}-\text{C}_4\text{H}_9\text{OCO}]^+$, 85).

Purification by flash chromatography [silica gel: 20 g, eluent: hexane/ethyl acetate (8:1)] provided *t*-butyl 1-fluoro-2-oxocyclopentanecarboxylate (**192**), (357 mg, 88%) as a colourless oil.

***t*-Butyl 1-fluoro-2-oxocyclopentanecarboxylate (192)**

^1H NMR (400 MHz, CDCl_3) δ 1.47 (s, 9H, $\text{C}(\text{CH}_3)_3$), 2.09 (quint, $J = 7.5$ Hz, 2H), 2.18—2.31 (m, 1H), 2.44 (t, $J = 7.5$ Hz, 2H), 2.4—2.5 (m, 1H); ^{13}C NMR (101 MHz) δ 18.0 (d, $^3J_{\text{CF}} = 3.5$ Hz, $\text{CH}_2\text{CH}_2\text{CF}$), 27.8 (s, $\text{C}(\text{CH}_3)_3$), 33.8 (d, $^2J_{\text{CF}} = 21.0$ Hz, CH_2CF), 35.7 (s, CH_2CO), 83.9 (s, $\text{C}(\text{CH}_3)_3$), 94.3 (d, $^1J_{\text{CF}} = 200.0$ Hz, CF), 166.3 (d, $^2J_{\text{CF}} = 28.0$ Hz, CFCOO), 208.1 (d, $^2J_{\text{CF}} = 18.0$ Hz, CH_2COCF); ^{19}F NMR (188 MHz, CDCl_3) δ -163.3 (m); IR (neat) 2979, 1768, 1751, 1719, 1371, 1151, 1127, 842 cm^{-1} ; mass spectrum, m/z (EI^+) 202 (M^+ , 5%), 187 ($[\text{M}-\text{CH}_3]^+$, 25), 146 ($[\text{M}-\text{C}_4\text{H}_8]^+$, 82),

(Found: $[M]^+$ 202.1010. $C_{10}H_{13}FO_3$ requires 202.1005). (As compared to the literature data: supporting information of ref.197)

Table 3.7 entry 3

The reaction was carried out using procedure A.

Ethyl 2-oxocyclohexanecarboxylate (**190**) (340 mg, 2.00 mmol), nickel (II) nitrate hexahydrate (58 mg, 0.20 mmol), *racemic*-BINAP (126 mg, 0.20 mmol), and elemental fluorine (6.00 mmol) gave a yellowish oil (579 mg); conversion was found to be 100%, which consisted of 86% ethyl 1-fluoro-2-oxocyclohexanecarboxylate (**193**) (GC); m/z (EI^+) 188 (M^+ , 21%), 115 ($[M-C_2H_5OCO]^+$, 66).

Purification by flash chromatography [silica gel: 20 g, eluent: hexane/ethyl acetate (8:1)] provided ethyl 1-fluoro-2-oxocyclohexanecarboxylate (**193**), (227 mg, 60%) as a colourless oil.

Ethyl 1-fluoro-2-oxocyclohexanecarboxylate (193)

1H NMR (400 MHz, $CDCl_3$) δ 1.31 (t, $J = 7.0$ Hz, 3H, CH_3), 1.78—1.97 (m, 4H), 2.08—2.18 (m, 1H), 2.40—2.52 (m, 1H), 2.56—2.63 (m, 1H), 2.67—2.76 (m, 1H), 4.29 (q, $J = 7.0$ Hz, 2H, OCH_2); ^{13}C NMR (101 MHz) δ 13.9 (s, CH_3), 20.9 (d, $^3J_{CF} = 6.0$ Hz), 26.5 (s, $CH_2CH_2C=O$), 35.9 (d, $^2J_{CF} = 21.0$ Hz, CH_2CF), 39.5 (s), 96.3 (d, $^1J_{CF} = 197.0$ Hz, CF), 166.8 (d, $^2J_{CF} = 25.0$ Hz, $CFCOO$), 201.8 (d, $^2J_{CF} = 19.5$ Hz, CH_2COCF); ^{19}F NMR (188 MHz, $CDCl_3$) δ -161.3 (m); IR (neat) 2949, 1752, 1734, 1289, 1095 cm^{-1} ; mass spectrum, m/z (EI^+) 188 (M^+ , 13%), 140 (86), (Found: M^+ 188.0853. $C_9H_{13}FO_3$ requires 188.0849). (As compared to the literature data.³²)

Table 3.7 entry 4

The reaction was carried out using procedure A.

t-Butyl 2-oxocyclohexanecarboxylate (**188**) (397 mg, 2.00 mmol), nickel (II) nitrate hexahydrate (58 mg, 0.20 mmol), *racemic*-BINAP (126 mg, 0.20 mmol), and elemental fluorine (6.00 mmol) gave a yellow oil (0.63 g); conversion was found to be 100%, which consisted of 89% *t*-butyl 1-fluoro-2-oxocyclohexanecarboxylate (**194**) (GC); m/z (EI^+) 216 (M^+ , 26%), 160 ($[M-C_4H_8]^+$, 79).

Purification by flash chromatography [silica gel: 20 g, eluent: hexane/ethyl acetate (8:1)] provided *t*-butyl 1-fluoro-2-oxocyclohexanecarboxylate (**194**), (288 mg, 67%) as a colourless oil.

***t*-Butyl 1-fluoro-2-oxocyclohexanecarboxylate (194)**

1H NMR (500 MHz, $CDCl_3$) δ 1.48 (s, 9H, CH_3), 1.76—1.97 (m, 4H), 1.99—2.07 (m, 1H, one of $CFCH_2$), 2.39—2.47 (m, 1H, one of $CFCH_2$), 2.53—2.59 (m, 1H, one of

COCH₂), 2.63—2.69 (m, 1H, one of COCH₂); ¹³C NMR (126 MHz) δ 21.2 (d, ³J_{CF} = 6.5 Hz CFCH₂CH₂), 26.4 (s, COCH₂CH₂), 27.8 (s, CH₃), 36.0 (d, ²J_{CF} = 21.5 Hz, CFCH₂), 39.8 (s, COCH₂), 83.8 (s, CCH₃), 96.3 (d, ¹J_{CF} = 196.5 Hz, CF), 165.7 (d, ²J_{CF} = 24.5 Hz, CFCOO), 202.2 (d, ²J_{CF} = 19.0 Hz, CH₂COCF); ¹⁹F NMR (188 MHz, CDCl₃) δ -159.7 (m); IR (neat) 2978, 2946, 1752, 1735, 1371, 1147, 1097, 839 cm⁻¹; mass spectrum, m/z (EI⁺) 216 (M⁺, 11%), 201 ([M-CH₃]⁺, 16), 160 ([M-C₄H₈]⁺, 62), (Found: M⁺ 216.1157. C₁₁H₁₇FO₃ requires 216.1156). (As compared to the literature data: supporting information of ref.197)

Table 3.7 entry 5

No catalyst was added. A mixture containing ethyl 2-oxocyclopentanecarboxylate (**189**) (312 mg, 2.00 mmol), and acetonitrile (20 mL) was placed in the PTFE reactor. The mixture was purged with N₂ for 30 minutes at 0 °C and elemental fluorine [10% (v/v) mixture with nitrogen] was introduced at a flow rate of 10 mL/min into the mixture (6.00 mmol). The reaction mixture was purged with N₂ for 30 minutes. The remaining work up was same as procedure A, which gave a colourless oil (375 mg); conversion was found to be 17%.

Table 3.7 entry 6

No catalyst was added. A mixture containing ethyl 2-oxocyclohexanecarboxylate (**190**) (340 mg, 2.00 mmol), and acetonitrile (20 mL) was placed in the PTFE reactor. The mixture was purged with N₂ for 30 minutes at 0 °C and elemental fluorine [10% (v/v) mixture with nitrogen] was introduced at a flow rate of 10 mL/min into the mixture (6.00 mmol). The reaction mixture was purged with N₂ for 30 minutes. The remaining work up was same as procedure A, which gave a colourless oil (410 mg); conversion was found to be 87%.

Estimation of enol contents of β-keto esters

The each compound was dissolved in acetonitrile-*d*₃ in 0.1 M, and ¹H NMR spectra were recorded within 30 minutes and 1 month later to determine the equilibrium concentration.

Ethyl 2-methyl-3-oxobutanoate (**176**)

(within 30 minutes)

¹H NMR (400 MHz, CD₃CN) δ 1.02 (t, *J* = 7.0 Hz, 3H, OCH₂CH₃), 1.04 (d, *J* = 7.0 Hz, 3H, CHCH₃), 1.98 (s, CH₃CO), 3.37 (q, *J* = 7.0 Hz, 0.92H, keto-CHCH₃), 3.81—4.01 (m, enol-OCH₂CH₃), 3.94 (q, *J* = 7.0 Hz, keto-OCH₂CH₃), 12.50 (s, 0.02H, enol-OH).

(1 month later)

^1H NMR (400 MHz, CD_3CN) δ 1.02 (t, $J = 7.0$ Hz, 3H, OCH_2CH_3), 1.04 (d, $J = 7.0$ Hz, 3H, CHCH_3), 1.98 (s, CH_3CO), 3.37 (q, $J = 7.0$ Hz, 0.93H, keto- CHCH_3), 3.81—4.01 (m, enol- OCH_2CH_3), 3.94 (q, $J = 7.0$ Hz, OCH_2CH_3).

Ethyl 2-oxocyclopentanecarboxylate (**189**)

(within 30 minutes)

^1H NMR (400 MHz, CD_3CN) δ 1.02 (t, $J = 7.0$ Hz, 3H, OCH_2CH_3), 1.59—2.32 (m, 6H), 2.95 (t, $J = 9.0$ Hz, 0.91H, keto- CH), 3.85—4.00 (m, enol- OCH_2CH_3), 3.92 (q, $J = 7.0$ Hz, keto- OCH_2CH_3).

(1 month later)

^1H NMR (400 MHz, CD_3CN) δ 1.02 (t, $J = 7.0$ Hz, 3H, OCH_2CH_3), 1.59—2.32 (m, 6H), 2.95 (t, $J = 9.0$ Hz, 0.88H, keto- CH), 3.85—4.00 (m, enol- OCH_2CH_3), 3.92 (q, $J = 7.0$ Hz, keto- OCH_2CH_3).

t-Butyl 2-oxocyclopentanecarboxylate (**185**)

(within 30 minutes)

^1H NMR (400 MHz, CD_3CN) δ 1.22 (s, 9H, $\text{C}(\text{CH}_3)_3$), 1.57—2.31 (m, 6H), 2.81 (t, $J = 9.0$ Hz, 0.92H, keto- CH).

(1 month later)

^1H NMR (400 MHz, CD_3CN) δ 1.22 (s, 9H, $\text{C}(\text{CH}_3)_3$), 1.57—2.31 (m, 6H), 2.81 (t, $J = 9.0$ Hz, 0.93H, keto- CH).

Ethyl 2-oxocyclohexanecarboxylate (**190**)

(within 30 minutes)

^1H NMR (400 MHz, CD_3CN) δ 1.02 (t, $J = 7.0$ Hz, keto- OCH_2CH_3), 1.04 (t, $J = 7.0$ Hz, enol- OCH_2CH_3), 1.37—2.25 (m, 8H), 3.22 (ddd, $J = 11.0, 5.5, 1.0$ Hz, 0.20H, keto- CH), 3.94 (dq, $J = 7.0, 2.5$ Hz, keto- OCH_2CH_3), 3.99 (q, $J = 7.0$ Hz, enol- OCH_2CH_3), 12.04 (s, 0.71H, enol- OH).

(1 month later)

^1H NMR (400 MHz, CD_3CN) δ 1.02 (t, $J = 7.0$ Hz, keto- OCH_2CH_3), 1.04 (t, $J = 7.0$ Hz, enol- OCH_2CH_3), 1.37—2.25 (m, 8H), 3.22 (ddd, $J = 11.0, 5.5, 1.0$ Hz, 0.39H, keto- CH), 3.94 (dq, $J = 7.0, 2.5$ Hz, keto- OCH_2CH_3), 3.99 (q, $J = 7.0$ Hz, enol- OCH_2CH_3), 12.04 (s, 0.50H, enol- OH).

t-Butyl 2-oxocyclohexanecarboxylate (**188**)

(within 30 minutes)

^1H NMR (400 MHz, CD_3CN) δ 1.24 (s, 2.79H, keto- $\text{C}(\text{CH}_3)_3$), 1.28 (s, 6.21H, keto- $\text{C}(\text{CH}_3)_3$), 1.33—2.16 (m, 8H), 3.08 (dd, $J = 9.5, 6.5$ Hz, 0.28H, keto- CH), 12.13 (s, 0.64H, enol- OH).

(1 month later)

^1H NMR (400 MHz, CD_3CN) δ 1.24 (s, 6.48H, keto- $\text{C}(\text{CH}_3)_3$), 1.28 (s, 2.52H, keto- $\text{C}(\text{CH}_3)_3$), 1.33—2.16 (m, 8H), 3.08 (dd, $J = 9.5, 6.5$ Hz, 0.67H, keto- CH), 12.13 (s, 0.25H, enol- OH).

Attempted catalytic enantioselective direct fluorination of 1,3-ketoesters

Table 3.9 entry 1

The reaction was carried out using procedure A.

Ethyl 2-oxocyclopentanecarboxylate (**189**) (312 mg, 2.00 mmol), nickel (II) nitrate hexahydrate (58 mg, 0.20 mmol), (*R*)-BINAP (126 mg, 0.20 mmol), and elemental fluorine (10.0 mmol) gave a yellowish oil (580 mg); conversion was found to be 100%, which consisted of, 100% ethyl 1-fluoro-2-oxocyclopentanecarboxylate (**191**) (GC).

Purification by flash chromatography [silica gel: 20 g, eluent: hexane/ethyl acetate (8:1)] provided ethyl 1-fluoro-2-oxocyclopentanecarboxylate (**191**), (286 mg, 82%) as a colourless oil (<1% ee).

Table 3.9 entry 2

The reaction was carried out using procedure B.

Ethyl 2-oxocyclopentanecarboxylate (**189**) (312 mg, 2.00 mmol), nickel (II) nitrate hexahydrate (58 mg, 0.20 mmol), (*R*)-BINAP (126 mg, 0.20 mmol), and elemental fluorine (10.0 mmol) gave a yellowish oil (651 mg); conversion was found to be 99%, which consisted of, 100% ethyl 1-fluoro-2-oxocyclopentanecarboxylate (**191**) (GC).

Purification by flash chromatography [silica gel: 20 g, eluent: hexane/ethyl acetate (8:1)] provided ethyl 1-fluoro-2-oxocyclopentanecarboxylate (**191**), (276 mg, 79%) as a colourless oil (<1% ee).

Table 3.9 entry 3

The reaction was carried out using procedure A.

t-Butyl 2-oxocyclopentanecarboxylate (**185**) (368 mg, 2.00 mmol), nickel (II) nitrate hexahydrate (58 mg, 0.20 mmol), (*R*)-BINAP (126 mg, 0.20 mmol), and elemental fluorine (10.0 mmol) gave a yellowish oil (683 mg); conversion was found to be 100%, which consisted of, 100% *t*-butyl 1-fluoro-2-oxocyclopentanecarboxylate (**192**) (GC).

Purification by flash chromatography [silica gel: 20 g, eluent: hexane/ethyl acetate (8:1)] provided *t*-butyl 1-fluoro-2-oxocyclopentanecarboxylate (**192**), (293 mg, 73%) as a colourless oil (<1% ee).

Table 3.9 entry 4

The reaction was carried out using procedure B.

t-Butyl 2-oxocyclopentanecarboxylate (**185**) (368 mg, 2.00 mmol), nickel (II) nitrate hexahydrate (58 mg, 0.20 mmol), (*R*)-BINAP (126 mg, 0.20 mmol), and elemental

fluorine (10.0 mmol) gave a yellowish oil (730 mg); conversion was found to be 100%, which consisted of, 100% *t*-butyl 1-fluoro-2-oxocyclopentanecarboxylate (**192**) (GC). Purification by flash chromatography [silica gel: 20 g, eluent: hexane/ethyl acetate (8:1)] provided *t*-butyl 1-fluoro-2-oxocyclopentanecarboxylate (**192**), (279 mg, 69%) as a colourless oil (<1% ee).

Determination of enantiomeric purity of the fluorinated products

The enantiomeric purity of the both of ethyl 1-fluoro-2-oxocyclopentanecarboxylate (**191**) and *t*-butyl 1-fluoro-2-oxocyclopentanecarboxylate (**192**) were determined by chiral shift reagent experiments using increasing amounts of Europium tris[3-heptafluoropropylhydroxymethylene]-(+)-camphorate] [Eu(hfc)₃]^{166,183} (See Figure 3.3). As the amounts of Eu(hfc)₃ increase, the enantiotopic protons of methyl group split in ¹H NMR. In the case of *t*-butyl 1-fluoro-2-oxocyclopentanecarboxylate (**192**), the enantiotopic protons could not completely be separated.

Fluorination of ethyl 2-oxocyclopentanecarboxylate (**189**) in a mixture of dichloromethane/acetonitrile [1:1 (v/v)]

A mixture containing nickel (II) nitrate hexahydrate (58 mg, 0.20 mmol), BINAP (126 mg, 0.20 mmol), anhydrous dichloromethane (8 mL), and anhydrous acetonitrile (8 mL) was placed in the PTFE reactor. The mixture was stirred for 30 minutes. Ethyl 2-oxocyclopentanecarboxylate (**189**) (312 mg, 2.00 mmol), anhydrous dichloromethane (2 mL), and anhydrous acetonitrile (2 mL) was added to the mixture. The mixture was immersed in a cooling bath of 0 °C and purged with N₂ for 30 minutes. Elemental fluorine [10% (v/v) mixture with nitrogen] was introduced at a flow rate of 10 mL/min into the mixture (10 mmol). The reaction mixture was purged with N₂ for 30 minutes. The remaining work up was same as procedure A, which gave a orange oil (610 mg); conversion was found to be 92%, which consisted of 93% ethyl 1-chloro-2-oxocyclopentanecarboxylate (**195**) (GC); *m/z* (EI⁺) 192 [M⁺ (C₈H₁₁³⁷ClO₃), 1%], 190 [M⁺ (C₈H₁₁³⁵ClO₃), 3].

Purification by flash chromatography [silica gel: 20 g, eluent: hexane/ethyl acetate (8:1)] provided ethyl 1-chloro-2-oxocyclopentanecarboxylate (**195**), (197 mg, 52%) as a colourless oil.

Ethyl 1-chloro-2-oxocyclopentanecarboxylate (**195**)

¹H NMR (400 MHz, CDCl₃) δ 1.30 (t, *J* = 7.5 Hz, 3H, CH₃), 2.08—2.19 (m, 2H), 2.34—2.44 (m, 2H), 2.52—2.60 (m, 1H), 2.71—2.78 (m, 1H), 4.28 (q, *J* = 7.5 Hz, 2H, OCH₂); ¹³C NMR (101 MHz) δ 13.9 (s, CH₃), 18.9 (s, CH₂CH₂CO), 35.2 (s, CH₂CCl),

38.3 (s CH₂CO), 63.0 (s, CCl), 167.1 (s, CClCOO), 206.1 (s, CH₂COCCl); IR (neat) 2983, 1767, 1751, 1721, 1248, 1151, 1020 cm⁻¹; mass spectrum, m/z (EI⁺) 190 [M⁺ (C₈H₁₁³⁵ClO₃), 1%], 164 ([M-C₂H₄]⁺ (C₆H₇³⁷ClO₃), 21%), 162 ([M-C₂H₄]⁺ (C₆H₇³⁵ClO₃), 64%), 107 (100).

Chapter 8

Experimental to Chapter 4

8.1 Fluorination of ethyl 3-oxobutanoate using multi-channel microreactor

For a description of the microreactor and operation, see section 4.2 and Appendix.

General procedure

The reactions below follow the procedure described, unless otherwise stated. Microreactor was cooled to reaction temperature (8—10 °C) by an external cryostat. Fluorine was passed through the microreactor (V-21-9) at a rate of $90 \text{ mLmin}^{-1} / 23.4 \text{ mmolh}^{-1}$ in total ($10 \text{ mLmin}^{-1}\text{ch}^{-1}$, $2.6 \text{ mmolh}^{-1}\text{ch}^{-1}$). Substrate solution was passed through the microreactor at a rate of about 4.5 mL in total ($0.5 \text{ mLh}^{-1}\text{ch}^{-1}$). Approximately 0.5 mL of sample was withdrawn from the reaction mixture before work-up, added to CDCl_3 , and analyzed by ^{19}F NMR. Reaction mixture was poured onto water, extracted with 3 portions of dichloromethane, and these were combined and washed with saturated sodium hydrogen carbonate. The remaining acidic aqueous phase was neutralized by solid sodium hydrogen carbonate, extracted by 3 portions of dichloromethane. All extracts were combined, dried over magnesium sulfate, and evaporated to give crude product which was analysed by GC (GC-MS) and NMR (^{19}F , ^1H) and compared with authentic samples.

Fluorination of ethyl 3-oxobutanoate (**196**) using multi-channel microreactor

(Substrate/formic acid = 1:4)

Substrate solution was prepared; the solution consisted of ethyl 3-oxo-butanoate (**196**) (270.0 g, 2.08 mol) and formic acid (380.0 g, 8.26 mol).

Table 4.2, run 1

Substrate solution was passed through the microreactor at a rate of 4.5 mLh^{-1} in total [$0.50 \text{ mLh}^{-1}\text{ch}^{-1}$, = $1.8 \text{ mmolh}^{-1}\text{ch}^{-1}$ ($d = 1.108$)]. Reaction duration 18 hrs. Gave a colourless oil (97.2 g); conversion was found to be 64%, which consisted of, 84% ethyl 2-fluoro-3-oxobutanoate (**197**), 6% ethyl 2,4-difluoro-3-oxobutanoate (**198**), and 1% ethyl 2,2-difluoro-3-oxobutanoate (**199**) (GC); 62% conversion [^1H NMR; estimated by comparison of the integration area between CH_3 of the ester group (both of the substrate and products, δ 1.1—1.2 ppm), CH_2 of the substrate (3.4 ppm), and CH_3 in

position 4 of the substrate (enol form, 1.9 ppm)]; 197/198/199 = 91.8:5.5:2.7 (¹⁹F NMR) (As compared to literature data.³²).

Analysis of reaction mixture; 197/198/199 = 82.0:15.3:2.7 (¹⁹F NMR).

Ethyl 2-fluoro-3-oxobutanoate (197) (not isolated)

¹H NMR (200 MHz, CDCl₃) δ 1.28 (t, *J* = 7.0 Hz, 3H, CH₂CH₃), 2.30 (d, ⁴*J*_{HF} = 3.5 Hz, 3H, CH₃CO), 4.27 (q, *J* = 7.0 Hz, 2H, CH₂), 5.17 (d, ²*J*_{HF} = 49.5 Hz, 1H, CHF); ¹⁹F NMR (282 MHz) δ -193.6 (dq, ²*J*_{HF} = 49.5 Hz, ⁴*J*_{HF} = 4.5 Hz); *m/z* (Cl⁺, NH₃) 166 ([M+NH₄]⁺, 100%), 148 (M⁺, 21).

Ethyl 2,4-difluoro-3-oxobutanoate (198) (not isolated)

¹H NMR (400 MHz, CDCl₃) δ 1.33 (t, *J* = 7.2 Hz, 3H, CH₃), 4.33 (q, *J* = 7.2 Hz, 2H, OCH₂), 5.21 (d, ²*J*_{HF} = 46.8 Hz, 2H, CH₂F), 5.45 (d, ²*J*_{HF} = 48.0 Hz, 1H, CHF); ¹³C NMR (101 MHz) δ 13.9 (s, CH₃), 63.2 (s, OCH₂), 83.2 (dd, ¹*J*_{CF} = 184.8 Hz, ³*J*_{CF} = 2.9 (3.6) Hz, 2-C), 89.7 (d, ¹*J*_{CF} = 194.7 Hz, 4-C), 163.1 (d, ²*J*_{CF} = 22.7 Hz, 1-C), 195.2 (dd, ²*J*_{CF(2)} = 22.7 Hz, ²*J*_{CF(4)} = 17.5 Hz, 3-C); ¹⁹F NMR (188 MHz, CDCl₃) δ -203.9 (d, ²*J*_{HF} = 48.5 Hz, 2-F), -236.2 (t, ²*J*_{HF} = 46.5 Hz, 4-F); *m/z* (Cl⁺, NH₃) 166 ([M+NH₄]⁺, 33%), 166 (M⁺, 67), 148 (100).

Ethyl 2,2-difluoro-3-oxobutanoate (199) (not isolated)

¹⁹F NMR (188 MHz, CDCl₃) δ -114.2 (s).

Table 4.2, run 2

Reaction duration 18 hrs. Gave a colourless oil (73.4 g); conversion was found to be 60%, which consisted of, 88% ethyl 2-fluoro-3-oxobutanoate (197), 7% ethyl 2,4-difluoro-3-oxobutanoate (198), and 1% ethyl 2,2-difluoro-3-oxobutanoate (199) (GC); 57% conversion (¹H NMR); 197/198/199 = 91.4:5.4:3.2 (¹⁹F NMR).

Analysis of reaction mixture; 197/198/199 = 83.2:14.0:2.9 (¹⁹F NMR).

Effect of the concentration of the substrate solution

Substrate/formic acid = 1:2 (Table 4.3, entry 1)

Substrate solution was prepared; the solution consisted of ethyl 3-oxo-butanoate (196) (182.2 g, 1.40 mol) and formic acid (128.9 g, 2.80 mol).

Substrate solution was passed through the microreactor at a rate of 4.1 mLh⁻¹ in total [0.45 mLh⁻¹ch⁻¹, = 2.2 mmolh⁻¹ch⁻¹ (d = 1.087)]. Reaction duration 18 hrs. Gave a colourless oil (92 g); conversion was found to be 36%, which consisted of, 91% ethyl 2-fluoro-3-oxobutanoate (197), and 9% ethyl 2,4-difluoro-3-oxobutanoate (198) (GC); 40% conversion (¹H NMR); 197/198/199 = 90.0:6.4:3.6 (¹⁹F NMR).

Analysis of reaction mixture; 197/198/199 = 74.8:22.1:3.1 (¹⁹F NMR).

Substrate/formic acid = 1:4 (Table 4.3, entry 2)

See the experimental part for table 4.2.

Substrate/formic acid = 1:8 (Table 4.3, entry 3)

Substrate solution was prepared; the solution consisted of ethyl 3-oxo-butanoate (**196**) (117.1 g, 0.900 mol) and formic acid (331.5 g, 7.20 mol).

Substrate solution was passed through the microreactor at a rate of 4.3 mLh^{-1} in total [$0.47 \text{ mLh}^{-1}\text{ch}^{-1}$, = $1.1 \text{ mmolh}^{-1}\text{ch}^{-1}$ ($d = 1.141$)]. Reaction duration 18 hrs. Gave a colourless oil (45.8 g); conversion was found to be 82%, which consisted of, 87% ethyl 2-fluoro-3-oxobutanoate (**197**), 5% ethyl 2,4-difluoro-3-oxobutanoate (**198**), and 3% ethyl 2,2-difluoro-3-oxobutanoate (**199**) (GC); 70% conversion (^1H NMR); **197/198/199** = 92.6:5.2:2.2 (^{19}F NMR).

Analysis of reaction mixture; **197/198/199** = 85.0:12.1:2.8 (^{19}F NMR).

Substrate/formic acid = 1:16 (Table 4.3, entry 4)

Substrate solution was prepared; the solution consisted of ethyl 3-oxo-butanoate (**196**) (45.55 g, 0.350 mol) and formic acid (257.8 g, 5.60 mol).

Substrate solution was passed through the microreactor at a rate of 4.2 mLh^{-1} in total [$0.47 \text{ mLh}^{-1}\text{ch}^{-1}$, = $0.63 \text{ mmolh}^{-1}\text{ch}^{-1}$ ($d = 1.164$)]. Reaction duration 18 hrs. Gave a colourless oil (20.2 g); conversion was found to be 74%, which consisted of, 88% ethyl 2-fluoro-3-oxobutanoate (**197**), 4% ethyl 2,4-difluoro-3-oxobutanoate (**198**), and 4% ethyl 2,2-difluoro-3-oxobutanoate (**199**) (GC); 76% conversion (^1H NMR); **197/198/199** = 93.5:4.0:2.5 (^{19}F NMR).

Analysis of reaction mixture; **197/198/199** = 86.9:9.7:3.4 (^{19}F NMR).

Substrate/formic acid = 1:32 (Table 4.3, entry 5)

Substrate solution was prepared; the solution consisted of ethyl 3-oxo-butanoate (**196**) (32.5 g, 0.250 mol) and formic acid (368.2 g, 8.00 mol).

Substrate solution was passed through the microreactor at a rate of 4.3 mLh^{-1} in total [$0.47 \text{ mLh}^{-1}\text{ch}^{-1}$, = $0.35 \text{ mmolh}^{-1}\text{ch}^{-1}$ ($d = 1.189$)]. Reaction duration 19 hrs. Gave a colourless oil (8.99 g); conversion was found to be 66%, which consisted of, 90% ethyl 2-fluoro-3-oxobutanoate (**197**), and 4% ethyl 2,4-difluoro-3-oxobutanoate (**198**) (GC); 69% conversion (^1H NMR); **197/198/199** = 92.5:5.6:1.9 (^{19}F NMR).

Analysis of reaction mixture; **197/198/199** = 88.2:9.5:2.3 (^{19}F NMR).

Effect of reaction temperature

(Substrate/formic acid = 1:2)

Substrate solution was prepared; the solution consisted of ethyl 3-oxo-butanoate (**196**) (182.2 g, 1.40 mol) and formic acid (128.9 g, 2.80 mol).

Reaction temperature: 7—8 °C (Table 4.4, entry 1)

See the experimental part for table 4.3, entry 1.

Reaction temperature: 20 °C (Table 4.4, entry 2)

Reaction was carried out at 20 °C. Reaction duration 18 hrs. Gave a colourless oil (61 g); conversion was found to be 32%, which consisted of, 91% ethyl 2-fluoro-3-oxobutanoate (**197**), and 9% ethyl 2,4-difluoro-3-oxobutanoate (**198**) (GC); 36% conversion (¹H NMR); **197/198/199** = 89.7:6.7:3.6 (¹⁹F NMR).

Analysis of reaction mixture; **197/198/199** = 73.1:23.4:3.5 (¹⁹F NMR).

(Substrate/formic acid = 1:4)

Substrate solution was prepared; the solution consisted of ethyl 3-oxo-butanoate (**196**) (195.2 g, 1.50 mol) and formic acid (276.2 g, 6.00 mol).

Reaction temperature: 1—3 °C (Table 4.4, entry 3)

Reaction was carried out at 1—3 °C. Reaction duration 18 hrs. Gave a colourless oil (37.0 g); conversion was found to be 59%, which consisted of, 83% ethyl 2-fluoro-3-oxobutanoate (**197**), 8% ethyl 2,4-difluoro-3-oxobutanoate (**198**), and 3% ethyl 2,2-difluoro-3-oxobutanoate (**199**) (GC); 56% conversion (¹H NMR); **197/198/199** = 88.9:8.0:3.1 (¹⁹F NMR).

Analysis of reaction mixture; **197/198/199** = 80.4:16.2:3.4 (¹⁹F NMR).

Reaction temperature: 8—10 °C (Table 4.4, entry 4)

See the experimental part for table 4.2.

(Substrate/formic acid = 1:8)

Substrate solution was prepared; the solution consisted of ethyl 3-oxo-butanoate (**196**) (117.1 g, 0.900 mol) and formic acid (331.5 g, 7.20 mol).

Reaction temperature: 2—3 °C (Table 4.4, entry 5)

Reaction was carried out at 2—3 °C. Reaction duration 18 hrs. Gave a colourless oil (25.9 g); conversion was found to be 81%, which consisted of, 84% ethyl 2-fluoro-3-oxobutanoate (**197**), 3% ethyl 2,4-difluoro-3-oxobutanoate (**198**), and 3% ethyl 2,2-difluoro-3-oxobutanoate (**199**) (GC); 70% conversion (¹H NMR); **197/198/199** = 92.3:5.2:2.5 (¹⁹F NMR).

Analysis of reaction mixture; **197/198/199** = 85.2:11.9:2.8 (¹⁹F NMR).

Reaction temperature: 8 °C (Table 4.4, entry 6)

See the experimental part for table 4.3, entry 3.

Reaction temperature: 15—16 °C (Table 4.4, entry 7)

Reaction was carried out at 15—16 °C. Reaction duration 18 hrs. Gave a colourless oil (27.4 g); conversion was found to be 79%, which consisted of, 91% ethyl 2-fluoro-3-oxobutanoate (**197**), 4% ethyl 2,4-difluoro-3-oxobutanoate (**198**), and 2% ethyl 2,2-difluoro-3-oxobutanoate (**199**) (GC); 77% conversion (¹H NMR); **197/198/199** = 92.8:4.8:2.4 (¹⁹F NMR).

Analysis of reaction mixture; **197/198/199** = 85.7:11.4:2.9 (¹⁹F NMR).

(Substrate/formic acid = 1:16)

Substrate solution was prepared; the solution consisted of ethyl 3-oxo-butanoate (**196**) (45.55 g, 0.350 mol) and formic acid (257.8 g, 5.60 mol).

Reaction temperature: 8—9 °C (Table 4.4, entry 8)

See the experimental part for table 4.3, entry 4.

Reaction temperature: 20 °C (Table 4.4, entry 9)

Reaction was carried out at 20 °C. Reaction duration 18 hrs. Gave a colourless oil (15.2 g); conversion was found to be 94%, which consisted of, 91% ethyl 2-fluoro-3-oxobutanoate (**197**), 3% ethyl 2,4-difluoro-3-oxobutanoate (**198**), and 2% ethyl 2,2-difluoro-3-oxobutanoate (**199**) (GC); 84% conversion (¹H NMR); **197/198/199** = 93.7:3.6:2.7 (¹⁹F NMR).

Analysis of reaction mixture; **197/198/199** = 87.4:8.6:4.0 (¹⁹F NMR).

(Substrate/formic acid = 1:32)

Substrate solution was prepared; the solution consisted of ethyl 3-oxo-butanoate (**196**) (32.5 g, 0.250 mol) and formic acid (368.2 g, 8.00 mol).

Reaction temperature: 8—9 °C (Table 4.4, entry 10)

See the experimental part for table 4.3, entry 5.

Reaction temperature: 20 °C (Table 4.4, entry 11)

Reaction was carried out at 20 °C. Reaction duration 19 hrs. Gave a colourless oil (8.85 g); conversion was found to be 85%, which consisted of, 92% ethyl 2-fluoro-3-oxobutanoate (**197**), 3% ethyl 2,4-difluoro-3-oxobutanoate (**198**), and 2% ethyl 2,2-difluoro-3-oxobutanoate (**199**) (GC); 83% conv. (¹H NMR); **197/198/199** = 93.1:4.4:2.5 (¹⁹F NMR).

Analysis of reaction mixture; **197/198/199** = 88.2:8.5:3.3 (¹⁹F NMR).

Effect of the flow rate of the substrate solution

(Substrate/formic acid = 1:1)

Substrate solution was prepared; the solution consisted of ethyl 3-oxo-butanoate (**196**) (130.1 g, 1.00 mol) and formic acid (46.03 g, 1.00 mol).

Flow rate of the substrate solution: $0.42 \text{ mLh}^{-1}\text{ch}^{-1}$ (Table 4.5, entry 1)

Substrate solution was passed through the microreactor at a rate of 3.8 mLh^{-1} in total [$0.42 \text{ mLh}^{-1}\text{ch}^{-1}$, = $2.5 \text{ mmolh}^{-1}\text{ch}^{-1}$ ($d = 1.050$)]. Reaction duration 18 hrs. Gave a colourless oil (55.8 g); conversion was found to be 55%, which consisted of, 72% ethyl 2-fluoro-3-oxobutanoate (**197**), 10% ethyl 2,4-difluoro-3-oxobutanoate (**198**), and 2% ethyl 2,2-difluoro-3-oxobutanoate (**199**) (GC); 52% conversion (^1H NMR); **197/198/199** = 84.5:10.4:5.1 (^{19}F NMR).

Analysis of reaction mixture; **197/198/199** = 74.5:20.5:5.0 (^{19}F NMR).

Flow rate of the substrate solution: $0.29 \text{ mLh}^{-1}\text{ch}^{-1}$ (Table 4.5, entry 2)

The results of the following two experiments were averaged.

(Experiment 1)

Substrate solution was passed through the microreactor at a rate of 2.6 mLh^{-1} in total ($0.29 \text{ mLh}^{-1}\text{ch}^{-1}$, = $1.7 \text{ mmolh}^{-1}\text{ch}^{-1}$). Reaction duration 18 hrs. Gave a colourless oil (44.8 g); conversion was found to be 85%, which consisted of, 78% ethyl 2-fluoro-3-oxobutanoate (**197**), 11% ethyl 2,4-difluoro-3-oxobutanoate (**198**), and 3% ethyl 2,2-difluoro-3-oxobutanoate (**199**) (GC); 77% conversion (^1H NMR); **197/198/199** = 83.2:10.4:6.4 (^{19}F NMR).

(Experiment 2)

Substrate solution was passed through the microreactor at a rate of 2.6 mLh^{-1} in total ($0.29 \text{ mLh}^{-1}\text{ch}^{-1}$). Reaction duration 18 hrs. Gave a colourless oil (52.0 g); conversion was found to be 80%, which consisted of, 76% ethyl 2-fluoro-3-oxobutanoate (**197**), 12% ethyl 2,4-difluoro-3-oxobutanoate (**198**), and 3% ethyl 2,2-difluoro-3-oxobutanoate (**199**) (GC); 76% conversion (^1H NMR); **197/198/199** = 82.9:11.5:5.6 (^{19}F NMR).

Analysis of reaction mixture; **197/198/199** = 70.5:23.5:6.0 (^{19}F NMR).

(Substrate/formic acid = 1:36)

Substrate solution was prepared; the solution consisted of ethyl 3-oxo-butanoate (**196**) (32.54 g, 0.250 mol) and formic acid (414.3 g, 9.00 mol).

Flow rate of the substrate solution: $0.49 \text{ mLh}^{-1}\text{ch}^{-1}$ (Table 4.6, entry 1)

Substrate solution was passed through the microreactor at a rate of 4.4 mLh^{-1} in total [$0.49 \text{ mLh}^{-1}\text{ch}^{-1}$, = $0.32 \text{ mmolh}^{-1}\text{ch}^{-1}$ ($d = 1.184$)]. Reaction was carried out at 20°C .

Reaction duration 5 hrs. Gave a colourless oil (2.24 g); conversion was found to be 84%, which consisted of, 87% ethyl 2-fluoro-3-oxobutanoate (197), 4% ethyl 2,4-difluoro-3-oxobutanoate (198), and 3% ethyl 2,2-difluoro-3-oxobutanoate (199) (GC); 84% conversion ($^1\text{H NMR}$); $\underline{197/198/199} = 91.6:5.2:3.2$ ($^{19}\text{F NMR}$).

Analysis of reaction mixture; $\underline{197/198/199} = 87.1:9.0:3.9$ ($^{19}\text{F NMR}$).

Flow rate of the substrate solution: $0.96 \text{ mLh}^{-1}\text{ch}^{-1}$ (Table 4.6, entry 2)

Substrate solution was passed through the microreactor at a rate of 8.7 mLh^{-1} in total ($0.96 \text{ mLh}^{-1}\text{ch}^{-1}$, = $0.64 \text{ mmolh}^{-1}\text{ch}^{-1}$). Reaction was carried out at 20°C . Reaction duration 5 hrs. Gave a colourless oil (4.75 g); conversion was found to be 84%, which consisted of, 87% ethyl 2-fluoro-3-oxobutanoate (197), 4% ethyl 2,4-difluoro-3-oxobutanoate (198), and 3% ethyl 2,2-difluoro-3-oxobutanoate (199) (GC); 55% conversion ($^1\text{H NMR}$); $\underline{197/198/199} = 92.4:5.6:2.0$.

Analysis of reaction mixture; $\underline{197/198/199} = 88.8:8.7:2.5$ ($^{19}\text{F NMR}$).

Flow rate of the substrate solution: $1.94 \text{ mLh}^{-1}\text{ch}^{-1}$ (Table 4.6, entry 3)

Substrate solution was passed through the microreactor at a rate of 17.5 mLh^{-1} in total ($1.94 \text{ mLh}^{-1}\text{ch}^{-1}$, = $1.3 \text{ mmolh}^{-1}\text{ch}^{-1}$). Reaction was carried out at 20°C . Reaction duration 5 hrs. Gave a colourless oil (8.67 g); conversion was found to be 84%, which consisted of, 87% ethyl 2-fluoro-3-oxobutanoate (197), 4% ethyl 2,4-difluoro-3-oxobutanoate (198), and 3% ethyl 2,2-difluoro-3-oxobutanoate (199) (GC); 27% conversion ($^1\text{H NMR}$); $\underline{197/198/199} = 93.2:4.9:1.9$.

Analysis of reaction mixture; $\underline{197/198/199} = 89.2:8.6:2.2$ ($^{19}\text{F NMR}$).

Flow rate of the substrate solution: $3.92 \text{ mLh}^{-1}\text{ch}^{-1}$ (Table 4.6, entry 4)

Substrate solution was passed through the microreactor at a rate of 35.2 mLh^{-1} in total ($3.92 \text{ mLh}^{-1}\text{ch}^{-1}$, = $2.6 \text{ mmolh}^{-1}\text{ch}^{-1}$). Reaction was carried out at 20°C . Reaction duration 2.5 hrs. Gave a colourless oil (8.67 g); conversion was found to be 84%, which consisted of, 87% ethyl 2-fluoro-3-oxobutanoate (197), 4% ethyl 2,4-difluoro-3-oxobutanoate (198), and 3% ethyl 2,2-difluoro-3-oxobutanoate (199) (GC); 15% conversion ($^1\text{H NMR}$); $\underline{197/198/199} = 92.5:5.7:1.8$.

Analysis of reaction mixture; $\underline{197/198/199} = 90.2:7.8:2.0$ ($^{19}\text{F NMR}$).

Effect of the flow rate of fluorine

(Substrate/formic acid = 1:4)

Substrate solution was prepared; the solution consisted of ethyl 3-oxo-butanoate (196) (195.2 g, 1.50 mol) and formic acid (276.2 g, 6.00 mol).

Flow rate of fluorine: $10 \text{ mLmin}^{-1}\text{ch}^{-1}$ (Table 4.7, entry 1)

See the experimental part for table 4.2.

Flow rate of fluorine: $7 \text{ mLmin}^{-1}\text{ch}^{-1}$ (Table 4.7, entry 2)

The results of the following two experiments were averaged.

(Experiment 1)

Fluorine was passed through the microreactor at a rate of $63 \text{ mLmin}^{-1} / 16.4 \text{ mmolh}^{-1}$ in total ($7 \text{ mLmin}^{-1}\text{ch}^{-1}$, $1.8 \text{ mmolh}^{-1}\text{ch}^{-1}$). Reaction duration 18 hrs. Gave a colourless oil (81 g); conversion was found to be 53%, which consisted of, 89% ethyl 2-fluoro-3-oxobutanoate (**197**) and 7% ethyl 2,4-difluoro-3-oxobutanoate (**198**) (GC); 50% conversion ($^1\text{H NMR}$); **197/198/199** = 89.9:6.9:3.2 ($^{19}\text{F NMR}$).

Analysis of reaction mixture; **197/198/199** = 80.7:16.1:3.2 ($^{19}\text{F NMR}$).

(Experiment 2)

Fluorine was passed through the microreactor at a rate of $63 \text{ mLmin}^{-1} / 16.4 \text{ mmolh}^{-1}$ in total ($7 \text{ mLmin}^{-1}\text{ch}^{-1}$, $1.8 \text{ mmolh}^{-1}\text{ch}^{-1}$). Reaction duration 18 hrs. Gave a colourless oil (39.5 g); conversion was found to be 52%, which consisted of, 86% ethyl 2-fluoro-3-oxobutanoate (**197**), 7% ethyl 2,4-difluoro-3-oxobutanoate (**198**), and 2% ethyl 2,2-difluoro-3-oxobutanoate (**199**) (GC); 54% conversion ($^1\text{H NMR}$); **197/198/199** = 90.2:6.2:3.6 ($^{19}\text{F NMR}$).

Analysis of reaction mixture; **197/198/199** = 80.7:16.0:3.3 ($^{19}\text{F NMR}$).

Effect of the solvent

Formic acid (Table 4.8, entry 1)

See the experimental part for table 4.2.

Acetonitrile (Table 4.8, entry 2)

Substrate solution was prepared; the solution consisted of ethyl 3-oxo-butanoate (**196**) (52.1 g, 0.400 mol), and anhydrous acetonitrile (65.7 g, 1.60 mol).

Substrate solution was passed through the microreactor at a rate of 5.2 mLh^{-1} in total [$0.58 \text{ mLh}^{-1}\text{ch}^{-1}$, = $1.7 \text{ mmolh}^{-1}\text{ch}^{-1}$ ($d = 0.866$)]. Reaction duration 5 hrs. Gave a colourless oil (13.3 g); conversion was found to be 27%, which consisted of, 76% ethyl 2-fluoro-3-oxobutanoate (**197**), 19% ethyl 2,4-difluoro-3-oxobutanoate (**198**) and 5% ethyl 2,2-difluoro-3-oxobutanoate (**199**) (GC); 36% conversion ($^1\text{H NMR}$); **197/198/199** = 73.3:21.2:5.4 ($^{19}\text{F NMR}$). Analysis of reaction mixture; **197/198/199** = 62.0:32.9:5.1 ($^{19}\text{F NMR}$).

Acetonitrile/formic acid (1:1) (Table 4.8, entry 3)

Substrate solution was prepared; the solution consisted of ethyl 3-oxo-butanoate (**196**) (84.6 g, 0.650 mol), anhydrous acetonitrile (53.4 g, 1.30 mol), and formic acid (59.8 g,

1.30 mol).

Substrate solution was passed through the microreactor at a rate of 4.6 mLh^{-1} in total [$0.51 \text{ mLh}^{-1}\text{ch}^{-1}$, = $1.6 \text{ mmolh}^{-1}\text{ch}^{-1}$ ($d = 0.974$)]. Reaction duration 19 hrs. Gave a colourless oil (45.6 g); conversion was found to be 57%, which consisted of, 91% ethyl 2-fluoro-3-oxobutanoate (**197**), and 9% ethyl 2,4-difluoro-3-oxobutanoate (**198**) (GC); 60% conversion ($^1\text{H NMR}$); **197/198/199** = 85.3:11.6:3.1 ($^{19}\text{F NMR}$).

Analysis of reaction mixture; **197/198/199** = 71.4:25.5:3.1 ($^{19}\text{F NMR}$).

t-Butanol (Table 4.8, entry 4)

Substrate solution was prepared; the solution consisted of ethyl 3-oxo-butanoate (**196**) (56.3 g, 0.432 mol), and dry *t*-butanol (128.2 g, 1.73 mol).

Substrate solution was passed through the microreactor at a rate of 5.2 mLh^{-1} in total [$0.58 \text{ mLh}^{-1}\text{ch}^{-1}$, = $1.1 \text{ mmolh}^{-1}\text{ch}^{-1}$ ($d = 0.832$)]. Reaction was carried out at 20°C . Reaction duration 19 hrs. Gave a colourless oil (29.3 g); conversion was found to be 36%, which consisted of, 67% ethyl 2-fluoro-3-oxobutanoate (**197**), 19% ethyl 2,4-difluoro-3-oxobutanoate (**198**) and 4% ethyl 2,2-difluoro-3-oxobutanoate (**199**) (GC); **197/198/199** = 76.3:18.9:4.8 ($^{19}\text{F NMR}$).

Analysis of reaction mixture; **197/198/199** = 70.0:24.5:5.5 ($^{19}\text{F NMR}$).

2,2,2-Trifluoroethanol (Table 4.8, entry 5)

Substrate solution was prepared; the solution consisted of ethyl 3-oxo-butanoate (**196**) (58.5 g, 0.450 mol), and 2,2,2-trifluoroethanol (180.0 g, 1.80 mol).

Substrate solution was passed through the microreactor at a rate of 4.4 mLh^{-1} in total [$0.49 \text{ mLh}^{-1}\text{ch}^{-1}$, = $1.1 \text{ mmolh}^{-1}\text{ch}^{-1}$ ($d = 1.238$)]. Reaction duration 19 hrs. Gave a colourless oil (27.0 g); conversion was found to be 69%, which consisted of, 79% ethyl 2-fluoro-3-oxobutanoate (**197**), and 12% ethyl 2,4-difluoro-3-oxobutanoate (**198**) (GC); **197/198/199** = 77.8:18.3:3.9 ($^{19}\text{F NMR}$). Analysis of reaction mixture; **197/198/199** = 62.6:34.4:3.0 ($^{19}\text{F NMR}$).

No solvent (Table 4.8, entry 6)

No solvent was used. Ethyl 3-oxobutanoate was directly passed through the microreactor at a rate of 2.9 mLh^{-1} in total [$0.32 \text{ mLh}^{-1}\text{ch}^{-1}$, = $2.5 \text{ mmolh}^{-1}\text{ch}^{-1}$ ($d = 1.021$)]. Reaction duration 18 hrs. Gave a colourless oil (70.2 g); conversion was found to be 52%, which consisted of, 75% ethyl 2-fluoro-3-oxobutanoate (**197**), 12% ethyl 2,4-difluoro-3-oxobutanoate (**198**), and 4% ethyl 2,2-difluoro-3-oxobutanoate (**199**) (GC); 49% conversion ($^1\text{H NMR}$); **197/198/199** = 82.5:10.9:6.6 ($^{19}\text{F NMR}$). Analysis

of reaction mixture; 197/198/199 = 68.5:25.3:6.2 (¹⁹F NMR).

Ethyl 2-fluoro-3-oxobutanoate (197) (Scheme 4.12)

A mixture of ethyl 3-oxobutanoate (**196**) and ethyl 2-fluoro-3-oxobutanoate (**197**) [33% and 67%, respectively (GC)] contaminated with ethyl 2,4-difluoro-3-oxobutanoate (**198**), and ethyl 2,2-difluoro-3-oxobutanoate (**199**) [34% ethyl 3-oxobutanoate (**196**) (¹H NMR), 197/198/199 = 97.1:1.1:1.8 (¹⁹F NMR)] was passed through the microreactor at a rate of 4.1 mLh⁻¹ in total [0.46 mLh⁻¹ch⁻¹, = 1.2 mmolh⁻¹ch⁻¹ (d = 1.100)]. Reaction duration 18 hrs. Gave a colourless oil (110.5 g); which consisted of, 11% ethyl 3-oxobutanoate (**196**), 76% ethyl 2-fluoro-3-oxobutanoate (**197**), 3% ethyl 2,4-difluoro-3-oxobutanoate (**198**), and 4% ethyl 2,2-difluoro-3-oxobutanoate (**199**) (GC); 14% ethyl 3-oxobutanoate (**196**) (¹H NMR), 197/198/199 = 90.7:3.6:5.7 (¹⁹F NMR).

Analysis of reaction mixture; 197/198/199 = 84.2:11.3:4.5 (¹⁹F NMR).

Control reaction

Fluorination of ethyl 2-fluoro-3-oxobutanoate (197)

Using microreactor (Scheme 4.13)

No solvent was used. Ethyl 2-fluoro-3-oxobutanoate (**197**) was directly passed through the microreactor at a rate of 2.8 mLh⁻¹ in total [0.31 mLh⁻¹ch⁻¹, = 2.5 mmolh⁻¹ch⁻¹ (d = 1.181)]. Reaction duration 5 hrs. Gave a colourless oil (15.9 g) which contained ethyl 2-fluoro-3-oxobutanoate (**197**) (79%); m/z (EI⁺) 148 (M⁺, 8%), 120 ([M-C₂H₄]⁺, 8), 106 ([M-C₂H₂O]⁺, 58), 78 (70), 43 (100), ethyl 2,4-difluoro-3-oxobutanoate (**198**) (2%); m/z (EI⁺) 166 (M⁺, 3%), 138 ([M-C₂H₄]⁺, 15), 121 ([M-C₂H₅O]⁺, 21), 61 (24), 28 (100), ethyl 2,2-difluoro-3-oxobutanoate (**199**) (1%); m/z (EI⁺) 121 ([M-C₂H₅O]⁺, 3), 96 (11), 43 (100), 2-fluoroethyl 2-fluoro-3-oxobutanoate (**215**) (9%); m/z (EI⁺) 166 (M⁺, 2%), 103 ([M-C₂H₄FO]⁺, 48), 43 (100), 1-fluoroethyl 2-fluoro-3-oxobutanoate (**216**) (6%); m/z (EI⁺) 166 (M⁺, 1%), 103 ([M-C₂H₄FO]⁺, 14), 43 (100); 197/198/199/215/216 = 72.7:2.4:1.9:15.6:7.4 (¹⁹F NMR).

Analysis of reaction mixture; 197/198/199/215/216 = 69.1:4.4:2.0:16.7:7.9 (¹⁹F NMR).

2-Fluoroethyl 2-fluoro-3-oxobutanoate (215) (not isolated)

¹⁹F NMR (188 MHz, CDCl₃) δ -225.6 (m); m/z (EI⁺) 166 (M⁺, 2%), 103 ([M-C₂H₄FO]⁺, 48), 43 (100).

1-Fluoroethyl 2-fluoro-3-oxobutanoate (216) (not isolated)

¹⁹F NMR (188 MHz, CDCl₃) δ -123.3 (m); m/z (EI⁺) 166 (M⁺, 1%), 103 ([M-C₂H₄FO]⁺, 14), 43 (100).

Batch conditions (Table 4.8, entry 1)

Ethyl 2-fluoro-3-oxobutanoate (**197**) (5.91 g, 39.9 mmol) was placed in the small PTFE reactor. The mixture was purged with N₂ and immersed in a cooling bath of 7–8 °C. Elemental fluorine as a 10% (v/v) mixture with nitrogen was introduced at a flow rate of 10 mL/min into the rapidly stirred mixture *via* PTFE tubing for 15 hours. The reaction mixture was purged with N₂ for 30 minutes. The work up procedure was similar to microreactor reactions. Gave a colourless oil (7.62 g) which contained ethyl 2-fluoro-3-oxobutanoate (**197**) (80%), ethyl 2,4-difluoro-3-oxobutanoate (**198**) (2%), ethyl 2,2-difluoro-3-oxobutanoate (**199**) (1%), 2-fluoroethyl 2-fluoro-3-oxobutanoate (**215**) (10%), 1-fluoroethyl 2-fluoro-3-oxobutanoate (**216**) (6%); **197/198/199/215/216** = 72.0:3.4:2.1:15.5:7.0 (¹⁹F NMR).

Analysis of reaction mixture; **197/198/199/215/216** = 69.2:5.1:2.2:15.5:8.0 (¹⁹F NMR).

Batch conditions, in the presence of formic acid (Table 4.9, entry 2)

The reaction was carried out in same manner described above. A mixture of ethyl 2-fluoro-3-oxobutanoate (5.92 g, 40.0 mmol) and formic acid (185 mg, 4.02 mmol) gave a colourless oil (8.55 g) which contained ethyl 2-fluoro-3-oxobutanoate (**197**) (80%), ethyl 2,4-difluoro-3-oxobutanoate (**198**) (2%), ethyl 2,2-difluoro-3-oxobutanoate (**199**) (1%), 2-fluoroethyl 2-fluoro-3-oxobutanoate (**215**) (10%), 1-fluoroethyl 2-fluoro-3-oxobutanoate (**216**) (6%); **197/198/199/215/216** = 73.3 : 3.8 : 2.0 : 14.0 : 7.0 (¹⁹F NMR).

Analysis of reaction mixture; **197/198/199/215/216** = 71.3:5.1:2.1:15.7: 5.8 (¹⁹F NMR).

Effect of the catalyst

General Procedure (batch condition)

The reactions below follow the procedure described, unless otherwise stated. A mixture containing ethyl 3-oxobutanoate (347 mg, 2.67 mmol), catalyst, and formic acid (10 mL, 265 mmol) was placed in the small PTFE reactor. The mixture was purged with N₂ and immersed in a cooling bath of 8–9 °C. Elemental fluorine as a 10% (v/v) mixture with nitrogen was introduced at a flow rate of 10 mL/min into the rapidly stirred mixture *via* PTFE tubing. The reaction mixture was purged with N₂ for 30 minutes. The reaction mixture was poured into water (20 mL), neutralized by NaHCO₃, and extracted with chloroform (3 x 20 mL). The combined organic extracts were dried over anhydrous MgSO₄ and evaporated to give a crude product.

No catalyst (batch condition) (Table 4.10, entry 1)

No catalyst was added. The reaction was carried out at 16 °C. Ethyl 3-oxobutanoate (**196**) (347 mg, 2.67 mmol), and elemental fluorine (5.34 mmol) gave a colourless oil (305 mg); conversion was found to be 44%, which consisted of, 100% ethyl 2-fluoro-3-oxobutanoate (**197**) (GC); 45% conversion (^1H NMR); **197/198/199** = 95.6:3.4:1.0 (^{19}F NMR).

Analysis of reaction mixture; **197/198/199** = 90.8:7.9:1.3 (^{19}F NMR).

10 mol % Nickel (II) nitrate hexahydrate (batch condition) (Table 4.10, entry 2)

Ethyl 3-oxobutanoate (**196**) (347 mg, 2.67 mmol), nickel (II) nitrate hexahydrate (78 mg, 0.268 mmol) and elemental fluorine (5.34 mmol) gave a colourless oil (400 mg); conversion was found to be 75%, which consisted of, 93% ethyl 2-fluoro-3-oxobutanoate (**197**), 3% ethyl 2,4-difluoro-3-oxobutanoate (**198**), and 4% ethyl 2,2-difluoro-3-oxobutanoate (**199**) (GC); 73% conversion (^1H NMR); **197/198/199** = 91.5:3.4:5.1 (^{19}F NMR).

Analysis of reaction mixture; **197/198/199** = 87.8:6.3:5.9 (^{19}F NMR).

(Substrate/formic acid = 1:4)

No catalyst (Table 4.11, entry 1)

See the experimental part for table 4.2.

0.5 mol % Nickel (II) nitrate hexahydrate (Table 4.11, entry 2)

Substrate solution was prepared; the solution consisted of ethyl 3-oxo-butanoate (**196**) (92.4 g, 0.710 mol), nickel (II) nitrate hexahydrate (1.03 g, 3.55 mmol) and formic acid (130.7 g, 2.84 mol).

Substrate solution was passed through the microreactor at a rate of 4.3 mLh⁻¹ in total [0.48 mLh⁻¹ch⁻¹, = 1.7 mmolh⁻¹ch⁻¹ (d = 1.108)]. Reaction duration 19 hrs. Gave a colourless oil (55.6 g); conversion was found to be 60%, which consisted of, 95% ethyl 2-fluoro-3-oxobutanoate (**197**), and 5% ethyl 2,4-difluoro-3-oxobutanoate (**198**) (GC); 64% conversion (^1H NMR); **197/198/199** = 88.9:8.1:2.9 (^{19}F NMR).

Analysis of reaction mixture; **197/198/199** = 78.2:18.7:3.1 (^{19}F NMR).

(Substrate/formic acid = 1:32)

No catalyst (Table 4.11, entry 3)

See the experimental part for table 4.3, entry 5.

4 mol % Nickel (III) nitrate hexahydrate (Table 4.11, entry 4)

Substrate solution was prepared; the solution consisted of ethyl 3-oxo-butanoate (**196**) (19.5 g, 0.150 mol), nickel (II) nitrate hexahydrate (1.74 g, 5.98 mmol) and formic acid (220.9 g, 4.80 mol).

Substrate solution was passed through the microreactor at a rate of 4.2 mLh⁻¹ in total [0.46 mLh⁻¹ch⁻¹, = 0.34 mmolh⁻¹ch⁻¹ (d = 1.189)]. Reaction duration 19 hrs. Gave a colourless oil (7.94 g); conversion was found to be 60%, which consisted of, 95% ethyl 2-fluoro-3-oxobutanoate (**197**), 2% ethyl 2,4-difluoro-3-oxobutanoate (**198**), and 2% ethyl 2,2-difluoro-3-oxobutanoate (**199**) (GC); 64% conversion (¹H NMR); **197/198/199** = 93.4:4.1:2.5 (¹⁹F NMR). Analysis of reaction mixture; **197/198/199** = 89.3:7.6:3.1 (¹⁹F NMR).

Effect of the vertical orientation of the reactor

(Substrate/formic acid = 1:4)

Substrate solution was prepared; the solution consisted of ethyl 3-oxo-butanoate (**196**) (206.1 g, 1.58 mol) and formic acid (291.6 g, 6.34 mol).

$\theta = 0^\circ$ (Table 4.12, entry 1)

Substrate solution was passed through the microreactor at a rate of 4.4 mLh⁻¹ in total [0.49 mLh⁻¹ch⁻¹, = 1.7 mmolh⁻¹ch⁻¹ (d = 1.108)]. The reactor was fixed so that θ was 0°. Reaction duration 19 hrs. Gave a colourless oil (49.0 g); conversion was found to be 57%, which consisted of, 92% ethyl 2-fluoro-3-oxobutanoate (**197**), and 8% ethyl 2,4-difluoro-3-oxobutanoate (**198**) (GC); 60% conversion (¹H NMR); **197/198/199** = 88.9:8.6:2.5 (¹⁹F NMR).

Analysis of reaction mixture; **197/198/199** = 77.9:19.5:2.6 (¹⁹F NMR).

$\theta = 5^\circ$ (Table 4.12, entry 2)

The reactor was fixed so that θ was 5°. Reaction duration 19 hrs. Gave a colourless oil (47.7 g); conversion was found to be 37%, which consisted of, 93% ethyl 2-fluoro-3-oxobutanoate (**197**), and 7% ethyl 2,4-difluoro-3-oxobutanoate (**198**) (GC); 41% conversion (¹H NMR); **197/198/199** = 91.2:6.3:2.4 (¹⁹F NMR).

Analysis of reaction mixture; **197/198/199** = 78.9:18.6:2.4 (¹⁹F NMR).

$\theta = 2^\circ$ (Table 4.12, entry 3)

The reactor was fixed so that θ was 2°. Reaction duration 19 hrs. Gave a colourless oil (52.7 g); conversion was found to be 49%, which consisted of, 94% ethyl 2-fluoro-3-oxobutanoate (**197**), and 6% ethyl 2,4-difluoro-3-oxobutanoate (**198**) (GC); 53% conversion (¹H NMR); **197/198/199** = 91.9:5.8:2.4 (¹⁹F NMR).

Analysis of reaction mixture; **197/198/199** = 78.6:18.8:2.6 (¹⁹F NMR).

$\theta = 1^\circ$ (Table 4.12, entry 4)

The reactor was fixed so that θ was 1° . Reaction duration 19 hrs. Gave a colourless oil (41.2 g); conversion was found to be 56%, which consisted of, 93% ethyl 2-fluoro-3-oxobutanoate (197), and 7% ethyl 2,4-difluoro-3-oxobutanoate (198) (GC); 59% conversion ($^1\text{H NMR}$); 197/198/199 = 88.9:8.8:2.3 ($^{19}\text{F NMR}$).

Analysis of reaction mixture; 197/198/199 = 78.5:19.0:2.5 ($^{19}\text{F NMR}$).

$\theta = 0^\circ$ (Table 4.12, entry 5)

The reactor was fixed so that θ was 0° . Reaction duration 19 hrs. Gave a colourless oil (54.5 g); conversion was found to be 56%, which consisted of, 94% ethyl 2-fluoro-3-oxobutanoate (197), and 6% ethyl 2,4-difluoro-3-oxobutanoate (198) (GC); 59% conversion ($^1\text{H NMR}$); 197/198/199 = 93.1:4.4:2.5 ($^{19}\text{F NMR}$).

Analysis of reaction mixture; 197/198/199 = 79.7:17.7:2.6 ($^{19}\text{F NMR}$).

$\theta = -1^\circ$ (Table 4.12, entry 6)

The reactor was fixed so that θ was -1° . Reaction duration 19 hrs. Gave a colourless oil (40.6 g); conversion was found to be 59%, which consisted of, 98% ethyl 2-fluoro-3-oxobutanoate (197), and 6% ethyl 2,4-difluoro-3-oxobutanoate (198) (GC); 60% conversion ($^1\text{H NMR}$); 197/198/199 = 88.5:8.3:3.3 ($^{19}\text{F NMR}$).

Analysis of reaction mixture; 197/198/199 = 78.4:19.0:2.6 ($^{19}\text{F NMR}$).

Effect of cleaning the reactor

(Substrate/formic acid = 1:4)

Substrate solution was prepared; the solution consisted of ethyl 3-oxo-butanoate (196) (130.1 g, 1.00 mol) and formic acid (184.1 g, 4.00 mol).

Before cleaning (Table 4.13, entry 1)

See the experimental part for table 4.12, entry 5.

After cleaning (Table 4.13, entry 2)

Substrate solution was passed through the microreactor at a rate of 4.3 mLh^{-1} in total [$0.48 \text{ mLh}^{-1} \text{ ch}^{-1}$, = $1.7 \text{ mmolh}^{-1} \text{ ch}^{-1}$ ($d = 1.108$)]. Reaction duration 19 hrs. Gave a colourless oil (46.6 g); conversion was found to be 73%, which consisted of, 89% ethyl 2-fluoro-3-oxobutanoate (197), 7% ethyl 2,4-difluoro-3-oxobutanoate (198), and 2% ethyl 2,2-difluoro-3-oxobutanoate (199) (GC); 75% conversion ($^1\text{H NMR}$); 197/198/199 = 88.6:8.7:2.7 ($^{19}\text{F NMR}$).

Analysis of reaction mixture; 197/198/199 = 77.0:20.2:2.8 ($^{19}\text{F NMR}$).

After cleaning (2) (Table 4.13, entry 3)

Reaction duration 19 hrs. Gave a colourless oil (49.1 g); conversion was found to be 74%, which consisted of, 93% ethyl 2-fluoro-3-oxobutanoate (197), and 7% ethyl

2,4-difluoro-3-oxobutanoate (198) (GC); 74% conversion (^1H NMR); 197/198/199 = 90.6:6.9:2.5 (^{19}F NMR).

Analysis of reaction mixture; 197/198/199 = 78.2:19.1:2.7 (^{19}F NMR).

Effect of work up

Investigation of the change of product distribution in work-up

The ratios of products were analyzed by ^{19}F NMR in each extraction during work up of an experiment (Table 4.4, entry 6). 1 mL of samples were withdrawn from each extraction or organic phase, evaporated and analyzed.

reaction mixture: 197/198/199 = 85:12:3

extract 1 (224 mL, 98 mg was recovered from 1 mL): 197/198/199 = 94:4:2

extract 2 (102 mL, 17 mg was recovered from 1 mL): 197/198/199 = 76:20:4

extract 3 (101 mL, 5 mg was recovered from 1 mL): 197/198/199 = 31:64:4

extract 1-3 (before washing, 446 mL, 54 mg was recovered from 1 mL): 197/198/199 = 91:7:2

extract 1—3 (after washing, 52 mg was recovered from 1 mL): 197/198/199 = 94:3:2

extract 4 (110 mL, 5 mg was recovered from 1 mL): 197/198/199 = 32:68:0

extract 5 (112 mL, 3 mg was recovered from 1 mL): 197/198/199 = 19:81:0

extract 6 (100 mL, 3 mg was recovered from 1 mL): 197/198/199 = 0:100:0

crude: 197/198/199 = 93:5:2

Investigation of the change of product distribution by washing with various aqueous solutions

General procedure

The experiments below follow the procedure described, unless otherwise stated. 1 g of crude product (197/198/199 = 88.3:7.3:4.4) was dissolved in 10 mL of dichloromethane and washed with 10 mL of various aqueous solutions. 1 mL samples were withdrawn from the resulting organic phase, evaporated and analyzed by ^{19}F NMR.

Experiment 1 washing with water:

85 mg of crude product was recovered; 197/198/199 = 92.4:3.7:3.9

Experiment 2 washing with saturated NaCl aqueous solution:

91 mg of crude product was recovered; 197/198/199 = 89.3:6.3:4.4

Experiment 3 washing with saturated NaHCO_3 aqueous solution:

91 mg of crude product was recovered; 197/198/199 = 92.7:3.5:3.8

Experiment 4 washing with saturated NH_4Cl aqueous solution:

87 mg of crude product was recovered; $\underline{197/198/199} = 91.3:4.2:4.5$

Experiment 5 washing with 10% K_2CO_3 aqueous solution; The organic phase was washed with water additionally.

61 mg of crude product was recovered; $\underline{197/198/199} = 96.4:0.5:3.1$

Experiment 6 washing with 1N HCl; The organic phase was washed with water additionally.

82 mg of crude product was recovered; $\underline{197/198/199} = 93.5:2.4:4.1$

Demonstration of purification by washing with basic aqueous solution

Experiment 7 washing with saturated NaHCO_3 aqueous solution:

9.0 g of crude product ($\underline{197/198/199} = 88.3:7.3:4.4$) was dissolved in 100 mL of dichloromethane and washed with 3 portions of saturated sodium hydrogencarbonate (in total 150 mL), dried over magnesium sulfate, and evaporated to recover a colourless oil (8.0 g, 89%); $\underline{197/198/199} = 92.8:2.9:4.3$ (^{19}F NMR).

Experiment 8 washing with 10% K_2CO_3 aqueous solution:

9.0 g of crude product ($\underline{197/198/199} = 88.3:7.3:4.4$) was dissolved in 100 mL of dichloromethane and washed with 10% potassium carbonate (50 mL) and saturated sodium chloride (50 mL), dried over magnesium sulfate, and evaporated to recover a colourless oil (7.6 g, 84%); $\underline{197/198/199} = 94.7:1.7:3.6$ (^{19}F NMR).

8.2 Fluorination of other 1,3-ketoesters using multi-channel microreactor

General procedure

The reactions below follow the procedure described, unless otherwise stated. Microreactor was cooled to reaction temperature (8—10 °C) by an external cryostat. Fluorine was passed through the microreactor (V-21-9) at a rate of $90 \text{ mLmin}^{-1} / 23.4 \text{ mmolh}^{-1}$ in total ($10 \text{ mLmin}^{-1}\text{ch}^{-1}$, $2.6 \text{ mmolh}^{-1}\text{ch}^{-1}$). Substrate solution was passed through the microreactor at an appropriate rate. Reaction mixture was poured onto water, extracted with 3 portions of dichloromethane, and these were combined and washed with saturated sodium hydrogen carbonate. The remaining acidic aqueous phase was neutralized by solid sodium hydrogen carbonate, extracted by 3 portions of dichloromethane. All extracts were combined, dried over magnesium sulfate, and evaporated to give crude product which was analysed by GC (GC-MS) and NMR (^{19}F , ^1H) and compared with authentic samples.

Direct fluorination of ethyl 2-oxocyclohexanecarboxylate (**190**)

Substrate solution was prepared; the solution consisted of ethyl 2-oxo-cyclohexane carboxylate (**190**) (100.9 g, 0.593 mol) and formic acid (109.1 g, 2.37 mol).

Substrate solution was passed through the microreactor at a rate of 4.4 mLh⁻¹ in total [0.49 mLh⁻¹ch⁻¹, = 1.54 mmolh⁻¹ch⁻¹ (d = 1.114)]. Reaction duration 19 hrs. Gave a colourless oil (48.0 g); conversion was found to be 90%, which consisted of, 82% ethyl 1-fluoro-2-oxo-cyclohexanecarboxylate (**193**) (GC). (As compared to literature data.³²)

Direct fluorination of ethyl 2-chloro-3-oxobutanoate (**200**)

Substrate solution was prepared; the solution consisted of ethyl 2-chloro-3-oxo butanoate (**200**) (50.0 g, 0.304 mol) and formic acid (56.0 g, 1.22 mol).

Substrate solution was passed through the microreactor at a rate of 2.5 mLh⁻¹ in total [0.28 mLh⁻¹ch⁻¹, = 0.93 mmolh⁻¹ch⁻¹ (d = 1.164)]. Reaction duration 5 hrs. Gave a colourless oil (10.1 g); conversion was found to be 36%, which consisted of, 65% ethyl 2-chloro-2-fluoro-3-oxobutanoate (**201**) and 14% ethyl 2-chloro-2,4-difluoro-3-oxo butanoate (**202**) (GC). (As compared to literature data.^{32,35})

Ethyl 2-chloro-2-fluoro-3-oxobutanoate (**201**) (not isolated)

¹⁹F NMR (188 MHz, CDCl₃) δ -123.5 (s); m/z (EI⁺) 183 ([M+H]⁺ (C₆H₈³⁵ClFO₃), 1%), 142 ([M-C₂H₂O]⁺ (C₄H₆³⁷ClFO₂), 10), 140 ([M-C₂H₂O]⁺ (C₄H₆³⁵ClFO₂), 29), 112 (73), 43 (100).

Ethyl 2-chloro-2,4-difluoro-3-oxobutanoate (**202**) (not isolated)

¹⁹F NMR (188 MHz, CDCl₃) δ -127.5 (s), -234.6 (t, ²J_{HF} = 46.5 Hz); m/z (EI⁺) 200 [M⁺ (C₆H₇³⁵ClF₂O₃), 1%], 174 ([M-C₂H₄]⁺ (C₄H₃³⁷ClF₂O₃), 4), 140 ([M-C₂H₄]⁺ (C₄H₃³⁵ClF₂O₃), 14), 61 (100).

8.3 Fluorination of 1,3-diesters using multi-channel microreactor

General procedure

The reactions were carried out as previously described for the last section.

Direct fluorination of diethyl malonate (**217**)

Substrate solution was prepared; the solution consisted of diethyl malonate (**217**) (64.07 g, 0.400 mol) and formic acid (294.6 g, 6.40 mol).

Formic acid, reaction temperature: 8–9 °C (Table 4.16, entry 1)

Substrate solution was passed through the microreactor at a rate of 4.6 mLh⁻¹ in total [0.51 mLh⁻¹ch⁻¹, = 0.65 mmolh⁻¹ch⁻¹ (d = 1.144)]. Reaction duration 19 hrs. Gave a colourless oil (23.5 g); conversion was found to be 24% (GC); **218/219/220** = 2:59:39

(^{19}F NMR). (As compared to literature data.³⁵)

Diethyl 2-fluoromalonate (**218**) (not isolated): ^{19}F NMR (188 MHz, CDCl_3)
 δ -195.6 (d, $^2J_{\text{HF}} = 48.5$ Hz).

2-Fluoroethyl ethyl malonate (**219**) (not isolated): ^{19}F NMR (188 MHz, CDCl_3)
 δ -225.2 (m).

1-Fluoroethyl ethyl malonate (**220**) (not isolated): ^{19}F NMR (188 MHz, CDCl_3)
 δ -123.8 (m).

Formic acid, reaction temperature: 20 °C (Table 4.16, entry 2)

Reaction was carried out at 20 °C. Substrate solution was passed through the microreactor at a rate of 4.6 mLh^{-1} in total ($0.51 \text{ mLh}^{-1}\text{ch}^{-1}$, = $0.65 \text{ mmolh}^{-1}\text{ch}^{-1}$). Reaction duration 19 hrs. Gave a colourless oil (17.8 g); conversion was found to be 20% (GC); **218/219/220** = 2:62:37 (^{19}F NMR).

Acetonitrile, 2 mol % copper (III) nitrate hexahydrate (Scheme 4.16)

Substrate solution was prepared; the solution consisted of diethyl malonate (**217**) (8.32 g, 51.9 mmol), copper nitrate hemipentahydrate (242 mg, 1.04 mmol), and anhydrous acetonitrile (136.6 g, 3.33 mol).

Substrate solution was passed through the microreactor at a rate of 18 mLh^{-1} in total [$2.0 \text{ mLh}^{-1}\text{ch}^{-1}$, = $0.56 \text{ mmolh}^{-1}\text{ch}^{-1}$ ($d = 0.778$)]. Reaction was carried out at 5 °C. Reaction duration 5 hrs. Gave a colourless oil (6.32 g); conversion was found to be 19% (GC); **218/219/220** = 38:2:59 (^{19}F NMR).

Direct fluorination of dimethyl malonate (221)

Formic acid (Scheme 4.17)

Substrate solution was prepared; the solution consisted of dimethyl malonate (**221**) (33.03 g, 0.250 mol) and formic acid (184.1 g, 4.00 mol).

Substrate solution was passed through the microreactor at a rate of 4.4 mLh^{-1} in total [$0.49 \text{ mLh}^{-1}\text{ch}^{-1}$, = $0.67 \text{ mmolh}^{-1}\text{ch}^{-1}$ ($d = 1.180$)]. Reaction duration 19 hrs. Gave a colourless oil (21.1 g); conversion was found to be 4% (GC); **222/223** = 9:91 (^{19}F NMR) (As compared to literature data.⁵²).

Dimethyl 2-fluoromalonate (**222**) (not isolated): ^{19}F NMR (188 MHz, CDCl_3)
 δ -195.7 (d, $^2J_{\text{HF}} = 48.5$ Hz). Spectral data for dimethyl 2-fluoromalonate (**222**) are also shown below (See the experimental part for scheme 4.19).

Fluoromethyl methyl malonate (**223**) (not isolated): ^{19}F NMR (188 MHz, CDCl_3)
 δ -158.8 (t, $^2J_{\text{HF}} = 50.0$ Hz).

Acetonitrile, no catalyst (Table 4.17, entry 1)

Substrate solution was prepared; the solution consisted of dimethyl malonate (**221**) (6.87 g, 52.0 mmol), and anhydrous acetonitrile (136.6 g, 3.328 mol).

Substrate solution was passed through the microreactor at a rate of 18 mLh⁻¹ in total [2.0 mLh⁻¹ch⁻¹, = 0.57 mmolh⁻¹ch⁻¹ (d = 0.780)]. Reaction was carried out at 5–6 °C. Reaction duration 5 hrs. Gave a colourless oil (7.35 g); conversion was found to be 2% (GC); **222/223/224** = 42:50:7 (¹⁹F NMR).

Dimethyl 2,2-difluoromalonate (224) (not isolated): ¹⁹F NMR (188 MHz, CDCl₃) δ -112.2 (s). Spectral data for dimethyl 2,2-difluoromalonate (**224**) are also shown below (See the experimental part for scheme 4.19).

Acetonitrile, 2 mol % nickel (II) nitrate hexahydrate (Table 4.17, entry 2)

Substrate solution was prepared; the solution consisted of dimethyl malonate (**221**) (6.87 g, 52.0 mmol), nickel (II) nitrate hexahydrate (303 mg, 1.04 mmol), and anhydrous acetonitrile (136.6 g, 3.328 mol).

Substrate solution was passed through the microreactor at a rate of 18 mLh⁻¹ in total (2.0 mLh⁻¹ch⁻¹, = 0.57 mmolh⁻¹ch⁻¹). Reaction was carried out at 5–6 °C. Reaction duration 5 hrs. Gave a colourless oil (5.84 g); conversion was found to be 9% (GC); **222/223/224** = 80:12:7 (¹⁹F NMR).

Acetonitrile, 2 mol % copper (II) nitrate hemipentahydrate (Table 4.17, entry 3)

Substrate solution was prepared; the solution consisted of dimethyl malonate (**221**) (6.87 g, 52.0 mmol), copper (II) nitrate hemipentahydrate (242 mg, 1.04 mmol), and anhydrous acetonitrile (136.6 g, 3.328 mol).

Substrate solution was passed through the microreactor at a rate of 18 mLh⁻¹ in total (2.0 mLh⁻¹ch⁻¹, = 0.57 mmolh⁻¹ch⁻¹). Reaction was carried out at 5 °C. Reaction duration 5 hrs. Gave a colourless oil (6.94 g); conversion was found to be 13% (GC); **222/223/224** = 81:13:6 (¹⁹F NMR).

Direct fluorination of 2,2-Dimethyl-1,3-dioxane-4,6-dione (Meldrum's acid, 225)

Substrate/Acetonitrile = 1:16, no catalyst (Scheme 4.18)

Substrate solution was prepared; the solution consisted of Meldrum's acid (**225**) (30.00 g, 0.208 mol), and anhydrous acetonitrile (136.7 g, 3.33 mol).

Substrate solution was passed through the microreactor at a rate of 4.4 mLh⁻¹ in total [0.49 mLh⁻¹ch⁻¹, = 0.51 mmolh⁻¹ch⁻¹ (d = 0.830)]. Reaction was carried out at 6–8 °C. Reaction duration 19 hrs. Gave a pale yellow oil (12.4 g); conversion was found to

be 15% (GC); 226/227 = 99:1 (¹⁹F NMR). (As compared to literature data.²³¹)

5-Fluoro-2,2-dimethyl-1,3-dioxane-4,6-dione (226) (not isolated): ¹H NMR (400 MHz, CDCl₃) δ 1.83 and 1.86 (2 x s, 6H, CH₃), 5.67 (d, ²J_{HF} = 44.5 Hz, 1H, CHF); ¹⁹F NMR (188 MHz, CDCl₃) δ -206.1 (d, ²J_{HF} = 44.5 Hz).

5,5-Difluoro-2,2-dimethyl-1,3-dioxane-4,6-dione (227) (not isolated): ¹⁹F NMR (188 MHz, CDCl₃) δ -108.5 (s).

Substrate/Acetonitrile = 1:16, 2 mol % nickel (III) nitrate hexahydrate (Scheme 4.19)

Substrate solution was prepared; the solution consisted of Meldrum's acid (225) (30.00 g, 0.208 mol), nickel (II) nitrate hexahydrate (1.21 g, 4.16 mmol), and anhydrous acetonitrile (136.7 g, 3.33 mol).

Substrate solution was passed through the microreactor at a rate of 4.4 mLh⁻¹ in total (0.49 mLh⁻¹ch⁻¹, = 0.51 mmolh⁻¹ch⁻¹). Reaction was carried out at 3—4 °C. Reaction duration 19 hrs.

(work up A)

Reaction mixture (44.1 g) was poured onto water (ca. 200 mL), extracted with 3 portions of dichloromethane (400 mL in total), and these were combined and washed with water (three times) and saturated aqueous sodium chloride. The organic phase was dried over magnesium sulfate, and evaporated to give a pale yellow amorphous (6.28 g); conversion was found to be 50% (¹H NMR; estimated by comparison of the integration area between CHF of compound 226 and CH₂ in position 5 of the substrate); 226/227 = 99:1 (¹⁹F NMR).

(work up B)

Reaction mixture (22.9 g) was added into anhydrous methyl alcohol (20 mL), and stirred for 3 days at room temperature. The resulting mixture was poured onto water (ca. 100 mL), extracted with 3 portions of dichloromethane (200 mL in total), and these were combined and washed with saturated aqueous sodium hydrogen carbonate. The remaining acidic aqueous phase was neutralized by solid sodium hydrogen carbonate, extracted by 3 portions of dichloromethane (in total 150 mL). All extracts were combined, dried over magnesium sulfate, and evaporated to give a pale yellow oil (4.49 g); conversion was found to be 66%; which consisted of, 71% dimethyl 2-fluoromalonate (222); m/z (Cl⁺, NH₃) 168 ([M+NH₄]⁺, 100%), and 27% dimethyl 2,2-difluoromalonate (224); m/z (Cl⁺, NH₃) 186 ([M+NH₄]⁺, 100%) (GC); 222/224 = 69:31 (¹⁹F NMR).

1 g of the crude product was purified by flash chromatography [silica gel: 30 g, eluent:

hexane/ethyl acetate (8:1)] to provide dimethyl 2-fluoromalonate (**222**) (269 mg) and dimethyl 2,2-difluoromalonate (**224**) (72 mg) as colourless oils.

Dimethyl 2-fluoromalonate (222)

^1H NMR (400 MHz, CDCl_3) δ 3.85 (s, 6H, CH_3), 5.31 (d, $^2J_{\text{HF}} = 47.5$ Hz, 1H, CHF); ^{13}C NMR (101 MHz) δ 53.3 (s, CH_3), 85.1 (d, $^1J_{\text{CF}} = 197.0$ Hz, CHF), 164.2 (d, $^2J_{\text{CF}} = 24.0$ Hz, C=O); IR (neat) 1775, 1757, 1439, 1295, 1255, 1019 cm^{-1} ; mass spectrum, m/z (Cl^+ , NH_3) 168 ($[\text{M}+\text{NH}_4]^+$, 100%), (ES^+) (Found: $[\text{M}+\text{NH}_4]^+$ 168.0664. $\text{C}_5\text{H}_{11}\text{FNO}_4$ requires 168.0667). (As compared to literature data.⁵²)

Dimethyl 2,2-difluoromalonate (224)

^1H NMR (400 MHz, CDCl_3) δ 3.94 (s, 6H, CH_3); ^{13}C NMR (101 MHz) δ 54.1 (s, CH_3), 106.0 (t, $^1J_{\text{CF}} = 261.5$ Hz, CF_2), 161.1 (t, $^2J_{\text{CF}} = 31.0$ Hz, C=O); IR (neat) 1785, 1442, 1336, 1283, 1153, 1071, 798 cm^{-1} ; mass spectrum, m/z (Cl^+ , NH_3) 186 ($[\text{M}+\text{NH}_4]^+$, 100%) (Found: $[\text{M}+\text{NH}_4]^+$ 186.0577. $\text{C}_5\text{H}_{10}\text{F}_2\text{NO}_4$ requires 186.0572).

Substrate/Acetonitrile = 1:64, no catalyst (Table 4.18, entry 1)

Substrate solution was prepared; the solution consisted of Meldrum's acid (**225**) (7.50 g, 52.0 mmol), and anhydrous acetonitrile (136.7 g, 3.33 mol).

Substrate solution was passed through the microreactor at a rate of 18 mLh^{-1} in total [$2.0 \text{ mLh}^{-1}\text{ch}^{-1}$, = $0.57 \text{ mmolh}^{-1}\text{ch}^{-1}$ ($d = 0.787$)]. Reaction was carried out at 5 °C. Reaction duration 5 hrs.

(work up A)

Reaction mixture (22 g) was poured onto water (ca. 100 mL), extracted with 3 portions of dichloromethane (150 mL in total), and these were combined and washed with 2% aqueous sodium hydrogen carbonate. The organic phase was dried over magnesium sulfate, and evaporated to give a pale yellow amorphous (4.94 g); conversion was found to be 6% (^1H NMR); **226/227** = 100:0 (^{19}F NMR).

(work up B)

Reaction mixture (22 g) was added into anhydrous methyl alcohol (25 mL). Sulfuric acid (0.5 mL) was added to the mixture, and the resulting mixture was stirred for 2 hours under reflux condition. The reaction mixture was poured onto water/dichloromethane [1:1 mixture (v/v) (200 mL), neutralized by solid sodium hydrogen carbonate, extracted with 2 portions of dichloromethane (100 mL in total), and these were combined and dried over magnesium sulfate, and evaporated to give a pale yellow oil (3.31 g); conversion was found to be 26%; which consisted of, 79% dimethyl 2-fluoromalonate (**222**), and 14% dimethyl 2,2-difluoromalonate (**224**) (GC); **222/224** = 83:17 (^{19}F NMR).

Substrate/Acetonitrile = 1:64, 2 mol % nickel (II) nitrate hexahydrate (Table 4.18, entry 2)

Substrate solution was prepared; the solution consisted of Meldrum's acid (**225**) (7.50 g, 52.0 mmol), nickel (II) nitrate hexahydrate (303 mg, 1.04 mmol), and anhydrous acetonitrile (136.7 g, 3.33 mol).

Substrate solution was passed through the microreactor at a rate of 18 mLh⁻¹ in total (2.0 mLh⁻¹ch⁻¹, = 0.57 mmolh⁻¹ch⁻¹). Reaction was carried out at 5–6 °C. Reaction duration 5 hrs.

Work up A (see above) gave a pale yellow amorphous (2.17 g); conversion was found to be 42% (¹H NMR); **226/227** = 94:6 (¹⁹F NMR).

Work up B (see above) gave a pale yellow oil (3.39 g); conversion was found to be 50%; which consisted of, 74% dimethyl 2-fluoromalonate (**222**), and 23% dimethyl 2,2-difluoromalonate (**224**) (GC); **222/224** = 72:28 (¹⁹F NMR).

8.4 Fluorination of 1-Cyclohexen-1-yl acetate (**228**) using multi-channel microreactor

General procedure

The reactions below follow the procedure described, unless otherwise stated. Microreactor was cooled to reaction temperature by an external cryostat. Fluorine was passed through the microreactor (V-21-9) at a rate of 90 mLmin⁻¹ / 23.4 mmolh⁻¹ in total (10 mLmin⁻¹ch⁻¹, 2.6 mmolh⁻¹ch⁻¹). Substrate solution was passed through the microreactor at an appropriate rate. Reaction mixture was poured onto water, extracted with 3 portions of dichloromethane, dried over magnesium sulfate, and evaporated to give crude product which was analysed by GC, GC-MS and NMR (¹⁹F, ¹H) and compared with authentic samples.

In acetonitrile (Table 4.19, entry 1)

Substrate solution was prepared; the solution consisted of 1-cyclohexen-1-yl acetate (**228**) (30.0 g, 0.214 mol) and anhydrous acetonitrile (52.7 g, 1.28 mol).

Substrate solution was passed through the microreactor at a rate of 4.1 mLh⁻¹ in total [0.46 mLh⁻¹ch⁻¹, = 0.99 mmolh⁻¹ch⁻¹ (d = 0.841)]. Reaction was carried out at 6–7 °C. Reaction duration 5 hrs. Gave a brown oil (13.0 g); conversion was found to be 98%, which consisted of, 67% 2-fluorocyclohexanone (**229**) (GC) (As compared to literature data.³³).

2-Fluorocyclohexanone (**229**) (not isolated)

¹⁹F NMR (188 MHz, CDCl₃) δ -188.6 (d, ²J_{HF} = 49.5 Hz); m/z (EI⁺) 116 (M⁺, 88%),

55 (100).

In formic acid (Table 4.19, entry 2)

Substrate solution was prepared; the solution consisted of 1-cyclohexen-1-yl acetate (**228**) (25.3 g, 0.180 mol) and formic acid (99.8 g, 2.17 mol).

Substrate solution was passed through the microreactor at a rate of 4.4 mLh^{-1} in total [$0.49 \text{ mLh}^{-1}\text{ch}^{-1}$, = $0.80 \text{ mmolh}^{-1}\text{ch}^{-1}$ ($d = 1.137$)]. Reaction was carried out at 8—9 °C. Reaction duration 8 hrs. Gave a brown oil (8.36 g); conversion was found to be 100%, which consisted of, 65% 2-fluorocyclohexanone (**229**) (GC).

Chapter 9

Experimental to Chapter 5

9.1 Preparation of ionic liquids

Methyltrioctylammonium bis(trifluoromethyl)sulfonylamide

[O_c3NMe][NTf₂] (**230**)

Aliquat® 336 (14.08 g, 34.83 mmol) and lithium bis(trifluoromethyl)sulfonylamide (10.00 g, 34.83 mmol) were dissolved in acetone (150 mL) at room temperature. After stirring the mixture for 24 hours, the reaction mixture was filtered through a plug of Celite®. The filtrate was evaporated and dissolved in dichloromethane. The resulting mixture was filtrated again through a plug of Celite®. The solution was evaporated and dried under reduced pressure at 70 °C for 24 hours to give the title compound (**230**) (20.92 g, 93%) as an orange clear oil; ¹H NMR (400 MHz, acetone-*d*6) δ 0.91 (t, 3H, *J* = 6.5 Hz, CH₃), 1.3—1.5 (m, 36H, remaining CH₂), 1.93 (m, 6H, NCH₂CH₂), 3.28 (s, 3H, NCH₃), 3.53 (m, 6H, NCH₂); ¹³C NMR (101 MHz, acetone-*d*6) δ 14.3, 14.4, 22.8, 23.2, 23.3, 27.0, 29.7, 30.0, 30.1, 30.2, 32.4, 32.6, 48.8, 62.5, 121.0 (q, ¹*J*_{CF} = 321.5 Hz, CF₃); ¹⁹F NMR (188 MHz, CDCl₃) δ -79.5 (s); IR (neat) 2923, 2858, 1351, 1197, 1138, 1059, 619 cm⁻¹; mass spectrum, *m/z* (ES⁺) 424 ([M-(CF₃SO₂)₂N+(CH₂)₄]⁺, 33%), 396 ([M-(CF₃SO₂)₂N+(CH₂)₂]⁺, 100%), 368 ([M-(CF₃SO₂)₂N]⁺, 83%), (ES⁻) 280 ([M-C₂₅H₅₄N]⁻ 100%). (As compared to the literature data.²³⁶)

1-Butyl-3-methylimidazolium bis(trifluoromethyl)sulfonylamide

[Bmim][NTf₂] (**231**)

1-Butyl-3-methylimidazolium bromide (15.27 g, 69.69 mmol) and lithium bis(trifluoromethyl)sulfonylamide (20.00 g, 69.67 mmol) were dissolved in deionised water (80 mL) at room temperature. After stirring the mixture at 70 °C for 2 hours, the reaction mixture was extracted with dichloromethane and the extract was washed with deionised water (2 x 50 mL) to remove lithium bromide (The aqueous phase was tested negative for Br⁻ by AgNO₃). The solution was evaporated and dried under reduced pressure to give the title compound (**231**) (28.51 g, 98%) as a yellow clear liquid; Found: C, 28.44; H, 3.62; N, 9.98. C₁₀H₁₅F₆N₃O₄S₂ requires C, 28.64; H, 3.61; N, 10.02%; ¹H NMR (400 MHz, CDCl₃) δ 0.95 (t, 3H, *J* = 7.5 Hz, 9-H), 1.36 (m, 2H,

8-H), 1.84 (m, 2H, 7-H), 3.93 (s, 3H, 10-H), 4.16 (t, 2H, $J = 7.5$ Hz, 6-H), 7.30 (m, 2H, 4-H and 5-H), 8.72 (m, 2H, 2-H); ^{13}C NMR (101 MHz) δ 13.2 (s, 9-C), 19.3 (s, 8-C), 31.9 (s, 10-C), 36.3 (s, 7-C), 49.9 (s, 6-C), 119.8 (q, $^1J_{\text{CF}} = 321.5$ Hz, CF_3), 122.2 (s, 4-C or 5-C), 123.6 (s, 4-C or 5-C), 136.0 (s, 2-C); ^{19}F NMR (188 MHz, CDCl_3) δ -79.6 (s); IR (neat) 1353, 1197, 1140, 1057, 616, 571, 514 cm^{-1} ; mass spectrum, m/z (ES^+) 139 ($[\text{M}-(\text{CF}_3\text{SO}_2)_2\text{N}]^+$ 63%), (ES^-) 280 ($[\text{M}-\text{C}_8\text{H}_{15}\text{N}_2]^-$ 100%). (As compared to the literature data.²³⁵)

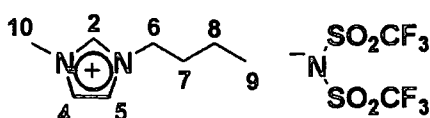

231

**1-Butyl-4-methylpyridinium bis(trifluoromethyl)sulfonylamide
[Bmp][NTf₂] (**232**)**

1-Butyl-4-methylpyridinium chloride (12.94 g, 69.67 mmol) and lithium bis(trifluoromethyl)sulfonylamide (20.00 g, 69.67 mmol) were dissolved in dry acetonitrile (300 mL) at room temperature. After stirring the mixture for 4 days, the reaction mixture was filtered to remove lithium chloride. The filtrate was evaporated, and the residue was dissolved in dichloromethane. The solution was filtered again to remove the newly formed lithium chloride. The filtrate was washed with deionised water (3 times) to remove residual lithium chloride. The solvent was evaporated and dried under reduced pressure to give the title compound (**232**) (26.12 g, 87%) as a red clear liquid; Found: C, 33.25; H, 3.74; N, 6.41. $\text{C}_{12}\text{H}_{16}\text{F}_6\text{N}_2\text{O}_4\text{S}_2$ requires C, 33.49; H, 3.75; N, 6.51%; ^1H NMR (500 MHz, CDCl_3) δ 0.94 (t, 3H, $J = 7.5$ Hz, 10-H), 1.36 (m, 2H, 9-H), 1.93 (m, 2H, 8-H), 2.65 (s, 3H, 11-H), 4.48 (t, 2H, $J = 7.5$ Hz, 7-H), 7.79 (d, 2H, $J = 6.5$ Hz, 3-H and 5-H), 8.60 (d, 2H, $J = 6.5$ Hz, 2-H and 6-H); ^{13}C NMR (126 MHz) δ 13.1 (s, 10-C), 19.1 (s, 9-C), 22.0 (s, 11-C), 33.2 (s, 8-C), 61.3 (s, 7-C), 119.7 (q, $^1J_{\text{CF}} = 321.5$ Hz, CF_3), 129.0 (s, 3-C and 5-C), 143.3 (s, 2-C and 6-C), 159.5 (s, 4-C); IR (neat) 1644, 1352, 1194, 1138, 1057, 617, 571, 514 cm^{-1} ; mass spectrum, m/z (ES^+) 150 ($[\text{M}-(\text{CF}_3\text{SO}_2)_2\text{N}]^+$, 100%), (ES^-) 280 ($[\text{M}-\text{C}_{10}\text{H}_{16}\text{N}]^-$ 100%).

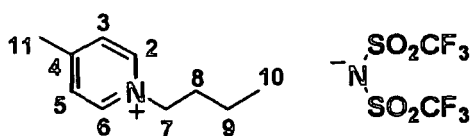

232

9.2 Direct fluorination of carbonyl compounds in ionic liquids

Direct fluorination of ethyl 3-oxobutanoate (**196**) in the presence of methyltrioctyl ammonium bis[(trifluoromethyl)sulfonyl] amide (**230**) (Scheme 5.5)

A mixture containing methyltrioctylammonium bis[(trifluoromethyl)sulfonyl] amide (**230**) (500 mg, 0.77 mmol), and anhydrous acetonitrile (10 mL) was placed in the small PTFE reactor. The mixture was purged with N₂ and immersed in a cooling bath of 0 °C. Elemental fluorine as a 10% (v/v) mixture with nitrogen was introduced at a flow rate of 10 mL/min into the rapidly stirred mixture *via* PTFE tubing (0.75 mmol). The reaction mixture was purged with N₂ for 30 minutes. No obvious N-F species was observed in ¹⁹F NMR of the reaction mixture. Ethyl 3-oxobutanoate (**196**) (358 mg, 2.75 mol) was added to the reaction mixture and purged with N₂. 10% F₂/N₂ was introduced again at a flow rate of 10 mL/min into the stirred mixture at 0 °C (5.33 mmol). The reaction mixture was purged with N₂ for 30 minutes. The reaction mixture was analysed by ¹⁹F NMR and the yields of the products were calculated by using the resonance of bis[(trifluoromethyl)sulfonyl] amide anion (NTf₂⁻, -79.3 ppm) as an internal standard; **197** (7%), **198** (3%), **199** (1%) (**197/198/199** = 62.2:28.6:9.2).

Direct fluorination of 1-cyclohexen-1-yl acetate (**228**) in 1-Butyl-3-methylimidazolium bis[(trifluoromethyl)sulfonyl]amide (**231**) (Scheme 5.6)

A mixture containing 1-cyclohexen-1-yl acetate (**228**) (564 mg, 4.02 mmol), and 1-butyl-3-methylimidazolium bis[(trifluoromethyl)sulfonyl] amide (**231**) (10 mL) was placed in the small PTFE reactor. The mixture was purged with N₂ and immersed in a cooling bath of 1 to 2 °C. Elemental fluorine as a 10% (v/v) mixture with nitrogen was introduced at a flow rate of 10 mL/min into the stirred mixture *via* PTFE tubing (10.1 mmol). The reaction mixture was purged with N₂ for 30 minutes. The reaction mixture was analysed by ¹⁹F NMR and the yields of the products were calculated by using the resonance of bis[(trifluoromethyl)sulfonyl] amide anion (NTf₂⁻, -79.6 ppm) as an internal standard; 2-fluorocyclohexanone (**229**) (65%). (As compared to literature data.³³) (See also the spectral data for **229** in section 8.3)

Direct fluorination of ethyl 2-oxocyclohexanecarboxylate (**190**) in 1-butyl-4-methylpyridinium bis[(trifluoromethyl)sulfonyl]amide (**232**)

A mixture containing ethyl 2-oxocyclohexanecarboxylate (**190**) (170 mg, 1.00 mmol), and 1-butyl-4-methylpyridinium bis[(trifluoromethyl)sulfonyl]amide (**232**) (10 mL) was placed in the small PTFE reactor. The mixture was purged with N₂ and immersed in a cooling bath of 0 °C. Elemental fluorine as a 10% (v/v) mixture with nitrogen was introduced at a flow rate of 10 mL/min into the stirred mixture *via* PTFE tubing (2.98 mmol). The reaction mixture was purged with N₂ for 30 minutes. The reaction mixture was diluted with dichloromethane and washed with water (5 x 30 mL). The resulting solution was heated at 200 °C under reduced pressure (0.6 mbar) and volatile components were condensed in a cold trap which was cooled with liquid nitrogen. A crude product was obtained from the cold trap as a yellow oil (163 mg); conversion was found to be 83%, which consisted of, 88% ethyl 1-fluoro-2-oxo-cyclohexane carboxylate (**193**) (GC). (As compared to literature data.³²) (See also the spectral data for **229** in section 7.2)

9.3 Direct fluorination of thioanisole (**239**) using microreactor technology

General procedure

The reactions below follow this procedure, unless otherwise stated. A microreactor was cooled to reaction temperature by an external cryostat. Fluorine was passed through the microreactor (V-21-9) at a rate of 90 mLmin⁻¹ / 23.4 mmolh⁻¹ in total (10 mLmin⁻¹ch⁻¹, 2.6 mmolh⁻¹ch⁻¹). Substrate solution was passed through the microreactor at an appropriate rate. Reaction mixture was poured onto water, neutralized by solid sodium hydrogen carbonate, extracted by 3 portions of dichloromethane. The extracts were combined, dried over magnesium sulfate, and evaporated to give crude product.

In acetonitrile (Scheme 5.12)

Substrate solution were prepared; the solution consisted of thioanisole (**239**) (9.00 g, 0.0725 mol) and anhydrous acetonitrile (59.5 g, 1.45 mol).

Substrate solution was passed through the microreactor at a rate of 3.0 mLh⁻¹ in total [0.33 mLh⁻¹ch⁻¹, = 0.28 mmolh⁻¹ch⁻¹ (d = 0.798)]. Reaction was carried out at 4–5 °C for 5 hrs and gave a brown oil (3.73 g); conversion was found to be 100% (GC). The crude mixture was analysed by ¹⁹F NMR (188 MHz, CDCl₃) in the presence of fluorobenzene (16.4 mg, 0.171 mmol) as an internal standard; δ -75.0 (s) (23.6%), -91.9 (d, *J* = 57.0 Hz) (17.9 %), -113.7 (s) [100%, (fluorobenzene)], -182.2 (t, *J* = 53.0 Hz) (12.2 %). [literature data for phenyl trifluoromethyl sulfoxide (**233**): δ -75.0

(s)²⁴⁵].

In formic acid/acetonitrile = 5:1 (Scheme 5.13)

Substrate solution were prepared; the solution consisted of thioanisole (**239**) (14.0 g, 0.113 mol), formic acid (103.8 g, 2.25 mol) and anhydrous acetonitrile (18.6 g, 1.45 mol).

Substrate solution was passed through the microreactor at a rate of 4.4 mLh⁻¹ in total [0.49 mLh⁻¹ch⁻¹, = 0.44 mmolh⁻¹ch⁻¹ (d = 1.093)]. Reaction was carried out at 5–6 °C. Reaction duration 5 hrs. Gave a brown oil (4.81 g); conversion was found to be 100%; which consisted of, 49% methyl phenylsulfone (**238**); m/z (EI⁺) 156 ([M]⁺, 71%), 141 (71), 94 (75), 77 (100) (GC).

Methyl phenylsulfone (238**) (not isolated)**

¹H NMR (200 MHz, CDCl₃) δ 2.99 (s, 3H, CH₃), 7.5—8.0 (m, 5H, Ar). (As compared to literature data.²⁵³)

Appendix

Operation Manual of Multi-channel Microreactor (V-21)

The Microreactor Fluorine Gas Handling Apparatus

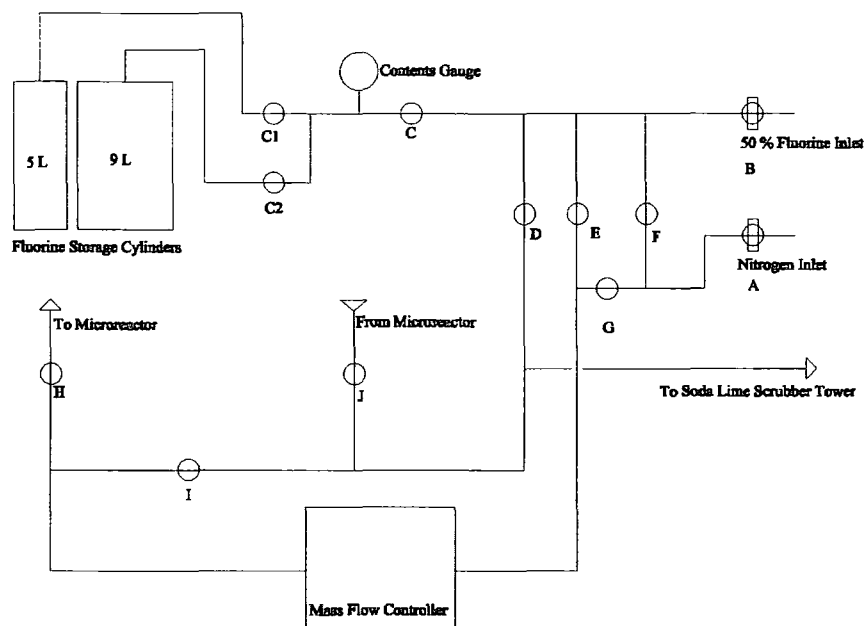

Fig A

Apparatus Construction

The apparatus is constructed from stainless steel pipe work and is fitted with Monel swagelok[®] valves (valves C to J: Integral bonnet needle valves, Valves A and B: Severe service union bonnet valves). The storage cylinders are constructed from stainless steel (5L) and mild steel (9L). The mass flow controller is a Brooks 5850S and is controlled by a DDE computer program obtained from Flotech Solutions[®] linked to a PC operating in Microsoft[®] Excel.

Microreactor Storage Cylinder Filling Procedure (See Fig A)

- 1) Ensure all valves are closed
- 2) The primary fluorine cylinder is turned on following usual procedure
- 3) Ensure storage tanks are empty (Open C1, C2, C, and D; then when empty close C1, C2, C, and D)
- 4) Open valve B
- 5) Open valve C1. Open valve C and slowly fill tank with required amount of Fluorine
- 6) Close valve C and then valve C1

- 7) Open valve C2 and then valve C, Slowly fill tank with the required amount of Fluorine
- 8) Close valve C, close valve C2
- 9) Close valve B. Isolate primary fluorine cylinder following usual procedure
- 10) Open valve D and then Close Valve D
- 11) Open valve A, open valve F
- 12) Repeat steps 5 to 8 with Nitrogen
- 13) Close valve F and valve A

Operation of Microreactor Rig Fluorination Procedure

- 1) Ensure all valves are closed
- 2) Open valves A, G, H, and J
- 3) Set flow at desired level using mass flow, purge with nitrogen for 15 minutes
- 4) Close valves A and G
- 5) Open valves C1, C2, C and then valve E, allow fluorine to flow for 5 minutes, before starting flow of liquid substrate through microreactor
- 6) Termination of the experiment, involves closing valves C1, C2, C and then E
- 7) Open valves A and G and purge for 15 minutes; close all valves

1. Operation for Fluorination

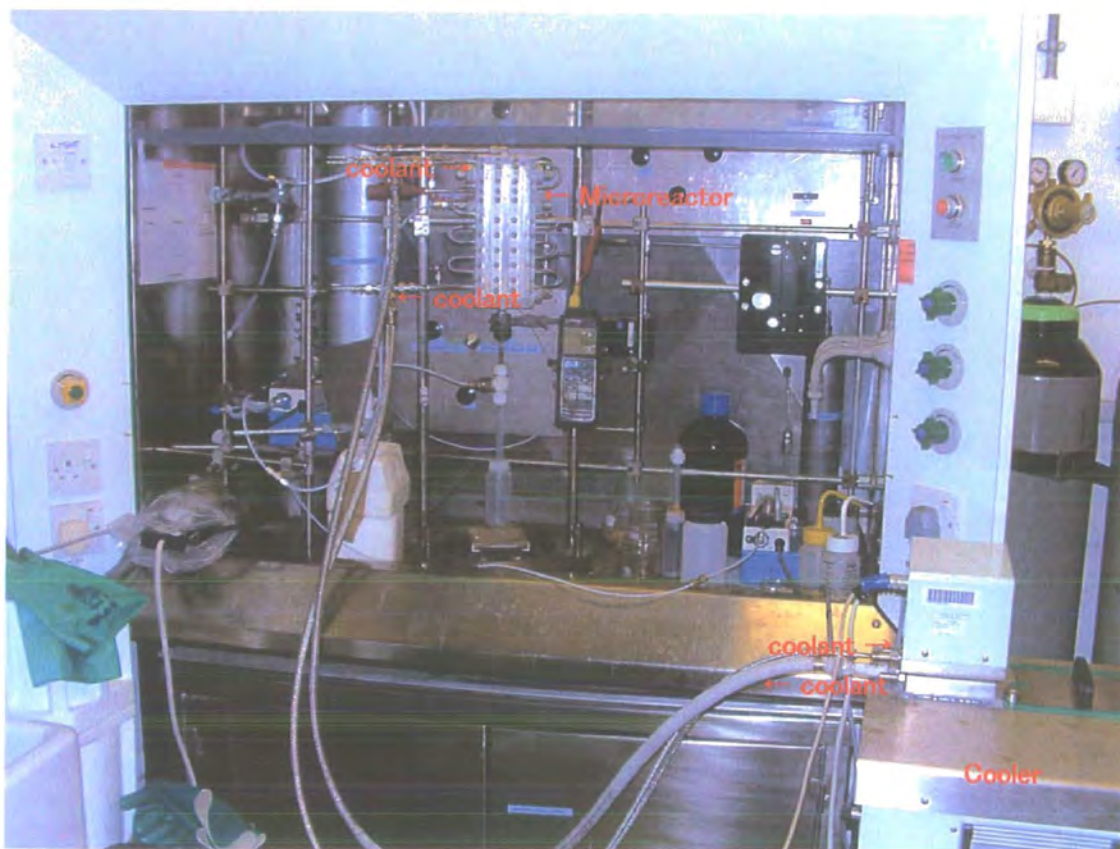

Fig 1 Microreactor (panoramic view)

1.1 Start of Fluorination

- 1) Turn on the cooler and set temperature required for the reaction beforehand (usually 3 or 4 hours before the start of the reaction) (Fig 2)
- 2) Check the temperature of the reactor (Fig 3)



Fig 2



Fig 3

3) Prepare substrate solution (Fig 4)

4) If necessary, measure the weight of known quantity of the solution for calculation of the density.



Fig 4

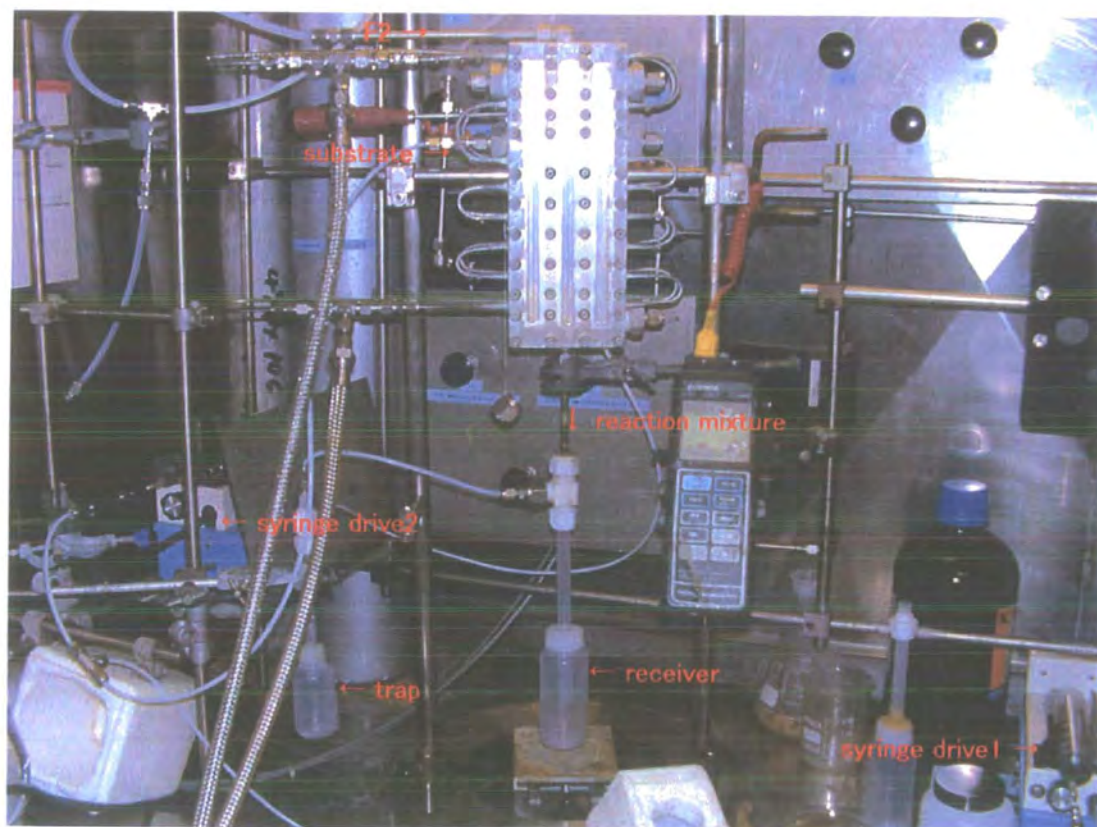

Fig 5

5) Cool the trap by dry ice (Fig 6-10)

N.B.; Do not fill dry ice above the top of the trap not to choke the pipe with solid (Fig 9)



Fig 6



Fig 7 (cover the trap by a polystyrene box)



Fig 8 (fill the box with dry ice)

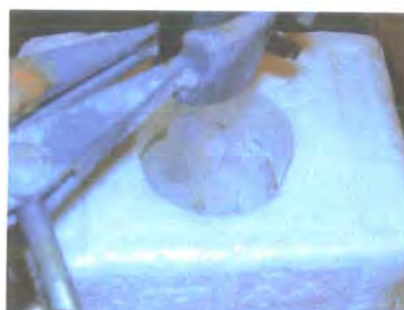

Fig 9



Fig 10 (block the hole with cotton)

6) Cool the receiver with ice (Fig 11-14)



Fig 11



Fig 12

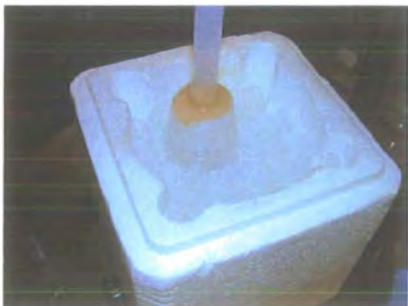

Fig 13

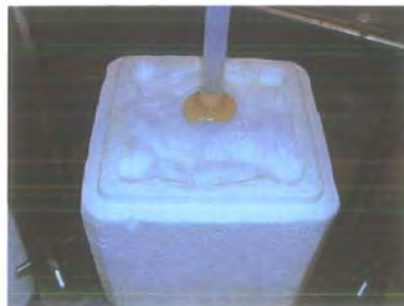

Fig 14

7) Pour the substrate solution into a beaker (Fig 15)



Fig 15

8) Take 45 mL of the substrate solution into a syringe (Fig 16)



Fig 16

N.B.; The air should be removed (Fig 17, 18)

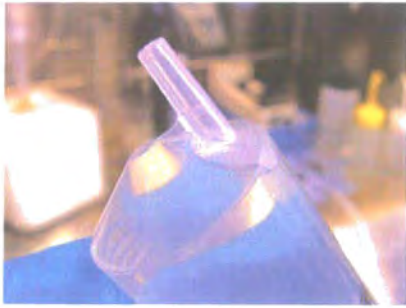

Fig 17

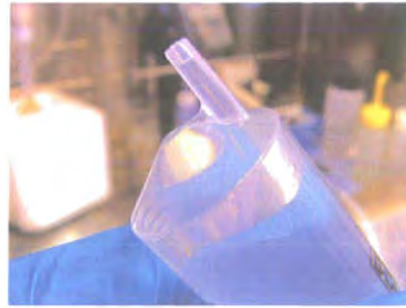

Fig 18

9) Change the syringe of one end of the line for another syringe filled with the solution (Fig 19, 20)

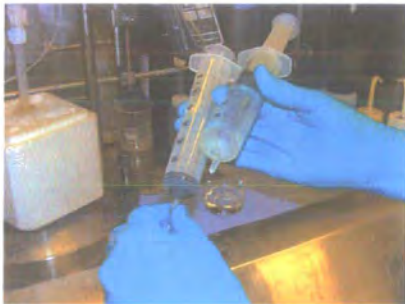

Fig 19

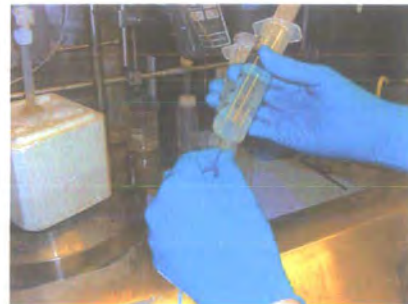

Fig 20

10) Feed 45 mL of the substrate solution to the reactor (Fig 21, 22)

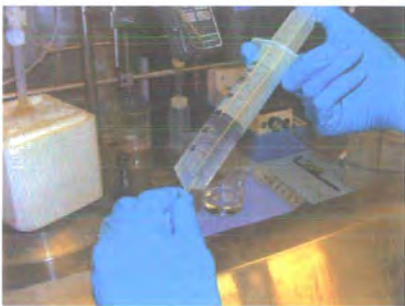

Fig 21

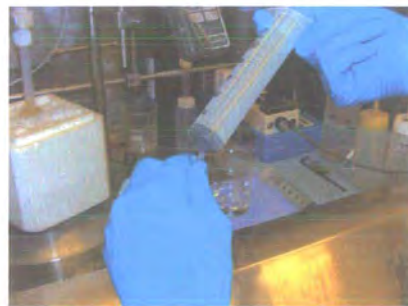

Fig 22

11) Take 2 x 55 mL of the substrate solution into two syringes and set to both of the syringe drives (Fig 23-28)



Fig 23

N.B.; When changing the syringes, keep them being above the upper level of the reservoir of the reactor to prevent the solution running back (Fig 24, 25)



Fig 24



Fig 25



Fig 26



Fig 27



Fig 28

12) Set the flow rate of the syringe drive
(Fig 29)



Fig 29

[set the three-digit dials to the number calculated by the guideline (Fig 30)]



Fig 30

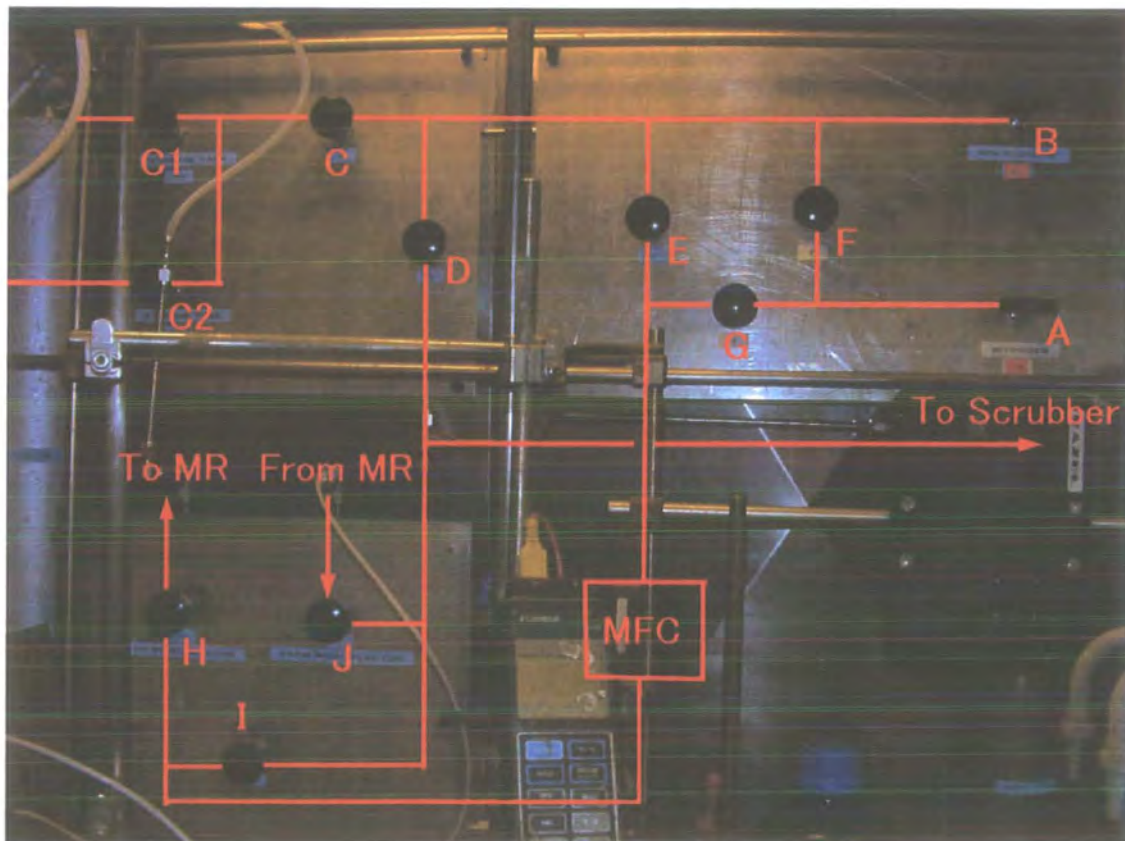

Fig 31 (valves)

N.B.; The reactor was usually purged through by nitrogen at 30 mL/min (valves A, G, H, and J are opened).

13) Close valve G

14) Set the flow rate of nitrogen at 99% (99 mL/min) on the CRT display (to eject the remaining nitrogen quickly). (Fig 32, 33)



Fig 32



Fig 33

- 15) Set the flow rate for fluorine gas as required (*e.g.* 90% means 90 mL/min = 10 mL/min/ch for 9 ch template)
 - 16) Open valve E
 - 17) Gradually open valve C (the flow rate and the pressure gauge should be checked; the flow rate and the pressure should rise once, and then drop)
- N.B.; Rapid change of the pressure may cause problems for the mass flow controller
- 18) Gradually open valve C1 (the flow rate and the pressure should rise again)
 - 19) Open C2
 - 20) Turn on the syringe drives (Fig 34)

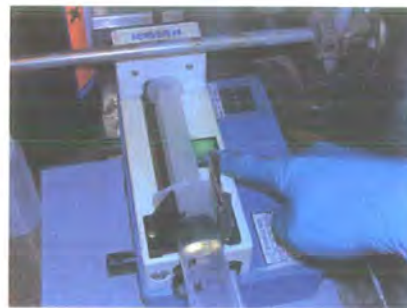

Fig 34 (syringe 1)

- 21) Turn the knob clockwise to feed more of the substrate solution to the reactor manually until the solution starts flowing in the channel (Fig 35)

N.B.; approximately 14 mL should be feed (7 mL each)



Fig 35 (syringe 2)

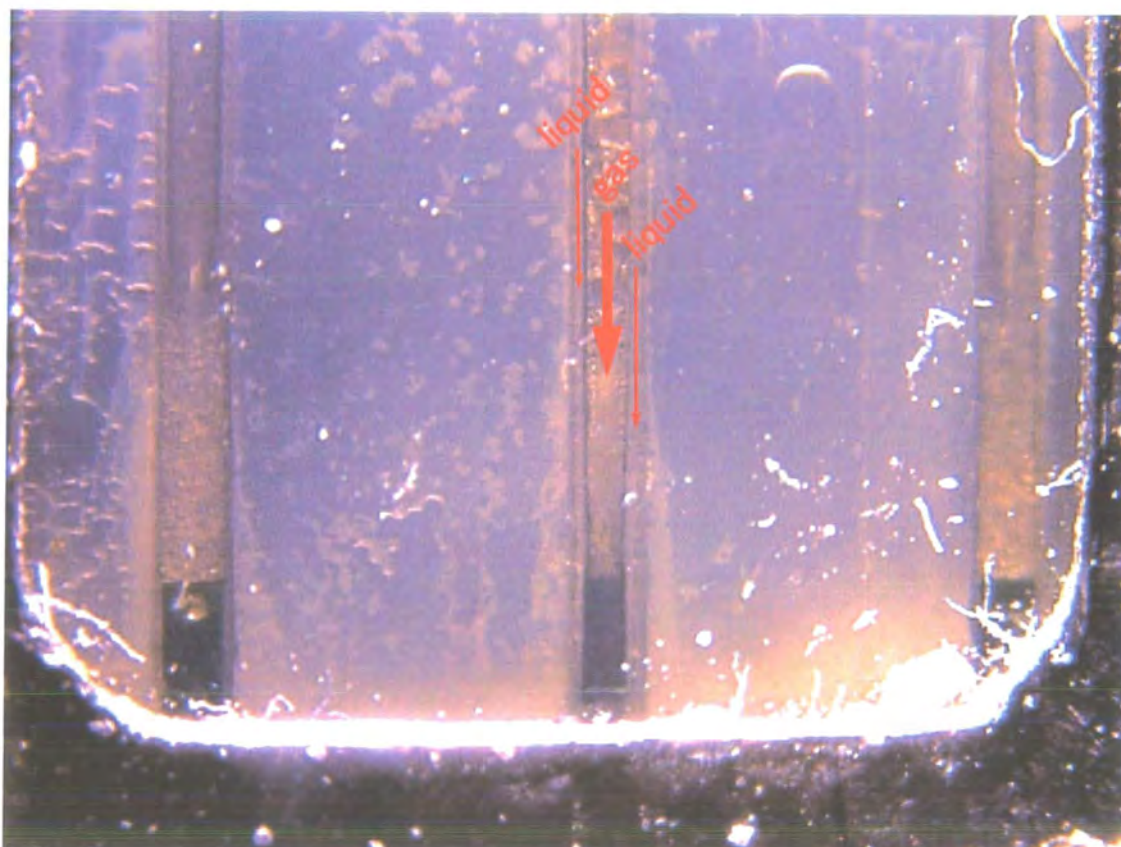

Fig 36 (the bottom of the channels under annular flow)

1.2 Termination of the Fluorination

- 1) Turn off the syringe drives
- 2) Pull one of the syringes back by 10 mL to stop providing the substrate to the channels (Fig 37)



Fig 37

- 3) Close valve C (wait until the flow rate drops to 0%)
- 4) Close valve E
- 5) Close valve C1 and C2
- 6) Set the flow rate at 50%

- 7) Gradually open valve G
- 8) Set the flow rate at 99% for purging
- 9) After 5 minutes, set the flow rate at 30%
- 10) Take the receiver and the trap off, and allow to room temperature (Fig 38)



Fig 38

- 11) Put the liquid in the trap back to the receiver
- 12) Work up the reaction mixture

1.3 Cleaning of the microreactor (daily)

N.B.; If the next reaction needs same substrate solution, following cleaning is not necessary.

- 1) Pull the syringes back to remove the rest of the solution in the reservoir (Fig 39, 40)

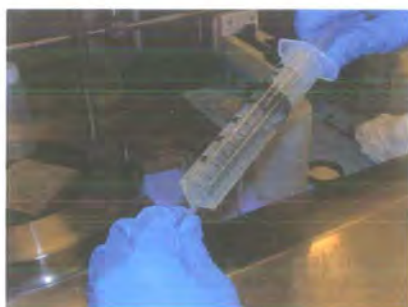

Fig 39



Fig 40

- 2) Take sample inlet off (Fig 41, 42)



Fig 41



Fig 42

3) Remove the rest of the substrate solution in the reservoir by a syringe (Fig 43)

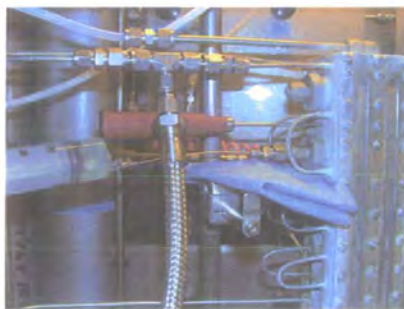

Fig 43

4) Put the inlet back (Fig 44)



Fig 44

5) Take acetonitrile into both syringes (50 mL each) (Fig 45-48)



Fig 45



Fig 46



Fig 47



Fig 48

6) Feed all of the acetonitrile to the reactor to wash the channels (Fig 49)

N.B.; Do not feed so fast to avoid the acetonitrile going into the gas reservoir.



Fig 49

7) Pull the syringes back to remove the rest of the solution in the reservoir

8) Take the sample inlet off (Fig 50)



Fig 50

9) Remove the rest of the acetonitrile in the reservoir by a syringe

10) If different substrate is to be used in the next reaction, repeat the operations 4)-9)

11) Open the reservoir (Fig 51, 52)

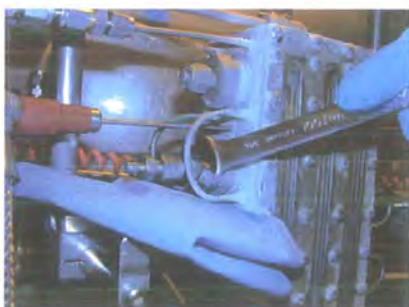

Fig 51



Fig 52

12) Wipe inside of the reservoir using blue roll (Fig 53-56)



Fig 53

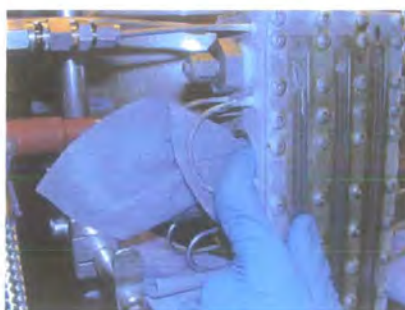

Fig 54



Fig 55



Fig 56

13) Close the reservoir and put the sample inlet back

14) Check the vertical alignment of the reactor
(Fig 57)



Fig 57

15) Dry the reactor overnight

1.4 Cleaning of the microreactor (every 2 or 3 months)

1) Disconnect the coolant inlet (A), the coolant outlet (B), the sample inlet (C), the volatile material outlet (D) and the fluorine gas inlet (E) (Fig 58-63)

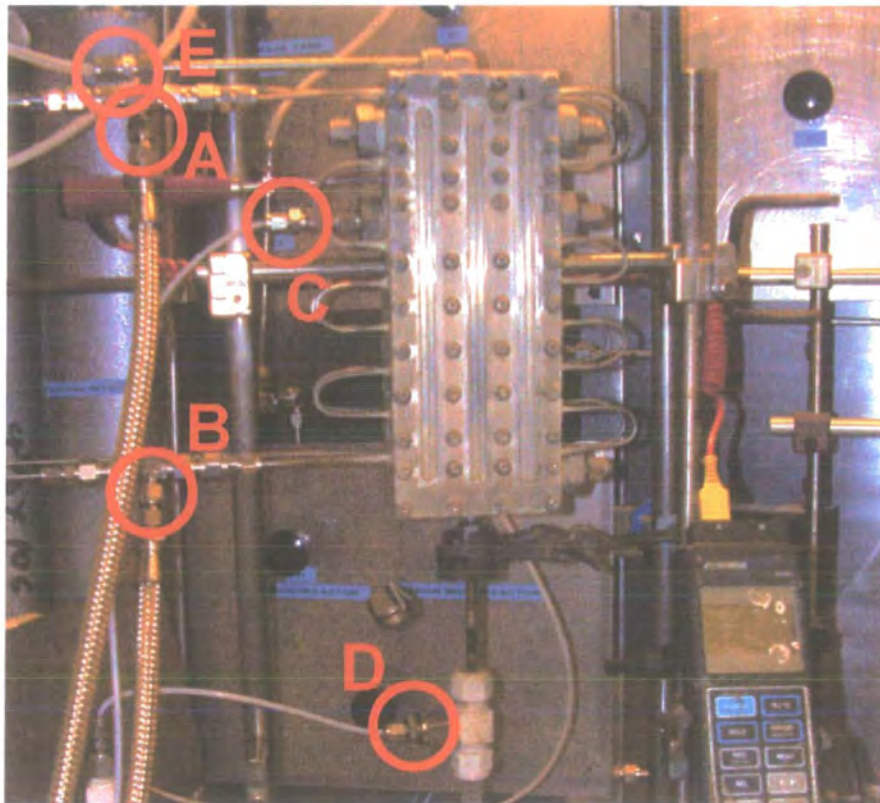

Fig 58

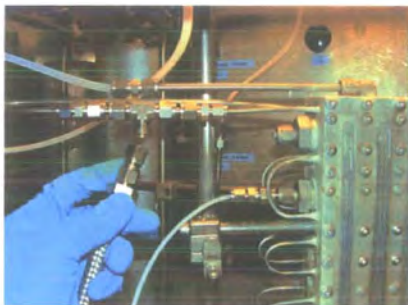

Fig 59 (A)

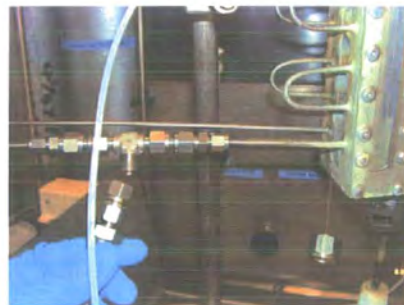

Fig 60 (B)

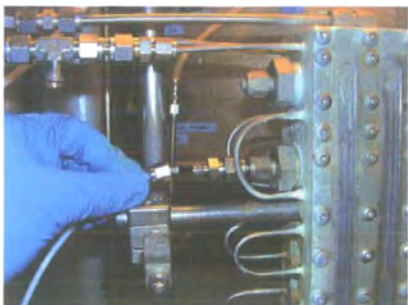

Fig 61 (C)



Fig 62 (D)



Fig 63 (E)

2) Loosener the side bar by an Allen wrench (Fig 64-66)



Fig 64



Fig 65



Fig 66

3) Take the microreactor off the stand and place it on an appropriate work space (Fig 67)



Fig 67

4) Using an Allen wrench and an electric screwdriver, take all of the screw fittings off from the microreactor (Fig 68, 69)



Fig 68



Fig 69

NB: If some screw fittings could not be taken off due to corrosion, saw a notch on the top of the fitting and take it off by screwdriver (Fig 70-73)



Fig 70



Fig 71



Fig 72



Fig 73

5) Disassemble all of the plates (Fig 74-78)



Fig 74



Fig 75

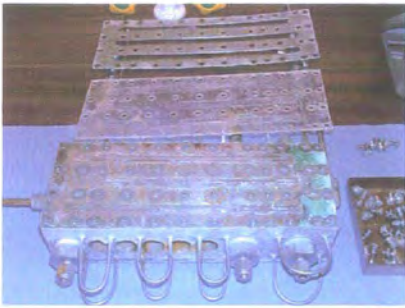

Fig 76



Fig 77



Fig 78

6) Wash the plates by water and acetone if needed (Fig 79, 80)



Fig 79



Fig 80

7) Shave the edge of the plates to remove extra PTFE which cover on the side faces (Fig 81-83)

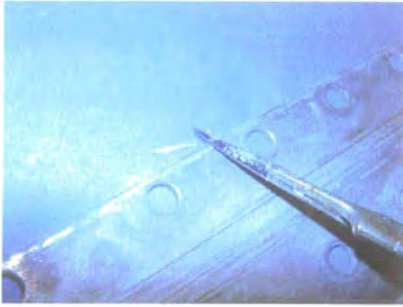

Fig 81

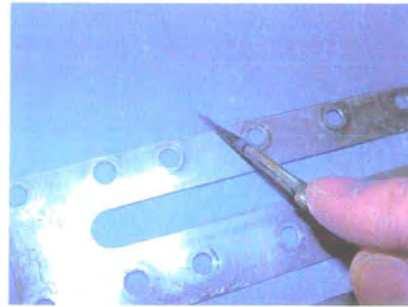

Fig 82



Fig 83

8) Cut a piece of PTFE seat for the gasket by using a template (Fig 84-86)

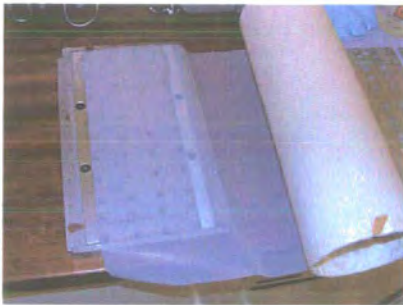

Fig 84



Fig 85



Fig 86

9) Cut three slits for the gas and substrate inlet and product outlet (Fig 87-90)



Fig 87



Fig 88



Fig 89

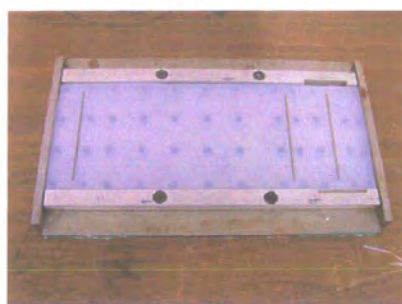

Fig 90

10) Cut "X" shapes on each position for screw fittings (Fig 91-94)



Fig 91



Fig 92



Fig 93



Fig 94

11) Reassemble the microreactor with each plate in order (Fig 95-101)



Fig 95 (base block)



Fig 96 (PTFE gasket)



Fig 97



Fig 98 (bottom plate)



Fig 99 (channel plate)



Fig 100 (PTFCE plate)



Fig 101 (steel top plate)

12) Put all screw fittings loosely at first (Fig 102-106), and then tighten in the order as shown in Fig 107

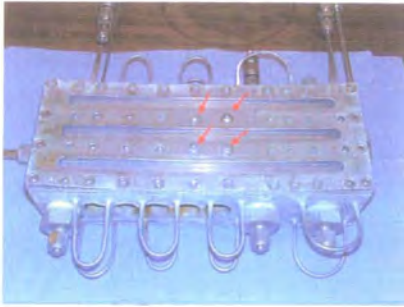

Fig 102



Fig 103



Fig 104



Fig 105



Fig 106



Fig 107

13) Mask the windows and spray PTFE on the side of the microreactor in order to ensure a gas-tight seal (Fig 108, 109)



Fig 108



Fig 109

- 14) Dry the reactor overnight
- 15) Spray PTFE again
- 16) Dry the reactor

References

1. D. B. Harper and D. O'Hagan, *Nat. Prod. Rep.*, 1994, **11**, 123.
2. D. O'Hagan and D. B. Harper, *J. Fluorine Chem.*, 1999, **100**, 127.
3. G. Sandford, *Phil. Trans. R. Soc. Lond. A.*, 2000, **358**, 455.
4. J. Dumas and E. Péligot, *Ann. Pharm.*, 1835, **15**, 246.
5. H. Moissan, *Compt. Rend.*, 1886, **102**, 1534.
6. F. Swarts, *Bull. Acad. Roy. Belg.*, 1892, **24**, 309.
7. G. Balz and G. Schiemann, *Chem. Ber.*, 1927, **60**, 1186.
8. J. Fried and E. F. Sabo, *J. Am. Chem. Soc.*, 1954, **76**, 1455.
9. Y.-S. Ding and J. S. Fowler, in 'Biomedical Frontiers of Fluorine Chemistry', ed. I. Ojima, J. R. McCarthy and J. T. Welch, ACS Symposium Series 639; American Chemical Society: Washington, DC, 1996, p.328.
10. A. Bondi, *J. Phys. Chem.*, 1964, **68**, 441.
11. T. Hiyama, K. Kanie, T. Kusumoto, Y. Morizawa and M. Shimizu, in 'Organofluorine Compounds'; Springer-Verlag: Berlin, 2000, Chap.1.
12. 'Organic Fluorine Chemistry', ed. W. A. Sheppard and C. M. Sharts; W. A. Benjamin: New York, 1969, p.4.
13. K. L. Kirk and R. Filler, in 'Biomedical Frontiers of Fluorine Chemistry', ed. I. Ojima, J. R. McCarthy and J. T. Welch, ACS Symposium Series 639; American Chemical Society: Washington, DC, 1996, p.1.
14. J. A. K. Howard, V. J. Hoy, D. O'Hagan and G. T. Smith, *Tetrahedron*, 1996, **52**, 12613.
15. J. T. Welch, *Tetrahedron*, 1987, **43**, 3123.
16. T. Allmendinger, P. Furet and E. Hungerbühler, *Tetrahedron Lett.*, 1990, **31**, 7297.
17. S. D. Taylor, C. C. Kotoris and G. Hum, *Tetrahedron*, 1999, **55**, 12431.
18. T. Hiyama, K. Kanie, T. Kusumoto, Y. Morizawa and M. Shimizu, in 'Organofluorine Compounds'; Springer-Verlag: Berlin, 2000, Chap.2.
19. J. Emsley, 'The Elements', Oxford University Press, New York, 1998.
20. J. F. Ellis and G. F. May, *J. Fluorine Chem.*, 1986, **33**, 133.
21. S. T. Purrington, B. S. Kagen and T. B. Patrick, *Chem. Rev.*, 1986, **86**, 997.
22. J. Hutchinson and G. Sandford, *Top. Curr. Chem.*, 1997, **193**, 1.
23. S. Rozen and C. Gal, *J. Org. Chem.*, 1987, **52**, 2769.
24. R. D. Chambers, M. Parsons, G. Sandford and R. Bowden, *Chem. Commun.*, 2000, 959.

25. R. D. Chambers, A. M. Kenwright, M. Parsons, G. Sandford and J. S. Moilliet, *J. Chem. Soc., Perkin Trans. 1.*, 2002, 2190.
26. C. Kaneko, A. Toyota, J. Chiba, A. Shigihara and H. Ichikawa, *Chem. Pharm. Bull.*, 1994, **42**, 745.
27. L. T. Eremenko, G. V. Oreshko and G. V. Lagodzinskaya, *Spectrochim. Acta Part A.*, 2001, **57**, 1663.
28. M. Kobayashi, T. Inoguchi, T. Iida, T. Tanioka, H. Kumase and Y. Fukai, *J. Fluorine Chem.*, 2003, **120**, 105.
29. T. Tsushima, K. Kawada and T. Tsuji, *J. Org. Chem.*, 1982, **47**, 1107.
30. S. T. Purrington, N. V. Lazaridis and C. L. Bumgardner, *Tetrahedron Lett.*, 1986, **27**, 2715.
31. R. D. Chambers, J. Hutchinson and G. Sandford, *J. Fluorine Chem.*, 1999, **100**, 63.
32. R. D. Chambers, M. P. Greenhall and J. Hutchinson, *Tetrahedron*, 1996, **52**, 1.
33. R. D. Chambers and J. Hutchinson, *J. Fluorine Chem.*, 1998, **89**, 229.
34. R. D. Chambers, J. Hutchinson and J. Thomson, *J. Fluorine Chem.*, 1996, **78**, 165.
35. R. D. Chambers and J. Hutchinson, *J. Fluorine Chem.*, 1998, **92**, 45.
36. R. D. Bowden and J. S. Moilliet, in 'Fluorination Method', WO0179143 A1, 2001.
37. W. J. Casteel and W. H. Bailey, in 'Direct Fluorination Process for Preparing High Purity Alpha-Fluoro-Beta-Dicarbonyl Compounds', EP1095928 A2, 2001.
38. K. Adachi, Y. Ohira, G. Tomizawa, S. Ishihara and S. Oishi, *J. Fluorine Chem.*, 2003, **120**, 173.
39. G. K. S. Prakash, J. Hu, M. M. Alauddin, P. S. Conti and G. A. Olah, *J. Fluorine Chem.*, 2003, **121**, 239.
40. M. A. Tius, *Tetrahedron*, 1995, **51**, 6605.
41. B. Zajc and M. Zupan, *Bull. Chem. Soc. Jpn.*, 1986, **59**, 1659.
42. B. Zajc and M. Zupan, *J. Chem. Soc. Chem. Commun.*, 1980, 759.
43. C. A. Ramsden and R. G. Smith, *J. Am. Chem. Soc.*, 1998, **120**, 6842.
44. C. A. Ramsden and R. G. Smith, *Org. Lett.*, 1999, **1**, 1591.
45. M. Constantinou, F. I. Aigbirhio, R. G. Smith, C. A. Ramsden and V. W. Pike, *J. Am. Chem. Soc.*, 2001, **123**, 1780.
46. R. K. Marat and A. F. Janzen, *Can. J. Chem.*, 1977, **55**, 3031.

47. A. F. Janzen, P. M. C. Wang and A. E. Lemire, *J. Fluorine Chem.*, 1983, **22**, 557.
48. S. Rozen, *Chem. Rev.*, 1996, **96**, 1717.
49. K. G. Kellogg and G. H. Cady, *J. Am. Chem. Soc.*, 1948, **70**, 3986.
50. W. Navarrini, V. Tortelli, A. Russo and S. Corti, *J. Fluorine Chem.*, 1999, **95**, 27.
51. S. Rozen, O. Lerman and M. Kol, *J. Chem. Soc. Chem. Commun.*, 1981, 443.
52. O. Lerman and S. Rozen, *J. Org. Chem.*, 1983, **48**, 724.
53. S. Rozen, A. Haggoly and R. Harduf, *J. Org. Chem.*, 2001, **66**, 7464.
54. J. Fried, D. K. Mitra, M. Nagarajan and M. M. Mehrotra, *J. Med. Chem.*, 1980, **23**, 234.
55. C. M. Sharts and W. A. Sheppard, *Org. React.*, 1974, **21**, 225.
56. V. C. O. Njar, T. Arunachalam and E. Caspi, *J. Org. Chem.*, 1983, **48**, 1007.
57. H. Fujisawa and Y. Takeuchi, *J. Fluorine Chem.*, 2002, **117**, 173.
58. S. Stavber and M. Zupan, *J. Org. Chem.*, 1985, **50**, 3609.
59. S. Stavber and M. Zupan, *Tetrahedron*, 1989, **45**, 2737.
60. S. Stavber and M. Zupan, *J. Chem. Soc. Chem. Commun.*, 1981, 795.
61. S. Stavber and M. Zupan, *J. Chem. Soc. Chem. Commun.*, 1983, 563.
62. G. G. Furin and A. A. Fainzilberg, *Russ. Chem. Rev.*, 1999, **68**, 653.
63. S. Singh, D. D. DesMarteau, S. S. Zuberi, M. Witz and H.-N. Huang, *J. Am. Chem. Soc.*, 1987, **109**, 7194.
64. A. G. Gilicinski, G. P. Pez, R. G. Syvret and G. S. Lal, *J. Fluorine Chem.*, 1992, **59**, 157.
65. G. Resnati and D. D. DesMarteau, *J. Org. Chem.*, 1991, **56**, 4925.
66. Z.-Q. Xu, D. D. DesMarteau and Y. Gotoh, *J. Fluorine Chem.*, 1992, **58**, 71.
67. J. Zhang and D. D. DesMarteau, *J. Fluorine Chem.*, 2001, **111**, 253.
68. J. Zhang, D. D. DesMarteau, S. Zuberi, J.-J. Ma, L. Xue, S. M. Gillette. H. Blau and R. Gerhardt, *J. Fluorine Chem.*, 2002, **116**, 45.
69. R. E. Banks, V. Murtagh, H. M. Marsden and R. G. Syvret, *J. Fluorine Chem.*, 2001, **112**, 271.
70. E. Differding and H. Ofner, *Synlett.*, 1991, 187.
71. F. A. Davis and W. Han, *Tetrahedron Lett.*, 1991, **32**, 1631.
72. D. A. Evans, T. C. Britton, J. A. Ellman and R. L. Dorow, *J. Am. Chem. Soc.*, 1990, **112**, 4011.
73. F. A. Davis and W. Han, *Tetrahedron Lett.*, 1992, **33**, 1153.
74. F. A. Davis and H. Qi, *Tetrahedron Lett.*, 1996, **37**, 4345.

75. F. A. Davis, H. Qi and G. Sundarababu, *Tetrahedron*, 2000, **56**, 5303.
76. D. Enders, S. Faure, M. Potthoff and J. Runsink, *Synthesis*, 2001, 2307.
77. D. W. Konas and J. K. Coward, *Org. Lett.*, 1999, **1**, 2105.
78. D. W. Konas and J. K. Coward, *J. Org. Chem.*, 2001, **66**, 8831.
79. Y. Takeuchi, T. Shibata, E. Suzuki, Y. Iimura, T. Ozasa, Y. Yamanishi and H. Sugimoto, in '1-Benzyl-4-[(5,6-dimethoxy-2-fluoro-1-indanon)-2-yl methyl piperidine]', JP2000-319257, 2000.
80. S. J. F. Macdonald, G. G. A. Inglis, D. Bentley and M. D. Dowle, *Tetrahedron Lett.*, 2002, **43**, 5057.
81. Z. Wang, Y. Gu, A. J. Zapata, G. B. Hammond, *J. Fluorine Chem.*, 2001, **107**, 127.
82. M. Shimizu, Y. Iwasaki, A. Ohno and S. Yamada, *Chem. Pharm. Bull.*, 2000, **48**, 1484.
83. W. E. Barnette, *J. Am. Chem. Soc.*, 1984, **106**, 452.
84. S. H. Lee and J. Schwartz, *J. Am. Chem. Soc.*, 1986, **108**, 2445.
85. E. Differding and R. W. Lang, *Helv. Chim. Acta*, 1989, **72**, 1248.
86. Y. Takauchi, T. Suzuki, A. Satoh, T. Shiragami and N. Shibata, *J. Org. Chem.*, 1999, **64**, 5708.
87. E. Differding, G. M. Rüegg and R. W. Lang, *Tetrahedron Lett.*, 1991, **32**, 1779.
88. I. Cabrera and W. K. Appel, *Tetrahedron*, 1995, **51**, 10205.
89. R. E. Banks, M. K. Besheesh and E. Tsiliopoulos, *J. Fluorine Chem.*, 1996, **78**, 39.
90. S. T. Purrington and W. A. Jones, *J. Fluorine Chem.*, 1984, **26**, 43.
91. R. E. Banks, V. Murtagh and E. Tsiliopoulos, *J. Fluorine Chem.*, 1991, **52**, 389.
92. K. K. Laali, M. Tanaka, F. Foroohar, M. Cheng and J. C. Fetzer, *J. Fluorine Chem.*, 1998, **91**, 185.
93. H. Meinerf and D. Cech, *Czech. Z. Chem.*, 1972, **12**, 292.
94. T. Umemoto and K. Tomita, *Tetrahedron Lett.*, 1986, **27**, 3271.
95. T. Umemoto, S. Fukami, G. Tomizawa, K. Harasawa, K. Kawada and K. Tomita, *J. Am. Chem. Soc.*, 1990, **112**, 8563.
96. T. Umemoto, M. Nagayoshi, K. Adachi and G. Tomizawa, *J. Org. Chem.*, 1998, **63**, 3379.
97. T. Tamura, T. Mukono, T. Kawada and S. Arai, in 'New 4,4-Difluoro benzoazepine Ketal Derivaive, and Production of 4,4-Difluorobenzoazepin-

- 5-One Derivative', JP2000-212165, 2000.
98. S. Takeda, Y. Kaneko, H. Eto, M. Tokizawa, S. Sato, K. Yoshida, S. Namiki and M. Ogawa, *Chem. Pharm. Bull.*, 2000, **48**, 1097.
 99. N. Shibata, T. Tarui, Y. Doi and K. L. Kirk, *Angew. Chem. Int. Ed.*, 2001, **40**, 4461.
 100. R. E. Banks and I. Sharif, *J. Fluorine Chem.*, 1991, **55**, 207.
 101. R. E. Banks, S. N. Mohialdin-Khaffaf, G. S. Lal, I. Sharif and R. G. Syvret, *J. Chem. Soc. Chem. Commun.*, 1992, 595.
 102. T. Umemoto and M. Nagayoshi, *Bull. Chem. Soc. Jpn.*, 1996, **69**, 2287.
 103. R. P. Singh and J. M. Shreeve, *Acc. Chem. Res.*, 2004, **37**, 31.
 104. R. E. Banks, N. J. Lawrence and A. L. Popplewell, *J. Chem. Soc. Chem. Commun.*, 1994, 343.
 105. Y. Takeuchi, T. Tarui and N. Shibata, *Org. Lett.*, 2000, **2**, 639.
 106. J. Baudoux, A.-F. Salit, D. Cahard and J.-C. Plaquevent, *Tetrahedron Lett.*, 2002, **43**, 6573.
 107. S. F. Wnuk, L. A. Bergolla and P. I. Garcia, *J. Org. Chem.*, 2002, **67**, 3065.
 108. S. Ladame, M. Willson and J. Périé, *Eur. J. Org. Chem.*, 2002, 2640.
 109. Y. Xu, L. Qian and G. D. Prestwich, *Org. Lett.*, 2003, **5**, 2267.
 110. A. J. Poss and G. A. Shia, US 5459267, 1995.
 111. S. Stavber, M. Jereb and M. Zupan, *Chem. Commun.*, 2000, 1323.
 112. S. Stavber, M. Jereb and M. Zupan, *Synthesis*, 2002, 2609.
 113. R. E. Banks and M. K. Besheesh, in 'Electrophilic Fluorination', EP1201628 A1, 2002.
 114. R. E. Banks, M. K. Besheesh, W. Fraenk and T. M. Klapötke, *J. Fluorine Chem.*, 2003, **124**, 229.
 115. R. E. Banks, M. K. Besheesh and R. G. Pritchard, *Acta Cryst*, 2003, **C59**, m141.
 116. C. J. Schack and K. O. Christe, *J. Fluorine Chem.* 1981, **18**, 363.
 117. O. D. Gupta and J. M. Shreeve, *Tetrahedron Lett.*, 2003, **44**, 2799.
 118. G. S. Lal, G. P. Pez and R. G. Syvret, *Chem. Rev.*, 1996, **96**, 1737.
 119. D. D. DesMarteau, Z.-Q. Xu and M. Witz, *J. Org. Chem.*, 1992, **57**, 629.
 120. E. Differding and G. M. Rüegg, *Tetrahedron Lett.*, 1991, **32**, 3815.
 121. J. Fried and E. F. Sabo, *J. Am. Chem. Soc.*, 1953, **75**, 2273.
 122. D. Alker, D. H. R. Barton, R. H. Hesse, J. Lister-James, R. E. Markwell, M. M. Pechet, S. Rozen, T. Takaeshita and H. T. Toh, *Nouv. J. Chem.*, 1980, **4**, 239.

123. S. Rozen and G. Ben-Scushan, *J. Org. Chem.*, 1986, **51**, 3522.
124. R. F. Merritt and T. E. Stevens, *J. Am. Chem. Soc.*, 1966, **88**, 1822.
125. S. Rozen and M. Brand, *J. Org. Chem.*, 1986, **51**, 3607.
126. S. Yamabe, T. Minato and S. Inagaki, *J. Chem. Soc. Chem. Commun.*, 1988, 532.
127. S. Rozen, O. Lerman, M. Kol and D. Hebel, *J. Org. Chem.*, 1985, **50**, 4753.
128. S. Rozen and Y. Menachem, *J. Chem. Soc. Chem. Commun.*, 1979, 479.
129. Y. Kobayashi, M. Nakazawa, I. Kumadaki, T. Taguchi, E. Ohshima, N. Ikekawa, Y. Tanaka and H. F. Deluka, *Chem. Pharm. Bull.*, 1986, **34**, 1568.
130. G. S. Lal, *J. Org. Chem.*, 1993, **58**, 2791.
131. T. Tsushima, K. Kawada and T. Tsuji, *Tetrahedron Lett.*, 1982, **23**, 1165.
132. R. B. Gabbard and E. V. Jensen, *J. Org. Chem.*, 1958, **23**, 1406.
133. M. Schlosser and G. Heinz, *Chem. Ber.*, 1969, **102**, 1944.
134. A. J. Poss, M. V. D. Puy, D. Nalewajek, G. A. Shia, W. J. Wagner and R. L. Frenette, *J. Org. Chem.*, 1991, **56**, 5962.
135. V. Reydellet-Casey, D. J. Knoechel and P. M. Herrinton, *Org. Proc. Res. Dev.*, 1997, **1**, 217.
136. D. Landini and M. Penso, *Tetrahedron Lett.*, 1990, **31**, 7209.
137. M. Hudlický, *Org. React.*, 1988, **35**, 513.
138. S. Rozen, Y. Faust and H. Ben-Yakov, *Tetrahedron Lett.*, 1979, 1823.
139. D. O. Kiesewetter, J. A. Katzenellenbogen, M. R. Kilbourn and M. J. Welch, *J. Org. Chem.*, 1984, **49**, 4900.
140. R. Breslow, in 'Templated Organic Syntheses', eds. F. Diederich and P. J. Stang, Chap. 6, Wiley-VCH, Weinheim, 2000.
141. R. Breslow and M. A. Winnik, *J. Am. Chem. Soc.*, 1969, **91**, 3083.
142. R. Breslow, S. Baldwin, T. Flechtner, P. Kalicky, S. Liu and W. Washburn, *J. Am. Chem. Soc.*, 1973, **95**, 3251.
143. R. L. Wife, D. Prezant and R. Breslow, *Tetrahedron Lett.*, 1976, 517.
144. R. Breslow and P. C. Scholl, *J. Am. Chem. Soc.*, 1971, **93**, 2331.
145. R. Breslow and L. M. Maresca, *Tetrahedron Lett.*, 1977, 623.
146. G. A. Russell and C. DeBoer, *J. Am. Chem. Soc.*, 1963, **85**, 3136.
147. D. D. Tanner and P. B. Van Bostelen, *J. Org. Chem.*, 1967, **32**, 1517.
148. R. Breslow, R. Corcoran, J. A. Dale, S. Liu and P. Kalicky, *J. Am. Chem. Soc.*, 1974, **96**, 1973.
149. R. Breslow, R. J. Corcoran, B. B. Snider, R. J. Doll, P. L. Khanna and R. Kaleya, *J. Am. Chem. Soc.*, 1977, **99**, 905.

150. R. Breslow, R. J. Corcoran and B. B. Snider, *J. Am. Chem. Soc.*, 1974, **96**, 6791.
151. B. B. Snider, R. J. Corcoran and R. Breslow, *J. Am. Chem. Soc.*, 1975, **97**, 6580.
152. D. Wiedenfeld, *J. Chem. Soc. Perkin Trans. 1*, 1997, 339.
153. R. Breslow, M. Brandl, J. Hunger and A. D. Adams, *J. Am. Chem. Soc.*, 1987, **109**, 3799.
154. M. Parsons, 'Electrophilic Fluorination at Saturated Carbon', Doctoral thesis, 2000.
155. F. Mutterer and C. D. Weis, *Helv. Chim. Acta* 1976, **59**, 222.
156. M. Langlois, C. Meyer and J. L. Soulier, *Synth. Commun.*, 1992, **22**, 1895.
157. R. E. Banks, I. Sharif and R. G. Pritchard, *Acta Cryst.* 1993, **C49**, 492.
158. M. Van Der Puy, *Tetrahedron Lett.*, 1987, **28**, 255.
159. T. Umemoto, K. Harasawa and G. Tomizawa, *J. Fluorine Chem.*, 1991, **53**, 369.
160. T. Umemoto, K. Harasawa, G. Tomizawa, K. Kawada and K. Tomita, *Bull. Chem. Soc. Jpn.*, 1991, **64**, 1081.
161. R. E. Banks and I. Sharif, *J. Fluorine Chem.*, 1988, **41**, 297.
162. M. Abdul-Ghani, R. E. Banks, M. K. Besheesh, I. Sharif and R. G. Syvret, *J. Fluorine Chem.*, 1995, **73**, 255.
163. R. E. Banks, R. G. Pritchard and I. Sharif, *Acta Cryst.* 1993, **C49**, 1806.
164. D. Cahard, C. Audouard, J.-C. Plaquevent, L. Toupet and N. Roques, *Tetrahedron Lett.* 2001, **42**, 1867.
165. N. Shibata, E. Suzuki, T. Asahi and M. Shiro, *J. Am. Chem. Soc.* 2001, **123**, 7001.
166. F. A. Davis, P. Zhou, C. K. Murphy, G. Sundarababu, H. Qi, W. Han, R. M. Przeslawski, B.-C. Chen and P. J. Carroll, *J. Org. Chem.*, 1998, **63**, 2273.
167. H. Kakuda, T. Suzuki, Y. Takauchi and M. Shiro, *Chem. Commun.* 1997, 85.
168. N. Shibata, Z. Liu and Y. Takauchi, *Chem. Pharm. Bull.* 2000, **48**, 1954.
169. Z. Liu, N. Shibata and Y. Takeuchi, *J. Org. Chem.*, 2000, **65**, 7583.
170. R. E. Banks, M. K. Besheesh, N. J. Lawrence and D. J. Tovell, *J. Fluorine Chem.*, 1999, **97**, 79.
171. K. O. Christe, M. D. Lind, N. Thorup, D. R. Russell, J. Fawcett and R. Bau, *Inorg. Chem.* 1988, **27**, 2450.
172. H. M. E. Cardwell, J. W. Cornforth, S. R. Duff, H. Holtermann and R. Robinson, *J. Chem. Soc.*, 1953, 361.

173. S. Rozen and G. Ben-Shushan, *Magn. Reson. in Chem.* 1985, **23**, 116.
174. J. A. Ramírez, E. G. Gros and L. R. Galagovsky, *Tetrahedron*, 2000, **56**, 6171.
175. R. P. Bonar-Law, A. P. Davis and J. K. M. Sanders, *J. Chem. Soc., Perkin Trans. 1*, 1990, 2245.
176. C. Cativiela, M. D. Díaz-de-Villegas and J. A. Gálvez, *Tetrahedron*, 1994, **50**, 9837.
177. J. P. Tam, *J. Org. Chem.*, 1985, **50**, 5291.
178. M. E. Jung and T. W. Johnson, *Tetrahedron*, 2001, **57**, 1449.
179. T. Hiyama, K. Kanie, T. Kusumoto, Y. Morizawa and M. Shimizu, in 'Organofluorine Compounds'; Springer-Verlag: Berlin, 2000, Chap. 5 and 6.
180. 'Asymmetric Fluoroorganic Chemistry: Synthesis, Application, and Future Directions', ed. P. V. Ramachandran, ACS Symposium Series 746; American Chemical Society: Washington, DC, 2000.
181. P. Bravo and G. Resnati, *Tetrahedron: Asymmetry* 1990, **1**, 661.
182. E. Differding and R. W. Lang, *Tetrahedron Lett.* 1988, **29**, 6087.
183. F. A. Davis, P. Zhou and C. K. Murphy, *Tetrahedron Lett.* 1993, **34**, 3971.
184. Y. Takeuchi, A. Satoh, T. Suzuki, A. Kameda, M. Dohrin, T. Satoh, T. Koizumi and K. L. Kirk, *Chem. Pharm. Bull.* 1997, **45**, 1085.
185. N. Shibata, E. Suzuki and Y. Takeuchi, *J. Am. Chem. Soc.*, 2000, **122**, 10728.
186. D. Cahard, C. Audouard, J.-C. Plaquevent and N. Roques, *Org. Lett.*, 2000, **2**, 3699.
187. B. Mohar, J. Baudoux, J.-C. Plaquevent and D. Cahard, *Angew. Chem. Int. Ed.*, 2001, **40**, 4214.
188. C. Baudequin, J.-C. Plaquevent, C. Audouard and D. Cahard, *Green Chem.*, 2002, **4**, 584.
189. B. Greedy, J.-M. Paris, T. Vidal and V. Gouverneur, *Angew. Chem. Int. Ed.*, 2003, **42**, 3291.
190. N. Shibata, T. Ishimaru, E. Suzuki and K. L. Kirk, *J. Org. Chem.*, 2003, **68**, 2494.
191. L. Zoute, C. Audouard, J.-C. Plaquevent and D. Cahard, *Org. Biomol. Chem.*, 2003, **1**, 1833.
192. L. Hintermann and A. Togni, *Angew. Chem. Int. Ed.*, 2000, **39**, 4359.
193. A. Togni, A. Mezzetti, P. Barthazy, C. Becker, I. Devillers, R. Frantz, L. Hintermann, M. Perseghini and M. Sanna, *Chimia*, 2001, **55**, 801.
194. S. Piana, I. Devillers, A. Togni and U. Rothlisberger, *Angew. Chem. Int. Ed.*,

- 2002, 41, 979.
195. R. Frantz, L. Hintermann, M. Perseghini, D. Broggini and A. Togni, *Org. Lett.*, 2003, 5, 1709.
196. D. Y. Kim and E. J. Park, *Org. Lett.*, 2002, 4, 545.
197. Y. Hamashima, K. Yagi, H. Takano, L. Tamás and M. Sodeoka, *J. Am. Chem. Soc.*, 2002, 124, 14530.
198. Y. Hamashima, D. Hotta and M. Sodeoka, *J. Am. Chem. Soc.*, 2002, 124, 11240.
199. Y. Hamashima, H. Takano, D. Hotta and M. Sodeoka, *Org. Lett.*, 2003, 5, 3225.
200. T. Iwaoka, T. Murohashi, M. Sato and C. Kaneko, *Tetrahedron: Asymmetry*, 1992, 3, 1025.
201. D. F. Shellhamer, M. J. Horney, B. J. Pettus, T. L. Pettus, J. M. Stringer and V. L. Heasley, *J. Org. Chem.*, 1999, 64, 1094.
202. K. V. Gothelf, I. Thomson and K. A. Jørgensen, *J. Am. Chem. Soc.*, 1996, 118, 59.
203. P. L. Coe, A. M. Stuart and D. J. Moody, *J. Chem. Soc., Perkin Trans. 1*, 1998, 1807.
204. N. Srivastava and B. K. Banik, *J. Org. Chem.*, 2003, 68, 2109.
205. S. Kobayashi, M. Araki and I. Hachiya, *J. Org. Chem.*, 1994, 59, 3759.
206. D. Ferraris, B. Young, C. Cox, T. Dudding, W. J. Drury, III, L. Ryzhkov, A. E. Taggi and T. Lectka, *J. Am. Chem. Soc.*, 2002, 124, 67.
207. M. Lautens and T. Rovis, *Tetrahedron*, 1998, 54, 1107.
208. D. J. Spielvogel and S. L. Buchwald, *J. Am. Chem. Soc.*, 2002, 124, 3500.
209. H. J. Gysling, *Inorg. Synth.*, 1979, 19, 92.
210. S. Sirol, J. Courmarcel, N. Mostefai and O. Riant, *Org. Lett.*, 2001, 3, 4111.
211. J. H. Babler and S. J. Sarussi, *J. Org. Chem.*, 1987, 52, 3462.
212. D. Henderson, K. A. Richardson and R. J. K. Taylor, *Synthesis*, 1983, 996.
213. S. J. Rhoads, *J. Org. Chem.*, 1966, 31, 171.
214. S. J. Rhoads and C. Pryde, *J. Org. Chem.*, 1965, 30, 3212.
215. J. J. Kampa, J. W. Nail and R. J. Lagow, *J. Fluorine Chem.*, 2000, 102, 333.
216. G. P. Gambaretto, L. Conte, M. Napoli and E. Legnaro, *J. Fluorine Chem.*, 1993, 60, 19.
217. S. J. Haswell and P. Watts, *Green Chem.*, 2003, 5, 240.
218. W. Ehrfeld, V. Hessel and H. Löwe, 'Microreactors'; Wiley-VCH: Weinheim, 2000.

219. S. J. Haswell, R. J. Middleton, B. O'Sullivan, V. Skelton, P. Watts and P. Styring, *Chem. Commun.* 2001, 391.
220. P. D. I. Fletcher, S. J. Haswell, E. Pombo-Villar, B. H. Warrington, P. Watts, S. Y. F. Wong and X. Zhang, *Tetrahedron*, 2002, **58**, 4735.
221. R. D. Chambers and R. C. H. Spink, *Chem. Commun.* 1999, 883.
222. R. D. Chambers, D. Holling, R. C. H. Spink and G. Sandford, *Lab on a Chip*, 2001, **1**, 132.
223. K. Jähnisch, M. Baerns, V. Hessel, W. Ehrfeld, V. Haverkamp, H. Löwe, C. Will and A. Guber, *J. Fluorine Chem.*, 2000, **105**, 117.
224. N. de Mas, A. Günther, M. A. Schmidt and K. F. Jensen, *Ind. Eng. Chem. Res.* 2003, **42**, 698.
225. H. Schuppich, K. Golbig and B. Dittmann, in 'Micro-Reactor for Reactions between Gases and Liquids' WO0209866 A2, 2002.
226. D. Wehle, M. Dejmek, J. Rosenthal, H. Ernst, D. Kampmann, S. Trautschold and R. Pechatschek, in 'Method for Selective Chlorination in Microreactors' WO0210094 A1, 2002.
227. R. D. Chambers, D. Holling, A. J. Rees and G. Sandford, *J. Fluorine Chem.*, 2003, **119**, 81.
228. D. Holling, 'Microreactors and Other Technologies for Direct Fluorination', Doctoral thesis, 2002.
229. W. Eisefeld and G. Maurer, *J. Phys. Chem. B*, 1999, **103**, 5716.
230. M. Zia-Ebrahimi, G. W. Huffman, *Synthesis*, 1996, 215.
231. H. Kamaya, M. Sato and C. Kaneko, *Tetrahedron Lett.* 1997, **38**, 587.
232. T. Fukuyama, M. Shinmen, S. Nishitani, M. Sato and I. Ryu, *Org. Lett.*, 2002, **4**, 1691.
233. C. C. Tzschucke, C. Markert, W. Bannwarth, S. Roller, A. Hebel and R. Haag, *Angew. Chem. Int. Ed.*, 2002, **41**, 3964.
234. J. Dupont, R. F. de Souza and P. A. Z. Suarez, *Chem. Rev.*, 2002, **102**, 3667.
235. P. Bonhôte, A.-P. Dias, N. Papageorgiou, K. Kalyanasundaram and M. Grätzel, *Inorg. Chem.*, 1996, **35**, 1168.
236. J. M. Fraile, J. I. García, C. I. Herrerías, J. A. Mayoral, D. Carrié and M. Vaultier, *Tetrahedron: Asymmetry*, 2001, **12**, 1891.
237. V. R. Koch, C. Nanjundiah and R. T. Carlin, in 'Hydrophobic Ionic Liquids' US5827602, 1998.
238. C. B. Murray, G. Sandford and S. R. Korn, *J. Fluorine Chem.*, 2003, **123**, 81.
239. B. R. Langlois and T. Billard, *Synthesis*, 2003, 185.

240. R. P. Singh and J. M. Shreeve, *Tetrahedron*, 2000, **56**, 7613.
241. I. Ruppert, K. Schlich and W. Volbach, *Tetrahedron Lett.*, 1984, **25**, 2195.
242. G. K. S. Prakash, J. Hu and G. A. Olah, *J. Org. Chem.*, 2003, **68**, 4457.
243. Q.-Y. Chen and J.-X. Duan, *Chem. Commun.* 1993, 918.
244. J. Russell and N. Roques, *Tetrahedron*, 1998, **54**, 13771.
245. J.-J. Yang, R. L. Kirchmeier and J. M. Shreeve, *J. Org. Chem.*, 1998, **63**, 2656.
246. J. Chiba, T. Sugihara and C. Kaneko, *Chem. Lett.*, 1995, 581.
247. R. D. Chambers, J. Hutchinson, G. Sandford, A. Shah and J. F. S. Vaughan, *Tetrahedron*, 1997, **53**, 15833.
248. S. Rozen and Y. Bareket, *J. Org. Chem.*, 1997, **62**, 1457.
249. T. A. Bryson, J. C. Wisowaty, R. B. Dunlap, R. R. Fisher and P. D. Ellis, *J. Org. Chem.*, 1974, **39**, 3436.
250. T. Kawato and G. R. Newkome, *Heterocycles*, 1990, **31**, 1097.
251. G. J. Edge, S. H. Imam and B. A. Marples, *J. Chem. Soc., Perkin Trans. 1.*, 1984, 2319.
252. J. Iriarte, G. Rosenkranz and F. Sondheimer, *J. Org. Chem.*, 1955, **20**, 542.
253. T. Chou and L.-J. Chang, *J. Org. Chem.*, 1985, **50**, 4998.

