

## Durham E-Theses

---

*TERRONI AND POLENTONI: WHERE DOES  
THE TRUTH LIE? AN ANTHROPOLOGY OF  
SOCIAL NETWORKS AND ETHNICITY IN  
PALERMO (SICILY), ITALY.*

STERGIOS PARDALIS

### How to cite:

---

PARDALIS, STERGIOS (2009) TERRONI AND POLENTONI: WHERE DOES THE TRUTH LIE? AN ANTHROPOLOGY OF SOCIAL NETWORKS AND ETHNICITY IN PALERMO (SICILY), ITALY. Doctoral thesis, Durham University.

### Use policy

---

The full-text may be used and/or reproduced, and given to third parties in any format or medium, without prior permission or charge, for personal research or study, educational, or not-for-profit purposes provided that:

- a full bibliographic reference is made to the original source
- a <https://etheses.durham.ac.uk/id/eprint/289/> is made to the metadata record in Durham E-Theses
- the full-text is not changed in any way

The full-text must not be sold in any format or medium without the formal permission of the copyright holders.

Please consult the [full Durham E-Theses policy](#) for further details.

***TERRONI AND POLENTONI: WHERE DOES THE TRUTH LIE?***  
**AN ANTHROPOLOGY OF SOCIAL NETWORKS AND ETHNICITY IN  
PALERMO (SICILY), ITALY.**

A THESIS SUBMITTED IN DECEMBER 2009  
TO THE DEPARTMENT OF ANTHROPOLOGY  
IN PARTIAL FULFILMENT OF THE REQUIREMENTS  
OF THE SCHOOL OF SOCIAL SCIENCES AND HEALTH  
OF DURHAM UNIVERSITY  
FOR THE DEGREE  
OF  
DOCTOR OF PHILOSOPHY

BY

Stergios Pardalis



Stergios Pardalis:

*‘Terroni and Polentoni: Where Does the Truth Lie?*

An Anthropology of Social Networks and Ethnicity in

Palermo (Sicily), Italy.

## **Abstract**

In this thesis, I argue that while Palermo and Sicily, must be understood in the context of both Mediterranean and Italian ethnography, the unique factors which lead to the subordinate economic position of Sicily have also resulted in distinct ethnic and identity politics. Ultimately, however, I suggest that the reduction of importance of the Italian nation-state, in relation to the emerging supra European Union state, renders much of Palermitan distinctiveness less relevant both economically and culturally. Although Italy’s North/South division is primarily based on economic criteria, the transformation of the poor economic conditions of the Italian south into a cultural issue helps perpetuate stereotypes which fuels tensions between the North and the South. Recent ethnic conflicts in Europe, as well as conflict over European Union expansion, have questioned the stability of national borders and have rendered research on national identity both timely and necessary. This anthropological study, carried out in Palermo, the capital of the autonomous region of Sicily, precisely addresses processes of national integration by critically assessing concepts and topics which have marked the anthropology of the Mediterranean. In addition to providing an ethnographic contribution of the particularities of Palermitan ethnic and identity construction, this thesis aims to deconstruct stereotypes that misrepresent Sicilian society. Palermo and its residents are shaped through relationships of unequal power between the centre and the periphery. Sicily’s integration into the European Union, paradoxically, appears to resolve several ongoing issues of national integration.

One of the principle conceptual tropes of Mediterranean anthropology has been the honour/shame debates popular from the 1960s. I argue that while such debates have served a variety of fruitful purposes, they neglect the complexities of contemporary Sicily. Instead, I concentrate on the conceptual cluster of honour, the family, social networks and power, as the means by which different levels of society interact, in order to better explain the dynamic relationship between local and national identity. I examine the ways in which the local and the national contrast with one another and how out of such contrasts emerges an identifiable Sicilian, if not Palermitan, identity. The thesis is based on data produced during extended field research in Palermo from April 2005 until August 2006 as well as brief subsequent visits in 2008.

***TERRONI AND POLENTONI: WHERE DOES THE TRUTH LIE?***  
**AN ANTHROPOLOGY OF SOCIAL NETWORKS AND ETHNICITY IN  
PALERMO (SICILY), ITALY.**

A THESIS SUBMITTED IN DECEMBER 2009  
TO THE DEPARTMENT OF ANTHROPOLOGY  
IN PARTIAL FULFILMENT OF THE REQUIREMENTS  
OF THE SCHOOL OF SOCIAL SCIENCES AND HEALTH  
OF DURHAM UNIVERSITY  
FOR THE DEGREE  
OF  
DOCTOR OF PHILOSOPHY

BY

Stergios Pardalis

**DURHAM UNIVERSITY**

# CONTENTS

ABSTRACT .....	i
LIST OF MAPS .....	vii
LIST OF TABLES .....	vii
LIST OF ILLUSTRATIONS .....	vii
ACKNOWLEDGEMENTS .....	ix
1. EXORDIUM .....	
1.1 <i>Introduction</i> .....	1
1.2 <i>An Overview</i> .....	6
1.3 <i>Identity</i> .....	12
1.4 <i>Ethnicity</i> .....	17
1.5 <i>Anthropology of the Mediterranean</i> .....	24
1.6 <i>Power</i> .....	28
2 HISTORY, POLITICS, AND DEMOGRAPHICS .....	
2.1 <i>The Italian Unification and the North/South Division</i> .....	33
2.2 <i>Current Italian and Sicilian Governing Systems</i> .....	35
2.3 <i>Demographics</i> .....	40
2.4 <i>Physical Environment and Economy</i> .....	41
2.5 <i>Palermo in History</i> .....	42
2.6 <i>Literature on the Area of Interest</i> .....	47
2.7 <i>Regional Identity and Local Characteristics</i> .....	49

3	METHODOLOGY.....	
3.1	<i>Introduction</i> .....	53
3.2	<i>Methods</i> .....	55
3.3	<i>Interviewing</i> .....	57
3.4	<i>Photo Elicitation</i> .....	58
3.5	<i>Press and Media Analysis</i> .....	58
3.6	<i>Archival Research</i> .....	59
3.7	<i>Ethical Considerations</i> .....	59
4	HONOUR TO THE FORE .....	
4.1	<i>Introduction</i> .....	61
4.1	<i>Seminal Anthropological Work</i> .....	64
4.2	<i>The Anthropology of the Mediterranean and the Issue of Honour</i> .....	72
4.3	<i>Critique and Synthesis</i> .....	75
4.4	<i>Egalitarianism Questioned</i> .....	77
4.5	<i>Mediterranean Shortcomings and Contradictions</i> .....	80
4.6	<i>From Theory to Practice</i> .....	85
5	A CONTESTED ANALYSIS OF HONOUR .....	
5.1	<i>Introduction</i> .....	90
5.2	<i>Local Definitions</i> .....	91
5.3	<i>'Parola d' Onore!' (My Word of Honour)</i> .....	95
5.4	<i>Images and Reflections, Private and Public Mirrors</i> .....	99
5.5	<i>Changes in the Last Decades</i> .....	103
5.6	<i>Living an Honourable Life</i> .....	107

5.7	<i>A 'Personal' Perception of Honour.....</i>	110
5.8	<i>Some 'Grey' Areas.....</i>	116
5.9	<i>'Bastardi' and 'Ignoranti' vs 'Belli' and 'Furbi'.....</i>	120
6	<b>THE FAMILY .....</b>	
6.1	<i>Introduction.....</i>	127
6.2	<i>Literature Review.....</i>	138
6.3	<i>Reflections on the Family.....</i>	141
6.4	<i>Access to Family.....</i>	145
6.5	<i>The Ethics of Admission.....</i>	148
6.6	<i>Common Destiny versus Independence.....</i>	151
6.7	<i>The Palermitans' Family Stereotype.....</i>	156
6.8	<i>Between Parallels and Perpendiculars.....</i>	160
6.9	<i>The Value of the Family.....</i>	164
6.10	<i>Changes in Economy and Sex Roles.....</i>	168
7	<b>THE PALERMITAN 'FAMILY-CENTRED' PERCEPTION OF SOCIAL NETWORKS .....</b>	
7.1	<i>Introduction.....</i>	176
7.2	<i>The Family and Social Networks.....</i>	180
7.3	<i>From Egalitarianism to the Class System.....</i>	184
7.4	<i>Neighbourhood, Class and Social Networks.....</i>	189
7.5	<i>The Centro Storico.....</i>	191
7.6	<i>The Sant Onofrio Neighbourhood.....</i>	194
7.7	<i>A Posh Neighbourhood.....</i>	196
7.8	<i>Friends.....</i>	199

8	MARKERS AND MANIFESTATIONS OF IDENTITY .....	
8.1	<i>Introduction</i> .....	208
8.2	<i>The Insiders' View</i> .....	213
8.3	<i>The Sicilian Boundaries from Two Different Perspectives</i> .....	218
8.4	<i>Contents of Boundaries, Meanings and Feelings</i> .....	223
8.5	<i>Playing Roles: Stability and Simultaneity</i> .....	227
8.6	<i>'Sicilia Indipendente, Sicilia Nazione'</i> .....	232
8.7	<i>The Police as an Oppressive Force</i> .....	237
8.8	<i>The Mayor as a Symbol of 'Palermitaness'</i> .....	241
8.9	<i>Santa Rosalia</i> .....	245
8.10	<i>Food and Identity, Bread and Circuses</i> .....	249
8.11	<i>Mass Media and National Integration</i> .....	252
8.12	<i>Landscape</i> .....	255
8.13	<i>Imaginary Bridges</i> .....	259
8.14	<i>Instead of a Conclusion</i> .....	265
9	EPILOGUE.....	270
	BIBLIOGRAPHY.....	280

## LIST OF MAPS

1.	Map of Italy.....	38
2.	Inner Political and Physical Divisions by ISTAT .....	39
3.	The ‘Route’ of Santa Rosalia .....	243

## LIST OF TABLES

1.	Working Women.....	129
2.	Family Size.....	131
3.	Age Gap.....	132
4.	Supporting the Family.....	133
5.	Working Women and Kids.....	134

## LIST OF ILLUSTRATIONS

1.	The Italian and Sicilian Flags .....	32
2.	The European Union’s, the Italian, and the Sicilian Flags.....	35
3.	The San Cataldo Church .....	45
4.	Police Officer Patrolling .....	114
5.	The Palermo Stadium .....	232
6.	Santa Rosalia .....	241
7.	The Official Site of the Palermo Team .....	257

I, the author, declare that none of the material in this thesis has been submitted previously by me or any other candidate for the degree in this or any other University.

The copyright of this thesis rests with the author. No quotation from it should be published in any form, including electronic and internet without the author's prior written consent. All information derived from this thesis must be acknowledged appropriately.

**©Copyright by Stergios Pardalis, 2009  
All Rights Reserved**

## ACKNOWLEDGEMENTS

This thesis is based on fieldwork I carried in Palermo, Sicily, in Southern Italy mainly from April 2005 to August 2006, returning to the field for short visits in 2007 and 2008. The research would have been impossible without the support of Palermitans. Therefore, I would like to thank all those Palermitans who have contributed to my research. The outcome of this research would have been poor if some families had not embraced me as their son, and thus, I would like to thank especially the D' Amico, D' Angelo, Scannavino, Provenzano and Di Lorenzo families for their inestimable help, as well as Paolo, Maria, and Gianfranco.

I would also like to express my gratitude to the personnel of Palermo's Main Library in *Via Corso Vittorio Emanuele* and to the students I met there for the time they dedicated to me and for their patience. Special thanks to the personnel of the *ESIS* Institute, cafe *Spinnato*, *Luminarie* bar/library, and the *Giuseppe Tomasi di Lampedusa* association. In addition, I would like to thank Harris Casasis who supported me throughout my fieldwork together with those I consider to have played an important role in my life and are namely Gerasimos Makris, Miltos Tsiakas, Ioannis Misentzis, George Filis, Soula, George Gkafas, Angelo Doukas, George Spiliotopoulos, Simeon Magliveras, Athanasios Alexakis, Panagiotis Theodoropoulos, and Roger Smedley.

My gratitude to Dr. Paul Sant-Cassia and Dr. Stephen Lyon cannot be properly expressed in words. However, I will attempt to express my sincere thanks. I consider their help to be of vital importance in both my academic and personal life. I would like to thank them both from deep in my heart for standing by to me under all kinds of conditions. In turn, I would like to thank the personnel in the Anthropology Department at Durham University for their exceptional cooperation all these years, but also all those who do not wish to 'come on stage' at this point.

Moreover, I cannot but acknowledge the important contribution of Palermitan professors to my understanding of Palermitan life. I would like to express my thankfulness to Renata Lavagnini and Antonia Sofikitou for their unflagging zeal and attention, and for introducing me to the following great professors at the University of Palermo: Vincenzo Rotolo (Literature), Vincenzo Guarrasi (Geography), Antonino Buttitta (Anthropology), and Marco Antonio Pirrone (Sociology).

Finally, I would especially like to thank my family for supporting me throughout this 'journey' at all costs. I would also like to thank my partner Ioanna for 'standing by me' for more than a decade now, being patient with this PhD's adversities, and reviving me whenever I lost faith. Thank you. During this period, I lost both my grandmothers to which I would also like to express my love. However, the love of my sister's two little angels, Antonis and Marianna, makes the wounds heal. I apologise to my family and friends for my long absence and I thank them for their understanding.

*To my Family*

## Chapter 1 EXORDIUM

### *1.1 Introduction*

‘Italy has been made. Now it remains to make Italians’, or ‘We have made Italy. Now we must make Italians’ writes Massimo D’ Azeglio in his memoirs in the second half of the nineteenth century<sup>1</sup>. Making Italians seemed to be still an unsuccessful issue in the first decades of the twentieth century. However, after World War II, when democracy was established in Italy, the *Casa per il Mezzogiorno* was created by the central government of Italy in order to invest money in the South and deal with the vast economic gap between northern and southern Italy (Colclough 1992). In 1998, the anthropologist Jane Schneider addressed the same issue in *Italy’s “Southern Question”: Orientalism in One Country* proving that the North/South division still held strong. Schneider published this book during the period of the Yugoslav wars, which wars can be characterised as ethnic conflicts. Europe experienced the deadliest conflicts since World War II, which showed that national borders were not as stable as Europeans perceived them to be. Instead, ethnicity proved to be a multi-faceted and multi-directional process that can still lead to conflict through groups’ diverse use of social and cultural capital in the process of maintaining or transforming boundaries. Conducting a library research on Sicily in 2003-2004, in order to write my MA dissertation, I attempted to enrich my awareness on the Mafia issue by having discussions with Italian students at Durham University. I discovered that although there was a rich bibliography dealing with the fascinating issue of the Sicilian Mafia, Italians were more concerned about the not so

---

<sup>1</sup> Marquis D’ Azeglio (1798-1866) was of Piedmontese noble descendant, and born in Turin. He was a politician, novelist and painter. Both kings Charles Albert and Victor Emmanuel II offered D’ Azeglio political authority. His memoirs, or *I Miei Ricordi*, was written toward the end of his life and was eventually published incomplete two years after his death.

well-documented issue of Italian integration. Usually, the discussion of the North/South division managed to trigger discussion of another issue: the ‘problematic’, as Italians put it, national integration of Italy.

The above anecdote shows that the issue of national integration is not recent but it is neither as intensely documented as it should probably be especially when comparing it to that of the *Cosa Nostra*. Instead, Italy’s North/South divide reveals, in the context given above, the existence of imaginary boundaries within Italy, and a rather fluid situation for which the future cannot be foreseen. Anthropological research could shed light on this fluidity and maybe provide those explanatory frameworks that would consistently analyse processes and present possible future scenarios. At first sight, the Sicilian case may not appear to be that different from any other case in which conflict characterises centre/periphery relations. However, I suggest that the Sicilian case should be seen neither as distinctive from nor as similar to other cases. Instead, the historically-grounded anthropological analysis of Sicilian life, focusing particularly on the island’s capital, could reveal how specific socio-political parameters are interwoven with Palermo’s trajectory, rendering the Palermitan case comparable with other similar examples. Especially because Palermo is the capital of Sicily, and Sicily is an independent region of Italy, anthropological research in Palermo allows for the comparison of power relations at differing levels. Palermo is the mediator between the local and the regional, and the regional and the national, in the reciprocal relationship between them. Moreover, the local and the regional are expressed through the national to the supra-national. Power relations could be seen as being interdependent and in such a balance that shapes interactions at all these different levels. Consequently, although individuals may not directly interact at all these levels, an individual’s identity is shaped through both direct and indirect relations. Therefore, this thesis examines Palermitan identity as dialectical and fluid

and as always being ‘in the making’ according to the circumstances that different levels shape.

I think that the title of this thesis - *Terroni and Polentoni: Where Does the Truth Lie?* - summarises the aims of my research and captures the situation in Sicily better than others. The first part of the title reveals the tension between the North and the South including the prevailing derogatory terms that the northerners and the southerners use to describe one another. The term *terrioni* derives from *terra* and corresponds to the stereotypical backward image of southern peasants cultivating the soil. The term *polentoni*, with which southerners refer to the northerners, derives from the Latin *pulmentum*; the *polenta* being a kind of mush made of ground yellow or white cornmeal, which is supposed to be a peasant food. The second part of this title is rather a play on words. Seeing things as black and white is probably feasible only when we read black letters on a white sheet of paper. However, life is colourful. The crisis of essentialism correlated to that of discipline, reveals an awareness of, and the need to cope with, distortion. In the tension between the *terrioni* and *polentoni* the ‘truth’ lies –in the sense that it rests- in a middle ground, somewhere in-between the extreme biases perpetuated by both the *terrioni* and *polentoni*. However, no one should be accused of lying in this case. As Herzfeld argues:

‘Social and cultural anthropology is “the study of common sense.” Yet common sense is, anthropologically speaking, seriously mis-named: it is neither common to all cultures, nor is any version of it particularly sensible from the perspective of anyone outside its particular cultural context. It is the socially acceptable rendition of culture, and it is thus as variable as are both cultural forms and social rules – those twin axes that define the formal objects of anthropological theory. Whether viewed as “self-evidence” (Douglas 1975:276-318) or as “obviousness,” common sense – the everyday understanding of how the world works – turns out to be extraordinary diverse, maddeningly inconsistent, and highly resistant to scepticism of any kind. It is embedded in both sensory experience and practical politics – powerful realities that constrain and shape access to knowledge.’ (2001:1).

Being aware of the above constraints, I attempt to document the representation of Palermitan life from various sources. Thus, although this study is anthropological, its theoretical framework borrows from other disciplines, such as history, sociology, and geography, aiming for a fruitful result. By mixing various approaches, which are driven from diverse theoretical and empirical areas, I attempt to provide an innovative approach to classic issues of the Mediterranean, i.e. honour/shame, family, etc., and produce an original but also comprehensive elaboration of ideas related to Palermo. I will try to develop an approach that is compliant with the recent theoretical developments in our discipline, but which is also based on the data that I collected in Palermo. Through this approach, I attempt to have fruitful insights into Palermitan life and explain that the backward image Italians have of the Italian south may be the outcome of a long process of fluid power relations, which image, however, serves the purpose of ‘making Italians’ up to the present time<sup>2</sup>. I suggest that neither Italy nor Sicily could survive alone the challenges of the current economic and political environment, and that the tension between the north and the south may have its roots in what really unites Italians, this being the economy. To reverse the research question, I suggest that Italy would not survive as a nation if the image of her ‘South’ changed to positive, not because this would make a long-lived stereotype collapse but because power relations would change. Therefore, I propose that it is even more crucial than ever before to re-address “Italy’s southern question”, now that the European Union and technology seem to bridge the gap between northern and southern Italy. Previous criticism of anthropology helps our discipline to find modern ways to address the important issue of nationalism, which has been revived thanks to the Europeans’ perception of the European Union as threatening national and regional identities.

---

<sup>2</sup> I suggest that the stereotypical images of the northerners and southerners play a vital role in the process of creating a national identity. This point becomes clear in the last chapter of this thesis.

This research aims to contribute to scholarship in three different ways: the issues addressed in this thesis, such as honour, family, and social networks, are the means through which I engage with the issue of identity in a Mediterranean context. Therefore, the critical evaluation of the literature I employ can be useful to anyone who is interested in each issue individually or a combination of them. For example, in chapter 4, I provide a detailed analysis on the issue of honour, suggesting that the focus should shift to how honour as a value system shapes relationships of unequal power, and why these relationships should be contested. Moreover, in chapter 6, I question the notion of “amoral familism<sup>3</sup>” and I present the circumstances that dictate interaction channelled through the family unit, as well as the changes I have observed in this process. This brings me to the second way this research contributes to scholarship, as it is based on updated data on Palermo that I have collected over a four years period<sup>4</sup>. I believe that anthropology is in need of both raw and elaborated material collected by anthropologists who see their field neither as exotic nor as completely familiar. Therefore, the third way this research contributes to the discipline is through the collection of detailed data that may provide an alternative view of the observed area, meeting the needs and interests of the discipline and people in the twenty-first century.

This thesis is divided into nine chapters, moving from pure theoretical analysis towards the mixing of theory with an augmented body of data I collected in Palermo.

---

<sup>3</sup> The term ‘amoral familism’ was introduced by E.C. Banfield in 1958. Banfield (1958) suggests that the backwardness of southern Italy can be partially, if not entirely, explained as the outcome of the southern Italian villagers’ inability to act together towards any end that transcends the nuclear family unit.

<sup>4</sup> This body of data was intentionally collected from the widest possible age range for the purpose of representativeness. The focus on identity and social change, and thus, on the fluidity of Sicilian society, demanded research among the younger generations. It was mostly among the young Palermitans of eighteen to thirty-five years of age that I tested the hypotheses generated primarily through the contrasting views they and older generations had of Palermitan life. However, school pupils played an equally important role in my study by giving me the opportunity to research how social and cultural capital is transmitted, internalized, and displayed. Thus, students gave me the opportunity to follow the least distorted view of a process, that of the social and cultural capital in their ‘making’.

The first chapter is an introduction to and an overview of the basic theoretical framework the hypothesis is contested in. It thus deals with identity, ethnicity, the anthropology of the Mediterranean, and power. The second chapter provides a short description of Italian democracy in historical, economic and demographic terms, as well as a brief history of Palermo and comments on the literature on the area of interest. The third chapter is dedicated to methodology, a brief analysis of the way these methods were used, and ethical considerations. Chapter 4 engages in a detailed analysis of seminal work on the issue of honour and suggests a new approach to it. In addition, chapter 5 provides a contested analysis of honour and links this value system to the Palermitan perception of the family. Chapter 6 is dedicated to the Palermitan family and its central role in Palermitan society. Chapter 7 then compares the family structure and its function within social networks, which are analysed in depth. The eighth chapter discusses the formation of Palermitan identity and its manifestation in various realms. Finally, the conclusion recapitulates the findings and proposes further research on issues related to those analysed in this thesis.

## *1.2 An Overview*

This thesis deals with Palermitan identity and the ways it is shaped through interaction at the local, regional and national levels. It is about power relationships and the changes in their balance that result in individual and socio-cultural modifications. I consider important, in the process of understanding Palermitan identity and cultural continuity, the analysis of the anthropology of the Mediterranean, which in turn dictates a contested and constructive criticism of the centrality of family, social networks and the issue of honour. Identity is the outcome of the relationship between the individual and society. In such a relationship,

imagined sociocultural boundaries interact with economic and political landscapes. Their perception not only varies from group to group, but from individual to individual as well. It is of extreme interest to shed light on the constructed 'nature' of boundaries and the shaping forces of the political division of the Italian nation into two antithetical parts, the North and the South, as well as on power balances and the implications they have for individuals and groups within contemporary Italian society. The focus on honour, family, identity, ethnicity, and nationality for their own sake are not the goals of this doctoral thesis, rather, I see these as critical factors in making sense of probable future scenarios of national integration within the European Union.

Identity may be understood as an individual's contested representation of the self within specific contexts that implicate various power relations. Sökefeld (1999: 417) argues that the work of Michael Foucault has been extremely influential in shaping our understanding of the individual as a socially constructed self and as a product of power and discourse (Foucault 1979). The 'difference' and the internal plurality of the subject is one way of explaining the interaction between the individual and the social at the level of subject (Sökefeld 1999: 418). Thus, political, ethnic, social identity, etc., are approached in this thesis as different aspects of an internally differentiated subject. Palermitans imagine only the Sicilian ethnos to be 'homogenous', the geographical boundaries of Sicily defining a different ethnic group for both Sicilians and their Italian fellow citizens. Still, Palermitans claim to be different from other Sicilians. Action and interaction being a contested representation of the self, in which the characteristics the individual and/or the group consider important for identification are highlighted, strengthens a feeling of belonging to the Palermitan community.

Power is also contested and operates relationally and reciprocally on, and through, individuals and groups (Foucault 1979). Palermitans, either individually, or in groups, use both coercion and/or consent in their attempt to control resources, family being a means of conceptualisation of, as well as a constant preoccupation in, asymmetrical power relations. Among others, I consider that the state, the church and the Mafia control of the majority of the resources. I approach honour as a set of values articulated through discourse. Discourse defines figures of authority and legitimises unequal access to resources. However, honour becomes a form of resistance when there is a conflict of interests<sup>5</sup>. Such conflicts are experienced at the extremes in Palermitan society due to a lack of absolute hegemony in ideology. The state has failed to monopolise the use of force, perhaps with a short-lived, but rather politically constructed, exception during the fascist period (Catanzaro 1992). Recent political activity aims to persuade Palermitans that their intentional exercise of power can reverse the situation. Although economic factors seem to achieve more in the ‘war against the Mafia’ (la lotta contro la Mafia) than the political system that is discredited due to corruption and its failure to address common Palermitan issues, local political discourse further widens the gap between ‘Sicilianess’ and ‘Italianess’. Local elites are proven more powerful than the nation in creating a local identity that praises the *piccola patria*<sup>6</sup> against national identity.

I approach identity as situational (Gluckman 1958); however, moving to ethnicity, I stress more specifically that Palermitans’ sense of simultaneity is expressed on both the local and the regional level, but not on the national. I shed light on the social procedures that have allowed local elites to impose values and ideas that legitimise

---

<sup>5</sup> Unlike Peristiany (1965:57) who holds that ‘a challenge is something which can only be given by a conceptual equal’, meaning that only a *señorito* can challenge another *señorito*, as only a *pueblo* can challenge another *pueblo* in Andalusia, in Palermo, honour is used by the ‘weak’ as a means of challenging the powerful indirectly when the interests of these two parties conflict.

<sup>6</sup> *Piccola patria* could translate into ‘birth place’. However, *patria* is also the ‘nation-state’ (thus patriot) and the etymology of the word reveals the sentiments that the *piccola patria* can provoke to the Italians, as well as the tension that could exist between the *patria* and the *piccola patria*.

their superiority over the other social classes, which they have strategically deprived of class-consciousness. The family unit is the backbone of Palermitan society because no other group has proven so potent over the course of time. A detailed analysis of the well-documented honour/shame issue illuminates the dual role of the family: on the one hand, Palermitans' attachment to it helps reproduce inequality, and on the other, the family is the unit that brings change to Palermitan society. If we define it either as patron/client relationships, to describe the relationship between landlords and landless peasants of the past, or as *clientelismo* to refer to political patronage of recent times, the result is the same. Generations of Palermitans learnt to accept patronage as the only means of advancement and to see their patrons as the only legitimate mediators between them and the hostile Italian state. Changes in the distribution of resources after WWI did not bridge the gap between poor and rich, but became the fertile soil upon which a conscious middle-class arose (Schneider & Schneider 1996). Perceptions of modernisation and the family went through parallel changes throughout Italy, but specifically in Palermo these changes brought all social classes closer in terms of values.

Political and economic changes in the last few decades made possible the redefinition of the so-called 'Palermitan values'. The educated middle-class that has undertaken this task stresses that education precedes in imperativeness; Palermitans have to understand their society first and then change it<sup>7</sup>. The growth of the Italian economy and technology has rendered the articulation of people and ideas within Italy easier. Although this could have positive effects on Italy's 'southern question'

---

<sup>7</sup> Colclough (1992:61), who also focuses on southern Italy, argues that 'until the early nineteen-fifties it was possible to discern a fairly straight-forward three class system of classification in Pertosa.' These classes were namely: the gentry, the artisans, and the peasants. Colclough (ibid: 64) stresses that from the 1980s 'the gap between the social classes has narrowed', the economy and education being the main parameters of such a change. However, he argues that because of the prevalence of patron/client relationships all the social class's 'internal competition for economic and political resources' discourages both overt class conflict and class interaction (ibid: 65). Unlikely in Palermo, the educated middle-class consciously interacts with both the lower and higher classes in an attempt to improve the condition of Palermitan society.

(Schneider 1998), the result is not that encouraging. The kind of change Palermitans opt for is to achieve standards of living equal to those of northern Italians, but the obstacles in such a process are local elites. Sicilian elites use poverty as an excuse to be granted funds by the central government; although, seen in its wider context, the circuit that profits from such funds is national. A vast flood of money from the North to the South and other complementary measures favour the South and should lead to economic growth. Instead, economic growth is targeted and the float of money is channelled in such a way that shapes political power balances at the national level and does not treat successfully the issue at hand. Although cases of corruption are brought to light, raw economic data make northern Italians perceive their southern fellow citizens not as poorer but also as culturally diverse, their poor economic conditions being perceived as the result of backwardness, while southerners sympathise with local politicians and accuse the central government of inexpedience.

It would be interesting to see why the North and the South interpret differently the same situation. I see some answers in the anthropology of the Mediterranean, local history and culture, and in national politics. The economic problem of the South does exist. Quantitative data prove the reality of the sense a traveller may acquire after comparing the living conditions in any city of the South to any of the North. The prevailing idea in the north is that money collected by taxation from their region could be invested in the local industry, instead of wasting it in the South. Southerners argue that northern politicians are 'Mafiosi'; they do not invest but they launder money in Sicily simply because they do not care about the Sicilians. Even if so, the question should be why the problem is not yet solved. Questions that arise consequently are how have these perceptions become so widely accepted, and why is political independence championed by both southerners and northerners as the only viable solution to Italy's southern question. I discuss the specific roles the two areas

have been ascribed on the stage by the local and national elites. During the Unification period, the diffusion of a certain political discourse by the elite aimed to facilitate the centralisation of power, as happened again later under Fascism. Today, an analogous political discourse flourishes on the ground of the European integration, centralisation being accused of devitalising national economies and threatening national identities. A similar preoccupation with the instability of the nation-state has led anthropologists to focus on specific issues in Mediterranean 'culture-areas' (Godderd, Llobera and Shore 1994: 2). Stereotypes of the South dating back to the Unification period were possibly 're-invented' through the honour/shame approach in order to explain the problematic national integration of Italy and to consolidate the new anthropological area.

The aim of this thesis is to deconstruct notions that distort the representation of Palermitan culture. Thus, my main concern in this process is cultural translation (Herzfeld 1980: 384). I do not only intend to provide academia with updated ethnographic data collected on the spot within an anthropological framework, but mainly to re-examine how honour relates to the Palermitan family, and these together to social networks. And as a consequence to shed light on the way boundaries are constructed and shift over the course of time. I stress that access to resources not only shapes choice in culturally specific ways, but also, even more importantly, that it is culturally driven. In other words, instead of focusing only on how many resources an individual has access to shape his/her choices, I claim that equally important it is to understand how a Palermitan is made to accept that there are only specific resources he/she is allowed to have access to. Palermitans are conscious of the devastating effects of patron/client relationships on their society. I document socio-cultural changes in Palermo, and I stress that Palermitan identity is situational. I approach Palermitans as 'strategising' people who benefit from shifting

identity according to their interests. In this sense, a European identity attracts Palermitans as another option in this ‘game’. Apart from the economic benefits from the European Union, Palermitans have also a moral one. Praising their culture for its plurality and great tolerance of any ‘other’, integration into the European Union gives Palermitans the chance to promote a cosmopolitan image of the ‘self’ that will counterbalance their stigmatisation as the ‘inner other’. Moreover, this thesis can be a useful addition to studies that deal with ethnic and national identity and the way these may conflict with the processes of integration.

### *1.3 Identity*

Identity as the outcome of the relationship between the individual and the society has been discussed much in the social sciences and especially anthropology has engaged this issue with profound interest. It is not the scope of this thesis to present all the anthropological approaches to this issue. However, in an attempt to contextualise my ethnographic findings theoretically, I will discuss concisely certain perspectives that I regard most relevant to the analysis of my own material from Sicily. Drawing on Foucault’s (1979) perception of the individual as a socially constructed self, concentrating on the difference, the internal plurality and the multiplicity of the subject is one way of explaining interaction between the individual and social at the level of the subject (Sökefeld 1999: 418). An important element in this strand of theoretical conceptualisation of subjectivity is the notion of inter-subjectivity, or relationality. Strathern, who among others stresses the relational aspect of identity, argues that the individual might not be the source of action, but ‘the one who acts because of relationships’ (1998: 273). The relational character of identity came to tackle the problem that some structural theories undermined the notion of agency.

Cohen (1994) favours individuality as well, but he takes a rather different position: he argues that we should look closely upon the relationship between the individual and society without neglecting the self in favour of a collectivist approach. He speaks of the need for the 'rehabilitation of the self' (ibid. 192) and a concept of society composed of creative and conscious individual agents. Rapport goes a step further, arguing that 'individuality is the root of the social and the cultural' (1997:2).

I perceive identity as the outcome of discourse, practice and relations that form the context of the individuals' conscious action. Ethnicity is also a kind of identification, and as such, I perceive it to be the outcome of relations, therefore, as being always 'in the making' and informed by social change. If the self is dynamic, reevaluation is constant in an individual's lifetime and it is the prerequisite of self-consciousness. Thus, political, ethnic, social identity, etc., are approached in this thesis as different aspects of the internally differentiated subject. It would be a fallacy to assume that when we are discussing a person's identity, trying to make sense of his/her political action we should not take into account his/her age, sex, status, religious affiliation, kinship, ethnicity, regional belonging and so on and so forth. The differences within individuals are equally important to the differences between them, and the same is valid for groups. Ethnic identities are not as homogenous as they might look (Hirschon 2003, Brown and Hamilakis 2003, Kirtsoglou 2006), but their content is 'constantly shifting' (Ardener 1989: 69). The same applies to ethnic groups despite the fact that they are imagined to be homogenous communities who engage in simultaneous action (Anderson 1983: 31). Theodossopoulos (2006) argues that Barth's seminal work (1969) *Ethnic Groups and Boundaries* has been leading to the above approach, because despite the criticisms for over-focusing on boundaries, Barth's work allowed us to regard ethnic categories as 'hollow entities'. If their form is stable while their content is always in the making, then perhaps the cultural

content of ethnic and national identities is not as important as their imagined form (Anderson 1983). Rapport (2002: 95) claims about individuals' unstable character of belonging to any community that they 'take themselves both seriously and playfully to be at once "in and out of any game"'.

However, identity is neither totally given nor totally invented, and thus a middle position between these two comes through focusing on action and interaction. As I have argued above, I perceive identity as the means of a person's or an individual's contested representation of the self composed by the characteristics the individual and/or the group consider important for identification in interaction. I mention both person and individual because the procedure of labelling does not always implicate the individual's consciousness or agreement. In other words, some aspects of identity are formed reflexively and others do 'not always require the mediation of consciousness, but [they] can be to a certain extent the direct result of power relations' (Kirtsoglou 2004: 31, Foucault 1980). The individual not only learns how to be a member of an ethnos, but he/she also attaches age, sex, status, religion, etc., and specific meanings provided by the social environment he/she lives in. Thus, ethnic identity becomes the result of human interaction, power relations and the competition between discourses and ideologies. Gellner's (1983) argument on the role of elites in the building of nationalist ideologies, supports the idea that ethnic and national identities are up to a point the outcome of power relations. Ethnicity is a very particular part of an individual's identity because it is 'dressed' with vague sentiments that are analogous to those attached to other groups, i.e. the family and the locality (Smith 2003, Kirtsoglou 2006). In addition, it is brought to the fore repeatedly (Woodward 1997), affecting individual action (Cohen 1985). As Lyon (2004) argues in his study of asymmetrical relations in Pakistan, it is a matter of transferral to extend patterns from the smaller to the wider group. Individuals

perceive ethnos and ethnicity similar to the way they perceive other smaller groups, for example the family (Loizos 1988, Just 1989, Sutton 1998, Hirschon 2000). This is not to say that human groups exist in nature from a primordialist point of view, but that like kinship, ethnicity is rather a perception of common origins (Banks 1996, Barth 1969, Cohen 1994). Cohen argues 'ethnicity has a definite appearance although it does not have such a definite substance' (1994: 62). Nevertheless, as Just claims, ethnic identity is often constructed on the basis of folk conceptions of blood and biology that follow kinship metaphors (1989).

Drawing from Cohen (1994), who holds that ethnicity is something you do as well as having, I would suggest that ethnic identity is instantiated in different practices of the individual. Ethnic identification can manifest itself in practices and even bodily dispositions, what Bourdieu (1990) calls 'habitus' and number of writers mention practice in relation to ethnicity (Billig 1995, Hamilakis 2003). However, the application of the notions of practice and habitus has also been proposed but criticised as being problematic for the theorisation of agency (Yelvington 1991: 160). Herzfeld, for example, argues that Greekness is 'embodied in social attitudes and physical movement' (1995: 126); Hamilakis claims that 'national pedagogical procedures...are instrumental in constructing a bodily mnemonic habitus, a sensuous perception of national truths' (2003: 60-61, cf. Kirtsoglou 2006). Practice can tie individuals to an ethnic community in a quite solid way; nevertheless, as Barth claims, ethnic groups are not always based on cultural similarities and differences (1969:14). The articulation of ethnic discourse and the socio-political procedures that shape 'ethnic identity' have an impact on an individual's evaluation of the other, thus of themselves as well. Ethnic opposition plays a very important role in the process of identification and this is another aspect of the relationality of ethnic identity. However, the individual is able to strategically manoeuvre within various groups

(see Bentley 1987). The relation between groups and the individual is interactive in the sense that not only a variety of groups express the variety of individuals, but also vice versa, the variety of individuals leads to the formation of various groups (Banks 1996). The complexity of the human self allows the individual to belong to different groups that partially express him/her. I suggest 'partially' not only because an individual's self cannot be expressed through only one group, but also because a group cannot even express fully the part of the individual self to which it refers. This allows individuals to move from group to group in order to achieve the best possible representation on various levels and contexts (Rapport 2002). The individuals' contested selection of groups reflects not only personal interests, but also the economic and social balance of groups within a society.

The aim of the manoeuvres an individual undertakes relates to the self. An individual can pretend to have another behaviour that implies another identity or accept his/her misrepresentation under certain circumstances (Cohen 1994). It is also possible that an individual's action can result in misunderstanding his/her identity when it takes place in contexts other than those in which this identity has been shaped, i.e. refugees' action within the reception country. The above two situations are different, as in the first case the individual is conscious of his/her identity's 'false' interpretation. In the second case, it is a matter of diverse social rituals between diverse social realms, which are expressed through different social networks that do not provide the individual with the capacity to understand how his/her action is interpreted in the new context. Protecting the self by manoeuvring or adjusting it to the social environment is not a contradiction but rather a matter of consciousness. Although the self presupposes the individual's consciousness, the individual cannot always grasp changes, especially when they are completed in a very short or a very long term.

#### 1.4 Ethnicity

Having discussed the main parameters of identity, I would like to proceed to a concise review of anthropological theories on ethnicity. Different theoretical approaches do not only reflect shifts of interests and a variety of viewpoints, but they also demonstrate the attempts of academia to cope with the vague nature of the topic in a variety of contexts. I engage Barth's, the 'Soviet ethnos', and the Manchester School's theories in order to combine various approaches on ethnicity in a synthesis that better addresses my focus.

Barth's (1969) influential introduction to *Ethnic Groups and Boundaries* that expresses the Scandinavian anthropologists' views on the social organisation of culture difference, challenges the traits used thus far in theory to identify social groups (these traits are mentioned below). He proposes that attention should be paid not on ethnic 'markers' as defining groups per se, but on the boundaries that mark the limits of these 'markers'. Ethnic groups are approached as socially constructed and consisting of certain characteristic markers and value orientations, shaped in contrast to other groups 'of the same kind'. Barth suggests that individuals can change groups when they become socially dislocated, and thus disconnects the existence of boundaries from the flow of persons across them. He also attributes to the individual the capacity of a strategic choice of features that serve to legitimise a *social actor's* location and status in diverse contexts. Despite his emphasis on strategic action, Barth's approach to ethnicity as a permanent superordinate identity is close to primordialism. Ethnic identity is perceived as superior or equivalent to all other identities, i.e. gender, class, and it is seen as shaping human behaviour; he

argues 'the constraints of a person's behaviour which spring from his ethnic identity...tend to be absolute.' (1969: 17).

Perhaps, the Soviet ethnos theory has best represented the 'primordialist stance'. According to this strand, although society is seen as dynamic, a core of ethnicity persists through the totality of social formations. Ethnicity is regarded as having a stable core but also the ability to change expression according to economic and political conditions. An ethnos' boundaries remain conceptually stable despite the potential changes in characteristics, and an ethnic community is being manifested as an 'ethno-social' organism (Bromley 1974). Ethnic characteristics that are seen as being cultural and psychological in kind, define ethnic groups only when they are combined with individual consciousness of difference from other groups of the same kind. Like Barth's theory, an ethnos is defined by opposition to other ethnic groups, and its existence is not based on the immutability of contents and characteristics (see Banks 1996). The ethno-social organism allows social class variations, but the core of the ethnos remains constant as ethnos, while ethnos and class are complementary to each other. In addition, overt cultural forms are the means of ethnic manifestation, but the ethnos is more than the sum of its features as it implicates individuals' consciousness for its integrity (Dragadze 1980). The problem in this theory is that, by posing a stable and persisting core of ethnicity, ethnic identification is not the result of history, cultural, economic and religious exchange, but something given that precedes society or coincides with its emergence. In addition, this perspective implies a passive individual and it thus reinforces a dichotomy between the individual and the social.

The Manchester School (Gluckman, Mitchell, Mayer, Epstein, and Cohen among others, see Banks 1996, Van Teeffelen 1978, Brown 1973) approach the issue of

ethnicity from a different perspective that facilitates the analysis of African societies. By focusing on the changes caused by urbanisation and colonialism, and the way in which industrialised nation-states were built in post-colonial Africa, they facilitate the shift of anthropological interest from the study of 'tribe' to the 'ethnic group' (Banks 1996). Especially Gluckman (1958), who focuses on the context of interaction between native Africans and colonialists, claims that identities are situational: there is a number of identities that an individual can manifest according to the situation he/she is in. The concepts of identity categories that individuals hold, allow them to exchange one identity for another. The criteria in this case are values and beliefs, and it is thus possible to have special interest sub-groups within ethnic groups. Although there is communication between different groups, constructed boundaries are patrolled by the dominant ones. Mitchell (1969) raises the above problem in an urban context and compares the function of the 'tribe' in rural areas and in towns. Mitchell suggests that 'tribal distance' is always relevant to the context. While in rural areas tribe is *the* means of division, in the city, familiarity between individuals of different tribes depends on their social and geographical distance (like Epstein's 'cognitive maps'). Mitchell examines the use of familiar metaphors, like that of the tribe, in urban, migrant settings. He argues that such metaphors serve to create 'cognitive maps' of spaces that now resemble the face to face community. Tribalism is thus seen as a mechanism of coping with uprootedness (cf. Banks 1996).

As I have mentioned, Cohen (1978) perceives ethnicity to be instrumental; a group asserts and maintains an ethnic identity because of economic and political, rather than psychological, reasons. Group characteristics are thus not primordial but constructed according to the needs of the group. One becomes a member of the group when he/she learns how to manipulate symbols and collective markers. Ethnicity is therefore political as it is goal-oriented and is built upon a pre-existing

cultural identity, shaped by external and internal (to the group) conditions. Cohen (ibid.) however, also suggests that there can be further divisions within ethnic groups through the process of 'retribalisation'. People in their effort to achieve privilege and power selectively manipulate values, customs, myths, symbols, and ceremonials to form informal political organisations that allow them collective representation in political struggles. Ethnicity is therefore viewed here 'not so much as a form of identity as ethnicity as a strategy for corporate action' (Banks 1996: 34). Epstein challenges the view that ethnicity is instrumental with his 'cognitive maps' theory (1978). Epstein is obviously influenced by psychology and psychoanalysis and argues that ethnic identity is a kind of 'terminal' identity that embraces and integrates a whole series of statuses, roles and identities (Banks 1996: 36). Epstein views identity as a kind of a never-ending process shaped by social factors as well as internal psychological ones.

The approaches on ethnicity mentioned so far are bound to specific needs and interests of academia within a specific political and historical context. The whole discussion revolves around the debate between primordialists and instrumentalists. However, most recent theories disengage from the above division, i.e. Eriksen's 'language games', and Bentley's 'praxis' theories, and/or are more sceptical of representation issues, for example Cohen (1986). Having presented the most well-known theoretical positions, I attempt a synthetic approach to ethnicity taking into account issues that have come to the fore in recent years. It can be argued that ethnicity is the individuals' feeling of belonging to a group defined as 'ethnos'. As Barth argues, it is the idea of the group (ethnos) that endures and not the group itself (1969).

Cohen (1994) argues that family life provides the young child with the parameters of self-consciousness. Family life, daily practices, as well as education affect identification with an ethnic group. Ethnic, like national identity is intensively shaped in educational institutions and through certain curricula (Frangoudaki 1997, Avdela 1997, Hamilakis 2003). Initially, the individual is conscious of his/her home as a spatial point of reference, and of his/her family and school as groups of which it is a member. It is through education that the individual becomes conscious of belonging to a wider ethnic group, a fact that broadens his/her previous points of reference (Barth 1969). This is not to say that the family, educational curricula, or the mass media, have a final overriding influence on the formation of ethnic identity. Personal interests also shape an individual's political stance that is based on the elaboration of the discourses of various political streams (see Eriksen 1993). Therefore, the individual can become Bailey's (1963) 'strategising man' that manipulates various means to achieve goals although the means employed by the individual are those that society or culture provide. The scope is not unlimited although interpretation may vary from person to person (Eriksen 1991). However, even if individuals of the same ethnic group differ from each other, their discourses relate to common themes. In the case of nation-states, the state's accomplishment is that it becomes a daily point of reference for the individual that correlates and compares (consequently, makes sense of) each and every aspect of his/her life to his/her experience gained within the ethnos to which he/she belongs. Thus, he/she consequently facilitates the state's reproduction, as the latter institutionalises its members' practice.

The parameters of difference within ethnic groups can be of various kinds, i.e. gender, class, language, religion, political stance, even the way members of the same ethnos interpret ethnicity (Cottle 2000). Diversity can even result in the opposition of

various intra-ethnic groups. A characteristic example is the tension between Sunni and Alevi Muslims in Turkey (Shankland 2003). Because of their dynamism, such tensions however are often seen as overtly questioning the integrity of the ethnos. This is partly a result of the ‘ideological’ role of ethnicity itself, which defines such diversities as different expressions of the same theme. As a result, individuals share the belief that their ethnic traits are common (even if their manifestation varies), in contrast to those of other ethnic groups that are perceived as different from the self. This is of course partly a result of ‘naturalisation’ mechanisms and perhaps of ideology that manages to portray the self as much more coherent, underplaying the differences within groups in comparison to the differences between them.

To be more explicit, I refer to Narroll’s (1964) definitional parameters of ethnic groups and I analyse the role of the individual in constructing his/her own group as integral and homogenous, bearing in mind Barth’s (1969) criticism of this approach, who argues that with this definition we cannot grasp the fluidity of the boundaries and the genesis of ethnic groups. To quote Barth (ibid. 10-11): ‘The term ethnic group is generally understood in anthropological literature [cf. e.g Narroll 1964] to designate a population which:

1. Is largely biologically self-perpetuating<sup>8</sup>
2. Shares fundamental cultural values, realised in overt unity in cultural forms
3. Makes up a field of communication and interaction
4. Has a membership that identifies itself, and is identified by others, as constituting a category distinguishable from other categories of the same order.’

---

<sup>8</sup> It is this pointed observation that led me to use the term ‘naturalisation’ to refer to mechanisms that produce the illusion of homogeneity and continuity. Biological metaphors are of course means of conceptualising political identities as discussed.

It would be a fallacy to assume that every individual makes sense of an ethnos' basic characteristics in the exact way its other members do. However, as I have argued, ethnicity legitimises the existence and facilitates the continuity of an actual or imagined ethnos partly through the institutionalisation of practice. Although interpretation may vary from individual to individual, all the members of an ethnos engage –or *imagine* they engage- in the same practices. This is what Anderson (1983) refers to as the 'sense of simultaneity'. The imagined or actual borders of an ethnos and their 'content' (tradition, history, values, and symbols) are such that they can be easily compared to those of other ethnic groups. This comparison further strengthens the sense of simultaneity by allowing individuals to perceive and imagine other ethnic groups, in the same naturalised manner, as stable, self-perpetuating and homogenous (Kirtsoglou 2006). As Banks (1996) argues, the above features imply specific roles for the members of an ethnos. If one follows a similar argument to that proposed by Gellner (1983), about ethnicity and nation-states, then an ethnos can be formed only with the diffusion of the elite's political discourse that will bring people together in a unified perception.

Based on the above, one can argue that ethnicity becomes a means of categorisation established by either assimilation or exclusion. Assimilation becomes possible through subtle strategies such as education, or radical measures such as ethnic cleansing. Exclusion reflects an ethnos' need to safeguard its boundaries when interaction with different ethnic groups appears to threaten its integrity. When group boundaries however are at stake *within* a nation-state (or else, when physical borders do not coincide with ethnic ones) the difference between ethnic groups is played at the level of evaluation. Consequently, ethnic groups within a state accept their 'inferiority' compared to other groups in the nation that they are part of, or engage in a struggle for autonomy (as is the case of Basques in Spain). Ethnicity in this case

becomes saturated with relations of power in so far as one group claims superiority over others attempting (and in many cases succeeding) in imposing its own vernacular as the national culture.

Sicilians 'pass' Narroll's 'test' and can be considered to form a distinctive ethnic group within the Italian nation-state. Palermitans' sense of simultaneity is expressed on both local and regional levels, but not on the national one. The imagined boundary between Sicily and the rest of Italy is strengthened as Sicilians distance themselves mentally or physically from their homeland, and by opposition to the inner 'other'. This opposition is constructed (or at the very least manipulated) by Italian elites for specific political and economic purposes. However, the Palermitan response implies an antithesis that diffuses a possible national crisis; on the one hand, Palermitans admit their economic inferiority, on the other, they perceive their culture as more complex and rich, especially compared to the North. Despite this discursive superiority, the Sicilian struggle for autonomy should be understood as a means of coping with inferiority.

### *1.5 Anthropology of the Mediterranean*

The anthropology of the Mediterranean became a specialised field of study, according to Davis (1977) and Gilmore (1982), in the 1950s when anthropologists turned their focus to the study of small, 'face to face' Mediterranean communities. The work of Pitt-Rivers (1954), Campbell (1964) and Peristiany (1966) is undoubtedly pioneering in the ethnographic establishment of a 'cultural landscape' (Braudel 1972: 276-352, Boissevain 1979: 8) that was seen as bound together by the values of 'honour and shame'. A concise presentation of the character and tone of Mediterranean anthropology is useful, not only because it contextualises my own

material on Sicily in a certain tradition, but also because it partially explains the reification of concepts that are central to the present research. Anthropological attention to the Mediterranean region is not altogether unrelated to particular social and political circumstances. Goddard, Llobera and Shore argue that in the Cold War climate, southern European countries were seen as unstable and potentially vulnerable to the spread of communism (1994: 2). The interest in Europe was thus not unrelated to politics and changes that affected the world economy (ibid: 15).

The anthropology of the Mediterranean was a first attempt to study cultures 'closer' to home. Anthropologists carried out these studies relying upon their knowledge and models on African societies (Goddard, Llobera and Shore 1994) and focused on what was seen back then as marginal and distant enough as to deserve anthropological enquiry (ibid.). Perhaps saturated with a kind of cultural nostalgia (Dubisch 1995) or in search of a model that would explain non-unilineal kinship ties (Goddard, Llobera and Shore 1994), anthropologists overemphasised the importance of 'honour and shame' as *the* cultural values that brought together otherwise different cultural communities. According to Sweet and O'Larey (1969), the Mediterranean was perceived as a set of complex communities so similar to each other that they formed a distinctive cultural pattern of civilisation whose similarities were attributed to common history and ecological circumstances. For Gilmore (1982) it was Redfield who initiated a pan-Mediterranean focus in anthropology. Then Rivers and Peristiany organised symposia aiming at exploring the distinctiveness of the Mediterranean, while in 1971 Jane Schneider 'published a theoretical paper on the origins of the pan- Mediterranean honour-shame complex...that was important because it was the first to demarcate a continuum of material variables which hypothetically constituted the basis of Mediterranean

unity.’ (ibid: 175). Davis’ (1977) and Boissevain’s (1979) comparative studies consolidated the field.

Honour and shame, as a set of cultural values presumably unique to the Mediterranean region, accounted in these earlier writings for structure and function, kinship of course, but also political and economic relations (Goddard 1994: 60). They tied the theorisation of economics, politics and gender to kinship and the family, and this is particularly obvious in the study of patronage as performed by Campbell (1964) and in the debate on ‘amoral familism’ (see Schneider and Schneider 1976; du Boulay 1987). According to Pitt-Rivers, honour was ‘the value of the person in his/her own eyes, but also to the eyes of the society’ (1954: 21). It needed to be publicly demonstrated and defended (ibid: 27) and pertained to male virility and the protection of the chastity of female members of the family (Campbell 1964). Shame on the other hand was a value upheld primarily by women and related to their moral integrity as well as their reputation of being virtuous (Dubisch 1995: 196). Honour and shame were not just social values that ‘tied’ Mediterranean peoples (Peristiany 1966: 11) but crucial traits of social stratification (Davis 1977: 89-101) that organised social and political life in the Mediterranean village, explained competition between households and elevated the household (and not the individual) as the basis of Mediterranean selfhood.

Voices that disagreed with such a neat conceptualisation of the area soon appeared. Scholars argued that there were great differences among the subjects of study that were as important as their commonalities in understanding Mediterranean societies (Wolf 1969; Goody 1983; Herzfeld 1980, 1984). Herzfeld (1980: 384), Dubisch (1995) and Just (2001: 45) speak of the problem of cultural translation, challenging the manner in which certain terms, like honour, were perceived and theorised by

earlier anthropologists. Argyrou also demonstrated that the uniqueness of Mediterranean values is 'not unique' after all (1996: 158) by using the work of Bourdieu on the identity of French working-class men (1984) and Willis' (1981) study of working-class high school boys in England. It would thus be fair to agree with Albera and Blok (2001) who argue that the Mediterranean became the experimental laboratory of the discipline of anthropology where diverse anthropological methods were applied for a number of diverse interests.

The cultural analysis of Mediterranean communities through the 'culture-area' concept and the 'honour-shame' complex rendered Sicily culturally unique. In spite of the simplifications, Sicily's problem of category ascription could not be easily tackled: how would Sicily fit into the Mediterranean pattern since it was the only society in which the Mafia was developed and played the role of mediator between the peasants and the proletariat? Moreover, how could honour be linked to both positive social connotations and to the Mafia as one of its basic values? Although Mediterranean peoples were seen as having experienced similar socio-political conditions, historically responding in comparable ways (Braudel 1972), the diversity of Sicily lay in the distribution of land and the existence of the Mafia. The absence of a middle class that could play the role of mediator between landlords and peasants, as well as the constant political fluctuations throughout Sicilian history due to various conquerors, facilitated the formation of the Mafia (Schneider 1976; Duggan 1989). The Mafia played the role of a stable, armed domestic 'authority', substituting for a state that was either absent or perceived by Sicilians as being so (Gambetta 1993). However, the 'honour-shame' approach that was applied to Sicilian communities in order to make sense of the Sicilian diversity perhaps diverted attention –partially at least- from politics to kinship. As it happened with gender relations (cf. Goddard, Llobera and Shore 1994), or with the concept of class

(see Argyrou 1996), the Sicilian Mafia as a socio-political and economic phenomenon might have been overanalysed through kinship and therefore insufficiently examined against larger theories of politics, history and economics.

### *1.6 Power*

In this part, I provide a concise analysis of the theoretical developments on ‘power’ from the 1960s until today. Gupta and Ferguson, discussing the critiques of culture since ‘the Boasian success in establishing the autonomy of the cultural from biological-cum-racial determination’, stress the importance of feminism in seeing culture not as ‘order’, but as containing partialities (1999: 1). In the 1960s and 1970s, feminism questioned authority and even more importantly something taken thus far for granted, that is the origin of cultural rules and their role in societies. Although power has a central role in the perception of culture as order, the theorisation of power did not advance before post-structuralism. Soon, however, power as an analytical tool threatened the notion of culture and its use in explaining social relations (Horowitz 1967: 11). Much of the polemic against power relied on the fact that such analyses were extremely politicised (see Giddens 1968). Parsons, for example, saw power as something quasi-natural and inherent in the system, serving collective action that according to Giddens ‘reads like a description of normative democratic theory, and often like an apologia for American Democracy in particular.’ (ibid: 268).

In 1971, McClelland stresses the shortcomings of power theory and proposes that not everything can be perceived as, and explained through, power if there is nothing else to form its counterpart and to which it can be compared. Thus, a few years later Baldus (1975) discusses the relationship between structure (institutions) and agency,

and the way an individual's position within institutional hierarchies shape his/her options. Another solution comes from Wrong (1979) who, based on previous ideas that stress the intrinsic aspect of the relationship between power and conflict (i.e. Dahl 1963), suggests that the interest should be shifted to the conscious use of power. Some twenty years later, Dahl (1986:40) insists that power can be analysed only after the fact (see also Etzioni 1993). Isaac (1987) concludes that the analysis of power should be supported by another kind of analysis, the historic one. Among others, Abu-Lughod (1991) and Appadurai (1991) expressed the need to move from culture to hegemony, discourse and *habitus* in an attempt to 'decolonise' further the discipline of anthropology itself.

Foucault (1978, 1980) substitutes Dahl's (1963) idea of conflict with that of 'resistance' arguing that power and resistance coexist at all levels of society. Rabinow (1984:175) argues that in Foucault's approach, power produces knowledge. This is because Foucault sees power not only in resistance but also in discourse, as 'Discourses are tactical elements or blocks operating in the field of force relations' (1978: 101). Discourse has two characteristics, as, on the one hand, the same strategy can embrace contrasting discourses, and on the other, a specific discourse can be adapted from opposing strategies. Thus, Foucault perceives power as the means that renders individuals conscious of their self and their relative position within a system, the categorisation of the individual through self-consciousness and dependence transforming the individual into a subject. Although this is achieved when discourse is considered common knowledge, resistance seen as inherent within this procedure can bring changes in the relationship between the subjects and their identities even to the point that the subjects reject their identities. According to the Marxist Gramsci (1971), power can take both the forms of coercion and consent. By asserting that within the capitalist system the bourgeoisie managed to impose their hegemonic

culture and render their values commonsensical to the working class, he argues why there was no socialist revolution in Italy. As with Bourdieu (1990), control of material resources or people grants the ability to garner symbolic capital, while in other contexts the same material resources and people can be seen as symbolic resources.

Lyon (2004) argues that ‘it would be wrong to insist that power can only be understood through an examination of conflict; yet there are risks in interpreting situations without conflict as expressions of power.’ To assert that ‘interpersonal conflict is endemic in Sicily’ (Schneider 1969: 130) would add more problems than it would solve. Variations in the control of material and cultural resources, however, exist in every society. Thus, variations in power do not only reveal hierarchies but also the relational character of power. Power, either coercive or not, may define figures of authority when certain discourses become ‘common sense’. However, changes in the material and cultural resources should logically result in parallel changes in terms of power. The same can be argued about resistance, since a discourse’s appeal to individuals is also a measure of its authority. Thus power augments with the elimination of ‘counter-powers’, but since they are all interwoven, power lies in the capacity to convince individuals to join their power towards the fulfilment of some specific collective goals rather than others.

Schneider (1969) provides the mechanism that ‘attaches individuals to their own identity’ (Foucault 1980). Schneider (1969: 131) argues that ‘In Sicily the locus of power is the individual and his nuclear family, and the problem of individual potency is both salient and central to the actor's personality.’ Moreover, ‘The structure of conflict over economic interests is reinforced in Sicily by the political mechanisms through which these interests are defended or enhanced.’ (ibid: 140). Honour in this

case is perceived as an ideology through which the individual ‘rationalises or enhances’ his/her power in interpersonal relations (ibid.). This ideology draws from another kind of honour that Schneider defines as social, and which is constituted by standards that are shared among the members of the community. However, I strongly disagree with the perception of standards on social honour as ‘relatively stable’ (ibid: 149), that deny agency and fluidity. Specifically, for the interests of this doctoral thesis, I suggest that the local elites’ power is greater in comparison to the national in convincing Palermitans that ideas, which lead to specific embodied practices and thus to common perceptions of locality, are primarily Palermitan and/or Sicilian but not Italian. Their success can be witnessed in the fact that today less resistance is enabled at the local and regional levels. I proceed by providing qualitative and quantitative data on Italy, Sicily and Palermo that bound the area of interest with the specific theoretical context discussed above.

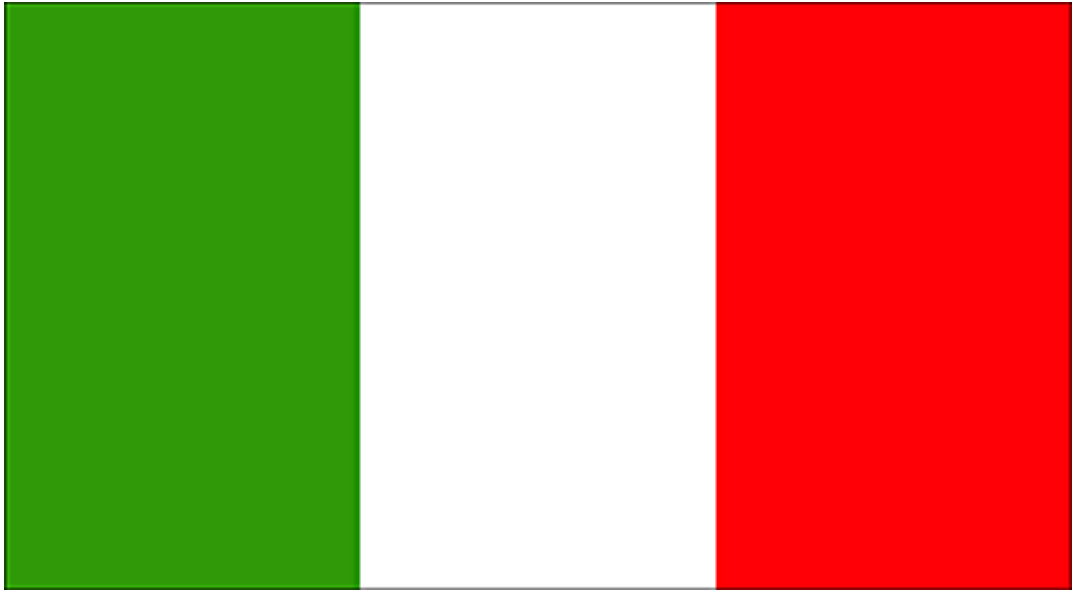

The Italian and Sicilian Flags.

## Chapter 2 HISTORY, POLITICS, AND DEMOGRAPHICS

### *2.1 The Italian Unification and the North/South Division*

Probably the most critical turning point in Italian history is the Risorgimento in the mid-nineteenth century A.D., not only because it signifies Italy's birth as a nation but also because it was crucial in what Hobsbawm and Ranger (1983) call 'invention of tradition'. Lyttelton (2001:27) argues that 'the Napoleonic cyclone shook the foundations of belief in the old territorial states.' Italy had to invent her own history that would bring together diverse histories of regions and municipalities it consisted of after 1860 into a common history that would 'prove' the Italian nation's continuity. However, Ascoli and Von Henneberg (2001) suggest that 'the metaphor of the dormant and pre-existing proved problematic when it came to the south.' (p.7).

Cavour<sup>9</sup>, the central figure in Italy's Unification war and Italy's prime minister since 17 March 1861, saw the Italian south as threatening the Piedmont dreams of a unified Italy. Carlo Farini, the chief administrator of the South writes to Cavour in October 1860<sup>10</sup>: 'But, my friend, what lands are these, Molise and the south! What barbarism! Some Italy! This is Africa: compared to these peasants the Bedouins are the pinnacle of civilisation. And what misdeeds!' (p. 129).

During the same period, Lady Holland writes to Cavour: 'It is remarkable that in the entire Kingdom of the Two Sicilies the new government will discover that

---

<sup>9</sup> Cavour (10 Aug. 1810-6 June 1861), or Camillo Paolo Giulio Benso, Count of Cavour of Isolabella and of Leri, was born in Turin. He started his political career in Piedmont and thanks to successful economic reforms he managed to become Prime Minister of Piedmont in 1852. He was equally successful in empowering Piedmont by leading it consecutively through the Crimean War and the Second Italian War of Independence. Cavour moved strategically between the French, King Victor Emmanuel II and Garibaldi, and achieved Italy's Unification after the annexation of the Papal States.

<sup>10</sup> The examples of the correspondence between Cavour and his envoys used in this text are quoted from N. Moe's *'This is Africa': Ruling and representing Southern Italy, 1860-1* in A.R. Ascoli and K. von Henneberg (2001).

everything remains to be done...All the cities of Naples and Sicily are in the state of indecency, almost inferior to that of the ancient tribes in Africa...' (p. 129).

Cassinis, the Minister of Justice concludes: 'In a certain sense it is necessary to remake the country, to remake or, better, create the public conscience; it is necessary to render these men capable of living under the constitutional system of government. And it would be something to despair over, to consider impossible, if this very land, so far from the ideas of progress and civilisation, didn't offer us special opportunities' (p. 129).

However, Chubb (1982) suggests that southern Italy's elites, attempting to maintain their *status quo*, played an equally important role in the maintenance of the south's backward image. Although the integration of the North and the South may have become problematic as early as when the polemic between Cavour and Garibaldi started, it should be seen as the complex outcome of a peculiar interaction on the political level that filtered down to the Italian society in the course of time. Overall, the Risorgimento failed as the base upon which national identity could be built because it brought to the fore local interests and strong regional identities that Italians preferred to protect against national integration (Dainotto 2001).

Neither under fascism, nor in democracy after World War II was the gap between the North and the South ever bridged, for the differences between the two regions remained in Italians' consciousness as vast as they have been in the second half of the 19<sup>th</sup> century. In fact, political and economic elites proved capable of protecting their interests at the expense of what the Italian War of Independence was started, leaving practically unchallenged the concepts of citizenship and political community that were diffused through the French Revolution.

## 2.2 Current Italian and Sicilian Governing Systems

The Italian boot-shaped peninsula is surrounded by the Tyrrhenian Sea on the west and the Adriatic on the east. The Alps form the northern border of the country; moving eastward, where Italy is bordered by France, Switzerland, Austria and



The European Union's, the Italian, and the Sicilian flag.

Slovenia. From the northwest of the country and along the Alps, flows Italy's largest river, the Po, which debouches into the Adriatic after meandering through the

Lombard plain. The Apennine mountains stretch along the Italian peninsula and form its backbone. Rome is both Italy's political and geographical centre. The Eternal City, the Italian capital, lies in the centre of the Italian peninsula. The national flag is a tricolour of rectangular parallelogram shape; starting from the hoist side, the first of the equally sized vertical columns is green (symbolising hope), the second is white (faith), and the third is red (charity). Sicily is bellow the south-west tip of Calabria; the strait between them is called in Italian the *Stretto di Messina*. The Sicilian island has a triangular shape and the Sicilian flag is the *Trinacria*, or *Triskelion*, which means in Greek 'three corners' and 'three legs' respectively. In the centre of the *Trinacria* stands the protector of the island, *Medusa*, which represents the ancient Greek goddess Athena. The red and yellow colours represent Palermo and Corleone, the two cities that fought together during the Sicilian Vespers against the French Angevins.

The Italian Republic (2<sup>nd</sup> June 1946) is governed under the constitution of 1948 (promulgated on 1<sup>st</sup> January). The parliament is bicameral (Chamber of Deputies and Senate);, and there is an executive Council of Ministers, which is headed by the prime minister and an independent judiciary. The President, who is elected every seven years by the parliament and regional delegates, is the nominal head of the State. Analytically, the legislature is composed of the 630 members (12 of whom are elected by Italians abroad) of the Chamber of Deputies, and a 315-member (six of whom are elected by Italians abroad) Senate. Italians vote every five years by a proportional representation system for both the Chamber (universal for all Italians above the age of eighteen) and Senate (universal for all Italians above the age of 25). The president nominates the prime minister, and the latter chooses his ministers. The government has to retain the confidence of both the Chamber of Deputies and the Senate. The largest political parties at the national level are the centre-right People of

Freedom and Lega Nord, the centre-left Democratic Party, Italian Radicals, Italy of Values, and the Union of Christian and Centre Democrats.

For administrative reasons, Italy is divided into 94 provinces and 20 regions. For each province a prefect is appointed by the central government to which he/she is answerable. Five out of the 20 regions, namely Sardinia, Sicily, Trentino-Alto Adige, Valle d'Aosta, and Friuli-Venezia Giulia have a statute of special autonomy (the highlighted regions on the following map of Italy). Sicily, which is the largest island in the Mediterranean, is also Italy's largest region. Sicily is divided into 9 regions (the capital Palermo, Agrigento, Caltanissetta, Catania, Enna, Messina, Ragusa, Syracuse, Trapani), which also include the small surrounding islands; the regions are further divided into municipalities (there are 8 in Palermo). In the Sicilian presidential representative democracy, the chief of the government is the President of the Regional Government which has executive power. Representing both Houses on the national level, the government has relatively equal legislative power with the Sicilian Regional Assembly. There are six major political parties in Sicily, namely the Sicilian National Front, Movement for the Independence of Sicily, Movement for Autonomies (Christian-Democratic and represented in Parliament), New Sicily, Pact for Sicily, and United for Sicily.

Map of

Italy



Source: Forgacs, D. & Lumley, R. (eds) 1996. *Italian Cultural Studies: An Introduction*. Oxford: Oxford University Press (p. 15)

Inner Political and Physical Divisions by ISTAT

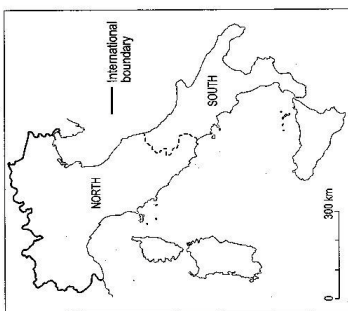

Map 2. A two-way division into North and South (Sicily and Sardinia belong to the latter): a division with a long history and strong ideological connotations

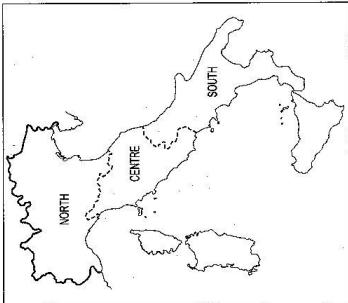

Map 3. A three-way division into North, Centre, and South, as used by the Istituto Centrale di Statistica (ISTAT) for its surveys

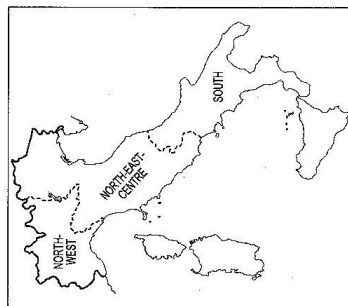

Map 5. The 'three Italies': a refinement of the ISTAT categories introduced by Arnaldo Bagnasco in his influential *Tre Italie* (Bologna, 1977), which distinguished between a North-West with its older large-scale industry, a Centre and North-East with newer, dynamic small industries, and a South marked by slower economic development

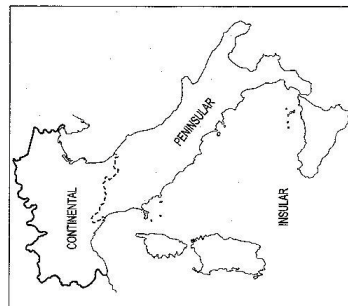

Map 6. A common physical distinction between continental Upper Italy (Alta Italia), from the Alps to the Po basin, linked to the European land mass, the peninsula, and the islands

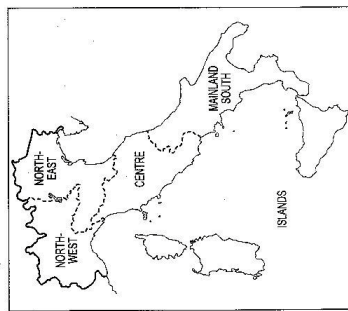

Map 7. Further physical divisions: another ISTAT model used mainly for settlement, population, and agricultural statistics.

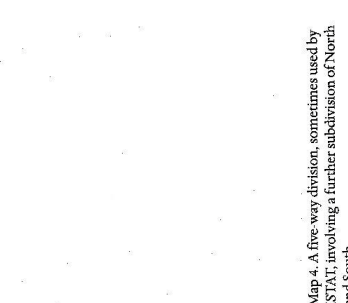

Map 4. A five-way division, sometimes used by ISTAT, involving a further subdivision of North and South

Maps 2-7 show other ways in which Italy may be subdivided within the same outer boundaries. Each map reflects a different judgement about inner divisions, either of a political or of a physical character, which are deemed significant. As a whole, they show the way that inner boundaries may 'move' as different discourses about the shape of the country are applied (see also the 'fantasy maps' reproduced and discussed on pp. 102-4 for some unorthodox products of the same procedure). Source: Maps 1-7 reproduced from Russell King, *Italy* (London, 1987), 26 and 175.

Source: Forgacs, D. & Lumley, R. (eds) 1996. *Italian Cultural Studies: An Introduction*. Oxford: Oxford University Press (Pp. 16-17)

### 2.3 Demographics

According to ISTAT (Istituto Nazionale di Statistica), or National Institute of Statistics, the total population of Italy is currently 60,045,068, of which 29,152,423 are male and 30,892,645 are female (data collected in 2008). Palermo, which is the fifth largest Italian city, numbers approximately 1 million inhabitants, while the total population of Sicily is slightly over 5 million people. Foreign residents number 425,778, or 6.5% of the total population. The vast majority of foreigners are in the north and centre of the island (8.6% in the centre-north against 2.4% in the south and the islands). The density of the Italian population is higher in the north-west and the south of the country (15,917,376 / 14,147,444, or 26.5% and 23.6% of the Italian population respectively). The total birth rate is the highest of the last sixteen years and it has slightly decreased only in the south (0.5%) where, nonetheless, births in absolute numbers are more in this region than in any other region in all of Italy. Italy's overall birth rate is slightly lower than the mortality rate, so the natural increase is close to zero (immigrants included). 99.5% of the Italians live in families, of which there are about 24,641,000 with an average of 2.4 members per family (the lowest being 2.0 in Liguria and the maximum 2.8 in Campania).

Previous data (ISTAT 2003) shows that 75.6% of Italian nuclear families are in Italy *Meridionale*, which is the South. The South scores the highest percentage of families (married couples) with children, and the lowest percentage of those without children. Only 26.8% of southern Italians dissociate procreation from marriage, and this hypothetically, while the percentage in central Italy is 34.9%; these percentages derive from a national total of 33.2% for women and 29.7% for men. Although the number of marriages has decreased from 419,000 in 1972 to approximately 250,800 in 2008, the southerners marry younger and score higher fertility rates. Moreover,

although religious weddings have declined from 80% in 1995 to 67.6% in 2006, the majority occur in the South. The number of divorces has doubled (2,635,000) for the same period, but the percentage in Sicily hardly reaches the average rate, while the overwhelming majority of second marriages occur in the North. Traditionally, the South is the poorest part of the country, where the total number of poor people represents 11.1% of the whole Italian population. One out of four families in the South experiences poverty, but the percentage is even higher in Sicily. The diffusion of poverty in Lombardy is approximately ten times less than that observed in Sicily (1/4 for Sicily versus 1/20 for Trentino).

#### *2.4 Physical Environment and Economy*

The three 'parts' of Italy have their own distinct climate and geographical landscape. In the North of the country, although the Alps form Italy's physical border with the rest of Europe, the climate of the Po valley is similar to that of central Europe. In this part, the seasons are distinct and the winter is cold with snow prevalent during the winter months. As the Apennine Mountains stretch down the Italian peninsula for 650 miles from the North to the South, on the west side of the country there is a broad plain whilst on the east the mountains are closer to the sea and descent sharply. Central Italy's climate is milder in winter compared to the North while the summer is hot and quite dry. The South has a typical Mediterranean climate, and its soil is fertile. Sicily in particular is a grain producing area. Etna, the tallest active volcano in Europe, and Stromboli in the Aeolian Islands are just two out of the numerous volcanic and other non-volcanic mountain ranges that characterise this region. Sicily's fertile soil attracted the Greeks to the island since very early on in its history. Even today, the Sicilian economy is based on agriculture, the main Sicilian products

being wheat, olives, corn, almonds and wine grapes. Sicily exports mainly wine and other beverages, as well as fish. Absentee landlords owned the largest part of the fertile land until the 1950s, when the national government established the *Casa per il Mezzogiorno* aiming to improve the economic conditions of the South, initiated a land reform. Not only did the absentee landlords not invest in technology, but they also suppressed the landless peasants with 'private armies' from which arose the Mafia. The Mafia is still an obstacle in the economic growth of Sicily. In contrast to the South, the North is prosperous and heavily industrialised. Italy is one of the Group of Eight industrialised nations. Italy's most important mineral resource is in the Po Valley where there are natural gas reserves. Moreover, locality plays an important role in the economic growth of this region, which has easy access to other prosperous European countries (the largest exchange of products is between Italy and Germany, France, and the Netherlands). With the exception of the Italian motor industries that reside in the north, the Italian fashion products that are of global fame are also produced in this region. The North also exports food, chemical products and electrical goods. The vast economic difference between the North and the South fuel Italy's 'southern question'.

### *2.5 Palermo in History*

The name of the Sicilian capital, Palermo, derives from 'Panormos', a name given to the city by the ancient Greeks to describe its natural harbour; literally, it means 'all port'. The city is surrounded and protected by three mountains, namely Monte Castlaccio, Monte Cuccio, and Monte Pellegrino. Sicily's strategic position and its fertile soil are the main reasons that attracted the Greeks and many others to the island. According to the Greek historian Thucydides, the first inhabitants of the

island were the Sicani who arrived from the Iberian Peninsula. Before the Greeks colonised the eastern part of the island and founded Syracuse, the Phoenicians had already used the harbour of Palermo for trading purposes. Later, despite the increasing influence of Greek culture on the island, the Carthaginians took over Palermo. The Sicilian Wars between the Greeks and Carthaginians did not allow Palermo to prosper until after the First Punic War, when the city became an important Roman trade centre. The Carthaginians were defeated and evacuated the island, while the Greeks maintained Syracuse that had an independent ally status, and Palermo became an important periphery that supplied the Roman centre with grain. In the Middle Ages, the Roman Empire declined and was attacked by the Germanic Vandals and Goths<sup>11</sup>. After the Gothic wars between the Byzantine Empire and the Ostrogoths, Sicily eventually passed to the Arabs<sup>12</sup>. Palermo experienced such an economic growth that it became the major city on the Island. Later, the Normans took control of Southern Italy (Palermo in 1091) and the County of Sicily became the 'Kingdom of Sicily' (1130-1816) under Roger II. The Kingdom of Sicily turned out to be one of the richest states in Europe and successively passed under Holy Roman, Angevin, Aragonese, Spanish, Savoyard, and Austrian rule. The highlight of Sicilian history is the rebellion against the Angevins at Easter 1282, which began in Palermo. Two earthquakes, the plague and revolts compose the Sicilian scene from the 15<sup>th</sup> until the 17<sup>th</sup> centuries. After the Napoleonic wars, and specifically from 1734, Sicily was part of the Bourbon-ruled Kingdom of the Two Sicilies. The Sicilians revolted again in 1848 and won their independence, but only for one year. Palermo remained under the Bourbons until Italian unification. Soon

---

<sup>11</sup> For the history of ancient Sicily I draw mainly from Finley (1979), while my main historical source for 'medieval' and 'modern' Sicily is the two-volume work of Denis Mack Smith (1968).

<sup>12</sup> According to the Catholic Encyclopaedia, the Byzantine governors are the first to call Sicily the southern part of Italy, and since they remained 'governors of Sicily' even when Sicily had fallen to the Arabs, the Normans considered that there were two Sicilies: one held by the Byzantines and the other by the Arabs.

after, both the Sicilian movement for independence and the struggle of the poor *Fasci*, or organised peasants and workers, were suppressed vigorously in 1866 and 1894 respectively. The political and economic climate in the aftermath of World War I allowed Mussolini to impose Fascism in 1922. In World War II, the Allies fought and won a significant battle against the Axis forces in Sicily. Following the establishment of democracy, Sicily became an autonomous region of the Italian Republic in 1946.

The architecture of the city combines different styles and, along with the city's structure, they indicate various influences on Palermitan society. One can witness the marks of World War II on the Palermitan buildings, or their remains, even today. Although the preservation of culturally important buildings has been successful, others in the historic centre of Palermo remain in poor condition. The regional government focused on the restoration of those buildings that have a historic and cultural value and the ones that reflect various influences on Palermitan identity. For example, the *Palazzo dei Normani*, which was built by the Emir of Palermo in the 9<sup>th</sup> century and was extended to accommodate the Norman administration, has been fully restored and is the seat of the Regional Assembly. In addition, the Cathedral (dedicated to *Santa Maria Assunta*), which was built in 1185 by the Anglo-Norman archbishop Walter Ophamil on the site of St. George's church and was turned into a Saracen mosque in the 9<sup>th</sup> century had further additions and alternations in the 14<sup>th</sup> and 15<sup>th</sup> centuries, is in perfect condition to this day. Fully restored are also most of the sites where there are red domes, which signify Arab influence, i.e. the church of *San Giovanni degli Eremiti*, or the famous *San Cataldo's* church near the town hall. In the same area and exactly in the centre of the city, brand-new-looking



The San Cataldo Church.

buildings stand next to relics, and this image is representative of the condition that prevails in the wider area of Palermo's historic centre. The city's historic centre is divided into quarters by the junction of the *Via Maqueda* and *Corso Vittorio Emanuele*; at the four corners of the *Quattro Canti* stand the four female patron saints of the city. Although there are numerous churches in Palermo, most of them lie in the city's historic centre. The majority of the Palermitans are Roman Catholic; Palermo's twenty ordinary saints and fifteen principal saints are an indicator of how religious Palermitans are. Although there are many religious feasts, the most important one is dedicated to the Patron Saint Santa Rosalia and the spectacular baroque style festival held in mid-July is the most attended of all the events in Palermo. The city's architecture renders both the Palermitan history and religion a daily experience for its inhabitants.

In contrast, the new part of the city to the north of the historic centre is characterised by its huge blocks of apartments and mirrors the modern history of Palermo as well. Although initially the city expanded westwards, modern blocks were built at the north of the historic centre after World War II to accommodate the rapidly increasing population of the city. Urbanisation was the outcome of land reform in the 1950s, which was accompanied by the mechanisation of production in both the rural and urban settings, as well as a flow of money towards the city. Along with the people who moved to Palermo from the rural areas came the Mafia, which had previously been repressed by the Fascists. The urban Mafia were/are involved in real estate construction and speculative businesses and as the plan for the city's expansion was ignored, the result has been the so-called 'sack of Palermo'. Aristocratic landowners who owned the land in this area, corrupt politicians and Mafiosi seized the opportunity to make money by destroying the city. Although both parts of the city were ugly and the lack of a plan has had lasting side effects, for example traffic jams, the major issue of that period was the empowerment of the Mafia and its protection by the political world. The Mafia has irritated the Italian state since the end of World War II. Nevertheless, the Antimafia Commission was formed in 1963 during the First Mafia War by an initiative of the Sicilian Assembly. In the modern history of Palermo, every success of the Antimafia Commission has been answered by the Mafiosi with assassinations of those who contributed to the *lotta contro la Mafia* (the war against the Mafia). However, the Antimafia Commission has started winning both battles against the Mafia and the sympathy of the public. Giovanni Falcone and Paolo Borsellino, after which the airport of Palermo is named, who became another two of the numerous modern martyrs, they had a tremendous impact on the anti-Mafia war. After the Maxi Trial, the third Antimafia Commission had enough information on the relationship between the Mafia and the political world, which it

decided to make public. The *Mani Pulite* (Clean Hands) investigation into political corruption revealed the *Tangentopoli* (Bribeville). The Mafioso Tommaso Buscetta revealed to the fourth Commission that the Mayor of Palermo, Salvo Lima, mediated between the Mafia and the Prime Minister Giulio Andreotti. Significant arrests of leading Mafiosi, as for example of Bernardo Provenzano, were accelerated during the short stay in power of Romano Prodi. Alas the Mafia is still an important aspect of Palermitan life.

## 2.6 Literature on the Area of Interest

Cronin argues in 1970 that the existing literature on southern Italians is limited in number and range of focus. Although ‘there is not one full-length monograph on the social organisation of an Italian village, town, or city in the Italian literature’ (p. 17) written by Italians, there is a vast body of literature focusing on Italian immigrants, but none of them is based on fieldwork in Italy. Stereotypes such as the importance of the family and the parental domination of children that prevail in this body of literature refer only to the Italo-American family, as Moss and Thompson (1959) stress. Therefore, Cronin suggests that: ‘in the absence of academic studies it is not out of place to note popular works of fiction and non-fiction (in Italian and English) which serve to place the available literature in a living social context.’ Among others, she mentions *the Italians* of Barzini (1964), Douglas (1915) *Old Calabria*, and Lampedusa (1961) *The Leopard*, as well as films that deal with family and social organisation.

However, the issue of lack of data on a series of topics, i.e. the husband/wife relationship that Cronin mentions, has been answered with an increasing number of accounts focusing on the Mediterranean. Gower Chapman conducted one of the first

anthropological researches in the Mediterranean and specifically on the Sicilian 'Milocca' as early as 1928, but her work was published nearly five decades later in 1973. In the same period, the French Marc Bloch and Charles Parain engaged in a comparative research of the peasantry in Europe and the Middle East, but again the *Les Paysans de Syrie du Proche-Orient* was published after the war. In the following decades, Boissevain, Gilmore, Herzfeld, Jane and Peter Schneider, Pitt-Rivers, Redfield, Peristiany, and Wolf to name a few, contributed to the field with their influential work. Especially Banfield's (1958) work focuses on the Italian nuclear family within its context.

The long tradition of social sciences in Italy in particular was not enough to cope with the dominance of the Anglo-American Schools. The progenitor of the Italian anthropology was the 19<sup>th</sup> century ethnology of the 'exotic other' (indicatively Cocchiara, De Martino, and Gramsci). Giuseppe Pitrè (1841-1916) and Giuseppe Sergi (1841-1946) were the first Italians to focus on the Mediterranean. They were both Sicilians, born in the same year and they both served under Garibaldi. Among other things, Sergi defined the 'European race' from the 'African' and the 'Northern European', and the folklorist Pitrè depicted the Sicilian life in his twenty-five volume work. Although Tullio Tentori established academic anthropology in Italy after World War II, the folklorist tradition remained important. For example, Pitrè's influence is evident in the work of modern Palermitan anthropologists (see Antonino Buttitta 1961, 1971, 1978, 1985).

In earlier structural and functional accounts of the anthropology of the Mediterranean, the importance of honour and shame was overemphasised as the cultural values that brought together otherwise different cultural groups (Goddard 1994). The same binary opposition tied together the theorisation of economics,

politics, gender, kinship and family, as for example in Campbell's work in 1964. Among the heavily discussed issues in the following years were the production system in relation to the family and land (see for example Blok 1966, Braudel 1973, and Davis 1973), fertility and gender (Livi-Bacci 1977, Saunders 1981, Schneider 1984), and political issues such as class ideology, racism and nationalism (Schneider 1996, Cole 1997, Schneider 1998).

One of the issues that the anthropology of the Mediterranean had to deal with in its first steps was the problem of cultural translation (Herzfeld 1980: 384, Dubish 1995, Just 2001: 45). In this context, Sicilian honour was defined as the set of values relative to friendship, cleverness and silence, which also characterised the *uomini di onore*, or in other words, the Mafiosi. Much ink has been shed on the analysis of the Mafia from different perspectives (Hess 1973, Catanzaro 1988, Gambetta 1993, Falcone & Padovani 1993, and Farrell 1997 to name just a few). This is because the Mafia made Sicily a particular case in the Mediterranean, but it was also a problem in the process of Italy's national integration, and it had managed to immigrate to the USA. As a result, the Sicilian culture was perceived as a *cultura mafiosa*, although the Palermitan identity is far more complex than the analysis of the 'mafia' values through kinship reveals (see Banfield 1958).

### *2.7 Regional identity and local characteristics*

To approach Sicilian identity as the outcome of a single experience within the three millenniums of the islands history would be an oversimplification. Therefore, to accept that the Sicilian identity was shaped primarily by the move from the Spanish occupation to the island's incorporation into the developing northern core (Gilmore 1982), would result in silencing local conditions for the sake of the Mediterranean

field's unity (see for example Schneider 1972, 1976; Blok 1975, and Hansen 1977). However, Jane and Peter Schneider (2003) focus on the particular conditions that prevailed in the Sicilian capital before and after the Italian unification in order to explain the genesis of the Mafia, and they make a distinction between Western Sicily and the rest of the island in terms of landed property and production with which I agree. The aroused landless peasants they describe are the stereotypical image of the Italian South that has survived in Italy since 1860. Indeed, the backwardness of the Sicilian society can be understood only in economic terms through its contradistinction to the developed North. However, the economic difference between the North and the South at the national and the European level is justified in cultural terms. As a result, although the interaction between Mediterranean cultures (Davis 1977, Braudel 1972) has rendered the Sicilian culture rich in diverse traits, the Sicilian identity is diminished as backward and *mafiosa*.

The geographic borders of the island define a particular part of Italy for both the Sicilians and other Italians. With the migration waves from the South to the North, the differences between the two were highlighted. For example, Krause (2005) shows how in Prato, in northern Italy, the modern nuclear family is contrasted to the negative stereotype of the peasant family even today. At the national level however, the extended peasant family remains *the* characteristic of the *terroni*, who were also stigmatised as lazy and violent. The earliest attribution of such characteristics to the southerners can be traced in the correspondence between Cavour and his administrators since the unification of Italy, such a political discourse being diffused to legitimise the centralisation of power.

Sicilians consider the diverse traits of their culture as positively distinct from other Italians. Differences (which I do not consider useful to refer to explicitly at this

point) can be traced in language, architecture, art, cuisine, and cultural values, and are attributed to influences dissimilar to those over other Italian regions. In this sense, the 'unique' course of the island through time is used in current Palermitan political discourse to legitimise the existence of a unique Sicilian 'political culture'. This discourse does appeal to the Sicilians, who stress that they form a discrete ethnic group within the Italian nation due to their distinctiveness in the spheres mentioned above. This 'continent in miniature' (Braudel 1972), 'today [Sicily] is Italian, though, as in so much of Italy, the local dialect retains deposits of earlier languages spoken on the island, the population is racially very mixed, and the cities are filled with architecture of nearly every age and style, sometimes...combined within a single building in the most remarkable way.' (Finley 1979:4). Sicilians argue that the mixture of cultures and races that has taken place on the island makes them superior to all other Italians.

Especially Palermitans pride themselves on their superiority since Palermo is the capital of Sicily. The rivalry between Palermo and Catania, which is manifested to the extreme in the encounters between the two so named football teams, reflects the contrast between the island's administrative and economic centres respectively. Although the Sicilian dialect is common on the island, each city has its own dialect, i.e. Palermitano in Palermo, as well as its own accent (*accento*). Moreover, an alternative is spoken in almost every neighbourhood of the Palermitan historic centre, which is so different from the Italian Standard (national language), the regional *Siciliano* and the local *Palermitano*, that cannot be understood by other Palermitans. Thus, according to Palermitans each alternative defines a different identity on the neighbourhood level. Since all the local traits that define the Palermitan culture are rich in foreign influences, the Palermitans consider themselves to be the only ones capable of a prolific mixture of different traits. The

Palermitans legitimise their superiority by asserting that their crucial role on the island consists of managing peacefully and creatively a variety of cultural traits that form the Sicilian identity. The centralisation of the administration in the Sicilian capital explains the above Palermitan perception. It is not my intention to accept the 'Palermitan superiority', but neither to simplify the Palermitan culture by focusing on the Mafia issue. Instead, my aim is to focus on constructed notions and unmask the stereotypes from an anthropological perspective. The following chapter discusses the methods employed to shed light on the topics of this research.

## Chapter 3 METHODOLOGY

### *3.1 Introduction*

Herzfeld (2001) argues that socio-cultural anthropology is an empirical discipline based on ethnographic research and description that seeks meaning in peoples' lives (see also Geertz 1973). All ethnographic research and description are inherently biased and subjective; far from undermining the anthropological endeavour, however, this has long been one of the discipline's strengths. Bailey argues that '[w]hat is ultimately learned from the field research is based on the subjective understanding and interpretation of the researcher.' (1996: 4). The history, personality, or status of the researcher, play a crucial role in the production of knowledge using field research (Wade 1984). In other words, while anthropologists go into the field in order to produce texts (see Clifford and Marcus 1986), they carry with them a number of foundational texts or narratives, from which they interpret, frame and understand the data and knowledge (or texts) produced in the field. Disciplinary trends also shape anthropological interests and inform decisions about specific fields of study. Moreover, Herzfeld suggests that anthropological interests are shaped through 'regional traditions of anthropological scholarship.' (2001: 22). Therefore, the researcher and, in effect, the people that anthropologists study interact in a field of disciplinary constructed interests that skew the flow of information and ultimately the anthropological account.

The difference between the anthropologists and the people being studied lies on whom inquiry and 'meaning' address. People make sense of their lives, but the anthropologist undertakes the task to produce an account of their lives that must make sense to academia. This means that the anthropologist artificially reproduces

peoples' practices in their context from a personal point of view (Denzin 1997, Atkinson 1990).

The ethics of anthropological research shift over time and reflect contemporary preoccupations of the academy (see Marcus 1998, Cohen and Rapport 1995). They may reveal assumptions of researchers, ethical review boards and the wider society about notions of responsibility and authority. The manner in which the research project or outcome may be legitimised is in itself a fascinating area for examination, particularly during periods of more explicit reflexivity and introspection, when such issues may be more visibly brought to the fore (see Asad 1973, Clifford and Marcus 1986, also Herzfeld 2001: 45 on the utility of reflexivity).

One of my aims in this study is to examine the reasons underlying Italian regional and social division, such as the rather infamous North/South split, in order to challenge critically the host of common and widespread stereotypical explanations. Southern Italy has been stigmatised for a number of reasons, which I argue are primarily political and economic and not because of cultural diversity. While this would probably cause much debate within the academic sociological or anthropological contexts, it directly challenges popular political discourse in modern Italy. One of the objectives of this doctoral thesis is, therefore, to document the extent to which cultural traits have been used to characterise southern Italy in order to legitimise northern Italian economic and political domination.

The methods specified below are clearly not the only ones that might reasonably address the issues at hand, nor are they without real limitations and constraints. However, these anthropological methods provide mechanisms for generating relevant anthropological data that enable analyses of the key issues of ethnicity and identity, and which I suggest will allow me to develop a robust thesis exploring the

wider national divisions within Italy. Moreover, the issues at stake in this thesis are not unique to Italy, so the results from this study will have important comparative implications for other parts of Europe and perhaps for areas around the world in which disparate 'nations' have been unified under a common set of state apparatuses.

### *3.2 Methods*

Ethnicity and identity are complex sociological phenomena and demand sophisticated research design and methodology to produce a range of data and knowledge that allow coherent analyses. It is no coincidence that studies of ethnicity and social identity (as opposed to more bureaucratic forms of identity such as social security numbers, passports and drivers' licences) are usually grounded in data generated from participant observation. Participant observation was crucial in gaining the necessary insights into Sicilian ethnicity and in particular in the ways that this category, or categories, may be perceived and manipulated by Palermitans. I suggest that the issues of interest in this research related to ethnicity fall into three categories: perceptions, institutions and symbols.

1. *Perceptions.* How do Palermitans in particular, and Sicilians more generally, perceive and articulate the social categories that include southern Italians and Sicilians and exclude northern Italians? What level of collective groupings is locally meaningful?
2. *Institutions.* To what extent is Sicilian ethnicity conceptualised and articulated by the elite and by social and state institutions, such as the school, family, and the press? One of the key ways of making sense of the role of institutions in framing concepts of ethnicity and identity is to focus on election propaganda (or

discourse) to locate boundaries of self and try to determine which such publics understand to be their 'audiences'.

3. *Symbols*. Institutions and individuals employ symbols to express aspects of ethnicity. The research includes a systematic documenting of political and cultural symbols that are consciously and possibly unconsciously invoked and displayed by people acting as individuals and as representatives of institutions.

Bernard, clearly an enthusiast of participant observation, states that 'research problems simply cannot be addressed adequately by anything except participant observation.' (1994: 142). He argues that participant observation 'makes it possible to collect different kinds of data' (1994: 140) and that it 'reduces the problem of reactivity.' (1994: 141). Moreover, this method 'helps anthropologists formulate sensible questions in the native language.' (p. 141). Fluency in Italian is a key factor of information access in Sicily, not only because people can easily become familiar with the anthropologist, but also because only a few Sicilians speak English. In addition, 'participant observation gives (you) an intuitive understanding of what is going on in a culture and allows (you) to speak with confidence about the meaning of data.' (p. 141). He goes on to suggest that fieldwork is a procedure in which the anthropologist gains scaled-up access to information and wider understanding of the society studied.

The 'University of Palermo', the 'Main Library of Palermo', central coffee shops, and my neighbourhood were the places where I spent most of my time socialising with individuals who were interested in my research. Luck or chance proved to be an important part of establishing social relations, but the contribution of my informants in expanding my social networks was equally crucial. Eventually, I managed to gather data from every corner of the city.

At the beginning, I engaged in informal interviewing in order to become familiar with Palermitans and with the issues that concern them while trying to get as much information on identity, ethnicity and the class system in Palermo. As this kind of interviewing lacks structure and control it is suitable in opening-up conversations with anybody who is interested in talking about his/her culture throughout the whole period of research (Gorden 1975). This method can also ‘uncover new topics of interest that might have been overlooked.’ (Bernard 1994: 209)<sup>13</sup>.

When I was able to determine the potential contribution of informants, I carried out unstructured interviews in order to achieve a better understanding of Palermitan life and observe the feelings with which Palermitans ‘dress’ their discourse. Both the above methods were used in public, schools and libraries according to the willingness of the interviewees.

### *3.3 Interviewing*

Semi-structured and structured interviewing have proven useful for a variety of anthropological studies (Spradley 1979). These provide specific data on interrelated themes, which in my case include class, ethnicity and identity. However, I manoeuvred strategically in order to address particular issues. This was especially useful when interacting with professors and journalists. Structured interviewing helped produce comparable data that permits some level of external validation of some of the most abstract, and consequently more challenging, aspects of studying Palermitan culture.

---

<sup>13</sup> Bernard (1994) argues that ‘there is a continuum of interview situations based on the amount of *control* (his italic) we try to exercise over the responses of informants.’ (p. 209). He divides the ‘continuum’ into: informal, unstructured, semi-structured, and structured interviewing; further he suggests that this is an appropriate sequence.

### *3.4 Photo Elicitation*

Informants were given photos of relevant themes and asked to carry out pile sorting, triad and pairing exercises (all introduced in the manner of party games so as to avoid any hint of psychological pseudo science) and were also asked to rank a list of stereotyped personages. My aim was to have a good idea of the criteria with which Palermitans evaluate individuals in order to determine contemporary means of social division.

### *3.5 Press and Media Analysis*

Moreover, Italian and Sicilian mass media (newspapers included) provide an invaluable source of data as well as a means of triangulating certain kinds of information provided by Palermitans. When in the field, I used current news to stimulate discussions with Palermitans, but even when I returned to the UK, I continued employing this technique from a distance focusing even more directly on the issues most pertinent to this study. I observed the articulation of diverse political discourses among regional and national mass media in order to grasp how ethnicity is informed and how the polemic between the North and the South is refuelled. Discourse analysis approach (see Garfinkel 1967) gave me fruitful insights that I also presented to the ‘Anthropological Postgraduate Conference’ at Durham University in 2008. I sought to determine variations between different readers’ and viewers’ inferences and consequently develop a more sophisticated representation of the range of discursive idioms and their interpretations.

### *3.6 Archival Research*

Archives and statistics were also useful in cross-checking the collected data and gaining a quantitative standpoint on the qualitative ones. Access to the municipal archives proved difficult, but in contrast, statistics can be easily accessed on the webpage of ISTAT. Combined with genealogies, quantitative data shed light on the issues that qualitative means were inadequate to address and at times provided me with an explanation of the issues where qualitative data did not result in a meaningful outcome.

### *3.7 Ethical Considerations*

The anthropologist must respect the rights, the dignity, and the diversity of the people with which he/she engages. According to the Code of Ethics of ASA (American Sociological Association, [www.asanet.org](http://www.asanet.org)) the researcher should not engage in any forms of discrimination based on age, gender, race, ethnicity, national origin, religion, sexual orientation, disability, health condition, or marital, domestic, or parental status. This poses very real challenges to social anthropologists since it is also incumbent upon us to respect the variability of attitudes, values and opinions we encounter during fieldwork. Ultimately, anthropological researchers must develop trust and confidence with local people and this poses peculiar and unique sets of ethical dilemmas.

Consent is a key word in the collection and production of data; all potential informants were made aware verbally of the issues and the purposes of the research. I have assured all informants that their privacy will be protected. I do this by anonymising all individual names of private citizens. Where this is inadequate to protect privacy, I alter certain facts about the individual that do not impact on the intellectual analysis (for example, I may change the number of children that a person has, or indicate that they live in a different part of Palermo, or alter their age). Where the people I write about are in the public eye, such as politicians or journalists, and I rely on public accounts of their thoughts or deeds, then I do not adopt such stringent measures to protect their privacy.

The ASA stipulates that researchers must be honest, fair, and respectful of others in their professional activities, and must not knowingly act in ways that jeopardise their own or others' professional welfare. I am confident that I have respected both the spirit and the letter of the ASA guidelines in my field research in Palermo.

## **Chapter 4 HONOUR TO THE FORE**

### *4.1 Introduction*

Although honour is an issue that is not of as much interest to anthropologists as it was in the past, it is discussed in this thesis from a different angle to shed light on patterned behaviours between persons or social groups bound to each other by relations of unequal power. This approach stresses that the very reason for the existence of honour is that it consists of a set of values that rule social interaction between groups with unequal access to political institutions giving a new focus to previous anthropological accounts on this issue. Different groups within the same society as defined by its political administration can stand well with the given political authority and thus have unequal access to resources. The theoretical analysis based on a critical synthesis of information drawn from anthropological accounts mostly of the Mediterranean will then be tested against Sicilian society (South Italy), supported by various examples drawn from my own data gathered in Palermo mainly from May 2005 until August 2006, and in June 2008. Anthropological literature and the data I gathered in Palermo advocate a direct link between honour and landed property. The struggle between landless peasants and landowners lasted longer in Sicily than in other European countries (see J.Schneider & Susser 2003). Since honour still plays an important role in Palermitan daily life, discussion of the reasons it survived can give insights into other related topics in an attempt to represent Sicilian culture to an anthropological audience. This approach can give an understanding of the current Palermitan political, ethnic and national identity and explain various perceptions as displayed in the social realm.

Various approaches cry out for synthesis given that although Mediterranean societies should not be perceived as identical to one another, insights from different areas can help raise a theory that will not lead to contradictory generalisations. In this way of thinking, the combination of contextual and comparative analyses will shed light upon the uniqueness of the Palermitan case within the so-called Mediterranean anthropological field, in terms that render this piece of work a useful reference for further research on related topics. This essay focuses on the northern shore of the Mediterranean due to my personal preoccupation that if Sicilian culture is linked to any African one it will only help the Italian conservatives' political discourse to be refuelled. Out of the plethora of anthropological accounts discussing the issue of honour, all those focusing on Sicilian society relate honour to the Sicilian Mafia. There is a sensitive approach towards the Mafia issue in order to avoid the stigmatisation of Sicilians as violent and brutal people. Instead, I propose a more fruitful approach based on my observation that an important and common element among Mediterranean societies has not been analysed adequately. I suggest that instead of focusing on individual groups, we should shift our focus to their interaction and the role that honour as a set of values plays in it. Honour as a value system has been used by the powerful to hold onto political power in order to exploit the weak and reproduce social hierarchy, the weak primarily being peripheral groups integrated into centralised systems. Peripheral groups lacked group-consciousness as part of the new order and did not acquire it due to physical, societal or cultural maltreatment. Maybe, this focus is feasible now because only recently did we understand the importance of showing interest in a global perspective, another equally important reason being that the new context is well documented by a plethora of accounts that allow comparison and synthesis. The pueblo, the Sarakatsani, the Sicilians and other groups already had an identity different to that

promoted by the new centralised administration. As peripheral groups, they all entered the new political arena with a disadvantage, their members struggling to cope with the tension that sprang from a rather conflicting relationship between the centre and the periphery. This struggle could be characterised as unequal since in all cases the peripheral groups were kept at the bottom of the new social hierarchy. This could explain some groups' negative perception of the government as it is witnessed up until the present day and could thus be linked to issues of ethnic identity and national integration<sup>14</sup>.

This chapter begins with a literature review that aims to provide an anthropological perspective of the Mediterranean, Sicilian and Palermitan context in which the issue of honour is discussed. I analyse seminal anthropological work to show how different perspectives placed in chronological order reveal an interdisciplinary continuity that despite grasping the fluidity of the issue, it misses the importance of honour in the interaction between groups of unequal power. Apart from my personal experience gained through observation and participation, I have also collected detailed data through first unstructured and later structured interviews and random conversations. I triggered some of these conversations by referring to issues that the Palermitan television channel (TGS: *Telegiornale Sicilia*) and newspaper (GdS: *Giornale di Sicilia*) presented to their audience, abandoning the use of other sources of national news, i.e. *Corriere della Serra*, because Palermitans did not show any interest in it. However, I always used other sources to make sense of the issue at

---

<sup>14</sup> Campbell, for example, discusses patronage and argues that 'the Sarakatsani face the jurisdiction of the State in their frequent adventures in courts of law. The laws that concern the Sarakatsani in their daily life do not generally favour them. The interests of shepherds tend to be opposed to those of peasants and townsmen.' (1964:239). He then argues that the Sarakatsani have many political difficulties and disabilities in relation to the 'State' (ibid: 243). In order to cope with them, the Sarakatsani look for patrons. However, as Campbell argues 'we see that the Sarakatsanos in facing the hierarchy of Government confronts persons of higher social status who share with him no bond of kinship or community.' (ibid: 246). Peristiany, as well, argues that 'the citizen thinks of the civil servant as of a person in whom power is vested by a group from which the citizen is excluded.' (1965: 185).

hand. Some others were initiated by looking at family albums or by asking my informants to categorise random photographs of persons and places. I have also consulted some professors from the anthropology, sociology, history, literature and geography departments at the University of Palermo for a ‘home-based’ academic point of view. All this effort was aimed at the vagueness of the issue at hand; honour is a sensitive issue for Palermitans and is not quantifiable. Since honour rests on evaluation, there are differences in how one evaluates the self and others and, particularly in some cases, the divergence of views does not allow a clear view on the subject. Time is always a limitation in the understanding of complex issues; however, I believe that my origin (Greek) and my extensive preparation on the topic not only counterbalanced the above setbacks but also provided me with an insight different from the prevailing Anglo-Saxon.

#### *4.1 Seminal Anthropological Work*

In this first part I will provide in chronological order a detailed account of Campbell’s, Pitt-Rivers’ and Davis’ ideas on honour which I consider to be of importance for they reflect the diversity of anthropological thought on, and approach of, this issue. It is not my intention at all to disregard other important accounts on the subject, which will be cited in my argument later, while moving towards the Sicilian case and focusing on ideas that come out of data I have collected. I rather want to reflect on changes within the discipline of anthropology as a whole and changes that went hand in hand with the maturing process of the so-called ‘anthropology of the Mediterranean’.

To begin with, Campbell (1964) studies on the Sarakatsani, which is a remote peasant group traced to Northern Greece and specifically in the Giannina region

during the time the research was conducted. He contextualises the group in its ecosystem to show how this affects the groups' organisation. To justify his interest on this particular group, Campbell places it within the national context and explains that changes in the Sarakatsani way of living are due to the process of nation-building, a fact that also renders sub-groups' variety an interesting issue for anthropological analysis but an imperative need as well. In order to confirm the above, Campbell stresses that it was mostly Metaxa's laws that pushed the Sarakatsani group towards permanent settlement and thus altered their customs to facilitate the process of national integration. It is rather a Durkheimian approach that is mainly concerned with the way social solidarity is maintained (Friedl 1966).

Following the then current anthropological trend, Campbell tried to make sense of the group's structure based on the issue of honour. He thus argues that the pattern of social groupings is that of family and that competition between families is based on honour. Honour is linked to the family structure, authority and economy, and to religious beliefs, all of which reflect the organisation of the Sarakatsani group around honour. Campbell (1964) argues that honour is the outcome of competition between families or relatives. Prestige, which is an important aspect of social interaction, and property are inherited through customary rules of inheritance and canons of popular judgement. The institution of the family is approached as a corporate group that is a response to competition, for competition leads to isolation and opposition between Sarakatsani families. Competition rests upon social reputation, honour being fundamental to prestige assessment as it reflects an individual's condition of integrity. Therefore, 'since the downfall of one family validates and in some sense improves the status of other families, men attempt by every means of allusive gossip and criticism of conduct to deny each other their pretensions to honour.' (Campbell 1964:272).

Campbell mostly focuses on the Sarakatsanis' interrelationships rather than on their interaction with other groups already integrated into the nation which have secured political representation if not representing the state themselves. Honour has to be safeguarded through the correct play of culturally established sex-roles as inspired by their sheep's behaviour and Christian belief. If this is not the case then severe social judgement will deprive the person and/or the group he/she 'represents' of honour which is a 'capital' given at birth, except if there is an immediate and apposite response to the case that gossip has created. Sarakatsani first turn for help to their kinship before turning outside their group, not just because of trust but also in an attempt to protect their identity. Therefore, the size of the family and relations with the extended kin are analogous to the protection they can provide to one of their members. The Sarakatsani establish patron-client relations only if their family and/or relatives can not provide a solution.

Although Campbell provides a useful account of changes in the Sarakatsani's way of living, he does not engage in depth with two important aspects. On the one hand, how are patron-client relationships legitimised within the Sarakatsani group ('us')? On the other, how does unequal power in terms of political authority legitimise the same kind of relationship for the 'other'? The hostility between the Sarakatsani or between the two groups cannot fully answer the above questions, neither the fact that religious belief permits this kind of behaviour.

A year later, Peristiany (1965) edits *Honour and Shame: the Values of Mediterranean Society*. Here, emphasis is put on the person and the value systems that mediate human conduct through the play of cultural roles. Combining information from a number of anthropological accounts on Mediterranean societies (Kena 1966), he argues that honour and shame are social evaluations that reflect

social ideals in social personality. Honour is at the top of the social values' hierarchy and cuts across all other social classifications dividing the members of a given group into those who hold honour and those who do not. Family in this case is defined as 'social isolate' in which values of honour and Christianity can be resolved. In addition, 'honour and shame are the constant preoccupation of individuals in small scale, exclusive societies where face to face personal, as opposed to anonymous, relations are of paramount importance and where the social personality of the actor is as significant as his office' as Peristiany (1965:2) argues in his introduction. He is in agreement with Campbell when arguing that honour is ascribed to people by birth, but along with shame they are both attributed to persons by others members of the same group over a struggle for precedence. However, 'actors' claim honour only in 'particularised relations, and in which each actor is a well defined social persona (see Gearing 1967). When actors are anonymous, honour is not involved.'(Peristiany 1965:14), since in this case their reputation cannot be affected.

Social evaluations differ from culture to culture and therefore conceptions of honour differ as well, but what they have in common is that they reflect the conflicts of the social structure, for honour rests on a facts' evaluation that can be contradictory. This approach allows us to understand conflicts between the Sarakatsani and the Greek state as the result of the interaction between two different social structures, although Peristiany does not engage with this. His functionalistic view allows the completion of honour's vicious circle: 'the sentiment of honour inspires conduct...honourable conduct receives recognition and establishes reputation, reputation is sanctified by the bestowal of honours' (Peristiany 1965:22). In accordance with Campbell, Peristiany supports the idea that honour is the basis for precedence in egalitarian societies. As in Sarakatsani society, one has to be able to

enforce his claim on honour in order to defend it. This is how the actor defends status and respect, which Campbell defines as prestige, between supposed equals.

Gender and class are brought to the fore as the criteria of diverse perceptions and the bestowal of honour in different contexts. Pitt-Rivers argues in the same collection edited by Peristiany (1965) that ‘rather than variations in the structure of the concepts, it is a matter of emphases upon their different properties’ (p.64). The author traces differences in properties within different societies as they are manifested in relations between persons where emphasis is given to culturally defined shared values. In an attempt to link related components of honour with different status groups, Pitt-Rivers is the first to engage in the analysis of the relationship between civil servants and citizens, and to define them as mutually hostile groups. Moreover, nepotism is approached as the mediator between centralisation and family. Yet, there is much more to be stressed on these issues, and especially cases in which there are varying emphases upon the different properties of concepts among groups of the same society.

In the same collection of papers, Bourdieu stresses that challenges to honour are expressed between those who are supposed to be equal. It is only the mutual recognition of equality in honour that can legitimise a fight over it. In case of inequality, the most probable result for the challenger is to lose his honour before the eyes of the society; this kind of challenge should not aim to defeat the weak but to give glory to the winner. Disputes should be fought only between those who can equally well defend their honour. Therefore, disputes can be interpreted as the symbolic demonstration of a society’s values and beliefs, and thus disputes reinforce social order.

Combined with Baroja's historical and Campbell's theological approach, and then compared to the South Mediterranean (Kabyle and Bedouins), the authors in this volume edited by Peristiany attempt to reveal patterns around honour. Regardless of whether it is not clearly stated, what comes to the fore is that honour shapes social life in peripheral egalitarian societies, in contrast to the prescriptive laws that are the controlling factor of those integrated into the centralised state. From the above authors, only Pitt-Rivers attempts to grasp the conflict between the legal system and the canonical role of honour in social life. Their approaches put aside the crucial issue of conflicting interaction between groups of the same political entity; they are mostly concerned with giving a detailed account of those groups they perceived to be changing so rapidly that they would eventually fully integrate into the nation. Maybe, structural analysis alone allowed focus on patterned similarities that indirectly tackled the issue of Mediterranean societies' diversity and the case for national integration.

A decade later, Davis shifts the focus and argues about the Mediterranean: 'it is the variety of political forms within a sufficiently homogenous area which makes Mediterranean anthropology so promising.' (1977:4). He is concerned with stratification and political representation, and he is aware of the flaws of the anthropology of the Mediterranean. This approach focuses on the results of honour in social life, which is the establishment of relationships of unequal power; especially interaction between centre and periphery is more important as societies move to contract. Honour becomes just one, even if the most important, of the factors that divide people into categories along with wealth and class, and all three relate to political representation. Findings must be compared to explain different cases within the Mediterranean as Freeman (1973) has argued earlier; this is the only way to grasp social change.

According to Davis, anthropology has to turn to urban settings and ‘abandon the pretence at holistic analysis.’(1977:7). After all, the nation-building process was completed some decades after WWII. What is of importance in ‘current’ anthropology is to investigate the relationship between the centre and the periphery and reveal the inequality between townsmen and peasants respectively. Patronage becomes *the* means of explaining social life for it reflects changes in political organisation that mostly shape peoples’ lives as it becomes clear through work by Silverman (1965), Waterbury (1970), Corbin and Stirling (1973), and Gilson (1973). The problematic lies between what Redfield defines as ‘big’ and ‘little’ traditions, for it is difficult to discern the origin of cultural traits within the process of nation-building with which the local and national identity are in constant interaction.

Therefore, the context for the study of groups in the Mediterranean should be extended to permit comparisons within the centre-periphery, local-national, and national-Mediterranean schemes. Thus far, it has only been Gearing (1968) who stresses the need for selectivity. Others focusing on the local level, i.e. Freeman (1970) and Gower Chapman (1973), attempt to provide holistic analyses, similar to those that were provided in previous decades and from different social settings where groups were defined by their autonomous political organisation. Davis is explicit: ‘Mediterranean social order does not (therefore) refer to an aboriginal society. Nor was it ever a complete social order, in the sense that there was a complete and uniform range of social institutions (a Mediterranean family, a Mediterranean economy, polity, religion).’ (Davis 1977:13).

Comparison is necessary to bring to the fore differences among Mediterranean societies; although there are similarities among Mediterranean societies, their

interaction with different groups at different times renders differences among them equally important to their understanding. According to Davis, institutions, customs and practices differ from group to group due to constant contact in the Mediterranean basin that has resulted in the 'creation of very different peoples' (ibid.). Accordingly, institutions and processes that facilitated diverse peoples' interaction have had diverse effects on societies as can be traced in history and crude material differences. Rather from a Marxist perspective, Davis argues that crude material differences are important in the organisation of Mediterranean societies as in cases associated with political activity and are converted into systems of stratification. Cases not included refer to small-scale egalitarian societies where cooperation is vital for the survival of all. Moreover, stratification results in rules of social interaction which discard other hierarchies based on age, physical strength and so on. The forms that stratification takes are bureaucracy, class and honour, which correspond to the insistence on citizen's rights, class struggle and patronage respectively.

Although cases may vary, and there may well be those that do not relate to wealth to crosscut stratification, the pattern observed is that class and honour relate to the control of resources. The state is excluded as it controls resources through bureaucracy. Honour is then 'the most important way in which material differences are construed' (Davis 1977:89). Thus, honour creates a hierarchy other than that based on class or rank, unlike what Pitt-Rivers has argued earlier. An important factor in the creation of a hierarchy based on honour is the physical vicinity of persons, for there are two ways to maintain it: the patron's insistence and gossip.

Davis underlines that historical factors shape the concept of honour, as well as its function from society to society. Variation is evident in anthropological accounts that cover different areas of the Mediterranean, another important reason being in this

case the personal point of view. However, what Davis achieves in making clear in his synthesis is that in all cases honour is the constructed expression of material differences that sets rules of conduct which leads to the regulation of social interaction.

Schematically speaking, Davis has a vertical perception of the social use of honour that allows him to come to different conclusions compared to the horizontal approach of the preceding work mentioned above. A hierarchy based on honour is not the same as one based on age or class and none annuls the other. These hierarchies coexist and safeguard the social order granting individuals the right to play a number of roles in the social realm. Role-playing relates to a person's struggle for advancement within societies where resources are unequally distributed. Unequal access to resources results in unequal political representation that reinforces the given social order which in turn legitimises relations of unequal power.

In my analysis I would like to turn away from the approaches mentioned so far; this is to discuss that if unequal power is taken as given (for two individuals or groups always have relatively unequal power), honour forms the platform of communication within and between 'powerful' and 'powerless'. Honour permits the two parts of an unequal relationship to trust one another when they consciously ally in order to gain access to one another's resources and advance, but let us first place this in the context of the so-called anthropology of the Mediterranean.

#### *4.2 The Anthropology of the Mediterranean and the Issue of Honour*

During the fifties, anthropologists, many of whom consisted of the elite of the discipline, shifted their interest to the Mediterranean. The seminal work of the

anthropologists mentioned above is pioneering in the ethnographic establishment of a 'cultural landscape' (Braudel 1972: 276-352, Boissevain 1979: 8). Participants disengage from colonial territories to satisfy western voices that challenge what was thus far considered politically correct. In the aftermath of World War II, anthropologists shed light on issues of social solidarity within the newly built nation-states. In addition, Goddard, Llobera and Shore (1994) argued that in the Cold War climate, southern European countries were seen as unstable and potentially vulnerable to the spread of communism (p.2).

In addition, Moe (1994) argues that due to the process of nation-building Europe was divided into two opposite poles, the North representing advancement and innovation whilst Southern Europe by contrast represented antiquity and laziness where sunlight would not allow the rise of a nobility (Schneider 1998). Therefore, these first attempts to studying cultures 'closer' to home, expressed mainly in the Mediterranean, were strikingly linked to methods, models and interests applied to African societies (Goddard, Llobera and Shore 1994). Consequently, the focus was on those areas that deserved anthropological enquiry, these being areas considered marginal and distant.

What was *the* link among all these societies if we take into account that what they shared was equally important with what they did not? Even if perceived to hold similarities attributed to common history and ecology, and thus to constitute a set so similar to each other that they formed a distinctive cultural pattern of civilisation (see Sweet and O' Larey 1969), there were also great differences (see Wolf, 1969, Herzfeld 1980, 1984) among them regarding economy, politics and sex-roles.

The pan-Mediterranean focus initiated by Redfield (Gilmore 1982) was taken further by Pitt-Rivers and Peristiany, who explored the distinctiveness of the area. The field

was bound together theoretically in 1971 by Jane Schneider, who ‘published a paper on the origins of the Pan-Mediterranean honour-shame complex ... that was important because it was the first to demarcate a continuum of material variables which hypothetically constituted the basis of Mediterranean unity.’ (ibid: 175). The field was consolidated with Davis and Boissevain conducting comparative studies within the Mediterranean in 1977 and 1979 respectively, but it was ‘honour and shame’ that became the tool that conjoined the theorisation of economics, politics and gender to kinship and the family (see Schneider and Schneider 1976, Loizos 1977, du Boulay 1987).

It is suggested that shame and honour is a set of social values that play a vital role in Mediterranean daily life, and are seen as a fundamental and total fact (Gilmore 1987). This binary opposition is related to *amoral familism* (Banfield 1958, Silverman 1968), *social atomism* (Gilmore, 1975) and *patronage* (Pitt-Rivers 1954, Campbell 1964, Wolf 1966, Davis 1977). Preceding work on structure and function, kinship and political and economic relations constituted the basis of the above (Goddard 1994). But what is honour and what is shame?

According to Pitt-Rivers, honour is ‘the value of the person in his own eyes, but also the eyes of the society.’ (1954: 21). It needs to be publicly demonstrated and defended (ibid: 27) and pertains to male virility and the protection of the chastity of female members of the family (Campbell 1964). Shame on the other hand is a value upheld primarily by women and related to their moral integrity as well as their reputation for being virtuous (Dubish 1995: 196). Honour and shame were not just social values that ‘tied’ Mediterranean peoples (Peristiany 1966: 11), but crucial traits of social stratification (Davies 1977: 89-101) that organised social and political life in the Mediterranean village, explained competition between households and

elevated the household (and not the individual) as the basis of Mediterranean selfhood.

#### *4.3 Critique and Synthesis*

Albera and Blok (2001) argue that the Mediterranean became the experimental laboratory of the discipline of anthropology where diverse anthropological methods were applied for a number of diverse interests. Pina-Cabral (1985) explicitly argues that the conception of the Mediterranean as a cultural area served western anthropologists to focus in this specific era. Moreover, as the danger of communism lurked and especially in areas where feudalism was still present, the Mediterranean along with Latin America was seen rather as belonging to the 'Orient' in the 'West/Orient' political division of the world (Goddard, Llobera and Shore 1996, see also Schneider 1998)<sup>15</sup>. Polyphony led scholars to discount one another's findings, and especially of the indigenous anthropologists, thus comparison remained poor (Sant-Cassia, personal communication).

The neat conceptualisation of the Mediterranean as presented above was well countered from its beginnings. Galt (1985) argues that southern Europe is less homogenous than its northern counterpart, and since the South is subjected to changes its conception as a whole becomes problematic. Moreover, there may be commonalities among the subjects of study but their differences are of the same importance in the process of understanding these subjects (Wolf 1969, Goody 1983, Herzfeld 1980, 1984).

---

<sup>15</sup> The criteria used for such a division and which were primarily cultural, economic and political, legitimised the West's sense of superiority over the Orient.

Another important issue discussed by Herzfeld (1980: 348), Dubisch (1995) and Just (2001: 45) is the problem of cultural translation, challenging the manner in which certain terms like honour were perceived and theorised by earlier anthropologists. Argyrou also demonstrates that the uniqueness of Mediterranean values is 'not unique' after all (1996: 158) by using the work of Bourdieu (1984) on the identity of French working-class men and Willis's (1981) study of working-class high school boys in England.

The anthropological methods transposed on the Mediterranean were problematic in their application towards the understanding of national integration. Focus areas were small-scale societies at the periphery of nations, and focus groups were usually the poorest (i.e. Moss 1979, Chapman 1971, Du Boulay 1983). Given the climate of the political preoccupations of the time, such groups were stigmatised as threatening to national integration and 'exoticised' as the 'inner other'. At the same time, research on other social classes was rare, i.e. Whyte (1943), Belmonte (1980).

The case of Sicily and especially of Palermo fits accurately into the above problematic situation: Sicilian culture is perceived as an entity that is not part of the Italian one, and is mostly approached as an exception in the anthropology of the Mediterranean. Starting from Italian integration, anthropologists focus mainly on the Mafia linking every other Sicilian cultural aspect to it. There seems to be a perpetuation of Cavour's preoccupation with national integration as it is witnessed in his correspondence with his officials in the South. Both the existence of the Mafia and the lack of a conscious middle class, due the persistence of feudalism, render Sicilian society closer to the African model (Blok 1966).

The major interest of all the anthropologists mentioned so far is social conflict, and the question that springs from the above context is why there is a means other than

the law that regulates social life? However, instead of focusing on how to explain the South's instability within the national context, this issue becomes common for all Mediterranean societies in juxtaposition to Northern Europe. The only means that can explain the differences between North and South at the European level is the unequal distribution of resources between the two poles. Although the southern economy is agricultural and the problem should be traced in the distribution of land, the backwardness of the South is perceived to be the outcome of a turn never taken, this being a turn to other resources. The turn to other resources would be interwoven with structural changes, or in other words with conflict. Nevertheless, conflict is diffused because of honour. If it is defined as respect, reputation, status and so on, honour gives an individual a value that has nothing to do with wealth and social class. Honour is about trusting an individual, a signature or a name, enough to engage in a patron/client relationship. From a patron's point of view, to trust a client means that the latter is expected to act in culturally approved ways, or to conform to the society's rules of conduct; but the same works in reverse. Therefore, I perceive the set of values under the title of honour as the ones which regulate the communication between persons of unequal power, and in this way reproduce stratification peacefully. Conflict between equals as has been documented above can be understood as a struggle for access to resources. There are three main parameters that perpetuate the relations of unequal power: first, the scarcity of resources, second the large number of clients, and third the corrupt administration.

#### *4.4 Egalitarianism Questioned*

If we assume that conflicts of honour 'between equals' reinforce social order (Bourdieu 1965), we must accept that equality is 'somehow' threatened within

egalitarian societies. The very belief of people -if there is such a thing- is that honour safeguards equality within egalitarian societies and can legitimise honour's prevalence over the rule of law. Nevertheless, in the seminal work on honour presented above, honour is linked to advancement in those societies where there are no other criteria, i.e. class, wealth, to form a different type of hierarchy. In this case, a society cannot be egalitarian any more if honour results in the establishment of a hierarchy. Since other members of a group attribute honour to individuals, the more honourable ones can legitimise access to more resources than others can.

In addition, even if we accept that honour suppresses all those factors that run counter to egalitarianism, it still cannot turn against itself, that is, to cancel its very existence so as not to provide a society with a means of differentiation between its members. Moreover, it has been argued above that the family is obliged to protect its honour and that the unit's ability to do so depends on the number of kinsmen involved in this process. Then, why do these persons unite only to protect their honour and do not unite for economic reasons? It is more likely that since culture permits coalitions between relatives, this will be applied to all situations even those that aim towards the achievement of financial profit. Campbell suggests that societies of the Sarakatsani type must be studied before they integrate into the nation and misplace their unique identity. The only threat against the Sarakatsani's identity was the patron/client relationships they formed with non-members of their group. Therefore, even if we assume that the Sarakatsani society is egalitarian, Campbell's preoccupation should be that this egalitarianism will be corroded by interaction with a stronger and stratified group. Thus, if we expand our view and see the Sarakatsani as part of the greater Greek nation, then their society will not qualify as an egalitarian one.

Moreover, claims to honour that require resolution may well be between equals but this equality is witnessed within groups that if compared to one another are unequal by various criteria, i.e. size, wealth, political power and so on. Examples make clear that one never provokes the other when both do not hold equal honour. A man who does so, that is to say, one who provokes somebody who cannot equally well defend the honour of either himself or of the group that he represents, puts his own honour in jeopardy. This alone implies that there is inequality, and shows that anthropologists have been aware –even if indirectly- of other social divisions based on the criteria mentioned above but they have not all tested honour in this wider context. Therefore, ‘holistic’ approaches can be argued not to be holistic since the groups being studied have been defined only by residence and not by social webs.

In addition, honour as a set of values can be diversely internalised and transformed into non-essentialised manifestations by each individual. Social criteria such as age, class, wealth, and status all help categorise perceptions of honour and inform its manifestation. However, the common ground is that in interaction elders hold more honour compared to the youth, as the higher classes do from the lower, or rich from poor, and so on, and this allows us to study how honour ascribed to each category shapes the outcome of interaction between them. Since all these criteria interrelate and the groups they form interact, it is important to see why both sides agree on such classifications. Among them, I suggest class to be playing the most important role in the internalisation and manifestation of honour.

The case of colonial Latin America shows the way in which we define our study groups and the importance of extended social webs in the societies we study (Johnson & Lipsett-Rivera 1998). In this account it is made clear that various aspects of social life which are linked to honour are seen from different points of view by

different social groups; social interaction between colonialists and those colonised play a pivotal role in the perceptions of honour withal. The above collection manages to link the Spanish church, the Spanish political world, the colonial elite and the colonised society in a single network in which every part is as important as any other to the final cultural amalgam witnessed in Latin America.

The similarities between Latin America and Sicily are striking; the connection between these two distant places is Spanish occupation. By comparing them, it becomes obvious that honour became a tool in the hands of the powerful that they used for political ends (ibid.). In general, similarities between the Sicilian and Latin American sense of honour, as well as an analogous hierarchy in terms of class and political power allow us to think that there was common influence in the case of Spanish hegemony (see Burkholder in the same collection, the Schneiders & Hansen 1972, the Schneiders 1976, Hansen 1977). While Twinam (1998) argues that honour and class were interrelated to the point that honour could reinforce economic hierarchies, Bulkholder (1998) provides us with the process of honour's 'transfer' to colonial America. Although I consider Spanish hegemony crucial in the particular form that stratification has taken in Palermo, I regard later conditions shaped by the relation between the centralised state and its periphery equally important in the outcome of this process.

#### *4.5 Mediterranean Shortcomings and Contradictions*

In this part I discuss developments in the 'anthropology of the Mediterranean area' based on Gilmore's (1982) paper with the same title. I consider the steps that have been made to tackle the controversies that Gilmore discusses as being crucial in the conceptualisation and perception of Sicily as part of the Mediterranean. In addition,

Sicily becomes an even more important focus in the anthropology of the Mediterranean due to its size (the largest island in the Mediterranean), and its strategic geographic position in the Mediterranean basin (as a melting pot of civilisations and an 'entrance' to Europe, Goiten *et al.* 1967). An equally important reason to discuss these developments is the crucial role that Jane and Peter Schneider played in the consolidation of this field, and the fact that they mainly draw from the Palermitan culture, which is my focus. Therefore, along with the description of developments, I note the shortcomings that I consider essential in the understanding of Mediterranean societies, and which I therefore tackle later in my attempt to represent Palermitan culture.

The context in which the anthropological shift of focus towards the Mediterranean takes place, and the way this shaped the field illuminates my argument. Gilmore (1982) stresses that although anthropological work in the Mediterranean dates back to the first decades of the twentieth century (Westermarck 1926, Chapman 1931), 'an anthropology of the Mediterranean area which includes both Christian and Muslim sides is both new and controversial.' (Gilmore 1982:175). In addition, Gilmore suggests that: 'One reason for this development is the recent upsurge in south European ethnography. Favouring the most marginal areas of the south, Europeanists have gradually become aware of many affinities between their peoples and those of North Africa and the Levant. Their resemblances start with environment but include many "core issues of life": male-female relations, community orientations, patron-client dependencies, and, more recently, a supposedly similar peripheral relationship to the core of industrial Europe.' (ibid.).

Gilmore's central issue in the challenges of the Mediterranean field is the very term 'Mediterranean'. His aim is to show how a more sophisticated 'geoenvironmental'

approach can explain similar historical responses in the area. The Mediterranean cannot really define the 'new' field, and thus its use is problematic: '... this thoughtless nominalisation leads to a false sense of security that the field of study has been adequately defined when it has not been.' (1982:177). Moreover, 'An anthropology of "the Mediterranean," strictly speaking, would be maritime and insular studies.' (ibid.). In case the criteria for ascribing societies in the same field are those that are touching the Mediterranean Sea, Portugal, 'as most typical Mediterranean country' (ibid.), would not fall in this category. There is also a reverse problem in the category ascription of countries with non-typical Mediterranean ecologies, such as Egypt and Libya. Instead, drawing from Pitkin (1963) and Braudel (1972), Gilmore suggests that "a better criterion for definition is ecology, including special types of both climate and topography. These can explain the Mediterranean societies' homogeneity in terms of settlement patterns and economy which is based on a common production system that Boissevain (1976) defined as a 'polarised agrarian dualism of scale'" (Gilmore 1982: 178).

To bind the field in sociocultural terms is also problematic. It is difficult to explain variations among Mediterranean societies when there are likewise historical responses. Gilmore is critical towards the uncontested analysis of cultural traits, which renders correspondences feasible between dissimilar traits. Indicatively, cultural affinities between Mediterranean societies have to do, for example, with 'a strong urban orientation' (ibid.), and 'an honour-and-shame syndrome which defines both sexuality and personal reputation.' (ibid: 179), as well as, religious and ritual traits, marriage patterns and politics. Gilmore defines the analogies of the above kind as 'disconnected' (ibid: 180). He gives examples of contradictions related to these affinities, i.e. 'A *machismo* which denies even a suspicion of femininity in males

often oscillates with festivals of male transvestism or with other manifestations of an insecure male identity.’ (ibid: 180), drawing from Eickelman (1981).

According to Gilmore, structural dualism is the prevailing pattern in the anthropological analysis of Mediterranean societies; further research is important to shed light on these contradictions. The way these contradictions are depicted can be misleading, for they are presented as ‘both more discernible and more systematic than in other societies.’ (1982:180). Gilmore also refers to Giovannini’s (1981) work on the women of a Sicilian town (Garre) as an example of the kind of studies needed to overcome the shortcomings at hand. Giovannini approaches the woman as symbolic from a structural point of view, by drawing mainly from Turner (1967, 1969) and Schneider’s (1971) preceding work. He contextualises the contrasting meanings that this construct carries, and he shows how ‘six types of women or female figures as a set of interrelated conceptual images [that] together form the more inclusive dominant symbol, woman.’ (Giovannini 1981: 410). Such approaches can render structural dualism constructive.

In addition, the ‘diffusion and acculturation’ approach based on the work of historians of the Mediterranean such as Braudel’s (1972), needs reconsideration if it is used to explain current similarities (i.e. Davis). Such an approach has to take into account voices like Hess’s (1978), who stresses a widening of the already existing gap between Christian and Muslim Mediterranean societies after the sixteenth century. Instead, Gilmore argues that ‘it is rather a combination of historical convergences with synchronic parallels in culture, all within a homogenous environment, that provides both internal consistency and distinctiveness in the Mediterranean area.’ (1982:181).

In the same way of thinking, the 'centre-periphery' approach that is related to Spanish hegemony is also inconsistent (see Schneider 1976, Hansen 1977). According to this approach, 'south European unity [was] forged by the preindustrial experience of Spanish preindustrial hegemony followed by the incorporation of the entire area in to the developing northern core.' (Gilmore 1982: 182). From this point of view, the role of local conditions is diminished in favour of external pressures from the so-called developing northern core. Gilmore draws our attention to the mediating structures between centre and periphery, as well as to the role of social class in the generation of group perceptions as they are reflected in varying values. Thus, one should first focus on the national level, and its relation with the local, in order to understand how considerable differences challenge the Mediterranean uniformity at this level, before moving to the extra-national North-South level. Although Davis (1975) considers class of minor importance when people lack class-consciousness, Mouzelis (1976), Loizos (1977), Gilmore (1980), Silverman (1981) and others' work proves the opposite (see also White 1980). Gilmore suggests that 'The resulting weakness in class analysis may be the single most disturbing failure of the Mediterranean anthropology to date.' (1982:186).

Moving to the local level, light should be shed onto other parameters that result in conflict but do not relate to class discontinuities, such as social atomism, and should thus be seen from a 'moral community' perspective (ibid: 189). Competition seems to be a common trait among Mediterranean peoples, as Gilmore observes in a number of relevant anthropological accounts. The same applies to a notion of cleverness, which is equally important to interfamilial tension, and 'generates behaviour as well (ibid.). Banfield's 'amoral familism' is not enough to explain the kind of tensions described above. In other words, the line between the private and the public sphere is not that clear, and is definitely not a line that defines serene and

antagonistic relationships respectively. In turn, the issues of honour and patronage should be placed in the above context of conflicting social relationships. The male-female relations, which correspond to the public-private dichotomy in terms of dominance, are interwoven with both the issues of class and honour. Again, there are differences from place to place that must be put forward, and which question a pan-Mediterranean definition of honour, as well as the perception that the public sphere is male-dominated whilst the private female-dominated.

#### *4.6 From Theory to Practice*

As far as it concerns the issue of honour, my question is why is there a means other than the law to mediate social life? The pervasiveness of honour proves both the intensity of conflict as well as a social need to deal with this conflict directly. Is law inadequate in resolving conflict, especially in southern Europe? The lack of civic consciousness allows for the ‘instability’ of the south at the national level. By dichotomising Europe into North and South the issue of the southern instability becomes pan-European. The main difference between the two poles can be traced to the unequal distribution of resources. Since the southern economy is primarily agrarian, historically the issue springs from the distribution of land. The backwardness of the south, in this sense, can be attributed to their close relation to the land as part of an ongoing contradistinction to the industrialised north. However, a turn to alternative resources is interwoven with structural changes, which in turn result in a clash. I suggest that honour is the means by which conflict is avoided. Honour grants a person with a ‘value’ irrelevant to class, status and wealth; this value corresponds to the social image of the person at hand. Therefore, social interaction between non-equals based on honour lessens other social differences

between the two parties and this is how tension is diffused. On the other hand, conflict between peers is the result of competition for access to scarce resources. In this context, the 'high supply' of clients reproduces the inequality of power between them and their patrons and, consequently, patrons maintain their mediating role between resources and clients. This vicious cycle produces reliance more on the patron than the state.

In the same way of thinking, can honour deal with all those contradictions that can potentially result in conflict? Drawing from my field, I observe three main structures of power that shape Palermitan life, namely the state, the church, and the Mafia. If we accept that their power can be measured by their number of 'followers', the fact that they draw supporters from the same 'pool' is enough to explain the conflicting character of their relationships. Winning supporters rests on the articulation of discourse; although there are parallels in the discourse of all three, the fact that they refer to different aspects of life consequently differentiates their discourse substantially. In this sense, these structures are interdependent and none alone can cover entirely the wider spectrum of a person's personality and life, but even if so, conflicts would nevertheless be unavoidable. For example, if we assume that only one identity prevails, a Mafioso could be in conflict with a civil servant and/or a religious individual due to their contrasting views on a property issue. In another case, the same issue could cause an individual identity conflict in a civil servant who is Catholic and member of the Mafia for example. Therefore, if honour is shared among all social classes, their diverse access to resources can result in variant emphasis on the conceptions of honour, which in turn can lead to class conflict.

Why does the state not take action against all those factors that, theoretically speaking, can result in conflict and even shake its foundations? Some of the

contradictions that can fuel social conflict spring from the state itself, and they are issues of conflicting power. Even if the state can address an issue of this kind, it is not possible to predict accurately the outcome of such a procedure. Therefore, the state does not challenge relations of unequal or overlapping power if these manage to balance themselves peacefully. A change in the structure of the state would signify parallel changes in terms of power, which could potentially threaten social stability. In a hypothetical example, the state is aware of the conflicting nature of two laws on employment. At the local level, politicians take advantage of this legal gap and employ persons with criteria that discourage meritocracy. Local people are aware of this practice, and may express their discontent, but as long as this is expressed only verbally and people take this kind of abuse for granted, the state does not take action against the corrupt politicians. In the opposite case, if the state decided to deal with this issue it would bring the conflict upon itself, which could jeopardise social cohesion. However, patron/client relationships limit conflicts at the personal, familial, or at most group levels. Thus, local honour that allows serene patron/client relationships is a means of reproducing unequal power, and consequently of safeguarding social stability. The most powerful patrons in the Palermitan context are in the circles of the state, the church and the Mafia.

Although politicians, clerics and Mafiosi distort shared Palermitan values that relate to the notion of family, they all become diversely important in Palermitan life, and shape the role of the family in the Palermitan society. I believe that the state, the church and the Mafia coexist because they have managed to find a balance. The pervasiveness of all three is evident in Palermitan life, for the reasons I have mentioned above. Unlike the state, both the church and the Mafia are characterised by proximity; immediacy is the Mafia's main source of power, while the church's relies on its insistence on ever-present dangers. Unlike the Mafia, the church uses

symbolic power to legitimise its mediating role between man and God. However, in the Palermitan case, both church and the Mafia mediate the interaction between the citizen and the state. Their economic and political powers allow them to play this part in Palermitan society. However, the decreasing popularity of the church and the Mafia in today's society allows Palermitans to see the inconsistencies of the state much clearer. However, Palermitans also know that between the church, the Mafia and the state, they can affect only the last one through their votes. Therefore, the family acquires an increasing significance as a pool of votes.

The aim of the Palermitans' political struggle is the improvement of living conditions. The standards of living that Palermitans fight for can be characterised as those held by their fellow countrymen in the north. Consequently, this struggle has a class character that can potentially tackle the issue of the Italian national integration indirectly, and I say indirectly because this is not a conscious aim. The effects of the European Union's policies for the development of its periphery are positive in this direction. On the other hand, the European Union can learn from the Palermitan case. Parallels can be traced between the two processes of Italian unification and the completeness of the European Union from a centre/periphery approach. Italian history and the Sicilian culture can reveal mistakes that rendered the Italian national integration problematic, and which the European Union can avoid.

I believe that my nationality allows me to have a perspective somewhat different to that of an Italian or an Anglo-Saxon anthropologist. Of course, I do not pretend that my insights on the above issues are unbiased, but that my identity gives me a different experience of the field I focus on. On the one hand, I believe that my relatively easy access to the field has given me the chance to have fruitful insights in the process of comparing parallels and contradictions between two Mediterranean

cultures, namely the Palermitan and the Greek. On the other hand, my experience of living in the UK for nearly five years gives me another perspective that allows me to distance myself and to conceptualise Mediterranean issues in a way that builds on the existing Anglo-American literature. Although my research is anthropological, I also combine history and sociology to address a wide range of issues that I consider of importance in the process of shaping the Palermitan identity. Since there are parallels between this process and the completeness of the European Union, it is both interesting and of great importance to research how the European Union's policies can be compatible with local characteristics. My research shows that Palermitans have a positive view of the European Union; they are also supportive of the centralisation of power as a way of sanitising the corrupt Italian political body. Thus, the centralisation of power should not be based on the existing administrative structures, because the pervasiveness of personal relationships will minimise the effect of European policies on people's lives and will thus jeopardise the European Union's promising undertaking. Further research could focus on the rhetoric that legitimises the existence of mechanisms that misappropriate European funds while attacking the European Union for the numerous setbacks at both the national and local level. The following chapter focuses on the Palermitan perception of honour and the adjustments this value system has been imposed in order to address better current issues of Palermitan society.

## Chapter 5 A CONTESTED ANALYSIS OF HONOUR

### 5.1 Introduction

In this chapter, I provide Palermitan interpretations of honour and I stress the role of the local elites in this process. Gellner argues that ‘the political and national unit should be congruent’ (2006: 1), however, I suggest that traditionally the Sicilian elites hold enough power to shape local meanings of honour upon which relationships of unequal power are based. The reproduction of inequality on the regional level shapes an identity other than the national Italian. In this chapter, I illuminate the honour and shame theory with data I have collected in Palermo, linking the individual with the local, the regional and the national level. This chapter is a path to the analysis of the family and its special role in Palermitan social networks, which I discuss in the next chapter. What does honour, or better *onore*, mean in Palermo and to Palermitans? Which are the relevant expressions and the context in which Palermitans use them? I do not attempt to provide a definition of honour but I rather apply a descriptive approach. I depict Palermitan life and I discuss the values of friendship, cleverness and ‘silence’ in relation to honour and the role models of the past and the present. Thus, honour is approached as a fluid but contemporarily shared set of values that regulates Palermitan life. Differences traced in time are illuminated by examples drawn from perceptions that different generations hold. For analytical purposes, I show variations in the perception and use of honour in a range of dualities and spheres, i.e. between men and women, the private and the public, among social classes, and in relation to the market, the state and the Church. This approach is compatible with Davis’ (1977) theory of the three main forms of stratification, namely bureaucracy, class and honour. Therefore, based on his theory I assert that honour allows Palermitans to crosscut bureaucratic and

class hierarchies. To see honour as a right (Stewart 1994), shared among all Palermitans, allows us to sustain the functionalistic point of view that honour is a means of social interaction that reproduces inequality. Honour seen as a right, specifically in the Palermitan case translates into avoiding social struggle. Thus, honour functions as a ‘safety valve’ in Palermitan society because bureaucracy is corrupted, and it will keep failing for as long as Weber’s ‘impersonalised office’ will be corroded by the practices of a society in which personal relationships thrive. In other words, patrons will pull strings to favour their clients for an exchange that practically reproduces the existing stratification. Class struggle has been so far fruitless due to a lack of consciousness and thus of solidarity. I conclude that the redistribution of resources after World War I (the Schneiders 1996), has signalled changes in the way Palermitans cope with the contradictions within their society. Therefore, there is an analogous adjustment of honour in order to fit into the current needs of Palermitan society. Palermitans invest in personal skills and struggle for meritocracy, thus they abandon their family-centric point of view that has allowed the pervasiveness of patron/client relationships that still endure to this day. This issue is discussed thoroughly in the next chapter.

## *5.2 Local Definitions*

To begin with, Palermitans are familiar with the terms honour and shame, to dispel Lever (1986) and Pina-Cabral (1989). Although Pitre, *the* folklorist of Sicily, does not include in his work data that would fall under the category of shame, i.e. divorces, abortions, adultery and the like, this binary opposition has been well documented by other resources and is also in accordance with the Catholic belief which prevails in all the country. The phrase ‘shame on you’ is heard on a daily basis

as it is one used in public to 'cure' behaviour that does not fit into the Palermitan role model. In contrast, claims on honour are realised in both the public and private sphere, for honour is not just personal but it consists of a criterion of perception of the world divided into two categories of persons, those honourable and those lacking honour. Therefore, this could be defined as a 'mode of thought' according to Peristiany (1966: 9).

Parca (1965) stresses that in Italy honour is not perceived in the same way within all parts of the country. Moreover, Marcus (1987) and Herzfeld (1987) draw our attention to diverse perceptions that cannot secure consistency to the concept of male honour and female shame in the Mediterranean. Especially in Palermo, women are esteemed members of society. Neither can one speak of 'one group of shameful people' in the case of Palermo (Wikan 1984: 636), for people in Sicily are not judged directly in public. The only case of shame is an 'experience-near' concept (Geertz 1976) that refers to actions (see Wikan 1983) when parents comment on their children's false behaviour. In addition, Palermitans do not hesitate to define a person '*onorato*' mostly in the public but also in the private sphere.

Honour and shame do become two sides of a coin in Palermo only as far as public behaviour is concerned. One can be either '*onorato/a*' or '*disonorato/a*' in the eyes of his/her fellow citizens. *Disonorato/a* can substitute the word shameful but its meaning is not exactly the same. '*Disonorato/a*' is used to characterise a person who has lost the right to claim honour because of a shameful act. This presupposes peoples' awareness of the shameful act. The way fellow citizens become aware of others' actions is through gossip or the mass media. It is through the same means that persons are granted honour, and especially in Palermo honourable acts are always advertised on the regional channel and in newspapers along with the

shameful. This means that nowadays reputation is not based on the physical presence of the person and thus the neighbourhood.

So far, if one of the family members was deprived of honour then they should be excluded from the family to prevent the characterisation of the family as *disonorata* in its entirety<sup>16</sup>. The first to leave their villages for Palermo were *disonorati*, for they would leave their families unprotected in seeking a better future in an unknown environment where they would lack control. Therefore, nowadays there are not many families in Palermo who are linked to the countryside. Moreover, Sicilian migration patterns also confirm that Sicilians consider control over family members to be vital for both the protection of the member and the family's reputation.

Generally, one is expected to avoid any kind of interaction with dishonoured people in order to protect himself/herself and his/her family from social stigmatisation. The reasons alter in time but the underlying concept is that socialisation with dishonoured individuals is avoided for they are perceived as the sick part of the society. This illness can be transmitted from person to person, thus physical distance is a means of stopping its expansion. This prevention of disease approach is reflected in the Palermitans' perception of their society as a human body. This 'body' also complies with social and religious rules that complement the rules of Palermitan everyday life.

---

<sup>16</sup> The situation should not be confused with Mafia patterns. Mafia families could never accept any kind of kinship with persons whose occupation symbolised the enemy of the organisation, thus the state. What would happen in the past in case, for example, the daughter of a Mafioso would insist on getting married to a police officer, the latter would be asked to change profession and the Mafioso would offer him the money to start a business. Only in case the police officer would accept this offer would the marriage take place, for otherwise it would be dishonourable for the Mafioso's family and would lead to the termination of any cooperation between his family and the organisation. Mafiosi argue that they were distanced from these patterns when the organisation got into drug-trafficking and needed both to increase in number, so as to hand the drugs out, and connections so as to be protected by kinsmen in key-positions. This is also where, according to some on the inside, the Mafia lost its honour and changed its social role shifting its interests from the society to politics. In fact, the Mafia's u-turn should be understood as an obligatory change of poles out of which it drew its power. However, in order to avoid any confusion such as that the Mafia and Sicilian society have the same 'evolution', I would like to stress that the Mafia kept increasing in members and connections, in contrast to the Palermitan family which kept decreasing in members.

One of the main parameters that has remained unaltered through time and leads to social exclusion is sexual abuse. Most of the preceding bibliography focuses on female sexual behaviour from that point of view that the interest is how the honour of the male members of a family can be harmed. However, sexuality cannot be approached monolithically, i.e. cuckoldry is as detrimental as rape to a family's reputation. A family's honour will be damaged in case a female member sleeps around or is raped, but a family unit's honour is equally damaged if a male member's sexuality is uncontrollable.

Issues of honour have a special 'ground' of their own in Palermitan culture, as the expression *campo d' onore* connotes, which relevant expressions and practices allow us to perceive them rather as a battleground. It is a matter of honour (or *è una questione d' onore*, as Palermitans say), to defend your own or your family's honour, but more important to defend the honour of a female relative (*difendere l' onore di una fanciulla*). In Palermitan society, both men and women can be of honour (*uomo/donna d' onore*). As honour can be 'damaged', it is obligatory to defend it in order to be respected in the private but mostly in the public sphere. In Palermo, to honour your 'word' and 'signature' is an imperative need (*debito d' onore*) and does result in 'honouring your name', but sometimes this is inadequate in coping with others' attempts to harm your honour (or *ledere l' onore di qualcuno*). Harming somebody's honour rests with the articulation of certain information through gossip. Pieces of information that can threaten a person's honour do not only have to do with the disgraceful actions of the same individual, but of other members of his/her family as well. The aim of charging a person with such acts is to deprive him/her of the right to use his/her honour as a guarantee, or *garantire sul proprio onore*. To be discredited in Palermitan society has devastating effects since everything depends on personal contact; thus, to lose the weight that your word carries equals to social and

economic exclusion. Of course, the Palermitans do not always try to discredit the other because they are culturally antagonistic, but they only do so when there are conflicting interests. The disputes fought on this 'battleground' reflect the scarcity of resources in Palermitan society and constitute agonistic displays of Palermitans' attempts to gain access to them.

Therefore, honour has an important function in daily life that cannot be fully grasped if it is simply perceived to define a person's 'value'. Instead, this 'value' has to be locally contested and analysed through a variety of situations in which honour may be equated with 'value', 'trust', 'respect', and so on. If not, it is possible to confuse the issue and misrepresent Palermitans. For example, an *onorato* (honoured/respectable) or *onorevole* (honourable) has nothing to do with an *uomo d'onore* (man of honour), and the *mafiosa* perception of *omertà* is different from the widespread practice among common people of avoiding the authorities, as in general Palermitans have nothing to do with the Mafia. Moreover, local perceptions must be approached as fluid, for variations in the interpretation of honour are not only traced among social classes but also among different generations of the same social class. As a result, the definition of honour does not only vary between a man and a woman, a Mafioso and a priest, and/or a rich and a poor person, but it varies between a man in his twenties and a man in his fifties and so on for all other pairings. Therefore, honour does not define a person's value, but honour is a value shared among Palermitans.

### 5.3 *Parola d' Onore! (My Word of Honour!)*

Pezzino argues that *omertà* derives from *umiltà*, which was used by nineteenth century gang members 'to indicate their duties (obedience, loyalty, and silence).'

(1987:927). To quote Triolo (1993: 312), '[A]ccording to Pezzino, *omertà* was probably tied to prison life and the need for self-defence in the face of authority, grounded in an atmosphere of fear that had little to do with chivalry sentiments.' Although Pezzino's rationalisation contrasts Pitrè's honourable view of the Mafia, it still explains a current issue as a remnant of the rural past (Lupo 1987). Moreover, especially Pitrè's (1971) analysis of the illiterates' lives that presumably represented the 'true' Sicilian culture deprived them of an 'independent historical status of their own' (Herzfeld, 1987: 57). Therefore, with the simplification of Sicilian life, various cultural practices came to represent both the Mafiosi and non-Mafiosi Sicilians. In this sense, Sicilians' awareness of the self resulted in an 'exaggerated idea of one's individual strength' (Pitrè 1889: 294), which legitimised an inherent inclination to violence as the prevailing means of dealing with personal offences. To close the vicious cycle, silence was important to protect violent Sicilians against the authorities, as Lupo (1977) argues.

Triolo's (1993) analysis of Pitrè's political role supports Herzfeld's (1987) argument that the exotic view of Sicilians silences important political ferment of that time, and sheds light on the close relationship between the political and intellectual worlds. This case reveals the plasticity of cultural values and thus the fluidity of both the Sicilian society and the construct of honour. Current Palermitans do have an idealistic perception of the Mafioso of the past that they contrast to the modern one: 'A man of honour was even-handed and his word was respected. He was a public person that never used his power but only his mind and his connections. In the old times, the Mafioso was like the police; he sat at the same place every day and people would go there to consult him and to ask to settle their disputes. The Mafioso would talk to all the persons involved and then he would decide what the best thing to do was. This was how things worked and everyone was satisfied. There was no

bloodshed, neither did you have to wait until a trial, which you never knew how it will end up.’ This widespread idyllic view of the men of honour that an old Palermitan describes above shows that Palermitans believe the old Mafiosi had no personal interests to protect, but on the contrary, their aim was to protect the peace of social life by settling the disputes of others. Palermitans do not provide an explanation of how the Mafioso was allowed primarily by the state but also by the church to play the role they describe.

On this ground, I argue that in Palermo to be able to use your word as a guarantee is of vital importance because not only everything revolves around personal relationships, but also due to the fact that the fragmentation of power renders various power centres inadequate for solely controlling social life. Thus, part of the strategy of surviving under these conditions is to change sides, and this is where honour becomes important because the ‘side’ one may choose to turn to has to trust the individual. One’s word of honour is an informal contract that serves to safeguard both sides especially in ephemeral relationships based on common interest. This kind of contract ensures that the other person is going to comply with the cultural rules that define a good relationship, and only in these terms can honour be linked to obedience, loyalty and silence, for these are the prerequisites of a successful alliance. In fact, these rules protect both sides, because they are employed to make sure that the persons engaged in a common task shall not attempt to exploit one another. In our days, the *parola d’ onore* is the expression used more often where there are financial implications. For example, I have witnessed many deals in various areas of economic activity, in which the ‘word of honour’ was crucial in making a deal. Indicatively:

- I want you to provide me with these goods, but I want to have them by Friday because I want to be honest with my clients.
- Sure! You will have them in time.
- If you cannot make it, I can get them from somebody else.
- No, as I told you I will deliver before Friday. *'Parola d' onore!'*

Or on a phone conversation:

- Good morning Caterina, how are you doing?
- ...
- Well, I called you about the loan...
- ...
- Yes, as I have explained to you, I will invest in my business and it is quite sure that I will make a profit.
- ...
- *'Parola d' onore?'*
- ...
- Stergios, we did it!

In another case:

- Fabio told me that I should come see you.
- Yes, I think I am the right person for you and you for me.
- Indeed, but I want to be sure that there will be no 'leakages'.
- *'Parola d' onore!'* It would be no good for me as well!

I have argued above that honour is important especially in temporary relationships because it is a convention used as a contract between two sides, which do not know each other well. However, these kinds of relationships depend on the reputation of the individuals involved, because everybody wants to secure his/her profit. In all the above cases, both sides could have chosen somebody else to ally with in order to achieve their goals. Instead, they chose the person they thought to be the best for the situation at hand. For example, in the last case, a civil engineer who wants to build on a particular piece of land turns for help to a priest although she could turn to a lawyer or the regional administration to get a building licence. The fact that there were other options however, made them swear on their honour that they were going to abide by the agreement. Moreover, the choice of the individual with whom Palermitans cooperate, even if for a short period, depends on their reputation. That is, Palermitans who ally may not know one another personally but their reputation is important in deciding with whom they will eventually associate. Trust in this case depends on the information provided by a third person that is not directly involved in the situation. Therefore, it is important to Palermitans to maintain an honourable image in all spheres of their lives. In other words, even temporary relationships depend on other long-lasting ones.

#### *5.4 Images and Reflections, Private and Public Mirrors*

The first thing one observes looking at old photos from Palermo is the remarkable sartorial homogeneity of Palermitans. This does not only apply to photos taken in public but also to those taken at home. Even the *artigiani*, or craftsmen, represent old Palermitan life in a stereotypical way, dressing the handmade puppets

they produce in the same clothes. In addition, any kind of art in Palermo represents a Sicilian aesthetic as if the taste of the *bello* (nice/beautiful) and the *brutto* (ugly/terrible) is common for all Palermitans. Is it possible that all Palermitans have the same taste or that all Palermitans dress in identical clothes accidentally? This is surely not the case. To start from the pictures taken in public, elders recall the days when any public appearance had to be a perfect performance of manners and aesthetics. The *bella figura* (looking nice/giving a positive impression) was a demonstration of civility expressed in clothing and interaction for men, while for women although clothing was equally important, interaction of any kind would be intentionally avoided. In both cases, there was a distinctive dress code for men and women that informed the stereotypical perception of masculinity and femininity and the way they should be displayed in public. To be able to dress tastefully and to demonstrate courtesy would be repaid in respect and courtesy, but most of all in trust since it identified a person with character, capable of taking care of him/herself and of complying with the current rules of social contact. A positive social image, based also on aesthetics, was *the* criterion of placing reliance on an individual, and thus rendering it honourable.

Pictures taken at home in the past do not differ very much aesthetically from those taken in public, for it was a big event having an image captured on film. A single person, a couple or a family had photos taken only for the most important events in their lives, since only professional photographers had access to this technology and hence pictures were costly. These were displayed at home and rarely sent to relatives, and therefore pictures were, symbolically speaking, the representation of an individual to the public. Since this was the logic behind it, Palermitans put on their best clothes and spruced themselves up to be represented in the best possible way once their pictures were displayed.

All leisure activities were concerned with the public and thus they were, and still are, a demonstration of wealth and civility. Therefore, there are patterns to be observed in dress and contact. Most of the few last *artigiani* left are located in a central area of Palermo, which is called *Champagneria*, and a few others on the *Corso Vittorio Emanuele* close to the Cathedral. They themselves have become important images for tourists as are their products, both representing stereotypes of Palermitan life. Male puppets are made wearing dark three-piece suits and various hats mainly of vintage or the *coppola*<sup>17</sup> type and the female ones long dresses that almost reach the ground, sometimes holding baskets full of oranges; both sexes are represented in work or leisure clothes.

Historically, dress has been an important aspect of Palermitan life and this has a geographical expression. The two streets, the *Corso Vittorio Emanuele* and the *Via Maqueda* that define the city centre, have had tailors since the unification of Italy. Many shops and products are dated 1860; it is impossible to crosscheck the validity of this information but its frequency denotes that it is rather used symbolically. Tradition in this case has won out over modernity in that Palermitans prefer the old tailors to mass-produced clothes when they want to buy quality. Even the shop owners of the *Via della Libertà*, the central avenue of the new part of Palermo that hosts the best modern shops and brands, know that they cannot match the bespoke tailors of the *Corso Vittorio Emanuele*. Although the *Via Maqueda* has been declining for the last ten years because most shops ‘have been sold to coloured foreigners’, the *Via Maqueda* is still noteworthy and habitually visited by Palermitans.

Dress becomes an indicator of change between generations in terms of aesthetics, quality and sex roles. Young Palermitans follow American trends and buy expensive

---

<sup>17</sup> The *coppola* is a flat cap that has become a symbol of Sicilian heritage at least in Italy.

casual products. Others, twenty to forty years old, who constitute a category that mediates between the youth and the elders, are casually dressed at leisure and formally when at work. They prefer expensive brand names and, from time to time, they mix casual and formal clothes, i.e. when I was doing my fieldwork the trend was for wearing suits with trainers. Men over forty wear three-piece suits on all special occasions and women prefer expensive gowns. The most progressive part of Palermitan society, the youth, is considered by the other two groups to be feminised, since boys and girls do not differ much in terms of clothing. Young boys do not consider depilation feminine and do not hesitate to reveal their underwear in public, wearing their trousers 'low'. Elders accuse all others of lacking honour even if the latter are modest; 'clothes do not make the person' many argue, connoting disapproval. This disapproval relies on the character of younger Palermitans who may make enough money to be able to afford attractive brand clothes but they are 'empty inside'; in other words, they lack honour.

The cases in which homogeneity is achieved among all, has to do with coexistence in public for religious purposes. That religious feasts dictate homogeneity for Christians is probably the only thing that unites Italians. Palermitans believe in presenting themselves when celebrating a saint or God and therefore dressing represents their purity, and, last but not least, because these feasts are a good opportunity for gossiping. Therefore, sartorial homogeneity works as a means of becoming part of the group, which is the aim of the feast, instead of any incongruity that triggers gossip and results in exclusion. In all cases of incongruity I witnessed, the attention was shifted from the saint to the so-called *disonorato/a*: comments were spoken loudly, and eventually harsh words were exchanged.

Aesthetics at present promote an age-based uniformity that is also achieved through publicity stunts apart from the cultural reasons mentioned above. Dress does not any more reflect on class differences, but by contrast has become *the* means of putting them aside. All social classes in Palermo claim to hold equal honour within the capitalist system, where differences are expressed in terms of consumption. Therefore, since Palermitans go for known brands without regard to their economic status, they in fact manipulate this wealth indicator to their advantage. Clothes and accessories allow interaction between social classes, and sustain one of the main Italian industries that this way has managed to increase its buying public. Today, the criterion for interaction has shifted from class to age because the effects of the mass media are so ubiquitous massive that they have managed to promote uniformity in these terms.

Palermitans are obsessed with effect and every appearance in public, even for a second, requires long preparation. Their dress code is not only ‘a matter of style’, as the mass media advertise, but also an exhibition of the self in a specific socio-cultural context. What is promoted on a national scale infiltrates down to the local level facilitating change. This change is evident between different age groups and in descriptions of past Palermitan life that elders give. Honour still depends on appearance but has been affected by capitalism in the sense that it has levelled in terms of honour all working Palermitans.

### *5.5 Changes in the Last Decades*

The biggest change as far as honour is concerned in Palermo lies in the economic realm. There are two parameters that have been completely altered over time, namely female occupation and familial economic prosperity. Palermitans consider women to

have always been part of the production system; however, their work outside the home was considered secondary and complementary to that of males. Now in Palermo both sexes are perceived to have an equal role in the production system and an equal contribution to the family's economy. Moreover, as in the past Palermitan society was egalitarian for the masses, the neighbourhood united in helping individuals in need. On the contrary, now Palermitan society is anything but egalitarian and as a result any economic crisis that cannot be overcome by the family itself affects its honour to the core.

If in the past the larger the family the more honourable it was, today the end of the nuclear family cycle comes with the creation of another nuclear family by one of its members. Children are expected to be able to leave their home at a certain age, and often they plan this along with their parents. The criteria for such an action are economic and the underlying reason is autonomy. In the past, the most common reason of creating a new household was marriage. It is documented that even in this case the parents' would cooperate with the children's household after marriage, the usual problem being the relationship between mother-in-law and daughter-in-law where control was practised directly. This interfered with the new household's autonomy that was supposedly achieved only through marriage, and this situation can therefore be defined as a cultural contradiction. Another form of control was the daily interaction of the groom with his parents due to the occupational pattern, which was that the son would follow the profession of his father; this also informed inheritance patterns, which was another means of control.

To clarify the above, autonomy was the carrot of cultural internalisation or in other words the promised prize for confirming cultural patterns. However, due to lack of old age pension funds, control over the newly established families was important for

it also assured the protection of the elder by the younger. Therefore, marriages were usually arranged between members of families inhabiting the same neighbourhood. Even in our time, there are neighbourhoods in Palermo inhabited by two or three extended families whose members practise the same profession. This can be mostly observed in poor areas of the city and it must be mentioned that the dominating pattern now is that of nuclear families.

The case of E and S is illuminating: E and S were living on the same street in the historic centre and S fell in love with E at the age of fifteen. S's family were all carpenters and each adult male of the family ran his own store in the same neighbourhood. At the end of the day, all sons returned their earnings to their mother who would be the accountant for the whole family. The father would do business with other men always keeping an eye on his sons; he was the manager. S was also working for the family helping one of his older brothers until adulthood, when he was promised he would have his own store funded by the family. But E had no brothers and therefore her marriage to S was not favoured by his family as it would not lead to the formation of a beneficial alliance. S kept working for his family and once he was given his own store he got married to E. His parents never accepted E in their home although she did her best to prove to them she was a good wife. S kept going to his family's Sunday dinners alone for a few years until he decided that his family was now his wife and children. He started accusing his parents of exploitation. He showed me the massive building they own in the area and informed me about the huge fortune they amassed on their children's labour. When S's store collapsed in the earthquake of 1999, his parents did not care at all even if S was financially destroyed.

S prizes his wife for recovering from this setback; it was E who managed to get the business running again. S was unable to face this challenge due to psychological reasons which were socially based; the word neighbours attached to his name during that period was '*disgraziato*', literally disgraced. However, both insisted on their children's education despite their financial difficulties. Having gone through that experience, they insist on helping their children become autonomous one day. They are already discussing with them possible future scenarios, as far as occupational opportunities are concerned. Their three children are free to create their own homes if their financial condition permits, and there is no interference at all regarding the choice of partners. Two out of the three children are in healthy relationships that may lead to marriage with a male and a female who are not of the same neighbourhood.

The reason I have expanded on this case is to show how Palermitan society has changed over the last twenty years; this is just one of many cases in which one can observe changes in the perception of what is considered to be honourable. To sum up, marriage was not a personal but a familial issue for it was linked to honour. Partners were picked from the same neighbourhood to secure the fulfilment of the criteria of honour and beneficial alliance between the two families. Households had to cooperate in order to protect the honour of the extended family if we bear in mind that there was a lack of social provision and that honour was vital for gentlemen's agreement in business. Therefore, if one of its members lost their honour s/he would be excluded from the family for the protection of all the rest. Changes in economic conditions favoured the persistence of the nuclear family. However, this rendered its members more vulnerable to economic changes and to claims against its members' honour. The most vulnerable to setbacks were men because they were the ones to feel mainly social pressure. The trend nowadays indicates that the answer comes from the women who re-establish their role in Palermitan society on a more dynamic

base as far as the public sphere is concerned. Currently, the main concern of Palermitans is economic prosperity, for wealth makes the person. The selection of partner can be partially linked to this concern, but the best capital nowadays is knowledge and that cannot limit choice by geographic limitations. Honourable is the one who has the wealth to protect his/her honour.

### *5.6 Living an Honourable Life*

In this part, I give examples that reflect the changes in the endowment of honour through time. Maybe honour had the same meaning for the two Sicilian social classes of the past, the landless peasants and the landlords. Even today, not only the elite, but Palermitans of every social class agree that manual labour and especially the cultivation of land do not add honour to individuals. In general, there is a perception that the more one takes pains to earn a living the less honourable he/she is. Therefore, the ideal is that one does not work, but has enough money to live a decent life. Palermitans whose labour is manual (*persone di fatica*) often complain about fatigue. To a stranger this may vindicate northern Italians' view of the southerners as laid back or lazy. However, in affluent Palermitan society, people are not trying to *fuggire le fatiche* (avoid work) but they believe that it is a pity to *buttar via la fatica* (work to no effect):

- How is it going Michelle [a 28-year-old waiter]?
- Well, you know...I am tired...going in and out all day long, from 25 [Celsius] degrees to 35, carrying this heavy tray...what a life! I have to find something else to do, something more tranquil.
- Like what?

- I have a couple of friends here and there. I can ask if they need somebody, and it is going to be office hours!
- Nevertheless, here you earn more than a civil servant does and, I think, more than you would make working for a travel agency for example.
- Sure, but what is my future here? After all, I do not think that they pay me well here. For the work I do, my salary should be at least 30% more.
- Well, in this case...
- I am at the right age to get out of here. Working in an office makes you important; it is not like in this job that you have to deal with all odd mannerism [in fact, he said referring to his clients: *con tutti kesti –questi-coglioni*] and so on. Clients pay me no respect and my boss exploits me. Instead, when they see you tranquil, wearing your suit and coming out of your air-conditioned office to drink your espresso, they treat you as if you were a king!

Alternatively, in Maria's case (40-year-old owner of a travel agency):

- At the beginning, I used to work for the *GdS* [*Giornale di Sicilia*, local Press].
- What did you do there?
- Manual work...anything...mostly carrying around things...
- And then?
- Then I saw this vacation package, an advertisement in the newspaper...and it just happened...
- Were you sure that you were going to succeed in this?

- No, but I did not care! Better start anew than working for nothing. Now, everybody respects me, even those who were mocking me before.

Pierino (55-year old merchant):

‘When I was young, I would do any kind of job to earn some money. Things were different in those times; we were all struggling to earn a living. Your dignity depended only on your good manners and your eagerness to work in order to pay the bills and feed your family. We used to help one another a lot. Then Palermo became cosmopolitan. Money meant power and power meant honour. People started showing off, wearing expensive clothes and consuming luxury goods. I used to admire these people and they used to look down on us. You thought they never worked while we looked like beggars. At a certain point I wanted to get married to the woman I loved. I went to her parents...nice and clean. They said no! There was a lawyer, who also wanted her, but she wanted me. I knew what to do from the first minute they rejected my offer. I invested all my money in my current job. I bought a nice car, clothes, etc. Thank God, it all went well. To be honest with you, I never felt different...money does not make the person, but this is probably only me.’

The examples I provide above reflect current Palermitan ideals that differ from those of the past. For example, the last case shows that although in the past the honour of the lower classes depended on their ability to sustain their family, nowadays even more important than that is the way one strives to sustain his/her family. Moreover, today a woman can also play the role of the breadwinner. A woman’s honour, and thus of the family she is a member of, does not depend on her sexuality but instead it is currently defined in educational and economic terms. Especially for the middle class, education is the main criterion of a person’s ‘value’. Education is not only a

means of upward social mobility, but lately all social classes consider it a single panacea as well. The higher social classes believe honour to be inherited, and the person that inherits it to have an easier task defending it compared to the other social classes. In a sense, the honour of the higher social classes is 'in the blood'. Francesco, a 65-year-old pensioner argues: 'You see these *ragazzi* (lads) dressed in suits every day, right? Well, they think that they are someone important; they have this attitude! Even from the way they walk, not to mention the way they talk, you can tell from afar that they fake it. They do not even know what honour is; they have no respect. We are so different! Go around the neighbourhood and ask about my family and me; we were born with honour. When everybody else was going to America to earn a living and feed his starving family, I went there to study finance. I came back recently to find out that nothing, and at the same time everything, has changed. Nothing, because the poor are still poor and the rich are still rich. The state is still corrupt and the Mafia controls everything. Everything, because people do not respect anymore, they all pretend to be equal, and especially the youth that has been 'Americanised'. Still, the elders know what honour is and who deserves to possess it.' Francesco notes a profound difference between his and the younger generations that signifies change. The fact that he lived away for a long time allows him to understand the fluidity of the Palermitan society, but his noble descent makes it difficult for him to accept such changes. In any case, the above examples reflect fluidity in the way Palermitans bestow honour on other members of their society.

#### *5.7 A 'Personal' Perception of Honour*

Should there be a meritocracy, probably honour will not be such an important aspect of Palermitan life. Clark (1984), discussing the issue of land reform in the 1950s,

argues that the relation between the state and the higher social classes has not changed at all in the course of time. In fact, the new liberal state protected the propertied classes (Schneider 1996: 97), 'just as the old state had been the slave of the feudal aristocracy' (Clark 1984: 17-18, quoted in Schneider 1996: 97). Schneider (1996: 97) explains how this situation was perpetuated: 'In Sicily and the south, national officials such as the prefects, whose jobs depended upon appointment by cabinet ministers, turned a blind eye to so-called *grande elettori* – civil notables who in each rural town controlled enough votes to sway the ministers' elections.' In addition, according to Meissner (1954: 39), 'The blame for the unsatisfactory state of affairs in the Italian South can, to a great extent, be put upon the indifference and often hostility of the dominant class of landowners toward the welfare of the agricultural masses. Despite nominal attempts at agrarian reform, the old order of landownership remained substantially unchanged.' (see also Mack Smith 1968). Similarly, Silverman (1971: 66) stresses that 'An agricultural area created by the Italian land-reform program of the 1950's was the site of a study designed to test the hypothesis that agricultural organization has priority over "morality" in determining southern Italian political behaviour. It was found that the reform program had effected significant changes in agricultural structure, but that the social and ideological changes anticipated had not occurred: there has not developed a new cultural "tradition"-a way of life with continuity in time.' Schneider (1996: 106) argues that the *civile* elites managed to take control of the resources through political power, 'wielding enormous power in the domains of taxation, education, municipal employment, policing, public works, and the governance of local charities', while 'poverty spelled powerlessness and humiliation.' From the end of the nineteenth century local hierarchies were challenged by 'returned migrants with savings' (most coming back from North America) (Schneider 1996: 116). Gilmore (1982: 185)

argues that the distribution of resources determines individual choice. Thus, it was only after World War II, when the Italian capitalist economy boomed and resources were redistributed, that honour became a right (see Stewart 1994) for all Palermitans. Previous accounts (for example, Bell 1979, White 1980) show that the role of the elites remained crucial in Italian society and also in Sicily (Schneider 1996). Nowadays, honour legitimises relationships of unequal power in Palermitan society. Palermitans consider such relationships to be the only means of advancement since there is no meritocracy, although things change. In order to cope with the contradiction between desirable individual autonomy and dependence on others (Loizos 1975, Brandes 1980), Palermitans emphasise the *moral* aspects of honour (Gilmore 1982: 191), and elevate themselves with positive estimations of the self above the powerful.

In terms of honour, there can be a difference between the evaluation of a Palermitan by his/her fellow citizens and the evaluation of the self. I suggest that this difference highlights the importance of honour in Palermitan society, instead of blurring it. In fact, nowadays class struggle allows social mobility (see Bourdieu), and does lessen tension that could result in revolt<sup>18</sup>. I have argued that Palermitans believe it to be easier for the higher social classes to defend their honour. The reasons that justify such a perception have not changed over time. It is not that the rich do better in defending their honour personally, but that they know people in key positions of whom they can make use. As in the past, ‘landlords were favoured by the authorities, while the illiterate peasants needed mediators to communicate with the administration and thus they were twice weaker compared to the landlords’, similarly today, the rich can ‘be free even if they have killed somebody, while the impotent end in prison for not being able to pay their taxes.’ (These are the exact words, which

---

<sup>18</sup> For examples of civil wars in the Mediterranean see Gilmore (1980), and White (1980).

a Palermitan historian used to explain to me). ‘Money can buy everything, even honour, if you ever care about it’, a rich sixty-eight-year-old man once told me, and added that ‘honour is something only those who do not have money and power care about.’ Indicatively, Palermitans of all social classes agree that Berlusconi, the Italian prime minister, is not an honourable person, nevertheless, he is someone to be admired for the way he manipulates the ‘system’ and to be feared because of his ability to use this system to destroy anyone who does not respect him or puts obstacles in his way. However, honour is also an evaluation of the self, in the sense that a rich man may use culturally inappropriate methods to make a profit but still think of himself as an honourable person unlike the view from the poor. In the same way, a poor person thinks of himself/herself as an honourable person because he/she struggles to make a living with culturally legitimate methods, unlike the example of the rich given above, and so on. Although diversely essentialised, honour instead of leading to conflict helps Palermitans cope peacefully with the contradictions of their society as they are expressed in the interaction between Palermitans of different power and mentality.

The evaluation of the self depends on the criteria deriving from the sphere that dictates a person’s life. A *carabiniere* (police officer) has the exact opposite view of a Mafioso on what honour is and thus on who is an honourable person. According to Palermitan tales, any relationship between a Mafia family and officials of the law was unacceptable in the past. There is a famous story of a young Palermitan who was forced out of his father’s *cosca*<sup>19</sup> once he married a woman whose third cousin was a traffic warden. Although the father was convinced that the woman was secretive about her husband’s activities, he could not accept any relationship with the ‘sordid cops’. On the contrary, all the *carabinieri* I have discussed this with claim to live the

---

<sup>19</sup> The actual meaning of the word *cosca* is ‘cell’, but it translates better in English as ‘clan’ as it refers to the organisation of the Mafiosi in ‘tight’ groups.

most honourable life; indicatively: ‘we cannot enjoy our lives because we are role models...we have to be always perfect. If a Palermitan sees you dropping a small piece of paper on the street this will have negative effects on the perception of the police. The same if you are not clean, or if you are not polite, or if you are not stern, etc. A police officer personifies the honourable man. We fight against the Mafia and all other illegal activities, and although we are always in this environment, we stay ‘clean’ and we try to improve our fellow citizens’ lives. We are the most honourable because we obey the law, while others take lives in an attempt to apply their ‘law’ that has for long devastated our city, and they are ironically self-defined as men of honour.’ Similarly, a cleric or a religious individual has a different perception of honour, and so on.



Police officers patrolling.

A positive evaluation of the self comes to counterbalance the contradictions deriving from not only different perceptions of honour among Palermitans, but also, from contradictions deriving from the sphere that dictates a single person’s life. When a police officer and a cleric discuss the Mafiosi, the former stresses that these people must be arrested and imprisoned for life, while the latter argues that imprisonment

will not make them regret their actions unless God helps them change. Both however, have experienced cases in which the office they represent has let them down by protecting the Mafiosi. Still, both claim that they are honourable individuals just because they are doing their duty and that their person should not be judged by what they represent. This distinction does exist in Palermitan society. However, even more important is the fact that an individual can distance himself/herself from what he/she represents to Palermitan society and compare the 'self' with the 'other' in terms of honour.

The fact that there are contradictions of the above kind reveals that there is social interaction among unequal individuals, their inequality defined by their power. A person's power in Palermitan society depends on what he/she represents, and therefore, conflicting ideas and ideals spring from diverse interests. However, Palermitans do form patron/client relationships in order to gain access to resources controlled by others. In these relationships, both parts are equally important in the achievement of their common goal, because this procedure requires the coordination of diverse resources to which the different sides have access. Thus, social differences are expected by both sides to be silenced for the sake of their common aim, and this happens through honour. In fact, although honour legitimises relationships of unequal power, inequality is not erased and, thus the superiority in terms of honour claimed by the weak after a personal evaluation of the self comes to ease contradictions that may arise in patron/client relationships and may shake their foundations.

Schneider (1996) stresses that local Sicilian elites shape perceptions of civility, which filter down to the other social classes. The bipolarisation of Palermitan society reflects the success of Sicilian elites in cooperating in order to maintain their power,

while depriving the rest of class-consciousness. Change came to Palermo because of migration; the landless that left their homeland in search of a better future returned when their money was important to the local economy (ibid.). This gave them access to resources and the right to assert honour. Individual choice however depended on the idea of civility that the local elites had shaped. As a result, the local elites managed to maintain social stability, but were the only ones that represented Sicilians at the national level, putting obstacles in the way of national integration (Lockwood 1975 discusses a similar situation). In fact, the local sense of honour reveals a regional identity that becomes more specific at the local level as I show in the following part. However, economic growth allows Palermitans to redefine honour in order to fit it in with current socio-economic conditions.

### *5.8 Some 'Grey Areas'*

Probably only the educated middle class is aware of the origin of expressions used in Palermitan daily life. There were many times when I addressed professors at the University of Palermo or teachers in order to be illuminated on such issues. The lower classes usually attempt to give an answer by drawing from the 'data base' of dialect that is not always adequate to answer complex issues. However, the elite consider these expressions to be of 'simple' folk and, therefore, they claim ignorance in an attempt to diversify themselves from the lower classes. It is a fact that with the exemption of the youth, the lower classes are coarser, especially in market settings, but the situation changes to the opposite at home. In private life all classes use the same expressions and all Palermitans agree on the fact that vulgar expressions always flavour verbal interaction along with the characteristic unceasing gestures. It applies to all Palermitan families that children must not listen to these vulgarities.

It is interesting that even the dialect *Palermitano*, which all Palermitans speak although it is considered to be characteristic of the lower classes, allows courtesy and at the same time is rich in vulgar expressions. In fact, the dialect does not differ in this way from the Standard Italian (*Italiano Standard*). This makes clear that unequal power relations are as old as the dialect is, which precedes standard Italian by centuries. Elders recall the days where courtesy was of vital importance in the interaction between people of different status and the use of the *Forma di Cortesia* between 'equals' was an expression of politeness. Even more interesting is that vulgar expressions are usually pronounced with the dialect's accent, which is to further dishonour the one addressed with an insinuation of class inferiority. The Italian language and the Palermitan dialect are both contrasting in their use as on the one hand the use of the *Forma di Cortesia* is still socially necessary in discourse, and on the other they both provide a multitude and plethora of choices from numerous offensive expressions.

I have chosen first the pair of '*uomo coi coglioni grossi*'-'*coglione*' to demonstrate the contrast mentioned above, as well as to show how expressions mirror changes in Palermitan life and ethos. A 'man with big balls' reflects a close link to nature as it connotes virility as it is probably witnessed in animals. Nowadays, this phrase has a fixed meaning for Palermitans, most of which cannot tell its origin. A man of this kind is one who has no fear, one who dares to do anything it takes to protect his social image. The change over time is the structure of power a man objects to in order to protect his social image, and what social image depends on; in the past, a man of this kind would turn against the landlords, but nowadays he has to fight those who have been established in the political arena. If in the past this was to improve his and his family's living conditions and protect their honour, nowadays this is to struggle for the whole Palermitan society that sympathises with him because he turns

against the mercenary motives of the powerful who attempt to destroy his life. Moreover, a woman 'with big balls' has only recently been adapted as an expression, and this is since women managed to be financially independent and therefore needed less male protection. Now, one is said to have big balls when he/she is fighting against the establishment.

On the opposite side, one is characterised as a 'testicle' and this is not seen as a sign of virility. It is not that one is driven by incredible vehemence due to virility, but rather that he lacks something since the word is singular. As Palermo has always been a rough city, and especially as aesthetics play a very important role in all Italian society, to have any deficiency is intimidating. This characterisation questions the very manliness of a person and since it is such an insult, it is voiced usually behind the back of the other. It is more likely that this word is used to relieve the one who voices it from the stress that springs from the unfortunate interaction in which there is no mutual respect. In this case, there is one who is called names and one who is calling names; the former is believed to have questioned the honour of the latter, and therefore the honour of the former has to be reduced to the point that this 'wrong' estimation has the less possible effect on the latter. In the past, this could result in a savage quarrel and eventually death. This change can be seen as the result of state expansion and the enforcement of laws against violence (see Tak 1990, pp. 90-100).

In the same way, Palermitans are not conscious of the ram-billygoat division and since when the word *cornuto* (horn) has been used to describe a cuckold. The exact pronunciation of this word is *cu(i)nutu* and its female corresponding is *putana* (prostitute) in Italian or *buttana* in dialect. I still recall that this was the first word my friends asked me never to employ, for I was informed Palermitans could even at present kill for this. Italian men were up until recently -5<sup>th</sup> August 1985- protected by

the law of '*delitto d' onore*' (crime of honour) if they killed a female of their family to defend their reputation, which resulted in just three to seven years of imprisonment. This change should not only be attributed to a law but also to changes in the market. In the past, one was a *cuinutu* if he could not sustain his family and therefore his wife had to work. The very fact that she was not 'kept' at home meant that the husband could not control her sexuality. The custody of women is no longer in men's hands in many cases so that a *cuinutu* is not anymore the one whose wife works, but one who cannot sexually satisfy his wife. As cheating on a man does not take place in the home nowadays and it is usually linked to economic reasons in reality, it is no longer related to honour in the strict sense and therefore this issue is not solved with bloodshed.

In addition, one would use the word *buttana* or *figghiu di buttana* (*figlio di putana*, or son of a bitch) only to intimidate the other in public if the latter shows no respect to laws and/or values. The rhythm of Palermitan life and anonymity do not allow taking this kind of offenses personally, but rather to accept them as the payback for unanticipated behaviour. This is when one breaks the law or the conventions of Palermitan society. In the same way, a female can be characterised *buttana* if she associates with many men even if they are friends. Ceremonialism is so important in Palermo that contrasts with the modern way of living but still survives. Males will not accept any offence against the female members of their family, especially when it comes from the neighbourhood. Therefore, there are other mechanisms to overcome these issues, such as the employment of other female family members as chaperones. Protection is the characteristic of current Palermitan society that is caught between past and present thanks to the contradictions between old values and modern needs. Hypocritical behaviour comes to reconcile parties in a dispute and to allow families to live a peaceful life. I have witnessed many cases in which parents

started a fight with their daughters because they would return home escorted by a man. The issue was ‘what will people say’ meaning the neighbours, and not the fact that the girl would come back home with somebody she is not engaged to. The girls were advised to come back home with a female friend of theirs and not to go out with males. Accordingly, one would be called ‘*figghiu di buttana*’ not because his mother is a ‘whore’, but because he would not respect the society in the above terms. In this way, Palermitans substitute the phrase ‘shame on you’ that is only employed for children in order to pressure them to conform to the rules according to the occasion. I continue with some other contradictions.

#### *5.9 Bastardi and ignoranti vs belli and furbi*

If Mediterranean cultures can only see black and white, this is probably because we ourselves cannot note the grey areas. We have to make clear that there is no definition of honour in any society, and what is shameful alters over time. This fluidity has to do with socio-economic factors that shape interaction, and interaction requires honour to be elastic enough, for the aim is to facilitate contact. After all, we are discussing a set of values that can be diversely perceived and manifested by individuals. I do claim that even the most *disonorata* act, such as for example assassination can be legitimised under certain conditions. Therefore, a truth about Palermitan culture should be sought in these grey areas. The way these cultural contradictions are resolved is by negotiation –also the Sicilian mass media operate this way with the exchange of interpretations until a common agreement is arrived at- and the course of it depends on the values and priorities of socio-economic conditions. In other words, this is how honour and shame evolve. Culture allows Palermitans a psychological balance through contrasting evaluations of the self and

the other that also reflect unequal power relations. Honour in all cases is in its purest form only in the hands of the one who compares himself/herself with the other, as if the other is blamed for having jeopardised the essence of honour and is therefore accused of a breach of contract. Nevertheless, honourable individuals can be bastards and ignorant as long as they are also beautiful and clever at the same time.

It was mostly during my second visit in Palermo that I interacted with Palermitans who dared define themselves as bastards. I was shocked because I tried to reverse the situation but they insisted that I have to accept it because 'this is the truth'. To define yourself as ignorant is not bad especially if you think that ancient Greek philosophy was also developed in Sicily. Palermitans often claim 'siamo ignoranti' or 'we are ignorant' to make you understand why their society does not develop. It is better to claim ignorance rather than give an answer that is incorrect, especially to an anthropologist who knows about Sicily. Specialisation is a thing Palermitans are aware of nowadays and this is transferred from the market to culture. However, how can 'bastards' be accepted? I was sure there was going to be a 'but' somewhere and it was there I tried to find the answer; there should be something to counterbalance these characterisations.

These offensive epithets united all Palermitans, if not Sicilians, in their common course of history. To be aware of your history made you more progressive, that is conscious of the defects of your culture that you wanted to alter. Every time I got in a discussion with a Palermitan, they would complain that their society has to change, and when I set the question, 'What are you doing about this,' I always got the same answer 'The other has to change, not me.' Therefore, in reality Palermitans were contrasting themselves to their backward fellow citizens. Eventually, the discussion would turn to politicians and others who control the society through wealth and/or

fear. So, backward fellow citizens were blamed for reproducing relations of unequal power. This meant that Palermitans were not ignorant because they wanted to be, but because some others deprived them of the means that would render them antagonistic to the “other’s” aims. This is another common bond between all Sicilians.

The ‘siamo bastardi’ declarations had two connotations linked to blood and culture, which legitimised the two following statements. They were ‘but we are the most beautiful and cleverest.’ Garibaldi’s ‘pure Italians’ claim not to be pure at all and that miscegenation has had the best outcome ever. The inhabitants of the largest island in the Mediterranean consider themselves the centre of ‘the centre of the world’. Their perception of the world has Sicily, the only island with ‘its own sun’ as many say, accumulating only the best from all others around it. Racially speaking, Palermitans consider themselves the most physically beautiful people on earth due to the mixing that took place on the island. Moreover, they believe to have turned into Sicilians all those who have come to the island in the past. The same applies to Palermitan culture that has managed to adopt the best cultural traits of others. All this interaction has helped Sicilians become ‘clever’ and since they have managed to survive both racially and culturally, they are the cleverest of all.

Sicilians, as any other group, cannot choose their history; therefore, they have to find ways to manipulate it in order to balance perceptions of Sicilian society. Cole (1997) shows how important it is for the poor not to feel at the bottom of the social hierarchy and the way immigrants are forced to take this place. Palermitans argue that their city is one of the richest in the world in historical buildings, and another thing they are proud of is their cuisine. They have turned both into tourist attractions under the auspices of the state. The municipality of Palermo has taken initiatives to

inform Palermitans about all places with historical and tourist value in the city, under slogans such as ‘Get to know your city’ or ‘Palermo, open city’ during my fieldwork. There were also feasts that promoted Palermitan cuisine. Palermitans enjoy their diversity and their capacity for incorporating characteristics of the ‘other’ in their lives, as they believe polyphony to be indicative of both their openness and of democracy.

Peoples’ openness contrasts with the Italian political world that is seen as a closed circuit of the powerful that controls all resources and exploits the powerless. Even if politics has played a major role in the backwardness of the Sicilian economy, the fact that Palermitans despise politicians, but at the same time the former expect the latter to take them by the hand reflects a fear of depreciation. Palermitans do use social webs to advance, as resources are limited and concentrated in a few hands. This pattern survives from the past and in reality reproduces hierarchy. So, values such as *omerta*’ (silence) and *amicizia* (friendship), which supposedly along with cleverness constitute the core of Sicilian honour (Falcone, Borsellino), in fact protect those with power against all others who have no access to resources. These bonds are difficult to brake because the one who turns to the powerful feels indebted, and the first payback is to respect the core values. However, since Palermitans consciously enter this bond to advance, cleverness plays a major role in the manipulation of power that is legitimised by the unequal access to resources.

From this perspective, honour along with shame regulates interaction and balances inequality by reinforcing it. The pyramids of power maintain the same structure but the difference is that, due to economic and political conditions, Palermitans nowadays openly question bureaucracy and the distribution of wealth. Palermitans are bastards and ignorant because those in control want them to be so, but people are

now aware of it and have defined as a core value the manipulation of unequal power relations. This perception legitimises every act against the state, mainly in the form of tax evasion, since on one hand this is the only way to make money; and on the other, it is the best way to weaken the exploiters. The state is personified in the local or national politician, the judge, the police officer and so on. In fact, Palermitans question the core of state administration which they perceive to be their enemy and which must be fooled and can be fooled with cleverness.

M, a forty-five year old Palermitan cabinet-maker maintains his small store in the centre without municipal fiat. He witnessed his fortune being destroyed in the 1999 earthquake, then he started anew and is now struggling to prosper again. All his family, his wife and three children give him a hand without pay. However, his income is just enough to cover the basic needs of the family. M complains that he never got the municipal funding that he was promised and he merits because those in power managed somehow to appropriate it. When he started asking why he was not funded as expected, he was told that when the provost visited his store he found nobody there. The point is that there is always somebody in the store and that the family residence is just ten metres away. M adds that the police officer managed to find them during the same period and hand them all the documents needed for local and regional elections. Since then, when the family is asked to show the municipal fiat, what they reply is: 'Stay here with us and at the end of the day we share what we will manage to earn today. If you think you can live with this amount then I will pay the fine.' In fact, this is very rare because most of the time control is in dispute, the family is informed and evacuates the store. M, who is an honourable man, as all in the neighbourhood argue, enjoys fooling the authorities and all the neighbours applaud.

Tax evasion is a common practice in Italy, but especially in Sicily where it has links to local and ethnic identity; due to Sicilian history, Palermitans equate taxation with exploitation and claim that their money either empowers corrupt politicians or is invested in the North. A, a thirty-three-year-old hotel receptionist employs his cleverness to avoid two northerners from Bologna, one of which asks A to help him cut his broken nail. All of a sudden, he turns to me and says, 'I am going right now before the water heater explodes!' On our way, A recovers his natural demeanour and says to me, 'I am a man with honour and I will not accept their insults. It is due to us southerners these people have advanced and they come here to show off. Don't you worry though, we are clever enough to handle them!' We then started discussing this issue, and for the sake of argument, I will just put forward here the importance of tax evasion as *the* means of resistance to northern exploitation. To end this discussion here, I will stress that A believes, as most Palermitans do, that a fellow Sicilian would never question his honour no matter his/her status. This statement does show how important respect is in Sicilian society, but mostly that honour is basic to interaction for it allows predictability. The predictable part in the above example would be that people of different status would interact harmoniously being equated in terms of honour, while both would recognise the other's different status. Thus, A would be of help if there were no claims on his honour.

Therefore, honour and the so-called 'core' Sicilian values are initial traits of Palermitan identity in their essentialised form. It is the Palermitans' belief that their fellow citizens also believe in these values and this mindset outlines interaction. On the one hand, this belief is confirmed on a local and regional level (meaning Sicily here) and therefore is a matter of identity even if it reproduces inequality, since it is a way of consciously interacting with people of a different status peacefully. On the other, interaction with Italians from other regions confirms the Sicilianess of these

values, a fact that also shapes identity. Endless examples I came across in my data prove that non-Sicilians are aware of the importance of honour in Sicilian society but, since they consider themselves more developed, they use this concept against ‘backward’ Palermitans to satisfy their superiority complex. Nevertheless, Palermitans have moved from the donkey to Fiat and from Fiat to Ferrari. Development allows Palermitans to have the same dreams as northern Italians, and the steps that have been taken to alter Palermitan society can be witnessed in the perception of honour.

This chapter has illuminated with examples drawn from Palermo different aspects of honour. Starting from the discussion of the local expressions which are related to honour, I have shown how these expressions are used in daily life in order to demonstrate how this value system regulates Palermitan life. On the one hand, there has been a discussion of honour in relation to various parameters, i.e. sex, age, status, etc., that shape the perception of the value system of honour, and which leads to culturally driven action. On the other, the personal perceptions and practices that were unfolded above showed that honour is also shaped by individuals according to the needs of their environment. In addition, the analysis of what I have described as ‘grey areas’ revealed the elasticity and the fluidity of honour, as well as the crucial role that the economy and power relations play in its elaboration. The interrelated issues of honour, economy, stereotypes and change, will be discussed in relation to family in the following chapter.

## **Chapter 6 THE FAMILY**

### *6.1 Introduction*

The two previous chapters focus on the issue of honour, which is in itself, an extremely complex concept, which must be discussed and understood in any attempt to analyze Mediterranean societies. Its discussion from a different perspective has brought to the fore the centrality of patron-client relationships in the Palermitan social realm. The manifestation of honour is plainly evident in both economic and political spheres, which links with the unequal access of scarce resources. In conclusion, it is argued that honour is the ‘guarantee’ in patron-client relationships which legitimise inequality. Patron-client relationships based on honour not only affect individuals but groups as well. Thus, it is important to discuss the Palermitan family in relation to the two spheres mentioned above in conjunction with the changes it has been subjected to over time, as well as those changes it has effected over time.

From my point of view, the so-called ‘amoral familism’, or in other words the fundamental significance of the family in Mediterranean societies, should be perceived as the value shared among the collective members of any particular family unit. Numerous accounts discuss the relationship between family, society, economy and political life from various perspectives. I will critically evaluate them in order to discuss the role of the family in the interaction of various institutions. More specifically, I will focus on the Palermitan family and the fact that this institution is always the centre of interacting social networks.

Currently, the nuclear family that consists of parents and their children is the most suitable size for a stable unit in the ‘agonistic’ Palermitan society. This has not always been the pattern for the Palermitan family. Past and current conditions have

resulted in a culturally specific perception of the family in Palermitan society. As happens with other Sicilian values, i.e. *amicizia* (friendship), *omertà* (silence) and so on, there is also an ideal concept of the family. This convention allows a family-centric way of living, although in actual Palermitan life, families diverge from this ideal construct.

Blim (1990) highlights the interaction between family and economy by arguing that family enterprises constituted the backbone of the Italian economy in previous decades. However, De Rose (1992: 89) holds that ‘the percentage of women participating in the labour force as a proportion of the total female population is lower in this country (Italy) than in most countries of Western Europe (27.1 per cent compared to 48 per cent in Sweden, 46 per cent in Denmark, 36 per cent in Great Britain, and 33 per cent in France). Belmonte (1979) argues that for poor Neapolitans the relationships between kinsmen is in fact limited compared to the relationships among the members of the nuclear family unit, a pattern which is in accordance with what Cornelisen (1976: 8) stresses about the residents of Basilicata. Belmonte (1979) supports that this pattern is the outcome of the poor’s strategy to protect the little they have from their relatives. Although in relation to Belmonte’s (1979) argument one would expect that women would work in order to contribute financially to the household, women prefer to play the role of the mother and wife. Less women work in the Italian south in comparison to the rest of the country and this percentage decreases further after women give birth, as the following table shows.

## 1. Working Women

Regions	Percentage single women working (a)	Percentage working women in couple with no kids (a)	Percentage working women in couple with kinds (a)	Percentage working women in couple 3+ kids (a)	Mother kinds 2-year-old/100 (c)	Couple no kids asymmetry working (b)	Couple no kinds asymmetry home-maker (b)	Couple with kids asymmetry working (b)	Couple with kids asymmetry home-maker (b)
North-West	89,6	81,5	68,8	51,3	15,7	71,5	81,0	73,6	82,3
North-East	90,0	82,0	71,9	58,7	17,0	76,0	83,1	71,7	79,4
Centre	86,1	78,7	62,9	49,1	18,2	64,7	90,4	75,6	83,0
South	58,9	54,0	36,8	28,4	25,3	75,6	87,6	80,9	87,8
Island	71,5	56,9	40,8	34,7	21,5	77,5	79,6	75,3	85,4
<b>Italia</b>	<b>83,0</b>	<b>75,4</b>	<b>56,9</b>	<b>40,5</b>	<b>18,8</b>	<b>71,7</b>	<b>84,9</b>	<b>74,9</b>	<b>84,6</b>

(a) Fonte: "Rilevazione continua sulle forze di lavoro"- Media 2006

(b) Fonte: Indagine Multiscopo "Uso del tempo"- Anno 2202-2003, percentuale di lavoro familiare nella coppia svolta dalla donna

(c) Fonte: Indagine campionaria sulle nascite - Anno 2005

Source: Cresce la famiglia, cresce l' Italia. Conferenza Nazionale della Famiglia. Firenze: 24-26 maggio 2007. La Famiglia in Italia. Dossier Statistico: Istat & Ministero per la famiglia.

Indeed, De Rose (1992) concludes that better educated women who have full-time jobs and live in urban areas are the ‘most exposed to the risk of marital disruption’ (p. 71). She explains the Italians’ need for family stability as a response to ‘economic vicissitudes, which have a strong influence on personal decisions, concerned both with work, and with interpersonal relationships’ (1992: 90).

If the above explain the Italians’ attachment to the family, then there is probably one way to explain the fertility decline and the persistence of the nuclear family in Italy: that big and extended families could not survive into the new economic environment. Indeed, Italy’s fertility decline is seen by some Italians as ‘pathological’ (Livi-Bacci 2001: 147). However, it reflects a traumatic process of adjusting the family to the current needs of Italian society (Krause 2005). For Livi-Bacci (2001) the Italian family is shrinking because it is difficult for the parents to provide their children with the means that will render the younger generation of a certain educational and economic status. However, this has been an old practice. Schneider and Schneider (1996) argue that the fertility declined in Sicily in the nineteenth century for both class-specific economic and cultural reasons. For example, the artisans limited their fertility in the interwar period in order to be able to provide their sons with apprenticeships. In addition, da Molin and Carbone argue that the prevalent typology of family among the *artigiani* class (artisans) of the *Mezzogiorno* has been the nuclear family from as early as the eighteenth century (2009: 307-308). They also stress that this is the broader tension of the *famiglia Meridionale* in both rural and urban areas of southern Italy, almost eighty per cent of the total being nuclear families and only a fifteen per cent of the total being extended families (ibid: 310). According to the following table, the number of extended families in Sicily is smaller than the Italian average.

## 2. Family Size

Regions	1 component	Elders (65+/100 families of 1 component)	2 components	3 components	4 components	5+ componets	couples with their kids (a)	couples without kids (a)	one-parent family (a)	extended family (b)
Piemonte	29,3	49,3	30,9	23,0	13,7	3,1	34,8	24,8	8,4	3,6
Valle d'Aosta	34,5	44,2	29,7	19,1	14,4	2,4	33,4	22,2	8,0	2,1
Lombardia	27,5	50,8	28,5	23,6	16,0	4,4	39,3	22,4	8,7	3,3
Trentino-Alto Adige	28,6	44,5	27,0	20,0	17,0	7,4	40,1	20,3	8,9	3,1
<i>Bolzano - Bozen</i>	29,2	35,9	25,6	19,0	16,3	9,8	39,8	19,3	9,8	4,7
<i>Trento</i>	28,1	52,9	28,2	20,9	17,6	5,2	40,4	21,2	8,0	1,6
Veneto	23,6	51,7	28,0	22,6	19,7	6,2	42,9	22,1	7,7	6,3
Friuli-Venezia Giulia	30,9	50,4	29,5	20,8	15,9	2,9	34,4	23,9	8,4	4,4
Liguria	35,6	52,7	31,1	19,2	11,0	3,1	28,7	23,7	9,0	3,9
Emilia-Romagna	27,7	51,1	31,3	22,3	13,9	4,8	35,2	24,4	9,5	5,6
Toscana	24,3	52,4	31,4	23,7	15,4	5,2	36,6	26,1	8,4	8,3
Umbria	25,9	53,9	26,9	22,7	18,1	6,4	39,9	21,0	9,5	8,7
Marche	23,5	53,9	28,6	22,6	18,5	6,8	41,4	21,6	9,0	7,2
Lazio	30,8	42,3	24,9	19,6	19,1	5,6	38,3	18,7	8,3	5,2
Abruzzo	24,1	53,5	27,0	20,2	20,4	8,3	42,4	21,7	7,9	6,6
Molise	24,7	63,4	25,9	19,9	21,4	8,2	44,2	20,8	7,6	4,4
Campania	19,5	56,6	21,3	20,3	25,3	13,5	51,8	14,9	8,9	6,4
Puglia	20,7	59,2	25,3	22,1	23,5	8,4	48,1	19,5	8,7	3,4
Basilicata	23,0	56,4	26,0	19,9	23,8	7,4	45,9	21,4	7,2	3,5
Calabria	24,8	56,8	23,9	20,4	20,6	10,2	46,0	17,7	8,9	3,4
Sicilia	25,2	55,7	23,8	20,3	22,5	8,2	44,8	18,2	9,1	4,0
Sardegna	23,8	49,3	22,7	22,1	22,3	9,1	46,8	17,0	8,8	4,6
<b>Italia</b>	<b>26,1</b>	<b>51,5</b>	<b>27,2</b>	<b>21,8</b>	<b>18,4</b>	<b>6,5</b>	<b>40,9</b>	<b>21,1</b>	<b>8,6</b>	<b>4,9</b>

(a) comprendono anche le famiglie con membri isolati

(b) comprendono famiglie con membri isolati e con più nuclei

Fonte: Indagine Multiscopo "Aspetti della vita quotidiana" - Media 2005-2006

Source: Cresce la famiglia, cresce l' Italia. Conferenza Nazionale della Famiglia. Firenze: 24-26 maggio 2007. La Famiglia in Italia. Dossier Statistico: Istat & Ministero per la famiglia.

However, for the Palermitans, the extended family is not only part of the recent past of Palermitan life but also the prevailing image of it; this is due to the intensity of the relationships between relatives in the recent past -as Palermitans ‘recall’ it- that contrasts with the limited, if not extinct, relations of this kind in the present time. In Sicily, the extended family organization is seen as ‘anomalous’, and this is in accordance with how the Calabrese perceive this type of family as Minicuci (1984: 158) argues. Nevertheless, solidarity between families of the same parental group is not completely absent in Sicily, but the best term to describe those families is rather ‘associated’ than ‘extended’. After all, age is an important parameter in the quality of relationships between Italians; the following table reveals that an Italian feels more distant from a person of another generation than from a person of other social class, ethnicity, or sex:

### 3. Age Gap

From whom do you feel more distant?	1995	2003
From another generation	40,0	40,6
From another social class	28,7	20,7
From a foreigner	24,4	29,5
Form the other sex	6,9	9,2

*Fonte:* indagini Censis, 1995 e 2003

Source: La Famiglia Italiana nei Dati del CENSIS. Conferenza sulla Famiglia. Firenze: 24-26 maggio 2007. Censis.

Modern state policies employed to deal with Italy’s low fertility rates were ‘aimed to fortify the political terrain of a nation-state struggling to achieve and maintain modernity against a backdrop of immigration and aging. Modernity became a

weapon of the state to exert control over Italian fertility practices and of its critics to deploy orientalisng representations of backwardness' (Krause and Marchesi 2007: 350). However, since backwardness is interwoven with the generations gap in Sicily, specific views of the modern and backward in relation to the family that were crystallised in Italy had as effect the prevalence of the nuclear family over the extended type of family. Indeed, the first table bellow shows that southern Italians are not as much involved with their grandchildren, and in addition, that most of the elders do not support their children at all. On the other hand, the second table shows that southern Italian parents prefer to take care of their children themselves or to entrust other parents and/or friends with this, instead of leaving this matter to the grandparents.

#### 4. Supporting the Family

	North West	North East	Centre	South/Island	Total
Employ their time with their grandchildren	37,9	39,5	37,3	30,4	35,8
Contribute financially	10,6	10,0	4,8	10,9	9,4
Help in domestic jobs, deal with bureaucracy	11,3	16,5	24,4	19,2	17,5
They do not support at all	40,2	34,0	33,5	39,5	37,3
Total	100,0	100,0	100,0	100,0	100,0

*Fonte:* Indagine Censis – La Repubblica, 2007

Source: La Famiglia Italiana nei Dati del CENSIS. Conferenza sulla Famiglia. Firenze: 24-26 maggio 2007. Censis.

## 5. Working Women and Kids

Regions	Parents	Grandparents	Babysitter	Day Nursery (public)	Day Nursery (private)	Other relatives or friends	Total
North-west	6,5	56,9	8,7	12,9	12,1	2,8	100,0
North-east	6,4	53,1	7,2	18,6	12,6	2,1	100,0
Centre	7,3	50,5	8,8	16,7	13,6	2,9	100,0
South	9,5	49,2	12,2	5,4	17,5	6,2	100,0
Island	8,0	44,3	10,2	11,8	21,4	0,1	100,0
<b>Total</b>	<b>7,3</b>	<b>52,3</b>	<b>9,2</b>	<b>13,5</b>	<b>14,3</b>	<b>3,4</b>	<b>100,0</b>

Fonte: Istat, indagine campionaria sulle nascite – anno 2005

Source: Cresce la famiglia, cresce l' Italia. Conferenza Nazionale della Famiglia. Firenze: 24-26 Maggio 2007. La Famiglia in Italia. Dossier Statistico: Istat & Ministero per la famiglia.

Is the family a stronghold in which its members find the means to cope with change as well as rationalise life in a way that ensures continuity? For Palermitans, trust is restricted to the family unit and thus reserved for the individual members only. This is so evident that it can easily lead to the false deduction that its society lacks a civic consciousness. Based on the research conducted for this project, the data collected disproves the argument that individualism and/or the lack of civic consciousness characterize Palermitan society. Rather, the data reveals that conflicts within the family unit are the result of ongoing change in an attempt to adapt collectively to external pressures. These pressures spring from economic factors and the new values that come with it. Historic reasons have so far prohibited any other form of long-lasting collective effort.

The Palermitan family prevails over any other group based on class, status, occupation, religious belief, political affiliation or even task-groups. The ideal size for most Palermitan families consists of four members (two parents and two children), but of course the size of any family varies. Even in the past, where family units were traditionally larger than “today’s” Palermitan family, everything revolved around the family. Any kind of interaction between individuals or groups that results in the formation of social networks is to help the initiator’s family advance.

Family members have distinct roles and are fully aware of the fact that their actions will reflect on their family. The roots of this perception can be traced far back in history and relate to the production system. Changes that refer to roles in the current society lie in the separation that exists between the private and public spheres with respect to capitalism. This in turn diminishes the importance of social pressures that derive from religion and political life. Therefore, although sex roles typically were

culturally distinguishable, in current society they can easily overlap depending on the needs of the family.

Inheritance rules and specialisation are the main reasons for the deterioration of extended blood relationships. Rapid urbanisation along with migration further weakened extended family bonds. The agrarian economy of large estates that prevailed until the twentieth century in Sicily and the power of mediators were the main setbacks towards a free market. In addition, professional specialisation was until recently a family issue and can be considered a primary reason for kin tension. Not only was inheritance not enough for each member of the numerous Palermitan family of the past, but also family members' specialisation in the same profession made Palermitans antagonistic with their own kin within a market controlled by mediators.

The response to the above situation has been a declining fertility that aimed to counterbalance the scarcity of resources. Feminism and Fascism were also crucial in the process of the Italian family's transformation. In parallel, state provision worked towards the same direction, for example with pensions for the care of the elderly now being in the hands of their sons. The more the state became active in the management of resources moving towards integration, the more important a role politics played in Palermitan life. With capitalism and urbanisation, power relations and structures changed along with honour while social networks broadened. This, for Palermitans, signified a change from insecurity to mistrust. Therefore, smaller families were safer and easier to protect in an antagonistic society and fitted better into the new national models.

This chapter discusses the evolution of the anthropology of family in the UK and the USA and suggests that the economic environment is closely linked to the perception

of the value of the family. I provide a relatively detailed account of my family in order to reveal the role that my bias played in the process of understanding Palermitan family. It is made clear that this process required time and skill, for family is an important and sensitive issue in Palermitan culture. Patience was important primarily for ethical reasons; although I could proceed 'undercover' or engage in gossip to gather pieces of information, I chose to wait until my informants felt free to discuss the issue. Therefore, I believe that the quality of my data allows me fruitful insights into the Palermitan culture. The access I have patiently gained to different families in terms of age, status, number of members, and so on, helped me get the essence of the issue from the Palermitan point of view and to crosscheck my data directly. This brought to the fore a Palermitan stereotype of the family that I contrast to daily life practices and power relations within the unit. I believe the power balance among the members of the Palermitan family to be changing according to the cultural and economic context in order to secure the viability of the unit, but for dissimilar reasons in different social classes. The scenario I consider most possible for the outcome of this witnessed fluidity is that Palermitan society will practically accept the equality of men and women in the future. However, light is shed on this process in chapter four where I discuss the relationships between family and social networks in order to reveal parallel tensions in the private and public sphere.

Nevertheless, I do not believe that at least in Palermo, if not in every corner of the island, individualism prevails over civic consciousness. Instead, I believe that individualism in the political world destroys every attempt at development and legitimates 'familism'. Mistrust of the political world has resulted in disgust which distances Palermitans (as all other Italians as well) from any form of collective reaction. Palermitans manipulate social networks not out of choice but because this

is the only means of surviving in a highly antagonistic environment. I conclude that a solution to the abuse of the value of the family by the Italian and Sicilian political and religious world can come only from the European Union.

## *6.2 Literature Review*

One of the initiating debates in the anthropology of the family has been the duality of the family and the household (Bender 1967, 1971, Vicary 1967, Sanjek 1982). The family is a kinship unit linked by blood or marriage, while household is a domestic unit consisting of individuals who may not have any blood or kin connection. The centrality of biological or affinal bonds in the definition of the family was strongly challenged in the mid nineties (Carsten 1995, Weistmantel 1995, Ragone 1996). Gay and lesbian 'chosen families' that came into play further undermined any attempt at a family's definition by the initiating criteria (Weston 1991, Hayden 1995, Kirtsoglou 2004).

Although anthropological studies render families and households meaningful to their audience, there is no definition of the family *per se* (Ilcan 1996). This is because the family is always observed in a wider social context that differs from place to place. Yanagisako's (1979) influential work is an initial attempt in contextual analysis concerning the relationship between domestic arrangements, economy and culture. The importance of the issue she introduced can be traced in the numerous accounts that followed; interaction between family and the other spheres became the focus of the anthropology of the family (Casey 1989).

An earlier comparative work by Nimkoff and Middleton (1960) on extended families in both agricultural and non-agricultural societies was an effort to link the household

size to production. Pasternak and Ember suggest that ‘extended family households will come to prevail in a society when there are incompatible activity requirements that cannot be met by a mother or a father in a one-family household.’ (1976:109). What they argue seems to be a logical assumption, for only household members would accept to engage in other members’ obligations on a basis of the mutual exchange of favours and conscious availability. However, the nuclear family in the current society has to cope with the same challenge. Thus, the matter is to find the connection between economic systems, cultural values and household size.

I approach the relationship between family, economy and culture as one of interaction. The family itself depends on both economy and culture, but the same applies to an economy that depends on both culture and family and so on. Therefore, I will combine both angles, the one departing from economy (i.e. Laslett 1972, Maclachlan 1987), and the other cultural-centric (i.e. Olsen 1989, Rutz 1989) to avoid what Goody calls a ‘too deterministic view’ (1996:15). My aim is to reveal Palermitan responses to changes in the economic realm; the Palermitan family acts as a unit within the context of Palermitan culture that it finally reshapes. Perceptions of honour and the reasons for fertility decline on the island shed light on this process (Schneider and Schneider 1996).

With regard to ‘non quick-response unit<sup>20</sup>’, I agree with Creed (2000) that although ‘the family is the depended variable in relation to capitalism and the state (Harrell 1997:27), [but] cultural commitments can influence “family adaptations” in nuanced ways that are only evident when focus is on the process rather than the outcome.’(p332). The family along with the Mafia are the basic means of interaction

---

<sup>20</sup> I agree with Creed (2000) that the family is a ‘non quick-response unit’, because the family unit cannot change as fast as the parameters that define its relationship with the economy and the state do. Continuous change in the socio-economic realms renders necessary the view of the family as in an everlasting process of change that is, however, culturally driven.

with the state (Catanzaro 1992). The family-centric Palermitan view of life compels the understanding of changes in the other spheres only in relation to the family. Although the value of the family changes over time, the family manages not only to survive but instead to be the most important unit in Italian society. Diverse views of the family in different parts of Italy depend on variable cultural commitments.

Nevertheless, only in the long term does the family seem to adjust to the economic environment. On the macro level, family size depended on the economy as early as the age of hunter/gatherers (Laslett 1972). Then in feudalism, the pattern was the extended family, later succeeded by the nuclear family that expanded again with early industrialisation (Ruggles 1987). The last decades have seen an alarming population decline in the capitalistic world, and in particular Europe (Douglass 2005, Gillis, Louise and Levine 1992). However, cultures react diversely under the same circumstances, as the discussion of the family in relation to capitalism reveals.

The attempt to grasp the expansion of capitalism in the United States of America and the northern half of Europe (Ryan 1981, Davidoff and Hall 1987) focuses on the family (Creed 2000). In particular, the centre of attention becomes the working class because of its gravity in the production system. Ryan (1981) observes in New York, and Creighton (1986) confirms, that in both Europe and the USA, middle-class family 'motives' and 'interests' respectively fertilised the soil upon which capitalism grew. The new economic system has had an effect on its very basis, the working class.

Capitalism may have challenged the family on various levels and at times threatened the institution's very existence (ibid.). The new production system along with feminism, led to the redefinition of sex roles in both workplace and home. Anthropological literature exposes that the division between household and

workplace blurred with the transfer of practices between the two (Lamphere 1987, Wolf 1992, Douglass 1992). From a feminist point of view, women challenged patriarchy in both workplace and family, and men struggled to meet the model of the breadwinner.

Changes in the economic and political environment affect society and thus its culture. However, the family persists thanks to its importance and adaptability. Roles within the family can change only if this permits its continuity. Especially in 'unsafe' environments, the institution of the family holds high value because of the stability it offers to its members. Therefore, the unity of the family relies on the conscious decision of its members to respond to external or interfamilial challenges as a unit. This union can cope better with scarce resources for both economic and cultural reasons. Family members support one another in periods of economic crisis, and society considers the family a prerequisite for access to resources. Roman Catholicism commands a particular view of nature; this shapes those values that in turn translate into honour and that informs Sicilian perceptions. Therefore, only by conforming to the stereotypes can one in Palermo get access to those social networks, which will allow him/her and the family he/she is a member of to survive or advance.

### *6.3 Reflections on the Family*

Only when I left home at the age of twenty-four for studies in the UK, did I understand how important my family was to me. I started recalling with nostalgia all the moments I had with my parents, my sister, my uncles, aunts and cousins. We were all living nearby in Nea Ionia, a suburb in the northern part of Athens, Greece. The family in those early years was everywhere; as my aunt and uncle were living

nearby visits were an everyday occurrence. Even when we were young, staying with my grandmother and sister while our parents were at work and time for them was limited, we would still meet with our relatives quite often. We were lucky to live nearby because my father had come from Grevena to Athens with his brother for work, and my mother with her sister from Kalamata for the same reason. When they got married, they decided to live close to each other. My father started his own business with my uncle and stayed together in this until they retired. My mother and aunt both became civil servants in Nea Ionia. Although my sister and I were born first, we were both attached to my aunt's daughter and son despite the five-year age gap between us. The same happened with my uncle's two daughters although we were seven years older than they were. We mostly experienced happy moments all together, but there were also crises. I had the feeling that as long as we were all together we could manage everything.

Our middle-class families could often afford holidays back in my parents' hometowns; these excursions further strengthened our bonds with my uncle's and aunt's families. Both my grandparents had equally passed their possessions to their sons and daughters long ago, and thus all families could meet at their childhood homes. Even though my parental grandfather had passed away when I was three years old and my grandmother lived with us in Athens, our trips to Kalamata and Grevena were frequent. This was the best time for us because we were surrounded by all those who really cared about us and loved us. Every time there was tension within the family, all others would interfere and the issue would be solved immediately. The same applied to all other spheres of our life; whenever one of us was in need, all the family would unite to help. In this case, the family would combine its social networks to get the best possible result. The fate of these households was somehow common and their members coordinated to protect this

union. Therefore, I always thought of them to find the courage to go on in order to make them both proud of me and to be able to contribute more to the family unit once I returned.

After a couple of months in England, waiting for a friend to come to Durham railway station, I had a shocking experience; a mother was in the driver's seat, the car parked outside the train station and her child was leaning out of the front left window. The mother was looking at the child but said nothing to him; neither did she pull him inside. A Greek mother, I thought, would have yelled at him before he even opened the window! When the train arrived, the child got so excited that he lost his balance; I felt a lump in the throat and started running towards him to prevent him from falling to the ground. I soon guessed that one could also learn by experience. I had heard many stories about the family in other places outside Greece, but they always seemed distant and stereotyped. Soon, I found out that Sunday dinner is also very important in Durham, as it is in Italy and Greece. An English friend invited my flatmate and me to his place. He was very excited; he said that his mother wanted to cook for us and make us feel at home. As he explained, this was the reason why Sunday was his favourite day. This was the only day he and his two brothers dined together with their mother; it was unfamiliar to me mainly due to its infrequency, the absence of the father, the relationships between the family members and eventually the actual taste of the food. The more I gained access to the local community, the more differences I could trace between the Greek and the English family.

My first hand experience did not end there. Rather, it expanded on the Palermitan family that was different from both the English and Greek. I expected the Italian family to be more like the Greek rather than the English, because all Mediterranean people boast about 'family'. Based on the Mafia issue I wrote about for my MA

dissertation, in the first pieces of data I gathered, the prevailing ideas on Palermitan family were contradictory at the very least. There was an evident attempt to prove that Palermitan society is '*mafiosa*' because the family and the Mafia share some basic traits, such as structure, support for their members, honour and so on. However, the Cosa Nostra and the Palermitan family are two different entities and the fact that they have common characteristics does not make Sicilian society *mafiosa*. On the contrary, the Cosa Nostra adapted Sicilian cultural practices and ideas to legitimise its malicious intentions and assure its continuity. That was to be tested in the field a few months later, as I began my PhD in Durham. The question bothering me was why everything seems to evolve around the Mafia in Sicily; was there a chance that the Palermitan family was so different from the Greek? I started reflecting on the data I was gathering in Durham, putting my experience against the academic literature. I knew I was biased, but I also knew I was lucky for the fact that I could compare three cultures rather than two.

My supervisor, Paul Sant-Cassia, had informed me from the beginning that Palermo is a difficult field, especially since people do not open up very easily. Therefore, during the intensive Italian course I took in Greece I kept discussing with Professor Soula the basis of my research so that we would know what to focus on. Soula had lived in Italy for many years and apart from perfecting her Italian, she was interested in integrating into Italian society, which she eventually succeeded in doing. Therefore, Soula was one of my first key informants who could give me a perfect overview of Italian society. Even better, she made me understand the "thin" meaning of Italian words used to describe emotions and feelings in the depiction of Italian daily life. Apart from becoming familiar with 'Siciliano' –the regional accent- and 'Palermitano' –the local dialect- I had the chance to consolidate an idea about what is important for Italians and the differences there are between Sicily and Italy. We

worked together on the way questions should be set to Palermitans in order to gather the best/most reliable results in terms of data. The general questions on my notepad started becoming more and more focused like an inverse pyramid. I kept in mind that my notes should include the exact words used in Palermitan discourse and this should help me deal with the difficulties of my field. Ideally, the better I would understand the field the more I would gain access to information. Nevertheless, nothing would be enough if it were not for my partner and my father.

#### *6.4 Access to Family*

My father insisted on meeting Ioanna's parents before we left for Sicily; although I had been in this relationship for almost four years, this was the first time my father had said to me such a thing as: 'You just cannot leave like this, her parents must know about your family, it will be good for them.' A few days later, we were all at the airport in Athens kissing goodbye as a 'proper' Greek family. I was lucky to have Ioanna with me for many reasons, one of which was the quality of information I managed to gather only because of her presence. Her role was crucial in the establishment of social relations. I would never have thought how important it is for Palermitans that a man was in a relationship. I had come across Cole (1997) whose work focuses on immigrants in Palermo, but I could never imagine that a Greek anthropologist would be a lonely immigrant in the eyes of the locals. If I had gone to Palermo alone, the field would not just have been difficult but impossible. In fact, the hotel we stayed in for the first month was next to Cole's locale in the sense that in the same street there were homes of and schools for immigrants. The first thing that we heard from the staff was to be careful of the 'big black people' when we returned to the hotel late at night. Two out of the three men working in the hotel

were the first Palermitan ‘family’ we had. The owner became our ‘father’, showing us around and telling us everything we should know in order to be safe. His ‘right hand man’ was also protective, but more like a brother, as he was also younger than the owner. As a good ‘brother’, he would wake us up early in the morning to get our breakfast, and then he would take a map out to show us which places we should visit day after day; we felt like pirates in the hunt for a precious treasure. They both forewarned us of the dangers in the city. We should also know that we were all alone in Palermo, something we heard again and again during the sixteen months the first fieldwork lasted, and that they were the only ones we should trust: ‘we are your family now and we will take care of you until you understand what is going on in Palermo.’ Indeed, the owner took us around to find a house to rent using his networks, and his employee advised us of our options. We kept in touch with them even after we moved to our home close to Piazza Marina in the historic centre of Palermo.

Soon after we moved to our own place, we met the family that first embraced us as their own children. On a sunny Monday morning in April of 2005, we left early to go to buy the basics for a home. We already knew the city quite well because we had gradually walked it from corner to corner thanks to our ‘brother’. We ended up in the carpenters’ area seeking a lounge table and a bed, as the ‘padrona’ had left only a single bed and a kitchen table in the house. After negotiating the prices with all the carpenters, we went back to the first one we encountered although he was a bit more expensive than the others. What took us back to him was his courteous manner and the kind presence of his wife and three children. We kept visiting them and soon enough we became a ‘family’ because as the couple said ‘we reminded them of their relationship’ when they were young. A few days later, Salvo brought the pieces of furniture we had ordered and from then on his role became crucial in the success of

my fieldwork. He was the one to inform our neighbours of who we were and what we were doing in Palermo, and ensured them that we were *bravi ragazzi* (good persons) and Christians. The old couple who lived below knocked on our door the same day and asked if we needed any help; Gaitano was also a carpenter he said. Giovanna kept visiting us and asking if there was any way they could be helpful. They also said that Ioanna (which is Giovanna in Italian- I had converted my name to Sergio) and I reminded them of their first steps as a couple, and this was the main reason they eventually ‘adopted’ us. However, it was only after my father paid us a visit in Palermo that we gained access to both the Scannavino and Di Lorenzo homes. Once they had met him, both families started inviting us to their homes for food, coffee and endless discussions. We started building our social networks with ease and all the Palermitans we became friends with sympathised with us because we were a couple.

Another family we gained access to and whose help turned out to be fundamental in my research were the D’ Amicos. The Greek consultant in Palermo we had come in contact with in order to have access to professors at the University of Palermo had invited us to a Greek feast. There we met many people with whom we became good friends. Silvia was also attending the feast and she introduced me to her aunt and her friend Francesca, and I introduced them to Ioanna. Silvia started telling Ioanna how we had met: ‘I was at Gatwick airport in London queuing up for the check-in; something happened at the front and we were all delayed. I could not understand what was going on but this was the first time I saw a man this angry. When I got closer, I heard Stergios explaining to his friends in Greek that they would not allow him on board unless he paid a huge amount. I did not approach him in the aeroplane although I both wanted to practise my Greek and understand what had happened. A few weeks later, I met him at the University and our Greek professor Sofikitou

introduced him to me. You should have seen his face when I told him that this was not the first time I had seen him, but that I had witnessed the airport incident! I am sure the words that crossed his mind were three: '*che brutta figura!*' (what a negative impression!) At least that was what I understood from his face. I have talked to my parents about you and they want you to come and visit us at our place and discuss your research.' Silvia and Francesca, and both their families, guided me throughout my fieldwork and helped me get in touch with the people I either wanted to or should meet. Then the Provenzano family came to fill in the last piece of the initiations and introduced us to the Palermitan elite. Our social networks expanded so much within a few months that we felt we could manage to understand 'what is really going on in Palermo'.

#### *6.5 The Ethics of Admission*

- 'Alessandro, what is Palermitan family like?' [38 years of age, receptionist]

- 'Like the Greek family, they are identical.'

- 'Mauro, do you have a family?' [28 years of age, waiter]

- 'Yes.'

- 'Consuelo, what do your parents say about your job?' [24 years old, bartender]

- 'Nothing.'

It did not take me long to realise that Palermitans do not want to mention the family, unlike the Greeks who refer to it constantly. Alessandro cunningly avoided talking about his family, and we learned that he had a wife and a son a month after we first

met him. We spent almost all our days with him at the hotel and although he was willing to talk about anything and explain to us the traits of Palermitan culture, he was extremely keen on his own private life to remain secret. Mauro was another local we met almost every day at the Caffé Spinnato, the busiest cafe in Palermo, and he would come and pick us up from our place to go around Palermo. He drove us to all the places the tourists do not see because as he said these were the places that represented the real Palermitan life. However, every time we asked anything that had to do with his family he would just take his tray and walk away. Consuelo was a good source because she had recently come to Palermo from Catania and she always discussed the differences between her place of birth and Sicily's capital. She was working in a bar at *Champagneria*, where all Palermitans go for their 'aperitivo'. The reason she did not refer to her family was not that her parents did not accept her doing her current job. The more I indirectly tried to discuss the topic of the family, the more Palermitans started opening up. Only after I had discussed many cases did I come to understand that Palermitans avoid any reference to the family in order to display independence. The fact that the family still acts as an economic unit in Palermo gives the elders of the household the right to interfere in the younger members' lives. Although their independence and ability to modernise is impinged upon by the elders, the younger members have turned to general networking as well as issues dealing with their own sexuality in an effort to express disagreement and displeasure with the existing hierarchy. The planned rupture of relations between family members of different ages within the family is a prerequisite for social acceptance within the younger generation; this rupture is promoted as a silent revolution displayed in the social realm.

Research on the family demanded patience, as I had to wait until my informants trusted me enough to discuss the most sensitive issue in Palermitan culture with me.

In the meantime, I was preparing the questions I would set to my informants every time I could link our discourse to the subject. Later on, I distributed questionnaires focused on the family to the Garibaldi elementary school pupils and I had discussions with the teachers at the same school. Signora Guallardo greatly helped me with the interpretation of the answers I managed to gather. We moved further with recordings, drawings and photo-grouping. Ioanna started teaching their daughter English, and this was just another reason we kept in touch throughout my fieldwork. We were invited to their home several times, where we had interesting discussions with her and her husband who is a sociologist. Moreover, structured and open-ended interviews were numerous and combined participant observation, mostly with the Scannavino, Di Lorenzo, D' Angelo, D' Amico, Provenzano and Vella families. These families were a representative sample as they differed in sex roles, income, social class, status, social networks, and so on. Every now and then, we were invited to different homes for lunch; most of the families we managed to meet were keen on discussing the 'Sicilian family', tracing the differences between their family and others in Palermo, Sicily, Italy and abroad. This helped me test the representativeness of the families I focused on. Eventually, all this revealed a pattern of perceptions, which I then tested on both a theoretical and practical level. My informants were fully aware of what my project was and I never pushed for an answer when they felt uncomfortable with my questions. These moments were rare as firstly, I was a Greek and not an Italian, and because for all they knew, I would stay in Palermo for a short while and never be heard from again. These factors helped build a relationship of trust between us. A Greek could understand better than a northern European, and thus I would never harm them by abusing the information I was given; this was also my promise to the institutions who granted me access to their archives. All our discussions involved comparisons between my family and

theirs. They wanted to know as much as I did, and since one day I was going to leave the island, they never felt threatened. I am sure about it because at some point they prompted me to turn the camera on and record their homes and lives. The more I went into details the more detailed answers I received. This brought me too close at times, especially to the families I mention above and I consider myself being a member of.

### *6.6 Common Destiny versus Independence*

Trust among family members seals the unit to protect it from the competitive and potentially dangerous elements of society. As we were used to having daily contact with all our friends back home or in England we would call our Palermitan friends to visit us or go out together. Although this was easy the first couple of times, we later began to hear various excuses in their attempt to avoid meeting regularly. At the beginning, I thought I was doing something wrong and after a while, I started asking directly for the reasons we did not meet that often. Finally, I got the answer, which was that when one insists on frequent interaction, it most likely means to a Palermitan that he/she wants to ‘get something’ from you, and this makes Palermitans suspicious of the other’s motives. One can trust and spend every day only with family members. Only as a member of a family can a Palermitan cope with the challenges of everyday life. The parable was that a pencil can break easily when it stands alone, but the more they are the more difficult it is to break them. The same applies to the family; the family provides its members with all the support needed to deal with external pressures. Palermitans take this for granted, but this is rather an ideal with a cultural basis.

Until the twentieth century, the Palermitan family was a production unit under feudalism and continued to be so with the medium-sized enterprises that initially thrived with the onset of capitalism. Lack of state provision and economic instability further strengthened the need for family support. Moreover, the family has a pious side that translates social pressure into religious belief, according to the Catholic example. Social pressure itself is based on sex roles, which command the male into being the breadwinner and the female the home-maker. The family is also important for political reasons, as the political world praises the Palermitan family and renders its creation almost compulsory. Therefore, for Palermitans the actualisation of the self is possible only through the family.

Tension between family members is the outcome of the unit's attempt to lessen external pressure. The tension of the situation at hand depends on the age gap between parents and their children. This reflects the contrast between the old Palermitan ethos and the role models promoted by the mass media today. The tension between the participants of 'amici' (friends) presented by Maria De Filippi, and the older people of the audience is indicative of the change Italian society is going through and the contrast between old and new Italian values. My research shows that the higher the class the more peacefully a family may overcome tensions within it. This is because the younger members have more to gain by sticking with their family if they are affluent, in contrast to the lower classes where to leave home might result in upward social mobility. External pressure is higher among the lower social classes because there is no wealth, or fame, or those social networks that counterbalance attacks against an individual or a family. Therefore, lower and middle class families are more in need of coordination and cooperation between their members for both economic and honour related reasons.

The reputation of the family is so important that Palermitans are judged by the society on both the personal and familial level. Therefore, a surname can either be an obstacle or a blessing<sup>21</sup>. A striking observation however is that Palermitans never refer to their family negatively, because not only have they learned to respect it even if they are in conflict with it, but also because they know that in so doing it would be like harming their own selves. Although Mauro was old enough to afford a house of his own, he lived with his parents and his brother. His parents never came to visit him at work, and when I asked him why his parents never came, he replied that he had asked them never to visit him there. Although he accepted the fact that his parents interfered in his life, he did not want others to know it. When Mauro started looking to buy a new car with his own money he was excited, but a few days later he became nervous and aggressive. I tried to find out why, but he always mentioned that he did not really like his job and that he had no time for his personal life. Time went on and one day he called me to go out to talk with him over a cup of coffee. He revealed to me that he was sad because of his parents; they did not want him to buy a new car although he needed it, but instead they proposed that he should save the money for them when they may need it in old age. He said he had had enough of that and that even though he loved his family very much, this time he would do what he wanted, and then he added: 'I have to leave home, find a good woman to get married to, and have my own family. I will still take care of them, but I am going to be independent. I know they love me but their mentality will never change.' Mauro wanted to make sure that no one would blame his family for losing their son, neither did he want himself to be seen by his neighbours as a bad son.

---

<sup>21</sup> Peristiany argues that 'the most respected members of the community are those who are said to come from families which on both the paternal and maternal side are noted for their respectability.' (1965: 177). Likewise, the Palermitans believe that each family's fate and fame is interwoven with that of their ancestors, in the sense that a family's reputation is passed on from generation to generation.

Anna's best friend, a twenty-two year old woman, was also struggling for her independence under different circumstances. She wanted to leave home especially after her parents said that she had let them down; she was in a relationship with a person of her own age and everybody in the neighbourhood knew she was with him. However, the young Palermitan male was not ready to get married yet. Of course, she could not tell her parents this and at the same time, she felt the time had come for her to leave home. Therefore, she decided to split up and look for another man who would be willing to marry her. Her parents were mad at her when they found out what she had done. At the beginning, I thought they felt ashamed of their daughter, but after I discussed it with Anna, her friend and eventually her parents, I found out that the main reason for their fight was that she was the only daughter and they wanted to be sure that she would take care of them when they reached old age. To punish her, her parents did not allow her to go out, except to go to Anna's house. Her father would drop her at Anna's and he would leave only after her parents opened the door; this meant that Anna's parents were responsible for their daughter's friend until he came back to pick her up. In one of these cases the girl started crying as soon as she arrived, and asked Anna's family to help convince her father to let her go out with her new boyfriend and then she would promise never to leave her parents alone. Anna's family did not interfere. They said that if they interfered everything could go wrong. One family could start blaming the other and this would result in gossip, and maybe the girl would never have the chance to become independent if the rumours spread. Anna's family sympathised with the 'poor' girl, but they suggested that the only way out would be a *fuitina* (elopement): 'If he really loves her, then elopement is the only solution.'

Although in both the above cases it is difficult for the protagonists to distance themselves from their family, this is still a possible scenario if there are no other

options left. However, young members of the upper classes lack this advantage in the process of negotiating their independence. Since they are on the top of the social hierarchy, any break from the family is considered a downfall. Sebastiano decided to leave his hometown and study in Germany at the age of twenty-four. As he explained, this was the only way to satisfy his parents and at the same time have the chance to be relatively independent. His parents wanted him to take over their business upon their retirement. Sebastiano knew that if he did not agree with his parents his future would be uncertain; on the contrary, as long as he complied, his parents provided him with everything he asked for. After Sebastiano finished his studies abroad, he returned to Palermo and worked with his parents. Thanks to his parents' social networks, which he used strategically, he managed to establish himself as one of the best in the Palermitan construction business. Although he earned enough to live well with his wife, his parents kept planning his life even after his first child was born. In one of our discussions, Sebastiano suggested that he was smarter than other Palermitans who do not admit that parents control their lives: 'I am smarter than all those others who pretend to be independent, but their parents have full control of their lives. I do not have a problem admitting that my parents contribute to my well-being as much as I contribute to theirs. We move on all together as a solitary unit and we stand stronger than we would if we were divided. Parents are always going to be parents and it is going to be the same even when I am eighty years old. Of this I am sure; it is going to be the same with my children.'

There are numerous examples of different cases I have gathered in which as soon as the younger family members start asserting their independence parents respond to it with the impingement of vested rights. Modern families support this structure as the practices of old-style families in which all members depend on one another to meet their needs. They sympathise with the 'victims' but they never turn against the

parents who they believe to be suffering as well. Independence comes with marriage, as this is the only acceptable way for a son or a daughter to leave home; but also this is not always a peaceful procedure and parents still interfere in the life of the new couple. However, independence is of vital importance for the young and the situation starts to change dramatically. Like Consuelo, it is easier for a young person to leave home and earn a living nowadays, in contrast to the past when the fate of a person depended exclusively on the fate of his/her family. The current economic conditions, education and communication allow the young to attempt to bring into effect the dream of a life similar to the one the Italian mass media promote.

#### *6.7 The Palermitans' Family Stereotype*

The stereotypical Palermitan family consists of two parents, and at least two children, preferably a male and a female. The untypical is looked down upon by Palermitan society. Absence of one of the parents is considered to be abnormal, unless one has passed away. Palermitan society expects widowers to remarry, but this issue is more complicated when it comes to widows and divorced women. However, women are 'not enough' to take care of children alone, just as men cannot take care of their children alone if they do not have a daughter to take over the domestic obligations.

A couple without children is deficient, and either the man 'is not man enough', or the woman is 'useless'. Fathers must be fearless and cunning enough to provide their family with all they need. They are also responsible for the control of all the family members' behaviour and thus their family's reputation. Accordingly, a good wife must first be faithful to her husband and able to give birth to children, which she must raise with care. Men do not talk much, but they let their wives play the role of

the mediator within the family unit. In view of that, women let men play the role of the family representative in the public sphere. Children must conform to the rules parents set and respect firstly their father and then their mother. Wives help their husbands build the image of the mighty father in the eyes of their children, for fathers spend less time with their children.

As soon as children reach a certain age, they are expected to help their parents in all possible ways and do everything it takes to make the latter proud of them. The Palermitan family stereotype stands as an inherent cultural model. This allows Palermitan views to converge as to the point of what is the 'perfect family', and thus Palermitans' try as much as possible to harmonise with this model. The role that has undergone the most extended change is that of the woman, which consequently affects all other roles. Today, the Palermitan family stereotype is being challenged by the struggle for woman's emancipation as it is expressed in education and occupations which is reflected on her advancement in the public sphere. The challenge targets the roles played within the family, but does not strike at the very foundations of the institution of the family. In the case of Palermitan culture, individual independence should not be confused with atomism. By contrast, the struggle for independence reveals the importance of the family in Sicilian society. Efforts made within the family are to help the unit assure its viability by adjusting to the given economic context, and changes which necessitate relevant adjustments to sex roles. The family is an important element of Palermitan culture to the extent that it becomes a criterion for access to social networks.

Today, the prevailing pattern in Palermo is the nuclear family which can be attributed to the intense rhythm of life for both sexes. Almost equal access for both sexes to the production system does not reflect a booming economy in need of a

work force as it did in the sixties, although families need to increase their income in order to meet rising standards of living. The weak Palermitan economy, combined with commodity fetishism, does not favour extended families. In addition, among Palermitans there is a vague but widespread negative idea of the extended peasant family that has persisted from the past; another vague but positive idea that expresses modernity is that of the nuclear urban family. The new type of family is a conscious logical procedure of controlled fertility that aims to maximise the chances its members have for advancement. As now 'women can control their fertility', their role extends towards a computable contribution to the family's income. Thousands of products especially designed for women render female economic autonomy more seductive than ever before. However, since the family is a core value of Palermitan culture, all its members struggle first for the well-being of the unit and then for their own individuality. The nuclear family persists because seen as a unit its costs are minimised while its income is maximised in relation to the extended family. Moreover, time is barely enough to meet with the household members between working hours. Many Palermitans argue that life in the past was far more relaxed and people were more sociable than they are now. For example, Sunday dinners have nowadays become a luxury, for this is the only day many do not work and thus prefer to stay home and rest. Many suggested that in the past one used to work to earn a living, but now it is as if one lives to work. Whatever time is left after work they want to spend it with their family because if they do not do so their family will be ruined. In all the occasions when I asked my informants if they keep in touch with other relatives, they replied that they did not really, as their communication was rare. The main reason they brought to the fore was that life is so intense that there is not enough time for things other than the basics.

Every Palermitan is expected to create his/her own family at a certain age when he/she will be psychologically and financially ready for this. Although the expected age in which one should get married has increased, the upper limit is thirty years old for both sexes. This is because marriage is linked to procreation. The only legitimate kids are those born by married mothers and the younger the couples are the more the chances to procreate and give birth to healthy children. Fertility is linked directly to masculinity and femininity, and since these should be tested only in marriage, fertility is also linked to marriage. This means, that all Palermitans should marry, otherwise it is understood that there is something wrong with them. Single Palermitans are thought to be homosexuals rather than fastidious or just unlucky. The situation is more difficult for those who are married and at an age when they should be having children yet they do not. Gossip is targeted at both husband and wife, and the neighbourhood makes a mockery of them. There is always a prevailing theory of the 'he cannot have children' type, which is countered with 'no, no, it is her that cannot give birth.'<sup>22</sup> In a dinner I attended, an elderly woman was talking about the early years with her husband; she admitted that although she loved her nephews and nieces that came to her home, she always wanted to give birth to her own children: 'I loved them; I still do, but the neighbours knew that they were not my children. I felt incomplete; as a woman, I mean. I was sad. I was praying to God every day, asking Him to bless me with children. The older I was getting the more stressed I felt because I thought I would never give birth. Eventually, God listened to my prayers as you can see for yourself I have a daughter and a son who I love more than anything else in this world.' Her husband added: 'I did not care at all about what neighbours said. I loved my wife and this was enough for me, but probably my love was not enough to take her sadness away. I could not stand watching her getting

---

<sup>22</sup> Different scenarios with respect to the subject of gossip are used to add fuel to the conversations between different groups.

worse day by day. Doctors said there was nothing wrong with us, that we could have children. God helped us.' Palermitan couples I have talked with told me that kids are a gift given to people by God. The immense social pressure Palermitans experience on getting married and procreating is because this is the natural course for humankind according to Catholicism. Whatever does not fall within that stereotype is considered strange and evil. Cole (1997) shows how immigrants in Palermo are marginalised because of this stereotype; Palermitans sympathise with immigrants because they are poor, but marginalise them because they are alone. For this, I felt lucky my partner was in Palermo with me and we were both young enough to be allowed not to have children, otherwise I would never have gained access to information. However, my friends' parents always put pressure on their daughters and sons to get married, and every time I was around I was advised to finish my studies as soon as possible and marry my partner.

### *6.8 Between Parallels and Perpendiculars*

My trips around the island made me experience firsthand that a common perception of the family is widespread in every corner of Sicily. According to the stereotype, a person is always a member of a nuclear family which he/she considers to be the most important thing in his/her life. Sicilians believe that family bonds are strong only in Sicily, without really knowing what happens in the rest of the world in order to be able to compare. It is enough for them to say that divorce rates are higher in the north of the country to prove in their own minds that they are right. Questionnaires randomly distributed to the widest possible age range and interviews throughout the period of my fieldwork, prove that for Palermitans the family is indeed the most important thing in their lives. According to all communications, Palermitans spend

more time with their (nuclear) family than they do in any other activity. Although some of them maintained intimate relations with their grandparents or other relatives, they did not include them in their definition of the family. Only parents are constantly at the disposal of their children. Palermitans claim that parents help their children decipher Palermitan culture and teach them Sicilian values. The common point is that children, irrespective of age, rely on their parents' help which they take for granted. Another thing taken for granted is that one can trust only the family unit's members; therefore, serious matters are discussed only among them. Parents forgive their children, but children have to respect their parents and return their love. Parents help their children develop an autonomous personality in order to be able to cope successfully with the challenges of Palermitan life, expecting that children will help their parents in return. Parents play their role successfully only if Palermitan society displays a good account of their children, and vice versa. The stereotype has all Palermitans constantly struggling to play their roles successfully.

Another commonality among Sicilians is that the younger generations accept the dominance of their elders. Contrasting with the ideal of reciprocal relations within the family unit the parents impose themselves on their children. It is not my intention to question the honourable motives that drive the parental conduct of their children, but to enunciate a practice that is rooted in the past but is still active. Although respect fades away in social interaction, and manners become studied in the public sphere, it is still a prerequisite for good relations within the family unit. All my informants when asked what a good son or daughter should do, the first quality they mentioned was that sons have to respect their parents. In practice, the most feared person within the family unit is the father, as mothers earn their children's respect by sharing secrets with them and by playing the role of the mediator between children and their father. None of my informants, either man or woman and irrespective of

age, had ever discussed any serious issue first with their father. They all turned first to their mother because they were not afraid of her, as they explained to me. Mothers informed their husbands about their children's issues only if the fathers' need for action was indispensable. Palermitans recall situations in which their mothers protected them from their fathers by keeping things secret. The feeling of fear that sons experienced as children, relative to the father, is so deep rooted and fundamental to their personalities that the residual effects of such fear is experienced many years later. The contrasting feelings towards the mother and father apply to their role within the family unit and not as to their person. Palermitans argue that they love their parents equally. This love has as a positive effect the security Palermitans feel within the family, and as a negative, the opportunities Palermitans turn down so as not to distance themselves from the family unit for the sake of their parents.

Expectations for family members vary according to class to such an extent that an individual's expectations reveal his/her class. Despite the differences among social classes, Palermitans believe in a shared perception of the family and more importantly, that the family is a shared value itself. Parents always want the best for their children but there are limitations related to social class. The lower the class the more obvious it is that the family unit will act as an economic unit as well. Lower class Palermitan families are proud of the common destiny of their members: 'We are better than the rich because we all fight together as one fist.' Although they desire upward social mobility, this has to be achieved by the unit and not the individual: 'Each one alone has no chances to improve his condition. Therefore, only if we all suffer together will we manage to advance.' According to the lower classes, the family is important for all Palermitans but it is even more important for the poor. The middle-class also believe first in family terms; many claim that they are better in

this than the poor are because the latter are not educated. The middle-class family compares better with the rich as well because family relations cannot be intimate if most of the time is consumed in moneymaking activities. A forty-year-old female professor has stated directly: 'We have the knowledge to cope with any situation within the family unit, but also plenty of time to dedicate to our children. We can do better than the lower classes who do not know how to guide their children on various issues, and better than the rich who are always absent because all they care for is money. The parents' role is not to make enough money to sustain their family and 'buy' love, or to leave their children unattended. Parents must be able to sustain their family and spend enough time with their children to make sure that their children are on the right path; that they study, they have manners, good friends and so on.' The higher classes are more practical: 'Money rules! I want my children to be clever enough to continue building on what I have built. With money you can buy everything; you can see how the law treats the rich and the poor, you can see how Palermitans treat the rich and the poor.' It is logical that the poor care about improving their living conditions, the middle class about education for the same reason as the poor, and the higher class about maintaining their position in the given hierarchy. The common point among parents of all social classes is that they are practically interested in the future of their children, but at the same time, they can limit the younger generations' options and thus reproduce the Palermitan social hierarchy. This is reflected on two fronts, namely in professional success as well as marriage between individuals of the same class, both of which practices are still common in Palermo.

## 6.9 *The Value of the Family*

The value of the family in Palermo is so prominent that even in case one leaves the island in an attempt to detach oneself from the problems of the Sicilian society he/she remains bound to his/her family. I have heard many stories from the past about people who were given the opportunity to pursue a better life, but their parents eventually held them back. All these stories were told to contrast modernity, in which persons are free to leave their hometown if conditions are better in other places. Nevertheless, in practice the past does not differ much from the present. All my Palermitan friends who decided to live abroad or in other Italian cities returned to Sicily every time they had the chance to (technology allows frequent communication, which is affordable nowadays). They all admitted that communication with their parents was frequent and that most sent money back to their families as well. They compared themselves to the Sicilian immigrants of past decades but argued that the conditions are better nowadays because now they can communicate easier with or visit their families. This reminds me of the famous line in Giuseppe Tomasi's di Lampedusa 'Il Gattopardo': *'If we want things to stay as they are, things will have to change.'* As other great Sicilian writers, i.e. Leonardo Sciascia and Giovanni Verga, have depicted it, in Sicily nothing ever changes. In the award-winning film '*Nuovo Cinema Paradiso*' (1988), directed by Giuseppe Tornatore, Alfredo, who stands as a father to Salvatore, asks the latter to leave the island in order to pursue his destiny and never return because in Sicily nothing is ever going to change. Nevertheless, the protagonist will go back, thirty years after he leaves Sicily, to attend Alfredo's funeral. Another who links the protagonist to the island is Elena the daughter of a wealthy banker. Her father did not approve their relationship because Alfredo was poor and fate never allowed Elena and Alfredo to forge a relationship. Krause, chooses Roberto Benigni's film *Berlinguer ti Voglio*

*Bene* to shed light on how poverty defines all spheres of life in Italian society. She shows how specific perceptions of masculinity, femininity and family result from the perception that poverty 'is inescapable because it is encoded in the blood' (2005:602). Nowadays, Palermitans think it is easier to advance with capitalism than for example in an agrarian economy but they still see it from the perspective of the family. Although everybody complains about the economic conditions in Sicily, only those who promise to continue helping their family leave the unit with their parents' consent.

Exceptions confirm the rule that the value of family is the epicentre of the Sicilian value system. Social pressure on the families of single parents, or of absent parents is immense. Questionnaires and interviews revealed that Palermitans presuppose the presence of both parents within the family unit. When asked to define other formations of households, as those mentioned above, they were all puzzled and hesitated to define them as families. In other words, Palermitans could not accept that a 'normal' family can be compared to 'abnormal' situations, which revealed a fear of family degradation. Many explained that the family unit is in crisis because couples divorce 'easier' than they used to in the past. They added that the family is probably the only shared Sicilian value left and therefore it should be protected. The reason for this according to most was capitalism, not as an economic system but as a set of values that corrode Palermitan culture. Students at the primary *Garibaldi* school grouped only those pictures of families in which both parents were present, considering those of a man and a child for example to be an uncle and nephew, or brothers and sisters of a similar age as friends. Another significant finding was that all preferred that if for some reason one of the parents were absent then this would be better for it to be the mother (I will analyse this later). The fact that Sicilians 'adopted' us as well is indicative of the significance of family in Palermitan society.

The case of Michela's family revealed to me in the best possible way the negative effects of living without parents. Michela's mother had passed away some years ago and her father decided to marry again. Michela and her older brother were already working and they could take care of their younger brother who went to school. She explained to me that she sympathised with us because we were all alone in Palermo, meaning that our parents were not around. One day she invited us for dinner suggesting that we should not expect others to do the same, as they would not trust us for the same reason mentioned above. Indeed, only after the *bella figura* (positive impression) that my father created when he visited us, did Palermitans start inviting us to their homes. Walking up the stairs to the fifth floor where Michela lived with her two brothers, she asked us to be quiet. Putting her finger to her nose, she said: 'Keep it quiet guys, if they see you they will start gossiping again. This is what they always do; we don't have parents you see!' Her younger brother opened the door, their older brother standing behind him. They pulled us in and shut the door; we were told that we could speak freely now. We introduced ourselves and we kissed on both cheeks. There was enough food for a small army on the table. Michela's brothers agreed with her that all their neighbours did was to gossip about them because they lived without their parents. 'They give us this look...it is as if we are criminals. All our choices are wrong and our father is not here to protect us. It was not our choice; our mother died of cancer seven years ago and our father left us all alone. He does not care about us. However, we are a family; we take care of each other,' the younger brother said. When he left, Michela and her older brother explained to us that the two of them play the role of the parents and do their best to raise their younger brother as best as possible. They could both be married but they would not do so until their younger brother finished school. 'He needs us' they concluded. The neighbours did not have a good opinion of their father as well for his

decision to abandon his children; Michela explained she was told this directly. In all the cases I was aware of that one of the parents created a new family he/she avoided having relations with his/her first family, a fact that also confirms how strong the stereotype of the Palermitan family is.

The strength with which Palermitan society defends the shared stereotype of the family is indicative of the unit's function within the given culture, and of the need for discernible roles according to sex and age. Although the perfect family requires the presence of both parents, the mother's role is of minor importance compared to the father's because the older daughter can undertake that role. A father's absence is more important than a mother's, because fathers are those who are supposed to protect children from any kind of peripheral threat. The findings of my research support that Palermitans trust their fathers more than their mothers in dealing with institutions and thus hierarchies. The rationalisation of this answer varies from person to person but the common ground is that men are more capable in dealing with social issues. For me it is not a matter of education or income, but the fact that men hold a higher status in general irrespective of whether their wives are better educated, earn more, or come from a family of higher status (although this is rare). In other words, men deal better with hierarchies because it was they who initially created them and staffed them; thus, men hold a higher position than women due to the way hierarchies have evolved. A mother would never negotiate with a professor, a car dealer, or an employer. In contrast, the presence of fathers in these situations is determinant because 'men know how to play the game.' Nevertheless, although the mother's role appears to be secondary this does not hold in practice. Only if all the kids of the family unit have reached a certain age and there is a daughter old enough to deal with the domestic duties can the mother's absence have only minor effects. This is because Palermitan mothers are charged with the complex task of shaping the

children's character and spend more time with them building relationships on the basis of mutual trust. In addition, the only culturally acceptable reason for children to leave home is to create their own family. If this is not the case then parents have failed in their mission. Today, when Palermitans leave for the North in search of a job, they must bear in mind that they should return often because otherwise their parents will become the neighbours' favourite topic of discussion. Since Palermitan society can adapt to changes, the only threat to the Palermitan family in its strictest sense is the interference of the elders in family affairs. The generation gap between grandparents and grandsons seems unbridgeable, and this combined with the influence of parents over their children can result in tension within the family unit. The same applies to extended kin relations, in which relatives tend to interfere in issues they are not fully aware of and thus they cannot grasp perfectly. This is probably why the nuclear family is currently the pattern in Palermitan society.

#### *6.10 Changes in Economy and Sex Roles*

In a society theoretically ruled by men, the women's struggle for equality is experienced as antagonistic between the sexes. Palermitan men argue that, on the one hand, the increased work force is a setback to the growth of the Palermitan economy; on the other, women abandon their traditional role, that of the mother for the sake of income, a fact that shakes the foundations of Palermitan culture. Women suggest that working is not a choice anymore but a duty and men complain because they are challenged. They also assert that they can combine both roles successfully. The men's argument about the economy holds some truth in the sense that women are most of the time exploited by their bosses and therefore salaries are kept low for

both sexes, even though men are slightly better paid. However, although steps are being taken, the division of labour according to sex is still prominent in Palermitan society. Most women work in the service sector. Indeed, it has become almost compulsory for women to work, for a man's income alone is not enough for a four-member family unit. As women are occupied in the service sector, one has the sense that only women work in Palermo; this can probably explain Palermitan men's discomfort.

However, as the aim is to keep the family together, Palermitans rationalise and legitimise antagonism between the sexes by drawing from the past, the present and Catholicism. As women gradually conquer the public sphere in the sense explained above, the result is changes in sex roles. Palermitans recall the old times when men and women had distinctive roles and they contrast it with what happens nowadays. In the extended families of the past, as the pattern was, the elders invigilated role-playing and helped make clear the roles to the younger members of the family. In addition, Palermitan men do not hesitate to claim that their fathers or grandfathers were 'real men!', and that modern men have to some extent become 'feminised'. Women, for their part can trace a difference in quality for their sex over time; women of the past were respected because they knew exactly what their role was, and thus they were better wives and mothers than the current ones are. In the past, women dominated in their sphere and never challenged the complementary domination of men in theirs. However, now that a woman's prestige rests on her income, these two spheres overlap and this becomes a source of disharmony for the couple and the family. Couples in Palermo, either married or not, have a religious sense of their union drawing from Adam and Eve. Metaphorically, the *anime gemeli* or 'twin souls' 'live in their own heaven' and this all can be lost if the 'serpent' convinces the woman to sin; Palermitans contrast their relationship to their society as

a battle between love and craftiness. However, nowadays women are 'exposed' to the public for economic reasons and therefore the woman's role in Palermitan society has been redefined. Women have to play both the role of the mother and the breadwinner, supplementing men instead of complementing them, and men have to accept this change.

However, as in Palermo the public realm was traditionally a male matter, currently, men use their access to social networks, of which women are in need of, to negotiate power issues. For men, it was always compulsory to develop or gain access to social networks in order to survive. Networking is still important in Palermitan society and it is the main obstacle to the establishment of a meritocracy<sup>23</sup>. This can be attributed to the lack of a powerful state that allowed the formation of numerous social networks with conflicting interests over scarce resources and political power.

Today, male domination of the public sphere is obvious in all types of hierarchies within Palermitan society as the higher posts are occupied by men. The fact that women can now run for those posts dominated by men is a recent development. To gain access to male dominated structures, women indirectly legitimise male dominance; thus women perpetuate current hierarchies which they can climb only to a certain extent. Nevertheless, the main difference between the past and the present, and women's greatest achievement in the last few years, is that they have gained direct access to the public sphere. Men's central role in the economic system of feudalism legitimised their superiority over women even with the use of physical power. Women's power rested on their role as homemakers and mothers, their last weapon being their sexuality. In contrast, nowadays Palermitan men and women are

---

<sup>23</sup> The Sicilian economy is based on the service sector, as industry never developed on the island. Even in 2005, it was easy for Ioanna who specialises in management/marketing to get a job in northern Italy; however, she was overqualified for all jobs advertised in Palermo. It was explained to her that there was no industry in Palermo she could work in. Of course, this is half the truth, as Ioanna lacked access to certain social networks that could help her find a job.

equal citizens of the Italian state and play an equal role in the capitalistic enterprise. The relative male dominance of the public sphere currently witnessed in Palermo will end as soon as women create powerful enough networks to challenge male structures<sup>24</sup>.

Talking with Gabriele, a ten-year-old boy, about his school, he informed me that his teacher was interested in anthropology. Soon, we arranged a meeting with her. I admit that the fifty-year-old teacher managed to impress me within seconds of being introduced. In a straightforward language that left me speechless, she said: ‘Tell me what I can do for you, and what you can do for me.’ Her education and her manner were the reasons she was respected by all others. Examples like the above are numerous at the University of Palermo, where the enormous contribution of female professors to academia grants them an equal status with men. As well, Francesca, a thirty year old Palermitan woman who owned an elegant restaurant on the maritime outskirts of Palermo, had the reputation of a woman *con le palle* (with ‘balls’). Once she stated: ‘Men always complain; that’s what they always do. They piss me off. I tell them to stop complaining and instead do something about the issues that concern them. I, a woman, have managed to have my own business, my own car, my own home, and all this with my money. The fishermen I get the supplies from respect me more than all these *coglioni* (assholes) I am talking to you about.’ In another case, Mauro was mad at his boss because the latter decided to promote to the post of manager a woman. He found numerous excuses to argue that his boss’s decision would be fatal for the café and he kept repeating the phrase ‘*ma è una donna!*’ (She

---

<sup>24</sup> My optimism about the positive outcome of woman’s struggle against their stereotypes derives from cases I have witnessed during my fieldwork in Palermo. Many women had managed to be respected by their male colleagues or the neighbourhood, and at times even be treated as if they were superior to men.

is a woman!). Mauro considered himself the best option for that post and he disliked the fact that a woman was chosen instead of him. However, in general, the new manager did her job well enough to be respected by the entire café's staff. Likewise, Elisa walked the streets of the Sant Onofrio area with an air of assurance. When her husband went bankrupt and his spirit was broken, Elisa assumed responsibility. Within two years, the family business was doing even better than before and all credited Elisa for this, who became a feminine role model in the neighbourhood. Irrespectively of class and age, modern women in Palermo do not hesitate to get involved in the public realm and advance themselves in male dominated hierarchies. The society is ready rather than forced to accept such a change and praises all successful women. I suggest that Palermitan society is ready because women have always been in a prominent position within Sicilian culture. Now that the criteria of status ascription have changed, there is an analogous shift in Palermitan culture, which changes in order to adapt to new conditions. Women are evaluated by the same means because they access the same structures that men do. In comparing like with like, Palermitan men and women are now in the process of becoming equal by definition.

The young are the most progressive part of the Palermitan society, and this age group is the one that adapts the easiest to change. Some of the changes are so strange to Palermitan culture that even those in their early twenties tend to denigrate those between ten to twenty-years of age by describing them as 'Americans'. Francesca, a twenty-three-year-old open-minded Palermitan girl, suggests that all young Palermitans look alike and she calls them '*surfisti*'<sup>25</sup>. The young ones are gadget freaks, spending all their money on technology such as cell phones, i-phones, i-pods and fifty c.c. cars for which they do not need a driving licence. A few years ago

---

<sup>25</sup> She means that they are all dressed in the same way, wearing the kind of clothes American surfers wear.

when Francesca was their age, 'life was simple' and everything the youth needed was a fifty c.c. scooter to go and find their friends at the nearest square. It is even more difficult for parents to rationalise these changes. A forty-year-old father told me: 'Every time my son comes back home he asks me to buy him things I have never heard of before. The problem is that I have to buy him some of these things because otherwise nobody will want to hang out with him.' His friend added: 'If you look at somebody in the street from behind you do not really know if you see a boy or a girl without seeing their face. All boys and girls dress alike in our days!' In another conversation, a fifty-year-old father said: 'When I was young, people used to dress nice, the older men in suits and women in nice long dresses. Now, it is the era of underwear; girls only wear a small piece of clothing and boys lower their trousers to show their underwear. What a shame!' Boys and girls have become so much alike that it is normal for parents to accept their daughters going out with boys or bringing them home; in the past, a boy would visit a girl's parents only to ask her to marry him. As a Palermitan couple has accurately put it: 'Although the youth are more titillating, it becomes more and more asexual. We are not worried if our daughter brings her male friends home because it is the same as if she were inviting girls. You will understand if you see them; boys and girls are all the same these days.' The young in general are far more liberal than all other age groups. Young boys and girls do not hesitate to open their windows or get out on the balcony and chat with their friends who may pass by at any time. They all mix and walk hand in hand on the *Via Principe di Belmonte* as though it were a catwalk, where they show-off their new clothes and style, along with their sense of modernised liberal values which makes the older Palermitans feel uncomfortable. The young have disengaged sexuality from friendship, sex from marriage, and the value of human beings from sex. Although boys and girls learn the traditional sex roles until around the age of ten, they easily

discard them later on. Young Palermitans adapt to current social conditions, but also play a large role in shaping them. Young boys and girls are the most powerful allies of their mothers. Reciprocal support between these allies in both the private and public realm force the pace toward a society that complies in practice with the institutionalisation of equality between men and women.



A fifty c.c. car.

The general stereotype of the Palermitan family complies with the rules of honour discussed in the previous chapter. The ideal size of the family unit correlates with both honour and the economy. The economic conditions seem to affect the family size as well as the ideal conception of the unit. Nevertheless, variations that have to do with social class, property, and specialisation do not seem to challenge the Palermitans' family stereotype. Even changes in the economy do not make Palermitans question the value of the family, because the family unit is the basic social group through which Palermitans cope with their needs, but also through which Palermitans interpret and change their society. In the following chapter I

discuss the interaction between the family and society through various social networks.

## Chapter 7 THE PALERMITAN 'FAMILY-CENTRED' PERCEPTION OF SOCIAL NETWORKS

### 7.1 Introduction

Boissevain (1966) suggests that patronage should be excluded from kin relations. However, Lyon argues that “Boissevain in particular, while carefully defining kin reciprocity of a different order than patronal relations, states that he believes ‘a conceptual distinction can be made between kinsmen, on the one hand, and patronage and friendship, on the other, although in *actual operation of the system they overlap*’ (1966:21, emphasis added).” (2004:72). This is a problematic issue for Boissevain because from his point of view, patron/client roles are voluntary and reciprocal, but within the family unit and kinship, roles can be neither voluntary nor reciprocal for biological and cultural reasons. Moreover, these relations cannot be defined as ‘instrumental’ but are rather closer to Wolf’s perception of ‘emotional friendship.’ However, intrafamilial relations meet the two other criteria that define the patron/client relationship in that relations between ‘kinsmen’ do exist systemically (see Lyon 2004) and in that roles are hierarchical (Boissevain 1966, Davis 1977, Gilmore 1977, Gellner 1977, Scott 1976, 1985).

A particular form of patronage can exist within the nuclear family as far as it concerns the Palermitan case specifically. Lyon (2004) argues that excluding patronage from kinship relations ‘in the Mediterranean context seems feasible and indeed highly appropriate for kin relations since the 1960s’; I agree that this holds true only for those kin relations that exceed the nuclear family unit. Of course, I do not suggest that there is a patron/client relationship in its standardised perception between parents and their children. However, it is particularly true in the microcosm of the nuclear family unit that Palermitans prepare their children for the relations of

asymmetrical power they are going to experience later on in the public sphere. The practicality of the issue does not only lie in the power *per se* that parents exercise over their children and which is legitimised by their role in child rearing, but also in the use of networks they create to help their children. These procedures constitute the first mechanism by which cultural capital is transmitted to the younger generations and is the earliest initiation to a culturally specific thought and behaviour (Benedict 1959, Mead 1930, 1955, 1961, 1964).

This early 'educative' procedure is of first importance to the kids' future as it shapes their ability to make sense of their experiences (Bourdieu, 1990). In other words, the internalisation of externality, or *habitus*, is processed through the 'mirror' that parents provide to their children because the parents are those who transfer their experience of the public to the private life, preparing their children in both a conscious and unconscious manner for dealing with the external. However, this preparation rests on the diffusion of collective perceptions and values which are put into practice only when the children deal with the public sphere. A child's access to the public realm is a systematic process invigilated by the parents. Parents test their children in various situations of escalated risk that first has to do with the geographical distance from the household and the difficulty of the situation at hand. The reward and penalty strategy parents use does allow a child to express its personality but in a culturally suitable way.

As children earn their parents' trust, they learn in parallel not to trust anybody else outside the family unit (the last survey by ISTAT shows that this is a pan-Italian phenomenon but the percentage is higher in the South). What threatens the family is mainly the state, the Mafia, and the poor economic conditions. These three are interwoven and hostile to the Palermitan people in general. Parents nourish a climate

of fear because they too have learnt to live in such an environment, but also because it helps them legitimise their control over their children's lives as well. It is not that something bad will happen, but that something like this could happen and since the enemy is 'invisible' the theoretically targeted fear becomes a vague but general and persisting sentiment of wariness. In addition, the local newspaper and television channels present the news in such a way that enhances Palermitans' suspiciousness. Finally, the Church, which is an important institution in Palermitan life, manipulates this fear to keep the believers close to it as well.

Since *la gente è cattiva*, or 'people are malevolent', the nuclear family is strengthened to the extreme allowing its members to trust only one another. The simplified core cognitive categories for Palermitans are the family and the non-family. This makes Palermitans mistrust even their extended kin, with individuals which they may have some kind of formal relationship. Within the first seventeenth months that I lived in Palermo, I never heard of a child staying overnight at a relative's home in the last ten years although my informants stressed that this was a common practice in the past. This can explain why Palermitans insist that one is alone in Palermo unless surrounded by his/her family.

The perception of the nuclear family as the only safe group in Palermitan culture allows the same means that fragments the society to be the mediator in any kind of social interaction. In fact, the family as a value crosscuts all the centres of power in Palermitan society, which are namely the household, the Mafia, the Church and the state. The fact that the family is the common ground reveals its importance in Palermitan society. To expand, the family as a model of organisation becomes the common characteristic of the above power structures and this is how they practically interrelate. However, this similarity is only organisational. The value of family in its

distorted version serves to accommodate differences between the above centres that misquote it in order to legitimise their power. Therefore, although the family is the basic social unit of Palermitan society, being dressed with both positive and negative sentiments, it constitutes an important contradiction that typifies Palermitan culture.

The above contradiction rebounds to the advantage of those who control the resources and contributes to the maintenance of power in the same hands, which explains the widespread perception that ‘nothing changes in Sicily’. The distorted use of the value of family strengthens the cohesion of each group individually, but it is mostly to the advantage of the State, the Mafia and the Church since the resources are under their control. The Palermitans are aware of this and form patron/client relations only if necessary. On the one hand, the Palermitan family tries to maintain control of its limited resources, because any relationships of a vertical type signify a transfer of rights to the powerful. On the other, the only means of social mobility is to ally with those who have access to resources, which is inevitable. These alliances involve all the family that becomes indebted as a unit although only one of its members may be favoured. This practically means that the family unit provides more to the ‘patron’ than he/she provides to one of its members. For example, when a patron helps a client find work through the regional government, all the client’s family members have to vote for him/her in the next election.

In this chapter, I analyse relations of asymmetric power within the above theoretical framework. The first part shows the central role of the Palermitan family in social networks. I draw from my fieldwork to explain what social networks are, why they exist and how they function particularly in the Palermitan case. I trace differences in time, which I attribute to economic and cultural changes that spring from the redistribution of resources. More specifically, I depict current Palermitan life by

comparing different cases in order to shed light on the issue at hand, and I show how Palermitans smooth relevant contradictions in a culturally coherent way.

### *7.2 The Family and Social Networks*

It was strange for me that in order to do anything in Palermo someone has to find ‘friends of friends’ and go through a social network. From the simplest thing, such as getting a landline installed at home, to the most complicated one, such as being elected to the regional government, Palermitans mobilise a whole network which most of the time is eventually effective. In respect to the examples I mention above, these networks are effective in the sense that some things would be realised nonetheless, but over a much longer period if ‘friends’ would not intervene, and/or in that some things would just never happen otherwise. I was shocked by the power of these social networks the second time I went back to the field; my friends had arranged everything for me this time. I had a place to stay for a rather nominal amount of money and I was provided with food, clean clothes and transportation all free of expense. Moreover, my friends had planned anything that had to do with my fieldwork in detail; within twenty days, I managed to do what took me six months of hard work the first time around. This time all the doors were open for me, and even better, behind those doors there were individuals willing to contribute as much as possible to my research.

It was so tempting for me to find out the way this worked that I eventually indulged; I asked some of my key-informants to arrange for me access to persons and services that I never thought I would ever gain before. The mobilisation of the family was something unique in my experience. I had never seen them working so passionately together, even in previously more important areas. Afterwards though, I experienced

this passion in its extreme in cases when one of the family members was in need of the unit's connections as, for example, when looking for a job. Especially parents talked on the phone with numerous individuals for hours and they drove countless miles around the city to go meet those who could help find a solution. My account of how these individuals were linked became so complicated that even my informants could not make sense of it at the end of the day. Many would say that they did not know how starting from their father we managed to reach the mayor, despite my detailed account of the contacts involved in this, because much of it went beyond their awareness. 'I do not know who this person might have come in touch with,' was what I heard in most of the examples.

My question then was, 'Then how do you know whom you are indebted to in this case?' the answer to which revealed a culturally based pattern: 'I think it is the third person; we are more indebted to Mr. X, but in fact it is not just him<sup>26</sup>. My father called his relative/friend who contacted Mr. X, who got in touch with Mr. Z who works there and can help us out. Therefore, I am indebted to Mr. X.' This in fact shows a flow of indebtedness and reveals the kind of relationships as well as the distance among those involved. The father and his relative/friend are probably in a potentially constant exchange in their horizontal relationship. This means that there is no additional indebtedness in case one helps the other and both are expected to do so. In this case, the 'contract' between them is based on mutual support. The relative/friend's relation with Mr. X is vertical, but access itself entails that the same group favours the father's friend and Mr. X. The same applies to the relationship between Mr. X and Mr. Z.

---

<sup>26</sup> I choose the third person to be a man for reasons of simplification but also because of the density of the phenomenon. I have explained in the previous chapter that this is a male dominated sphere, but this does not exclude women from key positions within social networks.

Schematically:

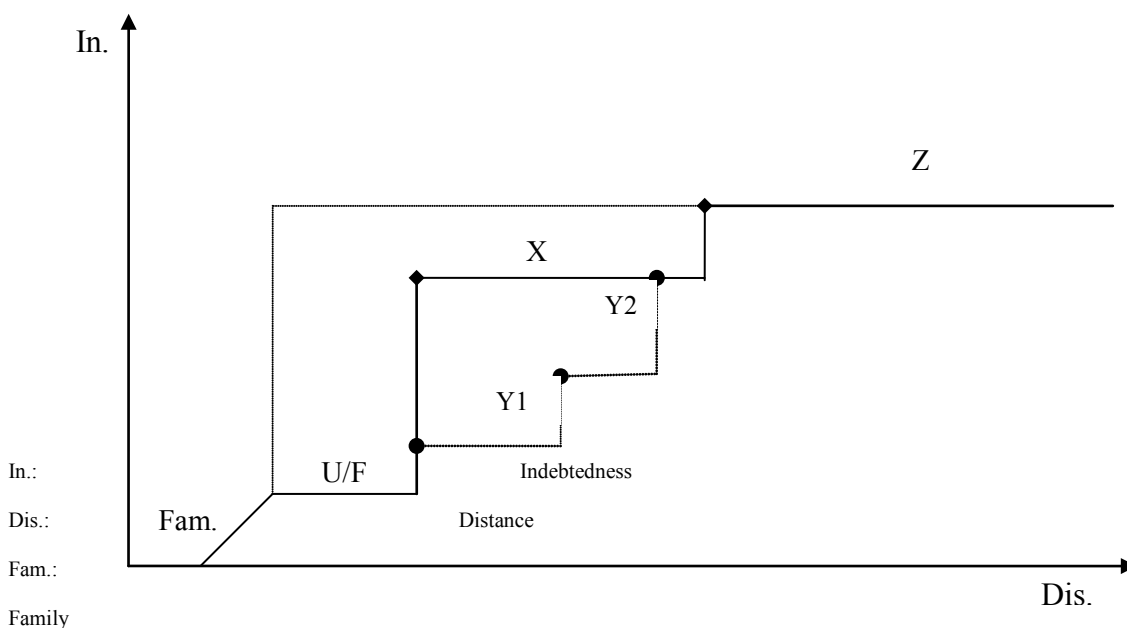

U/F: Relatives of first degree/Bosom friends

Y1: U/F's friend

Y2: Y1's friend

The vertical axis represents indebtedness, while the horizontal represents distance. The greater the distance is, the greater the indebtedness. The distance represents intercommunication; the distance opens as we move from blood kinship, to friendship, and to non-kinship or non-friendship relationships. Indebtedness depends on the differences in power between patron and client, while power depends on access to resources. The greater the power gap is between the persons involved in exchange, the greater the indebtedness. Therefore, if a member of the family unit asked Mr. Z for a favour, the indebtedness of the family towards him would be greater than if the same favour was asked from Mr. X. In other words, the more intermediaries there are the distance closes and indebtedness is reduced. Moreover, in this case, one owes directly only to the first person that he/she comes in touch with and indirectly to all the individuals involved. Although the fragmentation of indebtedness seems to decrease indebtedness, it allows access to the family's resources to more individuals.

This network works both ways allowing interchange, and this is exactly the reason why Mr. Z accepts to help somebody he does not really know. Most probably, Mr. Z will have the favour returned by Mr. X to whom the father's relative/friend owes and so on. Therefore, Mr. X legitimises his position by being close to Mr. Z in a culturally specific way and as an intermediary on which Mr. Z can rely. Both Mr. Z and Mr. X increase their power by 'helping' others. Variations in gaining power and the endurance of indebtedness lie in the kind of help provided as this determines the

expectations of all those involved. This is not a power game for individuals who have relatively equal power and who aim for an alliance that allows a continuous exchange between them.

Asymmetrical relationships presuppose the existence of other symmetrical relations and vice versa as only their coexistence allows the formation of patron/client relationships that function both as a means of social mobility and social control. The patron/client relationships should therefore be approached as culturally driven and perceived, and thus as fluid and constantly changing according to the distribution of resources. Variation in the distribution of and access to resources creates by definition a deviation in power. Change in these variables signifies an analogous social and cultural change because power, which is bound to the control of resources, is redistributed.

In Palermo, it is in the family unit that symmetrical and asymmetrical relationships meet, and it is not surprising that in a family-centred culture family constitutes both perceptually and practically the basis for all social networks. Perceptions of power and the way it should be accessed and manipulated are elaborated within the family unit. In addition, access to social networks is first sought within the family unit in order to diffuse and thus minimise the expected indebtedness that is a norm of patron/client relationships. Therefore, this practice is a form of resistance from the client's side that does not however annul the culturally inherent need of a patron, but it allows the former to manipulate strategically this relationship in order to make the maximum possible profit. The limited resources render patron/client relationships compulsory, and the same reason explains why both sides dress this relationship with a discourse that parallels the family. In fact, patron/client relationships are deliberately dressed with sentiments that 'naturally' exist only between family

members in order to ensure that both sides adhere to the rules of the patron/client relationship as these are only culturally established and not defined by the law.

### *7.3 From Egalitarianism to the Class-System*

Specifically in the Palermitan case, the lack of direct asymmetrical power relations has been until recently blocking the redistribution of resources and from my point of view, this is the main reason of the persistence of Italy's 'southern question' (Schneider 1998). While the peasantry was kept fragmented by the elite and the Mafia, the latter and the Church were the only groups that fought for power. Especially the elite and the Mafia formed a double barrier between the peasantry and the state blocking direct interaction between them. Indicative of the situation is that in western Sicily we are talking about 'absentee landlords' (Blok 1969), and a strong 'army' of mediators or *gabellotti* (see Orazio Cancila 1974), who mediated between the two other groups (Schneider 1976). The *gabellotti* did not allow 'voluntary and reciprocal' roles to grow between patrons and clients (Boissevain 1966).

The only patron/client relationships that existed systemically were between the *gabellotti* and the elite, and between the elite and the state (Hess 1970). However, neither the *gabellotti* nor the elite mediated between the state and the peasantry. The landlords protected the *gabellotti* against the state for all their illegal actions, since these illegal actions were to protect the interests of the landlords. The landlords had the economic and political power to pull the strings of the local administration and the forces of the law. The older generations in Palermo recall stories of that period in which they emphasise the lack of rights for the peasantry and a sense of impotence against the will of the powerful. Although the *gabellotti* were practically the patrons

of the peasants, mediation with the state was impossible because of the illegality mentioned above.

Even worse, the only forms of power that Palermitans experienced in their everyday life, the *gabellotti* and the elite that were already hostile to the peasantry, diffused the perception that the state is even more hostile towards the Sicilian people. Although the local elite ruled behind the scene, they used the image of the state as malevolent to their own aims. The same elite allowed the story of the *Beati Paoli* to be published in the local newspaper *Giornale di Sicilia*, which was the only and widespread means of information (see <http://www.bestofsicily.com/mag/art13.htm>). Widely known among Palermitans, the story of the *Beati Paoli* corresponds to that of Robin Hood, and thus can be seen as an indirect means used by the elite to control the poor. The story, which is about a secret organisation which redistributes money stolen from the elite and the Church to the poor, was used to lessen the pressure that the peasantry experienced and to highlight the distinction between these groups as well. Schneider stresses: 'The manipulation of them (a swollen subproletariat of underemployed and landless) enabled the successful patrons to accumulate enormous funds of power, enough indeed to both exploit the peasant class, and to "draw off" or absorb whatever rebellious tendencies it might produce.' (1969: 110-11).

The gravity of the above issue, which is a representation of the state as hostile towards its own citizens, is intense especially because Palermo became Sicily's administrative centre after Italian unification, a fact that proves by itself the power and the aims of the local elite. Unlike other cases in the Mediterranean, the Sicilian power centres did not mediate the relationship between the peasantry and the state. Wolf argues: 'the patron offers economic aid and protection against legal and illegal exactions of authority.' (1966: 87). Similarly, Campbell (1964) whose work is on the

Sarakatsani of northern Greece, Pitt-Rivers (1966) who draws from Andalusia, but also Kenny (1968) who also focuses on Spain but in particular on Castile, are in accordance with Wolf in that the role of the patron is to protect his client against the state. Even on the island of Pantelleria that is close to Palermo, Galt shows how in 1974 mediators bridge the gap between their clients and the state. Therefore, one can argue that the Palermitan elites wanted and could protect their resources by alienating the state and its citizens at least until the abolition of feudalism in the nineteenth century.

In the *Festival of the Poor: Fertility Decline and the ideology of Class in Sicily, 1860-1980*, Jane and Peter Schneider (1996) describe how in the period after unification, the redistribution of resources shaped new balances and perceptions of power which vastly altered the issue of representation in the terms of class<sup>27</sup>. In an earlier paper, Jane Schneider traces the first redistribution of resources in the aftermath of World War I. She argues that this redistribution went on until after World War II, but in different forms and ways. Although she simplistically argues that patron/client relationships existed long before and were 'put together by particular land-owners and leaseholders' in the nineteenth century, she claims that '[t]hese were usually associated with rural mafias which, following the unification of Italy, functioned as vast "election making" machines.' (1969: 110). In order to highlight the change, she claims that the outcome of this procedure is the following: 'In most parts of the island, land is distributed far more equitably than ever before, while the rural mafias and their electoral clientele have declined.' (ibid: 111).

The above shift in terms of representation was based on the democratisation of the country and mainly the laws about the redistribution of land, as well as on the access to other resources that Palermitans gained by immigration (see Silverman 1965). The

---

<sup>27</sup> See also Silverman 1965, for a discussion of the same issue in central Italy.

economic growth experienced in Palermo after unification with the passage to capitalism allowed other groups, such as the ‘upwardly mobile gentry landowners or the so-called *civili*’ that Schneider and Schneider (2003: 11) give examples of, not only to acquire property but also to invest in education and specialisation. These investments in turn created new resources in the Palermitan market (see also Epstein 1992). The expansion of the city northwards is the geographical expression of Palermitan economic growth from the Italian unification onwards. This expansion however corresponds with the empowerment of the Mafia through its engagement in the construction business and its deeper infiltration into the political world (Schneider & Schneider 2003).

However, the capacity of the Mafia to adapt and first fill the gap between the, according to Galt, ‘real’ and ‘official’ system did not allow other patrons to come into play and thus Palermitans to acquire class-consciousness until recently (Galt 1974, Hess 1973, Catanzaro 1992, Schneider and Schneider 2003). I believe that only today is there a conscious middle class in Palermo, defined by the criteria of education, income and social status, and which in turn defines the boundaries between the lower and the upper class. I perceive the above positive result to be the outcome of a process that mainly involves the anti-Mafia struggle and devolution that springs from the centralisation of power at both the national and the European level. In addition, I argue that this is a positive result because the role of the middle class is determinant in the institutionalisation of moral principles that relate to important issues, such as meritocracy, the Mafia, and national integration.

The middle class that has sprung from the particular context given above <sup>28</sup> -which was marked by the diffusion of the state through administration, redistribution of resources, and urbanism- has not been until recently powerful enough to succeed in

---

<sup>28</sup> For a more detailed account, see Schneider & Schneider (1976, 1996, 2003).

its role. Although the state ‘drew from this pool’ to staff its administration, at the local level meritocracy was displaced for the sake of its clientele. The weak Palermitan economy contributed in making the struggle for these prestigious posts even more antagonistic and thus favoured the patron/client relationships within the state mechanism. The system was corrupted because the new resources were never seen as ‘*cosa nostra*’ (our thing), but as a new means of personal economic growth through the abuse of administrative authority that was/is rather viewed as alien. Only in the last decades, has the administration begun to rationalise those procedures as detrimental to itself thanks to initiatives at the local, national and the European level, a fact that has rapidly changed Palermitan society. Many suggest that this change is best reflected in the Palermitan middle class. A professor at the University of Palermo has put it like this: ‘The middle-class in Palermo has been accused of many things, but today we are proud that we have become the number one enemy of the *mentalità mafiosa* (Mafia mentality) that has long characterised our society. We have undertaken the task to reverse the situation and convince our fellow citizens that our culture is not *mafiosa* but that the Mafia has falsified it for reasons we explain in detail. Everyday, we win more supporters and you can feel the optimism in the air. Palermitans change all those practices that link to the Mafia; they trust the law more than the word of a Mafioso. This is the first time that a social class can motivate all the society to participate in a collective action that will change everybody’s future. The result is visible even in the poorest areas of Palermo, but there is a long way to go; I feel that we have just started.’

Since economic conditions and social practices are interwoven, cultural change can only be the outcome of economic growth and stability. I consider the above optimism summarised in the professor’s words to be well grounded, but on the other hand, I also agree that there are many more steps required in the same direction to

ensure the result. The last economic recession held this process back as it widened the gap between the upper and the lower classes; the economic insecurity undermined Palermitans' morale. Although patron/client relationships are not inherently a negative practice, this kind of relationship is a setback to the democratisation of the Palermitan society in particular. On the other hand, meritocracy that is widely appreciated by the current Palermitan middle-class brightens the future because it becomes an effective weapon against favouritism that has deprived, mentally and practically, Palermitans of freedom. This freedom entails direct and transparent communication between the state and its citizen.

#### *7.4 Neighbourhood, Class and Social Networks*

Life in the neighbourhood revolves around the local Church, market and other places that provide services, i.e. restaurants, cafès and so on. The streets are always busy, and in some cases, this is the main reason that people go to the nearby piazzas to relax. The neighbourhood is so active that any time one goes out, he is sure to meet a neighbour in the street. Therefore, Palermitans dress well even if they go to the corner to buy cigarettes at the local *tabacchi* store. The local *tabacchaio* is also a central feature in neighbourhood life. The same applies to those who work at the local *agenzia immobiliare* (the estate agents). Moreover, the poorer the area the more developed the social relations between neighbours. This is because the lower classes spend more time in the public realm than the upper classes and this in turn depends on the time spent at work. In this sense, the elders and the young are more social than the middle aged. It takes time to understand the relationships between neighbours because Palermitans do their best to let others know as little as possible about their lives. Although they love gossiping, Palermitans do not want to be

gossiped about. There is such uniformity in the neighbourhood that the inhabitants of the same street can be seen as forming a small egalitarian society. The borders of the neighbourhood are clear-cut in Palermitans' minds<sup>29</sup>. The centre of the neighbourhood is always the main street where there is a square or the local church sits. Neighbourhoods in Palermo are parts of larger quarters. This division in quarters may well suit administrative purposes, but is also a time indicator of the city's gradual expansion north-west from the old harbour. Each quarter and neighbourhood has its own reputation and both reflect their inhabitants' social status. Nearby neighbourhoods speak in different accents if not dialects, and thus language becomes an indicator of residence and of social class. The areas around the city centre are poorer than the periphery. Nevertheless, Palermitans visit in masses well-known areas within the city even though many of these destinations are in fact located in some of the poorest neighbourhoods of Palermo.

I want to depict Palermitan daily life by comparing three different neighbourhoods, in terms of geography, status, and relations between neighbours. I start with my own experience as a resident in the historic centre of Palermo. I lived in a street close to the *Piazza Marina* of which Schneider and Schneider (2003) provide a vivid description in *Reversible Destiny*. The closest church to my residence was that of San Francesco d' Assisi. This area has gone through a long period of degradation, but it is winning its prestige back as Palermo's cultural centre. As a result, renting a house there is costly due to high demand and limited availability. However, this district is the most representative sample of Palermitan life because of the variety of its inhabitants' social status that is symbolically expressed in its architecture as well. Within the period I stayed there, I saw the area transformed and become a popular destination for Palermitans from every corner of the city. It also attracted many

---

<sup>29</sup> There was an unparalleled uniformity in terms of Palermitans' understanding of their neighbourhood's physical boundaries.

tourists because of the various festivals the municipality organised in its attempt to promote the intangible cultural heritage of the area<sup>30</sup>. The residents of the historic centre welcome these initiatives, which they see as changing their lives for the better. The most important change in the last few years is that they now feel safe to walk around the paved narrow streets of their neighbourhood. The second area is at the west of the historic centre. It is a poor neighbourhood with a patron saint for the poor (Sant Onofrio) and residents in the district are mainly artisans and traders. The setting is unique and full of contradictions; reconstructed buildings lie next to ruins from World War II, and children of poor families play with cultural treasures they find in the underground tunnels dating back to the Norman period in Palermo. The third neighbourhood is in the northern part of the city, the characteristic trait of which is the huge apartment blocks built through the instrumentality of the Mafia. This third neighbourhood is mainly occupied by middle and upper class families.

### *7.5 The Centro Storico*

Usually Palermitans live their entire lives in the neighbourhood they were born in, the lower the social class the closer to their parents' home even if the relations between them are strained. Only a few move to the periphery of the city when their economic status changes. Palermo is divided into thirty-five *quartieri*, and into eight governmental community councils for administrative reasons. These eight areas and the neighbourhoods in them are the geographical expression of class division. In the centre of each neighbourhood there is a main church; the building itself, as well as the saint it is dedicated to, indicate the conditions that prevail in the area. Poor patron

---

<sup>30</sup> For more detail visit UNESCO's page: <http://www.unesco.org/culture/ich/index.php?pg=00002>)

saints and simple churches thrive in the lower class *quartieri* of Palermo, and vice versa.

The local church is of central importance in the neighbourhood's life; the character of the neighbourhood conforms to that of the patron saint, the ringing of the bells and religious feasts harmonise the neighbourhood's rhythm of life, and the celebration of the mass is the symbolic representation of the neighbourhood's daily life. For example, only by the way the believers are seated in the church can one understand that there is a division in terms of gender and status. The status of the believers does not depend on material, but on spiritual wealth. In other words, the criterion of status in these kinds of egalitarian groups is measured by the daily contribution of each believer to the local church.

Mostly old people who were born there, and a few others who got married to someone who already lived there, inhabited my neighbourhood in Palermo. The relations between neighbours were extremely formal. In fact, the connection between the neighbourhood and the rest of the city were the children of the older people, who visited their parents every now and then to help them deal with bureaucracy or other heavy duties. The houses had almost no balconies but even where there were, they were covered with thick sunshades. Everybody knew details about everybody else in the neighbourhood as if they were best friends. However, even the residents of the same apartment building did not exchange more than a formal salutation. The same applies to their relationships with the people of the nearby market or the various shops and restaurants in the area.

The integrating force between observant neighbours was the Church of San Francesco D' Assisi. Our best friends in the *palazzo*, Gaitano and Giovanna, were a religious older couple. The couple had a second residence opposite the *palazzo*

where Gaitano used to work as a carpenter before he retired. In one of our discussions, Gaitano told me that people appreciate them because he stills works for the local church free of charge. Both he and his wife suggested that people are divided into two groups: 'those who are good and those who are bad.' The neighbours can tell who is a good or a bad person without knowing them personally. One could understand just by going to the church. The church they told me, 'Takes care of us. God protects us. We are satisfied because we have many good friends. We met them all through the church. Friends of ours call and ask if we are going back there for vacation again. Last time we did, we went there by the church's bus. Once we got off the bus, our friends had prepared food to welcome us. Sergio, you cannot imagine it...we were eating all day long; this is how much they love us! With these people here, we may not exchange a single word for days, but when we meet in the church, it is different; we are all brothers in the house of the Lord.'

Gaitano and Giovanna are mostly satisfied with the fact that they do not depend on anybody else. The couple has no reason to be in any other network than that of the church, because as they say God has blessed them with a decent life and love. They do not have any sons, and the only one who visits them regularly is Giovanna's sister who lives next door. However, when Gaitano needed to go to the hospital, people of the local church arranged for him to bypass bureaucracy and to be attended to by a good doctor immediately. Since the couple are self-sufficient there is no need to connect with anybody else. People in the neighbourhood appreciate them for this, but also for their kindness and their low profile. The couple express the same feeling for all but one couple who have stigmatised the whole neighbourhood. All neighbours stress that, 'This man is evil and his wife, even if less, she is evil as well. You should have expected that since they never go to the church.'

## 7.6 The Sant Onofrio Neighbourhood

The scenario in the *Sant Onofrio* neighbourhood is much different from the above. The characteristic of this area is its market; one can literally find anything there, from food to stolen cars. No matter the specialisation of each trader, he/she can also sell completely different goods from what he/she is typically known for selling. People there are proud of two things, first of being *furbi* (or clever) and second for their wide circle of acquaintances. Although this society is agonistic, there is a sense of ‘suffering together’ in a religious sense that unites the neighbours. Thus, people in this neighbourhood sympathise more with one another and help is mutual. The unwritten rule is to take advantage of the outsiders, but never of your neighbours. Therefore, although religious feasts are an important aspect of the neighbourhood’s life, trade shapes their lives; however, trade commands communication skills and socialisation. Since whole families in the area have the same specialisation<sup>31</sup>, the natural outcome is strained relationships with relatives and this climate favours the growth of social networks.

Corrado once told me: ‘I know everybody in this quarter; we were all born here and I have known them since we were kids. I know everything about their families, as they know everything about mine. You can see us sitting outside our shops with our kids and wives. People pass by and salute us, and we ask them to come in and have coffee with us. Unlike our homes, our shops are open to everybody. So, if I want something or the other wants something from me, we just ask. Of course, both of us seek to make a profit, but when someone is financially strained, we show empathy. Conditions of repayment often depend on the level of familiarity with the given person. Maybe, the one we helped today will help us tomorrow. We do not expect

---

<sup>31</sup> The kids learn their parents’ job and, after they get married, they become competitors in the same market, although this is changing nowadays.

anybody else to help us, and especially the politicians, who all they do is collect taxes from us the poor but not from the rich. For this reason, the more people you know the safer you feel and the easier it is to make money. For example, the other day a young boy came asking for a *Vespa* (scooter) engine. The other day I was having coffee with my friend who told me that he wants to sell his *Vespa*. I asked the *ragazzo* (lad) to wait here, and I went to my friend's. I estimated the amount of money the lad was willing to pay just from his appearance and therefore I negotiated the price with the owner of the scooter until I made sure that I make enough profit before I closed the deal. Had I not been aware of this opportunity, I would not have made some extra money, would I? Look at my son; he is playing with my supplier's son. In the future my son is going to do what I am doing today; he is going to make use of his network in order to maximise his profit.'

Social networks in this area are far more complex compared to the first case because of the market. Every person in the wider area of *Sant Onofrio* is a part of various social networks which are interrelated. There is an important difference between the two neighbourhoods discussed above; in the first case, the economic status of the neighbours allows the inhabitants to go for the best quality in terms of products and services. Therefore, their reputation rests on the money they spend in the market for specific preferences in restaurants, cafés and so on. In the second case, since most of the neighbours are traders and the market provides them with more options, they go for the best quality at the lowest price. This demands a good knowledge of the market. Hence, in the first case social networks are less developed than in the second, where apart from knowing the market well, one has to ally more often with others for doing business.

### 7.7 A *Posh Neighbourhood*

The third neighbourhood in the newest area of Palermo, north of the historic centre, differs from both the above neighbourhoods. This is an economically vibrant area with famous brand-name stores on both sides of the main avenue. Above these ground floor shops there are large attached blocks of flats that house several rows of ten or more individual family units. A couple of these apartment complexes, if not just a single one, can cover a single block. However, apartments there are new and cost much more than in any other part of the city. Therefore, Palermitans who live there are of a certain social status. Even if this is the cleanest and safest area of Palermo, all blocks of flats have a concierge if he is not superseded by CCTV (closed circuit television). In all the cases I am aware of, only the concierge or the man operating the CCTV cameras knew all the residents in the *palazzo*. Most of the residents in this kind of *palazzi*, although they would greet one another while coming in and out, they did not really know their neighbours, as they admitted.

Equal social status among men who live in the same *palazzo* cannot alone become the basis of social relations between them; instead, some of their wives meet or at least talk on the phone on a daily basis. Kids are the best ‘excuse’ for social interaction amongst the women. Although all Palermitans are extremely cautious with their children, women are attentive guards of them. Many of the women living in this area do not work, as the salaries of their husbands are high enough to sustain the family. Therefore, the role of the women is limited to child rearing. Of course, even in the case when women work, they still have more responsibilities towards their children than their husbands do. Usually, fathers spend most of the day at work. On the other hand, mothers have enough time to socialise. They visit one another to ask for help in domestic tasks and talk while watching their children playing

together. Between some of them there is constant exchange of low price products, such as onions, eggs and so on, which is an excuse for socialisation and mutual psychological support. By contrast, men develop social networks in their working environment that they use for the good of their families.

Although women are in constant communication, men do not help other families in the same palazzo as may be expected. Instead, they use their power that springs from their high position at work and their key positions in the administrative system only for personal advancement. Most of them claim that climbing up the social ladder is not an egoistical aim, but a way to protect better their families. Giuseppe's words speak for all men: 'Why should I help somebody I do not really know? I have never expected help from anybody else. All I have achieved is the result of hard work, and this hard work is appreciated in my environment. My word counts! In case my daughter wants to work, she will get a good position in a blink of an eye. Why should I waste it on somebody else?' Indeed, fathers of this social group can be far more helpful to their children. When children take up a post, both they and their fathers are expected to return the favour whenever this is asked, and this is how social networks evolve in this case.

The three examples show how neighbourhood and class affect social networks in the same culture. Although I agree with Schneider (1969) that the redistribution of resources allows more 'horizontal coalitions' (p. 109), the 'two-person ties' approach of 'action-sets' is an oversimplification of the complex social networks that exist nowadays in Palermo. These can be both horizontal and also vertical if observed in a wider context. For example, the first group may be perceived as egalitarian, but from a greater distance one can see the church as well, and the fact that it plays the role of the patron. Similarly, in the second case, there are differences in terms of wealth, for

example, that allow patron/client relationships, i.e. between the trader and his supplier. In addition, the third case reveals that relationships in the working environment can be strategic alliances of the vertical type that meet the criteria of patron/client relationships.

The new trend, however, is that the young are not keen on perpetuating this indebtedness because it is a heavy burden. On the one hand, they struggle for merit because they have invested much in education, and thus they believe that the skills they have acquired should be the only criterion for employment. Therefore, to be indebted to somebody contrasts with their ethics, in the sense that if they are 'helped' by somebody, then they in turn will have to help somebody else and bypass the meritocracy. On the other hand, to be indebted to someone blocks the progress one could have made in case he/she was not dependent on the person who grants him/her access to a specific network. In other words, this indebtedness serves the young client ensuring a quality of life similar to that experienced at home, but it is also the means by which the patron gains enough power to safeguard his/her role in this relationship. By questioning this continuity, young Palermitans' resistance expresses a cultural change: 'I am not my boss's slave because he is the one who needs me and therefore he should respect me. He should only pay me for my services and our relationship ends there.'<sup>32</sup> When my friend Francesca applied for a post in the regional government, she had to compete with a large number of other applicants. I asked her if she had any chance and she replied that it would be difficult for her to get the job. The reason was that some of the applicants' parents were already working for the regional government and 'they knew people' as she generally put it. My next question was whether she was going to use any of her family's 'friends' to

---

<sup>32</sup> See Kertzer (1983) for a discussion of unemployment in Palermo and the networks involved to cope with this problem.

increase her chances, but she replied that she would never do what she stood against. 'These are not real friends...' she said among other things.

### *7.8 Friends*

It took me some time to understand what Sicilian 'friendship' really means as it was quite different from the Greek and English sense of the word. In Sicily, friends are not just friends because they like one another, but because they have grown up together. Asking my informants about their friends, I found out that they divide them into two categories: those who came into their life in their childhood and others who happened to meet later on in their lives, which they define as 'satellites'. Of course, there are exceptions of Palermitans who became close friends at an older age. However, even in this case, another close friend introduced them; the expression used in this case is that one 'was born as a friend', when another close friend introduced him/her to the rest of the company. Most friendships in Palermo start at an early age; Palermitans become friends in the neighbourhood and at school, therefore they socialise with friends that parents approve of and trust due to their families. Since friends come from the same neighbourhood, they are also of the same social status. Palermitans depend a lot on their friends, and when they become adults, they can count even more on them than they do on their family. As they say, friends are brothers and are thus part of the family. Even better, friendship is less obligating than kin ties as Davis (1973: 60) argues. However, Palermitans have more expectations from their friends than from their relatives exactly because relations between friends are less obligating. A friend helps out of choice and because he/she feels like doing so. Therefore, friendship is based on exchange; this can be of insignificant value, i.e. one gives a lift to a friend, or of vital importance as for

example lending huge amounts of money with no interest or contract when a friend is in need. Friendships of long standing form an egalitarian social network, the function of which is to provide its members with the security of constant and mutual support at the minimum cost in terms of indebtedness.

Being able to rely on a friend is an everlasting process that starts in early childhood, even before Palermitan children go to school. At this age, Palermitan kids spend all day with their parents either at home or at work, depending on the nature of parents' work. In all cases however, friends are from the same area and of the same social status. The first friends of a child are either from the same *palazzo* or from the shop next to that of his/her parents. Therefore, friendship at an early age is not really a matter of choice although a child can choose between a limited number of options, but it rather depends on parents who their child can socialise with. Children cannot go anywhere without their parents and as I have argued above, children are a good excuse for mothers to share child caring while they talk among themselves. This is an early and compulsory socialisation for children who have to learn how to cope with other coevals. Friendships starting at an early age have a future only in the case when children who have become friends under the above circumstances meet again at school.

School age is the most important time for making friends, at which point young Palermitans choose their own. Although the choice of friends between pupils rests on the values that are the moral bedrock of their family, these are put to the test in interactions with other coevals. Most of the stories older Palermitans evoke from this period of their lives have to do with experiences that their parents would disapprove of and therefore have been kept secret. Gianni is in his late fifties, but he still recalls one of his childhood adventures as if it happened yesterday: 'My friend and I had

seen this brand new red football in the store and for a week or so we were planning how to 'borrow' it for a while. We asked our teacher's permission to go to the toilet, but the first time she said no. The second time though we took the ball but we did not know where to hide it...extra tension! Another teacher saw us and we tried to hide the ball behind our backs but it was much bigger than we were. We were so scared about the consequences, but the poor man did not really want to punish us. He asked us to tell our parents what had happened, and that for what we had done we had to go back to school to clean the forecourt later in the evening. Of course we could not tell our parents and we had to think of an excuse to leave our homes and go to school again. I said to my parents that I had to go and study at my friend's and he said that he is coming to my place for the same reason. Although we were worried for some time about whether the teacher said anything to our parents or if they would discuss anything about our 'homework', eventually everything worked out fine and since then Giuseppe and I have been best friends.' In the process of 'weaning', one is bound to make mistakes and the children's attempts to cope with them, while leaving their parents in complete darkness, strengthen their friendship.

Palermitans may talk about mutual trust between friends, as well as reliability, but underneath is hidden the belief that what makes a good friend is his/her ability to help under any circumstances. This becomes more obvious between friends of an older age, from the university years and beyond, when Palermitans become more autonomous and can provide more for their friends. Since thus far the members of a fraternity have a common course, the criteria of membership are clear. After all, at this age, Palermitans have chosen what they want to do in life and changes in the fraternity signify contrasting courses in life. Nevertheless, the same criteria that rejects, also allows a fraternity to integrate new members. Most of the companions' satellites appear in this period, for Palermitans socialise with more people at work or

university, which may not be the same for all members. Those that come in are either fully or partially integrated and this depends on older members who evaluate them over time. Only time can tell if one is good enough to be a close friend, evaluated by the criterion of how much he/she contributes.

School friends help one another with their workload as university friends also do, the difference between them being that the older generation builds its own networks at university or work that they use either to their own advantage or to help friends. The majority of current university students repine against the practice of *raccomandazione*, or of favouritism; instead, they use the skills they have developed in their field to fortify themselves against the *raccomandati*<sup>33</sup>. University students have to invest in personal relationships as much as they have to do in their studies. Therefore, the situation at the university necessitates the development of social skills along with those related to specialisation. Claudia, a fourth year university student of the *Facolta di Lettere* (letters) argues: ‘It does not really matter how good you are. It depends on whom you know. Even if you are the best, somebody else who has no idea of where the university is can be employed in a position that requires skills that only I have.’ Fausto (*ingegneria/engineering*) comments: ‘It takes more time to graduate not because you are not *raccomandato*, since you can study and pass the exams, but because they do not allow you to. For example, we should sit exams at the end of June but the professor decided to change the date to mid-June, because his son had to finish earlier and apply in time for postgraduate studies to other universities. The problem is that we did not find out there was a change in the

---

<sup>33</sup> The *raccomandazioni* practice evolves three individuals: the *raccomandatore*, or the one who, being in a position of power, asks the *raccomandatario*, who is in a strategic position, to favour the *raccomandato*, or the one who wants to be favoured. This practice thrives at university and the public sector, but exists in all other hierarchies as well. It is an important issue in university students lives because of its intensity and its effects on their progress. For example, a politician’s or a professor’s son or daughter can graduate with a ‘first’ much sooner than other students and without attending any classes. The major problem however is that the ‘favoured’ deprives better students of the chance to secure a job they deserve.

schedule until the end of June. Do not think that this is an exception; this is the rule!’ Then Irene, a medical student (*medicina*/medical studies), explains: ‘The first days at the university are a shocking experience; you do not know how things work and you run around like a headless chicken. Later on, when you make friends things become clear. One helps the other. We fight against the *raccomandati* together. When my professor asked me to participate in a programme funded by the regional government, I proposed that Aurora be part of the team, because she could be quite helpful in this. Both of us now have equal chances with the *raccomandati* because our professors know that we are good in our field.’ The same applies to those who work; friends help one another to find a job although the difference between the past and the present is that nowadays Palermitans propose friends who are adequate for specific tasks.

However, the fact that more Palermitans become specialised and the majority of the young invests in education, in combination with the scarcity of resources, has contrasting effects on friends. On the one hand, friends help one another to advance and this way maintain uniformity within the group, which in turn results in group cohesion and increases the benefit –of mutual support- for all its members. On the other, intense antagonism restricts social relations to the companion level thus downsizing the amplitude of social networks. This conscious action aims to protect friends, but it restricts the options that could come in useful, as well. Palermitans are strategic with their friendships; they are members of different groups of ‘friends’ that never mix. Since friends in Palermo translates into resources, the more networks one has access to equates to increased chances in ‘finding the right person’ (*la persona giusta*) that can be useful to the situation at hand. By mixing different groups of friends, one loses the presumably exclusive access to the person in the ‘right’ or strategic, position. Therefore, only close friends exchange detailed information about

their networks when this is necessary, or in other words, when a friend's contribution to the situation at hand is considered of vital importance.

Friendship is far simpler when no interests of the above kind are involved; but even in this case, the instinct is not exactly altruistic. Palermitans go to places owned by friends or to which friends of theirs work. The justification spoken loudly and openly is that they do this to support their friends. Nevertheless, another reason is that they want to make sure they will be treated well, and that they will be taken care of by somebody they trust, but this is always muted. The same applies to the market; Palermitans are obsessed with quality and a good way to make sure that they get the best product at a lower price is to buy it from a friend. Mistrust towards strangers and cautiousness even among friends, result in a general insecurity that regulates the Palermitans' universe. Especially when it comes to female friends, Palermitan men make sure that the girls have entered their homes and they are safe before they leave the neighbourhood<sup>34</sup>. The same role is also played by older cousins of the same sex, or by young aunts and uncles, whose relationship with their nieces and nephews accordingly is defined by both sides as friendship. Close friends, or *amici di cuore*,<sup>35</sup>

---

<sup>34</sup> One summer night, I had been out with my friends when Paolo asked me to join him to return Maria along with him to her place. When we arrived, Paolo asked Maria to ring him as soon as she entered her home in order to assure him that it was all right before we left. Once she got into the palazzo Paolo started driving away at low speed, but as Maria did not call back in time Paolo reversed; we jumped over the high fence and started running towards the entrance. That was when Maria called to listen to Paolo berating her because, as he said, she should first call him and discuss it with her father after this. It took Paolo some time to calm down while he was explaining to me how dangerous this area was and how responsible he feels about his 'sister' Maria.

<sup>35</sup> In Palermitan culture all sentiments are perceived to spring from the heart (*cuore*), a fact that from an organic view reflects how important they are in Palermitans' lives. When a Palermitan argues that a person is in his/her heart, it actually means that they would even die for this friend. Many couples call each other *sangò*, which derives from *sangue mio*, or 'my blood'. Since couples are not relatives, they use this expression to show their love towards their partners, which resembles the love felt between family members. There is no clear distinction between family, close age relatives, partners, and bosom friends. Roles interchange between relatives and friends, as can be observed in discourse, i.e. 'he is not a son of mine, but a friend of mine', helps demonstrate that one's strong feelings for the other do not exist due to a 'compulsory' relationship, but are a matter of choice. This allows the minimisation of indebtedness in the exchange of favours. Palermitan culture disapproves of any expectation of payback when one helps a friend, as is also the norm between family members. However, as has been argued in the above text, the older Palermitans get, the more they expect from friends rather than from relatives. For example, when a forty-five year old Palermitan went bankrupt he said to me: 'I do not expect my parents to help me although they are rich. I am not worried though.'

are part of a family's social network; bosom friends are linked indirectly to the family of the other through fictive kinship. In addition, cousins, aunts and uncles renounce blood kinship because it is not a privilege; instead, they prefer to be friends with their relatives because they can share more this way.

Groups of friends function as a network, the members of which are bound together with relationships of a horizontal type. In these networks, anyone may have a specific role that depends on the access he/she has to specific resources. Geographical and group size limitations result in gaps between the group's needs and other resources to which none of the group members has access. The so-called 'satellites' fill in the gaps, but if these gaps were a constant the group would probably incorporate other members to bridge them. Therefore, those resources the not-so-close friends provide with access are of secondary importance to the core, or satisfy impermanent needs and exigencies. These two cases differ in terms of indebtedness; for example, when I decided to rent a car in Palermo, Francesca told me that she has a friend who owns a rent-a-car company. She would ask for a good price, but I told her that there was no reason she should be indebted to him. Her answer was that we would pay him anyway, and we chose him instead of someone else, therefore he helped us as much as we helped him. By contrast, 'impermanent needs' can be met only through relationships of unequal power. For example, when Gabrielle had to take his father to the hospital he called a coeval of his of which he told me: 'I know this doctor from my childhood, but we are not friends in the strict sense. However, he is the only one who can help me with my father. I do not really like this situation because for as long as I need him I will be suffering his presence,

---

A friend of mine with whom I used to work alongside in the past is now well off, and he is going to support me. I am sure about this because when we started working together he did not have a single penny in his pocket and I used to buy for him and his family whatever I would buy for myself or for my own family. Even simple things; when I bought coffee for myself I bought for him as well, and so on. Now, I expect him to do the same thing, because we are more than friends, we are brothers.'

and even when all this is finished I will still owe him, but he is never going to be a friend of mine.’

The idea is that a group of friends must be egalitarian, in opposition to patron/client relationships that the unequal access to resources commands, and the process to achieve it requires strategic integration and the exclusion of others. Egalitarianism allows the exchange of favours among friends to resemble, sentimentally, family relations in which mutual support is considered a given. Therefore, friends become family members as family members become friends. This family-centred approach to friendship shapes the Palermitan perception of the public, and thus one can trust only a handful of individuals and deal mainly through them with the rest of society. However, it is impossible for Palermitans to have friends in all structures and consequently turning to non-members of the core group is inevitable. Groups of friends in Palermo are the only viable form of conscious resistance to patron/client relationships; friends share their resources in order to limit intermediaries.

The discussion of unequal access to resources in Palermo reveals far-reaching implications for the future of Palermitan society. These implications involve Palermitan culture and consequently affect Palermitans’ perception of the private and public sphere. Communication between these two spheres is achieved through the family unit. Idiomorphic structures of power reflect the centrality of the family unit in social networks. In other words, the family is perceived as the means by which Palermitans communicate with relatives, friends, the Mafia, the Church as well as the state in a wholly artificial way. This entails the Church’s, Mafia’s and State’s manipulation of the perception of the family in ways that allows them to retain their power or even increase it. However, the family is a means of resistance as well; for example, friendship dressed with sentiments that exist among family members

allows Palermitans to cohere and deal better with the issue of access to scarce resources. Having discussed all the parameters that I consider important in shaping Palermitan interaction, I will analyse in the following chapter how the Palermitan identity is in constant ‘building’ through the interaction of individuals within the greater society, thus shaping culturally specific ‘boundaries’ of various kinds.

## Chapter 8 MARKERS AND MANIFESTATIONS OF IDENTITY

### *8.1 Introduction*

*Sökefeld* (1999: 418) argues that a way to explain the interaction between individual and society is by focusing to the internal plurality and multiplicity of the subject. *Devereux* (1972: 162) holds that variations between subjects instead of dividing them allow them to group, because they are alike, through a ‘human identity’. *Foucault* (1979) sees the individual as a constructed self, but after *Cohen’s* suggestion for the rehabilitation of the self (1994: 192), *Rapport* (1997: 2) stresses that individuality is the root of the social and the cultural. ‘Culture’ also has its own course in the social sciences because of shifting approaches of its relation with the individual (*Cuche* 1996). *Alter* stresses that individuals identify themselves with various entities, such as a family, a religion, a class and so on, but also with a nation and a region, and they can move between these identifications according to the situation at hand. He also argues that there can be tension between centre and periphery, the periphery struggling for political, economic and social equality with the centre, while the nation-state tries to preserve its integrity and cohesion (1994: 98). *Barth* (1969) suggests that individuals can also change groups, although this does not affect the groups’ boundaries. In this case, it would be difficult to define with which society the individual interacts, especially nowadays that ideas and people can easily travel around the world. It is also out of the scope of this thesis to try to focus on each aspect that constitutes ‘the internal plurality and multiplicity’ of the subject. Instead, I focus on Palermitan identity by using data that I collected from informants who live in Palermo. This may be a limitation, but it can also be argued

that this limitation is counterbalanced by my first hand experience of the interaction between Palermitans and their local society.

Although I perceive boundaries as constructed, I see the physical borders of the island of Sicily as a significant factor in the process of Palermitans' identity. The natural geographical boundaries of islands are imaginatively more stable in comparison with any other constructed boundaries. I do not claim that because Sicily is an island, Sicilian ethnic identity is more 'homogenous' (see Hirschon 2003) than any other, but that the island's natural boundaries make it easier for Sicilians and others to 'imagine' (see Anderson 1983) the content of the island as homogenous although in reality it may not be so (Brown and Hamilakis 2003). Indeed, Sicilians claim to identify themselves as a group other to the Calabresi for example, to which however, the Sicilians believe to be closer to in terms of culture and social conditions in comparison to all other Italians. By contrast, Sicilians believe to share far less with the Sardinians, this being another 'easy' distinction because Sardinia has clear-cut natural boundaries as well. Thus, Sicilians believe they share more traits among themselves than with any other Italians. Nevertheless, Sicilians do not deny that there are differences between them. Nor do they deny that their society changes and they thus accept the fluidity of their ethnic identity. The east/west dichotomisation of the island that is based on historical and economic factors, affects the relationships between *Palermitani* and *Catanesi* even today. However, a common dialect, namely the Sicilian, blurs socio-economic and political variations between Sicilians to the extent that their identity can rest upon 'common' cultural traits when Sicily is contrasted to any other region or country. In an attempt to sum up the basic characteristics of Palermitans' 'cognitive maps', I shall argue that starting from their home, Palermitans circle concentrically their neighbourhood, their city and their island, Italy, Europe, and the USA, anything else being the rest of the world. Most

have argued that they present themselves as ‘Sicilians’ when they travel in Italy or abroad. Thus, the sense of simultaneity is stronger among Palermitans and Sicilians and between these two groups than it is between them and other Italians.

The multiple identities mentioned above serve the contested representations of the self within various spheres of interaction, the local being the most important one because this is where the individual’s initiation into society takes place. Palermitans interact mostly on the local level and interaction may often be with other fellow Sicilians as well, their relations with Europe and the USA are very limited, if they exist at all. Nevertheless, Sicilian immigration to the USA allows Palermitans to distinguish this country from others. In addition, the European Union changes Palermitan life in both political and economic ways, i.e. most of the public constructions are partially funded by the EU and thus the EU is an arbiter that local politicians must note. Due to the intensity of interaction at the local level, it is logical to assume that a local identity will be more often manifested, and the manifestation of the other identities to be decreasing due to the context of interaction. It is also logical to assume that the individual can manipulate better the characteristics that the group considers important at his/her own locality. Failure to use those characteristics that Palermitans consider important in identification and interaction results in stigmatisation and social exclusion. The case of immigrants in Palermo is illuminating. Cole (1997) fails to see a particular xenophobia because it is not targeted to specific ethnic groups, for immigrants in Palermo are generally stigmatised as foreigners. Moreover, foreigners are not by chance collectively called ‘Moroccans’, but because Palermitans believe the living conditions in Morocco to be worse than in Sicily. In Palermo, integration is not an option for the foreigners but a demand that must be satisfied. Foreigners are either fully integrated to the point that no one can tell that they are not Sicilians, or are extremely marginalised. Although

physical characteristics may play some role in this procedure, the common trait among marginalised foreigners is that they do not achieve, comprehend and use those local characteristics that Palermitans use as a means of identification. For example, an Indian owner of a small restaurant in my neighbourhood in Palermo was integrated, because as Palermitans said he was married and had children who went to school, he was fluent in *Palermitano*, which is the local dialect, he had many interests of which he was well informed, and although he was different, he was a respectful man. By contrast, a Spanish university student who lived in the same neighbourhood ‘never tried hard enough to learn the language’ or cared about what her classmates advised her, ‘nor did she ever have a clue about what is going on in Palermo because she never paid attention to the news’. Therefore, this girl was marginalised although ‘she could have been more easily integrated’ in comparison to the Indian.

Integration is not simply a matter of education, although education is important (Avdela 1997), but also a matter of learning through interaction. According to Hamilakis ‘national pedagogical procedures...are instrumental in constructing a bodily mnemonic *habitus*’ (2003: 60-61). Bourdieu (1990), claims that identification can manifest itself in practices and even bodily dispositions or *habitus*, with which Herzfeld somewhat agrees as he gives examples in bodily manifestations of ‘Greekness’ (1995: 126). Therefore, many curricula shape Palermitans’ identity as much as does their interaction with other Palermitans. Not only do curricula change over the course of time, but also the same applies to the way they are taught, as well as to the students’ interests and the way they interpret what they are being taught (see Eriksen 1991). For example, Palermitan teachers argue that students ‘are not taught the national history’, and that students are not interested in these classes nowadays, to express their dismay about the decreasing importance of history in the

current educational system, stating that this field is crucial in the process of shaping an ethnic identity. Nevertheless, this signifies only a change in the way that identity is being shaped. Curricula do take a local character, i.e. teachers draw examples from the local dialect to help their students understand the Italian grammar, or ask them to gather information about specific historical periods of national importance experienced in their locality, and so on. Employing local examples for the sake of understanding is not a condemnable strategy per se if such examples are given among others. In the Palermitan case, however, a coordinated effort to make Palermitans learn about their city does result in strengthening their local identity. Instead of promoting Palermo as an Italian city, or Sicily as an Italian region, the context of their representation is minimised to their own entities. In addition, social control reinforces local meanings and manifestations of identities. If the individuals' goal is to enrol in Palermitan society, interaction must conform to the local rules. Without questioning the fluidity of values and denying individual agency, I claim that the local and the individual have both the power to change values and also to enforce them. External influences are reshaped in and by the local society in a manner that they become compatible with the local culture, and, thus, acquire a local character. In this sense it is not education that promotes the Mercedes 'Smart' car as the symbol of a young, free-spirit Palermitan woman, which functions as a means of integration within specific social networks, when in Greece this car is a symbol of prestige and singleness simultaneously, while in north-east England it is not a symbol at all. Moreover, one can observe in Sicilian cuisine and sense of entertainment, which are a basic means of social interaction, how external influences blend with the local traditions. For example, *ruolo con würstel* is a mixture of Sicilian and German cuisine, while a foreigner can be easily traced into a bar by what he/she wears, what he/she drinks, and/or by his/her body expressions. Thus, if

‘the individual acts because of relationships’ (Strathern 1998: 273), it does more often so in his/her locality and in specific contexts with which the relation is direct and reciprocal.

## *8.2 The Insiders’ View*

It was a hot summer day when I left the library to go out for lunch with my friend, and having walked under the hot Sicilian sun for half an hour, I was already exhausted when I arrived at the restaurant. My friend was laughing at me: ‘Here you are, a glass of water will make you feel better, you Greek!’ Although summer is hot in Greece as well, the heat in Palermo was unbearable, and Caruso reminded me once more that ‘the Sicilian sun is different’. I had never taken it literally before, as it never became important, but this time was different. This was interesting enough for the Palermitans who had already finished their lunch and were enjoying their coffee. ‘We thought that you were Palermitan’, a man sitting next to me said, ‘congratulations!’ I recalled another situation in which a professor introduced me to a researcher, when the former said to the latter that I was a brilliant young man interested in the Palermitan culture, and although Greek I had a Palermitan ‘spirit’ and that my ‘manner’ was Palermitan as well, and thus, he should help me. Back in the restaurant, an old man joined the conversation, to explain to me that Sicily is the centre of the world, an autonomous island that can exist alone on earth because among other things it has a sun of its own. A professor adopted this doctrine, however symbolically. About twenty of us in the restaurant ended up discussing Sicilianess until we reached the conclusion that one does not have to be born in Sicily in order to be Sicilian, but to embrace the Sicilian way of living and to ‘give birth’ to Sicilians. This is when I recalled a prominent anthropologist I had met at the

University of Palermo several times, who stated to me that Palermitan and Sicilian cultures can be categorised as ‘hot’, meaning that they embrace the ‘other’ and borrow cultural traits that they mix in the ‘melting pot’. Thus, what Sicilians meant by arguing that they are ‘bastards’ is not controversial in a sense of biological self-perpetuation. Exactly the fact that Palermitans consider themselves a mixed race allows them to claim that their group is biologically self-perpetuating. To base this on blood purity would be at least funny, Palermitans reveal, because their mingling with others is not only obvious in Sicilian architecture but also on the phenotype of their fellow citizens. Instead, Palermitans consider Sicilians to be the basis upon which transformations have taken place. Sicilians are the ‘wax pattern’ because they are the autochthonous majority, and although there may well be changes in form, the base remains, even with modifications. In the same way of thinking, the metaphor that the Sicilian ‘body’ accepts only ‘compatible transplants’ can be sustained by the idea that anyone can become Sicilian. Thus, one who becomes Sicilian perpetuates the ‘race’ by giving birth to Sicilians.

Nevertheless, Sicilians mix not only with other peoples but with these other peoples’ cultures as well; and although these cultures leave their marks on the island, Palermitans emphasise the fact that these marks are left on “Palermitan” culture. The most distinguishable signs of all the other immigrant civilisations that have reached the island can be found in architecture, the Sicilian cuisine and language completing the basic trinity upon which foreign influences can be measured. From a Palermitan point of view, the Sicilian culture prevails over all the other cultures from which it borrows characteristics. In other words, the Sicilian culture does not submit to foreign ones, but on the contrary, foreign cultures strive to be expressed in the Sicilian one. This does not only mean that Palermitan culture is genuine, but also that it is tolerant to the point that other cultures find a way to communicate with it

and consequently enrich it. Again, traits that manage to survive are only those that are compatible with Sicilian culture. As happens with biological characteristics, there is also cultural unity in the sense that all Sicilians are believed to share fundamental cultural traits and values the basis of which is irrespective of the fact that 'they may have been diversely enriched'. Apart from the Sicilian dialect and cuisine, these have primarily to do with the special role of the family in the Sicilian society, religion, and folklore. A folkloristic example could be the famous puppets that are used in the Sicilian *teatro dei pupi*, or puppet theatre. Although the puppet theatre is widespread in all the corners of the island, there are variations of form from city to city, i.e. the Palermitan puppets are almost half the size of those in Catania (Cuticchio 1998). Nevertheless, all Sicilian theatres promote the same values through the same stories, i.e. that of Orlando and Rinaldo, or Roger, but also through new ones. For example, the *Figli d' Arte Cuticchio* have enriched the standard repertoire with about a dozen new stories since 1971 (ibid.). Since it is difficult to discern which cultural traits are only Palermitan, for example, and not Sicilian, comparison takes place only between Sicily and Italy. Not only in Palermo, but also in all the Sicilian cities I visited, these conditions encourage the belief among Sicilians that they share fundamental cultural values that result in cultural unity irrespectively of local variations.

On the one hand, communication and interaction among Sicilians should be logically more intense than it is between them and other Italian regions especially in the past. Chapman (1973), for example, speaks of a poor road network in west-central Sicily that was, however, characteristic of the whole island's underdeveloped transportation until the 1930s. On the other hand, Sicilian history shows that different parts of Sicily have experienced different influences to the extent that an East/West division of the island can be realised in cultural terms (Schneider 1969). Moreover, the distance between Messina and Calabria is far shorter than the distance between

Messina and Palermo, and seamanship could justify a more intense relationship between Messina and Calabria. After all, the easiest way to approach Sicily was its natural harbours as the island's history shows. If we need to support the idea that Sicily marks a field of communication and interaction, for the needs of this research such an attempt should be based on the intensified communication and interaction between Sicilians and Italians in modern times. King and Patterson (1992) report that the modernisation of Milocca had began five years before Chapman visited the village. Even if modernisation begun in the first decades of the twentieth century, Sicilian identity was already in the making, and it is safer for the needs of this research to argue that Sicily did mark a field of 'communication' and 'interaction' in the 'modern sense' of the terms only after the 1940s. The birth of the MIS (Sicilian Independence Movement) political party in 1943 and its popularity among Sicilians indicates that at least political networks were spread across the island. If interaction among Sicilians intensified with the improvement of the Sicilian road network, so did their communication with new technology. Sicilian identity rose to prominence after World War II, when the Sicilian struggle for autonomy resulted in the region's political autonomy. In the next decade, governmental funds from the *Cassa per il Mezzogiorno* (Register for the South) that were spent on infrastructure improved the 'field'. Since 1946, when Sicily became an autonomous region, central planning intensified the communication between Palermo and the other Sicilian cities. Moreover, there is a movement of people not only for administrative but also for educational reasons, since the educational system provides Sicilian students with the option to study at any university of their choice. Technology facilitates communication and supplies Sicilians with the means to test the local resources before they turn to non-Sicilian options. For example, Palermitans prefer to work and

spend their holidays in Sicily even if they have to travel to the other corner of the Island.

There are several reasons for which Palermitans prefer to stay in Sicily rather than living for shorter or longer periods ‘abroad’<sup>36</sup>; these are:

- a. Economic reasons
- b. Family reasons
- c. Social reasons
- d. Ethnic reasons

Indeed, most Palermitans are members of developed networks that principally include Sicilians, most of which reside in Sicily even if in different parts of it. These networks’ function can be of an economic nature. Since personal relationships play a pivotal role in the Sicilian economy, friends are used as mediators in those economic affairs that distance renders one’s physical presence impossible. Friends are used as economic resources on various occasions anyway. Moreover, Sicilians’ low income decreases their consumption capacity ‘abroad’, while they can afford more things in Sicily due to the lower prices that the weak Sicilian economy dictates. Of course, from another perspective a tenable argument would be that since salaries are higher in northern Italy, for example, Sicilians would have to have a good reason to abandon their homeland. Indeed, Palermitans do leave for other Italian cities but only when this is their last option. Their destination is usually a prosperous city, in Italy or abroad, where there is an already ‘made’ relative. The presence of a relative abroad is a good excuse for the one who leaves Sicily, his/her family, and the Sicilian society. The central role of the family in the Palermitan culture is endorsed

---

<sup>36</sup> I use the term ‘abroad’ in its Palermitan sense; in fact, Palermitans see Sicily as a country other than Italy. Palermitans who have been to different parts of Italy, as for example Rome or Firenze, stress that they have travelled abroad.

even in this example. The family unit plays a dual role, being an obstacle or an opportunity according to the occasion. Since the family members are responsible for the protection of one another, a member of the unit can leave his/her home only under certain conditions. That is, when the family is in need, but also when there is a relative who takes the responsibility to monitor the individual that will be under his/her protection. To leave Sicily is the last option because every Sicilian is an organic part of their social networks. Thus, on the one hand, these networks resist to changes in order to safeguard their functionality. On the other, a Sicilian will leave the island only if he/she believes that the new networks can serve better his/her interests. However, Sicilians believe that it is difficult for them to advance in alien environments, for many had a personal experience of stigmatisation in northern parts of Italy during previous decades, which they have transmitted to the younger generations and which they feel is a firsthand experience. I had the chance to meet Sicilians not only in Sicily, but also in Greece and the UK, and to understand that Sicilians believe, and stress that they are, a distinctive ethnic group within Italy. This was a shared view among Italians from different regions, even among those coming from parts of the Italian south other than Sicily. As the contradistinction made is between Italians and Sicilians, in the following part I focus on how these two groups become of the 'same order' and thus distinguishable through their ethnic identity.

### *8.3 The Sicilian Boundaries from Two Different Perspectives*

In this part, I argue that Sicilians are a distinguishable group only inside Italy, as it never occurred to me to meet a non-Italian who was aware of this distinction. In fact, whenever I have the chance to talk about my research, my interlocutors are often surprised by the fact that I distinguish the Sicilians from other Italians; less often,

some interlocutors do not understand to which group I refer to until I explain that Sicily is in Italy. In any case, the first questions set to me by non-Italians focus on the Sicilian Mafia, which they consider a quite fascinating subject. The Mafia is commoditised and it is exported along with other famous Italian products. Even the Sicilians consume this product, not because this is intrinsically intriguing to them but because as they say they ‘want to learn about their enemy in order to fight back’. However, from the Sicilian perspective, the *Cosa Nostra* is not enough to define the ‘Us’ and the ‘Other’ alone. For the Sicilians, the *Cosa Nostra* is just a part of the Italian Mafia, as the *Ndragheta* in Calabria, or *Camorra* in Naples also are. Nevertheless, for a northern Italian, the *Cosa Nostra* may be one of the basic characteristics of Sicily, if not *the* one. Irene’s words communicate the northerners’ feelings about Sicily: ‘It is at least funny to believe that there is something like Sicilian culture; all there is in Sicily is the Mafia. People there are animals. They do not hesitate to kill if they are offended. Down there, there is no other law than honour. This is because they are not Italians but savages, like the tribes in Africa where Sicilians come from! Sicily is not Italy but another country. You are talking about culture, architecture, language and so many other things. Did you really witness these things in Sicily? Come to Tuscany to see what culture is and try to compare it to Sicily. As for your comment, no, I have never been to Sicily and I do not intend to do so. I would not risk my life to visit a place that is only a burden to Italy.’

My last encounter with a northern Italian was with my good friend Paolo, who had warned me about the dangers I would encounter in Sicily, this *altro paese* (other country), before I went to the field. This time, he knew that he would have to try harder to defend his ideas about Sicily against mine, but I surprised him. I reminded Paolo of his own words; when he paid me a visit in Palermo during my fieldwork he

said that he felt uncomfortable with the fact that he would be introduced to Sicilian culture by a Greek who knew more about this Italian region than an Italian –meaning himself- did. Paolo had to answer a difficult question this time: if Sicily ‘is Italy’ or not. Paolo’s view was identical with Irene’s, but his national pride did not allow him to lay any claims to Sicily’s Italianess. This was the result of my insistence on the idea that Sicily was culturally speaking more Greek than Italian and, thus, Sicily should become part of Greece again, as it was in the past. It took hours for him to deal with the contradiction that Sicily was Italian as much as it was not, and eventually he claimed that we would have to discuss it again in the future, as he was not really content with the answer he gave me. Paolo claimed that his ideas were not clear because of the many pieces of information he used to support his point of view, to the point that even he was confused with his own argument. However, for Paolo, Sicily remained *un altro paese*.

Piero was another northern Italian that had never been to Sicily, and who also considered Sicily to be ‘another country’. I listened to him talking with his friends about Sicily, in Milan, depreciating its culture and its people, until he asked me if I agreed with him. He had also listened to me speaking Greek on the phone before, and since I was in Milan, I guess that he expected a concurrence of views. Piero was a middle-aged businessperson, quite successful and sociable and well-informed on political and economic issues. Although Piero was open-minded, Sicily was *un altro paese* for him as well. Piero had never been to Sicily before because ‘that place was neither good for business, nor for vacation.’ He identified more with the Renaissance-style artefacts exhibited in other European countries than with the Greek temples in Sicily and other Sicilian cultural traits he had seen on the web. His friends although indifferent and unaware of the Sicilian culture, agreed with him. I

just mentioned that Sicily is a ‘thing to see’ anyway, and later I recalled Piero while reading an article on the web under the following title:

**‘Erratum: Alitalia apologises for... Sicily’s disappearance from the map. Sicily is here!’**

According to this article, ‘Alitalia apologised...about Sicily’s ‘disappearance’ from the map contained in the magazine that the national, and since recently private, air carrier distributes during the flight.

A female passenger said to the *Corriere della Sera* (newspaper) that looking at the map while flying to Sicily she found out that her destination did not exist on it...

The publisher of the magazine, Aldo Canale, attributed Sicily’s elimination to a printing error and he promised that this is never going to happen again.

‘Travel agents complained about the incident, claiming that this inflicts Sicily’s image.’<sup>1</sup> ([www.in.gr](http://www.in.gr), *Newsroom AOA*: 18/06/09 14:54)

I am sure that Piero and his friends would agree with Caterina from Bologna who commented on the article that this was not an accident but a miracle, and added that ‘these rats should stay in their country, in Sicily.’

Incidents like the above make Sicilians argue that the boundaries of the Sicilian Island are ethnic. Eriksen (2002:76) stresses that ‘ethnic identity becomes crucially important the moment it is perceived as being under threat. Since ethnicity is an aspect of relationship, the importance of boundaries may thus be said to be conditional on the pressure exerted on them.’ Alitalia’s case was a big issue in Palermo when I was conducting research, and there was a shared fear among the Palermitans who were following the story that maybe Alitalia would not fly to, and

from, Palermo<sup>37</sup>. This fear originated from a certain political discourse that, although never linked the Alitalia issue with Sicilian ethnicity directly, was respectively to the political result successfully diffused before the 2006 regional elections in Sicily<sup>38</sup>. Local interpretations of the issue were so strategically articulated that changed its political character into a conspiracy theory based on rumours that some Palermitans had supposedly heard from the 'inside'. Thus, I can understand how Palermitans felt when they heard on the news that Sicily was eliminated from Alitalia's map. It was the feeling of exclusion. Unlike Piero or Caterina, who do not consider Sicilians to be Italians, Sicilians consider themselves Italians and stress that Sicilianess is another expression of Italianess. Although there is a distinction even in this case, Sicilians do not reject their national identity. Instead, Sicilians claim that Italy is an amalgam of cultures that have been melded together with the unification. The Sicilians reject their national identity when they are devalued by the inner 'Other'. In such cases, ethnic identity, that is the Sicilian identity, prevails over the national one. Although issues may not always be indirectly linked to Italy's Southern Question, and in examples Sicilians being blamed implicitly, equally important is a Sicilian mechanism that uses such kind of controversy for political purposes that consequently reinforces the interpretation of the island's boundaries as ethnic in its inhabitants' consciousness.

The withdrawal symptoms that Sciascia, Verga and Lampedusa depict as characteristic of the Sicilian people are the result of situations like the above. In Lampedusa's the *Leopard* for example, although Don Fabrizio is a powerful man who is given the chance to maintain his power even in the new post-unification

---

<sup>37</sup> The BBC documents with a series of articles that can be accessed on [www.bbc.co.uk](http://www.bbc.co.uk), Alitalia's economic problem, as well as the air carrier's attempts to deal with this by cutting flights.

<sup>38</sup> The politician who claimed in his public speeches that *Alitalia* will not be flying to Palermo, and that 'the right time for Palermitans to reconsider their relationship with Italy is now', was elected with a 65%.

system as a senator, he does not cooperate unless his title is only honorary. Don Fabrizio eventually turns down the offer, stressing that neither he nor any other Sicilian would like to govern. The cruel conditions prevailing on the island have made Sicilians accept no external intervention, but to feel better alone and perfect like 'God'. However, Don Fabrizio claims that the Sicilian character is conditioned by events outside the Sicilians' control and by "a terrifying insularity of mind". Hence, Lampedusa reveals a Sicilian characteristic that is not only inherent but has also been shaped by external pressure. Indeed, the pride Sicilians take in their Sicilianess could be seen as a means used by Sicilians to lessen the pressure that is put on them, or is felt likely to be put on them, through negative evaluations by the significant 'Other'.

#### *8.4 Contents of Boundaries, Meanings and Feelings*

Having shown that the Sicilian boundaries are well defined in Italians' consciousness and are perceived as marking an ethnic territory within Italy, I proceed with the 'content' of these boundaries and the 'feelings' this content is dressed with. As I have argued above, the Sicilians believe their culture and language to be the basic traits that define their group, which they consider to be ethnic. However, as Smith (2003) argues, ethnicity has the power to create feelings in individuals similar to those attached to other groups such as the family; Woodward (1997) argues that ethnicity is brought to the fore repeatedly. The way ethnicity affects individual action is more obvious especially when an ethnic group feels itself to be threatened (Cohen 1985, Eriksen 2002). In this case, for a Sicilian defending Sicily equals defending his/her own family. Cohen (1994:62), among others, links kinship to ethnicity by stressing that ethnicity is a perception of common origins. The Sicilians

believe that there is a Sicilian culture and a Sicilian territory to defend, and that by doing so they defend their own family that is part of this whole. Thus, the relationship between family and ethnos is organic. In addition, Sicilians make sense of their ethnos through the family. Sicily, as a symbol, is the *patria*, or motherland, the mother of the Sicilians. The Sicilian proverb ‘the husband is the state and the wife is the Mafia’ also links to the Sicilian perception of ethnos; metaphorically, the two sexes represent the powers that even in jest bound the Sicilians together. It is through the family that Sicilians identify with larger groups such as the neighbourhood, city, and region. Lyon (2004) holds that *it is a matter of transferral to extend patterns from smaller to wider groups*. Schematically, this can be represented as concentric circles. Variations augment not only when we expand from smaller to larger groups, but earlier as we move from the individual to groups. I have shown above that the Sicilian ethnic group may not be as homogenous as the Sicilians believe. Nevertheless, regional political discourse results in a unified perception that urges the Sicilians to defend their group when it is threatened. Therefore, the content of the Sicilian Island is in fact the Sicilians, who feel as a group different from the other Italians, and who consider the protection of this difference to be of vital importance. In the following, I provide some ethnographic examples of the way Palermitans discuss the content of the Sicilian Island and the need to protect it.

Andrea and his wife, both middle aged and occupied in the service sector, discuss a local politician who was elected as member of the regional government in 2006. They both praise the politician because he is a *Siciliano vero*, ‘a real Sicilian’, and recall how he has manifested his Sicilianess since he was young. Andrea and the politician were classmates and best friends for many years. Andrea’s wife stresses that the politician’s popularity grew beyond his neighbourhood to the whole island

because people were convinced that he would do anything to help his peoples. The couple agreed that ‘only Sicilians can govern us because they are aware of the situation and the culture. Whenever the government sends somebody here who is not Sicilian to deal with local problems the result is always failure. They are technocrats; all they know is what they have read in books. What can a book tell you about the way you should approach a Palermitan, his/her needs, and the way to deal with issues that spring from our culture? Only a Sicilian could find a solution to these problems. A Sicilian knows the ‘right’ people, the way to approach them, the ‘mechanism’ and the way to override it. Only a Sicilian would put himself at risk to see his *patria* improve. Just remember Falcone and Borsellino who died fighting the Mafia.’

I was not surprised by this stance as I had heard many politicians’ speeches before and I had discussed some of these basic points with Palermitans. There were patterns in this discourse irrespective of political affiliation. The sequence went like this: ‘Sicilian brothers and sisters, we have our own political culture. The only way to make this place experience a new spring is to protect our culture. This political culture is the means by which we are going to defend you and your family in Rome.’ Without questioning these politicians’ intentions and plans, I just mentioned this sequence to my informants asking if they can see the pattern, and if yes, how they can explain it. The majority agreed with this political discourse and did not find anything reprehensible in it: ‘Yes, it is true! Both family and culture are important and the politicians should protect them.’ My question was from what the politicians should protect the family and culture. The answer was ‘from change; we want to experience an improvement in economy and politics but without experiencing any change in family and culture.’

Another important part of political speeches focused on immigrants, and the negative effects of this massive phenomenon on Sicily. Of course, this was a pan-Italian issue that Berlusconi and Bossi distinguished among others as one of the major problems threatening national social cohesion. In Sicily, the alarmism was obvious; however, the above issue did not become as much economic in nature as cultural at the local level. The Palermitans sympathised with the ‘poor’ immigrants who arrived in Sicily ‘god-forsaken’. The Palermitans recalled their own relatives who had left the Island some decades ago: ‘the immigrants are as we were in the past, when the Sicilians arrived in the United States of America in abject poverty.’ On the one hand, the Palermitans were more cautious when immigrants were around; on the other, the Palermitans sympathised with the poor. Nevertheless, there was a significant difference between the Sicilian immigrants of the past and the modern *clandestini*: the Sicilians who went to America for example might have been poor economically, but they were culturally rich, in contrast to the Africans who arrive in Sicily poor in both economic and cultural terms. Even worse, the glorified Sicilian past does not allow the Palermitans to accept any cultural exchange with the immigrants of today: ‘our rich culture is the result of exchange, but all those who came to Sicily in the past are nothing like these people you see in the streets today. The Arabs for example, they introduced us to a new technology and we experienced an economic and cultural *primavera* (spring). In contrast, those who come now are poor. I do not care if they work here. Otherwise, they would probably starve to death back home. None of us would do what they do for living anyway. They do not threaten our lives, but our culture and the proof is that they do not adapt to our way of living, instead they want us to adapt to theirs.’ The Palermitans see their environment changing every day. The mass number of immigrants is concentrated in specific areas of the city and this makes Palermitans feel that the immigrants threaten the Palermitan identity.

Therefore, the immigrants in Palermo can be economically integrated but at the same time socially excluded.

From a northerner's point of view however, Sicilians are to Italy what illegal immigrants in Sicily are to Palermitans, and the differences between Italian Southerners and Northerners are linked to the diverse roles these two groups play in the Italian nation. Schneider (2003) argues that Mayor Leoluca Orlando based the fight against the Mafia on the Sicilian family and culture. He spoke of the need to re-evaluate them and give them back their 'traditional and true meaning' in order to understand how they have been distorted by the Mafia and how they have harmed the Palermitans, hoping that this understanding would reverse the situation. Although one could see in the Palermitans' wish to change their society, but maintain their values unaltered a contradiction, in fact, this tension is not confined to the local level. The South has accepted its role as the 'backward' group of Italians that conserves the traditional values of the nation. I would suggest that this role is complementary and equally important to that of the North that promotes capitalism and modernity. In the following, I will discuss what the Palermitans perceive to be their role within the Italian nation, to conclude that the complementary roles of the North and the South achieve stability at the national level although the sense of simultaneity may be stronger at the local or regional levels.

### *8.5 Playing Roles: Stability and Simultaneity*

Palermitans trace differences between themselves and Italians from other regions of the country in practice. According to Ortner (1984:149) practice is 'anything people do', thus it involves the study 'of all forms of human action'. Ortner holds that 'practice theory' is rooted in Bourdieu's 'cultural structuralism' and Giddens's

‘structuration’ theory (ibid: 127). Barth (1966) and Boissevain (1974) among others have carried out seminal work on the subject<sup>39</sup>. Practice theory shifts the focus from structure, function and/or the individual to a combination of elements that spring from the above focuses, viewing social life as the outcome of interaction between the creative individual and structures. Change is the outcome of the interaction between social action and structure. In Palermo, the institutionalisation of practice, makes Palermitans imagine that they engage in the same practices. Tradition, history, values and symbols are employed to construct the boundaries between Palermitans and ‘the Other’ and allow a sense of simultaneity at the local and/or the regional level; as Banks (1996) suggests, these features imply specific roles to the members of an ethnos as well. Tradition, history and values are those criteria of evaluation upon which the Palermitans’ positive image of the self rests. Thus, tradition, history and values also become symbols. The Sicilians use these symbols to claim superiority over other Italians. From a Palermitan point of view, every single act of a Palermitan in his/her daily life is a manifestation of the Palermitan or Sicilian identity. Supposedly shared practices strengthen a sense of simultaneity among Sicilians. A strong sense of simultaneity at the regional level may be the reason for tension between the regional and the national levels. On the other hand, I suggest that this sense of simultaneity is also the link between the regional and the national levels if the North and the South are seen as forces that counterbalance each other. In other words, the Italian nation’s cohesion rests upon the ability of the North and the South to collectively internalise and play opposing roles. In the following lines, I use ethnographic material to suggest that the manifestation of the Sicilian ethnic identity may be a conscious action aiming to diffuse tensions that could otherwise have disastrous effects on the Italian nation.

---

<sup>39</sup> See also Turner (1991) for a summary of the developments in action theory and a critical examination of Bourdieu’s and Giddens’s approaches.

Maria, a thirty five-year-old school teacher claims that ‘the boundaries are not just lines on the map but something more than that for what there is inside and what is out of them. There is nobody who lays claims on our territory, unlike in your case (referring to the tension between Greece and Turkey), but an internal enemy who threatens our culture. I want my sons to be Sicilians, and as for myself, I do not want to lose my identity. Everybody is important in this country; it is a chain. How is my identity threatened? Well...I am losing my power because others decide for me, for they make me poorer and they don’t let me think or do what I want to do, for they label me to keep me *adormentato* (dormant), for even the church struggles to make money instead of helping me become *una brava persona* (a good person). We are not like this, this is not the Sicilian character...we have to defend our boundaries, our cultural boundaries. I am coming back to my point: there will be Italy for as long as there are Sicilians. When the Sicilians disappear the Italian nation will disappear too.’

Giovanni, who is a fifty-three-year-old businessman, argues: ‘Sicilian is what you have in your heart, what you have in your mind and what you do. A Sicilian wakes up in the morning and embraces his wife and children. He drinks an espresso and goes to work. There he drinks another espresso reading the *Giornale di Sicilia*. He speaks with his neighbours and friends all day long. He goes back to his family for lunch. Although the table is full of delicacies, he definitely eats pasta as well and has another espresso before going back to work. Neighbours, friends and espresso again...an aperitif break. Back home for a shower and dinner, and then out with the family or friends. The usual hangouts, political conversations, shopping, church, beach and so on. But at the end of the day we all thank God for what He provides us and for making us Sicilians. We may have difficulties, but our life is perfect. The espresso I drink is much better than the espresso that the Milanese drinks (looking

around him to make me understand that everything is better ‘here’ than in the North). The northerners talk complete hokum; what would they do without us? Democracy started here with the Greeks and it was re-established here again by the Americans; Italy was born here and Italy’s economic development was based on Sicilian labour. Now, we are the ones defending the values that make the Italians, fighting against the rubbish that the mass media import to poison us and finish us off.’

In this last case, Geraldo’s (forty-two-year-old medical doctor) feelings are as strong as his words: ‘You haven’t seen Italy until you see Sicily. This is so true! Everything started here even if no one will accept it. But we know it. What would Italy be without Sicily? A leg without a metal ball tied on it (laughing loudly). We Sicilians work all day long to firm the rock that Italy will step on to avoid drowning. If you remove the stone, Italy will collapse. No one can remove it because no one wants to remove it; there is a chain under the sea. There is no need to build a bridge between Messina and Calabria (laughing again). The link cannot be broken because we are here to keep up the pace: either to delay Italy or to force her to run to keep up with us. If you take the chain off, none of us will survive; it will all collapse in a second (in a despairing tone). So we know: we are going to be the bad son and the others are going to be the good sons; we will be the poor ones and the others the rich ones, and so on. We do the same things they do, but we are still different. This is funny, isn’t it? The correct question is: what would they have been without us? (raising the tone of his voice). They take from us as much as we take from them, but we have learnt to live with our stigma because deep inside we know that it is fake, it is a lie (calming down). We can rely on the idea that this tension is constructed, and we can rely on the fact that Italy is there for us as we are there for Italy. In fact, none of the players wants anything to change because we know and we play the game well. Anything we

do is part of the game...try to understand it my son (his warm voice making me feel that he is addressing me as if I really were his son).’

The above examples suggest that there is a strong sense of simultaneity at the regional level that does not however threaten Italy’s social cohesion despite the diversities that exist among Sicily and other Italian regions. The relationship between the local and the national is one of interaction. Thus, the Sicilian ethnic identity is constantly in the making and strictly related to ‘the Other’. The fact that the definition of the self lies upon the contrast with the ‘inner other’, but does not result in Sicily’s division from Italy, further strengthens the validity of the hypothesis that the criteria of division are primarily economic rather than cultural. In reverse, cultural diversities are not enough to result in the separation of Sicily from Italy. Instead, economic and political reasons bound Sicily and Italy together. The tension between the regional and the national seems to lie in the fact that the fluid economic and political landscapes do not manage to coincide. The Sicilians seem to be conscious of the political game played between Sicily and Italy. Therefore, the Sicilians see the raising of ethnically conscious Sicilians as an obligation. From the Sicilian point of view, the Sicilians’ national duty, or the way to protect their country –that is Italy’s territorial integrity, economy and culture- is to prepare the next generations of Sicilians to play the role of a counterbalancing force to that of the North. In this, social control through the value system of honour could be argued to have an additional function. That is, honour and shame do not only shape the rules of conduct between individuals at the local level, but this value system also shapes an ethnic consciousness that mediates the relationship between the local and the national.

From this prism, an honourable Sicilian is not only the one who complies with the local rules of conduct, but also the one who could potentially be a good representative of the Sicilians to non-Sicilians. In this sense, the Sicilian role models extend to the national level. The manifestation of Sicilian identity may be a personal means of integration into the local society, but at the same time, it is a means of integration of the individual and the group that he/she represents into larger entities, such as the national. When a Palermitan prides his/her ethnic identity, he/she simultaneously prides his/her national identity, although indirectly. This could explain why politicians at the local and regional levels claim that Sicilian cultural traits are the only means for the local's integration into the national. In other words, Sicilians see Sicilian culture as a different version of Italianess. Thus, separatism could be seen as an extreme strategy that Palermitans employ in order to make 'the Other' accept the Italianess of Sicilian culture. This reveals that Sicilians do not really struggle for Sicily's independence, but that they attempt to make political and economic landscapes coincide. In the following part, I examine manifestations of Palermitan identity in order to shed light on the particular relationship between the local and the national.

#### *8.6 'Sicilia Indipendente, Sicilia Nazione'*

Palermo, the capital and the largest city of Sicily, is a centre that does not have the power other centres do in Italy, such as Rome or Milan. Palermo is the political and economic centre of Sicily, but it is neither Italy's political and/or religious centre since Rome is, nor Italy's economic centre, which is Milan. Palermo's large population –almost a million souls including the suburbs- and the centralisation of power in the Sicilian island's capital gives Palermitans 'the right to speak on behalf

of all the Sicilians', as a member of the Regional Government once told me. In practice, this 'right' allows Palermitans to increase their power in the struggle between North and the South, the Palermitans practically assuming the support of five million Sicilians instead of one million Palermitans. At the extremes, Palermitans use this power to assert Sicily's independence. This practice is more the expression of Palermitans' desire to see Palermo becoming a kind of 'centre' in Italy, rather than a wish for an independent and self-governed Sicily. This implies that Palermitans view Sicily merely as part of Italy, a fact that is consistent with my ethnographic data. On the one hand, the North has been leading Italy since the Risorgimento period, managing to influence national politics until the present day due to its economic power. On the other, the Sicilians' equivoque to the North's economic superiority is the Sicilian culture, while the South's counterpoise to the northerners' political power is the Sicilians' claim that Italian politicians are inefficient and corrupt. Palermitans believe that the state is controlled by and protects the interests of the North. Thus, Italy's Southern Question is for northern Italians a matter of culture, meaning that the South does not grow economically because the southern society is backward, while for the Sicilians, the reason the southern economy does not grow, is that the state mismanages its resources. The Palermitans claim that the situation could change *now*, but that the overt hostility between northern and southern Italy is constructed and maintained for political and economic reasons. In other words, Palermitans hold that personal interests within the political sphere and analogous economic networks have more power than the state itself. From this point of view, the manifestation of Sicilian identity could be perceived as a means of resistance. In the same way of thinking, one could argue that Sicilian ethnicity serves Sicilians to renegotiate their relationship with the Italian state anticipating a better agreement, rather than that Sicilian ethnicity will be used in

Sicily's struggle for independence. Therefore, manifestations of Palermitan and/or Sicilian identity should be perceived as integrating the local and/or the regional to the national rather than as signs of a developing Sicilian nationalism.

This 'public secret' is well hidden under the Sicilian ethnic discourse and for an outsider it takes an effort to understand how conscious Palermitans are of such a thing. Only when my relationship with certain Palermitans became intimate did I feel that I had the right to ask straightforwardly how they interpret certain discourses. Silvia had once come to my place to help me out with the research, when I mentioned that I had met a Palermitan lawyer distinguished for his Sicilianess. I started telling Silvia what we discussed when she suddenly stopped me: 'I do not want to hear anything else' she said blankly, leaving me wondering why. It was only recently that I found a video of this lawyer on the net and I asked Silvia to comment on it. Silvia sent me an email on which she had attached the lawyer's actual words, but there were no comments on it. The phone rang and she started speaking immediately: 'You see? Can you make sense of what he says? I cannot understand why you consider this man important. He cannot even speak properly; I wonder if he is Sicilian.' I explained to Silvia that there were many interesting things on this video, and first of all the flag behind him: 'look at the flag; *Sicilia Indipendente-Sicilia Nazione*?! You know what he is talking about!' A dialogue went on:

Silvia: 'Apart from some words...'

SP: 'I guess you understand more than I do!'

Silvia: 'I would not say so.'

SP: 'What do you think he is talking about?'

Silvia: 'He says that Sicilian lawyers should not have to travel to Rome for just a trial.'

SP: 'I do not think that he complains about the distance.'

Silvia: 'No, I do not think so, since all lawyers have to go there for this kind of trial.'

SP: 'So?'

Silvia: 'He wants all the trials that concern Sicilians to be processed here. There is this kind of people, you know it!'

SP: 'Indeed! How does this make you feel?'

Silvia: 'He is like the politicians; they talk and talk, but at the end of the day they do nothing about Sicily. Poor Sicily is down on her knees.'

SP: 'I disagree...and I agree'

Silvia: 'Good for you. You are a Sicilian now. You know...maybe it is better for some people to know that we Sicilians support patriots like this lawyer. It might be better for this god-forsaken place.'

The above dialogue is just one of many which suggest that Sicilians use the Sicilian ethnic discourse as a means to (re)negotiate for their group rights with the Italian state. I will use only parts of the lawyer's discourse to show how it develops in relation to ethnicity<sup>ii</sup>. The lawyer starts with the declaration that 'The Sicilian Statute is the Constitution of the Sicilian people, born before even the Constitution of the (Italian) Republic', providing his audience with the historic context of the 'conflict' between Sicily and Italy. He then stresses that this Constitution is eight-hundred years old and he links the Sicilian Statute to the Catalan one. This parallelism gives

the Sicilian case gravity as it is presented in a certain depth of time, and in a wider historical context in which peoples' autonomous movements in Europe were suppressed by powerful centres. Moreover, the Sicilians' positive bias towards the Catalans facilitates such a connection<sup>40</sup>. Thus, the lawyer attempts to present his action as a fight against the measures taken by the Italian government, measures that encroach on the liberties of the Sicilian people. In his analysis of Article 23, on which his strategic movements towards Sicilian independence are based, the lawyer declares that Sicily is the only region in Italy where two thirds of the article have been realised. Hence, he implies that the Sicilians can win the struggle for realisation of the last part of the article. The positive result in this case will be that the Sicilians will stand trials in Sicily, where their rights will be fully exercised. In an attempt to sanctify this struggle, the lawyer suggests that equality among people is the will of God, and he closes his speech by saying: 'God has given us equality among peoples; the equality between persons becomes real and for as long as there are states that oppress and states that are dominated, this equality will never exist. This is why the struggle for the independence of Sicily is not just a fight of a nation, but a fight for humanity, for the affirmation of the natural rights of humans, for the affirmation of equality among people.' It is clear that the dominated in this case are the Sicilians and the oppressor is the Italian state.

Decentralisation of power may be what the lawyer aspires to in the above case, but certainly not Sicilian independence. The lawyer does not question the Italian legal system; instead, he uses it to pursue a change in the relationship between centre and periphery. Silvia, as do many other Palermitans, consents to the lawyer's aims but

---

<sup>40</sup> In fact, there can be a kind of comparison between the Sicilian and the Catalan case in historical terms in the sense that both Sicilians and the Catalans opposed the French. Catalonia passed to the Aragonese in 1258, and so did Sicily after the famous Sicilian Vespers in 1282. Moreover, both Sicily and Catalonia are autonomous parts of Italy and Spain respectively. Spanish cultural traits in Sicily, and the Catalan struggle for autonomy, make the Palermitans perceive the Spanish as brothers.

not to his 'ways'. As Geraldo, a thirty-five-year-old lawyer has put it: 'We are on the same side; this is what this kind of people tend to forget. This lawyer and I struggle for the same things and we all know it. Why does he have to treat me as if I were a fool? But, then...you can say that others are listening too. Thus, we can forget the linkage and focus on the aim. There is a contradiction here, you know. There is another context you should see this issue in, and of which you might not be aware. Let me make myself clear: we, Palermitan lawyers –and I guess all Sicilian lawyers– work as much as our colleagues do in Rome or in Milan but we make one third of what they make. Although there is professional solidarity, we indirectly turn against our own trade. Do we do this to defend a substantial right of ours, or to increase our income? In fact, we do not turn against the Italian legal system, but maybe against our own country for both the above reasons. People should understand that...this is not an act of treachery.'

### *8.7 The Police as an Oppressive Force*

We were on our way to Palermo's football stadium *Renzo Barbera*, when Mauro stated that he feels uncomfortable with so many 'cops' around. The taxi driver nodded affirmative. 'What is the problem with them,' I asked, and for a moment, I wished I never had. They looked at me as if I should know and the fact that I did not was a crime. 'Who likes cops,' the taxi-driver said, and Mauro responded to this rhetorical question with a *già* (so it is). I just nodded. Mauro thought it would be better if he explained to me in private, so as soon as we were left alone he asked me to listen to him carefully. 'Sergio' he said, 'I hope you are not a cop'. I ensured him that I was not. Relieved, he went on: 'I do not know how things are in Greece, but here we do not like them.' 'Why do you care about them if nothing is wrong with

you?’ I insisted. Mauro had an answer for this one as well: ‘Because even if everything is alright, they can surely find something to accuse you of.’ I have had similar experiences back home, I explained to him, ‘Like police officers checking my driving license and then leaving me in peace. Well, some of them were irritating but they never harmed me anyway.’ Mauro’s conviction was firm: ‘Who gives them the right?’ The conversation went on even while we were watching the football game and it stopped only when all the spectators turned against the police rhythmically: *poliziotto-pezzo di merda* (police officer-piece of shit). ‘That was funny’, I told Mauro, ‘you call them *sbiri* (cops) all day long, and in the stadium they become *poliziotti*.’ ‘No matter what you call them they will always be *merda*; this can never change.’ On our way back to my place, Mauro felt the need to expand: ‘Most of the police officers in Palermo are not from Palermo. Even those police officers who are Palermitans, they change as soon as they become police officers (*diventano altre persone*, literally: become different persons). A cop has no friends; everybody leaves him when he joins the police force. Even their mothers hate them.’



The Palermo Stadium.

Gianfranco certainly did not have such an issue neither with his parents, nor with his friends. He joined the police force about five years ago and although he was transferred to Milan three years later, he maintains his social networks in Palermo. His family and his friends are proud of him because not only is he a good person but also because his people believe that he contributes to society. However, Gianfranco partially agrees with Mauro. He once told me that police officers are transferred to distant places for a simple reason: to restore the police force to health. However, this policy has both positive and negative effects. Gianfranco argues that, ‘On the one hand, when a police officer is transferred away from home there is no reason for him to favour somebody, instead when he stays in Palermo he will definitely be tempted to favour a relative or a friend. On the other, some of my northern colleagues in Palermo used to be prejudiced against the Sicilians looking at them as if they were all *Mafiosi*. Something similar happened to me when I started working in Milan; I was more professional in the sense that I was more severe when enforcing the law. Thus, I guess that a forbidding look is neither good for me to have nor for my colleagues. However, there is a difference of substance; that when I look at a Milanese I see an Italian fellow citizen of mine. Instead, when a Milanese looks at a Palermitan all he sees is an outlaw. Of course, the problem is deeper and it springs from our superiors’ views. If you listen to them in Milan, you will think that Sicily is a colony and that the only way it can be ruled is by force. What a shame! To recapitulate, the police are necessary, but some things have to change. We are here to protect the people and gain their trust, not to scare them away.’

Montemagno (1990), discussing the positive changes that Mayor Leoluca Orlando brought to Palermitan life at the end of the 1980s, provides an accurate account of how the Palermitans see the police<sup>iii</sup>. He suggests that the contribution of the *carabinieri* to Orlando’s plans was of vital importance. Montemagno (ibid: 9) argues

that: ‘Without the help of the *carabinieri* the political life of Palermo would may have taken a different turn. The ‘spring’ would have probably never started’ (my translation). He stresses that the Palermitan people give the police credit for their contribution to the Palermitan *primavera*, for the police helped the mayor realise what has been characterised as impossible before. He then refers to an important victory by the police that managed to get the people on their side. Before that the police officers were ‘always represented to the people as the forbidding presence of an alien power imposed from above’ (ibid: 9, my translation). In his book, Montemagno talks however of a ‘terminated spring’<sup>41</sup>. This means that the spring lasted for as long as Orlando was in charge. After that, Palermo returned to its previous condition. My ethnographic data support that Palermitans may show a dislike for the police, which they see as the oppressive force of an alien state, although Montemagno cannot grasp the fluidity of the Palermitan society due to his political affiliation<sup>42</sup>.

Palermitans’ dislike of the police can be seen within the context of what Herzfeld (1997) defines as ‘cultural intimacy’. While this ‘dislike’ is expressed openly in public, as it constitutes a criterion of Palermitaness, in private the situation is different. Especially in this case, the Palermitan view of the police is reversed in respect to the example that Herzfeld gives for the Greeks. That is, Palermitans in this case present an imperfect self in public that can create a bond with other Palermitans, while in private Palermitans retrieve their civic consciousness. Thus in the private sphere, the Palermitans become ‘perfect Italians’ by stressing that the police’s work is of vital importance to their society. Moreover, Gianfranco’s view of his northern colleagues rests primarily on impressions rather than facts. He attempts to highlight

---

<sup>41</sup> The content of the book is revealed by its title: *Palermo: Primavera Interrotta*, or ‘Palermo: Spring Terminated’.

<sup>42</sup> Tito Cortese clearly states in the preface of this book that ‘this is not, neither does it intend to be, a neutral book.’

how different he is from his northern colleagues by implying that he has mastered his emotions while his northern colleagues have not. From a Freudian point of view, this makes Gianfranco more civilised than Northern police officers<sup>43</sup>. Moreover, the fact that Gianfranco refers explicitly to the northerners as a group suggests that the difference is not only between him and them, but also between Sicilians and northern Italians. According to Sant-Cassia (2007), *diffèrence* is produced through national rhetoric and it is a state of being<sup>44</sup>. Thus, at a more theoretical level, Gianfranco implies different trajectories for Sicilians and Northern Italians, the Sicilians being culturally advanced in relation to northern Italians. In other words, Sicilian culture has provided Gianfranco with the means to ‘deface’ the regional stereotype of the northern Italians, while the northern Italians cannot deal equally well with the cultural stereotype of the South. Thus, Gianfranco implicitly supports that the Palermitans’ view of the police as an oppressive force may be grounded. A similar distinction between ‘us’ and ‘the other’ based on *diffèrence* exists in Palermo through the city’s Mayor.

### 8.8 The Mayor as a symbol of ‘Palermitaness’

The mayor of Palermo is the embodiment of political authority in the eyes of the Palermitans. However, Palermitans see the mayor as the representative of the local authorities. Since the Mayor is symbolic of the local authorities, Palermitans perceive him as a strategic knot within the local and regional politico-economic networks and also as the mediator between the regional and national levels. Thus, the

---

<sup>43</sup> I refer to Freud’s *Civilisation and its Discontents* that was written in 1929 and published a year later. Freud talks about the conflict between individual and civilisation. Since the laws that protect human communities suppress individual instincts, individuals have a perpetual feeling of discontent.

<sup>44</sup> Sant-Cassia refers to the opposition between Turks and Greeks, suggesting that once similar cultures are separated they follow a different course over time. In this process, sameness is obscured, nevertheless, since where there are shared traits there will also always be tension between the two cultures. The concept of *diffèrence* was developed by Derrida.

mayor is the centre of a network that includes, theoretically at least, all Palermitans. This perception fulfils Boissevain's (1968) criteria of ego-centric networks<sup>iv</sup>. Moreover, such a network could be defined as extended (ibid.), because the mayor could potentially know in person every Palermitan; this network could be open-ended. If seen within the context of patron/client relationships, the mayor could be the centre of an integrating system. Indeed, the Palermitans see the mayor as a powerful man that can protect their interests. This man is felt by Palermitans to be also physically close to them. Relatively easy access to such an important person makes Palermitans believe that their relationship with the mayor is the only one in which social status plays no role at all. This Palermitan perception can be seen in contrast to the relationship between Palermitans and the regional or national governments. Politicians of the regional and national governments are more distant from Palermitans both physically and psychologically. Instead, Diego Cammarata, the current mayor of Palermo, has built an image of a public individual to which Palermitans can have access.

Cammarata's popularity among Palermitans rests mainly on the fact that the mayor presents himself to Palermo as a politician who manipulates national politics in favour of Palermo, while when his audience is Italy he presents himself as a workaholic and lawful politician of limited power<sup>v</sup>. Diego Cammarata also presents himself as incorruptible although the Palermitans know that he is not<sup>vi</sup>. However, the mayor has convinced the majority of Palermitans that each act of his, even if not legitimate, aims to improve Palermitan life. Indeed, Diego Cammarata has changed the shape of the city of Palermo in the eyes of its citizens. Within the period of 2002-2007, the commune has spent €63 million on the restoration of 264 edifices and licenced another 380 restorations<sup>vii</sup>. When the broadcaster of the television programme *Faccia a Faccia* asks the mayor about the renovation of the Zisa area in

Palermo, the latter states: ‘To see this area reborn and blooming invokes an extraordinary feeling inside me. My father lives there, and I visit him every day, because he is eighty-seven years old and thus it is difficult for him to move. Therefore, I re-experience this feeling almost every day.’<sup>viii</sup> Statements like the above make some Palermitans feel that the mayor is ‘one of them’.

Luigi (57-year-old shop-owner in *Zisa*) states: ‘The mayor is one of us. We see him in the street and we talk to him as if he were friend of ours. Once we have dined in the same restaurant and we have met him several times in various pubs, all by luck, because he is a person who goes out and wants to know what is going on in the city. Come with me to watch a video of Mario the *posteggiatore*<sup>45</sup>. Even Mario respects Cammarata, but at the same time he publicly asks for Cammarata’s help! Cammarata is the perfect Palermitan: a public person with political power, resources and cleverness. He is the mayor because he helps people. Of course, there are still many problems in Palermo but I am sure that he is going to fix them. I so much enjoy the fact that he manages to get large amounts of money from the government for Palermo and that he then makes a fool of them by pretending to be a saint.’ One could wonder if Luigi is talking about Diego Cammarata or Silvio Berlusconi.

Like Berlusconi’s case, Diego Cammarata manages to be agreeable to the Palermitans because he does what any Palermitan would do if he/she were in the mayor’s shoes<sup>ix</sup>. The mayor is an imperfect man who, however, leads the fight of the local society against the Italian government. Similarly, Silvio Berlusconi is an imperfect man with all those passions that theoretically every Italian has, but also a man who remains a simple Italian even when he addresses the Queen of England. He

---

<sup>45</sup> The *posteggiatori* are men who are in control of specific areas as far as parking is concerned. The Palermitans pay these men money (usually €1) to be allowed to park their cars in the street. The Palermitans are forced to give this amount because they are afraid that if they do not pay they will find their car damaged. I have witnessed many cases in which Palermitans who refused to pay found their cars' wing mirrors broken.

fighters in the same way that any Palermitan would do, that is with the weapons that the system provides him with, and which he manages to manipulate because he is *furbo* (clever). Moreover, it is a commonplace in Palermo that 'he does everything with style'. Voters of his parallel the mayor with Zorro. Some put emphasis on his affection for his family. Others sum up these views by suggesting that Diego Cammarata is a breadwinner, though his home is not only his family but also the city of Palermo. Both men, Silvio Berlusconi and Diego Cammarata use the mass media to build a positive self image.<sup>x</sup> Berlusconi goes to young girls' birthday parties (*La Repubblica* 28 April 2009) and Cammarata visits high schools in Palermo (*Liceo Umberto I*). Berlusconi goes to the stadium to watch Milan's football matches, while Cammarata watches Palermo's matches with other Palermitans and he is asked to comment on the game on the local television channel *TgS*.

Accessibility and generosity are those characteristics of Diego Cammarata that make Palermitans believe that the mayor is the mediator between what Galt (1974) defines as 'real' and 'official' systems<sup>46</sup>. To quote Ezio Mauro<sup>xi</sup>, the editor of the Italian newspaper *La Repubblica*, Palermo like the rest of Italy 'no longer has a public opinion, capable of reacting autonomously or making spontaneous judgements. On the contrary, Italians are immersed in a "common understanding", which is something else altogether. It is Berlusconi –or in our case Cammarata– who is the great architect of this "common understanding" and, at the same time, the interpreter of its success. [...]There is, in short, a fundamental problem: Berlusconi has kept Italy in a state of high tension for 15 years. Using emotions is the most effective way of introducing a modern populism. This is a populism that asks citizens to mobilise,

---

<sup>46</sup> Galt argues that the two systems are interdependent. He analyses patron/client relationships on the Italian islands of Pantelleria and Sicily, and he argues that these relationships are exploitive and adaptive. Patrons manipulate the official system and its image to convince their clients that they need patronage. Both the 'real' (how things are actually done) and the 'official' (how it is codified that things be done) systems are used for obtaining things from above the local level (1974:182).

not so they can get involved in public debate, but so they can anoint the leader with their vote. He then thinks that he alone can solve the country's problems, with no need for the system of checks and balances typical of a modern state, that this direct coronation by the people makes his power neater and above all others.' Diego Cammarata uses the same methods that Silvio Berlusconi does. This is how the mayor manages to be seen in Palermo as a 'real' Palermitan. Thus, Diego Cammarata is a symbol of Palermitanness, as much as Silvio Berlusconi is a symbol of Italianess.

### 8.9 *Santa Rosalia*

'If there is something that unites us all as Palermitans, this is *Santa Rosalia*. *Santa Rosalia* is an idea, an ideal, something divine. It is more than a simple feast; it is sounds, odours, sentiments...*Santa Rosalia* demands all your senses...it is everything!' Benito's (48-year-old hotel owner) words sum up Palermitans' perceptions of their patron saint and feast dedicated to her in July<sup>xii</sup>. The officials' view corresponds to that of Benito. In the programme that the *commune di Palermo* released for the 381<sup>st</sup> *Festino di Santa Rosalia* in 2005, the Cardinal Archbishop *Salvatore De Giorgi* states: 'The manifestations of the 381<sup>st</sup> *Festino* in honour of *Santa Rosalia*, the fifth of the new millennium, return as an occasion of a festive aggregation for the numerous and diversiform civil society of Palermo.' (p.3). However, after a short analysis of the religious character of the feast the Archbishop's audience is only the religious Palermitans: 'My invitation to the Palermitan believers is thus to experience this feast as happy gratefulness to God...' (ibid.). Diego Cammarata adds: 'The *Festino* of *Santa Rosalia* is the feast of the Palermitans, the occasion not only to celebrate the patron saint, but also the memory

of the past, the faith in the present, the hope for the future. [...] it is a moment of collective happiness' (p.5). In the second paragraph, the mayor of Palermo states clearly: 'The spectacle is studied to strike (impress) the minds and the hearts of the Palermitans and of the numerous tourists that will visit our city in that period' (ibid.).

The *Festino* is promoted as *the* commemoration of Palermitaness. As seen above, the division between Palermitans and non-Palermitans is clear in both public men's words. Direct guidelines of the leaders of the spiritual and political life of Palermo reveal the seminal role of the feast in the continuous process of shaping Palermitan identity. Although Barth (1969) stresses that ethnic groups are not always based on similarities and differences, a particular kind of ethnic discourse in the above case aims to blur most of the various differences that may exist among Palermitans. Following Gellner's (1983) approach on the role of ethnic discourse, I suggest that in the case of the *Festino* the Palermitan authorities manage a kind of 'religious armistice' among Palermitans. During the *Festino* the contested representation of the self in Palermo is almost perfect, turning the feast of the local patron into a festival of civic consciousness as well. The authorities promote an ideal image of Palermitans and Palermitans accept playing this role. This may be the only time that the social construction of the self, as Foucault (1979) and Sökefeld (1999) describe it, becomes so obvious in Palermo. A simultaneous celebration makes it easier for Palermitans to imagine themselves as belonging to a community. However, as Rapport (2002) suggests, the character of belonging to a community can be unstable. Indeed, there is a feeling in Palermo that the truce ends with the end of the *Festino*.

Cohen (1994) and Billig (1995) stress that practice ties individuals to ethnic groups. In the case of the *Festino di Santa Rosalia*, the aim of the Palermitan authorities is to surpass the local level. On the one hand, the periodicity of the *Festino*, the fact that

the main spectacle is presented in front of Palermo's cathedral, and the importance this feast seems to have for the local authorities may reveal the *Festino's* role in Palermitan identification. On the other, all those involved in the preparation of the feast, like the artistic director or the scene painter, stress that they want to present to Palermitans something that they will always remember. However, in 2005, both the mayor of Palermo and the artistic director of the feast state that the *Festino* should renounce the label of an exclusively popular and local spectacle. Indeed, many tourists visit Sicily for the *Festino*. The impressive wagon of Santa Rosalia eventually reaches the harbour where Santa Rosalia welcomes her visitors. Luigi Marchione, the stage designer, and Davide Rampello who was the artistic director of the *Festino*, clearly state that their aim was to present to the people a simple but dramaturgically structured spectacle. In 2005, it was a common opinion among Palermitans that the whole team responsible for the preparation of the festival managed to touch Palermitans' minds and hearts.



Santa Rosalia.

Palermitans consciously participate in a feast that may seem to reinvigorate their ethnic consciousness, but that indirectly and maybe unconsciously reinvigorates their national esteem as well. On the last page of the programme of the *Festino* there is a map. This map indicates the main places where the festivities are held. In the centre of the map there is a clear sign of the Cross formed by the two main avenues of Palermo, the *Corso Vittorio Emanuele* and the *Via Maqueda*; there are two basic symbols of Palermitan but also Italian life: these are the first King of Italy, and the Holy Cross (see next page). Both are surrounded, and represented as well protected, by the city's old walls. If the connection between the local and the national is daring here, it becomes more obvious in the outline of the spectacles related to the *Festino*. Starting from July 1<sup>st</sup> and until July 6<sup>th</sup> (2005), Palermitans could consecutively listen to stories related to Santa Rosalia in Sicilian, Mediterranean music, ancient Greek music, Sicilian music, and religious music. However, on July 7<sup>th</sup> M. Norrito and G. Fichtner were performing together: according to the programme, 'M. Norrito and G. Fichtner are two musicians that ideally incarnate the collaboration and friendship between the North and the South, since the former lives in Milan and the latter in Palermo...<sup>xiii</sup>' (my translation). On July 8<sup>th</sup>, Palermitans could listen to the work of various European composers, and on July 11<sup>th</sup>, they could be the audience of Rosa Balistreti, 'the great interpreter and ambassador of our culture in the world.' However, only food could incorporate all senses.

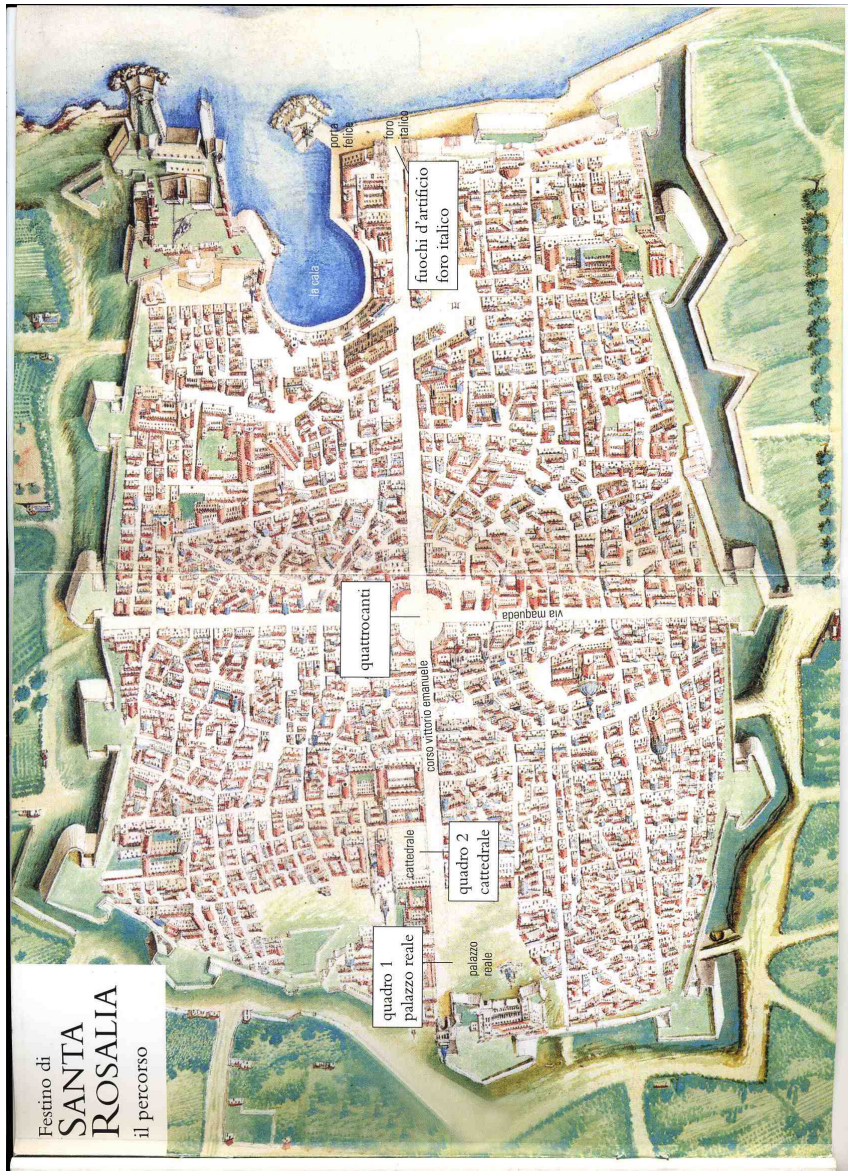

The 'Route' of Santa Rosalia.

### 8.10 Food and Identity, Bread and Circuses

Walking in the streets of Palermo during the *Festino* period one is carried away by the sounds, the smells, the tastes and the changed view of the city's historic centre. Especially Palermo's historic centre 'wears its cosmopolitan suit'. The festal environment pulls Palermitans out of their homes, and forces them to see their city from a more cheerful angle. Food plays an important role in this new perception of

the historic centre. It is not only the classic restaurants that provide food, but also numerous stalls scattered around the historic centre that give Palermitans the chance to experience familiar but also exotic tastes often free of charge. Palermitans relax in this festive atmosphere and are thus less circumspect about tasting new flavours. Women have the chance to take some time off from their daily round of preparing food for the family without threatening the power structure. Nevertheless, Palermitans taste foreign dishes only to be reassured that their local cuisine is better. Women take pride in it. Almost all families that visit the historic centre end up eating at Sicilian restaurants. However, it is mostly due to food that the *Festino* remains in Palermitans' minds until the next *Festino* the following year.

Most of the people who provide free food during the *Festino* receive a subsidy from the local authorities, which are the municipality and the Church. Food, seen as a system<sup>47</sup>, follows strict rules of sharing and generosity (Sahlins 1972). Thus, in this particular case, food provision reflects Diego Cammarata's generosity towards the Palermitans. As in Mauss (1967), and Counihan (1981), this treat demands amity in return. The obligation of amity remains strong in Palermitans' consciousness because it is tied to tastes and smells<sup>xiv</sup>. Food consumption is a composite of action, emotion and memory (Sutton 2001, Lupton 2005). Food can make individuals recall situations and feelings, but food has also another function, that of attaching smells and tastes to new experiences (Seremetakis 1994). Some Palermitans, however, see behind the mayor's generosity his power<sup>48</sup>. Thus, Palermitans experience a kind of tension that emanates from the conflicting procedures of enjoying a typical Palermitan need, legitimising power structures, and being contrasted with foreigners.

---

<sup>47</sup> Douglas (1973) approaches food as a system of inclusion and exclusion, suggesting that meals are culturally and grammatically specific.

<sup>48</sup> Bourdieu (1974, 1985, 2005) discusses food in relation to power, arguing that individuals who decide what actually is food, hold power and struggle to maintain it. In this, there are elements of hegemony, competition, resistance and violence.

Caplan (1992) suggests that in cases like the above, when food is displayed in the public it becomes an ethnic marker. Apart from the differences between the Palermitan and foreign cuisines however, there is another more important difference. Palermitans' decision to consume Sicilian food does not solely lie on the exotic taste of foreign cuisines, but primarily on perceptions related to food. For example, food should be prepared by women, served by them, and consumed at home by the whole family. Food taboos reinforce the differences between Palermitans and foreigners, if these differences refer either to ethnicity or religion. The importance of eating in Palermitan society can be traced in the expression used in commercial bargains *i bambini devono mangiare*, or 'the kids have to eat'. Poverty and starvation experienced in the past have made Palermitans intensely appreciate food. Thus, Palermitans may ask their intimate friends 'have you eaten pasta today?', for Palermitans are willing to provide the staple food to friends free of charge. Moreover, Palermitans customarily offer their visitors food. The food used in these rituals is solely Sicilian<sup>49</sup>.

Although there are typical Sicilian and Palermitan dishes, the Italian cuisine that incorporates various local elements blurs distinctions. In this sense, cuisines could be perceived as imagined as are the groups to which these cuisines are associated. Palermitans may promote their food in an attempt to question the superiority of the North. The *terroni* (southerners) eat much better than the *polentoni* (northerners) who eat the unappetising *polenta*. However, the Palermitans do not shun the Italian cuisine, maybe because there are shared elements between the local and the national cuisine. Since Italian cuisine is famous around the globe, Palermitans believe that the

---

<sup>49</sup> Anderson (2005), states that eating can be seen as a ritual associated with integration and cohesion. Williams (1993) argues that food is an identity marker. In addition, Sutton (2001) discusses the relationship between eating and religious affiliation and states that food binds people to their faith. Thus, the Sicilian cuisine is defined in opposition to foreign ones. Sökefeld (1999) stresses that ethnic and religious differences are reinforced by eating taboos.

local cuisine is indirectly promoted through the national. At the same time, Palermitans suggest that all Sicilians are specialists of, and enjoy a, cuisine far more advanced than the national and commercialised one. This Palermitan perception may seem to strengthen regional identity, but instead cuisine bridges the local with the national, since Palermitans see their regional cuisine as part of the national. In practice, typical Italian dishes, i.e. *spaghetti* (pasta) and *pizza*, make Palermitans feel members of the national imagined community, transforming the local consumption of food into a sense of simultaneous experience at the national level.

### *8.11 Mass Media and National Integration*

If cognition is seen as a system that is the outcome of the process of collective action and history (Bloch 1989), the feast described above could be understood as a means through which collective memories are maintained in Palermo<sup>50</sup>. Having already questioned the strict Palermitanness of the *Festino*, I suggest that this feast could be seen as a means of national integration as well. Food plays a vital role in this procedure, as the Italian cuisine becomes the mediator between the local and national, while indirectly excluding ‘the other’ who, in this case, are the immigrants living in Palermo. Thus, the information given to Palermitans through the dramatic commemoration of *Santa Rosalia* indirectly becomes a bridge between the local and the national. Likewise, the local is promoted as part, or as a diverse manifestation, of the national through the Italian mass media coverage of the festivities in Palermo. At least, this is how the Italian mass media and press promote the *Festino*. Anderson (1983) emphasises the role of print capitalism in provoking national sentiments. In

---

<sup>50</sup> Halbwachs (1992) holds that festivals and celebrations become and maintain collective memories when agents decide to maintain them as such. Such a decision depends on the meaning that a group attaches to festivals and celebrations. That is, the group decides if something should be/become a collective memory or not according to the memory’s significance in the group’s identity.

addition, Gellner (1983) correlates the diffusion of the elite's particular points of view to the masses on capitalism, and considers these two as prerequisites of nationalism. The Italian mass media promote essentialist models of Italianess to which Palermitans seem to adapt. Therefore, this process blurs the differences between the regional and national identity, differences that could trigger separatism (see Jenkins 2008). Although the older generations and conservative politicians hinder the progress of homogenisation, the Italian mass media seem to be able to overcome such contrarities.

In Palermo, resistance to homogenisation is primarily offered by separatist politicians, for the reasons that have been explained above, but even more importantly for the sake of this argument is the resistance offered by the older generations of Palermo. The elders in Palermo have a different perception of the world in comparison to the other generations. Older Palermitans are far more conservative than middle-aged and young Palermitans, and they see the role models promoted through the national media as threatening their ethnic identity. Giovanni and Maria, both in their late seventies and married for more than forty years, comment on the reality shows *Amici* (Friends) and *Uomini e Donne* (Men and Women) that Maria De Filippi presents on *Mediaset*:

- Giovanni: '*Disgraziati...*'
- Maria: 'Indeed...Bread and circuses!'
- Giovanni: 'Oh Lord, look what the kids are watching!'
- Maria: 'At least our sons are old enough now...'
- Giovanni: 'Real men...this is what they are! Not like these kids...'
- Maria: 'Those days were different, *caro*.'
- Giovanni: 'Indeed, my love.'

- Maria: ‘Are their mothers proud of them?’
- Giovanni: ‘There can be no comparison!’
- Maria: ‘We raised men, Sicilian men!’
- Giovanni: ‘Good persons most of all, and proud Sicilians!’
- Maria: ‘So different...things change.’
- Giovanni: ‘God bless us...where are we going?’
- Maria: ‘They turn us into identical rams...television is the stable.’
- Giovanni: ‘At least we have made it; we are nothing like them.’

Maria and Giovanni watch the local television channel and buy the local edition of the *Giornale di Sicilia* newspaper in preference to watching *Mediaset* programmes and buying the *Repubblica* for example. Customarily, central cafés that provide their customers with newspapers, make available one copy of each newspaper, but they offer two or more copies of the *Giornale di Sicilia*. The pattern in Palermo is that both women and men of thirty years of age and above take as a model traditional characters, putting emphasis on fidelity, loyalty, religious faith and labour. In contrast, the youth prefers a career related to the mass media and spectacles, and claim that they would accept any challenges in order to advance in this area. For the Palermitan young, age is the main criterion of identification, a fact that provides this group with a sense of simultaneity on the national level, in contrast to the older generations where identification depends more on ethnicity, religious and political affiliation, and so on. Nevertheless, the Italian youth imagines itself as a community of people of the same age but also pursuing the same goals. The youth’s goals are dramatically different from those of the other generations also due to their diverse preferences in media through which they keep up with the latest developments. However, an individual’s plans for the future depend on past and current experiences.

### 8.12 Landscape

The difference sense generations of Palermitans make of the world does not depend solely on their different experiences, but also on current perceptions of the self within various realms. Consecutively, a significant difference between the young and the other generations remains their perception of the landscape. For example, the young see the *Festino* as a chance to drink and have fun, but the older generations imply that this feast is a ritual that helps sustain Palermitan social memory. Connerton (1989:12) defines social memory as the ‘images of the past that commonly legitimate a present social order.’ Bender (1992) suggests that different memories mean individuals have a different view of the same landscape. The young lack images of the past that the older generations have experienced. Tilley (1994) and Bender (2003) suggest that biographical memories and the analogous sentiments of individuals are embedded in the landscape. The contrasting view of the landscape among generations rests on present evaluations that, however, are driven by different value systems, which in turn differentiate the way generations connect the local, regional, and national levels (see Stewart and Strathern 2003).

For older Palermitans, the Sicilian land is bloodstained with issues of power, in contrast to the young Palermitans who learn to see the cosmopolitan side of their environment. Cinel (1982:25-26) argues: ‘The first land reform law, passed in 1861, was followed by others in 1884, 1893, 1902, and 1904. The purpose of the laws was to create small farms and small landowners. But breaking up the land into economically inefficient units to be worked by illiterate peasants did not lead to the needed modernisation of agriculture.’ From a rather patriotic point of view, Meissner stresses in the aftermath of the 1953 Italian elections: ‘The blame for the unsatisfactory state of affairs in the Italian South can, to a great extent, be put upon

the indifference and often hostility of the dominant class of landowners toward the welfare of the agricultural masses. Despite nominal attempts at agrarian reform, the old order of landownership remained substantially unchanged. Under the terms of legislation of the Napoleonic Code and the Risorgimento, the ecclesiastical and secular feudal holdings were to have been liquidated. But the local administrators, influenced by the aristocracy, permitted many of the holdings to remain under the control of great landlords. Such land as peasants did acquire was in many instances soon lost because of lack of capital. The land thus passed back to the old aristocracy or into the hands of urban proprietors. Absentee owners continued to rule the South and hold the peasantry in economic and political subjection, in poverty, and in ignorance. The pre-Mussolini government allowed this situation to continue, receiving in turn electoral support from the landlords. The southern peasants became the stepchildren of united Italy. Some politicians certainly thought of solving the "*problema meridionale*" by developing a landowning peasantry and a small-scale industrialism. Agrarian reform was a perennial subject of debate in the national parliament. There was no lack of suggestions by well-intentioned individuals, but the money for translating proposals into actions was seldom made available. And it is not astonishing that, when the government did act, the interests of the big landowners were paramount.' (1954: 39-40). However, landownership has been problematic for Sicilians since the times of *Magna Grecia*.

In this highly agonistic environment land has not always been a means of gaining economic and political power as argued above, but also a criterion of honour in the absentee landowner/land-worker bipolar system that has its roots in the period of Sicily's Spanish domination. Although currently Sicilians have no experience of the times Sicily was under Spanish occupation, some residuals exist on the landscape. For example, Corr (2003:43) considers the effect of Spanish colonialism surviving

until now in Andean festivities: ‘The memory preserved in the performance of the *muq*<sup>51</sup> is enacted through physical movement along certain routes. It is reminiscent of early colonial and post-colonial practices in the Andes.<sup>52</sup>’ In Palermo, the style of the processions of various saints, as well as that of Santa Rosalia’s, are considered to be Spanish. The route and the last stop of Santa Rosalia’s wagon mark symbolically the Spanish territory in the city of Palermo as well as the social stratification of those times. Santa Rosalia’s journey ends at the walls of the old harbour, which was traditionally the nobility’s place of amusement. Although older generations of Palermitans recall the stories of older members of their families and relate the so-called *Muro delle Cattive* (wall of the bad women) with the Spaniards, younger generations see the same walls solely as the city’s frontier with the sea<sup>53</sup>.

---

<sup>51</sup> *Muy* is defined as ‘a form of bodily memory...of the local geography’ (p.43).

<sup>52</sup> Santos-Granero (1998) observes similar effects on the perception of the landscape for the Yaneshá people in Amamzonia.

<sup>53</sup> Another example of the same kind drawn from Italy’s modern history is the way different generations see Palermo’s post-office. For the older generations this imposing building symbolises Duce’s power and triggers sentiments from the experience of Fascism. Instead, young Palermitans see in this building only the imposing part of it, which they attribute to its size.



The post-office.

Overall, the Palermitans, but also the Sicilian landscape, are marked by the constructions or destructions of diverse peoples over different periods of time, and it might be due to this interaction that Sicilians are adaptive to fluidity, but at the same time resistant to any form of coercion. While the European Union leaves obvious marks on the Sicilian landscape, Palermitans do not believe the European Union threatens the Sicilian territory, but instead improves it. Analogous efforts have been, and are still, made by Italy's central government to invest in the development of the South's infrastructure. However, state and landscape are correlated negatively in the Palermitans' consciousness for the reason mentioned above, that is the central government's impotency in boosting the Sicilian economy through a real redistribution of land and resources in the South. Instead, from the period of Italian unification, the state has treated the Italian South as a colony and southerners as inferior to northern Italians<sup>xv</sup>. As Meissner (1954) argues, the central government accommodated itself in allying with the southern elites and exhausted itself in providing proposals that were never translated into actions until at least shortly after World War II. Likewise, the discussion of the *Ponte*, or of building a bridge to connect Sicily to Calabria, has lost its appeal among Palermitans because it remains just words.

### *8.13 Imaginary Bridges*

Irony and paradox are characteristic of Greek style I always thought, but Italians managed to make me question my viewpoint. 'Irony', a Palermitan once told me ironically in an attempt to recapitulate what we had discussed, 'is what you see in Ministers' eyes when they discuss the issue of the Italian South. The paradox is that our people cannot even get close to what foreigners have succeeded in making of this

island experience: an economic and cultural primavera.’ From my point of view, the paradox is that Palermitans can easier construct imaginary bridges between themselves and the European Union than they can between themselves and their own nation. ‘From absentee landowners to absentee politicians, this is the route of our history’ Domenico claims, referring to the Italian government. Thus, the more Palermo becomes more cosmopolitan the greater the gap between Sicily and northern Italy, and the more the European Union may invest in developing infrastructure in Sicily, the more European Palermitans may feel. Socio-economic conditions are such in Palermo that Palermitans do not count on words but on action. Salvo states: ‘Words...we are fed up...we want to see and touch...this is all you can believe in nowadays.’ It is the same with religious faith; Palermitans suggest that one must believe in the Pope, ‘Because the Pope is not only the representative of God, but someone you can touch’ as Alessandro told me. The same applies to politicians and the Mafiosi: ‘You are addressing people and not an invisible power.’ Instead, the state is invisible and it thus cannot legitimise its power but only enforce it.

Palermitans’ perception of the state probably resides in the circumstances under which it is instantiated. The relationship between the state and its citizens is procedural and not interactive, Palermitans claim. All those envelopes that find their way to Palermitans’ homes every month, give the relationship between Palermitans and the state a ceremonial character. This correspondence invokes in Palermitans negative feelings because it ‘usually encloses bad news’, like bills. Tension lies in the fact that on the one hand, Palermitans perceive the state as demanding everything and giving back far less. On the other, in that the state asserts its authority any time citizens commit irregularities instantly, whilst it makes it difficult for the citizens to assert their rights especially if these turn against the state. The frequency of positive and negative acts of the state, as these are evaluated by the Palermitans, affects

Palermitans' perception of the commonness of these events and consequently results in an adverse balance. On a video that praises Sicily, someone with the username 'scherifaitaly' comments: 'All I can say is that I have abandoned my place to provide my sons a better future, but I feel an emptiness inside my heart and [I also feel] that I miss my Sicily a lot! No one wants to change things, and it thus breaks my heart that no one tries to improve our Sicily, first because some people are accommodated to the fact that things do not change, and second, because some people are afraid to revolt [!] against a government that the only thing it thinks about is how to empty our pockets!' (my translation)<sup>xvi</sup>.

Therefore, on the one hand, Palermitans' negative evaluation of the state depends on what it does. On 2 February 2007, the Catania football team lost the classic Sicilian derby versus Palermo with a 1-2 defeat. Troubles started after Palermo scored the first goal. The police intervened and the match was suspended. Palermo fans were not allowed to re-enter the stadium until the second half started. Clashes in the streets next to the Catania stadium between Palermo and Catania fans and the police, climaxed when Palermo scored a controversial second goal. In these clashes, a juvenile Catania hooligan killed a police officer, Filippo Raciti. The news travelled around the world. Commissioner Luca Pancalli commented: 'What we are witnessing has nothing to do with soccer, so Italian soccer is suspended<sup>xvii</sup>.' All football matches in Italy were suspended for a week, including those of the national team. However, if the mass media had not presented Filippo Raciti's death as the loss of an excellent Sicilian paterfamilias, Sicilians might have reacted differently. Some Sicilians did not see Filippo Raciti's death as a dishonourable action. 'Death to the cop' and 'all cops are bastards' were some of the slogans written on walls throughout Italy, which the newspaper *la Repubblica* registered<sup>xviii</sup>. Some bloggers argued that the police were responsible for fans' deaths, i.e. of Gabrielle Sandri<sup>xix</sup>.

However, *Repubblica* promoted another equally important side of the issue. This was the tension between different localities and the negative image Italians have of the South<sup>xx</sup>: ‘*fuori la Sicilia dalla serie A*’ (Sicily out of the Premier League), or ‘*voi per me non siete Italiani*’ (you are not Italians). An official ceremony and close-ups of Filippo Raciti’s family, however, made the majority sympathise with the police officer’s family in their bereavement and managed to hide deeper issues. If the mass media had not handled the police officer’s death capably, an outbreak of hostilities would have been the most possible scenario<sup>54</sup>.

On the other hand, Palermitans’ negative evaluation of the state depends on what it does not do. In relation to the above, Palermitans turned against the state for not protecting Palermo’s image in Europe. Within a short period, the Palermo football team was associated with the Mafia three times. In September 2005, Palermo was playing against the Cypriot *Anorthosis* for the Uefa Cup. On *Anorthosis*’ official site there was an article titled *Mafia and Arrogance in Sicily*. In February of 2006, the Czech *Slavia Praga* promoted their match against the Palermo team as a match versus the ‘Kosa Nosrta.’ Seven months later, when Palermo was playing against West Ham in London, outside the stadium T-shirts were sold that associated Palermo with the film ‘The Godfather’ and thus with the Mafia<sup>55</sup>. For Palermitans, the Mafia is a highly sensitive issue, for the anti-Mafia war as a social movement started as early as after the end of the cold war (Jane and Peter Schneider 2003), and cases like the above are setbacks in this war. They reveal that the stereotype of

---

<sup>54</sup> As Cesare put it, “The revived local identity of the fans who were watching their local teams could have made them start a war against the ‘occupying forces’ that ‘kill innocent citizens’.”

<sup>55</sup> Ironically, on the 11<sup>th</sup> March 2008, the official site of the Palermo football team hosted the advertisement of an e-game called ‘Gangster’. By clicking onto it, the message was: ‘Become the new legend in the gangsters’ world! Respect is everything! Friendship, fidelity, treachery; an epos about illegality. The only law that counts is that of the street. With an exclusive design, start a new Mafia era.’ See illustration on the following page.

<http://www.ilpalemocalcio.it/home/>

U.S. Città di Palermo - Home

**FAN CLUB**

**ALBUM**

**TI RICONOSCI?**

**SE VUOI ESSERCI C'È UN SOLO MODO: INVIA LA TUA FOTO!**

ENTRA

**GWS**  
 GENERAL WORK SERVICE

11 marzo 2008 - 12:00  
**Inter - Palermo, biglietti in vendita da domani a venerdì**  
 Saranno in vendita da domani i tagliandi del settore ospiti per assistere alla gara Inter - Palermo, in programma...

10 marzo 2008 - 18:45  
**Amari domani a 'Playerlist'**  
 Carvalho De Oliveira Amari sarà il protagonista della puntata di domani di 'Playerlist', il programma di Sky Sport...

**DAL CAMPO**  
 010 mar 2008 - 19:25 - Squadra nuovamente in campo domani

**GIOVANILI**  
 009 mar 2008 - 14:05 - Domenica di sconfitte per le giovanili  
 008 mar 2008 - 17:50 - Primavera, Palermo batte 3-0 il Frosi...

**FAN CLUB**

**SCREENSAVER**

**IL NUOVO SCREENSAVER DELLA NUOVA STAGIONE**

**BIGPOINT**  
**GANGSTER**  
**LE REGOLE SONO FATTE PER ESSERE INFRANTE!**  
**GIOCA GRATIS!**

**lotto**

info@ilpalemocalcio.it

Copyright © 2003 U.S. Città di Palermo. Tutti i diritti riservati.  
 Tutte le foto sono Copyright ©. Tutti i diritti riservati.  
 U.S. Città di Palermo - Partita IVA 03529480828

Per la pubblicità su questo sito

Designed & powered **IM MEDIA**

The official site of the Palermo team.

‘Sicily=Mafia’ seems to hold still strongly, irrespectively of Sicilians’ efforts to ‘disconnect’ these two words. This fight has cost many Sicilian lives who, although they have become ‘martyrs’ in their homeland, they have not been promoted enough as such abroad. Moreover, Sicilians take risky initiatives against the Mafia, i.e. the *anti-pizzo* movement, refusing to pay the Mafia for protection, and although the results of such initiatives are positive at the local and regional level, they do not seem to have the desired effect at the national and international levels. Therefore, Palermitans are not satisfied with the state because it can protect neither its citizens’ lives nor their reputation against the Mafia.

The tension between the state and its citizens is more obvious in the stadium (or outside it), because for Palermitans a football match is a symbolic war of their hometown against its ‘enemies’. In fact, the cases mentioned above reveal that tension springs from the divergence there is between a glorious image that Palermitans have of their group and a negative image that others have of Palermitans. Palermitans consider the state responsible for reversing the situation by helping change the Sicilian stereotype of the ‘Mafia Island’. However, this in turn is also contradictory since the Sicilian stereotype is primarily a northern Italian construct and for Sicilians northern Italy symbolises the state. Thus, inferiority becomes the reason for Palermitans’ resistance against the state, but resistance legitimises the state. By diffusing tension, the state manages to naturalise chaos and make it part of the Sicilians’ daily life. Chaos becoming something ordinary, it can reinforce stability in a vicious circle. However, the perpetuation of tension makes Palermitans look in the direction of the European Union.

The Italian national team won the 2006 football World Cup and proved that Italians can unite in moments of joy. Palermitans in particular, surged as a homogenous

crowd along the streets in a feast that lasted all night long. In this magic atmosphere of an unprecedented manifestation of nationalism in Palermo, the regional and national flag stood side by side as if all Palermitan issues discussed in this thesis had been solved. Similarly to Italian cuisine, Palermitans saw in the national team a part of them being represented abroad. Palermo's football players that played for the national team represented Palermitans at the global level, and the national's triumph made Palermitans proud of both their country and their *piccola patria* ('small' homeland; in this case both Palermo and Sicily). The national team showed great toleration of the 'diverse', but also proved that the different parts of this cluster could cooperate and form a competitive group. Although the World Cup was an enviable achievement for non-Italians, Palermitans put emphasis on the importance of cooperation with no tone of disdain for their adversaries. As Gaitano said, multiculturalism won the World Cup because all Italians became one, adding that 'barbarians are those who cannot tolerate diversity. Things would be much better if we could bridge the gap.'

#### *8.14 Instead of a Conclusion*

My research shows that the local and the national are interrelated to the point that neither can the local survive outside the national, nor can the national afford constant challenges from the local without sustaining losses. Although there are cultural differences between the North and the South, Italy's Southern Question rests on the unequal distribution of resources that results in a vast economic gap between the North and the South. However, cultural difference is enough to maintain the above economic issue unresolved. The gap between the North and the South remains unbridgeable because, from the northerners' point of view, Sicilian culture is such

that it would not allow the economy to flourish in Sicily. In fact, northern Italians see Sicilian society as backward. However, Sicilian society seems to change and especially during the last decades, this change seems to have been in the 'right' direction. In other words, Sicilian society experiences economic and cultural changes that bring Sicily closer to the Italian North. Although these changes could solve the problem of national integration in Italy, Italy's Southern Question is still as much an important issue as it was back in the 1860s. The Palermitans match a Sicilian ethnic identity against the stigmatisation of the South. From the Palermitan point of view, the poor economic conditions of the Italian South have nothing to do with culture; instead, the regional culture is the only means to affect the national politics that are to be blamed for not being adequate to address the economic weakness of the Italian South. It is not my intention to reveal some kind of absolute truth, because I do not believe there is such a thing. Nevertheless, I would like to reverse the situation believing that Sicilian society should be rewarded for its painful but also successful attempts to change (Jane & Peter Schneider 2003). I wonder if the Italian North is also willing to change. If we accept that Sicily has made steps forward, this should be the time that the Italian North abandons its colonial views and practices for the sake of Italy's future. If not, Sicily could change from Italy's 'stepping stone' to a scorpion's sting that could poison Italy itself. On the contrary, the politics of inter-regional relations could shift towards the promotion of productive relations through large networked infrastructures. Since the South is internally homogenous, a higher centralisation of power would not find many obstacles among the Sicilians if it were presented as, and accompanied by, a better distribution of resources coordinated directly from the national government. Critical to the success of this procedure would also be the use of existing networks that can bring into play local knowledge and can guarantee that Sicilians will be represented in the Italian nation by Sicilians.

However, it is equally important not to allow specific social networks to create a bond that could corrupt this project. If corruption is minimised if not ended, the Italian periphery, which is also the periphery of the European Union, could experience economic growth by playing not only the role of the mediator between Italy and the Mediterranean, but between the European Union and its periphery as well. A balanced distribution of resources could ease the situation between northern and southern Italy, maybe eventually solving the problem of Italy's national integration, and consequently accommodate the process of European integration.

---

<sup>i</sup> Although the BBC's article is also brief, it provides important details of the incident such as 'Smaller islands, such as Sardinia, were in the right place on the map', and that 'One Italian Senator, Riccardo Villari, said it was unfortunate the big advertising campaign surrounding the re-launch had been followed by "unpleasant" errors.' Moreover, Aldo Canale's (stamp director) exact words according to BBC were the following: 'We have run lots of editions on the beauty of Sicily and we would never dream of eliminating it from maps of Italy.' (source: <http://news.bbc.co.uk/2/hi/europe/8106606.stm>, Page last updated at 10:14 GMT, Thursday, 18 June 2009 11:14 UK).

<sup>ii</sup> The transcription of the entire speech is given here in Italian because the reader can better understand the lawyer's sentiments and the probable effect of his words to his audience. The original video can be accessed on the net from this link: <http://www.youtube.com/watch?v=8TYyZHXVYUY&feature=related>

Lo Statuto siciliano è la Costituzione del popolo siciliano, nato ancora prima della Costituzione repubblicana. E va rispettata! E il Fronte Nazionale Siciliano, così come tutti gli altri movimenti indipendentisti, si sono battuti per il rispetto della Costituzione. Una Costituzione nata prima, una Costituzione che ha una storia di 8 secoli. Una costituzione che, per giunta, si è ispirato anche il popolo catalano, con l'ultima costituzione che è proprio entrata in vigore recentemente. Anche se devo dire che anche lo statuto siciliano ha preso molto a sua volta dallo statuto catalano, quasi a voler dimostrare questa sinergia tra il popolo catalano e il popolo siciliano. Io anche per questo motivo, per questa ragione, un anno fa, anzi meno di un anno fa, lo scorso anno nel mese di luglio, ho sentito il bisogno di costituire un comitato di avvocati avente un obiettivo: quella.. quello finale dell'attuazione di tutto lo statuto, ma in particolare quello dell'attuazione inizialmente degli organi giurisdizionali dello statuto siciliano, gli articoli dal 23 al 30. E questa è una mossa strategica, a mio avviso, per l'indipendentismo siciliano. Perché è una mossa strategica? Perché contiene l'attuazione di due articoli, uno quello di più facile attuazione, e uno quello di più difficile attuazione perché difende tutta l'autonomia siciliana. Quali sono questi due articoli? L'articolo 23 che riguarda gli organi giurisdizionali centrali. Questo articolo 23 perché è importante, perché per due terzi...la situazione, cioè un caso veramente singolare nello statuto siciliano, perché lo statuto siciliano è fatto da articoli mai attuati. Ebbene, l'articolo 23 per due terzi è stato attuato, e cioè la giurisdizione amministrativa ha avuto il suo decentramento col CTA che nessuna regione italiana ha, la giurisdizione contabile ha avuto il suo decentramento della giurisdizione contabile con la corte dei conti e la sezione...della corte dei conti. Rimane la giurisdizione ordinaria con la Corte di Cassazione. Io mi sono fatto promotore insieme ad altri avvocati di attuare questo articolo che prevede una cassazione civile e penale della Cassazione in Sicilia, unica regione d'Italia e penso che i tempi siano maturi perché nessuna motivazione c'è per non attuare questo statuto perché l'uniformità della giurisdizione cui si erano appellati gli oppositori -I ternatoi- dell'attuazione della cassazione in Sicilia è stata superata perché a Roma le stessa questione, in due giorni, da due sezioni diverse.... quindi anche sotto questo punto di vista questo scoglio (σκόπελος) non è stato superato. E quindi la Cassazione in Sicilia è un

---

diritto, è un diritto del siciliano perché è giusto che ogni siciliano che è imputato (κατηγορούμενος) o nel processo civile è attore e vuole fare valere i propri diritti, è giusto che l'intero procedimento, quindi dal primo all'ultimo caso, quindi primo e secondo caso in cui i giudizi...e l'ultimo caso di...decisita...venga celebrato in Sicilia. Noi come avvocati abbiamo detto, noi che siamo uomini liberi, noi che come avvocati ci battiamo per i diritti del popolo siciliano non dobbiamo dire che la cassazione in Sicilia è una rivendicazione di casto di questo punto di vista questo scoglio non è stato superato. E quindi la Cassazione in Sicilia è un diritto, è un diritto del siciliano perché è giusto che ogni siciliano che è imputato o nel processo civile è attore e vuole fare valere i propri diritti, è giusto che l'intero procedimento, quindi dal primo all'ultimo caso, quindi primo e secondo caso in cui i giudizi...e l'ultimo caso di...decisita...venga celebrato in Sicilia. Noi come avvocati abbiamo detto, noi che siamo uomini liberi, noi che come avvocati ci battiamo per i diritti del popolo siciliano non dobbiamo dire che la cassazione in Sicilia è una rivendicazione di casto di categoria, è una rivendicazione dei diritti dei cittadini siciliani ad avere interamente celebrato il... E veniamo all'altro articolo, ... questo è l'articolo più importante dello statuto, perché senza la..., per esempio il federalismo fiscale di cui parlerà l'avv. Spataro...

È che Dio ci ha dato l'uguaglianza tra i popoli, l'uguaglianza fra uomini diventa una realtà e finché ci saranno stati oppressori e stati dominati, questa uguaglianza non ci sarà mai. Ecco perché combattere per l'indipendenza della Sicilia è una battaglia non soltanto di una nazione, ma è una battaglia per l'umanità, per l'affermazione dei diritti fondamentali/naturali dell'uomo, per l'affermazione dell'uguaglianza fra gli uomini.

<sup>iii</sup> The paragraph I have chosen parts from is the following:

*Senza l' aiuto dei carabinieri forse la vita politica palermitana avrebbe preso un' altra svolta. La "primavera" probabilmente non sarebbe mai iniziata. Com' è noto, talvolta è il caso, la fortuna, a far emergere e a dare senso concreto a progetti per tanto tempo covati mi rimasti sempre sotto la coltre delle cose impossibili. Sarebbe toccata proprio a quei carabinieri, che in Sicilia hanno sempre rappresentato per la gente il volto arcigno di un potere estraneo e imposto dall' alto, di collaborare, inconsapevolmente, alla rivincta della gente su decenni di angherie subite e a spargere su Palermo un pizzico di utopia.*

<sup>iv</sup> The other two criteria being firstly, that the linkages between the central knot and the others, but among the others as well, are structurally diverse, and secondly, that the relationships between the ego and the other members of the network are also qualitative diverse.

<sup>v</sup> For some indicative interviews of Diego Cammarata follow these links:

<http://www.youtube.com/watch?v=XdbOn8py72I>

<http://www.youtube.com/watch?v=cuaubV3WoZY&feature=related>

<sup>vi</sup> Stefania Petyx broadcasts from Palermo for the favourite Italian TV show *Striscia La Notizia*, that Diego Cammarata asks the central government of Italy for €150 million which Silvio Berlusconi personally approves. Although Stefania Petyx comments that the municipality of Palermo is not in need of this money, in another interview on TG1 that the Mayor gives to Attilio Romita, it is made clear that Palermo is indeed in need of €200 million in order to save public enterprises from bankruptcy. Nevertheless, Stefania Petyx brings to the fore another important issue: she reveals that a man who is employed by *Gesip* –a society created by municipal funds to provide various services to the Palermitan municipality- never shows up at work. As the story unfolds, Stefania Petyx traces this man, Franco, on Diego Cammarata's yacht. Franco works for the mayor as a skipper, but his salary comes from the *Gesip* society. Illegalities do not stop there. Not only has Franco been twice promoted without having worked a single day for the six years he has supposedly been working for *Gesip*, but he also has responsibility for renting the mayor's yacht illegally. Soon, the case becomes a big issue in the Italian media, it is then published in the newspaper *La Repubblica Palermo.it*, and it finally ends up in court (<http://palermo.repubblica.it/dettaglio/skipper-assenteista-inchiesta-della-corte-dei-conti/1734047>).

<sup>vii</sup> For more detailed data follow the link: <http://www.youtube.com/watch?v=dy1ICiy8yXA>

<sup>viii</sup> Ibid.

<sup>ix</sup> Michael Day consults Ezio Mauro, who is the editor of the Italian newspaper *La Repubblica*, to write about Silvio Berlusconi for the English newspaper *The Independent* (25 July 2009). In this article, a thirty-year-old graphic designer from Turin comments on Silvio Berlusconi's sexual life that 'He's not done anything illegal – lots of men his age, with his money, would do similar things.' Palermitans argue the same about their mayor, Diego Cammarata. (source: <http://www.independent.co.uk/news/world/europe/silvios-sex-life-why-italians-dont-care-1760716.html>).

<sup>x</sup> In the above article, Ezio Mauro explains how Silvio Berlusconi controls the Italian mass media. The case of Diego Cammarata is similar as he manipulates the local mass media to build a positive self-image.

<sup>xi</sup> See notes ix-x.

---

<sup>xii</sup> Santa Rosalia was of Norman and noble descent. She lived as a hermit in a cave on Mount Pellegrino (in Palermo) until 1166, where she died at the age of thirty-six. The story is that the Saint (she was sanctified in 12<sup>th</sup> century A.D) appeared to a hunter in 1624 (July 12<sup>th</sup>), told him where her bones lied, and asked him to take her bones and carry them in procession through the city so as the plague that had hit Palermo would end.

The feast, or *Festino*, starts on July 10<sup>th</sup> but it reaches a climax on July 15<sup>th</sup>. Another related feast is the *festino* (small ‘f’) on September 4<sup>th</sup>, when Palermitans walk from the city to the cave where the bones of the Saint were found.

<sup>xiii</sup> Information from the same guide used above and titled *Festino di Santa Rosalia, 1624-2005. 381<sup>o</sup> edizione. Palermo, 10-15 luglio 2005: Città di Palermo* (pp 14-15).

<sup>xiv</sup> Seremetakis (1994), Counihan (1999), and Lupton (2005) among others discuss the relationship between food and memory. They suggest that food consumption stimulates all the senses and as a result smells, tastes, feelings and images relevant to this experience are stronger in the individuals’ memory. Taken to extremes, ‘food knocks out sensation like drugs do.’ (Roth 1982: 15-16).

<sup>xv</sup> If seen through this prism, Sicilians resemble indigenous people in Ecuador; Corr (2003:40) argues: ‘in Ecuador, invented traditions often take the form of performance of identities rooted in an indigenous past of authentic culture. The construction of a cultural heritage serves to define the collective self opposed to “others” who do not share this cultural heritage. In Ecuador, cultural heritage is crucial to the self-definition of indigenous ethnic groups and is a key element in the indigenous-rights movement within the nation state.’ Likewise, Sicilians have perceived themselves as ‘pure Italians’ since the unification period and claim to have a unique cultural heritage as a group, which some Sicilians use in order to ‘protect’ this group’s rights within the nation-state.

<sup>xvi</sup> Link: <http://www.youtube.com/watch?v=Lybeag13Af4&feature=fvw>

<sup>xvii</sup> Link: <http://news.bbc.co.uk/sport2/hi/football/6326513.stm>

<sup>xviii</sup> Link: [http://www.repubblica.it/2007/02/sezioni/sport/calcio/serie\\_a/agente-morto-catania/scritta-livorno/scritta-livorno.html](http://www.repubblica.it/2007/02/sezioni/sport/calcio/serie_a/agente-morto-catania/scritta-livorno/scritta-livorno.html)

<sup>xix</sup> Link: <http://www.youtube.com/watch?v=WJPBsIRWS9s&feature=related>

<sup>xx</sup> See note xix

## EPILOGUE

*Via Maqueda* and *Corso Vittorio Emanuele* crossroads in Palermo's centre could be seen as symbolising the role of Sicily in the Mediterranean: the crossroads of peoples and civilisations. A recent research shows that all the ancient Greek temples in Sicily are oriented eastward<sup>1</sup>. Although the first 'Sicilian' encounters were with peoples from the East, i.e. Greeks and Arabs, Sicilian culture has been influenced from all directions. Economically speaking, eastern influences might have been more positive for Sicilians than others, as a comparison between eastern and western Sicily reveals even at the present. However, eastern influences on the whole island are definitely more positive in comparison to northern influences if we match Sicily's Golden Era that was linked with the Arab expansion to the West against the peripheral role of the island in larger political entities of the 'West'. Ironically enough, I believe, Sicily's relationship with power centres remained problematic even after the Italian Unification in 1860. National integration has since been an issue in Italy, its extreme form being manifested in a wide range of levels within Italy through the comparison of the North and South of the country.

This research has sought to shed light on the Palermitan identity and to present Italy's problematic national integration as the result of contrasting economic, cultural, and political landscapes. Since research was conducted in Palermo, Sicily, this thesis illuminated a wide range of issues correlated to the above topics with analyses of tensions as experienced in Palermo. However, as these tensions have their roots at different levels, and since this thesis claims to be anthropological, analyses of such tensions were put in larger conceptual frameworks and were seen in the context of the interwoven local, national and international levels. I suggested that the core issue in this case is the contrasting relationship between Sicilian ethnic identity and

---

<sup>1</sup> Source: <http://www.in.gr/news/article.asp?lngEntityID=1078822&lngDtrID=252> (26/11/09).

national/Italian identity. Gellner (*et al.* 1983) stresses that nationalism is bound to ethnicity. He argues that a rather ethnic identity of the elite is diffused to the masses through capitalism and that the shared meaning of an ethnic culture shapes a new identity that serves the new social organisation of nationalism. Therefore, a prerequisite for the formation of national identity is a society's transition from an agrarian economy to industrialism. I claimed that this transition was rather problematic in Sicily because of a class-conscious and powerful Sicilian elite, which managed to maintain its *status quo* within the young Italian nation. On the one hand, the Sicilian elite took shelter in the backward image of the South that prevailed in the Italian government during that period. Moreover, the Sicilian elite manoeuvred strategically to fill in the gaps that the transition left behind with institutions that legitimised this elite's role as the mediator between the local/regional and national realms. On the other, the Sicilian elite's control of local resources, and its mediating role in the distribution of the national to the local market allowed patron/client relationships to flourish in Sicily and to play a pivotal role in Sicilian identity, rendering Sicilians an imagined community of a territorial entity.

In order to illuminate the above, I approached the theory of honour and shame in its original context, and I attempted to shift the focus on honour as a value system that shapes patron/client relationships and reinforces stratification. In other words, I claimed that prevailing and patterned behaviours in the Mediterranean relate to procedures of identity building and correspond to relations of unequal power. A detailed analysis of seminal work on the topic revealed that past interests, analytical tools, and focuses, probably left important issues poorly elaborated, such as the political representation of ethnic groups within the nation, for the sake of others that would bound the Mediterranean as a solid anthropological field. Therefore, I proposed that instead of focusing on the relationships between individuals and egalitarian groups, we should turn to the

analyses of relationships of unequal power among individuals and/or groups, as well as to relationships of unequal power between individuals and groups and *vice versa*. This shift accommodated the analyses of honour in relation to land property, but also of the reasons that the Sicilian elite managed – with the help of the *gabelloti*, who were the landowners' armed force - to maintain the gap between citizens and the state wide. The fluidity of Palermitan culture rendered almost obligatory the analysis of the issues of cultural translation and cultural intimacy in relation to Davis's (1977:89) statement that honour 'is the most important way in which material differences are construed.'

Thus, material and cultural differences at the regional and national levels proved to be sources of tension, and therefore patron/client relations were approached as adaptive strategies of dealing with hostile state apparatuses. These strategies proved to be culturally intimate and reinforcing dominant roles which relate to personal characteristics, i.e. sex, age, class etc. However, the perception of the so-called core Sicilian values of friendship, cleverness, and silence as changing in meaning in time, helped show that culturally driven roles are shaped in Palermitan society by centres of power, such as the state, Church and the Mafia are. Diverse behaviour in the public and the private sphere signalled that Palermitans are conscious actors capable of strategising in order to manipulate the 'system' and take advantage of the gaps that the contrasting, or sometimes overlapping, powers of the state, Church or the Mafia create. Nevertheless, even at the present, doors in Palermo are kept closed because although the re-distribution of resources and technological advancement may give Palermitans the chance to gain access to more resources than before, Palermitans gain access to these resources only if their social image is 'perfect'. Gossiping and social criticism in general are still the 'authoritative ruler' in an environment in which an individual's word grants access to resources. However, trust in those

personal relations that provide access to resources means that Palermitans' acceptance of unequal power relationships that reinforce the established stratification is –or for better was- a conscious action.

The Palermitan family, on the other hand, was approached as a dynamic, but relatively tranquil locus of transmission of cultural capital and of simulation of Palermitan life. In chapter 6, I provided a detailed account of my own family in order to demonstrate my bias in this extremely sensitive issue. I felt lucky enough to have gained the trust of some Palermitan families, as well as access to their private moments, and to have had the honour to hear them calling me 'my son.' The central role of the family in Palermitan society was dressed with the ultimate sentiments of love, affection and care. The importance of family in Palermo was also supported by quantitative data provided by *ISTAT*'s statistical analyses. Nevertheless, the family unit was also addressing the practical issues of Palermitan life that had to do, for example, with the 'unwritten rules' of marriage and inheritance, as well as, various social, economic, and legal issues. Patterns revealed a shared ideal conception of Palermitan family, of which the size was significantly smaller than the desired. Most Palermitans stressed that they would have liked more children if economic conditions were better. Although there were slight declensions from the 'rules' according to the class and age of the informants, the value of the family and of its size was shared amongst the overwhelming majority of Palermitans. Economic conditions proved to affect more than the negative image of the extended peasant family, which prevailed in the past, the size of the modern Palermitan family. However, changes in Palermitan economy, society and culture are not only filtered through, but are also shaped by the family as the changes in sex roles indicate.

In addition, the nuclear family represents the basic unit of collective action in Palermitan society, and a 'mediator' through which Palermitans are incorporated into larger social networks. Thus,

the family is a prerequisite of integration into the Palermitan society and its networks. I have argued before that the family offers a 'simulation' of Palermitan life; this 'simulation' helps family members to cope with the adversities of life. The diffusion of collective perceptions and values is a procedure that primarily takes place at home, and thus Palermitans learn within the family how to enter the public sphere and gain access to resources through various social networks. The family also teaches the way of, and unites in, manipulating relations of unequal power, because anything outside the home is seen as a potential threat to the family unit. Such a practice has its roots in the past although the circumstances have changed. Patron/client relationships flourished due to land property that divided the society into owners of large estates and landless peasants. Now, relationships of unequal power are mainly legitimised through the patrons' access to state resources and the clients' power to keep their patrons in strategic posts through their voting right. Thus, in this system of rewards, the bigger the family is the more the chances Palermitans have to gain access to resources. However, there is a major difference between the past and the present: in Palermo, at the present time, there is an educated middle-class. This class became conscious due to its vital role in the successful struggle against the Mafia in the recent past, which struggle, still goes on in Palermo. This middle-class abominates any form of 'dictatorship', invests in the development of skills and in education, and diffuses its values to the Palermitan people. This middle-class's aim is to establish meritocracy and elevate the Palermitan standards of living to the level enjoyed in northern Italy.

The formation of larger entities in Palermitan society and a better representation of the South at the national level is by no means an easy undertaking, but one that is surely worthwhile. Even if for Palermitans 'boundaries' present a theoretical continuity, developments in the last decades allow Palermitans to see also these boundaries as flexible and not as high walls that forbid them

to penetrate into the other side. Within a climate of questioning the traditional 'authorities', Palermitans feel more free than ever before to express the multiplicity and plurality of the self through groups that promote the 'human identity' in its Palermitan sense. Thus, the basis of groups in Palermo also represents the basic right these groups assert: the respect of the human race irrespective of variations within it. However, asserting such a right indicates that Palermitans are aware of the fact that the self is culturally constructed, but are also aware of the fact that they can be an influence on both a social and cultural level. On the basis that the local, the regional, the national, and sometimes the supra-national are interacting levels, Palermitans starting from the local level tend to present themselves as part of a socio-culturally coherent region - or in other cases act as representing this region - since Sicily as an entity of the above kind can supply better the need of the Palermitans for equality of rights at the national level. At a more theoretical level, social exclusion at the local level could be seen as the penalisation of actions that contrast cultural intimacy in a certain sense of *habitus*, and that jeopardise the sense of simultaneity in the process of struggling for a very specific representation of the Italian south at the national level.

Palermitans' promote their struggle for better representation within larger decision making units as a humanitarian objective. Not only does this render regional resistance to the core pressures politically correct, but it also does convert panmixia into a positive and creative characteristic of Sicilianess. Palermitans share with the famous Inca of South America a love for the sun, as well as the perception that their actions affect the globe in the sense, however, that Sicilians know the way but also have the duty to peacefully mix diverse cultural traits and in this way promote tolerance within the globalising world. This stance of Palermitans is the outcome of mainly three different historical parameters: first, that Sicily has traditionally been a 'melting pot' of peoples

and cultures in the Mediterranean; second, that more recently Sicilians left Sicily in masses, heading towards more developed places, i.e. northern Italy, Australia, and the USA, where the state was more effective in relation to the Italian; and last but not least, that discrimination follows Sicilians anywhere outside Sicily, even at the present time. However, I believe another parameter to be significant in rendering the above trajectory a political issue within Italy, which is the Italian state's weakness to have solved the issue of the *Mezzogiorno* over its one and a half century of existence. Sicily 'accidentally' disappears from the national air carrier's maps, and Sicilian stereotypes are eternalised in regional and national commemorations of the foundation of the Sicilian ethnos and the Italian nation, eternalising the supremacy of the North, not only in economic terms within the capitalistic context, but also in cultural terms within the context of the nation-state's crisis. Thus, the specific parameters which shape the interaction between various Italian regions and the state, as well as the interaction between regions, are the source of the problem that the head-on collision between strong regional identities and the national identity creates. This collision has been diminished into a minor centre/periphery issue –thus called Italy's *southern* question – in order for major implications with respect to the integrity of the Italian nation-state to be avoided. Palermitans see this centre/periphery relation from a family-centric point of view, in which the state is the father and the citizens his children. Therefore, from the Palermitan point of view, the state's mission of protecting its citizens becomes a human right issue that is dressed with strong sentiments analogous to those stirred up between the members of a family unit.

Balances of power both within and outside Italy specify the Sicilians' role in the Italian nation. I have suggested that the roles of the North and the South are complementary, but although these roles spring from the national level they are specified at the local level. Thus, the Italian nation's

stability is achieved through continuous change that springs from the interaction between structure and social action. My data support that the Palermitans play this role consciously, being aware that if they do not, this would have tremendous effects on the Italian nation. It is a 'public secret' in Palermo that the struggle for Sicily's independence is just an indirect means of integrating the local into the national. This struggle could not be other than culturally driven. Palermitans take pride in their culture as an attempt to counterbalance the negative stereotype the northerners maintain of Sicily and render the Sicilian culture a diverse expression of Italianess. Thus, the negative conception Palermitans have of the police and the positive one Palermitans have of the local political centres should be seen in the above context: the police represent the power of an alien –for the sake of the Palermitans struggle- state that oppresses the manifestation of Sicilianess. Instead, on the other side of the coin, the mayor of Palermo, for example, represents the Palermitan and Sicilian identity at the national level. However, the manifestation of the above Palermitan stance in rituals, such as a football match or the feast of the patron saint of Palermo, proves that the local is interwoven with the national, as the national is interwoven with the supra-national. In other words, markers of Palermitan identity, i.e. language, food, and landscape, can only be seen in the national context through which they are represented at higher levels such as the greater European community.

The Palermitans build imaginary bridges between Sicily and the European Union not because they feel European but because they see the European Union as the only decision making unit that could improve their lives through tackling the inconsistencies of the Italian state. In other words, Palermitans struggle for democracy instead of autonomy. Inspired by the Greek

philosopher Christos Giannaras's<sup>2</sup> ideas on the modern state, I would claim that as Greece has passed from democracy to a particular kind of anomy, so too has Italy. The source of anomy can be traced in what Christos Giannaras defines as *φավλοκρατία*, or a vicious circle of political corruption. Corruption becomes the rule when the political system does not discipline but rather rewards those individuals who perform any kind of illegal action which serves their personal interests at the expense of the society. However, the political system collapses when it cannot provide solutions on important issues such as education, security, syndicalism, transportation, and so on. The lack of a basic sense of security results in tensions between the state and its citizens, because the two parts of this relationship seem to have diverse priorities. Thus, Christos Giannaras suggests that in modern Greece, and I believe the same to apply in my field, individuals have become an “ego’ in defence” and they, thus, cannot enjoy their lives. The question is if individuals in this case would revolt. Wallerstein (1989) suggests that the French revolution was a manifestation of the artisans’ and proletarians’ indignation that sprang from the pressure put on them by the capitalists in a capitalists’ attempt to deal with their ‘semiperipheralisation’ in the late 19<sup>th</sup> century. In parallel, there was the joint emergence of larger decision making units. It probably is in need of further research to see Sicily in the wider context of the global economy of that period. It would also be interesting to compare how different peoples respond to their incorporation into larger political and economic units, and how this affects their identity through the changes that such a process breeds in relations of unequal power. Nevertheless, the European Union offers Sicilians a deconstruction and reconstruction of

---

<sup>2</sup> Christos Giannaras (Χρήστος Γιανναράς) was born in Athens, Greece in 1935. He studied theology and philosophy in Greece and France respectively and he has taught in Greek, French, Swiss and Serbian universities. His comparative work that focuses on Greece and the West has been translated into more than ten European languages. Giannaras is a public person in Greece and he is usually invited to participate in television shows and comment on complex social issues. On 10 Dec. 2008 he expressed his ideas on state and democracy in the show ‘Αντιγυεύσεις’ on the Greek ‘ET3’ channel.

the state that is definitely milder than that which took place at the time of Sicily's incorporation within Italy. The Russian anarchist Pyotr Alexeyevich Kropotkin<sup>3</sup> (1901) suggests in *Modern Science and Anarchism* that 'revolution' could be defined as a widespread popular movement in which the body politic reconstructs the society. Therefore, I would suggest that the middle social class is leading the revolution which has already started in Palermo, and that this revolution could indirectly affect the issue of the Italian national integration positively.

Maybe, imaginary bridges have led me to a specific view of my field and, therefore, to the conclusions I draw from it. Although I have been working on Palermo for a long period of time, I believe that this journey has just started. I expect my relationships with the Palermitans to grow and mature giving me the opportunity to gain more fruitful insights into Palermitan culture and identity. I would like to close this thesis with Salvo's words as an expression of my gratefulness to him. Salvo was the last friend I met with before leaving Sicily, and he said: 'I expect you to come back. This is what sons do; they fly away and some day they return. Let them know the truth; tell them about us.' I do not claim to represent any 'absolute truth', but I have tried my best to represent Sicilian life as I saw it and I hope that my bias does not wrong the Palermitans.

---

<sup>3</sup> Peter Kropotkin (1842-1921)

## BIBLIOGRAPHY

- Abu-Lughod, Lila, (1991) *Writing against Culture, In Recapturing Anthropology: Working in the Present*, ed. Richard Fox. Santa Fe, NM: School of American Research Press, pp. 137-62.
- Albera, D., Blok, A. (2001) *The Mediterranean as a field of Ethnological study. A Retrospective*, IN Albera, D. Blok, A., Bromberger, C. (eds.) *L'anthropologie de la Mediterranee, Anthropology of Mediterranean*, Paris: Maissonnueve et Larose, Maison mediterraneene des sciences de l'homme.
- Alter, P. (1994) *Nationalism*, London: Arnold.
- Anderson, B. (1983) *Imagined communities : reflections on the origin and spread of nationalism*, London: Verso.
- Appaduarai, A. (ed.) (1991) *Gender, genre, and power in South Asian expressive traditions*, Philadelphia: University of Pennsylvania Press.
- Ardener, E. (1989) *The Voice of the Prophecy and Other Essays*. London: Blackwells
- Argyrou, V. (1996) *Tradition and modernity in the Mediterranean: the wedding as symbolic struggle*, Cambridge : Cambridge University Press.
- Asad, T. (1973) *Anthropology & the colonial encounter*, London: Ithaca Press.
- Ascoli, A.R., Von Henneberg, K. (2001) *Making and Remaking Italy: The Cultivation of National Identity Around the Risorgimento*, New York: Berg.

- Atkinson, P. (1990) *The ethnographic imagination: textual constructions of reality*, London : Routledge.
- Ανδελ, Ε. (1997) *Χρόνος, Ιστορία και Εθνική ταυτότητα στο Ελληνικό Σχολείο*, IN Τι είναι η πατρίδα μας, Frangoudaki, A, Dragonas, T. (eds.), Athens: Alexandria Publications.
- Bailey, F.G. (1963) *Politics and social change: Orissa in 1959*, Bombay; London: Oxford University Press.
- Bailey, C.A. (1996) *A guide to field research*, Thousand Oaks, California: Pine Forge Press.
- Banfield, E.C. (1958) *The moral basis of a backward society*, New York: The Free Press.
- Baldus, B. (1975). The Study of Power: Suggestions for an Alternative, IN *The Canadian Journal of Sociology*, Vol. 1, No. 2, Summer, pp. 179-201.
- Banks, M. (1996) *Ethnicity: anthropological constructions*, London: Routledge.
- Barth, F. (ed.) (1966) *Ethnic groups and boundaries : the social organization of culture difference*, Bergen : Universitetsforlaget ; London : Allen & Unwin
- Barth, F. (ed.) (1969) *Ethnic groups and boundaries: the social organization of culture difference*, Bergen: Universitetsforlaget; London: Allen & Unwin.
- Barzini, L. (1964) *The Italians*, London: Hamish Hamilton
- Bell, M.J. (1979) The Relation of Mentality to Race William Wells Newell and the Celtic Hypothesis, IN *The Journal of American Folklore* Vol. 92, No. 363, Jan. – Mar., pp. 25-43.

- Bender, D.R. (1967) A Refinement of the Concept of Household: Families, Co-Residence, and Domestic Functions, IN *American Anthropologist*, New Series, Vol. 69, No. 5, October, pp. 493-504.
- Bender, D.R. (1971) De Facto Families and De Jure Households in Ondo, IN *American Anthropologist*, New Series, Vol. 73, No. 1, February, pp. 223-241.
- Bender, J.L. (1992) *North European textiles: until AD 1000*, Aarhus : Aarhus University Press.
- Bentley, J.W. (1987) Economic and Ecological Approaches to Land Fragmentation, In Defense of A Much-Maligned Phenomenon, IN *Annual Review of Anthropology*, Vol. 16, pp. 31-67.
- Bernard, H.R. (1994) *Research methods in anthropology: qualitative and quantitative approaches*, Thousand Oaks, California: Sage ; Walnut Creek, California: AltaMira Press.
- Belmonte, T. (1980) *The Broken Fountain*. New York: Columbia University Press.
- Billig, M. (1995) *Banal nationalism*, London: Sage.
- Bloch, M. (1989) *Ritual, history and power: selected papers in anthropology*, London: Athlone.
- Blok, A. (1966) Land Reform in a West Sicilian Latifondo Village: The Persistence of a Feudal Structure, IN *Anthropological Quarterly*, Vol. 39, No. 1, January, pp. 1-16.
- Blok, A. (1969) Peasants, Patrons, and Brokers in Western Sicily, IN *Anthropological Quarterly*, Vol. 42, No. 3, Social and Political Processes in the Western Mediterranean (Special Issue), July, pp. 155-170.

- Blok, A. (1975) *The Mafia of a Sicilian Village 1860-1960; a study of violent peasant entrepreneurs; with a foreword by Charles Tilley*, Oxford: Basil Blackwell.
- Boissevain, J. (1966) Patronage in Sicily, IN *Man, New Series*, Vol. 1, No. 1, March, pp. 18-33.
- Boissevain, J. (1968) The Place of Non-Groups in the Social Sciences, IN *Man, New Series*, Vol. 3, No. 4, December, pp. 542-556.
- Boissevain, J. (1974) Towards a Sociology of Social Anthropology, IN *Theory and Society*, Vol. 1, No. 2, Summer, pp. 211-230.
- Boissevain, J. (1976) [1980] *A village in Malta*, New York: Holt, Rinehart & Winston.
- Bourdieu, P. (1984) *Distinction: a social critique of the judgement of taste*, Translated by Richard N, Cambridge MA: Harvard University Press.
- Bourdieu, P. (1990) *The logic of practice*, Stanford, California: Stanford University Press.
- Bourdieu, P. (1990) The Scholastic Point of View, IN *Cultural Anthropology*, Vol. 5, No. 4, November, pp. 380-391.
- Brandes, S.H. (1980) *Metaphors of masculinity: sex and status in Andalusian folklore*, Philadelphia: University of Pennsylvania Press.
- Braudel, F. (1972) [1973] *The Mediterranean and the Mediterranean world in the age of Philip II: Vol 2*, London: Collins.

Bromley, J.S. (ed.) (1974) *The manning of the Royal Navy: selected public pamphlets, 1693-1873*, London: printed for the Navy Records Society.

Rdcliffe-Brown, A.R., (1973) On the Concept of Function in Social Science and on Social Structure. IN *High Points in Anthropology*, (eds) Paul Bohannan and Mark Glazer. NY: Alfred A. Knopf, 279-316

Brown K.S., Hamilakis Y. (eds.) (2003) *The usable past: Greek metahistories*, Lanham: Lexington books.

Buttita, A. (1961) *Cultura figurativa in Sicilia*. Palermo

Campbell, J.K. (1964) *Honour, family, and patronage: a study of institutions and moral values in a Greek mountain community*, Oxford: Clarendon Press.

Cancila, O. (1974) *Gabelloti e contadini in un comune rurale*, Caltanissetta: Salvatore Sciascia

Caplan, A. (1972) *If I were a rich man could I buy a pancreas? : and other essays on the ethics of health care*, Indiana University Press.

Caplan, D. (1992) *Language: structure, processing, and disorders*, Cambridge, Mass.: MIT Press.

Carsten, J. (1992) The Politics of Forgetting: Migration, Kinship and Memory on the Periphery of the Southeast Asian State, IN *The Journal of the Royal Anthropological Institute*, Vol. 1, No. 2, June, pp. 317-335.

Carsten, J. (1995) The Substance of Kinship and the Heat of the Hearth: Feeding, Personhood, and Relatedness among Malays in Pulau Langkawi, IN *Ethnologist*, Vol. 22, No. 2, May, pp. 223-241.

Casey, J. (1989) *The history of the family*, Oxford: Blackwell.

Catanzaro, R. (1988) *Title Men of respect: a social history of the Sicilian Mafia*, New York: Free Press; Toronto: Maxwell Macmillan Canada; New York: Maxwell Macmillan International.

Catanzaro, R. (1992) *Men of respect: a social history of the Sicilian Mafia*, New York: Free Press; Toronto: Maxwell Macmillan Canada; New York: Maxwell Macmillan International.

Chapman, G. (1973) *Milocca, a Sicilian village*, Cambridge : Schenkman Pub. Co.

Chubb, J. (1982) *Patronage, power, and poverty in southern Italy: a tale of two cities*, Cambridge University Press.

Cinel, D. (1982) *From Italy to San Francisco: the immigrant experience*, California: Stanford University Press.

Clark, M. (1984) *Modern Italy*, London: Longman.

Clifford, J., Marcus, G.E. (1986) The Poetics and Politics of Ethnography, IN *Anthropological Quarterly*, Vol. 59, No. 2, Ethnographic Realities/Authorial Ambiguities, April, pp. 97-99.

Cohen, R. (1978) Ethnicity: Problem and Focus in Anthropology, IN *Annual Review of Anthropology*, Vol. 7, pp. 379-403.

Cohen, A.P. (1985) *The symbolic construction of community*, Chichester: Horwood.

Cohen, A.P. (ed.) (1986) *Symbolising boundaries: identity and diversity in British cultures*, Manchester: Manchester University Press.

Cohen, A. P. (1994) *Self Consciousness. An Alternative Anthropology of Identity*, Oxford: Routledge.

Cohen, A.P., Rapport, N. (eds) (1995) *Questions of consciousness*, London: Routledge.

Colclough, N. (1992) *Land, politics and power in a southern italian community*, Canterbury: Centre for Social Anthropology and Computing, University of Kent at Canterbury.

Cole, J. (1997) *The new racism in Europe: a Sicilian ethnography*, Cambridge: Cambridge University Press.

Connerton, P. (1989) *How societies remember*, Cambridge: Cambridge University Press.

Corr, R. (2003) Ritual, Knowledge, and the Politics of Identity in Andean Festivities, IN *Ethnology*, Vol. 42, No. 1, Winter, pp. 39-54.

Cottle, S. (ed.) (2000) *Ethnic minorities and the media: changing cultural boundaries*, Buckingham: Open University Press.

Counihan, C. (1981) *The anthropology of food and body: gender, meaning, and power*, London: Taylor & Francis Ltd

Creed, G.W. (200) "Family Values" and Domestic Economies, IN *Annual Review of Anthropology*, Vol 29, pp. 329-355.

Creighton, Millie R.(1986) - "Revisiting shame and guilt cultures: a forty-year pilgrimage" / Millie R. Creighton. - In: *Ethos*. - Washington. - 1990, vol. 18, Nr 3, p. 279-307

Cronin, C. (1970) *The sting of change: Sicilians in Sicily and Australia*, Chicago; London: University of Chicago Press.

Cuche, D. (1996), Η έννοια της κουλτούρας στις κοινωνικές επιστήμες. Αθήνα: Γενηθήτω, Γιώργος Δαρδανός.

Cuticchio, M. (1998) *Guida all'opera dei pupi*, Palermo: Associazione figli d'Arte.

Dahl, R.A. (1963) *Modern Political Analysis*. Englewood Cliffs : Prentice-Hall.

Dahl, R.A. (1976) *Modern political analysis*, Englewood Cliffs, N.J: Prentice-Hall.

Dahl, R.A. (1986) *Democracy, liberty, and equality*, Oslo; Oxford: Norwegian University Press; New York: Distributed world-wide excluding Scandinavia by Oxford University.

Dainotto, R.M. (2001) [2000] *Place in Literature: Regions, Cultures, Communities*, Ithaca, NY and London: Cornell University Press.

Davidoff, L., Hall, C. (1987) *Family fortunes: men and women of the English middle class*, London: Hutchinson; Chicago: University of Chicago Press.

- Davis, J. (1973) *Land and family in Pisticci*, London: Athlone Press ; New York: Humanities Press.
- Davis, J. (1977) *People of the Mediterranean: an essay in comparative social anthropology*, London: Routledge & K. Paul.
- Denzin, N.K. (1997) *Interpretive ethnography: ethnographic practices for the 21st century*, Thousand Oaks, California; London: Sage Publications.
- Devereux, G. (1972) *Ethnopsychanalyse complementariste*,
- Douglas, M. (1975) *Implicit meanings: essays in anthropology*, London: Routledge & Kegan Paul.
- Douglas, N. (1915) [1962] *Old Calabria*, Harmondsworth: Penguin.
- Dragadze, T. (1980) Soviet Ethnos Theory, IN *RAIN*, No. 38, June, pp. 3-4.
- Du Boulay, J. and Williams, R. (1987) "Amoral Familism and the Image of Limited Good: A Critique from the European Perspective." IN *Anthropological Quarterly* 60: 12-24.
- Dubisch, J. (1995) *In a different place: pilgrimage, gender, and politics at a Greek island shrine*, Princeton, N.J.: Princeton University Press.
- Duggan, C. (1989) *Fascism and the Mafia*, New Haven; London: Yale University Press.
- Eickelman, D .F. (1981). A search for the anthropology of Islam: Abdul Hamid el-Zein. IN *International Journal of Middle East Studies* Vol. 13: 361-365

Epstein, A.L. (1978) *Ethos and identity: three studies in ethnicity*, London: Tavistock Publications; Chicago: Aldine Publisheing.

Epstein, S.R. (1992) *An island for itself: economic development and social change in late medieval Sicily*, Cambridge: Cambridge University Press.

Eriksen, T.H. (1991) Ethnicity versus Nationalism, IN *Journal of Peace Research*, Vol. 28, No. 3, August, pp. 263-278.

Eriksen, T.H. (1993) *Ethnicity and nationalism: anthropological perspectives*, London: Pluto Press.

Eriksen, T.H. (2002) *Ethnicity and nationalism*, London; Sterling, Va.: Pluto Press.

Etzioni, A. (1993) *The spirit of community: the reinvention of American society*, New York, touc hstone

Etzioni, A. (1995) *The spirit of community: rights, responsibilities and the communitarian agenda*, London: Fontana.

Falcone, G., Padovani, M. (1993) *Men of honour: the truth about the Mafia*, London: Warner.

Farrell, J. (ed.) (1997) *Understanding the Mafia*, Manchester: Manchester University Press.

Finley, M.I. (1979) *Ancient Sicily*, London: Chatto & Windus.

Forgacs, D., Lumley, R. (eds.) (1996) *Italian Cultural Studies: An Introduction*, Oxford: Oxford University Press.

Foucault, M. (1980) in Gordon, C., Marshall, L., Mepham, J. and Soper, K. (eds.), *Power/Knowledge: Selected Interviews and Other Writings 1972-1977*, Harvester Wheatsheaf, London (translated by Gordon, C.).

Foucault, M. (1978) [1979] *The history of sexuality. Vol. 1, An introduction*, New York: Pantheon Books.

Foucault, M. (1999) *Religion and culture*, Manchester: Manchester University Press.

Foucault, M. (2000) *The essential works of Michel Foucault, 1954-1984. Vol. 1, Ethics: subjectivity and truth*, London: Penguin.

Frangoudaki, A., Dragonas, T. (eds.) (1997) *Τι είναι η πατρίδα μας? Εθνοκεντρισμός στην Εκπαίδευση*, Athens: Alexandria.

Freeman, S.T. (1973) Studies in Rural European Social Organisation: Introduction. IN *American Anthropologist*, Vol. 75, pp. 743-750.

Friedl, E., (1966) *Regional variation in modern Greece and Cyprus: toward a perspective on the ethnography of Greece*. New York :New York Academy of Sciences.

Galt, A.H. (1974) Rethinking Patron-Client Relationships: The Real System and the Official System in Southern Italy, IN *Anthropological Quarterly*, Vol. 47, No. 2, April, pp. 182-202.

Galt, A. (1984/5) Does the Mediterraneanist dilemma have straw horns? IN *American Ethnologist* Vol 12: 369-71.

Gambetta, D. (1993) *The Sicilian Mafia: the business of private protection*, Cambridge, Mass.; London: Harvard University Press.

Garfinkel, H. (1967) *Studies in ethnomethodology*, Englewood Cliffs, N.J.: Prentice Hall.

Geertz, C. (1973) Deep play: notes on the balinese cockfight. Comments on Benjamin White's "Demand for Labor and Population Growth in Colonial Java", IN *Human Ecology*, Vol. 1, No. 3, March, pp. 237-239.

Geertz, C. (1976) *The interpretation of cultures: selected essays*, London: Hutchinson.

Gellner, E. (1983) *Nations and nationalism*, Oxford: Blackwell.

Gellner, E. (2006) *Nations and nationalism*, Malden, MA: Blackwell Pub.

Chapman, M. and Ardener, E. (eds) (1989). *The voice of prophecy and other essays*. Oxford : Blackwell,

Giddens, A. (1968) 'Power' in the Recent Writings of Talcott Parsons, IN *Sociology*; Vol. 2; pp 257.

Gillis, J.R., Louise, A.T., and Levine, D. eds (1992) *The European Experience of Fertility Decline. A Quiet Revolution, 1850-1970*. Oxford: Blackwell.

Gilmore, D. (1982) [1987] Anthropology of the Mediterranean Area. IN *Annual Review of Anthropology*, Vol. 11, pp. 175-205.

Gilmore, D. (1975) Patronage and Class Conflict in Southern Spain, IN *Man, New Series*, Vol. 12, No. 3/4, December, pp. 446-458.

- Gilsenan, M., (1973) *Saint and Sufi in modern Egypt: an essay in the sociology of religion*. Oxford: Oxford University Press.
- Giovannini, M. J. (1981) Woman: A Dominant Symbol within the Cultural System of a Sicilian Town. IN *Man* (NS) Vol. 16: 408-426.
- Gluckman, M. (1958) *Analysis of a social situation in modern Zululand*, Manchester: Published on behalf of the Rhodes-Livingstone Institute, by the Manchester University Press.
- Goddard, V.A., Llobera, J.R., Shore, C. (eds.) (1994) *The anthropology of Europe: identity and boundaries in conflict*, Oxford: Berg.
- Goitein, S. D. (1967) *A Mediterranean Society*. Berkeley: Univ. Calif. Press.
- Goody, J. (1983) *The development of the family and marriage in Europe*, Cambridge: Cambridge University Press.
- Goody, J. (1996) *The east in the west*, Cambridge: Cambridge University Press.
- Gorden, R.L. (1975) Living in Latin America: A Case Study in Cross-Cultural Communication. IN *Gorden Source: The Modern Language Journal*, Vol. 59, No. 3, March, pp. 142-143.
- Gramsci, Antonio, 1891-1937 (1971) Selections. English Selections from the prison notebooks of Antonio Gramsci [electronic resource], edited and translated by Quintin Hoare and Geoffrey Nowell Smith, New York: International Publishers.
- Gupta, A., Ferguson, J. (1997) *Culture, power, place: explorations in critical anthropology*, Durham, N.C.; London: Duke University Press.

Gupta, A., Ferguson, J. (1999) *Spatialising states: Toward an Ethnography of Neoliberal Governmentality*. London : Duke University Press.

Brown, K.S. and Hamilakis, Y. (eds) 2003. *The Usable Past: Greek Metahistories*. Lanham and Oxford: Lexington Books.

Hamilakis, Y., *Archaeology and the Politics of Pedagogy*. In: *World Archaeology*, Vol. 36, No. 2, *Archaeological Pedagogies* (Jun., 2004), pp. 287-309

Hansen, E.C. (1977) *Rural Catalonia under the Franco regime: the fate of regional culture since the Spanish Civil War*, Cambridge: Cambridge University Press.

Harrell, S. (1997) *Human families*, Boulder, Colo.: Westview Press.

Hayden, C.P. (1995) *Gender, Genetics, and Generation: Reformulating Biology in Lesbian Kinship*, IN *Cultural Anthropology*, Vol. 10, No. 1, February, pp. 41-63.

Herzfeld, M. (1980) *Honour and Shame: Problems in the Comparative Analysis of Moral Systems*, IN *Man, New Series*, Vol. 15, No. 2, June, pp. 339-351.

Herzfeld, M. (1984) *The Horns of the Mediterraneanist Dilemma*, IN *American Ethnologist*, Vol. 11, No. 3, August, pp. 439-454.

Herzfeld, M. (1995) *Anthropology and the Politics of Significance*, IN *Social Analysis* 41: 107-138.

Herzfeld, M. (1997) *Cultural intimacy : social poetics in the nation-state*, New York; London: Routledge.

- Herzfeld, M. (2001) *Anthropology: theoretical practice in culture and society*, Malden, Massachusetts : Blackwell.
- Hess, H., (1970) [1973] *Mafia and Mafiosi: the Structure of Power*. Lexington MA: Lexington Books.
- Hess, A.C. (1978) *The Forgotten Frontier: A History of the Sixteenth-Century Ibero-African Frontier*. Chicago: University Chicago Press.
- Hirschon, R. (2000) Territoriality and the home environment in a Greek urban community, *Anthropological Quarterly*, 55.
- Hirschon, R. (ed) (2003) *Crossing the Aegean: an appraisal of the 1923 compulsory population exchange between Greece and Turkey*, New York: Berghahn Books.
- Hobsbawm, E., Ranger, T. (eds.) (1983) *The Invention of tradition*, Cambridge: Cambridge University Press.
- Horowitz, M. (1967) *Morne-Paysan: peasant village in Martinique*, New York; London: Holt, Rinehart and Winston.
- Ilan, S.M. (1996) Fragmentary Encounters in a Moral World: Household Power Relations and Gender Politics, IN *Ethnology*, Vol. 35, No. 1, Winter, pp. 33-49.
- Isaac, J.C., (1987) *Power and Marxist Theory: A Realist View*. Oxford: Cornell University Press.
- Jenkins, R. (2008) *Social identity*, London: Routledge.

- Johnson, L.L. & Lipsett-River, S. (1998) *The Faces of Honor: Sex, Shame and Violence in Colonial Latin America*. New Mexico: University of New Mexico Press.
- Just, P. (2001) *Dou Donggo justice: conflict and morality in an Indonesian society*, Lanham, Md: Rowman & Littlefield.
- Kenny, M. (1968) Belmonte de los Caballeros: A Sociological Study of a Spanish Town by Carmelo Lison-Tolosana, IN *American Anthropologist*, New Series, Vol. 70, No. 1, February, pp. 125-126.
- Kenny, M., Kertzer, D.I. (eds.) (1983) *Urban life in Mediterranean Europe: anthropological perspectives*, Urbana: University of Illinois Press.
- Kirtsoglou, E. (2004) *For the love of women: Gender, Identity and Same-Sex Relationships in a Greek Provincial town*, London: Routledge.
- Kirtsoglou, E. (2006) *Unspeakable Crimes: Athenian Greek perceptions of local and international terrorism*, In *Terror and Violence: Imagination and the Unimaginable*. Strathern, A., Stewart, P. & Whitehead N.L. London: Pluto Press.
- Krause, E.L. (2005) Encounters with the "Peasant": Memory Work, Masculinity, and Low Fertility in Italy, IN *American Ethnologist*, Vol. 32, No. 4, November, pp. 593-617.
- Kropotkin, P. (1903) *Modern science and anarchism*, Translated from the Russian original by David A. Modell. Philadelphia: The Social Science Club of Philadelphia
- Lampedusa, T.G. (1961) *The leopard: Il gattopardo*, London: Collins.
- Lamphere, L. (1987) *From working daughters to working mothers: immigrant women in a New England industrial community*, Ithaca: Cornell University Press.

- Laslett, P. (ed.) (1972) *Household and family in past time: comparative studies in the size and structure of the domestic group over the last three centuries in England, France, Serbia, Japan and colonial North America, with further materials from Western Europe*, Cambridge: Cambridge University Press.
- Lever, W. (ed.) (1986) *The city in transition: policies and agencies for the economic regeneration of Clydeside*, Oxford: Clarendon Press.
- Livi-Bacci, M. (1977) *A century of Portuguese fertility*, Princeton: Princeton University Press.
- Lockwood, W.G. (1975) *European Moslems: Economy and Ethnicity in Western Bosnia*, New York: Academic Press.
- Loizos, P. (1975) *The Greek gift: politics in a Cypriot village*, Oxford: Blackwell.
- Loizos, P. (1975) Politics and Patronage in a Cypriot Village 1920-1970, IN Gellner E. & Waterbury, J., (eds) *Patrons and Clients in Mediterranean Societies*, pp 115-37. London: Duckworth.
- Loizos, P. (1988) Intercommunal Killing in Cyprus, IN *Man, New Series*, Vol. 23, No. 4, December, pp. 639-653.
- Lukes, S. (ed.) (1986) *Power*, Oxford: Basil Blackwell.
- Lupo, S. (1977) *La question siciliana a una volta; il sicilianismo tra dopoguerra e fascismo*, IN *Potere e societa in Sicilia nella crisi dello stato liberale*. G. Barone, ed. Pp. 151-223. Catania: Pellicano.
- Lupo, S. (1987) *L'utopia totalitaria del Fascismo (1918-1942)*, IN *Storia d'Italia. Le regioni dall'Unita a oggi. La Sicilia*. M. Aymarde and G. Giarrizo, eds. Pp. 370-482. Torino: Einaudi.

Lupton, C. (2005) *Chris Marker: memories of the future*, London: Reaktion.

Lyon, S. M. (2004) *An anthropological analysis of local politics and patronage in a Pakistani village*, Lewiston: Edwin Mellen Press.

Lyttelton, A. (ed.) (2001) *Liberal and Fascist Italy: 1900-1945*, Oxford: Oxford University Press.

Mack Smith, D. (1968) *A history of Sicily. Modern Sicily after 1713*, London: Chatto & Windus.

Maclachlan, M. D. (1987) *From intensification to proletarianization*, IN Maclachlan, M. D. (ed.), *Household Economies and Their Transformations. Monographs in Economic Anthropology*, No. 3. University Press of America, Boston.

Marcus, G.E. (1987) On Listening for Edifying Conversations: Resonant Discourses within and between Departments, IN *Cultural Anthropology*, Vol. 2, No. 1, Biological and Cultural Anthropology at Emory University, February, pp. 3-4.

Marcus, G.E. (1998) *Ethnography through thick and thin*, Princeton: Princeton University Press.

Mauss, M. (1967) *The gift: forms and functions of exchange in archaic societies*, New York; London: W.W. Norton.

McClelland, D.C. (1985) *Human Motivation*, London: Scott, Foresman & Co.

Mead, M. (1930) Rossel Island; An Ethnological Study by W. E. Armstrong. IN *American Anthropologist, New Series*, Vol. 32, No. 1 January-March, pp. 176-178.

Mead, M (1955) *Soviet attitudes toward authority*, London: Tavistock.

Mead, M. (1959). *An anthropologist at work: Writings of Ruth Benedict* . Boston: Houghton Mifflin Company

Mead, M. (1961) Anthropology among the Sciences, IN *American Anthropologist*, New Series, Vol. 63, No. 3, June, pp. 475-482.

Mead, M. (1964) Hazards Encountered in Publishing in Europe IN *American Anthropologist*, New Series, Vol. 66, No. 3, Part 1, June, p. 638.

Meissner, F. (1954) Politics of the Italian Land Reform, IN *American Journal of Economics and Sociology*, Vol. 14, No. 1, October, pp. 39-54.

Mitchell, J.C. (ed.) (1969) *Social networks in urban situations: analyses of personal relationships in Central African towns*, Manchester: Published for the Institute for Social Research, University of Zambia, by Manchester University Press.

Montemagno, G. (1990) *Palermo: la primavera interrotta*, Palermo: Nuova Editrice Meridionale.

Moss, L.W. and Thompson, H.T., (1959) The South Italian Family: Literature and Observation. IN *Human Organisation*: 18 : 35-41.

Mouzelis, N. 1976. The relevance of the concept of class to the study of modern Greek society. *Tranz NY Acad.* 268:395-409

Narroll, R. (1964). "Ethnic unit classification." IN *Current Anthropology*, 5, 4.

Nimkoff, M.F., Middleton, R. (1960) Types of Family and Types of Economy, IN *The American Journal of Sociology*, Vol. 66, No. 3, November pp. 215-225.

- Olsen, C.L. (1989) Applied Collaborative Biomedical Anthropology in a State Health Department Setting, IN *Medical Anthropology Quarterly*, New Series, Vol. 3, No. 4, December, pp. 377-384.
- Ortner, S.B. (1984) Theory in Anthropology since the Sixties IN *Comparative Studies in Society and History*, Vol. 26, No. 1, January, pp. 126- 166.
- Parca, G., (1965) *I Sultani. Mentalità e comportamento del maschio italiano*. Milano: Rizzoli.
- Pasternak, B., Ember, C.R. (1976) On the Conditions Favoring Extended Family Households. IN *Melvin Ember Journal of Anthropological Research*, Vol. 32, No. 2, Summer, pp. 109-123.
- Peristiany, J.G. (ed.) (1965) *Honour and shame: the values of Mediterranean society*, London: Weidenfeld and Nicolson.
- Pezzino, P (1987) Autonomia e accentramento nell'ottocento siciliano: Il caso di Navoro. IN *Annali della Fondazione L&L Basso*, vol. 9 88). –
- Pina-Cabral, (1989) The Mediterranean as a Category of Regional Comparison. A Critical View, IN *Current Anthropology*, Vol. 30, No. 3, June, pp. 399-406.
- Pitkin, D. S. (1963) Mediterranean Europe. IN *Anthropological Quarterly* Vol 36:120-9.
- Pitrè, G. (1889) *Usi e costumi credenze e pregiudizi del popolo Siciliano*, XV. Palermo: L. Pedone Lauriel.
- Pitrè, G. (1971) *Usi e costumi del popolo siciliano*,

Pitt-Rivers, J.A., (1954) [1971] *The people of the Sierra*, Chicago; London: University of Chicago Press.

Pitt-Rivers, J. (ed.) (1963) *Mediterranean countrymen. Essays in the social anthropology of the Mediterranean*, Paris, The Hague: Mouton.

Pitt-Rivers, G. (1966) *The riddle of the 'Labarum' and the origin of Christian symbols*, Henry Lane Fox, London: Allen & Unwin.

Rabinow, P. (1984) *The Foucault Reader. An Introduction to Foucault's thought*, Penguin Books, London.

Ragoné, H. (1996) Chasing the Blood Tie: Surrogate Mothers, Adoptive Mothers and Fathers, IN *American Ethnologist*, Vol. 23, No. 2, May, pp. 352-365.

Rapport, N. (ed.) (2002) *British subjects: an anthropology of Britain*, Oxford: Berg.

Rapport, N. (1997) *Transcendent individual: towards a literary and liberal anthropology*, London: Routledge.

Roger, J. (1989) *Women in Athenian law and life*, London: Routledge.

Ruggles, S. (1987) *Prolonged connections: the rise of the extended family in nineteenth century England and America*, Wisconsin: University of Wisconsin Press.

Rutz, H. and Orlove B.S. (eds.) (1989) *The Social economy of consumption*. Lanham, MD : University Press of America

- Ryan, M.P. (1981) *Cradle of the middle class : the family in Oneida County, New York, 1790-1865*, Cambridge, Eng ; New York: Cambridge University Press.
- Sahlins, M. (1972) *Stone age economics*, Marshall David, New York; Chicago: Aldine de Gruyter.
- Sanjek, R. (1982) The American Anthropological Association Resolution on the Employment of Women: Genesis, Implementation, Disavowal, and Resurrection, IN *Signs*, Vol. 7, No. 4, Summer, pp. 845-868.
- Sanjek, R. (1982) The Organization of Households in Adabraka: Toward a Wider Comparative Perspective, IN *Comparative Studies in Society and History*, Vol. 24, No. 1, January, pp. 57-103.
- Sant-Cassia (2007) *Bodies of evidence: burial, memory, and the recovery of missing persons in Cyprus*. New York ; Oxford : Berghahn Books.
- Schneider, P. (1969) Honor and Conflict in a Sicilian Town, IN *Anthropological Quarterly*, Vol. 42, No. 3, Social and Political Processes in the Western Mediterranean (Special Issue), July, pp. 130-154.
- Schneider, J. (1971) Of vigilance and virgins: Honor, Shame and Access to Resources in Mediterranean Societies, IN *Ethnology*, Vol. 10, No. 1, January, pp. 1-24.
- Schneider, P., Schneider J., Hansen E. (1972) Modernization and Development: The Role of Regional Elites and Noncorporate Groups in the European Mediterranean. IN *Comparative Studies in Society and History*, Vol. 14 (3): 328-50.
- Schneider, J., Schneider, P. (1976) *Culture and political economy in western Sicily*, New York; London: Academic Press.

- Schneider, D.M. (1984) *A critique of the study of kinship*, Ann Arbor: University of Michigan Press.
- Schneider, J. (1996) *Festival of the poor: fertility decline & the ideology of class in Sicily, 1860-1980*, Tucson: University of Arizona Press.
- Schneider, J. (ed.) (1998) *Italy's "Southern question": orientalism in one country*, Oxford: Berg.
- Schneider, J.C., Schneider P.T. (2003) *Reversible destiny: mafia, antimafia, and the struggle for Palermo*, Berkeley: University of California Press.
- Scott, J.C. (1985) *The moral economy of the peasant: rebellion and subsistence in southeast Asia*, New Haven: Yale University Press.
- Scott, K.L. (1976) *The Caxton Master and his patrons*, Cambridge: Published for the Cambridge Bibliographical Society by Cambridge University Library.
- Seremetakis, N. (ed.) (1994) *The senses still: perception and memory as material culture in modernity*, Boulder: Westview Press.
- Shankland, D. (2003) Reviewed work(s): A Nation of Empire: The Ottoman Legacy of Turkish Modernity by Michael E. Meeker, IN *American Ethnologist*, Vol. 30, No. 2, May, p. 324.
- Silverman, S.F. (1965) Patronage and Community-Nation Relationships in Central Italy, IN *Ethnology*, Vol. 4, No. 2, April, pp. 172-189.
- Silverman, S.F. (1971) The Italian Land Reform: Some Problems in the Development of a Cultural Tradition, IN *Anthropological Quarterly*, Vol. 44, No. 2, April, pp. 66-77.

Smith, A.D. (2003) *Chosen peoples*, Oxford: Oxford University Press.

Snauders, P.R. (1981) *Social theory and the urban question*, London: Hutchinson.

Sokefeld, M. (1999) Debating Self, Identity, and Culture in Anthropology. IN *Current Anthropology*, Vol. 40, 417-447.

Spradley, J.P. (1979) *The ethnographic interview*, New York: Holt, Rinehart & Winston; Fort Worth: Harcourt Brace Jovanovich.

Stewart, F.H. (1994) *Honor*, USA: Chicago University Press.

Stewart, P.J., Strathern, A. (2003) *Witchcraft, sorcery, rumors and gossip*, Cambridge: Cambridge University Press.

Strathern, M. (1998) [1990] *The gender of the gift: problems with women and problems with society in Melanesia*, Berkeley: University of California Press.

Sutton, D.E. (1998) *Memories cast in stone: the relevance of the past in everyday life*, Oxford: Berg.

Sutton, D.E. (2001) *Remembrance of repasts: an anthropology of food and memory*, Oxford: Berg Publishers.

Sweet, L.E., O'Leary, T. (eds.) (1969) *Circum-mediterranean peasantry: introductory bibliographies*, New Haven [Conn]: Human Relations Area Files Press.

Tak, H. (1990) Longing for Local Identity: Intervillage Relations in an Italian Mountain Area, IN *Anthropological Quarterly*, Vol. 63, No. 2, April, pp. 90-100.

- Theodosopoulos (2006). (ed.) When Greeks think about Turks: the view from anthropology, IN *Special issue of South European Society & Politics* Vol. 11, No 1.
- Triolo, N. (1993) Mediterranean Exotica and the Mafia "Other" or Problems of Representation in Pitre's Texts, IN *Cultural Anthropology*, Vol. 8, No. 3, August, pp. 306-316.
- van Teeffelen, T. (1978) [1977] *Anthropologists on Israel : a case study in the sociology of knowledge*, Amsterdam: Antropologisch-Sociologisch Centrum, Universiteit van Amsterdam.
- Twinam, A. (1998) The Negotiation of Honour. IN Johnson, L.L. & Lipsett-River, S. (1998) *The Faces of Honor: Sex, Shame and Violence in Colonial Latin America*. New Mexico: University of New Mexico Press.
- Turner, V. ( 1967) *Forest of Symbols*. U.S.A: Kingport Press.
- Turner, V. (1969) *The Ritual Process: Structure and Anti-structure*. Chicago: Aldine
- Waterbury, J., (1970) [1977] An Attempt to Put Patrons and Clients in Their Place. Pp. 330-9. IN Gellner, E. & Waterbury, J. *Patrons and Clients in Mediterranean Societies*. Hanover, New Hampshire: American Universities Field Staff.
- Wade, J.E. (1984) Role Boundaries and Paying Back: 'Switching Hats' in Participant Observation, IN *Anthropology & Education Quarterly*, Vol. 15, No. 3, Research Dilemmas in Administration and Policy Settings, Autumn, pp. 211-224.
- Weistmantel, M., (1995) Making Kin: Kinship Theory and Zumbagua Adoptions. IN *American Ethnologist* 22(4):685-709.
- Westermarck, E. (1926) *Ritual and Belief in Morocco*. London: Macmillan.

- Weston, K. (1991). Forever is a Long Time: Romancing the Real in Gay Kinship Ideologies. IN Yanagisako, S.J. and Delaney, C.L. *Naturalizing power: essays in feminist cultural analysis*; Meeting
- White, C. (1980) *Patrons and partisans: a study of politics in two southern Italian communities*, Cambridge: Cambridge University Press.
- Wikan, U. (1983) *Behind the Veil in Arabia: Women in Oman*, Baltimore: Johns Hopkins University Press.
- Wikan, U. (1984) Shame and Honour: A Contestable Pair, IN *Man, New Series*, Vol. 19, No. 4, December, pp. 635-652.
- Willis, P.E. (1981) *Learning to labour: how working class kids get working class jobs*, Aldershot: Gower.
- Willis, R. (1981) *A state in the making: myth, history, and social transformation in pre-colonial Ufipa*, Bloomington: Indiana University Press.
- Willis, R. (1981) Seeing Africa: A Colonial Ritual in Retrospect, IN *RAIN*, No. 45, August, p. 8.
- Wolf, E.R. (1966) *Peasants*, Englewood Cliffs, N.J: Prentice-Hall.
- Wolf, E.R. (1969) Society and Symbols in Latin Europe and in the Islamic near East: Some Comparisons, IN *Anthropological Quarterly*, Vol. 42, No. 3, Social and Political Processes in the Western Mediterranean (Special Issue), July, pp. 287-301.

Wolf, M. (1992) *A thrice-told tale: feminism, postmodernism, and ethnographic responsibility*, Stanford, California: Stanford University Press.

Woodward, K. (ed.) (1997) *Identity and difference*, London: Sage.

Wrong, D.H. (1979) *Power: its forms, bases, and uses*, Oxford: Blackwell.

Yanagisako, S. J. (1979) Family and Household: The Analysis of Domestic Groups, IN *Annual Review of Anthropology*, Vol. 8, pp. 161-205.

Yelvington, K.A. (1991) Ethnicity as Practice? A Comment on Bentley, IN *Comparative Studies in Society and History*, Vol. 33, No. 1, January, pp. 158-168.