

Durham E-Theses

Void Spaces

Edward H. Huijbens

How to cite:

Huijbens, Edward H. (2005) Void Spaces. Unspecified thesis, Durham University.

Use policy

The full-text may be used and/or reproduced, and given to third parties in any format or medium, without prior permission or charge, for personal research or study, educational, or not-for-profit purposes provided that:

- a full bibliographic reference is made to the original source
- a <https://etheses.durham.ac.uk/id/eprint/2867/> is made to the metadata record in Durham E-Theses
- the full-text is not changed in any way

The full-text must not be sold in any format or medium without the formal permission of the copyright holders.

Please consult the [full Durham E-Theses policy](#) for further details.

Void Spaces

Apprehending the use and non-use of public spaces in the urban

A copyright of this thesis rests with the author. No quotation from it should be published without his prior written consent and information derived from it should be acknowledged.

Edward H. Huijbens

Doctoral thesis at the University of Durham

Department of Geography

July 2005



07 DEC 2005

Void Spaces

Apprehending the use and non-use of public space in the urban

Abstract

This thesis builds up a three part genealogy of the theoretical apprehensions of space through a three part narrative of a recently constructed public square, serving as the gateway to Edinburgh's new financial quarter, the Exchange. The aim of this genealogy and its narrative counterparts is to re-imagine the ways in which public spaces in the urban environment can be understood with reference to their materiality and use or non-use. This re-imagining aims to move away from all subjective accounts that focus only on varying degrees of use and the use-value of materiality and can lend themselves all too easily to ideals and aspirations of city planners and various scripted political projects. The thesis argues that of key importance in this re-imagining is to give space a clear role to play in its own apprehension. The argument of the thesis is that in order to apprehend public spaces in terms of their own materiality at one with use, a detailing of their materiality and use or non-use is insufficient if set up in juxtaposition to each other or made to interact through a dialectical confrontation. The thesis maintains that a strong empirical focus on the relations between materiality and use or non-use, on the most general level, will yield the most productive way of apprehending public spaces in terms of not reducing interactions between its materiality and use or non-use to a scripted theatre of determined functions and their subversion.

© The copyright of this thesis rests with the author. No quotation from it should be published without the author's prior written consent and information derived from it should be acknowledged.

Acknowledgements

First and foremost I would like to thank my supervisors drs. Paul Harrison and Mike Crang for their invaluable insights, comments and thorough revision of drafts to each chapter and the thesis itself, not to mention their easy-going and pleasurable manner during supervision sessions. Additionally I would like to thank dr. Stuart Elden for his very helpful comments on drafts referring to Lefebvre and Heidegger, along with swift and positive response to my requests. Also my two examiners David Pinder and Ash Amin are thanked for their detailed reading of the thesis and their constructive and insightful comments, which greatly improved the thesis overall.

My interviewees I would like to thank for their time, along with the staff of Edinburgh's City Council Planning Department, the City's Archives, the Public Library and Ian White and Associates, who were wonderful in providing the necessary material for the thesis.

I would also like to thank the IT staff and design and imaging unit at the department of Geography for their quick, polite and valuable help with computers and image processing. Especially Dave and Terry who most certainly deserve a beer or two!

My fellow post-graduates at the department are also to be thanked for the time devoted to discussions and informal chats helping me to articulate my thoughts. Especially I thank Martin Bickl and Charles O'Hara for their rigorous scepticism, Colin McFarlane who not only critiqued my terminology and thought but made sure one smiled continuously too, Alex Jeffrey for his marvellous library and generous use of it, James Smith for his generous donation of computer programmes, Christian Broen for his enthusiastic interest and critique, and all the rest for being always ready for a laugh and a beer with my hat off to Alona Armstrong for always wanting to drag us all out.

Last but not least thanks to my former college flatmates for making my life in the Durham academic exile filled with fun and excitement and become the source of stories I can tell in my old age. The Elvet gang along with Andy and Dave you know you have a home in Iceland.

Table of Contents

	Abstract	i
	Acknowledgements	ii
	Table of Contents	iii-v
	List of Figures and Graphs	vi
	List of Abbreviations	vii
	Introduction	1
	Part I: Creating the Void	
	Noting the Ideal	14
I.1	The Context	19
1.1	Space relatively Absolute	19
1.1.1	The social space	20
1.2	Relational Space and Structuration Theory	26
1.2.1	Structuration Theory	27
1.3	Social Practice in Relational Space	31
1.3.1	The embodiment of <i>habitus</i>	31
1.3.2	The role of the body, <i>habitus</i> in action	33
1.3.3	The spatial	37
1.4	Sedimented Time-space Trajectories as Concluding	39
I.2	Making Space	42
2.1	First Conundrum	44
2.1.1	Clearing for enclosure	49
2.2	From Holes to Wholes	55
2.2.1	Exchanging idea(l)s	59
2.2.2	The opening for the public	66
2.3	Concluding	72
I.3	Walking the City	73
3.1	Inventory	75
3.1.1	Woman and Child from Soweto	77
3.1.2	The Shining Stars and cycles	79
3.1.3	Mr. Lamb and the use of Festival Square	83
3.1.4	A conundrum	90
3.1.5	The Usher Hall	96
3.1.6	Flows and paving	99
3.1.7	Break for coffee	103
3.2	Concluding	106
	Summary Conclusion of Part I	108

Part II: Filling the Void

	Producing Space	112
II.1	Producing Abstract Spaces	115
1.1	Lefebvre on Dialectics	115
1.1.1	The production of space	117
1.2	Framing Lefebvre	120
1.2	Abstracting Space	123
1.2.1	Grounding the abstract	123
1.3.	From the Abstract to the Concrete -the dialectics of space and place	125
1.3.1	Capital	126
1.3.2	The tourist	130
1.3.3	The third sector ideal	139
II.2	Politics of Place	142
2.1	Spatial Practices	143
2.2	Appropriating Festival Square	145
2.2.1	Subversive ideals, in theory	145
2.2.2	The confrontational city	147
2.2.3	The fight for public space	149
2.2.4	Semiological battles	151
2.3	Abstracting the Concrete -from place to space	153
2.3.1	Deliberative appropriation	154
2.3.2	Skateboarding	157
2.3.3	Skating on Festival Square	159
2.3.4	Skater-space	162
2.4	The Open Differentiation	165
II.3	Clearing through Rhythm	166
3.1	Habitual Production of Space	167
3.1.1	On Festival Square	168
3.2	Dwelling producing Space	171
3.2.1	Heidegger's <i>Dasein</i> and dwelling	171
3.3	Rhythm Producing Space	174
3.3.1	Rhythms	176
3.3.2	Discerning rhythms	177
3.3.3	Making Presence	180
3.3.4	Gathering rhythms	182
3.5	Disclosing Festival Square in terms of Flow	185
3.6	Further Paths	188
	Summary Conclusion of Part II	190

Part III: Emptying the Void

	Blank Figures	194
III.1	Relational Festival Square	198
1.1	Starting Example	200
1.2	Unpacking Dialectics	203
1.2.1	Baroque dialectics	205
1.2.2	Exteriority of relations	206
1.2.3	Slipping in difference	209
1.3	The Physical Space of Festival Square	214
1.3.1	Design as function	214
1.3.2	Using lamps	217
1.4	Concluding	222
III.2	Becoming-Reflexive	224
2.1	Being Reflexive	225
2.1.1	Reflexivity	226
2.1.2	Becoming-researcher	229
2.1.3	Immanence	232
2.1.4	Radical empiricism	235
2.2	Methods	236
2.2.1	Affect	237
2.2.2	Non-representing	239
2.3	Method of Conclusion	241
III.3	Becoming-Festival Square	247
3.1	Background	248
3.1.1	The urban	248
3.1.2	Everyday eventful city	249
3.2	Space, Use and Excess	251
3.2.1	Rupture	253
3.3	The Lurking Intensity	255
3.3.1	Virtual	255
3.3.2	A politics of the banal encounter	259
3.4	Festival Square 19 th October 2003 3am	263
3.5	Conclusion	266
	Summary Conclusion of Part III	267
	Appendix A: List of Interviewees	271
	References	272

List of Figures and Graphs

Figure I.1	A sketch of Festival Square, Edinburgh.	17
Figure I.2	Time-Geography Diagram.	23
Figure I.3	The Caledonian Railway Station and Associated Goods Yards, prior to closure 1965.	46
Figure I.4	The Site of Festival Square 1948-1988.	48
Figure I.5	Festival Square 1988 and today.	55
Figure I.6	The Exchange Masterplan with Usher Hall.	65
Figure I.7	A drawing by Farrell depicting the Exchange site's permeability.	68
Figure I.8	The Exchange in the cityscape.	70
Figure I.9	Festival Square, Edinburgh.	76
Figure I.10	Woman and Child, Festival Square, Edinburgh.	77
Figure I.11	Cleaned Stairs, cigarette butts, loose slabs and Joe cleaning the tree gratings.	81
Figure I.12	Bike rails at Capital House.	83
Figure I.13	Capital House and its entrance with slab cleaning in progress.	86
Graph I.1	Footfall on Festival Square.	88
Figure I.14	The Water Feature on Festival Square, during night and day.	94
Figure I.15	The Usher Hall with Edinburgh Castle in the background.	97
Figure I.16	Routes on Festival Square.	99
Figure I.17	The Clydesdale Bank Plaza.	102
Figure I.18	The Dash Coffee stall and the uses of the walled planters as seating.	105
Figure II.1	"The eye of power" rather boxed up.	120
Figure II.2	The promotion of the city as a lively, vibrant and festive place can also be read through photographic material.	132
Figure II.3	List of Events on Festival Square.	134
Figure II.4	Events on Festival Square.	136
Figure II.5	Events on Festival Square in terms of Struggle.	154
Figure II.6	Skating on Festival Square.	161
Figure III.1	The open system of disjunctive relations settled into a representable balance.	211
Figure III.2	The double articulation eventually producing strata that at each time are imbricate with the molecular.	213
Figure III.3	Streetlamps on Festival Square, Edinburgh.	218
Figure III.4	Thoughts articulated by those passing through Festival Square.	244
Figure III.5	Displaced slab on the SE corner of Festival Square.	263

List of Abbreviations

ABO	All-Bar-One
ATM	Automated Teller Machine
CALA	City of Aberdeen Land Association
CABE	Commission for Architecture and the Built Environment
CBP	Clydesdale Bank Plaza
CC	Conference Centre
CCTV	Closed Circuit Television
CERT	City of Edinburgh Rapid Transport
CH	Capital House
ECC	Edinburgh City Council
ECCM	Edinburgh City Centre Management Company
EDC	Edinburgh District Council
EDEC	Edinburgh Development and Estate Committee
EDG	Edinburgh Development Group
EICC	Edinburgh International Conference Centre
EU	European Union
EYAW	Edinburgh Youth Against War
F	French
G	German
GTR	General Theory of Relativity
HCE	Hotel Corporation of Edinburgh
HQ	Head Quarters
HR	Human Resources
LA	Los Angeles
LEEL	Lothian and Edinburgh Enterprise Ltd.
MBA	Master of Business Administration
PC	Police Constable
PDC	Planning and Development Committee
PFI	Private Finance Initiative
PPP	Public, Private Partnership
RFAC	Royal Fine Arts Commission
SCCI	Scottish Cycle Challenge Initiative
SCT	Scottish Cultural Trust
SDA	Scottish Development Agency
SE	Scottish Enterprise
SEEL	Scottish Enterprise Edinburgh and Lothian
SIP	Social Inclusion Partnership
SL	Standard Life
UH	Usher Hall
UK	United Kingdom
UN	United Nations
US	United States of America
UTR	Urban Task Force
WAR	West Approach Road
WCB	Western Corridor Busway

Introduction

“Public space is all around us, a vital part of everyday urban life: the streets we pass through on the way to school or work, the places where children play, or where we encounter nature and wildlife; the local parks in which we enjoy sports, walk the dog and sit at lunchtime; or simply somewhere quiet to get away for a moment from the bustle of a busy daily life. In other words, public space is our open-air living room, our outdoor leisure centre” (Stuart Lipton, chairman of CABE, quoted Woolley *et.al.* 2003, p. 2).

Space is “raw matter-energy, [which] through a variety of self-organising processes and an intense, immanent power of morphogenesis, generates all the structures that surround us...render[ing] matter-energy flows, rather than the structures thereby generated, the primary reality” (De Landa, 1997, p. 509)

The first quote is taken from a recent report issued by the Commission for Architecture and the Built Environment (CABE) called *The Value of Public Space* (see Woolley *et.al.* 2003) and is to indicate the publicly advocated understanding and official sense made of public spaces in the urban. The second quote on the other hand indicates the theoretical direction this thesis will take in order to apprehend the use and non-use of public spaces in the urban. The CABE report emphasises that our public spaces are an all inclusive ‘open-air living room’ from which we accrue economic benefit, help mental and physical health, children and young people and reduce the fear of crime. But in the thesis I will argue, through a tripartite take on one public square, that public spaces in the urban are about more than living up to the aspirations of those who write public policy guidelines. Firstly, these ‘living rooms’ are ordered spaces, made and maintained by certain people guided by rhetoric along the lines presented in the quote. Second, not only are these spaces ordered but made and remade through different usage by different people, making the ‘living room’ a contested terrain. Lastly and additionally, the force of this contestation does not only reside in scripted or determined political projects of those who order space and the different users of that space, but also lies in the very materiality of space making public spaces hold within their very materiality the force of their own transformation, which ever direction this transformation may take.

The quote from the CABE report and the most common official sense made of public spaces in the urban, I see as manifesting an ideal that Richard Sennett, in his book *The Fall of Public Man* (1996, originally published 1977), already critiqued some time



ago. His critique was of modern architecture and the production of what he termed 'dead public spaces', spaces void of meaning to the urban dweller. These spaces he saw as manifesting a rise of individualism and the compartmentalisation of social life. For him the public realm was being erased as people slowly were losing their sense of publicness and becoming individual strangers navigating the city. He saw "the effacement of the *res publica* by the belief that social meanings are generated by the feelings of individual human beings" (p. 339), with the consequence of obscuring public space as a realm for social life to be conducted at the impersonal level. On first impression the CAFE report may be seen as following Sennett's critique, seeing public spaces as an all inclusive open-air living room or a space where all can meet and interact, potentially restoring the *res publica* effaced by individualism. But when the claims made by the CAFE report receive critical attention, all these open-air living rooms in the urban reveal themselves as places of power struggles between groups of people sharing different ideas and desires. This critical attention has mostly been about documenting and mapping these ideas and desires and how these come into confrontation in public spaces. The literature documents the numerous formal and informal mechanisms of inclusion and exclusion, keeping public spaces void of those that are 'too' different from those in control. Therein are accounts and ethnographies of these mechanisms aiming to politicise public space through detailing how:

"the desires of other groups, other individuals, other classes, together with the violent power of the state, laws about property, and the current jurisprudence on rights all have a role to play in stymieing, channelling, or promoting the 'taking' and 'making' of public space and the claim to representation" (Mitchell, 2003, p. 35).

In the quote the prevailing Marxian understanding of the power struggles producing public spaces in the urban is outlined. Individuals and groups struggle for their ideas, knowing that perhaps "utopia is impossible, but the ongoing struggle towards it is not" (Mitchell, 2003, p. 235). This Marxian understanding on the whole and literature on mechanisms of inclusion and exclusion, I see mostly as understanding public spaces in terms of the individualism and social compartmentalization Sennett (1996) saw emerging as result of modern architecture. These understandings document the 'other side' of prevailing rhetoric or ideals on the uses of public space and assess their publicness through how present these other voices and view points are. Certainly this is part and parcel of Sennett's idea of the *res publica*, but I would like to argue for the

formation of public space's publicness on different terms in the thesis, allowing space itself a more explicit role in this formation.

Before going on I would like to state that I, in many ways, share an affinity with the above Marxian understanding. I can see the struggles playing out in our cities, these mechanisms of inclusion and exclusion and thus the necessity and value of the accounts and ethnographies detailing these struggles. Mitchell, following a lineage of Marxists geographers, argues for the necessity to take space to get your political message across, as is being done world wide today in numerous protests. Within his formulation a multitude of voices is allowed for, all in confrontation, taking and making the city. Here public space itself emerges as a realm for social interaction, but I find it lending itself all too easily to be seen as a mere stage in which these interactions play out. Thus what interests me especially in this thesis can be gleaned from Iveson's (2004) critique on the work of Mitchell. Iveson (2004) argues that Mitchell sees material public space as the space of the public, meaning that it is the space and its materiality that is to be taken over; appropriated and hence the nature of that space's publicness is determined. Iveson (2004) sees these struggles of appropriation as reductive of the role of space and, drawing on Lefebvre (1990) like Mitchell, argues that space is "simultaneously material *and mediated*" (p. 920, emphasis original). He argues that in public spaces, the events of appropriation do not give much insight into the mediation of space, seeing it more as a material stage set for this appropriation. Thus, Iveson (2004) argues, it is rather the lived spaces that are manifest everyday there, which play a more active, albeit smaller-scale role, in the mediation and production of public space. Focusing on everyday lived spaces can be formulated as struggles and to a certain extent be aligned with Mitchell's political project and seen in his work, but in this thesis my interest lies more squarely on the role space as physical material entity plays in these everyday lived spaces. By accounting for space's role I hope to have it emerge as co-constitutive of its own publicness and, by implication, its own transformation.

I restate that my aim in this thesis is in no way to do away with the Marxian reading and understanding of public spaces. But what I want to do is add to those accounts the material or make space more explicitly partake in the struggles of appropriation on equal terms with the individuals acting out their social relations. Seeing public space

in terms of its materiality, I aim to address Elden's (2004b) claim that "the political, as the ontological foundation of politics, is where politics takes place" (p. 99). Following both Lefebvre and Heidegger, I want to ultimately argue that "there is a politics of space, most fundamentally, because space is constitutive of the political" (Elden, 2004b, p. 100). The quote states that the whole Marxian formulation of the production of public space is inscribed on the earth or space (Deleuze and Guattari, 1983, p. 141-142) and that this inscription plays a role in the political. What I want to address is how this inscription and production of public space is done by "a crowd [that] must be fully individuated, but by group individuations that are not reducible to the individuality of the subjects that compose the crowd" (Deleuze and Guattari, 1987, p. 341). Thus, in the spirit of the second opening quote, people are energy, at one with the raw matter energy of space making public spaces a seething mass of energy, immanent to which is its own transformative potential, turning *the* politics of struggles and ideals into *a* politics of desire. The individual as such as one with public spaces reinstates the *res publica*, not so much "for active social life, for the conflict and play of interests, for the experience of human possibility" (Sennett, 1977, p. 340), but moreover in terms of how people become-public space.

In order to get to the understanding of public spaces that are constitutive of their own publicness and transformation, the thesis proceeds through three parts. In the first part of the thesis I introduce the site which will ground the theoretical moves presented in the thesis. The site under consideration is a public space serving as a gateway to Edinburgh's new financial district, the Exchange. The square is named Festival Square and intrigued me since my first visit to Edinburgh. As I first travelled to the city in the spring of 2001 I did a city sightseeing tour in one of the city's open topped double decked buses. The tour took us up Lothian Road where the guide pointed out the financial quarter and named Festival Square as the gateway to the quarter from the city centre. This function of Festival Square intrigued me as in my view the square looked grey, barren and void of all activity. I started wondering to myself how one would talk about this space without necessarily resorting to subjective evaluations based on perceptions such as the one I had or others presumably using the square. If there are no users, the space is void of all activity, as when I saw Festival Square, how can one make sense of the space? This question led me to another, can void spaces ever be? Is there such a thing as the void, an absolute nothing? The grander

cosmological question I leave aside in this thesis as my interest lies in the geographies of our cities and for me there can not be a nothing in our midst. Yet my initial perception of Festival Square was just that, it and the surrounding houses seemed nothing to me as I saw nothing going on there and if I would not have thought about them they would surely not have existed for me today. Hence the title of the thesis: Void Spaces, apprehending the use and non-use of public spaces in the urban.

The thesis' first chapter in this first part where I introduce the site under consideration is a theoretical chapter. This theory chapter, like the part itself, is made in order to set the backdrop of the thesis and provide theoretical material to expand upon in subsequent parts, but also stands on its own as a take on Festival Square. In this chapter the key terms that will be used throughout the thesis are presented such as time-space trajectories that I deploy to grasp the material sedimentation of actions. These actions I explain in terms of structuration theory and more specifically in terms of *habitus* as set forth by Pierre Bourdieu, in order to get to an understanding of space as generated through relations. With the relational understanding of space, as presented in structuration theory, I set out to detail the objective structures that then structure space and individuals therein in the second and third chapter of part I. Detailing these objective structures has these two chapters emerge as relatively unproblematic chorologies of Festival Square. The former descriptive chapter details how this space is ordered, like all others, through building and making by someone, with something and for a purpose. The description details archival work and interviews telling who built the square and why informed by the larger socio-economic structures of Edinburgh city through two different designs of the square. The latter chapter represents what the urban dweller might see and articulate if asked about this specific site. The narrative is about what is on the square as it is and the structuring of my own dispositions towards the square through detailing my own experience of the square. These two narratives talk about the square in terms of determined functions which I set up in juxtaposition with the space's materiality. Although the determined functions for this public space might seem as absences of history and of people on the square, these absences are deliberately constructed by people designing the square. Thus I see the materiality of the square as a collection of time-space trajectories generated in terms of structuration theory, sedimented in the materiality of the square. In the end of part I, I critique the lack of spatial referent in

the work of structuration theorists and the reductive role of space in older and more recent formulations of time-geography. These lacks make the narratives told in the part's chapters limited to the descriptive inventory detailed above of both the objective socio-economic structures and the square's materiality. These lacks notwithstanding allow the part to stand as a specific albeit limited take on Festival Square. Detailing these objective structures, first in terms of the socio-economic structures of Edinburgh and the structuring of the square in light of that, and secondly in terms of the square itself and how it structures individuals therein, myself especially, I argue that in order to grasp the use and non-use of public spaces, one has to grasp the space as such, objectively, void of activity. Thus the first part of the thesis as a whole emerges as a classic descriptive take on Festival Square as it stands in Edinburgh with focus on its materiality, as depicted in the background to the title page of part I.

In order to redress these two aforementioned lacks of spatial referent and reduction in time-geography and structuration theory I move on to part II where I pick up in more detail the backbone of structuration theory, dialectics. This I do in terms of a well known theorist on space Henri Lefebvre. Through his work I make room for the everyday use of the square bound up with its physical materiality through Lefebvre's dialectical framework. Hence with a detailed outline of the dialectical in the first chapter of part II and the Lefebvrian framework found in his *Production of Space* I can move Festival Square away from being apprehended through simple description and as deliberately constructed determinations and absences and start to unravel it in terms of its use. With this framework I can better grasp the deliberate constructions and actions that went into making the square and also those deliberate everyday actions or uses that take and remake the square possibly not in line with its determined functions. These I document with examples in the first and second chapter of part II, but in the last chapter of part II my initial fascination with the square comes to the fore again. There is not much taking and remaking of the square being done and most of the little use there is, is perfectly in line with the determined functions of the square. People in general rarely use Festival Square and there is very little active and deliberate remaking of this square or confrontations between different ideals or ways of doing in the everyday. Nonetheless what one is immediately struck with once spending a little time on Festival Square is that there is a specific manner in which the

square is used, people *pass through it* often several times a day. The square is thus not a living room as CABE would like to see public spaces but more like a corridor, or gateway as my city tour guide rightly described it, which in no way changes my critique of the CABE metaphor though. As I could find only scant articulations of this passing through in terms of confrontation or struggle through my ethnography of the square I term this passing 'non-deliberate uses' of Festival Square and as stated these are by far the most prominent of the little use there is. In order to get to these non-deliberate uses I carry on with the main theorist of part II, originally introduced to amend the spatial shortcomings of Bourdieu and time-geography, and through an excursion through Lefebvre's intellectual debt to Martin Heidegger I combine Bourdieu and Lefebvre in a narrative of Festival Square in terms of presencing. What I argue here more specifically is that these non-deliberate uses have become a habitual routine settled into *habitus* that seems to bear no relation to the space through which the movement passes. So in order to grasp these movements I apprehend them through the rhythms that maintain them and the rhythms that generate them and following Lefebvre and Heidegger argue that all rhythms are about presencing and hence the space of Festival Square can be apprehended through the rhythms of the movements through it. Lefebvre does not expand upon this argument in his work and argues that all rhythms are part of the dialectics that produce space making the apprehension of Festival Square something like a theatre of rhythms. Apprehending Festival Square as a theatre of rhythms in dialectical confrontation does not move far enough for me to allow the phenomenology, argued for in terms of presencing in order to get to the non-deliberate uses of Festival Square, to live up to its full potential. With this lack in apprehending the use and non-use of public space evident in the end of part II, I move on to part III.

Although in the above there are fairly exhaustive narratives and theoretical approaches to the use and non-use of Festival Square I feel that I have still not sufficiently accounted for the square's materiality, of which an inventory was made in part I, and the way in which it partakes in its own transformation and is constitutive of the *res publica*. This materiality was partly used in Lefebvre's formulation of the production of space but receives a more potent role in his project of rhythmanalysis where he states that all there is, is composed of rhythms. Lefebvre goes no further than indicate what is at stake once all there is is rhythm and sides with dialectics in

apprehending space. In part III I thus aim to address the reduction implicit with the dialectical apprehensions of space. Without doing away with the brilliant social science of both Bourdieu and Lefebvre I will attempt to add potential to their above presented analyses by soliciting the terms of their dialectics through their relationality through the post-structural theorising of Deleuze and Guattari, mainly. In terms of Bourdieu I aim to further the adding of spatiality to his work through having the dispositions of *habitus* composed of time-space trajectories as formulated in part I and II, but in part III, these trajectories become the relations, which affirm the dialectical divide between the objective structures and social practices. With this understanding I also aim to address the second critique set forth in part I on how *habitus*, formulated as beyond cognitive reckoning can change. In terms of Lefebvre, he argued that space disclosed through rhythms was the ultimate production of space, but he did subsume this production to the all consuming dialectic theatricality, which I argue in the first chapter of part III, cannot make sense of space's transformation without reduction. Detailing the reduction implicit in the dialectical thinking of both the above theorists, who arguably subsume everything there is into its relation generative machine, I can make sense of the inherent thought fallacy of believing that with perfect knowledge all use and non-use of Festival Square can be fully apprehended and predicted. Though I argue that dialectics are reductive in the above understanding, I in no way reject the notion of dialectics. Festival Square as a theatre of rhythms has its merits and detailing these rhythms is arguably work that all good research must undertake in order to grasp public spaces. But Lefebvre, with his rhythm analysis, does hint at a much more complex relation between space and its use and thus I carry on with his work on rhythms and tie Lefebvre's spatial apprehensions to those of the post-structural thinkers Deleuze and Guattari who formulated rhythms in terms of the refrain.

As stated above and in detail, the reason why I move to post-structuralism in the thesis' third part is in order to move away from the reduction implicit in the dialectical confrontational model and without rejecting juxtaposition and confrontation; on the contrary I will try and confirm them in order to make better sense of their relation. What I am saying is that the disjunction between elements set up in confrontation through the dialectical framework, on the most general level the square's materiality and use, is to be confirmed. These elements in confrontation had

been formulated in terms of objective structures and practical activity for Bourdieu and as the abstract and the concrete in Lefebvre's production of space and lastly as the theatricality of a multitude of rhythms. Confirming this disjunction, the part's theoretical argument builds up for radical empiricism with a firm focus on the relations themselves and only them as they and only they are able to generate more relations in the now-moment of apprehension, earlier formulated as presencing through rhythms. With this radical empiricist focus the reductive critique of dialectical thought is countered through soliciting or unpacking the infinite seriality of all elements confronting through their very own relationality. Rhythms become time-space trajectories and the relations that compose space, and are made accountable for unpredictable novelty through being exterior and irreducible to their terms. With the understanding of time-space trajectories as exterior and irreducible to their terms part III is an elucidation of the square's materiality in terms of assemblages of relations that connect through becoming. Becoming, as argued in the first chapter of part III, is not the way one can represent other relationalities or assemblages or physically become these, either which ties into systems of consciousness, perception or signification defining the assemblages in terms of their lack or by analogy to that which is to be represented. Becoming, is made through the relations to the material assemblage, or other assemblages, involuting or involving one set of time-space trajectories with the other assemblages already there, all of which are of constant movement through rhythm. Thus these elements become a set of relations themselves and become productive in truly unpredictable ways, stating that no matter the amount of knowledge one has of space there will always be more.

Without going further into the argument as that is done at length in the three chapters of part III, I would only add that each chapter in part III produces illustrations of Festival Square, kinds of vignettes of the theoretical discussion of each chapter. Thus the structure of the final part is through first, building an argument of how we become one with the space of the square, building on the last chapter of part II. Next I ask what a human geography researcher should focus on when apprehending space in terms of its ceaseless unfolding and essential oneness presented in chapter before. Finally with the set of tools from the two previous chapters I move to the last chapter where I try to apprehend the space in the now-moment of presencing, through a singular, banal event and aim to address the political potential implicit in this

apprehension. I argue that it is through openness, an openness to the affect elicited and exerted upon all forms of assemblages, that makes one able to account for the unpredictable directions and connections made by the constantly moving, rhythmic time-space trajectories.

Thus the argument maintained is that the world is ceaseless and ongoing and although having settled into balanced states such as public spaces in the urban, that need to be meticulously mapped out in terms of their materiality and struggles over use, these need to be opened up to future potentials to make sense of space as ceaseless. In other words, the argument revolves around how these 'sinkholes of stability' can always change and be reformulated, but not necessarily according to the cognised ideals or determinations formulated under the terms of social power struggles, but also in terms of space itself and infinite future potential.

At this point the question might be why this three part structure to the thesis? If the three parts outlined above are taken together what emerges is a continual addition, each part is about addressing what is missing or expanding a reduction or lack of the previous part. The rationale for the structuring of my thesis into this three piece narrative and theoretical take, lies in the theory presented in part III. The world is indeed ceaseless and on-going, there is always more to be added and a final apprehension or representation of space is never possible. Thus in a way each part is to draw a certain image, but one that does not say it all and with each successive attempt of adding to address that which was not said, more emerges to be said. The parts within themselves start with a theoretical chapter for two reasons, one being that I would like to set the backdrop for the part itself and the narrative it tells. But secondly, and more importantly, once having done the narratives of each part, certain shortcomings emerge. Thus as part of the genealogy of space presented in the thesis, the first chapter spawns the narratives in part I, but also underpins part II where I address the shortcomings of part I, both in theoretical and narrative terms. This adding on I do again between parts II and III with the overall argument that although each part has merits on its own and could fulfil certain purposes there is always more to be added. Thus in general the structure of the thesis is a three piece narrative, each containing three subsets, with these narratives reflecting a three part genealogy of the theoretical apprehensions of space. What I hope to argue through this structure is a

general post-structural argument; stating the use and non-use of public spaces in the urban can never be fully apprehended and that there is always more to be added once trying to come to terms with public space. So although each part tells an independent story the structure of the thesis makes a post-structural argument elaborated on in the last part, which states that in order to grasp the world one must be open to its ceaseless unfolding and continual excess, opening to an infinite future potential. Following Deleuze (1990) who states “thus, the beginning is truly in the void; it is suspended in the void” (p. 251), everything in whichever way it is conceived can never be fully apprehended, each part concludes with a beginning, there is always more, always an and...

The narratives of Festival Square hopefully demonstrate the use of the theoretical understanding presented in part III. These narratives were both of the mapping of the seemingly stable Festival Square and its cognitive reformulations, but in the end also trying to indicate that always present potential of time-space trajectories, that are the raw-energy of both use and materiality, to bifurcate and change and settle into new unpredictable balances be they fleeting or long term. Thus I argue why planning policy guidelines and the determined functions prescribed by well meaning architects and designers do not always play out according to their wishes. In the thesis I hope to answer why, all stemming from my original perception of Festival Square as a public space void of activity.

In sum I propose that the originality and contribution of the thesis is twofold. Firstly, and primarily an understanding of the *res publica* in terms of pure physical materiality, but secondly, it lies in the structure of the thesis as it presents in each part sets of theoretical and practical tools, each capable of imagining the use and non-use of public spaces in the urban. Once all these sets are taken together the thesis presents a set of tools that potentially re-imagines the use and non-use of these public spaces. These tools are of relevance to all human geography researchers who recognise the reduction implicit in subjective accounts of public spaces that focus only on varying degrees of their use and can lend themselves all too easily to the romantic ideals and aspirations of city planners, other utopian imaginings and implicitly individualism and social compartmentalisation. Through allowing space itself a clear role in its own

apprehension I hope to have produced an original account of *res publica* in a manner relevant to all those interested in our urban public spaces.

Lastly I would like to add a few words on the setup of the thesis. I use of footnotes¹ in the thesis and lots of abbreviations that are all listed on page vii. In the end there is a reference list detailing all work cited throughout the thesis.

Durham, England

January 2005

¹ I use footnotes in the thesis for two purposes: Firstly, I use them to indicate an avenue of research I will not explore, but demonstrate a knowledge of with references to literature. Secondly, and mainly though I use them to expand in detail on either theoretical backgrounds or detail conceptual moves made. These footnotes often tend to be lengthy and are there to complement the text but I feel justified in using them after reading this passage from Baker's (1988) footnote talking about scholars who appreciated footnotes:

"They knew that the outer surface of truth is not smooth, welling and gathering from paragraph to shapely paragraph, but is encrusted with a rough protective bark of citations, quotation marks, italics, and foreign languages, a whole variorum crust of 'ibid.'s' and compare's' and 'see's' that are the shield from a pure flow of argument as it lives for a moment in one mind. They knew the anticipatory pleasure of sensing with peripheral vision, as they turned the page, a gray silt of further example and qualification waiting in tiny type at the bottom...the footnote functions as a switch, offering the model-railroader's satisfaction of catching the march of thought with a superscripted '1' and routing it, sometimes at length, through abandoned stations and submerged leaching tunnels" (p. 122).

I hope that my model-railroader's inclinations creating a sediment of grey silt at the bottom of many pages will help indicate the rough edges of every argument made if only to indicate that there is always more, always an and...

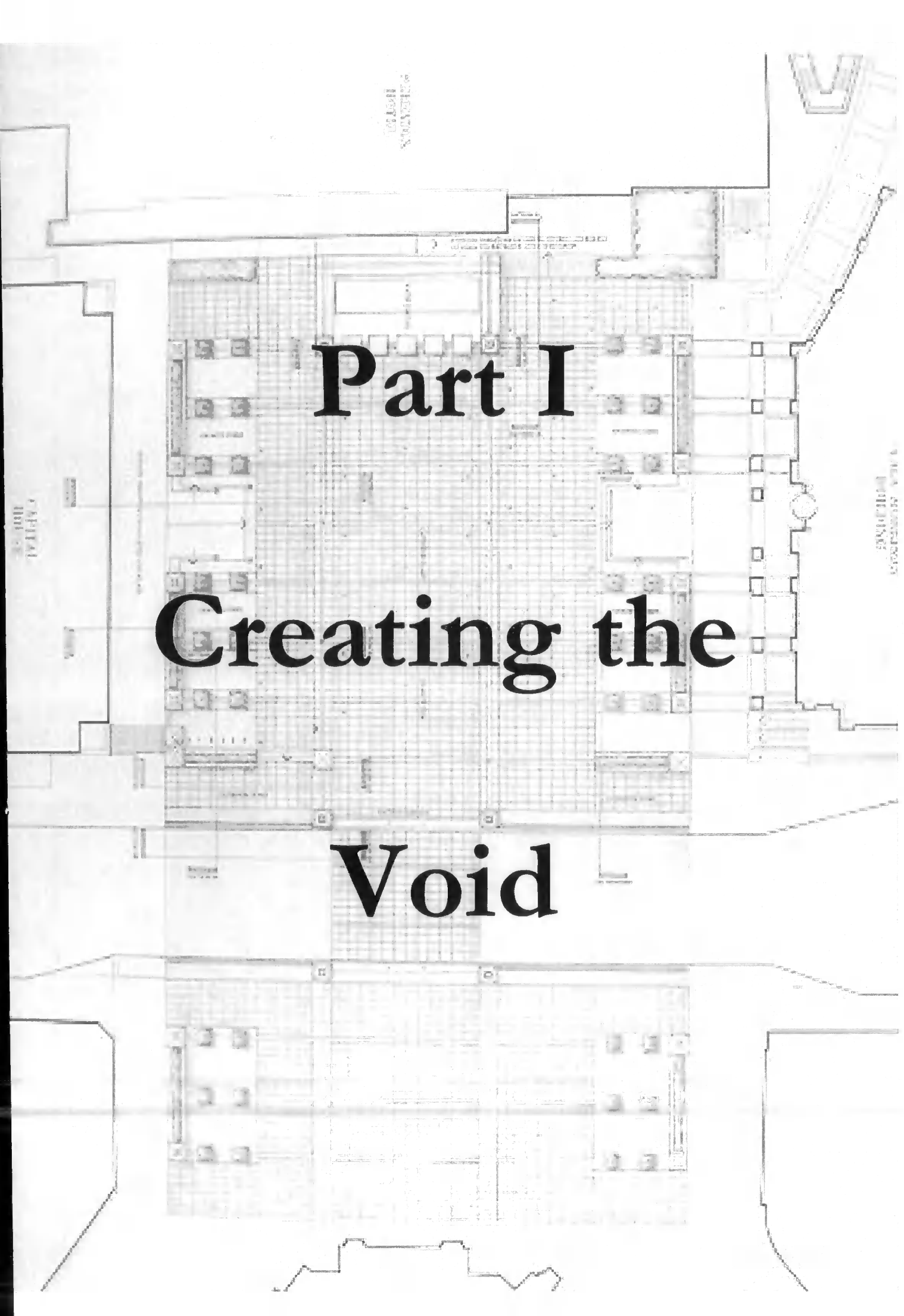

Part I

Creating the

Void

Noting the Ideal

Under the introductory heading of the first part of this thesis 'Creating the Void' I want to note how Festival Square was created as an inert materiality, i.e. a void representing the ideals of planning and design. In the chapters that follow I argue for this void being "a deliberately-constructed absence (of history, the vernacular, specific function) which enables the presence of carefully negotiated, overdetermined meanings" (Goh, 2003, p. 51). In the case of Festival Square, as it goes through two faces of construction there was an evident overdetermination of function, enabled by the constructed absence. Thus in the first part of the thesis the void refers to that which encapsulates all forms of the ideal, manifest as the deliberately constructed absence that is the square, and the chapters map out the overdetermined functions allowed for by the ideas of those who designed it.

These overdetermined functions are mapped out understanding space as relational and as a product of dialectical structuration. The part begins with an outline of this theoretical scene, starting the first chapter with a general outline of the notions of absolute and relative space. Creating the void does not refer to a creation of absolute space as I argue that design and planning has moved a long way from its modernist early days. On the other hand I argue that once creating a void a host of relations come to play composed of various ideals and design functions that inform the construction of Festival Square. In order to unpack the square as a relational space and how it gets created, more specifically I make an excursion through classical time-geography which came in way of response to absolute notions of space. The main reason though why I elaborate on time-geography is to trace the origin of the term time-space trajectories, which I will deploy through out the thesis. The exact nature of these time-space trajectories is dealt with in this thesis therefore I lay the foundations for my engagement with them through the discussion of space as relational, which surely by now is the paradigm in human geography today (see Amin, 2004; Massey, 2004, and Thrift, 2004a). Time-geography's response to absolute notions of space mostly took place through structuration theory and has multiple manifestations in the literature but I choose, what I consider to be, its most nuanced elaboration in the theory of practice as outlined by Pierre Bourdieu. There are three reasons why I choose to engage with Bourdieu: Firstly, he is explicitly dialectical in his

understanding of relational space, which provides a foundation to so much of the later theorisation of this thesis. Secondly, I choose structuration theory as an avenue to engage with relational space, as it has been done in geography through an engagement with time-geography as mentioned above and later through notions of dialectical production of space (see chapter II.1.1). But lastly and the main reason is that Bourdieu's elaborations were intricate, nuanced and often polemic prompting an engagement with his work by numerous theorists which, along with Bourdieu's own theorisation, gives foundations to build parts of the thesis on. Thus in subsequent parts his conceptualisations will be revisited and expanded upon considerably. But for the purposes of this part his *habitus* forms a backdrop against which one can understand the dialectical creation of relational space.

Bourdieu's structuration approach makes the case for the contingency of social practice. Thus Bourdieu (1990) talks about spatial arrangements or space as indicative of former and current social practices. These social practices are intricately lodged in their histories that are the generative material for new and/or repetitive social practices. Thus structuration argues for a certain continuity or constancy to social practices that, through the imagery of time-geography, become a part of material space, as individual paths composing its materiality. Hence I view the social practices as time-space trajectories and space thus as a cumulative sedimentation of time-space trajectories as Bourdieu theorised social practices would sediment in the body as forms of *habitus*. Chapter two thus outlines the socio-economic history of Festival Square that has sedimented to form that particular space, the socio-economic histories that structured social practices in their context, through attaining to what was ideal at each and every time, but have now come to a momentary stand-still in the space manifest as Festival Square. Having set up Festival Square as a cumulative sedimentation of those time-space trajectories the next chapter takes a voyage through that space to make an inventory of it. This inventory, along with the socio-economic backdrop from chapter two, gives the materiality of the square as a 'system of representations' generated from listing that materiality as it is present at hand. The inventory is thus to indicate how within all spaces there are to be found an infinity of other spaces, representative of the practices that go into creating that

space and structuring the *habitus* of those that navigate that space. Through the inventory and the description of the socio-economic backdrop in the city of Edinburgh that informed the creation of the square, a certain picture of relational space can be drawn, one that I argue is ultimately insufficient and unsuccessful in explaining how practices inspired by human desire constantly veer of track and never attain the prescribed ideal of planning and design, which will be the subject matter of part II.

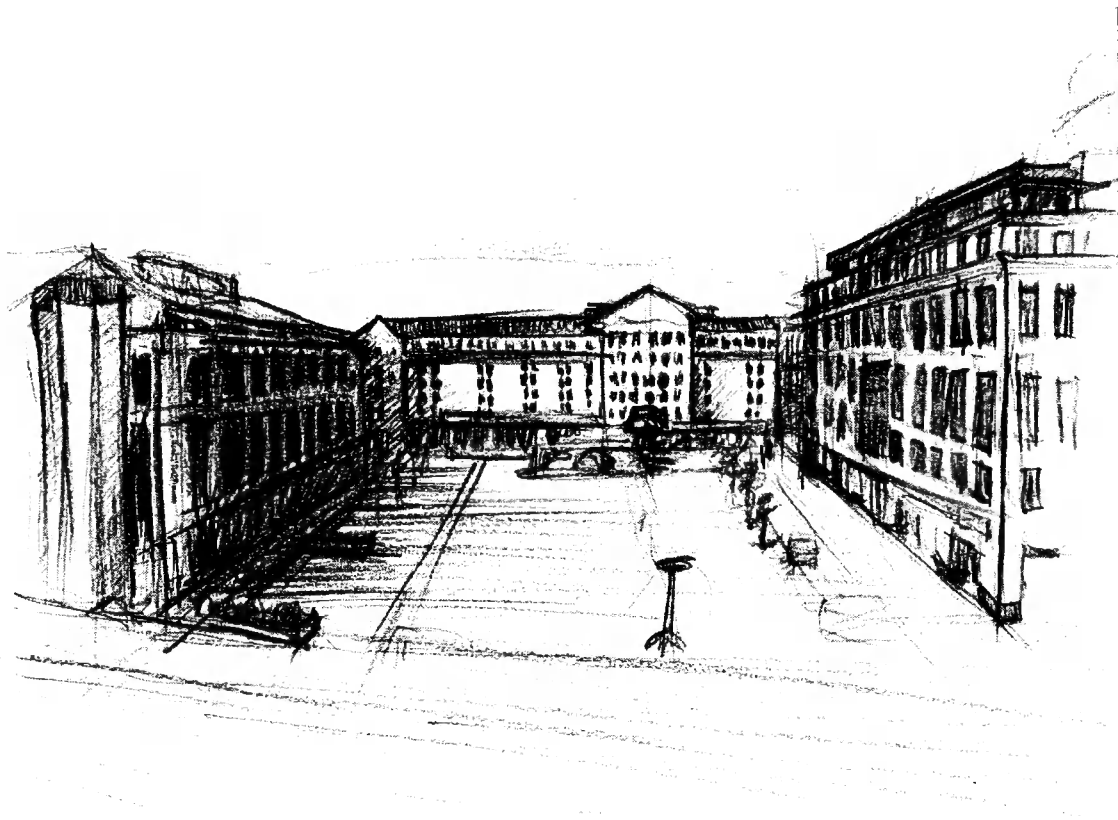

Figure I.1: A sketch of Festival Square, Edinburgh. Here as sedimentation of time-space trajectories.

Source: Jón Jens

I.1 The Context

In this first chapter of the thesis I intend to show how two prominent post-positivist theories of *structuration* (following Giddens, 1984), revolving around the relations between human agency and social structure, rely on an understanding of space as relational, with these relations generated through a dialectics between agency and structure. Space, thus defined, becomes a composition of relations that are generated from entities that only exist through their relationality, thus space is made contingent to the setting in which these relations are made. In order to clarify the above statements on space I will start the chapter with a discussion of *absolute* and *relative* notions of space. Relative notions of space came as a critique of space as absolute and, as a starting point to give a sense of space as relative, I outline the basic premises of time-geography as formulated by Torsten Hägerstrand. This original formulation was engaged with by theorists like Giddens (1985) and geographers in the early 1980s (Pred, 1981, 1985) and from that engagement stems a body of literature on historical contingency and localities viewing space as *relational* (Simonsen, 1996, 1999). This body of literature revolved around an engagement and debate around *structuration theory* and thus, in order to see how entities come to exist as relational and are at the same time generative of relational space, I will outline *structuration theory*, starting with Giddens in the 1980s and carrying on mainly through Pierre Bourdieu's concept of *habitus*. Through my engagement with these two, especially the latter, I will be able to create a dialectical framework for understanding the generation of relational space. This relational space I see as the context for the generation and orchestration of future spaces by relational entities. But in order to envision how this context works in the orchestration of future spaces I revisit the notion of time-geography formerly outlined in the start of the chapter but considerably expand upon it with reference to some recent geographic literature. All in all I view the time-space trajectories, formulated in the revisiting of time-geography, as representative of the relations that compose space and as able to sediment to form the context and framework for new trajectories to be generated through the reworking and reshuffling of those already sedimented, through the mediation of the *habitus* as form of structuration.

1.1 Space relatively Absolute

The *relative* view of space came as a critique on the previously predominant view of space as an inert container of events and objects, a pre-existing space in which things are embedded, a space that is an external coordinate of reality, or *absolute*. In order to explain what is at stake in the formulation of relative and absolute space I will start with the scientific revolutions of the 17th century and a brief outline of the debate about the understanding of space and how that debate unfolded till the 20th century.

The scientific revolutions of the 17th century are mostly attributed to Newton but with his outline of physics he has been awarded the status of father to the absolute notions of space. In his theorising the world was seen as composed out of distinct entities that are arranged into a space that is fixed and absolute, much like objects would be arranged in an inert container. Thus Newton made two key terms when it came to space, i.e. either it was *relative* or *absolute*. For him the absolute is a metaphysical term describing a reality behind the appearances of entities as they are arranged in the world, whereas the relative was about those distinct entities that could be empirically observed relative to that unobservable, absolute space. It is the relative space that appears to us in ever changing form while behind it lurks the absolute space beyond the influence of those entities arranged in it. Kant made the same argument for absolute space but whereas Newton derived his proof from the motion of the twirling liquid in a bucket, moving relative to the unobservable and hence absolute space, Kant derived his argument for the existence of absolute space through incongruent objects that derive their orientation through their outer relation to space, making absolute space necessary for their existence. Space in itself, according to the absolute view of it, has no explanatory power. The absolute space was the space where Newton's theory of gravity and his basic laws of physics were laid out in, the Euclidian space of pure forms that are the fixed contents of a penetrable fixed space.

A contemporary of Newton was Leibniz who launched an offensive on Newton's absolute notion of space. For Leibniz the appearance of movement relative to something unobservable was not rigid enough to satisfy his sense of rationality. For Leibniz it made

no sense to speak of a proof for absolute space when it could not be directly observed exerting its influence, the circumstantial evidence produced by Newton did not satisfy him. Leibniz also argued for the irrationality of Newton's concept of absolute space as by its very nature it should be uniform, homogenous and smooth and thus all placement and orientation within that space would be inconsequential. The idea of positions in such absolute space would be useless but, as Leibniz argued, we do observe that distinct entities have a position relative to each other, so the logical uselessness of positionality as derived from Newton was contrary to all reason.

Leibniz's attack on absolute space was based on the premise that only relative positions between distinct observable entities were acceptable to reason and thus all motion between these entities was relative. Following in his footsteps in the end of the 19th century Ernst Mach claimed, with extreme positivist zeal, that only bodies and relations between them existed, thus space for them does not exist independently, but as relations constituted between objects. This means that all movement and change is relative and produces space. Following on in the early 20th century, the rejection of absolute space was further advanced through Einstein's General Theory of Relativity (GTR). Einstein's break-through discovery was that space itself changes, it is not absolute or inert, space acts on substances as substance acts on space, space is produced through relative relations (Buchanan, 2000; Kennedy, 2003; Peet, 1998; Ray, 1991; Thrift, 2003a; Urry, 1985). Authors agree that Einstein's break through had profound impact on the way of thinking in the 20th century not only in the realm of physics and cosmology but also in the realm of our thoughts and actions. "Einstein transformed not only our image of the physical world but also our belief in reason and philosophy itself" (Kennedy, 2003, p. 158).

1.1.1 The social space

Science does not live in isolation from society and the way in which society is understood and formulated. Hence in social theorising the conceptual implications of absolute space were marked and carried far into the 20th century. In geography notions of space as absolute are most explicitly to be found in the descriptive (chorological) sciences, detailing differences between regions, places and entities arranged in this absolute space

(Hartshorne, 1960) but did also surface through environmental determinism (Semple, 1911). Here absolute space is the outside co-ordinate in which the observable is embedded, a pre-existing structure in which human actions, objects and events are contained and within the parameter of which they unfold. In such theories space is understood as outside the realm of social practice, an abstraction only to be thought of in terms of pure reason and abstract theorising. Thus human action and the interaction between entities is bound and determined by space that is beyond reach and is fixed merely functioning as a container. This absolute space also manifests in structural functionalism, where individuals' action is determined by the structure within which they reside, in systems theory where we are cogs in a machine or system that is outside our influence and urban and regional political economy built on chorological examinations of individual cases (Gregory and Urry, 1985; Lefebvre, 1991). This absolute space that determines action beyond our influence is one that wipes out all traces of history, practices and time and stands as the one, the absolute whole, having nothing to do within the realm of human action as it stands outside human reach (Gregory, 1994, p. 382) and is the void space created by abstract thinking (see Goh, 2003, p. 51).

The profound impact of GTR² was felt in social sciences and philosophy where notions of the absolute were questioned with philosophers (along with philosophically inclined scientists) starting to ask penetrating questions about theories relying on any kind of absolute or essential categories. Prominent amongst these philosophers was Alfred North Whitehead who is often credited with having brought the theory of relativity from the obscure language of higher mathematics to general philosophical discussion through three of his books (see mainly Whitehead, 1922). In these three books his rebuttal of absolute space was absolute:

“One important thought running through the three [books] is that the universe consists in part of ‘contingent’ facts and relations, and in part of ‘systematic relatedness,’ and that any definite character ‘is gained through the relatedness and not the relatedness through the character’” (McGilvary, 1941, p. 214, quoting Whitehead, 1922).

² Although Harvey (1989) dates this shift in the thinking of space to the social upheavals of the 1840s in Europe coinciding with the crisis of capitalist over-accumulation.

Social theory along with geography followed suit, albeit considerably later. Geography claimed a stake in space and time, with the rationale that general social theory neglected the fact that society and environment have an important spatial and temporal component, which social sciences could not overlook (Carlstein and Thrift, 1978, p. 263). Therefore space was seen as that which existed as relations between distinct entities. Space would derive its definite character through the relatedness between entities and thus their relative position in space was of profound consequence to space being produced through their relatedness. With seeing space as relative in this way geography could emerge as a spatial science and make a break with its earlier chorological connotations. Most Anglo-American post-war geography takes its point of departure from the repudiation of absolute space and the affirmation of relative space with numerous theoretical strands emerging, that in its basis seek inspiration from the relativisation of entities creating space as the relations between them (Doel, 1999, p. 136). Broadly speaking these theoretical strands view space as the relations between entities, which can either be individuals or structures of society or environment. These relations were given explanatory power through the way in which they were differentially constituted through the location and dynamics of structures and entities holding a relative position to each other in space. Hence geography became a positivistic discipline, with modelling becoming the main tenet of quantitative geography as a spatial science in earlier 20th century.³ Geography would explore the role relations as space play in various forms of social relations, such as innovation diffusion and spatial patterns of interaction that were based on relations.

It is within the theoretical landscape of unpacking spatial patterns of interaction that time-geography emerges as originally formulated by Torsten Hägerstrand. In what follows I would like to explain time-geography, as outlined by Hägerstrand (1973, 1975, 1984, 1987) and as worked with by later theorists (such as Kellerman 1989; Pred 1977, 1981; Raper, 2000; Raper and Livingstone, 2001), as an example of a basic holistic mapping of

³ The most famed of these models were those of location theory manifest in the rings of von Thünen and Weber's isodapanes of industrial location; these were though no strangers to social theory and fed into social debates at the time (Gregory and Urry, 1985). In urban geography the Chicago school can be seen as an example of ecological determinism (Simonsen, 1996, 1999).

space as relations created through relativisation. Time-geography builds on Hägerstrand's own work on innovation diffusion (1967), which was primarily a quantitative, chorological geographical information system. Time-geography as developed in Hägerstrand's later work in the 1970s provided a method of addressing what was seen as the neglected social aspect of diffusion modelling through mapping individual behaviour in space and at the same time shifting the focus from aggregate data to subjects (see Gregory, 1985). Focusing time-geography on the subject, built on the basis of spatio-scientific diffusion modelling, Hägerstrand addresses the empirical and spatially simple modelling of diffusion manifest in the models of von Thünen's and Weberian location theory. He began developing a three dimensional model of individual behaviour, depicting movements of individuals in time and space, where three-dimensional space was collapsed into two and the third used for time. These movements of individuals became *paths* that would wiggle their way through the model depicted in figure I.2 below.

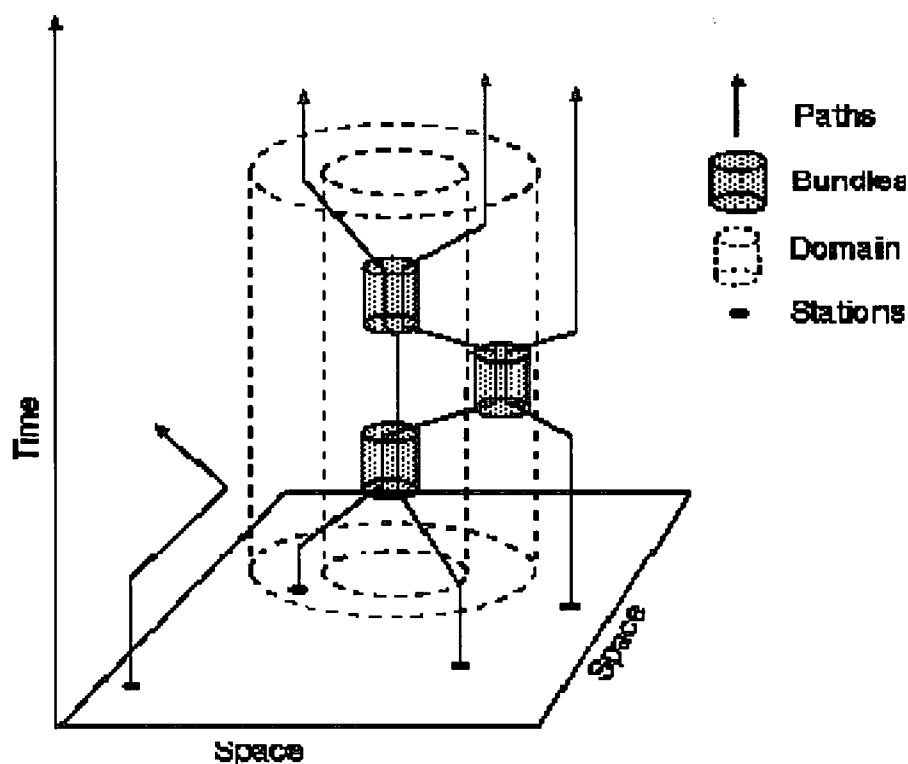

Figure I.2: Time-geography Diagram.

Source: adapted from Gregory (1994, p. 116)

His aim was a holistic mapping of relations, getting beyond the empirical tradition of classification of entities through taking them out of their spatial context. With his focus on individual paths through time and space, time for him becomes more than a line in space and became the interlacing of space through relations or: “the ‘momentary thereness’ of things in a constant and competitive flow of ‘interrelated presences and absences’” (Gregory, 1994, p. 117 quoting from Hägerstrand, 1984). His aspiration was to map the individual subject’s movement through time and space without losing track of the subject’s individuality and how that individual is always in competition for space, time and material. Giddens (1985, p. 266) characterises the Hägerstrandian notion of time-geography as being based on three fundamental elements. Firstly, the indivisibility of entities in space, secondly, the finitude of the subject’s life span and thus how time is a resource for the subject. Thirdly, the turn taking of tasks by the subject who is incapable of doing more than one thing at a time with each task taking a certain amount of time. Thus time-geography, as put forth here, involves an abstract physical realism that builds on the concreteness of the material context. In the words of Giddens (1985) time-geography is:

“concerned with the infrastructural constraints that shape the routines of day-to-day life, and shares with structuration theory an emphasis upon the significance of the practical character of daily activities, in circumstances where individuals are co-present with one another, for the constitution of social conduct” (p. 269).

These infrastructural constraints can best be put in Hägerstrand’s (1984) own words:

“When people and things are present together they have to do with each other and stand in proportion and power relations to each other in ways which cannot possibly be deduced from scientific laws” (p. 376).

To keep track of the individual he saw the paths as emanating from *stations* that are points in space, such as the home, workplace or a restaurant. The paths coalesce in certain places where there are resources for, and constraints to, human action depending on what is present or absent in the situation where the coalescence takes place, but these places Hägerstrand referred to as *bundles* and *domains*. At play in the coalescing paths are power relations as people have different access to materials to form their paths, with only

time imposing constraints on everyone (Hägerstrand, 1984). Where these paths coalesce and interact, the interaction is not only social, between the individuals forming different paths, but is also with the material setting. In the bundles the subjects' interaction with their surrounding social and material world is one of association with entities and subjects in a certain settings of interaction. These bundles form over time and represent a texture of paths having a complicated structure. Hägerstrand (1978) explains domains as:

“a specific kind of social construct brought into being in order to secure a certain amount of order and predictability in human affairs...[it] refers to the intricate lattice of earthbound spatial units in which specified individuals or groups have socially recognised rights to exert control” (p. 124).

The bundles and domains both share a depiction as a texture of paths, interwoven from indivisible objects of the physical world, divisible materials of economic and social production and other subjects' paths. The bundles and domains channel the paths, the paths that in themselves represent the material relations an individual has with the environment.

The key notion of time-geography as formulated by Hägerstrand is that movement in space is also movement in time, and is characterised in time-geography as individual paths that are referred to as individual time-space trajectories. These are always individual since no two entities can occupy the same space simultaneously (Holt-Jensen, 1999). On the other hand Hägerstrand did not elaborate on the material relations an individual has with the environment; Hägerstrand's concern was only with mapping the routines of everyday life in order to pin-point the infrastructural constraints upon the practical character of everyday life. For Hägerstrand the social world is explicitly material, material in the sense that everything social has a material grounding or physical extension. For Hägerstrand everyday life relies on a series of material transportation, e.g. we ride a train or a bus to get to work and our food is carried by trucks into a supermarket where we do the shopping. All these transportation processes are in order to maintain everyday life. His aspiration was to create a clearly legible frame of reference for these material processes that could then be the 'meeting ground' for various social theories. But more importantly, through his frame, these theories would be inevitably tied to space and

the creation of space. For Hägerstrand space is a consequence of the materiality of human practice (Carlstein *et.al.* 1978; Gregory, 1994; Gren, 1994).

Time-geography here served as an example of a relational understanding of space derived from its relativisation and an original attempt at tying social action to space. Hägerstrand's aspiration was to create a legible frame of reference for relational space that could serve further social theorisation. Hence Hägerstrand's formulation is not only limited in respect to the individuals' material relations to their environment but also in analysing what occurs in the bundles and domains, i.e. within the realms of interaction. It is within the bundles and domains where the weaving of individual time-space trajectories happens or where the relationality of entities is played out and most importantly sediments to form the context for further action. In order to give an idea of what might be occurring in these realms of interaction I will start with a focus on *structuration theory* drawing parallels between the bundles and domains and Giddens' *locale* but mainly illustrate the notion through Bourdieu's idea of *habitus* as it has been much more extensively deployed in research.

1.2 Relational Space and Structuration Theory

Spatial modelling based on relative notions of space as outlined above received their first critique in geography with Harvey's (1969) book *Explanation in Geography* and chimes the first revolution in geography according to Doel (1999, p. 123). In that book Harvey claims that prior research in geography, be it of the chorological vein or as spatial science of modelling, were both burdened with an absolutist notion of space as neither gave space any causal powers. The other strand of critique to emerge around the same time was that of Transcendental Realism (see Bhaskar, 1975) and had similar aspirations as Harvey; uncovering causal mechanisms behind our perceptions, all in an effort to make geography hold on to a predictive potential that was also the aim of the spatial science being criticised (Entrikin, 1991). Here I will not detail further the numerous theories that came as a response to geography as a positivistic spatial science, as that is done at length elsewhere (see Cloke *et.al.* 1991; Gregory, 1994; Holloway *et.al.* 2003; Holt-Jensen, 1999; Livingstone, 1992; Peet, 1998; Stoddard, 1986; Unwin, 1992). Rather, in what

follows, I would like to carry the discussion further with reference to two 'post-positivistic' theories. On the one hand I will shortly outline the theory of structuration as put forth in Anglophone geography by Anthony Giddens (Cloke *et. al.* 1991; Holt-Jensen, 1999; Painter, 2000; Peet, 1998), On the other hand I will mainly work through Pierre Bourdieu and his concept of *habitus* as that concept will serve in subsequent parts of the thesis dealing with practice more specifically.

My point of departure is thus from the advent of these strands of post-positivist humanistic thought that draw on phenomenological thinking and adopted the relational notion of space (Crang and Thrift, 2000; Peet, 1998). These humanistic theories have in common seeing relations as *produced* by the interaction of entities and thus not simply being the relative space between entities. These entities exist in relations with other entities and the relations these entities form generate space. It is through these entities constituting the relations between them through interaction, that space is created and thus a focus on how these entities interact heeds the warning of Massey (1992) that any pursuit of an autonomous sphere of the spatial that would explain relations, processes and distributions in space is flawed from the very start.

1.2.1 Structuration Theory

Structuration theory originates in the late 70s and early 80s from the efforts of making room for the subject in the generation of relations that produce space (Giddens, 1984). The theory aims to work beyond the then prominent debate that raged over if it was structure that dominated the generation of relations or the subject's intentionality and free will. Structuration theory gave the subject a role but without falling wholly pray to either, voluntarism of individual free will guiding interaction generative of relations, or the determinism of structure dictating interactions generative of relations. Not only that, structuration theory explicitly links space and time to social practice and action (Giddens, 1985) and works to theorise how change and the generation of new spatial relations might occur (Gregory and Urry, 1985). Structuration relies on a view that the subject's conception of space arises from a prior objective space already structured by former practices that then structure the practices that alter the contemporary space.

Structuration theory as most prominently advocated by Anthony Giddens is based on a realist approach to the world, seeing subject's actions as informed by a world already there but constantly subjected to change by that very same subject's actions (Cloke *et.al.*, 1991; Gregory and Urry, 1985). Realism as defined by Holt-Jensen (1999) is:

“a philosophy of science that uses abstraction to identify the *necessary* causal powers and the conditionalities of the structures that are realized under specific *contingent* conditions. Realism occupies a position between classical empiricism and transcendental idealism... realism seeks to recover the connections between different dimensional domains in order to identify the relations between structures, mechanisms and events” (p. 225, emphasis original).

There is an echo of Whitehead (see p. 21) in this quote, with the notion of contingency, i.e. the idea that the constitution of structures is dependant on the fulfilment of certain place specific conditions. The notion of contingency relates to a debate already started in geography in the 1980s with the attempts to ‘space the subject’ through practice, fulfilling place-specific conditions constitutive of social structures (Pred, 1984; Thrift, 1983). These debates drew inspiration from and built on structuration theory (see Gregory, 1994; Pred, 1981, 1983, 1984; Thrift, 1983, 1995, 1996; Urry, 1985). Drawing parallels between structuration theory and realism structure's determination is dissipated through the tripartite notion of structure, mechanism and events. Here structure refers to the *objective* world, i.e. space as the relations already generated and having sedimented as the structure or context for generation of relations. This structure shapes events in society through mediating mechanisms bringing about events that adjust the structure. The structure as it is used in this realist notion is interdependent to the fulfilment of events and the structuring of those very same events, thus contingent to them. Through realism the theory of structuration holds a certain degree of strategic abstraction to be able to identify structures or givens that are either reflexively or unquestionably adopted by actors and deployed in their everyday actions. In the words of Urry (1985):

“The view of the social world being sustained here – that it comprises a number of interdependent, mutually modifying, four-dimensional, space-time entities – means that we are confronted with a peculiarly complex ‘open system’” (p. 28).

It is this 'open system' that the theory of structuration is built upon when formulated by Giddens (1979, 1984).

The realist tripartite notion of structure, mechanism and event is Giddens' (1984) 'duality of structure' which entails structure, as a set of rules and resources that the subject has incomplete access to in the conduct of practice. Access is incomplete due to the intervening systems (mechanisms) that are the ways in which subjects interact with the structure of rules and resources. These systems through which subjects interact with the structures of rules and resources sediment in institutions and become the context for the subjects making all events contingent to the sedimentation that is place specific. Institutions are thus the mediators of action and are themselves the sedimentation of former actions and routines that then created them as the systems they now stand for. Thus Giddens (1984) argues for institutions being a kind of instantiated 'modalities', i.e. nodes where rules and resources are instituted by capable subjects (Peet, 1998).

In sum: the way in which Giddens gets around the dualism of structure and agency is by recognising the implication of structure in every moment of action hence duality replaces dualism, building on Giddens' prior work (see Giddens, 1976). What is combined herein is a fundamentally phenomenological notion of 'practical consciousness' with notions of transcendental idealism, i.e. that subjects' engagement with the world is conscious, reflexive and goal oriented towards the ideals the subject has on what it wants the world to be, but within the constraints of that world as it is. The success of structuration theory was in bridging structure and agency, making a coherent language and theory that demonstrated the interpenetrating nature of the two via the 'duality of structure'. Giddens' theory is consciously pragmatic in the sense of recognising its own practical utility and limitations thereto as it strives to bridge abstract notions with contextualised everyday knowledge (Gregory, 1994; Thrift, 1996). On the other hand, being so consciously pragmatic, it is reductive to the role of the subject seeing it as rational, conscious and reflexive.

But also, and more importantly as it constitutes the link made above with time-geography, by bridging the two extremes of the structure/agency dualism through place contingent mechanisms of interaction, emphasis is put on the temporal and spatial setting action unfolds in. Thus it is recognised with this theory that all action takes guidance from the time in place and the place itself; space has been endowed with causal powers. Giddens explicitly formulates this contextual notion of action with the concept of *locale* and thus makes structure contingent to its reproduction. The spatial anchoring of structuration theory as put by Giddens (1985) is:

“the positioning of the body in time-space, the nature of interactions in situations of co-presence, and the connection between these and ‘absent’ influences relevant to the characterisation and explanation of social conduct” (p. 292).

The theory of structuration as advocated by Giddens was much in fashion in the 1980s (see Agnew, 1988; Gregory and Urry, 1985) but in later days it is mainly being worked through neo-Marxist approach to social analysis (see Glassman, 2003; Parker, 2001). Giddens in later years has devoted himself much more to the modern everyday political agenda becoming an advisor to New Labour (see Giddens, 2003). Giddens indicates the role of the body in time-space in the above quote, but does not work with that role any closer but also, apart from his notion of locale there is very little explicit spatial reference in his work. To address these lacks I turn to the second structuration theorist I want to outline, Pierre Bourdieu (Thrift, 1983).

Of significance to the themes of this thesis, Painter has (2000) claimed “Bourdieu’s work has the potential to provide a very rich source of ideas on space and spatiality” (p. 253). For this reason I take him up rather than Giddens but also, on top of his arguably more recent relevance and prominence (see e.g. Agnew, 1995; Boyne, 2002; Crossley, 2001; Hillier and Rooksby, 2002; McNay, 1999; McRobbie, 2002; Nash, 2003; Robbins, 2002; Schinkel, 2003; Swartz, 2002, 2003; Sweetman, 2003, plus *Cultural Studies* (2003, Vol. 17, nr. ¾), *Theory and Society* (2003, Vol. 32, nr. 5/6) and *Space and Culture* (2003, Vol. 6, nr. 1)), I will maintain that Bourdieu held a more nuanced approach than Giddens to the theory of structuration, especially to the role of the body, which will be of relevance to later parts of the thesis.

1.3 Social Practice in Relational Space

In the following I will outline Bourdieu's 'theory of practice', which centres on the notion of *habitus* (Bourdieu, 1990). The concept of *habitus* is derived from Bourdieu's methodology premised on a rationalist epistemology, stating that theory can only be derived from practice (Robbins, 2002; Schinkel, 2003). Bourdieu's central motivation, like that of Giddens' outlined above, was to challenge what he saw as misleading dichotomies, dichotomies where difference is constituted in absolute, irreducible oppositions. He advocated a dialectical view, seeing difference as contradiction generative of solutions.⁴ The central mediating concept or intervening mechanism in realism's terms, and key to Bourdieu's theory of practice, is the concept of *habitus* and reflects Bourdieu's dialectical view as it refers to the subject's incremental internalisation of objective structures or how the subject adjusts to the particular situations under which action is constituted. The dialectic backbone of the *habitus* allows for the coherence and regularity within human practice but at the same time allowing for the negotiated and strategic nature of human practice (Crossley, 2001). The internalised objective structures are the *habitus*, while the objective structures themselves he refers to as 'fields' and 'capital' of various kinds (Bourdieu, 1990, 1998). The concept of *habitus* thus makes for a structured theory of practice, which connects structure (the objective) and agency (the subjective) in a dialectical relationship between culture, structure and power.

1.3.1 The embodiment of *habitus*

The concept of *habitus* is drawn from the idea of habits as being social practices that maintain the social structures that then orient and contextualise later actions. With his refusal to reduce the agent to neither the epiphenomena of social structures nor the narrow rationalism of agent's social practices and actions, Bourdieu collapses the dichotomy of structure and agency and highlights "codes of spatial performance in the context of social situations" (Robbins, 2002; Shields, 1991, p. 37). Through *habitus* he argues for the incorporation of objective structures in the agent, stating how the mind and

⁴ The notion of dialectics will be unpacked at length in part II. For the purpose of this part this short definition will suffice.

the body work in concert, that becomes then the concert of agency and structure, making for his notions of embodiment. The subject's actions are thus made "through a complex process of experience [of the structure at hand] and incremental adjustment [to that same structure]" (Shields, 1991, p. 32). *Habitus* is thus a mediator conferring certain objective conditions onto subjects as they are engaged in improvising practices later informing and adjusting the same mediating structure. Thus the *habitus* orients actions and events and is at the same time generative of the conditions under which the orientation takes place (Hillier and Rooksby, 2002; Noble and Watkins, 2003; Painter, 2000; Shields, 1991; Thrift, 1996).

For the subject the objective structures or conditions for action are what Bourdieu (1990) calls structured dispositions that become ingrained in the subject's body and form a basis for action generative of future actions and events setting the context for further action. In Bourdieu's notion of structured dispositions one can identify Giddens' 'duality of structure' therefore he has been placed by most theorists under the banner of structuration theory (Cloke *et.al.* 1991, p. 95; Gregory, 1994, p. 407; Peet, 1998, p. 154; Thrift, 1983, p. 27). The ingraining of the structured dispositions that is generated by and generative of social structures produce what Bourdieu (1998) defines as:

"the habitus [, a] generative and unifying principle which retranslates the intrinsic and relational characteristics of a position into a unitary lifestyle, that is, a unitary set of choices of persons, goods, practices" (p. 8)

The most frequently cited definition of the term comes from Bourdieu (1990):

"The conditions associated with a particular class of conditions of existence produce *habitus*, systems of durable, transposable dispositions, structured structures, that is, as principles which generate and organize practices and representations that can be objectively adapted to their outcomes without presupposing a conscious aiming at ends or an express mastery of the operations necessary in order to attain them" (p. 53).

Habitus is thus differentiated and differentiating, i.e. differentiated in terms of being composed of systems of durable and transposable dispositions and differentiating as it generates and organises practices and representations that then inform the differentiated *habitus*. The *habitus* is thus a generative principle of distinct and distinctive practices that

unfold in a social world that becomes one with the agent allowing for their freedom but within constraints. So subjects are active and endowed with the practical sense of *habitus* that thus gives them a certain 'feel for the game' as Bourdieu (1998) calls it, there is thus a certain notion of embodiment explicit in *habitus*.

1.3.2 The role of the body, *habitus* in action

With the above conceptualisation of *habitus* and the definitions arrived at it is evident that Bourdieu's emphasis was on the body and it is on those terms that most recent theorists have taken his *habitus* up. Here I pick up on Bourdieu's less reductive stance to the subject, as compared to Giddens who primarily saw the subject as a reflexive agent, and explain the *habitus* through the acting body of the subject. According to Bourdieu (1990) subjects go about their everyday practice by orchestrating, without necessarily organizing, their surroundings, incrementally internalising as bodily dispositions that which is around them, adjusting to it and then enacting their surroundings through the body. The body as *habitus* is thus lodged into an arrangement of practices that subjects have already maintained and enacted (Pryke, 2003; Shields, 1991). Hence it becomes in the words of Crossley (2001):

"the practical-social basis for innovative and improvised action. It consists of forms of competence, skill, and multi-track dispositions, rather than fixed and mechanical blueprints for action" (p. 88).

Through the use of words like skills, competence and dispositions the focus is on what the body of the subject does and is also indicated with the simple origin of the concept in the verb *habit*.⁵ As already stated, by turning to the body, informed by phenomenology (see Nash, 2003), Bourdieu managed to escape reducing the subject to either structure or free agency and thus to some kind of transparent self presence and control. He brings in practical sense specific to the place in which the subject acts through the body at each moment. The subject, through the mediation of the *habitus* is decentred and socialized. Following on Schinkel (2003) adds that the notion of the body as *habitus* is especially effective as it works on levels below the reach of introspective thought and that of the will (see also Noble and Watkins, 2003). Bourdieu (1998) claims that cognitive

⁵ Although Bourdieu is not keen to trace the word to that root (see Noble and Watkins, 2003).

reckoning with the world is an objective structure *already* applied to the dispositions of the body. Hence what attaches us to objective structures is a tacit or immediate pre-reflexive agreement between the objective and incorporated structures. This pre-reflexive agreement relies on the *habitus* to be understood as layers of embodied experiences and not immediately open to self-fashioning, i.e. mediation through the rational action of a reflexive subject (Bourdieu, 1998; Hillier and Rooksby, 2002; Sweetman, 2003). This self-fashioning is not immediately amenable as modification of the *habitus* can only take place through a practical mimesis, i.e. a kind of subconscious imitation of objective structures and action unfolding around the subject, thus *habitus* is dynamic (McNay, 1999) but lacking in intentionality. Fleshing out enactment of the objective world through practical mimesis and giving no space for intentionality Bourdieu's turn to the body was vague, seeing it as a site of precognitive social exchange and adjustments through experience (Widick, 2003). A problem with Bourdieu's theorisation is that he does not combine this nuanced outline of preconscious embodiment with intentionality and cognitive reflection upon social structures and institutions and hence the 'tantalising' vagueness, as Shields (1991) puts it (p. 33). But as stated, for Bourdieu (1998) cognitive reckoning is already an acquired disposition. Adding an intentional body-subject to the concept of *habitus* it could avoid being likened to a mechanical self-perpetuating habit⁶ (Noble and Watkins, 2003), but *habitus* as mechanical self-perpetuating habit indicates the other problem with Bourdieu's theorisation, i.e. he does not elaborate on the ways in which the incorporation of objective structures and practical mimesis takes place. Bourdieu (1990) merely states that:

"the habitus is an infinite capacity for generating products-thoughts, perceptions, expressions and actions – whose limits are set by the historically and socially situated conditions of its production, the conditioned and conditional freedom it provides is as remote from creation of unpredictable novelty as it is from simple mechanical reproduction of the original conditioning" (p. 55).

How does this 'embodied unconscious' (Thrift, 1996, p. 15) actually adjust and change (Hillier and Rooksby, 2002; Noble and Watkins, 2003)?

⁶ Bourdieu has been criticised for the alleged deterministic slant to his *habitus* concept (see Jenkins, 1992).

Bourdieu (2002) himself claims this metaphor of the mechanical self-perpetuating habit is a misrecognition of his work; *habitus* is a product of history and can thus be changed by history. He claims that when dispositions encounter conditions different from those in which they were constructed there is a dialectical confrontation between *habitus* and the confronted objective structure. So change occurs but only within the limits of the previously generated structure, this *habitus* is not a fate but a destiny (p. 29). The central critique of the *habitus* revolves around how immutable⁷ it seems as Bourdieu was not explicit on the means of incorporation by the unconscious body, except from the notion of practical mimesis. As the *habitus* refers to one's sense of place and role in the lived environment, as it works primarily below the cognitive, then all reaction to a situation is an intuitive practical reaction based on experience. This precognitive level of intuitive practical action develops over time through the incremental ingraining of experience and thus is *habitus*. By basing the concept in precognitive experience the only way the *habitus* is open to change is through the encountering of other different ways of doing, i.e. other forms of *habitus*, as there is no specific way of determining change from within or any kind of plasticity to the notion itself (Gregory, 1994). This leads to the *habitus*' determination of subject's actions; at least it is difficult to see how individual actors can transcend this particular frame of preconscious mediation (Noble and Watkins, 2003; Shields, 1991). Bourdieu (1990) himself outlines this determination in terms of 'reasonable' and 'common-sense' behaviours:

“being the product of a particular class of objective regularities, the *habitus* tends to generate all the 'reasonable', 'common-sense', behaviours (and only these) which are possible within the limits of these regularities, and which are likely to be positively sanctioned because they are objectively adjusted to the logic characteristic of a particular field, whose objective future they anticipate” (p. 55-56).

The *habitus* as 'embodied unconscious', as defined above, cannot but uncritically generate and re-produce the 'commonsensical' in each situation, as the *habitus* precognitively tends to favour experiences likely to reinforce it (Bourdieu, 1990, p. 61).

⁷ Although there seems to be a division in the literature between what I would call 'pessimistic' and 'optimistic' views on this immutability. The pessimistic view outlined by McNay (1999) who uses the immutability to demonstrate how hard it is to dislodge certain ingrained dispositions when it comes to

Thus Bourdieu only perceives of change in the form of confirmation or reinforcement, i.e. the incremental rather than transformative thus:

“The *habitus* is the principle of a selective perception of the indices tending to confirm and reinforce rather than transform it, a matrix generating responses adapted in advance to all objective conditions identical to or homologous with the (past) conditions of its production; it adjusts itself to a probable future which it anticipates and helps bring about because it reads it directly in the present of a presumed world, the only one it can ever know” (p. 64).

Bourdieu (1998) thus claims that agents in general may indeed engage in reasonable forms of behaviour without being rational. Their behaviour might thus be explainable through rationality but it does not have to rely on reason or explicit reasoning. Bourdieu (1998) goes on to claim that lodging the accounts of practice in consciousness is the most serious epistemological mistake of the human sciences (p. 133), thus falling prey to structuralism by creating a rationality without a subject (Boyne, 2002, p. 121).

The *habitus* as embodied unconscious is thus a determining mediating screen of experience and doing and as Shield (1991) claims: “Any number of mediating screens still fails to solve the dilemma of [this] determinism; fails to deal with the problem of causal determinism” (p. 34) or the “after-so because fallacy” (p. 37). The fallacy is best clarified by the use of *habitus* itself; since it exists it is the cause of the everyday practices it was supposed to explain. Crossley (2001) explains that Bourdieu’s attempt to get out of the circular logic implicit in the above is by emphasising the perpetual motion of this seemingly tautological cycle. Hence Bourdieu (1990) introduces endless time as central to the *habitus* and its development, with each *habitus* unique saying that:

“The principle of the difference between individual *habitus* lies in the singularity of their social trajectories, to which there correspond series of chronologically ordered determinations that are mutually irreducible to each other” (p. 60).

Bourdieu explains well how social and objective structures are embodied but not really how they can be modified apart from unconscious incremental adjustments through mimesis and encountering other ways of doing. Bourdieu’s body is the centre for the

gender identities. The optimistic view, seen in Noble and Watkins (2003), emphasises what needs to be done to dislodge the immutability itself.

accumulation of acquired habits and somatic tactics that provide the tools, which shape and acquire future tactics and habits. So although the body as *habitus* is a dynamic centre of social relations incrementally changing and adapting over time, there is a lack of a clearer notion of the body and embodiment, i.e. what a body can do especially with regards to novelty and how it is spatial in its doing (Hillier and Rooksby, 2002; Low, 2003).

1.3.3 The spatial

Evident in the above is the main weakness of *habitus*, i.e. explaining the subject as a spatial being, and is the one of most consequence in this thesis. My aim is to explore the concept's potential for ideas on space, claimed by Painter (2000), building on earlier attempts found in Mohanty (2000) and Shields (1991). There they add a spatial dimension to a body-subject with intentionality inherent in its acting, creating what Shields (1991) terms 'social spatialisation' (p. 31) or the way in which certain places play a role in the formulation of *habitus*.

The only explicit reference to space and the spatial in Bourdieu's own work is to be found in his concept of the 'field' that is an integral feature of understanding the dynamics of *habitus*. But this concept is a mere metaphor and does not lend itself to analysis through having any causal powers, as Painter (2000) argues; Bourdieu's understanding and analysis of space would not be acceptable to most human geographers today as the 'field' seems to be interpreted merely in terms of distance, distributions and arrangements. The field is a relatively autonomous network of objective relations between positions, lacking an explicit role for the mediating role of the body (Bielik-Robson, 2000; McNay, 1999; Thrift, 1996). Bourdieu (1998) defines the 'field' as the space of relations of power between, on the one hand actors differently endowed with various kind of capital ingrained as their *habitus*, and on the other objective structures, e.g. in the form of institutions and mechanisms. These objective structures are the culmination of a process of concentration of different species of capital (be it cultural, as in an art gallery, social, as in various political institutions or money as in the stock market or business institutions) that thus create a certain power differential in a field in which

agents struggle for their perspective place in the objective structures. In his notion of the field he is thus spatial, breaking with any absolutist notions of space, as the objective structures of the field are at one with the agent through the embodiment of the *habitus*, but lacking in explaining how space itself in the form of objective structures and relations acts on and through the body.

The relational nature of the field is a social space, in which agents and structures such as institutions form relations that maintain and produce this social space. To grasp the forces at play one needs to map the distribution of the kind of capital that is effective in each field. Through this map the field becomes theorised in a constant state of temporal dynamic tension as the agents struggle for their positions. There is thus a 'power geometry' (Massey, 1993, 1997) to each field that can be unpacked when viewing it as relational, in order to see the forces at play in that social space. But being of a mere metaphorical nature the notion of field has the consequence of having subjectivist approaches to human action resurface as they might be conceptualised as 'players in the field' (Painter, 2000). The field is a relational one where subjects act on the grounds of their *habitus* modifying the field and at the same time modified by it through time, but how is not explained in any sense in Bourdieu, merely how one *habitus* can change or be changed by another, albeit that is also limited as argued above. For the purpose of this part of the thesis I would like to draw out that *habitus*, by being neither reducible to objective structures nor the intentionality of actors, transcends that classical duality. Furthermore *habitus* does make room for embodiment through the incremental ingraining of dispositions informed by the objective structures, albeit primarily on the level of the unconscious.⁸ But most importantly for this part of the thesis, these objective structures are *earlier sedimented social practices* themselves that inform the ongoing engagement within the 'power geometry' of the field, which I will demonstrate in chapter 3.

⁸ I refer to McNay (1999) who, through working with Bourdieu, claims the *habitus* to be in certain aspects a set of very deeply entrenched nature of certain dispositions that are only maintained as such by being on the level of the unconscious. As Bourdieu (1990) points out himself then *habitus* can continue to work long

1.4 Sedimented Time-space Trajectories as Concluding

The concept of time-space trajectories was earlier outlined through the work of Torsten Hägerstrand in its original formulation as time-geography paths. He originally formulated time-geography in the 1970s in collaboration with researchers at the department of geography at Lund University, Sweden. With the imagery produced from that work, fruitful combinations of time-geography and structuration started to emerge (see Carlstein *et.al.* 1978). Certainly Giddens (1984, 1985), through his notion of the *locale*, along with Thrift (1983, 1996) and Pred (1984, 1985), combined time-geography and the theory of structuration, although each author combines the two in different ways. They all argued though on the basis of the graphical representations of time-geography as making it possible to appreciate the place specific logic of structuration and thus saw place as central to the theory of structuration (Holt-Jensen, 1999). This place specific logic has been more recently exemplified by Chatterton (1999) who explicitly links the imagery of paths with Bourdieu and his *habitus* creating a network of routes and pathways through the city of Bristol between the social spaces that formulate the *habitus*, although adding more nuance to the spatiality of being through Shields (1991) and Massey (1993).

But Hägerstrand's paths are not mere lines in space they are "actions [that] become space-time trajectories of matter" (Gren, 1994, p. 85) as all human action has material and physical extensionality. Combined with *habitus*, that theorises how action comes to be in the body of the subject and how action plays out in combination with the already sedimented practices, I have set up a certain dialectical framework for engaging with and understanding the material setting that is space and the subject's interaction with it. Time-geography might never have been intended to be a social theory and any kind of adaptation to one might be flawed from the very start but that is why I choose to refer to it merely in order to excavate a certain imagery that is rich in geographic literature, but link it to *habitus* and the field in a first approach of spatialising the notion in order to get an idea about what is going on in Hägerstrand's bundles, domains and stations where these time-space trajectories coalesce. These points I view as sedimentations of practices,

after the objective conditions of its emergence are gone (p. 13) betraying the functionality of the concept with his very words.

but as indicated above, *habitus* sediments into objective structures that then inform its very constitution and as each *habitus* is a time-space trajectory, their sedimentation entails the sedimentation of time-space trajectories. As Gren (2001) succinctly noted, there is no one time-geography open for interpretation and adoption as such, but many time-geographies and thus I allow myself to merely appropriate the useful notion of path from this body of work without adopting it wholesale. The path as time-space trajectory combined with *habitus* can thus be used to expand Hägerstrand's notation system for space and thus heed Olsson (1981) who claims, countering the critique on the physical reductionism of the time-geography diagram:

“Notation was nevertheless his misunderstood gift: Concepts both for catching reality and for setting it free; walls both for containment and for climbing; musical scores for composer and performer alike. To read diagrams literally is therefore to thingify, while reading them metaphorically is to understand their double meaning. To read in order to know is too simple, for to read is not to describe the empirical world but to enter a hall of mirrors” (p. 123).

I will, in the following chapters, be entering the hall of mirrors that is the space of Festival Square with the imagery provided above of time-space trajectories sedimented in the form of objective structures that are embodied by and modified by *habitus*. In way of conclusion for this chapter I would like to summarise the above strands of thought in the words of Massey (2001a):

“if space-time is relational then the ‘nature’ of the phenomenon is itself a product of its spatio-temporal locality (meaning: position within an articulation of interrelations); *and also*: where the articulation of interrelations ‘produces’ the space. In other words spatio-temporal locality is an element in the constitution of difference, even where space-time is conceptualized as relational, precisely through the constitution of the ‘nature’ of phenomena” (p. 259-260, emphasis original).

So if space is generated from the relations that entities make in space already constituted by earlier relations, i.e. time-space trajectories either momentarily sedimented or in motion, I will ask what are those entities and what is it that they manifest? Which forces feed the dialectical generative machine that sediments as space through our embodiment of them as we live in the everyday and what is it that we experience and sense everyday as space? In the following I will list the forces at play in the ‘power geometry’

responsible for the structuration of the field and in chapter three I will list the manifestations of these forces in all their nuance and variation as the space constructing my *habitus* or lived experience of Festival Square.

I.2 Making Space

In this chapter I will introduce Festival Square in Edinburgh and focus on the context in which it and its surroundings, the Exchange site, were created. The idea is to map the objective social and economic structures which inform the structuration of that space as it was made originally and then recently remade, with reference to chapter I.1.2.1. These social and economic structures manifest throughout the chapter as reports, studies and references to minutes of various city council bodies. In this mapping I will place emphasis on two factors, firstly the socio-economic context of the city of Edinburgh that informed the planning policies that then informed the creation of the city's first public square to be built in almost 200 years. Secondly, emerging from this context is the design rationale or the square as it was envisioned by the architects, designers and planners. Thus what I intend to narrate is the socio-spatial history of Festival Square describing it from the perspective of the relations generated by objective structures informing the square's structuration, as exemplified by Eade (1997) in his work on London and the Docklands in particular.

In creating the narrative of Festival Square that will unfold below I cite the minutes of the Economic Development and Estates Committee (EDEC) of Edinburgh City Council, the Planning and Development Committee (PDC) of Edinburgh City Council along with archived letters and documents all relating to the development of Festival Square and the Exchange as a whole, that were found in Edinburgh's city archives and library. Through the much appreciated help of the city's Planning Department, I also cite any documents they had related to the socio-spatial history of the square. As Edinburgh is also a site of great architectural heritage, a context that could not be overlooked once creating a new space in that city, I found several references to the development in the major newspapers, *The Scotsman* and *The Evening News*, detailing the city's undertaking on the site of the old railway Goods Yard in the heart of Edinburgh and throughout the thesis I cite these. But also, as Edinburgh is so famed for its architecture, I found numerous publications about the architecture, design and planning of Edinburgh to date, such as from the *Edinburgh Architect and Design Council* (1994) and *Gifford* (1991). These and articles from the back issues of *The Architects Journal* and *The Journal of Architecture* will also

be cited. The redevelopment of the old Goods Yard site was not started until early 1980s and thus, when searching for references, I went no further back than 1970 as before then there was very little reason to believe that there were any references to the site of value. Along with this archival research I took interviews with people that had featured in those minutes and documents and came through as being key informants as their names came up on several occasions and/or were in important positions then and now. For a list of my informants I refer to Appendix A. What I have here outlined is what informs the narrative or socio-spatial mapping of Festival Square as it will unfold in this chapter, references will be made to the appropriate sources using the full name of interviewees, the date and abbreviated committee name of minutes, with documents and articles referenced in the usual way.

In order to contextualise the making of Festival Square in its socio-spatial history I will start with an outline of the economy and society that drove the change of a disused railway goods yard (Lothian Road Goods Yard) to the square as it was in its first manifestation. It is these changes which informed the overdetermination of function implicit in the design rational of the architects and designers that made and envisioned the square. After discussing the square in its first manifestation I will then move on to describing what prompted the change from its first manifestation to its second manifestation. Again in the same way I will talk about the general socio-economic context within the city that was the catalyst for this change and again elaborate on the design rational and the square as it was envisioned by the architects, designers and the planning authorities.

The chapter's discussion can also be seen within the context of the recent debate on urban regeneration in the UK manifest in the Urban Task Force (UTF) (1999), set up by the British Government in order to give policy guidelines for an Urban Renaissance in Britain. According to the UTF, cities in the UK have been subjected to a steady decline since the industrial revolution. In order to counter this decline they produced a report outlining the policies to be implemented for the regeneration of the urban in the United

Kingdom. UK cities evidently manifest poor design, economic dispersal and social polarisation. What the Task Force suggests is, in summary:

- 1) To give power to local governments to allocate public finance to attract the market and involve the public in planning and development. This is to be done through the establishment of Regional Investment Companies, Public/Private Partnerships (PPP) and Private Finance Initiatives (PFI).
- 2) Use of empty or disused spaces in the city (brownfield sites, see Waters, 1998) for development, i.e. to fill up holes in the urban fabric with well designed, useful buildings with suitable public spaces in between where people meet and congregate. Design of these sites should be compact, facilitating dense public transportation networks, with the aim of allocating 65% of public funding for transportation to pedestrian, cycle and public transport routes.

Overall they promote a holistic approach to city planning with sites being developed via masterplans that are assessable by the public. Here this report will not be dealt with as an engagement with the report exists in the book *Cities for the Many Not the Few* (Amin *et.al.* 2000) where the authors critique the report for not actually holding a holistic understanding of cities and who they are for, thus implying a lack of understanding in how to imagine the urban and urban citizenship (Amin and Thrift, 2002; Lees, 2004).

The Urban Task Force's report had implications in the city of Edinburgh, as in other UK cities and is surely one of the social factors informing the structuration of the square. Edinburgh has been faced with the decline of its centre, economic dispersal, as people move to the suburbs whence they commute by private car to the centre for work, and poor design manifest in 'holes in the ground' riddling the cityscape.

2.1 First Conundrum

To respond to the above mentioned problems Edinburgh has been mounting an effort to promote itself, building on its status as the capital of Scotland in recent years. The site upon which Festival Square stands is at the West End of Princes Street, between the West End and the Tollcross area, leading into the Old Town of Edinburgh, and the Georgian

New Town. The site was formerly the site of the Caledonian railway station and associated Lothian Road Goods Yards that was part of the railway line that links Edinburgh to the west of Scotland, mainly Glasgow and northern England. The Station was closed in 1965 in the first round of the so-called Beeching cuts where the railway authorities were addressing the decline in the use of railways, with increasing pressure from buses, trams and public car ownership, seeing the nearby Waverley station, as sufficient to serve this rail link. With the increase in public car ownership Edinburgh suffered from depopulation and urban sprawl and by the 1970s the city can be characterised as a motorcar city with most of its inhabitants living in suburbs and commuted by car to the inner city itself. This increase in public car ownership reflected the 1970s ethos of increasing car ownership and was thus actively facilitated through urban design (see Buchanan, 1971) by building roads to cope with this increase and subsequent commuting.

In general though the decline of the city centre of Edinburgh can be traced to the fact that no coherent town planning or concerted building efforts had been made in the city since the planning and building of the New Town developed by James Craig in 1767. This decline also coincides with the end of the Scottish Enlightenment, the decline of which started in 1828 (Edwards, 1993). This decline manifested as a steady deflation of the city's predominantly small manufacturing industrial base, especially with the large scale consolidation of industries in Scotland and UK in general. Through the decades the cityscape slowly but surely started to be riddled with 'holes in the ground', vacant or vacated sites and lots that are referred to as 'urban brown field sites'.

The particular 'hole in the ground' upon which Festival Square was to be built had never been part of the original plan of the New Town although lying adjacent to it and between it and the Old Town. Thus the site constituted a certain rift between "the haphazard charm of the Old Town [and] the discipline and elegance of the New Town" (The Edinburgh Development Group, 1988, p. 2). This rift had been maintained by the Caledonian Railway as they built their Princess Street West End station there, completed

in 1899 along with the station hotel, the now Caledonian-Hilton completed in 1903, and associated Lothian Road Goods Yards and railway lines.



Figure I.3: The Caledonian Railway Station and associated Goods Yards prior to closure 1965.

Source: Terry Farrell and Partners, Edinburgh.

The station and its associated Lothian Road Goods Yard and railway lines occupied a prime location in the heart of Edinburgh (see Figure I.3) and ideas for the site's redevelopment had been around for some time. In 1949 according to the Civic Survey made then (Town Council, 1949) the intention was to redevelop the plot from railway use. That first idea was to plan for modern housing with box-like, low-rise apartment buildings with plenty of open space that would provide a suitable setting for Usher Hall, one of the city's major performance space that had been completed across Lothian Road in 1914 and plays a major role, especially during the August Festival in Edinburgh (see Edinburgh Festival Fringe, 2003; Owl Leisure, 1989). The main idea though with this

redevelopment was to repair the split that the Caledonian Railway Station had maintained between the Old and the New Town of Edinburgh. Although the idea already in 1940 was to repair the split it was further maintained after the Station's closure by the West Approach Road (WAR) which was built through the site as a relief road in the spirit of the 1970s emphasis on facilitating the commuting of the public by private motorcar (Tobin, 2002). The building of the WAR through the site was a result of the land having been passed on from the railways to the local authorities with the closure of the Station and having been frozen for transportation considerations. All in all it was not until 1979 that the City approved of the complete re-development of the Station site and the associated Lothian Road Goods Yards. As a result the old Festival Square emerges as an element of that redevelopment and was set upon the site of the old Goods Yard as can be seen on figure I.4.

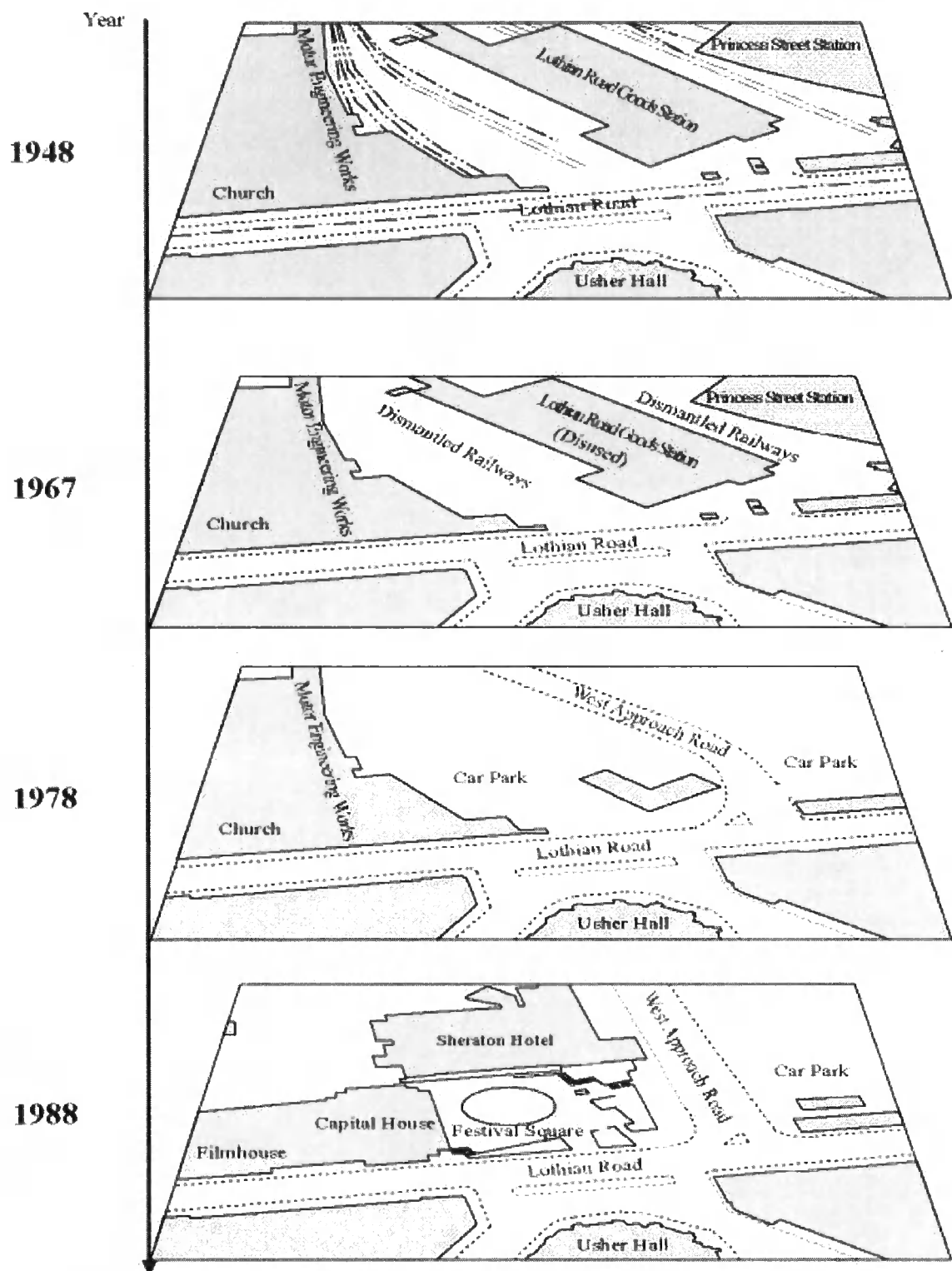

Figure I.4: The Site of Festival Square 1948-1988.
 Source: E. Huijbens, courtesy of the National Geodetic Survey.

2.1.1 Clearing for enclosure

The 1979 decision to clear up and re-develop the site coincided with a study published by the City Council on the feasibility of a proposed conference centre on Lothian Road. The study claims that Edinburgh had a stake in the national and international conference market but existing facilities were too small to house big conferences and also lacked exhibition space. Also recognized in the study was the lack of accommodation for guests to the city. The study claimed a broad consensus on the sensibility of developing a conference centre that could address the explosive growth in conferences world wide and put Edinburgh on the world conference map (Ian Banks and Associates, 1980). More reports and studies, commissioned by the city council, indicated growth in the service sector and visitor economy and it was claimed that therein lay the future of the city's economic prosperity. But dreams of a conference centre on the old Goods Yard site had to wait, as the first building to be built on the site was the Sheraton Hotel, addressing the projected growth in the visitor economy.

Edinburgh is a world heritage site and in the late 1970s and early 1980s one of the emphases of the planning authorities was on facilitating the growth of tourism so licences were being given to hotel development. Thus the first people to act on the above mentioned studies and the City Council's proposals to partake in the international conference market was Sheraton plc, now known as the Hotel Corporation of Edinburgh (HCE), a large family/privately owned property investor. They built the Sheraton Hotel on the site, which stands there to date, with the co-operation and approval of the city council. In 1983 the construction of the Sheraton Hotel, Edinburgh was started and by autumn 1984 it was completed. The hotel opened on the 3rd of January 1985, but the hotel was built on the agreement with the city council that they would make the hotel's environs attractive. The original Festival Square was thus explicitly designed as an "attractive frontage to the Hotel" (*The Scotsman*, 21/11 1984). The co-operation between the city council and the HCE was thus in order to redevelop the site completely and thus Sheraton plc was the private partner in the PPP in filling up that 'hole in the ground'. There can be no doubt about the role which the hotel played in creating the original square as, Douglas Sampson, the square's designer, of Derek Lovejoy and partners who

were the architects approached by the city council to make the original Festival Square, explained. Mr. Sampson elaborated in detail on how the square was oriented, with the main 'desire line' being from the busy junction of Lothian Road and the West Approach Road into the hotel without obstruction from any major feature. This 'desire line' was to be complemented by a secondary one, enhanced by a small water feature, towards Capital House (CH), a later building in the original scheme, from Rutland Square. Mr. Sampson also emphasised how the square was to be the hotel's aesthetically attractive frontage. Festival Square in its first manifestation was opened on 1st of May 1985, a few months later a second building was ready on the site, Capital House completed on the 2nd October 1985, a speculative project for an office building based on the same City Council studies indicating growth in financial services (see chapter I.3.1.3).

But in order to give a more detailed of the design rationales and their social and economic hinterland, structuring the square there is a need to go a bit further back in time than to the opening of the Sheraton hotel, the old square and CH. First reference made to the making of the square is in the guise of a 'civic square on the Lothian Road Goods Yard Site' and comes from the minutes of the PDC of the Edinburgh City Council (ECC). The reference is made 25/8 1982 where it is recommended that Douglas Sampson become the architect of the square. On a meeting of the PDC on the 16/6 1983 Mr. Sampson outlines his ideas, i.e. of a square sheltered from traffic, attracting people into an oasis-like enclosure that would serve the Sheraton as well as the public, this outline was agreed in principal by the PDC. Later, in a meeting on the 14/9 1983 the PDC decided to approve of the design and give the go-ahead for the building of the square so its completion would coincide with that of the surrounding buildings. Work was to commence at the start of the 1984-1985 fiscal year and take 7 months. But there was a delay due to two letters from the public that required the plans to be assessed by the Scottish Development Agency (SDA). Due to the concerns raised in these letters the SDA recommended that the planning be sent to the Secretary of State (21/12 1983). 14th of March 1984 the Secretary of State recommended that some of the planting should be removed and the paved area extended. This seemed to be the only thing standing in the way of the building of the square and the PDC tried to rush matters due to pressure from the District Council that

had made an agreement with the Sheraton developers that all landscaping would be complete before the opening of the hotel planned in December 1984. At a meeting 11/4 1984 a list of tenders was presented by the architects. Due to the savings recommended to meet the budget Mr. Sampson had to cut out integrated sculptures designed by Hamilton Finley that 'were to draw the Edinburgh Castle, terraced above to the East, into the square through the juxtaposition of a place of war and a humane place of social gatherings' (Douglas Sampson) along with smaller features such as benches and hedging.

With an agreement reached the construction of the square could now start in July 1984. The remaining main cost on the budget after changes made, and the major feature of the square, was a large circular display fountain in the middle of the square, one which in a meeting 10/10 1984 the PDC decided to ask the Sheraton and CH developers to help bear the cost of. Additionally the PDC decided to try to find some seating and sculptures through grants from the public and arts councils. But once the Sheraton Grand Opening took place only a few seats had been donated.

The naming of the square is also a feature of its design history indicative of different social emphasis. There were some different names used to refer to the square in early planning documents and in minutes of the PDC. The term Lothian Road Landscaped Square is originally used but after 13/6 1984 the square is referred to as Edinburgh's new civic space, the Civic Square or Plaza which is how it was talked of in all documents and drawings from Derek Lovejoy and Partners, the company Mr. Sampson worked for. As the square neared completion some competing names appear for the square: Connery Square, as Sean Connery was born nearby, Menuhin Square, in honour of the famous violinist who played in the Edinburgh Festival of 1964, and St. Cuthbert's Square, but 6/2 1985 the PDC settled on the name Festival Square in honour of and to reflect the Edinburgh Annual Festival, dating back to 1947.

This Festival being a major draw to the city it is not surprising that upon opening 1st of May 1985 the square was celebrated as 'Edinburgh's latest tourist attraction' (*The Scotsman* 2/5 1985). The opening ceremony was presided over by the Lord Provost, Rt.

Hon. Dr. John McKay and took place at 3pm in the afternoon, with the designers and contractors present. Edinburgh's city councillor Mr. Imrie introduced the Lord Provost to the designers and contractors involved and then introduced the Lord Provost in a short speech that emphasised the need to further develop the area to the North, in the direction of Rutland Square. Then the Lord Provost opened the square with a brief speech stressing the importance of the square for the city centre and for tourism and the public. He drew on the name and linked it firmly to the Edinburgh Festival and ended thanking all those involved in the construction, design and planning of the square. After the speech he unveiled a stone plaque with the opening date engraved upon; and as he walked into to the Sheraton, he turned and gave the sign for the display fountain to be set in motion; Edinburgh's first public space to be built in 200 years was now open.

The total cost of the square was £580.000, considered rather high but such concerns were countered by citing the elegance and quality of the square, since everything from seats, litterbins and lights were placed to enhance the design. The only thing that was not in place at the time of opening and was yet to be commissioned was a sculpture for the square but it was anticipated that this matter would be a lively public issue for the future, and that proved to be the case once the sculpture was placed on the square in early year 1986 (see chapter I.3.1.1).

The original intention behind developing the square was to counter the predominance of traffic enclosed Georgian Squares that are to be found in the centre of the city. In the end, as can be read from the above, the square was structured according to the social and economic emphasis on tourism and public access. It was the first civic square to be added to the city in 200 years and Douglas Sampson, the square's architect is quoted saying: "This square is designed to be used" (*The Scotsman* 7/5 1985), thus the square was envisioned as an oasis-like enclosure drawing in the public and sheltering them from the two flanking very busy trunk roads. The square had 40 trees planted along the edges in raised planters, a fountain in the centre shooting 40ft columns of water in the air and a sculpture in one corner. The designer and architect of the square Mr. Sampson was

pleased with it and applied for the award for Urban Renewal from the Royal Institution of Chartered Surveyors in 1991 with the support from the City Council.

Although the architect determined the square's function as one of use by the public and the visitors to the Sheraton, *The Scotsman* (24/8 1991) reveals a difference in opinions in a commentary sent in by Richard Pontet:

“...the only sign of human activity witnessed by this correspondent was the occasional scurry of suited gentlemen making a dash across the bleak terrain from an office building to rejoin the human race down Lothian Road”.

The commentary goes on to regret the lack of cafés, barrow vendors and street artists and cites this as the main reason for the square not being worthy of its name, suggesting Dead Square as an alternative. Although this is a rather harsh critique it resounds through interviews and comments made by those familiar with the old square. On top of critique of the non-use of the square Mr. Sampson himself suspected difficulty in the square's maintenance and as the circular water feature became a popular playground for local boys testing their courage by jumping to the island in the fountains basin, damage was done to it and litter started to accumulate. Graham Tully, a team leader in property development for the city council, cites the reasons for redevelopment being firstly the display fountain in the middle that was constantly subjected to vandalism and littering and secondly that the fountain simply took up too much space preventing use of the square. This was especially pronounced by the fact that the display fountain shot columns of water 40ft in the air, not suitable to Scotland's notorious weather of high winds, thus often forcing those coming from the offices of CH and guests from the Sheraton to take an even longer route round the fountain.

The old square, at its inception, was built in a very different planning environment. The existence of the two major trunk roads, the WAR to the north and Lothian Road flanking on the east, necessitated a design that would function as an enclosure, sheltering people from those busy roads (see Figure I.5 greyscale). In that effort high walled planters were raised on the perimeter with dense vegetation and steps led down into (on the SE side) and up to (on the NE and N side) the square. The visual inspiration was from the view to

Edinburgh Castle, terraced above and behind Usher Hall. As opposed to the earlier planned public space being a setting for the concert hall itself (see Town Council, 1949) this square was a setting for the hotel as “the geometry flowed from seeing that the castle and not UH had the major influence on [the square]” as Mr. Sampson put it. Although the ideal move would have been to take Lothian Road behind the Sheraton, that was not an option at the time as the emphasis was on facilitating traffic flows into the city. In addition, the space behind the Sheraton was designated for a huge parking lot that would serve people coming to the hotel and the city centre, making the square also function as a space that would greet people into Edinburgh city centre, coming from the West or the South. As elaborated on above this version of the square was being seen as “uninviting and not fulfilling its role” and as it got subject to increasing vandalism and littering, the council’s attitude towards it changed. The authorities aimed at turning the square, becoming an acclaimed notorious trouble spot on Lothian Road, into a new gateway serving the city’s new financial centre (*The Evening News* 26/1 1998).

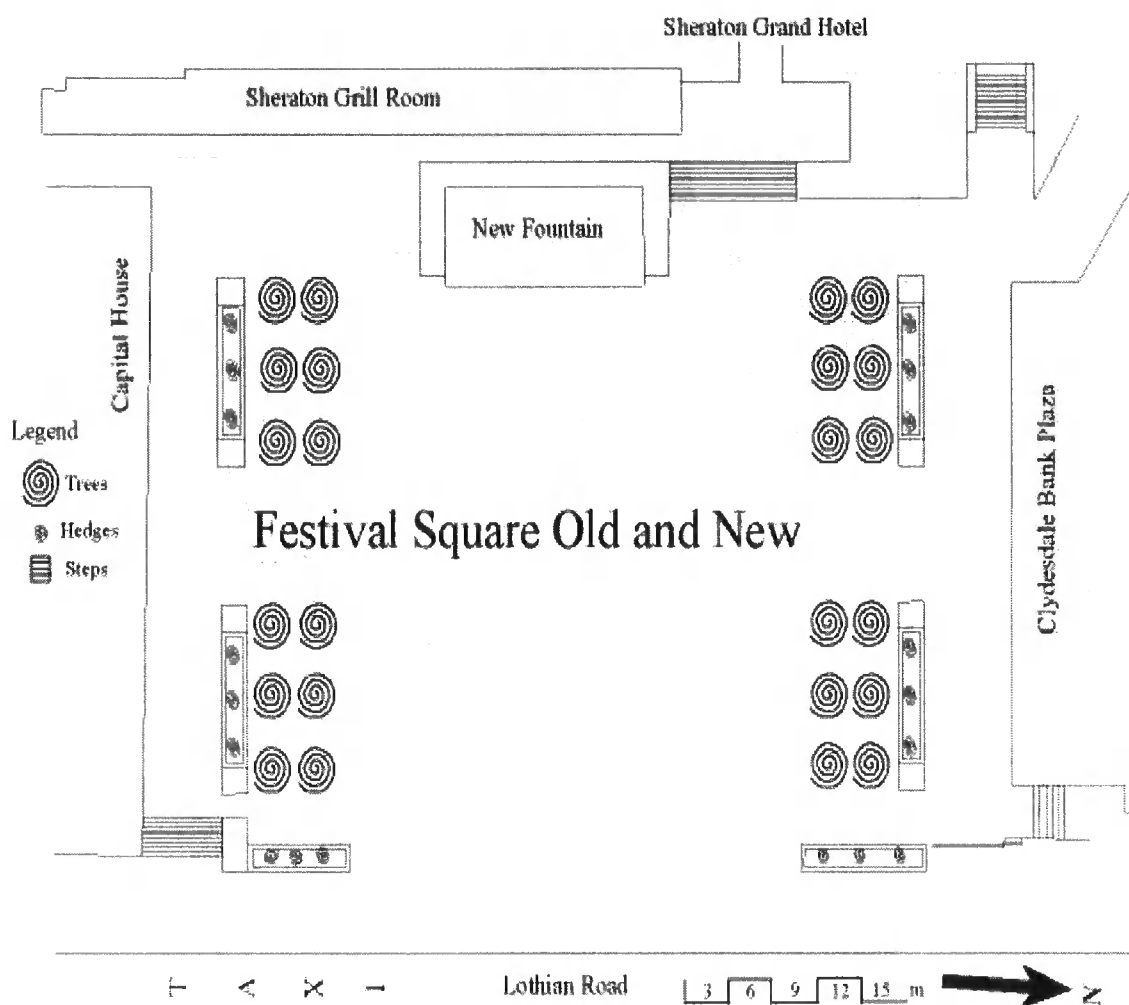

Figure I.5: Festival Square 1988 and today.

Source: E. Huijbens, courtesy of Ian White and Associates, Stirling and the National Geodetic Survey.

2.2 From Holes to Wholes

The old square was seen as uninviting and inadequate but not only by public opinion, there were other forces at play that eventually brought about the remake of the then 13-year-old square (see Figure I.5). Edinburgh was asserting itself as the capital of Scotland and as a financial centre in Europe only to be rivalled by London within the UK. So new developments were now not only to fill up ‘holes’ in the urban fabric to reinstate the urban continuity and address growth in tourism and financial services, but also to reinstate Edinburgh’s former glory as the nation’s capital and a capital city in Northern Europe. These forces underwrite the economic and social structures, structuring the remaking of the square and will be dealt with in more detail in chapter II.1 in terms of the

square itself. For now the focus will be on the socio-economic context of the city in general that brought about the square's remaking.

The outline of the socio-economic structures informing the redevelopment of the square starts in the context of the recession afflicting the UK economy through the 1980s. This recession was not felt as strongly in the Lothian region along with Scotland in general due to more successful economic reordering there compared to the rest of the UK. In the case of the Lothian region and Edinburgh in specific, this reordering was outlined in the 1985 Structure Plan for the Lothian region. The Structure Plan planned for investment in infrastructure with an emphasis on the city becoming an international centre for banking and finance that would be the city's way out of recession. The aim was to bring about an increase in employment and economic growth that would sustain the city till 2005 (The City of Edinburgh Council, 1985; Johnston, 1989). In subsequent reports the growth in employment in the financial sector is recognised and recorded and later projected to last till 2015 along with economic expansion (Lockhart, 2002; Lothian Regional Council, Department of Planning, 2000a; Lothian Regional Council, Department of Planning, 2000b). These also emphasise the role of Edinburgh and its city centre as the mid-point of the region's economy and finance and thus becoming globally attractive as a financial player. Today Edinburgh is believed to be the second banking capital in the UK and houses for example 9 major insurance companies (Lockhart, 2002).

The investment in the Edinburgh economy is mainly made by the private sector and growth in employment and the economy is premised on that investment. Therefore the District Council sees its role as in providing attractive infrastructure for investment and hence the council is to provide sites for development by private capital. The role of the council is thus to: ensure land for development, create investment opportunities, reconcile land-use and transportation issues, make infrastructure and minimise harm to the environment and quality of life.

In light of the above the Lothian Region Structure Plan Alteration (Lothian Regional Council, Department of Planning, 1984) stated that restrictions in office development, put

in place in 1978 due to them generating too much traffic into the city, should be relaxed to cope with the projected growth of office employment. But a problem of immediate concern then was where to place new developments answering to the growth in office employment within a city of such architectural heritage. It was clear that the attractive buildings and the open spaces of the city centre along with the existing residential areas there were not to be lost, and hence office developments were endorsed in the outer suburbs and the centre, where possible.

The Structure Plan Alteration from 1984 claims that Edinburgh can cope with the projected growth in office employment till 1991 with the main office sectors projected for growth being insurance, banking and finance. These sectors were at the time of the report all to be found in the 'Golden Rectangle', between St. Andrew's Square and Charlotte Square where scope for development was very restricted as well as the buildings being of outdated Victorian or Georgian style and thus unable to facilitate new technologies and systems of administration in the financial sector. Hence in order to address post 1991 growth the need was:

“to enable the finance sector to achieve its growth potential a new core area for prestige office development needs to be identified close to the existing core on George Street.” (Lothian Regional Council, Department of Planning, 1984, p. 21)

The area thought ideal was to be around 4 ha and the offices built had to take into account the growth of floor space *per* worker projected through the 1990s along with parking demands for the development, i.e. that one parking *per* 500m² floor space is required (see also a report made by the director of Planning, 28/1 1993, PDC minutes). The Structure Plan Alteration also indicated that a consolidation in the financial services was required outside the Golden Rectangle but that it had to coincide with one in hotel and conference facilities. All in all new buildings were required in a new site. To place this new office area in the city centre was first openly proposed in the Lothian Structure Plan 1986 and detailed in the City of Edinburgh District Council's West Central Redevelopment Strategy (May 1987). The reason why these proposed the city centre specifically was because it lies at the hub of the road and rail network and is thus easily accessible by public transport, countering the concerns raised over traffic generation by all new

developments into the city. Also cited as a reason was a postulated role of the commercial gains procured by proximity of various firms in the finance sector in general, derived from the predominant Porterian (see 1998) idea of 'clustering'. An additional reason for focusing development in the city centre is that the projected growth in employment is not only in finance sector firms but also in tourism and leisure, activities traditionally tied to the city centre. All this projected growth in the economy and employment would result in growing pressure on existing infrastructure, something the District Council sees its role in reacting to (The Edinburgh Partnership Group, 1999; Lothian Regional Council, Department of Planning, 1991).

Edinburgh's aspirations to capital status can thus be seen in the context of the 1980s when the economic dynamic in the city changed and planning and development aims were introduced to address those aspirations. In sum; till 1984 there were restrictions on office development set in place to reduce traffic generation to the city, these were lifted that year to answer the projected growth in office sector employment and projected increase in finance, insurance, banking and other services, especially tourism. As the City Development Strategy (The City of Edinburgh Council, 1997) put it in 1997, the aim is to make:

"Edinburgh as one of the world's leading knowledge-creating cities, a confident, prosperous, outward looking place – a truly global city" (p. 20).

But relics of the pre 1984 policy were concerns over traffic generation into the city and a concern for design standards addressing the architectural heritage of the city specifically concerning height restrictions and general roof-scape concerns (The City of Edinburgh Planning Department, 1982).⁹

⁹ The view that new developments should not err from the cityscape at hand and can be seen as far back as 1972 in a report (Nuttgens, 1972) that sets out the standards for conservation and new developments in the city. In that report there is manifest the holistic approach to city with all new developments to blend into the cityscape. In order to contextualise this design rhetoric in the city the proceedings of a 1990 conference in Edinburgh called: *Civilising the City* serves well to give an idea of the claimed importance of seamless integration of developments for the financial future of a city:

"The development necessary to maintain the economic and commercial competitiveness of towns and cities should take place in ways which enhance their attractive qualities and do not jeopardise them for short term economic gain. To this end local authorities in historic towns and cities should be encouraged to evolve procedures by which the commercial advantage of rival bids for the

2.2.1 Exchanging idea(l)s

The above listed general socio-economic structures informed the restructuring of Festival Square via the redevelopment of the whole site that was once the Princes Street Station of the Caledonian Railways. Till now the site had only been partially developed with the building of the Sheraton, CH and the original Festival Square, with the rest used for parking, but the whole site was the ideal plot, near the city centre, that the Lothian Regional Council (1984) was looking for to be developed. From this recognition grew the Exchange 'masterplan'¹⁰ and 'the New Town started going West' across the rift that had once been (Spense, 1993). The construction of the Exchange is a recognised catalyst in shifting the centre to the West, along a corridor being defined and created from the airport via Edinburgh Business Park on the outskirts of the city, the Exchange and leading on to the new Scottish Parliament (Lothian Regional Council, Department of Planning, 1994).

The process of developing the whole site was initiated in 1987, but then cancelled, as the site was perceived to be too small. After an extension to the site, adding the acquisition of certain tenement lodgings on Morrison Street, making it its current size, the Scottish Development Agency (SDA, later to become Scottish Enterprise) and the Edinburgh District Council (EDC) (Edinburgh City Council collapsed with the Lothian Regional

development of sensitive sites may be weighted against clearly formulated long term objectives" (Harrison, 1990, p. 99).

These strict demands for a seamless integration of new developments into the city at hand played a large role in the development of the Exchange masterplan and most of the concerns raised by the council and others revolved around how and to what extent the new development would blend into the cityscape. One example of these demands would be the height verification exercise Farrell and partners had to go through to make sure the buildings on the Exchange site would not stick out of the cityscape, performed in 1990 to address RFAC concerns. The datum for these height verifications is based on several angles of view from certain key points in the city that the city's planning authorities define.

¹⁰ The idea of the 'masterplan' can be explained with reference to Cowan (2000) and his *Policy Statement for Scotland* in designing places. He argues that the most successful places, that thrive socially and economically, are those that share, firstly a distinct identity, secondly, safety and pleasant environment, thirdly ease of mobility and lastly a sense of welcome. These places should have the ability to adapt and be sustainable over time, thus Cowan (2000) sets forth the idea that planning and design, must be executed in four dimensions, the fourth being time and thus the design being able to adapt to its use. The planning and design must furthermore be set in local context. Thus he argues for 'masterplanning' that can give coherence and a strong sense of place, providing a planning and design guide kit to be used when

Council) got the go ahead to fully develop it from the Secretary of State. He celebrated the development in a press release (15/7, 1988) saying it was important to Edinburgh as the second financial capital in the UK and rehearsed the need for office space and improvements to unsightly spots in the city. The SDA celebrated for much the same reason and saw the earlier mentioned dreams of a conference centre on the site as adding strength to the plan. In the autumn of 1988 the SDA and EDC made an agreement on the redevelopment scheme and held a development competition for the site,¹¹ advertised amongst developers (17/9 1988). The SDA and EDC then drew up a selection of four applications and on 6th January 1989 those short-listed handed in their proposal. The design proposals coming from these four teams were put on display for the public in Waverley Market for two weeks with over 2000 visitors coming and 280 comments made. The comments received from the public can be summed as wanting the scheme to be implemented quickly, public transport and cycle routes to be facilitated, enough parking, space devoted to art, quality landscaping and make for an interesting skyline.

Terry Farrell and Partners, that were the hired architects of the Edinburgh Development Group (EDG) consisting of Sheraton Securities Ltd (the main backer), Greycoat plc, Sheraton Caltrust plc and Tarmac Constructions Ltd., won the development competition and were accepted by the PDC on the 2/3 1989. They devised the Exchange plan, that was to be, and would, along with Edinburgh Business Park, be the new housing for Europe's fourth largest financial centre (UK's second). Terry Farrell is an acclaimed architect, described as a formalist and a monumental designer so the idea of a 'masterplan' for the site suited him (Colin Ross). The monumentalism was surely manifest in the original conceptual scheme, proposed by Farrell. In this scheme the conference centre (CC) was on Festival Square since at that time tenement lodgings on Morrison road (the current site of the CC) were still being bought and it was still under debate what to do with the WAR. In this original scheme the CC was a very large towering high rise that was to straddle WAR, with the road thus going underneath the

converting, e.g. an unpromising brownfield site and to be referred to when adapting the place to its use through time.

¹¹ This was not the first one to be done in the West End, but Castle Terrace and Saltire Court had been built earlier behind Usher Hall for the purposes of providing office space (see Slessor, 1992).

building. The city accepted this original scheme much to the annoyance of the Board of Commerce who saw too much uncertainty in the layout of the site to make a decision at this stage.

On top of the range of comments from the public on the scheme more were received from various associations in the city. These emphasised the importance of avoiding all grand architecture and also the importance of public and pedestrian access. Although comments by the public wanted quick implementation the scheme was still seen as bold, the layout confusing and fussy, eccentric, over-indulgent and with extravagant architecture not in keeping with the rest of Edinburgh. Along with these concerns the Royal Fine Arts Commission (RFAC), an independent advisory body to local planning authorities, in a letter addressed to the PDC 20/12 1989, claimed that clearer competition drawings should be presented to the public as the project was of extreme importance to the expansion of the city centre. The letter claimed that the drawings being displayed were misleading on two accounts: Firstly, the height of the buildings was depicted as less than intended and secondly, the size of the area of the project was depicted 29% smaller than it really was due to omission of public spaces and the impact on the perimeter of the area. All in all according to the RFAC the public was made to believe the project would lead to less intrusion than it would. But the city council liked the scheme, as their main concern was the projected lack of office space.

The Exchange masterplan by the EDG was built around the two already existing buildings on the site, the Sheraton Hotel and Capital House, along with the old Festival Square. The negotiations for the masterplan started 9/3 1989, with constructions to start in November that year. On behalf of the city the economic development and estates committee (EDEC) did the negotiating of the details of the planning. The matter was introduced as very complex due to the sensitive urban context and traffic issues, therefore design and architecture had to be carefully scrutinised. Based on the approval of the EDEC on the 12/6 and after having the masterplan approved by the council on the 16/6 1989, Terry Farrell and partners applied to the PDC for a detailed planning permission on the 5/10 1989. The masterplan submitted for detailed planning permission had been

adjusted to address the aforementioned concerns, in a response to which the CC had been moved to its current location on Morrison Street and reduced in size by a third. Having the CC in its original form was very hard to justify in terms of land value not being high enough in Edinburgh. In terms of land value another significant motif for the moving was that by building the CC on Morrison Street more value was added to the whole site in terms of other developments being placed on the prime site on Lothian Road. In retrospect the first plan had been excessive indeed and was not financially viable (Liam Fennel, Henri Gibson), the original CC, described by Duncan Whatmore, was “a colossal double structure that had to span over the road and then the railway tracks, very complicated structural feat that would also be very expensive”.

The restrictions and the requirements made by the PDC for the planning of the site were that it would provide ample car parking, open spaces and there would be height limitations on the buildings. Additional requests were filed by the EDEC for the design of the WAR to allow for a metro type rail that would run along the road and under Lothian Road, also adding a request for the lowering of the proposed buildings (13/2 1990). Further concerns by EDEC committee members were on the status of colour and ‘hard landscaping’ in relation to the rest of Edinburgh (15/1 1998) and a question on the effect on the roof-scape of Edinburgh (12/3 1998). These concerns were addressed by Terry Farrell, who claimed that the architecture of the site was inspired by the dominance of spirals and domes in the Edinburgh skyline and would only add richness and detail to that with continuity in scale and detail (The Edinburgh Development Group, 1988).

Going back to the site, in 1990 the masterplan seemed to be on hold as the EDG ran into financial troubles compounded with the pulling out of Greycoat plc. But as the city was very keen on having the development go ahead, wanting to promote itself on the world stage, the local authorities stepped in. Thus on 13/5 1991 the Edinburgh International Conference Centre (EICC) was created, using the masterplan owned by EDG, with the Sheraton as the main member, but still keen to advance the proposal. The EICC became the operational arm of EDG and was a partnership of the Edinburgh District Council

(EDC) and Lothian and Edinburgh Enterprise Ltd. (LEEL), thus a PPP¹² as public money was very much needed to complete the ideas of the EDG. The reason for the District Council and LEEL to take part in this through founding the EICC was that by partaking in the completion of the Exchange, Edinburgh could get the Conference Centre that had been the dream for so many years. The way in which the idea was to work was that through the EICC via EDC the City Council would provide the land, leasing it to the EICC, along with the railway tunnels underneath connecting Waverley with Haymarket station in the West End, for 125 years for the sum of one pound a year, but not Festival Square, the Sheraton nor the Capital House. By leasing the land, value was created of it for the council through so called nominal capital receipts, value against which the council could borrow money to start the building of the CC, through its involvement in the EICC. The WAR was gifted to the project by Lothian Regional Council and then the role of LEEL was also to lend money to the project in order to jump start the building of the Conference Centre. The building of the CC was then to attract other developers to develop the rest of the site, but those would lease the land of the EICC that would go into paying back the council and LEEL.

By moving the CC up onto Morrison Street the position of the WAR and power supply to the city coming in from the West became a constraint. But in 1992 the West Approach Road was realigned and placed on top of the railway tunnels and with the power cables collected and diverted, work began on the Edinburgh International Conference Centre. Standard Life Assurance Company followed and purchased a plot on the north side of WAR for the construction of their global headquarters in 1993 while in 1994 Cala-Morrison Constructions ltd. bought for speculative development Phase 1a of the Exchange Crescent, on behalf of the Railways Pension Trust Company. 1a was the bit of land created with the realignment of the WAR leading up to the Conference Centre thus

¹² LEEL being part of Scottish Enterprise (SE), which is the regional development and training agency for the lowlands of Scotland. Its sister organization is the Highlands and Islands Enterprise that covers the Highlands and the Western Isles. The Project is an excellent example of public private partnership the public element being the EDC, Lothian Regional Council and SE, with the private being the EDG composed of various private bodies with interests in the project. The issues of urban regeneration with PPP will not be followed up in this thesis as that is done at length elsewhere (see e.g. Bache, 2001; Bailey, 1994; Carley *et.al.* 2000; Carter, 2000; Chapman, 1998; Geddes, 1997; Harding, 1998; Miller and Dickson, 2000; Stewart, 1998).

being the part that now flanks Festival Square to the north and became the Clydesdale Bank Plaza, completed in 1998 as can be seen on figure I.6. In 1998 Standard Life forward-funded development of Phase 1b of the Exchange Crescent, flanking the passage to Conference Square, and later purchased Phase 1c for its own occupation connecting these via a bridge across the WAR to their headquarters across the street. Standard Life wanted offices with a larger floorspace and more flexible workspace than was available at that time in Edinburgh. Office development in Edinburgh, historically, is in the New Town where the floorspace usually is around 4000 sqf with the average floorspace in Edinburgh offices round 3500-6000 sqf. With Edinburgh's aspiration in the 1990s competing with London, companies started coming in that needed floorspace in excess of 10.000 sqf. At that time there were two buildings in Edinburgh that could comply with that floorspace demand. Although floorspace of about 7500 sqf existed in Capital House more was needed. Eventually with all private investment accounted for more than 1 million square feet of office accommodation was developed on the Exchange with £60 million of public sector expenditure leveraging £400 million of private sector investment (Edwards *et.al.* 1995; Henri Gibson; Liam Fennel).

THE EXCHANGE MASTERPLAN

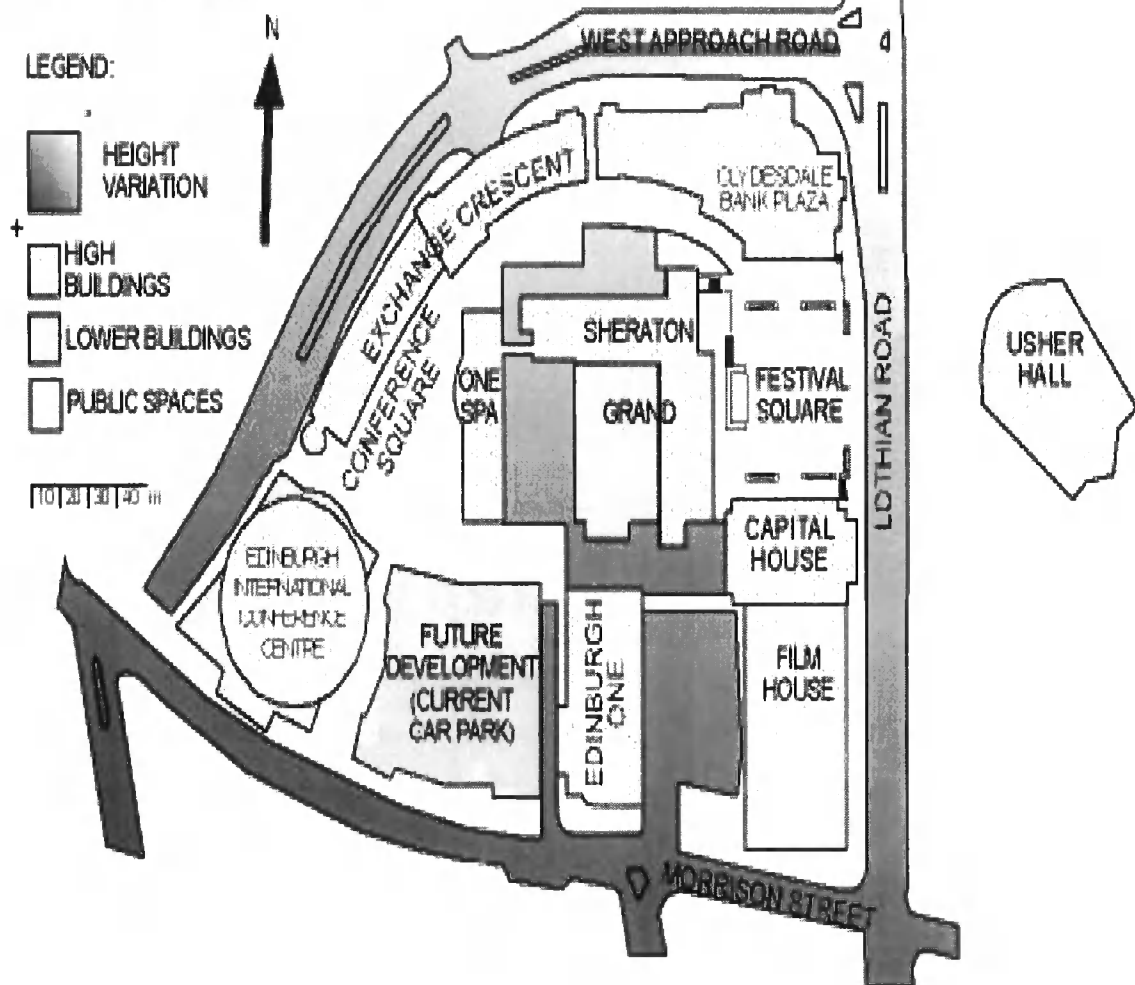

Figure I.6: The Exchange Masterplan with Usher Hall.

Source: E. Huijbens, courtesy of EICC.

The whole site has a gradient from South to North constituting a considerable drop (see Figure I.6). This necessitated the artificial levelling of the site in order to facilitate the whole design and building of phases 1a, b, and c, making the main entrance of the Sheraton hotel, facing North West, seem below ground. The aim was to have a line from the Conference Centre, the height of which is defined by Morrison Street, down to the level of Festival Square with as little a drop as possible. The idea was to level to the extent that people would actually not be aware of the difference in height. The levelling made the rise from Festival Square round to the CC about 1 in 45, which by Edinburgh standards is nothing, with all the buildings of the Exchange standing at the same level.

The Hotel Corporation of Edinburgh, the owner of the Sheraton hotel was leasing the area upon which the levelling was to be done and used it as a car park. Therefore an agreement needed to be reached with the HCE on the development of the site and for some time the HCE had their doubts about re-leasing this plot to the development. The break through with the HCE was that the lawyers representing them were dismissed and the Hotel Corporation brought in another individual, an engineer who had an interest in the project, so the HCE started to see the benefits of it. Then the CC was also starting to become operational and the hotel could see a direct benefit in having good linkages to it. The hotel decided to take part in the development and expanded building the Sheraton Hotel Health Club, One, completed in 2001. The making of the artificial levelling created 'underground' car parks for the hotel, on top of which was built the Conference Square that makes for an open public space to the back of the CC and in front of the health club and the Standard Life developments of phase 1b and c.

In the Edinburgh Development Strategy (The Edinburgh City Council, 1997) the site is listed as one of the achievements when it comes to developing the city as an economically prosperous one with a global outlook concerned with sustaining inclusive community life and the environment. The problems the report sites though are traffic and the lack of inward investment from prospering companies and hence there is a decline in local manufacturing and service. The City of Edinburgh Council nominated the whole design for the Scottish Award for Quality in Planning on the ground 2001, an award given by the Scottish Executive, but they did not win. Quoting the judges:

“The judges are pleased that the pattern of activity and mix of uses were considered for the land covered by the masterplan, and that houses have been provided in large numbers in the surrounding area. But they were disappointed that the entry did not provide them with the evidence they normally look for on community involvement” (see <http://www.scotland.gov.uk/planning/award/0135.asp>).

2.2.2 The opening for the public

One of the major issues gleaned through the above section is the constant problem of how to facilitate pedestrians and the public coming into the city without too much traffic

generation from commuting. It was already recognised by the Lothian Regional Council (Department of Planning, 1984) that by relaxing the restrictions on office development traffic generation into the city would increase and hence create a problem for the city. The Lothian Regional Council (Department of Planning, 2000a) drew attention to that all business development should be accessible by public transport, pedestrian or cycle routes, i.e. supported by good infrastructure. With the aim of improving infrastructure, the Lothian Regional Council launched a two-year study into the feasibility of various public transport options in April 1987, concluding with suggesting a light rail system for the city based on the former existence of trams in the city. The District Council responded to the study saying that existing public transport systems needed to be enhanced to cope with the growing office floorspace in the city centre. Their suggestion was to increase bus links instead of promoting a light rail system, metro or trams. The bus link was considered better due to the adverse impact rails would have on the city fabric. This bus link idea was known as the Western Corridor Busway (WCB) but in 1995 it became the City of Edinburgh Rapid Transit (CERT) after a careful revision of the WCB from 1993. The CERT entails an express bus link from the city centre through to Edinburgh airport and thus links the aforementioned corridor of developments from the Scottish Parliament via the Exchange to the airport. Thus manifest with these developments was a certain change in planning ethos from the motorcar city to one of public transport and especially pedestrianisation.

On the topic of pedestrianisation a report was made by the director of Planning in Edinburgh dated at 25/2 1992 about how to improve pedestrian access to the city centre and other areas. A year later the PDC recommended that pilot routes should be tried and tested through the city. With the experience of those the Edinburgh Development Strategy (The Edinburgh City Council, 1997) states the main aim till 2010, is to preserve the city's unique townscape and focus on accessibility by promoting walking and cycle routes. This ethos is reflected in a quote from a prominent art project in Edinburgh:

“Not to walk the city is not to know the city. All cities are disclosed in magical pedestrian trajectories: the walker is the essential artist of the city, the writer of its novel, the maker of its poems, its imaginary architect” (Guest, 1996, p. 2)

As this quote shows then there was a change in thought towards the pedestrian city as was also confirmed in an interview with Ian Spence at the Edinburgh City Planning Dept. The masterplan of the Exchange endeavoured to reflect this change by linking the public spaces of the old and the new town of Edinburgh with pedestrian routes through the site. Those links were seen as sufficient except from the North, where a bridge built by SL served as the only link to the New Town. The masterplan was thus defined under terms of permeability, i.e. the design and buildings were to be able to allow flows of people to pass through on foot or on bicycles (see Figure I.7).

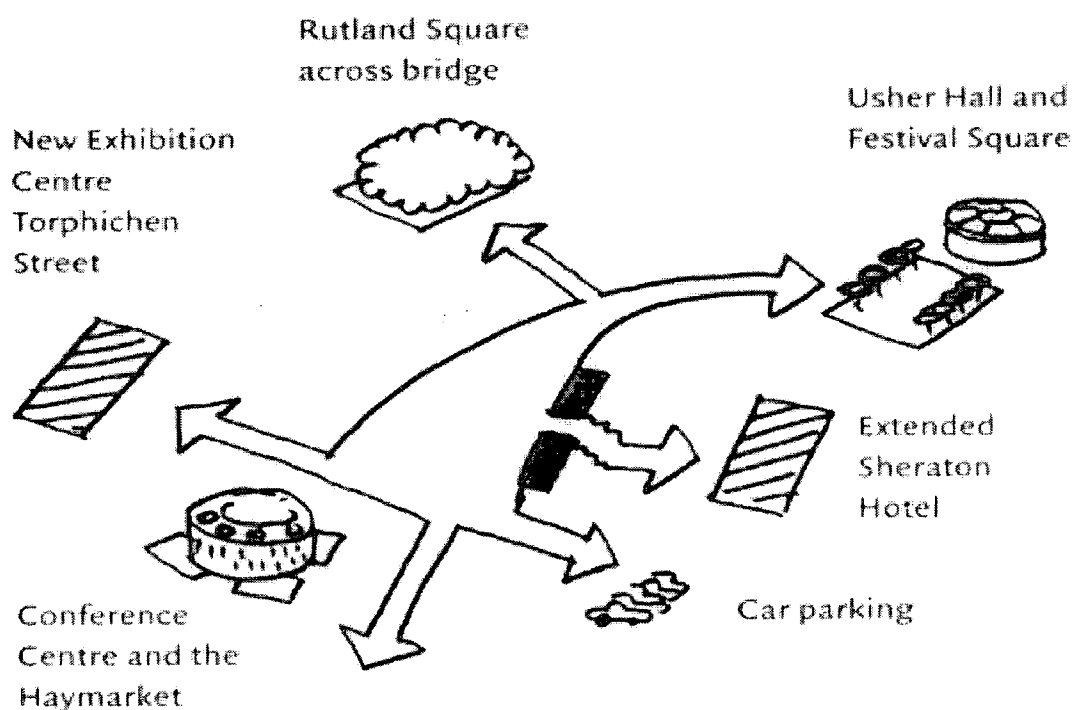

Figure I.7: A drawing by Farrell depicting the Exchange site's permeability.

Source: Whatmore, 2002, p. 29.

It is in terms of flow and permeability that the new Festival Square emerges. With the bridge across the WAR, a link was created from the Exchange crescent to Rutland Square through the Standard Life Building allowing people to come from the New Town. The idea was to promote flows of people from the Conference Centre, through Conference Square, along the crescent and into Festival Square. As part of the development, and to

accommodate these flows, there were aspirations to redesign Festival Square but certain remodelling was necessary aligning it with the new building of phase 1a. With the new building to the North of the square it became flanked on three sides with buildings and in effect the space of the square drew itself. Farrell saw an opportunity to make this space much larger by taking away the previous barriers originally designed to shield the square from the busy junction of WAR and Lothian Road. Not only was the idea to realign the square and open it up to the flow of pedestrians, but it was also to be opened towards the rest of the city so that the masterplan did not terminate in an abrupt line. It was always Farrell's intention that when the buildings would be finished the Exchange would not be a new development, but would just be a part of Edinburgh (see Figure I.8); it was to blur into the next bit and the routes of flow were instrumental in tying the masterplan together with the rest of the city (see Figure I.7). There is another way the masterplan can be said to blur into the cityscape. Since after its inception other new developments started springing up in nearby locations that were not part of the masterplan at all. One can talk of a 'spatial spill' effect and due to the strict planning policy guidelines of Edinburgh city council with reference to the cityscape at hand these new developments took their cue from the Exchange. What I am mainly getting at in the above is how the new Festival Square was determined as one of flow that came out of a holistic planning idea of a cityscape that was to be coherent and without interruptions. The flow was to be maintained on foot not by car as had been the original idea and the new Festival Square became an opening up, informed by perceptions of how to boost and maintain the status of the city.



Figure I.8: The Exchange in the cityscape. Seen from the air looking Northeast.
Source: EICC

The old square was deemed as not too overly attractive and also hampering the idea of flow, as it was developed as an enclosure. The new square was level, flat and open, void of objects and thus able to facilitate flow and all kinds of activities. All the way through Festival Square from CC to the Usher Hall there was to be a flow of people that would make all these venues work together. Events were envisioned that would promote the idea of the area as pedestrian and for the people. The square was designed to create a good relationship between the new buildings on the site and with an extra wide pelican crossing over Lothian Road, also with the Usher Hall. The link to the theatre area across the street was to be part and parcel of the square, integrated with the crossing and feature lighting going across Lothian Road (see Figure I.7).

In order to open up the square and make it accessible to the flow of people and as part of the grander levelling of the site, the primary concern was the levelling of the square. Lothian Road is quite steep and it drops almost 3 meters from the South end of the square to the North. Previously the planters and the steps enclosing the square allowed the sloping pavement along the Lothian Road side and the square to co-exist. The levelling of the new square was done by 'twisting', as in creating a slight undulation of the square in order to get it to one level but with small stairs at either end. The previous planters were replaced with just two planters at the Eastern edge to help give a sense of levelling within the square, but the aim was to keep the square as open as possible to encourage people to see it as a single space along with UH and the theatres. In an effort to underline the coherence of the spaces across the Lothian Road the lighting was planned as the same all the way across, but this is outside of the control of the EICC as their ownership only goes up to Lothian Road.

The square was also not only to serve the round 10.000 office workers that now populate the Exchange but also to be attractive in its own right to the public and the surrounding community. Thus it was not designed to be simply an attractive frontage to the Sheraton hotel or Usher Hall, but the welcoming gateway to the Exchange for all those that come to the city. With this in mind the masterplan envisioned cafes and retail activity on the ground floors of all the new buildings. Quoting Duncan Whatmore at length on the topic gives an idea of the new vision Terry Farrell had with his partners:

"We want to promote different kinds of activity on the site that would continue beyond office hours. We felt it important to keep the space lively and that there would be a lot of pedestrian flow through it. We did not feel it necessary to have new vehicle routes across the surface. What we were very conscious of is that there is a whole tradition in Edinburgh to have squares and crescents and open spaces but very few of them are publicly accessible, they are dominated by key-holders e.g. Charlotte Sq. you cannot get into except for a couple of weeks during the book festival. So we thought it was important to make sure that these spaces would be able to be used. We were also keen not to encourage a further encroachment of vehicles into the city" (interview).

This quote serves to highlight one of the primary concerns of the RFAC from 1994 over the lack of café and shop space. But they, as the judges for the Scottish Award for

Quality in Planning, also flag up the lack of housing planned into the masterplan and hence how there is no life after office hours and distinct lack of community involvement, weakening the plan as a consequence.

2.3 Concluding

All of the above was an outline of the socio-economic structures informing the design of a square, from an enclosure from busy traffic routes and an attractive frontage to the hotel, to an open square facilitating flow and maintaining coherence in the cityscape. The backdrop for these design rationales can be drawn out of the context of the general planning ethos of the city of Edinburgh changing from one of motorcar city to one of preservation and pedestrianisation. But most importantly this general planning ethos and the driving force of the structuration of the square, is the socio-economic structures of a city aspiring for a role in the world of finance and banking and thus creating attractive office developments to remain competitive with London and other financial centres. With the backdrop of these socio-economic structures determining the square's function I can start to draw a picture of the space of Festival Square as it looks today, seen as a sedimentation of the multiple time-space trajectories actively relating through those socio-economic structures outlined in this chapter.

I.3 Walking the City

“Anyway, I know that if I classify, if I make inventories, somewhere there are going to be events that will step in and throw the order out” (Perec, 1999, p. 132).

Festival Square as it is today is the result of a £1,5m remake in 1998, adapting it to the vision of Terry Farrell’s masterplan outlined in the previous chapter. There, in making sense of the socio-economic structures informing the structuration of the square, I portrayed a place that can be viewed as inert; an empty stage set as it were, an architect’s dream, an idea brought to fruition in space. Here *is* Festival Square. In this chapter my intention is threefold. Firstly, my main aim is to map the spatial order of Festival Square’s materiality and the knowledge I acquired of it through my fieldwork in order to make sense of how that spatial order structures dispositions or one’s *habitus* as I walk the square. The resulting inventory of the material on the square serves my second aim, as I will refer back to it in later chapters in the thesis. Thus, and thirdly, with this inventory in hand I hope to later make room for encounters and events to occur within the context of that very materiality and throw out the order set up.

By posing an inventory against the ideal I am not suggesting that the architects and designers of the square work on the purely ideal, as one would be rather hard pressed to find a prominent architect today that claims to build architecture purely as art or as rational design ideal (see e.g. Farrell, 1984). Architects today build spaces, spaces that are not universal in aspiration but of movements, echoed in Terry Farrell’s design of Festival Square as one of permeability and flow and as an event space (The Edinburgh Development Group, 1988; Tobin, 2002; Whatmore, 2002). This is architecture of pragmatic function, not defined in terms of the ideal. This architecture creates spaces that are made for people who live in them and use them in their everyday life, but still this is architecture that determines function for spaces and applies certain ideals to space although not anymore in the spirit of universal rationality. So in order to understand how designed physical environments “play [in] the unbreakable tension between bodies and objects, ourselves and the ground on which we walk” (Vidler, 2000, p. 142) one first needs an inventory of the designed physical environment in order to understand which objects are at play in the unbreakable tension cited. Allowing material to inhabit spaces

and then asking how the people using those spaces interact with that material setting (as I will later) is the key to make space for events that throw out the order of space as we encounter it. This chapter is about moving through the square detailing its materiality of the square and the structuring of my dispositions towards the square through an inventory of its materiality and my knowledge acquired through my field work period, also serving as founding material for subsequent parts of the thesis.

Through my primary aim of detailing the structuring of my dispositions towards the square I am addressing a quote from the preceding chapter from Guest (1996) (see p. 67), signposting the change in city planning ethos from the motor-car city to the city for the pedestrian. In the quote the way of knowing the city is to walk it, have the city disclose itself in the trajectories of the pedestrian to show how the objective structures of the spatial order become familiar to the walker and internalised. In later chapters of the thesis I will delve further into the latter parts of that quote and how the pedestrian can create spaces in the city but in this chapter, I will detail what I see as informing my dispositions when walking around the square illustrated with pictures and graphs. The path I followed I filmed on digital video camera on the 27th of March 2003. But the narrative I tell is a composition of my daily visits to the square during my 10 months in Edinburgh. In the text I try to enhance the experience of the written word by having the spatial order, objects and buildings I talk about, depicted in black and white combined and collaged, drawing inspiration from Pluciennik and Drew's (2000) attempts at the same. I choose to have them black and white in order to convey a sense of the material as plainly and clearly as possible emphasising that it is only the material objective structures that are now under consideration. Key elements in the structuring of dispositions when walking the city along with the visual are the sounds, smells and other sensory stimulants that accompany and enhance our perception of our surroundings. Those haptic, olfactory, auditory, aural and visual geographies can not feature on these pages. But the existence of these, recognised in the work of authors such as Crouch (1998); Duneier (1992, 1999); Eyerman (1999); Fife (1998); Harper (2000); Lees (1998); Lingis (1996); Nast and Pile (1998); Pinder (2001); Pryke (2002); Raban (1974); Rodaway (1994); Schafer (1977); Smith (1994), impacts the way in which one's *habitus* sediments in bodily practices of

walking a city and must be incorporated into any holistic understanding of the city in order to counter the predominance of the visual which architects and designers draw their main inspiration from. An inventory to detail the structuring of *habitus* is always incomplete without recognition of those sensual geographies and in later chapters the implications of this will be explored. The aim of my walk is to give glimpses of the multiple time-space trajectories coalescing in the materiality of Festival Square, informing the structuration of my *habitus* in the square. The account itself draws inspiration from the books *The Rings of Saturn* (Sebald, 2002) and *Life: A User's Manual* (Perec, 1987). The former details the walks of the author along the Suffolk coast from Lowestoft to Orfordness, where he weaves into his walk a compendium of stories and tales of life and work from around the world inspired by the objects he encounters. The latter combines threads of stories and related imagery from many points in history and space, a "non-computerised version of hypertext" (Becker, 2001, p. 63), whilst remaining a snap shot of a single Parisian building.¹³ Aiming to "stress the importance of vivid, compelling descriptions of the world, infusing an understanding of place with human values, meanings and experience" (Blunt, 2003, p. 76) I make an inventory which is a snapshot of Festival Square as I see it on my walk.

3.1 Inventory

I lived in the South of Edinburgh on Comiston Road that, going north, turns into Morningside Road and eventually Lothian Road that flanks Festival Square on the Eastern side. As I walked from my home towards Festival Square between 6 and 6.30 am I experienced how life was slowly shifting into gear as the roar of the traffic grew to deafening levels and the exhaust fumes slowly overtook the fresh smell of spring emerging during the my latter months. The traffic was heading into the city, like me on foot, and by 7am it was very heavy, with peaks at 7am, 8am and 9am and then another lunch hour rush from 12.30-14.00. The road is generally a very busy one, being the A 702, a major trunk road taking traffic to the South through the Pentland Hills onto England's North Pennines. As I was about to arrive at the square I came past the

¹³ Perec (1987) does in practice what Jenkins (2002) theorises about in the context of a single building in Paris.

Filmhouse, slipped under the archway of Capital House and as I walked around that corner the square opened up in front of and below me as I had an elevated position, provided by Lothian Road's natural South-North gradient.



Figure I.9: Festival Square, Edinburgh. Seen from across Lothian Road looking Northwest.

Source: E. Huijbens

As I stood in the SE corner of the square I was at the top of a flight of stairs that lead down to the level of the square, these stairs being the only relic of the old square that was there prior to 1998. As I turned into the square the Sheraton hotel forms the backdrop but immediately in front of me is a statue of a woman.



Figure I.10: Woman and Child, Festival Square, Edinburgh.
Source: E. Huijbens

3.1.1 Woman and Child from Soweto

As stated in the last chapter, the only thing missing at the opening of the old square was a sculpture that would fulfil the role of a natural reference point for the users of the site along with conferring identity to the site and aggregating it (Favole, 1995). The matter was anticipated to be an issue for lively public debate for the future and it certainly manifested one of the major international political issues of those times, the boycotting of the South African Government for their Apartheid policies. What the particular piece of work, that became the square's sculpture, draws into the square is June 1976, in Soweto township near Johannesburg. Then, around 15,000 young students participated in a peaceful protest march, which was met by police with tear gas, and eventual, armed response, killing at least two and wounding dozens more. This event set off riots across

South Africa and for many marked the first signs of cracking of the S. African apartheid system from within (Biko, 1988; Mathabane, 2000).

The EDC were very much linked to the freedom movement in S. Africa and the Lothian administration of the time gave overt political support to that movement. They commissioned a sculpture competition that aimed to reflect provocatively the nature of the struggle against apartheid. There were a variety of entrances specifying this in many different ways, but the sculpture that won was created by Ann Davidson from Aberdeen and was, as the creator described it, to honour those South African dissidents of the apartheid regime that had given their lives for the cause. The statue was accepted on the provocation of Alliance members and the Labour party in Edinburgh's District Council, with the support of the Edinburgh anti-apartheid political campaign group active between 1975 and 1985. The acceptance of the sculpture was a message of unity to those dissidents and a symbol against the apartheid regime and alleged Tory sympathy towards their agenda (*The Scotsman* 29/8 1986). The sculpture is named 'Woman and Child' and depicts a woman and a child standing in front of arched corrugated iron, very simple, provoking images of the destitution and deprivation of South African townships living under the apartheid regime (Ian Spence).

On the 22/7 1986 the statue was placed on a pedestal on the end of a walled planter enclosing the square to the East and used to continue halfway down to the corner of the old WAR/Lothian Road junction. Because of the gradient of Lothian Road and the pedestal being at the end of the planter to the North it was at least a 1 ½ metre above street level and consequently Mr. Sampson felt it detached from the square losing its proposed visual impact on that account. That pedestal does not exist anymore as it was swept away in the remaking of the square in 1998, but what was not swept away was a part of the walled planters, facing Lothian Road in the corner at CH, where the steps go down. This is where the sculpture was placed after the remaking of the square, at street level so you face the woman and her child directly as you walk past. But as you pass you see the Sheraton hotel, part of a world famous hotel chain renowned for its quality, that forms the backdrop for this provocative image of deprivation and poverty. This seemed to

elude all my interviewees apart from Ian Spence of the city's planning department, as they described the square for me. Not only does this symbol of destitution stand in front of a symbol of affluence, it also stands at the gateway to Edinburgh's new financial district that is to attract investment and promote capitalism that for so many is seen as the source of the inequality manifest in the statue and its backdrop.

The political momentum of the apartheid struggle has surely died down now 13 years after the repeal of the last apartheid laws. 10 years ago Nelson Mandela was voted president of South Africa and his prominent figure in the apartheid struggle might go a long way to explain why so many of my respondents associated this particular sculpture, when asked, with Winnie Mandela and her struggles, through harassment and deprivation, against the apartheid regime.

After standing in front of this woman I turned left and walked down the stairs that are the only remnants of the old square. Going down I only had the weak rays of the early morning sun in my back but as it rises, the Capital House that now was on my left hand side perpetually casts a shadow on these stairs and parts of the square. This shadow leaves the stairs constantly very damp with moss and algae growing there more rapidly than elsewhere. Therefore the maintenance crew of the square, the Shining Stars, need to monitor and wash these stairs at least once a month, as opposed to once every three months as with other areas of the square.

3.1.2 The Shining Stars and cycles

The Shining Stars came on the square in the end of 2002 according to Bill Strang, the coordinator of those working on the square. He said that then everything was covered in moss, green and dirty and it took them a while to clean and get the square the way in which they wanted it and it can be seen today. The Shining Stars are the cleaning and maintenance branch of Edinburgh City Centre Management Company (ECCM), with a public service and information arm being the Guiding Stars that are seen around Edinburgh, giving people advice, especially tourists. The ECCM is an independent company supported and financed by the City of Edinburgh Council and over 90 city

centre organisations and businesses that are stakeholders in the company. The ECCM has, as one of its strategic objectives, the aim of providing a nexus of communication and co-operation between public and private stakeholders in the city centre, along with promoting clean, safe and friendly environment for all city centre users (ECCM, 2004).

On Festival Square the day-to-day cleaning cycle of Joe and Wayne, the Shining Stars of Festival Square, is to empty bins and clear away litter, mainly cigarette butts, as people from surrounding office buildings will frequent the square to smoke producing so many butts that they often have to be swept up twice a day. The reason why they are on the ground is because the bins that are on the square are designed with no 'ashtrays', on which to put out your cigarette and throwing the cigarette lit into one of the bins seems not to be an option. More daily cycles are litter picking in the hedges that grow in the walled planters, but users, mainly though the teenage skateboarders that frequent the square leave their soft drink cans along with empty wrappings in the hedges and in the water feature found at the Sheraton entrance (see later), with a bench being the biggest piece of 'litter' taken from it, so the water feature also needs its daily litter picking. Amongst the tasks of these daily cycles is to watch out for algae growth on slabs and slippery steps (Bill Strang).

The Shining Stars wash the stairs with a jet wash system to get the moss and algae of using only hot water at the lowest pressure. Apart from being environmentally friendly, as opposed to using biocides, the low pressure jet wash is only to wash away the moss and spare the jointing material between the slabs along with the slabs themselves, none the less both slowly erode through this procedure. Stone cleaning is a delicate business and the York Stone slabs that are in this particular corner and were raised from the old square, cleaned and replaced, are soft and easily eroded. The delicacy with which the Shining Stars approach the paving slabs reflects a general trend in Edinburgh towards the conservation of its architectural heritage through dealing with biological growth on sandstone, as the city's buildings are predominantly made in sandstone (see Cameron *et.al.* 1997). More related to the paving slabs on Festival Square, is the preservation of the jointing material rather than the slabs themselves, as these slabs were not laid with

concrete jointing but have dirt between them. Water washes up the dirt and makes the slabs loose creating the problem of people tripping up, further compounded by vehicle traffic onto the square as the weight of them will crack slabs, especially those that are loose.

There are other things the Shining Stars do, but not on a daily basis. They clean under the gratings at the foot of the trees, lifting them up and plucking the litter and cigarette butts accumulated there. The water feature is emptied and washed at least three times a month, but that is in the hands of a private company. In the winter they come in early and put salt on the steps for safety. But they are not only responsible for Festival Square, in a 6 month cycle they do all the cleaning right up to the Conference Centre and their job involves not only cleaning but also trouble shooting in the area and reporting all malfunctions or faults to the appropriate body. I encountered them over and over on my walk through the square.

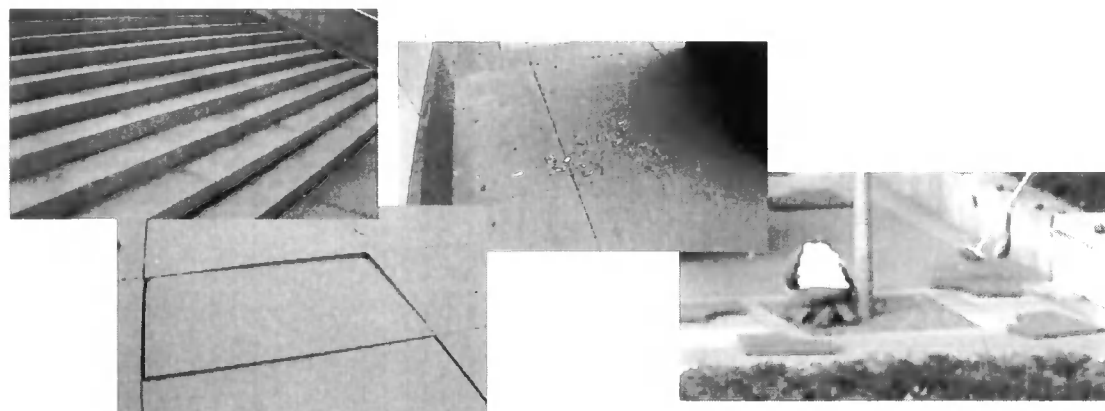

Figure I.11: Cleaned Stairs, cigarette butts, loose slabs and Joe cleaning tree gratings.
Source: Bill Strang and E. Huijbens

As I descended to the bottom of the stairs I could feel the damp cold of the shade cast by CH and see the morning delivery vehicles driving without hesitation into the open square to the entrances of the buildings. On my right hand side there are bike rails and one of the ill-designed bins Bill Strang spoke of. The bike rails stand to remind one of the changes occurring in planning ethos from the motor-car city to the pedestrian city and the city

authority's active promotion of cycle routes all through the city. Evidently across Festival Square there are demarcated cycle-routes that in the future will be potentially marked on the ground with brass buttons that will have a cycle logo on it. But as the square is today there is no way to make out any special cycle routes and a cyclist is a rare sight on the square. In the city there are now 147 km of marked cycle-routes that the city's Highways and Transportation authorities have demarcated as a response to the increased emphasis on multi-modal transportation in the city, initiated to improve health, lessen congestion and pollution and contribute to general well being of the city dwellers. This increased emphasis started in 1977 through the founding of the Lothian Cycle Campaign, 'Spokes' (see: www.spokes.ork.uk) a voluntary organisation with current membership of over 1000. Their lobbying was reinforced in 1996 as the Government set a national target of doubling the amount of cycling between 1996 and 2002, and doubling it again by 2012. As a response and to identify and promote good practice, the Scottish Cycle Challenge Initiative (SCCI) was launched in 1997 by the Scottish Executive, which Edinburgh City Council responded to positively (Halden *et.al.* 2002), as can be seen in the bike rails.



Figure I.12: Bike rails at Capital House.

Source: E. Huijbens

Stood now in front of Capital House I faced the plain stone face of that building with its brand new and thoroughly out of context entrance, made with pale green-blue pastel colours, with the letters Capital House written in red neon capitals overhead.

3.1.3 Mr. Lamb and the use of Festival Square

The CH building looks different from the other buildings on the square; it is much darker. The reason cited by Bill Strang is that the other buildings get the sun which dries out the stone but as CH faces North it does not get much sun thus the stones are constantly exposed to dampness and have been for some time as CH is the second oldest building on the square. Earliest reference to CH is from the minutes of the PDC dated 14/12 1983 detailing the application of James Miller and Partners (now Miller Group) for the building of CH. The foundation stone was laid on the 15th October 1984, (*The Scotsman* 16/10 1984) with the building complete in just under a year, by time of completion none

of the 55.000 sqf of floorspace had been allocated, but interest was being shown by fund managers, accountants, bankers and solicitors (*The Evening News* 3/10 1985). The rationale for building CH came from the 1980 survey already cited (Ian Banks and Associates, 1980) that showed that the economic upturn in the city would soon absorb existing and planned office space. The development was thus purely speculative but took into account the changed business practices emerging in the 1980s and was thus based on an open-floor planning to allow for maximum flexibility in office arrangements. What the developers counted to the advantage of the development was its high quality, the parking availability, access to western parts of the city, airport and West Scotland via the WAR and the proximity to the Sheraton for meetings and food. In *The Scotsman* the building is extolled as one of the new generation of buildings sat on the fringe of Edinburgh's business heartland designed with great care as to allow the building to blend in with the surrounding environment of the Sheraton and the Filmhouse (8/10 1985).

The building today (February 2004) houses four offices, one home office of a local company and three branch offices of global corporations, but all four belong to the financial sector in one way or another. Firstly there is the Mellon Newton Group UK, an asset management corporation of global proportions with its base in the US. It was created with Mellon's acquisition of the Newton Group, a UK based asset management firm, in November 2000. The Edinburgh office of the Mellon Newton Group represents Mellon's Financial Corporation, an umbrella organisation for Mellon Global Investment that encompasses all non-U.S. based asset management businesses. In the UK they work through their acquired Newton Investment Management Limited, headquartered in London, which manages in excess of £17.8 billion in the UK (www.mellon.com). Secondly CH houses the home-office of Eric Young & Co founded in 1983 as a chartered surveying company that specialises in retail and commercial property. Their focus is the North of England and Scotland (www.eyco.co.uk). Thirdly there is the Royal Bank of Scotland with its private investment branch. The Royal Bank of Scotland represents one of Britain's oldest banks and the Europe's second largest after its takeover of the NatWest Group in 2000, the biggest takeover in Britain's history of banking. The bank's functions are in the financial services provision and here, in CH, individuals wanting to

invest can seek opportunities (www.rbs.co.uk). Lastly there is the HSBC Investment bank. This office represents the HSBC group that is named after its founding member, the Hong Kong and Shanghai Banking Corporation Limited, which was established in 1865 to finance the growing trade between China and Europe. HSBC was established as a uniform, international brand name in 1999 putting together its world wide constitutive elements of banks and financial corporations. In 2002 HSBC became 'the world's local bank' but is headquartered in London and has global operations at all levels of banking and financial services, but in CH there is the corporate investment branch for Edinburgh (www.hsbc.com). Capital House is surely a house of capital management but the building itself is managed by the international property advisor Jones Lang LaSalle that leases it on behalf of their client the Miller Group, the original constructor of CH and UK's largest privately owned property development, house building and construction service company. The Miller Group has its head offices in Edinburgh and is currently involved in the construction of Edinburgh Business Park through New Edinburgh Limited, a joint venture between the Miller Group and CEC Holdings Ltd that is a subsidiary of Edinburgh City Council. The Miller Group has always had strong links with the Edinburgh City Council from its founding in 1934. The Group's founding father was James Miller who was elected to Edinburgh City Council in 1936, becoming City Treasurer in 1947 and Lord Provost between 1951-54, during which time he was knighted and later became the Lord Mayor of London in 1964.



Figure I.13: Capital House and its entrance with slab cleaning in progress.

Source: E. Huijbens

As I stood gazing at the building and the spectacular glass and steel entrance that was added to the building in 2002 (see Figure I.13) I was greeted by the building supervisor Mr. Michael Lamb. He was out to receive the daily milk being delivered to the door by an elderly man driving an old dilapidated Mazda pick-up car, one of the delivery vehicles I had seen driving onto the square. I started chatting to him about the square seeing that he has been working in the reception of Capital House since 1989. I asked him about the users of the square and he told me that in his experience on a good day 30-50 people would stay on the square for more than 10 minutes.

I established who these users were through a survey of 200 questionnaires in order to establish who the people were that went through the square. I covered the time between 6 am till 9 pm and along with my questionnaires I did footfall measurements on the square. The footfall I established through the amount of people that would reject my approach

with the questionnaire, so I was constantly active in approaching people and would count them as they said no until one would say yes and then I would count that person also along with doing the 2 minutes of questions. All in all I derived my footfall measures from 830 people to reveal distinct peaks of activity at 8am and 12.30 with smaller peaks at 2.30 pm and 5 pm as can be seen on graph 1 (see p. 88).

The people staying are office workers that come out for their lunch breaks, 3% of the 200 I approached with a questionnaire cited lunch as their reason to stay on the square, the majority or 81% were just passing through without stay. Those staying have limited lunch times but also hampering any loitering was the lack of benches, forcing people to sit on the planters which are not too comfortable (see Figure I.18), leading the remaining 19% to stay mostly no more than 20 minutes. But Mr. Lamb emphasised that people only come out onto the square to stay if the weather is good. What those staying did came through in my questionnaire as I asked why people were staying; with 61% of those staying just relaxing, smoking, waiting or having lunch. Mr. Lamb also claimed that the uses of the square were mainly through the day but during the night not many people come there, the few that do are only passing through, it seems that none of the office workers tend to stick around after work. These uses can be seen in the graph below representing footfall on the square.

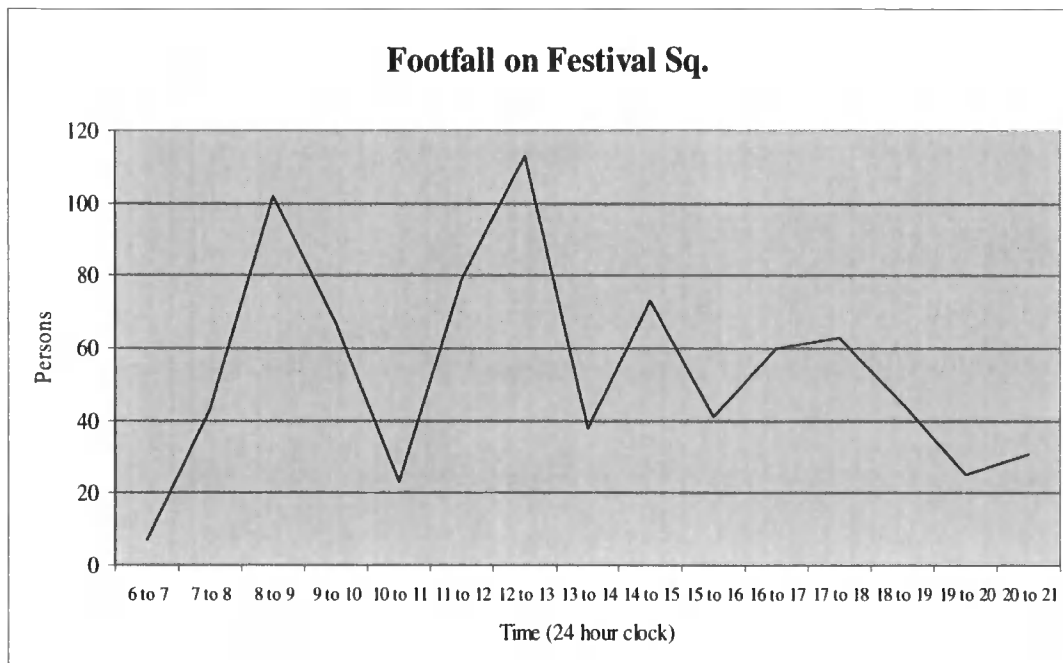

Graph I.1: Footfall on Festival Square.
Source: E. Huijbens

The people represented in the graph above were surely office workers of one kind or another with 35% of my respondents describing their job directly as office workers, while in total 74% of my respondents worked in offices, ranging from directors, senior office workers and management to various services and IT officers. These people were predominantly 26-35 (37%), other age groups, arranged in ten years intervals, were just under 20% till the age of 56. These office workers came mostly from buildings around the square (45%) but adding on the whole of the Exchange site and businesses around then 67% of my respondents had their workplace there. Mr. Lamb said though that on a good day there would also be people coming into the square from the street to take a seat somewhere on the square but mostly around the water feature (see Figure I.14).

The other main users were the skateboarders and due to the useful features on the square for them especially around the water feature, up to 30 will be there on a good day coming in the afternoon and on weekends. With the skateboarders coming in the afternoon there is a clash between the office workers and those young people as is manifest in most of my respondent's view on the square when asked if they had any comments on the square.

I would ask present the again to elaboration on striking the dislike for with 33 of 200 them, 29 of lines of



once and then question once provoke an the response. A reoccurrence was skateboarders commenting on those along the “bloody

skateboarders” or more subtle “nice, pleasant in the city centre but shame about the skateboarders” and even “skateboarders damage and make [the square] look dirty”, resonating with Cresswell’s (1996) argument equating certain activities and behaviours with dirt or dirt generating, dirt being matter that does not suit a place, or is out of place. The skateboarders are mostly students and they come to train their skills where there are not so many to watch. Bristo Square is where the good ones go; here are the training grounds according to one of my respondents. What makes the square so good for training is the flatness and openness of the space facilitating experimentation on the planters and the water feature and using the gentle curvature that is in front of the CH entrance produced by the ‘twisting’ of the square when levelled. To avoid the use of the walled planters by skaters Peter Robinson, the project architect of the new square, had little brass balls placed on the walls facing the square, these balls draw inspiration from the water feature and will be talked of later in this chapter, but the skaters will be revisited in part II chapter 2.

Mr. Lamb also mentioned other uses such as when the square is let by the council (now in the form of ECCM) for events. He mentioned one event in particular; the Christmas March that would end on the square with a big stage in front of the Sheraton hotel. The event most frequently cited by my respondents was a Christmas market that was tried on the square during the weekend of 3-5/11 2000, by the ECCM. After that trial complaints came in from the surrounding offices and businesses about noise pollution, safety issues and littering. Additionally it was feared that the market would distract the workers of the

Clydesdale Bank Plaza (CBP) and CH. The city's planning department was there taking pictures to evaluate the trial and according to them it was a success and they wanted a rerun on the 20-23/12 with a week of local producers market before that (*The Evening News* 30/10, 9/11, 14-19/12 2000). Surely in retrospect the trial was a success as thousands of shoppers came and it obviously made an impression on people as it was almost always cited in my interviews when an interviewee was asked about any events taking place on the square, but in the end this market ended up around the Scott Monument near Waverley station. Another event frequently sited by my interviewees was an inflatable structure with a light show inside, set up in relation to the Edinburgh annual film festival in 2001 referred to as the "inflatable monstrosity" by Peter Murphy, one of my interviewees. During my stay in Edinburgh the square was used on seven occasions, two of those using the square as a rallying point to protest the war in Iraq, once the post office set up a service booth for a day due to the refurbishment of a nearby branch, two car shows were held there and a 2 hour musical event during Easter, with the explicit aim of extending Edinburgh's festival calendar, was held there. Finally the square is used for various events during the Edinburgh Fringe Festival in August as one of the venues, the Pod, was set up there in 2003 (see Edinburgh Festival Fringe, 2003). All in all the appropriation of the space as event space is developing and intensifying, a point I will pick up on in part II, chapter 2 (Ian Spence, Henry Gibson).

Thanking Mr. Lamb for his elaboration I went on following the wall of Capital House. Upon reaching the end of the wall there is an alleyway between the Sheraton hotel and CH leading up to a car park on Morrison Street. There is an archway under the western wall of CH that runs parallel to that path and where it starts there is a shady corner which I caught a glimpse of before turning towards the water feature and the Sheraton hotel.

3.1.4 A conundrum

This shady corner is the only place on the square the local police have had any serious dealings with. When asked in general about police dealings on Festival Square the local P.C. Charles Hardy, who was the community officer for Tollcross and thus Festival Square, said the main complaints were to do with the skateboarders and the damage that

they are causing to the stonework on the square. In this case the police are powerless to act and at best can only tell them to move along. However, more seriously, recently it had been brought to their attention that the square was being used for dealing in drugs. The reason why the square has become used is due to its closeness to the centre of town but also because it is not overlooked by any private houses, only businesses that are mostly closed evening and weekends. The Sheraton is busy round the clock, but does not overlook the entire square, in particular that corner. Therefore this corner has been chosen by dealers to do their business, the corner having the additional benefit for them of having a two-way escape route, both up the alleyway and over the square. Having the square in view from that corner also gives a good oversight to spot police coming from a long distance. The ease with which they can spot police means that those caught also have time to rid themselves of any incriminating evidence and thus will not be in possession of any drugs, but P.C. Hardy carries on to claim they know that they are dealing as the last one caught is an established dealer and a regular of the police.

To put this problem in the context of Edinburgh city, according to P.C. Hardy and corroborated by a study by the Scottish Executive (2003), there is an increase in heroin at the moment and in the Tollcross area in particular, it is an area that has got a drug problem, due to it being central and having many homeless people. P.C. Hardy claimed they have been seizing a lot more of hard drugs such as heroin and crack cocaine over the last couple of years compared to when he started with the force 6 years ago. In general having drugs move into Festival Square is a manifestation of the increased drug problem in the city of Edinburgh but there is growing use of heroin and crack cocaine but almost solely noted in age groups above 30. These claims are established from the increase in deaths related to drug use along with police seizure of class A drugs (Scottish Executive, 2003).

With a glimpse into the drug problem of Edinburgh and Scotland in general I turned to follow the front of the Sheraton and as I did so, directly in front of me was the main feature of the square, a fountain that has been placed under the front of the Sheraton hotel. The fountain itself is a big silver sphere with water coming out from the joint

between the two half spheres forming the whole one. Around the main sphere there are other spheres of varying sizes 'spilling out' from the main silver sphere and onto the square. With the redevelopment of the square the aim was to replace the rather too big water feature of the old square with one that was to be "softer and warmer" (*The Evening News* 26/1 1998) and would be "a work of art that uses water and sculptural form to provide a focus for the square" (Whatmore, 2002, p. 19). The original intention was to apply for National Lottery money to fund it (*The Scotsman* 28/1 1998) but as that funding did not come through the water feature was chosen and paid for by the EICC. Thus the EICC held an international competition with the piece chosen by a committee on which there were Peter Robinson, the new square's project architect along with its landscape architect, Ian White, one member representing the city council and one representing SEEL. This committee came up with a short list of about six artists; with the winning design coming from Remco de Fouw, a Dutch born artist living in Dublin.

His design inspiration came from extremely intricately carved stone balls, with Celtic interweaving, repetitive patterns, dating back to Neolithic times. These had been unearthed all over Scotland and were believed to have been used, in earlier times, for purposes of exchange. The designer said he was representing creation thus in the water feature there is the 'mother ball', one that spawns or generates smaller balls that then 'spill out' onto the square and tie the space together centring on the water feature (EICC, 2000). These balls were eventually to spread, in time, all the way over to the Usher Hall and rather than trying to fight against that Peter Robinson and Terry Farrell picked up on that. Hence Mr. Robinson designed the brass, tennis-ball sized spheres, reflecting those in the water feature, that were placed on the planters all the way around the square to discourage skateboarders, although they seem to have become more an attraction rather than anything else. The actual building of the water feature also took into account the distraction of skateboarders and hence material chosen for it was to be supposedly skateboard proof, but the reality turned out to be very different and actually the skateboarders make mostly use of the water feature and the area around it. The balls, being generated from a centre or 'mother ball' and spilling out onto the square, represent another feature of the design idea, the fact that the stones were used for purposes of

exchange which sings nicely to the tune of the capitalist logic behind Edinburgh's new financial district, The Exchange.

In general the design has been criticised with the view of the HCE that the back wall of the water feature should be about 600mm, or as much as a meter lower. This would allow those sitting in the terrace restaurant of the Sheraton to see everything that is going on in the square and have a clear line of vision to the UH and the castle, rather than just to the back wall of the water feature. Also the Scottish Cultural Trust (SCT) criticised the decision made for not involving locals in the process of choosing the piece of art and also that not much thought had gone into the work (*The Evening News* 3/2 2000). This lack of thought cited by the SCT was claimed to stem from the late involvement of artists into the design process of the new square. If the artist would have been involved from the start the look of the work would have been kept in check (*The Evening News* 7/1 2000). Instead the artist had to work his ideas into a predefined and already constructed lot on the square that put restraint on the design leading some to see the water feature as stunted, an impression I share.

The name of the piece was *First Conundrum* (*The Evening News* 15/12 2000) and we are left guessing what was on the artists mind coining that name, but the feature surely draws attention of those passing on foot down the busy Lothian Road with many coming to sit around the water feature on a good day. The draw of the water feature is especially evident during night time with couples coming into the perceived privacy of the square to make out and boys having fun jumping onto the 'mother ball' and sliding down into the water.



Figure I.14: The Water Feature on Festival Square, during night and day.

Source: E. Huijbens

The feature also draws the attention of people as they pass through the square as was evident from the frequency of citations when I asked if people had any comments on the square, but apart from the skateboarders the water feature had the most (32 of 200) but neither outweighing the complaint over lack of seating on the square (41 of 200). Most people liked the water feature and described it as ‘nice’ although a few considered it ‘tacky’, but what was noticeable when asking people to look around and say if they had any comments, this seemed to be the only visual primer perceivable to them on the square. By far most of the people I asked looked around the square, shrugged and just said ‘nice’ or ‘clean’ and ‘tidy’ (76 of 200) being unable to hook onto anything that they could formulate an opinion on, reflecting clearly the open flat emptiness of the space.

What produces opinion though, at least amongst my interviewees, was the Sheraton hotel that was the first building on the site and forms the backdrop for the water feature with

the Grill Room, its terraced restaurant completed in 1992, looking onto the square (see Figure I.14, lower right corner). Invariably my respondents would describe the hotel as a bad piece of architecture, very bland at best, and not really anything of special appeal or note for the site. The hotel is the oldest building on the site, completed in January 1985 and the only comment to be found on it, in the numerous books on Edinburgh's architecture was one by McKean (1992) who described it as 'plain stone-faced monolith with a neo-classical tinge' while Mr. Sampson said it was not anything really and surely no monumental design. It is though a five star hotel with 260 en-suite bedrooms and 16 specially decorated luxury suites with room prices ranging from £120 to £380 a night depending on the room chosen. The hotel is part of a chain of more than 400 hotels and resorts in over 70 countries and is the largest brand of Starwood worldwide, other brand names being St. Regis®, The Luxury Collection®, Westin®, W® and Four Points®. Through these brands, Starwood is represented around the world with two business segments, hotels and vacation ownership operations. At December 31 2002, Starwood's portfolio included in total 748 hotels owned, leased, managed or franchised, with approximately 227,000 rooms in 79 countries (www.starwood.com).

The hotel caters for luxury and the main clientele is there for leisure but also corporations that book in for some conferences or events. The hotel is responsible for some of the traffic on the square although the entrance to the hotel facing the square is not its main entrance. The main entrance is on level with the road system and faces to the West and from the point of view of Festival Square that entrance is underground. The hotel thus has the main stream of visitors coming and going by car, making use of the car parks constructed underneath the Conference Square once the site was levelled. Those passing through the square are guests going to town on foot with 7.5% of those responding to my questionnaire describing themselves as tourists there for leisure but 6.5% said they were visiting for work. Also on numerous occasions people attending meetings or conferences hosted by the hotel, would come out onto the steps leading to the square. All these guests pass through the square just like the office workers and run the same risk of collision with skateboarders as was one of the main worries of the hotel's general manager Peter Murphy, but in the year 2002 two literally crashed into guests. Without doubt the main

clashes between users on the square are the ones between skateboarders and the other users and in a way represent the square's first conundrum.

3.1.5 The Usher Hall

As I stood on the steps of the Sheraton behind the *First Conundrum* and looked onto the square I saw immediately why it is important for the Sheraton to have the view from its terraced restaurant and rooms not obscured by the water feature or any event or item put on the square. Towering on the escarpment above is the Edinburgh Castle, the focal point of the city and its main attraction making it worth its UN World Heritage Site status. It was the view to the castle Mr. Sampson saw as primary when designing the square as enclosure but now it complements a more direct view across the square to the Usher Hall on the other side of Lothian Road.

With the construction of the Conference Centre and the rest of the Exchange, a financial quarter had been constructed in the city along with two new public spaces. The area was to be teeming with pedestrian life and activity and hence the ground floor of the buildings in the Exchange crescent and CBP were designed to house retail units and restaurants. What was to complement the site was a close and clear link with the theatre and entertainment quarter across the street, but on that side there are clubs and bars along with the Lyceum Theatre, the Traverse Theatre and Edinburgh's major performance venue; the Usher Hall.



Figure I.15: The Usher Hall with Edinburgh Castle in the background.

Source: E. Huijbens

In order to facilitate this link the masterplan envisioned a wide crossing, functionally “rolling Festival Square like a carpet over to the UH” (Duncan Whatmore). This has not happened yet but with the remodelling of the UH, being undertaken by Law Dunbar-Naysmith architects, these ideas are still very much on the table and both John Farquhar and Colin Ross are engaged in negotiations with the Highways and Transportation authorities of Edinburgh City Council on how the crossing can best be executed, the current idea being of a toucan crossing intended for cyclist and pedestrians. The crossing is over Lothian Road, which along with its junction with the WAR, generates a great deal of traffic into the city. Regulating this traffic to allow for the flow of pedestrians is no easy matter. But there is another problem with establishing the link to the UH and that is a visual one.

Mr. Sampson recognised, when designing the original square, that the Usher Hall is a very curious building in its axial alignment. The doors which face Festival Square are not

the main doors so the axis of the UH did not align in any satisfactory way with the square. Although there was consideration also given at that time, and further back (see Town Council, 1949), to try and integrate Festival Square with UH, Mr. Sampson could not see anything gained by creating an axis between the Sheraton hotel and UH. It would be an axis between, what was after all, a back entrance to the hotel, the front entrance being on the other side, and the side entrance to the UH and it seemed to him "sterile to pursue that as the main axis of design" (Douglas Sampson). The curious axial alignment is very well recognised by the project architect for the Hall's remodelling, Colin Ross, seeing UH as a piece in isolation, without a strong sense of context. Its axis bears no relation to the surrounding built environment but that is deliberate in the original design. The design is about the geometry of the building and is antipathetic to the space within which it resides; its design is about form, not context so setting it as the focal point for the square seems to him a bit problematic. Yet in Farrell's masterplan the idea is to set the building as one of the axis for the square although it does not communicate with its architectural environment.

With the Usher Hall in view and the Edinburgh Castle as backdrop I descended the stairs down to the NW corner of the square where the Exchange crescent starts that leads up to Conference Square. Barely noticeable and set in the wall of the Sheraton are two doors both of which are used by the Shining Stars, one as their equipment room and the other as their coffee/storage room, the latter referred to as the Saddam bunker. It is through this very corner that most of the traffic through the square flows (see Figure I.16) and it was here that I spent most of my time watching the people on the square and filming and photographing their movements.

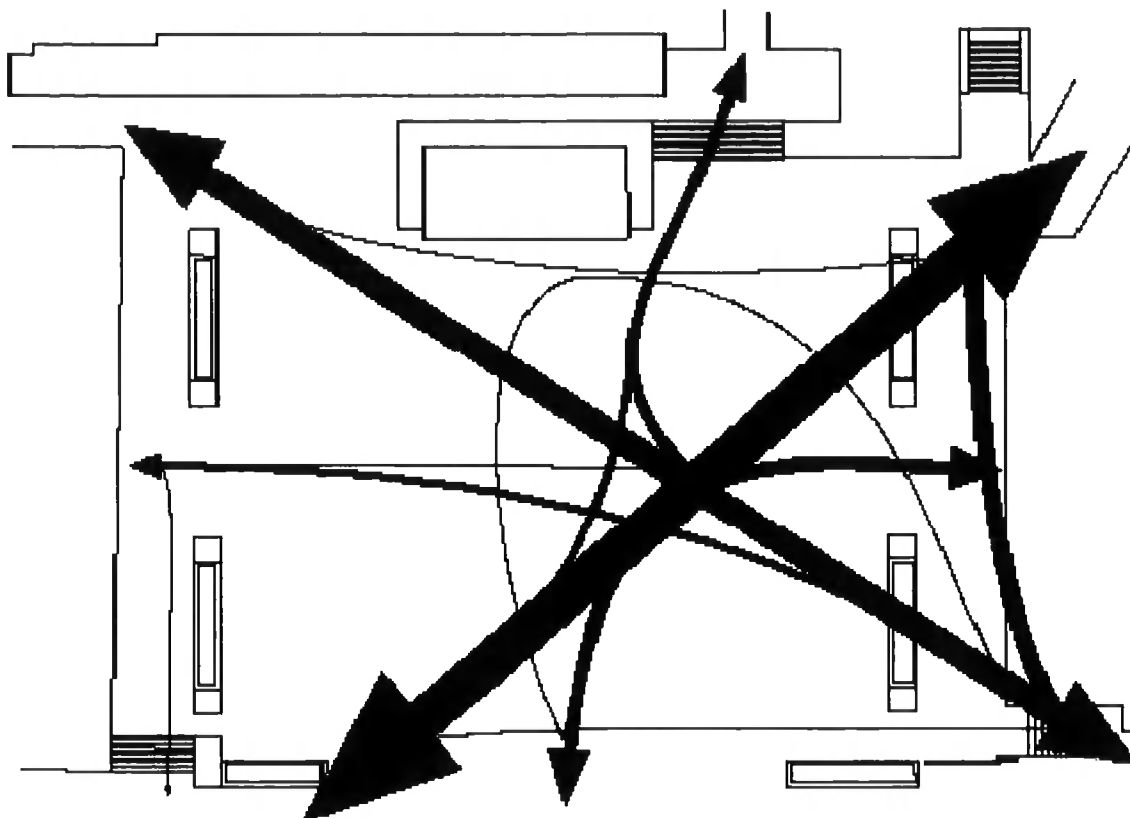

Figure I.16: Routes on Festival Square. The arrows represent the major directions of flow across the square.

Source: E. Huijbens

3.1.6 Flows and paving

The corner is on the boundary of the responsibility of the city council and the design by Ian White and Associates. This boundary is most clearly manifested in the paving slabs the material of which changes abruptly at that boundary. In the square there is a distinct grid pattern to the paving with the boxes in the grid made of Scottish Caithness slabs, which are slate, and the banding of the grid made of Portuguese Montemuro granite. These slabs were chosen as Ian White and Associates found the York stone of the old square unsuitable for the prevailing damp weather conditions in Edinburgh and Scotland as it retains too much moisture, being sandstone. The grid's N-S lines symmetrically line up with the main columns on the frontage of Clydesdale Bank Plaza (see Figure I.17), while as the E-W grid is asymmetrical, pointing to UH with two rows of trees and one row of planters on either side of the square. The materials were chosen as they are

durable but in the walls of the planters around the square the material is York stone, earlier mentioned, reflecting especially the material of the Sheraton hotel, while as CBP is made from Dunhouse Buff sandstone. In areas especially 'twisted' due to the levelling of the square there are granite cubes. On the other hand where the involvement of Ian White and Associates ceases and the CALA Morrison, the builders of the CBP and the crescent, takes over the slabs are smaller, thinner and made from York stone again. These slabs tend to be all more or less loose and broken due to being thinner and weaker. This area of jumbled broken slabs makes for interesting acoustics especially in the corner by the storage room where they are mostly concentrated, but at the same time poses a considerable danger to passers by as they run the risk of tripping over these slabs, the slabs being thus a constant source of annoyance to the Shining Stars.

The main reason why I chose this corner originally was because it is the sunniest, when the sun is out. The South side of the square is in shadow for most of the year thus people always gather on the Northern side under and in front of the walls and arcades of the CBP, where the sun manages to peek above the CH during the winter months. The limited sunlight on the square was to be remedied with the planting as it was designed to bring light into the square, through reflection of the canopies of the box-shaped pleated lime trees that are in double rows on either side of the square. This effect becomes clear once the trees are in full foliage, but again for most of the year that is not the case. The difference in sunlight on different sides of the square was most clearly manifest in spring when there was a whole two weeks difference between the leaves coming out on the south side and the north side, with the exception of a part of one tree that received a shaft of sun light from the gap between CH and the Sheraton hotel. The other plants on the square are the evergreen conifers in the low planters that are trimmed low to maintain the openness of the square.

In the background of that corner towers the Clydesdale Bank Plaza (CBP), the most recent addition to the square's surroundings, completed in 1998. The side that actually faces the square is again a back entrance with the front being designed in conjunction with the Standard Life Bank headquarters on the other side of the WAR and linked to it

via a steel bridge, crossing the WAR, which is a key to the sites permeability and link to the New Town (see Figure I.7). Both of these buildings together form an impressive towered gateway to the WAR as seen from Lothian Road a bit before you come into view of the square coming from the centre of town. The CBP derives its name from mainly housing the Clydesdale Bank, and the building can be seen on the back of the 10 pound notes they issue. Clydesdale Bank was taken under the umbrella of the National Australian Group in 1987 and is unique amongst the four Scottish banks for being the only one headquartered in Glasgow instead of Edinburgh. The National Australian Group is the umbrella name for the National Australian Bank Group with banks trading under their own name in the UK, Ireland, New Zealand and Australia. The bank has a retail bank facing the square along with two ATM machines on the corner of the square and Lothian Road, along with offices in the building for their Edinburgh operations (www.cbonline.co.uk). The CBP also houses State Street, a global investment advising company founded in London in 1972. State Street advises companies, including pension funds, supranational organisations, large corporations, insurance companies, banks and investment managers on where to invest on a global scale and has offices in 29 countries worldwide (www.statestreet.com). Burness, a Scottish commercial legal practice with offices in Glasgow and Edinburgh is also housed in the CBP along with Cairn Energy, an independent, public oil and gas exploration and production company with operations in the North Sea, India and Bangladesh. Cairn's head offices are in the CBP while as Burness' office is equal to the Glasgow office, both of those housing the whole company.

Terry Farrell has openly criticised the CBP for its design, as he did not see it fitting with the masterplan. The Royal Fine Arts Commission is in agreement but as CBP was being developed the designers at Cochrane McGregor working for CALA Morrison constructions had their own ideas independent of the masterplan and took guidance from the SL headquarters designed on the other side of WAR (*The Scotsman* 30/7 2001). The critique waged against the CBP echoes also a grander critique of the Exchange scheme itself with Martin Hulse, the director of the Cockburn Association, Edinburgh's Heritage Society, quoted saying that the buildings are "purely functional buildings...the overall standard could have been much higher" in an article assessing Rodger's (2001) book (*The*



Evening News 12/6 2001). Another critique comes from the architect and professor Charles McKean who is quoted saying that the buildings are designed on “empty clichés” and are “pieces of architectural emptiness” (*The Evening News* 6/5 2002).

The Royal Fine Arts Commission has been cited before in this thesis with their concern for the lack of retailing and non-office functions in the design. The response to that was to design the ground level of the buildings along the Exchange Crescent and the CBP, with the aim of housing retail. The CBP is the only place where that has happened with the retail branch of the Clydesdale Bank and the All-Bar-One.



Figure I.17: The Clydesdale Bank Plaza.

Source: E. Huijbens

3.1.7 Break for coffee

On the ground floor in the corner right behind me is the All-Bar-One (ABO), a restaurant and bar open 11.30 in the week but 12.30 on a Sunday till 1am. ABO rent their space there and opened along with the opening of the CBP in 1998. It is owned by Bass Brewers, with 49 branches all together throughout the country, but with the majority in London. The ABO started up in 1994 in the City of London, and has now two branches in Edinburgh the other ABO being on George Street in the heart of the old financial quarter of the Golden Rectangle. Their main concentration is in the City of London and the West End and they aim for financial office spaces in other cities too. The reason is that ABO is traditionally aimed at young professionals of the age 21-40, with emphasis on being a female friendly bar. Based on a study done into what attracts women of that age group the bar is designed with plenty of space, non-cigar-smoking, with good ventilation and large windows open to the outside. Children are specifically not allowed into the bar along with all people under the age of 21.

The ABO is busy around office hours, getting very busy at lunch times with all the office workers from the CBP and the SL especially. The next rush is in the late afternoon and early evening after work, after that it tends to die down as the night wears on and the office workers head home. On weekends the clientele will vary more than during the working week with the predominance of office workers compromised by people coming in of Lothian Road, so Fridays and Saturdays along with the evening can get very busy, especially if the sun is out and people can make use of the outside seating that is in the corner where the Exchange Crescent starts (see Figure I.17, lower left corner). On an annual basis the ABO is busy over Christmas and the three weeks leading up to it. But immediately after, beginning January, and for the rest of winter it is very quiet, with probably half the normal trade. By the end of April business starts picking up culminating with the Festival coming in August with the place packed for about 6 weeks.

When walking further along the CBP reaching the corner at Lothian Road there is another point which people use a lot for mainly two reasons. Firstly there are two ATM machines of the Clydesdale Bank that constantly attract people at any time (see Figure I.17, lower

right corner), secondly this is a favoured spot for clubbers going to or coming from Lothian Road to congregate, most often to urinate on the walls below the steps leading down to Lothian Road. Towering above is a mounted CCTV camera that faces down the Lothian Road and here the flow of people both during day and night, up and down that busy road, can be felt the most. In light of how busy that corner is a blue coffee stall was placed there in order to capitalise in a certain way on this flow of people, that stall is, what one could call, the Big Issue manifested on the square.

One thing I found striking about Edinburgh is the amount of homeless people begging in the streets, especially in the centre with Lothian Road being no exception. But no one begs on Festival Square as homeless do not see it as a busy place and hence not a lucrative 'turf'. But especially since the square is not too busy, the Dash coffee stall was placed there. This stall is the manifestation of an Edinburgh based organisation called Streetwork, a voluntary sector organisation helping the homeless. The placing of the stall there was based on the success of a two years pilot project with a coffee stall in the heart of Edinburgh on Hunter square. Streetwork secured government funding for this project and it is considered of an innovative nature entailing the rehabilitation of extremely vulnerable young homeless people into the job market. The idea was to do that through job training in a coffee stall with not too excessive a workload (Richard Dufner). The stall was opened in June 2003 and is open to date (March 2004) but will be revisited in part II, chapter 1.

The stall was set up with enthusiastic support from the Sheraton hotel that provides the organisers with supplies and provisions such as water and electricity. On top of that Sheraton is one of the parties that have guaranteed jobs for those young people successfully completing the program. The Sheraton became involved due to its general manager's personal interest in Streetwork, which he learned about through the hotel's HR manager who organised a charity wall for the hotel's staff to support the organisation. Although the Sheraton is backing this project not all find it appropriate to have this stall on the square, although the matter is not highly contested.



Figure I.18: The Dash Coffee Stall and the uses of the walled planters as seating.
Source: E. Huijbens.

After drinking a coffee bought at Dash, sitting on the planters next to the stall, I joined the flow of pedestrians up Lothian Road. As I pass the square on my right the lights on the square are being turned on with the sun setting. There are four levels of lighting on the square, one mounted on large poles inspired by a Dutch design and put there by Terry Farrell on each end of the square, next to the water feature and then on Lothian Road. Secondly, there are big lighthouse-like cones to illuminate the square placed on the planters. The idea and inspiration for these lights came from Barcelona, where similar lights had been set up in relation to the Olympics in 1992 and these will be revisited in part III chapter 1. Thirdly in the planters themselves there are little light 'eyes' also to be found in the paving at ground level. The water feature also has its lighting and after seeing the square illuminate in the dark I got back to where I had started out next to the 'Woman and Child' facing the taxi rank and looking as the pubs closed how the rank emptied of taxis only to be filled again before the next rush at 2 am.

3.2 Concluding

In the above I have tried to convey a sense of the structuring of my dispositions towards Festival Square or the formation of my *habitus* in a space I had never used. The above narrative is an accumulation of my 10 months on Festival Square. To give a sense of the way in which I went about my everyday practice on the square, orchestrating without necessarily organising and incrementally internalising the materiality and uses of the square, I give an excerpt from my field diary on 16th of June 2003, 11.30-15.00:

“A warm, sunny day, clear skies and a slight breeze. Bill and Joe are mending the bins and Dash coffee is up and running and petrol being poured into the generator. The square is empty apart from a woman standing smoking and a person at the ATM...[later] People generally seem relaxed and calm the Volvo booth is gone and the square opened up considerably. The other point is that people seemed to be using ABO more on this sunny wonderful day, the sun seems to have a marked effect. Again I was seeing people staying on the square for lunch. Wendy was very friendly, got me one victim for my questionnaire and wants to meet me for a beer.”

The sounds and smells that accompany these experiences are absent, but ones that by now I am intricately familiar with and can bring me back to Festival Square wherever I hear them. For me the smell of boiling hops, laying over Edinburgh in certain directions from McEwan breweries, will always be Festival Square.

It was not my only aim to give a sense of the structuring of my *habitus* on Festival Square but also to set up the current spatial order. This spatial order manifests space as envisioned by Terry Farrell in the masterplan but what I hope to have shown, along with the making of my own *habitus* on the square, a host of other spaces ephemerally playing into this one space and thus indicating how still “landscape architecture and urban design are deeply ideological, both in artistic style and political purpose” (Low, 2000, p. 180) to be expanded in the next part of this thesis. The spatial order is one that we encounter everyday in interactions with the material setting manifesting the determined functions of planners and architects. These encounters show “the opposition between the rules of the game you’ve set yourself and the paroxysms of real life that submerge, that are continually undoing the work of setting in order – luckily moreover” (Perc, 1999, p. 132). Having set up the way in which my dispositions toward Festival Square were

structured using the notion of *habitus* set forth by Bourdieu in chapter 1, I hope to address some of the critique mentioned there in the subsequent parts, finally to make room for the paroxysms of real life.

Summary Conclusion of Part I

This part of the thesis I call creating the void referring to the creation and the structuring of the square with its prescribed functions and materiality as ready to hand. As indicated in the introduction the ideals that inform the creation of space might not be there to be found within that space, as these ideals represent deliberately constructed absences determining functions of the square. What is absent I hope to have shown glimpses of in the last chapter in forms of use, desires and manifest social practices that always have a subtle curvature that eventually shies away from all that is determined. Still some notion of the determination seems constantly to inform the creation of space, although having moved away from universal rationalised planning, architects and designers still retain a notion of the ideal belied in their determinations for space's functions. In order to understand the way in which these determinations function as deliberately constructed absences I started the first chapter outlining space in terms of its relationality thus arguing that all that is made cannot be seen in isolation, the square never emerges as set apart from the space within which it resides. Although this is well recognised by the architects as they determine functions of flow and how planning guidelines make the buildings blur into the cityscape at hand, there is more to relationality than this. Thus I moved on to the second chapter where I argued for the objective socio-economic structures and the way in which they structured the making of Festival Square. Lastly in my final chapter I fleshed out this relationality in terms of my engagement with the square as a pedestrian narrating the spatial ordering of the square and the structuring of my *habitus* on the square by this objective spatial ordering.

In chapter 2 I demonstrated how the first design of the square was to function as enclosure being the constructed absence. In its second manifestation the new Festival Square was determined as a space of flow, designed as part of a grander scheme of permeability linking spaces within the city of Edinburgh. These determinations appear as the result of an engagement with the idea of the motorcar city that was reflected in the design of the earlier square. The outcome of this engagement was the idea of pedestrianisation and the city as a theatre of lively interaction between people on foot in open pleasant spaces. The new Festival Square was structured towards these functions,

being able to facilitate events, manifesting the ideal of the lively theatre but also clearly setting up a venue for Edinburgh marketed as a Festival City. The ideal of Edinburgh as a Festival City is inseparable from the city's aspirations to boost its economy through tourism as will be detailed in the next chapter. Both squares manifested this ideal as the former was to be attractive for the Sheraton hotel, but the later design was to be open to the whole city. In that openness is manifest another ideal that the city was not only to draw tourism but also global capital. The whole area was designed and built in order to attract global capital and finance, manifesting the city's ideal of reinstating its former glory as the capital of Scotland and a capital city in Northern Europe. The square, with its links to the theatre quarter across the street, was to create a sense of open welcome to the city for those conducting business in the financial quarter and those attending conferences in the International Conference Centre. But although the city is aiming to attract tourism and global capital through the promotion of its Festival calendar and amenable quality of life through emphasis on pedestrian and street life, the city has a long and very specific design and architectural heritage and the square and its environs have to be seen as structured by that too.

But the socio-economic structures are not the only manifest relationality that needs to be mapped. The everyday uses and practices conducted on the square are profoundly relational to the square itself, structuring individual dispositions. Thus building on the theory outlined in the first chapter I prepare for the spatialisation of Bourdieu's *habitus* through narrating the spatial order, or the time-space trajectories settled in the present space of Festival Square. It is in this spatial order that social practices, informing the construction of *habitus* take place and in order to allow for space's role in this construction its current ordering needs to be mapped. Thus I became a pedestrian myself and took a stroll around the square listing and itemising what I saw on my walks. I was attempting to show how the very materiality of the space itself is a sedimentation of other social practices generated in other contexts. These processes are time-space trajectories that have local to global reach, that then materialise in each item or part of the materiality of the space. Hence through that materiality one can draw in the world, endlessly and that is what I attempted, giving a glimpse of that world contained in each space, in order to set

up for the coming part where I will try to set those time-space trajectories, momentarily stilled, in motion again through explaining how they play a role in the dialectical production of space.

All in all in this part I looked at the creation of a space born out of certain relationality that can be mapped by archival work and then be experienced through a walk through that space listing items and tying them to the information gathered. In the part Festival Square's relationality was talked of mostly in terms of socio-economic structures and with a spatial narrative in which the square's materiality acted as mere props in an endlessly complex 'system of representations' but was ultimately an inert object. But space emerging through its relationality is a constantly ongoing endeavour. What I want to do in the following part is to engage the very materiality also in the active constitution of the square. Thus I will need to address Bourdieu's lack of concern for space in his engagement with structuration theory where his use of space is limited to seeing it as an abstracted field of relationality not giving it any causal powers in itself, much like the spatial narrative of this part provided. Thus this spatial narrative will be picked up again in the subsequent parts in order to bring the square's materiality into its very construction. The theory of structuration as dialectical confrontation is clearly visible in the geographic literature on public spaces, i.e. how public space emerges under conditions of dialogical generation or dialectical confrontations and it is there I will go next.



Part II

Filling the

Void

Producing Space

The introduction to Part I revolved around the creation of void spaces and spoke of the void in terms of ideals and determinations informing the creation of Festival Square by macro-political forces, planners and designers. This void space, constructed as an artefact in the city of Edinburgh, gave insight into notions of construction or how it came about especially, as was shown in chapter I.2, when the ideals creating the void changed rather drastically over a period of only 13 years, manifesting in two very different materialities. In the previous part Festival Square was narrated in terms of the concretisation of ideals, described firstly through the socio-economic backdrop or macroscopic, institutionalised forces and secondly, through the materiality of the square. These chapters were in a sense scene-setting for the thesis in terms of theory and place where structuration theory served to argue for a relational space between the objective structures of earlier sedimented social practices and the materiality of the square. But this void space only gives insight into its construction indicating a broader, deeper loss or emptiness, cannily coded in abstracted ideals, which sets the context for the square's everyday usage and appropriation which will be fleshed out in this part. Hence this part of the thesis is about filling the void, or populating the square with the people that use it everyday in the context of its materiality and at the same time critique the idealism manifest in the first part that enabled overdetermined meanings (Goh, 2003, p. 51) or primarily functions to prevail.

This part aims to address the loss coded in the abstract by showing how everyday uses and appropriation of Festival Square come to fill the void. Therefore I will explain the politics that are inherent in the dialectical production of space, addressing Bourdieu's lack of spatial grammar and thus how he sustained a conception of the physical materiality of the space as void. Thus I build on Harvey's (2000) discussion from his book *Spaces of Hope* in order to talk about idealised, void spaces arguing for the reintroduction of utopian imaginings when formulating alternative spaces. Firstly there are different ideals or utopian imaginings of what the city is and could be that run parallel to the overdetermined functions prescribed by the planners and designer. On those terms the determination for the latter Festival Square was as an event space, a festive space that would become through use or what Harvey (2000) would call 'utopianism of social process' (p. 173). These determined social processes I outline in

the first chapter which is about ideals and utopian imaginings that those in power hold and are able to implement in the physical making of the materiality of the square.

But this temporal utopianism or ideal that sees space as malleable through time runs afoul once encountering space in its own materialisation. As Harvey (2000) argues “urban politics is fraught with deeply held though often subterranean emotions and political passions in which utopian dreams have a particular place” (p. 157). Hence in terms of Festival Square, although being designed on the ideal of facilitating processes and events, through being prescribed as such it becomes overdetermined as certain dominant forces dictate what events and processes are to be and how the material is to be used. As an alternative to this process oriented utopianism, Harvey (2000) proposes a ‘dialectical utopianism’ (p. 182), which would be explicitly spatio-temporal, recognising (and citing) Lefebvre (1991) that “the production of space must always remain as an endlessly open possibility” (p. 183). Therefore I go on in the second chapter of the part to outline how other ideals and the everyday uses of the square do not always go parallel to the prescribed functions of the planners and designers. Therefore sustaining Harvey’s (2000) argument that instead of refuting utopianism, one should harness the political force derived from the ideals that he claims lurk in all human desire allowing for a utopianism of alternative imaginings when grappling with the materiality of space. Through a dialectics of alternative imaginings, informed by ideals, and space as determined the struggle for the production of space can be furthered and hence the scene is set for much of this part.

“The task is then to define an alternative, not in terms of some static spatial form or even of some perfected emancipatory process. The task is to pull together a spatiotemporal utopianism – a dialectical utopianism – that is rooted in our present possibilities at the same time it points towards different trajectories for human uneven development” (Harvey, 2000, p. 196).

The thesis is set in public space and thus I take the dialectics outlined above through the literature on public spaces to further contextualise, in more practical terms, what the preceding part elaborated on in more abstract terms of structuration theory with reference to more institutional forces, backing up the creation of the void. By fleshing out in detail the dialectical understanding of the production of space and presenting empirical examples of events on the square and skateboarding based on productive dialectics and dialectical utopianism, I will give an idea how the dialectical

production of space can be used to understand the small scale political confrontation of different groups using and creating the space of the city, filling its void spaces. But at the same time I will start to indicate what is lacking in this dialectical understanding of space.

This lack is to be glimpsed through the main theorist engaged with in this part, Henri Lefebvre, who is inevitably credited with the aforementioned idea of the *Production of Space*. In his own work there is a strong leaning to phenomenology, which he formulated in terms of rhythmanalysis and represented the culmination of his critique on everyday life. This leaning I will address in the last chapter of the part where the rhythms will be explicitly linked to the habitual everyday routine that is the people's main use of the square. Thus firstly the chapter's focus is one on space following Crang (2001) as he states that: "Thinking of the rhythms of particular locales begins to offer a better grasp on the linking of space and time" (p. 206). Secondly I build on Bourdieu's *habitus* but tie it to the useful spatial grammar presented by Lefebvre (see Mitchell, 2000, p. 84). With both theorists combined I arrive at an understanding of these rhythms as habitual and disclosive of space through an order emerging from multiple rhythms once they are made sense of. But as Crang (2001) further argues: "The balance of the city in motion between repetitive rhythmical activity making place and passage through place is a matter that will vary empirically" (p. 206) and in the case of Festival Square I make the argument for the way in which it is a space of rhythmic flow fulfilling the determined function of the prior created void. Thus I maintain that the space emerges through flow composed of rhythmic time-space trajectories but since ultimately seen in a dialectical confrontation, will indeed fill the void but not without certain lack or damage being done which I will address in part III.

II.1 Producing Abstract Spaces

In this first chapter of part II I intend to outline the current debate in geographic literature on flows and the city in terms of the dialectical 'production of space'. This chapter thus picks up the main empirical observations presented in chapter 2 in part I. There I explicitly made the argument for place being structured by the objective socio-economic structures, or how place is historically contingent and went about mapping these contingencies. Here I want to introduce a more potent theoretical device than the rather simplistic history presented in part I. Premising my discussion on the idea of the 'production of space', I start the chapter with a short introduction of the way in which Henri Lefebvre grappled with dialectics (1968), forming the backbone of the production of space and then attribute the notion to him (1991) and talk about his 'writings on cities' (1996). Lefebvre's writings have informed the way in which understandings of urban spaces have been formulated in geography (see p. 117-8). To illustrate how space can be grasped through Lefebvre I will, in the second half of the chapter, outline abstracted ideals or produced abstract spaces and how these are made concrete through top-down management in the public space of Festival Square in terms of global finance, tourism and ideals of social justice. With the summary of the abstract debate and then concrete examples of work by other geographers, ending with my own empirical examples I will conclude this chapter with an understanding of how space is produced from the abstract.

1.1 Lefebvre on Dialectics

As shortly presented in chapter I.1.2 and 3, the term dialectics refers to the way in which one can critically examine all notions of process as being driven by a mechanism of contradictions.¹⁴ Genesis through contradiction is attributed to Hegel

¹⁴ Originally the term was developed as a response to dualisms that are premised on categories of the absolute and the essential. Thus it represents the first move away from essentialism, a move Hegel is usually credited with having made a conceptual break with the legacy of dualistic thinking in Western European thought. He argued that through introducing each element to its contradiction the two become locked in a dynamic constant confrontation. Thus, in dialectics, one element (thesis) cannot advance before engaging with its own contradiction (anti-thesis), be they internal or external, and through this engagement (or *aufhebung*) of the element and its contradiction, comes the process that projects the said element into the future as synthesis of the two. Each element in itself is also constituted by a former engagement through contradiction and propels onwards through that engagement, thus internal to each element is its own seeds of change. By explicitly tying elements to their contradiction in order to propel them into the future, they are made historically and socially contingent. By making these processes contingent to history and society the dialectical scheme moves away from the idea of truths that stand for all times or unalterable knowledges, as by being defined by

and dates to the early 19th century, but Karl Marx furthered that scheme through a critical reading of Hegel formulating his dialectics on explicit materialist groundings, i.e. the interactions of capital, labour and land, which in the later Marx was trimmed down to a political economy detailing the struggles between labour and capital leaving behind the role of land. This trimming down of Marx was the prevailing understanding reigning in French Marxism at the time of the original writing of Lefebvre's *Dialectical Materialism* in 1938. In the prevailing French reading Marx's political economy was equated with science drawing inspiration from Stalin's reading of Marx. This Stalinist dogmatism of the French left was based on seeing the dialectics as the laws dictating the development of society and

“hence social life, the history of society, ceases to be an agglomeration of ‘accidents’, and becomes the history of the development of society according to regular laws, and the study of the history of society becomes a science” (Stalin, 1951, p. 22).

The prime task of this science was to disclose the laws of the economic development of that society (*ibid.* p. 37). This purely materialist conception neglected the fact that all science of whatever kind is in a dialectical relation with ideas and abstractions. Thus Lefebvre, countering the then prevailing dogma that shunned early Marx claiming it was tainted with Hegelian idealism, brought the two together producing:

“the dialectical method, worked out first of all in an idealist form, as being the activity of the mind becoming conscious of the content and of the historical Becoming, and now worked out again, starting from economic determination, loses its abstract, idealist form, but it does not pass away...idealism and materialism are not only re-united but transformed and transcended” (Lefebvre (1968, p. 84-85).

Further Lefebvre excavated the role of land from the writings of Marx's and therewith all the three elements at play in the Marxian dialectic. Hence Lefebvre “in 1939

the contradiction the true and correct become relative. Marx critiqued Hegel for reducing contradiction to a logical essence, i.e. making the contradiction determinable *a priori* by an analytical mind. Where Marx took issue especially is that in the Hegelian formulation everything is reduced to thought; reducing the contradictions in the end to a mere postulation of the mind (see Lefebvre, 1968, p. 65, p. 79). In response Marx formulated his dialectics on explicit materialist groundings, i.e. the interactions of capital, labour and land. So while the Hegelian dialectics was about moving away from fixed essentials and how elements are propelled into becoming through an engagement with contradiction, albeit them eventually being reduced to the postulations of an analytical mind, Marx developed... historical materialism that was explicitly materialist showing how the politics of the real world contradictions played in propelling society and being. The three major contradictions at play, capital, labour and land, in Marx's formulation later became trimmed down to a solely political economy and struggles between labour and capital leaving behind the role of land (Elden, 2004a; Gottdiener, 1993; Holt-Jensen, 1999; Lefebvre, 1968).

[English translation in 1968] announce[d] that the dialectic was spatial as well as temporal, and that this realisation put Marx's system in a new light" (Gottdiener, 1993, p. 130). Upon this transformed and transcended understanding of idealism and materialism Lefebvre started to make sense of the role of space in material production through detailing how the abstract created space in confrontation with space that already is.

1.1.1 The production of space

The understanding of public spaces and the general production of space, as I showed in the case of structuration theory before, are built on the mechanism of dialectics. Dialectics create a relative space of constant movement as nothing can come into being unless through a relation, through contradiction and negation, i.e. "the concept 'production of space' means what Giddens calls 'the duality of structure'" (Gottdiener, 1993, p. 132). The previous section worked more closely with the dialectical in forms of structuration theory through the work of Pierre Bourdieu but, as stated in the conclusion of that chapter, his work separates time from space and he only pays lip service to spatial production and analysis. On the other hand the clearest formulation of the workings of the dialectic in the production of space is to be found in the work of Henri Lefebvre, especially his book, *The Production of Space* (1991). The key term here is 'the production of space' as opposed to Bourdieu's spatial metaphors of field and arrangements where social relations and their reproduction at best 'took place'. Hence I now turn to the later work of Lefebvre to understand precisely what is meant by production of space and later follow that up with implications for spatial analysis. The understanding presented below draws heavily on Elden's (2004a) close reading of Lefebvre's texts in both French and English.

The Production of Space, Lefebvre's (b. 1901) most influential book for geographers, was published in English in 1991, the year of his death. Lefebvre was still a Marxist scholar who now highlighted the role of space through his reading of Marx's dialectical materialism premised upon a synthesis with Hegelian dialectics, as I have shown in the previous section. His intention set him apart from other Western Marxist scholars and made him the only one to focus his concern on geographical matters. His influence on Marxist thought in radical geography is undoubted as he is built upon in

the work of David Harvey,¹⁵ Ed Soja (1996 and 1999) and Rob Shields (1991, 1999) and within the discipline and social sciences there is an ongoing concern for his work (Allen and Pryke, 1994; Amin and Thrift, 2002; Borden, 2001; Brenner, 2000; Crang, 1999; Elden 2004a; Franzén, 2002; Gottdiener, 1993, 1994, 2000; Grönlund, 1993; McCann, 1999; Merrifield, 1993, 2000; Mitchell, 2003; Smith, 1984, 1996). However Elden (2004b) claims that the work of most Anglophonic scholarship overlooks the main thrust of Lefebvre's politics and philosophy and through an engagement with the work of Soja and Shields, Elden (2001) suggests that they at best 'muddy' Lefebvre's political agenda (Elden, 2004a; Elden *et.al.* 2003; Gottdiener, 2000). Henri Lefebvre's politics and philosophy will hopefully be done justice to as I detail the role of Festival Square in the production of space as for Lefebvre space was produced in and through those social relations in a dialectical oscillation of the material (concrete) and the ideal (abstract) (Blunt and Wills, 2000; Elden, 2004a).

This dialectical oscillation needs further clarification. Lefebvre's notion of the production of space was the culmination of his previous sociological engagement with the transition of human population from the rural to the urban. He saw the urban, as conceived in modern times, as the epitome of calculated rationality through geometric patterning and rationalised planning, what he termed abstractions of space. His example was that of a new town in France called Mourenx, a town deliberately built and designed only to house the workers of a nearby sulphur mine. Here space was being created from abstracted logic and calculated rationality, certainly a production of space, but for Lefebvre (1991) the matter was not so simple as to conceive of space as merely a kind of material production of abstracted ideals as that led to the fallacy "of treating space as space 'in itself', as space as such" (p. 90). For him there were more spaces that got created, all informed by a host of different conceptions and ideals, implicit or explicit, of what a space could or should be, "thus covering the social relations that are latent in spaces" (p. 90). Hence production needs to be grasped as both material process and a mental process as well, as the move to abstraction and conceiving space as mental construct is always grounded in the concrete social relations latent in space and reproduces these (Elden, 2004a). Thus the mental means introducing the abstraction informed by the Hegelian dialect, to the

¹⁵ Harvey (1973) being the first to bring the attention of Anglophonic geographers to Lefebvre in his book *Social Justice and the City*. (Gregory, 1994; Merrifield, 2000).

progressive sense of the material production talked about by Marx. Hence, for Lefebvre, space itself is born out of the contradictions within the relations of production at the same time it profoundly shapes the apparatus of production. So “productive forces do not merely operate within space but on space, and space equally constrains them” (Elden, 2004a, p. 144). By accentuating the differences that the abstraction attempts to usurp and negate, Lefebvre (1991) says “space is at once *work* and *product* – a materialisation of ‘social being’” (p. 101-102, emphasis original).

In fleshing out the role of the concrete in the formation of the abstract Lefebvre’s emphasises the social being and critiqued Althusserian Marxism for conceiving of space in mere abstractions applied to the technocracy and rational planning advocated by the French 5th Republic under de Gaulle, with the consequence that all spatial discourses ultimately only represent dominant ideas. Lefebvre drew inspiration from art; especially cubist paintings that challenged geometric (abstracting) representations of space through “render[ing] the abstract space of three dimensions perceivable (*sensible*) and makes the perceivable abstract” (Lefebvre in Elden, 2004a, p. 182):

“There is not the material production of objects and the mental production of ideas. Instead, our mental interaction with the world, our ordering, generalizing, abstracting, and so on produces the world that we encounter, as much as the physical objects we create. This does not simply mean that we produce reality, but that we produce how we perceive reality” (Elden, 2004a, p. 44).

Here Elden (2004a) explains further how Lefebvre saw space as consisting of objects *and* the relations between them and the subject and the potential for the creation of multiple spaces. With this understanding space becomes conceived of as multiple, space that most certainly contains things that can be abstracted but is not a thing in itself, but a set of relations between things and subjects and thus also a matter of perception (Crang, 1999; Peet, 1998). Making space part and parcel of multiple social and material relations Lefebvre made his conceptual break with the Marxist tradition of his era. His emphasis was on how space is produced by and through the production and reproduction of social and material relations, thus avoiding fetishizing space through masking it as an objective ‘thing’ in itself, an inert container, or to be considered in isolation (Merrifield, 1993, 2000). For Lefebvre (1991) space “is always now and formerly, a present space, given as an immediate whole, complete with its associations and connections in their actuality” (p. 37). For him space “isn’t just the

staging of reproductive requirements, but part of the cast, and a vital, productive member of the cast at that” (Merrifield, 2000, p. 173). As Gregory (1994) writes:

“His purpose is to prise open the sutures between ‘immobilised space’ and ‘realized Reason’ by bringing the production of space into human history and disclosing the social processes through which ‘abstract space’ has been historically superimposed over ‘lived space’” (p. 354).

1.1.2 Framing Lefebvre

In order to understand those imperceptible processes at play in the production and reproduction of space Lefebvre sets up a “dialectical simplification” that is not supposed to be “a mechanical framework or typology” but “fluid and alive” with “each moment messily blur[ring] into other moments in real life contexts” (Merrifield, 2000, p. 173). Below I have adapted Lefebvre’s dialectics from Gregory (1994, p. 401) in what he calls “the eye of power” detailing the “lines of power” (Olsson, 1991) or forces that are acting in the production of space, as abstract space interacts with the concrete spaces of everyday life.

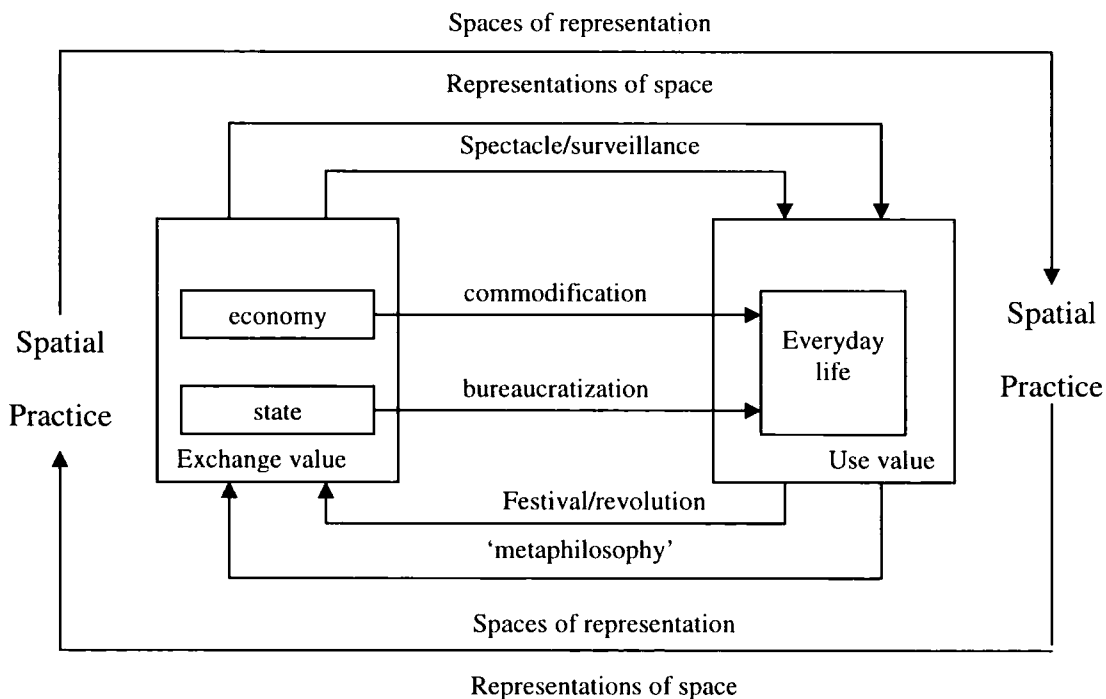

Figure II.1: “The eye of power” rather boxed up.

Source: Gregory, 1994, p. 401.

In this diagram the processes active in the production of space can be seen. Firstly there are two kinds of spaces, abstract and concrete. Abstract space is concrete space

conceived through the rational mind that serves to optimise and concretise the aims and logic of the modern capitalist economy and the state (Lefebvre, 1991, p. 49). This abstract space thus comes to us in the guise of exchange value through commodification and bureaucratisation that conceive of concrete spaces via the ideals of spatial sciences as manifest in city planning and architecture and space as spectacle. Hence abstract space is produced and that “production of ever more abstract spatialities reach[es] ever further into the intimacies of everyday life” (Gregory, 1994, p. 364). The main consequence is the erasure of time and history from space through its abstraction and thus space receives autonomy to transcend everyday life. Hence the naming of the scheme ‘the eye of power’ since those doing the abstraction exercise power over space. Concrete space on the other hand is the scene of everyday life, where space itself has a use value and through spatial practices of festival or revolution, the Dionysiac life, or “metaphilosophy”, has the potential to reformulate abstract space. The struggle here is between representations of space and spaces of representation and is played out in spatial practices. In order to further understand these three ideas struggling through producing space I will now talk broadly on each of them.

In order to analyse the production of space Lefebvre (1991, p. 16) proposed a triad of spatial concepts that frame the ‘eye of power’ in the above. First, the social relations composing space and the one Lefebvre saw as dominating today are representations of space that entail conceptualisations of space as done by an assortment of people that conceive of space within the context of the prevailing order in that society.

“Representations of space: conceptualised space, the space of scientists, planners, urbanists, technocrats...all of whom identify what is lived and what is perceived with what is conceived” (Lefebvre, 1991, p. 38)

The way these people conceive space becomes manifest in planning, buildings, monuments that reflect the dominant forces in each society, with their codes, knowledges and symbolisms legible from those spatial manifestations. The representations of space are the codifications used and produced by those who have the power to make their ideals manifest. These representations are seen as timeless and considered without history as it is rooted in the ideal. On the other hand spaces of representation are where everyday lives of people are lived out. These spaces are the physical material spaces perceived by those going about their everyday, or “space as

directly *lived* through its associated images and symbols, and hence the space of 'inhabitants' and 'users'" (Lefebvre, 1991, p. 39). Spaces of representation are the elusive spaces of lived experience, the "experiential realm that conceived and ordered space will try to intervene in, rationalise and ultimately usurp" (Merrifield, 2000, p. 174). By being lived through space is implicitly one where time and history are qualitative, fluid and dynamic.

What keeps representations of space and spaces of representation together but yet apart is spatial practice.

"Spatial practice is lived directly before it is conceptualised, but the speculative primacy of the conceived over the lived causes practice to disappear along with life, and so does very little justice to the unconscious level of lived experience" (Lefebvre, 1991, p. 34).

The spatial practices of those that go about their everyday live in space can thus be formulated in two ways. Firstly, in terms of those who consciously use space in a contradictory manner to the prevailing spatial order and coding. What I am indicating here is what Harvey (2000) argued for in this part's introduction, i.e. that one's spatial practice should be informed by ideals and imaginings of what one wishes space to become. Thus, in his reading, one should counteract the prevailing order through a reading of space as it is and then consciously re-imagine it. Secondly there are those that through being and using space in their everyday life unconsciously subvert the determined functions of space merely through being there or acting in ways 'inappropriate'. These two kinds of subversion are what Lefebvre highlighted, with special emphasis on the latter, when he talked of the appropriation of space but both aspects will be drawn out in chapter 2. All in all there is thus a dialectical interaction of the conceived and lived space, between that which is ideal or mental and that, which is practiced and material. These practices structure and embrace both production and reproduction of social and material relations and assure their cohesion while travelling routes, paths and networks of conceived and lived spaces through spatial practice. Here I want to carry on to the second half of the chapter that details the material manifestations of the modern day dominant ideals or representations of space and how these manifest in the space of Festival Square.

1.2 Abstracting Space

In Lefebvre's analysis the prime motor in conceiving of space in the abstract is the capitalist economy. In terms of Festival Square the capitalist logic behind its development and the redevelopment of the whole Exchange has been discussed in the previous part. In the following I will formulate the ideals and determinations of the capitalist economy in terms of abstract spaces, or how the determination of functions and deliberately constructed absences from the previous part are handled by Lefebvre.

A prevailing myth in the planning and development discourse outlined in the previous part is that of the absolute fluid conditions of finance and capital, of all kinds, on the world stage allowing for a top-down management approach to public spaces as planners and developers resort to rationalisations from this myth (see later). Several authors have dealt with this myth (see Albrow, 1996; Appadurai, 1990; Archibugi, 2003; Brenner, 1999; Harvey, 1998; Robinson, 2001), but here I will work through Lefebvre in outlining what, on first impression, might seem what Giddens (1990) terms disembedding, or how through lifting time and space into abstract dimensions, social and productive relations become disembedded from their place-bound worlds of reference and get reconstructed through the infinite expanses of timespace.

What I would like to argue below is that on close inspection, viewing the spatialities of the contemporary social organisation as disembedded social practices of localities is not the full picture as Crang (1999), following Lefebvre, points out. Crang (1999) sees capitalist ideals as acting through a variety of spatial categories which are pre-eminently produced spaces in the abstract. Seeing ideals and determinations as more than purely produced spaces in the minds of planners and developers resounds with Amin's (2002) spatial ontology for a globalised world where he emphasises a topology of overlapping near and far connections and relations (p. 386) that are "produced through practises and relations of different spatial stretch and duration" (p. 389), echoing Massey's (1991a) 'global sense of place'.

1.2.1 Grounding the abstract

The abstract spaces of flow are grounded in concrete space. Most geographic literature focuses on the city as the prime site for the grounding of these flows. The

city offers the clearest signs of the networking and ordering of these abstracted flows. The city has linkages world wide and is the basing point for flows of capital, people, images, technology and ideas, i.e. 'disembedded' social practices, that are produced through a topology of near and far relations (see Abu-Lughod, 1999; Appadurai, 1990; Dear, 2000; Dear and Flusty, 1998; Giddens, 1990; Sassen, 1994, 1995, 1996, 1999, 1999a, 2000, 2000a, 2000b; Sassen-Koob, 1984). This city where connections converge and are constructed is often termed a global city or world city, but as Short *et.al.* (2000) point out, all cities are influenced by global processes, though they can be ordered in a hierarchy of global cities, world cities and gateway cities respectively, according to their role played in networks of flows. Simply put "there is no such entity as a single global city..." (Sassen, 2000, p. 4), but rather the city is here viewed as a post-industrial production site, where it continues to exist as a territorial unit, but through a redefined spatial orientation and reach, i.e. outwards and global (Amin 2000, 2002; Sassen, 2000, 2000b).

Abstraction is always *in* process. This process has been abstracted in terms of flows and 'disembedded' social practices, but as Lefebvre pointed out, this abstraction, as all others, has its grounding in the concrete, producing that concrete. So the production of the concrete is a matter of practice, i.e. a "place making, through the myriad network practices and memorialisations that mark the sites we choose to call places" (Amin, 2002, p. 392 see also Amin, 2004, p. 40) or "places are also the moments through which the global is constituted, invented, coordinated, produced" (Massey, 2004, p. 11). In this world there is thus a play of varying practises making for the radical openness of the abstracted flows. The redefined spatial orientation and reach of the city through social practices leads here to a definition of its territorial unity as inherently open and borderless. This city is thus still in the making through social practices grappling with the linkages formed close and far.

Also to be recognised is that the social practices constitutive of the flows do not only function in the now but also have in the past. Thus social practices maintain a city's territorial unity through sedimenting through time and through this sedimentation,

capitalism has structured cities to its needs through the centuries.¹⁶ This sedimentation makes the city a product of both its past and present geographical openness (see Abu-Lughod, 1999; Allen *et.al.* 1999; Castells, 1996; Clark, 2000; King, 1996; Massey, 1991, 1991a, 1994, 1996, 2000, 2001; Sassen, 2000; Smith, 1992, 2001). Today cities are structured to the needs of abstracted flows that produce the city's infrastructure in a very concrete sense (Kofman, 1998). The city can thus be seen as the material hardening of the overarching metaphor of each era or epoch, but with the focus on practice there are more metaphors and histories at play.

In the above focus on practices and place making constituting the concrete at the same time as the abstracted, I am setting the scene for my fieldwork. I looked at a sample of a city, as looking at a whole city and its constitution is rather ambitious, to grasp how abstracted spaces constitute and are constitutive of the concrete in producing space. This sample is the space of Festival Square, which, by the nature of it being a public space, gives insight into official governmental policy of place making but also gives insights into practices recognising like Low that:

“purely aesthetic and macropolitical interpretations, however, are not sufficient for understanding the plaza because they leave out the people who use the plaza and its importance in their everyday life” (Low, 2000, p. 33).

The people I will be visiting in chapter 2 of this part.

1.3 From the Abstract to the Concrete

-the dialectics of space and place

As has already been outlined in chapter 2 of part I there were various factors at play in the original development of the site and its later redevelopment. I outlined the square's historical contingency in terms of a general urban renaissance in Britain in the wake of industrial decline, changing transportation practices and ethos, but most importantly, and especially with reference to the square's redevelopment, to the explicit place marketing of Edinburgh. Here I want to orient the debate to the future and the ideals informing the ongoing creation of the city in each moment of conflict and change. Thus, in this example, I will be tracing the ideals informing the planning

¹⁶The city seen as a historically contingent creation can be seen in evidence outlined on European cities being en-mythed in their imperial past (see Jacobs, 1996, Maspero, 1994) and as Dear (2000) points out is still to be seen in the creation of cities influenced by a globalised world.

and design conceiving the square. These conceptions stem from the abstractions made by those planning and designing as they rationalise the ideals informed by the political and social atmosphere producing abstract spaces.

This second part of the chapter deals specifically with three examples of the abstracted political and social forces informing the planning and design rationales that produced the square and its surroundings. There are three main ideals manifest in its production: Firstly, there is the notion of global capital and how the Exchange and thus Festival Square in its second formulation is conceived within the context of reinstating Edinburgh's glory as a capital city in Northern Europe and the second most important financial centre in the UK. Secondly, I pick up on the notion of place marketing¹⁷ from another perspective, i.e. that of Edinburgh promoting itself as a Festival city and an attractive destination for tourism throughout the year. Lastly I will pick up on a smaller example how subsequently, after its completion, the square manifests an aspect of the debate on third sector initiatives throughout the UK and how that is indicative of a socio-political force informing the politics that produce a certain space there.

1.3.1 Capital

Edinburgh is the capital of Scotland but the word capital features frequently in a double sense when it comes to the rhetoric surrounding the city's economy. The quarterly economic bulleting from the city council bears the name *Capital Review* a review of the capital city's capital revenues. Other examples abound, with 'capital earnings' referring to the wage structure of the city, 'capital skills' (see *Capital Review*, winter, 2004) on the workforce and 'capital comments' from the city's economy expert (Peat, 2004). In an article in the *Evening News* (Ferguson, 2003), *Two tales of one city*, the parodying of the word reaches a climax. The article summarises a report written on the future of Edinburgh city and what has become of it in the year 2020 (The City of Edinburgh Council and University of St. Andrews, 2004; McTernan, 2004). Currently the city of Edinburgh is experiencing an economic

¹⁷ The notion of place marketing has become the focus of local economic development strategies over the last 25 years and thus a focus of academic attention. For a summary of the academic literature on the topic and different uses of the notion see Millington *et.al.* (1997) (see also Hall and Hubbard (eds.), 1998). Here I use the notion as the application of marketing principals and activities along with place advertising and promotion through major projects and events that aim to raise the city's international profile in a globalised world.

boom (Lockhart, 2002) and it is with the aim of maintaining that boom that the council commissioned the research project that produced the report. In the report one city is viewed in terms of 'Capital punishment' (p. 51) and the other in terms of 'Capital gains' (p. 46). The report's main claim is the unique importance of the city of Edinburgh for the whole of the Scottish economy and consequentially the national economy and its competitiveness on the global market.

According to the report's claim of the unique importance of Edinburgh for the national economy, the Scottish Executive and the Westminster government are to pump millions of pounds into the city in order for its current economic boom not to 'fizzle out' (Ferguson, 2004). If these statutory bodies fail to do so they will contribute to the first city of Edinburgh the report outlines, a gloomy city, suffering capital punishment with extended ramifications for the rest of the country's economy. This capital is epitomised in the image of the future Lord Provost as:

"The Lord Provost was not looking forward to the press conference. Although she knew that Edinburgh desperately needed assistance from the Executive she still could not help feeling it was an enormous admission of economic failure to have to establish an Employment Task Force for the city. But she had no choice, not now the Royal Bank had successfully concluded its takeover of the Chinese State Bank and under its new branding as the Royal Bank of Beijing had announced that it was moving its HQ, and the remaining processing jobs, to Pearl River City. At the turn of the century, when she had been finishing her MBA at Harvard, it had all looked so different. Where had it all gone wrong?" (McTernan, 2004, p. 51).

What is being portrayed here is a city that has failed to address its current problems of a lack of affordable housing for a growing population and one of congestion and inefficiency of the transport system, but these are factors that threaten the current economic growth. With these factors not addressed the city has failed to remain competitive against the growing economies of Eastern Asia and Europe. These economies are identified as posing a mounting risk to Edinburgh's economy and future prosperity as they exert a pull on the major companies and those workers who are educated and skilled. The major companies that the Edinburgh of 2020 will lose are the Royal Bank of Scotland and Standard Life Insurance that through offshoring undercut the city's skilled workforce who are not competitive with those in the growing economies of the world. The suffering city of 2020 is one from which people move out fed up with the journey time of commuting, a city of failed transportation

infrastructure contributing to a slump in tourism further compounded by the atrophying Edinburgh Festival Calendar that has lost corporate sponsorship. All in all presented is a vicious cycle that potentially could culminate in the city's loss of its world heritage status due to its decay.

On the other hand, an alternative scenario is outlined in the report, where the city has succeeded in addressing the current issues threatening to curtail the economic growth. Hence McTernan (2004, p. 46) outlines what the Capital stands to Gain, again evoking the image of the future Lord Provost:

“The Lord Provost relaxed as her flight took off. As the land fell away, below her she could see the data havens of Dunfermline, the bio-campus of Bathgate and the bullet train heading to Glasgow. Being the first leader of a European city to hold the post of President of the European Union was an enormous privilege, but having led the decade long fight to have city-regions acknowledged as the fundamental building blocks of the new European prosperity she did not anticipate anything she would be unable to handle. The very flight she was on was a symbol of Edinburgh's advance in the last two decades. It was hard to remember that the Executive had once had to underpin direct flights to and from Scotland and now all Edinburgh's major partner cities – LA, Shanghai, Petersburg and Mumbai – were all on direct routes. With a million people living in the city region air travel opportunities had been transformed. Perhaps it could have been different, but somehow it had all gone right” (*ibid*, p. 46).

Here a future is depicted that has surely addressed the issue of transportation, culminating in Edinburgh becoming the hub for flights to major cities around the world through the early support of the Scottish Executive, presumably recognising Edinburgh's importance to the national economy. The city has retained those educated and trained in the higher education institutes of the city by providing jobs in 'data havens' and 'bio-campuses' built within its limits and has obviously provided affordable housing as the city's population has grown to a million. The city holds a key status in a united Europe, manifest in the provost's presidency of the EU, mainly through having convinced the Union (and presumably the Scottish Executive) of the importance of cities and city regions in the economy (see Brenner, 2004) and thus reoriented EU economic policy to the cities, based on Edinburgh's exemplary success.

Naturally both members of the city council and SEEL would like to see the second scenario unfold and thus planning and policy documents all focus on tackling the

problems mentioned above. Thus the Major Issues Report (Lothian Regional Council, Department of Planning 2000b), a precursor to the Edinburgh and Lothian's Structure Plan 2015, outlines the current problems facing the city's economy in detail. Firstly there is the problem of housing that comes as a response to the growth in the city's economy and population. Real-estate prices rise and people have to move further away from the city thus compounding an already sizeable problem of traffic congestion. Another key problem is how to keep the growing population employed and hence answer demand for more office space in order to keep major companies operating within the city. The demand for more office space should emerge in 2005, as by that time available space should be depleted, according to the report. The general undertone of the planning policy interrogated is on how to keep the city competitive in a global market of finance and investment. The planning initiatives are directed towards the ideal outlined in the second scenario. One of these is the creation of a major transportation corridor from the Scottish Parliament to the airport and further to Glasgow, dotted along which there are business parks and office spaces, the Exchange being the prime one in the city itself. These parks and spaces are to attract companies and induce them to stay in the city to cater for jobs both for blue-collar office workers as for those trained in the higher education institutes of the city.

It is surely within the context of that transportation corridor and the demand for office space that the Exchange was created as has been outlined, along with other factors in chapter 2 of part I. But in the above I orient the dialectic to the future with reference to the ideals informing those in charge of producing urban spaces in the material sense. Ideals that are manifest not only in gender aware images of the future Lord Provost, but dot the literature gathered and interview transcripts. These ideals revolve around the city as an economically prosperous place where "there is a glow of optimism on the cheeks of many executives and board members" (Peat, 2004, p. 3). There is an emphasis on the "economic advantages it brings of having a good public environment and public transport" (Ian Spence) thus the city of economic prosperity is one that seems to be able to hold on to wealth generating skilled professionals through a quality of life that "the heritage and fantastically built environment combined with outstanding cultural facilities and the strength of its universities [can] contribute to the city's consistently high appearance in the quality of life indices" (Garvie, 2004, p. 10-11). The high quality of life attracts the 'creative class';

educators, writers, entertainers, artists, architects, scientists and engineers to name a few that are seen as the backbone of successful economies in the 21st century city (Florida, 2004). But the role of the city in the quality of life indices not only attracts people but also companies of prestige with “an increasing number of English and overseas firms hav[ing] relocated all or part of their function to the Edinburgh area” (Martin, 2004, p. 12). All in all the rhetoric resounds with the vision of SEEL for a Smart Successful Scotland, entailing the construction of an enterprise network in order to secure “growing businesses, global connections and learning and skills” (Scottish Executive, 2001, p. 6) where Scotland is “a fast learning, high earning nation, a globally connected nation [with] every Scot ready for tomorrows’ jobs” (*ibid*, p. 6).

The whole of the Exchange was originally premised upon the creation of the Conference Centre that was a major flagship project of the SDA and the city council. The project was designed to raise the city’s international profile and precipitate the making of the Exchange that was considered integral to the economic viability of the city, which could not survive without suitable office spaces in an attractive environment. Implicit in the development of the whole Exchange is the remaking of Festival Square that was to be the gateway to this new financial quarter, thus I see the conception of Festival Square as very much informed by ideals born in the context of the globalised economy that cities today all try to carve a piece out of.

1.3.2 The tourist

Apart from the major businesses providing office work for a growing population the other ruling part of the economy of Edinburgh, and a recognised key to its ongoing prosperity, is the visitor economy, or tourism to the city, accounting for some 8% of jobs in the city (SEEL, 2003). Edinburgh is a world heritage site with some of the more spectacular architecture to be found in Britain along with some of the country’s most historic sites, notably Edinburgh Castle. Building on its status as a world heritage site has been easy for the city and it has an international reputation for its attractions being the second most visited city in the UK following London (National Statistics, 2003). But the city is not only building on its architectural and historic heritage, another aspect of the active place marketing is the promotion of spectacle events. On a national scale this promotion can be seen in the newly founded joint

venture between the Scottish Executive and VisitScotland, Scotland's tourist board, called EventScotland. The aim of EventScotland is to build Scotland through major events or "to lead and co-ordinate the drive to secure major events for Scotland, [their] mission is to enhance [the] international profile and make Scotland one of the world's foremost event destinations" (see: www.scotexchange.net/events_conferences/home_eventsotland_eventsotland.htm).

Spectacular events in Edinburgh have a long history starting with the Edinburgh International Festival (since 1947) and its accompanying 'Fringe'. These are now run along with the Book and Film Festival through the month of August, which culminates around the Military Tattoo. This height of the Edinburgh Festival Calendar is now actively being expanded through the summer and also into the 'shoulder seasons', i.e. early spring and autumn. To name a few in the beginning of September, following the Festival, there is a celebration of the multicultural Scottish identity called the Edinburgh Mela (E. gathering), started in 1995. Prior to the Festival there is a Science Festival in April, the Beltane Fire Festival on the 30th of April, celebrating the coming of summer (although debated a bit this year (see Ferguson, 2003a)), a Children's International Theatre Festival in May and June and a Jazz & Blues Festival in July (see <http://www.edinburgh-festivals.com>). Here I have named 10 but in total the city hosts 16 festivals annually with about 12% of visitors to the city citing them as their reason for visit (SEEL, 2003). Added to these Festivals starting early spring and lasting till the autumn there are: Edinburgh's Winter Festivals, a month long celebration in December, Edinburgh's Capital Christmas, that reaches its peak around the Hogmanay celebrations, the self-styled "world's best new year celebrations" (see <http://www.edinburghshogmanay.org>). Not only is the festival calendar being expanded but new festivals are being brought in with this year's (2004) latest addition being the Festival Erotique building on a successful pilot from last year (Davidson, 2004), along with Edinburgh's Easter Festival which will be discussed below.

The city council gives major financial support to the Winter and International Festivals and plays a large role in their management, while supporting the others less, these having grown in the wake of the success of the larger ones, mainly through corporate sponsorship. The promotion of the Edinburgh Festival Calendar is to be found in the rhetoric of the city's place marketing strategies with comments reflecting

the variety of festivals stating “it’s no wonder that Edinburgh has truly become the FESTIVAL CITY”, found on the Edinburgh’s Festivals site (see <http://www.edinburgh-festivals.com>) run by the *The Scotsman*. Others naturalise the city’s status saying, “everyone knows that Edinburgh is world famous for its festivals” as the Edinburgh and Lothian Tourist Board run by the city council state (see <http://www.edinburgh.org>). Eventful Ed, Edinburgh’s city guide to the events of the city states in unison with the above “The city’s world famous for its fantastic festivals and events” (see <http://www.eventful-edinburgh.com/city>).



Figure II.2: The promotion of the city as a lively, vibrant and festive place can also be read through photographic material.

Source: <http://www.edinburgh.org/>

With the view towards the Exchange site, the construction of the CC, that became the catalyst for the site’s development, was not only to catalyse office development on the site but was also to attract a certain kind of tourism. The city officials wanted to make the city attractive to the international business community and the existence of the Sheraton and its expansion with the health club is most certainly the concrete manifestation of that ideal. The city is now listed amongst the top 10 worldwide conference destinations, the only UK city to make the list compiled by the International Congress and Convention Association. Most certainly a vast amount of public money was poured into the CC, something the city’s treasury got back with the success of the site’s development (see p. 64) development, but will also generate income as a ‘shop window for the rest of the city’ having conference delegates returning on holiday. By now business tourism, boosted by events at venues such as the EICC and leading hotels, annually brings in an estimated £125m to the city’s economy (Ferguson, 2004a). Thus the city argues that the attractiveness and perceived quality of life surrounding these venues is of key importance. With this in mind the

redevelopment of Festival Square starts to make sense, as integral to the ideal of life quality in the city is pedestrianisation and eventfulness of the city's spaces.

Festival Square most certainly plays a role in the Festival imagery the city promotes. The name itself testifies to the city's International Festival and Farrell's idea with the design of the square, as flat open space was to make it an event space accessible to pedestrians making it especially useful during the International Festival. Designed to facilitate events and to be taken over by performances, the square also lends itself to events taking place outside the main International Festival. In what follows I will shortly describe the events that took place on the new square during my time of fieldwork there for ten months in the winter 2002-2003 adding events taking place outside my fieldwork period that I found through my archival work

The start of my fieldwork on this proclaimed event space was on a notably dull point; there was a single conifer tree with lights placed on the square, near Lothian Road, over Christmas. It was fenced off with guardrails and would stand there rather lonely in the greyness of the winter square till mid-January, amidst workers scurrying through to avoid the wind and rain. The first event of any note took place on 19th March 2003 with the local school children using the square as a rallying point for a protest against the war in Iraq, but to start at the beginning.

Date	Event	Organiser
3 rd to 5 th November 2000	Christmas Market	City Council
August 2001	Film Festival 'Bouncy Castle'	City Council
19 th March 2003	Rally Point for Protest Against the War in Iraq	Edinburgh Youth Against War
3 rd April 2003	Post Office Collection Point	Post Office
4 th April 2003	Rally Point for Protest Against the War in Iraq	Edinburgh Youth Against War
18 th to 20 th April 2003	Edinburgh Easter Festival	Destination Events
11 th to 13 th June 2003	Volvo Display Booth	Russell Organisation
August 2003	Festival Fringe 'Pod'	Edinburgh International Festival Fringe

Figure II.3: List of Events on Festival Square.

Source: E. Huijbens

The new Festival Square, as it was redeveloped was designed as an event space:

“Lighting, water and trees help to structure an accessible public space, poised to become a new platform for activities during and beyond the Festival” (Whatmore, 2002, p. 19).

After its reconstruction, the first event to take place on the square was the Christmas market on the weekend of 3-5/11 2000 in an effort to integrate the square into the Winter Festival Calendar. The Film Festival's 'inflatable monstrosity' was put up in 2001 but these events were talked of in more detail in chapter 3 of part I (section 3.1.3.1). During my time on the square seven events took place either in relation to the extension of the Festival Calendar of the city or as spontaneous use of the space. As I said, the first event to take place was a rally that Edinburgh Youth Against War had organised through circulation through word-by-mouth in the city's schools on the 19/3 2003. Edinburgh Youth Against War is a group of secondary school students from schools across Edinburgh that were responsible for spreading the idea of a mass walkout of schools on Wednesday the 19th of March and a subsequent demonstration acclaimed as the largest political mobilisation of young people Britain had seen in 30 years. The events and demonstrations are documented in the film *Old Enough to Know Better*, (Edinburgh Youth Against War, 2003) made by the protesters

themselves using DV camcorders, compiling what is known as Pilton Video¹⁸ and published with the support of UK Film Council's First Light scheme, a lottery funded scheme to promote young filmmakers. As stated the rally was a real success with huge turnouts and the square filled with young people that then marched on through Princess Street to the site of the new Scottish Parliament. The turnout was mainly due to the presence of the young people in schools as the word was spread there just before the Easter break. A second rally was held 4th April 2003 but this time word had been spread by e-mail, leaflets and chalking on pavements (where I got wind of the event) as the schools were having Easter break, resulting in a considerably less turnout. But as with the previous rally there was a massive police presence this time resulting in them being in similar numbers as the protestors themselves. These young people saw the venue of the square as the perfect rallying point, as here was an open empty space near the city centre as confirmed in my interviews with the organisers as will be discussed in more detail in the next chapter.

In between those rallies, on the 3rd of April a post-office collection point was set up on the square to provide service for a day to customers of a nearby branch that was closed due to renovations. The presence of the post office is a salient indicator of the perceived publicness of the square albeit short-lived and feeds into ideas of semiotic battles discussed in the next chapter. But soon the square was to be filled with people again though this time through the active extension of the city's Festival Calendar by the Edinburgh Easter Festival, run for the first time that year by Destination Events, an organisation independent of the city council. The event, which was three days, was a success with estimated revenue of £4m for the city and will be held next year and expanded to five days. 4000 performers from all over the world, mainly the US and 40.000 visitors mostly local came to the events organised during the days this festival was run (King, 2003). The funding came from corporate sponsorship and the EICC contributed through hosting evening concerts by the CC. The main event on the square took place on 19th April and drew a crowd of some 200 people. This event featured musical performances, such as jazz, a US high school brass band and a French folk artist group and lasted for 2 hours (*Evening News* 18/4 2003). It was

¹⁸ The Pilton Video was piloted in West Pilton, an estate of Edinburgh, as a community video workshop, using video production and training to improve the quality of life on the estate. By 1995 it has become a city-wide video resource, providing access to equipment, training and expertise all funded by the city council.

placed on a stage on the North side of the square facing South, in front of the CBP entrance. The day after, or Easter Sunday, also in relation to the Easter weekend festivities, there was an exhibition of old cars on the square that drew a leisurely crowd of strollers.

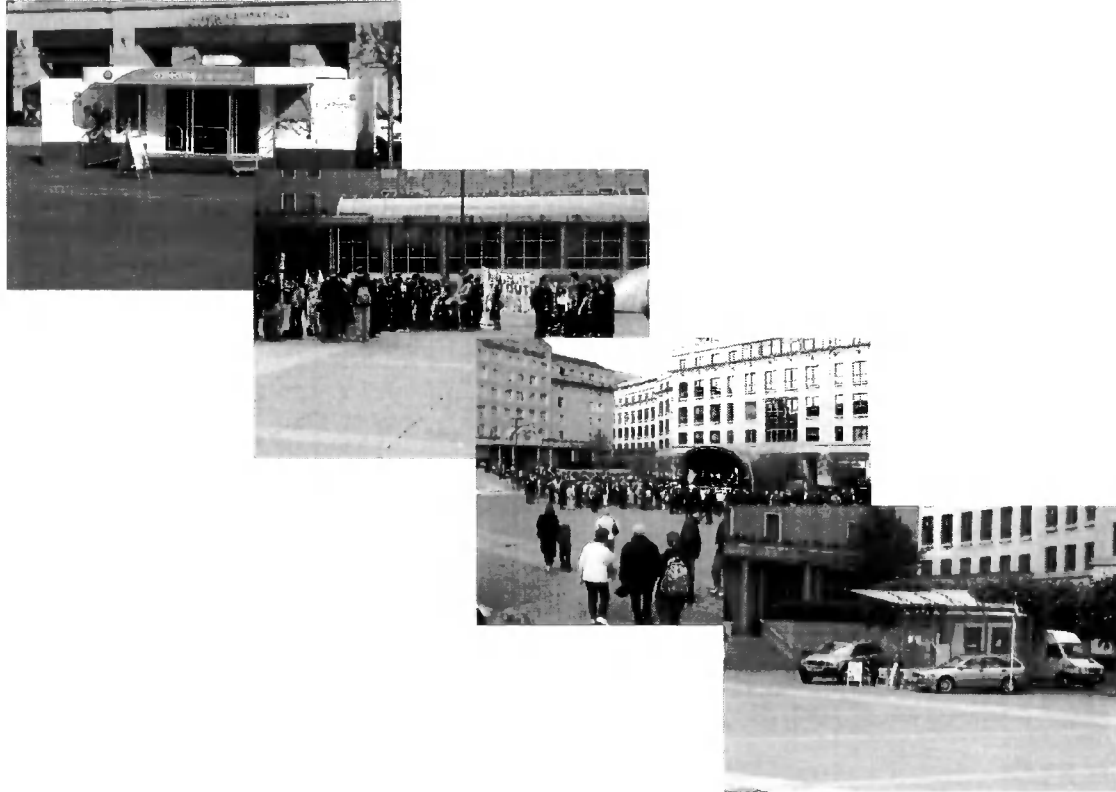

Figure II.4: Events on Festival Square. From left; post office collection point, second protest rally, Easter Festival and the Volvo display booth.
Source: E. Huijbens

The next use of the square was from the 11th to 13th June 2003 where a display booth and two Volvo cars were placed in the NW corner of the square where most people would pass by, right in front of the Sheraton entrance. In the booth there were two women, there from 8-5, promoting a range of motors sold by the John Martin Group, from Rolls Royce to Vauxhall and Citroen. These women were not overly busy and claimed the going was rather slow, with a few tourists from the hotel marvelling at the cars and a few by-passers on Lothian Road making a slight detour to view them too. The booth was put up by the Russell Organisation that is an independent organiser for live events and face-to-face marketing in the UK. During night there was a watchman staying in the booth to make sure that the cars were not vandalised, although he had little to do as there is almost no traffic on the square during night.

At the height of summer people and activity were drawn to the square with the Edinburgh International Festival starting. The first event was the Jazz & Blues Festival in July with events in Usher Hall on the 31/7 and 1/8 2003 and also in the nearby Henry's Jazz bar on Morrison Street. The events in those venues did in no way spill onto the square but with the official start of the Edinburgh International Festival and the associated Fringe Festival the square became a focus of attention for many of the events on the Fringe programme with the Pod, as it was known, a major staging of events placed on the square. Through August 2003 comedians, actors and a medium performed regularly with comedy, comedy magic show, children's workshop, circus performance and music events featured, along with comedy and theatre on two occasions in the Sheraton. This culmination of eventfulness on the square, in the placing of the Fringe Festival Pod there, marked an appropriate end point to my stay there. Through the listing of these events I put them in the context of the ideals that conceive space in the city, the ideal that states that Edinburgh is a Festival City on a global scale. This promotion has been termed by many critics; 'civic boosterism' promoting festivals and celebration that become 'static festival' like animated film sets that in effect theme spaces to attract people to it (Sussman, 1998, p. 37, see also Borden *et.al.* 1996).¹⁹ This is a far cry from Lefebvre's festive reclamation and appropriation of space, though there is the example of the organic protest of the Edinburgh Youth Against War and this example along with another daily use and appropriation I will endeavour to detail in the next chapter.

As a final example of concrete manifestations of abstract ideals in this chapter I want to look at a different ideal that is not as much informed by the economic gains, but revolves more around redistribution of those gains and social justice. Both of the economic aspects outlined in the two parts above epitomise the neoliberal spirit of festive free competition in collaboration with state provision of necessary infrastructure. The infrastructure provided maintains the city as competitive in a global world and the benefits reaped between those competing are to secure benefits

¹⁹ The thematisation of spaces has been talked about in the literature, in terms of shopping malls (see e.g. Barber, 2001; Chaney, 1990; Goss, 1993; 1996; 1999). For a discussion of the theme in terms of public spaces I refer to *The Drama Review*. 1998 Vol. 42, nr. 1, where it is talked about in terms of the 'Disneyfication' (Venturi, *et.al.* 1989; Zukin, 1993) of Times Square, New York. The issue of thematisation will be visited in the next chapter, section 2.2.4 in terms of semiotic reading of space.

for all in the end. This policy, guiding economic decision-making, creates an increasingly unregulated capitalism serving the interests of the state and multinational companies (Harvey, 2000). In the context of the Exchange and the policymaking behind its creation I draw parallels with Boyer's (1993) summary of the policy reconstructing Battery Park City in New York. There she talks about, in a rather convoluted and metaphorically dense manner, how the interstitial spaces of capital accumulation have been squeezed through the sieve of spatial restructuring that creates a focus, by planners and architects, on the node of capital attraction, but leaves the city itself lagging behind. This 'revanchist city' (Smith, 1984, 1996) arguably leaves tracks of the city lagging behind.

In the case of Edinburgh it cannot be fairly argued that the rest of the city, i.e. outside the newly constructed financial quarter, is left to languish. In the city there is a certain form of state provisioned active distribution of the benefits of a prospering economy and thus a recognition of the need to actively redistribute wealth, contrary to the neo-liberal dogma. Edinburgh as a city of social disparity was vividly portrayed in the cult hit *Trainspotting* (Boyle, 1996), which was filmed in areas of extreme social deprivation of the city. Today these areas are gone as demolition has made way for new buildings housing new activities, as can be read in the *Daily Telegraph* (Cramb, 2004; see also *de Volkskrant*, 22/5 2004), although arguably the troubled sites and problems have been 'farmed of' to other areas of the city. The active state provisioned distribution of economic benefits is mainly manifest in the key social justice objectives published by the Scottish Executive (1999). Several public bodies are to execute these objectives, but the major one in Edinburgh is the Capital City Partnership in Edinburgh. It is a partnership of key statutory, voluntary and community agencies in the city working together to promote social inclusion and achieve social justice for the people of Edinburgh. This partnership (of which SEEL is a member) works through Social Inclusion Partnerships (SIPs) that is about community planning partnerships that aim at "closing the gaps between SIP areas and the city as a whole" (Capital City Partnership, 2004, p. 5). Without wanting to paint a too rosy picture of the city's social justice agenda, bearing in mind the civic boosterist overtones of the literature also produced by these actors in the city, I want to use the example of efforts of redistribution as the third ideal which along with global capital and global place marketing, instrumental in producing the space of Festival Square.

1.3.3 The third sector ideal

In Britain today there is a debate on the economic benefits that can be derived from what is interchangeably called, the voluntary sector, social economy or third sector, whose role is to regenerate local economies that suffer from failing public or private sector initiatives. Due to lacking economic initiatives from these classic economic agents, economic benefits are to stem from allowing more inclusive participation in the local economy based on voluntary or social work that will integrate people into the formal sectors of the economy and thus solve social disparities suffered by that local economy. The concrete manifestation of this on Festival Square is the Dash Coffee stall that started daily operations on 9th June 2003. Here I want to talk a little about the third sector ideal and its manifestation.

The aim of the third sector²⁰ is to deliver economic regeneration principally through three means. Firstly, through the empowerment of the local inhabitant, i.e. through involving the third sector in the city's management, democratic participation is formalised and potentially brings about a revitalisation of local democracy (Buček and Smith, 2000). Secondly, that by being economically sustainable, i.e. through community participation in management and a democratic management structure, the aim is inclusion and distribution of its benefits as it is non-profit run. Thirdly, through being an alternative to the mainstream public and private economies it implies a widening scope of participation. These economic regeneration initiatives are autonomous from other private and public bodies but in essence are private in nature and often have public sector involvement and are thus often claimed to have yet to realise their full potential (Amin *et.al.* 1999). The third sector in Edinburgh is composed of about 1000 voluntary organizations, some so small that they are run from private homes, but nonetheless gainfully employing scores of people in their offices and bases of various sizes around the city. These run several, often government funded, projects for work placement with the aim of having young people gain experience at work through the third sector economy, that later could secure them work in the formal sectors (Richard Dufner).

²⁰ Third sector is the term I choose to apply in the following. It literally refers to its status as an alternative to the public and private sectors.

One of these organisations is Streetwork, which works in the city centre of Edinburgh with young people at risk in the streets. Streetwork's aim is to provide education and support, preventing homelessness, drug abuse and crime. In 2001 the then director of Streetwork, Tam Hendry, had the idea to create work experience placements for young people through working in a street vending coffee stall. That project was run through EVOC (Edinburgh's Voluntary Organisations' Council) a council committee based organisation linking voluntary initiatives to the public sector. The Streetwork idea for a coffee stall got funding through EVOC, from its budget for trying out innovative ideas, and as a result a pilot stall was placed on Hunter Square in the city centre for one year, starting March 2001. The pilot was a success with 5 of the 6 vulnerable, previously homeless and begging, young people trained at the stall getting secure employment as a consequence. But the EVOC funding was tenuous and support for placing the stall in the city centre was difficult to obtain. As a consequence funding ran out and the project was discontinued. Tam Hendry at Streetwork and Richard Dufner at EVOC, were keen to see the continuation of the project and found that possible through Streetwork's links to the Sheraton. The Sheraton Grand Hotel has always been very supportive of Streetwork through the personal interest of the general manager Peter Murphy. The hotel gives financial support from fund raising events organised amongst the staff, but more importantly, when approached with the idea of the stall, the hotel promised the logistical support for the operation of it on Festival Square. Funding for a continuation of the project was secured through the innovation fund of Jobcentre Plus, a recently founded governmental agency and part of the department of work and welfare, on the premise that if it worked the idea could be implemented nationally. This funding secured operation for 15 months and, starting in the autumn of 2002, the initial stage was to gather two groups of 6 people at risk in the streets. Through the period of the next 6 months these people went through courses with the aim of tackling their personal issues, which had previously barred them from formal employment, and training in how to make quality coffee that could compete with the major coffee houses to be found around Edinburgh. By 9th June 2003 these people were ready to work shifts in the coffee stall that had been set up on the Lothian Road front on Festival Square.

What I find in this third example of mine is the ideal of the third sector economy that through various social networks is to help in the redistribution of economic gain by

helping people become included in the formal sector. This ideal is concretely manifest on Festival Square in the form of the Dash Coffee stall, just as the idea of eventfulness and pedestrianisation, which represents the ideal of quality of life that attracts tourism and business, produced the space of the square in its current manifestation set within the grander scale remodelling of the whole site through the ideal of marketing the city for global capital investment. These examples serve to illustrate the forces of abstraction Lefebvre stated were acting in the city, those forces that rationalise and create ideas, conceiving spaces that then create the concrete spaces in which the lived spaces of inhabitant and users play out. Lefebvre explicitly talked about the lived spaces of the everyday and how the activity of those going about their everyday life are the spatial practices that highlight the dialectics occurring between the created (conceived) space and lived space. These spatial practices are the appropriation of spaces by various groups of people in the city in many different ways. In the next chapter I will illustrate examples of these appropriations of space, or bottom-up approaches to understanding the production of space, arguing that these are none the less productive of space than those dominant ideals and moreover have the potential power to subvert them.

II.2 Politics of Place

In this chapter, I want to pick up the main theoretical argument left from the previous chapter and join it with those of chapter 3 in part I. There I mapped out the materialities composing the square and stated that events are capable of throwing out the established order. Here I want to delve closer into how events, or each present moment is capable of doing so and as a consequence, produce space. Thus this chapter revolves around the practices that make use of the square and consciously or unconsciously manipulate its materiality, surrounding buildings and monuments that reflect the ideals outlined in chapter 1 of this part and chapter 2 of part I. These materialities are representations of space that are the codifications used and produced by those who have the power to make their ideals manifest. Manipulating these representations of space places an emphasis on the materiality of the space itself, but in Lefebvre's theorisation the focus was always on the way in which space was mediated through practices that produced space as he surely recognised that "there cannot be a dichotomy between meaningful place and a space which is abstract" (Massey, 2004, p. 8).

In order to work my way through the above I start the chapter with a short introduction to the theoretical side of Lefebvre, left somewhat wanting in the previous chapter. I then carry on with detailing the understanding of public spaces in current geographical literature²¹ seen through Lefebvre's ideas based mainly on Mitchell's (2003) book *The Right to the City: Social Justice and the Fight for Public Space*. This understanding is then substantiated with empirical examples listing events that have taken place on the square and fitting them into ideas of the appropriation of space drawing on Law (2000). But these examples do not give insight into the active mediation of space through practice and hence in the end of the chapter, I talk about skateboarding as the practice that mediates and appropriates the space of Festival Square mostly in a non-deliberate fashion. So while the former examples detail the dialectic between directly deliberative productions of space from the perspective of conscious use of space already produced by dominant ideals, the latter highlights more covert examples of the appropriation of space, more related to the festive

²¹ For an overview see *Urban Geography* Vol. 17, nr. 1 and 2. For more recent references see Staeheli and Mitchell, 2004.

reclamation of space or the non-deliberative appropriation of space that is then the main subject of chapter 3 of this part.

2.1 Spatial Practices

I left Lefebvre at the start of section 1.2 in the last chapter and started detailing the abstract forces at play constructing the materiality of Festival Square. This outline, done in the previous chapter and also chapter 1.2, was about the prior conceived spaces that were read from that which is manifest in the concrete space thus revealing the processes that informed the constitution of the present. This outline was historicizing space, revealing the mental and material dialectics that informed the material as it is.

“As Lefebvre makes clear, a simple description can never be sufficient. A sociological account must be supplemented by a historical analysis, and the two together will also provide insight into the structural whole” (Elden, 2004a, p. 127).

This historical materialism, stemming from Lefebvre’s synthesis of Hegel and Marx, argues that dialectics producing space are set in a scene that is the outcome of former dialectics. Through the synthesis of lived spaces, perceived or not, and the space materially there, conceived of by society’s dominant forces, there lies the possible, in the everyday life of people that through their bodies enact and sense space in multifarious ways.

These materialities or sedimentations in which there lies the possible were detailed in chapter 1.3, but what the Marxian Lefebvre emphasised especially in his notion of lived space was how the enactments and sensing of space contain the possible. Thus, as argued, seeing abstract space in isolation from the materiality of the concrete does not lend itself to useful analysis. Lefebvre’s focus is on the mediation or interaction between the conceived or abstract space and lived space in the concrete. These are spatial practices that are enacted in the concrete materialities of space, one composed out of prior dialectics. Through these practices bodies open the path to contradict schematised conceptualisations of space imposed onto them by the formal, homogenous and quantitative ideals of those that practice the abstraction of space. Hence Lefebvre argues for ‘spaces of representation’, that stand in opposition to representations of space, getting created through festival and revolution (see Figure

II.1, p. 120), i.e. the Dionysiac life of “drink and feast, mockery and irony” (Merrifield, 2000, p. 178) and the ‘meta-philosophy’ that transcends all dualisms or binaries that underpin the abstraction of space. This meta-philosophy links “speculative philosophy and critical theory with political action” (*ibid.* p. 178) or opens up ways of thinking through transcending both political action and speculative philosophy through linking the two in the body. This transcending or unifying of action and theory, lived space and the conceived, the political and libidinal economy, is grounded in concrete space and is to occur with a spirit of festive reclamation of space, taking to the streets and demonstrating different ways of being and doing in the spirit of free association and joyfulness. Hence the creation of spaces of differentiation in the context of the abstracted, conceptualised spaces of the everyday, upsetting the structured order to inject abstract space with the life of being (Gregory, 1994; Merrifield, 2000).

For the social scientist wanting to understand space remaining endlessly open to differentiation through the constant struggle of the conceived and lived, Lefebvre proposes the primacy of material activity, i.e. the focus on the spatial practices unfolding as the mediating dialectics between spaces of representations and representations of space. As indicated above this material activity can firstly, be tied to a process of signification and hence the reading of space since “abstract conceptions of space use a system of verbal and graphic signs” (Peet, 1998, p. 103) that are “spatial languages, parts of practical relationships between subjects and their surroundings” (Peet, 1998, p. 103) thus hiding social order in the order of space (Lefebvre, 1991, p. 289). Thus informed by contrasting ideals from the dominant order one can appropriate space in an active subversion of its codes (Mitchell, 2003). But secondly, the material activity can be tied to subversive uses that unconsciously produce spaces that undermine the dominant order of space. Be these material activities of either kind, Lefebvre claims that conflict effectively comes into play *in* space and in so doing the conflicts are about contradictions *of* space. Space thus harbours all differences and they are produced in space by human action, conscious or not. Analysing those differences of space is about understanding intent, power relations and contexts that inform the production of space and it is through this kind of illustration that I turn to now.

2.2 Appropriating Festival Square

In terms of Festival Square I have uncovered how the square was designed, by whom and for what purposes following Low (2000, p. 122), but further through “the place [itself as] a contested terrain of architectural representation” (*ibid*, p. 123) one can see how this design is still contested, reconceived, redefined and reworked by the people and those responsible for the design, through those people that use the space. Thus what follows deals with the square as a lived space or as space of social practice that manifests the ongoing dialectic of conceived and lived spaces, captured by Jacobs (1996), in line with Lefebvre above, as expressions and negotiations of a city’s identity not only occur *in* space and are articulated *through* space but also are especially *about* space (p. 1). But first I will put the foregoing theory in the context of recent geographical literature in order to arrive at an understanding of how public spaces are viewed within Lefebvre’s particular scheme.

2.2.1 Subversive ideals, in theory

“Utopia is impossible, but the ongoing struggle towards it is not”
(Mitchell, 2003, p. 235).

The above quote resounds with Harvey’s (2000) claims in the introduction to this part and is premised upon the claim made by Lefebvre (1991) that the production of space always had to remain an endlessly open possibility through a constant struggle towards the ideal, emphasising the mental and material dialectics he advocated. Harvey (2000) sees the city as the prime site for the possible utopian imaginings as the city has for long been seen as the scene in which personal and political freedom has its most vivid manifestations. “The associations between city life and personal freedoms, including the freedom to explore, invent, create, and define new ways of life, has a long and intricate history” (p. 158) but not without its paradoxes (see Lees, 2004). More specifically in the context of the fieldwork site I refer to Low (2000) who states that:

“aesthetic, political, and social aspects of the plaza are dynamic, changing continually in response to both personal action and broader socio-political forces. They are also contested through conflicts about the use, design and meaning of the space” (p. 33).

In the previous chapter I outlined the abstractions or ideals that inform broader socio-political forces in the creation of the material, concrete space. That space is also

created through personal cognitive action in conflicts over use, design and meaning and how our being in space creates space in an active way, informed by our abstracted or ideal notions of space. This is only one of the two ways a Lefebvrian appropriation of space can be formulated but in the end, and more specifically in the last chapter of this part I will deal with the unconscious subversive uses that occur through the body.

The appropriation of spaces done through personal cognitive action can overtly assert a lived presence that reformulates and models space. It is from this idea of appropriation that Mitchell (2003) mostly conceives his book *The Rights to the City. Social Justice and the Fight for Public Space* as for him the right to the city lies in the right to be able to participate and be seen in space in order to influence its production. Explicitly drawing on Lefebvre he grounds these rights stating:

“The struggle for rights is a determinate of the actual social content of the dialectic between abstract and differentiated space; the struggle for rights *produces* space” (p. 29, emphasis original).

Mitchell, a student of Neil Smith who was a student of Harvey, draws heavily on Lefebvre, especially his book *Espace et Politique: le droit à la Ville II* (Lefebvre, 2000). In the quote Mitchell (2003) sees rights to the city (F. *droit à la Ville*) as determining the actual social content of the interaction between the space of mental perception (abstract) and material space (being differentiated). As this interaction produces space, the struggle for rights, being the actual social content of the interaction, must produce space. It is with the role of mental perceptions in mind that both Mitchell (2003) and Harvey (2000) claim the role of utopian imaginings in their books. The aim of Mitchell’s book is to reveal urban structures of injustice in the US so they can be modified towards more just ones. Hence he explores the dialectic of mental and material space through historical geography of U.S. public spaces carrying a normative theory of a progressive right to the city.

Mitchell (2003) claims that the city is a production in which all its citizens have a right to participate. Thus the right to the city is to inhabit its spaces in order to participate in the social interactions that inform the production of the city. This right needs to be constantly fought for and hence the city is understood in terms of the different groups constantly struggling over the shape of the city, access to the public realm and the right to citizenship. If these groups are to be able to struggle they need

to be allowed participation and it is for the right to this participation, as presence in space, that Mitchell (2003) argues. This presence then is to overtly assert an ideal or a differential space, perceived as more just than the dominant one. The above gives a short introduction to the general argument of Mitchell's book. In order to get to the political issues involved I will go through what the public means and who is confronting whom in the struggle for space.

2.2.2 The confrontational city

In the above section there is the potential to contextualise the notion of public space in the broader debate on the city as a democratic forum for the public and thus flesh out the underlying assumptions of democracy. Mitchell states that groups struggle over the spaces of the city and all must be allowed to take part in that struggle. Thus his formulation is one based on the confrontation of people that each holds their ideals of what is the best or most just city. For Mitchell the subject is to be able to achieve its fullest articulation and development through social interaction with others. Thus "arising from our social interdependence, democratic citizenship should be directed to the social development of all" (Twine, 1994, p. 6). This 'democratic citizenship' is one premised on the idea of all being together irrespective of place attachment or *ethnos*, where democracy presupposes an equal relation between two or more based on shared rights or set of assumptions.

The urban as a scene for this 'democratic citizen' is premised on the idea that cities are implicitly places of social interaction between those who are different.²² The interactions of 'democratic citizens', that then constitute the citizen as democratic, are differently formulated and thus have different implications for public spaces: Firstly, where the political institutions of the city promote an open forum of debate for citizens to voice their concerns and mediate them to the institutional powers. Here the citizens are seen as individuals that struggle for their rights in an open public forum with other individuals, echoing Harvey (2000) seeing the city as the scene of personal and political freedom. What is at stake here is how the democratic citizen is

²² On the topic of the inter-subjective interactions in the city there is a host of literature concerned with the notion of other and self and how these interact in the formation of identity. A political slant to these theorisation, more linked to the current debate, can be found in e.g. Iveson (under review) where he argues for the formation of political agendas based on 'occasioned' struggles (see also Laurier *et.al.* 2002). A further engagement with the inter-subjective is to be found in part III.

constituted through progressive politics based on interaction through being together (see Copjek and Sorkin, 1999). The implication for public spaces is that they should be maintained at all cost as a forum for this interaction (Amin and Thrift, 2002; Entrikin, 2002).

Another, and second, formulation of the constitution of the 'democratic citizen' is one based on group solidarity, that solidarity being around certain perceived common goods for the members of that group. While as the first formulation was premised upon individual interaction, the notion of group solidarity postulates that different groups communicate and interact. Implicit in both formulations is a public space that is to be the forum for the interactions to take place but also that this interaction is based on, what Habermas (1985) termed communicative action or deliberative democracy. The model of deliberative democracy thus states that the constitution of the democratic citizen is best done through institutionalising debates on how to progress democracy, a debate that takes place through benign rational reasoning and is thus based upon communicative rationality. The approach is echoed in Bickford (2000) where she states that "just as the construction of social space makes certain interactions rare, so can it create and foster better interactions-ones for a better democratic polity" (p. 371), echoing and citing Sennett (1998) (Amin and Thrift, 2002; Entrikin, 2002).

The third way to formulate the constitution of the 'democratic citizen' is premised on the critique of communicative rationality that states that what constitutes the rational often disguises interests and agendas of the powerful that are thus pushed and promoted as rational or even 'common-sense'. Hence the third way emphasises confrontation, where different groups confront as 'friendly enemies' or in agonistic ways once debating the just city. These diverse groups have irreconcilable notions of the common good and hence the debate must take place in an agonistic way. There is no rational consensus or universals to be relied upon and thus the promotion of politics is through the empowerment of conflicting and different voices. The implications for the space of the city is that there is little chance of a common project, unless with reference to ideals of either communicative rational or romantic notions of respectful tolerance, meaning that spaces in the city are heterogeneous with open borders and gain meaning from their appropriation through conflict. Thus spaces must

be open for appropriation, i.e. the rights of the citizen to take to the streets must be guaranteed, condemning segregation but advocating the freedom to cluster. It is within this third formulation that space receives its most prominent role integral to the formation of 'democratic citizenship' (Amin and Thrift, 2002; Archibugi, 2003a; Entrikin, 2002).

2.2.3 The fight for public space

Mitchell (2003) goes against seeing the public as some autonomous sphere in which, once established and maintained, all association is free and unproblematic, as the formulations based on deliberative democracy would assume. All thought and communication claim a representation through speech, "the act through which ideas are put into circulation [and] must thus be protected in a democracy" (*ibid.* p. 46). But Mitchell sees that the speech acts, formulating ideas that go into circulation in society, can never be divorced from their performance and hence, drawing on Lefebvre, the body and its taking and making of space becomes the centre of his concerns. For him speech and action are inseparable, occurring in space. But like with Lefebvre this turn to the body is only insofar as the body physically occupies space and the right to access to space and hence ability to be represented and participate is key in Mitchell's book. Thus the way in which groups participate is through taking to the streets of the city, carving out spaces for representation, or becoming visible, in order to be able to partake in the overt dialectics that produce space, as outlined by Lefebvre. Public space is thus produced through appropriations as public space, but that same public space originates as a representation of space as public. Thus planning public spaces where it is assumed that free association takes place cannot be done through abstraction alone, i.e. some enlightened planning directive, but must come through the dialectics driven by the confrontation of people taking to the streets and squares of the city.

These people that take to the streets, through making themselves visible, thus both demand space and create space, but rarely under the conditions of their own choosing.

Hence:

"the desires of other groups, other individuals, other classes, together with the violent power of the state, laws about property, and the current jurisprudence on rights all have a role to play in stymieing, channelling, or promoting the

‘taking’ and ‘making’ of public space and the claim to representation” (Mitchell, 2003, p. 35).

In other words, public space reflects a social order that is made:

“through a complex culture-making process in which cultural representations are produced, manipulated and understood by designers, politicians, users, and commentators within changing historical, economic, and socio-political contexts. These spatial/cultural representations express the power relations between different groups” (Low, 2000, p. 50).

The power relations manifest in public spaces are “to convey the legitimate order to citizens” (Cresswell, 1999, p. 227). The struggle is between that order and citizens and will thus always be a “dialectic between the ‘end of public space’ and its beginning” (Mitchell, 2003, p. 36). The ability to be represented centred on the body’s presence does give Mitchell (2003) the edge of claiming that the voicing of concerns and ideas is not everything, only to be seen plays also a role in the claim to representation hence “public space is created through a dialectics of inclusion and exclusion, order and disorder, rationality and irrationality, violence and peaceful dissent” (p. 51). These are politics that function through the dialectics of inclusion and exclusion, e.g. how rationality has been defined in differing ways through history in terms of gender, age and race and how the term order is often manifesting a notion of order protecting those that can afford to be orderly. Thus notions of order, rationality and peace, along with their antinomies, are historically and socially contingent as well as politically necessary (Low, 2000).²³

2.2.4 Semiological battles

As stated above the taking and making of space in Mitchell’s formulation is informed by ideals and thus conceives of spaces of different ways of being. He premises his

²³The literature on inclusion and exclusion is substantial and each issue warrants much attention, but to indicate a few of the issues in relation to public spaces one has to bear in mind that by its very nature of publicness or being public, the space signifies a particularity in terms of actions therein (Cresswell, 1999). Who is allowed to be where and how, and how the urban is ‘divided’ (Fainstein *et.al.* 1992), ‘dual’ (Mollenkopf and Castells, 1991), ‘fortressed’ (Davis, 1998), ‘quartered’ (Marcuse, 2000), ‘patchwork quilt’ (Harvey, 2000), and one of ‘walls’ (Caldeira, 2000) is the driving question. The urban, so formulated becomes a site of ‘marginality’ (Wacquant, 1999) and ‘poverty’ (Mingione (ed.), 1996) with economic and social divisions widening (Berner, 1994; Storper, 2000) and the potential formation of an economic and social ‘underclass’ (Morris, 1994) or those socially marginalized, e.g. through disability (Kitchin, 1998), fear (Pain, 2002) or racial origin (Anderson, 1998). The resulting spatial inequalities are the material manifestation of exclusion, allowing for the geography of exclusion (for general discussion see Levitas, 1998; Sibley, 1981, 1995).

politics on being present or being heard or seen in order to produce space. One can be actively heard or seen undermining the symbolism or representations of the dominant order and this warrants attention to the symbolic nature of the conflict over space. A semiological reading of space would see buildings, architecture and art as representative of the ordering of the society. Here the urban landscape is viewed as text, but a text which reading would take recourse to aesthetic philosophy and psychology in order to unveil the underlying orderings and powers manifesting themselves, complementing a reading of the struggles that take place in space. Thus “the examination of the built environment provides insights into meanings, values, and processes that might not be uncovered through other observations and offers a mechanism for exploring the social and political forces of the past” (Low, 2000, p. 49). Jacobs (1996) and Maspero (1994) examined the built environment once decoding the imperial past of London and Paris, respectively, since “meanings from the past are encoded in the built environment and manipulated through spatial representation and architecture to create the socio-political present” (Low, 2000, p. 102-103 see also p. 238). The general idea here is that architecture and design reflect changes in the social and power relations of each society.

It is in the vein of unveiling the orderings and powers in society that Ellin (1996) embarks upon her analysis of postmodern architecture and the *esprit de temps*. She claims that cities today have become the theatres of memory, a collage of history and local contexts, replete with symbolism as opposed to grander schemes of modernist architecture premised upon universal styles in building (see also Moughtin, 1999). With the cities becoming the theatres of memory they represent the postmodern condition as one being where we compose cultures and identity out of collaged facets of the past, but at the same time they impinge upon that very cultural condition. With this dialectic I refer to Lefebvre (1991) for whom the urban landscape is replete with symbolism of the prevailing order in society. These symbols are generative of the myths and legends that then impinge explicitly or implicitly upon current spatial practices, e.g. once people appropriate space in their struggle for rights to the city (Merrifield, 1993). But Lefebvre himself did not spend much time on the semiotics of space or in “connecting the symbolic realm to the logic of capital accumulation” (Gottdiener, 2000, p. 96), something that is important, especially with postmodernity being the cultural logic of late capitalism (Harvey, 1989; Jameson, 1991).

Paraphrasing the modernist dictum Ellin (1996) sees the results of the dialectic of the material and the mental as form following fiction or fear. Even more strongly Ellin (1996) states that form follows finesse, i.e. the semiotics of everyday life, and finance. With form following finesse and finance the cultural logic of late capitalism is explicit as consumption, it being the main driving force of the economy, which is evermore based on cultural symbolisms of all kind. The implications for architecture are often that spaces are designed as spaces of consumption and financing subsuming space as commodity dictated by the logic of exchange value (see Charley, 1996, Sussman, 1998; Turner, 1996 for critique). As explained in the previous section above Mitchell (2003) states a decline in a formerly dominant ideology of seeing public spaces as the democratic forum for the public where the issue was who were accorded the status of being public. This decline leads to an emphasis on the material setting itself in which political action occurs when groups appropriate that setting to make them seen or heard. Hence “politics of symbolism, imaging and representation increasingly stands in the stead of the democratic *ideal*” (Mitchell, 2003, p. 141, emphasis original). Public spaces were formerly a hybrid of commerce and politics, but with the domination of commerce that in its postmodern form is driven by cultural symbolisms, Mitchell indicates an erosion of the public spaces of the democratic ideal. The result is that corporative images of the ideal start to dominate with the creation of what Sennett (1996; Bell, 1998) terms ‘dead public space’. These are spaces where the taking and making of space is getting more and more restricted due to the dominance of laws of private property. This restriction comes from corporate or private capital as well as authorities; be they local or national, as they, in ever increasing ways, prescribe roles to spaces that are manifesting an ideology divested of political content. Surely the divesting of political content through abstracting space is what has been spoken of in all of the above, but Mitchell (2003) seems to be indicating an acceleration of this process, whereby space is annihilated by law to promote a ‘quality of life’ that would attract e.g. footloose global capital in the form of investment or tourism (see Rossi, 1998), and hence argues for the importance of his work and the politics implicit in Lefebvre’s formulation of space (Mitchell, 2003).

2.3 Abstracting the Concrete

-from place to space

I ended the last section with a review of Mitchell's (2003) book on the right to the city and how that right can be fought for through the appropriation of space. In the space of Festival Square grand events of this nature, i.e. overtaking and the visible political message conferred by that, might one day take place. Here I am referring to events that inspired Lefebvre and Mitchell: the events of May 1968 (Elden, 2004a, p. 134; Gregory, 1994, p. 395) and the struggle for People's Park (Mitchell, 1992, 1995, 2003). On the square the only event coming close to these classic formulations of taking over space was when the square was used as a spontaneous gathering point for the protest marches at the end of March and beginning of April 2003. What took place was a 'manifest protest' to use the words of Low (2000, p. 50), one that could potentially serve to illuminate the power relations in the society and the workings of the democratic ideal. In a more detailed account Low (2000) further outlines three modes of appropriation classifying how people use the streets and squares of the city: Firstly, there is 'manifest protest', where people actively and publicly take to the streets to demonstrate for or against certain political issues of current relevance. Secondly, there is 'latent protest', visible in symbolic struggles over architectural and cultural representations, where for instance certain dominating symbolism is subverted either through use or object oriented action. Thirdly she identifies 'ritual protests' that are festivals, parades and carnivals that take to the street and refashion it on fixed dates according to the religion's calendar or tradition.

2.3.1 Deliberative appropriation

In the expanded table below from the previous chapter I have attempted to classify those events witnessed into the tripartite scheme of Low and will discuss each in turn below.

Date	Event	Organiser	Protest Type
3 rd to 5 th November 2000	Christmas Market	City Council	Ritual
August 2001	Film Festival 'Bouncy Castle'	City Council	Ritual
19 th March 2003	Rally Point for Protest Against the War in Iraq	Edinburgh Youth Against War	Manifest
3 rd April 2003	Post Office Collection Point	Post Office	Latent
4 th April 2003	Rally Point for Protest Against the War in Iraq	Edinburgh Youth Against War	Manifest
18 th to 20 th April 2003	Edinburgh Easter Festival	Destination Events	Ritual
11 th to 13 th June 2003	Volvo Display Booth	Russell Organisation	Latent
August 2003	Festival Fringe 'Pod'	Edinburgh International Festival Fringe	Ritual

Figure II.5: Events on Festival Square in terms of Struggle.

Source: E. Huijbens

Although Low's (2000) scheme can be used to categorise events on the square I have reservations about the use of the word protest as will become clear below. The threefold categorisation is firstly, the festivals and organised events that Festival Square is supposed to facilitate (marked Ritual). These are events conceived by those in charge and manifest is the dominant political ideal of the day, of which festival and play is the cultural logic (Jameson, 1991). Thus the events marked on the table above belonging either to the classic or expanded festival calendar of the city of Edinburgh cannot be seen as protest as such but as perpetuation of the manifested ideal. They are fulfilling the prescribed role of Festival Square, manifesting ideology divest of political content as it is through the active application and agreement with those running the square that these events are there (Graham Tully). These are events that would not have inspired Lefebvre as, contrary to the events in May 1968 in Paris which he witnessed, they are in no way undermining the dominant order of space. On the other hand and secondly, I classify events that do not belong to the festival calendar as latent as I see those being part and parcel of the semiotic grasping of the square by parties unrelated to those that created the square. Again there is not a protest of any kind going on, there is a certain latent struggle over the meaning of the

square, primarily in terms of its publicness as these events help to define the square as public and being open to appropriation. Here the post-office, a classic public institution, finds the square useful as a collection point as it is manifestly public and open as does the Russell Organisation, for displaying their Volvo's. On the other hand all uses of the square in this manner are subject to the council's approval (see part I chapter 3.1.3). The reading and manipulation of the square as open and public ties in with the examples of the manifest protest listed in table above. The organisers that I interviewed on the square as the protest took place told me that the choice of this location was because it was convenient, open and public.

These two gatherings of EYAW were examples of manifest protest and the only occasions I find the language of protest and appropriation partially useful. These gatherings were not subject to council's approval but were on the other hand done with the knowledge and co-operation of the local constabulary, which turned out in great numbers for 'trouble-shooting' according to the local PC Hardy. Most importantly the protest was an appropriation in the sense of absolute occupation and a temporary re-imagining of the square that sent an overt political message, albeit unrelated to any specificity of the square apart from its location and convenient design for public gatherings. I argue that the language of protest is partially useful as the appropriation that took place is what Borden (2001) terms 'co-opting' and entails the taking of space for a short time, which is tolerated, where as your permanence there would not be. These gatherings had the purpose of sending out a political message and by necessity it entailed the taking of space in the city and thus re-imagined it, albeit in a very acceptable manner to the council as they see the square as a place for spontaneous performance and events. The co-opting was most certainly colourful and lively events and would be in line with Lefebvre's emphasis on festive appropriation, but what Lefebvre argued more strongly for was that the appropriation would entail the creative reworking of the materiality of the physical settings, i.e. that the appropriation also happens through mediation of space. Such a reworking occurred only in a very small scale with only a few chalked graffiti slogans on the paving and the big balls that annoyed the cleaners for a couple of days.

Not intending to deflate the importance of manifest protest and taking to the streets to air your views and opinion, what I would though like to draw out is that this 'co-

opting', which I find more suitable than appropriation in the example above, is a momentarily *lived space* as Lefebvre would call it. In this context I would like to draw out Iveson's (2004) main critique on the work of Mitchell upon which the above is based. Iveson (2004) argues Mitchell sees material public space as *the* space of the public, meaning that it is the space and its materiality that is to be taken over, appropriated and hence would change meaning. Arguing against this kind of wrangling over representations of space Iveson (2004) emphasises, citing Lefebvre, that space is "*simultaneously material and mediated*" (p. 920, emphasis original). Thus in the context of the square, the fleeting events do not give much insight into this mediation but the lived spaces that are manifest everyday on the square play a more active, albeit smaller-scale role, in the mediation and formulation of the square. Focusing on everyday struggles can to a certain extent be aligned with Mitchell's (2003) political project elaborating on the politics manifest in the survival struggle of the homeless. But with the example that follows, not based on the homeless as they are not to be seen on Festival Square, a spatial practice that can serve to highlight the dialectics of the conceived and lived producing space through appropriation *and* mediation will be analysed. This is the practice of skateboarding and in what follows I will describe the skateboarder's lived space on the square and, through Borden's (2001) *Skateboarding, Space and the City*, I will illustrate Lefebvre's notion of the appropriation of space *through* the body as opposed to *by* the body as was the case in all of the above.

2.3.2 Skateboarding

As stated in part I, chapter 3.1.3 the main users of the square, apart from the office workers passing through daily, are the skateboarders coming in the afternoon and on weekends. In that section I hinted at the politics of inclusion and exclusion with reference to Cresswell's (1996) argument about matter in and out of place. Here I aim to see how skateboarders, through their presence (and absence), produce the space of Festival Square through their everyday practice on the square with reference to Borden (2001) who states that skateboarding:

"produces space, but also time and the self...[thus] it is architecture, not as a thing but as production of space, time and social being" (p. 1).

In the next chapter a similar argument will be made for those everyday pedestrians that pass through the square.²⁴ Using them as examples of appropriation is very small-scale indeed and is harder to use to illuminate as a significant term as Lefebvre's appropriation as means of producing space. What is at stake in the everyday passage is a non-deliberate reworking of the materiality of the square, a reworking that is only slightly manifest in that which follows below, but in order to understand it certain further conceptual moves need to be made building on the discussion which follows.

As the quote above indicates, Borden's (2001) study is well illustrated with Lefebvre's theoretical insights emphasising how space is not only perceived and read as text, that feeds into conflicting conceptions of space, but is fundamentally a lived through experience. Borden (2001) argues for skateboarders as those living space as experience but these people are teenagers of all classes and races sharing a global affinity through their practice, creating a subculture maintained through the expression of style (Hebdige, 1992). He further claims the practice is shared by nameless millions across the globe through the course of time and, especially, through a variety of spaces and substantiates his claim with rich empirical evidence throughout the book.

In a short summary of Borden's book I will now outline what skating is about. The sport originates in California in the late 60s and early 70s and quickly caught on in the Western states of the US. Originally what skaters did was to appropriate 'lost spaces' within the city and on its outskirts, i.e. spaces that people had forgotten about or had been left or abandoned for one reason or another. These were spaces awaiting their disclosure, i.e. to be rethought and rearticulated by the skateboarders that would find them, those that did often kept the place to themselves in order not to get them overcrowded or attract attention to themselves, as often these would be prohibited places. By the late 1970s and early 80s skateboarding was a global practice that had, to a large extent, been commercialised through merchandise and skateparks, i.e. purpose built facilities for skating, with only a fraction of its practitioners still out hunting for 'lost spaces' to be rearticulated. Due to the limitations to action imposed

²⁴ A point Borden (2001) neglects where his "tight focus on skater-centred experience leads him to be dismissive of other social groups' critiques of skateboarding; he denies the authenticity of *their* ideals and lived experiences" (Stevens, 2001, p. 2088, emphasis original).

by skateparks, through being of fixed size and design and the imposition of safety rules, along with the drive to commercialisation of both the practice and the parks themselves many starting to charge entry fees, the number of practitioners and the prominence of the sport slumped in the early 80s. Later revitalisation came about with the recognition that:

“The best skatepark a city could give to its skaters would be a piece of land with nothing on it and let them design and produce it themselves” (Gravstad, 1992, in Borden, 2001, p. 77)

The cities did not give skaters a piece of land so skaters went ahead and took land in the city developing a new style of skating, i.e. streetstyle, resulting in the practice picking up again by the late 1980s and early 1990s. What the streetstyle entailed was a navigation of the urban environment in search for places that could provide for stunts and experiments with techniques of handling the skateboard. What took place was a kind of consumption of the city’s everyday active environment, in conflict with existing use, in search for pleasure and challenge where each different piece of architecture and design demanded different ways of skating. Hence the architecture of the city became not a thing in itself to be read or taken over, but a “set of flows, a set of experiences and reproductions” (Borden, 2001, p. 6), this architecture is thus not space, but a way of looking at space and producing space.

2.3.3 Skating on Festival Square

The space, which sets the scene for skateboarding on Festival Square, is the square’s very materiality. The abstractions that brought about the grand scale reformulation of the square’s materiality have already been outlined, creating the void space of Festival Square, that very same void that has been occasionally re-imagined and ‘co-opted’ but more saliently is constantly being mediated or filled through everyday negotiation and reformulation by practices of young men, skateboarding.

The city of Edinburgh had no plans of designating an empty piece of land to skateboarders, but did plan to build a skatepark in the Meadows that to date has not come to fruition and most likely is off the table now (Ian Spence and Graham Tully). On the other hand Festival Square, after its reformulation in 1998, provided a piece of land, which fitted well into the streetstyle of skating as it is an active environment of the city, built for certain purposes as has been outlined. Skaters on Festival Square

recognise the prescribed role of the space as one of spontaneous events and performance but that is not the way in which they use it, for them it is an everyday playground, very much in conflict with the predominant everyday use of the square as a place of passing, as has been already outlined. But for the purpose of this chapter what skating on the square did was to design and reproduce the square, according to their use and appropriation of it.

The architecture and design of Festival Square is produced and provided by the city with a determined function and role, which primarily represents a certain exchange value in the city's marketing strategies as has been discussed in previous chapters. To place skateboarding, using the same terminology, I argue the skater's quest is about manipulating the use value of space. To clarify the terminology the dialectical framework previously set up (see p. 120) can be reworked.

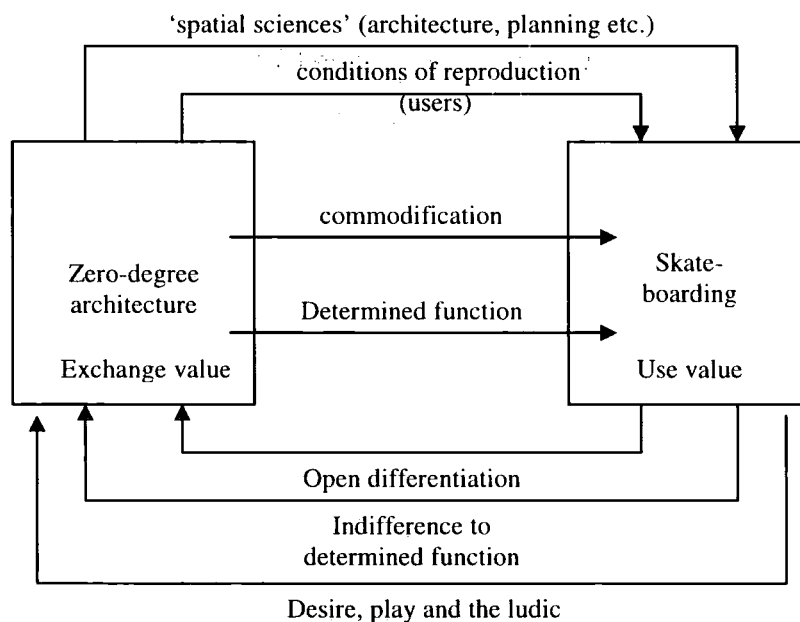

Figure II.6: Skating on Festival Square.

Source: Adapted from Gregory, 1994, p. 401.

Highlighted here are Borden's (2001) two major themes of argument, i.e. firstly how skating is a search for pleasure, a desire for fun and play that in itself is not an overt political strategy, but a "lived critique sustained by practice" (p. 206). Thus secondly this lived critique highlights the dialectical confrontation of the lived and conceived

space, or between the determined and/or dominant function²⁵ of the space and everyday use, creating a differential social space (Stevens, 2001). With these two themes public space gets a certain reappraisal highlighting the multiple spatialities and temporalities that co-exist in a place and how these are constituted. Here through skateboarders I argue for the core of Lefebvre's festive appropriation of space that takes place through play, fun and desire covertly undermining the conceived order and determined function of space.

Referring again to part 3.1.3 the skateboarders are teenagers, male students aged 15-25, young women do not as much participate in this practice since they are "discouraged by the forces of convention, including within skateboarding those of sexist objectification" (Borden, 2001, p. 263). When talking to the skateboarders that hung out on Festival Square they explained to me two dynamics that brought them to the square. Firstly was the fact that the established streetskating scene in Edinburgh, Bristo Square (quoted in Borden, 2001, p. 118), was where the better skateboarders hung out. Those on Festival Square were younger and more inexperienced and practiced on the square safe from the gaze of their 'superiors'. Here there are certainly issues of boundary formation and how these inform the identity of the skaters. Additionally there are rituals of entry based on skills, which the skaters on Festival Square tirelessly practice for, all from the basic flip tricks of the board to the very prestigious long-jump of the stairs leading to Sheraton's entrance or sliding down its handrail. Once having mastered the different tricks there is a move up the hierarchy with the eventual aim of performing a stunt no-one has done before, either on Festival Square or in the city as whole. These group politics cast a certain shadow on Borden's (2001) romantic notions of skateboarding as practiced with global affinity through style. Although skateboarding is a global practice, once witnessed it is the practice of a group of young men internally hierarchical through selective affinities based on skills, already established networks of friendship, age and gender. Although for other users of the square skateboarders all look the same through their practice and homogenous dress codes of baggy trousers and skate-caps, prompting Borden's

²⁵ Void spaces of determined function is defined by Borden (2001) as: "zero degree architecture [is] a field of the meaningless, a series of signals, a code reductive in individual signs and complex in its multitudinous instructions" (p. 229).

notions of the global affinity through style, there is on Festival Square a rule to who can do what and where as evident from the above.

But, secondly and more important for this discussion, is how skateboarders on Festival Square make use of the materiality of the square. In informal interviews they elaborated on the square's usefulness by describing spaces such as the gentle curvature in front of the CH entrance that was produced by the 'twisting' of the square to make it level²⁶. Along with slightly curved slabs to allow for drainage these make for good practice grounds for some of the more basic skateboarding moves, such as elementary flips of the board without running the risk of too much bodily harm. The slipperiness of the stonework of the water feature, makes for an excellent sliding ramp, which serves as a safe training ground for the eventual sliding down the handrails on the steps leading up to the Sheraton. These were all to train for the square's ultimate stunt of jumping the longest of anyone, as they would leap from the Sheraton entrance to the level of the square. Additionally due to the flat, open expanse of the square, objects were introduced onto it, such as pallets and wood to create makeshift structures for performing stunts. Festival Square thus became designed and reproduced as result of the dialectics occurring in the lived spaces of the skaters between the perceived materiality and produced spaces through practice. Hence the handrail placed by the designers of the square to support people going up the stairs to the Sheraton has become a ramp for young men coming down the very handrail itself. The Montemuro granite of the slightly 'twisted' area in the front of CH, placed there by the designer as the Caithness slabs could not be lain on such undulating ground and additionally forms the light geometric patterning of the square reflecting the structure of the surrounding buildings, is for skaters only a useful training terrain for basic board flip stunts. The flat emptiness of the space made to facilitate events is cluttered with wood and make shift structures that are for stunt training. Drainage ducts, planters, water-feature, steps and slabs the purpose of which has been dutifully listed in chapter 3, part I as envisioned by the planners, designers and architects all become differentiated spaces through the mediation of their very materiality through the practice of a few skateboarders.

²⁶ Something the managers of CH, John Long Wootton, had already recognised stating that skaters will "undoubtedly flock to the sloping paved surface of the square" (Letter from John Long Wootton to City Council, 28/11 1996).

But further adding nuance to those lived spaces Borden (2001) draws a phenomenological account of those practices in the way he describes in detail how the body absorbs the underlying architecture through the skateboard. By drawing attention to this reproduction occurring through the collusion of “the proximate body...the skateboard and the terrain” (p. 97) a skateboarder creates a unique unrepeatable whole (Rinehart, 2003), a whole that extends further than the very materiality of the square.

2.3.4 Skater-space

The space produced by the skater is body-oriented and immediate but not purely so. Borden (2001, p. 97), through quoting Simmel, draws attention to these spaces produced by the body in action but also highlights the spatio-temporal trajectories, or range of the subject as the sum of effects, that extend from the body at various lengths in space and time. These effects, extending from the skateboarder spatially and temporally, are the spaces produced by the skateboarder through the unrepeatable whole of body-board-terrain. Borden (2001) explains what happens during the body-oriented and immediate production of space that occurs when skating:

“Skateboarding is nothing less than a sensual, sensory, physical emotion and desire for one’s own body in motion and engagement with the architectural and social other (p. 135).

The spaces produced by this action are:

“a production outwards from the skater’s body, created in relation to genetic properties of its symmetries and orientation” (p. 262).

In relation to the above quote Borden (2001, p. 35) cites Rodaway (1994) to claim that the experience of skating is not solely visual but draws on all the sensory apparatus, especially the physical experience of heightened adrenaline through the thrill and competition associated with the practice. The skater’s body desires the fun and thrill derived from the competition with his peers and grafts this quest onto space through a confrontation with the architectural and social other. The key to the production of space lies in the second quote, i.e. how space is produced outwards from the skater’s body in relations to symmetries and orientations. Through a reorientation of the objectivity/materiality of the square through use and the skater’s

own body, through the skateboard, spaces are produced that are differentiated from those being produced by others on the square. Thus skateboarding is the active retranslation of the space of the square, creating simultaneity of spaces and times that through their very being pose a critique or confrontation to other spaces and times on the square.

The embodied spatial practices detailed above are manifest in the markings the skaters leave on street furniture and architecture. These “marks, scratches and other material manifestations are only the traces of a much deeper critique of contemporary urban life”, Borden claims (2001, p. 263). But on Festival Square the overt critique is as shallow as the markings on the slabs as the young men playing on the square did not articulate any such issues or conflicts, thus what I argue, in line with Borden, is that here there are starting to form links with a non-deliberative production of space, one that is not lodged in counter-domination but is an “appropriative negation of the space which precedes it” (*ibid.* p. 211). This space is appropriated merely from the perspective of its materiality and not from deliberate counter action, reducing “architecture to an element” (*ibid.* p. 216) or object that is decentred through its use with the traces left on it marking that engagement, stating that this space is lived by someone.

In the space of Festival Square these markings, albeit shallow, are very obvious and are to be found everywhere on the square and its street furniture. The street furniture that could not take the use of skateboarders were the benches that were mostly removed from the square prior to my arrival as the skateboarder’s use of them damaged them. Both Bill Strang and Charles Hardy focused on damage caused by skateboarding along with other of my respondents and interviewees that constantly saw skateboarders as an annoyance and causing damage. There is without doubt an obvious confrontation here between the space produced by the people creating it and those maintaining it, and also those that live that space as their working environment and the skateboarder on the square. Thus the spatial practice of skateboarding, this lived space can usefully highlight the tensions between those living that space differently and those creating spaces with certain ideals in mind. Hence Festival Square served here as an example of politics constituting the theatricality of public life in public spaces. But as I argued, what for me is coming through here more

strongly is a sense of the non-deliberative practices active in producing spaces that are not only derivative of the materiality of the square, but mediated through it. These spaces were above read in conflict with other spaces being produced, those other non-deliberative practices of which the best example is from all those that predominantly go about their everyday on Festival Square, the office workers in the surrounding buildings and to them I turn to in the next chapter.

2.4 The Open Differentiation

In the last chapter I outlined the way in which the space of Festival Square had been conceived in terms of abstract ideas such as global place marketing, through capital and tourism and also through ideals of the role of the third sector in the economy. These sketches were to highlight the conception of space from the rational mind of the planner, designer, architect or politician. This conception of space then creates the concrete space as fleshed out in part I and the last chapter, but is also used everyday and lived through as I was drawing out in this chapter. The way in which the space of the square is used was highlighted firstly through deliberate action that appropriated the space of the square to formulate it according to the ideals being promoted in the action. Hence I took examples of events that could be seen as latent, ritual or manifest protest, albeit with reservations as to the appropriateness of using the word 'protest' as these events did not actively re-constitute the imaginings and understanding of what Festival Square is about in any subversive manner. Secondly, the uses of the square could be gleaned through the spatial practice of skateboarding, which is one of the everyday uses of the square. While both examples are premised on the very materiality of the square, the second example places more emphasis on the way in which these materialities are mediated through practices that produce a wide range of spaces and times into the square adding onto the appropriation of the materiality of the square highlighted in the first example. The spaces produced through this mediation are certainly in conflict with other spaces being produced but more importantly, in the context of the thesis, with the emphasis placed on this mediation what started to emerge were the non-deliberative actions that produce space and were the main concern of Lefebvre when he stated the role of everyday lived spaces in which spatial practices take place. These spatial practices highlight the ongoing dialectical struggle between lived and conceived space recognising that:

“Spatial practice is lived directly before it is conceptualised, but the speculative primacy of the conceived over the lived causes practice to disappear along with life, and so does very little justice to the unconscious level of lived experience” (Lefebvre, 1991, p. 34).

So it is to the unconscious level of lived experience I turn to next.

II.3 Clearing through Rhythm

In this final chapter of part II the preceding discussion on the body-centred notion of *habitus* in part I and the space generative notions introduced through *The Production of Space* in part II will be brought together to make a mutually complementary account of the subject's making of and being in space. Both are premised upon a dialectical way of grasping the subject's engagement with the world and entail notions of habits, rhythm and dwelling as will be demonstrated below. Combined they offer a way to grasp the simultaneity of space and time on the square (see p. 114 and 163-4) through the subject's everyday practices producing space. Thus I will build on the lived space of Lefebvre but here more particularly detailing the non-deliberative actions that produce Festival Square building on the quote on the preceding page, bringing Bourdieu's formulation to bear on Lefebvre.

These non-deliberate actions are the habitual everyday routines that I argue produce space in no less a way; as do the deliberative actions outlined in the previous chapter. Seeing the square as a habitually lived space I start drawing on phenomenology as put forth by Martin Heidegger, premised on his elaboration of *Dasein*. Heidegger, through this elaboration, was a mutual influence on both Bourdieu and Lefebvre. Lefebvre's explicit debt²⁷ to Martin Heidegger extends to *The Production of Space* where his lived space holds resonance with *Dasein*'s being-in-the-world, as does Bourdieu's notion of *habitus*. As I bring these two theorists together through an explanation of *Dasein* I will inevitably be forced to present an abbreviated version of the thought and writings of the prolific Heidegger and will only focus on terms that bear directly upon the discussion of Festival Square as a product of non-deliberate actions or habitual routine. These terms emerge once I start to talk explicitly of rhythms which represent the culmination of Lefebvre's (2004) work. Here he draws more heavily on Heidegger's later work (see p. 44, 49 and 50), especially with the notion of 'presencing' or disclosure. Through introducing 'presencing' I link Lefebvre's rhythms with the term 'gathering', both of which I will explain through Heidegger's discussion of dwelling. Through an empirical example in the end of the chapter I will

²⁷ This debt is most certain and claimed by Elden (2004b) as relating to his understanding of the social in the notion of the production of space while as the production part is the Marxist in Lefebvre (see p. 98). The full extent to which he dealt with Heidegger's work though remains unexplored (Elden, 2004b, 2004c).

explain the rhythmanalytical project of Lefebvre (2004) taking it up as a way of approaching the body and space as “a garland of rhythms, [or] one could say a bouquet” (p. 20). The example will be an experiment in what Lefebvre was aiming to do with his rhythmanalysis, as it is a conceptual tool, albeit a vague one, allowing one to grasp the presencing of Festival Square as a flow that is a gathering of the rhythms generated by a habitually lived space. In conclusion I will explain how Lefebvre (2004), although swayed to phenomenology, retained strong notions of the dialectical understanding of the production of space through rhythms linking it directly to the production of space as he had earlier conceived it (p. 96). This retention of the dialectical will be addressed in part III.

3.1 Habitual Production of Space

In the start of the thesis I argued for space being composed of infinite sedimented time-space trajectories. People plot their way through these sedimented trajectories through practical activity and in order to understand the way in which this interaction occurred part I argued mainly around Bourdieu’s notion of *habitus*, which was defined on the most abstract level as “the system of internalised dispositions that mediates between social structures and practical activity, being shaped by the former and regulating the latter” (Brubaker, 1985, p. 758). But also, and more importantly, the existing social grounding, in forms of institutions in a social field, had sedimented within the body as forms of dispositions that inform its every action, dispositions that were mostly internalised onto subconscious levels, through doing and being or simply habit.

As has been stated before one of the limitations to Bourdieu’s formulation of *habitus* is that it seems to be shaping and conditioning human action without any explicit mentioning of how one can go about examining this. There is also a limit in Bourdieu on how to account for creative and generative practices that modify the *habitus* (Crossley, 2001) as the internalisation of dispositions is primarily mapped onto the subconscious. But, especially with respect to this thesis which is about space and written to present ways of understanding and grasping space, the specific relation between the body and the physical material setting or everyday space is only paid lip-service to in Bourdieu as he “dismiss[es] geographic space as merely an obfuscatory

veil” (Painter, 2000, p. 258). Hence as a response to these problems I introduced Henri Lefebvre and his book *The Production of Space* that was explained in detail in the previous chapters. His dialectics were in terms of abstract and the concrete, conceptions and perceptions, the mental and the material, demonstrating in a critique of abstract notions of space how “our mode of reaction to space is not geometric, only our mode of abstraction is” (Elden, 2004b, p. 95). He showed how perceptions of space play in the context of conceptions of space which form the material groundings for the lived spaces of everyday life and hence how the everyday reality can be actively changed informed by different ideals, as demonstrated in the last chapter. The dialectics of abstract and concrete spaces, or the objective social structures and subjective perception, occur through the body thus it is through different ways of being that the abstraction is upset and new spaces of representation can be made. Hence it is the people that are to take to the streets in order to make their presence felt in space that has been subordinated to abstraction (Gregory, 1994). These differential spaces are produced as people claim spaces in a deliberate manner through subversive or different practices as shown with reference to events or the skateboarding on Festival Square. It is here with the demonstration of different ways of being, either conscious or subconscious through doing that links start to form with the outline of Bourdieu in the first part. With injecting abstract space with the life of being, Lefebvre sets the body in space seeing space as directly informing the body’s presence in space, as Bourdieu did clearly in his formulation of *habitus* with respect to the social world (see Gregory, 1994; Harvey, 1989). This combination thus produces an account that recognises both the deliberative and the non-deliberative production of space through dialectical mechanisms both working through the body, one internally through generating dispositions, the other generating spaces through the body. These mechanisms I will strive to illustrate shortly in the following, leading up to an account of dwelling.

3.1.1 On Festival Square

In order to demonstrate how space can be grasped in terms of a combination of both theorists presented above and thus as a habitual production I refer to those users of Festival Square that were most prominent during my fieldwork period. As stated in chapter 3 of part I, 81% of those I encountered on the square were just ‘passing through’ and gave that as an answer to the question: “How long would you say your

average stay was on the square". When prompted further on any comments on the square many, or about 40%, of those queried would look around, shrug and give a non-descript comment such as "nice", "quite pleasant" or "open", "empty", "clean" or "tidy". Others that took more time would postulate on the lack of seats, the skateboarders or the water feature, which seems to be the only visual primer to be found on the square. The movements and motions of those passing through were evident from the numerous pictures and video-footage taken and can be described in terms of 'non-engagement', with a space that seems non-existent to those doing the passing and only becomes a matter of perception, and potential conceptions of annoyance, once it exerts its presence upon them. Examples of the square exerting its presence were people tripping over broken slabs or being jolted from deep introspection by a skateboarder coming too close or when a researcher stopped them to ask them to conceptualise the space they are in and articulate it. As could be argued through Bourdieu, their daily routine governed by social organisation has sedimented to form certain bodily dispositions making for the everyday navigation of the square as one of subconscious exercise. The body's *habitus* in the space of Festival Square is one of passing, moving through without stopping which was quite evident in my attempts to stop people, as it was not until I had attempted to stop about 800 people that enough actually stopped to complete the 200 2-minute questionnaires I had prepared.

In order to explain the argument of habitual routine with reference to *habitus*, the notion can be grasped through three distinct sets of relations: Firstly, the conditions under which it was formed, secondly, the immediate situation of the action and thirdly, the practices it produces (Brubaker, 1985, p. 760). In terms of Festival Square the first set of relations refers to the conditions that generate the movement across the square. Here I am talking about the fact that most people crossing the square do so on their way to or from work, going home or out for lunch. These conditions are dictated by the social organisation of the work place, e.g. timetables that set the structure of the day representing the social discipline demanded by the work, dictated by instruments of time-keeping (May and Thrift, 2001). These conditions sediment as *habitus* and, although detailed in length in Bourdieu's numerous studies unveiling the objective social structures that impact everyday being (Honneth, 1986), I will refrain from doing so till the end of the chapter once I have outlined Lefebvre's

rhythmanalysis, as his work has a more direct bearing on physical material space. The physical material space is the second set of relations producing *habitus*, i.e. the immediate setting in which action occurs. Here the square's design as a flat empty space, made to facilitate flows of pedestrians, is appropriated into the bodily dispositions of those passing over the flat emptiness itself, producing as they pass the third set of relations, the practice of moving across or passing through without effort or thought.

What is here presented is the utility oriented strategy of the body that Bourdieu formulates as a collective perceptual and evaluative schemata operating on subconscious levels as *habitus*. Thus the argument is presented here that *habitus* is a matter of habit or the unconscious doing or action that is structured by society's objective structures. These objective structures Bourdieu himself only formulated with respect to time or temporality and not with respect to space apart from metaphors of fields and arrangements. "The result is an engaging if ultimately contradictory attempt to sustain simultaneously the perfect systematicity of the social world and the infinitely rich concrete diversity of human practices" (Brubaker, 1985, p. 770). But as hinted at in the second and third set of relations the physical material setting has a role to play. Although passing through the square is talked about in the above as passive and non-obtrusive, merely fulfilling the determined function of the square, there is all the same an active production of space that is taking place. Here I want to argue that the non-deliberative action of movement across the square, the everyday unobtrusive flow of people through the square constitutes a spatiality that is no less important in the production of the space of Festival Square, constructing it as a space of flow. The habitual dispositions that have sedimented in the subject's body passing through Festival Square can be seen as a Bourdieuan dialectics acting through the first set of relations outlined above, but through the second and third set these dispositions are productive of a lived space born out of dialectic between the body and the physical material space. The space of Festival Square is thus primarily a space of passing and non-function and how Bourdieu and Lefebvre can both be further fruitfully brought to bear on this kind of space is through their phenomenological roots addressing questions of Being amongst beings.

3.2 Dwelling producing Space

As set forth in part I Bourdieu's *habitus* is implicitly structuralist, as he lodges the sedimentation of dispositions squarely with the unconscious (see p. 35-6). Through tying it with Lefebvre's notion of lived space in the above I attempt to give the relation between objective structure, in this case the physical material space, and the body some salience. With his notion of lived space Lefebvre's first ties to phenomenology emerge when he explicitly pays tribute to the influence of Heidegger and Bachelard (see Lefebvre, 1991, p. 121). With further reference to Heidegger I will tie together the thought of Bourdieu and Lefebvre, as both have engaged with his groundbreaking work in phenomenology and understanding of Being, to create an account of *Dasein* and dwelling (see Bourdieu, 1991, Elden, 2004b and Rockmore, 1995).

3.2.1 Heidegger's *Dasein* and dwelling

Heidegger's early phenomenology was dealing with the ways in which the world makes itself available to the knowing person, recognising that "in order for something to be something, it must first be. Being in general is the condition of possibility for being in particular" (Elden, 2001a, p. 9 and 22). Thus Heidegger's concern was the distinction between being and Being, or the distinction he made between *ontic* (examining the nature of being through observation and empiricism) and *ontological* (what is the condition of possibility for the *ontic*) knowledge. Elden's short Heideggerian definition of a long tradition of thought should be borne in mind through this chapter.

The concept of Being is basic to Heidegger's project and he distinguished it from beings, i.e. entities that have defined and determined attributes of existence, by stating that those entities also have an existence as such, i.e. they are prior to their determination as such, and thus he set up an ontological difference between Being and beings on the basis of Being not being *a* being with any properties or characteristics but existence. But his was a phenomenology that broke with that of Husserl²⁸ through an engagement with the practical life world of the everyday, recognising Being as

²⁸ Husserl is generally considered the father of modern phenomenology and was primarily concerned with how beings could become Being through abstracting them via consciousness. Hence his end move, getting to the Being of beings entailed a reference to the Transcendental Ego, or a kind of ultimate self that was Being.

being-in-the-world. This means that Being is not lent an abstract, detached status from the ground it originates from, it is there at one, in relation to all other entities, effectively an event of Being (Blattner, 1999; Caputo, 1982). Thus to make sense of being-in-the-world, every being must be recognised in terms of its relationality to other beings. Thus each and every being is always a being of something else, or one with other beings. In order not to relapse into simple empiricism describing those relations based on the attributing beings, Heidegger started with a reformulation of the being that is the human (Polt, 1999).²⁹ As this chapter focuses on people's use of space this reformulation has immediate relevance to the argument presented and thus I will proceed with an outline of *Dasein*.

Dasein is a being whose Being is an issue for it or "that entity in its being which we know as human life; this entity in the specificity of its being, the entity we each ourselves are, which each of us finds in the fundamental assertion: I am" (Collins and Selina, 1999, p. 51). In Heidegger's philosophy *Dasein*'s ontological basis is in experience and it precedes all knowledge, or 'existence precedes essence' as the Sartrean dictum goes, itself based on a reading of early Heidegger. Heidegger analysed *Dasein* in terms of its concerned being-in-the-world (Dreyfus, 1991; Polt, 1999). This concerned being-in-the-world manifests in *Dasein* through two modes of concern, firstly towards beings that are ready-to-hand for *Dasein*, i.e. ready for practical use, with ascribed meaning, functions and significance that have been construed by those ready-to-hand beings in relation to other beings, or themselves fundamentally being-in-the-world. Secondly, towards beings that are present-at-hand, i.e. those of not immediate practical use, but seen through detached observation, abstraction or contemplation, e.g. the wind or the current of the sea. This presence-at-hand is not of immediate use to *Dasein* as is the ready-to-hand and hence for *Dasein*'s concerned being-in-the-world, concern to that which is ready-to-hand has primacy. Thus in order to understand *Dasein*'s Being it must be examined in its practical everydayness. Or in a word, *Dasein*'s being-in-the-world comes through its skilful

²⁹ This engagement with the subject relates to a period in Heidegger's thought that is prior to what is called his *Kehre* (E. turning). Heidegger's thought is divided up into two periods separated by the *Kehre*. The former period of thought is one with existentialist overtones making the case for *Dasein* (E. being-there, see Elden, 2001a, p. 15) carefully not formulated in terms of subjectivity. In the latter period of thought these existentialist overtones all but disappear as he decentres *Dasein*, or sidelines it in a grander scheme of beings and Being. His engagement with the subject prior to the *Kehre* serves well to illustrate the nuances of Heidegger's thought that influenced Bourdieu and Lefebvre.

engagement with objects in the world in a complex context of significance mediated by concern (Polt, 1999). It is this *Dasein* as being-in-the-world of beings ready-to-hand that is the object of what follows and will thus be scrutinised further.

Bourdieu's *habitus* draws inspiration from *Dasein*'s being-in-the-world as it involves dispositions to the world setting the body thoroughly *in* the world. In his case the general social world was where concerned relations and practical dispositions play out politically, thus fleshing out what Heidegger did not, i.e. what people's subjective concerns are. But the same applies for physical material space that Lefebvre argued for in terms of lived space drawing inspiration from *Dasein*. Lived space is one of concern prior to any abstraction or contemplation, the space of experience one that can stretch and distort in lieu with concern. Space is thus opened up, in one sense, by the concerned presence of *Dasein*. What this opening up entails is not a contemplation of the world by *Dasein*, but an unveiling or disclosure of the world in a particular way. In short, *Dasein*'s concerned dealing with the world discloses a pragmatic spatiality, one that I have outlined in the previous chapter in terms of lived spaces productive of differentiated spaces, be it events or skateboarding or simply walking as I will be arguing in this chapter. Thus the disclosure of a pragmatic spatiality is a lived space that becomes the space of the available in nearness and is centred on *Dasein*. As a consequence *Dasein*'s pragmatic spatiality must be ontologically primary in order to understand everyday spatiality (Dreyfus, 1991; Kockelmans, 1992; Polt, 1999).

Heidegger (1971) explained the disclosing of pragmatic spatialities in terms of dwelling. Dwelling is *Dasein*'s concerned being-in-the-world. This is to say that dwelling, motivated and propelled by concern, takes space as caring.³⁰ Thus dwelling itself is therefore always staying with the world, dwelling as a preserving of the world (Ingold, 2000). It is worth repeating the resonance here with Bourdieu (1990, p. 271) as he interprets the built space as an ordering principle of life consciously or unconsciously adopted by us, along with the power-geometries they represent, through sedimenting as dispositions or *habitus*. But since Bourdieu did very little in

³⁰ Here I call space what Heidegger (1971) termed the 'unity of the fourfold'. This is the grander space of Being, as mentioned before with *Dasein* not centre-stage, and will be picked up again later in the chapter.

line with spatial analysis, explaining how dwelling is the space of *Dasein*, I referred to Lefebvre. The link between the production of space and phenomenology of Heidegger has been established as Elden (2004b) argues, the primacy Lefebvre puts on space draws inspiration from Heidegger, while as in his formulation a Marxian emphasis the most prominent. It is essentially in the latter period of Heidegger's thought, or post-*Kehre* that Lefebvre picks up on the Heideggerian critique of existentialism through his *Letter on Humanism* (1993), especially directed against Sartre and his reading of earlier Heidegger, prior to the *Kehre*. Mainly Lefebvre would try to ground in the concrete what eluded practicality in Heidegger, especially the Heideggerian notion of concern as living with the world in an experiential way or dwelling. Thus Lefebvre formulated his lived space and more importantly politicised dwelling by lodging it with the capitalist mode of production, as has been demonstrated in the previous chapter with the production of differential spaces, while Heidegger went on to formulate the space of Being as will be followed up in the next part. But in an even more explicit reference to Heidegger, Lefebvre's use of *habiter* is a direct translation of *wohnen* and is translated 'to dwell' (Elden, 2004b, p. 96) as with Bourdieu's *habitus* in the above.

Thus in order to explain the notion of concern I have argued for the role of dwelling as formulated above by Heidegger and shown how it inspires both *habitus* and *The Production of Space*. As demonstrated in the above dwelling on Festival Square is in terms of habitual routine, one that can be grasped with Lefebvre's rhythmanalysis which I will use to further tie together Lefebvre and Heidegger in what follows through the notions of 'presencing' and 'gathering'.

3.3 Rhythm Producing Space

Lefebvre indicates in the early 1970s the role of rhythm and time in the original publication of his book *The Production of Space* although he does not start to outline these roles until in his last days with a couple of small publications from 1985 and 1986 (see Lefebvre, 2004), finally outlining the elements of his rhythmanalysis published originally in 1992, a year after his death (translated in Lefebvre, 2004). Although this project represented an uncompleted thought experiment in Lefebvre's oeuvre it was nonetheless the culmination of his work on everyday life. This work

extends back to 1947 with the publication of the first volume of his critique of everyday life with the subsequent volume II appearing in 1961 and III in 1981. The way in which Lefebvre, the Marxist in the previous chapters carried on to analyse subject's actions was through seeing them in confrontation through difference that then gives shape and form to the world allowing for classification and labelling. These then become political devices for social control and discipline dictating the mechanisms of inclusion and exclusion and thus the necessity of ideals to struggle and appropriate spaces in order to produce differentiated spaces. None the less implicit with his work are ideas of the 'promiscuous' geographies of dwelling in place where Self/Other, Here/There, Past/Present constantly solicit one another (Jacobs, 1996, p. 5 see also Mendieta, 2001, 2001a). So though within his later notions of rhythm is to be found the ultimate "exposition of the production of space" (Lefebvre, 1991, p. 404), Lefebvre stated and recognised already another strand of his thought, more concerned with the concrete everyday lives of individuals that he formulated through adapting Heidegger's phenomenology, that he then tied together with his Marxism in rhythmanalysis (Elden, 2004c).

In his *Production of Space* Lefebvre is concerned with the everyday concrete lives of individuals, most evident in his notion of lived spaces. By adding this dimension to Marxist analysis and its dialectical methodology, it is extended beyond the economic to encompass factors of socio-cultural life. Lefebvre's basic argument was that Marxism is ineffectual if it does not take into account all aspects of life and upon this understanding he added his 'critique of everyday life' or how the everyday should be understood. The everyday, Lefebvre understood to be, that which is closest to people, i.e. those spaces surrounding those journeying to and from work, in the local street or at home, doing the shopping and in general those daily routines that make for everyday uses of space. This is "space as encountered in everyday life, and lived in, not encountered in geometrically measurable forms and shapes and distances" (Elden, 2001a, p. 17). Most certainly Heidegger delves into this experiential side of life (*ibid.* p. 52) but Lefebvre, more explicitly analysed the everyday as such.

With rhythmanalysis being the ultimate expression of the production of space Lefebvre aimed to show "the interrelation of understandings of space and time in the comprehension of everyday life" (Elden, 2004c, p. vii) presenting a non-linear

understanding of time in the form of rhythms and cycles in order to grasp the ever-on-going nature of the everyday. With rhythms he moved away from a reductive account of time seen as a linear progression, or to use the vocabulary developed in the previous chapters, for him the linear account of time is an abstraction of time, a conceptualisation opposed to the concrete ground of the everyday where Lefebvre saw infinitely superimposed rhythms constituting space, time and the body. Hence he saw rhythm as the most concrete of things, the basic underlying organising principle of everyday life that keeps it in a perpetual state of becoming.

3.3.1 Rhythms

Rhythm, as formulated by Lefebvre (2004) in *Rhythmanalysis*, is a general concept that, although everywhere, eludes meaning. The constitutive part of rhythms or the 'first element' of rhythmanalysis that needs to be fleshed out is repetition, i.e. all rhythms entail repetition. But Lefebvre argued that there can be no pure repetition or no absolute, unchanging repetition. An absolute, unchanging rhythm is a pure logical abstraction, a kind of eternal machine, and does not exist in reality.³¹ With this argument he stated further that repetition, as it cannot be absolute, gives rise to repetition holding within itself difference, i.e. sooner or later repetition will give rise to difference. But although difference is inherent in the repetition and it will sooner or later give rise to it the abstracted repetition also has a role to play. Just as in the production of space where the transcendental conceived (abstract) spaces had real concrete manifestations playing a role in people's everyday, in the same way implicit with all notion of rhythm there is measure, i.e. an abstraction through making it "law, calculated and expected obligation, a project" (Lefebvre, 2004, p. 8) that has concrete manifestations. The manifest examples of rhythms he cited through his book are of music, language and media, bodily training in terms of dressage³¹ and acquired gestures, dance and work and, as he makes very clear, although these examples can be understood as abstractions or pure measure they are all intricately bound with difference since "rhythm appears as regulated time, governed by rational laws, [it is] in contact with what is least rational in human being: the lived, the carnal, the body" (*ibid.* p. 9). With these two constitutive elements of rhythm, i.e. as difference and

³¹ In this chapter of the book (Lefebvre, 2004, p. 38-45) his argument closely resembles that of Bourdieu as he argues how dressage or training are not the same as education or learning as the former represents ways of "knowing how to live, knowing how to do something" (p. 39).

measure, Lefebvre can claim that rhythm has logic although it inherently escapes logic. This interaction of the cyclical (difference producing repetition) and linear (measure) has a folding of interacting component rhythms or polyrhythmia that constitutes the concrete or the present.

With the notion of polyrhythmia it becomes clear what Lefebvre (2004) means when he stated that the body and space can be viewed as “a garland of rhythms, [or] one could say a bouquet” (p. 20). This symphony of rhythms, to pick up on another metaphor (see p. 31), can work in synchronisation to maintain a healthy state of affairs in the case of ‘eurhythmia’, i.e. “eurhythmia (that of a living body, normal and *healthy*) presupposes the association of rhythms” (p. 67, emphasis original) that is mutually complementary. On the other hand what would constitute a failure or disharmony is ‘arrhythmia’ or where interlocking rhythmic cycles repel each other or at best lock in an awkward way producing a pathologic state of affairs.

To concretise the understanding of rhythms further in terms of the lived spaces of the body Lefebvre (2004) went on to classify four kinds of rhythms: Firstly there are what he called ‘secret rhythms’ those that were physiological and also psychological or those circadian rhythms of the body and in living things and those of the functioning mind, e.g. in memory. Secondly there were ‘public rhythms’ those found on calendars, work routine, ceremonies and those of the body rhythms one can express, e.g. tiredness or hunger. Thirdly there were ‘fictional rhythms’ or the imaginary rhythms of the learning person those rhythms one picks up and appropriates, e.g. dispositions. Fourthly and last there were ‘dominating-dominated rhythms’ or those that were completely made up and aim for effect that is beyond which that could be found in themselves (p. 18). Next I turn to how these ‘types’ of rhythms can be discerned or grasped.

3.3.2 Discerning rhythms

My earlier references to the body have mostly been in terms of Bourdieu’s *habitus*. As has been argued, Lefebvre’s (1991) concern for the body was lacking in terms of how it generates spaces (Gregory, 1994, see part II, chapter 1), where his emphasis was on spatial practices and not how the body mediates space. In the rhythm analysis project Lefebvre became much more explicit about the body and how to understand it.

In opposition with Bourdieu, who analysed the body through an interpretation of the sedimented dispositions informing conscious or subconscious action within the social field, Lefebvre analysed the body starting from the conscious knowledge of the work of the abstract and abstraction. Hence the body was for Lefebvre (2004) a point of analysis able to discern the rhythms that compose it. The focus of analysis was to be on the moment in time, when rhythms collide in and on the body and with the focus on the moment of collision the rhythm analyst could start to indicate how future trajectories of the rhythms spawned by the body could be changed and influenced.

The lived experience of the rhythm analyst through the body, Lefebvre juxtaposed to that of the interpretive psychoanalyst, who carries the burden of the past and its cognitive recognition.³² Thus in contrast to a semiotic or cognitive reading of that which is already inscribed on the body and the environment and sediments in the subconscious, allowing for an unpacking of the sedimented dispositions and concerns through empirical observation in line with Bourdieu (1989), the rhythm analyst unleashes the power of that which is observed by “listen[ing] – and first to his body; he learns rhythm from it, in order consequently to appreciate external rhythms” (Lefebvre, 2004, p. 19). The orientation of the rhythm analyst is to the future or the constancy of the rhythms that comprise the analyst and the analyst’s environment, be it social or physical. Thus the body of the rhythm analyst serves as a metronome discerning the noise of the world, that noise which Serres (1982, 1995, 2003) likened to the ocean, from which there emerges order. Hence the starting point of analysis is the body as posed by Serres (1982) in terms of Q and A: “What is an organism? A sheaf of times. What is a living system? A bouquet of times” (p. 75).

For Lefebvre (2004) the method of the rhythm analyst was to go forth and listen to all the other rhythms that composed the living and the seemingly inert, to “garb himself in this tissue of the lived, of the everyday” (p. 21). Here I refer back to chapter 3 of part I where I did a walk of Festival Square recognising this tissue of the lived that along with the visual are the sounds, smells and other sensory stimulants that accompany and enhance the perception of the surroundings (see p. 74-5). As

³² The reason why I produce here the image of the psychoanalyst is because later on it will indirectly feature in the critique presented against dialectical thought via Deleuze and Guattari (1983 and 1987). The links between the post-structural phenomenology of Deleuze and the thoughts of Lefebvre remains unexplored (see Elden, 2004c, p. xiii).

recognised there those haptic, olfactory, auditory, aural and visual geographies cannot be represented in written words, lest potentially by way of prose, hence Lefebvre (2004) likened the work of the rhythm analyst to that of “the poet, or the man of the theatre” (p. 25) thus “exceeding the narrow framework of objectivity by bringing to it [the object] a multiplicity of (sensorial and significant) **meanings**” (p. 32, bold original).

The above placed emphasis on the living body, able to discern the polyrhythmic ensemble composing the world, i.e. the knowing body composed of rhythms and able to use those rhythms as a metronome against which other rhythms are measured through an immersion in the tissue of the lived. Thus I stated that all living systems are a symphony of rhythms. By putting primacy on the role of the living system is not to say that inert things do not have rhythms too. As Lefebvre (2004) argued:

“This *object* is not inert; time is not set aside for the *subject*. It is only slow in relation to our time, to our body, the measure of rhythms. An apparently immobile *object*, the forest, moves in multiple ways: the combined movement of the soil, the earth, the sun. Or the movements of the molecules and atoms that compose it (the object, the forest). The object resists a thousand aggressions but breaks up in humidity or conditions of vitality, the profusion of miniscule life. To the attentive ear, it makes a noise like a seashell” (p. 20, emphasis original).

From the above I understand that, all that is, is composed out of rhythms. These rhythms are merely of varying speeds, some slow, others faster as compared to the measure of rhythms which is the living body. Everything moves and changes it is merely for the attentive ear to discern that movement and change. Thus implicit with the notions of polyrhythmia and rhythm, is not only the living body but all there is. With the notion of rhythms objects that seem stable and material that seems inert get a concrete conceptual treatment. With everything being rhythms space, which I earlier referred to as sedimented but alluded to as still not at rest, is set in motion and room allowed for events that can throw the order out (see p. 73). Hence I have gone back to the arguments of the first chapter about space being made from time-space trajectories that have sedimented to varying degrees forming varying states of apparent inertia or stability or that which is. Thus, what is can be in a constant state of motion, but yet the same, and as there is no absolute repetition there is always an implicit potential to change.

Lefebvre (2004) himself made two attempts at a rhythmanalysis of this kind, trying to probe the infinite depths of the world through discerning its rhythms. He saw his project as “clarify[ing] and actualis[ing] the concept of *dialectical thought*” (p. 37, emphasis original). But adding to his dialectics is a phenomenology of which the basic argument is all about how the world makes itself present in the form of rhythms and thus he argues for those to be the tools to analyse this presencing of the world.

Thus:

“The act of rhythmanalysis transforms *everything* into presences, including the *present*, grasped and perceived as such...this wall, this table, these trees – in a dramatic becoming, in an ensemble full of meaning, transforming them no longer into diverse things, but into presences” (Lefebvre, 2004, p. 23, emphasis original).

I will carry on to illustrate how Festival Square possibly makes itself present, using the notion of rhythms. But before that illustration I will need to outline the notion of ‘presencing’ through the work of the later Martin Heidegger along with some relevant clarifications of his thought that bring to bear on the rhythmanalysis of Lefebvre.

3.3.3 Making presence

Above I introduced Heidegger through the centrality of *Dasein* in his paper *Building Dwelling Thinking*. I left him at a point, halfway through the paper and with an understanding of *Dasein* as the centre for disclosing being as Being. The later Heidegger in the 1930s, on the other hand, started to argue for *Dasein* as merely one of the beings that disclose their Being through encounters in, what he exotically termed, ‘the clearing’.

In the basic formulation of *Dasein* above it was presented as the Being whose being is an issue for it and as being central to disclosing the Being of beings that are either ready- or present-to-hand. This disclosure Heidegger formulated in terms of presencing and I aim to add depth to the above explanation of Lefebvre’s rhythmanalysis through disclosure as presencing that is an:

“openness which opens up in the mutual self-extending of futural approach, past and present. This openness exclusively and primarily provides the space in which space as we usually know it can unfold” (Heidegger, quoted in Elden, 2001a, p. 91).

The idea of presencing has thus a temporal and spatial signifier. Making present is through a set of relations composed of both spatial and temporal co-ordinates in which beings are embedded. Heidegger called this openness 'a clearing' that arguably is the physical material space as it is ready-to-hand, but that is merely one of the possible constitutions of that physical material space as the beings composing that space have a role in their own disclosure as Being and through a different set of relationalities can presence themselves in a different way.³³ In the case of this thesis the clearing is Festival Square and the argument being made is that the very materiality of that square has a role to play in the constitution of the square along with the people creating the square as has been argued before through *habitus* and expanded through the production of space. What is being introduced here, on the other hand, is the germination of a different spatial ontology that all of part III of the thesis will deal with to expand further the previous notions and arrive at an understanding of Festival Square as an emptied void. As Heidegger (1996) puts it:

“What is characteristic of human abode is grounded in the fact that being in general has opened itself to humans and is this very open. As such an open, it receives human beings for itself, and so determines them to be in a site” (p. 91).

Thus the world is not made by *Dasein* for *Dasein*, but is disclosed to *Dasein* in ways addressing its concern for it. Or “it is not man who determines Being, but Being that via [space] discloses itself to and in man” (Steiner, 1992, p. 128). What he sought after is clear from the quote below by Heidegger (as quoted in Bruns, 1989) as:

“The world presences by worlding. That means: the world’s worlding cannot be explained by anything else nor can it be fathomed through anything else. This impossibility does not lie in the inability of our human thinking to explain and fathom in this way. Rather, the inexplicable and unfathomable character of the world’s worlding lies in this, that causes and grounds remain unsuitable for the world’s worlding. As soon as human cognition here calls for an explanation, it fails to transcend the world’s nature, and falls short of it. The human will to explain just does not reach the simpleness of the simple onefold of worlding” (p. 80).

³³ This singular multiplicity of presencing beings constituting the clearing is not only of those that make themselves present, but implicit with a disclosure of being through presencing is absence of that which is not disclosed. Hence the clearing becomes a realm of possibility as that which is absent can be disclosed as anything that is at any later point in time or through a different set of relationality paving the way for eschatology of actualisation.

Having started here on the topic of space as one possible manifestation of *Dasein*'s concerned engagement with the world and how this manifestation is one of ordering presences rather than making present I move on to revisit the *Building Dwelling Thinking* paper.

3.3.4 Gathering rhythms

Heidegger's *Building Dwelling Thinking* paper is effectively concerned with two questions, i.e. firstly *Dasein*'s relation to space i.e. "of finding a more truthful way of characterizing the human's relationship with, and perceptions of, space" (Elden, 2001a, p. 86). And then secondly questioning place's relation to space in the sense of how the physical material setting discloses space. The first question was addressed in the above outline of *Dasein* but now I can start to address the second question in order to establish clear links with the rhythms of Lefebvre. This link I base on the understanding of disclosure through presencing that stated that beings have the capacity to disclose their own Being through the relationality provided for by the clearing, to other beings, of which *Dasein* is merely one.

All through his paper Heidegger is making an argument for *Dasein*'s role in engaging with the environment, but in light of the above displacement of *Dasein* he is careful to formulate it only in terms of concern, care, sparing, preservation or safeguarding of what he termed 'the fourfold', a term derived from the poet Hölderlin. The fourfold he used as a metaphor or shorthand for the primary unity or oneness of the world or the aforementioned relationality of being, the four are earth, sky, mortals and divinity. The earth and sky are diametrically opposed as all that happens on earth is already under the sky in the same way as mortals stay on the earth already under the sky before the divinities. This is to say that in being the fourfold comes together. Stating that which comes together in the relationality of being in the words of Heidegger (2000): "what comes is the whole in-finite relation which, along with god and mankind, earth and heaven belong" (p. 200). Thus in whichever way one conceives of it, and at whichever scale one chooses, all presencing or being disclosing their Being always happens in an immediate relation to something else, or in an immediate presence of that which is or can possibly be. Extending the understanding of the fourfold to address all beings sheds some of the more discomfoting aspects of it, e.g. the reference to the divinities, and takes Heidegger up not quite literally (see Elden,

2001a, p. 84). Hence *Dasein*'s is the earlier mentioned ordering of presences through care or safeguarding, but at the very same time beings in themselves, once disclosed as Being, have implicit the relationality or primary unity or oneness as they presence themselves in this immediate relationality. Thus the being that discloses its Being through the relationality of the clearing by presencing does so through what Heidegger termed 'gathering' or (*G. Versammlung*), i.e. each being as it discloses its Being gathers the relations necessary or implicit for its presencing. In the context of this discussion, which is about displacing *Dasein* from the central role of disclosing being and answering the question of the relation between space and place, this gathering as formulated by Heidegger is the gathering done by objects, or beings that can disclose their Being through relationality (Clark, 2002; Davis, 1992; Elden, 2001, 2001a; Heidegger, 1971, 1996; Malpas, 1999; Olwig, 2002; Steiner, 1992).

In his paper he uses a bridge as an example of being disclosing its Being and how through that disclosure it contains within it the primary unity of the bridge and its surrounding. This unity he unpacked in the case of the bridge by stating that the bridge not only connects the banks of the river, but makes the banks emerge as such; bringing the land around the banks and the bridge together into a unity having thus the bridge essentially gather the whole landscape around in the disclosing of its Being. It is with the notion of gathering that links start to form with the conceptualisations earlier made about the physical material space as being made of sedimented time-space trajectories that maintain coherence through rhythm. These time-space trajectories are the relations that constitute the clearing and its beings and are never at rest, as they are constituted by rhythm. Gathering these rhythmic trajectories is thus the way beings disclose their Being through presencing in the clearing and can do so without necessarily the presence of *Dasein*, although the example cited was of a specific anthropogenic origin. Thus seen, the bridge, through disclosing its Being, gathers the time-space trajectories that have settled into certain rhythmic patterns composing the landscape around, into its presencing. Put another way; through this gathering the object allows a site for rhythms to come together and compose it as stated above by Lefebvre. Quoting Heidegger: "place always opens a region, in which it gathers things in their belonging together [and that we must] learn to recognise that things themselves are places and not only occupy a place" (quoted in Elden, 2001a, p.

90). Hence by the same way *Dasein* dwells, an object dwells and hence “dwelling, however, is *the basic character of Being*” (Heidegger, 1971, p. 160).

What is mainly being argued for is how presencing or the disclosure of Being occurs through ways of gathering; therefore through this excursion through Heidegger certain ontological nuance and depth is added to Lefebvre’s phenomenological conceptual tools of rhythmanalysis. Below I would like to attempt an illustrating of the above in the space of Festival Square.

So to recap: In the very first chapter of the thesis I presented early time-geography as the construction of paths, which represented the individual subject’s practice, which was then outlined in terms of the theory of structuration, but most specifically in terms of *habitus*. As was argued further the spatial representations of *habitus* and time-geography was rather rarefied and thus Lefebvre’s production of space was explained to address these shortcomings. Key in that formulation was the notion of lived space, which opened up for questions of the phenomenological grasping of the world and hence *Dasein* and dwelling were introduced and the argument made from Festival Square was that dwelling there was in terms of habitual routine. The habitual routines are generated by rhythms that have been gathered into the flows that are represented in figure I.16 (p. 109). These flows depicted in the figure represent people walking as a habitual routine performed in the material context of the square (Ingold, in manuscript). Walking is thus seen as producing the space of the square but at the same time the square is one that allows or enables this kind of production. Walking becomes a disposition, habituated in these patterns of flow as earlier argued or settled in a certain time-space trajectory of practice that in essence is a gathering of the rhythms generative of the flow. What is being argued is for the way in which *Dasein* is necessarily a part of space and time and produces space, but is not the only being able to disclose space. Thus I argue that *Dasein*’s disclosure of the space of Festival Square, illustrated in terms of flows of people across Festival Square is at the same time the presencing of Festival Square. The flows are movements that are dwelling, that I propose to grasp with the conceptual tool devised by Lefebvre as rhythmanalysis.

3.5 Disclosing Festival Square in terms of Flow

In order to disclose Festival Square, i.e. in order to bring a language of apprehending the primary unity of the square and all that is on it, I propose understanding dwelling as movement that can be grasped through rhythms as these gather in the flow lines that cross the square. To start with I refer to my earlier illustration of Festival Square as a space of flow in chapter 3, part I (see Figure I.16, p. 99). Although I did not elaborate much on the notion of flow there I picked it up again in the illustration above when I went on to describe the square in terms of habitual production of space, noting how people would pass through the square as a matter of habit and thus not really having a cognitive reckoning of the square itself. Thus the way I want to sustain the argument presented above, of the square being disclosed through the flow of people, is that this passing is one of habitual repetition done by people without really thinking of the locality through which they journey, but through this journeying disclose the space of the square. Further I argue that the flow lines on the map presented in chapter 3 part I, are in effect dwelling as movement disclosing the essential unity of space and time through their presencing as such. These flows have the capacity to disclose the space of the square and more specifically do so; through the rhythms that gather in them.

These rhythms I attempt to depict in graph I.1 of chapter 3 part I (see p. 88) in the way that the peaks, that represent heightened activity or presence of people on the square, and the troughs that would reappear every working day and then in different ways during days off. Thus combined the flow of people passing through the square along the lines represented in figure I.16 can be seen as flows with rhythm that is not one, but a combination of many extending over several different stretches of time or a polyrhythmic ensemble. The flow of people on Festival Square has its diurnal, weekly, monthly, annual and perennial rhythms. The people become one with the space of the square as they act on the impulse of their 'secret rhythms' dictated by 'public rhythms' that become 'fictional rhythms' in terms of dispositions that then dominate the passing through Festival Square. With the above typology of rhythms (see p. 177 for details) I have indicated a few of the conceptual tools for grasping rhythms devised by Lefebvre but, to be more precise, drawing on Lefebvre's (2004) own experiments in rhythmanalysis, garbing oneself in the tissue of the lived (p. 21)

and thus listening to “the noise of their footsteps. To be forever able to indicate the direction they have taken” (Apollinaire, quoted in Lefebvre, 2004, p. 88).

As I stood in the corner of the square I mostly used for videotaping and interviewing people I could so clearly discern the footsteps of the people as they passed over the paving slabs approaching and then distancing. Blindfolded I could have been able to discern the rhythms that compose the flows crossing the square by the mere din of the footfall, and most certainly the direction through the subtle Doppler effect of heels clapping against the Caithness slabs, with a distinct change as they pass the bands of Montemuro granite. Depending on the direction people would cross the square different rhythms were produced by those two kinds of slabs. Thus it is through that Doppler effect that I could discern the direction of the flow and thus establish if it was the end or the start of either the lunch break or the working day, those two interrelated cycles that compose the diurnal rhythm of the flow across the square.

The mechanism that mostly structures the rhythms that gather in these flows is that of the work schedule of the companies surrounding the square. Each of these holds a specific routine to their work hours constituting the ‘public rhythms’ that are found in calendars, work routine and ceremonies and have been constituted in relation to those bodily rhythms that can be publicly expressed, such as tiredness and hunger. Workers in these companies demand their lunch and coffee breaks to address hunger and an 8-hour average working day to address tiredness. As each company around the square has a different routine one will find, on close inspection, various smaller rhythms submerged in those larger ones that could be represented in the graph and figure above. E.g. the staff that cater for breakfast in the Sheraton hotel cross the square at 6.30 in the morning and go from Lothian Road, right across to the service entrance of the hotel to be found in the SW corner of the square. This flow on the other hand is a mere trickle once compared to the main rush of 8 am and 9 am when the office workers and support staff of, mainly, Standard Life Insurance start cascading across the square from SE to NW. Hence in terms of the flows that disclose the square they can be grasped as a polyrhythmic ensemble conducted by the varying hours of the various staff of each of the surrounding companies. These smaller rhythms gather on figure I.16 as those smaller flow lines that cross the square at different places and times and if each of the constituting paths of the flow-lines represented would be

tagged with a time of occurrence these smaller rhythms would be discernible, but that would demand a much lengthier and detailed surveying of the people crossing the square than this project allowed for.

Lefebvre (2004) in his experiment, through discerning all the small-scale rhythms he observes and is able to gather in a Mediterranean city along with its large-scale rhythms, makes a historic-social analysis of those cities. Hence he argues as comparison, stating that if his hypothesis is correct, that “in the lived everyday, in practice, social relations in Nordic towns are founded on contractual, therefore juridical, basis, which is to say on reciprocal good faith” (p. 93), stating further that all action there is civil and political. This is to say that what composes rhythm on the large scale are the underlying socio-economic factors responsible for the social-economic organisation and landscape at hand. Thus with chapter 2 of both part I and II, I hope to have mapped out this organisation and landscape in order to show which companies are surrounding the square and why they are there and thus with a detailed mapping of their working hours the generation of flow from these can be constituted and why these flows are generated in this rhythmic pattern and not some other pattern. Thus discerning those rhythms allows for an entry into the above kind of analysis.

Using the example of All-Bar-One, which sits on the NW corner of the square, their staff does not arrive till 11am as the opening hours are structured around the office hours, catering for lunch and after work drinks, reflected in the rush hours identified by Colin Corson (Appendix A). He not only identified the diurnal rhythms structuring their work pattern that, as I say, reflects the office work routine, but also long term cycles, weekly, monthly and annual (see p. 103), most of which gather in the flow line on the North side of the square. Another example is Standard Life, that by far represents the largest employer on the Exchange, their staff turn up in three rhythmic patterns, firstly around 7am as the support and technical staff arrive, cleaners, janitors and such, but then in large numbers at 8am as junior staff such as IT and customer services arrive and then in another boom at 9am when most of the senior staff arrive. These differing hours of arrival are again reflected in the lunch break when those earliest in take their lunch break sooner than those later in during the mornings and those early arrivals are also the first to leave in the afternoon.

In the above these illustrations are small scale and serve to indicate what is at stake in the presencing or disclosing of the square through rhythms that gather as flows across the square and are discernible through rhythm analysis. I chose the rhythms that gather in the flows that cross the square as these flows are the ones one is immediately struck with once on the square for some time. The space is empty, dead and unused mostly apart from these sudden bursts of people crossing it in a hurried manner. There were other rhythms I could have chosen as this illustration such as the cleaning cycles talked of in part I, chapter 3.1.2 or the cycles of events occurring on the square as talked of in part II, chapter, 2.1.2, I could even go into outlining how the 'rhythms of self', those manifest at home and in private life, are imbricated and interact with the 'rhythms of other', represented in the above as those of work and public life (Lefebvre, 2004, p. 95). With all these rhythms the notion of polyrhythmia as struggle and dialectic emerges thus "there is a struggle between measured, imposed, external time and a more endogenous time" (*ibid.* p. 99). Apart from the fact that these flows are the ones one immediately recognises once on the square, more importantly, what I hope to have presented in the above is the way in which *Dasein* or the concerned being-on-the-square is explained in terms of a non-deliberate engagement with the square's materiality, represented as flows. These flows on the other hand disclose the space of the square and thus *Dasein* becomes one with the disclosure of space in time without any specific centrality to *Dasein* through these flows. These flows thus presence themselves in terms of localities of journeying and the journeying of a locality or simply as dwelling through movement. The locality is the path taken across Festival Square whereas the journeying is one along that path, both disclosing the space of the square.

3.6 Further Paths

I ended on the note of the flows combining space and time through presencing themselves disclosing the space of the square and bringing *Dasein* at one with space and time, but mainly what I have done in all of the above is to grasp these flows as gatherings of rhythms. But what Lefebvre argued is that all these rhythms are in a dialectical confrontation i.e. through making rhythms discernible through an analysis of work routine that represent a wider more fundamental socio-economic organisation and landscape, he turns them into representation. But Lefebvre is clear on a

distinction between those rhythms of representation and those of presencing, setting up a dialectic between the two in order to show how public and private rhythms interact in place and space. Therefore:

“civil, therefore social, time seeks to and succeeds in withdrawing itself from linear, unirhythmic, measuring/measured state time. Thus public space, the space of representation, becomes ‘spontaneously’ a place for walks and encounter, intrigues, diplomacy, deals and negotiations – it theatricalises itself. Thus the time and the rhythms of the people who occupy this space are linked back to space” (Lefebvre, 2004, p. 96).

This quote smacks right back to his appropriation of spaces through lived space, but what I have done in the above is to make the argument that the rhythms composed by those socio-economic landscapes, represented as flows, are in themselves presencing and disclose the space of Festival Square. These flows are rhythmic as those people that constitute these flows are passing as a matter of habitual routine. As these people pass they certainly appropriate the space in certain ways that can become explicit once clashes occur with other groups, e.g. skateboarders. But their appropriation is mostly about just passing and hence I would argue for the presencing of Festival Square again as void space. In order to sustain my claim that the square is a void space I need make further conceptual moves and empty the void I just filled in this part with the politics of appropriation. With viewing the square as void and using these flows as representative for the disclosure of Festival Square I am starting to indicate a certain problem with the dialectics that can work so fine to explain clashes and differential spaces produced by groups, that has been popularly described as a theatricalised space (see e.g. Sharp, 1989). Does the dialectic really work to disclose space in its Being as such? Void spaces like Festival Square serve well to address this question, which will be picked up in the next chapter.

Summary Conclusion of part II

The main issue of this part was an engagement with the work of Henri Lefebvre and his outline and understanding of the production of space. Initially this engagement came as a response to the inadequate spatial understanding presented in part I through the structuration theory of Bourdieu and mainly his *habitus* concept but, as the part moved on to argue, there are avenues of fruitful combination between the two theorists.

As both Bourdieu and Lefebvre premise their thinking upon an explicit dialectical framework the part started, in the first chapter, with an explanation of the concept of dialectics through the work of Lefebvre but his take on dialectics revolved around how representations of space interacted with spaces of representations spawning of differential spaces through the spatial practice of people's everyday lives. With fleshing out this mechanism Lefebvre arrived at his notions of the production of space that I then carried on to outline in terms of abstract spaces with some general illustrations in chapter 1, that I then materialised in the space of Festival Square. These illustrations were about how the apparent abstract forces of globalised capitalism always have a grounding in the concrete. The forces of globalised capitalism I made concrete on Festival Square were three, the rhetoric of global flows and capital of all kinds and the economic argument that created the square and its surroundings. This economic argument is linked to the second and another abstracted space of flow, tourism, of which the square is also a manifestation, mainly through promoting the city's quality of life through pedestrianisation and the status of Edinburgh as an event-city. Thirdly I made the argument for the Third Sector rhetoric being manifest on the square in the Dash coffee stall. These three I saw as manifesting conceived spaces in the perceived space of Festival Square and thus a kind of overt making and taking of space.

Once in the concrete space of Festival Square I explained the Marxian nature of Lefebvre's agenda. He envisioned that through being informed by different spatial imaginings and through different ways of doing and being, people could take to the streets in order to demonstrate differential spaces created by their lived presence. Thus his agenda goes against what he perceived as the dominant forces of the

capitalist economy mostly responsible for the creation of space in the concrete. Lefebvre's lived spaces and deliberative action producing spaces is to him no less important than the production of space by these dominant forces and more importantly could undermine them. In order to demonstrate how I moved to the work of the geographer Don Mitchell and how the 'fight for public space' could be seen through Lefebvre's lived spaces. This fight takes place in two ways, firstly, in Mitchell's elaboration, through the taking of space, i.e. appropriating space with one's presence to make evident how different spaces coincide in the city. Secondly, through architectural semiology, i.e. how space can be read as representation of current socio-economic order and how the representations can be contested through different readings and semiotic manipulation. These elaborations were then substantiated with empirical examples from Festival Square. In the second part of chapter 2 these case studies of Festival Square argue for a more subtle manifestation of Lefebvre's appropriation, toning down Mitchell's 'fighting talk', and making for a more direct link to Lefebvre's notion of lived spaces and how these can be productive of differential space. These more subtle appropriations are found in the presence of skateboarders on the square. Thus critiquing Mitchell, in order to explain how the presence of skateboarders can be understood on Lefebvrian terms I picked up on Iain Borden's in-depth study of skateboarding and the city and thus got to notions of lived space in subtle detail, again substantiated with case studies of Festival Square.

With this understanding of lived spaces and how they are produced and maintained the third chapter of this part drew together part I and part II. The current part had started with addressing an apparent lack in Bourdieu's spatial grammar but in the final chapter he is picked up again and combined with Lefebvre to address a certain lacking in Lefebvre's account of the body. Both of these theorists on the other hand are indebted to the German philosopher Martin Heidegger in their basic ontology. By thus combining the *habitus* of Bourdieu, in order to get to an understanding of how the subject internalises social practices, and the production of space, in order to understand how that internalisation can be productive of new spaces and different ways of being, I got to notions of dwelling. I centred the idea of dwelling on the notion of *Dasein*, as put forth by early Heidegger, in order to centre the discussion on the habitual users of Festival Square, those that pass through there everyday, in some cases many times a day. But as further argued the centrality of *Dasein* is insufficient

in disclosing the space of Festival Square, as dwelling “is *the basic character of Being*” (Heidegger, 1971, p. 160) in general. In order to make space for the very materiality of the square itself and thus Being in general I outlined Lefebvre’s project of rhythmanalysis where he states that all objects and living beings are composed of rhythms. This means that everything there is, is in a perpetual state of movement and can never be grasped in terms of the present, but only via presencing. All beings thus disclose their Being through presencing, and here I brought Lefebvre back to Heidegger in order to add depth to the phenomenological side of Lefebvre’s rhythmanalysis project. I demonstrated how beings presence themselves through gathering the relations composing them and as all these relations are rhythms of various speeds, I argued for rhythmanalysis as a way to grasp the presencing of Festival Square. In the end of the chapter I indicated ways of doing this rhythmanalysis on Festival Square. Thus to make sense of the habitual, non-deliberative actions from the previous illustration that was people’s everyday on the square, I argued that *Dasein* is necessarily a part of space and time and produces space, but is not the only being able to do so.

With this part and the combination presented with the first part I aim to have set up the foundations for further arguments that will be presented in the third part of this thesis. Part III will start to unpack the dialectics implicit in the above theorists and capitalise on the phenomenological potential of both introduced in the last chapter. I aim to understand the diabolical art of poststructuralist geographies (Doel, 1999) in the context of Festival Square, as “we go around this void, which fills itself up with things and people in order to empty itself, and so on” (Lefebvre, 2004, p. 34-5).

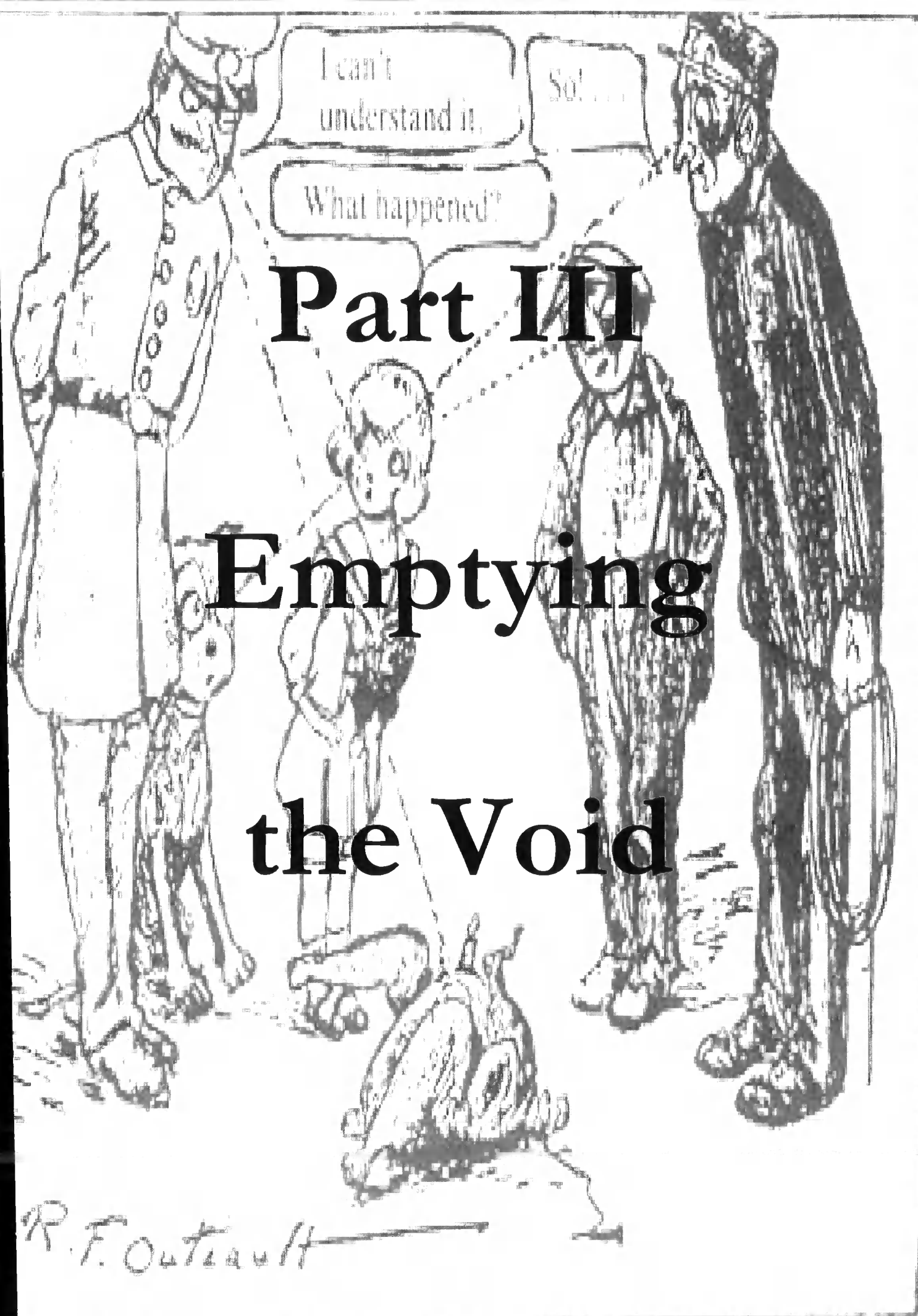

Part III

Emptying

the Void

R. F. Outcault

Blank Figures

“Voids are paradoxically both bound and open, empty and already filled” (Goh, 2003, p. 63)

The last part ended arguing that everything is rhythm and thus in a perpetual state of movement, presencing rather than being present. This presencing I proposed to grasp through rhythmanalysis, but ended by stating it did not live up to its full phenomenological potential as set forth by Henri Lefebvre. Thus in this part I elaborate on the ‘now-moments’ of presencing and how they have the capacity to ‘affect’ and ‘become’, firstly addressing the critique on Bourdieu in the first section, on how dispositions change and develop and secondly addressing the reductive dialectics of Lefebvre’s production of space through rhythms.

In order to contextualise this part I move back to the first part where I placed my *habitus* in the void space of Festival Square, through my inventory of the square’s materiality. More importantly, in the second part I elaborated on how this void space get theatricalised, filled with the politics of representation, recognising that void spaces are ideal, but that the ideal is non-existent and necessarily politicised through demonstrating the struggles of different imaginings. Filling the void with imaginings and counter ideals or how people can and do, through overt and covert practice, subvert dominant ideologies and powers manifest in the design, planning and determined functions of the square, made it into a theatre of confrontation. As demonstrated through examples, users of the square strive for differential spaces through spatial practices that are either overt or covert, the latter entailing differential spaces through lived presence and different ways of doing. By populating the void space of Festival Square with people who continuously use the square, the space eluded its determined ideal function or role elaborated on in part I. But then also evident is that the square does get a fair amount of uses that fulfil its determined function and thus to a certain extent represents the design ideals. As the final chapter of part II illustrated, these are, for instance, the main users of Festival Square that habitually and routinely pass through it having acquired certain dispositions of subconscious routine. Arguably, advocated by the above Marxist interpretation, these users are appropriating the space in certain ways, manifested in clashes with other

groups, e.g. skateboarders, producing the dialectical theatricality of rhythms and appropriation necessary to ascribe meaning to space or essentially historicise it. But, as argued further, through presencing the square is disclosed through the people doing the passing, and this disclosure is graspable through rhythmanalysis. So although these users fulfil the square's determined function facilitated by the square's structural minimalism, they are at the same time part of the very materiality of the square in the sense they facilitate the square's presencing through their passing. Hence I argued for the presencing of Festival Square or its disclosure as essentially void space, but yet paradoxically filled so now I move to empty the void, addressing the reduction to politics of representation and appropriation in the dialectical theatricality of *habitus* culminating in rhythmanalysis.

This part aims "to overturn the theatre of representation into the order of desiring-production" (Deleuze and Guattari, 1983, p. 271). What follows is an emptying of the void in the sense of:

"while void structures may permit brief informal encounters, they do not permit more permanent expressions and interventions by individual subject upon the built environment. Brief encounters are of-course easier to manage and facilitate, but they leave no permanent record of popular expression, no articulation of particular voices such as the contributions of local troupes, artists, historical memories or individual personalities to the constructed environment" (Goh, 2003, p. 63).

I want to allow the void space a voice and grasp Festival Square and its main users through the 'now-moments' of presencing but, more specifically, grasp the ordering of the production of desire implicated in each and every event or encounter. To do so I aim to solicit the settled dispositions and time-space trajectories, which disclosed Festival Square in prior parts via historicising, theatricalising and presencing, through a spatial ontology that departs from the these prior disclosive manoeuvres. Hence the first chapter starts with an example indicating what is at stake and then contextualised in a poststructuralist understanding of spatiality that is worked primarily through the thought of Gilles Deleuze. Once having fleshed out the basic spatial understanding implicit with Deleuzian philosophy, chapter 2 illustrates how I came to this understanding within the context of Festival Square and lastly I proceed to chapter three where I will make sense of events on Festival Square in terms of space described as the mathematical land of 'Topologica' as Ian Stewart (2001) outlines:

“‘Topologica,’ replied the Space Hopper, ‘the Rubber-sheet Continent, which doesn’t so much drift as *stretch* ... We have entered the realm of topology, from which rigidity was long ago banished and only continuity holds sway. The land of topological transformations, which can bend-and-stretch-and-compress-and-distort-and-deform’ (he said this all in one breath) ‘but not tear or break” (p. 89).

‘Topologica’ or space of flows and movements that are of differing intensities composing the space of the square brings me to argue for the political in terms of differentiation and affect. The space of flows or ‘topologica’ is the ‘smooth space’ of Deleuze and Guattari (1987) as continuous variation that affects and exists as involution of the ‘striated space’ of fixity, order and ‘lines of power’, the void spaces of part I and those power geometries of the filled void in part II.

In order to reach the understanding presented in the final chapter several conceptual moves need to be made and thus this part will be heavily oriented to theory but in each chapter I aim to illustrate this theory from the square. With emptying the void the square becomes void in the sense of “all good voids, it is a place for casual, undirected, spontaneous lounging...it enables a kind of aimless non-activity” (Goh, 2003, p. 58). This is to say, as was argued in chapter 3 of part II, that the habitual routine that informs the main users is a productive non-deliberate action which, along with the encounters, create the space, but as further argued there is no specific primacy between subjects encountering each other or the materiality of the square. As will be maintained here following Deleuze (1991) “habits are not themselves natural, but what is natural is the habit to take up habits” (p. 44) and hence “dispositions are never abstracted from the means which we organize in order to satisfy them” (p. 45).

All in all I set the part in the context of and addresses the proliferating body of literature on Deleuze and his ideas of the working of this world (Doel, 1996, 1999, 2000, 2001; Grosz, 1995, 1999; Hayden, 1998; Macdonald, 2002; Massumi, 1992, 1996, 2000, 2002a, 2002b; Rajchman, 1998, 2000, 2001; Smith, 2003a,b,c; Tschumi, 1994, 1997, 2000). I want to take on board his understanding of relationality and grasp Festival Square in terms of the radical empiricism as promoted by Deleuze (1991, 1998, 2001; see also Deleuze and Guattari, 1983, 1987) along with adopting his specific terminology. The above body of literature is represented in geography

through work attempting to transcend the classical binary divide that dialectics were originally addressing, following Murdoch (1997) where he says:

“Spanning the divides, overcoming the dualisms, will not simply be a matter of adding terms such as ‘hybrid’ or ‘cyborg’ into our existing modes of thought, but will require a much more thorough re-examination of our theories and methodologies for there is an ever present danger that the dualisms will prise apart the connections and associations we might stitch together” (p. 732).

Thus the aspirations of this part share affinities with methods being devised trying to get around the binary and beyond the dialectical production of space. These methods are evident in the massive literature burgeoning around Actor-Network Theory where ideas about the ‘hybrid’ are to be found and are also manifest in Haraway’s (1997) ‘cyborg’ metaphor and in Whatmore’s (2002) spanning the nature/culture divide. I situate myself with Deleuze and his radical empiricism on the same task as the above mentioned theorists, i.e. of re-examining theory in geography to achieve a productive immersion into dialectical thinking, opening it up through Deleuze’s vitalistic phenomenology, leaving the future, earlier conceived through utopian imaginings and produced differential spaces creating and filling the void, as a blank figure able to facilitate becomings.

III.1 Relational Festival Square

In this last part of the thesis I propose to depart from the relational spatial ontology built up in the preceding parts mainly through dialectical relationality culminating in the end of the last chapter, seeing that relationality expressed through rhythmic flows disclosing the space of Festival Square. The first chapter of this part deals more closely with this departure and revolves around relationality as presented by post-structural theorists, mainly though Deleuze (1991, 1992, 1994, 1998, 2001) and Deleuze and Guattari (1983, 1987, see also Emirbayer, 1997; Dillon, 2000; Hayden, 1998; Massumi, 1992, 1996, 2000, 2002a, 2002b; Rajchman, 1998, 2000, 2001) and their argument that the dialectical relationality is fundamentally reductive. I argue further that even with Heidegger's argument for dwelling and becoming one with space, there is a reduction. The flows, disclosing the space of the square and thus presencing the oneness of *Dasein* and space I argue, as with dialectical relationality, is reductive in the sense that people are made representable or brought 'back to the ground' so to speak. By making them representable as flows I allow for the politics of representation, in the case of the last chapter the flows of people with various rhythms, to interact. Allowing for this interaction to be represented in terms of either deliberate or non-deliberative actions is very useful, but as I will argue in this chapter and the following two, there is more to be gained. Hence, as will be argued in this chapter, the spatial understanding of Deleuze and Guattari varies considerably from the politics of appropriation and presencing that insist upon the disclosure of space as the ground for meaning and representation, while in Deleuze and Guattari there is never such an insistence, simply always an and...

Indeed it is the "Earth... on which the whole process of production is inscribed...[it is] a megamachine that codes the flows of production" (Deleuze and Guattari, 1983, p. 141, 142). It is thus on the ground where the social politics of Bourdieu, the dialectics of Lefebvre's productive spatial appropriations and the disclosed spaces through beings relational Being play out as has been mapped out in the previous parts. Lefebvre's dialectics culminated in rhythmanalysis as he tied it to the dialectical appropriation of space stating that space "theatralises itself. Thus the time and the rhythms of the people who occupy this space are linked back to space" (Lefebvre, 2004, p. 96). Rhythms, that conceptual tool, were thus tied to the production of spaces

but without a detailed analysis of how that rhythmic production came about or how that particular process of production is inscribed upon the Earth, arguably since Lefebvre never had time to complete his work on rhythmanalysis. Hence I argue that the phenomenological potential, which I will claim Lefebvre was starting to unpack, is to be furthered in the idea of 'pure multiplicity' that will be outlined below. His rhythmanalysis created a relational space of constant movement, which bridged structuralism and phenomenology (Elden, 2004a, p. 148). Rhythmanalysis is thus indicative and useful, but I will further that project through post-structural thought where the movements implicit in rhythms hold the potential for transformation through multiplicity explained in terms of 'becoming'. But this idea of 'becoming' is premised upon a radical relational ontology, which will be fleshed out below and illustrated with an example in the end of the chapter.

As can be gleaned from the above, and in ways of a disclaimer, I do not argue for the rejection of dialectics that are so useful to make sense of the politics of space, but I would like them to become more productive in terms making space for the infinity of events and actions that unfold in an infinitely complex materiality of Festival Square. Thus a kind of synthesis between the:

“statistical wholes whose outlines are blurred, *molar*, or collective formations comprising singularities distributed haphazardly (a living room, a group of girls, a landscape). Then within these nebulae or these collectives, ‘sides’ take shape, series are arranged, *persons* figure in these series, under strange laws of lack, absence, asymmetry, exclusion, noncommunication, vice, and guilt. Next, everything becomes blurred again, everything comes apart, but this time in a *molecular* and pure multiplicity, where the partial objects, the ‘boxes’, the ‘vessels’ all have their positive determinations, and enter into aberrant communication following a transversal that runs through the whole work” (Deleuze and Guattari, 1983, p. 68-69, emphasis original).

By returning to the ground and being able to state a representational whole that can then be politicised through struggle between various groups using the space be it in deliberative or non-deliberative manner, the preceding theories are inherently reductive as they discard the excessive and that which is truly absent but yet potential (Hertz-Ohmes, 1987). Deleuze and Guattari (1987) recognise the protective function implicit in the contradictory drive of dialectics in pure terms as they fend against becomings that spin out of control or an absolute fixity of being, both resulting in

death (p. 276). Thus they recognise dialectics as necessary but at the same time disavow them as I aim to clarify in the following.

1.1 Starting Example

Reading Lefebvre one gets a sense of lived spaces that exceed the dialectic framework. In his outline of rhythmanalysis there is a sense of the account that contradicts the deliberate flatness of rhythms as presented in the preceding chapter. I would like to start this chapter with an example, building on the preceding chapter, where I attempt to make sense of the rhythms presented there but making room for this sense of excess.

The flow of the people across the square was apprehended as rhythmic and disclosing the space of the square in the last chapter, or producing it as a space of rhythmic flow or habitual passing. As I established through interviews and questionnaires during my fieldwork, the people that do this passing through do so in a precognitive manner, without thinking about the space they pass through or its materiality. The people seemed unable to articulate what they were doing or thinking with reference to square they were passing through. This, in part, led me to adopt a methodology which entailed watching the people on the square, not only gazing at them from a distance, but also video taping and photographing them in order to try and elicit how the materiality of the square was co-constitutive of the trajectories presented in figure I.16 (see p. 99).

These trajectories I argued were aggregates of individual movements across the square. In this chapter I will argue how these molar aggregates form and allow a role for each individual movement, but recognising that it can never be understood in any way separate from the aggregated trajectory. To adapt Deleuze and Guattari (1987) to those trajectories constituted by individual movements: “a crowd must be fully individuated, but by group individuations that are not reducible to the individuality of the subjects that compose the crowd” (p. 341). Namely one has to make sense of the flow of people in terms of aggregates imbricate with its molecular components and thus: “The people must be individualised, not according to the persons within it, but according to the affect it experiences, simultaneously or successively” (*ibid.* p. 341).

Here the key word is affect but the rearrangement of each trajectory or its potential to differentiate is always the result of force. This force is the affect exerted on the individual through the aggregate, rearranges it and can have lasting ramifications through the successive rhythm of the articulation (see Figure III.2). Or as Deleuze (1988) would have it: "Concretely, if you define bodies and thoughts as capacities for affecting and being affected, many things change. You will define an animal, or human being, not by its form, its organs, and its functions, and not as a subject either; you will define it by the affects of which it is capable" (p. 124).

Hence each footstep taken across the square exerts a force or has an affect upon the square in the very same way as the slabs that receive the blow of the heel act back upon in. The rhythmic movement produces grinding wear on the shoe and the body as the hardness of the surface reverberates up the spine, all slowly adding up to the eventual snapping of the shoe or the constancy of passing results in the eventual tripping of the passer by. Here I do not want to focus on observable ruptures in the sequence of events that are constitutive of the rhythmic aggregate, as that will be done in the thesis' last chapter. Rather I want to get to the rhythmic constitution and maintenance of the square's materiality through use. To do so I used my methodology of videotaping and photographing in order to try and slow time. This slowing was brought about through slowing the video and arranging still photos into sequences so as to show that at each and every moment no matter how small or how insignificant, walking across the square always entailed an engagement with its materiality, rhythmic and monotonous but also of potential consequence for it or the passer by.

To take a specific example, as usual those passing through the square would mostly pass from NW to SE or vice versa, depending on the time of day. If I considerably slowed down the video of those passing one could see by the expressions given and glances made that the square was acting upon the individual passer-by. As stated in the beginning my attempts of having these passers-by reckon with the square through articulation and conceptualisation were to no avail. Hence upon slowing the footage I was delighted to find those very same people, continually glancing down at the slabs, making expressions and gestures that clearly indicated that these slabs and their jointing material was exerting an affect upon them. I will not go so far as to state that

this leapt out of the footage, nor that every individual passer-by showed signs of this engagement, but what I did find were some clear expressions of this engagement, something I could not find at all in my interviews nor questionnaires. The clearest example I found in the footage was of a young man, dressed according to the standards of Standard Life Insurance and most likely a sales representative there. Not that my subjective opinion matters, I merely judge this from the data I gathered on the people that did almost all of the passing through Festival Square. Walking across the square the man made a quick sweep with his foot, one that was quite evident but the reasons why were not until at a close inspection of the footage. A small clot of jointing material had become loose and stuck slightly out between the paving slabs. The man passing had somehow noticed and as he strode over that point, quickly broke the piece loose and sent it flying onto another slab where it broke into smaller pieces. One could argue for a rupture here, one that had the square's materiality emerge albeit for a mere split second, but what I want to argue is that through rhythmic patterns of its own the jointing material had come loose and started to inch its way onto to the surface of the slab. The infinity of affects exerted upon that piece of jointing material is beyond comprehension, the continuous effects of weathering, the constant reverberation of footsteps and vehicular traffic, the regular water blasting of the square to clean it, the sweep of the cleaner's brush and the occasional eccentric picking at the jointing material out of curiosity, all gathering to contribute to the eventual engagement with another entity present through a gathering of infinite rhythms, the man passing through the square. The rhythms that make up both entities can be retrospectively constructed as building up to the miniscule rupture of the foot-sweep and breaking of the piece but, as I will rather argue, they were always connected. These rhythms are all part of the same ensemble of rhythms, rhythms that are imbricate with one another and constitute assemblages that can be represented as done in the previous chapter, but through a focus on the miniscule these rhythms can be revealed in their connectivity. The young man passing through the square everyday had accumulated infinite knowledge of the square and its materiality, so much that his passing was one of subconscious routine. His engagement with the square was one continually the same so when a piece of the square presented itself as 'out of place' to this man, with one sweep the square was 'levelled' again as part of the routine of passing through. One can only argue in terms of the affects exerted by the gathering of rhythms presencing themselves through the jointing material and the man passing

through. An affect which made a slight difference to the square but was nonetheless a result of rhythmicity; that of continual passing along with that of the material itself.

1.2 Unpacking Dialectics

The above example indicates what is at stake in this part and will be addressed in the following sections and next two chapters. But under pinning the spatial ontology which will be presented in this part is an engagement with dialectics. Dialectics, as presented in the previous parts introduced movement into fixed relations between entities through having them interact through contradiction. Hence the driving forces in Bourdieu's formulation are the dispositions generated from the contradictions between objective social structure and practical activity. On the other hand Lefebvre's movements were the spatial practices that were generated from the interaction between representations of space and spaces of representation that ultimately became the theatre of rhythms generated through the same mechanism, but this time contradicting those various rhythms and also measured time imposed upon the rhythms of the everyday. This dialectical theatricality selectively hybridises entities, dissolving them through contradiction through events and actions that had earlier been formalised in terms of binary oppositions. As I demonstrated in the previous chapters there is very much going on in Festival Square that on first impression was a seemingly void space in the sense of being empty of people and activity. There are people who use that space, each and every one in very different manners making for the complex polyrhythmic ensembles described before but which through Bourdieu, Lefebvre and Heidegger I essentially formalised into representations. With reference to Lefebvre, as he is explicitly spatial in formulating his rhythms, the square becomes a theatre of contradictions that in each and every case are productive of spaces that stand to generate future contradictions. Herein lies, on the most general level, the main post-structural critique of dialectics, i.e. that through the internalisation of contradiction a certain closed totalisation results. The closing functions through the logic of 'sublation' or subsumption, arguably makes thus for a metaphysics of presence stating that there is no outside to the system as it is always everywhere open to the outside (Doel, 1999).

From the perspective of the politics of representation I formalised the complexity of the multiple rhythms and events that shape the square in relation to its complex materialities, into representations allowed for by the three theorists mentioned above. Thus I made the politics that emerged from the combination of all the individual actions and events on the square become premised upon a certain ground fixity that functions as a closed totalisation through having actions and events aggregated into representations. This fixity, be it identities of skateboarder vs. office worker, or the office worker in the context of the material fixity of the square dispositioned to merely pass through it, are made into a represented whole rendering that which is emergent from or produced through the relations between those people or them and the physical material space explicit through the representation. Through making these relations into an explicit representational whole, I have homogenised these actions and events allowing for an abstraction that is represented on the pages of the preceding chapters. Essentially what has happened is that from the ground of Festival Square, upon which I stood and observed actions, events and rhythms unfolding, I looked towards a holistic understanding, a graspable whole that could be relocated, in this case to do justice to the square on these pages (Law, 2004).

Thus by passing from actions, events and rhythms that are detachable and partial to the position of the whole of the square, that then in itself is detachable as an abstraction to be represented, I had to make each actual disjunction between contradiction premised upon what was contradicted. Therefore a definition of the actions, events and rhythms was continually needed: what actions, which events, what rhythms and why and how these came about. The passage required fixity of the actions, events and rhythms that necessarily become defined in terms of lack from the whole (Deleuze and Guattari, 1983, p 60). Thus “we pass from a detachable partial object to the detached complete object, from which global persons derive by an assigning of lack” (*ibid.* p. 73). Fixing these actions, events and rhythms allows them to enter into a synthesis of contradiction on their own terms. Their disjunction or difference is to be affirmed as “no one has ever died from contradictions” (Deleuze and Guattari, 1983, p. 151). But what I aim at, following and quoting from Deleuze (1994), is:

“a ‘philosophy of difference’ [that] refuses a concept of the dialectic that is founded by contradiction, because this method fails to ground a species of

difference that is 'in itself' and 'the negative and negativity do not even capture the phenomenon of difference, only its phantom or epiphenomenon'...contradiction is less and not more profound than difference" (Lambert, 2002, p. 73, see also Deleuze, 1994, p. 63).

1.2.1 Baroque dialectics

The problem in the dialectical scheme grasping space in the preceding parts is stated by Doel (1999) as he argues: "...writing-earth-writing-earth-writing...which came first: this earth or this writing, this map or this territory, this (social) space or this perspective" (p. 104). The solution presented by post-structural thinkers such as Deleuze and Guattari (1983) is the affirmation of the disjunction between earth and/or writing into earth/writing (see Gren, 1994), thus "without restricting one by the other or excluding the other from the one" (Deleuze and Guattari, 1987, p. 76) the disjunction is made inclusive affirming the two as different along with that which relates them. Implicit is an internal reversal of the dialectic from exclusive and formalising to inclusive and non-restrictive, an involution of kinds affirming the disjunction between contradictions.

"Between things does not designate a localizable relation going from one thing to the other and back again, but a perpendicular direction, a transversal movement that sweeps one *and* the other away, a stream without beginning or end that undermines its banks and picks up speed in the middle" (Deleuze and Guattari, 1987, p. 25).

What I will did in the starting example and will do in the following is to take my representations from the preceding chapters and turn them around in a way that I will be looking back to the ground or the concrete setting in which the events and actions unfolded in order to bring forth the heterogeneity and complexity earlier reduced into meaningful representations. By continually looking into the concreteness of the actions and events as they unfold a path to infinite discovery is opened up where "everything is connected and contained within everything else" (Law, 2004, p. 22). Naturally there is no way to grasp and represent the space of the square in such detail and I can only refer to chapter 3 of part I where an attempt to detail its materiality through an inventory that then, through a later combination with the users of the square, would make space for events. With recognising the impossibility of the task of making perceptible the numerous time-space trajectories that come to settle as physical material space, there is tolerance to the implicit non-coherence of events and actions. This is to say that each and every time-space trajectory, that in itself is a

trajectory of actions and events, is detachable and partial but not defined in terms of lack from a whole, but defined from non-coherence between the actions and events that compose it and between it and other time-space trajectories composing the square. Thus relations that are constituted in the space of the square can be divergent and uncertain (Law, 2004).

In recognising the non-coherence one affirms the disjunction between contradictions placing emphasis on the disjunction itself or the relation that maintains each and every non-coherent contradiction, as it is through those relations that the disjunction can break away and diverge in uncertain ways. The emphasis here is not on contrasting the elements in contradiction but on “how each exhibits their liveliness” (Dillon, 2000, p. 1) and hence on how “nothing is without being in relation, and [thus] everything is – in the way that it is – in terms and in virtue of relationality” (*ibid.* p. 4). Arguably Lefebvre’s lived spaces is a way to grasp how each contradictory element displays its liveliness as he strives to show how it must be a product of the concrete materiality or the manifest actuality of relations. But where Lefebvre gets bogged down is to include the relationality itself in its own conceptual creation, i.e. to state that the concrete determines the expression of the lived and that expression reacts upon the concrete in active ways. Thus for Lefebvre spaces created always have to do some work, or be productive in the classical Marxian sense. But by following Deleuze and Guattari (1987, p. 89), as in the preceding, the productivity of relations is taken further in recognition that the only actuality to be found in a relation is the fact that it works as a disjunction or difference (Bough, 1993; Deleuze, 1991).

1.2.2 Exteriority of relations

The term ‘exteriority of relations’ is derived from Deleuze (1991) and argues against the above fixity of contradictions through the internalising drive of the dialectical relationality. Thus the idea is not to derive relations from the nature of things in themselves, as a defined set of aggregate parts, but the relations they constitute. Thus by saying relations are external to their terms one recognises that relations are not grounded in an essence or foundation somehow interior to entities. Since if entities had an essence all relations would be simple associations between two or more entities and relations would be nothing but an extension of those essences. If the relation as association and extension of essences “is necessary in order to make all

relations in general possible, each relation is not in the least explained by the *association*” (Deleuze, 1991, p. 103, emphasis original). Thus to explain relations, rather than seeing them as mere extension of the essences of entities, the relations need to be formulated as irreducible to their terms (Deleuze, 1991; Hayden, 1998).

Seeing relations as exterior and irreducible to their terms builds on two key premises. Firstly the principle of difference meaning; that entities are separable because they are different and different because they are separable. By being separable because they are different and different because they are separable means that the difference is imminent and not relying on any underlying principle of organisation. From the notion of this difference separating entities as being imminent to them the second premise is derived, that of the seriality of different entities, i.e. they are held together by the difference that separates them. Thus, “unities in question [are found] in *series* which determine the connections, disjunctions and conjunctions of organs” (Deleuze and Guattari, 1983, p. 142, emphasis original). The seriality of different entities emphasises the relation itself, i.e. not seeing the world as a movement or change from one entity to another, but focusing on the suspension between separate entities that is the relation. Hence by seeing relations as exterior and irreducible to their terms the mover and the motion are indistinguishable (Boundas, 1991; Doel, 1999).

Having relations exterior and irreducible to their terms and thus not residing in the quality of things, they are movements or motions as outlined above. Hence Deleuze (1991) circumvents one of the key conundrums encountered if relations are seen as associations, i.e. how unpredictable novelty and change can occur. The problem with seeing relations as associations between entities that through the association hybridise their essence, is that if any change occurs not only the relation changes but also the essence from which it is derived would have to change. Although a hybridisation occurs there is always a core essence to be dealt with, that by nature is unalterable as it is essential. That is to say that if relations were not taken as external and irreducible to their terms then we would always be led back to the essence of entities, eventually being able to trace ourselves back to the foundation of everything that by its very definition is unalterable. Hence, through adopting relations as mere associations, we are able to unpack the myriad of associations constituting space and arrive at a definition of what that space is. Premised upon an absolute foundation of what that

space is; real change would never occur in that space but only variations of the theme of the absolute foundation (Hayden, 1998).

Accepting that the world merely sings to the tune of an absolute foundation argues that results and effects of all actions and events are, in the end of the day, pre-determined. That is to say no matter what happens, nothing ever really changes. To inflect upon relations as associations, necessarily based on an ultimate absolute foundation, in another way; thinking in terms of foundations makes the world only resemble or repeat what it is founded upon, the proposition of essence formalises that repeatability (see Cache, 1995, p. 15). On the contrary in Deleuze (1991) the relation is itself the focal point of change through being involuted, 'folded' (see Deleuze, 1992) or even 'scrumpled' (see Doel, 1996) with no constants but is in itself a pure variation, a field of immanence. This relation as field of immanence is self-enfolding and holds all variations in different intensities depending on the angle of approach. The co presence of variations makes for the immanent emerging potential of relations. The idea of immanence will be visited in more detail in the next and the last chapter.

In sum as argued before the dialectical relational space was a mere set of associations be they presented in terms of rhythms or appropriations that could be unpacked to arrive at a fixed definition of that space as a theatre of interaction. This theatre is the absolute foundation of space, a fixity disclosing itself in graspable flows and rhythms from which causal explanations of all kinds can be built. In contrast seeing space as emergent from and immanent to the relationality constituting the difference separating entities, there is a more productive way to think about space than from the stance of there actually being a fixed set space out there which we needed to unravel in its complex relationality. Through seeing relations as suspensions between entities exterior and irreducible to their terms, and actually seeing the entities themselves emerge from relations as pure difference, those relations become constant movements and continuously engaged in their own ontological transformations (Doel, 1999, p.127; Callon and Law, 2004).

"Hence everything is production" Deleuze and Guattari (1983, p. 4) would concur with Lefebvre. Lefebvre sees the concrete determining the expression of the lived through the production of space, at the same time this production makes lived spaces

as forms of expressions in terms of spaces of representation or various rhythms. Reading Lefebvre these forms of expressions gain independence as representable abstractions that do not partake in the actual struggle that the production entails. Hence there is a certain fallacy of ideology implicit within Lefebvre's work, work that Deleuze and Guattari (1987) articulate on different terms.

1.2.3 Slipping in difference

“...via a pure becoming of minorities” (Deleuze and Guattari, 1987, p. 471).

Before proceeding to an illustration of the above in the space of Festival Square I would like to establish a further link to the preceding chapter. In the above I argued that the rhythms had been formalised into representations or expressions, independent of the actual struggle of production and thus able to partake in causal explanations about the constitution of the square. The rhythmanalysis done was based upon Lefebvre (2004) and although stated in the above that he backs down from the phenomenological potential implicit in his analysis and falls prey to a certain ideology through allowing the forms of expression to work independent of the struggle producing them, it would be disingenuous to state that he did not realise that inherent in each productive rhythm was its own difference (see p. 176) as I state in the starting example. Not only did he argue that since there can be no absolute repetition, difference must be inherent in it, but also, with a more fundamental reference to Nietzsche and his early engagement with temporality, that cyclical rhythm essentially disrupts linearity and thus causality (Elden, 2004a, p. 179). But I argue again that Lefebvre backs away from delving any further into that inherent difference as in terms of unpacking what it can do and how. Hence I refer to Deleuze and Guattari (1987) where they, drawing also on Nietzsche argue for the refrain.

Earlier, relations were seen as suspensions, exterior and irreducible to their terms making for pure difference, and having the relations become constant movements. Seeing the relations as pure difference and constant movements there are links to the ideas of Lefebvre (2004). I would like to refer back to his quote in the previous chapter (see p. 179) but draw out specifically:

“the movements of the molecules and atoms that compose it (the object, the forest). The object resists a thousand aggressions but breaks up in humidity or conditions of vitality, the profusion of miniscule life” (p. 20).

It is with the reference to the molecules and the profusion of miniscule life that compose the object that links start to form with the molecular as formulated by Deleuze and Guattari (1983). The molecular, as defined by them taken from the quote in the introduction to the chapter, was where: “everything comes apart, but this time in a *molecular* and pure multiplicity” (p. 69). These are the elementary particles that make up Festival Square and in terms of the preceding chapter they would be the individual passing of each of the office workers that compose the molar aggregate of the flow of people crossing. The molar, again from the above quote, is “collective formations comprising singularities distributed haphazardly” (p. 68). The distinction between the two defined above, a distinction between “one molecular and the other molar; one microphysic or micrological, the other statistical and gregarious” (Deleuze and Guattari, 1983, p. 283) is not to be made as it is through their direct involvement with each other that space is produced. Thus Deleuze and Guattari reject the “representative individualism of classical confrontation” (Hertz-Ohmes, 1987, p. 246) and argue for the integration of minorities into majorities, or steeping the molecular or having it immanent to the molar in line with the above discussion on the exteriority of relations.

Thus producing space is about eliciting the molar from the molecular, i.e. coding or writing/earth, this is not to say that molar order is derived from the molecular disorder, but purely through their suspension or relation space is produced. It is through the molecular that the materiality of the square starts to receive its role, as with each individual passing the molecular components of the square that have settled into the molar aggregates of the space of the square interact with the molecular components of the individual as an entity of consistent elementary particles in another form of molar aggregate (Deleuze and Guattari, 1987, p. 195). What is created in this interaction is an open system that settles into a balance that can be discerned by the rhythm analysis of Lefebvre as what holds the interaction together is rhythm. As Deleuze and Guattari (1987) argue:

“There is rhythm whenever there is a transcoded passage from one milieu to another, a communication of milieus, coordination between heterogeneous space-times” (p. 313).

The key argument in the above is that the disjunctive relation that is exterior to its terms creates an open system that *settles into a balance* that can be represented (see Figure III.1). This balance is the rhythm perceived and can be usefully ascribed a productive causal relation or ascribed with meaning that partakes in the theatricality producing space, but that would miss the production that continuously maintains each and every coordination between heterogeneous space-times, or time-space trajectories as earlier formulated. It is at this coordination or communication between molecular milieus that the potential resides for the non-coherent disjunction to be divergent and truly uncertain.

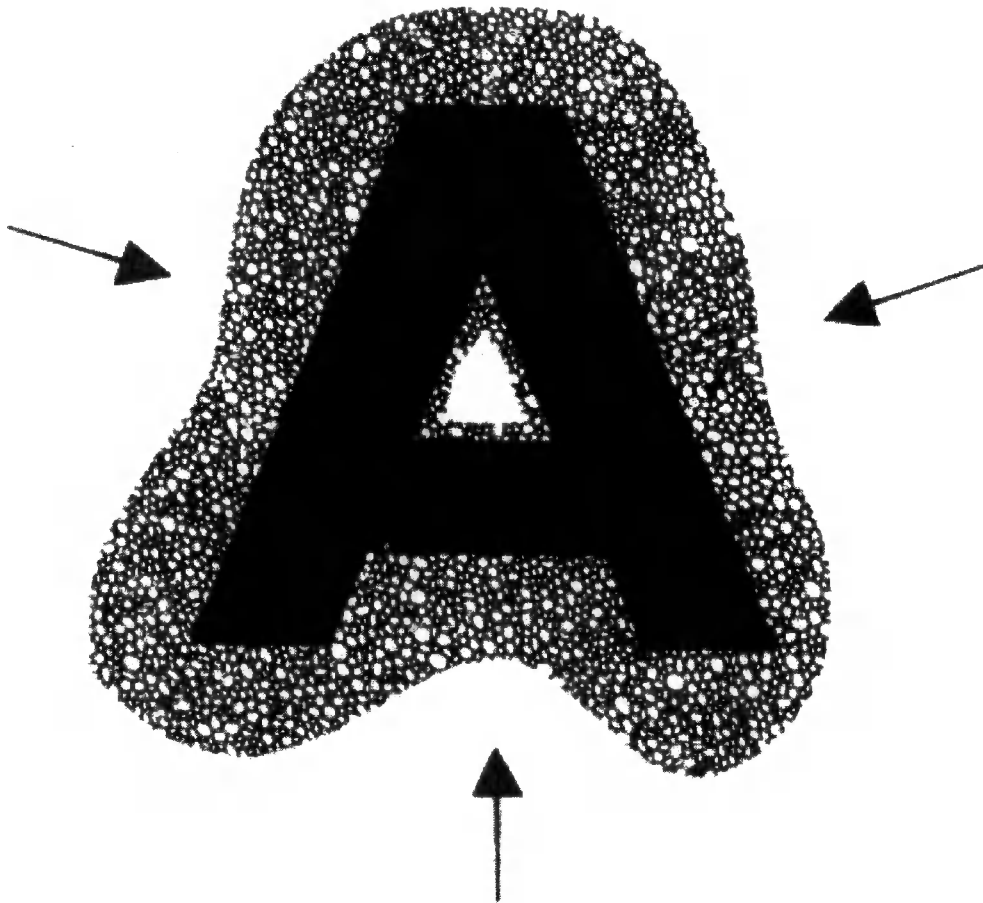

Figure III.1: The open system of disjunctive relations settled into a representable balance. The molar steeped in the molecular.

Source: Stewart (1997, p. 98).

In order to flesh out in more detail the interaction taking place it is worth quoting Deleuze and Guattari (1987) further as they define the milieus communicating or those heterogeneous space-times. These are milieus that are imbricated into a single multiplicity defined not by:

“the elements that compose it in extension, not by the characteristics that compose it in comprehension, but by the lines and dimensions it encompasses in ‘intension’” (p. 245).

Or in other words; the molecular level can be viewed as a ‘plane of consistency’ immanent to stratification or sedimentation of the time-space trajectories, as they state:

“the strata rigidify and are organised on the plane of consistency, and that the plane of consistency is at work and is constructed in the strata, in both cases piece by piece, blow by blow, operation by operation” (*ibid*, p. 337)

Thus the strata is about locking the lines and dimensions that the multiplicity encompasses into “systems of resonance and redundancy, of producing upon the body of the earth molecules large and small and organising them into molar aggregates” (*ibid*. p. 40, see also Deleuze and Guattari, 1983, p. 324). These organised molar aggregates composed by the strata are held imbricate to the molecular by the pinchers of double articulation elaborated on below.

What is being said in the above is that the physical material space is composed of strata that each are constructed and maintained on the molecular level manifest in consistencies at the molar level. What holds the consistent transformation or the imbrications of the two together is rhythm and “the involuted (feedback) connectivity of the system is a measure of its very liminality” (Dillon, 2000, p. 13). Here the words most likely evoke the imagery of molecular interactions on the scale of particle physics and indeed at the smallest of scales this is the case, but all these scales are imbricate to form the space and us in it. The rhythm holding the two together even at the smallest of scales produces a pincher movement or what Deleuze and Guattari (1987, p. 40, see also p. 143) term ‘double articulation’ that through constant repetition or refrain produces strata or the aggregates composing space in balance (see Figure III.2). Each rhythmic motion thus holds within it a point in which the subsequent aggregate or strata can be different depending on the route taken, as each double move is immanent with the meta-stable molecular units, composing each

molar aggregate. Or to put it another way: Each assemblage *effectuate* the strata “insofar as it is developed on the plane of consistency or enveloped in the stratum” (Deleuze and Guattari, 1987, p. 71).

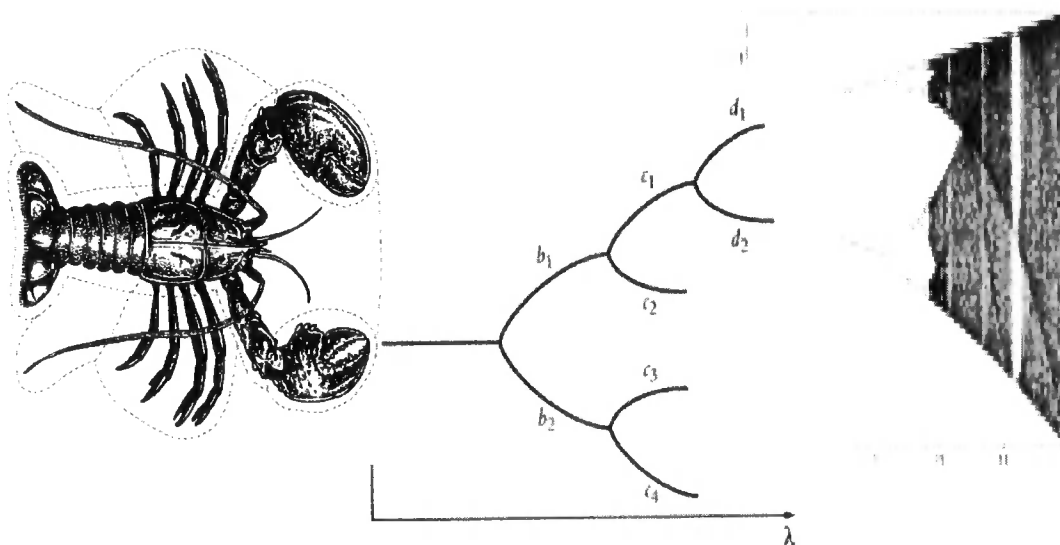

Figure III.2: The double articulation eventually producing strata that at each time are imbricate with the molecular.

Source: Deleuze and Guattari (1987, p. 39); Prigogine (1996, p. 70) and <http://www.yiin.ca/chaos/fig.htm>, viewed 23/9 2004.

In sum through apprehending rhythm in terms of the double articulation it is opened up to difference. Through the above one is now capable of understanding how rhythm can entail difference, as at each and every moment in time the articulation takes place between imbricated assemblages and strata, or at the smallest level, the molecular and the molar. In other words each stratum has at each time a molecular moment and the potential for rearrangement or to become something else. Hence making sense of the production of space implies making sense of:

“the molecular, or microeconomics, micropolitics, [is] defined not by the smallness of its elements but by the nature of its ‘mass’ – the quantum flow as opposed to the molar segmented line. The task of making the segments correspond to the quanta, of adjusting the segments to the quanta, implies hit-and-miss changes in rhythm and mode rather than any omnipotence; and *something always escapes*” (Deleuze and Guattari, 1987, p. 217, emphasis mine).

The ‘quantum flow’ will be revisited in chapter 3 but for now an illustration of the critique on dialectical theatricality and politics of representation is in order.

1.3 The Physical Space of Festival Square

In this illustration of Festival Square I will be picking up on the relationality of space as has been argued for in the above. I will firstly talk in the terms of the physical material space of the square and again talk in terms of architecture and design that determines function. This time though I argue for this function in terms of an open relationality, i.e. in the sense of these relations being merely the actualisation of a disjunction in themselves, confirming non-coherence that then allows for divergence, but mostly through certain paths of consecutive double articulations that have settled into the space as the discernible molar aggregate or strata. Following the architecture and design debate I will put the users of the square in place, this time drawing on those who work on the square and follow how they can be existentially made relational as a molar aggregate themselves, connecting to the square's materiality that I will explain in the end of the chapter through notions of embodiment and performance.

1.3.1 Design as function

What I have done in the preceding chapters, both in part I and in part II, is to demonstrate the abstracted conceptions that have their concrete manifestations as Festival Square and have sedimented over time into its present form of materiality and function. I argued that the office buildings surrounding the square and neighbouring buildings generated flows of people that the square is designed to facilitate and is certainly one of its central functions as demonstrated in the illustration of the previous chapter in terms of habitual dispositions.

The basic existential notion of dwelling presented in the previous chapter in combination with *habitus* and the production of space illustrated as flows disclosing Festival Square was presented from Heidegger's (1971) *Building Dwelling Thinking* paper. There he stated that dwelling and building are related as end and means.

“Building as dwelling, that is, as being on earth, however, remains for man's everyday experience that which is from the outset ‘habitual’ – we inhabit it” (p. 147).

Thus I argue that the disclosure of the square through the flows outlined in the previous chapter can be done just as well through the square's architecture or the understanding of the square as building. As discussed in part II, chapter 2.2.4, these abstractions, would lead to a semiological reading of the space of Festival Square, which is not the aim of this thesis. On the other hand building as dwelling starts to open the path into seeing building as an ordering of molar aggregates that is done by various actors in the circumstances that is Festival Square. To gain insight into how this ordering can go about I build my discussion on Hillier (1996) as it is through a reading of his engagement with post-modern architecture that Festival Square can be built as dwelling in the sense of the continuous ordering of molar aggregates.

In a project started in 1984 Hillier (1996) tries to devise ways to grasp the relation between society and space, with the recognition that concrete structures as designed and made by architects, dictate how people move and structure encounters. By seeing spatial patterns as prescriptive and thus directly impinging upon the social world, the model would approach the social content of the spatial patterning. Through this model the focus would be on the purpose of the materiality of the square in the ordering of space, thus not an analysis of the square as an object in itself. Here I build on the quote from Heidegger (1996) in the last chapter 3.4.1, where ordering was seen in terms of calculable accountability and used to displace *Dasein*, but as the quote further indicates "order means...of every relation between actual things to every other relation" (p. 40). Thus physical material space takes as much part in ordering as does any being as Hillier (1996) argues in the above.

Through a previous study (see Hillier and Hansen, 1984) models were formulated about the way in which these encounters ordering space take place. These were rather functional and would have proposed a correlation between types and density of social relations and the spatial morphology of the square. This functionalism of the previous model approach has, on the other hand, resonance with the modernist dictum 'form follows function' which Hillier³⁴ (1996) later builds on as he proposes to analyse form

³⁴ An important facet of Hillier's (1996) analysis is spatial typology and seeing where Festival Square stands in the types of spaces society produces attaining dwelling, I rely on Moughtin's (1999) outline of squares that can be categorized in two main fashions, from their form or function. These are equally important and a neglect of them leads to the barren windswept empty spaces surrounding under-utilised

as a complex family of social organisation and as affecting cognition and behaviour.

Thus form informs functions as:

“space both gives the form to the social abstractions which we name in buildings, and space seems to be the content of the building that can be taken back to the more abstract conception of society and organisation” (Hillier, 1996, p. 373).

With this dual abstraction Hillier (1996) proposes a revival of the modernist architecture catchphrase attributed to Le Corbusier that buildings are machines, resounding with the key metaphor in Deleuze and Guattari (1983, 1987) but here articulated in the sense that space is constructed of parts that work through facilitating movement of people by being configurationally persistent. The configurational persistence is the material form society takes and works back upon it. Society is thus the abstraction but real through being realised in space via the “configurational patterns underlying the interactions” (p. 401) that constitute social relations. Those patterns are our institutions, modes of production and spatial form. Festival Square is here represented as the configurational persistency of the society that made it and is made by it, tying back to Heidegger stating that we attain dwelling through building. But of key note and importance here is that although through the discussion above Hillier (1996) obviously falls prey to the same fallacy of ideology as Lefebvre (see p. 209), he argues for space’s ‘configurational persistency’ or consistency. This notion I see as directly related to the previous outline of how imbricate molar and molecular multiplicities attain to balance through rhythmic consistent double articulation. So in

buildings, or the enclosed traffic islands. Firstly, he defines squares from their function claiming that the types of squares needed in a city are:

“the setting for a civic building; the principal meeting places; places for great ceremonial occasions; spaces for entertainment around buildings such as theatres, cinemas, restaurants and cafes; spaces for shopping, shopping street, arcades and markets; spaces around which offices are grouped; spaces of semi-public nature around which residential accommodation is arranged; and, finally, the spaces associated with urban traffic junctions” (p. 88).

Naturally spaces can have an overlapping of these determined functions, but a function they must have, preferably one that sustains activity through a variety of uses in the surrounding buildings. Secondly, outlining the form of the square he refers to three: firstly, the enclosed square where the space is self-contained by the surrounding buildings. Secondly, there is the dominated square where the focal point is the main building on the square. Thirdly, there are linked squares with either a nucleus, centre or internal reference point, or an external one.

Seen from the typology of Moughtin (1999) Festival Square is a space around which offices are grouped, although having some commercial activity through the hotel and the ABO. The aspirations for the function of the square is to tie it to the theatre and entertainment quarter across the street in an effort to sustain a variety of uses, that is the planning paradigm of the day (Ian Spence). The form of the square is an enclosed one, albeit on one side by a road.

his close analysis of architecture Hillier (1996), in the final pages of his book, demonstrates how a spatial form like Festival Square's configurational persistency gives rise to certain ways of being in the square that then again makes some interactions, or certain rhythmic cohesion of multiplicities or molar aggregates, more persistent, to the point of representability (see Figure III.1).

1.3.2 Using lamps

Hence before Festival Square disclosed its space in terms of flow, put in the context of the above, the square orders space into a set of flows that then structure interactions that one has with that space. As demonstrated in the previous chapters these interactions with the space can be deliberate use of the space in very different ways, e.g. skateboarding or a gathering, or non-deliberate in terms of habitual passing, but all will have to take cue from the materiality of space. In each of these interactions there is played out the refrain that settles into molar aggregates manifest as skateboarding scrape marks or a spontaneous gathering that should generate more of the same, but each and every interaction also holds the potential of bifurcation along other paths creating a potential for new, different molar aggregates. In order to explain further the notions presented above in the context of the architecture and design of Festival Square viewed in terms of its configurational persistency or consistency, I take an example of one of the lamps on the square. Thus I aim to explain the rhythmic double articulation responsible for creating space, albeit in ever so small ways or "...via a pure becoming of minorities" (Deleuze and Guattari, 1987, p. 471) as stated earlier.



Figure III.3: Streetlamps on Festival Square, Edinburgh.

Source: E. Huijbens

To begin with, a small description of the lamp follows (see Figure III.3) as it stands along with 7 other identical ones on Festival Square. This description is based on my interview with Duncan Whatmore as he described the lamps and their function on the square for me. The lamps were designed by a Spanish Lighting Company, but they had designed them for the 1992 Olympic Games in Barcelona. Later the design had been picked up in Wales, but never in Scotland and as Terry Farrell and partners were very keen on the sculptural layout of the lamps, figuring they would work well in the context of the square they installed them there. The lamps are square boxes, with a pointy top, about 1.5m in height made out of grey-painted steel bands and glass and in many ways remind one of little light-houses. I could spend time seeking the origin of all the individual time-space trajectories that have come to settle in the form of this lamp. I could unravel all of them through listing all the materials that were used in making it, where they come from and why they were joined in this particular way and not the other. From there I could go on and talk of the ideas and all the work that went into creating these materials being used, e.g. how glass and steel came to be and where they come from. In unpacking the infinity of the time-space trajectories that come to settle in the form of an object, the lamp in this case, the only thing to be

revealed is the ever increasing complexity and continually more depth to the object at hand, what Law (2004) following Leibniz called “a world of ponds within ponds and gardens within gardens” (p. 19). Like the brick in the following quote:

“The brick is a domain in which different realities have been transducted and mediated. Making a brick [...] links ‘realities of heterogeneous domains’. The technicity of brick – its durability, resistance to weathering, capacity to bear certain kinds of loads, the bond the mortar can make to it – emerges from the mediation of different domains. The capacity of the material to be moulded is itself an outcome of a series of transformative operations. The clay must be prepared, for instance, so that it is homogeneous, plastic, and yet able to maintain consistency so that it can take on contours without spilling like water. [...] The materialised form and prepared material interact through a set of energetic exchanges which transform the potential energy of the clay under pressure into a stable, determinate equilibrium” (McKenzie, 2002, p. 47-58).

In the terminology of this thesis the lamp, in a short-hand analysis based on the above and my interview with Duncan Whatmore, is there bringing in Barcelona, all the people that had something to do with its making or design in one way or another and all the material and its history that is to be found in the lamp. From the lamp emerge spaces of safety in the darkness of the city night, its ascribed aesthetics and usefulness. In other words the lamp is a host of time-space trajectories of materiality and subjectivity rolled into an object of apparent fixity. The lamp is thus in itself a multiplicity bringing together a host of time-space trajectories that render distances in absolute time and space relative, but more importantly time-space trajectories present in a certain form or relationality we see as the lamp. It means that simply there is no bottom or essence to be reached for in the object, although it appears there as fixed and constitutive of space. What is thus recognised is that all of the time-space trajectories have always been, in one context or another, in a state of becoming, and as I will try to demonstrate below, still are.

Once the lamp is understood in terms of its multiple relationality and continuous state of becoming I can use the above ideas about the strata as the comprehensible molar aggregates that have settled into a balance that is the lamp. But as both Lefebvre and Deleuze and Guattari argue this balance is one that is a continual rhythm or refrain, albeit most of them are slow and indiscernible. This refrain is constant enough to maintain the lamp as a discernible entity in space and although one picks apart the time-space trajectories that have come to settle in this balance, the object’s rhythmic

cohesion makes certain that the lamp loses none of its tangibility on Festival Square. But as hinted at in the above the time-space trajectories, although settled, are by no means stationary or frozen in time. Every moment they are in rhythmic motion, constantly holding the potential to change or become different. Going to the level of each and every moment these differences are truly of the molecular level, but as rhythm can never be absolute it immerses the molar aggregate of the lamp continuously in the molecular. Through constant movement there is always the potentiality to become.

It is here with the time-space trajectories in a perpetual state of becoming that I want to unpack a small example to demonstrate what has been said in the above through the lamp on Festival Square. It is here where I introduce Joe who works for the Shining Stars taking care of the daily maintenance of Festival Square in terms of cleaning and trouble-shooting. With his daily engagement with the square he makes it become what it is while at the same moment he becomes Festival Square, as often the square will not become quite what Joe wants it to become nor what it was before as I will explain further through the example. One of the many tasks Joe has to take care of on the square, apart from picking garbage and cleaning, is to turn on the lamps at night. In order to do so he has an electronic switchboard, the switches upon which he needs to turn in a specific order and way so that all eight lamps will be lit. Despite a new and fancy design it was not long until the lamps stopped switching on for reasons unbeknownst to Joe as he was not equipped nor qualified to give the square's whole electronic system and overhaul. All the same Joe was not perturbed and each and every day he would carry on with his task of lighting the lamps, devising ways in dealing with his switchboard so that each and every lamp would be lit. All his meddling and fixing was eventually getting out of hand and most certainly had flouted all regulation as to workplace safety so in the end Joe was ordered to stop his innovative fixing as he put himself and potentially others in lethal danger. Joe thus had to come to terms with the fact that these lights would not work and no one was about to do anything about it apart from banning him to do anything about it. His frustration was manifest in the many sarcastic comments voiced with a sense of despair once the subject of the lamps was brought up.

What I argue for in this seemingly trivial example is that the rhythmicity, of turning on the lights, everyday, around the same time as dictated by the designers, was ordered by the very materiality of the square. Joe had to engage with a very material object, the lamp, in a rhythmic fashion and through his continuing encounters a molar aggregate of Joe becoming-lamp accumulated “piece by piece, blow by blow, operation by operation” (Deleuze and Guattari, 1987, p. 337). What I emphasise here is not that Joe in some way represented the lamp or physically became a lamp himself, either which ties into systems of consciousness, perception or signification defining him in terms of the lack of his ‘lampishness’ or by analogy. Through his connections to the materiality of the lamp he became one entering into an ‘assemblage’ with that materiality through his relations with the relations already there in the lamp, all of which are of constant movement through rhythm. Becoming involves (involution) “a block that runs its own line ‘between’ the terms in play and beneath assignable relations” (*ibid.* p. 239). Thus what I emphasise is that in every fleeting moment, captured in each interaction, there was a becoming-lamp brought about from the play of molecular interactions of innumerable proportions as “all becomings are already molecular” (*ibid.* p. 272). Hence using Deleuze and Guattari (1987)

“the technical machine is the medium between two subjects. But one is enslaved by [lamp] as a human machine insofar as the [lamp] users are no longer consumers or users, nor even subjects who supposedly ‘make’ it, but intrinsic component pieces, ‘input’ and ‘output,’ feedback or recurrences that are no longer connected to the machine in such a way as to produce or use it” (p. 458).

In sum; through Joe’s encounter with the lamps on the square he in a very real sense entered into their materiality making them become what he intended, becoming-lamp at the very same time, but eventually the lamp’s materiality made for another becoming. Arguably this latter becoming came about as a causal culmination of frequent encounters, but how could that explain why he chose each and every action necessary for maintaining the lamps in their everyday continual encounter as at each and every turn he always had to improvise and innovate in unforeseeable ways? In this sense I do not want to argue for a production of differential space following Lefebvre, as each and every momentary becoming that in the next instant had moved on could not become a form of expression, as arguably nothing can. Hence I argue for “look[ing] only at the movements” (Deleuze and Guattari, 1987, p. 282) but as movement has “an essential relation to the imperceptible; it is by nature

imperceptible” (*ibid* p. 280) there is a slight problem of representation. That problem will be the subject of the end of the next chapter. For now the key is that Joe was able to enter into the material relationality that is the lamp on Festival Square, but only through being a relational entity himself and most importantly this interaction could never be understood *except in terms of the relationality itself*. Hence next I would like to make the argument why an individual with an assignable name, arguably personality and apparent fixity can partake in such a moment of mere movement and be consistent in terms of being movement himself. I want to argue how to make sense of the individual in terms of a consistency of elementary particles or a form of molar aggregate, like the lamp, or space for that matter.

1.4 Concluding

The question I have raised in the above is about how one can make sense of those relations the body forms with the material space in conscious and subconscious ways once using that space? How does the body dwell or produce lived spaces that can be understood in terms of non-reductive continuous becoming? How is space of relations constituted in the numerous relations constantly forming through time in space? This set of questions, depart from Bourdieu and his notion of *habitus*, especially addressing the critique of how *habitus* can change and become different, and have resonance with discussions on embodiment and performance (see Dewsbury *et.al.* 2002; Grosz, 1995; Latham, 2003; Longhurst, 1997; Nast and Pile, 1998; Nelson, 1999; Ness, 1992; Seamon, 1980, 1980a, 1998; Simonsen, 2000, 2001; Teather, 1999; Thrift, 1999; Thrift, 2003b; Thrift and Dewsbury, 2000).

The last example aims for ways of understanding the body in its relationality to the world and how the body is not neutral but rather a nexus of activities and relations with other relational entities. It is a body not alone in its relationality as Serres (1995a) shows:

“Look at those children out there, playing ball. The clumsy ones are playing with the ball as if it was an object, while the more skilful ones handle it as if it were playing with them: they move and change positions according to how the ball moves and bounces. As we see it the ball is being manipulated by human subjects; this is a mistake - the ball is creating the relationships between them. It is in following its trajectory that their team is created, knows itself and represents itself. Yes, the ball is active. It is the ball that is playing” (p. 47-48, see also Massumi, 2002b, p. 73).

A term coined by Massumi (2000) comes to mind seeing the body in physical material space as the “life glue of matter” (p. 193). For Massumi (2000) the body glues space into a network of practices, through preconscious or consciously choreographed movements and care.³⁵ The person Joe, represented here by his name, and any subject for that matter, in each moment of practice is thus to be understood as:

“not [that] referring to [a person] or to effectuating moments; on the contrary, it is the names and dates that refer to the singularities of the machines, and to what they effectuate” (Deleuze and Guattari, 1987, p. 511).

³⁵Here notions of emotions are rendered audible (see Anderson and Smith, 2001; Illouz, 2001; Thrift, 2004). As Hunter (1999) claims: “...emotions and feelings are often unauthorised modes of knowing” (p. 2), these will be the subject of the next chapter, section 2.2.1.

III.2 Becoming-Reflexive

The previous chapter argued for understanding the relationality of Festival Square built on a critique of those spatial relations that are produced in a dialectical encounter following Lefebvre (1991) and Bourdieu (1990). As stated these dialectics are useful when understanding space but once in the business of unpacking those relations and their production I found that the cultural, political and material content of those relations proved to be elusive, the more work I did, the more there was, there was always an excess to the contents produced, always more to be added. I noted in my field diary 13th of January 2003 in the middle of my archival work along with visits to the square: "How the square became alive as I started doing my research into it. Looking at that little sample of mine". Alive it would yield any final or concrete answers, neither from the people navigating that space everyday, giving it cultural and political content nor from the built environment. I found myself at an impasse where I saw a problem in trying to give a complete representation of that space, based on a space that never is complete. I found there was a profound problem in unpacking those spatial relations, dialectically produced in the clashes between opposing forces, and represent them to others. As I thought reflexively about my conundrum I was startled to find that I could be as reflexive as I wanted, openly or to myself and still I would not have found a way to complete my representation of the square. This chapter is about how I dealt with the problem of my impasse stemming originally from my problem of understanding space and then the problem of being reflexive about my problem.

Hence I will start the chapter in the reverse order of problems, i.e. beginning with the impasse of reflexivity. The structure of the chapter proceeds as follows. In the first section, I give an account of the debate on reflexivity and how it can lead to an ultimate impasse of infinite reflection if premised on defined categories of representation. I go on to deal with that impasse building on the previous chapter through outlining Deleuzian radical empiricism advancing the understanding of relationality presented there. In the second part of the chapter I carry on by setting forth some practical notions of method in light of radical empiricism, i.e. how the reflexive impasse can be productive in itself. Hence in the end I argue through an example how Festival Square and researching it can be understood through being

affected by being there, or rather how the researcher is always becoming-research taking further the relationality presented before and addressing the final quote of chapter 1 (see p. 223).

In general I would like to venture an attempt to explain what kind of questions a researcher in human geography could be concerned with out in the field when trying to make sense of that which eludes the dialectical production of space. Based on Doel's (1999) earlier critique of the totalising drive of dialectics I concur that apprehending space through dialectics "take[s] flight without ever leaving the ground, voyage[s] without ever leaving the spot, and become[s] the dissimulative other of the same" (p. 27-28). Once taking that voyage without ever leaving the spot one is led to the infinite navel gazing of reflexivity that I will outline below and really does not hold any productive potential. What I will argue on the other hand is that a researcher can be productively reflective, which necessitates an understanding of how to "voyage in place: [that] is the name of all intensities, even if they also develop in extension" (Deleuze and Guattari, 1987, p. 482). Thus being reflective in the context of knowing there is always more, there is always a continual becoming once you start unpacking the politics at play in dialectics. Again I make for the excess in terms of the radical relationality earlier outlined, i.e. the actual voyaging of becoming that has no point of origin, nor a final destination.

2.1 Being Reflexive

In this first section I want to talk about my stay on Festival Square for the ten months of my field period in the winter of 2002-2003. There I realised that no matter how hard I reflected on my presence there as a researcher I could not find a way to be true to that space nor the people there if I was going to understand them as a representative product of dialectical relations with their environment and each other, set in a stage-set that was the product of prior dialectics between people and objective socio-economic structures, as has been detailed in previous parts. I was at an impasse, one that I had to find a way out of and thus I started to delve into the literature. Below I outline the context of the debate on reflexivity and point to the ultimate impasse I encountered in the field.

2.1.1 Reflexivity

The idea of reflexivity has in many ways become a catch phrase in Human Geography in recent years, countering the neo-positivistic dogma of obtainable objective knowledge. The idea entails that by reflecting upon oneself in terms of positionality, auto-ethnography and how one influences the research, the researcher holds a key to open up new geographies and knowledges. The underlying claim here is that all knowledge is marked by its origin and reflexive self-disclosure will reveal its origin. Reflecting upon oneself thus entails knowledge of oneself or recognition of where one is coming from, one's own dispositions, so to speak, that one brings to the research (Cloke, 1999) as I itemised in part I. It was mainly feminist geographers who brought the idea of reflexivity into geographic literature, seeing reflexivity as: "[the] self-critical sympathetic introspection and the self-conscious *analytical* scrutiny of the self as researcher" (England, 1994, p. 82, emphasis original). Feminist geographers, with their commitment to situated knowledges followed the call of McDowell (1992a) to recognise in their research their social position, along with that of those being researched and most importantly, make that part of their practice as researchers. McDowell places the emphasis on the positionality made for by gender and the emphasising of "the *partial* nature of information that is exchanged between researcher and the subject" (McDowell, 1992b, p. 214, emphasis original). With the recognition of the partial nature of information exchanged in research one of the main issues in debating reflexivity comes into focus, i.e. the inherent power play of positions and how, once recognising positionality and how all participants in the research carry certain dispositions into the research process, there are certain, often asymmetrical powers at play. Thus from the work of geographers and others (e.g. England, 1994; Fine, 1993; Herod, 1993, 1999; Jackson, 1983, 1985; Katz, 1994) the list of positions, the mapping of their 'power geometries' (Massey, 1993) and ethico-practical issues researchers should incorporate in their research, started to grow. Additionally, how researchers can write themselves, as part of those geometries, in various ways into the research process.

As the list of the positions of researchers and those researched grew, with notions such as age, gender, nationality, social status, economic status, education, along with issues of power and ethics, researchers could construct some wonderfully nuanced accounts of their research, unpacking their own identity, at the same time unpacking

their relation to the research along with unpacking the subject's identity (see Bourdieu, 1990; Mitchell, 2003; Low, 2000). With the preceding unpacking the underlying thought is one of 'double reflexivity', derived from the idea of double hermeneutics like structuration theory in chapter I.1 (see Giddens, 1976), stating that the subject is relational, just as the researcher is relational along with the relations they form in the process of the research. The relation in the process of the research is recognised as part of the 'power geometry' the research plays out in and the introspective search is the auto-ethnographic positioning needed to unpack the dispositions brought to the research by the researcher, at the same time as trying to get to the relationality of the subject in the research (see Cook and Crang, 1995 on methods). Recognising that the relations formed in the research are part of the power geometry of the research process the observation of participation is brought into play (see Tedlock, 1991). Thus the researchers can also reflect on their own power geometries within academia and the power geometries of their research or even the language used in analysis e.g. use of space (see Olwig, 2002). This unpacking and engagement with oneself as researcher is surely the strength of reflexive research as opposed to the positivist zeal of truth and essence exposure.

But there is an inherent problem in the notion of reflexivity as outlined above. Reflexivity as outlined above has been criticised for deriving its notions and drawing inspiration from the Enlightenment ideal of self-knowledge, i.e. an introspective questioning of one's beliefs and assumptions will disclose one's essential positionality and knowledge. So when unpacking positionality and relationality the elementary reflexive thought is one where, while saying something about the world out there, one at the same time discloses something about oneself (Pels, 2000, p. 2, see also Crang, 2002, 2003). Approaching the unpacking of positionality from the ideal of self-knowledge makes the researcher the reader of some deeper underlying fundamental, but once trying to do research along those lines the researcher is led into an infinite regress of reflection, i.e. when reflection spins out of control and one becomes unable to distinguish what was a reflection on what (Lynch, 2000, following Latour, 1988). Within the above lies the fundamental conundrum, i.e. the one of the infinite regress of reflection once the researcher starts on the unpacking of self, the relations of the research and the subject researched.

The danger in seeking to disclose self-knowledge from the endless reflective spiralling is, as Pels (2000) points out (see also Lynch 2000), that the reflexive writer tends to practice reflexive 'spinning' when unpacking the relations of the subject and self, but without recognising it as the infinite regress it is and hence lends the self-disclosing reflexive stance "a pontifical prerogative to expose the self-contradictions of the observed" (p. 2). This means that the reflexive stance, as outlined above, gives the researcher a preferred position in understanding, that is not recognised on those terms and hence the reflexive researcher becomes one best captured with a quote again from Pels (2000):

"I, the reflexive sociologist, knowing myself, also know who you are, where you come from, what your deepest interests are, why you remain unconscious of what you actually do and why you entangle yourself in performative contradictions. If you are unprepared to 'know thyself' on my theoretical conditions, you are an unreflexive bastard, and I must tutor you in my explanatory theory, which will liberate us both" (p. 8).

Pels (2000) attempts to address the reflexive conundrum through arguing for the recognition of the infinite regress of reflection and hence how all accounts of the world have an implicit in-exhaustiveness. Pels (2000) sees geographical research as an ongoing inter-subjective activity, a never ceasing doing of research that constantly transforms the researcher as much as the researched and the research itself (England, 1994, p. 82) and only has to be recognised as such. So rather than seeing reflexivity as researchers being more conscious or aware of what they are doing, it becomes more about feeling the unintended consequences of actions upon the researcher, thus one is conscious that consciousness and awareness can never mean full control (Bingham, 2003; Crang, 2003; Lash, 2003; Latour, 1999, 2003; Lynch, 2003).

Never having full control means seeing reflexivity as a relational practice recognising that the researcher does not have the distance from the research to construct reflections (and never actually had, see Latour, 1993). Hence reflexivity has to be seen as more than the dialectical relationality of the subject, researcher and research, but also as a constantly immanent emergent potential of relations as they become the research in order for it to become truly productive as I will outline later on. As Rose (1997) points out, summarising the debate on reflexivity, the relations in a research are mutually constitutive. As researcher one constantly makes sense of one's own dispositions in relation to the research and is thus as much transformed by the

research and the researched as they are by the researcher. By assuming a knowable position or context in which the research is done one opens up for an endless proliferation of questions about positionality, the infinite regress of reflexivity, which spirals out of control if one tries to fully apprehend the research scenario. Adding the view of the reflexive practice as emergent under the terms of the relations created in the research, the researcher becomes one with the field being researched. In the next section I wish to outline the implications of being constantly 'in spaces of betweenness' (see Katz, 1994, p. 72) where the researcher emerges from the disjunction between the researcher and researched through the research process itself, by being affected by it (Crang, 2003; Thrift and Dewsbury, 2000).

Through out my field diary on Festival Square, there are comments and thoughts on the methods I could use to get people to reveal to me what they did in that space so I could start building a representation of the cultural, political and material contents encoded in the spatial relations that constitute Festival Square. As I reflected on my numerous attempts and approaches of doing so I was faced with endless, ever proliferating questions on all the possible positions and subjectivities I had to deal with as will be demonstrated in the example in this chapter (see p. 241). In the end I realised that there was no way to think on those terms, I had to affirm the gap between the research and myself, a realisation that came through reflection on the research. Hence the reflection is necessary but with the recognition that it is an emergent relational property of the research process, it emerges in the context of the research, an unavoidable one as it is the context. In the following I would like to take these thoughts further, i.e. the recognition that as researcher you are at one with the context of the research at the same time you create the context.

2.1.2 Becoming-researcher

From the affirmation produced above, in the context of this thesis between space and the reading of space, there emerges a fluid conception of becoming. The becoming is one of me in that space, as part of that space, creating that space as it creates me. With this recognition I can grasp it in a way that I cannot have, either by trying to unpack the forces forming space, as out there, nor by wholly rejecting the necessity of this unpacking and banishing it to obscurity, hence one has to become one with the research process, or become-research. To recap on the earlier formulation of

becoming from the previous chapter as it was done in terms affirming the divide between objects and bodies, I quote more from Deleuze and Guattari (1987) as they elaborate on the idea of becoming built on their understanding of relationality:

“A becoming is not a correspondence between relations. But neither is it a resemblance, an imitation, or, at the limit, an identification” (p. 237). “We fall into a false alternative if we say that you either imitate or you are. What is real is the becoming itself, the block of becoming, not the supposedly fixed terms through which that which becomes passes” ... “becoming lacks a subject distinct from itself; but also that it has no term, since its term in turn exists only as taken up in another becoming of which it is the subject, and which coexists, forms a block, with the first. This is the principle according to which there is a reality specific to becoming” (p. 238).

Thus:

“Becoming is a verb with a consistency all its own; it does not reduce to, or lead back to, ‘appearing,’ ‘being,’ ‘equaling,’ or ‘producing’ (*ibid*, p. 239).

The above emerges from the previous dense passage making the interaction with the space being researched an emergent new combination or assemblage, the becoming. The research, most importantly, is not an addition of the researcher to the space in forms of positionality or relations, i.e. where both maintain their properties and simply add on some of them. During research there is a transformation, a becoming, a doing that occurs as all elements interacting are changed by their entry into the new assemblage (Protevi and Bonta, 2004). To bring my thoughts to becoming the space researched, I will have to outline some basic premises implicit in the above quotation, in order to build up for Deleuze’s empiricism premised on the radical relationality outlined in the previous chapter. Through outlining those basic premises I will introduce a few key concepts that I will then deploy in the end of the chapter.

In the whole discussion on reflexivity above, which in the end brought about an affirmation of the gap between the researcher of space and the space itself, I juxtaposed more or less two stances towards being reflexive. One is where positionality and knowledge of self were given as paradigmatic and the second saw reflexivity as emergent from the relations within the research context. The former rests on essentialist notions of the self, seeing the self as a set of properties that define it and thus from which the principle of linear causality can be deployed based on the inference of this defined set of properties as fixity. That is to say that putting primacy

on the positionality and knowledge of self as essential givens provides for a teleological constructivist ontology, stating there is a goal or aim separate from the positionality and knowledge of self, that can be revealed through reflection. The assumption is thus that positionality and knowledge of self once reflected upon can be fully apprehended or grasped. This kind of essentialist ontology lead to the impasse of reflection being one of infinite regress since once trying to apprehend or grasp a situation there is always something slipping away, not accounted for, always a slight excess or a 'slight surprise to action' (following Latour, 1988, 1999). Thus a different ontology has to be adopted, i.e. one of 'radical relationality' as previously outlined in terms of the exteriority of relations, which shares affinity with the second stance towards being reflexive. Thus instead of basing a search for understanding space on inference from a given moment of fixity the focus becomes one on the relations itself being created once trying to apprehend that moment of fixity and the potential this relation holds.

To explain how to make sense of radical relationality in terms of Festival Square I will use the example of my first reflexive conundrum on Festival Square, i.e. the one on how to make sense of the space in terms of people just passing through it continuously. Daily, for months on end, I had watched the movements of people as they crossed the square. I had realised that there was a temporal pattern to the intensity of movement and number of people on the square. With that intensity in mind I set out to map it, through footfall measurements, and finally got a graph that showed peaks and troughs of people on the square at each time (see graph I.1, p. 88) from which I derived a chart of flow lines (see figure I.16, p. 99). With the chart I had a given moment of fixity, a point upon which I could build a series of explanations that I could then put to the subjects on the square, actually doing the passing through.

With this chart in hand and answers derived from my questionnaire that I put to people as they were passing through, I got to know why they were passing through, where they were going, where they came from and such basic variables as job, age, gender and workplace. Also, in the questionnaire I had asked about their thoughts at that moment and asked what they thought of their surroundings. Thus I asked people what they were doing and had them explain it to me. This I did in order to create an explanation for those movements through the square but what it revealed to me was

such a host of explanations that I had a hard time classifying them and making any sense of them that would lend me a narrative I could relate to other audiences. Surely though this was something that I had to do in order to create a nuanced account of my research as good social science demands. I decided the classification boxes and put explanations in those, making some austere decisions on where each belonged in order to claim some explanations as being the main one for movements through the square at each time. With this work I wrote an account that looked sturdy enough as I found that people will always cross the square in certain directions and at those times because they are office workers in the surrounding buildings, the structure of the organisation dictates their movements, they need food for lunch and the stores are across from the square. I reflected on and unpacked my querying to find explanation of the role and function of the space of Festival Square, based on the reasons people gave once reflecting on my questions, all resting on the foundation of my footfall measurements that spawned the chart that I established as the moment of fixity for my analysis.

The second stance on relationality focusing on the relations themselves tells me, on the other hand, that my focus should also be on *how* people go about crossing the square in all ways of manners and movements and allowing for the host of explanations given to me. With that principal the idea is not to reveal people's reason for doing and hence the role of the space they pass through, as the reason can never be fully apprehended, but to reveal the potential that is implicit in their crossing of the square and thus for the space being traversed and the body traversing it. Now this entails further elaboration, what is the potential? How can it be talked about?

2.1.3 Immanence

In order to be able to talk about the potential that is implicit in relations I will have to deploy and explain the term 'immanence', which adds depth to the previous discussion of how the molar is always steeped in the molecular (see Figures III.1 and 2). In the above debate on reflexivity and in the previous chapter I mentioned the term emergence and how relations have emergent potentials. The emergent³⁶ potential of

³⁶ Emergence has also been conceptualised in terms of complexity theory as Buchanan (2002) states; "the study of emergence in all its forms is one of the most important scientific enterprise of our era" (p. 207). Here Buchanan (2002) is talking about the linkages made in seemingly complex systems and

the relations, in this case the ones created in the process of research and reflection, is through the combination earlier outlined in terms of becoming; the assemblage created that is more than a sum of its parts. This emergence is in Deleuzian terms, the actualisation of that which is immanent within relations, thus immanence is that of passing into each other, e.g. "in the gap between content and expression is the immanence of their mutual 'deterritorialization'" (Massumi, 2002a, p. xviii). Here immanent to relations being created in research of any kind there are people that are not merely a defined set of parts or fixed entities in a system dialectically producing space or rhythmically generating flow that disclose the square. But these people interact with each other and interact with the objects there, as demonstrated in the previous chapter, also creating assemblages that are qualitatively different and exceed the simple summation of the parts interacting. Hence the creation of space always exceeds itself through constant interaction as those people constantly make for more than a sum of some positionalities and subjectivities would ever yield. By linking two or more interacting assemblages together, those assemblages themselves being understood as emergent properties of their own relationality, you will have an emergence of a new or different assemblage exceeding the simple addition of properties when mixing fixed entities. The emergence of a new assemblage is not the simple dialectical totality building on the association of fixed entities, the key is to realise that each entity that interacts with another is itself a constantly emergent property of the relations that constitute it and thus an assemblage in itself. Thus it is never given, never fixed and thus cannot relate, but only become an effect of relation as explained in the last chapter through an example.

Thus immanence is one of non-resemblance that breaks any symmetry proposed by dialectic or polar thinking since the movements in relations can be in so many ways and so manifold and are all contained in the relations as potentialities. Thus immanent in the interaction of entities is not a synthesis but the potential emergence of qualitatively new spaces, different spaces, not unlike the differential spaces of

from them there emerges order albeit often in a delicate state, easily alterable by some miniscule changes in the complex system. Attempts are being made of marrying Deleuze's thought with that of complexity theory (see DeLanda, 2002; Massumi, 1992; Protevi and Bonta, 2004) and also complexity theory with geography (see Manson, 2001, 2003; Reitsma, 2003). The problem I find here is though the positivistic overtones of the whole enterprise, especially as outlined by Buchanan (2000, 2002), as it strives for a holistic grasping of the world in all its complexity, a somewhat Romantic enterprise as Law (2004) would have it.

Lefebvre, but their mode of production is different and cannot be argued as being in any way reductive as was possible in terms of Lefebvre. The conception of space here is fluid, space as composed of innumerable movements of various entities, that themselves are effects of relations as emergent properties of a set of fluid relations, immanent to which is the potential emergence of space (Massumi, 2002a, 2002b). These innumerable movements I will formulate in terms of different intensities in the following chapter, but here I carry on with the outline of emergence and immanence.

For the purposes of this chapter the usefulness of the above lies in the potential of the research process to emerge. The research is thus constantly up for change as the system from which it emerges is a relational and fluid one, without any kind of fixity or essence at its heart or any outside organising agents. Through fluidity the immanent potential for the emergence of relations in the research is not about some possible relations being actualised and then transported into 'reality's' plane of existence. Thinking in terms of possible relations in research, one has set up a transcendental plane of those possible relations and thus introduced the seeds of dualist thinking arresting the fluidity and constant emergence of the relational logic, like I argued for in the case of Lefebvre (see p. 209). Thinking in terms of possible relations they become then transcendental and one starts to prescribe roles for entities, the reflective entity presumably being the one that can bring possible relations to reality. The difference between the ideas of that which is immanent to relations as opposed to that which is possible through relations; is that immanence can only be immanent to itself and not confinable to any entity. Thus immanence as only immanent to itself sets up a plane of immanence³⁷ that is the force that has the potential to emerge from the relation between entities, e.g. researcher and others, and is what makes relations always exceed, keeping the world in motion. This plane of immanence is a set of relations that are self-ordering intensities, i.e. have no outside organising agents; it is thus an internalisation of heterogeneous entities that through their multiple interactions acquire emergent properties, i.e. the potential to create new and qualitatively different relations in research (Protevi and Bonta, 2004).

³⁷ Arguably setting up a plane of immanence requires a place or location for that plane thus presupposing transcendence or quoting from Serres (2003): "I always asked Deleuze the following

2.1.4 Radical empiricism

In the above, the aim is to settle on a definition of the world as emergent through potential that is immanent to relations. With this conception of fluidity the entity becomes an emergent relational entity embedded in a plane of immanence as it interacts with other entities. The entity is not reducible to a 'whole' that is a mere aggregate of parts, but a relational whole that immanent to its interaction through relations with other entities (bodies and objects that themselves are as relational) is the emergence of novelty and space itself. The people in my research, e.g. the people crossing the square, are effects of relations or assemblages. Arguably a human being can be viewed as in a deeper-seated equilibrium or as a more intensely ordered relational effect than a table or a dog, explaining the host of designations and affirmations of a human being's character and personality. But seen another way a human being emerges from more sets of relations and thus holds a considerably more potential to become, thus the human body can be argued to be a set of more intensely ordered and immediately active relationalities. Seeing all entities as emergent through their relationality one has to be very empirical when researching these relationalities, i.e. one has to become one with them as by researching them, the researcher is another assemblage to the interactions taking place. Thus when becoming-researcher one becomes part of the relationality of the field and being aware of that starts to indicate how the infinite regress of reflection can start to be productive (Protevi and Bonta, 2004). Becoming the field in this way is empiricism gone radical following Deleuze (1991; see also Hayden, 1998).

Radical empiricism is a practical philosophy that is built up on relations and the relational logic outlined in the preceding. Thus,

“A more helpful definition of empiricism, in Deleuze's estimate, must respect the irreducible dualism that exists between things and relations, atoms and structure, perception and their causes *and also* relations and their causes” (Boundas, 1991, p. 6, emphasis original).

The above quote is stating that there is an irreducible dualism between *also* relations and their causes and hence empiricism is a theory of the exteriority of relations as explained in the previous chapter. Thus for the radical empiricist becoming the object

question: in what space do you draw your plane of immanence? If there is a *plane* of immanence it

of study, relations are not derived from the nature of things in themselves, as a defined set of aggregate parts, but the relations they constitute. Thus the focus should be on the relation's "contingency, difference and incommensurability, and a resistance to universalising abstractions through emphasis on the particularity of situated, historical practices" (Bough, 1993, p. 15) or "the global is situated, specific, and materially constructed in the practices that make each specificity" (Law, 2004, p. 24).

Thus the anchoring point is in the notion of allowing space to become and for oneself to become the object of study. Hence one has to grasp the emergence of the relationality of space and the unfolding of space within the context of that relationality recognising and quoting from Deleuze (1991) "*circumstance* gives the relation its sufficient reason" (p. 103, emphasis original). It is the circumstance that forms the context for the emergence but is at the same time that very same context. The research agenda here, derived from the focus on this anchoring point, is to map the potential for change that composes the space as it can be seen through multidimensional methodology that I will outline in the next section. The research is moved by change and points in the direction of all the potential change to come, all that a space can become. These are the politics this understanding brings, which I will flag up in the next chapter, before that some practical notions for method need to be noted. The focus of this chapter is on the human geography researcher, researching people's actions in the context of material space. Hence in order to focus on actions in space and how people become space through relations I will go make some practical points leading up to an elaboration on 'non-representing' space.

2.2 Methods

What I have outlined as a moment of fixity at the start of the chapter was a graph representing movement of people in time across the space of Festival Square, later unpacked as flow lines across the square. That chart can be seen in the context of the classical time-geography graphs as they were originally developed Hägerstrand (1973) seeing everyday life as relying on a series of material transportation and thus criticised for physical reductionism. But following Gren (2001) I would like to argue that this chart, this moment of fixity, although being reducible to the physical, is not

must indeed be somewhere. I got no reply" (p. 234, emphasis original).

physical enough and that within that selfsame representation lie the seeds of its own 'non-representation' following Thrift (1996, 1997, 1999, 2000, 2004). In order to get to those seeds I will need to step into the intensities mapped on the chart, i.e. recognise them as emergent properties and that observing this emergence is becoming the intensities themselves. In my chart I had 'stilled the stirrings' (Harrison, 2002) made for by the emergence of each of the persons moving through the square, and made them one of many lines forming the chart. In line with revealing that which cannot be represented, one has to recognise that:

"the corporeal basis for representation is instead based on the *difference between the embodied mind and its environment*. In that sense, the overtly complex environment is reduced to the material complexity of the corporeal Observer" (Gren, 2001, p. 219, emphasis original).

In this quote Gren evokes the difference that makes entities separable without any recourse to an underlying organising principle. This is the difference that drove relations as movements and was the premise for seeing relations as exterior and non reducible to their terms. The recognition lies in that entities become space as assemblages through their interactions with it and do not only grasp space as a form of representation (Martin, 2000). The boundary between physical space and other entities is thus very fussy and diffused. By adopting radical empiricism I have renounced the existence of pure fixity and teleology and thus advocate the need to 'surf the crest' of the emergence (Serres, 1995a). Surfing the crest of emergence demands taking up a position amid, 'in spaces of betweenness' (Katz, 1994, p. 72) of the emergent assemblage, accommodating the relationality of being and thus the cracked-I, the otherness in self, not only to others but objects as well. When surfing the crest of emergence it cannot be represented, as the researcher is at one with the research, becoming-research. The fluid relations, emergent from assemblages, thus have the capacity to affect, as they affect all relations they are embedded in with acting (Massumi, 1996). Reversing the argument "affects are becomings" (Deleuze and Guattari, 1987, p. 256).

2.2.1 Affect

The chapter revolves around the object of study, which is the body outlined as an entity constantly emerging from its own relationality in the material space of Festival Square. These bodies are the people passing through Festival Square, using it every

day deriving their relationality to space from the circumstance, and hence affectivity is a matter of circumstance (Deleuze, 1991, p. 103). As the emergent relationality affects and is affected by all that becomes in relation to it my focus is through the notion on affect, which I will elaborate on below.

The notion of affect as presented here is drawn from a conceptual genealogy going from Spinoza, through Deleuze to the current apprehension, mainly based on geographic literature. There is no stable definition of affect; it is rather a form of, often non-reflective, thinking as a set of bodily practices (Thrift, 2004a). The word affect has parallels to emotions, which one can view as affect sedimented as dispositions in bodies, or in a way, emotions are affects that are 'domesticated' by bodies, by way of *habitus*. Thus arguing for the role of affect is greatly in line with Anderson and Smith (2001) advocating the look for the emotional component of social relations and recognising emotions, through affect, as ways of being and doing (see also Illouz, 2001). But affect is not quite emotion as "affect is not a personal feeling, nor is it a characteristic; it is the effectuation of a power of the pack that throws the self into upheaval and makes it reel" (Deleuze and Guattari, 1987, p. 240). What is meant specifically with affect is how the body changes and becomes different through the intensity of the affect exerted upon it once entering an assemblage. Affect is the initial jab of the emergence immanent in relations and is part of this immanence. In the above affect is theorised as being the emergent property of the encounter between entities such as the researcher and the research setting (s)he is in. As affect emerges it gives the body an increased or diminished potential to act, the outcome of that act depends on the compositions the body is able to enter into with the surrounding unfolding space at each time. Here imagination is essential and the body's ability to make sense of that shimmer of immanence through the relationality of its own being and all that is around so that it can have more affectual material to inform its actions (Thrift, 2003c). I am here not intending to reduce the grasping of the emergent capacity of relationality to the body's reflective faculties by saying that imagination is what allows it to make sense, the capacity is always already there, immanent to those relations an intensity ready to affect and be affected.

With the capacity to affect immanent to the emerging relations the problem is that "affect figures mainly in perceptual registers like proprioception which are not easily

captured in print” (Thrift, 2004a, p. 58). Thus the subject ‘enacts’ space, i.e. suggesting in line with Dewsbury *et.al.* (2002), that acting is “to be considered enactments, neither subjects nor objects, signs or referents, but processual registers of experience” (p. 438). In order to talk of this enactment or apprehend the unfolding of research on space one has to adopt ‘non-representation’.

2.2.2 Non-representing

Seeing the two (affecting and being affected) as one means one can never get out of the endless chain of emergent relationalities, in this case, the assemblage of the material space of Festival Square and bodies in space, which is saying:

“the fact remains that we are *foreigners* on the inside – *but there is no outside*”
(de Certeau, 1984, p. 13-14).

The methodological implication is that the researcher can never stand outside the unfolding of space, (s)he can never black-box it and set it up as a representation, space is always at one with its own unfolding and the research on it. Space as constantly unfolding becomes a space where there are no insides or outsides,³⁸ the outside is infolded, there is no outside and yet we are foreign to the inside. In capturing this one-dimensional foldedness of space, this spiral of difference producing repetition (that at the same time implies its multidimensionality) the illustration of the Möbius band, or the fold seeing the inside as the operation of the outside (Boundas, 1991, p. 11), is used when discussing what Serres (1995) would term “the chain of genesis” (p. 71) (Conley, 2002; Deleuze, 1992; Doel, 1996, 1999, 2000, 2001).

Thrift (1996, 1997, 1999, 2000, 2004) summons the above problematic of being foreign to the inside while there is no outside into a coherent idea of ‘non-representation’. His inclination is to be affective focusing on the emergence of relations, which creates the becoming of the world where in the midst of unfolding nothing can be fixed. With the understanding of affect as unqualified intensity as outlined above, it is in perpetual movement, movement that disappears once you try to make sense of it. Thus non-representation is about “valuing the *vagueness* of affect as

³⁸ As there is no outside, the metaphysics of presence argued for in the previous chapter as hampering dialectic’s productive capacities is circumvented by recognising that what is absent truly is absent as

a way of facilitating the emergence of new relations of movement” (McCormack, 2003, p. 499, emphasis original). Moreover since “representations *cannot* present relations” (Deleuze, 1991, p. 30, emphasis original), “representations become *presentations*, processual ways of going on” (McCormack, 2003, p. 502, emphasis mine).

Thus the idea of non-representation marks a confluence between ontological and epistemological concerns as real world relations according to the above are always engaged in ontological transformation (Doel, 1999). In that sense the idea goes beyond calls for greater situated reflexivity, beyond the body as the focus of research and thus the research becomes processually enactive and pre-reflective (McCormack, 2003). Thrift (2004) ties the threads of the idea of non-representation neatly together as he maps out five influences to the idea of non-representation, those corresponding mostly with what has been outlined so far in this chapter. The first influence is the reworking of Bergson through Deleuze that makes for the radical empiricism outlined above and is often named a new vitalism, with its focus on affectivity and will be revisited in the following chapter. The second influence is from the work on, both cognitive and non-cognitive dimensions of embodiment. Thirdly work that integrates objects into relationality, giving objects in a way agency. The fourth influence is from psychoanalysis, i.e. recognising the mutual construction of reality with objects and others through relations and how to make sense of it, through e.g. languaging. The final influence is from ideas of performance, where intelligence is seen as an act. These five strands of influence on the idea of non-representation share some features in common that can be read out of the chapter so far:

- The world is incomplete and inconsistent and must be approached through a spirit of affirmative experimentation.
- The world is demonstrative, i.e. the material setting has potential to affect too.
- The world is built of relations of varying intensities, which do not subsume to causality.
- The world is a set of moving relational intensities, which produce different territories of becoming creating new potentials.

there is no ‘outside’ in which it could reside. Thus absence can only come into being by emerging from

All in all in the above is a summary of radical empiricism as advocated for in the above, along with a call for being on the ground to make sense of the constant unfolding of the world (Thrift, 2004).

The idea of non-representation is in itself a method, short-circuiting the role of the reflexive intellectual, exemplified in the quote by Pels (2002) in the beginning (see p. 228). The idea entails a generosity to the world making space for the researcher to be affected by the immanent emergent potential of relational being and thus able to see and create new spaces into what seems fixed and immutable (Dewsbury *et.al.* 2002). By using ideas of non-representation built on the premises outlined under radical empiricism that then underpins the notions of emergence and becoming one acquires a theory that becomes:

“a box of tools. It has nothing to do with the signifier. It must be useful. It must function. And not for itself. If no one uses it, beginning with the theoretician himself...then the theory is worthless or the moment is inappropriate. We don't revise a theory but construct new ones; we have no choice but to make others” (Deleuze in conversation with Michael Foucault, quoted from Hayden, 1998, p. 80).

The methodology of adopting this theory, as a set of tools, lies in riding the crest of that which unfolds in space. Being there, becoming one with the research, which aligns non-symmetrically with the object of study and thus constitutes itself in a very fluid unstable way, is the method to be adopted in a space where order and fixity are mere temporary phenomenon. This is a method emphasising creative potential where, through non-reflection of a pre-given absolute foundation, there is truly potential for change. How to exemplify this method I turn to in the conclusion.

2.3 Method of Conclusion

In the above I have emphasised the necessity of reflexivity and added the argument that it needs to be opened up to its own constant excess that is implicit in the infinite regress of reflection. This infinite regress is the constant suspension of reflection; a sliding that frustrates the integrating drive of binary oppositions and dialectics. The implication is that one has to become the field of research as “we think that one

the very relationality it is immanent with and cannot be anything anywhere prior to that.

cannot write sufficiently in the name of an outside” (Deleuze and Guattari, 1987, p. 23); thus the research becomes an event of experimentation and improvisation that intervenes in the space under research, to reveal how manifold that space is and entities in it. Through experimentation and improvisation one can show how each and every entity is emergent from the relations it is composed out of. By revealing how entities are emergent from the relations that compose them the idea is not to pull apart these relations as that would be their destruction, rather the idea through experimentation and improvisation is to solicit these relations, i.e. show how, by virtue of their emergent potential, they can become-other, hence open them up to the infinity of regress (Doel, 1999). The subject of research thus is seen as:

“acquir[ing] its form through the principles of associations while it is individuated through the principles of passion. Affectivity activates a tendency of the subject making her want to identify with the effects of her actions in all cases where these effects are the result of the means chosen” (Boundas, 1991, p. 17).

In way of conclusion I would like to go back to my example of the footfall measurements I made on the Festival Square that I based my flow chart on that I had earlier set up as a moment of fixity. From this moment of fixity I could build a causal explanation structure upon which I would presumably be lent a forceful voice as I would have thereby apprehended the world, arrested it in a form I am able to reproduce as often as I please, knowing really the answers before hand. How could I have written and conveyed my experience in light of what has been said in the above. How could I have ‘non-represented’ the people as they crossed the square with this observable regularity?

In the above the emphasis has been on the now moment, the crest of emergence, i.e. people’s actions and thoughts as they are moving through space at each and every moment. So in my fieldwork I decided to do a questionnaire where I would stop those crossing the square and along with basic data gathered to produce my footfall measurements I would also ask what people were thinking about in addition to what their impression of the space they traversed was. I asked people directly: What are you thinking about? I would ask once and then present the question once again to provoke an elaboration on the response. In this way I was asking people how they felt

and what was occupying their mind trying to make sense of the affects that potentially were being exerted upon them.

Not only did I ask about their thoughts but also what they were doing there, now, asking in the same fashion as above. The people moving through the square resorted to all kinds of rationales and designations that made their use of the space become the content of thousands of tiny aspirations and desires of the everyday. But these rationales and designation were in no way the same as the thoughts coursing through people's minds. Thus, after carefully reading through all the responses I could see how new spaces started to emerge (see Figure III.4, below with reference to Figure III.2, p. 213) that could never be wholly apprehended as there was always an excess to them. Space in its apparent material fixity was composed of such an infinity of relations and relational entities that there was always space for the emergence of novelty as new relations are made.

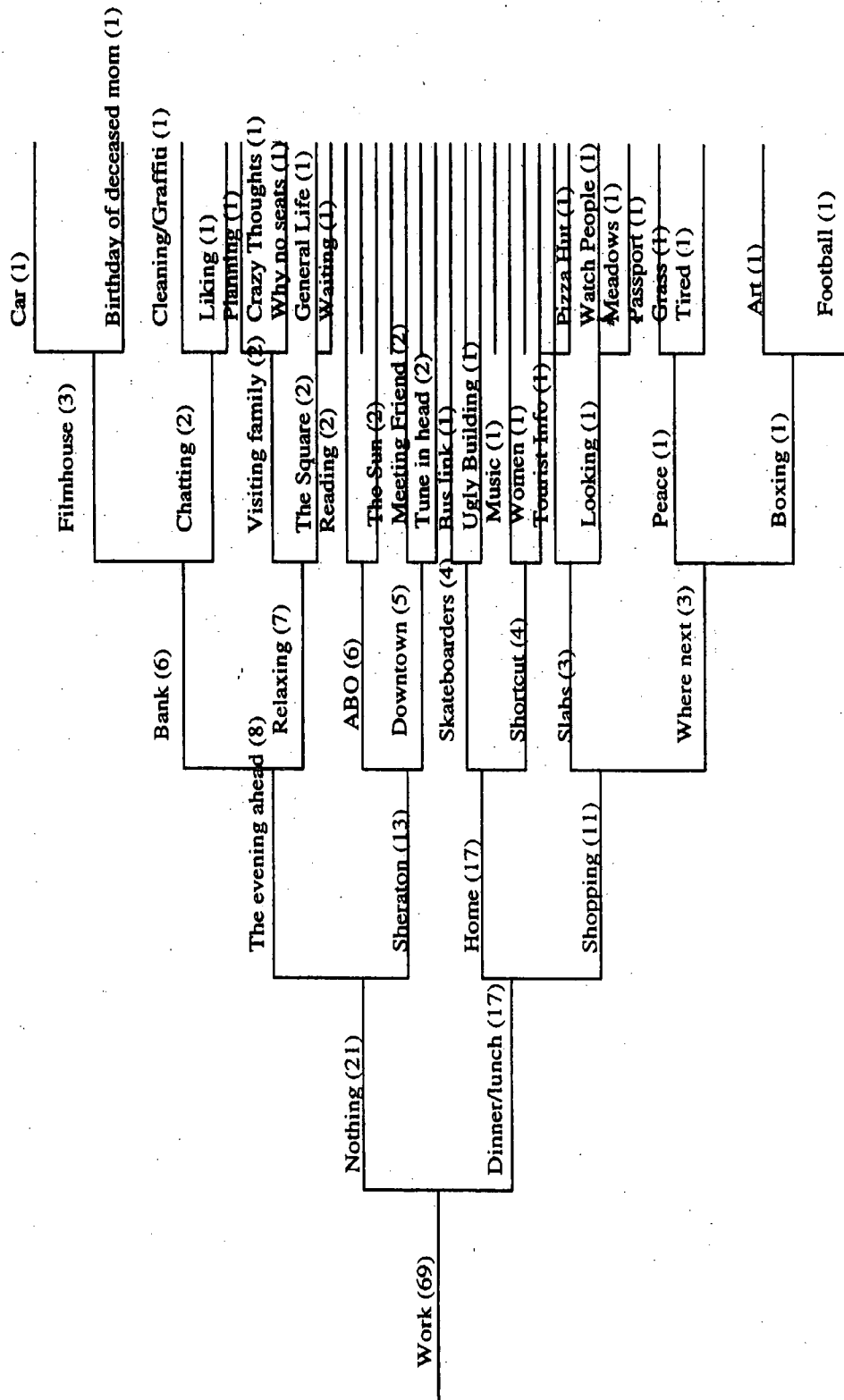

Figure III.4: Thoughts articulated by those passing through Festival Square.
 Source: E. Huijbens

The figure should be read from the bottom of the page to the top. The figure is to exemplify the ongoing addition to the world where I strive for a generosity towards all that was happening in the minds of some 200 people asked what they were thinking about or feeling as they passed through the square. With the above exemplification I aim to show that if one goes on there would always be more thoughts emerging, the ponds within ponds or gardens within gardens (Law, 2004), but eventually strata start to emerge. These strata can thus form representations, e.g. discernible through rhythmanalysis, but what the above shows with reference to figure III.2 and the debate there is that each and every emergence is constantly steeped in its molecular moment.

The methodology I used is experimental and open ended, one that allows the audience to which the space is being presented to be affected by the space just as the researcher was when undertaking the research (Thrift, 2003a, 2003b). Thus effectively allowing space to 'stammer' "placing all elements in variation, both variables of expression and variables of content. A new form of redundancy. AND...AND...AND..." (Deleuze and Guattari, 1987, p. 98) emerges.

It is with the above methods in mind I set out to do my little walk around the square in chapter I.3. At this stage in the thesis one can look back to that chapter to see exactly how I went about being affected by the space, which I then tried to capture with the limitations of the written word and in terms of *habitus*. Chapter I.3 will be revisited in the next chapter but what I argue here is that although in chapter I.3, there emerges a fairly straight forward description of the impression I had, linking spaces I saw emerging out of the relationality of that which I observed, these spaces were the result of all the reading I did on the square (see p. 42-3), the interviews I did (see Appendix A) and the conversations I had with people who had to do with planning and design, those working on the square and in general being on the square myself for the period of my fieldwork, and thus were the result of me allowing myself to be affected by that space and others as all others always are. Not only did I do a written presentation of the square in the terms of the above presented methodology that can now mostly be seen in I.3, but also I approached the square with the aim of making a presentation of the space using mixed media, thus video-taping it, photographing it, drawing it,

recording it aiming to fold all my methods into one comprehensive presentation of the square. This presentation I hope to have an affect on an audience removed from the square but can sadly not be reproduced here with the limitations of thesis writing. In general my hope is though not to freeze the space and make it an interpretable, repeatable image based on the causal inference of relations as associations that could lead me to a definition and freezing of space. One can never reach a definition; no matter how hard one tries or reflects. Thus what I hope to make is an open-ended, continuously unfolding space that constantly moves away from all attempts of apprehending. With having space constantly unfolding relations are put centre stage and are able to truly change and create.

III.3 Becoming-Festival Square

In this last chapter of the thesis I would like to argue in more detail for the role of the material in the process of becoming. I build on the previous chapter and outline an affectual event in terms of an encounter between everyday use and the materiality of Festival Square. In this encounter I understand affect as being a result of the friction between movements of varying intensities. What is meant by intensities is built on the previous understanding of seeing material space as movement, kept in perpetual motion through rhythm but also the potential to differentiate. Thus I understand all the movements composing space as constantly exceeding through the processual consistency of the everyday use of space. I make sense of this excess through notions of the virtual and see affect as produced through the friction sparked in the encounter between variations in intensities. Through making sense of the material physical space in terms of the preceding discussion in this part and what will be added here, my ultimate goal is to give an indication of how urban politics should be apprehended.

These are politics I will explain to make a decisive break with Lefebvrian Marxism steering thus clear of a 'left Heideggerianism' (see Elden, 2004b), which could be read from the last part. To do this I will address a more profoundly phenomenological question of how to make physical material space also political and ultimately argue for an ethico-political stance based on the singularity of each and every encounter with that physical material space. These ethics are "understood, [instead], in terms of the ethos or way of being of things derived from their location within an inescapable matrix of relationality that is both diachronic as well as synchronic, temporal as well as spatial" (Dillon, 2000, p. 2). Hence existence is always already ethical and does not adhere to a higher moral law or superior being. The ethico-political is programmatic, strategic and situational and is about the way or the manner of geography in the context of the world's ceaseless unfolding (Doel, 1999, 2004; Elden, 2003). Seen in terms of the physical material space I aim to address Elden's (2004b) claim that "the political, as the ontological foundation of politics, is where politics *takes place*" (p. 99) following both Lefebvre and Heidegger, ultimately arguing that "there is a politics of space, most fundamentally, because space is constitutive of the political" (p. 100). This is a politics that occurs through the affective, making affects ubiquitous and vital elements of cities, which are:

“roiling maelstroms of affect. Particular affects such as anger, fear, happiness and joy are continually on the boil, rising here, subsiding there, and these affects continually manifest themselves in events which can take place either at a grand scale or simply as a part of everyday life” (Thrift, 2004a, p. 57).

3.1 Background

There are two contexts in which the following discussion is lodged. Firstly, there is the debate and understanding of the urban in current geographical literature and secondly, on how to understand a city’s everyday life. Hence I start with a brief discussion of each in turn.

3.1.1 The urban

The above I place, along with the whole of the preceding discussion of part III, in the context of which the city and the urban can be theorised and understood. The theorising on the spaces of cities is becoming ever more intricate and nuanced in recent geographical literature as urban spaces have become understood more in terms of multiple relationalities and flows. A host of literature about the global city (Abu-Lughod, 1999; Sassen 1991, 1994, 1995, 1996, 1998, 1999, 1999a, 2000, 2000a, 2000b), world cities (see GaWC network at <http://www.lboro.ac.uk/gawc>), “quartered” cities (see Marcuse, 2000) and more (Allen *et.al.* 1999; Amin, 2002, 2004; Amin and Thrift, 2002; Amin *et.al.* 2000; Castells, 1996; Massey, 1991a, 1993, 1997, 1999, 2000, 2001, 2004; Smith, 1992, 2001), share in many ways the idea of the city as one of flows and multiple relations. They build on a progressive sense of place, a sense that recognises our cities as unbounded, open, and mobile, as movements of various intensities where space and time are unhinged. Smith (2003b) neatly outlines the city (for similar see also Smith, 2003a; 2003c) as “the polyrhythmic world city – a liquid theatre alive with the unruly times of urban uses” (p. 562). All these movements come together to form a city Grosz (1995) outlines as:

“By ‘city,’ I understand a complex and interactive network that links together, often in an unintegrated and ad hoc way, a number of disparate social activities, processes, relations, with a number of architectural, geographical, civic and public relations” (p. 105).

This ‘polyrhythmic world city’ is one of movements that are of varying speeds and intensities, movements that are unruly in the sense of being constantly moving or pressing on. The city is thus viewed as an open and borderless entity, a layered

sedimentation of multiple times and spaces that are never at rest but continually linking, outwards and inwards, numerous relations. The city is thus a product of its past and present geographical openness, a product of open intensities, the city as becoming. In the above the city is recognised as a product of internal multiplicity as well as relations beyond it (Massey, 2004), one that is without “prescribed or proscribed boundaries” (Amin, 2004, p. 34). In what follows the focus is on those internal multiplicities within the urban and how they produce urban spaces. In apprehending the city as a product of open intensities where encounters take place with those architectural and geographical movements, which are creative of spaces, I arrive at a redefinition of urban actuality towards the city-events, event-cities in spirit of Tschumi’s elaborations (see 1994, 2000). The city here is constituted through events as singularities, where the immanent potential of the relations converging in the event informs the actualisation of the city form.

In sum what I intend is to align, in a non-symmetrical fashion, in the context of re-imagining the urban, is the collision of users and the physical space at hand. They are non-symmetrical due to the varying intensities of speeds and movements, which compose users and the material setting, producing friction in each encounter. With the creation of this friction the potential for everyday encounters to be a politics of affect becomes apparent which not only upsets the idea of space as an inert container or merely functionally pragmatic, but makes space productive in a non-reductive sense. In the following I carry on by laying the context for understanding these encounters non-reductively through what I mean by the everyday and this non-symmetrical aligning of the users and physical space creating friction and the notion of the eventful city.

3.1.2 Everyday eventful city

The term ‘everyday’ has in recent social science become synonymous with ambiguities and instabilities. The everyday goes from being the realm of boredom and routine to the marvellous and spectacular, but most often the term seems to have been a receptor of all those experiences and events that do not fit into various prevailing social theories (Featherstone, 1995, 1998). But the everyday most certainly is a feature of our representations of life and making sense of it, allowing for its ceaselessness and the way in which it always exceeds attempts to be apprehended, gives the

everyday potential to be political (Crouch, 2003; Featherstone, 1995, 1998; Highmore, 2002; Seigworth, 2000). To underpin the understanding of the everyday as political I use Lefebvre's understanding of the everyday (see p. 175). There he refers to that which is closest to us in our surroundings as we journey to and from work, as we walk our street, as we do the shopping and in general go about the daily routines that make for everyday uses of space. Thus it is about that which is habitual and following McCormack (2003): "The habitual economies of the everyday are not simply the matter upon which power works. They are powers in themselves" (p. 490). Or following Amin (2004) "...the habitual cannot be written out of a politics of propinquity, yet [it] tends to be undervalued in accounts of the everyday taken as the geographically proximate" (p. 39). Hence with the reference to the everyday, in the above, the context of the chapter is not only in re-imagining the urban but is also one in a long line of research being undertaken aiming to politicise the everyday.

This long line of research extends from the poetic flânerie of Benjamin (see e.g. Featherstone, 1998) to the more concrete notions of rhythms and flows in the production of space found in Lefebvre with many theorists, poets and novelists viewing, analysing and trying to make sense of the everyday (see Highmore, 2002; Roberts, 1999). De Certeau's (1984) poetic apprehensions of the everyday, seeing our streets and squares as a play of spaces, ephemeral, as the people there fill them "...with the forests of their desires and goals" (p. xxi), I find of value here. My intention is to expand de Certeau's notions of the everyday politics of desire by combining the city itself, its material space with its everyday uses through the previously outlined understanding of it as movements of varying intensities. With the basic understanding of the everyday uses of the city as an undissected topology of movements of intensities and mobile relations, an inventory, like the one made of the materiality of the square in the last chapter of part I, becomes necessary. In the example in the end I will exemplify uses of an inventory to show how the forest of desires and goals that all users bring to everyday uses of the urban space politicises it through affecting and being affected by it. An inventory cannot ever be complete or exhaustive, based on the previously outlined understanding of space as a path to infinite discovery where "everything is connected and contained within everything else" (Law, 2004, p. 22).

In order to grasp this in-exhaustiveness, I focus on the everyday use of space that entails encounters that constitute physical material space.³⁹ Thus the uses that occur in the everyday are evasive; the challenge is to grasp the *poiesis* of them, i.e. grasping uses of space as a self-constituted emergent sphere (see Gren and Zierhofer, 2003). As these encounters occur between movements of varying intensities, friction occurs that sparks of affects that can potentially constitute new arrangements of space and new spaces. Understanding space as mobile and encounters as occurring between movements of varying intensities, encounters are open. I hope in the end to indicate ways of accounting for uses of space to grasp the ceaselessness and excess of these everyday uses, how they are a self-constituted emergent sphere of potential and hence in the process allow for a politics to emerge which I elaborate on more closely in the next section.

3.2 Space, Use and Excess

As elaborated on before, the square is the gateway for pedestrians to Edinburgh's new financial district. Within the Exchange there are about 10,000 office workers and most of these keep normal office hours, passing through the square on their way to or from work, but on some occasions, a few will stop there to eat a packed lunch, depending on weather. These are the primary users of the square but, as has been demonstrated in previous chapters there are other users and in this chapter I will discuss everyday users that arrive in the night. These are the people that come to the square and use the taxi rank on the Lothian road front after a night out in the theatres or some of Edinburgh's seedier clubs across the road. In the previous part I recognised the production of space through use or how the interaction between the actual physical space of the square and its everyday usage produce space and thus how "spaces are qualified by actions just as actions are qualified by spaces" (Tschumi, 1997, p. 131). But as I argue here it is moreover through the processual consistency that is produced through the ceaselessness of everyday usage, that space constantly exacerbates and disrupts the logic of representation promoted in the previous parts. As the use of space

³⁹ These encounters can be formulated in terms of inter-subjective social dynamics that through encounters are productive of affects that rearrange what occurs during the encounter (for an interesting ethnography see Wolfinger (1995)). Deleuze has been critiqued for a lack of discussing the inter-subjective encounters and a theory of the subject for that matter, but this will not be engaged with here as it would require an extensive discussion of work by theorists such as Emmanuel Levinas and George Simmel to name but two (see Amin, 2004 on the politics of propinquity (Copjek and Sorkin, 1999)).

is ceaseless, there always follows another act from the preceding one, there is always an and..."the taking place of space is always already" (Doel, 1999, p. 144). Or as Düttman (2002) argues at length:

"The notion of usage entails multiplicity, since it makes no sense to conceive of one usage alone or of single relation. From the moment there is usage, there is more than one usage; from the moment one relates to something, there is more than one way of doing so. What is used always overshoots its usage only to let itself be used differently, only to enable a different relation to it. Usage is inseparable from an excess that it produces and that renders it possible, from an excess that introduces an irreducible asymmetry, imbalance or anachronism" (p. 173).

By focusing on the interaction between the physical space and use and by formulating them as always constantly exceeding, the focus is placed squarely on the excess itself and its role in the creation of space. In terms of this ceaselessness, space starts to unfold in an endless chain, an endless procession. This is a world of constant movement, involved in its own self-construction as the chain of use always picks up from the preceding use and adds an AND, never arresting itself to the IS of predication and representation. The poststructural logic of the ceaseless unfolding of space sees the physical space at hand as one with its use as I have demonstrated in the previous chapters. But as the ceaseless unfolding cannot be juxtaposed to the static except through relations of movement and rest, speed and slowness, rhythm and consistency (Doel, 1999), I focus on space and use as being of differing intensities in terms of their movements.

In seeing material space and use as one and mutually constitutive in the ceaseless unfolding of space I have an anchoring point allowing a grasp on the apparent difference between the materiality of space and the uses unfolding within the context of that materiality. This anchoring point is the encounter between the users and the physical space and I will use encounter as a term to grasp this anchoring point or 'point of inflection' as Cache (1995) would have it. As these encounters are constantly unfolding within their own context, at one with the material space they are set in, they hold within them the potential for novelty as elaborated on in the last section. For space unfolding within its own context through use means that ruptures can occur within the manifest fabric of space, ruptures through which new spaces can emerge, generated by the excess of each movement combined in the encounter. This

means that encounters are potential ruptures, which can occur in the relationship of the constructed order of physical space and the everyday usage, generated by the friction of movements combined. By adopting the notion of encounters as potential ruptures I allow for the potential of novelty, as ruptures imply the emergence of a novel arrangement of space. The notion of encounters as potential ruptures gives a conceptual tool to grasp how uses in space are excessive of intentions and interpretations. One is never able to completely contain or control use, grasping use can never be exhaustive, there is always excess and potential ruptures, be they ever so slight, that stem from this excess as becoming, thus ruptures are soaked, so to speak, in a 'plane of immanence' which will be addressed later (Rajchman, 2000, 2001).

3.2.1 Rupture

The preceding ended on a moment of rupture so to speak. I introduced the potential of the encounter through the concept of rupture and now, to add to the above theorisation, I want to delve further into the idea of rupture to make sense of the encounter unfolding where space and use is one. I have in the above elaborated on ruptures potentially unfolding in the encounter between the physicality of space and its uses in terms of excess. Here I want elaborate further in terms of aligning the physicality of space and its uses in a non-symmetrical fashion in order to explain how the ruptures can potentially occur. This is to say that ruptures do not occur in one way, neither is there a polarity between the physical space and the uses within that space nor some dialectical sublation or subsumption striving to attain a final resolution of contradictions. The rupture is one of immanence, one of non-resemblance that breaks the symmetry between space and use proposed by any model of simple communication.

To explain this in the terms of Festival Square and its users one can say that those who go about their everyday use of Festival Square are unconscious of the ongoing spatial creativity of their movements. People make use of all kinds of rationales and designations and make use become the content of the thousands of tiny aspirations and desires of the everyday as de Certeau (1984) argued. These rationales and designation, although representable as I have done in the previous parts of the thesis, I argue can never wholly apprehend peoples' use of space; there is always an excess. This excess is constantly immanent as I tried to show in figure III.4 and is also

immanent to encounters with the materiality of the square as I will show in this chapter's example. This immanence allows for a future oriented understanding how these encounters are always open, making for potential change (Massumi, 2002b).

Here I am making my way to the aforementioned ruptures as enabling, and even empowering, as signalled by Seigworth (2000, p. 229) building on Morris' (1990) paper on banality in cultural studies. In peoples' everyday encounters with space there is always a lurking potential for rupture, there is always excess that is immanent to all use. This elusive nature of use has been termed the 'processual excess' of the everyday (see Seigworth, 2000), the relationship between everyday use and the physical space of the square can be apprehended as a 'rubber-sheet' (Stewart, 2001), always stretched and filled with ruptures that are self-varying deformation of space. Seigworth (2000) gets to this lurking potential through deploying the banal as the processual excess of the everyday. Within the banal he sees the non-symmetry between intentions and actions and hence the processual excess of the everyday. So immanent in the banal, for him, is the potential for rupture. Where I take my point of departure is in more concrete terms of the physical/material space that is navigated through the everyday, seeing, as outlined before, the processual excess lying in the encounters with the materiality of space through use. The encounters with that material space through everyday uses can most certainly be banal, but the potential for rupture is always immanent to the everyday encounters through use of space. These encounters are thus understood as:

“a chance concatenation of forces, of converging and diverging series of fluxes, differentials of intensity and rates of change, which together produce something new and unforeseeable” (Bough, 1993, p. 23).

Thus through its relationality each encounter is singular “defined by [its] contingent and actual interrelations with other beings, rather than isolated” (*ibid.* p. 26).

Above I have made the argument for the everyday as being where encounters take place with the physical/material space of the city as urban space is navigated or used. These encounters can never be wholly apprehended as there is always an excess to them due to the processual consistency of the world, i.e. it is constantly unfolding. This consistent excess makes potential for rupture immanent in each and every encounter with Festival Square, be they ever so banal and hence I can see the urban as

always eventful. In the following section I want to move on to elaborate on intensities in order to make room for a politics in the immanent potential of the encounter.

3.3 The Lurking Intensity

In this section I will argue for a politics of the encounters that I have outlined in the above as 'now-moments' of potential ruptures. These politics I see as lurking in ruptures, which are always immanent to each and every encounter between physical space and users, as the encounter is one between varying movements of intensities. These are politics that are produced through affect or being affected by the friction occurring between these intensities in the encounter as Thrift (2004a) argues: "affect structures encounters so that bodies are disposed for action in a particular way" (p. 62). I will argue that a scope of potential shines through the material at hand, i.e. that the material space has a kind of 'non-cognitive resonance' that affects us through coming into friction with it at levels often below consciousness, not only through acquired dispositions following Bourdieu, but also in each and every passing moment of use. Thus I argue how affects are materially inspired and then acted back upon that material. Before proceeding to the ethico-political I will outline the idea of the virtual in order to give the notion of immanence some nuance and weight so it can be later deployed more efficiently when explaining a politics of encounters built on affects produced by the friction between differing intensities of movement.

3.3.1 Virtual

"real without being actual, ideal without being abstract" (Deleuze, 1998: p. 254)

"Something that happens too quickly to have happened, actually, is *virtual*. The body is as immediately virtual as it is actual. The virtual, the pressing crowds of incipencies and tendencies, is a realm of *potential*. In potential is where futurity combines, unmediated, with pastness, where outsides are infolded and sadness is happy" (Massumi, 2002a, p. 30).

The virtual derives from the Latin *virtus* meaning potential essence or force, a bundle of dormant forces awaiting actualisation, almost tangible but not yet. Being real without being actual, the virtual is not set apart from the real material world around us onto some alternative plane of existence. The virtual resides with the actual on the

material plane. It is not some potential that is imaginary but very real, but without being actual since the virtual can never be totally actualised, as it offers an infinite number of potential. So the virtual offers something of an oscillating force in a shifting field from the actual and the virtual, the actual and the virtual thus do exist through and across each other (Zellner, 1999). What is to be gained from the introduction of the virtual is the enrichment of space and an understanding of Latour's (1999) 'slight surprise of action' (p. 266) along with having an analytical tool to pick apart those bundles of dormant forces awaiting actualisation in the material city all around us.

Through encounters with the material through everyday use, there is the potential for new arrangements of space, a potential rupture, which occurs by seeing the material as infused with the virtual. This infusion of the virtual in the material makes it become in a way always exceeding, always stretching into its own becoming along with its being, the material is thus informed by the virtual at the same time it is. The encounter with this materiality features here as being 'untimely' always already being "the future anterior of what I shall have been for what I am in the process of becoming" (Lacan, 1977, p. 304 quoted in Doel and Clarke, 1999, p. 279). In the everyday encounters with the physical/material world, the use of space composes and orchestrates the movements of use and those of space whilst actualising the virtual in being as becoming (Doel and Clarke, 1999).

What I am saying in the above is that through use space composes and orchestrates that use and itself through the encountering of that space. Users thus take space in with their sensory apparatus along with its 'non-cognitive resonance' that in the above is formulated as the virtual. Thus users 'enact' space and are 'enacted' by space in the way of actualising what is virtually presented in the material space (Dewsbury, 2000). These encounters of users with their material space can be small and banal, such as the curse uttered tripping over a broken slab once crossing Festival Square. But I view the encounter as *any* mutually constitutive interplay between our surrounding material space, and users as they go about their daily use in that space. Within those encounters there lies a bundle of almost tangible dormant forces not quite actualised, potential ruptures always already there (Dewsbury *et.al.* 2002; Massumi, 2002b; McCormack, 2003). What I am saying here might best be illustrated with an example.

The virtual does not lack reality in any sense as it is engaged in the actualisation of the physical space and of the uses that make this actualisation happen (Deleuze, 2001). To take a concrete example in the case of Festival Square I would like to pick up on the second major change, i.e. the complete levelling of the square and its emptying out of objects. The levelling led to new paving slabs being put in place, those in the centre being thick and sturdy and able to take a lot of weight whereas the ones on the periphery are thinner and smaller. The reason is that around the square different designers with different budgets and design emphasis used different materials. What this boils down to is that once HGV pass through the square they are carried by the slabs in the centre, while not by the thinner slabs in the periphery that are now, as a consequence, broken and loose. These loose and broken slabs are especially concentrated in the NW corner of the square where a passage leads to the other major public space in the Exchange, Conference Square. There is heavy pedestrian traffic in that corner and people frequently trip over these broken slabs. It is only a matter of time, as the saying goes, until someone will break a leg there, but in the context of the foregoing discussion I would rather phrase it that the broken leg is always a pure virtuality, immanent and permeating through and through the everyday use as passage through this site. Thus it existed before itself, not as an alternate actuality on some other plane of existence, but immanent, always there, but virtually so in the context of the present materiality of the square, that was certainly a result of the encounter with the HGVs.

As the short example above illustrates, the virtuals that are immanent to encounters with space and are not taken from a reservoir of possible forms that were actualised once transported into our plane of existence. Thus the difference between the idea of the virtual and what is possible lies in the understanding of the virtual as immanent, but immanence can only be immanent to itself and not confinable to any object or subject as was argued in terms of exteriority of relations in the preceding chapter. Thus the virtual rather infuses and soaks the relation between the material world and users and is what makes encounters with the world always exceed and thus keeps the world in motion that has potential for rupture.

“If there were no escape, no excess or remainder, no fade-out to infinity, the universe would be without potential, pure entropy, death. Actually existing,

structured things live in and through that which escapes them. Their autonomy is the autonomy of affect” (Massumi, 2002b, p. 35).

The virtual seen in this case as the ‘non-cognitive resonance’ of the material impinges upon the users of space through affect. What is meant specifically with affect is how users change and become different through the intensity of the affect exerted upon them by space and vice-versa. Affect is the initial jab that the scope of potential opening up exerts on users, i.e. the emergent property of the encounter between the surrounding physical world and use. In the encounter the affect gives an increased or diminished potential to act, the outcome of that act depends on the composition users are able to enter into with the surrounding unfolding space at each time (Thrift, 2003). As argued above, everyday use of space is an ‘enactment’ of space, i.e. here more specifically suggesting in line with Dewsbury *et.al.* (2002), that uses are “to be considered enactments, neither subjects nor objects, signs or referents, but processual registers of experience” (p. 438).

Thus the understanding is that the world is in constant motion through the excess of each encounter with it as it is always immersed in the virtual, that which constantly escapes. Encounters with material space stretch into their own becoming at the same time as they are, since immanent to the encounter is always the chance of rupture or the actualisation of the virtual. I will carry on from here to make the argument for the political potential of the encounter through notions of affect. To phrase the above in another way: the friction between movements of varying intensities, i.e. between material space and its use, spark of affects that have the potential to constitute new spatial arrangements. Herein lies the key to my understanding of space and its use; these lurking intensities are themselves self-disjunctive movements of the oscillating force between the actual and the virtual, as these intensities vary, encounters between them produce friction that affects users as they affect space back in their everyday encounters with this physical space, ‘enacting’ that space through being affected by it.

3.3.2 A politics of the banal encounter

It is through everyday use that people encounter space. As that encounter can never be wholly apprehended, through constantly escaping through its own excess, a politics emerges, a politics about the potential to become as Highmore (2002) says:

“Only *after* the everyday is allowed to emerge would something like a politics of the everyday become possible...[and it isn't] about having certain ends in mind, but about generating beginnings” (p. 172-173 emphasis original).

In the quote Highmore places faith in the everyday for its own transformation as a politics emerge from the use of space in the everyday. In what follows I will argue for the necessity of seeing affect as political in the context of the materiality of urban spaces (Amin, 2004; Thrift, 2004a).

I start the discussion by addressing a critique levied against such open-ended politics as Highmore advocates in the above. By seeing a politics emerging from consistently unfolding uses of space Morris (1990) argues that there is the danger of condemning the users to silence through infinite reification, as more and more beginnings get constantly generated. This, she claims occurs since this kind of open-endedness does not take into account the situated nature of the doer, by knowledge and social experience, along with the politics of exercising established institutional powers. In order to address this critique one has to invoke the Deleuzian understanding of encounters and circumstance or situation, outlined in the last chapter. The silence of reification is avoided through connecting encounters into a whole that is consistent through its constant unfolding. The only way to grasp this consistency is through the ways it is constantly maintained, which does not, through the encounters being between entities composed of so many varying intensities, reduce to any reification. In order to make sense of these encounters one makes the encounter an anchoring point through which one can make sense of the excess, that keeps the world in motion. The politics exemplified here revolve around the potential to become and possibilities inherent, in this case, in the materiality of space. What I am arguing here is that Morris, along with many others, too rapidly does away with the ‘vitalist’ notions implicit in the understanding of the processual consistency I have outlined above and in the preceding and I will exemplify in the following.

The encounters between the physical material space and users can generate potential ruptures through affect, ruptures that do not have a goal or any kind of bottom line. This is a politics since:

“to assert that a decision is ultimately undecidable does not mean that there can be no such thing as truth, right or good. It means rather, that if we purport

to know in advance the specific contents of such notions, then the event of the decision is divested of its political content, it is simply ‘deduced from an existing body of knowledge ... [as] by a calculating machine’” (Derrida, 1999 quoted in Popke, 2003, p. 307).

It is in the encounter that these politics unfold, we make assessments, analyse and decide based on our aspirations, hopes, dreams, faith, longings in every moment, every encounter, those being inspired, amongst other things, by the ‘non cognitive resonance’ of the material surrounding, I claim. Thus I argue for the role of activities and relations that have an impact prior to cognitive reckoning and that which plays out prior to reflective thinking. These politics are thus premised upon ethic as sensibility to events and the potential imminent in each encounter. This is a sensibility of attending to and through the relations that are constituted in the encounter (McCormack, 2003) or an

“ethical praxis [that] likewise emerges in the performance of multiple lived worlds, weaving threads of meaning *and matter* through the assemblage of mutually constituting subjects and patterns of association that compromise the distinction between the ‘human’ and the ‘non-human’ (Whatmore, 2002, p. 159, emphasis mine).

One is thus to “*make way* for that which is coming...*step aside* as things come to pass. (In the United Kingdom, it is customary to keep to the left whilst so doing)” (Doel, 2004, p. 456, emphasis original). Basing politics in this way on ethics sensible to the emergent relationality of the encounter invokes ‘vitalist’ notions, in the sense of being a-signifying and non-textual, sympathetic to the stance argued by Derrida in the quote above. Thus I see these politics as adding on to debates around seeing geography as a normative practice or one that should revolve around struggles for social justice as argued in previous parts (Proctor, 1998). Thus agency is not reduced “to the impartial and universal enactment of instrumental reason, or ‘enlightened self-interest’” (Whatmore, 2002, p. 149) but is difference-in-relation constituted in the context of the practical and lived (*ibid.* p. 153). Through this vitalism I am arguing further for the role of the material space as being an immanent virtual that gives potential for novelty⁴⁰ and thus rise to a politics that are of affect. It is those politics of

⁴⁰ Although here I debate in terms of novelty and new spatial arrangements, arguably with slightly optimistic overtones of the potential being libratory, I do recognise the ways in which affects can also be brought about by the aspiration to the unattainable or that which will potentially never be (see Anderson, forthcoming, under review(a), under review(b); Deleuze and Guattari, 1987, p. 167-191).

affect that I scrutinised in the context of Festival Square in the end of my field work period.

The vocabulary to argue for affect in the encounters with material space is drawn from the work of Doel (1996, 1999, 2000, 2001, 2004). In Doel's work there is a clear elaboration on how space is allowed to take place through the encounter. Doel refers to the materiality of space as playing a role in these encounters through ideas such as 'vibratology' and 'aleatory materialism' when making sense of the constant unfolding of space. Although Popke (2003) critiques Doel, and his theoretical inspiration Deleuze, for lacking a concern for the political in their work, I argue again that this critique too readily dismisses the vitalism inherent in that work. The ethics upon which this vitalist politics are premised upon, take the body's mode of existence as its model and the encounters through which it can enter into assemblages that either work or fail (Turetzky, 2002). Thus:

“a body is never defined by (the constancy of) its form nor by (the regularity of) its functions (habit), but by the folding of forces that affect its composition and render it affective in its turn” (Doel, 1999, p. 162).

Thus the subject exists in the midpoint between extension and infinite divisions and has the potential to become through existing there between “the possibility of its existence and the reason for its distinct existence” (Deleuze, 1991, p. 91). Thus vitalism allows for the excess of use, those immanent potential ruptures or becomings, and hence a non-prescriptive politics or politics that precede being (Deleuze and Guattari, 1987, p. 203) and can be talked of in terms of the affectual in the context of the material space around us as all assemblages are basically territorial (*ibid.* p. 503).

Vitalism lends itself to the way affect can be made sense of through the immanent potential for rupture shining through the material, as users navigate space and affect it and are affected by it. To put this another way; users have a conception of the potential of the physical space around them and in each instant can 'enact' a certain scope of potentialities into being that reflects on their use and what is to come. Each user is affected by this shine of immanence in a different way and how each is affected makes for the scope of potential that guides each users action in space. Mostly everyday use of space is rhythmic and routine; the shine of immanence dulls, as the same path is trudged everyday, or users stop being affected by the potential

illuminating space around them. But ever so often there are encounters, which produce a scope of potential, a sense that affects and moves users to a certain direction, and a rupture occurs. This rupture is an event in which assemblages created are open to change through the differential inequality that composes the assemblage (Turetzky, 2002).

In sum: In the physical material space around there lurks the potential to affect and be affected by use, affect that can potentially present new spatial arrangements. This affect is generated by the friction between movements of varying intensities, those intensities being self-disjunctive movements of the oscillating force between the actual and the virtual. In everyday encounters with the physical material space users enact that space in movements of repetition or rupture, these are events and the urban is the scene for those events and thus inherently political, a take on the Event-Cities, but as always this is best exemplified with a rupture.

“Space *can* talk back” (Amin, 2004, p. 39, emphasis original)



Figure III.5: Displaced slab on the SE corner of Festival Square.

Source: E. Huijbens and J. Eshuis

3.4 Festival Square 19th October 2003 3am

The title refers to the quote ending chapter III.1 as the name and date indicates a moment of effectuation of the assemblages at play as will be outlined below. The above figure is a collage of three pictures, the one furthest to the left was taken during my fieldwork period in the winter of 2002-2003, the two on the right both taken one Sunday morning in October 2003. What is being depicted is a change in the materiality of one spot on the square. This site is in the southeast corner of the square right on the Lothian Road front, by the taxi rank. The site is used as seating by clubbers coming up Lothian Road heading home, as they wait for taxis to appear in the rank. This has on occasions lead to the site being very busy, especially around 3 am. A favourite past time of many of these people waiting there is to try and get one of the small brass balls off the planters, and in places on the square the odd ball is missing now. But on this occasion someone obviously opted for a bigger piece of memorabilia from the night out in Edinburgh.

I would like to mobilise the terminology of the preceding theoretical discussion to help understand what might have happened here. The chapter is set within the context of everyday uses and banal encounters. In order to address the production of space in terms of desire and also demonstrate the potential of non-reductive dialectics, I do not opt to explain more drastic changes in the materiality of the square. As argued in the preceding parts, the everyday use of space does most certainly create change in physical space. The everyday use of these planters as seating creates a social space there during night time, a social space that, though absent in the morning, has left a clear mark, changed that space in a very physical sense. Through my inventory of the square I can reveal the reasons why the planters were made in this way in the first place and why those balls were placed on it in style with the water feature by Remco de Fouw. But moreover that physical inventory, outlining the socio-material practices, informed by abstractions of space, that have come to form that concrete space allows me to demonstrate the multiplicity of movements inherent in each and every seemingly inert piece of material that come together to form space. Moreover the inventory allows the material to be solicited through entering into combination with them creating a friction of intensities that affect and potentially spark ruptures as new spatial arrangements, not unlike Joe becoming-lamp in the first chapter of this part.

The stone in those hedge planters that form the edge of the square in this southeast corner is York stone used to reflect the material in the surrounding buildings. These stones are not typical Scottish material and retain moisture quite a bit, resulting in their turning green and becoming slippery if not constantly cleaned. The hedges in the planters are thick and low, the former aimed at ease of maintenance, the latter reflecting the open nature of the new square; that is to be welcoming to all those entering the Exchange. The small brass balls on the planters were put in place to deter skate-boarders from grinding away the walls and doing damage to the slabs. The balls also reflect the design of the water feature and the idea of the artist that the 'mother ball' within the fountain itself would spawn 'baby balls' that would migrate all over the square.

But, as mentioned above, this particular spot has its particular everyday uses. It is the main waiting place for taxis in the night as, demarcated along the sidewalk (see Figure I.5, p. 55), there is a taxi rank there, during day serving the office workers, but during night the clubbers and theatre goers from across the Lothian Road. Over on that side there are three of Edinburgh's major theatres and some of the seedier clubs of Edinburgh. From 3 am the spot gets busy as the taxis cannot keep up with demand, hence people start to wait and, while waiting, what better then to take a seat on those planters that are of such convenient height due to the downward gradient of Lothian Road? In the designing of the square these planters were never intended for seating, as interviews with the designer made clear, but all the same that has become their main use all around the square (see Figure I.18). Once seated on the planter the small brass balls start to become an annoyance, source of curiosity or opportunity for entertainment as people test their strength on them, sometimes to some success. The deterring of skate-boarders has attracted other uses, e.g. strength competitions.

The slabs themselves on the planters are glued on top with cement, but due to the nature of the slabs as highly moisture absorbent, the temperature fluctuations in the weather in Scotland, and further that in order to keep the slabs from going green with algae, they are regularly washed with low-pressure hot water that erodes the cement. As a consequence the slabs become loose, once loose they can be dislocated as was done that night. With the dislocation of the slab Tschumi's event cities have become

actual, a concrete manifestation of what Tschumi (1994) terms the “dimension of action, in what makes up a city” (p. 12). What I find in this banal example is evidence of the solicitation of the intensities composing the physical space that an inventory, following Perec (1999), is able to demonstrate. Inventory, of which I have given a small example of in the preceding and in part I.

Where are politics in this? I would argue that manifest here is an affect of the scope of potential that shone through the material at hand. An affect of that non-cognitive resonance of the material or that immanent potential that is materially inspired and affects users and they affect back upon the material. The person (or persons) who dislocated that slab was engaged in a setting in which the low intensity of movements/rhythms composing material space provoked an affect, along with others, sparked off by the friction with the high intensity of movements/rhythms composing the body and its dispositions, with the result of dislocating that slab for whatever intentional returns that were perceived. What I state is that through the present materiality, that person was affected by the shimmer of the imminent potential of dislocating the slab, which was one of the affects emanating from the friction between that person and the materiality at hand. Part of this friction is the result of the various intensities, revealed in part by the short inventory, coming together to form this particular bit of space, but most comes from that between the person and the material. To put the above more radically, that shimmer was elicited by the intensities that compose that present materiality, that through entering into an assemblage with another entity composed of different intensities, in this case the subject through use becoming-Festival Square, sparked a friction that affected with the result of making space become new in a way certainly not pleasing the cleaner showing up on Monday morning. These are then affectual politics based on the affect exerted upon the person as the scope of potential unfolds in the encounter of users and the material space.

3.5 Conclusion

I would like to conclude this chapter by drawing briefly together the arguments presented above. Urban dwellers go about their lives through the everyday, minute by minute, hour by hour, and day by day. Most of those activities are rhythmic, rehearsing the refrain of action and maintaining the space of earlier spatial uses (see

Crang, 2001) but ever so often ruptures rearrange the fabric of space. These ruptures can occur in everyday encounters through uses of space as argued in the above. These ruptures are the potential outcome of affect generated by frictions sparked of by the encounters occurring between movements of different intensities, in the case of this chapter; users encounter with space in the context of the everyday. By understanding encounters as potential ruptures two benefits emerge, first a certain grasping of the world in terms of its ceaseless unfolding in recognition of and working with that unfolding in a non-reductive manner. Secondly, a nuance on eventfulness is added to our understanding of urban spaces, eventfulness that can reside in the everyday use of space. Emerging from these two benefits is a politics of affect that stem from our enactment of space affected by the scope of potentialities elicited from space's present materiality as it is composed of movements of so many intensities. This affect is a constant emergent property of every user's ongoing encounter with the physical material world and allows space to be not what it is or should be by some benign design decree or affirmative or normative political agendas but, what it becomes, becoming-desire, becoming-hope.

Summary Conclusion of Part III

The part revolved around emptying the void in the sense of making space for a politics that is non-prescriptive and reliant upon the encounter, leaving the future a blank figure. The conceptual moves of this part were set up in three chapters, each using an example to illustrate the moves made. Firstly, I built up a spatial ontology premised upon an expansion of the relational space presented and elaborated on in terms of structuration and dialectics in the previous parts. This spatial ontology is presented through an example which argues that the dialectical framework, earlier presented was fundamentally reductive, albeit useful, and moreover that the phenomenology presented in the end of part II was not living up to its full potential in apprehending space. The theoretical moves that follow from this example open up the dialectic, so to speak, through an emphasis on the disjuncture, or the relation suspending contradictions. I countered what Law (2004) would call 'romantic aspirations of grasping the whole' through the struggle of different representations, to an affirmation of their difference and focus squarely on the relation itself seeing it as exterior and irreducible to its terms. With having relations exterior to their terms their non-prescribable productivity was assured through a take on rhythms, building on the last chapter of part II, that emphasised how each and every rhythmic moment was permanently immersed in its own moment of potentiality. In order to illustrate this argument I took another example, this time of Joe, the Shining Star, and his dealings with the square's street-lighting using the Deleuzian metaphor of becoming or how, by way of entering into the material assemblage of the lamp, Joe, himself an assemblage, became-lamp.

In the second chapter I made my conceptual move, attaining to my addition to a dialectical relational spatial ontology, through the human geography researcher or more specifically myself as researcher, becoming-research in the space of Festival Square. The chapter was designed in order to recognise how the researcher is entangled in space's web of relationality and is as productive of that relationality as is the space itself and those who use it. With this recognition I contextualised the chapter in terms of the debate on reflexivity, recognising its necessity, but arguing in the same way as for dialectics, i.e. in terms of opening it up to its inherent productivity in terms of becoming through non-prescribed futurity with focus on the

relations generated in the research. In the chapter I made further conceptual moves to build up for my final chapter, introducing the productive potential in terms of immanence and emergence, i.e. premised upon the exteriority and irreducibility of relations to their terms, they are inherently productive in themselves. With this productivity in mind I outline some key questions a human geography researcher should be concerned with once doing fieldwork in terms of radical empiricism. Building on this kind of empiricism I ended the chapter trying to demonstrate how a previously established moment of fixity could be solicited through affect to produce an infinity of worlds within worlds.

With the key word affect and the focus of radical empiricism I moved on to the third chapter where the final set of conceptual moves was presented. There I talked in terms of the pure physical materiality of the square and how it, through use, could be solicited, again through affect, to produce potential and unpredictable ruptures into the urban fabric itself. I started by contextualising the debate in terms of recent geographical understandings of urban spaces and how they are to be re-imagined: Furthermore I contextualised the debate in terms of everyday life, as the uses of Festival Square mainly occur in the everyday and are, almost without exception, rather banal. I made further conceptual moves through notions of excess that fed into productivity of relations and explained excess further through the Deleuzian idea of the virtual. With these I mobilised the terminology presented in part I, which saw physical material space as a sedimentation of time-space trajectories, hence they became movements of varying intensities, mostly rhythmic maintaining space's tangibility, but as stated in the first chapter of part III, within each rhythmic moment there is the potential for ruptures that are immanent in the relationality constituting that moment. Hence the time-space trajectories became relations themselves, individual or assembled into strata, which through each and every encounter, be it ever so banal, has the potential to be rearranged and reshuffled, informed by affect that is generated from frictions occurring in the encounter between the entities encountering being of so many degrees of intensities.

Space and its use and non-use have thus been put in a perpetual state of movement making these an essential oneness, a continuous surface without breaks or tears, but with ruptures of novelty and sinkholes of stability, observable with the lens of radical

empiricism. Thus space is composed of infinite time-space trajectories forming a moving mass of a thousand plateaux that are our cities today. From the ontology of space outlined in part III there emerges a sense of politics that does not rely solely on conscious aspirations to be attained through struggle and affirmations of presence, as was talked of in part II, mainly through Mitchell's work. What also constitutes politics is a host of non-conscious aspirations, informed by our habitual everyday life. Everyday we act and do things that are not that readily explainable but at the same time sediment in bodily dispositions and spatial formations that structure further encounters as argued in part I. But these structuring dispositions and spatial formations are not settled, but driven by their inherent ceaselessness and rhythmic movements that continually press on. As a consequence they can never be fully determined and allowed a singular voice in the struggle for differing aspirations, but need to be thought of in terms of their potentiality. Therefore politics of the urban, politics of the everyday, are multiple, innumerable and cannot be categorised on definite terms. Nonetheless we do categorize, we do take cognitive stands based on wishes, desires, wants and aspirations. With the understanding presented in this final part, these stands form political forces that are aggregates, molar equilibriums, continually engaged in their own transformation attaining to an incomprehensible multiplicity of aspirations and desires. These political forces can be formulated in terms of dialectics and clashes between opposing forces be it through deliberative or non-deliberative actions in space, but this formulation misses the potential immanent to these forces, a potential I argue can be gleaned through banal everyday actions as exemplified in this part. All the examples in this part made the case that space is an aggregate at one with the forces of use and non-use. Space is thus a tangible manifestation of human aspirations but, as has been demonstrated above, is mobile, fluid and itself engaged in its own transformation, along with its makers everyday, in ever so small ways.

Understanding public spaces in the urban in terms of their fluidity and ongoingness makes them part and parcel of a politics that has no determinable function or goal, but open to what it may become. Through this openness responsibility and care is placed on each of our shoulders in each moment and every encounter, to allow for this openness and allow space to become, guided by the situation at hand. This responsibility can be talked of in terms of hospitality, generosity, openness or

experimentation, but basically revolves around situations that do not lend themselves to straight forward rationalisations or scripted political projects. As a consequence, politics are everywhere in everything we do, with each and every moment there is “an endless struggle with the difference of daily existence” (Caputo, 2003, p. 171) engaging space in its own transformation.

Appendix A: List of Interviewees

Colin Corson, Manager of All-Bar-One, Festival Square. 11th June 2003 15:30.

Richard Dufner, Project Manager for Dash Coffee. 26th March 2003 10.00.

John Farquhar, Ian White Associates, Landscape Architects and Planners, designer of the new Festival Square. 7th February 2003 14:00.

Liam Fennel, Development Manager LEEL (formerly SEEL). 20th March 2003 15:30.

Henry Gibson, Architecture Planning Design Manager, Cochrane McGregor, designer of CALA Morrison Building. 30th January 2003 16:00.

P.C. Charles Hardy, Lothian and Borders Police Force, West End. 27th April 2003 13:00.

Ruth McDonald, Development Manager EICC. 24th March 2003 10:00am

Peter Murphy, General Manager of the Sheraton Hotel. 9th April 2003 16:30.

Peter Robinson, Project Architect of the new Festival Square, also representing the Hotel Corporation of Edinburgh. 3rd April 2003 12:30.

Colin Ross, Partner of Law & Dunbar-Nasmith, Re-modeling the Usher Hall. 3rd February 2003 16:00.

Douglas Sampson, Retired Architect, designer of old Festival Square. 28th January 2003 15:00.

Ian Spence, Development Quality Manager, Edinburgh City Council Planning Department. 21st January 2003 14:00.

Bill Strang, Coordinator for Edinburgh City Centre Management Ltd. The Shining Stars. 3rd April 2003 10:30am.

Graham Tully, Team Leader, Property Development Team, The City of Edinburgh Council. 25th June 2003 14:15.

Duncan Whatmore, Architect and Managing Director of Terry Farrell and Partners in Scotland. 20th January 2003 10:00am.

References

Abu-Lughod, Janet L. 1999: *New York, Chicago, Los Angeles. America's Global Cities*. University of Minnesota Press, Minneapolis.

Agnew, John 1988: *Place and Politics: The Geographical Mediation of State and Society*. HarperCollins, New York.

Agnew, John 1995: Classics in human geography revisited. Commentary 1. In *Progress in Human Geography*. Vol. 19, nr. 4, pp. 525-530.

Albrow, Martin 1996: *The Global Age. State and Society beyond Modernity*. Polity Press, Cambridge.

Allen, John; Massey, Doreen and Pryke, Michael 1999: *Unsettling Cities*. Routledge, London.

Allen, John and Pryke, Michael 1994: The production of service space. In *Environment and Planning D: Society & Space*. Vol. 12, pp. 453-475.

Amin, Ash 1997: Placing Globalisation. In *Theory, Culture and Society*. Vol. 14, nr. 2, pp. 123-137.

Amin, Ash. 2000: The Economic Base of Contemporary Cities. In Bridge, G. and Watson, S. (eds.) *A Companion to the City*. Blackwell, Oxford.

Amin, Ash 2002: Spatialities of Globalisation. In *Environment and Planning A*. Vol. 34, nr. 3, pp. 385-399.

Amin, Ash 2004: Regions Unbound: Towards a New Politics of Place. In *Geografiska Annaler B*. Vol. 86, nr. 1, pp. 33-44.

Amin, Ash and Thrift, Nigel 2002: *Cities. Reimagining the Urban*. Polity Press, Cambridge.

Amin, Ash; Cameron, Angus and Hudson, Ray 1999: Welfare as Work? The Potential of the UK Social Economy. In *Environment and Planning A*. Vol. 31, nr. 11, pp. 2033-2051.

Amin, Ash; Massey, Doreen and Thrift, Nigel 2000: *Cities for the Many Not for the Few*. Policy Press, Bristol.

Anderson, Ben forthcoming: Time Stilled – Space Slowed: How boredom matters. In *Geoforum*.

Anderson, Ben under review(a): Transcending without transcendence: utopianism and a practice of hope. In *Antipode*.

Anderson, Ben under review(b): Hope/Affect. In *Environment and Planning D: Society and Space*.

Anderson, Kay 1998: Sites of Difference: Beyond a politics of race polarity. In Fincher, R. and Jacobs, J. M. (eds.) *Cities of Difference*. Guilford, New York.

Anderson, Kay and Smith, Susan J. 2001: Editorial: Emotional Geographies. In *Transactions of the Institute of British Geographers NS*. Vol. 26, nr. 1, pp. 7-10.

Appadurai, Arjun 1990: Disjuncture and Difference in the Global Cultural Economy. In Featherstone, M. (ed.) *Global Culture. Nationalism, Globalization and Modernity*. Sage, London.

Archibugi, Daniele 2003: Cosmopolitical Democracy. In Archibugi, Daniele (ed.) *Debating Cosmopolitics*. Verso, London.

Archibugi, Daniele 2003a: Demos and Cosmopolis. In Archibugi, Daniele (ed.) *Debating Cosmopolitics*. Verso, London.

Bache, Ian 2001: Different Seeds in the same Plot? Competing Models of Capitalism and the incomplete Character of Contracts of Partnership. In *Public Administration*. Vol. 79, nr. 2, pp. 337-359.

Bailey, Nick 1994: Towards a Research Agenda for Public-Private Partnerships in the 1990s. In *Local Economy*. Vol. 8, pp. 292-306.

Baker, Nicholson 1988: *The Mezzanine*. Granta Books, London.

Barber, Benjamin R. 2001: Malled, Mauled, and Overhauled: Arresting Suburban Sprawl by Transforming Suburban Malls into Usable Civic Space. In Henaff, M. (ed.) *Public Space and Democracy*. University of Minnesota Press, Minneapolis.

Bell, John 1998: Disney's Times Square. The New American Community Theatre. In *The Drama Review*. Vol. 42, nr. 1, pp. 26-33.

Berman, Marshall 1983: *All that is Solid Melts into Air: The Experience of Modernity*. Verso, London.

Berner, Erhard 1994: The Metropolitan Dilemma: global society, localities and the struggle for urban land in Manila. In Öncü, A. and Weyland, P. (eds.) *Space, Culture and Power. New Identities in Globalizing Cities*. Zed Books, London.

Bhaskar, Roy 1975: *A Realist Theory of Science*. Leeds Books, Leeds.

Bielik-Robson, Agata 2000: Bad Timing. The subject as a work of time. In *Angelaki*. Vol. 5, nr. 3, pp. 71-91.

Bickford, Susan 2000: Constructing Inequality. City Spaces and the Architecture of Citizenship. In *Political Theory*. Vol. 28, nr. 3, pp. 355-376.

Bingham, Nick 2003: Writing Reflexively. In Pryke, M.; Rose, G. and Whatmore, S. (eds.) *Using Social Theory. Thinking Through Research*. Sage, London.

- Biko, Steve 1988: *I write what I like*. Penguin, London.
- Blattner, William D. 1999: *Heidegger's temporal idealism*. University Press, Cambridge, Cambridge.
- Blunt, Alison 2003: Geography and the Humanities Tradition. In Holloway, Sarah L; Rice, Stephen P. and Valentine, Gill (eds.) *Key Concepts in Human Geography*. Sage, London.
- Blunt, Alison and Wills, Jane 2000: *Dissident Geographies. An introduction into radical ideas and practice*. Prentice Hall, Harlow.
- Borden, Iain; Kerr, Joe; Pivaro, Alicia and Rendell, Jane (eds.) 1996: *Strangely Familiar*. Routledge, London.
- Borden, Iain 2001: *Skateboarding, Space and the City. Architecture and the Body*. Berg, Oxford.
- Bough, Bruce 1993: Deleuze and Empiricism. In *Journal of the British Society for Phenomenology*. Vol. 24, nr. 1, pp. 15-31.
- Boundas, Constantin, V. 1991: Introduction. In Deleuze, G. *Empiricism and Subjectivity. An essay on Hume's theory of Human Nature*. Columbia University Press, New York.
- Bourdieu, Pierre 1989: *Distinction: a social critique of the judgment of taste*. Routledge, London.
- Bourdieu, Pierre 1990: *The Logic of Practice*. Stanford University Press, Stanford CA.
- Bourdieu, Pierre 1991: *The Political Ontology of Martin Heidegger*. Polity Press, Cambridge.
- Bourdieu, Pierre 1998: *Practical Reason*. Polity Press, Cambridge.
- Bourdieu, Pierre 2002: Habitus. In Hillier, J. and Rooksby, E. (eds.) *Habitus: A Sense of Place*. Ashgate, Aldershot.
- Bourdieu, Pierre *et.al.* 1999: *The Weight of the World: Social Suffering in Contemporary Society*. Polity Press, Cambridge.
- Boyer, Christine M. 1993: The City of Illusion: New York's Public Spaces. In Knox, P. L. (ed.) *The Restless Urban Landscape*. Prentice Hall, New Jersey.
- Boyle, Danny 1996: *Trainspotting*. Universal Pictures.
- Boyne, Roy 2002: Bourdieu: From Class to Culture. In *Memoriam Pierre Bourdieu 1930-2002*. In *Theory, Culture & Society*. Vol. 19, nr. 3, pp. 117-128.

Brenner, Neil 1999: Globalisation as reterritorialisation: the European Re-scaling of Urban Governance in the European Union. In *Urban Studies*. Vol. 36, nr. 3, pp. 431-451.

Brenner, Neil 2000: The Urban question as a Scale Question: reflections on Henri Lefebvre, urban theory and the politics of scale. In *International Journal of Urban and Regional Research*. Vol. 24, nr. 2, pp. 361-378.

Brenner, Neil 2004: *New State Spaces. Urban Governance and the Rescaling of Statehood*. Oxford University Press, Oxford.

Brubaker, Rogers 1985: Rethinking Classical Theory: The Sociological Vision of Pierre Bourdieu. In *Theory and Society*. Vol. 14, nr. 6, pp. 745-775.

Bruns, Gerald L. 1989: *Heidegger's Estrangements. Language, Truth and Poetry in the Later Writings*. Yale University Press, New Haven.

Buchanan, Colin 1971: *(Kuwait): studies for national physical plan and master plan for urban areas. 2nd report. 4v*. Durham University Library, document.

Buchanan, Mark 2000: *Ubiquity. The Science of History... Or why the World is Simpler Than we Think*. Weidenfeld & Nicholson, London.

Buchanan, Mark 2002: *Nexus: Small Worlds and the Groundbreaking Science of Networks*. W.W. Norton and Company, New York.

Buček, Ján and Smith, Brian 2000 New approaches to local democracy: Direct Democracy, participation and the third sector. In *Environment and Planning C: Government and Policy*. Vol. 18, nr.1, pp. 3-16.

Cache, Bernard 1995: *Earth Moves. The Furnishing of Territories*. MIT Press, Cambridge, MA.

Caldeira, Teresa Pires do Rio 2000: *City of walls: crime, segregation, and citizenship in São Paulo*. University of California Press, Berkeley, CA.

Callon, Michel and Law, John 2004: Guest Editorial. In *Environment and Planning D: Society and Space*. Vol. 22, pp. 3-11.

Cameron, Sonja; Urquhart, Dennis, C.M. and Young, Maureen 1997: *Historic Scotland Technical Advice Note 10. "Biological growths on sandstone buildings: Control & treatment"*. Historic Scotland, Edinburgh.

Capital City Partnership 2004: *Capital City Partnership Annual Report 2003*. Capital City Partnership, Edinburgh.

Caputo, John, D. 1982: *Heidegger and Aquinas, an essay on overcoming metaphysics*. Fordham University Press, New York.

Caputo, John, D. 2003: Against principles: a sketch of an ethics without ethics. In Wyschogrod, E. and McKenny, G.P. (eds.) *The Ethical*. Blackwell, Oxford.

Carley, Michael; Chapman, Mike; Hastings, Annette; Kirk, Karryn and Yong, Raymond 2000: *Urban Regeneration through Partnership. A study in nine urban regions in England, Scotland and Wales*. Policy Press, Bristol.

Carlstein, Tommy; Parkes, Don and Thrift, Nigel (eds.) 1978: *Timing Space and Spacing Time Vol 2. Human Activity and Time Geography*. Edward Arnold, London.

Carlstein, Tommy and Thrift, Nigel 1978: Afterword. In Carlstein, T.; Parkes, D. and Thrift, N. (eds.) *Timing Space and Spacing Time Vol 2. Human Activity and Time Geography*. Edward Arnold, London.

Carter, Andrew 2000: Strategy and Partnership in Urban Regeneration. In Roberts, P. and Sykes, H. (eds.) *Urban Regeneration: a Handbook*. Sage, London.

Castells, Manuel. 1996: Cities, Information, the Global Economy. In LeGates, R.T. and Stout, F. (eds.) *The City Reader*. Routledge, London.

Chapman, Michael 1998: *Effective Partnership Working. Good Practice Note 1*. Scottish Office, Edinburgh.

Chaney, David 1990: Subtopia in Gateshead: The Metrocentre as Cultural Form. In *Theory, Culture & Society*. Vol. 7, nr. 4, pp. 48-68.

Charley, Jonathan 1996: Sentences upon Architecture. In Borden, I.; Kerr, J.; Pivaro, A. and Rendell, J. (eds.) *Strangely Familiar*. Routledge, London.

Chatterton, Paul 1999: University Students and City Centres – the formation of exclusive geographies. In *Geoforum*. Vol. 30, nr. 2, pp. 117-133.

The City of Edinburgh Council, 1985: *Structure Plan 1985-2005*. The City of Edinburgh Council, Edinburgh.

The City of Edinburgh Council, 1997: *Edinburgh's Way Ahead. City Development Strategy*. The City of Edinburgh Council, Edinburgh.

The City of Edinburgh Council and University of St. Andrews, 2004: *Edinburgh 2020 Scenario Planning Exercise for the Edinburgh City Region, Final Report*. The City of Edinburgh Council and University of St. Andrew's, Edinburgh.

The City of Edinburgh Planning Department, 1982: *Planning Policies for the First New Town*. The City of Edinburgh Planning Department, Edinburgh.

Clark, Nick 2000: 'Botanizing on the Asphalt'? The Complex Life of Cosmopolitan Bodies. In *Body & Society*. Vol. 6, nr. 3-4, pp. 12-33.

Clark, Timothy 2002: *Martin Heidegger*. Routledge, London.

Cloke, Paul; Philo, Chris and Sadler, David (eds.) 1991: *Approaching Human Geography. An Introduction to Contemporary Theoretical Debates*. The Guilford Press, New York.

Cloke, Paul 1999: Self-Other. In Cloke, P.; Crang, P. and Goodwin, M. (eds.) *Introducing Human Geographies*. Arnold, London.

Collins, Jeff and Selina, Howard 1999: *Introducing Heidegger*. Icon Books, Cambridge.

Conley, Verena A. 2002: Chaosmopolis. In *Theory, Culture & Society*. Vol. 19, nr. 1/2, pp. 127-138.

Cook, Ian and Crang, Mike 1995: *Doing Ethnographies*. Environmental Publications, Norwich.

Copjek, Joan and Sorkin, Michael (eds.) 1999: *Giving Ground: The Politics of Proximity*. Verso, London.

Cowan, Robert 2000: *Designing Places a Policy Statement for Scotland*. Scottish Executive, Edinburgh.

Cramb, Auslan 2004: Cleaner city derails 'Trainspotting' tour. In *The Daily Telegraph*. 19th January 2004.

Crang, Mike 1999: Globalization as Conceived, Perceived and Lived Spaces. In *Theory, Culture & Society*. Vol. 16, nr. 1, pp. 167-177.

Crang, Mike 2001: Rhythms of the city: temporalised space and motion. In May, J. and Thrift, N. (eds.) *timespace. Geographies of temporality*. Routledge, London.

Crang, Mike 2002: Qualitative Methods: The New Orthodoxy? In *Progress in Human Geography*. Vol. 26, nr. 5, pp. 647-655.

Crang, Mike 2003: Qualitative methods: touchy, feely, look-see? In *Progress in Human Geography*. Vol. 27, nr. 4, pp. 494-504.

Crang, Mike and Thrift, Nigel (eds.) 2000: *Thinking Space*. Routledge, London.

Cresswell, Tim 1996: *In place/out of place: geography, ideology, and transgression*. University of Minnesota Press, Minneapolis.

Cresswell, Tim 1999: Place. In Cloke, P.; Crang, P. and Goodwin, M. (eds.) *Introducing Human Geographies*. Arnold, London.

Crossley, Nick 2001: The phenomenological habitus and its construction. In *Theory and Society*. Vol. 30, nr. 1, pp. 81-120.

Crouch, David 1998: The Street in the Making of Popular Geographic Knowledge. In Fife, N. R. (ed.) *Images of the Street. Planning, Identity and Control in Public Space*. Routledge, London.

Crouch, David 2003: Spacing, performing, and becoming: tangles in the mundane. In *Environment and Planning A*. Vol. 35, nr. 11, pp. 1945-1960

Davidson, Lynn 2004: Erotica part of festival menu again. In *The Evening News*. 13th March 2004.

Davis, Mike 1998: *City of quartz: excavating the future in Los Angeles*. Pimlico, London.

Davis, Steven 1992: The path of a Thinking, Poetizing Building: The Strange Uncanniness of Human Being on Earth. In McWarther, L. (ed.) *Heidegger and the Earth*. The Thomas Jefferson University Press, Kirksville.

de Certeau, Michael 1984: *The Practice of Everyday Life*. University of California Press, Berkeley, CA.

Dear, Michael J. 2000: *The Postmodern Urban Condition*. Blackwell, Oxford.

Dear, Michael J. and Flusty, Steven 1998: Postmodern Urbanism. In *Annals of the Association of American Geographers*. Vol. 88, nr. 1, pp. 50-72.

DeLanda, Manuel 1997: Immanence and Transcendence in the Genesis of Form. In *South Atlantic Quarterly*. Vol. 96, pp. 499-514.

DeLanda, Manuel 2002: *Intensive Science and Virtual Philosophy*. Continuum, London.

Deleuze, Gilles 1990: *The Logic of Sense*. Continuum, London.

Deleuze, Gilles 1991: *Empiricism and Subjectivity. An essay on Hume's theory of Human Nature*. Columbia University Press, New York.

Deleuze, Gilles 1992: *The Fold: Leibniz and the Baroque*. University of Minnesota Press, Minneapolis.

Deleuze, Gilles 1994: *Difference and Repetition*. Athlone, London.

Deleuze, Gilles 1998: How do we recognise Structuralism. In Stivali, C. (ed.) *The Two-Fold Thought of Deleuze and Guattari*. The Guilford Press, New York.

Deleuze, Gilles 2001: *Pure Immanence. Essays on A Life*. Zone Books, New York.

Deleuze, Gilles and Guattari, Felix 1983: *Anti-oedipus, capitalism & schizophrenia*. University of Minnesota Press, Minneapolis.

Deleuze, Gilles and Guattari, Felix 1987: *A Thousand Plateaux, capitalism & schizophrenia*. University of Minnesota Press, Minneapolis.

Dewsbury, John D, 2000: Performativity and the event: enacting a philosophy of difference. In *Environment and Planning D: Society and Space*. Vol. 18, pp. 473-496.

Dewsbury, John D.; Harrison, Paul; Rose, Mitch and Wylie, John 2002: Enacting geographies. *Geoforum* Vol. 33, nr. 4, pp. 437-440.

Dillon, Michael 2000: Poststructuralism, Complexity and Poetics. In *Theory, Culture & Society*. Vol. 17, nr. 5, pp. 1-26.

Doel, Marcus A. 1996: A hundred thousand lines of flight: a machinist introduction to the nomad thought and scrumpled geography of Gilles Deleuze and Felix Guattari. In *Environment and Planning D: Society and Space*. Vol. 14, pp. 421-439.

Doel, Marcus 1999: *Poststructuralist Geographies. The Diabolical Art of Spatial Science*. Edinburgh University Press, Edinburgh.

Doel, Marcus A. 2000: Un-Glunking Geography. Spatial science after Dr. Seuss and Gilles Deleuze. In Crang, M. and Thrift, N. (eds.) *Thinking Space*. Routledge, London.

Doel, Marcus A. 2001: 1a. Qualified Quantitative Geography. In *Environment and Planning D: Society and Space*. Vol. 19, pp. 555-572.

Doel, Marcus A. 2004: Waiting for Geography. In *Environment and Planning A*. Vol. 36, nr. 3, pp. 451-460.

Doel, Marcus A. and Clarke, David B. 1999: Virtual Worlds. Simulation, Suppletion, S(ed)uction and Simulacra. In Crang, M.; Crang, P. and May, J. (eds.) *Virtual Geographies. Bodies, Space and Relations*. Routledge, London.

Dreyfus, Hubert L. 1991: *Being-in-the-World*. The MIT Press, Cambridge, MA.

Duneier, Mitchell 1992: *Slim's Table*. University of Chicago Press, Chicago.

Duneier, Mitchell 1999: *Sidewalk*. Farrar, Strauss and Giroux, New York.

Düttman, Alexander G. 2002: ...AND...AND...Deleuze Politics. In *Angelaki*. Vol. 7, nr. 3, pp. 171-176.

Eade, John 1997: *Living the Global City, Globalisation as Local Process*. Routledge, London.

The Edinburgh Architect and Design Council, 1994: *Edinburgh Modern Architecture*. District Council Economic and Estate Development, Edinburgh.

Edinburgh City Centre Management Company, 2004: *About Us*. On: http://www.edinburghcc.com/ECC/about_us.htm. Viewed 28th February 2004.

The Edinburgh Development Group, 1988: *Edinburgh International Financial Centre. A statement by Terry Farrell & Company on behalf of the Edinburgh Development Group*. Edinburgh Development Group, Edinburgh.

Edinburgh Festival Fringe, 2003: (*Edinburgh Festival*) *fringe 3-25 Aug 03*. Edinburgh Festival Fringe, Edinburgh.

Edinburgh International Conference Centre, 2000: Luck of the Irish. In *Conference Call*. Vol. **Spring**, p. 5.

Edinburgh Partnership Group, 1999: *A Vision for Edinburgh*. Edinburgh Partnership Group, Edinburgh.

Edinburgh Youth Against War, 2003: *Old Enough to Know Better*. First Light Films, Film Council UK, London.

Edwards, Brian; Henderson, Stewart, A. and Whatmore, Duncan 1995: Edinburgh Bangs the Drum. In *The Architects Journal*. Vol. **202**, October 5th, pp. 31-40.

Edwards, Owen D. 1993: *Burke & Hare*. Mercot Press, Edinburgh.

Elden, Stuart 2001: Politics, Philosophy, Geography: Henri Lefebvre in recent Anglo-American Scholarship. In *Antipode*. Vol. **33**, nr. 5, pp. 809-925.

Elden, Stuart 2001a: *Mapping the Present. Heidegger, Foucault and the Project of Spatial History*. Continuum, London.

Elden, Stuart 2003: Book Reviews. Poststructural Geographies: The Diabolical art of spatial science. In *Political Geography*. Vol. **22**, nr. 2, pp. 238-240.

Elden, Stuart 2004a: *Understanding Henri Lefebvre*. Continuum, London.

Elden, Stuart 2004b: Between Marx and Heidegger: Politics, Philosophy and Lefebvre's *The Production of Space*. In *Antipode*. Vol. **36**, nr. 1, pp. 86-105.

Elden, Stuart 2004c: Rhythmanalysis: An introduction. In Lefebvre, H. *Rhythmanalysis. Space, time and everyday life*. Continuum, London.

Elden, Stuart; Lebas Elizabeth and Kofman, Eleonore 2003: Introduction. In Lefebvre, H. *Key Writings*. Continuum, London.

Ellin, Nan 1996: *Postmodern Urbanism*. Blackwell, Oxford.

Emirbayer, Mustafa 1997: Manifesto for a Relational Sociology. In *American Journal of Sociology*. Vol. **103**, nr. 2, pp. 281-317.

England, Kim V. L. 1994: Getting Personal: Reflexivity, Positionality, and Feminist Research. In *Professional Geographer*. Vol. **46**, nr. 1, pp. 80-89.

- Entrikin, Nicholas J. 1991: *The Betweenness of Place*. MacMillan, London.
- Entrikin, Nicholas J. 2002: Democratic Place-Making and Multiculturalism. In *Geografiska Annaler B*. Vol. **84**, nr. 1, pp. 19-25.
- Eyerman, Ron 1999: Moving Culture. In Featherstone, M. and Lash, S. (eds.) *Spaces of Culture*. Sage, London.
- Fainstein, Susan S.; Gordon, Ian and Harloe, Michael 1992: *Divided cities: New York & London in the contemporary world*. Blackwell, Oxford.
- Farrell, Terry 1984: Farrell Figures it Out. In *Architectural Review*. Vol. **175**, April, pp. 50-56.
- Favole, Paolo 1995: *Squares in Contemporary Architecture*. Architecture and Natura Press, Amsterdam.
- Featherstone Mike 1995: *Undoing Culture: Globalization, Postmodernism and Identity*. Sage, London.
- Featherstone, Mike 1998: The Flaneur, the City and Virtual Public Life. In *Urban Studies*. Vol. **35**, nr. 5/6, pp. 909-925.
- Ferguson, Brian 2003: Two tales of one city. In *The Evening News*. 9th December 2003.
- Ferguson, Brian 2003a: City bans public from Beltane hill. In *The Evening News*. 29th April 2003.
- Ferguson, Brian 2004: 21st century city unveils multi-million shopping list. In *The Evening News*. 23rd April 2004.
- Ferguson, Brian 2004a: Chiefs battle to save city tourism millions. In *The Evening News*. 8th May 2003.
- Fife, Nicholas R. 1998: Introduction Reading the Street. In Fife, N. R. (ed.) *Images of the Street. Planning, Identity and Control in Public Space*. Routledge, London.
- Fine, Gary A. 1993: Ten Lies of Ethnography Moral Dilemmas of Field Research. In *Journal of Contemporary Ethnography*. Vol. **22**, nr. 3, pp. 267-294.
- Florida, Richard 2004: *The Rise of the Creative Class: And How It's Transforming Work, Leisure, Community and Everyday Life*. Basic Books, New York.
- Franzén, Mats 2002: A Weird Politics of Place: Sergels Torg, Stockholm (Round One). In *Urban Studies*. Vol. **39**, nr. 7, pp. 1113-1128.
- Garvie, Susan 2004: People. Issue Analysis. In *Capital Review. Quarterly Economic Bulletin from the City of Edinburgh Council*. Vol. **7**, nr. Winter, pp. 10-11.

Geddes, Michael 1997: *Partnerships against Poverty and Exclusion: Local Regeneration Strategies and Excluded Communities in the UK*. Policy Press, Bristol.

Gifford, John; McWilliam, Colin and Walter, David 1991: *The Buildings of Scotland, Edinburgh*. Penguin, London.

Giddens, Anthony 1976: *New Rules of Sociological Method*. Stanford University Press, Stanford.

Giddens, Anthony 1979: *Central Problems in Social Theory: action, structure and contradiction in social analysis*. Macmillan, Basingstoke.

Giddens, Anthony 1984: *The Constitution of Society: outline of the theory of structuration*. Polity Press, Cambridge.

Giddens, Anthony 1985: Time, Space and Regionalisation. In Gregory, D. and Urry, J. (eds.) *Social Relations and Spatial Structures*. St. Martin's Press, New York.

Giddens, Anthony. 1990: *The Consequences of Modernity*. Stanford University Press, Stanford.

Giddens, Anthony, 2003: *The Progressive Manifesto. New Ideas for the Centre-left*. Blackwell, Oxford.

Glassman, James F. 2003: Structural power, agency and national liberation: the case of East Timor. In *Transactions of the Institute of British Geographers NS*. Vol. 28, nr. 3, pp. 264-280.

Goh, Robbie B.H. 2003: Things to a Void: Utopian Discourse, Communitarity and Constructed Interstices in Singapore Public Housing. In Goh, R.B.H. and Yeoh, B.S.A. (eds.) *Theorising the Southeast Asian city as text: urban landscapes, cultural documents and interpretative experiences*. World Scientific, Singapore.

Goss, Jon 1993: The 'Magic of the Mall': An Analysis of Form, Function and Meaning in the Contemporary Retail Built Environment. In *Annals of the Association of American Geographers*. Vol. 83, nr. 1, pp.18-47.

Goss, Jon 1996: Disquiet on the Waterfront: Reflections on Nostalgia and Utopia in the Urban Archetypes of the Festival Marketplaces. In *Urban Geography*. Vol. 17, nr. 3, pp. 221-247.

Goss, Jon 1999: Once-Upon-a-Time in the commodity World: An Unofficial Guide to the Mall of America. In *Annals of the Association of American Geographers*. Vol. 89, nr. 1, pp. 45-75.

Gottdiener, Mark 1993: A Marx for our time: Henri Lefebvre and The Production of Space. In *Sociological Theory*. Vol. 11, nr. 1, pp. 129-34.

Gottdiener, Mark 1994: *The Social Production of Urban Space : 2nd Edition*. University of Texas Press, Austin.

Gottdiener, Mark 2000: Lefebvre and the Bias of Academic Urbanism. In *City*. Vol. 4, nr.1, pp. 93-101.

Gravstad, Nels 1992: Bowl Builders Busted. In *Thrasher*. Vol. 12, nr. 7, pp. 14-22.

Gregory, Derek 1985: Suspended Animation: The Stasis of Diffusion Theory. In Gregory, D. and Urry, J. (eds.) *Social Relations and Spatial Structures*. St. Martin's Press, New York.

Gregory, Derek 1994: *Geographical Imaginations*. Blackwell, Cambridge MA.

Gregory, Derek and Urry, John (eds.) 1985: *Social Relations and Spatial Structures*. St. Martin's Press, New York.

Gren, Martin 1994: *Earth Writing: Exploring Representation and Social Geography in between Meaning/Matter*. Department of Geography, University of Gothenburg, Gothenburg.

Gren, Martin 2001: Time-Geography Matters. In May, J. and Thrift, N. (eds.) *timespace. Geographies of temporality*. Routledge, London.

Gren, Martin and Zierhofer, Wolfgang 2003: The unity of difference: a critical appraisal of Niklas Luhmann's theory of social systems in the context of corporeality and spatiality. In *Environment and Planning A*. Vol. 35, nr. 4, pp. 615-630.

Grosz, Elizabeth 1995: *Space, Time and Perversion*. Routledge, New York.

Grosz, Elizabeth 1999: *Becomings. Explorations in Time, Memory and Futures*. Cornell University Press, Ithaca.

Grönlund, Bo 1993: *Lefebvre's Ontological transformation(s) of Space*. Nordplan, Stockholm.

Guest, Andrew 1996: *The City as a Work of Art – Edinburgh*. Scottish Sculpture Trust, Edinburgh.

Habermas, Jürgen 1985: *The Theory of Communicative Action*. Beacon Press, Boston.

Halden, Derek; McGuigan, David and Toy, Jonathan 2002: *Evaluation of the Cycle Challenge Initiative*. Scottish Executive, Edinburgh.

Hall, Tim and Hubbard, Paul (eds.) 1998: *The Entrepreneurial City. Geographies of Politics, Regime and Representation*. John Wiley & Sons, Chichester.

Haraway, Donna 1997: *Modest_Witness@Second_Millennium. FemaleMan_Meets_OncoMouse: feminism and technoscience*. Routledge, New York.

- Harding, Alan. 1998. Public-Private Partnerships in the UK. In Pierre, J. (ed.) *Partnerships in Urban Governance. European and American Experiences*. Palgrave, Basingstoke.
- Harper, Douglas 2000: On the Authority of the Image. Visual Methods at the Crossroads. In Denzin, N.K. and Lincoln, Y.S. (eds.) *The Handbook of Qualitative Research*. Sage, London.
- Harrison, Paul 2002: The Caesura: remarks on Wittgenstein's interruption of theory, or, why practices elude explanation. In *Geoforum*. Vol. 33, nr 4, pp. 487-503.
- Harrison, Patrick (ed.) 1990: *Civilising the City. Quality or Chaos in Historic Towns*. Civilising the City Conference Committee, Edinburgh.
- Hartshorne, Richard 1960: *Perspectives on the Nature of Geography*. Murray, London.
- Harvey, David 1969: *Explanation in Geography*. Edward Arnold, London.
- Harvey, David 1973: *Social Justice and the City*. Edward Arnold, London.
- Harvey, David 1989: *The Condition of Postmodernity: an enquiry into the origins of cultural change*. Basil Blackwell, Oxford.
- Harvey, David 1998: Globalisation and the Body. In Wolff, R.; Schneider, A.; Schmid, C.; Klaus, P.; Hofer, A. and Hitz, H. (eds.) *Possible Urban Worlds. Urban Strategies at the end of the 20th Century*. Birkhäuser Verlag, Basel.
- Harvey, David 2000: *Spaces of Hope*. Edinburgh University Press, Edinburgh.
- Harvey, David 2000a: Cosmopolitanism and the Banality of Geographical Evils. In *Public Culture*. Vol. 12, nr. 2, pp. 529-564.
- Hayden, Patrick 1998: *Multiplicity and Becoming. The Pluralist Empiricism of Gilles Deleuze*. Long Publishing Inc., New York.
- Hägerstrand, Torsten 1967: *Innovation diffusion as a spatial process*. University of Chicago Press, Chicago.
- Hägerstrand, Torsten 1973: The domain of human geography. In Chorley, R.J. (ed.) *Directions in geography*. Methuen, London.
- Hägerstrand, Torsten 1975: Space, time and human conditions. In Snickars, F. (ed.) *Dynamic allocation of urban space*. Saxon House Lexington Book, Lexington.
- Hägerstrand, Torsten 1978: Survival and Arena. In Carlstein, T.; Parkes, D. and Thrift, N. (eds.) *Timing Space and Spacing Time Vol. 2. Human Activity and Time Geography*. Edward Arnold, London.

- Hägerstrand, Torsten 1984: Presence and Absence: A Look at Conceptual Choices and Bodily Necessities. In *Regional Studies*. Vol. 18, nr. 5, pp. 373-380.
- Hägerstrand, Torsten 1987: Time-geography: focus on the corporeality of man, society and environment. In *The Science and Praxis of Complexity*. Bernan Assoc Inc, USA.
- Hebdige, Dick 1992: Report on the Western Front: postmodernism and the politics of style. In Frascina, F. and Harris, J. (eds.) *Art in Modern Culture*. Phaidon Press, London.
- Heidegger, Martin 1971: *Poetry, Language, Thought*. Harper & Row, London.
- Heidegger, Martin 1993: *Basic Writings*. Routledge, London.
- Heidegger, Martin 1996: *Hölderlin's Hymn "The Ister"*. Indiana University Press, Bloomington.
- Heidegger, Martin 2000: *Elucidations of Hölderlin's Poetry*. Humanity Books, Amherst.
- Herod, Andrew 1993: Gender Issues in the Use of Interviewing as a Research Method. In *Professional Geographer*. Vol. 45, nr. 3, pp. 305-317.
- Herod, Andrew 1999: Reflections on interviewing foreign elites: praxis, positionality, validity and the cult of the insider. In *Geoforum*. Vol. 30, nr. 4, pp. 313-327.
- Hertz-Ohmes, Peter 1987: Serres and Deleuze: Hermes and Humor. In *Canadian Review of Comparative Literature*. Vol. 14, nr. June, pp. 239-250.
- Highmore, Ben 2002: *Everyday Life and Cultural Theory*. Routledge, London.
- Hillier, Bill 1996: *Space is the Machine*. Cambridge University Press, Cambridge.
- Hillier, Bill and Hanson, Julienne 1984: *The Social Logic of Space*. Cambridge University Press, Cambridge.
- Hillier, Jean and Rooksby, Emma (eds.) 2002: *Habitus: A Sense of Place*. Ashgate, Aldershot.
- Holt-Jensen, Arild 1999: *Geography. History & Concepts*. Sage, London.
- Holloway, Sarah L.; Rice, Stephen P. and Valentine, Gill (eds.) 2003: *Key Concepts in Geography*. Sage, London.
- Honneth, Axel 1986: The Fragmented World of Symbolic Forms: Reflections on Pierre Bourdieu's Sociology of Culture. In *Theory, Culture & Society*. Vol. 3, nr. 3, pp. 55-66.

Hunter, Lynette 1999: *Critiques of Knowing. Situated textualities in science, computing and the arts*. Routledge, London.

Ian Banks and Associates, 1980: *The Potential Conference Market for Edinburgh*. Edinburgh City Council, Edinburgh.

Illouz, Eva 2001: What Role for Emotions in Sociological Theory? In *Body and Society*. Vol. 7, nr. 1, pp. 97-102.

Ingold, Tim 2000: *The Perception of the Environment. Essays in livelihood, dwelling and skill*. Routledge, London.

Ingold, Tim in manuscript: Culture on the Ground: the world perceived through the feet. Presented as conference paper at the ASA Conference, Durham, 29/3-1/4 2004.

Iveson, Kurt 2004: Book Reviews. The Right to the City: Social Justice and the Fight for Public Space. In *Urban Studies*. Vol. 41, nr. 4, pp. 919-920.

Iveson, Kurt under review: City Life and Strangers: critical reflections on cosmopolitanism in urban theory. In *International Journal of Urban and Regional Research*.

Jackson, Peter. 1983: Principles and Problems of Participant Observation. In *Geografiska Annaler B*. Vol. 65, nr. 1, pp. 39-46.

Jackson, Peter 1985: Urban Ethnographies. In *Progress in Human Geography*. Vol. 9, nr. 2, pp. 157-176.

Jacobs, Jane, M. 1996: *Edge of Empire. Postcolonialism and the City*. Routledge, London.

Jameson, Fredric 1991: *Postmodernism, or, the cultural logic of late capitalism*. Duke University Press, Durham, NC.

Jenkins, Richard 1992: *Pierre Bourdieu*. Routledge, London.

Jenkins, Lloyd 2002: Geography and Architecture: 11 Rue de Conservatoire and the Permeability of Buildings. In *Space & Culture*. Vol. 5, nr. 3, pp. 222-236.

Johnston, Edwin 1989: Financial Futures. In *The Architects Journal*. Vol. 189, March 1st, pp. 24-29.

Katz, Cindy 1994: Playing the Field: Questions of Fieldwork in Geography. In *Professional Geographer*. Vol. 46, nr. 1, pp. 67-72.

Kellerman, Aharon 1989: *Time, space and society: Geographical-societal perspectives*. Kluwer Academic Publishers, Boston.

Kennedy, J.B. 2003: *Space, Time and Einstein*. Acumen, Chesham.

King, Anthony D. 1996: Introduction: Cities, Texts and Paradigms. In King, A.D. (ed.) *Re-Presenting the City. Ethnicity, Capital and Culture in the 21st century Metropolis*. MacMillan Press, Houndmills.

King, Diane 2003: Easter fun on march for five days. In *The Evening News*. 10th September 2003.

Kitchin, Rob 1998: 'Out of Place', 'Knowing one's Place': space, power and the exclusion of disabled people. In *Disability & Society*. Vol. 13, nr. 3, pp. 343-356.

Kofman, Eleonore 1998: Whose City? Gender, Class and Immigrants in Globalizing European Cities. In Fincher, R. and Jacobs, J.M. (eds.) *Cities of Difference*. Guilford, New York.

Kockelmans, Joseph J. 1992: Heidegger on time and being. In Macann, C. (ed.) *Martin Heidegger, critical assessments Vol. I*. Routledge, London.

Lambert, Gregg 2002: Deleuze and the 'Dialectic' (a.k.a. Marx and Hegel). In *Strategies*. Vol. 15, nr. 1, pp. 73-83.

Lash, Scott 2003: Reflexivity as Non-linearity. In *Theory, Culture & Society*. Vol. 20, nr. 2, pp. 49-57.

Latham, Alan 2003: Guest editorial. *Environment and Planning A*. Vol. 35, nr. 11, pp. 1901-1906.

Latour, Bruno 1988: The Politics of Explanation. In Woolgar, S. (ed.) *Knowledge and Reflexivity: New Frontiers in the Sociology of Knowledge*. Sage, London.

Latour, Bruno 1993: *We have never been Modern*. Harvester Wheatsheaf, New York.

Latour, Bruno 1999: *Pandora's Hope. Essays on the Reality of Science Studies*. Harvard University Press, Cambridge, MA.

Latour, Bruno 2003: Is Re-modernisation Occurring - And If So, How to Prove It? A Commentary on Ulrich Beck. In *Theory, Culture & Society*. Vol. 20, nr. 2, pp. 35-48.

Laurier, Eric; Whyte, Angus and Buckner, Kathy 2002: Neighbouring as an occasioned activity : "Finding a lost cat". In *Space & Culture*. Vol. 5, nr. 4, pp. 346-367

Law, John 2004: And if the global were small and noncoherent? Method, complexity, and the baroque. In *Environment and Planning D: Society and Space*. Vol. 22, pp. 13-26.

Lees, Loretta 1998: Urban Renaissance and the Street. Spaces of Control and Contestation. In Fife, N.R. (ed.) *Images of the Street. Planning, Identity and Control in Public Space*. Routledge, London.

- Lees, Loretta (ed.) 2004: *The Emancipatory City. Possibilities and Paradoxes*. Sage, London.
- Lefebvre, Henri 1968: *Dialectical Materialism*. Jonathan Cape, London.
- Lefebvre, Henri 1991: *The Production of Space*. Blackwell, Oxford.
- Lefebvre, Henri 1996: *Writings on Cities*. Blackwell, Oxford.
- Lefebvre, Henri 2000: *Espace et Politique: le droit à la Ville II*. Anthropos, Paris.
- Lefebvre, Henri 2004: *rhythmanalysis. space, time and everyday life*. Continuum, London.
- Levitas, Ruth 1998: *The Inclusive Society? social exclusion and New Labour*. MacMillan, Basingstoke.
- Lingis, Alphonso 1996: *Sensation: Intelligibility in Sensibility*. Humanities Press, New Jersey.
- Livingstone, David N. 1992: *The geographical tradition: episodes in the history of a contested enterprise*. Blackwell, Oxford.
- Lockhart, Suzanne 2002: Sector Analysis: Finance. In *Capital Review. Quarterly Economic Bulletin from the City of Edinburgh Council*. Vol. 1, nr. Summer, pp. 8-11.
- Longhurst, Robyn 1997: (Dis)embodied Geographies. In *Progress in Human Geography*. Vol. 21, nr. 4, pp. 486-501.
- Lothian Regional Council, Department of Planning, 1984: *Lothian Region Structure Plan Alteration*. Lothian Regional Council, Department of Planning, Edinburgh.
- Lothian Regional Council, Department of Planning, 1991: *Discussion Paper of Review of the Lothian Region Structure Plan*. Lothian Regional Council, Department of Planning, Edinburgh.
- Lothian Regional Council, Department of Planning, 1994: *Lothian Region Structure Plan*. Lothian Regional Council, Department of Planning, Edinburgh.
- Lothian Regional Council, Department of Planning, 2000a: *Consultation Draft for the 2005 Structure Plan*. Lothian Regional Council, Department of Planning, Edinburgh.
- Lothian Regional Council, Department of Planning 2000b: *Edinburgh and the Lothian's Structure Plan Major Issue Report*. Lothian Regional Council, Edinburgh.
- Low, Setha M. 2000: *On the Plaza. The Politics of Public Space and Culture*. University of Texas Press, Austin.
- Low, Setha M. 2003: Embodied Space(s). In *Space and Culture*. Vol. 6, nr. 1, pp. 9-18.

Lynch, Michael 2000: Against Reflexivity as an Academic Virtue and Source of Privileged Knowledge. In *Theory, Culture & Society*. Vol. 17, nr. 3, pp. 26-54.

Macdonald, Bradley J. 2002: Multiplying Deleuze: Introduction. In *Strategies*. Vol. 15, nr. 1, pp. 5-8.

Malpas, Jeff 1999: *Place and Experience*. Cambridge University Press, Cambridge.

Manson, Steven M. 2001: Simplifying Complexity: a review of complexity theory. In *Geoforum*. Vol. 32, nr. 3, pp. 405-414.

Manson, Steven M. 2003: Epistemological possibilities and imperatives of complexity research: a reply to Reitsma. In *Geoforum*. Vol. 34, nr. 1, pp. 17-20.

Marcuse, Peter 2000: Cities in Quarters. In Bridge, G. and Watson, S. (eds.) *A Companion to the City*. Blackwell Publishers, Malden.

Martin, Belinda 2004: Why Edinburgh really is the best. In *Capital Review. Quarterly Economic Bulletin from the City of Edinburgh Council*. Vol. 7, nr. Winter, pp. 12.

Martin, Ron 2000: Editorial: In Memory of Maps. In *Transactions of the Institute of British Geographers*. Vol. 25, nr. 1, pp. 3-5.

Maspero, François 1994: *Roissy Express: A Journey through the Paris Suburbs*. Verso, London.

Massey, Doreen 1991: Flexible Sexism. In *Environment and Society D: Society and Space*. Vol. 9, pp. 31-57.

Massey, Doreen 1991a: A Global Sense of Place. In *Marxism Today*. Vol. June, pp. 24-29.

Massey, Doreen 1992: Politics and space/time. In *New Left Review*. Vol. I/196, nr. November, pp. 65-84.

Massey, Doreen 1993: Power-Geometry and a Progressive Sense of Place. In Bird, J.; Curtis, B.; Putnam, T.; Robertson, G. and Tickner, L. (eds.) *Mapping the Futures*. Routledge, London.

Massey, Doreen 1994: *Space, Place and Gender*. Polity Press, Cambridge.

Massey, Doreen 1996: Space/Power, Identity/Difference. In Merrifield, A. and Swyngedouw, E. (eds.) *The Urbanisation of Injustice*. Lawrence and Wishart, London.

Massey, Doreen 1997: A Global Sense of Place. In Barnes, T. and Gregory, D. (eds.) *Reading Human Geography, the poetics and politics of inquiry*. Arnold, London.

Massey, Doreen 1999: Cities in the World. In Massey, D.; Allen, J and Pile, S. (eds.) *City Worlds*. Routledge, London.

Massey, Doreen 2000: Understanding Cities. In *City*. Vol. 4, nr. 1, pp. 135-144.

Massey, Doreen 2001: Geography on the Agenda. In *Progress in Human Geography*. Vol. 25, nr. 1, pp. 5-17.

Massey, Doreen 2001a: Talking of space-time. In *Transactions of the Institute of British Geographers NS*. Vol. 26, nr. 2, pp. 257-261.

Massey, Doreen 2004: Geographies of Responsibility. In *Geografiska Annaler B*. Vol. 86, nr. 1, pp. 5-18.

Massumi, Brian 1992: *A User's Guide to Capitalism and Schizophrenia: Deviations from Deleuze and Guattari*. MIT Press, Cambridge, MA.

Massumi, Brian 1996: Becoming-deleuzian. In *Environment and Planning D: Society and Space*. Vol. 14, pp. 395-406.

Massumi, Brian 2000: Too-Blue: Colour-Patch for an Expanded Empiricism. In *Cultural Studies*. Vol. 14, nr. 2, pp. 177-226.

Massumi, Brian 2002a: *A Shock to Thought. Expressions after Deleuze and Guattari*. Routledge, London.

Massumi, Brian 2002b: *Parables of the Virtual*. Duke University Press, Durham, NC.

Mathabane, Miriam 2000: *Miriam's Song: a memoir*. Simon & Schuster, New York.

May, Jon, and Thrift, Nigel 2001: Introduction. In May, J. and Thrift, N. *timespace. Geographies of temporality*. London, Routledge.

McCann, Eugene J. 1999: Race, Protest and Public Space: Contextualizing Lefebvre in the U.S. City. In *Antipode*. Vol. 31, nr. 2, pp. 163-184.

McCormack, Derek 2003: An event of geographical ethics in spaces of affect. In *Transactions of the Institute of British Geographers NS*. Vol. 28, pp. 488-507.

McDowell, Linda 1992a: Doing Gender: feminism, feminists and research methods in human geography. In *Transactions of the Institute of British Geographers*. Vol. 17, nr. 4, pp. 399-416.

McDowell, Linda 1992b: Valid Games? A response to Erica Schoenberger. In *Professional Geographer*. Vol. 44, nr. 2, pp. 212-214.

McGilvary, Evänder, B. 1941: Space-Time, Simple Location and Prehension. In Schilpp, P.A. *The Philosophy of Alfred North Whitehead*. Northwestern University, Evanston.

McKean, Charles, 1992: *Edinburgh. An Illustrated Architectural Guide*. RIAS, Edinburgh.

McKenzie, Adrian 2002: *Transductions: Bodies and Machines at Speed*. Continuum, London.

McNay, Lois 1999: Gender, Habitus and the Field. Pierre Bourdieu and the Limits of Reflexivity. In *Theory, Culture & Society*. Vol. 16, nr. 1, pp. 95-117.

McRobbie, Angela 2002: A Mixed Bag of Misfortunes? Bourdieu's Weight of the World. In *Theory, Culture & Society*. Vol. 19, nr. 3, pp. 129-138.

McTernan, John 2004: *Edinburgh's Growth is Scotland's Success – the case for Edinburgh*. The City of Edinburgh Council, Edinburgh.

Mendieta, Eduardo 2001: The City and the Philosopher: on the urbanism of phenomenology. In *Philosophy and Geography*. Vol. 4, nr. 2, pp. 203-218.

Mendieta, Eduardo 2001a: Invisible Cities. A Phenomenology of Globalisation from below. In *City*. Vol. 5, nr. 1, pp. 7-26.

Merrifield, Andy 1993: Space and Place: A Lefebvrian reconciliation. In *Transactions of the Institute of British Geographers NS*. Vol. 18, nr. 4, pp. 516-531.

Merrifield, Andy 2000: Henri Lefebvre. A socialist in space. In Crang, M. and Thrift, N. (eds.) *Thinking Space*. Routledge, London.

Miller, Bill and Dickson, Malcolm 2000: Local Governance: The Assessment of Councillors, Quango Members and the Public. In Stoker, G. (ed.) *The New Politics of British Urban Governance*. MacMillan, London.

Millington, Steve; Young, Craig and Lever, Jonathan 1997: A Bibliography of City Marketing. In *The Journal of Regional and Local Studies*. Vol. 17, nr. 2, pp. 16-42.

Mingione, Enzo (ed.) 1996: *Urban poverty and the underclass: a reader*. Blackwell, Oxford.

Mitchell, Don 1992: Iconography and Locational Conflict from the Underside: Free Speech, People's Park, and the Politics of Homelessness in Berkeley California. In *Political Geography*. Vol. 11, nr. 2, pp. 152-169.

Mitchell, Don 1995: The End of Public Space? People's Park, Definitions of the Public, and Democracy. In *Annals of the Association of American Geographers*. Vol. 85, nr. 1, pp. 108-133.

Mitchell, Don 2000: *Cultural Geography. A Critical Introduction*. Blackwell, Malden.

Mitchell, Don 2003: *The Rights to the City. Social Justice and the Fight for Public Space*. The Guilford Press, New York.

- Mohanty, Jitendra N. 2000: *Self and its Other: Philosophical essays*. Oxford University Press, Oxford.
- Mollenkopf, John H. and Castells, Manuel 1991: *Dual city: restructuring New York*. Russell Sage Foundation, New York.
- Morris, Lydia 1994: *Dangerous classes: the underclass and social citizenship*. Routledge, London.
- Morris, Meeghan 1990: Banality in Cultural Studies. In Mellencamp, P. (ed.) *Logics of Television*. Indiana University Press, Bloomington.
- Moughtin, Cliff 1999: *Urban Design Street and Square*. Architectural Press, Oxford.
- Murdoch, Jonathan 1997: Inhuman/non-human/human: actor-network theory and the prospects for a non-dualistic and symmetrical perspective on nature and society. In *Environment and Planning D: Society and Space*. Vol. 15, pp. 731-756.
- Nash, Roy 2003: Social explanation and socialization: On Bourdieu and the structure, disposition, practice scheme. *The Sociological Review*. Vol. 51, nr. 1, pp. 43-62.
- Nast, Heidi J. and Pile, Steve 1998: *Places through the Body*. Routledge, London.
- National Statistics 2003: Travel Trends 2002. A report on the International Passenger Survey. TSO, London.
- Nelson, Lise. 1999: Bodies (and Spaces) do Matter: the limits of performativity. In *Gender, Place and Culture*. Vol. 6, nr. 4, pp. 331-353.
- Ness, Sally Ann. 1992: *Body, Movement and Culture. Kinesthetic and Visual Symbolism in a Philippine Community*. University of Pennsylvania Press, Philadelphia.
- Noble, Greg and Watkins, Megan 2003: So, How did Bourdieu learn to play tennis? Habitus, Consciousness and Habituation. In *Cultural Studies*. Vol. 17, nr. 3/4, pp. 520-538.
- Nuttgen, Patrick 1972: The principles of conservation. In Matthew, R.; Reid, J. and Lindsay, M. (eds.): *The Conservation of Georgian Edinburgh*. University of Edinburgh Press, Edinburgh.
- Olsson, Gunnar 1981: Thunderbolt on Heron's Shore. In Pred, A. (ed.) *Space and Time in Geography: Essays dedicated to Torsten Hägerstrand*. Gleerup, Lund.
- Olsson, Gunnar 1991: *Lines of Power, Limits to Language*. University of Minnesota Press, Minneapolis.
- Olwig, Kenneth 2002: The Duplicity of Space: Germanic 'Raum' and Swedish 'Rum' in English Language Geographical Discourse. In *Geografiska Annaler B*. Vol. 84, nr. 1, pp. 1-17.

Owl Leisure, 1989: *EICC May 1989 Review*. Scottish Development Agency, Edinburgh.

Pain, Rachel 2002: Gender, race, age and fear in the city. In *Urban Studies*. Vol. **38**, nr. 5-6, pp. 899-913.

Painter, Joe 2000: Pierre Bourdieu. In Crang, M. and Thrift, N. (eds.) *Thinking Space*. Routledge, London.

Parker, Simon F. 2001: Community, social identity and the structuration of power in the contemporary European city. In *City*. Vol. **5**, nr. 2, pp. 189-202.

Peat, Jeremy 2004: The view from here. In *Capital Review. Quarterly Economic Bulletin from the City of Edinburgh Council*. Vol. **7**, nr. Winter, pp. 3.

Peet, Richard 1998: *Modern Geographical Thought*. Blackwell, Oxford.

Pels, Dick 2000: Reflexivity One Step Up. In *Theory, Culture & Society*. Vol. **17**, nr. 3, pp. 1-25.

Perec, Georges 1987: *Life: A User's Manual*. David R. Godine Publisher, Boston.

Perec, Georges 1999: *Species of Spaces and Other Pieces*. Penguin Books, London.

Pinder, David 2001: Ghostly footsteps: voices, memories and walks in the city. In *Ecumene*. Vol. **8**, nr. 1, pp. 1-19.

Pluciennik, Mark and Drew, Quentin, 2000: 'Only Connect' Global and Local Networks, Contexts and Fieldwork. In *Ecumene*. Vol. **7**, nr. 1, pp. 67-104.

Polt, Richard 1999: *Heidegger. An Introduction*. UCL Press, London.

Popke, Jeffrey E. 2003: Poststructuralist ethics: subjectivity, responsibility and the space of community. In *Progress in Human Geography*. Vol. **27**, nr. 3, pp. 298-316.

Porter, Michael E. 1998: *The Competitive Advantage of Nations*. Palgrave Macmillan, Houndmills.

Pred, Allan 1977: The choreography of existence: Comments on Hagerstrand's time-geography and its usefulness. In *Economic Geography*. Vol. **53**, nr. 2, pp. 207-221.

Pred, Allan (ed.) 1981: *Space and Time in Geography: Essays dedicated to Torsten Hägerstrand*. Gleerup, Lund.

Pred, Allan 1983: Structuration and Place: On the Becoming of Sense of Place and Structure of Feeling. In *Journal for the Theory of Social Behaviour*. Vol. **13**, pp 45-68.

Pred, Allan 1984: Place as a Historically Contingent Process: Structuration and the Time-Geography of Becoming Places. In *Annals of the Association of American Geographers*. Vol. 74, nr. 2, pp. 279-297.

Pred, Allan 1985: The Social Becomes the Spatial, the Spatial Becomes the Social: Enclosures, Social Change and the Becoming of Places in the Swedish Province of Skåne. In Gregory, D. and Urry, J. (eds.) *Social Relations and Spatial Structures*. St. Martin's Press, New York.

Prigogine, Ilya 1996: *The End of Certainty. Time, Chaos and the New Laws of Nature*. The Free Press, New York.

Proctor, James D. 1998: Ethics in geography: giving moral form to the geographical imagination. In *Area*. Vol. 30, nr. 1, pp. 8-18.

Protevi, John and Bonta, Mark 2004: *Deleuze and Geophilosophy*. Edinburgh University Press, Edinburgh.

Pryke, Michael 2002: The white noise of capitalism: audio and visual montage and sensing economic change. In *Cultural Geographies*. Vol. 9, nr. 4, pp. 472-477

Pryke, Michael 2003: Situated audiences. In Pryke, M.; Rose, G. and Whatmore, S. (eds.) *Using Social Theory. Thinking through Research*. Sage, London.

Raban, Jonathan 1974: *Soft City*. Fontana/Collins, London.

Rajchman, John 1998: *Constructions*. MIT Press, Cambridge, MA.

Rajchman, John 2000: *The Deleuze Connections*. MIT Press, Cambridge, MA.

Rajchman, John 2001: Introduction. In Rajchman, J. (ed.) *Pure Immanence. Essays on A Life*. Zone Books, New York.

Raper, Jonathan F. 2000: *Multidimensional geographic information science*. Taylor and Francis, London.

Raper, Jonathan F. and Livingstone, David E. 2001: Let's get real: spatio-temporal identity and geographic entities. In *Transactions of the Institute of British Geographers*. Vol. 26, nr. 2, pp. 237-42.

Ray, Christopher 1991: *Time, Space and Philosophy*. Routledge, London.

Reitsma, Femke 2003: A response to simplifying complexity. *Geoforum*. Vol. 34, nr. 1, pp. 13-16.

Rinehardt, Robert 2003: Book Reviews. In *International Review for the Sociology of Sport*. Vol. 38, nr. 2, pp. 239-244.

Robbins, Derek 2002: Pierre Bourdieu, 1930-2002. In *Theory, Culture & Society*. Vol. 19, nr. 3, pp. 113-116.

Robinson, William, I. 2001: Social Theory and Globalisation: The Rise of a Transnational State. In *Theory and Society*. Vol. 30, nr. 2, pp. 157-200.

Roberts, John 1999: Philosophizing the Everyday: The philosophy of praxis and the fate of cultural studies. In *Radical Philosophy*. Issue. 98, pp. 16-29.

Rockmore, Tom 1995: *Heidegger and French Philosophy. Humanism, Antihumanism and Being*. Routledge, London.

Rodaway, Paul 1994: *Sensuous Geographies. Body, sense and place*. Routledge, London.

Rodgers, Johnny 2001: *Edinburgh. A Guide to recent Architecture*. Ellipsis, London.

Rose, Gillian 1997: Situating knowledges: positionality, reflexivities and other tactics. In *Progress in Human Geography*. Vol. 21, nr. 3, pp. 305-320.

Rossi, Roberto 1998: Times Square and Potsdamer Platz. Packaging Development as Tourism. In *The Drama Review*. Vol. 42, nr. 1, pp. 43-48.

Sassen, Saskia 1991: *The Global City. New York, London, Tokyo*. Princeton University Press, Princeton.

Sassen, Saskia 1994: *Cities in a World Economy*. Pine Forge Press, Thousand Oaks.

Sassen, Saskia 1995: On Concentration and Centrality in Global City. In Knox, P.L. and Taylor, P.J. (eds.) *World Cities in a World System*. University Press, Cambridge, Cambridge.

Sassen, Saskia 1996: Rebuilding the Global City. In King, A.D. (ed.) *Re-Presenting the City. Ethnicity, Capital and Culture in the 21st century Metropolis*. MacMillan Press, Houndmills.

Sassen, Saskia 1998: The City: Strategic Site/New Frontier. In Wolff, R.; Schneider, A.; Schmid, C.; Klaus, P.; Hofer, A. and Hitz H. (eds.) *Possible Urban Worlds. Urban Strategies at the end of the 20th Century*. Birkhäuser Verlag, Basel.

Sassen, Saskia 1999: Globalization and the Formation of Claims. In Copjec, J. and Sorkin, M. (eds.) *Giving Ground. The Politics of Proximity*. Verso, London.

Sassen, Saskia 1999a: Whose City is it? Globalization and the Formation of New Claims. In Body-Gendrot, S. and Beauregard, R. (eds.) *The Urban Moment. Cosmopolitan Essays on the Late 20th Century City*. Sage, London.

Sassen, Saskia 2000: *Cities in a World Economy*. Pine Forge Press, Thousand Oaks.

Sassen, Saskia 2000a: Economy and Culture in the Global City. In Bridge, G. and Watson, S. (eds.) *A Companion to the City*. Blackwell, Oxford.

Sassen, Saskia 2000b: Spatialities and Temporalities of the Global: Elements for a Theorisation. In *Public Culture*. Vol. 12, nr. 1, pp. 215-232.

Sassen-Koob, Saskia 1984: The New Labour Demand in Global Cities. In Smith, M.P. (ed.) *Cities in Transformation*. Sage, London.

Schafer, Murray R. 1977: *The Tuning of the World*. Knopf, New York.

Schinkel, Willem 2003: Pierre Bourdieu's Political Turn? In *Theory, Culture & Society*. Vol. 20, nr. 6, pp. 69-93.

Scottish Enterprise Edinburgh and Lothian, 2003: *Edinburgh Visitor Survey. Summary Report 2001/2002*. Scottish Enterprise Edinburgh and Lothian, Edinburgh.

Scottish Executive, 1999: *A Scotland where Everyone Matters*. Scottish Executive, Edinburgh.

Scottish Executive, 2001: *A Smart Successful Scotland. Ambitions for the Enterprise Networks*. Scottish Executive, Edinburgh.

Scottish Executive, 2003: *Know the Score. Scottish Executive's Annual Report on Drug Misuse*. Scottish Executive, Edinburgh.

Seamon, David 1980: Afterword: Community, Place and Environment. In Buttimer, A. and Seamon, D. (eds.) *The Human Experience of Space and Place*. Croom Helm, London.

Seamon, David 1980a: Body-Subject, Time-Space Routines and Place Ballets. In Buttimer, A. and Seamon, D. (eds.) *The Human Experience of Space and Place*. Croom Helm, London.

Seamon, David 1998: Concretising Heidegger's Notion of Dwelling: The Contributions of Thomas Thiis-Evensen and Christopher Alexander. In *Subject*. Vol. 3, nr. 2, pp. –

Sebald, Winfried G. 2002: *Rings of Saturn*. Vintage, London.

Seigworth, Gregory J, 2000: Banality for Cultural Studies. In *Cultural Studies*. Vol. 14, nr. 2, pp. 227-268

Semple, Ellen C. 1911: *Influences of Geographic Environment, on the Basis of Ratzel's System of Anthro-Geography*. Constable, London.

Sennett, Richard 1996: *The Fall of Public Man*. WW. Norton, New York.

Sennett, Richard 1998: *The corrosion of character: the personal consequences of work in the new capitalism*. Norton, New York.

Serres, Michel 1982: *Hermes. Literature, Science, Philosophy*. The John Hopkins University Press, Baltimore.

- Serres, Michel 1995: *Genesis*. The University of Michigan Press, Ann Arbor.
- Serres, Michel 1995a: *Angels a modern myth*. Flammarion, Paris.
- Serres, Michael 2003: The Science of Relations. An interview. In *Angelaki*. Vol. 8, nr. 2, pp. 227-237.
- Sharp, Dennis 1989: City as Theatre. In *Architectural Review*. Vol. 185, June, pp. 58-65.
- Shields, Rob 1991: *Places on the Margin. Alternative geographies of modernity*. Routledge, London.
- Shields, Rob 1999: *Lefebvre, love and struggle: Spatial Dialectics*. Routledge, London.
- Short, John, R.; Breitbach, Carrie; Buckman, Steven and Essex, Jamey 2000: From World Cities to Gateway Cities. Extending the boundaries of globalisation theory. In *City*. Vol. 4, nr. 3, pp. 317-340.
- Sibley, David 1981: *Outsider's in Urban Societies*. St. Martin's Press, New York.
- Sibley, David 1995: *Geographies of Exclusion: Society and Difference in the West*. Routledge, London.
- Simonsen, Kirsten 1996: What kind of space in what kind of social theory? In *Progress in Human Geography*. Vol. 20, nr. 4, pp. 494-512.
- Simonsen, Kirsten 1999: Rum som Social Kategorj. In *Grus*. Vol. 58, pp. 5-21.
- Simonsen, Kirsten, 2000: Editorial: The Body as Battlefield. In *Transactions of the Institute of British Geographers NS*. Vol. 25, nr. 1, pp. 7-9.
- Simonsen, Kirsten 2001: Space, culture and economy a question of practice. *Geografiska Annaler B*. Vol. 83, nr. 1, pp. 41-52.
- Slessor, Catherine 1992: Raising the Saltire. In *The Architects Journal*. Vol. 195, April 29th, pp. 21-41.
- Smith, Michael P. 1992: Cities after Modernism. In Smith, M.P. (ed.) *After Modernism*. Transaction Publishers, New Brunswick.
- Smith, Michael P. 2001: *Transnational Urbanism. Locating Globalization*. Blackwell, Oxford.
- Smith, Neil 1984: *Uneven Development: Nature, Capital and the Production of Space*. Basil Blackwell, Oxford.

Smith, Neil 1996: *The New Urban Frontier. Gentrification and the Revanchist City*. Routledge, London.

Smith, Richard G. 2003a: World city actor-networks. In *Progress in Human Geography*. Vol. 27, nr. 1, pp. 25-44.

Smith, Richard G. 2003b: World city topologies. In *Progress in Human Geography*. Vol. 27, nr. 5, pp. 561-582.

Smith, Richard G. 2003c: Actant Cities. On <http://www.lboro.ac.uk/gawc/rb/rb117.html>. Viewed on 9th September 2004.

Smith, Susan J. 1994: Soundscapes. In *Area*. Vol. 26, nr. 3, pp. 232-240.

Soja, Edward W. 1996: *Thirdspace: journeys to Los Angeles and other real-and-imagined places*. Blackwell, Oxford.

Soja, Edward W. 1999: Thirdspace: Expanding the Scope of the Geographical Imagination. In Massey, D.; Allen, J. and Sarre P. (eds.) *Human Geography Today*. Polity Press, Cambridge.

Spense, Michael, 1993: New Town Goes West. In *RIBA Journal*, Royal Institute of British Architects, London.

Staeheli, Lynn A and Mitchell, Don 2004: Spaces of Public and Private: Locating Politics. In Barnett, C. and Low, M. (eds.) *Spaces of Democracy. Geographical Perspectives on Citizenship, Participation and Representation*. Sage, London.

Stalin, Josef 1951: *Dialectical and Historical Materialism*. Foreign Language Press, Moscow.

Steiner, George 1992: *Heidegger*. Fontana Press, London.

Stevens, Quentin 2001: Reviews. In *Environment and Planning A*. Vol. 33, nr. 11, pp. 2087-2088.

Stewart, Ian 1997: *Does God Play Dice? The New Mathematics of Chaos*. Penguin Books, London.

Stewart, Ian 2001: *Flatterland. Like Flatland, only more so*. MacMillan, London.

Stewart, Murray 1998: Partnership, Leadership and Competition in Urban Policy. In Oatley, Nick (ed.) *Cities, Economic Competition and Urban Policy*. Paul Chapman, London.

Stoddard, Robert H. 1986: *Human geography: people, places, and cultures*. Prentice-Hall, London.

Storper, Michael 2000: Lived Effects of the Contemporary Economy: Globalisation, Inequality and the Consumer Society. In *Public Culture*. Vol. 12, nr. 2, pp. 375-409.

Sussman, Mark 1998: New York's Facelift. In *The Drama Review*. Vol. 42, nr. 1, pp. 34-42.

Swartz, David L. 2002: In memoriam: Pierre Bourdieu 1930-2002. In *Theory and Society*. Vol. 31, nr. 4, pp. 547-553.

Swartz, David L. 2003: From critical sociology to public intellectual: Pierre Bourdieu and politics. In *Theory and Society*. Vol. 32, nr. 5-6, pp. 791-823.

Sweetman, Paul 2003: Twenty-first century dis-ease? Habitual Reflexivity or the reflexive habitus. In *The Sociological Review*. Vol. 51, nr. 4, pp. 528-549.

Teather, Elizabeth 1999: *Embodied geographies: spaces, bodies and rites of passage*. Routledge, London.

Tedlock, Barbara 1991: From Participant Observation to the Observation of Participation: The Emergence of Narrative Ethnography. In *Journal of Anthropological Research*. Vol. 47, nr. 1, pp. 69-94.

Thrift, Nigel 1983: On the determination of social action in space and time. In *Environment and Planning D: Society and Space*. Vol. 1, pp. 23-57.

Thrift, Nigel 1995: Classics in Human Geography Revisited. In *Progress in Human Geography*. Vol. 19, nr. 4, pp. 525-530.

Thrift, Nigel 1996: *Spatial Formations*. Sage, London.

Thrift, Nigel 1997: The Still Point: Resistance, Expressive Embodiment and Dance. In Pile, S. and Keith, M. (eds.) *Geographies of Resistance*. Routledge, London.

Thrift, Nigel 1999: Steps to an Ecology of Place. In Massey, D.; Allen, J. and Sarre, P. (eds.) *Human Geography Today*. Polity Press, Cambridge.

Thrift, Nigel 2000: Still Life in Nearly Present Time: The Object of Nature. In *Body & Society*. Vol. 6, nr. 3/4, pp. 34-57.

Thrift, Nigel 2003a: Space. In Holloway, S.L.; Rice, S.P. and Valentine, G. (eds.) *Key Concepts in Geography*. Sage, London.

Thrift, Nigel 2003b: Performance and In *Environment and Planning A*. Vol. 35, nr. 11, pp. 2019-2024.

Thrift, Nigel 2003c: Practicing ethics. In Pryke, M.; Rose, G. and Whatmore, S. (eds.) *Using Social Theory. Thinking through Research*. Sage, London.

Thrift, Nigel 2004: Summoning Life. In Cloke, P.; Crang, P. and Goodwin, M. (eds.) *Envisioning Human Geographies*. Hodder Arnold, London.

Thrift, Nigel 2004a: Intensities of Feeling: Towards a Spatial Politics of Affect. In *Geografiska Annaler B*. Vol. **86**, nr. 1, pp. 57-78.

Thrift, Nigel and Dewsbury, John D. 2000: Dead Geographies – and how to make them live. *Environment and Planning D: Society and Space* Vol. **18**, nr. 3, pp. 411-432.

Tobin, Jane 2002: *Ten Years, Ten Cities. The work of Terry Farrell and Partners 1991-2001*. Lawrence King Publishing, London.

Town Council, 1949: *A Civic Survey and Plan for the City and Royal Burgh of Edinburgh*. Oliver and Bayd, Edinburgh.

Tschumi, Bernard 1994: *Event-Cities Praxis*. MIT Press, Cambridge, MA.

Tschumi, Bernard 1997: *Architecture and Disjunction*. MIT Press, Cambridge, MA.

Tschumi, Bernard 2000: *Event-Cities 2*. MIT Press, Cambridge, MA.

Turetzky, Philip 2002: Rhythm: Assemblage and Event. In *Strategies*. Vol. **15**, nr. 1, pp. 121-138.

Turner, Tom 1996: *City as Landscape. A post-postmodern view of design and planning*. E & FN Spon, London.

Twine, Fred 1994: *Citizenship and Social Rights. The Interdependence of Self and Society*. Sage, London.

Unwin, Tim 1992: *The Place of Geography*. Longman, Harlow.

The Urban Task Force, 1999: *Towards an Urban Renaissance*. Department of the Environment, Transport and the Regions, London.

Urry, John 1985: Social Relations, Space and Time. In Gregory, D. and Urry, J. (eds.) *Social Relations and Spatial Structures*. St. Martin's Press, New York.

Venturi, Robert; Brown, Denise S. and Izenour, Steven 1989: *Learning from Las Vegas*. MIT Press, Cambridge, MA.

Vidler, Anthony 2000: *Warped Space*. MIT Press, Cambridge, MA.

Wacquant, L  ic 1999: Urban Marginality in the Coming Millennium. In *Urban Studies*. Vol. **36**, nr. 10, pp. 1639-1648.

Waters, Brian 1998: Creating a Brown Study. In *The Architects Journal*. Vol. **207**, May 28th, pp. 54-55.

Whatmore, Duncan 2002: *Terry Farrell in Scotland*. Tuckwell Press ltd. East Linton.

Whatmore, Sarah 2002: *Hybrid geographies: natures, cultures, spaces*. Sage, London.

Whitehead, Alfred, N. 1922: *The principle of relativity, with applications to physical science*. CUP.

Widick, Richard 2003: Flesh and the free market: (On taking Bourdieu to the options exchange). In *Theory and Society*. Vol. 32, nr. 5-6, pp. 679-723.

Wolfinger, Nicholas H. 1995: Passing Moments Some Social Dynamics of Pedestrian Interaction. In *Journal of Contemporary Ethnography*. Vol. 24, nr. 3, pp. 323-340.

Woolley, Helen; Rose, Sian; Carmona, Matthew and Freedman, Jonathan 2003: *The Value of Public Space. How quality parks and public spaces create economic, social and environmental value*. CABE Space, London.

Zellner, Peter 1999: *Hybrid Space. New Forms in Digital Architecture*. Thames & Hudson Ltd., London.

Zukin, Sharon 1993: *Landscapes of Power: From Detroit to Disney World*. University of California Press, Berkeley, CA.

