

## Durham E-Theses

---

*Alternatives to hypochlorite treatment for destruction  
of cyanide in effluent water.*

Julie Wright

### How to cite:

---

Wright, Julie (2004) Alternatives to hypochlorite treatment for destruction of cyanide in effluent water. Masters thesis, Durham University.

### Use policy

---

The full-text may be used and/or reproduced, and given to third parties in any format or medium, without prior permission or charge, for personal research or study, educational, or not-for-profit purposes provided that:

- a full bibliographic reference is made to the original source
- a <https://etheses.durham.ac.uk/id/eprint/2833/> is made to the metadata record in Durham E-Theses
- the full-text is not changed in any way

The full-text must not be sold in any format or medium without the formal permission of the copyright holders.

Please consult the [full Durham E-Theses policy](#) for further details.

## ABSTRACT

This study focuses on the treatment of cyanide containing wastewater from a chemical process for cyanide liquor manufacture. An introduction to cyanide is given including legislation and governmental controls in place for Britain and the works. The effluent treatment system at present uses sodium hypochlorite and there are low concentrations of chloroform formed within the system, which then remains untreated. This study summaries the array methods for cyanide degradation currently available and evaluates the most promising for the sites cyanide wastewater treatment. The appraisal highlights the potential of using hydrogen peroxide and sonication in unison to rapidly degrade the high cyanide content of the wastewater. Experimental laboratory results show that sonication rapidly increases the reaction potential of the hydrogen peroxide. Sonication was shown, by statistical analysis (Tukey) to have a significant effect on cyanide reduction compared with hydrogen peroxide alone. This study emphasises the issues of working with hydrogen peroxide and the basics of sonication. It also describes a pilot study that could be carried out in the future and the changes that may be required for this system to be put in place at the work.

**A copyright of this thesis rests with the author. No quotation from it should be published without his prior written consent and information derived from it should be acknowledged.**



# CONTENTS

	<b>Page</b>
<b>ABSTRACT</b>	<b>i</b>
<b>CONTENTS</b>	<b>ii</b>
List of Figures	vii
List of Tables	ix
List of Appendices	ix
Acknowledgements	xi
Declaration	xii
<b>1. INTRODUCTION</b>	<b>1</b>
<b>1.1 Cyanide</b>	<b>1</b>
1.1.1. International Importance	1
1.1.2. British Legislation	3
1.1.3. Cyanide in Air	3
1.1.4. Cyanide in Wastewater	4
1.1.5. Cyanide Cycle	4
<b>1.2 Life Cycle Approach</b>	<b>7</b>
1.2.1 Limits and Controls; CEFIC	8
1.2.1.1 Responsible Care	8
1.2.2 Limits	9
<b>1.3 Toxicity and the Fate of Cyanide</b>	<b>11</b>
1.3.1 Cyanide Toxicity	12
1.3.2 The Degradation Mechanisms of Cyanide	13
<b>1.4 Analytical Techniques</b>	<b>16</b>
1.4.1 Methods for Cyanide Release	16
1.4.2 Titrimetric Techniques	17
1.4.2.1 Interferences	18

# CONTENTS

	<b>Page</b>
1.4.3 Cyanide by Instrumental Methods	19
1.4.3.1 Electrometric Methods	19
1.4.4 Opticometric Methods	21
1.4.5 Radiochemical Methods	23
1.4.6 Chromatographic Methods	24
<b>1.5 Cassel Works Cyanide Plant</b>	<b>25</b>
1.5.1 Cyanide Plant Process	25
1.5.2 Cyanide Plant Effluent Process	29
1.5.3 Cyanide Plant Effluent Characterisation	31
1.5.4 Chemistry of Cyanide Wastewater at Cassel	32
1.5.5 Plant Effluent Feed inputs and outputs; Mass Balance	33
1.5.6 Detrimental Effects of Sodium Hypochlorite	36
1.5.7 Legislation applied to the Cyanide Plant	38
1.5.7.1 Environment Agency	38
1.5.7.2 COMAH	40
<b>1.6 Aims of Study</b>	<b>42</b>
<b>2.0 LITERATURE REVIEW</b>	<b>43</b>
<b>2.1. Chemical Destruction of Cyanide</b>	<b>43</b>
<b>2.2. Biological Oxidation of Cyanide</b>	<b>51</b>
<b>2.3. Enzymatic Processes</b>	<b>57</b>
<b>2.4. Thermal Destruction of Cyanide</b>	<b>58</b>

# CONTENTS

	<b>Page</b>
<b>2.5. Removal of Cyanide by Precipitation</b>	59
<b>2.6. Removal of Cyanide by Electrolysis</b>	60
<b>2.7. Removal of Cyanide by Membrane electrodes</b>	65
<b>2.8. Removal of Cyanide by Photocatalysis</b>	66
<b>2.9. Removal of Cyanide by Filtering through Packed Columns</b>	68
<b>2.10. Removal of Cyanide by Ultrasound</b>	70
<b>2.11. Removal of Cyanides by Polymers &amp; Resins</b>	72
<b>2.12. Removal of Cyanide by Photocatalytic Oxidation using Silica Aerogel</b>	74
<b>3.0 IDENTIFICATION OF ALTERNATIVE APPROACHES</b>	<b>75</b>
<b>3.1. Comparison of Techniques</b>	75
<b>3.2. Criteria for Selection</b>	85
3.2.1 Discussion on Criteria Selection	94
<b>3.3. Pilot Studies: Short-listed Trials</b>	<b>96</b>
3.3.1 Hydrogen Peroxide with Activated Carbon	96
3.3.2 Electrolysis	98
3.3.3 Hydrogen Peroxide	100
3.3.4 Hydrogen Peroxide and Sonication	101

# CONTENTS

	<b>Page</b>
3.3.5 Photocatalytic oxidation using titanium dioxide semi-conductor	102
3.3.6 Cyclecar™ & Ozone	104
3.3.7 Discussion about Problems and Recommendations	104
<b>4.0 METHODOLOGY, RESULTS and DISCUSSION</b>	<b>106</b>
<b>4.1. Sonication Trials</b>	
4.1.1 Initial Sonication/Hydrogen Peroxide time trials using a Mettler autotitrator for cyanide determination	106
4.1.2 Sonication/Hydrogen Peroxide time trials using Dionex Chromatography for cyanide determination	115
4.1.2.1 Initial time trial to establish decrease in cyanide	115
4.1.2.2 Actual time trials to establish decrease in cyanide with hydrogen peroxide and sonication	116
4.1.3 Solid related time trial with Sonication/Hydrogen Peroxide	129
4.1.4 Temperature related time trial with Sonication/Hydrogen Peroxide	131
<b>4.2. ANOVA</b>	<b>133</b>
4.2.1 Significance	133
4.2.2 Interactions	133
4.2.3 General Linear Model ; Significance Table	134
4.2.4 Tukey (Computer Model)	134
4.2.5 Errors	135

# CONTENTS

	<b>Page</b>
<b>5.0 DISCUSSION</b>	<b>136</b>
<b>5.1. Experimentation</b>	<b>136</b>
5.1.1 Problems and Recommendations	136
5.1.2 Accuracy and sources of Error	138
5.1.3 Equipment advantages, disadvantages and improvements	139
<b>5.2. Adaptation for Cassel Plant</b>	<b>140</b>
5.2.1 Hydrogen peroxide	140
5.2.1.1 An Introduction to Hydrogen Peroxide	140
5.2.1.2 Analytical method for the detection of Hydrogen Peroxide between 0.1 and 6 %	141
5.2.1.3 Health & Safety	143
5.2.1.4 Uses & Applications viable for Cassel site	144
5.2.2 Sonication	147
5.2.2.1 An Introduction to Sonochemistry	147
5.2.2.2 Power Ultrasound	148
5.2.2.3 General Principles of Sonochemistry	149
5.2.2.4 Health & Safety	150
5.2.2.5 Uses & Applications	150
5.2.3 Implications	157
<b>6.0 CONCLUSSIONS</b>	<b>159</b>
<b>6.1. Short list</b>	<b>159</b>
<b>6.2. Pilot Studies</b>	<b>159</b>

## CONTENTS

	<b>Page</b>
<b>6.3. Degradation with hydrogen peroxide</b>	160
<b>6.4. Further work</b>	160
<b>7.0 PROPOSALS</b>	<b>163</b>
<b>7.1 Changes required for Hydrogen Peroxide &amp; Sonication system to work</b>	<b>163</b>
<b>8.0 BIBLIOGRAPHY</b>	<b>165</b>

### List of Figures:

<b>FIGURE 1.1: The Cyanide Cycle</b>	<b>6</b>
<b>FIGURE 1.2: Basic layout of Cyanide plant</b>	<b>27</b>
<b>FIGURE 1.3: Basic layout of Cyanide plant Sumps</b>	<b>28</b>
<b>FIGURE 1.4: Diagram to show inputs of cyanide and sodium hypochlorite into the Effluent Treatment system and traces present in the final effluent to BBO3</b>	<b>34</b>
<b>FIGURE 3.1: Effect of Sonication and Activated Carbon on Cyanide levels in Cassel works effluent</b>	<b>97</b>
<b>FIGURE 3.2: Effect of 3%v/v H<sub>2</sub>O<sub>2</sub> on Cyanide levels in 100 mls of Effluent</b>	<b>100</b>
<b>FIGURE 4.1: Decrease in cyanide using hydrogen peroxide and sonication over 1 minute</b>	<b>107</b>
<b>FIGURE 4.2: Decrease in cyanide using hydrogen peroxide and sonication over 2 minutes</b>	<b>108</b>

## CONTENTS

	Page
<b>FIGURE 4.3: Decrease in cyanide using hydrogen peroxide and sonication over 3 minutes</b>	109
<b>FIGURE 4.4: Decrease in cyanide using hydrogen peroxide and sonication over 4 minutes</b>	110
<b>FIGURE 4.5: Decrease in cyanide using hydrogen peroxide and sonication over 5 minutes</b>	111
<b>FIGURE 4.6: Decrease in cyanide with increasing hydrogen peroxide over time without sonication</b>	112
<b>FIGURE 4.7: Decrease in cyanide with increasing hydrogen peroxide over time with sonication</b>	113
<b>FIGURE 4.8: Results from the initial time trial to establish decrease in cyanide using 10 mls of sample with 0.5 mls of 30% <math>v/v</math> <math>H_2O_2</math></b>	116
<b>FIGURE 4.9: Decrease in cyanide using hydrogen peroxide and sonication over 1 minute</b>	117
<b>FIGURE 4.10: Decrease in cyanide using hydrogen peroxide and sonication over 5 minutes</b>	118
<b>FIGURE 4.11: Decrease in cyanide using hydrogen peroxide and sonication over 10 minutes</b>	118
<b>FIGURE 4.12: Decrease in cyanide using hydrogen peroxide and sonication over 13 minutes</b>	120
<b>FIGURE 4.13: Decrease in cyanide using hydrogen peroxide and sonication over 15 minutes</b>	121
<b>FIGURE 4.14: Decrease in cyanide using hydrogen peroxide and sonication over 20 minutes</b>	122
<b>FIGURE 4.15: Decrease in cyanide using increased hydrogen peroxide without sonication</b>	123
<b>FIGURE 4.16: Decrease in cyanide using increased hydrogen peroxide with sonication</b>	124

## CONTENTS

	Page
<b>FIGURE 4.17: Decrease in cyanide using increased hydrogen peroxide with sonication to show optimum time</b>	125
<b>FIGURE 4.18: Decrease in cyanide using increased hydrogen peroxide without sonication to show optimum time</b>	126
<b>FIGURE 4.19: Decrease in cyanide with increased solids added, 1.5 mls hydrogen peroxide with and without sonication for 10 minutes</b>	130
<b>FIGURE 4.20: Decrease in cyanide with increased temperature, 1.5 mls hydrogen peroxide with and without sonication for 10 minutes</b>	131
<b>FIGURE 6.1: Proposal for Further Laboratory Trials</b>	162

### List of Tables

<b>TABLE 1.1: Results from ENRON's Purge &amp; Trap test</b>	31
<b>TABLE 1.2: Results from ENRON's Characterisation test</b>	32
<b>TABLE 3.1: Comparison of Techniques</b>	76
<b>TABLE 3.2: Numerical application to criteria to aid in Selection</b>	86
<b>TABLE 3.3: Short list of Best Performance Methodology</b>	94
<b>TABLE 3.7: Results from preliminary test of Electrolysis</b>	99
<b>TABLE 4.1: Analysis of Variance for cyanide</b>	134

### List of Appendices

<b>Appendix 1: Conversion and Waste Heat Recovery</b>	175
<b>Appendix 2: HCN Absorption</b>	176
<b>Appendix 3: Liming &amp; Filtration</b>	177
<b>Appendix 4: NaCN Liquor Storage and Tanker Filling</b>	178
<b>Appendix 5: N<sup>o</sup>2 Evaporator SHQL Production</b>	179
<b>Appendix 6: Effluent Treatment</b>	180
<b>Appendix 7: ENRONs Analytical Report</b>	181

## CONTENTS

	<b>Page</b>
<b>Appendix 8: Mass Balance Report</b>	<b>184</b>
<b>Appendix 9: Consents imposed by Environment Agency</b>	<b>185</b>
<b>Appendix 10: Analytical Method for Cyanide determination</b>	<b>186</b>
<b>Appendix 11: Results for the Initial Sonication/Hydrogen Peroxide time trials using a Mettler autotitrator and Dionex HPLC Chromatograph for cyanide determination</b>	<b>190</b>

## Acknowledgements

Thanks go to Dr Fred Worrall for his guidance, patience and assistance during this study. Gratitude is also given Lucite International UK for funding this project and to Dr Neil Tindale for his initial guidance and Ian Robins for subsequent support with the time allowed to carryout the practical work and support during its compilation. Also, thanks go to Jamie Thorpe thanked for his continual support and guidance during times of stress and elation.

## **DECLARATION**

I certify that the information contained within this thesis has not been previously submitted for a degree in this or any other university without my knowledge and does not contain material written or published by another person where a reference is not made in the text.

**COPYRIGHT:** The copyright of this thesis rests with the author. No quotation from it should be published without their prior written consent and information derived from it should be acknowledged.

## **1.0 INTRODUCTION**

### **1.1 Cyanides**

Cyanides are essential intermediates in a wide range of industrial processes used for the manufacture of commercially and socially important products (Yan, 1993). These include pharmaceuticals, fertilisers and pesticides, plastics, pulp and paper processing, metal finishing, electroplating and heat treating industries, steel smelting, coal gasification and petroleum refining industries. Cyanide and cyanide containing compounds are also used in the extraction of precious metals, in food processing and in photographic processing (ENV/EC/WMP (91)1). Cyanides are also used in the production of a very wide variety of goods which society demands, including shampoo and dyes. Due to its toxicity in some chemical forms, cyanide needs to be carefully managed through its entire life cycle, from the design of the process through to disposal of wastes containing cyanides. European Community Member Countries all have instituted controls concerning the use of cyanides and the waste-containing cyanide is tightly controlled as hazardous waste. Cassel works at Billingham produces sodium cyanide liquor, functional methacrylates with the main product being Methyl methacrylate. Hydrogen cyanide (HCN) is used as an intermediate in the methacrylate process. It is also known as hydrocyanic acid, prussic acid or formonitrile.

#### **1.1.1 International Importance**

In the chemical industry, cyanide-containing solutions are used for the production of other chemicals such as acrylonitrile, adiponitrile and methyl methacrylate (Wild *et al*, 1994). In the electroplating industry cyanide containing solutions are used to hold metallic ions such as zinc and cadmium in solution. Cyanide wastes originate from the plating vats, rinse waters and from spills and can be relatively high in cyanide concentrations. Cyanide wastes from the iron and steel industries are generated in the blast furnace gas scrubber water, the cooling water and as by-products of coke operations. These industrial effluents can contain high cyanide concentrations and often require treatment prior to discharge. Rough estimates are that 25 to 35% of the sodium cyanide used in electroplating and heat treating industries ends up in various waste streams (ENV/EC/WMP (91)1). In the petroleum industry cyanides are formed

in cracking and coking operations (Wild *et al*, 1994). While wastewater discharged from the iron industry and coke plants can contain up to 20 mg/l (milligram per litre) of cyanide. Spent electroplating baths contain 10 to 80g of cyanide and washing water contains varying amounts, which may be up to 400 mg/l (Bernat, 1979). Varying concentrations may also be contained within the water from thermal processing. The United States Environmental Protection Agency (USEPA) dictates in many US states that the level of cyanide must be below 0.1 to 1 mg/l, depending on the receiving medium, therefore the cyanide needs to be virtually eliminated before effluent is discharged to the environment. The extraction of gold and silver from their ores is established with the use of soluble cyanide compounds such as sodium or potassium cyanide (Ward, 2000). The waste water was previously discharged to watercourses at levels of 50 – 100 mg/l soluble cyanide, with the expectation it would be diluted, dissipated and inactivated by the natural stream of river waters. The retention of wastewater in tailings ponds is stated as being the oldest and still the most common method for treatment of gold mill wastewater effluents (Domvile, 1992). The method of retention promotes separation and settling of particulate contaminants. Photodegradation of both free and metallo-cyanides contained in the wastewater can be promoted by ultraviolet light. However, severe weather conditions impair their efficiency since natural degradation, photodegradation, precipitation and volatilisation of contaminants cannot occur when the pond is frozen.

Research results in New Zealand and Canada suggest that combining such processes as ion exchange and acidification could recover about 95% of the residual waste slurries produced from precious metal winning. Generally in Europe dilute aqueous cyanide bearing waste streams are often treated by alkaline chlorination with the two-tank method favoured with costs of treatment dependent on many factors. Within the European community hydrogen peroxide is becoming increasingly popular as an oxidising agent to convert cyanide to cyanate in handling dilute liquors at a pH of 10. The hydrogen peroxide reaction occurs without limit on the cyanide concentration and is temperature dependent. The problem in the past has been the reduced speed of the reaction. However, the reaction can be catalysed with a proprietary additive, which does not in itself generate hazardous wastes (ENV/EC/WMP (91) 1). Important advantages of this method are that the by-product

is water and not sodium chloride as is the case with chlorination. Thus, the treated wastewater does not become enriched with salt but rather are diluted by the reaction itself. Possible chlorate contamination of the effluent is eliminated, along with the chloroform formation associated with chlorination of effluents.

### **1.1.2 British Legislation**

In Britain controls are managed by the Environment Agency (EA), originally set up by the government to monitor all British sites but are now a private company working for the government (Bell, 1997). They have laid out rules and guidelines for companies to adhere to. Part I of the Environmental Protection Act 1990 uses an approach known as Integrated Pollution Control (IPC) where each prescribed process follows guidelines; best available technique not entailing excessive cost.

(BATNEEC). If a company wishes to use a process, the process needs to be listed under IPC (very soon with IPPC (Integrated Prevention Pollution and Control)) and authorisation from the EA needs to be obtained before that process can be carried out. Integrated Pollution Prevention and Control (96/61) was adopted in September 1996 and was brought into force in European member states by 14<sup>th</sup> Oct 1999, new processes had to adhere to the BATNEEC guidelines by that date. However any existing processes have until October 2007 to adopt BATNEEC.

### **1.1.3 Cyanide in Air**

The atmospheric cyanide levels are low, therefore elevated and toxic cyanide levels in the environment are thought only to occur because of human activity and industrial and commercial inputs are likely to dominate (Wild *et al*, 1994). Some plants naturally produce cyanide when in association with a glycoside (sugar) called amygdalin. It is also present in concentrated forms in the seeds of some fruits such as apples, apricots, cherries, peaches and plums. Cyanides are present at low concentrations in several naturally occurring environmental sources such as the combustion of tobacco i.e. cigarette smoke and produced by living organisms (ENV/EC/WMP (91) 1).

#### **1.1.4 Cyanide in Wastewater**

Wastewater arriving at sewage treatment works is likely to contain detectable levels of cyanide (Wild *et al*, 1994). There are three main sources;

- (i) domestic discharges;
- (ii) atmospheric deposition and surface run-off ; and
- (iii) commercial and industrial discharges.

Domestic sewage accounts for 90% of the flow at the treatment plant and any cyanide content is of natural origin as a contaminant of organic material.

As cyanide concentrations in air are generally low, therefore their accumulation from the air into watercourses is minimal (Wild *et al*, 1994). Inputs of cyanide to wastewater from run-off sources are currently unquantified, although high concentrations may occur in run-off where road salt is used because cyanide is contained as an anti-sticking agent. The anti sticking agent used is a complex metal cyanide and is inert therefore, the cyanide is not biologically available (Sharpe, 1986). It has been shown that free cyanide ions can be formed by a reaction of polyhydroxybenzenes (especially 1,2,4- and 1,3,5-trihydroxybenzene) and nitrous acid, if the wastewater is at room temperature and slightly acidic. This reaction could be found occurring with exhaust fumes in a wet atmosphere.

Most environmental sources of cyanide are thought to be from human activities i.e. industrial and commercial. The other sources named above contribute very small amounts in comparison.

#### **1.1.5 Cyanide Cycle**

The cyanide cycle (Figure 1.1) represents the tailings solid/tailing pond/atmosphere system (Smith & Mudder, 1991), showing the large number of chemical, biochemical and geochemical reactions cyanide is involved in. For cyanide in the environment there are many potential geochemical reactions that could possibly take place. Ores, rocks and soils contain to a greater or lesser extent silicates, aluminosilicates (clay minerals), sulphides, carbonates and oxides, plus organic matter, water and in some cases gases. The solid components such as rocks can control pH of the cyanide containing water adjusting it to acid or alkaline, acting as a

buffer and to a certain degree with oxidation or reduction resulting in ion exchange adsorption or chemical reaction within the cyanide solution. This could even result in precipitation of insoluble species.

Cyanide ion is toxicologically important because of the hydrogen cyanide with which it is in equilibrium, as shown in equation 1.1 (Moore, 1976);

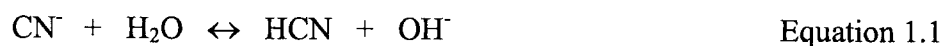

The ratio of hydrogen cyanide in a sample varies with temperature, pH and ionic strength (Moore, 1976). The dissociation constant for hydrocyanic acid at 25°C is  $6.2 \times 10^{-10}$ , the ratio of hydrogen cyanide to cyanide at infinite dilution in distilled water is 161 at pH 7. At pH 8 the dissociation constant is 16, at pH 9 the dissociation constant is 1.6 and a constant of 0.16 at pH 10. This results in hydrocyanic acid being largely undissociated at pH values of 8 and less. Natural gases such as carbon dioxide (CO<sub>2</sub>) in the soil can change the pH of infiltrating solutions (Smith & Mudder, 1991). Carbon dioxide in the soil is 100 times greater than that in the atmosphere.

Cyanates are the product of a number of detoxification processes including alkaline chlorination (Moore, 1976). Cyanates are stable in aerobic water at pH 7 and 20°C for at least 10 days. Eventually cyanates undergo hydrolysis to ammonium carbonate. In anaerobic solutions cyanates are reduced to a mixture of formic acid and ammonia. The toxicity of cyanate is given as 100-250 mg/l and considered to be one thousand times less toxic than cyanides.



## 1.2 Life Cycle approach

Due to the toxicity of cyanides, it is essential that the level of cyanide in the environment, both in industry and in the wider natural environment is carefully managed (ENV/EC/WMP (91) 1). In-line with other very harmful materials, a holistic 'life cycle' approach is taken, where the risks involved in all steps from manufacture to disposal are considered. This includes design of industrial processes through to disposal of cyanide containing wastes, which is strictly regulated by government. Cyanide toxicity to organisms is due to its ability to restrict the utilisation of oxygen and at an acute toxic level this is both rapid and fatal. If the integrated life cycle approach is taken for the control of cyanides, the initial step is to establish how dependent goods and services are on cyanides in general and could cyanide usage be eliminated. Current information suggests that this is not possible and that there is a lack of suitable substitutes. An approach to arrange voluntary agreements with cyanide producers and users to limit demand has been discussed. In practice these voluntary agreements have already been achieved, as demands for cyanide from precious metal refiners increases while production is low, this instigates the pressure to increase cyanide prices and in turn increases prices for legal disposal of cyanide wastes. The conclusion drawn is that the only way to cut the demand for cyanides is to cut back on the precious metal winning operations mostly in the developing countries. Member governments of the cyanide producing states cannot force a reduction in global demands for cyanides, but they could take steps to ensure that cyanide containing wastes generated by major cyanide producers within their jurisdiction are minimised by imposing inspections, audits and or cyanide disposal taxes.

Restrictions of the transportation of cyanides are listed in the United Nations Recommendations on the Transport of Dangerous Goods, this book is also known as the "Orange book". This states that the net weight of solid sodium cyanide per container is limited to 1000 kg, within a polypropylene heat sealed bag in a plywood box set upon a standard integral pallet base.

### **1.2.1 Limits and Controls; CEFIC**

Control of cyanide has now developed into an issue of international importance, as evidenced by the presence of international, multi-industry, multi national organisations, e.g. CEFIC " Conseil Européen de l'Industrie Chimique / European Chemical Industry Council." as stated by their website (<http://www.cefic.org>). The CEFIC group is made up of the national chemical industry federations of 25 countries in Europe and large international companies which are members in their own right. The General Assembly, the Board and the Executive Committee determine the policy. It is a scientific base where problems and information are shared on all aspects of industry including health and the environment. It is stated that CEFIC is "both the forum and the voice of the European chemical industry". It represents, directly or indirectly, about 40,000 large, medium and small chemical companies in Europe, which employ about two million people and account for more than 30% of the worlds chemical production. Since June 1998, the CEFIC Board and Executive Committee have been extended to include representatives from other related organisations. Their decisions are implemented by a Director General and staff whose offices are in Brussels, where CEFIC was incorporated in 1972 as an international association with scientific objectives. Responsible Care is a CEFIC initiative which companies, through their national associations, "commit to work together to continuously improve the health, safety and environmental performance of their products and processes, and so contribute to the sustainable development of local communities and of society as a whole".

#### **1.2.1.1 Responsible Care**

Responsible Care focuses on improving performance, communication and accountability (<http://www.cefic.org>). Its intention is to improve performance by identifying and spreading good management practices through the publication of guidance documents. There is a mutual support between companies and associations sharing experiences with peer pressure replacing the competitive approach of the past in health, safety and environmental areas. Companies are encouraged to share information with the public about what they make and do, about their performance

including data, and about their achievements and challenges. It is hoped that industries can engage and work with stake-holders at local, national and international levels, to listen to and address their concerns and aspirations. There is a co-operation with governments and organisations in the development and implementation of effective regulations and standards, and helps companies to meet or exceed these requirements. Accountability is important to the chemical associations to develop credible processes and ensure those member companies are meeting Responsible Care expectations. Responsible Care started in 1985 in Canada and is now in 46 countries where more than 85% of the world chemicals (in volume) are manufactured.

### 1.2.2 Limits

Most industrialised countries set limits on the amount of cyanide containing waste, which can be discharged by industrial users (ENV/EC/WMP (91)1). These are typically made up of permitted maximum levels of cyanide containing waste in all three states of matter, i.e. as solids, in the form of liquids or dissolved solids, or in the form of gaseous HCN. Associated with the maximum levels, the methods by which the effluent will be tested are often also stipulated. Some countries set limits, for permissible cyanide concentrations within waste for example, the Netherlands set their limit at 50 mg/Kg (milligrams per kilogram) for inorganic cyanides (ENV/EC/WMP (91) 1). A wide range of test methods are used, in Japan the limits set for the cyanide are found by an extraction method (cyanide containing waste samples mixed with water and shaken six hours under acidic conditions - absorbed HCN measured) limit of 1 mg/l of free cyanide in the extractate. The US has set effluent discharge standards for total cyanides of 1.2 mg/l daily maximum and 0.65 mg/l maximum monthly average. The UK requirement set in 1991 for aqueous waste solutions was 4.6 mg/l.

It is important that any levels, which are set for cyanide in wastewater must be specific and obtainable (Lordi *et al*, 1980). The presence of cyanide in the natural environment results in biological systems being able to tolerate a certain amount, an example of arbitrary level setting follows. The Illinois pollution control board set a

standard upper limit of 0.025 mg/l of cyanide in their wastewater, due to the problems in municipal wastewater treatment plants in Illinois. However this was an arbitrary figure and the standard did not state which type of cyanide (free or complex) it referred to. This led to studies carried out by the Metropolitan Sanitary District of Greater Chicago between 1973 and 1977 to evaluate the districts compliance with these regulations. It was established that many companies outfalls were not compliant with the ruling and cyanide levels were greater than 0.025 mg/l after treatment. A series of acute toxicity tests were then carried out on Fathead minnows using the actual waste discharge from the plants, which showed no correlation in effluent cyanide concentrations and percentage survival. These results found the Fathead minnows had a tolerance of up to 0.15 mg/l cyanide. The acute toxicity test results were used in court to have the consent levels changed for the state. After a series of hearings, amendments were then made to the standard for this industrial area, of monthly averages of 0.1 mg/l and 0.2 mg/l for a 24 hour composite.

### 1.3 Toxicity and Fate of Cyanide

Cyanide can exist in water in many different forms, “cyanide” is an all-inclusive term, which includes all compounds containing the cyanide ion ( $\text{CN}^-$ ) group, and in many forms both organic and inorganic (WHO, 1998). There are three types of cyanide;

(i) Free cyanide ( $\text{CN}_F$ ) classification is only given to hydrogen cyanide (HCN) and cyanide ions ( $\text{CN}^-$ ) that are in solution (Menne, 1998). The amounts of either of these in a solution are dependent on the pH of the solution. Free or simple cyanides are found in water as molecular acid hydrogen cyanide or as the free ion. Simple cyanides are those that readily convert to hydrogen cyanide after acidification (pH less than 4).

(ii) Weak acid dissociable cyanide ( $\text{CN}_{WAD}$ ) is the cyanide that is detected by a certain analytical technique. The cyanides liberated by these methods using a pH of 4.5 includes solutions of HCN and  $\text{CN}^-$  and most of Cu, Cd, Ni, Zn, Ag complexes and others with low dissociation constants. Cyanide acts as a ligand it can be found associated with many metal complexes, in which it provides the electrons in dative bonds. The weakly complexed cyanides includes those bonded with cadmium, lead, nickel and zinc, whereas the strongly complexed group includes the very stable bonds of hexacyanoferrates, hexacyanocobaltates and thiocyanates.

(iii) Total cyanide ( $\text{CN}_T$ ) the measurement for this includes all free, dissociable, complex and strong metal cyanide including ferro-cyanide  $\text{Fe}(\text{CN})_6^{-4}$ , ferri-cyanide  $\text{Fe}(\text{CN})_6^{-3}$  and some hexocyano cobaltate  $\text{Co}(\text{CN})_6^{-3}$  and those of gold and platinum. Only compounds excluded from the definition of total cyanide are cyanate ( $\text{CNO}^-$ ) and thiocyanate ( $\text{SCN}^-$ ). These complex cyanides require vigorous decomposition such as heating or digestion before hydrogen cyanide is liberated.

### 1.3.1 Cyanide Toxicity

When a substance is released from a large area, such as an industrial plant, or from a container, such as a drum or bottle, it enters the environment (Research Triangle Institute, 1997). A release does not always lead to exposure to living organisms. Exposure occurs when contact is made with a substance by breathing, eating, or drinking the substance or by skin contact. When exposed to cyanide, many factors determine whether the exposure will lead to harm. These factors include the dose (how much), the duration (how long), and by which exposure route the contact is made. Other considerations to be taken into account are exposure to other chemicals, age, sex, diet, family traits, lifestyle, and state of health.

Hydrogen cyanide (HCN) is widely distributed throughout the animal kingdom and believed not to have any detrimental effects on vegetation (ENV/EC/WMP (91) 1). Residual HCN is removed from the environment by hydrolysis to form formic acid. The toxicity of cyanide is dependent on the speciation and chemical form, free hydrogen cyanide in solution or as a liquid is extremely poisonous with a smell described as bitter almonds (Wild *et al*, 1994). Within the human body the enzyme Rhodenase enables detoxification of low levels of hydrogen cyanide into non-harmful substances (ICI Acrylics, 1992). This non-ionic form of cyanide, by inhibiting the enzyme cytochrome oxidase, prevents the living tissue taking up oxygen. Cyanide may enter the body by inhalation, oral or by skin absorption (ICI acrylics, 1998). A lethal dose for a human being is 100-150 mg/ Kg but death has occurred with a dose as low as 0.5 mg/Kg of HCN due to its rapid action on body tissue through absorption and circulation in blood plasma. Inhalation of this volatile substance leads to shortness of breath, paralysis, unconsciousness, convulsions and death. For these reasons hydrogen cyanide has been used as a fumigating agent in pest control and used in the USA between 1940 and 1967 for the gas chamber executions. However, some human exposure to low levels of cyanide 4.7 mg per day (mg/day) has been found not to be fatal, as the body converts the cyanide to thiocyanate ion, which is only toxic in larger amounts. However, the symptoms of nausea, vomiting and headaches could be experienced. In water, concentrations as low as 0.01 to 0.1ml cyanide are capable of killing more sensitive animals. Toxicity tests have shown that embryonic and juvenile stages of fish are the most sensitive to

toxic products. When complexed with metals cyanide becomes less toxic, the more strongly bonded the less toxic it is. Even at sub-lethal concentrations effects on aquatic life are found and some metal cyanide bonds have cumulative effects on life.

The most dangerous, toxic compounds are listed by the European community on a “black list”. Less dangerous substances forming the “green list” chemicals include their toxicity, persistence and potential for bioaccumulation (Mason, 1996). The seventh in this list are cyanides and fluorides. Copper is more than additive with chlorine, zinc, cadmium and mercury whilst it does decrease the toxicity of cyanide. Organic and inorganic cyanides above certain concentrations are highly toxic to all forms of life, plants and animals (Singh *et al*, 1986). The high toxicity necessitates its detection and determination even when present in trace amounts.

### **1.3.2 The Degradation Mechanisms of Cyanide**

#### **(i) Complexation**

There are seventy-two cyanide complexes possible ranging in solubility, many of the transition metals bond, resulting in metal–cyanide compounds that are much less toxic than free cyanide (Smith & Mudder, 1991). Some complexes are not stable and release cyanide on decomposition. The weak acid dissociable cyanides for example zinc and copper cyanide dissociate to cyanide at different rates at pH of 4.5. The tightly bound iron cyanide releases cyanide slowly due to photochemical decomposition. Within soil environments the complexation of cyanide has very diverse effects on its mobility. If the complex is with iron it is less able to adsorb onto the soil surface increasing its mobility except when free transition metals (copper or nickel) are present a ferrocyanide precipitate will facilitate the bound cyanide to adsorb onto organic carbon, metal oxides and clay surfaces for example.

#### **(ii) Cyanide complex precipitation**

The ferrocyanide and ferricyanide ions form insoluble salts with for example copper, magnesium, cadmium and zinc at any pH.

(iii) Adsorption

Adsorption is another mechanism that attenuates cyanide in soils with test results showing soils with high concentrations of hydrous oxides of iron and manganese have the best cyanide retention (Smith & Mudder, 1991).

(iv) Oxidation to cyanate

In the presence of strong oxidisers cyanide is converted to cyanate but also if exposed to ultraviolet light in the presence of a catalyst there is a direct oxidation with air, as shown in equation 1.2;



Within soil environments cyanide can bond to the surface of organic or inorganic materials, oxidation will occur near the surface and produce hydrogen cyanate as shown in equation 1.3;



(v) Volatilisation

Volatilisation within the soil environment is dependent on a number of factors these include (Smith & Mudder, 1991);

- (a) pH; Decreasing pH down to 5 increases the cyanide removal rate.
- (b) Temperature; increasing temperature increases the removal rate 10°C increase relates to a 40% increase in removal.
- (c) Interfacial surface area; there is an increased difference in removal rate between aerated and non-aerated soils.
- (d) Pressure.
- (e) Concentration.
- (f) Degree of agitation.

When cyanide is in contact with water the following reaction shown in equation 1.4 takes place;



(vi) Biodegradation

Cyanide salts have a short mobility through soil before being converted under aerobic conditions to nitrates or fixed by trace metals by complexation (Smith & Mudder, 1991). The anaerobic method of degradation is not as effective and cyanide above 2 mg/l is toxic to the anaerobic micro-organisms.

Anaerobic degradation can only occur when the cyanide is exposed to hydrogen sulphide as shown in equations 1.5 and 1.6;

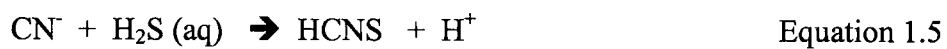

(vi) Formation of Thiocyanate

Cyanide in its free state reacts with various forms of sulphur the most predominant reactions produce polysulphide and thiosulphate. Thiocyanate is relatively non toxic in comparison with cyanide.

(v) Hydrolysis/Saponification of cyanide

At low pH values cyanide is hydrolysed to give formate as either ammonium formate as shown in equation 1.7 or formic acid as shown in equation 1.8. The lower pH favouring the formation of formic acid (Smith & Mudder, 1991);

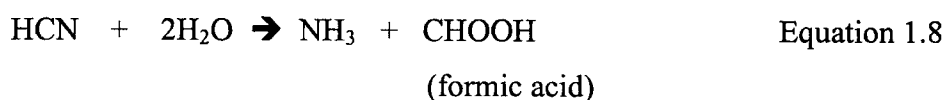
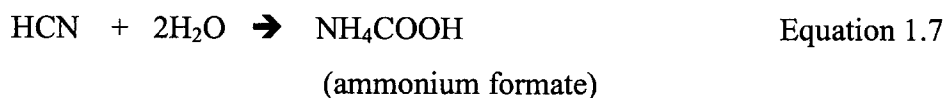

## 1.4 Analytical Techniques

Analytical techniques for the determination of cyanides as total cyanides are based on the decomposition of nearly all of the metallocyanide complexes plus the free cyanides (Singh *et al*, 1986). Decomposition is achieved during a 1 hour reflux distillation procedure of the sample under highly acidified conditions with resultant HCN gas being absorbed into a sodium hydroxide solution. Tightly bound iron cyanide complexes are decomposed by the addition of magnesium chloride as a catalyst, which includes the exposure of this to ultraviolet light. Some procedures recommend the acid reflux procedure be repeated to maximise cyanide recoveries from samples containing tightly bonded cyanide complexes and from solid/sludge samples. The resulting free cyanides are quantified in accordance with standard methodologies. Cyanides amenable to chlorination are the difference between “toxic” and “non-toxic” cyanide forms. Certain rapidly dissociated simple cyanides are toxic, other complex cyanide ions (such as iron complexes) are not easily dissociated and are non-toxic (unless photodecomposed by ultraviolet light).

### 1.4.1 Methods for Cyanide Release

#### (i) Chlorination

All simple cyanides are oxidised by chlorine. The initial sample procedure consists of two distillations (Singh *et al*, 1986). The sample is split in two, one portion is chlorinated (for 1 hour at a pH of 11 to 12) with excess calcium hypochlorite ( $\text{Ca(OCl)}_2$ ) the other portion is not. Both portions are then distilled as the total cyanide test to collect and measure free cyanides. The cyanide collected from the sample without chlorination is the total cyanide value. The difference in collected cyanide between the two samples is termed cyanide amenable to chlorination.

#### (iv) Distillation

Weak acid dissociable cyanide by reflux distillation for one hour liberates the HCN (Smith & Mudder, 1991). The sample is buffered with acetate buffer to a pH of 4.5. The cyanide is then established from the solution remaining. This method covers free

and weakly complex cyanides but not effective for zinc and cobalt. However, this method is least susceptible to interferences including either thiocyanate or sulphides.

(v) Colourimetric

The picric acid colourimetric method develops a colour with picric acid in the presence of nickel then heated in a water bath for twenty minutes then analysed using a visible range spectrophotometer (Smith & Mudder, 1991). The colourimetric method is mainly used for samples below 0.5 mg/l down to 0.1 to 0.2 mg/l.

(vi) Reactive

“Reactive” cyanide by USEPA (United States Environmental protection Agency) test protocol using sulphuric acid to ensure pH of 2 and passing a stream of nitrogen over the sample for 30 minutes (Smith & Mudder, 1991). The gas stream is purged through sodium hydroxide to collect any cyanide in the gas. The cyanide content can then be determined.

#### 1.4.2 Titrimetric techniques

The earliest report on the determination of cyanide is by a method called Leibig’s argentometric method which was used for the detection of cyanides greater than 1mg/l (Singh *et al*, 1986). It is based on the appearance of turbidity due to the formation of silver argentocyanide ( $\text{Ag}[\text{Ag}(\text{CN})_2]$ ) as shown in Equation 1.9. Erroneously called ‘insoluble silver cyanide’ in alkaline or an ammonical medium.

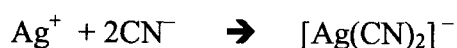

The test was later modified using potassium iodide, as the visual indicator in the presence of ammonium hydroxide, though in excess ammonia does not seriously affect the results it is best to keep it to a minimum (Menne, 1998). The method used

for free cyanide determination is by silver nitrate titration with a small amount of potassium iodide, as described in Appendix 10. Weak acid dissociable cyanide titrations are the preferred analytical method is by distillation according to ASTM (American society for testing and materials) or ISO/DIS (International Standards Organisation/Draft International Standard). Within these chemical conditions dissolved HCN is liberated then carried by the distillation unit into sodium hydroxide absorption when the  $CN_{WAD}$  appears as  $CN_F$ . The HCN is absorbed in a smaller volume than the original sample solution, the  $CN_F$  concentration is then typically ten times higher than the original  $CN_{WAD}$  the distillation product is then titrated with silver nitrate. The method of total cyanide determination is by distillation where strong acidic conditions are used in conjunction with high temperatures, into sodium hydroxide.

Other successful indicators include murexide *p*-dimethylamino benzylidene rhodanmine and dithizone. In the case of dithizone a sharp colour change from orange yellow to deep red-purple is observed owing to the formation of silver-enol-dithizone complex. Bordeaux red has been used as an indicator and N-bromo-succinimide as titrant. The colour change at the end point is rose-red to yellow but iodine (I), thiocyanate( $SCN^-$ ), hydrogen sulphite ( $HSO_3^-$ ), thiosulphite ( $S_2O_3^{2-}$ ), sulphite( $SO_3^{2-}$ )seriously interfere.

#### **1.4.2.1 Interferences**

Interferences to these methods can be both positive and negative affecting the precision and accuracy of the method (Smith & Mudder, 1991);

- (i) Oxidising agents interfere as they continue to react with the cyanide during storage and handling, these include chlorine, oxygen, ozone and hydrogen peroxide.
- (ii) Sulphides are only present in solutions with oxygen deficiency; these can be removed by precipitation. Permanganate can be utilised to destroy residual sulphides. Taking care not to destroy any cyanide with the permanganate.

- (iii) Thiocyanate is generated by the reaction of cyanide with sulphides.
- (iv) Both nitrite and nitrate are potential interferences at levels as low as 25 mg/l. These interferences are usually positive (adding to the cyanide levels) but can be negative (reducing the cyanide levels). Sulphamic acid can be added to the sample prior to distillation to prevent interference.
- (v) Carbonates under strongly acid conditions produce excess gassing during distillation and may reduce the sodium hydroxide content of the sample.
- (vi) Thiosulphates, sulphites and related sulphur compounds formed by decomposition during distillation causing bleaching of the colourmetric endpoint. Samples can be pre-treated with hydrogen peroxide with care not to oxidise the cyanide.
- (vii) Metals at high concentrations can interfere with cyanide analysis; iron, cobalt and mercury interfere with simple cyanide analysis forming more stable complexes, which cannot be quantified, reducing the true cyanide content.

### **1.4.3 Cyanide by Instrumental Methods**

Analysis of the cyanide ion can be classified into four main groups; Electrometric, optometric, radiochemical and chromatographic (Singh *et al*, 1986).

#### **1.4.3.1 Electrometric Methods**

- (i) Potentiometric titrations

Potentiometric titrations of cyanide with silver nitrate are reported to be superior to Leibigs method for determining cyanide because it uses a cation sensitive electrode, which indicates the completion of the complexation reaction. A silver iodide membrane electrode is most suitable for determining cyanide in the concentration range 26 mg/l down to 0.26 mg/l. The response of cyanide ion selective electrode operated at different flow rates has been studied. The iodide / sulphide electrodes

have been widely used for the determination of 2600 mg/l to 26000 mg/l of cyanide in river water. An automated method based on a computerised “Gran plot” technique uses an ion selective electrode. The solutions are passed through an auto-analyser system and a “Gran plot” generated using computer programmes. Silver ion selective electrodes have been used as indicator electrodes. A packed bed silver electrode method uses standard current potential curves and the rectilinear relationship between plateau current and cyanide that exists. This method is used to determine low level cyanide in the presence of chlorine and has a tolerance to dissolved oxygen, but bromine, iodine and sulphide cause interference.

(ii) Polargraphic and Amperometric methods

Anode reactions take place in aqueous solution of cyanide of 2 mg/l at a dropping mercury electrode (Singh *et al*, 1986). The limiting current is linearly dependent on cyanide concentration not on pH, however interference is caused by iodine and  $S_2O_3^{2-}$ . This method is recommended for monitoring industrial effluents. There are methods that use differential pulse polarography found to be better than conventional dc polarography reacting cyanide ions with mercuric iodate. Another indirect method of complexing the cyanide with copper (II) then polarography is used to determine any excess copper (II), from the amount of un-complexed copper the cyanide is calculated. The “Piezoelectric” quartz crystal method which is in contact with one drop of cyanide solution measures the cyanide content by dissolution of the gold electrode of the crystal by frequency changes.

Several amperometric methods are known, one of which is the reaction of cyanide with iodine to form iodine cyanide, that then generates iodine on treatment with perchloric acid, as shown in Equation 1.10.

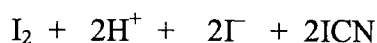

(Equation 1.10)

The regenerated iodine that is equivalent to the amount of cyanide present is transferred to the gas phase by purging with nitrogen and subsequently determined at a gold gas-porous electrode by electro-oxidation to iodate.

#### 1.4.4 Opticometric Methods

(i) Opticometric methods are based on the formation of coloured metal complexes or increase in extinction coefficient (Singh *et al*, 1986). Spectrophotometric methods are quite sensitive for the detection of traces of cyanide. The formation of red coloured ferric ferrithiocyanate produced on reaction with ammonium polysulphide and ferric chloride is an excellent spot test for cyanide ion. An extremely sensitive method for the detection of cyanide results in the formation of Prussian Blue, the method described by the equation below (Equation 1.11).

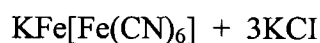
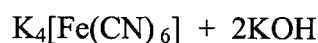
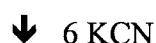

Prussian blue

(Equation 1.11)

The Prussian blue method has been used for estimating cyanide in animal and plant tissues. Formation of coloured palladium chelates has also been used. A spot test method where a blue colour is formed when adding copper sulphate followed by ammonium molybdate to a solution containing cyanide ions. The colour is due to a reduction of the molybdate to molybdenum blue in the presence of  $\text{Cu}^+$ . The blue stain is obtained with as little as 0.1 mg of cyanide present mixed with ethylacetoacetate and is used for detection of cyanide in wines and spirits.

Picric acid has also been widely used for the automated analysis of cyanides, forming the distinctive red dye in water (Singh *et al*, 1986) as shown in Equation 1.12 with cyanate produced.

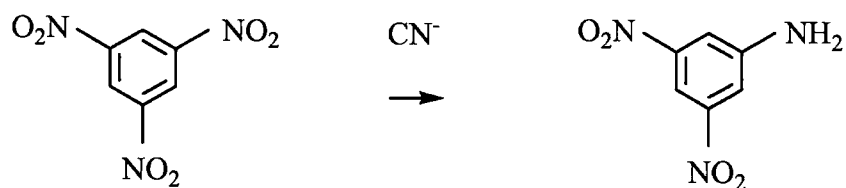

2,4,6-Trinitrophenate

Red colour

(Equation 1.12)

“König” synthesis is the best known spectrophotometric method (also known as the Aldridge method), where cyanogen bromide/chloride reacts quantitatively with pyridine giving glutaconicaldehyde. This couples with an aromatic amine to form a coloured polymethine dye, as shown below in Equations 1.13 and 1.14 (Singh *et al*, 1986);

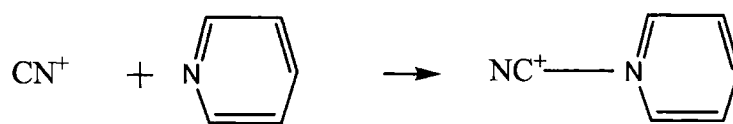

Pyridine

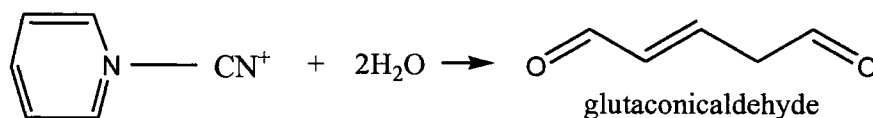

glutaconicaldehyde

↓  
Coloured Species

(Equation 1.14)

(ii) The second opticometric method is based on the formation of colourless metal complexes or the decrease in extinction coefficients (Singh *et al*, 1986). Cyanide has the ability to form stable colourless complexes from coloured chelates. Fluorometric methods include an indirect chemiluminescence determination of cyanide which the oxidation of immoluminol by copper (II) at a pH of 1.4 is suppressed in the presence of cyanide. However, ions which interfere are silver manganese, cobalt, mercury, nickel, iron (III) and chromium. The use of quinones has also been reported for the fluorometric determination of cyanide. Polarimetric methods use the change in optical rotation due to the decrease in inhibitory effects of  $\text{Hg}^{2+}$  on the invertase catalysed hydrolysis of sucrose (Singh *et al*, 1986). Atomic absorption (AA) uses the formation of complexes, also based on the principle that metallic silver reacts with cyanide to give a soluble  $[\text{Ag}(\text{CN})_2]^-$  determined by AA spectroscopic method.

#### 1.4.5 Radiochemical Methods

Radiochemical methods have been successfully used for the determination of micro amounts of cyanide using radioactive silver. A cyanide solution is passed through a column of silver iodide labelled with  $^{110}\text{Ag}$  and counting the activity of the filtrate. Each mole of silver requires two moles of cyanide; this is an accurate, fast and sensitive method,  $^{110}\text{Ag}$  is made by irradiating pure silver in a nuclear reactor.

#### 1.4.6 Chromatographic Methods

Gas liquid chromatography has been used for the determination of hydrogen cyanide (Singh *et al*, 1986). Methods have been developed for the detection of complex cyanides in water, this is based on a reaction as shown in Equation 1.15:



(Equation 1.15)

Cyanogen bromide (BrCN) is separated by a gas chromatographic method and then detected by electron capture detector.

Flame thermionic detectors and paper chromatography have also been used and recently high performance liquid chromatography has been employed for cyanide detection.

## **1.5 CASSEL WORKS CYANIDE PLANT**

The aim of this section is to give an overall picture of how the Cassel works cyanide plant produces the sodium cyanide and the effluent treatment process involved. A summary of the effluent characterisation is given along with the chemistry involved. A basic mass balance of the cyanide process is given to highlight the losses from the process. The issues that are associated with the use of sodium hypochlorite and the legislation applied to Cassel works cyanide plant.

### **1.5.1 Cyanide Plant Process**

There are two processes used at Cassel to produce sodium cyanide liquor. The first describes the convertor process that produces a low grade of cyanide (due to the impurities within the cyanide and the second the evaporator process, which produces a purer form of sodium cyanide.

The sodium cyanide liquor process (Figure 1.2) shows the overall flow of the process with the inputs of ammonia, natural gas and air to the HCN converter, from here the product steam is exported to other areas of the plant. The hydrogen cyanide produced is absorbed into caustic (sodium hydroxide at 50%), which is then transported through the liming and filtration (ROVAC and metafilter shown in Figure 1.2) section of the plant. At this point the strength of the cyanide is tested, diluted with water and once the strength is between 29.0% and 31.0%, this standard quality cyanide liquor product is sent to liquor storage ready for distribution. Other grades of cyanide are produced including high quality liquor and super high quality liquor. These have less impurities and tighter specifications for cyanide strength, 29.8% and 30.0%.

The second method of cyanide liquor production uses the Evaporators, of which there are two. The evaporators are known as numbers 1 and 2. They can only be used one at a time and produce the purest cyanide liquor known as Super High Quality Liquor (SHQL). Pure hydrogen cyanide (HCN) is piped from HCN 6 plant via the

acetone cyanohydrin (ACH3) plant to the evaporators. The HCN is then mixed directly with the 50% caustic to produce the cyanide liquor.

The engineering diagrams (Appendix 1 to 6) show each critical area of the cyanide plant, broken down by area. The conversion and waste heat recovery diagram (Appendix 1) shows the initial process in more detail. The flame failure monitor is a critical safety detection device to ensure the system is shut down immediately the flame fails. Hydrogen cyanide absorption (Appendix 2) shows the inputs from caustic storage and the processed HCN gas from the converter mixing within the absorber tower. The product is then fed to the liming and filtration section (Appendix 3). The liming section adds hydrated lime ( $\text{Ca}(\text{OH})_2$ ) directly to the cyanide liquor in a stirred vessel. The cyanide liquor disproportionates with the sodium carbonate impurity, forming sodium hydroxide and calcium carbonate precipitate. This cyanide solution then goes onto the filter section where water is added. At this point the solution of cyanide liquor and calcium carbonate is vacuum filtered (ROVAC) through a lining material (of fine nylon) into the metafilter feed tank. Then filtered through the metafilters, and cooled then routed to the cyanide storage facility. The sodium cyanide liquor storage (Appendix 4) and tanker filling facility shown in Figure 1.2 indicates the areas where the manual stop buttons are when there is a problem with tanker filling. This will ensure no cyanide is spilt if there were a problem. The (1 and 2) evaporator SHQL production (Appendix 5) takes HCN from HCN6 via ACH3 pipeline and caustic from storage, which is mixed with steam in the calandria (a cylindrical vessel in which vertical tubes pass, similar to a heat exchanger). The sodium cyanide is then transferred to the evaporator. The product is then concentrated and transported onto the designated super high quality stock tanks. The effluent treatment system is shown (Appendix 6) displaying the effluents fed from Liquor loading, HCN plants, the acetone cyanohydrin plants (ACH) 3 and 4 plus border chemicals spent sodium hydroxide and storm water with the cyanide plant effluent, all treated as discussed in section 1.5.2. (The storm water includes water from the surrounding open areas; the pavements, roads and roof areas of the cyanide plant). The total flow rate under normal operating conditions  $105 \text{ m}^3/\text{hr}$  (meters cubed per hour) plus  $25 \text{ m}^3/\text{hr}$  estimated storm water run off.

**FIGURE 1.2: Basic layout of Cyanide plant**

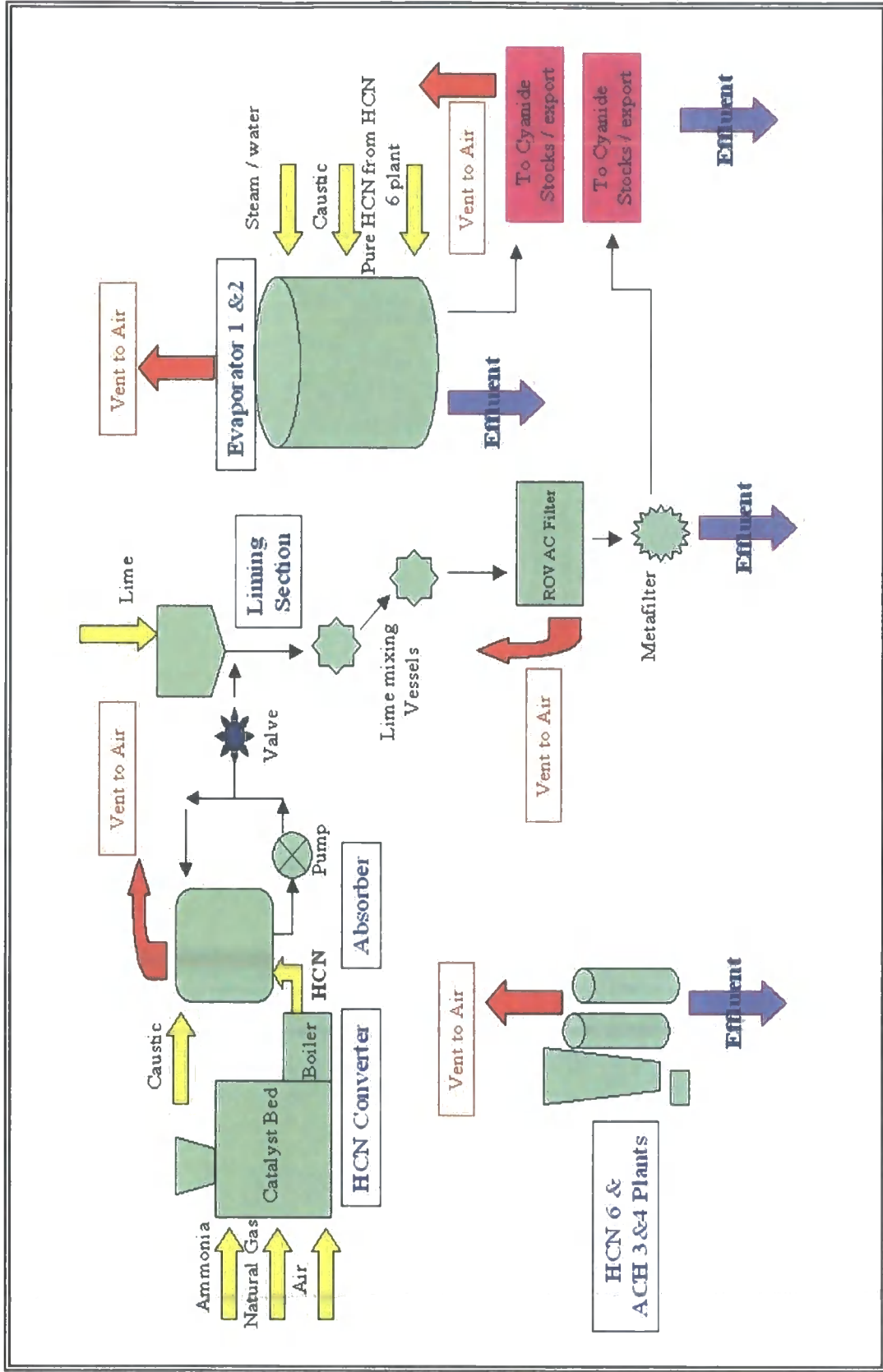

**FIGURE 1.3: Basic layout of Cyanide plant Sumps**

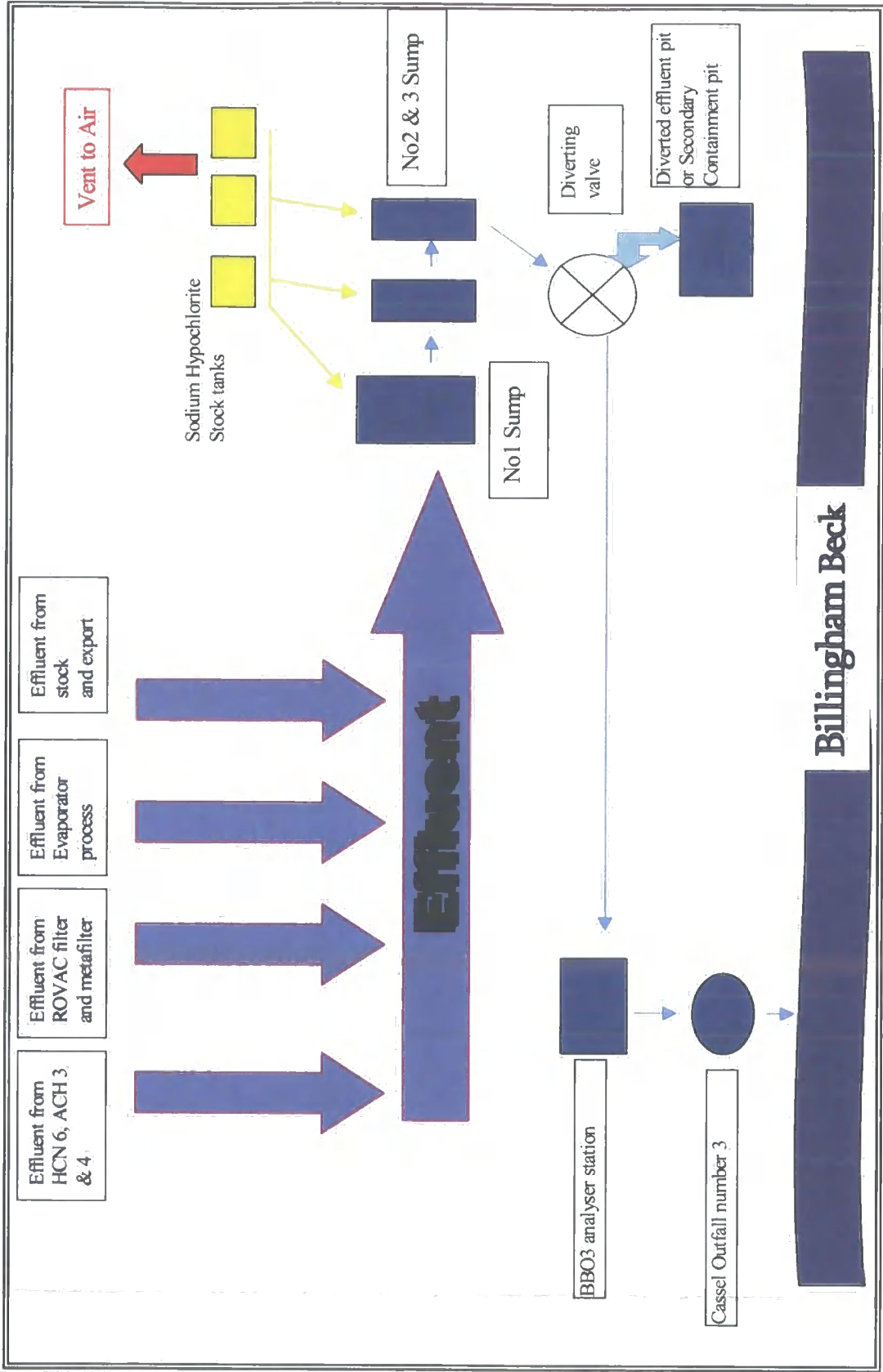

### 1.5.2 The Cyanide Plant Effluent Process

While the cyanide plant is in standard operation all liquid effluent (shown as arrows on figure 1.2 & 1.3) and the slurry from the liming section are channelled to the cyanide effluent treatment section, via a series of drains and gulleys on each of the three floors of the plant. The cyanide waste from the liquor loading area, where the cyanide product tankers are filled, ACH plants and HCN plant are all diverted to the cyanide effluent treatment system. The effluent treatment section consists of four stirred treatment pits, sumps 1, 2 and 3 connected in series. Cyanide present in the sumps is destroyed by reaction with sodium hypochlorite to produce sodium cyanate.

The sodium hypochlorite from the stock tanks is added to all three sumps which is automatically controlled using an analyser that measures the extent of the cyanide destruction reaction (Equation 1.16). The oxidation-reduction reaction is measured by means of millivolt ("eH" on the plant graphics: Appendix 6) measurement of the redox potential using a platinum electrode.

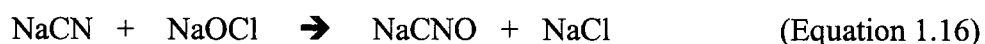

The potential (eH measurement) is affected by the pH of the effluent and sensitive to chlorite, resulting in a need to control these. The excess of hypochlorite raises the potential to an immediate plateau past the end point and a change in the pH shifts the potentials by 60mV while the difference in reactions remains the same. The sodium hypochlorite is required in slight excess to ensure the analyser can detect the fall in redox potential, required to halt the hypochlorite addition.

Emissions reaching the drain would then flow to the Billingham Beck outfall number 3 shown in Figure 1.3. This outfall known as BB03 is tidal and is a tributary of the Tees downstream of the Tees Barrage. The plant operation complies with its permit to operate from the Environment Agency, and there are no emissions to public sewers. The BBO3 outfall is the route for the cyanide effluent treatment plant as well as stormwater run-off from site roads, the site laboratories, stormwater run-off from the caustic import depot and the site restaurant. In addition 'scour water' is added to ensure that there is sufficient velocity in the drain to ensure that the suspended solids

do not settle out, which could ultimately lead to blockages. The scour water is excess water added from a separate water source, when the plant is not operational the 'scour water' is isolated.

If the treatment facility were in danger of being overwhelmed by a sudden large increase in cyanide load or if the treatment process failed to function the plant operator can divert the effluent. The flow leaving the final sump can be redirected into a large (300 m<sup>3</sup>) secondary containment pit as shown in Figure 1.3, whilst the problem is rectified. This ensures there is no loss of cyanide containment to Billingham Beck. The effluent is diverted by means of a large valve, remotely operated from the sodium cyanide control room immediately blocking all drain access. The effluent then overflows via a weir into the secondary containment pit. It takes three minutes for the diversion valve to move from fully open to fully closed position. If the diversion valve fails to close, identified from the valve position indicator in the control room, the operator would be required to manually close the valve on the plant. The plant personnel on a regular basis test the operation of the manual valve. The secondary containment pit has sufficient capacity to contain all the liquor released from the catastrophic failure of the largest vessel on the sodium cyanide plant.

The BBO3 analyser station continuously monitors the outfall for consented analytes and alarms set at warning values ensure that the diversion valve is closed soon enough to prevent consents being breached. The auto-analyser at BBO3 can also monitor for free chlorine (hypochlorite) in the treated waste by spectrophotometric measurements with ultraviolet light at 289 µm (Bainbridge, 1975). To avoid contamination with turbidity a reference band of light is used at 436 µm. The cyanide is detected using an ion selective electrode. The instrument can automatically zero its electrodes every four hours and is calibrated on weekly basis by plant personnel.

### 1.5.3 Cyanide Plant Effluent Characterisation

The cyanide plant effluent was extracted from number 1 sump prior to the addition of the sodium hypochlorite. Ten litres were obtained which were immediately bottled into one-litre bottles ready to be used for analysis, duplicate 250 ml and 100 ml volatile organic compound (VOC) samples were taken from this without any headspace, for characterisation. The importance of ensuring no headspace, i.e. no air trapped between the liquid level and the bottle top, results in accurate purge and trap analysis. Purge and trap analysis consists of purging the volatile components of the sample. If a headspace were present the volatile components would be able to gather in that headspace and would be lost on opening of the bottle top. One of the sample sets was sent out to ENRON of Teesside for full characterisation. The results obtained from Enron are shown in Appendix 7.

Purge and Trap analysis concluded there were only three major volatile components;

TABLE 1.1: Results from ENRON's Purge & Trap test

<i>Component</i>	<i>Result obtained (%)</i>	<i>Calculated or obtained (µg/l)</i>
Water	99.3	
Acetonitrile	0.63	108
Chloroform	0.07	12

The calibrated method ENRON had gave a concentration for chloroform at 12 micrograms per litre ( $\mu\text{g/l}$ ) and acetonitrile approximately 108  $\mu\text{g/l}$  (no calibration was available for this component). The acetonitrile figure was established with total normalisation of the GC percentage results in ratio with the chloroform results.

Ion chromatography was used to determine inorganic and organic anions.

ENRONs Semi quantitative inductively coupled plasma (ICP) analysis showed there was 1 mg/l silicon and 1 mg/l strontium. Quantitative IPC analysis was used to obtain the major metal components, which were found to be to be calcium & sodium with less magnesium and low mg/l levels of aluminium, boron, iron, manganese, antimony, vanadium and zinc.

TABLE 1.2: Results from ENRON's Characterisation test

<i>Component</i>	<i>Result (mg/l)</i>
Fluoride	0.2
Chloride	13
Nitrite	6
Sulphate	41
Nitrate	4
Thiocyanate	0.06
Silicon	1
Strontium	1

ENRONs analysis of the cyanide found it to be weak acid dissociable cyanide. The Cassel laboratory testing of the effluent established cyanide content of 3000 mg/l and suspended solids of 8344 mg/l.

#### 1.5.4 Chemistry of Cyanide Wastewater at Cassel

The effluent process of the waste from the sodium cyanide plant and other site cyanide containing streams are denatured in a two stage continuous process. In the first stage the waste is mixed with sodium hydroxide to ensure a pH of 11, then in the second stage cyanide is treated with sodium hypochlorite before being released down BB03 (ICI acrylics, 1998). The treatment process currently consists of adding sodium hypochlorite to react with the cyanide to produce relatively harmless sodium cyanate shown in Equation 1.17.

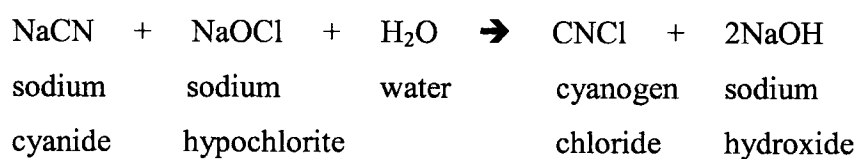

(Equation 1.17)

Cyanogen chloride is just as toxic as sodium cyanide, however if in the presence of excess sodium hydroxide the reaction proceeds further in Equation 1.18.

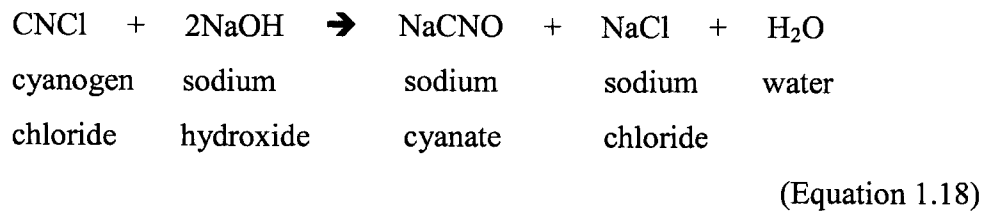

The overall reaction is shown in Equation 1.19.

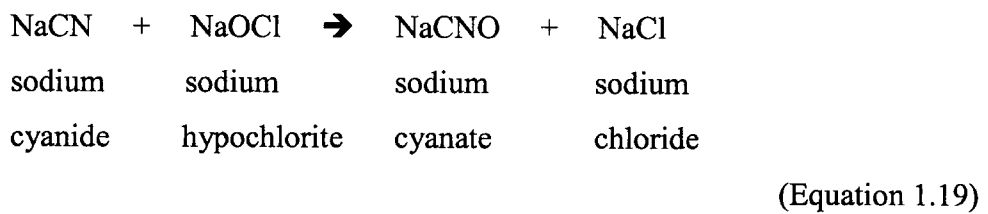

### 1.5.5 Plant Effluent Feed inputs and outputs; Mass Balance

The feeds into the effluent system are sodium cyanide, sodium hypochlorite, sodium hydroxide and hydrogen cyanide (Equations 1.20 and 1.21) with the outputs shown to be sodium cyanate, sodium chloride and water.

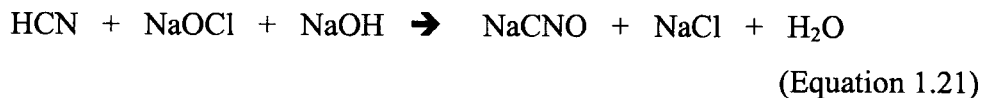

In general all mass balance system are divided into several control volumes (CV) which are connected to each other and the rest of the world by mass fluxes. For each of the control volumes a mass balance equation is written;

$$\begin{array}{l}
 \text{(Change of mass = (sum of + (sum of all - (sum of - (sum of all} \\
 \text{in CV with time) all inputs) internal sources) all outputs) internal sinks)} \\
 \text{(Equation 1.22)}
 \end{array}$$

Models can be used which predict the amount of a pollutant, which resides in each of the mediums (air, land and water) in the long term. The biosphere will effect the distribution, to a small extent, of the pollutant between these three environments. The mass balance can be calculated by the total quantity of pollutants in the environments equal to the sum of the quantities in the air, water and soil as described in Equation 1.22.

Cassel works produces a mass balance report (Appendix 8) for the sodium cyanide plant. This establishes the efficiency of the process. From this report the figures have been placed into the diagram (Figure 1.4) to show the inputs and outputs to demonstrate the change of mass of the basic components. However, the calculation for the change of mass cannot be calculated as there is no information on the internal sinks (for example carbonate solids retained in gullies, any cyanide trapped within the solid) for the cyanide plant.

FIGURE 1.4: Diagram to show inputs of cyanide and sodium hypochlorite into the Effluent Treatment system and traces present in the final effluent to BBO3

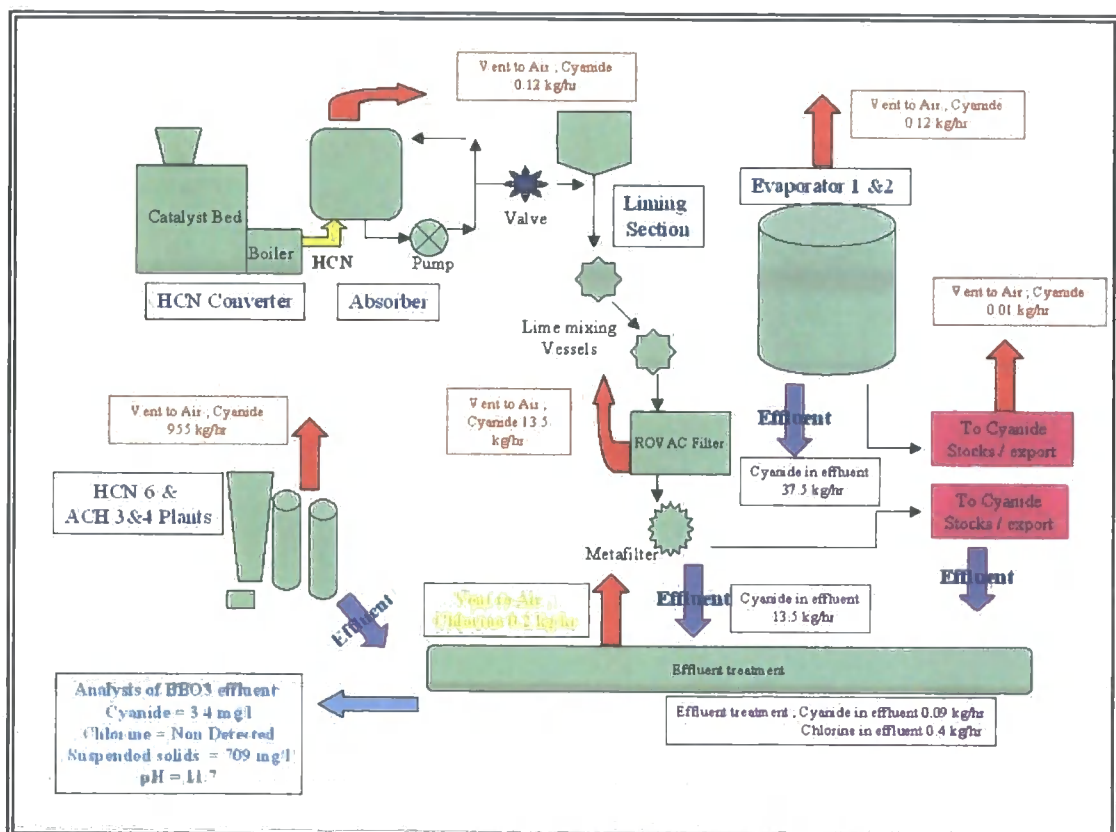

Wastewater from the converter process is estimated to contain 0.05 kilogram per hour (kg/hr) of cyanide and the amount of cyanide wastage from the SHQL process is 0.7 kg/hr. This is due to wastage at the input of the HCN and sodium hydroxide stage.

The total theoretical feed rate of sodium hypochlorite is 141 kg/hr into the three sumps from the mass balance (Appendix 7). The feed rate includes the estimated requirement of hypochlorite when the SHQL process is running at full capacity. This is an over exaggeration as the SHQL (evaporator) process is a batch process and not run continuously. On a single day the rate of sodium hypochlorite was 0.48 m<sup>3</sup>/hr but this is dependent on the amount of cyanide released from the plant at any one time. The figure 1.4 also shows the theoretical amount of cyanide from the different process and chlorine from the effluent process released to the atmosphere. The actual free chlorine in the final effluent is gained from the laboratory results of the final sump sample, other results obtained every four hours is the amount of untreated cyanide in the final effluent and its pH.

The mass balance report (Appendix 7) indicates the amount of cyanide gathered within this process that requires reacting, needs a theoretical amount of 1.9 kg/hr of sodium hypochlorite. Cyanide is oxidised to formate by hydrolysis reducing the amount of cyanide to be treated. The mass balance shows the amount of cyanide consumed to formate in the SHQL (evaporator) process is 6.9 kg/hr.

The mass balance information shown in Figure 1.4 is based on the plant process working at 135 % load and assumes the SHQL process to be continuous, however it is not. The calculations on load and the assumption on the SHQL are based on current maximum capacity for both cyanide processes. These are the results that are discussed with the Environment Agency for consents, which cannot be exceeded.

The consents are formalised and shown in Appendix 9.

Effluent from cyanide storage/offloading, HCN and ACH plants is not calculated or tested due to these being very low levels and difficult to obtain samples from.

The usual load for the cyanide plant is 60% including the shutdowns. The mass balance results are "thought" by plant engineers, to be too high for the HCN figure

(1000 kg/hr) and too low for the NaCN (0.46 kg/hr), as the cyanide figures are expressed as an average. The term “%Load” is an historic term used to describe the rate the plant works at; it is the utilisation of the plant compared to its original design capacity. Therefore, the plant running at 60% load is running at 60% of the original design capacity. The plant is able to run at 135% load because of improvements made to the plant to improve its efficiency and to enable the plant to be run at % loads greater than the original intention.

A comparison of the theoretical figures against the actual figures was obtained for a week in July 2002. The flow value from the cyanide plant has never been evaluated to establish the difference in expectations. The flow was gained by using secondary containment pit level rise and fall and the recycle flow from it. This gave the calculated flow at 100% load as 60 m<sup>3</sup>/hr. The actual amount of cyanide treated in the same week was calculated using the sodium hypochlorite stock tank levels, the raw NaCN leaving the plant in the effluent being 58 kg/hr sodium cyanide. The SHQL process is calculated (mass balance) to waste 1000 kg/hr of cyanide. The converter process is calculated to waste 0.5 kg/hr of cyanide (Appendix 7). This shows a discrepancy between the actual result of 58 kg/hr and the theoretical results for each process 1000 kg/hr and 0.5 kg/hr. There is an increase over the expected cyanide wastage for the converter process that is over compensated for by the decrease under the expected wastage for the SHQL process. This is because the SHQL process does not work continuously (being a batch process) the cyanide effluent figures in reality are very much lower. The reason for the calculation of the SHQL process assumed as continuous is because it was easier to calculate. The solids flowing from the plant was estimated by the usage of hydrated lime in the liming section (Figure 1.2) over the week and given as 149.3 kg/hr calcium carbonate.

### **1.5.6 Detrimental Effects of Sodium Hypochlorite**

The main issue with using sodium hypochlorite is the problem of chloroform formation within the drains. There is no guarantee that the effluent, which is drained through the cyanide plant effluent system, does not contain organics. The effluent

from the Border Chemicals effluent pit (the name is an historic one) is the main concern as the component characteristics of this mix of effluents from the ACH plants, including general washings and acetone from the process have not been established. The assumption is that some acetone must get washed from the process into the pit and end up in the cyanide plant treatment process. Due to the pit receiving plant washings its component content is likely to be different each time the pit is full. Therefore a definitive list of the effluent contents cannot be made, only surmised. The contents of the Border Chemicals effluent pit are only diverted to the cyanide treatment process when it is full, which occurs every few months. However, it is known to contain much higher levels of organics than the wastewater from the cyanide plant. It is important to understand that the sodium hypochlorite intended to destroy the cyanide will also be reacting with the organic carbons to produce chloroform. The electrodes in the "sumps" are engineered to work in conditions of excess sodium hypochlorite, as discussed in 1.5.2. The intention was to establish the approximate amount of sodium hypochlorite remaining in the sump effluent being diverted to BBO3 and ultimately Billingham Beck. Over August 2003 the amount of sodium hypochlorite found in the 4 sump effluent was an average of 18 mg/l, with a range between <1 mg/l and 117 mg/l at its peak on the 8th of August 2003. The amount of sodium hypochlorite used corresponds to the amount of cyanide that is being disposed of from the plant, as the levels of cyanide increase, the hypochlorite levels are increased to denature the cyanide. The average 18mg/l sodium hypochlorite is then available in the BBO3 analyser station to react with any of the components that arrive untreated from the canteen, office block and laboratory wastewater. The rainwater washings from then roads may also contribute slightly to the addition of organics in the BBO3 flow.

Mass balance calculates the volume of sodium hypochlorite used in an average year as 141 kg/hr. The predicted emissions of chlorine associated with use of hypochlorite, from the hypochlorite storage vent tanks for short term emission is  $214.8 \mu\text{g}/\text{m}^3$  which is classed as a significant emission, according to the guidelines set by the Environment Agency. To retain this method of cyanide removal more work is required to establish detailed modelling of this vent to ascertain if this is a significant release in terms of Best Available Technology (BAT).

## 1.5.7 Legislation applied to the Cyanide Plant

### 1.5.7.1 Environment Agency

The Environment Agency (EA) has responsibility for enforcing water pollution regulations under the water resources act of 1991, previously controlled by the National Rivers Authority (Ball & Bell 1997). The regulatory system involves setting water quality objectives for inland, coastal, estuarine and ground waters and there is a requirement for discharge consents to be obtained before wastewaters can be released into these waters.

Pollution of waters comes in many forms for example;

- (i) deoxygenating materials such as organic wastes
- (ii) nutrient enriching materials such as fertilisers
- (iii) solids
- (iv) toxic materials, often dependent on the level of the dose received
- (v) materials which cause an impact on amenity, such as car tyres
- (vi) disease carrying agents such as bacteria
- (vii) heat

The effect of a pollutant on a watercourse will vary according to the size, temperature and rate of flow into the watercourse. Other factors which affect a pollutants contamination effect are the oxygen content of the receiving waters, geology and presence of other pollutants and synergistic effects. The watercourse use is also important in deciding which pollutants may be permitted, if already polluted compared to those that have never been polluted. The control of pollution encompasses the control of liquid discharges to land.

The EA has a wide discretion on consent setting depending on a number of factors, but these are not stipulated, the EA are required to regard all material considerations by public law. The emphasis is on the effect on the receiving waters and then of downstream users, especially if the water is intended for supply and irrigation. The other considerations include the “cocktail” effect the discharge would have on future

discharges and the desire to minimise discharges. Certain informal standard tests are carried out on a monthly basis of the effluent being released.

The dangerous substances directive was adopted in 1976, requiring prior authorisation for discharges of two classes of pollutants to surface, territorial and coastal waters (Gillies, 1999). List I ; the “black list” of more dangerous substances, these are selected on the basis of toxicity, persistence and bioaccumulation including carcinogens, organophosphorous compounds, mercury and cadmium compounds. List II ;the “Grey List” includes less dangerous substances such as zinc, copper, lead, cyanide and ammonia. The authorisation stipulates limits on listed substances’ emissions.

Authorisations for specific industrial processes are regulated under the system of Integrated Pollution Control (IPC) (Tromans, 1993). The IPC approach is structured to pollution control with the aim of adhering to guidelines set by the Environment Agency. The IPC process considers the environmental effects as a whole including releases to air, water and land from prescribed process. The objectives are to prevent or minimise releases of prescribed substances and to render harmless any substance released from the process.

The objectives set are (Tromans, 1993);

- (i) when carrying out a prescribed process, the best available technique not entailing excessive cost will be used for preventing or reducing or rendering harmless any prescribed substance or any other potentially damaging substance
- (ii) compliance to any United Kingdom regulations and international law
- (iii) compliance with any limits or requirements and achievements to quality standards or objectives specified by the Secretary of State
- (iv) compliance with any requirement applicable to the grant of authorisation.

A prescribed process or substance are those considered to have an impact on the environment and are listed in the prescribed Process & Substance Regulations of 1991. Companies such as Lucite were required to adopt the Best practicable

Environmental Option (BPEO) (Tromans, 1993) this approach was used when different legislative bodies controlled releases to land air and water. In case of a likely release into more than one environmental medium. Best Available Technique not Entailing Excessive cost (BATNEEC) is to be used to minimise, render harmless or reduce pollution caused to the environment as a whole not just the receiving medium, having regard to the best practicable option for controlling emissions. This assessment also includes the options of operational and equipment setting out to improve the environmental performance on a continual basis. It is not restricted to the application of technology but takes into account staffing, training, building layout and maintenance.

Within 2003 and 2004 Cassel Works is expected to work to the new Pollution Prevention and Control Regulations known as (IPPC). Cassel works site as a whole was granted the IPC authorisation with the cyanide plant granted under the Cassel authorisation; AO2175/BE7770-04-30/3/99. The release point number at BBO3 is W5 and the authorisation grants release parameters on certain components (Appendix 9). A report on the released components at release point W5 is compiled on a yearly basis as a legal requirement for the Environment Agency.

The IPPC directive (1996) on integrated pollution prevention and control sets out the framework to which Cassel works is expected to comply (Gillies, 1999). Common European Community set emission limits to be applied within the framework of this directive will be adopted later. All industries are applied to the framework and require a permit to run any process. The requirements apply to new installations from the end of October 1999 and to existing installations from October 2007. Any substantial change to the operation of an installation has to obtain a new permit. Applications to permits are made available to the public to allow them to comment before the national authority makes any decision; the results are then made public.

#### 1.5.7.2 COMAH

Cassel works site also complies with the Control Of Major Accident Hazard (COMAH) regulations of 1999 (<http://www.hse.gov.uk>). Their main aim is to prevent and mitigate the effects of any accident involving hazardous substance.

Specific to Cassels' case is the sodium cyanide liquor with the strength of 30%. Sodium cyanide is listed as a very toxic substance in the COMAH guidelines. It is possible that the product itself can become a pollutant. The COMAH guidelines try to help prevent and if not ensure that in the vent of a spillage that the effects to people and the environment are mitigated. A competent authority (CA) consisting of the Health and Safety Executive and the Environment Agency enforce these regulations. Dependent on the volume of dangerous chemicals held by a company they will determine if the company site is classed as a top or lower tier site. Cassel is classed as a top tier site and must produce a safety report that includes a policy on how to prevent and mitigate major accidents. The policy shows that there is a system for implementation and identification of any major incident that may occur on and off site. Safety precautions are built into the plant and equipment for prevention of pollution for example the diversion of the effluent to the containment pit in case of a major spillage on site. The inclusion of an emergency plan and its supply to the local authorities for off site emergency planning purposes is also expected. Cassel has a major accident prevention plan that discusses the prevention of cyanide release with the use of trip systems, high level alarms and monitoring. The loss of general services, for example electricity and water, is also included and what controls are in place if this happens.

## **1.6 Aims of Study**

The aims of this study were to establish a comprehensive account of all available methodologies for cyanide destruction. Compare the methodologies and establish an alternative to the sodium hypochlorite method currently being used on the Cassel site. This is to include a method for the detection of cyanide for this alternative method and analytical methods for the analysis of the residues of the treatment process in the wastewater. The results obtained are to be statistically analysed and conclusions drawn. Recommendations are to be made on how the plant could be converted for the new process.

## **2.0 LITERATURE REVIEW**

The aim of this literature review is to comprehensively cover all the current methodologies of cyanide destruction and reduction. The more commonly known chemical and biological methods are discussed, such as thermal, precipitation methods, electrolysis, membrane electrodes, photocatalysis, filtering through packed columns and ultrasound methods. The more novel methodologies are covered including the use of macroporous copolymer resins and amorphous "aerogels" utilising sunlight.

### **2.1 Chemical Destruction of Cyanide**

Cyanide removal from wastewater is essential prior to sludge treatment processes (Domvile, 1992). Oxidation of the cyanide is completed before the sludge treatment, which in combination with an improved ferric adsorption process could be used to remove inorganic and cyanide contaminants. Catalysed oxidation of cyanide contaminants, for example with copper sulphate, may also be combined with ultraviolet photodegradation to provide substantial removal of soluble cyanide contaminants. Then the multiple stage sludge treatment process mixes sludge with the wastewater in a multiple of discrete reaction stages for relatively short retention times. These conditions which promote chemical and or physical reaction of soluble contaminants with sludge are maintained, and liquid solid separation are effected after each sludge treatment stage. The addition of powdered activated carbon and cupric chloride to an activated sludge unit has also been tested for the removal of low levels of cyanide in petroleum refinery wastewater (Huff & Bigger, 1980). According to the authors, levels of 0.5 mg/l were reduced to 0.025 mg/l with the addition of powdered activated carbon (PAC), cupric chloride and dissolved oxygen. The presence of the cupric ions greatly enhanced the adsorption of the cyanide with a removal rate increase of up to 99%. However, concerns were raised over fluctuating organic loading levels of a sludge treatment process and effects on this type of treatment.

A process for removing cyanide and base metal complexes from industrial waste streams utilises liquid sulphur dioxide (SO<sub>2</sub>) and air mixing in the presence of a soluble copper catalyst (copper sulphate) is known as the “INCO” SO<sub>2</sub>/Air process (Devuyst *et al*, 1991). The liquid sulphur dioxide is obtained from burning elemental sulphur but can be liquid, gas or a solution of sulphite salts. During the oxidation reaction acid is produced which is neutralised with lime at a pH between 7 and 10. This methodology is mainly utilised with wastes from mine tailings and plating shops. The advantage of using the INCO SO<sub>2</sub>/Air process is its selectivity in detoxifying total cyanide, which is removed as a precipitate using safe low-cost reagents. The disadvantage to this process is it is on license (73 worldwide to date), payable every year and costs approximately £3.1 million to be installed. The test results show that the reduction of cyanide using this method is from 364 mg/l down to 0.4 mg/l. The retention time to optimise the reaction kinetics varies from 15 minutes to over 2 hours but this is generally described using tailing ponds. The SO<sub>2</sub> - INCO process was patented in the United States in 1985 and oxidises free and weak acid dissociable cyanide, however hexacyanoferrates are not oxidised but removed by the precipitation process (Mosher & Figueroa, 1996).

The destruction of soluble cyanide in industrial wastewaters for some company's comprises of acidification of the stream then chlorination at a minimum of 80°C (Sury *et al*, 1979). The soluble cyanide complex breaks down into free cyanide which subsequently hydrolyses to ammonium chloride and carbon dioxide. The authors found by conducting a hot acid chlorination technique the resultant cyanide content was reduced to a level below about 1 mg/l at contact periods between 1 and 15 minutes. Ensuring the wastewater was at a temperature of 95°C or more with sufficient mineral acid to provide a pH level of 3 with additional chlorine a rapid, efficient and complete reduction of the soluble cyanide complex was achieved. It was believed that this increased speed of reaction was unfavourable to the formation of toxic free hydrogen cyanide. However, the addition of chlorine to the hot medium rapidly drives the reaction forward to completion. The excess chlorine in the effluent can then be destroyed using compounds such as sodium bisulphite, ferrous sulphate and sulphur dioxide. Sury *et al* also found that the preferred method of conducting this process was by a countercurrent column operation. The acid

washings were fed to the top of a packed ceramic column and steam added at the bottom to strip out the cyanogen chloride. A countercurrent flow of chlorine gas was used in view of its low solubility in hydrochloric acid at 80°C, efficiently utilising the chlorine through the column liquid-gas interface.

The mechanism associated with alkaline chlorination is shown below, the first stage of the reaction is formation of cyanogen chloride, which is rapid shown in Equation 2.1 (Moore, 1976).

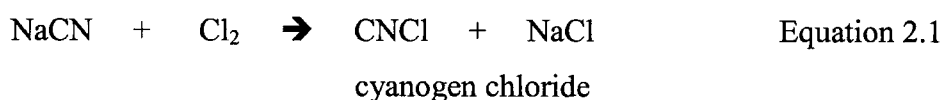

The second stage is hydrolysis of cyanogen chloride to cyanate, as shown in Equation 2.2:

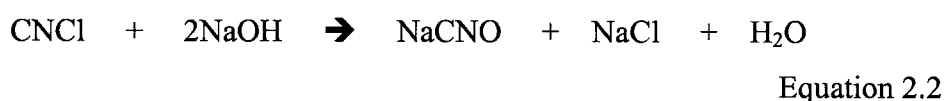

Cyanogen chloride is extremely toxic and hydrolysis is almost instantaneous at temperatures above 10°C and pH's above 11 in excess chlorine (Moore, 1976). The overall reaction can be represented in Equation 2.3:

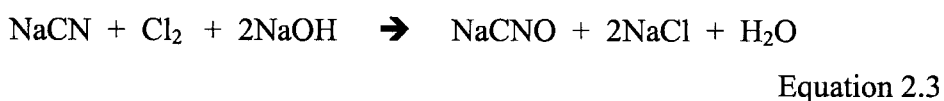

The hydrolysis of cyanogen chloride is given by Equation 2.4:

$$\frac{-d[\text{CNCl}]}{dt} = k[\text{CNCl}][\text{OH}^-] \quad \text{Equation 2.4}$$

k was calculated to be at 10°C, = 200l/mole/min and at 25 °C = 530l/mole/min. This experiment shows that increased pH or temperature accelerates the reaction.

Further reactions of cyanate are also important including the production of sodium carbonate, ammonia, sodium chloride and nitrogen especially at lower pH levels, as shown in Equation 2.5 and 2.6 (Moore, 1976):

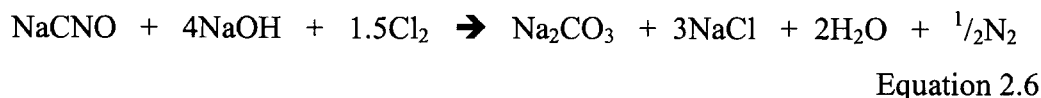

Hydrolysis of cyanate is slow in alkaline conditions but increases with a fall in pH. In 1863 a chemist called Attfield discovered the formation of oxamide crystals when experimenting on the action of high strength hydrogen peroxide on hydrocyanic acid (Mason, 1907). In 1907 Mason carried out experiments to establish the effects of hydrogen peroxide on potassium cyanide and found the reaction initially rose in temperature without any gases being evolved. Mason also found that violent reactions occurred if the experiment was not cooled. Cooling was obtained by immersing the mixing vessel in water at room temperature, this effect was partially counteracted. Using one molar solutions of peroxide and cyanide, the oxamide crystals were not produced, except when the peroxide was initially acidified with one molar or stronger sulphuric acid. Crystals (magnesium ammonium phosphate) were sometimes produced, apparently due to the impurities in the peroxide itself. Using pure hydrogen peroxide the test solution remained clear and colourless with reaction products of potassium cyanate and potassium and ammonium carbonate. The cyanide was hydrolysed forming formate and oxidised forming cyanate and carbonate. Any residual cyanide was oxidised in equal molarity to the peroxide left and the residual peroxide (when there was no cyanide present) was catalytically decomposed and oxygen evolved. The ratio of peroxide to cyanide needed to be greater than 4:5 for the reaction to take place.

The mechanism associated with the oxalate formation is shown below (Moore, 1976):

The oxalate ions show that another reaction was taking place with cyanogen forming as an intermediate, which is then hydrolysed, as shown in Equations 2.7 and 2.8.

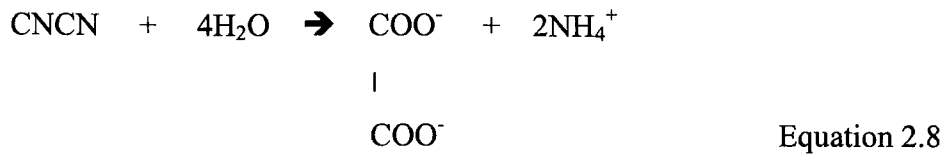

Followed by hydrolysis, as shown in Equations 2.9 and 2.10:

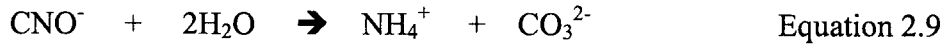

Hydrolysis reaction is shown in Equation 2.11:

This is an exothermic reaction with the production formate and ammonia.

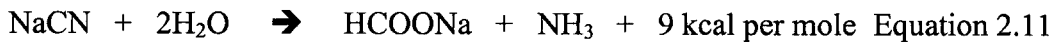

The rate constant for cyanide hydrolysis in alkaline solution is given by Equation 2.12 and 2.13:

$$k = \frac{2.303}{t_2 - t_1} \log_{10} \frac{\text{CN}_1}{\text{CN}_2} \quad \text{Equation 2.12}$$

$$\log_{10}k(\text{hr}^{-1}) = 12.126 - \frac{5017}{T} \quad \text{Equation 2.13}$$

Where T is the absolute temperature of 383 Kelvin or 110°C.

At 100°C  $k = 0.4739 \times 10^{-1} \text{hr}^{-1}$  and after 20 hours at 100°C 38.8% of the original cyanide remains.

The detoxification of effluents containing cyanide utilises a process with hydrogen peroxide and sulphuric acid (Griffiths *et al*, 1990). The reaction between sulphuric acid and hydrogen peroxide produced monoperoxysulphuric acid, with excess sulphuric acid added to maximise the amount of monoperoxysulphuric acid present in the equilibrium mixture. The pH was maintained between 9.5 and 11.5 with the addition of lime slurry. The experiments found that reducing the ratio concentrations

to one tenth gave proportions that corresponded to between 0.025 and 0.25 moles of sulphuric acid per mole of hydrogen peroxide. The reduction in the amount of acid used in turn reduced the amount and cost of neutralising agent (lime slurry) needed during detoxification of cyanide. The suspension created was filtered off and disposed of in a suitable landfill.

A method for treating wastewaters containing zinc cyano complexes included the use of formaldehyde, hydrogen peroxide and a heavy metal catalyst (Wolf, 1996). In the first stage of the reaction formaldehyde (continuous or period addition) produced cyanohydrin (glycolnitrile) and in the second the peroxide was used to perhydrolyse the glycolnitrile to glycolic acid amine and glycolic acid at a constant pH between 8.5 and 12.0 using hydrochloric acid. The source of formaldehyde is either an aqueous formaldehyde solution, an oligomeric formaldehyde or paraformaldehyde. Initially the cyanide concentrations of the wastewater were required, but the use of a pH meter eliminated the need for those initial determinations and it was used as an aid to controlling the addition of the formaldehyde and acid. On detoxification and after pH adjustment, metal hydroxide sludge present can be separated and the remaining wastewaters disposed of. The disadvantages found were that in some cases the heavy metal catalysts decomposed the peroxide before its action on the cyanide and the reuse of the catalyst or heavy metals was not viable.

The mechanism associated with formaldehyde treatment is shown below (Moore, 1976):

Formaldehyde reacts with cyanide at room temperature to form the cyanohydrin, as shown in Equation 2.14:



Equation 2.14

Alkaline hydrolysis of the cyanohydrin gives ammonia and glycollate anion as shown in Equation 2.15:



Equation 2.15

Other reactions that could occur are reaction of liberated ammonia with the cyanohydrin to form  $\alpha$ -amino acetonitrile as shown in Equation 2.16



The combination of the nitrile with one or two molecules of cyanohydrin can occur and the hydrolysis of the nitrile and its combination product produces the salts of the acids used.

The advantages of using peroxide over chlorine include the formation of non-toxic intermediates and the lack of total dissolved solids (Pak & Chang, 1997). However, it is slower due to the disproportionation reaction occurring, resulting in the production of oxygen and water. The addition of excess peroxide to overcome this problem was estimated to become costly, so the addition of a heterogeneous catalyst such as magnesium supported ruthenium at room temperature was tested. It was shown that there was a marked improvement in the speed of the reaction in the presence of this catalyst, however other factors affected the reaction including pH, temperature and the ratio of the cyanide content of the waste to the amount of peroxide used. Experiments established the optimum pH was between 6 and 8. To oxidise a solution of 0.3 mg/l of cyanide, a 0.6 mg/l solution of peroxide was found to be sufficient. In the presence of the catalyst a temperature of 50°C resulted in the optimum ratio of cyanide 1.2 to 1.6 of peroxide required.

Other processes using peroxide include the use of copper (in 2<sup>+</sup> form) as the catalyst, in order to accelerate the reaction and lower the amount of peroxide used (Proulx *et al*, 1993). The authors also used phosphoric acid with peroxide to detoxify slurries and high solid suspensions and solutions. However, as it is undesirable to add toxic heavy metals to waste water, sodium silicate was tested as a catalyst instead of the copper, which appeared to work more effectively. A source of silicon oxide was used on the wastewater, a solution of sodium silicate under alkaline conditions, with the addition of oxidising peroxide. The sodium silicate precipitated out of solution as a colloidal suspension of silicon dioxide, whereupon filtration was required. As a natural occurring material similar to sand, the silicate was discharged with the treated water.

The mechanism involved with the reaction with hydrogen peroxide is shown below (Moore, 1976):

Oxidation of cyanide by hydrogen peroxide yields the relatively non-toxic cyanate ion shown in Equation 2.17, which is subsequently, hydrolysed to carbonate and ammonia Equation 2.18:



Ozonation is an alternative treatment for the destruction of cyanides mostly used in electroplating and photoprocessing waste streams (Desai *et al*, 1998). It takes place in two stages; the first at a pH between 9.5 and 10 where a rapid reaction evolves cyanate (CNO<sup>-</sup>) and oxygen with complete oxidation of the cyanide. The second stage involves the slow reaction of cyanate hydrolysis at a lower pH of between 8 and 8.5 producing hydrogen carbonate, nitrogen and oxygen. Ozone is twice as powerful than peroxide as an oxidising agent, resulting in only 1.85g of ozone required to oxidise 1g of cyanide. A useful treatment for low concentrated cyanide wastes, ozone is very reactive and unstable and requires generation on site, resulting in high generation costs. Effective for free cyanide ozone however is unable to oxidise stable metal cyanide complexes. To overcome this it can be used in conjunction with photolysis (application of UV light) in a process called “Photozone”. Ozone is widely used in the production of drinking water and removes the cyanide, cyanate and thiocyanate with a low capital cost (Menne, 1998). Ozone should be generated on site due to handling and storage problems. The methods are highly automated with low labour requirements. Ozone can be used for batch or continuous processes. The disadvantage with the method is its sensitivity to power costs as the power consumption is high.

Batches of alkaline potassium cyanide solution were destroyed using a stirred tank reactor whilst bubbling through ozone-containing air or oxygen resulting in the formation of cyanate (Zeevalkink *et al*, 1979). It was shown that one mole of ozone oxidised one mole of cyanide. The reaction rate is so fast that it enhances the mass transfer rates of ozone. Within the experiment the conversion rate is for a given

initial cyanide concentration proportional with the ozone concentration in the gas phase and independent of the decreasing cyanide concentration.

The mechanism involved with the reaction with ozone is shown below (Moore, 1976):

The ozonised air oxidises cyanides in strongly alkaline solutions, as shown in Equation 2.19:

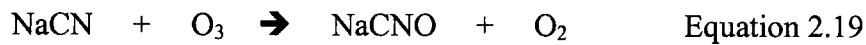

Further oxidation of the cyanate to nitrogen and carbon dioxide is slow.

## 2.2 Biological Oxidation of Cyanide

The United States Steel Corporation denatured its coke plant wastewater by reducing the ammonia by distillation followed by biological oxidation to reduce the cyanide (Glassman, 1976). The authors conventional ammonia distillation system consisted of a free still, followed by alkali addition to release the fixed ammonia, and a fixed ammonia still. Generally lime is used but due to its fouling nature the use of sodium hydroxide was considered. However, it was found that eliminating the fouling problem (lime) resulted in the alternatives being more costly. Even with the cost of the lime sludge removal the inexpensive lime made this method the most economical. After oil and tar removal the wastewater was delivered to their “CYAM” (cyanide/ammonia) system, this process which passes the wastewater into a flow of water vapour whereupon the cyanide, hydrogen sulphide, ammonia and carbon dioxide and other contaminants were removed. The ammonia vapour is then mixed with the coke oven gas and flowed to their “Phosam”(phosphate/ammonia) process . The lower liquid was treated with alkali and sent to an activated sludge system. When the “CYAM” system was used in conjunction with an activated sludge treatment plant the levels of contaminants were reduced even lower.

Previous to this work, during the late 1960’s cyanide was found to disappear from a medium supporting actively growing cells of *Bacillus megaterium* (Castric &

Strobel, 1969). This organism was isolated from a soil which had supported the growth of flax (a cyanophoric plant) for 72 years, appeared to adapt its respiration to the presence of cyanide and convert this toxic molecule into common metabolites, indicating a detoxification process.

During the 1980's a mutant strain of *Pseudomonas paucimobilis* was utilised to effectively degrade and remove 90-98% of cyanide, thiocyanate, toxic heavy metals and ammonia from the Homestake mining company's (South Dakota) discharge of 21000 m<sup>3</sup>/d wastewater (Whitlock, 1987). In the majority of biological degradation treatments, it is those indigenous microorganisms; those that have been acclimatised to the wastewater, which were the most successful. The parent strain *Pseudomonas* was isolated from the company's tailing impoundment, its ability to degrade cyanide and strong physical characteristics, motility and aggressiveness indicated it was an ideal starting point. It was subjected to increased concentrations of cyanide and specifically subjected to their wastewater. From this *Pseudomonas paucimobilis mudlock* became the patented mutant organism. Initially the cyanide species are oxidised to ammonia and the heavy metals are removed by adsorption into the biofilm, in the second stage the ammonia is converted through nitrite intermediates to nitrate and the oxidation of residual cyanide to sulphites then sulphates, continuing metal adsorption. The nitrifying bacteria require carbon dioxide as the sole carbon source and this was initially thought to be the rate limiting stage of the process. However, in large-scale operations carried out, the actual rate limiting stage was the incomplete removal of the complex iron cyanides.

A fed-batch procedure was modified and used to grow *Pseudomonas fluorescens* to feed on both free and complex cyanide (as a nitrogen source) (Kunz *et al*, 1992). The feeding process is oxygen dependent and inducible with carbon dioxide and ammonia as the resultant products. The authors concluded that there are two alternative routes of cyanide metabolism; (i) conversion to formate and ammonia and (ii) conversion to formamide. Both routes are oxygen independent. A solution of potassium cyanide with a strength of 65 g/l was tested and reduced by 90%.

In early 1990's this process was investigated utilising a system called aerobic fluidised bed reactors (Petrozzi & Dunn, 1994). The authors advised that "biological detoxification would not be applicable to the high toxic wastewater because of the

lethal combination of high cyanide and high metal concentrations contained in the wastewater that would render bacterial degradation impossible.”

Cyanide has been shown to inhibit the production of methane in the early stages of exposure, methanogens can however, adapt and recover (Yang *et al*, 1980). The cyanide does not kill the methanogens but blocks metabolism until detoxification or acclimation, therefore it is bacteriostatic rather than bactericidal (Yang & Speece, 1985).

Almond seed extracts were used to confirm the applicability of this aerobic process to treat food-processing waste streams containing low levels of cyanide with high chemical oxygen demand content (Petrozzi & Dunn, 1994). Despite the toxicity of cyanide many microorganisms have adapted to utilising cyanide as a source of nitrogen, various microorganisms can produce (cyanogenesis) or degrade cyanide. Tests demonstrated biological conversion of cyanide to formamide and ammonia in fungi in 1972. Petrozzi & Dunn found that during their fluidised bed reactor experiments, the removal of cyanide from the aqueous solution could be attributed to several reactions. These included microbial transformation/degradation, loss to the air, complex formation and adsorption. The culture used was adapted from soils using lactate as a carbon source and a retention time of 24 hours. The system was able to reduce a concentration of 160 mg/l cyanide to 0.5 mg/l cyanide with the end products of ammonia and nitrogen. The same system using ethanol as an alternative carbon source was found to be less effective, but using cyanide as the only source of carbon and nitrogen was unsuccessful. The limiting factors are oxygen transfer rate and high biomass growth and it is suggested that an anaerobic reactor would possibly offer a better process for treating these wastewaters.

A two-stage biotransformation process of an acclimated trickling filter and activated sludge process has been described using alkali cyanide (Shivaraman *et al*, 1997). Derived from a 1960 laboratory scale system that used activated sludge with dextrose supplement converting the cyanide nitrogen to ammonia and its oxidised products. In 1963 a strain of *Arthrobacter* degraded cyanide concentrations up to 60 mg/l, most processes were all single stage activated sludge or trickle filter processors. An investigation into a two-stage system comprising a “completely mixed aeration

system" (CMAS) followed by an oxidation pond was carried out. The first stage was to detoxify the cyanide and the second to stabilise the resulting ammonia with the use of nitrifying and denitrifying bacteria and algae. The system was shown to handle effluent containing 190 mg/l of cyanide and that the final effluent could also be used to dilute higher strength cyanide wastewater. Trickling filter experiments have also been tested on gold mining effluent utilising a 7.4 metre high filter, packed with polypropylene rings (Evangelho *et al*, 2001). The experiments were carried out at pilot scale and found to be useful for effluent loads with varying contaminant concentrations. It was observed that microbial activity was found to be responsible for thiocyanate degradation and copper removal. The system is stated to be easy to operate with low energy requirements. Trickling filter was shown to be capable of removing 98% of the free cyanide, thiocyanate, copper and zinc from the original effluent. Initial cyanide concentrations were given as between 21 to 35 mg/l and these were reduced to between 0.03 and 0.09 mg/l, respectively. The thiocyanate concentrations were initially between 39 and 26 mg/l and were reduced to between 0.5 and less than 0.1 mg/l, respectively. The only issue the authors found was the renewal rate of the biomass due to metal accumulation resulting in inhibition of the biological activity.

The biological treatment to reduce cyanide in the wastewater from gold ore mining utilises fixed bed reactors containing microbial supports of activated carbon, pozzolana (porous volcanic ash) and a mixture of pumice stone and zeolite (Dictor *et al*, 1997). The treatment of the cyanide waste was studied for a period of 6 months and found the thiocyanate ( $\text{SCN}^-$ ) produced from the fixed bed reactors was effectively degraded by the micro-organisms. The degradation products of the thiocyanate were sulphate, carbonate and ammonium under aerobic conditions. The ammonium is detoxified by a nitrification stage of aerobic autotrophic bacteria (*Nitrosomonas* and *Nitrobacter*) which had previously been acclimated to degrade up to 200 mg/l thiocyanate. The results of the experiments found the activated carbon the most efficient support for the removal of cyanide at 100%. The efficiencies of the other two supports were affected by the changes in feed conditions. Explanations for the activated carbons high efficiency were because of its high specific surface area providing more fixation points for the bacteria and high residence time of the effluent through the carbon.

Membrane technology utilising a surface immobilised enzymatic fraction isolated from a strain of *Pseudomonas* is known as an ultrafiltration process (Bodzek *et al*, 1996). The membrane is a flat layer of polyacrylonitrile. The optimum rates for the process in batch mode were determined, which included the transmembrane pressure and stirring rate in the bioreactor, as well as the influence of the concentration of xenobiotics (enzyme denaturers) on the effectiveness of the process. The wastewater was initially treated mechanically to remove mineral suspensions, oil and tar substances. The wastewater was then placed into an aeration tank with activated sludge adapted to decompose the toxic substances. The introduction of the ultrafiltration with enzymatic membranes at this first stage makes it possible to remove some amounts of the phenols and cyanides. The enzymes were cultivated in the laboratory by exposing the chosen bacteria to increasing volumes of cyanide and phenol. The membrane support for the enzymes was also prepared in the laboratory from the casting solution of 15% <sup>w/w</sup> polymer in dimethylformamide. The membranes were formed on a glass plate then rinsed in water for 12 hours. The enzymes were then immobilised onto the surface of the membrane by adsorption. It was found that the biodegradation of the cyanide and the phenol was slower in the real water situation than in the model wastewater, the process should be conducted in the cross-flow mode of operation, where the feed flows parallel to the membrane surface.

The polyacrylonitrile membranes were later modified chemically with hydrazine hydrate and glutaraldehyde and tested for the biodegradation of phenol and cyanide in industrial wastewaters (Kowalska *et al*, 1998). There were three types of microorganism isolated from a mixed population of activated sludge, which were adapted to the decomposition of phenol and cyanide, these were immobilised for the experiments. The membrane with a mixture of microorganisms from the strains *Agrobacterium radiobacter*, *Staphylococcus seiuri* and *Pseudomonas diminuta* appeared to be the most effective. The biodegradation coefficients of phenol and cyanide were given as 36 and 20.3% respectively.

Sequencing batch biofilm reactors (SBBR) have been used in the biological treatment of synthetic leachate containing cyanide using a mixed culture of

organisms (White & Schnabel, 1998). The organisms grew on silicone tubing and the cyanide was the sole carbon and nitrogen source. Over a 24-hour cycle they were able to consume 20 mg/l down to 0.5 mg/l and produced ammonia in an approximate yield of 1 to 1. The experiments showed that if they were fed glucose, the organisms would readily consume excess ammonia. The ratio used was 1 mole of glucose to 10 moles of ammonia. Large volumes of low cyanide concentration wastewater can be treated in the SBBR due to the steady state of the organisms.

Many gold mines in the United States of America have the problem of cyanide rich leachate from the spent ore heaps. A sequencing batch biofilm reactor (SBBR) has been developed as a mobile, closed system unit to treat these waste streams (White *et al*, 2000). The cyanide degrading microbes were fed a substrate of glucose and phosphate that enabled them to treat 0.5 mg/l per hour of cyanide. The microbes were capable of removing 20 mg/l of cyanide if provided with 156 mg/l of glucose. Many biofilm designs are open systems, which cannot be housed in warm enclosed spaces due to the evolution of hydrogen cyanide gas. In northern environments many treatment plants are located indoors due to cold outdoor temperatures which would otherwise lead to slow reaction kinetics. As with the previous experiments, if the glucose was not added the rate of cyanide destruction was greatly reduced, this design was reported to have been successful at pilot scale.

A microbiological system containing a consortium of bacteria (a species of *Citrobacter* and 3 species of *Pseudomonas*) were isolated from a soil sample and were capable of utilising metal cyanides as a source of nitrogen from electroplating wastewater (Patil & Paknikar, 2000). The experiments show that the optimal conditions for biodegradation were:

- (i) ensuring the wastewater was at pH of 7.5
- (ii) a temperature of 35°C
- (iii) an inoculum size of  $10^9$  cells/ml
- (iv) a glucose (as the carbon source) level of 0.6 ml/l.

Precipitates were found after biodegradation and established to be metal hydroxides. The experiment was then carried out in a 27 litre rotating biological contactor (RBC)

in continuous mode for 15 hours and found to be greater than 99% efficient at removing 25 mg/l of cyanide in sugarcane molasses.

A study investigated the short and long term effects of increasing levels of cyanide to an upflow anaerobic sludge blanket reactor (UASB) (Gijzen *et al*, 2000). The UASB was operated with a hydraulic retention time of 12 hours. The acetoclastic and hydrogenotrophic methanogenic populations in the cyanide acclimatised and non-acclimatised UASB sludge was tested using a batch process of incubation, with the substrates of acetate or formic acid. Both reactors were set up with an inoculation from a working UASB plant and artificial wastewater supplemented with micro-nutrients. Starch and fatty acids were added to obtain the desired levels of chemical oxygen demand (COD). The feed was kept at pH 7 whilst the solution was continually stirred in a refrigerator kept at 6°C. The reactors were ran at 33°C and ran for 92 days identically, then from day 93 onwards increasing concentrations of potassium cyanide were added to the media feed for reactor 1 whilst reactor 2 was operated as a control. The studies showed that once the sludge was acclimatised to the cyanide gradual increases were tolerated and degradation was taking place. Sludge activity tests showed that the hydrogenotrophic methanogens were less sensitive to cyanide compared to the acetoclastic methanogens. The high cyanide concentrations at short hydraulic retention times resulted in volumetric loading rates of 250 mg/l of cyanide. The cyanide degradation efficiency was estimated to be around 91 to 93%.

### **2.3 Enzymatic Processes**

An immobilised fungal enzyme has been developed from *Fusarium lateritium* by ICI (Imperial Chemical Industries) known as Cyclear™ for the detoxification of cyanide (Desai, 1998). It is supplied in the form of granules to be used in batch or continuous reactors apparently treating cyanide levels of between 200 and 10000 mg/l. However, it is sensitive to salts of heavy metals commonly present in cyanide wastewaters and ineffective for complex metalocyanides.

Another enzymatic biocatalyst is Cyanidase™, characterised by its high affinity and high stability towards cyanide (Basheer *et al*, 1992). The cyanide content is reduced to less than 0.02 mg/l in the remaining sample. Cyanidase biocatalyst was developed by Novo Nordisk A/S in Denmark and based on gram-negative bacterial isolates from *Alcaligenes denitrificans*. The biocatalyst was then sieved and kept under nitrogen atmosphere at 4°C. The “cyanidase” was packed in a fixed bed reactor and 100 ml of 30 mg/l cyanide solution at a pH of 7.4 was passed through the catalyst bed. The influence of common ions on the reactivity of the bed was established and ions found in low concentrations did not influence enzyme activity. The long term operational stability was also checked, with a steady state gained after two and half-hours, with an initial conversion of 84% of the cyanide. Under these experimental conditions the half-life of the enzyme was eleven days. The enzyme decomposes the cyanide down to ammonia and formic acid in one step.

## 2.4 Thermal Destruction of Cyanide

The reactor and heat exchanger system for the removal of cyanide from wastewater uses a reactor operating at sufficiently high temperatures and pressure to effect hydrolysis of the cyanide in the wastewater (Robey, 1989). The incoming wastewater is heated from the hot reactor effluent using the heat exchanger giving a large temperature gradient between the effluent streams. This allows for significant hydrolysis of the cyanides and formation of a scale on the hot surfaces of the heat exchanger. The reactor is designed for intermittent discharge of effluent for brief intervals, which avoids solid build up in the system.

Wet air oxidation (WAO) is the oxidation of dissolved or suspended organic substances by oxygen or air (at high temperatures ranging from 175 to 320°C and 300 to 3000 Psig (pounds per square inch guage) pressures) in the aqueous phase (Desai, 1998). The WAO method was found to be effective for high strength cyanide wastewaters including acetonitrile wastewater, those which are too expensive to incinerate and too toxic for biological treatment. The process is capable

of treating both organics and inorganics simultaneously however, the running costs are very high.

## **2.5 Removal of Cyanide by Precipitation**

One of the oldest common methods of purifying wastewater of cyanide ions is by binding them to non-toxic compounds of divalent ferrous salts. The difficulty is in separating the finely dispersed slime of the divalent ferrous cyanide (Evtyugina *et al*, 1984). The method of flotation using a cation surface-active substance (SAS) - quaternary ammonia and pyridine salts was used as a flotation reagent. The method included the use of a trivalent iron (iron sulphate) resulting in the production of roughly dispersed, easily precipitated composite ferrous cyanide. The pH was between 8.8 and 9.2 with the addition of iron chloride until the pH was between 6.8 and 7.2 with airflow of 300 ml/min(millilitre per minute); the SAS with a concentration of 40 mg/l was discharged. The cyanide levels must be greater than 80 mg/l for this system to work effectively.

Polysulphides have been used in the conversion of cyanide from coal gasification wastewater to the more treatable thiocyanate chemical form (Trofe & Page, 1985). The results of lab studies were obtained to establish the design data for cyanide conversion. The polysulphide solutions were used to scrub hydrogen cyanide from gas produced in the fluid catalytic cracking (FCC) and coking processes, others have treated concentrated cyanide solutions from electroplating shops with polysulphides. Batch kinetic tests were carried out with known amounts of polysulphide and the initial rates were used to determine kinetic parameters. The effects of pH were also looked at and at pH of 8 the reaction was very slow while at a pH of 9 it was faster. The effect of temperature on the rate of reaction saw a twofold increase for every 12°C. Two types of reactor were looked at; plug flow (PFR) and continuous flow (CFSTR). Studies showed that the retention times required to convert the cyanide present in the wastewater down to 0.5 mg/l was 41 hours for the PFR and 6580 hours for the CFSTR. However, using two CFSTR in series reduced the retention times to one-sixth of that required by the single. The treatment of cyanide with polysulphide

in gasification wastewaters is the treatment most applicable for low flow/high temperature effluents. The reaction of polysulphide-sulphur on cyanide wastewater was also studied (Granczarczyk *et al*, 1985). It was as early as 1896 when this reaction was used to remove hydrogen cyanide from coke-oven gas. In the studies the source of the polysulphide-sulphur was given as a commercially available pesticide/fungicide "limesulfur". The experiments were conducted using sealed glass bottles, kept in the dark at 3°C. The total cyanide content of the bottles was tested every day for at least 6 days. The experiments undertaken found moderately exothermic but very rapid degradation of cyanide. The greater the concentration of cyanide present the greater the amount of polysulphide-sulphur was required. The polysulphide-sulphur was capable of removing the more stable metal-cyanide complexes. The thiocyanate was produced from the cyanide within 3 days. It was stated that this reaction provides a safe, effective and practical means of detoxifying highly concentrated cyanide waste solutions and making this ideal for small-scale processes and developing countries due to its simplicity and readily available polysulphide reagent.

## **2.6 Removal of Cyanide by Electrolysis**

An alternative method for the removal of cyanide from wastewater is electrolysis (Yang, 1994). The method uses an electrolyser cell containing positive and negative electrode plates, where the wastewater is combined with salt at high concentrations. In this study, the pH was maintained at 10.5 with the use of hydrochloric acid and sodium hydroxide. The wastewater was mixed using air and a current was applied. The cyanide decomposed and the metals were separated out. The waste gases were directed to the purifying tower by use of a fan, the gas was sprinkled with liquid alkali purifying the gases before release.

The mechanism involved in electrolysis is shown below in Equation 2.20 (Moore, 1976):

The principle products of reaction are ammonium and cyanate ions. Urea and carbonate ions (along with hydrogen gas) have also been found to be consistent with the anode reaction.

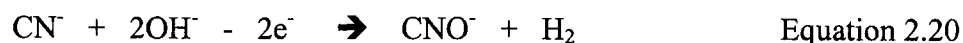

Followed by hydrolysis, as shown by Equations 2.21 and 2.22:

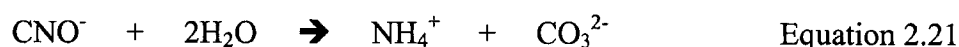

Electrochemical methods were tested to establish the most effective one for the destruction of radioactive and hazardous (mixed) wastes at a bench scale (Dziewinski *et al*, 1998). The equipment used was flow-through cells, a membrane cell and a graphite packed bed cell. Test methods included open cell electrolysis, pulsating current, and mediated electro-oxidation. The study established with the 12 litre cell, that the graphite anode was the most suitable of the ones tested. These included aluminium, copper, and graphite. During electrolysis it was found that efficiencies exceeded 100% indicating a chemical reaction was also taking place. The reaction taking place was found to be the production of cyanide radicals due to high cyanide concentrations. The radicals formed at the anode and tended to polymerise with hydronium ions to form azulmine (a polymer of hydrogen cyanide). Formation of azulmine was dependent on the ratio of cyanide to hydroxyl ions, with a ratio above 5 giving the solution a yellow discoloration after electrolysis. When this ratio dropped the solution began to clear and as the electrolysis finished, only carbonate and ammonia were left in solution.

Experiments have been devised using packed bed electrodes which have been found to be effective up to a thickness of 1.9 cm (Ho *et al*, 1990). The use of stainless steel fibre as packing material with a layering effect helps to remove cyanide at the anode and copper at the cathode simultaneously. The feed solution was a mixture copper cyanide and potassium cyanide in solution. This was fed through the reactor from the bottom to the top with a pH between 11 and 12 during electrolysis. The copper was

found to speed up the reaction along with the multiple electrodes useful on scaling up the experiment with the possibility of reducing energy consumption. The current efficiency was found to be 80% even with low cyanide strength, this coupled with the low electrical resistance (advantage of the multiple electrodes) resulted in low energy consumption.

Destruction of copper complex cyanides within an electrochemical reactor has been developed to recover the copper in a lab scale-based environment (Szpyrkowicz *et al*, 2000). The experiments establish the difference in using stainless steel plate and titanium/platinum anodes. Under highly alkaline conditions copper oxide was generated and deposited on the anode surface in both reactors. It was established that under highly alkaline conditions (pH above 12) and at high copper concentrations the reactor with titanium/platinum anode proved to have slightly better performance resulting in efficient degradation of cyanide with the highest current efficiency. The copper being deposited could also be re-used. The experiments established that if energy consumption was a determining factor then the stainless steel anode reactor was to be used in continuous mode and titanium/platinum anode for batch-wise functioning.

Along these same lines, the use of an electrolysers was described using an anode separated from the cathode by a semi-permeable diaphragm to the cathode (Bernat, 1979). The diaphragm was permeable to cations, with an alkali solution passing through it. The wastewater was added to the anode, at a rate in proportion to the current flowing to the cell, where it was oxidised and the cations simultaneously discharged at the cathode. The cyanide was destroyed in two stages, oxidation to cyanic ion and subsequently to nitrogen and carbon dioxide. At the end of the operation oxygen was liberated and the pH fell in the anode compartment, this was adjusted to between 11 – 13 using sodium hydroxide.

Cyanide has been catalytically oxidised by oxygen in the presence of heterogeneous catalyst, activated carbon (Bursova & Moiseeva, 1989). The study tested the adsorption of complex zinc and copper cyanides onto three different types of “Soviet carbons” (type SKT, BAU, AG-3), with BAU exerting the highest catalytic effect and the copper cyanides oxidised at a higher rate, due to the added catalytic effect of

the copper. The process was shown to take place in three stages, adsorption of the cyanides and oxygen on the carbon, oxidation of the complex ions (cyanide) with simultaneous hydrolysis of the dicyanogen, then oxidation and hydrolysis of the cyanates and resulting in the generation of active catalyst centres. The advantages given for this process include that it takes place in a neutral medium with no chemicals necessary, with no residual salts or contaminants. The catalyst process is automated with low labour demands, lower energy demands and lower capital costs, with an estimated capacity of 240 m<sup>3</sup>/day.

The mechanism involved in catalytic degradation is shown below in Equations 2.23 and 2.24 with aerated wastewater using granular activated carbon as the catalyst (Moore, 1976):



The hydrocyclone cell (HCC) has been tested to establish its effectiveness on the oxidation of dilute electroplating cyanide rinse water (Dhamo, 1996). Oxidation of the cyanide occurs at the graphite anode while silver is obtained by electrodeposition, from the rinse waters. The process is surmised to occur mainly with one-electron transfer, through cyanogen and cyanate as intermediate species. In open bath conditions and there is a continuous flow through cathodic and anodic compartments, as described by this system, the cyanide could be produced by the direct oxidation of air or the generated peroxide. The cyanide could be lost as hydrogen cyanide, which could not be excluded or prevented. The cyanide in solution was in the range of 2.5 to 0.69 mg/l and destruction occurred at almost constant rate which lead to the formation of carbon dioxide and nitrogen.

A gas-sparged hydrocyclone reactor (GSH) has also been tested for the treatment of cyanide solutions by oxidation with chlorine dioxide gas (Parga & Cocke, 2001). Chlorine dioxide is similar to chlorine in odour and effect. It readily decomposes on exposure to ultraviolet (UV) light and is extremely sensitive to temperature and

pressure variations. But can be handled safely in the gaseous phase at 10% by diluting with air or nitrogen. It is highly soluble in water but does not react with it but aeration or exposure to UV light will destroy it. The reaction showed that 5.2 kg of chlorine dioxide would be needed to destroy 1 kg of cyanide. The experiments showed that at a pH of 11.23 with cyanide strength of 250 mg/l a maximum reduction of cyanide was obtained down to 53 mg/l. This system has the benefits of reduced processing costs with high capacity and efficiency.

An electroflotation device was built to deal with ground water contamination in situ (Poon, 1997). This device combined a platinum clad columbium screen as an anode and stainless steel screen as a cathode with rock salt solution as the electrolyte, contained within a 910 cm deep polyethylene tank. The electrolyte was of similar strength to that of seawater and on electrolysis generated hypochlorite to oxidise the cyanide and hydroxides to form metal hydroxide precipitates. The cyanide in solution was in the range of 82 to 191 mg/l and was reduced to less than 0.05 mg/l after the 75-minute hydraulic retention time.

The reduction of cyanide in wastewater has been described by the use of a bipolar trickle tower electrochemical reactor (Ögutveren *et al*, 1999). This system efficiently utilises 32 layers of graphite Raschig rings in a tower. The anode at the top with electrolyte distributed by a perforated ceramic disc by gravity in continuous (by peristaltic pump) and re-circulating modes, the use of more energy decreased the amount of cyanide that remained. The advantage of this electrochemical method is the destruction of cyanide at the anode and the collection of heavy metals at the cathode simultaneously without generating sludge (the problem experienced by the chlorination method). This method can also process complex and concentrated cyanide wastes but has only been carried out in a pilot plant. The process operates for cyanide concentration of 500 mg/l by addition of sodium chloride and an indirect in-situ electrochemical liberation of hypochlorite resulting in oxidation of the cyanide wastewater. For stronger cyanide solutions a direct oxidation of the cyanide at the anode occurs which decomposes to carbon dioxide, nitrogen and ammonium carbonate depending on the pH. Iron ions were shown to interfere while zinc, copper, nickel and cadmium was shown to promote the oxidation of the cyanide.

## 2.7 Removal of Cyanide by Membrane electrodes

The wastewater purification automatic control system has two sensors, membrane selective electrodes specifically for cyanide with one at the inlet to the reactor and one at the outlet (Karpunin *et al*, 1976). Depending on the signal obtained from the first sensor, the correction unit limits and increases the amount of reagent dispensed. The signal from the inlet is balanced with that from the outlet controlling the reagent due to the concentration difference and improves cyanide removal.

In combination with a batch reactor a technique utilising a liquid membrane to aid in the separation of cyanide in wastewaters was found to be highly selective and rapidly effective (Xueling *et al*, 1989). Studies were carried out to establish the optimum operating conditions of the system. The internal phase utilised an aqueous solution of sodium hydroxide, which ionised the sodium cyanide to cyanide ion and a sodium ion. The membrane of oil (mix of paraffin and kerosene) phase contained surfactant, a non-polyamine –E644. The surfactant was the most important factor effecting the membrane performance by emulsion stability and mass transfer rates through the membrane. The speed of mixing had very little effect, while pH was most effective between 6 and 7. Temperature was found to have a complex effect on the membrane varying its physical and chemical properties. As the temperature increased the viscosity of the oil decreased, then selectivity of the membrane decreased, the optimum temperature was found to be 30°C.

The use of a gas membrane in cyanide recovery has been explained within a four-stage process (Kenfield *et al*, 1988). Initially strong acid is pumped through an ion exchanger, this enables hydrogen cyanide to become the predominant cyanide species. In the second stage the eluate containing the hydrogen cyanide is fed to the gas membrane module where the gas is diffused through the membrane wall. The hydrogen cyanide dissolved at the wall now volatilises and diffuses across the gas-filled pores of the membrane. The last step involves the hydrogen cyanide diffusing into the stripping solution of sodium hydroxide reacting to form sodium cyanide. Mass transfer studies were completed on this process and the rate of transfer across the gas-permeable membrane was established to be rapid and complete. It is limited

by the diffusion within hollow fibres but is also influenced by the rate of reaction of the hydrogen cyanide with the base outside of the fibres. Copper and silver cyanides are less readily treated by this method while effective separation is gained from zinc and cadmium cyanide wastes.

A gas-filled membrane (GFM) is a hydrophobic microporous membrane in which the pores are filled with gas, especially suited to separating and recovering volatile substances from water (Shen *et al*, 1997). The system used the GFM and a chemical absorbent such as sodium hydroxide or hydrochloric acid to recover the hydrogen cyanide (HCN), water was driven back and air was confined to the membrane pores. Initially the HCN diffused through the boundary layer to the feed-membrane interface, then through the membrane pores to the stripping side of sodium hydroxide. The HCN immediately reacted with the caustic and was recovered in the non-volatile form of sodium cyanide. The advantages of gas-filled membrane absorption are that the cyanide can be recovered rather than destroyed, no secondary pollutants are produced, the energy and chemical requirements are low and the equipment is simple and easy to operate. For this process to work effectively the membrane required regular cleaning as fouling was found to be one of the biggest problems. The forms of fouling are suspended solids, colloids, microorganisms, and microorganic compounds, which could be removed by back washing.

## **2.8 Removal of Cyanide by Photocatalysis**

In 1990 toxic waste was being denatured by the use of sunlight energy (Hecht, 1990). Sunlight was intensified one thousand times with solar reflectors to create temperatures of 1000°C and used to destroy dioxins at lower temperatures than conventional incineration, leaving fewer by-products. Whilst in New Mexico solar energy was being used in conjunction with titanium dioxide catalysts to destroy concentrated organic liquids and organic compounds in water. Other scientists had used solar energy and within five minutes had reduced trichloroethylene from 1.2 mg/l to less than 0.05 mg/l.

A few years later, complex cyanides such as nickel, iron and cobalt were being oxidised using UV-irradiated titanium dioxide microelectrodes (Bhakta *et al*, 1992). The photocatalytic oxidation of cyanide takes place principally at the titanium dioxide semi-conductor – solution interface. It was necessary to have a large surface/volume ratio for the titanium dioxide. This was established by keeping the titanium dioxide in the form of a colloidal suspension or “sol”. The sol was prepared by adding titanium tetrachloride into cold water and stabilising the sol in an alkaline solution with vinyl alcohol. The experiment consisted of adding the sol into a fused silica cuvette with a known amount of potassium ferricyanide and exposed to UV light. The highest rates of cyanide degradation were observed at a pH of 10. The experiment was repeated using inexpensive solar radiation as the UV source and with the titania sol, photocatalysis of the cyanide waste was observed after an hour and a half. The non-toxic titanium dioxide sol colloid can be easily coagulated and removed after the degradation reaction. The precipitated titania can be recycled to make fresh titanium tetrachloride. However, the authors suggest further work is necessary before this can become a reality.

Photo-oxidation leading to detoxification of various cyanide species was investigated with the use of titanium IV oxide catalyst (Rader *et al*, 1995). The studies were carried out with a simulated sunlight source and with and without the titanium oxide semi-conductor photocatalyst. Free and complex cyanide ions were oxidised by this method, into nitrate via cyanate and nitrite. A litre of waste containing cyanide was placed in a PVC dish and placed within the solar simulator, 10 g of titanium oxide powder was added. The solution was 3 cm deep with the dish and controls were set up in conjunction, they were placed in the irradiation source for 24 hours a day, samples for testing taken at regular intervals. The cyanide levels were found to decrease to below detection within 3 days.

Studies have been carried out using the photocatalytic oxidation of cyanide in aqueous titanium oxide suspension irradiated by sunlight in mild and strong oxidising conditions (Augugliaro *et al*, 1999). The strength of the cyanide solutions, the catalysis amount and the concentration of phenol used in the presence of hydrogen peroxide influences this method. The photoreactivity experiments were carried out using compound parabolic collectors (CPC). The catalyst used was

polycrystalline titanium dioxide (from Degussa) consisting of 80% anatase and 20% rutile. The reacting mixture was mixed with sodium hydroxide until it reached a pH of 10, then the cyanide and catalyst were added. The tubes were filled and were operated for 20 minutes. The oxygen required for the experiment was obtained while the solution was in a holding tank open to the atmosphere. The oxidation products were found to be cyanate, nitrite, nitrate and carbonate. At mild oxidation conditions of the photoprocess the nitrogen mass balance, carried out on the dissolved compounds indicated that some volatile species were formed. The addition of hydrogen peroxide resolves this issue. The efficiency of cyanide oxidation was shown to decrease in the presence of phenol.

The advanced oxidation processes (AOP) exploit the high reactivity of the  $\text{OH}^\bullet$  (radical) in driving oxidation reactions (Malato *et al*, 2001). The process utilises sunlight to produce hydroxide radicals (in the study as at pilot-plant scale) in a solar photocatalytic reaction. Two AOP systems were evaluated; heterogeneous photocatalysis with titanium dioxide and homogeneous photocatalysis by photo-Fenton process. The first detoxification process utilises the near-UV part of the spectrum (shorter than 380 micrometer ( $\mu\text{m}$ )) to photoexcite a semiconductor catalyst in the presence of oxygen. The commonly used catalyst is the semiconductor titanium dioxide as it is cheap and non-toxic. The second process produces the OH radicals by Fenton reagent; hydrogen peroxide is added to iron 2+ salts. Organic pollutants were degraded quicker when the Fenton-like reagent was exposed to UV-VIS (visible) light. The disadvantage of this process is that it cannot degrade high COD wastewater with incurring high usage of expensive reactants.

## **2.9 Removal of Cyanide by filtering through packed columns**

Substances that increase the chemical oxygen demand of wastewater include; cyanide, sulphide, thiosulphate, mercaptan or disulphide (Yan, 1994). A method for reducing the chemical oxygen demand of wastewater was established by passing air (used as an oxidising agent) through the water then passing the water through an absorbent porous solid, such as a zeolite, erionite or chabazite. To facilitate the

oxidation of the wastewater, the porous solid is partially ion-exchanged using copper as the catalyst for the process. The packed column was found to reduce the offensive substrates and minimises the deposition of undesirable residues or solids. The copper was leached from the substrate by ammonia, but was reduced depending on the zeolite used.

Removal of cyanide from aqueous solutions using impregnated activated carbon has been established as a cost-effective method (Adhoum & Monser, 2002). The method uses activated carbons in packed fixed bed columns. These are carbonaceous adsorbents with silver and nickel distributed on their surfaces, which optimises the properties of the activated carbon giving greater cyanide removal capacity to the carbon. The impregnated materials were tested against the non-impregnated ones resulting in the silver impregnation was shown to have a cyanide removal capacity of nearly two times that of the nickel and four times that of the plain activated carbon. The tests used activated carbon with a particle size of 100-150  $\mu\text{m}$  and potassium cyanide at 40 mg/l in a caustic solution with a pH greater than 11 to ensure hydrogen cyanide gas is not produced. The tests showed using the silver impregnated activated carbon that solutions containing 200 mg/l or less of cyanide can be totally removed from the solution. Alternatively these carbonaceous adsorbents (modified activated carbons) within fixed bed reactors could be impregnated with tetrabutyl ammonium iodide (TBAI) and sodium diethyl dithiocarbamate (SDDC) resulting in their surfaces being immobilised. The addition of modified impregnated carbons enhanced the removal capacity of the carbon, increasing the cost-effective removal of metals and cyanide from the electroplating unit wastewater (Monser & Adhoum, 2002). The tetrabutyl ammonium (TBA) column was used for the cyanide removal and SDDC for multi-species metal ion removal. The cyanide content of the wastewater was 40 mg/l, which was reduced to 2 mg/l. Some considerations are important with certain functional groups on activated carbon such as phenolics, lactonics and carbonyl groups that could be formed during the activation process and the functional groups on the immobilising agents that selectively formed bonds with the ions.

## 2.10 Removal of Cyanide by Ultrasound

In the process of aluminium smelting, carbon cathodes are used which during this process become contaminated with fluoride, cyanide and sodium, which need removing before their disposal (Saterlay *et al*, 2000). The studies followed the leaching of powdered and crushed carbon samples in aqueous solutions in the presence and absence of ultrasound by using a sonic horn that operated at 20 kilohertz (kHz). Total leaching was demonstrated after 20 minutes of sonication using ultrasound. However, the size of the particles was also important and was established at below 5 mm. The cyanide was found to be destroyed in the presence of ultrasound, it was suggested that hydrogen peroxide was generated by the sonication of the water, and its oxidative action on the cyanide removed it. There are many reports of the use of sonochemical degradation of organic compounds, stating that ultrasonic radiation appears to be an effective method in the removal of pollutants in waste water, for example chlorinated hydrocarbons, pesticides and aromatic compounds (Gondrexon *et al*, 1998). Cavitation is cited to be the main alternative for degradation due to its chemical and physical effects with many sonochemical reactors available, but it is rare to find a scaled up version for wastewater treatment. The degradation of pentachlorophenol (PCP) has been investigated at laboratory scale in a continuous flow reactor. A peristaltic pump was used to produce the flow that could be altered and the PCP solution contained in a stirred vessel. The reactor consisted of three ultrasonic units connected by plastic pipes. The performance of the experiment was shown to depend upon the operating parameters such as flow rate and ultrasonic power, with increasing ultrasonic power increasing the degradation due to the enhancement of the cavitation zone. The study showed that there was 80% degradation but reservations were held on the scale up of the experimental device with the envisaged technical problems.

Ultrasonics have also been introduced into the electrochemical environment, with a source of high-intensity ultrasound from a horn type transducer being inserted into an electrochemical cell (Hardcastle *et al*, 2000). The ultrasound intensity being localised at the working electrode found the cavitation effects accounted for the increased mass transport within the cell. One of the major factors cited was the presence of

cavitation in both the bulk and interface of the solution. "Hot spots" are said to be produced by voids (gas bubbles) in solution affected by the oscillating pressure field. One of the reported experiments uses a weak potassium cyanide solution in caustic within a sonochemical reaction vessel and an ultrasonic horn. The decrease in cyanide level was detected using an ion-selective electrode. The rate of cyanide destruction was greatly dependent on the power of the ultrasonics as well as the volume used in the experiment. It was demonstrated that as the volume of sample increased the cyanide reduction was increasingly limited. Limited cyanide removal could be due to the sonochemical reactions taking place close to the tip of the horn and therefore increasing the reaction volume decreases the apparent rate of cyanide removal. Problems stated with this experiment were the erosion of the surface of the electrode and the break-up of the conventional mass transport models for the convective diffusion process at the electrode/solution interface.

The ultrasonic irradiation of chemical contaminants in water has been tested in batch reactors using frequencies between 20 and 500 kHz (Hoffmann *et al*, 1996). The transformation of chemical such as esters, chlorinated hydrocarbons, pesticides and explosives into short chain organic acids, carbon dioxide and inorganic ions as the final products have been shown. The localised high concentrations of hydroxyl radicals and hydrogen peroxide in solution during sonication induce high-localised temperatures and pressures and the formation of transient supercritical water. The two areas where the chemical activity takes place during the cavitation event are in the centre of the collapsing bubble and the thin shell of superheated liquid surrounding the vapour phase. During the cavitation bubble collapse the water undergoes thermal dissociation within the vapour phase producing the hydroxyl radical and hydrogen atoms. The atoms produced ensure effective rapid destruction of organic compounds.

Pulsing operation has been used to optimise a sonochemical reactor determined by the measurement of sonoluminescence (Mitome & Hatanaka, 2002). The high amplitudes of sound can enhance the reaction when the power level is kept at a constant low. At high power levels, the quenching effects from excessive sound pressures appear and pulsing operation is not effective. The pulsing was found to be

more effective at high frequencies corresponding to the “Bjerkness” secondary force and production of clusters of cavitation bubbles.

Organic compounds in aqueous solutions behave differently when subjected to ultrasonic irradiation depending on their physical and chemical properties (Pétrier & Francony, 1997). The degradation rates of phenol and carbon tetrachloride were assessed at different frequencies. It was found that sonication decomposed carbon tetrachloride more easily than phenol.

The degradation of *p*-chlorophenol was tested using three methods of sonication, beaker system, cup-horn and probe (Teo *et al*, 2001). Their emitted sonication surface areas were calculated as 70.8, 38.5 and 1.8 cm<sup>2</sup> respectively. A temperature variation was also noticed during the reaction of between 36 and 39°C. The beaker system had a higher frequency and higher power output than the horn system, while the probe system had the highest power output. During a 20 minute reaction, half of the *p*-chlorophenol was degraded by the probe system, a quarter degraded with the beaker system and only 2% degraded using the cup-horn system. However, the beaker system was slower but 100% degradation was achieved within 2 hours. Hydrogen peroxide was found to contribute to the degradation of *p*-chlorophenol but concluded to only play an auxiliary role. As with other technologies it was stated that more work was required before this approach could be applied for practical wastewater treatment.

## **2.11 Removal of Cyanides by Polymers & Resins**

The use of a macroporous copolymer resin having N-chlorosulfonamide groups was shown to remove cyanide ions from aqueous solutions (Kociolek-Balawejder, 1997). The redox copolymer “poly(S/DVB)” (styrene/divinylbenzene) resin contains active chlorine in functional groups with oxidative properties. It was tested, by adding the effluent with the copolymer on a shaker, for the possibility of oxidising the cyanide ions to less toxic / non-toxic compounds, in media with different cyanide concentrations and varying pH's. They showed that in many of the experiments the

cyanide concentrations of the solutions in contact with the resin dropped below 0.05 mg/l cyanide. One mole of the activated chlorine reacted with one mole of cyanide ions. Results also showed that oxidation of the cyanide ions was faster in weakly alkaline mediums and the cyanide ions were effectively decomposed by the action of the N-chlorosulphonamide resin. It was also noted that the resin N-chlorosulphonamide groups, could be regenerated by the use of hypochlorite solutions.

The use of polymeric ion exchange and chelating resins in gold recovery are continually being researched (Kolarz *et al*, 1998). For gold cyanide removal, batch tests have been carried out to establish the best combination of ligand basicity, hydrophobicity and structure, which influence sorption. The authors have optimised the conditions of the reaction of N-substituted amides between nitrile groups of acrylonitrile/vinyl acetate/divinylbenzene (AN/VA/DVB) copolymer and aminoguanidine bicarbonate (AGB). It was found that when water was used as a solvent in an aminolysis reaction the structure of the resin remained similar to that of the starting copolymer. Sorption of the gold cyanide under alkaline conditions with potassium cyanide present was dependent on the acrylic resins but not on the amino group content. Resins modified with AGB in a butanol/water mix were 9 times more efficient at cyanide removal than those modified in water. The highest amount of gold cyanide was sorbed on the polymers;

Methyl acrylate/ trimethyl-olpropanetrimethacrylate (MA/TMPMA) and vinylbenzylchloride/styrene/divinylbenzene (VBC/St/DVB). The latter polymer was said to contain 2% weight/weight(<sup>w/w</sup>) of cross-linking agent and the sorption of gold cyanide was 55.0 milligrams per gram (mg/g) of polymer. However it was discussed that “crowding effects” of the groups already attached to the matrix of the resin may hinder the metal ions ability to protonate at the sites of the functional groups.

Studies were carried out on the removal of metal cyanides using polymers formed by free radical polymerisation (Ward, 2000). In general these compounds contain 1,4diazabicyclo[2.2.2]octane from the free radical polymerisation of N-4-vinyl benzyl-N<sup>1</sup>-1,4-diazabicyclo[2.2.2]octane dichloride (VBBD).The polymers were water soluble and can be in the form of solution polymers, dispersion polymers, emulsion polymers or solid polymers. Dosage of the treatment agent was influenced

by the agent selected and the conditions of the wastewater stream. The contaminants formed an electrostatic or geometric complex with the polymer. The polymer complex had a low solubility in water so the treated liquid could be passed through a filtering device which captured complexes formed.

An anionic exchange resin called Lewatit MP62, was used in the treatment of excess zinc cyanide in an alkaline leachate (Kurama & Catalarik, 2000). The leachate containing 530 mg/l cyanide was drained through a glass column containing the Lewatit exchange resin and the cyanide was reduced to 5 mg/l. The optimum load capacity was obtained when the pH of the influent was 7.8. During the regeneration of the influent the hydrocyanic acid produced was collected in the effluent solution instead of a sodium hydroxide trap.

## **2.12 Removal of Cyanide by photocatalytic oxidation using silica aerogel**

Silica “aerogels” are amorphous silica with very large surface areas (Pajonk, 1999). They have open porous structures with a relatively large number of catalytic sites per unit weight. The author describes many applications for these aerogels but the photocatalytic oxidation of ferric cyanide in wastewater is relevant. Studies described how the aerogel was produced; tetraethoxisilane and titaniumisopropoxide in an alcoholic solution (isopropanol) was mixed with nitric acid, which was used as gelation agent, these solutions are known as alcogel of silica-titania. The alcogel can then be treated at a high temperature of 280°C to drive off the alcohol and nitric acid to produce the aerogel. The aerogels were said to have higher relative surface areas and less rapid catalytic deactivation than crystal silica for example rutile and anatase. The higher the silica content the more photocatalytic activity was observed. Results from the experiment showed that on a sample of 1000 mg/l ferric cyanide solution a 95% removal rate took 6 hours to reduce the cyanide content to 50 mg/l.

## **3.0 IDENTIFICATION OF ALTERNATIVE APPROACHES**

### **3.1 Comparison of Techniques**

All of the summaries of the results obtained from the literature search have been compiled into a table (TABLE 3.1), which enabled an effortless review of the data and techniques available. The review narrowed down a number of techniques, which could be used within the Cassel laboratory to assess their affect on the untreated effluent from N<sup>o</sup>1 sump.

**TABLE 3.1: Comparison of Techniques**

<i>Method</i>	<i>Levels</i>	<i>Catalyst</i>	<i>Other treatment</i>	<i>Advantages</i>	<i>Disadvantages</i>	<i>Ref.</i>
<b>Chemical</b> Catalysed oxidation -activated carbon	99% removal 0.5 - 0.025 mg/l	copper	UV light dissolved oxygen	Complete removal of soluble cyanide	1.Fluctuation of organic loads 2.Copper added to effluent	Huff & Bigger 1980
Alkaline chlorination - Chlorination by countercurrent flow	<1 mg/l in 1-15 minutes		Acidified at 95 °C (chlorine)	1. Technology well established 2. Cyanate less toxic and oxidised to CO <sub>2</sub> and N <sub>2</sub> at low pH 3. Metals can be ppt' out at high pH 4. Suitable for high and low cyanide strengths 5. Ammonium chloride & carbon dioxide evolved	1.Excess hypochlorite is toxic 2. Chlorine can react with organics to form chlorinated compounds 3. Intermediates toxic 4. Chlorine required due to formation of hydrogen cyanide 5. Need to reduce excess Cl <sub>2</sub> using sodium bisulphate for example	Sury <i>et al</i> 1979  Mosher & Figueroa 1996
Hydrogen peroxide	200 mg/l to 0.5 mg/l over 2 hours		Potassium monosulphate  Cooling necessary	1. Excess reagent decomposes to water & oxygen 2. Simple to operate. Not reactive with thiocyanate	1. Reagent costly. 2. Precipitates ferrocyanates with copper disposal of precipitate (ppt) required 3. Requires accurate chemical dosing 4. Not suitable for low level cyanide	Mason 1907

<i>Method</i>	<i>Levels</i>	<i>Catalyst</i>	<i>Other treatment</i>	<i>Advantages</i>	<i>Disadvantages</i>	<i>Ref.</i>
<b>Chemical</b>						
Hydrogen peroxide With sulphuric acid	over 45 minutes		Lime slurry & sodium hydroxide	1. No gasses evolved 2. Less acid used	1. Crystals can be produced –impurities in peroxide 2. Suspended Solids produced on using liming slurry	Griffiths <i>et al</i> 1990
Hydrogen peroxide & formaldehyde	1410 mg/l to 2.3 mg/l over 6 hrs 45 minutes		8.5 – 12 pH	Use of sodium salicylate instead of copper – more efficient	1. Colloidal suspension silicon dioxide filtration required 2. Formaldehyde in effluent Copper in effluent	Wolf 1996
Hydrogen peroxide & copper	430 mg/l to 5 mg/l	Copper 2+	Silicate oxide 7 –10 pH at 35 °C	1. Inexpensive 2. Silicates naturally occurring instead of copper 3. Less peroxide required		Proulx <i>et al</i> 1993
INCO process – SO <sub>2</sub> /air	Quoted to <1 mg/l  Over 30 minutes	copper	Sulphur dioxide & oxygen	1. Inexpensive reagent. 2. Used over wide pH range	1. For mining waste sludges 2. Licence payments 3. Sulphates added 4. ppt to dispose of when using copper 5. For low cyanide levels only 6. Copper in effluent	Mosher & Figueroa 1996
Ozone	100 mg/l to 10 mg/l over 2 hours		1.85g O <sub>3</sub> to 1g of CN pH 8 – 8.5	1. Ozone 2 times more powerful than peroxide 2. Effective for all CN levels	1. Not for complex cyanides 2. Generation of ozone is costly 3. Produces ammonia 4. Off gas thermal treatment	Desai <i>et al</i> 1998

<i>Method</i>	<i>Levels</i>	<i>Catalyst</i>	<i>Other treatment</i>	<i>Advantages</i>	<i>Disadvantages</i>	<i>Ref.</i>
<b>Biological</b> Homestake Mining Co. <i>Pseudomonas</i>	11 mg/l 91 – 95 % removal		10-30°C	Biofilm adsorbs heavy metals capacity 21000 m <sup>3</sup> /d	1. Incomplete removal of ferric cyanides 2. Not for high cyanide wastes	Whitlock 1987
Bacterial – aerobic fluidised bed reactor (AFBR)	160 -0.5 mg/l (24hrs) 90 –98% removal			Microorganisms usually denatured by cyanide but become resistant using CN as only source of nitrogen	1. Not for high cyanide and high metal wastes 2. Carried out on Amygdalin– almond seed extract	Petrozzi & Dunn 1994
Trickle Filter – activated sludge <i>arthobacter</i>	190 mg/l 35 – 0.1 mg/l 98% removal			Good for varying load concentrations	Renewal of biomass	Shivaraman <i>et al</i> 1997
Membrane technology <i>Pseudomonas</i>	20.3 mg/l			23% bio degradation coefficient	55% degradation of cyanide	Kowalska <i>et al</i> 1998
Sequence batch biofilm reactors (SBBR)	20 – 0.5 mg/l 24hr cycle		glucose	Good for large volumes	Requires room temperature ie does not work in cold climates	White & Schnabel 1998
Rotating biological contactor (RBC)	52 mg/l 99% efficient 15 hours		Sucrose / molasses at 35°C	Safe for discharge	Precipitated metal hydroxides which require disposal	Patil & Paknikar 2000.
Upflow anaerobic sludge blanket	250 mg/l to <10 mg/l 93 days 12 hr cycle		33°C	1. Reduces chemical oxygen demand 2. 91-93% efficient		Gijzen <i>et al</i> 2000

<i>Method</i>	<i>Levels</i>	<i>Catalyst</i>	<i>Other treatment</i>	<i>Advantages</i>	<i>Disadvantages</i>	<i>Ref.</i>
<b>Biological</b>						
Enzymatic cyclear™	200 – 1000 mg/l				Not suitable for complex cyanides and heavy metals	Desai 1998
Enzymatic “cyanidase”	30 mg/l to <0.05 mg/l over 3 hrs 40 minutes			1. Decomposes cyanide to ammonia & formic acid 2. 84% conversion rate	Half-life of 11 days	Basheer <i>et al</i> 1992
<b>Thermal</b>						
Heat exchanger from warm effluent	Not Given		250°C high pressure	1. Uses the heat that is already present 2. Can treat up to 4546 litres/day	For intermittent use only as scale builds up.	Robey 1989
Wet Air Oxidation (WAO)	109 mg/l to <0.1 mg/l 3 minutes		pH6-7	For high cyanide strength loading - acetonitrile & inorganic	Very high running costs	Desai 1998
<b>Precipitation</b>						
Divalent ferrous salts – surface active substance (SAS)	180 mg/l to <2 mg/l		pH7 ±0.2	For cyanide levels above 80 mg/l	Finely dispersed slime difficult to separate	Evtyugina <i>et al</i> 1984
Polysulphide	56200 mg/l to 30 mg/l over 24 hours		pH9 at 3°C Catalysed by metals	1. Can handle low/high temp changes 2. More stable complexes degraded 3. Used in small scale in developing countries	1. Residual metals 2. Post treatment coagulation may be required for metal removal – nickel and cadmium	Trofe & Page 1985

<i>Method</i>	<i>Levels</i>	<i>Catalyst</i>	<i>Other treatment</i>	<i>Advantages</i>	<i>Disadvantages</i>	<i>Ref.</i>
<b>Electrolysis</b>						
Packed bed electrodes (stainless steel fibre)	188 mg/l to 19 mg/l over 90 mins		pH between 11-12 & Copper	Cyanide removed at anode & copper at cathode with reduced energy	1400 mg/l to 100 mg/l took 20 hours	Ho <i>et al</i> 1990
Electrodialyser	20 mg/l to <0.1 mg/l		Sodium hydroxide	Cyanide destroyed to nitrogen & carbon dioxide. Oxygen liberated	1. Instability of current efficiency 2. Generation of harmful gasses 3. High processing costs	Bernat 1979
With catalysis (activated carbon)	Estimated capacity 240 m <sup>3</sup> /day	BAU		1. No chemicals necessary 2. No residues 3. Low labour, energy demands & capital costs		Bursova & Moiseeva 1989
Hydrocyclone cell (HCC)	2.5 mg/l to 0.69 mg/l		Sodium chloride & acid/hydroxide pH12		Hydrogen cyanide evolved & could not be prevented	Dhamo 1996
Gas sparged hydrocyclone reactor (GSH)	250 – 53 mg/l		Chlorine dioxide	High capacity & efficiency	Not demonstrated to reduce cyanide enough	Parga & Cocke 2001
In-situ electroflotation 30 gallon reservoir	191 mg/l to <0.05 mg/l 75 minutes		Salt sea water strength		1. Further study in process optimisation 2. No metal recovery	Poon 1997
Trickle tower 7 hours 200 minutes	1500 mg/l to <300 mg/l 300 mg/l to 30 mg/l		Sodium chloride	1. Collection of heavy metals at cathode 2. No sludge when no metals 3. Low energy	Process has only been carried out at pilot scale	Ógutveren <i>et al</i> 1999

<i>Method</i>	<i>Levels</i>	<i>Catalyst</i>	<i>Other treatment</i>	<i>Advantages</i>	<i>Disadvantages</i>	<i>Ref.</i>
<b>Electrolysis</b>						
Trickle tower cont.				consumption 4. Low operating costs		
<b>Membrane electrodes</b>						
Liquid membrane	5 to >1 mg/l 20 minutes		30°C pH 6-7 NaOH & surfactant	Highly selective & rapidly effective	High temperatures reduce effectiveness of membrane	Xueling <i>et al</i> 1989
In combination ; Batch reactor & hollow fibre gas membrane	10000 mg/l		Sodium hydroxide pH 6-7 at 30°C	Highly selective, rapidly effective	Copper & silver cyanide less readily treated	Kenfield <i>et al</i> 1988
Gas membranes	5000 mg/l to 5 mg/l 30 minutes		Strong acid & Sodium hydroxide	1. Effective separation from zinc & cadmium cyanide wastes 2. No secondary pollutants	1. Copper & silver cyanide less readily treated 2. Fouling of membrane requires back-washing	Shen <i>et al</i> 1997
<b>Photocatalysis</b>						
Gas membranes cont.				produced		
Titanium dioxide microelectrodes	26 mg/l 9 hours	Titanium dioxide / titanium	pH 10	Used on complex nickel, iron & cobalt	1. Further work required 2. 73% reduction	Bhakta <i>et al</i> 1992
Titanium dioxide cont.		tetrachloride				
Photo-oxidation	48.1 mg/l	Titanium IV oxide		Free & complex cyanide ions oxidised	3 days to below detection	Rader <i>et al</i> 1995
Use of compound parabolic collectors	10.7 mg/l to <0.1	Titanium oxide	Sodium hydroxide		Efficiency decreased in presence of phenol	Augugliaro <i>et al</i>

<i>Method</i>	<i>Levels</i>	<i>Catalyst</i>	<i>Other treatment</i>	<i>Advantages</i>	<i>Disadvantages</i>	<i>Ref.</i>
<b>Photocatalysis</b> parabolic collector cont.	mg/l over 20 minutes	suspension	Phenol & hydrogen peroxide			1999
Advanced oxidation processes or photo-Fenton process	Not Given	Titanium dioxide		1. Organic pollutants degrade quicker with Fenton process 2. Titanium dioxide – cheap & abundant, non-toxic	Cannot degrade high COD wastewaters	Malato <i>et al</i> 2001
<b>Filtering through packed columns</b> Porous solid Catalytic oxidation	Not Given	copper	38°C	Minimise deposition of undesirable residues	Ammonia leaches the copper from substrate	Yan 1994
Impregnated activated carbon - tetrabutyl ammonium (TBA)	200 mg/l removed over 5-6 hrs @ 2 mls/min from 40mg/l to 2 mg/l	Silver Nickel		Silver impregnated carbon best	Functional groups can be non specific	Adhoum & Monser 2000
<b>Sonication</b> Carbon particles <5mm	Not Given			Sonication accelerates destruction of CN and formation of H <sub>2</sub> O <sub>2</sub>		Saterlay <i>et al</i> 2000

<i>Method</i>	<i>Levels</i>	<i>Catalyst</i>	<i>Other treatment</i>	<i>Advantages</i>	<i>Disadvantages</i>	<i>Ref.</i>
<b>Sonication</b>						
Stirred reactor & 3 sonication units	80% degradation		Flow rate dependent		Scale up problems envisaged	Gondrexon <i>et al</i> 1998
Horn type Transducer	Not given		Electrolysis	Increased mass transport of the cell	1. Hot spots produced 2. Erosion of electrode surface 3. Effect on diffusion at electrode/solution interface	Hardcastle <i>et al</i> 2000
Batch Reactors with sonication	Not given			Effective for rapid destruction		Hoffmann <i>et al</i> 1996
Beaker Cuphorn Probe	100% 2% 50% degradation	Hydrogen peroxide found to play auxiliary role	Increased temp up to 39°C	Hydrogen peroxide produced in reaction	1. Beaker system slow 2. More work required	Teo <i>et al</i> 2001
<b>Polymers &amp; Resins</b>						
Poly(St/DVB) Poly(St/DVB)	26 - 26000 mg/l to <0.05 mg/l			1. Resins regenerated by hypochlorite 2. Takes from 2 hours to days		Kociolek-Balawejder 1997
Poly(VBC/St/DVB)	55 mg CN /g of polymer		pH 9		1. Crowding effects 2. Contact time 96 hours	Kolarz <i>et al</i> 1998
VBBD / poly TEDX	300 mg/l to 2.1 mg/l			PPT resulted when mixed with cyanide – filtered off		Ward 2000

<i>Method</i>	<i>Levels</i>	<i>Catalyst</i>	<i>Other treatment</i>	<i>Advantages</i>	<i>Disadvantages</i>	<i>Ref.</i>
<b>Polymers &amp; Resins</b> Ionic exchange resin Lewatit MP62	530 mg/l to 5 mg/l		pH 7.8 Acid addition	HCN produced was collected in sodium hydroxide and recycled		Kurama & Catalasarik 2000
<b>Silica aerogel</b> Silica-titania after 6hrs	1000 mg/l to 50 mg/l		UV light	Higher surface area than crystalline silica	Reduction no lower than 50 mg/l	Pajonk 1999

### 3.2 Criteria for Selection

A more objective process was applied to the information gained in the literature search as shown in Table 3.2. This was to establish a more unbiased selection of the methods to be used with in the trial process. The higher the score obtained in the table the more superior the processes was against the criteria used for the adaptation to Cassel site.

**Key:** Potential for additional Safety Health and Environmental (SHE) problems includes; Reagents used; corrosive, toxic, harmful production of gases or other issues. The more SHE issues the lower the score. Capital cost estimate based on modification to existing Cassel plant – marking scheme based on no new capital required = 10 marks, 10 million pounds = 0 marks. Annual variable costs estimate based on zero variable cost = 10 marks, £1 million/year = 0 marks.

**TABLE 3.2: Numerical application to criteria to aid in Selection**

Criteria for Selection	Potential for additional SHE problems Low/High 10 - 1	Capital cost Low/High 10 - 1	Operating variable costs Low/High 10 - 1	Application for rest of site plants Yes / No 10 - 1	Controllable Yes / No 10 - 1	Effectiveness High/Low 10 - 1		Demonstrated effectiveness; Lab verses used elsewhere High/Low 10 - 1	Total	Ref
						Low level	High level			
<b>Method:</b>										
Catalysed oxidation - activated carbon	8	1	6	2	7	9	1	1	35	Huff & Bigger 1980
Alkaline chlorination - counter-current flow	5	4	9	9	7	8	8	9	59	Sury et al 1979 Mosher & Figueroa 1996
Hydrogen peroxide	9	10	7	7	8	7	7	8	63	Mason 1907
Hydrogen peroxide With sulphuric acid	5	10	7	7	7	8	7	8	59	Griffiths et al 1990
Hydrogen peroxide & formaldehyde	2	10	7	6	6	5	5	2	43	Wolf 1996

Criteria for Selection	Potential for additional SHE problems Low/High 10 - 1	Capital cost Low/High 10 - 1	Operating variable costs Low/High 10 - 1	Application for rest of site plants Yes / No 10 - 1	Controllable Yes / No 10 - 1	Effectiveness High/Low 10 - 1		Demonstrated effectiveness; Lab verses used elsewhere High/Low 10 - 1	Total	Ref
						Low level	High level			
<b>Method:</b>										
Hydrogen peroxide & copper	1	10	7	6	6	8	5	2	45	Proulx et al 1993
INCO process - SO <sub>2</sub> /air	5	1	8	7	8	7	7	8	51	Mosher & Figueroa 1996
Ozone	5	1	5	6	7	6	6	2	38	Desai et al 1998
Homestake Mining Co. Pseudomonas	7	5	10	3	4	8	1	2	40	Whitlock 1987
Bacterial - aerobic fluidised bed reactor (AFBR)	7	2	10	3	4	7	1	2	36	Petrozzi & Dunn 1994
Trickle Filter - activated sludge <i>arthobacter</i>	7	5	10	3	4	7	1	2	39	Shivaraman et al 1997

Criteria for Selection	Potential for additional SHE problems Low/High 10 - 1	Capital cost Low/High 10 - 1	Operating variable costs Low/High 10 - 1	Application for rest of site plants Yes / No 10 - 1	Controllable Yes / No 10 - 1	Effectiveness High/Low 10 - 1		Demonstrated effectiveness; Lab verses used elsewhere High/Low 10 - 1	Total	Ref
						Low level	High level			
<b>Method:</b>										
Membrane technology <i>Pseudomonas</i>	7	2	8	3	4	6	1	2	33	Kowalska <i>et al</i> 1998
Sequence batch biofilm reactors (SBBR)	7	2	10	3	4	8	1	2	37	White & Schnabe 1998
Rotating biological contactor (RBC)	7	5	10	3	4	8	1	2	40	Patil & Paknikar 2000
Upflow anaerobic sludge blanket (UASB)	7	5	10	3	4	7	1	2	39	Gijzen <i>et al</i> 2000
Enzymatic "cyclear"	5	6	10	4	4	7	7	2	45	Desai 1998
Enzymatic "cyanidase"	5	4	10	4	4	7	1	2	37	Basheer <i>et al</i> 1992

Criteria for Selection	Potential for additional SHE problems Low/High 10 - 1	Capital cost Low/High 10 - 1	Operating variable costs Low/High 10 - 1	Application for rest of site plants Yes / No 10 - 1	Controllable Yes / No 10 - 1	Effectiveness High/Low 10 - 1		Demonstrated effectiveness; Lab verses used elsewhere High/Low 10 - 1	Total	Ref
						Low level	High level			
<b>Method:</b>										
Heat exchanger from warm effluent	5	4	9	2	6	1	1	1	29	Robey 1989
Wet Air Oxidation (WAO)	5	4	9	5	5	2	6	1	37	Desai 1998
Divalent ferrous salts - surface active substance (SAS)	3	4	4	7	4	7	2	7	38	Evtuygina <i>et al</i> 1984
Polysulphide	4	4	3	5	4	8	8	2	38	Trofe & Page 1985
Packed bed electrodes (stainless steel fibre)	9	5	2	6	3	7	7	2	41	Ho <i>et al</i> 1990

Criteria for Selection	Potential for additional SHE problems Low/High 10 - 1	Capital cost Low/High 10 - 1	Operating variable costs Low/High 10 - 1	Application for rest of site plants Yes / No 10 - 1	Controllable Yes / No 10 - 1	Effectiveness High/Low 10 - 1		Demonstrated effectiveness; Lab verses used elsewhere High/Low 10 - 1	Total	Ref
						Low level	High level			
<b>Method:</b>										
Electro-dialyser	9	5	2	2	2	2	7	5	34	Bernat 1979
Electrolysis with catalysis (activated carbon)	6	4	4	7	6	6	6	6	45	Bursova & Moiseeva 1989
Hydro-cyclone cell (HCC)	9	4	2	2	2	7	2	2	30	Dhamo 1996
Gas sparged hydrocyclone reactor (GSH)	8	4	8	5	5	6	2	2	40	Parga & Cocke 2001
In-situ electroflotation 30 gallon reservoir	5	6	9	5	5	7	2	2	41	Poon 1997
Trickle tower 7 hours 200 minutes	8	5	9	6	5	7	7	3	50	Ögütveren et al 1999

Criteria for Selection	Potential for additional SHE problems Low/High 10 - 1	Capital cost Low/High 10 - 1	Operating variable costs Low/High 10 - 1	Application for rest of site plants Yes / No 10 - 1	Controllable Yes / No 10 - 1	Effectiveness High/Low 10 - 1		Demonstrated effectiveness; Lab verses used elsewhere High/Low 10 - 1	Total	Ref
						Low level	High level			
<b>Method:</b>										
Liquid membrane	6	5	2	3	4	7	2	2	31	Xueling et al 1989
Batch reactor & hollow fibre gas membrane	6	1	7	6	5	4	6	5	40	Kenfield et al 1988
Gas membranes	6	5	1	6	5	6	6	5	40	Shen et al 1997
Titanium dioxide micro-electrodes	5	5	2	6	5	6	2	5	36	Bhakta et al 1992
Photo-oxidation	8	5	2	7	5	7	2	3	39	Rader et al 1995
Use of compound parabolic collectors	8	3	9	7	5	7	2	3	44	Augugliaro et al 1999

Criteria for Selection	Potential for additional SHE problems Low/High 10 - 1	Capital cost Low/High 10 - 1	Operating variable costs Low/High 10 - 1	Application for rest of site plants Yes / No 10 - 1	Controllable Yes / No 10 - 1	Effectiveness High/Low 10 - 1		Demonstrated effectiveness; Lab verses used elsewhere High/Low 10 - 1	Total	Ref
						Low level	High level			
<b>Method:</b>										
Advanced oxidation processes or photo-Fenton process	2	2	7	6	6	2	2	7	34	Malato et al 2001
Porous solid Catalytic oxidation	4	2	5	4	5	2	2	5	29	Yan 1994
Impregnated activated carbon - tetrabutyl ammonium (TBA)	6	6	5	4	5	7	2	4	39	Adhoum & Monser 2000
Sonication - Carbon particles <5mm	7	6	6	7	8	7	2	2	45	Saterlay et al 2000
Sonication - Beaker, Horn & Probe	7	5	7	7	8	7	2	2	45	Teo et al 2001

Criteria for Selection	Potential for additional SHE problems Low/High 10 - 1	Capital cost Low/High 10 - 1	Operating variable costs Low/High 10 - 1	Application for rest of site plants Yes / No 10 - 1	Controllable Yes / No 10 - 1	Effectiveness High/Low 10 - 1		Demonstrated effectiveness; Lab verses used elsewhere High/Low 10 - 1	Total	Ref
						Low level	High level			
<b>Method:</b>										
Poly (St/DVB)	4	4	5	7	6	6	2	2	36	Kociolk-Balawejder 1997
Poly (VBC/St/DVB)	4	4	5	7	6	6	2	2	36	Kolarz et al 1998
VBBD / poly TEDX	4	4	5	7	6	6	2	2	36	Ward 2000
Ionic exchange resin Lewatit MP62	4	1	6	7	6	7	2	2	35	Kurama & Catalasarik 2000
Silica-titania	5	1	7	7	6	6	8	2	42	Pajonk 1999

### 3.2.1 Discussion on Criteria Selection

The methodologies with the highest scores are placed in Table 3.3, from this table a number of methodologies were chosen for a trial to establish their ability to decompose the collected cyanide wastewater. Each test chosen was given a number from 1 to 5 to distinguish them from the other methodologies.

**TABLE 3.3: Short list of Best Performance Methodology**

<i>Test No</i>	<i>Methodology</i>	<i>Score Rating</i>
<b>3/4</b>	<b>Hydrogen peroxide</b>	<b>63</b>
	Alkaline chlorination - counter-current flow	59
	Hydrogen peroxide With sulphuric acid	59
	INCO process – SO <sub>2</sub> /air	51
	Trickle tower 7 hours 200 minutes	50
<b>2</b>	<b>Electrolysis with catalysis (activated carbon)</b>	<b>45</b>
<b>6</b>	<b>Enzymatic “cycleclear”</b>	<b>45</b>
	Sonication - Carbon particles <5mm	45
	Hydrogen peroxide & copper	45
<b>1/4</b>	<b>Sonication - Beaker, Horn &amp; Probe</b>	<b>45</b>
	Hydrogen peroxide & formaldehyde	43
	Silica-titania	42
	Packed bed electrodes (stainless steel fibre)	41
	In-situ electroflotation ;30 gallon reservoir	41
	Homestake Mining Co. ; Pseudomonas	40
	Rotating biological contactor (RBC)	40
	Batch reactor & hollow fibre gas membrane	40
	Gas membranes	40
	Gas sparged hydrocyclone reactor (GSH)	40
	Upflow anaerobic sludge blanket (UASB)	39
	Trickle Filter – activated sludge <i>arthobacter</i>	39
<b>5</b>	<b>Photo-oxidation</b>	<b>39</b>
	Impregnated activated carbon - tetrabutyl ammonium (TBA)	39
<b>6</b>	<b>Ozone</b>	<b>38</b>
	Polysulphide	38

The scoring system shows that hydrogen peroxide is potentially the best method for the removal of cyanide, closely followed by the alkaline chlorination which is currently used on Cassel site. The intention was to trial a method from each of the areas qualifying. However there are some areas, for example the biological methods which

are very difficult to construct in the laboratory environment. Other areas for example using copper as a catalyst, which were dismissed due to the polluting nature of the copper or formaldehyde. The methods using an adsorbent material such as carbon were dismissed due to the disposal issue of the spent adsorbent.

### **3.3 Pilot Studies: Short-listed Trials**

#### **3.3.1 Sonication with Activated Carbon**

##### **Method:**

The ultrasonic bath was set up in the laboratory fume cupboard, containing sufficient water to ensure the sample would be submerged. A wire basket was then placed into the bath to rest the sample beaker on. A 50 ml aliquot of effluent was placed into a 250 ml plastic beaker. The beaker was then placed into the ultrasonic bath for nine minutes. The effluent was tested before the analysis to establish the cyanide content and at intervals during the nine minutes and the results recorded.

A duplicate test sample was set up containing 0.0506g of activated carbon to 50 mls of sample and another test sample was filtered through a Whatmans grade 40 filter paper and the test repeated.

##### **Results:**

The cyanide results were established using a standard method shown in Appendix 10 with these results using a Mettler autotitrator given as % <sup>w</sup>/<sub>w</sub> free cyanide in the sample.

##### **Free hydrogen cyanide (HCN) released:**

To establish the cyanide released from the samples during sonication a Draeger pump and Draeger tube were used. The Draeger pump is a hand held instrument comprising bellows that attach to a Draeger tube. The bellows are used to draw up a fixed volume of air, which is sucked through the tube. Within the tube are HCN adsorbent granules, which change colour as increasing amounts of HCN is sucked through. On the tubes glass wall is a scale of zero to 10 ppm so the point the colouration stops is the amount of HCN being released from the samples. During all the experiments the Draeger tube readings for hydrogen cyanide were between 3 and 4 ppm HCN based on 10 pumps of the Draeger each time.

The cyanide results obtained for each of the experiments (Appendix 11; Table 3.4, 3.5, 3.6) are represented on Figure 3.1 as Sonication without activated carbon,

sonication only, sonication with activated carbon and sonication after filtering without activated carbon, represented on the chart as Sonication after solids removal.

**FIGURE 3.1: Effect of Sonication and Activated Carbon on Cyanide levels in Cassel works effluent**

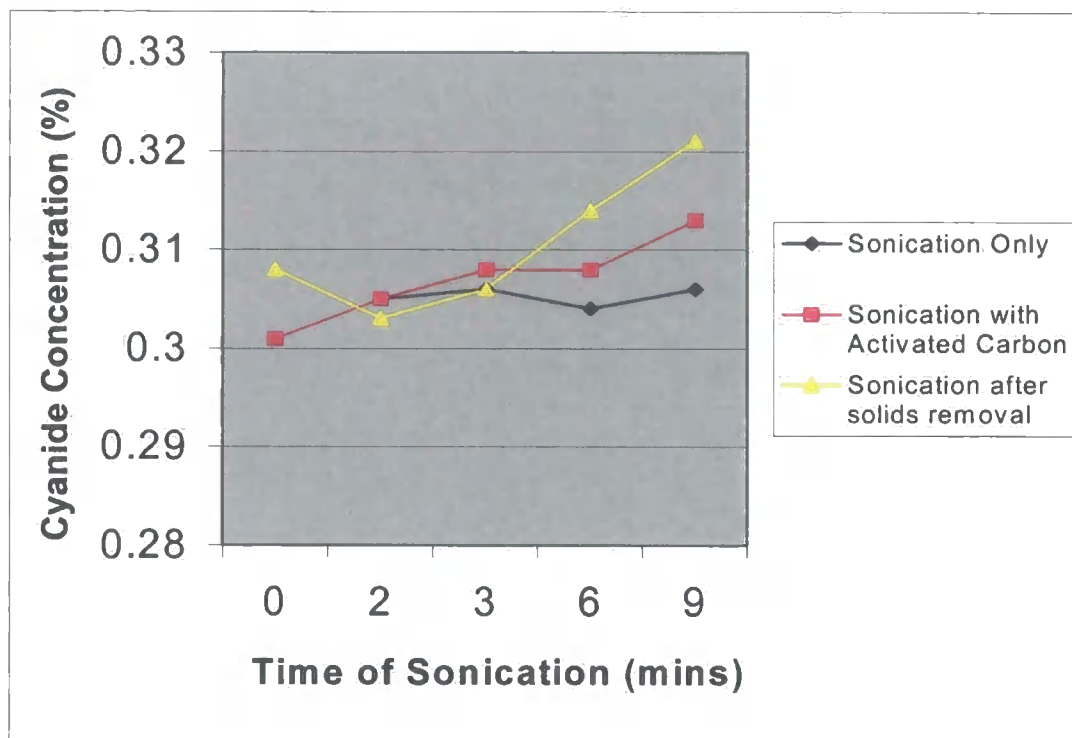

**Discussion:**

The experiments (results displayed in Figure 3) show that sonication increases the cyanide content of the effluent. The initial conclusion about the increased cyanide concentrations after sonication was of the presence of suspended solids releasing cyanide from their outer surface (adsorbed cyanide). The presence of solids is due to sodium carbonate being released from the cyanide plant process and adsorbing cyanide to the particle wall. The filtration of the sample had no effect on the decrease in cyanide level therefore the suspended solids had no effect in increasing the cyanide concentration. Treatment with activated carbon also showed an increased cyanide concentration over time (Figure 3.1). Although hydrogen cyanide was evolved at the surface of the liquid the expectation was the cyanide level would decrease however, the cyanide content of the samples were increasing in all cases,

even when the sample was filtered. Filtering eliminated the idea that cyanide bonded to the particles was being released due to sonication.

The conclusion drawn from these series of experiments was that sonication was adding energy to the complex cyanide bonds, which was released from the bonded cyanide as free cyanide. As previously stated complex cyanide cannot be titrated using sodium hydroxide and silver nitrate, as these reagents do not break down the strong bonds of complex cyanide. There was no evidence of hydrogen peroxide formation using the cyanide plant effluent as stated by the author.

### **3.3.2 Electrolysis**

#### **Method:**

The electro-analyser used was an EG-G Instrument with carbon/reference and counter electrodes within the reaction vessel which was exposed to a nitrogen purge. The reaction vessel was contained within the fume cupboard, 5 mls of sample was placed in the reaction vessel with 5 mls of distilled water. Various voltages and currents were applied at different time intervals. Sodium hydroxide was added at stages to establish any effect. Instead of activated carbon a carbon electrode was used.

After each experiment the cyanide content was established by manual titration with 0.1N Silver Nitrate. Potassium iodide (5%) was used as the indicator with 2mls of 1N sodium hydroxide to a turbid end-point.

#### **Results:**

The initial test used 5 mls of effluent (sample) with 5 mls of distilled water. The millivolts were set to -0.42 and left to run for 15 minutes. Black specs were seen in the reaction vessel. On testing the cyanide concentration before and after, there had been no effect.

The electrolysis experiment was then repeated to establish if higher voltages would have an effect. Table 3.7 shows the results obtained.

**TABLE 3.7: Results from preliminary test of Electrolysis on Cyanide levels**

<i>Time (mins)</i>	<i>Addition of 1N NaOH (mls)</i>	<i>Millivolts applied</i>	<i>Concentration of cyanide remaining (%)</i>	<i>Observations</i>
0	-	none	0.333	
15	-	-0.42	0.333	Black deposit from carbon electrode
60	-	1.5	0.118	
60	4	2.0	0.147	Bubbles at counter electrode. Black deposit from carbon electrode
20	2	1.0	0.147	none
10	-	1.0	0.147	none
5	-	1.35	0.157	none
10	-	-1.0	0.137	none
Work below carried out on a different piece of equipment able to reach greater millivolt ranges.				
Initial	-	-	0.294	
10	-	2.0	0.294	Gas evolved from anode and cathode
20	-	5.0	0.265	none
60	-	5.0	0.118	Slight yellow colouration
10	-	10.0	0.274	Gas evolved from anode
20	-	10.0	0.235	Gas evolved from anode and cathode
10	-	1.0	0.274	none
5	-	1.0	0.274	none
5	-	1.0	0.255	none
10	-	1.0	0.255	none

**Discussion:**

The initial tests showed that applied voltage decreased the cyanide concentration of the effluent. The sixty-minute experiments showed a reduction of half the cyanide content and that the addition of sodium hydroxide had little effect on the decrease in cyanide. The range between 1 and 2 millivolts appeared to be the optimum and a noticeable decrease in cyanide was seen. Using the second piece of equipment that worked to higher millivolt ranges showed that 5 millivolts was the optimum for cyanide decrease however this test was over sixty minutes.

### 3.3.3 Hydrogen Peroxide

#### Method:

A range of sample volumes (5 to 100 mls) were added to beakers with a magnetic "flea" and placed on the stirrer plate, set up in the fume cupboard. A retort stand was set up holding a burette containing hydrogen peroxide. Increments of hydrogen peroxide were added to the sample and left stirring, the un-reacted cyanide was then tested for. The hydrogen peroxide was diluted from 30 %  $v/v$  to 3 %  $v/v$  for this experiment.

The cyanide results were obtained using the standard method (Appendix 10) with results from the Mettler given as %  $w/w$  free cyanide in the sample.

#### Results:

The cyanide results obtained for each of the experiments (Appendix 11; Table 3.8) are represented on Figure 3.2.

**FIGURE 3.2: Effect of 3%  $v/v$   $H_2O_2$  on Cyanide levels in 100 mls of Effluent**

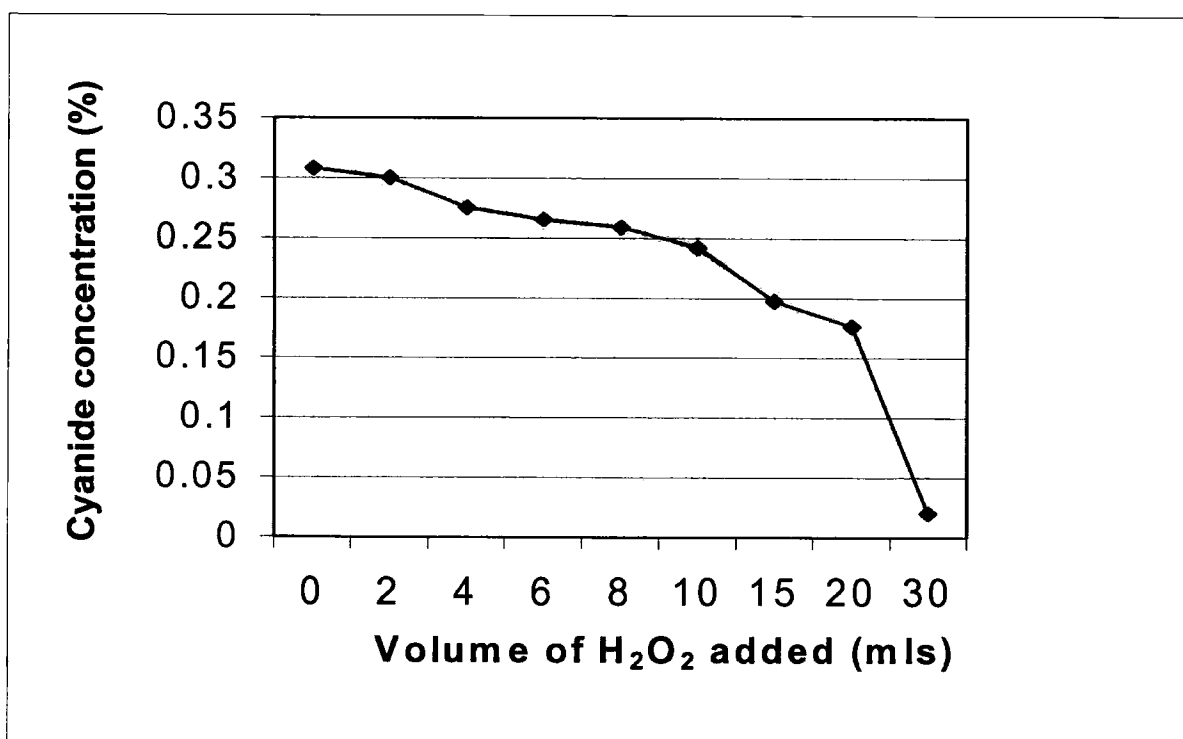

**Discussion:**

Hydrogen peroxide has been proven by these experiments to be the pre-eminent methodology for decreasing the cyanide concentration of the effluent. The reaction appears to be repeatable at different concentrations of peroxide in the effluent.

**3.3.4 Hydrogen Peroxide and Sonication****Method:**

A 10 ml aliquot of sample was placed in a plastic beaker and then a measured amount of hydrogen peroxide was added. The beaker was then placed in the ultrasonic bath (set up in the fume-cupboard) for a specific length of time. The cyanide content of the effluent was established before during and after the experiments.

The cyanide results were obtained using the standard method (Appendix 10) with results from the Mettler given as % <sup>w</sup>/<sub>w</sub> free cyanide in the sample.

**Results:**

The cyanide results obtained for each of the experiments (Appendix 11; Table 3.9) are represented on Figure 3.3. Test the effectiveness of hydrogen peroxide addition to a cyanide effluent sample with the application of sonication.



**Figure 3.3: Results from preliminary test of 30%  $v/v$  Hydrogen Peroxide and Sonication**

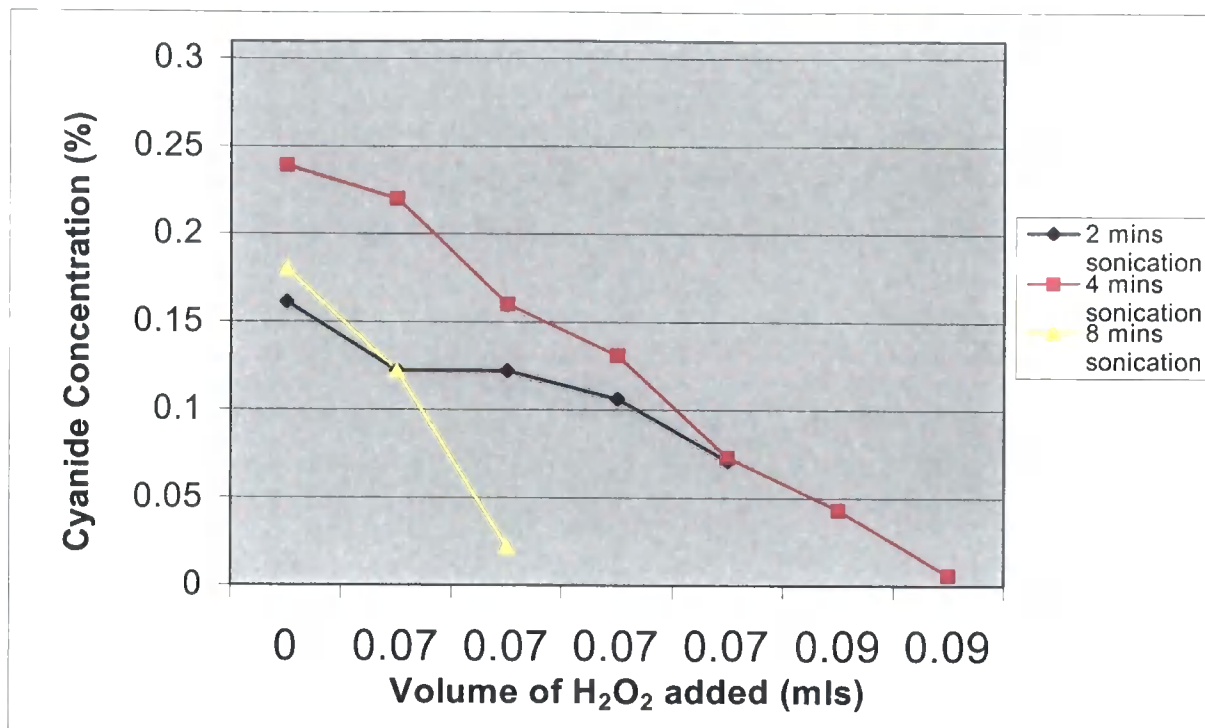

**Discussion:**

The application of sonication to the hydrogen peroxide experiment has proven to increase the rate of reaction on the cyanide which is being reduced quicker with less hydrogen peroxide being added.

**3.3.5 Photocatalytic oxidation using titanium dioxide semi-conductor**

**Method:**

A beaker containing 250 mls of effluent was placed in a fume cupboard, 2.5 g of solid titanium (IV) oxide was added to the beaker. The solution in the beaker was adjusted to pH 10 and stirred using a magnetic stirrer. An ultraviolet light source was directed at the beaker and protective screen surrounded the experiment. The cyanide concentrations of the test samples were determined every 30 minutes. The reference material advised a light wavelength around 350  $\mu\text{m}$ . Two controls were set up;

- (i) without UV light
- (ii) without UV & titanium dioxide.

The cyanide results were obtained using the standard method (Appendix 10) with results from the Mettler as % <sup>w</sup>/<sub>w</sub> free cyanide in the sample.

**Concerns:**

- (i) Any heat generated from the light source would be dispersed within the fumecupboard.
- (ii) Evolution of HCN to be tested using the labs, HCN tester papers and solution.

(The HCN tester papers consisted of blotting paper soaked in potassium chromate, then dried. The HCN test solution of *p*-nitrobenzaldehyde solution described as detector reagent. A drop of the reagent is placed on the paper and in presence of HCN gas the test paper turns orange.)

**Results:**

After the first 30 minutes the cyanide levels of the effluent in all three cases were determined and found to be exactly the same at 0.301%. The effluent was then tested after one hour and results were found to be exactly the same again. After two hours the effluent was tested again and there was still no decrease in cyanide concentration in any of the samples.

**Discussion:**

The reasons for this experiment failing are unknown, one explanation could be of the UV source not working. The source was checked by the electrician and found to be working electrically but there is no way of knowing if the UV light source was effective. If this methodology was to be used more work would be required to firstly ensure the light (UV) source had the correct wavelength. Experimental work would be required to establish time scales for the experiments.

### **3.3.6 Cyclear™ & Ozone**

The intention was to obtain some Cyclear™ bio-active granules, however the company that once produced them is now no longer in operation (ICI Biological Products). An alternative source to obtain the bio-active granules was not available.

The ozone preliminary trials were also discarded due to not being able to source an ozone generator. The University of Durham does own a generator however, an insurmountable difficulty was the safety issue of transporting and handling cyanide waste in an establishment unable to deal with a cyanide exposure or spillage incident.

### **3.3.7 Discussion about Problems and Recommendations**

The issues highlighted with the trial of sonication and activated carbon were the increased cyanide levels with all three of the experiments; sonication only, sonication after filtration and sonication with activated carbon. The initial thoughts were that sonication was not going to be a useful application, contradicting the results raised by Hoffmann *et al*, 1996, Gondrexon *et al*, 1998, Saterlay *et al*, 2000, Hardcastle *et al*, 2000 and Mitome & Hatanaka, 2002. A possible explanation for this phenomenon is that the cyanide solutions in the literature search experiments were pure solutions of simple cyanides where as the cyanide sample used in the trial was from the cyanide plant and contained other components. These other components, for example complex cyanide compounds may have a detrimental effect on the simple cyanide levels during sonication. The recommendation would be not use sonication as the main application for the reduction of cyanide in the Cassel wastewater. The electrolysis trial showed that some of the cyanide was reduced by this method, however the instruments used were unable to reduce the cyanide by anything less than half. Even when more robust equipment was used the results did not improve. This appeared to be an energy consuming process and would not be cost effective for the cyanide plant. This method may also be effected by the additional components within the wastewater and therefore not suitable. The use of hydrogen peroxide in the destruction of cyanide was shown to be effective. The levels of cyanide were dramatically reduced but large amounts of peroxide were required for the cyanide reduction to be immediate. Less peroxide could be used to reduce the cyanide if the

sample and peroxide had been left longer to react. This trial could be extended to incorporate longer reaction times to establish if smaller amounts of peroxide could be viable. The trial using hydrogen peroxide and sonication showed an advantage in using sonication. Less hydrogen peroxide was required to reduce the cyanide when sonication was being used. The recommendation from this trial would be to complete all future tests with and without sonication to establish if the sonication was having an effect in reducing the cyanide content of the effluent. The trial using photocatalytic oxidation using titanium dioxide as the semi-conductor did not work, either due to the UV emitting instrument being broken or the wrong frequency being used. If this methodology were to be examined again for cyanide destruction the UV source needs to be verified that it is working at the wavelength stated. Other issues may include the components within the wastewater causing problems with the reaction. This methodology could be expensive to set up on the Cassel site and therefore not worth pursuing. It was hoped that Cycleclear™ would still be available however, it could not be sourced. This methodology may be useful but there is still the issue of disposal of the spent solid. It is not clear if the spent solid would have traces of cyanide present and if it did not where would it be disposed of. The conclusions drawn from this methodology show it would not a viable method to use. There was also difficulty in obtaining an ozone generator for such a small scale experiment. There is a possibility that this method would be feasible on Cassel site, but more work would be required with small and large scale experiments to establish results. This is a “greener” methodology but, the cost to run an ozone generator at plant scale is not discussed in the literature available and could be quite expensive.

## **4.0 METHODOLOGY, RESULTS and DISCUSSION**

The aim of this section was to establish the best methodology for determining the decrease in cyanide from the findings found in section 3. To establish if the cyanide reduction was due to sonication and or the use of hydrogen peroxide. The best instrumentation to use to establish the cyanide concentrations of the samples and the problems and findings associated are also discussed.

### **4.1 Sonication Trials**

#### **4.1.1 Initial Sonication/Hydrogen Peroxide time trials using a Mettler autotitrator for cyanide determination**

##### **Method:**

The ultrasonic bath was set up in the laboratory fume cupboard, as described in section 3.3.1. A 10 ml volume of sample was placed into a 250 ml plastic beaker. (The sample was allowed to stand for one hour prior to analysis, to equilibrate to room temperature. The cyanide content as free sodium cyanide was established each time.) Aliquots of zero to 0.30 mls of 30 %  $v/v$  hydrogen peroxide ( $H_2O_2$ ) were added to the beaker and their effects tested, to establish the reduction in cyanide content. The beaker was then placed in the ultrasonic bath for one minute time intervals up to five minutes. The sample was tested before and after to establish its cyanide content and reduction. The steps above were repeated using the same amount of sample but without sonication. The amount of free HCN being released from the liquid surface in all experiments was given as 3 – 4 ppm hydrogen cyanide based on 10 pumps of the Draeger each time as described in 3.3.1.

##### **Initial Cyanide Content:**

5 mls of sample was placed into a 150 ml plastic autotitrator beaker. Then 20 mls of 1N sodium hydroxide was added and 20 mls of distilled water. The beaker was then attached to the Mettler autotitrator and the test sample was titrated with 0.1N silver nitrate using a DM141 silver electrode. Results from the Mettler were given as %  $w/w$

free cyanide in the sample. The determination of cyanide content was based on the Cassel works analytical method (Appendix 10).

**Results:**

Results from the tests of the decrease in cyanide using hydrogen peroxide and sonication over 1 minute (Appendix 11; Table 4.1.) are represented on Figure 4.1 as with sonication and without sonication for 1 minute.

**FIGURE 4.1: Decrease in Cyanide using Hydrogen Peroxide and Sonication over 1 minute**

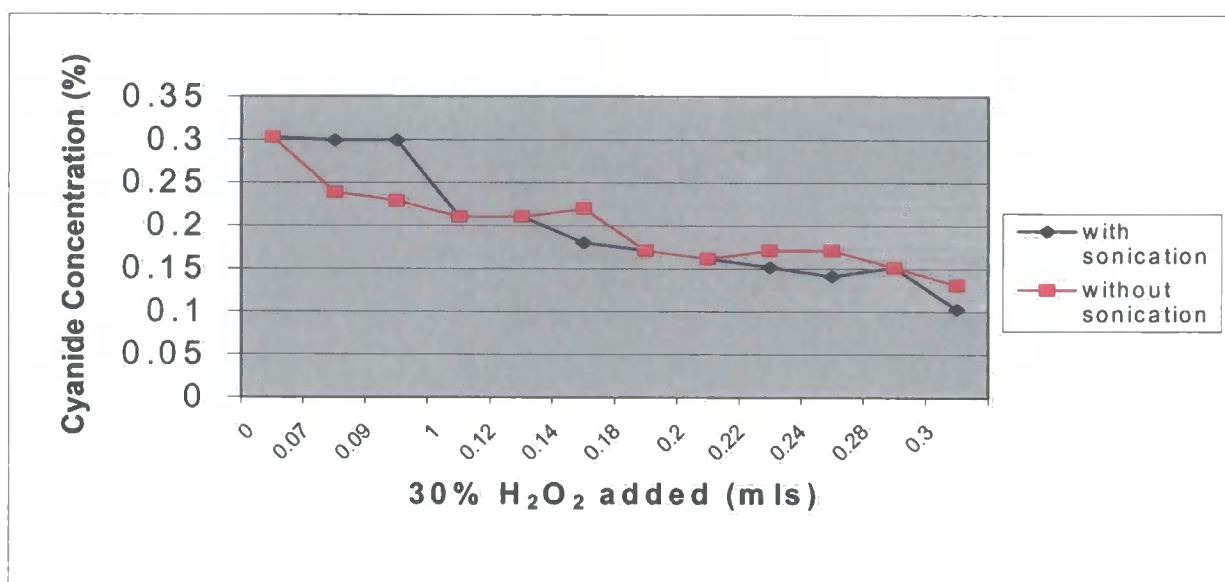

Results from the tests of the decrease in cyanide using hydrogen peroxide and sonication over 2 minutes (Appendix 11; Table 4.2) are represented on Figure 4.2 as with sonication and without sonication for 2 minutes.

**FIGURE 4.2: Decrease in Cyanide using Hydrogen Peroxide and Sonication over 2 minutes**

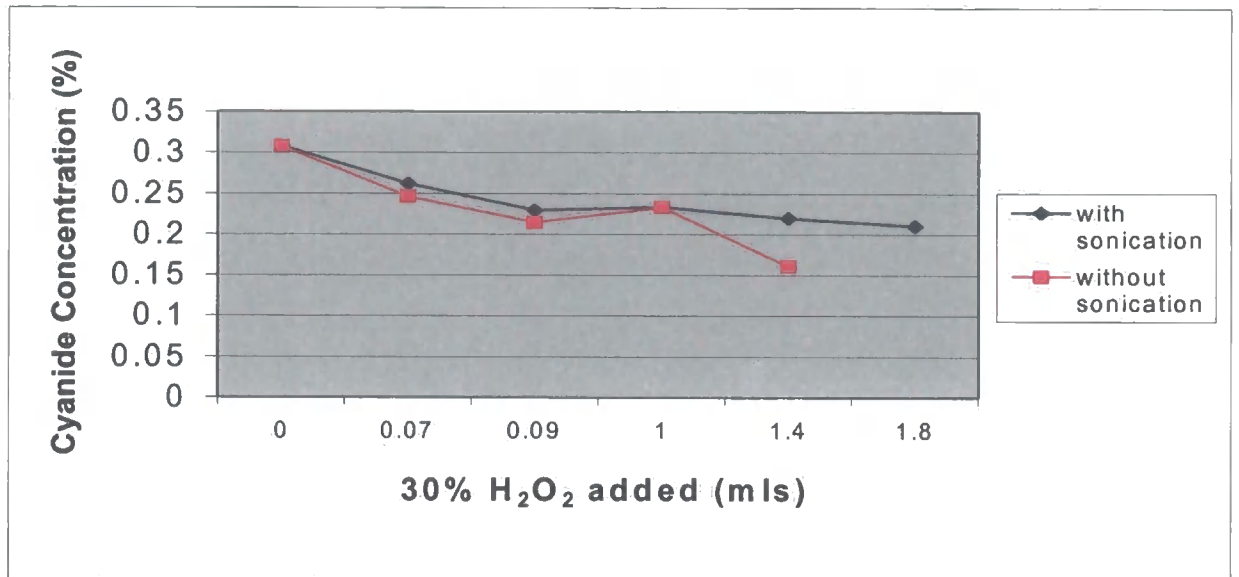

Results from the tests of the decrease in cyanide using hydrogen peroxide with and without sonication over 3 minutes (Appendix 11; Table 4.3) represented on Figure 4.3 as with sonication and without sonication for 3 minutes.

**FIGURE 4.3: Decrease in Cyanide using Hydrogen Peroxide and Sonication over 3 minutes**

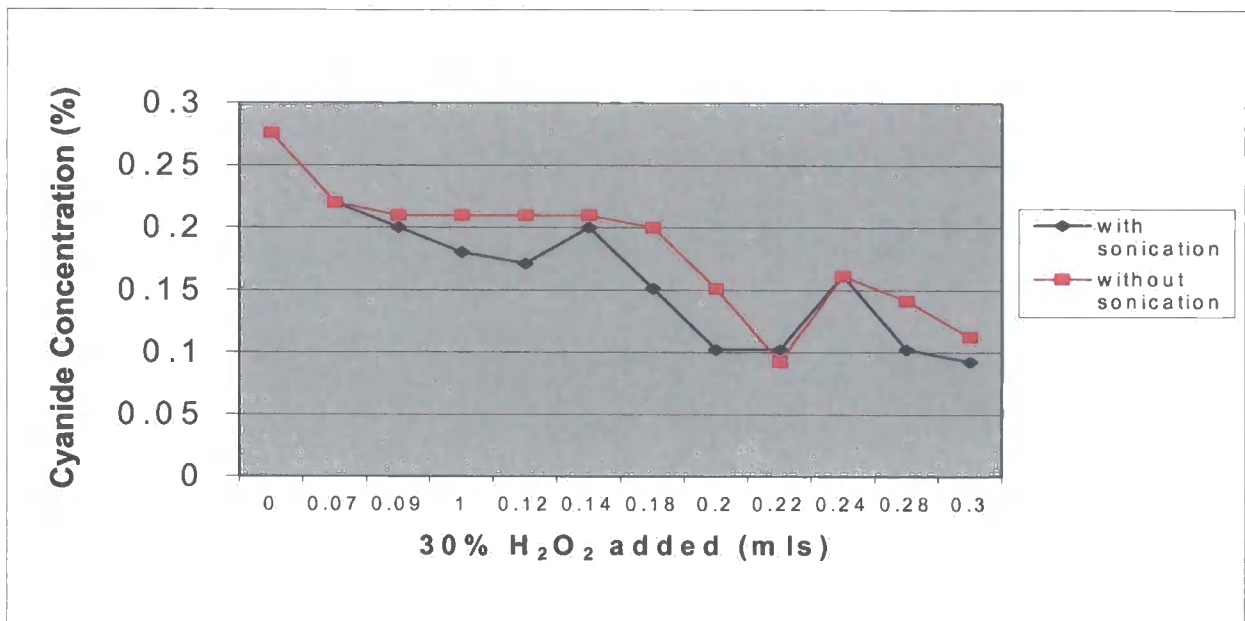

Results from the tests of the decrease in cyanide using hydrogen peroxide with and without sonication over 4 minutes (Appendix 11; Table 4.4) represented on Figure 4.4 as with sonication and without sonication for 4 minutes.

**FIGURE 4.4: Decrease in Cyanide using Hydrogen Peroxide and Sonication over 4 minutes**

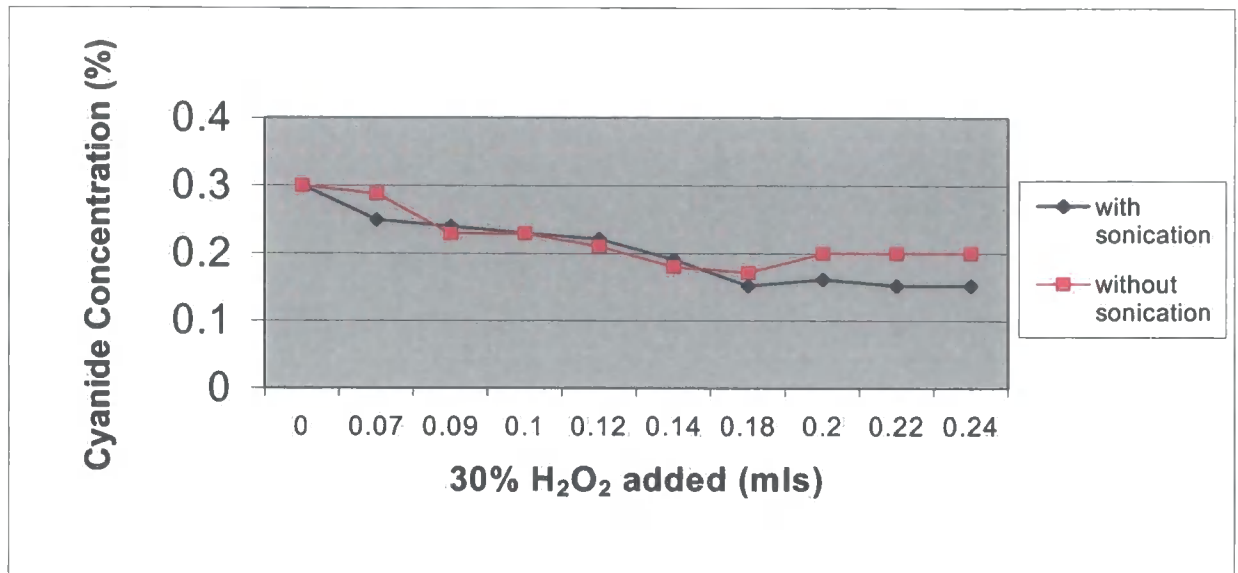

Results from the tests of the decrease in cyanide using hydrogen peroxide with and without sonication over 5 minutes are shown in Appendix 11; Table 10. These results are represented on Figure 4.5 as with sonication and without sonication for 5 minutes.

**FIGURE 4.5: Decrease in Cyanide using Hydrogen Peroxide and Sonication over 5 minutes**

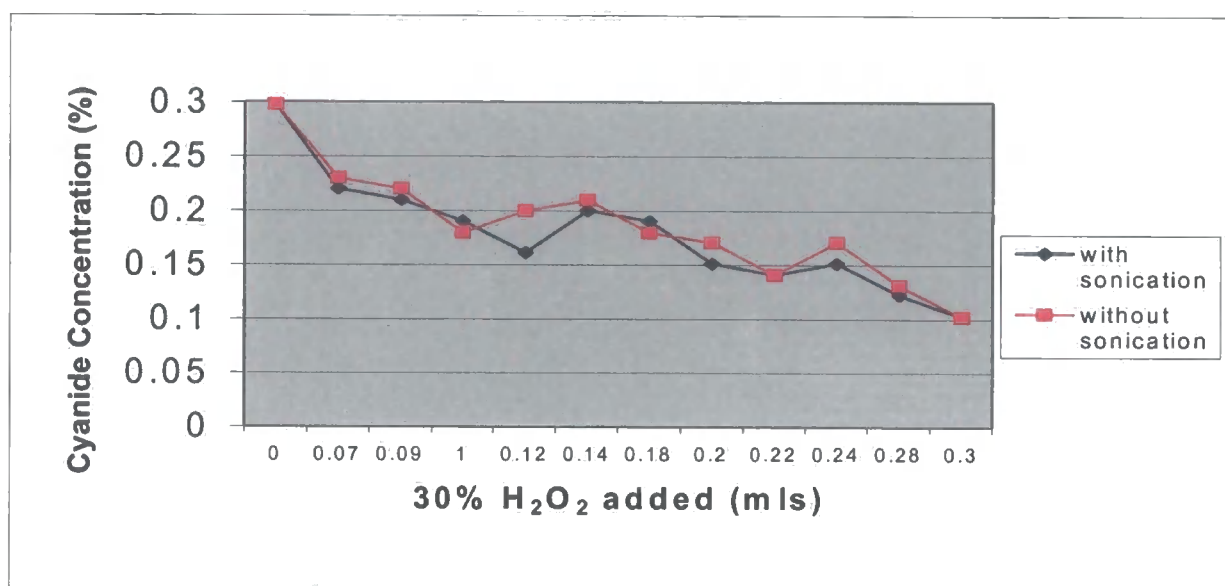

Results from the tests of the decrease in cyanide with increasing hydrogen peroxide volume over time without and with sonication (Appendix 11; Tables 4.6 and 4.7) and represented on Figure 4.6 and 4.7 with the volumes used shown in different colours.

**FIGURE 4.6: Decrease in cyanide with increasing hydrogen peroxide over time without sonication**

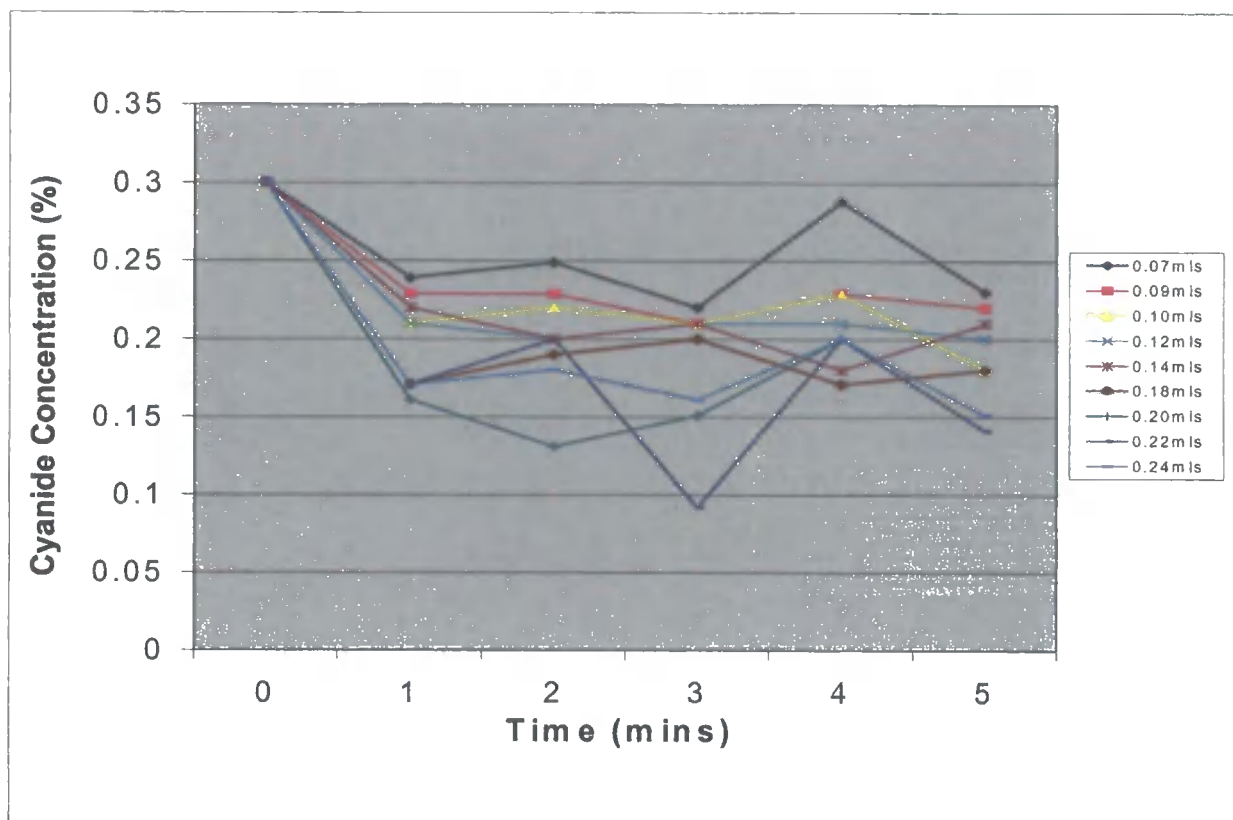

**FIGURE 4.7: Decrease in cyanide with increasing hydrogen peroxide over time with sonication**

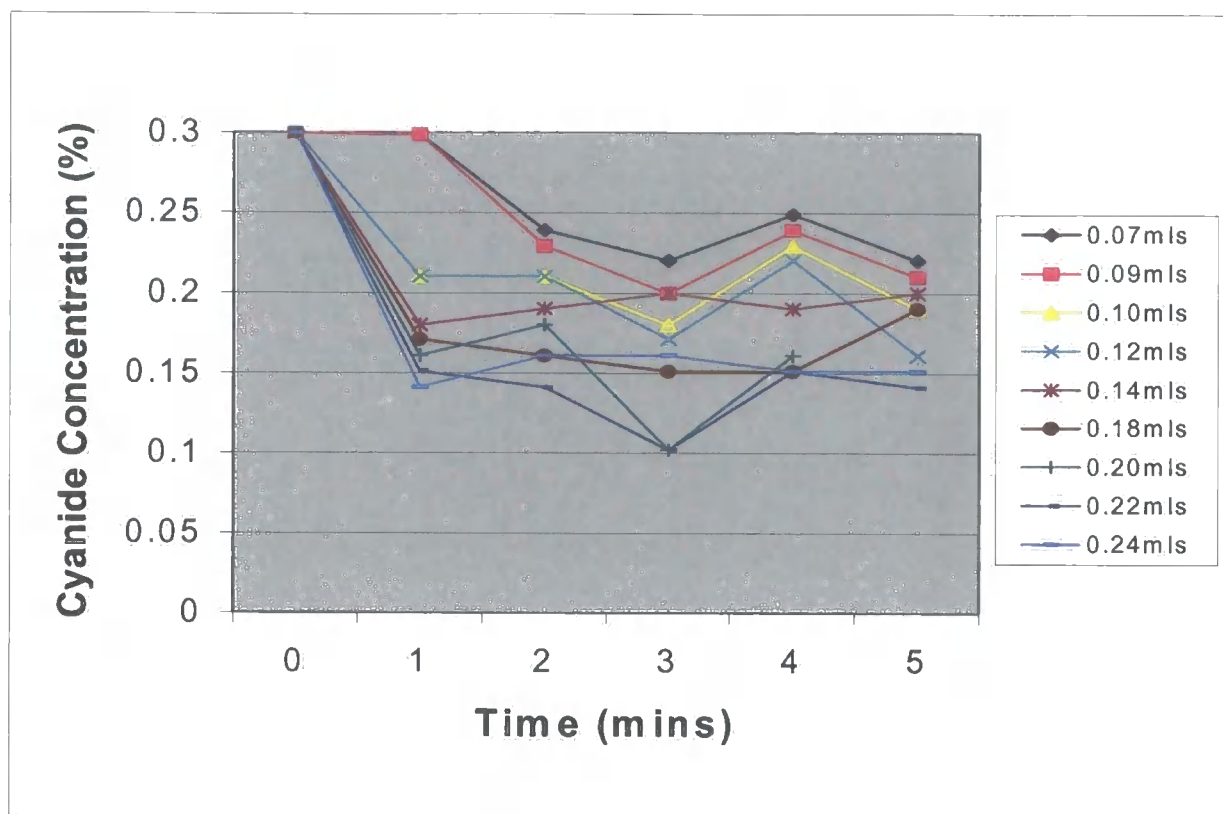

**Discussion & Conclusion:**

The results shown in figure 4.1, show that applying 1 minute of sonication the overall cyanide level decreases by over a half as the hydrogen peroxide added is increased. The effect of cyanide degradation due to sonication at this time interval is only slight. At a two minute time interval (figure 4.2) a marked decrease in cyanide concentration is noticeable on the graph as the hydrogen peroxide is increased. It is evident at this time interval there is no affect from the sonication. Once again at the three minute time (figure 4.3) interval the cyanide concentration is decreased by over a half as the hydrogen peroxide is increased. The sonication shows an increased effect at this time interval. At the four minute interval (figure 4.4) the cyanide concentration decreases by 50 % as the peroxide is increased and it would appear that the sonication is becoming more significant. A similar scale of decrease in cyanide content is observed at the five minute time interval (figure 4.5). Once again the use of sonication does not appear to have any significance at this time interval.

The graph showing increasing volume of hydrogen peroxide without sonication shows the expected decrease in cyanide with increase in hydrogen peroxide. Three minutes appears to be the optimum time interval for the greatest cyanide decrease. Increasing volumes of hydrogen peroxide with sonication also shows that 3 minutes is the optimum time scale, whilst at four minutes the decrease in cyanide concentration is not as great. There is however, a marked decrease in cyanide concentration generally when the sonication is applied to the sample.

Overall it can be seen from the results that the sonication does appear to have some effect on the reduction of the cyanide in these samples. This could be due to the ultrasonic action speeding up the rate of reaction of the peroxide.

A problem noticed during experiments was the issue of the Mettler and how long it took to analyse the sample. Whilst one is being titrated the next was left waiting (continuing to react). It would appear that time is a significant factor in the decrease in cyanide and therefore, some of the results may be reading incorrectly low due to the time taken in the titration.

## **4.1.2 Sonication/Hydrogen Peroxide time trials using Dionex Chromatography for cyanide determination**

### **4.1.2.1 Initial time trial to establish decrease in cyanide**

The rate of cyanide decomposition over time was carried out without ultrasonic.

#### **Method:**

A 10ml volume of sample was placed into a 250ml plastic beaker. To the beaker 0.5 ml of 30%  $\text{v/v}$   $\text{H}_2\text{O}_2$  was added and tested to establish the reduction in cyanide concentration. Out of the beaker 0.1 ml of the test mixture were removed at random time intervals and injected on to the Dionex. This was repeated until the cyanide concentration had fallen to zero. The results from the Dionex were given in mg/l.

#### **Initial Cyanide Content:**

As described in 4.1.1. The determination of cyanide content is based on the Cassel works analytical method Appendix 10.

#### **Results:**

Results from the tests of the decrease in cyanide over time using a fixed volume of hydrogen peroxide (Appendix 11; Table 4.8) represented on Figure 4.8 as time taken to reduce cyanide content of 10 mls of sample with 0.5 mls of 30%  $\text{v/v}$   $\text{H}_2\text{O}_2$ .

**FIGURE 4.8: Results from the initial time trial to establish decrease in cyanide using 10 mls of sample with 0.5 mls of H<sub>2</sub>O<sub>2</sub>**

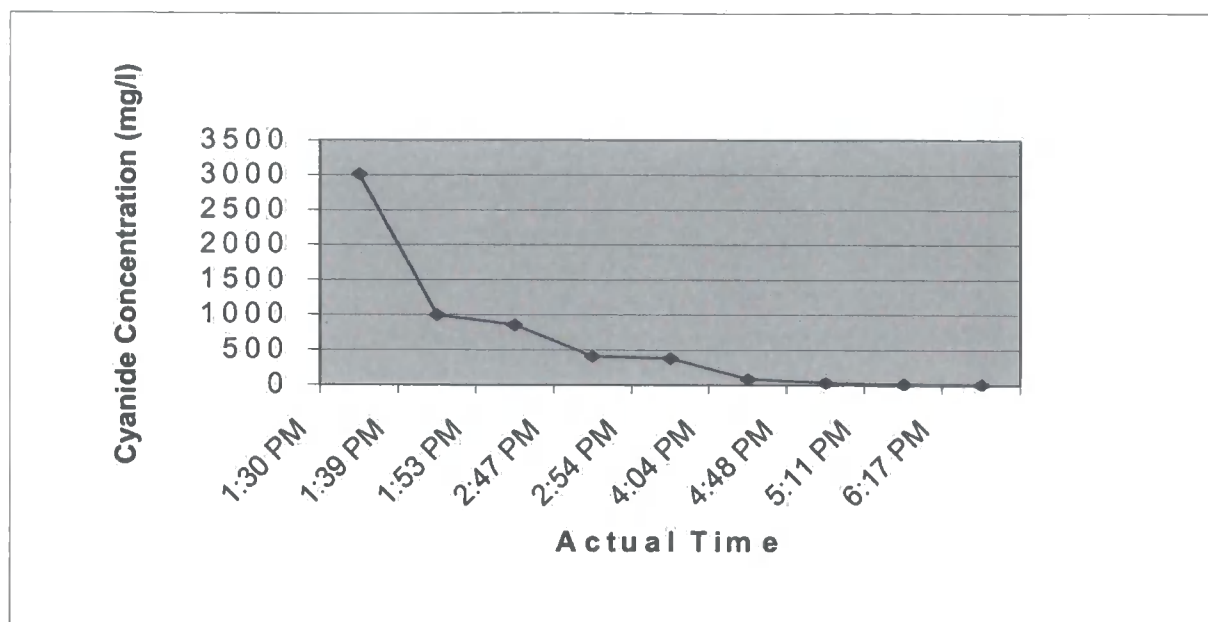

#### **4.1.2.2 Actual time trials to establish decrease in cyanide with hydrogen peroxide and sonication**

##### **Method:**

The ultrasonic bath was set up in the laboratory fume cupboard, as described in section 3.3.1. A 10 ml aliquot of sample was placed into a 250ml plastic beaker. Added to this were volumes of up to 50 mls of 30%  $\text{v/v}$  H<sub>2</sub>O<sub>2</sub>. The beaker was then placed in the ultrasonic bath at specific time intervals. The sample was tested before reaction using a Mettler (initial cyanide concentration as described in 4.1.1) and after using the Dionex to establish its cyanide content and reduction in mg/l. The steps above were repeated using the same amount of sample but without sonication.

The free HCN being released was established each time, as described in 3.3.1. The results obtained from the Draeger were found to be the same as in 3.3.1.

**Results:**

Results from the tests of the decrease in cyanide using hydrogen peroxide and sonication over 1 minute (Appendix 11; Table 4.9) are represented on Figure 4.9 as with sonication and without sonication for 1 minute.

**FIGURE 4.9: Decrease in cyanide using hydrogen peroxide and sonication over 1 minute**

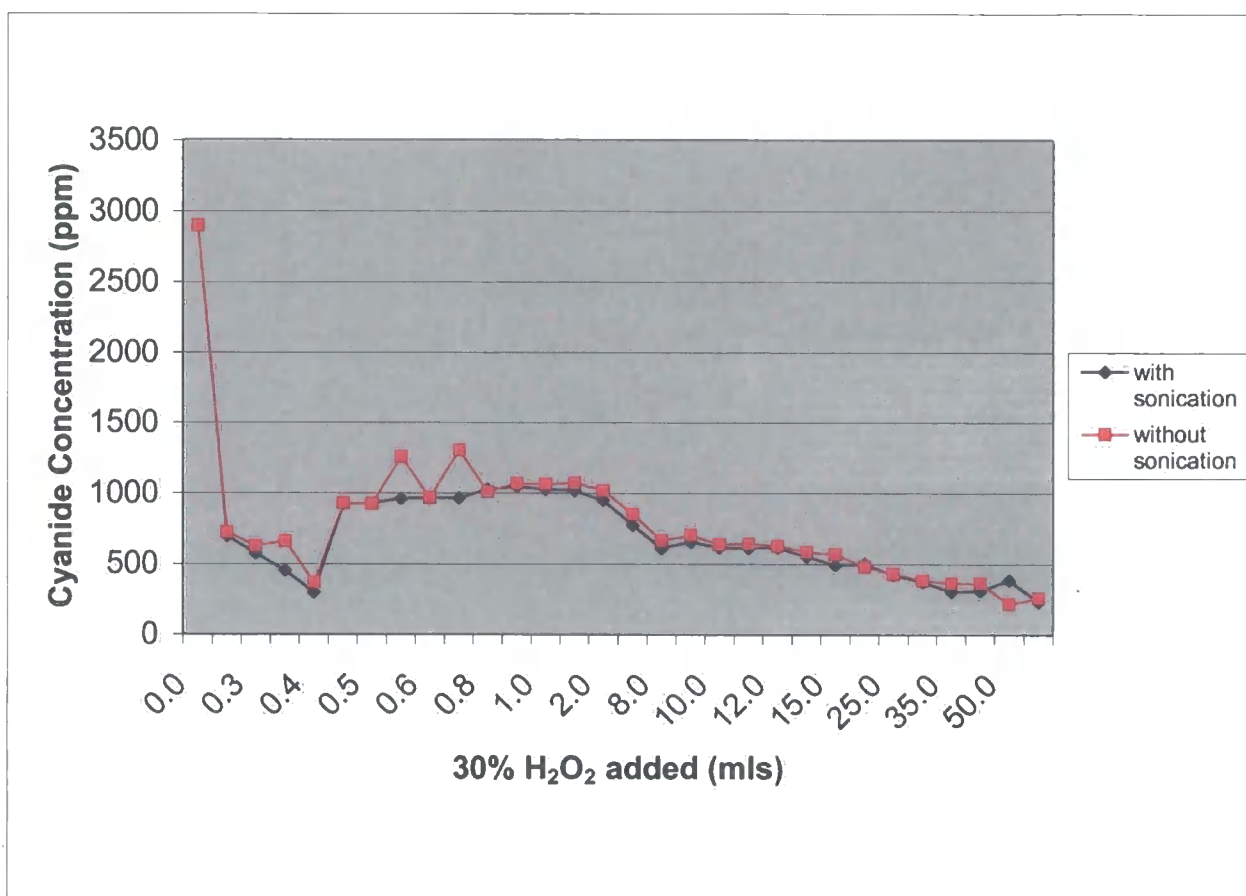

Results from the tests of the decrease in cyanide using hydrogen peroxide and sonication over 5 minutes (Appendix 11; Table 4.10) are represented on Figure 4.10 as with sonication and without sonication for 5 minutes.

**FIGURE 4.10: Decrease in cyanide using hydrogen peroxide and sonication over 5 minutes**

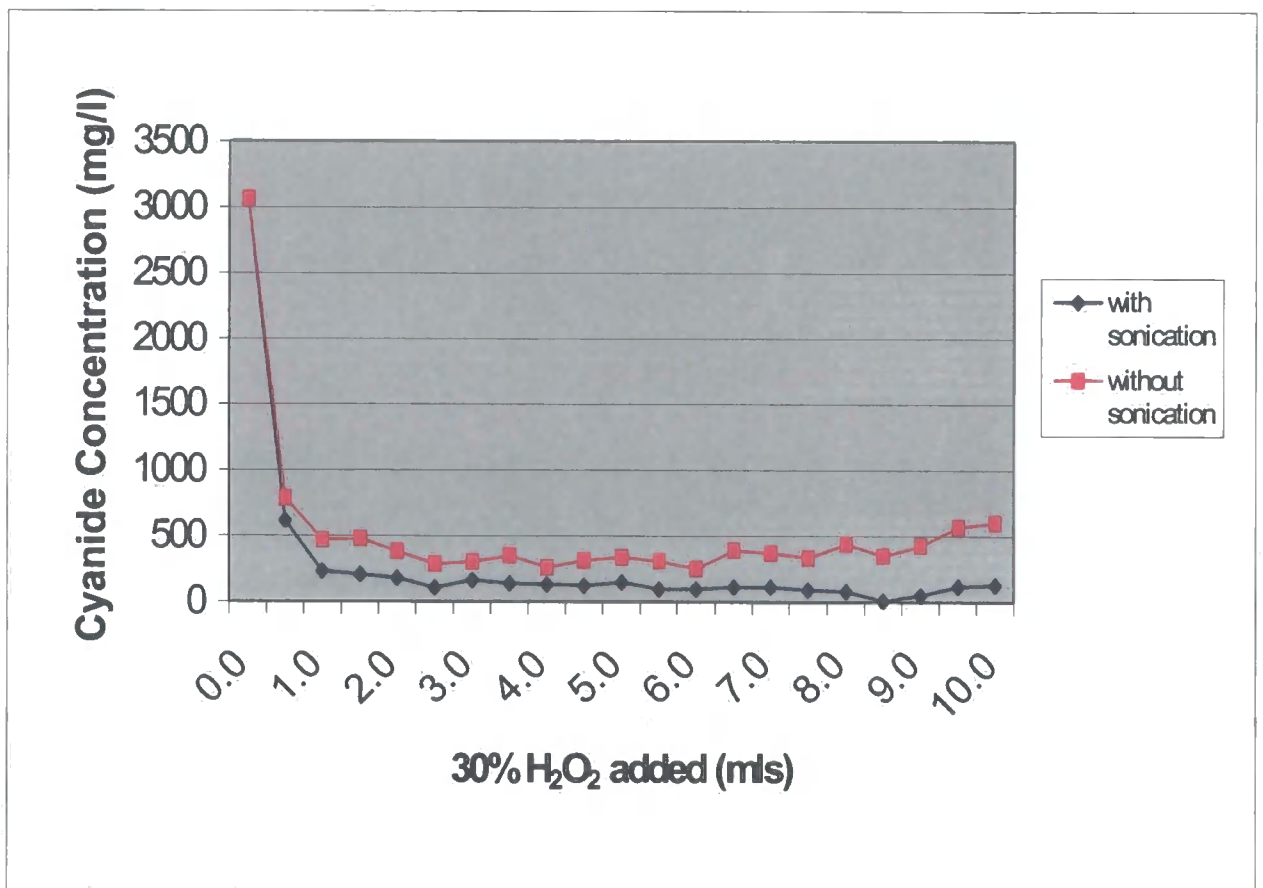

Results from the tests of the decrease in cyanide using hydrogen peroxide and sonication over 10 minutes (Appendix 11; Table 4.11) are represented on Figure 4.11 as with sonication and without sonication for 10 minutes.

**FIGURE 4.11: Decrease in cyanide using hydrogen peroxide and sonication over 10 minutes**

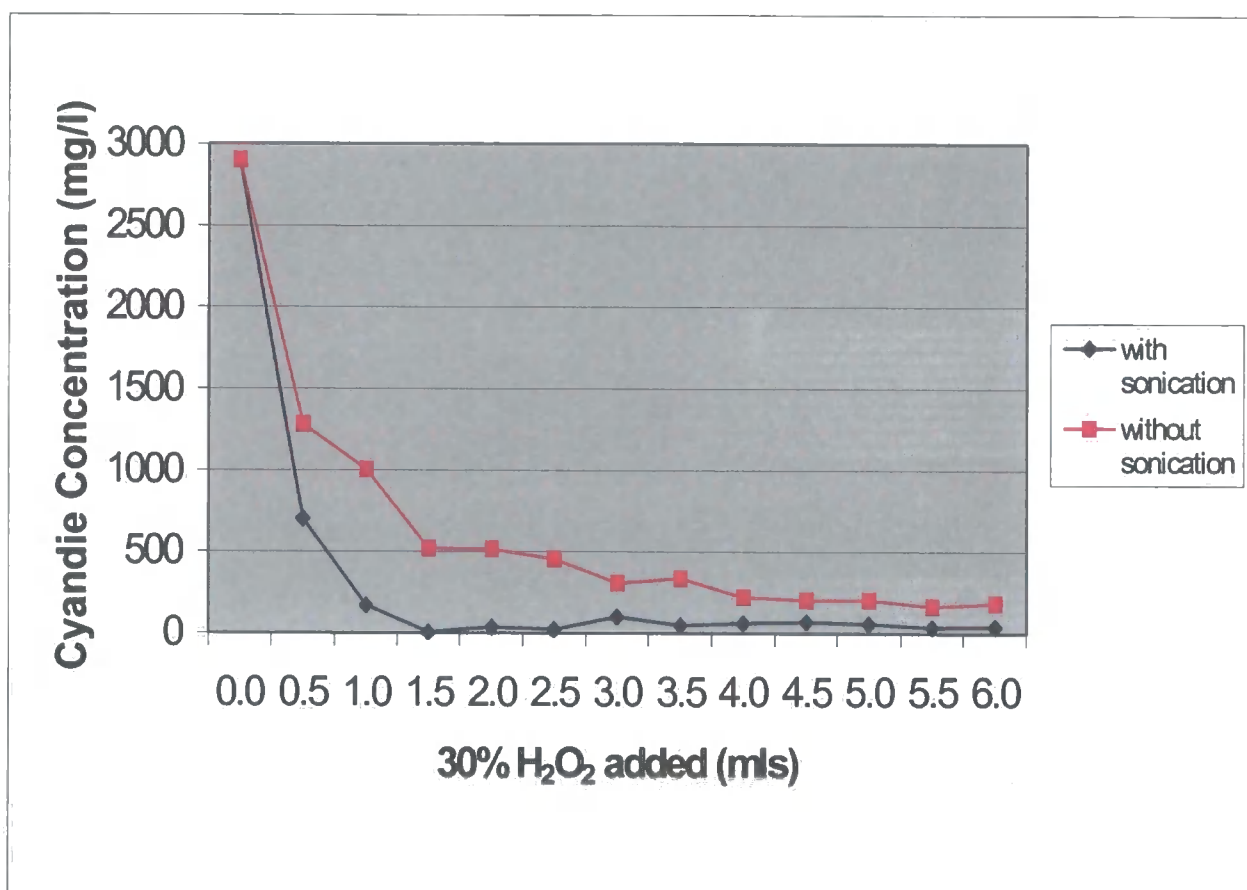

Results from the tests of the decrease in cyanide using hydrogen peroxide and sonication over 13 minutes (Appendix 11; Table 4.12) are represented on Figure 4.12 as with sonication and without sonication for 13 minutes.

**FIGURE 4.12: Decrease in cyanide using hydrogen peroxide and sonication over 13 minutes**

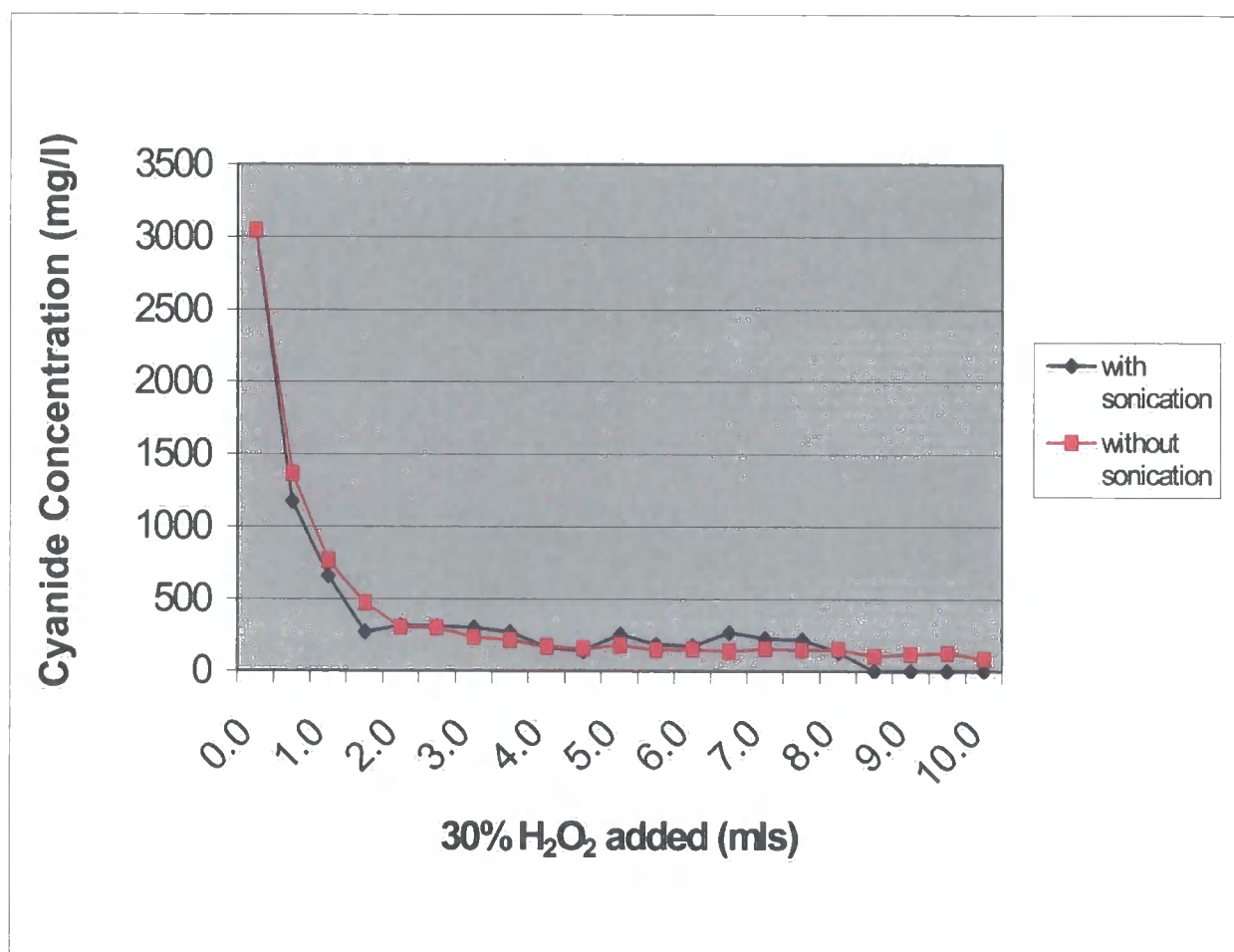

Results from the tests of the decrease in cyanide using hydrogen peroxide and sonication over 15 minutes (Appendix 11; Table 4.13) are represented on Figure 4.13 as with sonication and without sonication for 15 minutes.

**FIGURE 4.13: Decrease in cyanide using hydrogen peroxide and sonication over 15 minutes**

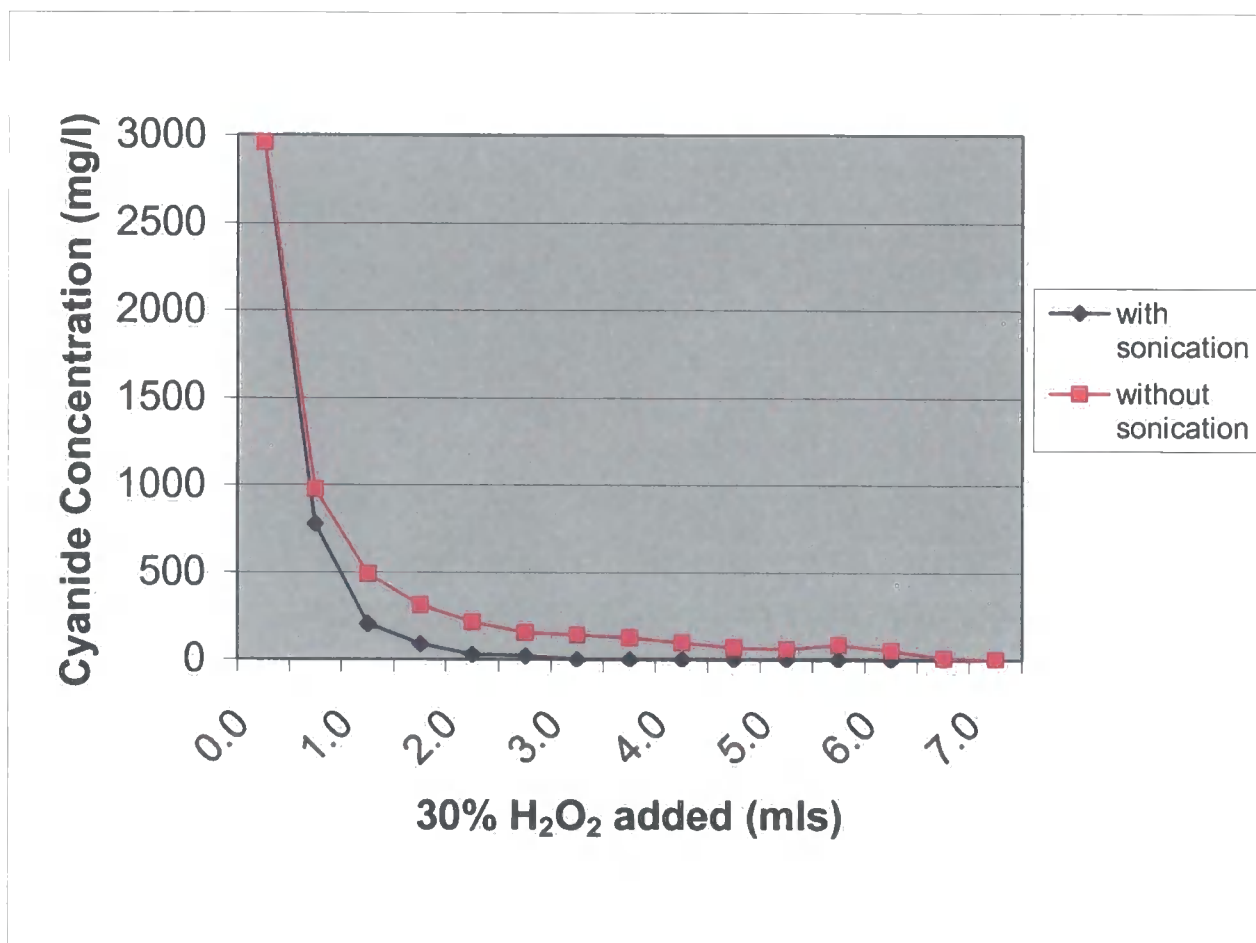

Results from the tests of the decrease in cyanide using hydrogen peroxide and sonication over 20 minutes (Appendix 11; Table 4.14) are represented on Figure 4.14 as with sonication and without sonication for 20 minutes.

**FIGURE 4.14: Decrease in cyanide using hydrogen peroxide and sonication over 20 minutes**

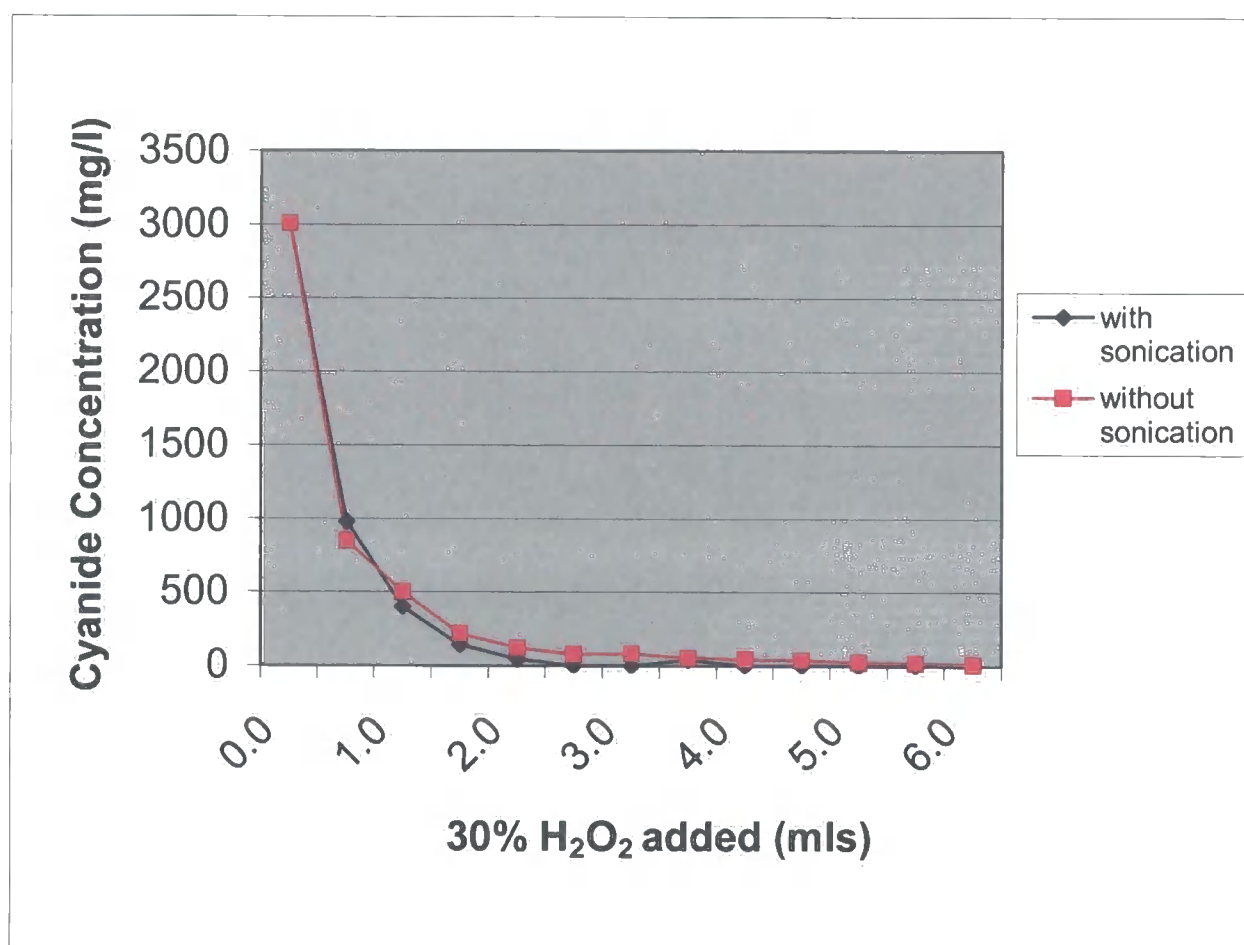

Results from the tests of the decrease in cyanide with increasing hydrogen peroxide over time (Appendix 11; Table 4.15) are represented on Figure 4.15 as effect on cyanide concentration with increasing H<sub>2</sub>O<sub>2</sub> levels.

**FIGURE 4.15: Decrease in cyanide using increased hydrogen peroxide without sonication**

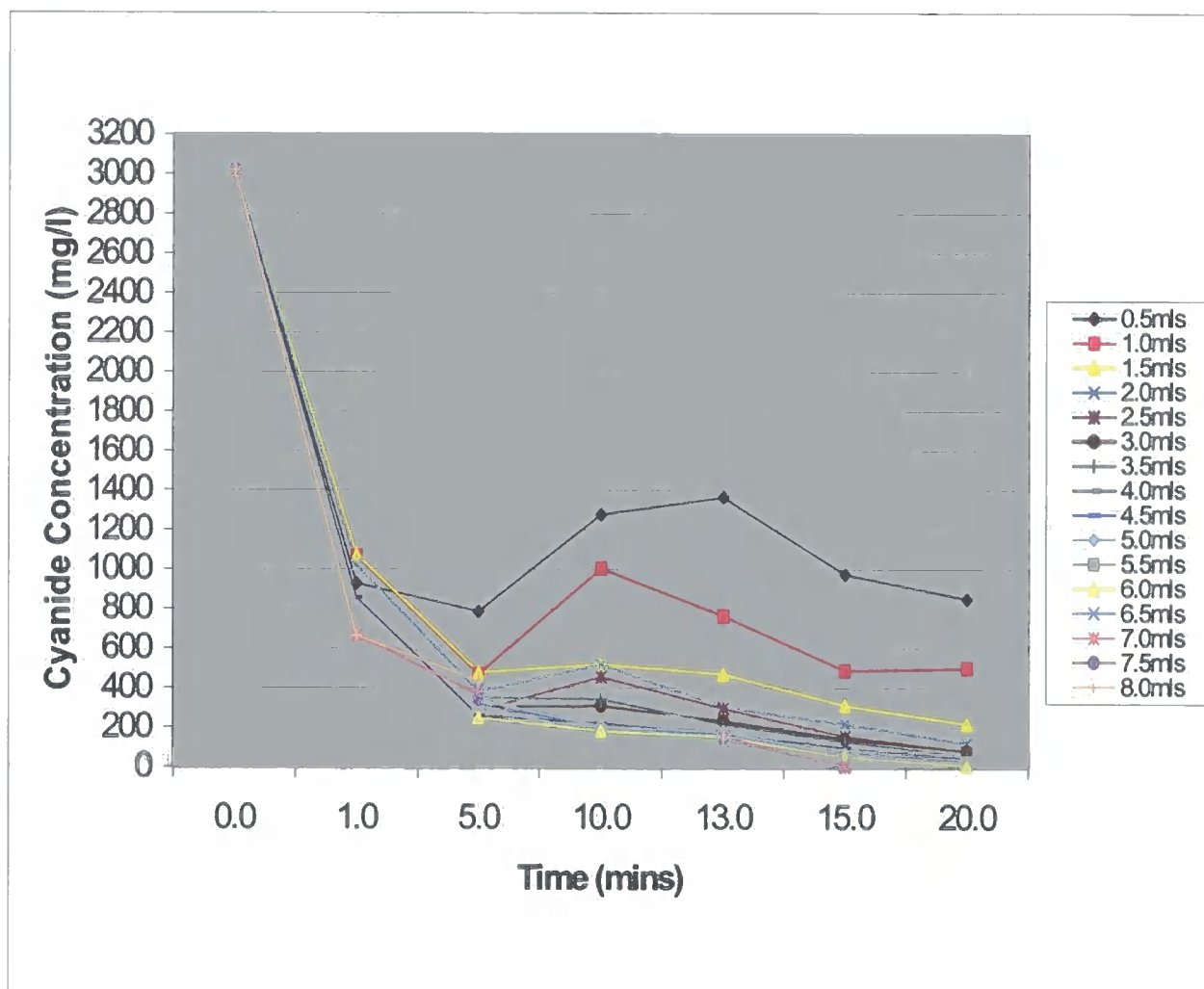

Results from the tests of the decrease in cyanide with increasing hydrogen peroxide and sonication over time (Appendix 11; Table 4.16) are represented on Figure 4.16 as effect on cyanide concentration with increasing H<sub>2</sub>O<sub>2</sub> levels and sonication.

**FIGURE 4.16: Decrease in cyanide using increased hydrogen peroxide with sonication**

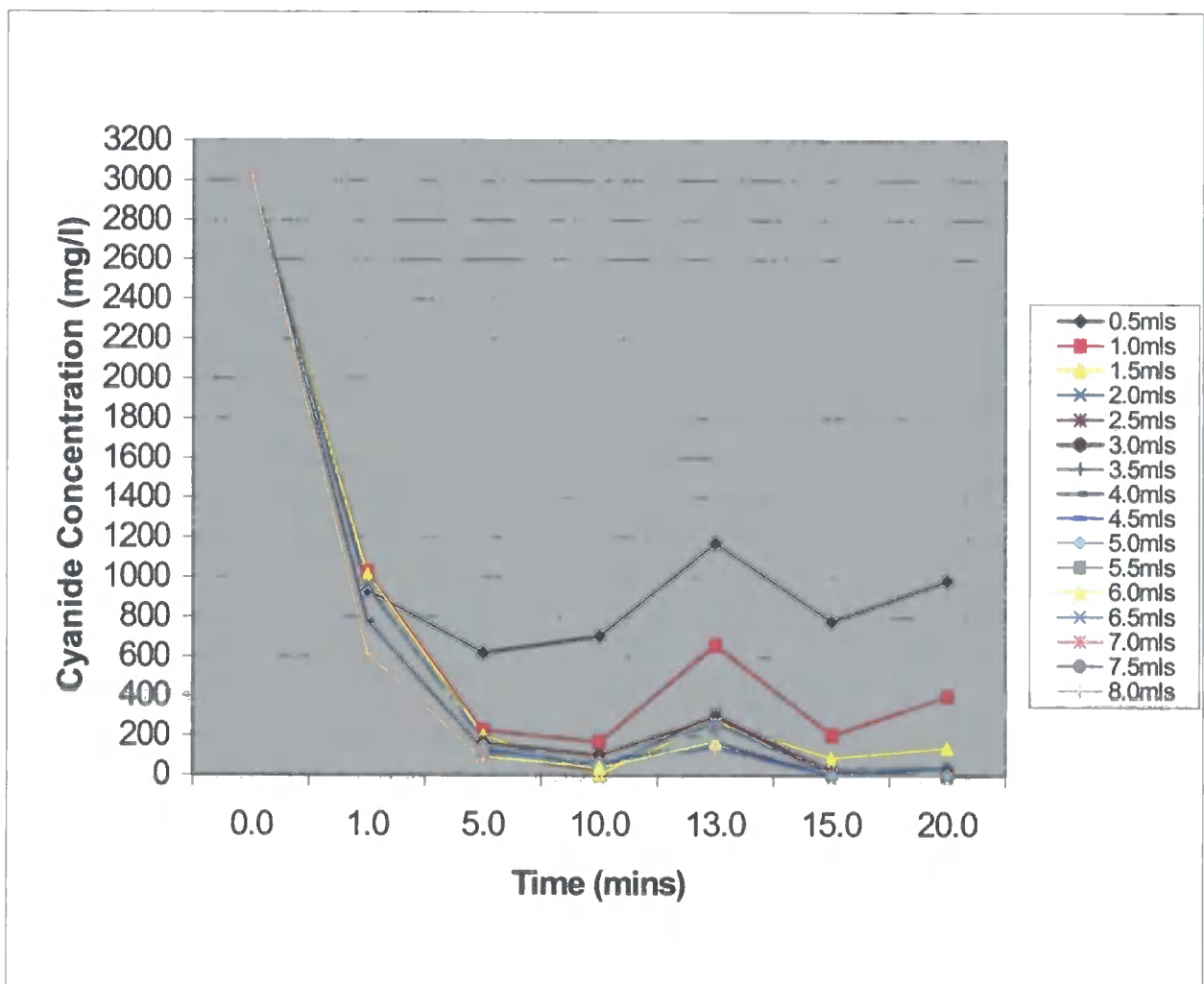

Results from the tests of decrease in cyanide concentration against volume of hydrogen peroxide added with sonication (Appendix 11; Table 4.17) are represented on Figure 4.17 as decrease in cyanide level with increasing H<sub>2</sub>O<sub>2</sub> over time.

**FIGURE 4.17: Decrease in cyanide using increased hydrogen peroxide with sonication to show optimum time**

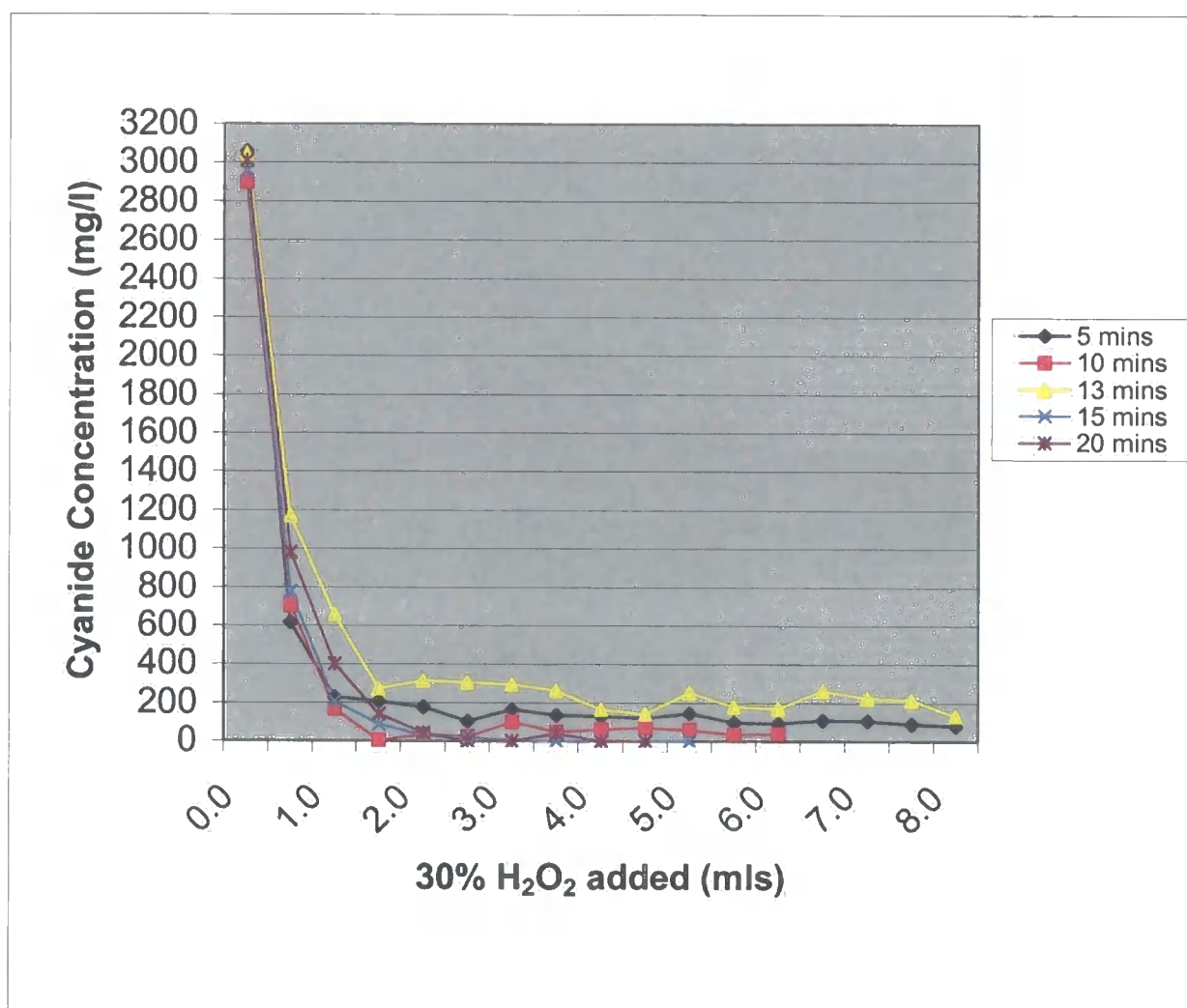

Results from the tests of the comparison in cyanide level against volume of hydrogen peroxide used without sonication (Appendix 11; Table 4.18) are represented on Figure 4.18 as decrease in cyanide concentration over time without sonication.

**FIGURE 4.18: Decrease in cyanide using increased hydrogen peroxide without sonication to show optimum time**

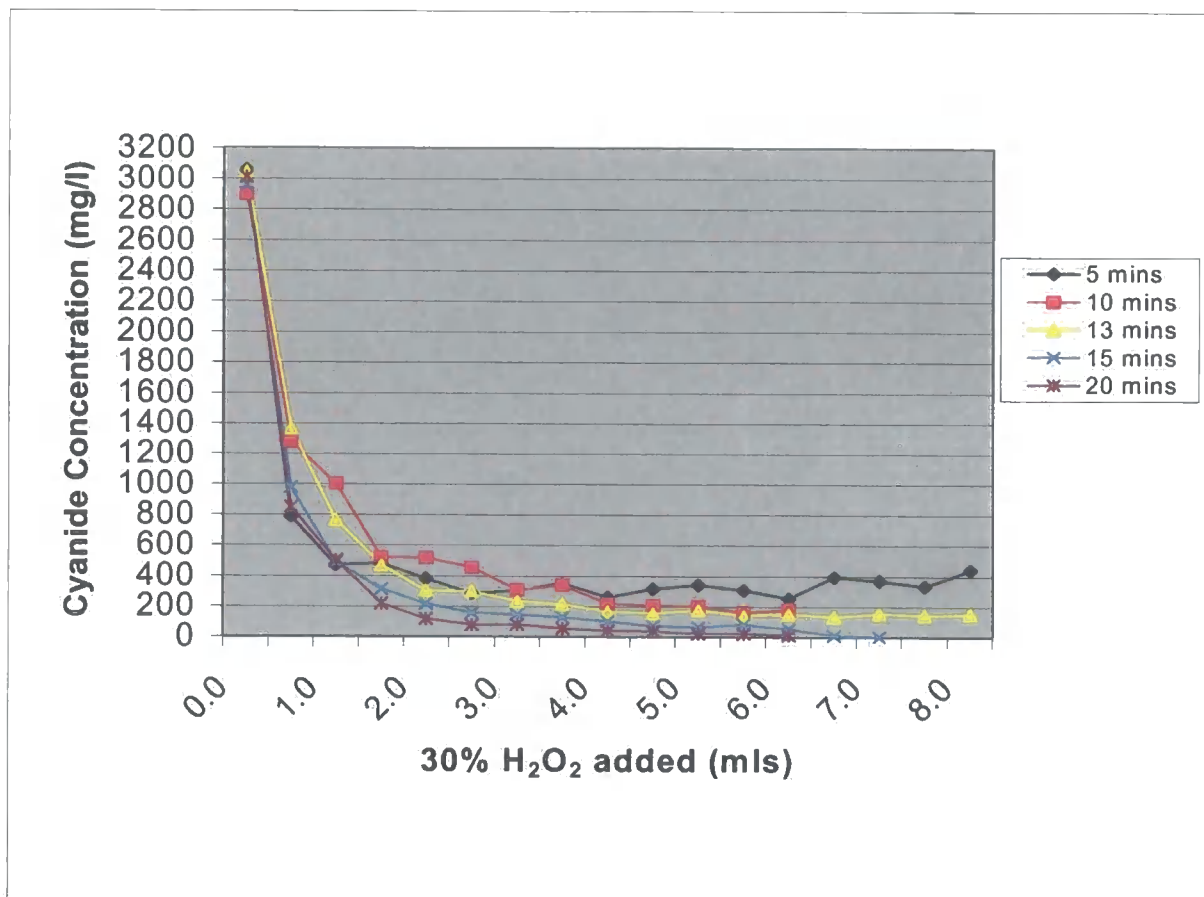

#### Discussion & Conclusion:

It can be seen from the results that the sonication does appear to have an effect on the reduction of the cyanide in these samples. This could be due to the ultrasonic speeding up the rate of reaction of the peroxide. From the first experiment it can be seen that given enough time (4-5hours) a small amount of peroxide can decompose all the cyanide present in the plant effluent sample even without ultrasonic. The initial major drop in cyanide occurs with the first 10 minutes of decomposition and the cyanide concentration goes down by approximately a third. The decrease after this ten-minute delay is much less pronounced.

Ranges of experiments were then performed to establish the optimum time scale for the peroxide/ultrasonic to work. The one-minute test reduced the cyanide with a small amount of peroxide (0.32 mls) however the short time was not sufficient to reduce the cyanide below 50 mg/l, even when 60 mls of peroxide was added. The five-minute test showed an advantage in using sonication, but after using 1 ml of peroxide the increments in peroxide had very little effect on the cyanide concentration of the sample. The ten-minute test showed again that the significance of using the sonication when adding more than 1.5 mls of peroxide the cyanide content was practically zero. However, without sonication a ten minute delay with 1.5 mls of peroxide only reduced the cyanide level to 500 mg/l. Increased additions of peroxide up to 6 mls (without sonication) after this had very little effect on the cyanide concentration. Thirteen minutes delay time test showed that after 2 mls of peroxide and no sonication there was very little decrease in the cyanide content of the solution. With sonication 1.5 mls was sufficient to reduce the cyanide to around 200 mg/l. The added peroxide after this had very little effect in bringing down the cyanide content further. After fifteen minutes of delay time using sonication the addition of 2 mls of peroxide reduced the cyanide content to below 50mg/l and 3 mls of peroxide removed the cyanide completely. Without sonication 6 and 7 mls of peroxide were required to have the same effects over the same time period. The 20-minute experiment showed that after 2 mls the cyanide was reduced below 50mg/l and after 2.5 mls the cyanide was reduced to zero using sonication. Without sonication 4 mls was required to reduce the cyanide to below 50 mg/l and over 6 mls to reduce the cyanide content to zero. However, this also showed that there was little advantage in using sonication over the 20-minute time period.

Increasing peroxide volume without sonication shows that 15 to 20 minutes were required for the peroxide to have an effect of bringing down the cyanide below 50 mg/l. For 15 minutes 6.6 mls of peroxide was required. For 20 minutes only 4 mls of peroxide was required. With sonication the 10-minute test showed that using 2 mls of peroxide reduces the cyanide concentration to below 50 mg/l. This was also the case for the longer 15 and 20-minute tests.

From these experiments it can be concluded that the use of sonication could halve the amount of peroxide required to reduce the cyanide below 50mg/l. There is also some indication that sonication increases the rate of the peroxide reaction and the reduction below 50 mg/l cyanide is quicker. Therefore, the best methodology for decreasing the cyanide content is the use of hydrogen peroxide and use of sonication. Due to the problem with hydrogen peroxide interfering with the Mettler electrodes the best method for testing the cyanide was found to be the Dionex.

#### 4.1.3 Solid related time trial with Sonication/Hydrogen Peroxide

The aims of these short experiments were to establish what detrimental effects increased solids or increased temperature would have on cyanide reduction using sonication and peroxide treatment of cyanide plant effluent.

##### **Method:**

The ultrasonic bath was set up as stated in the method of section 3.3.1. The initial samples were filtered to remove all of the solids; the solids and filtrate retained. A series of 10ml volumes of filtrate was placed into a 250ml plastic beakers. Then 1.5 ml aliquots of 30 %  $\text{v/v}$   $\text{H}_2\text{O}_2$  were added to all the samples. Known masses of solids (harvested) were added into the 10 mls of filtrate, two beakers were treated with the same mass of solids. One sample was placed in the ultrasonic bath for 10 minutes the other was left to stand for 10 minutes. The samples were tested for cyanide content as explained in section 4.2.1.

##### **Results:**

Results from the tests of the comparison in cyanide level against volume of hydrogen peroxide used without sonication (Appendix 11; Table 4.19) are represented on Figure 4.19.

**FIGURE 4.19: Decrease in cyanide with increased solids added, 1.5 mls hydrogen peroxide with and without sonication for 10 minutes**

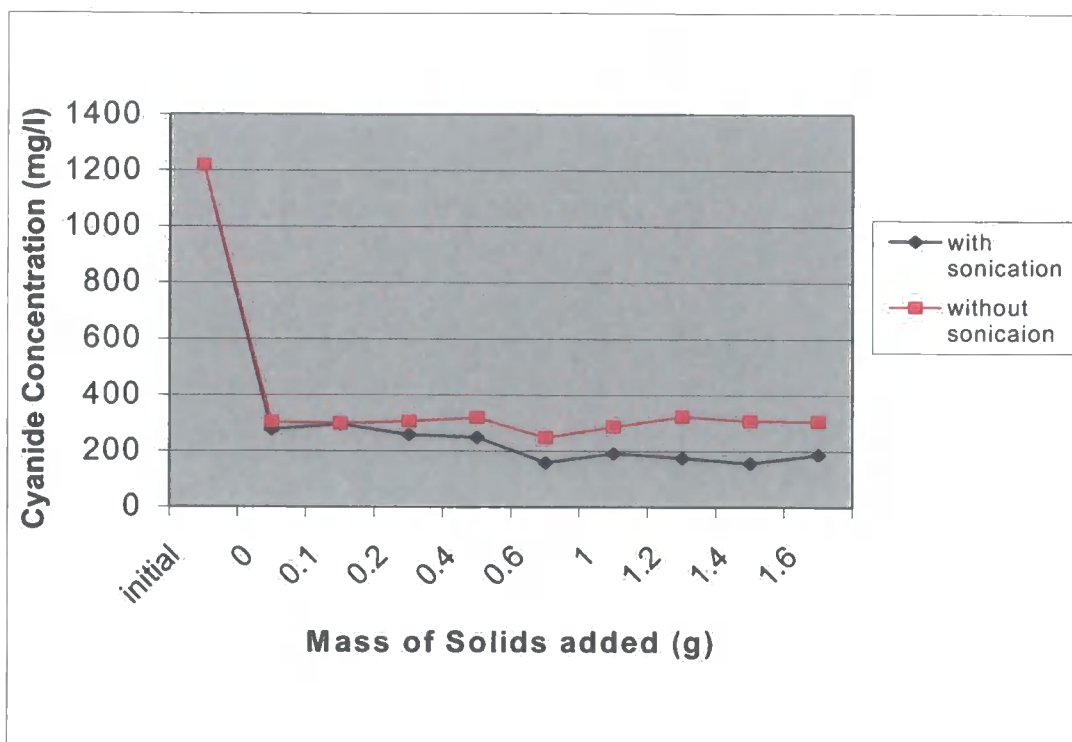

**Discussion and Conclusion:**

The results displayed within figure 4.19 show that without sonication the cyanide content remains virtually the same as more solids are added. Therefore, the conclusion is that an increase in solids within the samples has no effect on the peroxides ability to decompose the cyanide present. With the addition of sonication it would appear that the increase in solids aids slightly in the reduction of cyanide. The results show the addition of excess solids has little effect on the cyanide destruction and as with the other experiments sonication still has a significant effect in helping to reduce the cyanide content.

#### 4.1.4 Temperature related time trial with Sonication/Hydrogen Peroxide

##### Method:

The ultrasonic bath was set up as stated in the method of section 3.3.1. A series of 10 ml volumes of sample were placed into 250 ml plastic beakers. Then 1.5 ml aliquots of 30 %  $v/v$   $H_2O_2$  were added to all the samples. One sample was placed in the ultrasonic bath for 10 minutes the other was left to stand without sonication for 10 minutes and the temperature noted. The steps above were repeated using the same sample matrix but treated to increasing temperatures.

The temperature increases were obtained using beakers of warm water to heat the samples to the temperature required. The samples were tested for cyanide content as explained in section 4.2.1.

##### Results:

Results from the tests of the comparison in cyanide level against volume of hydrogen peroxide used without sonication (Appendix 11; Table 4.20) are represented on Figure 4.20

**FIGURE 4.20: Decrease in cyanide with increased temperature, 1.5 mls hydrogen peroxide with and without sonication for 10 minutes**

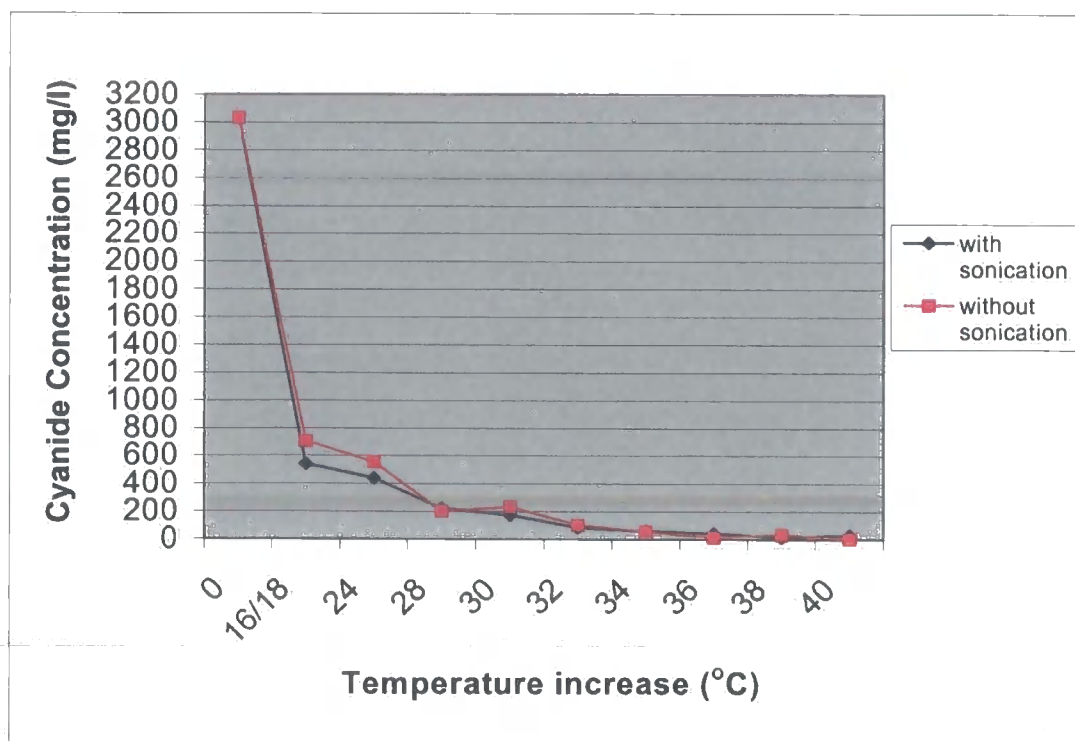

**Discussion and Conclusion:**

It can be seen that from the graph in figure 4.20, the rise in temperature is increasing the rate of reaction of the peroxide within the sample and the cyanide is being reduced more quickly. In summer as plant effluent temperatures are increased due to an increase in ambient temperatures there will be an increase in cyanide decomposition. In the winter months the colder ambient temperatures may reduce the effluent temperatures and more peroxide may be required or longer retention time within sump system. From the graph it can be seen that there is an additional benefit in using sonication at slightly increased effluent temperatures as the cyanide content has shown to be reduced to zero.

The increased effluent temperature has shown to have a positive increased effect on the cyanide removal of the effluent.

## 4.2 Analysis Of Variance (ANOVA)

### 4.2.1 Significance

The statistical analysis applied to all the data obtained in the laboratory test was the General Linear model (ANOVA or analysis of variance). The general linear model was chosen because it looks at the difference between the sample means with no restrictions on the number of means analysed. The model also takes into account all the independent variables at the same time, with the ability of testing the interactions each one in turn against the others. The approach does assume homogeneity of variance and the normality of distribution (Howell, 1997).

The model was used to establish if any one of the variables, for example temperature or sonication, differs from the group as a whole (Meier & Zund, 2000). The model is used to test the significance of the factors believed to be controlling the experiment.

### 4.2.2 Interactions

The general linear model considered the following factors as interactions;

- (i) the cyanide level in mg/l
- (ii) the time in minutes for a reaction to occur
- (iii) the application of sonication on the cyanide reduction
- (iv) the volume of hydrogen peroxide used
- (v) their interactions with each other.

The general linear model is a factorial approach and advantageous over other statistical approaches which keep factors static whilst varying only one, because the other factors of peroxide, sonication and time left reacting are all acting simultaneously (Worrall, *et al* 2002). The relative importance of the factors interacting is calculated, whereas, the interactions between factors cannot be established using a “one at a time” statistical approach. It is also possible to account for those uncontrollable factors within the design but are measurable. These are called covariates. This allows for the linear adjustment of the survey data with emphasises on the controllable factors. This is considered a four-factor experiment, where the loss or decrease in cyanide is determined by the other three factors

effecting it. The importance in quantifying the interaction effects shows at which point within the interaction there is a significant decrease in cyanide concentration.

#### 4.2.3 General Linear Model; Significance Table

The general linear model was used to collate and analyse the results obtained in the laboratory tests of sonication and hydrogen peroxide on cyanide concentration. Analysis of variance for cyanide (as mg/l) with adjustments for the tests, was displayed in a significance table (Table 4.1). This shows that the main effects are time, hydrogen peroxide used and sonication are all significant.

**TABLE 4.1: Analysis of Variance for cyanide removal experiments**

<i>Source</i>	<i>Adj MS (Adjusted Mean Squares)</i>	<i>F</i>	<i>P</i>
Time (min)	179362	34.67	0.000
Sonication	582244	112.56	0.000
H <sub>2</sub> O <sub>2</sub> used	6372674	1231.92	0.000
Time*H <sub>2</sub> O <sub>2</sub>	11146	2.15	0.004
Time*Sonication	92322	17.85	0.000
Sonication*H <sub>2</sub> O <sub>2</sub>	18902	3.65	0.001

#### 4.2.4 Tukey (Computer Model)

The computer model Tukey simultaneous test was used on the general linear model to assess the effect on cyanide concentration. The Tukey model assumed all interactions effects were due to error and calculated the variation between each of the six variables (Table 4.1) against all the other variables, eliminating one variable each time. The model calculated this by least square means – unweighted means (residual

variance) for each time intervals 5, 10, 13, 15 and 20 minutes, for each increment of peroxide from zero with 0.5 ml increments up to 6.0 mls and for the use of sonication being either off or on. Those interactions with the higher residual variances calculated using Tukey 95% confidence intervals were discarded as part of the model as being error. The lowest residual variance was found to be for sonication. The tests found the effect on cyanide concentration against time gave positive values for the 10 minute and 20 minute time intervals, Tukeys' calculation of the optimum time intervals to be used. Using the Tukey simultaneous tests the adjusted P values for the effect on cyanide concentration against levels of peroxide used became positive at 2.0 mls indicating the first volume at which the results are most significant. Assessing sonication the mathematical calculations gave the adjusted P value of zero when sonication is not used and therefore, sonication has a significant effect in reducing the cyanide concentration of the sample. The Tukey statistical results showed that the optimum for the variables to obtain the most significant drop in cyanide concentration for a 10 ml aliquot of sample would be sonication for ten minutes with 2 mls of 30%  $v/v$  hydrogen peroxide.

#### **4.2.5 Errors**

There are several problems associated with the general linear approach, possibility of the type II errors and I require testing. The sample during analysis may have had cyanide present but below the limit of detection would give a reading of zero. ANOVA, assumes normality and similarity of data variance (Worrall, *et al* 2002).

## **5.0 DISCUSSION**

### **5.1 Experimentation**

The aims of section 5.1 are to cover the problems found during all the trials including experimentation and a discussion of the recommendations drawn from the conclusions of the trial work. Other important areas included are of accuracy and known sources of error associated with the tests and results. The equipment used for the trials and their methods raised some areas for improvement and these will be discussed.

#### **5.1.1 Problems and Recommendations**

(i) Cyanide removal using sonication and activated carbon.

The first problem encountered was with the experiment of cyanide removal using sonication and activated carbon. The initial conclusion was that cyanide bound to the suspended solids' surface was released during sonication causing the increased cyanide concentrations. However, even when the suspended solids were removed from the sample the cyanide concentration increased, thus disproving this conclusion. The increase in cyanide content was also noticeable when the activated carbon was added to filtered effluent, therefore results showed the use of activated carbon increased the cyanide level of the Cassel effluent samples. The previous recommendation in section 3.3 suggested the use of sonication was the main issue, this has been disproved with later experiments. The recommendation drawn would be activated carbon and sonication should not be used in the cyanide removal from the Cassel effluent. Components within the Cassel effluent may be the initiator of the increased cyanide concentration.

(ii) Cyanide removal using electrolysis

Electrolysis has been an established method for cyanide removal from various effluents, discussed in section 2. In the case of the Cassel works effluent it was difficult to establish a method with the kit available that would reduce the cyanide content to below half the original concentration. The recommendations for this

method of cyanide destruction would be to establish the optimum voltage setting to use for the cyanide plant effluent with the ability to reduce the cyanide content further, possibly to below 50 mg/l. The cost of implementing an electrolysis system at Cassel site and running the system would be large, in variance with the requirement to reduce the cyanide content in the quickest amount of time in order to reduce the running costs.

(iii) Hydrogen peroxide only

The use of hydrogen peroxide was proven to be effective at reducing the cyanide content of the effluent. The problems noticed initially were that excessive amounts hydrogen peroxide were required to rapidly reduce the cyanide, the recommendation would be to allow time for the peroxide to react with the cyanide and so reduce the amount of peroxide necessary.

(iv) Hydrogen peroxide and sonication

The reduction in cyanide using the peroxide and sonication method appeared to work more effectively than just peroxide alone. All the experiments carried out on the cyanide effluent using this method showed sonication was significant in reducing the cyanide concentration further than just peroxide alone. The method was also found to give repeatable cyanide reduction results. The recommendation from these trials would be to develop this method at pilot scale to ensure it works with large volumes of Cassel works effluent.

(v) Photocatalytic oxidation using titanium dioxide semi-conductor

Many problems were encountered with this experiment including some unresolved factors such as:

- (i) The viability of the ultra-violet source.
- (ii) The ability of the source to have an effect on the effluent.
- (iii) The specific wavelength required.

The recommendations for this method would be to establish a wavelength at which cyanide can be reduced then establish if the use of solid titanium dioxide helps reduce or catalyses the experiment. A trial at laboratory scale would establish if this method were viable at pilot scale.

(vi) Cyclear™ (biologically active granules)

The main problem encountered was the availability of the product, the manufacturer of this product no longer exists. However, other methods for the biological degradation of cyanide could be researched, for example a reed bed could be set up or a biological trickle tower developed to establish effectiveness.

(vii) Ozone

The generation of the ozone for the experiments was the problem because ozone is not sold in cartridge form in the manner of nitrogen or helium, and can only be created effectively by a generator. This method is potentially good for cyanide removal. An inexpensive generator would have to be purchased or hired to establish if this method works for the cyanide plant effluent.

### 5.1.2 Accuracy, Precision and sources of Error

(i) Experimental Work: Short listed trials

For the short listed trials the accuracy for the manual titration experiments was established by ensuring only analytical grade reagents were used (assumed correct from supplier) with "A" grade glassware. The minimum visible division on the 50ml burette was 0.05 of a ml so for a titration of 1ml the accuracy is  $\pm 5$ . The manual titrations for cyanide according to the analytical method available (cyanide values of 10 to 10,000 mg/l) were accurate to 1%. Precision data for the manual titration obtained under conditions of reproducibility on 30 tests gave a mean of 2200 mg/l, standard deviation of 300 mg/l and 95% confident using the sample mean of 2200 mg/l the results obtained would be in the range of 2100 to 2300 mg/l. The Mettler is stated to be accurate to 0.1% (in the Mettler Tolloedo reference hand book) with precision data for the Mettler stated in Appendix 10, section 10. The Mettler autotitrator is the routinely used piece of equipment in the ISO9001 accredited laboratory for cyanide product strength analysis, calibration stickers showed the instrument was within calibration.

(ii) Sonication Trials

The main set of Dionex results are accurate to 1% (linearity given as 0.999 in the Dionex manual) however there was no written method for analysis of cyanide and no

precision data was available. The Dionex was calibrated using 10, 30 and 50 mg/l cyanide standards, these were then saved on the instrument computer. When I came to use the instrument a 1000 mg/l standard was run and an aliquot of 100 times diluted untreated sample of 3100 mg/l cyanide (determined using the Mettler) which gave a result of 32 mg/l and from this linearity was assumed.

(iii) The sources of error for all the experimental results were taken into account when the analysis of variance was applied to them. The general linear model tested all the results assuming that all observed differences were due to error and significant differences would be demonstrated beyond that which is due to error. The conclusion drawn from the analysis of variance was that there is significant advantage in using hydrogen peroxide and sonication together, i.e. errors do not obscure the conclusions.

### **5.1.3 Equipment advantages, disadvantages and improvements**

The advantage of using the Mettler was founded to be its accuracy compared with manual titration. The Mettler autotitrator is used in the Cassel laboratory for testing cyanide in solutions around 30% but is capable to detect cyanide concentrations as low as 100 mg/l. The disadvantages were found to be excess hydrogen peroxide that appeared to have adverse effect on the electrodes ability to detect the cyanide left within a treated sample. The reaction time of the samples was increased due to the delay in titrating using the Mettler. The delay resulted in the peroxide having longer to react with the cyanide, and therefore giving falsely low readings. If this method were to be the sole method for cyanide testing then some method of peroxide destruction would be necessary prior to titration for cyanide. This can be done using sodium metabisulphite solid, which reacts with the hydrogen peroxide when in contact.

The second method for cyanide detection was the Dionex chromatograph, this was ideal because it was not affected by the excess hydrogen peroxide, and it was an instantaneous test for cyanide and reduced extended reaction times. The chromatography only took four minutes per run and the samples could be staggered accordingly. The disadvantage of this method was the accuracy at high levels of cyanide due to the low cyanide standard, which could be improved by including a high standard when calibrating.

## **5.2 Adaptation for Cassel Plant**

The aims of section 5.2 are to introduce the practical aspects of using hydrogen peroxide and sonication on Cassel site. To give a brief background of the safe use, risks and potential hazards associated with the alternative. The different adaptations of hydrogen peroxide for Cassel site and the different methods of sonication are also discussed. To highlight the main aspects that may affect installation and adaptation to the Cassel works cyanide plant effluent process. The current requirements on the process are regular tests on the effluent leaving the plant to ensure levels of chlorine residue from the sodium hypochlorite treatment process are low. Although there are no detrimental effects of residual hydrogen peroxide in effluent in general it would be advantageous to know if the hydrogen peroxide is being wasted. Methods are therefore required to establish the potential amounts of residual peroxide in the effluent flowing to BBO3.

### **5.2.1 Hydrogen Peroxide**

#### **5.2.1.1 An Introduction to Hydrogen Peroxide**

Hydrogen peroxide is a clear, colourless and water-like in appearance with a characteristic pungent odour ([www.h202.com](http://www.h202.com)). It is non-flammable and miscible with water in all proportions and sold as a water solution. When sold it is expressed as a percentage weight of peroxide to weight of water for example 35% volume ( $\frac{v}{v}$ ) has 35% peroxide and 65% water. A solution about 8% peroxide is deemed as oxidising. Under normal conditions hydrogen peroxide is stable, within a large tank the loss would be less than 1% a year at normal ambient temperatures. The larger the ratio of the storage containers surface area to the volume of hydrogen peroxide, the greater the rate loss i.e. smaller vessel higher loss and larger vessel smaller loss.

The decomposition of hydrogen peroxide liberates oxygen and heat, in dilute solutions the heat produced is absorbed into the water of the solution. In more concentrated solutions the heat produced raises the temperature of the solution and

helps to accelerate the rate of decomposition. Stabilisers are added during manufacture of all grades to inhibit the catalytic decomposition effects of small amounts of impurities, which may contaminate the solution. Hydrogen peroxide does not burn but does decompose to liberate oxygen that assists in combustion. Therefore, fires involving hydrogen peroxide are best controlled using large quantities of water. Hydrogen peroxide is not considered as an explosive hazard, but in contact with certain metals such as, lead, copper, mercury, chromium or iron oxide it will rapidly decompose and pressurise the container. Low temperatures have little effect on hydrogen peroxide, temperatures need to go down to  $-33^{\circ}\text{C}$  before crystal effects are noticed.

#### **5.2.1.2 Analytical method for the detection of Hydrogen Peroxide between 0.1 and 6%**

If peroxide was to be used on Cassel site a method for determining the content of peroxide in the effluent would be required. If high levels of peroxide were to be released into the sump system some will have the potential to flow to the outfall (which is less susceptible to interference by organics) the following analytical method could be used.

The principle of the method shows the hydrogen peroxide oxidises iodide to iodine in the presence of acid and molybdate catalyst (Equation 5.1). The iodine formed is then titrated with sodium thiosulphate using starch as the indicator (Equation 5.2).

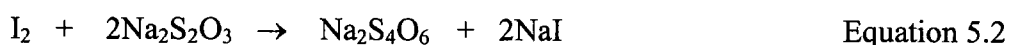
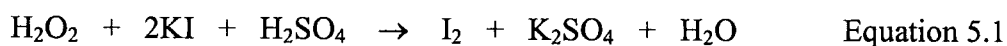

The interferences associated with hydrogen peroxide detection are other oxidising agents which also produce iodine, whereas any reducing agents (and unsaturated organics) within the sample will react with the liberated iodine. The contribution

from other oxidising agents is determined by repeating the test without adding the acid and the molybdate catalyst.

The reagents required to carry out this method are:

- (i) Potassium iodide solution (1%<sup>w/v</sup>) made by adding 1.0g of potassium iodide solid dissolved up to 100 mls with distilled water in a volumetric flask.
- (ii) Ammonium molybdate solution is made by adding 9g of ammonium molybdate into 10 mls 6N ammonium hydroxide in a 100 mls volumetric flask Then 24g of ammonium nitrate is added and diluted to 100 mls with distilled water.
- (iii) Sulphuric acid solution 20% made by pipetting 50 mls of concentrated sulphuric acid into 250 ml volumetric flask half full of distilled water and then make up to the mark with distilled water.
- (iv) Starch indicator made with 1g of starch up to 100 mls of boiling distilled water. Allow cooling before placing in a bottle.
- (v) Standard Sodium thiosulphate solution at a strength of 0.1N.

The apparatus required to complete this analysis include:

- (i) Analytical balance accurate to within  $\pm 0.1$  mg.
- (ii) Small weighing bottles.
- (iii) 250 ml Erlenmeyer flasks (iodine flask).
- (iv) 50 ml "A" grade burette.
- (v) Indicator bottle.

The procedure for analysis is weigh (note the weight taken) a known amount of sample (dependent on the suspected amount of peroxide present) into the iodine flask. Then add 50 mls of distilled water, 10 mls of sulphuric acid solution, 10-15 mls of potassium iodide solution and two drops of ammonium molybdate solution. The contents of the flask is then titrated with 0.1N sodium thiosulphate to a faint yellow colour then add a few drops of starch indicator and the solution will go black. Continue titrating until the faint blue colour disappears. The blank determination is obtained by repeating the steps using water and omitting the sample.

The calculation for this method is shown in Equation 5.3 where N is normality.

$$\text{Weight \% H}_2\text{O}_2 = \frac{(\text{Sample titre} - \text{blank titre}) \times \text{N of the thiosulphate} (0.01) \times 1.7}{\text{Sample weight in grams.}}$$

Equation 5.3

### 5.2.1.3 Health & Safety

Britain's Health and Safety Commission (HSC) and the Health and Safety Executive (HSE) are responsible for the regulation of almost all the risks to health and safety arising from work activity. The use of hydrogen peroxide is regulated by the HSE and their guideline state that the 8-hour time weighted average for example is 1 mg/l and the 15 minute short-term exposure limit is 2 mg/l (EH40, 2002). The chemical industry in general is required to adhere to the guidelines set by the HSE and therefore Cassel site must ensure that the exposure limits are not exceeded. If peroxide were used at Cassel protection for workers would be required to ensure that over an eight-hour period workers are not exposed to over an average of 1 mg/l. If working for a short period of 15 minutes the worker is not exposed to an atmosphere of over 2 mg/l.

The protective clothing required when working with hydrogen peroxide includes eye protection, rubber gloves and neoprene aprons ([www.h202.com](http://www.h202.com)). It is advised that any protective clothing that does not have fire resistance requires washing thoroughly after being in contact with hydrogen peroxide, as the fire risk remains when the garment dries.

Contact with moderate concentrations of peroxide will cause whitening of the skin along with a stinging sensation. Gas bubbles in the epidermal layer of the skin cause the whitening. After thorough washing of the effected area the stinging sensation will go without any damage, unless high concentrations are spilt on the skin, when the blistering on the skin becomes more apparent. Inhalation of the fumes causes the respiratory tract to become irritated and inflamed.

The potential hazards associated with the use of hydrogen peroxide are as follows (Solvay, 1990):

- (i) Condensed phase explosion arises if the peroxide is of a high strength and mixed with oxidisable organic compounds. The commercial solutions of hydrogen peroxide are not explosive.
- (ii) Vapour phase explosion occurs when the decomposed peroxide is in contact with flammable liquids, vapours or gases and their flash points are exceeded. The widening of explosive limits due to oxygen enrichment and reducing the minimum ignition energy required aids such explosion risks.
- (iii) Formation of dangerous derivatives could occur if the circumstances allowed inorganic and organic derivatives, which are potentially explosive. These derivatives include nitrogen trichloride and organic peroxides.
- (iv) Runaway decompositions of hydrogen peroxide could occur due to catalysis from a wide range of contaminants, even at low concentrations or incompatible surfaces.
- (v) Slow gas evolution occurs within a solution of hydrogen peroxide at all strengths. Therefore, it is essential that there is no hermetic sealing even with low strength solutions.

#### **5.2.1.4 Uses & Applications viable for Cassel site**

The uses for hydrogen peroxide are wide ranging the short listed are a few which would be of use to the Cassel site effluent ([www.h202.com](http://www.h202.com)):

- (i) BOD (Biological oxygen demand) & COD (chemical oxygen demand) removal by hydrogen peroxide being able to oxidise both organic and inorganic pollutants and with catalysts can oxidise more resistant substances. The suspected organics introduced into the cyanide plant effluent process from the Border Chemicals area of the site should be degraded and so reduce the oxygen demand of the effluent.
- (ii) Inorganic oxidation, hydrogen peroxide being able to oxidise cyanides, nitrous and sulphurous oxides, nitrates, hydrazine, carbonyl sulphides and other reduced compounds.

- (iii) Organic oxidation reactions include the hydrolysis of formaldehyde, carbon disulphide, carbohydrates, organophosphorus and nitrogen compounds. With catalysis it can destroy phenols, pesticides, solvents, plasticisers and chelants. It is possible solvents and chelants could enter the effluent process from general usage on the Cassel site.
- (iv) Metal oxidation by hydrogen peroxide oxidising ferrous iron, manganese, arsenic and selenium to improve their adsorption, filtration, or precipitation from wastewaters.
- (v) At Cassel chlorine (in the form of sodium hypochlorite) is used as an oxidant and depending on how much is used chlorine residues will be present in their wastewater from as little as parts per billion to as much as percent. It is noted that chlorine even at low levels is toxic to fish and other aquatic life. For Cassel the upper discharge limit is 100 mg/l whilst in some areas of the United States the upper limit is as low as 0.1 mg/l. The use of peroxide eliminates these issues and is known to be one of the most powerful oxidisers. The use of catalysts can convert it into hydroxyl radicals ( $\cdot\text{OH}$ ) with reactivity second only to fluorine.

Hydrogen peroxide is considered a safe chemical, as it is a natural metabolite of many organisms, decomposing the peroxide to oxygen and water. It can also be produced by the reaction of sunlight on water.

The application of hydrogen peroxide is required in a controlled manner and it is important that hydrogen peroxide is added to the effluent and not vice versa (Solvay, 1990). Keeping the concentration of hydrogen peroxide lower than 20% in a liquid phase will ensure no condensed phase explosion. As hydrogen peroxide is sold commercially as 35% it should be used in an effluent treatment plant maximising mixing efficiency. The pH is required above 3 for the hydrogen peroxide reaction to progress safely. The Cassel work effluent is usually around pH 11, and therefore this reaction would be safe. The oxygen released from hydrogen peroxide can strip dissolved materials from effluents, if they contain volatile, toxic or malodorous compounds. Chemicals such as ammonia, organics, especially solvents and inorganic such as hydrogen sulphide, carbon monoxide and hydrogen. The system for hydrogen peroxide requires a loose top or open environment to ensure there is no build up gases. As the Cassel works system is continuous a worse case scenario must

be applied to establish the maximum volume of hydrogen peroxide that could accumulate to estimate the pressure build up produced. The pressure calculated from this needs releasing if the system cannot control the pressure. For this emergency vents must be designed and installed. The oxygen enrichment of the headspace of the effluent pit will not alter the lower flammable limit of any flammable present. Other considerations include the possibility of a flammable layer of liquid separating to the top of the effluent. The reaction could produce substances of low flash points or even flammable gases. Alternatively the reaction produces heat which may increase the effluent above its flash point. These issues could be prevented by specific controls, for example cooling or dilutions ensuring all variations of effluent are taken into account. When running at high temperatures with cooling tests are advised to check levels of residual peroxide are not excessive. The risks of vapour phase explosions are, preventable however the method used must be of a high integrity. The volatilisation system must be controlling well below the lower explosive limit or the oxygen level kept below 5%.

## 5.2.2 Sonication

### 5.2.2.1 An Introduction to Sonochemistry

Described as “a promising technique in chemical engineering due to unique effects and its addition to a greener chemistry.” (Mitome & Hatanaka, 2002).

There are a range of techniques for increasing the rate of chemical reactions (Mason, 1990):

- (i) An increase in reaction temperature increases molecular mobility and thereby increases collision rate.
- (ii) An increase in the concentration of a reactant or reactants increases the probability of molecular collisions.
- (iii) An increase the external pressure applied to the system increases the molecular collisions by decreasing the overall volume of the sample.
- (iv) The use of a catalyst provides a low energy pathway.
- (v) The use of power ultrasound to irradiate the system increases the rate of reaction.

Ultrasound is more familiar to us in the context of medical uses, scans and animal communication, dogs, bats and whistles, material testing, sonar and cleaning by use of ultrasonic baths. The first commercial exploitation of ultrasound came in 1912 after the Titanic disaster, when a competition to find a method of avoiding icebergs was entered by L. F. Davidson with a suggestion of emitting sound underwater and estimating the time lapse to the echo.

The applications of ultrasound are becoming more widespread for example:

- (i) Mixing of pigments and solids into paints, inks and resins.
- (ii) Acoustic filtration.
- (iii) Ultrasonic drying.
- (iv) Welding of thermoplastics by the initiation of polymerisation.
- (v) Measurement of resin cure rates with high frequency ultrasound.

### 5.2.2.2 Power Ultrasound

Within an ultrasonic bath filled with clean water, once switched on the disturbance caused by the passage of sound through the liquid is visible and the noise generated by vibrations of the casing can be heard, the ultrasound itself cannot be heard.

Detergent can be added to the water to reduce the surface tension, the energy then required to pull apart the molecules is reduced and the disturbance in the water is increased therefore increasing the sonication effectiveness. This is useful when using the ultrasonic bath for chemical reactions (Mason, 1990).

Early studies showed the sonolysis of water produced  $H^\bullet$  and  $HO^\bullet$  radicals that generated hydrogen peroxide (Mason, 1990 and Saterlay *et al* 2000). Power ultrasound has an effect on chemical reactivity by cavitation. Cavitation is described as the effect seen in water by badly set propeller blades, when rapid motion causes a reduction in pressure in the water and the water molecules are “torn apart” to produce tiny bubbles. The tiny bubbles do not compress but continue to fill with gas on cycles of sonication waves (rarefaction cycles) and eventually float to the surface. The rarefaction cycles occur so rapidly that the gas bubbles appear instantaneously resulting in ultrasound being an effective degasser of liquids. Solids in liquids are dissolved more readily when sonication is applied. This is due to the cavitational collapse on or near the surface breaking the particle down at the solid liquid interface as demonstrated with the use of coloured chalks in water (Mason, 1990).

Pulsed ultrasound increases yields due to the behaviour of residual cavitation nuclei during the inactive periods of the pulse (Mitome & Hatanaka, 2002). The bubbles formed are under two types of force, Bjerknes primary and secondary forces. The primary force determines the motion of travel of the bubbles. The larger bubbles (larger than resonant size) travel to the nodes of sound pressure and do not contribute to the formation of a reaction field. The smaller bubbles that collapse in on themselves create an extreme environment travelling to the pressure antinodes. The energy stored in these bubbles is sufficient to break chemical bonds. These smaller bubbles also act upon an attracting force so the bubbles will be seen in a cluster. The pulsing operation stops the formation of these clusters during the inactive periods and so enhances the chemical reaction. Fluid motion also inhibits the cluster formation.

### 5.2.2.3 General Principles of Sonochemistry

Sonication is described as longitudinal motion likened to the movement of a tuning fork, with the right prong as the transducer, as it moves forward it compresses the air next to it (Mason, 1990). On returning to its initial position it pulls the molecules next to it with it, then it moves sideways leaving a rarefaction region. On its second move forward it produces another compression layer beginning another cycle and continuing a wave motion. As the micro-particles are in motion they have kinetic energy, due to the wave itself, more commonly known as the intensity of the wave. Intensity of a wave is the energy flowing per unit time and is dependent on the maximum acoustic pressure related to the density of the medium and the velocity of the sound in that medium. Intensity is measured as  $W/cm^2$  with the larger the intensity the greater displacement of the molecules.

Within an ultrasonic bath the intensity will not be evenly distributed throughout the water due to absorption of the sound within the water. Absorption occurs due to the frictional movement of the micro particles resulting in some of its energy being converted to heat energy as shown by a rise in the temperature of the medium.

There are different types of cavitation, firstly stable cavitation with violently oscillating bubbles, and secondly, transient cavitation when the bubble collapses (Hardcastle *et al*, 2000). The ultrasound frequency as well as the intensity can effect the experimental process, this determines its vigorousness. A cavitation bubble can be produced at a low intensity and as intensity increases the bubble increases in size along the rarefaction pressure wave. Without the onset of the cavitation bubble there will be no sonochemistry. The factors that effect cavitation are (Mason, 1990);

- (i) The pressure of the gas, the removal of gas from a liquid reduces the nuclei available to cavitate the liquid.
- (ii) The external pressure, if the external pressure is increased the larger the intensity or wave energy required.
- (iii) The viscosity and surface tension, the rarefaction pressure needs to be greater than the surface tension and cohesive forces of the liquid to produce a bubble, any increase in viscosity requires increased energy to separate the liquid.

- (iv) The choice of solvent, based on vapour pressure, the lower the vapour pressure compared to the external pressure on the surface, the more energy required.
- (v) The temperature as increasing the temperature lowers the threshold intensity required for cavitation, due to a rise in the liquids' vapour pressure.
- (vi) The frequency, to produce sonication bubbles the frequency needs to be a certain size. To create and grow a bubble, time and frequency are important as a higher frequency decreases the ability for the bubble to grow due to the time required for the rarefaction cycle as this is when the bubble grows. The bubble contracts on the compression cycle.

#### **5.2.2.4 Health & Safety**

Cavitation effects produced during sonication generate a wide spectrum of noise, which is radiated into the atmosphere (Mason, 1990). The HSE also set permitted noise exposure limits for humans which are between 85 and 90 decibels over an 8 hour period, but shorter exposure times increase the permitted levels. Noise can be guarded against with the use of acoustic earmuffs, earplugs or shield around the apparatus.

#### **5.2.2.5 Uses & Applications**

##### **(a) Ultrasonic Bath**

Within the ultrasonic bath system the transducers are mounted on the external walls of the bath usually operated at a power density of 1 to 5 W/cm<sup>2</sup> the ultrasound is then transmitted through the water and on into the reaction solution contained within a beaker (Mason, 1990).

The beaker is placed in the non-uniform field, the maximum intensity is 10 W/cm<sup>2</sup> but usually works at 1 to 2 W/cm<sup>2</sup>. An ultrasonic bath was used within the laboratory for all the sonication experiments mainly because one was available.

The advantages are;

- (i) The ultrasonic baths are cheap and readily available.

The major disadvantages are;

- (i) While cavitation is occurring in the water of the bath, the ultrasound is focused at the glass/water interface and the intensity is reduced within the beaker.
- (ii) A non-uniform ultrasonic field is produced.
- (iii) Controlling the temperature within the bath because the operating frequency and power output is constant and not adjustable.

#### **(b) Direct immersion of sonic probes**

Direct immersion of sonic probes is becoming the preferred method of introducing ultrasound to a reaction mixture, they are more expensive than the ultrasonic baths. (Mason, 1990) They consist of an electrically driven transducer coupled to a probe (or horn) of specific material for example titanium. The probe is immersed into the reaction mixture and capable of generating ultrasonic intensities in excess of 100 W/cm<sup>2</sup>.

The advantages include;

- (i) The reproducible operating conditions and the careful choice of probe tip means that various sample sizes and vessels can be used.
- (ii) The modern units have a pulse facility giving the receiving solution chance to cool before repeating application.

The disadvantages are;

- (i) The intense zones of ultrasound at the tip of the probe, at high intensities the probe tip can generate unwanted radicals.
- (ii) After prolonged use tip erosion can lead to sample contamination.
- (iii) A single probe is only useful for batch reactions but multiple probes will cope with larger continuous volumes.

Direct immersion probes would have been the preferred method of laboratory sonication, if available. The sample sizes were small and this method would have been more reproducible and more accurate for scaling up to the plant scale option.

More power is available using the probe system but it is more expensive than the bath option

### **(c) Cleaning Bath Reactors at plant scale**

The reactors at plant scale are based on the small-scale laboratory baths with externally mounted transducers fixed to the walls of the reactor vessel (Mason, 1990).

The advantages include;

- (i) There is no contamination of the reactants from erosion of the ultrasonic source.
- (ii) The vessels can be operated under pressure without the necessary sealing of the ultrasonic source.

The disadvantages are similar to those of the laboratory bath;

- (i) A low intensity and non-uniform field throughout the vessel.
- (ii) The bulk heating of the reaction mixture which is not always wanted.
- (ii) The transducers are required to be glued to the outside of the vessel to ensure efficient coupling of the ultrasonic energy into the reaction mixture.

To engineer a production scale sonoreactor of 3 meters high and 1.5 meters diameter with a 20 kHz transducer of diameter 6 cm and 100% coverage, 5,700 transducers would be required and would be powered by 300 generators these alone would cost of £25,000.

The high implementation costs would rule out this method of sonication on the plant, the easy implementation of the transducers, as the sumps are rectangular and would accept a sonoreactor but this is out weighed by the bulk heating and localised effects.

### **(d) Sonoreactor employing Immersible Transducers for plant use**

The ultrasonic cleaning industry uses immersible transducers as they are relatively cheap, readily available and can be retrofitted to most large vessels (Mason, 1990).

They consist of a steel box with mounted ultrasonic transducers. The units are then dipped into the solution to be sonicated.

The method is advantageous for large-scale operations because;

- (i) As many or as few of these steel boxes can be used within one area.
- (ii) They are able give higher ultrasonic intensities than cleaning bath reactors and can be inputted without any permanent modifications to a reaction vessel.

The disadvantages to this system include;

- (i) There can be erosion of the metal transducer cover.
- (ii) There are stronger areas of sonication nearer to the transducers, than away from them.
- (iii) They are intrusive and would interfere with stirring and any other equipment within the vessel.
- (iv) The electrics and transducers require sealing from the corrosive reaction mixture, which could be difficult.

An average transducer unit is 0.7 x 0.25 x 0.1 meters the unit described for the bath reactor would require 32 immersible units with a surface area of 0.18m<sup>2</sup>. Their costs to acquire would be similar to that of the bath reactor approximately £25,000. However the transducers would occupy a significant amount of the vessel area.

#### **(e) Sonoreactors incorporating sonic probes**

Ultrasonic probes were originally designed to generate high intensity ultrasonic field within a small volume (at the tip) with the intention of disrupting biological cells (Mason, 1990). They are considered the most practical method of scaling up sonochemical reactions because they can be inserted into a reaction mixture through a small aperture in the vessel top.

The advantages to this method are;

- (i) A high intensity is generated.
- (ii) The sonic probes can be retrofitted to a system.

The disadvantages include;

- (i) There is erosion at the probe tip, which is very localised reaction of high intensity.
- (ii) There are problems insulating the ultrasonic transducer from the chemical environment.
- (ii) The probe could stall in highly viscous liquids.

The largest commercial sonic probe is a 2.5 kW unit with a 5 cm diameter probe tip, ten of these were estimated to be required to work at the optimum intensity within the 5 m<sup>3</sup> vessel with a cost in excess of £100,000. But their installation cost being stated as significantly less than the alternatives mentioned earlier. Therefore the overall cost would be less than the total costs of installing the cleaning bath or immersible transducer approaches.

Cheapness of implementation and ease of retro fit make this an appealing method of sonication for the plant. However, there could be an issue with the chemical environment being at pH 12 and degradation of the sonic probe.

The "sonopush" submersible transducers with "sonopower" ultrasonic generators have lengths that vary from 600 to 1000 mm and operating frequencies 25 to 40 kHz and a range of power outputs of 1000 to 2000 W (<http://www.kerry.co.uk/subgen.htm>). Sonoreactors incorporating sonic probes could easily be retro-fitted to the current effluent sumps.

#### **(f) Flow systems incorporating wall mounted transducers for plant use**

The basis of this method is to attach the transducers to the external surface of a pipe through which the reaction mixture is travelling (Mason, 1990). The ultrasonic field is then applied during the solutions residence time. Some reaction will require one slow pass along the zone whilst other solutions will react during a fast pass through the ultrasonic area. The size of the zone of ultrasonics is dependent on the number of transducers attached to the pipe, their intensities and the diameter of the pipe.

The advantages of this method include;

- (i) They are not intrusive and do not contaminate the reaction mixture.

- (ii) With only a small number of transducers required an overall reduction of the cost of this method compared to the cleaning bath system.
- (iii) The transducers can be retro fitted to existing industrial plant reactors.

The disadvantages are;

- (i) There are mechanical problems associated with mounting the flat transducers on cylindrical pipes.
- (ii) The ultrasonic intensity is critically dependent on the dimensions of the pipe.
- (iii) There is a difficulty in circulating solid reagents through the irradiated zone.
- (iv) The larger units will only operate at much lower frequencies.

Literature was not available for the costs associated with this method, implementation would be feasible on the Cassel site. The plant area has a number of flow streams where these wall mounted transducers systems could be incorporated. The lack of contamination associated with the wall-mounted transducers is an advantage with the caustic nature of the effluent.

#### **(g) Flow systems employing a sonic probe for plant use**

A sonic probe is inserted into a flow cell in the path of the following reactants as they flow they are passed through an irradiated zone (Mason, 1990).

The advantages for this system are;

- (i) There are high intensity fields generated within the flow cell.
- (ii) The commercial units are capable of processing up to 250 litres an hour.
- (iii) The flow cells can be used in series.
- (iv) The flow cells can be inserted in to an existing reaction loop.

A number of disadvantages include;

- (i) The difficulty of obtaining a seal around the probe in high-pressure reactions.
- (ii) There is erosion of the probe tip and flow cell during use.
- (iii) The degradation of the reagents at the probe tip due to the high ultrasonic fields.

Unable to find costs for this system either, however as the current system is flowing already. It would be easy to retrofit sonic probes to enable the effluent to flow through an irradiated zone. However, the contamination from the erosion of the probe tip would cause problems.

In general all these methods for plant scale sonication have advantages and disadvantages. The implantation of a preferred method would have to involve a site test and a number of methods would be evaluated to ensure the most appropriate sonication method was chosen.

### 5.2.3 Implications

Hydrogen peroxide will decompose releasing oxygen and liberating heat, in higher concentrations the heat generated increases the rate of decomposition. These issues need to be taken into consideration when implementing the peroxide system. The safety wear is also important, just in case there is an accident. Currently hydrogen peroxide is used on Cassel site for other applications and stored in intermediate bulk containers (IBC), no issues have been raised about handling or safety.

Mixing high strength hydrogen peroxide with oxidisable organic compounds may cause explosions. The content of the effluent routed through the sump system could possibly contain organic compounds such as ACH and acetone. However, commercial solutions of hydrogen peroxide are not explosive and are currently held as Cassel site. Contact of flammable liquids with hydrogen peroxide could help exceed their flash points due to oxygen enrichment with a potential for explosion. Slow gas evolution occurs with hydrogen peroxide at all strengths therefore, it is essential that there is no hermetic seal made with the storage container. These issues are currently dealt with and no issues have been raised with the current peroxide storage system.

The peroxide should be kept at a concentration lower than 20% in the liquid phase to ensure no condensed phase explosion occurs. Addition into the sumps would be controlled to ensure excessive amounts were not used.

Sonication increases the reaction temperature and in turn increases molecular mobility. Cassel works effluent leaves the plant at about 30°C, and therefore any additional increase in temperature must be monitored to ensure no excessive rise occurs. The experiments did show that a slight rise in temperature does have a positive effect on reducing the cyanide level of the effluent. Industrial usage's include the mixing of pigments, filtration, drying and plastics applications but no literature was found on its use with cyanide effluents. The sonication of water molecules is stated to produce hydrogen and hydroxyl radicals which are said to generate hydrogen peroxide (Mason, 1990). During the trials an ultrasonic bath was used, these are stated to have uneven distribution of intensity (Mason, 1990). Perhaps if this method were to be implemented then a pilot plant would need to be designed with a smaller version of the intended for the sumps. On looking at the literature one

proposal would be probes, due to their adaptability to be retrofitted. The only health issue associated with sonication is the wide spectrum of noise produced during operation. This would be minimised by the solid lids that are already in place on the 3 sumps. However, if there was external noise associated with the implementation of the probes, Cassel works has a system of testing for noise and implementing noise restriction areas where hearing protection must be worn. If direct immersion sonic probes could be used, though care would need to be taken to ensure tip corrosion did not occur.

When incorporating the hydrogen peroxide and the sonication probes it would be advisable to add the hydrogen peroxide into the process first before the sonication process is initiated.

## **6.0 CONCLUSIONS**

### **6.1 Short list**

The short list of trials was established from a system of scoring the methods obtained by the literature search. The criteria took into account the considerations of safety, health or environmental issues arising from the method used and a decision was made on how controllable the method would be. The costs to implement and run each of the methods on site were considered along with effectiveness in the lab and ability to be implemented into the Cassel effluent system. The costs were assessed against the prices of current methodologies and costs for reagents were also taken into account (pers.comm.). The criteria also looked at whether the method had been used previously as a large-scale cyanide destruction process and whether it had been successful. Forty-four methods were assessed and the more favourable ones listed to establish a short list of trials that could be attempted within a laboratory environment. A number of these were selected for a trial of experimental work on the basis of choosing a trial from different destruction processes. These destruction processes were chemical, electrical, biological, photocatalytic and ultrasonic, others were not chosen due to the difficulty in implementing them into a laboratory and sourcing the specialised chemicals.

### **6.2 Pilot studies**

Initial pilot studies showed that:

- i) The activated carbon and sonication method to treat the Cassel site effluent was found to increase the cyanide content of the effluent. This combination of methods was not ideal for the Cassel cyanide effluent.
- ii) Electrolysis was inconclusive as after one hour only half of the initial cyanide content was destroyed. The conclusions drawn were of the need to establish the correct voltage at which to work at and time required for the experiment to reduce the cyanide further.

- iii) The hydrogen peroxide alone appeared to work very well and reduced the cyanide to less than ten percent of the original concentration. Therefore this method is one of the better ways to remove cyanide from the Cassel effluent.
- iv) Hydrogen peroxide with sonication was shown to increase the reaction rate with removal of the cyanide being quicker than the peroxide alone method. The addition of sonication also gave the added improvement of less peroxide being required.
- v) The photocatalytic oxidation using titanium dioxide method was unsuccessful and therefore would require retesting whilst ensuring all of the factors were working and contributing to the reduction of cyanide in the effluent.

### **6.3 Degradation with hydrogen peroxide**

The conclusions to all the experimental work were that hydrogen peroxide was the most effective method of cyanide removal in the Cassel works effluent. The use of sonication significantly enhanced the peroxide method and improved on efficiency of cyanide reduction. The issue of increasing solids in the effluent would not hinder the cyanide reduction process, if hydrogen peroxide and sonication were chosen. The increased temperature expected during the summer months was found in the trial to aid in the reduction of cyanide. Checks would be required to ensure the temperature increases are not too excessive.

### **6.4 Further Work**

The laboratory experiments have established that the addition of hydrogen peroxide followed by sonication has a significant effect in reducing the cyanide content. Further work required would be to engineer a small scale plant effluent system within a laboratory fume cupboard. An example of the construction of this pilot plant is shown in Figure 6.1. The small scale plant could include three rectangular containers to hold a total of 10 litres of effluent to simulate the sumps in miniature. The effluent feed system would require a peristaltic pump to feed the stored untreated effluent at a constant feed rate. Within each of the sumps  $E_n$  probes

determine the redox potential, if the potential in the first sump is too low (required to be above 400 mV) sodium hydroxide needs to be introduced. The sodium hydroxide would be stored in another vessel linked by tubing to the first sump. The addition could be made using a Gilson pump. The Gilson style pumps are programmable pumps that use a piston to regulate the flow, ensuring an accurate amount is discharged. A second check would be made to ensure the redox potential of the effluent is within the correct range, then addition of the hydrogen peroxide would start. The main volume of peroxide should be introduced within sump 1 by another Gilson pump. The effluent should then be transferred into sumps 2 and 3 for treatment with sonic probes. The  $E_h$  probes should indicate a fall in potential as the effluent travels through the system. There should be a mechanism for introducing hydrogen peroxide into sumps 2 and 3 by Gilson pump, if required.

The  $E_h$  probes currently used on the cyanide plant should be tested for their ability to work with excess hydrogen peroxide. It is surmised that the plant probes should work due to their robustness compared with the laboratory type of pH probe. This could be tested if they were used on the pilot plant. Information required before starting would be to establish the exact capacity and flow rate into the sump system minimum, normal to max and peak values so these scenarios can be tested on the pilot plant. The residence time within each of the three sumps would also be helpful to aid in the design of the pilot process. The optimum residence time for the effluent through this process was calculated by the experiments to be 10 minutes using sonication. The flow rate should be adjusted accordingly to enable hydrogen peroxide addition at 2 litres for every 10 litres of effluent and sonication for 10 minutes. The sonication probes could be hired from companies such as Kerry Ultrasonics Ltd. They have recommended that 25 kHz "sonopush" probes would be ideal for effluent application. (pers.comm. Kerry Ultrasonics Ltd.). As the effluent flows from sump 3 it should be tested by ion chromatography (Dionex) to determine the cyanide content.

The experiment would need to be repeated using different volumes of hydrogen peroxide addition and sonication retention times within the sumps to establish the optimum levels for this lab scale test to work and reduce the cyanide level to an agreed low limit of perhaps 50 mg/l.

To establish the results a warmer effluent has on the effectiveness of this process a heater block should be incorporated in effluent flow line before sump one to mimic changes in effluent temperature found in the effluent system.

**Figure 6.1: Proposal for Further Laboratory Trials**

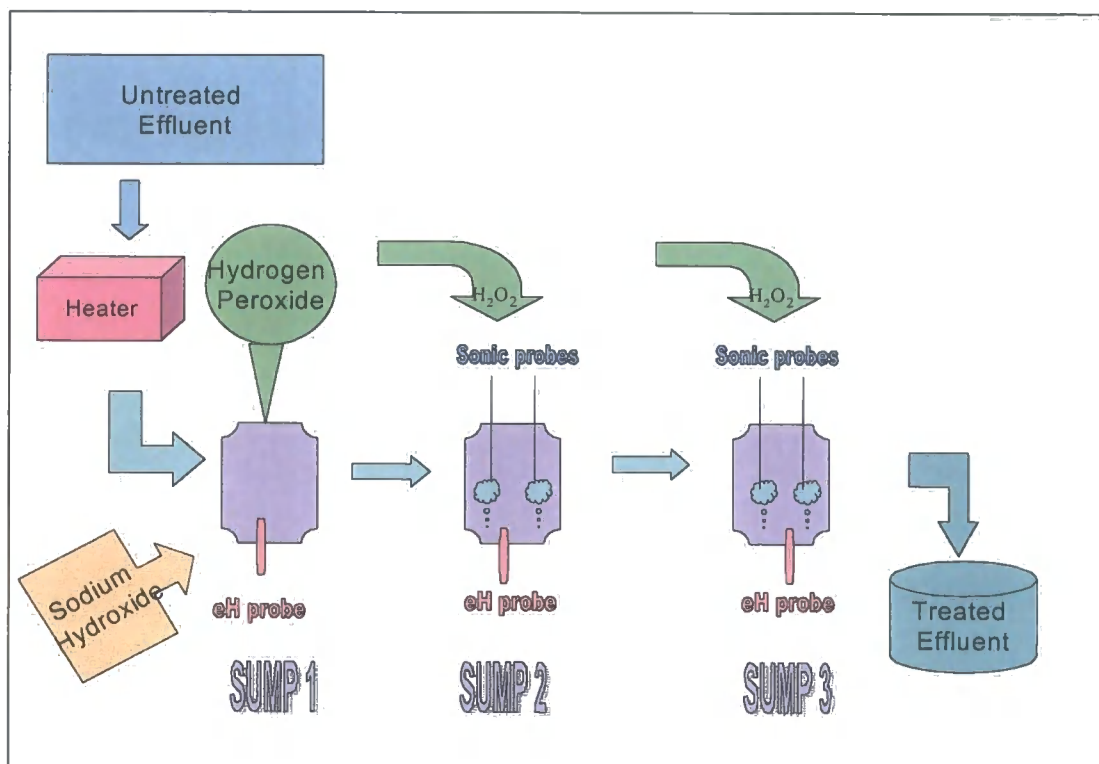

## **7.0 PROPOSALS**

### **7.1 Changes required for Hydrogen Peroxide & Sonication system to work**

#### **(i) Hydrogen Peroxide**

The dosing system already in place could be used and the sodium hypochlorite could be substituted for the hydrogen peroxide. Care will need to be taken to ensure the hydrogen peroxide IBC is not in line of direct sun light (this is also the case for sodium hypochlorite). The current IBC's have metal tops to prevent direct sunlight and best practise to keep them free from sunlight. Checks would need to be made to the pipe work and dosing system to ensure the system will withstand hydrogen peroxide contact.

The reaction of peroxide with some organics compounds is violently exothermic, 5 times that of decomposition of hydrogen peroxide (pers.comm. Solvay.). Therefore, a sufficiently low concentration (%<sup>v</sup>/<sub>v</sub>) of peroxide could be used (established from the laboratory trials on pilot plant).

#### **(ii) Sonication**

The sonic probes were chosen from the trials as the ideal system because of their ease of retro-fitting. The sonic probes can be attached to the sump lids using large bolts or suspended from supports that span the lip of the sumps. These probes work best at above 5 watts per litre or above. The "sonopush" probes (Kerry Ultrasonics) could be ideal for this application, however at this stage prices are not available. The ultrasonic bath runs at 35/45 KHz with frequency sweep operating by continuous random sweeps between these frequencies reducing the stratification to a minimum. (pers.comm. econ Laboratories Ltd) Therefore, the recommended 25kHz "sonopush" probes may even work better than the laboratory experiments. The transducers are generally resistant to most chemicals, being constructed of titanium or hardened chrome steel.

Adjustments would need to be made to the power supply to the effluent treatment area, currently very little power is required by the electrodes. Extra power cable would need to be installed before the sonic probes could be introduced.

The cyanide plant sumps are constructed of brick and are not lined. These would need to be retro-fitted with butyl liners covered with stainless steel sheeting. Concrete and brick are mildly porous and sonication of the water could have the potential to erode away the brick surface. (pers.comm. Kerry Ultrasonics Ltd.)

**(iii) Post reaction: In-line tests for Hydrogen peroxide.**

An instrument for detecting hydrogen peroxide in the range of 10 – 100 mg/l, in waste streams would cost around £20,000. Qualitative and quantitative immersion "sticks" are also available "merquant" for estimations up to 100 mg/l. However, hydrogen peroxide does report as COD even though it is not (pers.comm. Solvay).

## 8.0 BIBLIOGRAPHY

Adhoum N. & Monser L. 2002. Removal of cyanide from aqueous solution using impregnated activated carbon. Chemical Engineering and Processing, Vol 41, pp 17-21.

Augugliaro V., Blanco Galvez J., Caceres Vazques J., Garcia Lopez E. , Loddo V., Lopez Munoz M.J., Malato Rodriguez S., Marci G., Palmisano L., Schiavello M. & Soria Ruiz J. 1999. Photocatalytic oxidation of cyanide in aqueous TiO<sub>2</sub> suspensions irradiated by sunlight in mild and strong oxidising conditions. Catalysis Today. Vol 54, pp 245-253.

Bainbridge K. 1975. Detoxification of Acidic cyanide –containing effluents at Cassel works: Laboratory investigations and preliminary process design. BX section memorandum. ICI Mond Division.

Basheer S., Kut O. M., Prenosil J.E. & Bourne J.R. 1992. Kinetics of Enzymatic Degradation of cyanide. Biotechnology and Bioengineering, Vol 39, pp 629-634.

Bell S. 1997. Ball and Bell on Environmental Law. 4<sup>th</sup> Edition, Blackstone Press Limited. ISBN 1 85431 686 9.

Bernat J.P. 1979 Removal of Cyanide from wastewater. United States Patent No 4,179,348.

Bhakta D., Shukla S.S., Chandrasekharaiah M.S. & Margrave J.I. 1992. A novel Photocatalytic Method for Detoxification of Cyanide Wastes. Environmental Science and Technology, Vol 26, pp 625-626.

Bodzek M., Bohdzejwicz J. & Kowalska M. 1996. Immobilised enzyme membranes for phenol and cyanide decomposition. Journal of Membrane Science, Vol 113, pp 373-384.

Bursova S.N. & Moiseera R. F. 1989. Treatment of cyanide containing wastewater by catalytic oxidation with oxygen. Soviet Journal of Water Chemistry Technology. Vol 11, No1, pp 45-48.

Castric P.A. & Strobel G.A. 1969. Cyanide metabolism by *Bacillus megaterium*. Journal of Biological Chemistry. Vol 244, No15, pp 4089-4094.

Cheng S.C., Gattrell M., Guena T. & MacDougall B. 2002. The Electrochemical oxidation of alkaline copper cyanide solutions. Electrochimica Acta. Vol 47, pp 3245– 3256.

Desai J.D., Ramakrishna C., Patel P.S. & Awasthi S.K. 1998. Cyanide wastewater treatment and commercial applications. Chemical Engineering World. Vol 33, No6, pp 115-121.

Devuyst E.A., Robbins G., Vergunst R., Tandi B. & Iamarino P. F. 1991. Mining Engineering. Reprinted by INCO Exploration & Technical Service INC.

Dhamo N. 1996. Electrochemical oxidation of cyanide in the hydrocyclone cell. Waste Management. Vol 16, No 4, pp 257-261.

Dictor M.C., Battaglia-Brunet F., Morin D., Bories A. & Clarens M. 1997. Biological treatment of Gold ore - Cyanidation wastewater in fixed bed reactors. Environmental Pollution. Vol 97, No 3, pp 287-294.

Dionex Corporation 2000. IC Systems Operational and Performance Qualification and User's Guide. Document number 031726 - 02.

Domvile S.J. 1992. Process for removal of inorganic and cyanide contaminants from wastewater. United States Patent No 5,093,007.

Dziewinski J., Marczak S., Nuttall E., Purdy G., Smith W., Taylor J. & Zhou C. 1998. Developing and testing electrochemical methods for treating metal salts,

cyanides and organic compounds in waste streams. Waste management. Vol 18, pp 257-263.

Evangelho M.R., Goncalves M.M.M., Sant'Anna Jr. G.L. & Villas Boas R.C. 2001. A trickling filter application for the treatment of a gold mining effluent. International Journal of Mineral Processing. Vol 62, pp 279-292.

Evtuygina N.M., Derbysheva E.K. & Kopytova L.A. 1984. Flotation purification of industrial wastewater by removing cyanide ions. Coke Chemistry USSR, No 1, pp 54-55. English translation by Allerton Press Inc.

Ganczarzyk J.J., Takoaka P.T. & Ohashi D.A. 1985. Application of polysulfide for pretreatment of spent cyanide liquors. Journal of Water Pollution Control Federation. Vol 57, pp 1089-1093.

Gijzen H.J., Bernal E. & Ferrer H. 2000. Cyanide toxicity and cyanide degradation in anaerobic wastewater treatment. Water Resources. Vol 34, No 9, pp 2447-2454.

Gillies D. 1999. A guide to EC Environmental Law. Earthscan Publications Ltd. ISBN 1 85383 585 4.

Glassman D. 1976. USS CYAM System—An improved process for Ammonia and Cyanide removal from coke-plant wastewater. Ironmaking Proc. Metall. Sic. AIME 35, pp 121-133.

Gondrexon N., Renaudin V., Pétrier C., Boldo P., Bernis A. & Gonthier Y. 1999. Degradation of pentachlorophenol aqueous solutions using a continuous flow ultrasonic reactor: experimental performance and modelling. Ultrasonics Sonochemistry. Vol 5, pp 125 –131.

Griffiths A., Ahsan Q., Norcross R., Knorre H. & Merz F. W. 1990. Process for the treatment of effluents containing cyanide and other oxidisable substances. United States Patent No 4,915,849.

Hardcastle J.L., Ball J.C., Hong Q., Marken F., Compton R.G., Bull S.D. & Davies S.G. 2000. Sonoelectrochemical and sonochemical effects of cavitation: correlation with interfacial cavitation induced by 20 kHz ultrasound. Ultrasonics Sonochemistry. Vol 7, pp 7 – 14.

Hecht J. 1990. Sunlight gives toxic waste a tanning. New Scientist magazine. Vol 126, issue 1712, 14.04.1990 page 28.

Ho S.P., Wang Y.Y. & Wan C.C. 1990. Electrolytic decomposition of cyanide effluent with an electrochemical reactor packed with stainless steel fibre. Water Resources. Vol 24, No 11, pp 1317-1321.

Hoffmann M. R., Hua I. & Höchemer R. 1996. Application of ultrasonic irradiation for the degradation of chemical contaminants in water. Ultrasonics Sonochemistry. Vol 3, pp S163 – S172.

Howell D. C. 1997. Statistical Methods for Psychology. 4<sup>th</sup> Edition. Wadsworth Publishing Company. ISBN 0 534 51993 8.

<http://www.cefic.org>

<http://www.hse.gov.uk>

<http://members.iinet.net.au/~menne/aumet.htm> ; Managing cyanide waste discharges. D Menne. 1998

web-link via ([http://technology.infomine.com/enviromine/publicat/pub\\_main.html](http://technology.infomine.com/enviromine/publicat/pub_main.html))

<http://www.kerry.co.uk/subgen.htm>. Pulsatron KST submersible transducers and S500 generators.

Huff J.E. & Bigger J.M. 1980. Cyanide removal from refinery wastewater using powered activated carbon. United States of America Environmental Protection Agency. EPA-600/2-80-125.

ICI Acrylics. 1998. Code of Practice for Hydrogen Cyanide – Properties, Uses Storage and Handling.

ICI Acrylics. 1992. CIMAH Regulation 7 safety report for hydrocyanic acid and acetone cyanohydrin installation at MM8.

Karpunin N.Y., Manusova N.B. & Smirnov D.N.B. 1976. Automatic waste water purification control. Soviet inventions illustrated. Vol X, No 44, pp1.

Kenfield C.F., Qin R., Semmens J. & Cussler E.L. 1988. Environmental Science and Technology. American Chemical Society. Vol 22, No 10, pp 1151–1155.

Kociolek-Balawejder E. 1997. A redox copolymer having N-chlorosulfonamide groups for cyanide ion decomposition in dilute aqueous solutions. Reactive and Fuctional Polymers. Vol 33, pp 159-165.

Kolarz B.N., Bartkowiak D., Trochimczuk A.W., Apostoluk W. & Pawlow B. 1998. New selective resins with guanidyl groups. Reactive & Fuctional Polymers. Vol 36, pp 185-195.

Kowalska M., Bodzek M., & Bohdzeiwicz J. 1998. Biodegradation of phenols and cyanides using membranes with immobilised micro-organisms. Process Biochemistry. Vol.33, No 2, pp 189–197.

Kunz D.A., Nagappan O., Silva-Avalos J. & Delong G. 1992. Utilisation of Cyanide as a Nitrogenous substrate by *Pseudomonas fluorescens* NCIMB 11764: Evidence for multiple pathways of metabolic conversion. Applied and Environmental Microbiology. Vol 58, No 6, pp 2022-2029.

Kurama H. & Catalasrik T. 2000. Removal of zinc cyanide from a leach solution by an anionic ion-exchange resin. Desalination. Vol 129, pp 1-6.

Ladd M. F. C. & Lee W.H. 1988. Introduction to Physical Chemistry. 1<sup>st</sup> Edition. Press Syndicate of the University of Cambridge. ISBN 0521 26995 4.

Lordi D.T ., Lue-Hing C., Whitebloom S.W., Kelada N & Dennison S., 1980. Cyanide problems in wastewater treatment plants. Journal WPCF. Vol 52, No 3, pp 597-609.

Malato S., Blanco J., Vidal A. & Richter C. 2001. Photocatalysis with Solar energy at a pilot-plant scale:an overview. Applied Catalysis B: Environmental. No 967, pp 1-15.

Mason C. F. 1996. Bology of Freshwater pollution.3<sup>rd</sup> Edition Longman. ISBN 0 582 24732 2.

Mason O. 1907. The action of hydrogen peroxide on potassium cyanide. Journal of Chemistry in society (Trans). pp 1449-1474.

Mason T. J. 1990. Sonochemistry ; the uses of ultrasound in sonochemistry. 1<sup>st</sup> edition The Royal Society of Chemistry. ISBN 0 85186 293 4.

Mettler Toledo Reference handbook. 1999

Mitome H. & Hatanaka S. 2002. Optimisation of a sonochemical reactor using a pulsing operation. Ultrasonics. Vol 30, pp 683–687.

Monser L & Adhoum N. 2002. Modified activated carbon for the removal of copper, zinc, chromium and cyanide from wastewater. Separation and Purification Technology. Vol 26, pp 137-146.

Moore G. J. 1976. Removal of cyanide from industrial waste waters. Imperial Chemical Industries Limited. Mond Division Report No MD17,412.

Organisation for Economic co-operation and development, Environment Directorate, Environment Committee, Waste management policy group guidance document : Approaches and options for minimising and managing wastes containing cyanides. 1991.ENV/EC/WMP(91)1

Ögutveren U. B., Toru E. & Koparal S. 1999. Removal of cyanide by anodic oxidation for wastewater treatment. Water Resources. Vol 8, pp 1851-1856.

Pajonk G.M. 1999. Some catalytic applications of aerogels for environmental purposes. Catalysis Today. Vol 52, pp 3-13.

Pak D. & Chang W. 1997. Oxidation of Aqueous cyanide solution using hydrogen peroxide in the presence of heterogeneous catalyst. Environmental Technology. Vol 18, pp 557-561.

Parga J.R. & Cocke D.L. 2001. Oxidation of cyanide in a hydrocyclone reactor by chlorine dioxide. Desalination. Vol 140, pp 289-296.

Patil Y.B. & Paknikar K.M. 2000. Development of a process for biodegradation of metal cyanides from wastewaters. Process Biochemistry. Vol 35, pp 1139-1151.

Pétrier C. & Francony A. 1997. Ultrasonic wastewater treatment; incidence of ultrasonic frequency on the rate of phenol and carbon tetrachloride degradation. Ultrasonic Sonochemistry. Vol 4, pp 295 – 300.

Petrozzi S. & Dunn I.J. 1994. Biological cyanide degradation in aerobic fluidised bed reactors: treatment of almond seed wastewater. Bioprocess Engineering. Vol 11, pp 29-38.

Poon C.P.C. 1997. Electroflotation for groundwater decontamination. Journal of Hazardous Materials. Vol 55, pp 159-170.

Proulx C.R., Chattopadhyay J., Eul W. & Vickell G. 1993. Destruction of cyanide and other pollutants in aqueous solutions. United States Patent No 5,246,598.

Rader W.S., Solujic L., Milosavljevic E.B., Hendrix J.L. & Nelson J.H. 1995. Photocatalytic detoxification of cyanide and metal cyano-species from precious-metal mill effluents. Environmental Pollution. Vol 90, No 3, pp 331-334.

Research Triangle Institute. 1997. Toxicological Profile for Cyanide. Prepared for the US department of health & Services. Contract number 205-93 0606. pp 1-291.

Robey H.L. 1989. Reactor and Heat exchanger system for cyanide waste water treatment. United States Patent No 4,877,519.

Saterlay A.J., Hong Q., Compton R.G. & Clarkson J. 2000. Ultrasonically enhanced leaching : removal and destruction of cyanide and other ions from used carbon cathodes. Ultrasonics Sonochemistry. Vol 7, pp 1-6.

Shen Z. Huang J. & Qian G. 1997. Recovery of cyanide from wastewater using gas-filled membrane absorption. Water Environment Research. Vol 69, No 3, pp 363-367.

Shivaraman N., Kshirsagar D.G, Badrinath S.D., Kaul S.N. & Parhad N.M. 1997. A two-stage biodegradation process for treatment of cyanide wastewater. Chemical Engineering World. Vol 32, pp 111-119.

Singh H.B., Wasi N. & Mehra M.C. 1986. Detection and Determination of Cyanide – A Review. International Journal Environmental Chemistry. Vol 26, pp 115-136.

Solvay. 1990. The Safe use of Hydrogen Peroxide in liquid effluent treatment. Interlox. The peroxide professionals.

Smith A. & Mudder T. 1991. Chemistry and Treatment of Cyanidation Wastes. 1<sup>st</sup> Edition Mining Journal Books Ltd. Isbn 0 900117 51 6.

Stevenson S.M. 1996. Method for treatment of wastewater contaminated with cyanide ion. United States Patent No 5,552,062.

Sury Y. S. & Guillory M.J.Jr. 1978 Process for soluble cyanide removal from wastewater streams. United States Patent No 4,176,060.

Szpyrkowicz L., Kaul S.N., Molga E. & DeFaveri M. 2000. Comparison of the performance of a reactor equipped with a Ti/Pt and an SS anode for simultaneous cyanide removal and copper recovery. Electrochimica Acta. Vol 46, pp 381-387.

Teo K.C., Xu Y. & Yang C. 2001. Sonochemical degradation for toxic halogenated organic compounds. Ultrasonics Sonochemistry. Vol 8, pp 241 – 246.

Trofe T. W. & Page G.C. 1985. Cyanide removal in coal gasification wastewater using polysulfide. Proceedings of the 40<sup>th</sup> industrial waste water. pp 13-22

Tromans S. 1993. Environmental Protection Act 1990. 2nd Edition, Sweet & B Maxwell. ISBN 0 42156780 2.

Ward J.W. 2000. Polymers for the chemical treatment and precipitation of soluble metal cyanide and oxoanion compounds from wastewater. United States Patent No 6,114,484.

Whitlock J.L. 1987. Performance of the Homestake Mining Company biological cyanide degradation wastewater treatment plant August 1984 – August 1986. Society of Mining Engineers of AIM PAP 87-36, pp 1-17.

White D.M., Pilon T.A. & Woolard C. 2000. Biological treatment of cyanide containing wastewater. Water Resources. Vol 34, No 7, pp 2105 – 2109.

White D.M. & Schnabel W. 1998. Treatment off cyanide waste in a sequencing batch biofilm reactor. Water Resources. Vol 32, pp 254-257.

Wild S.R, Rudd T & Neller A.1994. Fate and Effect of cyanide during wastewater treatment processes. The Science of the Total Environment. Vol 156, pp 93-107.

Wolf H. 1996. Method for controlling the detoxification of cyanide wastewaters. United States Patent No 5,569,386.

Worrall F., Besien T. & Kolpin D.W. 2002. Groundwater vulnerability: interactions of chemical and site properties. The Science of the Total Environment. Vol 299, pp 131-143.

Xueling Q., Xinsheng M. & Yajun S. 1989. Removal of cyanide from wastewater with liquid membranes. Water Treatment. Vol 4, pp 99-111.

Yan T.Y. 1994. Removal of cyanide, sulphides and thiosulphate from ammonia-containing wastewater by catalytic oxidation. United States Patent No 5,360,552.

Yang J. & Speece R.E. 1985. Effects of engineering controls on methane fermentation toxicity response. Journal of Water Pollution. Cont. Fed. Vol 57, pp 1134-1141.

Yang J., Speece R.E, Parkin G.F., Gossett J. & Kocher W. 1980. The response of methane fermentation to cyanide and chloroform. Prog. Water Technology. Vol 12, pp 977-989.

Yang X. 1994. Process of removing cyanide from wastewater. United States Patent No 5,288,373.

Zeevalkink J.A., Visser D. C., Arnoldy P. & Boelhouwer C. 1979. Mechanism and kinetics of cyanide Ozonation in water. Water Research. Vol 14, pp 1375-1385.

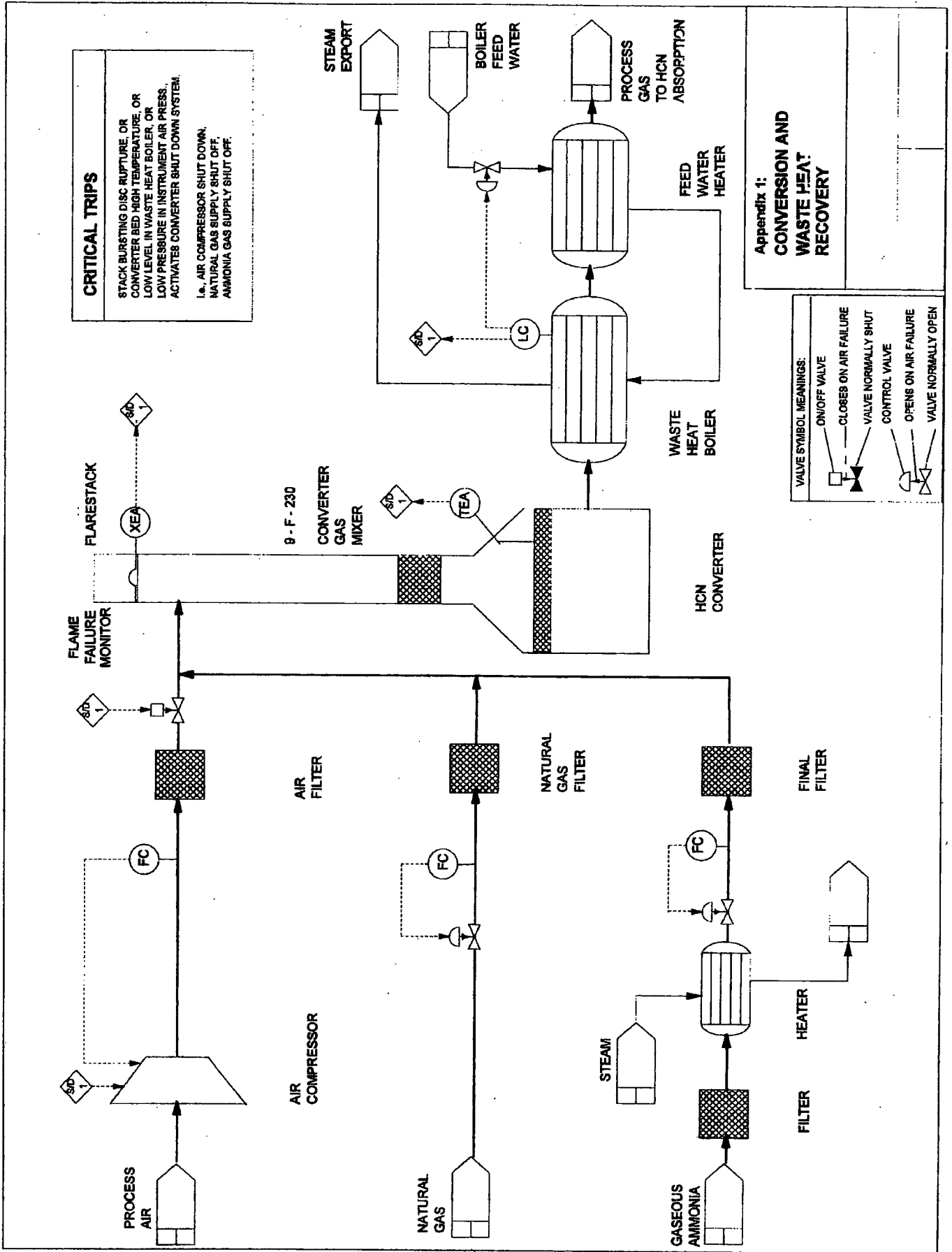

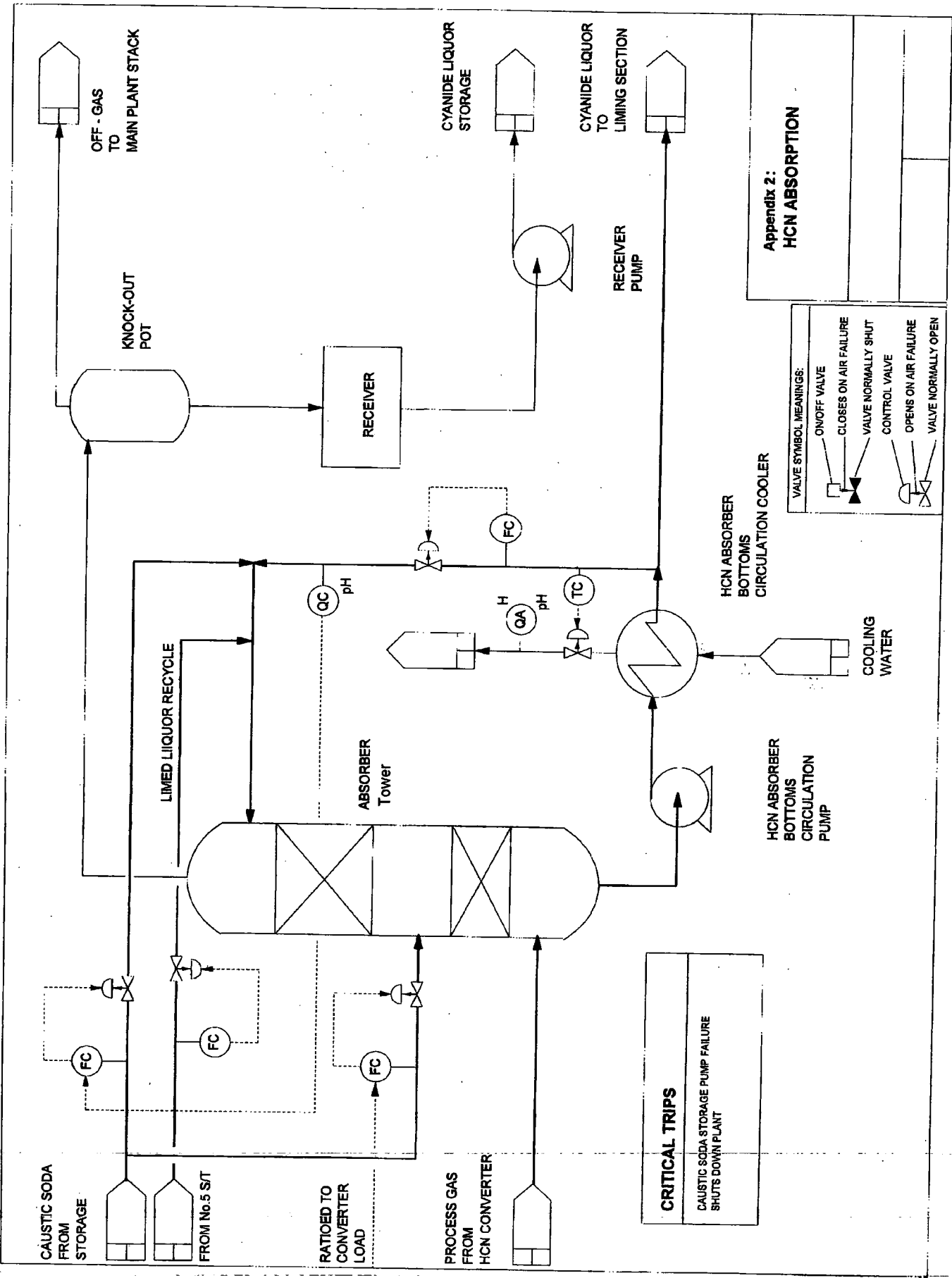

**Appendix 2:  
HCN ABSORPTION**

**VALVE SYMBOL MEANINGS:**

- ON/OFF VALVE
- CLOSES ON AIR FAILURE
- VALVE NORMALLY SHUT
- CONTROL VALVE
- OPENS ON AIR FAILURE
- VALVE NORMALLY OPEN

**CRITICAL TRIPS**

CAUSTIC SODA STORAGE PUMP FAILURE  
SHUTS DOWN PLANT

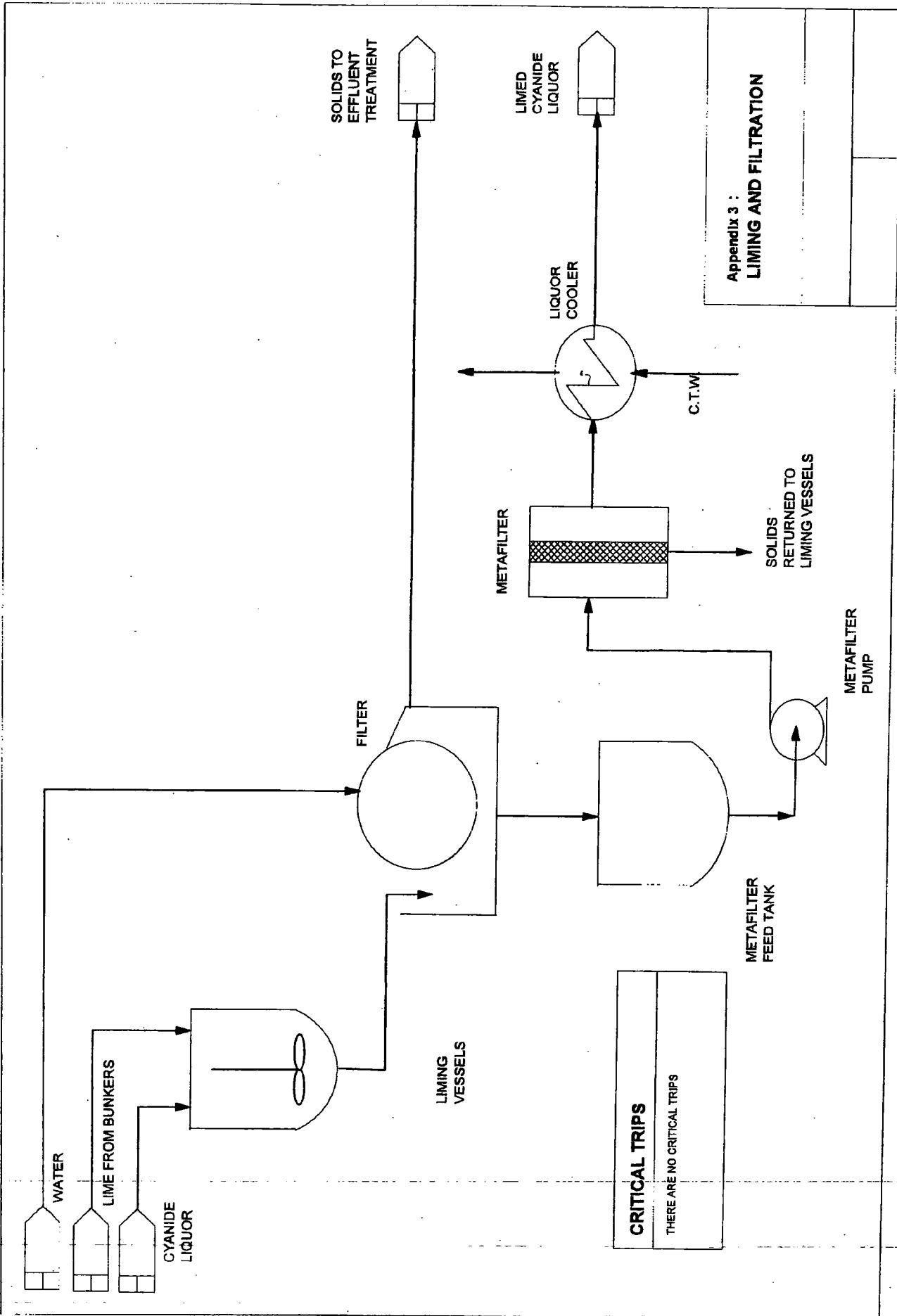

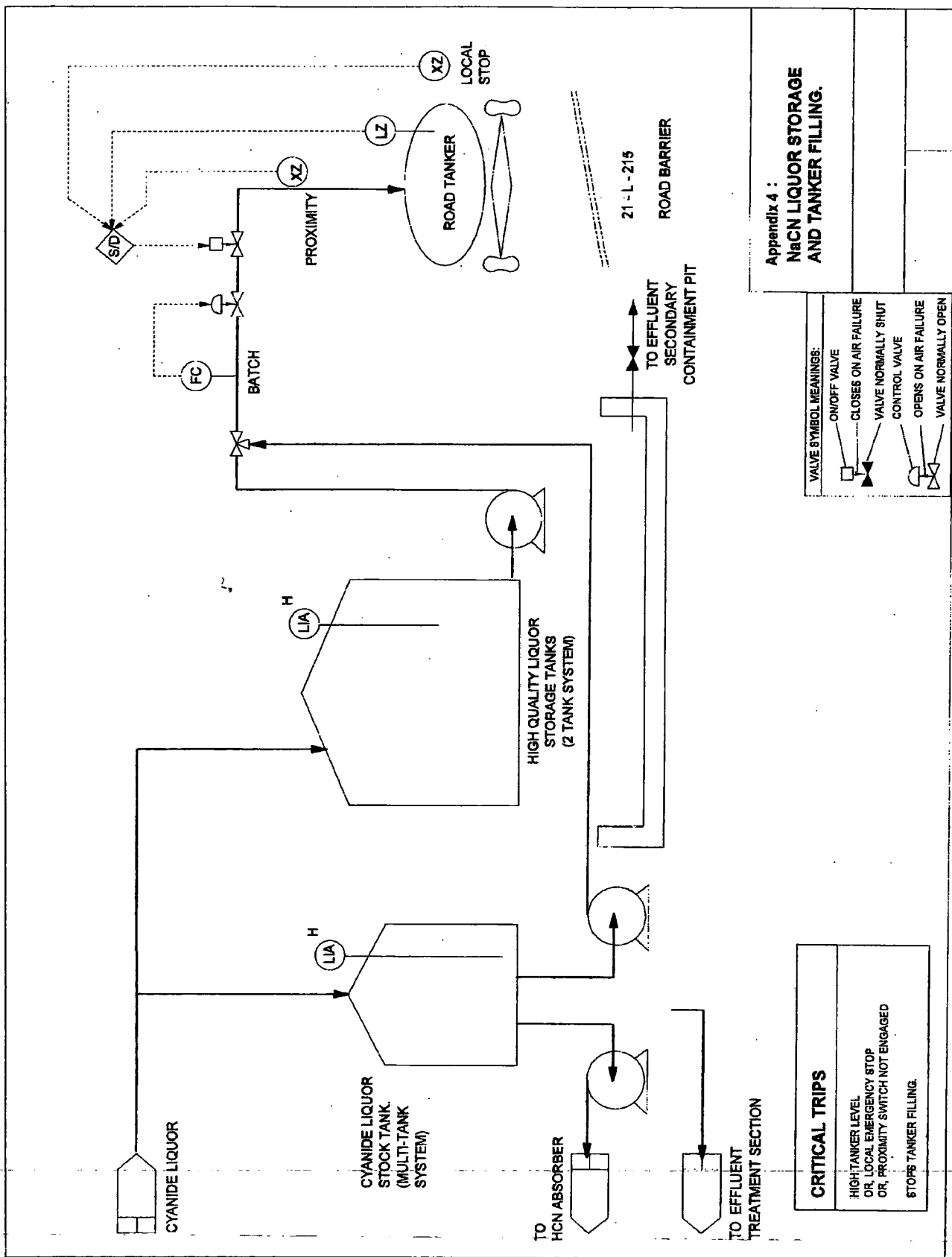

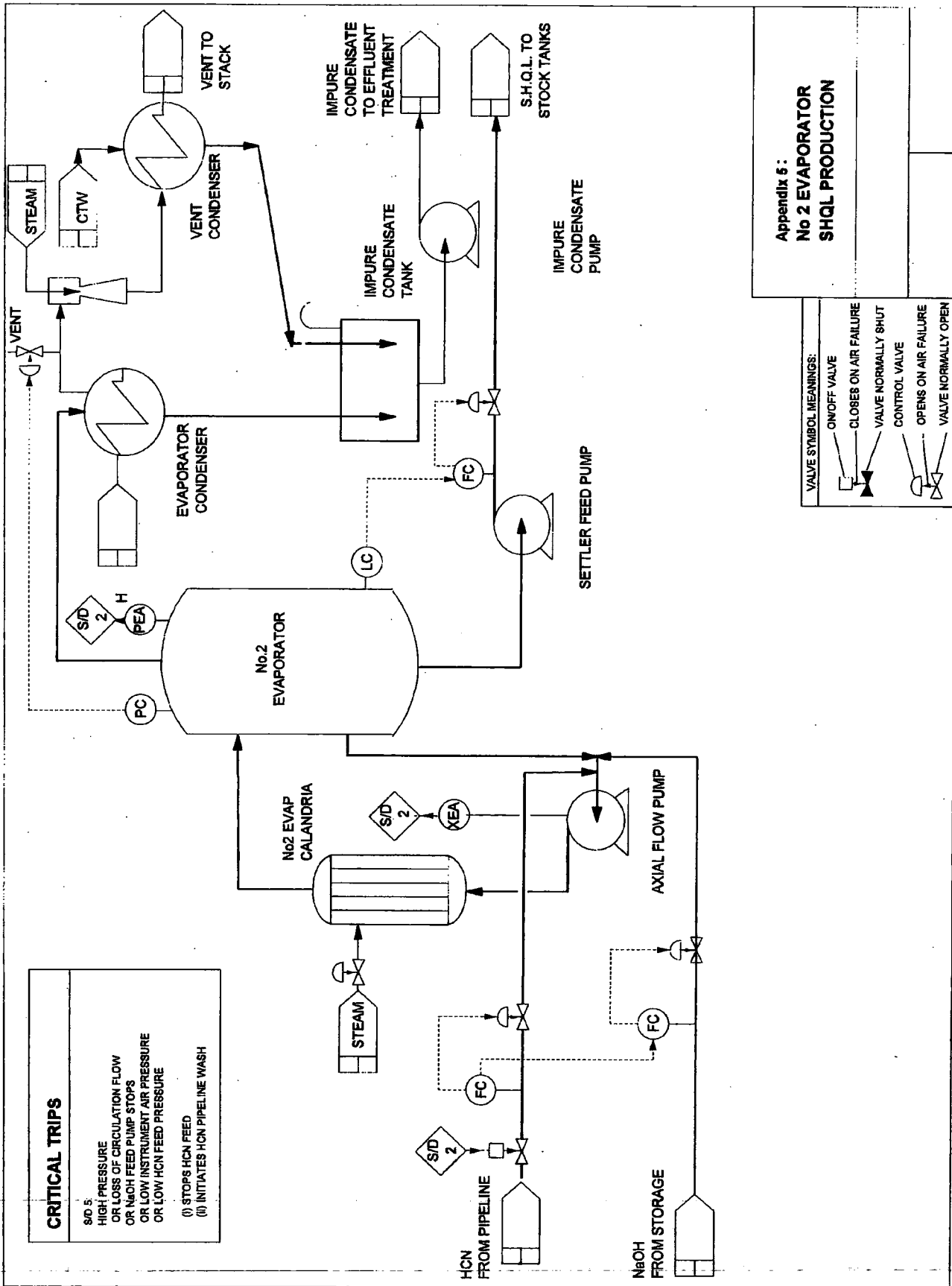

**CRITICAL TRIPS**

S/O 5:  
 HIGH PRESSURE  
 OR LOSS OF CIRCULATION FLOW  
 OR NaOH FEED PUMP STOPS  
 OR LOW INSTRUMENT AIR PRESSURE  
 OR LOW HCN FEED PRESSURE

(i) STOPS HCN FEED  
 (ii) INITIATES HCN PIPELINE WASH

VALVE SYMBOL MEANINGS:

ON/OFF VALVE  
 CLOSURES ON AIR FAILURE  
 VALVE NORMALLY SHUT  
 CONTROL VALVE  
 OPENS ON AIR FAILURE  
 VALVE NORMALLY OPEN

Appendix 5:  
**No. 2 EVAPORATOR**  
**SHQL PRODUCTION**

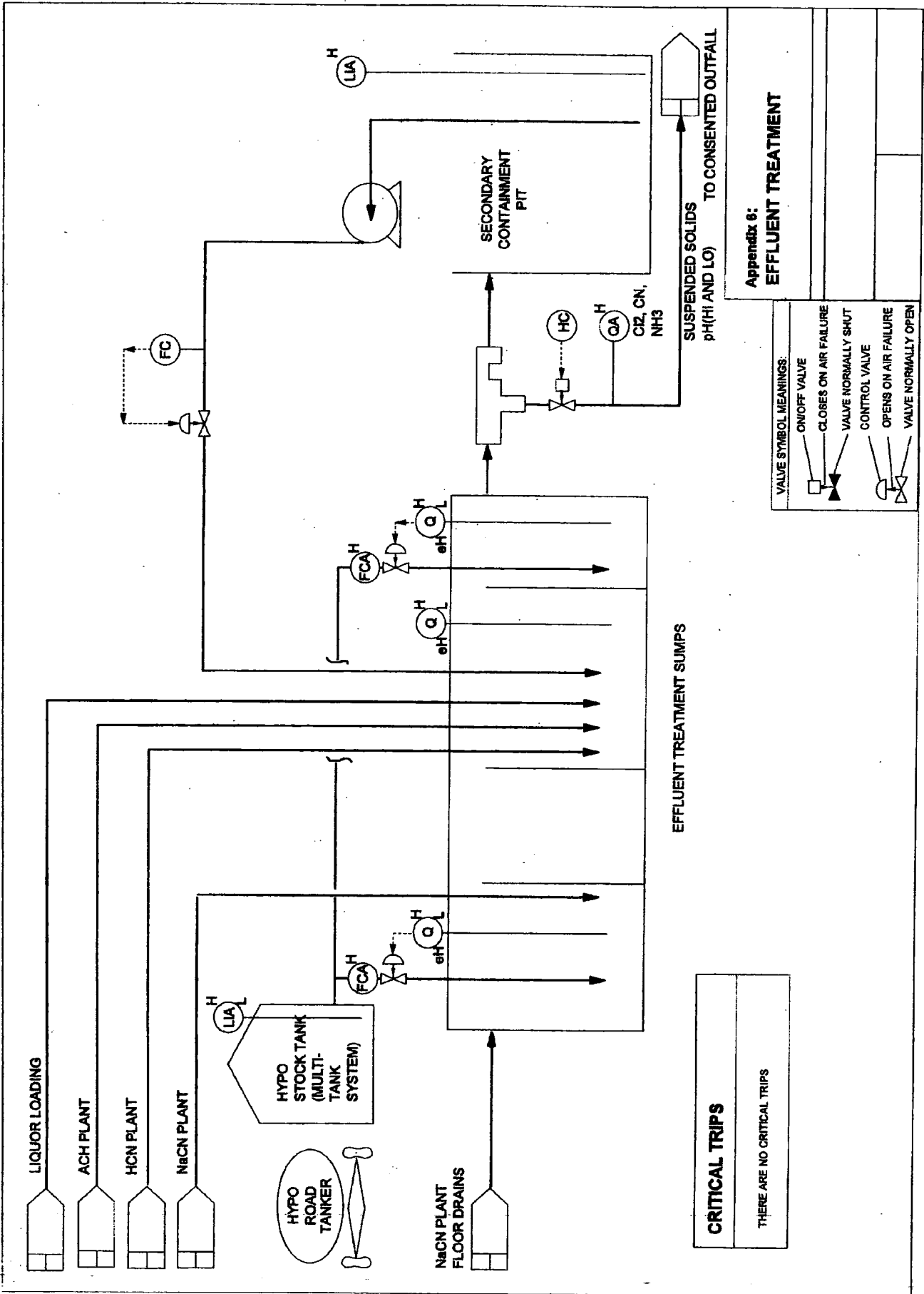

Appendix 6:  
EFFLUENT TREATMENT

VALVE SYMBOL MEANINGS:

	ON/OFF VALVE
	CLOSES ON AIR FAILURE
	VALVE NORMALLY SHUT
	CONTROL VALVE
	OPENS ON AIR FAILURE
	VALVE NORMALLY OPEN

**CRITICAL TRIPS**  
THERE ARE NO CRITICAL TRIPS

# APPENDIX 7

"Sigsworth, Dave" <Dave.Sigsworth@etol.co.uk> on 24/06/2002 07:43:01

To: Julie [Wright/GB/ACRYLICS@INEOS](mailto:Wright/GB/ACRYLICS@INEOS)

cc:

Subject: Lucite Effluent Sample

Julie,

Neil is still working on a few bits of the analysis, but I have done the P&T side.

Only three major components present and have calculated then out as a relative percentage.

Water 99.3%  
Acetonitrile 0.63%  
Chloroform 0.07%

Calculating the chloroform against the current calibrated method gives 12ppb.

If you want quantitative on the acetonitrile let me know, otherwise hope the above is OK.

Here from you soon,

Dave

\*\*\*\*\*  
\*\*\*\*\*

The information contained in this e-mail and any files transmitted with it is confidential and intended for the addressee only. If you have received this e-mail in error, please notify the originator or telephone 01642 459955.

This e-mail and any attachments have been scanned for viruses prior to leaving Enron Teesside Operations Limited (ETOL). ETOL will not be liable for any losses as a result of any viruses being passed on.

Enron Teesside Operations Limited. Registered in England  
Reg. No. 3647087. Registered Office: ETOL HQ, PO Box 1985, Wilton  
International, Middlesbrough, TS90 8WS

\*\*\*\*\*  
\*\*\*\*\*

## IMPORTANT NOTICE:

This email is confidential, may be legally privileged, and is solely for the use of the intended recipient. Access, disclosure, copying, distribution, or reliance on any of it by anyone else is prohibited and may be a criminal offence. If you have received this e-mail by mistake, please notify the sender immediately by e-mail and delete this e-mail from your system. The sender has taken reasonable precautions to ensure no viruses are present in this e-mail however the company cannot accept responsibility for any loss or damage arising from the use of this e-mail or attachments. Please note that this e-mail has been created in the knowledge that Internet e-mail is not a 100% secure communications medium. We advise that you understand and consider this lack of security when e-mailing us.

## APPENDIX 7



Neil Tindale  
Lucite International  
F217  
Wilton Centre  
Redcar

**Enron Teesside  
Operations Limited**  
ETOL Environmental Services  
PO Box 1985  
Wilton International  
Middlesbrough  
TS90 8WS  
Tel: 01642 212363  
Direct: 01642 212181  
Fax: 01642 212718

*Our Ref: RFA 1700*

*Date: 25 May 2004*

Dear Neil

### **No1 SUMP- CASSEL SITE - ANALYSIS**

Ion Chromatography was used to determine inorganic and organic anions. Inductively Coupled Plasma was used to determine metals. Organics were identified by GC-MS. The ratio of free to total cyanide was determined by distillation with appropriate releasing agents followed by a colourimetric finish.

<i>Anion analysis</i>	
Analyte	Result (ppm w/v)
Fluoride	0.2
Glycolate	<1
Acetate	<1
Formate	<1
Chloride	13
Propionate	<1
Nitrite	6
Butyrate	<1
Sulphite	<1
Sulphate	41
Oxalate	1
Bromide	<1
Nitrate	4
Phosphate	<1
Thiosulphate	<1
Thiocyanate	0.06

<i>Semi quantitative ICP analysis</i>	
Analyte	Result (ppm w/v)
Silver	<1
Gold	<1
Barium	<1

Beryllium	<1
Mercury	<1
Potassium	<1
Lithium	<1
Molybdenum	<1
Selenium	<1
Silicon	1
Tin	<1
Strontium	1
Titanium	<1
Thallium	<1
Zirconium	<1

*Quantitative ICP analysis*

Analyte	Result (ppm w/v)
Aluminium	1.7
Arsenic	<0.05
Boron	0.32
Cadmium	<0.005
Cobalt	<0.01
Chromium	<0.05
Copper	<0.05
Iron	1.6
Manganese	0.08
Nickel	<0.02
Lead	<0.05
Antimony	0.09
Vanadium	0.01
Zinc	0.51
Calcium	1900
Magnesium	10
Sodium	1500

The free/total cyanide analysis indicates that all of the cyanide is present as 'free' (weak acid dissociable) cyanide.

GC-MS analysis only produced one small peak, which was identified as acetonitrile.

Yours sincerely

Neil Borrell  
Analytical Technologist

**Endless possibilities.™**

# APPENDIX 8

<b>Balance over Liming and Filtration</b>					
HCN in	=	HCN out	=	1.406	
HCN out	=	In vent A7	+ NaCN stock tank vents	+ To effluent treatment	+ Converted to formate
kmol/hr		0.000231	0.00035	0.4996	0.906
<b>Effluent treatment reaction</b>					
NaCN	+	NaOCl	=	NaCNO	+ NaCl
HCN	+	NaOCl	+ NaOH	=	NaCNO + NaCl + H2O
kg/hr NaOCl Feed rate		141.288	Includes SHQL		
kg/hr lost via vents		0.200			
kmol/hr		1.896			
Free Cl2 kg/hr in effluent		0.379644			
Free Cl2 kmol/hr		0.005362			
Hence NaOCl reacting		1.885625	kmol/hr		
CN- Not reacting in effluent (kg/hr)		0.0922	From analysis and mass flow of effluent (measured)		
CN- Not reacting in effluent (kmol/hr)		0.0035			
HCN Lost in sump vent (kmol/hr)		4.23E-05			
Hence CN- in		1.88921	kg/h	kmol/hr	
CN- from SHQL	HCN	1000		37.037	
	A4 vent	0.12		0.00442	
As product (as HCN)		955.4715		35.3878	
HCN in cubicle vent Consumed to formate		0.004566		0.00017	
		6.885		0.255	
Hence To Effluent		37.52		1.38961	
CN- from Converter route		0.49960	kmol/hr		
NaOCl in effluent from free Cl2		0.002681	kmol/hr		
		0.199474	kg/hr		
CN- as NaCN in effluent		0.046	kg/hr	ASSUMES NOMINAL	
CN- as HCN in Effluent		0.070	kg/hr	SPLIT	

# APPENDIX 9

Parameters (See Note )		Release Point Number W5
Mercury	mg/litre	0.05
Free Chlorine (as Cl ) (Note 2)	mg/litre	100
Total Simple Cyanide (as CN) (Note 3)	mg/litre	100
Ammoniacal Nitrogen (as N)	mg/litre	500
Ammoniacal Nitrogen (as N) (Note 1)	tonnes/day	0.8
Zinc (Total as ZN)	mg/litre	0.6
Copper (Total as Cu)	mg/litre	0.5
Solids in Suspension (Note 4)	mg/litre	4000
Visible Oil and/or Grease		Absent
Flow (Note 5)	m <sup>3</sup> /day	3480
Flow (Note 5)	m <sup>3</sup> /hour	160
pH	min/max	5 - 13
Temperature	°C	30

**Notes:**

- 1 Five points moving average on monitoring regime detailed in letter dated 17/3/99.
- 2 Measured from the iodine liberated from a dilute alkaline solution of the sample, to which potassium iodine has been added, by titration with sodium arsenite.
- 3 Measured after cold acidification of the sample by a method agreed with the Environment Agency in writing.
- 4 Measured after drying at 105°C.
- 5 Flows are based on dry weather flow conditions.
- 6 All concentration limits shall be based on spot or composite samples taken in the manner described in the original application for authorisation.

## APPENDIX 10



**Lucite**  
International  
*Going further*

The information contained in this document is believed to be accurate but Lucite International accepts no responsibility for loss of claim resulting from use thereof. A Chemical Risk Assessment for this method will be required.

The information contained in this document is confidential. It must only be copied or disclosed to any third party by the Methods Controller with the permission of the Responsible Manager at the point of use

### STANDARD ANALYTICAL METHODS

NUMBER : CASSEL/CNL/35

PAGE NO : 1 of 4

VERSION : 5

COPY NO :

PREPARED BY : J Wright

DATE :

AUTHORISED BY : I J Robins

DATE :

ACCEPTED BY :

DATE:



NEW



REVISION OF

ACRY/CW/CNL/35 Rev 4



SUPPLEMENT



SUPERSEDES

### Title: Cyanide Production - Determination of Cyanide in Aqueous Drain Effluent by Titration with Silver Nitrate using a Mettler Autotitrator

CYANIDES ARE EXTREMELY TOXIC AS VAPOUR, IN SOLID FORM AND IN AQUEOUS SOLUTIONS. BECAUSE OF THEIR FREE CAUSTIC CONTENT, THE SOLIDS READILY ATTACK THE SKIN. THE SOLIDS ARE READILY DECOMPOSED, LIBERATING HYDROGEN CYANIDE ON CONTACT WITH ACIDIC SOLUTIONS, ACID FUMES OR MOIST AIR. IN SOLUTION THEY ARE READILY DECOMPOSED BY ACIDS. SAFETY PROCEDURES DETAILED IN ACRY/CW/CNL/001 MUST BE FOLLOWED WHEN HANDLING CYANIDES.

#### 1 Scope and Field of Application

This method is for the determination of cyanide in the range of 1 to 187 ppm as cyanide in aqueous drain effluent by titration with silver nitrate using a Mettler autotitrator.

#### 2 Principle

After addition of a standard cyanide solution to the sample volume, the solution is titrated, in the presence of excess sodium hydroxide, with a standard silver nitrate solution using a Mettler autotitrator equipped with a silver ring electrode.

#### 3 Reactions

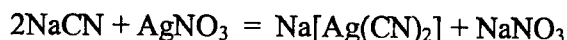

## APPENDIX 10

CASSEL/CNL/35  
Revision 5

### 4 Substances

During the analysis, unless otherwise stated, use only reagents of recognised analytical grade and only distilled water or water of equivalent purity.

#### Site Effluent

SITE EFFLUENT IS CORROSIVE AND MAY CONTAIN CYANIDE.

**Potassium nitrate electrolyte**, standard volumetric solution,  
 $c(\text{KNO}_3) = 3.0 \text{ mol/l. (3.0 N)}$

**Sodium hydroxide**, (1.0 N)

SODIUM HYDROXIDE IS CAUSTIC AND CAN CAUSE SEVERE BURNS.

**Silver nitrate**, standard volumetric solution,  $c(\text{AgNO}_3) = 0.01 \text{ mol/l. (0.01 N)}$

**Cyanide solution**, 1000 $\mu\text{g/ml}$

CYANIDE IS EXTREMELY TOXIC BY ALL ROUTES OF EXPOSURE. READILY ABSORBED THROUGH THE SKIN, CONTACT WITH POWDER, SOLUTION OR VAPOUR MAY PROVE FATAL. DECOMPOSITION TO HCN INCREASES TOXIC AND FIRE HAZARD.

- . Add 1904g of solid Sodium Cyanide to a one litre flask.
- . Add 5ml of N Sodium Hydroxide to the flask
- . Make up to 1 litre with distilled water.
- . Stopper and shake well.

The hazards of the substances used can be found on the Cassel COSHH database under the complete listings view.

### 5 Apparatus

**Mettler Autotitrator**, DL50 or equivalent.

**Electrode**, silver DM141.

**Beaker**, 100 ml, graduated, glass or polythene to fit Mettler autotitration head.

**Mettler autotitrator burette**, 20 ml, connected to a suitable sized glass reservoir.

**Measuring cylinder**, 50 ml.

**Anachem dispenser**, or equivalent, capable of dispensing 1 ml.

**Dispenser**, to deliver 20 ml.

## APPENDIX 10

CASSEL/CNL/35  
Revision 5

### 6 Sampling

The laboratory sample should be taken into a acceptable polythene capped plastic bottle.

### 7 Hazards

Toxic substance  
Corrosive substance  
Use of Glassware

### 8 PPE

As defined in COSHH (Chemical Risk) Assessment.

### 9 Determination

- Ensure the DM141 electrode and correct burette containing N/100 Silver Nitrate is in place on the Mettler
- Add 50ml of test sample to a Mettler beaker.
- Add 20ml of approx. N/1 Sodium Hydroxide using dispenser.
- Then dispense 1.0ml of standard Sodium Cyanide solution (1000µg/ml)
- run the sample on Method 35 on the Mettler.

### 10 Expression of Results

#### Method of Calculation

The cyanide content, expressed in parts per million as cyanide, in the ratio of mass to volume, is given by the formula

$$\frac{(T - V) \times 0.00052 \times 10^6}{50}$$

T is the volume, in millilitres, of the silver nitrate solution used for the test;

V is the volume, in millilitres, of the silver nitrate solution for cyanide standard solution added  
0.00052 is the mass, in grams, of cyanide corresponding to 1.00 ml of silver nitrate solution,  
 $c(\text{AgNO}_3) = 0.01 \text{ mol/l}$ .

50 is the volume, in millilitres, of the test portion;

The result should be expressed as a whole number.

## APPENDIX 10

CASSEL/CNL/35  
Revision 5

Note: If the concentration of the standard volumetric solution is not exactly as specified in the list of reagents, an appropriate correction should be made.

### Precision

The following data was obtained under conditions of reproducibility, with the number of tests  $n$ , being equal to 30.

Mean,  $\bar{x}$  = 17.3 ppm  
Standard deviation  $\delta_{wr}$  = 0.5 ppm

\*\* within laboratory reproducibility

For a given sample of mean 17.3 ppm we are 95 % confident that the result obtained using this method will be in the range 16.3 ppm to 18.3 ppm.

### 11 Notes on Procedure

Check test on Cyanide Standard 1000 $\mu$ g/ml

- To a dry, clean 100ml beaker add 50ml of distilled water.
- The dispense 20ml of the N/1 approx. Sodium Hydroxide.
- Add 1ml of the Cyanide Standard Solution.
- Run on the mettler on Method 35.
- This should be repeated three times to ensure factor is correct.

## APPENDIX 11

Results for the Sonication/Hydrogen Peroxide time trials using a Mettler autotitrator and Dionex HPLC Chromatography for cyanide determination

TABLE 3.4: Results from preliminary test Sonication without activated carbon

<i>Time of sonication (mins)</i>	<i>Volume of Sample (mls)</i>	<i>Cyanide Concentration remaining (%)</i>
0	50	0.301
2	50	0.305
3	45	0.306
6	40	0.304
9	35	0.306
Blank without sonication	50	0.302

TABLE 3.5: Results from preliminary test of Sonication with activated carbon

<i>Time of sonication (mins)</i>	<i>Volume of Sample (mls)</i>	<i>Cyanide Concentration remaining (%)</i>
0	50	0.301
2	50	0.305
3	45	0.308
6	40	0.308
9	35	0.313
Blank without sonication	50	0.307

TABLE 3.6: Results from preliminary test of Sonication without activated carbon after filtering

<i>Time of sonication (mins)</i>	<i>Volume of Sample (mls)</i>	<i>Cyanide Concentration remaining (%)</i>
0	50	0.308
2	50	0.303
3	45	0.306
6	40	0.314
9	35	0.321
Blank without sonication	50	0.308

## APPENDIX 11

Results for the Sonication/Hydrogen Peroxide time trials using a Mettler autotitrator and Dionex HPLC Chromatography for cyanide determination

TABLE 3.8: Results from preliminary test of Hydrogen Peroxide

<i>Volume of Sample (mls)</i>	<i>Volume of Hydrogen Peroxide (3%) added (mls)</i>	<i>Concentration of cyanide remaining (%)</i>
5	0	0.308
100	2	0.300
100	4	0.275
100	6	0.265
100	8	0.259
100	10	0.242
100	15	0.197
50 (100)	10 (20)	0.176
50 (100)	15 (30)	0.020
<i>Volume of Sample (mls)</i>	<i>Volume of Hydrogen Peroxide (30%) added (mls)</i>	<i>Concentration of cyanide remaining (%)</i>
5	0.08	0.176
5	0.10	0.163
5	0.12	0.137
5	0.14	0.118

TABLE 3.9: Results from preliminary test of Hydrogen Peroxide and Sonication

<i>Sonication time (mins)</i>	<i>Volume of sodium hydroxide added (mls)</i>	<i>Volume of Hydrogen Peroxide (30%) added (mls)</i>	<i>Concentration of cyanide remaining (%)</i>
-	4	0	0.302
-	4	0.07	0.216
-	-	0.07	0.294
-	20	0.07	0.259
1.0	(5mls of sample)	0.07	0.165
2.0	(5mls of sample)	0.09	0.145
4.0	(5mls of sample)	0.09	0.086
4.0	-	0.07	0.239
4.0	-	0.10	0.220
4.0	-	0.14	0.160
4.0	-	0.18	0.131
4.0	-	0.24	0.073
4.0	-	0.28	0.043
4.0	-	0.32	0.006
2.0	-	0.07	0.210
2.0	-	0.10	0.161
2.0	-	0.18	0.122
2.0	-	0.24	0.122
2.0	-	0.28	0.106
2.0	-	0.30	0.071
8.0	-	0.10	0.180

## APPENDIX 11

Results for the Sonication/Hydrogen Peroxide time trials using a Mettler autotitrator and Dionex HPLC Chromatography for cyanide determination

<i>Sonication time (mins)</i>	<i>Volume of sodium hydroxide added (mls)</i>	<i>Volume of Hydrogen Peroxide (30%) added (mls)</i>	<i>Concentration of cyanide remaining (%)</i>
8.0	-	0.18	0.122
8.0	-	0.30	0.022

**Results for the Initial Sonication/Hydrogen Peroxide time trials using a Mettler autotitrator for cyanide determination**

TABLE 4.1: Decrease in cyanide using hydrogen peroxide and sonication over 1 minute

<i>Volume of H<sub>2</sub>O<sub>2</sub> added (mls)</i>	<i>Cyanide Conc. (%) remaining after sonication</i>	<i>Cyanide Conc. (%) remaining after No sonication</i>
None (initial)	0.303	0.303
0.07	0.299	0.239
0.09	0.299	0.229
0.10	0.21	0.21
0.12	0.21	0.21
0.14	0.18	0.22
0.18	0.171	0.171
0.20	0.161	0.161
0.22	0.151	0.171
0.24	0.141	0.171
0.28	0.151	0.151
0.30	0.102	0.131

TABLE 4.2: Decrease in cyanide using hydrogen peroxide and sonication over 2 minutes

<i>Volume of H<sub>2</sub>O<sub>2</sub> added (mls)</i>	<i>Cyanide Conc. (%) remaining after sonication</i>	<i>Cyanide Conc. (%) remaining after No sonication</i>
None (initial)	0.308	0.308
0.07	0.262	0.246
0.09	0.229	0.215
1	0.233	0.233
1.4	0.22	0.161
1.8	0.21	*

\* Result missing due to problem with the Mettler not being able to detect low result.

## APPENDIX 11

Results for the Sonication/Hydrogen Peroxide time trials using a Mettler autotitrator and Dionex HPLC Chromatography for cyanide determination

TABLE 4.3: Decrease in cyanide using hydrogen peroxide and sonication over 3 minutes

<i>Volume of H<sub>2</sub>O<sub>2</sub> added (mls)</i>	<i>Cyanide Conc. (%) remaining after sonication</i>	<i>Cyanide Conc. (%) remaining after No sonication</i>
None (initial)	0.276	0.276
0.07	0.22	0.22
0.09	0.2	0.21
0.1	0.18	0.21
0.12	0.171	0.21
0.14	0.2	0.21
0.18	0.151	0.2
0.20	0.102	0.151
0.22	0.102	0.092
0.24	0.161	0.161
0.28	0.102	0.141
0.3	0.92	0.112

TABLE 4.4: Decrease in cyanide using hydrogen peroxide and sonication over 4 minutes

<i>Volume of H<sub>2</sub>O<sub>2</sub> added (mls)</i>	<i>Cyanide Conc. (%) remaining after sonication</i>	<i>Cyanide Conc. (%) remaining after No sonication</i>
None (initial)	0.276	0.276
0.07	0.22	0.22
0.09	0.2	0.21
0.1	0.18	0.21
0.12	0.171	0.21
0.14	0.2	0.21
0.18	0.151	0.2
0.20	0.102	0.151
0.22	0.102	0.092
0.24	0.161	0.161
0.28	0.102	0.141
0.3	0.92	0.112

## APPENDIX 11

Results for the Sonication/Hydrogen Peroxide time trials using a Mettler autotitrator and Dionex HPLC Chromatography for cyanide determination

TABLE 4.5: Decrease in cyanide using hydrogen peroxide and sonication over 5 minutes

<i>Volume of H<sub>2</sub>O<sub>2</sub> added (mls)</i>	<i>Cyanide Conc. (%) remaining after sonication</i>	<i>Cyanide Conc. (%) remaining after No sonication</i>
None (initial)	0.298	0.298
0.07	0.22	0.23
0.09	0.21	0.22
0.10	0.19	0.18
0.12	0.161	0.2
0.14	0.2	0.21
0.18	0.19	0.18
0.20	0.151	0.171
0.22	0.141	0.141
0.24	0.151	0.171
0.28	0.122	0.131
0.30	0.102	0.102

TABLE 4.6: Results from the tests of the decrease in cyanide with increasing hydrogen peroxide volume over time without sonication

	<i>0.07mls</i>	<i>0.09mls</i>	<i>0.10mls</i>	<i>0.12mls</i>	<i>0.14mls</i>	<i>0.18mls</i>	<i>0.20mls</i>	<i>0.22mls</i>	<i>0.24mls</i>
<i>Time</i>	<i>CN Conc %</i>	<i>CN Conc %</i>	<i>CN Conc %</i>	<i>CN Conc %</i>	<i>CN Conc %</i>	<i>CN Conc %</i>	<i>CN Conc %</i>	<i>CN Conc %</i>	<i>CN Conc %</i>
0	0.3	0.3	0.3	0.3	0.3	0.3	0.3	0.3	0.3
1	0.239	0.229	0.21	0.21	0.22	0.171	0.161	0.171	0.171
2	0.249	0.229	0.22	0.2	0.2	0.19	0.131	0.2	0.18

TABLE 4.7: Results from the tests of the decrease in cyanide with increasing hydrogen peroxide volume over time with sonication

	<i>0.07mls</i>	<i>0.09mls</i>	<i>0.10mls</i>	<i>0.12mls</i>	<i>0.14mls</i>	<i>0.18mls</i>	<i>0.20mls</i>	<i>0.22mls</i>	<i>0.24mls</i>
<i>Time</i>	<i>CN Conc %</i>	<i>CN Conc %</i>	<i>CN Conc %</i>	<i>CN Conc %</i>	<i>CN Conc %</i>	<i>CN Conc %</i>	<i>CN Conc %</i>	<i>CN Conc %</i>	<i>CN Conc %</i>
0	0.3	0.3	0.3	0.3	0.3	0.3	0.3	0.3	0.3
1	0.299	0.299	0.21	0.21	0.18	0.171	0.161	0.151	0.141
2	0.239	0.229	0.21	0.21	0.19	0.161	0.18	0.141	0.161
3	0.22	0.2	0.18	0.171	0.2	0.151	0.102	0.102	0.161
4	0.249	0.239	0.229	0.22	0.19	0.151	0.161	0.151	0.151
5	0.22	0.21	0.19	0.161	0.2	0.19	0.151	0.141	0.151

## APPENDIX 11

Results for the Sonication/Hydrogen Peroxide time trials using a Mettler autotitrator and Dionex HPLC Chromatography for cyanide determination

TABLE 4.8: Results from the initial time trial to establish decrease in cyanide

<i>Actual time</i>	<i>Cyanide Concentration (ppm)</i>
13:30	3020
13:39	993
13:53	850
14:47	404
14:54	373
16:04	78
16:48	28
17:11	7
18:17	0

TABLE 4.9: Results from the time trial to establish decrease in cyanide over a 1 minute reaction time

<i>Volume of H<sub>2</sub>O<sub>2</sub> added (mls)</i>	<i>Cyanide Conc. (ppm) remaining after sonication</i>	<i>Cyanide Conc. (ppm) remaining after No sonication</i>
None (initial)	2900	2900
0.32	697	725.6
0.34	572.5	627.9
0.38	452.4	663.3
0.4	300.4	368.6
0.45	928.6	932.1
0.5	931.7	929.3
0.55	961.3	1259.4
0.6	966.7	968.2
0.70	967.4	1307.2
0.8	1027.5	1011.7
0.9	1047.5	1070.4
1.0	1026.7	1068
1.5	1015.8	1075
2.0	949.1	1019.4
4.0	774.6	855
8.0	612.5	665.5
9.0	654.8	704.6
10.0	615.4	640.4
11.0	611.8	643.2
12.0	615.9	629.8
13.0	552.5	587.3
15.0	493.5	568.7
20.0	501.1	482.1
25.0	421.6	432
30.0	371.7	382.3
35.0	301.5	363.9

## APPENDIX 11

Results for the Sonication/Hydrogen Peroxide time trials using a Mettler autotitrator and Dionex HPLC Chromatography for cyanide determination

<i>Volume of H<sub>2</sub>O<sub>2</sub> added (mls)</i>	<i>Cyanide Conc. (ppm) remaining after sonication</i>	<i>Cyanide Conc. (ppm) remaining after No sonication</i>
40.0	310.8	366.2
50.0	382.3	217.3
60.0	230.9	258.9

TABLE 4.10: Results from the time trial to establish decrease in cyanide over a 5 minutes reaction time

<i>Volume of H<sub>2</sub>O<sub>2</sub> added (mls)</i>	<i>Cyanide Conc. (ppm) remaining after sonication</i>	<i>Cyanide Conc. (ppm) remaining after No sonication</i>
None (initial)	3060	3060
0.5	617	786.2
1.0	228	468.9
1.5	204	478.8
2.0	176.3	378.8
2.5	102.7	284.6
3.0	162.6	303.3
3.5	133.6	349.3
4.0	128.9	258.8
4.5	119.8	312.7
5.0	144.4	340.8
5.5	96.1	306.4
6.0	93.8	250.2
6.5	108.4	390.6
7.0	107.4	367.9
7.5	89.9	331.7
8.0	80.8	438
8.5	3.8	348.1
9.0	44.6	427.9
9.5	115.4	567.7
10.0	123.7	598

## APPENDIX 11

Results for the Sonication/Hydrogen Peroxide time trials using a Mettler autotitrator and Dionex HPLC Chromatography for cyanide determination

TABLE 4.11: Results from the time trial to establish decrease in cyanide over a 10 minutes reaction time

<i>Volume of H<sub>2</sub>O<sub>2</sub> added (mls)</i>	<i>Cyanide Conc. (ppm) remaining after sonication</i>	<i>Cyanide Conc. (ppm) remaining after No sonication</i>
None (initial)	2900	2900
0.5	702	1278.2
1	167.4	1002.5
1.5	3.5	519.3
2	35	516.2
2.5	22.4	454.3
3	99.5	308.1
3.5	47.6	338.2
4	62	218.5
4.5	69.1	204.9
5	58.1	202.9
5.5	35	163
6	37.4	180.5

TABLE 4.12: Results from the time trial to establish decrease in cyanide over a 13 minutes reaction time

<i>Volume of H<sub>2</sub>O<sub>2</sub> added (mls)</i>	<i>Cyanide Conc. (ppm) remaining after sonication</i>	<i>Cyanide Conc. (ppm) remaining after No sonication</i>
None (initial)	3050	3050
0.5	1171.7	1365.4
1	657.4	765.6
1.5	271.7	469.6
2	313	301
2.5	305.6	298
3	296.3	232.6
3.5	263.8	215.9
4	164.6	167.4
4.5	141.3	153.4
5	252.8	175.4
5.5	180.8	142
6	170.7	150.9
6.5	263	134.6
7	225	154.8
7.5	214	145.3
8	131	150.9
8.5	0	101.3
9	0	115.9
9.5	0	126.1
10	0	83

## APPENDIX 11

Results for the Sonication/Hydrogen Peroxide time trials using a Mettler autotitrator and Dionex HPLC Chromatography for cyanide determination

TABLE 4.13: Results from the time trial to establish decrease in cyanide (ppm) over a 15 minutes reaction time

<i>Volume of H<sub>2</sub>O<sub>2</sub> added (mls)</i>	<i>Cyanide Conc. (ppm) remaining after sonication</i>	<i>Cyanide Conc. (ppm) remaining after No sonication</i>
None (initial)	2960	2960
0.5	776.9	974.9
1	203.8	488.7
1.5	88.1	311.8
2	29.5	214
2.5	19.6	155.2
3	0	143.3
3.5	0	126.3
4	0	98.5
4.5	0	70.5
5	0	62.6
5.5	0	83
6	0	52.6
6.5	0	8.5
7	0	0

TABLE 4.14: Results from the initial time trial to establish decrease in cyanide (ppm) over a 20 minutes reaction time

<i>Volume of H<sub>2</sub>O<sub>2</sub> added (mls)</i>	<i>Cyanide Conc. (ppm) left after sonication</i>	<i>Cyanide Conc. (ppm) left after No sonication</i>
None (initial)	3010	3010
0.5	980.7	849.4
1	399.7	501.2
1.5	140.3	217.4
2	41	118.3
2.5	0	79.3
3	0	80.4
3.5	40	53.7
4	0	41.5
4.5	0	37.5
5	0	22.5
5.5	0	20.3
6	0	10.1

## APPENDIX 11

Results for the Sonication/Hydrogen Peroxide time trials using a Mettler autotitrator and Dionex HPLC Chromatography for cyanide determination

TABLE 4.15: Results from the time trial to establish decrease in cyanide (ppm) with increasing hydrogen peroxide volume without Sonication

mls	0.5	1.0	1.5	2.0	2.5	3.0	3.5	4.0	4.5	5.0	5.5	6.0	6.5	7.0	7.5	8.0
Time	CN Conc ppm	CN Conc ppm	CN Conc ppm	CN Conc ppm	CN Conc ppm	CN Conc ppm	CN Conc ppm	CN Conc ppm	CN Conc ppm	CN Conc ppm	CN Conc ppm	CN Conc ppm	CN Conc ppm	CN Conc ppm	CN Conc ppm	CN Conc ppm
0	3020	3020	3020	3020	3020	3020	3020	3020	3020	3020	3020	3020	3020	3020	3020	3020
1	929.3	1068	1075	1019				855							665.5	665.5
5	786.2	468.9	478.8	378.8	284.6	303.3	349.3	258.8	312.7	340.8	306.4	250.2	390.6	367.9	331.7	438
10	1278.2	1003	519.3	516.2	454.3	308.1	338.2	218.5	204.9	202.9	163	180.5				
13	1365.4	765.6	469.6	301	298	232.6	215.9	167.4	153.4	175.4	142	150.9	134.6	154.8	145.3	150.9
15	974.9	488.7	311.8	214	155.2	143.3	126.3	98.5	70.5	62.6		52.6	8.5	0		
20	849.4	501.2	217.4	118.3	79.3	80.4	53.7	41.5	37.5	22.5	20.3	10.1				

TABLE 4.16: Results from the time trial to establish decrease in cyanide (ppm) with increasing hydrogen peroxide volume with Sonication

mls	0.5	1.0	1.5	2.0	2.5	3.0	3.5	4.0	4.5	5.0	5.5	6.0	6.5	7.0	7.5	8.0
Time	CN Conc ppm	CN Conc ppm	CN Conc ppm	CN Conc ppm	CN Conc ppm	CN Conc ppm	CN Conc ppm	CN Conc ppm	CN Conc ppm	CN Conc ppm	CN Conc ppm	CN Conc ppm	CN Conc ppm	CN Conc ppm	CN Conc ppm	CN Conc ppm
0	3020	3020	3020	3020	3020	3020	3020	3020	3020	3020	3020	3020	3020	3020	3020	3020
1	931.7	1027	1015.8	949.1				774.6								612.5
5	617	228	204	176.3	102.7	162.6	133.6	128.9	119.8	144.4	96.1	93.8	108.4	107.4	89.9	80.8
10	702	167.4	3.5	35	22.4	99.5	47.6	62	69.1	58.1	35	37.4				
13	1171.7	657.4	271.7	313	305.6	296.3	263.8	164.6	141.3	252.8	180.8	170.7	263	225	214	131
15	776.9	203.8	88.1	29.5	19.6	0	0	0	0	0						

TABLE 4.17: Decrease in cyanide (ppm) using increased hydrogen peroxide with sonication to show optimum time.

<i>H<sub>2</sub>O<sub>2</sub> added(mls)</i>	<i>5 minutes</i>	<i>10 minutes</i>	<i>13 minutes</i>	<i>15 minutes</i>	<i>20 minutes</i>
0	3060	2900	3050	2960	3010
0.5	617	702	1171.7	776.9	980.7
1	228	167.4	657.4	203.8	399.7
1.5	204	3.5	271.7	88.1	140.3
2	176.3	35	313	29.5	41
2.5	102.7	22.4	305.6	19.6	0
3	162.6	99.5	296.3	0	0
3.5	133.6	47.6	263.8	0	40
4	128.9	62	164.6	0	0
4.5	119.8	69.1	141.3	0	0
5	144.4	58.1	252.8	0	
5.5	96.1	35	180.8		
6	93.8	37.4	170.7		
6.5	108.4		263		
7	107.4		225		
7.5	89.9		214		
8	80.8		131		

## APPENDIX 11

Results for the Sonication/Hydrogen Peroxide time trials using a Mettler autotitrator and Dionex HPLC Chromatography for cyanide determination

TABLE 4.18: Decrease in cyanide (ppm) using increased hydrogen peroxide without sonication to show optimum time.

<i>H<sub>2</sub>O<sub>2</sub> added (mls)</i>	<i>5 minutes</i>	<i>10 minutes</i>	<i>13 minutes</i>	<i>15 minutes</i>	<i>20 minutes</i>
0	3060	2900	3050	2960	3010
0.5	786.2	1278.2	1365.4	974.9	849.4
1	468.9	1002.5	765.6	488.7	501.2
1.5	478.8	519.3	469.6	311.8	217.4
2	378.8	516.2	301	214	118.3
2.5	284.6	454.3	298	155.2	79.3
3	303.3	308.1	232.6	143.3	80.4
3.5	349.3	338.2	215.9	126.3	53.7
4	258.8	218.5	167.4	98.5	41.5
4.5	312.7	204.9	153.4	70.5	37.5
5	340.8	202.9	175.4	62.6	22.5
5.5	306.4	163	142	83	20.3
6	250.2	180.5	150.9	52.6	10.1
6.5	390.6		134.6	8.5	
7	367.9		154.8	0	
7.5	331.7		145.3		
8	438		150.9		

TABLE 4.19: Solid related time trial with Sonication/Hydrogen Peroxide

<i>Weight of solids added (g)</i>	<i>Cyanide Conc. (ppm) left after sonication</i>	<i>Cyanide Conc. (ppm) left No sonication</i>
initial	1220	1220
0	276	304.3
0.1	293.3	296.9
0.2	256.6	306.3
0.4	246.9	319.6
0.6	158	247.6
1.0	190.4	285.7
1.2	175.5	322.5
1.4	155	308.1
1.6	187	304.6

## APPENDIX 11

Results for the Sonication/Hydrogen Peroxide time trials using a Mettler autotitrator and Dionex HPLC Chromatography for cyanide determination

TABLE 4.20: Temperature related time trial with Sonication/Hydrogen Peroxide

<i>Temperature (°C)</i>	<i>Cyanide Conc. (ppm) left after sonication</i>	<i>Cyanide Conc. (ppm) left after No sonication</i>
None (initial)	3030	3030
16/18	537.7	702.1
24	438.1	554.1
28	218.6	200
30	173.9	232.6
32	83.8	103.3
34	58.9	55.7
36	39.4	12.4
38	12.6	31.9
40	28.1	0

