

Durham E-Theses

Ottaviano Petrucci's Lamentationum liber primus and liber secundus (1506/1 and 1506/2); a bibliographical contextual and analytical study

Peter James David Scott

How to cite:

Scott, Peter James David (2004) *Ottaviano Petrucci's Lamentationum liber primus and liber secundus (1506/1 and 1506/2); a bibliographical contextual and analytical study*. Doctoral thesis, Durham University.

Use policy

The full-text may be used and/or reproduced, and given to third parties in any format or medium, without prior permission or charge, for personal research or study, educational, or not-for-profit purposes provided that:

- a full bibliographic reference is made to the original source
- a <https://etheses.durham.ac.uk/id/eprint/2828/> is made to the metadata record in Durham E-Theses
- the full-text is not changed in any way

The full-text must not be sold in any format or medium without the formal permission of the copyright holders.

Please consult the [full Durham E-Theses policy](#) for further details.

ABSTRACT

Peter James David Scott

Ottaviano Petrucci's *Lamentationum liber primus* and *liber secundus* (1506/1 and 1506/2); a bibliographical, contextual and analytical study

This thesis examines the context, manufacture and content of the Italian printer Ottaviano de Petrucci's two Lamentation volumes of 1506. It addresses issues such as Petrucci's initial decision to dedicate a print series to Lamentations, as well as his production methods and commercial considerations. This thesis offers an explanation for the seemingly disparate assortment of composers, together with a discussion concerning the non-Lamentation texts; chapter 5 argues that these texts were central to the commercial viability and success of the prints, intended, as they undoubtedly were, for the Italian *laudesi*. Such interest partly explains the simple musical style of the *laude* contained in 1506/1, that print having the distinction of being the only Petrucci print to contain two-part sacred polyphony.

Computer software enabled microscopic analysis of the print elements in the extant copies, resulting in a surprisingly large number of variants, errors and stop-press corrections. They indicate disruption to the printing process and probably contributed to the publication date of 1506/1, being as late as the Wednesday in Holy Week that year.

There are three principal findings in this thesis: first, the two-part *Trecento* setting of 'Aleph' in the manuscript Vicenza, Seminario Vescovile, MS U.VIII.3, and the anonymous Lamentations in Bologna, Biblioteca Universitaria, MS 2931, support the notion that polyphonic Lamentations existed in Italy from the fourteenth century, suggesting a diverse and widespread tradition. Musicologists have previously considered the settings of Johannes de Quadris as being the earliest complete extant liturgical or para-liturgical Lamentations; those in Bu 2931 are somewhat earlier. Second, the printing disruption suggested by the variants and errors is supported by the watermark evidence. Third, the discovery of an independent version of Marbrianus de Orto's Lamentations in the manuscript Cape Town, Grey, 3.b.12, shows the monastic enthusiasm for the embellishment of Holy Week music during the fifteenth century.

Ottaviano Petrucci's *Lamentationum
liber primus* and *liber secundus* (1506/1
and 1506/2); a bibliographical,
contextual and analytical study

Peter James David Scott

Doctor of Philosophy Thesis

University of Durham
Department of Music

2004

A copyright of this thesis rests
with the author. No quotation
from it should be published
without his prior written consent
and information derived from it
should be acknowledged.



20 APR 2005

CONTENTS

Preface	viii
Editorial policy	ix
Acknowledgements	x
Abbreviations	xiii
Manuscript sigla	xiv
Print sigla	xvi

I HISTORICAL AND LITERATURE REVIEW

HISTORICAL REVIEW

1.1	A brief introduction to 1506/1 and 1506/2	2
1.2	The liturgical context of pre-1506 Lamentations	5
1.3	Lamentation settings pre-1506	9

LITERATURE REVIEW

1.4	Pre-1506 Lamentations	20
1.5	Text sources of 1506/1 and 1506/2	21
1.6	1506/1 and 1506/2 composers and their musical style	22
1.7	Bibliographical issues: Paper and watermark studies	26
1.8	Bibliographical issues: Print production and Petrucci	27
1.9	Bibliographical issues: Print viability and commercial issues	30
1.10	Manuscript sources of 1506/1 and 1506/2	34

2 TEXTS AND THEIR PERFORMANCE IN 1506/1 AND 1506/2

2.1	Lamentation texts	39
2.2	Textual content in pre-1506 sources	41
2.3	<i>Laude</i> and miscellaneous texts	46
2.4	Conclusion	56

3 MUSICAL STYLE IN 1506/1 AND 1506/2

3.1	The Lamentations	59
3.2	<i>Laude</i> and miscellaneous music in 1506/1	83
3.3	The canticles 'Benedictus Dominus Deus Israel' in 1506/2	90
3.4	Conclusion	96

4 A BIBLIOGRAPHICAL PROFILE

4.1	Physical description of extant copies of 1506/1 and 1506/2	99
4.2	Introduction to paper issues	104
4.3	Watermarks in 1506/1 and 1506/2	105
4.4	The implications of 'twin' watermarks	111
4.5	Introduction to production process, layout and presentation in 1506/1 and 1506/2	116
4.6	The notion of print perfection	117
4.7	Standing type: Stave-sets	118
4.8	Type availability and the use of matrices	126
4.9	Standing type: Part names	127
4.10	Decorated capital letters	136
4.11	Use of page headers	139
4.12	Text underlay	140
4.13	Stop-press variations and errors	149
4.14	Conclusion	159

5 COMMERCIAL VIABILITY AND COMPOSER CHOICE		
5.1	Commercial considerations in respect of 1506/1 and 1506/2	163
5.2	Commercial influences affecting the production of 1506/1 and 1506/2	173
5.3	Composer choice and influence	180
5.4	Conclusion	184
6 SOURCES		
6.1	Introduction to sources	186
6.2	Manuscript concordances: Mid- to late fifteenth century	187
6.3	Summary of mid- to late fifteenth-century manuscripts containing concordances of 1506/1 and 1506/2	193
6.4	Manuscript concordances: Early sixteenth century	197
6.5	Summary of early sixteenth-century manuscripts containing concordances of 1506/1 and 1506/2	203
6.6	Print concordances	204
6.7	Summary of prints containing concordances of 1506/1 and 1506/2	207
6.8	Readings	209
6.9	Conclusion	213
7 CONCLUSION		
7.1	Conclusion	215
APPENDICES		
1	A comparative edition of Lamentation X	220
2	Texts set in 1506/1 and 1506/2	226
3	A comparative edition of de Orto's Lamentations in CapePL 3.b.12 and 1506/1	236
4	'Adoramus te Domine Jesu Christe', 1506/1 (Anon., fol. 2 ^r)	243
5	'Benedictus Dominus Deus Israel', 1506/2 (Anon., fols 50 ^v -51 ^r)	245
6	Examples of decorated capitals used in 1506/1 and 1506/2	248
7	A summary of Passiontide texts in Capetown Grey	251
8	Critical commentary of unpublished concordances of 1506/1 and 1506/2	254
BIBLIOGRAPHY		
8.1	Primary material: Manuscripts	264
8.2	Primary material: Prints	265
8.3	Secondary material: Printed resources	266
8.4	Secondary material: Internet resources	297

TABLES

Table 1.01	Contents, clefs, texts and modern editions of 1506/1	3
Table 1.02	Contents, clefs, texts and modern editions of 1506/2	4
Table 1.03	Chronological table of polyphony Lamentation settings considered as pre-1506	14
Table 2.01	Lamentation chapters and verses used in 1506/1 and 1506/2	39
Table 2.02	Polyphonic Lamentation verses found in a selection of pre-1506 Italian manuscripts	42
Table 2.03	Polyphonic Lamentation verses found in a selection of pre-1506 Spanish manuscripts	43
Table 2.04	Text variations in sources of de Quadris's Lamentations	44
Table 2.05	Provenance of miscellaneous texts in 1506/1 and 1506/2	46
Table 3.01	Mensurations in the 1506 Lamentations	72
Table 3.02	Phrase structure in Marbrianus de Orto's Lamentations [1506/1 and Cape Town 3.b.12]	77
Table 3.03	Mensurations in the non-Lamentation settings in 1506/1 and 1506/2	90
Table 4.01	Distribution of marks in 1506/1 and 1506/2	110
Table 4.02	Distribution of main and twin watermarks in 1506/1 and 1506/2	114
Table 4.03	Elements involved in twin impression imposition	118
Table 4.04	Pattern of identifiable stave-sets in 1506/1, Bologna copy	121
Table 4.05	Stave-set groups in 1506/1	121
Table 4.06	Pattern of identifiable stave-sets in 1506/2, Bologna copy	125
Table 4.07	Stave-set groups in 1506/2	125
Table 4.08	Pattern of part names for 'Tenor' in 1506/2	129
Table 4.09	Decorated capitals in 1506/1	137
Table 4.10	Decorated capitals in 1506/2	137
Table 4.11	Variations and errors in 1506/1	150
Table 4.12	Analysis of variants found in formes 1-2 and 3-4 in 1506/1	154
Table 4.13	Variations and errors in 1506/2	157
Table 5.01	Calculations equating Italian wages with book prices	168
Table 5.02	Printer's inventory from Spain	170
Table 5.03	Music print inventory from Spain	171
Table 5.04	Petrucchi's Venetian and earlier Fossombrone publications within the context of Ash Wednesday, 'Spy' Wednesday and Easter	178
Table 6.01	Manuscript concordances of 1506/1	186
Table 6.02	Manuscript concordances of 1506/2	187
Table 6.03	Manuscript concordances of <i>laude</i> in 1506/1	188
Table 6.04	Print concordances of <i>laude</i> in 1506/1	205

MUSICAL EXAMPLES

Example 3.01	<i>Roman Lamentation tone</i>	59
Example 3.02	<i>Lamentations</i> (de Quadris)	60
Example 3.03	<i>Lamentations</i> (Tromboncino)	60
Example 3.04	<i>Lamentations</i> (Tromboncino)	60
Example 3.05	<i>Lamentations</i> (Weerbeke)	61
Example 3.06	<i>Lamentations</i> (Lapicida)	61
Example 3.07	<i>Lamentations</i> (Lapicida)	61
Example 3.08	<i>Lamentations</i> (Anon., ParisBNC 967; Tenor)	62
Example 3.09	<i>Lamentations</i> (Anon., ParisBNC 967; Tenor)	62
Example 3.10	<i>Lamentations</i> (de Orto; Tenor)	62
Example 3.11	<i>Lamentations</i> (de Orto; Tenor)	62
Example 3.12	<i>Lamentations</i> (Ycart; Tenor)	62
Example 3.13	<i>Lamentations</i> (de Orto; CapePL 3.b.12 new section; Tenor)	63
Example 3.14	<i>Lamentation tone</i> (Toledo codex)	64
Example 3.15	<i>Lamentations</i> (Weerbeke)	64
Example 3.16	<i>Lamentations</i> (Ycart's Discantus)	64
Example 3.17	<i>Lamentations</i> (de Orto)	65
Example 3.18	<i>Clefs and range in 1506/1 and 1506/2</i>	67
Example 3.19	<i>Lamentations</i> (Tinctoris)	70
Example 3.20	<i>Lamentations</i> (Anon. 1, CapePL 3.b.12)	74
Example 3.21	<i>Lamentations</i> (Anon. 1, 1506/1)	74
Example 3.22	<i>Lamentations</i> (de Orto, 1506/1 and CapePL 3.b.12 readings)	75
Example 3.23	<i>Lamentations</i> (Anon. 1, 1506/1 and CapePL 3.b.12 readings)	78
Example 3.24	<i>Lamentations</i> (Weerbeke)	80
Example 3.25	<i>Lamentations</i> (Agricola four-part)	82
Example 3.26	<i>Adoramus te</i> (Anon., 1506/1)	84
Example 3.27	<i>Adoramus te</i> (Anon., 1506/1)	84
Example 3.28	<i>Popule meus</i> (Anon., 1506/1)	86
Example 3.29	<i>Cum autem</i> (Anon., 1506/1)	87
Example 3.30	<i>Passio sacra</i> (Francesco Ana)	89
Example 3.31	<i>Benedictus Dominus Deus Israel</i> (Anon., fols 33 ^v -35 ^r)	91
Example 3.32	<i>Benedictus Dominus Deus Israel</i> (Anon., fols 33 ^v -35 ^r)	93
Example 3.33	<i>Benedictus Dominus Deus Israel</i> (Anon., fols 50 ^v -51 ^r)	95
Example 3.34	<i>Benedictus Dominus Deus Israel</i> (Anon., fols 50 ^v -51 ^r)	96

FIGURES

Fig. 4.01	Standard gathering pattern in 1506/1 and 1506/2	103
Fig. 4.02	Gathering 'F' in 1506/1	103
Fig. 4.03	Cross on a hill mark: Mold A (main mark)	106
Fig. 4.04	Mount-petal mark: Mold A (main mark)	107
Fig. 4.05	Samuel Sotheby and Samuel Leigh Sotheby, [A collection of specimens...], volume III, 1858, a tracing of an anchor watermark from Dionyssis de Burgo's <i>Declaratio valerii maximi</i> of 1470	108
Fig. 4.06	Mount-petal mark: Mold B (twin mark)	112
Fig. 4.07	Mount-petal mark: Mold A (main mark with triple petals)	113
Fig. 4.08	Cross on a hill mark: Mold B (twin mark)	114
Fig. 4.09	1506/1, B1, stave-set group I	120
Fig. 4.10	1506/1, B2, stave-set group II	120
Fig. 4.11	1506/1. The half-sheet F5 illustrating the conjectural work and turn method using stave-set group I.1	123
Fig. 4.12	1506/2, B2, stave-set group III	124
Fig. 4.13	1506/2, A4, stave-set group IV	124

PLATES

1506/1, fol. 50 ^r (Pca), showing the final setting and Petrucci's colophon	xvii	
Plate 4.01	1506/1 (Pca), rear cover	100
Plate 4.02	1506/1, fol. 48 ^v (Bc)	129
Plate 4.03	1506/1, fol. 48 ^v (Pn)	129
Plate 4.04	1506/2, fol. 1 ^r (Bc)	130
Plate 4.05	1506/1, fol. 13 ^v (Lbl)	132
Plate 4.06	1506/1, fol. 19 ^r (Pca)	133
Plate 4.07	1506/1, fol. 19 ^r (Bc)	133
Plate 4.08	1506/1, fol. 5 ^r (Pca)	134
Plate 4.09	1506/1, fol. 5 ^r (Bc)	134
Plate 4.10	1506/1, fol. 15 ^r (Bc)	135
Plate 4.11	1506/1, fol. 16 ^r (Bc)	135
Plate 4.12	1506/2, fol. 33 ^v (Bc)	135
Plate 4.13	1506/1, fol. 31 ^v (Pca)	139
Plate 4.14	1506/1, fol. 3 ^v (Pn)	142
Plate 4.15	1506/1, fol. 3 ^v (Bc)	142
Plate 4.16	1506/1, fol. 16 ^r (Pca)	143
Plate 4.17	1506/1, fol. 16 ^r (Bc)	143
Plate 4.18	1506/1, fol. 9 ^r (Pca)	144
Plate 4.19	1506/1, fol. 9 ^r (Bc)	144
Plate 4.20	1506/1, fol. 43 ^r (Bc)	145
Plate 4.21	1506/1, fol. 43 ^r (Pn)	145
Plate 4.22	1506/1, fol. 47 ^v (Bc)	146
Plate 4.23	1506/2, fol. 48 ^r (Pn)	147
Plate 4.24	1506/2, fol. 48 ^r (Bc)	147
Plate 4.25	1506/2, fol. 31 ^r (Lbl)	148
Plate 4.26	1506/2, fol. 31 ^r (Bc)	148
Plate 4.27	1506/2, fol. 31 ^v (Bc)	148
Plate 4.28	1506/1, fol. 4 ^r (Pca)	152
Plate 4.29	1506/1, fol. 4 ^r (Bc)	152
Plate 4.30	1506/1, fol. 41 ^r (Bc)	153
Plate 4.31	1506/2, fol. 42 ^r (Pn)	155
Plate 4.32	1506/2, fol. 42 ^r (Bc)	155
Plate 4.33	1506/2, fol. 41 ^r (Bc)	156
Plate 4.34	1506/2, fol. 41 ^r (Pn)	156
Plate 4.35	1506/2, fol. 44 ^v (Bc)	158
Plate 4.36	1506/2, fol. 47 ^v (Bc)	158
Plate 4.37	1506/2, fol. 45 ^r (Bc)	159
Plate 4.38	1506/2, fol. 48 ^r (Bc)	159

DECLARATION

I confirm that no part of the material offered has previously been submitted by me for a degree in this or any other university. If material has been generated through joint work, my independent contribution has been clearly indicated. In all other cases material from the work of others has been acknowledged and quotations and paraphrases suitably indicated.

STATEMENT OF COPYRIGHT

The copyright of this thesis rests with the author. No quotation from it should be published without his prior written consent and information derived from it should be acknowledged.

P R E F A C E

The object of this thesis is to examine the context, manufacture and content of Petrucci's two Lamentation editions of 1506. It will address issues such as Petrucci's initial decision to dedicate a print series to Lamentations as well as his choice of composers, production methods and commercial considerations. The two Lamentation prints pose numerous questions to musicologists, some being specific to genre. Why did Petrucci publish these Lamentation prints – what was his intended market? Polyphonic Lamentation settings were considered by musicologists to have emerged later than other polyphonic genres such as the Mass and motet; what was the basis for this presumption? Was the market for printed music large enough to justify two Lamentation volumes and how did Petrucci acquire the repertoire to fill these volumes? Is it possible to explain the seemingly disparate assortment of composers in the volumes, combined with the inclusion of non-Lamentation texts? Why are the Lamentations the first of his more specialised prints, following the success of the popular chanson, motet, Mass and frottola prints? Were these settings performed during Lent and, if so, were they sung at private or public performances?

There are many production and printing issues to be addressed. *Liber primus* was dated 6 April 1506, being the Wednesday in Holy Week that year – are there any implications for this specific date? Why are there some differences in print layout between the two volumes? Did Petrucci deserve the label of excellence bestowed upon him by musicologists? Is there any evidence to the contrary – are there indications of errors, corrections and proofing during his print runs?

1506/1 and 1506/2 are important since they represent a number of *unica*, including the settings of Johannes Tinctoris, Alexander Agricola and Bartholomew Tromboncino as well as the lesser-known Bernardus Ycart and Erasmus Lapidica. Furthermore, the majority of concordances of music in 1506/1 and 1506/2 belong to the oldest pieces, rather than the most recent.

The task of data collection has been particularly satisfying, and my quest for primary materials has involved research trips to London, Oxford, Paris, Bologna and Padua. Analysis of my findings involved a number of interrelated methods. First, I assembled a half-size mock-up of the gathering patterns (including specific watermark details) for each of the seven extant copies of 1506/1 and 1506/2; such procedures enabled me to compare watermarks between copies and assisted my investigations into marks and their twins. Second, I took detailed measurements of the print elements within each copy. Third, I made electronic facsimiles of all copies with each one scaled to an identical size, enabling detailed and microscopic examination between copies. This process was probably the most fruitful in terms of overall results since it resulted in the identification of many stop press variants between copies. Fourth, I analysed each musical setting in the prints, resulting in the discovery of some stylistic patterns apposite to their genre. Every attempt has been made to place these findings within the context of Petrucci's Venetian publications, although lack of resources has prohibited a wider examination of primary materials.

EDITORIAL POLICY

All musical excerpts and editions in this thesis contain halved note values, unless otherwise noted. Italics indicate the editorial realisation of word abbreviations in original prints and manuscripts except, by bibliographical convention, where a title is cited in italics (and the realisation therefore appears in plain text).

ACKNOWLEDGEMENTS

The completion of a doctoral thesis is a long, arduous and often lonely task. It is with the greatest pleasure that I record the names of those who have offered such expert, enthusiastic and often unqualified support. I would also like to record my appreciation to the Department of Music, University of Durham, for appointing me as Teaching Assistant and providing financial support towards my tuition, research travel and materials.

The following colleagues have been particularly helpful: Professor Jeremy Dibble; Professor David Greer, Emeritus Professor; Professor Peter Manning, Chairman of the Board of Studies; Professor Max Paddison; Dr Andy Nercessian and Dr Bennett Zon. Thomas Muir and Richard Bruce, two of my postgraduate companions, provided much support and entertained some of my ideas. Five Durham academics outside music have been especially helpful: Dr Ian Doyle, University Library; Mr Roger Norris, Dean & Chapter Librarian; Dr Iain MacPhee, Mathematics, Professor John McKinnell, English and Dr Michael Stansfield, Palace Green Library. Special mention must be given to my supervisor, Dr Fabrice Fitch; his critical eye has been invaluable. He has shaped and moulded my thinking during the past five years and I am deeply indebted to him.

Various academics have generously given their expertise, supplied and cited articles and references, sent encouragement and permitted me to use findings; they are listed below:

Dr Karl Appuhn, University of Oregon

Dr Margaret Bent, All Souls College, Oxford

Dr Bonnie Blackburn, Wolfson College, Oxford

Professor Stanley Boorman, University of New York

Dr John W. Briggs, independent scholar

Professor Giulio Cattin, University of Vicenza

Professor David Fallows, University of Manchester

Professor Maria del Carmen Gómez Muntané, University of Barcelona

Dr Leofranc Holford-Strevens, Oxford University Press
 Professor James Haar, Professor Emeritus, University of North Carolina,
 Chapel Hill
 Dr Martin Ham, University of Surrey
 Dr Robert Judd, American Musicological Society
 Dr Tess Knighton, University of Cambridge
 Dr Tong Soon Lee, Emory University, Atlanta
 Dr Daniel Leech-Wilkinson, University of London
 Professor Honey Meconi, University of Rochester
 Dr John Milsom, independent scholar
 Dr Robert Mitchell, independent scholar
 Ms Marilee Mouser, University of California, Santa Barbara
 Professor Jeremy Noble, Professor Emeritus, State University of New York,
 Buffalo
 Professor Rob Provine, University of Maryland
 Professor Wyndham Thomas, University of Bristol
 Dr John Wagstaff, Music Librarian, University of Oxford
 Professor Rob Wegman, Princeton University
 Dr Peter Wright, University of Nottingham

I have been fortunate to have had the opportunity to visit a number of British and European libraries and have always been granted full co-operation and assistance. I would like to acknowledge the assistance of the following: University of Durham, particularly the staff of Palace Green (Anne Farrow, Sally Hodges, Barbara Johnson, Judy McKinnell and Trish Alderson) and Inter-Library loans (Judith Walton); Bodleian, Oxford (William Hodges); Lady Margaret Hall, Oxford (Roberta Staples); Music Faculty, Oxford (John Wagstaff); British Library, London (Nicolas Bell, Sita Gunasingham); Civico Museo Bibliografico Musicale, Bologna (Jenny Servino, Alfredo Vitolo, Barbara Ventura); Università di Bologna (Laura Miami); Biblioteca Antoniana, Padua (Sergio Cattazzo); Bibliothèque Nationale de France, Paris (Theodora Psychoyou of the RISM department); Capetown Public Library (Sibusiswe Mgquba) and the University of Illinois (Gerry Stigberg). The

libraries of Civico Museo Bibliografico Musicale, Bologna and Biblioteca Antoniana, Padua have granted permission to use reproductions from their Petrucci prints.

I must single out Jeremy Noble for his considerable generosity and thoughtfulness in allowing me to use his extensive watermark data. This invaluable resource saved me countless time and expense but, perhaps more importantly, gave me confidence in my bibliographical working practices. Professor Noble has informally suggested that his material might be ideally suited as a web resource and it is my hope that we can achieve this. I wish to record the huge contribution of two academics, now deceased, from my former university at Trinity College, Dublin. Professor Brian Boydell and Dr Joseph Grocock taught me music history and counterpoint respectively – I only hope they realised how much they enhanced my scholarship and love of Renaissance and Baroque music.

Finally, the support of one's family is central to the successful completion of any project of this scope and size. This thesis is dedicated to the memory of my dear father Walter (1926-1980), who encouraged and influenced my musical interests from an early age. I would never have completed my work without the love, support and assistance of my wife, Catherine. She has provided innumerable hours of advice, encouragement and expert proofing during the last six years; words are insufficient to express my thanks.

Durham, November 2004

ABBREVIATIONS

I have adopted the system of library sigla used in RISM although individual manuscripts follow Charles Hamm and Herbert Kellman's patterns (these are listed below). I have followed Massenkeil's 1965 identification of anonymous Lamentations; 'Anon. 1' is the three-part setting in *Liber primus* (print series follow those set by RISM). References to specific chapters and verses of the Lamentations follow the format chapter: verse, for example, Lamentations ch. 1:3.

15C	Fifteenth century
16C	Sixteenth century
A	Altus
B	Bassus
C	Contra
c.f.	<i>Cantus firmus</i>
C ₃	Clef C ₃
C ₄ fl	Clef C ₄ with B flat
CMM	<i>Corpus Mensurabilis Musicae</i>
D	Discantus
LU	<i>Liber Usualis</i> , Tournai; New York: Desclée, 1961
MGG	<i>Die Musik in Geschichte und Gegenwart</i>
T	Tenor
TOC	Table of contents
[n.d.]	no date
[n.p.]	no place
[n.pub.]	no publisher

MANUSCRIPT SIGLA

BergBC 1208	<i>Bergamo, Biblioteca Civica, Archivio di S. Maria 1208d</i>
BerlS 4002I	<i>Berlin, Staatsbibliothek Preussischer Kulturbesitz. MS Mus. 4002I (olim Z 2I)</i>
BolC Q13	<i>Bologna, Civico Museo Bibliografico Musicale. MS Q13</i>
BolC Q16	<i>Bologna, Civico Museo Bibliografico Musicale. MS Q16</i>
BolA A179	<i>Bologna, Biblioteca Comunale dell'Archiginnasio. MS A. 179 (olim 16.b. iii.20)</i>
BrusC 16857	<i>Brussels, Bibliothèque du Conservatoire Royal de Musique. MS 16857</i>
BrusBR 228	<i>Brussels, Bibliothèque Royale. MS 228</i>
Bu 293I	<i>Bologna, Biblioteca Universitaria, MS 293I</i>
CambriP 1236	<i>Cambridge, Magdalene College, Pepys Library. MS 1236</i>
CapePL 3.b.12	<i>Cape Town, The South African Library. MS Grey 3.b.12</i>
FlorBN BR 230	<i>Florence, Biblioteca Nazionale Centrale. MS Banco Rari 230 (olim Magliabechi XIX. 141)</i>
FlorBN II.I.232	<i>Florence, Biblioteca Nazionale Centrale. MS II. I. 232 (olim Magliabechi XIX. 58)</i>
FlorBN II.I.350	<i>Florence, Biblioteca Nazionale Centrale. MS II. I. 350 (olim Magliabechi XXXVI, 113)</i>
FlorBN Panc. 27	<i>Florence, Biblioteca Nazionale Centrale. MS Panciatichi 27</i>
FlorD 2I	<i>Florence, Duomo, Archivio Musicale dell'Opera di Santa Maria del Fiore. MS 2I</i>
FlorR 2356	<i>Florence, Biblioteca Riccardiana. MS 2356</i>
FlorR 2794	<i>Florence, Biblioteca Riccardiana. MS 2794</i>
MilD 1	<i>Milan, Archivio della Veneranda Fabbrica del Duomo, Sezione Musicale. Librone 1 (olim 2269)</i>
MilD 2	<i>Milan, Archivio della Veneranda Fabbrica del Duomo, Sezione Musicale. Librone 2 (olim 2268)</i>
MilD 3	<i>Milan, Archivio della Veneranda Fabbrica del Duomo, Sezione Musicale. Librone 3 (olim 2267)</i>
ModD 2	<i>Modena, Archivio del Duomo Mus. MS II</i>
ModE F.9.9	<i>Modena, Biblioteca Estense e Universitaria. MS α.F.9.9. (Ital. 1221; olim VIII.F.27)</i>
MonteA 87I	<i>Monte Cassino, Biblioteca dell'Abbazia. MS 87I</i>
PadBC c56	<i>Padua, Biblioteca Capitolare. MS C56</i>

- ParisBNC 676 *Paris, Bibliothèque Nationale de France, Département de la Musique, Fonds du Conservatoire. MS Rés. Vm⁷ 676*
- ParisBNC 967 *Paris, Bibliothèque Nationale de France, Département de la Musique, Fonds du Conservatoire. MS Rés. F. 967*
- Paris BNF 15123 *Paris, Bibliothèque Nationale de France, Département des Manuscrits, Fonds Français. MS 15123 (olim Suppl. Fr. 2637) ('Pixérécourt Chansonnier')*
- PavU 361 *Pavia, Biblioteca Universitaria. MS Aldini 361 (olim 130.a.26)*
- PerBC 431 *Perugia, Biblioteca Comunale Augusta. MS 431 (G20)*
- PL-Ka1706 *Cracow, Biblioteka Polskiej Akademii Nauk. MS 1706 (olim 2216?)*
- PozR 1361 *Poznań, Miejska Biblioteka Publiczna im. Edwarda Raczyńskiego. MS 1361*
- SegC ss *Segovia, Archivo Capitular de la Catedral. MS ss*
- TarrAA *Tarragona, Archivo Archidiecésano, MS ss*
- UrbU L712 *Urbana, University of Illinois, Library (Urbana), Rare Book room. MS M783.2, L 712 c. 8*
- Vnm 145 *Venice, Biblioteca Nazionale Marciana. MS Ital. CI.IX.145 (Collocazione 7554)*
- VerBC 690 *Verona, Biblioteca Capitolare. MS DCXC*
- VerBC 760 *Verona, Biblioteca Capitolare. MS DCCLX*
- VicAC 3 *Vicenza, Seminario Vescovile. MS U.VIII.3*
- VicAC 11 *Vicenza, Seminario Vescovile. MS U.VIII.11*
- WarU 2016 *Warsaw, Biblioteka Uniwersytecka, Oddział Zborów Muzycznych. MS Mf. 2016 (olim Mus. 58)*
- WashLC J6 *Washington, Library of Congress, Music Division. MS ML 171 J6 case*

PRINT SIGLA

- 1503/1 *Motetti de passione de cruce de sacramento de Beata Virgine et huiusmodi*, Ottaviano Petrucci, Venice
- 1506/1 *Lamentationum Jeremie Prophete liber primus*, Ottaviano Petrucci, Venice
- 1506/2 *Lamentationum liber secundus. Auctores Tronboncinus [sic], Gaspar, Erasmus*, Ottaviano Petrucci, Venice
- 1508/3 *Laude libro secondo*, Ottaviano Petrucci, Venice
- 1508 *Laude libro primo*, Ottaviano Petrucci, Venice
- 1523 *Cantus monastici formula noviter impressa...*, Luc'Antonio Giunta [Venice]
- 1523/1 *Liber sacerdotalis nuperrime ex libris...*, [Alberto da Castello], Venice
- 1535 *Cantus monastici formula noviter impressa...*, Luc'Antonio Giunta, Venice
- 1537 *Liber sacerdotalis nuperrime ex libris...*, [Alberto da Castello], Venice
- 1563/6 *Libro primo delle laudi spirituali da diversi ...*, Serafino Razzi, Venice

50

Bassus

Dientissimus nre saluto autor hodierna die humanus alege peccari liberio genus
 affixus cruci cu accepisset acetum dixit consumatus est & inclinato capite emisit spiritum Amen

Dientissim^o nre saluto, autor hodierna die humanus alege peccari liberio genus
 affixus cruci cu accepisset acetum di xit consumatus est & inclinato capite emisit spiritus
 Amen

Impressum Venetijs per Octavianum
 Petrucci Forolapponensem. Die Octava
 Aprilis Salutis anno 1506. Et p[ro]p[ri]e
 g[ra]t[ia] iurisdictionis Domini Venetiarum
 q[ui] nulla posse cantum figuratum impi-
 nare sub pena in ipso privilegio contenta. Neg[ati]v[us]. H[ab]et[ur] Omne
 q[ui]erit p[ro]p[ri]e S[ed] est quieremus



Fol. 50^r, *Lamentationum Jeremie Prophete liber primus* (1506/1), showing the final setting and Petrucci's colophon [copy at the Biblioteca Antoniana, Padua]

Chapter I

HISTORICAL AND LITERATURE REVIEW



HISTORICAL REVIEW

1.1 A brief introduction to 1506/1 and 1506/2

Petrucchi published his two Lamentation volumes within the first half of 1506; 1506/1 and 1506/2 bear the dates 8 April 1506 and 19 May 1506 and consist of 50 and 51 folios respectively. Although both titles specify Lamentations, other texts are present; in chapters 2 and 5 I will argue that these non-Lamentation texts were equally important to the success of the two prints. While the setting of polyphonic Lamentations was somewhat later than other genres, there is evidence of a monastic tradition of polyphonic Lamentations during the fifteenth century and earlier. Chapter 1 discusses the significant contribution of the Benedictine order to Holy Week polyphony, particularly the importance of the non-Lamentation texts in their sources. Chapter 3 contains a discussion of the simple and direct musical style of the settings in 1506/1 and 1506/2, particularly the two-part settings of Johannes de Quadris and the four-part Lamentations of Marbrianus de Orto.

It might appear extraordinary that Petrucci decided to print two volumes of Lamentations and other music suitable for Holy Week; in chapter 5 I shall argue that he had given due commercial consideration to such a project. Integral to his decision were the various Italian confraternities; they must have provided a welcome addition to Petrucci's list of prospective purchasers. Stanley Boorman and others have shown that Petrucci prints were frequently subjected to stop-press corrections and other variants, resulting in unique copies. Despite such a small survival rate from 1506/1 and 1506/2, each of the surviving seven copies is unique. There is evidence of corrections, particularly in 1506/1, and the implication of these variants, given Petrucci's presumed desire to publish the first volumes by Holy Week of 1506, are discussed in detail in chapter 4. I will also tentatively suggest that Petrucci's usual high standards were somewhat compromised during the printing of 1506/1.

Tables 1.01 and 1.02 (below) provide a list of contents and represent a variety of northern and native composers; in chapter 5 I will discuss Petrucci's

choice. He presumably used whatever settings were available prior to editing; chapter 6 presents a list and discussion of manuscript and printed sources.

Table 1.01: Contents, clefs, texts and modern editions of 1506/1

Composer	Voices	Text	Clefs	MS	Published edition
Anon. (fol. 2 ^r)	[D], Altus, Tenor, Bassus	Adoramus te Domine Jesu Christe...	C1ff; C3ff; C3ff; F4ff	<i>unicum</i>	No published edition; it may be found in appendix 4.
Tinctoris (fols 2 ^v -6 ^r)	[D], Altus, Tenor, Bassus	1: 1-3, J. ¹	C2ff; C4ff⇒C3ff; C4ff; F4ff	<i>unicum</i>	William E. Melin, ed., <i>Johannes Tinctoris: Opera omnia</i> , CMM 18 ([Rome]: American Institute of Musicology, 1976), pp. 115-124.
Ycart (fols 6 ^v -13 ^r)	[D], Altus, Tenor, Bassus	In, 1:1-3, J. 2:1-2, 9, J. 5:1-8.	C2; C4⇒C2⇒ (C4)⇒C3; C4; F4ff	<i>unicum</i>	Günther Massenkeil, ed., <i>Mehrstimmige Lamentationen aus der ersten Hälfte des 16. Jahrhunderts</i> (Mainz: B. Schott's Söhne, 1965), pp. 1-13.
Anon. 1 (fols 13 ^v - 16 ^r)	[D], Tenor, Contra	1506/1 = 1:1-3, J. CapePL 3.b.12 = 5:1-4, 6-7, 15-17, 20, 22, J.	C1ff circle; C3ff circle; F4ff circle	Cape PL 3.b.12	Massenkeil, <i>Mehrstimmige Lamentationen</i> , pp. 14-18. Giulio Cattin, ed., <i>Italian Laude and Latin Unica in MS Capetown</i> , Grey 3.b.12, CMM, 76 (Rome: American Institute of Musicology, 1977), pp. 42-48 [CapePL. 3.b.12's reading].
Agricola a3 (fols 16 ^v -22 ^r)	[D], Tenor, Contra	1:1-3, J, 4-7, J.	C2ff; C4ff; F4ff	WarU 2016; FlorR 2794	Edward R. Lerner, ed., <i>Alexandri Agricola: Opera omnia</i> , CMM 22 (Rome: American Institute of Musicology, 1966), pp. 1-7.
Agricola a4 (fols 22 ^v -28 ^r)	[D]. Tenor, Altus, Bassus	2:1-2, J, 3 ^{*2} , 4 [*] , 5 [*] , J, 6, J.	C2; F3; C4; F4ff	<i>unicum</i>	Lerner, <i>Alexandri Agricola</i> , pp. 8-16.
De Orto (fols 28 ^v - 30 ^r)	[D], Altus, Tenor, Bassus	In, 1:1-3, J.	C3; F3; F3; F4	CapePL 3.b.12	Massenkeil, <i>Mehrstimmige Lamentationen</i> , pp. 19-23.
De Quadris (fols 30 ^v - 45 ^r)	[D], Tenor	In, 1:1-4, J, 5-8, J, 9-12, J. 2:8-11, J, 12-15, J, 16- 18, 20, J. 3:33-45. 4:17, J, 18-22, J. 5:1-4, 7-11, 14-18, J.	C1ff; C2⇒C3ff	Flor BN II.I. 350; VicAC 11	Giulio Cattin, ed., <i>Johannes de Quadris: Opera</i> , <i>Antiquae musicae italicae, monumenta veneta sacra</i> , 2 (Bologna: Antiquae Musicae Italicae Monumenta, 1972), pp. 10-63. Massenkeil, <i>Mehrstimmige Lamentationen</i> , pp. 24-32. This edition is not complete.
[De Quadris] (fols 45 ^v - 46 ^r)	[D], Tenor	Venite et ploremus... Sources: PadBC C56; 1523/1; 1537	C1; C3ff	See left	Cattin, <i>Johannes de Quadris</i> , pp. 66-67.
[De Quadris] (fols 45 ^v - 47 ^r)	[D], Tenor	Popule meus quid... Sources: CapePL 3.b.12; FlorBN Panc 27; PadBC C56	C1; C3ff	See left	Cattin, <i>Johannes de Quadris</i> , pp. 67-71.

¹ 'j' indicates the refrain 'Jerusalem convertere ad Dominum Deum tuum'. 'In' represents the prefatory text 'Incipit Lamentatio Jeremie prophete' (chapter 1) or 'Incipit oratio Jeremiae prophete' (chapter 5).

² An asterisk indicates an incomplete verse.

Table 1.01: Contents, clefs, texts and modern editions of 1506/1 (cont.)

Composer	Voices	Text	Clefs	MS	Published edition
[De Quadris] (fols 47 ^v -48 ^r)	[T], Tenor	Cum autem venissem... Sources: Bol A 179; Bol C Q13; CapePL 3.b.12; FlorBN Panc. 27; FlorD21; PavU Ald 361; PozR 1361; VerBC 690; Wash LC J6; 1523/1; 1523; 1535; 1537; 1563/6	C4fl; F3fl	See left	Cattin, <i>Johannes de Quadris</i> , pp. 71-72.
[De Quadris] (fols 47 ^v -48 ^r)	[D], Tenor	Sepulto Domino signatum est... Sources: CapePL 3.b.12; PadBC C56; Wash LC J6; 1523/1; 1535; 1537	C1fl; C1fl	See left	Cattin, <i>Johannes de Quadris</i> , pp. 72-73.
	text only	O dulcissime filie Sion... Sources: Bol C Q13; CapePL 3.b.12; FlorD 21; PavU 361; PozR 1361; VerBC 690; WashLC J6; 1523/1; 1523; 1535; 1537; 1563/6		See left	
Francesco Ana (fols 48 ^v -50 ^r)	[D], Altus, Tenor, Bassus	Passio sacra nostri redemptoris...	C1; C3; C3⇒C4; F3⇒F4	unicum	Luigi Torchi, ed., <i>L'Arte musicale in Italia</i> , vol. 1, Composizioni sacre e profane a più voci, secolo XVI (Milan: Ricordi, 1897, reprinted 1968), pp. 13-18.

Table 1.02: Contents, clefs, texts and modern editions of 1506/2

Composer	Voices	Text	Clefs	MS	Published edition
Tromboncino (fols 1 ^v -33 ^r)	[D], Altus, Tenor, Bassus	In, 1:1-4, J, 5-7, J, 8-12, J, 'Sequitur...', 13-16, J, 18-21, J. 2:1-4, J, 5-8, J, 9-12, J. 5:In, 1-16, J.	C2; C4; C4fl; F3fl	unicum	Massenkeil, <i>Mehrstimmige Lamentationen</i> , pp. 33-50. This edition is not complete. Torchi, <i>L'Arte musicale</i> , pp. 19-30. This edition is not complete.
[Tromboncino?] (fols 33 ^v -35 ^r)	[D], Altus, Tenor, Bassus	Benedictus Dominus Deus Israel.. [only odd numbered verses set to polyphony]	C2fl; C4fl; C4fl; F3fl	unicum	Knud Jeppesen, <i>Italia Sacra Musica III: Unknown Italian Cathedral Music of the Early Sixteenth Century</i> (Copenhagen: Hansen, 1962), pp. 108-115.
Weerbeke (fols 35 ^v -43 ^r)	[D], Altus, Tenor, Bassus	In, 1:1-2, J, 4, 5 [*] , J, 6 [*] , 7 [*] , J. 3:22, 23, 25, J. 4:1, 3 [*] , J. In, 5:1-3, J.	C2⇒C3⇒C2⇒C1fl; C3⇒C4⇒C3fl; C4⇒F3⇒C4⇒C4fl; F3⇒F4⇒C4fl	unicum	Arnold Schering, ed., <i>Geschichte der Musik in Beispielen</i> (Leipzig: Breitkopf & Härtel, 1931), p. 54. This edition is not complete and is published in close score. Gerhard Croll and Eric F. Fiedler are expected to publish Weerbeke's Lamentations in CMM 106, vol. 5.
Erasmus Lapidica (fols 43 ^v -50 ^r)	[D], Altus, Tenor, Bassus	In, 1:1-3, J, 4-5, J, 6-7, J.	C4; C4; C4; F3	F1 or BN Panc. 27	Massenkeil, <i>Mehrstimmige Lamentationen</i> , pp. 51-59. This edition is not complete.
[Lapidica?] (fols 50 ^v -51 ^r)	[D], Altus, Tenor, Bassus	Benedictus Dominus Deus Israel...	C1fl; C4fl; C4fl; F4fl	unicum	No published edition; it may be found in appendix 5.

I.2 The liturgical context of pre-1506 Lamentations

It is not my intention to provide a comprehensive history of polyphonic Renaissance Lamentations since substantial contributions have already been made in this respect by Watkins, Schröder, Massenkeil, Thomas, Klimisch and Snow.³ The following summary intends to place the 1506 Lamentations in their historical and contextual background.

The five Old Testament poems which constitute the Lamentations of Jeremiah describe the sacking of Jerusalem in 586 or 587 BC, an event of considerable importance in the Jewish church.⁴ The early Christian church realised the symbolic potential of those catastrophic events; the Lamentation verses symbolised the dramatic and tragic events of Holy Week in the Christian calendar.⁵ A feature borrowed from the Hebrew manuscripts was the use of a prefatory letter for each verse which, in the original Hebrew text, formed an acrostic.⁶

It had been the practice of the early Christian church to meet for a prayer vigil in the week before Easter; this is recorded from the beginning of the second century. It was this tradition which developed into the Holy Week

³ See Glenn E. Watkins, 'Three Books of Polyphonic Lamentations of Jeremiah, 1549-1564' (Unpublished Doctoral Dissertation, University of Rochester, 1953); Aukje Engelina Schröder, 'Les Origines des lamentations polyphoniques au XVe siècle dans les Pays-Bas', in *Kongress-Bericht, Internationale Gesellschaft für Musikwissenschaft, Utrecht 1952*, ed. A. Smijers (Amsterdam: G. Alsbach and Co., 1953), 352-359; Massenkeil, *Mehrstimmige Lamentationen*; Elmer R. Thomas, 'Two Petrucci Prints of Polyphonic Lamentations, 1506' (Unpublished DMA Dissertation, University of Illinois, 1970); Mary Jane Klimisch, 'The Music of the Lamentations: Historical and Analytical Aspects' (Unpublished Doctoral Dissertation, Washington University, 1971) and Robert J. Snow, ed., *A New-World Collection of Polyphony for Holy Week and the Salve Service: Guatemala City, Cathedral Archive, Music MS 4*, *Monuments of Renaissance Music*, 9 (Chicago: University of Chicago Press, 1996), for a detailed discussion.

⁴ Recent scholarship has suggested that the style of the book of Lamentations is not that of Jeremiah the Prophet; see N. K. Gottwald, 'Book of Lamentations', *The Interpreter's Dictionary of the Bible*, ed. George A. Buttrick, 4 vols. (Nashville; New York: Abingdon Press, 1962), III, 61-63 (p. 62).

⁵ Christ's crucifixion and the notion of his body as a temple would have had a strong correlation with the destruction of Jerusalem's temple. Eric Werner, *The Sacred Bridge: The Interdependence of Liturgy and Music in Synagogue and Church during the First Millennium* (London; New York: Dobson Books; Columbia University Press, 1959), p. 479, suggested that the Lamentations had become an integral part of Christian liturgy before the Council of Nicaea in 325.

⁶ The Hebrew alphabet contains twenty-two letters; each elegy (chapter) of the Lamentations (apart from the third) contains 22 verses. The practice of setting a letter as an acrostic before each verse is quite ancient. The third chapter contains three sections consisting of 22 verses; every *fourth* verse was therefore set with an incipit. The final chapter does not use an acrostic.

liturgy during the first millennium, based around the office of Matins which had probably emerged in the Roman Breviary during the eighth century.⁷ Matins (known also as Nocturns or Vigils) was a night office and the only office to include a substantial number of scriptural readings; the precise time was influenced by such factors as local practice and time of year.⁸ During Holy Week the office of Matins, like all other offices, was stripped of its regular content, particularly from Maundy Thursday through to Holy Saturday (the *Triduum*). Scriptural verses were provided by the Lamentations and candles which had been previously lit were symbolically extinguished at each Nocturn as antiphons such as 'Tenebrae factae sunt' were sung (Matins in the *Triduum* is known as *Tenebrae*).⁹ The intense and devout focus of the *Triduum* offices served as a substitute for the Mass which was banned during Good Friday and Holy Saturday (except the Vigil for Easter Sunday). The celebration of the offices was central to monastic life in the Middle Ages; the various monastic orders were instrumental in establishing the northern Italian lay confraternities, particularly during the fourteenth and fifteenth centuries.

The music for other offices besides Matins was curtailed during the *Triduum* in Holy Week – for example, hymns and responds were omitted. The use of Psalms with antiphons was considered appropriate, as was the performance of the canticle 'Benedictus Dominus Deus Israel'. Christian liturgy reached a climax with the Good Friday devotions; much of the material still used in the Catholic church survives from the Middle Ages. The principal service began after the office of *None* with the Liturgy of the Word; this included a rendition of the Passion. The Passiontide drama continued with the

⁷ Herbert Thurston, 'Holy Week', *Catholic Encyclopedia*, ed. Charles G. Herbermann, Edward A. Pace, Condé B. Pallen, Thomas J. Shahan, John J. Wynne and others, 17 vols. (New York: The Encyclopaedia Press Inc., 1913), VII, 435-438 (pp. 435-436).

⁸ Liturgical information concerning Holy Week is based upon John Martin Harper's monograph, *The Forms and Orders of Western Liturgy from the Tenth to the Eighteenth Century: A Historical Introduction and Guide for Students and Musicians* (Oxford: Clarendon, 1991), pp. 139-146.

⁹ *Tenebrae* is prepared with a large candle holder for 15 candles being displayed; six candles are also placed on the altar and all candles are yellow, the colour for burial services. At the conclusion of each psalm or canticle a candle is extinguished, but the candle at the top of the 15 is left lighting. During the singing of the canticle 'Benedictus Dominus Deus Israel' at *Lauds*, the six altar candles are extinguished (there are two settings of this canticle in 1506/2). The last and highest candle is taken by the Officiant and concealed behind the altar during the singing of the 'Miserere'. After a loud noise [traditionally the choir forms are disturbed], the candle is revealed and its light signifies the conclusion of *Tenebrae*.

Veneration of the Cross which included the *Improperia* (or reproaches), typified by 'Popule meus' and other texts related to the cross. The priest took communion in the final part of this service, following which the remaining Host and the Cross were transferred to the Place of Deposition. It was this latter ceremony which particularly thrived within the practices of the secular clergy. The surviving documents and manuscripts of the *laudesi* frequently include texts associated with the Veneration of the Cross and found in 1506/1.

There was considerable variety within the extant Italian liturgical and para-liturgical rites dating before the Tridentine reforms.¹⁰ During the Middle Ages, it was expected that the complete book of Lamentations would be read during the last three days of Holy Week.¹¹ This intensive prescription, stipulated by the Roman *curia*, was gradually reduced by Western churches during the fourteenth and fifteenth centuries but each diocese decided which verses were appropriate, resulting in a myriad of selections. The variety of Lamentation verses set in 1506/1 and 1506/2 and the different versions of the *Improperia* reflect this.

The political and religious upheaval within the Catholic church during the Great Schism may have been a factor in the relatively late emergence of polyphonic Lamentation settings during the Renaissance.¹² While the Council of Constance (1414-18) was successful in resolving the Schism, the power of the Pope and centralised powers of Rome had been challenged and weakened. One particular outcome was that the church had less power over liturgical matters in regions and countries beyond Rome than it had before the Schism; this new freedom in decision-making must have resulted in the decision to allow polyphonic settings of the Lamentations in the various Italian dioceses. I can support this by noting that the oldest extant liturgical manuscript containing a complete Lamentation setting, Bu 2931, dates from the early fifteenth century. The first Lamentations pertaining to Rome date from as late

¹⁰ The variety of Lamentation verses set in manuscripts containing concordances of 1506/1 and 1506/2 such as MonteA 871, PadBC c56, PavU 361 and VicAC 11 will be discussed later.

¹¹ This paragraph has been largely derived from Snow, *A New-World Collection*, pp. 49-50.

¹² Reinhard Strohm, *The Rise of European Music, 1380-1500* (Cambridge: Cambridge University Press, 1993), p. 7, suggested that the Great Schism was more momentous for music history than the Reformation.

as the first quarter of the sixteenth century and are preceded by many extant Lamentation manuscripts originating in non-Roman regions and countries.¹³

A parallel may be made with the setting of the Requiem Mass where the first polyphonic examples emerged during the early Renaissance, well after the first flowering of the polyphonic Mass and motet. A common misconception is that polyphony was banned during Lent, being somehow too indulgent. Documentation of the various Italian monastic orders suggests otherwise, particularly those of the Benedictines (whose musical sources are central to 1506/1 and 1506/2). The Italian Benedictines were reformed during the early fifteenth century, the movement originating in the monastery of S. Giustina of Padua under the direction of the Venetian Ludovico Barbo.¹⁴ With the entry of the influential Montecassino monks, the order became known as the *Congregatio Casinensis alias S. Iustinae* by 1504. The Benedictines had revoked the ban on polyphony after the middle of the fifteenth century, allowing the performance of *cantus figuratus* during Holy Week.¹⁵ The Augustinians were also encouraging polyphony about this time. Bonnie Blackburn's discovery of a document permitting polyphony during Lent (discussed in chapter 5) supports this idea;¹⁶ she has also revealed the importance of Petrucci's editor, Petrus Castellanus, a Dominican monk working in Venice. Another Dominican, Serafino Razzi, was responsible for a polyphonic book of *laude* in 1563.

¹³ These manuscripts, and possible reasons for a lack of Roman Lamentations, will be discussed later.

¹⁴ Cattin, *Italian Laude*, p. ix.

¹⁵ *Ibid.*, p. x.

¹⁶ Bonnie Blackburn, private correspondence dated 25 July 2002. I am most grateful to Dr Blackburn for sharing her findings and permitting me to use them.

1.3 Lamentation settings pre-1506

Musicologists had long claimed Dufay's 'O tres piteulx' as the first polyphonic example of a setting of Jeremiah's verses.¹⁷ This might have been true inasmuch as 'O vos omnes' (Lamentations ch. 1:2) is placed in Dufay's Tenor; however, the remaining parts present a French text, thus preventing a liturgical or para-liturgical performance of this work. The use of the Lamentation text is symbolic rather than functional; Compère's 'O devotz cueurs/O vos omnes' with its *contrafactum* 'Tant ay d'ennuy' follows a similar approach.¹⁸ Even if Dufay's lost Lamentation compositions with a *terminus post quem* of 1456 were liturgical in any respect,¹⁹ they could not claim to be the first polyphonic Lamentations. The discovery of Johannes de Quadris's Lamentations in VicAC II (c. 1430-40) pre-dates Dufay's alleged compositions and was previously thought to be the first extant polyphonic Lamentation setting with a purely liturgical function (see table 1.03 for a chronological list).²⁰ These same settings were deemed fit for publication by Petrucci in 1506/1, some sixty years or so following their composition.²¹ De

¹⁷ Schröder, 'Les Origines des lamentations', 353, stated that the repertoire did not begin before the middle of the century and cited as evidence Dufay's letter of 1456 to Piero and Giovanni di Medici concerning four Lamentation settings. She suggested Cornago's 'Patres nostri peccaverunt' as the earliest extant example of a Lamentation setting. A. Gastoué, 'Manuscrits et fragments de musique liturgique, à la Bibliothèque du Conservatoire, à Paris', *Revue de Musicologie*, 13 (1932), 1-9 (p. 6) suggested Binchois as the possible composer of the Lamentation setting in ParisBNC 967 (this manuscript dates from the late fifteenth to the early sixteenth century).

¹⁸ Sylvia W. Kenney, 'In Praise of the Lauda', in *Aspects of Medieval and Renaissance Music: A Birthday Offering to Gustave Reese*, ed. Jan LaRue (New York: Norton, 1966), pp. 489-499, argued the motet-chanson was a specific genre and was related to the *lauda*. Recent opinion is contrary to this opinion; Fabrice Fitch, 'Restoring Ockeghem's Mort, Tu As Navré', *Tijdschrift van de Koninklijke Vereniging voor Nederlandse Muziekgeschiedenis*, 51 (2001), 3-24 (p. 17), suggested that such pieces were an extension of medieval polytextual practices and would not have been regarded as a distinct category in the Renaissance.

¹⁹ Dufay's reference to four Lamentation compositions is gleaned from his 1456 letter to Piero and Giovanni de Medici. Gustave Reese, *Music in the Renaissance* (New York; London: W. W. Norton; J. M. Dent, 1954), p. 59, was certain that 'Lamentatio sancte...' was one of the four mentioned in the letter. David Fallows, *Dufay* (London: J. M. Dent, 1982), p. 71, agreed with Isabel Pope and Masakata Kanazawa, eds., *The Musical Manuscript Montecassino 871: A Neapolitan Repertory* (Oxford: Oxford University Press, 1978), p. 630, that one of the group of four Lamentations cited by Dufay must have been 'O tres piteulx'; Fallows, *Dufay*, p. 287, estimated that Dufay's Lamentations must have been composed in 1455.

²⁰ Giulio Cattin, 'Il presbyter Johannes de Quadris', *Quadrievium*, 10/2 (1964), 5-47 and tav. I-IV, was the first musicologist to describe this manuscript. His findings were subsequently published as 'Johannes de Quadris musico del secolo XV', *Quadrievium*, 10/2 (1969), 5-47 and tav. I-IV.

²¹ Concordant manuscripts with 1506/1 and 1506/2 are discussed in detail in chapter 6.

Quadris's settings were suitable for liturgical or para-liturgical ceremonies and appear in manuscripts devoted to such music (in contrast to the mainly secular manuscripts containing the previously-mentioned motet-chansons of Dufay and Compère).

Giulio Cattin discovered two polyphonic settings crucial to the development of the Lamentations. Cattin suggested that the first, a simple two-part setting of the letter 'Aleph' in *cantus planus*, must date from the 1300s.²² While it is possible that this setting may be an isolated piece, we cannot ignore the fact that it is associated with the Veneto, a region which is crucial to the emergence and development of the polyphonic Lamentation genre. This short marginal edition exists in a Bible commissioned in Vicenza in 1250; Cattin noted that the polyphony for 'Aleph' lacked mensuration and that the parts moved predominately in contrary motion.²³ The tones used in this setting do not resemble any of the extant Lamentation tones that I have inspected.

The two-part anonymous Lamentation setting in Bu 2931 is the earliest extant polyphonic example of a complete setting; the manuscript originated in the convent of S. Salvatore, Bologna [I have labelled this setting 'Lamentation X'].²⁴ The importance of this simple, formulaic Lamentation setting is emphasised by reworkings in several late fifteenth-century manuscripts, some of which were associated with the Italian Benedictine order, namely BrusC 16857, UrbU L712, ParisBNC 967 and CapePL 3.b.12 (the latter being distinctive in that it is the manuscript with the most concordances of 1506/1 and 1506/2).²⁵ Furthermore, these Lamentations continued to be transmitted

²² Giulio Cattin, 'La musica nelle istituzioni fino alla caduta della repubblica', in *Storia di Vicenza, l'età della repubblica veneta (1404-1797)*, ed. Franco Barbieri and Paolo Preto, III/2 (1990, Vicenza, Neri Pozza Editore), 163-184 (pp. 180-181). The short setting is found in the margin of VicAC 3, fol. 73^r. I am grateful to Dr. Margaret Bent for informing me about this article.

²³ *Ibid.*, p. 180.

²⁴ Lodovico Frati, 'Codici musicali della R. Biblioteca Universitaria di Bologna', *Rivista musicale italiana*, 23 (1916), 219-242 (p. 229). Giulio Cattin first cited these Lamentations in 'Tradizione e tendenze innovatrici nella normativa e nella pratica liturgico-musicale della congregazione di S. Giustina', *Benedictina*, 17 (1970), 254-299 (p. 276); furthermore, he considered the manuscripts WashLC J6, Bol Q13, Brussels 16857 and UrbU L712 as Benedictine (p. 263). Cattin did not mention that Bu 2931 pre-dates all other Lamentations manuscripts; he dates the manuscript as early fifteenth century.

²⁵ These manuscripts will be discussed later in more detail.

in the sixteenth century; they were included in the Benedictine *Cantus Monastici* [*Cantorino*] prints and appeared in the 1506, 1523 and 1535 editions.²⁶

The existence of this early Lamentation setting, combined with the multitude of readings, obliges me to describe it in some detail. Its musical style is apposite to the earlier fifteenth century or even the fourteenth century (see appendix 1 for a comparative edition, illustrating the differences between the sources; every reading, excepting CapePL 3.b.12, is written in black notation). The parts move in discant style, the opening of each phrase beginning with a unison *d-f* before the parts diverge (note that Bu 2931 is the only source to place the music of the Tenor on the higher staff). The Discantus and Tenor move by step to the reciting tones *a* and *d* respectively, CapePL 3.b.12, UrbU L712 and the 1506 *Cantorino* being the only sources to contain a momentary high *b* in the Discantus; the two parts eventually arrive by step on a unison *e*.²⁷ These are the essential elements of the primary musical phrase ['A', bars 1-2] and each reading presents slightly different versions, such as mid-phrase embellishment and cadential decoration. All readings contain at least one phrase in which there are parallel fifths; additionally, the inclusion of parallel fourths in the opening phrase of the majority of readings suggests a deliberate gesture towards earlier medieval polyphony. The range of each voice is extremely limited, being a 6th.

The music for the first letter 'Aleph' is new, and the readings present much more diversity than phrase 'A' except each reading cadences to a unison *e* (note that Bu 2931 does not set music for any letter. The opening sentence of ch. 1:1, 'Quomodo sedet sola civitas...' is set to a variant of the initial phrase ['A1', bars 4-5]. All readings commence as before but cadence to *f* [only BrusC 16857 cadenced to *f* in phrase 'A']. The following textual phrase of ch. 1:1, 'facta est quasi vidua...', is virtually identical to phrase 'A1' with the following exceptions:

²⁶ Cattin, *Italian Laude*, p. XI, suggested that these Lamentations were probably passed from monastery to monastery.

²⁷ BrusC 16857 cadences to *f*; the end of the first phrase of UrbU L712 concludes on the pitches *d* and *e*. Presumably, this is unintentional but subsequent statements of phrase 'A' cadences to *f*.

- (1) the Tenor of Bu 293I includes *divisi* for the opening set of pitches²⁸
- (2) the cadential decoration in the Discantus of CapePL 3.b.12 is marginally different.

The final part of verse 1, 'princeps provinciarum...', receives a completely new musical phrase in all readings ['B', bars 8-9], beginning on a unison *g* and cadencing to a unison *e* in every reading. This phrase behaves in a similar style to that of 'A'; there are parallel 3rds, 5ths and, in the reading of Bu 293I, 4ths. Embellishment is evident again – the repetitions of the opening notes of UrbU L712's Discantus are particularly distinctive (this reading contains the most differences in the 'B' phrase, and is also the shortest). The music for the 'Jerusalem' refrain begins with phrase 'A' or 'A1' in each reading but diverges from the text 'convertere...'. The music of Bu 293I is a new and comparatively extended phrase, eventually cadencing to *e* with no leap greater than a third (the widest leap in this reading is a fourth at the beginning of phrase 'A1'). The remaining readings set the 'B' phrase at the text 'convertere...'; each version finally resolves to an *e*. CapePL 3.b.12, as Bu 293I, contains no leap greater than a third but UrbU L712 and the Benedictine *Cantorino* print (1535) both contain fourths in this final phrase. There are further distinctions between readings, particularly the use of repeated pitches in UrbU L712 and 1535 (bar 34) and the problem of *musica recta* in Bu 293I's Tenor at bar 31 where the flattening of *b* would result in a vertical tritone.

One can see why these Lamentations would have been eagerly disseminated by the monks as Cattin has suggested; this would also have been responsible for the improvisations found in each reading.²⁹ Such differences may also reflect the influence of the oral transmission, the repetitive characteristics and restrained style making these Lamentations likely candidates for embellishment and improvisation. Margaret Bent, discussing the writings of Tinctoris, described the likely role of the performer in the process of composition, suggesting that feedback from performers must have been integral to the

²⁸ Inspection of the folio's verso did not suggest show-through.

²⁹ Cattin, 'Tradizione e tendenze', 261-270.

process of composition.³⁰ The versions of Lamentation X provide us with evidence of performance practices and traditions, particularly the singers' enthusiasm for embellishment and enhancement. This desire for enhancement is not exclusive to Lamentation X; I shall present further examples in the settings of Anon. 1, de Quadris and de Orto in chapter 3.

Why did this setting refer to a more retrospective musical style? The answer partly lies in its stylistic features. My musical survey of the 1506 Lamentations (chapter 3) describes some rather awkward compositional and retrospective polyphonic practices in the works of certain composers, all of whom were capable of writing complex and refined counterpoint. The incidence of rough-hewn counterpoint in the various readings of Lamentation X may suggest that polyphonic Lamentations did not use the latest compositional practice since that would have been considered too ostentatious. Charles van den Borren, commenting on the reading of Lamentation X in BrusC 16857, remarked that it was a 'curious example of archaism'.³¹ I do not believe that this style would have been considered curious, a point to which I shall return in chapter 3. Hughes observed that Lamentation X 'appears to use two of the numerous Lamentation tones simultaneously, one in each voice'.³² The dated discant style, which Hughes described as 'crude and uninteresting', epitomises a functional style associated with penitential settings; a parallel may be drawn between these pieces in CapePL 3.b.12 and de Quadris's Lamentation settings in 1506/1, which I shall discuss in chapter 3. It is more difficult to ascertain when these works were composed, particularly since they have been written in a retrospective style. Table 1.03 provides details of pre-1506 Lamentation settings:

³⁰ See Margaret Bent, '“Resfacta” and *Cantare Super Librum*', *Journal of the American Musicological Society*, 36 (1983), 371-391 (pp. 376-378).

³¹ Charles van den Borren, 'Inventaire des manuscrits de musique polyphonique qui se trouvent en Belgique', *Acta musicologica*, 5 (1933), 66-71, 177-183 (p. 178).

³² Andrew Hughes, 'New Italian and English Sources of the Fourteenth to Sixteenth Centuries', *Acta musicologica*, 39 (1967), 171-182 (p. 180). Cattin, 'Tradizione e tendenze', 274, agreed with this opinion, adding that Lamentation X emerged as a Mediterranean tradition with the second voice being added in the second half of the 15th century. Hughes described the tone in the Discantus as the principal voice, noting a similarity to the standard Roman tone. The version in VerBC 690 took the Tenor and transposed it a fifth higher; however, its upper part is new (see Appendix 1).

Table 1.03: Chronological table of polyphonic Lamentation settings considered as pre-1506

<i>MS & print sources</i>	<i>Composer</i>	<i>Lamentations</i>	<i>Notes</i>
VicAC 3, fol. 73 ^r	Anon.	'Aleph' (a2)	<i>Cantus planus</i> setting in margin of a Vicenza MS; the polyphony is <i>trecento</i> .
Bu 2931, fols 27 ^r -28 ^r	Lamentation X	Lamentations (a2)	Black notation, earlier fifteenth century?
BrusC 16857, fols 20 ^v -21 ^r	Lamentation X	Lamentations (a2)	Lamentations dated 1490 or 1491.
UrbU L712, fols 43 ^v -45 ^r	Lamentation X	Lamentations (a2)	2nd half fifteenth century; dates 1501 and 1504.
CapePL 3.b.12, fols 2 ^v -3 ^r	Lamentation X	Lamentations (a2)	Pre 1506.
VicAC 11, fols 1 ^v -10 ^r	De Quadris	Lamentations (a2)	Lamentations copied c. 1430-40 in Vicenza.
PadBC c56, fols 61 ^r -62 ^v	Anon./de Quadris ³³	Lamentations (a2)	Fifteenth century.
Lost	Dufay	3 Lamentation(?) settings	Dufay's letter of 1456 to Piero and Giovanni di Medici.
CambriP 1236, fols 36 ^r -42 ^r	Tuder	Lamentations [one part extant only in black notation]	c. 1460-65.
Lost	Héniart	Lamentation(?) setting	1475 <i>terminus ante quem</i> . ³⁴
Lost	Ockeghem	Lamentation(?) setting	1475 <i>terminus ante quem</i> .
Lost	Busnois	Lamentation(?) setting	1475 <i>terminus ante quem</i> .
Lost	Matteo di Paolo	Lamentation setting	1480 commission for Florence Cathedral. ³⁵
FlorR 2794, fols 76 ^r -78 ^r	Agricola	Lamentations (a3)	1480 or 1488.
MonteA 871, fol. 17 ^r	Oriola	'O vos homines' (a3)	c. 1480.
MonteA 871, Lost	Anon.(s)	Lamentations (3 settings)	c. 1480; missing Lamentations cited in manuscript's TOC.
MonteA 871, fols 1 ^v -2 ^r	Cornago	'Patres nostri peccaverunt' (a4)	c. 1480.
MonteA 871, fols 105 ^v -110 ^r	Anon.	Lamentations (a3)	c. 1480.
MonteA 871, fols 110 ^v -114 ^r	Anon.	Lamentations (a3 with short a4 section)	c. 1480.
BolC Q16, fol. 152 ^v	Anon.	Lamentations (a2)	1487 with additions in 1490s.
WarU 2016, fols 132 ^v -136 ^r	Agricola	Lamentations (a3)	c. 1500.

³³ Musical phrases based upon de Quadris's Lamentations have been used as formulae.

³⁴ Further information about these Lamentations may be found in Fallows, *Dufay*, p. 83. Fallows suggests the possibility that these settings were composed in Dufay's memory.

³⁵ Frank A. D'Accone, 'The Musical Chapels at the Florentine Cathedral and Baptistery during the First Half of the 16th Century', *Journal of the American Musicological Society*, 24 (1971), 1-50 (p. 6). D'Accone speculated that a payment to 'Ser Arnolfo Giliardi' in 1479 may also have related to Lamentation settings.

<i>MS & print sources</i>	<i>Composer</i>	<i>Lamentations</i>	<i>Notes</i>
TarrAA ³⁶	Anon.	Lamentations (a2?)	Late fifteenth century.
PL-Kar1706, fol. 62 ^r	Anon.	'Lamech' (a3) ³⁷	Late fifteenth century.
ParisBNC 967, fols 23 ^v -26 ^r	Anon.	'Dona jube...Aleph...' (a3) ³⁸	Late fifteenth century/early sixteenth century.
ParisBNC 967, fols 26 ^v -28 ^r	Anon. [Anon. 3]	Lamentations (a2)	Late fifteenth century/early 16th century.
VerBC 690, fols 60 ^r /73 ^v	Anon.	Lamentations (a2), in black notation	Late fifteenth century/early 16th century.
MilD 3, fols 11 ^v -20 ^r	Anon.	Lamentations (a4)	1500; post 1484 (Strohm, <i>Rise of European Music</i> , p. 591).
MilD 3, fols 20 ^v -24 ^r	Anon.	Lamentations (a4)	1500; (Strohm, <i>Rise of European Music</i> , p. 591).
SegC ss, fols 151 ^v -153 ^v ³⁹	Anon.	Lamentations (a3)	1500-03, prob. 1502.
SegC ss, fols 153 ^v -155 ^r	Anon.	Lamentations (a3)	1500-03, prob. 1502.
CapePL 3.b.12, fols 90 ^v -95 ^r	de Orto	Lamentations (a4)	Pre 1506.
CapePL 3.b.12, fols 95 ^v -101 ^v	Anon. 1	Lamentations (a3)	Pre 1506.
FlorBN Panc. 27, fols 144 ^v -145 ^r	Lapicida	Lamentations (a4)	c. 1510.
FlorBN Panc. 27, fols 150 ^v -156 ^r	Anon. ['Anon. 4']	Lamentations (a4)	c. 1510.
FlorBN Panc. 27, fols 82 ^v -84 ^r	Anon.	Lamentations (a3)	c. 1510.
FlorBN Panc. 27, fols 147 ^v -149 ^r	Anon.	Lamentations (a4)	c. 1510.

There are few surviving pre-Reformation manuscripts originating in England during this period but one such example is CambriP 1236, dating from c. 1465-75. This manuscript contains a comprehensive representation of liturgical settings although Roger Bowers suggested that the manuscript was probably a private collection of pieces, rather than a performing manuscript.⁴⁰

³⁶ I am most grateful to Professor David Fallows for bringing this fragment to my attention. His attention was alerted by Professor María del Carmen Gómez Muntané, to whom I am also grateful for permission to list this fragment; details (including the accompanying fragment containing secular music by Cornago) are listed in David Fallows, *A Catalogue of Polyphonic Songs, 1415-1480* (New York: Oxford University Press, 1999), p. 46.

³⁷ Plainchant is set for the remainder of this Lamentation setting.

³⁸ Only the letter 'Aleph' relates to the Lamentations; the remaining text is based upon the biblical writings of St. Paul.

³⁹ Günther Massenkeil, 'Eine spanische Chormelodie in mehrstimmigen Lamentationskompositionen des 16. Jahrhunderts', *Archiv für Musikwissenschaft*, 29-30 (1962-63), 230-237 (p. 233).

⁴⁰ Roger Bowers, 'Cambridge, Magdalene College, MS Pepys 1236', in *Cambridge Music Manuscripts 900-1700*, ed. Iain Fenlon (Cambridge: Cambridge University Press, 1982), III-

The musical items are meticulously arranged in liturgical order and include one voice from a setting of Lamentations ch. 1:1-3 by 'John Tudor' in black notation; Bowers suggested that this work was originally polyphonic.⁴¹

There are a surprising number of extant sources containing Lamentations, mainly in dedicated sacred manuscripts.⁴² There is evidence of Lamentation compositions which have since been lost; Houdoy mentioned Lamentations by Ockeghem, Hénart and Busnois with a date of 1475 *terminus ante quem*.⁴³ The manuscript PavU 361 contains a Lamentation for one voice only (although it was probably part of a polyphonic composition); this monastic manuscript contains theoretical writings (by Marchettus de Padua) as well as liturgical repertoire, a characteristic shared with WashLC J6 and BolC Q16.

The Neapolitan court manuscript MonteA 871 has been dated *c.* 1480 and contains several settings of Jeremiah's verses and other texts for Holy Week in common with 1506; its table of contents also cites Lamentations that have since been lost.⁴⁴ This manuscript was commissioned for Alfonso of Aragon and thus links the Italian, Spanish and Flemish Holy Week repertoire. FlorR 2794 dates from approximately the same period as MonteA 871 but is primarily a chansonnier. It contains a concordance of Agricola's three-part Lamentations (which escaped E. R. Lerner's attention in his 1966 Agricola edition, probably due to the lack of an attribution in that manuscript). Dufay's 'O tres piteulx' appears about midway through this manuscript amidst a number of French chansons but Agricola's liturgical Lamentations are at its conclusion. The repertoire in UrbU L712 dates from the second half of the

114 (pp. 111-112). Bowers noted the small format of the manuscript and the absence of wear and tear. Sydney R. Charles, 'The Provenance and Date of the Pepys MS 1236', *Musica disciplina*, 16 (1962), 57-71 (p. 70), observed that the intensive use of accidentals, many of which are superfluous under the usual rules of *musica ficta*, suggested that the manuscript was not intended for highly trained performers.

⁴¹ Roger Bowers, 'Tuder [Tudor, Tutor], John', *New Grove Dictionary of Music & Musicians*, 25 (2001), 872-873.

⁴² Thomas, 'Two Petrucci Prints' catalogued many of these manuscripts. Bruno Stäblein, 'Lamentatio', *Die Musik in Geschichte und Gegenwart*, 8 (1960), 133-142, estimated there were 150-200 Lamentations during the Renaissance, the vast majority having since been lost.

⁴³ Jules Houdoy, *Histoire artistique de la Cathédrale de Cambrai, ancienne église métropolitaine Notre-Dame* (Paris, Lille: [n.pub.], 1880), p. 201.

⁴⁴ For a detailed discussion of the missing sections of MonteA 871, see Pope and Kanazawa, *The Musical Manuscript Montecassino 871*, p. 46.

fifteenth century and the manuscript has a *terminus post quem* of 1501 and contains a reading of Lamentation X.

The manuscript BolC Q16 (dating from 1487) is principally a secular manuscript although it contains a handful of sacred works. It contains a short section from Lamentations, ch. 5:1, a two-part anonymous setting beginning 'Recordare domine' on fol. 152^v. It is the final musical setting in the manuscript and is followed by an anonymous treatise. Other manuscripts which contain both Holy Week music and treatises are WashLC J6 (Johannes de Muris, Marchettus de Padua, Johannes de Garlandia, Johannes de Anglia, Johannus Franciscus Preottonus, Guido of Arezzo, Pierre de St. Denis) and PerBC 431 (rudimentary theoretical notes by an anonymous hand and anonymous settings of the *laude* 'Adoramus te Christe' and 'Verbum caro'). It has been conjectured that BolC Q16 was copied in Naples while PerBC 431 was definitely compiled in the Naples area.⁴⁵ WashLC J6 has no known connections with Naples and its copyist was a Benedictine monk from Venice.

BrusC 16857 is dated a few years later (1490 or 1491) and contains a reading of Lamentation X in black notation.⁴⁶ This manuscript may also be associated with a Northern Italian monastery and contains at least one concordance of CapePL 3.b.12.⁴⁷

The turn of the century produced some important commissions in respect of the Holy Week repertoire, the most important being CapePL 3.b.12. It contains concordances of Lamentations by Anon. 1 and de Orto as well as the 1506/1 non-Lamentation settings (principally Latin *laude*).⁴⁸ FlorBN Panc. 27 has also been dated c. 1510 and contains a concordance of Lapidida's Lamentations as well as four further anonymous settings. There are further concordances of the 1506/1 *laude* contained therein. Mild 3, one of the

⁴⁵ Allan W. Atlas, *The Cappella Giulia Chansonier (Rome, Biblioteca Apostolica Vaticana C. G. XIII.27)*, No. 27 of *Musical Studies*, 2 vols. (Brooklyn: Institute of Mediaeval Music, 1975-76), I, 236.

⁴⁶ This manuscript was described by Hughes, 'New Italian and English Sources', 171-182; he noted its connection with Capetown's Lamentation at fol. 2^v-3^r on p. 180.

⁴⁷ See v. d. Borren, 'Inventaire des manuscrits', 177-178, for details.

⁴⁸ The readings of CapePL 3.b.12 are significant since they offer a completely new version of part of de Orto's Lamentation and a substantial variation of that of Anon. 1. These variants will be discussed in chapters 3 and 6.

choirbooks of Milan cathedral, contains no fewer than four four-part Lamentation settings and has a *terminus post quem* of 1505.⁴⁹

Spanish interest in Lamentation settings is betokened by ParisBNC 967, a liturgical book dating from the turn of the century. There are two anonymous works for three voices and two voices. The three-part work begins with the text 'Dona jube...' followed by 'Aleph' and 'Christus...'; the main text is taken from St Paul's letter to the Hebrews. The use of 'Aleph' as a prefatory word may have something to do with the proximity of the genuine two-part-Lamentation beside it.⁵⁰ The Tarragona fragment, discovered by María del Carmen Gómez Muntané, is measured and in white notation but only contains one part at a time (the other part or parts must have been on another folio). There is a Discantus using clef C1 on one side and a Tenor with C3 on the other. A late fifteenth-century manuscript from Poland, PL-Ka1706, contains a three-part anonymous setting of the Hebrew letter 'Lamech' towards the end of its sacred repertoire (the remaining Lamentation text is set to plainchant). The rather retrospective style of this small excerpt suggests an affinity with late fifteenth-century Polish polyphony.⁵¹

Another eastern European source containing Holy Week music is WarU 2016 – fols 132^v-136 contain an unascribed concordance of Agricola's three-part Lamentations. This manuscript contains sacred settings and a few secular pieces. Three-part Lamentations are also found in a manuscript belonging to Segovia cathedral dating from 1500-03; these are anonymous. SegC ss was probably compiled for Toledo cathedral and contains repertoire brought to Spain by Philip and Joanna in 1502. The manuscript VerBC 690 contains a concordance of the 1506/1 *lauda* 'Cum autem venissem' (the only white notation work in the manuscript) and a two-part discant Lamentation based upon the Tenor of Lamentation X.

⁴⁹ MilD 3 contains a concordance of a 1505 print.

⁵⁰ Massenkeil, *Mehrstimmige Lamentationen*, labelled this work 'Anon. 3'.

⁵¹ Polish polyphony from this period was described as retrospective by Gustave Reese and Hieronim Feicht; see Reese, *Music in the Renaissance*, p. 745 and Hieronim Feicht, ed., *Muzyka Staropolska = Old Polish Music: a Selection of Hitherto Unpublished Works from the XIIth-XVIIIth Centuries* ([Cracow]: Polskie Wydawnictwo Muzyczne, 1966), p. xviii.

An examination of table 1.03 reveals a striking pattern, namely, the lack of Lamentations contained in sources originating from, or held by, Rome. The north of Italy is well represented and the cultural capital of the south, Naples, had an interest in Lamentations and Holy Week liturgy as I shall discuss in chapter 2. The lack of extant fifteenth-century sources from Rome (excepting a few in the Papal chapel) prohibits us from evaluating the development, or otherwise, of Holy Week polyphony in Rome before the Lamentations of Carpentras in the 1520s. We know that confraternities were flourishing in Rome during the fifteenth and sixteenth centuries but little or no evidence relating to the performance of Holy Week music has been discovered.⁵²

These extant and diverse sources illustrate the considerable interest in polyphonic Lamentations and Holy Week repertoire; however, the table of contents in MonteA 871 represents a considerable amount of repertoire that has since been lost. The pattern of extant sources suggests that the composition of Lamentations did not feature in the work of composers before the mid-fifteenth century, despite the earliest source of a Lamentation dating from the beginning of the fifteenth century.

Petrucchi's awareness of the various liturgies and their music is represented by the inclusion of settings of the *Improperia*. He also used a text inspired by the Passion ('Passio sacra'), following the musical style of the *lauda* and the office canticle 'Benedictus Dominus Deus Israel'. All of these texts were well known in Italy (with the exception of Ana's 'Passio sacra'), as witnessed by their survival in a number of contemporary Italian manuscripts (which I will discuss in chapter 6). The 'Benedictus' is found in contemporary manuscripts; there are three anonymous settings in CapePL 3.b.12. It is also found in manuscripts associated with the *laudesi*, ParisBNC 967 being one such example.

⁵² I shall discuss the role of the Roman confraternities in more detail in chapter 5.

LITERATURE REVIEW

1.4 Pre-1506 Lamentations

It is somewhat surprising that there is relatively little literature devoted to Holy Week polyphony, considering the importance of this liturgy during the Renaissance. Nevertheless, several scholars devote some thought to the subject of Lamentations dating from the early to mid-renaissance. Glenn E. Watkins's 1953 doctoral dissertation partially encompasses the earlier Renaissance.⁵³ While the focus of his dissertation is considerably later than Petrucci, Watkins gives some general insight into musical and liturgical aspects of Lamentation settings. He was one of the first scholars to provide a detailed discussion of mode and *cantus prius factus* in polyphonic Lamentation settings. A. Engelina Schröder published her conference paper in the same year; she summarised the principal studies of polyphonic Lamentations in the fifteenth and sixteenth centuries.⁵⁴ E. R. Lerner discussed the 1506 Lamentation settings in his doctoral dissertation, arguing that some of the works contained therein were available to Petrucci prior to 1506.⁵⁵ Günther Massenkeil explored the influence of Spanish and Roman *cantus firmus* in polyphonic Lamentations.⁵⁶ He discussed the use of a Spanish *cantus prius factus* in a setting of a three-part Lamentation in ParisBNC 967 and noted that the selected Lamentation verses in this manuscript did not conform to the more typical patterns found in the Roman church.⁵⁷ Massenkeil developed these ideas in his 1962-63 paper, concluding that the Spanish *cantus prius factus* was found in Spanish manuscripts while Roman chants and intonations were found in Italian sources.⁵⁸ Mary Klimisch discussed the Lamentations as a genre in

⁵³ Watkins, 'Three Books of Polyphonic Lamentations'.

⁵⁴ Schröder, 'Les Origines des lamentations'.

⁵⁵ Edward R. Lerner, 'The Sacred Music of Alexander Agricola' (Unpublished Doctoral Dissertation, Yale University, 1958), pp. 48-49.

⁵⁶ Günther Massenkeil, 'Zur Lamentationskomposition des 15. Jahrhunderts', *Archiv für Musikwissenschaft*, 18 (1961), 103-114.

⁵⁷ *Ibid.*, 107-108.

⁵⁸ Massenkeil, 'Eine spanische Choralmelodie'.

her 1971 doctoral dissertation.⁵⁹ She observed that musicologists had ignored Lamentation settings due to their strong association with the laity and consequent estrangement from the liturgy.⁶⁰ Klimisch described and discussed the effects of pre-Tridentine liturgy and the context of the Lamentations.

Giulio Cattin was responsible for discovering both the earliest evidence of a Lamentation setting and the earliest complete setting (Lamentation X).⁶¹ Both settings relate to Italian sources as might be expected; what is most surprising is the early period of the former (the two-part setting of 'Aleph') and the proliferation of the latter (perhaps dating from the 1420s but found in prints up to 1535; I shall discuss sources in chapter 6). Such important discoveries, in an area where much material has been lost through the ages, must dispel notions that the composition of polyphonic Lamentations began as late as the mid-Renaissance.

1.5 Text sources of 1506/1 and 1506/2

John Stevens published his book discussing medieval music texts in 1986.⁶² He traced the effects of perceived and intentional dramatic elements in the texts for Holy Week in his chapter on drama in the liturgy, particularly the reproaches (which are central to 1506/1). Elisabeth Diederichs's 1986 study included a section relating to the etymology of the texts, as well as a study of related *lauda* manuscript sources.⁶³

Giulio Cattin provided a rich and comprehensive liturgical resource in his volumes published in 1992.⁶⁴ He presented a considerable collection of

⁵⁹ Klimisch, 'The Music of the Lamentations'.

⁶⁰ *Ibid.*, p. 142.

⁶¹ Cattin discussed the medieval 'Aleph' in 'La musica nelle istituzioni', pp. 180-181. Lamentation X is first described in 'Tradizione e tendenze', 276.

⁶² John Stevens, *Words and Music in the Middle Ages: Song Narrative, Dance and Drama, 1050-1315* (Cambridge: Cambridge University Press, 1986).

⁶³ Elisabeth Diederichs, *Die Anfänge der mehrstimmigen Lauda von Ende des 14. bis zur Mitte des 15. Jahrhunderts* (Tutzing: Hans Schneider, 1986).

⁶⁴ Giulio Cattin, *Musica e liturgia a San Marco: Testi e melodie per la liturgia delle ore dal XII al XVII secolo: Dal graduale tropato del Duecento ai gradualini cinquecenteschi*, ed. Giordana Mariani Canova and Susy Marcon, Fondazione Levi. Ser. 4, Collezione speciale per la musica veneta. A, Monumenti, 4 vols. (Venice: Edizioni Fondazione Levi, 1992).

liturgical manuscripts, with an introduction to the context of each manuscript and their importance and usefulness within the worship at St. Mark's. In 1993 William Prizer observed the use of the Latin *lauda* in Florence and noted that Lenten texts concerning the Holy Cross were also apt for any procession, considering their penitential nature.⁶⁵ Although Robert Snow's 1996 study concerned a Central American Renaissance manuscript, he provided an excellent appraisal of the music of Holy Week, particularly the use of Lamentation verses.⁶⁶ This manuscript presented a diversity in its choice of verses similar to that of the European Lamentations.

I.6 1506/1 and 1506/2 composers and their musical style

Massenkeil's 1965 Lamentations edition was the first publication to include a substantial representation of music from 1506/1 and 1506/2.⁶⁷ He included the settings of Bernard Ycart, Anon. 1 (the anonymous three-part setting), Marbrianus de Orto, Johannes de Quadris (not complete), Bartolomeo Tromboncino (not complete) and Erasmus Lapidica in addition to some settings from later prints and manuscripts. This edition pre-dates Cattin's discovery of CapePL 3.b.12 (described in Cattin 1973 and 1977) which contains concordances of Anon. 1 and de Orto. E. R. Thomas's 1970 DMA was the first musicological study specifically devoted to 1506/1 and 1506/2.⁶⁸ He provided a complete musical edition of the two prints, even though the majority of settings had previously been published in modern editions.⁶⁹ He

⁶⁵ William F. Prizer, 'Laude di popolo, laude di corte: Some Thoughts on the Style and Function of the Renaissance *Lauda*', in *La musica a Firenze al tempo di Lorenzo Il Magnifico: Congresso internazionale di studi Firenze*, ed. P. Gargiulo (Florence: Leo S. Olschki, 1993), 167-194.

⁶⁶ Snow, *A New-World Collection*.

⁶⁷ Massenkeil, *Mehrstimmige Lamentationen*.

⁶⁸ Thomas, 'Two Petrucci Prints'.

⁶⁹ Massenkeil, *Mehrstimmige Lamentationen*, opted to publish incomplete settings of the Lamentations by de Quadris and Tromboncino. The two settings of Agricola were edited by Lerner, *Alexandri Agricola*, while Torchi, *L'Arte musicale*, included an edition of Ana's 'Passio sacra' and the opening section of Tromboncino's Lamentations. Tinctoris's Lamentations may be found in Fritz Feldmann, ed., *Johannes Tinctoris: Opera omnia*, I, CMM 18, ([n.p.]: American Institute of Musicology, 1960) and Melin, *Johannes Tinctoris*. Schering, *Geschichte der Musik*, included the opening sections of Weerbeke's Lamentations.

presented 'Adoramus te Christe', the second 'Benedictus Dominus Deus Israel' and complete editions of Lamentations by Weerbeke and Lapidida for the first time. Thomas's dissertation also provided some useful discussion of the layout of 1506/1 and 1506/2. He correctly suggested that the presentation of 1506/2 had been given adequate thought by Petrucci, implying that the material following the de Quadris Lamentations in 1506/1 was not quite so well organised.⁷⁰ However, Thomas did not realise the significance of this material as *laude*. He also criticised the description of the prints in RISM, showing that the number of Lamentations had been incorrectly calculated.

One of the composers central to the Petrucci Lamentations is Johannes de Quadris; Cattin first discussed the sources, works and style of this composer in 1964, revealing de Quadris's association with St Mark's, Venice.⁷¹ Laurenz Lütteken's subsequent discovery of documents relating to de Quadris supported Cattin's theories that the composer was a priest at St Mark's.⁷² Margaret Bent's article provided proof that the earliest manuscript of de Quadris's Lamentations, VicAC II, was compiled as part of the bequest of the Bishop of Vicenza.⁷³ This discovery partially explained the significance of the de Quadris Lamentations in 1506/1. Leeman L. Perkins mentioned the Lamentations of de Quadris and questioned his decision to use only two voices in this setting, at a time when most polyphonic settings were composed for a minimum of three parts.⁷⁴ While he suggested that any restriction on voice parts might be due to limited performance resources or the inappropriateness of a large scale setting for such a sensitive text as the Lamentations, he failed to connect the potential for performance by secular and para-liturgical groups, in particular the *laudesi*. Perkins observed the stylistic contrast between the

⁷⁰ Thomas, 'Two Petrucci Prints', pp. 46-47.

⁷¹ Cattin, 'Il presbyter Johannes de Quadris', 5-47.

⁷² Laurenz Lütteken, 'Musicus et cantor diu in ecclesia Sancti Marci de Veneciis: Note biografiche su Johannes de Quadris', *Rassegna veneta di studi musicali*, 5-6 (1989-90), 43-62 (pp. 47-53).

⁷³ Margaret Bent, 'Pietro Emiliani's Chaplain Bartolomeo Rossi da Carpi and the Lamentations of Johannes de Quadris in Vicenza', *Il saggiatore musicale*, 2 (Florence: L. S. Olschki, 1995), 5-15.

⁷⁴ Leeman L. Perkins, *Music in the Age of the Renaissance* (New York; London: Norton, 1999), p. 347.

restrained 1506 settings and later sixteenth-century Lamentations.⁷⁵ He also noted the similarity of the versions of 'Cum autem venissem' in 1506/1 and Serafino Razzi's 1563 *lauda* print.

William Melin's 1973 doctoral thesis presented a thorough examination of the music of Tinctoris; his analysis of cadential behaviour in the Lamentation settings was particularly useful. In 1976 he provided a printed edition of Tinctoris's Lamentation settings, expanding Feldmann's 1960 Tinctoris edition and including the previously unedited 1506 Lamentations.⁷⁶

Cattin's 1973 discovery of CapePL 3.b.12 was undoubtedly too late for inclusion in Ronald L. Miller's 1974 doctoral dissertation which discussed de Orto's Lamentation setting.⁷⁷ Miller concurred with Massenkeil and suggested that there was no *cantus prius factus* in the de Orto Lamentation setting (I will discuss the suggestion of a Spanish *cantus firmus* in chapter 3).⁷⁸ Miller noted a more restrained style in de Orto's Lamentations and suggested that this was analogous with the textual material. He also concluded that the setting was a 'later work' due to a strong sense of chordal progression.⁷⁹ This was a somewhat contradictory statement, considering that de Orto lived for at least another 23 years following the publication of 1506/1. Allan Atlas and Anthony Cummings revealed that Agricola had returned to Naples in early 1494, following his visit in 1492, suggesting that his popularity at that court was considerable.⁸⁰

The life and works of Erasmus Lapidica are somewhat mysterious and the 2003 entry in MGG by Michele Calella contains some new theories, the principal one being that 'Rasmo' and 'Lapidica' may be two different composers.⁸¹ Calella presented some stylistic evidence to support his theory but was forced to note that his findings must remain inconclusive.

⁷⁵ Perkins, *Ibid.*, p. 567, noted the absence of strophic and repetitive procedures in the music of Carpentras and others.

⁷⁶ Melin, *Johannes Tinctoris*.

⁷⁷ Ronald L. Miller, 'The Musical Works of Marbriano de Orto: Transcription and Commentary' (Unpublished Doctoral Dissertation, Indiana University, 1974).

⁷⁸ See *ibid.*, p. 153, and Massenkeil, *Mehrstimmige Lamentationen*, p. 8*.

⁷⁹ Miller, 'The Musical Works', p. 158.

⁸⁰ Allan W. Atlas and Anthony M. Cummings, 'Agricola, Ghiselin and Alfonso II of Naples', *Journal of Musicology*, 4 (1989), 540-548.

⁸¹ Michele Calella, 'Lapidica, Lapidice, Erasmus, Rasmo', *Die Musik in Geschichte und Gegenwart*, 10 (2003), 1202-1204 (p. 1203).

Jonathan Glixon presented a musical analysis of the *lauda* in 1990, specifically the music of Innocentius Dammonis.⁸² He summarised the *lauda* style of the sixteenth century, noting that 'the true *lauda* style seems rather far removed from the refined motets of the Netherlanders in Italy, but may well have been the only polyphonic *lauda* form of the period during which the supposed influence took place'.⁸³ Glixon's findings demonstrated the interest of the Venetian *Scuole* in the music of Holy Week and provided intricate details of the processions. The *lauda* style, particularly the strictly chordal Latin motets found in the Milanese *motetti missales* and other devotional text settings composed in Italy around the turn of the century, received the attention of Bonnie Blackburn in 2001.⁸⁴ She proposed the label 'devotional style' for such motets, noting that they frequently used consecutive fermatas and were far more chordal than the typical Italian *lauda*. Jonathan Glixon's comprehensive archival research pertaining to the Venetian *Scuole* culminated in his 2003 book.⁸⁵ The principal focus of the book is the *Scuole Grandi*, although his examination of the activities of the lesser known *Scuole Piccole* is arguably more useful. We are lacking crucial evidence relating to the repertoire of the *Scuole Grandi* although Glixon noted that the professional *cantadori de laude* contained a Soprano, Contra (whether this is a high or low voice is not recorded) and Tenor during the later fifteenth century.⁸⁶ Might these have been some of the personnel to sing the Lamentations of de Quadris and the *laude* in 1506/1?

⁸² Jonathan E. Glixon, 'The Polyphonic Laude of Innocentius Dammonis', *Journal of Musicology*, 8, no. 1 (1990), 19-53.

⁸³ *Ibid.*, 40.

⁸⁴ Bonnie J. Blackburn, 'The Dispute about Harmony c. 1500 and the Creation of a New Style', in *Théorie et analyse musicales 1450-1650/Music Theory and Analysis. Actes du colloque international, Louvain-la-Neuve, 23-25 septembre 1999*, ed. Anne-Emmanuelle Ceulemans and Bonnie J. Blackburn. *Musicologica neolovaniensia, studia 9* (Louvain-la-Neuve: Département d'Histoire de l'Art et d'Archéologie, Collège Érasme, 2001), 1-37 (p. 13).

⁸⁵ Jonathan E. Glixon, *Honoring God and the City: Music at the Venetian Confraternities, 1260-1807* (New York; Oxford: Oxford University Press, 2003).

⁸⁶ *Ibid.*, p. 101.

1.7 Bibliographical issues: Paper and watermark studies

There are few studies devoted to the analysis, effect and use of paper in early music prints and the lack of sample evidence would appear to be a significant factor in this respect. Since the study of paper is common to many disciplines, musicologists have relied upon the findings of bibliographers, particularly in respect of specialised studies. Allan Stevenson's writings have been particularly influential upon musicologists; his article 'Watermarks Are Twins' was one of the first studies to investigate the usefulness of twin watermarks, particularly relevant to students of Petrucci. Stevenson provided ample evidence to suggest that papermakers frequently made the twin distinctive (rather than providing an imitation of the main mark).⁸⁷ Jan LaRue challenged some of Stevenson's assumptions in his 1998 work; the distortion of chain lines concerned LaRue, particularly their effect in causing erratic watermarks (although he noted that this effect was generally found in inferior papers).⁸⁸

Jeremy Noble was one of the first musicologists to tackle music papers in a scientific manner and his innovative 1978 article concerned paper distribution in the prints of Petrucci; Noble revealed that 1506/2 was one of only a few Petrucci copies to contain two watermarks.⁸⁹ His scholarship contrasted with the cautious approach to paper study by Stanley Boorman. Peter Wright's 1995 paper also used contextual evidence; he provided a detailed analysis of the papers constituting Trent MS 91.⁹⁰ He compared the paper found in the musical fascicles with that found in dated legal and civil papers from the Trent area. Wright showed that there was a strong possibility that most of the

⁸⁷ Allan Stevenson, 'Watermarks Are Twins', *Studies in Bibliography*, 4 (1951-52), 57-91.

⁸⁸ Jan LaRue, 'Watermarks and Musicology', *Acta musicologica*, 33 (1961), 120-146; Jan LaRue, 'Watermarks Are Singles, Too: A Miscellany of Research Notes', in *Haydn, Mozart and Beethoven: Studies in the Music of the Classical Period - Essays in Honor of Alan Tyson*, ed. S. Brandenburg (Oxford: Clarendon, 1998), pp. 1-12.

⁸⁹ Jeremy Noble, 'Ottaviano Petrucci: His Josquin Editions and Some Others', in *Essays Presented to Myron P. Gilmore*, ed. S. Bertelli and G. Ramakus, 2 vols. (Florence: La Nuova Italia, 1978), II, 433-445 (p. 442).

⁹⁰ Peter Wright, 'Paper Evidence and the Dating of Trent 91', *Music & Letters*, 76 (1995), 487-517.

manuscript must have been copied in Trent itself (at a slightly later date than previously thought).

Research relating to Petrucci vastly improved towards the end of the twentieth century and musicologists will warmly welcome Professor Boorman's imminent monograph on Petrucci.⁹¹ A useful asset would be a catalogue of Renaissance musical manuscript and print watermarks; so far we only have piecemeal studies in this respect. The internet-based Thomas Gravell watermark archive and the internet version of Piccard's volumes have demonstrated the potential to students of bibliography; perhaps the data of Jeremy Noble would provide a basis for an internet music-based archive.⁹²

1.8 Bibliographical issues: Print production and Petrucci

Studies devoted to Petrucci date from as far back as the nineteenth century although none specifically discuss 1506/1 and 1506/2 in any detail. Anton Schmid completed the first comprehensive study of Petrucci in 1845 and was the first musicologist to identify Francesco Ana as being a Venetian organist. Augusto Vernarecci's monograph provided much biographical information in 1881 and was the first to reveal Petrucci's commercial interests in paper mills.⁹³ Schmid and Vernarecci's findings subsequently influenced a number of scholars including Chrysander, Squire, Meyer and Pattison.⁹⁴

⁹¹ Stanley Boorman, *Ottaviano Petrucci: Catalogue Raisonné* (New York: Oxford University Press, forthcoming).

⁹² The Thomas Gravell watermark archive is based at the University of Delaware, USA: and incorporates the C-M Briquet at the Bibliothèque publique et universitaire, Geneva: <<http://www.gravell.org/>> [accessed 2 July 2004]. An online version of Piccard's watermark volumes, based at the Hauptstaatsarchiv Stuttgart, is available at: <<http://www.lad-bw.de/ladsu/piccard/sitemap.php>> [accessed 2 July 2004].

⁹³ Anton Schmid, *Ottaviano dei Petrucci da Fossombrone, der erste Erfinder des Musiknotendruckes mit beweglichen Metalltypen, und seine Nachfolger im Sechzehnten Jahrhundert* (Amsterdam: Gruner, 1845/1968r); Augusto Vernarecci, *Ottaviano de' Petrucci da Fossombrone* (Fossombrone: [n. pub.], 1881), p. 163.

⁹⁴ Friedrich Chrysander, 'A Sketch of the History of Music-Printing from the Fifteenth to the Nineteenth Century', *Musical Times*, 18 (1877), 265-268; William Barclay Squire, 'Notes on Early Music Printing', *Bibliographica*, 3 (1897), 99-122; Kathi Meyer (in Collaboration with Eva Judd O' Meara), 'The Printing of Music 1473-1934', *The Dolphin*, 2 (1935), 171-207 and Bruce Pattison, 'Notes on Early Music Printing', *The Library*, 4th ser., 19 (1939), 389-421.

The first major work of the twentieth century dedicated to Petrucci's catalogue was compiled by Claudio Sartori. He provided a useful work list for the publications of Petrucci, and described contents, attributions, ascriptions and holding libraries for these prints. Sartori's principal emphasis concerned the central Petrucci prints such as *Odhecaton*, but he didn't discuss the context of the Lamentation or *laude* volumes. Jeppesen evaluated this scholarship in the same year and Sartori produced his corrections in 1953.⁹⁵ George Warren Drake's 1972 doctoral thesis provided a useful analysis of the contents and style of Petrucci's prints,⁹⁶ and suggested that the anonymous pieces in 1503/1 may be *contrafacta of laude*.⁹⁷

The ground-breaking methodology of Boorman in relation to music printing, particularly the output of Petrucci, has been highly influential. In his 1976 doctoral dissertation, he supplied us with a wealth of material concerning Petrucci and presented much new data relating to Petrucci's catalogue.⁹⁸ Boorman first tested his theories concerning font analysis, Petrucci's order of imposition and paper types in this thesis. His analysis of *Odhecaton* gave a valuable insight into the compilation methods of Petrucci.⁹⁹ Boorman established a list of criteria by which he began to assess the reasons for the different sheets in the Bologna copy of *Odhecaton*; these criteria included watermark and typographical differences.

⁹⁵ Claudio Sartori's *Bibliografia delle opere musicali stampate da Ottaviano Petrucci*, Biblioteca di bibliografia italiana, 18 (Florence: Leo S. Olschki, 1948) was reviewed by Knud Jeppesen, 'Canzoni sonetti strambotti et frottole, libro tertio (Andrea Antico, 1517) edited by Alfred Einstein. Smith College Music Archives. Number IV. Copyright 1941. Claudio Sartori: *Bibliografia delle Opere musicali stampate da Ottaviano Petrucci*. Firenze, Leo S. Olschki, 1948', *Acta musicologica*, 20 (1948), 78-85. Claudio Sartori's amended list is 'Nuove conclusive aggiunte alla "Bibliografia dal Petrucci"', *Collectanea historiae musicae*, 1 [= *Biblioteca historiae musicae cultores*, 2] (1953), 175-210.

⁹⁶ George Warren J. Drake, 'The First Printed Book of Motets, Petrucci's *Motetti A. numero trentatre A* (Venice, 1502) and *Motetti de passione de cruce de sacramento de Beata Virgine et huiusmodi* (Venice, 1503); A Critical Study and Complete Edition' (Unpublished Doctoral Dissertation, University of Illinois, 1972).

⁹⁷ *Ibid.*, p. 92. He quoted weak stylistic practice, such as poor voice leading, as one of his reasons for assuming an association with the Italian *lauda*.

⁹⁸ Stanley Boorman, 'Petrucci at Fossombrone: A Study of Early Music Printing with Special Reference to the *Motetti de la Corona (1514-1519)*' (Unpublished Doctoral Dissertation, University of London, 1976).

⁹⁹ Stanley Boorman, 'The "First" Edition of the *Odhecaton A*', *Journal of the American Musicological Society*, 30 (1977), 183-207.

Helen Hewitt's doctoral dissertation and subsequent editions were the first systematic and comprehensive Petrucci print studies.¹⁰⁰ Her extensive 1942 preliminary material (with Isabel Pope) described many aspects of *Odhecaton* including composer choice and production issues. She noted that none of Petrucci's song series had an accurate title; Warren Drake also addressed this theme and I will discuss it in chapter 5.¹⁰¹ Boorman continued his work on the typography of Petrucci in 1981.¹⁰² He identified patterns of use in the decorated capital letters, watermarks and printer's annotations employed in Petrucci's prints; these enabled him to identify cancel sheets in the later publications of Petrucci. Boorman published his seminal work on Petrucci's production methods, proving that the half sheet work-and-turn method was used in various editions published in Venice (I will show in chapter 4 that there is evidence of this method in all extant copies of 1506/1).¹⁰³ William Prizer commented that Petrucci's second *laude* book was full of errors;¹⁰⁴ might there be parallels between the production of this volume and 1506/1?

John Milsom's 1996 paper is essential reading for those analysing production methodology in early music prints.¹⁰⁵ He showed that a single extant printed copy may be unique amongst surviving copies of that work and suggested that extreme caution is required when analysing data.¹⁰⁶ He also extended some of Boorman's doctoral theories concerning the identity and characteristics of individual typesetters. Jeremy Smith's 1999 paper concerned the prints of William Byrd; Smith's methodology, particularly that concerning

¹⁰⁰ Helen Hewitt, ed., *Harmonice musices odhecaton A*, Edition of the Literary Texts by Isabel Pope (Cambridge, Mass: The Mediaeval Academy of America, 1942); Helen Hewitt, ed., *Canti B numero cinquanta. Venice 1502*, With an Introduction by Edward E. Lowinsky, Texts Edited and Annotated by Morton W. Briggs, Translated by Norman B. Spector (Chicago; London: University of Chicago Press, 1967).

¹⁰¹ George Warren J. Drake, ed., *Motetti de passione, de cruce, de sacramento, de Beata Virgine et huiusmodi B: Venice, 1503*, Monuments of Renaissance Music; 11 (Chicago; London: University of Chicago Press, 2002). His comprehensive introduction included discussions concerning target markets and the wording of the title of this print.

¹⁰² Stanley Boorman, 'Petrucci at Fossombrone: Some New Editions and Cancels', in *Source Materials and the Interpretation of Music: A Memorial Volume to Thurston Dart*, ed. Ian Bent and Michael Tilmouth (London: Stainer & Bell, 1981), 129-153.

¹⁰³ Stanley Boorman, 'A Case of Work and Turn: Half-Sheet Imposition in the Early Sixteenth Century', *Library*, 8/4 (1986), 301-321.

¹⁰⁴ Prizer, 'Laude di popolo', 180. It should be noted that Petrucci's second *laude* book was published before the first *laude* book.

¹⁰⁵ John Milsom, 'Tallis, Byrd and the "Uncorrected Copy": Some Cautionary Notes for Editors of Early Music Printed from Movable Type', *Music & Letters*, 77 (1996), 348-365.

¹⁰⁶ *Ibid.*, 348-349.

the deterioration of individual sorts, is applicable to all early music printing. His analysis was combined with other evidence, including legal and geographical findings, resulting in a challenge to previously held theories about Byrd's music prints.¹⁰⁷

Birgit Lodes made another important contribution to the analysis of music printing in 2001, examining the differences between stave imposition, ligature use and text setting in the printing of Jacob Obrecht Masses by Petrucci and the German printer Gregor Mewes (for example, Mewes managed to set multiple ligatures whereas Petrucci's maximum was *ligatura binaria*). Lodes concluded that Petrucci's technical influence was more limited than previously thought.¹⁰⁸

1.9 Bibliographical issues: Print viability and commercial issues

There were several important papers relating to commercial issues in early music printing; most of them mention the problem of lack of data and exercise caution when making deductions about their findings. These papers raised questions pertaining to print runs, pricing structure, contracts between printer and composer, commissioning of prints, distribution and demand. Catherine W. Chapman's study was one of the first to provide some data; her report, concerning the registers of Columbus's extensive library, revealed the monetary value of much of the Petrucci catalogue and compared its prices with those of other printers in this collection. Chapman also listed a print of German lute transcriptions of Lamentations, now lost.¹⁰⁹ More Spanish valuations were revealed by Tess Knighton who discussed the existence of a number of Petrucci prints in a bookseller's inventory of the mid-sixteenth

¹⁰⁷ Jeremy L. Smith, 'From "Rights to Copy" to the "Bibliographic Ego": A New Look at the Last Early Edition of Byrd's "Psalms, Sonets & Songs"', *Music & Letters*, 80 (1999), 511-530.

¹⁰⁸ Birgit Lodes, 'An Anderem Ort, auf Andere Art: Petruccis und Mewes Obrecht-Drucke', *Basler Jahrbuch für historische Musikpraxis*, 25 (2001), 85-111.

¹⁰⁹ Catherine Weeks Chapman, 'Printed Collections of Polyphonic Music Owned by Ferdinand Columbus', *Journal of the American Musicological Society*, 21 (1968), 32-84 (p. 84).

century. She noted the existence of a 'lamentaciones Geremie a 4 veus' amongst the Petrucci items.¹¹⁰

Richard Agee tackled issues of finance, investment and marketing in early music publishing in 1983 and 1986.¹¹¹ The latter article described the conditions for the commission of a set of mid-sixteenth-century Lamentations, supplying valuable information about print runs in Venice. Jane Bernstein's work of 1991 discussed the implications of the relationship between printer, publisher and composer during the sixteenth century.¹¹² She suggested that most musical publications involved substantial underwriting, particularly for specialised prints. Bonnie Blackburn's 1994 article focused upon an Italian printing contract, extending the meagre data available on such material.¹¹³ Blackburn took a more contextual approach in her 1995 work which examined the relationship between Petrucci and his musical editor.¹¹⁴ She also hypothesised that Petrucci's repertoire was reliant on composers working in Rome since one of Castellanus's singers probably visited that city. She noted that several singers including Josquin des Prez, Gaspar van Weerbeke and Marbrianus de Orto who worked at the Papal chapel during 1487, were later represented in Petrucci's prints.¹¹⁵ Reinhard Strohm briefly discussed the music of de Quadris, as well as mentioning the concept of market value in relation to the 1506 prints.¹¹⁶

Bernstein's 1997 research proved that there was a wide profile to the purchaser of music books during the sixteenth century.¹¹⁷ In her survey she

¹¹⁰ Tess Knighton, 'Petrucci's Books in Early Sixteenth-Century Spain', Conference Paper Presented in Venice, October 2001: 'Venezia 1501: Petrucci e la stampa musicale'. I am extremely grateful to Dr Knighton for allowing me to use her findings.

¹¹¹ Richard J. Agee, 'The Venetian Privilege and Music-Printing in the Sixteenth Century', *Early Music History*, 3 (1983), 1-42; Richard J. Agee, 'A Venetian Music Printing Contract and Edition Size in the Sixteenth Century', *Studi musicali*, 15 (1986), 59-65.

¹¹² Jane A. Bernstein, 'Financial Arrangements and the Role of Printer and Composer in Sixteenth-Century Italian Music Printing', *Acta musicologica*, 63 (1991), 39-56.

¹¹³ Bonnie J. Blackburn, 'The Printing Contract for the *Libro primo de musica de la salamandra* (Rome 1526)', *Journal of Musicology*, 12 (1994), 345-356.

¹¹⁴ Bonnie J. Blackburn, 'Petrucci's Venetian Editor: Petrus Castellanus and his Musical Garden', *Musica disciplina*, 49 (1995), 15-45.

¹¹⁵ *Ibid.*, 29-30.

¹¹⁶ Strohm, *The Rise of European Music*, pp. 588-589.

¹¹⁷ Jane A. Bernstein, 'Buyers and Collectors of Music Publications: Two Sixteenth-Century Music Libraries Recovered', in *Music in Renaissance Cities and Courts: Studies in Honor of Lewis Lockwood*, ed. Anthony Cummings and Jessie Anne Owens (Michigan: Harmonie Park Press, 1997), 21-33.

noted that printing enabled a new category of purchaser to benefit from the cheaper and more widely distributed printed music book, a theme I shall address in chapter 5. Martha Feldman discussed print repertoire in her 2000 paper; she suggested that music publishers avoided the inclusion of anonymous works on financial grounds, preferring to suggest any likely ascription instead.¹¹⁸ Boorman provided a résumé of his latest findings in 2001 and presented a series of important arguments.¹¹⁹ He suggested that print runs for the specialised market were not likely to be anything near 500; one of the methods by which he arrived at this conclusion was by comparing print runs against the number of supposed singers in Italy (he concluded that there were far too few singers to purchase all those books).¹²⁰ The Basle Petrucci conference produced several important findings relating to commercial issues, including those of Bonnie Blackburn, Stanley Boorman, David Fallows and John Kmetz.¹²¹ Most papers mentioned that Petrucci was making these prints for a living; opinions differed slightly as to his rationale. Kmetz suggested that the early song series was aimed at an international market, arguing that the lack of texts (particularly *Odhecaton*) made them suitable for text substitution in performance.¹²² Fallows observed the change in performance complexity following Petrucci's early song series; he concluded that the switch in production to the single Mass volumes suggested that Petrucci may have aimed these products at collectors, as well as the usual outlets.¹²³ Blackburn also addressed the effects of the market and suggested that Petrucci's much-simplified canonic instructions and solutions, particularly when compared to

¹¹⁸ Martha Feldman, 'Authors and Anonyms: Recovering the Anonymous Subject in Cinquecento Vernacular Objects', in *Music and the Cultures of Print*, ed. Kate van Orden (New York: Garland Publishing Inc., 2000), 163-199.

¹¹⁹ Stanley Boorman, 'Thoughts on the Popularity of Printed Music in 16th-Century Italy', *Fontes artis musicae*, 48/2 (2001), 129-144.

¹²⁰ *Ibid.*, 136-137.

¹²¹ Bonnie J. Blackburn, 'Canonic Conundrums: The Singer's Petrucci', *Basler Jahrbuch für historische Musikpraxis*, 25 (2001), 53-69; Stanley Boorman, 'Did Petrucci's Concern for Accuracy Include Any Concern with Performance Issues?', *Basler Jahrbuch für historische Musikpraxis*, 25 (2001), 23-37; David Fallows, 'Petrucci's *Canti* Volumes: Scope and Repertory', *Basler Jahrbuch für historische Musikpraxis*, 25 (2001), 39-52; John Kmetz, 'Petrucci's Alphabet Series: The ABC's of Music, Memory and Marketing', *Basler Jahrbuch für historische Musikpraxis*, 25 (2001), 127-141.

¹²² Kmetz, 'Petrucci's Alphabet Series', 134-135.

¹²³ Fallows, 'Petrucci's *Canti* Volumes', 41.

the complexity of contemporary manuscripts, probably indicated that he was aware of the newly emerging amateur market in music printing.¹²⁴

Jane Bernstein's 2001 book addressed the subject of marketing with a focus on the mid-sixteenth-century publishers Antonio Gardano and Ottaviano Scotto.¹²⁵ She reminded us that these two publishers produced a wide range of music, encompassing various genres and often specialising in specific geographical areas. Petrucci, in many respects, was responsible for laying the foundations for the profitable Venetian music publishing business and while his double impression method of printing was soon abandoned, his successors owed much to his business acumen and enterprise.¹²⁶

Teresa M. Gialdroni and Agostino Ziino revealed some of Petrucci's financial assets in their 2001 collaboration.¹²⁷ They expanded Vernarecci's 1881 findings concerning Petrucci's paper mill and revealed that he had managed to overcome his significant financial outlay and presumably make a profit from his emerging music publishing business. Such creation of wealth and prosperity often resulted in peer respect and social status; James Haar's recent finding supported these ideas and he suggested that 'Ottavium fososempronensis', mentioned in a list of the top one hundred citizens in Venice, was indeed Petrucci.¹²⁸

Jonathan Glixon published the first of several important contributions relating to the Italian *laudesi* in 1981.¹²⁹ Glixon's painstaking archival research inspired a new understanding of the Italian *laudesi*, including their organisation, finances and enthusiasm for the performance of *laude* (which resulted in

¹²⁴ Blackburn, 'Canonic Conundrums', 57.

¹²⁵ Jane A. Bernstein, *Print Culture and Music in Sixteenth-Century Venice* (New York, Oxford: Oxford University Press, 2001).

¹²⁶ Bernstein, *Ibid.*, p. 140, noted the early involvement of the Scotto and Gardano printing houses in commercialising printing and moving from Petrucci's double impression to single impression.

¹²⁷ Teresa M. Gialdroni and Agostino Ziino, 'New Light on Ottaviano Petrucci's Activity, 1520-38', *Early Music*, 29 (2001), 501-532.

¹²⁸ James Haar, 'Petrucci as Bookman', Conference Paper Presented in Venice, October 2001: 'Venezia 1501: Petrucci e la stampa musicale'. I am extremely grateful to Professor Haar for allowing me to use his findings.

¹²⁹ Jonathan E. Glixon, 'Music at the Venetian Scuole Grandi, 1440-1540', in *Music in Medieval and Early Modern Europe*, ed. Iain Fenlon (Cambridge: Cambridge University Press, 1981), 193-208.

several dedicated music manuscripts). I will later argue that the *laudesi* were probably considered as a potential market for 1506/1 and 1506/2.

1.10 Manuscript sources of 1506/1 and 1506/2

In 1927 D. Paolo Guerrini undertook a short but comprehensive analysis of the context and contents of WashLC J6.¹³⁰ It was one of the first manuscript studies relating to a 1506 concordance and revealed the manuscript's connections with the Benedictine Congregation of S. Giustina in Venice, a theme which Giulio Cattin was to develop during the 1960s and 1970s. F. Alberto Gallo's 1966 article briefly discussed the context of WashLC J6, stating its connection with the church of S. Giorgio Maggiore in Venice. Giulio Cattin considerably expanded and enhanced Gallo's 1966 work on the manuscript WashLC J6.¹³¹ He revealed a wide range of concordances of that manuscript and concluded that it must reflect the tastes and context of a northern Italian monastic tradition. Cattin's other paper published in 1968 provided an inventory and introduction to PavU 361.¹³²

Cattin discussed the contents and dates of WashLC J6 and BolC Q13, placing these sources in the context of the Benedictine reformed Cassinese congregation.¹³³ He provided the first detailed analysis of VicAC 11 in 1970 and presented evidence for a connection with Vicenza and Venice as well as information relating to the liturgical context and contents of this important manuscript.¹³⁴ Cattin also revised his previously-held theory that the manuscript dated from the first quarter of the fifteenth century, having discovered an association between VicAC 11 and a Saint's festival in Vicenza

¹³⁰ D. Paolo Guerrini, 'Un codice piemontese di teorici musicali del medioevo', *Rivista musicale italiana*, 34 (1927), 63-72.

¹³¹ Giulio Cattin, 'Polifonia quattrocentesca italiana nel codice Washington, Library of Congress, ML 171 J 6', *Quadrivium*, 9 (1968), 87-102 and tav. III-IV.

¹³² Giulio Cattin, 'Le composizioni musicali del Ms. Pavia Aldini 361', *L'Ars nova italiana del Trecento*, 2 (1968), 1-21.

¹³³ Cattin, 'Tradizione e tendenze', 254-299.

¹³⁴ Giulio Cattin, 'Uno sconosciuto codice quattrocentesco dell'Archivio Capitolare de Vicenza e le lamentazioni di Johannes de Quadris', *L'Ars nova italiano del Trecento*, 3 (1970), 281-304.

around the middle of the fifteenth century.¹³⁵ The short but important study dealing with FlorD 21 by Federico Ghisi appeared in 1953.¹³⁶ Ghisi described the contents of this processional and noted the significance of the 'Processione Veneris Sancti'.

André Pirro's 1929 article described MonteA 871 and noted the inclusion of Lamentation settings; this was another manuscript associated with the Benedictines.¹³⁷ Pirro suggested that the ascription 'Bernardus', supplied by Montecassino's scribe to the first work in the manuscript, was Bernard Ycart (Isabel Pope; Pope and Masakata Kanazawa supported this theory).¹³⁸ Rudolf Gerber published a second study of MonteA 871 in 1956; he continued Guerrini's 1927 work on this manuscript and provided a partial work list as well as discussing aspects of musical style.¹³⁹ MonteA 871 received some extremely detailed attention from Isabel Pope commencing with her 1966 article.¹⁴⁰ Pope continued the work of Gerber (1956) and supplied vital information about the missing fascicles of that manuscript as well as discussing the existing contents and providing a complete contents list. She noted the connection between the Holy Week repertory and the records of the Neapolitan court; the latter revealed an intense interest in the representation of the Crucifixion within the *Depositio* ceremonies. Isabel Pope continued her work on the manuscript MonteA 871 with Masakata Kanazawa; their 1978 complete edition presented details of the missing fascicles, revealing that much of the Holy Week repertoire belonging to the Naples court had been lost.¹⁴¹ They included the

¹³⁵ *Ibid.*, 292-298, suggested a *terminus post quem* of 1440 for this manuscript.

¹³⁶ Federico Ghisi, 'Un processionale inedito per la settimana santa nell'opera del Duomo di Firenze', *Rivista musicale italiana*, 55 (1953), 362-369.

¹³⁷ André Pirro, 'Un manuscrit musical du XVe siècle au Mont-Cassin', *Cassinensia*, 1 (1929), 205-208.

¹³⁸ Isabel Pope, 'The Musical Manuscript Montecassino N879 [sic]', *Anuario musical*, 19 (1966), 123-153 (p. 137); Pope and Kanazawa, *The Musical Manuscript Montecassino 871*, p. 33.

¹³⁹ Rudolf Gerber, 'Die Hymnen der Handschrift Monte Cassino 871', *Anuario musical*, 11 (1956), 1-21.

¹⁴⁰ Pope, 'The Musical Manuscript Montecassino'.

¹⁴¹ Pope and Kanazawa, *The Musical Manuscript Montecassino 871*, pp. 45-46. They estimated that there were 11 Lamentation settings now missing from MonteA 871 (p. 20). The list of missing Lenten texts also included 'Ubi caritas' [antiphon for Maundy Thursday], 'Sepulto Domino' [part of the Deposition responsory which is set in two parts in 1506/1], 'Passio Domini nostri Jhesu Christi' and 'Alter a autem die'.

tabula that exists in the present binding, but stated that it is not totally reliable (due to the addition of certain pieces following the completion of the *tabula*).

Fritz Feldmann's useful commentary on WarU 2016 (then at Breslau University) was published in 1932.¹⁴² Feldmann supplied a complete index with incipits to WarU 2016; however, he did not attribute the unascribed three-part Lamentation setting in that manuscript to Agricola (Edward Lerner identified this in his 1958 dissertation).¹⁴³ Mirosław Perz discussed the provenance of PozR 1361, particularly the Franciscan origins of this Polish manuscript (he provided an edition of the three-part 'Cum autem' in 1966).¹⁴⁴

In 1972 Cattin provided a complete critical edition of the works of Johannes de Quadris.¹⁴⁵ However, his edition did not include readings for the various stanzas following the *lauda* text 'Cum autem venissem'. He supplied details of these stanzas in 'Canti polifonici...'; he also revealed the extensive use of secular *contrafacta* on the part of the second scribe of CapePL 3.b.12.¹⁴⁶ Cattin noted the use of the Benedictine Cassinese *cantus firmus* in the canticle 'Benedictus Dominus Deus' and he discussed the provenance and addition of a third voice to the two-part *laude* settings found in 1506/1. He suggested tentative links with MonteA 871 and stronger connections between other Benedictine manuscripts such as WashLC J6 and BolC Q13.

The discovery of CapePL 3.b.12 by Giulio Cattin is crucial to our understanding of the Holy Week repertoire. He presented his findings in 1973 and provided an invaluable study of the organisation and rationale behind the selection of this music.¹⁴⁷ Cattin discussed the use of secular models as sacred *contrafacta* and described the style and preferences of the two principal

¹⁴² Fritz Feldmann, *Der Codex Mf. 2016 des Musikalischen Instituts bei der Universität Breslau. Eine palaeographische und stilistische Beschreibung* (Breslau: [n.pub], 1932).

¹⁴³ Lerner, 'The Sacred Music of Alexander Agricola', p. 58.

¹⁴⁴ Mirosław Perz, 'Handschrift Nr. 1361 der Öffentlichen Städtischen Raczyński-Bibliothek in Poznań als Neue Quelle zur Geschichte der Polnischen Musik in der II. Hälfte des XV. Jahrhunderts', in *The Book of the First International Musicological Congress Devoted to the Works of Frederick Chopin, Warszawa, 16th-22nd February 1960*, ed. Zofia Lissa (Warsaw: Polish Scientific Publishers, 1963), 588-592.; Mirosław Perz, ed., 'Cum autem venissent', in *Muzyka Staropolska*, ed. H. Feicht (Cracow: [n.pub.], 1966).

¹⁴⁵ Cattin, *Johannes de Quadris*.

¹⁴⁶ Giulio Cattin, 'Canti polifonici del repertorio benedettino in uno sconosciuto «Liber Quadragesimalis» e in altre fonti italiane dei secoli XV e XVI inc.', *Benedictina*, 19 (1972), 445-537.

¹⁴⁷ Giulio Cattin, 'Nuova fonte italiana della polifonia intorno al 1500 (MS. Cape Town, Grey 3.b.12)', *Acta musicologica*, 45 (1973), 165-221.

scribes. Cattin turned his attention towards FlorD 21 in 1974.¹⁴⁸ His comprehensive musicological study placed this manuscript in its liturgical context, revealing its principal function as a source of music for the *Depositio* Procession. Cattin's 1977 edition of the *laude* in CapePL 3.b.12 included transcriptions of Anon. 1's Lamentation setting (illustrating the considerable difference between CapePL 3.b.12's Contra and that of 1506/1) and the anonymous 'Sepulto Domino' with its additional Contra part.¹⁴⁹ He discussed much of the music of this manuscript and reinforced his argument that its repertoire was synonymous with the Benedictine congregation of S. Giustina, showing that this manuscript had several concordances of the Giustinian manuscript MonteA 871 and emphasising the Benedictine enthusiasm for sacred and secular polyphony.

¹⁴⁸ Giulio Cattin, 'Un processionale fiorentino per la settimana santa: Studio liturgico-musicale sul Ms. 21 dell'opera di S. Maria del Fiore', *Quadrivium*, 15 (1974), 53-204.

¹⁴⁹ Cattin, *Italian Laude*.

Chapter 2

TEXTS AND THEIR PERFORMANCE IN 1506/1 AND 1506/2

2.1 Lamentation texts

1506/1 and 1506/2 contain two categories of text: verses which originate from the Lamentations of Jeremiah and miscellaneous texts relating to Holy Week. Table 2.01 (below) shows the considerable variety of Lamentation verses within the settings; the second column from the left [*Ch. 1*] indicates that chapter 1 of the Lamentations was the most popular.

Table 2.01: Lamentation chapters and verses used in 1506/1 and 1506/2

<i>Composer</i>	<i>Lamentation chapter and verse</i>				
	<i>Ch. 1</i>	<i>Ch. 2</i>	<i>Ch. 3</i>	<i>Ch. 4</i>	<i>Ch. 5</i>
Tinctoris	1-3, J				
Ycart	1-3, J	In; 1-2, 9, ¹ J			1-8
Anon. 1	1-3, J				
Agricola (a3)	1-3, J; 4-7, J				
Agricola (a4)		1-2, J; 3-5, J; 6, J			
de Orto	In; 1-3, J				
de Quadris	In; 1-4, J; 5-8, J; 9-12, J	8-11, J; 12-15, J; 16-18, J; 20, J	33-45	17, J; 18-22, J	1-4, 7-11, 14-18, J
Tromboncino	In; 1-4, J; 5-7, J; 8-12, J; ² 13-16, J; 18-21, J	1-4, J; 5-8, J; 9- 12, J	27 ³		In; 1-16, J
Weerbeke	In; 1-2, J; 4, 5*, J; 6*, 7*, J		22-23, 25, J	1, 3*, J	In; 1-3, J
Lapicida	In; 1-3, J; 4-5, J; 6-7, J				

What are the reasons for the wide variety of verse choice evident in the 1506 Lamentations? Does this diversity reflect liturgical or para-liturgical influences, or the lack thereof? It is clear that the pre-Tridentine church followed a diverse pattern of liturgical practices, based on local Uses and customs.⁴ The initial

¹ Verse 9 is not complete.

² Verse 13 is prefaced with the text 'Sequitur de Lamentatione Jeremie prophete'. This is the only use of such a phrase in the 1506 prints.

³ Ch. 3:27 follows the end of ch. 2:12, being set in the Tenor and Bassus on fols 28^v-29^r, 1506/2 (Tromboncino); this verse is then followed by the word 'sua' in all voices.

⁴ David Crawford, 'Vespers Polyphony at Modena's Cathedral in the First Half of the Sixteenth Century' (Unpublished Doctoral Dissertation, University of Illinois, 1967), p. 219. He added that present day liturgical books were not a good representation of pre-

practice of the early medieval church in dividing the five chapters of the Lamentations more or less equally to be presented at the first Nocturns of Matins in Holy Week had been somewhat curtailed by the fourteenth and fifteenth centuries.⁵ The *Triduum* was one of the few liturgies to have survived various reforms since the Middle Ages;⁶ Matins was divided into three Nocturnes with preceding Psalms and responds. The practice of adding a prefatory non-scriptural text emerged during the late Middle ages; Lesson 1 on Maundy Thursday is prefaced by 'Incipit Lamentatio Jeremie Prophete', Lesson 1 on Good Friday by 'De Lamentatione Jeremiae Prophete' and Lesson 3 on Holy Saturday by 'Incipit Oratio Jeremiae Prophete'. The concluding statement 'Jerusalem convertere ad Dominum Deum tuum' was also appended to the close of each section around the same period.⁷

The popularity of the first chapter of the Lamentations is illustrated by its inclusion in every 1506 setting with the exception of Agricola's four-part setting (although Agricola's three-part setting begins with ch. 1:1). Table 2.01 shows that there is considerable variety in the placing of the 'Jerusalem' refrain. The initial statement of this refrain in chapter 1 is typically found after verse 3; however, de Quadris and Tromboncino state the refrain after verse 4 and Weerbeke after verse 2. Some settings preface the first verse of chapter 1 with 'Incipit Lamentatio Jeremie' although Ycart, one of the composers who omits the 'Incipit' before ch. 1:1, uses it before setting chapter 2.

Chapters 2-5 are not as prevalent in the 1506 Lamentations, particularly chapters 3 and 4. De Quadris is the only composer to include extracts from each of the five chapters although concordant manuscripts with his setting do not include the same verse choice (this will be discussed below).⁸

Each of the twenty-two letters of the Hebrew alphabet successively prefaces each verse in chapters 1-4. While there is some consistency in the use of these

Reformation practices and that Italian churches did not follow set liturgical books till after the Council of Trent.

⁵ Snow, *A New-World Collection*, pp. 49-55. Snow's findings showed that there was much variety in the selection of verses retained and used by the Renaissance church during this period. Thomas, 'Two Petrucci Prints', p. 3, suggested that it was not possible to use each chapter in its entirety due to length.

⁶ Harper, *The Forms and Orders*, p. 140.

⁷ Schröder, 'Les Origines des lamentations', 353.

⁸ Weerbeke's is the only setting to omit words and change word order. Appendix 2 notes the differences in text use between the 1506 texts and contemporary Breviaries.

letters in the 1506 Lamentations, there are a couple of variants. De Quadris's setting of chapter 1:5 prefaces 'Teth', rather than 'He' as found in Agricola's three-part setting, Tromboncino's setting in 1506/2 and contemporary Breviaries. Weerbeke's setting of ch. 3:22 is prefaced by 'Beth' rather than 'Heth'.⁹

Thomas stated that the setting of verses in 1506/2 was better organised than in 1506/1 and suggested that Petrucci might have realised that verses suitable for the liturgy would have led to wider use of the print.¹⁰ His opinion is not corroborated by the evidence, as table 2.01 (shown previously) confirms. None of the settings in 1506/2 place the 'Jerusalem' refrain in the same position for any section; the only consistent textual pattern is the use of the 'Incipit' preface for all settings of chapters 1 and 5.

2.2 Textual content in pre-1506 sources

Was such textual variety exclusive to the 1506 Lamentations or was it found in other contemporary sources? If so, was such variety exclusive to Italian sources or did it also exist outside Italy? Tables 2.02 and 2.03 (below) address some of these issues by listing verses in a selection of pre-1506 sources; it should be noted that any findings need to be carefully balanced against the small number of surviving manuscripts.

⁹ There are minor spelling variations present in some Hebrew letters in 1506/1 and 1506/2. For example, the prefatory letter to ch. 1:5 in Agricola's three-part setting is 'He'; it is 'Hee' in Tromboncino's setting and 'Heth' in contemporary Breviaries.

¹⁰ Thomas, 'Two Petrucci Prints', p. 48.

Table 2.02: Polyphonic Lamentation verses found in a selection of pre-1506 Italian manuscripts¹¹

Composer/MS	Lamentation chapter and verse				
	Ch. 1	Ch. 2	Ch. 3	Ch. 4	Ch. 5
ITALIAN					
Lamentation X (BolU 2931), fols 27 ^r -28 ^r (a2)	In; 1, J				
Lamentation X (BrusC 16857), fols 20 ^v -21 ^r (a2)	In; 1				
Lamentation X (UrbU L712), fols 43 ^v -45 ^r (a2)	In; 1-2, J				
Lamentation X (CapePL 3.b.12), fols 2 ^v -3 ^r	In; 1, J				
Anon. (PadBC C56), 61 ^r -62 ^v 12 (a2)				20, J	3, 15, 16, J
Anon. (BolC Q16), fol. 151 ^v (a2)					1
Anon. (MilD 3), fols 11 ^v -24 ^r (a4)	In; 1-4, J; 5-8, J; 9-12, J				In; 1-10, 12-16, J
Anon. (FlorBN Panc. 27), fols 82 ^v -84 ^r (a3)					In; 1-8, J
[Lapicida] (FlorBN Panc. 27), fols 144 ^v -145 ^r (a4)	In; 1, J				
Anon. 4 (FlorBN Panc. 27), fols 147 ^v -156 ^r (a4)	In; 1-2, J; 3-4, J; 5-7, J				In; 1-4
Anon. 1 (CapePL 3.b.12), fols 95 ^v -101 ^v (a3)					In; 1-4, 6*, 15-17, 20, 22, J
[de Orto] (CapePL 3.b.12), fols 90 ^v -95 ^r (a4)	In; 1-3, J				

¹¹ The inclusion of 1506/1 and 1506/2 concordances is due to different verse selection in these sources.

¹² These texts are used within the context of the *Depositio* procession on Good Friday. They are a compilation of Lamentation verses; the polyphony is based on formulae found in de Quadris's Lamentations.

Table 2.03: Polyphonic Lamentation verses found in a selection of pre-1506 Spanish manuscripts

<i>Composer/MS</i>	<i>Lamentation chapter and verse</i>				
	<i>Ch. 1</i>	<i>Ch. 2</i>	<i>Ch. 3</i>	<i>Ch. 4</i>	<i>Ch. 5</i>
SPANISH					
Anon. (TarrAA)			26-28, J		1-5
Anon. 3 (ParisBNC 967), fols 26 ^v -28 ^r (a2)		1-3, J			
Anon. (SegC ss), fols 151 ^v -155 ^r (a3)	4-5, J			1-2, J	

The popularity of chapter 1 in the 1506 Lamentations is also reflected in the settings shown in the two tables above. Chapter 5 is the next most popular chapter (with the exception of the Spanish settings); this compares with the 1506 Lamentations where chapters 5 and 2 are the next most popular following chapter 1. Every setting of chapter 1 in tables 2.02 and 2.03, with the exception of SegC ss, uses the prefatory 'Incipit Lamentatio...' phrase. The position of the 'Jerusalem' refrain in the Italian and Spanish sources is as varied as those in the 1506 Lamentations, leading one to conclude that there was no uniformity. The Spanish sources contain too few verses to make any reasonable deductions about textual patterns and configurations.¹³

An illustration of the diversity of verse choice is provided by the concordances of de Quadris's Lamentations. The two manuscript sources of this work were associated with liturgical institutions, yet there were variations between the sources (it should be noted that there was also a time lapse of approximately 80 years between the compilation of VicAC II and FlorBN II.I.350; see table 2.04 below). The modular nature of de Quadris's music must have contributed to the significant variations between sources; the musical phrases found in VicAC II are re-used and re-ordered to the texts set in both 1506/1 and FlorBN II.I.350 (the latter essentially uses the same musical ordering of phrases as the other two sources, even though it uses fewer verses).

¹³ The Lamentations found in SegC ss begin with a short extract from chapter 4 and are followed by ch. 1:4-5. It is difficult to tell whether this three-part setting is the work of the same person; therefore I have listed this setting independently.

Table 2.04: Text variations in sources of de Quadris's Lamentations

<i>Holy Week</i>	Contemporary Breviaries	VicAC II	1506/1	FlorBN II.I.350
<i>Thursday</i>	In	In	In	In
<i>Lesson 1</i>	1:1-5	1:1-4	1:1-4	1:1-2
<i>Lesson 2</i>	1:6-9	1:5-8	1:5-8	1:3-4
<i>Lesson 3</i>	1:10-14	1:9-11, 20	1:9-12	1:5-6
<i>Friday</i>	De lamentatione...			
<i>Lesson 1</i>	2:8-11	2:8-11	2:8-11	2:8-9
<i>Lesson 2</i>	2:12-15	2:12-15	2:12-15	2:10-11
<i>Lesson 3</i>	3:1-9	2:16-18, 20	2:16-18, 20	2:12-13
<i>Saturday</i>	De lamentatione...			
<i>Lesson 1</i>	3:22-30	3:33-45	3:33-45; 4:17	3:33-36, 43-45
<i>Lesson 2</i>	4:1-6	5:1-4, 7-11	4:18-22	In; 5:1-4, 7-8
<i>Lesson 3</i>	In; 5:1-11	5:14-22, 12-13	5:1-4, 7-11, 14-18	5:9-11, 14-16a, 21-22

We must conclude that the variety of verse choice found in all pre-1506 settings indicates the diversity of the liturgy during the fifteenth century.

While the *laude* formed the central focus during Holy Week in the various para-liturgical rites of the Italian *Laudesi*, the influence of the Divine Office was also reflected in their practices.¹⁴ Cyrilla Barr, describing the activities of the confraternities in Umbria, stated that the Holy Week lessons for Matins originated from the same sources as their liturgical models but were almost always abbreviated in length.¹⁵ This may explain the shorter versions of the Lamentation verses found in manuscripts associated with the *Laudesi*. The Lamentation verses are mentioned specifically in the rubrics for 'Spy' Wednesday of an Umbrian confraternity; the same fifteenth-century documents prove that these Lamentations were sung.¹⁶ Frank D'Accone showed the interest of the Florentine guilds in polyphonic Lamentations; the records of the Calimala Guild state that singers were paid to perform them (in addition to *laude*).¹⁷

¹⁴ Cyrilla Barr, *The Monophonic Lauda and the Lay Religious Confraternities of Tuscany and Umbria in the Late Middle Ages* (Kalamazoo: Western Michigan University, 1988), p. 139. She also suggested that this was due to clerical influence within the Confraternities.

¹⁵ *Ibid.*, p. 140.

¹⁶ *Ibid.*, p. 140.

¹⁷ D'Accone, 'The Musical Chapels', 8-10. While D'Accone acknowledges that the exact start date of the performance of polyphonic Lamentations at Florence cathedral is unknown,

A polyphonic Mass is characterised by its five distinct musical sections and the motet is essentially a self-contained unit. What exactly constitutes a Lamentation setting? The lack of liturgical information concerning the performance of Lamentations has confused the categorisation of Lamentations in the past, particularly the function of the concluding 'Jerusalem' refrain. Does this refrain indicate the conclusion of a complete Lamentation unit at Matins? Thomas argued that a complete Lamentation is determined by the closing Jerusalem refrain since it is the conclusion of a scriptural lesson.¹⁸ There are dangers in such an assumption, particularly as the variety of liturgical and para-liturgical texts suggests a regional diversity in practice and customs. It is possible that the scribe or compositor of some manuscripts or prints might not have included the 'Jerusalem' refrain after the initial statement, thus saving space and relying on local practices. These factors make the Lamentations difficult to categorise; many of the verses chosen by composers in 1506/1 and 1506/2 were not included in the 1568 post-Tridentine reformed Breviary of Pius V.¹⁹ The independence and tradition of the monastic orders may have been influential in the diversity of Lamentation verses, sections and chapters set by composers.

It is impossible to say whether Petrucci exercised any control over such choice; this was highly unlikely since he would almost certainly have used whatever was available at the time. His choice reflected the variety and flexibility found in the various settings; such diversity was matched by the stylistic variety of the polyphonic Lamentation settings.

he states that they must have begun before 1480 since a commission for Lamentations is recorded that year.

¹⁸ Thomas, 'Two Petrucci Prints', p. 37.

¹⁹ The following Lamentation verses are set in 1506/1 and 1506/2 and are not found in the Tridentine *Breviarium Romanum* of Pius V (1568); Ch. 1:18-21; ch. 2:1-7, 20; ch. 3:34-45; ch. 4:17-22; ch. 5:17-18 [facsimile and edition by Manlio Sodi, Achille Maria Triacca, eds., *Breviarium romanum: Editio princeps (1568)*. Monumenta liturgica concilii tridentini, ser. 3 (Vatican City: Libreria editrice vaticana, 1999)].

2.3 *Laude* and miscellaneous texts

The provenance of the non-Lamentation texts in 1506/1 and 1506/2 is quite varied although the function of the majority of these texts was strongly associated with Italian rites. Most of these texts are Latin *laude* (with the exception of the 'Benedictus' canticles), there being no Italian *laude* included. Petrucci chose to begin 1506/1 with one of these texts; 'Adoramus te Domine Jesu Christe' is characteristic in that it existed in liturgical and para-liturgical sources (I shall discuss this text later). However, Petrucci's principal motive in placing this text first in 1506/1 was probably one of convenience, rather than any textual or symbolic reason (this will be discussed in chapter 4). Table 2.05 provides a brief description of the function of the non-Lamentation texts:

Table 2.05: Provenance of miscellaneous texts in 1506/1 and 1506/2

<i>Text incipit</i>	<i>Liturgical provenance</i>	<i>Para-liturgical provenance</i>
<i>Adoramus te Domine Jesu Christe</i>	First antiphon at Holy Communion on Good Friday; ²⁰ part of a tract in the votive mass for the Invention of the Holy Cross on 3 May; short responsory during Vespers of the Office for the Exaltation of the Holy Cross on 14 September	<i>Adoratio Crucis</i> ; Versicle and response for the office of the Hours of the Holy Cross at Matins
<i>Venite et ploremus</i> ²¹	<i>Adoratio Crucis</i>	<i>Processio Veneris Sancta</i>
<i>Popule meus</i> ²²	<i>Adoratio Crucis</i>	<i>Processio Veneris Sancta</i>
<i>Cum autem</i>	<i>Depositio Hostiae</i>	<i>Processio Veneris Sancta</i>
<i>Sepulto Domino</i>	<i>Depositio Hostiae</i> ; 2nd Nocturne for Holy Saturday ²³	<i>Processio Veneris Sancta</i>
<i>O dulcissime</i> and various strophes	<i>Depositio Hostiae</i>	<i>Processio Veneris Sancta</i>
<i>Passio sacra nostri redemptoris</i>		
<i>Benedictus Dominus Deus Israel</i>	<i>Lauds</i> on Holy Saturday	Part of the Office for the Dead in the Book of Hours

²⁰ The liturgical relevance will be discussed later.

²¹ There is a concordance of this music in the Processional for Padua Cathedral (PadBC C56) which supplies the variant 'Venite o fidelis'. This suggests that there were local variations for this invitation.

²² *LU*, pp. 737, 739-741.

²³ It is set as the first Nocturn in the Sarum rite.

The various offices during the *Triduum* required specialised texts as well as the verses from the Lamentations of Jeremiah. The texts contained in 1506/1 were associated with the Mass of the Presanctified Host on Good Friday, a ritual which incorporated the *Adoratio Crucis* and the *Depositio Hostiae*. Both liturgies exploited dramatic potential; the *Adoratio Crucis* commenced with the short introductory verse 'Venite adoremus' following which the Cross was set before the altar. The ancient reproaches (or *Improperia*) 'Popule meus quid fecit tibi' were then sung.²⁴ The answer to these reproaches, stated in Greek, 'Agios O Theos', was not included by Petrucci; I have not yet discovered any polyphonic settings of this text (it is set to plainchant in the *Cantorino* prints).

The *Depositio Hostiae* followed the *Adoratio Crucis*; the presanctified host was deposited on Good Friday (the Eucharist was not celebrated from Maundy Thursday to the Easter Vigil).²⁵ In the Roman Use the host was taken with the Cross in silence to the Place of Deposition but other Uses permitted musical settings, including the various monastic traditions. This particular feature of the Mass of the Presanctified did not thrive in Rome and had been deleted from the liturgy, probably during the Tridentine reforms.²⁶ The texts 'Cum autem', 'Sepulto Domino' and 'O dulcissime' were part of the *Depositio Hostiae* and tended to be found in sources associated with monastic orders.²⁷ 'Cum autem venissem' was the most widely disseminated text included in the 1506 miscellaneous pieces; the majority of settings used the music found in 1506/1 in two parts at fols 47^v.48^r. They include BolA A179, BolC Q13, FlorD 21, PavU 361, VerBC 690 and WashLC J6. Significantly, WashLC J6 and the two processions listed above (BolC Q13 and FlorD 21) contain a setting of 'O dulcissime filie Sion o dulcissime videte dolorem', the only text in 1506/1 not

²⁴ Stevens, *Words and Music*, pp. 318-319. Harper, *The Forms and Orders*, p. 145, suggested that the monastic liturgies laid particular emphasis upon the singing of the *Improperia*.

²⁵ Karl Young, *The Drama of the Medieval Church*, 2 vols. (Oxford: The Clarendon Press, 1933), I, 114, observed that such dramatic offices like the *Depositio* were extra-liturgical and not officially approved for use. He added that the sentences sung were traditional pieces for the liturgy itself. Neil C. Brooks, *The Sepulchre of Christ in Art and Liturgy*, University of Illinois Studies in Language and Literature, VII/2 (Urbana: University of Illinois, 1921), p. 32f, argued that the extra-liturgical *Depositio* ceremonies were influenced by the liturgical *Adoratio*; Brooks reckoned that the *Depositio* originated north of the Alps.

²⁶ See Young, *The Drama of the Medieval Church*, I, 121.

²⁷ 'Sepulto Domino' survives in the modern liturgy as a responsory for the third Nocturn of Holy Saturday; see *LU* (1932), p. 648. It was also included in the Sarum rite for Good Friday.

set to music [fols 47^v-48^r] and following 'Cum autem' and 'Sepulto Domino'. The music set to 'Cum autem' was reused for the verses of 'O dulcissime' in these processions, rather in the manner of the secular 'cantasi come', and probably the intended method for 1506/1. Cattin noted the inclusion of these motets in PadBC c56, a procession for the Benedictine congregation of S. Giustina in Padua.²⁸ The Benedictines had an affinity with several musical and textual concordances relating to 1506/1 and 1506/2; PadBC c56 reflects much of their liturgical practice and preference. Other examples are BolC Q13 (copied in Mantua at the Benedictine monastery of S. Benedetto di Polirone – its contents include 'Cum autem venissem' and 'O dulcissime'),²⁹ CapePL 3.b.12 ('Popule meus' as well as Lamentations by Anon. 1 and de Orto) and WashLC J6 (originally owned by a Benedictine monk and containing the two-part settings from 1506/1 'Cum autem venissem' and the anonymous 'O dulcissime'). Other Benedictine sources include settings of the texts found in 1506/1, notably MonteA 871 ('Adoramus te', a four-part anonymous 'Cum autem', and a listed but now lost setting of 'Sepulto Domino'), and PerBC 431 (two anonymous four-part 'Adoramus te' settings). The Benedictines fostered and encouraged the *laudesi* companies in Italy during this period; the inclusion of *laude* amongst the musical settings in their manuscripts testifies to this fact.

The various verses following the de Quadris Lamentations in 1506/1 are also found in a number of subsequently printed liturgical books. The Giunta publications *Liber Sacerdotalis*, printed in Venice in 1523 and 1537, contain settings of the opening verses of 'Popule meus' (the second to fourth verses are not present), the complete verses of 'Cum autem venissent [*sic*]', 'O dulcissime filie Syon', 'O vos omnes qui transitis', 'O nimis triste speculatum', 'Attendite vos, o populi' [but not the verses following, viz. 'Mortuum iam' and 'Cum portaretur'], and 'Cum vero venissent [*sic*] ad locum'. The responsory 'Sepulto Domino, signatum est' follows immediately, and after some further verses not included in 1506/1, the rite concludes with 'Venite et ploremus ante Dominum'.³⁰ The latter is placed by Petrucci immediately following de

²⁸ Cattin, *Johannes de Quadris*, pp. 84-85.

²⁹ Cattin, 'Tradizione e tendenze', based on inscription on fol. 52'.

³⁰ The 1523 edition states that 'Sepulto Domino' was to be sung while the host was placed in the sepulchre – this was the highlight of the ceremony. It is logical that Petrucci would

Quadris's Lamentations in 1506/1 rather than at the conclusion of these texts; this is its correct position, being the introductory text to the *Improperia*.³¹

Further evidence of the importance of these texts may be found in another Giunta publication, the pocket format *Cantorino*, printed in Venice in 1523 and 1535. As well as containing concordances of 1506/1's 'Cum autem' and 'O dulcissime filie Syon', it also contains two-part settings of the Lamentations and a setting of the canticle 'Benedictus Dominus Deus Israel'. All these texts are part of the Holy Thursday and Good Friday liturgy; the text 'Adoramus te' is not part of the *Adoratio Crucis* ceremony (it is set to chant in the 1540 *Cantorino* print and is mentioned later).

The rubric printed in 1506/1 at the conclusion of 'Sepulto Domino' is quite specific, stating 'Ponentes | postea iterum reiteratur. Sepulto domino.'³² This suggests that these texts were structured and set to music – the existence of a musical setting of the complete text in WashLC J6 might suggest that Petrucci had run out of space.³³ He had already set a precedent in 1506/1 by writing out the music of 'Popule meus' but chose not to repeat that technique with the verses of 'Sepulto Domino', due to lack of space.

The Italian *lauda* had been established in the Middle Ages and was particularly popular within the ceremonies of the confraternities.³⁴ Such societies were supported and nurtured by a range of monastic orders, not only

want to have it included in 1506/1. WashLC J6 also omits the verses 'Mortuum iam' and 'Cum portaretur', but is one of the few sources to include the textual variation 'Cum autem venissent'. However, it omits the word 'omnes' in the verse beginning 'O vos omnes'. Solange Corbin, *La Déposition liturgique du Christ au vendredi saint* (Paris; Lisbonne: Amadora, 1960), pp. 74-84, included several examples of the *Depositio* texts. Her list cited the liturgical text 'Sepulto Domino' in manuscripts dating from the eleventh to the sixteenth centuries and originating from (present day) Germany, Scandinavia, England, Ireland, France, Belgium, Hungary, Bohemia, Italy and Portugal.

³¹ The text translates 'Come let us weep before the Lord, who died for us saying'. It should be noted that the version of the text used in de Quadris's setting of 'Venite et ploremus' in PadBC C56 differs from his setting in 1506/1. The text printed in 1523 is analogous with 1506/1.

³² Translation: 'Ponentes | after which is repeated. Sepulto Domino'. The Renaissance *Missale Herefordense* also contains an identical format.

³³ Kmetz, 'Petrucci's Alphabet Series', 136, showed that Petrucci set a precedent in secular music printing by imposing additional verses in the *frottole* prints. Kmetz suggested that musical memory was important when singing secular music; it would have posed little difficulty to performers to match the text of 'O dulcissime' to the music.

³⁴ For a general introduction to the *lauda*, see Blake Wilson, 'Laude spirituale', *New Grove Dictionary of Music & Musicians*, 14 (2001), 367-374. For an extensive description of the *laudesi*, see Cyrilla Barr, 'Lauda Singing and the Tradition of the Disciplinati Mandato: A Reconstruction of the Two Texts of the Office of Tenebrae', *L'Ars nova italiano del Trecento*, 4 (1978), 21-44; Barr, *The Monophonic Lauda*, and Blake Wilson, *Music and Merchants: The Laudesi Company of Republican Florence* (Oxford: Clarendon Press, 1992).

the Benedictines. These societies organised an intensive programme of ceremonies during Lent, leading to a climax in Holy Week. Some of their texts were taken directly from the liturgy; Latin texts such as 'Cum autem venissem' were particularly popular. Most of the *laude* texts in 1506/1 are found in contemporary manuscripts and prints, many being associated with the *laudesi*.³⁵ Several survive in manuscripts and prints which post-date 1506 including 'Adoramus te Domine Christe' [BergBC 1208, FlorBN II.I.232], 'Sepulto Domino' [Berg 1208D, FlorBN II.I.350, ModD 2, VerBC 760, 1523/1] and 'Cum autem venissem' [1523/1, 1563/6]. This suggests that the demand for such texts continued after the publication of 1506/1.

Howard M. Brown, Warren Drake and David Crawford have described the importance of devotional texts, prayers and non-liturgical texts in the Renaissance.³⁶ Drake, in particular, emphasised the importance of prayer texts for the individual and suggested that such texts were as much a selling-point as the music.³⁷ It is significant that the non-Lamentation texts in 1506/1 and 1506/2 are found in sources related to organisations like the confraternities, suggesting that they might have been highly desirable to individual members.

Petrucchi's inclusion of *laude* settings in 1506/1 and his subsequent publication of two *laude* volumes would suggest that there was a market for these texts. Furthermore, the singing of Lamentations was an integral part of *laudesi* Holy week activities.

³⁵ The exception is the final text in 1506/1 by Francesco Ana beginning 'Passio sacra...'

³⁶ See Crawford, 'Vespers Polyphony', p. 219; Howard M. Brown, 'The Mirror of Man's Salvation: Music in Devotional Life About 1500', *Renaissance Quarterly*, 43 (1990), 744-773 (pp. 751-753) and Drake, *Motetti de passione*, pp. 10-11.

³⁷ For a discussion see Drake, *Motetti de passione*, pp. 10-11.

The use of *laude* settings was quite varied – Prizer has suggested these four categories:³⁸

1. Semi-professional singers employed by the *laudesi* companies
2. Professional church and cathedral singers
3. Monks and nuns
4. Performers of the *rappresentazioni sacre*

The *laude* were also performed by cathedral choirs; D'Accone's research into the repertoire at Florence Cathedral revealed that the cathedral choir sang *laude* during the evening of all feast days.³⁹ His findings support the inclusion of de Quadris's 'Cum autem venissem', 'Sepulto Domino' and other associated *laude* texts in FlorD 21, a processional for Florence cathedral. This manuscript includes other music for the 'Processionale veneris Sancti'.

Petrucci must have been familiar with the activities of the confraternities operating in his adopted city; the Venetian *Scuole grandi* were the best-known of these. Glixon outlined the elaborate processions of these confraternities, during which *laude* were sung at intervals.⁴⁰ It is noteworthy that the singers were not walking when performing *laude* – Brown observed the dangers in regarding simple polyphony as suitable for processions and more complex polyphony as not being appropriate.⁴¹ It is therefore quite feasible that the more elaborate contrapuntal settings, such as those found in 1506/1, were performed in Venice and other Italian cities and towns during Lent.

The opening text of 1506/1, 'Adoramus te Domine Jesu Christe', is notable for several reasons. It is not a setting of the Lamentations of Jeremiah, being a

³⁸ William F. Prizer, 'Lauda spirituale: 2. Polyphonic', *New Grove Dictionary of Music & Musicians*, 10 (1980), 540-543.

³⁹ See D'Accone, 'The Musical Chapels', 3. His work described repertoire and personnel at Florence during this period.

⁴⁰ Jonathan E. Glixon's article, 'Music and Ceremony at the Scuola Grande di San Giovanni Evangelista: A New Document from the Venetian State Archives', in *Crossing the Boundaries: Christian Piety and the Arts in Italian Medieval and Renaissance Confraternities*, ed. K. Eisenbichler (Kalamazoo, Michigan, 1991), 56-89, described the route and procedure for the processions, which took place on various occasions throughout the year, including the Sundays in Lent and Good Friday.

⁴¹ Howard M. Brown's article, 'On Gentile Bellini's *Processione in San Marco* (1496)', in *International Musicological Society. Report of the Twelfth Congress, Berkeley, 1977*, ed. Daniel Hertz and Bonnie C. Wade (Kassel: Bärenreiter, 1981), 649-656., discussed the depiction by the artist Gentile Bellini of the 'Processione in San Marco', Venice. He noted on p. 654 that the singers may clearly be seen to perform polyphony, dispelling the previously-held notion that processional music was purely monophonic.

short, homorhythmic, four-part motet with underlay in all voices. It is the second shortest text in 1506/1 ('Venite et ploremus' being the shortest) and as a consequence, the only work to be set on a single folio and begin on a recto side. It is followed by the Lamentations of Tintoris *et al.* Apart from printing convenience, why did Petrucci begin 1506/1 with such a pithy motet, instead of introducing a setting of the Lamentations by one of the established composers who appear later in the volume? Several scholars have noted that the text of 'Adoramus te' was essentially the same as that for the first antiphon on Good Friday; it has also been cited as the first part of a tract in the votive mass for the Invention of the Holy Cross on 14 September (where that mass happens to be said after Septuagesima Sunday [*Graduale Romanum*, 104-5; not in *LU* editions] and also as a short responsory during Sext of the Office for the Invention of the Holy Cross on 3 May [*LU*, p. 1458; text given as: 'Adoramus te Christe, et benedicimus tibi, alleluia']).⁴² The inclusion of any text in *LU* does not necessarily suggest pre-Tridentine relevance; 'Adoramus te Christe' would appear to support a more cautious approach. The 1961 edition of the *LU* is often cited, due to its inclusion in Bryden and Hughes's *Index*.⁴³ I have looked at *LU* editions pre-1961 and failed to find 'Adoramus te Domine Jesu Christe' included in the Holy Week ceremonies.⁴⁴ The text is found in the 1540 *Cantorino* print, where it is set to plainchant on fol. 34^r as a response for the Invention of the Holy Cross. This would suggest that the text was important in the para-liturgical rites of the Benedictines, along with most of the other non-liturgical texts in 1506/1. We must conclude that the use of this liturgical antiphon in the Renaissance during Holy Week was not certain, even if it is now considered as an appropriate text.⁴⁵

⁴² Thomas, 'Two Petrucci Prints', p. 52; Allan W. Atlas, *Music at the Aragonese Court of Naples* (Cambridge: Cambridge University Press, 1985), p. 138. This text is set polyphonically in a number of manuscripts including MonteA 871, PerBC 431, CapePL 3.b.12, MilD 1, MilD 3, I-Rocca di Mezzo, s.s., GB-Oxford Bodleian, Lat. lit. e 14, as well as 1508 and 1508/3. The reading of 1506/1 is distinctive since its second line states: 'Quia per sanctissimam crucem et passionem tuam redemisti mundum' whereas most other versions read 'Quia per sanctam crucem tuam redemisti mundum'.

⁴³ John R. Bryden and David G. Hughes, *An Index of Gregorian Chant*, 2 vols. (Cambridge: Harvard University Press, 1969).

⁴⁴ I have checked the following editions of *LU*: 1923, 1932, 1934 and 1953.

⁴⁵ The Holy Week Masses in the Use of Salisbury were distinctive in that they lacked any systematic organisation of the Lamentation texts. Tuesday in Holy Week is the only example of Jeremiah's texts.

The earliest extant print containing a setting of 'Adoramus te' is 1503/1 where a version may be found as part of Compère's *Officium de cruce*.⁴⁶ The most important of these prints is Petrucci's *Laude libro primo* [1508] and *Laude libro secondo* [1508/3] where further settings of the texts 'Adoramus te', 'Cum autem venissem' and 'Popule meus' may be found.⁴⁷ Furthermore, Cattin's discovery and subsequent inventory of CapePL 3.b.12 revealed the existence of many *laude contrafacta* from settings that had originally been secular.⁴⁸ Cattin has shown how one of the scribes of CapePL 3.b.12 went to great lengths to camouflage the profane origins of the music for the *laude* in that manuscript.⁴⁹

'Adoramus te' was also highly popular in Books of Hours; it was commonly found as a versicle and response for the office of the Hours of the Holy Cross and the Office for the Dead. Significantly, its inclusion in this context might also suggest a para-liturgical function, as well as the more obvious liturgical function suggested by Thomas and Atlas. If this text, and other similar texts in 1506/1 and 1506/2, had a function beyond the strict confines of the liturgy of Italian churches and cathedrals, this would support Strohm's notion that Petrucci was already aware of a wider and more significant market when publishing his Lamentation volumes (I shall discuss this in chapter 5).⁵⁰

There is good reason to believe that Petrucci printed the anonymous 'Adoramus te' at the beginning of 1506/1 because it featured in the *Adoratio*

⁴⁶ Drake, *Motetti de passione*, p. 53, discussed this text and noted it was a *responsorium breve* at Sext in *Exaltatione Sanctae Crucis*. He also showed that Petrucci used several settings from 1503 as *contrafacta* in 1508/3. It is also found as a Versicle and Response in the feast *Inventionis Sanctae Crucis* on 3 May.

⁴⁷ Knud Jeppesen and Viggo Brøndal, *Die mehrstimmige italienische Laude um 1500* (Leipzig: Breitkopf & Hartel, 1935), pp. LXV, LXVII-LXVIII, LXX, 8-9, 42-43, 49, 50-51, listed these works and include editions of Petrucci's two later *laude* prints. It should be noted that neither of Petrucci's *laude* volumes include the other miscellaneous texts from 1506/1 beginning 'Venite et ploremus', 'Sepulto domino' or the 'Passio sacra' by 'Fran. Vene.'

⁴⁸ See Cattin, 'Nuova fonte italiana'.

⁴⁹ *Ibid.*, for further details.

⁵⁰ Strohm, *The Rise of European Music*, p. 589. This theory was supported by Drake, 'The First Printed Book', pp. 34-35, who suggested that Petrucci's prints were intended for the *bourgeoisie*, rather than for performance in cathedrals and chapels, due to their small format. The books would be more suitable as a basis for copying, rather than as a performing edition. Blackburn, 'Canonic Conundrums', 57, opposed this idea; these arguments will be discussed in chapter four.

Crucis which was celebrated before the *Depositio*.⁵¹ By so doing, he clearly defined the para-liturgical structure of the print, suggesting that he was aware of the performance possibilities of these texts. Young admitted that there were probably many local variations based on the *Adoratio Crucis* and *Depositio Hostiae*;⁵² it is possible that Lamentation verses followed the *Adoratio* in some rites, thus making sense of the order of presentation in 1506/1.

Various settings of the text 'Adoramus te' are also extant in a variety of Italian manuscripts, including CapePL 3.b.12, MonteA 871, PerBC 431 (two settings), MilD 3 (two settings), MilD 1 (two settings), FlorR 2356 and FlorBN II.I.232 and BergBC 1208. The various settings are attributed to Tromboncino, Innocentius Dammonis, Compere, Franchino Gafurius and Jacobus Foglianus. The inclusion of works by Tromboncino in 1508/3 is noteworthy, since he is the only attributed composer from either of the 1506 prints to be represented in this volume. The second setting of 'Adoramus te' in 1508/3 was ascribed to 'B.T.' by Petrucci; Jeppesen and Brøndal believed this was Tromboncino.⁵³ However, while this work bears stylistic similarities to the 'Adoramus te' in 1506/1, it is a different piece. Indeed, it is somewhat surprising that the 1506/1 setting of 'Adoramus te' is unique to this source, considering the widespread use of this text in Italy during the later fifteenth and sixteenth centuries.

The context of the four-part setting of 'Cum autem venissem' in 1508/3 is significant; it is the first anonymous work in the print and is followed by another popular Latin *lauda*, 'Lauda Sion salvatorem'.⁵⁴ While the setting of 'Cum autem venissem' in 1508/3 is four-part and that in 1506/1 is two-part, Perkins noted a similarity in melodic content.⁵⁵ The work following 'Lauda Sion salvatorem' is an Italian-texted *lauda* by Tromboncino (who is frequently represented in this print). Petrucci did not include other texts from the

⁵¹ Young, *The Drama of the Medieval Church*, I, 117-118, suggested that the *Depositio* might have occurred immediately after the *Adoratio Crucis* or possibly following either the *Communio Fidelium* or Vespers.

⁵² See Young, *The Drama of the Medieval Church*, I, 117-122, for a full discussion on the various possibilities for the *Depositio* rite.

⁵³ Jeppesen and Brøndal, *Die mehrstimmige italienische Laude*, p. 49.

⁵⁴ It should be noted that this text in 1503/1 is much longer, being a sequence for Corpus Christi.

⁵⁵ Perkins, *Music in the Age*, pp. 452-454.

'*Depositio Hostiae*' in 1508/3, nor did he group similar texts with 'Cum autem venissem' as in 1506/1. 'Sepulto Domino signatum est' [1506/1, 47^v-48^r] is found in manuscripts containing other texts from the *Depositio Hostiae* and 'Processionale Veneris Sancti', and is frequently found after 'Cum autem' (a full description of sources may be found in chapter 6 and a summary in tables 6.01 and 6.02).

The final text in 1506/1, Ana's 'Passio sacra', has been categorised as a *lauda* by Cattin.⁵⁶ Leofranc Holford-Strevens has very kindly analysed and translated this text for me, noting that the *prima pars* is written in an Italian metre while the *secunda pars* is prose.⁵⁷ This curious *unicum* text was probably a penitential substitute for the Passion in the *laudesi*'s liturgy during Holy Week and would have fulfilled a function as a private, devotional text.⁵⁸

The office canticle 'Benedictus Dominus Deus Israel' was the final canticle of Lauds on Holy Saturday in the Roman rite and signified the end of *Tenebrae*. This text is found in sources associated with 1506/1 and 1506/2 and with the *laudesi*; the earliest of these is probably ParisBNC 967 and contains a four-part anonymous setting. There are three anonymous settings of the 'Benedictus' in CapePL 3.b.12, the first of which is placed with other Passiontide texts such as the Hymn 'Pange lingua gloriosi corporis' and 'Cum autem venissem'. One

⁵⁶ Giulio Cattin, 'I due libri di lamentazioni (1506) e l'affermazione d'un genere polifonico', Unpublished Paper Presented in Basle, January 2001: 'Petrucci Jahres'. I am most grateful to Professor Cattin for sending me a copy of his conference paper.

⁵⁷ Dr Holford-Strevens made the following observations in a private communication dated 18 February, 2002: 'The *prima pars*, although in Latin, is written according to Italian metre (in endecasillabi) and rhyme (Italians in those days read 'redempti' as 'redenti'), except that l. 5 is a syllable short:'

Passio sacra nostri redemptoris
munda nos manans rivulus cruoris
Jesu salvator veniam peccati
tribue nobis qui a te creati
Sanguine tuo sumus <iam?> redempti
Inferni prius legibus detenti
Amen

[Translation: Sacred passion of our Redeemer, cleanse us, flowing stream of blood, Jesus our Saviour, grant forgiveness of sin to us, who, created by Thee, have by Thy blood (now?) been redeemed, having previously been imprisoned by the laws of Hell].

The *secunda pars* is in prose:

Pientissimus nostre salutis autor. hodierna die. humanum. a lege peccati. liberans genus affixus cruci. cum accepisset acetum dixit. consumatum est. Et inclinato capite. emisit spiritum. Amen.

[Translation: The most merciful author of our salvation, who today is freeing the human race from the law of sin, having been nailed to the cross, when he had received the vinegar said 'It is accomplished' and, with bowed head, gave up the ghost].

⁵⁸ Crawford, 'Vespers Polyphony', p. 219 suggested that sacred non-liturgical texts would have been intended for private devotions, such as those supported by a courtly chapel.

mensural voice of a 'Benedictus' setting survives in the *laudesi* manuscript Vnm 145. The manuscript FlorBN II.I.350 contains six unascribed settings; they are paired and each pair follows Lamentations by Carpentras, Brumel and Johannes de Quadris. The Italian Benedictines stipulated the 'Benedictus' as part of their Holy Week polyphony.⁵⁹ The words of this canticle were also found in the Book of Hours as an Office for the Dead at Lauds.⁶⁰

2.4 Conclusion

The existence of the Latin *laude* texts in a wide variety of pre-1506 sources indicates their popularity. The use of these texts in processions, particularly the inclusion of texts associated with the 'Processio Veneris Sancti', also points towards para-liturgical practices. The ordering of the texts in 1506/1 may reflect para-liturgical practice, particularly the *Adoratio Crucis* and *Depositio Hostiae* associated with the Benedictine order (especially the congregation of S. Giustina). Young suggested one hypothesis, whereby the *Adoratio Crucis* was followed by *Communio Fidelium*; this preceded Vespers (at which the Lamentation verses were sung) and concluded with the *Depositio*, a format which would match Petrucci's layout of 1506/1.⁶¹

The texts in 1506/1 and 1506/2 were important in the ceremonies of the Italian *laudesi* and confraternities. Petrucci published several of these *laude* in two printed volumes dedicated to *laude* in 1508; he may have regarded 1506/1 as a prototype for these subsequent volumes. There was interest in these texts from the monastic communities, shown by the inclusion of the 1506/1 *laude* texts in the sixteenth-century printed books of the Benedictines.

There is little doubt as to the value of such texts amongst the pious Italian *bourgeoisie* as Crawford and others have shown.⁶² I would suggest that a parallel exists between the function of these dedicated Holy Week texts and the

⁵⁹ Cattin, 'Tradizione e tendenze', 261-262.

⁶⁰ *Ces presentes heures longues sont a lusiage de Romme toutes au long sans riens requerir...* (Paris: n.p., 1520), fol. 25^r.

⁶¹ Young, *The Drama of the Medieval Church*, I, 118.

⁶² Crawford, 'Vespers Polyphony', p. 219.

function of the icons, images and statues found in any medieval church. Each had a specific association for clergy and laity alike and their function served many different facets of medieval worship. The inclusion of texts such as 'Adoramus te' in the Book of Hours supports this; the images and texts were designed to inspire piety within the soul (I shall explore issues relating to private devotion in chapter 5).

Petrucci had already tested the market with specialised texts in 1503/1; the non-Lamentation texts in 1506/1 and 1506/2 indicate that he had subsequently identified a more dedicated and lucrative market.

Chapter 3

MUSICAL STYLE IN
1506/1 AND 1506/2

3.1 The Lamentations

I do not intend to provide a comprehensive stylistic and technical analysis of the music of 1506/1 and 1506/2 since the main thrust of this thesis lies elsewhere. Nevertheless, it is useful to identify certain stylistic features within these settings, particularly those which might assist in identifying any common patterns in Petrucci's composer choice. Musicologists have previously discussed the Lamentations of Tinctoris, Agricola, de Orto, de Quadris, Tromboncino and Weerbeke in some detail.¹ The majority of settings in the 1506 Lamentations present the Roman Lamentation tone (illustrated in example 3.01), although Ycart and de Orto appear to use a different tone.

Example 3.01: *Roman Lamentation tone*²

The image shows four staves of musical notation in a single system. Each staff begins with a treble clef and a common time signature (C). The notes are mostly half and quarter notes, with some rests. A flat sign (b) is placed above the second staff, indicating a key signature of one flat. The lyrics are written below the notes, with hyphens indicating syllables that span across multiple notes. The lyrics are: "In - ci - pit La - men - ta - ti - o Je - re - mi - e Pro - phe - te. A - leph. Quo - mo - do se - det so - la ci - vi - tas ple - na po - pu - lo: fa - cta est qua - si vi - du - a do - mi - na gen - ti - um: prin - ceps pro - vin - ci - a - rum fac - ta est sub tri - bu - to. Gimel etc."

¹ A stylistic discussion may be found in the following: Johannes Tinctoris (William E. Melin, 'The Music of Johannes Tinctoris (c. 1435-1511): A Comparative Study of Theory and Practice' (Unpublished Doctoral Dissertation, Ohio State University, 1973); Alexander Agricola (Lerner, 'The Sacred Music of Alexander Agricola'), Marbrianus de Orto (Miller, 'The Musical Works of Marbriano de Orto'); Johannes de Quadris (Cattin, 'Johannes de Quadris'; Cattin, 'Tradizione e tendenze', Cattin, 'Uno sconosciuto codice', Cattin, 'Canti polifonici', Cattin, 'Nuova fonte italiana', Cattin, *Italian Laude*, Margaret Bent, 'The Use of Cut Signatures in Sacred Music', in *Johannes Ockeghem: Actes du XLe Colloque International d'Etudes Humanistes*, ed. Philippe Vendrix (Paris: Centre d'Etudes Supérieures de la Renaissance, Éditions Klincksieck, 1998), 641-680); Bartholomeo Tromboncino (Gerhard Croll, 'Zu Tromboncinos "Lamentationes Jeremiae"', *Collectanea historiae musicae*, 2 (1957), 111-114); Gaspar van Weerbeke (Massenkeil, 'Eine spanische Choralmelodie').

² This tone is found in the 1540 *Cantorino* print at fol. 61^r. In the 1550 and 1566 *Cantorino* prints, it is preceded by the words 'Iterum alius tonus'. In all three editions, it follows the 'Cantor. Roma' (the medieval Lamentation tone based upon the Dorian; see Peter Wagner, *Einführung in die gregorianischen Melodien*, 3 vols., iii, *Gregorianische Formenlehre* (Leipzig, 1911; reprinted Wiesbaden: Breitkopf and Härtel, 1970), p. 240). The Council of Trent subsequently ratified this alternative tone (Massenkeil, *Mehrstimmige Lamentationen*, p. 8*) but its inclusion in the majority of 1506 Lamentations shows that it was accepted in polyphonic settings by the beginning of the sixteenth century. The absence of the Benedictine 'Lamentations X' setting in all three *Cantorino* prints and its replacement by these Roman chant tones suggests it was no longer considered relevant or popular from 1540.

The Roman tone is in mode 6 (Hypolydian), with *a* as *flexa* and the initial pitches *f g a* are presented unadorned. B flat is consistently used to avoid the tritone as this note represents the highest pitch of the chant. Ycart, Anon. 1 and Weerbeke place the *cantus prius factus* in the Discantus while Agricola, Tromboncino and Lapidida place it in the Tenor; Agricola's four-part setting shares it between both voices. Agricola's three-part setting also contains a phrase where the *cantus firmus* is placed in the Contra. The oldest setting (by de Quadris) presents a slightly paraphrased version of the intonation in his Discantus (example 3.02), while Tromboncino's setting states the chant in the Tenor in equal note values (see examples 3.03 and 3.04).

Example 3.02: *Lamentations* (de Quadris)

Quo-mo-do se-det so-la ci-vi-tas ple-na po-pu-lo

Example 3.03: *Lamentations* (Tromboncino)

In-ci-pit La-men-ta-ti-o Je-re-mi-ae Pro-phe-tae.

Example 3.04: *Lamentations* (Tromboncino)

A-leph. Quo-mo-do se-det so-la ci-vi-tas ple-na
po-pu-lo: fa-cta est qua-si vi-du-a do-mi-na gen-ti-um:

It is somewhat ironic that Tromboncino, arguably the composer in the 1506 *Lamentations* most practised in writing secular music, chose the most retrospective method of presenting the chant.³ The majority of composers show more freedom than Tromboncino in the use of the intonation for the

³ One possibility is that Tromboncino chose the most established method of chant presentation since he had little or no experience in using extended sacred techniques.

Hebrew letters; Weerbeke and Lapidida paraphrase the order of pitches (see examples 3.05, 3.06 and 3.07).

Example 3.05: *Lamentations* (Weerbeke)

1 [Discantus]
In - ci - pit La - men - ta - ti - o Je - re - mi - ae Pro - phe - tae.

12 [Discantus]
A leph. Quo mo - do sedet so - la ci - vitas ple - na po - pu - lo:

Example 3.06: *Lamentations* (Lapidida)

Tenor
In - ci - pit La - men - ta - ti - o Je - re - mi - ae Pro - phe - tae.

Example 3.07: *Lamentations* (Lapidida)

Tenor
A - leph. Quo - mo - do se - det so -

la ci - vi - tas ple - na po - pu - lo:

There is a remarkable similarity between the *cantus firmus* of a polyphonic setting in the Spanish manuscript ParisBNC 967 and certain phrases in the *Lamentations* of Ycart and de Orto. ParisBNC 967 contains two polyphonic settings which have been influenced by the *Lamentations*. The three-part setting at 23^v-24^r sets the words of St Paul rather than those of Jeremiah but the influence of the *Lamentations* is illustrated by the use of the prefatory letter 'Aleph' (example 3.08) and the concluding 'Jerusalem' refrain (example 3.09). The similarity between ParisBNC 967's *cantus firmus* and the Tenors of Ycart and de Orto may be seen in examples 3.10 - 3.12.

Example 3.08: *Lamentations* (Anon., ParisBNC 967; Tenor)⁴

A-leph.

Example 3.09: *Lamentations* (Anon., ParisBNC 967; Tenor)

Je - ru - sa - lem, Je - ru - sa - lem, con - ver - te - re
ad Do - mi - num, De - um tu - um.

Example 3.10: *Lamentations* (de Orto; Tenor)

In - ci - pit Lamen - ta - ti - o Je - re - mi - ae Pro - phe - tae.

Example 3.11: *Lamentations* (de Orto; Tenor)

con - ver - te - re ad Do - mi - num, Deum tu - um.

Example 3.12: *Lamentations* (Ycart; Tenor)

A-leph.

The independent section of de Orto's setting in CapePL 3.b.12 is even more significant since it contains a further statement of the ParisBNC 967 melody, illustrated in example 3.13.⁵ It could be argued that this phrase is not related to any *cantus prius factus* but the number of coincidences with the Paris melody would suggest otherwise. Furthermore, the works of Ycart and de Orto are the

⁴ This excerpt is based on the edition in Massenkeil, 'Zur Lamentationskomposition', 112-114. The 'X' indicates the primary pitches of the *cantus firmus*.

⁵ An edition may be found in appendix 3.

only Lamentations in 1506/1 or 1506/2 to cadence on *D*, all other settings cadencing on *f*.

Example 3.13: *Lamentations* (de Orto; CapePL 3.b.12 new section, Tenor)



Ycart was born in Spain and de Orto worked for Philip the Fair from 24 May 1505 until late 1506; the inclusion of a Spanish *cantus firmus* would be congruent with their employment and experience.⁶ Furthermore, Ycart was living in Naples as an employee of the Spanish king Ferdinand I, whose court placed considerable emphasis upon the Holy Week repertoire.⁷

Massenkeil observed a similarity between a Toledo Lamentation intonation (example 3.14) and Josquin's opening Discantus phrase of his motet-chanson 'Nymphes des bois'.⁸ His 1962-63 article expanded the list of pieces apparently influenced by this Spanish *cantus firmus*; amongst the works cited is the Altus of Weerbeke's Lamentation (example 3.15 - the relevant notes are circled).⁹ I would suggest that the latter is probably coincidence since the Roman intonation is also present in the Discantus and Weerbeke uses the Roman intonation consistently throughout his setting. I would also suggest that the Josquin connection is quite tenuous; a similarity with only one phrase in a complete work is not consistent with established practices of borrowing.

⁶ See Miller, 'The Musical Works of Marbriano de Orto'; Pope and Kanazawa, *The Musical Manuscript Montecassino 871*, p. 33; Allan W. Atlas and Jane Alden, 'Ycart [Hycart, Icart, Ycaert], Bernhard [Bernar, Bernardus]', *New Grove Dictionary of Music & Musicians*, 2nd edition, 27 (2001), 648-649 (p. 648); Atlas, *Music at the Aragonese Court*, pp. 77-80; Martin Picker, 'Orto, Marbrianus [Marbriano] de [Dujardin, Marbrianus]', *New Grove Dictionary of Music & Musicians*, 18 (2001), 764-766, for biographical information concerning Ycart and de Orto.

⁷ See Pope and Kanazawa, *The Musical Manuscript Montecassino 871*, p. 45 who suggested that a number of Passiontide compositions in MonteA 871 may have been associated with court ceremonies.

⁸ Massenkeil, 'Zur Lamentationskomposition', 105.

⁹ Massenkeil, 'Eine spanische Choralmelodie', 230-237.

Example 3.14: *Lamentation tone* (Toledo codex)¹⁰Example 3.15: *Lamentations* (Weerbeke)

One can see a similarity between Massenkeil's Toledo tone and the Discantus of Ycart's 'Gimel' (example 3.16); however, this is another coincidence since the upward leaping third was a practicable and common interval in Renaissance polyphony.

Example 3.16: *Lamentations* (Ycart's Discantus)

There are several settings that display what may best be described as compositional restraint. The works of de Orto, de Quadris and Anon. 1 (with the exception of its more lively Contra) all show restraint in range and contrast,

¹⁰ Based on Massenkeil, *ibid.*, 105.

with more typical late fifteenth-century ranges in the Lamentations of Agricola (four-part), Tintoris and Lapidida.¹¹ Miller discussed the concept of restraint within the Lamentations of de Orto, observing the strict *nota contra notam* style within most sections (excepting the Hebrew letters and 'Jerusalem' refrain). Such sacrifice of texture is replaced by what Miller described as chordal sonority and was rarely used in de Orto's extant compositions.¹² His example of chordal sonority (which is shown in example 3.17) may also be applied to other 1506 Lamentations.

Example 3.17: *Lamentations* (de Orto)

The musical score for Example 3.17 shows four staves. The top staff is labeled [Discantus] and has a '20' above it. The other three staves are labeled Altus, Tenor, and Bassus. Each staff contains a line of music with lyrics underneath. The lyrics are: Quo - mo - do se - det so - la ci - vi - tas. The Discantus part is a single melodic line, while the other three parts are more chordal in nature, with some notes beamed together.

Lerner considered the implications of *nota contra notam* counterpoint in Agricola's three-part Lamentations, noting the poet Cretin's comment that it was particularly suitable for solemn occasions (Cretin requested a *Requiem* for Ockeghem).¹³ Lerner observed that the sections which followed duets in Agricola's setting were frequently written in *nota contra notam* style, providing contrast with the more florid duets.

Voice ranges also provide a useful means by which to examine compositional procedures. Lapidida's Lamentations contain the widest ranges with its Discantus stretching a 12th, Altus 13th, Tenor 11th and Bassus 12th. The ranges in de Orto's Lamentations span a mere 7th for his Discantus, a 9th

¹¹ Howard M. Brown and Louise K. Stein made some brief comments about Agricola's Lamentation settings, suggesting that they were his only stylistically restrained works. See *Music in the Renaissance* (Upper Saddle River, N. J.: Prentice Hall, 1999), p. 138.

¹² Miller, 'The Musical Works of Marbriano de Orto', p. 156.

¹³ Lerner, 'The Sacred Music of Alexander Agricola', pp. 61-63.

for Altus, 8th for Tenor and 10th for Bassus. Most settings maintain their initial clef choice although Tinctoris, de Quadris and (in particular) Weerbeke slightly adjust clefs after certain chapters or sections. No Lamentation setting was intended to be performed as a complete entity since the various liturgical and para-liturgical rites stipulated certain verses from chapters; this would have had the effect of disguising such clef changes in the longer 1506 settings (the same selection also concealed the widespread use of musical repetition in certain settings). The clef configurations of de Orto's Lamentations and the 'Benedictus' following Lapidida's Lamentations are undoubtedly the most extreme of these exceptions and raise the possibility that these works may have been composed for specific performing ensembles (see example 3.18 below).

Example 3.18: Clefs and range in 1506/1 and 1506/2

1506/1

Adoramus te

Tinctoris

Ycart

Anon. I (1506)

Anon. I (Cape)

Agricola a3

Agricola a4

de Orto (CapePL 3.b.12)

de Orto (1506)

de Quadris Lamentations

Musical notation for 'de Quadris Lamentations' featuring a [Discantus] part on a five-line staff with a treble clef and a Tenor part on a five-line staff with a bass clef. Both parts contain a single note.

Venite et ploremus

Musical notation for 'Venite et ploremus' featuring a [Discantus] part on a five-line staff with a treble clef and a Tenor part on a five-line staff with a bass clef. Both parts contain a single note.

Popule meus

Musical notation for 'Popule meus' featuring a [Discantus] part on a five-line staff with a treble clef and a Tenor part on a five-line staff with a bass clef. Both parts contain a single note.

Cum autem

Musical notation for 'Cum autem' featuring a [Discantus] part on a five-line staff with a treble clef and a Tenor part on a five-line staff with a bass clef. Both parts contain a single note.

Sepulto Domino

Musical notation for 'Sepulto Domino' featuring a [Discantus] part on a five-line staff with a treble clef and a Tenor part on a five-line staff with a bass clef. Both parts contain a single note.

Passio sacra (Ana)

Musical notation for 'Passio sacra (Ana)' featuring four parts: [D.] (Discantus) on a five-line staff with a treble clef, and A., T., and B. (Alto, Tenor, Bass) on five-line staves with their respective clefs. Each part contains a single note.

I506/2

Tromboncino

Musical notation for 'Tromboncino' featuring four parts: [D.] (Discantus) on a five-line staff with a treble clef, and A., T., and B. (Alto, Tenor, Bass) on five-line staves with their respective clefs. Each part contains a single note.

Benedictus (fol. 33^v)

Musical notation for 'Benedictus (fol. 33^v)' featuring four parts: [D.] (Discantus) on a five-line staff with a treble clef, and A., T., and B. (Alto, Tenor, Bass) on five-line staves with their respective clefs. Each part contains a single note.

Weerbeke

Musical notation for 'Weerbeke' featuring four parts: [D.] (Discantus) on a five-line staff with a treble clef, and A., T., and B. (Alto, Tenor, Bass) on five-line staves with their respective clefs. Each part contains a single note.

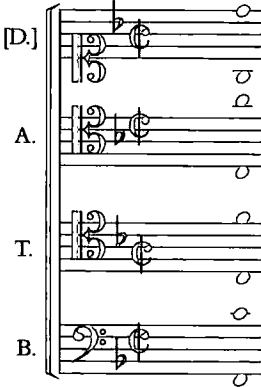
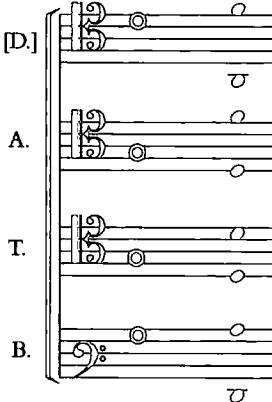
<i>Lapicida</i>	<i>Benedictus (fol. 50^v)</i>
	

The de Quadris Lamentations and *laude* distinguish themselves not only by their two voices but by their use of higher clefs. The *laude*, following de Quadris's two-part Lamentations, share similar clef configurations with the exception of 'Cum autem venissem' which adopts C₄fl and F₃fl. It is known that 'Cum autem venissem' was 'ancient' and its clef configuration may have been well established by the mid-fifteenth century.¹⁴

While several Lamentations employ imitation, it is used far less exuberantly than in the motets and Masses of the same composers. Imitation may be found in the settings of Tinctoris, Ycart, Agricola (both settings), Tromboncino (very short imitative ideas) and Lapicida. There is virtually no imitation in the Lamentations of Anon. 1, de Orto, de Quadris and Weerbeke; it is significant that these are the same composers who use restricted range in the same settings. Not one of the 1506 Lamentations display any suggestion of canon; this technique was undoubtedly considered too complex for the nature of Holy Week music.

Textural variety was another characteristic of the motet and Mass, developed in the early Renaissance by Dufay and perfected by Josquin and his contemporaries. It was often used in conjunction with imitation, particularly in paired imitative duets which are so characteristic of the music of Dufay, Josquin and several others. There is only one work in the 1506 Lamentations where textural manipulation is not possible due to lack of parts – the two-part

¹⁴ Razzi noted 'Le parole insieme col canto, sono antichissime, & d'authore incerto.' following his version of *Cum autem* on fol. 116^r in his 1563/6 edition, *Libro primo delle laudi spirituali da diversi...* (Venice).

Lamentations of de Quadris. However, few works exploit such textural changes characteristic of the motet or Mass. The Lamentations of Ycart and Lapidida exploit textural change while Agricola (four-part), Tinctoris and Weerbeke have a few short sections that include configural changes. The remaining pieces are relatively conservative in their use of texture, typified by homorhythmic sections combined with carefully controlled figurative polyphony.

While the 1506 Lamentations display a varied approach towards contrapuntal treatment, texture, clef configuration and structure, the majority of settings show a consistency in their treatment of phrase structure. Individual phrase lengths are typically short; there would appear to be a conscious effort by composers to avoid lengthy, mellifluous phrases, so often found in Masses and motets of the period.

Only one of the ten Lamentations avoids a *cantus prius factus*. The setting of Tinctoris, the first Lamentation setting in 1506/1, is essentially a free composition (although Melin observed a brief allusion to a *cantus firmus* in the opening phrases; see example 3.19).¹⁵ This work is also distinctive in that it is through composed, exploits dissonance and displays uninhibited figurative and polyphonic phrases.

Example 3.19: *Lamentations* (Tinctoris)

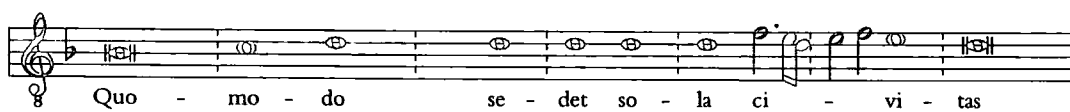

There are two distinct categories in the 1506 Lamentations based upon their structural organisation: through-composed settings and those employing repetition. Through-composed works are written by Tinctoris, Ycart, Agricola (both settings), Weerbeke and Lapidida (although some of these works repeat the same music for each Hebrew letter). Repetition and the use of formulae

¹⁵ Melin, 'The Music of Johannes Tinctoris', p. 259, cited the notes *b flat-c'-d'* with which the Tenor introduced the text 'Quomodo sedet sola civitas' and the Discantus's repeated *d*'s. He conceded that there is no further suggestion of the use of the formula following this event. If this is the *cantus firmus* then Tinctoris has transposed it, making it one of the few settings not to use *f* as its final.

are present in the works of Anon. 1, de Orto, de Quadris and Tromboncino. The two longest settings in the prints, de Quadris's Lamentations in 1506/1 and Tromboncino's Lamentations in 1506/2, display the most extensive use of cyclic repetition while the established northern composers are amongst those who demonstrate the least amount of repetition. The use of repetition in Anon. 1's work is possibly another reason for stylistic disassociation with the name of Ycart, since the theorist's setting is completely through-composed (as is the setting by his colleague Tinctoris).¹⁶

A feature common to several settings is the use of the same music for the Hebrew prefatory letters, thus creating a liturgical and musical symmetry. The settings of Agricola, de Orto, de Quadris, Tromboncino and Lapidida include such musical repetition. Although Agricola's three-part Lamentations use the same music at 'Ghimel', 'Deleth', 'He' and 'Zain' as 'Beth' (Agricola sets no music for 'Aleph'), there are slight rhythmic variations in each, resulting in Petrucci having to print this music each time rather than use an 'ut supra' prompt. The de Quadris setting stipulates 'ut supra' for the letters 'Beth' and 'Gimel' but the fourth letter 'Teth' is set again, despite there being very few differences from 'Aleph'. The setting repeats this pattern throughout; it may have been thought prudent to repeat the music periodically rather than rely on memory during performance. 1506/2 shows a similar approach; Tromboncino's setting periodically repeats music previously set for certain Hebrew letters although the repeated music is newly typeset (even when exact repetition is used). Again, there are often several pages between the initial instance and the repetitions. Lapidida only uses one musical repetition of a Hebrew letter in his setting, where 'He' uses identical music to the previously set 'Beth'.

It might be presumed that the inherent liturgical symbolism of Holy Week, particularly those aspects which highlight denial and restraint, would be reflected by the absence of ornate music. It may therefore come as some surprise that polyphonic settings existed and were encouraged during the

¹⁶ Thomas, 'Two Petrucci Prints', pp. 37-38, argued that the three-part Lamentation following that of Ycart's four-part setting was also by that composer. He suggested that Petrucci did not bother to repeat ascriptions, citing the one ascription to de Quadris in 1506/1 as an example of this practice.

Renaissance, rather than being replaced in favour of monophonic renditions or even by avoiding music altogether. I believe that 1506/1 and 1506/2 reflect the changing attitudes towards the function of Lenten music from the mid-fifteenth century through the early sixteenth century. The scoring of the mid-fifteenth-century de Quadris Lamentations illustrates this; the most common scoring in sacred works during the period of composition for these Lamentations was at least three parts; yet de Quadris chose only two voices for his lengthy settings. There are few works extant by de Quadris but amongst them is a four-part Magnificat and a three-part Hymn, showing his ability to use these configurations. The majority of the 1506 Lamentation settings date from the late fifteenth century and are set in four parts, with only two settings in three parts. The configuration of the vast majority of sacred settings from this period is four-part; the 1506 Lamentation settings may therefore reflect a change in attitude towards restraint in vocal configuration amongst Holy Week settings. However, 1506/1 and 1506/2 contain no works in more than four parts.

Table 3.01: Mensurations in the 1506 Lamentations

<i>Composer</i>	<i>Lamentation Chapter</i>				
	<i>Ch. 1</i>	<i>Ch. 2</i>	<i>Ch. 3</i>	<i>Ch. 4</i>	<i>Ch. 5</i>
Tinctoris	♢				
Ycart	♢	♢			♢
Anon. 1	○				
Agricola (a3)	♢ ; ϕ ; ♢				
Agricola (a4)		♢			
de Orto	♢				
de Quadris	○ ; ϕ ; ○ <i>etc.</i>	ϕ ; ○ <i>etc.</i>	ϕ ; ○ <i>etc.</i>	ϕ ; ○ <i>etc.</i>	○ ; ϕ
Tromboncino	♢ ; c ; ♢ ; c ; ♢ ; (♢ 2) ; c ; ♢ ; ♢ 2 ; c ; ♢ 2 ; c <i>etc.</i>	♢ ; ♢ 2 ; ♢ ; c ; ♢ ; ♢ 2 ; ♢ ; ♢ 2 ; ♢ ; c ; ♢ 2 ; ♢			♢ ; ♢ 2 ; ♢ ; ♢ 2 ; ♢
Weerbeke	♢ ; c ; ♢		♢	♢	♢
Lapicida	♢ ; ϕ ; ♢ ; c ; ♢				

Table 3.01 (above) shows the range of mensural changes and illustrates the popularity of ♩ ; the only Lamentations that do not commence with ♩ are those of de Quadris (O) and Anon. 1 (O). Several settings feature sections in which the mensuration deviates from ♩ including Agricola's three-part setting (♩ is used at the beginning and end; 'Viae Syon' states ♩), Tromboncino (mainly ♩ ; it contains short sections in ♩^2 and ♩), Weerbeke (principally ♩ but contains a short section in ♩) and Lapidida (principally ♩ but 'Viae Syon' is in ♩ and 'Recordata' in ♩). The choice of opening mensuration reflects the difference between the more archaic preferences of de Quadris and the somewhat retrospective writing of Anon. 1 compared with the later style of Agricola, de Orto and Weerbeke.¹⁷

A variety of cadential treatment is evident in the 1506 Lamentations. While the cadencing of the majority of works is based around the typical Discantus-Tenor resolution onto the final, it is the behaviour of the other voices which distinguishes certain composers. This is most evident in the three-part settings where the usual resolution by the Discantus and Tenor is complemented by an octave leap cadence in the Contra. CapePL 3.b.12's reading of Anon. 1's three-part Lamentation shows this (example 3.20); a sharp contrast may be seen in 1506/1 where its Contra always cadences to a unison or below the Tenor (example 3.21).

¹⁷ The mensural devices of de Quadris's Lamentations attracted the attention of Bent, 'The Use of Cut Signatures', 656-657, who noted the difference in mensural marks between Petrucci and VicAC 11. She argued that the stroke sign does not necessarily imply diminution and may indicate cues (the 1506 readings would appear to support this notion). Bent observed that circle (or no tempus indication) is standardised for the verses and cut-circle for the Hebrew letters and Jerusalem refrains throughout the de Quadris setting.

Example 3.20: *Lamentations* (Anon. 1, CapePL 3.b.12)

Supra
pro - phe - te,

Tenor
pro - phe - te,

Contratenor
pro - phe - te, pro - phe -

10
pro - phe - te.

pro - phe - te.

te.

Example 3.21: *Lamentations* (Anon. 1, 1506/1)

Supra
[Ale]

Tenor
[Ale]

Contra
[Aleph]

10
ph.

ph.

Example 3.22 from de Orto's *Lamentations*, provides a more convenient comparison between CapePL 3.b.12 and 1506/1 since the music is essentially the same up to the beginning of ch. 1:3. CapePL 3.b.12's Bassus consistently employs octave leap cadences whereas the 1506/1 reading tends to avoid them

(there are seven in CapePL 3.b.12 compared to three in 1506/1). The difference between de Orto's use of this cadence and the more conventional application by Tinctoris and Anon. 1 is that de Orto does not resolve the upward leaping part on the fifth above the Tenor but allows it to fall a third, settling upon the third of the final chord. Thus, de Orto achieves a blend of old and new technique in his adaptation of the octave leap cadence. Tromboncino's Lamentations provide many examples of octave leap cadences in four parts although there are no instances of the Bassus resolving to a third (taken by the Altus in most of the octave leap cadences).

Example 3.22: *Lamentations* (de Orto, 1506/1 and CapePL 3.b.12 readings)

The musical score consists of six staves. The top staff is labeled [Discantus] and is in G-clef. It contains a melodic line with a final cadence. The second staff is labeled Altus and is in G-clef. It contains a vocal line with the lyrics 'Pro - phe - te.' The third staff is labeled Tenor and is in G-clef. It contains a vocal line with the lyrics 'pro - phe - te.' The fourth staff is labeled Bassus [1506/1] and is in F-clef. It contains a vocal line with the lyrics 'Pro - phe - te.' The fifth staff is labeled Bassus [CapePL 3.b.12] and is in F-clef. It contains a vocal line with the lyrics 'pro - phe - te.' The lyrics are written below the staves, with hyphens indicating syllable placement.

The discovery of a new section of polyphony within de Orto's *Lamentations* in CapePL 3.b.12 deserves special comment. The independent polyphony commences near the beginning of verse three and concludes towards the end of that verse (see edition in appendix 3 and phrase analysis in table 3.02 below). While the divergence is at the beginning of a phrase and the polyphony is independent thereafter, the similarity in sources at the end of the verse (at the text 'angustias') might indicate knowledge of both versions. The concluding cadence for verse 3 is essentially the same in both versions, save for the favoured octave leap cadence in CapePL 3.b.12 (discussed above). There is a

similarity in that the beginning of each phrase in both versions of this verse is homorhythmic and gradually develops into more figurative polyphony but, apart from that, there are no other correspondences. The range of parts in both versions is identical except for the Bassus; 1506/1's is *F-g* while CapePL 3.b.12's is *F-a*.

There is little stylistic evidence to differentiate between the readings of verse three. Homorhythmic control is evident in both and there is very little figuration. Both versions contain tightly controlled counterpoint and clearly defined phrases. However, the existence of different versions of the same Lamentation setting within a monastic tradition has a precedent; one only needs to inspect the versions of Lamentation X, undoubtedly generated by aural transmission and performance practice, to see that such practices already existed (this will be discussed in chapter 6).

Table 3.02: Phrase structure in Marbrianus de Orto's Lamentations [1506/1 and Cape Town 3.b.12]

	I	Incipit			
	II	Lamentatio			
	III	Jeremie			
	IV	Prophete			
	V-VI	Aleph			
		[Lamentations 1:1]			
	VII	Quomodo sedet sola civitas			
	VIII	plena populo:			
	IX	facta est quasi vidua domina gentium:			
	X	princeps provinciarum			
	XI	facta est			
	XII	sub tributo			
	V-VI	Beth [1506/1 = 'ut supra']			
		[Lamentations 1:2]			
	XIII	Plorans ploravit in nocte,			
	XIV	et lacrimae ejus			
	XV	in maxillis ejus			
	XVI	non est qui consoletur eam			
	XVII	ex omnibus caris ejus			
	XVIII	omnes amici ejus spreverunt eam,			
	XIX	et facti sunt ei inimici.			
	V-VI	Ghimel [1506/1 = 'ut supra']			
		[Lamentations 1:3]			
1506/1	VII'	Migravit Judas propter afflictionem,	Cape Town	VII''	Migravit Judas propter afflictionem,
	IX	et multitudinem servitutis:		XX	et multitudinem servitutis:
	XVI	habitavit inter gentes,		XXI	habitavit inter gentes,
	XVII	nec invenit requiem:		XXII	nec invenit requiem:
	XVIII	omnes persecutores ejus apprehenderunt eam		XXIII	omnes persecutores ejus
	XIX	inter angustias.		XXIV	apprehenderunt eam
				XXV	inter angustias.
	V	Jerusalem,			
	VI	Jerusalem			
	II	convertere			
	III	ad Dominum			
	IV	Deum tuum			

Although the readings of Anon. 1 in CapePL 3.b.12 and 1506/1 are different (particularly in their rhythmic organisation), it is possible to compare certain sections. Example 3.23 illustrates the difference between the Contra parts and

demonstrates 1506/1's lively writing compared to CapePL 3.b.12's more static part (the upper two voices are essentially the same in both readings). It is possible, in both readings, to remove the Contras and still produce musically and theoretically-sound settings. The implication that this setting was originally two-part, to which both Petrucci and the Cape Town scribes, added a Contra, is supported by evidence in other contemporary and related manuscripts containing concordances of 1506/1. These manuscripts include CapePL 3.b.12, FlorBN Panc. 27 and PozR 1361 and will be discussed later.

Example 3.23: *Lamentations* (Anon. 1, 1506/1 and CapePL 3.b.12 readings)

83

[Discantus]

qui conso - le-tur e - am ex om - ni-bus ca-ris

Tenor

qui conso - le-tur e - am ex om - ni-bus ca-ris

Contra [1506/1]

[lacking text]

Contra [CapePL 3.b.12]

ver - sa est ad a - li - e - nos do - mus nos - tre

The CapePL 3.b.12 variants discussed above are characteristic of the diversity of this manuscript and suggest the influence of performance practice. It is possible that the scribes were not content to borrow music and replace text (as illustrated by the *frottole contrafacta*); the variants show that there must have been a distinctive performance practice which the scribes duly copied. Although the provenance of this manuscript is unclear, Giulio Cattin has convincingly argued the manuscript's monastic origins, noting the interest of the Italian Benedictines in its repertoire. The fifteenth-century reforms had affected the performance of music in the Benedictine monasteries and counterpoint was initially forbidden. However, the tendency to prohibit or discourage polyphony had diminished by the middle of the century and

Cattin's findings revealed some 'rudimentary and "homemade" ' polyphony in this manuscript.¹⁸

Cattin suggested that the former *frottole* by Tromboncino and others were included in CapePL 3.b.12 because the scribes wished to represent secular music, but were unable to do so, since they were constrained by the ethos and function of the manuscript.¹⁹ However, while the evidence points towards scribal creativity, the possibility exists that they may have copied the alternative versions of de Orto's and Anon. 1's Lamentations from elsewhere.

The emergence of the Bassus as the third most important voice is frequently demonstrated in 1506/1; de Orto's setting in particular illustrates this. Other Lamentations incorporating a supporting Bassus part are Tinctoris, Ycart, Agricola (four-part), Tromboncino, Weerbeke and Lapidica. The function of the Bassus contrasts with that of the Contra; de Orto's Bassus occasionally crosses the Tenor (whereas the Contra frequently crosses) and it frequently cadences onto a unison with the Tenor (unlike the Contra which finds its own note of resolution).

The notes of resolution within a cadence are revealing, particularly with the gradual emergence of the vertical third within the final chord of a section. The majority of composers in the 1506 Lamentations use at least one example of a final cadence that includes a vertical third, namely Ycart, Agricola (both settings), de Orto, Tromboncino, Weerbeke and Lapidica. Of the seven settings cited, Tromboncino and Lapidica were most consistent in their use of thirds, reflecting the influence of the *frottola* style in their Lamentations. The avoidance of resolving thirds in the music of other Lamentation composers suggests a more austere stylistic approach towards the Lamentation texts.

In the Renaissance motet and Mass, the rate of dissonance typically increases towards a cadence by the use of prepared and passing dissonance. However, there is considerable variety in the use or avoidance of dissonance in the 1506 Lamentations. Tinctoris's Lamentation setting uses a considerable range of passing and prepared dissonance, noticeably at cadences. An upper voice is typically delayed while approaching a cadence, creating a suspended

¹⁸ Cattin, *Italian Laude*, p. x.

¹⁹ *Ibid.*, p. ix-x.

fourth, seventh or ninth. The lowest part is occasionally suspended, an upper voice creating a second above that part. Melin drew attention to a specific example of cadential dissonance in Tinctoris's setting at bar 35 where the combined upper voices create a simultaneous 7-6/4-3 suspension.²⁰ The stepwise descending Tenor cadences to the modal final and the effect is characteristic of mid-fifteenth-century settings; the use of these specific dissonances at cadences is found in a number of settings in the 1506 Lamentations. This decorated cadence became quite uncommon during the early years of the sixteenth century and its use in the 1506 Lamentations may have been another deliberate archaic gesture. The Lamentations of Ycart, Tromboncino, Agricola (three-part; only one instance), Agricola (four-part) and Weerbeke (example 3.24) contain examples of this cadence. The use of the delayed or suspended fourth at cadences is far more common in the Lamentations and less dated than the 7-6/4-3 cadence cited above; most of the 1506 Lamentations include at least one example. The 9-8 suspension is the least common dissonance while the 7-6 is slightly more prevalent.

Example 3.24: *Lamentations* (Weerbeke)

55

[Discantus] ex om - ni - bus ca - ris e - ius

Altus ex om - ni - bus ca - ris e - ius

Tenor ex om - ni - bus ca - ris e - ius

Bassus ex om - ni - bus ca - ris e - ius

ca - ris	e - ius
	7 6
	4 3

The two *frottolists*, Tromboncino and Lapidica, exploit the greatest amount of dissonance in the 1506 Lamentations. Lapidica is often quite casual in his treatment of dissonance, particularly passing dissonance. There are instances in his setting where the resolution of a passing dissonance is sounded at the

²⁰ Melin, 'The Music of Johannes Tinctoris', p. 165.

same moment as the dissonance itself. His greater freedom towards prepared dissonance is illustrated by his use of the *cambiata*. The setting of the canticle 'Benedictus Dominus Deus Israel' following Lapidida's Lamentations contains a similar casual attitude towards its dissonance treatment, suggesting Lapidida's authorship.

A few Lamentations display a noticeable lack of dissonance usage, the best example being the de Orto setting. His counterpoint is positively frugal when compared to other Lamentations in the prints; the difference is even more distinctive when compared to contemporary motets and Masses. There are few examples of prepared dissonance in de Orto's setting, the only examples occurring at cadences. He is slightly more adventurous in his use of passing dissonance but his prevalent homorhythmic texture is not really interrupted by such techniques. De Quadris's Lamentations are also extremely economic in their use of dissonance; this work is most unusual in that there is virtually no prepared and little passing dissonance. Massenkeil, in his brief analysis of the anonymous Lamentation in ParisBNC 967, noted the 'curious stiffness' of the cadences in this setting.²¹ An ungainly compositional style is evident in some of the 1506 Lamentations, particularly in those works in which certain parts have a signature and others do not. It is particularly noticeable between the two versions of Anon. 1; CapePL 3.b.12's Tenor is the only voice to contain a flat as a signature whereas all three voices in the 1506/1 reading have a flat. An unusual example of this may be seen in Agricola's four-part Lamentations where the Bassus, rather than the Tenor, is the only voice to have a flat as signature. This creates some difficult decisions leading up to cadences. Example 3.25 illustrates a problematic passage for the Tenor; if the singer feels governed by the soft hexachord from the beginning of his imitative phrase, a flattened *b* will create a diminished fifth with the Bassus.

²¹ Massenkeil, 'Zur Lamentationskomposition', 108.

Example 3.25: *Lamentations* (Agricola four-part)

[Discantus] 6
Quo - mo - do

Altus
Quo - mo - do

Tenor
Quo - mo - do

Bassus 8
Quo - mo - do

The contrapuntal dexterity of the 1506 *Lamentations* provides a stark contrast with the *laude* of 1506/1 which I shall discuss in section 3.2.

3.2 *Laude* and miscellaneous music in 1506/1

The *laude* in 1506/1 are quite diverse, continuing the variety of style and technique found in the Lamentations. The volume begins with the *lauda* 'Adoramus te', a setting in four parts.²² While this text survived the Tridentine reforms and is found in various manuscript and print sources, the setting in 1506/1 is a unique source. It is virtually homorhythmic and syllabic throughout and its vocal configuration of C1fl, C3fl, C3fl and F4fl is unique within the two prints. While the Tenor is predominantly stepwise and has arc-shaped phrases, I have not been able to identify a *cantus prius factus*.²³ Each text phrase is clearly structured; the Tenor-Discantus relationship forms the basis for the composition while the Bassus acts as a supporting voice, falling by a fourth or fifth at all cadential points. The use of dissonance is relatively restrained, consisting of some passing dissonance and a few prepared 4-3s at cadences.

Although this setting is quite conservative in many respects, there is a distinct sense of adventure in the cadence at bars 15-16. The use of the flattened second degree (*a* flat) in the Bassus (example 3.26, penultimate bar) which finally resolves to *b* flat (preceded by the false relation of the Discantus's *a*') is often found in settings in the transposed mixolydian mode.

²² An edition of this setting may be found in appendix 4.

²³ There is no similarity between the Tenor or Discantus of 1506/1's 'Adoramus te' and extant plainchant settings or other polyphonic settings of this text. The homorhythmic style inherent in 1506/1's 'Adoramus te' is also found in the following pre-1506 settings of the same text: GB-Oxford Bodleian, Lat. lit. e 14, fol. 56^v, a4, anon. (described and transcribed in Andrew Hughes, 'The Choir in Fifteenth-Century English Music: Non-Mensural Polyphony', *Essays in Musicology in Honor of Dragan Plamenac*, ed. Gustave Reese and Robert J. Snow (Pittsburgh: University of Pittsburgh, 1969), 127-145); MonteA 871, fol. 2^v, a2, anon. (Pope and Kanazawa, *The Musical Manuscript Montecassino 871*, pp. 113-114); PerBC 431, fols 161^v-162^r, a4, anon. (Atlas, *Music at the Aragonese Court*, pp. 204-205); CapePL 3.b.12, fols 30^v-32^r, a4, anon. (Cattin, 'Canti polifonici', 517-518); I-Rocca di Mezzo, s.s. (the anonymous four-part setting is described and transcribed in Agostino Ziino, ed., *Documenti di polifonia in Abruzzo*, *Musica rinascimentale in Italia*, 2, ed. Domenico Cieri (Rome: Pro Musica Studium, 1974), pp. 38-39. The second 'Adoramus' ascribed to Laurentius Gaspard in the same manuscript is set in an imitative style).

Example 3.26: *Adoramus te* (Anon., 1506/1)

12

[Discantus] Qui - a per sanc-tis - si - mam cru-cem

Altus Qui - a per sanc-tis - si - mam cru - cem

Tenor Qui - a per sanc-tis - si - mam cru - cem

Bassus Qui - a per sanc-tis - si - mam cru - cem

I would suggest that the use of consecutive fermatas for the text phrase 'Domine Jesu Christe' may have been a liturgical (or para-liturgical) reference point; the participants might, for example, have genuflected at this moment (see example 3.27, below). There are a number of works in 1506/1 that use consecutive fermatas; amongst them are the Lamentations of Ycart (three phrases with five, six and four consecutive fermatas), Ana's 'Passio sacra' (three phrases with five, eight and six fermatas) and the *lauda* 'Venite et ploremus' (one phrase with seven fermatas) and 'Sepulto Domino' (three phrases with three, six and four fermatas). In most instances, words with specific textual significance have had fermatas added.²⁴

Example 3.27: *Adoramus te* (Anon., 1506/1)

[Discantus] A - do - ra-mus te Do - mi - ne Je - su Chri - ste

Altus A - do - ra-mus te Do - mi - ne Je - su Chri - ste

Tenor A - do - ra-mus te Do - mi - ne Je - su Chri - ste

Bassus A - do - ra-mus te Do - mi - ne Je - su Chri - ste

²⁴ Blackburn, 'The Dispute about Harmony', 13-37, discussed the use of consecutive fermatas within strictly homorhythmic and syllabic sacred settings, noting a systematic use of this feature in certain settings by Dufay, Binchois, Weerbeke and other northern composers.

Pope and Kanazawa, referring to the anonymous 'Adoramus te' in MonteA 871, noted that the style of this piece is comparable to Oriola's 'In exitu Israel' and Cornago's 'Patres nostri [*sic*] peccaverunt', due to its four-voice chordal style and lack of any chant melody as *cantus firmus* in the Superius.²⁵ They identified the strong ternary rhythmic drive, typified by the use of *tempus perfectum*, as representing the 'popular style' in MonteA 871.²⁶ While the 1506/1 setting of 'Adoramus te' is not in the same mensuration, the other elements cited by Pope and Kanazawa would suggest that it is akin to this 'popular' style. Bonnie Blackburn analysed the strictly syllabic and homorhythmic style evident in certain fifteenth-century sacred settings composed in Italy, particularly in the Milanese *motetti missales* of Loyset Compère and Gaspar van Weerbeke.²⁷ She noted that these motets, in this restrictive 'devotional style', were frequently associated with northern composers and flourished towards the end of the fifteenth century.²⁸ While the setting of 'Adoramus te' in 1506/1 was doubtless influenced by the devotional style, it was not composed in a strict *nota-contra-notam* style (there being a little figuration and dissonance).

The two-part *laude* following the Lamentations of de Quadris essentially continue the same stylistic trends. Discantus and Tenor are texted in a syllabic style; phrases are clearly defined and both parts cadence simultaneously. The opening text, 'Venite et ploremus' (not, as such, a *lauda*, but written in the same style), uses two independent clefs with the upper voice lacking the key signature B flat (as in the Lamentations). The mensuration [C] is different, and there is no suggestion of a *cantus firmus* in either voice. The notation is white-note although the Discantus uses coloration for a couple of notes. The authorship of these *laude* by de Quadris is not certain; Cattin acknowledged that they were in the same style as the de Quadris Lamentations, suggesting that they must have been written by de Quadris or somebody heavily

²⁵ Pope and Kanazawa, *The Musical Manuscript Montecassino 871*, p. 36.

²⁶ *Ibid.*, pp. 43-44. *Tempus perfectum* was the mensuration favoured for hymn settings of the second quarter of the fifteenth century; *tempus imperfectum* [C or C] became popular after the middle of the century.

²⁷ Blackburn, 'The Dispute about Harmony', 13.

²⁸ *Ibid.*, 13.

influenced by his style.²⁹ Strohm assumed that the composer of these *laude* was de Quadris.³⁰

'Popule meus' was a well-known text during the Renaissance and is the only text in 1506/1 or 1506/2 that is set strophically. It shares the same clefs as the previous composition but uses the mensuration ©. The music of the 'A' phrase is used four times and the 'B' phrase thrice. There is no prepared dissonance and tension is achieved by passing dissonance and syncopation when approaching certain cadences (See ex. 3.28 below). The use of an under-third cadence at the final cadence in the example is analogous with the earlier Renaissance. There is also a neat symmetry in the presentation of these two final phrases; the phrase beginning on the bottom system is effectively a repeat of the opening of the previous phrase up a fourth.

Example 3.28: *Popule meus* (Anon., 1506/1)

[Discantus]

et man-na ci - ba - vi te

Tenor

et man-na ci - ba - vi te

et in-tro - du - xi in ter - ram satis op - ti-mam.

et in-tro - du - xi in ter - ram sa - tis op - ti-mam.

'Cum autem venissem' was one of the most popular Latin *laude* in Italy, judging from the number of extant sources. Perkins stated that its melody was found in various sources.³¹ He suggested two possible reasons for this; firstly, that its popularity resulted in modification and adaptation and secondly that it reflected local development of musical style and taste. He also observed that the 1506/1 'Cum autem' is extremely close to a version in 1563/6.³² Even though the setting of 'Cum autem' in Montecassino is in four parts, Perkins

²⁹ Giulio Cattin, 'Johannes de Quadris [Quatris]', *New Grove Dictionary of Music & Musicians*, 2nd edition, 13 (2001), 143-144 (p. 144).

³⁰ Strohm, *The Rise of European Music*, p. 588. Petrucci's table of contents states 'eiusdem'; therefore Petrucci clearly thought the settings were those of de Quadris.

³¹ Perkins, *Music in the Age*, pp. 452-53. He also noted that the melody used in 1506/1 is the same as the cantus part for MonteA 871 and Petrucci's second book of *laude*.

³² *Ibid.*, p. 452.

suggested that it is still similar to the setting in 1506/1 except for a more luxurious texture (it is my opinion that this setting bears little similarity, except for the use of the melody). He suggested that one effect of the very simplistic style would be the possibility of embellishment by the performers;³³ this contrasts with *laude* composed towards the end of the fifteenth century which reveal the influence of the *frottola* and are thus more developed.

The higher part of the 1506/1 'Cum autem' setting differs from the remaining 1506/1 *laude* since it is set to clef C₄. While it generally lies above the Tenor, it does cross on several occasions, proportionally more than the other two-part *laude* (see example 3.29). Text is underlaid in both voices and there is little interruption to the severely syllabic style. There is no prepared dissonance and little passing dissonance but the two parts tend to move in thirds in mid-phrase, more so than the other *laude*.

Example 3.29: *Cum autem* (Anon., 1506/1)

sta-tu-erunt e - um in medi - o omnis po - pu - li et
 ve - sti - bus ex - po - li - a - tis nu - dum di - mi -
 se - runt cor - pus sanc - tis - si - mum.

'Sepulto Domino' shares some of the characteristics of 'Cum autem' such as clearly defined phrasing and texting and a predilection for parallel thirds. The Discantus is more lively than that of 'Cum autem' and features occasional

³³ *Ibid.*, pp. 452-453.

short syncopated phrases. Text underlay in the Discantus is more melismatic than 'Cum autem' and dissonance treatment is more flexible, although there is little prepared dissonance. This *lauda* must have been perceived as a *cantasi come* since there are several textual variations for the same music in various sources. This might explain why it is more melismatic than the other two-part *laude*; it must have required greater musical and textual flexibility when fitting the text.

'Sepulto Domino' is another *lauda* which exists in CapePL 3.b.12 in a different configuration to its 1506/1 version. CapePL 3.b.12's reading has an extra Contra which is quite inventive and frequently crosses the middle [Tenor] part. It again shows the thriving repertory shared by such sources as CapePL 3.b.12, MonteA 871 and 1506/1.

The final work in 1506/1, 'Passio sacra nostri redemptoris' by 'Fran. Vene', is a *unicum*. Gustave Reese noted that it is not a true Passion;³⁴ Leofranc Holford-Strevens's analysis of the text (discussed in chapter 2.3) supports this notion. This is the only piece in 1506/1 and 1506/2 which is based upon the modal final *a*. The clef configuration is strongly reminiscent of the *frottola*, as is much of the part writing. Texture is essentially chordal with the higher tessitura of the Discantus dominating while the Altus and Tenor overlap within the middle of the texture. The Bassus underpins the other voices and falls at structural cadences. Text phrases are clearly defined in the music and the influence of the *frottola* may be seen with the greater rhythmic drive towards cadential points as illustrated in example 3.30 below (except in the Bassus). The use of dissonance is relatively free, particularly in the upper voices and especially with prepared dissonance in the Discantus at cadences. Brown & Stein briefly described Ana's *Passion* as 'surprisingly expressive, considering its economy of means'.³⁵ It is an effective setting and justifies its inclusion in the print as a piece of native polyphony.

³⁴ Reese, *Music in the Renaissance*, p. 165.

³⁵ Brown and Stein, *Music in the Renaissance*, p. 99.

Example 3.30: *Passio sacra* (Francesco Ana)

The image shows a musical score for a four-part setting of a Latin text. The score is divided into two systems. The first system (measures 16-19) features four vocal parts: [Discantus], Altus, Tenor, and Bassus. Each part has a vocal line with lyrics and a lute line (marked with a 'g' for guitar). The lyrics for this system are: "Je - su sal - va - tor ve - ni - am pec - ca - ti". The second system (measures 20-23) continues the Discantus part, with lyrics: "ti tri - bu - e ti tri - bu - ti". The notation includes various note values, rests, and articulation marks.

Mensuration in the non-Lamentation settings, unlike the Lamentations, is not dominated by ♩ , due to the antiquity of the *laude* following the de Quadris Lamentations in 1506/1 (see table 3.03 below). While Ana's 'Passio sacra' begins and ends in ♩ , the use of a section in ♩ is also characteristic of the Mass and motet, especially the manner by which the work reverts to ♩ in mid-phrase.³⁶

³⁶ Bonnie J. Blackburn, 'The Sign of Petrucci's Editor', Conference Paper Presented in Venice, October 2001: 'Venezia 1501: Petrucci e la stampa musicale', observed that this sign was unusual for sesquialtera and was probably adopted during the early sixteenth century by Petrucci or his editor. She suggested that it may indicate the editorial hand of Petrus Castellanus's Venetian phase since the sign is far less common in the Fossombrone prints; Dr Blackburn will discuss these issues in her forthcoming article.

Table 3.03: Mensurations in the non-Lamentation settings in 1506/1 and 1506/2

<i>Title</i>	<i>Mensuration</i>
'Adoramus te Domine'	♠
'Venite et ploremus'	♣
'Popule meus'	○
'Cum autem venissem'	♣
'Sepulto Domino'	○
'Passio sacra' (F. Ana)	♠ ; ♯ ; ♠
'Benedictus Dominus Deus Israel' (1506/2, fols 33 ^v -35 ^r)	♠
'Benedictus Dominus Deus Israel' (1506/2, fols 50 ^v -51 ^r)	○

3.3 The canticles 'Benedictus Dominus Deus Israel' in 1506/2

The first 'Benedictus' beginning at fol. 33^v (following Tromboncino's Lamentations) is set for four voices employing clefs C2fl, C4fl, C4fl and F3fl respectively. There is no ascription for this canticle (nor the second setting at fol. 50^v) although it follows Lamentations by Tromboncino. Only odd numbered verses are set to polyphony; even numbered verses would have been sung to plainchant. The Discantus presents the Roman intonation at the beginning of each verse with the exception of verse five (where the Tenor presents it).

The *cantus firmus* uses the Mixolydian mode with the final transposed to *f* rather than *g* (due to the B flat signature and the clef of the Discantus). Having stated the intonation, the Discantus invariably cadences onto *d'* with the Tenor. The only verse where the *cantus firmus* is in the Tenor still allows a cadence to *d*, due to a phrase extension. A characteristic coloration of these *d* cadences is the sharpening of the third, mostly by the Altus. The Discantus paraphrases the *cantus firmus* from verse eleven (the final verse of polyphony before the 'Gloria Patri'); the *cantus firmus* is even more disguised in the Doxology. It may be no coincidence that the Discantus and Tenor have the smallest range; by contrast the Altus has an ambitus of *c - g'* and the Bassus *A - d'*.

The polyphony appears to be carefully controlled in each verse of this setting. Furthermore, there is an unusual effect whereby the polyphonic intensity of each subsequent verse diminishes, contrary to the expected custom. The opening verse is remarkable with its swiftly moving, stepwise inner voices under the long-note equal-value statements of the Discantus. Verses seven and eleven both feature static and prolonged chording, although the latter sustains interest with the use of dissonance. Final cadences are constructed around the Discantus-Tenor *clausula vera* and each verse, without exception, concludes with an octave leap by the Bassus (see example 3.31).

Example 3.31: *Benedictus Dominus Deus Israel* (Anon., fols 33^v-35^r)

The musical score consists of four staves. The top staff is labeled [Discantus] and contains the full text underlay: "lo sunt pro - phe - ta - rum ei - us." The second staff is labeled Altus, the third Tenor, and the fourth Bassus. The Discantus part is characterized by long, equal-value notes, while the other three voices (Altus, Tenor, Bassus) feature more active, stepwise motion. The piece concludes with a final cadence involving an octave leap by the Bassus.

Only the Discantus has the full text underlay; the other three voices use text incipits. Text setting in the Discantus is predominantly syllabic although Petrucci's word setting is often vague in melismatic passages (not one single word is split into syllables). The first verse has the greatest proportion of melismatic writing while the remaining text incipits in Altus, Tenor and Bassus

are set syllabically. Imitation is restricted to the occasional short phrase within two voices.

The setting contains a wide variety of dissonance treatment, both passing and prepared. One distinguishing feature of dissonance treatment in this setting is the regular use of anticipated dissonance (particularly fourths; see bars 6, 8 and 16 in example 3.32); this occurs most frequently in the Discantus following the statement of the *cantus prius factus* (the only other setting to use anticipated fourths is Tromboncino's Lamentations). There are instances of more conventionally prepared dissonance although the archaic compound 7-6/4-3 pattern is not present (unlike Tromboncino's Lamentations which feature several such examples).

Example 3.32: *Benedictus Dominus Deus Israel* (Anon., fols 33^v-35^r)

The musical score is presented in three systems, each with five staves. The top staff is labeled [Discantus] and contains a melodic line with a soprano clef and a key signature of one flat. The following four staves are for the vocal parts: Altus (soprano clef), Tenor (alto clef), Bassus (bass clef), and another Bassus (bass clef). The lyrics are written below the vocal staves.

System 1 (Measures 5-8):

- Discantus: Do - mi - nus De -
- Altus: [De]- us
- Tenor: De - us
- Bassus: De - us

System 2 (Measures 9-13):

- Discantus: us Is - ra - el
- Altus: Is - ra - el
- Tenor: Is - ra - el
- Bassus: Is - ra - el

System 3 (Measures 14-17):

- Discantus: qui - a vi - si - ta - vit
- Altus: [qui - a vi - si - ta - vit]
- Tenor: [qui - a vi - si - ta - vit et]
- Bassus: [qui - a vi - si - ta - vit et]

This setting is skilfully crafted with its linear polyphony matched to a horizontal structural awareness. Voice leading is convincing throughout and there is variety in the contrapuntal texture (although the exuberance of the opening verse is not matched elsewhere). Lack of evidence of other sacred settings by Tromboncino prevents an assessment of authorship although some common elements link the Lamentations and canticle 'Benedictus', such as a predilection for octave-leap cadences and the use of a *cantus firmus* in long,

equal note values. I would tentatively suggest that these factors are sufficient on stylistic grounds to suggest Tromboncino's authorship.³⁷

The second 'Benedictus Dominus Deus Israel' in 1506/2, which follows the Lamentations of Lapidida on fol. 50^v, presents only the first verse of this canticle, placing the intonation in the Tenor throughout.³⁸ Another distinctive feature is the mensuration, being perfect throughout. This is another work with a low clef configuration, using C₄, C₄, C₄ and F₃. Vocal range is expansive (with the exception of the Tenor), exploiting the notes *A - f'* in the highest voice, *d - f'* Altus, *d - d'* Tenor and *F - c'* Bassus. The opening phrase of the highest voice which begins on *c'* illustrates exploitation of range, gradually descending to *A* and rising back to *c'* before its first rest (a considerably long phrase lasting almost seven perfect breves).

The *cantus firmus* determines the structure of the setting, its intonation beginning with *f-g-a* and a *g-a flexa*. There is no flat acting as key signature (unlike Tromboncino's setting discussed above) and accidentals are relatively infrequent. The composer presents the *cantus firmus* in a similar fashion to that of Tromboncino with equal, longer note values used to distinguish it from other voices. Following the presentation of the *cantus firmus*, the Tenor resorts to free polyphony and descends to the modal final *D* at the conclusion of the setting.

The imitative interplay between voices combined with the stepwise descending and ascending runs in short note values invite comparisons with the Lamentations by Lapidida and extended phrase lengths are common to both works. The proximity of the upper three voices creates some dense textures and the top voice is distinctive in that it frequently descends below the middle two voices, even dipping below the Bassus for one phrase (see example 3.33, bars 13-15). The hyperactive polyphony created by the consistent use of semiminims leads to occasional dissonant incongruities, often caused by the complex texture. Bar 17 (example 3.33) provides an example where competing

³⁷ Dr Bonnie Blackburn has indicated privately that the lack of Discantus-Tenor relationship suggests this piece was probably composed by an Italian, possibly Tromboncino. She also observed that Tromboncino's *lauda* in 1508/3, 'Salve croce', features several examples of anticipated fourths.

³⁸ An edition of this setting may be found in appendix 5.

semiminims in the Tenor and Bassus create passing fourths and seconds before resolving to a unison (circled in the example).

Example 3.33: *Benedictus Dominus Deus Israel* (Anon., fols 50^v-51^r)

13
[Discantus] Qui - a vi - si - ta - vit et fe - cit

Altus
Qui - a vi - si - ta - vit et fe - cit

Tenor
Qui - a vi - si - ta - vit et fe - cit

Bassus
Qui - a vi - si - ta - vit et fe - cit

17
etc

re - demp - ti -

Cadential control is sometimes archaic, the 7-6/4-3 dissonance over the cadence at bars 11-12 being a good example (see example 3.34 below). There are further moments illustrating confusion between parts; the work narrowly avoids parallel intervals at bar 24 (Altus and Bassus). Lapidica's *Lamentations* also display a similar casual approach to dissonance as discussed in section 3.1.

Example 3.34: *Benedictus Dominus Deus Israel* (Anon., fols 50^v-51^r)

The musical score consists of four staves. The top staff is labeled [Discantus] and begins with a '8' above the staff. The lyrics 'us' and 'Is-ra-el' are written below the notes. The second staff is labeled 'Altus' and has the lyrics 'Is - ra-el'. The third staff is labeled 'Tenor' and has the lyrics 'el'. The bottom staff is labeled 'Bassus' and has the lyrics 'de - us' and 'Is - ra - el'. At the end of the piece, there are two measures with the numbers 7 and 6 above the staff, and 4 and 3 below the staff.

The brevity of the work does not assist in ascertaining authorship; however, I believe there is sufficient evidence to support Wessely's claim that this is the work of Lapidica.³⁹ The same predilection for wide-ranging voices is present, combined with the use of short note value stepwise runs. Another common feature is the use of a wide ambitus in every voice. Arguably, the lower standard of counterpoint employed in Lapidica's Lamentations is also present, illustrating a number of poor compositional choices within a relatively short setting.

3.4 Conclusion

There is a great variety of compositional practice represented in the 1506 Lamentations although the majority of settings have a common feature in their use of a *cantus firmus*. For example, the controlled, dextrous style of the northerner Tinctoris sharply contrasts with the restrained notes of his younger compatriot de Orto. There are considerable variants in the representation of native music, the flexible approach of Tromboncino and Lapidica contrasting with the restrained, almost severe, style of de Quadris (transcending the different periods of composition as I have previously discussed). The *laude* in 1506/1 reflect the functionality of that genre and its association with private

³⁹ Othmar Wessely, 'Lapidica, Erasmus', *New Grove Dictionary of Music & Musicians*, 10 (1980), 465-466 (p. 465). Susan F. Weiss, 'Lapidica [Steinschneider], Erasmus [Rasmo]', *New Grove Dictionary of Music & Musicians*, 14 (2001), 267, continued to attribute this setting to Lapidica.

music-making while the advanced writing of composers such as Agricola and Weerbeke suggest performance by semi-professional or professional singers.

There is sufficient evidence for the theory of restraint in this Holy Week music, although much of the polyphony represented in the 1506 Lamentations is quite complex and involved (the theory of restraint in Lenten music will be discussed further in chapter 5). Most works exhibit restraint in their phrase lengths, combined with a more terse word-setting style. Many settings exercise restraint in their handling of dissonance, excepting the two *frottolists*, who tend to show greater flexibility. Both Lamentation prints display a variety of vocal ranges; economy in vocal texture is particularly evident in the Lamentations of de Orto and Anon. 1 (particularly the CapePL 3.b.12 source) while Tinctoris and Lapidida appear unaffected by such constraints.

The functional, controlled polyphony of the *laude* in 1506/1 contrasts sharply with the intricate part writing of the two *cantus firmus* based 'Benedictus' settings in 1506/2. While the nature of the former meant that performance would have been possible by semi-professional or even amateur singers, the complexity and dexterity of the two canticles in 1506/2 suggest that these pieces were probably composed for a professional ensemble.

Chapter 4

A BIBLIOGRAPHICAL PROFILE

4.1 Physical description of extant copies of 1506/1 and 1506/2

The seven extant copies of the two Lamentation volumes are in remarkably good condition, considering the passage of time.¹ Each copy contains a wealth of bibliographical information, reinforcing the opinion of Boorman and Milsom that one must not assume that printed music copies are in an identical state.² Petrucci's preferred oblong quarto format is used in 1506/1 and 1506/2. It is believed that most of Petrucci's prints were stored and sold unbound to save cost, space and effort.³ The Padua, London and Paris copies of 1506/1 would each appear to have a contemporary binding while that of the Bologna copy is later; the absence of similarities supports the notion that they were not bound by Petrucci.

The Padua copy of 1506/1 (plate 4.01 shows the rear cover) has the clearest watermark evidence and is bound in hard black leather covers with metal clasps; the leather has been reinforced with wooden stiffeners measuring *c.* 236 x 168 mm. An elaborate pattern has been worked into the leather covers, suggesting that some thought and expense was given to the presentation of this volume. Folio 50 has been glued to the rear board – there is evidence of backing paper but this is unlikely to be sixteenth century. The leather covers are quite loose and there is some bookworm damage to the paper but otherwise this copy is in very good condition (with the exception of fol. 35 which is missing and contains part of ch. 1:12 and ch. 2: 8-11 of de Quadris's Lamentations). Several pages have deckle edges surviving, assisting calculation of the size of the original sheet. The date '8 feb 1624' with some subsequent indecipherable handwriting is found on fol. 1^v.

¹ Copies of 1506/1 and 1506/2 are held by the British Library, London; Civico Museo Bibliografico Musicale, Bologna and Bibliothèque Nationale, Paris. Only 1506/1 is held by the Biblioteca Antoniana, Padua.

² See Boorman, 'Petrucci at Fossombrone: A Study', pp. 120-124 and Milsom, 'Tallis, Byrd', 350-358, for discussion concerning the bibliographical interpretation of early printed music books.

³ Knighton, 'Petrucci's Books', discussed a 1563 Spanish bookseller's inventory. She observed that most of the books (including some Petrucci editions, discussed in chapter 5) were sold unbound as was customary at that time.

Plate 4.01: 1506/1 (Pca), rear cover



The Bologna copy of 1506/1 is in good condition though missing fol. 35. It has been bound with later stiff covers, possibly eighteenth or nineteenth century. Watermarks are evident in every gathering but are difficult to determine due to the cloudy nature of the paper. The Bologna copy of 1506/2 also has a much later binding and the final folio, fol. 50, has been glued to the rear board. Stitching is evident and the quality of inking is very good.

The copies of 1506/1 and 1506/2 belonging to London were acquired on 16 July, 1926; the first and last folios have been removed (possibly to prevent identification as Jeremy Noble has privately indicated). Both copies have been bound together with a vellum outer cover, inscribed with monophonic musical notation and text. Dr Nicolas Bell, British Library, very kindly identified the following features:

[This binding] ...is part of a bifolio from a monastic antiphonal, showing part of the office for Septuagesima. It was a bifolio from the middle of a gathering, and the inner pages of the bifolio are visible on the outside: what is now the back cover came first, then the front cover. The back cover has the part of the 1st Nocturn: the end of the 3rd responsory, the 4th lesson and part of the 6th responsory. The front cover has part of the 2nd Nocturn: the 7th and 8th responsories. For date, I think I would say 14th century, and as for country of origin, it is difficult to say when there is virtually no ornamentation, but one could at least say 'not German'.⁴

Dr Bell notes faint evidence of a five-line stave pasted to both endpapers; however, this is devoid of notes and clefs and is obscured by sheets of paper which were probably installed by the British Library bindery. I have measured the length and height of the staves and while there are six to each page, each stave is about 2.5 mm higher than those of Petrucci. There is some bookworm damage to the cover and the music on the front is slightly more faded than that on the rear cover.

The copies of 1506/1 and 1506/2 belonging to Paris are bound together in a brown leather cover with two metal clasps intact. The binding may be contemporary with the print or may be slightly later and is distinctive in that the metal clasps have survived. The front and rear covers have an embossed border and associated design. There is evidence of letters which have been crudely scored into the front leather cover but they are indecipherable; it is possible that someone may have altered them at a later date to hinder identification. The evidence of liturgical headings written in Italian and found at the beginning of several settings may suggest that it originated in that country. This copy has undergone some restoration, particularly some of the pages of the opening gatherings of 1506/2, where paper edges have been reinforced. The final additional folio of 1506/2 contains evidence of writing on 52^r but the ink has either deteriorated or some effort has been made to conceal these hieroglyphs. Foliation, which was not imposed in 1506/2, has been added by hand.

The title folio of the Paris copy of 1506/1 (1^r) has evidence of handwriting; an attempt has subsequently been made to erase it. While that attempt was

⁴ Private correspondence, 14 October, 2004. I am indebted to Dr Bell for these findings.



largely successful, it is possible to read some of the text under ultra-violet light. The text above Petrucci's printed title reads:

'Fr Jos marise de [...]'⁵

The same hand has repeated the text of Petrucci's title at the bottom of fol. 1^r and there is further (indecipherable) writing underneath the name cited above. An additional page has been bound into the Paris copy and may be found following the last page of 1506/1; the chain lines are not analogous with that of Petrucci's paper. The hand responsible for the writing at the beginning of the print has written the 'Pater noster' in full on the additional page; the title 'Lamentario liber secundus' has been written on its verso side. The pages of both Paris copies would appear to have been cut since they are generally uniform and have no deckle edges surviving.

The Paris copies contain pages where music has been written on empty staves, although it is difficult to ascertain the details due to the deterioration of the ink and the poor quality of the hand.⁶ These additions appear to be mainly monophonic although there are some examples of rather rudimentary two-part and three-part polyphony in 1506/1 at fols 46^v-47^r and 1506/2 at fols 25^v-26^r, probably in *tempus imperfectum*.

The two Lamentation volumes are imposed in Petrucci's standard oblong quarto format; 1506/1 contains five quaternions (AI-4, BI-4, CI-4, DI-4, EI-4) and a quinternion (FI-5) totalling 50 folios.⁷ Figure 4.01 illustrates the gathering pattern of the quaternions in 1506/1 and 1506/2 while figure 4.02 shows the quinternion of 1506/1. The signature pattern consists of Roman double capitals followed by Roman numbers with the exception of 'FF 5'; Arabic foliation is used throughout. The colophon appears on fol. 50^r but

⁵ 'Fr' is an abbreviation for 'Frater' or brother.

⁶ Hand-written music may be found in 1506/1 on folios 20^r, 22^r, 46^v-47^r and in 1506/2 on folios 9^v, 16^v, 17^r and 25^v-26^r. All examples are in white notation with the exception of 1506/2, 16^v which shows a series of longs in black notation.

⁷ The colophon in 1506/1 on fol. 50^r is as follows: 'Impressum Venetijs per Octavianum|Petrutium Forosemproniensem. Die Octava||Aprilis Salutis anno 1506. Cum privile||gio invictissimi Dominij Venetiarum||quod nullus possit cantum figuratum impri||mere sub pena in ipso privilegio contenta.||Registrum. A B C D E F Omnes quaterni preter F quod est quinternus'.

Petrucchi's device is not present in extant copies.⁸ 1506/2 consists of six quaternions (AI-4, BI-4, CI-4, DI-4, EI-4, FI-4) with a duernion (GI-2) totalling 52 folios.⁹ Signatures employ single Roman capitals followed by an Arabic number with the exception of 'B ii'. Petrucchi's characteristic device appears with the colophon on fol. 51^v.

Fig. 4.01: Standard gathering pattern in 1506/1 and 1506/2

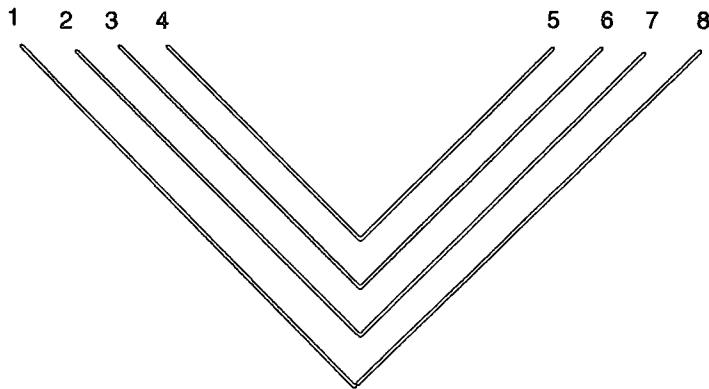
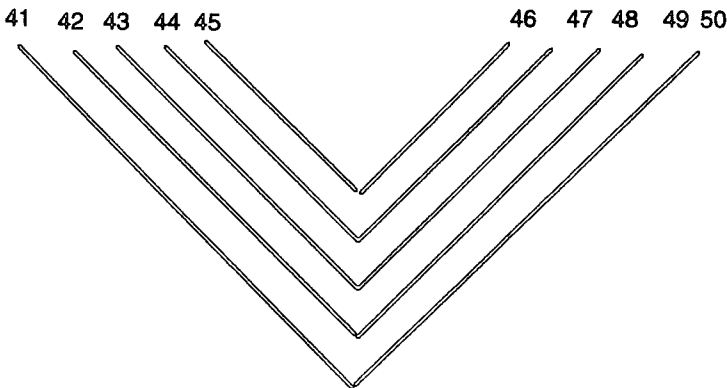

Fig. 4.02: Gathering 'F' in 1506/1



The size of sheet used by Petrucchi can be estimated by taking sample dimensions from the various copies. The copy of 1506/1 at Padua would appear to be the most intact since it contains the most deckle edges (indicating the original edge of the paper – deckles were commonly trimmed by printers). I would estimate that the sheets used in this copy were *c.* 34.6 cm x 47.6 cm;

⁸ Jeremy Noble has suggested privately that there was no room for Petrucchi's device in this print.

⁹ The colophon of 1506/2 reads thus: 'Impressum Venetiis per Octavianum Pe||trutium Forosemproniensem. Die.xxix Madii||Salutis anno M.ccccc vi.Cum privilegio|| invictissimi Domini Venetiarum quod nullus||possit cantum Figuratum imprimere sub pena|| in ipso privilegio contenta.||Registrum.||A B C D E F G Omnes quaterni.Preter G||qui est duernus.' Petrucchi's device appears below the colophon.

this figure might be subject to shrinkage, other deterioration and an allowance for binding. Nevertheless, these dimensions equate with the Renaissance paper size known as 'Mezane' which measured 34.5 cm x 51.5 cm.

4.2 Introduction to paper issues

The analysis of paper evidence in Renaissance musical prints is a relatively recent science and is hindered by a lack of resources (such as convenient and cheap access to beta-radiographing). Notable contributions have been made by certain musicologists, particularly Jeremy Noble and Stanley Boorman. Noble guided musicology into the fledgling territory of Petrucci print and paper study and Boorman's thorough and methodical approach into Petrucci's Fossombrone publications continued these advances.¹⁰ Both authors expressed contrasting opinions on the value of paper study. While Noble's discoveries lead him to suggest that a detailed investigation of paper could yield results,¹¹ Boorman, noting the distinct lack of comparative samples in any musical print run, suggested that such research was 'virtually useless'.¹²

My analysis of the use of paper in 1506/1 and 1506/2 has reflected both Noble's optimism and Boorman's caution. The survival of only seven copies out of a possible print run of several hundred copies would suggest that extreme caution is required when analysing data.

The use of double impressions in Petrucci's process was central to his use of paper; it is very likely that the ordered piles of paper, which were delivered from the paper mills, became mixed with other papers due to Petrucci's method and order of imposition. Such practices may have inadvertently prolonged the use of one type of paper and caused a possible overlap in paper types, depending on the number of presses in operation. It has been suggested that Petrucci used two presses from 1503;¹³ an analysis of watermark evidence

¹⁰ See Noble, 'Ottaviano Petrucci', 433-445, and Boorman, 'A Case of Work and Turn', 301-321.

¹¹ Noble, 'Ottaviano Petrucci', 444.

¹² Boorman, 'A Case of Work and Turn', 301.

¹³ *Ibid.*, 319.

may prove useful in determining the order of imposition of 1506/1 and 1506/2 and the efficiency of each press.

4.3 Watermarks in 1506/1 and 1506/2

A main watermark is normally found in oblong quarto at the top of two pages which were originally conjugate while a countermark, if it exists, will be found at the lower outer corner of another page. The watermarks used in the Lamentations have two designs, both being in the countermark position.¹⁴ There is no evidence of a main watermark in any extant copy. The two marks are:

1. A 'cross on a hill' akin to Briquet 11722¹⁵ (although the Briquet example is atop three mounts whereas the 1506 mark has only one mount). This mark is the older of the two that appear in 1506/1 and 1506/2; the earliest example may be found in *Fragmenta missarum* (31.x.1505); an example of that in 1506/1 is illustrated in fig. 4.03. The complete version is between 27-35 mm high.

2. An angular mount with a petal motif to its side with no apparent Briquet equivalent¹⁶ (I have labelled this the 'mount-petal' mark and it is shown in fig.

¹⁴ The countermark appears at the edge of a sheet whereas the principal mark is normally centrally located on a sheet. When the sheet is folded, the mark is divided between the various pages.

¹⁵ Noble, 'Ottaviano Petrucci', 442, suggested that the 'cross on a hill' mark is somewhat similar to Briquet 5660; the latter is about 8 mm higher than the 'cross' but its proportions are almost identical. However, the Briquet mark does not have a horizontal base and there are small circles at the three extremities of the cross.

¹⁶ I have also made an exhaustive search through Gerhard Piccard, ed., *Wasserzeichen Hand und Handschuh Bearb. von Gerhard Piccard*, 17 vols. (Stuttgart: Kohlhammer, 1961-97), and Charles M. Briquet, ed., *Les Filigranes*, 4 vols. (Geneva: A. Jullien, 1907), but failed to find an exact match, either as a main or countermark. Vladimir Mosin, ed., *Anchor Watermarks*, [edited and translated by J. G. S. Simmons and B. J. van Ginneken-van de Kastele] (Amsterdam: The Paper Publications Society; Labarre Foundation, 1973), showed that the three-leaf petal was common as a countermark to several fifteenth-century Italian papers, particularly those which had an anchor in a circle; see numbers 1023 (dated 1560/75, enclosed anchor with six point barb) and 1215 (Zagreb, 1515, an enclosed anchor with a six point barb). The small angular mount also appears as a countermark to other enclosed anchors, particularly 1161-1176 (all enclosed anchors with six point barbs from the mid-sixteenth-century) and 1252 (enclosed anchor but with a five leaf flower emblem on top). 1496-1499 (enclosed anchor but with a three leaf petal on top dating from the late sixteenth century into the seventeenth century) have a combined letter, three-leaf petal and inverted hill symbol but still does not match the mark in 1506. The main mark in *Misse Izac* (1506), GB-Lbl copy, is an enclosed anchor with a small ring outside the circle, underneath the six point barb (very similar to Mosin 620 (1507, Syracuse), 621 (1510/20, Belgrade) and 623

4.04). The earliest example of this mark is found in *Frottole libro sexto* (5.ii.1506), the print preceding the Lamentation volumes, although a smaller version appears as a countermark to the main anchor mark in *Motetti libro quarto* (4.vi.1505). The complete version is between 18-23 mm high.

Fig. 4.03: Cross on a hill mark: Mold A (main mark)¹⁷

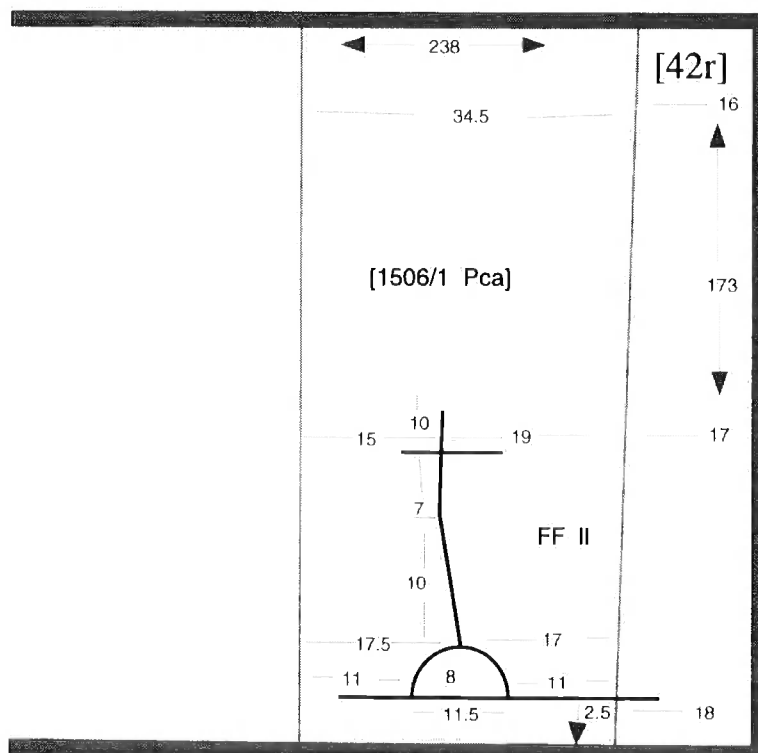

(1500/20, Nikolac, Montenegro). However, these particular marks have no countermark. Mosin's work suggested that the use of petals and hills as countermarks was not uncommon in Italy during the period of Petrucci's prints. Jane A. Bernstein, *Music Printing in Renaissance Venice: The Scotto Press* (New York, Oxford: Oxford University Press, 1998), p. 64, noted that she could not find records of the marks in the Scotto volumes. I believe that there is much work to be completed on the use of watermarks in Renaissance printed music.
¹⁷ The 'cross on a hill' mark itself is approximately actual size; the thick grey lines indicate the edge of the page. The watermark is represented by the heavy, continuous black lines; dimensions are indicated in grey. Chain lines are indicated by the long vertical grey lines extending from the top to the bottom of the page.

Fig. 4.04: Mount-petal mark: Mold A (main mark)

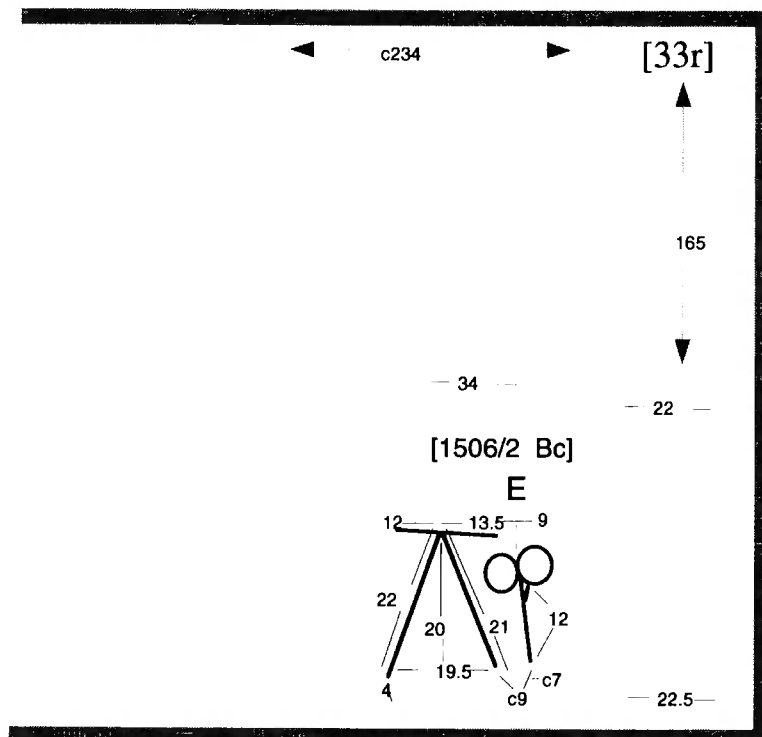

The use of a cross was quite common as a watermark device in the fifteenth century; it is more difficult to find a cross on a single mount (three mounts being a typical base for crosses). The various collected watermarks of Samuel Leigh Sotheby, held by the British Library, provide another possible source for the inspiration of the 'cross on a hill' mark (see fig. 4.05). A further example of a cross is found in Sotheby's tracings, attached to an anchor;¹⁸ the symbol of an anchor also connects the use of the 'mount-petal' since it appears as a countermark to that symbol (see Noble's findings below).

¹⁸ Sotheby's volumes may best be described as an invaluable series of unique scrapbooks. Father and son apparently collected paper samples and tracings from a range of European and British manuscripts and books. The various volumes are bound with printed titles; the volumes I examined were:

[A collection of specimens, in tracing or facsimile, of early printing, of tracings of early watermarks on paper, and of specimens of papers with watermarks, brought together and illustrated with copious manuscript notes by S. and S. L. Sotheby.]. classmark C.135.k.1(1)-(6) and c.184.e.5.

Fig. 4.05: Samuel Sotheby and Samuel Leigh Sotheby, [A collection of specimens...], volume III, 1858, a tracing of an anchor watermark from Dionyssi de Burgo's *Declaratio valerii maximi* of 1470.

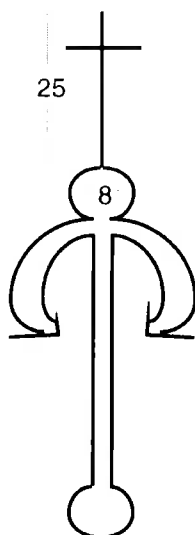

Jeremy Noble's unpublished research revealed that paper featuring the 1506 'cross on a hill' mark is first evident in Bologna's copy of *Fragmenta missarum* (31.x.1505).¹⁹ This mark is also present in *Frottole libro quinto* (23.xii.1505; copies at A-Wn and D-Mbs), *Frottole libro sexto* (5.ii.1506; copies at A-Wn and D-Mbs), the two Lamentation copies described above, *Misse Gaspar* (7.i.1507; copies at I-Bc, I-Mc, A-Wn, GB-Lbl), *Frottole libro septimo* (6.vi.1507; copy at D-Mbs), *Frottole libro quarto* (31.vii.1507; copy at A-Wn) and *Misse Josquin* (undated; copy at A-Wn). The 'mount-petal' mark is extant in *Frottole libro sexto* (5.ii.1506; copies at A-Wn and D-Mbs), 1506/2 as described in detail later in this chapter, *Misse Izac* (20.x.1506; copies at I-Bc, I-Mc, A-Wn, GB-Lbl²⁰ and D-Mbs), *Misse Gaspar* (7.i.1507; copies at I-Bc, I-Mc, A-Wn) and *Misse Josquin* (undated; copy at A-Wn). Noble discovered the use of this mark as a countermark to a large anchor in a circle in the following prints: *Motetti libro quarto* (4.vi.1505; copy at I-Mc), *Missarum Josquin liber secundus* (30.vi.1505; copies at I-Bc, I-Mc, I-Fm) and *Fragmenta missarum* (31.x.1505; copy at I-Bc). Noble's data revealed that the 'cross on a

¹⁹ I am indebted to Professor Jeremy Noble for information on watermarks, particularly for the loan of his watermark tracings and findings.

²⁰ Professor Noble discovered the mount-petal mark in the GB-Lbl copy of *Misse Izac*; it should be added that the Altus, fol. 9 (forme FfF) also features the large anchor. The mount-petal mark is found in other gatherings of this book.

hill' and the mount-petal marks are unique to Petrucci's output; these are the only marks to be shared within individual prints, namely *Frottole libro sexto* (1506/3), [Noble checked A-Wn and D-Mbs], *Misse Gaspar* (1507) and 1506/2 [Noble did not have an opportunity to check the copy at F-Pn]. I can add a fourth print to his list – the British Library's copy of *Misse Izac* contains the 'cross on a hill' mark as well as the mount-petal mark.²¹ Noble's findings supported the established theory that paper bearing the same watermark was usually used up within four years.²²

The 'cross on a hill' is evident in copies of Petrucci prints dating from October 1505 to July 1507 while the 'mount petal' lasts from February 1506 to January 1507. The majority of Petrucci prints contain only one mark; 1506/2 is unusual in having two marks distributed throughout its gatherings. Table 4.01 illustrates the basic distribution of marks in the two volumes:

²¹ The part-books of I-Bc's *Misse Izac* (Q68) also contain evidence of the anchor mark. The Bassus book features a circular design on GgG 4, GgG 5, GgG 6, HhH 2 and HhH 3. On HhH 5 the mount-petal watermark is present in the countermark position with part of a possible main mark in the top of that page. Furthermore, the Altus book at FfF 3 contains a suggestion of the 'cross on a hill' mark (and possibly FfF 5 also). This would indicate that the Bologna copy of *Misse Izac* may actually have evidence of three watermarks or countermarks. Unfortunately, my time was limited to an examination of 1506/1 and 1506/2 at Bologna, preventing a complete inspection of *Misse Izac*.

²² See Gerhard Piccard, 'Wasserzeichen und Urbarforschung im Württembergischen Hauptstaatsarchiv', *Archivum: Revue Internationale des Archives*, 2 (1952), 65-81 (p. 66).

Table 4.01: Distribution of marks in 1506/1 and 1506/2

forme	1506/1 GB- Lbl Cross	1506/1 I-Bc Cross	1506/1 I-Pca Cross	1506/1 F- Pn Cross	1506/2 GB-Lbl Cross	1506/2 GB-Lbl mount- petal	1506/2 I-Bc Cross	1506/2 I-Bc mount -petal	1506/2 F-Pn Cross	1506/2 F-Pn mount- petal
A1-2	fol. 7	fol. 1	fol. 1	fol. 8		fol. 7		fol. 8	missing	missing
A3-4	fol. 6	fol. 3	fol. 6	fol. 4	fol. 6		fol. 4		missing	missing
B1-2	fol. 15	fol. 15	fol. 16	fol. 15		fol. 15		fol. 10		fol. 9
B3-4	fol. 13	fol. 13	fol. 12	fol. 12	fol. 11		fol. 14		fol. 11	
C1-2	fol. 18	fol. 23	fol. 17	missing?		fol. 18		fol. 24		fol. 23
C3-4	fol. 20	fol. 19	fol. 19	fol. 19	fol. 21		fol. 22		fol. 19	
D1-2	fol. 26	fol. 26	fol. 32	fol. 26		fol. 32		fol. 25		fol. 31
D3-4	fol. 27	fol. 28	fol. 29	fol. 27	fol. 29		fol. 28		fol. 28	
E1-2	fol. 40	fol. 39	fol. 40	fol. 39		fol. 34		fol. 33		fol. 33
E3-4	fol. 38	fol. 35	missing fol. 35 ²³	fol. 37	fol. 35		fol. 35		fol. 37	
F1-2	fol. 50	fol. 49	fol. 42	missing?		fol. 41		fol. 47		fol. 47
F3-4	fol. 44	fol. 43	fol. 47	fol. 43		fol. 45		fol. 46		fol. 45
F5	fol. 46	missing mark ²⁴	fol. 46	missing?						
G1-2					missing fol. 51 ²⁵	missing		fol. 50		fol. 50

The regular distribution of marks in 1506/2 supports the notion of production by two printing presses: if one assumes that each press had its own independent paper supply, then one press appeared to set formes 1-2 and the other formes 3-4. The press setting formes 1-2 possibly had a higher work rate than that setting formes 3-4 and consequently required more paper (that with the mount-petal mark) sooner than the other. The change of paper use for F3-4 may have been due to the efficient press taking a gathering that should have been completed by the slower press; it is also possible that this was the gathering where the slower press ran out of paper (i.e., that with the 'cross on a hill' mark).²⁶ While we cannot assume that the sheets of the extant copies were imposed in that order, the regular distribution of alternating marks in all extant copies of 1506/2 suggests a systematic method of production. Boorman examined the pattern of watermarks in copies of Petrucci's *Misse Brumel* and

²³ The Padua copy of 1506/1 is missing fol. 35; this was undoubtedly the page with the mark. The spacing of chain lines on the opposite pages to fol. 35 do not conform to pages which contain the mark and the page on the same side as fol. 35 has no evidence of a mark.

²⁴ Forme F5 is a half sheet produced by the work and turn method; the other half of the sheet used in the Bologna copy must have contained the mark.

²⁵ The page with Petrucci's device, fol. 51, is missing from the British Library's copy of 1506/2. It is likely that this page, or the extraneous page from this gathering (which would have been fol. 52 had it been required) would have contained the mark.

²⁶ Boorman, 'A Case of Work and Turn', 319, observed the use of two paper types in copies of *Misse Brumel* and *Misse Ghiselin* and concluded it was caused by each press running out of paper independently.

Misse Ghiselin.²⁷ The copy of *Misse Ghiselin* held by Assisi contains three watermarks while the Bologna copy of the same edition contains two watermarks.²⁸ Furthermore, the transition from one paper to another occurred at different places in the two copies, contrasting with the identical change of papers in all extant copies of 1506/1 and 1506/2. Boorman suggested that the use of two (even three) papers shared between consecutively produced volumes was evidence of two presses which were working simultaneously.²⁹ Bibliographical scholars have observed that it was common practice to use more than one paper in early book production;³⁰ however, further evidence is required to show that the use of two papers in a copy indicated simultaneous imposition. I shall address these issues in section 4.13.

4.4 The implications of 'twin' watermarks

It is known in bibliographical research that all watermarks have 'twins', that is to say, a second version.³¹ The use of a second mold allowed a more efficient working practice in manufacturing paper; the paper was stored in the order in which it was manufactured with main and twin marks alternating throughout the pile of finished paper. I intend to show that both papers used in

²⁷ *Ibid.*, 316-319. Evidence relating to watermarks in *Misse Brumel* and *Misse Ghiselin* is derived from Boorman.

²⁸ *Ibid.*, 319, consulted *Misse Brumel* and *Misse Ghiselin* in Bologna, Civico Museo Bibliografico Musicale and Assisi, Biblioteca Comunale.

²⁹ *Ibid.*, 319.

³⁰ Stevenson, 'Watermarks Are Twins', 57, suggested that the distribution, usage and storage patterns of paper by early book printers lead to a variety of papers being used in one volume. Boorman, 'The "First" Edition of the *Odhecaton A*', 187, observed 'the presence of so many different papers in a volume is not, of itself, a matter for remark. Indeed, in a study of a manuscript it would be welcomed; in printed books of the period it is no less common.'

³¹ The use of twin watermarks has been largely ignored by Petrucci scholars and Stanley Boorman's suspicion of the value of watermark study may account for a lack of interest. LaRue, 'Watermarks are Singles, Too', 1-12, drew our attention to the use of single watermarks although his work is not pertinent to Petrucci's early papers. The mount-petal watermark proves that the manufacturers of Petrucci's 1506/1 and 1506/2 papers used twin marks.

1506/1 and 1506/2 contain twins and to ascertain whether there is systematic distribution of these twins which may assist in determining the order of imposition of the prints.³²

The twin mark was usually manufactured in a manner that imitated the main mark although there are many examples containing obvious differences between main and twin marks which show the creativity of the papermaker.³³ Such obvious distinction is apparent in the twin of the mount-petal paper; the papermaker has placed them in the wrong order, i.e., the petal is to the left of the mount in the twin (see fig. 4.06 and compare it to fig. 4.04).

Fig. 4.06: Mount-petal mark: Mold B (twin mark)

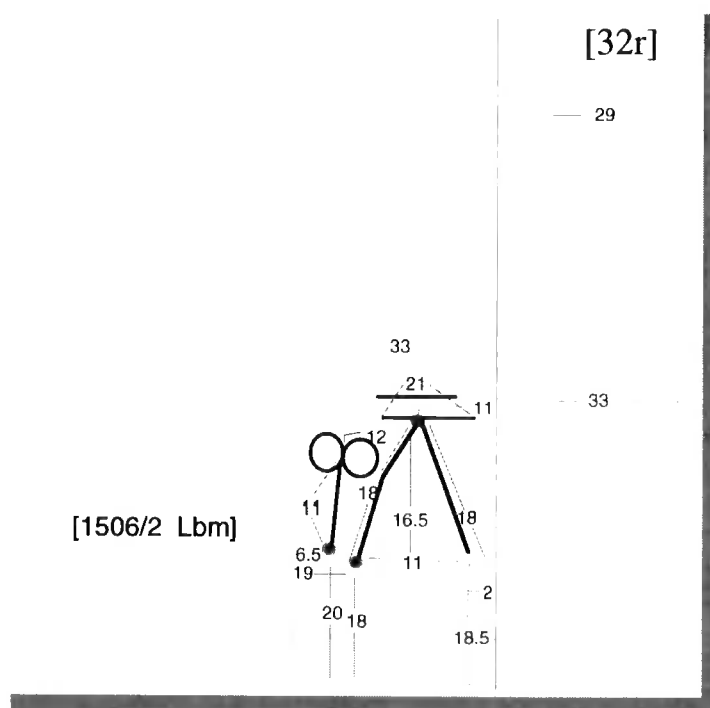

The petal has only two leaves evident in the twin while some versions of the main mark show three (fig. 4.07 illustrates an example). The mount in the twin has an extra horizontal line parallel to that which intersects at the apex of the mount, a feature lacking in the main mark. The stitching holes are often apparent in the twin whereas they are invisible in the main mark. This supports Stevenson's notion that twins were sometimes made deliberately distinctive,

³² Peter Wright has proved the value of paper analysis within manuscript fascicles, particularly the identification of twin watermarks, in 'Paper Evidence', 487-517.

³³ Stevenson, 'Watermarks Are Twins', 57-91, gave ample evidence to suggest that the makers of twins often deliberately made them distinctive, such as re-ordering the features (right hand feature switched to left in the twin, for example).

rather than trying to create a mirror image of the main mark. I have labelled the main mold of the mount-petal mark Mold A (fig. 4.04 shown previously and fig. 4.07 below) where the petal is set to the right of the mount, and its twin, Mold B (fig. 4.06).³⁴

Fig. 4.07: Mount-petal mark: Mold A (main mark with triple petals)

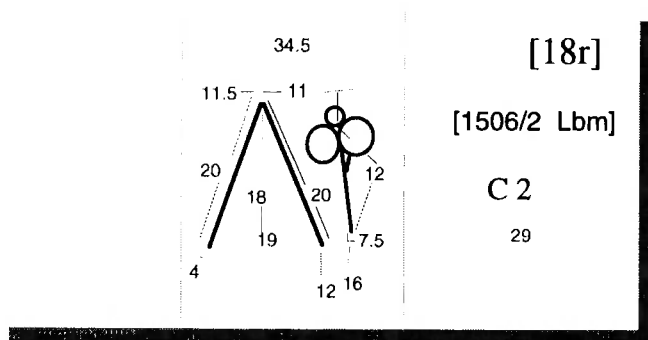

The twin of the 'cross on a hill' mark is less easy to identify since this mark is essentially symmetrical. There are two basic placements of this mark in respect of its distance from the bottom of the page; it is my opinion that these determine the characteristics of main and twin. One places the mark quite high up in the paper from about 25 mm to 43 mm (with most samples falling within the 28-35 mm range). I have labelled this mark Mold A (see fig. 4.03 above). The twin, Mold B (fig. 4.08), is generally placed much lower on the sheet and its base falls within the range 0 mm - 10.5 mm (with most samples near zero). A few samples are missing part of their base indicating particularly aggressive guillotining during the binding of the print.³⁵

³⁴ Marks are described from the rough side of the paper as required by bibliographic convention.

³⁵ I have not been able to determine the molds of two of the 'cross on a hill' marks in the Padua copy of 1506/1; formes B3-4 and C3-4. I have identified all other main and twin marks.

Fig. 4.08: Cross on a hill mark: Mold B (twin mark)

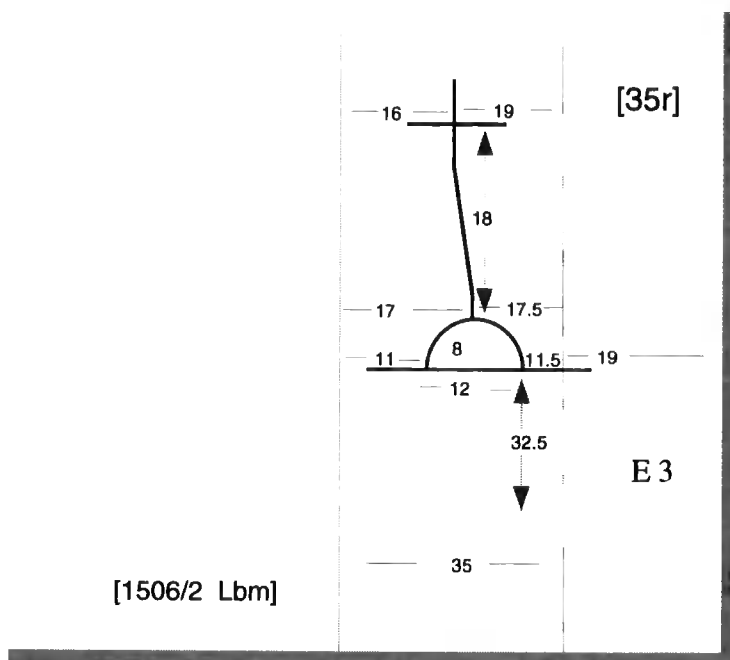

It is possible to identify the distribution of twins in the extant copies of the Lamentations, particularly those sheets which use the mount-petal mark (see table 4.02):

Table 4.02: Distribution of main and twin watermarks in 1506/1 and 1506/2

<i>formes</i>	1506/1 GB-Lbl Cross	1506/1 I-Bc Cross	1506/1 I-Pca Cross	1506/1 F-Pn Cross	1506/2 GB-Lbl Cross	1506/2 GB- Lbl mount- petal	1506/2 I-Bc Cross	1506/2 I-Bc mount- petal	1506/2 F-Pn Cross	1506/2 F-Pn mount- petal
A1-2	Mold B	Mold A	Mold A	Mold A		Mold A		Mold A	missing	missing
A3-4	Mold A	Mold A	Mold A	Mold A	Mold A		Mold B		missing	missing
B1-2	Mold A	Mold A	Mold A	Mold A		Mold A		Mold A		Mold A
B3-4	Mold B	Mold B	Mold A or B	Mold B	Mold A		Mold A		Mold A	
C1-2	Mold A	Mold A	Mold A	missing?		Mold A		Mold B		Mold B
C3-4	Mold B	Mold A	Mold A or B	Mold A	Mold B		Mold A		Mold A	
D1-2	Mold B	Mold B	Mold A	Mold B		Mold B		Mold B		Mold A
D3-4	Mold A	Mold B	Mold B	Mold A	Mold B		Mold B		Mold B	
E1-2	Mold A	Mold B	Mold A	Mold B		Mold A		Mold A		Mold B
E3-4	Mold A	Mold A	missing	Mold B	Mold A		Mold A		Mold B	
F1-2	Mold B	Mold B	Mold B	missing?		Mold B		Mold A		Mold B
F3-4	Mold B	Mold A	Mold B	Mold A		Mold A		Mold A		Mold B
F5	Mold B	missing	Mold A	missing?						
G1-2					missing	missing		Mold B		Mold A

The table shows that the distribution of twins is quite random; indeed, some copies do not even have equal distribution of the two molds (the copy of

1506/2 at GB-Lbl has five of the mount-petal's Mold A and only two of Mold B). This random order does not assist in identifying a pattern of imposition of 1506/1 and 1506/2; such irregularity is not surprising since Petrucci's double impression method must have led to sheets being randomly transferred between the two presses following their initial distribution and first pass through each press. While the evidence concerning twin marks reflects Boorman's caution, the consistent distribution of the two main marks in 1506/2 suggests that one compositor imposed formes 1-2 and the other formes 3-4, each keeping his own paper supply and imposing their formes simultaneously. I shall now attempt to show how the imposition of particular print elements supports the notion that 1506/1 and 1506/2 were simultaneously produced by two presses.

4.5 Introduction to production process, layout and presentation in 1506/1 and 1506/2

Recent bibliographical studies of Petrucci have yielded an immense amount of data and information, particularly the work of Stanley Boorman, Jeremy Noble and Bonnie Blackburn.³⁶ This research has led to a reappraisal of Petrucci's production methods, output, choice of repertoire and source readings; however, I believe the prints themselves have much to reveal. I shall divide my bibliographical analysis of 1506/1 and 1506/2 into four principal areas:

- Standing type: stave-sets and type availability
- Standing type: part names
- Decorated capital letters, page headers and text underlay
- Stop-press variations and errors

The title of 1506/1 is set in Petrucci's Gothic fount and reads:

'Lamentationum Jeremie || prophete Liber primus.' It is followed by a table of contents on fol. 1^v:

Adoramus te <i>Christe</i>	1
Lamen: Tinctoris	1
Lamen. Ber: ycart	8
Lamen. cum tribus vocibus	13
Lamen. Alexandri cum tribus vocibus	16
Lamen: Alexandri cum quatuor vocibus	22
Lamen. de. orto.	28
Lamen. Jo. de quadris. duo.	30
Popule meus eiusdem. duo.	45
Cum autem venissent. eiusdem. duo.	47
Sepulto. domino. eiusdem. duo.	47
Passio sacra. Fran. veneti	48

³⁶ Boorman, 'Petrucci at Fossombrone: A Study'; Boorman, 'Petrucci at Fossombrone: Some New Editions'; Stanley Boorman, 'Petrucci's Type-Setters and the Process of Stemmatology', in *Formen und Probleme der Überlieferung mehrstimmiger Musik im Zeitalter Josquins Desprez*, ed. Ludwig Finscher, Quellenstudien zur Musik der Renaissance, no. 1 (Munich: Kraus, 1976), 245-280; Boorman, 'A Case of Work and Turn'; Boorman, 'Thoughts on the Popularity'; Noble, 'Ottaviano Petrucci'; Blackburn, 'Petrucci's Venetian Editor' and Bonnie J. Blackburn, 'Lorenzo de' Medici, a Lost Isaac Manuscript, and the Venetian Ambassador', *Musica Franca: Essays in Honor of Frank A. D'Accone*, ed. Irene Alm, A. McLamore and C. Reardon (Stuyvesant, New York: Pendragon, 1996), 19-44.

The volume includes Arabic foliation throughout (although there are variations between copies which I will discuss later).

The title of 1506/2 also uses a Gothic fount and reads:

'Lamentationum liber || Secundus. Auctores || Tronboncinus [*sic*] || Gaspar. || Erasmus.' There is no table of contents and no foliation present; 1506/2 is the first Petrucci print in choirbook format lacking a table of contents. Petrucci's device appears on fol. 51^v, following the gathering details.

4.6 The notion of print perfection

Krummel & Sadie noted that Petrucci's productions were splendid and that his

characters were elegant, the punchcutting, justification of the matrices and typesetting were accomplished. The presswork was so meticulous that he was consistently able to achieve perfect register of notes, staves and text though (at least initially) three impressions were required: first for the notes, second for the staves, and third for the text, initial letters, signatures and page numbers.³⁷

Comments such as these have often been cited by musicologists in their summary of Petrucci's production and there is little argument that the overall production was extremely good. This was all the more admirable considering two impressions (or three in the early years) doubled (or tripled) the risk of error and failure in production. The development of dedicated single impression founts from the 1520s suggests that Petrucci's successors found his methods too challenging and time-consuming.

Boorman suggested that there was evidence that Petrucci changed from multi-impression printing to double impression *c.* 1503.³⁸ Boorman stated that since only one typographical element can occupy a single space in the compositor's frame, then any two overlapping elements on the page must have

³⁷ Donald W. Krummel and Stanley Sadie, *Music Printing and Publishing* (Basingstoke: Macmillan, 1980, 1990 for UK), p. 20.

³⁸ Boorman, 'A Case of Work and Turn', 305.

been produced by successive impressions. He has proved that Petrucci's stave patterns were semi-permanent (i.e., they were retained in the forme between impositions) and overlapped with the notes, accidentals, clefs and initial letters.³⁹ The vocal text never overlapped with the staves, suggesting that these two elements were imposed together.

Table 4.03 illustrates Boorman's conjectural method by which Petrucci's compositors may have organised their two impressions:

Table 4.03: Elements involved in twin impression imposition⁴⁰

<i>IMPRESSION 1 (or 2)</i>	<i>IMPRESSION 2 (or 1)</i>	<i>ELEMENTS FOR EITHER IMPRESSION</i>
Initial capitals	staves (i.e., stave-sets)	gathering signatures ⁴¹
notes	vocal text	page numbers
clefs		
mensuration signs		
key signatures		
fermatae		
part names ⁴²		

4.7 Standing type: Stave-sets

Petrucci's production was dominated by part-book format during the period of the Lamentation volumes (although the Lamentations are set in choirbook format and he continued to use both formats following 1506).⁴³ The

³⁹ See *ibid.*, 305, which stated that Petrucci must have had two formes, one containing the staves and verbal text with the other containing preliminary matter and colophon, music, decorative capital letters and whatever headers were required. Petrucci's use of both foliation and signatures was also noted by Boorman who suggested that one of these elements was given to each of the two required formes. Philip Gaskell, *A New Introduction to Bibliography* (Oxford: Clarendon Press, 1972), pp. 116-117, labelled the use of repeated elements as 'standing type', a term which I shall adopt.

⁴⁰ This table is based on Boorman's hypotheses in 'A Case of Work and Turn', 306.

⁴¹ I have noted an overlap in the British Library's copy of *Misse Izac* (1506) between the signature 'AaA 2' and the lowest line of text, suggesting that in this case, Petrucci imposed this (or all) signature with the forme containing the music.

⁴² Boorman, 'Petrucci at Fossombrone: A Study', p. 159, suggested that the part names were imposed with the text in 1506/2.

⁴³ Boorman, 'Did Petrucci's Concern for Accuracy', 31, suggested that the small size of Petrucci's choirbook format, combined with the arrangement of parts, meant that these prints were not intended for direct performance. Blackburn, 'Canonic Conundrums', 57,

Lamentation volumes were followed by the part-books *Misse Izac* (1506) and *Misse Gaspar* (1507). Part-books must have been easier to produce since standing type remained relatively constant. Choirbook format was more challenging in that type elements (particularly standing type and specifically part names) were constantly changing between gatherings – 1506/1 illustrates this. A cursory inspection of gathering B reveals that three of the four formes display distinctive versions of standing type; there is considerable positional variety in the imposition of the part names in these gatherings.⁴⁴ 1506/2, by comparison, shows a more consistent use of standing type since every setting is four-part; this must have enabled a less disruptive production run.

The most permanent elements of standing type in Petrucci's process were the staves; these were imposed at the same time as the vocal text.⁴⁵ Boorman proved that four semi-permanent formes were kept by Petrucci; two contained staves (five or six to a page comprising a set) and the others contained clefs and part names.⁴⁶ Thus, each of Petrucci's two printing presses would have had two formes (in the examples below I have allocated a number to each stave-set; this is the number enclosed in a circle). Figure 4.09 illustrates B1 from 1506/1, showing the stave-sets 1, 4, 5 and 8 (which I label collectively as 'stave-set group P') while figure 4.10, B2 shows stave-sets 2, 3, 6 and 7 which I refer to as 'stave-set group II'.⁴⁷

countered this by suggesting that the format might be suitable for performance in small church choirs with one person per part.

⁴⁴ Gathering B1 contains the names Altus and Bassus [fol. 9^r], Tenor [10^v], Contra [15^r] and Contra [16^v]; B2 contains Tenor [9^v], Altus and Bassus [10^r], Tenor [15^v] and Contra [16^r]; B3 contains Altus and Bassus [11^r], Tenor [12^v], Altus and Bassus [13^r] and Tenor [14^v] and B4 contains Tenor [11^v], Altus and Bassus [12^r], Tenor [13^v] and Contra [14^r]. Some of the aforementioned part names are imposed beside different staves, for example, the Contra on 16^v [forme B1] is set to stave 5 while that in forme B2 is set to stave 1 [Boorman, 'Petrucci at Fossombrone: A Study', p. 159, numbered staves from the highest downwards; I have followed his convention].

⁴⁵ Each page of the Lamentation prints contains six staves; the lowest stave of certain pages in 1506/1 has been blanked out (indicated by an asterisk in my diagrams and tables). Staves vary in length from 172–181 mm in the two Lamentation prints; the shorter staves are found mainly in 1506/1. While the horizontal tolerance of Petrucci's type setting is remarkable (within 1 mm), the varying lengths of individual and of stave-sets often leads to a shortfall such as found in 1506/1, fol. 2^r, lowest stave. Boorman, 'A Case of Work and Turn', 306–307, observed that individual staves were sometimes replaced within a stave-set; this would explain the varying lengths of stave found within stave-sets by 1506.

⁴⁶ Boorman, 'A Case of Work and Turn', 315.

⁴⁷ Stave-sets 1–8 appear only in 1506/1 and 9–16 appear in 1506/2. Sets 10, 11, and 16 are introduced towards the end of 1506/1.

Fig. 4.09: 1506/I, B1, stave-set group I

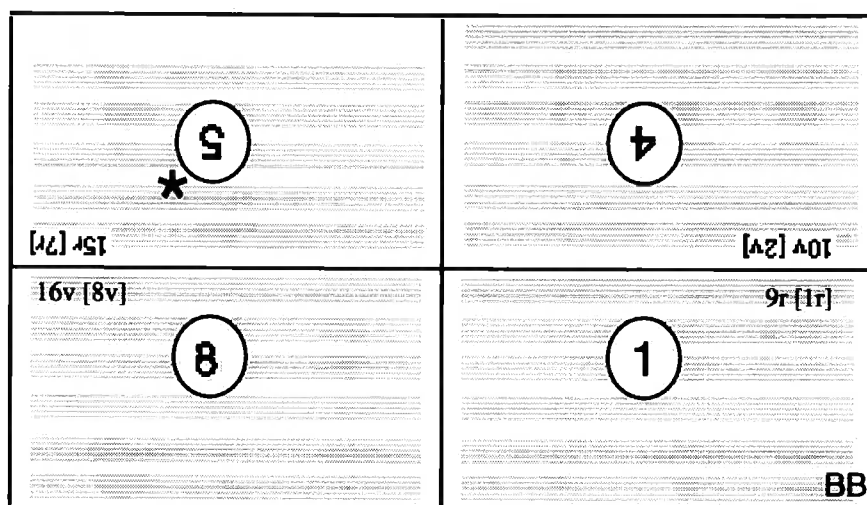

Fig. 4.10: 1506/I, B2, stave-set group II

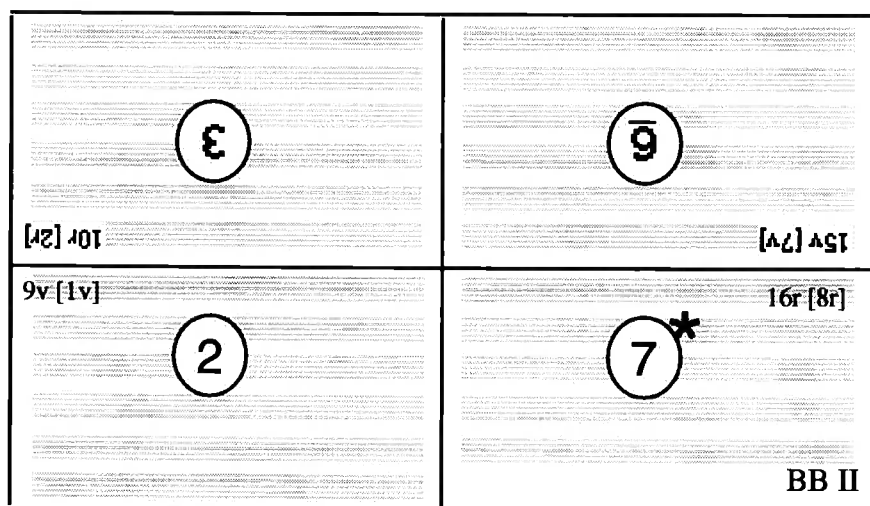

Table 4.04 illustrates the regular use of the same stave-sets throughout the gatherings in 1506/I, showing that there was considerable benefit in such consistency throughout the print run. The use of two formes allowed some flexibility in the composition of these prints; 'casting off', namely the ability to calculate space and fount elements in advance, was a required skill for compositors. The formes containing the musical symbols, clefs and part names were the more complicated of the two formes of standing type since these elements were constantly changing.

Table 4.04: Pattern of identifiable stave-sets in 1506/1, Bologna copy⁴⁸

Folio	Gathering					
	A	B	C	D	E	F
1 ^r	-	I	5*	1*	1*	1*
1 ^v	-	2	2	2	2	2
2 ^r	?	3	3*	3*	3*	II?
2 ^v	4	4	8	4	4	10
3 ^r	3	I	1*	1*	1*	1*
3 ^v	4	2	2	2	2	2
4 ^r	I	3	3*	3*	II	II
4 ^v	2	4	4	4	4	10
5 ^r	7	5*	5*	5	5	I
5 ^v	8	6	6	6	6	10
6 ^r	5?	7*	7*	7	7	5*
6 ^v	6	8	8	8	8	8*
7 ^r	5	5*	I	5	5	5*
7 ^v	6	6	6	6	6	16*
8 ^r	7	7*	7	7	7	7*
8 ^v	8	8	4	8	8	8
9 ^r						5
9 ^v						6
10 ^r						7*
10 ^v						

Boorman proved that a detailed study of the use of stave-sets could yield useful results in respect of the sequence of imposition;⁴⁹ he also demonstrated that Petrucci had to replace these staves during the early part of 1503. I intend to show that Petrucci had to replace his staves again during the production run for 1506/1 and will suggest that this added to the delay in producing this volume. Table 4.05 (below) shows that only two stave-set groups are actually required:

Table 4.05: Stave-set groups in 1506/1

Forme	Gathering					
	A	B	C	D	E	F
I	?	I	I	I	I	I.1
2	?	II	II	II	II	II.1
3	II	I	I	I	I	I.1
4	?	II	II	II	II.1	II.2
5						I.1

⁴⁸ While I have adopted Boorman's convention in numbering stave-sets, they do not necessarily match the staves identified in 'A Case of Work and Turn', 307.

⁴⁹ *Ibid.*, 313.

The replacement of stave-set 4 by 10 in stave-set group *I* first appears in forme F1 and then F3 and F5; I have indicated this change by labelling the stave-set group *I.1*. The other stave-set group was also modified during the production of 1506/1; stave-set group *II* becomes *II.1* due to the replacement of stave-set 3 by 11 at E4 and *II.2* by further replacing 6 with 16 at F4. The new stave-sets 11 and 16 subsequently appear in the production of 1506/2.

The gradual replacement of stave-sets from gathering E of 1506/1 would suggest that this part of the production was disrupted and may have been a factor in the late printing of the volume (discussed in detail in chapter 5). It also suggests that 1506/1 was produced in gathering order.

Forme F5 is important since this is a half-sheet; the use of the same stave-set group for the previous formes F1 and F3 shows that F5 was produced using the work and turn method described by Boorman and illustrated by the conjectural diagram in figure 4.11.⁵⁰ This technique involved the imposition of a normal four-sided forme, in this instance consisting of folios 45^r, 45^v, 46^r and 46^v (using stave-set group *I.1*). Following the completion of the heap of sheets and when the ink was dry, the heap was then turned end over end and the same forme imposed on the other side. Finally, the sheets were cut in half and the two half sheets used in two separate prints. If Petrucci used the formes containing the stave-set group for this half sheet, it might follow that he would also reuse the forme that contained the music. Close inspection of common elements between the pages of F3 and F5 (using work and turn) reveals that standing elements (particularly clefs) have been used again.

⁵⁰ *Ibid.*, 305-315.

Fig. 4.II: 1506/1. The half-sheet F5 illustrating the conjectural work and turn method using stave-set group I.1

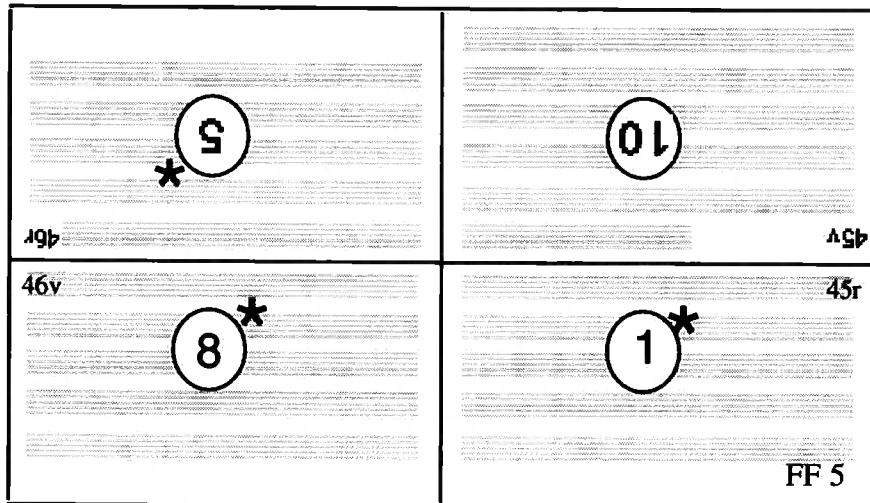

The use of stave-sets is more regular in 1506/2 than in 1506/1 and the new sets introduced towards the end of 1506/1 are consistently used throughout 1506/2; the sets used at the outset of 1506/1 were presumably abandoned. Diagrams of the stave-sets in 1506/2 may be found in figures 4.12 and 4.13 (below). I have made a perfunctory examination of the British Library's copy of *Misse Izac* (1506), the next print following 1506/2; *Misse Izac* contains several examples of the new stave-sets.

The only irregular feature in the 1506/2 stave-sets is the imposition of the same stave-set group on both sides of a sheet, a unique feature in extant copies of 1506/1 and 1506/2. This occurs at formes B1 and B2, suggesting an interruption or aberration in production. It also supports the notion that Petrucci's two presses must have been close together (probably under the same roof) since it would have been problematic and risky to transport type elements through Venice. There are no pages with five staves in 1506/2 although several pages do not have music imposed on the lowest stave. Stave-sets 10, 11 and 16 had already seen service in 1506/1 while 9 and 12-15 were presumably newly manufactured for this print (details in table 4.06 below).

Fig. 4.12: 1506/2, B2, stave-set group III

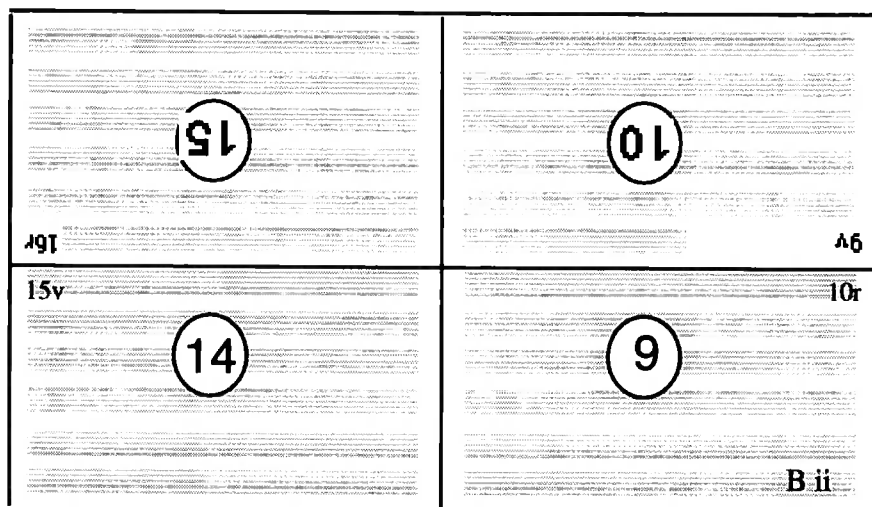

Fig. 4.13: 1506/2, A4, stave-set group IV

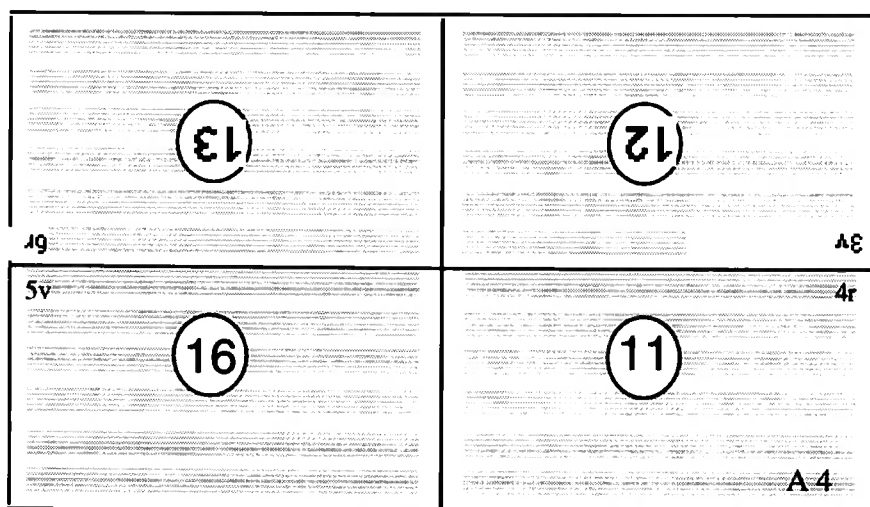

Table 4.06: Pattern of identifiable stave-sets in 1506/2, Bologna copy

<i>Folio</i>	<i>Gathering</i>						
	A	B	C	D	E	F	G
1 ^r	-	9	11	11	11	11	11
1 ^v	12	10	10	10	10	10	10
2 ^r	11	9	9	9	9	9	9
2 ^v	10	10	12	12	12	12	12
3 ^r	9	11	11	11	11	11	13
3 ^v	12	10	10	10	10	10	
4 ^r	11	9	9	9	9	9	
4 ^v	10	12	12	12	12	12	
5 ^r	15	13	13	13	13	13	
5 ^v	16	14	14	14	14	14	
6 ^r	13	15	15	15	15	15	
6 ^v	14	16	16	16	16	16	
7 ^r	15	15	13	13	13	13	
7 ^v	16	14	14	14	14	14	
8 ^r	13	15	15	15	15	15	
8 ^v	14	14	16	16	16	16	

The use of stave-set groups in 1506/2 are summarised in table 4.07 below; the replacement group sets are represented by *III* (stave-sets 9, 10, 14 and 15) and *IV* (stave-sets 11, 12, 13 and 16):

Table 4.07: Stave-set groups in 1506/2

<i>Forme</i>	<i>Gathering</i>						
	A	B	C	D	E	F	G
1	<i>III</i>	<i>III</i>	<i>IV</i>	<i>IV</i>	<i>IV</i>	<i>IV</i>	<i>IV</i>
2	<i>IV</i>	<i>III</i>	<i>III</i>	<i>III</i>	<i>III</i>	<i>III</i>	<i>III</i>
3	<i>III</i>	<i>IV</i>	<i>IV</i>	<i>IV</i>	<i>IV</i>	<i>IV</i>	
4	<i>IV</i>	<i>III</i>	<i>III</i>	<i>III</i>	<i>III</i>	<i>III</i>	

The change of stave-set pattern in B1-B2 mentioned above coincides with a unique signature pattern on fol. 10^r where the expected pattern 'B 2' appears as 'B ii' in all copies. Boorman's commentary on 1506/2 noted:

Unusually, some damaged type re-appears in various places in the volume. The bar-line on B1^r, stave 1, penultimate symbol is the same as one on B4^r, line 3. The different one on B4^r, line 4 can be equated with that on B6^r, line 1 and perhaps with one on C4^r, last line. These suggest that the formes were set up separately (rather than proceeding with type-setting in strict sequence).⁵¹

⁵¹ Boorman, 'Petrucci at Fossombrone: A Study', p. 159.

The change of pattern in staves in formes BI-2 would concur with Boorman's comments; Petrucci obviously encountered some disruption to this part of the print. Boorman's review of typographical characteristics of 1506/2 stated that Petrucci printed the signatures with the music and the part names with the text (he cited Paris as an example).⁵² It would appear most unlikely that part names could be included in the forme with the text; that forme also contained the staves and many pages illustrate considerable overlap between part names and staves.

4.8 Type availability and the use of matrices

The availability of type was a crucial element in the production of a print. Work on a print often commenced some considerable time before its publication, allowing the compositors to cast off.⁵³ The work of the compositor required considerable planning, skill and experience which reduced time and expense during the production of a musical print. Boorman suggested that the rapid increase in Petrucci's production from 1503 may have reflected the growing experience of his compositors and the fullest exploitation of such production methods.⁵⁴

The manufacture of musical type and the implications of the function of a matrix were discussed in detail by Krummel and Sadie.⁵⁵ They argued that each individual type (or sort) was intended to be identical, considering it was cast from the same matrix (the number of sorts cast for a fount depended on its rate of use in the print shop). The crux of recent research by Paul Needham and Blaise Aguera y Arcas was that a comparison of type supposedly cast by Gutenberg from the same matrix revealed that there were wide-ranging differences in appearance.⁵⁶ These differences went beyond the normal wear

⁵² See Boorman, *Ibid.*, p. 159.

⁵³ For more details concerning the imposition of musical prints, see Krummel and Sadie, *Music Printing*, pp. 11-20.

⁵⁴ Boorman, 'A Case of Work and Turn', 305.

⁵⁵ See Krummel and Sadie, *Music Printing*, pp. 11-13.

⁵⁶ Needham and Aguera y Arcas designed computer-assisted software to examine the print patterns effected by individual letters in the Gutenberg Bible. Their findings were broadcast

and tear expected from a type fount and prompted Needham and Aguera y Arcas to re-examine the processes to which matrices and types were subjected. While their research is ongoing (and, to my knowledge, has not yet been documented), initial indications appear to suggest that there were considerable anomalies in the production of individual type from Gutenberg's matrices. There is evidence of individuality and distinction in the sorts of Petrucci's elements when subjected to large-scale magnification; analysis of such data has proved useful in assessing methods of composition type. This technique has been particularly useful when examining the larger letters in the Lamentation volumes since it is possible to trace the employment of a particular sort throughout the copies.

4.9 Standing type: Part names

Boorman has shown that existing copies of the same Petrucci title are not necessarily identical, even though they originated from the same press.⁵⁷ Petrucci's rate of production by 1506 was quite impressive and his workforce would have had considerable experience by that time. This would have led to more efficient working practices, expertise in identifying possible errors and a greater turnover of sheets through the presses. The use of stave-sets as part of standing type is one example of such efficiency; there is evidence that the part names were kept as standing type around which the other musical elements were changed (being imposed in the same forme as the music). The use of part names as standing type must have provided an important reference point for the composers setting the forme with the musical type (the forme containing the stave-sets must have been considerably easier to set since the staves provided a horizontal reference point for each line of text). The part names were always imposed at ninety degrees to the left of the same stave on each

on the BBC's Open University series 'Renaissance Secrets' on 19 November, 2002. There is supporting information in the BBC's web site at:

'www.open2.net/renaissance2/doing/gutenberg.html'

⁵⁷ Boorman, 'Petrucci at Fossombrone: Some New Editions' and Boorman, 'A Case of Work and Turn'.

opening, namely the fourth stave for the Tenor on each verso side and first and fourth staves respectively for the Altus and Bassus on the recto side (there was more positional variety in the placing of part names in 1506/1).⁵⁸ A typical forme in 1506/2 required two of each specified part designation, i.e., Tenor, Altus and Bassus. Petrucci obviously intended these part designations to look identical from page to page – a cursory examination of the 1504 *Odhecaton* suggests that type used for these part designations is identical, being approximately 5 mm for the 'x' height and 7 mm for the capital height. The uniformity achieved in the *Odhecaton* was not maintained in 1506/1 and 1506/2 – the capital letters for the part names are two basic sizes, comprising some of the *Odhecaton*'s 7 mm set combined with a later set measuring c. 4-5 mm (capital height). The smaller set was used extensively in other Petrucci prints around 1506 suggesting that the original 7 mm capitals had been damaged beyond repair by 1506.

Close inspection of a typical gathering in 1506/2 shows that the initial capital of each part designation is unique – every second forme has a further unique set of part names. This supports Boorman's hypothesis concerning twin impressions – his 1986 findings proved that Petrucci kept two sets of skeleton staves as part of standing type as I have already discussed.⁵⁹

The part name 'Tenor' in 1506/2 is easiest to trace due to its consistent use. There are four distinct versions of this name, each forme containing two, labelled 'Tenor 1-4' in table 4.08. This table shows the pattern changes at formes B1 and B2; this is important since it coincides with the change in stave-set group pattern for those gatherings (discussed above). It proves that the pattern of work was interrupted between B1 and B2; perhaps B2 was imposed at a later stage, resulting in the change of signature pattern from the expected 'B 2' to 'B ii'.

⁵⁸ Petrucci does not impose the part names for the highest voice in 1506/1 or 1506/2; the initial capital letter would have obstructed such a designation although subsequent pages do not include it. The highest part was easier to find since it normally starts on the top of the verso folio; this practice also saved Petrucci having to find letters that he needed elsewhere. This feature also occurred in the production of manuscripts in choirbook format. Petrucci, in this instance, was simply imitating manuscript convention.

⁵⁹ See Boorman, 'A Case of Work and Turn', 301-321.

Table 4.08: Pattern of part names for 'Tenor' in 1506/2

Part name	Forme											
	A1	A2	A3	A4	B1	B2	B3	B4	C1	C2	C3	C4
'Tenor 1'		7 ^v		5 ^v			14 ^v		24 ^v		22 ^v	
'Tenor 2'	8 ^v		6 ^v		16 ^v	15 ^v		13 ^v		23 ^v		21 ^v
'Tenor 3'	2 ^v		4 ^v		10 ^v	9 ^v		11 ^v		17 ^v		19 ^v
'Tenor 4'		1 ^v		3 ^v			12 ^v		18 ^v		20 ^v	

Close examination of 1506/1 reveals a variety of problems with these part names. The Bologna copy of 1506/1, fol. 48^v [forme F3] displays the part name 'Teno', while the copies at the British Library, Padua and Paris have the missing 'r' included (see plates 4.02 and 4.03).⁶⁰

Plate 4.02:⁶¹ 1506/1, fol. 48^v (Bc)

Plate 4.03: 1506/1, fol. 48^v (Pn)



⁶⁰ Lack of samples prevents serious analysis of the implications of these differences. One cannot imply that London is a later copy than Bologna since the missing 'r' may have been caused by a different stop-press correction and accidentally removed: Milsom demonstrates such consequences in his 1996 article, 'Tallis, Byrd'.

⁶¹ Plates 4.02 and 4.03 are actual size; however, other plates are not to scale unless indicated. The variation in reproduction is due to the quality and method of the copies for which I have not been responsible. However, I have printed all examples at their best possible setting.

This variant suggests that proofing was evident during the production process. It might also suggest that the lower-case 'r' was in short supply. Folio 48^v belongs to forme F₄ which was one of the last formes imposed in 1506/1; it is possible that this letter was borrowed for the title page of 1506/2, which contains five 'r's (see plate 4.04).⁶² It is difficult to ascertain whether Petrucci included the title in the forme containing the staves and vocal underlay, or whether it was included in the forme with the notes and, crucially, the part designations (since they share the same fount).⁶³

Plate 4.04: 1506/2, fol. 1^r (Bc)

Lamentationum liber
Secundus. Auctores
Tronboncinus
Gaspar.
Erasmus.

The intensive use of this sort 'r' may have been responsible for the variations in the title pages of 1506/1 and 1506/2; both use an identical fount. Other Petrucci series use consistent titles beginning with the first *frottole* book of 1504, thus suggesting Petrucci's awareness of the importance of continuity of material.⁶⁴

⁶² One of the five 'r's used in the title page of 1506/2 is the alternative Rotonda sort (often mistaken for the numeral '2'); see plate 4.04 above. The 'r' used in 1506/1, fol. 48^v in the copies with the complete Tenor part name in 1506/1 is quite similar to the 'r' in the name 'Erasmus' on 1506/2's title page.

⁶³ The latter hypothesis is not so likely since the title page of the prints shares formes with part designations.

⁶⁴ The titles of the earliest series – the first song series *Harmonice musices odhecaton A, Canti B* and *Canti C* – suggest no overall plan in Petrucci's mind. The titles of the first motet books might indicate a broader plan, even though the second book in the series deviates from that plan – *Motetti A, Motetti de passione...* and *Motetti C*. The *frottole* prints show a greater consistency by 1504, beginning with *Frottole libro primo* (although broken in 1507 for volume

The missing 'r' in the Tenor of the Bologna copy is not the only problematic part designation for this voice; The London copy of 1506/1 shows the imposition of 'Teonr' on fol. 13^v (see plate 4.05). A further error in imposing this particular part is found in all extant copies on fol. 19^r (see plate 4.06 and 4.07); although the mis-spelling is the same as found in the London copy at fol. 13^v, it is not the same imposition (compare the position of the letters 'n' and 'r' in plates 4.05 and 4.06/4.07; the baseline of the two letters is exactly vertical in plates 4.06/4.07 whereas there is a distinctive difference in alignment in plate 4.05). This may be explained by the two versions being on different sectors of the forme and therefore independently imposed. Such errors suggest that these letters may also have been required elsewhere and were (hastily) reassembled before impressions were made. One sort in this part name which was extensively used was 'e'; it was imposed seven times in the title page of 1506/1, as well as being used each time in the part designation 'Tenor'. The character 'n' was also in heavy use, appearing six times in the title of 1506/2.⁶⁵ Another sort in short supply for these part designations was 's'; the short letter 's' used as the last character in most 'Altus' and 'Bassus' designations has been replaced in 1506/1, fol. 8^v by a long 's'.

IV, *Strambotti, ode, frottole...*). The culmination of Petrucci's consistency in titles is the four *Motetti de la Corona* volumes published in Fossombrone. Petrucci's title content does not appear to have a parallel with contemporary Italian printed books, principally due to lack of information (Petrucci's name does not appear on any title page). The *Odhecaton's* appearance is more akin to book titles since it is the only extant Petrucci print with dedicatory pages. Petrucci may have thought that a detailed title page containing his name and the place of an item's publication was not necessary, due to his unique position in the music publishing industry. Margaret M. Smith, *The Title-Page: Its Early Development, 1460-1510* (London; Delaware: The British Library; Oak Knoll Press, 2000) has analysed the bibliographic development of the title page during this period.

⁶⁵ One of these 'n's is used for the ascription 'Tronboncino' (rather than Tromboncino), suggesting a substitution for an 'm'; there are three 'm's in the title of 1506/2 (I have not had an opportunity to check the ascriptions to Tromboncino in original prints but I have inspected Sartori, *Bibliografia*, Jeppesen, 'Canzoni sonetti strambotti' and Sartori, 'Nuove conclusive'. Early ascriptions in the initial *frottole* publications show 'B.T.', but Petrucci began to use the longer form of the name by *Frottole libro quinto* (23.xii.1505), i.e. 'B. Tromboncino' (although the 'B.T.' which appears again in *Laude libro secondo* 1508/3 was believed to be Tromboncino by Jeppesen and Brøndal, *Die mehrstimmige italienische Laude*). Familiarisation and context must have been uppermost in Petrucci's mind when ascribing Tromboncino's name in the *frottole* volumes; the number of contemporary *frottole* manuscripts attests to their popularity. The only other ascription to Tromboncino in 1506/2 is 'Bartho. T.' which may be found in the header to fol. 1^v.

Plate 4.05: 1506/1, fol. 13^v (Lbl)



Plate 4.06: 1506/I, fol. 19^r (Pca)

19

TCORF

Deleib Tie non lugēt eo q non sint qui vētant ad solēpni tates

Omēs porte eius destruce Sacerdotes eius gemētes virgines eius squalide ⁊ ipsa oppressa

amaritu dine

CC III

Plate 4.07: 1506/I, fol. 19^r (Bc)

19

TCORF

Deleib Tie non lugēt eo q non sint qui vētant ad solēpni tates

Omēs porte eius destruce Sacerdotes eius gemētes virgines eius squalide ⁊ ipsa oppressa

amaritu dine

CC III

Further evidence of shortage and manipulation of individual letters is provided by plates 4.08 and 4.09 which illustrate the different offset in the final 's' of 'Bassus' in the Padua copy and the other extant copies of fol. 5^r (represented here by Bologna). This letter was probably required for the title page of 1506/2, since it uses the same fount; these independent impositions of the same typographic elements within extant copies indicate disruption to the print run.

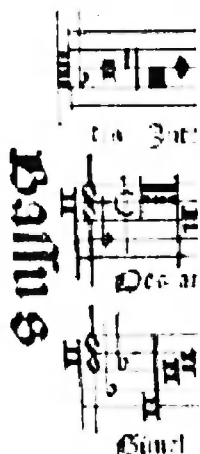
Plate 4.08: 1506/1, fol. 5^r (Pca)Plate 4.09: 1506/1, fol. 5^r (Bc)

There is another instance of an unusual typographical decision in 1506/1, forme B2, fol. 16^r. The part configuration should read 'Contra' but the capital 'C' has been mutilated, being an adapted letter 'T' [plate 4.10 shows the standard 'C' in 1506/1, plate 4.11 the adapted 'T' and 4.12 shows a comparable 'T'].⁶⁶ I have previously suggested that lack of type may have been responsible for such anomalies, but no other page in this gathering uses the 'Contra' configuration and therefore these letters should have been available. The positioning of part designations in forme B2 is identical to B4 (as are the stave-sets which were imposed in the alternate forme); what is even more puzzling is that the actual part names imposed in forme B1 are the same as those in B2, except for the exchange of the capital 'C' in 'Contra' on fol. 16^r

⁶⁶ I have examined other 6.5-7 mm 'T's in the 1506 prints but failed to find a resemblance to this type. It is distinctive due to its horizontal axis being higher at its left-hand side, and may not even have originated from the same matrix as other 'T's. Streaks of ink to the left and lower left of the imposition suggest that the letter might have been partly inked or even blanked at its leftmost side.

(comparison of plates 4.10 and 4.11 reveal the positioning of the remaining letters is identical). Why was it necessary for the compositor to substitute the mutilated 'T' for a 'C'? The use of this surrogate 'C' might imply that terminal damage had been caused to one or other of the regular capital 'C's during the production of 1506/1, resulting in a time delay between the imposition of formes B2 and B4. Nevertheless, the decision to use a very poor type substitution might reflect a drop in quality assessment in Petrucci's printing shop. The evidence suggests that 1506/1 was produced under pressure.⁶⁷

Plates 4.10: 1506/1, fol. 15^r (Bc); 4.11: 1506/1, fol. 16^r (Bc); 4.12: 1506/2, fol. 33^v (Bc)

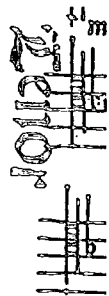
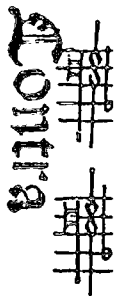

⁶⁷ Several Petrucci prints contain errors in foliation (some listed below): therefore the inclusion of one wrong page number in 1506/1 would not be enough by itself to suggest a general drop in proofing standards for this volume. However, the existence of other errors, particularly in the gathering containing the incorrect foliation, suggests that there were problems.

Of the editions that I have investigated to date, foliation errors were present in:

- 1503 *Missa Obrecht* (1 error in Superius, 3 in Tenor, 2 in Altus)
- 1504/1 *Motetti C* (4 in Altus)
- 1504/2 *Odhecaton* (1 error)
- 1505/1 *Fragmenta missarum* (1 in Tenor, 2 in Bassus)

4.10 Decorated capital letters

Boorman proved that examination of the large, decorated capital letters which prefix the principal textual sections could yield important information; I intend to place the print context of the 1506/1 and 1506/2 capital letters within Boorman's findings.⁶⁸ The imposition of capitals is not part of standing type, since they are too varied in position and character; however, the limited number of sorts resulted in restrictions within each forme (containing anything from none to three letters). A cursory glance at the decorated capitals in *Odhecaton* suggests that Petrucci had striven to present a uniform fount but few letters from his early period were still usable by 1506.

Appendix 6 illustrates examples of all of the decorated capitals used in the two Lamentation prints; I have assigned a number to each. It should be noted that each letter is unique since its use is more limited than, for example, the characters required for the part names (where typographical evidence shows that the same mold produced several sorts). It is possible to trace the gradual deterioration of each letter from first to last print and 1506/1 and 1506/2 are typical of Petrucci's mid-Venetian phase, where a mixture of original and replacement letters may be found. It was standard practice not to repeat the decorated capital when spelling the remainder of the initial word. However, there are three instances in 1506/1 and one in 1506/2 where the capital is repeated (this is indicated in the 'Remarks' column in tables 4.09 and 4.10). The letter 'I' is most prone to this practice although 'Vau' is spelt again following the use of the capital 'V' in 1506/2, fol. 38^v.

Tables 4.09 and 4.10 (below) list the placing of each capital letter in 1506/1 and 1506/2; the most common letters are 'I' and 'S', each of which is used seven times in the two prints.⁶⁹

⁶⁸ Boorman, 'Petrucci at Fossombrone: Some New Editions'.

⁶⁹ Capital letters are indicated in italics to distinguish them from formes and gatherings.

Table 4.09: Decorated capitals in 1506/1

<i>Letter</i>	<i>Folio</i>	<i>Forme</i>	<i>Height</i>	<i>Condition</i>	<i>Remarks</i>
<i>A</i> ₁	2 ^r	A ₂	19	Excellent	
<i>A</i> ₂	2 ^v	A ₁	25.5	Fair	
<i>I</i> ₁	6 ^v	A ₃	27	Good	Capital letter is repeated in the word.
<i>A</i> ₃	8 ^v	A ₁	c. 24.5	Very good	
<i>R</i> ₁	11 ^v	B ₄	26	Fair	
<i>A</i> ₃	13 ^v	B ₄	27	Good	
<i>Q</i> ₁	16 ^v	B ₁	25	Excellent	
<i>A</i> ₂	22 ^v	C ₃	25.5	Excellent	Better than on fol. 2 ^v . Capital letter is repeated in the word.
<i>I</i> ₂	28 ^v	D ₃	6.5	Good	
<i>I</i> ₁	30 ^v	D ₃	26.5- 27	Fairly good	Capital letter is repeated in the word.
<i>T</i> ₂	31 ^v	D ₂	7	Fair	
<i>T</i> ₁	33 ^v	E ₂	25.5	Good	De Quadris's Lamentations are the only setting to get a decorated capital mid-section.
<i>B</i> ₁	34 ^v	E ₁	25	Fair	
<i>B</i> ₂	35 ^r	E ₃	7	Very good	
<i>L</i> ₁	36 ^v	E ₃	26	Fairly good	
<i>P</i> ₁	37 ^v	E ₄	18	Poor	
<i>C</i> ₁	39 ^v	E ₂	7.5	Fair	
<i>S</i> ₁	41 ^v	F ₂	18.5	Fairly good	
<i>R</i> ₁	43 ^v	F ₄	26	Fair	Different damage to fol. 11 ^v .
<i>P</i> ₁	45 ^v	F ₅	18	Fairly poor	
<i>C</i> ₂	47 ^v	F ₄	26	Poor	
<i>S</i> ₁	47 ^v	F ₄	18.5	Poor	
<i>P</i> ₂	48 ^v	F ₁	25	Excellent	

Table 4.10: Decorated capitals in 1506/2

<i>Letter</i>	<i>Folio</i>	<i>Forme</i>	<i>Height</i>	<i>Condition</i>	<i>Remarks</i>
<i>I</i> ₁	1 ^v	A ₂	25	Good	Not as good as 1506/1, fol. 6 ^v .
<i>H</i> ₁	4 ^v	A ₃	27	Excellent	
<i>H</i> ₁	7 ^v	A ₂	27	Excellent	Identical to fol. 4 ^v above.
<i>S</i> ₁	11 ^v	B ₄	18.5	Good	Better than 1506/1, fol. 47 ^v .
<i>S</i> ₁	15 ^v	B ₂	18.5	Good	Identical to fol. 11 ^v above.
<i>A</i> ₃	19 ^v	C ₄	25.5	Very good	
<i>H</i> ₁	22 ^v	C ₃	27	Very good	Not as good as fol. 7 ^v .
<i>T</i> ₁	25 ^v	D ₂	25.5	Very good	Better than 1506/1, fol. 33 ^v above.
<i>I</i> ₁	29 ^v	D ₄	26- 26.5	Very good	Better than fol. 1 ^v above.
<i>B</i> ₁	33 ^v	E ₂	25	Excellent	Better than 1506/1, fol. 34 ^v above.
<i>I</i> ₁	35 ^v	E ₄	26.5	Very good	Identical to fol. 29 ^v above.
<i>V</i> ₁	38 ^v	E ₃	24.5	Excellent	Capital letter is repeated in the word.
<i>B</i> ₂	39 ^v	E ₂	7.5	Good	
<i>A</i> ₃	40 ^v	E ₁	26	Very good	Almost identical to fol. 19 ^v .
<i>I</i> ₁	41 ^v	F ₂	27	Good	More damage than fol. 35 ^v .
<i>I</i> ₁	43 ^v	F ₄	26.5	Good	
<i>B</i> ₁	50 ^v	G ₁	25	Good	More damage than fol. 33 ^v .

The preferred capital size was *c.* 26-27 mm high, the standard size of those in *Odhecaton*, but three letters measuring *c.* 18-19 mm [*A*₁, *P*₁ and *S*₁] were occasionally used in 1506/1. The larger format letter 'S' must not have been available to Petrucci in any other format, *S*₁ being found as early as *Motetti C* in 1504. There was still a selection of letters from the largest fount; the letter 'A', required twice in forme *A*₁ (see table 4.09 above), is represented by *A*₂ (25.5 mm) and *A*₃ (about the same size). The use of the 7 mm capitals set towards the end of 1506/1 (the same fount was used as the capital letters for the part names) suggests that Petrucci's stock of matching founts was severely depleted during the imposition of 1506/1. Forme *D*₃ required two capital 'T's and Petrucci apparently had only one 27 mm letter.⁷⁰ A very inferior 6.5 mm 'T' is used for the Discantus of de Orto's Lamentations on fol. 28^v while the opening of de Quadris's Lamentations presents the more respectable capital. Another letter from the same sort is *T*₂, appearing on fol. 31^v (this letter is frequently used for the part name 'Tenor'; see plate 4.03 shown previously). No space was reserved for a capital letter on fol. 31^v, hardly surprising since the music setting is very crowded. Furthermore, the letters 'eth' are set tightly to the right of the clef, allowing little or no space for a matching *c.* 2 mm capital 'T'. The compositor presumably wished to signify the beginning of a new set of verses following the 'Jerusalem' refrain and the result is an unusual offset of the 7 mm 'T' to the left of the stave (see plate 4.13 below). An identical approach may be seen at fol. 39^v where the 7.5 mm letter 'C' was used for 'Caph' (also used as the capital for the part name 'Contra'; see plate 4.10). This folio is another page congested with notes and the compositor may have decided that a 27 mm capital was too costly of space.

⁷⁰ This capital 'T' was identified by Boorman, 'Petrucci at Fossombrone: Some New Editions', 132, as a replacement sort for Petrucci's earliest letters. Type deterioration of this letter by 1506 was considerable.

Plate 4.13: 1506/1, fol. 31^v (Pca)

There is only one example of the 7 mm capital in 1506/2; fol. 39^v uses the letter 'B' (this sort is frequently used in both Lamentation prints as the capital for the part name 'Bassus'). This small capital is included since the forme E2 includes another capital 'B' on fol. 33^v ['B1']. Uniformity is maintained throughout the print and there are only two instances of the 18 mm fount, *Si* being used in B2 and B4.

The pattern of use of capitals in the two Lamentation volumes suggests that the uniformity achieved in *Odhecaton* was no longer possible by 1506. The cost of replacing a complete fount was probably considerable and the mixture of letter sizes and styles (particularly in 1506/1) suggests Petrucci had decided to 'make do and mend' by this time.

4.II Use of page headers

The inclusion of page headers as standing type was common in publications since the origins of movable type;⁷¹ however, 1506/1 and 1506/2 use few headers. The ascription to 'B.ycart.' on folios 6^v and 8^v (Ycart being the only composer to be allocated two ascriptions in the course of his work) is imposed

⁷¹ Gaskell, *A New Introduction*, p. 109 and Stanley Boorman, 'Upon the Use of Running Titles in the Aldus House in 1518', *The Library*, 27 (1972), 126-131, discussed the imposition of titles and proved that they were retained from gathering to gathering.

independently since the fount and position are different.⁷² This would have been an obvious opportunity for the use of a running header since both are in different formes (A1 and A3) and are in the same position in each forme, i.e., the left-hand page; type availability and working practices presumably dictated otherwise.

4.12 Text underlay

The underlay of text in 1506/1 and 1506/2, like many Petrucci vocal prints and some contemporary manuscripts, is somewhat arbitrary. While specific word underlay was not of major concern to Petrucci, it was necessary to ensure that the beginning and end of text lines corresponded with the music. Texting is generally good in this respect and there are few missing words, misprints, alternative spellings or other errors (these are listed in appendix 2). The majority of works are fully texted with the exception of Ycart (the Discantus is texted but only incipits are provided for each section in other voices for some verses), Anon. 1, Agricola (four-part),⁷³ and the 'Benedictus Dominus Deus' following Tromboncino's Lamentations (the Discantus is texted but incipits are provided in other voices for some verses). There is a considerable vertical difference in the imposition of the two impressions on fol. 3^v of 1506/1 between the Paris copy and the other extant copies (see plate 4.14, where the vertical difference is indicated in black, and plate 4.15, being the copy at Bologna and representing the other editions).⁷⁴ The vertical difference is 3.5 mm; the Paris version sets its first syllable 'Be-' under a mensuration sign. It is possible to determine the implied underlay of the Paris print for some phrases, particularly when punctuated by rests or pauses. Syllables or words in

⁷² The table of contents incorrectly numbers the beginning of the Ycart Lamentations; perhaps there are two ascriptions in an attempt to rectify any ambiguity.

⁷³ While the Discantus is texted for most of the setting, other voices lack text at some point. This includes a section in the second lesson where the text 'et succendit in Jacob' is completely omitted during the Tenor and Bass duet at bars 105-113. There is a similar omission of text further in the lesson where the final words of the Altus and Tenor duet are omitted at bars 184-189, thus creating problems for the editor.

⁷⁴ The technical term for the alignment of multiple impressions is 'register'.

the middle of phrases may have been more difficult to resolve. There are two other examples of such widespread difference in the vertical offset of a complete page in 1506/2 (listed in table 4.13, section 4.13). These variations show that Petrucci had considerable difficulty imposing double impressions; they might also reflect a more relaxed attitude to word setting and quality control, being the most usable examples of his print run. The possibility also exists that these imperfect sheets were the result of several attempts, and that there must have been a considerable amount of previously imposed sheets with far more errors and variants that, as a consequence, had to be discarded.

Plate 4.14: 1506/1, fol. 3^v (Pn)

Deus tuus plorans plorans ut innocens lacrimis

Deus tuus plorans plorans ut innocens lacrimis

Deus tuus plorans plorans ut innocens lacrimis

Deus tuus plorans plorans ut innocens lacrimis

Deus tuus plorans plorans ut innocens lacrimis

Plate 4.15: 1506/1, fol. 3^v (Bc)

Deus tuus plorans plorans ut innocens lacrimis

Deus tuus plorans plorans ut innocens lacrimis

Deus tuus plorans plorans ut innocens lacrimis

Deus tuus plorans plorans ut innocens lacrimis

Deus tuus plorans plorans ut innocens lacrimis

Evidence of quality control is shown by plates 4.16 and 4.17 which illustrate the Padua and Bologna copies of 1506/1, fol. 16^r. There are only two words on this page yet comparison of the offset of the word 'Jerusalem' reveals two completely different placings. These placings cannot be explained by variation in printing conditions, paper shrinkage or the like, since they exceed the 2 mm limit caused by such conditions. It would appear that the proof reader wished to change the overlap caused between the long and the letter 'J' of 'Jerusalem' in the Bologna, Paris and London copies. We may not necessarily assume that the 'corrected' copy (Padua) is the most perfect; more evidence needs to be provided since the sample rate is so low.

Plate 4.16: 1506/1, fol. 16^r (Pca)

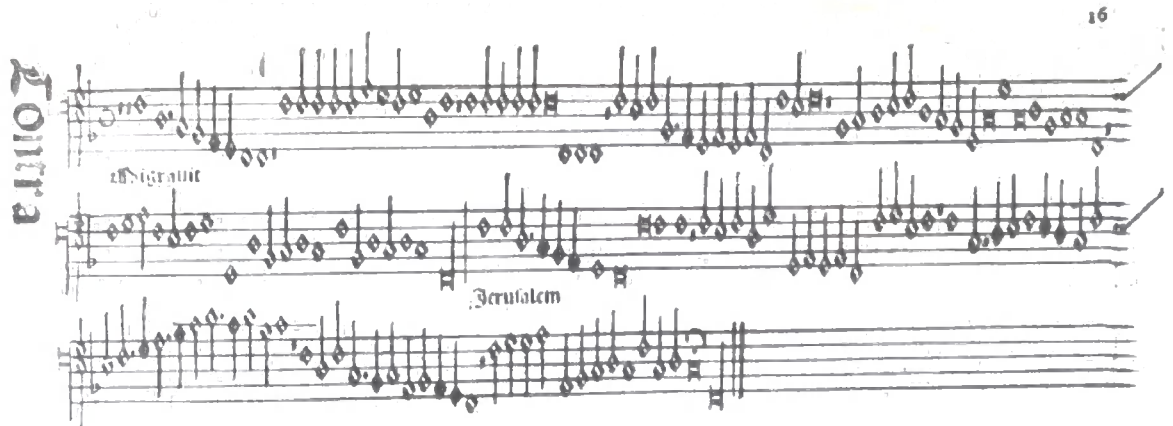

Plate 4.17: 1506/1, fol. 16^r (Bc)

Further definitive evidence is provided by 1506/1, fol. 9^r (plates 4.18 and 4.19) where another word has been moved to correct an overlap between it and a musical element. Crucially, the Padua copy lacks the offending overlap (at the word 'Beth') while the remaining copies show the overlap, caused by the C clef.

Plate 4.18: 1506/1, fol. 9^r (Pca)

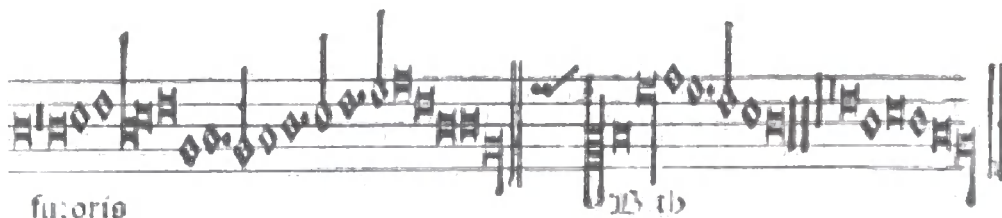
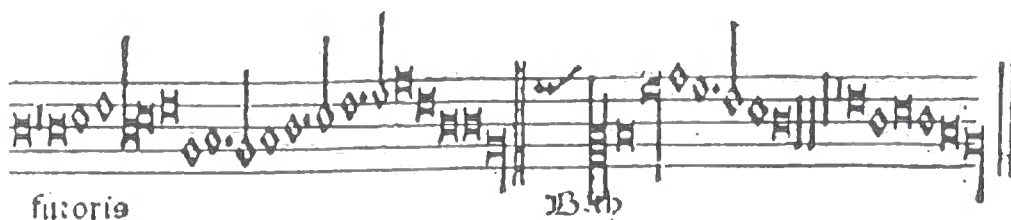

Plate 4.19: 1506/1, fol. 9^r (Bc)



The resetting of the text 'disco-oper-uit' on fol. 43^r between the imposition of Bologna/Padua and London/Paris copies is somewhat mystifying (see plates 4.20 and 4.21); Leofranc Holford-Strevens suggested that it would make sense if the compositor suddenly thought that the 'u' was consonantal as in 'discoper-vit'. However, Holford-Strevens stated that it would only make sense if the '-uit' was set to only one note.⁷⁵ The difference in the imposition of this word provides another example of text manipulation during the print run of 1506/1.

⁷⁵ Private correspondence, 8 July 2003. I am most grateful to Dr Holford-Strevens for his suggestions.

Plate 4.20: 1506/1, fol. 43^r (Bc)

filia non no addet ultra vt transmigrat te visitauit iniquitates tuas filia edon pisco ope
ruit, peccata tu a Jerusalem ierusalem conuertere ad dñm deum

Plate 4.21: 1506/1, fol. 43^r (Pn)

filia non no addet ultra vt transmigrat te visitauit iniquitates tuas filia edon pisco ope
uit, peccata tu a Jerusalem ierusalem conuertere ad dñm deum

One of the more unusual impositions of text may be found in 1506/1 at fols 47^v-48^r. Petrucci printed the remaining verses of 'Cum autem' in the space left by the omission of the lowest stave; it is significant that these extra verses were not imposed with the forme containing the staves and text since there is distinct overlap with these elements on fol. 47^v (see plate 4.22). One likely reason is that the fount used for the extra verses is the same as that used for underlaid text; Petrucci would have had a limited number of type available at any one time. The alignment of the extra text on fol. 47^v against the underlaid text of the lowest stave is slightly different and also overlaps the underlaid text, confirming that it was imposed separately (the context of these verses was discussed in chapter 2). I have inspected many Petrucci sacred volumes and 1506/1 is the only example I have found that contains the use of such additional verses.⁷⁶

⁷⁶ The verses of 'Cum autem' are also imposed in an identical format to 1506/1 in the editions of *Liber sacerdotalis nuperrime ex libris* (1523/1, 1537) and *Cantus monastici formula nouiter impressa...* (1523, 1535).

Plate 4.22: 1506/I, fol. 47^v (Bc)

Um aut venissem ad locu ubi crucifigendus erat filius meus statuerunt euz in medio
omnes ppli z vestib' expoliatis nudum dimisunt corpus sanctissimum
Epulto dno signatus est monumentus volentes lapides ab hostio monumenti
Ponentes milites q custodirent illum Ne forte veniant discipuli eius z furentur eum
Ponentes postea res referas. Sicut dno
z dicant plebi surrexit a mortuis
Dulcissime filie non o dulcissime videre dolo: em. maximum inspecto nudus in medio omnis
populi filium meuz dulcissimuz vulneratus est in medio eoz
Quos omnes qui transitis per viam venite z videte: si est dolo: sicut mea desolata sum nimis
nec est qui me confortetur: hinc mea confirmata est vita occiditur z amittitur
O nimis triste spectaculum o crudele supplicium inpenitus filio o felice rex indecenti morte
coronatur pontificia iniquitate: tantum ne in vestrum exardescitis deum.
Attendite vos o populi. z uniuersae plebes dolo: em maximum morte turpissima mactauerunt
filium meuz vos optime fo: o: res fete vna mecum de filio conqueramur.

While the extant copies of 1506/I do not contain blatant textual variations and manipulation, there are some pages which suggest variety. Plates 4.23 and 4.24 show a slight variation towards the right-hand side of the page (illustrated in black in the plates); there does not appear to be a rationale for these differences. However, the vertical difference is more than 2 mm and there is correspondence towards the left-hand side of these pages.

Plate 4.23: 1506/2, fol. 48^r (Pn)

De. Feci sicut hostes eius in capite inimici illi locupletati sunt. Quia dicit locus et super eas propter multitudinem iniquitatum eius. Ducti sunt in captivitate ante faciem turbantis Jerusalem. Convertere ad dominum deum tuum.

De. Feci sicut hostes eius in capite inimici illi locupletati sunt. Quia dicit locus et super eas propter multitudinem iniquitatum eius. Ducti sunt in captivitate ante faciem turbantis Jerusalem. Convertere ad dominum deum tuum.

Plate 4.24: 1506/2, fol. 48^r (Bc)

De. Feci sicut hostes eius in capite inimici illi locupletati sunt. Quia dicit locus et super eas propter multitudinem iniquitatum eius. Ducti sunt in captivitate ante faciem turbantis Jerusalem. Convertere ad dominum deum tuum.

De. Feci sicut hostes eius in capite inimici illi locupletati sunt. Quia dicit locus et super eas propter multitudinem iniquitatum eius. Ducti sunt in captivitate ante faciem turbantis Jerusalem. Convertere ad dominum deum tuum.

Further minor variations in text setting may be found in 1506/2 by comparing plates 4.25 (London) and 4.26 (Bologna) where the difference is most prominent at the left-hand side on the third stave (this is highlighted in black in the Bologna copy). There is a chance that such slight difference in the offset may have been due to conditions at the time of printing (although no other text on the page is affected, as an examination of the second stave will confirm).

Plate 4.25: 1506/2, fol. 31^r (Lbl)

Bassus

panc patres nri pecca uerunt c no sunt Et nos iniquitates eorum po:tauimus

Et quas nra pecunia bibipua Ligna nra p:cio coparauim? Ceruicib? nris minabamur Lalla

Plate 4.26: 1506/2, fol. 31^r (Bc)

Bassus

panc patres nri pecca uerunt c no sunt Et nos iniquitates eorum po:tauimus

Et quas nra pecunia bibipua Ligna nra p:cio coparauim? Ceruicib? nris minabamur Lalla

One further textual aberration appears in all extant copies of 1506/2 (shown in plate 4.27); there is a distinct curve on the horizontal alignment at the left-hand side (this is the lowest stave of the six). The simple explanation is that this part of the page was an outside edge of the forme and was possibly weakened by the force exerted upon it by the press.

Plate 4.27: 1506/2, fol. 31^v (Bc)

nobis a facie gladij in deserto | Mellis nra qsi cibus exul

Mulieres in sion humiliauerunt Et uirgines incitibus iuda

4.13 Stop-press variations and errors

Extant copies of 1506/1 and 1506/2, in common with much of Petrucci's output, contain many stop-press variants. The vast majority of these variations may be found in 1506/1 but 1506/2 also has a proportion of notable differences. The small number of extant copies makes these differences all the more important. It should be noted that the gatherings in each surviving copy may not necessarily have been manufactured in the same order. While the Padua copy of 1506/1 would appear to be the copy with the majority of stop-press corrections and the 'best' copy, it does share some errors with other copies. Such findings remind us that we may not necessarily assume that the Padua copy was the latest to be imposed, simply because it contains the least number of errors; sheets and gatherings were probably stored unbound in Petrucci's shop, enabling further selection of sheets prior to selling.

I have been able to identify variations, often imperceptible to the naked eye, by using computer software.⁷⁷ It has been possible to overlay pages of extant copies, allowing distinction between variations caused accidentally (for example, differences in page size, changes in paper) and those that were deliberate (stop-press corrections – see table 4.11 below for details). While the manipulation of the part name 'Tenor' is indicative of quality control, computer analysis has revealed changes in text imposition, particularly where flags were seen to conflict with the frame containing the text. Some errors are common to all of the surviving copies, such as the part name 'Teonr' on fol. 19^r of 1506/1 which has been discussed previously.

⁷⁷ A programme called *Graphic Converter*, manufactured by Lemke Software of Germany, enabled a detailed analysis of comparative electronic copies of each print.

Table 4.II: Variations and errors in 1506/I⁷⁸

<i>Folio [forme]</i>	<i>I-Bc</i>	<i>I-Pca</i>	<i>GB-Lbl</i>	<i>F-Pn</i>
1 ^v [A2]	TOC states that Ycart begins on '8' rather than 6	TOC states that Ycart begins on '8' rather than 6	TOC states that Ycart begins on '8' rather than 6	TOC states that Ycart begins on '8' rather than 6
2 ^r [A2]	no folio '2'	'2'	'2'	'2'
3 ^v [A4]	page offset: complete page	page offset: complete page	page offset: complete page	page offset: complete page
4 ^r [A4]	'AA IIII'	'a IIIII'	'AA IIII'	'AA IIII'
4 ^r [A4]	Signature [SIG] offset ⁷⁹ = 7	Signature offset = 13.5	Signature offset (horizontal) = 7	Signature offset (horizontal) = 7
4 ^r [A4]	'4'	no folio '4'	'4'	'4'
5 ^r [A3]	Bassus normal	Final 's' of Bassus offset	Bassus normal	Bassus normal
5 ^r [A3]	text offset: 'ei inimici'	text offset: 'ei inimici'	text offset: 'ei inimici'	text offset: 'ei inimici'
6 ^r [A4]	'6'	no folio '6'	'6'	'6'
6 ^v [A3]	Decorated letter is repeated in first word	Decorated letter is repeated in first word	Decorated letter is repeated in first word	Decorated letter is repeated in first word
9 ^r [B1]	'Beth' partly obscured	'Beth' offset	'Beth' partly obscured	'Beth' partly obscured
13 ^v [B4]	'Tenor'	'Tenor'	'Teonr'	'Tenor'
16 ^r [B2]	'Jerusalem' offset	'Jerusalem' offset	'Jerusalem' offset	'Jerusalem' offset
18 ^v /19 ^r [C1 & C3]	Text 'non sint' and 'non est'	Text 'non sint' and 'non est'	Text 'non sint' and 'non est'	Text 'non sint' and 'non est'
19 ^r [C3]	'Teonr'	'Teonr'	'Teonr'	'Teonr'
19 ^r [C3]	SIG = c.1.5	SIG = c.4	SIG = 4	SIG = c.1.5
19 ^r [C3]	'CC III'	'CC IIII'	'CC IIII'	'CC III'
19 ^v /20 ^r [C4]	Text 'in capite inimici eius' and 'in capite inimici illius'	Text 'in capite inimici eius' and 'in capite inimici illius'	Text 'in capite inimici eius' and 'in capite inimici illius'	Text 'in capite inimici eius' and 'in capite inimici illius'
22 ^v [C3]	Decorated letter is repeated in first word	Decorated letter is repeated in first word	Decorated letter is repeated in first word	Decorated letter is repeated in first word
22 ^v /23 ^r [C3 & C1]	Text 'et non est recordatus scabilli' and 'et non recordatus scabillum'	Text 'et non est recordatus scabilli' and 'et non recordatus scabillum'	Text 'et non est recordatus scabilli' and 'et non recordatus scabillum'	folio missing
23 ^v [C2]	Text 'in terram dolluit' and 'in terram polluit'	Text 'in terram dolluit' and 'in terram polluit'	Text 'in terram dolluit' and 'in terram polluit'	folio missing
29 ^v [D4]	Text 'persecutoers' in Supra	Text 'persecutoers' in Supra	Text 'persecutoers' in Supra	Text 'persecutoers' in Supra

⁷⁸ Entries in bold type in table 4.11 [and 4.13 following] denote variation between copies. Differences of a millimetre or less have not been noted.

⁷⁹ When only one figure appears in this table and table 4.13 following, it indicates the offset measured from the top of the signature to the nearest stave line in millimetres [horizontal offset]. The second figure, if present, is the vertical offset measured from the right-hand side of the lowest stave line. The latter figure is dependent upon the inking of the lines in each copy (the inking of stave ends is sometimes variable) but electronic comparisons have confirmed these variants.

<i>Folio</i> [<i>forme</i>]	<i>I-Bc</i>	<i>I-Pca</i>	<i>GB-Lbl</i>	<i>F-Pn</i>
30 ^v [D3]	Decorated letter is repeated in first word	Decorated letter is repeated in first word	Decorated letter is repeated in first word	Decorated letter is repeated in first word
31 ^r [D1]	'A' missing	'A' missing	'A' missing	'A' missing
32 ^v /33 ^r [D1 & E1]	Text 'viderent' and 'viderunt'	Text 'viderent' and 'viderunt'	Text 'viderent' and 'viderunt'	Text 'viderent' and 'viderunt'
32 ^v /33 ^r [D1 & E1]	Text 'Eth'	Text 'Eth'	Text 'Eth'	Text 'Eth'
36 ^r [E4]	'perdidit' offset	'perdidit' offset	'perdidit' offset	'perdidit' offset
38 ^v /39 ^r [E3 & E1]	Text 'fecit deus' and 'fecit dominus'	Text 'fecit deus' and 'fecit dominus'	Text 'fecit deus' and 'fecit dominus'	Text 'fecit deus' and 'fecit dominus'
39 ^v [E2]	Discantus omits 'ut contereret'	Discantus omits 'ut contereret'	Discantus omits 'ut contereret'	Discantus omits 'ut contereret'
41 ^r [F1]	'41' inverted	'41' inverted	'41' inverted	folio missing
43 ^r [F3]	'disco ope ruit' imposition	'disco ope ruit' imposition	'disco oper uit' imposition	'disco oper uit' imposition
43 ^v /44 ^r [F4]	Text 'pupilli facti sunt' and 'pupilli facti sumus'	Text 'pupilli facti sunt' and 'pupilli facti sumus'	Text 'pupilli facti sunt' and 'pupilli facti sumus'	Text 'pupilli facti sunt' and 'pupilli facti sumus'
48 ^v [F3]	'Temo'	'Tenor'	'Tenor'	'Tenor'

There are some differences between copies in the imposition of signatures and foliation; Boorman noted that these elements were sometimes imposed manually later in the process.⁸⁰ The Bologna copy is missing its foliation on fol. 2 while the Padua copy is missing numbers 4 and 6 (see plates 4.28 and 4.29). The imposition of fol. 41^r evidently caused problems in all copies and the folio number appears to have been inverted (see plate 4.30). This folio belongs to gathering F which contains a number of other discrepancies. The substitution of the signature pattern in Padua at fol. 4^r from 'AA IIII' to 'a IIII' again suggests a shortage of founts (see plate 4.28). 1506/1 contains more variation in signature patterns between editions; plate 4.06 (shown previously and representing the Padua copy) and plate 4.07 (also shown previously representing the Bologna and Paris copies) show different spacings between the letters and numerals, indicating independent impositions.

⁸⁰ Boorman, 'Petrucci at Fossombrone: A Study', pp. 158-159.

Plate 4.28: 1506/1, fol. 4^r (Pca)

Altus

D: r̄p̄ plorans plora uit ⁊ lacrimae e
tus inmaxillae e. tus Nō est q̄ p̄soler eam ex oibus ca

Bassus

D: r̄p̄ plorans plora uit ⁊ in nocte lacrimae eius inmaxillae e
tus

AA XII

Plate 4.29: 1506/1, fol. 4^r (Bc)

Altus

D: r̄p̄ plorans plora uit ⁊ lacrimae e
tus inmaxillae e. tus Nō est q̄ p̄soler eam ex oibus ca

Bassus

D: r̄p̄ plorans plora uit ⁊ in nocte lacrimae eius inmaxillae e
tus

AA XII

Plate 4.30: 1506/1, fol. 41^r (Bc)

I propose a categorisation of the variants and errors in 1506/1 and I have identified two patterns:

- blatant inaccuracies or errors (category 1)
- visual improvements and adjustments (category 2)

The incorrect part designations and omission of occasional folio numbers fall into category 1 while the adjustments of word underlay belong to category 2; variants such as the different signature offsets have not been considered. Following Boorman's suggestion that two men worked on the same print, one being responsible for the outer forme and the other for the inner forme (i.e., formes 1-2 and 3-4);⁸¹ it is possible to distribute the variants in 1506/1 between formes 1-2 and formes 3-4 (see table 4.12). There are more blatant errors in formes 3-4 such as the 'Teonr' mis-spellings [B4, C3 and F3] and the missing foliation (two errors in A4). Formes 1-2 generally show fewer mistakes and contain the textual corrections, for example the 'Beth' and 'Jerusalem' realignments on B1 and B2 (although forme F3 contains the intriguing 'discooper-uit/ope-ruit' modification). Table 4.09 (previously shown) reveals that the four folios in which the initial of the decorated capital is repeated in the following word all belong to formes 3-4, namely A3, C3 and D3 (two occurrences in D3), supporting the notion that the compositor of these formes was less meticulous in his quality control than his colleague. Further evidence of differences in formes exists between the version of the wording of 'Cum autem venissent' in the table of contents for 1506/1 (fol. 1^v, A2) and the words

⁸¹ See *ibid.*, pp. 108-118, for a detailed discussion.

set in fols 47^v-48^r, F4, namely 'Cum autem venissem'. Extant manuscripts containing these words use both versions although the pre-1506 manuscripts tend to use 'venissem'. The extant copies show that compositor of formes 3-4 manipulated the placement [offset] of several signatures; I have discovered no such examples in formes 1-2. There may be several reasons for this including correction or visual improvement; however, the fact that there are no such variants between copies in formes 1-2 suggests that this compositor was more accurate when imposing signatures.

I have discussed the use of paper in 1506/2, particularly the division of two watermarks between formes 1-2 and 3-4; this also supports the theory that Petrucci's compositors each worked on their respective formes. Table 4.12 (below) shows that there are 57% more category 1 variants in formes 3-4 than 1-2. I have already shown how the distribution of watermarks in 1506/1 supports the notion of labour division; the typographical evidence discussed above supports the notion that formes 3-4 in 1506/1 were imposed by someone with less experience and expertise than the person responsible for formes 1-2.

Table 4.12: Analysis of variants found in formes 1-2 and 3-4 in 1506/1

<i>Forme</i>	<i>Category 1</i> ⁸²	<i>Category 2</i>
A1-2	2	0
B1-2	0	2
C1-2	1	0
D1-2	2	0
E1-2	1	0
F1-2	1	0
A3-4	3	5
B3-4	1	0
C3-4	3	1
D3-4	2	0
E3-4	0	0
F3-4	2	1
F5	0	0

The number and category of variations in extant copies of 1506/2 is not as dramatic as in 1506/1 (see table 4.13 below). The imposition of signatures in

⁸² Table 4.11 provided the evidence for this table; I have not included text variations between formes 1-2 and 3-4 as Boorman, 'Petrucci at Fossombrone: A Study', pp. 110-112, has shown such practices indicate the interpretation of the two compositors.

this volume also creates some variations and errors; one such example is the signature 'B ii' which has been discussed previously. The Paris copy of 1506/2 incorrectly uses the number '3' for the signature F2 (see plate 4.31 and compare it to the correctly imposed 'F 2' in the Bologna copy, plate 4.32). Lack of such numerals may have been a factor in Petrucci's decision to omit folio numbers in 1506/2; the two prints following 1506/2, *Misse Izac* (1506) and *Misse Gaspar* (1507), also omit foliation.⁸³

Another variation in the position of a signature may be seen at 'F' in 1506/2 in the Bologna copy, compared to the Paris and London copies (plates 4.33 and 4.34); the vertical difference is over 2 millimetres.

Plate 4.31: 1506/2, fol. 42^r (Pn)



Plate 4.32: 1506/2, fol. 42^r (Bc)

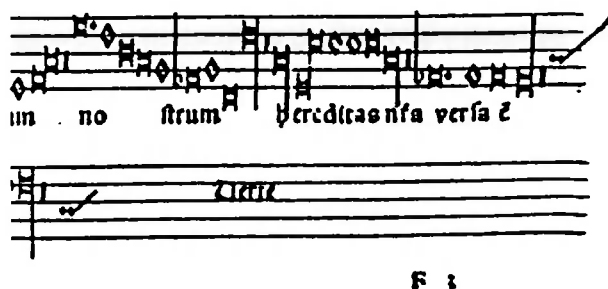

⁸³ The prints prior to 1506/1, *Frottole libro quinto* (Venice: Ottaviano Petrucci, 1505/6) and *Frottole libro sexto* (Venice: Ottaviano Petrucci, 1506/3), both contain foliation.

Plate 4.33: 1506/2, fol. 41^r (Bc)

terunt carulos suos Jerlm ierusalcm.

F

Detailed description: This image shows a musical score for Plate 4.33. It consists of two staves. The upper staff contains a single line of music with square neumes on a four-line red staff. The text 'terunt carulos suos' is written below the first part of the staff, and 'Jerlm ierusalcm.' is written below the second part. The lower staff is a lute tablature, showing a G-clef and a key signature of one flat (B-flat). It contains a few notes on the first few strings, followed by a large space, and then a final 'F' at the end.

Plate 4.34: 1506/2, fol. 41^r (Pn)

terunt carulos suos Jerlm ierusalcm.

F

Detailed description: This image shows a musical score for Plate 4.34, which is a duplicate of Plate 4.33. It consists of two staves. The upper staff contains a single line of music with square neumes on a four-line red staff. The text 'terunt carulos suos' is written below the first part of the staff, and 'Jerlm ierusalcm.' is written below the second part. The lower staff is a lute tablature, showing a G-clef and a key signature of one flat (B-flat). It contains a few notes on the first few strings, followed by a large space, and then a final 'F' at the end.

Table 4.13: Variations and errors in 1506/2

Folio [forme]	I-Bc	GB-Lbl	F-Pn
09 ^r [B1]	SIG = 0.75 & 6.5	SIG = 0.5 & 6	SIG = 12 & 4.5
09 ^r [B1]	stave 4 offset: 'erectus'	stave 4 offset: 'erectus'	stave 4 offset: 'erectus'
10 ^r [B2]	B ii (not B 2)	B ii (not B 2)	B ii (not B 2)
12 ^r [B4]	'erudivit' offset	'erudivit' minor offset	'erudivit' offset
12 ^r [B4]	'ignem' lacking in Bassus	'ignem' lacking in Bassus	'ignem' lacking in Bassus
15 ^r [B1]	'sont' rather than 'sunt' in Bassus	'sont' rather than 'sunt' in Bassus	'sont' rather than 'sunt' in Bassus
16 ^r [B2]	'Bassus'	'Bassus'	'Bassus' offset
21 ^v /22 ^r [C4 & C4]	Text 'tabarnaculo' and 'tabernaculo'	Text 'tabarnaculo' and 'tabernaculo'	Text 'tabarnaculo' and 'tabernaculo'
24 ^v /25 ^r [C1 & D1]	Text 'dissipavit', 'dissipavre' and 'dissipare'	Text 'dissipavit', 'dissipavre' and 'dissipare'	Text 'dissipavit', 'dissipavre' and 'dissipare'
27 ^v [D4]	page offset: complete page	page offset: complete page	page offset: complete page
31 ^r [D1]	stave 3 offset: 'pane patres'	stave 3 offset: 'pame patres'	stave 3 offset: 'pane patres'
31 ^r [D1]	stave 4 'Cervicibus nostris...' offset	stave 4 'Cervicibus nostris...' offset	stave 4 'Cervicibus nostris...' offset
31 ^v [D2]	stave 6: deflection of initial text	stave 6: deflection of initial text	stave 6: deflection of initial text
38 ^v [E3]	Decorated letter is repeated in first word	Decorated letter is repeated in first word	Decorated letter is repeated in first word
41 ^r [F1]	SIG = 2.75 & 3	SIG = 5.5 & 1.25	SIG = 5.5 & 1.25
41 ^v [F2]	page offset: complete page	page offset: complete page	page offset: complete page
42 ^r [F2]	F 2	F 2	'F 3'
43 ^v [F4]	stave 2 offset: 'genti'	stave 2 offset: 'genti'	stave 2 offset: 'genti'
47 ^r [F1]	stave 2 offset: 'gementes...opressa' offset	stave 2 offset: 'gementes...opressa' offset	stave 2 offset: 'gementes...opressa' offset
47 ^v /48 ^r [F1 & F2]	Altus reads 'subsequentis' while other parts read 'tribulantis'	Altus reads 'subsequentis' while other parts read 'tribulantis'	Altus reads 'subsequentis' while other parts read 'tribulantis'
48 ^r [F2]	stave 1 offset: 'domina...eam'	stave 1 offset: 'domina...eam'	stave 1 offset: 'domina...eam'
48 ^r [F2]	stave 3 offset: 'Convertere...tuum'	stave 3 offset: 'Convertere...tuum'	stave 3 offset: 'Convertere...tuum'
48 ^r [F2]	stave 5 offset: 'Jerusalem'	stave 5 offset: 'Jerusalem'	stave 5 offset: 'Jerusalem'
48 ^v /49 ^r [F1 & G1]	Text 'egressus' and 'egressa'	Text 'egressus' and 'egressa'	Text 'egressus' and 'egressa'

The imposition of the Lapidica Lamentations provides an opportunity to examine the working practices of Petrucci's composers. The same music is used for the Hebrew letters 'Beth' and 'He', yet both have been freshly imposed. The possibility existed for the reuse of some of the type since the offset of notes and clefs is identical (compare plate 4.35 with 4.36 and plate

4.37 with 4.38). The composers have set both texts afresh – furthermore, the use of *ligatura binaria* is different since the Altus and Tenor for ‘Beth’ (fol. 45^r, F3) use no *binaria* but the repetition for ‘He’ (fol. 48^r, F2) uses a *binaria* in both Altus and Tenor (see plates 4.35 and 4.36). There is one obvious reason for a lack of *binaria* for ‘Beth’; the compositor had already used the available descending *binaria* sorts in forme F3 (there are six available – three on fol. 43^r, one on fol. 44^v and two on fol. 46^v). The compositor does not appear to have been concerned with the potential of standing type, possibly since most typesetting involved through-composed music and the chances of repetition being in the correct location on a forme were too remote. I have already proposed that formes 1-2 and 3-4 were imposed by two different compositors in 1506/1; there was a slim chance that one compositor might identify the use of standing type but no chance of these descending *binaria* on formes F2 and F3 being used again since they were set by different compositors. Such typographic findings strongly support the notion that musical elements were not treated as standing type.

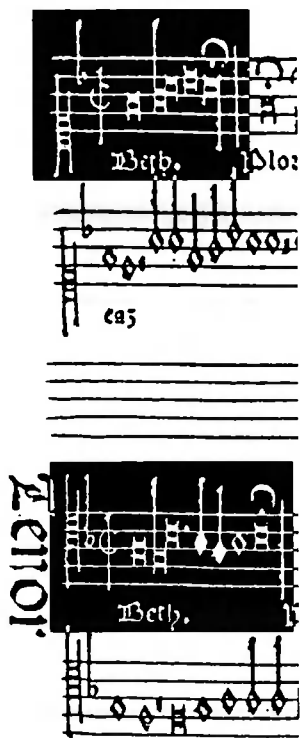
Plate 4.35:⁸⁴ 1506/2, fol. 44^v (Bc)Plate 4.36: 1506/2, fol. 47^v (Bc)

⁸⁴ Plates 4.35 - 4.38 are actual size.

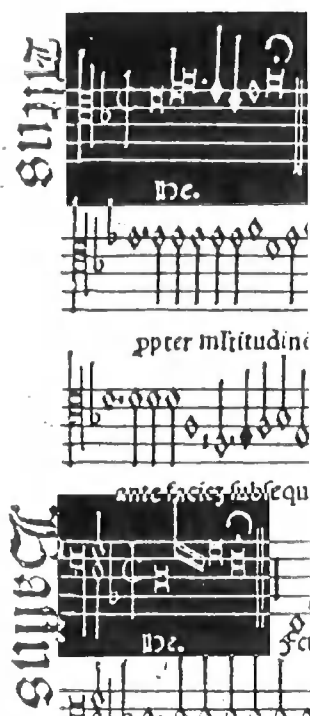
Plate 4.37: 1506/2, fol. 45^r (Bc)Plate 4.38: 1506/2, fol. 48^r (Bc)

4.14 Conclusion

Petrucchi's 1501 'cutting edge' technology, like all such innovations, created problems which were only gradually overcome during the early years of his activity. The transition from multiple to dual impression must have resulted in a significant improvement to both production and quality, reducing errors and the waste of valuable paper. The presence of production flaws in his Lamentations and other prints would suggest that he was under pressure to produce prints, perhaps since he had created such a demand for his products. The high price of his basic product – paper – probably forced him to avoid costly reprints and cancel sheets where possible.

The distribution of paper in extant copies, particularly the alternation of the two watermarks in 1506/2, is consistent with the theory of two independent compositors and supports the printing evidence discussed previously. These watermarks are analogous with other prints of this period although it has not been possible to identify the marks in the standard bibliographical literature. While I have proved that twin watermarks existed, their random distribution

shows the effect of double imposition and suggests that sheets were not imposed systematically on either or both sides.

The physical condition of the extant copies of 1506/1 and 1506/2 tells us little about their manufacture, although we may surmise that they were sold unbound. The apparent name of a priest in the Paris copies, combined with additional liturgical headings in those copies, indicate the interest of the clergy in these prints.

Petrucchi's prints continue a tradition of matrix manufacture from the days of Gutenberg.⁸⁵ The selection of founts employed in 1506/1 and 1506/2 strongly suggests that Petrucchi's success brought its own minor problems and that wear and tear in the printing shop must have been considerable. The resourcefulness of his compositors was stretched to the limit in 1506/1, demonstrated by the mutilation of the sort 'T' as a replacement for 'C' in the imposition of the part name 'Contra'. The replacement of stave-sets towards the end of 1506/1, the poor foliation from gathering F and the juxtaposition of 'r' in the part name 'Tenor' suggest problems with the imposition of this print (the implications of an external deadline will be discussed in chapter 5). The change in the pattern of production in 1506/2 at formes B1-2, caused by the stave-set group repetition, the repeated 'Tenor' part and the break in signature pattern to 'B ii', indicate difficulties in the imposition of this gathering.

It would not be surprising to discover that Petrucchi had workmen of varying standards and ability. Petrucchi had an undoubted desire to maintain his skilled work force in the face of the growing print industry in Venice. While there is no evidence to suggest that he had labour problems, there must have been many printers and publishers willing to entice his workmen since their skills must have enabled them to impose non-musical prints of a technical nature. Such effects would have deprived Petrucchi of their expertise and experience, causing him to recruit new employees for a long and costly apprenticeship. It is quite possible that the compositor responsible for formes 3-4 in 1506/1 did not have

⁸⁵ Boorman, 'Petrucchi at Fossombrone: A Study', pp. 29-30, 38, 61, 63, 101, suggested that the finely detailed founts of Petrucchi's Fossombrone volumes were probably the work of Francesco Griffo, one of the foremost type designers of this period.

the same experience as the person responsible for formes 1-2; could he have been a replacement for an experienced compositor?

The masterful achievement of Petrucci's double impression method cannot be underestimated and his house design and style match that accomplishment. Nevertheless, the existence of several obvious errors in 1506/1 combined with stop-press corrections indicate that Petrucci's compositors must have been under great pressure in April 1506.

Chapter 5

COMMERCIAL VIABILITY AND COMPOSER CHOICE

5.1 Commercial considerations in respect of 1506/1 and 1506/2

There is little information or data relating to the music printing business in the early sixteenth century that might allow serious statistical analysis. The financial risks involved in music publishing during the early years of moveable type were considerable, since expensive equipment and expert staff had to be acquired. Careful consideration of potential material has always been a major factor in the decision to publish; it is not surprising that the Bible was one of the first Western books produced using moveable type considering its potential financial returns. Specialised modern publishing is typified by extreme caution – why would it have been any different in the early sixteenth century when paper was expensive, unestablished production methods resulted in prolonged manufacturing periods, and the recruitment pool was extremely limited? Scholars such as Gustave Reese have suggested that the inclusion of anchor composers, particularly Josquin, reduced the risk to publishers (Georg Forster's famous 1540 recollection testifies to that approach¹). What were the market possibilities for Petrucci's Lamentations, lacking, as they did, any ascriptions to Josquin?² What made Petrucci publish such a series of texts which appear to be relevant only to a very small portion of the liturgical year? I intend to address these issues and to demonstrate that Petrucci gave careful consideration to the commercial viability of these Lamentation prints before making the decision to publish.

One must have been assured of quality in most of Petrucci's collections; the best composers of the mid-Renaissance were represented in his prints. His catalogue was also strengthened by choice of format (choirbook and partbook) and by series (motets, masses, *frottole*, chanson and lute intabulations).

¹ See Gustave Reese, 'Josquin Deprez [Juschino, Josse etc; Prés, Josquin des; Jodocus Pratensis, Jodocus a Prato etc]', sections 1-7, *New Grove Dictionary of Music & Musicians*, 9 (1980), 713-718, (p. 717). German publisher Georg Forster quipped 'I remember a certain eminent man saying that, now that Josquin is dead, he is putting out more works than when he was still alive'. This translation is taken from Edgar H. Sparks, *The Music of Noel Bauldeweyn* (New York: American Musicological Society, 1972), p. 95.

² Josquin's Passiontide music had been published by Petrucci in 1503/1; it is possible that there were no further Passiontide compositions by Josquin available to Petrucci.

Petrucci based his publishing reputation upon these foundations and the quality of his products must have sent a serious message to those with disposable income that these prints were collectable and highly desirable. Sartori revealed how Petrucci's first application for a printing licence in Venice mentioned sale and distribution. The renewal of the licence was made in 1514 by Amadeo Scotto and Nicolò di Raffaele on Petrucci's behalf; it suggested that Petrucci was in partnership with Scotto and di Raffaele from the outset.³ It was common practice for printers and publishers to share financial risk and this partnership was clearly no different. Petrucci's business acumen was clearly focused; the preamble to his first publication, *Odhecaton*, claimed he invented a system of type setting for figural music and included dedicatory material which was commonly found in early printed books. All of his subsequent publications avoided such material; one might speculate that he had decided there was no need for further dedications since he had little competition in his early career and saved expense by omitting unnecessary pages.⁴ Petrucci had invested in a paper mill in his native Fossombrone by 1520, thus reducing, or at least controlling, the considerable risk involved in obtaining his basic material.⁵

Petrucci's early years must have been financially challenging, particularly his attempts to recoup some of his investment in machinery and equipment. The success of *Odhecaton* may partially be measured in terms of its reprints, supporting the notion that it was a viable proposition. Petrucci arguably began his more adventurous phase with the publication of *Motetti B* [1503/1] in 1503. While this print is part of the motet series, its contents are frequently specific to liturgical seasons such as Lent and various devotions. The intervening publication list prior to 1506/1 and 1506/2 follows a more secure path with the developing chanson, single composer Mass books, motet and *frottole* series.⁶ While it might be considered that the publication of such specialised prints was a considerable financial risk, there is some evidence of financial underwriting

³ See Sartori, *Bibliografia*, pp. 15-16 for an account.

⁴ Blackburn, 'Petrucci's Venetian Editor', 17, discussed the second dedicatory letter contained in the *Odhecaton* by Bartolomeo Budrio in which he claimed Petrucci to be the inventor of figural music printing by movable type. Bernstein, *Print Culture*, pp. 73-78, provided further discussion on the possible relationships between printer, publisher and financier.

⁵ See Gialdroni and Ziino, 'New Light', 505-509.

⁶ *Fragmenta missarum* (1505/1) might be considered an exception.

for specialised prints during the sixteenth century – 500 copies of Paolo Ferrarese's *Lamentations* were commissioned for a Venetian monastery in 1565.⁷ What little evidence we possess suggests that printers and publishers took financial risk very seriously – one can assume that Petrucci and his colleagues considered specialised music prints very carefully.

1506/1 and 1506/2 are distinctive due to content and choice of composer; they include texts which are appropriate for a small part of the liturgical year and, for the first time, they feature sacred music by native composers as well as established northerners.⁸ While this list of composers initially appears to be quite disparate, connections may be drawn – Tinctoris, Ycart and Agricola with Naples, de Quadris and Ana with the Veneto and de Orto and Weerbeke with Rome. Tromboncino and Lapicida also appear in previous *frottole* prints by Petrucci.

⁷ Boorman, 'Thoughts on the Popularity', 129-144, challenged previous theories concerning the interpretation of contracts and commissions relating to early printed music. He emphasised the lack of evidence and suggested that we cannot accept a figure of 500 as being the standard for a sixteenth-century music book run. The printing of Ferrarese's *Lamentations* was described by Agee, 'A Venetian Music Printing Contract', 59-65, who discussed details pertaining to the printing of these *Lamentations* by Girolamo Scotto in Venice for the monastery of S. Giorgio Maggiore, Venice, a Cassinese Benedictine congregation. Agee, 'The Venetian Privilege', noted a privilege application by Zuan Battista and Marchio Sessa for *Lamentations* by Paolo Aretino in 1563. Bernstein, *Music Printing*, pp. 116-117 argued the implications of the contract for Aretino's *Lamentations* which was negotiated by the printer and publisher Scotto; Bernstein concluded that he made a handsome 100% profit from this commission.

Georg Rhau produced a volume in 1538 entitled 'Selectae harmoniae quatuor vocum de passione domini'. A mixture of Teutonic and Flemish composers were represented including Walther, Senfl, Matthias Eckel, Compere and Isaac. Compere's substitute Milan Mass was included, with 'Adoramus te Christe' and Isaac's *Lamentations*. A four-part setting of the text 'Popule meus' followed Senfl's 'Tenebrae factae sunt' but Rhau did not include an ascription (Senfl's name appeared again for the piece before 'Tenebrae', namely 'Ingressus Pilatus'). This print demonstrates the viability of producing Passiontide music well after the publication of Petrucci's *Motetti de passione*, *Lamentations* and *laude*. Antonio Gardano printed a set of four-voice *Lamentations* and music for Holy Week by M. Jan in 1551; settings included the canticle 'Benedictus Dominus Deus Israel' (two settings), 'Cum autem venissent ad locum' and 'Sepulto Domino accesserunt pharisei'; see Mary S. Lewis, *Antonio Gardano, Venetian Music Printer, 1538-1569*, Garland Reference Library of the Humanities; vol. 718 (New York; London: Garland, 1997), p. 200, for a bibliographical description. These works were ascribed by Gardano to 'M. Jan', probably Maistre Jhan who was the Duke of Ferrara's choirmaster; see George Nugent and James Haar, 'Maistre Jhan [Jan, Jehan]', *New Grove Dictionary of Music & Musicians*, 16 (2001), 644-645 (p. 644). Further evidence of interest in the publication of *Lamentations* and Holy Week music during the sixteenth-century was provided by Agee, 'The Venetian Privilege', 32-33, who cited the publication and application for privileges by Gardano for *Lamentations* by Kerle, Morales and 'Giovan Nasco' in 1561.

⁸ Brown, 'The Mirror of Man's Salvation', 755-757, argued that devotional texts found in the *Motetti* series may have been used during various votive masses held throughout the liturgical year, rather than being restricted to a specific period. However, the texts in 1506/1 are mainly appropriate for Holy Week.

Bonnie Blackburn has recently discovered an important unpublished Venetian document relating to the performance of polyphony during Holy Week, specifically the *Triduum*.⁹ It suggests that the Augustinians did not normally sing polyphony but specified its use for Matins and during Holy Week. This supports Cattin's discovery relating to the performance of polyphony by the Benedictine Giustinians – his description of several Benedictine polyphonic manuscripts containing Lamentations strongly suggests that the Benedictines were also performing simple polyphony during Holy Week.¹⁰ Such practices were not confined to the monastic orders and in Italian cities such as Florence, choirs were performing figural music during Holy Week; the Florentine guilds were also involved in the commissioning and performance of this repertoire.¹¹ The notion that polyphony was prohibited during Lent and Holy Week is contrary to the evidence provided by these documents.¹² Cattin has suggested that the order of presentation of the *laude* in 1506/1 mirrored their position in the para-liturgical ceremony for the

⁹ I am most grateful to Dr Blackburn for supplying the material below (e mail dated 25 July, 2002). The document comes from the church of S. Salvatore and is in the Archivio di Stato, in the fondo Corp. Rel. Soppr. S. Salvatore, no. 42, which are the acts of the order (in this case Augustinian Canons Regular). The register is dated 1534 but includes acts from earlier chapter meetings. The transcript of the document is as follows:

fol. 341^r. Item precipimus quod cantu figurato non utantur fratres nostri in ecclesijs in celebrationibus Missarum vel divinorum officiorum: nisi ubi iam propter introductam consuetudinem quorundam locorum in matutinis precipue tridui maioris hebdomode [sic] sine periculo scandali dimitti non possent: Et tunc si fieri potest sine comistione secularium vel personarum alterius professionis ubique locorum.

Dr Blackburn noted that there was an almost identical document on fol. 322^r (except with the spelling 'hebdomadae'), but it continues: 'inter se ipsos tantum concinant fratres nostri: similiter etiam devitent privata conventicula occasione huiusmodi cum supradictis personis ubique locorum'.

Dr Blackburn observed the prohibition on lay persons or those of other professions – did this prevent professional singers from performing this music for the Augustinians?

¹⁰ Cattin, 'Tradizione e tendenze', 261-262. Cattin, *Italian Laude*, p. x, described the change in attitude towards the performance of Benedictine Holy Week polyphony which occurred from the mid-fifteenth century onwards. The inclusion of Lamentation X in the early fifteenth-century manuscript Bu 2931, and the two-part *cantus planus* 'Aleph' in the fourteenth-century Ms. VicAC 3 suggest a somewhat earlier acceptance date.

¹¹ See D'Accone, 'The Musical Chapels', 6. Other documents uncovered by D'Accone specified the repertoire of Holy week music in 1540 including 'the Reproaches and other things...'. The reproaches or *Improperia* are the ancient dialogues between Christ and his people beginning with 'Popule meus'. Albert Seay, 'The 15th-Century Cappella at Santa Maria del Fiore in Florence', *Journal of the American Musicological Society*, 11 (1958), 45-55 (p. 54) noted a 1491 payment by Florence cathedral for a composition of polyphonic Lamentations.

¹² Attitudes and practices varied considerably; Manfred F. Bukofzer, *Studies in Medieval and Renaissance Music* (London: J. M. Dent, 1951), p. 120, noted the avoidance of polyphony on Good Friday at the Cistercian abbey of Meaux, Yorkshire, England during the mid-fifteenth century.

'Processio in die Veneris Sancte'.¹³ The importance of these settings with their repetitive and old melodies must have enhanced the saleability of 1506/1 amongst the *laudesi*, clergy and patrons.

Recent debate has produced a number of important arguments relating to Petrucci's intended market. Such discussions have addressed the category of purchaser; Stanley Boorman and John Kmetz suggested that Petrucci was aiming his products at the same purchaser who commissioned manuscripts and that such prints were considered as luxury items; Bonnie Blackburn widened the debate and suggested that amateurs might have been influenced some of Petrucci's musical instructions in making them simpler.¹⁴ While such amateurs may have considered these prints as expensive, I will attempt to argue that 1506/1 and 1506/2 (particularly the former) were aimed at a new category of purchaser, namely the Italian *laudesi*.

Is it likely that individual *laudesi* members would have purchased Petrucci's Lamentations, given their interest in its contents?¹⁵ Textbooks were well within the financial reach of skilled and even semi-skilled Italian artisans from the mid-sixteenth century; the average book cost between one and two *lire* and equalled the approximate daily wage of a skilled artisan.¹⁶ It is accepted that Italian music prints were more expensive than text books but there is little data

¹³ See Cattin, 'Il presbyter Johannes de Quadris', 38-40.

¹⁴ See Boorman, 'Did Petrucci's Concern for Accuracy', 37; Kmetz, 'Petrucci's Alphabet Series', 134-135; Blackburn, 'Canonic Conundrums', 57.

¹⁵ Strohm, *The Rise of European Music*, p. 589, suggested that Petrucci must have had a market for the Lamentation prints but did not expand upon this notion. There is plenty of evidence of collective sponsorship for Holy Week activities by the Italian confraternities; Barbara Wisch, 'The Passion of Christ in the Art, Theater, and Penitential Rituals of the Roman Confraternity of the Gonfalone', in *Crossing the Boundaries: Christian Piety and the Arts in Italian Medieval and Renaissance Confraternities*, ed. K. Eisenbichler (Kalamazoo: Western Michigan University, 1991), 237-262 (pp. 239-240), noted that the Roman confraternity of *raccomandati della Vergine* ['Gonfalone'] spent many *scudi* on Passiontide dramatic presentations [*sacra rappresentazione*] during the fifteenth and sixteenth centuries and commissioned a painting of Christ's Passion in their chapel in Rome which would have been visited many times during the *Triduum*. I have already mentioned the findings of D'Accone and Glixon in relation to the funding of singing during Holy Week.

¹⁶ Brian Pullan, 'Wage-Earners and the Venetian Economy, 1550-1630', in *Crisis and Change in the Venetian Economy in the Sixteenth and Seventeenth Centuries*, ed. Brian Pullan (London: Methuen, 1968), 146-174 (p. 158), noted that the typical master mason or carpenter in the second half of the sixteenth century earned 30-50 *soldi* per day while a semi-skilled worker earned 20-37 *soldi* per day. Paul F. Grendler, *The Roman Inquisition and the Venetian Press, 1540-1605* (Princeton: Princeton University Press, 1977), p. 14, referring to the average price of a *text* book as 1-2 *lire*, concluded that a merchant or professional could afford a library of moderate size. Bernstein, *Music Printing*, p. 117, noted that the average retail price in 1541 for four part books with five gatherings was one *lire* and four *soldi* each, an affordable price for those in higher paid crafts.

available to confirm this. Catherine Weeks Chapman's list of Columbus's prices cites that he paid 105 *quatrines* in Perugia in 1530 for Petrucci's second *Laude* volume of 1508 (*Frottole libro undecimo* cost him 100 *quatrines* at the same time). My approximate calculations (see table 5.01), acknowledging some other possible factors such as inflation, transport, tax and depreciation, reveal that Petrucci's *Laude libro secondo* (1508/3) would have cost an Italian craftsman between one and two days' wages.¹⁷

Table 5.01: Calculations equating Italian wages with book prices

Date	Data	Source
Italy, 1550 onwards	Italian master craftsman earned 30-50 <i>soldi</i> per day	Grendler, <i>The Roman Inquisition</i> , p. 14.
Italy, 1550 onwards	Italian text book cost averaged at 1-2 <i>lire</i>	Grendler, <i>The Roman Inquisition</i> , p. 14.
	20 <i>soldi</i> = 1 <i>lira</i> 124 <i>soldi</i> = 1 <i>ducat</i> ¹⁸	
Perugia (or Spain?), 1530	420 <i>quatrines</i> = 1 <i>ducat</i>	Chapman, 'Printed Collections', 51.
Perugia, 1530	1508/3 (Petrucci) cost Columbus 105 <i>quatrines</i>	Chapman, 'Printed Collections', 51.

If 124 *soldi* = *ducat*, then a quarter of a *ducat* is roughly equal to a day's wage for an artisan. If 420 *quatrines* = *ducat* at Perugia in 1530, then the price of 1508/3 or *Frottole libro undecimo* (105/100 *quatrines*) would have been a day's wage, allowing for inflation, tax and other associated costs.

¹⁷ Drake, 'The First Printed Book', p. 211, observing that the *bourgeoisie* were the essential market for Petrucci's products, commented that some must have been bought by a more discriminating and wealthy public, owing to the high quality and expense of these books, a view shared by Boorman, 'Petrucci at Fossombrone: A Study', p. 286, and others in respect of music prints of this period. Honey Meconi has also expressed caution when assessing the commercial possibilities of early music printing, due to the lack of available data; see Honey Meconi, 'The Naming of Things: Petrucci's Mass Prints and the Commodification of Music', Conference Paper Presented in Venice, October 2001: 'Venezia 1501: Petrucci e la stampa musicale'. While I respect these views, I would like to expand this argument by suggesting that the complete lack of Petrucci's *Frottole* prints extant in modern Italian collections was not simply a result of their popularity and usage. It may also have been due to a new category of purchaser (i.e., the artisan) who did not have the tradition, respect or means to store and keep these books. Dora Thornton, *The Scholar in his Study: Ownership and Experience in Renaissance Italy* (New Haven; London: Yale University Press, 1997), pp. 86-88, outlined the treatise (c. 1480) of Francesco di Giorgio concerning Italian architecture in which he described the need and desire of artisan and merchant for a study. Di Giorgio suggested that there should be a room for paperwork and administration under the house or, if this was not possible, there should at least be a little room ['stanzietta'] in which manual and paper work could be engaged. It may have been in such a space that artisans kept their purchased book collections – hardly ideal if they were expected to create their product in the same space. It is quite likely that these buyers could not afford to bind their music adequately, thus accelerating the deterioration of the material.

¹⁸ This is probably the 'silver' *ducat*; it was valued as 124 *soldi* between 1510-80. See Frederic C. Lane, *Money and Banking in Medieval and Renaissance Venice*, Volume 1 of *Coins and Moneys of Account* (Baltimore; London: The Johns Hopkins University Press, 1985), p. 472.

Drake argued that the presence of motets in printed books (especially those with dedicatory, seasonal and devotional texts) was a sure sign that they were in demand as music for recreational use, whether in court circles or in private homes.¹⁹ The non-Lamentation texts in 1506/1 and, to a lesser extent, in 1506/2, belong to this category; they support the notion that Petrucci struck a careful commercial balance between the Lamentation settings (primarily aimed at institutions) and *laude* and miscellaneous texts (intended for the sizeable private market).

Tess Knighton's analysis of a Spanish bookseller's inventory dating from 1561-63 shows the pricing structure of several Petrucci prints, including the Lamentations.²⁰ She observed that the inclusion of several Petrucci prints in a mid-sixteenth-century Spanish bookseller's inventory may have indicated that there was, or at least had been, a demand for Petrucci prints in Spain, despite the additional costs incurred in importing them. Knighton suggested that the flat pricing structure reflected several factors including the commercial nature of the list, namely a valuation for transfer of contents to another bookseller. These prices may have reflected the poor condition of the books by 1563, since most printed music was sold unbound. Knighton observed that the inclusion of any titles in this data did not necessarily imply that those titles had not sold in Spain; simply that these copies were still remaining in stock by 1563. Table 5.02 shows the Petrucci prints in her findings while table 5.03 shows Chapman's 1968 data; number 14 in Knighton's list is probably 1506/1 and/or 1506/2. This inventory indicates that there was international interest in Petrucci's prints and that Lenten music also interested the Spanish market.²¹

¹⁹ Drake, *Motetti de passione*, p. 4.

²⁰ Knighton, 'Petrucci's Books'. I am most grateful to Dr Knighton for allowing me to use her data.

²¹ Kmetz, 'Petrucci's Alphabet Series', 134, noted the number of German-speaking collectors who owned Petrucci print copies, reminding us that one of the most ancient trade routes from Venice was through the Brenner pass.

Table 5.02: Printer's inventory from Spain

Source: Knighton, 'Petrucci's books'; *Spanish bookseller's inventory from 1561-63*²²

No	Entry	RISM	Composer	Title and publication	Value	Comments
14	1 llamentaciones Geremie a 4 veus venetie 5s	1506/1 & ?1506/2		1506/1 (& 1506/2?)	5s	Not in 1563. Or possibly the edition of <i>Lamentationes Hieremie</i> (Venice: Antonio Gardano, 1551). ²³
15	3 musica algebi 40 Paris 8s			Paris	2s 8d	1563: '3 Musica algebri 8s'.
16	1 madrigali de arioci de aut a 4 veus venetie 6s	?1557/17		<i>Madregali ariosi a quatro voci</i> (Venice: Gardano, 1557)	6s	1563: '1 Madrigali de ariosi 4to 5s'. Possibly one of later editions: 1558/12 or 1559/18.
17	1 misçe alexandri agricole 5s	A431	Agricola	<i>Misse</i> (Venice: Petrucci, 1504)	5s	Not in 1563.
18	1 misçe petri dela rue 5s	L718	La Rue	<i>Misse</i> (Venice: Petrucci, 1503)	5s	Not in 1563.
19	1 misçe de orto 5s	O137	de Orto	<i>Misse</i> (Venice: Petrucci, 1505)	5s	Not in 1563.
20	1 misçarum diversarum auctorum 5s	1509/1		<i>Missarum diversorum auctorum liber primus</i> (Venice: Petrucci, 1509)	5s	Not in 1563.
21	1 misçarum joannis monton [sic] 5s	M4015	Mouton	<i>Missarum liber primus</i> (Fossombrone: Petrucci, 1515)	5s	1563: '1 misas de monton [sic] 4s'.
24	1 fragmenta missarum 8s	1505/1		<i>Fragmenta missarum</i> (Venice: Petrucci, 1505)	8s	Not in 1563.

²² Knighton mentioned that the Spanish 1561-63 prices were cited in 'suos'; this may not be the same unit as the 'sueldos'. She will address these issues in her forthcoming paper.

²³ Lewis lists the Gardano Lamentations as no. 155 in her catalogue; see *Antonio Gardano*, p. 200.

Table 5.03: Music print inventory from Spain

Source: Chapman, 'Printed collections'; Columbus's Petrucci purchases from Italy

No	Entry	RISM	Composer	Title and publication	Value	Place of purchase
		1502/1		<i>Motetti A</i>	247 quatrines	Rome, Feb. 1513.
				<i>Magnificat I</i> ²⁴	81.4 quatrines (= 26 sueldos)	Venice, July 1521.
		1508/3		<i>Laude libro secondo</i>	105 quatrines	Perugia, Sept. 1530.
				<i>Frottole libro undecimo</i>	100 quatrines	Perugia, Sept. 1530.
18	Liber primus no. 12. 4989. V. 1506. 4b	1506/1		1506/1	-	
19	Lamentationum liber secundus tromboncini gasparis et erasmi. 4980. V. 1506 4	1506/2		1506/2	-	

The enthusiasm for, and importance of, the Holy Week repertoire in Naples, Venice and other Italian cultural centres is likely to have enhanced the attractiveness of these prints to prospective purchasers. Lewis Lockwood revealed further evidence of interest in this repertoire by describing Ercole I d'Este's elaborate Holy Week ceremonies at Ferrara; it is possible that the 'oratione et prophetie' sung at the Ferrara court in the late fifteenth century, described by Ercole's chronicler Sabadino degli Ariente, may have included settings subsequently published in 1506/1 and 1506/2 or other prayer settings in Petrucci's repertoire.²⁵ Conversely, it might be argued that what little

²⁴ No copies extant.

²⁵ See Lewis Lockwood, *Music in Renaissance Ferrara 1400-1505* (Oxford: Clarendon Press, 1984), p. 286, whose source is Werner L. Gundersheimer, *Art and Life at the Court of Ercole I d'Este: The "De triumphis religionis" of Sabadino degli Ariente* (Geneva: Librairie Droz, 1972), p. 91. I am most grateful to Bonnie Blackburn for this reference. Sabadino's description, which Gundersheimer, 'Art and Life', p. 90, dated as c. 1497, is thus:

'In questo mezo che tanto sacramento è portato et reposto nel'ornato sepulcro, li cantori, con solemne voce, oratione et prophetie non cessano de cantare.' I would suggest that the 'solemn voice' may refer to the devotional style identified by Blackburn, 'The Dispute about Harmony', 28, and discussed in chapter 3.2 of this thesis. Later in his description of Holy Week, Sabadino mentions that a skilled priest would sing 'Evangelii et Prophetie' while the poor dined at Ercole's table in his absence; these 'Gospels and Prophecies' could well have included the Lamentations of Jeremiah since no other Prophet is prescribed for Holy Week. The complete extract is: 'Et aciò che ali poveri civi dela tua mensa per la absentia de ti a loro levassi vergogna, perche più arditamente desinare potesseno, facendoli ad reverentia de Ihesu Christo ad tua voluntate Evangelii et Prophetie sempre cantare ad uno parato

bibliographical evidence remains suggests that 1506/1 and 1506/2 had limited appeal. The extant editions originated from the same press run and were not reprints; the later sixteenth-century date of the aforementioned Spanish documents discussed by Knighton might suggest that this was stock which had remained unsold for some considerable time after publication.²⁶

A comparison may be made with the extant copies of 1503/1 of which there are three; there is also a listing in the catalogue of the Biblioteca Colombina.²⁷ While the small sample rate may affect deductions, a tentative comparison may be made between the number of extant copies of 1503/1, 1506/1 and 1506/2 and the *frottole* copies. Although no figures survive that relate to the *frottole* print run, they must have been extremely popular amongst the Italian *bourgeoisie*. Only one or two from each edition have survived, suggesting that they were used throughout the year (except perhaps during Lent) and consequently deteriorated quite rapidly. 1503/1, 1506/1 and 1506/2, with their restricted liturgical relevance, were not so intensively used and survived in proportionally greater numbers. We cannot conclude that they were a financial failure; on the contrary, the evidence suggests that Petrucci had calculated his intended market and produced a smaller print run than that for his mainstream publications.

I would suggest that 1503/1 must have been regarded as an inspiration or even prototype for 1506/1 and 1506/2, considering its elaborate title and Lenten texts (it includes a setting of 'Adoramus te Christe', being the second text of Compere's *Officium de cruce*). Warren Drake noted that the title of 1503/1 is the only print to specifically indicate subject matter; its contents include a version of the Good Friday text 'Tenebrae factae sunt' by Weerbeke.²⁸ 1503/1 contains 'Lauda Syon', another text closely associated with the ceremonies of the

sacerdote.' (Gundersheimer, *Art and Life*, p. 92). I am most grateful to Dr Blackburn for this translation: 'And in order to remove any sense of shame from the poor citizens at your table because of your absence, and so they will be able to dine the more eagerly, provide for them willingly for the sake of Christ a skilled priest who will continually sing [texts from the] Gospels and prophets.'

²⁶ Part of the binding material for a print of Thomas Aquinas's *Summae divi Thomae*, Bergomi, 1589, now held by the Biblioteca Ovidia, Sulmona, Italy, is a partial page from an unidentified Lamentation print [shelfmark: CSST8]. This may support the notion that the shelf-life of sixteenth-century Lamentations was somewhat limited.

²⁷ See Chapman, 'Printed Collections', 59. Columbus's library also included the 1506 Lamentations; *Ibid.*, 61.

²⁸ Drake, *Motetti de passione*, p. 5.

Laudesi. The inclusion of Latin *laude* in 1506/1 suggests that Petrucci took this opportunity to test the market for the two dedicated *laude* volumes of 1508.

5.2 Commercial influences affecting the production of 1506/1 and 1506/2

Only three prints from Petrucci's Venetian output contain material relating to a specific period of the liturgical year. These are 1503/1, 1506/1 and 1506/2. While 1503/1 contains texts suitable for Passiontide and for other ceremonies during the liturgical year such as the Invention of the Holy Cross on 3 May, most of the works in the two Lamentation volumes appear to be confined to Holy Week, which is determined each year by the date of Easter Sunday. The publication dates of 1506/1 and 1506/2 are of particular interest and it is my intention to discuss their relevance and context, particularly in respect of 1506/1. I will also address some bibliographical issues and try to determine whether work on printing 1506/2 began only after the completion of 1506/1, or was undertaken simultaneously with it.

Customs and work practices in Renaissance Venice, as in any other Christian city, were strongly influenced by church and state. Although Venice had important status as a great commercial hub and as a centre for cultural pursuits, the church's influence was particularly noticeable during the season of Lent. Stanley Boorman discussed various external effects upon Petrucci's production processes, notably 'the inevitable holidays for the craftsmen'.²⁹ In the same article, Boorman provided a table illustrating elapsed days between prints from 1503 and 1504 and commented that 'Easter fell within the period of preparation for *Motetti B*, and Christmas within that for *Canti C*; it may be relevant to note that *Misse Obrecht* is dated the day before the Feast of the Annunciation, and *Misse Petri de la Rue* the day before All Saints'.³⁰ The date printed by Petrucci in 1506/1 is 8 April 1506, which was Wednesday of Holy

²⁹ Boorman, 'A Case of Work and Turn', 301-321.

³⁰ *Ibid.*, 316.

Week that year, known as 'Spy' Wednesday. 1506/2 was published as late as 29 May 1506, some 51 days after 1506/1.

The interpretation of publication dates is central to my argument, although little is known about their significance. No register of Renaissance printers has been discovered which might correlate with these dates, which are included in the colophon at the rear of each publication. The date in 1506/1 appears on fol. 50^r, which belongs to forme F2 and was probably one of the last formes printed.³¹ Folio 51^v of 1506/2 contains Petrucci's colophon and is found in the final forme G2. It is difficult to know whether the date represents termination of work or is an accountable or taxable date; nevertheless it indicates an approximate period for the final imposition of a publication.³²

There might have been both commercial and religious reasons for Petrucci's Spy Wednesday publication of 1506/1. Although Venice was an important trading post for both goods and travellers, business activities would probably have been suspended by Spy Wednesday due to religious prohibitions during the *Triduum*. Petrucci would probably have had no composers available after Spy Wednesday (he would not, in any event, have wished to offend the church by working during this period, not least since his principal editorial advisor was a cleric as Bonnie Blackburn has suggested³³). Some or all of Petrucci's craftsmen would also have been confraternity members and Holy Week was the busiest time of the year for these organisations; we know that the earliest Venetian printers were recorded as members of the fifteenth-century *Scuola di San Girolamo*.³⁴ Ironically, the non-Lamentation texts found towards the end of 1506/1 would have featured prominently in the liturgical and para-

³¹ I am grateful to John W. Briggs for his suggestion that the placement of a date might be congruent with the imposition of the final gathering of a volume.

³² Stanley Boorman has suggested privately that it may indicate termination of work on a print.

³³ See Blackburn, 'Petrucci's Venetian Editor', 18-41.

³⁴ John of Speyer and Nicolas Jensen belonged to this *Scuola* before the establishment of a dedicated printer's guild in the sixteenth century; the *Scuola di San Girolamo* included other craftsmen such as painters, stonemasons, glassblowers and engravers, who had no dedicated guild. The *raison-d'être* of these guilds was to represent their members in professional situations, and their devotional and charitable works would have been secondary to this. See Frederic C. Lane, *Venice: A Maritime Republic* (Baltimore; London: John Hopkins Memorial Press, 1973), p. 318, whose source is Emmanuele A. Cigogna, ed., *Delle iscrizioni veneziane* (Venice: Presso Giuseppe Orlandelli, 1824-53), VI, 954-955.

liturgical ceremonies of the various *Scuole* and confraternities during Holy Week.

There is a possibility that the production of 1506/1 was interrupted by factors outside Petrucci's control, delaying its completion and causing the postponement of 1506/2. Venice was an island and depended on the sea for supplies; commerce was therefore affected during periods of bad weather. Additionally, flooding was a problem, particularly in November and during the spring tides; such occurrences would disrupt supply and production, affecting trade and commerce in the city. Spring flooding would have particularly affected the production of 1506/1; while I have not been able to find direct evidence relating to flood disruption during the winter of 1505-1506, I have found evidence of plague which would have been equally disruptive to Venetian commerce.³⁵

Would it have been possible for Petrucci to produce 1506/2 from scratch, following the release of 1506/1 only 51 days before? I believe that this is very unlikely, and my initial findings support the argument that 1506/2 was planned simultaneously, rather than being inspired by the success of 1506/1. The

³⁵ I have checked the diaries of Marino Sanuto for this period but there is no suggestion of Venetian flood disruption; see F. Visentini, ed., *I diarii di Marino Sanuto*, 58 vols. (Venice 1879-1903, reprinted Bologna: Forni Editore, 1969-1970), vi. The Venetian ambassador to the court of Philip the Fair, Vincenzo Querini, was accompanying Philip and Joanna on their epic voyage from Bruges to Spain during the winter of 1505 (and the entourage included Agricola and de Orto). Querini described the events in detail to the Venetian Signoria, describing how their intended journey had to be abandoned due to storms, and they had to seek refuge from the weather in England having lost several craft. They landed on 23 January 1506, and eventually left after a considerable delay on 23 April 1506 after several attempts; Querini, on 6 April 1506, wrote 'since the King's arrival at Falmouth, the weather has never served for departure'; see R. Brown, G. Cavendish-Bentinck, H. F. Brown, A. B. Hinds and others, eds., *Calendar of State Papers and Manuscripts, Relating to English Affairs, Existing in the Archives and Collections of Venice, and in Other Libraries of Northern Italy. 1202-[1674]*, 38 vols. (London, 1864-1947; reprinted Nendeln/Liechtenstein, Kraus Reprints: 1969-1970), 1, 319. While I would not suggest that the severe weather during 1505-06 affecting Philip's voyage in the English channel and the Atlantic had any influence upon Venice and the Adriatic, it is ironic that weather conditions may have affected the journey of Agricola and de Orto and simultaneously delayed the publication of their latest printed music in the 1506 Lamentations.

However, there is more solid evidence for potential disruption to commerce in Venice during this period; on 7 November 1505, Sanuto's diary mentions that the effects of plague were beginning to cease in nearby Padua (Visentini, *I diarii di Marino Sanuto*, vi, 253). Venice would undoubtedly have taken measures to prevent plague from spreading, particularly since Padua was a dependency of the republic. The plague cited by Sanuto was the deadly petechial fever and had ravaged Italy throughout 1505 and visited again in 1506 (George M. Gould and Walter L. Pyle, *Anomalies and Curiosities of Medicine: Being an Encyclopedic Collection of Rare and Extraordinary Cases, and of the Most Striking Instances of Abnormality in All Branches of Medicine and Surgery, Derived from an Exhaustive Research of Medical Literature from its Origin to the Present Day, Abstracted, Classified, Annotated, and Indexed by George M. Gould and Walter L. Pyle* (Philadelphia: W. B. Saunders, 1897), p. 916).

market possibilities for the second volume might have been severely weakened had the first not been produced before or during Holy Week. It is highly unlikely that 1506/1 and 1506/2 were intended to be published on the same day, considering that no other volumes in a Petrucci series share the same publication date. Furthermore, Petrucci would not have been able to afford the luxury of storing completed prints for simultaneous release, since he undoubtedly wished to get a financial return on his publications as soon as they were ready. The closest publication dates belonging to a series are the first two volumes of Spinacino's lute intabulations (1507/5 and 1507/6), which contain the dates 3 March 1507 and 31 March 1507 respectively, almost a full month apart; the second of Spinacino's intabulations is the only other Petrucci print published on 'Spy' Wednesday (perhaps a further example of a desire in Petrucci's workshop to complete work before the holiday period). Another factor negating the argument that Petrucci produced 1506/2 from scratch after Spy Wednesday 1506 was that the holiday period following Easter Sunday would have reduced the time available for preparation. I have already discussed some of the typographical evidence which relates to this argument in chapter 4; the most significant evidence is that the signature patterns in 1506/1 and 1506/2 were deliberately different in order to avoid confusion during simultaneous imposition.

Boorman suggested that Petrucci was producing about three printed sheets per week during the period 1503-04.³⁶ Since Petrucci's output was not much greater in 1506, it is probable that he was still producing about the same number of sheets per week then as in 1503-04. It would have been impossible for 1506/2 to have been produced from scratch, assuming that the earliest start date was Tuesday of Easter week (14 April 1506) and that six and a half weeks would have been required to complete the 15-sheet 1506/2. I have already described the introduction of new stave-set groups from the final gatherings of 1506/1 (see chapter 4). Furthermore, I suggested that there is sufficient evidence supporting the notion of two composers – one being more efficient than the other. It is quite possible that the efficient composer concluded his

³⁶ Boorman, 'A Case of Work and Turn', 316.

allocated formes for 1506/1 and was responsible for the introduction of the new stave-set groups in 1506/2. This is congruent with the idea that the imposition of 1506/2 overlapped with 1506/1; the less efficient compositor would still have been completing his work on 1506/1.

No other prints were produced between the Lamentation books 1506/1 and 1506/2, suggesting that completion of the series was a priority for Petrucci.³⁷ Only the lute intabulations and Lamentations display this consistency: the publication patterns of all other Petrucci series are broken by intervening prints. I would tentatively conclude that there is sufficient evidence to suggest that 1506/1 and 1506/2 were planned and executed simultaneously.³⁸

Table 5.04 illustrates Petrucci's Venetian and early Fossombrone editions, and shows their publication dates relative to Ash Wednesday (the symbolic start of Lent and the day following Carnevale), Spy Wednesday and Easter Sunday.³⁹ Some striking patterns are apparent, particularly in the lack of secular publication dates during Lent, with two major exceptions which I shall discuss shortly. The publication of *Frottole libro primo* and *Frottole libro secondo* centres on winter/spring of 1504-05, and is followed by a similar pattern in the following year's winter/spring, with *Frottole libro quinto* and *Frottole libro sexto* published well before Lent. This pattern suggests that the publication of *frottole* during Lent was avoided: the release of secular texts must have seemed inappropriate. The first of the two exceptions to this pattern is the publication of *Frottole libro tertio* (1505/4) on 6 February, 1505, the day following Ash Wednesday. The proximity of the publication date of this third book to *Frottole libro secondo*, which appeared just 29 days previously on 8 January 1504/1505,

³⁷ Stanley Boorman's 'Petrucci in the Light of Recent Research', Conference Paper Presented in Venice, October 2001: 'Venezia 1501: Petrucci e la stampa musicale', included his latest findings relating to Petrucci's reprints and cancel sheets. His data shows no new work between the two Lamentation prints; I am grateful to Professor Boorman for allowing me to use his unpublished findings. His findings will be published in *Ottaviano Petrucci, Catalogue Raisonné* (New York: Oxford University Press, forthcoming).

³⁸ It might be argued that Petrucci was not concerned with the relevance of these volumes to the liturgical season. The publication date of 1503/1 is 10 May 1503, almost a month following the end of Lent that year. A few of the texts in 1503 are also suitable for the invention of the Holy Cross on 3 May, so Petrucci missed this particular target by seven days.

³⁹ The vertical line in the left-hand margin of the table indicates the Lenten period for each year.

may have been a factor.⁴⁰ The other exception is Bossinensis's first book of lute intabulations (1509/3), dated 27 March 1509, some five weeks into Lent that year and one of Petrucci's final Venetian productions before his eventual move to Fossombrone.⁴¹ I cannot say whether his impending move from Venice, as well as the effects of the Italian wars during this period, influenced his decision to publish this volume at this time. It is worth noting that the second volume in this lute series was not published until after Petrucci's move to Fossombrone. My data reveals that no Petrucci print contains a publication date between Holy Thursday and Easter Sunday from 1501-1515 with one exception; Holy Saturday (22 March) 1505 for de Orto's Masses.

Table 5.04: Petrucci's Venetian and earlier Fossombrone publications within the context of Ash Wednesday, 'Spy' Wednesday and Easter

<i>Print/publication date</i>	<i>Title</i> ⁴²
15 May 1501 (?) ⁴³	Harmonice musices odhecaton
5 February 1501/1502	Canti B
Ash Wednesday, 9 February 1502	
Easter Sunday, 27 March 1502	
9 May 1502	Motetti. A. numero trentatre
27 September 1502	Misse Josquin
14 January 1502/1503	Harmonice musices odhecaton
Ash Wednesday, 1 March 1503	
24 March 1503	Misse Obrecht
Easter Sunday, 16 April 1503	
10 May 1503	Motetti de passione de cruce de sacramento [Motetti B]
17 June 1503	Brumel
15 July 1503	Joannes Ghiselin
4 August 1503	Canti B
31 October 1503	Misse Petri de la Rue
10 February 1503/1504	Canti C
Ash Wednesday, 20 February 1504	
23 March 1504	Misse Alexandri Agricole
'Spy' Wednesday, 3 April 1504	
Easter Sunday, 7 April 1504	

⁴⁰ The Venetian year officially began on 1 March (*more veneto*); therefore dates printed between 1 January and 28 February belonged to the previous calendar year.

⁴¹ These lute intabulations are sometimes accompanied by text underlay with remaining strophes printed underneath. The texts are amorous but not overtly crude or vulgar.

⁴² Untexted publications or those containing secular texts appear in bold.

⁴³ See Blackburn, 'Lorenzo de' Medici', 34n, for a discussion regarding the possibility that the intended publication date was 14 June 1501. Fallows, 'Petrucci's *Canti* Volumes', 41, argued that the dedicatory material was written at the start of production and therefore it might have been published as late as November 1501.

<i>Print/publication date</i>	<i>Title</i>
25 May 1504	Harmonice musices odhecaton
15 September 1504	Motetti C
28 November 1504	Frottole libro primo
8 January 1504/1505	Frottole libro secondo
6 February 1504/1505	Frottole libro tertio
Ash Wednesday, 5 February 1505	
22 March 1505	Misse de Orto
Easter Sunday, 23 March 1505	
4 June 1505	Motetti libro quarto
30 June 1505	Missarum Josquin. Liber secundus
[August 1505] ⁴⁴	Strambotti, ode, frottole...libro quarto
31 October 1505	Fragmenta missarum
23 December 1505	Frottole libro quinto
5 February 1505/1506	Frottole libro sexto
Ash Wednesday, 25 February 1506	
8 April 1506	Lamentationum Jeremie Prophete liber primus
'Spy' Wednesday, 8 April 1506	
29 May 1506	Lamentationum liber secundus
20 October 1506	Misse Henrici Jzac
7 January 1506/1507	Misse Gaspar
Ash Wednesday, 17 February 1507	
1 March 1507	Intabulatura de lauto libro primo
31 March 1507	Intabulatura de lauto libro secondo
'Spy' Wednesday, 31 March 1507	
Easter Sunday, 4 April 1507	
21 May 1507	Frottole libro octavo
6 June 1507	Frottole libro septimo
31 July 1507	Strambotti, ode, frottole...libro quarto
26 November 1507	Frottole libro tertio
1507	Hymnorum Lib. primus. Io Martini
1507	Magnificat liber primus
11 January 1507/1508	Laude. libro secondo
29 January 1507/1508	Frottole libro secondo
Ash Wednesday, 8 March 1508	
15 March 1508	Missarum diversorum auctorum liber primus
Easter Sunday, 23 April 1508	
20 June 1508	Libro III di intabolatura de lauto
7 July 1508	Laude libro primo. In. Dammonis
31 December 1508	Intabolatura de lauto libro quarto
1508	Motetti a cinque libro primo
22 January 1508/1509	Frottole libro nono
Ash Wednesday, 21 February 1509	
27 March 1509	Tenori e contrabassi intabulati col sopran...libro primo. Francisci Bossinensis opus
Easter Sunday, 8 April 1509	

⁴⁴ Stanley Boorman's unpublished list included in 'Petrucci in the Light' suggested this new publication period for *Strambotti, ode, frottole...libro quarto* (Venice: Ottaviano Petrucci, 1505/5); I am most grateful to Professor Boorman for allowing me to include this information.

<i>Print/publication date</i>	<i>Title</i>
10 May 1511	Tenori e contrabassi intabulati col sopran... libro secundo. Francisci Bossinensis opus
1512	(Frottole. libro decimo)
1 March 1514	Missarum Josquin liber tertius
Ash Wednesday, 1 March 1514	
Easter Sunday, 16 April 1514	
17 August 1514	Motetti de la corona. Libro primo
20 October 1514	Frottole libro undecimo
Easter Sunday, 8 April 1515	
11 April 1515 ⁴⁵	Missa Josquin liber secundus

5.3 Composer choice and influence

Petrucci provided ascriptions for 13 settings in 1506/1 and 1506/2; was there any commercial influence in the inclusion of these names? Of the nine composers named, only Bernardus Ycart and Johannes de Quadris had not been previously included in Petrucci publications, although both were represented in contemporary manuscripts. Ycart's recruitment to the Naples court must have been influenced by his Catalan origins since Ferrante's court musicians were more often Spanish than Italian.⁴⁶ Ycart's arrival at Naples pre-dates the compilation of the court manuscript MonteA 871;⁴⁷ other musicians employed there included Tinctoris and probably Agricola, both of whom are represented in 1506/1.⁴⁸ Agricola and de Orto present another possible Spanish connection with the 1506 Lamentations. At the time of publication, they were in the employment of Philip the Fair and had travelled to Spain for the negotiations between Philip and Ferdinand in the same year. The inclusion of a Spanish *cantus firmus* in de Orto's Lamentations may have some association with his visit to Spain (the music is discussed in chapter 4).

⁴⁵ My list stops here since the Fossombrone publications are primarily sacred and none bear the months January - April in their colophons.

⁴⁶ Atlas, *Music at the Aragonese Court*, p. 78.

⁴⁷ *Ibid.*, p. 79.

⁴⁸ See Atlas and Cummings, 'Agricola, Ghiselin', 540-548, for a discussion concerning Agricola's involvement with the court at Naples.

Gaspar van Weerbeke had also worked for Philip the Fair from 1495 to 1497 but had returned to the Papal Chapel by 1500.⁴⁹

The importance of the manuscript CapePL 3.b.12 has been mentioned (and will be discussed in more detail in section 5.4); this manuscript supports the notion that there was an interest in the *frottola* style in Italy amongst the clergy. This style is represented by three composers in 1506/1 and 1506/2; Francesco Ana, Bartolomeo Tromboncino and Erasmus Lapidida. Little is known about 'F.V.', believed to be Francesco Ana, second organist at S. Mark's, Venice in the 1490s; he had previously been organist at S. Leonardo in the same city.⁵⁰ He was probably born in Venice and therefore may have been known to Petrucci, who featured 'F.V.' in several *frottole* prints. Having only used the identity 'F.V.' in the earlier *frottole* prints, Petrucci qualified him in 1509 as 'Francesco Varoter' [furrier].⁵¹

Primarily a frottolist, Ana is represented, along with Brocco and Cara, in the earliest extant *frottola* manuscript, ModE F.9.9, written in Padua in the 1490s.⁵² Petrucci included his works in several volumes of *frottole* including *Frottole libro secondo* (1504); *Frottole libro tertio* (1504); *Strambotti, ode, frottole...libro quarto* (1505) [where he is ascribed as 'F.V.'] and *Frottole libro septimo* (1507). It is also significant that 'Passio sacra' is Ana's only extant printed sacred work; it represents the newer Italian polyphonic tradition. Ana (like de Orto) must have been born about 1460.⁵³

There are relatively few sacred compositions by Tromboncino – the majority of his extant repertoire is secular. His sacred works exist in a limited number of sources as well as in CapePL 3.b.12 and 1506/2; Prizer noted that other sources include ParisBNC 676 [dated 1502], some Petrucci *frottole contrafacta* dating from 1504 and 1505, FlorBN Panc. 27 [c. 1500], BergBC

⁴⁹ Gerhard Croll and A. Lindmayr-Brandl, 'Weerbeke [Werbeke, Werbeck], Gaspar [Jaspar, Gaspard] van', *New Grove Dictionary of Music & Musicians*, 27 (2001), 207-210 (p. 207).

⁵⁰ See William F. Prizer, 'Ana [Anna], Francesco d' [Franciscus Venetus; Francesco Varoter, etc]', *New Grove Dictionary of Music & Musicians*, 2nd edition, 1 (2001), 524.

⁵¹ Bossinensis: *Intabulatura I* (Venice: Ottaviano Petrucci, 1509/3). Albert Einstein, *The Italian Madrigal*, 3 vols. (Princeton, N. J.: Princeton University Press, 1949) I, 230, noted that Lapidida wrote a combinative frottola on Tromboncino's 'La pietà chiuso' and M. Cara's 'Pietà, cara signore'.

⁵² Strohm, *The Rise of European Music*, p. 583.

⁵³ Prizer, 'Ana [Anna], Francesco d' ', 339.

1208 [c. 1520s] and Bologna Q18 [c. 1502-06].⁵⁴ Tromboncino underwent some serious turmoil in his personal life towards the end of the century, culminating in him murdering his wife in July 1499 in Mantua. Although he was pardoned for these offences, he apparently fled Mantua in 1501 for Ferrara. Is it possible that his Lamentations were composed as an act of repentance?

Little is known about the identity of Erasmus Lapidida; it has been suggested that he was born in Trent, Venice or the Netherlands c. 1440-45 and died in Vienna in 1547 at the age of about 100.⁵⁵ Weiss suggested that he may have had contact with northern composers working in Italy since his style shows associated techniques such as imitation, stretti and 'systematised tenor patterns'.⁵⁶ He is represented in Petrucci's collections by a few motets, a *frottola* and the Lamentations. The ascription in 1506/2 simply refers to 'Erasmus', both in the title page and in the header at the beginning of his Lamentations. Other ascriptions by Petrucci resembling this name may be found in *Canti C* (1504/1503) as 'Lapicide', *Motetti libro quarto* (1505) as 'Erasmus Lapicide' and *Frottole libro nono* (1509/1508) as 'Rasmo'. Since no other ascribed composer bears the name 'Erasmus', it has been assumed that these ascriptions refer to the same person (although Michele Calella raised doubts as I mentioned in chapter 1.6).⁵⁷ There was a Venetian printer with the same name – Franciscus Lapidida printed Johannes Baptista Abiosus's astronomical book, *Dialogus in astrologiae defensionem cum vaticinio...* in 1494;⁵⁸ however, there is no evidence to suggest that he was in any way related to the composer due to the Latinisation of names during the period.

⁵⁴ William F. Prizer, 'Tromboncino [Trombonzin, Trombecin, etc], Bartolomeo', *New Grove Dictionary of Music & Musicians*, 2nd edition, 25 (2001), 758-762 (pp. 760-761).

⁵⁵ Wessely, 'Lapidida, Erasmus', 465, summarised contemporary evidence for this claim, based upon an statement in Johann Rasch's *Schottencloster...Stiftung und Prelaten...zu Wienn* (1586). Vernarecci, *Ottaviano de' Petrucci*, p. 101, included the name of Lapidida in the list of non-Italians published by Petrucci.

⁵⁶ Weiss, 'Lapidida [Steinschneider], Erasmus [Rasmo]', 267.

⁵⁷ See Weiss, 'Lapidida [Steinschneider], Erasmus [Rasmo]', 267; Calella, 'Lapidida, Lapicide, Erasmus, Rasmo', 1203.

⁵⁸ The wording of the relevant part of the colophon reads thus: '...Et Impressum Venetijs Die.20.octobris || 1494.Per Magistrum Franciscum Lapididam in contrata [sic] Sancte Lucia.' Bonnie Blackburn has indicated privately that 'contrada' indicates a section of a city, except that the Venetian term was 'sestiere', 6th. I have not been able to discover any relationship with S. Lucia, Venice; this is the only extant publication by the printer Lapidida.

In conclusion, Petrucci's mainstream products were more obviously saleable than 1506/1 and 1506/2 (the former being the prototype for the 1508 *Laude* series). The inclusion of composers such as Agricola, combined with the importance of the Holy Week repertoire, would have offset the lack of works by Josquin. It might be argued that the inclusion of the *laude* in 1506/1 has been justified by their survival in numerous manuscript sources and, as I have shown, probably reduced the financial risk of publishing such specialised and restrictive material as the Lamentation settings themselves.⁵⁹ Almost all of the manuscript concordances of the 1506/1 *laude* pre-date 1506 and several were directly associated with the *laudesi*. The strong association of the *laude* texts in 1506/1 with the Italian *laudesi* would have proved a major selling point to Petrucci, who probably belonged to one or more of the Venetian *Scuole*. Individual members of the *laudesi* would probably have been able to afford these volumes, supplementing Petrucci's presumed subscription list of priests, patrons, bibliophiles and book resellers. 1506/1 also provided a unique opportunity for enthusiasts of more ancient music to possess the Lamentations of de Quadris. The instinctive attraction to musicologists of the northern Lamentation settings needs to be balanced by the inherent but understated value of native polyphony, particularly the *laude* in 1506/1. The two Lamentation prints contain music that would have been popular in sixteenth-century Italy, particularly amongst the emerging *bourgeoisie*. James Haar's recent discovery of Petrucci's name amongst the most eminent citizens of Venice is testament to the vision of music's first publishing entrepreneur.⁶⁰

Lerner suggested that the inclusion of the Lamentations of Anon. 1 indicated that Petrucci was using works already available to him, and added that Petrucci would surely have ascribed these Lamentations had they been commissioned.⁶¹ This may well be true although we cannot discount the possibility that Anon. 1, like Lamentation X, belonged to a continuing monastic

⁵⁹ The *laude* in 1506/1 and the Lamentations of de Quadris are the only two-part works in Petrucci's sacred prints, reinforcing their historical importance (in contemporary terms) and justifying their inclusion in his catalogue.

⁶⁰ Haar, 'Petrucci as Bookman'.

⁶¹ Lerner, 'The Sacred Music of Alexander Agricola', p. 48. He also added that Petrucci must have been 'obliged to publish the settings of such minor composers as Ycart, Tromboncino, and de Quadris' (p. 46).

tradition which thrived on anonymous dissemination and embellishment but was founded in an unornate and functional Lamentation style. In these respects it matches the compositions of other Lamentations in the 1506 prints.

5.4 Conclusion

There is ample evidence to suggest that there was a viable market for Passiontide music, long after the publication of 1506/1 and 1506/2. There had been little or no restriction in the setting of polyphonic Lamentations and Passiontide music and the burgeoning Italian confraternities provided an outlet for such publications. Although the Latin *laude* were a small proportion of the overall *laude* market, the inclusion of 'Cum autem venissem' in a variety of manuscript and post-1506 print sources shows that they continued to be marketable.

We still lack much evidence about Petrucci's activities as a publisher, particularly details pertaining to the actual sizes of print runs. The contents of Petrucci's publications during Lent suggest there was a self-imposed or externally-imposed ban on secular prints (a comparison with the publication of secular prints in Venice or Rome during the *Triduum* might yield more results). Although the relevance of the publication date of 1506/1 cannot be fully interpreted, the evidence strongly suggests that Petrucci made a determined effort to complete this print before the commencement of the *Triduum*.

The evidence of stop-press additions and variants (discussed previously in chapter 4) suggests that Petrucci's proofing procedures were somewhat inconsistent, particularly during the production of 1506/1; the result was a late publication date. The existence of alternating papers in 1506/2, the independent use of type and the introduction of new stave-set groups in that latter print point towards an overlap in production. The publication dates of two-thirds of his prints relating to the liturgical calendar might suggest that Petrucci shared much in common with publishers then and since – a difficulty in keeping to deadlines.

Chapter 6

SOURCES

SOURCES

6.1 Introduction to sources

1506/1 and 1506/2 are very unusual within the realm of print and manuscript music in that the majority of extant sources belong to the oldest pieces in the series, rather than the most recent. This is due to the popularity of the Latin *laude* which survive in ten manuscripts, all dating prior to 1506 (see tables 6.01, 6.02 and 6.03). A further curiosity is that the oldest Lamentations in 1506/1 and 1506/2, those of de Quadris, are also found in the most recent concordance dated 1521 [FlorBN II.I.350], testifying to their enduring popularity into the earlier sixteenth century. The Lamentations of de Quadris and Agricola (three-part) are found in two other sources besides 1506/1; those of Anon. 1, Lapidida and de Orto have one other source while the Lamentations of Tinctoris, Agricola (four-part), Tromboncino, Weerbeke and Ycart are *unica*. The anonymous *lauda* 'Adoramus te Domine', Francesco Ana's 'Passio sacra' and the two 'Benedictus' canticles are also *unica*.

Table 6.01: Manuscript concordances of 1506/1

<i>Liber primus</i> [1506/1]	
Title/Composer	number of concordances
Adoramus te domine (a4)	0
Tinctoris Lamentations (a4)	0
Ycart Lamentations (a3)	0
Anon. 1 Lamentations (a3)	1 (CapePL 3.b.12, fols 95 ^v -101 ^v ; Contra is new)
Agricola Lamentations (a3)	2 (WarU 2016, fols 132 ^v -136 ^r ; FlorR 2794, fols 76 ^r -78 ^r)
Agricola Lamentations (a4)	0
De Orto Lamentations (a4)	1 (CapePL 3.b.12, fols 90 ^v -95 ^r , music for ch. 1:3 is different)
De Quadris Lamentations (a2)	2 (VicAC 11, fols 1 ^v -10 ^r ; FlorBN II.I.350, fols 80 ^v -90 ^f)
Venite et ploremus (a2)	2 [details of <i>laude</i> concordances in tables 6.03 and 6.04]
Popule meus (a2)	3
Cum autem venissem (a2)	10 (including versions for more than two voices)
Sepulto Domino (a2)	4
O dulcissime [text only in 1506/1]	8
Passio sacra nostri redemptoris (a4)	0

Table 6.02: Manuscript concordances of 1506/2

Title/Composer	number of concordances
Tromboncino Lamentations (a4)	0
Weerbeke Lamentations (a4)	0
Lapicida Lamentations ¹ (a4)	1 (FlorBN Panc. 27, fols 144 ^v -145 ^r)

6.2 Manuscript concordances: Mid- to late fifteenth century

The oldest manuscript containing a concordance of 1506/1 or 1506/2 is undoubtedly VicAC 11, dating from the mid-fifteenth century. It includes the Lamentations of de Quadris (which are unattributed) and some monophonic sequences; this manuscript was compiled in accordance with the bequest of the Bishop of Vicenza who died in 1453.² The music of de Quadris was faithfully reproduced in 1506/1 (even if the verse choice was not the same as VicAC 11); the importance of this setting may have influenced Petrucci's decision to include it, even though it was at least fifty years old by the time it was printed.

There are several common traits which link the fifteenth-century manuscript concordances [all of the manuscripts cited in this section contain concordances of the 1506/1 *laude* unless stated; table 6.02 shows concordances]. The first category of manuscript contains liturgical polyphony and was associated with the monastic orders, including BolC Q13 (Benedictines), FlorD 21 (Florence cathedral processional), PavU 361 (probably originating in a Veneto monastery), PozR 1361 (Franciscan devotional manuscript) and WashLC J6 (originally owned by a Venetian Benedictine monk). The interest of the Italian monasteries in the *lauda* is not surprising, since some (possibly all) of these *laude* had a function within the Holy Week liturgy; I have already discussed the enthusiasm of the Italian Benedictines in chapter 2. PavU 361 contains a total of eight Latin *laude*, four Italian *laude*, two Hymns and a Kyrie; this content and its relation to the *laude*

¹ Weiss, 'Lapicida [Steinschneider], Erasmus [Rasmo]', 267, has continued Othmar Wessely's erroneous description in *New Grove* (1980) of these Lamentations as three-part.

² See Bent, 'Pietro Emiliani's Chaplain', 10-13.

manuscript Vnm 145 (which does not contain a concordance of 1506/1 or 1506/2) suggests that the Padua manuscript was a source connected to the *lauda* repertoire. The manuscript is also significant since it contains the earliest unattributed Lamentation excerpt after Bu 2931. WashLC J6 shares a very similar type of repertoire, containing a mixture of *laude* and service music.

Table 6.03: Manuscript concordances of *laude* in 1506/1³

Venite et ploremus [Invitatorium]

<i>MSS</i>	<i>Description</i>	<i>Location</i>	<i>Provenance</i>	<i>Notes</i>
PadBC c56, fols 62 ^v -63 ^r (a2)	Processional	Padua	Processional for Padua Cathedral	This section of the manuscript dates from the fifteenth century.

Popule meus [Improperia]

<i>MSS</i>	<i>Description</i>	<i>Location</i>	<i>Provenance</i>	<i>Notes</i>
PadBC c56, fols 62 ^v -65 ^r (a2)	Processional	Padua	Processional for Padua Cathedral	See 'Venite' above.

³ Most of this table is based upon data published by Giulio Cattin.

Cum autem [Lamentum virginis]

MSS	Description	Location	Provenance	Notes
CapePL 3.b.12, fols 19 ^v -20 ^r (a3)	<i>Laude</i> MS	Montecassino (Cattin), N. Italy (Atlas)	Congregation Cassinese S. Giustina, Benedictines (Cattin)	Pre-1506. An additional Contra has been added to de Quadris's work.
WashLC J6, fols 122 ^v -125 ^r (a2)	<i>Laude</i> MS	Venice and Piacenza	Original owner a Benedictine monk (Cattin)	Contains theoretical polyphony. Dates c.1465-80 (Gallo 1966).
PavU 361, fols 8 ^v -9 ^r (a2)	<i>Laude</i> MS	Veneto region; probably Venice (Cattin)	Related closely to Vnm 145, a <i>laude</i> MS	Contains theoretical polyphony. Dates c.1440-60.
FlorD 21, fols 8 ^r -12 ^r (a1)	Processional	Florence	Processional for Florence Cathedral. There was a considerable <i>laudesi</i> presence in Florence	Dates c. 1480- 1500 with additions in early decades of 16th century.
FlorBN Panc. 27, fol. 28 ^v (a3)		Florence	Florence (Jeppesen) or Mantua/N. Italy (Atlas)	Dated c. 1510. An additional Contra has been added to de Quadris's work.
BolC Q13, fols 38 ^v -44 ^r (a2)	Processional	Mantua	Benedictine processional	The year '1482' appears on fol. 65.
BolA A179, fols 183 ^v -184 ^r (a2)	Liturgical book	?Bologna/N. Italy (Cattin)		Dates from the second half of the 15th century.
VerBC 690, fols 53 ^v -57 ^v (a2)	Liturgical book			Late 15th century, early 16th century.
PozR 1361, fols 6 ^v -7 ^r (a3)			Franciscan devotional MS	Dates from the late 15th century. An additional Contra has been added to de Quadris's work.

Sepulto Domino

MSS	Description	Location	Provenance	Notes
PadBC c56, fols 65 ^v -67 ^r (a2)	Processional	Padua	Processional for Padua Cathedral	See 'Venite' above.
CapePL 3.b.12, fols 25 ^v -26 ^r (a3)				An additional Contra has been added to de Quadris's work.
WashLC J6, fols 126 ^v -128 ^v (a2)	<i>Laude</i> MS	Venice and Piacenza	Original owner a Benedictine monk	Contains theoretical polyphony.

O dulcissime & various strophes [music as for *Sepulto Domino*]

MSS	Description	Location	Provenance	Notes
CapePL 3.b.12, fols 20 ^v -25 ^r (a3)				An additional Contra has been added to de Quadris's work.
PavU 361, fols 8 ^v -9 ^r (a2)	<i>Laude MS</i>	Veneto region	Related closely to Vnm 145, a <i>laude</i> MS	Contains theoretical polyphony.
VerBC 690, fols 53 ^v -58 ^r (a2)				
WashLC J6, fols 122 ^v -126 ^r (a2)	<i>Laude MS</i>	Venice and Piacenza	Original owner a Benedictine monk	Contains theoretical polyphony.
FlorD 21, fols 8 ^r -12 ^r (a2)	Processional	Florence	Processional for Florence Cathedral. Heavy <i>laudesi</i> presence in Florence	
BolC Q13, fols 38 ^v -44 ^r (a2)	Processional	Mantua	Benedictine processional	
PavU 361, fols 8 ^v -9 ^r (a2)	<i>Laude MS</i>	Veneto region	Related closely to Vnm 145, a <i>laude</i> MS	Contains theoretical polyphony.
PozR 1361, fols 6 ^v -7 ^r (a3)				An additional Contra has been added to de Quadris's work.

The monastic enthusiasm for education is manifest in two manuscripts containing polyphony and theoretical treatises; PavU 361 (which contains several fourteenth-century treatises including those of Marchettus de Padua) and WashLC J6 (containing the writings of Marchettus de Padua, Jean de Muris, etc.).⁴ The origin and location of concordances offer some patterns, particularly northern Italian locations; WashLC J6 (Venice), VicAC 11 (Vicenza, near Venice), PavU 361 (the Veneto area), PadBC c56 (Padua cathedral, a Veneto dependency), FlorD 21 (Florence cathedral), BolA A179 (perhaps Bologna but certainly northern Italy) and BolC Q13 (which originated in a monastery in Mantua). The only later fifteenth-century non-Italian concordance is FlorR 2794 which contains Agricola's three-part Lamentations and dates from the late 1480s. Rifkin supported the notion that this manuscript

⁴ RISM BIV/4, 1173. Although Bu 2931 (which contains Lamentation X) is not concordant with 1506/1 or 1506/2, it belongs to this category since it contains treatises with Passiontide music as musical examples.

originated in French or Burgundian territory but he implied that some of the repertoire had an association with Florence itself.⁵

The court of Ferdinand I at Naples is of paramount importance to the interpretation of the importance of Holy Week in Italy; Pope and Kanazawa and Atlas suggested that the manuscripts MonteA 87I and PerBC 43I were linked to that court.⁶ Atlas observed that the 'large-scale setting of the *Lamentations* in Petrucci 1506/I accords well with the lavish role that music played in the celebration of Holy Week at the court'.⁷ However, he didn't develop this hypothesis (although he discussed composers working at the court who also appear in the 1506 *Lamentations*).

The first ascribed composers of 1506/I, Tinctoris and Ycart, were known to have worked at Naples in the late fifteenth century.⁸ Agricola, the only composer in 1506/I represented by two *Lamentation* settings, appears to have been recruited for the Naples court from mid-1492 to early 1493.⁹ It is significant that the text of Dufay's song motet 'O tres piteulx' originated in Naples; we can only speculate as to the inspiration for his integration of a *Lamentation* tone in the Tenor.¹⁰ Other possibilities existed for communication between Naples and northern Italy; Blackburn described Petrucci's editor, the Dominican friar, Petrus Castellanus, and suggested that the music was brought to Venice by the Venetian emissary and ardent music enthusiast, Girolamo Donato.¹¹ Donato had written to Lorenzo de' Medici in the past about music manuscripts; Lorenzo had close ties with Naples relating to a treaty which dated from 13 March 1480.

⁵ Joshua Rifkin, 'Pietrequin Bonnel and Ms. 2794 of the Biblioteca Riccardiana', *Journal of the American Musicological Society*, 29 (1976), 284-296 (p. 288).

⁶ See Pope and Kanazawa, *The Musical Manuscript Montecassino 87I*, pp. 44-46 and Atlas, *Music at the Aragonese Court*, pp. 120-121.

⁷ Atlas, *Music at the Aragonese Court*, p. 79.

⁸ See *ibid.*, pp. 71-80.

⁹ Atlas and Cummings, 'Agricola, Ghiselin', 540-548, revealed that Agricola and Ghiselin both stayed at Naples in 1494, and traced Agricola's movement through Italy and France from 1491-1494.

¹⁰ Fallows, *Dufay*, p. 71, discussed the context of Dufay's laments; in 1456 Dufay wrote that he had received texts from Naples and composed four laments at the Fall of Constantinople (May 1453). While Fallows deduced that one of the laments was 'O tres piteulx' and therefore a song-motet, the association of laments with the Neapolitans is important.

¹¹ See Blackburn, 'Lorenzo de' Medici'.

The first work in the extant fascicles of MonteA 87I is a setting of the text 'O princeps Pilate' by 'Bernardus';¹² the source of this text is unknown but Pope and Kanazawa suspected it was connected with the representation of the Deposition in Naples.¹³ The second setting in MonteA 87I is the Lamentation text 'Patres nostri peccaverunt' by Johannes Cornago for four voices;¹⁴ Robert Mitchell has suggested that no. 9I in MonteA 87I, a textless, anonymous piece, may be a possible second half to Cornago's setting. Mitchell conjectured that the opening phrase of the Superius was similar in both pieces and that no. 9I would probably accept the logical text continuation 'Servi dominati sunt nostri' as underlay.¹⁵ The third work in MonteA 87I is an anonymous four-part setting of the opening text in 1506/I, 'Adoramus te Domine Jesu Christe'.

The only concordance in MonteA 87I of 1506/I is a four-voice setting of 'Cum autem', at fols 138^v-139^r. Two lower voices have been added to the two-part version printed in 1506/I and the Tenor has been slightly altered between cadences. Petrucci may not have had access to this version in MonteA 87I, although the rather rudimentary characteristics of the added voices may have dissuaded Petrucci, even if he had seen this source. It suggests that the Benedictine scribe of MonteA 87I added voices; a parallel for this practice may be made with the additions of the Benedictine scribe of CapePL 3.b.12 (which I will discuss later). Although MonteA 87I has only one concordance of the 1506 Lamentations, they share a common repertoire. The missing Lamentations in this manuscript may have been the exemplars for some of Petrucci's 1506 pieces.

Little is known about VerBC 690 which dates from the late fifteenth century or perhaps early sixteenth century. It contains a version of

¹² Pope and Kanazawa, *The Musical Manuscript Montecassino 87I*, p. 33, suggested that the author may well be Bernardus Ycart.

¹³ *Ibid.*, p. 555.

¹⁴ The text of this motet is Lamentations 5: 7.

¹⁵ Robert Mitchell, private letter dated 27 August 2002. Mitchell's theory is supported by the fact that the folio containing 'Patres nostri' was loose and had been attached to the remainder of the first fascicle (see Pope and Kanazawa, *The Musical Manuscript Montecassino 87I*, p. 12). However, no. 9I belongs to an inside gathering of fascicle 6 and Pope and Kanazawa (*The Musical Manuscript Montecassino 87I*, p. 12) observed that no page would appear to be missing. I believe that there is not enough evidence to support Mitchell's assertion.

Lamentation X and a concordance of 'Cum autem' (the only white-note piece in the manuscript).

The inclusion of 'Cum autem' and other *laude* in PozR 1361 is evidence that they were used outside Italy; this manuscript contains a translation of a Latin *lauda* into Polish. Furthermore, a Contra has been added to the two-part *lauda* 'Cum autem' although it does not strictly quote the original two parts following the opening measures. This version is the only one which cadences on the final *f*, all other versions cadencing on *c*. The practice of adding a Contra to this particular *lauda* is shared with the slightly later manuscripts CapePL 3.b.12 and FlorBN Panc. 27.

The widespread pattern of manuscript sources containing the 1506/1 *laude* supports the notion of their popularity in northern Italy, particularly amongst the monastic orders and the *laudesi*.

6.3 Summary of mid- to late fifteenth-century manuscripts containing concordances of 1506/1 and 1506/2¹⁶

BolC Q13

Bologna, Civico Museo Bibliografico Musicale. MS Q13. A Processional with polyphony; the date 1482 appears on fol. 65. It belonged to the Benedictine Giustinian monastery of S. Benedetto di Polirone at Mantua.¹⁷ The contents include detailed rubrics for Holy Thursday and Good Friday which specify the texts below.

Cum autem venissem (fols 38^v-44^r) [J. de QUADRIS]

O dulcissime filie Syon¹⁸ (fols 38^v-44^r) [J. de QUADRIS]

¹⁶ Information contained in the list of manuscripts below is derived from Charles Hamm and Herbert Kellman, eds., *Census Catalogue of Manuscript Sources of Polyphonic Music 1400-1550*, 5 vols. (Neuhausen-Stuttgart: American Institute of Musicology, 1979-1988). I have also cited references which are central to my arguments or which have been published since Hamm and Kellman's volumes.

¹⁷ Cattin, 'Tradizione e tendenze', 263-264, 290-91.

¹⁸ The associated verses following the text 'O dulcissime filie Syon' vary considerably between manuscripts; Cattin, 'Il presbyter Johannes de Quadris', 37; Cattin, 'Canti polifonici', 471-475; Cattin, 'Un processionale fiorentino', 115-125, has listed each reading.

BolA A179

*Bologna, Biblioteca Comunale dell'Archiginnasio. MS A. 179 (olim 16.b. iii.20). A liturgical book with polyphony dating from the second half of the fifteenth century. It was copied in northern Italy, perhaps at Bologna.*¹⁹

Cum autem venissem (fols 183^v-184^r) [J. de QUADRIS]

FlorD 21

Florence, Duomo, Archivio Musicale dell'Opera di Santa Maria del Fiore. MS 21.

A processional for Florence Cathedral dated c.1480-1500 with additions in the early decades of the sixteenth century.²⁰

Cum autem venissent (fols 8^r-12^r) [J. de QUADRIS]

Sepulto Domino (fols 13^v-17^r) [J. de QUADRIS]

O dulcissime filie Syon (fols 32^v-33^r) [J. de QUADRIS]

Omnes amici eius (fol. 9^r) [J. de QUADRIS]²¹

Cui comparabo te (fol. 13^r) [J. de QUADRIS]

FlorR 2794

*Florence, Biblioteca Riccardiana. MS 2794. It has been dated as late fifteenth century and probably originated in French or Burgundian lands.*²²

Quomodo sedet sola civitas (fols 76^r-78^r) [A. AGRICOLA]

¹⁹ Cattin, 'Canti polifonici', 468ff. and Cattin, 'Il presbyter Johannes de Quadris', 40-41.

²⁰ See Cattin, 'Un processionale fiorentino', 53-204, and Ghisi, 'Un processionale inedito', 362-369.

²¹ Only one voice survives; the formula used in de Quadris's 1506/1 Lamentations is adapted in these verses.

²² Rifkin, 'Pietrequin-Bonnel', 288.

MonteA 87I

Monte Cassino, Biblioteca dell'Abbazia. MS 87I. A Neapolitan late fifteenth-century manuscript. The repertoire is sacred and includes Lamentation settings; its *tabula* lists Lamentations and other texts related to Holy Week which have since been lost.²³

Cum autem venissem²⁴ (fols 138^v-139^r)

PadBC C56

Padua, Biblioteca Capitolare. MS C56. A fourteenth-century Processional with polyphonic additions; the latter date from the fifteenth century. This manuscript was copied for Padua Cathedral.²⁵

Popule meus (fols 62^v-65^r) [J. de QUADRIS]

Sepulto Domino (fols 65^v-67^r) [J. de QUADRIS]

Venite o fidelis²⁶ (fols 62^v-63^r) [J. de QUADRIS]

PavU 36I

Pavia, Biblioteca Universitaria. MS Aldini 36I (olim 130.a.26). It was copied 1440-60 and probably originated in Venice.²⁷ This manuscript was owned by Petrus de Fossis, choir master at St. Marks (1491-1527); it is related to the *laude* manuscript Vnm 145 by concordances.²⁸ The contents include a plainchant Lamentation and there are theoretical treatises by Boethius, Marchettus de Padua, Jacobus Theatinus and Johannes de Muris.

Cum autem venissem (fols 8^v-9^r) [J. de QUADRIS]

²³ Pope, 'The Musical Manuscript Montecassino', 127; Pope and Kanazawa, *The Musical Manuscript Montecassino 87I*, pp. 28, 46.

²⁴ This is a four-part version with a Discantus similar to that in 1506/1.

²⁵ Giuseppe Vecchi, *Uffici drammatici padovani*, Biblioteca dell' "Archivium Romanicum", ser. I, storia, letteratura, paleografia. vol. 41. Testi drammatici medievali. A. Testi latini, no. 2. (Florence: [n.pub.], 1954), p. 133.

²⁶ A *contrafactum* to the text 'Venite et ploremus' found in 1506/1.

²⁷ Cattin, 'Le composizioni musicali', 1-21.

²⁸ Elise Murray Cambon, 'The Italian and Latin Lauda of the Fifteenth Century' (Unpublished Doctoral Dissertation, Tulane University, 1975), p. 128.

PozR 1361

Poznań, Miejska Biblioteka Publiczna im. Edwarda Raczyńskiego. MS 1361

A manuscript of Franciscan devotional texts, dating from the late fifteenth century.²⁹

Cum autem venissent³⁰ (fols 6^v-7^r) [J. de QUADRIS/ANON.]

O dulcissime fili mi (fols 6^v-7^r) [J. de QUADRIS/ANON.]

VeronaBC 690

Verona, Biblioteca Capitolare. MS DCXC. A liturgical book dated from the late fifteenth and early sixteenth century. 'Cum autem' is the only white notated piece in the manuscript which also contains a two-part anonymous Lamentation setting.³¹

Cum autem venissem (fols 53^v-57^v) [J. de QUADRIS]

VicAC II

Vicenza, Seminario Vescovile, MS U. VIII. II. This manuscript of sacred music was copied c. 1430-40 in Vicenza;³² Bent proved that it was compiled as a bequest for the Bishop of Vicenza.³³

Incipit Lamentatio Jeremie (fols 1^v-10^r) [J. de QUADRIS]

²⁹ Perz, 'Handschrift Nr. 1361', 588-592.

³⁰ A Contra part has been added but is not the same as that in CapePL 3.b.12 nor FlorBN Panc. 27.

³¹ The Tenor of this Lamentation setting (Lamentation X) is also found in CapePL 3.b.12, UrbU L712 and BrusC 16857 although the upper voice is new.

³² Cattin, 'Uno sconosciuto codice', 291-292.

³³ Bent, 'Pietro Emiliani's Chaplain', 10-15.

WarU 2016

Warsaw, *Biblioteka Uniwersytecka, Oddział Zborów Muzycznych. MS Mf. 2016* (olim Mus. 58)[was: Breslau 2016]. Copied in Silesia or Bohemia c. 1500. A sacred manuscript with a small representation of secular texts in Italian, German and French.

Quomodo sedet sola civitas (fols 132^v-136^r) [A. AGRICOLA]

WashLC J6

Washington, *Library of Congress, Music Division. MS ML 171 J6 case*. This manuscript contains theoretical treatises by Marchettus of Padua, Johannes de Muris, Johannes de Garlandia and others and has been dated c. 1465-80 and c. 1489-1507.³⁴ It was copied in Venice and Piacenza by Johannus Franciscus Preottonus, a Benedictine monk at S. Giorgio, Venice.³⁵

Cum autem venissem (fols 122^v-123^r) [J. de QUADRIS]

Sepulto Domino (fols 126^v-128^v) [J. de QUADRIS]

O dulcissime filie Syon (fols 122^v-124^r) [J. de QUADRIS]

6.4 Manuscript concordances: Early sixteenth century

The 1506/1 concordances dating from the turn of the century are distinctive since they feature Lamentations (unlike most of the fifteenth-century concordances which contain *laude*); the contents of these manuscripts tend to be more diverse than the dedicated liturgical function of the majority of fifteenth-century concordances. FlorBN Panc. 27 is a typical example since it contains a mixture of sacred and secular music by northern and native composers. It is dated c. 1510 and originated from northern Italy;³⁶ amongst

³⁴ F. Alberto Gallo, '“Cantus planus binatim”: Polifonia primitiva in fonti tardive', *Quadrivium*, 7 (1966), 79-89 (pp. 84-86) dated it c. 1465-80 while Michel Huglo and Nancy C. Philips, eds., *Manuscripts from the Carolingian Era up to c. 1500 in Great Britain and in the United States of America*, Répertoire International des Sources Musicales, B III4 (München: G. Henle Verlag, 1992), p. 191, suggested c. 1489-1507 (based on manuscript inscriptions).

³⁵ Cattin, 'Tradizione e tendenze', 263-264.

³⁶ Atlas, *The Cappella Giulia Chansonnier*, I, 186, argued that it was probably from Mantua; Knud Jeppesen, *La Frottola II: Zur Bibliographie der handschriftlichen musikalischen*

its contents is the opening verse of the Lamentations of Lapidida. It contains a further five anonymous Lamentation settings including those of Anon. 4;³⁷ the missing fascicles following the Lapidida setting suggest that the remainder of that setting (and possibly some other Lamentations) have now been lost. FlorBN Panc. 27 also contains a Requiem Mass, hymns, motets and Magnificats as well as a *frottola* and a chanson.

The repertoire of WarU 2016 is principally sacred and the manuscript, dated c. 1500, contains six Masses and an assortment of other liturgical music.³⁸ This manuscript was copied in Silesia or Bohemia and contains Agricola's unascribed three-part Lamentations (being the only Lamentations in this manuscript).³⁹ The majority of composers in this collection are northern European with a small selection of eastern European composers.

The manuscript CapePL 3.b.12 is central to the 1506 Lamentations since it is the only extant manuscript to contain two Lamentation concordances of the 1506 prints (including the alternative setting of de Orto's verse three). This interest in providing alternative polyphony extends to the *laude* in the manuscript since the two-part 'Cum autem' is one of a number of works to have parts or text added or substituted. It should be noted that none of the additional Contra parts of 'Cum autem' found in CapePL 3.b.12, MonteA 871 (two extra parts), PozR 1361 or FlorBN Panc. 27 are identical. One possible explanation, particularly relevant to CapePL 3.b.12, is that the two-part 'Cum autem' was used as a basis for contrapuntal exercises, possibly within the monastic community.

Cattin noted that there were two copyists; scribe A, working from the beginning of the manuscript to fol. 28^r and scribe B who continued from that

Überlieferung des weltlichen italienischen Lieds um 1500, vol. XL/1 of *Acta Jutlandica* (Copenhagen: University of Aarhus, 1969), pp. 37-42, suggested Florence or somewhere in Tuscany. The preface to Gioia Filocamo's forthcoming edition, *Florence, BNC, Panciatichi MS 27: Text and Context* (Fondazione Pietro Antonio Locatelli), states that it was compiled from the beginning of the century but contains several pieces that were copied from publications by Petrucci and the *Canzoni nove* of Antico (1510). See Gioia Filocamo, 'Forthcoming', *Fondazione Pietro Antonio Locatelli* <<http://www.fondazione locatelli.org/IT/Pubblicazioni/Mon1.htm>> [accessed 23 September 2004].

³⁷ For an edition of Anon. 4, see Massenkeil, *Mehrstimmige Lamentationen*, pp. 142-148.

³⁸ Feldmann, *Der Codex Mf. 2016*, p. 2.

³⁹ *Ibid.*, p. 2.

folio to the completion of the manuscript.⁴⁰ Scribe A concerned himself with Holy Week compositions but Cattin observed that while scribe B initially continued that policy, he gradually introduced other pieces connected with the offices and concluded the manuscript with a large number of *contrafacta*, many with secular origins.⁴¹ Thus Cattin associated the more functional Benedictine polyphony found at the beginning of the manuscript with scribe A, and the more daring selection of sacred *contrafacta* with scribe B. He suggested that the compilers of CapePL 3.b.12, particularly scribe B, made a deliberate attempt to conceal the secular nature of the polyphony; this accounts for the general lack of ascriptions in the manuscript.⁴²

The two-part 1506/1 *laude*, 'Cum autem' and 'Sepulto Domino', exist as three-part versions in CapePL 3.b.12. It is also significant that they were copied by scribe A, being found at fols 19^v-25^r and 25^v-27^r respectively. No other sources except 1506/1 attribute these works to de Quadris; the Superius and Tenor in CapePL 3.b.12's 'Sepulto Domino' are essentially the same parts as those in 1506/1.

CapePL 3.b.12 has a number of works associated with Holy Week; some of its motet texts also appeared in 1506/1. The compositions of over half of the attributed composers in 1506/1 and 1506/2 appear in this manuscript, more than any other single manuscript concordance. CapePL 3.b.12 is a substantial manuscript containing mostly religious or liturgical texts, of which a handful are secular. There are no Mass settings but it contains two canticles, nine Psalm settings, three Hymns, three Lamentations, 41 motets, 24 *laude* and a French and Italian texted setting.⁴³ Most pieces are unasccribed although concordances reveal that the vast majority of works are by northern composers including Agricola, Compere, Hayne, Isaac, Busnois, de Orto and Weerbeke. The emerging interest in native polyphony is represented by Tromboncino, as well as the older *laude contrafacta* from the mid-fifteenth century.

It is significant that the first of the three Lamentations in CapePL 3.b.12, Lamentation X, is the opening work, announcing the tone of this manuscript

⁴⁰ Cattin, *Italian Laude*, pp. ix-x.

⁴¹ Cattin, 'Nuova fonte italiana', 172-175.

⁴² Cattin, *Italian Laude*, p. ix.

⁴³ Hamm and Kellman, *Census Catalogue*, I, 142-143; IV, 325.

(as perceived by scribe A). It should be noted that the de Quadris Lamentations and following *laude* settings which appear in 1506/1 were all copied by scribe A in CapePL 3.b.12 while the Lamentations by Anon. 1 and de Orto were copied by scribe B. This suggests that scribe B was a more progressive compiler (if indeed he did compile as well as copy the manuscript) but, perhaps more importantly, that Petrucci made a conscious decision to represent both the older, more restrained style of music associated with such orders as the *Congregatio Casinensis* as well as the more modern style of Weerbeke and Agricola which would have been more attractive to Italy's progressive courtly circles (judging by manuscripts associated with such courts).

The discovery of a different setting of the final verse of de Orto's Lamentations comes as no surprise, considering the alternatives already offered by CapePL 3.b.12's scribe B. There is no resemblance whatsoever to any of the 1506/1 parts in CapePL 3.b.12's version of de Orto's verse three (see appendix 4 for a comparative edition; the music is discussed in section 3.01). It is impossible to tell whether de Orto wrote both versions and we may not assume that the 1506/1 reading is more authentic, simply because it exists in print.

Further examples of Scribe B's variants are demonstrated in CapePL 3.b.12 version of Anon. 1's Lamentation at fols 95^v-101^v. The version in 1506/1 is different in that it has a completely new Contratenor and the other two voices have been substantially reworked and reordered. The modular, repetitive nature of the CapePL 3.b.12 version has been retained, although the sections are presented in a different order.

The variants and versions in CapePL 3.b.12 are indicative of a number of factors in the transmission of Renaissance music. Primarily, they represent the sources available to the scribes but must also reflect local performance practices. Evidence of such practices date from the middle of the fifteenth century, where the monastic readings of Lamentation X show considerable development within a relatively simple model. Thus, the variants in CapePL 3.b.12 of Anon. 1 with the enthusiastic presentations of octave-leap cadences

(also found in de Orto's Lamentations), and the independent version of verse three of de Orto's Lamentations must reflect performance practice within this monastic community.

The inclusion of several *frottole contrafacta* by Tromboncino towards the latter part of CapePL 3.b.12 is highly significant. Cattin's findings revealed that four *laude* were subsequently published as *frottole* by Petrucci;⁴⁴ the allocation of these works into three dedicated volumes by Petrucci, viz. *Strambotti, ode, frottole, sonetti* (1505/5), *Frottole libro primo* (1504/4) and *Laude libro secondo* (1508/3) suggests that the publisher had planned these productions for some time. There are other works in CapePL 3.b.12 which appear in Petrucci publications including *Odhecaton* (1501) and *Motetti A* (1502/1) as well as *Motetti de passione* (1503/1) and *Misse Izac* (1506).⁴⁵

Several pieces in CapePL 3.b.12 have concordances of other Petrucci prints, apart from Anon. 1, de Orto and the 1506/1 *laude*; appendix 7 lists concordances of CapePL 3.b.12 and other contemporary manuscripts or Petrucci prints.⁴⁶ This appendix reveals the relatively small number of *unica* in CapePL 3.b.12 and the wide correspondence with a selection of pivotal manuscripts and prints. A total of 15 motets, Lamentations or *laude* appear in Petrucci's works. Admittedly, some of the 15 works in CapePL 3.b.12 are *contrafacta* but this does not necessarily lessen their value as alternative readings.

Tromboncino's *laude* and other sacred works in CapePL 3.b.12 were described by Prizer as 'typical examples of the Italian sacred style in the early 16th century'.⁴⁷ He further suggested that they were 'all basically homorhythmic with sections of non-imitative polyphony included for contrast'. The inclusion of the Tromboncino *contrafacta* in CapePL 3.b.12 suggests that there was a demand for his music amongst the clergy – his Lamentations in 1506/2 must have been warmly welcomed, due to their *frottola* style.

⁴⁴ Cattin, *Italian Laude*, p. x.

⁴⁵ Cattin provided a complete list of concordances of CapePL 3.b.12 in Cattin, 'Nuova fonte italiana', 190-220.

⁴⁶ This table is based on Cattin, 'Nuova fonte italiana' 190-220. Texts listed in bold also appear in 1506/1 and 1506/2.

⁴⁷ Prizer, 'Tromboncino [Trombonzin, Trombecin, etc.], Bartolomeo', p. 161.

There are other texts in CapePL 3.b.12 which also appear in 1506/1 and 1506/2 including a four-part 'Adoramus te Christe' (fols 30v-32r) and three four-part settings of the canticle 'Benedictus Dominus Deus Israel'. Cattin observed that only the odd-numbered verses of the 'Benedictus' were set polyphonically since a *tonus de Benedictus* was sung to the even-numbered verses.⁴⁸ However, the *cantus firmus* used in the two settings in 1506/2 would not appear to be the same as the CapePL 3.b.12 Benedictine version. Nevertheless, the 1506/2 readings only set alternative verses, suggesting that the other verses were performed *alternatim* in the Benedictine tradition.

The contents of CapePL 3.b.12 show an enthusiasm for a repertory which was shared in 1506/1, 1506/2 and other sources. Further research concerning CapePL 3.b.12's sources remains to be completed; Marilee Mouser's preliminary findings would suggest that they relied upon a northern Italian tradition although somewhat removed from Petrucci's primary manuscript sources such as the Milanese choirbooks.⁴⁹ Although CapePL 3.b.12 postdates the death of Ferdinand I, the channels of musical communication may well have remained open between Naples and northern Italy. The repertoire of CapePL 3.b.12 clearly demonstrates the importance of, and interest in Holy Week repertoire in later fifteenth-century Italy, a feature shared with MonteA 871.

The most modern manuscript concordance of 1506/1 or 1506/2, FlorBN II.I.350, dates from the early 1520s and contains a substantial number of Lamentations including those by de Quadris, Pisano, Carpentras and Brumel. It also contains other Holy Week motets and six unascribed settings of the canticle 'Benedictus Dominus Deus Israel'. There is a greater representation of Italian composers throughout this collection, reflecting the emerging interest in native polyphony during the sixteenth century. The inclusion of de Quadris's Lamentations is significant since it demonstrates their popularity over 70 years

⁴⁸ Cattin, *Italian Laude*, p. xvii.

⁴⁹ Dr Mouser's doctoral thesis is entitled 'Petrucci and his Shadow: A Study of the Filiation and Reception History of the Venetian Motet Anthologies, 1502-08' (University of California at Santa Barbara). I am most grateful to Dr Mouser for sharing her findings prior to submission.

after its composition. A continuing interest in the *lauda* is represented by Pisano's unascribed four-part setting of 'Sepulto Domino'.

6.5 Summary of early sixteenth-century manuscripts containing concordances of 1506/1 and 1506/2

CapePL 3.b.12

Cape Town, The South African Library. MS Grey 3.b.12. It was probably copied in a Benedictine monastery in northern Italy around 1500 and certainly no later than the first decade of the sixteenth century.⁵⁰ There are concordances of FlorBN Panc. 27 and ParisBNC 676.⁵¹

Incipit Lamentatio Jeremie (fols 90^v-95^r) [M. de ORTO]

Incipit oratio hieremie prophete (fols 95^v-101^v) [ANON. I]

Cum autem venissem⁵² (fols 19^v-20^r) [J. de QUADRIS/ANON.]

Sepulto Domino (fols 25^v-26^v) [J. de QUADRIS/ANON.]

O dulcissime filie Syon (fols 20^v-21^r) [J. de QUADRIS/ANON.]

FlorBN II.I.350

Florence, Biblioteca Nazionale Centrale. MS II. I. 350 (olim Magliabechi XXXVI, 113). It originates from Santa Maria Novella, first half of the sixteenth century.⁵³ The date 1521 may be found on fol. 83 and the manuscripts contains settings for Holy Week.

Incipit Lamentatio Yeremie (fols 80^v-90^r) [J. de QUADRIS]

⁵⁰ Cattin, *Italian Laude*, p. x.

⁵¹ Giulio Cattin, 'Nuova fonte italiana', 185-187.

⁵² These three anonymous *laude* have had a Contra part added.

⁵³ See Bent, 'The Use of Cut Signatures', 656n.

FlorBN Panc. 27

Florence, *Biblioteca Nazionale Centrale. MS Panciatichi 27*. This manuscript has been dated c. 1500 or c. 1510; suggestions for its provenance include Florence, Tuscany and Mantua.⁵⁴ It contains sacred and secular pieces including motets, Mass movements, a complete Mass ordinary, Magnificats, Lamentations, hymns, *laude* with Latin and Italian texts, secular texts in French, Italian and Dutch and some instrumental ensemble music.

Cum autem venissem⁵⁵ (fol. 28^v) [J. de QUADRIS/ANON.]

Incipit Lamentatio ieremie (fols 144^v-145^r) [E. LAPICIDA]

6.6 Print concordances

The monastic orders were quick to harness the new technology of print, and their liturgical printed manuals sometimes included polyphonic extracts. These extracts include concordances with the 1506/1 *laude* but with no other settings in 1506/1 or 1506/2; indeed, it would appear that no other music in the two prints was subsequently reprinted. There may be a number of reasons for this; Petrucci's market might have been saturated or limited and there was no demand to reissue his selection of Holy Week music.

The Benedictines were particularly enthusiastic in producing printed liturgies and their *Cantus Monastici* [Cantorino] prints of 1506, 1523 and 1535 include music relating to Holy Week [the 1506 print does not contain any concordances with 1506/1].⁵⁶ These pocket-sized manuals also include detailed rubrics relating to the ceremonies, showing the context of the texts relating to the *Improperia*. Furthermore, the inclusion of Lamentation X in all three prints increases their importance in relation to the propagation and development of the Holy Week repertoire (ensuring that this setting lasted a remarkable 100 years).

⁵⁴ Knud Jeppesen suggested Florence or somewhere in Tuscany – see *La Frottola II*, pp. 37-42; Atlas, *The Cappella Giulia Chansonier*, 1, 252, argued that it was more likely to be compiled in northern Italy or perhaps Mantua.

⁵⁵ A Contra part has been added but is not the same Contra as that found in CapePL 3.b.12.

⁵⁶ See Cattin, 'Tradizione e tendenze', 254-99. The music is either plainchant or simply two-part polyphony in black notation.

The Dominican Alberto da Castello published the other series of monastic prints that contain concordances with the 1506/1 *laude* under the title *Liber sacerdotalis*. These elegant volumes are similar in concept to the *Cantorino* prints containing liturgical headers on each page, together with related texts and occasional measured music in simple black notation (that is to say, complex notational devices such as ligatures tend to be avoided). The layout of 'Cum autem' in 1537 is unusual, since the Discantus is on one opening and the Tenor on the next. This suggests that this music was intended as a record and an aide-mémoire to performers already familiar with it, rather than as a direct performing edition. Blackburn discovered a connection between Alberto da Castello and Petrus Castellanus and noted that they lived in adjacent cells in 1512; one wonders whether such familiarity resulted in 1506/1 forming the inspiration for Alberto da Castello's version of 'Cum autem' in the *Liber sacerdotalis* prints.⁵⁷

The 1563 *laude* collection of Serafino Razzi was aimed at a completely different market to that of the monastic prints; it does not contain detailed liturgical directions and most of the texts are in Italian. There are a few Latin *laude* including a white-note version of 'Cum autem' (see table 6.04 below):

Table 6.04: Print concordances of *laude* in 1506/1

Venite et plorems [Invitatorium]

<i>Print</i>	<i>Description</i>	<i>Location</i>	<i>Notes</i>
1523/1, fol. 269 ^v (a2)	<i>Liber sacerdotalis</i>	Printed in Venice	Black notation consisting entirely of semibreves, breves and longs.
1537, fol. 255 ^r (a2)	<i>Liber sacerdotalis</i>	Printed in Venice	Black notation consisting entirely of breves and longs.

⁵⁷ See Blackburn, 'Petrucci's Venetian Editor', 24-25, which includes Albert da Castello's impressive opinion of Petrucci.

Cum autem [Lamentum virginis]

<i>MSS</i>	<i>Description</i>	<i>Location</i>	<i>Notes</i>
1523/1, fols 267 ^v -268 ^r (a2)	<i>Liber sacerdotalis</i>	Printed in Venice	Black notation consisting entirely of semibreves, breves and longs.
1523, fols 73 ^v -74 ^r (a2)	<i>Cantus monastici</i>	Printed in Venice	Black notation consisting entirely of semibreves, breves and longs.
1535, fols 58 ^v -61 ^r (a2)	<i>Cantus monastici</i>	Printed in Venice	Black notation consisting entirely of semibreves, breves and longs.
1537, fols 253 ^r -253 ^v (a2)	<i>Liber sacerdotalis</i>	Printed in Venice	Black notation consisting entirely of breves and longs.
1563/6, fols 115 ^v -116 ^r (a2)	<i>Libro primo delle laudi spirituali</i>	Printed in Venice	White notation consisting of semibreves and breves. Includes some binary ligatures.

Sepulto Domino

<i>MSS</i>	<i>Description</i>	<i>Location</i>	<i>Notes</i>
1523/1, fols 268 ^r -269 ^r (a2)	<i>Liber sacerdotalis</i>	Printed in Venice	Black notation consisting entirely of semibreves, breves and longs.
1535, fols 58 ^v -61 ^r (a2)	<i>Cantus monastici</i>	Printed in Venice	Black notation consisting entirely of semibreves, breves and longs.
1537, fols 254 ^r -254 ^v (a2)	<i>Liber sacerdotalis</i>	Printed in Venice	Black notation consisting entirely of breves and longs.

O dulcissime & various strophes [music as for *Sepulto Domino*]

<i>MSS</i>	<i>Description</i>	<i>Location</i>	<i>Notes</i>
1523/1, fols 267 ^v -268 ^r (a2)	<i>Liber sacerdotalis</i>	Printed in Venice	Black notation consisting entirely of semibreves, breves and longs.
1523, fols 73 ^v -76 ^r (a2)	<i>Cantus monastici</i>	Printed in Venice	Black notation consisting entirely of semibreves, breves and longs.
1535, fols 58 ^v -61 ^r (a2)	<i>Cantus monastici</i>	Printed in Venice	Black notation consisting entirely of semibreves, breves and longs.
1537, fols 253 ^r -253 ^v (a2)	<i>Liber sacerdotalis</i>	Printed in Venice	Black notation consisting entirely of breves and longs.
1563/6, fols 115 ^v -116 ^r	<i>Libro primo delle laudi spirituali</i>	Printed in Venice	No music is underlaid here but the print layout suggests that the same music for 'Cum autem' is used.

6.7 Summary of prints containing concordances of 1506/1 and 1506/2

1523/1, [red ink:] *Liber Sacerdotalis nuperrime ex libris sanctae Romane ecclesie et quarundam aliarum ecclesiarum: [...].* [in fine; red ink:] *Impressus fuit hic Liber Sacerdotalis Venetijs per Melchiorem Sessam et Petrum de Rauanis Socios: summa cum diligentia et industria. Anno domini. M.ccccc.xxiiij. xiiij. cal. Augusti. Presidente ecclesie dei Sanctissimo patre et domino Domino Adriano. vj. pontifice maximo. Et Illustrissimo Domino Andrea grito Venetiarum Serenissimo duce.*

[Compiled by Alberto da Castello], Venice 1523, printed by Melchior Sessa and Petrus de Ravanis.

The music is set in black notation and is mensural.

Cum autem (fols 267^v-268^r) [J. de QUADRIS]

Sepulto Domino (fols 268^r-269^r) [J. de QUADRIS]

O dulcissime filie Syon (fol. 267^v) [J. de QUADRIS]

Venite et ploremus (fol. 269^v) [J. de QUADRIS]

1523, [red ink:] *Cantus monastici formula nouiter impressa: ac in melius redacta: cui aliqua que ve[n]erant adiuncta: non nulla vero que supersina videbant dempta sunt: cum tono lamentationis hieremie prophete et aliquibus alijs cantibus mensuratis ipsi tempori[s] congruis.* [In fine; red ink:] *Cantorinus et processionarius per totum annum in diuinis officijs celebrandis secundum ritum congregationis cassinensis alias sancte Justine ordinis sancti benedicti [...]: curaque & expensis spectabilis viri domini Luceantonij de giunta florentini in alma civitate venetiarum regnante Serenissimo domino: domino Antonio Grimano huius civitatis duce ac congregationis huius cassinensis [...]. Impressus. Anno domini. MD xxiiij. pridie kalendas maij feliciter explicit.*

The music is set in black notation and is mensural.

Cum autem (fols 73^v-76^r) [J. de QUADRIS]

O dulcissime filie Syon (fols 73^v-76^r) [J. de QUADRIS]

1535, [red ink:] *Cantus monastici formula nouiter impressa: [...] cum tono lamentationis hieremie prophete et aliquibus aliis cantibus mensuratis ipsi tempori[s] congruis.* [In fine; red ink:] *Cantorinus et processionarius per totum annum in diuinis officijs celebrandis secundum ritum congregationis cassinensis alias sancte Justine ordinis sancti benedicti [...]. studiosissime reuisus: et in officina Luceantonij Junte florentini Venetijs excusus Anno domini M.D.xxxv mense februario.*

The music is set in black notation and is mensural.

Cum autem (fols 58^v-61^r) [J. de QUADRIS]

O dulcissime filie Syon (fols 58^v-61^r) [J. de QUADRIS]

Sepulto Domino (fols 61^v-62^r) [J. de QUADRIS]

1537, *Liber Sacerdotalis nuperrime ex libris Sancte Romane ecclesie: et quarundam aliarum ecclesiarum: et ex antiquis codicibus apostolice bibliothecae: et ex iurium sanctionibus: et ex doctorum ecclesiasticorum scriptis: [...]* [red ink:] *Addito* [black ink:] *vtili enchyridiolo ad agendum de feria tempore aduentus: quadragesime: tempore paschali: et de mense septembris: necnon infra annum: secundum curiam Romanam. Et declaratione rubricarum generalium: et ad inueniendum pascha: et alia festa mobilia: que in alius hactenus impressis minime reperiuntur.* [in fine; red ink:] *Victor a Rabanis: et Socij Venetijs excudebant anno M. D. XXXVII. mense Maio.*

[Compiled by Alberto da Castello.] Venice.

The music is set in black notation and is mensural. The Discantus and Tenor are not presented on the same opening; this layout suggests that performance was not of the highest priority. While the majority of settings are plainchant, there are a few examples of polyphony.

Cum autem venissent (fols 253^r-253^v) [J. de QUADRIS]

O dulcissime filie Syon (fols 253^r-253^v) [J. de QUADRIS]

Sepulto Domino (fols 254^r-254^v) [J. de QUADRIS]

Venite et ploremus ante dominum (fol. 255^r) [J. de QUADRIS]

1563/6, *Libro Primo delle laudi spirituali da diversi eccell. e divoti autori, antichi e moderni composte. Le quali si usano cantare in Firenze nelle Chiese doppo il Vespro ò la Compieta à consolatione et trattenimento de' diuoti serui di Dio.* [italics:] *Con la propria musica e modo di cantare ciascuna laude, come si è usato da gli antichi, et si usa in Firenze.* [plain text:] *Raccolte dal R. P. Fra Serafino Razzi Fiorentino, dell'ordine de' Frati Predicatori, à contemplatione delle Monache, et altre diuoti persone.* [italics:] *Nuouamente stampate.* [ornamental device] *Con Priuilegij della Illustrissima Signoria di Venetia, et del Duca di Firenze, et di Siena.* [plain text:] *In Venetia, ad instantia de' Giunti di Firenze. M. D. LXIII.* [plain text; fol. 148r:] [...] *Stampata in Venetia, per Francesco Rampazetto, ad instantia de gli heredi di Bernardo Giunti di Firenze. 1563.*

Serafino Razzi [author], F. Rampazetto [printer], Venice, 1563. The music is set in white notation and is mensural. While the vast majority of this print consists of polyphonic settings of Italian-texted *laude*, there are a small number of Latin-texted settings.

*Cum autem venissent*⁵⁸ (fols 115^v-116^r) [J. de QUADRIS]

6.8 Readings

The readings of the de Quadris Lamentations and the 1506/1 *laude* have been presented by Cattin.⁵⁹ I propose to examine concordances of the Lamentations of Agricola, de Orto and Lapidida which have not been published or analysed; this section is accompanied by a critical commentary in appendix 8. I intend applying Stanley Boorman's criteria for analysing the variants in these concordances, acknowledging the limitations imposed by such a small sample rate.⁶⁰

⁵⁸ The text of the various verses of 'O dulcissime filie Syon' follows the musical setting of 'Cum autem'; the layout is not dissimilar to that in 1506/1.

⁵⁹ A critical commentary of de Quadris's Lamentations and *laude* may be found in Cattin, *Johannes de Quadris*, pp. 78-85. There is not enough evidence to form any conclusions about Petrucci's readings.

⁶⁰ Stanley Boorman, 'Limitations and Extensions of Filiation Technique', in *Music in Medieval and Early Modern Europe*, ed. Iain Fenlon (Cambridge: Cambridge University Press, 1981), 319-346 (p. 331) presented five categories:

The concordance of Anon. 1's Lamentations in CapePL 3.b.12 is very problematic since the music is radically different as I have mentioned. Furthermore, the note values are consistently different and only an approximate ordering of pitches in certain phrases in the Discantus and Tenor is common to both sources. It is not practically possible to prepare a critical commentary of Anon. 1, apart from a few summary stylistic observations which I presented in chapter 3.

CapePL 3.b.12's concordance of de Orto's Lamentations presents some important reflections upon turn-of-the-century scribal practices. There are two main areas of interest in CapePL 3.b.12; the discovery of the new setting of verse three and the preponderance of 'octave leap' cadences in the Bassus. The latter belong in Boorman's category E since they constitute a major variant; there are four examples in 1506/1's reading while CapePL 3.b.12 presents an extra seven such cadences (four extra octave leap cadences in the verses which correspond with 1506/1 and three in the independent setting of verse three). These cadences are important since none conclude on the customary fifth above the Tenor but are extended by falling a third, thus sounding the third of the chord (the significance of this alteration was discussed in chapter 3). We may assume that de Orto wrote this extended version of the octave leap cadence since it appears in both concordances; the inclusion of further examples in CapePL 3.b.12 suggests that this feature was very popular with its scribe.

There are very few other category E variants in the first two verses; the only significant pitch difference (Tenor, bar 41 has an *f* in CapePL 3.b.12 and an *e* in 1506/1⁶¹) is a syntactically viable alternative in both versions. There are only seven category C variants and the majority of these are decorations within phrases, CapePL 3.b.12 tending to present the less intricate version. The remaining variants concern musical spelling, particularly the use of compound ligatures in CapePL 3.b.12 and the substitution of alternative note values

-
- A = a notational change, with no effect on pitch or rhythm
 - B = a change in the rhythmic treatment of long or repeated notes
 - C = a change in decorative figuration
 - D = an 'error' or minor variant
 - E = a major variant.

⁶¹ Bar numbers refer to Massenkeil's 1965 edition, *Mehrstimmige Lamentationen*.

(categories A and B). CapePL 3.b.12's scribe B was particularly fond of *ligatura quinaria*; Petrucci did not have many compound ligatures beyond the *binaria*.

The independent setting of verse three in CapePL 3.b.12 dovetails with the opening of the 1506/1 reading (see appendix 4), and apart from a convergence towards the end of the section (discussed in chapter 4), there are no similarities. The CapePL 3.b.12 version of verse three is longer than the 1506/1 setting of that verse by three breves [original note values].

While the concordance of Agricola's three-part Lamentations in FlorR 2794 is not complete, there are some similarities between it and 1506/1. Rifkin identified the scribe of this section as the third of four recognisable scribes; this person copied comparatively few works in this manuscript (his other transcriptions also include Agricola works).⁶²

There are enough variants between 1506/1, FlorR 2794 and WarU 2016 to suggest that they were not closely related. These include the variety of initial clefs set (and the various clef changes during the work), key signatures (although FlorR 2794 and WarU 2016 agree), ligatures, coloration and errors. Analysis of pitch and rhythm (category E) shows considerable variants; for example, the second note of bar 47 in the Superius is *b* flat in 1506/1 while the two manuscript sources state *a*.⁶³ The third note of the Contra in bar 77 is *A* in both 1506/1 and WarU 2016 but FlorR 2794 states *G*. The phrase beginning with the text 'et lacrimae ejus' in FlorR 2794 contains incorrect note values in its Discantus and Contra (it is correct in 1506/1 and WarU 2016 with minor variants). Pitches are marginally different in this section with the 1506/1 reading being slightly more decorated. The use of binary ligatures is similar between the three sources; 1506/1 does not replicate the larger compound ligatures (such as the Tenor at bars 32-33) found in the manuscripts. FlorR 2794 provides an extra note of resolution for a few phrases in the Contra and the

⁶² Joshua Rifkin, 'Scribal Concordances for Some Renaissance Manuscripts in Florentine Libraries', *Journal of the American Musicological Society*, 26 (1973), 305-326 (p. 319). The third recognisable scribe of FlorR 2794 copied 'Vostre oeul' [J. Prioris] (fols 24^v-25^r); 'La saison en est', L. Compere, (fols 66^v-67^r but only Superius survives); 'A la mignonne' [Agricola] (fols 71^v-72^r); 'Soit loing ou pres', [Agricola] (fols 72^v-73^r); 'Je scay tout' [Hayne] (fols 73^v-75^r); 'Mon souvenir', Heyne (fol. 75^v) Lamentations [Agricola] (fols 76^r-78^r).

⁶³ Bar numbers refer to Lerner's 1966 edition, *Alexandri Agricola*, pp. 1-7.

Tenor. While the reading of 1506/1 divides certain words into syllables, FlorR 2794's does not split any word. The rather cramped presentation of text towards the end of certain lines suggests that the scribe of FlorR 2794 wrote the music initially, adding the text later. The textual placement is quite similar between the three sources.

Edward Lerner suggested a reason for the use of a B flat signature only in the Contra of WarU 2016 (it is also present in FlorR 2794 although Lerner did not know this source).⁶⁴ He noted that this apparent 'error' in WarU 2016 was due to the chant's mode six and its tendency to cadence on the notes *c*, *d*, or *f*. Lerner suggested that the problematic cadence to *a* at bar 163 where the *b* flat in 1506/1's Tenor formed a tritone with the Contra was read as a *b* natural in WarU 2016, thus avoiding a tritone (implying that the manuscript's Superius and Tenor would infer most B flats by hexachordal practice). As if to reinforce this idea, WarU 2016 has a number of B flat accidentals positioned where there might be ambiguity in the interpretation of hexachords. If Petrucci's editor was working from such a manuscript and had decided that the majority of Bs were to be flattened (and therefore better served by a B flat key signature in Superius and Tenor), then he forgot or did not realise that the Tenor's *b* in bar 163 would have to be raised. The possibility also remains that this incongruity was known and the editor assumed that the problem would be solved by *musica recta*. We are thus reminded that similar dilemmas were often encountered by editors of prints and by scribes.

FlorBN Panc. 27 provides a brief concordance of the opening of Lapidica's Lamentations. The readings are quite close, particularly the lack of ligatures other than *binaria* in FlorBN Panc. 27, and the identical placing of those *binaria* in 1506/2. Text setting is identical between the two sources; the Florence scribe was more specific and often split words (no words are split in the corresponding 1506/2 reading). There are a few marginal differences in the use of alternative note values and slight cadential embellishments, particularly in the Bassus. The only blatant pitch difference between the two sources may be found in the Bassus in bar 24 (the B flat is incorrect in 1506/2).

⁶⁴ Lerner, 'The Sacred Music of Alexander Agricola', pp. 67-68.

6.9 Conclusion

We are hindered by a general lack of concordances of the music of 1506/1 and 1506/2. Nevertheless, the sources share an enthusiasm for Passiontide music with Petrucci and, excepting the *laude* in 1506/1 and the readings of CapePL 3.b.12, provide many similarities. This is not to diminish the importance of CapePL 3.b.12; its variants, and the scribal inventiveness of several pieces in that manuscript, show us that it was part of an ongoing process of musical development. Although few manuscripts with Lamentations have survived, we have two precedents for the diversity of CapePL 3.b.12. The first instance may be found in PadBC c56, which features a reordering of de Quadris's Lamentation phrases; the selection of Lamentation verses differs to those set in 1506/1 and FlorBN II.I.350. The other instance may be found in the manifestations of the two-part Lamentation X; the diversity of its sources (including some sixteenth-century printed sources), combined with the extended time between earliest and latest, supports the notion that this setting was both important and apposite for Holy Week. Such instances remind us that polyphonic settings for Holy Week were part of a living and thriving tradition; the selection of music in 1506/1 and 1506/2 is merely an early sixteenth-century snapshot.

Chapter 7

CONCLUSION

7.1 Conclusion

This thesis has attempted to examine the production of 1506/1 and 1506/2 and to investigate the origins of polyphonic music for Holy Week in the Renaissance. I have periodically warned of the dangers of the interpretation of small sample rates but believe that there are sufficient findings to establish some preliminary conclusions.

We must re-evaluate our assessment of the period from which polyphonic Lamentations emerged in the Renaissance. Although Johannes de Quadris, in my opinion, would have been most worthy to be the first composer to set polyphonic Lamentations, it is clear that Lamentation X pre-dates the de Quadris settings (the two-part setting of 'Aleph' in the medieval manuscript VicAC 3 had set the precedent of polyphonic Lamentations in the Veneto region). These anonymous Lamentations serve to remind us of the important contribution of the monastic orders in establishing and practising polyphonic music for Holy Week, particularly the Benedictines. Not only do we find these early Lamentations in manuscripts and prints associated with the Benedictines such as WashLC J6, CapePL 3.b.12, MonteA 871 and the *Cantorino* and *Liber sacerdotalis* prints but the Benedictines continued to promote Holy Week polyphony throughout the sixteenth century, as illustrated by the commissioning of Paolo Ferrarese's 1565 Lamentations for S. Giorgio, Venice. The diversity of *laude* texts such as 'Cum autem' and 'Sepulto Domino' also indicates the monastic enthusiasm for dissemination and improvement. The music of 1506/1 and 1506/2 reflects what must have been a vibrant and thriving tradition in Italy. The additional voices in CapePL 3.b.12, FlorBN Panc. 27 and PozR 1361, combined with the strong possibility that 1506/1's and CapePL 3.b.12's setting of Anon. 1 was originally two-part, supports the notion that there was a rich performing tradition by the early sixteenth century which Petrucci was keen to exploit.

The contribution of the monks to Holy Week polyphony was not limited to their own liturgical practices; they were partly responsible for the tremendous growth of the Italian confraternities during the late Middle Ages and

Renaissance. The confraternities were central to developing various liturgical and para-liturgical Passiontide rituals but, crucially, they added additional financial power to that of the monastic orders. The various versions of the *Adoratio* liturgies were central to the monastic and *laudesi's* Holy Week and contributed to the significant number of extant sources. Young asserted that the *Depositio* ceremonies did not thrive at Rome; however, we are unable to support or argue his statement since there is no musical evidence in the Papal chapel relating to the Holy Week ceremonies in the earlier Renaissance.¹ We have sufficient evidence to show that such polyphony was used in various locations within northern Italy and Naples; furthermore, we know that the use of a more simple musical style was also dependent upon liturgy and location.

There is no evidence relating to accounts of Holy Week performances; the musical style and configuration of extant settings varies widely, reflecting the diversity of possible performance contexts. We know that Naples and other important courtly centres hired professional singers to perform works such as Tinctoris's Lamentations; the *laudesi* also hired singers to perform their polyphony. It is possible that the monks sang Lamentation X and de Quadris; such performances probably included *ad lib.* embellishment. Variants in the readings of Lamentation X support this notion.

There is sufficient evidence to suggest that the Lamentation volumes were not such a huge publishing risk for Petrucci. The prospective interest in these prints from such groups as the Italian *laudesi*, clergy, libraries and courtly circles must have been considerable, even though it is quite likely that these specialised and dedicated volumes may have been partly subsidised by Petrucci's 'mainstream' publications. The decision to publish in the less convenient choirbook format may have reflected the function of the majority of the Lamentations: a source of music, a book with pertinent Holy Week music and a collector's item. These prints provided Italians with an opportunity to purchase the music of Johannes de Quadris, an established composer of the Veneto, as well as music by their latest composers, Bartolomeo Tromboncino and Francesco Ana. The inclusion of tried-and-

¹ Young, *The Drama of the Medieval Church*, 1, 121.

tested northern composers may have provided Petrucci with some insurance in these progressive volumes.

It is quite likely that the 1506/1 and 1506/2 attracted interest amongst prospective purchasers beyond Italy. We know that Ferdinand Columbus had copies of both prints; the inclusion of Lamentations in the Spanish bookseller's list from the mid-sixteenth century confirms foreign interest. Further research, particularly in Eastern Europe, may reveal more editions (the various Polish Renaissance manuscripts containing Holy Week music might indicate that country to be a worthwhile start for such a search).

The continuation of the polyphonic Holy Week repertoire during the sixteenth century and the publication of prints dedicated to the genre justify Petrucci's decision to publish 1506/1 and 1506/2. Georg Rhau's 1538 print, 'Selectae harmoniae quatuor vocum de passione domini', and other such prints demonstrate the viability of producing Passiontide music well after the publication of the Petrucci *Motetti de passione*, Lamentations and *laude* prints.² They also show that the demand for music of the contemporaries of the 1506 composers continued up to the middle of the sixteenth century.

The small numbers of extant copies of 1506/1 and 1506/2 provide a considerable amount of data relating to their production, particularly in respect of stop-press corrections. While an initial inspection of printing quality reveals a favourable comparison with Petrucci's earlier prints, there is sufficient evidence to show that five years of production had taken its toll upon Petrucci's methods (Lodes's conclusion that Petrucci's influence upon his peers was not as important as previously thought is apposite³). It is evident that there was some disruption during the production stage; 1506/1 was produced under pressure since Petrucci undoubtedly intended its completion by Holy Week. The dubious quality of the proofing in that volume is evidence of the pressure Petrucci's men were under during Lent of 1506. 1506/2 was not without problems, particularly gathering BI-2 where damage to type elements and

² The Lamentations in Rhau's 1538 print, previously attributed to Isaac, have been proved doubtful by Nigel St. John Davison, who attributes them to La Rue, Stephan Mahu or Antoine de Fevin; see Nigel St. John Davison, ed., *Pierre de la Rue Collected Works*, 8. The Motets, CMM, 97, ([n.p.]: American Institute of Musicology, 1996) pp. XLIII-XLIV.

³ Lodes, 'An Anderem Ort', 110-111.

stave-sets is evident (along with the shortage of sorts shown by the imposition of the 'Tenor' part name). We have enough evidence to support the notion that two men imposed 1506/1 and 1506/2; one of these men was somewhat less experienced than the other and his work undoubtedly suffered when under pressure.

The finished results of 1506/1 and 1506/2 are quite fine but lack the splendour and finesse of Petrucci's earlier print series. One wonders if the differences in house style between the two prints may have discouraged collectors from buying both prints (1506/2 presumably benefited from a decision to publish it later in the year although it was an easier and more consistent volume to impose). There is a distinctive variation in the quality of compositions, reflecting the undoubtedly wide variety of sources available to Petrucci prior to editing and publication. Even the relatively small amount of surviving concordances shows a rich diversity in their respective traditions, encompassing Italian monastic and ecclesiastic sources, courts and the *laudesi* (the latter particularly shows Petrucci's desire to represent native polyphony). Manuscripts with concordances that originated beyond Italy, including PozR 1361 and WarU 2016, must be representative of a much wider influence of the music in 1506/1 and 1506/2; the traditions contained in MonteA 871 also reflect interest in this music by non-Italians. However, the vast majority of purchasers probably ignored these factors; they were content to own prints containing texts and music which represented the highlight of the liturgical year, combined with the names of composers representing some of the best in their profession.

APPENDICES

a) *[facile]*

Quo - mo - do se - det so - la
 ci - vi - tas ple - na
 po - pu - lo

Quo - mo - do se - det so - la
 ci - vi - tas ple - na
 po - pu - lo

b) *A - leph.*

Quo - mo - do se - det so - la
 ci - vi - tas ple - na
 po - pu - lo

Quo - mo - do se - det so - la
 ci - vi - tas ple - na
 po - pu - lo

c) *A - leph.*

Quo - mo - do se - det so - la
 ci - vi - tas ple - na
 po - pu - lo

Quo - mo - do se - det so - la
 ci - vi - tas ple - na
 po - pu - lo

d) *A - leph.*

Quo - mo - do se - det so - la
 ci - vi - tas ple - na
 po - pu - lo

Quo - mo - do se - det so - la
 ci - vi - tas ple - na
 po - pu - lo

e) *A - leph.*

Quo - mo - do se - det so - la
 ci - vi - tas ple - na
 po - pu - lo

Quo - mo - do se - det so - la
 ci - vi - tas ple - na
 po - pu - lo

a) 

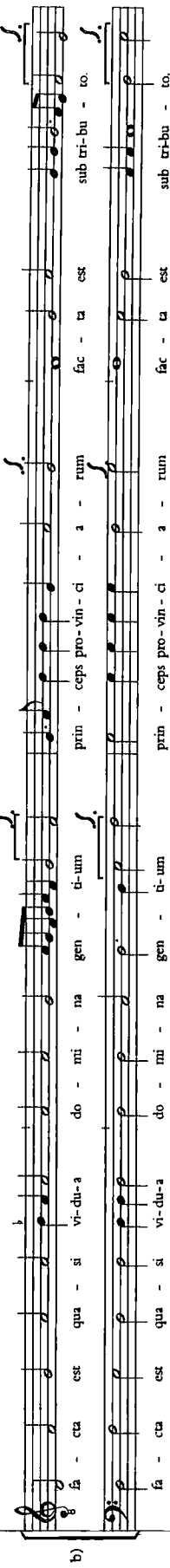
b) 

c) 

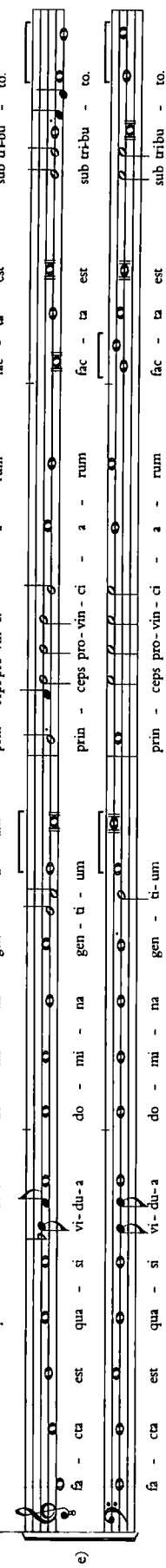
e) 

a) 

Je - ru - sa - lem, Je - ru - sa - lem, con - sa - lem, ve - te - re

b) 

Je - ru - sa - lem, Je - ru - sa - lem, con - sa - lem, ve - te - re

c) 

Je - ru - sa - lem, Je - ru - sa - lem, con - sa - lem, ve - te - re

e) 

Je - ru - sa - lem, Je - ru - sa - lem, con - sa - lem, ve - te - re

a) Musical notation for system a) showing two staves (treble and bass clef) with lyrics: do - mi - num de - um tu - um. The word 'ad' is written above the first staff.

b) Musical notation for system b) showing two staves with lyrics: do - mi - num de - um tu - um. The word 'ad' is written above the first staff. The word 'Beth.' is written below the second staff.

c) Musical notation for system c) showing two staves with lyrics: do - mi - num de - um tu - um. The word 'ad' is written above the first staff. The word 'Beth.' is written below the second staff.

e) Musical notation for system e) showing two staves with lyrics: do - mi - num de - um tu - um. The word 'ad' is written above the first staff. The word 'Beth.' is written below the second staff.

A double bar line with a repeat sign.

c) Musical notation for system c) showing two staves with lyrics: Plo - rans plo - ra - vit in noc - te et la - cri - mae ei - us. The word 'ad' is written above the first staff. The word 'Beth.' is written below the second staff.

19

b)

Gi - mel. Deleth. Deleth.

c)

in ma - xil - lis e - ius in ma - xil - lis e - ius

e)

Gi - mel. De - leth. He. De - leth. He.

Detailed description: This block contains three systems of musical notation, labeled b), c), and e). Each system consists of a vocal line (treble clef) and a bass line (bass clef). System b) features the lyrics 'Gi - mel. Deleth. Deleth.' with a melisma 'mel.' and two instances of 'Deleth.'. System c) features the lyrics 'in ma - xil - lis e - ius in ma - xil - lis e - ius' with a melisma 'mel.' and two instances of 'e - ius'. System e) features the lyrics 'Gi - mel. De - leth. He. De - leth. He.' with a melisma 'mel.' and two instances of 'De - leth.' and 'He.'. The notation includes various note values, rests, and dynamic markings.

APPENDIX 2

Texts set in 1506/1 and 1506/2

*Lamentations chapter 1*¹

- 1 ALEPH Quomodo sedet sola
civitas plena populo
facta est quasi vidua domina
gentium
princeps provinciarum facta est sub
tributo
- 2 BETH Plorans ploravit in nocte et
lacryme eius in maxillis eius
non est qui consoletur eam² ex
omnibus caris eius
omnes amici eius spreverunt eam et
facti sunt ei inimici
- 3 GIMEL Migravit iuda³ propter
afflictionem et multitudinem
servitutis
habitavit inter gentes nec invenit
requiem
omnes persecutores eius
apprehenderunt eam inter
angustias⁴

- 4 DELETH Viae syon lugent eo
quod non sint⁵ qui veniant ad
solemnitatem
omnes porte eius destructe
sacerdotes eius gementes
virgines eius squalide et ipsa
oppressa amaritudine
- 5 HE⁶ Facti sunt hostes eius in
capite inimici eius⁷ locupletati
sunt
quia dominus locutus est super eam
propter multitudinem
iniquitatum eius⁸
parvuli eius ducti sunt in⁹
captivitatem ante faciem
tribulantis¹⁰
- 6 VAV Et egressus¹¹ est a filia
syon omnis decor eius
facti sunt principes eius velut¹²
arietes non invenientes pascua

¹ Latin word abbreviations in 1506/1 and 1506/2 have not been noted here, except for the *unica* texts 'O dulcissime filie Sion' and 'Passio sacra'. GB-Lbl. 1497, *Breviarium Romanum*, Venice, shelfmark: I.A. 22569, provided the Lamentation verses for most of this appendix, except as noted (I could not find one single contemporary source containing the complete Lamentation verses).

Lamentation verses not set in 1506/1 and 1506/2 have been omitted in this appendix; layout follows that of *Biblia sacra iuxta latinam vulgatam...*, 18 vols. (Rome: Typis Polyglottis Vaticanis, 1972), XIV, 285-307.

² 'qui consoletur eam' omitted fols 6^v-7^r, 1506/1 (Ycart).

³ All Lamentations in 1506/1 and 1506/2 use 'iudas'.

⁴ 'omnes persecutores eius apprehenderunt eam inter angustias' omitted fols 15^v-16^r, 1506/1 (Anon. 1).

⁵ Discantus reads 'quod non est' on fol. 18^v, 1506/1 (Agricola three-part). 'sit' rather than 'sint' on fols 37^v-38^r, 1506/2 (Weerbeke).

⁶ Discantus and Tenor read 'Teth' rather than 'He' on fols 31^v-32^r, 1506/1 (de Quadris).

⁷ Discantus and Tenor read 'in capite inimici eius' while Contra reads 'in capite inimici illius' on fols 19^v-20^r, 1506/1 (Agricola three-part); 'in capite inimici illius' on fols 4^v-5^r, 1506/2 (Tromboncino, all parts) and on fols 47^v-48^r, 1506/2 (Lapicida, all parts).

⁸ 'locupletati sunt quia...iniquitatum eius' omitted fols 31^v-32^r, 1506/1 (de Quadris); 'Facti sunt ...iniquitatum eius' not set on fols 37^v-38^r, 1506/2 (Weerbeke).

⁹ 'in' omitted on fols 37^v-38^r, 1506/2 (Weerbeke).

¹⁰ Altus reads 'subsequentis' while other parts read 'tribulantis' on fols 47^v-48^r, 1506/2 (Lapicida).

¹¹ Altus and Bassus read 'egressa' on fols 48^v-49^r, 1506/2 (Lapicida).

¹² 'velud' on fols 31^v-32^r, 1506/1 (de Quadris).

et abierunt absque fortitudine ante
faciem subsequenteris¹³

7¹⁴ ZAI Recordata est i<e>rusalem
dierum afflictionis sue et
prevaricationis
omnium desiderabilium suorum
que habuerat a diebus antiquis
cum caderet populus eius in
manu hostili¹⁵ et non esset
auxiliator
viderunt¹⁶ eam hostes et
deriserunt sabbata eius¹⁷

8 HETH¹⁸ Peccatum peccavit
i<e>rusalem propterea¹⁹
instabilis facta est
omnes qui glorificabant eam
spreverunt illam quia viderunt
ignominiam eius
ipsa autem gemens et conversa
retrorsum²⁰

9 TETH Sordes eius in pedibus eius
nec recordata est finis eius²¹

deposita est vehementer non habens
consolatorem
vide Domine afflictionem meam
quoniam erectus est inimicus²²

10 IOTH Manum suam misit hostis
ad omnia desiderabilia eius
quia vidit²³ gentes ingressas
sanctuarium suum
de quibus preceperas ne intrarent in
ecclesiam tuam

11 CAPH Omnis populus eius
gemens et querens panem
dederunt preciosa queque pro cibo
ad refocilandam animam
vide domine et considera quoniam
facta sum vilis

12 LAMED O vos omnes qui transitis
per viam
attendite et videte si est dolor
sicut²⁴ dolor meus
quoniam vindemiavit me ut locutus
est dominus in die furoris sui

13 MEM De excelso misit
ignem²⁵ in ossibus meis et
erudivit me
expandit rete pedibus meis convertit
me retrorsum
posuit me desolatam tota die
merore confectam

14 NUN Vigilavit iugum iniquitatum
mearum in manu eius
convolute sunt et imposite collo
meo
infirmata est virtus mea dedit me
dominus in manu de qua non
potero surgere

15 SAMECH Abstulit omnes
magnificos meos dominus de
medio mei

¹³ 'velut arietes' and 'et
abierunt...subsequentis' are not set on fols
38^v-39^r, 1506/2 (Weerbeke).

¹⁴ GB-Lbl. 1481, [lacking title page;
Breviary], Venice, shelfmark: I.A. 19879;
(henceforth '1481') provided verses 7-9.

¹⁵ 'eius in captivitatem' rather than 'eius
in manu hostili' on fols 6^v-7^r, 1506/2
(Tromboncino).

'que habuerat...auxiliator' is not set on fols
38^v-39^r, 1506/2 (Weerbeke).

¹⁶ Discantus reads 'viderent' on fol. 32^v,
1506/1 (de Quadris).

¹⁷ 'eam hostes deriserunt' on fols 32^v-33^r,
1506/1 (de Quadris).

'et deriserunt sabbata sua' on fols 21^v-22^r,
1506/1 (Agricola three-part).

¹⁸ Discantus and Tenor read 'Eth' rather
than 'Heth' on fols 32^v-33^r, 1506/1 (de
Quadris).

¹⁹ 'peccatum peccavit iudas et israel
propterea' on fols 32^v-33^r, 1506/1 (de
Quadris).

²⁰ 'et conversa est retrorsum' on fols 32^v-
33^r, 1506/1 (de Quadris); 'conversa est
retrorsum' on fols 7^v-8^r, 1506/2
(Tromboncino).

²¹ 'sui' rather than 'eius' on fols 33^v-34^r,
1506/1 (de Quadris) and on fols 7^v-8^r,
1506/2 (Tromboncino) and in the
Breviarium Romanum of Pius V (1568);
(henceforth '1568').

²² 'est inimicus meus' on fols 33^v-34^r,
1506/1 (de Quadris).

²³ 'viderunt' on fols 8^v-9^r, 1506/2
(Tromboncino).

²⁴ 'dolor similis sicut' on fols 10^v-11^r,
1506/2 (Tromboncino).

²⁵ 'ignem' omitted in Bassus on fol. 12^r,
1506/2 (Tromboncino).

vocavit adversum me tempus ut
contereret electos meos²⁶

16²⁷ AIN Id circo ego plorans et
oculus meus deducens
aquam²⁸
quia longe factus est a me
consolator convertens animam
meam
facti sunt²⁹ filii mei perditii
quoniam invaluit inimicus

18 SADE Iustus est dominus quia
os eius ad iracundiam provocavi
audite obsecro universi populi et
videte dolorem meum
virgines mee et iuvenes mei abierunt
in captivitatem

19 COPH Vocavi amicos meos et
ipsi deceperunt me
sacerdotes mei et senes mei in urbe
consumpti sunt
quia quesierunt cibum sibi ut
refocillarent animam suam

20 RES Vide Domine quoniam
tribulor venter meus
conturbatus est³⁰
subversum est cor meum in memet
ipsa quoniam amaritudine plena
sum
foris interfecit gladius et domi mors
similis est

21 SEN³¹ Audierunt quia
ingemisco ego et non est qui
consoletur me

²⁶ Tromboncino's text continues:
'torcular calcavit me dominus virgini filie
iuda' on fols 13^v-14^r, 1506/2, and in 1568.

²⁷ GB-Lbl. 1522, *Officium Hebdomade
sancte: secundum Romanam curiam*, Venice,
shelfmark: C.52.aa (henceforth '1522')
provided verses 16, 18-21.

²⁸ 'aquas' on fols 14^v-15^r, 1506/2
(Tromboncino).

²⁹ 'sont' rather than 'sunt' in Bassus on
fol. 15^r, 1506/2 (Tromboncino).

³⁰ 'conturbatus est venter meus' rather
than 'venter meus conturbatus est' on fols
17^v-18^r, 1506/2 (Tromboncino).

³¹ 'Sin' rather than 'Sen' on fols 17^v-18^r,
1506/2 (Tromboncino).

omnes inimici mei audierunt malum
meum letati sunt quoniam tu
fecisti
adduxisti diem consolationis et fient
similes mei

Lamentations chapter 2

1³² ALEPH Quomodo obtexit
caligine in furore suo dominus
filiam³³ syon
projecit de celo in³⁴ terram
inclytam israel³⁵
et non recordatus³⁶ est scabilli
pedum suorum in die furoris sui

2 BETH Precipitavit dominus³⁷
nec pepercit omnia speciosa
iacob
destruxit in furore suo munitiones
virginis iuda
deiecit in terram polluit³⁸ regnum
et principes eius³⁹

3 GIMEL Confregit in ira furoris sui
omne⁴⁰ cornu israel
avertit retrorsum dexteram suam a
facie inimici
et succendit in iacob⁴¹ quasi
ignem flamme devorantis in gyro

³² 1522 provided verses 1-7.

³³ 'filia' rather than 'filiam' on fols 22^v-23^r,
1506/1 (Agricola four-part).

³⁴ 'in' omitted on fols 19^v-20^r, 1506/2
(Tromboncino).

³⁵ 'ierusalem' rather than 'israel' on fols
22^v-23^r, 1506/1 (Agricola four-part).

³⁶ 'et non est recordatus' on fols 8^v-9^r,
1506/1 (Ycart) and on fols 19^v-20^r, 1506/2
(Tromboncino).

³⁷ 'dominus' omitted on fol. 10^r, 1506/1
(Ycart).

³⁸ Discantus reads 'in terra dolluit' on fol.
23^v, 1506/1 (Agricola four-part); 'in terra
polluit' on fols 20^v-21^r, 1506/2
(Tromboncino).

³⁹ 'eius' omitted on fols 9^v-10^r, 1506/1
(Ycart).

⁴⁰ 'confregit in furore suo omne' rather
than 'confregit in ira furoris sui omne' on
fol. 24^v, 1506/1 (Agricola four-part).

⁴¹ 'et succendit in iacob' omitted on fol.
24^v, 1506/1 (Agricola four-part).

- 4 **DELETH** Tetendit arcum suum
quasi inimicus
firmavit dexteram suam quasi hostis
et occidit omne quod pulchrum
erat visu
in tabernaculo filie syon effudit
quasi ignem indignationem suam
- 5 **HE** Factus est dominus velut
inimicus precipitavit israel⁴²
precipitavit omnia menia⁴³ eius
dissipavit munitiones eius
et replevit in filia iuda⁴⁴
humiliatum et humiliatam
- 6 **VAV** Et dissipavit quasi hortum
tentorium suum demolitus est
tabernaculum suum
oblivioni tradidit dominus in syon
festivitatem et sabbatum
et opprobrio in indignatione
furoris⁴⁵ sui regem et
sacerdotem
- 7 **ZAI** Repulit dominus altare suum
maledixit sanctificationi sue
tradidit in manu inimici muros
turrium eius
vocem dederunt in domo domini
sicut in die solemnii
- 8 **HETH** Cogitavit dominus
dissipare⁴⁶ murum filie syon
tetendit funiculum suum et non
avertit manum suam a
perditione
luxitque antemurale et murus
pariter dissipatus est
- 9 **TETH** Defixe sunt in terra porte
eius
perdidit et contrivit vectes eius
regem eius et principes eius in
gentibus⁴⁷
non est lex et prophete eius non
invenerunt visionem a domino
- 10⁴⁸ **IOTH** Sederunt in terra
conticuere⁴⁹ senes Filie syon
consperserunt cinere capita sua
virgines hierusalem⁵⁰ accincti
sunt ciliciis⁵¹
abiecerunt in terra capita sua⁵²
virgines iuda
- 11 **CAPH** Defecerunt pre lachrymis
oculi mei conturbata⁵³ sunt
viscera mea
effusum est in terra iecur⁵⁴ meum
super contritionem filie populi
mei
cum deficeret parvulus et lactens in
plateis oppidi
- 12 **LAMED** Matribus suis dixerunt
ubi est triticum et vinum
cum deficerent quasi vulnerati in
plateis civitatis
cum exhalarent animas suas in sinu
matrum suarum⁵⁵
- 13 **MEM** Cui comparabo te vel cui
assimilabo te filia hierusalem

⁴² 'ierusalem' on fols 22^v-23^r, 1506/2
(Tromboncino).

⁴³ 'precipitavit dominus menia' rather
than 'precipitavit omnia menia' on fol.
26^v, 1506/1 (Agricola four-part).

⁴⁴ 'et replevit in filia iuda' omitted on fols
26^v-27^r, 1506/1 (Agricola four-part).

⁴⁵ 'Dominus Sion festivitatem et sabbatum
et opprobrium indignatione' on fols 27^v-
28^r, 1506/1 (Agricola four-part).

'dominus festivitatem et sabbatum et in
opprobrium et in indignatione furoris'
[Altus omits 'in' before 'indignatione'] on
fols 23^v-24^r, 1506/2 (Tromboncino).

⁴⁶ Discantus reads 'dissipavit', Altus reads
'dissipavre' while Tenor and Bassus read
'dissipare' on fols 24^v-25^r, 1506/2
(Tromboncino).

⁴⁷ 'et contrivit vectes eius: regem eius'
omitted on fols 10^v-11^r, 1506/1 (Ycart).
'in gentibus' omitted on fols 35^v-36^r,
1506/1 (de Quadris).

⁴⁸ 1481 provided verse 10.

⁴⁹ 'continuerunt' on fols 26^v-27^r, 1506/2
(Tromboncino).

⁵⁰ 'virgines hierusalem' omitted on fols
26^v-27^r, 1506/2 (Tromboncino).

⁵¹ 'cilitijs' on fols 26^v-27^r, 1506/2
(Tromboncino).

⁵² 'accincti sunt...capita sua' is not set on
fols 35^v-36^r, 1506/1 (de Quadris).

⁵³ 'turbata' on fols 35^v-36^r, 1506/1 (de
Quadris).

⁵⁴ 'decus' rather than 'iecur' on fols 35^v-
36^r, 1506/1 (de Quadris).

⁵⁵ Lam. ch. 3:27 follows the end of ch.
2:12, being set in the Tenor and Bassus on
fols 28^v-29^r, 1506/2 (Tromboncino); this
verse is then followed by the word 'sua' in
all voices.

cui exequabo te et consolabor te
virgo filia syon
magna est enim velut⁵⁶ mare
contritio tua quis medebitur tui

14⁵⁷ NUN Prophete tui viderunt
tibi falsa et stulta
nec aperiebant iniquitatem
tuam ut te ad penitentiam
provocarent
viderunt autem tibi assumptiones
falsas et eiectiones

15 SAMECH Plauserunt super te
manibus omnes transeuntes
per⁵⁸ viam
sibillaverunt et moverunt capita
suum super filiam hierusalem
heccine est urbs dicentes perfecti
decoris gaudium universe terre

16 AYN⁵⁹ Aperuerunt super te os
suum omnes inimici tui
sibillaverunt et fremuerunt dentibus
et dixerunt⁶⁰ devorabimus
en ista est dies quam expectabamus
invenimus vidimus⁶¹

17 PHE⁶² Fecit dominus⁶³ que
cogitavit
complevit sermonem suum quem
preceperat a diebus antiquis
destruxit et non pepercit
et letificavit super te inimicum et
exaltavit cornu hostium
tuorum⁶⁴

⁵⁶ 'magna enim velud' rather than 'magna est enim velut' on fols 36^v-37^r, 1506/1 (de Quadris).

⁵⁷ 1481 provided verse 14.

⁵⁸ 'per' is not set on fols 37^v-38^r, 1506/1 (de Quadris).

⁵⁹ 'Phe' rather than 'Ayn' on fols 37^v-38^r, 1506/1 (de Quadris), and in 1568.

⁶⁰ 'dentibus suis dixerunt' on fols 37^v-38^r, 1506/1 (de Quadris).

⁶¹ 'invenimus et vidimus' on fols 37^v-38^r, 1506/1 (de Quadris).

⁶² 'Ain' rather than 'Phe' on fols 38^v-39^r, 1506/1 (de Quadris), and in 1568.

⁶³ Tenor reads 'fecit deus' while Discantus reads 'fecit dominus' on fols 38^v-39^r, 1506/1 (de Quadris).

⁶⁴ 'suorum' rather than 'tuorum' on fols 38^v-39^r, 1506/1 (de Quadris).

18⁶⁵ SADE Clamavit cor eorum ad
dominum super muros filie syon
deduc quasi torrentem lacrymas per
diem et noctem⁶⁶
non des requiem tibi⁶⁷ neque
taceat pupilla oculi tui

20 RES Vide domine et considera
quem vindemiaveris ita
ergone comedent mulieres fructum
suum parvulos ad mensuram
palme
si occidit in sanctuario domini
sacerdos et propheta

Lamentations chapter 3

22 HETH⁶⁸ Misericordie domini
quia non sumus consumpti quia
non defecerunt⁶⁹ miserationes
eius

23 HETH Novi dilucolor multa est
fides tua

25 TETH Bonus est dominus
sperantibus in eum anime
querenti illum

27 TETH Bonum est viro cum
portaverunt iugum ab
adolescentia sua

33 CAPH Non enim humiliavit ex
corde suo et abiecit filios
hominum

34 LAMED⁷⁰ Ut contereret⁷¹ sub
pedibus suis omnes vinctos terre

⁶⁵ 1522 provided verses 18 and 20.

⁶⁶ 'et per noctem' rather than 'et noctem' on fols 38^v-39^r, 1506/1 (de Quadris).

⁶⁷ 'ultra' rather than 'tibi' on fols 38^v-39^r, 1506/1 (de Quadris).

⁶⁸ 'Beth' rather than 'Heth' on fols 39^v-40^r, 1506/2 (Weerbeke).

⁶⁹ 'quia defecerunt' on fols 39^v-40^r, 1506/2 (Weerbeke).

⁷⁰ 'Lamed' is not set on fols 39^v-40^r, 1506/1 (de Quadris).

⁷¹ Discantus omits 'ut contereret' on fol. 39^v, 1506/1 (de Quadris).

- 35 LAMED Ut declinaret iudicium
viri in conspectu vultus altissimi
- 36⁷² LAMED Ut perverteret
hominem in iudicio suo dominus
ignoravit
- 37 MEM Quis est iste qui dixit ut
fieret domino non iubente
- 38 MEM ⁷³ Ex ore altissimi non
egredientur nec mala nec bona
- 39 MEM Quid murmuravit homo
vivens vir pro⁷⁴ peccatis suis
- 40 NUN Scrutemur vias nostras et
queramus⁷⁵ et revertamur ad
dominum
- 41 NUN ⁷⁶ Levemus corda nostra
cum manibus ad dominum in
celis
- 42 NUN Nos inique egimus et ad
iracundiam provocavimus
idcirco tu inexorabilis es⁷⁷
- 43 SAMECH Operuisti in furore et
percussisti nos occidisti nec
pepercisti
- 44 SAMECH⁷⁸ Opposuisti nubem
tibi ne transeat oratio
- 45 SAMECH Eradicationem et
abiectionem posuisti me in
medio populorum

⁷² 1522 provided verses 36-45.

⁷³ 'Mem' is not set before verses 38 and 39
on fols 39^v-40^r, 1506/1 (de Quadris).

⁷⁴ 'in' rather than 'pro' on fols 39^v-40^r,
1506/1 (de Quadris).

⁷⁵ 'nostras queramus' on fols 39^v-40^r,
1506/1 (de Quadris).

⁷⁶ 'Nun' is not set before verses 41 and 42
on fols 39^v-40^r, 1506/1 (de Quadris).

⁷⁷ 'in inexorabilis est' rather than 'tu
inexorabilis es' on fols 39^v-40^r, 1506/1 (de
Quadris).

⁷⁸ 'Samech' is not set before verses 44 and
45 on fols 39^v-40^r, 1506/1 (de Quadris).

Lamentations chapter 4

- 1⁷⁹ ALEPH Quomodo obscuratum
est aurum mutatus est color⁸⁰
optimus
dispersi sunt lapides sanctuarii in
capite omnium platearum
- 3 GIMEL Sed et lamie nudaverunt
mammas lactaverunt catulos
suos
filia populi mei crudelis quasi strutio
in deserto⁸¹
- 17⁸² AIN Cum adhuc
subsisteremus defecerunt oculi
nostri ad auxilium nostrum
vanum⁸³
cum respiceremus attenti⁸⁴ ad
gentem que salvare nos⁸⁵ non
poterat
- 18 SADE Lubricaverunt vestigia
nostra in itinere platearum
nostrarum
appropinquavit finis noster completi
sunt dies nostri quia venit finis
noster
- 19 CAPH Velociores fuerunt
persecutores nostri aquilis⁸⁶
celi
super montes persecuti sunt nos⁸⁷
in deserto insidiati sunt nobis

⁷⁹ 1481 provided verses 1 and 3.

⁸⁰ 'dolor' rather than 'color' on fols 40^v-
41^r, 1506/2 (Weerbeke).

⁸¹ 'filia populi...deserto' omitted on fols
40^v-41^r, 1506/2 (Weerbeke).

⁸² 1522 provided verses 17-22.

⁸³ 'vanum' omitted on fols 40^v-41^r, 1506/1
(de Quadris).

⁸⁴ 'attenti' omitted on fols 40^v-41^r, 1506/1
(de Quadris).

⁸⁵ 'nos' omitted on fols 40^v-41^r, 1506/1 (de
Quadris).

⁸⁶ 'equalis' rather than 'aquilis' on fols
40^v-41^r, 1506/1 (de Quadris).

⁸⁷ 'nos' omitted on fols 41^v-42^r, 1506/1 (de
Quadris).

- 20 RES Spiritus oris nostri christus dominus⁸⁸ captus est in peccatis nostris
cui diximus in umbra tua vivemus in gentibus
- 21 SEN Gaude et letare filia edon que habitas in terra hus ad te quoque perveniet calix inebriaberis atque nudaberis
- 22 THAU Completa est iniquitas tua filia syon non addet ultra ut transmigret te
visitavit iniquitatem tuam filia edon discooperuit peccata tua

Lamentations chapter 5

- 1 Recordare domine quid acciderit nobis intueri et respice obprobrium nostrum
- 2 Hereditas nostra versa est ad alienos domus nostre ad extraneos
- 3 Pupilli facti sumus⁸⁹ absque patre matres nostre quasi vidue
- 4 Aquam nostram pecunia bibimus ligna nostra precio conparavimus
- 5 Cervicibus minabamur⁹⁰ lassis non dabatur requies
- 6 Egypto dedimus manum et assyrijs ut saturaremur pane⁹¹
- 7 Patres nostri peccaverunt et non sunt et nos iniquitates eorum portavimus

- 8 Servi dominati sunt nostri non fuit⁹² qui redimeret de manu eorum
- 9⁹³ In animabus nostris afferebam⁹⁴ panem nobis a facie gladii in deserto
- 10 Pellis nostra quasi clibanus exusta est a facie tempestatum famis
- 11 Mulieres in syon humiliaverunt et virgines in civitatibus iuda
- 12⁹⁵ Principes manu suspensi sunt facies senum non erubuerunt
- 13 Adulescentibus inpudice abusi sunt et pueri in ligno corruerunt
- 14 Senes de portis defecerunt⁹⁶ iuvenes de choro psallentium
- 15 Defecit gaudium cordis nostri versus est in luctum chorus noster
- 16 Cecidit corona capitis nostri vobis quia peccavimus
- 17 Propterea mestum factum est in dolore cor nostrum ideo contenebrati sunt oculi nostri
- 18 Propter montem syon quia disperiiit vulpes ambulaverunt in eo

⁸⁸ 'dominus' is not set on fols 41^v-42^r, 1506/1 (de Quadris).

⁸⁹ Discantus reads 'pupilli facti sunt' while Tenor reads 'pupilli facti sumus' on fols 43^v-44^r, 1506/1 (de Quadris).

⁹⁰ 'cervicibus nostris minabamur' on fols 30^v-31^r, 1506/2 (Tromboncino).

⁹¹ 'panibus' rather than 'pane' on fol. 12^v, 1506/1 (Ycart).

⁹² 'nostri et non fuit' on fols 12^v-13^r, 1506/1 (Ycart).

⁹³ 1481 provided verses 9-11.

⁹⁴ 'ferebamus' on fols 31^v-32^r, 1506/2 (Tromboncino). 'afferebamus' in 1568.

⁹⁵ 1522 provided verses 12-18.

⁹⁶ 'senes defecerunt de portis' rather than 'senes de portis defecerunt' on fol. 33^r, 1506/2 (Tromboncino), and in 1568.

Adoramus te Domine

Adoramus te domine Jesu christe Et benedicimus tibi
Quia per sanctissimam crucem Et passionem tuam
Redemisti mundum

Venite et ploremus

Venite et ploremus ante dominum qui passus est pro nobis dicens

Popule meus

Popule meus quid feci tibi
aut in quo contristavi te responde mihi.
Quia eduxi te de terra egipti
parasti crucem salvatori tuo

Quia eduxi te per desertum
quadraginta annis
et manna cibavi te
et introduxi in terram satis optimam

Quid ultra debui facere tibi
ego quidem plantavi te
vineam meam speciosissimam
et tu factam es mihi nimis amara

Aceto namque sitim meam potasti
et lancea perforasti latus salvatori tuo
Ego propter te flagellavi egiptum
cum primogenitis suis et tu me flagellatum tradidisti

Ego eduxi te de egipto demerso pharaone
in mare rubrum et tu me tradidisti principibus sacerdotum
Ego ante te aperui mare et tu aperuisti lancea latus meum.

Ego ante te preivi in columpna [*sic*] nubis
et tu me duxisti ad pretorium pilati
Ego te pavi manna per desertum
et me cecidisti alapis et flagellis

Ego te potavi aqua salutis de petra
et me potasti felle et aceto
Ego propter te cananeorum regem percussi
et tu percusisti arundine caput meum

Ego dedi tibi sceptrum regale
et tu meo capiti spineam coronam
Ego te exaltavi magna virtute
et tu me suspendisti in patibulo crucis

Cum autem venissem

Cum autem venissem ad locum ubi crucifigendus erat filius meus statuerunt eum in medio omnes populi et vestibus expoliatis nudum dimiserunt corpus sanctissimum

Sepulto Domino

Sepulto domino signatum est monumentum
volventes lapidem ab hostio monumenti
Ponentes milites qui custodirent illum
Ne forte veniant discipuli eius et furentur eum
et dicant plebi surrexit a mortuis.

O dulcissime filie Sion

O dulcissime filie sion o dulcissime videte dolorem maximum inspicite nudum in medio omnis || populi filium meum dulcissimum vulneratus est in medio eorum || O vos omnes qui transitis per viam venite et videte si est dolor sicut meus desolata sum nimis || nec est qui consoletur salus mea confirmata est vita occiditur et a me tollitur || O nimis triste spectaculum o crudele supplicium inpensum filio o felix rex indecenti morte || coronatur: pontificis iniquitate: tantum ne in vestrum exardesitis deum. || Attende vos o populi et universe plebes dolorem maximum morte turpissima mactaverunt || filium meum vos optime sorores flete una mecum de filio conqueramur. ||

Mortuum iam deposuerant eum exanimis amplector corpus sanctissimum nunc caput deosculabar || nunc pedes et vulnera et amarissimis fletibus exanimata cecidi super terram || Cum portaretur ad sepulcrum illos sequebar amarissime plorando et lamentabar post eos dicendo || sinite me osculari corpus sanctissimum dulcissimi filij. ||

Cum vero venissem ad locum ubi sepelliendus erat filius meus statuerunt cum in medio mulierum || et sindonem involventes sepultum dimiserunt corpus sanctissimum:

Passio sacra nostri redemptoris

Passio sacra nostri redemptoris
munda nos manans rivulus cruoris
Jesu salvator veniam peccati
tribue nobis qui a te creati
Sanguine tuo sumus redempti
Inferni prius legibus detenti
Amen

Pientissimus nostre salutis autor hodierna die humanum a lege peccati liberans genus affixus cruci cum accepisset acetum dixit consumatum est Et inclinato capite emisit spiritum Amen.

Benedictus Dominus Deus Israel

Benedictus dominus deus israel quia visitavit et fecit Redemptionem plebis sue
Sicut locutus est per os sanctorum quia seculo sunt prophetarum eius
Ad faciendam misericordiam cum patribus nostris
et memorari testamenti sui sancti
Ut sine timore de manu inimicorum nostrorum liberati serviamus illi
Et tu puer propheta altissimi vocaberis prebis enim ante faciem domini parare
vias eius
Per viscera misericordie dei nostri in quibus visitavit nos oriens ex alto
Gloria patri et filio et spiritui sancto.

116

ha - bi - ta - vit in - ter - gen - tes nec in - ve - nit re -

ha - bi - ta - vit in - ter - gen - tes nec in - ve - nit re - qui

ha - bi - ta - vit in - ter - gen - tes nec in - ve - nit re -

ha - bi - ta - vit in - ter - gen - tes nec in - ve - nit re - qui

116

gen - tes nec in - ve - nit re - qui - em Om -

ter gen - tes nec in - ve - nit re - qui - em Om -

ter gen - tes nec in - ve - nit re - qui - em Om -

ter gen - tes nec in - ve - nit re - [qui - em] Om -

Detailed description: This is a musical score for five vocal parts, likely a choir or soloists. The score is divided into two systems. The first system (measures 116-120) features five staves. The lyrics are: 'ha - bi - ta - vit in - ter - gen - tes nec in - ve - nit re -' for the first three staves, and 'ha - bi - ta - vit in - ter - gen - tes nec in - ve - nit re - qui' for the last two. The second system (measures 121-125) continues with: 'gen - tes nec in - ve - nit re - qui - em Om -' for the first three staves, and 'ter gen - tes nec in - ve - nit re - qui - em Om -' for the last two. The notation includes treble clefs, a key signature of one flat (B-flat), and a common time signature. Various musical symbols such as slurs, ties, and dynamic markings (e.g., 'V') are present. The lyrics are written below the notes, with hyphens indicating syllables that span across multiple notes.

133 in - ter an - gus - ti - as Je - ru - sa -
In - ter an - gus - ti - as Je - ru - sa -
in - ter an - gus - ti - as Je - ru - sa -
in - ter an - gus - ti - as Je - ru - sa -
in - ter an - gus - ti - as Je - ru - sa -

138 In - ter an - gus - ti - as [no pause] Je - ru - sa - lem
In - ter an - gus - ti - as Je - ru - sa -
In - ter an - gus - ti - as Je - ru - sa -
In - ter an - gus - ti - as Je - ru - sa -
In - ter an - gus - ti - as Je - ru - sa -

APPENDIX 4

Adoramus te Domine Jesu Christe (1506/1, fol. 2^r)

The musical score is arranged in two systems. The first system contains the vocal parts and a discantus. The second system contains the vocal parts and a discantus.

System 1:

- [Discantus]:** A single staff with a treble clef, key signature of one flat, and a common time signature. It begins with a sharp sign and contains a series of rhythmic patterns.
- Vocal Parts:**
 - Altus:** Treble clef, lyrics: Ad - or - a - mus te do - mi - ne Je - su Chri - ste
 - Tenor:** Treble clef, lyrics: Ad - or - a - mus te do - mi - ne Je - su Chri - ste
 - Bassus:** Bass clef, lyrics: Ad - or - a - mus te do - mi - ne Je - su Chri - ste

System 2:

- Vocal Parts:**
 - Altus:** Treble clef, lyrics: Ad - or - a - mus te do - mi - ne Je - su Chri - ste
 - Tenor:** Treble clef, lyrics: Ad - or - a - mus te do - mi - ne Je - su Chri - ste
 - Bassus:** Bass clef, lyrics: Ad - or - a - mus te do - mi - ne Je - su Chri - ste
- Discantus:** A single staff with a treble clef, key signature of one flat, and a common time signature. It contains a series of rhythmic patterns.

System 3:

- Vocal Parts:**
 - Altus:** Treble clef, lyrics: Et be - ne - di - ci - mus ti - bi Qui - a per sanc - tis -
 - Tenor:** Treble clef, lyrics: Et be - ne - di - ci - mus ti - bi Qui - a per sanc - tis -
 - Bassus:** Bass clef, lyrics: Et be - ne - di - ci - mus ti - bi Qui - a per sanc - tis -
- Discantus:** A single staff with a treble clef, key signature of one flat, and a common time signature. It contains a series of rhythmic patterns.

14

si - mus cru - cern - tu - am
Et pas - si - o - nem tu - am
si - mus cru - cern - tu - am
Et pas - si - o - nem tu - am

21

si - mus cru - cern - tu - am
Et pas - si - o - nem tu - am
Re - de - mis - ti - mun - dum.
Re - de - mis - ti - mun - dum.
Re - de - mis - ti - mun - dum.
Re - de - mis - ti - mun - dum.

APPENDIX 5

Benedictus Dominus Deus Israel (1506/2, fols 50^v-51^r)

The musical score is presented in two systems. The first system includes lute tablature and vocal parts for Alto, Tenor, and Bass. The second system continues the vocal parts.

System 1:

- [Discantus]**: Lute tablature for the lute.
- Alto**: Vocal line with lyrics: Be - ne - dic - tus
- Tenor**: Vocal line with lyrics: Be - ne - dic - tus
- Bassus**: Vocal line with lyrics: Be - ne - dic - tus

System 2:

- Alto**: Vocal line with lyrics: Do - mi - nus
- Tenor**: Vocal line with lyrics: Be - ne - dic - tus
- Bassus**: Vocal line with lyrics: Be - ne - dic - tus

System 3:

- Alto**: Vocal line with lyrics: De - us
- Tenor**: Vocal line with lyrics: De - us
- Bassus**: Vocal line with lyrics: De - us

System 4:

- Alto**: Vocal line with lyrics: Is - ra -
- Tenor**: Vocal line with lyrics: De - us
- Bassus**: Vocal line with lyrics: De - us

System 5:

- Alto**: Vocal line with lyrics: De - us
- Tenor**: Vocal line with lyrics: De - us
- Bassus**: Vocal line with lyrics: De - us

10







Is - ra - el qui - a vi - si - ta - et fe - cit
 qui - a vi - si - ta - vit et fe - cit
 qui - a vi - si - ta - vit et

16

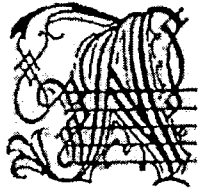
Is - ra - el re - demp - ti - o - nem
 re - demp - ti - o - nem re - demp - ti - o - nem
 re - demp - ti - o - nem re - demp - ti - o - nem

APPENDIX 6¹

Examples of decorated capitals used in 1506/1 and 1506/2

<i>Letter</i>	<i>Designation</i>	<i>Print and folio</i>
	<i>A1</i>	1506/1, fol. 2 ^r
	<i>A2</i>	1506/1, fol. 22 ^v
	<i>A3</i>	1506/2, fol. 40 ^v
	<i>B1</i>	1506/2, fol. 33 ^v
	<i>B2</i>	1506/2, fol. 39 ^v
	<i>C1</i>	1506/1, fol. 39 ^v
	<i>H1</i>	1506/2, fol. 4 ^v

¹ Letters are illustrated at actual size (approximately).

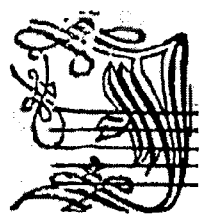
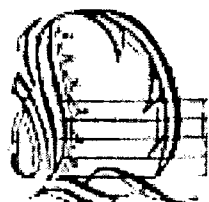
*I₁*1506/2, fol. 43^v*I₂*1506/1, fol. 28^v*L₁*1506/1, fol. 36^v*L₂*1506/1, fol. 47^v*P₁*1506/1, fol. 45^v*P₂*1506/1, fol. 48^v*Q₁*1506/1, fol. 16^v*R₁*1506/1, fol. 43^v

*SI*1506/2, fol. 11^v*TI*1506/2, fol. 25^v*T2*1506/1, fol. 31^v*VI*1506/2, fol. 38^v

APPENDIX 7

A summary of Passiontide texts in Capetown Grey¹

<i>Manuscripts</i>				<i>Prints</i>	
CapePL b.3.12	FlorBN Panč. 27	Other contemporary manuscripts	Monte A 871	1506/1 1523 1535	Other Petrucci prints
Incipit lamentatio hieremie, fols 2^v-3^r, D, T		BrusC 16857; Bu 2931, 27 ^r -28 ^r ; UrbU L712, 43 ^v -45 ^r			
Passio domini nostri, fols 3 ^v -4 ^r , monodic voice in white notation					
Altera autem die, fols 5 ^r -7 ^r , D, T, Ct					
Benedictus dominus deus Israel, fols 10^v- 13^r, D, T, Ct				1523, 55 ^v - 58 ^r ; 1535, 55 ^v -58 ^r	
CUM AUTEM, fols 19^v-25^r, D, T, Ct	28 ^v , a3		138 ^v - 139 ^r , a4 [D is similar to 1506]	47 ^v -48 ^r , a2	1508/3, 5 ^v - 6 ^r
SEPULTO DOMINO, fols 25^v-26^v, D, T, Ct				1506/1, 47 ^v -48 ^r , a2	
Sepulto domino, fols 26 ^v -28 ^r , D, T, Ct					
Adoramus te domine, fols 30^v-32^r, D, T, Ct, B					
Ubi charitas, fols 32 ^v - 36 ^r , D, T, Ct		UrbU L712, 44 ^v -45 ^r			
Miserere mei deus, fols 36 ^v -37 ^r , D, T, A, B	48 ^v -49 ^r				
Benedictus dominus deus Israhel, fols 51^v- 56^r, , D, T, Ct, B					
Benedictus dominus deus Israhel, fols 55^v- 56^r, D, T, Ct, B		ParisBNC 676, 9 ^v -10 ^r			
Ave maris stella, fols 56 ^v -57 ^r , T, D, Ct			36 ^r		
Benedicamus domino, fol. 57 ^r , D, T, Ct	19 ^r				
Ave dulcis ave pia, D, T, A, B, fols 58 ^v -60 ^r	29 ^v -30 ^r				1508/3, 31 ^v - 32 ^r
O Jesu dulce, fols 67 ^v - 68 ^r , D, T	50 ^v (a3)				
Cum desiderio, fols 68 ^v - 69 ^r , D, T, B	79 ^r , D, T, Ct				

¹ Texts cited in bold are found in 1506/1 and 1506/2; concordances appear in uppercase letters.

CapePL b.3.12	FlorBN Panc. 27	Other contemporary manuscripts	Monte A 871	1506/1 1523 1535	Other Petrucci prints
Quia per viam [Tromboncino], fols 74 ^v -75 ^r , D, T, A, B					<i>Strambotti</i> 1505
L oration e sempre ² [Tromboncino], fols 75 ^v -76 ^r , D, T, A, B	60 ^v -61 ^r (anon.)	FlorBN BR 230, 22 ^v - 23 ^r (Tromboncino)			<i>Frottole</i> <i>libro primo</i> , 1504, 18 ^v - 19 ^r
A maria fonte/vada ogni ³ , fols 78 ^v -79, D, T, A, B	14 ^v -15 ^r (anon.)				
Patientia ognum me dice, fols 80 ^v -82 ^r , D, T, A, B	80 ^v -81 ^r (anon.)				
Per quella croce [Tromboncino], fols 82 ^v -83 ^r , D, T, B, A					1508/3, 7 ^r
Primum querite ⁴ [P. Congiet or J. Japart], fols 83 ^v -84 ^r , D, T, Ct					<i>Odhecaton</i> 1501, 4 ^v -5 ^r ; Canti B 1503, 34 ^v - 35 ^r
Cum defecerint ligna [sic] ⁵ [Hayne], fols 84 ^v - 85 ^r , D, Ct, B		FlorR 2356, no 22			<i>Odhecaton</i> 1501, 22 ^v - 23 ^r ; = 'De tous biens plaine'
Tenebrae facte sunt [Weerbeke], fols 86 ^v - 88 ^r , D, T, A, B					<i>Motetti de</i> <i>Passione</i> 1503, 16 ^v - 17 ^r
Ave maria gratia plena [Tromboncino], fols 88 ^v -89 ^r , D, T, A, B	7 ^v -8 ^r (B.T.)				1508/3, 39 ^v - 40 ^r (B.T.)
O gloriosa regina mundi (J. Touront or Cesus), fols 89 ^v -90 ^r , D, T, B	53 ^v -54 ^r (anon.)	PerBC 431, 58 ^v -59 ^r (Cesus); ParisBNF 15123, 3 ^v -4 ^r (anon.)			
INCIPIT LAMENTATIO JEREMIAE [de Orto], fols 90 ^v -95 ^r , D, T, A, B				1506/1, 28 ^v -30 ^r (de Orto)	
INCIPIT ORATIO HIEREMIE [Anon. 1], fols 95 ^v -101 ^v , D, T, Ct				1506/1, 13 ^v -16 ^r [Anon. 1]	
O pulcherrima mulierum [Weerbeke], fol. 102 ^r , A, B	59 ^v -60 ^r , a4 (Gaspar)				<i>Motetti A</i> 1502, 40 ^v - 41 ^r , a4 (Gaspar)
Memento mei domine [Isaac], fol. 102 ^v , D, T, B					<i>Misse Izac</i> 1506, D, A, T, B

² *Contrafactum* of *Se ben hor non scopro el focho* (frottola).

³ *Contrafactum* of *Vive lieto*.

⁴ *Contrafactum* of *Je cuide*.

⁵ *Contrafactum* of *De tous biens playne*.

CapePL b.3.12	FlorBN Panc. 27	Other contemporary manuscripts	Monte A 871	1506/r 1523 1535	Other Petrücci prints
Non nobis domine ⁶ , fols 106 ^v -107 ^r , D, T, Ct		FlorR 2356, 64 ^v -65 ^r (anon.)			
Mater digna dei venie [Weerbeke], fols 107 ^v - 108 ^r , D, T, A, B	39 ^v -40 ^r (anon.)				<i>Motetti A</i> 1502, 54 ^v - 55 ^r (Gaspar)
Beatissima uirgo dei genitrix maria ⁷ [Hayne] fols 108 ^v -110 ^r , D, A, T, B		MilD 1			
Da pacem domine, fols 110 ^v -111 ^r , D, T, Ct	31 ^v -32 ^r a4 (anon.)				<i>Motetti A</i> 1502, 45 ^v - 46 ^r , a4 [Altus si placet]
Nam nulli tacuisse nocet ⁸ [Caron], fols 111 ^v -112 ^r , D, T, Ct		FlorR 2356, 70 ^v -71 ^r (anon.); ParisBNF 15123, 136 ^v -137 ^r (anon.)			
Veruntamen universa ⁹ [Isaac], fols 113 ^v -114 ^r , D, T, Ct		PerBC 431, 91 ^v -92 ^r (Henricus Isahc)			
Vidi impium ¹⁰ , fols 115 ^v -116 ^r , D, T, Ct	37 ^v -38 ^r (anon.)				
Quanto magnus ¹¹ [Basin], fols 116 ^v -117 ^r , D, T, Ct		ParisBNF 15123, 93 ^v - 94 ^r (anon.)			
O mira circa ¹² [Busnois], fols 117 ^v - 118 ^r , D, T, Ct		ParisBNF 15123, 178 ^v -179 ^r (solo 1st pt Busnoys)			
Omnis habet ¹³ [Isaac], fols 119 ^v -120 ^r , D, T, Ct	49 ^v -50 ^r (Yzach)				
Homo cum ¹⁴ [Isaac], fols 122 ^v -123 ^r , D, T, A, B					<i>Misse Izac</i> 1506, fols 115 ^r -116 ^r
Omnis laus ¹⁵ [Isaac], fols 123 ^v -124 ^r , D, T, A, B	52 ^v -53 ^r (anon.)	MilD 2, 159 ^v (Isach)			<i>Misse Izac</i> 1506
Amice ad quid ¹⁶ [Agricola], fol. 124 ^v , D, T	15 ^v -16 ^r (Agricola)				

⁶ *Contrafactum* of *Benedicite*; *La plus dolente qui soit née*.

⁷ Information in this entry is derived from Cattin, *Italian laude*, p. xxix.

⁸ *Contrafactum* of *Madame qui tant est mon cuer*.

⁹ *Contrafactum* of *Je suys mal content*; *Serviteur suis*.

¹⁰ *Contrafactum* of *Illuxit dies* [in BerlS 40021].

¹¹ *Contrafactum* of *Madame m'amie*; *madame faites moy savoir*.

¹² *Contrafactum* of *J'ay mains de biens*.

¹³ *Contrafactum* of *Les biens d'amours*; *Ave amator casti*.

¹⁴ *Contrafactum* of the Kyrie of *Missa Chargé de deul*.

¹⁵ *Contrafactum* of the Agnus I of *Missa Chargé de deul*.

¹⁶ *Contrafactum* of *Dictes moy toutes*.

APPENDIX 8

Critical commentary of unpublished concordances of 1506/1 and 1506/2

I have adopted the standard CMM formula;¹ readings from the unpublished sources are noted against the published editions cited below. Note values in the commentary refer to the original values, not to the values of the various editions. Variations and errors in the published editions are also included; the text underlay commentary refers to the position of words in the specific manuscript. I have provided commentaries for five works in 1506/1 and 1506/2; Lerner's edition of Agricola's three-part Lamentations with FlorR 2794; the first two verses of Massenkeil's edition of de Orto's Lamentations with CapePL 3.b.12, Massenkeil's edition of Lapidida's Lamentations with FlorBN Panc. 27 and the unpublished *unica* 'Adoramus te Domine' and 'Benedictus Dominus Deus Israel'. A complete edition of the final verse of de Orto's Lamentations in CapePL 3.b.12 and 1506/1 may be found as Appendix 3; I have not provided a commentary for this section.

[musical variants cited in this commentary are in original note values]

Critical commentary abbreviations

bl	–	note blackened
Br	–	Brevis
cor	–	corona
C ₃	–	Clef C ₃
DL	–	Duplex Long
dot	–	dotted
fl	–	flat
Fu	–	Fusa
L	–	Longa
lig	–	ligature
M	–	Minima

¹ I have included rests in estimating positioning within bars.

Max	–	Maxima
n cor	–	no corona
n bl	–	note not blackened
n lig	–	no ligature
PL	–	Petrucchi's 1506/1 or 1506/2 reading
Sb	–	Semibrevis
sig con	–	signum congruentiae
Sfu	–	Semifusa

Agricola's three-part Lamentations: reading of FlorR 2794

Published edition: Lerner, *Alexandri Agricola*, pp. 1-7² [All comments relate to the Florence source unless noted otherwise]

SIGNATURES:

CONTRA:

1-100 B fl

CLEFS:

DISCANTUS:

28-100 C₂

TENOR:

1-21 F₃; 21-25 C₃; 26-82 F₃; 82-83 C₄; 83-100 F₃

CONTRA:

1-100 F₄

² Lerner's edition of Agricola four-part Lamentations in *Alexandri Agricola* may be found at pp. 8-16.

VARIANTS:

DISCANTUS:

31(2-3) lig || 37(2-5)-38(1-4) Sb dot *f'* M *f'* Sb *f'* Fu *e'* Fu *d'* Sb *e'* Sb *f'* ||
 41(3) [*b*] || 45(3) [*b*] || 47(2) *a* || 48(4) [*b*] || 52(3) [*b*] || 69(1-3) Br bl
 Fu bl Fu bl || 77(1-3) Br bl Fu bl Fu bl || 92(1) [*b*] || 92(5) [*b*] ||
 99(1-7) Sb *c'* Br *f'* Sb *e'* .

TENOR:

20(3-4) M M || 21(4)-25 C3 || 32(1-3)-33(1) lig || 40(2)-43(1) lig ||
 52(2)-53(1) lig || 61(1-3) M dot *d'* SFu *c'* SFu *b* [or *b* fl] || 66(3)-67(1) n lig
 || 70(1) *c* and *f* || 82(3)-83(3) C4 || 86 Double barline after corona ||
 93(1)-93(3) Br bl Fu bl Fu bl || 99(6)-101(1) n lig.

CONTRA:

9(2) *e* || 19(4) *G* || 25(1) *L* || 25(2) *F* and *f* || 35(1-3) Br Sb Sb || 35(1-
 2) Br *d* Br *A* || 37(1-4) Sb *A* Sb *F* Sb *F* Sb *c* Sb *d* || 52(5-6) M *A* ||
 55(1-2) lig || 61(4-5) M *f* || 64(3-4) through 65(1) lig || 65(3) n bl ||
 65(4) n bl || 75(1-2) lig || 77(3-4) lig || 86 Double barline after corona.

TEXT UNDERLAY IN FlorR 2794:

DISCANTUS:

31(2) 'in' || 32(3) 'nocte' || 40(4) 'est' || 41(3) 'qui' || 44(7)
 'consoletur' || 47(4) 'eam' || 52(2) 'eius' erased by scribe || 52(5) 'caris
 eius' || 77(2) 'servitutis' || 94(3) 'inter' || 96(2) 'angustias'.

TENOR:

13(1) 'domina' || 14(1) 'gentium' || 16(1) 'princeps' || 18(1)
 'provinciarum' || 20(3) 'facta' || 21(4) 'est' || 23(3) 'tributo' || 31(2)
 'nocte' || 43(1) 'est' || 44(3) 'qui' || 45(3) 'consoletur' || 48(3) 'eam' ||

56(4) 'eius spreverunt' || 60(4) 'eam' || 77(1) 'servitutis' || 80(1) 'habitavit inter gentes' || 83(4) 'invenit' || 85(3) 'Requiem' || 92(4) 'eam' || 94(4) 'inter angustias'.

CONTRA:

1(1) 'quomodo' || 6(4) 'facta est' || 8(1) 'quasi' || 9(1) 'vidua' || 12(2) 'domina' || 13(1) 'gentium' || 14(2) 'princeps' || 16(2) 'provinciarum' || 30(1) 'ploravit' || 32(4) 'In nocte' || 51(3) 'eius' || 94(1) 'eam inter angustias'.

Lapicida's Lamentations: reading of FlorBN Panc. 27

Published edition: Massenkeil, *Mehrstimmige Lamentationen*, pp. 51-59. All comments relate to the Florence source unless noted otherwise.

SIGNATURES:

CANTUS:

I-34 *b'* fl

ALTUS:

I-34 *b* fl

TENOR:

I-34 *b* fl

BASSUS:

I-34 *B* fl

CLEFS:

CANTUS:

I-34 C1

ALTUS:

I-34 C4

TENOR:

I-34 C4

BASSUS:

I-34 F4

VARIANTS:

CANTUS:

8(1) n cor || 18(7) L || 18(7) DL (PL) || 18(7) n cor (PL) || 38(1) Br (PL).

ALTUS:

18(4) n cor (PL) || 28(1-2) Sb M M || 38(2-3) Sb || 38(1) Br (PL).

TENOR:

8(1) n cor (PL) || 18(2) n cor (PL) || 18(2) DL || 38(1) DL || 38(1) Br (PL).

BASSUS:

8(3-4) Sb M M || 8(1) n cor || 18(4) DL (PL) || 18(4) n cor (PL) ||
18(4) n cor || 23(1) B flat (PL) || 38(1) Br (PL) || 38(1) L.

TEXT UNDERLAY IN FlorBN Panc. 27:

CANTUS:

23(5) 'gentium' || 30(3) 'facta est'.

ALTUS:

1(1) 'In-' || 1(3) 'cipit' || 6(3) 'prophete' || 14(1) 'sedet' || 15(3) 'sola
civitas' || 17(1) 'plena populo' || 20(2) 'vidua' || 22(2) 'domina' || 25(3)
'princeps' || 27(3) 'provinciarum'.

TENOR:

23(1) 'gentium' || 24(2) 'princeps provin' || 26(2) 'ci-arum' || 28(3)
'facta est' || 30(1) 'sub' || 30(4) 'tribu' || 31(4) '-to'.

BASSUS:

1(1) 'In-cipit' || 6(2) 'prophe' || 6(5) 'te' || 9(1) 'A-leph' || 14(2) 'civitas'
|| 16(3) 'populo' || 19(6) 'est' || 22(2) 'domina' || 25(3) 'princeps' ||
26(7) 'provinciarum' || 28(1) 'facta' || 29(1) 'est' || 30(2) 'sub' || 32(2)
'tributo'.

De Orto's Lamentations: reading of CapePL 3.b.12

Published edition: Massenkeil, *Mehrstimmige Lamentationen*, pp. 19-23. All comments relate to CapePL 3.b.12 unless noted otherwise. Music is provided for the letters 'Beth' and 'Gimel' although it is essentially a repetition of the music for 'Aleph' (Petrucci provides the instruction 'ut supra' for 'Beth' and 'Gimel').

SIGNATURES:

NONE

CLEFS:

SUPERIUS:

I-157 C3

ALTUS:

I-157 C4

TENOR:

I-157 C5

BASSUS:

I-157 F4

VARIANTS:





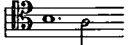
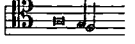
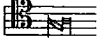

SUPERIUS:

18(1-2) lig || 18(2) L || 28(1-2) lig || 39(3)-48(1) lig || 68(3)-68(1) lig
|| 68(1) sig con || 71(1-2) lig || 78(1-2) lig || 81(1) cor || 88(1) Br ||
88(1-2) lig || 98(2-3) lig || 98(1) cor.

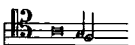

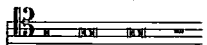
ALTUS:

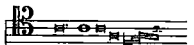
9(I-2) lig || 18(I-2) lig || 15(I) L || 18(I-2) lig || 22(I-2) lig ||
 29(I)-30(I) lig || 39(I)-41(I) lig || 42 (I) Sb Sb || 59 (I-2) lig ||
 62(I)-63(2) lig || 66(4)-67(I) lig || 70(2)-72(I) lig || 74(3-5)  ||
 75(I-2) lig || 79(2-4) lig || 81(3) cor || 82 (I-4)  || 85 (I-3) lig
 || 86(I)-87(I) lig || 88(I) n cor || 89(I-4) Br bl, Fu bl Fu bl || 91 (I) b
 || 92(2)-93(3) 

TENOR:

5(I-2) lig || 6(3-5)  || 7(I-2) lig || 8(2)-12(I) lig || 13(2-4)
 || 16(I)-17(2)  || 17(3)-18(I) lig || 18(2-3) lig ||
 21(I-5)  || 27(I)-28(2) lig || 29(I) n lig || 29(2) n cor ||
 34(I)-37(I)  || 38(I-2) n lig || 40(2)-41(I) lig || 41(I) *f*
 (probably; scribal intention not clear) || 41(2) Sb *f* Sb *f* || 42(I-2) n lig ||
 48(I)-49(I) lig || 62(I-3) lig || 66(I-3) lig || 69(I)-71(2) lig || 76(I-2)
 lig || 80(2)-81(I) lig || 81(I) cor || 82(I) Br || 85(I-3) lig || 86(4)-
 87(I) lig || 88(I) n cor || 89(I)-90(3)  || 91(I-2) lig || 92(2)-
 93(I) lig.

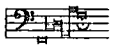
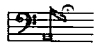
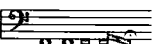
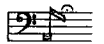
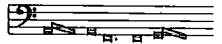
BASSUS:

5 (I) Sb *B* Sb *B* || 6(2-3) lig || 9(I)-11(I)  || 14(I)-15(I) lig ||
 17(I-3) lig || 21(I-3) lig || 26(I-2) lig || 27(I)-30(I) lig || 36(I-2) Br *D*
 || 36(I)-37(I) lig || 38(I-2) lig || 39(I)-41(I) lig || 42(I-2) lig ||
 48(I)-49(I)  || BETH as Aleph except corona on final note ||
 62(I)-63(2) lig || 65(3)-67(I)  || 69(I)-72(I) lig || 75(3)-76(2)
 lig || 76(2) n cor || 80(2)-81(I)  || 82(I) Br || 86(I)-90(2)
 || 92(2)-93(I) 

TEXT UNDERLAY IN CapePL 3.b.12:

SUPERIUS:

9(2) 'phe' || 10(I) 'te' || 22(2) 'modo' || 26(I) 'plena' || 27(2) 'po' ||
28(2) 'pulo' || 43(2) 'fac' || 44(2) 'ta est' || 87(I) 'runt'.

ALTUS:

9(3) 'phete' || 35(2) 'gentium' || 41(2) 'provin' || 42(I) 'tiarum' || 66(4)
'eius' || 70(2) 'eius' || 86(I) 'runt'.

TENOR:

21(4) 'mo' || 38(I) 'princeps' || 71(I) 'eius' || 87(2)-88(I) 'runt eam' ||
90(2) 'sunt' || 91(I) 'ei' || 91(3) 'inimici'.

BASSUS:

48(I) 'to' || 71(2) 'eius' || 75(3) 'eam' || 88(I) 'eam' || 10(I).

Adoramus te Domine Jesu Christe: reading of 1506/1

VARIANTS:

ALTUS:

9(2-3) e' d'.

BASSUS:

16(I) e.

Benedictus Dominus Deus Israel: reading of 1506/2

VARIANTS:

ALTUS:

12(I) n cor.

BIBLIOGRAPHY

8.1 Primary material: Manuscripts

F-Pn: *MS Rés F. 967.*

F-Pn: *MS Rés Vm⁷ 676.*

GB-Lbl: [*A Collection of Specimens, in Tracing or Facsimile, of Early Printing, of Tracings of Early Watermarks on Paper, and of Specimens of Papers with Watermarks, Brought Together and Illustrated with Copious Manuscript Notes by S. and S. L. Sotheby.*] [n. pub.] [n.d.].

GB-Lbl: Sotheby, Samuel Leigh, *The Typography of the Fifteenth Century: Being Specimens of the Productions of the Early Continental Printers, Exemplified in a Collection of Fac-similes from One Hundred Works, Together with their Water Marks* (London: [n. pub.], 1845).

GB-Lbl: Sotheby, Samuel and Samuel Leigh Sotheby, *Principia Typographica. The Block-Books ... Issued in Holland, Flanders and Germany During the Fifteenth Century, Exemplified and Considered in Connexion with the Origin of Printing. To which Is Added an Attempt to Elucidate the Character of the Papermarks of the Period. A Work Contemplated by ... S. Sotheby and Carried Out by his Son*, 3 volumes (London: British Library, 1858).

GB-Ob: *MS Canon. Ital. 193.*

I-Bu: *MS 2931* [microfilm].

I-Fn: *MS Panciatichi 27* [microfilm].

I-Fr: *MS 2794* [microfilm].

US-U: *MS M783.2, L 712 c. 8* [microfilm].

US-Wc: *MS ML 171 J6 Case* [microfilm].

ZA-Csa: *Cape Town, South African Public Library, Grey 3. b. 12* [microfilm].

8.2 Primary material: Prints

- Breviarium romanum* (Venice: n.p., 1497), GB-Lbl: I.A. 22569.
 [Breviary, lacking title page] (Venice: n.p., 1481), GB-Lbl: I.A. 19879.
*Ces presentes heures longues sont a lusiage de Romme toutes au long sans riens
 requerir...* (Paris: n.p., 1520), GB-DRu: Routh SR.8.D.13.
Cantorinus pro his, qui cantum ad chorum pertinentem... (Venice: Luc'Antonio
 Giunta, 1540), GB-Lbl: A.466.b.
Cantorinus pro his, qui cantum ad chorum pertinentem... (Venice: Luc'Antonio
 Giunta, 1550), GB-Lbl: A.466.c.
Cantorinus pro his, qui cantum ad chorum pertinentem... (Venice: Luc'Antonio
 Giunta, 1566), GB-Lbl: A.466.e.
Cantus monastici formula noviter impressa... (Venice: Luc'Antonio Giunta,
 1523), GB-Lbl: M.A.466.f.
Cantus monastici formula noviter impressa... (Venice: Luc'Antonio Giunta,
 1535), GB-Lbl: C.52.aa.9.
Dialogus in astrologie defensionem cum Vaticinio a diluvio usque ad Christi annos
 (Venice: F. Lapidica, 1494), GB-Ob: Douce 123 (2).
Fragmenta missarum (Venice: Ottaviano Petrucci, 1505/1), I-Bc: Q64 [facsimile
 print, Cologne: Dr B. Chr. Becker, 1997].
Harmonice musices odhecaton (Venice: Ottaviano Petrucci, 1504/2), I-Bc: Q51
 [facsimile print, Bologna: Arnaldo Forni Editore, 2003].
Lamentationum Jeremie Prophete liber primus (Venice: Ottaviano Petrucci,
 1506/1), F-Pn: Rés VMC 17.
Lamentationum Jeremie Prophete liber primus (Venice: Ottaviano Petrucci,
 1506/1), GB-Lbl: K.I.d.6*(1.).
Lamentationum Jeremie Prophete liber primus (Venice: Ottaviano Petrucci,
 1506/1), I-Bc: Q66.
Lamentationum Jeremie Prophete liber primus (Venice: Ottaviano Petrucci,
 1506/1), I-Pca: C III; 1185.
Lamentationum liber secundus (Venice: Ottaviano Petrucci, 1506/2), GB-Lbl:
 K.I.d.6*(2.).

- Lamentationum liber secundus* (Venice: Ottaviano Petrucci, 1506/2), F-Pn: Rés VMC 17.
- Lamentationum liber secundus* (Venice: Ottaviano Petrucci, 1506/2), I-Bc: Q67.
- Liber sacerdotalis nuperrime...* (Venice: Melchior Sessa, Petrus de Ravanis, 1523/1), GB-Lbl: 3366.e.38.
- Liber sacerdotalis nuperrime...* (Venice: Victor a Rabanis, 1537), GB-Lbl: 3405.f.19.
- Libro primo delle laudi spirituali da diversi ...* (Venice: F. Rampazetto, 1563/6), GB-Lbl: K.8.f.10.
- Misse Obrecht* (Venice: Ottaviano Petrucci, 1503), D-Mbs: Mus. pr. 160/1 [facsimile print, Cologne: Dr B. Chr. Becker, 1992].
- Misse Izac* (Venice: Ottaviano Petrucci, 1506), I-Bc: Q68.
- Misse Izac* (Venice: Ottaviano Petrucci, 1506), GB-Lbl: K.1.d.7.
- Motetti C* (Venice: Ottaviano Petrucci, 1504/1), GB-Lbl: K.1.d.4.
- Motetti C* (Venice: Ottaviano Petrucci, 1504/1), D-Mbs: Mus. pr. 160/2 [facsimile print, Cologne: Dr B. Chr. Becker, 1992].
- Motetti de passione de cruce de sacramento de Beata Virgine et huiusmodi* (Venice: Ottaviano Petrucci, 1503/1), GB-Lbl: K.1.d.2.
- Motetti libro quarto* (Venice: Ottaviano Petrucci, 1505/2), GB-Ob: Don. d. 12.
- Officium hebdomade sancte: Secundum romanam curiam* (Venice: Antonium Fratres de Sabio, 1522), GB-Lbl: C.52.aa.
- Passionarium Toletanum* (Brocar: Alcalá de Henares, 1516), GB-Lbl: C.35.k. 10.
- Summae divi Thomae* (Bergomi: C. Venturæ, 1589), I-SULc: csst8.

8.3 Secondary material: Printed resources

- Agee, Richard J., 'The Venetian Privilege and Music-Printing in the Sixteenth Century', *Early Music History*, 3 (1983), 1-42.

- Agee, Richard J., 'A Venetian Music Printing Contract and Edition Size in the Sixteenth Century', *Studi musicali*, 15 (1986), 59-65.
- Anglès, Higiní, 'Un manuscrit inconnu avec polyphonie du XVe siècle à la Cathédrale de Ségovia (Espagne)', *Acta musicologica*, 8 (1936), 6-17.
- Arnold, Denis, 'Music at the Scuola di San Rocco', *Music & Letters*, 40 (1959), 229-241.
- Arnold, Denis, 'Music at a Venetian Confraternity in the Renaissance', *Acta musicologica*, 37 (1965), 62-72.
- Atlas, Allan W., *The Cappella Giulia Chansonnier (Rome, Biblioteca Apostolica Vaticana C. G. XIII.27)*, No. 27 of Musical Studies, 2 vols. (Brooklyn: Institute of Mediaeval Music, 1975-76).
- Atlas, Allan W., 'On the Neapolitan Provenance of the Manuscript Perugia, Biblioteca Comunale Augusta, 431 (G 20)', *Musica disciplina*, 31 (1977), 45-105.
- Atlas, Allan W., 'Alexander Agricola and Ferrante I of Naples', *Journal of the American Musicological Society*, 30 (1977), 313-319.
- Atlas, Allan W. and Jane Alden, 'Ycart [Hycart, Icart, Ycaert], Bernhard [Bernar, Bernardus]', *New Grove Dictionary of Music & Musicians*, 2nd edition, 27 (2001), 648-649.
- Atlas, Allan W., *Music at the Aragonese Court of Naples* (Cambridge: Cambridge University Press, 1985).
- Atlas, Allan W., *Renaissance Music: Music in Western Europe, 1400-1600* (New York; London: Norton, 1998).
- Atlas, Allan W. and Anthony M. Cummings, 'Agricola, Ghiselin and Alfonso II of Naples', *Journal of Musicology*, 4 (1989), 540-548.
- Bailey, Terence, *The Processions of Sarum and the Western Church* (Toronto: Pontifical Institute of Mediaeval Studies, 1971).
- Barr, Cyrilla, 'Lauda Singing and the Tradition of the Disciplinati Mandato: A Reconstruction of the Two Texts of the Office of Tenebrae', *L'Arts nova italiano del Trecento*, 4 (1978), 21-44.

- Barr, Cyrilla, *The Monophonic Lauda and the Lay Religious Confraternities of Tuscany and Umbria in the Late Middle Ages* (Kalamazoo: Western Michigan University, 1988).
- Barr, Cyrilla, 'From Devozione to Rappresentazione: Dramatic Elements in the Holy Week Laude of Assisi', in *Crossing the Boundaries: Christian Piety and the Arts in Italian Medieval and Renaissance Confraternities*, ed. K. Eisenbichler (Kalamazoo: Western Michigan University, 1991), 11-32.
- Becherini, Bianca, 'Alcuni canti dell' "Odhecaton" e del codice fiorentino 2794', *Bulletin de L'Institut Historique Belge de Rome* (1942-43), 327-350.
- Becherini, Bianca, 'Musica italiana a Firenze nel XV secolo', *Revue Belge de Musicologie*, 8 (1954), 109-121.
- Becherini, Bianca, *Catalogo dei manoscritti musicali della Bib. Nat. di Firenze*, (Kassel: [n.pub.], 1959).
- Bent, Margaret, ' "Resfacta" and *Cantare Super Librum*', *Journal of the American Musicological Society*, 36 (1983), 371-391.
- Bent, Margaret, 'Some Criteria for Establishing Relationships between Sources of Late-Medieval Polyphony', in *Music in Medieval and Early Modern Europe*, ed. Iain Fenlon (Cambridge: Cambridge University Press, 1981), 295-317.
- Bent, Margaret, 'The Definition of Simple Polyphony. Some Questions', in *Le polifonie primitive in Friuli e in Europa, atti del congresso internazionale Cividale del Friuli, 22-24 Agosto 1980*, ed. Pierluigi Petrobelli (Rome: Edizioni Torre D'Orfeo, 1989), 33-42.
- Bent, Margaret, 'Pietro Emiliani's Chaplain Bartolomeo Rossi da Carpi and the Lamentations of Johannes De Quadris in Vicenza', *Il saggiautore musicale*, 2 (Florence: L. S. Olschki, 1995), 5-15.
- Bent, Margaret, 'The Use of Cut Signatures in Sacred Music', in *Johannes Ockeghem: Actes du XLe Colloque International d'Etudes Humanistes*, ed. Philippe Vendrix (Paris: Centre d'Etudes Supérieures de la Renaissance, Éditions Klincksieck, 1998), 641-680.
- Berenson, Bernard, *The Italian Painters of the Renaissance* (London and New York: Oxford University Press, 1952).

- Bernard, Madeleine (under the direction of Corbin, Solange), *Répertoire de manuscrits médiévaux contenant des notations musicales*, 3; Bibliothèques Parisiennes: Arsenal, Nationale (Musique), Universitaire, École des Beaux-Arts et Fonds Privés (Paris: Centre National de la Recherche Scientifique, 1974).
- Bernstein, Jane A., 'Financial Arrangements and the Role of Printer and Composer in Sixteenth-Century Italian Music Printing', *Acta musicologica*, 63 (1991), 39-56.
- Bernstein, Jane A., 'Buyers and Collectors of Music Publications: Two Sixteenth-Century Music Libraries Recovered', in *Music in Renaissance Cities and Courts: Studies in Honor of Lewis Lockwood*, ed. Anthony Cummings and Jessie Anne Owens (Warren, Michigan: Harmonie Park Press, 1997), 21-33.
- Bernstein, Jane A., *Music Printing in Renaissance Venice: The Scotto Press* (New York, Oxford: Oxford University Press, 1998).
- Bernstein, Jane A., *Print Culture and Music in Sixteenth-Century Venice* (New York, Oxford: Oxford University Press, 2001).
- Bernstein, Lawrence F., 'The Bibliography of Music in Conrad Gesner's Pandectae (1548)', *Acta musicologica*, 45 (1973), 119-161.
- Black, Christopher F., *Italian Confraternities in the Sixteenth Century* (Cambridge: Cambridge University Press, 1989).
- Blackburn, Bonnie J., 'The Printing Contract for the *Libro primo de musica de la salamandra* (Rome 1526)', *Journal of Musicology*, 12 (1994), 345-356.
- Blackburn, Bonnie J., 'Petrucci's Venetian Editor: Petrus Castellanus and his Musical Garden', *Musica disciplina*, 49 (1995), 15-45.
- Blackburn, Bonnie J., 'Lorenzo de' Medici, a Lost Isaac Manuscript, and the Venetian Ambassador', in *Musica Franca: Essays in Honor of Frank A. D'Accone*, ed. Irene Alm, A. McLamore and C. Reardon (Stuyvesant, New York: Pendragon, 1996), 19-44.
- Blackburn, Bonnie J., 'For Whom Do the Singers Sing?', *Early Music*, 25 (1999), 593-609.

- Blackburn, Bonnie J., 'The Virgin in the Sun: Music and Image for a Prayer Attributed to Sixtus IV', *Journal of the Royal Musical Association*, 124 (1999), 157-195.
- Blackburn, Bonnie J., 'The Dispute about Harmony c. 1500 and the Creation of a New Style', in *Théorie et analyse musicales 1450-1650/Music Theory and Analysis. Actes du colloque international, Louvain-la-Neuve, 23-25 septembre 1999*, ed. Anne-Emmanuelle Ceulemans and Bonnie J. Blackburn. *Musicologica neolovaniensia, studia 9* (Louvain-la-Neuve: Département d'Histoire de l'Art et d'Archéologie, Collège Érasme, 2001), 1-37.
- Blackburn, Bonnie J., 'The Sign of Petrucci's Editor', Conference Paper Presented in Venice, October 2001: 'Venezia 1501: Petrucci e la stampa musicale'.
- Blackburn, Bonnie J., 'Canonic Conundrums: The Singer's Petrucci', *Basler Jahrbuch für historische Musikpraxis*, 25 (2001), 53-69.
- Boorman, Stanley, 'Upon the Use of Running Titles in the Aldus House in 1518', *The Library*, 27 (1972), 126-131.
- Boorman, Stanley, 'Petrucci at Fossombrone: A Study of Early Music Printing with Special Reference to the Motetti de la Corona (1514-1519)' (Unpublished Doctoral Dissertation, University of London, 1976).
- Boorman, Stanley, 'The "First" Edition of the *Odhecaton A*', *Journal of the American Musicological Society*, 30 (1977), 183-207.
- Boorman, Stanley, 'Petrucci at Fossombrone: Some New Editions and Cancels', in *Source Materials and the Interpretation of Music: A Memorial Volume to Thurston Dart*, ed. Ian Bent and Michael Tilmouth (London: Stainer & Bell, 1981), 129-153.
- Boorman, Stanley, 'Petrucci's Type-Setters and the Process of Stemmatology', in *Formen und Probleme der Überlieferung mehrstimmiger Musik im Zeitalter Josquins Desprez*, ed. Ludwig Finscher, *Quellenstudien zur Musik der Renaissance*, no. 1 (Munich: Kraus, 1976), 245-280.
- Boorman, Stanley, 'Limitations and Extensions of Filiation Technique', in *Music in Medieval and Early Modern Europe*, ed. Iain Fenlon (Cambridge: Cambridge University Press, 1981), 319-346.

- Boorman, Stanley, 'A Case of Work and Turn: Half-Sheet Imposition in the Early Sixteenth Century', *Library*, 8/4 (1986), 301-321.
- Boorman, Stanley, 'Early Music Printing: Working for a Special Market', in *Print and Culture in the Renaissance*, ed. Gerald P. Tyson and Sylvia S. Wagonheim (Newark, Delaware: University of Delaware, 1986), 222-245.
- Boorman, Stanley, 'Some Non-Conflicting Attributions, and Some Newly Anonymous Compositions, from the Early Sixteenth Century', *Early Music History*, 6 (1986), 109-157.
- Boorman, Stanley, 'Petrucci, Ottaviano', *New Grove Dictionary of Music & Musicians*, 2nd edition, 19 (2001), 518-521.
- Boorman, Stanley, 'Thoughts on the Popularity of Printed Music in 16th-Century Italy', *Fontes artis musicae*, 48/2 (2001), 129-144.
- Boorman, Stanley, 'Did Petrucci's Concern for Accuracy Include Any Concern with Performance Issues?', *Basler Jahrbuch für historische Musikpraxis*, 25 (2001), 23-37.
- Boorman, Stanley, 'Petrucci in the Light of Recent Research', Conference Paper Presented in Venice, October 2001: 'Venezia 1501: Petrucci e la stampa musicale'.
- van den Borren, Charles, 'Inventaire des manuscrits de musique polyphonique qui se trouvent en Belgique', *Acta musicologica*, 5 (1933), 66-71, 177-183.
- van den Borren, Charles, 'Inventaire des manuscrits de musique polyphonique qui se trouvent en Belgique', *Acta musicologica*, 6 (1934), 116-121.
- van den Borren, Charles, *Polyphonia sacra* (London: Plainsong and Mediaeval Music Society, 1962).
- Bouquet, Marie-Thérèse, 'La capella musicale dei Duchi di Savoia dal 1450 al 1500', *Rivista italiana di musicologia*, 3 (1968), 233-285.
- Bowers, Roger, 'Cambridge, Magdalene College, MS Pepys 1236', in *Cambridge Music Manuscripts 900-1700*, ed. Iain Fenlon (Cambridge: Cambridge University Press, 1982), 111-114.

- Bowers, Roger, 'Tuder [Tudor, Tutor], John', *New Grove Dictionary of Music & Musicians*, 25 (2001), 872-873.
- Bridgman, Nanie, 'Un manuscrit du début du XVIe siècle à la Bibliothèque Nationale (Département de la Musique, Rés. Vm.7 676)', *Annales Musicologiques*, 1 (1953), 177-267.
- Bridgman, Nanie, 'Un manuscrit du début du XVIe siècle à la Bibliothèque Nationale', *Annales Musicologiques*, 4 (1956), 259-260.
- Bridgman, Nanie, 'Manuscrits clandestins: A propos du Ms. Res. 862 de la Bibliothèque Nationale de Paris, Fonds du Conservatoire', *Revue de Musicologie*, 43, no. 1 (1967), 21-27.
- Bridgman, Nanie, ed., *Manuscrits de musique polyphonique: XVe et XVIe siècles: Italie*, Répertoire International des Sources Musicales, B IV5, (München: G. Henle Verlag, 1991).
- Briquet, Charles M., ed., *Les Filigranes*, 4 vols. (Geneva: A. Jullien, 1907).
- Brooks, Neil C., *The Sepulchre of Christ in Art and Liturgy*, University of Illinois Studies in Language and Literature, vol. VII/2 (Urbana: University of Illinois, 1921).
- Brown, Horatio F., *The Venetian Printing Press 1460-1800: an Historical Study Based upon Documents for the Most Part Hitherto Unpublished* (Amsterdam: Gerard Th. van Heusden, 1969; Facsimile Reprint of Work Published London: Nimmo, 1891).
- Brown, Howard M., ed., *Milan, Archivio della veneranda fabbrica del Duomo, sezione musicale: Librone 1-3 (olim 2269, 2268, 2267)*, Renaissance Music in Facsimile, 12a-c (New York: Garland, 1987).
- Brown, Howard M., 'On Gentile Bellini's *Processione in San Marco* (1496)', in *International Musicological Society. Report of the Twelfth Congress, Berkeley, 1977*, ed. Daniel Hertz and Bonnie C. Wade (Kassel: Bärenreiter, 1981), 649-656.
- Brown, Howard M., *A Florentine Chansonnier from the Time of Lorenzo the Magnificent: Florence Biblioteca Nazionale Rari 229*, vol. 7 of *Monuments of Renaissance Music* (Chicago; London: University of Chicago Press, 1983).

- Brown, Howard M., 'The Mirror of Man's Salvation: Music in Devotional Life About 1500', *Renaissance Quarterly*, 43 (1990), 744-773.
- Brown, Howard M. and Louise K. Stein, *Music in the Renaissance* (Upper Saddle River, N. J.: Prentice Hall, 1999).
- Brown, R., G. Cavendish-Bentinck, H. F. Brown, A. B. Hinds and others, eds., *Calendar of State Papers and Manuscripts, Relating to English Affairs, Existing in the Archives and Collections of Venice, and in Other Libraries of Northern Italy. 1202-[1674]*, 38 vols. (London, 1864-1947; reprinted Nendeln/Liechtenstein, Kraus Reprints: 1969-1970).
- Bryden, John R. and David G. Hughes, *An Index of Gregorian Chant*, 2 vols. (Cambridge: Harvard University Press, 1969).
- Bukofzer, Manfred F., 'An Unknown Chansonnier of the 15th Century', *Musical Quarterly*, 28 (1942), 14-49.
- Bukofzer, Manfred F., *Studies in Medieval and Renaissance Music* (London: J. M. Dent, 1951).
- Burke, Peter, *Tradition and Innovation in Renaissance Italy* (London: Fontana/Collins, 1974).
- Calella, Michele, 'Lapicida, Lapicide, Erasmus, Rasmus', *Die Musik in Geschichte und Gegenwart*, 10 (2003), 1202-1204.
- Cambon, Elise Murray, 'The Italian and Latin Lauda of the Fifteenth Century' (Unpublished Doctoral Dissertation, Tulane University, 1975).
- Cardamone, Donna G., 'Madrigale a tre et arie napoletane: A Typographical and Repertorial Study', *Journal of the American Musicological Society*, 35 (1982), 436-481.
- Carter, Tim, 'Music-Selling in Late Sixteenth-Century Florence: the Bookshop of Piero di Giuliano Morosi', *Music & Letters*, 70 (1989), 483-504.
- Cattaneo, E., 'Il rituale romano di Alberto Castellani', in *Miscellanea liturgica in onore di S. E. il Card. G. Lercaro*, 2 (Rome; Paris; Tournai; New York: Desclée, 1967), 629-647.
- Cattin, Giulio, 'Contributi alla storia della lauda spirituale', *Quadrivium*, 2 (1958), 45-75.

- Cattin, Giulio, 'Il presbyter Johannes de Quadris', *Quadrivium*, 10/2 (1964), 5-47 and tav. I-IV.
- Cattin, Giulio, 'Le composizioni musicali del Ms. Pavia Aldini 361', *L'Ars nova italiana del Trecento*, 2 (1968), 1-21.
- Cattin, Giulio, 'Polifonia quattrocentesca italiana nel codice Washington, Library of Congress, ML 171 J 6', *Quadrivium*, 9 (1968), 87-102, tav. III-IV.
- Cattin, Giulio, 'Johannes de Quadris musico del secolo XV', *Quadrivium*, 10/2 (1969), 5-47 and tav. I-IV [also separately 1971].
- Cattin, Giulio, 'Tradizione e tendenze innovatrici nella normativa e nella pratica liturgico-musicale della congregazione di S. Giustina', *Benedictina*, 17 (1970), 254-299.
- Cattin, Giulio, 'Uno sconosciuto codice quattrocentesco dell'Archivio Capitolare de Vicenza e le lamentazioni di Johannes de Quadris', *L'Ars nova italiano del Trecento*, 3 (1970), 281-304.
- Cattin, Giulio, ed., *Johannes de Quadris: Opera, Antiquae musicae italicae, monumenta veneta sacra*, 2 (Bologna: Antiquae Musicae Italicae Monumenta, 1972).
- Cattin, Giulio, 'Canti polifonici del repertorio benedettino in uno sconosciuto «Liber Quadragesimalis» e in altre fonti italiane dei secoli XV e XVI inc.', *Benedictina*, 19 (1972), 445-537.
- Cattin, Giulio, 'Nuova fonte italiana della polifonia intorno al 1500 (MS. Cape Town, Grey 3.b.12)', *Acta musicologica*, 45 (1973), 165-221.
- Cattin, Giulio, 'Un processionale fiorentino per la settimana santa: Studio liturgico-musicale sul Ms. 21 dell'opera di S. Maria del Fiore', *Quadrivium*, 15 (1974), 53-204.
- Cattin, Giulio, ed., *Italian Laude and Latin Unica in MS Capetown, Grey 3.b.12, Corpus mensurabilis musicae*, 76 (Rome: American Institute of Musicology, 1977).
- Cattin, Giulio, '“Contrafacta” internazionali: Musiche europee per laude italiane', in *Musik und Text in der Mehrstimmigkeit des 14. und 15. Jahrhunderts*, ed. Ursula Günther und Ludwig Finscher, Göttinger

- Musikwissenschaftliche Arbeiten, Band 10 (Kassel; Basel; and London: Bärenreiter, 1984), 411-443.
- Cattin, Giulio, 'La musica nelle istituzioni fino alla caduta della repubblica', in *Storia di Vicenza, l'età della repubblica veneta (1404-1797)*, ed. Franco Barbieri and Paolo Preto, III/2 (1990, Vicenza, Neri Pozza Editore), 163-184.
- Cattin, Giulio, *Musica e liturgia a San Marco: Testi e melodie per la liturgia delle ore dal XII al XVII secolo: Dal graduale tropato del Duecento ai gradualini cinquecenteschi*, ed. Giordana Mariani Canova and Susy Marcon, Fondazione Levi. Ser. 4, Collezione speciale per la musica veneta. A, Monumenti, 4 vols. (Venice: Edizioni Fondazione Levi, 1992).
- Cattin, Giulio, 'Johannes de Quadris [Quatris]', *New Grove Dictionary of Music & Musicians*, 2nd edition, 13 (2001), 143-144.
- Cattin, Giulio, 'I due libri di lamentazioni (1506) e l'affermazione d'un genere polifonico', Unpublished Paper Presented in Basle, January 2001: 'Petrucci Jahres'.
- Cazeaux, Isabelle, *French Music in the Fifteenth and Sixteenth Centuries* (Oxford: Blackwell, 1975).
- Chapman, Catherine Weeks, 'Printed Collections of Polyphonic Music Owned by Ferdinand Columbus', *Journal of the American Musicological Society*, 21 (1968), 32-84.
- Charles, Sydney R., 'The Provenance and Date of the Pepys MS 1236', *Musica disciplina*, 16 (1962), 57-71.
- Charles, Sydney R., ed., *The Music of the Pepys MS 1236, Corpus mensurabilis musicae*, 40 ([Rome]: American Institute of Musicology, 1967).
- Chrysander, Friedrich, 'A Sketch of the History of Music-Printing from the Fifteenth to the Nineteenth Century', *Musical Times*, 18 (1877), 265-268.
- Cigogna, Emmanuele A., ed., *Delle iscrizioni veneziane* (Venice: Presso Giuseppe Orlandelli, 1824-53).
- Clulow, Peter, 'Publication Dates for Byrd's Latin Masses', *Music & Letters*, 47 (1966), 1-9.

- Corbin, Solange, *La Déposition liturgique du Christ au vendredi saint* (Paris; Lisbonne: Amadora, 1960).
- Crawford, David, 'Vespers Polyphony at Modena's Cathedral in the First Half of the Sixteenth Century' (Unpublished Doctoral Dissertation, University of Illinois, 1967).
- Croll, Gerhard, 'Gaspar van Weerbeke: an Outline of his Life and Works', *Musica disciplina*, 6 (1952), 67-81.
- Croll, Gerhard, 'Zu Tromboncinos "Lamentationes Jeremiae"', *Collectanea historiae musicae*, 2 (1957), III-III4.
- Croll, Gerhard and A. Lindmayr-Brandl, 'Weerbeke [Werbeke, Werbeck], Gaspar [Jaspar, Gaspert] van', *New Grove Dictionary of Music & Musicians*, 27 (2001), 207-210.
- D'Accone, Frank A., 'The Singers of San Giovanni in Florence during the 15th Century', *Journal of the American Musicological Society*, 14 (1961), 307-358.
- D'Accone, Frank A., 'The Musical Chapels at the Florentine Cathedral and Baptistry during the First Half of the 16th Century', *Journal of the American Musicological Society*, 24 (1971), 1-50.
- D'Accone, Frank A., 'The Performance of Sacred Music in Italy during Josquin's Time, c. 1475-1525', in *Josquin des Prez: Proceedings of the International Josquin Festival-Conference Held at the Juilliard School at Lincoln Center in New York City, 21-25 June 1971*, ed. Edward E. Lowinsky in Collaboration with Bonnie J. Blackburn (London: Oxford University Press, 1976), 601-618.
- D'Accone, Frank A., 'Some Neglected Composers in the Florentine Chapels, ca. 1475-1525', *Viator* (1989), 263-288.
- Damilano, Don Piero, 'Fonti musicale della lauda polifonica intorno alla metà del sec. XV', *Collectanea historiae musicae*, 3 (1963), 59-90.
- Damilano, Don Piero, 'Laudi latine in un antiphonario bobbiese del Trecento', *Collectanea historiae musicae*, 3 (1963), 15-41.
- Davison, Nigel St. John, ed., *Pierre de la Rue Collected Works*, 8. The Motets, *Corpus mensurabilis musicae*, 97 ([n.p.]: American Institute of Musicology, 1996).

- Diederichs, Elisabeth, *Die Anfänge der mehrstimmigen Lauda von Ende des 14. bis zur Mitte des 15. Jahrhunderts* (Tutzing: Hans Schneider, 1986).
- van Doorslaer, George, 'La Chapelle musicale de Phillippe le Beau', *Revue Belge d'Archéologie*, 4 (1934), 21-57, 139-165.
- Drake, George Warren J., 'The First Printed Book of Motets, Petrucci's *Motetti A. numero trentatre A* (Venice, 1502) and *Motetti de passione de cruce de sacramento de Beata Virgine et huiusmodi* (Venice, 1503); A Critical Study and Complete Edition' (Unpublished Doctoral Dissertation, University of Illinois, 1972).
- Drake, George Warren J., ed., *Motetti de passione, de cruce, de sacramento, de Beata Virgine et huiusmodi B: Venice, 1503*, *Monuments of Renaissance Music*; 11 (Chicago; London: University of Chicago Press, 2002).
- Driscoll, Eileen R., 'Alfonso of Aragon as Patron of Art', in *Essays in Memory of Karl Lehmann*, ed. Lucy Freeman Sandler ([New York]: Institute of Fine Arts, New York University, 1964), 87-96.
- Duffy, Eamon, *The Stripping of the Altars* (New Haven; London: Yale University Press, 1992).
- Duggan, Mary Kay, *Italian Music Incunabula: Printers and Type* (Berkeley; Los Angeles: University of California, 1992).
- Einstein, Albert, *The Italian Madrigal*, 3 vols. (Princeton, N. J.: Princeton University Press, 1949).
- Eisenstein, Elizabeth, *The Printing Press as an Agent of Change: Communications and Cultural Transformations in Early-Modern Europe* (Cambridge: Cambridge University Press, 1979).
- Eitner, Robert, *Biographische-bibliographisches Quellen-Lexicon der Musiker und Musikgelehrten der christlichen Zeitrechnung bis zur Mitte des neunzehnten Jahrhunderts* (Leipzig: Breitkopf and Härtel, 1900-04).
- Elders, Willem, *Composers of the Low Countries* (Oxford: Oxford University Press, 1991).
- Fallows, David, 'Neapolitan Repertories 1460-90: Three Recent Editions', *Review, Early Music*, 8 (1980), 493-501.
- Fallows, David, *Dufay* (London: J. M. Dent, 1982).

- Fallows, David, *A Catalogue of Polyphonic Songs, 1415-1480* (New York: Oxford University Press, 1999).
- Fallows, David, 'Petrucci's *Canti* Volumes: Scope and Repertory', *Basler Jahrbuch für historische Musikpraxis*, 25 (2001), 39-52.
- Federhofer, Hellmut, 'Musikdrücke von Ottaviano Petrucci in der Bibliothek des Franziskanerklosters Güssing (Burgenland)', *Die Musikforschung*, 16 (1963), 157-158.
- Feicht, Hieronim, ed., *Muzyka Staropolska = Old Polish Music: A Selection of Hitherto Unpublished Works from the XIIth-XVIIIth Centuries* ([Cracow]: Polskie Wydawnictwo Muzyczne, 1966).
- Feldman, Martha, 'Authors and Anonyms: Recovering the Anonymous Subject in Cinquecento Vernacular Objects', in *Music and the Cultures of Print*, ed. Kate van Orden (New York: Garland Publishing Inc., 2000), 163-199.
- Feldmann, Fritz, *Der Codex Mf. 2016 des Musikalischen Instituts bei der Universität Breslau. Eine palaeographische und stilistische Beschreibung* (Breslau: [n.pub], 1932).
- Feldmann, Fritz, ed., *Johannes Tinctoris: Opera omnia*, 1, *Corpus mensurabilis musicae*, 18 ([n.p.]: American Institute of Musicology, 1960).
- Fenlon, Iain, *Music, Print and Culture in Early Sixteenth-Century Italy* (London: The British Library, 1995).
- Fenlon, Iain, *Music and Culture in Late Renaissance Italy* (Oxford; New York: Oxford University Press, 2002).
- von Fischer, Kurt, *Handschriften mit mehrstimmiger Musik des 14., 15. und 16. Jahrhunderts*, *Répertoire International des Sources Musicales*, B IV3 and IV 4 (Munich: G. Henle Verlag, 1972).
- Fitch, Fabrice, *Johannes Ockeghem: Masses and Models* (Paris: Honoré Champion Éditeur, 1997).
- Fitch, Fabrice, 'Restoring Ockeghem's "Mort, Tu As Navré"', *Tijdschrift van de Koninklijke Vereniging voor Nederlandse Muziekgeschiedenis*, 51 (2001), 3-24.

- Fрати, Lodovico, 'Codici musicali della R. Biblioteca Universitaria di Bologna', *Rivista musicale italiana*, 23 (1916), 219-242.
- Fuller, Sarah, 'Additional Notes on the 15th-Century Chansonnier Bologna Q16', *Musica disciplina*, 23 (1969), 81-103.
- Gallagher, Sean, 'Models of Varietas: Studies in Style and Attribution in the Motets of Johannes Regis and his Contemporaries' (Unpublished Doctoral Dissertation, Harvard University, 1998).
- Gallico, Claudio, 'Il laboratorio di Ottaviano Petrucci a Venezia: Musica e immagine grafica', in *Tempi di Giorgione* (Rome: Gangemi, 1994), 78-83.
- Gallo, F. Alberto, '“Cantus planus binatim”: Polifonia primitiva in fonti tardive', *Quadrivium*, 7 (1966), 79-89.
- Gallo, F. Alberto and Giuseppe Vecchi, eds., *I più antichi monumenti sacri italiani*, Monumenta lyrica medii aevi italica. Ser. 3/1 (Bologna: Università degli Studi di Bologna, 1968).
- Gaskell, Philip, *A New Introduction to Bibliography* (Oxford: Clarendon Press, 1972).
- Gastoué, A., 'Manuscripts et fragments de musique liturgique, à la Bibliothèque du Conservatoire, à Paris', *Revue de Musicologie*, 13 (1932), 1-9.
- Gerber, Rudolf, 'Die Hymnen der Handschrift Monte Cassino 871', *Anuario musical*, 11 (1956), 1-21.
- Gerulaitis, Leonardas V., *Printing and Publishing in Fifteenth-Century Venice* (Chicago; London: American Library Association, Mansell Information Publishing Ltd., 1976).
- Ghisi, Federico, 'Un processionale inedito per la settimana santa nell'opera del Duomo di Firenze', *Rivista musicale italiana*, 55 (1953), 362-369.
- Ghisi, Federico, 'Di una lauda nel codice pavese Aldini', in *Essays in Musicology in Honor of Dragan Plamenac*, ed. Gustave Reese and Robert J. Snow (Pittsburgh: University of Pittsburgh, 1969), 61-64.
- Gialdroni, Teresa M. and Agostino Ziino, 'New Light on Ottaviano Petrucci's Activity, 1520-38', *Early Music*, 29 (2001), 501-532.

- Glixon, Jonathan E., 'Music at the Venetian Scuole Grandi, 1440-1540', in *Music in Medieval and Early Modern Europe*, ed. Iain Fenlon (Cambridge: Cambridge University Press, 1981), 193-208.
- Glixon, Jonathan E., 'The Polyphonic Laude of Innocentius Dammonis', *Journal of Musicology*, 8, no. 1 (1990), 19-53.
- Glixon, Jonathan E., 'Far Una Bella Procession: Music and Public Ceremony at the Venetian Scuole Grandi', in *Altro Polo: Essays on Italian Music in the Cinquecento*, ed. R. Charteris (Sydney: Frederick May Foundation for Italian Studies, 1990), 190-220.
- Glixon, Jonathan E., 'Music and Ceremony at the Scuola Grande di San Giovanni Evangelista: A New Document from the Venetian State Archives', in *Crossing the Boundaries: Christian Piety and the Arts in Italian Medieval and Renaissance Confraternities*, ed. K. Eisenbichler (Kalamazoo, Michigan, 1991), 56-89.
- Glixon, Jonathan E., 'Con Canti et Organo: Music at the Venetian Scuole Piccole during the Renaissance', in *Music in Renaissance Cities and Courts: Studies in Honor of Lewis Lockwood*, ed. Anthony Cummings and Jessie Anne Owens (Warren, Michigan: Harmonie Park Press, 1997), 123-140.
- Glixon, Jonathan E., *Honoring God and the City: Music at the Venetian Confraternities, 1260-1807* (New York; Oxford: Oxford University Press, 2003).
- Göllner, Theodor, 'Unknown Passion Tones in Sixteenth-Century Hispanic Sources', *Journal of the American Musicological Society*, 28 (1975), 46-71.
- Gottwald, N. K., 'Book of Lamentations', *The Interpreter's Dictionary of the Bible*, ed. George A. Buttrick, 4 vols. (Nashville; New York: Abingdon Press, 1962), III, 61-63.
- Gould, George M. and Walter L. Pyle, *Anomalies and Curiosities of Medicine: Being an Encyclopedic Collection of Rare and Extraordinary Cases, and of the Most Striking Instances of Abnormality in All Branches of Medicine and Surgery, Derived from an Exhaustive Research of Medical Literature from its Origin to the Present Day, Abstracted, Classified, Annotated, and Indexed by George M. Gould and Walter L. Pyle* (Philadelphia: W. B. Saunders, 1897).

- Grendler, Paul F., *The Roman Inquisition and the Venetian Press, 1540-1605* (Princeton: Princeton University Press, 1977).
- Guerrini, D. Paolo, 'Un codice piemontese di teorici musicali del medioevo', *Rivista musicale italiana*, 34 (1927), 63-72.
- Günther, Ursula and Ludwig Finscher, eds., *Musik und Text in der Mehrstimmigkeit des 14. und 15. Jahrhunderts* (Kassel: Bärenreiter, 1984).
- Haar, James, 'The Early Madrigal: A Re-appraisal of its Sources and its Character', in *Music in Medieval and Early Modern Europe*, ed. Iain Fenlon (Cambridge: Cambridge University Press, 1981), 163-192.
- Haar, James, 'Petrucci as Bookman', Conference Paper Presented in Venice, October 2001: 'Venezia 1501: Petrucci e la stampa musicale'.
- Haggh, Barbara, 'The Meeting of Sacred Ritual and Secular Piety: Endowments for Music', in *Companion to Medieval and Renaissance Music*, ed. David Fallows and Tess Knighton (London: J. M. Dent, 1992), 60-68.
- Hale, John Rigby, ed., *Renaissance Venice* (London: Faber & Faber, 1973).
- Hamm, Charles and Herbert Kellman, eds., *Census Catalogue of Manuscript Sources of Polyphonic Music 1400-1550*, 5 vols. (Neuhausen-Stuttgart: American Institute of Musicology, 1979-1988).
- Hardison, Osborne B., *Christian Rite and Christian Drama in the Middle Ages: Essays in the Origin and Early History of Modern Drama* (Baltimore: Johns Hopkins University Press, 1965).
- Harper, John Martin, *The Forms and Orders of Western Liturgy from the Tenth to the Eighteenth Century: a Historical Introduction and Guide for Students and Musicians* (Oxford: Clarendon, 1991).
- Harrison, Frank L., 'Music for the Sarum Rite: MS. 1236 in the Pepys Library, Magdalene College, Cambridge', *Annales Musicologiques*, 6 (1958-63), 99-144.
- Henderson, W. G. ed., *Missale ad usum percelebris ecclesiae herfordensis* (Farnborough, Hampshire: Gregg International Publishers, 1969).
- Hewitt, Helen, ed., *Harmonice musices odhecaton A*, Edition of the Literary Texts by Isabel Pope (Cambridge, Mass: The Mediaeval Academy of America, 1942).

- Hewitt, Helen, ed., *Canti B numero cinquanta. Venice 1502*, with an Introduction by Edward E. Lowinsky, Texts Edited and Annotated by Morton W. Briggs, Translated by Norman B. Spector (Chicago; London: University of Chicago Press, 1967).
- Houdoy, Jules, *Histoire artistique de la Cathédrale de Cambrai, ancienne église métropolitaine Notre-Dame* (Paris, Lille: [n.pub.], 1880).
- Hudson, Barton, ed., *Hayne van Ghizeghem: Opera omnia, Corpus mensurabilis musicae, 74* ([n.p.]: American Institute of Musicology, 1977).
- Hudson, Frederick, 'Musicology and Paper Study—A Survey and Evaluation', in *Essays in Paper Analysis*, ed. Stephen Spector (New Jersey: Associated University Presses, 1987), 34-60.
- Hughes, Andrew, 'The Choir in Fifteenth-Century English Music: Non-Mensural Polyphony', in *Essays in Musicology in Honor of Dragan Plamenac*, ed. Gustave Reese and Robert J. Snow (Pittsburgh: University of Pittsburgh, 1969), 127-145.
- Hughes, Andrew, 'New Italian and English Sources of the Fourteenth to Sixteenth Centuries', *Acta musicologica*, 39 (1967), 171-182.
- Hughes, Andrew, *Medieval Manuscripts for Mass and Office: A Guide to the Organisation and Terminology* (Toronto; London: University of Toronto Press, 1982).
- Huglo, Michel, and Nancy C. Philips, eds., *Manuscripts from the Carolingian Era up to c. 1500 in Great Britain and in the United States of America*, Répertoire International des Sources Musicales, B III4 (München: G. Henle Verlag, 1992).
- Hunter, Dard, *Papermaking* (London: Pleiades Books, 1947).
- Jeppesen, Knud, 'Ein venezianisches Laudenmanuscript', *Theodor Kroyer-Festschrift*, ed. H. Zenck, H. Schultz and W. Gestenberg (Regensburg: Gustave Bosse, 1933), 69-76.
- Jeppesen, Knud, 'Canzoni sonetti strambotti et frottole, libro tertio (Andrea Antico, 1517) edited by Alfred Einstein. Smith College Music Archives. Number IV. Copyright 1941. Claudio Sartori: *Bibliografia delle*

- Opere musicali stampate da Ottaviano Petrucci*. Firenze, Leo S. Olschki, 1948', *Acta musicologica*, 20 (1948), 78-85.
- Jeppesen, Knud, *Italia Sacra Musica III: Unknown Italian Cathedral Music of the Early Sixteenth Century* (Copenhagen: Hansen, 1962).
- Jeppesen, Knud, *La Frottola: Bemerkungen zur Bibliographie der ältesten weltlichen Notendrucke in Italien*, vol. XL/2, *Acta Jutlandica* (Copenhagen: University of Aarhus, 1968).
- Jeppesen, Knud, *La Frottola II: Zur Bibliographie der handschriftlichen musikalischen Überlieferung des weltlichen italienischen Lieds um 1500*, vol. XLI/I of *Acta Jutlandica* (Copenhagen: University of Aarhus, 1969).
- Jeppesen, Knud, *La Frottola III: Frottola und Volkslied*, vol. XLII/I of *Acta Jutlandica* (Copenhagen: University of Aarhus, 1970).
- Jeppesen, Knud and Viggo Brøndal, *Die mehrstimmige italienische Laude um 1500* (Leipzig: Breitkopf & Hartel, 1935).
- Kellman, Herbert, 'Josquin and the Courts of the Netherlands and France: The Evidence of the Sources', in *Josquin des Prez: Proceedings of the International Josquin Festival-Conference Held at the Juilliard School at Lincoln Center in New York City, 21-25 June 1971*, ed. Edward E. Lowinsky in Collaboration with Bonnie J. Blackburn (London: Oxford University Press, 1976), 181-216.
- Kenney, Sylvia W., 'In Praise of the Lauda', in *Aspects of Medieval and Renaissance Music: A Birthday Offering to Gustave Reese*, ed. Jan LaRue, (New York: Norton, 1966), 489-499.
- King, Alex Hyatt, *Four Hundred Years of Music Printing* (London: British Museum, 1964).
- Kinkeldey, Otto, 'Music and Music Printing in Incunabula', *Papers of the Bibliographical Society of America*, 26 (1932), 89-119.
- Klimisch, Mary Jane, 'The Music of the Lamentations: Historical and Analytical Aspects' (Unpublished Doctoral Dissertation, Washington University, 1971).
- Kmetz, John, 'Petrucci's Alphabet Series: The ABC's of Music, Memory and Marketing', *Basler Jahrbuch für historische Musikpraxis*, 25 (2001), 127-141.

- Knighton, Tess and Carmen Morte, 'Ferdinand of Aragon's Entry into Valladolid in 1513: The Triumph of a Christian King', *Early Music History*, 18 (1999), 119-164.
- Knighton, Tess, 'Petrucci's Books in Early Sixteenth-Century Spain', Conference Paper Presented in Venice, October 2001: 'Venezia 1501: Petrucci e la stampa musicale'.
- Kreitner, Kenneth, 'Very Low Ranges in the Sacred Music of Ockeghem and Tinctoris', *Early Music*, 14 (1986), 467-479.
- Krummel, Donald W., 'Oblong Format in Early Music Books', *The Library*, 5th ser., 26 (1971), 312-324.
- Krummel, Donald W., 'Musical Functions and Bibliographical Forms', *The Library*, 5th ser., 31 (1976), 327-350.
- Krummel, Donald W. and Stanley Sadie, *Music Printing and Publishing*, (Basingstoke: Macmillan, 1980, 1990 for UK).
- Labarre, Emile J., *The Briquet Album* (Hilversum: The Paper Publications Society [vol. 2 of *Monumenta chartae papyraceae historiciam illustrantia*], 1952).
- Labarre, Emile J., *Dictionary and Encyclopaedia of Paper and Papermaking*, 2nd edition (Oxford: Oxford University Press, 1952).
- Lane, Frederic C., *Venice: A Maritime Republic* (Baltimore; London: John Hopkins Memorial Press, 1973).
- Lane, Frederic C., *Money and Banking in Medieval and Renaissance Venice*, vol. 1 of *Coins and Moneys of Account* (Baltimore; London: The Johns Hopkins University Press, 1985).
- LaRue, Jan, 'Watermarks and Musicology', *Acta musicologica*, 33 (1961), 120-146.
- LaRue, Jan, 'Watermarks Are Singles, Too: A Miscellany of Research Notes', in *Haydn, Mozart and Beethoven: Studies in the Music of the Classical Period – Essays in Honor of Alan Tyson*, ed. S. Brandenburg (Oxford: Clarendon, 1998), 1-12.
- Lerner, Edward R., 'The Sacred Music of Alexander Agricola' (Unpublished Doctoral Dissertation, Yale University, 1958).

- Lerner, Edward R., 'The "German" Works of Alexander Agricola', *Musical Quarterly*, 46 (1960), 56-66.
- Lerner, Edward R., ed., *Alexandri Agricola: Opera omnia, Corpus mensurabilis musicae*, 22 (Rome: American Institute of Musicology, 1966).
- Leuterman, D. Teodoro, *Ordo casinensis hebdomadae maioris (Saec. XII)*, *Miscellanea Cassinese*, ed. Montecassino (Montecassino: Badia di Montecassino, 1941).
- Lewis, Mary S., *Antonio Gardano, Venetian Music Printer, 1538-1569*, *Garland Reference Library of the Humanities*; vol. 718 (New York; London: Garland, 1997).
- Lockwood, Lewis, *Music in Renaissance Ferrara 1400-1505* (Oxford: Clarendon Press, 1984).
- Lodes, Birgit, 'An Anderem Ort, auf Andere Art: Petruccis und Mewes Obrecht-Drucke', *Basler Jahrbuch für historische Musikpraxis*, 25 (2001), 85-111.
- Logan, Oliver, *Culture and Society in Venice 1470-1790: The Renaissance and its Heritage* (London: Batsford Ltd., 1972).
- Lowinsky, Edward E., ed., *The Medici Codex of 1518: A Choirbook of Motets Dedicated to Lorenzo de' Medici, Duke of Urbino*, vols. 3-5 of *Monuments of Renaissance Music*, ed. E. E. Lowinsky, and Bonnie J. Blackburn (New York: Norton, 1968).
- Luisi, Francesco, *Laudario Giustiniano*, 2 vols. (Venice: Edizioni Fondazione Levi, 1983).
- Lunelli, Renato, 'Contributi trentini alle relazioni musicali fra l'Italia e la Germania nel rinascimento', *Acta musicologica*, 21 (1949), 41-70.
- Luper, Albert T., 'Portuguese Polyphony in the Sixteenth and Early Seventeenth Centuries', *Journal of the American Musicological Society*, 3 (1950), 93-112.
- Lütteken, Laurenz, 'Musicus et cantor diu in ecclesia Sancti Marci de Veneciis: Note biografiche su Johannes de Quadris', *Rassegna veneta di studi musicali*, 5-6 (1989-90), 43-62.

- Macey, Patrick, 'The Lauda and the Cult of Savonarola', *Renaissance Quarterly*, 45, no. 3 (1992), 439-483.
- Macey, Patrick, 'Inflamma il mio Cor: Savonarolan Laude by and for Dominican Nuns in Tuscany', in *The Crannied Wall: Women, Religion, and the Arts in Early Modern Europe*, ed. Craig Monson (Ann Arbor: University of Michigan, 1992), 161-189.
- Macey, Patrick, 'Josquin des Prez', *New Grove Dictionary of Music & Musicians*, 2nd edition, 13 (2001), 220-229.
- Mackenney, Richard, 'Devotional Confraternities in Renaissance Venice', in *Voluntary Religion: Studies in Church History*, vol. 23, ed. W. J. Sheils and D. Woods (Oxford: Basil Blackwell, 1986), 85-96.
- Mackenney, Richard, *Tradesmen and Traders: the World of the Guilds in Venice and Europe, c1250-c1650* (London; Sydney: Croom Helm, 1987).
- Madan, Falconer, 'The Localization of Manuscripts', in *Essays in History Presented to Reginald Lane Poole*, ed. H. W. C. Davis (Oxford: Clarendon Press, 1927), 5-29.
- Massenkeil, Günther, 'Zur Lamentationskomposition des 15. Jahrhunderts', *Archiv für Musikwissenschaft*, 18 (1961), 103-114.
- Massenkeil, Günther, 'Eine spanische Choralmelodie in mehrstimmigen Lamentationskompositionen des 16. Jahrhunderts', *Archiv für Musikwissenschaft*, 29-30 (1962-63), 230-237.
- Massenkeil, Günther, ed., *Mehrstimmige Lamentationen aus der ersten Hälfte des 16. Jahrhunderts* (Mainz: B. Schott's Söhne, 1965).
- Massenkeil, Günther, 'Lamentations', *New Grove Dictionary of Music & Musicians*, 2nd edition, 14 (2001), 188-190.
- Meconi, Honey, 'The Naming of Things: Petrucci's Mass Prints and the Commodification of Music', Conference Paper Presented in Venice, October 2001: 'Venezia 1501: Petrucci e la stampa musicale'.
- Melin, William E., 'The Music of Johannes Tinctoris (c. 1435-1511): A Comparative Study of Theory and Practice' (Unpublished Doctoral Dissertation, Ohio State University, 1973).

- Melin, William E., ed., *Johannes Tinctoris: Opera omnia*, Corpus mensurabilis musicae, 18 ([Rome]: American Institute of Musicology, 1976).
- Meyer, Kathi (in Collaboration with Eva Judd O' Meara), 'The Printing of Music 1473-1934', *The Dolphin*, 2 (1935), 171-207.
- Migliavacca, Luciano, ed., IX. *Anonimi, motetti. Archivum musices metropolitanum mediolanese*, Collana musicale diretta da Luciano Migliavacca ([Milan]: Veneranda Fabbrica del Duomo di Milano, 1961).
- Miller, Clement A., 'Early Gaffuriana: New Answers to Old Questions', *Musical Quarterly*, 56 (1970), 367-388.
- Miller, Ronald L., 'The Musical Works of Marbriano de Orto: Transcription and Commentary' (Unpublished Doctoral Dissertation, Indiana University, 1974).
- Milsom, John, 'Tallis, Byrd and the "Incorrected Copy": Some Cautionary Notes for Editors of Early Music Printed from Movable Type', *Music & Letters*, 77 (1996), 348-365.
- Milsom, John, 'Songs and Society in Early Tudor London', *Early Music History*, 16 (1997), 235-293.
- Moore, John D., 'New Light on Diomedes Carafa and his "Perfect Loyalty" to Ferrante of Aragon', *Italian Studies*, 26 (1971), 1-23.
- Morpurgo, Salomone, *I manoscritti della R. Biblioteca Riccardiana di Firenze* (Rome: [n.pub], 1900).
- Mosin, Vladimir, ed., *Anchor Watermarks*, [edited and translated by J. G. S. Simmons and B. J. van Ginneken-van de Kastele] (Amsterdam: The Paper Publications Society; Labarre Foundation, 1973).
- Mosser, Daniel W., Michael Saffle and Ernest W. Sullivan II, eds., *Puzzles in Paper: Concepts in Historical Watermarks* (New Castle, DE: Oak Knoll Press; London: The British Library, 2000).
- Müller, Paul, 'Agricola, Alexander', *Die Musik in Geschichte und Gegenwart*, 1 (1949-51), 158-160.

- Noble, Jeremy, 'Ottaviano Petrucci: His Josquin Editions and Some Others', in *Essays Presented to Myron P. Gilmore*, ed. S. Bertelli and G. Ramakus, 2 vols. (Florence: La Nuova Italia, 1978), II, 433-445.
- Noblitt, Thomas, 'Textual Criticism of Selected Works Published by Petrucci', in *Formen und Probleme der Überlieferung mehrstimmiger Musik im Zeitalter Josquins Desprez*, ed. Ludwig Finscher, *Quellenstudien zur Musik der Renaissance*, no. I (Munich: Kraus, 1976), 201-244.
- Nugent, George and James Haar, 'Maistre Jhan [Jan, Jehan]', *New Grove Dictionary of Music & Musicians*, 16 (2001), 644-645.
- Olarte Martinez, Matilde, 'Estudio de la forma lamentacion', *Anuario musical: Revista de musicologia del C.S.I.C.*, 47 (1992), 81-101.
- van Orden, Kate, ed., *Music and the Cultures of Print* (New York: Garland Publishing Inc., 2000).
- Pattison, Bruce, 'Notes on Early Music Printing', *The Library*, 4th ser., 19 (1939), 389-421.
- Pease, Edward, 'An Edition of the Pixérécourt Manuscript: Paris, Bibliothèque Nationale, Fonds Fr. 15123' (Unpublished Doctoral Dissertation, Indiana University, 1959).
- Pease, Edward, 'A Report on Codex Q16 of the Civico Museo Bibliografico Musicale (formerly of the Conservatorio Statale di Musica "G. B. Martini"), Bologna', *Musica disciplina*, 20 (1966), 57-94.
- Perkins, Leeman L., *Music in the Age of the Renaissance* (New York; London: Norton, 1999).
- Perkins, Leeman L. and H. B. Garey, *The Mellon Chansonnier*, 2 vols. (New Haven: Yale University Press, 1979).
- Perz, Mirosław, 'Handschrift Nr. 1361 der Öffentlichen Städtischen Raczynski-Bibliothek in Poznań als Neue Quelle zur Geschichte der Polnischen Musik in der II. Hälfte des XV. Jahrhunderts', in *The Book of the First International Musicological Congress Devoted to the Works of Frederick Chopin, Warszawa, 16th-22nd February 1960*, ed. Zofia Lissa (Warsaw: Polish Scientific Publishers, 1963), 588-592.

- Perz, Mirosław, ed., 'Cum autem venissent', in *Muzyka Staropolska*, ed. H. Feicht (Cracow: [n.pub.], 1966).
- Piccard, Gerhard, 'Wasserzeichen und Urbarforschung im Württembergischen Hauptstaatsarchiv', *Archivum: Revue Internationale des Archives*, 2 (1952), 65-81.
- Piccard, Gerhard, ed., *Wasserzeichen Hand und Handschuh Bearb. von Gerhard Piccard*, 17 vols. (Stuttgart: Kohlhammer, 1961-97).
- Picker, Martin, 'A Letter of Charles VIII of France Concerning Alexander Agricola', in *Aspects of Medieval and Renaissance Music: A Birthday Offering to Gustave Reese*, ed. Jan LaRue (New York: Norton, 1966), 665-672.
- Picker, Martin, 'Orto [Dujardin], Marbrianus de', *New Grove Dictionary of Music & Musicians*, 13 (1980), 877-878.
- Picker, Martin, 'Orto, Marbrianus [Marbriano] de [Dujardin, Marbrianus]', *New Grove Dictionary of Music & Musicians*, 18 (2001), 764-766.
- Pirro, André, 'Un manuscrit musical du XVe siècle au Mont-Cassin', *Cassinensia*, 1 (1929), 205-208.
- Pirro, André, *Histoire de la musique de la fin du XIVe siècle à la fin du XVIe*, (Paris: Librairie Renouard, 1940).
- Plamenac, Dragan, 'The "Second" Chansonnier of the Biblioteca Riccardiana', *Annales Musicologiques*, 2 (1954), 105-187.
- Plamenac, Dragan, 'A Postscript to "The "Second" Chansonnier of the Biblioteca Riccardiana"', *Annales Musicologiques*, 4 (1956), 261-265.
- Plamenac, Dragan, 'Excerpta Colombiniana: Items of Musical Interest in Fernando Colon's "Regestrum"', in *Miscelánea en homenaje a Monsenor Higinio Anglés*, ed. Miguel Querol, 2 vols. (Barcelona: Consejo Superior de Investigaciones Científicas, 1958-61), II, 663-687.
- Pope, Isabel, 'The Musical Manuscript Montecassino N879 [sic]', *Anuario musical*, 19 (1966), 123-153.
- Pope, Isabel and Masakata Kanazawa, eds., *The Musical Manuscript Montecassino 871: A Neapolitan Repertory* (Oxford: Oxford University Press, 1978).

- Prizer, William F., 'Performance Practices in the Frottola', *Early Music*, 3 (1973), 227-235.
- Prizer, William F., 'Lauda spirituale: 2. Polyphonic', *New Grove Dictionary of Music & Musicians*, 10 (1980), 540-543.
- Prizer, William F., 'Tromboncino [Trombonzin, Trombecin, etc], Bartolomeo', *New Grove Dictionary of Music & Musicians*, 19 (1980), 161-163.
- Prizer, William F., 'Music at the Court of the Sforza: the Birth and Death of a Musical Center', *Musica disciplina*, 43 (1989), 141-193.
- Prizer, William F., 'Laude di popolo, laude di corte: Some Thoughts on the Style and Function of the Renaissance Lauda', in *La musica a Firenze al tempo di Lorenzo Il Magnifico: Congresso internazionale di studi Firenze*, ed. P. Gargiulo (Florence: Leo S. Olschki, 1993), 167-194.
- Prizer, William F., 'Ana [Anna], Francesco d' [Franciscus Venetus; Francesco Varoter, etc]', *New Grove Dictionary of Music & Musicians*, 2nd edition, 1 (2001), 524.
- Prizer, William F., 'Tromboncino [Trombonzin, Trombecin, etc], Bartolomeo', *New Grove Dictionary of Music & Musicians*, 2nd edition, 25 (2001), 758-762.
- Prodi, Paolo, 'The Structure and Organisation of the Church in Renaissance Venice: Suggestions for Research', in *Renaissance Venice*, ed. John Rigby Hale (London: Faber, 1973), 409-430.
- Pullan, Brian, 'Poverty, Charity and the Reason of State: Some Venetian Examples', *Studi veneziani*, 2 (1960), 17-60.
- Pullan, Brian, 'Wage-Earners and the Venetian Economy, 1550-1630', in *Crisis and Change in the Venetian Economy in the Sixteenth and Seventeenth Centuries*, ed. Brian Pullan (London: Methuen, 1968), 146-174.
- Pullan, Brian, *Rich and Poor in Renaissance Venice* (Oxford: Blackwell, 1971).
- Reaney, Gilbert, 'The Manuscript Oxford, Bodleian Library, Canonici Misc. 213', *Musica disciplina*, 9 (1955), 73-104.
- Reese, Gustave, 'The First Printed Collection of Part-Music (the Odhecaton)', *Musical Quarterly*, 20 (1934), 39-76.

- Reese, Gustave, *Music in the Renaissance* (New York; London: W. W. Norton; J. M. Dent, 1954).
- Reese, Gustave, 'Josquin Deprez [Juschino, Josse etc; Prés, Josquin des; Jodocus Pratensis, Jodocus a Prato etc]', sections 1-7, *New Grove Dictionary of Music & Musicians*, 9 (1980), 713-718.
- Rifkin, Joshua, 'Scribal Concordances for Some Renaissance Manuscripts in Florentine Libraries', *Journal of the American Musicological Society*, 26 (1973), 305-326.
- Rifkin, Joshua, 'Pietrequin Bonnel and Ms. 2794 of the Biblioteca Riccardiana', *Journal of the American Musicological Society*, 29 (1976), 284-296.
- Ropa, Giampaolo and Vittorio Gibelli, *Contributi e studi di liturgia e musica nella regione padana* (Bologna: Antiquae Musicae Italicae Studiosi, 1972).
- Sandon, Nick, ed., *The Masses and Ceremonies of Holy Week*, vol. 4 of *The Use of Salisbury* (Moretonhampstead, Devon: Antico Edition, 1996).
- Sartori, Claudio, *Bibliografia delle opere musicali stampate da Ottaviano Petrucci*, *Biblioteca di bibliografia italiana*, 18 (Florence: Leo S. Olschki, 1948).
- Sartori, Claudio, 'A Little-Known Petrucci Publication: The Second Book of Lute Tablatures by Francesco Bossinensis', *Musical Quarterly*, 34 (1948), 234-245.
- Sartori, Claudio, 'Nuove conclusive aggiunte alla "Bibliografia dal Petrucci" ', *Collectanea historiae musicae*, 1 [= *Biblioteca historiae musicae cultores*, 2] (1953), 175-210.
- Sartori, Claudio, ed., *Dizionario degli editori musicali italiani (tipografi, incisori, librai-editori)*, *Biblioteca di bibliografia italiana*, 32 (Florence: Leo S. Olschki, 1958).
- Sbriziolo, L., 'Per la storia delle confraternite veneziane, dalle deliberazioni miste (1310-1476) del Consiglio dei Dieci. Le scuole dei battuti', in *Miscellanea Gilles Gerard Meersseman*, ed. G. Gualdo and L. Sbriziolo (Padua: Antenore, 1970), 715-763.

- Schering, Arnold, ed., *Geschichte der Musik in Beispielen* (Leipzig: Breitkopf & Härtel, 1931).
- Schmid, Anton, *Ottaviano dei Petrucci da Fossombrone, der erste Erfinder des Musiknotendruckes mit beweglichen Metalltypen, und seine Nachfolger im Sechzehnten Jahrhunderte* (Amsterdam: Gruner, 1845/1968r).
- Scholderer, Victor, 'Printing at Venice to the End of 1481', in *Fifty Essays in Fifteenth- and Sixteenth-Century Bibliography*, ed. D. E. Rhodes (Amsterdam: M. Hertzberger & Co., 1966), 74-89.
- Scholderer, Victor, 'Printers and Readers in Italy in the Fifteenth Century', in *Fifty Essays in Fifteenth- and Sixteenth-Century Bibliography*, ed. D. E. Rhodes (Amsterdam: M. Hertzberger & Co., 1966), 202-215.
- Schröder, Aukje Engelina, 'Les Origines des lamentations polyphoniques au XVe siècle dans les Pays-Bas', in *Kongress-Bericht, Internationale Gesellschaft für Musikwissenschaft, Utrecht 1952*, ed. A. Smijers (Amsterdam: G. Alsbach and Co., 1953), 352-359.
- Seay, Albert, 'The 15th-Century Cappella at Santa Maria del Fiore in Florence', *Journal of the American Musicological Society*, 11 (1958), 45-55.
- Sevillano, Justo, 'Catálogo Musical del Archivo Capítular de Tarazona', *Anuario musical*, 16 (1961), 149-176.
- Shaaber, M. A., 'The Meaning of the Imprint in Early Printed Books', *The Library*, 24 (1943-44), 120-141.
- Sherr, Richard, 'The Relationship between a Vatican Copy of the Gloria of Josquin's Missa de Beata Virgine and Petrucci's print', in *Atti del XIV congresso della Società Internazionale di Musicologia, Bologna, 1987: Trasmissione e recezione delle forme di cultura musicale*, ed. L. Bianconi, Angelo Pompilio et al. (Turin: Edizioni di Torino, 1990), 266-271.
- Sherr, Richard, 'The Performance of Chant in the Renaissance and its Interaction with Polyphony', in *Plainsong in the Age of Polyphony*, ed. T. F. Kelly (Cambridge: Cambridge University Press, 1992), 178-208.
- Sivec, Joze, 'Lamentationes Ieremiae Prophetae Jakoba Gallusa', in *GALLUS Carniolus in Europäischer Renaissance: Gallus Carniolus und die Europäische Renaissance; Mednarodni Simpozij / Internationale Tagung, Ljubljana, 21.-*

- 24.10.1991, ed. D. Cvetko and D. Pokorn, vol. 2 (Ljubljana: [n.pub], 1992), 101-131.
- Smith, Jeremy L., 'From "Rights to Copy" to the "Bibliographic Ego": A New Look at the Last Early Edition of Byrd's "Psalmes, Sonets & Songs" ', *Music & Letters*, 80 (1999), 511-530.
- Smith, Margaret M., *The Title-Page: Its Early Development, 1460-1510* (London; Delaware: The British Library; Oak Knoll Press, 2000).
- Snow, Robert J., ed., *A New-World Collection of Polyphony for Holy Week and the Salve Service: Guatemala City, Cathedral Archive, Music MS 4*, *Monuments of Renaissance Music*, 9 (Chicago: University of Chicago Press, 1996).
- Sodi, Manlio, Achille Maria Triacca, eds., *Breviarium romanum: Editio princeps (1568)*. *Monumenta liturgica concilii tridentini*, ser. 3 (Vatican City: Libreria editrice vaticana, 1999).
- Southern, Eileen, 'El Escorial, Monastery Library, MS IV.a.24', *Musica disciplina*, 23 (1969), 41-79.
- Sparks, Edgar H., *The Music of Noel Bauldeweyn* (New York: American Musicological Society, 1972).
- Sparks, Edgar H., 'Problems of Authenticity in Josquin's Motets', in *Josquin des Prez: Proceedings of the International Josquin Festival-Conference Held at the Juilliard School at Lincoln Center in New York City, 21-25 June 1971*, ed. Edward E. Lowinsky in Collaboration with Bonnie J. Blackburn (London: Oxford University Press, 1976), 345-359.
- Squire, William Barclay, 'Notes on Early Music Printing', *Bibliographica*, 3 (1897), 99-122.
- Stäblein, Bruno, 'Lamentatio', *Die Musik in Geschichte und Gegenwart*, 8 (1960), 133-142.
- Stäblein, Bruno and Magda Marx-Weber, 'Lamentatio', *Die Musik in Geschichte und Gegenwart*, 5 (1996), 894-904.
- Staehelin, Martin, *Die Messen Heinrich Isaac*, Publikationen der Schweizerischen Musikforschenden Gesellschaft; Serie II, vol. 28/1-3 (Berne; Stuttgart: Verlag Paul Haupt, 1977).

- Stevens, John, *Words and Music in the Middle Ages: Song Narrative, Dance and Drama, 1050-1315* (Cambridge: Cambridge University Press, 1986).
- Stevenson, Allan, 'Watermarks Are Twins', *Studies in Bibliography*, 4 (1951-52), 57-91.
- Stevenson, Robert, *Spanish Music in the Age of Columbus* (The Hague: Martinus Nijhoff, 1960).
- Strohm, Reinhard, *The Rise of European Music, 1380-1500* (Cambridge: Cambridge University Press, 1993).
- Tessier, Andrea, 'Stampatori in Venezia nel secolo XV', *Archivio veneto*, 34 (1884), 193-201.
- Thomas, Elmer R., 'Two Petrucci Prints of Polyphonic Lamentations, 1506' (Unpublished DMA Dissertation, University of Illinois, 1970).
- Thornton, Dora, *The Scholar in his Study: Ownership and Experience in Renaissance Italy* (New Haven; London: Yale University Press, 1997).
- Thurston, Herbert, 'Holy Week', *Catholic Encyclopedia*, ed. Charles G. Herbermann, Edward A. Pace, Condé B. Pallen, Thomas J. Shahan, John J. Wynne and others, 17 vols. (New York: The Encyclopedia Press Inc., 1913), VII, 435-438.
- Torchi, Luigi, ed., *L'Arte musicale in Italia*, vol. I, Composizioni sacre e profane a più voci, secolo XVI (Milan: Ricordi, 1897, reprinted 1968).
- Turrini, Giuseppe, 'Il patrimonio musicale della Biblioteca Capitolare di Verona dal sec. XV al XIX', *Atti e memorie della Accademia di Agricoltura Scienza e Lettere di Verona CXXVII* (1953), 95-176.
- Tyson, Alan, 'Beethoven's "First" Leonore Overture', *Journal of the American Musicological Society*, 28 (1975), 292-334.
- Varanini, Giorgio, Giulio Cattin, Anna Ceruti Burgio and Luigi Banfi, eds., *Laude cortonesi dal secolo XIII al XV*, 4 vols. (Florence: Leo S. Olschki, 1981-85).
- Vecchi, Giuseppi, *Uffici drammatici padovani*, Biblioteca dell' "Archivium Romanicum", ser. I, storia, letteratura, paleografia. vol. 41. Testi drammatici medievali. A. Testi latini, no. 2. (Florence: [n.pub.], 1954).

- Vecchi, Giuseppi, 'Tra monodia e polifonia', *Collectanea historiae musicae*, 2 (1957), VII-XII; 133-61; 242-554.
- Vernarecci, Augusto, *Ottaviano de' Petrucci da Fossombrone* (Fossombrone: [n. pub.], 1881).
- Visentini, F., ed., *I diarii di Marino Sanuto*, 58 vols. (Venice 1879-1903, reprinted Bologna: Forni Editore, 1969-1970).
- Vogel, Emil, *Bibliothek der gedruckten weltlichen Vocalmusik italiens aus den Jahren 1500-1700. Enthaltend die Litteratur der Frottole, Madrigale, Canzonette, Arien, Opern, etc.* (Biblioteca della Musica Vocale Italiana di Genere Profano, etc.) (Berlin: [n.p.], 1892).
- Wagner, Peter, *Einführung in die gregorianischen Melodien*, 3 vols., iii, *Gregorianische Formenlehre* (Leipzig, 1911; reprinted Wiesbaden: Breitkopf and Härtel, 1970).
- Walsh, Richard, 'Music and Quattrocento Diplomacy: The Singer Jean Cordier between Milan, Naples, and Burgundy in 1475', *Beihefte zum Archiv für Kulturgeschichte*, 60 (1978), 439-442.
- Wangermée, Robert, *Flemish Music & Society in the Fifteenth and Sixteenth Centuries* (New York; London: F. A. Praeger, 1968).
- Ward, Lynn H., 'The *Motetti Missales* Repertory Reconsidered', *Journal of the American Musicological Society*, 39 (1986), 491-523.
- Watkins, Glenn E., 'Three Books of Polyphonic Lamentations of Jeremiah, 1549-1564' (Unpublished Doctoral Dissertation, University of Rochester, 1953).
- Wegman, Rob, Fabrice Fitch and Edward Lerner, 'Agricola [Ackerman], Alexander', *New Grove Dictionary of Music & Musicians*, 1 (2001), 225-229.
- Weiss, Susan F., 'Lapicida [Steinschneider], Erasmus [Rasmo]', *New Grove Dictionary of Music & Musicians*, 14 (2001), 267.
- Werner, Eric, *The Sacred Bridge: The Interdependence of Liturgy and Music in Synagogue and Church during the First Millennium* (London; New York: Dobson Books; Columbia University Press, 1959).

- Wessely, Othmar, 'Lapicida, Erasmus', *Die Musik in Geschichte und Gegenwart*, 8 (1960), 204-207.
- Wessely, Othmar, 'Lapicida, Erasmus', *New Grove Dictionary of Music & Musicians*, 10 (1980), 465-466.
- Wexler, Richard, 'Newly Discovered Works by Bartolomeo Degli Organi in the MS Bologna Q 17', *Journal of the American Musicological Society*, 23 (1970), 107-118.
- Wilson, Blake, *Music and Merchants: The Laudesi Company of Republican Florence* (Oxford: Clarendon Press, 1992).
- Wilson, Blake, 'Laude spirituale', *New Grove Dictionary of Music & Musicians*, 14 (2001), 367-374.
- Wisch, Barbara, 'The Passion of Christ in the Art, Theater, and Penitential Rituals of the Roman Confraternity of the Gonfalone', in *Crossing the Boundaries: Christian Piety and the Arts in Italian Medieval and Renaissance Confraternities*, ed. K. Eisenbichler (Kalamazoo: Western Michigan University, 1991), 237-262.
- Woodley, Ronald, 'Iohannes Tinctoris: A Review of the Documentary Biographical Evidence', *Journal of the American Musicological Society*, 34 (1981), 217-248.
- Woodley, Ronald, 'Tinctoris, Johannes [Le Taintenier, Jehan]', *New Grove Dictionary of Music & Musicians*, 25 (2001), 497-501.
- Wright, Peter, 'Paper Evidence and the Dating of Trent 91', *Music & Letters*, 76 (1995), 487-517.
- Young, Karl, *The Drama of the Medieval Church*, 2 vols. (Oxford: The Clarendon Press, 1933).
- Ziino, Agostino, ed., *Documenti di polifonia in Abruzzo*, *Musica rinascimentale in Italia*, 2, ed. Domenico Cieri (Rome: Pro Musica Studium, 1974).

8.4 Secondary material: Internet resources

- Anon., *The Thomas L. Gravell Watermark Archive Incorporating The University of Delaware Library's Thomas L. Gravell Watermark Collection and The Unpublished Watermarks and Records from the C-M Briquet Archive at the Bibliothèque Publique et Universitaire, Geneva* <<http://www.gravell.org/>> [accessed 2 July 2004].
- British Broadcasting Corporation, 'BBC Renaissance Secrets 2: What Did Gutenberg Invent?', *British Broadcasting Corporation* <<http://www.open2.net/renaissance2/doing/gutenberg.html>> [accessed 2 July 2004].
- Filocamo, Gioia, 'Forthcoming', *Fondazione Pietro Antonio Locatelli* <<http://www.fondazione locatelli.org/IT/Pubblicazioni/Mon1.htm>> [accessed 23 September 2004].
- Fricke, Thomas, *Hauptstaatsarchiv Stuttgart-Bestand J 340, Wasserzeichenkartei Piccard*, <<http://www.lad-bw.de/ladsu/piccard/sitemap.php>> [accessed 2 July 2004].
- Spencer, Peter, 'Researchers Re-examine Gutenberg's Role in Bookmaking', *Princeton-Weekly Bulletin* 2/12/01 <<http://www.princeton.edu/pr/pwb/01/0212/>> [accessed 2 July 2004].

I have produced this thesis using an Apple Macintosh PowerPC 7200/75; an Apple LaserWriter 4/600PS printed the text while a Hewlett Packard Deskjet 5550 generated the graphics. Signor Romanin of Padua especially prepared the photographs of the Padua copy of 1506/1 on CD-ROM; I am most grateful to him for his beautiful work.

The main text is set in Plantin 12 point; numerals and textual ligatures appear in Plantin Expert 12 point. I have used Coda Finale to originate the musical examples and Microsoft Word 5.1a for the text.

