

Durham E-Theses

Analysis of manufacturing operations using knowledge- Enriched aggregate process planning

David Graham Bramall

How to cite:

Bramall, David Graham (2006) Analysis of manufacturing operations using knowledge- Enriched aggregate process planning. Doctoral thesis, Durham University.

Use policy

The full-text may be used and/or reproduced, and given to third parties in any format or medium, without prior permission or charge, for personal research or study, educational, or not-for-profit purposes provided that:

- a full bibliographic reference is made to the original source
- a <https://etheses.durham.ac.uk/id/eprint/2586/> is made to the metadata record in Durham E-Theses
- the full-text is not changed in any way

The full-text must not be sold in any format or medium without the formal permission of the copyright holders.

Please consult the [full Durham E-Theses policy](#) for further details.



School of Engineering

**Analysis of Manufacturing Operations using Knowledge-
Enriched Aggregate Process Planning**

David Graham Bramall

Ph. D. Thesis

2006

The copyright of this thesis rests with the author or the university to which it was submitted. No quotation from it, or information derived from it may be published without the prior written consent of the author or university, and any information derived from it should be acknowledged.

09 JUN 2006

This thesis is submitted to the University of Durham in partial fulfilment of
the requirements for the degree of Doctor of Philosophy.



Table of Contents

Table of Contents.....	ii
List of Figures.....	ix
List of Tables.....	xiii
Abstract.....	xv
Acknowledgements.....	xvi
Declaration.....	xvii
Copyright Notice.....	xvii
Nomenclature.....	xviii
Chapter 1 Introduction.....	1
1.1 Preface.....	1
1.2 Introductory Remarks on Process Planning and Manufacturability Analysis.....	3
1.2.1 A History of Aggregate Process Planning Research.....	3
1.3 Exposition on Knowledge-Enriched Aggregate Planning.....	4
1.3.1 Establishing Research Priorities.....	5
1.3.2 The Perceived Benefits of Applying Knowledge-Enriched Aggregate Planning in a DET Framework.....	7
1.3.3 Linkages with European Design and Process Development Research.....	9
1.4 Research Outline.....	10
1.4.1 The Adopted Research Methodology.....	10
1.4.2 Thesis Structure.....	11
1.4.3 Publications Related to this Research.....	14
Chapter 2 Literature Review.....	16

2.1	Introduction.....	16
2.2	Product Development in the Context of Agile Manufacture	16
2.3	Research in Process Planning	18
2.3.1	Foundations of Process Planning.....	18
2.3.2	Time-Phased Planning in Product Development	20
2.3.3	Emergent Synthesis Methodologies for Process Planning	22
2.4	Development of Enabling Technologies.....	23
2.4.1	Feature-Based Product Modelling	23
2.4.2	Process Selection in Generative Planning	23
2.4.3	Design Evaluation Methodologies.....	25
2.4.4	Development of Standards in Product Design and Process Planning.....	26
2.4.5	Computer-Based Planning Architectures.....	29
2.5	Knowledge Management in Enterprise-Wide Design and Planning	31
2.5.1	Knowledge Management Ideology	31
2.5.2	Classifications in Knowledge Management Theory	33
2.5.3	Scientific Methods in Knowledge Capture.....	34
2.5.4	Knowledge Acquisition, Transfer and Re-Use	35
2.5.5	Applications of Knowledge Management in Process Planning.....	37
2.5.6	Ontologies in Process Planning	39
2.5.7	Treatment of ‘Knowledge’ in Current Commercial Applications.....	40
2.6	Conclusion	41
Chapter 3	System Overview.....	43
3.1	Introduction.....	43
3.2	Incorporating Knowledge-Enriched Aggregate Process Planning in the DET Framework	44
3.2.1	Establishing Resource Aware Aggregate Planning as a Class II/III Emergent Synthesis Problem.....	45

3.2.2	The Undefined (Class II) Planning Environment	46
3.2.3	Realising a Knowledge-Enriched Planning Methodology.....	48
3.3	Functional Description of the CAPABLE Space System.....	49
3.4	Implementation Issues	53
3.4.1	Object-Oriented Programming Paradigm	53
3.4.2	Development Tools.....	55
3.4.3	The UML Modelling Language	55
3.5	The Adoption of Spacecraft Manufacture as an Industrial Test Bed.....	55
3.6	Conclusion	57
Chapter 4	Aggregate Data Modelling: Product, Process and Resource Models	59
4.1	Introduction.....	59
4.2	Principles of Aggregate Data Modelling	60
4.2.1	Modelling Incomplete Early Manufacturing Data.....	60
4.2.2	Constructing ‘Data-Resistant’ Aggregate Models.....	61
4.3	The Aggregate Product Model.....	63
4.3.1	Assembly Modelling and Representation	63
4.3.2	Feature-Based Component Modelling	64
4.3.3	Joint Features for Modelling Assembly Sequences.....	67
4.3.4	Tolerancing at the Feature-Based Level	68
4.3.5	Visualising the Aggregate Product Model.....	69
4.3.6	Construction of Example Aggregate Product Models.....	70
4.3.7	A Comparison of the Aggregate Product Data Model with the Core Product Model of NIST	71
4.4	The Aggregate Resource Model	72
4.4.1	General Characteristics of Resource Models.....	72
4.4.2	Resource Classes for Modelling Equipment.....	73
4.4.3	Resource Type Classes for Describing Processing Capability	75

4.5	The Aggregate Process Model.....	76
4.5.1	Functionality of Aggregate Process Models.....	76
4.5.2	Aggregate Process Model Structure	78
4.5.3	Manufacturability Metrics for Evaluating Alternative Process Plans	79
4.5.4	Delivery Calculation Method Described for Mass Reducing Processes	80
4.5.5	The Calculation of Cycle Time for Assembly and Handling Processes.....	82
4.5.6	The Quality Estimation Method	83
4.6	Conclusion	87
Chapter 5	Aggregate Knowledge Representation	89
5.1	Introduction: Motivation for Enriching Aggregate Process Plans with Enterprise Knowledge.....	90
5.2	The DET Framework as a Source of Design and Planning Knowledge.....	91
5.2.1	Study of Typical Knowledge Sources in Spacecraft Manufacture	92
5.3	An Aggregate Knowledge Representation Protocol.....	95
5.3.1	Principles of Aggregate Knowledge Representation	96
5.3.2	Functionality and Specification of Knowledge Statement Classes for Quantitative and Qualitative Knowledge Capture	98
5.3.3	Qualitative and Qualitative Knowledge Measurement Classes.....	99
5.4	Structuring the Knowledge Representation Protocol in the Enterprise	101
5.4.1	Establishing Correct Capability Factors	101
5.4.2	Linking Knowledge to the Overall Business Objectives	102
5.5	Worked Example of the Knowledge Representation Protocol	105
5.6	Limitations of the Knowledge Representation Protocol.....	107
5.6.1	Critical Analysis of the Practical Application of the Proposed Implementation	108
5.7	Conclusion	109
Chapter 6	Aggregate Knowledge Management using Capability Analysis	111

6.1	Introduction.....	112
6.2	Fusion of Capability Analysis with Aggregate Process Planning	113
6.2.1	Theoretical Setting.....	113
6.2.2	Aligning Capability Analysis with Aggregate Process Planning Methodology	114
6.3	Procedure for Determining Priority Confidence Scores	117
6.3.1	Further Examples of Capability Analysis.....	121
6.4	Representing Priority Confidence Scores at Higher Levels	122
6.4.1	Contribution of a Group of Factor Scores to Higher Level Performance..	123
6.4.2	Reporting Priority Confidence Scores: the Recovery Schedule	124
6.5	A Suggested Configuration of Capability Analysis for Process Plan Analysis.	125
6.5.1	Detailed Process Plan Analysis.....	125
6.5.2	Structure-Based Process Plan Analysis	129
6.6	Exploitation of the Knowledge-Enriched Plans in the DET Framework	130
6.6.1	Use in Intelligent Exploration.....	130
6.6.2	Prioritising Virtual Manufacturing and Simulation Tasks in DET	130
6.7	Conclusion	132
Chapter 7	Intelligent Exploration for Aggregate Process Planning	134
7.1	Introduction.....	134
7.2	Modelling the Process Planning Problem.....	135
7.2.1	Fundamentals of The Aggregate Process Plan	137
7.2.2	Initial Option Generation: Process and Resource Mappings.....	139
7.2.3	Application of Technological and Physical Constraints.....	141
7.3	Manufacturability Evaluation	143
7.3.1	Delivery Lead Time Analysis.....	144
7.3.2	Calculation of Job Cost.....	144
7.3.3	Estimation of Quality Cost	145

7.3.4	Incorporating a Cost Penalty for Poor Capability: Knowledge Loss.....	145
7.3.5	Overall Cost Energy Calculation	146
7.4	Worked Example of Job Creation in Process Planning	146
7.4.1	Example QCD calculation	148
7.5	A Search Method Based on Simulated Annealing.....	150
7.6	Modifications to the Intelligent Exploration Procedure	152
7.7	Conclusion	154
Chapter 8	System Implementation and Industrial Testing	155
8.1	Introduction.....	155
8.2	Design of the Testing Procedure.....	156
8.3	Case Study 1: Structure Concept Trade-Off.....	157
8.3.1	Aims and Objectives.....	158
8.3.2	Creation of Quantitative Knowledge Statements.....	158
8.3.3	Capability Analysis Example Based on the SCTO Data	159
8.4	Case Study 2: SSPA Housing	161
8.4.1	Aims and Objectives.....	161
8.4.2	Product Model Description.....	162
8.4.3	Resource Model Used in Testing Planning Functions.....	163
8.4.4	Exercising Planning Functionality	163
8.4.5	Knowledge-Enriched Planning Results	167
8.4.6	Closing Remarks on Planning Case Study	169
8.5	Case Study 3: Service Module (SM) Floor Panel.....	169
8.5.1	Aims of the Case Study	169
8.5.2	Product Distributed Analysis and Resource Distributed Analysis	170
8.5.3	Population of Product and Resource Models.....	172
8.5.4	Knowledge-Enriched Aggregate Planning Results.....	173
8.5.5	Problems Encountered with Large Datasets	175

8.5.6	Closing Remarks for SM Floor Example	176
8.6	Summary and Analysis of Case Study Material	176
8.7	Future Research Directions and Challenges Identified.....	177
8.8	Conclusion	178
Chapter 9	Discussion and Conclusion	179
9.1	Introduction.....	179
9.2	Discussion.....	179
9.2.1	Synopsis of Original Objectives	179
9.2.2	Specific Contributions to Aggregate Process Planning Research	180
9.2.3	Originality of Knowledge-Enriched Planning Concept.....	181
9.2.4	Limitations of the Research	184
9.2.5	Appraisal of the Knowledge-Enriched Planning Methodology.....	185
9.3	Future Work and Exploitation Plans.....	186
9.3.1	Connection With the Development of Commercial CAPP Systems	187
9.3.2	Connection With Logistic-Oriented Design Proposition.....	187
9.4	Conclusion	188
References.....		189
Bibliography		202
Appendix A	ViP-RoaM Roadmap.....	206
Appendix B	Aggregate Product, Process and Resource Data Models.....	210
Appendix C	Test Data.....	217
Appendix D	Open CASCADE Product Model Viewer	228

List of Figures

Figure 1.1 Original Diagrammatic Representation of the DET Framework. Reproduced from Maropoulos, *et al.* (2003a)..... 2

Figure 1.2 The Precursor Aggregate, Management and Detailed Architecture. Reproduced from Maropoulos (1995)..... 4

Figure 1.3 Incurred and Committed Costs With and Without Aggregate Planning. 8

Figure 1.4 The Adopted Research Methodology Showing Key Sections in this Thesis. 13

Figure 2.1 Relative importance of domains in the Responsive Manufacturing Model (adapted from Gindy [1999])...... 17

Figure 2.2 Simplified Version of Diagram A31 – ‘Generate Process Plan’ – reproduced from International Organisation for Standardisation (ISO) [1999])...... 27

Figure 2.3 Annual Publication of Articles pertaining to ‘Knowledge Management’ in ‘Engineering and Technology’ (source <http://www.sciencedirect.com>, Elsevier B. V. 2003). 31

Figure 2.4 Essential Knowledge to Achieve Business Objectives Over the Next 3 to 5 years. (reproduced from The Economist Group [1998]). 32

Figure 2.5 The KIPP Methodology (Lindsay, *et al.* 1998). 35

Figure 3.1 Layout of Chapter 3..... 43

Figure 3.2 Aggregate Planning in the DET Framework..... 44

Figure 3.3 Key to UML Use Case Diagrams..... 49

Figure 3.4 Product model Designer Use Case Diagram. 50

Figure 3.5 Process Modeller Use Case Diagram. 50

Figure 3.6 Resource Modeller Use Case Diagram. 51

Figure 3.7 Process Planning Use Case Diagram..... 51.

Figure 3.8 Knowledge Representation and Management Use Case Diagrams. 52

Figure 3.9 Example of Object-Orientation.	54
Figure 3.10 HotBird Satellite Undergoing Final Testing.	57
Figure 4.1 Layout of Chapter 3.....	59
Figure 4.2 The Construction Elements of the Aggregate Product Model.	64
Figure 4.3 Top Level Product Model Class Hierarchy.....	65
Figure 4.4 Partial Detail of Negative Prismatic Feature Classification.....	66
Figure 4.5 The Joint Type Classes.....	67
Figure 4.6 The Hierarchy of Joint Method Classes.	67
Figure 4.7 Tolerance Classes Implemented in the Aggregate Product Model.	68
Figure 4.8 Alternative Product Configuration I - Doubler Removal.....	70
Figure 4.9 Alternative Product Configuration II - Doubler Bonded into Position.	70
Figure 4.10 A Typical SM Floor Panel.....	71
Figure 4.11 Resource and Resource Type Classes with their Attributes.....	73
Figure 4.12 Top Level Resource Types.....	75
Figure 4.13 Aggregate Process Model Data Flows.	76
Figure 4.14. The Top Level Process Model Class Hierarchy.....	78
Figure 4.15 Example Method for Cycle Time Calculation for Machining Processes.....	81
Figure 4.16 Process Quality Calculation Method.....	83
Figure 5.1 Development of Knowledge Representation Methods.....	89
Figure 5.2 Primary DET Knowledge Sources within the Sponsoring Company.	92
Figure 5.3 The Knowledge Representation Procedure.	96
Figure 5.4 UML of Knowledge Statement Classes.	98
Figure 5.5 Changing Domain Importance for Maximising Competitive Advantage.	103
Figure 5.6 Capability Factors for SCTO Exercise.....	105
Figure 6.1 Chapter 6 Schematic.	111
Figure 6.2 UML Activity Diagram Showing Integrated Capability Analysis Method.	115

Figure 6.3 Generic Capability Levels related to Process Plans. 116

Figure 6.4 Illustration of the Four Satellite Panels Used in Testing 117

Figure 6.5 Visualisation of Capability Analysis Concepts for a Capability Factor..... 119

Figure 6.6 Scenarios used to Describe Effect of Environment on PCS..... 122

Figure 6.7 Deconstruction of the High Level Recovery Schedule. 124

Figure 6.8 Collation Activities shown for Product Analysis. 128

Figure 6.9 Validation of a Satellite Build Sequence using an Ergonomic Simulation..... 132

Figure 7.1 Chapter 7 Schematic..... 134

Figure 7.2 Overview of Aggregate Process Planning Method. 136

Figure 7.3 Process Model Job Tree Container Class for Storing Jobs in the Correct
Assembly Sequence. 137

Figure 7.4 Screenshot of Planning Output Derived from Analysis of Job Tree Containers.
..... 139

Figure 7.5 UML Dynamic Object Model Showing the Mapping Procedure for a Single
Feature. 140

Figure 7.6 Partial Product Model..... 146

Figure 7.7 Process Plan Structure Produced using the Two Mappings 147

Figure 7.8. An Example Resource: the Desitech Panel Machining Centre. 149

Figure 7.9 Detail of the Annealing Procedure. 152

Figure 7.10 Probability Distributions of Process and Resource Substitutions for Controlling
the Hybrid Algorithm..... 153

Figure 8.1 The Evaluation Procedure as Described in this Chapter. 155

Figure 8.2 Screenshots of the CAPABLE Space System in Testing..... 161

Figure 8.3 Generating Higher Level Scores. 161

Figure 8.4 Annotated Screenshot of the CAPABLE Space Resource Model Design module.
..... 164

Figure 8.5 The Energy of Candidate Plans for Each Run..... 164

Figure 8.6 Results for Multiple Trials	166
Figure 8.7 The RDA Workflows Identified and Communicated for this Case Study.....	171
Figure 8.8 Example of a Completed SM Floor Panel to Show True Complexity.	172
Figure 9.1 The Research Achievements (Shown in the Context of the DET Framework).	180

List of Tables

Table 1.1 Co-authored Peer-Reviewed Conference and Journal Papers.....	15
Table 2.1 Development of Process Planning Systems.....	18
Table 2.2 Summary of Ackoff's Knowledge Hierarchy.	33
Table 2.3 Classifications of Different Types of Knowledge for Process Planning.	33
Table 2.4 List of Other Notable Software Systems Mentioned in the Literature Review...	41
Table 4.1 Summary of Key Quantitative Data Passed to Planning Methods.	88
Table 5.1 Detailed Analysis of Some Knowledge from a Typical Design Review.....	95
Table 5.2 Normalised Knowledge Metric.....	100
Table 5.3 Domain Weightings for Development of Existing Products (Eurostar 3000)...	105
Table 5.4. Domain Importance for New Product Introduction (Teledesic).....	105
Table 5.5 Benchmarking Scale for Structural Efficiency.	107
Table 5.6. Manufacturing Domain Importance for the SCTO Exercise.....	107
Table 6.1 Analysis of Factor Mass of Structural Components.	118
Table 6.2 Scenario 1: Typical set of capability scores assigned to a single factor.....	121
Table 6.4 Scenario 2: Change in Improvement Potential of the Group.....	122
Table 6.4 An Example Recovery Schedule.	124
Table 6.5 Typical Capability Factors Defined at the Assembly Level.....	126
Table 6.6 Typical Capability Factors Defined at the Component Level.....	127
Table 6.7 Example Quantitative and Qualitative factors used to Compare Process Objects	129
Table 7.1 Size of Search Space.....	141
Table 8.1 Aims and Objectives for Each Case Study.....	157

Table 8.2 The Four Alternative Concepts.....	158
Table 8.3 Historical Benchmarking for Qualitative Knowledge Statements.....	159
Table 8.4 Extract of Encoded Knowledge Statements given in Appendix C.	160
Table 8.5 Domain Rankings for the SCTO Exercise.....	160
Table 8.6 Bandwidth and Improvement Potential Values.	160
Table 8.7 Summary of Product Model Data.	162
Table 8.8 Example Resource Model Data for Mill/Turn Area.	162
Table 8.9 Process Selection for the Example.	165
Table 8.10 Example Resource Selection Options in the Process-to-Resource Mapping. .	165
Table 8.11 Intermediate Job Data for a Single Process/Resource Combination.	165
Table 8.12 A Near-Optimal Process Plan (Run 1).....	167
Table 8.13 A Near-Optimal Process Plan (Run 2).....	168
Table 8.14 Recovery Schedule for a plan, combining QCD with DFM/DFA Qualitative Knowledge Factors.	168
Table 8.15 Summarised Planning Results for Runs 1 and 2.....	173
Table 8.16 Summarised Planning Results for Runs 3 and 4.....	173
Table 8.17 Effect of Including Plan Knowledge Loss in Objective Function.	174
Table 8.18 Comparison of Capability Factor Improvement Potentials.	175
Table 8.19 Resource Level Recovery Schedule.	175
Table 8.20 Equipment Level Recovery Schedule.....	176

Analysis of Manufacturing Operations using Knowledge-Enriched Aggregate Process Planning

David Graham Bramall

Abstract

Knowledge-Enriched Aggregate Process Planning is concerned with the problem of supporting agile design and manufacture by making process planning feedback integral to the design function. A novel Digital Enterprise Technology framework (Maropoulos 2003) provides the technical context and is the basis for the integration of the methods with existing technologies for enterprise-wide product development.

The work is based upon the assertion that, to assure success when developing new products, the technical and qualitative evaluation of process plans must be carried out as early as possible. An intelligent exploration methodology is presented for the technical evaluation of the many alternative manufacturing options which are feasible during the conceptual and embodiment design phases. ‘Data resistant’ aggregate product, process and resource models are the foundation of these planning methods. From the low-level attributes of these models, aggregate methods to generate suitable alternative process plans and estimate Quality, Cost and Delivery (QCD) have been created.

The reliance on QCD metrics in process planning neglects the importance of tacit knowledge that people use to make everyday decisions and express their professional judgement in design. Hence, the research also advances the core aggregate planning theories by developing knowledge-enrichment methods for measuring and analysing qualitative factors as an additional indicator of manufacturing performance, which can be used to compute the potential of a process plan. The application of these methods allows the designer to make a comparative estimation of manufacturability for design alternatives.

Ultimately, this research should translate into significant reductions in both design costs and product development time and create synergy between the product design and the manufacturing system that will be used to make it. The efficacy of the methodology was proved through the development of an experimental computer system (called CAPABLE Space) which used real industrial data, from a leading UK satellite manufacturer to validate the industrial benefits and promote the commercial exploitation of the research.

Acknowledgements

I wish to express my sincere thanks to my supervisor, Prof. Paul G. Maropoulos, who formulated much of the early thinking on Aggregate Process Planning; many of the ideas herein build upon his previous research. I also owe a debt of gratitude to many other people at the University of Durham. In particular, I acknowledge the significant contribution of Mr Kevin R. McKay, whom I worked alongside on the CAPABLE Space research programme for four years. Kevin lead the development of the product and resource models, was jointly responsible for programming the prototype computer systems and co-authored many of the publications resulting from the work. I am also particularly grateful to another colleague, Peter G. Colquhoun, who implemented the distributed database functionality.

The industrial perspective plays an important part in this thesis: I am indebted to the contributions made by various individuals at the main industrial sponsor, EADS Astrium Ltd. (formerly Matra Marconi Space Systems). Two of Astrium's suppliers, namely, Verdict Aerospace Components Ltd. and Northern Precision Engineering Ltd., were also involved in the evaluation and testing of the system.

Finally, this project would not have been possible without the financial support of the Engineering and Physical Sciences Research Council, UK.

Declaration

I confirm that no part of the material offered in this thesis has previously been submitted by me for a degree in this or any other university. This thesis presents entirely my own work, except where appropriately acknowledged citations are given. Where material has been generated through joint work, my independent contribution has been clearly indicated.

Copyright Notice

The copyright of this thesis rests with the author. No quotation from it should be published without their prior written consent and information derived from it should be acknowledged.

Nomenclature

Symbol	Description	Unit
c_j	Cost of a single job	£
c_m	Raw material cost	£
d_b	Batch set-up time	min
d_c	Process cycle time	min
d_e	Maximum delivery time before l is applied	Min
d_j	Delivery time for a single job	min
d_p	Part set-up time	min
d_t	Part transportation time	Min
e	Energy of Simulated Annealing objective function	£
e_i	Energy of an individual job	£
FP	Feature-to-process compatibility matrix	
I	Improvement potential of the group	
k_B	Boltzmann constant	
k_j	Total PCS value of a job	
l	Liquidated loss rate for late process plans	£/min
n	Total number of contributory capability scores at lower level	
$p(\text{fail})$	Quality (expressed as probability of producing a defective product)	
$p(k)$	Likelihood of reoccurrence of the knowledge statement	
PR	Process-to-resource compatibility matrix	
q_j	Quality cost of a job	£
r_a	Activity-based cost rate for resource	£/min
r_d	Depreciation-based cost rate for resource	£/min
s	Capability score	varies per factor
S	Priority confidence score	
S'	Calculated higher level capability score	
s_d	Capability deficiency	
s_e	Expected capability score	varies per factor
S_i	PCS value corresponding to capability score	
s_m	Marginal capability of the capability score	
s_o	Optimum capability score	
s_{oz}	Total bandwidth of the collated group	
s_r	Required capability score	
s_{rz}	Bandwidth of the collated group	
s_z	Worst capability score	
$T_{(0)}$	Temperature _(initial)	°C
w	Normalised domain weighting	
$w_{q,c,d,k}$	Cardinal weighting for quality, cost, delivery and knowledge domains	
x	Overall impact of the knowledge statement	

Chapter 1 Introduction

1.1 Preface

The need to plan and manage manufacturing operations within a constantly changing environment has led to the recognition of ‘agile manufacturing’ as a strategic business ambition. To be considered to be agile, or have agility a company must possess *‘the ability to thrive in an environment of continuous and unpredictable change’* (Ward 1994). Like the predominant ‘lean thinking’ philosophy of the late 1990’s (Womack and Jones 2003), agile manufacturing is intended to manage high product variety (mass customisation) and dynamic product volumes, but it is focussed on delivering a more proactive response to the changes in the wider environment. It does this by concentrating on effective, quick communication and information flows to create rapid manufacturing alliances to respond to market opportunities.

To realise agile manufacture, new ‘Digital Enterprise Technologies’ (DET) are required for integrating design, manufacturing and other functions. DET is formally defined as:

‘The collection of systems and methods for the digital modelling of the global product development and realisation process, in the context of lifecycle management.’

(Maropoulos, *et al.* 2003b)

DET is a theoretical framework for the dynamic organisation of the myriad of computer-aided design tools around the core manufacturing models of product, process and resource that exist throughout the lifecycle of a design. Five technical strands of DET cover: distributed and collaborative design; process design and planning, advanced factory equipment and layout design and modelling, physical-to-digital environment integrators and enterprise integration technologies (Figure 1.1). The key philosophy of DET is that of mitigating risk and controlling costs (without stifling innovation or flexibility) by providing appropriate computer based-solutions for virtual product creation whilst retaining appropriate links and feedback to the physical environment. As such, DET is a



Figure 1.1 Original Diagrammatic Representation of the DET Framework. Reproduced from Maropoulos, *et al.* (2003a).

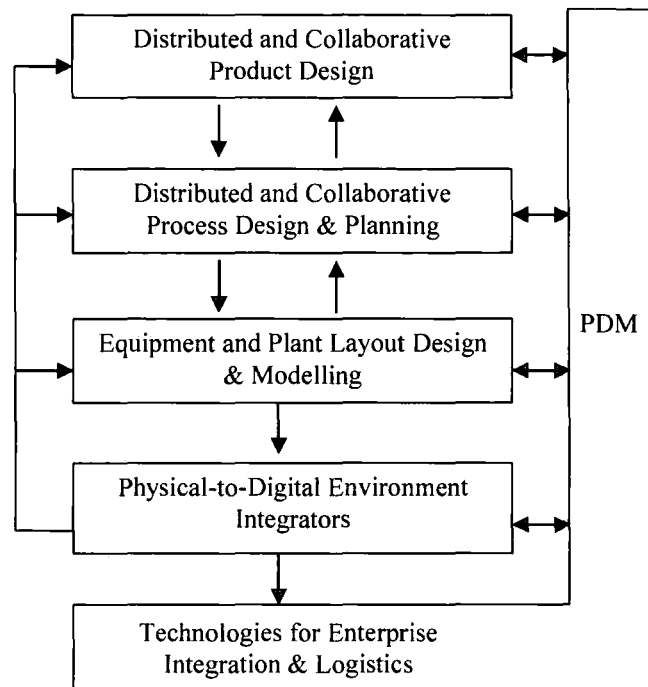

generic architecture for global product development – it is up to the end user to configure appropriate software tools to fit in with their development activity.

The technical area of process design and planning is an important component of DET as it provides the means of linking the distributed product design functions with factory and supply chain design. Prior to the development of DET, Aggregate Process Planning (Maropoulos 1995) had already been pioneered as a method for the early evaluation of manufacturing plans. It allowed integrated product and process design teams to evaluate the manufacturing needs of a partially specified product design based on identifying and evaluating key process criteria.

The Knowledge-Enriched Aggregate Process Planning system reported here is an advancement of this previous aggregate planning research, intended to exploit the aforementioned DET framework. The knowledge-enriched aspects provide a new dimension of decision support necessary for the validation of continually evolving manufacturing plans during the development of complex products.

1.2 Introductory Remarks on Process Planning and Manufacturability Analysis

Design processes start from the interpretation of high level requirements (sometimes referred to as conceptual design [Pahl and Beitz (2003)]) through intermediate specification of components (sometimes referred to as embodiment design) to detailed design development. It is not necessarily useful to classify a design as being in one of these states. The term ‘early design’ is used throughout this thesis to refer to the continuum of design that happens prior to a component being released for final detailing and manufacture. In most manufacturing companies, process planning occurs after the product design stage and prior to the production control activity and there is an inherent lack of concurrency between design and process planning and very little opportunity for communication. The process planning technology developed since the 1980’s has concentrated on the use of ‘design by feature’ CAD models from which generative process plans can be derived. Such process planning systems are by definition analytical in nature and use heuristics and knowledge-based techniques to derive repeatable solutions. By contrast in early design, the number of possible solutions (the search space) can be very large and potentially bounded by soft constraints unsuitable for solving analytically.

1.2.1 A History of Aggregate Process Planning Research

In response to the lack of support for planning throughout the design cycle, the aggregate, management and detailed planning paradigm was developed under the direction of Professor P. G. Maropoulos at the University of Durham. In 1995 a novel set of modelling and optimisation methods was conceived (Maropoulos 1995) to enable process planning with incomplete and partially specified product designs. The aggregate paradigm subdivided the process planning activity into discrete levels, each having data models and planning methods appropriate to the amount of design information available. The planning methods are integrated with traditional design and scheduling systems, as shown in Figure 1.2, in order to fulfil the following time-phased functions:

- (1) To identify the processing options at the aggregate level.
- (2) To rationalise the processing options at the management level.
- (3) To provide optimised, approved plans for manufacture at the detailed level, with similar functionality to traditional process planning systems.

Figure 1.2 The Precursor Aggregate, Management and Detailed Architecture. Reproduced from Maropoulos (1995).

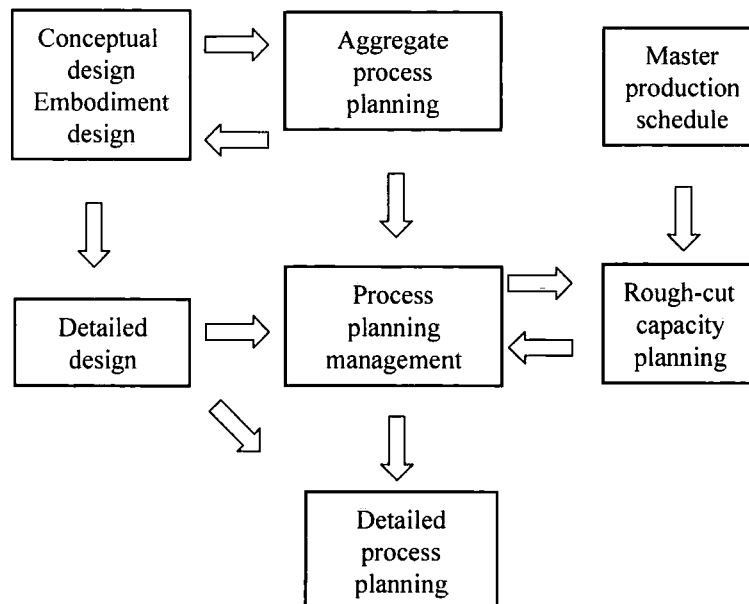

Early feasibility studies in aggregate planning were carried out for welding and machining operations (Bradley 1997) and latterly extended into the area of assembly modelling and planning (Betteridge 2002) and (Laguda 2002). The result of this early research was a first attempt at aggregate product, process and resource modelling methods and a rudimentary genetic algorithm optimiser were taken as the starting point for the development of the new knowledge-enriched planning methods. The major limitation of the this early research was that the assessment methodology focussed on comparing and selecting between alternative process options under a set of unchanging conditions and with limited scope for comparing alternative production scenarios. For example, a number of early prototype systems were produced that were capable of calculating the difference in processing time between two different design configurations of a component but had no ability to determine the effect of alternative layouts or additional equipment.

1.3 Exposition on Knowledge-Enriched Aggregate Planning

Whereas prior attempts at aggregate planning focussed on the local optimisation of specific operations (machining, welding or assembly), this research is concerned with creating the underpinning modelling technology and multi-criteria planning algorithms for practical aggregate planning systems. Knowledge-Enriched Aggregate Process Planning fuses newly extended aggregate planning methods with capability analysis methods (tailored to

evaluating manufacturability in process planning) and applies them within the DET framework to provide increased capability for making ‘resource-aware’ planning decisions based on limited product information.

1.3.1 Establishing Research Priorities

When a new product is proposed, the designers will start to work up a product concept and in order for a decision to be made on the viability, it is necessary to know something about the product’s manufacture. To do this, most enterprises rely on the use of a design-and-review process where experienced designers, engineers and managers meet at set intervals to discuss progress and iron out problems. To support the concept of agile enterprises, an alternative methodology is proposed which uses Knowledge-Enriched Aggregate Process Planning to instigate alternative manufacturing plans and then evaluates them on the designer’s desktop using relevant decision-making criteria.

Of the five elements of DET, the most important area for supporting decision making in agile manufacturing systems is seen as the integration between design and process planning within the context of the extended enterprise. The principles of Concurrent Engineering (CE); set out in the 1980’s, state that integration efforts must be concentrated at the earliest stages of design since the effects of design decisions made at this point have the greatest influence on the final product’s manufacturability and cost. The normal approach to CE, is to perform product development activities concurrently using cross-functional teams, rather than sequentially, to reduce the overall development time. However, existing CE and virtual product creation tools are not well suited to this task because of their differing information needs, in particular their dependence on having fully specified CAD geometry before any process planning can begin.

The flexible management of both quantitative and qualitative information (regarding manufacturability) is critical to the creation of a workable, collaborative architecture for the application of DET, and should ensure that DET succeeds where previous attempts at CE and Computer Integrated Manufacture (CIM) have failed due to its overly dogmatic philosophies. This research addresses the need for product and process development tools that address the specific requirement for rapid and flexible design evaluation and exploration of alternatives using methods which can be executed early in the design cycle to reduce still further the design time and mitigate implementation risks. In most cases, the complexity of modern multi-site operations makes optimal solutions viable only for a short

period of time. Therefore, it is seen as much more meaningful to be able to explore the dynamic decision-making space intelligently using rapid exploration techniques and to ascertain the impact of change to the process plan as and when such change occurs. Techniques for the intelligent exploration of dynamic production environments are termed emergent approaches (Ueda, *et al.* 2001). This concurs with the concept of configuring DET frameworks unique to each enterprise's needs; each implementation of a DET framework will be unique (and may vary over time) yet must retain the core functionalities for time-phased digital product and process development. DET frameworks must also be capable of assimilating design data at various levels of completeness and exhibit a high degree of feedback from production.

This research takes the core aggregate modelling theory envisaged by Bradley (1997) and places it in a new DET context by incorporating; (i) new methods of automated plan generation, (ii) more sophisticated optimisation techniques, (iii) new systems for reporting and prioritising product requirements and (iv) new knowledge modelling techniques capable of capturing the performance of internal and external manufacturing operations, both internally and within supply chain companies. As such, the new methods can be termed 'resource-aware'. Critically, to be of use during early design, the knowledge representation techniques developed in this thesis are not be limited to quantitative technical considerations, but include user evaluations of past supplier relationships and qualitative assessment of supplier credibility.

The original vision of Aggregate Process Planning envisaged that the analysis would be restricted to the evaluation of product manufacturability through the traditional metrics of Quality, Cost and Delivery (QCD). Bradley (1997) was to prove that, in order to generate QCD estimates, just three models are required to store the technical information for use in aggregate level planning systems:

- (1) Aggregate (feature-based) product models.
- (2) Aggregate process models.
- (3) Aggregate resource models.

To fully realise the new 'Resource-Aware' Knowledge-Enriched Aggregate Process Planning methodology, extensions to the original models were required to enrich the product model with (i) 'assembly feature relations' for modelling assemblies, (ii) to expand the process model classes (to cover specialist satellite manufacturing processes in the application area selected for testing the methods) and (iii) to include resource models

capable of representing enterprise resources from labour, to production machines, transportation equipment, production units and factories. To be able to explore potential manufacturing scenarios intelligently, new planning and resource allocation functions are also required. These consist of methods for measuring quality cost and delivery at the process plan level, methods for automatically generation valid alternative process and machine selection as routings and a hybrid optimisation algorithm, tailored to explore the alternative routings in a computationally efficient manner. Furthermore, the original notion of aggregate planning omitted the intrinsic human decision making aspects of design development, namely the undocumented information which designers and planners really consider when they design products. Part of this research deals with ‘knowledge enrichment’ methods for the representation and prioritisation of product and process knowledge which can have a significant bearing on DET-based decision-making and on the performance of agile manufacturing systems. The continued evolution of the aggregate planning paradigm is proposed to facilitate the exchange of such, non-essential, knowledge and to manage the product development activity within Aggregate Process Planning effectively.

The type of design decision making aid envisaged by knowledge-enriched planning is clearly identified with the aggregate level. At this level, the process planning activity is predominantly concerned with the rapid technical evaluation, intelligent exploration and decision-making between multiple product configurations and manufacturing scenarios using new ‘data-resistant’ planning algorithms.

1.3.2 The Perceived Benefits of Applying Knowledge-Enriched Aggregate Planning in a DET Framework

The perceived industrial benefits from the deployment of DET methods in general are defined by Maropoulos, *et al.* (2003b) as:

- (1) Minimization of risk in global product realisation.
- (2) Provision of analysis and computer support throughout the product’s ‘life cycle’.
- (3) Enabling ‘digital manufacture and assembly’ for complex products with short life cycles.
- (4) Integrated feedback can be received regarding:
 - (a) The status of production machines as well as of cells and plants,

- (b) The capacity and logistics of the extended enterprise.
- (5) High plant re-configurability, to meet product complexity and production network needs.
- (6) Low technology redundancy, as investment levels are linked to requirements and are distributed, facilitating renewal.

Ultimately, it is anticipated that the development of Knowledge-Enriched Aggregate Process Planning within DET will demonstrate that a number of these benefits are achievable and substantial. Primarily, it is expected that a decision making aid will be created with the ability to control product specification and resource selection at the early design stage will result in a dramatic reduction of risk and cost in product realisation. There is likely to be substantial improvement in QCD when the design reaches the manufacturing stage, but it also has a positive effect of the incurred cost of development process itself. A typical profile of cost commitment and expenditure (Rush and Roy 2000) in Figure 1.3 (shown as the dashed line). Although, the limitations of such a simplistic representation have been recognised (Barton, *et al.* 2001), it does at least enable a comparison of committed and incurred costs with and without aggregate planning to be made. The graph shows that the proposed aggregate planning methodology has the potential to improve both the time to market, the incurred cost (due to less errors and the elimination of difficult to manufacture designs) and the cost of the final product (as indicated by the solid line). Additionally, there are two other major benefits. Firstly, there is a delayed need for investment, which reduces the overall project risk and secondly, the improved communication between design and manufacture means that there are less likely

Figure 1.3 Incurred and Committed Costs With and Without Aggregate Planning.

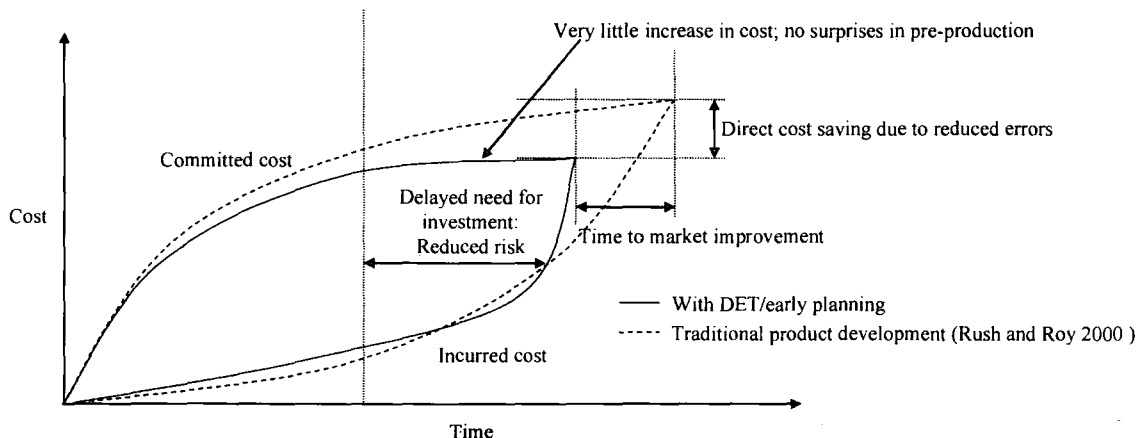

to be problems during the implementation phases, show by the flatter profile of the committed cost curve.

1.3.3 Linkages with European Design and Process Development Research

As part of the European Union's 6th Framework programme it is planned to establish a Europe-wide strategy for bringing together research into product development and production methods, covering both industrial and academic perspectives. This strategy, enunciated in the *MANUFUTURE* report (*MANUFUTURE* High-Level Group 2004), expresses a view that European manufacturing must move towards '*innovating production*'. This term means the adoption of new infrastructures to enable manufacturing enterprises to carry out knowledge-intensive research and development and integrate it with networked product and process design activities. This strategy includes the formation of a Network of Excellence for collaborative research called the Virtual Research Laboratory for Knowledge Centres in Production (VRL-KCiP) (VRL-KCiP 2005b) which is establishing an ontology-based platform for knowledge sharing. There are also several working groups, such as ViP-RoaM (ViP-RoaM 2003), and other consortia planning future European research projects within this strategic agenda.

Through the ViP-RoaM workshops (in which the author participated), a roadmap, presented in Appendix A, was developed to outline future research activities and implementation paths for the creation of new knowledge management activities for product development. The roadmap not only confirmed the industrial need for knowledge management and decision support during product development, but also more importantly, showed that the majority of proposed ideas and solutions are not likely to become available during the next five years. The industrial relevance of this thesis is also confirmed by the current pace of software development in commercial 'knowledge-enabled' CAD systems. However, these solutions are still fairly rudimentary approaches to knowledge integration largely based around parametric CAD (Liese and Anderl 2003) and much of the recent research which is identified in Chapter 2 has yet to filter down into mainstream CAD applications.

The VRL-KCiP is a network of 24 engineering laboratories from 15 different countries who agree to share knowledge and resources, carry out jointly executed research activities with the ultimate aim of develop a sustainable, unified research strategy. The development of workable DET toolboxes will be an important input to the network as are likely to serve

as a common base for interaction and common understanding among the network partners as well as a test-bed for the applications.

1.4 Research Outline

1.4.1 The Adopted Research Methodology

The main aim of this research is to develop new aggregate planning technology for linking the early stages of product design with manufacturing operations to:

- (1) Rapidly translate product specifications into process requirements and manufacturing routings for multiple sites and feedback to the product design team for rapid product and process realisation.
- (2) To broaden the traditional boundaries of process planning by incorporating a technical evaluation expert knowledge and DET-based analysis results to aid decision making and to guide the prioritisation of detailed design tasks.

The development of this functionality requires the investigation of appropriate data structures, process planning algorithms and new knowledge management methods which was systematically researched through the following primary objectives:

- (1) To review the current academic thinking and industrial practice regarding the use of computer-aided tools for decision support during early design and process planning.
- (2) To develop the next version of aggregate planning technology to link the early stages of product design with extended manufacturing operations using 'data-resistant algorithms capable of estimating manufacturability earlier in the design cycle than has been previously possible.
- (3) To propose a new methodology for supporting aggregate planning with the technical assessment of qualitative and quantitative knowledge from sources within the DET framework and historical knowledge. The new functionalities expected to be provided by the knowledge enriched process planning methods are:
 - (a) To develop methods for the representation of product, process and resource knowledge within aggregate planning.

- (b) To feedback design and manufacturing knowledge to constrain product designs to available, technically feasible and cost-effective processes to limit production costs.

These primary objectives are supplemented by the following supplementary objectives:

- (1) To develop a suitable means of representing limited or incomplete design data, process knowledge and multi-site resource information available in a form suitable for early process planning.
- (2) To derive an effective and accurate means of measuring manufacturability in early design using aggregate process models, taking information from and providing feedback to external DET applications.
 - (a)
 - (b) To identify and prioritise the detailed design tasks that are necessary to allow a design to progress from the aggregate stage to the management level. And by doing so to reduce development time, cost and realisation risk for a product.
 - (c) To manage and control the early resolution of design conflict and uncertainty, through applying appropriate Digital Enterprise Technology solutions.
- (3) To develop and implement a technology demonstrator, showing that the methods identified are workable solutions and permitting experimentation.
- (4) To evaluate this experimental system through rigorous testing with real industrial design data to permit comparisons with existing non DET-based design methods.

1.4.2 Thesis Structure

This thesis is organised into nine chapters; covering the investigate research, development and testing of the proposed knowledge-enriched planning methods which is shown schematically in Figure 1.4.

Chapter 2 presents a review of research in the field of product and process development support. The literature review studies existing systems and literature to understand prevalent problems. Based on this literature review a hypothesis was formed and a novel system for generating knowledge-enriched process plans is subsequently presented; CAPABLE Space.

A general overview of the system, showing aggregate data models and functional modules, is given in Chapter 3. Chapters 4 covers the implementation of the aggregate product and resource models and manufacturability analysis using process models.

A detailed description of the knowledge representation and management methods proposed for use in aggregate planning is given in Chapters 5 and 6 respectively. Chapter 7 describes the intelligent exploration of process plans according to quantitative manufacturing analysis and qualitative knowledge factors outlined in the preceding chapters. Chapter 8 presents a report on the testing of the methods and the CAPABLE Space computer system and shows the potential of the system.

Finally, a discussion of the effectiveness of CAPABLE Space as a design tool, and the overall conclusions that can be drawn from this work are provided in Chapter 9.

Figure 1.4 The Adopted Research Methodology Showing Key Sections in this Thesis.

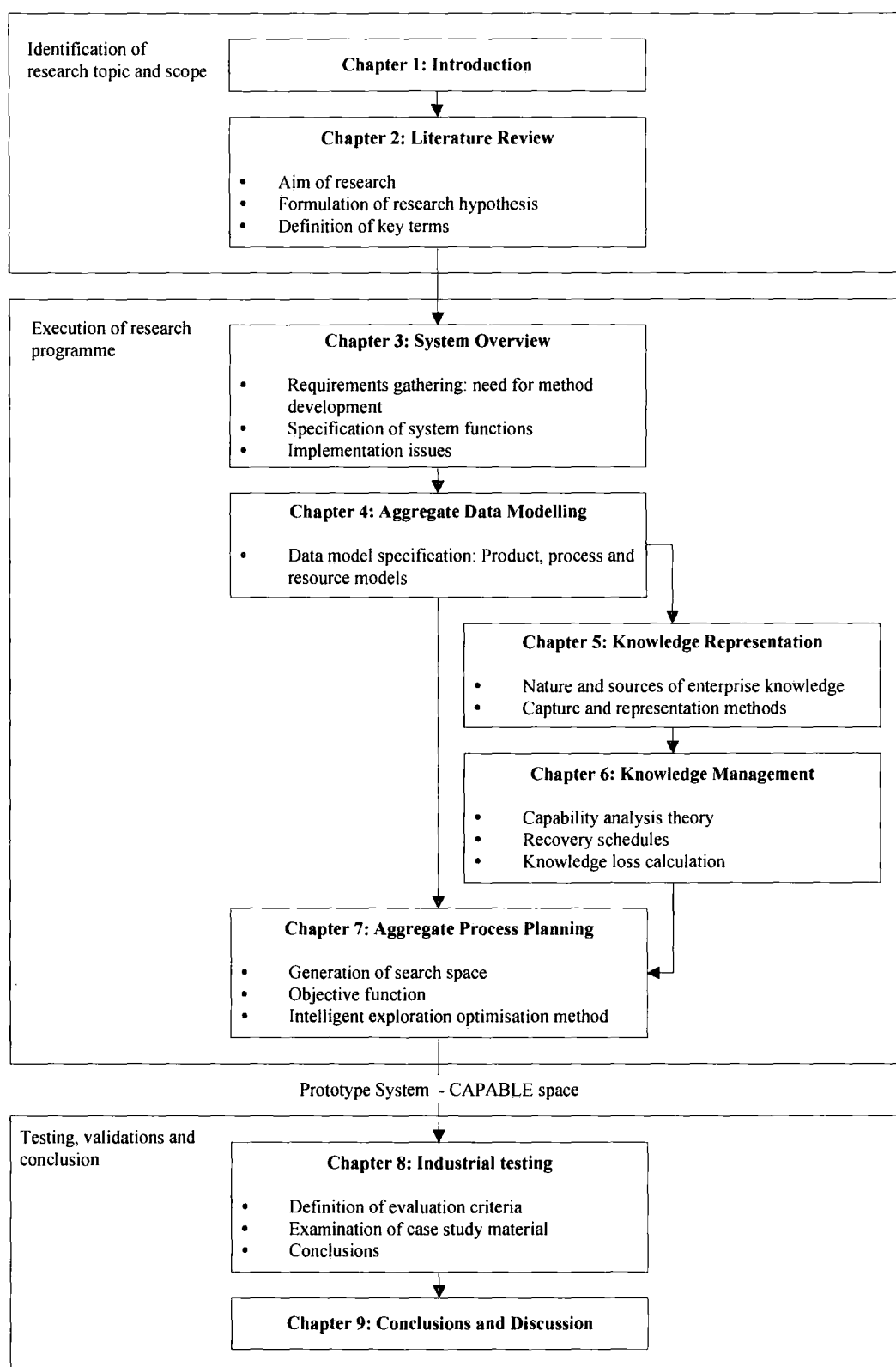

1.4.3 Publications Related to this Research

The underlying research was carried out under a grant from the UK Engineering and Physical Sciences Research Council (GR/L98572: *Integrated Planning of Manufacturing Operations using Knowledge-Enriched Aggregate Planning*) with the satellite manufacturers Astrium (Stevenage, UK) acting as industrial collaborators. The final EPSRC assessment of this grant was *'Tending to Outstanding'*.

The primary contribution of this author to the project was to bring to bear the specification and implementation of the novel hybrid aggregate planning engine and the embodiment of the supplementary knowledge-enriched product, process and resource models. Additional research into the management of engineering changes on the process planning data and distributed architectures to support planning was the responsibility of other researchers.

Earlier versions of this work have appeared in numerous internal technical reports, conference papers and refereed journal articles. Over the past five years, the research results have been disseminated by writing a total of 27 papers for learned journals and refereed conferences as shown in Table 1.1 and referenced in the Bibliography. Eleven of the published papers were principally written, by this author, on the topics covered in Chapters 3 to 8 as indicated in Table 1.1. The most important journal publications relating to this thesis are; *'Manufacturability Analysis of Early Product Designs'* which describes knowledge-enriched manufacturability analysis of early product designs and *'Assessing the manufacturability of early product designs using aggregate process models'* which reports the aggregate process models and a co-authored paper on the planning engine. The DET framework itself was first published in the co-authored paper entitled *'A Novel Digital Enterprise Technology Framework for the Distributed Development and Validation of Complex Products'*.

Title	Bibliography Reference	Chapter					
		3	4	5	6	7	8
<i>Manufacturing analysis of conceptual and embodiment aerospace designs: An aggregate process model specification.</i>	Bramall, et al. 2000		♦				
<i>A System Architecture for Distributed Aggregate Process Planning.</i>	Bramall, et al. 2001a	♦					
<i>Manufacturability assessment of conceptual and embodiment designs using aggregate process models.</i>	Bramall, et al. 2001b	♦					
<i>A New Methodology for Managing Enterprise Knowledge.</i>	Bramall, et al. 2001c			♦	♦		
<i>Supporting Aggregate Process Planning with Product, Process and Resource Knowledge.</i>	Bramall, et al. 2001d			♦			
<i>Manufacturability Assessment of Early Product Designs.</i>	Bramall, et al. 2002a	♦					
<i>A Capability Analysis Method for the Technical Assessment of Qualitative Design and Process Planning Knowledge.</i>	Bramall, et al. 2002b			♦			
<i>Decision Support Systems for New Product Introduction.</i>	Bramall, et al. 2002c	♦				♦	
Manufacturability Analysis of Early Product Designs.	Bramall, et al. 2003a	♦				♦	♦
<i>Adaptive lifecycle models for product design.</i>	Bramall, et al. 2003b		♦				
<i>Structure-based Aggregate Process Models for Complex Assemblies.</i>	Chapman, et al. 2002	♦	♦				♦
<i>An Integrated and Distributed Planning Environment for Spacecraft Manufacture.</i>	Maropoulos, et al. 2001	♦					
Resource-Aware Aggregate Planning for the Distributed Manufacturing Enterprise	Maropoulos, et al. 2002	♦	♦			♦	♦
<i>Assessing the manufacturability of early product designs using aggregate process models.</i>	Maropoulos, et al. 2003a	♦				♦	♦
<i>Dynamic and distributed early planning assessment by a hybrid Simulated Annealing and Greedy algorithm.</i>	Maropoulos, et al. 2003b	♦					♦
<i>An aggregate resource model for the provision of dynamic 'resource-aware' planning.</i>	Maropoulos, et al. 2003c	♦				♦	♦
<i>Agile Design and Manufacturing in Collaborative Networks for the Defence Industry</i>	Maropoulos, et al. 2004a					♦	
<i>Digital Enterprise Technology in Spacecraft Design and Manufacture</i>	Maropoulos, et al. 2004b	♦			♦	♦	
<i>Manufacturing analysis of conceptual and embodiment aerospace designs: An aggregate product model specification.</i>	McKay, et al. 2000	♦					
<i>Manufacturing models for a distributed process planning system.</i>	McKay, et al. 2001a	♦	♦				
<i>Capable Space: A distributed process planning environment.</i>	McKay, et al. 2001b	♦	♦				
<i>Providing enterprise-wide Aggregate Process Planning with multiple criterion solutions.</i>	McKay, et al. 2001c					♦	
<i>Managing engineering change on process plans via a new concept of feature elasticity.</i>	McKay, et al. 2001d					♦	
<i>An aggregate resource model for the provision of digital mock-up within a distributed manufacturing planning system.</i>	McKay, et al. 2001e	♦					
<i>Controlling the manufacturing phase-space of the extended enterprise.</i>	McKay, et al. 2002a					♦	
<i>Rapid CE Change Assessment on Early Product Definition.</i>	McKay, et al. 2002b					♦	
Design Change Impact Analysis during Early Design Specification.	McKay, et al. 2003					♦	

Table 1.1 Co-authored Peer-Reviewed Conference and **Journal** Papers.

Chapter 2 Literature Review

2.1 Introduction

Having proposed that the rapid technical evaluation of design options during the critical early stages of design will result in reduced cost and lower risk, the challenge is to determine both theoretical and practical requirements and to establish the means by which this task may be achieved. Two areas of research are directly relevant to the research presented in this thesis: process planning and knowledge management. Using Concurrent Engineering as the general foundation, this chapter presents a review of the relevant literature to establish the current state and future direction of process planning research. Related work is critically reviewed and discussed in relation to requirements for implementing next generation process planning systems (particularly those targeted at early design stages). Subsequently, the knowledge management techniques and methods that could be used to enhance existing process planning functionality are considered.

2.2 Product Development in the Context of Agile Manufacture

The task of bringing new, ever more complex, products to market faster, cheaper and more reliably is fundamental to the success of manufacturing companies. Concurrent Engineering (CE) represented the first real attempt at decreasing product cost and time to market at the same time as increasing the quality of the product by carrying out parallel activities which are normally done in sequence (Sohlenius 1992). CE was the genesis of the integration of design and manufacturing and was to become a fertile research area: despite being a relatively simple concept, it is in fact extremely difficult to implement due to the time-phased integration requirements of each task.

In agile manufacturing systems, one of the most important areas for the development of CE is seen as the interaction between design and process planning within the context of the extended enterprise. The results of Gindy's survey of the UK aerospace industry (Gindy 1999) (summarised in Figure 2.1) confirms this view, with 30% of respondents indicating that streamlining the product development process is key to achieving responsive

Figure 2.1 Relative importance of domains in the Responsive Manufacturing Model (adapted from Gindy [1999]).

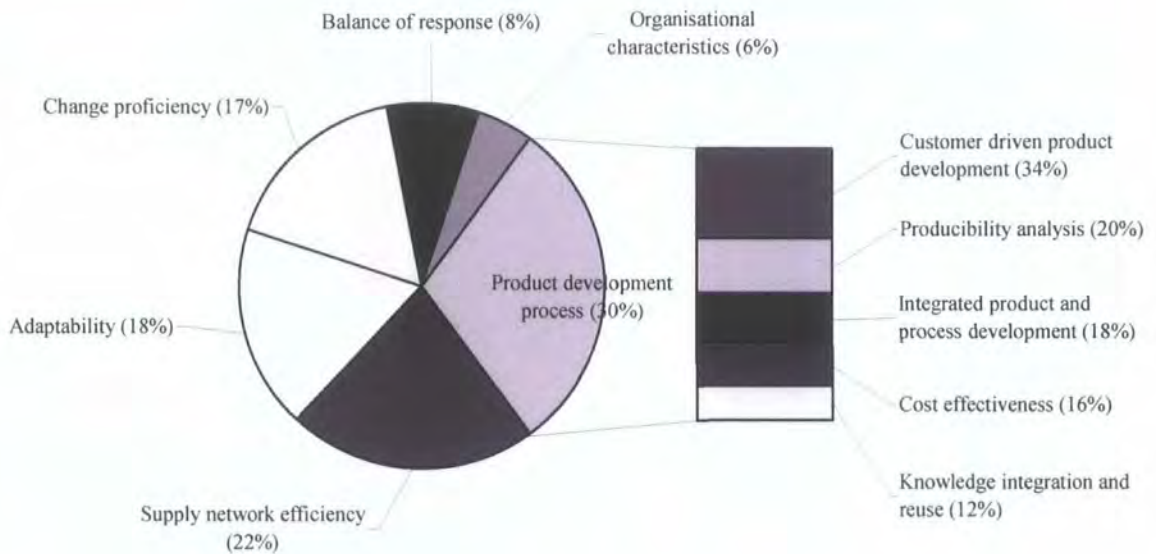

manufacturing. Producibility analysis (20%) and integrated product and process development are seen as two significant contributors to effective product development.

In a report on innovation in manufacture (Howell 2000), Reinertsen opines that suppliers only become involved in the late stage of design development, yet they have much to contribute:

'It [the infrastructure] reflects the hidden assumption that firms should have a fully defined component requirement and then select among several possible suppliers on the basis of cost quality and delivery performance...This is unfortunate, since 90% of the influence that a supplier can have exists in the first 10% of the development process.'

Of course, many companies will be reluctant to share information because of security and commercial concerns. This attitude is slowly changing, as Wiendahl and Lutz (2002) comment, the prevailing view is that openness (in production networks) is compensated for by the increased benefits of co-ordination and planning. Their view is that future production in networks will be about co-operation in the supply chain, optimising the allocation of jobs with respect to factory loading and availability of resources.

2.3 Research in Process Planning

This section looks at the technical advances in automated planning of manufacturing operations. The intention is not to produce a comprehensive review of process planning literature or systems; rather to present the historical background (highlighting trends, and general obstacles to achieving the vision outlined above) and to provide a more detailed analysis of the most recent innovations pertinent to the task of early planning.

2.3.1 Foundations of Process Planning

Several key texts have been written on the subject of process planning, notably *An introduction to automated process planning systems* (Chang and Wysk 1985) and *Principles of Process Planning* (Halevi and Weill 1995). From these texts a practical description of the process planning activity emerges: it is an activity that translates product information into manufacturing instructions, including the selection of processes and process parameters. Process planning involves a number of elements, particularly: selection of process, selection of tools and equipment, selection of process parameters, generation of machine instructions and fixturing and set-up planning.

To aid the understanding of process planning research to date, its development has been classified into four stages as shown in Table 2.1: the earliest attempts at planning in a Group Technology environment, variant and generative computer-aided planning and the latest generation of systems for dynamic planning.

Table 2.1 Development of Process Planning Systems

Name	Era/Context	Description
Manual planning	1970s. Conception and development of CAD, CAM and other CAE tools.	Standardised process plans are created for part families using stand-alone software tools.
Variant computer-aided planning	1980s. Interfaces between CAD, CAM, CAE based on neutral formats, each retain own data structures	The variant approach involves retrieving an existing plan for a similar part and making the necessary modifications to the plan for the new part.
Generative computer-aided planning	1990s. Information integration via PDM tools, single repository for design data utilised by CAD, CAM and CAE.	At this stage, feature-based decision rules are built into the process planning system. Process plan is derived from first principles and requires minimal manual interaction and modification.
Dynamic, generative	2000-. Emergent approaches.	The process plan varies over time. Generative methods adapted to cope with uncertain environmental conditions.

From the earliest research, an important division in process planning systems was made according to the way in which the plans are generated:

- (1) **Variants** planning systems produce process plans by searching historical databases for similar products and making the necessary modifications to the plan for the new part. Variant planning has been the most widely implemented method in industry. The major drawbacks of this type of planning are the limited repeatability, reliance on the skill of the planner and the use of standalone software tools.
- (2) **Generative** planning involves making original process plans from a set of rules based on first principles by means of decision logics and process knowledge. These systems require more information about both processes and parts. The use of neutral file formats meant that these software packages could utilise existing design geometry.

Only generative process planning can develop a process plan at the early design stage where manufacturability evaluation is most effective. Also it does not keep the designer tied to earlier process plans and allows to develop alternative process plans for the same design. Although, usable under controlled conditions this variant planning remains fairly inflexible. However, there is renewed interest in variant planning on the back of a hybrid planning approach (Elinson, *et al.* 1997) on the basis that existing plans represent knowledge about best practice.

As CAD evolved, parametric geometrical and feature-based models emerged, taking advantage of the existing data and design intent provided via Product Data Management programs and linking them with entities used in process planning (Paris and Brissaud 2000). Various mechanisms for linking product data with proprietary process planning systems are described in (NIST 1994). The limitation of the current technology is that the majority of these process planning systems are designed to operate at the back end of the design cycle and require a CAD model with a high levels of geometrical and tolerance data, which is unavailable during early design.

Furthermore, the impact of process planning is felt in areas other than manufacturing; Halevi and Weill (1995) point out the relationship between process planning and the economic management of a company. Materials cost, manufacturing cost, economic quantities and capital investment decisions can all affect the economic evaluation of a process plan. This does not correspond to the emphasis of most process planning research

which relates to the optimisation of a single manufacturing step. Until recently, CAPP research and development efforts have focussed almost exclusively on narrowly focussed application such as metal removal (ElMaraghy 1993). Moreover, ElMaraghy offers a classification of process planning technology into four levels, according to the detail involved:

- (1) **Generic** (or conceptual) process planning is concerned with the selection of suitable production technology for the part and with providing rapid feedback to the designer so that designs may be optimised for the process.
- (2) **Macro** planning is concerned with routing and sequencing. Such systems are characteristically able to consider several process technologies.
- (3) **Detailed** process planning systems are typically narrowly focussed on a specific application area, such as machining. These systems are concerned with selection of tools and resources and sequencing of operations.
- (4) **Micro** planning is concerned with the optimisation of a single process operation.

This view neglects the importance of time considerations; with reference to the aims of aggregate planning, the timing of process planning is another important factor. DET frameworks require that different levels of process planning are performed throughout the product development cycle.

2.3.2 Time-Phased Planning in Product Development

Up until this point the importance of time considerations has been neglected. Of critical importance to CE is the timing and level of detail in process planning. Pham and Dimov (1998) recognised that feature-based design tools could be used in early design, and predicted that a new breed of computer systems aimed at assisting the designer by providing early feedback would emerge.

Pahl and Beitz (2003) made a practical attempt to break the design and planning process down into discrete stages, each with associated design tasks:

- (1) Planning and clarifying the task.
- (2) Conceptual design and planning.
- (3) Embodiment design and planning.
- (4) Detailed design and planning.

These begin with broad objective setting and require steadily increasing amounts of detail until production instructions, which are very specific and detailed but narrow in scope, have been produced. Whilst the idea of conceptual design has, over time, become widespread the notion of conceptual process planning is relatively new.

Conceptual process planning defines the additional tools necessary to create dynamic planning systems, capable of operating on emerging product data. Feng and Zhang (1999) define this activity thus:

'Conceptual Process Planning is an activity of preliminary manufacturability assessment of conceptual design in the early product design stage. It aims at determining manufacturing processes, selecting resources and equipment, and estimating manufacturing costs roughly. Conceptual process planning supports product design to optimize product form, configuration, and material selection and to minimize the manufacturing cost.'

Continuing this theme, Lutters, *et al.* (1999) propose information management architectures which cover product engineering, resource engineering and order engineering. These models operate at both production and management levels, thus facilitating both micro and macro-level process planning.

According to Giachetti (1997), it is important to consider *every* possible alternative during the design process since design decisions greatly influence costs. However, he foresees two major problems in achieving this:

- (1) Determining feasible combinations of material and manufacturing processes during conceptual design is impeded since the requirements and product characteristics are only imprecisely known.
- (2) It is becoming increasingly clear that the tremendous number of materials and manufacturing processes precludes an iterative single point search for alternatives.

The use of non-geometrical models, termed '*functional models*' in CAPP has been considered by Roucoules, *et al.* (2003). Using functional models, they proved the principle that process planning can be performed without geometrical data, instead using formal communication structures to answer 'what-if?' questions via manual evaluations of planned scenarios. However, they require the use of a second '*detailed*' design model to store geometric data and progress the design to a full CAPP system.

2.3.3 Emergent Synthesis Methodologies for Process Planning

The problems of uncertainty and complexity in manufacturing, are widely recognised but not well understood. A keynote paper by Ueda, *et al.* (2001) was significant because it classified the ‘problem’ according to the level of completeness of design specification and of the knowledge about the environment:

- (1) Class I problems are fully defined and can be solved by traditional optimisation techniques.
- (2) Class II emergent synthesis problems deal with an application environment that is not fully defined in terms of its scope or composition.
- (3) In a Class III problem the system requires human intervention for the interpretation of interim results and the specification of new options concerning the environment’s configuration.

According to these definitions, Aggregate Process Planning is, somewhere between a class II and a class III emergent synthesis problem. Early (aggregate) planning has the following emergent characteristics:

- (1) The product model accepts incomplete and evolving design information.
- (2) The resource model is dynamically configured by the supply chain.
- (3) The knowledge-enriched planning methodology is ‘driven’ by the evaluation of feedback regarding improvement opportunities, demanding the interactive evaluation of interim results.
- (4) The DET framework can be employed to carry out modelling and optimisation at various levels of abstraction within the system. The amount of detail required is determined on a case by case basis.

This leads to the conclusion that deterministic planning methods are not suitable and that emergent approaches having some degree of human interaction would be more feasible. To deal with uncertainty in the environment, the notion of dynamic and adaptive process planning systems is brought into being. One early example of a adaptive system is iViP (integrated Virtual Product Creation). This was a European Framework 5 programme led by the Fraunhofer Institute (Fraunhofer IPK 2002) which investigated the configuration of a uniform working environment for multiple virtual product creation tools which could be specified according to the needs of the end user. The programme included two sub-projects focussed on Knowledge Management systems: ‘*Knowledge Management Methods*’ and

'Managing Experienced Knowledge' and a knowledge management portal interfacing to existing ERP systems: *'Promotion of Knowledge Transfer'*.

Although process planning has traditionally relied upon knowledge- and rule-based systems, emergent synthesis problems are more suited to evolutionary computing methods largely because of the need for optimisation and multiple conflicting constraints. Various evolutionary computing methods have been attempted for assembly line design, production planning and layout design (Pierreval, *et al.* 2003) and process planning (Ma, *et al.* 2000). Furthermore, the highly changeable environments supported by Type II emergent synthesis problems, has prompted a new decision-making paradigm called Engineering as Collaborative Negotiation (Jin and Lu 2004), in which *'stakeholders with different expertise and mixed motives engage in interactive and joint conflict resolutions to co-construct consensual agreements of some engineering matter'*. However by their interactive nature ECN systems will not succeed unless there are process planning tools which can quickly provide information on the consequences of engineering decisions.

2.4 Development of Enabling Technologies

2.4.1 Feature-Based Product Modelling

Product modelling only became really useful for manufacturing with the definition of form features (Gindy 1989). This allowed various systems to map feature characteristics to the manufacturing domain (Gao and Huang 1996, Case and Hounsell 2000) to examine factors such as cost, constraints (Chan and Lewis 2000). Feature-based product modellers can be used as the 'kernel' to perform a variety of product development tasks such as design, measurement planning, process simulation, process planning and fixture planning (Krause, *et al.* 1993). The use of feature models also encourages the re-use of design data, both in re-design (Andrews, *et al.* 1999) and across part families (Costa and Young 2001). Vancza and Markus (1993) extend the modelling of features to include the concept of intermediate features, which exist temporarily during production but not in the final component. This is an attempt to handle certain difficulties in feature to process mapping, such as multi-step processing, and processes covering multiple features.

2.4.2 Process Selection in Generative Planning

The process selection task is performed by examining the shape and tolerance requirements of an individual feature and selecting a process that is capable of meeting the requirements.

Process knowledge about the shape producing capability and technological constraints for each of the available processes is used to suggest economic combinations of materials and processes (Govil and Magrab 2000). Process selection is greatly aided by the classification of processes according to their morphological characteristics (Allen and Alting 1986). Several automated assembly evaluation and advisory systems have been developed such as;

- (1) van Vilet and van Luttervelt (2004) developed a DFM system that continuously offers design support for DFM during the entire design cycle by checking and quantifying violations of design rules to provide the user with a manufacturability score.
- (2) Swift and Booker (1997) presented a process information map methodology, called PRIMA, for process selection based upon technological and economic factors.
- (3) Giachetti (1998) described a prototype material and manufacturing process selection system, called MAMPS, which uses multi-attribute decision making criteria, both physical (material properties) and technological manufacturing considerations.

For a given part, the process operations cannot be necessarily performed in any arbitrary order. Planning systems such as VITool, (Maropoulos and Baker 2000) include setup considerations and tool approach directions which increases the amount of detail required before production plans can be generated. Precedence constraints are also important in generating and evaluating alternative assembly sequences.

Latterly, more ambitious planning systems have included resource models capable of capturing data regarding specific equipment. As a more integrated attitude to planning they aim to; assign the required equipment and tools, select process parameters and determine manufacturing cost (Kulvatunyou, *et al.* 2004). These advanced systems promote a holistic view of modelling and enterprise-wide, multi-view (hierarchical) models have been developed to manage multiple planning scenarios. Harding and Popplewell 's enterprise models (2001) and the 'Integrated Product and Process Data' representation of Kulvatunyou, *et al.* (2004) typify these advanced systems. From a DET point of view, the links between the functions of process planning and other product development disciplines are important; process selection provides a feedback to embodiment design, so that designs may be optimised for the production method. Also, the production routing draws on

facility layout data and also can provide feedback into facility design such as cell clustering; process plan data can be used in simulations to balance production lines.

2.4.3 Design Evaluation Methodologies

Prior to the proliferation of concurrent engineering, there was no recognised requirement for the consideration of manufacturability during the design process. Design for X (DFX) is a generic term for the set of methodologies which ensued to improve the link between design and downstream development activities. The first DFX evaluation method was Design for Assembly proposed by Boothroyd, *et al.* (2002). Their DFA methodology employs three basic steps:

- (1) A formal method questioning whether every part is necessary to minimise part count.
- (2) Calculation of estimated assembly time based on handling and insertion.
- (3) Derived design efficiency index for comparison of alternative assembly strategies.

The DFA methodology spawned a number of different solutions to the more general problem of designing for manufacture (DFM). Many of these methods involve a sets of guidelines and checklists relating design features to particular processes in order to generate a 'good design'. Additional examples of DFX methodologies include; Design for end-of-life, design for serviceability, design for the environment and design for reliability. One thing all these methods have in common is the use of multi-criteria methods to select the best options under several often conflicting criteria (Xirouchakis, *et al.* 2002).

Quality function deployment (QFD) (Akao 1990) is another successful tool for integrating the customer's requirements into the design process. QFD uses a series of hierarchies and tables (commonly referred to as the 'House of Quality') to transfer qualitative customer needs into a set of ranked engineering product attributes. QFD has also been extended to cover the re-engineering of business processes (Jagdev, *et al.* 1997) and latterly incorporated into a formal DFM system (Lowe, *et al.* 2000). These systems generally suffer from a lack of integration with product models.

A more precise metric that can be applied is cost; and in particular if cost can be modelled during design it can also be controlled (Brinke, *et al.* 2004). As part of their work on process modelling and selection, Allen and Alting (1986) proposed a model for manufacturing cost prediction to highlight '*expensive and difficult to manufacture*'

designs. Shehab and Abdalla (2001) have also produced a systems for modelling product cost in conceptual design using a fuzzy logic technique. Additionally, there is a vast range of literature pertinent to performance measurement in supply chains (Gunasekaran, *et al.* 2004). In their survey, it is interesting to note that on time delivery, cost, quality and capacity were found to be 'highly important' metrics for determining supplier performance.

For completeness it is also worth mentioning axiomatic design at this juncture., axiomatic design (Suh 2001) is an analytical design methodology based on the concept of determining whether a solution to a given design problem is 'good' or 'bad' based on two axioms:

1. The **independence axiom**. Which states that 'good' design occurs when the functional requirements of the design are independent of each other.
2. The **information axiom**. In which 'good' design is defined by achievement of a minimum 'information' content (where good design corresponds to minimum complexity).

In summary, the use of design evaluation techniques, such as DFA, other DFX and QFD, is objective and can only assist engineers in deciding whether the degree of manufacturability is 'sufficient'. So, whilst systematic methods such as DFX and axiomatic can prove valuable in improving designs, they do not necessarily provide an integrated solution to the requirements of product development. Each DFX system tends to give priority to one aspect of the product development, whereas concurrent engineering and DET emphasises the need to consider all aspects together.

2.4.4 Development of Standards in Product Design and Process Planning

The STEP (STandard for the Exchange of Product data) standard (International Organisation for Standardisation (ISO) 1999) represents the most concerted effort to date, to create and use shared data models within an engineering setting, facilitating the development of standalone generative-type planning software, free from the need for feature recognition. STEP comprises many different protocols for the exchange of product-related (not solely geometrical) information between engineering domains and is rapidly becoming the pre-eminent standard for data exchange between disparate CAD systems. The most relevant STEP standards relating to this work was identified as:

Figure 2.2 Simplified Version of Diagram A31 – ‘Generate Process Plan’ – reproduced from International Organisation for Standardisation (ISO) [1999]).

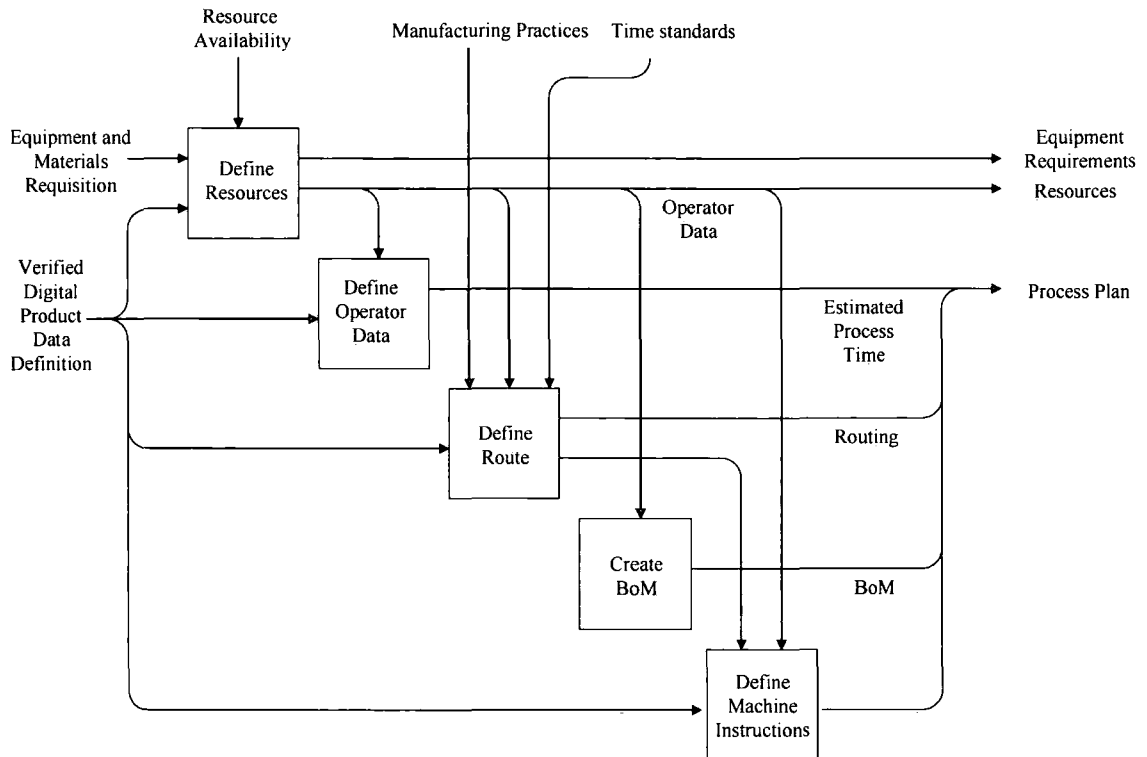

- (1) *ISO 10303-224:1999(E) Application protocol: Mechanical product definition for process planning using manufacturing features.* This standard contains a feature-based product definition for process planning. Figure 2.2 shows a simplified representation of the STEP model for business processes involved in generating a process plan.
- (2) AP233 (SEDRES 2003) is an emerging STEP standard for systems engineering data representation which is actively being developed by a consortium whose members include including NASA and BAE Systems. The standard will cover; requirements (elicitation and analysis), configuration management, functional design (including behavioural description), physical design and industrial processes and workflow.
- (3) STEP AP 240 (SC4 Online [1997]) defines the information for macro process planning. It provides process plans, revisions, machine tool resources such as fixtures and tools, process planning activities, activity sequencing, setups, materials, properties, process requirement documents, and part shape with features and tolerances.

- (4) The MANDATE standard (International Organisation for Standardisation (ISO) [1997]) (comprising the documents of ISO 15531) for manufacturing management data exchange which includes the representation of data relating to the management of the production process and the exchange and sharing of management data in the supply network. The standard identifies three main categories of data to be managed as part of the design process (i) exchange of data with suppliers (ii) management of the resources used during the manufacturing processes and (iii) the management of the manufacturing data flows. ISO 15531 does not provide a standard model of the manufacturing process itself. The objective is to facilitate the integration between numerous industrial applications by means of a common, standardized tool able to represent these three sets of data that are shared and exchanged.

Fenves (NIST 2001) pinpoints the major drawback to STEP as its limited capability for representing design intent and describes STEP as being used almost exclusively for *'the exchange of product data after that product has been designed.'* Accordingly, he goes on to describe the basis of a further product model which could be used for representing (early) design information as a precursor to STEP: the NIST Core Model. This development of this work into a workable standard is thus deemed extremely important for the development of dynamic planning systems.

Closely allied to the STEP standard is the Process Specification Language (PSL) developed at NIST (NIST 2000b), which attempts to model the relationships between discrete manufacturing processes for transfer between process planning, scheduling and simulation environments. In contrast to other, more freeform, process modelling languages, such as IDEF or UML, PSL is more rigorous and as such is interpretable by computers. PSL uses the formal Knowledge Interchange Format (KIF), developed at Stanford University, to define an ontology of process modelling constructs (semantics) which can be used to communicate manufacturing process information (including reasoning and rules which are procedural) between applications (Stanford University Logic Group 1992).

Although STEP represents a key step forward for integrated descriptions of manufacturing entities, and has produced a workable information model that requires further development of the following communication channels, as identified in the NIST Design/Process Planning Integration Project by Feng, *et al.* (1999):

- (1) Communication protocols.

- (2) Design intent (design history, plans, and goals).
- (3) Content (features, constraints, geometry, and processes).
- (4) Objects (fundamental data objects).

Young (2003a) describes the three most common standards for the integration of design and planning; interfacing, neutral file formats and information sharing (where all systems utilise a single common database).

2.4.5 Computer-Based Planning Architectures

During the 1980's Computer Integrated Manufacturing (CIM) was pioneered as the integration of company-wide information processing systems including CAD, CAM, CAPP, CAE and Production Planning and Control. Several architectures for CIM were proposed such as the CIM Open System Architecture (CIM-OSA) (Kosanke, *et al.* 1999) and other less popular enterprise modelling systems (Chen and Vernadat 2004). However none of these solutions have really gained industrial acceptance. There were two primary reasons for this;

- (1) CIM is very well suited to the 'make and sell' business model but cannot be easily applied to dynamic enterprise (Wiendahl and Lutz 2002) and resource allocation problems.
- (2) The failure of CIM is also attributed by many, including McGaughey and Roach (1997) to the incompatible needs and data structures of the various functions. The biggest growth area during the 1980s was in computer-based product design tools which utilised proprietary geometrical product models. For more than twenty years, many manufacturing integration projects, involved the use of CIM software and comprehensive manufacturing models but these were characterised by deep information structures and complex modelling constructs which were inflexible, especially for small-to-medium enterprises (Bagshaw and Newman 2001).

The MOSES project (Molina and Bell 1999, 2002) is a good example of a flexible product and manufacturing model able to store a broader set of information than the former CIM systems (which concentrated purely on managing data for systems integration.) Continuing this theme, the key finding of Lenau (1996), although primarily discussing the material selection problem, was that all automated design systems, including process planners, depend on having a systematic methodology and information models which provide access

to all relevant information. Taking this further, research is taking place into the use of distributed manufacturing data repositories for use with existing software for manufacturing planning and simulation (McLean and Riddick in NIST 2000a) and general distributed product design systems (Pahng, *et al.* 1998).

In conclusion, early attempts at implementing concurrent engineering using Computer Integrated Manufacturing (CIM) have not been successful because rigid data structures and procedures are wholly unsuited to the constantly changing manufacturing environment. The observed reality is that current generation systems maximise the use of shared data, however the majority of design information still flows downstream into manufacturing operations. This is the situation that is address through the flexible approach of having a DET framework around which interchangeable design and manufacturing data models and decision aids, such as Knowledge-Enriched Aggregate Process Planning can be constructed.

2.5 Knowledge Management in Enterprise-Wide Design and Planning

2.5.1 Knowledge Management Ideology

The need to create intelligent enterprises has been highlighted in several UK Government reports including, '*Manufacturing 2020 Panel: We can make it - A consultation document*' (Department of Trade and Industry 2000) and the white paper entitled '*Our competitive future: Building the knowledge driven economy*' (Department of Trade and Industry 1998). Contemporary academic research into the importance of knowledge management to the economy has also been undertaken by many leading business schools, essentially reaching the same conclusion, for example Roberts (2001). This interest in knowledge management dates back to the 1980's and the birth of artificial intelligence and the creation of knowledge-based software tools for engineering design. Figure 2.3 shows that number of published academic papers relating to 'knowledge management' in the field of 'engineering and technology' alone (source Elsevier B. V. 2003) has risen, from below 100 per annum in the 1980s, to around 600 publications annually. This has been mirrored in the level of research funding: in the UK the Engineering and Physical Sciences Research Council have to date sponsored 1,513 projects with a knowledge management theme (including the CAPABLE Space project), totalling £317 million in research expenditure (Engineering and Physical Sciences Research Council (EPSRC) 2003).

Figure 2.3 Annual Publication of Articles pertaining to 'Knowledge Management' in 'Engineering and Technology' (source <http://www.sciencedirect.com>, , Elsevier B. V. 2003).

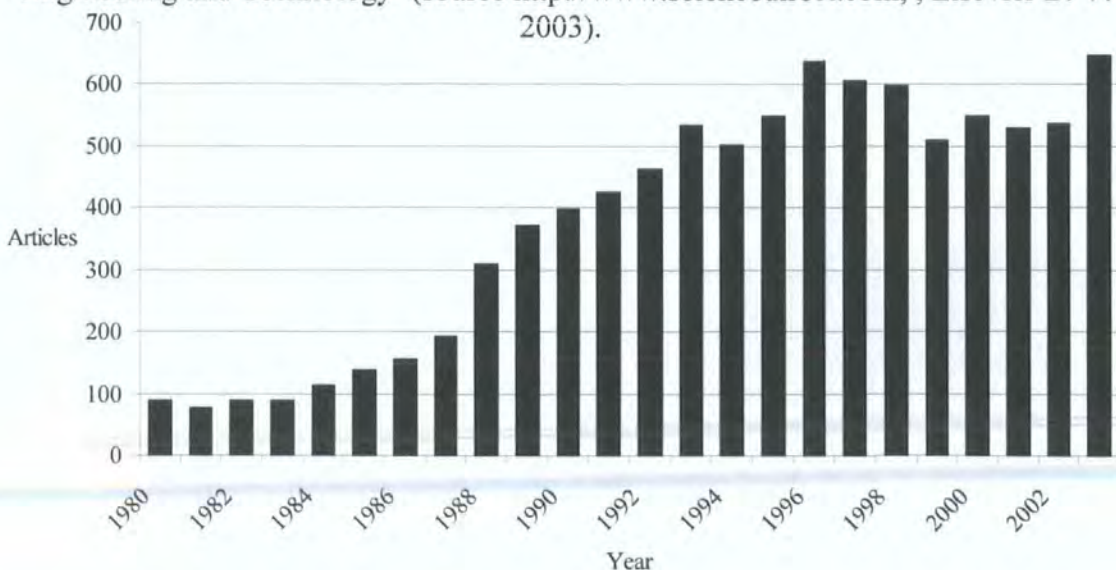

Unfortunately, despite the plethora of research interest, companies have not adopted a coherent view on knowledge management. Murray's research into knowledge management in European companies (published by The Economist Group [1998]) identified a consensus on the importance of knowledge to major business processes (see the large proportion of companies who consider knowledge as 'important' or 'very important' aspects of achieving business objectives in a variety of disciplines in Figure 2.4) but revealed many different attitudes towards knowledge. In fact, seven styles of knowledge management were identified:

- (1) Knowledge as an intellectual asset.
- (2) Knowledge as a human resource.
- (3) The technology approach (treat knowledge as information).
- (4) Virtual organisations (assimilated knowledge on a per project basis).
- (5) The strategic approach (innovation-based companies).
- (6) The philosophical approach.
- (7) The process approach.

Knowledge management is a rapidly expanding field and the developments in knowledge management theory and artificial intelligence systems are of interest because, although they exist as research topics in their own right, DET systems will eventually need to use the methods which are borne from this research. Feigenbaum and McCorduck (1984) believes that the true problem-solving power of a computer program comes from the underlying knowledge it possesses about a given domain, rather than from *'the programming techniques and formalism it contains or the hardware on which it is run'*.

Figure 2.4 Essential Knowledge to Achieve Business Objectives Over the Next 3 to 5 years. (reproduced from The Economist Group [1998]).

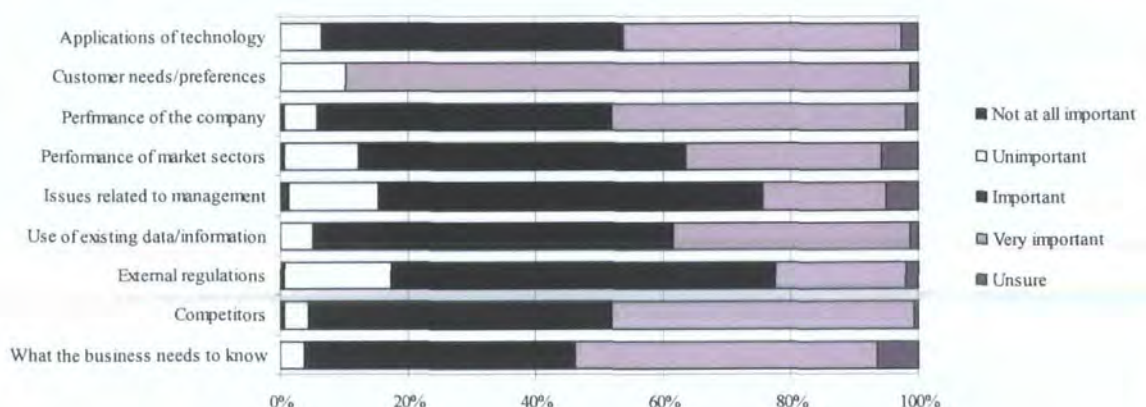

Table 2.2 Summary of Ackoff's Knowledge Hierarchy.

	Level of abstraction	Quantity	Description
Data	Low	High	Symbols not yet interpreted.
Information	Medium	Medium	Data which has been assigned a localised meaning.
Knowledge	High	Low	Information placed in context so that it can be applied to different situations.
Wisdom	Very high	Low	Deep knowledge and understanding, based on considerable personal experience.

Table 2.3 Classifications of Different Types of Knowledge for Process Planning.

	Deep	Shallow
Declarative	Formulae, Algorithms, Rules,	Symbolic and factual information
Procedural	Fuzzy logic.	Heuristics
Meta knowledge	Wisdom	Understanding

2.5.2 Classifications in Knowledge Management Theory

The strict epistemological definition of knowledge is '*justified true belief*' (Nonaka and Teece 2001) which, empiricists argue, arises when expert opinion is collated over time and is subsequently related to new situations. Conversely, in everyday parlance, information which is stored in files and documents is often incorrectly referred to as knowledge. Hence we need a more pragmatic view of the origin knowledge such as that instigated by Ackoff (1974) who first separated knowledge into a hierarchy of Knowledge, Information and Data, as summarised in Table 2.2. Using this categorisation, a piece of information only becomes knowledge when it is interpreted by the receiver. This distinction becomes important in Chapter 5 of this thesis, which concentrates on the storage of the interpreted impact of knowledge rather than the information on which the knowledge is based.

In the literature there are multiple classifications of knowledge, for example deep and shallow, declarative and procedural, explicit (or documented) and tacit (undocumented) as described by Turban and Aronson (1998) and finally, structured, semi-structured and unstructured (Gardoni, *et al.* 2000). Table 2.3 relates how different types of process planning knowledge can be expressed according to the most common of these classifications. Factual knowledge, for example, knowing that '*the mass of a panel is 12kg*' is said to be shallow, declarative knowledge. Concepts and relationships which can be expressed as formulae, algorithms or rules, are also declarative knowledge. Rules are facts which are triggered by the characteristics of the objects themselves. Procedural knowledge is knowledge which relates to how tasks are performed and is usually acquired by experience.

Another interesting type of knowledge is meta-knowledge (Brazier, *et al.* 1998) which may be loosely defined as ‘knowledge about knowledge’ and usually refers to high-level information about the knowledge the system possesses and the efficiency of certain methods used by the system. For example it is possible to know that one does not possess enough knowledge to make a decision. Meta-knowledge is generally used to guide future planning or execution phases of a system.

Thannuber, *et al.* (2001) opine that most recorded enterprise knowledge is in fact ‘microscopic’, and is declarative and goal driven. They put forward blue-sky ‘macroscopic’ knowledge management methods which relate to the ability of a system to regulate itself according to changes in the external environment through meta-information. The development of this type of natural self-organising systems is particularly interesting in the light of the progress in emergent synthesis (recall Ueda, *et al.* [2001]) to process planning.

2.5.3 Scientific Methods in Knowledge Capture

Traditional methods of knowledge capture have previously been applied to manufacturing domain. Expert systems are the most common type of knowledge-based system currently found in engineering but electronic repositories of company know-how are also widely used to capture manufacturing information (Aziz, *et al.* 2003). Warschat, *et al.* (2003) stress the need for ontologies for structuring early design information for sharing. The Analytic Hierarchy Process (Saaty 1994) is an statistical tool, supported by simple mathematics, that enables people to explicitly rank tangible and intangible factors against each other for the purpose of resolving conflict or setting priorities. The process has been used in a wide variety of problem areas. Another (frame-based) technique, favoured by financial managers, for extracting key knowledge from enterprises in the balanced scorecard concept (Kaplan 1994). In this technique regular snapshots of financial measures, performance metrics (principally related to lead time), internal processes (yield, quality and cost) and product performance in the marketplace are taken and compared over time. This technique is particularly useful for medium term control as the relevant metrics can be tailored to the desired corporate strategy.

Thurston (1991) realised the difficulty in obtaining realistic attribute values from previously mentioned design techniques, such as QFD and DFM, during the preliminary

design stage. A further paper by Carnahan, *et al.* (1994), develops the mathematical aspect; using fuzzy set methods to express and analyse such imprecise information.

As well as these semi-structured methods, it has also been show that data mining can be used to extract relationships as heuristics during early design (Matthews, *et al.* 2002, Shaik, *et al.* 2005). Methods such as Baysian Inferencing and Claude Shannon's Information Theory can be used to extract and categorise structured information from non-structured documents (*Autonomy Technology White Paper*, available from Autonomy Corporation 2003). It is also worth considering that these scientific knowledge capture methods will always be subject to a number of human factors such as bias, uncertainty (probability), subjectivity (Wokutch 1979).

2.5.4 Knowledge Acquisition, Transfer and Re-Use

For the much the same reason that Aggregate Process Planning was suggested, namely the difficulty in extracting accurate algorithmic models from early design models, Rush and Roy (2001a) looked at the challenges of using expert judgement for cost estimation. They highlight the importance of past knowledge to the cost estimating process. Their 'Knowledge = Expert – Novice' methodology (Rush and Roy 2001b) is designed to structure the process of turning tacit knowledge into explicit knowledge for use by new users. Ongoing research at Cranfield University, including the XPat system, (Oduguwa and Roy [2001] and Bailey, *et al.* [2000]) is directed towards qualitative methods for extracting in-process knowledge for re-use.

Lindsay, *et al.* (1998) have defined a way of representing the use of knowledge in a system – the KIPP (Knowledge, Information, Process and Purpose) model show in Figure 2.5.

Figure 2.5 The KIPP Methodology (Lindsay, *et al.* 1998).

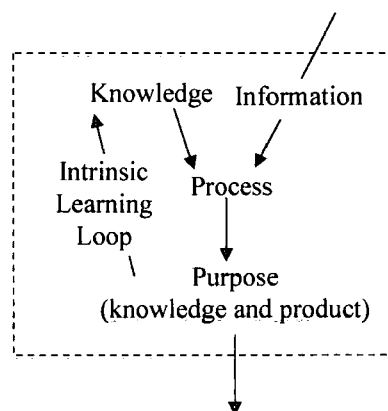

They stress the need to create ‘intrinsic learning loops’ to make sure that the knowledge provided ‘fits’ the purpose.

In any case, best practice in knowledge capture is dependant on being able to identify critical success factors (CSFs) as defined by Daniel and Rockart (referenced in Butler and Fitzgerald [1999]) and somehow measure performance against them (Poolton, *et al.* 2000). This idea is similar to that of benchmarking (Camp 1989) which seeks to identify a gap between company performance in a given area and that of leading practitioners in the field. Hoshin planning (Akao and Mazur 1991) also uses the identification of key strategic targets to drive internal performance improvements.

The ability to filter information and provide structured, useful feedback of previous design knowledge is in itself a research problem (Brissaud, *et al.* 2003), albeit one that concentrates on capturing design rationale.

Nonaka and Takeuchi (1995) describe four modes of knowledge conversion:

- (1) **Socialisation** is the process of sharing experiences and thereby creating tacit knowledge by experience and communication, such as sharing mental models and technical skills.
- (2) **Externalization** refers to the process of transferring tacit knowledge into explicit form. Lessons learned from projects or experimental results are documented.
- (3) **Combination** is the process of combining explicit knowledge from different domains, and occurs where sorting, adding, combining and categorising of explicit knowledge can lead to new knowledge discovery.
- (4) **Internalisation** is ‘learning by doing’ and results in tacit knowledge being incorporated and applied to improve a person’s or an organisation’s tasks based on past experiences.

Garcia and Sriram (1997) investigated a framework for the continuously evaluating trade-offs between competing design proposals. Young (2003b) also proposed a holistic information model which encompass all aspects of design and manufacture. The key characteristics identified for such models are:

- (1) They must be integrated and directly used by software applications.
- (2) They must have multiple views to support different user requirements.

Baker and Maropoulos (1998, 2000) describe a generic Capability Analysis methodology for ranking qualitative factors during tool selection in VITool. The method incorporates techniques for comparing dissimilar indicators of performance and as a result, can make suggestions to the user as to how the manufacturing system may be improved. The research into knowledge-enrichment of aggregate process plans is concerned with the application, and extension, of the of Capability Analysis concept in the context of aggregate planning and the DET framework, which is fully described in Chapter 6.

Some other successful research projects involving knowledge acquisition tools are briefly described below:

- (1) **KADS (commonKADS)** is a methodology (and software tools) for knowledge elicitation. The CommonKADS analysis framework provides an extensive method for describing business processes in which knowledge-intensive tasks are carried out (Schreiber, *et al.* 2000). Frame-based ontologies have also been developed using knowledge management systems, such as Protégé, for populating knowledge bases for use by external problem solving methods or with manufacturing models (Aziz, *et al.* 2003).
- (2) Also focussing on the implementation aspects of knowledge-based systems was the ‘Methodology and software tools Oriented to Knowledge-based engineering Applications’ (**MOKA**) project (Stokes 2001). This pan-European project looked at providing a structured knowledge capture strategy, compatible with any knowledge-based system in order to increase the uptake of such systems within European industry. The MOKA project also devised some tools for knowledge management, most relevant being the ICARE forms which provide a way of capturing procedural and informal knowledge regarding ‘entities’.

2.5.5 Applications of Knowledge Management in Process Planning

Artificial Intelligence (AI) techniques such as knowledge-based DFA expert systems, fuzzy logic, neural networks, genetic algorithms, cased-based reasoning and their hybrids may be used in design. This section describes some of the more successful attempts at creating ‘knowledge-aware’ design systems.

GNOSIS, one of the six test cases of the international research programme IMS, carried out a demonstration combining tools and methods with the theme of ‘Knowledge

Systematization: Configuration Systems for Design and Manufacturing' (Ranta, *et al.* 1996 and NIST 2000b). Mostly, the work concentrated on the creation of models capable of both feature-based and functional product description. Surprisingly, the authors concluded that in many cases, designers naturally worked in terms of features;

'It was a surprise even to the implementors [sic] that the outcome of the functional design was quite close to a rough assembly description.'

This result is significant, because it supports the idea that enterprise knowledge can be associated with design features for use in process planning.

The MEDIATOR system (Gaines, *et al.* 1995), borne out of the GNOSIS project, was an open architecture information and knowledge management system designed to support the management of complex manufacturing activities throughout the product life cycle. Its most significant contributions were the development of a web-architecture and the creation of a 'virtual language' used to represent knowledge about any activity or system from requirements through design, engineering, production, to maintenance and recycling.

The EPSRIT Knowledge Acquisition and Sharing for Requirements Engineering (KARE) program investigated the use of tools for capturing enterprise knowledge for requirements engineering (Dignum and Heimannsfeld 1999). It started by defining knowledge as '*matching objects to object types*' by which they mean that, to determine the status of knowledge, a customer requirement (object) must be matched to the company's knowledge (object type). By evaluating the attainment of goals they aim to answer the question '*are we able to meet the customer's requirements?*'. Their sources of knowledge are; products, processes, people and production means. Another issue is the representation of uncertainty in design. Crossland, *et al.* (2003) used Monte Carlo simulation to link probabilistic models to object-based attributes of a design. Struck, *et al.* (2000) have developed some of the ideas borne from the KARE project relating to management of the requirements gathering process.

The Integrating Design and Manufacturing Knowledge in an Extended Enterprise (INDEMAND) project (Ward, *et al.* 1997) developed tools for supporting the design process within an extended enterprise. INDEMAND had two interesting features; a supplier capability store to capture generic and specialist supplier knowledge and the creation of a system for rating supplier capability based on best practice.

2.5.6 *Ontologies in Process Planning*

An ontology is a formal specification of domain knowledge which codifies the semantics used to represent (and reason within) a body of knowledge. Hence ontologies can be used as the basis for communicating between product models, process planning and scheduling applications, in a way that is unambiguous (but not necessarily complete). For pragmatic reasons, most ontologies in engineering are formed as a set of definitions of formal vocabulary (VRL-KCiP 2005a).

The World Wide Web Consortium (W3C) has developed the Extensible Mark-up Language (XML) which allows information to be more accurately described using tags. DARPA agent mark-up language (Popp 2005) is being developed as an extension to XML having the capability to describe the relationships (schemas or ontologies) with respect to objects. Specific ontology-based languages such as RDF Schema (World Wide Web Consortium [W3C] 2005a) and OWL (World Wide Web Consortium [W3C] 2005b) provide the ability to declaratively express the relationships between entities.

A survey of research into the use of ontologies for process planning revealed a large amount of pontification on the subject, but very few descriptions of successful applications. However, two distinct branches of application-oriented ontology research are emerging, many which are closely related to the PSL. Firstly, it has been successfully demonstrated that ontologies can be applied to model the fundamental communications between planning applications, for example:

- (1) **TOVE**. The goal of the TOVE project was to develop a set of integrated ontologies for the modelling of both commercial and public enterprises. The ontologies were made freely available over the internet. An overview of the TOVE project can be found in Gruninger, *et al.* (2000), but no recent publications have appeared.
- (2) **The Process Ontology** extends the basic concept of ‘a process as an activity’ (as defined in the PSL) into rich knowledge models that can readily be used and understood by domain experts, yet which retain the ability to be directly applied by computational algorithms (Aitken 2005).
- (3) **VRL-KCiP**. Recent related work on creating shared ontologies by VRL KCiP is intended to allow re-usable descriptions of processes, activities, tasks and plans. As described in VRL-KCiP (2005a), the work is at the formative stages,

and to date has concentrated on creating the ‘building blocks’ necessary to establish future workable ontologies.

Secondly, researchers have used ontologies to create a common shared understanding of the engineering design domain, thus widening the application of ontology-based methods, for example:

- (1) I-DIMS. This project has been initiated to address the problem of collaborative design, and to investigate and develop holistic knowledge management tools for the design process by developing ontologies and intelligent agent based systems. This differs from the first two ontologies as the central idea of this project is to translate information between different tools and distribute it within the organisation (Tormey, *et al.* 2003).
- (2) The Rapid Knowledge Formation Project (RKF) (Aitken and Curtis 2002) addresses the issue of providing formal semantics which extend the PSL to enable domain experts to author knowledge directly.

2.5.7 Treatment of ‘Knowledge’ in Current Commercial Applications

The development of digital manufacturing (sometimes called virtual manufacturing) tools does not solely take place in the world of academia. Many software tools (including some notable ones listed in Table 2.4) have adopted theoretical and proprietary techniques and architectures and are sold on the basis that they will reduce the time to specify production plans for products with complex build sequences (Bernard 2005). Bernard points out that to be effective, these systems are only effective when they are correctly configured; which is a corollary of DET. The market leader in such software is DELMIA, who have developed a manufacturing database called the ‘PPR Hub’ (Product, Process and Resource) to manage project-based manufacturing information created using their process and resource simulation tools QUEST and IGRIP (Brown 2000). Another noteworthy software system (which provides similar functionality to DELMIA) is Tecnomatix.

The use of knowledge within CAD and product definition has led to the development of several IT technologies to enhance the product definition process, the primary two being knowledge-based engineering modules, for example ICAD, ImpactXoft and other functional modelling systems and lastly the use of product data management software as a supporting architecture. Knowledge-based engineering has become a hot topic for the CAD industry over the last two to three years. Latterly, several CAD systems have reached the

marketplace, claiming ‘knowledge capture and re-use’ capabilities, for example CATIA V5’s ‘Knowledgware’ module. This trend is partly due to the fact that geometrical and product definition capabilities of CAD systems have reached a functional plateau and partly to cater for mass customisation requirements. However, functionally, these systems are rather simplistic and depend, like expert systems, on declarative knowledge applied to detailed CAD models (Roucoules, *et al.* 2003). The major benefits of such systems are seen as the ability to rapidly create and optimise product definitions, without the need to perform time-consuming engineering calculations.

2.6 Conclusion

This literature survey has identified that key elements of competitiveness for the manufacturing industry of the future will be methods for rapid product and process realisation, early integration of design with manufacturing operations and the technical integration of the supply chain. Existing planning technology has been shown to be very focused on rigid integration for detailed design. The product development activity is characterised by the application of knowledge and experience to create new, and better products. This is especially true of high value, high complexity production environments, such as automotive, aerospace. In these sectors existing CAPP methods have been found wanting due to their focus on detailed analysis of discrete parts, excessive domain-specific knowledge requirements and a lack of consideration of dynamic supplier information. This frequently results in lengthy product development periods, uncompetitive manufacturing

Table 2.4 List of Other Notable Software Systems Mentioned in the Literature Review.

Name	Vendor	Hyperlink for further information
Digital manufacturing		
Process Engineer, QUEST, IGRIP	Delmia, UK	http://www.delmia.com
eMPower	Tecnomatix Technologies.	http://www.tecnomatix.com/
Design software with knowledge elements		
ICAD	Knowledge Technology International (KTI)	http://www.ktiworld.com/home.shtml
IX Functional Modelling	ImpactXoft	http://www.impactxoft.com/
CATIA	Dassault Systèmes	http://www.3ds.com
Knowledge management tools		
Autonomy	Autonomy Corporation	http://www.autonomy.com
Protégé	Stanford University, USA	http://protege.stanford.edu/

operations and increased lifecycle costs. This strain on the interface between design and manufacturing is exacerbated by the need for reduced product lifecycles.

It has been established that future integration efforts should ideally be focused on the early stages of product development, where the majority of product lifecycle cost is decided. However, planning technology for linking the early stages of product design with manufacturing operations within the extended enterprise, is not commercially available at present. The main area where there is a lack of progress in reaching this vision is in the provision of tools which allow manufacturability analysis to take place on partially designed products enabling rapid assessment of production alternatives during the concept design stages. Therefore, the principal target of this research is to developing a system is to provide early analysis and intelligent exploration of designs and to augment the quantitative manufacturing analysis with the human rationale and knowledge which influence the real-world selection of processes and resources and leads to true competitive advantage.

Chapter 3 System Overview

3.1 Introduction

CAPABLE Space is an experimental process planning system which applies the knowledge-enriched aggregate planning methodology via a DET framework to provide decision support and hitherto unavailable technical analysis of quantitative and qualitative manufacturability from initial concept through to detail design and validation. This chapter presents the system architecture of CAPABLE Space which has been created to validate and test the proposed aggregate Knowledge-Enriched Aggregate Process Planning theories and the allied knowledge representation and management methods. The name ‘CAPABLE’ has been carried over from earlier work and is an acronym of ‘Concurrent Assembly and Process Assessment Blocks for Engineering Manufacture’. Implementation issues are

Figure 3.1 Layout of Chapter 3.

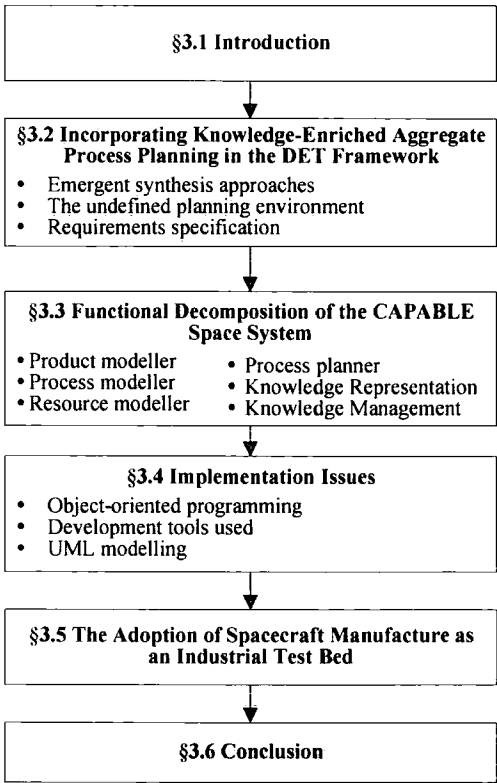

considered including choice of programming language. The Unified Modelling Language (UML) is also introduced as it represents best design practice and was used extensively in the system specification (and in this thesis). This chapter presents UML activity and use case diagrams to show the interaction of all modules within the proposed CAPABLE Space system. Figure 3.1 provides a schematic representation of the structure of this chapter.

3.2 Incorporating Knowledge-Enriched Aggregate Process Planning in the DET Framework

The Knowledge-Enriched Aggregate Process Planning methodology logically maps onto the DET framework as shown in Figure 3.2; the key consideration being the provision of rapid, iterative feedback on the impact of product design decisions and the instigation of detailed manufacturing planning via the provision of suggested manufacturing routings complete with manufacturability estimates and prioritised improvements. Key technology components requiring development (as highlighted in Figure 3.2) are;

Figure 3.2 Aggregate Planning in the DET Framework.

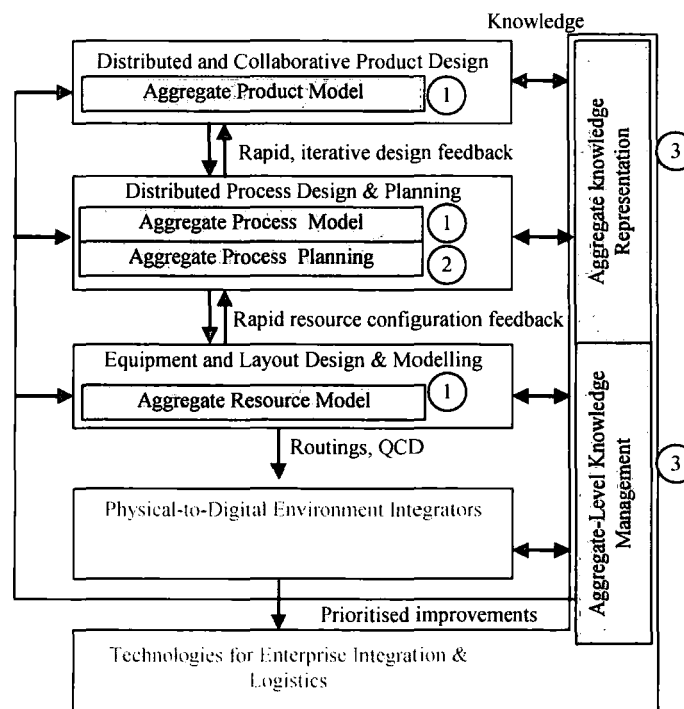

- (1) Development of modelling methodologies and tools for aggregate-level distributed and collaborative design and process and resource modelling in the supply network.
- (2) Methods for manufacturability estimation and early (aggregate) process planning given incomplete, or approximate, product data.
- (3) Aggregate-level knowledge representation and management methods and tools to establish the likely downstream impact of design decisions for feeding into the planning intelligent exploration, and to increase the understanding between design and manufacturing.

Design is a continuous activity which begins with a conceptual idea and finishes with a fully specified product model and a detailed set of manufacturing instructions (a process plan). According to the principles of concurrent engineering, all the activities required to support design, including process planning, should occur in parallel (starting as early as possible) and there should be many feedback loops. The proposed design and planning activities in knowledge-enriched planning concentrate on the early application of Aggregate Process Planning and the new feedback paths between design and process planning, to facilitate iterative design changes and process and equipment selection. The process planning activity itself is sub-divided into three iterative loops with two way information flow linking design and process planning. The new aggregate design philosophy is to instigate an iterative process whereby manufacturing considerations (albeit of varying accuracy) are available throughout the design cycle and facilitate ‘what-if?’ design analyses; using early feedback loops combined with effective design management. The application of aggregate level planning should result in the presentation of feasible early process plans, which require further investigation using more specific DET tools.

3.2.1 Establishing Resource Aware Aggregate Planning as a Class II/III Emergent Synthesis Problem

According to the theoretical definition of emergent synthesis (Ueda, *et al.* 2001), a system or function is classified as ‘Class II’ problem when it has to deal with an application environment that is not fully defined in terms of its scope or composition. In a Class III problem the system requires human intervention for the interactive; (i) interpretation-of interim results, (ii) evaluation of functions, and (iii) the specification of new options concerning the environment’s configuration. Knowledge-enriched aggregate planning has the following characteristics:

- (1) It deals with the early stages of product development, hence is accepting incomplete and changing design information from the aggregate product model.
- (2) The resource model is dynamically configured by the supply network companies. Hence, the resource model represents an 'unknown environment'.
- (3) The aggregate planning methodology is 'driven' by the business objectives and the evaluation of feedback, mainly generated via the knowledge-enrichment of process plans.
- (4) The process plans are modified by the enrichment of plan entities with knowledge.

The feedback of knowledge-enriched process plans within a distributed planning environment invariably demands human intervention, with all the associated ambiguity, and interactive evaluation of interim results and/or functions hence is by definition a Class III problem. However, at this stage of the research, little or no interactive evaluation of factors, outside the exploration of the process plan itself, is performed during the optimisation stages, hence the uncertain environment is simplified to a Class II emergent synthesis problem.

3.2.2 The Undefined (Class II) Planning Environment

Three distinct stages of aggregate planning have been identified, which interface with the various activities of product development and recognise that modelling must take into account the lifecycle status of the product. In this way design and planning are treated as iterative processes, whereby, designs are updated and refined based on suggestions from process planning, tolerance analysis, simulation and verification using metrology, that is to say the models are adaptive and progress via increased level of detailing. In total there are three such feedback loops between design and process planning and manufacturing at the aggregate level:

- (1) **Structure-based** product models view the early planning problem from a high level to produce an abstract definition of a product by separating the design into major structural blocks based on form, function, criticality or other interfacing relationship. Key groups of structural elements are modelled and parameters are attached from which parametric process models can evaluate rough build times for each assembly stage. Methods to interrogate previous

designs and the associated process plans (utilising corporate knowledge and historical data), to confirm the selection of structural blocks in terms of their impact on build times and costs and establish the most favourable structure-based configurations are currently under development in a follow on EPSRC research programme (GR/N11285/01: '*Evolution of Spacecraft Manufacture by Vertically Integrated Systems for Bill-of-Materials Interpretation*').

- (2) During the **feature-based** design stages, key attributes of the structure-based models are expanded to give a true feature-based design model, that is to say that the product model is *adaptive* and maximum use is made of the existing structure-based model. By definition, the aggregate feature classes are closely aligned with aggregate process and resource models (so that reasonably accurate estimates of quality, cost and delivery can be produced). The resulting feature-based plans are routings which can act as input to discrete event simulations for final, dynamic verification of plan.
- (3) **Tolerance-enriched** planning is required only for components with critical integration requirements. Assembly simulation is required at this stage with the bi-directional transfer of data between real world and digital models. For example, this level should have interfaces with metrology to permit the late finalisation of component designs to ensure compatibility with 'as built' geometry of sub assembly parts. The resulting planning strategies are similar to those of feature-based designs, except they must also target minimal tolerance stacks in a process plan (Jietong, *et al.* 2003).

Process plans must therefore be generated using unified 'data-resistant' planning methods able to handle product structures containing mixed representations at all three levels. These early planning methods enhance the early stages of design by providing a mechanism for the integrated technical evaluation of early product designs and associated manufacturing requirements. The most promising production scenarios are, thus, identified and form the output of aggregate planning ready for input to detailed design tools for further work.

The supplementary knowledge representation management methods proposed are intended to be generic and are specifically designed to operate during all three phases of the aggregate planning architecture outlined above. However, the majority of examples in this thesis will concentrate on proving the concept using the more mature feature-based planning methods.

3.2.3 Realising a Knowledge-Enriched Planning Methodology

In order to perform aggregate planning and manufacturability analysis during feature-based design, seven areas requiring further research and development were identified:

- (1) Representation of multiple design ideas (containing incomplete information) during early design via structure-based, feature-based and tolerance enriched models. Appropriate modelling techniques for design synthesis and the communication and storage of such information is required.
- (2) Description of enterprise resources to reflect the manufacturing capabilities of specific resources. This implies that the system must have access to factory data including; factory layout, available equipment and labour and comprehensive cost data about individual machines to balance technical, commercial and economic concerns in early planning stages.
- (3) Encapsulation of production process expertise; to simulate the manufacturing scenarios, the system must capture process knowledge, including the shape-producing capabilities of each process, rules for selecting process parameters and the calculation of manufacturability. For each type of operation a time-based process model consisting of a set of equations obtained from the simplification of detailed physical models is required. Time calculation is unique to each process, unlike the cost and quality calculations that are process independent. Through simplification of detailed process models, aggregate process models function with the limited amount of product and resource information available at the concept design stage. The most significant feature characteristics and operating parameters, relating to process performance, should be used to drive process models. Core capability checks must also be made in order to eliminate infeasible combinations due to mismatches in geometrical or material limitations.
- (4) Acquisition of product, process and resource knowledge for re-use and evaluation of process plans.
- (5) Automatic generation of process plans in an ill-defined planning environment. The hybrid optimisation algorithm systematically decomposes the product model and assigns processes and equipment to features and evaluates the manufacturability of the resulting solution. A summary of how the optimised aggregate plan is generated is; (i) create a feasible solution, (ii) explore the

processes and resources search space. The exploratory nature of the algorithm requires the output of the process models to be converted into a overall cost to be minimised. The quality function generates cost through the probable levels of scrap and rework generated, whilst the delivery function converts the late delivery of a product into cost through a liquidated loss rate. Penalties for plans which have poor performance, measured through Capability Analysis, are also applied. Using user-defined weightings, the resultant process plans should converge on solutions which ‘best fit’ the operating environment.

- (6) Manufacturability analysis of aggregate process plans using incomplete planning data. To measure manufacturability, aggregate process models calculate approximate values of quality, cost and delivery for the manufacture of individual features.
- (7) Capability Analysis methods for prioritising design and process planning information and interfacing the methods with existing team-based design methods.

3.3 Functional Description of the CAPABLE Space System

In order to be a viable planning system, the system must have an underlying architecture capable of gathering all relevant information from production-related activities for use in the planning algorithms. The system comprises a number of separate software components or modules, which are accessed through a common desktop, called CAPABLE Space. The UML use case diagrams (UML is described in §3.4.3), showing all system functions, are shown in Figure 3.4 to Figure 3.8. The interface is event-driven and the end user is able to run any of modules independently:

Figure 3.3 Key to UML Use Case Diagrams

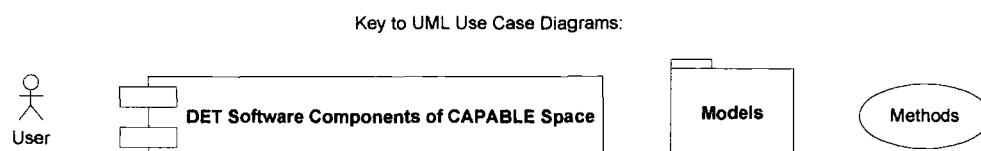

(1) **Product Modeller.**

Figure 3.4 Product model Designer Use Case Diagram.

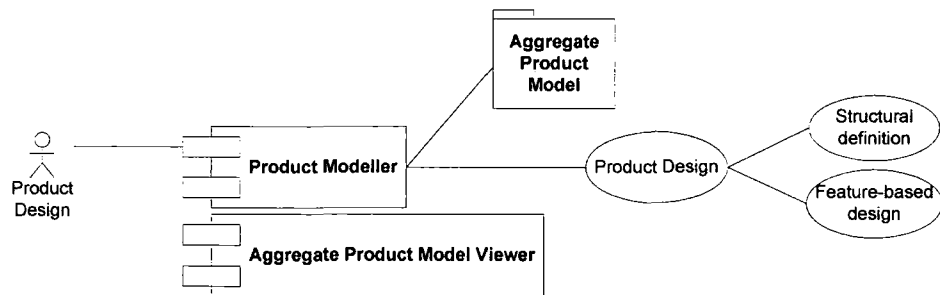

The product design module enables the user to manage all the structure-based and feature-based information created by designers. The product model designer is used to configure a manufacturing-based product model consisting of hierarchical, object-oriented data structures which represent alternative product configurations. At the lowest level, the elements of the structure-based design are configured to represent the assembly sequence of the product and are similar to that of the bill-of-materials. At each level within this basic structure, manufacturing feature objects can be specified in terms of key geometry. Thus, the primary functions of the module are:

- (a) To define and edit configured product structures.
- (b) To represent product data using a library of features.
- (c) To be compatible with standards, such as the NIST core product model (NIST 1994) to allow the import and export of product geometry.

A software application written using Open CASCADE allows the viewing of product models and the communication with external CAD systems via industry standard STEP files. Further details of the 3D viewer's implementation are provided in Appendix D.

(2) **Process Modeller.**

Figure 3.5 Process Modeller Use Case Diagram.

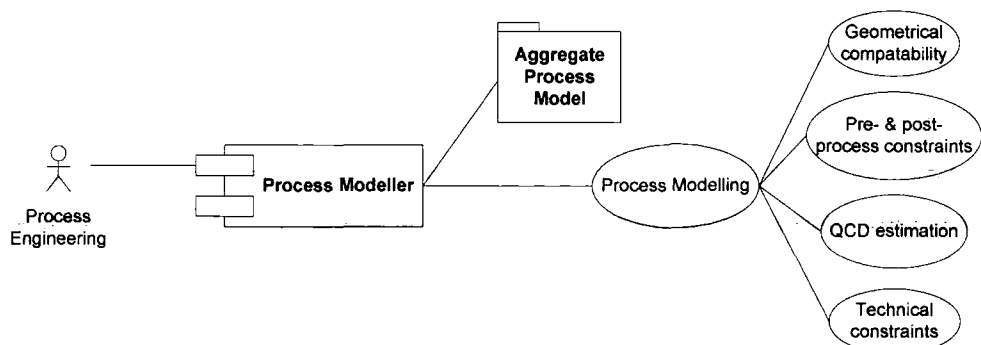

The system mostly utilise standard, generic process models for common industrial processes. However, industrial users of the system would need the ability to be able to enter equations and rules to describe process models to their specific requirements. Thus, the process design module can:

- (a) View details about the standard process library.
 - (b) Edit enterprise-specific process models.
- (3) **Resource Modeller.**

Figure 3.6 Resource Modeller Use Case Diagram.

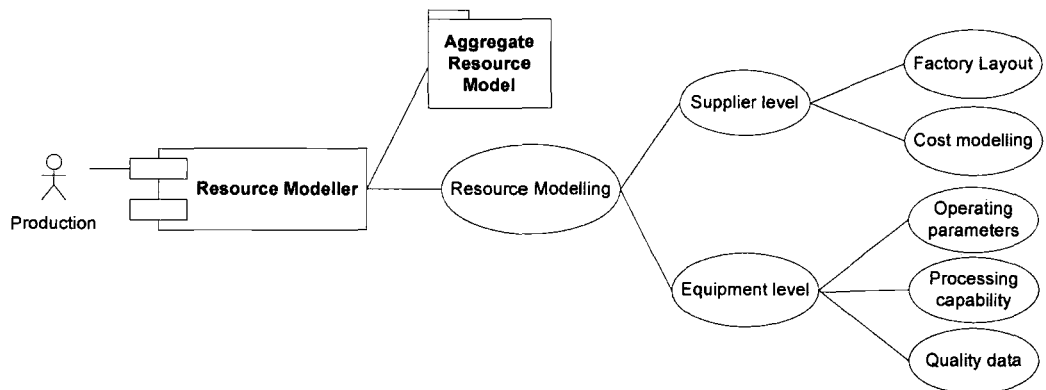

The factory design module facilitates resource configuration during process planning. The key goal of the module is to capture all the functional parameters required to specify a company's manufacturing resources and associated manufacturing capability.

- (a) Define and edit factory resource models.
 - (b) Library of standard tools and equipment. Operating parameters are entered for the chosen resources using algorithms and historical quality data.
- (4) **Process Planner.**

Figure 3.7 Process Planning Use Case Diagram.

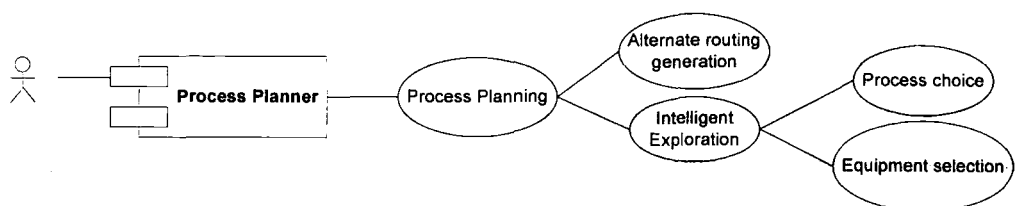

Fundamental to the ideology behind CAPABLE Space is the use of (i) matrix-based mapping methods to generate the sequence of processes and assign resources to form the aggregate process plan and (ii) a hybrid algorithm, based on Simulated Annealing (a computational technique for finding near globally-minimum solutions to large combinatorial optimisation problems), for the intelligent exploration of process and resource alternatives. The process planning module also sets up the parameters for the multi-criteria exploration of the resulting search space and handles the reporting functions. The search space is controlled through the user's definition of the products and resources to consider. This module also allows the user to define business strategy by way of weightings which are assigned to the multi-criteria objective function. The appeal of CAPABLE Space to a process planner is the ability to provide a host of feasible process plans suitable for a given supply chain configuration. The power of the system lies in the provision of this type of analysis for new products in existing factories or new supply chain configurations. For example, a rough idea of the required production methods and capacity can quickly be obtained for a new product. However, for an existing product the process planner could exercise the system to optimise the (re)allocation of parts to factories.

(5) Knowledge Representation Module.

Figure 3.8 Knowledge Representation and Management Use Case Diagrams.

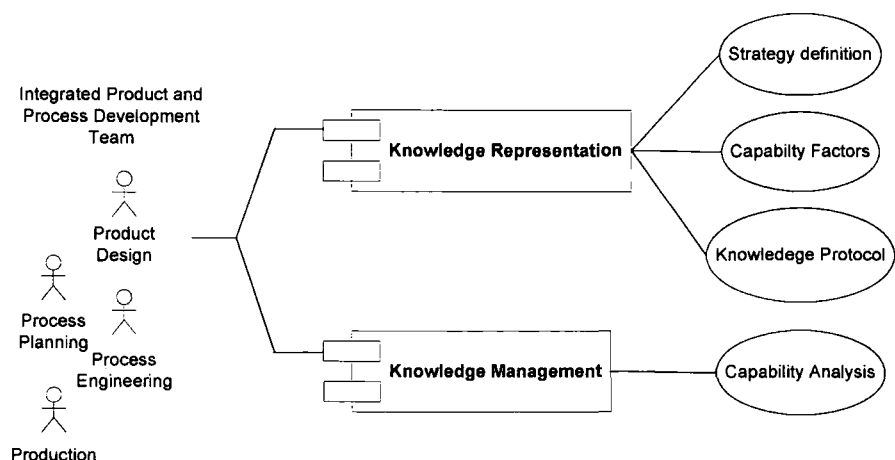

The knowledge representation module is designed to allow multiple domain experts to interact with the product, process and resource data models in order to enrich them with qualitative data concerning the likely impact of selecting particular objects in process plans. Thus, the following features are required:

- (a) Recognition of knowledge sources and success factors.
 - (b) Identification of target objects and knowledge conditionality.
 - (c) Codification of various types of qualitative knowledge against known benchmarks.
- (6) **Knowledge Management Module.** Utilising the stored knowledge within the planning objects, a knowledge management system, based on Capability Analysis techniques has the requirement to rationalise the number of possible process plans and provide a fast-feedback system in order to prioritise further design development tasks. The goal of the system is to provide a transparent method of comparing dissimilar indicators of performance at various levels with the process plan, providing an appropriate level of analysis dependant on user needs.

It is envisaged that CAPABLE Space will essentially be used by an integrated product and process development team working in a DET framework to accelerate the design process. The proposed knowledge-enriched planning system is attractive to the product design engineer because it provides a means of understanding quality, cost and delivery and knowledge implications of design decisions leading to less re-design. For production managers and process planners the system gives them a chance to start planning for new product introduction before the design is finalised, specifying appropriate downstream design and analysis via DET and hence facilitating rapid and smooth product introduction.

3.4 Implementation Issues

3.4.1 *Object-Oriented Programming Paradigm*

Object-orientation is a well-established technique for managing complexity in computer programming. The use of classes in object-oriented programming offers a powerful way of representing the physical entities that are being reasoned about, their properties and the relationships between them. The overarching concept of object-orientation is that of abstraction, which concerns the level of complexity modelled by the system and allows the programmer to ignore those aspects of the system which are irrelevant and concentrate on the important factors. A powerful way of managing abstractions is through the use of hierarchical classifications. There are three attributes of object-oriented programming languages are:

- (1) **Encapsulation** is the mechanism which implements information hiding and modularity (abstraction).
- (2) **Inheritance** is the process by which one object acquires the properties of another object further up the hierarchical classification. New classes and behaviour based on existing classes to obtain code re-use and code organisation.
- (3) **Polymorphism** is a feature that allows a single interface to be used for a general class of actions.

Combining the three attributes enables manufacturing models to be constructed in modular fashion. For example, satellite product models can be subdivided into their constituent parts, such as structural panels, equipment panels and closure panels. Each of these may then 'inherit' properties from their class, such as the structure-based attributes which define mass of a structural panel as shown in Figure 3.9. All objects inheriting from the **Panel** super class have a structural mass, however more specific classes such equipment panels in the Communication Module (**CM Panel** class) also store specific information about the mass of the equipment mounted on them.

Figure 3.9 Example of Object-Orientation.

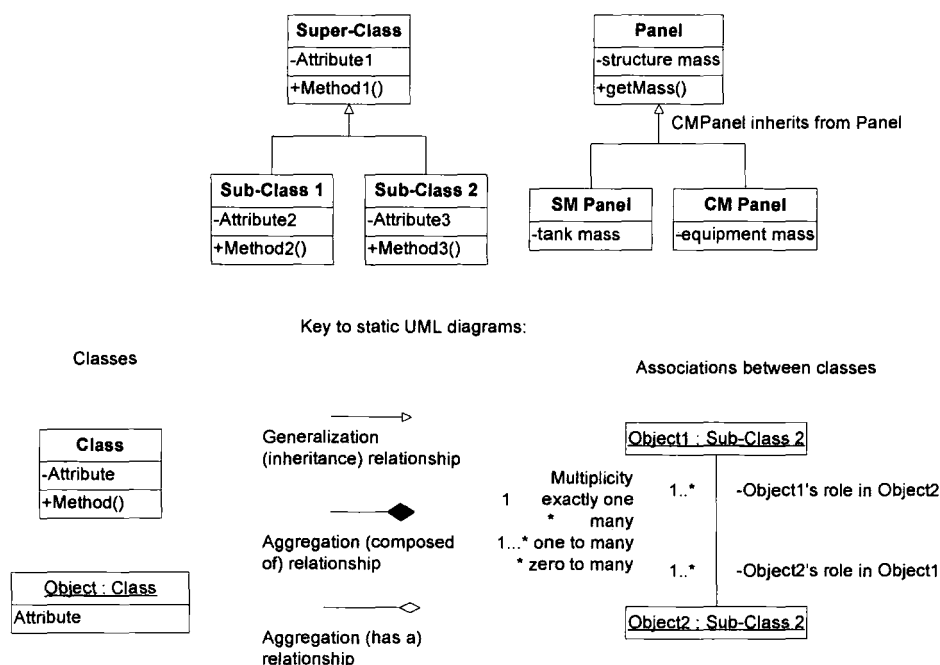

3.4.2 Development Tools

The overall system architecture has been implemented as a technology demonstrator on the Java™ platform. The system has modules for the core functionalities described in this chapter and an underlying set of class libraries for each of the aggregate data models. Persistent storage of objects is provided by a JDBC-compliant database which is accessed via Java Remote Method Invocation methods – meaning that the system can be used over intranet/internet network connections. This means that the system is capable of distributed operation, where designer and factory are geographically separate. For the visualisation of product model, the Open CASCADE object libraries (a C++ library of proprietary classes for geometrical and topological operations) and viewer application were used. (More detail on the aggregate product model viewer is provided in §4.3.5 and Appendix D.)

3.4.3 The UML Modelling Language

The Unified Modelling Language (UML) (Object Management Group Inc. 2003) provides a consistent language for specifying, visualizing, constructing, and documenting object-oriented software systems, as well as for business modelling and has previously been used for enterprise modelling (Dorador and Young 2000). The UML is a diagramming toolkit for systems modelling and includes additional expressiveness to handle modelling problems that these earlier languages did not fully address. This specification represents the current industry best practices in and hence is used throughout this thesis. Also the UML style of denoting **classes** in bold type and underlining references to instances of objects is also adopted.

3.5 The Adoption of Spacecraft Manufacture as an Industrial Test Bed

The launch of the first commercial telecommunications satellite, Early Bird, in 1965 saw the start of the commercial space industry. Ever since, the high technology requirements of the product and the specialist, low volume market have ensured that satellite manufacturing (at least in the UK) remains a highly specialist, craft-based industry. The relatively recent growth in the use of communications technology has dramatically increased the importance of this sector and the main problems facing the industry are no longer primarily technology-based but surround issues relating to production such as shortened delivery schedules, multiple orders and cost.

In order to cope with increasing demand for mass customisation (Alford, *et al.* 2000), the traditional one-off designs and craft-based manufacturing techniques of satellite manufacture must give way to modern flexible manufacturing methods and it is already evident that DET-like framework approaches will be the driving technology; following the lead from the aerospace industry a great deal of emphasis is already being placed on digital mock-up to reduce design time and mitigate risk. Typically, the design time for a standard communications satellite has gone from over eight years to three over the space of a decade (Jilla and Miller 1997). Given the current growth forecasts it is not unreasonable to expect that similar reductions will be required within the next ten years. The problems of planning in such a dynamic environment are primarily related to managing uncertainty and the rapidity of decision making which bring to the fore the risk mitigation and cost avoidance goals of DET. Hence, a solution to these problems would represent a large step towards the achievement of agile manufacturing, and bring benefits such as responsiveness, modularity and scalability of operations to bear. These problems are not unique to the space industry, but it is in this type of environment, where the very nature of the product means that costs cannot be recouped over long production runs, that the results will be most visible and be of potentially significant commercial benefit which is why the research was focussed on this sector.

Figure 3.10 shows a HotBird telecommunications satellite undergoing final testing. The Hotbird range of satellites are based on the E2000+ version of the sponsoring company's Eurostar series. The principal areas of interest for this thesis are the design of components for the communication and service modules, termed the bus structure. The E2000+ design is based on a box-type external structure, 2.8 m x 2.1 m x 2.0 m, on which all sub-systems and payload equipment are mounted. The box structure is built around a vertical thrust tube, containing the propellant tanks, which is affixed to the launch vehicle. The overriding design drivers are quality (reliability) and minimum mass to keep launch costs down. To keep mass low, the entire structure is constructed from honeycomb sandwich panels, which require specialist processes for machining and joining.

Satellites such as this are highly complex, high value products with a multitude of sub-systems. Historically, the bus structures for such satellites have been required in small numbers, hence, many of the existing manufacturing methods are craft-based. An unwanted consequence of this is a reliance on well proven designs and technologies. Anecdotal evidence suggests that 80% of the sponsoring company's products are handed over later than planned. A typical E2000+ bus structure has a value of £3.7 M and requires 100,000 man hours construction time. Individual panels range in complexity, but have recurring costs ranging from £ 188k (5085 hrs) for a service module (SM) floor panel to £258k (6971 hrs) for a Y-wall equipment panel.

Figure 3.10 HotBird Satellite Undergoing Final Testing.



3.6 Conclusion

This chapter has outlined the scope, functionality and application of the proposed planning architecture and has outlined the rationale for the main techniques presented in this research, providing a preview of the material covered in Chapters 3, 4 and 5 respectively. In summary, the CAPABLE Space system comprises:

- (1) Aggregate data models for modelling of products, processes and resources for the enterprise.

- (2) An intelligent optimiser for the selection of processes and resources for a given product.
- (3) Knowledge representation technique for representing the manufacturing implications of knowledge related to products, processes and resources.
- (4) Capability Analysis methods for managing and prioritising knowledge to increase the effectiveness of the design process.

Finally, detailed industrial testing of the proposed methods has taken place and is documented in Chapter 8.

Chapter 4 Aggregate Data Modelling: Product, Process and Resource Models

4.1 Introduction

For the purposes of early process planning, an abstract model of the product and the manufacturing environment must be constructed for storing technical information and related design knowledge. This chapter presents three interconnected models which form the building blocks of CAPABLE Space; the aggregate product, process and resource models. The work presented herein addresses both the complexity and (in)completeness of product data and resource models during early design.

As shown in Figure 4.1, §4.3 and §4.4 describe the data structures and taxonomies, with examples, used in the creation of the modelling of physical entities: the products and the supply chain that will be used in their manufacture. Subsequently, §4.5 covers the process taxonomy created to calculate the QCD data using the properties of the above two models.

Figure 4.1 Layout of Chapter 3.

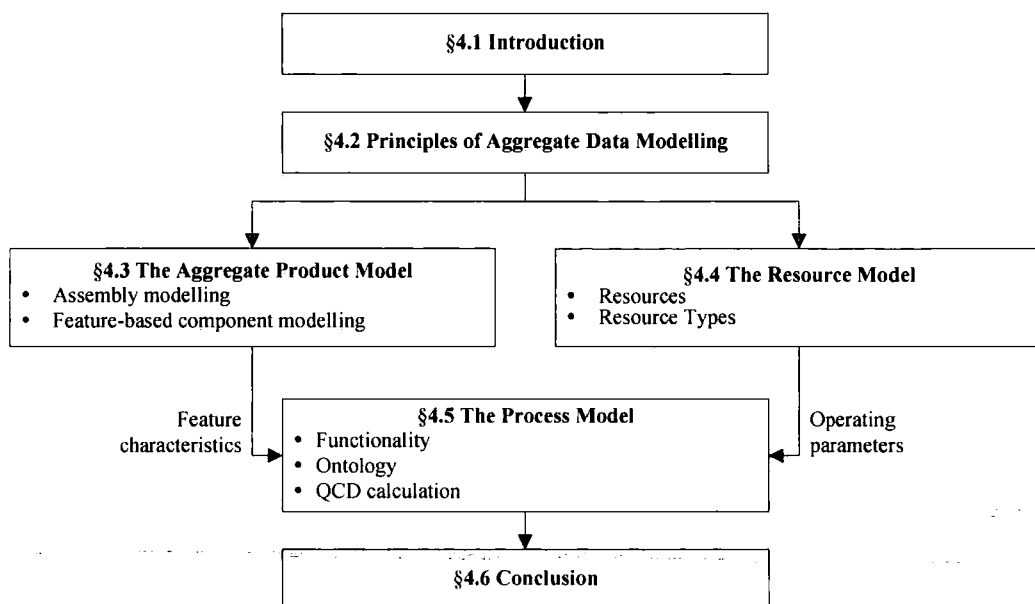

The chapter explicitly identifies the quantitative data stored in, or created by, these models that is passed to the planning methods. Only aggregate-level information specifically related to process planning was considered in the development of CAPABLE Space. Future work may investigate the potential for using a holistic manufacturing ontology as the basis for the process and resource models, but the research and development of such a large, complex model is outside the scope of this thesis.

4.2 Principles of Aggregate Data Modelling

4.2.1 Modelling Incomplete Early Manufacturing Data

CAPABLE Space is built around three object-oriented class libraries: models of the physical product and resource objects and a core process model used to evaluate manufacturability. ‘Data resistant’ process models allow for manufacturability evaluation to proceed with varying degrees of product specification data as found in structure- and feature based product models. In each case the technical basis of aggregate modelling is the simplification of detailed process knowledge into highly modular, parametric models capable of rapidly building manufacturing scenarios for evaluation. For the purpose of evaluating the resulting manufacturing performance, methods to calculate quality, cost and delivery using only most salient data from the product and resource models are essential components of the core aggregate process model. The inherent novelty lies in the ‘data resistant’ algorithms for design evaluation that do not rely on hard-coded product and resource model data and the ability to interchange one process or resource with another. Furthermore, the flexible way in which these data models are used to capture information from a variety of sources and locations (including geographically distributed suppliers) so that they can function seamlessly within the DET framework has not been previously attempted.

Liu and Young (2004) have contrasted the use of three distinct aggregate product, process and resource models, as advocated here, with their own integrated manufacturing model. The integrated manufacturing model they favour concentrates on the use of manufacturing models for linking order management with production planning as a way of increasing the quality of planning decisions by allowing ‘what-if?’ planning scenarios to be evaluated. The integrated model is designed to enhance the global co-ordination and control aspects of the task assignment problem by incorporating real-time data such as resource availability and delivery dates. The integrated models have clear benefits for capturing

information about manufacturing capability for the type of analysis proposed, but it is not so well suited to exploring the effect of interchanging alternative processes and resources as has been attempted in this research. For this reason separate process and resource models which use of encapsulation and polymorphism (see §3.4.1) to enforce a high degree of modularity and an ability to model systems with various degrees of detail are essential. The extensible nature of the aggregate modelling framework means that it would be possible, sometime in the future, to populate the resource model with real-time data from external DET sources such as an Enterprise Resource Planning (ERP) system to develop supply chain management functions akin to the integrated model.

4.2.2 Constructing 'Data-Resistant' Aggregate Models

According to Bradley (1997), there are nine essential principles for generating aggregate process models (and the product and resource models which provide data to them). These principles have been adapted to make them compatible with the DET framework, primarily to extend their usage into the modelling of processes and resources at the supply chain level and to take advantage of existing data sources and external software. These principles are:

- (1) **Controlled simplification of detailed process models.** In order to balance the amount of data required with the accuracy of the system, process models should, through simplification of detailed physical and empirical models, isolate the correct manufacturability drivers and appropriate heuristics to establish an accurate estimation of process performance at the appropriate structure- or feature based level. (Tolerance-enriched process models are considered a special case; they rely on detailed computational techniques and calculation of tolerance stack up and are thus not considered here.)
- (2) **Limited input data requirements.** Only the minimum amount of data which determines the manufacturability of a product should be required to create valid product and resource models. The basic elements of a design, such as structure and overall dimensions, should be present but exact geometry, tolerance levels and feature locations can be left undefined until detailed design. Similarly, the amount of information required to model the available resources within the supply chain should be kept to a minimum. This clearly defined minimum data level and low information requirement is critical in

enabling the real-time technical evaluation of production requirements of multiple early design configurations. Additionally, the re-use of data from external sources should be considered. For example, the co-creation of a solid model and feature-based one may allow automatic population of the feature-based model with information such as mass, or surface area which would otherwise be difficult to calculate.

- (3) **Perform core capability checks concerning processes.** Capability checks should be made to confirm the applicability of a possible solution to ensure that the proposed process plans are rational and feasible. Core capability checks eliminate infeasible feature-process combinations due to mismatches in geometrical or material limitations. However, detailed capability checks requiring full geometric analysis such as tool path validation or 3D assembly simulation should be done during detailed design using appropriate DET software.
- (4) **Model manufacturing operations.** Subject to the limited data requirements outlined above, the process models should allow the process planning system to model manufacturing operation as they would be carried out on the shop floor, so that production routes are as accurate as possible. For example, set-up and transportation times between machines should be considered as they have significant bearing on the delivery time.
- (5) **Measure manufacturing performance.** The purpose of aggregate process models is to present relevant manufacturability information governing quality, cost and delivery of a feature-process-resource combination to form the input to the objective function of the process planning engine.
- (6) **Utilise company-specific knowledge.** Company specific knowledge should be used to increase the accuracy of aggregate models in a given supply network.
- (7) **Function-driven operation.** The aggregate data models should be designed to take advantage of the object-oriented application architecture and use the characteristics of inheritance, encapsulation and polymorphism.
- (8) **Conformance with standards.** Wherever possible, the new modelling methods should be made compatible with existing standards. In particular, Chapter 2 identified the exchange of non-geometric, application specific product information via the Standard for Exchange of Product Data (STEP),

the Process Specification Language (PSL) and data transfer to CAD as key areas where overlap with aggregate modelling may occur.

- (9) **Conformance with team-based engineering.** The original definition of this principle stated that ‘all models should be accessible to and usable by process planners’, however the new planning methods should provide decision support based upon multiple aspects of product performance through feedback of relevant performance indicators to allow iterative feedback loops between design and production.

4.3 The Aggregate Product Model

The first stage of aggregate planning is the translation of functional design requirements into an aggregate product model, which must represent the (incomplete) design in a format suitable for early manufacturability analysis. The aggregate product model uses object-oriented methods for the representation and management of a multi-level product structure, comprising products, components and features. When the designer specifies a component or feature to be created, attributes must be provided to describe the (aggregate) characteristics of the object, storing relevant information such as dimensions and material properties. A key requirement is that the product model must support the transition of the design from uncertain early design through to detailed design stages in a form that is suitable for integration with the process planning system.

4.3.1 Assembly Modelling and Representation

In early design it is possible to present product information at a ‘structural’ level of detail in which abstract information is associated with elements of the product model based on form or function. It is proposed that, in future research, this attribute data will be used to synthesise new high-level process plans (Chapman, *et al.* 2002). However, this research utilises aggregate structural models as a pre-cursor to the creation of a feature-based specification. A manufacturing definition of the product can be represented as a structure-based model of the product; detailing the sub-assemblies and components, similar to a multi-level bill-of-materials, containing any number of levels of sub-levels to represent discrete states of manufacture.

To this structural model, the following types of manufacturing feature may be added: positive features, structural joint features, major and minor functional features (with some

Figure 4.2 The Construction Elements of the Aggregate Product Model.

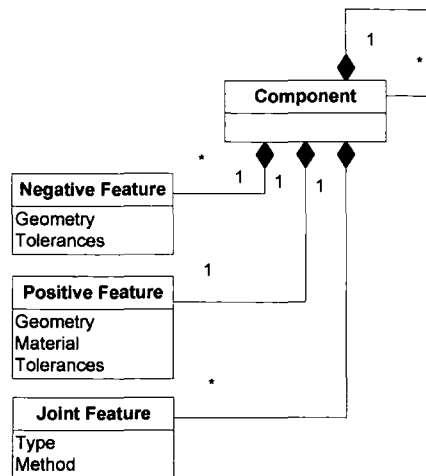

critical tolerances). Existing feature-based design techniques form the basis of the feature-based aggregate product model as they can easily be extended to support these product representations and are an effective medium for transferring information between design and process planning (Shah and Mäntylä 1995). However, it is worth noting that an aggregate product model is not necessarily the same as a model in CAD. For example a boss is more useful to a designer than to a manufacturer who would be more interested in the negative features that may be cut from around the boss in order to make it.

During the modelling process, a hierarchy of components and feature objects, as shown in Figure 4.2 is dynamically built which serves to represent a unique product configuration. The resulting bill-of-materials-like structure hierarchy is critical for defining the assembly sequence of the product; within each assembly the components are assembled in the order in which they are to be manufactured. Hence, the planning results are dependant on the model structure, but because the system does not require detailed product information, multiple product structures can be worked on simultaneously to achieve the optimum design configuration. Note that the crude initial sequence generated from the product model structure will be subsequently enhanced using full process knowledge and feature precedence rules at the process planning stage.

4.3.2 Feature-Based Component Modelling

The feature-based part representation is based on the concept of constructive solid geometry. Individual parts are built up using Boolean operations (cut and fuse) between negative and positive features. The top level hierarchy of feature of classes is shown in Figure 4.3. UML diagrams showing the complete list of features implemented for testing

Figure 4.3 Top Level Product Model Class Hierarchy.

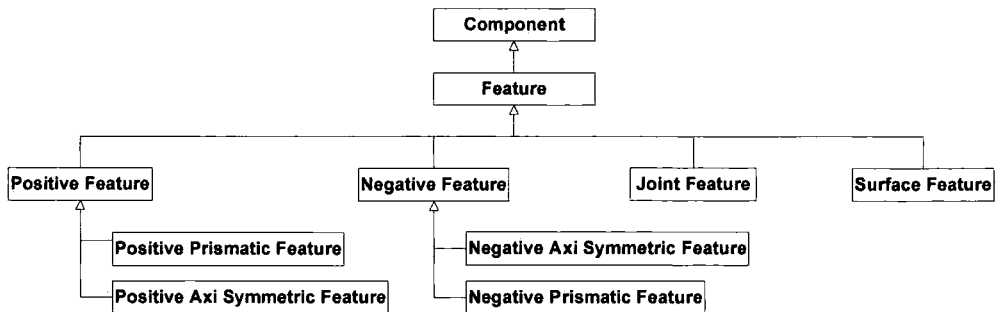

CAPABLE Space can be found in Appendix B. The following list outlines the function of each type of feature:

- (1) The **Positive Feature** is a mechanical part with simple or complex geometry that is composed of a single piece of material. Stock material can be considered as a positive feature, as can forgings and castings. A raw material cost, c_m , and important material properties which may be required in process time calculation are associated with each type of positive feature.
- (2) **Negative Feature** classes relate to the material removal processes, such as milled faces and drilled holes. The negative features are used to (re)create the component from machine reproducible geometries.
- (3) **Joint Feature** classes define the configuration and physical method for the joining of two or more components or positive features. The joint feature thus consists of a joining type and a joint methods. The type is used to define the configuration of the joint to be made, for example butt or lap, and the methods is used to indicate to type of joint required, such as mechanically fastened, chemically bonded.
- (4) **Surface Feature** classes define characteristics of the component which are not shape related, for example, surface coating requirements.

Figure 4.4 Partial Detail of Negative Prismatic Feature Classification.

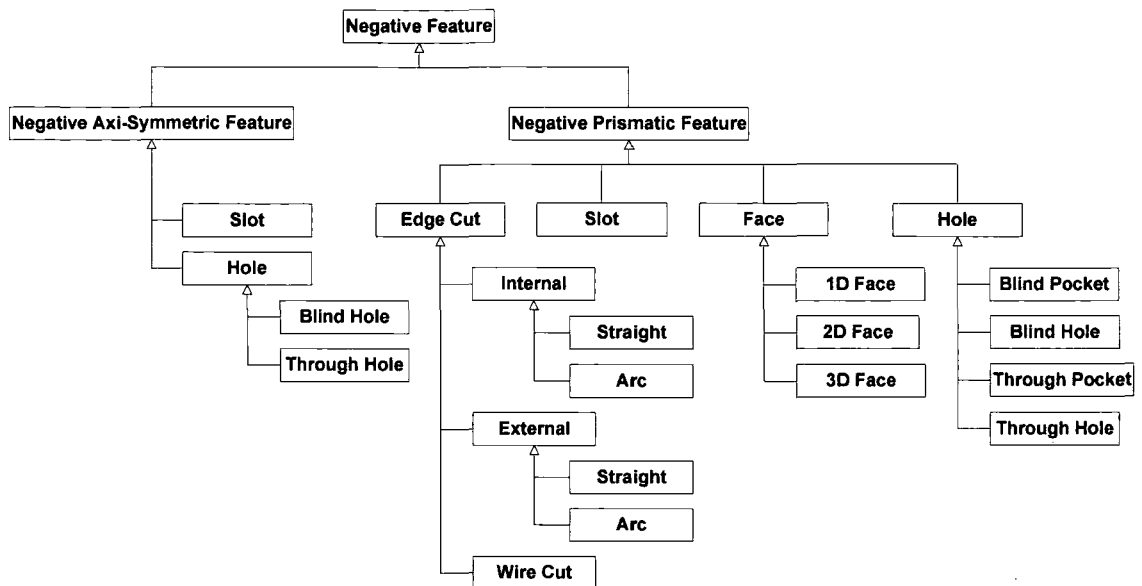

Figure 4.4 shows a subset of the negative prismatic feature classification. Features can have either an axis of rotational symmetry or not, an obvious example of a prismatic feature being a square **Blind Pocket**. Note that although the hole features have axis-symmetric geometry, they may be positioned off the axis of symmetry of the parent component, or in a prismatic parent, thus the classification reflects the ability of different processes to make these off-axis features and include negative hole features as both prismatic and axis-symmetric features. For the same reason, the **Slot** feature class also appears in the axis-symmetric feature classification. **Internal Edge Cut** classes are those that produce a component from the inside of a closed wire, **External Edge Cut** features are not enclosed but are found on the outer surface. (The full classification of features is shown in Appendix A.)

The **Positive Feature** class defines the overall shape of the component, or more usually the shape of the raw material used to manufacture the component. Positive features can only exist as child objects of components. The primary classification of features in the positive feature taxonomy is between prismatic and axis-symmetric. In this way when the process planning algorithm developed it should be quickly able to distinguish when to apply processes that are only capable of producing rotationally symmetric components. The prismatic feature classification is further divided into sheets, solids and formed parts.

4.3.3 Joint Features for Modelling Assembly Sequences

Complex products consist of many components and can have many levels of sub-assembly. An important feature of the aggregate product model is the ability to represent the logical grouping of product components into the intermediate sub-assemblies as using the joint types shown in Figure 4.5. These cover the common configurations of joints between two or more components; butt, tee, lap, corner and so on. However, to physically realise these specific form of joint classes (shown in Figure 4.6) describing the specification of fastening or permanent joining methods such as bolting or the intention to use of specific adhesives are required. Assembly features are specific instances of a feature, that provide high level information regarding assembly relationships between components and joining methods. The separation of connectivity information between the component-child relationship and the joint feature class is designed to give the flexibility to support evolving

Figure 4.5 The Joint Type Classes.

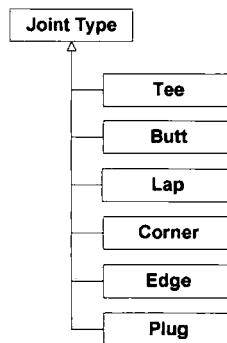
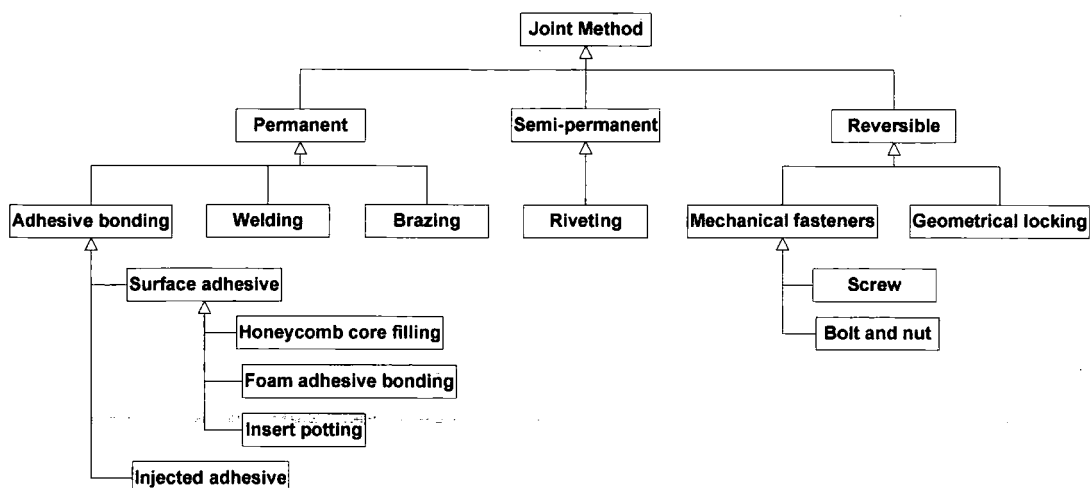

Figure 4.6 The Hierarchy of Joint Method Classes.



design information.

Special combinations of joining methods are commonplace within the space industry. These can all be represented using the product model using multiple joint methods. For example, joint designs which are both bonded and mechanically fastened are referred to as hybrid joints. These are modelled by creating two separate joint features at the component level. An example hybrid joining processes is that of panel splicing whereby two panels are butted together using adhesive and then butt straps are bonded, externally, across the joint. These type of joints are deconstructed and modelled as two separate joint features because the associated manufacturing process is normally done in two stages, and indeed the secondary joining operation of the butt straps can be either bonded or mechanically fastened.

4.3.4 Tolerancing at the Feature-Based Level

The feature-based aggregate product model also requires a set of tolerance classes which can be associated to features to be defined. For simplicity, tolerances which require a datum reference to be explicitly inputted (and hence would require a relationship between two features, possibly at different levels in the product model tree) are omitted at the feature-based level. The additional complexity this entails means that external software is required to perform tolerance-stack-up analysis and return the result to the aggregate models. The tolerance class hierarchy implemented in the prototype CAPABLE Space application follows the previously identified International Organisation for Standardisation

Figure 4.7 Tolerance Classes Implemented in the Aggregate Product Model.

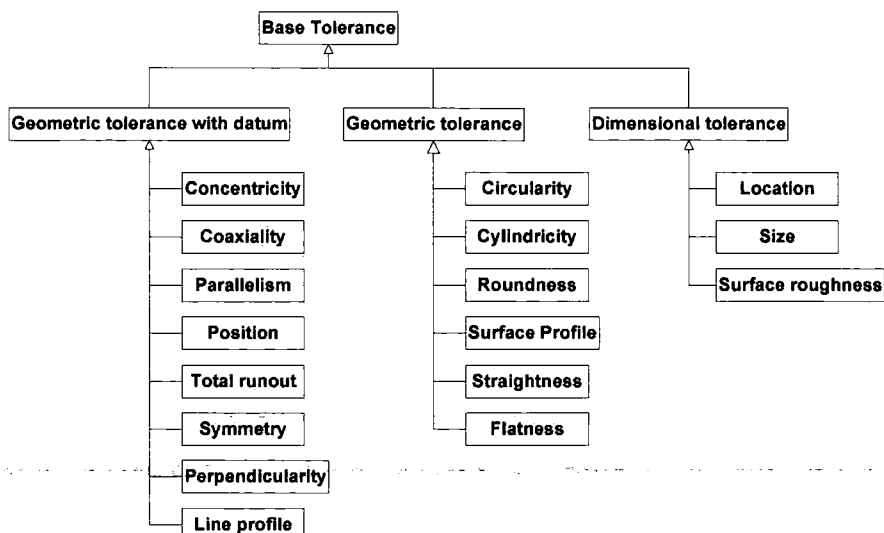

(ISO) (1999) and is summarised in the UML class diagram (Figure 4.7). Both geometric tolerances, such as cylindricity, and dimensional tolerances such as size and position were included. For example, when a *position tolerance* is applied to a hole feature, the allowable deviation will be defined by a circle, with radius equal to the magnitude of the tolerance value, and an automatically generated datum which is the nominal position of the hole.

The aggregate product model is toleranced by applying these tolerances as child objects at the feature level. Only the key tolerances which are known to affect the product's performance should be included in the aggregate model. Presently, the identification and verification of these tolerances is left to the discretion of the designer however, more methods of automatically identifying key tolerances, using other DET tools such as advanced tolerance management software, is an area for further research. Each tolerance defined in the product model therefore results in an opportunity for quality defects to occur when the product model is analysed using the process quality calculation outlined in the description of the process model (§4.5.6).

4.3.5 Visualising the Aggregate Product Model

Depending on the degree of information is available, it possible to create a product model that can support Aggregate Process Planning but has insufficient information to generate a 3D solid from it. However, if sufficient geometrical information is available, it is useful to be able to visualise the design in a CAD setting. DET encourages connectivity across the (proprietary) data models used by different tools used in the design process. In this case, the feature-based product generated as part of the early design in CAPABLE Space is required to be compatible with a solid model which can subsequently be imported into a CAD system for detailed design work. This has been achieved through the use of the Open CASCADE solid modelling libraries (see Appendix D). For each feature, an Open CASCADE class (in C++) has been created which mirrors the geometrical information contained in the feature based model (by virtue of the Java Native interface [Liang 1999]). Standard Boolean CAD operators are used to build the solid model in Open CASCADE by adding material (in the case of positive features) and removing it according to the hierarchical precedents established in the product model (in the case of negative features). The created shapes can subsequently be displayed in a viewer and saved into neutral file formats such as STEP or IGES for export to CAD applications. Additionally, functions are

provided to query the resulting model for weight, volume, surface area *et cetera* which can be returned to populate the aggregate product model with data.

4.3.6 Construction of Example Aggregate Product Models

In early design, decisions are made between alternative structures, which meet the functional specifications of the product. Figure 4.8 and Figure 4.9 show the design of a honeycomb panel with a reinforced skin. Two different configurations are possible, which will require different processing capabilities and, hence, will have different process times and costs. Figure 4.8 shows the component constructed from a single Skin A object. In this case, the component must be created by chemical etching of the skin surface to produce the Doubler A feature. In Figure 4.9, the same component is made by joining two components. Because two components are required, the joint feature JF1 is added. Joint 1 describes the nature of the joint (lap) and the key geometrical characteristics such as bond area.

Figure 4.8 Alternative Product Configuration I - Doubler Removal.

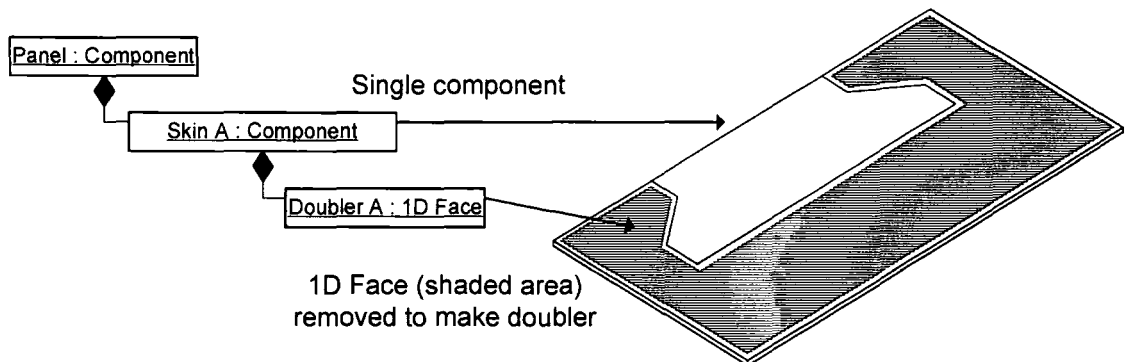

Figure 4.9 Alternative Product Configuration II - Doubler Bonded into Position.

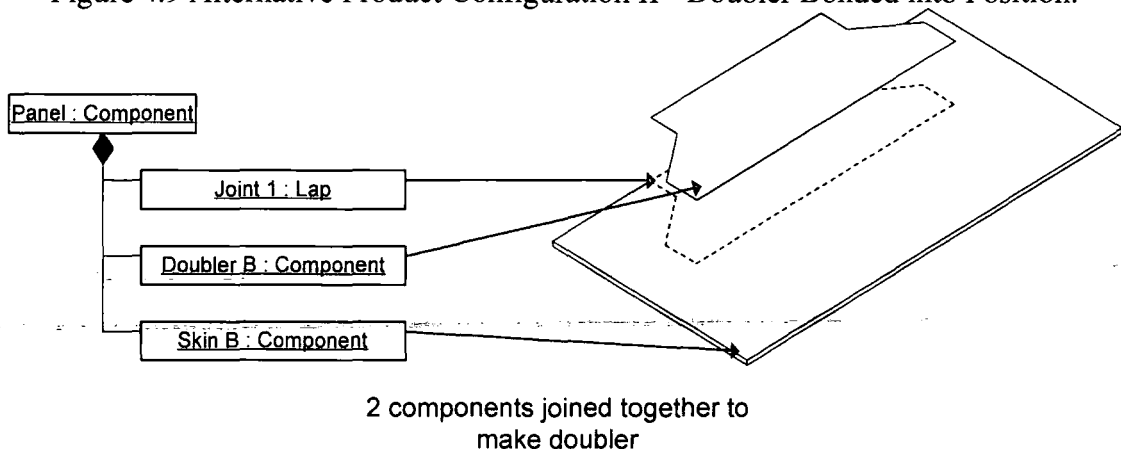
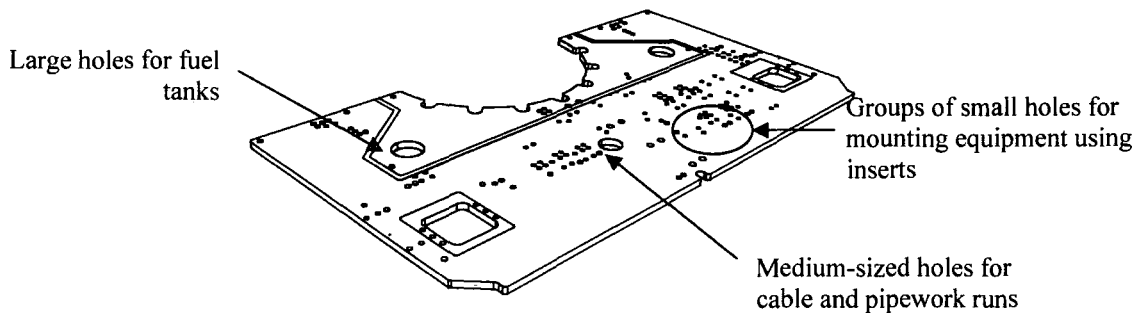

Figure 4.10 A Typical SM Floor Panel.



A typical satellite panel such as the one shown in Figure 4.10, has approximately 200-500 features, the majority of these are holes for inserts, but there are also larger holes for pipework clearance and mounting the fuel tanks. At the feature-based level the aggregate planning system only recognises the geometry of the feature so each hole must be planned individually. At this stage the relevance of structure-based aggregate planning would be appropriate; combining groups of holes into panel-level attributes, which can be planned using either historical data or calculating data using 'best fit' synthetic features and multiplying the result by the actual number of similar features.

4.3.7 A Comparison of the Aggregate Product Data Model with the Core Product Model of NIST

The 'core' product model of NIST is a generic (object-oriented and feature based) method for representing a product definition in terms of its form, function, and behaviour (NIST 2001). The 'form' of a product contains information about, geometry, material and physical properties and the creation of domain-specific class hierarchy structures is similar in nature to the feature-based aggregate product model. The creation of a product structure is somewhat more sophisticated, involving the concept of 'relationships', which can be either simple membership functions or more complex constraint types. Through applying the 'assembly relationship' to 'artefacts' and 'features', the core model could easily model parent-child relationships between assemblies, components and features and thus support integration with process planning systems such as CAPABLE Space. However, the main purpose of the NIST core model is as a design repository and to date only limited research seems to have been done on extending the semantics of the model to support interoperability of the model with a process planner. The NIST core model is certainly more generic than the aggregate product model, and because it is designed for domain

specific customisation it may be more attractive for CAD vendors and industry to adopt as a standard. However, the similarities between the two approaches means that it would be feasible to either create software to interface between the two models or re-write CAPABLE Space to use the NIST core model as its source of product information.

4.4 The Aggregate Resource Model

4.4.1 General Characteristics of Resource Models

The term 'resource-aware' planning is used to indicate a dynamic inter-relationship between the planning entities (products and processes) and the enterprise resources, including humans and machines. As well as being able to compare alternative production methods, the aggregate planning system is designed to take into account the effect of selecting different resources. A description of the capabilities of available equipment, workcells and labour, is stored in the resource model. The resource model, which is again constructed by building a hierarchy of object-oriented classes, represents the manufacturing system at an aggregate level of detail. The basic information required to add a machine to a resource model includes:

- (1) Process compatibility map.
- (2) Critical operating parameters.
- (3) Historical process capability data.
- (4) Activity-based cost data.
- (5) Machine availability.
- (6) Physical location of resources.

A generic aggregate resource model has been defined to allow the systematic representation of enterprise resources from production units and factories, to production machines, labour and transportation. Since many manufacturing companies rely on outsourcing operations to supply chain companies, for technical or economic reasons, the resource model is specifically designed with high level classes to model external suppliers. The resource model is composed of two libraries of classes, namely **Resource** classes (the physical entities) and **Resource Type** classes (the behaviours). To construct a resource model, the physical resources are first instantiated and then **Resource Types**, describing the distinct characteristics of each resource, are associated with the resource. This object-oriented structure provides the ability to represent hierarchies of resources at different levels of abstraction as occurs in the real world.

This aggregate resource model differs from the purely cell-based resource model of Bradley (1997) as it must facilitate the representation of generic factory layouts and organisational data. Bradley's cell-based model, whilst allowing the creation of a valid search space, results in a much flatter hierarchy, listing the available equipment, populated with data. Importantly for aggregate-level representation, the model supports modelling factories at various stages of abstraction; a supplier may be added to the aggregate resource model with simply a single resource capable of performing a specialised process. Information can be added later on to populate the supplier's resource model with more detailed descriptions of layout and equipment. When detailed models are present, the use of resource classes to represent the internal manufacturing units allows the aggregate resource model to differentiate alternative configurations of the same factory for the purposes of layout design, for example clustering certain process in cells or by resource type and allowing the CAPABLE Space planning system to work out the necessary transportation and set-up requirements. Finally, the model also allows different supplier to use different vocabulary when creating their resource models, for example one supplier may use the term 'mechanical workshop' whilst another may refer to it as a 'machine shop'.

4.4.2 Resource Classes for Modelling Equipment

A resource class library (given in Appendix B) has been created, which is sufficiently extensive to model the equipment and resources found in most enterprises. The majority of the functionality of the resource classes is contained within the top level resource object as shown in Figure 4.11.

Figure 4.11 **Resource** and **Resource Type** Classes with their Attributes.

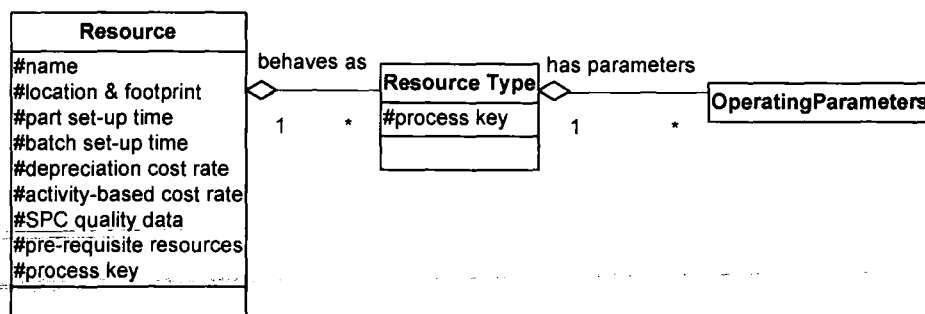

When creating resource objects, the following types of information must be entered:

- (1) The **Footprint** describes the physical position and area taken up by the resource, referenced as Cartesian co-ordinates from the footprint of the parent resource object. For example, a machine will be located within a cell, which in turn is located in a higher-level factory resource. The hierarchical nature of the resource model means that the distance from one resource to another can easily be determined for assessing transportation requirements.
- (2) The **Process Key** is a textual identifier of the process classes which may be executed on a resource type. To represent resources with multiple abilities, when a resource type is added to a resource, the type's process keys are automatically appended to that of the resource which then 'understands' all the different processes that may be executed on it.
- (3) Resources which are dependent upon other resources, such as a machine which requires labour to operate it, also require a description of all the pre-requisite resources.
- (4) The **part** and **batch set-up times** must be defined for each resource, representing the time required to set-up a single part, d_p , and for producing a batch of parts, d_b , respectively.
- (5) **Activity-based** and **depreciation cost rates**, r_a and r_d respectively, are required to indicate the costs incurred in using the resource. Detailed cost models are not essential at the early stages of design, since quite a lot of information may be unavailable or too time consuming to collect. The main costs in manufacturing are direct labour, machine time required and the raw materials cost. Since the aim of the Aggregate Process Planning system is to consider the effect of design decisions and equipment choice on production cost, these costs must be apportioned to individual jobs via the selected resource. Two cost rates have thus been included in the resource model; activity cost rate and depreciation cost rate. The standard method for calculating the activity-based cost rate for a resource is to divide the overall cost of running a resource for a year by the total production time during that period. Yearly depreciation costs are also treated in the same manner. This allows the planning system to evaluate the effect of using new and expensive

pieces of equipment as opposed to lower capability, fully-depreciated resources.

- (6) A **statistical process control (SPC)** history records the process capability of the **Resource**. At the point of quality assessment within the process planning algorithm, this record is searched to find matching criteria in terms of the feature, its dimensions and process parameters.

4.4.3 Resource Type Classes for Describing Processing Capability

The **Resource Type** classes describe the processing capability of a **Resource** through a series of **Operating Parameter** classes. A resource may have more than one resource type, for example a lathe can operate as a turning centre or a drill. The hierarchy of **Resource Type** objects used in CAPABLE Space, is given in Figure 4.12. The operating parameters are a critical set of variables that describe processing capability, in an aggregate manner, essential for executing the simplified process models and performing core technological checks. Each **Resource Type** class has a different set of operating parameters ranging from workrate of a labour type, to tool speeds and feed rates. The range of operating parameter data required for a particular resource type is defined in the corresponding aggregate process models. The required operating parameters are obtained from the simplification of detailed process models and their values are derived from literature, the simplification of process optimisation algorithms and databases of production equipment manufacturers.

Figure 4.12 Top Level Resource Types.

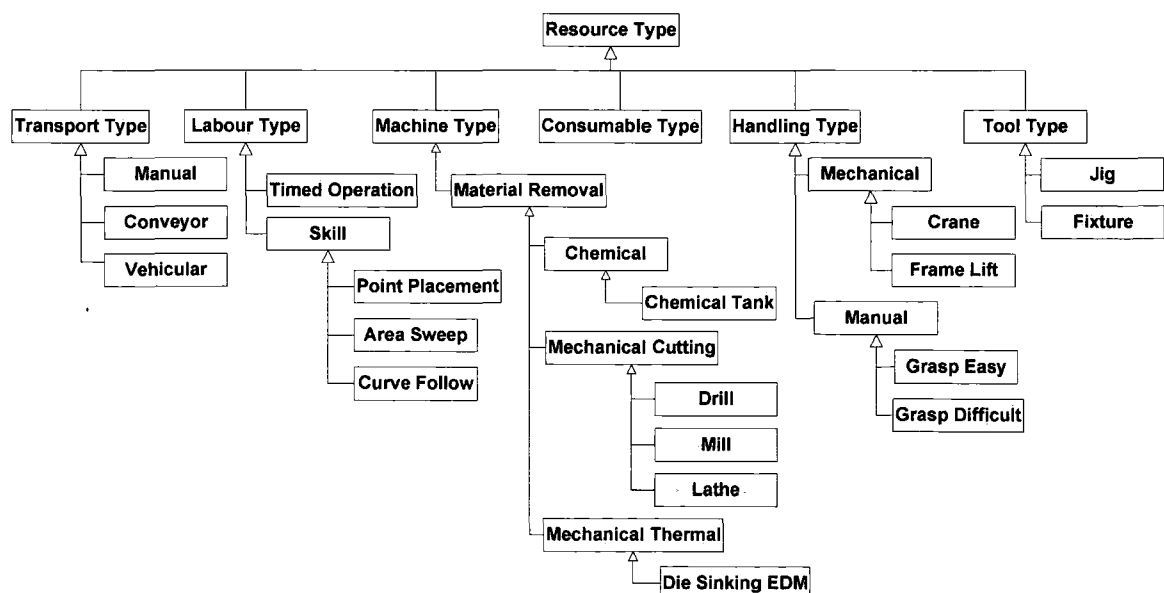
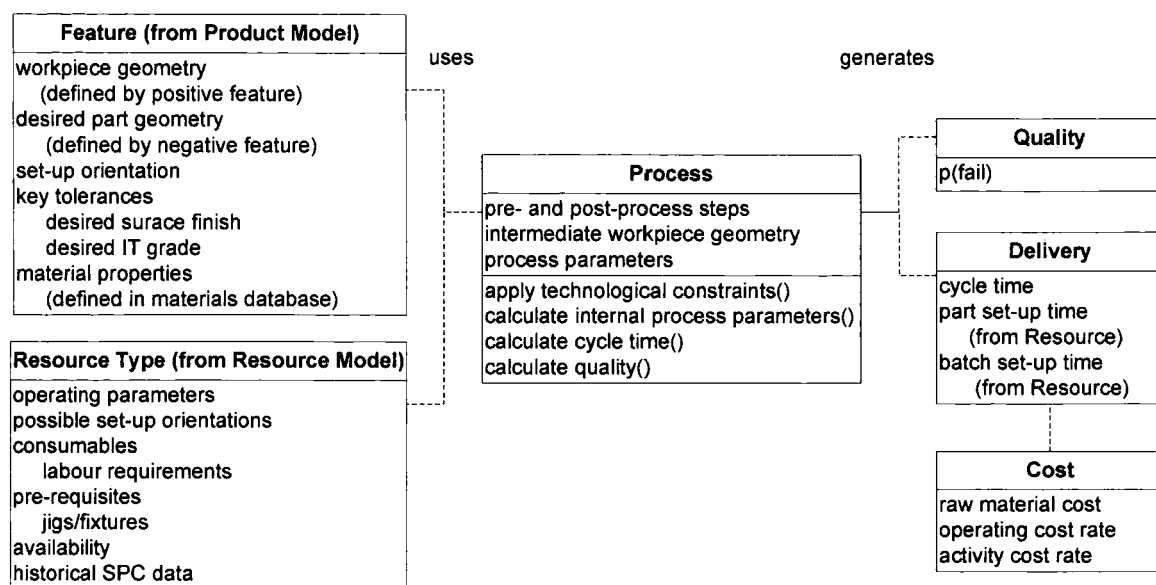

Figure 4.13 Aggregate Process Model Data Flows.



4.5 The Aggregate Process Model

Whilst, the product and resource models are simply repositories for information, the process models must also contain procedural knowledge and methods for constraint checking and manufacturability evaluation. The aggregate process models are distinguished from earlier work by their ability to generate ‘resource-aware’ QCD estimates, linking the capture of dynamic operating parameters and SPC quality data for actual equipment in the supply chain. The linkages between the three models, described in §4.5.1 are shown in Figure 4.13 and are an important and novel aspect of the work reported. Furthermore, additional original research has been done on the extended early manufacturability evaluation using ‘data resistant’ models.

4.5.1 Functionality of Aggregate Process Models

The selection of process is initially driven by their shape producing capability. For example, parts with cavities can be produced by various process including; end milling, electrical discharge machining, electrochemical machining and casting. After initial process selection, based on shape producing ability, additional technological checks are made by the process model to reject any processes which are incompatible with the specific geometry of the negative feature class. As an example, for drilling operations,

these technological constraints include geometrical limits such as the maximum drillable diameter, the minimum ratio of length to diameter and, the surface finish and interval of tolerance limits of the process. Secondly, the process models contain the analytical methods for the calculation of cycle time, d_c , and process quality, $p(\text{fail})$. Each aggregate process model thus contains the following basic information:

- (1) A **Feature-to-Process** compatibility map comprising overloaded class constructors for each feature type that can be produced using the process which allows the process model 'to understand' the data *encapsulated* in the features of the product model.
- (2) Similarly, a **Process-to-Resource** compatibility map for each **Resource Type** that can be execute the process which allows the process model 'to understand' the data *encapsulated* in the operating parameters of the resource model.
- (3) A simplified physical or empirical time-based process model which is driven by the feature characteristics, such as size and material, stored in the aggregate product model and operating parameters, selected using heuristics and historical quality data, from the aggregate resource model.
- (4) Additional processing steps that are required are indicated by the presence of a pre- and post-process keys, which are a textual identifiers of a process type required as a sub-process. For example bonding operations are usually preceded by a degreasing process to remove contaminants.
- (5) Constraints used by the planning algorithm to ensure that those processes and resources obtained through the mappings are physically capable of producing the features defined within the product model to the required tolerance levels.
 - (a) Technological constraints prevent jobs being specified where feature dimensions and tolerances along with surface finish and empirical dimensional ratios (such as drilling hole length to diameter) negate the use of a particular process. These constraints are also responsible for ensuring that hard constraints, for example, in machining roughing operations must occur before finishing ones.
 - (b) Physical constraints limit the feature and process combinations to capable resources; the constraints ensure that selected resources are capable based upon their operating parameters, such as bed size, tool, feed and spindle

speed as well as the statistical process control history in producing a similar feature.

Unsuitable processes and resources are thus eliminated by applying these 'hard' constraints.

4.5.2 Aggregate Process Model Structure

Manufacturing is characterised by two kinds of activities; discrete parts production and the subsequent assembly of these parts to generate the finished product. The hierarchy of process models for discrete parts manufacture broadly follow the top-level classification presented by Allen and Alting (1986), which groups processes according to their morphological characteristics. Two broad categories of processes exist within this classification, shape-changing (or mass reducing) and non-shape changing (mass conserving). This work is closely related to that of the creation of manufacturing ontologies, particularly that of the VRL-KCiP previously described.

Inheritance, encapsulation and polymorphism (fundamentals of object-oriented programming) have been extensively used in the implementation of the aggregate process models. A hierarchy of manufacturing process classes has been created (the top level of which is sub-divided into discrete part manufacture and assembly operations) are shown in Figure 4.14, which are used to model the different types of process at various levels of abstraction. For each process class which can be instantiated, the aggregate planning system has a set of functions which calculate process times based on the attributes of the selected feature and resource. These functions include sub-routines for selecting the most appropriate process parameters. Since the processes exist within a taxonomy, a great deal

Figure 4.14. The Top Level Process Model Class Hierarchy.

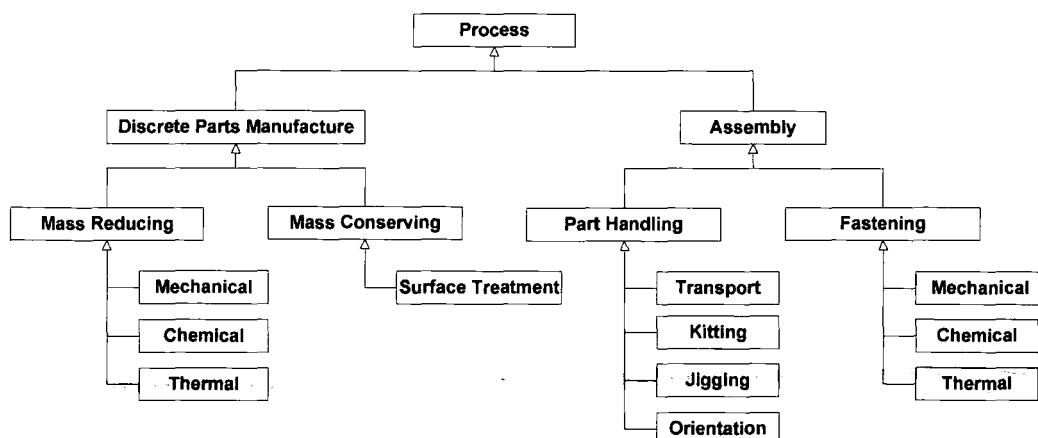

of information is inferred from parent classes and thus simplifying the creation of variant processes. Ideally, the process model should contain a comprehensive hierarchy of manufacturing processes since the aggregate planning paradigm depends on having a wide variety of alternative process to select from. Due to the limitations of time, however, the development of aggregate process models has concentrated on realising those processes which are specifically required to demonstrate the methods for spacecraft manufacture.

Machining is one of the most common part producing activities found in industry and as such aggregate process models were initially developed by Bradley (1997) for the major forms of machining (**Turning, milling and Drilling**). To make the system applicable to application in the space industry these standard models were modified to take into account the use of these processes with exotic materials such as aluminium honeycomb and composites. For example, new classes (inheriting attributes and methods from the traditional mass reducing machining process classes) have been created to cover (honeycomb) **Core Milling, Core Skim Milling** and **Skin Interpolated Milling**. Specialist processes classes such as **Chemical Milling** have also been added to the class hierarchy under chemical mass reducing branch.

Assembly processes are fundamental to the manufacture of most products. Assembly operations model the joining of multiple parts to form a new sub-assembly. Assemblies are represented within an aggregate product model through the concept of joint features. As previously described, the creation of a joint feature requires a combination of part handling (alignment of the parts) and the physical process of making the joint. The ‘feature-to-process mapping’ initially selects the physical method of making the joint and subsequently the handling requirements are identified based on alignment of the smaller of the two parts to be joined. Process models for mechanical joining, for example standard process models for screwing, bolting and riveting are included in the CAPABLE System, as are adhesive joining processes such as these used to bond the honeycomb-cored panels which are found in most satellite bus structures.

4.5.3 Manufacturability Metrics for Evaluating Alternative Process Plans

The intention of the aggregate modelling paradigm is to feed manufacturability information back the designer as realistic cost and lead time estimates. Manufacturability is a measure of how easy or difficult it is to implement the production routings specified in a

process plan. It encompasses both calculated, quantitative measures such as QCD and qualitative decision making criteria arising from design and planning knowledge.

The requirement for minimal resource information means that it is possible to quickly generate hypothetical resource models containing state-of-the-art equipment or models or process models for new suppliers benchmarked against industry standards. This means that the manufacturability outputs of the process models can be used to assess whether in-house manufacture is possible or whether external suppliers should be engaged to produce components or sub-assemblies or complete products. The calculated cost and quality values can be used as target figures for evaluating detailed bids from sub-contractors.

4.5.4 Delivery Calculation Method Described for Mass Reducing Processes

The aggregate process modelling approach is generic, but at this stage of the research only a selection of models relevant to the space industry have been fully defined. Of those, the shape producing processes, based on the simplification of traditional process models which were identified in the Literature Review (Swift and Booker 1997, Bradley 1997), are the maturest. Figure 4.15 illustrates the generic parameter selection strategies implemented for the calculation of cycle time for common machining processes. Appendix B gives details of the process parameters and technological constraints implemented in CAPABLE Space.

At the aggregate level machining processes are modelled at the level of processing steps, and the principle model required is the estimation of a rough-cut cycle time, d_c . For all shape changing processes inheriting from the machining class the calculation of d_c is based on the assumption that a theoretical maximum process rate, such as material removal rate, can be obtained. This rate is initially based on look-up tables containing maximum feeds and speeds suitable for cutting a particular material; such information is commonly available in tooling catalogues.

Figure 4.15 Example Method for Cycle Time Calculation for Machining Processes.

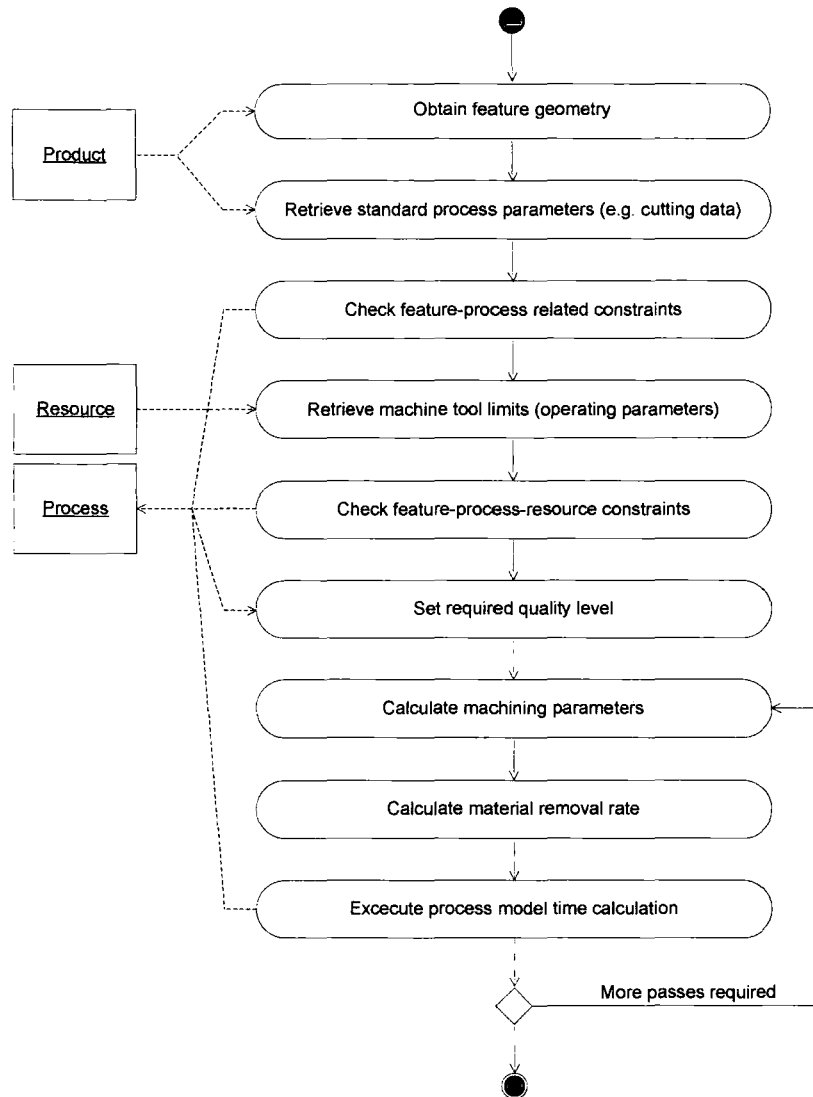

Further detailed process optimisation considerations such as tool life balancing and work-holding forces are omitted. Obviating the need for actual tool selection will inevitably result in some loss of accuracy in the aggregate process model, but this drawback is outweighed by the ability to evaluate rapidly the effect of changes to the feature geometry on cycle time so that a decision can be made on the best design option to pursue. These suggested maximum parameters are modified to take into account the capability (available power, table feed rates and so on) of the chosen machine tools. Critically, the application of resource operating parameters in the process model needs to be able to differentiate between machines, of similar type but different capability, in a given factory. The geometry of the workpiece is also an important consideration, and heuristic methods are applied to determine; (i) the number of set-ups required and (ii) the number of passes of a

'generic' cutting tool with default geometry are used to estimate the volume of material to be removed in each pass. For parts which have large set-up times (in comparison to their cycle time), the number of set-ups is determined by matching possible set-up faces specified in the product model to tool approach directions specified in the resource model. Even though the process models make some internal calculations about the machining steps, this information is obfuscated from the user, since it is expected that in most cases downstream DET software applications will be employed to optimise the final machining strategy.

4.5.5 The Calculation of Cycle Time for Assembly and Handling Processes

Assembly processes are fundamental to the manufacture of satellites and include support functions such as material handling. Assemblies are represented within an aggregate product model through the concept of 'joint features' that link two or more components together. The creation of a 'joint' requires a combination of part handling (alignment of the parts) and the physical process of making the joint. The 'feature-to-process mapping' initially selects a method of joining and subsequently the handling requirements are identified based on alignment of the smaller of the two parts to be joined. These features are initially categorised according to the type of connection method, either reversible or permanent types as shown in the taxonomy of Figure 4.6. Process models for mechanical joining processes, such as bolting and riveting are included in the system as well as adhesive joining processes such as those used to bond the honeycomb-cored panels. The method of generating process time models for assembly operations makes use of recent work on assembly planning (Laguda 2002) in which data from Boothroyd, *et al.* (2002) was analysed to determine the relationships between assembly features on the product model and assembly cycle times. Inevitably there will be implications of simplifying complex process models; cycle time equations, should be regularly monitored for accuracy. It is suggested that simplifications are only made where the result will not deviate more than 10% from detailed model outputs. As with any system, continuous monitoring of its performance will be necessary to keep the system up to date. From experience, this 10% target value is realistically achievable and gives sufficiently accurate results to evaluate the viability of a product design and to perform comparisons between alternative production methods.

Finally, for completeness a small set of process model classes has been developed to model a time penalty incurred in transporting parts between sequential processing on different machines, both within and between factories. These classes determine a transportation time based upon maximum speeds and the distance between machines determined by querying the resource model. (In this instance the cycle time is not related to features of the product model.) The selection of appropriate transportation methods is made on the basis of distance constraints. In future versions of the software, more accurate methods of modelling transportation of part would need to be investigated.

4.5.6 The Quality Estimation Method

Figure 4.16 Process Quality Calculation Method.

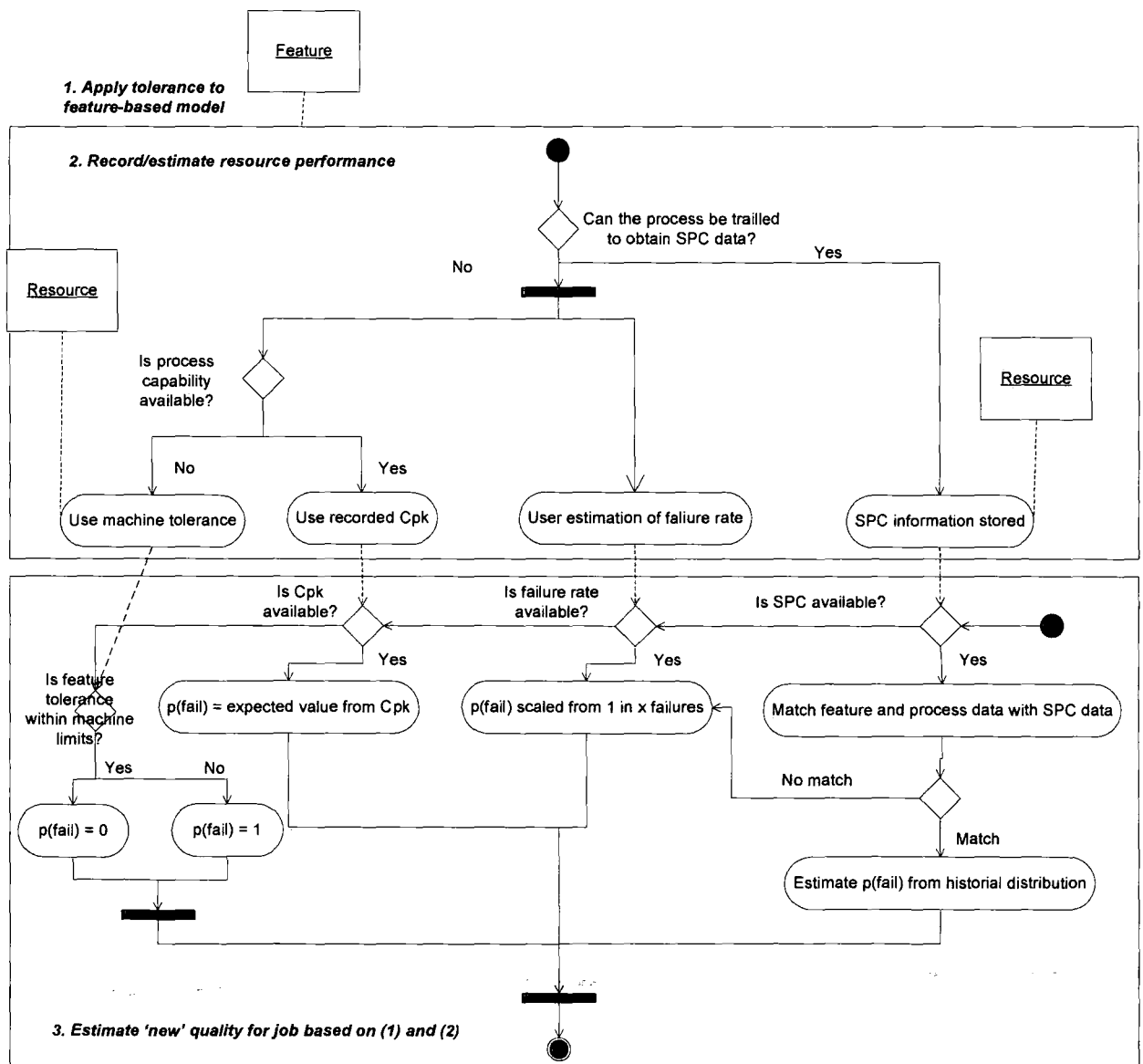

In aggregate planning 'quality' is a measure of the capability of the manufacturing system in meeting the design tolerances specified in the product model translated into yield. Information about likely quality levels are required during early planning to balance the accuracy of the process against the processing required. Quality is measured stochastically in a Six Sigma fashion (shown in Figure 4.16) using a standard measure of the number of defects per million opportunities (DPMO). In order to use this model the minimum information which is required is a *tolerance* specified in the product model and *a posteriori* knowledge about producing this feature from the resource model. Where historical data is unavailable subjective judgement can be used to estimate how the resource will perform. Tolerance information from the product model and the historical capability of a resource (when making similar features) are processed to determine the likely failure rate, $p(\text{fail})$, expressed as defects per million opportunities, DPMO, if required. The quality calculation routines are designed to be compatible with both existing quality systems and the aggregate planning paradigm. They work on the premise that, when a new feature with a tolerance is process-planned, historical or expected performance of a resource producing similar features can be used to estimate the likely quality of the new design. The quality calculation method can be summarised as follows:

- (1) **Apply tolerance objects to features.** Tolerance objects, compatible with ISO10303, are instantiated from a library of classes and added to the list of tolerances for a feature. Tolerance objects describe the upper and lower specification limits for a particular tolerance. Only un-related tolerances (i.e. those which do not reference a datum, for example circularity, length) can be handled by the current methods. Tolerances are usually the last part of a design to be specified. However, since tolerances should relate to the interrelationships between key features, it should be possible, and desirable, to specify them during early design to appreciate their effects.
- (2) **Record or estimate historical resource performance.** Statistical process control (SPC) data or estimated resource performance must be entered into the resource model. Several formats are available to represent historical quality information at different levels of detail:
 - (a) **Manufacturer's machine tolerance.** The minimum of quality information about the machine, intended for use when considering purchase of new machines.

- (b) Defects per million opportunities. This value is used if no detailed historical data is available. Estimated as number of observed failures, or from look-up tables relating process capability to DPMO.
- (c) Tolerance distribution. The user has the ability to define a normal distribution curve, by providing the mean value and standard deviation taken from production samples.
- (3) Estimate new quality based on the above. For every tolerance in the feature object, a new *quality estimate* class is generated. It consists of the upper and lower tolerance limits from the tolerance and a function representing the past performance of the resource when used to produce similar tolerances. This historical data is used to construct an estimate of the quality performance according to the available data, ranging from raw statistical process control data to machine maximum and minimum limits, as shown in Figure 4.16 and described below:
- (a) **Process capability.** Process capability is a measure of how well the process can cope with design tolerances. If the tolerance band is known then this can be converted to a DPMO value for the particular tolerance. This metric will only be used in rare cases as the data needed to calculate C_{pk} can be used to get the mean and variance values.
- (b) **Process mean and variance.** Because most engineering processes produce output which in which variation about a central value occurs as a result of multiple sources a normal distribution obtained by sampling the output can be used to represent this kind of data. A normal distribution can be defined using the process mean and its variance using the standard formula obtained from Creveling (1997):

$$f(x) = \frac{1}{\sigma\sqrt{2\pi}} e^{-\frac{1}{2}\left(\frac{x-\mu}{\sigma}\right)^2} \quad \text{Equation 4.1}$$

(from Creveling 1997)

To calculate the failure rate the distribution function is obtained by summing the result of integrating from $-\infty$ to the lower specification limit and from the upper specification limit to ∞ .

$$f(x) = \frac{1}{\sigma\sqrt{2\pi}} \left(\int_{-\infty}^{LSL} e^{-\frac{1}{2}\left(\frac{v-\mu}{\sigma}\right)^2} dv + \int_{USL}^{\infty} e^{-\frac{1}{2}\left(\frac{u-\mu}{\sigma}\right)^2} du \right) \quad \text{Equation 4.2}$$

(from Creveling 1997)

The integral cannot be solved by calculus and so a numerical method using Simpson's rule is used. The data for this metric can easily be collected from samples of the output.

- (c) **Machine limitations.** Where *a posteriori* quality information is unavailable, for example, when new equipment is being evaluated, the only data which is available is the maximum and minimum limits supplied by tool manufactures or in catalogues or texts. Specifically in this case the probability of a unit failing is one if the tolerance lies outside the machines tolerance limits and zero otherwise.

$$f(x) = \begin{cases} 0 & \text{if } LSL \leq t \leq USL \\ 1 & \text{otherwise} \end{cases} \quad \text{Equation 4.3}$$

Using this function does not really help the designer assign tolerances because all processes which are inside the tolerance are considered equally good and this makes it difficult to drive improvements.

- (d) **Observed rate of failures.** A less specific measure of quality, although one for which data can easily be obtained, is the observed rate of failures for a specific process. This measure is susceptible to problems of measuring first time yield. However, where no raw data exists this is a useful gauge of process performance and is better than having no information at all.
- (e) **Raw measurement data.** Using data from a quality information system, raw measurement data can be analysed to generate the mean and variance values above. This level of connectivity allows a shared repository for quality information and means that the CAPABLE Space system can operate with the most up-to-date information and becomes less intrusive to the user because no additional effort is required to collate the data.
- (4) **Determine Overall Product Quality.** In order to estimate the number of products which will contain a failure, the effect of each critical to quality tolerance on the products must be accounted for. In the simplest case a product is deemed to fail if any of its sub-components fail. (It is also assumed that the failures will be independent events, although in case of problems like tool wear or machine calibration two distinct failures may be attributed to the same source.) From probability theory the chance that a component (A) consisting of

two sub-components (B & C) is given by the probability that either sub-component will be a failure:

$$p(A \text{ fail}) = p(B \text{ fail} \cup p \text{ fail}) = p(B \text{ fail}) + p(C \text{ fail}) \quad \text{Equation 4.4}$$

The two main advantages of carrying out systematic calculation of quality in aggregate planning are seen as (i) the specifications of new products will be automatically checked and (ii) the data produced can be used as a basis of making improvements to the manufacturing system before new products are introduced.

Since the dimensions of features in the aggregate product model will not necessarily be exact matches with the stored data, the SPC data in the resource model is queried to find the closest possible equivalent using a case-based similarity heuristic. Once the quality measurement has been retrieved from the resource for a feature/process combination, the $p(\text{fail})$ for the new tolerance can be calculated. From SPC data described by a distribution this is achieved by adjusting the mean value (if necessary) and calculating the area of the distribution (using Simpson's rule) which lies outside the upper and lower specification limits specified by the feature's tolerance.

4.6 Conclusion

This Chapter has presented the underlying information models on which the knowledge-enriched planning system is built: facilitating both the quantitative analysis of QCD, see Table 4.1, and providing the structure for onto which a qualitative knowledge representation system can be added. These models achieve the following:

- (1) The aggregate product model allows the effective representation of early product configurations via manufacturing features.
- (2) The aggregate resource model describes the manufacturing capability of a machine or person by capturing a prescribed set of data and associated knowledge covering operating parameters (machine specification), historical quality information and cost data.
- (3) Finally, the aggregate process model utilises information from the above models to estimate, the QCD implications of producing the specified feature on a particular resource in anticipation of 'resource-aware' planning described in Chapter 7.

The models have the potential to be further developed into a comprehensive manufacturing ontology, or otherwise incorporated into external formats for knowledge sharing and re-use.

Notation	Description	Units
c_m	Raw materials cost	£
d_p	Part set-up time	min
d_b	Batch set-up time	min
c_a	Activity-based cost rate	£/min
c_d	Depreciation cost rate	£/min
d_c	Process cycle time	min
$p(\text{fail})$	Quality expressed as failure rate	-

Table 4.1 Summary of Key Quantitative Data Passed to Planning Methods.

Chapter 5 Aggregate Knowledge Representation

Chapters 5 and 6 describe the research and development of the knowledge-enriched aspects of CAPABLE Space. The functionality of the knowledge-enriched aspects encompasses both the capture of ‘knowledge’ from multiple sources in the DET framework using a novel protocol and the subsequent evaluation of the accumulated knowledge in the context of a process plan. This chapter begins by discussing the role of manufacturing knowledge in the digital product development process, and analysing the types of manufacturability knowledge, emanating from DET sources and from existing business processes, that are necessary for early design evaluation as shown in Figure 5.1. The research proceeds to develop a protocol for recording an expert knowledge via the concept of capability measurement; whereby empirical (that is observed, rather than inferred) knowledge and

Figure 5.1 Development of Knowledge Representation Methods.

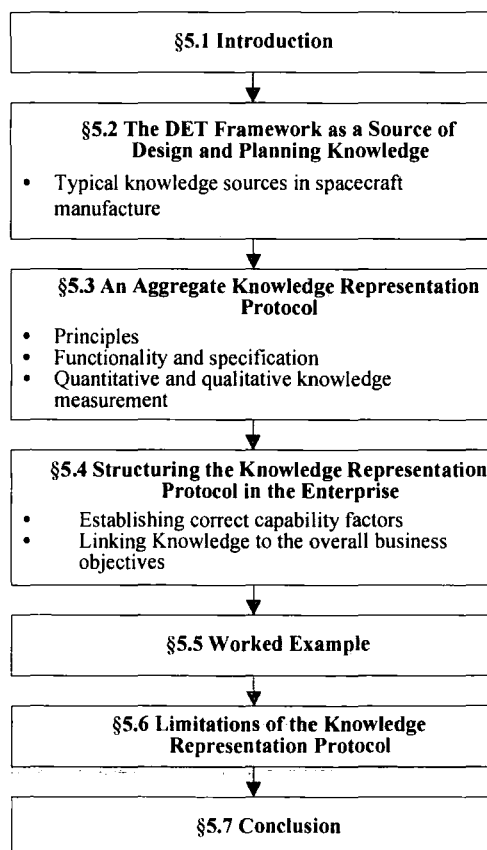

data about manufacturing issues (from the 5 areas of DET) can be expressed in terms of its impact on manufacturing performance and linked with objects in the aggregate product, process and resource data models by expert engineers and designers. When designers want to explore a new manufacturing scenario, the resulting aggregate-level knowledge statements can subsequently be used in the technical evaluation of design and engineering planning concerns for new designs and fed back to non-expert designers using the knowledge management techniques (which are described in the next chapter).

5.1 Introduction: Motivation for Enriching Aggregate Process Plans with Enterprise Knowledge

To achieve the objective of technical assessment of qualitative and quantitative knowledge from sources within the DET framework and historical knowledge (objectives set in §1.4.1), it is first necessary to establish procedures to extract this knowledge from current information frameworks including DET sources in both the digital and physical domains. It has been assumed that, at early stages of design evaluation, there is little point in representing knowledge with absolute mathematical precision and hence ‘rough-cut’ performance evaluations will be sufficient to allow the technical comparison of alternative process plans. The fundamental principle of the knowledge-enrichment of aggregate process plans is that simple measurable indicators of manufacturing performance for decision making purposes may be derived from detailed analysis, simulation or historical knowledge. The primary outcome of this research is a protocol for representing DET-based enterprise knowledge in a format suitable for computational analysis, which can be related to objects in the aggregate data models previously described.

Indeed, decisions made throughout a product’s design and planning are based on engineering judgements that are made in various technical fields and are determined by both technical considerations and the personal experience accrued by staff. Due to the huge amount of information and design criteria to be considered on even relatively straightforward projects, not even the most experienced designers can possess enough knowledge or judgement skills to guarantee reaching the best design solution. The knowledge representation procedures should support decisions based on existing knowledge, providing enhanced visibility of potential problems and introducing the ability to simulate ‘what-if?’ scenarios which supply data about the impact of each proposed process plan to the designer. Hence by bridging the gap between the real and digital

environments, enriching Aggregate Process Planning with the results of DET-based manufacturability analyses and past information to forecast the behaviour of a proposed solution should prove an effective means improve the automation (and hence the pace of design development) and the manufacturability of the final product design.

Most of the investigative work described in this chapter was carried out in the space industry, particularly with the main sponsoring company who are a relatively new adopter of the DET technology. It is not unreasonable to assume that this exemplar is typical of the majority of companies operating in the aerospace sector, and indeed is likely to be some way ahead of the majority of manufacturing companies. Hence, it is believed that, whilst the scope of the research is thus limited, this is a valid method of collecting research data such that the results should be timely in order to be directly applicable to the wider range of manufacturing companies in due course.

5.2 The DET Framework as a Source of Design and Planning Knowledge

Most manufacturing activities today are performed in digital environments but the literature review discovered that the development of robust ontologies for capturing the engineering knowledge produced is some way off. Therefore a pragmatic approach to the development of a knowledge representation protocol is being proposed instead. It is hoped that future developments in the field of ontologies will, in time, establish more complete methods to capture the interaction between design engineers, manufacturing planners, project managers and related functions in the supply chain. However, to facilitate contemporary research, a protocol is proposed for creating 'knowledge statements' for use in aggregate design and planning which will:

- (1) Support the representation of imprecise qualitative information and specialist knowledge as well as quantitative manufacturability measurements with the aggregate data models.
- (2) Model the effect of knowledge across multiple business functions and domains and subsequently relate the impact of knowledge on company strategy.
- (3) Maximise the re-use of existing knowledge obtained from current DET sources and existing business processes.

Figure 5.2 Primary DET Knowledge Sources within the Sponsoring Company.

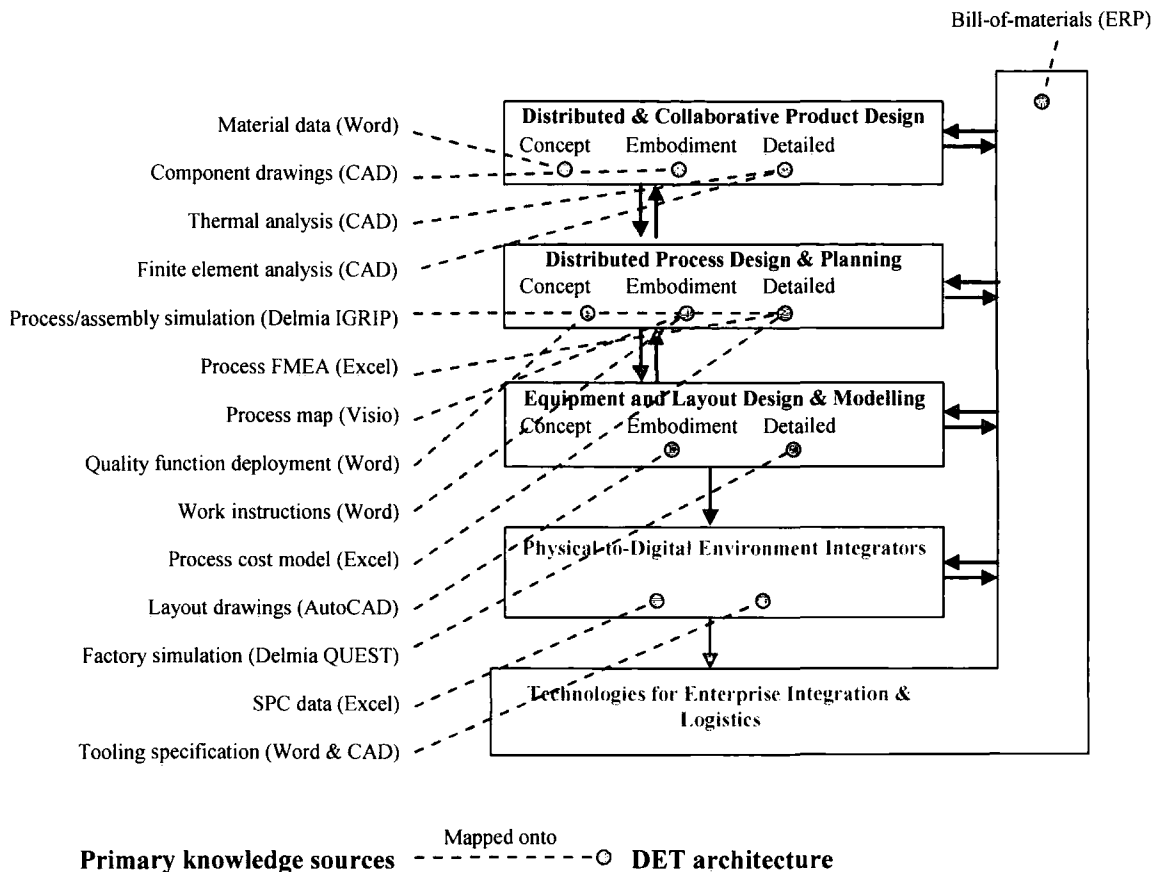

- (4) Recognise the conditionality of knowledge, to be able to indicate how certain knowledge can be conditional on the presence of certain elements in the process plan.
- (5) Promote the transfer of knowledge across departmental boundaries and from experts to non-expert users at a level appropriate for use in early design.

5.2.1 Study of Typical Knowledge Sources in Spacecraft Manufacture

Expert opinion, product documentation and computer files are all sources of knowledge which can be related to elements of a process plan. Figure 5.2 shows how the primary knowledge sources can be mapped onto the 5 areas of the DET framework. The illustrative examples used within this research were limited to the analysis of manufacturing knowledge sources, but there is no reason why commercial, economic and other business-related knowledge should not be included as a future enhancement. The analysis confirmed that a wide variety of manufacturing knowledge contains information relevant to process planning and hold data which can be collated using simple knowledge elicitation methods.

(It assumed that a designer or engineer has enough skill to be able to model his own knowledge.) Documents and computer files commonly referred to as part of the product design process include databases and CAD files with very little formalised knowledge capture. Where CAD data must be shared with external suppliers, the preferred option is to provide printed copied of drawings, rather than CAD files. At the process and resource planning stage, knowledge is documented in process maps and formal analysis frameworks, such as Failure Models and Effects Analysis (FMEA). The information produced is stored electronically. All information regarding a particular process is collated and is filed on a shared server. Extensive use was found to be made of virtual manufacturing simulations, however the output of these tools frequently resulted in wide dissemination of video files, but very little accompanying documentation to allow non-experts to interpret the simulation results. A large amount of quality documentation and experimental data is produced during the physical manufacture of a satellite, although the primary purpose of collating such information is to ensure traceability of the final product. It was concluded that design and manufacturing information and knowledge is primarily held by a key individuals such as designers, planners and people with specialist knowledge and that such knowledge is rarely shared across internal groups or with the extended enterprise of clients or suppliers. It is these 'islands' of knowledge which make the qualitative analysis of manufacturability a difficult task and gives rise to poor visibility of areas for improvement and preventing an enterprise from becoming agile.

Further analysis (see Table 5.1) of DET-based knowledge from a typical design review was carried out to identify in more detail the focus and perceived consequences of planning-related knowledge held by these individuals. This table shows how different types of knowledge can be; (i) mapped to the relevant classes in the aggregate data models and (ii) associated with an observable, measurable effect in one of six key domains which represent the key areas of manufacturing agility; quality, cost, delivery, risk, logistics and product performance. The level of abstraction at which such knowledge is present is seen as critical to the concept of early planning; rules, algorithms and laws are essential aspects of engineering design but many of the review documents and analysis tools identified contained purely qualitative information. It was discovered that at very earliest stages of design, designers would provide qualitative answers to questions normally considered quantitative. Design decisions were frequently made on the basis that an expert predicted one solution would be 'heavier' or 'better' than another. In general, the decision to choose one

design over another was made according to; reference (or baseline) designs, rules of thumb, implicit knowledge of likely outcome, both positive and negative aspects and project memory. Based upon this assertion, three kinds of knowledge must be modelled to make design and planning knowledge explicit in the form of knowledge statements:

- (1) **Numerical attribute information** obtained through data mining, regression or direct use of trusted or approved quantitative data, such as process capability data, machine breakdown rates and deterministic design attributes.
- (2) **Expert knowledge** modelled as, for example cost models, acquired through structured and guided interviews such as design reviews. This is the most difficult to capture as it frequently relates to rules (algorithms and heuristics) rather than facts.
- (3) **Probabilistic knowledge** such as historical data (as an indicator of future performance) and the use of simulation results (which contain some degree of uncertainty). This type of knowledge is particularly relevant in trying to model knowledge about the *effect* of selecting a particular process or resource.

Using all of these different forms of knowledge, it is theorised that a picture of the true effect of process and resource selection on actual production performance (as determined by an expert's attitude to the selection) can be established. For example, the results of digital process simulation (see Table 5.1) are quantitative, but probabilistic as certain assumptions will have been made in the creation of the simulation model which will change before a design reaches production. However, the results do express useful knowledge which can be considered when evaluating elements any product, process or resource elements of the plan; for example a digital simulation of a *supplier's* factory may indicate the likelihood of a supplier exceeding a planned *delivery* schedule. Similarly, knowing that a *supplier* was previously responsible for late in *delivery* may also indicate future problems; two different sources of knowledge which have the same ultimate effect. The role of the knowledge protocol, is therefore, to associate an engineer's interpretation of future performance with relevant objects in the process plan, irrespective of the source of that knowledge.

Source	Description	Type of knowledge	Relevant aggregate classes	Consequence of observation
Specialist process knowledge	Some processes are known to be more risky than others, but may improve QCD	Qualitative: Expert knowledge	Process	Quality, Cost, Delivery, Risk
QFD results	Best designs selected to give customer satisfaction	Quantitative but subjective: Expert knowledge	Product	Quality, Product performance
Design best practice	Design 'rules of thumb' obtained through experience	Qualitative: Expert knowledge	Product	Quality, Cost, Delivery
Engineering analysis	Numerical attributes; tolerances, mass data and materials data;	Quantitative: Numerical attribute	Product	Quality, Cost, Delivery, Product performance
Process FMEA /Process capability	Employee's tacit process 'know how' with some factual DFx analysis	Qualitative/ Quantitative Expert knowledge/ Numerical attribute	Process	Quality
Results of digital process simulation	Results indicate acceptability of cost, mass, risk and cycle time estimates	Quantitative: Probabilistic	Product, Process, Resource	Quality, Cost, Delivery, Risk, Logistics
Equipment performance & reliability	Equipment performance may indicate future problems with delivery schedule and product reliability	Quantitative: Probabilistic	Resource	Delivery, Quality
Investment cost	Used to indicate level of additional costs to be incurred	Quantitative : Expert knowledge	Process, Process, Resource	Cost
Past supplier performance	Supplier performance may indicate future problems with delivery schedule and product reliability	Qualitative: Probabilistic	Resource	Delivery, Quality

Table 5.1 Detailed Analysis of Some Knowledge from a Typical Design Review.

5.3 An Aggregate Knowledge Representation Protocol

A formalised protocol for capturing design and planning knowledge is proposed, which reduces complex knowledge down to quantifiable information stored within the product, process or resource data models. The protocol is based on the concept of *capability* (Baker and Maropoulos 1998), which will be more fully described in Chapter 6, as the foundation for the technical assessment of the knowledge contained within a process plan. A major assumption is that the enterprise knowledge is regarded as *ipse dixit*, which means that the knowledge declared by users is treated as a dogmatic and unproven statements. These statements can then be captured and used for predictive purposes.

Figure 5.3 The Knowledge Representation Procedure.

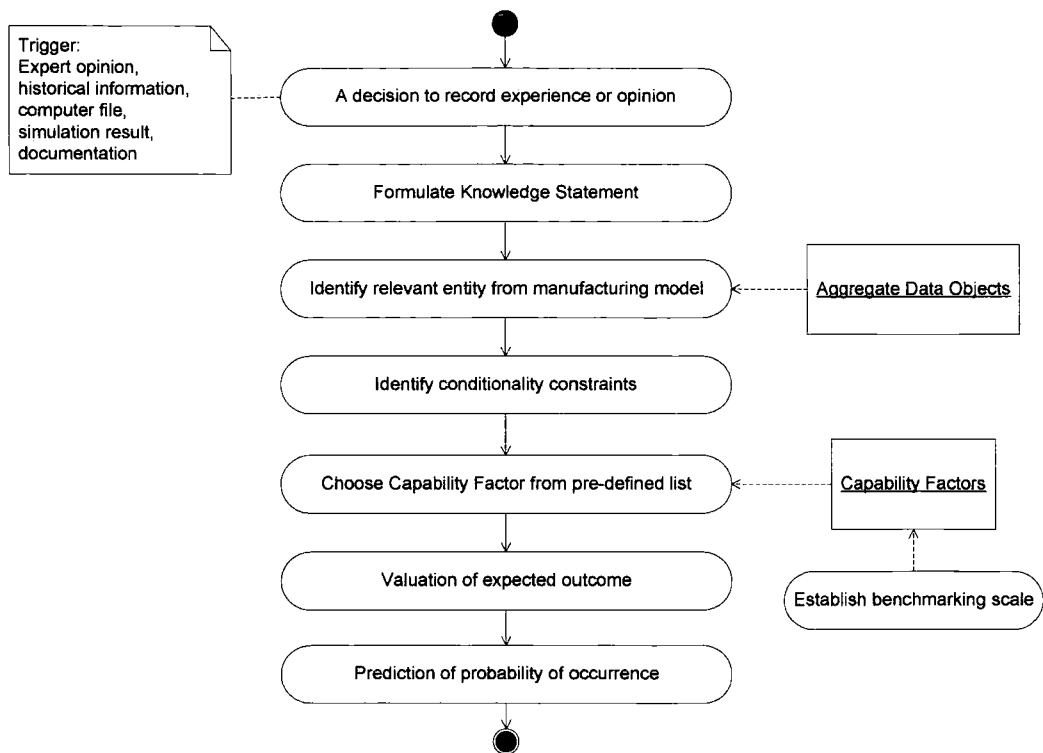

The procedure (the outline of which shown in Figure 5.3) is triggered by the creation, or identification, of an existing source of knowledge which is subsequently related to an entity from the aggregate data models. The procedure instigates the creation of a *knowledge statement* class, codifying the effect of design and planning knowledge against pre-defined technical criteria, called *capability factors*. The procedure also includes, a user assessment of two key parameters; the conditions under which the knowledge is valid and the of the probability that the knowledge will be applied in future.

5.3.1 Principles of Aggregate Knowledge Representation

All models are a simplification of reality, and even though the literature review established that 'knowledge' is a highly complex and unstructured phenomenon, does not mean that it cannot be modelled. The overarching objective of the aggregate-level knowledge representation research (as a precursor to Capability Analysis) is the creation of a protocol for turning explicit and implicit knowledge about antecedent product designs, manufacturing processes and the performance of internal and external manufacturing resources into an simplified explicit form for analysis and improvement. For the purposes of process planning, it is assumed that, only knowledge relevant to product, process and resource classes is to be considered.

Based on the finding of investigate research into the types of knowledge originating from the DET framework, the principles followed in the creation of the knowledge statement class are:

- (1) It shall support the representation of imprecise qualitative information and specialist domain knowledge as well as quantifiable manufacturability metrics. This means mapping the complex language of specialist engineers to a universal terminology compatible with the aggregate information models.
- (2) It should provide a basis for objective comparisons between objects in the process plan via standard capability factors (manufacturability metrics). Therefore, the effect of a process should be measured against a pre-defined benchmark corresponding to industry best-practice. Clearly, the measurement must be as unambiguous as possible to ensure that different experts give the same result, otherwise some other form of calibrating the experts would be required.
- (3) It should relate the effect (impact) of knowledge should relate to company strategy to model the effect of operating in a changing business environment.
- (4) It should facilitate the meaningful exchange of information across departmental or company boundaries, at a level appropriate to the user.
- (5) It should recognise the conditionality of knowledge, that is, to be able to provide a means of contextualising the knowledge to indicate how certain knowledge is conditional on the presence of one or more external factors.
- (6) Be simple, clear and transparent removing all ambiguity between users. Also, the measures should minimise the effort required to extract knowledge from the expert.

To implement the required knowledge representation protocol, the high-level concept of capability, as defined by Baker and Maropoulos (1998, 2000), has been adopted. In order to be applied in the context of manufacturability evaluation for Aggregate Process Planning, the term capability has been re-interpreted as;

'The extent to which a manufacturing enterprise achieves "best" performance with respect to specific manufacturability targets.'

The procedure utilises a set of capability factors (a series of pre-defined performance criteria related to the manufacturability domains of quality, cost, delivery, risk, logistics and product performance) which are specific to each enterprise, or even each project. Once

these criteria have been identified and made explicit as capability targets, any subsequent knowledge can be graded directly by the domain expert according to its likely impact (that is, the impact of the knowledge is interpreted by the user and stored as fact-based information for later re-use). Furthermore, to facilitate aggregate level use, this knowledge can be harvested irrespective of the planning status and completeness of the geometrical model.

5.3.2 Functionality and Specification of Knowledge Statement Classes for Quantitative and Qualitative Knowledge Capture

A UML representation of the implemented knowledge statement classes is shown in Figure 5.4. Separate classes have been used to support entry of qualitative and quantitative data. In fact to record quantitative data three separate sub-classes are required depending upon the nature of the target value; some variables have an optimum value of zero, some have a larger-the-better characteristic and some have a known target value. Irrespective of the type of knowledge recorded, each instance of a Knowledge Statement class can be directly attached to the top-level objects from the aggregate product, process and resource models (and hence all lower-level classes) as shown. Multiple knowledge statements can be

Figure 5.4 UML of Knowledge Statement Classes.

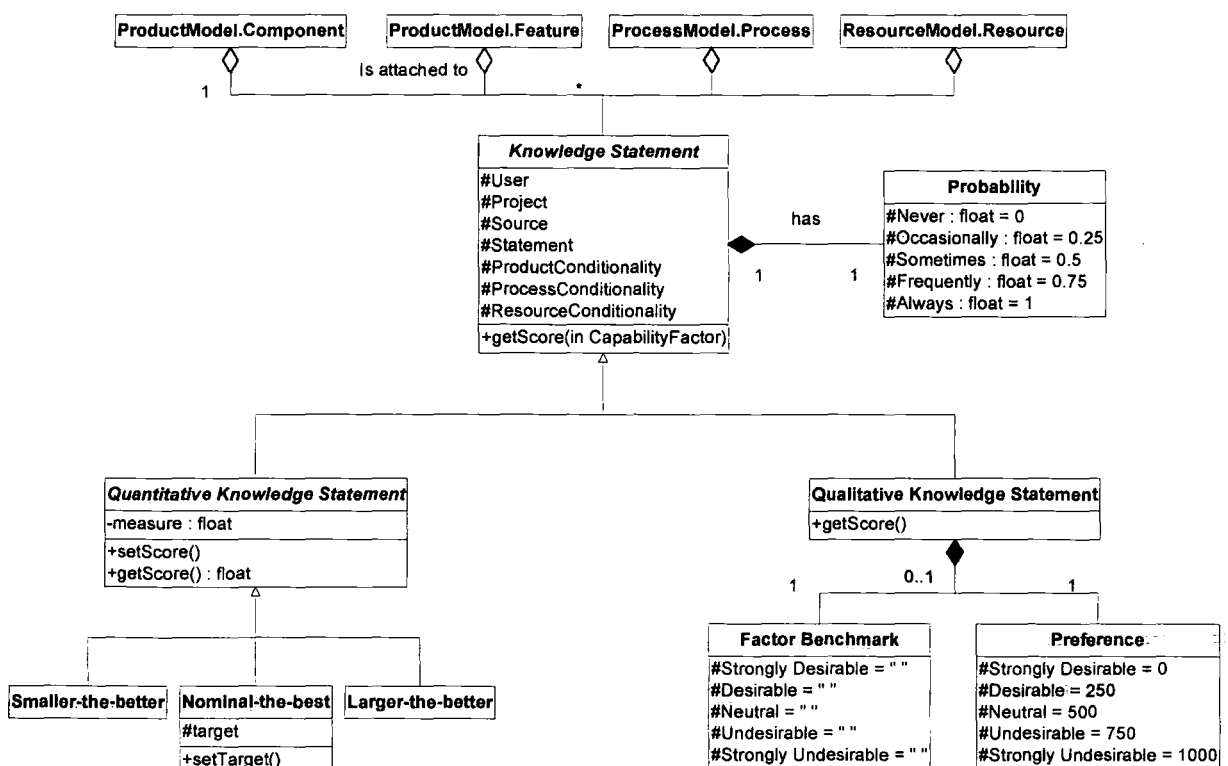

associated with any object in the model of the manufacturing system.. Other key functions of the knowledge statement class are to record the probability and conditionality of knowledge and attributes to store and access meta-data such as the user, creation date and project name.

In the knowledge representation protocol, a capability factor is defined as an unambiguous and measurable indicator of some aspect of manufacturing performance (having the notion of a 'best' value) against which all knowledge statements can be evaluated. Capability factors can be defined corresponding to the major levels of a process plan, namely, feature, component, assembly, process, factory and resource. And a capability score is the measured value, either calculated or user-defined, of a capability factor. Scores can be directly measured at each level or, they can be calculated from lower level scores. The main premise of the subsequent Capability Analysis methods is that all capability scores should be equal and ideally reach the 'best' value.

Often, the validity of knowledge statement objects will be conditional on the presence of a particular combination of feature, process and resource. By default knowledge statements are valid under all conditions, but alternatively, experts can restrict the knowledge to be conditional on the presence of external factors. Text strings are used to record object attributes that determine under what circumstances the knowledge statement will be retrieved for use in planning assessment. For example, quality problems arising due to burrs when the twist drilling process is selected are only an issue when producing through holes.

5.3.3 Qualitative and Quantitative Knowledge Measurement Classes

The ability to make effective, repeatable decisions depends upon have a common frame of reference against which the outcome of the a evaluation of the capability factor can be measured. The key to effective measurement of qualitative knowledge is a clear of understanding of what the measure truly represents. And so, for each qualitative capability factor, a reference scale of knowledge has been defined via a factor benchmark of expert-defined definitions of potential outcomes overlaid on a continuous spectrum of possible values. Implicit within this concept is the definition of an 'ideal' state of knowledge, representing the customer's (internal or external) requirement. This measurement of success in terms of goal attainment is not new, indeed the idea of using critical success factors to measure business performance was popularised in the 1960s by Daniel (Butler and Fitzgerald 1999).

Unfortunately, there are no standard units in terms of which to measure things like *manufacturability*. Since measurement is just a systematic way of assigning numbers or names to objects and their attributes, a simple way of capturing qualitative knowledge is to measure relative value. If there is some prior agreement about what represents good and bad performance, a distinction can be made between a single observation and others. Thus, an arbitrary scale for a factor could be defined as shown in Table 5.2, and specific factor benchmarks associated with each observable characteristic.

This definition can be transposed onto a numerical scale which will be used to represent the value of knowledge as a continuous variable which ranges between *strongly desirable* and *strongly undesirable*. The expected consequences of each option are assigned a numerical score on the strength of the preference scale given in Table 5.2. More preferred options are assigned a score of zero, less preferred options higher up the scale. In practice, a 0 to 100 scale is used where 100 is associated with a real (or hypothetical) worst case scenario. The value assigned to a knowledge statement is an expression of an expert's preference for including an object in the plan as a result of his or her experience or interpretation of data/information. From this perspective, statements of the type '*the panel's mass is 300kg*' convey only information and are not particularly useful, whereas a statement expressed in the form '*the panel's mass of 300kg is well within the customer's 400kg requirement*' is much more useful because it also conveys the user's interpretation of outcome (in terms of achieving the factor's ideal score) which can be applied to future events.

Qualitative knowledge statement objects are stochastic elements, that is, past events which they refer to may or may not take place in the future. This fact is accounted for by assigning a probability to the knowledge statement to indicate the perceived likelihood of reoccurrence. Thus, when a knowledge score (x) is assigned to the knowledge statement a partial 'risk analysis' is effectively performed by calculating the expected value (s_e) of the

Table 5.2 Normalised Knowledge Metric.

Characteristic	Observation/Correlation
Strongly desirable	A strong, direct positive influence on the factor performance.
Desirable	A direct or indirect positive influence on factor performance.
Neutral	Virtually no impact on factor performance.
Undesirable	A direct or indirect negative influence on factor performance.
Strongly undesirable	A strong, direct negative influence on the factor performance.

capability score based on the likelihood of reoccurrence ($p(k)$) thus:

$$s_e = p(k) * x \quad \text{Equation 5.1}$$

To be compatible with the qualitative knowledge representation schema, factor scores of qualitative variables are consequently an indicator of how well a design choice meets a specification target. Thus, there are three types of measurements possible:

- (1) Smaller-the-better. Responses which should be minimised; their response is ideally zero, for example, the mass of a satellite.
- (2) Nominal-the-best. The measured impact has a target value, such as the size of a fuel tank.
- (3) Larger-the-better. Responses are more desirable as their value grows. For example, the strength of a bonded joint.

5.4 Structuring the Knowledge Representation Protocol in the Enterprise

5.4.1 Establishing Correct Capability Factors

Quality, cost and delivery are undeniably the most commonly quoted indicators of manufacturing performance as they are directly visible to the customer. However, other elements such as risk, logistics and perceived product performance were also common criteria for decision making because they affect the practicality of any decision. Such knowledge will ultimately be reflected in the QCD as seen by the customer, (using high risk processes, for example, frequently leads to delays and missed delivery schedules) but unless these indicators can be measured they cannot be used as a basis for improvement or indeed to compare two alternative process plans. The tactic taken was to construct a relatively simple domain model to demonstrate that expert judgement can be systematised from expert judgement obtained from the identified knowledge sources. Six strategic domains were identified on which to focus the modelling of design and planning knowledge for process planning: quality, cost, delivery, product performance, risk and logistics. By using indicators relevant to these strategic domains, the subsequent knowledge management methods should be able to target improvements to the design of products and manufacturing systems that fit the company's strategic priorities.

- (1) Quality Improvement; Getting things right first time.



- (2) Cost Reduction; Delivering value to customers.
- (3) Delivery Performance; Assuring the organisation is responsive.
- (4) Risk; Assuring the organisation is responsive.
- (5) Logistics; Ensuring organisational agility.
- (6) Product Performance/Innovation; Creating conditions that give customer satisfaction.

By creating a (project-specific) classification of capability factors to map the design and planning knowledge domain, the knowledge codification activity then becomes the task of relating the personal understanding of the relationship between the likely outcome and the factor. The use of factors is closely tied in with the concept of Capability Analysis – the value judgement is subsequently to be used to compare scores associated with factors. Knowledge representation involves identifying measures which are selected within the context of the analysis taking place. Specific measures for performance measures of enterprises will be discussed in the following chapter.

Quality Function Deployment (QFD) also has some capabilities in this area as it transfers qualitative customer needs into a set of ranked engineering product attributes (Govers 1996). QFD, like Capability Analysis, aims to predict (only) product performance based on ranking customer requirements against subjective measures in a matrix called the ‘House of Quality’. However, a limitation of the QFD procedure remains that it must be carried out for each version of a design, whereas the nature of Capability Analysis is to associate the original knowledge directly with the aggregate models so that it can be automatically re-applied each time a design is changed. Also, QFD has no means to accommodate uncertainty in either the scoring or the relationships.

5.4.2 Linking Knowledge to the Overall Business Objectives

As external business conditions change then the emphasis placed upon knowledge statements pertaining to the six different domains is also likely to vary. For example, under growth conditions, knowledge statements that relate to the quality and product performance domains will be considered as highly important and the process planning module should give preference to processes or resources that have been assigned high scoring ‘knowledge statements’ associated with these domains. At the factor level a normalised weighting method has been developed to model scenarios to control the impact of the changing businesses environment.

With reference to Figure 5.5, an analysis has been made of how the importance attached to each of the domains might vary according to the business environment and the product's lifecycle status. Under growth conditions, products differentiation is key, and companies might wish to concentrate on developing high 'quality' products new levels of 'product performance' and developing new customised features for existing products at low 'risk'. Alternatively if there is less investment available due to recessionary conditions, then companies may look to optimise their supply network, by concentrating on factors such as improved 'delivery' performance and better 'logistics'. By changing weightings to the domains, to reflect their importance in the current or future business climate, 'what-if?' scenarios can easily be tailored to individual companies' needs and can readily be played out once process plans have been generated.

The can be illustrated using two examples from the sponsoring company, plotted in Figure 5.5. The Eurostar 2000 platform is a well proven product, much of the development cost already has been recouped. Further developments of the Eurostar platform, such as the larger 3000 series, has to take place quickly and at low risk to avoid incurring further cost, hence DET solutions, which provide knowledge to mitigate risk (especially virtual manufacturing), would be favoured techniques. A potential ranking of domains for this scenario is shown in Table 5.3; product performance and risk have been prioritised first and second whilst. The actual manufacturing metrics of QCD have a normalise weighting, w , which is just one third that of the risk domain. The logistics performance, having a normalised weighting of 0.09 is considered unimportant (as the supply network is already established) and a poor knowledge statement score here would have very little effect in guiding the intelligent optimisation routines.

In contrast, the Teledesic programme was a new venture, requiring a large number of satellites to be built in a short space of time. Here, knowledge about the delivery performance was critical, as well as organisation and agility of the supply chain (as indicated in Figure 5.5) leading to the analysis shown in Table 5.4. It was also predicted that at the time of building the satellites, there would be downward cost pressure due to the presence on alternative suppliers for this type of satellite, hence cost was one of the top three domains. Because this is a new design risk is considered one of the least important factors.

Table 5.3 Domain Weightings for Development of Existing Products (Eurostar 3000).

Domain	Rank		Weighting	Normalised domain weight, w
Quality	3	=	0.333333	0.121212
Delivery	3	=	0.333333	0.121212
Cost	3	=	0.333333	0.121212
Product performance	2		0.5	0.181818
Risk	1		1	0.363636
Logistics	4		0.25	0.090909

Table 5.4. Domain Importance for New Product Introduction (Teledesic).

Domain	Rank		Weighting	Normalised domain weight, w
Quality	5		0.2	0.081633
Delivery	1		1	0.408163
Cost	3		0.333333	0.136054
Product performance	4		0.25	0.102041
Risk	6		0.166667	0.068027
Logistics	2		0.5	0.204082

5.5 Worked Example of the Knowledge Representation Protocol

In the space industry an early form of design review common is known as the Structure-Concept Trade Off (SCTO). An exemplar of such a trade-off exercise, (which also forms the test data used in Chapter 8), is documented in Appendix C. The factors chosen for this analysis included four quantitative measures and several qualitative ones as shown in Figure 5.6. This section uses some specific examples from the SCTO to discuss how the knowledge representation techniques could be made to integrate with the design review.

Figure 5.6 Capability Factors for SCTO Exercise.

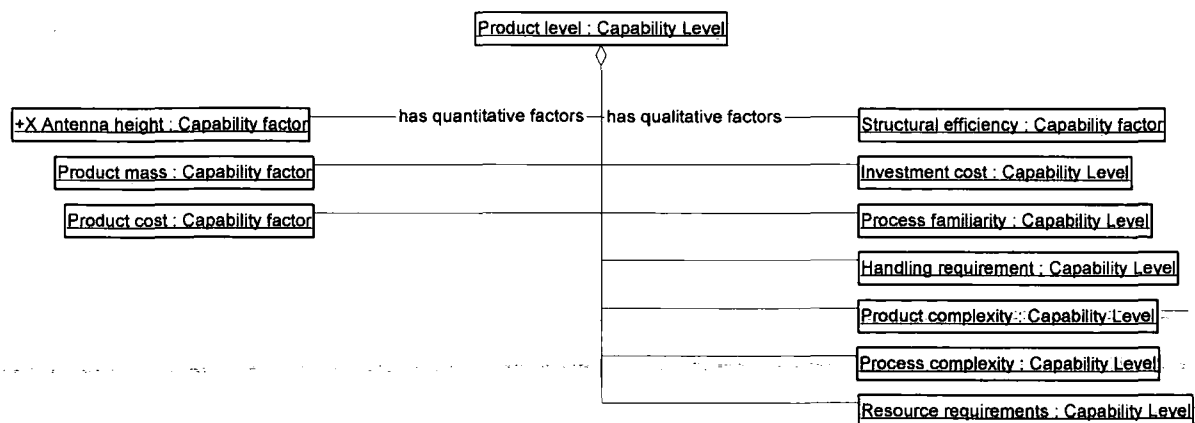

In this particular SCTO, the objective was to analyse the suitability of four early satellite designs for a novel series of satellites requiring particularly tight control over mass and higher than normal production volumes. Thus, four of the primary domains were considered; risk, logistics, product performance and cost. Several factors were used to model the requirements discussed during this exercise; some such as mass (calculated from CAD models) and estimated cost (parametric cost models) were quantitative but many were qualitative and subjective, for example the critical measure of product performance at this stage was structural efficiency. This factor was defined as *'the effect of material, construction, sizing and mass on meeting structural requirements defined by customer'* and given a benchmarking scale as shown in Table 5.5.

For each of four alternative designs modelled as top level components in the Product Model Design module of CAPABLE Space, statements which pertained to each of these factors were identified from notes taken during the SCTO. The following declaration was found *'The structural efficiency of this design [Concept D] is poor because the shear stiffness of the payload panels is not fully exploited'*, which directly related to the structural efficiency. Thus, a new knowledge statement was attached to the object representing Concept D in the product model and because part of the structure is not optimally designed for loading a factor score of 640 was assigned. As this statement was purely factual, a probability of '1' was assigned to the statement. Another statement relating to the same factor, structural efficiency of Concept A was *'CFRP/Al composite design may have a thermoelastic loads issue'*. This could have serious implications for the suitability of the concept, so was immediately assigned a factor score of 1000, but it was subjectively assessed that there would only be a 65% chance that this would manifest itself. At the end of the exercise, 31 knowledge statements had been modelled, at least three scores were associated with each factor, which is critically important for Capability Analysis.

After completing the declaration of statements, a senior engineer was responsible for classifying the importance of each domain to the analysis as shown in Table 5.6. This meant that statements, such as those pertaining to structural efficiency, had relatively high recorded capability scores of 251.55 and 247.68 respectively, whereas statements relating to low importance issues such as handling requirements were moderated from an expert's initial score of 750 to a relatively low recorded capability score of just 72.5. Obviously, the factor weightings could be reversed later in the design process to highlight handling issues when considering enterprise level resource assignment.

Table 5.5 Benchmarking Scale for Structural Efficiency.

Characteristic	Observation/Correlation
Strongly desirable	Exceptional structural performance exceeds customer specification
Desirable	Sufficient compliance with specified load cases and safety factors.
Neutral	Compatible with specified load cases.
Undesirable	Some elements of structure compromise overall structural integrity.
Strongly undesirable	Entire concept liable to fail static load test.

Table 5.6. Manufacturing Domain Importance for the SCTO Exercise.

Domain	Rank	Weighting	Normalised domain weight, w
Quality	1	1.000	0.387
Delivery	2	0.500	0.194
Risk	4 =	0.250	0.097
Logistics	4 =	0.250	0.097

5.6 Limitations of the Knowledge Representation Protocol

The knowledge representation procedure described in this chapter *is not* intended to be a fully-formed, validated method of knowledge acquisition *nor* is it intended to be applied in practice; its purpose being solely to demonstrate the potential for harvesting and storing manufacturing knowledge for use during the early planning stages. There are many outstanding technical issues surrounding the reliability of data collection, which are beyond the scope of this practical method; uppermost is the fact that knowledge is subjective and the system has no way of assessing the objectivity (or otherwise) of the input data. Also, there is a limitation on the amount of knowledge which can be captured before the benefits of increased data collection are outweighed by the complexity in managing it. These two limitations would be obvious candidates for further work.

It is virtually impossible to fully assess all aspects of a process plan on the basis of the described capability metrics alone. Without more complex methods of data capture, the system relies on the user to ensure a dense repository of ‘knowledge statements’ whereby *all* relevant, up-to-date knowledge is attached to the aggregate data models. The proposed solution is however entirely compatible with the aggregate concept; the collection of ‘knowledge statements’ can evolve to model the changing state of knowledge about the design and become more specific as the design proceeds. However, despite the obvious limitations of systematising knowledge down to a limited number of capability factors, it is believed that the proposed solution represents a compromise between excessively complicated

data capture methods and the benefits of early identification of possible problems via the methods developed.

5.6.1 Critical Analysis of the Practical Application of the Proposed Implementation

Knowledge validation is concerned with maintaining and checking the stored knowledge and ensuring that the system performs to an acceptable level of accuracy. By taking a pragmatic attitude to encoding 'knowledge statements', two key questions about knowledge validation arise; how confident is the expert in his own judgement and how truthful are the expert(s) in describing their expertise?

- (1) In practice people rarely conclude things with absolute certainty. To allow for this sort of variation it would be possible to attempt to model accuracy using fuzzy logic, or more detailed (but time consuming) knowledge extraction methods such as pairwise comparisons. The worth of increasing the complexity of the knowledge extraction process in early design is questionable, but worthy of further investigation. Also, knowledge statements can be considered transient: as external conditions change then the encoded knowledge may no longer be valid or be less accurate. Knowledge statements must therefore be monitored and effective measures to prevent the inclusion of undesirable obsolete information would need to be developed in a commercial system.
- (2) The term 'accuracy' is used to denote how well the system reflects reality. The validity of expert judgement can vary depending on the designer's mental model of the observation. In the proposed method the designer is trusted to validate the data. To implement a working version of the system the experts would need to be calibrated by monitoring the outcome of the actual plans in production, and reviewing the accuracy of each expert's knowledge statements.
- (3) The protection of intellectual property will become more and more important in the future of complex supply chains. The nature of the knowledge statements emanating from this research, means that valuable procedural knowledge is never recorded knowledge statements, however, they may contain commercially sensitive judgements about costs or supplier capability. To realise a workable business system, more advanced methods and techniques for

sharing (and hiding) sensitive commercial information and proprietary knowledge will need to be developed.

Whilst acknowledging these limitations of the solution adopted in this research, the methods are capable of meeting the requirements laid down in §5.2, in particular the requirement for representing inexact qualitative information and quantitative manufacturability measurements for use in early design. In short, further investigation will undoubtedly be required to expand the scope of the research to include psychological and broader organisational factors. Further developments in the field of ontologies (VRL-KCiP 2005a and others) will also play a large part in increasing the commercial applicability of the, hitherto non-standard, methods. Interestingly, the eXtensible Mark-up Language (XML) language provides a contemporary opportunity for formalising the semantics of knowledge for inclusion in knowledge statements. XML schemas express shared vocabularies and allow shared dictionaries. Documents marked-up using XML provide a means for unambiguous communication across enterprise boundaries. The class structures in this chapter can easily be made compatible with XML through the creation of appropriate schemas and could be incorporated into any CAD system.

5.7 Conclusion

The knowledge representation protocol is able to rapidly encapsulate qualitative as well as quantitative engineering and planning knowledge and expertise derived from analysis, simulation and historical data into the aggregate product, process and resource information models and has proved the supposition that the information models used in aggregate planning can be enriched with design and planning knowledge. The 'knowledge statement' class and the knowledge capture procedures described herein are an initial attempt at forming a systematic, reliable way of capturing and defining qualitative, imprecise design and manufacturing knowledge feedback within an DET framework. The major feature that distinguishes this research from tradition knowledge-based expert systems for process planning is the high level of abstraction needed for conceptual planning. The approach does not attempt to model detailed reasoning but records shallow knowledge on which process planning decisions can be made. Another innovative feature of this work lies in the integration of human experience and knowledge, within an object based (data-centric as opposed to document-centric) process planning methodology. This ultimately enables designers with a narrow field of expertise to make informed design decisions and formulate early production strategies without recourse to time consuming discussions with planners.

Enriching Aggregate Process Planning with non-geometrical product and process knowledge is especially useful during the early design stage where the main decision criteria are the expected manufacturability and cost of the concept, not the actual production plans for the components. The limitations of the methods have been identified, but during early design, having some information to make decisions with is obviously more important than decision making with no information.

The next chapter presents the knowledge management techniques which relate stored knowledge statements to new process plans to predict the manufacturing implications during Aggregate Process Planning.

Chapter 6 Aggregate Knowledge Management using Capability Analysis

This chapter introduces the theoretical concept of Capability Analysis as applied to the Aggregate Process Planning paradigm. It describes how the method has been integrated into the DET framework to aid decision making in early design as shown schematically in Figure 6.1. In particular, it describes the procedure by which knowledge statements applied to objects within the aggregate data models can be used to compute the capability of

Figure 6.1 Chapter 6 Schematic.

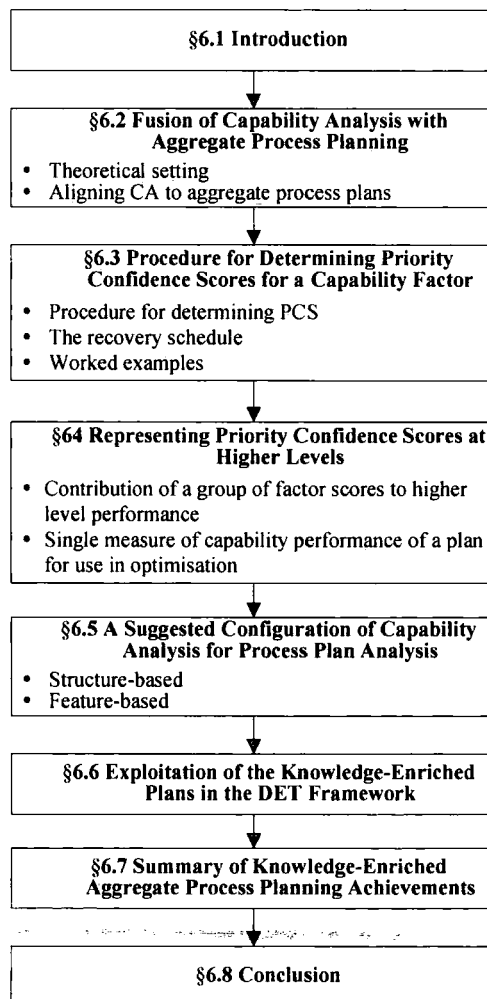

elements within a process plan and give feedback to the designers, at multiple levels of abstraction. The developed methods provide the opportunity to measure performance at various levels of abstraction including the all important process plan level, necessary for the intelligent exploration methods.

6.1 Introduction

Knowledge management in CAPABLE Space (and early planning systems in general) is about providing designers and planners with relevant information to make informed decisions about actions which may affect production or the downstream design stages. In the context of aggregate planning, the goal is to provide increased awareness about the relative performance of *elements* within a process plan, which should be used as a basis for further action or improvement, thus providing a feedback mechanism to moderate iterative design and process planning decisions. A suitable computational technique, called Capability Analysis, proposed by Baker and Maropoulos (1998, 2000) as part of an investigation into the design and improvement of cellular manufacturing systems was identified as a means for comparing the performance of objects in a process plan using the concept of ‘capability’ measured by the knowledge representation protocol.

Recall that the knowledge representation protocol has already defined capability as: *‘The extent to which a manufacturing enterprise achieves “best” performance with respect to specific manufacturability targets.’* An important aspect of this definition is that the performance of an organisation must be measured in terms of its strategic objectives. From earlier chapters, it has already been shown that the impact of planning decisions can be modelled via the application of knowledge statement objects to instances of aggregate data objects. When applied to the complex combinatorial process planning problem, Capability Analysis would make it possible to identify knowledge statements that represent potential design or implementation problems with the candidate plans to:

- (1) Feed them back to designers, or process planners, or managers to prompt further detailed analysis or re-design. In Knowledge-Enriched Aggregate Process Planning, the specific purpose of Capability Analysis is to collate and compare the performances attributed, via knowledge statement objects, across the range of features, selected processes and selected resources in an aggregate process plan. Furthermore, the output of the Capability Analysis methods assign a priority to each contributing element to form a ranked list of

suggestions for investigation or action for which more sophisticated DET methods can be employed to resolve key manufacturing related issues and refine the design of the product or the manufacturing system. The techniques also provide a mechanism to interrogate the data to pinpoint the low level planning objects that are the root cause of higher-level capability deficiencies within the plan. Thus, once the most suitable plan(s) have been identified, the Capability Analysis method forms a decision making aid that acts as basis of (knowledge-driven) assessment and improvement of the aggregate product, process and resource models.

- (2) Determine a single measure to represent the overall capability of a process plan which can be used as input to the objective function of the aggregate process planner. In this case the measure characterises the achievement of “best” performance by *all* the elements selected in the plan. Equally, plans which contain objects which experts have indicated, through the application of knowledge statements, might lead to near optimal quantitative QCD performance but poor performance with respect to other qualitative factors are identified. By penalising process plans with low capability, the intelligent exploration of a plan can be made more relevant to early design, and in particular the selection of production processes, allocation of sub-assemblies to suppliers and make-or-buy decisions can be enriched with an appreciation of qualitative knowledge factors.

6.2 Fusion of Capability Analysis with Aggregate Process

Planning

6.2.1 Theoretical Setting

The basic premise of applying Capability Analysis in Aggregate Process Planning is that the aggregate data model objects of a process plan can be broken down into independent groups called capability levels, for example, all suppliers, similar components, all equipment. Objects within each of these groups should be as similar as possible in terms of their capability (the performance they achieve). The Capability Analysis of a group of scores establishes the potential for improvement within that group (by comparing the best, worst and ideal cases) and measures the likelihood of being able to improve a particular performance score. Thus, capability can be thought of as being analogous to process

capability, which analyses the variation that exists in a system and effectively measures likelihood of producing out of tolerance parts. Areas of high capability deficiency in an early process plan anticipates risks and identifies improvement opportunities.

The generic Capability Analysis methods have been developed and aligned with the aggregate data models of CAPABLE Space system to achieve the following:

- (1) The ability to compare dissimilar indicators of manufacturing knowledge and performance identified via knowledge statements attached to standard planning entities of feature, process and resource models which have previously been defined for Aggregate Process Planning.
- (2) The provision of a prioritised list of improvement targets covering product, process and resource information to guide the progression of design from concept to embodiment to detailed. And also to monitor change and drive continuous improvement using the detailed design tools available in the DET framework.
- (3) To establish the relationship between the improvement potential of a factor and the potential (adverse) effect of not addressing the issue on the final product cost.
- (4) Filter out the lower level causes of poor performance at the plan level; enabling planning-level decision making based on low level product, process and resource model data.

6.2.2 Aligning Capability Analysis with Aggregate Process Planning

Methodology

A Capability Factor has already been defined (§5.3.2) as a criterion for capability assessment and a capability score as a value assigned to capability factor as a result of encoding a knowledge statement. Additionally, a **Capability Level** class is now defined as a group of capability factors which address a given aspect of the process plan; in the case of Aggregate Process Planning these levels are defined as; process, component, resource, feature, equipment, process plan.

A method, based upon the original Capability Analysis concept (Baker and Maropoulos 1998); for prioritising improvements to a process plan defined using the above concepts has been implemented. Three main steps are required to integrate Capability Analysis with Aggregate Process Planning as shown in Figure 6.2:

Figure 6.2 UML Activity Diagram Showing Integrated Capability Analysis Method.

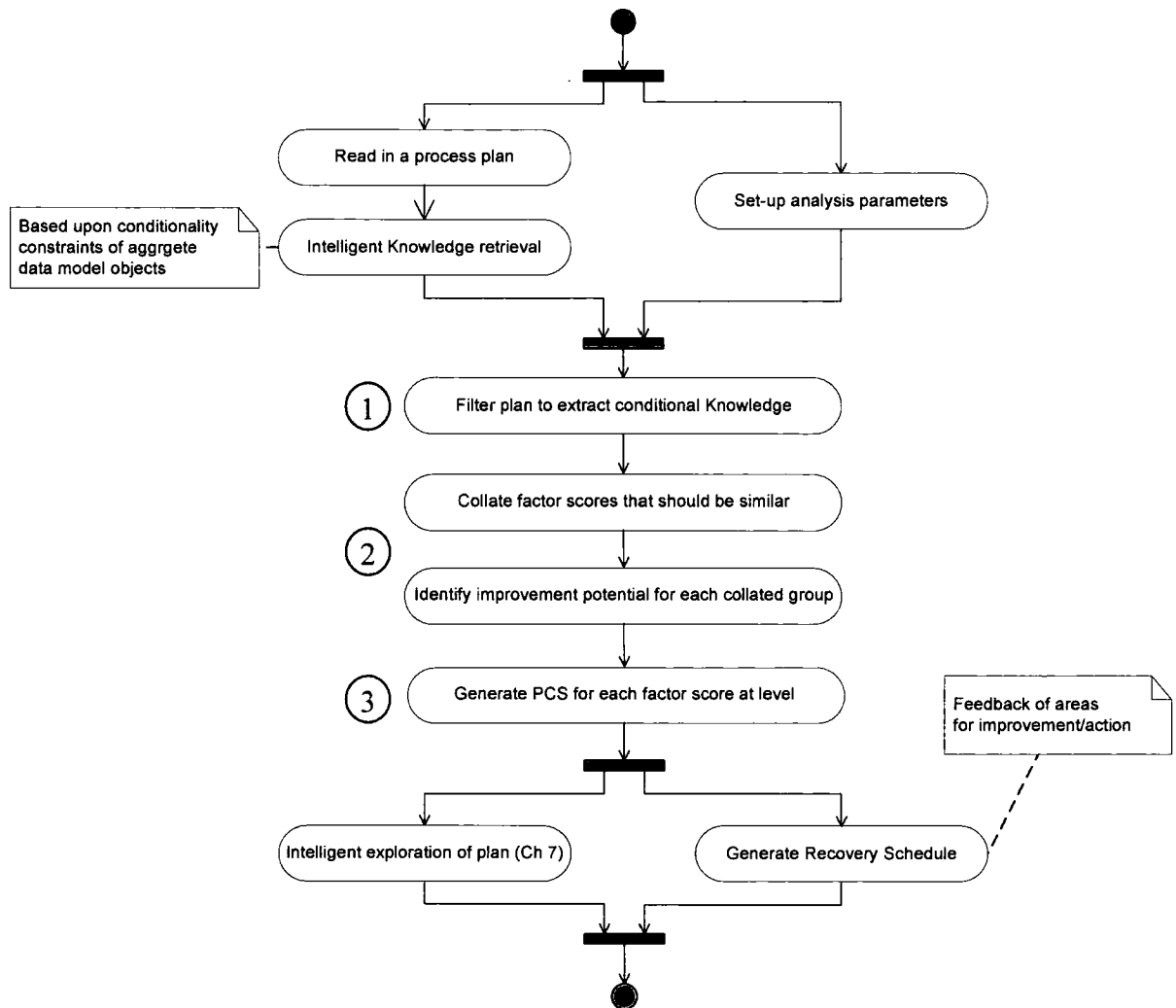

- (1) The first stage is to identify the criteria to be included in the analysis and set-up the analysis parameters.
- (2) Collate and determine bandwidth and marginal bandwidth for a capability factor.
- (3) Determine the priority of each score/knowledge statement. Ranking these values at each capability level produces a list of knowledge statements requiring action, called the Recovery Schedule. The target at the top of the Recovery Schedule is the one most benefiting from improvement effort and the one at the bottom is in least need of improvement.

The process plan structure, read in at the start of the procedure, provides the framework for the transparent analysis of recovery schedules at the various levels of abstraction consistent with the decision making levels within an organisation. The control of the recovery procedure within CAPABLE Space is done through the use of capability levels. Capability

levels categorise capability factors according to their relevant 'physical' objects, such that the lowest level, corresponds to the basic elements such as features of a design and individual pieces of equipment, whereas higher levels of abstraction relate to processes, components and factories and ultimately the process plan itself as shown in Figure 6.3. The abstraction of data in the aggregate models being expressed in terms of one level being higher than another. At the lowest level capability factors are defined to represent the elementary entities of the plan; features, process and resources. Each feature is collated to the component level and finally all the components can be collated to an assembly or product. A manufacturing system can also be considered in the same way. Each resource type is collated to the resource level (representing a multi-functional piece of equipment or workstation) and then ultimately to the factory level. This should be adequate to describe the extent to which a give resource type selection impacts supplier performance. Factors can also be defined at the job and process plan levels to indicate how the performance of the generated objects meets a desired specification. As each capability factor is associated with one of the six primary domains, it is logical that when collating factors to a higher level both factors should share the same domain. The capability factors at each level specify the types of knowledge which should be captured in order to describe a particular problem to be answered during the design phase. Pre-defining the problem in this way ensures that the systems retains its Class II emergent synthesis properties. This breakdown of knowledge into pre-defined technical criteria also makes sure that the capture of knowledge is limited to only usable data and ensures that no redundant knowledge is included. The Section 6.5 gives a suggested configuration of the typical capability levels and factors that may be implemented, at each level, in a distributed enterprise.

Figure 6.3 Generic Capability Levels related to Process Plans.

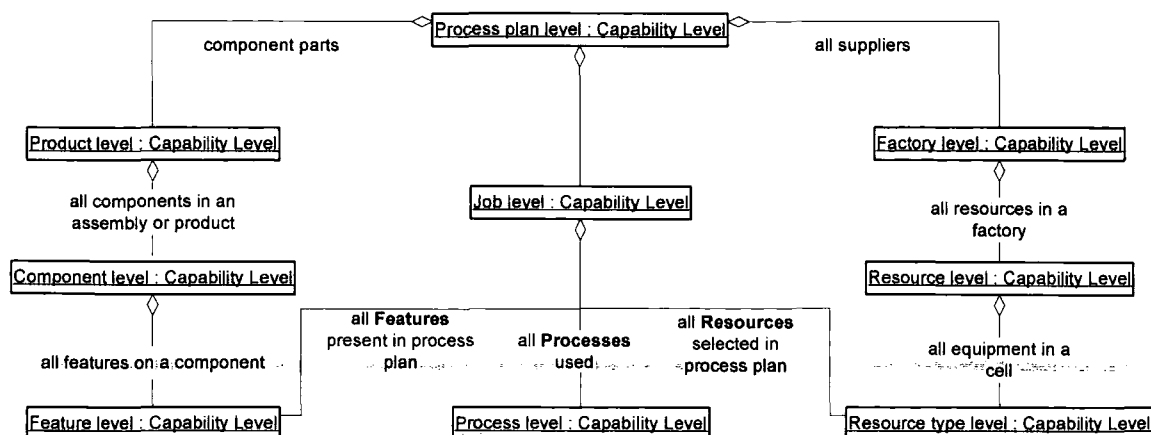

At each level, the Recovery Schedule is the feedback mechanism which provides suggested areas to investigate to improve the process plan performance; processes to optimise, resources to improve or component designs to modify.

6.3 Procedure for Determining Priority Confidence Scores

The primary function of Capability Analysis is to identify areas where there is a large disparity between the scores in a group. Collating is the act of grouping together capability scores that should be similar, and is best demonstrated through the use of an example. The priority confidence score for the mass of the major structural panels for a structure-based design is computed using a simple analysis as an illustration - obviously, the true power of the method is only apparent when dealing with a significant number of factors and scores, which would otherwise be unmanageable. A simple model of a concept for a satellite design will be used. As shown in Figure 6.4 this comprises: a Y wall panel for mounting the electronics payload, upper and lower shear walls for transferring the load from the Y wall to the central cone/cylinder and the SM (service module) floor which takes the propulsion units. The example will consider how the mass of each panel can be controlled during the design process, by performing a capacity analysis to minimise the weight content of the sub-components used in each panel. For simplicity, this example will consider each panel to be a honeycomb composite, having two aluminium skins. Generally, the Y walls will be of greater area, and thickness so will be heavier.

Figure 6.4 Illustration of the Four Satellite Panels Used in Testing

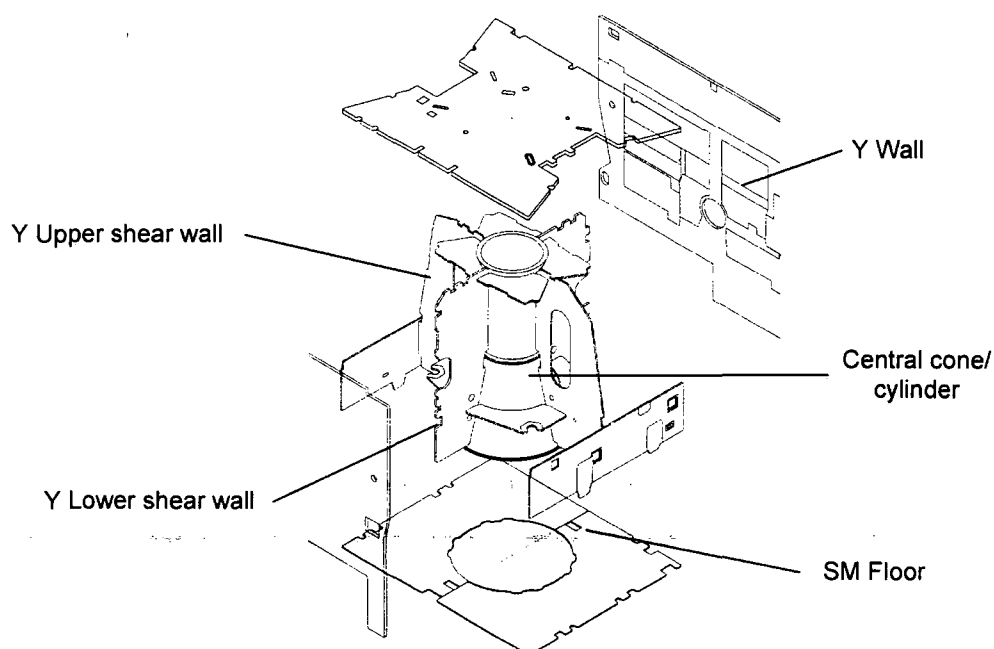

Two types of collation activities are supported in CAPABLE Space:

- (1) (Generic) decomposition relationships as shown in Figure 6.3 within the manufacturing model structures (objects). A high-level collated capability score is derived for lower level scores, for example the mass of a product is the sum of *all* the masses of the components that make up that product.
- (2) Inheritance relationships within a family (classes). For example identification of similar products which possess generic functional capabilities with minor differences corresponding to product families. For example, the cycle time for process will obviously vary greatly, however it may be desirable for a capability factor to try to force all 'assembly operations' to have similar assembly times.

In practice, capability scores which are assigned to a factor all vary, thus each collated group will have a worst and a best score. The optimum capability score can be set as either 0 (default) or can be set directly on the factor. For simplicity, the analyses assume that the required score will always be the best score in the group.

Priority confidence scores (S) are the primary unit for measuring capability and show the amount of potential for the improvement of an isolated score within a collated group. Table 6.1 shows some example data used to illustrate the concepts described. The data relates to the capability factor object Mass of Structural Components which is collated to the component level of the plan. Note that the actual quantitative data used has units of kg.

Table 6.1 Analysis of Factor Mass of Structural Components.

Component	Capability score	Capability deficiency, s_d	Marginal capability, s_m	Priority Confidence Score, S
SM Floor	19.83	12.26	3.18	2.54
Y Upper Shear Wall	13.89	6.31	2.23	1.78
Y Lower Shear Wall	7.57	0.00	1.21	0.97
Y Wall	24.12	16.55	3.87	3.09

The specific technical Capability Analysis procedure (is taken from Baker and Maropoulos [1998]) and relies on the fact that all the capability scores associated with a factor should be similar, and all have a target value. The priority confidence score is thus used to represent a scores capability deficiency from the 'best in class' performance. With

Figure 6.5 Visualisation of Capability Analysis Concepts for a Capability Factor.

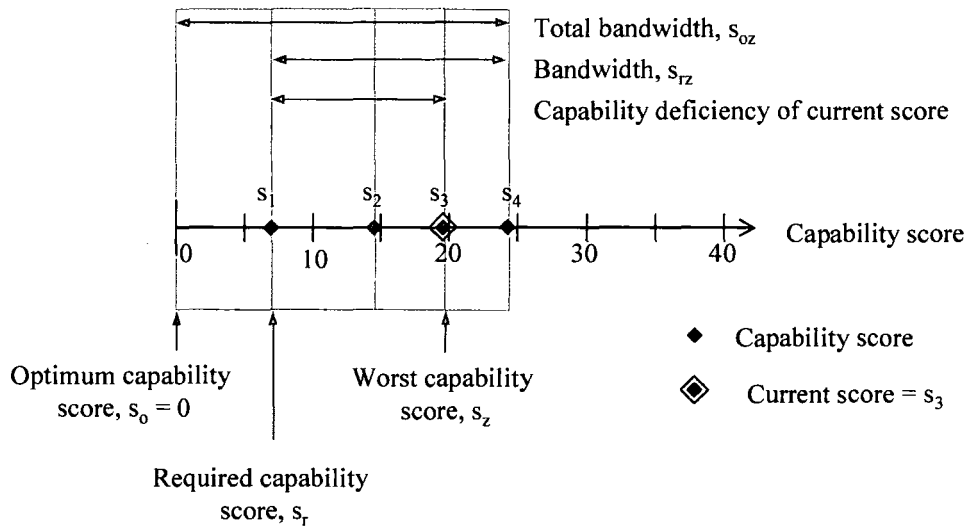

reference to the example data, the priority confidence scores for the collated group are formulated as follows:

- (1) The bandwidth, s_{rz} , of a collated group is defined as the difference between the required capability score (usually the best score in the group), s_r , and the worst capability score, s_z , as shown graphically in Figure 6.5:

$$s_{rz} = s_z - s_r \quad \text{Equation 6.1}$$

Physically, bandwidth describes the variance in performance of the group. Ideally, it should be made as small as possible, indicating that the target being considered is under control.

- (2) For each score a capability deficiency, s_d , is defined thus:

$$s_d = s - s_r \quad \text{Equation 6.2}$$

- (3) To facilitate the comparison of dissimilar indicators of manufacturing performance, marginal capability score, s_m , is defined to express the capability score as a percentage of the required capability of the collated group:

$$s_m = s_d / s_{rz} \quad \text{Equation 6.3}$$

- (4) Calculate the improvement potential, I , of the group of scores to indicate the improvement possible through moving the required score nearer the optimum:

$$I = s_{rz} / s_{oz} \quad \text{Equation 6.4}$$

An interesting feature of the improvement potential is that they can be used to provide a quick assessment of how much further a design or process can be improved. By simply ranking the improvement potentials of all groups in the analysis, the design team can observe the ‘slackness’ in capability for each capability factor, quickly forming an opinion to questions such as ‘*can we make this 20% cheaper?*’.

- (5) Finally, to convert each individual score into a target for improvement, based upon its marginal capability score and reflecting the improvement potential of the collated group, a Priority Confidence Score (S) is calculated. Also, recall that the original capability score derived from the knowledge statement already includes a factor weighting denoting its strategic importance to the analysis.

$$S = s_m \cdot I \quad \text{Equation 6.5}$$

These are dimensionless and can thus be directly compared with one another, even where the source data is not comparable.

As the marginal capability and improvement potential of the group are both ratios, the PCS score will always be a number between zero and one, irrespective of the units of the original factor score.

- (6) A recovery schedule is a list of all priority confidence scores, ranked in order of priority. Each level of the analysis has its own recovery schedule. The objective of the recovery schedule is to identify the targets for improvement at each level.

For the collated factor scores of this example, the following data can be calculated using the above procedure:

Worst capability score, s_z	24.12
Best/required capability score, s_r	7.57
Bandwidth, s_{rz}	16.55
Optimum capability score, s_o	0
Total bandwidth, s_{oz}	24.12
Improvement potential, I	0.69

Table 6.2 Scenario 1: Typical set of capability scores assigned to a single factor.

	Scores	Required score	Capability Deficiency	Marginal Capability	Priority Confidence Score
Score 1	16	5	11	0.647058824	0.5
Score 2	17		12	0.705882353	0.545454545
Score 3	18		13	0.764705882	0.590909091
Score 4	19		14	0.823529412	0.636363636
Score 5	22		17	1	0.772727273
Bandwidth			17		
Total Bandwidth			22		
Improvement Potential			0.772727273		

6.3.1 Further Examples of Capability Analysis

This section is intended as an aid to understanding the concepts of Capability Analysis. It shows how PCS values are effected by changes to the underlying data, as a result of specific engineering scenarios; and ultimately how the recovery schedule would be impacted.

Table 6.2 shows a typical set of quantitative capability scores, in this case set-up time of five machines collated to the equipment level. This is a particularly good illustration of why Capability Analysis looks to drive all factor scores to be identical; in a cell operation times should be balanced to achieve 'flow'. For the group, which initially has a required capability score of 5 min, the improvement potential of the group of recorded scores was identified as 0.773 and the PCS is determined as shown in the table.

Now consider the effect of changing the required capability score for set-up times to 1 minute reflecting a desire to increase part variety in a cell to implement single piece flow. The calculation shown in Table 6.3 indicates that, in the event of a shift in required capability score, the marginal capability increases for each individual factor and the improvement potential of the group is raise to 0.954. The net effect is an increase in the PCS values. If the required score becomes equal to the optimal score, then the PCS value of the worst score in the group achieves a maximum value of one.

Figure 6.6 shows two further developments of the problem data. Scenario 3 is a hypothetical situation where all score have been moved closer to the target by a similar

amount. This has spread out the PCS values as reducing the total bandwidth has increased the improvement potential for the entire group to 0.64. In the final scenario, the worst capability score was moved to the middle of the group, resulting in a reduced improvement potential for the group, but a significant increase in marginal capabilities. (Note that only improving the worst capability score, will change the PCS of the scores in the group.)

6.4 Representing Priority Confidence Scores at Higher Levels

An important aspect of the Capability Analysis methods is the provision of higher level scores which denote performances at a lower level. Essentially, this can be achieved in two ways. Firstly, new capability scores can be calculated directly from lower level capability scores of lower level factors, and secondly, the lower level priority confidence scores can be further analysed to show the contribution of a grouped set of performances to the higher level targets. This provides the all-important ability to drill down from the process plan

Table 6.3 Scenario 2: Change in Improvement Potential of the Group.

	Scores	Required score	Capability Deficiency	Marginal Capability	Priority Confidence Score
Score 1	16	1	15	0.714285714	0.681818182
Score 2	17		16	0.761904762	0.727272727
Score 3	18		17	0.80952381	0.772727273
Score 4	19		18	0.857142857	0.818181818
Score 5	22		21	1	0.954545455
Bandwidth			21		
Total Bandwidth			22		
Improvement Potential			0.954545455		

Figure 6.6 Scenarios used to Describe Effect of Environment on PCS.

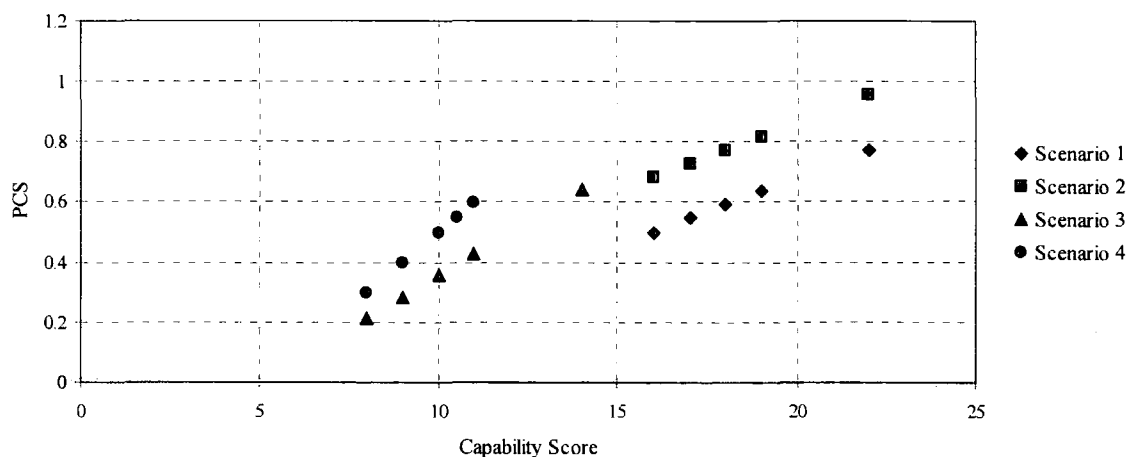

level recovery schedule uncover the root causes of poor performance.

Where simple qualitative metrics are used at the lower level, it is possible to simply sum or average these lower level scores. For example, the factor object Product mass is a directly calculated capability score measured at the product level and is automatically derived from a component-level factor, Component mass. Unfortunately, for some factors a direct calculation is not sufficient because it does not take into account the number of scores recorded. For example, consider the factor Set-up time defined at the process level. At the higher process plan level we would like to find out which process plans make best use of processes which can be quickly changed-over irrespective of the number of processes involved in that plan. Here a simple summation would imply that the best plan would be one with no processes and no set-ups.

6.4.1 Contribution of a Group of Factor Scores to Higher Level

Performance

Since priority confidence scores identify relative performance, not value, they can be re-analysed using to show the performance of the higher level object, in terms of the priority confidence scores of its corresponding lower level objects. This is done by re-analysing the priority confidence scores using the Capability Analysis method (for a given set of capability factor(s)) of all elements that contribute to higher level objects. In general, all factors relating to a specific domain (quality, cost, delivery, logistics, product performance and risk) are combined into a high level score. Thus, the system is effectively combining micro-level knowledge from isolated product, process or resource knowledge sources to feedback macro level knowledge about the plan for decision making purposes. This procedure is reversible, so, once a suitable plan has been identified it is possible to query the high level recovery schedule thus identifying low-level causes of poor performance in order to generate suggestions for further improvement.

Table 6.4 An Example Recovery Schedule.

Priority Confidence Scores (Level 1)	Priority Confidence Scores (Level 2)	Object	Original Value
3.09		Mass of Y Wall	24.12 kg
	1.19	Mass of Y Wall:Skin A	9.02 kg
	1.19	Mass of Y Wall:Skin B	9.02 kg
	0.41	Mass of Y Wall:Honeycomb	3.09 kg
	0.39	Mass of Y Wall:Doubler	2.98 kg
2.54		Mass of SM Floor	19.83 kg
1.78		Mass of Y Upper Shear Wall	13.89 kg
0.97		Mass of Y Lower Shear Wall	7.57 kg

6.4.2 Reporting Priority Confidence Scores: the Recovery Schedule

The ability to investigate the priority confidence scores in detail and provide summarised information suitable for user interpretation is achieved through the use of a Recovery Schedule. A Recovery Schedule is created for each capability level and ranks the scores belonging to factors at the current level. Thus, the knowledge statements with the highest priority are immediately brought to the attention of the designer. The recovery schedule greatly aids product redesign and factory reconfiguration during subsequent design phases. Recovery schedules can be re-generated at each level and sub-level in order to discover root causes of high capability deficiencies at the higher level. For example, Table 6.4 shows the recovery schedule for the ‘Structural Component Mass’ example. It shows that

Figure 6.7 Deconstruction of the High Level Recovery Schedule.

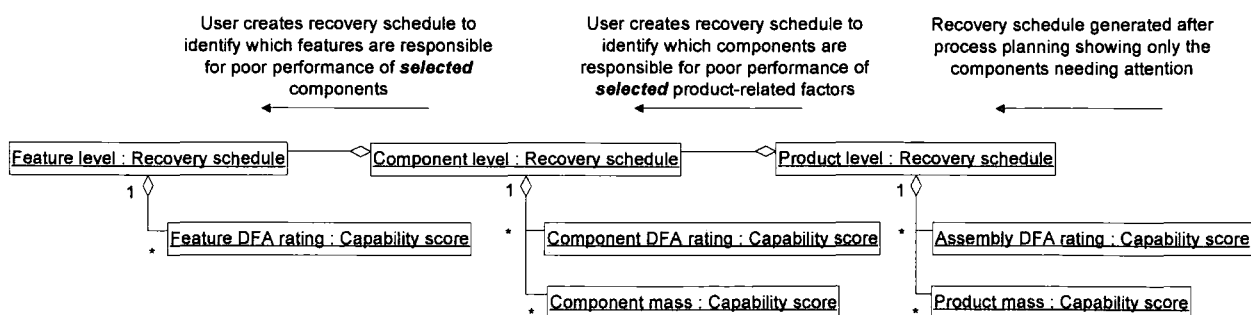

the Y Wall component has the greatest opportunity for weight saving and presents the designer with a repeated analysis of the lower-level factor contributions, directing the designers attention immediately to the heaviest Skin A and SkinB components. The recovery schedule also integrates the calculation of PCS scores for multiple factors spanning both qualitative and quantitative variables. An example of this is shown in Figure 6.7 which deconstructs the recovery schedule for the capability factors described earlier in this chapter. The initial recovery schedule would normally be generated automatically after process planning has been completed, highlighting the worst performing capability factors at the highest level. The user would then be able to carry out further capability analyses to drill down the data in order to discover the low level causes of poor performance.

6.5 A Suggested Configuration of Capability Analysis for Process Plan Analysis

6.5.1 Detailed Process Plan Analysis

Secondly, factor priority confidence scores can be collated from the component, process and factory levels to give a detailed breakdown of qualitative performances. At this level, the intention is to give an early indication of the early technical difficulties associated with the plan. Accordingly, a much broader range of capability factors relating to qualitative design and planning knowledge must be defined. These factors normally arise as a result of the selection of particular feature, process or equipment choices and are calculated from these lower level capability scores as defined in §6.4. The examples provided below are given as illustrative examples of the capability factors that may be relevant to a typical manufacturing enterprise. Whilst all of these factors have been in validating the system, the list is not exhaustive and would invariably need to be tailored to the end user's requirements. This is particularly important as, although the collation procedures provide a good way to summarise large amounts of data, the original need to collect and maintain a large volume of knowledge statements is an important consideration.

(1) Assembly Analysis.

By comparing assemblies, a Capability Analysis can be used to quickly determine areas of the design where improvements may be desirable. Suggestions made at this level will not directly tell the designer how to correct the problem, but rather enable to designer to gauge where the design may need further modification. As this level of

Table 6.5 Typical Capability Factors Defined at the Assembly Level

Capability Factor	Description	Collated from	Qualitative or Quantitative	Calculated from lower level factor	Primary domain
<u>Product mass</u>	The calculated mass	All components	Quantitative	<u>Component mass</u>	Product performance
<u>Structural efficiency</u>	Estimated structural efficiency of the product	All panel components	Quantitative	No	Product performance
<u>Product performance</u>	Sum of component performance values	All components	Qualitative	<u>Component performance</u>	Product performance
<u>Modularity</u>	Interchangability of parts	All components	Qualitative	No	Product performance
<u>Lifespan</u>	Reliability target	All mechanical components	Qualitative	No	Quality
<u>Assembly DFA rating</u>	Estimated manufacturability indicator	All components	Quantitative (calculated from lower level)	<u>DFA rating of component</u>	Delivery
<u>Product development cost</u>	Estimated cost of developing a new product	All components	Quantitative	No	Cost
<u>Material cost</u>	<i>Relative</i> cost of materials	All components	Qualitative	No	Cost

analysis may be the basis of high-level decision making, important factors (indicated in Table 6.5) include cost and key performance related criteria; in this case the mass of the final satellite. As the purpose of the analysis is to compare different designs and alternative configurations, the purpose of defining factors is to measure relative performance. An example of this shown in Table 6.5 is the Material cost factor; during early design the actual cost are not known which any accuracy, therefore the factor is set-up with a smaller-the-better quantitative knowledge statement and the user is asked to enter relative costs of each component against a benchmark.

- (2) **Component Design Improvement.** The objective of defining factors at the component design level is to find out from existing feature level factors, job level factors and new component-level knowledge, the capability deficiencies for component level objects. The sort of questions that might be answered at this level are primarily related to; the overall processing time and cost of the component, how well the product's functional performance meet the

Table 6.6 Typical Capability Factors Defined at the Component Level

Capability Factor	Description	Collated from	Qualitative or Quantitative	Calculated from lower level	Primary domain
Component mass	Mass calculated from product model	All components	Quantitative	No	Product performance
Component DFA rating	Is the component designed for assembly?	All assembled components	Qualitative	<u>DFA rating of feature</u>	Delivery
Materials cost	The estimated cost of raw materials for the component	All components	Quantitative	No	Cost
Material properties	Material performance rating	All structural components	Qualitative	No	Product performance
Component risk	Risk of component not meeting customer specification	All components	Qualitative	No	Risk

customer's needs and detailed evaluation of the design's manufacturability. Table 6.6 shows some example factors defined at the component level, including those compiled from lower level factors (Component DFA rating being one example) and those submitted to higher level factors for analysis.

- (3) **Feature Level Analysis.** At the feature level, performances are defined that relate to the basic design features, such as design for assembly criteria (Feature DFA rating), complexity. Collating these feature level score to the higher component level, produces a measure of the ease of assembly and complexity of the entire sub-assembly. Typically, the feature level will have the most number of capability factors of all the product-based levels and, generally speaking, they will be technical factors with quantitative variables thus needing minimal user input. The collation procedure facilitates the combination of these score into higher level factors for user initial feedback through the recovery schedule. The collation of these factors is shown in more detail (using UML) in Figure 6.8. This figure gives an example of both qualitative and quantitative knowledge; a user-inputted User DFA rating knowledge statement object defined at the feature level and a quantitative factor, Component Mass, (having a smaller-the-better characteristic). The diagram shows how the capability

Figure 6.8 Collation Activities shown for Product Analysis.

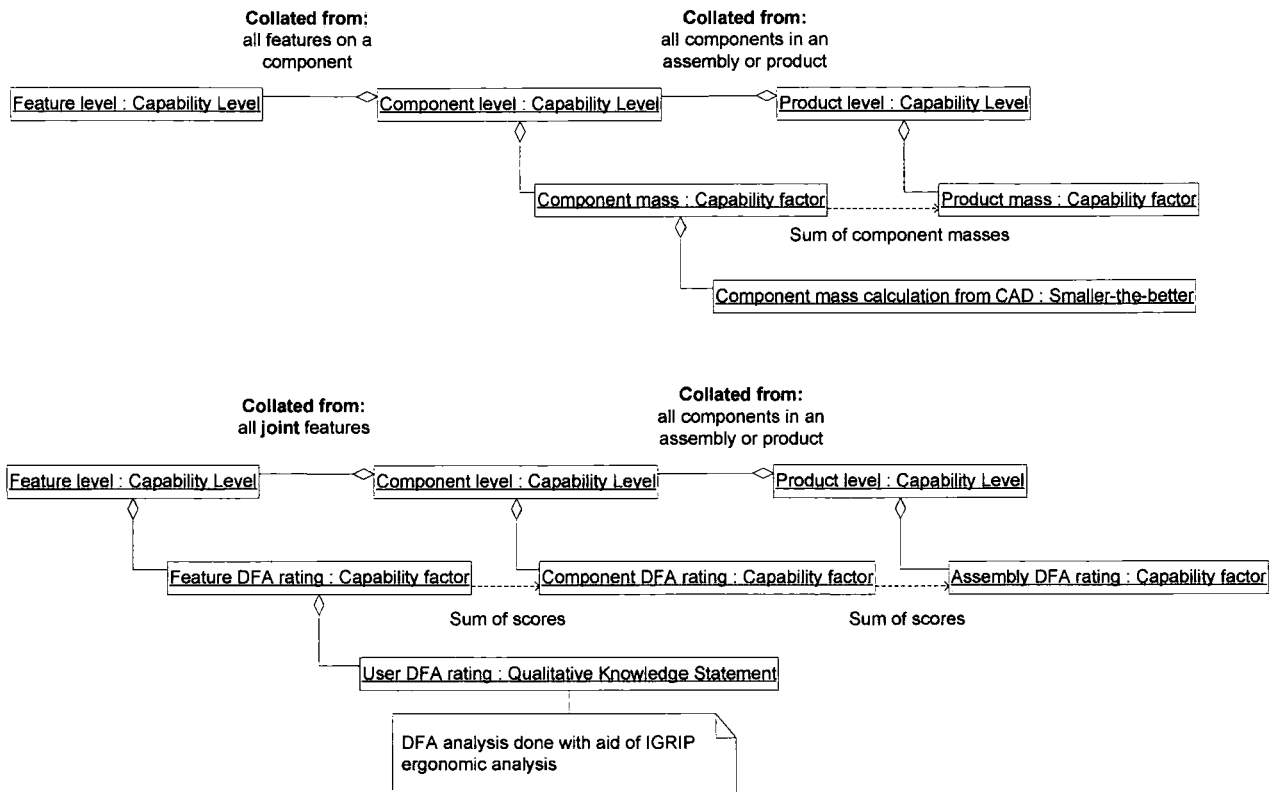

scores are collated; in the case the DFA rating, initially for all assembly features indicated by a joint feature in the product model, and then for all the components in the final assembly.

- (4) **Process Improvement.** Having selected the most appropriate plans, the recovery procedure can be used to determine whether the selected processes are capable, and appropriate. Some capability factors which affect this decision relate to the following and examples are listed in Table 6.7:
- Delivery performance (cycle time, set-up times, lead times for bought in components). It is important to note that that this is not the directly calculated QCD value, but the performance with respect to an expected or target value.
 - Direct process cost.
 - Past process knowledge on any of the six domains, for example features that give quality problems with a particular process.
 - Process familiarity and risk associated with new processes.

Table 6.7 Example Quantitative and Qualitative factors used to Compare Process Objects

Capability Factor	Description
Cycle time	<i>with respect to an expected or target value</i>
Set-up time	<i>with respect to an expected or target value</i>
Quality	<i>with respect to an expected or target value</i>
Additional costs	Cost associated with consumables
Process development cost	Estimated cost of developing a new process
Process wastage	Cost of materials wasted during process
Labour requirement	Labour requirement of the process
Labour skill	The degree of skill required by process operators
Process risk	The risk associated with this process
Process flexibility	The flexibility of the process

- (5) **Resource Level Improvement.** The objective of this level is to identify the equipment and machines are unsuited to making the features of a component and to identify changes that will make it easier to integrate the design into the manufacturing system. Factors should consider the following aspects necessary for decision making:
- (a) Capacity.
 - (b) Down time/overall equipment effectiveness.
 - (c) Number of set-ups required and set-up time.
- (6) **Factory Level Improvement.** The collated capability factors at factory level typically indicate the relative performance of suppliers in the following areas:
- (a) Lean measures and agile performance, including stock an work in progress levels which represent waste.
 - (b) Reliability, on time delivery performance and other vendor rating characteristics.
 - (c) Material handling distance, time and cost.

6.5.2 Structure-Based Process Plan Analysis

At the structure-based level, the analysis of a process plan is used to determine the capability of the current component, process and factory level performances, primarily in terms of the QCD domains. The sort of analysis that may arise as a result of preliminary process plan analysis is related to low-level capability planning (for each job in the plan) for example within an individual plan, Capability Factors can be defined at the Assembly level to reveal any initial issues regarding the suitability of preliminary sections of

processes and resources capable of manufacturing the geometric shape of the feature. Meta information about the plan can also reveal initial areas for development, for example, at factory level, a quantitative capability factor may be used to report the number of resources which do not have any SPC data.

Only the resource allocation and QCD aspects need be considered this level and hence the analysis can be carried out at the very outset of design before any qualitative knowledge statements are defined. This high-level analysis reinforces the aim of Knowledge-Enriched Aggregate Process Planning as an early design decision making aid as the designer can obtain immediate feedback regarding production difficulties of potential manufacturing solutions.

6.6 Exploitation of the Knowledge-Enriched Plans in the DET Framework

6.6.1 Use in Intelligent Exploration

With reference to the original aims of knowledge-enriched planning outlined in §1.3, the Recovery Schedule should not only facilitate the primary requirement of continual improvement of the design, but also that of semi-automatic decision making.

For the purposes of intelligent exploration it is necessary to be able to compare two recovery schedules to show the effect of making a change to the plan. By measuring the total PCS value, k_j , of all, or some selected, capability factors at the process plan level the penalisation of plans which have large capability deficiencies can be made. The total PCS of all scores relating to each object involved in the plan is an important result, that allows the trade-off between QCD and quantitative knowledge in the objective function, which is discussed in the next chapter.

6.6.2 Prioritising Virtual Manufacturing and Simulation Tasks in DET

After highlighting objects within the plan that have high improvement potential, or those of major importance to the business, it is possible to further re-fine the plan by the realisation of these objects in a digital environment. Virtual manufacturing technologies enable the planner to investigate the areas where likely problems or conflicts may occur within manufacture and analyse possible solutions to these issues. 3D graphics-based systems for manufacturing technology evaluation and advanced factory design are widely used,

especially in the aerospace and automotive sectors, for risk mitigation and cost avoidance. However, these process and factory design methods are not well integrated with product design and process planning tools.

One of the key industrial requirement for DET is to integrate the Aggregate Process Planning activities with detailed simulations of the assembly sequence of these components. By operating in a virtual manufacturing environment both of these aspects can be taken account of, while mitigating a sizeable portion of risk in terms avoidance of manufacturing errors, rework and unsuitable process selection.. Different combinations of processes and resources can be considered, as well as analysis of alternative routings for product manufacture and assembly.

The ability to establish the most effective manufacturing process plan and then to use Capability Analysis to highlight and resolve any production difficulties encountered, regularly throughout a product's development cycle, leads to increased production flexibility and process control. The use of aggregate process models as an integration technology between high-end design and manufacturing analysis systems means that data collected across multiple simulation runs can be captured and used to increase the accuracy of early planning estimates. This data can also be made available for use in downstream applications such as capacity planning and discrete event simulation. The advantages of using knowledge-enriched planning methods to control the design process in DET are seen as:

- (1) The improvement procedures resulting from Capability Analysis is open and explicit: the decision making criteria are clear and determined in advance.
- (2) Scores and weightings can be developed according to known benchmarks and can be tailored to match the needs of the project.
- (3) Performance measurement is left to the experts, who are best placed to interpret their knowledge with little additional effort required. Capability Analysis does not require complete information to be useful, although the more knowledge stakeholders who have input, the better the solution.
- (4) Capability Analysis provides a means of filtering appropriate information to the different decision making levels encountered in an organisation.

Figure 6.9 shows a still taken from a simulation of a satellite assembly operation with a high degree of human interaction. The picture shows how detailed models of the satellite products, the assembly processes and the resources within a satellite manufacturing facility

Figure 6.9 Validation of a Satellite Build Sequence using an Ergonomic Simulation.

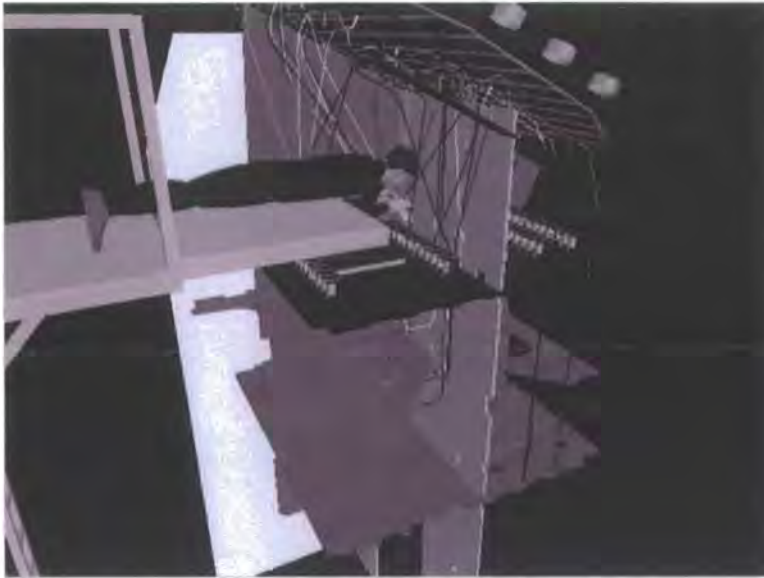

have been modelled for only this difficult part of the assembly process, namely the installation of the phase array on top of the satellite bus structure. This work was not done by the author, but it serves to highlight the nature of detailed design tasks that are envisaged to follow on from Capability Analysis.

6.7 Conclusion

One of the primary objectives of this research was the development of knowledge-enriched functions to support early planning. This research developed a knowledge statement protocol for capturing qualitative and quantitative knowledge and has now established a Capability Analysis method to *compare* and *prioritise* such statements. The primary advantage of applying this technique is that imprecise qualitative and quantitative knowledge attached to the standard planning entities of product, process and resource, can now be evaluated, when new process plans are generated, for the purposes of:

- (1) Providing a prioritised list of improvement targets (the recovery schedule) which can be used by designers to quickly assess a design's manufacturability and uncover the lower level causes of poor performance. This enables users to focus improvement efforts on areas that offer the most potential reward and encourages users to employ external DET software to analyse likely problem areas before moving on to the next stages of design. The significance of this

outcome can be put into context by considering that a typical satellite design has thousands of components, all being worked on by different groups of people.

- (2) Quantifying the direct consequence of knowledge statements on manufacturability which is an important result on the way towards the intelligent exploration of process plans, which is discussed in the next chapter.

Chapter 7 Intelligent Exploration for Aggregate Process Planning

7.1 Introduction

This chapter outlines the process planning problem, the proposed aggregate manufacturability calculation and the new methods which have been created for the intelligent exploration of aggregate planning scenarios as outlined in Figure 7.1. They use a hybrid Simulated Annealing (Kirkpatrick, *et al.* 1983) and Greedy algorithm (Dechter and Dechter 1989) to intelligently explore the search space. Ideally, the goal of process planning should be to minimise the total manufacturing cost (including processing cost, material cost and cost due to non-conformance with quality, delivery and knowledge-based specifications). The term ‘optimal aggregate process plan’ is used to describe the selection of the most appropriate processes and resources to achieve this goal. In many cases there is no one single best answer, the intelligent exploration of process plans is about selecting multiple solutions which closely resemble the ideal case, thus providing the designer with a variety of feasible solutions to further develop using specialist DET software. The metrics

Figure 7.1 Chapter 7 Schematic.

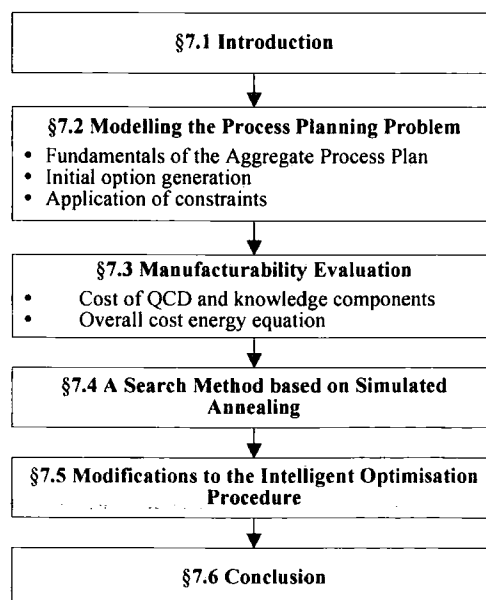

presented are only suggested, albeit fairly generic, metrics; individual organisations may prefer to use their own particular cost equations; but obviously the requirement for minimal data input would remain.

7.2 Modelling the Process Planning Problem

Within the context of the DET-framework, the process plan which is fed back to the designer is intended as a guide to indicate the manufacturing options for a product, alongside an indication of cost, manufacturing time and quality. As planning occurs during the early stages of product development, the planning engine must accept imprecise and changing design information from the aggregate product model and the supply chain resource model and must be capable of providing immediate feedback (indication of potential problem areas, as identified by knowledge management methods) to designers, to allow the evaluation of many alternative ideas which is key to the success of early design.

The Simulated Annealing procedure for process and equipment selection is shown in Figure 7.2. The key features which result in *dynamic* and *intelligent* operation of the planner, according to the definition of a Type II emergent synthesis problem Ueda, *et al.* 2001 are:

- (1) The hybrid algorithm and associated methods utilise the key attributes from the product, process and resource models (Chapter 4) to create an initial valid plan and a dynamic search space. The search space is referred to as dynamic because, in line with the definition of a class II emergent synthesis problem, the available resources (and hence processes) are not fixed and the resource model is dynamically configured by the supply network companies at the outset of planning. Hence, the resource model represents an ‘unknown environment’ and the ‘Feature-to-Process’ and ‘Process-to-Resource’ mappings must be re-generated at runtime.
- (2) The intelligent nature of the planning procedure (highlighted in Figure 7.2) is indicated by (i) the decision to perform the three tasks of process selection, equipment selection and sequencing sequentially instead of concurrently. This decision was taken partly to reduce the computational load as the size of the search space increases exponentially with product complexity and the number of supplier options. (Indeed for many problems involving extended supply chains, the search space would be too difficult to explore in its entirety hence

there is a need to reduce the number of options to a manageable level via constraints), (ii) an effective way of reducing the number of route possibilities at the same time as forcing a logical similarity of processes (within a single plan) is a ‘quenching’ of the solution via the Greedy Algorithm, thereby effectively reducing the level of component complexity whilst maintaining the ability to evaluate a large number of potential options.

Figure 7.2 Overview of Aggregate Process Planning Method.

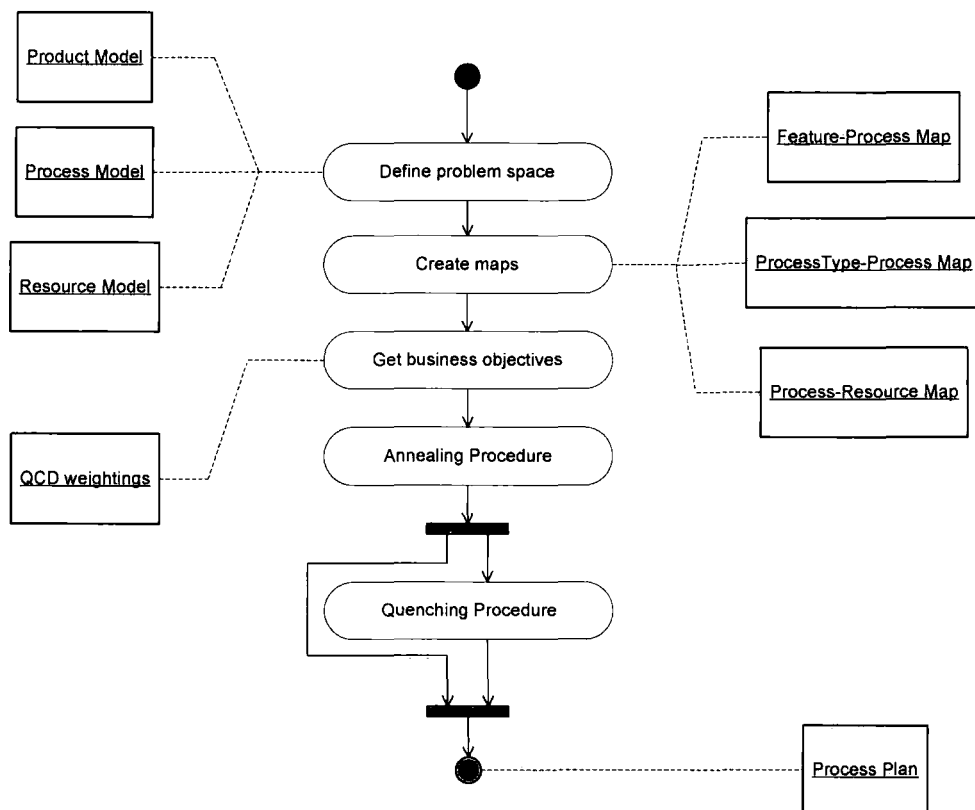

- (3) User-defined weightings of quality, cost and delivery are used to model the effect of the changing business objectives on the fitness of the solution, which again contributes to the dynamic nature of the problem. The evaluation of potential solutions is thus based on the identification of the process plan which best satisfies an objective function having quality, cost, delivery and knowledge components individually weighted to reflect the prevailing, or anticipated, business priorities.
- (4) The close integration with the DET framework via (i) the extraction and processing of data directly from the aggregate models and (ii) the feedback of

the results to act as a decision aid for selecting and prioritising the next digital design tasks.

7.2.1 Fundamentals of The Aggregate Process Plan

The aggregate product model is used as the base structure for the process plan; the planning engine starts by generating a skeleton process plan consisting of a hierarchical series of Job Tree Container objects (see Figure 7.3), indicating an ordered series of sub-activities with sequential 'start times' which form the process plan. The job tree container objects are instantiated from the assembly structure of the product model according to the following four precedence rules which ensure that features are held in the correct manufacturing sequence:

- (1) The order of components at any given level in the hierarchy is determined as the reverse orders that they appear in the product model.
- (2) For any given component, all child components must be completed first, before any features of that component.
- (3) Within each component the planning algorithm will plan the features in the flowing order; positive features, negative features and lastly joint features.
- (4) For components that have multiple positive, negative or joint features, the planning algorithm will plan each feature in the reverse order that they appear in the aggregate product model.

Figure 7.3 Process Model Job Tree Container Class for Storing Jobs in the Correct Assembly Sequence.

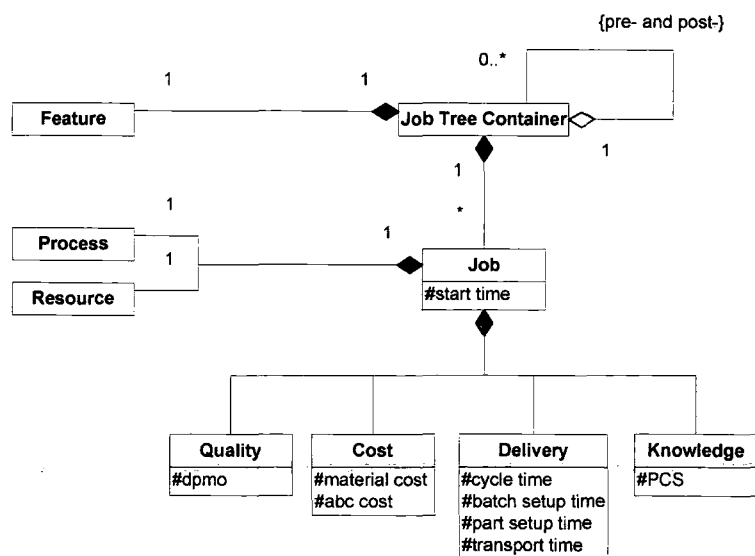

It is important to note that the correct sequencing of job tree containers is entirely dependant upon the adroit use of specific parent–child relationships between features and components in the product model; the features at the bottom level of the product model hierarchy will always be scheduled first. It would be possible add further rules to the system to incorporate other planning considerations, for example an alternative strategy for machined components could be created to group all axi-symmetric features before prismatic ones.

Each job tree container has a unique job object, which is the primary entity of a process plan. Each job object references exactly one process and one resource to complete the activity. Figure 7.3 shows a UML description of the job class, which holds the interim process and resource objects selected during planning, and the results of the manufacturability assessment as references to quality, cost, delivery and knowledge objects created by the manufacturability analysis methods of the process models.

Since a feature may require more than one processing step, a main job tree container may contain multiple Job Tree Container objects with the same feature. As shown in the diagram, this is the mechanism used to manage pre- and post-processes. Pre-process jobs map to the PSL as ‘*sub-activities*’ with ‘*occurrence-earlier*’ relationship to the current job. The current job can also have a ‘*occurrence-earlier*’ relationship with a post-process job, indicating that the post-process occurs after the current job.

Once the process planning is complete, the data from the job tree container objects can be viewed in different formats via the user interface (a screenshot featuring the four options described below is shown in Figure 7.4):

- (1) **Macro plan statistics.** This details the total quality, total cost and start and end dates for the whole plan.
- (2) **Feature, Process and Resource.** Provides a simplified breakdown of the plan showing feature, process and resource for each job. The parent objects, such as factory name of each supplier, can also be viewed in the table.
- (3) **QCD data.** Gives a breakdown of the available QCD information for each job.
- (4) **Gantt chart view.** Shows a graphical output of the plans delivery, with colour coding to indicate cycle, part, batch, transport and lead times.

Figure 7.4 Screenshot of Planning Output Derived from Analysis of Job Tree Containers.

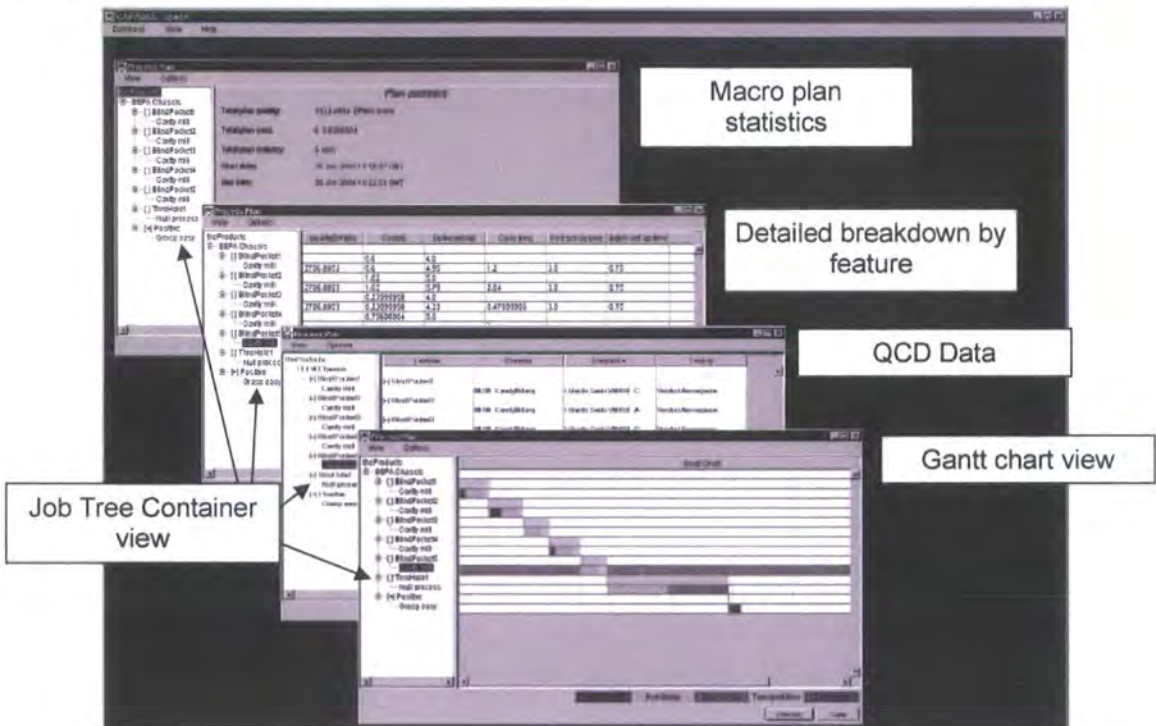

In the case of windows 2-3, the table containing the data is linked to the tree shown on the left, so that individual jobs can be navigated as desired.

7.2.2 Initial Option Generation: Process and Resource Mappings

The intelligent exploration algorithm requires that valid plans are available to work with, hence, the generation of the search space that comprises all possible manufacturing solutions suggested by the provided product, process and resource models is critical. A process plan is considered feasible if, firstly, a valid, practicable operations sequence is present and secondly, no technological constraints are contravened and manufacturability (quality, cost and delivery) can be calculated.

By virtue of three mappings the system is capable of identifying every conceivable manufacturing option, for each feature, within the enterprise (as shown in Figure 7.5). The first, the feature-to-process map is used to identify every process capable of producing a feature, based on its class type, regardless of its geometric and tolerance values.

Figure 7.5 UML Dynamic Object Model Showing the Mapping Procedure for a Single Feature.

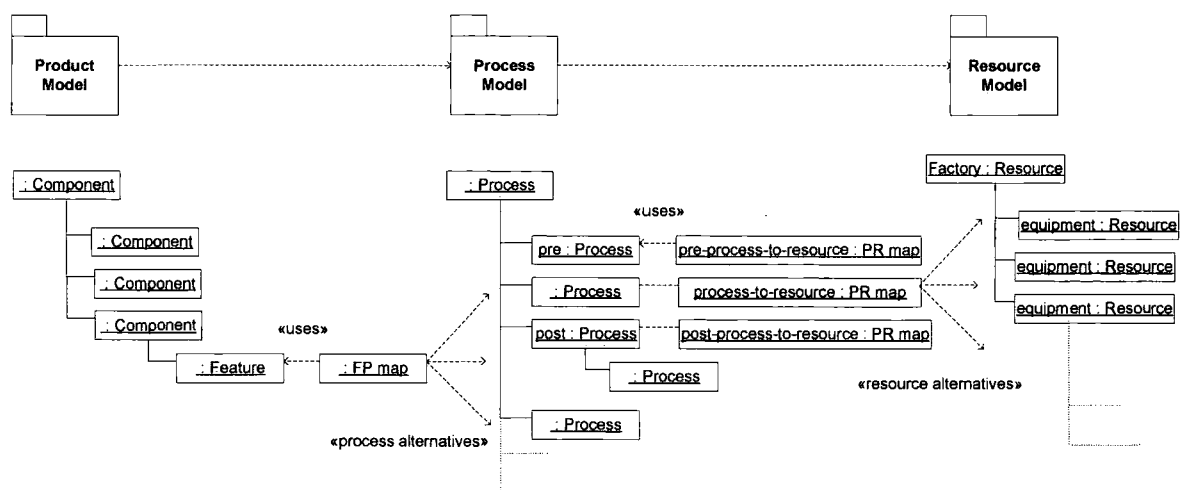

To identify the processing requirements, each type of manufacturing feature in the product model, is mapped to a number of feasible production methods in the process model via a compatibility matrix FP , which is defined as:

$$FP = \{fp_{ab}\} \quad \text{Equation 7.1}$$

where,

$$fp_{ab} = \begin{cases} 1 & \text{if process, } a, \text{ is capable of making feature, } b \\ 0 & \text{otherwise} \end{cases}$$

The rows of FP are populated to encode the feature producing capability of a process. For each feature in the product model, the columns of FP are used to randomly select alternative processes. Preliminary checks are made to ensure feature-process compatibility. If an incompatible process is found further random processes are selected until no more alternatives exist. In the case that no suitable process is found, a 'null' process object is selected allowing the planning to proceed but highlighting the feature which cannot be made in the current supply network. Sub-matrices of FP can be created to represent specialist operations for industry-specific features.

Just as each feature has many process alternatives, each process can be executed on multiple resources in the enterprise model. A mapping of processes to resources is also required, however, the supply network is dynamic and hence the mapping must be done at run time. To facilitate this each resource in the resource model maintains a list of the

process which it can perform. The process-to-resource compatibility matrix PR is obtained by interrogating the resource model thus:

$$PR = \{pr_{cd}\} \quad \text{Equation 7.2}$$

where,

$$pr_{cd} = \begin{cases} 1 & \text{if resource } c, \text{ is capable of performing process } d \\ 0 & \text{otherwise} \end{cases}$$

For each process selected in the previous stage, random resources are returned from this mapping. If PR is a null matrix then, obviously the product cannot be made using resources in the selected enterprise model.

Referring back to Figure 7.5 it quickly becomes clear how the two mappings can lead to a very large search space indeed. In satellite manufacture, each feature typically has at least two or three alternative (or variant) processes, which in turn may require pre- and post-operations. Then each of these process will then have a number of resource options, the number of which will be dependant on the number of suppliers. For this case in point, Table 7.1 highlights just how the number of plans (which are combinations of feature, process and resource choices in a specific order) increases exponentially with the complexity of the product and according to a power law as more alternative processes and resources are added. Hence, increasing the number of alternatives in the mappings will have a significant effect on the size of the search space to explore.

7.2.3 Application of Technological and Physical Constraints

Table 7.1 Size of Search Space

	Number of features			
	1	2	4	16
3 alternative processes (3^n), one resource	3	9	81	43046721
3 alternative process, each having 3 alternative resources (9^n)	9	81	6561	1853020188851800

Technological and physical constraints, stored in the process and resource models are subsequently checked to ensure that the resource is technically capable of making the required feature object. Constraints are checked by the planning algorithm, stepping through the provisional sequence and testing technological constraints and physical constraints to ensure that those processes and resources obtained through the mappings are physically capable of producing the features defined within the product model to the required specification. Four such constraints have been included in the process models:

- (1) **Materials suitability.** A process may only be appropriate for a certain range of materials. Each process thus maintains a list of materials for which it is suitable. If a material has been assigned to a component which is not contained in this list the process will be rejected.
- (2) **Workpiece geometry.** The workpiece, defined by the area of the parent component, must lie within the maximum working envelope of the selected resource, such as the bed size of a machining centre.
- (3) **Feature size and location.** Feature dimensions, defined using maximum and minimum limits, are used to check feature size limits. The location of the feature, close to an edge or on a counter-bore for example, may also preclude the application of certain processes.
- (4) **Tolerance and surface roughness.** The capability of the process to produce an appropriate level of surface finish is also checked. Each process which can be used to produce a face maintains details about its maximum and minimum tolerance producing capability obtained from sources such as Swift and Booker (1997).

At this stage it also is possible for soft constraints, such as user clustering of features, to be applied if required. In particular, it may be desired to override the ordering of job tree containers to ensure that at the component level, all large-scale material removal operations should be performed before finer processes and finishing operations. These two types of constraint were deemed sufficient to enable the resulting plan to be representative of the final manufacturing. At this stage of the research, no interactive evaluation of the interim planning results was performed, in order to simplify the intelligent optimisation to a Class II emergent synthesis problem. To extend the functionality of CAPABLE Space to Class III would require the system to provide for human intervention in the interactive

specification of new options concerning the environment's configuration and interpretation of interim results. The system could hence be further extended to incorporate:

- (1) **Detailed planning rules** to cluster certain processes at component, or sub-assembly levels within the same set-up, or to specify that two or more set-ups are required in special cases. The downside of incorporating too many rules is that the potential for creating incompatible sequences of job tree container is increased, which would necessitate some form conflict resolution to be performed. Also, it should be borne in mind that the objective of the system is to generate a number of potential solutions for evaluation by the annealing algorithm and the more rules that must be satisfied, the less options would be available to search.
- (2) **Pre-selection of preferred options** within the set-up phase of the optimiser to force the intelligent optimisation to use only pre defined sub-sets of the process-to-resource mapping at the sub-assembly level. This would mean that the designer could be given the option to interactively limit the product of sub-component to just a selected number of alternative or preferred suppliers, so that for example the manufacture of high value added items can be kept in house whilst the system is allowed free range to assign parts with low margin to any external suppliers.

7.3 Manufacturability Evaluation

Planning is about making choices between alternatives and is primarily a decision making activity. The Simulated Annealing algorithm combines the various manufacturing characteristics of the process plan into a single, multi-criteria cost energy equation as given in Equation 7.3. As can be seen, a distinct 'QCD+K' format is present, thus, the intelligent exploration algorithm can be used to trade-off quality, delivery, cost and knowledge loss (a cost penalty due to the presence of jobs with low priority confidence scores) against each other as part of a global search for potential optimal solutions,

To derive a single indicator of manufacturability, suitable for evaluation in the Simulated Annealing algorithm the quality, delivery and knowledge characteristics of a process plan are converted into a *cost*. The following cost factors are thus used as the plan evaluation criteria in the objective function.

$$e = f(\text{quality cost, manufacturing cost, cost of not meeting delivery, cost penalty due to knowledge loss}) \quad \text{Equation 7.3}$$

7.3.1 Delivery Lead Time Analysis

Equation 7.4 describes the total delivery time for a job, d_j . This consists of four elements: cycle time (d_c), part set-up (d_p), batch set-up (d_b) and transportation time (d_t). For each job the selected process object is responsible for calculating an estimate of the cycle time, based on key characteristics of the feature and operating parameters defined in the resource. Once the system has determined all the jobs in a plan, a post processor identifies processes which are executed on the same machine and removes the batch set-up time, d_b , accordingly.

$$d_j = d_c + d_p + d_b + d_t \quad \text{Equation 7.4}$$

The calculated job time is used to determine job cost. The delivery time for the whole component is used to determine whether a delivery penalty is added to the Simulated Annealing energy function.

7.3.2 Calculation of Job Cost

For the purposes of manufacturing planning, the cost of manufacturing operations is represented by the cost of direct labour and/or machine tool time required (which is proportional to the job delivery time, d_j) and the materials cost, c_m . Once the system has determined the delivery for each job, its cost is calculated according to Equation 7.5, where a resource dependent activity-based and depreciation cost rates, r_a and r_d respectively, are applied.

$$c_j = c_m + d_j(r_a + r_d) \quad \text{Equation 7.5}$$

The apportioning of overheads to individual components is done using the following procedure based on the common ABC accounting method. ABC well suited to the problem since products consume activities and activities consume resources.

- (1) Cost centres are identified as resource model objects within the enterprise.
- (2) Wherever possible overheads are directly allocated the cost centre.
- (3) The overhead cost for the service centre is transferred to the individual resources in that area.
- (4) The total overhead cost for each resource is divided by the available machine hours (historical) to give the overhead recovery rate.
- (5) The overhead recovery rate is used to absorb the overheads to products.

7.3.3 Estimation of Quality Cost

The quality cost of a job, q_j , is measured by estimating the percentage of features produced which will not meet the specified tolerance criteria. Un-related tolerance information from the product model and the historical capability of a resource (when making similar tolerances) are processed to determine the likely failure rate, $p(\text{fail})$. The cost of the job is dependant on whether the failure requires the part to be scrapped or whether rework is possible. Cost calculations for the two alternatives are given in Equation 7.6.

$$q_j = \begin{cases} p(\text{fail}) \cdot \sum c_j & \text{for scrap} \\ p(\text{fail}) \cdot c_j & \text{for rework} \end{cases} \quad \text{Equation 7.6}$$

7.3.4 Incorporating a Cost Penalty for Poor Capability: Knowledge Loss

The inclusion of quantitative and qualitative knowledge factors in the optimisation criteria also allows for the assessment of performance-related information that cannot be represented solely through the QCD criteria already established. This is made possible through the ability of the Capability Analysis method to generate Priority Confidence Scores at the **Job** level.

The Capability Analysis method, described in §6.3, is executed once each a valid plan is generated to generate a high-level Priority Confidence Score for each job object in the plan, k_j . This determines the *capability* of that job to achieve the required performance compared with all the other jobs in the plan. Recall that this high-level PCS ranges from 0 (awarded to the best or 'fittest' object in the plan) to 1, inclusive, which represents the

worst value. To translate this numerical value into a cost, suitable for addition into the overall objective function, the value k_j is multiplied by the cost of a job and gives a cost penalty known as the knowledge loss for that job.

7.3.5 Overall Cost Energy Calculation

Using these cost elements calculated at the job level (q_j , c_j , and d_j), the total cost of the all jobs in the process plan is calculated thus; the quality and cost components are the sum of the individual job values, the penalty for exceeding the target delivery for the whole plan is calculated using the liquidated loss rate (l) and the knowledge cost for each job is added to the QCD cost of the jobs; the objective function, e , which is to be minimised by the Simulated Annealing algorithm is given algebraically in Equation 7.7. Each of the calculated QCD criteria is given a user-defined weighting, which is dependant on the operating environment and product lifecycle status, to bias the outcome of the process plan in QCD or K through the application of the weightings (w_q , w_c , w_d , and w_k).

$$e = w_q \sum_{j=1}^J q_j + w_c \sum_{j=1}^J c_j + w_d \cdot l \left(d_e - \sum_{\text{all jobs}} d_j \right) + w_k \sum_{j=1}^J c_j k_j \quad \text{Equation 7.7}$$

7.4 Worked Example of Job Creation in Process Planning

This section demonstrates the operation of the job creation procedures and the generation of the search space. The example is a reworked version of that presented in Bramall, *et al.* (2001). The partial product model shown in Figure 7.6 represents part of a larger assembly.

Figure 7.6 Partial Product Model.

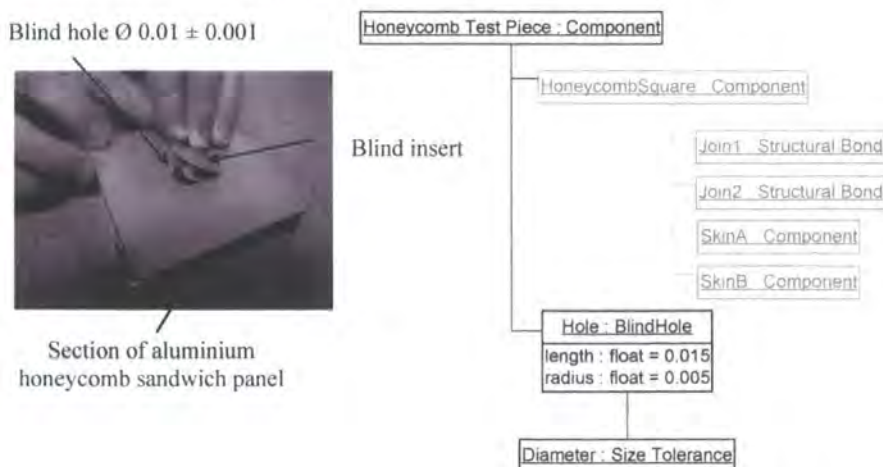

It is known that the Hole feature in question will be required to hold a blind-spool insert to connect some item of payload equipment to a satellite. At the early stages of design, the position of the hole is yet to be finalised, hence the position is defined using nominal values, however the hole's diameter and the associated diametrical tolerance is known as it is determined by the particular type of insert required.

From the generic process model taxonomy, described in §4.5, the list of classes capable of producing any kind of blind hole feature (irrespective of material) includes; **Drilling**, various sub-classes of **Milling** operations and **Chemical milling**. The algorithm first instantiates its job tree container and randomly chooses between the process options from the hard-coded Feature-to-process map object. Then it checks the process-based technical constraints. For example one option, the Interpolated milling process, has two sets of constraints defined; the first being material choice followed by the length to diameter ratio of the hole.

If the process requires either pre-processes or finishing operations the algorithm must use the internal pre, or post process keys to find appropriate processes from a second, fixed mapping, process-type to process, and add them to the job tree container. For aerospace applications it is common that the hole making processes in honeycomb material must be followed the Picking process to check and remove swarf from the honeycomb cells and, in

Figure 7.7 Process Plan Structure Produced using the Two Mappings

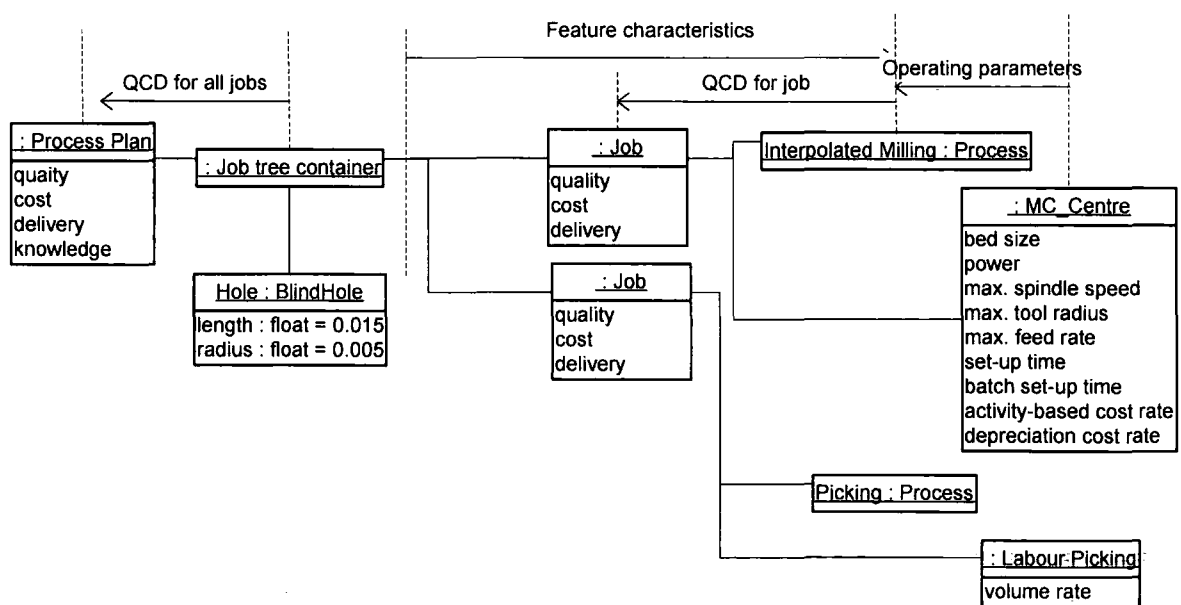

this case, the generic **Drilling** process class has been modified accordingly. Other common types of process required in aerospace applications are pre-treatments and cleaning processes which must be done prior to bonding. The use of the secondary mapping ensures that alternative processes are also considered for these operations, for example where the cleaning process type is specified, the Solvent Degrease object might be chosen instead of Vapour Degrease. It would be typical that, irrespective of industry sector, each type of feature would have at least two or three alternative processing options.

The next stage is to assign a random set of resources to carry out each process. Unlike the hard coded, Feature-to-process map, the Process-to-resource map object must be dynamically created at runtime to take account of the particular supply chain configuration that is available. Each process is mapped to exactly one resource model object; Figure 7.7 shows the Interpolated milling process is to be executed on the Desitech object.

7.4.1 Example QCD calculation

A description of the available resources, such as equipment, cells and labour, is also required during process planning. This information is maintained in the resource model. Like the product model, resource model objects are built from a library of classes. The information required to construct a resource model includes; footprint, location, maximum operating conditions, cost and quality data. Carefully determined operating parameters that are essential for effecting the simplified process models and performing core technological checks, are defined for appropriate resource types. A simple model, consisting of a machining centre (the Desitech object) in a potential supplier's factory is shown in Figure 7.8.

Suppose that the algorithm chooses to drill these holes by using machine tool Desitech in this factory, then the following data shall apply to the job shown in Figure 7.7.

- (1) **Delivery.** The actual process cycle time, d_c , is calculated as 0.156 min. Adding the set-up time (part set-up time, d_p , of 1 min, batch setup time, d_b , of 4 min) for this job gives a total time for the job, d_j , of 5.156 min. If more holes were added to the same level line the product model tree, only the cycle time part set-up times would be increased, so two hole would take 6.312 min. When passed to the objective function, if the cycle time is below the target time for the plan, d_e , no liquidated loss rate would be applied, as the majority of the time-related cost would appear as an activity-based cost.

Figure 7.8. An Example Resource: the Desitech Panel Machining Centre.



- (2) **Cost.** If the total activity-based cost rate, r_a , for the Desitech is 36 £/hour, and the depreciation per unit time for an estimated 85% utilisation, r_d , is 0.35 £/hour. The materials cost for the parent positive feature is estimated as £4.50. This gives a total cost for this job of , $c_j = 3.82 + 4.50 = £8.32$.
- (3) **Quality.** If previous quality data for is available for similar hole features, the mean and variance of historical data can be used to estimate the DPMO. In this case a DPMO of 11.12 is predicted for the case where the diametrical tolerance of $\pm 0.001\text{m}$ is specified. If two identical holes were present then the probability of producing a defective component, would double to 22.24. The function of the holes in the panel is such that any defects caused by out of tolerance holes will require the parent part to be scrapped, so the quality cost of the scrapped component would include the cost of any previous jobs as well. Because the DPMO is near 6 sigma, the effect of using this tolerance has negligible effect of the overall cost of the component.

Using Equation 7.7, the total cost for this simple part is a summation of the delivery, cost and quality components, which is £8.32, excluding the knowledge penalty. The effect of knowledge statements is not modelled at the job level, but for the plan as a whole. The overall energy of the solution is dependant upon the calculation of the part's high level priority confidence score as part of the total plan. The effect of including the PCS on the overall energy is multiply the QCD-based cost by up to twice the calculated amount.

This exemplar has demonstrated the calculation of QCD metrics for a very simple part, however, the true power of these methods only becomes apparent when applied to complex products, where the intelligent exploration of production methods and the ability to automatically evaluate QCD criteria at assembly level can be used as a benchmark for evaluating the effectiveness of the determined aggregate product plan.

7.5 A Search Method Based on Simulated Annealing

With a mechanism in place to generate a manufacturing routing, and the means to evaluate its performance, the resulting search space of possible solutions must be searched for the optimal, or near optimal solutions. Since, satellites may be made of up to 10,000 parts, this combinatorial optimisation problem cannot be solved using an exhaustive search of all possible solutions. In fact, optimisations of this type often have stochastic search techniques applied to them. These methods, such as Simulated Annealing, Genetic Algorithms and Tabu search, have been proven to find nearly optimal solutions without recourse to enumerating every solution.

The exploration strategy adopted is to use an algorithm based on Simulated Annealing (Kirkpatrick, *et al.* 1983) to minimise the manufacturability cost of alternative plans. Simulated Annealing mimics the physical thermodynamic annealing process and can generally be described as follows. As a solid is heated to liquid its atoms are free to move, however as it cools a crystalline lattice is formed. The rate of cooling determines the structure of the lattice and the final energy of the solid. The controlling factor is the temperature, and the idea is to allow sufficiently long cooling time for even re-distribution of energy, such that the final lattice energy is minimal. The following section illustrates the operation of the hybrid Simulated Annealing and Greedy algorithm that controls the intelligent exploration process. The algorithm works by starting with an initial, random, solution. A neighbouring solution is then generated from this existing one. A plan can be modified by making changes to its 'process' or 'resource' selections on a job which are obtained directly from the valid search space as detailed above.

- (1) Alternative candidate processes, from *FP*, can be substituted for existing processes already in the plan. Implicit within this change is the re-allocation of resource requirements using the *PR* mapping. Hence, this may result in a dramatic change in the manufacturability of the production routing, particularly when changes to pre-processing and/or post-processing steps are involved.

- (2) Alternative candidate resources, across the distributed enterprise, are assessed in performing a specific process. Again, this can result in a change in overall performance, by selecting superior, but costlier resources or vice versa.

The Simulated Annealing-based search algorithm uses the concept of the ‘temperature’ of the solution or plan, to control changes to the plan that have an undesirable effect on the process plan: it can be viewed as an iterative improvement method where an initial solution is repeatedly improved by making small local alterations until no further improvements can be made. If a new solution, e_i , is better (has a lower energy) than the old one, e_j , it is accepted and another change is made. If it is worse, then in order to prevent the solution being stuck at a local maxima, a change is made with probability according to the Boltzmann expression;

$$p(\text{accept worse solution}) = \exp\left(-\frac{e_i - e_j}{k_B T}\right) \quad \text{Equation 7.8}$$

Where, T is temperature, a parameter that starts high and approaches zero as the number of iterations increases and k_B is the Boltzmann constant,.

The annealing procedure, as implemented in CAPABLE Space, is presented in Figure 7.9. Starting from an initial solution, i , generated using the mappings described in §7.2, the hybrid algorithm generates a new alternative, feasible process plan, j , by interchanging jobs in the process plan. Then the energy of the new plan, e_j , is evaluated using the methods described in §7.3. Providing $e_i - e_j < 0$, the transition to the new alternative plan is accepted. However if $e_i - e_j > 0$, the new alternative is accepted with a probability denoted by then Boltzmann function given in Equation 7.8. By allowing such non-optimal moves like this, the algorithm can escape from local minima in its search for a global minimum. The probability of accepting a large deterioration of the energy of the plan is moderated by the $e_i - e_j$ component in the Boltzmann function, and the use of reciprocal of the current temperature ensures that as the system cools, the likelihood of the accepting inferior solutions diminishes. This evaluation function sits inside an iterative loop which keeps on repeating, gradually reducing the temperature, until a stable solution is reached; the annealing section of the algorithm stops when the temperature either reaches a limiting value, or fails to reduce after many alternative evaluations. Two user-defined parameters are required to control the procedure; the initial temperature, T_0 and the amount to reduce the temperature with each iteration. In CAPABLE Space, the initial temperature was set

Figure 7.9 Detail of the Annealing Procedure.

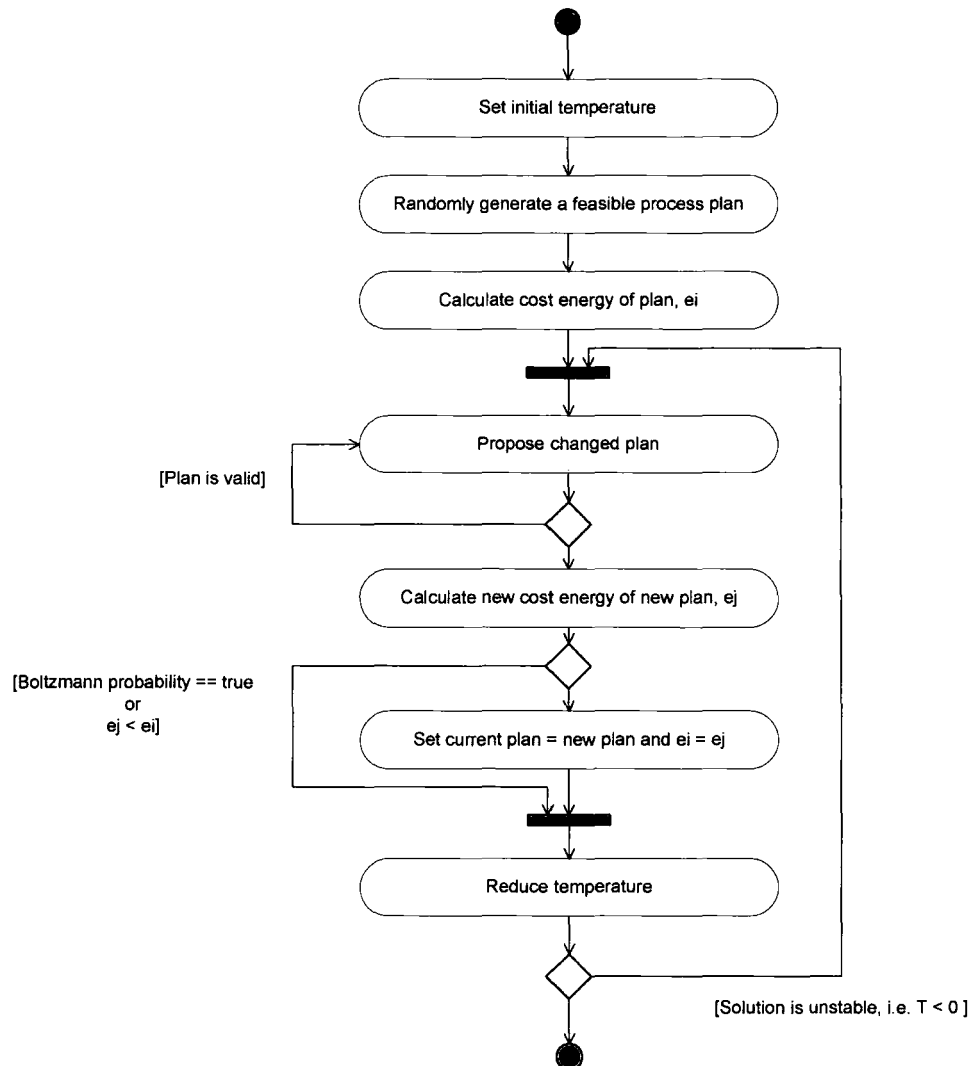

equal to the number of jobs in the plan; the larger the search space, the higher the initial temperature thus a greater number of alternatives will be evaluated. The amount of cooling was set to be a percentage of the current temperature which can be controlled to ensure a compromise between the speed of execution of the algorithm can thus be traded off against the amount of exploration done.

7.6 Modifications to the Intelligent Exploration Procedure

By evaluating the results of the initial implementation of the pure Simulated Annealing algorithm it became apparent that in certain cases, it was desirable to limit the randomness of certain changes imposed by the Simulated Annealing algorithm alone. Two modifications to the Simulated Annealing procedure were thus implemented, firstly to

Figure 7.10 Probability Distributions of Process and Resource Substitutions for Controlling the Hybrid Algorithm.

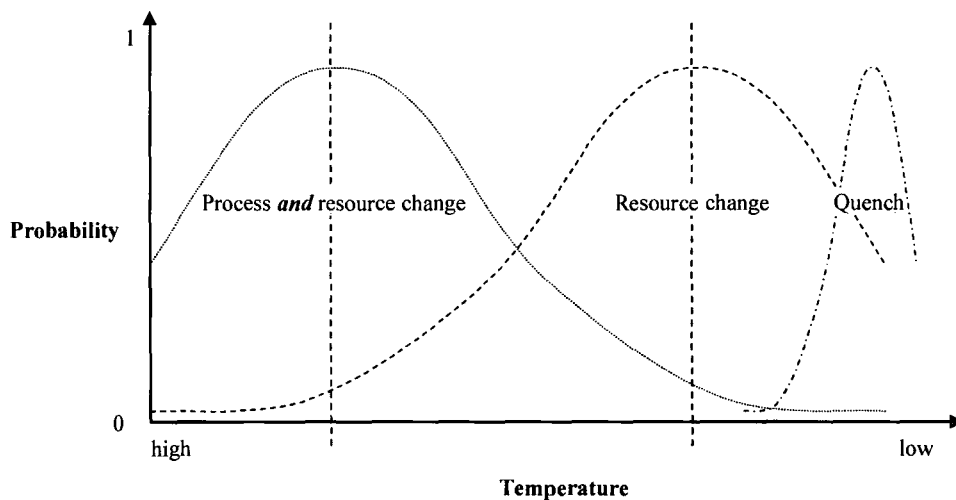

control the selection of alternatives according to the degree of improvement desired and, secondly to speed up the local optimisation of similar jobs using a Greedy algorithm.

A probability function was employed to tune the type of alternative selection - process alternatives are favoured during the initial stages the Simulated Annealing algorithm (at high temperatures) and prevented from being evaluated at lower temperatures where there is a higher probability of considering alternative resources as shown in Figure 7.10. This ensures that the hybrid algorithm evaluates changes with potentially large impact, such as those arising from selecting a different process (and hence resource), prior to considering relatively lower-impact changes, where only the resource is changed. The effect of this is to speed up the convergence of the algorithm and to reduce the likelihood of leaving un-optimised jobs in the plan.

A Greedy algorithm (Dechter and Dechter 1989) executes a heuristic procedure which tries to force, or quench, a solution based on examining local conditions. As the name suggests, it functions by 'grabbing' the most optimum alternatives, working on the assumption that local optimums form the near-globally optimum solution. This is useful where numerous minor features which share similar characteristics, such as holes for inserts, appear in the product model. The Greedy algorithm, called after each change made by the Simulated Annealing, recognises similar jobs (termed the feasible set) which occur at the same level in the product model and forces each instance to have the same process and resource combination as that of the job with the lowest energy (using the best-in rule). Checks are made by re-applying the technical and physical constraints to ensure that the quenched jobs

remain feasible. These rules are particularly attractive because of their efficiency and simple implementation. In the case of aggregate planning, such a strategy provides a compromise that produces acceptable approximations, significantly reducing the number of optimisation cycles required to find a stable solution. For example, this strategy will attempt force all sibling machined features on a component to be made on the same resource, which may not necessarily produce optimal QCD, but is nevertheless acceptable.

7.7 Conclusion

Optimisation normally relates to the process of identifying the best solution to a well defined problem, as would be the case if a fully specified product model were available. In the case of class II emergent problems in early process planning, which are poorly constrained and ill defined, the aim is to seek multiple, alternative routings which display 'characteristics' of the optimal solution. The intelligent exploration techniques used support aggregate planning in the following ways;

- (1) Provide a rough-cut economic optimisation of alternative routings, based upon QCD, plus knowledge criteria.
- (2) Intelligently use heuristics to reduce the search space as much as possible, particularly the Greedy algorithm which significantly cuts down computational effort required.
- (3) Because the hybrid algorithm quickly identifies near-optimal plans, the planning procedure can be rapidly executed by the designer, facilitating easy determination of the effect of design changes.

Chapter 8 System Implementation and Industrial Testing

8.1 Introduction

This chapter presents an empirical validation and evaluation of the work discussed in this thesis. The first section discusses the basic procedures used; subsequent sections discuss the evaluation of the modelling techniques (from Chapter 4) and of the Knowledge-Enriched Aggregate Process Planning ideas built into CAPABLE Space (from Chapters 5 and 6). Three independent case studies, designed to replicate the conditions of a particular product introduction activity; conceptual evaluation, early design feedback for a new component design and analysis of manufacturing operations are presented. The aim is to prove that (i) the basic hypothesis of knowledge-enriched aggregate planning is valid, (ii)

Figure 8.1 The Evaluation Procedure as Described in this Chapter.

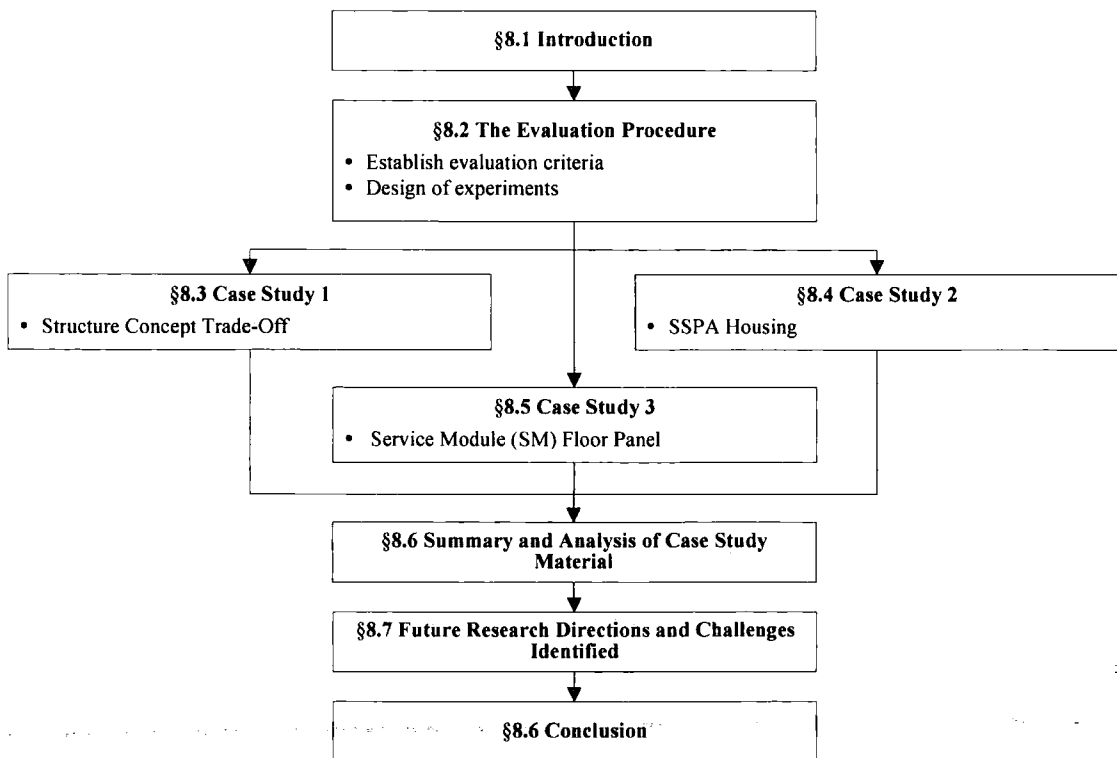

the logic behind the methods is practicable, and most importantly of all, (iii) that the methods have significant potential for industrial application. To avoid disclosing commercially sensitive information, all the examples use synthetic data, albeit based upon actual industrial examples.

8.2 Design of the Testing Procedure

It is recognised that, due to the disruptive nature and level of risk involved, in-company testing of the full knowledge-enriched planning methodology would be impossible. Therefore, the system has been tested ‘off-line’ using three example components provided by the main industrial sponsor and comparing the results with known data and user feedback. When enterprise-wide testing of large, complex computer systems is required, it is standard practice to adopt a multi-stage validation procedure for individual sub-systems and prior to full system testing under controlled conditions (Klösch, *et al.* 2002). The procedure used to evaluate this research was to verify the methods using small, controllable examples, and then to extrapolate the findings to surmise the effect of using the system ‘live’ on real life projects with fully populated knowledge bases.

The overall criterion for evaluating the system is that the knowledge-enriched planning methods must be shown to improve the design process. This requirement is broken down into the following testing objectives:

- (1) Prove the basic hypothesis of knowledge-enriched planning and the use of fast-feedback design methods. Does the implementation achieve better working methods and does it have potentially significant industrial application?
- (2) Demonstrate the logic of the proposed system and show that it can be (technically) achieved.
- (3) Prove that the system generates accurate results which are useful and appropriate for the user.

Testing was executed using three case studies, each demonstrating different aspects of the CAPABLE Space system (and hence exercising the knowledge-enriched planning methods), as shown in Table 8.1. The testing was designed to verify both the theoretical method and the underlying mathematical models. The case studies were carefully designed to exercise the following system functions:

- (1) Construction of example aggregate models within the system.

- (a) Typical component designs can be modelled in the CAPABLE Space product model.
 - (b) Generic process models can be created.
 - (c) The system can be used by multiple, distributed users.
- (2) Generation of aggregate, knowledge-enriched process plans for example designs using the system.
- (a) The methodology is generic, and can be applied to a variety of product model configurations.
 - (b) It can produce alternative production options for the same design, identifying alternative processes automatically.
 - (c) Technically feasible process plans are always returned (i.e. no machine or process constraints are violated) and the proposed routings are realistic.
 - (d) Estimated times and quality levels calculated are sufficiently accurate.
 - (e) Process plans are produced in a sufficiently automated way in an acceptable time scale.

Table 8.1 Aims and Objectives for Each Case Study

Objective	Case Study 1	Case Study 2	Case Study 3
1a. Component and resource modelling.		♦	♦
1b. Generic process models.		♦	♦
1c. Multiple distributed users.			♦
2a. Generic approach	♦	♦	♦
2b. Option generation and evaluation	♦	♦	♦
2c. Technically feasible plans		♦	♦
2d. Accuracy		♦	♦
2e. Level of user intervention	♦		♦

8.3 Case Study 1: Structure Concept Trade-Off

From an initial product specification, described using structure-based product models, it should be possible, using the Capability Analysis methods, to confirm the selection of structural blocks in terms of their impact on design and planning outputs and establish the preferred structure-based aggregate models for new product development. This case study demonstrates, by example, the use of Capability Analysis in scrutinising the manufacturability of four alternative structure-based design concepts.

8.3.1 Aims and Objectives

The following section gives several examples to illustrate how Knowledge Statements are derived from traditional, common knowledge sources. The example is based on an actual ‘Structure Concept Trade Off’ exercise undertaken by Astrium (Slade, *et al.* 1998). To protect their data some of the knowledge statements have deliberately been mixed up or modified. The exercise concerned the evaluation of four alternative structural designs for a new type of constellation-based satellite bus structure, presented in Table 8.2. Crucially, this early stage evaluation proves that detailed models are not required to execute the Capability Analysis methods.

Table 8.2 The Four Alternative Concepts.

Concept	Description
<u>Concept A</u>	Longeron/Bulkhead Assembly with Panels
<u>Concept B</u>	Moulded Framework with Panels
<u>Concept C</u>	Space Frame with Panels
<u>Concept D</u>	Central Structure with Panels

8.3.2 Creation of Quantitative Knowledge Statements

The factors used and the scales against which each of the capability scores were established are shown in Table 8.3. Key areas of discussion for the introduction of such a radically different product line were to trade cost (investment) against risk (product complexity, process complexity and novelty) and potential reward (increased product performance). The qualitative factor scales given were designed to reflect this, for example the Resource requirement capability factor has a scale ranging from ‘No additional resources required’ to ‘Heavily dependant on dedicated equipment and/or skills’. Note that this factor is related only to the risk domain, so if new tooling must be developed then, as well as a statement indicating high project risk, a further statement related to investment cost should also be created. The important quantitative information contained in the SCTO document was converted into knowledge statements based upon the strengths and weaknesses of each design for each of these factors. (Full data sets are provided in Appendix C.) An example set of the knowledge statements is given in Table 8.4. For Concept B two issues related to investment were raised; firstly, the use of auto tape placement could the reduce labour requirement and would be highly desirable, hence is given a score of 100. However, this would require the purchase of dedicated equipment which gives rise to a further knowledge statement, with an strongly undesirable score of 900. The primary reason for carrying out

Table 8.3 Historical Benchmarking for Qualitative Knowledge Statements.

Factor (Domain)	Strongly Desirable	Desirable	Neutral	Undesirable	Strongly Undesirable
Investment cost (Cost)	Little or no additional incurred cost. (£0-50k).	Small investment in training and consumables. (£50-100k).	Reasonable capital investment required. (£100-150k).	Significant investment on non project specific resources. (£150-200k).	Significant investment on project specific resources. (>£250k).
Resource requirement (Logistics)	All required resources are readily available.	Some specialist resources will be needed.	Typical resource requirements, non-project specific.	Project specific resources and jigs required.	Heavily dependant on dedicated equipment and/or skills.
Process familiarity (Risk)	All processes are generic, and have been used before.	Generic, low skilled processes with minimal operator training.	Selected processes are well understood within the enterprise.	Novel, but relatively simple processes will be needed.	Novel, high tech processes will be required.
Process complexity (Quality)	Simple processes with poke yoka, mistake -proofing and FMEA	Processes in control with well understood failure modes.	All processes under statistical process control.	Processes documented but out of control.	No process control and poor repeatability.
Product complexity (Product performance)	Modular products, with reduced part count.	Low part count.	All product components deemed necessary and design review.	Some redundancy of parts.	Product is over complex or contains multiple redundant elements.
Handling requirement (Logistics)	Product has stiff structure and is self-jigging.	Some parts require additional in process support.	Modular tooling is sufficient.	Product specific jigs and platens required.	Product requires external support and in-process jigging.
Structural efficiency & performance (Product performance)	Structural elements exactly specified for load requirements.	Good space utilisation and optimisation of load carrying parts.	All available space is utilised.	No structural optimisation has taken place.	Structure has poor space utilisation.

*effect of moving from 'strongly undesirable' to 'strongly desirable'.

the Structure Concept Trade-Off exercise was the customer's concern on rising cost. To carry out a full analysis the domain rankings were given in Table 8.5 were agreed upon.

8.3.3 Capability Analysis Example Based on the SCTO Data

Using the encoded knowledge statements a straightforward Capability Analysis can be performed, collating all the factors to a single 'product' level. Processing the data, as described in Chapter 6, the 10 factors used are prioritised by their improvement potential as shown in Table 8.6. The actual Recovery Schedule for this level is presented as a screenshot in Figure 8.2.

Table 8.4 Extract of Encoded Knowledge Statements given in Appendix C.

Manufacturability Analysis Discussion	Factor	Domain	Predicted Value	Probability	Returned score
'Auto tape placement reduces labour cost.'	Resource requirement	Logistics	100	1	100
'Auto tape placement increases capital cost.'	Investment cost	Cost	900	1	900

Table 8.5 Domain Rankings for the SCTO Exercise.

Attribute	Rank	Weighting	Normalised weight
Quality	5	0.20	0.081
Cost	1	1.00	0.408
Delivery	3	0.33	0.136
Product performance	2	0.50	0.204
Risk	4	0.25	0.102
Logistics	6	0.16	0.068

Table 8.6 Bandwidth and Improvement Potential Values.

Factor grouping	Bandwidth	Improvement potential
Handling requirement	220	0.659
Likely investment cost	900	0.944
Potential suppliers	0.1	0.333
Process complexity	1000	0.325
Process familiarity	725	0.931
Product complexity	820	0.847
Calculated product cost	301000	0.296
Product mass	306	0.402
Product structural efficiency	950	0.868
+X antenna height	0.350	0.800

Finally, this case study was used to illustrate the concept of using priority confidence scores to determine higher level performances. By combining the scores determined for each capability factor, at the product level, an overall performance score for each design was determined for use in the intelligent exploration methods. This information is shown graphically in Figure 8.3.

The case study has demonstrated how Capability Analysis can be implemented even at the earliest stages of design, using knowledge that is readily available. It has shown how the recovery procedure of Capability Analysis highlights the areas that must be satisfied during

Figure 8.2 Screenshots of the CAPABLE Space System in Testing.

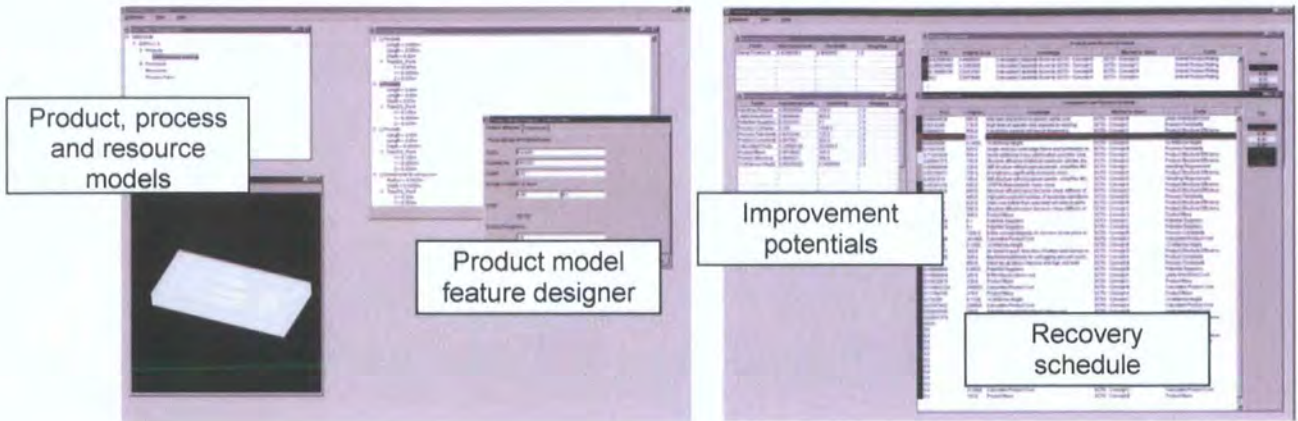
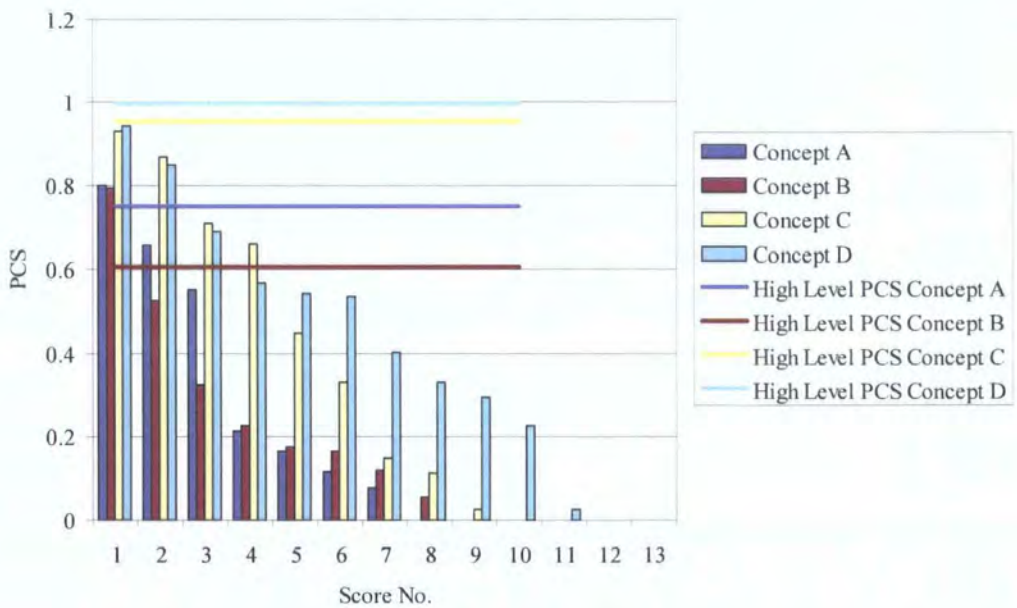

Figure 8.3 Generating Higher Level Scores.



early design and how the domain importance can be used to increase the priority of certain aspects of knowledge.

8.4 Case Study 2: SSPA Housing

8.4.1 Aims and Objectives

The main aim of this case study was to demonstrate the interoperability between the Product, Process and Resource Models and the verify that the key planning functions operate as intended. Excerpts from these results have appeared in Bramall, *et al.* (2003).

The example relates to a small machined component used to mount equipment onto a satellite panel: the Solid State Power Amplifier (SSPA) housing. The manufacture of the component is sub-contracted, by Astrium, to a number of precision engineering firms. A product model and two resource models from suppliers were constructed according to the methods, and using the class structures described in Chapter 4.

8.4.2 Product Model Description

The Solid State Power Amplifier (SSPA) housing is a machined component designed to accommodate the electrical amplifier circuits of a satellite. Figure 8.2 shows a session window with the product model for an early design configuration for an SSPA component; shown clockwise from the top right are (i) the database access window (ii) the product model tree (iii) a feature-editing window and (iii) the product model viewed in the Open

Table 8.7 Summary of Product Model Data.

Feature name	x(m)	y(m)	z(m)	Volume (m ³)	Height tolerance		Required surface roughness (Ra) (μm)
					+(m)	-(m)	
Positive	0.128	0.104	0.012	0.000160	n/a	n/a	n/a
BlindPocket1	0.025	0.100	0.010	0.000025	0.000150	0.000150	1.6
BlindPocket2	0.085	0.049	0.010	0.000042	0.000150	0.000150	1.6
BlindPocket3	0.020	0.049	0.010	0.000010	0.000120	0.000120	1.6
BlindPocket4	0.063	0.049	0.010	0.000031	0.000110	0.000110	1.6
BlindPocket5	0.010	0.100	0.010	0.000010	0.000090	0.000090	1.6
	Height (m)	Radius (m)					
ThroHole1	0.002	0.0025					

Table 8.8 Example Resource Model Data for Mill/Turn Area.

Resource name	Power (kW)	Max. RPM	Feed (mm/min)			Quality		
			x	y	z	Mean	Variance	
H-S VK45-II_A	11.2	8000	0.16	0.16	0.16	0.1	3.05x10 ⁻⁵	
H-S VK45-II_B	11.2	8000	0.16	0.16	0.16	0.1	3.01x10 ⁻⁵	
H-S VM40-II_A	5.5	8000	0.25	0.25	0.25	0.1	2.45x10 ⁻⁵	
H-S VM40-II_B	5.5	8000	0.25	0.25	0.25	0.1	2.40x10 ⁻⁵	
H-S VM40-II_C	5.5	8000	0.25	0.25	0.25	0.1	1.34x10 ⁻⁵	
H-S HG400III	26.1	12000	0.25	0.25	0.25	0.1	2.08x10 ⁻⁵	
Drill	5.0	10000	-	-	0.40	n/a for pocket tolerance		
Agietron EDM	n/a for EDM process model max. cutting rate of 300mm ² /min used					-	0.11	1.09x10 ⁻⁵

CASCADE viewer application. Table 8.7 gives a breakdown of the attributes assigned to the various feature objects of the SSPA. The component has been modelled at the feature-based level using a single positive feature (the Positive, instantiated from the **Sheet** class) and negative features (BlindPocketX and ThroHole1). Each of the pocket features have general geometry, surface roughness and a critical height tolerances (to accommodate the electrical circuit boards). To highlight certain functions of the system, a variety of tolerances were assigned to the features.

8.4.3 Resource Model Used in Testing Planning Functions

Figure 8.4 shows the factory design module of CAPABLE Space, clearly showing the position of the machines within an Open CASCADE view of the MillTurn area of the Verdict Aerospace factory; for clarity the screen shot has been annotated with photographs of the machines. The hierarchical resource model can also be seen in the figure. Datasheets for machine tools were used to specify process parameters for the machining centres (see Table 8.8), giving a range of machine tools able to perform all milling and turning operations. It was assumed that the resource model of the enterprise is capable of executing all the possible process models.

8.4.4 Exercising Planning Functionality

The preliminary tests were designed to investigate planning at the level of individual features, showing the operation of process option generation, machine selection and evaluation. Table 8.9 shows a sub-set of the fixed feature-to-process map, showing that the system has 6 alternative presses for manufacturing the blind hole features and two different milling strategies. Similarly, Table 8.10 shows a sub-matrix of the process-to-resource map, **PR**, generated at the start of process planning.

As described in previous chapters, the evaluation of individual process and resource selections is performed by process specific methods which have been developed to calculate manufacturing time and by a generic method to estimate production quality. The range of processes available combined with the product model's feature set was sufficient to test the technical process constraints, for example the alternative hole producing processes had different constraints set on the maximum achievable radius and depth: the Hole sawing process was consistently rejected during this test because the hole radius in the product model conflicted with the minimum radius (15mm) specified in the technological constraints method of the process model.

Figure 8.4 Annotated Screenshot of the CAPABLE Space Resource Model Design module.

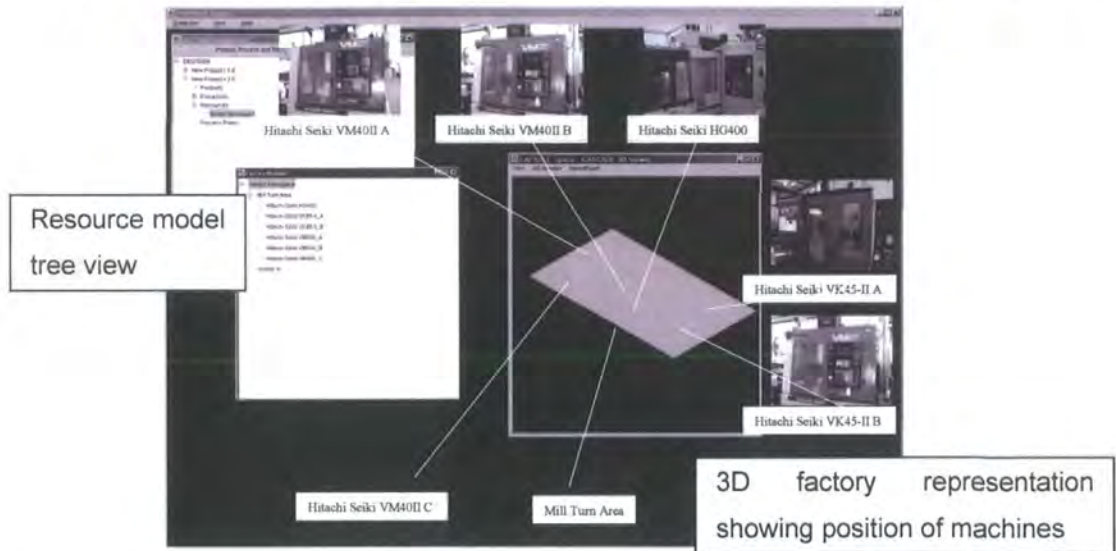

Table 8.11 shows an example of the parameter selection and output of the intermediate process option generation stage. The times and quality levels calculated by the process model are then used by the intelligent exploration stage of the planning process to select from the alternative options.

The next stage of testing was to validate the methods and check the effect of modifying the business objectives. The parameters used in the Simulated Annealing procedure, were given the following fixed values:

- (1) Initial temperature = 200.
- (2) Stopping criterion = a fixed number of rejected changes (100).

Figure 8.5 The Energy of Candidate Plans for Each Run.

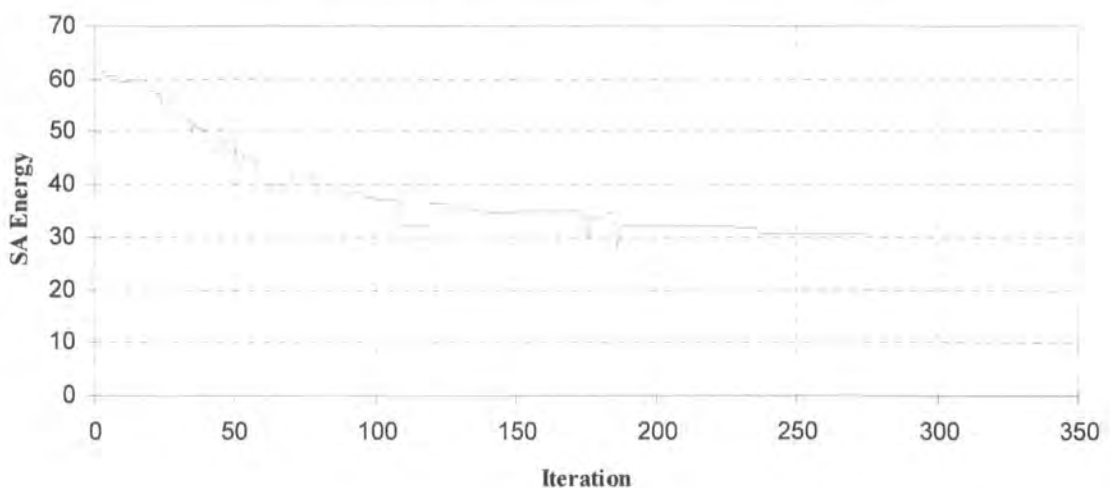

Table 8.9 Process Selection for the Example.

Sub-matrix of <i>FP</i>	<u>Cavity milling</u>	<u>Electrical Discharge Machining</u>	<u>Interpolated milling</u>	<u>Twist drilling</u>	<u>Peck drilling</u>	<u>Hole sawing</u>
<u>Blind hole</u>		♦		♦	♦	♦
<u>Through hole</u>		♦		♦	♦	♦
<u>Blind pocket</u>	♦	♦	♦			
<u>Through pocket</u>	♦	♦				

Table 8.10 Example Resource Selection Options in the Process-to-Resource Mapping.

Sub-matrix of <i>PR</i>	<u>H-S VK45-II_x</u>	<u>H-S VM40-II_x</u>	<u>Agiecut 2S EDM</u>	<u>HG400III</u>
<u>Cavity milling</u>	♦	♦		
<u>Interpolated milling</u>	♦	♦		
<u>Twist drilling</u>	♦	♦		♦
<u>Peck drilling</u>	♦	♦		♦
<u>Hole sawing</u>	♦	♦		♦
<u>Thermal Die sinking EDM</u>			♦	

Table 8.11 Intermediate Job Data for a Single Process/Resource Combination.

Alternative 1 – <u>Cavity milling process on HG400III</u>		
Optimal feedrate (at max rpm)	mm/min	947
Material removal rate MRR	m ³ /min	3.1168 x10 ⁻⁰⁵ (constrained by geometry)
No Passes (inc roughing)		3
Time	min	2.406
Cost per feature	£	0.79
Calculated DPMO		3.08

The business objectives for the first test were set thus: the delivery and cost weightings were both set at 40 per cent, while the quality weighting is set to 20 per cent. The liquidated loss rate was set at £0.5/min with a delivery window of 5 min. These weightings represent a strong primary interest in cost and quality; the hybrid optimization algorithm should therefore choose alternatives that deliver clear cost and quality benefits at the expense of delivery.

In the case of the hybrid algorithm implemented, the target is not the identification of an absolute ‘globally optimum’. Instead the requirement is the rapid and targeted exploration of the search space by the Simulated Annealing algorithm. This convergence is shown by the rapidly falling cost, as shown for a typical run in Figure 8.5. It can be seen that

Figure 8.6 Results for Multiple Trials

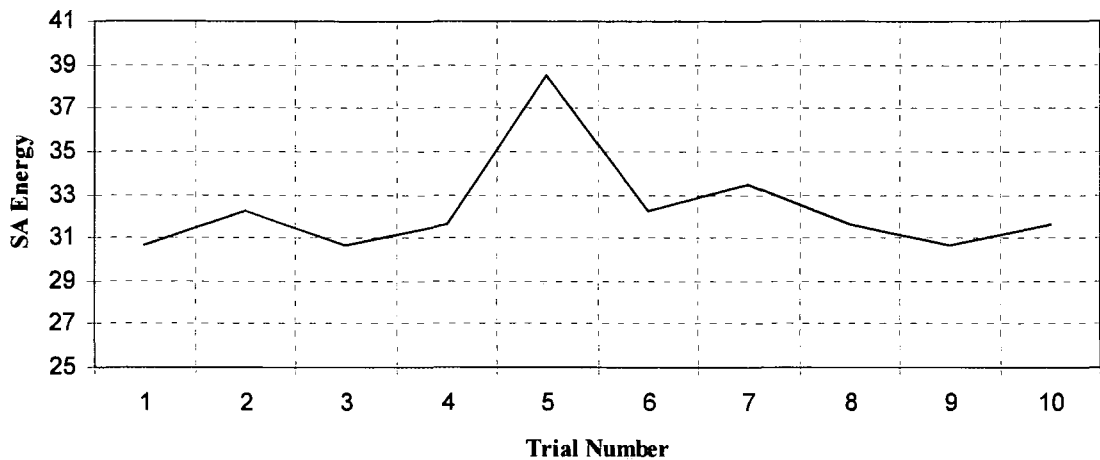

although the solution has converged, it has not identified the optimum process plan, but has chosen a plan with significantly lower energy than the initial random solution.

The repeatability of the system was therefore checked using multiple runs (as shown in Figure 8.6). For the above problem, 10 trials (using the same parameters, but with a different initial plan) were conducted. The best run (found three times) gave a total cost of £3.70, and nine the solutions were within 10% of this value. One run did not produce an optimal route. Whilst, these results show that the intelligent exploration methods are not perfect, they are acceptable for use as part of early design system where multiple runs giving slightly different results may even be beneficial.

Table 8.12 shows a near-optimal aggregate process plan generated from a run. Whilst four machines could be selected, the minimum number which can be used is one - only milling machines are required for the selected combination of operations. The system has selected drilling on a milling machine (HG400III) instead of a the dedicated Drill object (which was in the resource model) to minimise the number of set-ups (hence cost).

Meetings with the collaborating company established that the results were credible. In particular, the plans were technically feasible and provided sufficient detail for planners to work with. The available cost breakdown for this part from the company indicates that total manufacturing cost is £6.11 per unit, of which material cost is £1.05, much higher than shown for this plan, but this discrepancy was put down to, firstly, the amortisation of batch set-up time across large batches in the company's quote and, secondly, the specific costing and quotation systems used by the company which were not comparable with the ABC costing method used. However, forcing different machines to be chosen correctly

Table 8.12 A Near-Optimal Process Plan (Run 1).

Feature	Process	Resource	Cycle time (min)	Set-up time (min)	Cost of job	Quality	Total cost
<u>Material</u>	<u>Grasp easy</u>	<u>Labour1</u>	2.00	-	£1.05	-	
<u>BlindPocket1</u>	<u>Cavity Mill</u>	<u>HG400III</u>	1.20	5.20	£6.05	1.63×10^{-6}	
<u>BlindPocket2</u>	<u>Cavity Mill</u>	<u>HG400II</u>	2.04	0.00	£1.93	1.63×10^{-6}	
<u>BlindPocket3</u>	<u>Cavity Mill</u>	<u>HG400III</u>	0.48	0.00	£0.75	1.90×10^{-2}	£12.15
<u>BlindPocket4</u>	<u>Cavity Mill</u>	<u>HG400III</u>	1.51	0.00	£1.53	0.27	
<u>BlindPocket5</u>	<u>Cavity Mill</u>	<u>HG400III</u>	0.48	0.00	£0.75	2.78	
<u>ThroHole1</u>	<u>Twist Drill</u>	<u>HG400III</u>	0.09	0.00	£0.09	-	

established relative costs, so expensive process and machines will always be penalised if cost criteria is adjudged important. Finally, it was established that the routing of parts was frequently dependant on the existing loading of the machining centres, the integration of process planning and real time capacity planning is thus seen as an area which could be improved in future work.

The optimisation parameters were now modified as follows: the delivery and cost weightings were both set at 20 per cent, while the quality weighting is increased to 60 per cent. The new plan (Table 8.13) shows that the increased quality requirement has forced the selection of the new VM40-II C machine tool object because of its better quality performance. This is clearly a sub-optimal route, since it involves an unnecessary workpiece and machine set-up. This fact is reflected in an overall cost of £17.13, an increase of 60% in the cost. Since the processing times are unchanged because the cutting parameters were controlled by the tool geometry, this cost increase is due to the set-up and transfer requirements. The great majority of this cost will be from the set-ups, since the transfer times per unit can be seen to be up to two orders of magnitude lower, as in this example.

8.4.5 Knowledge-Enriched Planning Results

In line with the high quality requirement, the system was subsequently asked to generate two recovery schedules to identify any quality problems in the design. Whilst the analysis is trivial in terms of complexity it clearly demonstrates that the system is capable of prioritising improvements in different areas.

Table 8.13 A Near-Optimal Process Plan (Run 2).

Feature	Process	Resource	Cycle time (min)	Set-up time (min)	Cost of job	Quality	Total cost
<u>Material</u>	<u>Grasp easy</u>	<u>Labour1</u>	2.00	-	£1.05	-	
<u>BlindPocket1</u>	<u>Cavity Mill</u>	<u>HG400III</u>	1.20	5.20	£6.05	1.63×10^{-6}	
<u>BlindPocket2</u>	<u>Cavity Mill</u>	<u>HG400III</u>	2.04	0.00	£1.93	1.63×10^{-6}	
<u>BlindPocket3</u>	<u>Cavity Mill</u>	<u>HG400III</u>	0.48	0.00	£0.75	1.90×10^{-2}	£17.13
<u>BlindPocket4</u>	<u>Cavity Mill</u>	<u>VM40-II_C</u>	1.51	4.50	£5.68	1.44×10^{-6}	
<u>BlindPocket5</u>	<u>Cavity Mill</u>	<u>VM40-II_C</u>	0.48	0.00	£0.45	1.44×10^{-6}	
<u>ThroHole1</u>	<u>Twist Drill</u>	<u>Drill</u>	0.09	1.20	£1.22	-	

Based upon the results of an open-forum discussion with the selected SSPA suppliers, it was established that from their point of view the most effective test of the CAPABLE Space system would be as a design evaluation and feedback tool. It was anticipated that this would allow the suppliers to use their experience to comment on the manufacturability of the designed geometry (which has already been validated in terms of QCD) with the a view to possible cost reduction or quality improvements. The following analysis (as presented to the designer), Table 8.14, shows a recovery schedule in which a series of design-related improvements have been identified from a simple two factor (quantitative DPMO and qualitative DFM) analysis. In all, 7 knowledge statements were added to the product model and the 5 DPMO measurements calculated during planning were used.

Table 8.14 Recovery Schedule for a plan, combining QCD with DFM/DFA Qualitative Knowledge Factors.

Object	Capability Factor	Statement	Priority confidence score, <i>S</i>
<u>BlindPocket4</u>	<u>Machinability</u>	Thin wall may cause vibration/surface finish problems.	0.30
<u>BlindPocket3</u>	<u>Machinability</u>	Thin wall may cause vibration/surface finish problems.	0.30
<u>BlindPocket3</u>	<u>DPMO</u>	Calculated DPMO.	0.20
<u>BlindPocket2</u>	<u>Machinability</u>	Thin wall may cause vibration/surface finish problems.	0.18
<u>BlindPocket1</u>	<u>Machinability</u>	Thin wall may cause vibration/surface finish problems.	0.16
<u>BlindPocket5</u>	<u>Machinability</u>	Wiper insert required to achieve surface finish.	0.12
<u>BlindPocket4</u>	<u>Machinability</u>	Wiper insert required to achieve surface finish.	0.12
<u>BlindPocket5</u>	<u>Machinability</u>	Long thin pocket requires 2 axis ramping (3 axis better).	0.10

8.4.6 Closing Remarks on Planning Case Study

This case study has demonstrated that CAPABLE Space is able to generate feasible aggregate process plans from aggregate product model data. Because the system does not guarantee to find optimal solutions, it is suggested that multiple runs are necessary, but this gives the advantage of offering multiple possible solutions to the designer.

The fact that the results closely match the actual routes is an excellent validation of the 'data-resistant' modelling and planning methods, as these predictions will be available during the very early stages of design, allowing the teams to identify and improve problem areas and choose the right production routes for manufacture.

8.5 Case Study 3: Service Module (SM) Floor Panel

8.5.1 Aims of the Case Study

This final exemplar was designed to demonstrate the operation of the knowledge-enriched planning system under more complex product, and planning scenarios. The results of this case study were presented in Maropoulos, *et al.* (2003a) The aggregate data models are representative of a typical satellite manufacturing scenario in terms of complexity and scale of operations involved. Again, to protect proprietary data, the actual data used in this example has been changed; the intention being to demonstrate the methods, rather than report actual figures. The overall vision for CAPABLE Space is perhaps best illustrated through this final scenario. It shows the possible industrial application of the methods, and as such represents as close to a 'real-life' setting as possible. This section, therefore, addresses the issues of the success of the methodology, as distinct from the technical evaluation of the computer methods.

The following user needs were established as being desirable in such a system, and were examined in this research:

- (1) Can process plan be generated without precise (payload) specifications?
- (2) What are the major manufacturing steps?
 - (a) How many components need to be assembled?
 - (b) What are the tooling requirements for these joints and components?
- (3) Which components are required to be outsourced?
 - (a) Which suppliers may cause us delivery/quality problems?

8.5.2 Product Distributed Analysis and Resource Distributed Analysis

Two distinct methodologies for utilising the distributed process planning methods have been identified and validated. Termed Product Distributed Analysis (PDA) and Resource Distributed Analysis (RDA) the two techniques differ in the way that the product model(s) and resource model(s) are created and shared across the internet/intranet networks. Because this test was designed to directly involves supplier communication, the system was configured to be run in a network environment with remote database servers.

The first distributed operational mode, termed Product Distributed Analysis (PDA) utilises the suppliers in generating process plans based upon their own resource models and the distributed product model. This is the standard configuration of the system as used in the previous two case studies. In summary, the procedure for utilising this is as follows:

- (1) The main company posts the specified design to the database and informs the supplier network of the models for download and specifications thereof.
- (2) Individual suppliers submit a notification of interest and post a request for access; with subsequent permissions they can then download the product models.
- (3) A distributed process planning analysis is performed utilising the supplier's own resource model and the resultant planning information is uploaded back to the database.
- (4) The main company collates the submitted process plans and assesses the response; a new Request For Interest (RFI) may be posted, if necessary.
- (5) The main company selects the supply chain based upon the submitted plans.

The advantage of PDA is to exploit the more increased knowledge that exists at the supplier, leaving the details of process modelling and the final detailing of the product to experts.

The second distributed operational mode, termed Resource Distributed Analysis (RDA), shown in Figure 8.7 utilises the aggregate planning engine to a greater extent, with the system evaluating upon the distributed resource models of the suppliers. The RDA configuration was chosen as the configuration for the this example, as follows:

- (1) Suppliers, who wish to become part of the main company's supply network, submit a resource model of their facilities and equipment to the web-enabled database.

Figure 8.7 The RDA Workflows Identified and Communicated for this Case Study.

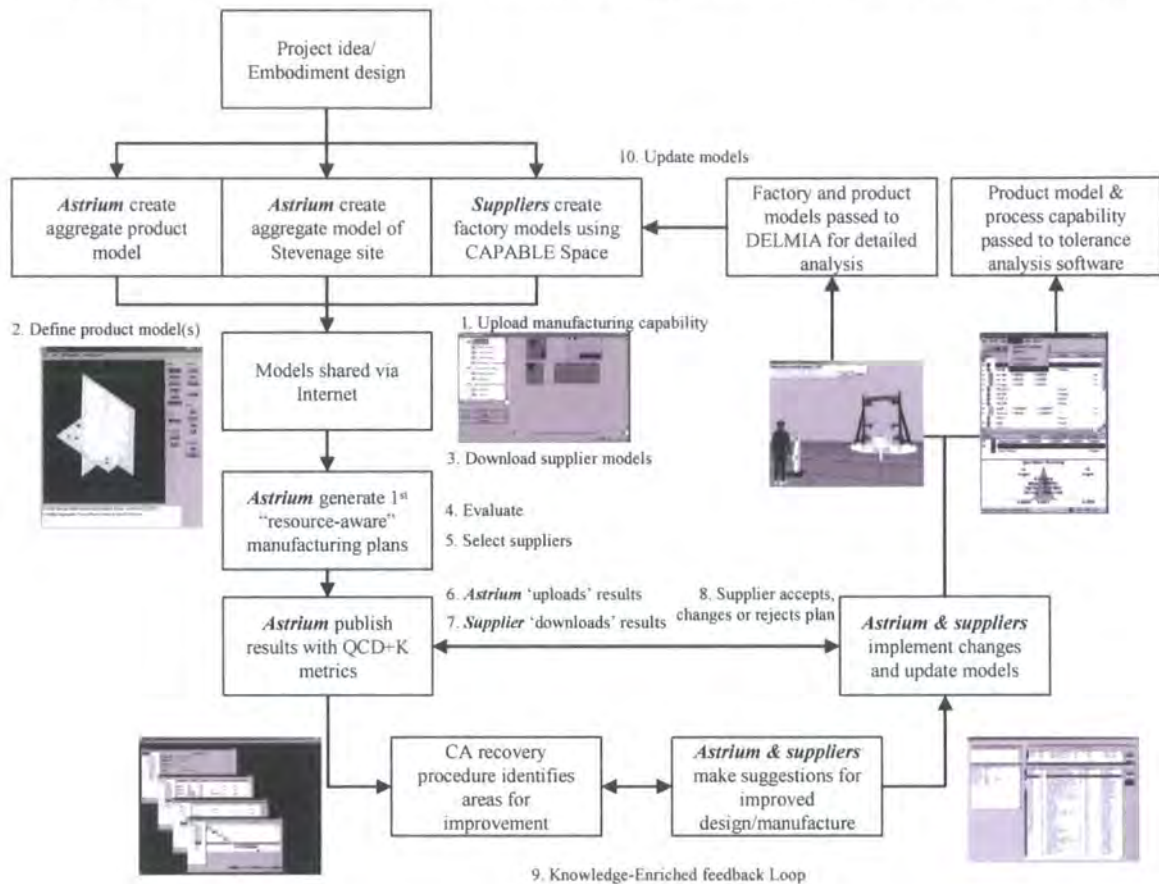

- (2) The main company downloads these supplier models and with a given product model utilises the intelligent exploration algorithms to evaluate and rank the selected suppliers.
- (3) The selected plans are uploaded into the web-enabled database and the appropriate suppliers informed.
- (4) Each supplier retrieves their respective process plans and decides to accept, reject or improve the results.

The advantage of RDA is a global search for near-optimal solutions over the entire search space, rather than piecing together fragments of plans and schedules from many low level suppliers. Also, this method can be carried out without the involvement of suppliers. The interaction with suppliers in this case is of interest and may be the subject of further research. In particular, the mechanisms by which feedback and design progression is managed directly relates to the novel work of Jin and Lu (2004) in the area of Engineering as Collaborative Negotiation (ECN).

Figure 8.8 Example of a Completed SM Floor Panel to Show True Complexity.



8.5.3 Population of Product and Resource Models

In this example, it was proved that the aggregate data models can be used to construct a model of a panel SM Floor Panel (see Appendix C). This panel is representative of a the complexity of a typical satellite panel, as shown in Figure 8.8. In this case, the product model was reverse engineered from four separate engineering drawings. The product model has 6 major hole features, and a large number of smaller holes which are required to interface with other elements of the satellite's structure. In order for the product model to be validly deconstructed by the process planner, additional intermediate components were required. For example, the two structural bond features, Structural Bond 1 and Structural Bond 2 are used to ensure that the panel and honeycomb are joined first, before the tooling holes are drilled into the honeycomb. This condition is primarily due to the requirement to have the honeycomb stiffened by bonding to the skin before any machining can take place, but does demonstrate how product models can be loosely configured or have specific assembly constraints imposed. The SM Floor Panel component also contains a large number of insert holes used for location of payload equipment. Traditionally, this meant that the finalisation of the component's design could not occur until after payload specifications were confirmed and hence no process planning was done until late in the design cycle. Using CAPABLE Space, it was demonstrated how a plan can be generated using groups of holes with no specific location.

Four resource models were constructed for this test, consisting of 15 machine types, including various configurations of machine tools, work centres capable of lay-up and

point placement operations. The manufacturing capability of the Astrium plant, which is responsible for the manufacture and assembly of the structural panels, was obtained over a series of visits to the collaborators. This involved interviews with manufacturing management, engineers and shop floor workers, reviews of documentation, such as pre-existing-routing information as well as statistical process control data and searches of the relevant literature to obtain particular machine capabilities. From this data, a series of process specification and resource capability documents were generated and were used to populate the process and resource models. During such conversations and with specific mention to certain products, processes and resources many knowledge statements were captured and entered into the relevant models. Similar data gathering exercises also took place at two supply chain companies. A range of machining centres were specified, capable of coping with panels of up to 4m by 4m. Set-up times for batch and part were provided for each resource and a comprehensive set of operating parameter data was also entered using machine data sheets. Data governing the manual operations was established using process specifications provided by the companies involved.

As well as generic process models such as machining and assembly, additional specialist process models for satellite manufacture ranging from panel lay-up to machining and insert potting were constructed using expert interviews. These process generally had multiple operations and require pre- and post-processing steps, such as degreasing and surface preparation.

8.5.4 Knowledge-Enriched Aggregate Planning Results

This case study was designed to replicate a major new product introduction activity, where the first planning task might be to ask, ‘can the design be manufactured in-house?’. Hence, the product model and a single Astrium factory were selected for planning. The results of the plan identified that the object SM Floor Panel had a number of features (Doubler A and

Table 8.15 Summarised Planning Results for Runs 1 and 2.

Plan	Quality (DPMO index)	Total cost (£)	Delivery (min)
Run 1	0.4834	15,793	7959
Run 2	0.5269	15,514	7787

Table 8.16 Summarised Planning Results for Runs 3 and 4.

Plan	Quality (DPMO index)	Total cost (£)	Delivery (min)
Run 3	5.486	12,076	6296
Run 4	5.288	13,075	5792

Table 8.17 Effect of Including Plan Knowledge Loss in Objective Function.

Plan	Quality (DPMO index)	Total cost (£)	Delivery (min)	Knowledge loss (£)
Run 4	5.288	13,075	5792	0
Run 5	5.113	13,557	6120	5,489

Doubler B) which could not be manufactured internally. This was due to a failure to map suitable resources to the only capable process, Chemical Milling. To test the allocation of multiple parts/fabrications to remote facilities (using distributed functionality) a number of additional factories, capable of carrying out the required chemical milling operations were, therefore, modelled for testing these components.

With a full supply chain model available, the planning engine was re-run demonstrate the allocation of multiple parts/fabrications to remote facilities and to observe the effect of modifying the business objectives on the planning results. For runs 1 and 2 the QCD domain importance weightings were set at 100, 100, 50%. Table 8.15 shows the summarised planning results for these two runs as they would be presented to a designer. These weightings represent a strong primary interest in cost and quality. For Runs 3 and 4 the weightings were changed to 0, 30 and 100% respectively, giving the results shown in Table 8.16. With these business objectives set, the Simulated Annealing algorithm should not select delivery improvements as a rule, however such an improvement has emerged as a consequence of relaxing the quality requirements.

The planning engine was also run for the SM Floor Panel both with and without knowledge statements attached. This showed how the process plan would change as a result of including this analysis in the objective function. It can be seen from Table 8.17 that the inclusion of knowledge loss into the objective function has worsened the QCD performance of the overall plan, as a result of avoiding job combination that would be otherwise undesirable.

Using previously identified knowledge statements the Capability Analysis can be used by the designer to indicate the capacity for improving the design in the various areas relating to capability factors at each level. For run 5, the improvement potentials of selected capability factors is shown in Table 8.18. Comparing these it was indicative that it would be more advantageous to improve quality through changes to the process design rather than product design or resource model configuration changes.

When these issues have been resolved, a further development task might be to look at continuous improvement of the enterprise. Looking at a resource level recovery schedule (Table 8.19), ‘Logistics performance’ on the Astrium factory object is shown as the second most important target for improvement. Performing a lower analysis (Table 8.20) reveals the cause of this poor performance; issues which would almost certainly need to be tackled before implementing the optimised process plan.

8.5.5 Problems Encountered with Large Datasets

In the supplier example, discussed above, 64 jobs were necessary to complete the plan and the system took less than five minutes to intelligently explore it. This means that the performance of normal PC desktop systems is suitable for analysing fairly complex scenarios using CAPABLE Space. However, to analyse a full satellite may require in excess of 800 jobs leading to unacceptably large computing times. It is thought that the choice of the Java language and the associated Remote Method Invocation interface impart much of the computing overhead and rewriting the methods to use newer PDM solutions

Table 8.18 Comparison of Capability Factor Improvement Potentials.

Factor	Improvement Potential, <i>I</i>	Collated to Level
Production quantity	0.64	Process
Structural efficiency	0.44	Component
Tooling costs	0.42	Process
Labour intensity	0.38	Process
Process waste	0.38	Process
Overall equipment effectiveness	0.30	Resource
DSA of supplier	0.09	Factory

Table 8.19 Resource Level Recovery Schedule.

Object	Capability Factor	Statement	Priority Confidence Score, <i>S</i>
‘Verdict’	Overall equipment effectiveness	n/a – directly calculated score	0.44
‘Astrium’	Logistics performance	n/a - calculated score	0.41
‘NPE’	Logistics performance	n/a - calculated score	0.40
‘NPE’	Delivery schedule achievement	Not a local supplier - delivery schedules sometimes not met.	0.37
‘Verdict’	Qualitative cost performance	n/a - calculated score	0.36
‘Astrium’	Risk performance	n/a - calculated score	0.34

Table 8.20 Equipment Level Recovery Schedule.

Object	Capability Factor	Statement	Priority Confidence Score, <i>S</i>
'Desitech'	Machine usage	Desitech machine is running at near capacity.	0.95
'Desitech'	Breakdown	Requires frequent maintenance and calibration	0.88

(Filtered to Show Only Priority Confidence Scores Corresponding to the Second Target in Resource Level Recovery Schedule).

would increase performance.

When considering the recovery schedule for a large process plan, if the number of knowledge factors increases beyond a manageable level, of say 20 factors, this tends to over-complicate and devalue the analysis, which in reality would exacerbate known issues, such as out-of-date knowledge and ownership and control issues. It was, therefore, concluded that the system is best employed as a decision support tool rather than an all-encompassing Knowledge Management system. It is, thus, better to think about the enterprise's objectives and create tailor-made analyses which are transparent to the user. Increasing the number of Knowledge Scores however provides no obvious problems, and indeed shows off the ability of the system to simplify results for the user.

8.5.6 Closing Remarks for SM Floor Example

In summary, this case study has proved that the methods can handle real-world levels of complexity and fit into the 'normal' working practices of a design department. It is worth noting that the knowledge statements used in this test were tightly controlled: if unlimited, uncontrolled knowledge is entered into the system it tended to lead to problems with data control issues and the identification of problems not critical to early decision making. Hence, it was concluded, that to gain maximum advantage from the system, the user must use carefully chosen capability factors tailored to the enterprise's decision making needs.

8.6 Summary and Analysis of Case Study Material

Although it would have been desirable, it was unfortunately not possible to roll out the system into a full-scale, working concurrent engineering situation as the system has been designed for. Although, initial results and feedback have been positive no firm conclusions can be drawn as to the feasibility of such a system as part of an integrated system.

However, the fundamental hypothesis and logics that underpin CAPABLE Space have all been validated. The experimental results show that:

- (1) The new aggregate data models, described in Chapter 4, can support the transition of the design from uncertain early design through to detailed design.
- (2) Based on the results of the first two case studies, it can be concluded that the combined planning and Capability Analysis methods are highly effective in providing highly relevant, timely information in order to support decision making in early planning.
- (3) Process planning module is able translate product model design data into manufacturing sequences and optimise manufacturing processes parameter selection.
- (4) The hybrid intelligent exploration method developed as part of the research has been extensively tested to ensure that it performs as intended and that its results have been verified.
- (5) The method itself has been validated to prove the usefulness of the rapid and targeted exploration of the process planning search space.
- (6) Proven for most industrial sectors, such as general batch and special projects manufacture.
- (7) The system functions best when treated as a decision support tool – applying specific factors and knowledge scores related to the user’s overall objective.

8.7 Future Research Directions and Challenges Identified

Based upon the findings from this extensive testing of the system and feedback from the parties involved, the following recommendations for future development were made:

- (1) The CAPABLE Space system was developed as a proof-of-concept system and there remains much work to be done to resolve identified problems and make the system capable of dealing with the large amounts of industrial data. Most of these problems relate to resolving conflicts and data incompatibilities between the many options that can exist.
- (2) Interoperability with other systems and platforms so that a standard for integrating other tools easily is supported. In the medium term, the CAPABLE Space system needs to be developed to strengthen its links with popular, commercial software systems for product development. For example, linking

the Product Model design methods with a CAD solution such as CATIA V5 and linking the knowledge representation functionality with a PDM solution. Feasibility studies of such integrations are being investigated at present. Another possibility, would be to link the software with other research tools such as the iVIP workbenches (Fraunhofer IPK 2002) which share common features with DET.

- (3) Whilst, the tests performed to date have proven the technical feasibility of the systems and given positive feedback from a limited number of users, the financial benefit which could be obtained through the use of the aggregate planning methods remains an unknown quantity. The benefits are potentially quite large since the majority of production costs are decided during the early stages of design. Further investigation, involving a wider range of users and commercial software vendors would be required to determine the costs of developing robust versions of the software and the actual market size.

8.8 Conclusion

The key issues identified at the beginning of this Chapter have been answered here – CAPABLE Space provides a useful tool to product development, bringing tangible benefits for design problems of varying complexity. The most powerful features of CAPABLE Space are the provision of early process plans, encompassing a variety of manufacturing options for each product design and the provision of an automated system for applying design and planning knowledge in order to rapidly evaluate the designs for further work. It is expected that integrated design teams would benefit from both of these features, since they will be empowered with the ability to bring processing knowledge to bear on the early designs. In particular, CAPABLE Space gives the ability to consider multiple processes and to investigate the effects on production costs of a range of product development decisions, including factory layout and equipment changes as well as design changes.

Chapter 9 Discussion and Conclusion

9.1 Introduction

Motivated by the design and manufacturing integration opportunities offered by the DET framework, this research addressed the issue of early decision in the context of agile manufacturing. As a direct result of this research, a DET-based knowledge-enriched aggregate planning system was developed and applied to a number of practical situations within the UK space industry. This final chapter recalls the original objectives, summaries the research achievements and discusses how, by meeting these objectives, the work has addressed the industrial need. Finally, the ongoing development and potential avenues for the commercial application of these methods is explained.

9.2 Discussion

9.2.1 Synopsis of Original Objectives

The two main research objectives were to develop new aggregate planning technology to link the early stages of product design with manufacturing operations to (i) rapidly translate product specifications into process requirements and manufacturing routings and (ii) to broaden the traditional boundaries of process planning by incorporating a technical evaluation expert knowledge and DET-based analysis results to aid decision making (by validating early process and resource selection) and to guide the prioritisation of detailed design tasks.

These aims, were supplemented by the need to research and develop supporting technology components in the DET-based Knowledge-Enriched Aggregate Process Planning architecture. These outcomes are shown in Figure 9.1 and described in the sections below.

Figure 9.1 The Research Achievements (Shown in the Context of the DET Framework).

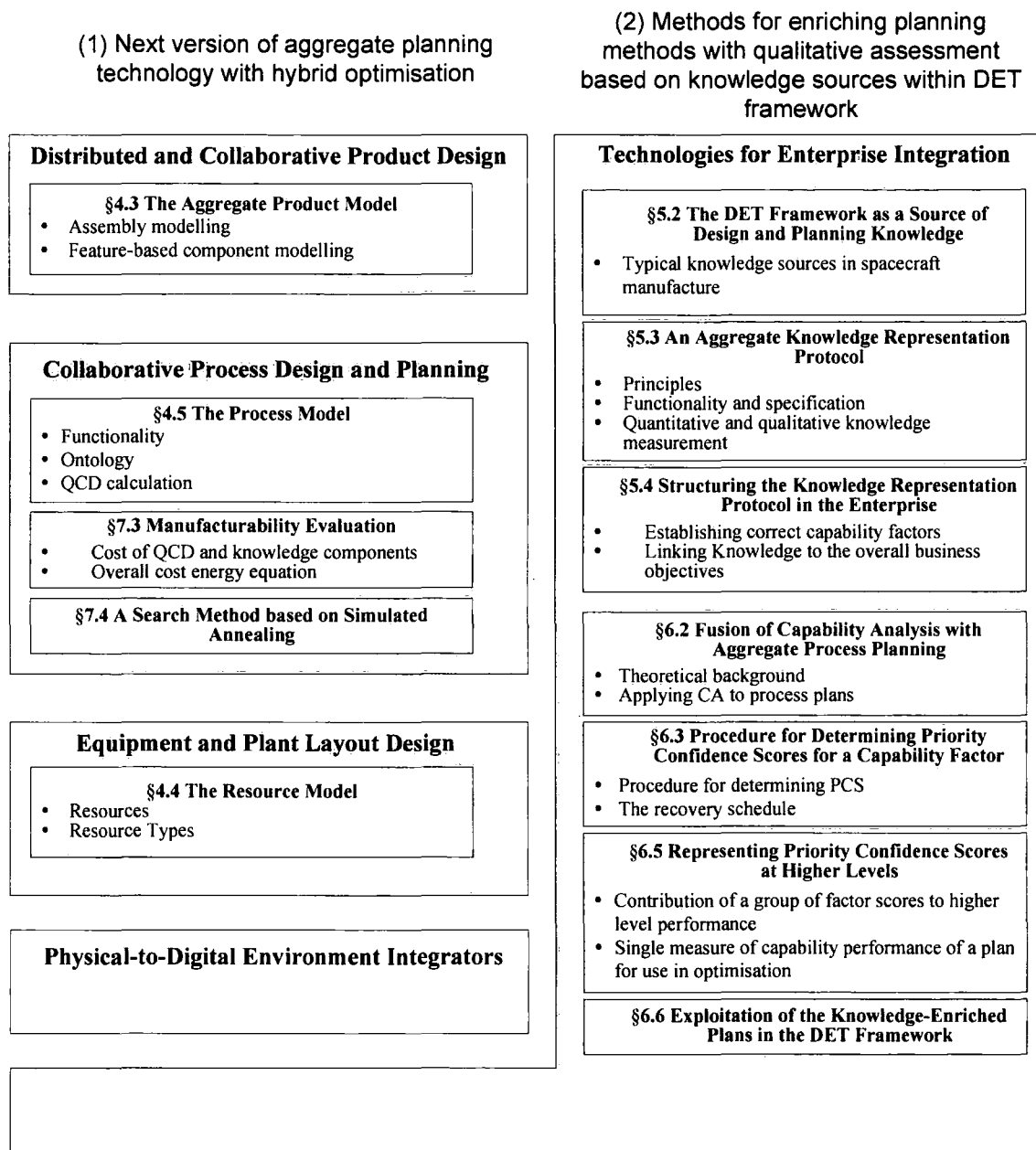

9.2.2 Specific Contributions to Aggregate Process Planning Research

The theoretical definition and formalisation of the concept of Resource-Aware Aggregate Process Planning was presented and realised; creating new methods for the translation of product specifications into process requirements, the creation of manufacturing routings and the technical evaluation of possible plans to be made and communicated throughout the enterprise. This was achieved by developing (or making enhancements to) the following key technology components:

- (1) The concept of an aggregate product model was realised and enhanced with the capability to model alternative product configurations via the creation of joint features. The aggregate product deals with the early stages of product development, hence it has been configured to accept incomplete design data.
 - (a) A software application was also written to allow the viewing of aggregate product models when an appropriately specified feature-based product model is available. This also facilitates communication with DET software such as CAD systems and analysis packages using the STEP neutral file format.
- (2) A generic aggregate resource model has been defined to allow the systematic and consistent representation of the manufacturing capability of companies in a distributed enterprise. Crucially, the resource model is capable of re-configuring, scaling or changing the availability of the resources made available for use during aggregate planning.
- (3) A library of aggregate process models, expanded to cover specialist satellite manufacturing processes, has been created. The limited availability of detailed product and resource information available during early design necessitated the development of new procedures to model manufacturability and assemblability at the aggregate level.
- (4) A hybrid evolutionary computing method, combining a Simulated Annealing algorithm and a Greedy algorithm, for the intelligent and objective exploration of production options within the distributed enterprise using user-defined quality, cost and delivery and knowledge optimisation criteria. Specifically, this give rise to a dynamic relationship between the specification of the entities of the product model and the resources available to make it.

9.2.3 Originality of Knowledge-Enriched Planning Concept

This research has pioneered the concept of fusing Aggregate Process Planning with methods for the technical assessment of qualitative and quantitative knowledge, to produce *knowledge-enriched* plans. The knowledge enriched concept has broadened the traditional boundaries of process planning research beyond a purely technical evaluation. –The knowledge enrichment methods support the representation of DET-based product, process and supplier knowledge, not otherwise captured in the QCD-based aggregate manufacturability evaluations, and its prioritisation for further evaluation and improvement

in DET-based design systems. The result is a *distributed product and process design and planning* system to support early design decisions based increasing the available knowledge about technical design and predicted evaluations network performance. The academic achievements of this particular part of the research includes:

- (1) A systematic method has been developed for the capture of both quantitative and qualitative design and planning knowledge from multiple sources within a DET framework and expert supplier knowledge and its subsequent 'relation' to elements within the aggregate process plan. A novel knowledge representation protocol has been demonstrated which can:
 - (a) Support the representation of imprecise qualitative information as well as quantitative manufacturability measurements from the DET framework. Capability factors have been identified to represent measurable aspects of performance.
 - (b) Model the effect of knowledge (at an appropriate 'aggregate' level) across multiple business domains and subsequently relate the impact of knowledge on company strategy.
 - (c) Maximise the re-use of existing information from existing business processes within the DET framework. QFD, FMEA, process simulation and expert opinion have all be demonstrated as suitable sources of knowledge which can be distilled into individual knowledge statements.
 - (d) Recognise the conditionality of knowledge, to be able to indicate how certain knowledge can be conditional on the make up of the process plan.
- (2) In knowledge-enriched planning, a Capability Analysis method has been applied to prioritise knowledge statements within a process plan, according to their potential from improving that plan. By including the output of the Capability Analysis in the optimisation criteria the system avoids generation of plans which, whilst technically feasible, are otherwise impracticable or undesirable. As applied to aggregate planning the Capability Analysis method has been shown to:
 - (a) Compare dissimilar indicators of manufacturing knowledge and performance.

- (b) Provide a prioritised list of improvement targets (the recovery schedule) covering product, process and resource information to guide the progression of design and highlight areas of concern to reduce risk.
 - (c) Uncover the low level causes of poor performance at the process plan level.
- (3) The combined output of the aggregate planning and Capability Analysis methods act as a trigger for detailed design tasks. The Capability Analysis techniques in particular can facilitate new ways of working that stimulate early product optimisation by facilitating iterations with respect to performance QCD and knowledge in order to address multiple design aspects at once

Based on the testing of the above methods, in the CAPABLE space application, it has been proven that resource-aware planning is a feasible planning technology to link the early stages of product design with manufacturing operations within an extended enterprise and the perceived industrial exploitation (and benefits) of this technology of this may be as follows:

- (1) Improved manufacturability and quality of product designs; when used as part of a DET system, major manufacturing problems are easily identifiable; parts for which no feasible process or resource selection is available are quickly determined, parts which are difficult to manufacture can be identified and investigated using detailed analysis packages. The methods allow the comparative study of alternative design configurations to take place on a designer's desktop computer, from the earliest stages of design and throughout the product's lifecycle.
- (2) Better involvement of designer in downstream processes and better communication between design and manufacturing.
 - (a) Aggregate product and process models allow the analysis and evaluation of design decisions without the need for a fully specified CAD model. Significantly, the implementation of the above techniques allows digital product, process, resource and planning information to be communicated across DET frameworks, facilitating integrated product and process design.
 - (b) The aggregate-level manufacturability analysis of process plans is a unique and flexible approach. It facilitates new ways of working that

stimulate early product optimisation by facilitating iterations with respect to performance QCD in order to address multiple design aspects at once.

- (3) Enabling earlier production planning and capacity planning, using the early planning estimates of build time. The flexible and generic planning scenarios supported by the dynamic mappings between product, process and resource models give the capability for re-configuring, scaling or altering the configuration of enterprise resources at the design stage leading to high plant and supply chain reconfigurability. There is also reduced risk as the capacity and logistics of the extended enterprise are known and controlled from the outset of product development.
- (4) Shortened time to market for new products.
- (5) Most significantly, the implementation of the above techniques allows digital product, process, resource and planning information to be communicated across DET frameworks, facilitating integrated product and process design, significantly reducing the risk of developing un-manufacturable products.

9.2.4 Limitations of the Research

Presently, the CAPABLE Space demonstration system illustrates the potential of the system, there are a number of issues yet to be addressed including:

- (1) The aggregate data models and planning methods are currently not adequately well integrated with existing design software. A further development of the system is planned to integrate the aggregate data models within existing CAD and PDM-centred design environments and execute the planning methods through a middleware software solution.
- (2) An obvious limitation on aggregate planning is the lack of volume considerations and batching rules which result in the generation of plans which need further user intervention and may not be optimal. This is not considered too limiting in the context of early planning as the current generation of simulation packages needed to optimise product flows require significant time and effort to be placed into the development of models.
- (3) The CAPABLE Space system would benefit with closer links to data mining tools (such as Shaik, *et al.* 2005) in order to facilitate the rapid generation of

process models and extraction of design and planning knowledge, as currently this is a very time-consuming task.

- (4) As CAPABLE Space system was developed primarily as a research tool, it is not sufficiently robust enough to operate in an industrial setting.

9.2.5 Appraisal of the Knowledge-Enriched Planning Methodology

This research has identified how DET-based planning technology can benefit from knowledge-enrichment techniques for informing decision making in the dynamic environment of early design. However, these methods are entirely dependant upon having the right knowledge in the enterprise in the first place. To successfully capture knowledge requires companies to foster a working environment where people actively record and pass on their knowledge. The psychology of knowledge management is well documented, but the inclusion of systems to manage it remain outside the scope of this research, but would undoubtedly be required for a commercial application of these tools. Capability Analysis does not (implicitly) address the human interaction aspects of continuous improvement and in order to carry out the improvements identified in the recovery schedule, it is necessary to have in place a management structure that allows all employees to be involved in activities.

Nor is knowledge management only about capture and re-use, in fact it also needs procedures to be put in place for verification and validation checking: knowledge can potentially be incorrect, or expire, or change over time. Thus, as a prerequisite for the adoption of these methods it would be necessary for a company to inculcate a strong knowledge-based design and manufacturing culture. However, this does not mean that a company would be required to model their gamut of enterprise knowledge: a lack of knowledge or uncertainty could even be considered as capability factors in their own right.

Finally, a major stumbling block to the widespread adoption of the methods for collaborative design is concern over intellectual property and security an open design environment. The fact that collaborative working can provide such a large competitive advantage, means that in the long term more companies are expected to overcome these cultural issues and work together in extended enterprises.

9.3 Future Work and Exploitation Plans

In the near to medium term, the general direction of process planning research is expected to focus more towards the evaluation of very early stage design, for which the work presented forms a key component. It is expected that this point standardisation will be a large issue; clearly, a key requirement for adoption of new methods is that they should be compatible with existing and future enterprise management software, and indeed at the University of Durham, such additional functionality is already being developed in two follow-on research programmes sponsored by EPSRC (GR/N11285 and GR/R26757). The second of these projects in particular, is directly extending the knowledge-enriched planning functionality via the creation of methods to support the automatic translation of design information held in an internet-based Product Data Management system and an enterprise IT system into aggregate data models. It also considers the necessary interface standards to link the aggregate planning methods with proprietary systems. Other research papers, notably Feng and Song (2002), Feng, *et al.* (2003) and Scholz-Reiter and Höhns (2003) have begun to apply the theory of autonomous, intelligent agents to process planning, particularly with regard to the interoperability of distributed data sources for purchasing and logistics. Such functionality would, of course, be relevant to CAPABLE Space particularly with regard to checking inconsistencies in the aggregate data models and the process plans generated. Fundamentally, procedures and methods are required to manage the system in a full scale, real world system.

Other possibilities for future work centre around the workflow and lifecycle concerns:

- (1) To control how the transfer knowledge is managed between projects.
- (2) To investigate how well the knowledge models predict the future and create feedback loops to provide a self-regulating system for knowledge scoring.
- (3) To extend the scope of the system beyond purely manufacturability issues by incorporating more stakeholders, such as, accounting, sales and marketing into the working definition of design and planning knowledge. Ideally, the system can only be truly successful if the QCD+K measures are used for decision making at all levels of the organisation.
- (4) To establish the most appropriate Capability Factors for particular industry sectors.
- (5) To add sensitivity analysis to the system in order to identify the contribution of individual factors to the overall manufacturability.

9.3.1 Connection With the Development of Commercial CAPP Systems

This methods presented are not designed to exist in isolation, but to compliment traditional product and process design tools. A recent software release, Process Engineer, from DELMIA is ideally placed to take advantage of these methods (CIMdata 2003). This is the first attempt at a truly integrated production simulation software suite. The system is flexible to use but the emphasis is on using experts to input (historical, estimated or calculated) process information. So, in reality the sheer complexity of the real world applications can easily result in the definition of sub-optimal solutions. Offering the ability to automatically derive assembly times and provide early suggestions for manufacturing concepts (as provided by CAPABLE Space) would further enhance the use of the software for very early design. Unlike CAPABLE Space, the DELMIA software makes no attempt to select optimum processes or look for manufacturing improvements through alternative allocations of resources although it clearly does aim to validate, monitor and control manufacturing systems (Brown 2000).

The purpose of describing the Process Engineer software here, is to show the possible exploitation paths and to emphasise that, at present, there is great potential for the software, but further development of the experimental system will be required to produce a robust commercial system. It is difficult to calculate the expected return on investment of any further development, although if the system is used during early design as intended, these benefits are potentially very large.

9.3.2 Connection With Logistic-Oriented Design Proposition

Another area which will benefit significantly from the methods described in this thesis is logistic-oriented design. Indeed some initial investigations have taken place to identify the suitability of using the core system architecture of CAPABLE Space as the foundation for a commercial planning system. Other avenues related to 'Design for Logistics' have also been explored, including one suggestion to use CAPABLE Space's evaluation functions to evaluate the decision to integrate two processes on a single machine to offset handling, transport and re-tooling operations; as proposed by Scholz-Reiter, *et al.* 2004. (Note that is a highly novel research area regarding the design and development of new processes and should not be confused with the hard automation of the 1980s.) Another topic of investigation may be the use of process plans as input to more in depth investigative validation tools such as capacity management or inventory control which can incorporate

more specific data on product value (the demand) and real time modelling of the flow of parts (the capacity).

9.4 Conclusion

Traditional process planning research concentrated on the technical aspects, but did not appreciably improve the product development process. DET has the potential to become the *de facto* framework for the realisation of agile enterprises but its success will be reliant on the development of robust planning functions with the capability for rapidly introducing new products and (re)organise manufacturing systems and supply networks. This thesis described a new knowledge-enriched aggregate planning methodology, for DET, to facilitate the integration of the underpinning modelling, planning and knowledge representation technologies for making early product development ‘data resistant’ and ‘resource-aware’. The aggregate concept uses hierarchical models to describe designs with evolving information content and augmented with qualitative and quantitative knowledge about probable manufacturing issues. Capability Analysis has been applied to demonstrate the feasibility of carrying out a technical evaluation of knowledge contained in process plans, before any significant effort is invested in detailed design; something which could not have been done with traditional modelling techniques. Core methods and experimental software tools have been developed to prove the technical feasibility and potential application for dynamic, aggregate planning and intelligent exploration of manufacturing operations within large, complex production networks during the formative stages of design. The results were encouraging; it was proven that it is possible to use process planning as a *design tool* to foment innovation, aggregate planning methods can generate indicative product manufacturability and allow the cost-based evaluation of alternative design configurations and manufacturing scenarios, through the intelligent allocation of parts to processes and process to factories within the supply network. This achievement is important, since a large proportion of lifecycle cost is determined during early design; the knowledge-enriched planning analysis can thus be exploited in future digital manufacturing (DET) architectures to shorten development time, reduce cost and optimise the use of resources.

References

- Ackoff, R. L., 1974. The systems revolution. *Long Range Planning*, 7(6), 2-20.
- Aitken, S., 2005. An ontological account of action in processes and plans. *Knowledge-Based Systems*, 18(6), 295-305.
- Aitken, S. and Curtis, J., 2002. Design of a Process Ontology: Vocabulary, Semantics, and Usage. *In: Proceedings of the 13th International Conference on Knowledge Engineering and Knowledge Management*, 1st-4th October, Sigüenza, Spain. Springer Verlag, 108-113.
- Akao, Y., 1990. *Quality Function Deployment: Integrating Customer Requirements into Product Design*. English translation. USA: Productivity Press.
- Akao, Y. and Mazur, G. H., 1991. *Hoshin Kanri: policy deployment for successful TQM*. Cambridge, USA: Productivity Press.
- Alford, D., Sackett, P. and Nelder, G., 2000. Mass customisation - an automotive perspective. *International Journal of Production Economics*, 65(1), 99-110.
- Allen, D. K. and Alting, L., 1986. *Manufacturing Processes: Student Manual*. Utah, USA: CAM Software Research Laboratory.
- Andrews, P. T. J., Shahin, T. M. M. and Sivaloganathan, S., 1999. Design Reuse in a CAD Environment - Four Case Studies. *Computers & Industrial Engineering*, 37(1-2), 105-109.
- Autonomy Corporation, 2003. Autonomy Technology White Paper. <http://www.autonomy.com> [Accessed 08/12/03].
- Aziz, H., Gao, J. X., Cheung, W. M. and Maropoulos, P. G., 2003. A design environment for product knowledge management and data exchange. *In: Proceedings of 2003 International CIRP Design Seminar 2003*, 12-14 May 2003, Grenoble, France.
- Bagshaw, R. W. and Newman, S. T., 2001. Structured approach to the design of a production data analysis facility - Part 1: Conceptual design and information requirements. *International Journal of Production Engineering Research*, 39(10), 2121-2141.

- Bailey, J., Roy, R. and Tanner, A., 2000. Cutting Tool Design Knowledge Capture. In: R. Roy, ed. *Industrial knowledge management: A micro level approach*. London: Springer-Verlag.
- Baker, R. P. and Maropoulos, P. G., 1998. Manufacturing capability measurement for cellular manufacturing systems. *International Journal of Production Research*, 36(9), 2511-2527.
- Baker, R. P. and Maropoulos, P. G., 2000. Cell design and continuous improvement. *International Journal of Computer Integrated Manufacturing*, 13(6), 522-532.
- Barton, J. A., Love, D. M. and Taylor, G. D., 2001. Design determines 70% of cost? A review of implications for design evaluation. *Journal of Engineering Design*, 12(1), 47-58.
- Bernard, A., 2005. Virtual engineering: methods and tools. *Proceedings of the Institution of Mechanical Engineers: Part B: Journal of Engineering Manufacture*, 219(B), 413-421.
- Betteridge, M., 2002. *A methodology for aggregate assembly modelling and planning*. Thesis (Ph.D.). The University of Durham, UK.
- Boothroyd, G., Dewhurst, P. and Knight, W., 2002. *Product design for manufacture and assembly*. 2nd. New York, USA: Marcel Dekker.
- Bradley, H. D., 1997. *Aggregate process planning and manufacturing assessment for concurrent engineering*. Thesis (Ph.D.). The University of Durham, UK.
- Bramall, D. G., McKay, K. R. and Maropoulos, P. G., 2001. Manufacturability assessment of conceptual and embodiment designs using aggregate process models. In: *Proceedings of the 2nd International Conference on Advances in Production Engineering*. 7th-9th June 2001. Warsaw, Poland. 121-130.
- Bramall, D. G., McKay, K. R., Rogers, B. C., Chapman, P., Cheung, W. M. and Maropoulos, P. G., 2003. Manufacturability analysis of early product designs. *International Journal of Computer Integrated Manufacturing*, 16(7-8), 501-508.
- Brazier, F. M. T., van Langer, P. H. G. and Treur, J., 1998. Strategic knowledge in design: a compositional approach. *Knowledge-Based Systems*, 11(7-8), 405-416.
- Brinke, E. T., Lutters, E., Streppel, T. and Kals, H., 2004. Cost estimation architecture for integrated cost control based on information management. *International Journal of Computer Integrated Manufacturing*, 17(6), 534-545.
- Brissaud, D., Garro, O. and Poveda, O., 2003. Design process rationale capture and support by abstraction of criteria. *Research in Engineering Design*, 14(3), 162-172.

- Brown, R. G., 2000. Driving Digital Manufacturing to Reality. *In: J. A. Jones, R. R. Barton, K. Kang and P. A. Fishwick, Proceedings of the 2000 Winter Simulation Conference, 10-13 December, Orlando, USA. 224-228.*
- Butler, T. and Fitzgerald, B., 1999. Unpacking the systems development process: an empirical application of the CSF concept in a research context. *Journal of Strategic Information Systems, 8(4), 351-371.*
- Camp, R. C., 1989. *Benchmarking: the search for industry best practices that lead to superior performance.* Milwaukee, USA: Quality Press.
- Carnahan, J. V., Thurston, D. L. and Liu, T., 1994. Fuzzy Ratings for Multiattribute Design Decision-Making. *Transactions of the ASME: Journal of Mechanical Design, 116(3), 511-521.*
- Case, K. and Hounsell, M. S., 2000. Feature modelling: a validation methodology and its evaluation. *Journal of Materials Processing Technology, 107(1-3), 15-23.*
- Chan, D. S. K. and Lewis, W. P., 2000. The integration of manufacturing and cost information into the engineering design process. *International Journal of Production Engineering Research, 38(17), 4413- 4427.*
- Chang, T.-C. and Wysk, R. A., 1985. *An introduction to automated process planning systems.* New Jersey, USA: Prentice-Hall.
- Chapman, P., Rogers, B., Bramall, D. G., McKay, K. R. and Maropoulos, P. G., 2002. Structure-based Aggregate Process Models for Complex Assemblies. *In: Advances in Manufacturing Technology XVI: Proceedings of the 18th National Conference on Manufacturing Research, 10th-12th September, Leeds, UK. 133-138.*
- Chen, D. and Vernadat, F., 2004. Standards on enterprise integration and engineering - state of the art. *International Journal of Computer Integrated Manufacturing, 17(3), 235-253.*
- CIMdata, 2003. *The Benefits of Digital Manufacturing: An Independent Report on Achieved Benefits and Return on Investments with DELMIA Solutions.* Michigan, USA: CIMdata.
- Costa, C. A. and Young, R. I. M., 2001. Product range models supporting design knowledge reuse. *Proceedings of the Institution of Mechanical Engineers: Part B: Journal of Engineering Manufacture, 215(3), 323-337.*
- Creveling, C. M., 1997. *Tolerance Design: A Handbook for Developing Optimal Specifications.* Reading, USA: Addison-Wesley.

- Crossland, R., Williams, J. H. S. and McMahon, C. A., 2003. An object-oriented modeling framework for representing uncertainty in early variant design. *Research in Engineering Design*, 14(3), 173-183.
- Dechter, A. and Dechter, R., 1989. On the Greedy Solution of Ordering Problems. *ORSA Journal on Computing*, 1(3), 181-189.
- Department of Trade and Industry, 1998. *Our competitive future: Building the knowledge driven economy*. London, UK: HMSO, Cm 4176.
- Department of Trade and Industry, 2000. *Manufacturing 2020 Panel: We can make it - A consultation document*. London, UK: HMSO, URN 00/688.
- Dignum, V. and Heimannsfeld, K., 1999. Knowledge management for requirements engineering. *In: Twelfth Workshop on Knowledge Acquisition, Modeling and Management*, 16-21 October, Alberta, Canada.
- Dorador, J. M. and Young, R. I. M., 2000. Application of IDEF0, IDEF3 and UML methodologies in the creation of information models. *International Journal of Computer Integrated Manufacturing*, 13(5), 430-445.
- Elinson, A., Herrmann, J. W., Minis, I., Nau, D. and Singh, G., 1997. Toward hybrid variant/generative process planning. *In: CD-ROM Proceedings of DETC97: 1997 ASME Design Engineering Technical Conferences*, September 14-17, Sacramento, USA. 1-11.
- ElMaraghy, H. A., 1993. Evolution and Future Perspectives of CAPP. *Annals of the CIRP*, 42(2), 739-751.
- Elsevier B. V., 2003. ScienceDirect - All Sources Search. <http://www.sciencedirect.com> [Accessed 16/10/03].
- Engineering and Physical Sciences Research Council (EPSRC), 2003. EPSRC Web Site - Grants on the Web. <http://www.epsrc.ac.uk> [Accessed 10/10/03].
- Feigenbaum, E. A. and McCorduck, P., 1984. *The fifth generation : artificial intelligence and Japan's computer challenge to the world*. London, UK: Pan Books.
- Feng, S. and Zhang, Y., 1999. Conceptual Process Planning - A Definition and Functional Decomposition. *In: 1999 ASME International Mechanical Engineering Congress and Exposition*. November 14-19. Nashville, USA. 97-106.
- Feng, S. C., Nederbragt, W., Kaing, S. and Sriram, R. D., 1999. Incorporating process planning into conceptual design. *In: Proceedings of DETC99: The 1999 ASME Design Engineering Technical Conferences*, September 12-15, Las Vegas, USA. 1-7.

- Feng, S. C. and Song, E. Y., 2002. Preliminary Design and Manufacturing Planning Integration Using Intelligent Agents. *In: Proceedings of the 7th International Conference on Computer Supported Collaborative Work in Design*, 25-27 September, Rio de Janeiro, Brazil. 270-275.
- Feng, S. C., Stouffer, K. A. and Jurens, K. K., 2003. Intelligent Agents-Enabled Integrated Manufacturing Planning and Control. *In: Proceedings of 8th International Conference on CSCW in Design*, October 22-24, Xiamen, China. 208-214.
- Fraunhofer IPK, 2002. *Project iViP - Integrated Virtual Product Creation: Final Report*. Germany: Fraunhofer IPK.
- Gaines, B. R., Norrie, D. H. and Lapsley, A. Z., 1995. Mediator: an Intelligent Information System Supporting the Virtual Manufacturing Enterprise. *In: Proceedings of 1995 IEEE International Conference on Systems, Man and Cybernetics*, 22-25 October, Vancouver, Canada. New York: IEEE, 958-963.
- Gao, J. X. and Huang, X. X., 1996. Product and Manufacturing Capability Modelling in an Integrated CAD/Process Planning Environment. *International Journal of Advanced Manufacturing Technology*, 11(1), 43-51.
- Garcia, F. and Sriram, R. D., 1997. Developing Knowledge Sources to Identify and Evaluate Tradeoffs among Alternate Designs in a Cooperative Engineering Framework. *Concurrent Engineering: Research and Applications*, 5(3), 279-292.
- Gardoni, M., Spadoni, M. and Vernadat, F., 2000. Harnessing Non-Structured Information and Knowledge and Know-How in Integrated Engineering: Case Study at Aerospatiale Matra. *Concurrent Engineering: Research and Applications*, 8(4), 281-296.
- Giachetti, R., 1997. Manufacturing Process and Material Selection During Conceptual Design. *In: Proceedings of the 6th Industrial Engineering Research Conference*, 17-18 May, Miami, USA. 772-777.
- Giachetti, R., 1998. A Decision Support Systems for Material and Manufacturing Process Selection. *Journal of Intelligent Manufacturing*, 9(3), 265-276.
- Gindy, N. N. Z., 1989. A hierarchical structure for form features. *International Journal of Production Research*, 27(12), 2089-2103.
- Gindy, N. N. Z., 1999. Responsive manufacturing in UK aerospace industry. *In: P. G. Maropoulos and J. A. McGeough*, 15th International Conference on Computer-Aided Production Engineering, 19-21 April, The University of Durham, UK. 557-565.

- Govers, C. P. M., 1996. What and how about quality function deployment (QFD). *International Journal of Production Economics*, 46-47(Proceedings of the 8th International Working Seminar on Production Economics), 575-585.
- Govil, M. K. and Magrab, E. B., 2000. Incorporating production concerns in conceptual product design. *International Journal of Production Research*, 38(16), 3823-3843.
- Gruninger, M., Atefi, K. and Fox, M. S., 2000. Ontologies to Support Process Integration in Enterprise Engineering. *Computational and Mathematical Organization Theory*, 6(4), 381-394.
- Gunasekaran, A., Patel, C. and McGaughey, R. E., 2004. A framework for supply chain performance measurement. *International Journal of Production Economics*, 87(3), 333-347.
- Halevi, G. and Weill, R. D., 1995. *Principles of Process Planning*. London, UK: Chapman & Hall.
- Harding, J. A. and Popplewell, K., 2001. Enterprise design information: the key to improved competitive advantage. *International Journal of Computer Integrated Manufacturing*, 14(6), 514-521.
- Howell, D., 2000. Half-full or half-empty? *Professional Engineering*, 13(15), 31.
- <http://www.sciencedirect.com>. <http://www.sciencedirect.com> [Accessed 16/10/03].
- International Organisation for Standardisation (ISO), 1997. *MANDATE: MANufacturing management DATa Exchange - Overview and fundamental principles*. France: International Organization for Standardization, ISO TC184/SC4/WG8 N 138 R1.0.
- International Organisation for Standardisation (ISO), 1999. *Industrial automation systems integration - Product data representation and exchange - Part 224: Application protocol: Mechanical product definition for process planning using machining features*. Genève: International Organization for Standardization, ISO 10303-224:1999(E).
- Jagdev, H., Bradley, P. and Molloy, O., 1997. A QFD based performance measurement tool. *Computers in Industry*, 33(2-3), 357-366.
- Jietong, L., Thimm, G. and Britton, G. A., 2003. Alternative geometric design specification of prismatic parts for manufacturability. In: Y. Qin and N. Juster, Proceedings of the First International Conference on Manufacturing Research (ICMR 2003), 9-11 September, Strathclyde, UK. 265-269.

- Jilla, C. D. and Miller, D. W., 1997. Satellite Design: Past, Present and Future. <http://www.ee.surrey.ac.uk/EE/CSER/UOSAT/IJSSE/index.html> [Accessed 16/9/98].
- Jin, Y. and Lu, S. C.-Y., 2004. Agent Based Negotiation for Collaborative Decision Making. *Annals of the CIRP*, 53(1), 121-124.
- Kaplan, R. S., 1994. Management accounting (1984-1994): development of new practice and theory. *Management Accounting Research*, 5(3-4), 247-260.
- Kirkpatrick, S., Gelatt, J., C. D. and Vecchi, M. P., 1983. Optimization by Simulated Annealing. *Science*, 220(4598), 671-680.
- Klösch, R. R., Glaser, P. W. and Truschnegg, R. J., 2002. A testing approach for large system portfolios in industrial environments. *The Journal of Systems and Software*, 62(1), 11-20.
- Kosanke, K., Vernadat, F. and Zelm, M., 1999. CIMOSA: enterprise engineering and integration. *Computers in Industry*, 40(2-3), 83-97.
- Krause, F.-L., Kimura, F., Kjellberg, T. and Lu, S. C.-Y., 1993. Product Modelling. *Annals of the CIRP*, 42(2), 695-706.
- Kulvatunyou, B., Wysk, R. A., Cho, H. and Jones, A., 2004. Integration framework of process planning based on resource independent operation summary to support collaborative manufacturing. *International Journal of Computer Integrated Manufacturing*, 17(5), 377-393.
- Laguda, A., 2002. *Aggregate Assembly Process Planning for Concurrent Engineering*. Thesis (Ph.D.). The University of Durham, UK.
- Lenau, T., 1996. The Missing Element in Design for Manufacture. *Annals of the CIRP*, 45(1), 105-108.
- Liang, S., 1999. *The Java Native Interface: Programmer's Guide and Specification*. Massachusetts, USA: Addison Wesley.
- Liese, H. and Anderl, R., 2003. Knowledge-based and agent-supported modelling in the field of parametric 3D-CAD systems. In: U. Baake, J. Herbst and I. Graessler, 10th European Concurrent Engineering Conference - 'Concurrent Engineering: 10 years on', April 14-16, Plymouth University, Plymouth, UK. Ghent, Belgium: Eurosis, 75-79.
- Lindsay, J., Struck, T. and Baber, C., 1998. Evaluation of the Management of Knowledge in Cardiovascular Perfusion Using the KIPP-Model. In: Proceedings of the 2nd International Conference on Practical Aspects of Knowledge Management, Basel, Switzerland, 29-30 October. 24 1-6.

- Liu, S. and Young, R. I. M., 2004. Utilizing information and knowledge models to support global manufacturing co-ordination decisions. *International Journal of Computer Integrated Manufacturing*, 17(6), 479-492.
- Lowe, A., Ridgway, K. and Atkinson, H., 2000. QFD in new production technology evaluation. *International Journal of Production Economics*, 67(2), 103-112.
- Lutters, D., Wijnker, T. C. and Kals, H. J. J., 1999. Information Management in Process Planning. *Annals of the CIRP*, 48(1), 385-388.
- Ma, G. H., Zhang, Y. F. and Nee, A. Y. C., 2000. A simulated annealing-based optimization algorithm for process planning. *International Journal of Production Engineering Research*, 38(12), 2671-2687.
- MANUFUTURE High-Level Group, 2004. *MANUFUTURE: A Vision for 2020*. Belgium: European Commission.
- Maropoulos, P. G., 1995. A novel process planning architecture for product-based manufacture. *Proceedings of the Institution of Mechanical Engineers: Part B: Journal of Engineering Manufacture*, 209(B4), 267-276.
- Maropoulos, P. G., 2003. Digital enterprise technology - defining perspectives and research priorities. *International Journal of Computer Integrated Manufacturing*, 16(7-8), 467-478.
- Maropoulos, P. G. and Baker, R. P., 2000. Integration of tool selection with design: Part 1. Feature creation and selection of operations and tools. *Journal of Materials Processing Technology*, 107(1-3), 127-134.
- Maropoulos, P. G., McKay, K. R., Bramall, D. G., Rogers, B. C. and Chapman, P., 2003a. Dynamic and distributed early planning assessment by a hybrid simulated annealing and greedy algorithm. *Proceedings of the Institution of Mechanical Engineers: Part B: Journal of Engineering Manufacture*, 217(10), 1429-1442.
- Maropoulos, P. G., Rogers, B. C., Chapman, P., McKay, K. R. and Bramall, D. G., 2003b. A Novel Digital Enterprise Technology Framework for the Distributed Development and Validation of Complex Products. *Annals of the CIRP*, 52(1), 389-392.
- Matthews, P. C., Blessing, L. T. M. and Wallace, K. M., 2002. The introduction of a design heuristics extraction method. *Advanced Engineering Informatics*, 16(1), 3-19.
- McGaughey, R. E. and Roach, D., 1997. Obstacles to computer integrated manufacturing success: a study of practitioner perceptions. *International Journal of Computer Integrated Manufacturing*, 10(1-4), 256-265.

- Molina, A. and Bell, R., 1999. A manufacturing model representation of a flexible manufacturing facility. *Proceedings of the Institution of Mechanical Engineers: Part B: Journal of Engineering Manufacture*, 213(3), 225-246.
- Molina, A. and Bell, R., 2002. Reference models for the computer aided support of simultaneous engineering. *International Journal of Computer Integrated Manufacturing*, 15(3), 193-213.
- NIST, 1994. *A State-of-the-Art Survey on Product Design and Process Planning Integration Mechanisms*. Gaithersburg, USA: NIST, NISTIR 5548.
- NIST, 2000a. *The IMS Mission Architecture for Distributed Manufacturing Simulation*. Gaithersburg, USA: NISTIR 6559.
- NIST, 2000b. *Process Specification Language (PSL), Part 1: Overview and basic principles*. Gaithersburg, USA: NIST, NISTIR 6459.
- NIST, 2001. *A core product model for representing design information*. Gaithersburg, USA: NIST, NISTIR 6736.
- Nonaka, I. and Takeuchi, H., 1995. *The Knowledge-Creating Company: How Japanese Companies Create the Dynamics of Innovation*. Oxford: Oxford University Press.
- Nonaka, I. and Teece, D. J., 2001. *Managing Industrial Knowledge*. London: Sage Publications.
- Object Management Group Inc., 2003. *OMG Unified Modeling Language Specification: Version 1.5*. <http://www.omg.org/technology/documents/formal/uml.htm>: Object Management Group Inc., formal/03-03-01.
- Oduguwa, V. and Roy, R., 2001. Quantitative and qualitative knowledge in engineering systems design. In: D. T. Pham, S. S. Dimov and V. O'Hagan, *Advances in Manufacturing Technology XV, Proceedings of the 17th National Conference on Manufacturing Research, 4th-6th September, Cardiff, Wales*. Bury St. Edmunds, UK: Professional Engineering Publishing, 81-86.
- Open CASCADE, 2003. Open CASCADE, simulation integrator. <http://www.opencascade.com> [Accessed 23/08/03].
- Pahl, G. and Beitz, W., 2003. *Engineering Design: A Systematic Approach*. 4th. London: Springer-Verlag.
- Pahng, F., Senin, N. and Wallace, D., 1998. Distribution modeling and evaluation of product design problems. *Computer-Aided Design*, 30(6), 411-423.

- Paris, H. and Brissaud, D., 2000. Modelling for process planning: the links between process planning entities. *Robotics and Computer Integrated Manufacturing*, 16(4), 259-266.
- Pham, D. T. and Dimov, S. S., 1998. An approach to concurrent engineering. *Proceedings of the Institution of Mechanical Engineers: Part B: Journal of Engineering Manufacture*, 212(1), 13-27.
- Pierreval, H., Caux, C., Paris, J. L. and Viguier, F., 2003. Evolutionary approaches to the design and organization of manufacturing systems. *Computers & Industrial Engineering*, 44(3), 339-364.
- Poolton, J., Ismail, H. S. and Shahidipour, S. M. M., 2000. The New Products Process: Effective Knowledge Capture and Utilisation. *Concurrent Engineering: Research and Applications*, 8(2), 133-143.
- Popp, B., 2005. About DAML. <http://www.daml.org/about> [Accessed 28/09/05].
- Ranta, M., Mäntylä, M., Umeda, Y. and Tomiyama, T., 1996. Integration of functional and feature-based product modelling - the IMS/GNOSIS experience. *Computer-Aided Design*, 28(5), 371-381.
- Roberts, J., 2001. The drive to codify: implications for the knowledge-based economy. *Prometheus*, 19(2), 99-116.
- Roucoules, L., Solomons, O. and Paris, H., 2003. Process planning as an integration of knowledge in the detailed design phase. *International Journal of Computer Integrated Manufacturing*, 16(1), 25-37.
- Rush, C. and Roy, R., 2000. Analysis of cost estimating processes used within a concurrent engineering environment throughout a product life cycle. In: 7th ISPE International Conference on Concurrent Engineering: Research and Applications, 17th - 20th July 2000, Lyon, France. Pennsylvania USA: Technomic Inc.,
- Rush, C. and Roy, R., 2001a. Capturing Quantitative & Qualitative Knowledge for Cost Modelling within a CE environment. In: R. Roy, 8th ISPE International Conference on Concurrent Engineering: Research and Applications, July 28th - August 1st, Anaheim, USA. Pennsylvania, USA: CETEAM, 209-218.
- Rush, C. and Roy, R., 2001b. Expert judgement in cost estimating: Modelling the reasoning process. *Concurrent Engineering: Research and Applications*, 9(4), 271-284.
- Saaty, T. L., 1994. Highlights and critical points in the theory and application of the Analytic Hierarchy Process. *European Journal of Operational Research*, 74(3), 426-447.

- SC4 Online, 2006. ISO TC184/SC4. <http://www.tc184-sc4.org/> [Accessed 22/05/2006].
- Scholz-Reiter, B. and Höhns, H., 2003. Integrated software agents: enabling technology for collaborative E-logistics and E-business. *International Journal of Computer Integrated Manufacturing*, 16(7-8), 517–525.
- Scholz-Reiter, B., Windt, K. and Freitag, M., 2004. Autonomous Logistic Processes – New Demands and First Approaches. *In: Proceeding of 37th CIRP International Seminar on Manufacturing Systems, 19th-21st May 2004, Budapest, Hungary.* Budapest, Hungary: MTA-Sztaki, On CD ROM.
- Schreiber, G., Akkermans, H., Anjewierden, A., de Hoog, R., Shadbolt, N., van de Velde, W. and Wielinga, B., 2000. *Knowledge engineering and management: the CommonKADS methodology*. Massachusetts, USA: The MIT Press.
- SEDRES, 2003. Systems Engineering Data Representation and Exchange Standardisation. http://www.sedres.com/ap233/sedres_iso_home.html [Accessed 06/10/03].
- Shah, J. J. and Mäntylä, M., 1995. *Parametric and feature-based CAD/CAM : concepts, techniques, and applications*. New York, USA: Wiley.
- Shaik, T., Stockton, D. and Khan, Z., 2005. Process Time Estimating Model Development using Virtual Process Models and Data Mining. *In: Proceedings of the International Conference on Manufacturing Research 2005, 6th - 8th September, Cranfield University, UK.* On CD-ROM.
- Shehab, E. M. and Abdalla, H. S., 2001. Manufacturing cost modelling for concurrent product development. *Robotics and Computer Integrated Manufacturing*, 17(4), 341-353.
- Slade, R., Loakes, D., Stacey, G., Horne, G., Dakin, D., Scott, F., Phillpot, D. and Putrell, S., 1998. *Teledesic: Structure Concept Trade-Off*. Matra Marconi Space internal discussion document. Unpublished.
- Sohlenius, G., 1992. Concurrent Engineering. *Annals of the CIRP*, 41(2), 645-655.
- Stanford University Logic Group, 1992. *Knowledge Interchange Format: Version 3: Reference Manual*. California, USA: Stanford University, Logic-92-1.
- Stokes, M., 2001. *Managing Engineering Knowledge: MOKA: Methodology for Knowledge-based Engineering Applications*. London, UK: Professional Engineering Publishing.
- Struck, T., Ratchev, S., Pawar, K. S. and Barson, R., 2000. Management of Requirements Engineering Knowledge in Virtual Enterprises. *In: Proceedings of the 6th International Conference on Concurrent Enterprising, Toulouse, 28-30 June, France.* 101-108.

- Suh, N. P., 2001. *Axiomatic design : advances and applications*. Oxford: Oxford University Press.
- Swift, K. G. and Booker, J. D., 1997. *Process Selection: From Design to Manufacture*. London: Arnold.
- Thannuber, M., Tseng, M. M. and Bullinger, H.-J., 2001. An Autopoietic Approach for Building Knowledge Sources in Manufacturing Enterprises. *Annals of the CIRP*, 50(1), 313-318.
- The Economist Group, 1998. *The Cranfield and Information Strategy Knowledge Survey*. London, UK: The Economist Group.
- Thurston, D. L., 1991. A Formal Method for Subjective Design Evaluation with Multiple Attributes. *Research in Engineering Design*, 3(2), 105-122.
- Tormey, D., Chira, O., Chira, C., Brennan, A. and Roche, T., 2003. The Use of Ontologies for Defining Collaborative Design Processes. *In: Proceedings of 32nd International Conference on Computers and Industrial Engineering*, 11th-12th August 2003, University of Limerick, Ireland.
- Turban, E. and Aronson, J. E., 1998. *Decision Support Systems and Intelligent Systems*. 5th. New Jersey, USA: Prentice Hall.
- Ueda, K., Markus, A., Monostori, L., Kals, H. J. J. and Arai, T., 2001. Emergent synthesis methodologies for manufacturing. *Annals of the CIRP*, 50(2), 1-17.
- van Vilet, H. W. and van Luttervelt, K., 2004. Development and application of a mixed product/process-based DFM methodology. *International Journal of Computer Integrated Manufacturing*, 17(3), 224-234.
- Vancza, J. and Markus, A., 1993. Features and the principle of locality in process planning. *International Journal of Computer Integrated Manufacturing*, 6(1-2), 126-136.
- ViP-RoaM, 2003. ViP-RoaM Homepage. <http://www.vip-roam.de> [Accessed 22/08/03].
- VRL-KCiP, 2005a. *Lexicon, taxonomy and ontology for design, manufacturing and engineering management*. University of Patras, Deliverable D19, Version 2.0.
- VRL-KCiP, 2005b. VRL-KCiP: About. <http://vrl-kcip.hmg.inpg.fr> [Accessed 30/07/05].
- Ward, C., 1994. What is Agility? *Industrial Engineering*, 26(11), 14,16.
- Ward, N. J., Cooper, S., Fan, I. S., Roy, R. and Sehdev, K., 1997. A supplier capability model to support product development in the extended enterprise. *In: D. K. Harrison, Advances in manufacturing technology XI: Proceedings of the 13th*

- National Conference on Manufacturing Research, 9th-11th September, Glasgow Caledonian University, UK. 608-612.
- Warschat, J., Auernhammer, K. and Slama, A., 2003. A framework for an ontology-based approach for knowledge management in innovation. *In: R. Jardim-Gonçalves, J. Cha and A. Steiger-Garçao, Concurrent Engineering - The Vision for the Future Generation in Research and Applications - Proceedings of the 10th ISPE International Conference, Madeira, 26-30 July. The Netherlands: A. A. Balkema, 139-144.*
- Wiendahl, H.-P. and Lutz, S., 2002. Production in networks. *Annals of the CIRP*, 51(2), 573-586.
- Wokutch, R. E., 1979. Measuring corporate social performance: The problem of values. *Evaluation and Program Planning*, 2(1), 17-24.
- Womack, J. P. and Jones, D. T., 2003. *Lean Thinking; Banish Waste and Create Wealth in Your Corporation*. 2003 Edition. Bath, UK: Simon & Schuster.
- World Wide Web Consortium [W3C], 2005a. Resource Description Framework (RDF) / W3C Semantic Web Activity. <http://www.w3.org/RDF> [Accessed 28/09/05].
- World Wide Web Consortium [W3C], 2005b. Web Ontology Language OWL / W3C Semantic Web Activity. <http://www.w3.org/2004/OWL> [Accessed 28/09/05].
- Xirouchakis, P., Snaddon, K., Adda, S., Lamvik, T. and Kate Goggin, K., 2002. Multi-criteria decision aid for product end of life options selection. *In: Proceedings of the 1st CIRP(UK) Seminar on Digital Enterprise Technology, 16th-17th September, University of Durham, UK. 31-35.*
- Young, R. I. M., 2003a. Information and knowledge sharing in design decision support. *In: R. Jardim-Gonçalves, J. Cha and A. Steiger-Garçao, Concurrent Engineering - The Vision for the Future Generation in Research and Applications - Proceedings of the 10th ISPE International Conference, Madeira, 26-30 July. The Netherlands: A. A. Balkema, 147-153.*
- Young, R. I. M., 2003b. Informing decision-makers in product design and manufacture. *International Journal of Computer Integrated Manufacturing*, 16(6), 428-438.

Bibliography

This is a list of co-authored publications related to this research (as identified in Table 1.1), but which are not necessarily referenced in the text.

- Bramall, D. G., McKay, K. R., Colquhoun, P. G. and Maropoulos, P. G., 2000. Manufacturing analysis of conceptual and embodiment aerospace designs: An aggregate process model specification. *In: Proceedings of the 16th International Conference on Computer-Aided Production Engineering. 7th-9th August 2000. Edinburgh, UK. 633-642.*
- Bramall, D. G., McKay, K. R., Colquhoun, P. G. and Maropoulos, P. G., 2001a. A System Architecture for Distributed Aggregate Process Planning. *In: Proceedings of the 17th National Conference on Manufacturing Research. 4th-6th September 2001. Cardiff, UK. 269-274.*
- Bramall, D. G., McKay, K. R. and Maropoulos, P. G., 2001b. Manufacturability assessment of conceptual and embodiment designs using aggregate process models. *In: Proceedings of the 2nd International Conference on Advances in Production Engineering. 7th-9th June 2001. Warsaw, Poland. 121-130.*
- Bramall, D. G., McKay, K. R. and Maropoulos, P. G., 2001c. A New Methodology for Managing Enterprise Knowledge. *In: Proceedings of the 5th International Conference on Artificial Intelligence and Applications. 13th-16th August 2001. Marbella, Spain. 313-317.*
- Bramall, D. G., McKay, K. R. and Maropoulos, P. G., 2001d. Supporting Aggregate Process Planning with Product, Process and Resource Knowledge. *In: Proceedings of the 8th European Concurrent Engineering Conference. 18th-20th April 2001. Valencia, Spain. 70-74.*
- Bramall, D. G., McKay, K. R. and Maropoulos, P. G., 2002a. Manufacturability Assessment of Early Product Designs. *In: Proceedings of the 1st International CIRP Seminar on Digital Enterprise Technology. 16th-17th September 2002. Durham, UK. 141-144.*
- Bramall, D. G., McKay, K. R., Maropoulos, P. G., Rogers, B. C. and Chapman, P., 2002b. A Capability Analysis Method for the Technical Assessment of Qualitative Design and Process Planning Knowledge. *In: Proceedings of the 9th European Concurrent Engineering Conference. 15th-17th April 2002. Modena, Italy. 136-140.*

- Bramall, D. G., McKay, K. R., Rogers, B. C., Chapman, P., Cheung, W. M. and Maropoulos, P. G., 2003a. Manufacturability Analysis of Early Product Designs. *International Journal of Computer Integrated Manufacturing*, 16(7-8), 501-508.
- Bramall, D. G., McKay, K. R., Rogers, B. C., Chapman, P. and Maropoulos, P. G., 2002c. Decision Support Systems for New Product Introduction. *In: Proceedings of the 9th International Conference on Concurrent Engineering: Research and Applications*. 27th-31st July 2002. Cranfield, UK. 23-28.
- Bramall, D. G., Rogers, B. C., Chapman, P., Maropoulos, P. G. and Reiter, W. F., 2003b. Adaptive lifecycle models for product design. *In: 10th ISPE International Conference on Concurrent Engineering: Research and Applications*. 26 - 30 July, 2003. Madeira Island, Portugal. 809-815.
- Chapman, P., Rogers, B., Bramall, D. G., McKay, K. R. and Maropoulos, P. G., 2002. Structure-based Aggregate Process Models for Complex Assemblies. *In: Advances in Manufacturing Technology XVI: Proceedings of the 18th National Conference on Manufacturing Research*, 10th-12th September, Leeds, UK.
- Maropoulos, P. G., Bramall, D. G. and McKay, K. R., 2003a. Assessing the manufacturability of early product designs using aggregate process models. *Proceedings of the Institution of Mechanical Engineers: Part B: Journal of Engineering Manufacture*, 217(9), 1203-1214.
- Maropoulos, P. G., Bramall, D. G., McKay, K. R. and Colquhoun, P. G., 2001. An Integrated and Distributed Planning Environment for Spacecraft Manufacture. *In: Proceedings of the 8th International Conference on Concurrent Engineering: Research and Applications*. 29th July-1st August 2001. Anaheim, USA. 288-296.
- Maropoulos, P. G., Bramall, D. G., McKay, K. R., Rogers, B. C. and Chapman, P., 2003b. An aggregate resource model for the provision of dynamic 'resource-aware' planning. *Proceedings of the IMechE Part B: Journal of Engineering Manufacture*, 217(10), 1471-1480.
- Maropoulos, P. G., McKay, K. R. and Bramall, D. G., 2002. Resource-Aware Aggregate Planning for the Distributed Manufacturing Enterprise. *Annals of the CIRP*, 51(1), 363-366.
- Maropoulos, P. G., McKay, K. R., Bramall, D. G., Rogers, B. C. and Chapman, P., 2003c. Dynamic and distributed early planning assessment by a hybrid Simulated Annealing and Greedy algorithm. *Proceedings of the IMechE Part B: Journal of Engineering Manufacture*, 217(10), 1429-1442.
- Maropoulos, P., Armoutis, N., Bramall, D., Lomas, C., Chapman, P. and Rogers, B., 2004a. Agile Design and Manufacturing in Collaborative Networks for the Defence Industry. *In: IFAC Conference on Manufacturing, Modelling, Management and Control*. 21st-22nd October. Athens, Greece. On CD-ROM.

- Maropoulos, P. G., Rogers, B. C., Chapman, P., Lomas, C. D. W., Zhang, D. and Bramall, D. G., 2004b. Digital Enterprise Technology in Spacecraft Design and Manufacture. In: Proceedings on the 37th CIRP International Seminar on Manufacturing Systems, May 19-21, 2004. 19th-21st May 2004. Budapest, Hungary. On CD-ROM.
- McKay, K. R., Bramall, D. G., Chapman, P., Rogers, B. C. and Maropoulos, P. G., 2002a. Controlling the manufacturing phase-space of the extended enterprise. In: Proceedings of the 1st International Conference in Manufacturing Engineering. 3rd-4th October 2002. Kassandra-Halkidiki, Greece. 337-346.
- McKay, K. R., Bramall, D. G., Colquhoun P. G. and Maropoulos, P. G., 2001a. Manufacturing models for a distributed process planning system. In: Proceedings of the 5th International Conference on Applied Simulation and Modelling. 13th-16th August 2001. Marbella, Spain. 134-137.
- McKay, K. R., Bramall, D. G., Colquhoun, P. G. and Maropoulos, P. G., 2000. Manufacturing analysis of conceptual and embodiment aerospace designs: An aggregate product model specification. In: Proceedings of the 16th International Conference on Computer-Aided Production Engineering. 7th-9th August 2000. Edinburgh, UK. 623-632.
- McKay, K. R., Bramall, D. G., Colquhoun, P. G. and Maropoulos, P. G., 2001b. Capable Space: A distributed process planning environment. In: Proceedings of the 8th European Concurrent Engineering Conference. 18th-20th April 2001. Valencia, Spain. 62-65.
- McKay, K. R., Bramall, D. G., Colquhoun, P. G. and Maropoulos, P. G., 2001c. Providing enterprise-wide Aggregate Process Planning with multiple criterion solutions. In: Proceedings of the 2nd International Conference on Advances in Production Engineering. 7th-9th June 2001. Warsaw, Poland. 141-150.
- McKay, K. R., Bramall, D. G. and Maropoulos, P. G., 2001d. Managing engineering change on process plans via a new concept of feature elasticity. In: Proceedings of the 17th National Conference on Manufacturing Research. 4th-6th September 2001. Cardiff, UK. 263-268.
- McKay, K. R., Bramall, D. G. and Maropoulos, P. G., 2002b. Rapid CE Change Assessment on Early Product Definition. In: Proceedings of the 1st International CIRP Seminar on Digital Enterprise Technology. 16th-17th September 2002. Durham, UK. 167-170.
- McKay, K. R., Bramall, D. G., Rogers, B. C., Chapman, P., Cheung, W. M. and Maropoulos, P. G., 2003. Design Change Impact Analysis During Early Design Specification. *International Journal of Computer Integrated Manufacturing*, 16(7-8), 598-604.

McKay, K. R., Colquhoun, P. G., Bramall, D. G. and Maropoulos, P. G., 2001e. An aggregate resource model for the provision of digital mock-up within a distributed manufacturing planning system. *In: Proceedings of the 2nd International Conference on Advances in Production Engineering*. 7th-9th June 2001. Warsaw, Poland. 131-140.

Appendix A ViP-RoaM Roadmap

The ViP-RoaM working group (ViP-RoaM 2003) was established, as part of the European Framework 6 initiative, to develop a Virtual Product Creation (VPC) strategy enabling European Industry to improve their product creation processes to be successful in international market. As part of this remit, a series of workshops (to which the author contributed), a survey of external experts by questionnaire and the investigation of public information sources a roadmap was developed to outline future research activities and implementation paths for the creation of new Knowledge Management activities for VPC.

Participants in the Knowledge Management Applications Workshop:

Name	Institution	e-mail
F. Andersch	FhG IPK	frank.andersch@ipk.fhg.de
S. Schulte	Ruhr-Universität Bochum	stefan.schulte@itm.ruhr-uni-bochum.de
C. Ludwig	SBS, C-Lab	christine.ludwig@c-lab.de
R. Lossack	Universität Karlsruhe	lossack@rpk.uni-karlsruhe.de
S. Tichkiewitch	INP Grenoble	serge.tichkiewitch@hmg.inpg.fr
M. Sanseverino	CR FIAT	marialuisa.sanseverino@crf.it
D. Bramall	University of Durham	d.g.bramall@durham.ac.uk
S. Aslanidis	FhG-IAO	Stephanie.Aslanidis@iao.fhg.de

5th December 2002, Turin

Cluster 1:
Knowledge-Management
Applications

Topic	Description	Priority	Required Functions and Methods	Estimated difficulty of the solution	Planning horizon	Software development necessary?	Method development necessary?	
		very important		very easy to solve				
		important		easy to solve				
		indefinite		indefinite				short term (<2 years)
		less important		difficult to solve				long term (2-5 years)
		completely unimportant		not to solve				vision (>10 years)
1.1 Intelligent knowledge-based systems in virtual product creation	The creation of applications which use/are based on knowledge - make design systems more 'intelligent', i.e. give them more information about VPC-relevant processes, rules, dependencies etc. because knowledge can be procedural as well as technical							
1.1.1 Semantic-based methods for providing product creation information on different devices	Daily work gets mobile, therefore, the same content has to be provided on different output devices (Palm OS, PC, ...) with product creation meta-information based on semantics in order to adapt the representation of the content to the device.	indefinite	1 Provide/standardise markup language 2 Design platform-based delivery of content	very easy to solve	short term	Yes	Yes - new ways of working required	
1.1.2 Mapping of engineering-ontologies (e. g. and production ontologies)	An ontology is a kind of hierarchy of words which gives information about dependencies. Since different people/organisations use different ontologies communication (human and machine based) gets complicate. The mapping of ontologies can help to cope with these problems.	very important	1 Find objects and context 2 Collect definitions 3 Find the group which are concerned with 4 Find common sense 5 Map the ontology	very easy to solve	long term	Yes - may include development of standards	No	
1.1.3 Role- or competency-based knowledge-delivery	Kind of personalised and task based knowledge delivery. The system 'knows' what you need and what you understand.	important	Intelligent systems which are able to 'know' and to learn how the user acts	difficult to solve	vision	Yes	Yes	
1.2 Knowledge harvesting for virtual product creation	Applications for knowledge acquisition							
1.2.1 Automatic understanding of content structure of individual knowledge flows	Automatically extract information from communication flows in order to capitalise on these highly valuable and content rich person to person communications	important	Adaption of methods from social sciences and psychology	indefinite	vision	Yes	Yes	
1.2.2 Access to several document-types (emails, videotapes, technical docs, ...)	Extract automatically information from different types of documents in order to link them in a knowledge map	indefinite	Communication of multimedia and enhanced 3D visualisations via the web	easy to solve	short term	Yes - technology driven solutions	No	
1.2.3 Save the best people know-how while they are doing their real work	extraction of knowledge from the work	important	1 Tools which measure success of projects 2 Protocol analysis of human computer interaction	difficult to solve not to solve	long term vision	Yes	Yes	

1.3 Task-based personalized knowledge-supply in VPC	Applications which serve directly the user						
1.3.1 Knowledge processes in product creation networks	The working environment for knowledge sharing, integration and reuse	important	Enhance PDM and ERP systems	easy to solve	long term	Yes	Yes
1.3.2 Access to and capturing of implicit knowledge	A big amount of knowledge is not documented but stays at persons. So often a demand for information can only be respond personally. Therefore the support of integration of those experts has to be improved. Moreover methods and techniques should be found	very important	1 Rule based design	easy to solve	short term	Yes	Yes
			2 Motivation systems	not to solve	long term		
			3 Interactive systems for capturing implicit knowledge	difficult to solve	vision	Yes	Yes
			4 Representation systems for imprecise knowledge	indefinite	long term	Yes	Yes
			5 Structuring and representation of knowledge	easy to solve	short term	Yes - see 1.1.2	No
			6 Transformation of implicit knowledge in explicit knowledge	indefinite	vision	No	Yes
1.3.3 VPC-process-oriented knowledge management	Knowledge supply according to the dynamic and flexible VPC-process	important	Methods for controlling ad-hoc design processes	difficult to solve	vision	No	Yes
1.3.4 Personalized knowledge management	The user gets the information which is relevant for him.	important	Intelligent systems which are able to 'know' and to learn about what the user is doing	difficult to solve	long term	Yes	Yes
1.3.5 Support of the whole knowledge life cycle in VPC	One system which manage all steps of knowledge management (acquisition, generation, extraction, use, adaption)	indefinite	Use of single system for knowledge-based design	not to solve	vision		
1.4 Integration of Knowledge and Knowledge Management systems	Consider organisational aspects and Integration of applications and systems						
1.4.1 Integration of knowledge management systems with workflow	Combination and integration of knowledge management tools with PLM/PDM-Systems	very important	1 New software tools as extension to PLM-systems	easy to solve	long term	Yes	No
			2 Include explanations about the steps in PDM use (why someone adds a fact etc.)	difficult to solve	short term	Yes	Yes
			3 Analysis of structure of content of PDM in order to make conclusions (e.g. lack of knowledge may trigger a new process)	difficult to solve	long term	No	Yes
			4 Represent different data models in the PLM-System with relations	easy to solve	short term	No	Yes
1.4.2 Integration of knowledge management with quality management	Combination and integration of knowledge management tools with QM-tools	completely unimportant					
1.4.3 Sharing and Integration of knowledge	Creation of flexible design systems capable of integrated design and knowledge management	very important	1 Knowledge decomposition; provide the right level of detail	difficult to solve	vision	No	Yes
			2 Feature-based systems	very easy to solve	short term	No	No
			3 Rule based systems	very easy to solve	short term	No	No
			4 Transformation of context (in order to support the knowledge sharing)	difficult to solve	vision	No	Yes
			5 Standardisation for knowledge exchange	easy to solve	long term	Yes	No
			6 Working motivation systems	not to solve	long term		
			7 Create 'dictionaries'	difficult to solve	long term	No	No
			8 Responsibility for knowledge exchange (push or pull)	difficult to solve	short term	No	Yes
			9 Multilingual support for communication	easy to solve	long term	Yes	No
			10 Multiple domain knowledge base (relation between different domains is represented)	difficult to solve	long term	No	Yes
1.5 Management of 'forgetting' in virtual product creation	The productive use of 'new' methods and tools is often not possible because of 'old' structures, habits and patterns of thought. Therefore methods has to be invented, which enable organisations and people to stay open for really new ideas.						
1.5.1 Prevention of 'worst practices'	How can be made sure, that a 'best practice' is still a 'best' practice when the conditions are changing?	important	Give time element to knowledge	indefinite	long term	No	Yes
1.5.2 Ability to use disruptive new approaches	Keep the mind - and organisational structure open for completely new approaches.	important	Management of innovation	difficult to solve	vision	No	Yes

1.6 Competency management		Competency management is part of knowledge management (esp. for virtual/networked enterprises)					
Competencies mapping, updating and evaluation	Map and organize where and how the competencies are in the organisation. Important for planning	important	Expert finding system	easy to solve	long term	No	Yes
Competencies strategic planning		important		indefinite	long term	No	Yes
Competencies economic evaluation		important		indefinite	long term	No	Yes
1.7 Knowledge on customer		Design with knowledge about the user					
1.7.1 Knowledge about the end-user	Introduce knowledge about the customer into the product creation process	very important	1 Map requirements of customers to knowledge of the company (translate user requirements into product specification)	easy to solve	vision	Yes	Yes
			2 Identify and prioritize the significant information about the user demand	easy to solve	vision	Yes	Yes
			3 Motivation system for the end-user in order that he share his knowledge/requirements with the company	not to solve	long term	No	Yes
			4 Integrate customer as co-producer in the product development process	difficult to solve	vision	No	Yes
			5 Tools to integrate the customer	difficult to solve	vision	~Yes	Yes
1.7.2 Knowledge about different cultural context	Understand the end-users needs	important	Methods for modular/customised design	very easy to solve	long term	Yes	No
1.8 Protection of knowledge							
1.8.1 IPR- intellectual property rights	definition and management of IPR	very important	1 Techniques which make sure that the IPRs are created	easy to solve	short term	No	Yes
			2 Techniques which make sure that the IPRs are respected	indefinite	long term	No	Yes
			3 Find techniques that make sure that reduced information can be understood	difficult to solve	long term	Yes	Yes
			4 How to transform subcontractor to co-designer	difficult to solve	vision	No	Yes
1.8.2 Security	Concerns IT and humans - regard difference between knowledge and data security. Basis for all other points of KM	very important	Data security tools	easy to solve	short term	Yes	No - use existing cryptography
1.8.3 Accuracy	Measurement of "correctness" of knowledge, validity of knowledge when applied to new circumstances,.....	important	Data integrity tools	difficult to solve	long term	Yes	Yes

Note 1 functions are defined as actions/applications which solve a specific problem, a method is a process which controls a function

Appendix B Aggregate Product, Process and Resource Data Models

This appendix documents the aggregate data model classes created to support the prototype CAPABLE Space system implementation.

B.1 Product Model Classes

Taxonomy of Top-level Product Model Classes

- Positive Feature Classes
- Negative Feature Classes
- Tolerance Classes

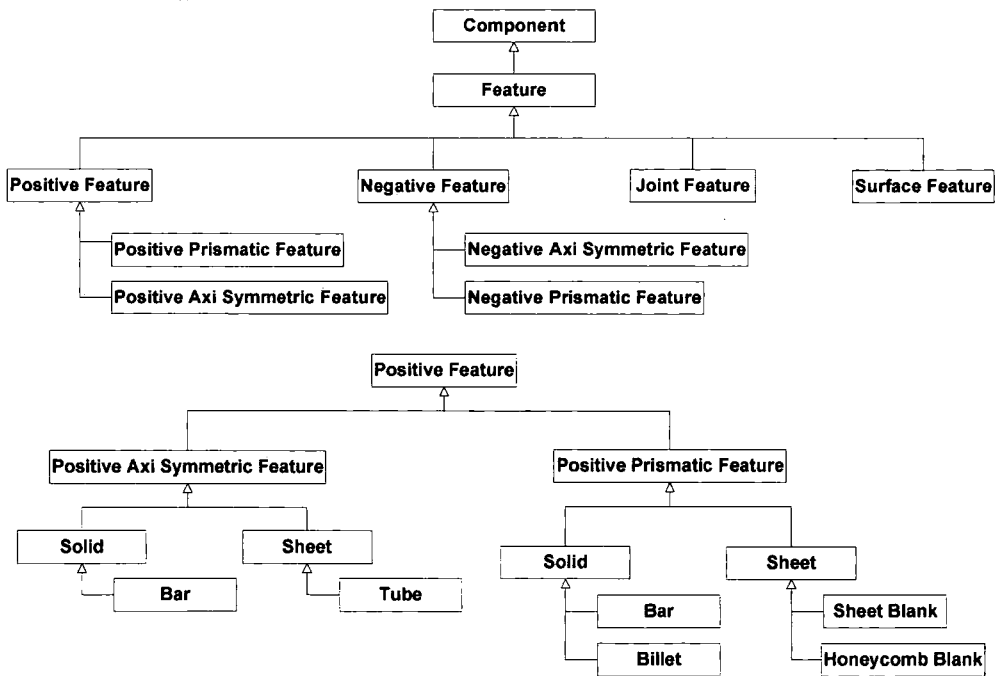

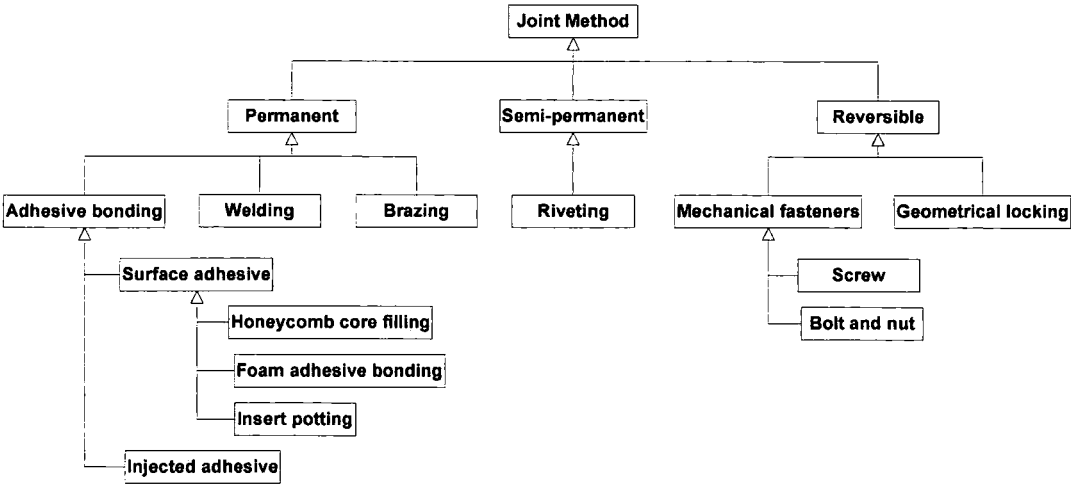
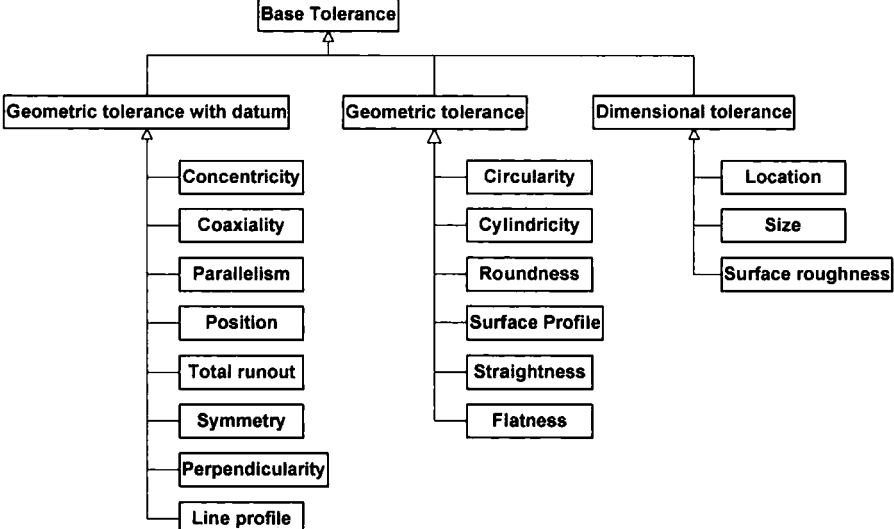
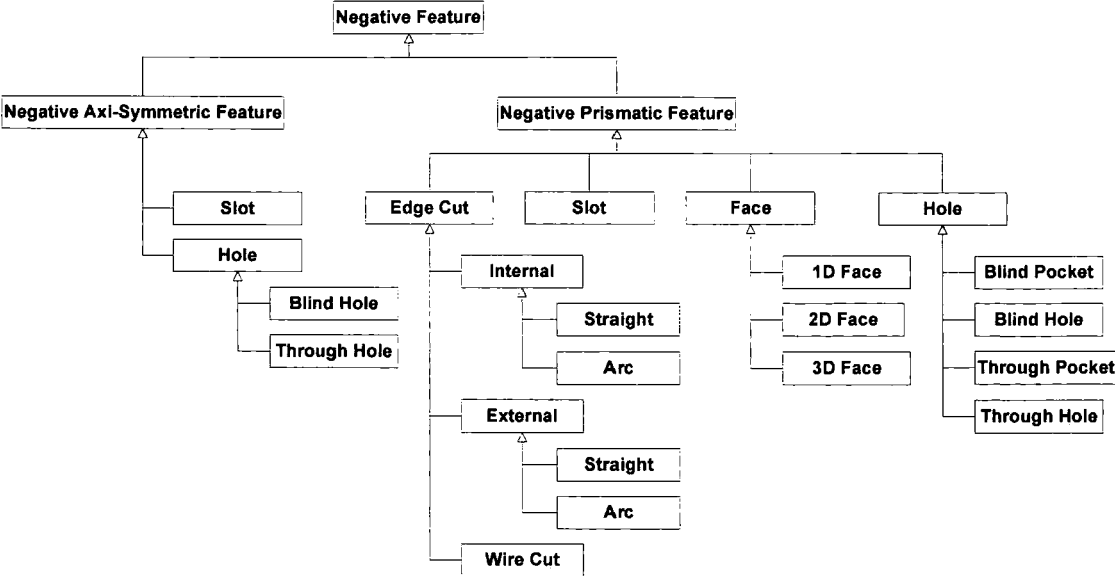

B.2 Resource Model Classes

Taxonomy of Top-Level Resource Type Classes

Machine Type Resource Classes

Labour Type Resource Classes

Transport Type Resource Classes

Handling Type Resource Classes

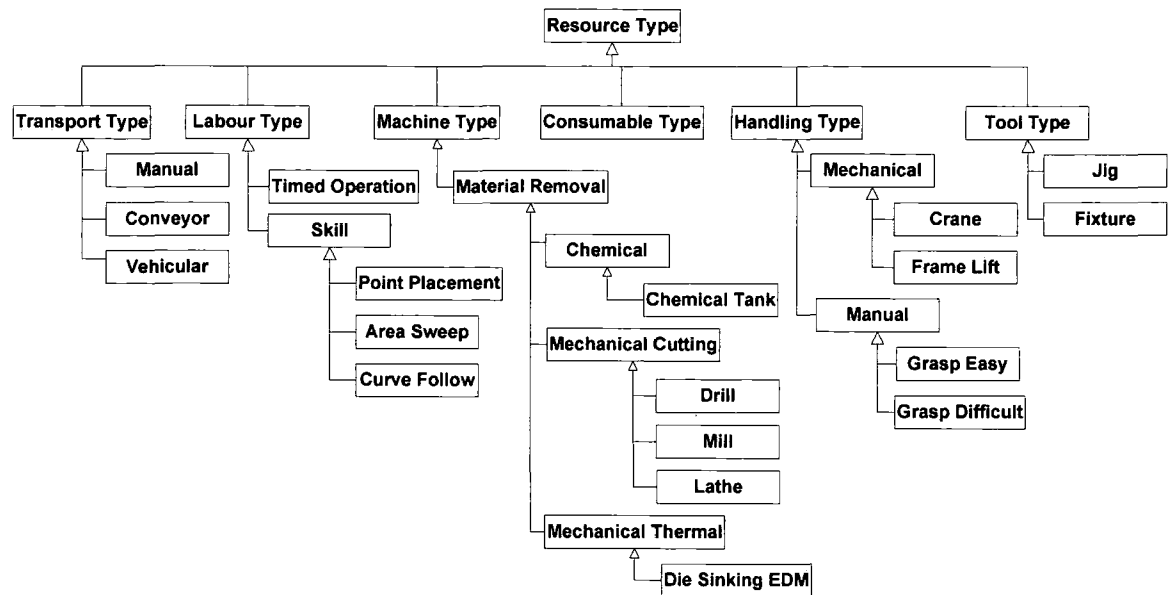

B.3 Aggregate Process Models

This section gives the hierarchy of classes in the Aggregate Process Model and presents the governing equations and technological checks for the non-proprietary assembly and machining level classes.

B.3.1 Process Model Class Diagrams

Taxonomy of Top-Level Process Model Classes

Mass-Reducing Process Classes

Surface Treatment Classes

Assembly Process Classes

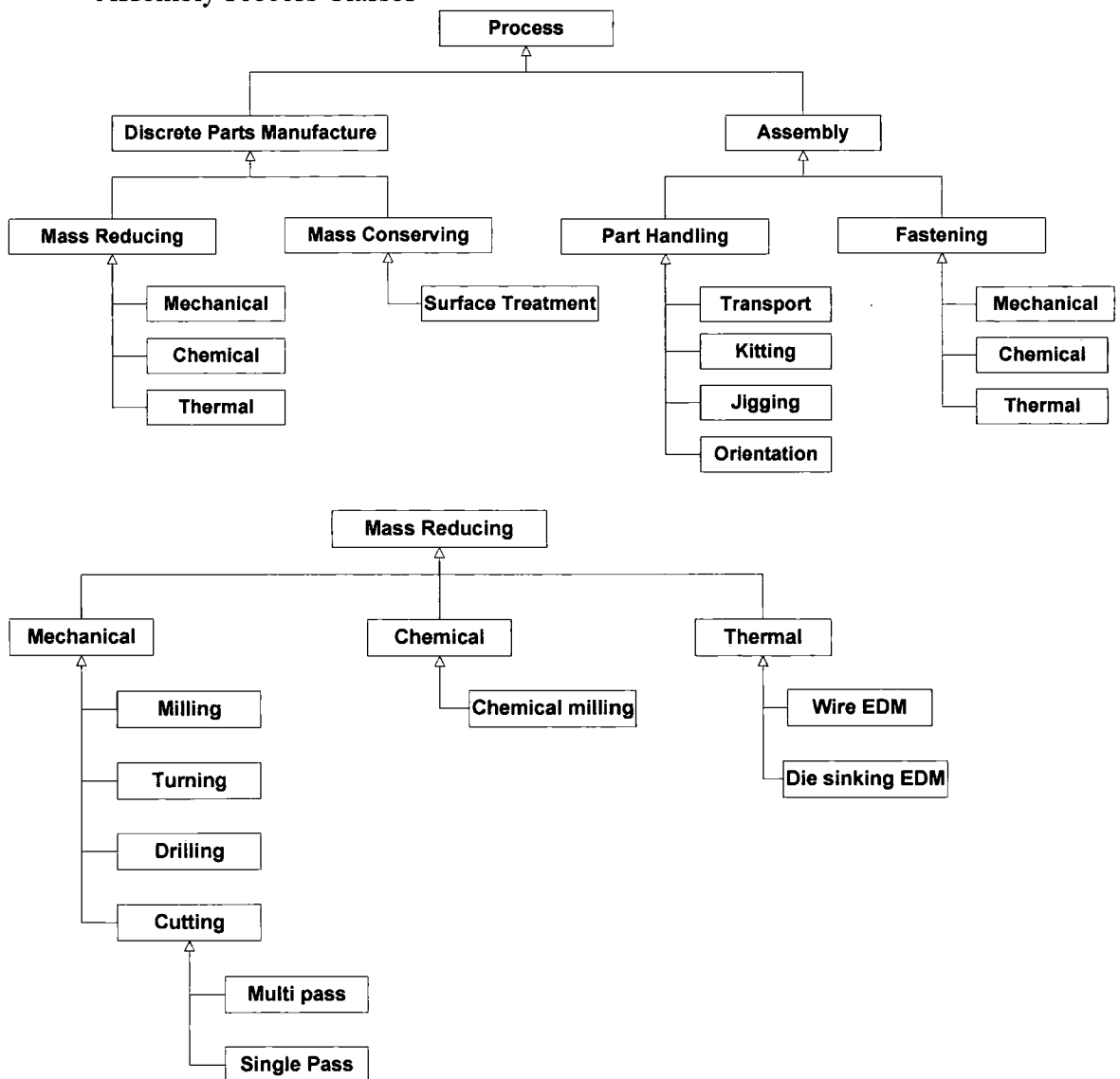

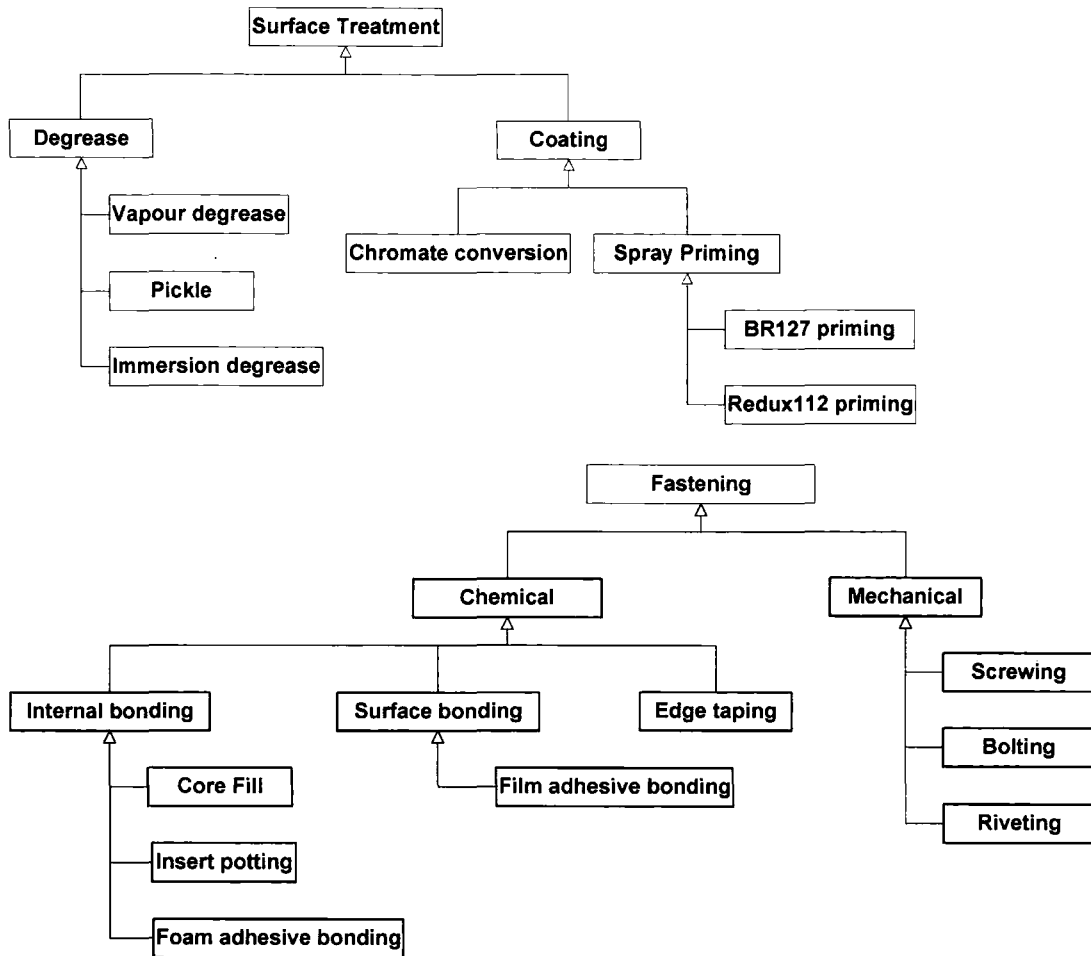

Calculation of machining times:

Process category	Characteristic equation	Parameter Selection Strategy
Turning	$t_m = \frac{L \cdot \pi \cdot \phi}{1000 \cdot v \cdot s}$	Get v, s from machine tool limits/ recommended data Calculate depth of cut (i.e. number of passes required) using maximum machine tool power
Milling	$t_m = \frac{H \cdot W \cdot D}{M}$	Calculate M for machine tool power Calculate M according to feature geometry Select appropriate processing rate
Drilling	$t_m = \frac{H}{v}$	Select v from either recommended data or machine tool limits

Nomenclature

- 1.
2. material removal rate (cm³/min)
- 3.
- 4.

B.3.2 Technological Constraints for Machining Processes

Technical constraints are used to express the practical limitations of a process. The following two tables give process capability limits for various types of machining processes. Sources: ASM Materials handbook and Oberg.

Process	Roughness average, Ra (μm)										
	50	25	12.5	6.3	3.2	1.6	0.8	0.4	0.2	0.1	0.05
Sawing											
Drilling											
Milling											
Chemical milling											
Electrical Discharge Machining											

Average application
 Less frequent application

Surface Roughness Capability of Machining Processes

B.3.3 Example Materials Datasheet for Machining

Process parameters used in cycle time calculation are the most commonly applied values, they do not represent the ultimate capabilities of the process. The following references give sources of data used in the process models:

- (1) Sandvik Coromant, Rotating tools catalogue, 2001, published by AB Sandvik Coromant, Sweden.
- (2) HexWeb Honeycomb Sandwich Design Technology guide, 2000, published by Hexcel Composites, Duxford, UK.

- (3) Redux Bonding Technology guide, 1997, published by Hexcel Composites, Duxford, UK.

B.3.4 Calculation of Times for Some Standard Assembly Operations:

Process category	Characteristic equation	Operation Sequence
Bolt and Nut Systems (BN1)	$t_a = \left((4 + 6n) * 2.78^{-1} \right) + nf(N)$	Collect handful of bolts Insert single bolt & repeat n times Collect single nut, tighten and repeat n times
Screwing Systems (SCR2)	$t_a = 8n(2.78^{-1}) + n(f(N) + g(N_e))$	Collect handful of screws Engage single screw and repeat n times Fasten single screw with desired tool and repeat n times
Riveting Systems (RIV3)	$t_a = (10n + 11) * (2.78^{-1})$	Collect single rivet and insert into predrilled hole Apply riveting tool and actuate. Repeat n times.

Appendix C Test Data

This Appendix documents the specific model objects used in the case studies.

C.1 Knowledge Statements used in the SSPA Example

C.1.1 *Factor: +X Antenna Height, domain: Product Performance*

The height of the +X antenna deck must be tightly controlled and is given a nominal value of 4.65m. Hence four Nominal the Best Knowledge Statements are created.

Concept	Target (m)	Value (m)	Returned score
<u>Concept A</u>	4.65	5	0.35
<u>Concept B</u>	4.65	4.5	0.15
<u>Concept C</u>	4.65	4.76	0.11
<u>Concept D</u>	4.65	4.72	0.07

C.1.2 *Factor: Product Mass, domain: Product Performance*

Customer requirements set launch mass of 2000kg. This is a smaller-the-better characteristic.

Concept	Value (kg)	Returned score
<u>Concept A</u>	219	219
<u>Concept B</u>	183	183
<u>Concept C</u>	229	229
<u>Concept D</u>	306	306

C.1.3 *Factor: Potential suppliers, domain: Risk*

Potential suppliers. For each concept the number of specialist suppliers required was also considered as a risk factor and is implemented as a larger-the-better Knowledge Statement.

Concept	Value	Returned score
<u>Concept A</u>	15	0.06666667
<u>Concept B</u>	12	0.08333333
<u>Concept C</u>	10	0.1
<u>Concept D</u>	10	0.1

C.1.4 Factor: Product Cost, domain: Cost

Estimated Total Cost. The total cost of producing each type of satellite was generated from baseline cost estimates, over an estimated production run of 185. Costs include design and development, capital and tooling. Again a smaller-the-better Knowledge Statement is required.

Concept	Value	Returned score
<u>Concept A</u>	236,000	236,000
<u>Concept B</u>	248,000	248,000
<u>Concept C</u>	212,000	212,000
<u>Concept D</u>	301,000	301,000

C.2 Knowledge Statements for SCTO Example

C.2.1 Qualitative Knowledge Statements for Concept A

Manufacturability Analysis Discussion	Factor	Domain	Predicted Value	Probability	Returned score
'RTM reduces labour cost.'	Investment cost	Cost	200	1	200
'Al longerons reduce risk and cost.'	Investment cost	Cost	50	1	50
	Process familiarity	Risk	100	0.5	50
'Al longerons significantly increases mass.'	Structural efficiency	Product performance	750	1	750
'Machined bulkheads for self jigging and part count reduction.'	Handling requirement	Logistics	75	1	75
	Product complexity	Risk	300	1	300
'CFRP/Al thermoelastic loads issue.'	Structural efficiency	Product performance	1000	0.65	650
'Corrugated panels complicate Ag-Teflon tape application.'	Process complexity	Risk	750	0.9	675

C.2.2 *Qualitative Knowledge Statements for Concept B*

Manufacturability Analysis Discussion	Factor	Domain	Predicted Value	Probability	Returned score
'Auto tape placement reduces labour cost.'	Resource requirement	Logistics	100	1	100
'Auto tape placement increases capital cost.'	Investment cost	Cost	900	1	900
'Hand lay-up labour intensive and high skill level.'	Process complexity	Risk	895	0.95	850
'Entire concept depends on success of one piece moulding process.'	Process complexity	Risk	1000	1	1000
'Single shot (co-cured edge frame and bulkheads) reduces number of operations but increases risk.'	Product complexity	Risk	625	0.2	125
	Process familiarity	Risk	833	0.75	625
'Oven cure (rather than autoclave) will reduce performance: mass impact.'	Structural efficiency	Product performance	625	1	625
'Requires large autoclave (length approx. 5m).'	Resource requirements	Logistics	800	1	800

C.2.3 *Qualitative Knowledge Statements for Concept C*

Manufacturability Analysis Discussion	Factor	Domain	Predicted Value	Probability	Returned score
'Stiff structure without payload panels: simplifies MGSE and handling.'	Handling requirement	Logistics	220	1	220
'Adhesive bonded joints permits high strength alloys to be exploited.'	Structural efficiency	Product performance	250	0.5	125
'Some additional mass optimisation possible: save 20-30 kg on Al Alloy tubes and nodes (part count).'	Structural efficiency	Product performance	1000	0.8	800
'Structure efficiency poor because shear stiffness of payload panels not exploited.'	Structural efficiency	Product performance	550	1	550
'High level of operator skill required for welding.'	Process familiarity	Risk	725	1	725
'NDT of all bonds and welds.'	Process complexity	Risk	700	1	700
'Constrains payload unit layout (diagonals).'	Structural efficiency	Product performance	950	1	950

C.2.4 Qualitative Knowledge Statements for Concept D

Manufacturability Analysis Discussion	Factor	Domain	Predicted Value	Probability	Returned score
'Low risk. Manufacturing processes all well established at MMS.'	Process familiarity	Risk	50	1	50
'Clampband interface to dispenser: lower release shocks.'	Structural efficiency	Product performance	150	1	150
'Stiff structure without payload panels: simplifies MGSE and handling.'	Handling requirement	Logistics	400	0.5	200
'Structure efficiency poor because shear stiffness of payload panels not exploited.'	Structural efficiency	Product performance	640	1	640
'Structure efficiency limited by maximum cylinder diameter.'	Structural efficiency	Product performance	780	1	780
'SV layout impact: relocation of battery and reaction wheels required (volume available inside cone/cylinder).'	Structural efficiency	Product performance	435	0.8	340
'High part count and number of assembly operations.'	Product complexity	Risk	820	1	820
	Process familiarity	Risk	550	0.8	440

C.3 SM Floor Example

C.3.1 System Configuration (Distributed Architecture)

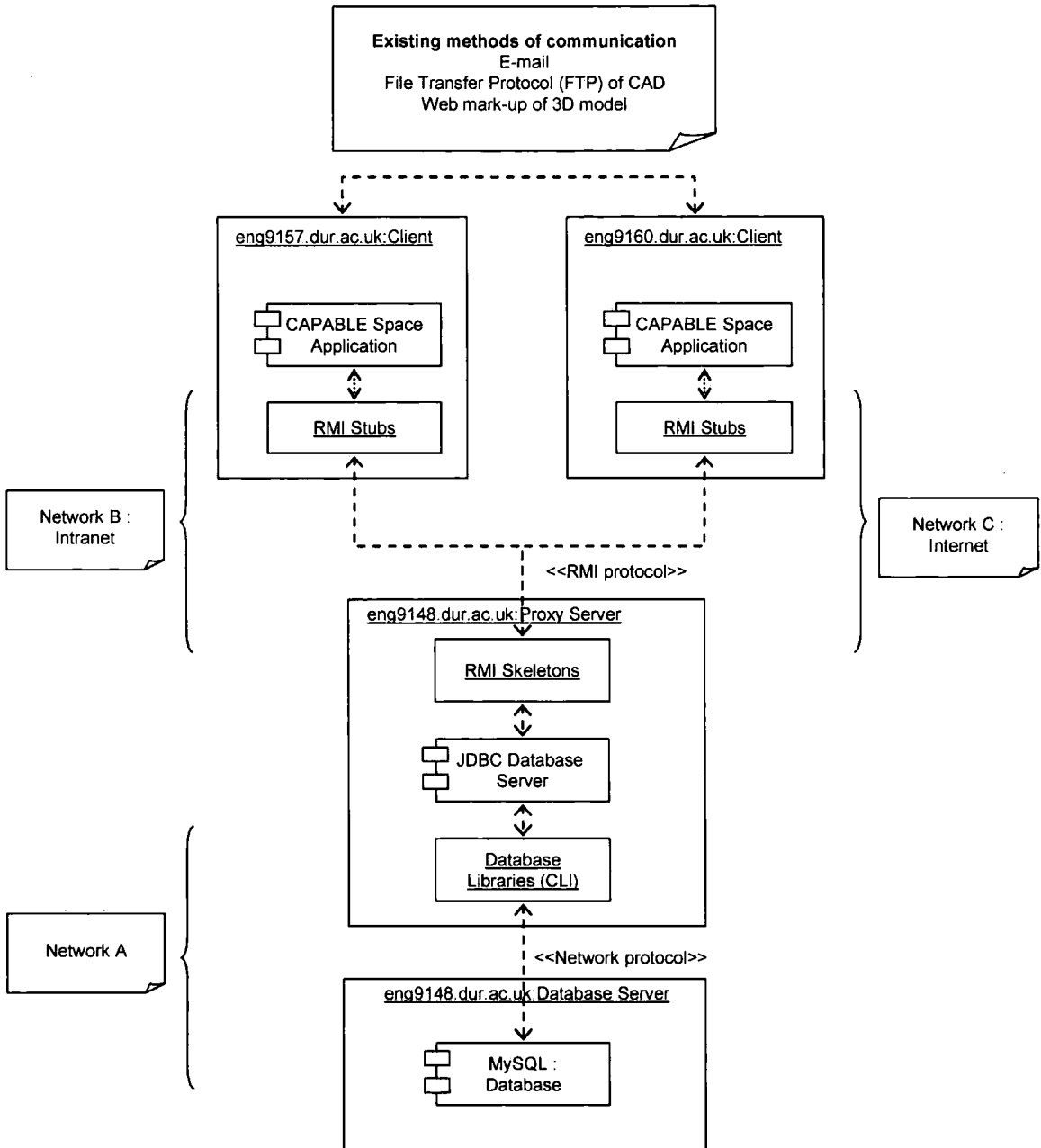

CAPABLE Space: Software Component Deployment as Used in Testing

C.3.2 Product Model for SM Floor

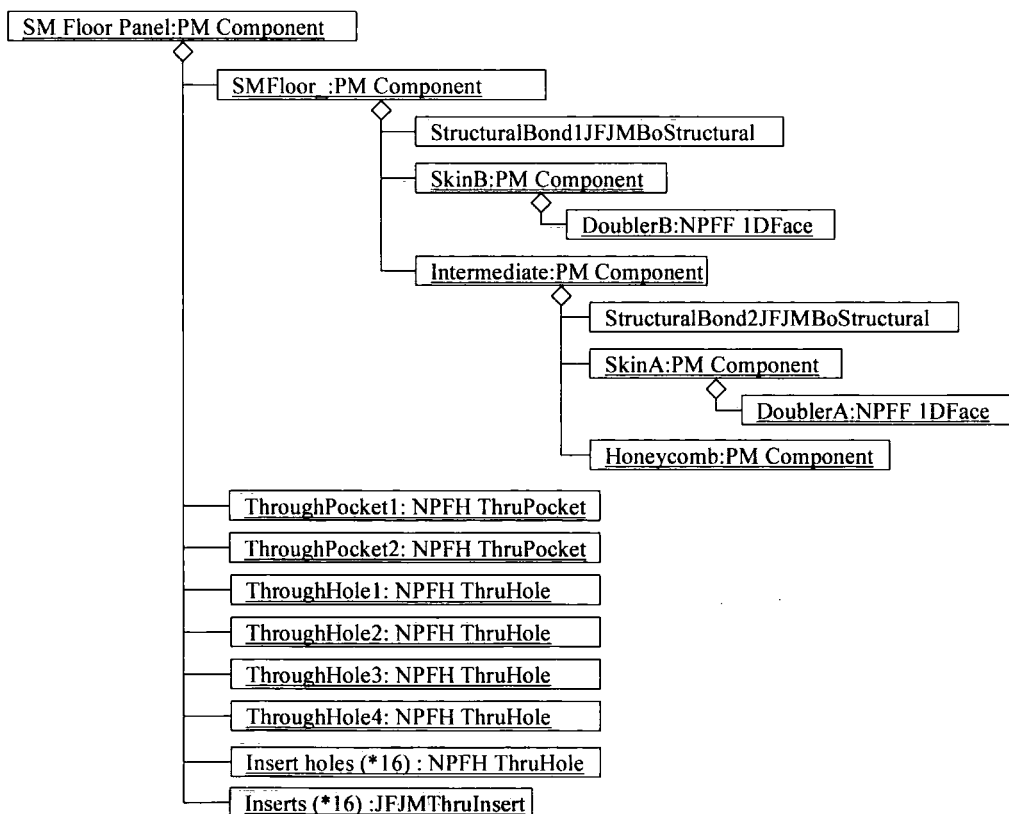
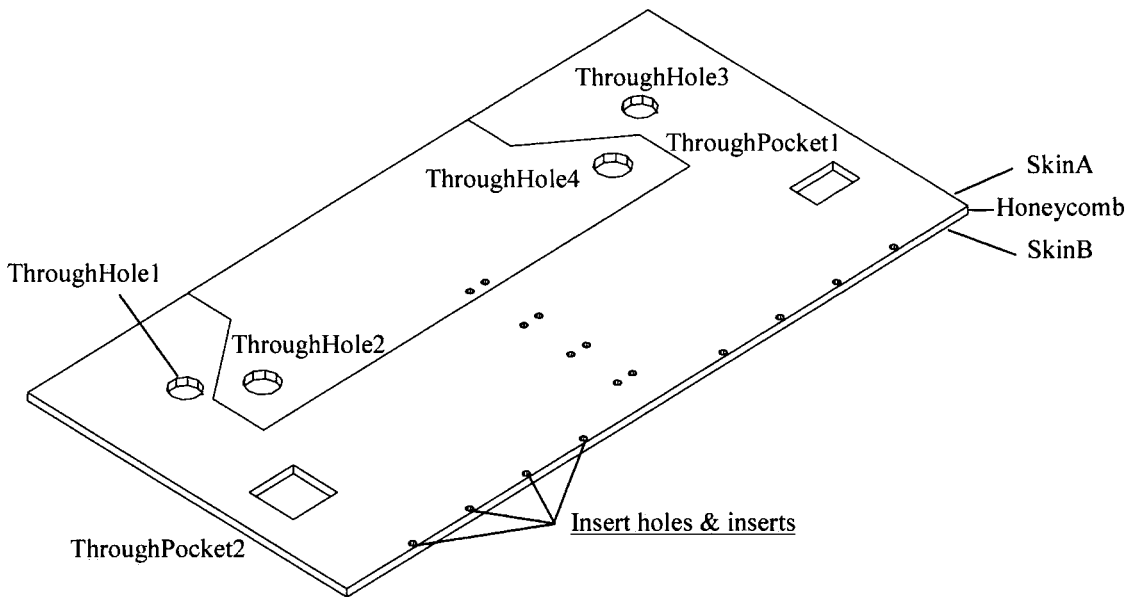

C.3.3 Resource Model Classes for SM Floor Example

Resource Type	Process Key(s)	Parameter	Value	Units
MC_Treatment_Surface_Immerse_Degrease				
	SP_Immersion_Degrease	Max_Area	9	m ²
	SP_Chemical_Degrease	Max_Unit_Rate	0.067	items/min
	SP_Solvent_Degrease	Max_Units	1	items
MC_Treatment_Surface_Immerse_Wash				
	SP_Washing	Max_Area	9	m ²
		Max_Unit_Rate	0.5	items/min
		Max_Units	1	items
MC_Treatment_Surface_Spray				
	SP_VapourDeg_rease	Max_Area	9	m ²
		Max_Area_Rate	1.5	m ² /min
		Max_Units	1	items
MC_Cutting_Mechanical_Drill				
	MRM_Hole_Sawing	Max_Axial_Feed_Rate	1	m/min
	MRM_Twist_Drilling	Max_Axial_DOC	0.03	m
		Max_RPM	2500	rpm
		Max_Tool_Dim	0.02	m
		Max_Units	1	items
		Max_X_Dim	0.75	m
		Max_Y_Dim	0.6	m
MC_Cutting_Mechanical_Mill				
	MRM_Cavity_Milling	Max_Power	100	kw
	MRM_Chanfer_Milling	Max_RPM	7000	rpm
	MRM_Core_Milling	Max_X_Dim	3	m
	MRM_Core_Skim_Milling	Max_Y_Dim	3	m
	MRM_Face_Milling	Max_X_Feedrate	0.5	m/min
	MRM_Hole_Sawing	Max_Y_Feedrate	0.5	m/min
	MRM_Routing	Max_X_Travel	1.5	m
	MRM_Shoulder_Milling	Max_Y_Travel	1.5	m
	MRM_Skin_Interpolated_Milling	Max_Tool_Dim	0.06	m
	MRM_Slot_Milling	Max_Units	1	items
	MRM_Twist_Drilling			

Resource Type	Process Key(s)	Parameter	Value	Units
MC_Cutting_Mechanical_Centre				
	MRM_Cavity_Milling	Max_Power	100	kW
	MRM_Chanfer_Milling	Max_RPM	7000	rpm
	MRM_Core_Milling	Max_X_Dim	3	m
	MRM_Core_Skim_Milling	Max_Y_Dim	3	m
	MRM_Face_Milling	Max_Z_Dim	0.6	m
	MRM_Hole_Sawing	Max_X_Feedrate	0.5	m/min
	MRM_Routing	Max_Y_Feedrate	0.5	m/min
	MRM_Shoulder_Milling	Max_Z_Feedrate	0.3	m/min
	MRM_Skin_Interpolated_Milling	Max_X_Travel	2.5	m
	MRM_Slot_Milling	Max_Y_Travel	2.5	m
	MRM_Twist_Drilling	Max_Z_travel	0.5	m
		Max_Tool_Dim	0.06	m
		Max_Units	1	items
Labour_Skill_Layup				
	JIG_Disposable_Vacuum_Bag	Max_Unit_Rate	0.05	items/ min
	JIG_Reuseable_Vacuum_Bag	Max_Units	1	items
		Max_Area_Rate	0.1	m ² /min
		Max_Area	9	m ²
Labour_Skill_Contour_Fit				
	CF_Edge_Taping	Max_Distance	10	m
	MRM_Knife_Cutting	Max_Velocity	0.3	m/min
	SP_Deburr			
Labour_Skill_Point_Placement				
	CF_Insert_Potting	Max_Unit_Rate	2	items/ min
	CF_Core_Fill	Max_Units	1	items
	OR_Insertion			
	MF_Bayonett_Connector			
	MF_Install_Connector			
	MF_Latch_Connector			
	MF_Manual_Mass_Termination			
	MF_Spring_Clip_Connector			
	MF_Screw_Fit_Connector			

Resource Type	Process Key(s)	Parameter	Value	Units
Labour_Skill_Area_Sweep				
	CF_Surface_Bonding	Max_Area	5	m ²
	CF_Paste_Adhesive_Bonding	Max_Area_Rate	0.5	m ² /min
	SC_BR127_Priming			
	SP_ScotchBrite_Abrading			
	SP_Washing			
	SP_Masking			
Labour_Skill_Kitting				
	KIT_Grasp_Difficult	Max_Unit_Rate	100	items/ min
	KIT_Grasp_Easy	Max_Units	100	items
	KIT_Two_Person_Lift			
MC_Treatment_Surface_Spray				
	SP_Grit_Blast	Max_Area	9	m ²
	SC_Airgun_Alocrom	Max_Area_Rate	1.5	m ² /min
	SC_Airgun_Chromate_Conversion	Max_Units	1	items
	SC_Airgun_Painting			
	SC_Airgun_Spray_Coating			
	SC_Airgun_Spray_Priming			
	SC_Redux112_Priming			
MC_Treatment_Heat_Oven				
	HD_Oven_Curing	Max_Units	10	items
	HD_ForceDrying	Max_Temp	400	celcius
		Max_Unit_Rate	0.0017	items/ min
MC_Treatment_Heat_Autoclave				
	HD_Autoclave_Curing	Max_Units	10	items
	HD_Oven_Curing	Max_Temp	400	celcius
	HD_Force_Drying	Max_Pressure	40	psi
		Max_Unit_Rate	0.0017	items/ min
MC_Cutting_Chemical_Milling				
	MRC_Chemical_Milling	MAX_Velocity	0.03	m/min
		Max_Units	4	items

Appendix D Open CASCADE Product Model Viewer

The data presented in this appendix relates to the programming of the ‘CAPABLE Space 3D Viewer’. The aim of this module is to demonstrate connectivity across the (proprietary) data models used by different tools used in the design process. In this case, the feature-based product generated as part of the conceptual and embodiment design in CAPABLE Space is required to be compatible with a solid model which can subsequently be imported into a CAD system for detailed design work.

Open CASCADE (Open CASCADE 2003) is a powerful modelling application development platform suitable for visualisation of the 3D geometry. It consists in reusable C++ object libraries and development tools that are available as open source software. Modelling Data and Modelling Algorithms packages supply object-oriented data structures for the creation of 3D geometry and topology. The shapes can subsequently be displayed in a viewer (Visualisation package), and saved into neutral file formats such as STEP or IGES for export to CAD applications. Additionally, functions are provided to query the resulting model for weights, volumes etc. which can be returned to populate the aggregate product model with data. The Open CASCADE modules used are shown in Figure D.1.

Figure D.1. UML package diagram of Open CASCADE classes required for viewer.

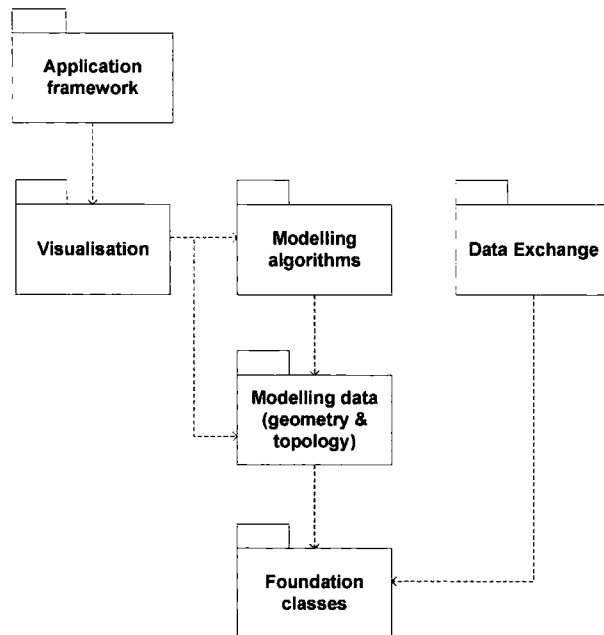
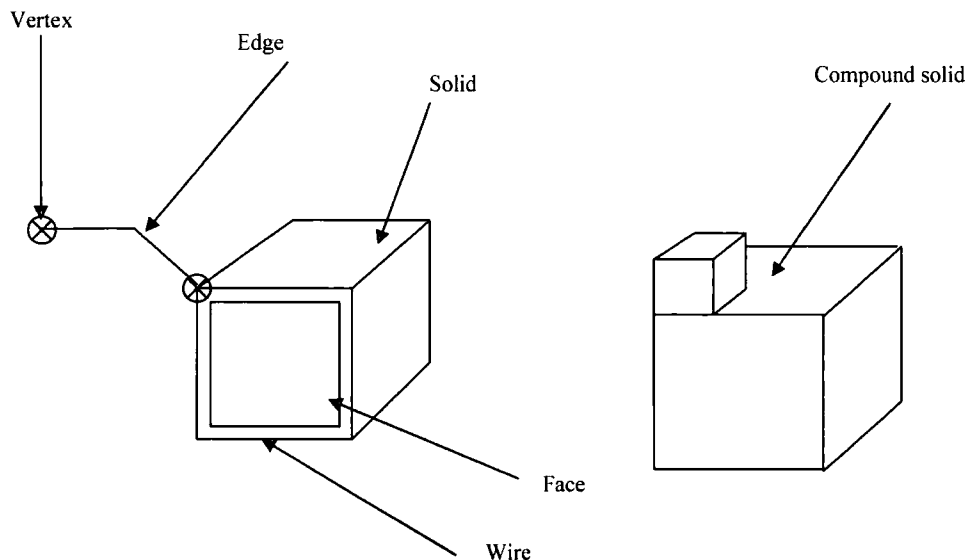

Figure D.2. Open CASCADE Topology used to Construct Feature Shapes.



D.1 JNI implementation of Open CASCADE classes

To interface between the Java Product Model and the C++ Open CASCADE libraries an implementation of the Java Native Interface (JNI) has been employed (Liang 1999). The JNI is a standard programming interface for calling native (C++) methods from within a Java application (i.e. CAPABLE Space).

This section lists the classes and methods that have been implemented (though the creation of JNI wrapper classes) in the CAPABLE Space prototype technology demonstrator.

D.1.1 Geometric Primitives

Class	Description
gp_Ax2	Construct an axis
gp_pnt	Construct a point in 3D space
gp_Vec	Construct a 3-dimensional vector

D.1.2 Topological Objects

Class (see Figure D.2.)	Description
TopoDS_Edge	} Construct a topological object (See Figure)
TopoDS_Face	
TopoDS_Wire	
TopoDS_Shape	

D.1.3 Topological Algorithms

Class	Description
BRepBuilderAPI_MakeEdge	Functions to build edges from points
BRepBuilderAPI_MakeFace	Functions to build faces from wire
BRepBuilderAPI_MakeShape	Superclass of shape construction algorithms
BRepBuilderAPI_MakeWire	Functions to build wires from edges
BRepBuilderAPI_MakeBox	Function to build simple box
BRepBuilderAPI_MakePrism	Describes functions to build linear swept topologies, called <i>prisms</i> from a shape and a vector

D.1.4 Boolean Operations

Class	Description
BRepAlgoAPI_Cut	Method to cut the shape S_2 from the shape S_1 and return the result
BRepAlgoAPI_Fuse	Method to return the fuse (Boolean union) of the shapes S_1 and S_2
BRepAlgoAPI_Common	Method to return the common (Boolean intersection) of the shapes S_1 and S_2

D.2 Procedure for Creating Shapes from Product Model Classes

For each feature a method exists to create a native TopoDS_Shape object, which can be viewed, from the Open CASCADE modelling data package. The 3D representation of a component is created from the TopoDS_Shape objects of each feature using the Open CASCADE modelling algorithms package which are called from a method in the

ProductModel.PMComponent class. This method carries out the following operations on a master TopoDS_Shape object:

- (1) If the object has any positive features, then create the TopoDS_Shapes and add them the vector of shapes to fuse.
- (2) If the object has any joint features, then create any TopoDS_Shapes referenced by the joint feature.
- (3) If the object has any negative features, then create the TopoDS_Shapes, fuse them together and add them to the vector of shapes to cut.
- (4) Repeat steps 1-3 for all the sub-components.
- (5) Perform the boolean operations to create the final shape,
 - (a) Fuse all the shapes in the vector of shapes to fuse to create a master TopoDS_Shape.
 - (b) Perform a cut operation between the master TopoDS_Shape and the shapes in the shapes in the vector of shapes to cut.

Finally, the master TopoDS_Shape is passed to the viewer application from where it can be viewed and exported to neutral file formats. The properties of TopoDS_Shape classes can be queried to give information about lengths, areas and volumes which can be manually used to further the construction of the Aggregate Product Model.

Figure D.3. Screenshot of an SM Floor Panel in the Viewer Application

