

# Durham E-Theses

---

## *"Development of wireless fire products"*

Sarah Jackson

### How to cite:

---

Jackson, Sarah (2006) "Development of wireless fire products". Masters thesis, Durham University.

### Use policy

---

The full-text may be used and/or reproduced, and given to third parties in any format or medium, without prior permission or charge, for personal research or study, educational, or not-for-profit purposes provided that:

- a full bibliographic reference is made to the original source
- a <https://etheses.durham.ac.uk/id/eprint/2409/> is made to the metadata record in Durham E-Theses
- the full-text is not changed in any way

The full-text must not be sold in any format or medium without the formal permission of the copyright holders.

Please consult the [full Durham E-Theses policy](#) for further details.

# “Development of Wireless Fire Products”

Master of Science

**The copyright of this thesis rests with the author or the university to which it was submitted. No quotation from it, or information derived from it may be published without the prior written consent of the author or university, and any information derived from it should be acknowledged.**

Sarah Jackson

September 2006



- 5 FEB 2007

## **Abstract**

The project was to develop a radio controlled door holder system as the first in a range of radio based products for Stephenson Gobin Eng Co. Ltd. Stephenson Gobin manufacture and market a wide range of electromechanical products, including retaining devices for fire doors and smoke vents. Typical installations are in hospitals, nursing homes, shopping centers, hotels or any building open to the public. The author discusses why a radio controlled door holder system is commercially and technically viable. Various wired and wirefree door holder systems are evaluated on merits of safety and ease of installation. Stephenson Gobin developed a bi-stable latching door holding device which consumed no current in a state that was capable of holding a fire door open. This was due to a rotating magnetic slug assembly which only drew current to latch from one state to other. The device needed to be controlled wirelessly and possible methods of communication were assessed. Communicating using the license free radio frequency spectrum was selected due to the falling costs of radio components and the huge growth in the radio communication sector. The author developed and tested the hardware and software necessary to communicate with and actuate such a device.

## **Acknowledgements**

It is a pleasure to thank the many people who made this thesis possible.

I am indebted to Jim Swift my MSc supervisor/TCS knowledge base supervisor. His great efforts, enthusiasm for the project and sound advice were invaluable at every stage.

I would like to thank Nick Goddard my company supervisor for all his hard work with the mechanical design of the device. His enthusiasm and dogged determination to see the project through always kept me going.

I am grateful to Clive Atkinson the company technician who helped me whenever he could with the everyday practicalities of running the project whether he was building a test rig or providing an entertaining working environment.

I am also grateful to the technicians in the engineering department at Durham University for all their hard work and time spent developing and assembling prototype PCBs for me.

Finally, I would like to thank other colleagues who also contributed to the success of the project, David Wilson, Peter Baxendale, Gary Elsbury, Alan Hogg and everyone at Stephenson Gobin Eng Co Ltd.

**ABSTRACT**

**ACKNOWLEDGEMENTS**

**Table of Contents**

**Figure List**

**Table List**

**Chapter 1: Introduction**

- 1.1 Project Aims
- 1.2 Project Objectives
- 1.3 Envisaged End Point

**Chapter 2: Background Information**

- 2.1. Wireless Technologies
- 2.2. Evaluation of Radio Transceiver Chips and Modules
- 2.3. Evaluation of Suitable Microprocessor
- 2.4. Evaluation of Wireless Alarm System
- 2.5. General Overview of the System

**Chapter 3: Evaluation of Development Kit**

- 3.1. Does RF chip meet the specification?
- 3.2. Description of Technology Demonstrator
- 3.3. Modifying the Embedded Software
  - 3.1.1. Description of software

**Chapter 4: Prototype Design**

- 4.1. Prototype Circuit Design Specification
- 4.2. Design Elements
  - 4.2.1. Interfacing the ATMEGA128L and AT86RF211
  - 4.2.2. ATRF211 Circuit Diagram
  - 4.2.3. ATMega128L Circuit Layout
    - 4.2.3.1. In System programming
    - 4.2.3.2. Motor Drive
    - 4.2.3.3. General I/O Pins
    - 4.2.3.4. Printed Antenna
    - 4.2.3.5. Printed Inductors
- 4.3. Prototype PCB Design

**Chapter 5: Prototype Testing**

- 5.1. In-System programming Board
- 5.2. Testing Microprocessor Section
- 5.3. Testing RF Section
  - 5.3.1. Range Test
- 5.4. Pre-Compliance Testing
- 5.5. Mechanical Development of Door Holder
- 5.6. Final Specification for Slave Board
  - 5.6.1. External Interrupts
    - 5.6.1.1. Tamper Switch
    - 5.6.1.2. Un-enrol Pads
    - 5.6.1.3. Manual Release Switch
  - 5.6.2. Driving the motor

**Chapter 6: Pre-Production Slave Board**

- 6.1. Design Elements
- 6.2. Hardware Testing

## Contents Page

- 6.2.1. Current Consumption Measurements
- 6.2.2. Battery Life Calculations
- 6.2.3. Driving the Motor

### **Chapter 7: Pre-Production Controller Board**

- 7.1. Design Elements
  - 7.1.1. Pre-Production Controller Board
  - 7.1.2. Pre-Production PCB Layout
- 7.2. Advanced Versus Standard Design

### **Chapter 8: Software Specification**

- 8.1. Protocol Description
  - 8.1.1. Hibernation Protocol
  - 8.1.2. Calibration Mode
  - 8.1.3. Pre-Installation Frequency Setting
  - 8.1.4. Message Structure
  - 8.1.5. Error Correction & Detection Protocol
- 8.2. Transmission and Reception
- 8.3. Standard Controller Software Description and Flowchart
- 8.4. Advanced Description and Flowchart
- 8.5. Slave Description and Flowchart
- 8.6. Repeater Description and Flowchart

### **Chapter 9: Approvals**

- 9.1. BS EN 300 220 Compliance Tests Results
- 9.2. EN 301 489 – 3 EMC Standard for Short Range Devices
- 9.3. EN1155
  - 9.3.1. Test Cycles
  - 9.3.2. Power off Test
  - 9.3.3. Operating Voltage Range
- 9.4. Electrical Equipment Regulations (Low Voltage Directive) 1994 (SI 1994/3260)

### **Conclusion**

### **Recommendations for Further Work**

### **Bibliography**

## Figure List

- Figure 1 – Fire Door Wedged Open
- Figure 2 – Door Wedges
- Figure 3 – Acoustically Activated Door Stop
- Figure 4 – Electromagnetic Door Holders
- Figure 5 – Door Opener Closer
- Figure 6 - System Overview
- Figure 7 – SPI Write Cycle to a 10 Bit Register
- Figure 8 – SPI Read Cycle from a 10 Bit Register
- Figure 9 – FSK Modulation
- Figure 10 – ATRF211 Circuit Diagram
- Figure 11 – ATMEGA128L Circuit Diagram
- Figure 12 – Prototype PCB Layout (Top Layer)
- Figure 13 – Prototype PCB Layout (Bottom Layer)
- Figure 14 – AVRISP PCB Layout (Top Layer)
- Figure 15 – AVRISP PCB Layout (Bottom Layer)
- Figure 16 – Communication Link Test Procedure Diagram
- Figure 17 – Crystal Oscillator Circuit
- Figure 18 – 300MHz 1GHz Scan Results
- Figure 19 – Equipment Set Up
- Figure 20 - Screen Image of scan from 300 – 1000MHz, measuring quasi peak (dBuV), 2ms dwell time, 50kHz resolution with no capacitor
- Figure 21 - Screen Image of scan from 300 – 1000MHz, measuring quasi peak (dBuV), 2ms dwell time, 50kHz resolution with 22nF capacitor.
- Figure 22- Door Holder
- Figure 23 - Door Closer
- Figure 24 – Magnetic Field Configuration through Pole Pieces
- Figure 25 – Prototype Motor Design
- Figure 26 – Solenoid latching Design (Engaged/Disengaged)
- Figure 27 – Solenoid latching Design
- Figure 28 – Final Motor Design (Internal/External)
- Figure 29 – External Interrupts Configuration
- Figure 30 – Release & Hold Positions for Reed Switch
- Figure 31 – Pre-production Slave Circuit Diagram
- Figure 32 – Pre-production PCB Layout (Top Layer)
- Figure 33 – Pre-production PCB Layout (Bottom Layer)
- Figure 34 – Power Supply Components
- Figure 35 – Dallas Real Time Clock
- Figure 36 – Zener Inputs
- Figure 37 – Pre-Production Controller Circuit Diagram
- Figure 38 – Pre-Production Controller PCB Layout (Top Layout)
- Figure 39 – Pre-Production Controller PCB Layout (Bottom Layout)
- Figure 40 – Advanced vs Standard
- Figure 41 – Calibration Procedure
- Figure 42 - Hibernation Protocol
- Figure 43 – Pre-Installation Frequency Scanning
- Figure 44 – Unit Frequency Scanning
- Figure 45 – Message Packet Organisation Chart
- Figure 46 – Output Compare Interrupt Diagram
- Figure 47 – Manchester Encoding
- Figure 48 – Dataclk recovery
- Figure 49 – Enrolment
- Figure 50 – Standard Software Flowchart
- Figure 51 – Standard Software Interrupt Flowchart
- Figure 52 – Advanced Software Flowchart (i)

- Figure 53 – Advanced Software Flowchart (ii)
- Figure 54 – Advanced Software Flowchart (iii)
- Figure 55 – Slave Software Flowchart(i)
- Figure 56 – Slave Software Flowchart(ii)
- Figure 57 – Repeater Organisation Example
- Figure 58 – Repeater Software Flowchart
- Figure 69 – Spurious Emission Requirement Graph
- Figure 60 – Locations of Extra Vias to Ground
- Figure 61 – Atmel Modifications to PCB
- Figure 62 – Antenna Matching Circuit
- Figure 63 – Wired Repeater Example
- Figure 64 - CC2420 ZigBee Transceiver Application Circuit

## **Table List**

Table 1 – Summary of Wireless Technologies

Table 2 – Summary of Radio Transceiver Chips and Modules

Table 3 – Summary of Suitable Microprocessors

Table 4 – AVRISP Connections

Table 5 – Propagation versus Antenna Type

Table 6 – PA Power Level Settings

Table 7 – EN 300 220 Pre-Compliance Testing Results

Table 8 – EN 301 489 Pre-Compliance Testing Results

Table 9 – Cycles Completed with Prototype Motor Design

Table 10 – Reducing Current Consumption Measurements

Table 11 – Current Consumption vs Mode

Table 12 – Measuring MVCC vs Actual Voltage measured

Table 13 – Data Fields In Message Structure

Table 14 – Standard EEPROM Configuration

Table 15 – Advanced EEPROM Configuration

Table 16 – Slave EEPROM Configuration

Table 17 – 1<sup>st</sup> Level Stage Repeater

Table 18 – Conducted Measurements varying C3

Table 19 – Conducted Measurements varying C4

## **Abbreviations**

<b>dB</b>	<b>Decibel</b>
<b>dBm</b>	<b>Decibel Metres</b>
<b>LED</b>	<b>Light Emitting Diode</b>
<b>LD</b>	<b>Laser Diode</b>
<b>AM</b>	<b>Amplitude Modulation</b>
<b>FM</b>	<b>Frequency Modulation</b>
<b>FSK</b>	<b>Frequency Shift Keying</b>
<b>DECT</b>	<b>Digital Enhanced Cordless Telecommunications</b>
<b>TDMA</b>	<b>Time Division Multiple Access</b>
<b>GSM</b>	<b>Global System for Mobile Communications</b>
<b>GPRS</b>	<b>General Packet Radio Service</b>
<b>WAP</b>	<b>Wireless Access Point</b>
<b>LAN</b>	<b>Local Area Network</b>
<b>WLAN</b>	<b>Wireless Local Area Network</b>
<b>UMTS</b>	<b>Universal Mobile Telecommunications System</b>
<b>ISM</b>	<b>Industrial, Scientific and Medical</b>
<b>PCB</b>	<b>Printed Circuit Board</b>
<b>LCD</b>	<b>Liquid Crystal Display</b>
<b>TX</b>	<b>Transmitter</b>
<b>RX</b>	<b>Receiver</b>
<b>TRX</b>	<b>Transceiver</b>
<b>VHF</b>	<b>Very High Frequency</b>
<b>UHF</b>	<b>Ultra High Frequency</b>
<b>TQFP</b>	<b>Thin Quad Flat Pack</b>
<b>QFN</b>	<b>Quad Flat package No leads</b>
<b>BGA</b>	<b>Ball Grid Array</b>

LQFP	Low Quad Flat Pack
IC	Integrated Chip
EEPROM	Electrically Erasable Programmable Read-Only Memory
VCC	Voltage Supply
GND	Ground
I/O	Input/Output
BOM	Bill Of Materials
ISP	In System Programmer
TX LVL	Transmit Level
ERM	Electromagnetic compatibility and Radio spectrum Matters
SRD	Short Range Devices
R&TTE	Radio and Telecommunications Terminal Equipment
MVCC	Measured Voltage Supply
CRC	Cyclic Redundancy Check
FEC	Forward Error Correction
OCR	Output Compare Register
TCNTR	Timer Counter
EMC	Electro Magnetic Compatibility
LVD	Low Voltage Directive
DC	Direct Current
IF	Intermediate Frequency
RSSI	Received Signal Strength Indicator

## Chapter 1: Introduction

### Fire Doors

Fire doors are installed in buildings to protect escape routes, to separate areas of high risk and resist the spread of a fire. Fire doors are provided with a fire rating (30 or 60 minutes) which translates to the length of time the door can resist fire before becoming unstable. It is therefore essential that these doors be maintained to a good standard. The standard BS 8214 states that:-

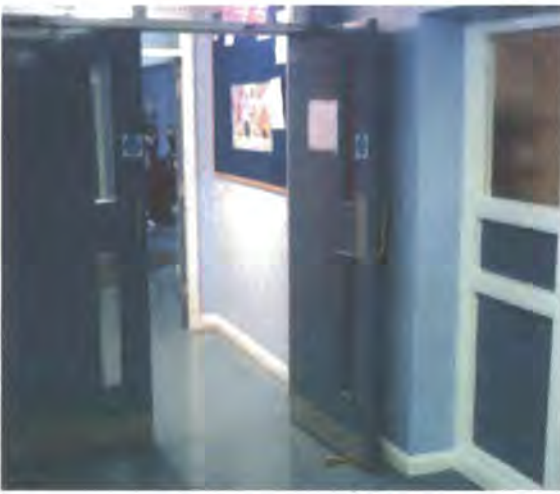

Figure 1 – Fire Door Wedged Open

- Doors and door frames must be in good condition.
- Doors should close properly into the frame and not be unduly distorted
- Doors must not stick in the open position unless fitted with an approved door holder.
- Smoke seals must be in good condition.

Fire doors tend to be located between different parts of buildings, along corridors and on stairwells to protect means of escape incase of fire and protect other parts of the building from the effects of fire and smoke. As these doors may have a lot people passing through them everyday there is often a requirement for them to be held open:-

- Provide access for wheelchair users
- Ease of passage for frequently used doors i.e. corridor doors in a hotel
- Tours in commercial buildings such as stately homes require doors to be open



## Typical Methods for Holding Doors Open



### Wedge

*Advantages:* Can be installed anywhere.

*Disadvantages:* Illegal. No automatic means of closing in case of fire.

Figure 2 – Door Wedges

### Sound Activated Door Stop

A sound activated door stop holds the door open with the stop which the user has to activate. It is battery operated and listens for fire alarm siren, when one is detected the stop is released and the door closes.

*Advantages:* Small installation costs, easily moved to other location, no wires. It will close on detecting (hearing) fire alarm siren at correct frequency and duration.

*Disadvantages:* One way communication. Status of door unknown to user should it fail.



Figure 3 – Acoustically Activated Door Stop

### Electromagnetic Door Holder



Figure 4 – Electromagnetic Door Holders

An electromagnetic door holder is mounted on the wall beside the door so that it makes contact with a plate fitted to the door. It retains the door by making contact between its magnetic face and the plate. The door holder's typically takes 24Vdc although mains powered

versions are available. When the power is removed the magnetic field dissipates and the door is released. Typically a relay output from a fire alarm system would cut the power in the presence of an alarm.

*Advantages:* Fail Safe, very little maintenance. Easy to install in new builds.

*Disadvantages:* Troublesome to install in old buildings especially if they are in use i.e. hospitals, hotels. High cabling and labour costs typically £200 per unit. The status of the door is unknown to the user. Price is prohibitive for small businesses that may only require 5 – 20 doors to be held.

### **Door Opener Closer**



Figure 5 – Door Opener Closer

A door opener/closer is mounted at the top of the door and is a hinged device. The action of the hinge with a spring closes the door and DC motor drives it in the opposite direction back to an open position. This requires power and they are typically mains powered devices. The power can be wired through a relay to control the closing on detection of a fire alarm.

*Advantages:* Fail Safe, very little maintenance.

*Disadvantages:* Expensive typically £350 per unit. The status of the door is unknown to the user. Price is prohibitive for small businesses that may only require 5 – 20 doors to be held.

### **Radio Controlled Wired Door Holders**

In the mid 1980s Tyco launched a wireless system (Fire Alarm Controller plus Smoke Detectors etc) but withdrew the products after 2 years. The technology was prone to reliability problems and there was a lot of resistance to wireless devices in this conservative market. However, they did

install systems at Blenheim Palace and Swallow Hotel in Gateshead etc. They have disclosed that they were at that time installing wired door holders that were controlled via radio controlled relay boxes. So the principle had been looked at before but only using wired door holders.

### **Wirefree Solution**

For buildings that require minimal disruption during installation a wire free solution would be the answer. The device would have to be:-

1. battery operated
2. hold the door independently
3. detect the presence of an alarm
4. release the door when a fire alarm is detected

### **Detecting a Fire Alarm**

When a fire alarm is in progress a number of things happen:-

1. siren/bell rings
2. beacons flash
3. Host fire alarm triggers various outputs on the alarm panel to change state i.e. relays switch, volt free contacts close/open.

1 and 3 are reasonable methods for detecting a fire alarm.

### **Siren/Bell**

The door holder device could listen using an acoustic sensor for the alarm bell and release the door. This however has technical and legal difficulties. Technically such a system is prone to reliability issues:-

- What if another noise at the same dB level is present?
- What if there is lot of doors between the bell and door holder?
- Status of door holder unknown.

This method is protected with a worldwide patent and so therefore will not be implemented.

### **Host Fire Alarm Panel Outputs**

Using the outputs to trigger a communication device that transmits information wirelessly to the door holder is a viable method. The information could be transmitted sonically, by infra red or over a radio frequency band.

#### **Communication Methods: Ultrasonic Transducer**

A high sensitivity ultrasonic transmitter and receiver can be used for sending and receiving ultrasonic sound through the air, either as a continuous wave or pulses. A microprocessor could generate and decode the pulses to create a simple method of communication.

*Advantages:* Very cheap to implement.

*Disadvantages:* It will have very limited range and angle of use.

#### **Communication Methods: Infrared**

Infrared communication refers to the use of light waves in the near infrared band as a transmission medium for communication. A transmitter converts an electrical signal possibly created by a microprocessor to an optical signal. The two most appropriate types of device for transmitter are a light-emitting diode (LED) and semiconductor laser diode (LD) but most commercial systems currently use LEDs. A receiver then converts that optical power into electrical current to be analysed by a microprocessor.

*Advantages:* High data rate, considered very reliable.

*Disadvantages:* A few metres range and limited angle of use.

#### **Communication Methods: Radio Frequency Communication**

The radio frequency band has been used for many years to transmit and receive data wirelessly. It is a portion of the electromagnetic spectrum in which electromagnetic waves are generated by an alternating current fed to an antenna. A carrier wave is generated at the fundamental frequency and a digital signal is generated for the data. Either the frequency or the amplitude of

the signal to be transmitted may be modified in a process called modulation. This accounts for the option on the radio dial for AM or FM stations. The receiver's antenna picks up the combined wave and it is then demodulated.

*Advantages:* Two way communication, falling costs of radio components, tried and tested methods, lots of literature regarding the subject, good range, reliable.

*Disadvantages:* May require large antenna. License Issues, may have to pay to communicate.

## **Conclusions**

There is a requirement in the fire & safety marketplace to hold open fire doors for general use and release them in case of fire. There is a further requirement to do such installations quickly, cost effectively and with limited disruption to the building/business itself. As fire and safety regulations have become stricter a self monitoring device is encouraged. A wireless door holder device would have to be battery operated but have some link to the fire alarm system to release the door when instructed. These instructions would be communicated to it by the most appropriate method. Communicating over the radio frequency band was the most suitable method due its relative cheapness, prolonged existence as a communication tool and good range.

### **1.1. Project Aims**

The project aim is to develop a battery powered radio controlled door holder system as the first in a range of radio based products for Stephenson Gobin Eng Co. Ltd.

### **1.2. Project Objectives**

This project aim will be achieved by:

- Survey of current wireless technologies and components
- Define all electromagnetic interfacing requirements
- Selected and designed the required computing and electronic components and circuitry required

- Design, develop and test a wireless door holder prototype
- Satisfy all necessary regulations and compliance issues
- Develop into a final production unit.

### **1.3. Envisaged End Point**

The envisaged end point for the project is to have a fully functioning wireless door holder and system controller. The product will be ready for mass production and saleable.

## **Chapter 2; Background Information**

### **2.1. Wireless Technologies**

In recent years there has been a 'boom' in the area of wireless technologies. Many new technologies emerged on the market and some, like Bluetooth or Wireless LAN, are widely discussed in public. This section discusses the major wireless technologies, including their main features and application fields, as well as a short comparison.

#### **DECT**

DECT (Digital Enhanced Cordless Telecommunications) is the dominant standard in cordless phones. It was developed by ETSI in 1988. It is basically a cordless phone system consisting of a base station and a picocell. DECT uses time division multiple access (TDMA) to transmit radio signals to phones at 1.9GHz in a protected band to minimize interference problems. Good voice quality is achieved by digitally coding voice into a 32 kbit/s signal. The range can be up to 300 m if there is a clear line of sight.

#### **GSM/GPRS**

Mobile phones are based on an underlying mobile network. The Global System for Mobile Communications (GSM) was introduced in the early nineties and currently services about 500 million mobile users world-wide. The GSM standard communicates at 900, 1800 or 1900 MHz in a licensed band. Due to limiting bandwidth the GSM standard only allows 13 kbit/s for speech transmission. This leads to a noticeable reduction in the voice quality compared to fixed line telephones. Speech compression algorithms give GSM land line quality.

An extension to the GSM standard was defined as its 9.6kbit/s data rate is too slow for most data services. The General Packet Radio Service (GPRS) was developed allowing faster transmission. Data is sent in packets and the cost is based on the amount of transmitted data. So a GPRS telephone can always be 'online' without incurring any costs as long as no data service is used. This means WAP users can have faster downloads and lower costs.

## 802.11b/802.11a

There are several standards defined to enable wireless access for data terminals like PCs or notebooks. The Wireless Local Area Network (WLAN) standard 802.11, and in 1999 standards 802.11a and 802.11b were approved.

802.11b referred to as 'WiFi' operates in the license free 2.4 GHz band, allows 11 Mbit/s data speed and a range of up to 300 m. There are various application fields, like the easy and comfortable setup of an Adhoc network. 802.11b is rather a wireless access standard than a full mobile network specification with e.g. Quality of Service, charging mechanisms and sufficient security.

Further standards like IEEE 802.11a or the ETSI standard Hiperlan/2, enabling data rates of up to 54 Mbit/s are available. Both operate at around 5 GHz. Hiperlan/2 technology seems to be more advanced than 802.11a as it allows for power management and dynamic frequency change in case of interference.

A summary of the key various standards are highlighted below in table 1.

Technology	Frequency	Data Rate	Range	Typical Usage	Links
DECT	1.9 GHz	552kbit/s, up - 2Mbit/s	300 m	cordless phones, local loop	<a href="http://www.etsi.org/dect">www.etsi.org/dect</a>
GSM	0.9/ 1.8/ 1.9 GHz	13kbit/s - voice, 9.6kbit/s - data	max 30..50 km to next base station	voice and data, WAP	<a href="http://www.gsmworld.com">www.gsmworld.com</a>
GPRS	0.9/1.8/1.9 GHz	171 kbit/s	see GSM, less for max. data rates	data services, WAP	<a href="http://www.gsmworld.com">www.gsmworld.com</a>

802.11b	2.4 GHz	11 Mbit/s	150 m	WLAN	www.standards.ieee.org
802.11a	5.15 GHz	54 Mbit/s	150 m	WLAN	www.standards.ieee.org
Hiperlan/2	5.2 GHz	54 Mbit/s	30..200 m	WLAN, local access to ATM	www.etsi.org/bran www.hiperlan2.com
Bluetooth	2.4 GHz	721 kbit/s	0.1,10, 100 m	Peripheral devices	www.bluetooth.com
Hiperaccess	40.5/43.5 GHz	25 Mbit/s	5 km	Remote access to IP / ATM	www.etsi.org/bran

Table 1 – Summary of Wireless Technologies

Similar radio controlled systems such as burglar and fire alarms were investigated to see how they transmit and receive data. Most if not all used a proprietary protocol that drove the communication link on a frequency band that was licence free. A wireless burglar system was purchased and evaluated. It is discussed in chapter 2.4.

## ISM Band

The ISM band is the Industrial, Scientific and Medical band which is unlicensed in most countries and therefore free. It is an open standard and due to the rules of co-operation multiple systems can share the band reliably. The license free frequencies are 433MHz, 868MHz, 915Mhz, 2.4MHz and 2.5Mhz. To operate legally in this band all transmitters/receivers must adhere to the European Standard EN 300 220 which stipulates spurious emission level, channel spacing and duty cycle allowance.

## 2.2. Evaluation of Radio Transceiver Chips and Modules

Due to the recent boom in wireless technologies there is now a large range of communications devices on the market, which have produced a number of solutions to designing an effective two way radio communication devices.

A summary of possible solutions are given below.

### **Separate RF Transmitter and Receiver Devices**

- A transmitter, receiver and a microprocessor must be interfaced to create a two way communication system with these devices. The system on receipt of a radio packet at the fundamental frequency produces modulated data at the receiver output to be the microprocessor. To transmit, the microprocessor outputs on a general I/O pin the data to be transmitted at the correct frequency onto the transmitter input. These devices typically have extra features such as low power modes, transmitter level settings and are of a suitable package size.

### **Transceiver Devices**

- A transceiver and a microprocessor must be interfaced to create a two way communication system with these devices. The system on receipt of a radio packet at the fundamental frequency produces modulated data at the transceiver output to the microprocessor. To transmit, the microprocessor outputs on a general I/O pin the data to be transmitted at the correct frequency onto the transceiver input. These devices typically have extra features such as low power modes, transmitter level settings and are of a suitable package size.

### **Transmitter/Receiver/Transceiver Modules**

- Various combinations of these modules exist and typically used for low cost, low radio packet overhead applications and therefore do not have and the extra features of those listed above.

A detailed evaluation of some of the devices available at the time (first quarter 2003) was completed.

Product Name	Product Description	Mfr	Freq Range (MHz)	Sleep mode	Data Rate kbps	Package
AT86RF211	FSK TRX for ISM Applications	Atmel	400 - 950	3 $\mu$ A	> 64	48 TQFP
XTR-433	TRX Module	Aurel	433.92	N	100	
RTF-DATA-SAW	RF Data TRX	Aurel	433.92	N		
RF2516	VHF/UHF Transmitter	RF Micro Devices	315/433	1 $\mu$ A	?	16 QSOP
RF2514	VHF/UHF Transmitter	RF Micro Devices	868/915	1 $\mu$ A	?	16 QFN
RF2915	433/868/915MHz FSK/ASK/OOK Transceiver	RF Micro Device	433/868/915	1 $\mu$ A	?	32 TQFP
SWRF2	Multi-Standard RF Transceiver	Sirific	400- 2500	N	?	
RFD97224	Raw Serial Data Wireless RF Transceiver Module.	RF Digital	433	N	?	
RFD27988	Dual Mode 433 MHz Wireless RF Transceiver Board.	Parallax inc	433	N	9.6	17 pin 0.1 Inch header.
CC1020	Single Chip Low Power RF TRX for ISM	Chipcon	433, 868 and 915 MHz	0.2 $\mu$ A	153.6	QFN 32
nRF903	430-950MHz Single Chip RF TRX	Nordic VLSI	430-950M	N	76.8	32pin TQFP
FM-RTFQ1-xxx	FM Transmitter & Receiver Hybrid Modules	RF Solutions	315/433/868	0.1 $\mu$ A	9.67	Separate TX and RX modules
BCC 418	UHF TRX	Caxapa	433.92	<1 $\mu$ A	100	44 pin TQFPT
max2420 - max2463	900MHz Image-Reject TRX'S	Maxim	900	0.5 $\mu$ A	?	28 pin SSOP
DR3100	433.92M TRX Module	RFM	433.92	0.75 $\mu$ A	2.4-19.2	14 pin PCB Assembly
DR3001	868.35M TRX Module	RFM	868.35	0.75 $\mu$ A	2.4-19.2	14 pin PCB Assembly
BIM-433	Low power Data TRX Module	Radiometrix	433.92	1 $\mu$ A	40	0.1 inch pin spacing
ASTRX1	Single TX /RX	AMI	868-870M	<10 $\mu$ A	20	64 pin smt
TXE-433-KH	KH SERIES RF Transmitter with integrated decoder	Linx	433	1 $\mu$ A		24 pad smd module
RXD-433-KH	KH SERIES RF Receiver with integrated decoder	Linx	433	700 $\mu$ A		24 pad smd module

Table 2 – Summary of Radio Transceiver Chips and Modules

Due to the specifications of the project a wish list of features the wireless device would require was created.

- To minimise current consumption a sleep/power down mode is essential
- Operating frequency was still undetermined so a multi-channel device is preferred
- Quick route to development would facilitated using device with a high level of integration
- To avoid 'teething problems' an already established device would also be preferred

Two of the above devices were considered to be the most suitable and meet the requirements the fullest. The Atmel ATRF211 and the Chipcon CC1020. They are both low power mutli-channel transceivers that require few external components and are highly integrated.

However, the Chipcon CC1020 was the 'newest' device and was just coming into production hence its availability/stock levels were viewed unfavourably. The decision was taken to run with the Atmel ATRF211 device.

Atmel provide a development kit for the AT86RF211. It has an AT90 microprocessor mother board with detachable RF daughter boards. The daughter boards can be purchased with different frequency configurations. Daughter boards for 433MHz and 868Mhz were purchased

### **2.3. Evaluation of Suitable Microprocessor**

The main considerations in deciding a suitable microprocessor are:-

- memory requirements
- low voltage range
- sleep/power down mode functionality

- easy to use package.

Below is a table of some of the options with regards to the microprocessor choice.

Mfr	Part Name	Sleep/Power Down Mode	Flash	RAM	Voltage (V)	Package	ADC
Atmel	8-bit ATMega8535	y	8k	5144b	2.7-5.5	TQFP-44	y
Atmel	16-bit AT91FR4081	y	1M	136k (SRAM)	2.7-3.6	BGA-100	y
Atmel	16-bit AT91FR4042	y	512k	256k (SRAM)	2.7-3.6	BGA-121	y
Atmel	8 - bit ATMega128L	y	128k	4096b	2.7-5.5	TQFP - 64	y
Fujitsu	32-bit MB91F233L	y	256k	16k	3.3	LQFP-120	y
Fujitsu	16-bit MB90F482	y	256k	6144b	2.4-3.6	?	y
Fujitsu	16-bit MB90F474	y	256k	16384b	2.4-3.6	LQFP-100	y
Renesas	16-bit H8S/2377	y	384k	24k	3.3	144-pin	y
Renesas	16-bit H8S/2238B	y	256k	16k	3.3	100-pin	y
Renesas	32-bit HD64F7145F50	y	256k	8k	3.3	QFP-112	y
Renesas	16-bit HD 64F3026F25	y	256k	8k	3	TFP-100	y

Table 3 – Summary of Suitable Microprocessors

It was decided that a device with a comparatively large RAM (over 4k) was necessary. This was due to:-

- unknown code size
- incorporate future development

- possible customer change requests.

A reasonable amount of flash (greater than 64k) would also be essential for storing strings for the LCD display. In addition a practical package for prototype development and testing was also prudent i.e. a QFP versus a BGA.

The Atmel ATmega128L was chosen as the most suitable and cost effective option.

#### **2.4. Evaluation of Wireless Alarm System**

To begin to understand the function and requirements of a wireless door holder system a similar system was assessed. A wireless burglar system with a mains powered central controller, wireless repeaters and battery powered peripheral devices operating in the ISM band was thought to be reasonably close to what the project was trying to achieve and therefore one system was purchased.

The system is a wireless alarm control system that provides protection against burglary and fire. Status information is presented visually and verbally on the control panel. The control panel collects data from various sensors that are strategically located within the protected site.

The enrolment procedure for the system involved getting the controller in the correct enrolment mode via its installation menu i.e. enroll key fob or enrol peripheral. Once in the correct mode the user would cause the enrolling device to transmit i.e. press key fob button. The controller would indicate a successful enrolment. If the user thought a wrong device was enrolled it could be deleted through the installation menu.

The control panel sits in receive mode waiting for an alarm or supervision message. The wireless peripherals within the protected site send periodic supervision messages, six supervision messages are sent at pseudo random time intervals. The peripherals have only transmitters, so

no acknowledgment protocol was possible. If none of the messages are received correctly, the system displays an 'inactivity' trouble message. If smoke or a disturbance is detected an alarm is initiated. A 4-digit security code is required to access the functions on the control panel.

All of the peripherals in this system are for detection purposes only and therefore only transmit to the control panel. For actuation devices such as a door holder two way communications is necessary.

### 2.5. Proposed Door Holder System

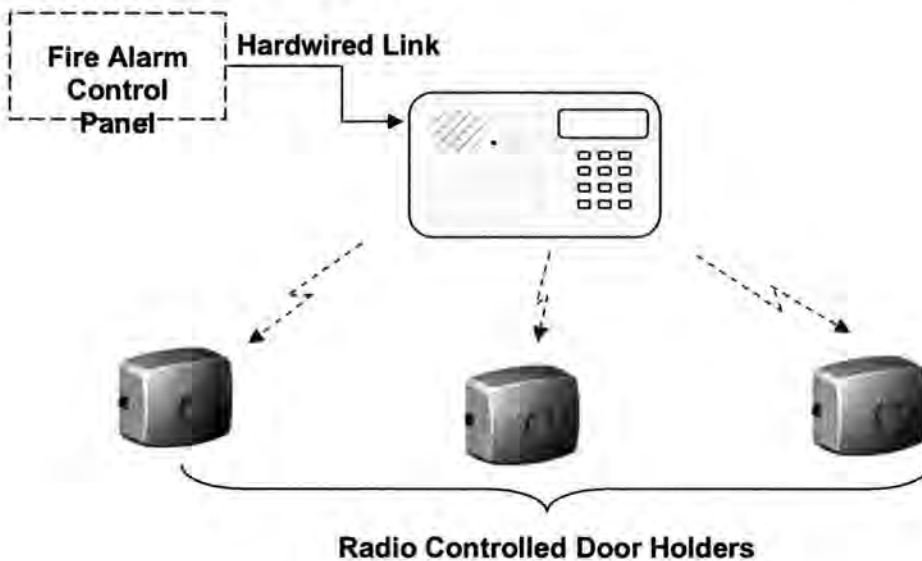

Figure 6 - System Overview

It is thought that the system configuration will be close to the figure above. The controller will be mains powered and have a hard wire link to the host fire alarm panel to detect if a fire alarm does occur. Under normal operation the controller monitors each door holder unit for low battery level and low signal strength. If all is well the unit enters a holding state and the door is capable of being retained. If a fire alarm is detected the door holders are sent a message to release the doors. Each door holder unit can also release its door by pressing the manual release switch, which will be conveniently located.

Each unit will have a unique ID that will be stored in the controller's memory during enrolment.

The system may have a number of features such as the user can specify a time when all the doors are released for example, event logging etc. For economical reasons two versions of the controller were developed. A high end multi-feature device with a more user friendly interface and a more basic controller with less features to be sold at a reduced price. Due to this there will be two versions of the controller a standard and an advanced.

Standard and advanced versions could be developed but designed on the same PCB.

### **Standard Controller**

The standard controller will have a much simpler user interface and fewer options. Basic features such as:-

- Enrol
- Un-Enrol
- Release All Doors
- Poll door holders units for status automatically and when requested by user.

### **Advanced Controller**

The advanced version will have a numeric keypad and reasonably sized LCD. It will have advanced features such as:-

- event log
- password protection
- release doors at pre-defined time

- signal strength and battery levels displayed in percentage format

### **Repeater**

To extend the range of the system a repeater unit must also be developed. The door holder PCB would be used with embedded software written specifically for the repeater functionality.

## **Chapter 3: Evaluation of Development Kit**

An Atmel AT86RF211 development kit was purchased to evaluate the RF IC and to build a technology demonstrator. The kit includes embedded demonstration software which is provided on a CDROM for editing. Other software functions required to set up the transceiver and send/receive data were provided. The kit was battery operated and had an LCD for debugging. It is programmed using In System Programming. A 3-bit encoder and push button are provided as inputs. The kit was purchased with 433MHz and 868MHz daughter boards.

### **3.1. Does RF chip meet the specification?**

Using the development kit a good evaluation of the chip and the RF channels was achieved. There was feature on the kit that allows the measurement of received signal strength. This feature will be used to measure signal strength through different types of buildings on the two considered frequency channels.

Two buildings were chosen for comparison:

- Modern building made of steel and glass.
- Older building made of reinforced concrete and glass.

Both buildings have over three floors so propagation through up and down through the levels can be observed.

### **Results**

The results showed that at both frequencies the ranges through both buildings were very similar but with the 868MHz being slightly better. As expected the range through the modern building

was better and could reach approximately 40m across the building and 20m up through it. A line of sight test was also conducted and a range of 200m was achieved.

## **Conclusion**

The range results of the development kit were reasonable and the device easy to use and set up. Due to the 868MHz channels slightly better propagation through buildings and the requirement for an antenna only half the size it was chosen as the system frequency.

Note: The PCB layout for the 433MHz design is identical to the 868MHz and the AT86RF211 is a dual band device requiring only small external component and software changes to set it up in either frequency.

The concept of a wireless door holder system was relatively new and untested. So a small 'technology demonstrator' that could demonstrate the principle was developed. The fire and security market was historically conservative so the demonstrator was presented to potential customers, distributors and fire officers first to gauge their feedback. It was then in addition used as a marketing tool.

## **3.2. Description of Technology Demonstrator**

The technology demonstrator's purpose is to demonstrate the working principal of a wireless door holder system. Therefore one controller and a number of door holders needed to be assembled. The development kits can be re-programmed, have small transistors added to actuate an electromagnet and housed in enclosures. The controller needs no such modifying.

With this system the communications link and release/hold of an actual door can be tested. The development kit was provided with embedded software which was available on a CDROM. This software would have to be modified to suit the demonstrators specification.

### **3.3. Modifying the Embedded Software**

The embedded software can be compiled using the freeware WinAVR compiler and programmed into flash using AVR Studio 4. The choice of compiler was very expensive time wise as the embedded software provided with the kit was written with an IAR development toolkit. The software designer had used the tool kit fully and many macros and header files were now causing WinAVR compiler issues. The software had to be re-written to become WinAVR 'friendly'.

#### **3.3.1 Software Description**

The low level functions for transmitting and receiving the data packets that were supplied with development kit were kept. The main function of the controller program is to poll three door holder units with ID's 1, 2 and 3. This would be hard coded so no enrol features are developed yet. Once each unit was polled the controller would wait in receive mode for a reply;

- If a reply was received the controller LCD would display Unit X OK
- If a reply was not received the controller LCD would display Unit X OK

Each units main function is to sit in receive mode and wait to be polled by the controller. Each unit has its ID hard coded into EEPROM during programming. When the unit is first polled by the controller the electromagnet is energised and the door held and the unit replies to the poll. If a message is not received within a certain time limit then door is released.

To demonstrate the action upon a fire alarm the controller has a button which when pressed prompts it to transmit a fire alert message rather than a polling message. The unit had code to deal with this message will turn the magnet off and release the door.

#### **3.3.2 Problems**

Firstly as the software needed to be changed so completely, this lead to initial problems getting the communication link set up correctly. As the transmitter and receiver code had now been

changed it was very difficult to track down which end, transmitter or receiver (or both) was causing the problem.

By fully utilizing the LCD output and displaying every data bit that was received at the receiver and only transmitting a string 01's the communication link was established. The problem was found to be at the receiver end not interrupting the microprocessor correctly.

### **3.3.3 Conclusions**

The demonstrator was assembled and presented to potential customers, distributors and fire officers. The development kits microprocessor only had a small amount of flash (8k) so it didn't take long for the code size to become too large and no further features could be squeezed on.

As development had come to an end it was time to begin designing the first prototype using the knowledge gained from the technology demonstrator.

## **Chapter 4**

### **4. Prototype Design**

The technology demonstrator was useful in proving the principle of the system but due to limited memory constraints on the motherboard (AT90S 8k Flash) certain features could not be developed. A prototype PCB interfacing the RF211 with the selected microprocessor was developed.

#### **4.1. Prototype Circuit Design Specification**

This prototype PCB is to test both the ATMEGA128L and AT86RF211 devices. Once the PCB has been developed test software was written and the viability of using these devices fully examined. The basic design requirements are:-

- Interface the RF and microprocessor devices
- Each device set up with correct external components
- Develop motor drive circuit
- Design antenna
- Suitable decoupling.

#### **4.2. Design Elements**

##### **4.2.1. Interfacing the ATMEGA128L and AT86RF211**

###### **Control Logic**

The ATMEGA128L can control the ATRF211 via a bi-directional synchronous 3-wire serial interface. The three signals are:-

- SLE (enable input)
- SCK (clock input)
- SDATA (data in/out)

When SLE = 1 the interface is disabled and no communication with the ATRF211 can occur. When SLE = 0 a read/write cycle can be initiated but only one cycle at a time so only one register can be read or written to in one operation.. This interface controls the reading and writing to the

16 RF211 internal registers. The reading and writing cycles discussed below adhere to the SPI (Serial Port Interface) standard.

**Writing**

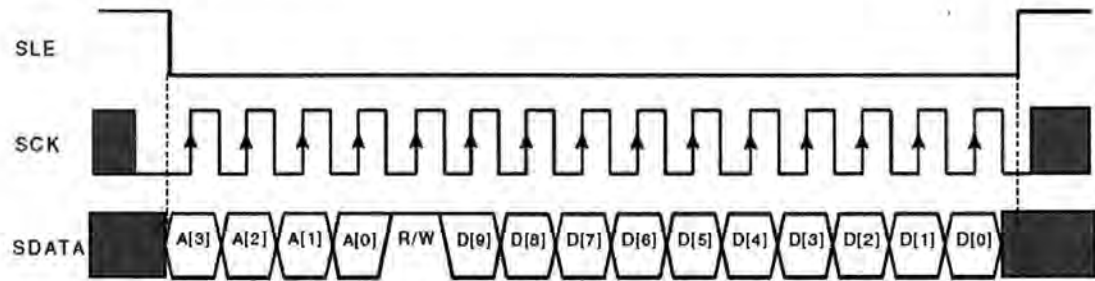

Figure 7 – SPI Write Cycle to a 10 Bit Register

The data bits are clocked on the rising edge of SCK

**Reading**

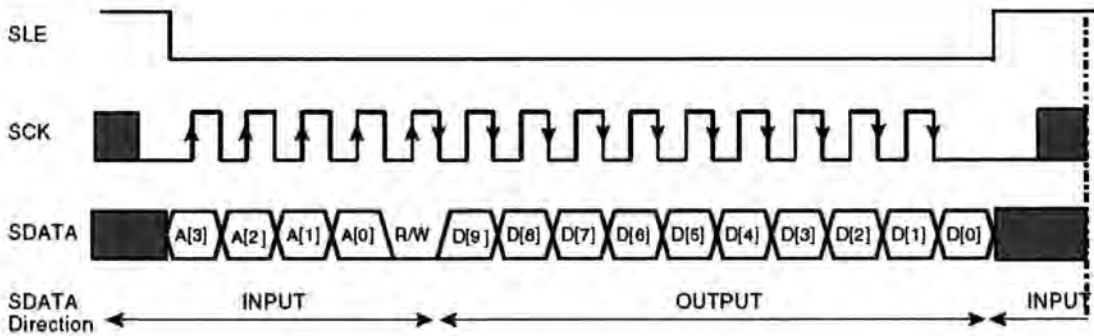

Figure 8 – SPI Read Cycle from a 10 Bit Register

The address and RW bits are clocked on the rising edge of SCK and the data bits are changed on the falling edge of SCK. The registers MSB is read first.

There are two other interface connections required:-

- DATAMSG actual input/output for data message
- DATACLK synchronises signal

These lines are connected to general I/O lines with DATAMSG set up as bi-directional as the actual receive and transmit data for the RF link.

Signal DATACLK is connected to an external interrupt pin. The clock recovery feature of the RF211 provides a clock edge in the center of the received data bits and this signal drives the external interrupt line. Once the interrupt has occurred the interrupt service routine reads and stores the value of the DATAMSG line immediately. Further details on how transmission and reception of packets is given in chapter 8.

### FSK Modulation

The AT86RF211 is an FSK Transceiver which means it modulates the carrier wave using Frequency Shift Keying modulation. The instantaneous frequency is shifted between two discrete values termed the mark frequency and the space frequency. A one is represented at the higher frequency and a 0 represented at the lower frequency.

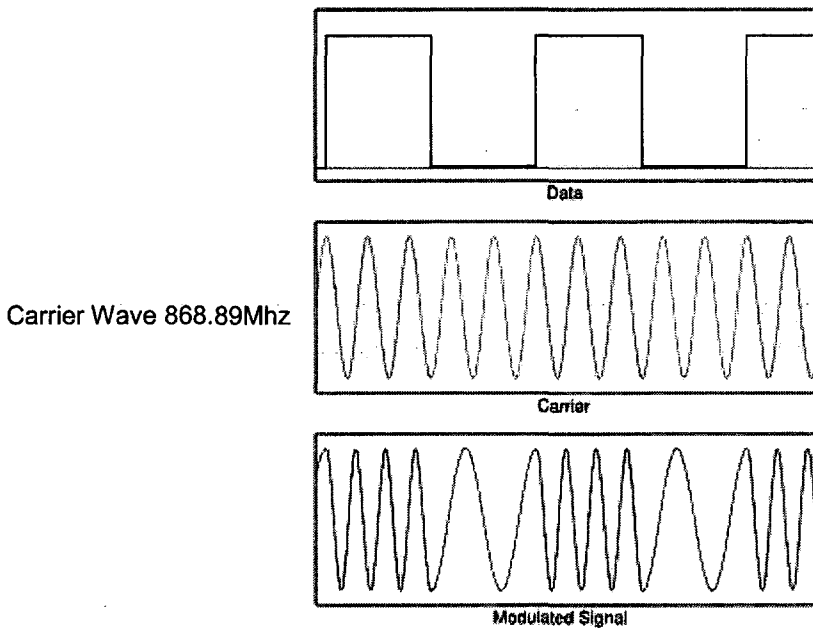

Figure 9 – FSK Modulation

The microprocessor at initialisation must transmit to the AT86RF211 the values of these frequencies. The AT86RF211 has three frequency registers:-

- F0 register hold the frequency value for the 0 code in FSK.
- F1 register hold the frequency value for the 1 code in FSK.

- F2 register hold the frequency value for reception.

There is no simple relationship between frequency registers and the exact frequency as they configure frequency dividers. Atmel provides a tool to generate these values.

#### 4.2.2. ATRF211 Circuit Diagram

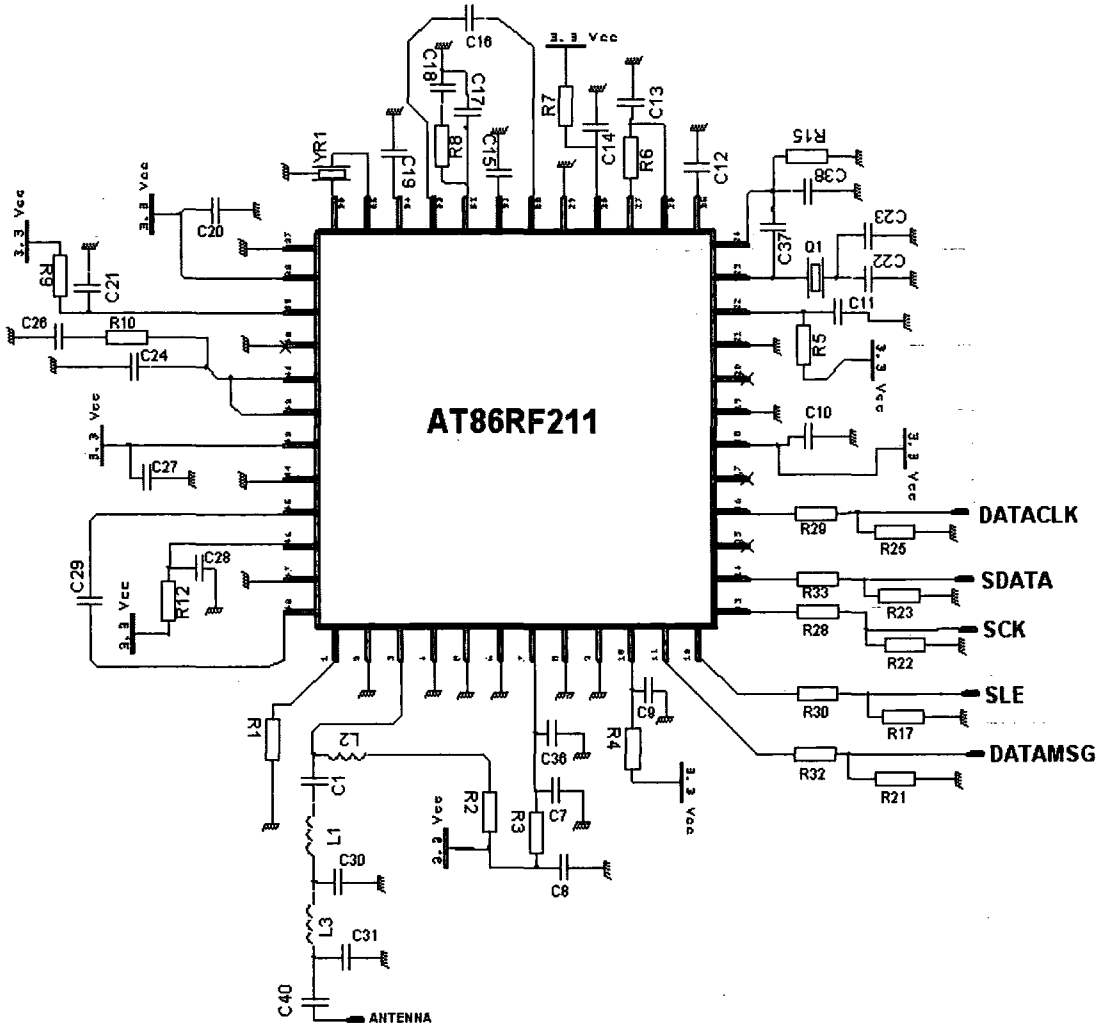

Figure 10 – ATRF211 Circuit Diagram

Atmel provide a variety of reference circuits ranging from high sensitivity narrow band down to lower sensitivity wide band receiver designs. The difference between them being the quality, cost and variation of the external components. The above design is for a medium to wide channel medium sensitivity receiver.

The AT86RF211 device requires very little external components. All sensitive RF circuitry is contained within the device and only a crystal, ceramic filter, antenna matching components, and power supply filtering components are external to the device.

#### 4.2.3. ATmega128L Circuit Layout

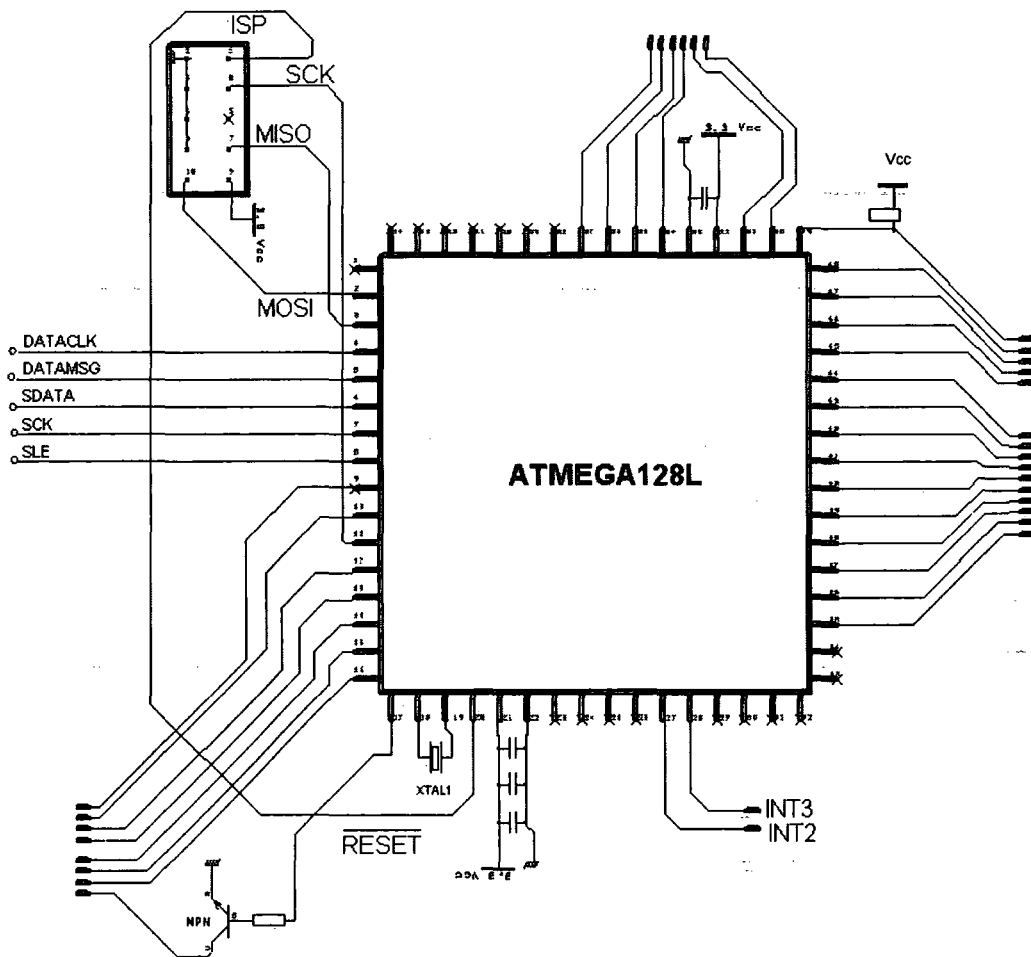

Figure 11 – ATMEGA128L Circuit Diagram

The circuit design for the microcontroller is quite simple.

##### 4.2.3.1 In System programming

The AVRISP from Atmel is a low cost In-System Programmer covering all AVR 8-bit RISC microcontrollers. The programmer connects via a RS232 serial interface to a PC to program the



target board. The Flash and EEPROM memory arrays are then programmed using the serial SPI bus on the target chip while RESET is pulled to GND. The connections for the AVRISP are:-

Signal	10-Pin	I/O	Description
VTG	2	-	Power is delivered from the target board
GND	3,4,6, 8,10	-	Ground
MOSI	1	Output	Commands and data from AVRISP to target AVR
MISO	9	Input	Data from target AVR to AVRISP
SCK	7	Output	Serial Clock, Controlled by AVRISP
RESET	5	Output	Reset. Controlled by AVRISP

Table 4 – AVRISP Connections

Further information on In System programming is covered in chapter 5.2.

#### 4.2.3.2. Motor Drive

An NPN transistor is placed on the board for the door holding power switching.

#### 4.2.3.3. General I/O Pins

The general I/O pins were tracked out to headers for possible prototyping use. One has a resistor in parallel to VCC for an interface to an LCD unit.

#### 4.2.3.4. Printed Antenna

For the prototype board a printed antenna has been used. These antennas are very low-cost and very compact and can be manufactured easily. The frequency response of the antenna can be adjusted very easily by the inclusion or exclusion of one capacitor C43. The exact proportions for the printed antenna were taken from Atmel RF BOM vs Requirements reference document.

#### 4.2.3.5. Printed Inductors

For the prototype board printed inductors are used. These inductors like the antenna are very low-cost. The exact proportions for the printed inductors are taken from Atmel RF BOM vs Requirements reference document. They are designed to give an inductance of 10nH.

### 4.3. Prototype PCB Design

The exact PCB layout of the RF components was taken from an Atmel reference design. Other sensible layout considerations were;

- Keep RF and microcontroller sections separate.
- Decouple power lines to each section.
- Bottom layer should be dedicated to a ground plane.
- Ground plane filling every empty space especially around RF device.
- Ground plane underneath both IC's with vias directly to ground plane underneath.
- No ground plane underneath or near the printed antenna.
- Two layer board to give ground plane on bottom

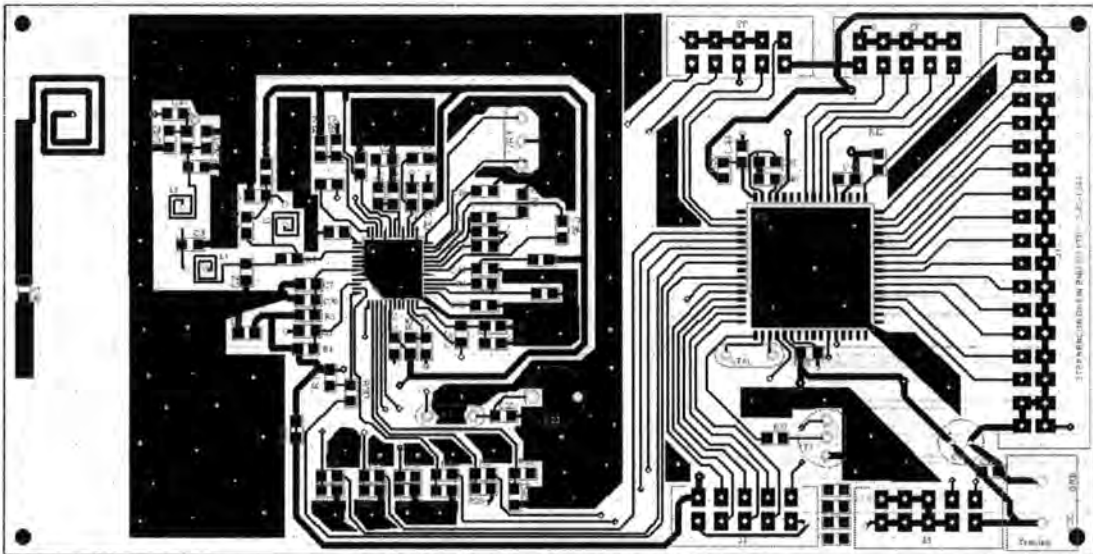

Figure 12 – Prototype PCB Layout (Top Layer)

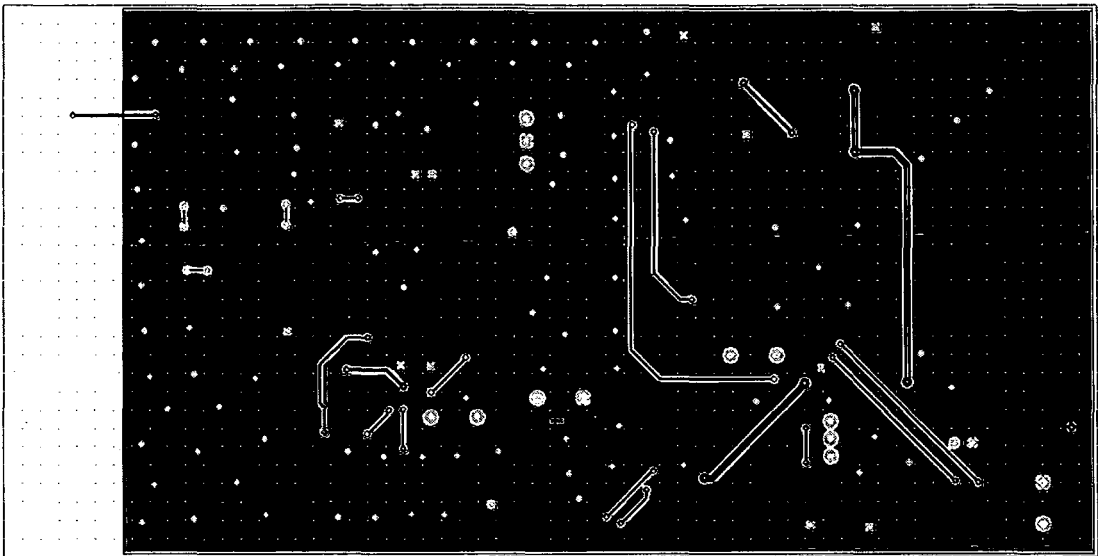

Figure 13 – Prototype PCB Layout (Bottom Layer)

#### 4.4. Prototype PCB Manufacture and Assembly

##### PCB Manufacture

The PCB was manufactured in small batches by a local company using a photo-resist method of PCB manufacture. With this method, a board is covered with a resist material that is activated when exposed to Ultra Violet light. A positive UV translucent artwork film of the layout pattern is made which is opaque where a circuit trace is wanted and clear where not. After the photo positive film is made it is placed onto a photo sensitized board and exposed to UV. The UV light transmits through the clear portions of the film and cures the photo resist. After that, the board is submerged into a developer bath that develops and removes the sensitized photo resist. The resist that is left is in the shape of the artwork that represents the circuit. Due to small batch numbers this process was costly at about £7.00 per board.

##### PCB Assembly

The PCB was populated mainly by surface mount components. The process to mount them involved creating a solder resist of the PCB which literally masks off areas on the PCB where no solder is to be placed. Solder is then added to the surface and each surface mount component is put in its correct location using a programmable pick and place machine. The through hole components were mounted by hand. Due to small batch numbers this process was costly at about £10.00 per board.

## Chapter 5: Prototype Testing

### 5.1. In-System programming Board

As discussed in chapter 4 an In System Programmer (ISP) is used to program the Flash and EEPROM memory arrays. These components are not required for mass production and therefore a supplementary PCB was built. This ISP board creates a bridge between the prototype PCB and the programming dongle (AVRISP). The connection between these external programming components and the PCB has a number of considerations.

A 10 pin IDC connector is used; VCC and GND are connected to the appropriate pins on the target board. The target voltage will not exceed 3.1Vdc which is well in the range of the programmer (2.7V – 5.5V). To enter programming mode the AVRISP needs to pull RESET low. A pull-up resistor of value no less than 1kOhm should be used to pull the pin high. The remaining AVRISP lines should be connected directly to the AVR pins. I have added 0 ohm resistors across these lines incase series resistors are required later.

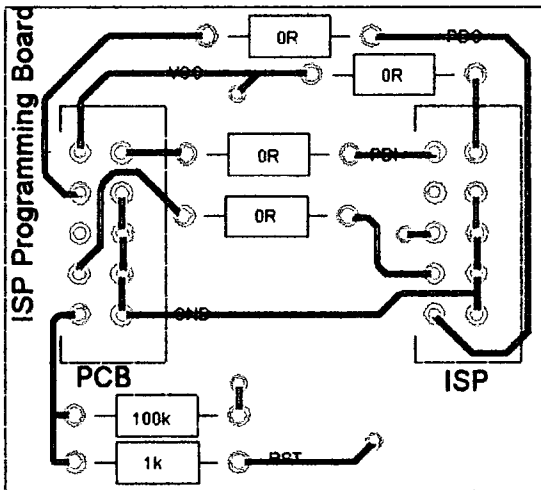

Figure 14 – AVRISP PCB Layout (Top Layer)

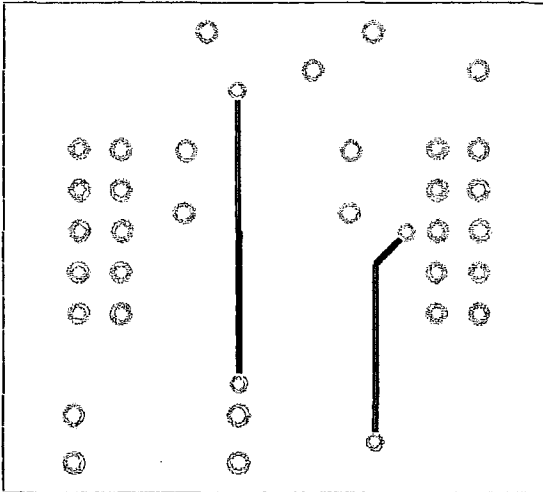

Figure 15 – AVRISP PCB Layout (Bottom Layer)

### Programming Procedure

- Connected ISP board to the PCB and to the AVRISP dongle.
- Power up the PCB. AVRISP indicates Status OK via an LED.
- Start AVRStudio Ver 4.0 and select *ISP tool*.
- Browse to downloadable hex file created by WinAVR compiler. Select *program flash*.

### 5.2. Testing Microprocessor Section

The first stage in verifying the prototype design is testing the microprocessor section. For debugging purposes an LCD is added to the prototype board.

Verify correct operation of the microprocessor:-

- Step 1: Program microprocessor successfully.
- Step 3: Set up I/O pins.
- Step 2: Set up Internal RC Oscillator value (4MHz)
- Step 4: Toggle I/O lines
- Step 5: Set up external interrupts and timer/counters.

Once the microprocessor is up and running the RF portion of the board can be tested.

### 5.3. Testing RF Section

A small program was created to test the communication link between two prototype units.

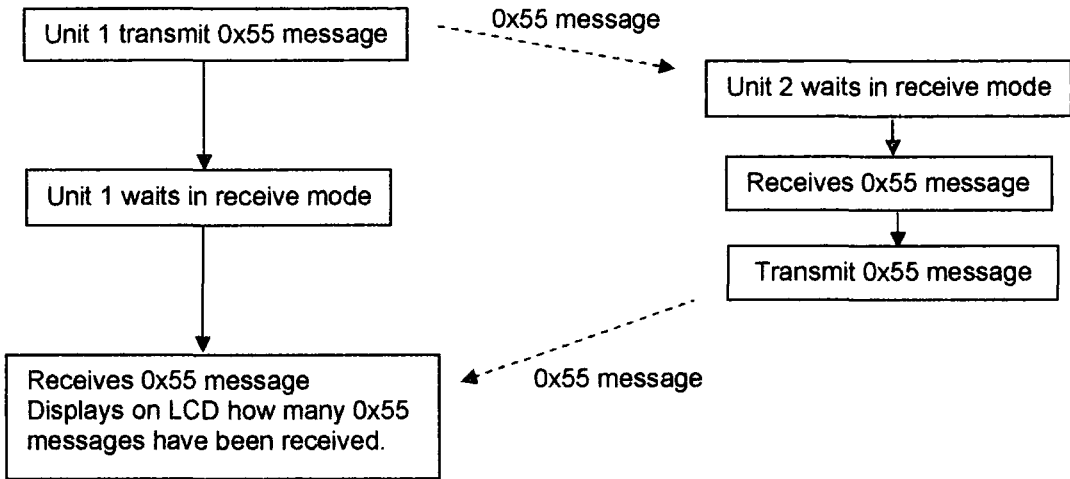

Figure 16 – Communication Link Test Procedure Diagram

This program will test the transmission and reception of both units and display how many successful communications have occurred.

#### Results: Communication problems

The number of successful communications was very poor, less than 5%. This could have been due to:-

- Transmitter error (software or hardware)
- Receiver error (software or hardware)
- General hardware or software bug
- Frequency Error
- Poor antenna

#### Transmitter/Receiver Error

The development kits software were modified to run with the same program as above and at the same transmitting and receiving frequency. A prototype was tested with a modified development kit unit. Transmission and reception were both tested. The development kits could neither transmit

nor receive any messages from or to the prototype PCB but could successfully with another development kit. This eliminates the likelihood of a software error causing the problem, except that the different processors have slightly different code to achieve the same purpose.

### Check Antenna

The antenna and antenna matching circuit was checked for open circuits or any inconsistencies and the program repeated. The results were the same.

### Check Fundamental Frequency

The fundamental frequency was checked by turning the transmitter on and measuring the carrier wave frequency with a spectrum analyzer. The frequency was measured at about 868.9 MHz. This was a little higher than the expected value of 868.899MHz.

### Check Crystal Reference Oscillator

The crystal oscillator gives the reference frequency for the AT86RF211s synthesizer. Various load capacitance crystals can be used but the surrounding circuit must be recalculated. The reference circuit incorporates a trimmer capacitor to fine tune the crystals output. Varying this trimmer and repeating the test gave a small improvement to the results but only by a small margin.

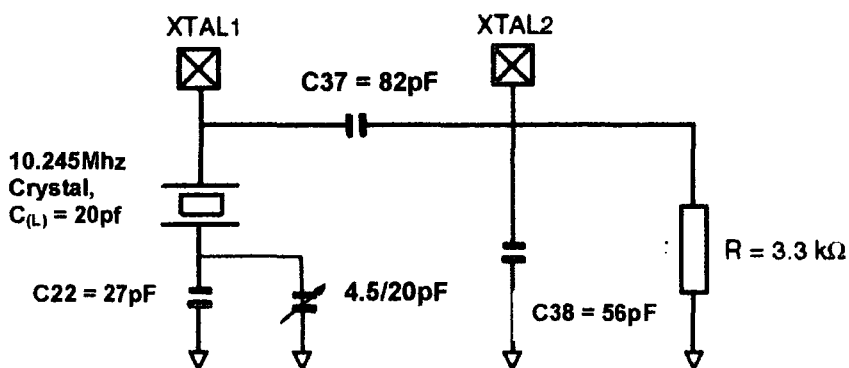

Figure 17 – Crystal Oscillator Circuit

It was then realized that the load capacitance of the crystal was incorrect at 30pF and the surrounding circuitry was not well matched to the crystal. Instead of changing the surrounding component values, new crystals were ordered at the correct load value. After the new crystals were installed a massive improvement was observed. The number of successful transmissions and receptions became close to 100% after fine tuning.

Load capacitance is an important specification. The crystal's total reactance is slightly inductive and is in parallel with the oscillator's load capacitance, forming an LC tank circuit which determines the oscillator frequency. As the value of the load capacitance is changed, so does the output frequency.

### **Conclusion**

Hardware and software tested positively for RF communication. Incorrect component specification lead to initial problems.

### **Range Test**

The next feature of the radio device to be tested is the range. The prototype board was designed with a printed antenna for a low cost option. However this choice may have an impact on range which would need to be clarified.

Simple range tests were conducted with a wire antenna and a printed antenna and the results compared.

The wire antenna is a ¼ wave dipole which means it is a quarter wavelengths long and lies in a vertical orientation to the ground. To calculate the length of the antenna is simply the wavelength divided by four.

$$\text{Antenna Length} = \left( \frac{\text{Speed Of Light}}{\text{Fundamental Frequency}} \right) \div 4$$

$$\text{Antenna Length} = (\lambda \times e^{-8} / 868 \times e^6) / 4 = 86\text{mm}$$

Antenna Type	Line of Sight Range	Propagation through Buildings
Printed Antenna	150m	30m
Wire Antenna	200m	40m

Table 5 – Propagation versus Antenna Type

The wire antenna has a better range and the design will be changed to incorporate it.

### Selecting Output Power

A resistor is used to set the maximum power delivered by the internal power amplifier by limiting the current it sinks. The power can then be adjusted by the selecting a power level by programming three bits in the appropriate register. There are eight programmable levels.

TX LVL	Power Output at 868MHz (dBm)
000	-2
001	0
010	3
011	5
100	7
101	8
110	9
111	10

Table 6 – PA Power Level Settings

The above tests were carried out with TXLVL = 111. For every one drop in power level a few meters of range were lost.

As range is extremely important to the project the maximum power level will be selected, this will still remain within the maximum power level allowed for the 868MHz radio band as specified by the European Standard BS EN 300 220. This is discussed in chapter 9.

## 5.4. Pre-Compliance Testing

### Why Pre-Compliance Testing?

The PCB has to be tested to certain European standards to achieve a CE mark and be legally sold in the UK and Europe. Prior to final product testing it was decided to get some pre-

compliance testing performed to check for any major problems that would involve a redesign of the board. The relevant European Standards are:

ETSI EN 300 220-1 V1.3.1 (2000-09)

Electromagnetic compatibility and Radio spectrum Matters (ERM); Short Range Devices (SRD); Radio equipment to be used in the 25 MHz to 1 000 MHz frequency range with power levels ranging up to 500 mW;

*Part 1: Technical characteristics and test methods*

ETSI EN 300 220-2 V1.3.1 (2000-09)

Electromagnetic compatibility and Radio spectrum Matters (ERM); Short Range Devices (SRD); Radio equipment to be used in the 25 MHz to 1 000 MHz frequency range with power levels ranging up to 500 mW;

*Part 2: Supplementary parameters not intended for conformity purposes*

ETSI EN 300 220-3 V1.1.1 (2000-09)

Electromagnetic compatibility and Radio spectrum Matters (ERM); Short Range Devices (SRD); Radio equipment to be used in the 25 MHz to 1 000 MHz frequency range with power levels ranging up to 500 mW;

*Part 3: Harmonized EN covering essential requirements under article 3.2 of the R&TTE Directive*

ETSI EN 301 489-3 V1.4.1 (2002-08)

Electromagnetic compatibility and Radio spectrum Matters (ERM); ElectroMagnetic Compatibility (EMC) standard for radio equipment and services;

*Part 3: Specific conditions for Short-Range Devices (SRD) operating on frequencies between 9 kHz and 40 GHz*

The testing was carried out by TRL Compliance Services, September 2004.

Test Requirements

Radio Testing: State 1 - PCB transmitting modulated data.  
 State 2 - PCB transmitting carrier only (CW).  
 State 3 - Receiver operating continuously.

To achieve the radio testing requirements one unit was used with specially written code. The position of a rotary switch selected which state the unit was in.

EMC Testing: Two units communicated under normal operating conditions. For the ESD testing to be performed the units had to be in their enclosures.

Results : Radio Testing

<i>Test</i>	<i>Pass/Fail</i>	<i>Description</i>
Occupied Bandwidth	Passed	A noisy signal was seen at 868Mhz. TRL* suggested adding a lot more decoupling.
Pre-Scan 300M – 1GHz : cw	Failed	Spurious emissions at 623, 633.25, 642.25, 651.8MHz all approx. 10dBm above the limit. Possibly due to 10.245Mhz crystal. TRL suggest moving xtal closer to RF chip.
Pre-Scan 300M – 1GHz : rx only	Passed	
Pre-Scan 30M – 300MHz : rx only	Passed	
Pre-Scan 300M – 1GHz : cw	Passed	
Blocking & Desensitisation	Passed Class 2	A 1kHz square wave is created with a signal generator and injected down the receive part of the circuit until it can be viewed with an oscilloscope. A second signal generator is used to inject another signal at different deviations and different power strengths. When the 1kHz signal is corrupted, the ratio of the two signals is used to determine what class the receiver is.

Table 7 – EN 300 220 Pre-Compliance Testing Results

\* TRL were the Compliance Test House

Results: EMC Testing

Test	Pass/Fail	Description
Conducted Frequency Scan	Pass	Injects a frequency down the 3V power line. Frequency from 150k – 80Mhz.
Radiated Electrical Fast Transients	Failed	Inject a fast transient down the 3V and 0V line and observe effect on operation. LCD becomes corrupted and requires a manual reset, this causes the failure. Unit would pass if it recovered after transient is gone. TRL feel that the amount of cabling in the mock up controller unit may be picking up the fast transients, decoupling caps on each keypress line are required. A $\pi$ filter on the power input may also fix problem.
Radiated Frequency Scan : 80M – 1GHz	Passed	Signal ranging from 80 to 1Ghz is radiated to the operating units and their function monitored.
PowerLine Conduction 3Vdc : 150k – 30MHz	Passed	Injects a frequency down the 3V power line. Frequency from 150k – 30Mhz.
Powerline Conduction 0Vdc	Passed	Injects a frequency down the 00V power line. Frequency from 150k – 30Mhz.

Table 8 – EN 301 489 Pre-Compliance Testing Results

Using resources available at Durham University the failed tests could be investigated using identical equipment and methods

Failed Test: Pre-Scan Carrier Wave Signal 300M – 1GHz

Failure Details: The PCB exhibited spurious emissions at around 620MHz, all above acceptable limits.

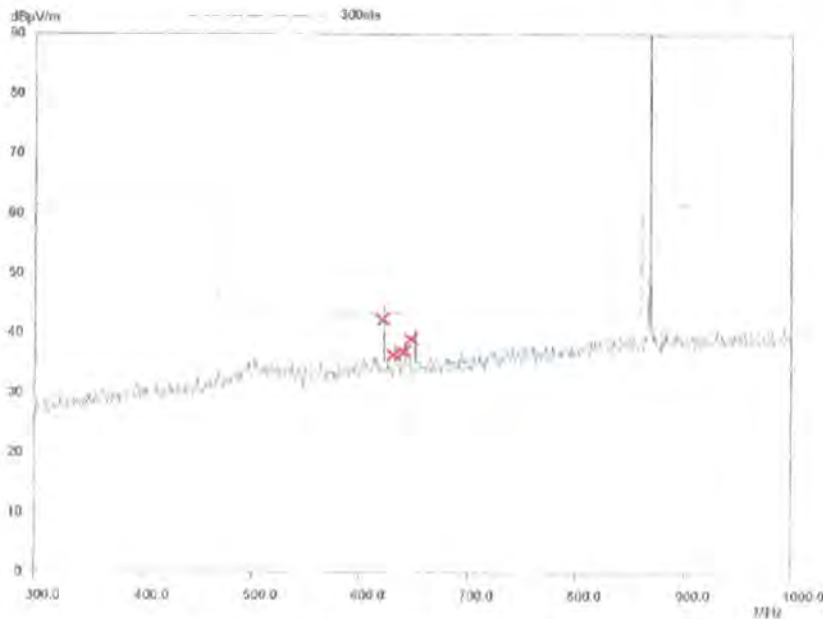

Figure 18 – 300MHz 1GHz Scan Results

- Equipment:
- PC
  - Rohde & Schwarz EMI Test Receiver
  - PCB transmitting at 868MHz carrier wave only.
  - 3Vdc Power Supply
  - Yagi Antenna (150 – 1000MHz)
  - 50Ω Coax Cable
  - Various range of capacitors.

Set up:

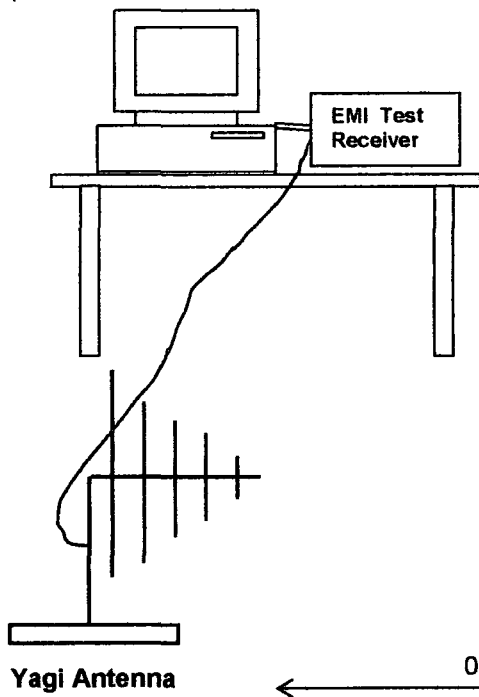
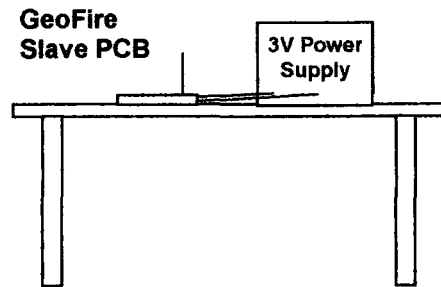

Figure 19 – Equipment Set Up

An EMI test receiver is connected to a yagi antenna half a metre from the PCB transmitting an 868MHz carrier wave.

Figure 10 – Equipment Set Up



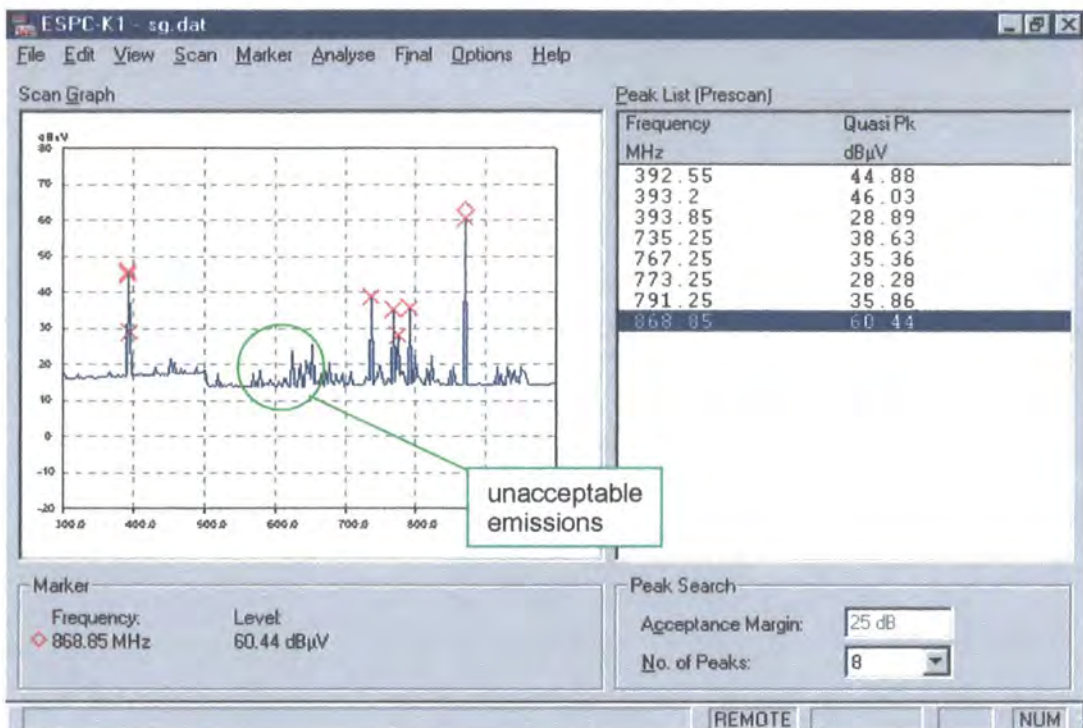

Figure 20 - Screen Image of scan from 300 – 1000MHz, measuring quasi peak (dBuV), 2ms dwell time, 50kHz resolution with no capacitor.

The peaks at 392.55 , 735.25, 767.25, 773.25, 791.25MHz were all tested with the PCB turned off and were found to still exist, so they were shown to be background noise.

Procedure: Different value capacitors were soldered around the board and the affect on the emissions noted.

Results: A number of capacitors were soldered across various signal paths and power lines but only one had an effect on the emissions when quickly observed on a spectrum analyser. A capacitor placed from the antenna matching circuit to ground had an instant effect on reducing the emissions. Various value capacitors were tested but a tantalum 22nF capacitor had the largest reducing effect.

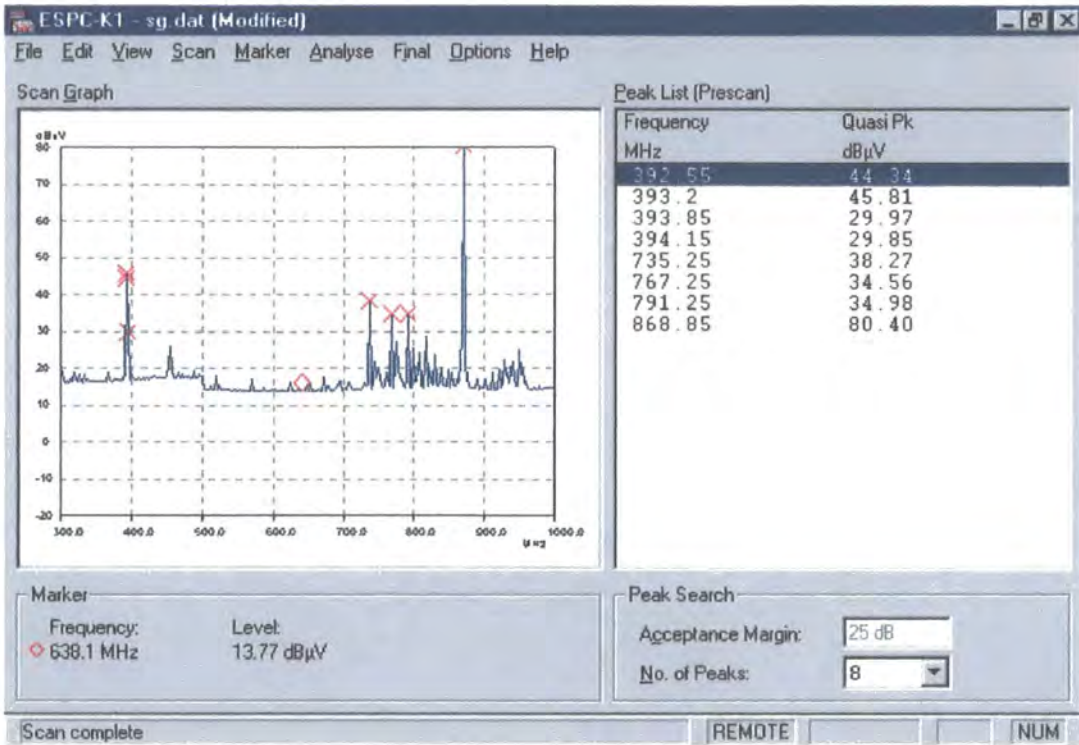

Figure 21 - Screen Image of scan from 300 – 1000MHz, measuring quasi peak (dBuV), 2ms dwell time, 50kHz resolution with 22nF capacitor.

Another noticeable outcome has been the affect on the power level of the 868MHz signal. It has increased to 80.40dBuV from 60.44dBuV.

## Conclusions

The antenna matching circuit is incorrect and tuned to 600Mhz not 868Mhz and was not efficient. The spurious emissions have now been sufficiently minimised and the PCB meets the requirements of ETSI EN 300 220-1 V1.3.1 (2000-09).

## 5.5. Mechanical Development of Door Holder

The door holder mechanism was designed concurrently as the PCB was being developed. The development of the mechanism was undertaken by Stephenson Gobins design engineers.



Figure 22 - Door Holder



Figure 23 - Door Closer

A standard electromagnetic door holder could not be used as it would take too much current when holding the door as the electromagnet needs to be powered up. The basic principle of the design is a wall mounted switching permanent-magnet that retains a plain steel plate mounted to the door. The switching magnet consists of two ferrous pole pieces separated by an air gap with a slug of permanent magnet material in the centre. The slug can be rotated within the pole pieces the position of which either completes the magnetic or breaks its as shown in figure 24. Thus the outer surfaces of the pole pieces can be magnetic or not allowing effective control of retention and releasing of the door. This design is protected by a worldwide patent taken by Stephenson Gobin.

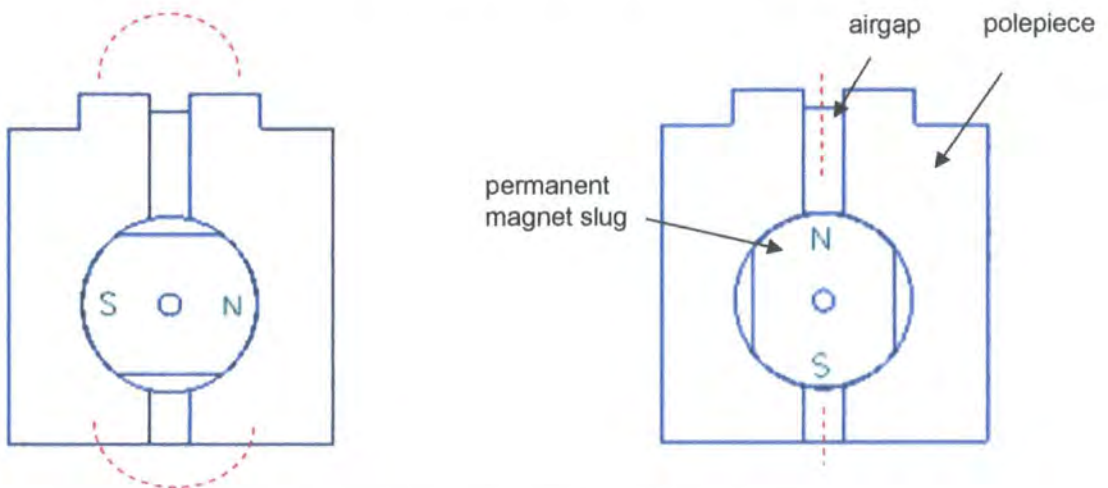

Figure 24 – Magnetic Field Configuration through Pole Pieces

### Design 1: Prototype Motor Design

So the development largely concentrated on how to rotate the slug reliably from the 'held' to 'release' position. The initial idea was to rotate the slug using a small DC motor with a suitable

gear train. Bearing cap (1) and (2) are fixed on either side of the slug. Bearing cap (1) has a gear secured to it that engages the gear train, allowing the drive from the motor to be translated into rotation of the slug. Bearing cap (2) was used to give feedback regarding the position of the slug via a microswitch lever being depressed by a nodule on the cap itself. The PCB reads the change of state of the microswitch and stop/start the motor.

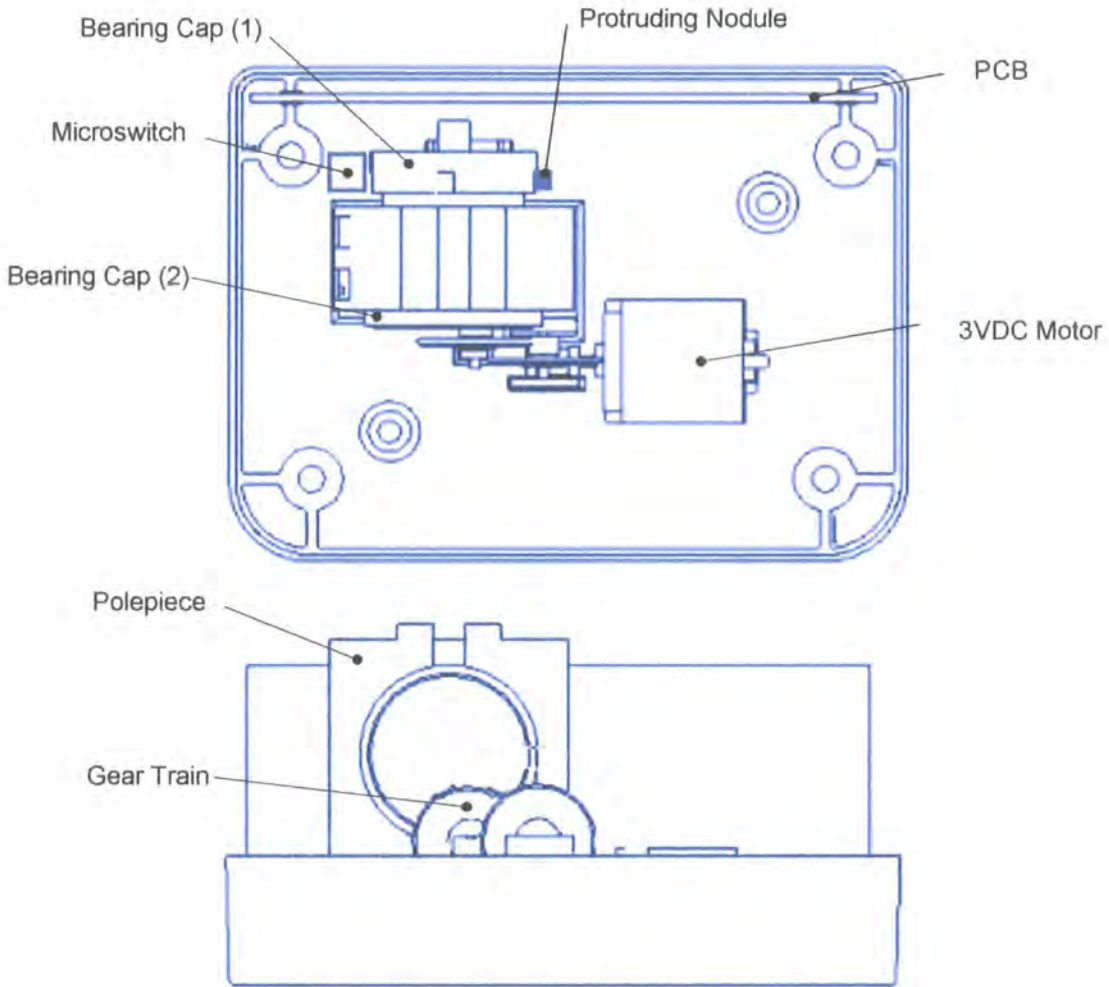

Figure 25 – Prototype Motor Design

One prototype was built using standard 'off the shelf' parts. A small program was developed to switch the magnet assembly from the 'held' to 'release' state continuously with a small delay in between. A 3V LCD was connected to the PCB to display information regarding the test such as number of cycles completed. Initial tests were run on the bench and the results were obvious. The gear train slipped then jammed and stalled the motor.

Cycles completed	Reasons for failure
52	Gear Train slipped
50	"
48	"
46	"
42	"
40	"
38	"
35	"
35	"
32	"
29	"
28	"

Table 9 – Cycles Completed with Prototype Motor Design

### Design 2: Solenoid latching Design

A design involving a latching solenoid was then developed. A latching solenoid will latch in one direction or the other depending on the polarity of the voltage applied to it. It only takes current to latch and draws no current in either state, a good solution to maximise battery life. The same basic rotating magnet mechanism is used.

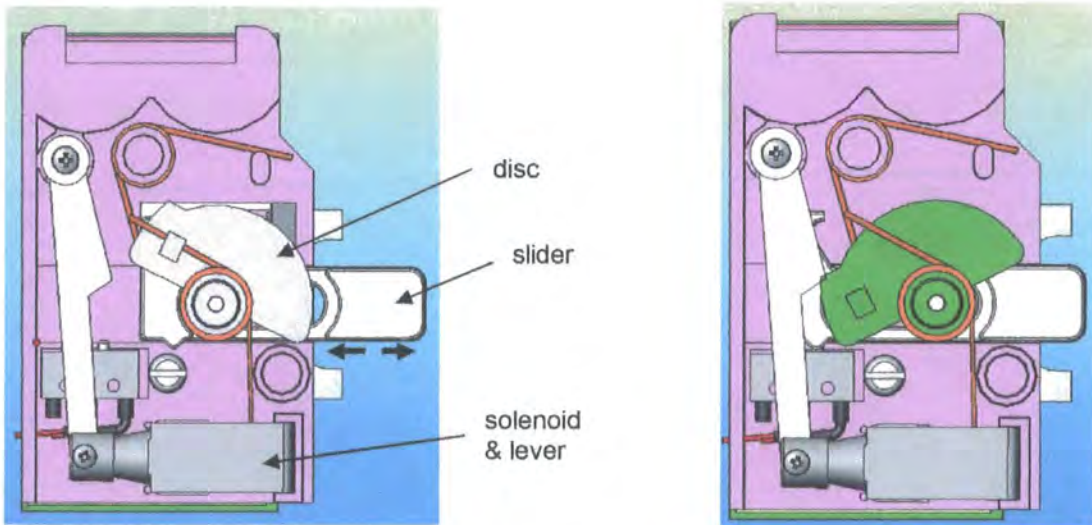

Figure 26 – Solenoid latching Design (Engaged/Disengaged)

The sliders lateral movement back and forth causes rotation of the disc, which is fixed to the permanent magnet slug. Therefore, the lateral motion rotates the slug in the ferrous polepieces.

When the door is pushed against the slider it travels past the ball on the microswitch. The PCB recognizes the change in level of the microswitch and energizes the solenoid. The solenoid pulls the lever across to hold the disc and slider in the 'held' state (Fig 15 (2)). The door is released by a change in polarity of the voltage applied to the solenoid causing it to fire in the opposite direction. The disc is now free and a powerful spring aids its return of the release state.

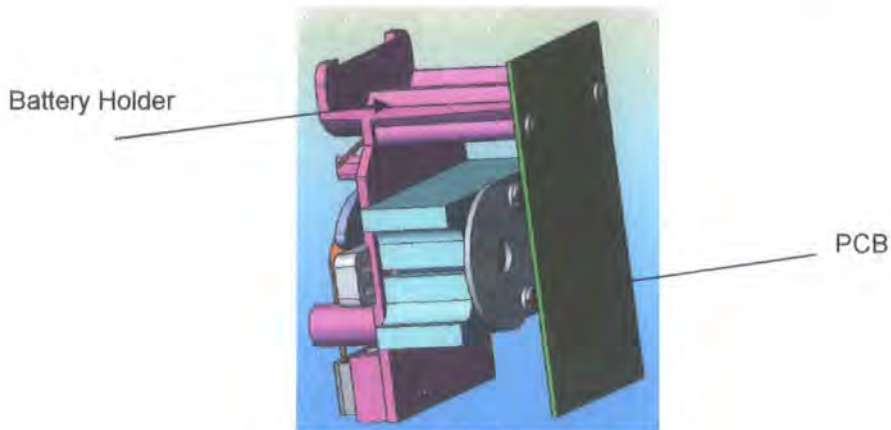

Figure 27 – Solenoid latching Design

Twenty prototypes of this design were made and after one month of testing, it became clear the design was flawed. This was for a number of reasons.

- Unit would fail to latch reliably due to variable speed that slider would be pressed inwards. This meant that the lever would sometimes not engage with the disc.
- The angle of engagement between the disc and level was critical. Too acute an angle and the solenoid would not have enough force to pull the lever away, and too an obtuse angle and the disc would not hold.
- The above problem would be worsened after unreasonable wear on the latching parts was discovered after 20k cycles.

### Design 3: Final Motor Design

It was decided to take the best parts of the solenoid design and return to a motor driven concept.

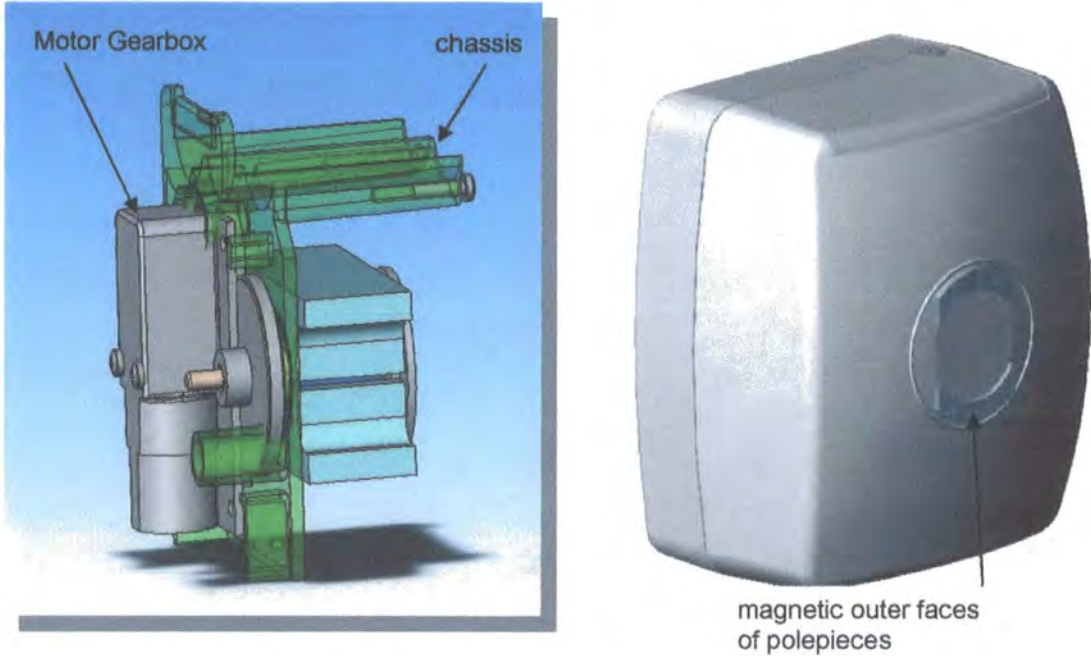

Figure 28 – Final Motor Design (Internal/External)

The chassis that supported the polepieces and held the batteries is kept. The disc is replaced with a suitable gear train (special size gears were made) and a 3Vdc motor gearbox is fitted. This new 'hybrid' design involved fewer parts than design 2 and hopefully more reliable than design 1.

The PCB is mounted via two fixing screws to the chassis to give a compact design. The outer faces of the polepieces protrude through the enclosure to make good contact with the keeper plate fixed to the door.

All door holder units have to pass the standard for electrically powered hold-open devices for doors BS EN1155 which states a unit must operate for 50,000 cycles continuously.

### **1<sup>st</sup> Stage Verification**

To verify the motor gearbox it was run through double the cycles required at double the torque needed to rotate the slug. Ten mechanisms were assembled and tested.

#### **Results**

All gearboxes under test passed the 100,000 cycles mark with no problems at all. Following this the gears were examined for wear for which there was no visible indication of.

### **2<sup>nd</sup> Stage Verification**

To verify that the transistor could source enough current to drive the motor reliably a PCB was 'patched' onto the chassis and the whole unit tested to the BS EN1155 standard, as described above the unit must complete 50k hold and release cycles without fail. This entails the PCB driving the motor to the held position (retaining a specified weight of door) then when prompted release the door. The prompt being the manual release switch being pressed.

#### **Results**

The unit passed these tests and the specifications for the final PCB circuit design can be finalized.

## **5.6. Final Specification for Slave Board**

### **5.6.1. External Interrupts**

These external interrupts all wake the processor up from sleep mode.

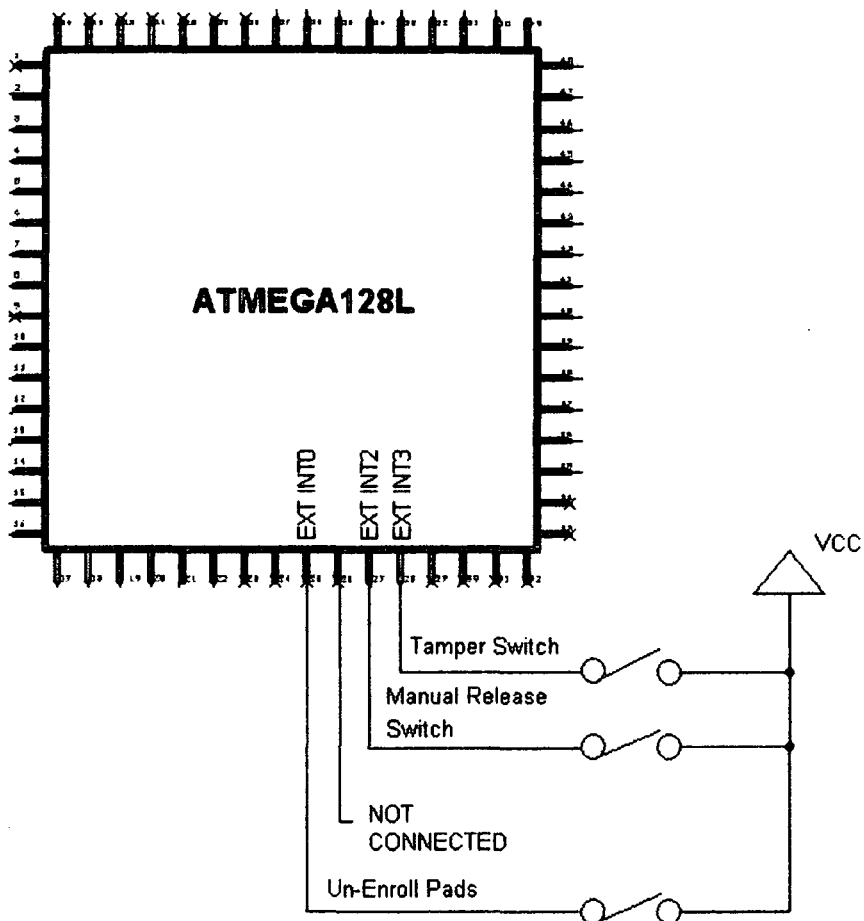

Figure 29 – External Interrupts Configuration

### 5.6.1.1. Tamper Switch

The BS EN1155 standard states that a unit must release a door if the power was removed. As the unit is battery powered and is switched from one state to the other only by the control of the PCB, a method of detecting the removal of the batteries is required. This was achieved using a levered microswitch engaged by the removal of the battery cover screw. The output of the microswitch was directly connected to one of the external interrupts to trigger the PCB to drive the unit to the release position.

### 5.6.1.2. Un-Enrol Pads

For full freedom of mobility the system must be capable of being easily moved and units enrolled and un-enrolled simply. A unit can be un-enrolled from the controller but then needs to be un-

enrolled itself (this simply involves a flag being cleared in software). This also will utilize an external interrupt to trigger that section of the source code.

### 5.6.1.3. Manual Release Switch

A method by which the door could be release manually was essential. A push button switch connected to an external interrupt line would perform the task. The pushing of the switch will engage the unit to enter a release state.

### 5.6.2. Driving the Motor to the Correct Position

The motor drives the magnetic slug until feedback regarding its position is known. The magnetic field can be directly read using a reed switch located near the polepieces. A microswitch was considered with some form of protrusion on the bearing cap housing the magnetic slug but knowing the state of the magnetic field would be more fail safe than knowing the location of the slug i.e. if the bearing cap slipped etc.

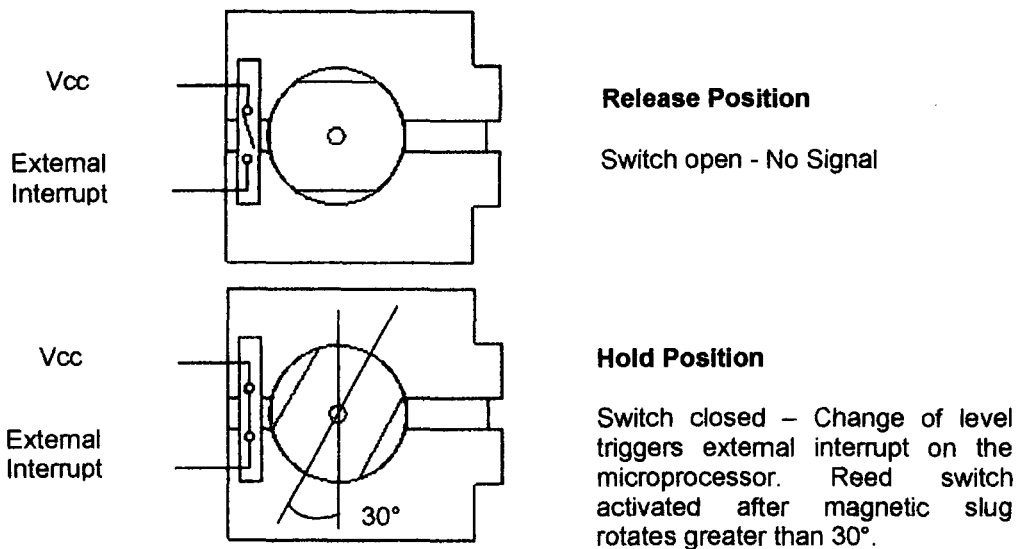

Figure 30 - Release & Hold Positions for Reed Switch

### **5.6.3. Physical Considerations**

The mechanical part of the door holder unit had been decided so some of the other physical aspects of the PCB were designed in. Such as fixing Holes, battery connections and tamper switch location.

## **Chapter 6: Pre- Production Slave Board**

### **6.1. Design Elements**

The pre-production slave board is very similar to the prototype board except,

- board size reduced
- extra decoupling
- footprints for tamper microswitch
- battery contact footprints
- printed antenna removed.

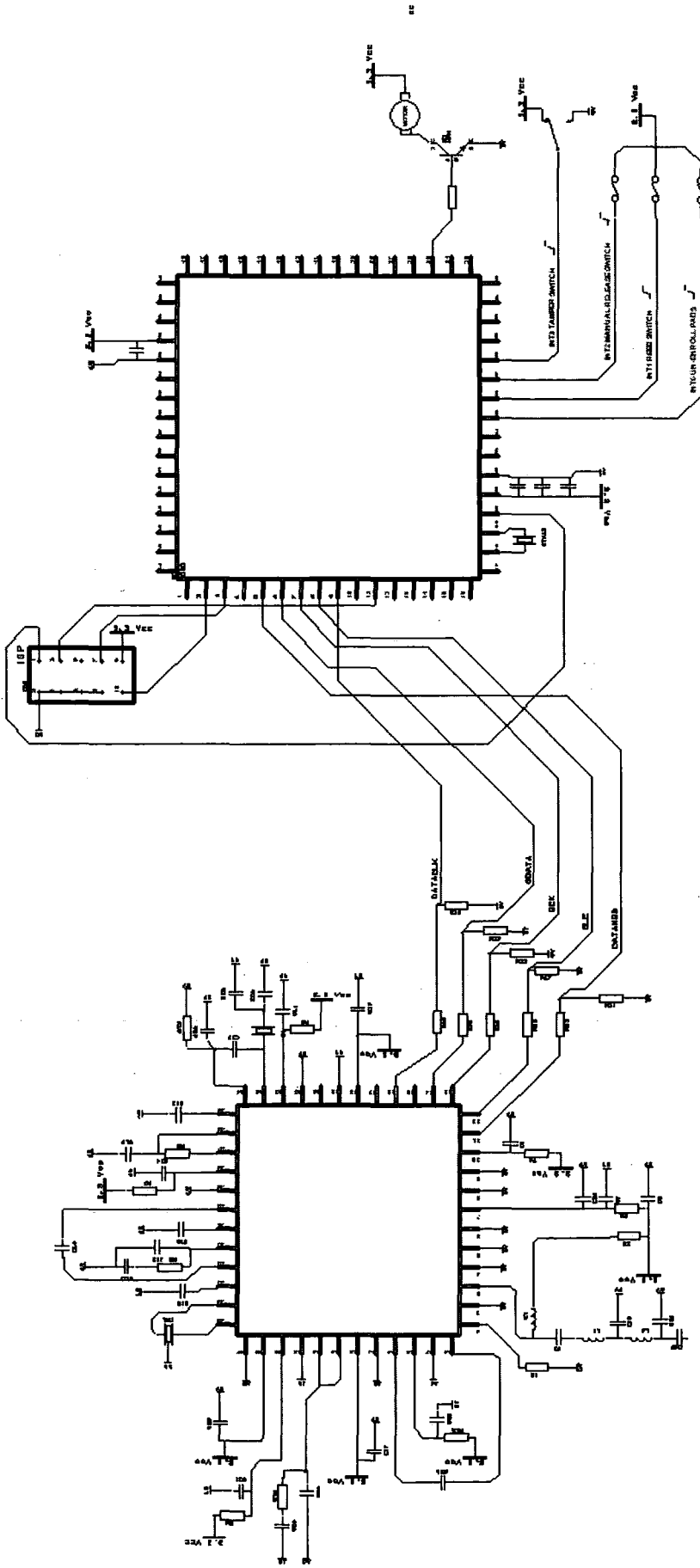

Figure 31 – Pre-production Slave Circuit Diagram

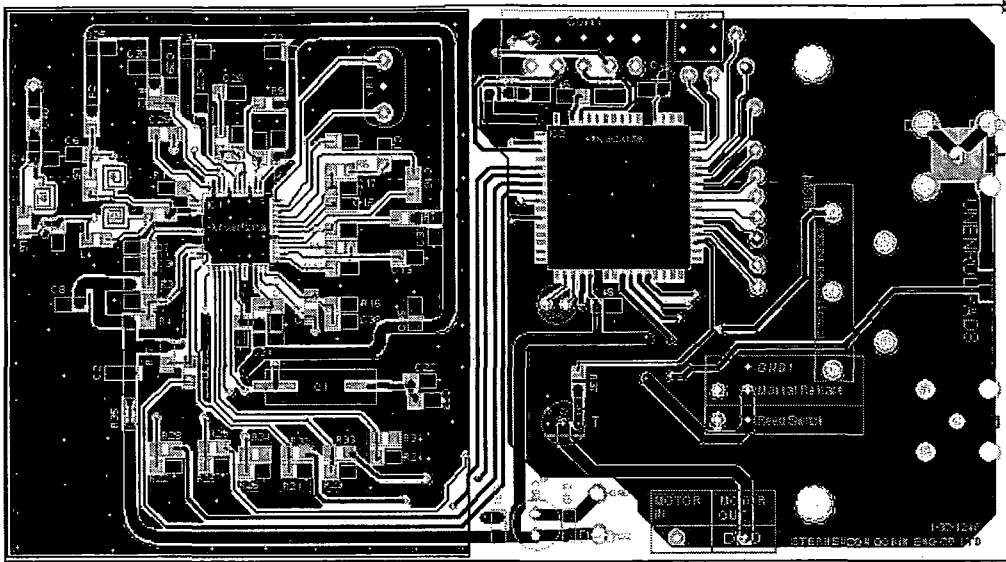

Figure 32 – Pre-production PCB Layout (Top Layer)

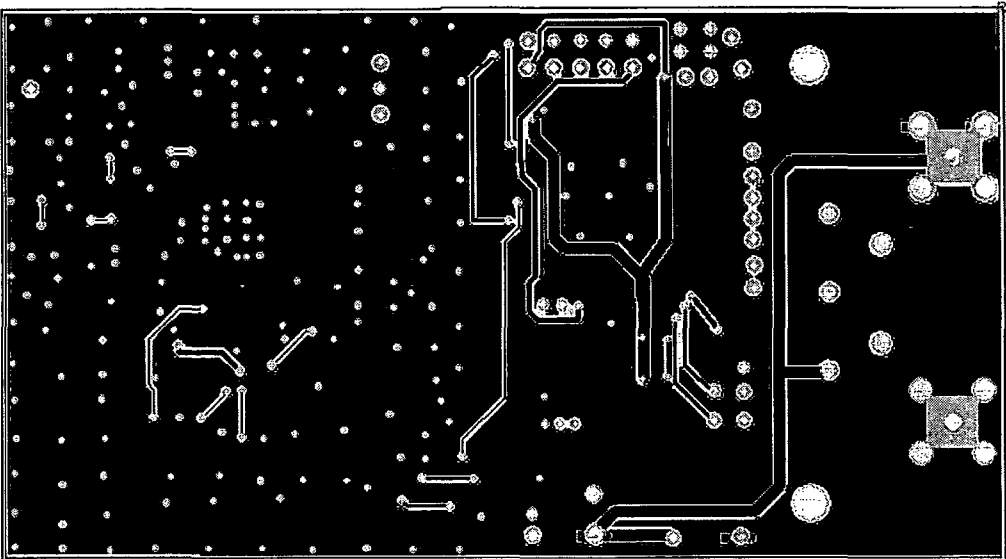

Figure 33 – Pre-production PCB Layout (Bottom Layer)

## 6.2. Hardware Testing

### 6.2.1. Current Consumption Measurements

The current consumption of the door holder unit is absolutely critical to its performance and must consume minimum power to prolong battery life. However even though sleep mode was achieved the unit was drawing 38mA. The following table shows the various steps taken to reduce this.

Current mA	State
38	With manual Release Switch
33	Remove Switch
32.5	ADC OFF
32.5	Analogue Comparator off
32.5	Watchdog Timer
7.34	*Pull up all unused pins
0.110	External Interrupts Disabled
0.110	INT0 enabled only (Un-enrol Function)
7.34	INT2 enabled only (Manual Release Switch)
0.110	INT3 enabled only (Battery Cover Switch)
0.110	INT0 enabled & INT3 enabled
7.34	INT0, INT2 and INT3 enabled
0.110	All external interrupts enabled but switch on INT2 is swapped for a push to make type not a push to break.

Table 10 – Reducing Current Consumption Measurements

\* Pulling up all unused pins via the internal pull ups on the ATmega128L. This reduces power consumption especially in sleep mode.

The original push to break switch was connected to VCC and a falling edge interrupt was used to detect a button press. This meant the pin was pulled high during sleep mode and drawing current.

A push to make switch should correct this if one side is connected to VCC and the other connected to the external interrupt input. A rising edge interrupt is used. This method performs the same purpose but with minimal current draw, approximately 7.23mA less.

**6.2.2. Battery Life Calculations**

As the current consumption is at a minimum battery life can now be calculated.

**Assumptions – Typical Case – 5 releases per day**

- 1 Controller and 1 Door Holder Unit.
- Each unit interrogated every 32 seconds.
- 2 x C Type 1.5Vdc Batteries 7.8Ah
- 5 release per day
- Leakage current is neglected.

Mode	Current	Time
Receive	30mA	50ms
Transmit	66mA	50ms
Sleep	110uA	*31891ms
<i>Driving Motor</i>	130mA	**9.25ms

Table 11 – Current Consumption vs Mode

\* 1 broadcast interval = 32s = 32000ms, (less the other timings of the other modes)

\*\* 1 release drives the motor for 5 seconds (off to on), so 25000ms in one day, there are 2700 intervals in one day so on average the motor drives 25000/2700 = 9.25ms per interval

$$\text{Total Charge mA.ms} = (50 \times 30) + (50 \times 66) + (31891 \times 0.105) + (9.25 \times 130) = 9351.055\text{mA.ms}$$

$$\text{Number of Intervals from 2 C Cells } 14.04 \text{ e9}/9351.055 = 1539933.19$$

Equates to 570.3 days approximately.

**Assumptions – Worst Case – 50 releases per day**

- 1 Controller and 1 Door Holder Unit.
- Each unit interrogated every 32 seconds.
- 2 x C Type 1.5Vdc Batteries 7.8Ah

- 50 releases per day
- Leakage current is neglected.

\* 1 broadcast interval = 32s = 32000ms, (less the other timings of the other modes)

\*\* 1 release drives the motor for 5 seconds (off to on), so 250000ms in one day, there are 2700 intervals in one day so on average the motor drives  $250000/2700 = 92.5$ ms per interval

Total Charge mA.ms =  $(50 \times 30) + (50 \times 66) + (31891 \times 0.105) + (92.5 \times 130) = 20173.55$ mA.ms

Number of Intervals from 2 C Cells  $14.04 \text{ e}9/20173.55 = 695960.8$

Equates to 257 days approximately.

### 6.2.3. Measuring Vcc

The battery voltage must be read to trigger the unit to drive to a safe position in case the batteries fall below a predefined charge level indicated by the battery voltage. This feature will make the system 'fail-to-safe'. The AT86RF211 has an on board A/D embedded converter which it uses to measure the discriminator offset for data slicing. This converter can be used give a six bit reading of its VCC as well as received signal strength. The LSB of the six bit register is 85mV which means in the likely operating range of the 2 C type batteries (2.7V – 3.2V) there will only be 5 or 6 levels read between minimum and maximum. A number of boards were tested to determine what tolerance can be seen from one device to the next.

MVCC: Vcc of the system recorded by the AT86RF211s AD converter.

Test MVCC					
Recorded Vcc – Unit	Recorded Vcc – Unit	Recorded Vcc – Unit	Recorded Vcc – Unit	Recorded Vcc – Unit	MVCC Reading
1	2	3	4	5	
2.43	2.42	2.44	2.45	2.46	27
2.52	2.51	2.51	2.53	2.53	28
2.61	2.58	2.57	2.62	2.60	29
2.70	2.67	2.70	2.70	2.69	30
2.77	2.76	2.76	2.79	2.77	31
2.85	2.85	2.84	2.88	2.85	32
2.94	2.92	2.93	2.96	2.94	33
3.00	3.01	3.01	3.05	3.03	34
3.09	3.12	3.12	3.14	3.11	35
3.18	3.21	3.23	3.23	3.19	36
3.26	3.3	3.29	3.31	3.28	37
LSB =					0.085

Table 12 – Measuring MVCC vs Actual Voltage measured

The above table shows that a battery threshold of 2.7V would be read as an MVCC value of 30. This is different to the calculated value of  $2.7V / 0.085 \text{ (LSB)} = 32$ . Hence a low battery would be detected incorrectly.

### **6.2.3. Driving the Motor**

The motor will drive at different speeds depending on the battery voltage. The higher the voltage the faster the speed. So the VCC will be measured prior to engaging the motor and its value used to modify the length of time the motor is driven.

At the slowest speed i.e. 2.7V the motor needed to be driven for 5000 milliseconds to rotate the magnetic slug to the hold position.

At the fastest speed i.e. 3.2V the motor needed to be driven for 3600 milliseconds to rotate the magnetic slug to the hold position

# Chapter 7: Pre - Production Controller Board

## 7.1. Design Elements

### Integral Power Supply

The controller will be supplied power from the 230Vac mains supply. This supply will have to be converted to a suitable dc level to drive the electronics.

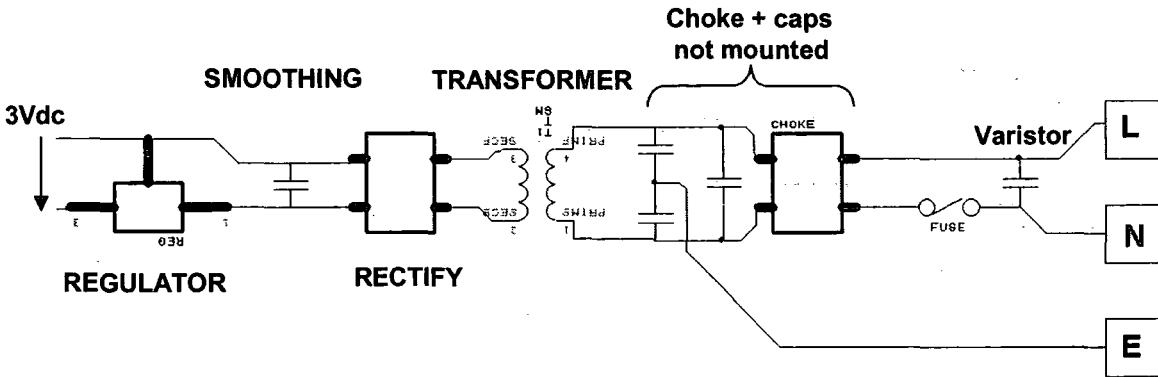

Figure 34 – Power Supply Components

### Real Time Clock

An attractive feature on the advanced version of the board is the ability to set a particular time that the doors can all be released at. To achieve this a real time clock is necessary. The user can set the time and the alarm using the numeric keypad and the time displayed on the LCD. The Dallas DS1302 chip is ideal for this purpose.

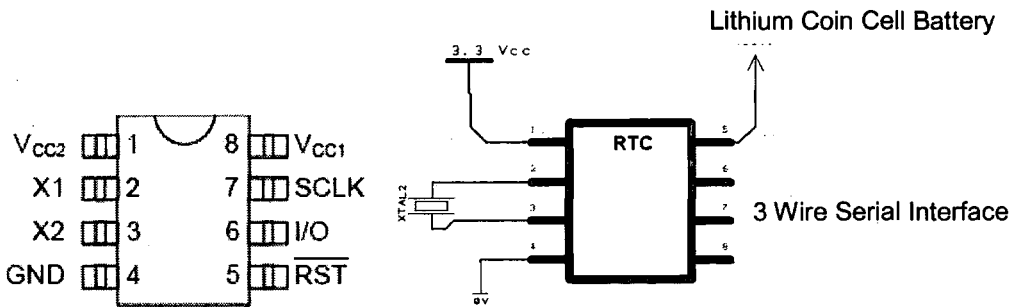

Figure 35 – Dallas Real Time Clock

- Real-time clock (RTC) counts seconds, minutes hours, date of the month, month, day of the week, and year with leap-year compensation valid up to 2100.

- 31-byte, battery-backed, nonvolatile (NV) RAM for data storage.
- 2.0V to 5.5V full operation - Vcc2 is the primary power supply and Vcc1 is connected to a
- back-up source (Lithium Coin cell) to maintain the time and date in the absence of primary power.
- 8-pin SOICs for surface mount
- Simple 3-wire interface for communication with the ATMEGA128L

### Zener Inputs

The controller must detect when a fire alarm has occurred. Most fire alarm panels have a 24Vdc output which drives 24Vdc devices (e.g. sounder/bell) line if an alarm occurs. The controller panel can detect this change via an external interrupt and instruct the doors to be released. The 24Vdc input needs to be regulated to provide a steady 3Vdc input to the microprocessor. The simplest way to do this is to use a Zener diode reverse biased with a breakdown voltage of 3V. This will give a steady 3V output regardless of minor changes a the input.

Zeners drop voltage and conduct current so they dissipate heat in accordance with Joule's Law ( $P=IE$ ). Therefore, the regulator circuit must be designed in such a way that the diode's power dissipation rating is not exceeded.

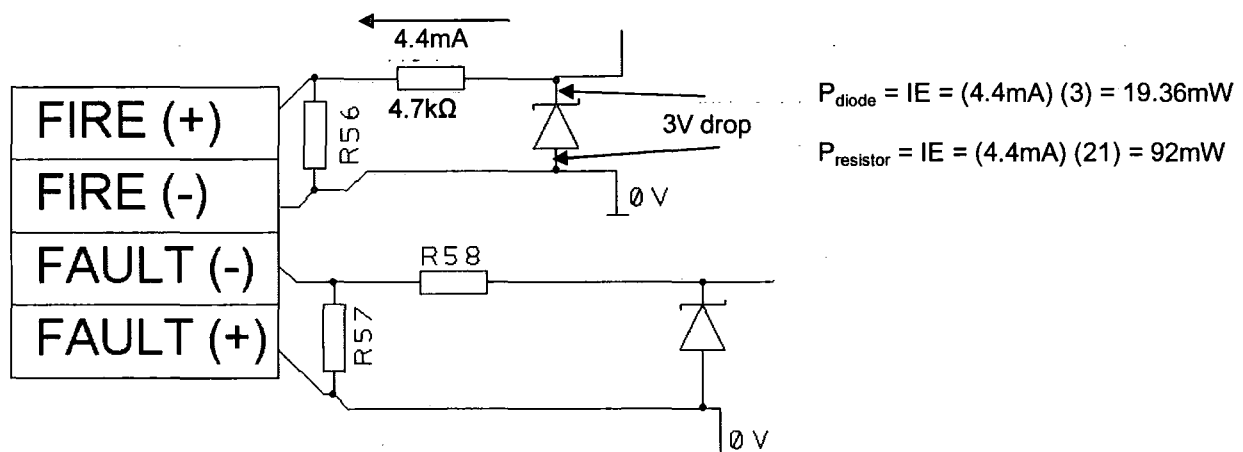

Figure 36 – Zener Inputs

The zener diode dissipates less than 20mW so a low power rated zener diode can be chosen.

### 7.1.1. Pre-Production Controller Board

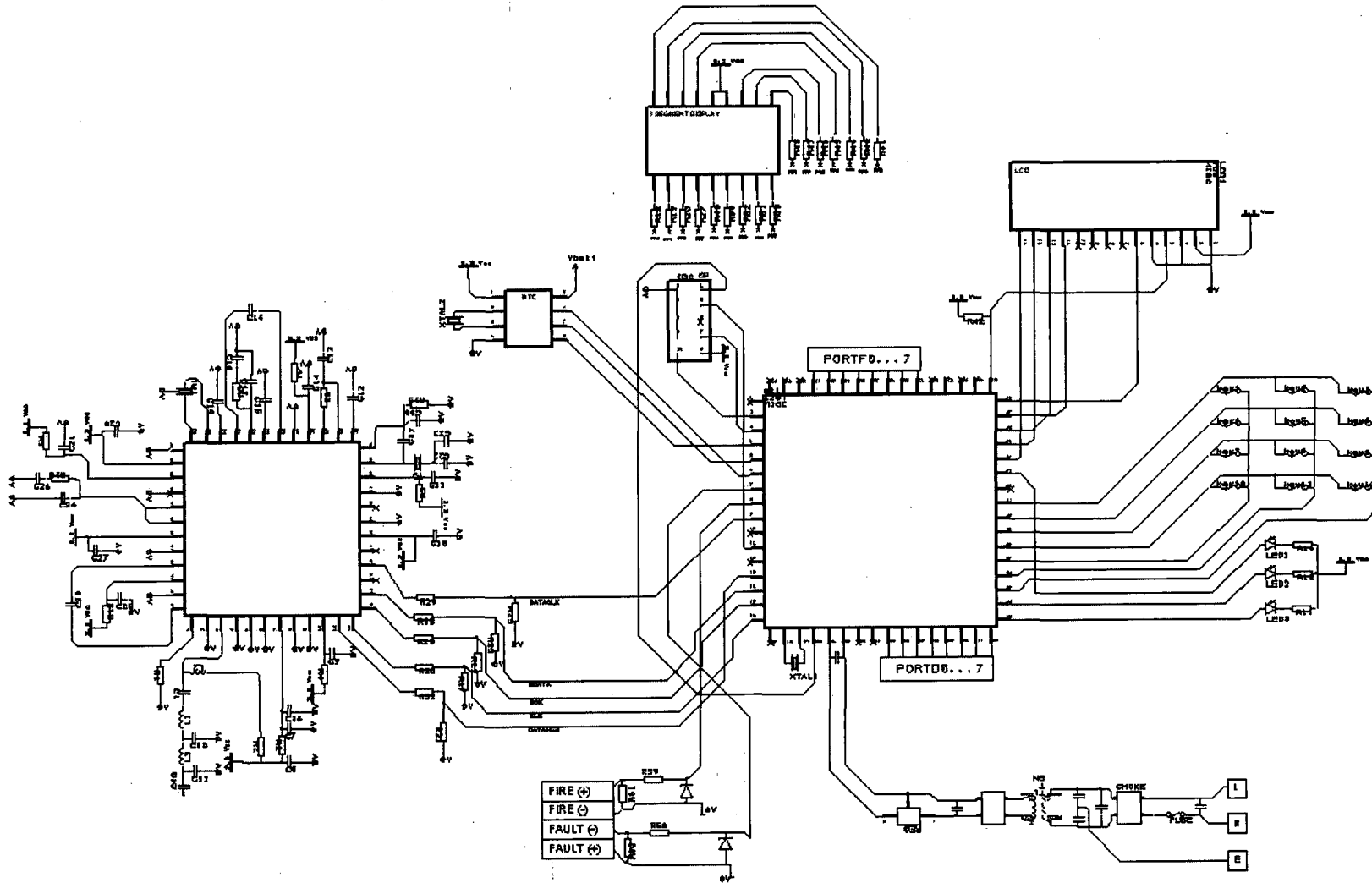

Figure 37 – Pre-Production Controller Circuit Diagram

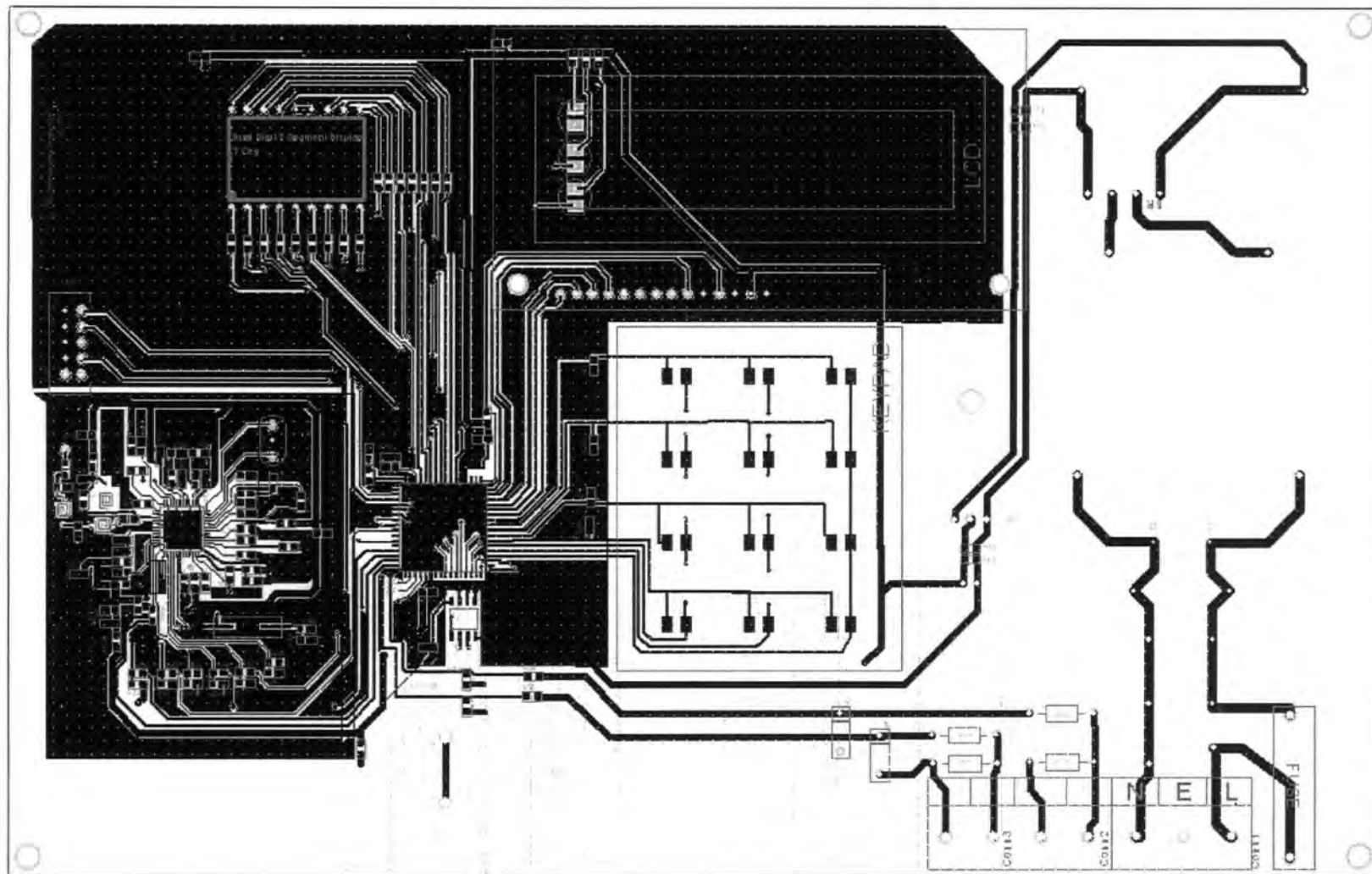

Figure 38 – Pre-Production Controller PCB Layout (Top Layout)

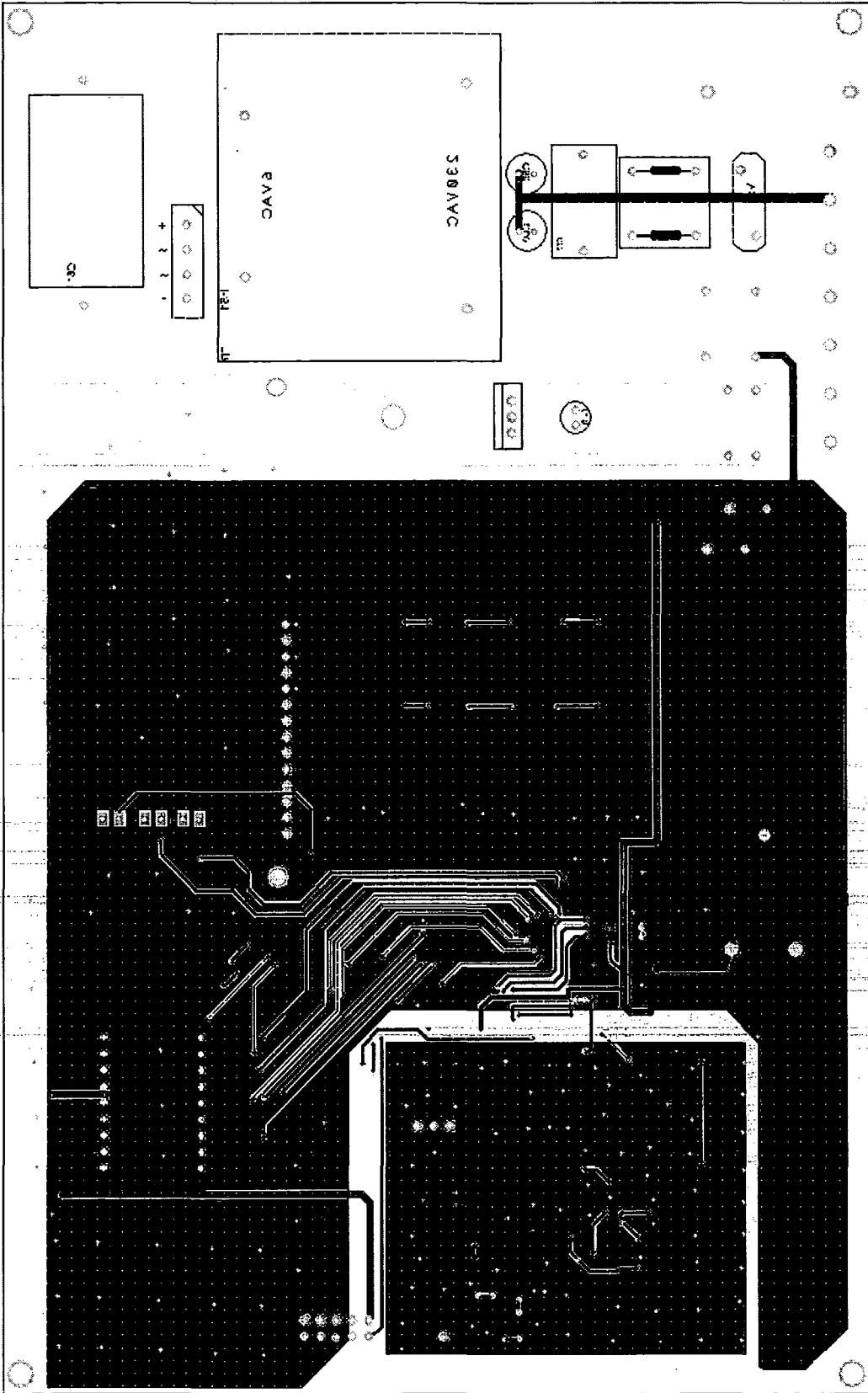

Figure 39 – Pre-Production Controller PCB Layout (Bottom Layout)

## 7.2. Advanced versus Standard Design

As discussed in earlier chapters the controller PCB had two configurations.

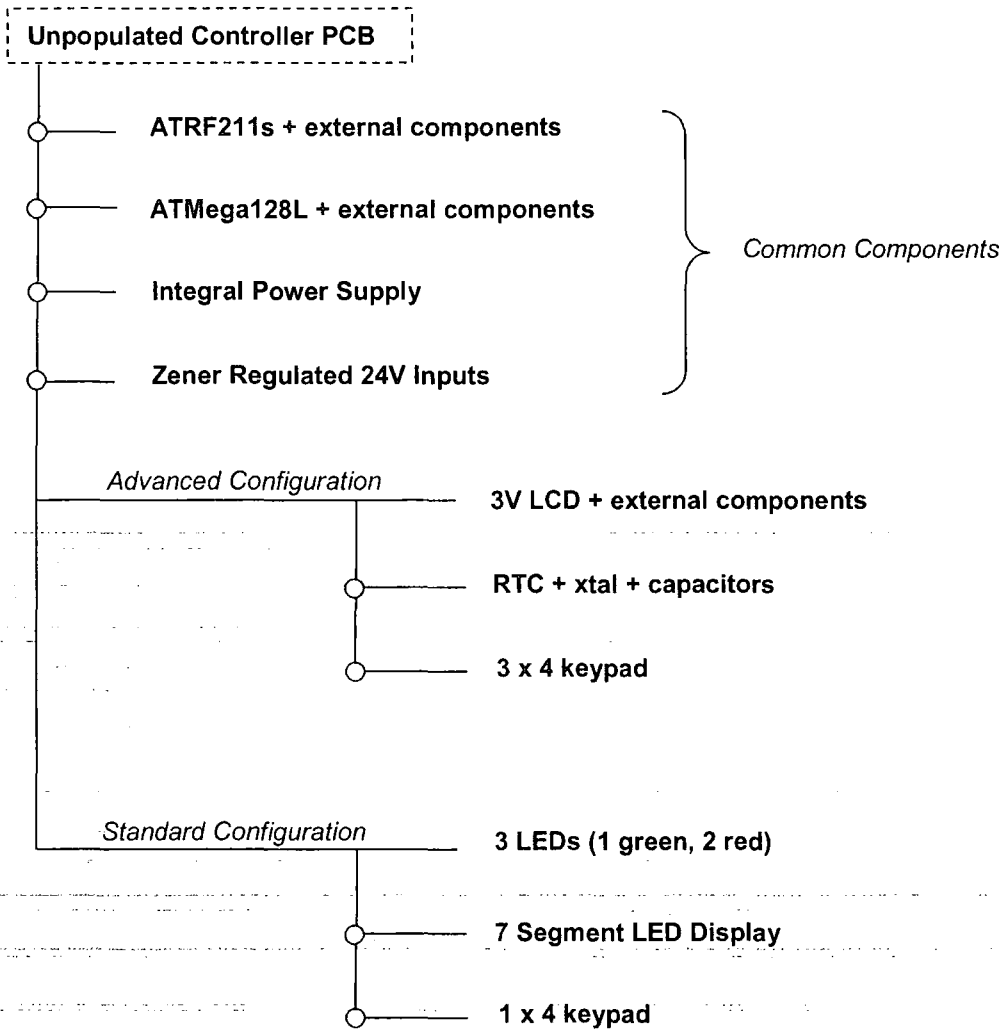

Figure 40 – Advanced vs Standard

## Chapter 8: Software Description

### 8.1. Protocol Description

#### 8.1.1. Hibernation Protocol

The door holder units cannot sit in receive mode waiting for a message as this will drain the batteries very quickly. So a hibernation protocol has been developed to conserve battery life. The control panel transmits a broadcast message approximately every 30s, this time can be changed by the user. The basic concept is for the unit to be in sleep mode until it expects a message. The unit will know when to 'wake up' as it will have measured the time between broadcast messages and that will approximate the time it will be in sleep mode. This measuring process is called Calibration Mode.

#### 8.1.2. Calibration Mode

On activation the door holder unit waits in receive mode. On receipt of the first broadcast message, the unit starts a timer which is not stopped until a further three broadcast messages have been received. See figure 1 below.

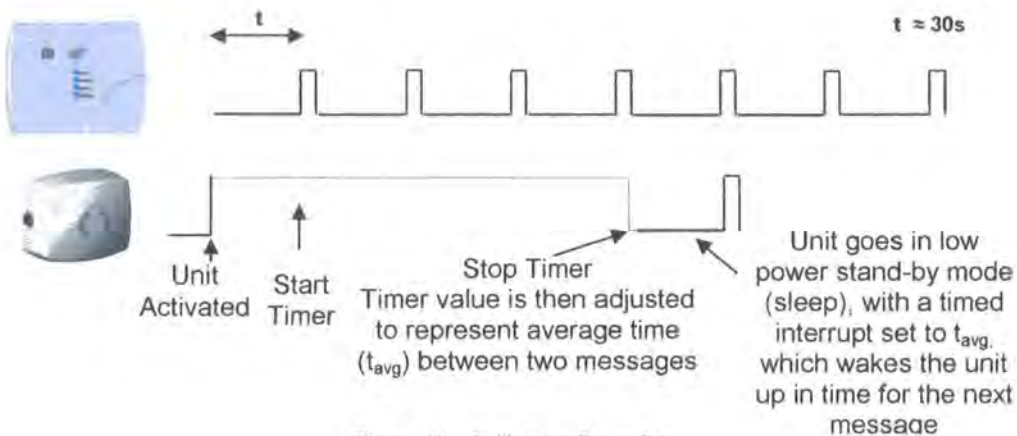

Figure 41 – Calibration Procedure

Once the four broadcast messages have been received the halted timer value is adjusted to represent the average length of time ( $t_{avg}$ ) between two received broadcast messages. The unit then goes into a sleep mode which consumes minimal current ( $\mu A$ ). In this sleep mode a timed interrupt is set to  $t_{avg}$ , which wakes up the unit when the interrupt occurs. The unit wakes in receive mode and expects a broadcast message to be received – see figure 2.

At this point three situations may occur.

- 1) If a broadcast messages is not received, the unit will automatically release the door

and enter calibration mode

- 2) A broadcast message is received, the unit returns to sleep mode.
- 3) A broadcast message with an embedded status request is received. See figure 3.

There is a requirement for the system to perform diagnostic testing. This is also handled by the controller, embedded within a broadcast message is another message informing a specific unit to stay awake, self-test and report the results back to the controller. The controller can be set by the user to interrogate each unit x times per day. The default is ten diagnostic tests per day.

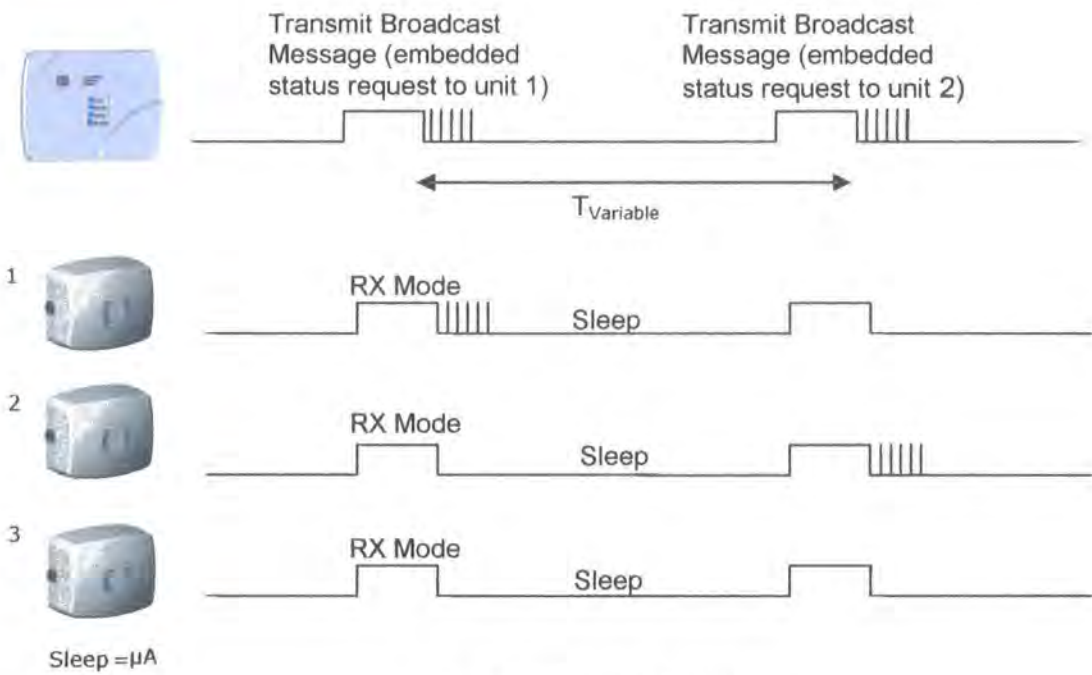

Figure 42 - Hibernation Protocol

### 8.1.2. Pre-Installation Frequency Setting

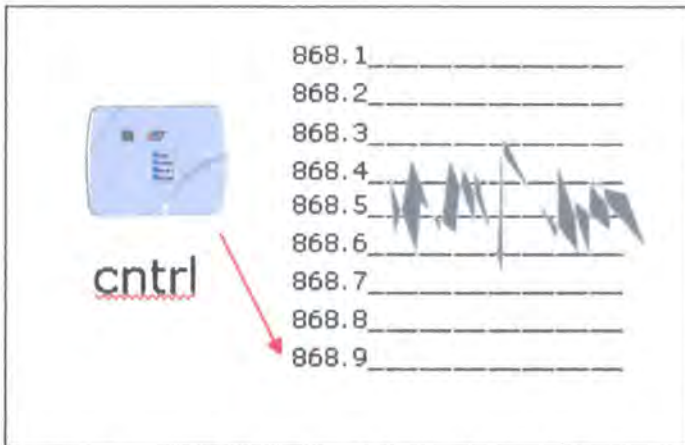

Figure 43 – Pre-Installation Frequency Scanning

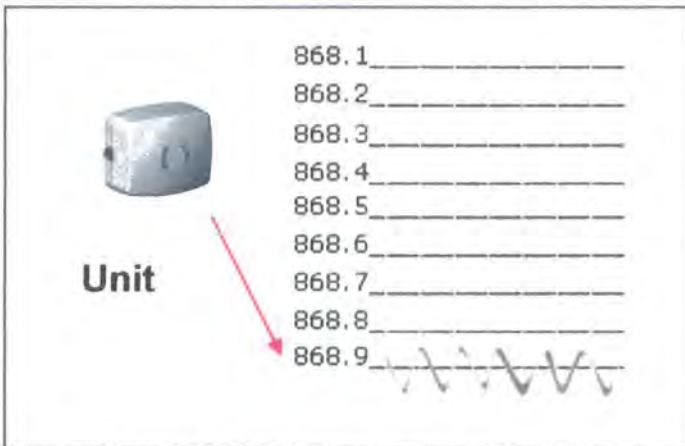

Figure 44 – Unit Frequency Scanning

When the controller is activated for the first time it, it scans a range of frequencies to find a quiet channel. Using this method the software avoids noisy channels where transmissions are most likely to fail due to interference.

When the unit is likely changing the frequency it transmits messages on, the unit also needs to re-tune itself to the same frequency. This time it scans the same frequency range but sets itself to the frequency it receives a 'clean' message on.

### 8.1.4. Message Structure

The message structure had to include various fields for the system to function as described above.

The ID of the transmitting and receiving devices would have to be included in each message.

**24 bit Sender ID**

24 bit Target ID

A command byte would be used to dictate what the intention of the message was.

8 Bit Command Field

Status information will be transmitted from the units to the controller so a few bytes could be used for this purpose.

24 Bit Status Field.

The system could be developed in the future to control individual areas or zones, so one byte has been set aside.

8 Bit Zone Field.

A Cyclic Redundancy Check (CRC) will be appended to the message for error detection when the message has been received.

16 bit CRC Field.

---

Table 13 – Data Fields In Message Structure

A 24 bit ID field was used as it gave  $2^{24}$  possible combinations. Hopefully the product will sell more than  $2^{16}$  devices (65000). For encoding and decoding data more simply the fields were created to be divisible by 1 byte (8 bits).

### 8.1.5. Error Correction & Detection Protocol

To maximize the reliability of the communication link error correction and detection algorithms can be applied to the message to be transmitted and then decoded on receipt to correct any received errors.

A Golay code is commonly used for this purpose it encodes 12 bits of data in a 24-bit word in such a way that any triple-bit error can be corrected and any quadruple-bit error can be detected.

#### Transmitting a Packet

The first stage in applying this security protocol is using a 16 bit CRC (Cyclic Redundancy Check) and the second is 24 bit Golay FEC (Forward Error Correction). This is detailed in figure 6. The raw data has a CRC applied to it and the 16 bit result is appended to the end of the 13 bytes.

The 15 bytes in total are then split into 10 x 12 data bit portions. Each set of 12 data bits are then passed through a Golay word generator that creates 12 check bits. The 12 check bits are appended to the 12 data bits, which create the 24 bit Golay word. There are 10 of these in total, which creates a 30 byte packet to be transmitted.

#### Receiving a Packet

When a message is received, the 30 bytes are divided into the 10 Golay words and passed through the reverse of the Golay word generator. This process will detect and correct 3 bit errors out of each 24 bit word and still detect 4 errors. This means 30 bits out of the packet could be corrupt and the message would still be received ok.

As a further check, the raw data is recreated and the CRC bytes retrieved. New CRC bytes are then generated from the transmitted data and the two sets of CRC bytes are compared. If they differ, then the transmitted message is different to the received message, indicating an error and the message is ignored.

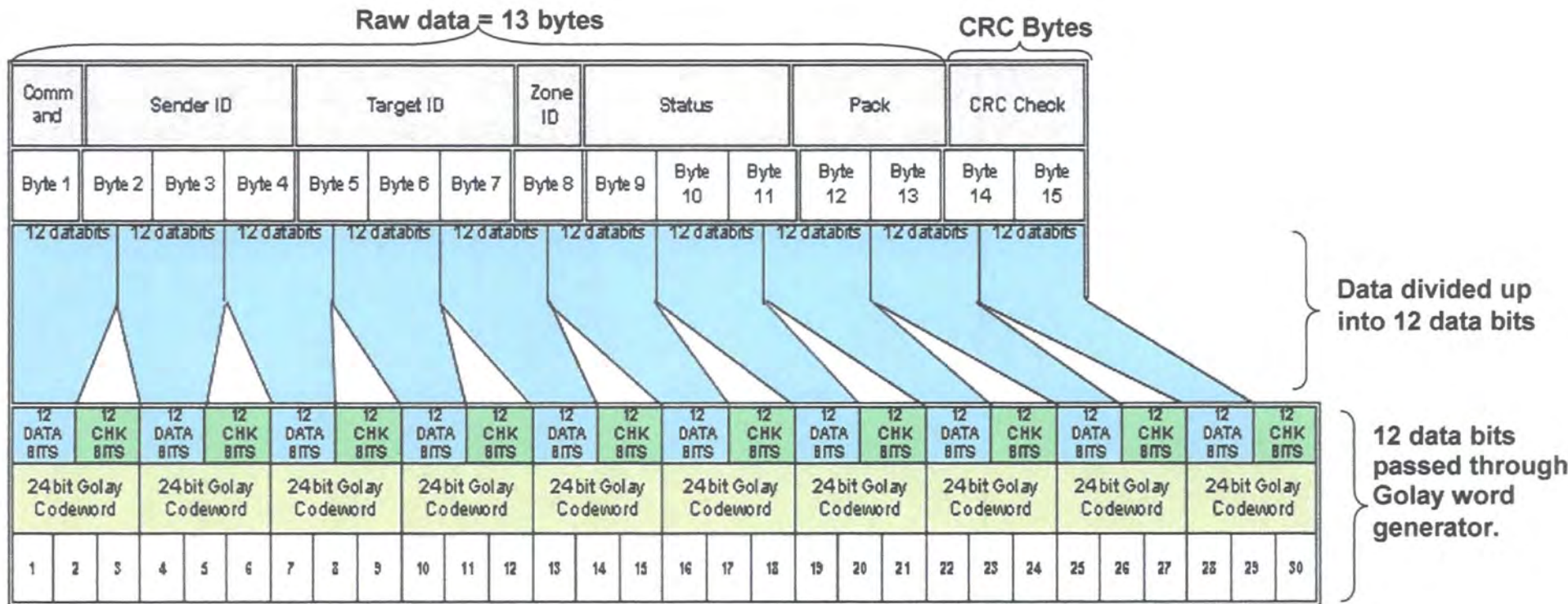

Figure 45 – Message Packet Organisation Chart

**Golay word = 12 data bits + 12 check bits**

## 8.2. Transmission and Reception

### Transmission

The right bit rate is generated using the output compare register (OCR) of Timer1 of the microprocessor.

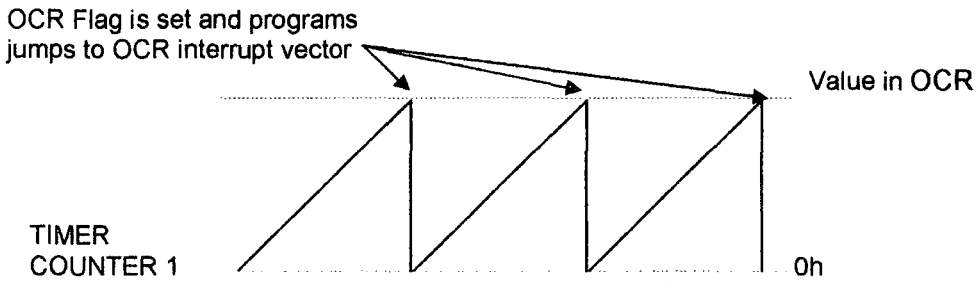

Figure 46 – Output Compare Interrupt Diagram

Timer counter 1 increments according to its prescaling settings. When its value matches that in the output compare register the appropriate interrupt flag is set and the program jumps to the interrupt service routine that handles transmission. The counter is reset back to zero and starts counting again. There is a bit rate of 10kbps which is manchester encoded so an interrupt every 50µs is required. Manchester encoding avoids sending a long strings of 1's or 0's which some receivers may have a problem with.

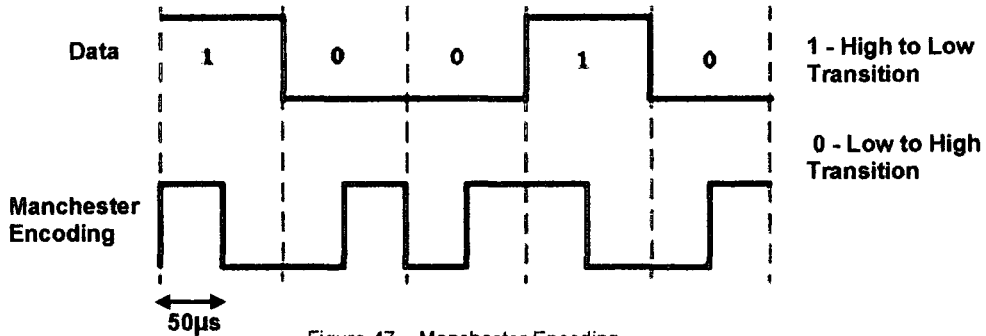

Figure 47 – Manchester Encoding

If the Timer Counter 1 has no prescaling it will increment every 1/System Clock, 1/4Mhz = 250ns.

A value in the output compare register equal to 200 decimal will give a full count of 50µs.

Every 50µs when the interrupt occurs the correct bit value is output on the DATAMSG pin and sent to the AT86RF211. For the receiver to sync properly and indicate that a packet is arriving

four preamble bytes 0x 55 are sent and then followed by a codeword 0xCD. These are sent before every packet.

### Reception

The AT86RF211 acts as pipe simply outputting the data it has received on the DATAMSG pin. The data clock recovery feature on the AT86RF211 outputs a synchronised clock on the DATACLK pin. Synchronisation of the DATACLK is carried out on the first received bit. The AT86RF211 knows the bit length to expect by the programming of the data rate in one of its programmable registers.

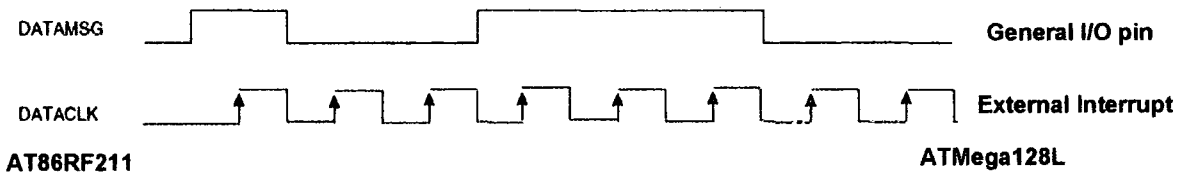

Figure 48 – Dataclk recovery

The DATACLK pin is configured as an external interrupt by the ATmega128L when the unit is in receive mode. Any rising edge will trigger the reception interrupt routine. The interrupt service routine then reads the value on the DATAMSG pin and puts it in a buffer. If the preamble and code word bytes are received correctly the following received bits are shifted into a buffer until a certain number of bytes have been received. The CRC decoding operation is performed and the checksum calculated to determine if the received packet is valid. If the preamble and codeword bytes are received incorrectly or not all, the receive buffers are cleared.

### 8.3. Standard Controller Software Description and Flowchart

#### Main

On power up the controller enters the main function and sets up timers, counters and interrupts. It then reads from EEPROM to see if it has any units or repeaters enrolled in its memory. If not it enters find quiet frequency mode which reads the signal strength on 10 different adjacent channels and sets its frequency registers to the quietest channel.

#### Activate System

The system is 'activated' in the main function on power up. This means the interrupt to transmit the BROADCAST message is enabled. The interrupt is generated by timer/counter compare and a message is transmitted every 32 seconds. It is not necessary to request the status of a unit more than ten times a day. A status request message is a BROADCAST message with the units ID in the target field. This is so other units will pick up the BROADCAST message but not respond to it. The controller will only fill the target field when necessary.

*Note: Transmission is only allowed when the FIRE\_Flag is set to 0.*

Maximum Number of TX slots in one day =  $24\text{h} \times 60\text{m} \times 60\text{s} / 32\text{s} = 2700$  TX slots.

If there are only 10 units in the system they will have 270 status requests a day.

So therefore the algorithm,

MAX = Number of TX Slots per day / Number of Status Requests per day;

MAX =  $2700 / 10 = 270$

ID = Total number of units enrolled in system

Transmit to Unit X if FIRE\_Flag = 0

If  $X \leq ID$  enter receive mode

Increment X

If  $X = MAX$  then  $X = 0$

If Unit  $X \leq ID$  the system enters receive mode and waits for a reply. In a system with repeaters the controller would receive its own BROADCAST message after its repeated. On receiving a message from a repeater the controller will ignore it and re-enter receive mode immediately. The controller is expecting a STATUS message back from the unit with information on its signal strength and battery levels in the status field. If either are determined to be beneath a pre-defined threshold then the display will flash the relevant ID and flash the Low Battery or Low Signal LED. If no message is received at all the system will flash the relevant ID and the Low Signal LED will be on permanently.

## Menu Functions

### Enrol unit

To enrol a unit the controller must first tell the unit what frequency channel it is transmitting on. The controller firsts transmits a `FREQ_CMD` message on channel 0 and waits for an `ACK` message, if the `ACK` message is not received then the process is repeated on channel 1 up to channel 10.

When the `ACK` message is received the controller transmits an enrol message embedded with a number that represents the delay time for a repeater and waits for a response. Only one un-enrolled unit can be enrolled at a time as the message is transmitted with no ID embedded in the target field.

Enrol message transmitted with target field = 0. Any un-enrolled unit will respond. An enrolled unit will ignore the message.



Figure 49 – Enrolment

If a repeater responds to the enrol message its ID is saved to EEPROM and the delay time incremented, the display will flash to show a repeater is enrolled. If a unit responds its ID is saved to EEPROM and the delay time remains the same, the number on the display increments to show

successful enrolment. The ID variable which is equal to the number of units enrolled in the system increments.

### **System check**

This button when pressed simply sets variable X to 0, this will initiate the system to check the status of all the units straight away. A user may do this to update the display with the most recent status information.

### **Un-enrol unit**

Press un-enrol button, User selects which unit to un-enrol and presses select button. The code simply removes that address from the EEPROM and shifts all the other addresses up.

### **Release doors**

To release the doors they only need miss one BROADCAST message. This is when the FIRE\_Flag variable is used. When set to 1 it prevents one transmission of the BROADCAST message then clears itself so the system returns to normal.

### **What happens when a fire alarm occurs?**

When a fire alarm occurs the fire alarm panel outputs a nominal 28Vdc on its auxiliary outputs. The controller is wired onto one of these outputs. If a rising edge is detected on the external interrupt pins 5 or 6 then an interrupt service routine is executed. It is simply a repeat of the Release Doors function except a flag (FIRE\_Flag) is set to 1. This setting of this flag prevents one transmission of the BROADCAST message then it is cleared so the system returns to a normal state. The system however begins a system check from the first unit. Not transmitting the BROADCAST messages causes the units to drive to the off position and release the doors.

### **EEPROM Configuration**

Below is a table showing the EEPROM configuration that was used to save non-volatile information. The information in italics shows the values that were programmed into the EEPROM during production. The information in normal font depicts information that is updated and saved whilst the system is running.

<b>Standard EEPROM Usage</b>	
<b>Address</b>	<b>Function</b>
<b>0</b>	<b>Number of units enrolled</b>
<b>1</b>	<b>Number of repeaters enrolled</b>
<b>2</b>	<i>Upper byte of 24 bit address</i>
<b>3</b>	<i>Middle byte of 24 bit address</i>
<b>4</b>	<i>Lower byte of 24 bit address</i>
<b>5</b>	<i>Password</i>
<b>6</b>	<i>Password</i>
<b>7</b>	<i>Password</i>
<b>8</b>	<i>Password</i>
<b>9</b>	<i>Password</i>
<b>10</b>	<i>Password</i>
<b>3500</b>	<i>Repeater ID</i>

Table 14 – Standard EEPROM Configuration

The following two diagrams depict the software flowchart for the standard controller source code at a functional level. It shows the main function and then interrupt service routines.

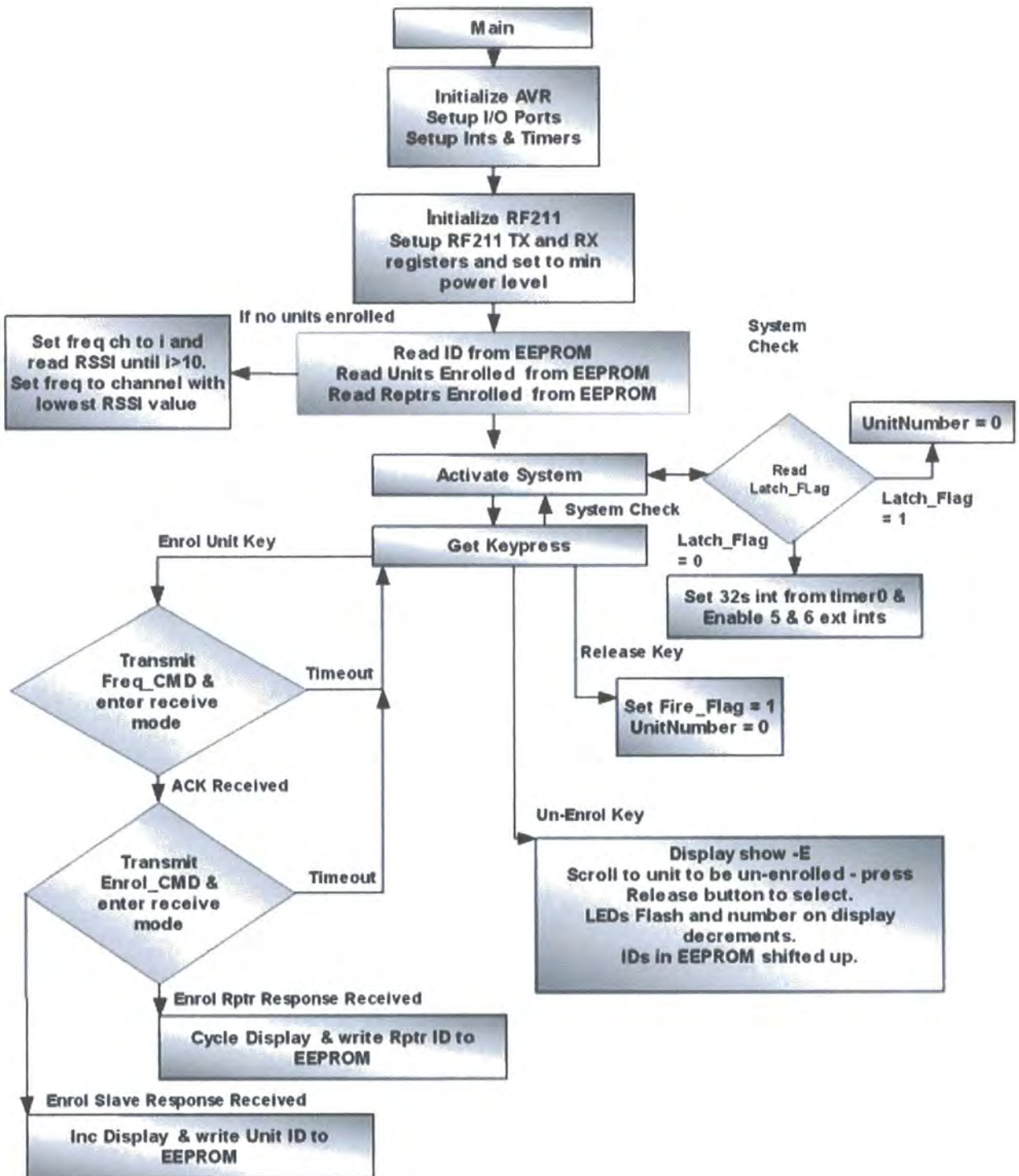

Figure 50 – Standard Software Flowchart

This output compare interrupt drives the transmission of the broadcast message.

These external interrupts are called when a fire alarm has occurred and 24 – 28VDC is seen on the fire alarm panel outputs. Their effect is to stop the transmission of the broadcast message by setting Fire\_Flag = 1.

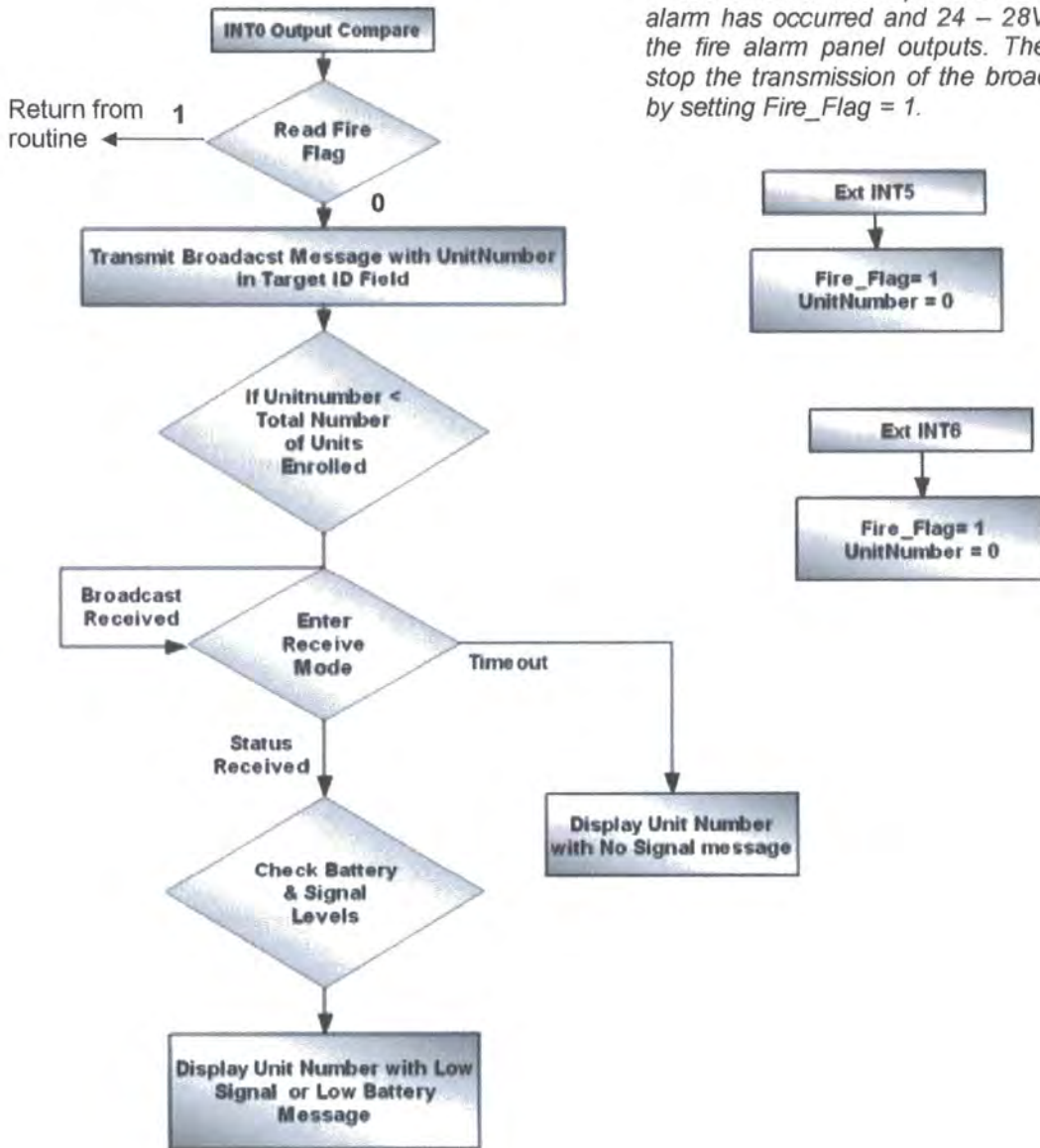

Figure 51 – Standard Software Interrupt Flowchart

## **8.4. Advanced Description and Flowchart**

### **Main**

All menu functions are password protected. The differences between the 'standard' controller and 'advanced' controller are:

### **Enrol unit**

To enrol a unit is the same software function except the outcome of the enrolment is displayed on the LCD.

### **System check**

The system check is the same software function except the outcome of the check is displayed on the LCD. The controller receives a 6 bit word indicating the battery level and a 6 bit word indicating signal level of the unit it interrogating. Both words are converted into percentage format and displayed to the user.

### **Release doors**

The release doors function is exactly the same as in the standard software.

### **Un-enrol unit**

How to select which unit to un-enrol is the only difference in this code. The user scrolls through a list displayed on the LCD and selects the unit.

### **What happens when a fire alarm occurs?**

This is also the same as in the standard software.

### **Installation**

The installation menu is where system parameters etc can be set.

**Change Password**     The user can change the password and the new password is stored in EEPROM.

**System Parameters**     Two parameters can be changed by the user here. Door release time is dependant on how often a broadcast message is transmitted. If the

message is transmitted every 32 seconds the average time it takes for the door to release is 16 seconds. This is controlled by a value in a compare register that generates an interrupt when a counter value matches it. Hence, the user can input via the keypad the number of seconds they wish the door to release in.

The number of status messages sent per day to each unit can also be changed. The default is 270 requests per day meaning each unit is polled approximately every 2.5 hours ( $32s * 270 = 157$  minutes).

#### **View Event Log**

The controller records certain events for the user to view. These events are low signal level, communications failure and low signal level. The events are stored in EEPROM with the relevant ID. A maximum of 100 events are stored at any one time.

#### **Test Unit**

The user can select which unit they want interrogated next by scrolling through the unit list. The selected unit's ID is then updated in the UnitNumber variable.

#### **RSSI Test**

This test is used when a unit is calibrating and the user wants to ensure they have maximum signal strength from the unit i.e. better signal at top of door as opposed to bottom. The controller transmits an rssi command which any unit in calibration mode in the vicinity will respond to with the signal strength embedded in a message. It is up to the user to ensure that there is only one unit being tested at a time otherwise more than one unit will respond and messages may be lost.

#### **Initialise Clock**

The user sets the current time by entering on the numeric keypad.

#### **Set Alarm**

The user sets an time for all the doors to be released daily.

## EEPROM Configuration

Below is a table showing the EEPROM configuration that was used to save non-volatile information. The information in italics shows the values that were programmed into the EEPROM during production. The information in normal font depicts information that is updated and saved whilst the system is running.

<b>Advanced EEPROM Usage</b>	
<b>Address</b>	<b>Function</b>
<b>0</b>	<b>Number of units enrolled</b>
<b>1</b>	<b>Number of repeaters enrolled</b>
<b>2</b>	<i>Upper byte of 24 bit address</i>
<b>3</b>	<i>Middle byte of 24 bit address</i>
<b>4</b>	<i>Lower byte of 24 bit address</i>
<b>5</b>	<i>Password</i>
<b>6</b>	<i>Password</i>
<b>7</b>	<i>Password</i>
<b>8</b>	<i>Password</i>
<b>9</b>	<i>Password</i>
<b>10</b>	<i>Password</i>
<b>1001</b>	<b>Freq Flag</b>
<b>1008</b>	<b>Freq Value</b>
<b>1009</b>	<b>Msgs Flag</b>
<b>1010</b>	<b>Msgs Value</b>
<b>1011</b>	<b>Doortimr Flag</b>
<b>1012</b>	<b>Doortime Value</b>
<b>1999</b>	<b>Event NO Address</b>
<b>2000</b>	<b>Event Logging</b>

Table 15 – Advanced EEPROM Configuration

The following two diagrams depict the software flowchart for the advanced source code at a functional level. It shows the main function, the installation functions and then the interrupt service routines.

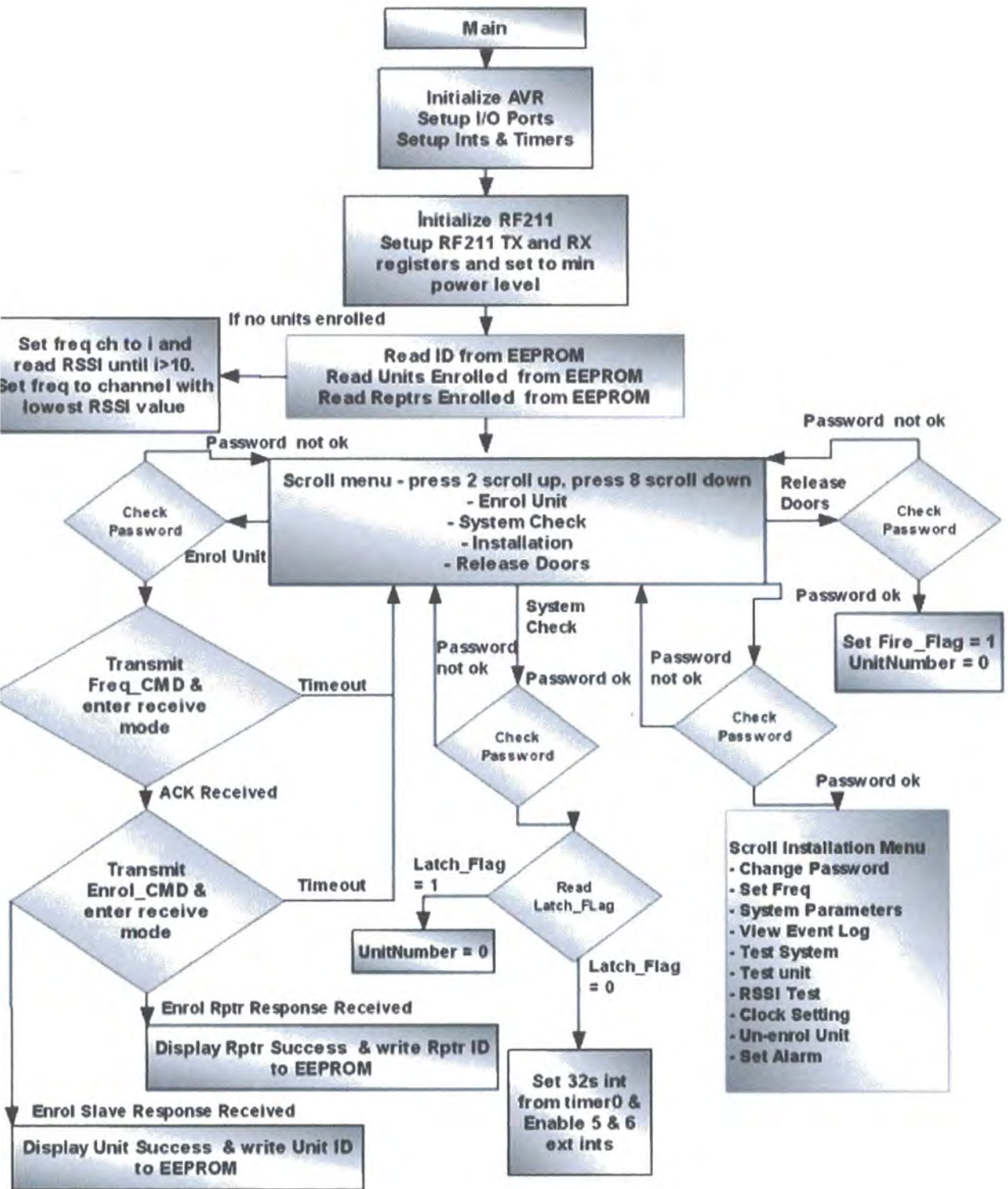

Figure 52 – Advanced Software Flowchart (i)

Installation menu  
User selects .....

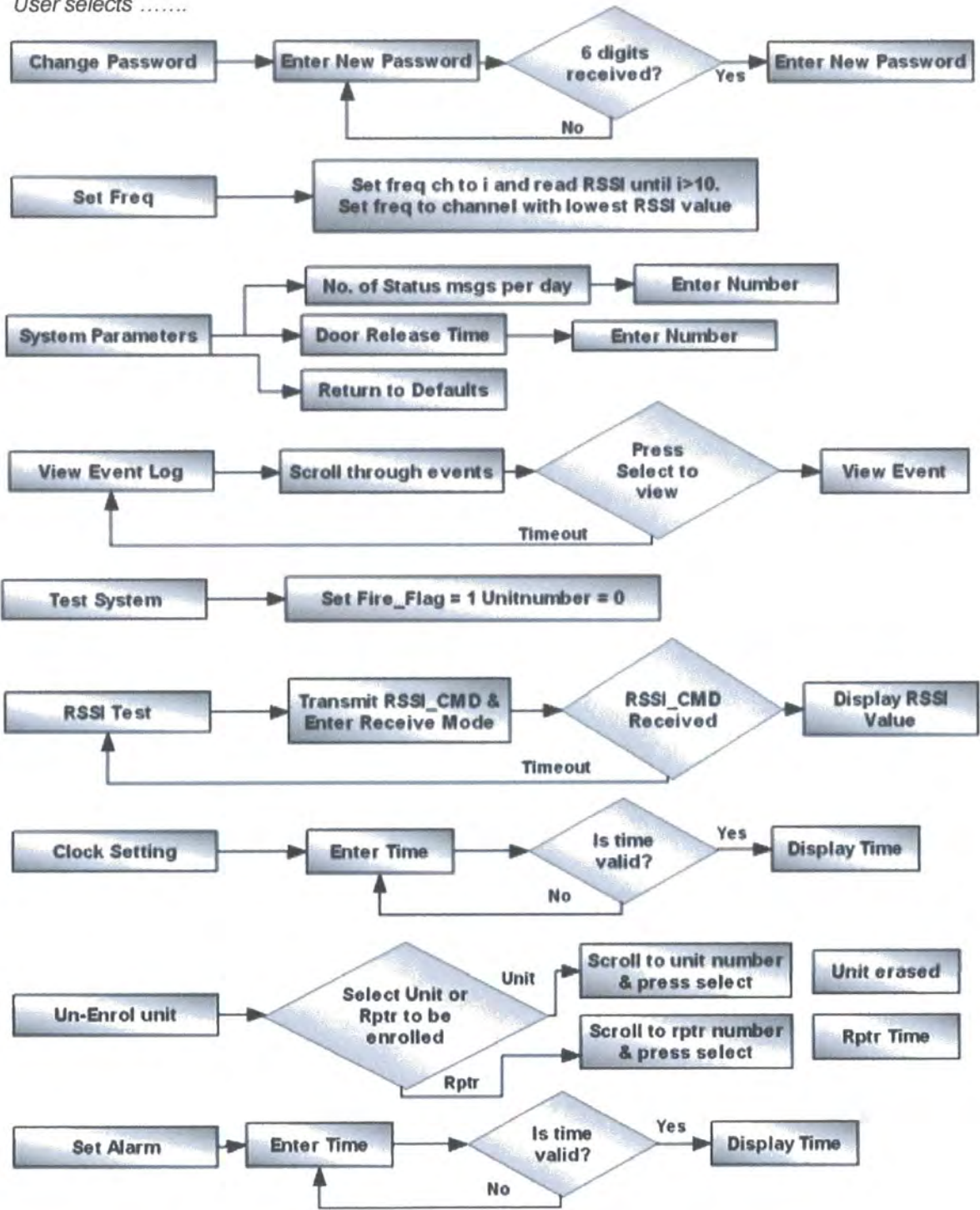
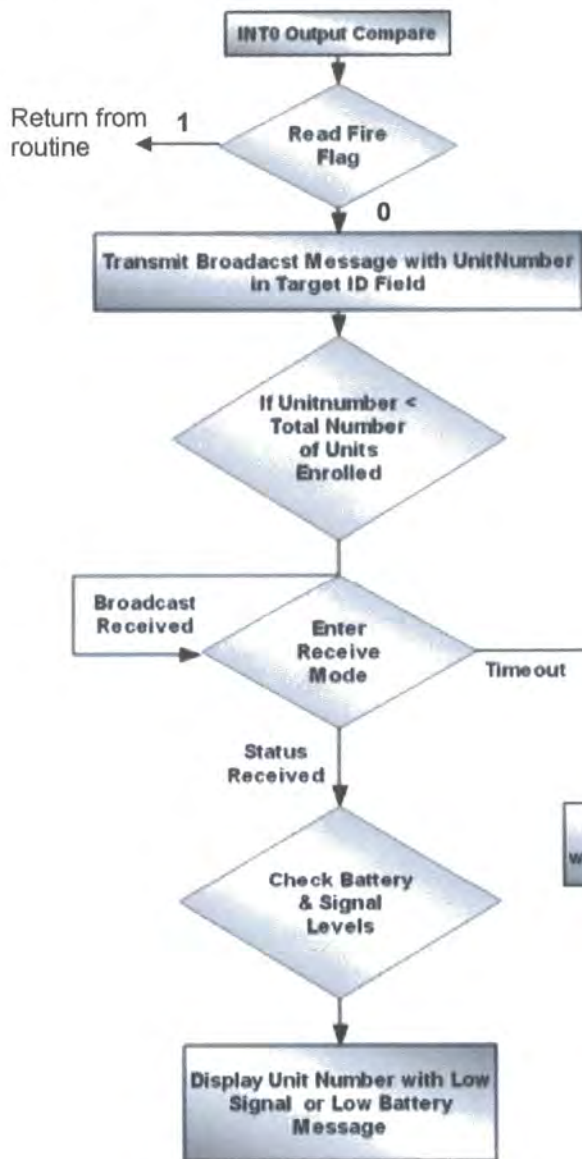

Figure 53 – Advanced Software Flowchart (ii)

This output compare interrupt drives the transmission of the broadcast message.



These external interrupts are called when a fire alarm has occurred and 24 – 28VDC is seen on the fire alarm panel outputs. Their effect is to stop the transmission of the broadcast message by setting Fire\_Flag = 1.

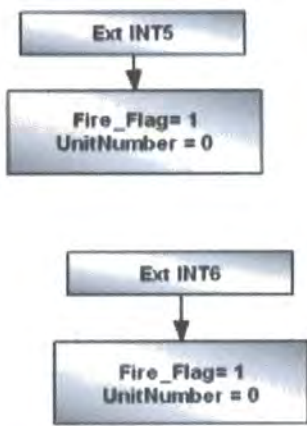

Figure 54 – Advanced Software Flowchart (iii)

## 8.5. Slave Description and Flowchart

The unit enters the main function and sets up timers, counters and interrupts. The first task for the software is to determine if it's enrolled or not by reading the status of the enrol flag from the correct EEPROM location. If a zero is returned the unit is not enrolled and enters enrol mode.

### Enrol Function

The first task of this function is to find what channel the controller is transmitting on. The unit listens on 10 different channels 200Hz apart. If it does not receive a frequency command from the controller the unit switches to the next channel. If no command is received for 5 minutes then the unit enters sleep mode.

When a frequency command is received the unit transmits an ack command back and stores the channel number in EEPROM. At this point the unit expects the controller to transmit an enrol command. On receiving this, the unit transmits 'I'm a door holder' message and sets the enrol flag to 1 and stores it in EEPROM. The controller 24 bit unique ID is stored in EEPROM.

### Calibrate Function

When the unit has enrolled it enters calibrate mode. This is when the unit calculates how long it can sleep for before it has to wake up to receive a broadcast message. If no broadcast messages are received the unit enters sleep mode. When the first Broadcast message is received an 8 bit counter is started. The counter is incremented every 1/32.768kHz. An interrupt is written to handle the overflow of the 8 bit counter and reset it and increment a variable called Calibration\_Timer that is used to determine the length of time between broadcast messages.

$$\text{Counter Overflow} = (1/32.768\text{kHz}) * 256 = 8\text{ms}$$

After a small offset to account for receiver settling time the value of Calibration\_Timer is placed in an output compare interrupt to wake the unit from sleep mode.

During calibration if ever a RSSI command is received from a controller the unit will immediately transmit the received signal strength back to that controller.

The unit drives the motor to the hold position and enters sleep mode.

### **Driving Motor to the Hold Position**

The function to drive the motor to the holding position will only be accessed if the unit is enrolled, calibrated and the tamper switch is down. This is obviously to prevent the door being held in an unacceptable situation.

The unit reads its own battery level from the RF211s onboard A/D converter to determine how long it should drive the motor for i.e. low battery requires the motor to be driven longer to reach the same position that a motor driven on a full battery would.

### **Driving Motor to the Release Position**

If the battery cover is removed an interrupt routine is activated that drives the motor to the off position or if the manual release switch is pressed an interrupt routine is activated that drives the motor to the off position.

### **Wake up**

The unit is woken from sleep mode by an output compare interrupt on timer 1. It checks its battery level by reading the internal A/D on the RF211 device, if the level is below a pre-defined threshold the magnet is driven to the release position and the door closes.

The unit then enters receive mode immediately to receive the broadcast message. One of three events can now occur:-

- Broadcast message received ok – unit goes back into to sleep mode.
- A broadcast message is received with the target ID matching its own ID – unit transmits a status message back to the controller and re-enters sleep mode
- No message received - door is released and the units software goes into calibration mode.

The unit can also be woken up from sleep mode by pressing the manual release switch. This feature has been added so that if a unit is enrolled but does not calibrate and goes to sleep it can easily woken, otherwise the unit would have to reset by removing power i.e. the batteries.

### EEPROM Configuration

Below is a table showing the EEPROM configuration that was used to save non-volatile information. The information in italics shows the values that were programmed into the EEPROM during production. The information in normal font depicts information that is updated and saved whilst the system is running.

<b>Address</b>	<b>Slave EEPROM Usage</b>
<b>0</b>	<b>Function</b>
<b>1</b>	<b>Enrol Flag</b>
<b>2</b>	<i>Upper byte of 24 bit address</i>
<b>3</b>	<i>Middle byte of 24 bit address</i>
<b>4</b>	<i>Lower byte of 24 bit address</i>
<b>5</b>	<b>Not used</b>
<b>6</b>	<b>Sender Flag</b>
<b>7</b>	<b>Upper Byte Sender Addr</b>
<b>8</b>	<b>Middle Byte Sender Addr</b>
<b>9</b>	<b>Lower Byte Sender Addr</b>
	<b>Freq Channel</b>

Table 16 – Slave EEPROM Configuration

The following two diagrams depict the software flowchart for the door holder source code at a functional level. It shows the main function and then the interrupt service routine.

The main function has two purposes. To wait for an enrol message if door holder not enrolled. Then to calibrate to the controller once enrolled. If neither occur within a pre-define time then door holder goes to sleep to conserve battery life.

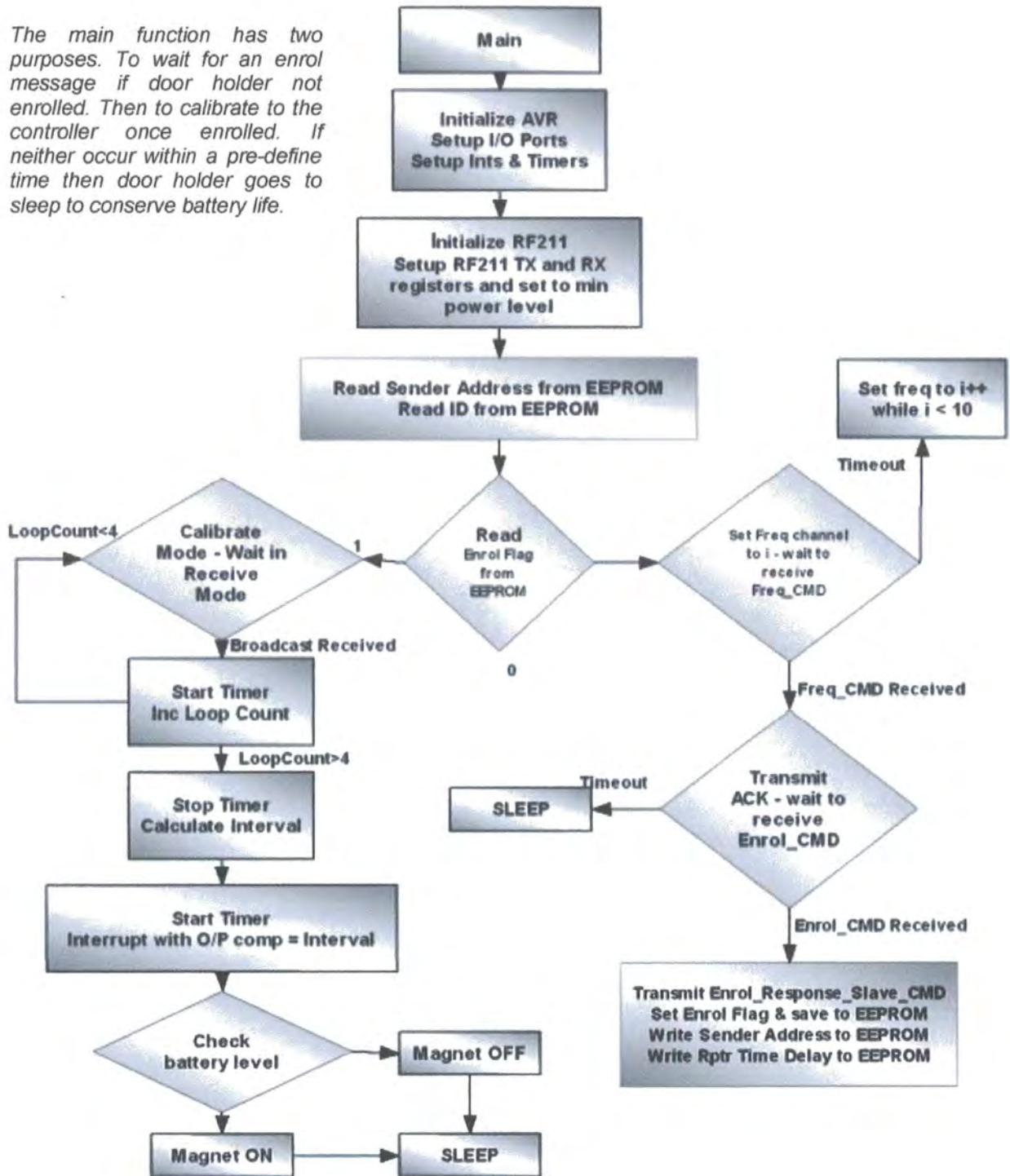

Figure 55 – Slave Software Flowchart(i)

Output compare interrupt to wake up AT86RF21, put it in receive mode and receive broadcast message.

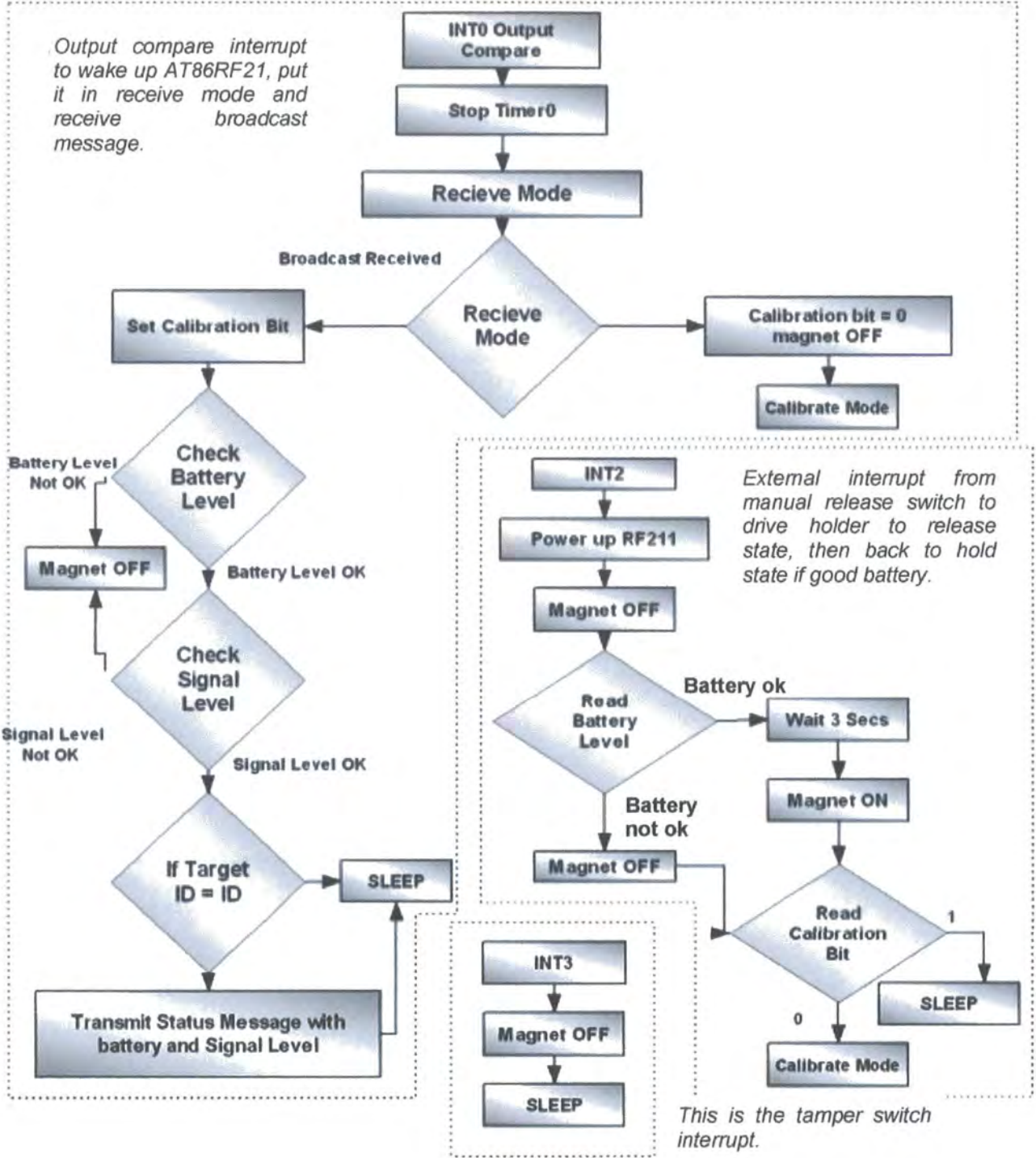

Figure 56 – Slave Software Flowchart(ii)

### 8.6. Repeater Description and Flowchart

The repeater protocol has to be designed to repeat the message without any chance of collision. The example below shows a system where two units are out of range and therefore require repeaters. If these two repeaters are in range of each other their repeated messages would interfere. Any slave in the system that was responding to a status request would also pick up the repeated message. If each repeater waits a certain length of time before transmitting the messages will 'avoid' each other.

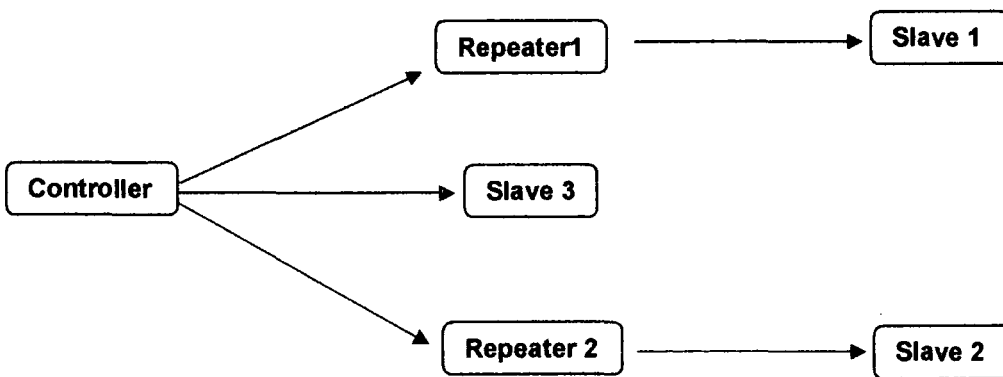

Figure 57 – Repeater Organisation Example

The minimum delay before a repeater should transmit must be long enough to allow a message to be sent back from a 2<sup>nd</sup> level slave to the controller. The figure below represents the case when the controller is requesting the status of a 1<sup>st</sup> level slave.

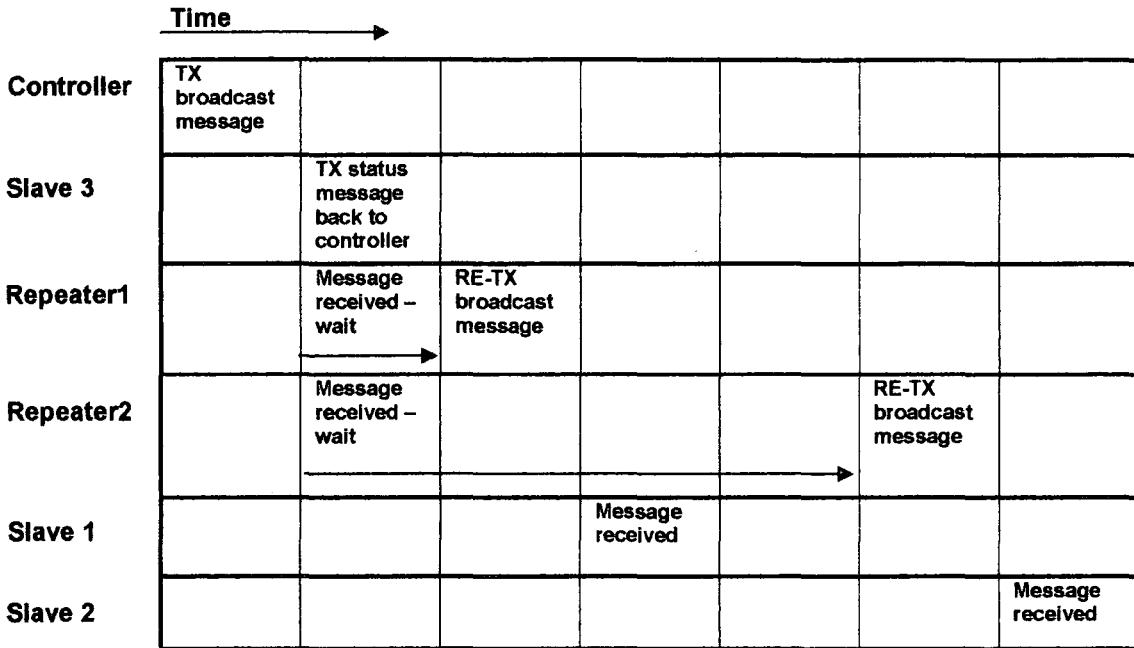

Table 17 – 1<sup>st</sup> Level Stage Repeater

The figure below represents the case when the controller is requesting the status of a 2<sup>nd</sup> level slave.

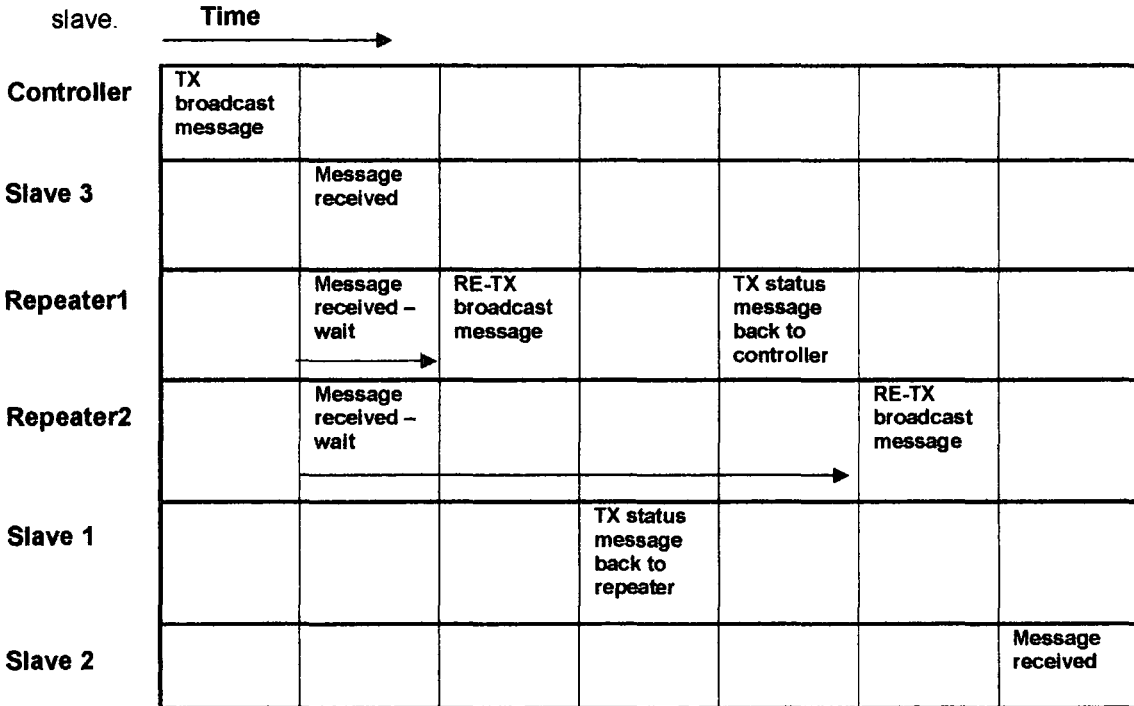

Table 18 – 2<sup>nd</sup> Level Stage Repeater

With the above protocol in place each message would have its own time slot to transmit in.

### 8.6.1. Enrolling a Repeater

A repeater will be enrolled and look for a suitable channel in the same way as a door holder unit. Within the enrol message that the repeater receives there is a byte allocated to the delay number. The ID of the controller and the delay number are stored in EEPROM so can be recalled after a reset.

### 8.6.2 Message Organising

During normal operation there are two types of messages that are transmitted and received.

- Broadcast messages are always transmitted from controller to repeater to slave.
- Status messages are always transmitted from slave to repeater to controller.

All messages are re-transmitted exactly. Broadcast messages are re-transmitted after the delay and the status messages re-transmitted immediately. If a slave is in range of a repeater and a slave it will 'see' any message twice. The slave calibrates to only one ID e.g. controller ID and ignores messages from the repeater ID.

### EEPROM Configuration

Below is a table showing the EEPROM configuration that was used to save non-volatile information. The information in italics shows the values that were programmed into the EEPROM during production. The information in normal font depicts information that is updated and saved whilst the system is running.

<b>Address</b>	<b>Repeater EEPROM Usage</b>
<b>0</b>	<b>Function</b>
<b>1</b>	<b>Enrol Flag</b>
<b>2</b>	<b>Repeater Flag</b>
<b>3</b>	<i>Upper byte of 24 bit address</i>
<b>4</b>	<i>Middle byte of 24 bit address</i>
<b>5</b>	<i>Lower byte of 24 bit address</i>
<b>6</b>	<b>Repeater Delay</b>
<b>7</b>	<b>Upper Byte Sender Addr</b>
<b>8</b>	<b>Middle Byte Sender Addr</b>
<b>9</b>	<b>Lower Byte Sender Addr</b>
	<b>Freq Channel</b>

Table 17 – Repeater EEPROM Configuration

The following diagram depicts the software flowchart for the repeater source code at a functional level. The main function has two purposes. To wait for an enrol message if the repeater is not enrolled. Then to calibrate to wait in receive mode and re-transmit any messages it receives.

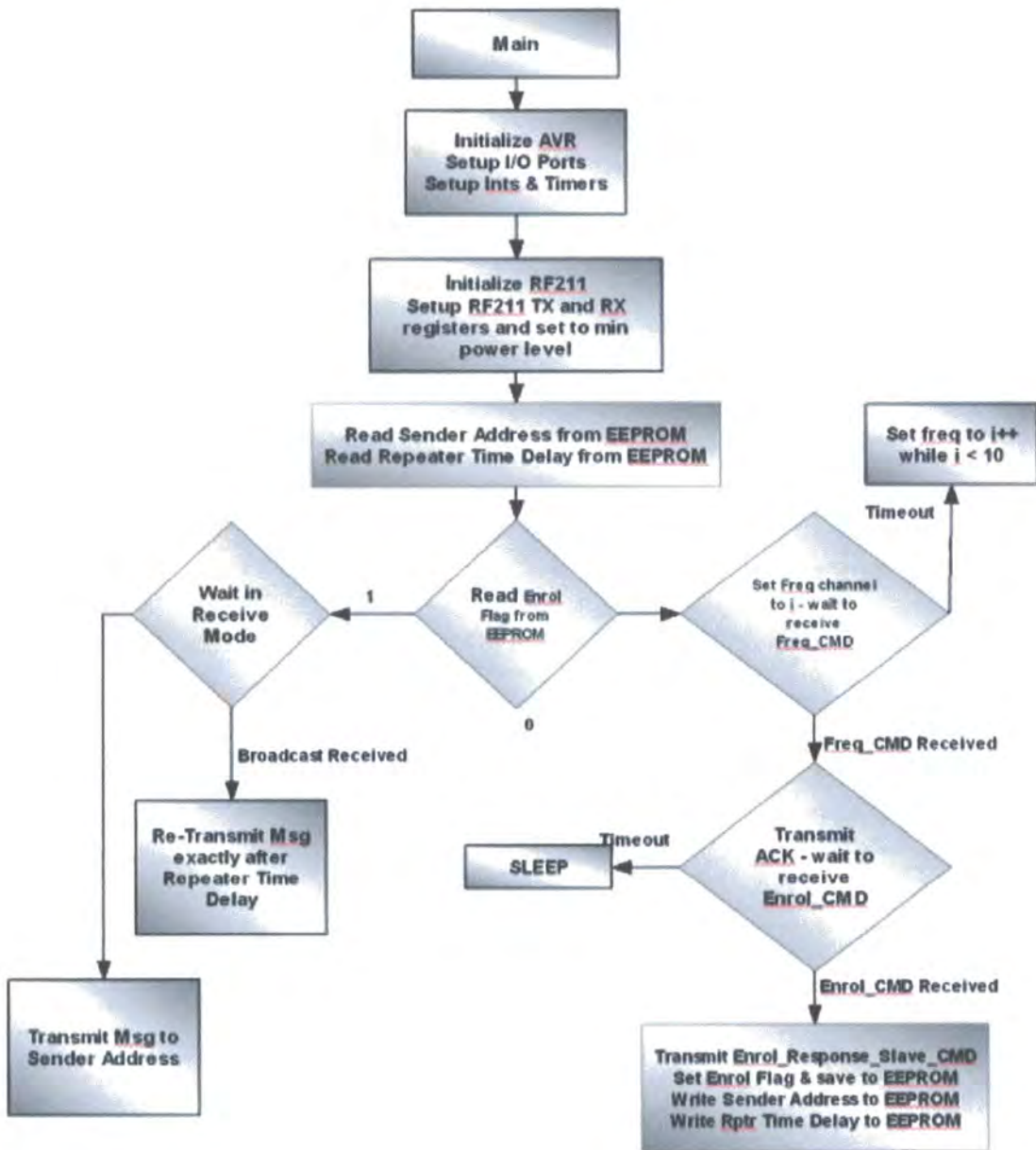

Figure 58 – Repeater Software Flowchart

## Chapter 9: Approvals

For the company to legally sell the product it must adhere to and pass a number of international and European Standards.

### 9.1. BS EN 300 220 Compliance Tests Results

As discussed in chapter 5.5. Any short range device that intends to transmit and receive information in the ISM band must pass the European Standard BS EN 300 220. As the RF section of the slave PCB is exactly the same as the controller PCB only one had to be tested. The prototype had been pre-compliance tested so no major problems have been envisaged in conforming to the standard.

However, the pre-production unit failed on spurious emissions. All spurious signals except the emission at the intended frequency and the adjacent channels shall be measured. If they are above acceptable limits (displayed in the graph below) the device fails.

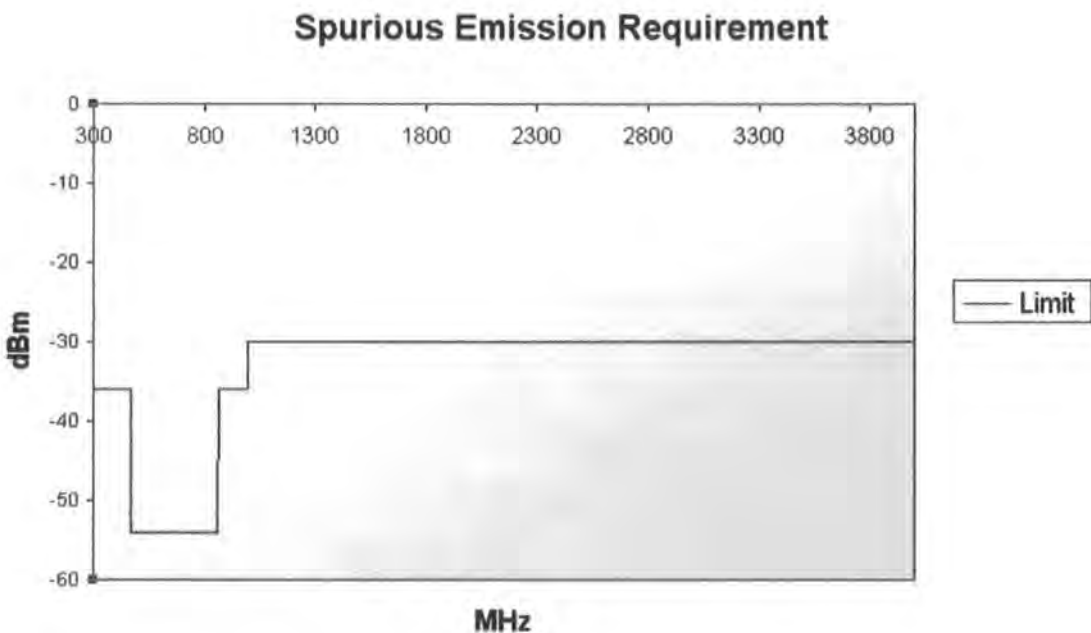

Figure 59 – Spurious Emission Requirement Graph

### Failed Spurious Emissions

The 1<sup>st</sup> and 3<sup>rd</sup> harmonics are over the limit.

The levels are as follows:

**Radiated Measurements with 50Ohm load using Pre-Production PCB**

1.737284GHz vertical polarization level -28.6dBm limit -30dBm

3.475452GHz Horizontal polarization level -26.27dBm limit -30dBm

As the prototype unit had passed pre-compliance testing this failure was extremely puzzling as the RF portion of the PCB had remained the same. However the pre-production PCB had one very major change and that was the 'upgrading' of the RF chip to a shrink version. Essentially the chip was the same but with added features and a shrunken die. In case any of these features were causing the unwanted signals an Atmel FAE was contacted as a quick route to finding a solution. A pre-production PCB was sent to the Engineer to examine. His first thoughts were that there was not enough grounding around the antenna matching circuit and underneath the chip itself.

To incorporate these changes into the design quickly pre-production PCBs have been modified to take more grounding vias. This was achieved by drilling 0.8mm holes from the top ground plane to the bottom, inserting 1.0mm track pins and soldering both ends. Extra vias could not be placed under the chip.

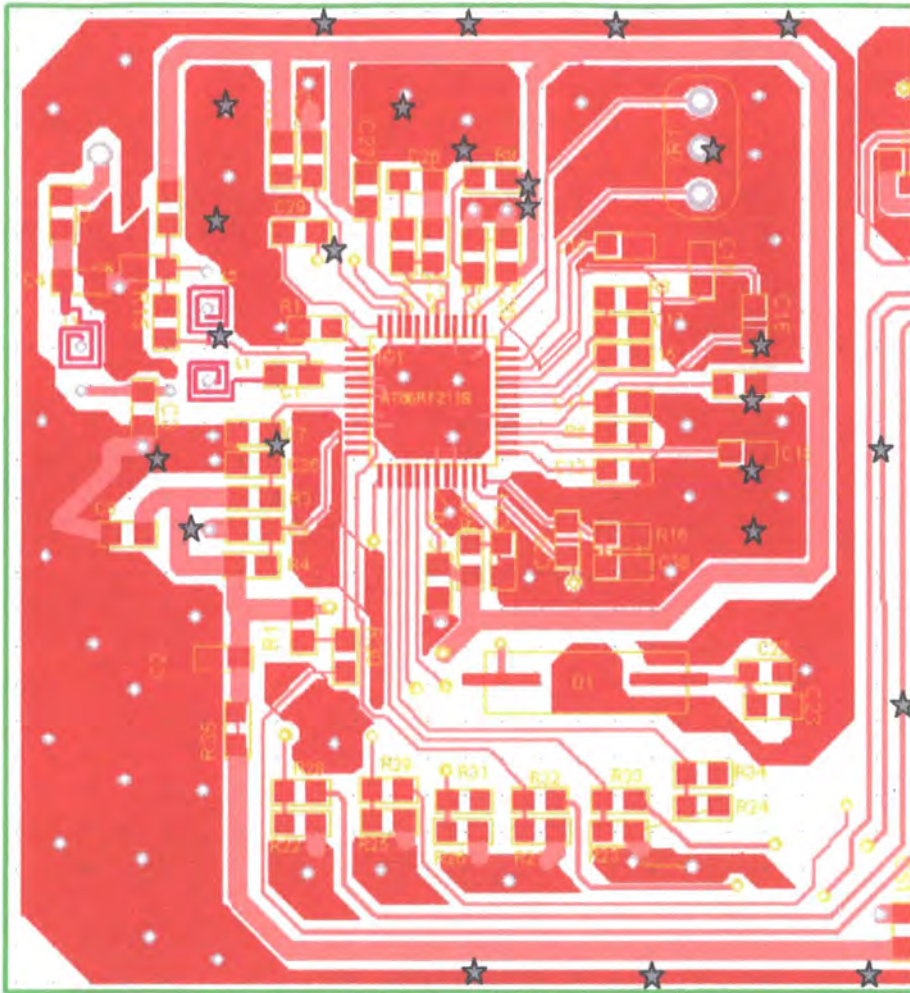

Figure 60 – Locations of Extra Vias to Ground

These changes were made and the modified unit sent back to the test house.

**Failed Spurious Emissions:**

The 1<sup>st</sup> and 3<sup>rd</sup> harmonics have reduced and the carrier power increased by 3dBm. However, the 2<sup>nd</sup> harmonic is now over the limit.

**Radiated Measurements with 50Ohm load using modified Pre-Production PCB**

- 868.8636MHz level -0.5dBm Limit 14dBm
- 1.737284GHz level -33.1dBm Limit -30dBm
- 2.606587GHz level -25.4dBm Limit -30dBm
- 3.475452GHz level -35.7dBm Limit -30dBm

Using Durham University's PCB production plant it was possible to produce a small number of boards to incorporate the extra grounding underneath the chip.

Atmel advised:-

- adding extra pads to take bead inductors
- adding decoupling capacitors on every VCC branch
- via to grounds extremely near capacitor pads
- rounding the corners.

All of the modifications should reduce noise on the board and hopefully reduce the unwanted emissions.

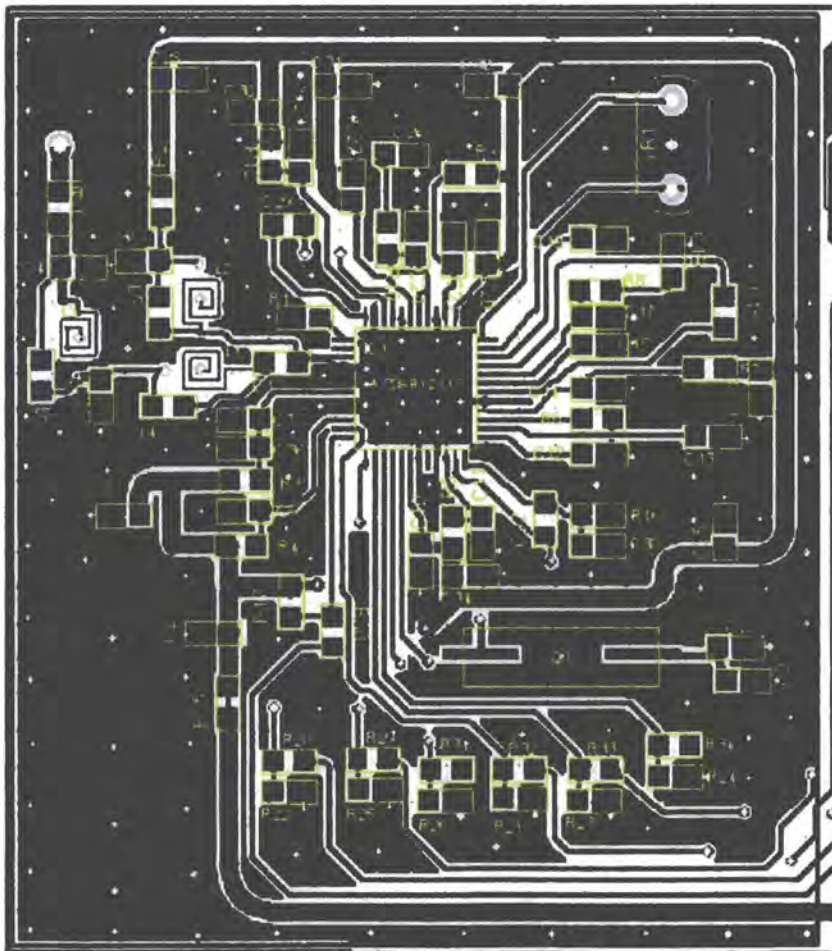

Figure 61 – Atmel Modifications to PCB

However these boards once assembled and tested also emitted the 2<sup>nd</sup> harmonic above the acceptable limits. This was tested using a Spectrum Analyser on loan from Durham University.

**Radiated Measurements with 50Ohm load using Pre-Production PCB (version 2)**

2.606587GHz level -26 dBm Limit -30dBm

The test house confirmed this but thought the noise was coming from an ill tuned antenna matching circuit or that the noise could 'tuned out' by modifying the matching circuit.

**Antenna Matching Circuit**

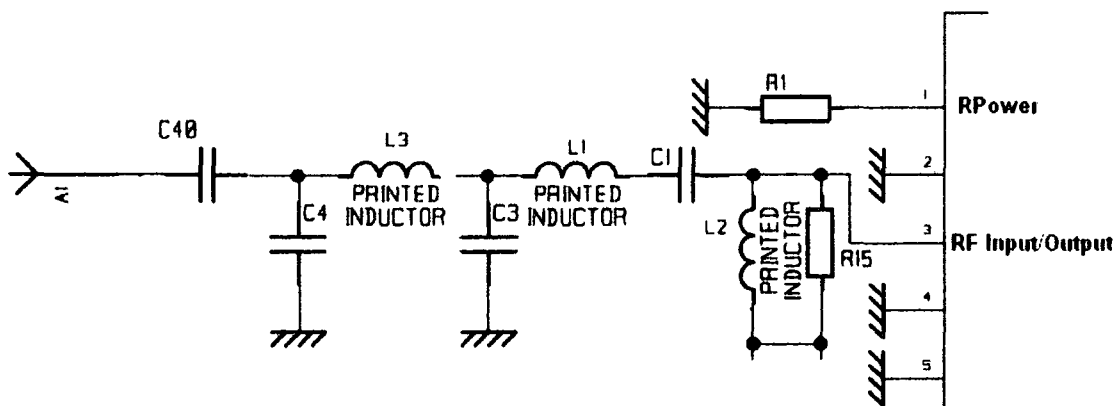

Figure 62 – Antenna Matching Circuit

Tuning the matching circuit is a matter of trial and error. However it is known that C4 and C3 will affect the spectral response of the circuit more than C40 which affects the DC level instead.

So the process was change the value of one of these capacitors at a time and measure the effect on the spectrum analyser. The results from the test house cannot be reproduced with the equipment at the company but conducted measurements can be performed to attempt to reduce the 2<sup>nd</sup> harmonic to a level that might pass the spurious emissions test. The first line of the table (i) shows what the configuration as the test house measured it. From experience with the testing methods a -60dBm level will be below the limit.

C40 = 1pF, C4 = 2.7pF

	C3	Fundamental (dBm) 868.9GHz	1st Harmonic (dBm) 1.74GHz	2 <sup>nd</sup> Harmonic (dBm) 2.61GHz	3 <sup>rd</sup> Harmonic (dBm) 3.46GHz
<b>(i)</b>	<b>6.8</b>	<b>-25</b>	<b>-55</b>	<b>-48</b>	<b>-59</b>
	18	-25	-53	-52	-55
	15	-21	-54	-51	-56
	12	-20	-56	-52	-58
	10	-15	-56	-53	-55
	8.2	-15	-56	-55	-57
<b>(ii)</b>	4.7	-11	-61	-59	-58
	3.3	-9	-59	-61	-58
	2.2	-9	-55	-59	-57
	1.5	-8	-50	-57	-58
<b>(iii)</b>	1	-9	-57	-65	-66

Table 18 – Conducted Measurements varying C3

- (ii) This configuration using a value of C3 = 4.7pF is quite close to a good result and has brought down the all the harmonics but not enough.
- (iii) This configuration using a value of C3 = 1pF is also close to a good result and has brought down the 2<sup>nd</sup> and 3<sup>rd</sup> harmonics a lot but the 1<sup>st</sup> harmonic is still too high.

C40 = 1pF, C3 = 6.8pF

	C4	Fundamental (dBm) 868.9GHz	1st Harmonic (dBm) 1.74GHz	2 <sup>nd</sup> Harmonic (dBm) 2.61GHz	3 <sup>rd</sup> Harmonic (dBm) 3.46GHz
	<b>2.7pF</b>	<b>-25</b>	<b>-55</b>	<b>-48</b>	<b>-58</b>
	18	-25	-57	-50	-53
	15	-21	-57	-51	-53
	12	-20	-56	-52	-56
	10	-15	-56	-53	-58
	8.2	-15	-56	-55	-57
	4.7	-11	-57	-58	-56
	3.3	-9	-55	-60	-55
	1.5	-8	-57	-59	-54
	1	-9	-56	-59	-55

Table 19 – Conducted Measurements varying C4

### Conclusion

Varying the values of C4 and C3 both affect the measured harmonics but neither has achieved a suitable result. It seems though that the 1<sup>st</sup> and 3<sup>rd</sup> harmonics are directly related but then inversely related to the 2<sup>nd</sup> i.e. if the 1<sup>st</sup> and 3<sup>rd</sup> harmonics come down the 2<sup>nd</sup> increases and vice versa.

There may be a configuration that could balance these effects. Using trimmer capacitors instead of re-soldering discrete capacitors may help find this configuration. Two trimmer capacitors were added.

C3 = 5 – 20pF trimmer capacitor

C4 = 2 – 6pF trimmer capacitor

Eventually after a lot of fine tuning using the trimmers and observing the effect on the spectrum analyser a good result was found. This board was sent to the test house and found again to have the 2<sup>nd</sup> harmonic just a few dBm too high.

### **Radiated Measurements with 50Ohm load using modified Pre-Production PCB with Trimmer Capacitors**

2.606587GHz level -28 dBm Limit -30dBm

The signal is now very near the limit and it only needs to be reduced by a few more dBm. The output power can be selectively reduced by one of the AT86RF211s registers. If the power of the unwanted harmonic can be reduced without reducing the fundamental frequencies output power this could be the solution to bringing the device within the standards limits.

The output power can be adjusted in hardware and software. Rpower is a resistor connected to pin 1 on the device which limits the amount of current the power amplifier can sink and in CTRL1 register 3 bits (TXLVL) are used to select one of 8 levels for the output power.

Originally Rpower = 5.6k and TXLVL set to 111 (highest level).

The easiest to reduce the output power is to do so in the software. No effect on the 2<sup>nd</sup> harmonic was noticed until the level was changed to 001 (one above the lowest level). All the harmonics disappeared and were all measured at approx -65dBm.



Harmonic distortion (clipping) from the power amplifier could have been the cause for the harmonics and having it set to highest power level could have 'amplified' these distortions. The power amplifier feeds straight into the antenna matching circuit and this was where the harmonics were located.

There are a number of other tests specified in EN 300 220 that the unit must also pass.

**Effective radiated power** is tested to not be above 25mW.

**Frequency stability for low voltage battery operation** This requirement applies for battery-operated equipment only. The requirement is that when reducing the operating voltage to zero, the equipment should stay on the desired frequency, or cease to function altogether.

#### **Duty cycle**

This requirement states the transmitter on/off ratio measured during 1 hr period. The duty cycle ratio for this frequency is 0.1%.

#### **Blocking and Desensitization**

Blocking is a measure of the capability of the receiver to receive a wanted modulated signal without exceeding a given degradation due to the presence of an unwanted input signal at any frequencies other than those of the spurious responses or the adjacent channels.

These were all passed and the unit certified to EN 300 220.

### **9.2. EN 301 489 – 3 EMC Standard for Short Range Devices**

EMC testing involves looking for certain phenomena from the unit. The units operation is tested for immunity and emissions.

#### **Radiated Emissions**

This test assesses the ability of the unit to limit internal noise from being radiated from the enclosure.

## **Immunity**

### **RF EM Field (80MHz – 2000MHz)**

This test assesses the ability of the system to operate as intended in the presence of a radio frequency electromagnetic field disturbance.

### **Electrostatic Discharge**

This test assesses the ability of the system to operate as intended in the event of an electrostatic discharge.

### **Fast Transients – Common Mode**

This test assesses the ability of the system to operate as intended in the event of fast transients present on one of the input/output ports.

### **Radio Frequency – Common Mode**

This test assesses the ability of the EUT to operate as intended in the presence of a radio frequency electromagnetic disturbance on the input/output ports.

The system passed these tests and conforms to EN 301 489 – 3.

## **9.3. EN1155**

The European Standard EN 1155 regulates the operation of electrically powered hold-open devices. It specifies number of test cycles, door mass and corrosion resistance.

### **9.3.1. Test Cycles**

The unit has to be tested driving the motor to the release and hold state 50,000 times without fail. The unit is not designed to hold a door without enrollment and communicating with a controller. So a special program was written to drive the unit back to the hold position two seconds after it was released by the manual release button.

**Result: The unit passed this test.**

### **9.3.2. Power off Test**

The standard also specifies that the door must be driven to the release position when power is removed. As the unit draws current to latch from the release state to the hold state, the tamper switch is used as a trigger. The tamper switch is activated by the release of the battery holder fixing screw. So before power can actually be disconnected by the removal of the batteries the unit has driven to the release state.

**Result: The unit passed this test.**

### **9.3.3. Operating Voltage Range**

The operating voltage range of the unit must be  $\pm 20\%$  of the nominal voltage. However the unit must release at below 80% of the nominal voltage. The voltage of the unit is recorded before the motor is driven. If the voltage is determined to be below a certain threshold the unit will not drive to the hold position but will also release to a safe position. The reading of the battery voltage is discussed in chapter 6.

The unit passed these tests and conforms to EN1155.

## **9.4. Electrical Equipment Regulations (Low Voltage Directive) 1994 (SI 1994/3260)**

The Regulations apply to all electrical equipment that is designed or adapted for use between 50 and 1,000 volts (in the case of alternating current) or 75 and 1,500 volts (in the case of direct current). The Regulations cover domestic electrical equipment and equipment that is intended for use in the workplace.

The LVD is applicable to the design of the controller PCB or essentially its layout. Limits on creepage and clearance distances between high voltage components must be strictly adhered to. Clearance Distance is the insulation distance through air. Insulation distance along a surface is known as the Creepage Distance. In this case distances of 2mm and 2.5mm must be maintained respectively.

This directive is self-certifiable and a technical document detailing the conformance must be written.

## **Conclusion**

The project was to develop a radio controlled door holder system. Hardware and software was designed and implemented to communicate with a door holder and to actuate it in case of a fire alarm. The project aim was satisfied.

## **RF Solution**

At the time the project began (first quarter 2003) the AT86RF211 IC was the most viable option:-

- It offered a higher level of integration than any other product.
- It had been in the market for some time.
- Atmel offered good support and good development kits for the device.
- It was relatively cheap.

There are now a plethora of RF solutions on the market.

- RF transceivers with on board microcontrollers and flash memory such as the Chipcon CC1110.
- ZigBee compliant transceivers Chipcon CC2430.
- Atmels AT86RF230 2.4GHz transceiver designed for ZigBee applications.
- Integrated RF Modules with advanced features such as sleep modes.

The integrated RF modules would have saved a great deal of time as they are already compliant to EN 300 220 and saved development time and costs. However, they are fixed design with no room for improvements, are high cost pieces and tend to be bulky.

## **RF Communication Range**

The range of the final product was approximately 50m in doors. This was a good result as only a low specification RF design was implemented. A higher specification RF design would have improved range and sensitivity but the product would have had higher component cost

The Blband reference design which was implemented had a stated range of 50 – 200m (line of sight) only included:-

- 1 intermediate filter.
- Used printed inductors.

The high sensitivity/selectivity design had a stated range of 600 – 1000m (line of sight) would incorporate:-

- 1 additional intermediate filter 455kHz (approx £1.00)
- RF SAW Filter (SAW filter SMT 869MHz CF 20MHz BW from RS £1.90 @ qty 500)

## **PCB Development**

The PCBs were designed specifically for the each product. A separate PCB was designed for the door holder that was designed for the controller. The door holder PCB consisted of a microprocessor section and an RF section. The controller PCB also consisted of a microprocessor section and an RF section. A stand alone RF PCB could have been developed that could mount onto to a separate microprocessor PCB specifically designed for that product. The microprocessor PCB would have to accept and send the correct bit patterns to set up the transceiver and provide a suitable decoupled power supply.

This would have involved additional PCB development as the controllers microprocessor PCB, the door holders microprocessor PCB and the RF stand alone PCB would have to be developed in parallel. However any future devices would be RF compliant.

### **Software Protocol**

The protocol that was developed had huge advantages:-

- Battery life was conserved through the use of sleep modes.
- Functionality and two way communication was maintained.
- It was very safe as if the protocol failed (no message sent or received) the door holder released the door.

The software did have some limitations in that:-

- The repeater software would only cover one level of repeaters.
- The user could only un-enrol a door holder manually by making contact with the un-enrol pads and then selecting the unit to be un-enrolled from the controller.
- The controller only looked for a suitable frequency channel to communicate on immediately after power up. If this happened more frequently noisy channels could be actively avoided.

Some of the topics listed above are covered in the Recommendations for Further Work chapter.

### Further Recommendations

There is scope for improving the system. It could be expanded over larger ranges by increased numbers of wireless repeaters. Multi-building installations could be a real possibility using wired repeaters. Reliability and interoperability with other systems can be achieved through a new wireless standard called ZigBee which wasn't available at the time the project began. These three enhancements are discussed here.

### Wireless Repeater Enhancement

The system is limited for larger installations when distances between the controller and a device are greater than 100m. Typical range of a device/repeater is 50m. The system has only been designed to include one level of repeaters, an example is shown below with two door holders communicating through a repeater each and one door holder in range of the controller.

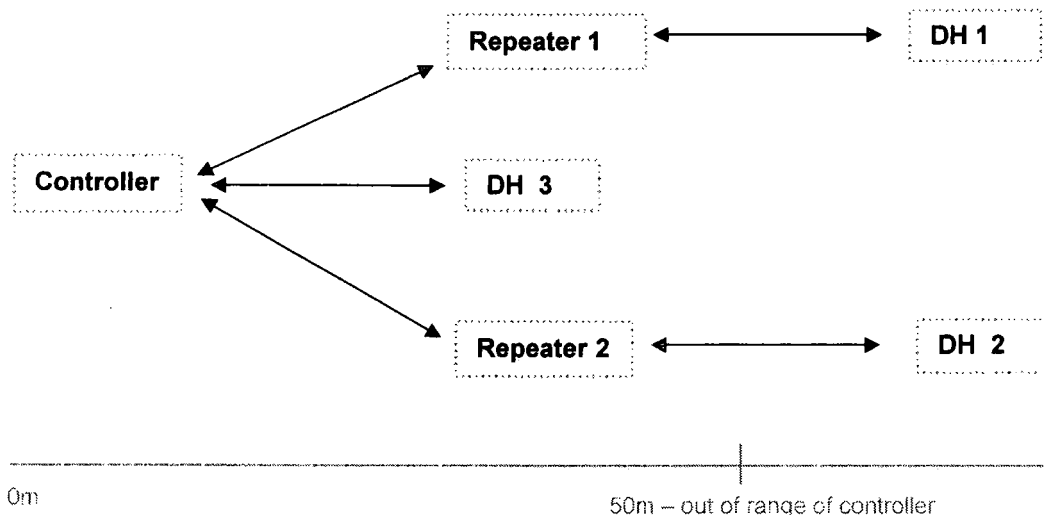

Figure 64 – Repeater Configuration Example (i)

There is the scope to enhance the repeater protocol to include level 2 and level 3 repeaters. The repeater protocol is essentially a 'dumb' protocol; the repeater simply repeats whatever it receives after a pre-defined delay to avoid collisions. To extend this protocol to include more levels of repeaters will involve software development only. Delay times would have to be adjusted for the increased message cycle time.

The solution is for the each repeater to know which devices it receives from and transmits to. The system when installed would have to implement a routine by which the repeaters and door holders would find the best communication paths.

When a communication is successful the repeater and door holder will have to store in memory which device ID it responds to. The timing of the broadcast messages would be critical and to avoid collisions an algorithm would have to be developed to organise which message would be transmitted and when.

### **Wired Repeaters using a CAN Bus**

For multi-building installations the number of repeaters required to cover a large distance (>200m) could become unworkable. A wired repeater that would repeat messages from one building to the other would be a good solution as device count and therefore cost would be decreased. A suitable approach to transmitting the information down a wire would be a CAN bus.

#### **The Controller Area Network (CAN)**

- Is a high-integrity serial data communications bus for real-time control applications
- Operates at data rates of up to 1 Mega bits per second
- Has excellent error detection and confinement capabilities
- Was originally developed for use in cars
- Is now being used in many other industrial automation and control applications

Physically, it is a balanced (differential) 2-wire interface running over either a Shielded Twisted Pair (STP), Un-shielded Twisted Pair (UTP), or Ribbon cable. Each node uses a male 9-pin D connector. The bit encoding used is Non Return to Zero (NRZ) with bit-stuffing this ensures compact messages with a minimum number of transitions and high resilience to external disturbance.

An asynchronous transmission scheme is controlled by start and stop bits at the beginning and end of each packet. The packet is composed of an Arbitration field, Control field, Data field, CRC field, ACK field.

The data field is 8 bytes long which is enough for the project requirements. The Arbitration field and Control fields determine which message is dealt with first. The distance data can be transmitted is dependent on the data rate, a distance of 10km can be achieved with a bus speed of 5kbps.

Atmel have developed an 8-bit AVR Microcontroller with 128K Bytes of ISP Flash and a CAN Controller. It is based on the ATmega128 and has the same pin out, the AT90128CAN. The controller board could be modified to incorporate the changes required for the CAN bus and only one board then need be used for the standard/advanced controller and the wired repeater.

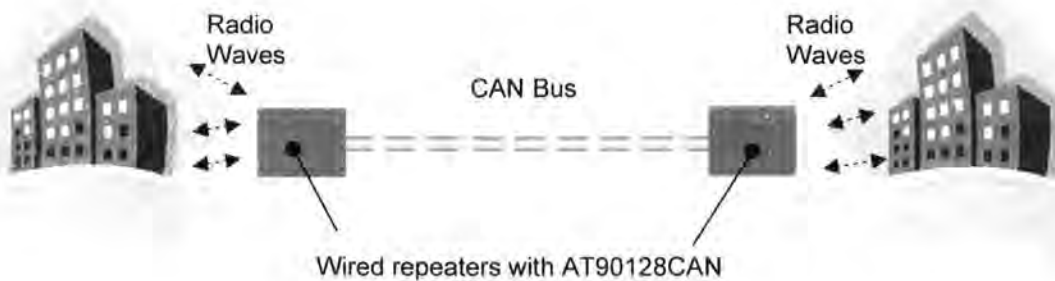

Figure 65 – Wired Repeater Example

### ZigBee /IEEE 802.15.4

ZigBee and IEEE 802.15.4 are low data rate wireless networking standards that were not available at the time the project was specified. Devices compliant to the standards can be placed anywhere in a system and still communicate with the rest of the system. The ZigBee standard is based on the IEEE 802.15.4 standard. The ZigBee part of the standard guarantees interoperability between equipment from different manufacturers and also supports complex, self-

healing "mesh" networks with as many as 65,000 nodes. The ZigBee standard is continuing to evolve and some of the application frameworks and profiles have not even been defined.

In a mesh network each node (or device) is connected directly to each of the other nodes. It is reliable and offers redundancy i.e. if one node can no longer operate, all the rest can still communicate with each other, directly or through one or more intermediate nodes. Nodes act as repeaters to transmit data from nearby nodes to peers that are too far away to reach, resulting in a network that can span large distances.

However, it is not always necessary to implement a ZigBee wireless network. For many applications 802.15.4, which is simpler and easier to implement, is sufficient. If the application doesn't require interoperability with equipment from other manufacturers and can be implemented in a point-to-point or star network, 802.15.4 may be the best way to go. The ZigBee standard as opposed to 802.15.4 would be more suitable for the wireless door holder system as the self-healing networks would be hugely beneficial as they are a big step towards a fail-safe reliable system.

Each node in the system has a radio, a microcontroller and media access control software that manages the interface between the radio and the rest of the system.

### **ChipCon CC2420**

The CC2420 is a low-cost transceiver designed specifically for low-power, low-voltage RF applications in the 2.4 GHz unlicensed ISM band. It is the first commercially available RF Transceiver compliant with the IEEE 802.15.4 standard and the first RF-IC that can be qualified for use in 2.4 GHz ZigBee products. Some of its features are:-

- DSSS Direct Sequence Spread Spectrum, 250 kbps effective data rate
- Low current consumption (RX: 19.7 mA, TX: 17.4 mA, Power Down: 20uA)
- Low supply voltage with internal voltage regulator (2.1 V - 3.6 V)
- No external RF switch/filter needed
- Programmable output power
- I/Q low-IF receiver
- Few external components
- Packet handling with 128 byte (RX) + 128 byte (TX) data buffering
- Digital RSSI/LQI support
- Hardware MAC encryption and authentication (AES-128)
- Battery monitor
- QLP-48 package (7x7 mm)
- Complies with EN 300 440
- Powerful, flexible development tools available
- Easy-to-use software for performance evaluation

#### **Application Circuit**

Very few external components required.

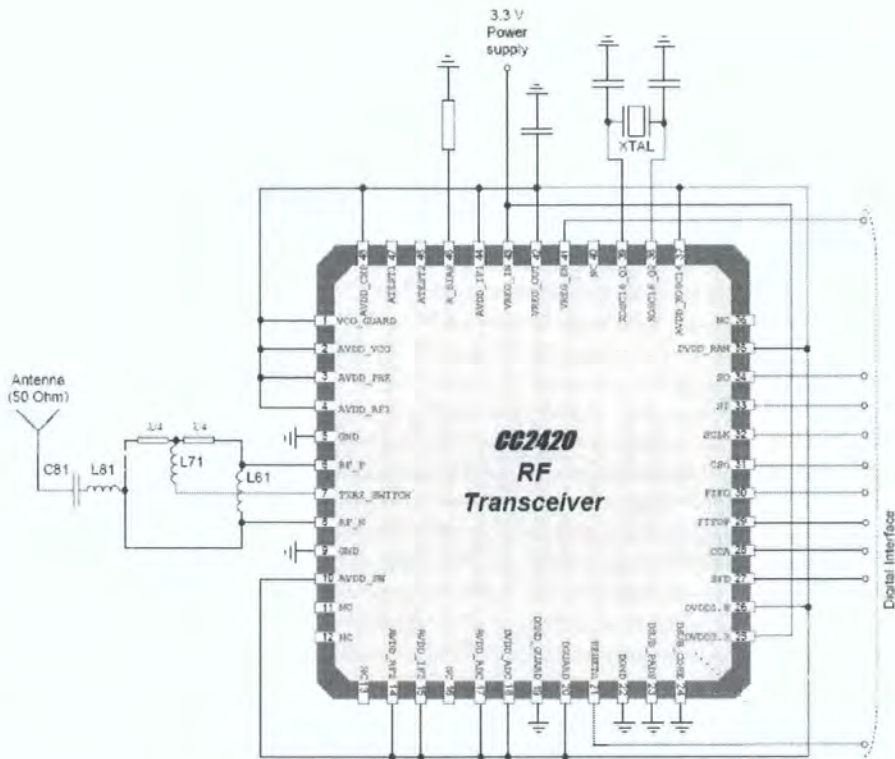

Figure 66 - CC2420 ZigBee Transceiver Application Circuit

The door holder PCB would have to be re-designed and the radio and EMC compliance tests redone. There are a few software development suites for application and product development available. The Figure 8 Wireless Z-Stack is one of them. The proprietary software protocol would have to be modified to work acceptably with the ZigBee protocol.

## **Bibliography/References**

[AT86RF211 – Using the AT86RF211ISM Band Transceiver as an AVR® Peripheral.pdf](#)

[AT86RF211 – Understanding the demodulation and data slicing features – Implementing DC demodulation.pdf](#)

[Conversion guide AT86RF211 to AT86RF211S.pdf](#)

[AT86RF211S – RF BOM vs. Application Requirements.pdf](#)

[AT86RF211 – Power Management using the Embedded Stand-alone Wake-Up Mode Protocol.pdf](#)

[AT86RF211 Development Kit.pdf](#)

[AN001 – SRD regulations for licence free transceiver operation.pdf](#)

[UK Radio Interface Requirement 2030 Short Range Devices.pdf \(Version 1.2.\)](#)

[DECT CI Standards ETS 300 175](#)

[EN 300 220 V1.2.1. \(1997-11\) Electromagnetic compatibility and Radio spectrum matters \(ERM\); Short Range Devices; Technical characteristics and test methods for radio equipment to be used in the 25MHz to 1000Mhz frequency range with power levels ranging up to 500 mW.pdf](#)

[EN1155:1997 Building Hardware. Electrically powered hold-open devices for swing doors. Requirements and test methods.pdf](#)

[www.AVRFreaks.net](http://www.AVRFreaks.net)

[www.zigbee.org](http://www.zigbee.org)

[www.atmel.com](http://www.atmel.com)

[www.chipcon.com](http://www.chipcon.com)

[www.radio.gov.uk](http://www.radio.gov.uk)

[www.ofcom.org.uk](http://www.ofcom.org.uk)

[www.winavr.sourceforge.net](http://www.winavr.sourceforge.net)

[www.dectwen.com](http://www.dectwen.com)

[www.eurescom.de](http://www.eurescom.de)

[standards.ieee.org](http://standards.ieee.org)

Programming in C by Stephan Kochan, (Paperback 2000)

Mobile Telecommunications Standards: UMTS, GMS, TETRA and ERMES (Mobile Communications Library) by Rudi Bekkers (Hardcover – 1 sep 2001)

The C Programming Language (2<sup>nd</sup> Edition) (Paperback) by Brian W. Kernighan, Dennis Ritchie, Dennis M. Ritchie

The handbook of Antenna Design by A. W. Rudge, K. Milne, A.D. Olver, P. Knight – Technology – 1986

Antenna Engineering Handbook by Richard C. Johnson – Technology – 1992

Wireless Telecommunications FAQs by Clint Smith – Technology – 2000

Wireless Radio: A history by Lewis Coe– Technology – 1996

Secrets of RF Circuit Design by Joseph J. Carr – Technology - 2000

