

Durham E-Theses

Moduli of symplectic bundles over curves

George H. Hitching

How to cite:

Hitching, George H. (2005) Moduli of symplectic bundles over curves. Doctoral thesis, Durham University.

Use policy

The full-text may be used and/or reproduced, and given to third parties in any format or medium, without prior permission or charge, for personal research or study, educational, or not-for-profit purposes provided that:

- a full bibliographic reference is made to the original source
- a <https://etheses.durham.ac.uk/id/eprint/2351/> is made to the metadata record in Durham E-Theses
- the full-text is not changed in any way

The full-text must not be sold in any format or medium without the formal permission of the copyright holders.

Please consult the [full Durham E-Theses policy](#) for further details.

Moduli of symplectic bundles over curves

George H. Hitching

A copyright of this thesis rests with the author. No quotation from it should be published without his prior written consent and information derived from it should be acknowledged.

A Thesis presented for the degree of
Doctor of Philosophy



Pure Mathematics Group
Department of Mathematical Sciences
University of Durham
South Road
Durham DH1 3LE
England

May 2005



0 7 DEC 2005

Moduli of symplectic bundles over curves

George H. Hitching

Submitted for the degree of Doctor of Philosophy

May 2005

Abstract

Let X be a complex projective smooth irreducible curve of genus g . We begin by giving background material on symplectic vector bundles and principal bundles over X and introduce the moduli spaces we will be studying. In Chapter 2 we describe the stable singular locus and semistable boundary of the moduli space $\mathcal{M}_X(\mathrm{Sp}_2 \mathbb{C})$ of semistable principal $\mathrm{Sp}_2 \mathbb{C}$ -bundles over X . In Chapter 3 we give results on symplectic extensions and Lagrangian subbundles. In Chapter 4, we assemble some results on vector bundles of rank 2 and degree 1 over a curve of genus 2, which are needed in what follows. Chapter 5 describes a generically finite cover of $\mathcal{M}_X(\mathrm{Sp}_2 \mathbb{C})$ for a curve of genus 2. In the last chapter, we give some results on theta-divisors of rank 4 symplectic vector bundles over curves: we prove that the general such bundle over a curve of genus 2 possesses a theta-divisor, and characterise those stable bundles with singular theta-divisors.

Many results on symplectic bundles admit analogues in the orthogonal case, which we have outlined where possible.

Declaration

The work in this thesis is based on research carried out with the Pure Mathematics Group at the Department of Mathematical Sciences of the University of Durham, and with the Équipe de Géométrie Algébrique of the Université de Nice et Sophia-Antipolis. No part of this thesis has been submitted elsewhere for any other degree or qualification.

We indicate broadly the originality of this thesis; there is a more detailed summary at the start of each chapter. Chapter 1 is expository apart from Theorem 1.4, which comes from combining definitions and results of several authors. In Chapter 2 we adapt results of Ramanan [42] on orthogonal bundles to the symplectic case, and give some consequences. Chapter 3 generalises results of Kempf [19] and Mukai [32], and the statement of Criterion 3.4 came from S. Ramanan. Chapters 4, 5 and 6 apart from § 6.1 are original apart from results quoted from the literature.

I have in several places given proofs of results which are well known but for which I did not find references.

Copyright © 2005 by George H. Hitching.

The copyright of this thesis rests with the author. No quotations from it should be published without the author's prior written consent and information derived from it should be acknowledged.

Acknowledgements

I have been most fortunate in the number of people who have shown interest in this project. Firstly, I thank very sincerely my doctoral supervisors for their time, ideas, expertise and patience over the last few years: Bill Oxbury, with whom I began to study this subject; Christian Pauly, who gave me an opportunity to continue this work; Wilhelm Klingenberg and John Bolton for constant mathematical and practical support.

Warm thanks to all the staff and students at the Department of Mathematical Sciences of the University of Durham for creating a very stimulating and comfortable atmosphere in which to work, and for many good times besides.

I am very grateful to the staff and students of the Laboratoire J.-A. Dieudonné at the Université de Nice et Sophia-Antipolis for their hospitality and generosity of time and ideas. I thank in particular Arnaud Beauville, André Hirschowitz and Charles Walter.

Thanks to the many people involved with the courses and workshops in which I have participated both in Durham and Nice, for their constant help and good humour.

I renew my thanks to Miles Reid, who has given generously of his expertise, wisdom and practical support over the course of my postgraduate studies.

I am grateful to Sundararaman Ramanan for useful discussions and encouragement. In particular, he gave me the statement of Criterion 3.4, which was central to the work in this thesis.

My sincere thanks to the Engineering and Physical Sciences Research Council and the Department of Mathematical Sciences of the University of Durham for financial support which made it possible for me to become a doctoral student. I am

grateful to the Université de Nice et Sophia-Antipolis for granting me the post of Attaché Temporaire d'Enseignement et de Recherche for the academic year 2004-2005, which provided indispensable teaching experience and financial support.

I thank the Universities of Durham, Nice and Warwick and the European Commission for financial support enabling me to attend many conferences and make several research trips during my doctoral studies.

Thanks to Niels Hendriks Abelshus at Universitetet i Oslo for hospitality and generous financial support on several occasions. In particular, I thank Pål H. Johansen and Inger Christin Borge for invitations, and Ragni Piene, Kristian Ranestad and Arne Sletsjøe for useful and enjoyable discussions.

I add my voice to the many others who have thanked M. Imran for preparing the template for this thesis.

I would now like to thank the many other people who have enriched my life with their company and friendship during the last four years. In Durham, I thank in particular Theo Harman, the Speight family and the residents of the beautiful Shincliffe Hall where I was lucky enough to live for over a year; in particular, Dajana Dzanovic, Nada Elzeer, Alistair Hamilton, Chris Joyce and Paul McNulty.

In Nice, I thank all the people who reached out in friendship and helped me settle in. Thanks in particular to my colocataires Fabien Herbaut and Aurélien Chéron for much good company and practical help. I thank Ken and Isabel Letts, Isabelle Dubard and the Doyle family for their friendship and support through some difficult times as well as good ones. Thanks to Georges Elenywaig for his friendship, abundant good humour and many enjoyable talks.

I have spent a good deal of time in Norway since 2003, and during that time it has been my great pleasure to make the acquaintance of the Raddum family, who have extended to me the warmest and most open hospitality and friendship. Tusen hjertelig takk! I also thank Pål H. Johansen, Maria Samuelsen and Inger Christin Borge for many good times.

Love and warm thanks to my parents George and Maura, my sister Elinor, my brother-in-law Féidhlim Harty and my nieces Susie and Kate for all their love and

support, emotional and practical.

The last person I mention is my fiancée Tonje Raddum. Since we met in 2002, Tonje's love, companionship and wisdom have given my life a richness and depth not easily described in words. I look forward with the greatest pleasure to becoming her husband.

Lastly, I thank God for the many gifts He has given me and for making His presence known.

Contents

Abstract	iii
Declaration	iv
Acknowledgements	v
1 Introduction	1
1.1 Symplectic and orthogonal vector bundles	1
1.2 Moduli of vector bundles over curves	3
1.3 Principal bundles and their moduli	6
1.4 Proof of Theorem 1.4	11
2 Singular and semistable loci of $\mathcal{M}_X(\mathrm{Sp}_2 \mathbb{C})$	21
2.1 Stable singular points of $\mathcal{M}_X(\mathrm{Sp}_2 \mathbb{C})$	21
2.2 The semistable boundary of $\mathcal{M}_X(\mathrm{Sp}_2 \mathbb{C})$	24
3 Symplectic and orthogonal extensions	27
3.1 Extensions of vector bundles	27
3.2 Symplectic and orthogonal extensions	31
3.3 Vector subbundles and graphs	34
3.4 A criterion for isotropy	38
4 Vector bundles of rank 2 and degree 1 over curves of genus 2	40
4.1 The moduli space $\mathcal{U}_X(2, 2k + 1)$	40
4.2 Genericity of bundles in $\mathcal{U}_X(2, 1)$	44
4.3 A ruled surface in \mathbb{P}^5	46

5	A cover of $\mathcal{M}_X(\mathrm{Sp}_2 \mathbb{C})$ in genus 2	51
5.1	Statement of the main theorem	51
5.2	Nonstable loci of \mathbb{P}_E^5	53
5.3	Maximal Lagrangian subbundles	56
5.4	The degree of Φ	62
5.5	Future work	65
6	Theta-divisors of symplectic vector bundles	66
6.1	Preliminaries	66
6.2	Theta-divisors of strictly semistable bundles	70
6.3	The genus 2 case	71
A	Results needed in the proof of Theorem 1.4	84
	Bibliography	95

Chapter 1

Introduction

In this chapter, we introduce the objects we will be studying. Throughout this thesis, X will denote a complex projective smooth irreducible curve of genus $g \geq 2$. Later we will focus on the genus 2 case.

The first three sections are expository, and the result in § 1.4 is proven essentially by comparing the definitions of S -equivalence for vector bundles and principal bundles.

Convention: Let Y be a smooth variety and $W \rightarrow Y$ a vector bundle which has local trivialisations

$$\varphi_i: W|_{U_i} \xrightarrow{\sim} U_i \times \mathbb{C}^r$$

over some open cover $\{U_i : i \in J\}$ of Y . Then we denote the transition function $\varphi_j \circ \varphi_i^{-1}|_{\varphi_i(W|_{U_i \cap U_j})}$ by $w_{i,j}$.

Note: All our vector bundles are algebraic.

1.1 Symplectic and orthogonal vector bundles

References for vector bundles include Le Potier [29], Vishwanath [53], Seshadri [47] and Griffiths-Harris [15, Chapters 0, § 5 and 3, § 4] and for curves include Arbarello-Cornalba-Griffiths-Harris [1] and Griffiths-Harris [15, Chapter 2].



Let K be a field and V and M vector spaces over K of dimensions n and 1 respectively. Let $\alpha: \text{Hom}(V, M) \rightarrow V$ be a linear map. Then the *transpose* of α is the unique linear map ${}^t\alpha: \text{Hom}(V, M) \rightarrow V$ such that

$$\phi_1(\alpha(\phi_2)) = \phi_2({}^t\alpha(\phi_1))$$

for all linear maps $\phi_1, \phi_2: V \rightarrow M$. If A is the matrix of α with respect to some basis then the matrix of ${}^t\alpha$ with respect to this basis is just tA . If $M = K$ then ${}^t\alpha$ is naturally identified with the dual map of α .

We show that this notion also makes sense for vector bundles. Let Y be a smooth complex variety, $F \rightarrow Y$ a vector bundle of rank n and $L \rightarrow Y$ a line bundle. Let $\alpha: \text{Hom}(F, L) \rightarrow F$ be a homomorphism of vector bundles over an open set $U \subseteq Y$. Suppose that F and L have transition functions $\{f_{i,j}\}$ and $\{l_{i,j}\}$ respectively relative to an open cover $\{U_i : i \in J\}$ of Y . Then the map α is given by a cochain $\{\alpha_i\}$ of $n \times n$ matrices which satisfy

$$\alpha_i({}^t f_{i,j}^{-1})l_{i,j} = f_{i,j}\alpha_j$$

over $U \cap U_i \cap U_j$. Again, to get the local expression for ${}^t\alpha$ we should take the transposes of the α_i . By the above relation, we have

$$l_{i,j}f_{i,j}^{-1}({}^t\alpha_i) = ({}^t\alpha_j){}^t f_{i,j},$$

equivalently

$${}^t\alpha_i({}^t f_{i,j}^{-1})l_{i,j} = f_{i,j}({}^t\alpha_j)$$

since the $l_{i,j}$ commute with the other transition functions. This shows that the cochain $\{{}^t\alpha_i\}$ defines a map $\text{Hom}(F, L) \rightarrow F$ over U .

Thus in particular it makes sense to speak of symmetric and antisymmetric homomorphisms $\text{Hom}(F, L) \rightarrow F$. We denote these respectively by

$$\text{Sym}(\text{Hom}(F, L), F) \quad \text{and} \quad \bigwedge(\text{Hom}(F, L), F).$$

Remark: Similar statements hold for maps $F \rightarrow \text{Hom}(F, L)$.

A *symplectic* (resp., *orthogonal*) *vector bundle* over X is a pair (W, ω) where $W \rightarrow X$ is a vector bundle and ω is a bilinear nondegenerate antisymmetric (resp.,

symmetric) form on $W \times W$ with values in a line bundle $L \rightarrow X$. Two immediate consequences of the nondegeneracy of ω are:

- There is an antisymmetric (resp., symmetric) isomorphism $W \xrightarrow{\sim} \text{Hom}(W, L)$. In particular, $(\det W)^2 = L^{\text{rk } W}$.
- W is symplectic only if it has even rank, since skew-symmetric matrices have even rank.

We will consider most often bundles of rank $2n$, even if W is orthogonal. If there is no ambiguity we may write just W for (W, ω) . For example, if W is stable then ω is unique up to nonzero multiplicative scalar.

A subbundle of W is *isotropic* if ω restricts to zero on it. For any subbundle $E \subseteq W$, we have the short exact vector bundle sequence

$$0 \rightarrow E^\perp \rightarrow W \rightarrow \text{Hom}(E, L) \rightarrow 0$$

where the surjection is the map $w \mapsto \omega(w, \cdot)|_E$ and

$$E^\perp = \{w \in W : \omega(w, E) = 0\}$$

is the *orthogonal complement* of E . Clearly E is isotropic if and only if $E \subseteq E^\perp$; this shows that the rank of an isotropic subbundle is at most $\frac{1}{2} \text{rk } W$. An isotropic subbundle of maximal rank is called a *Lagrangian* subbundle.

1.2 Moduli of vector bundles over curves

General references for the theory of moduli spaces include Newstead [36] and Seshadri [48]. We will just state the results we need. We begin by recalling the definition of a coarse moduli scheme (see for example Ramanathan [43, p. 307]). Denote by **Sch** and **Set** the categories of schemes over \mathbb{C} and sets respectively and let $\underline{F}: \mathbf{Sch} \rightarrow \mathbf{Set}$ be a functor. Then a *coarse moduli scheme* for \underline{F} is a scheme \mathcal{M} and a natural transformation $\Psi: \underline{F} \rightarrow \text{Mor}(-, \mathcal{M})$ satisfying the following properties:

1. There is a bijection between closed points of \mathcal{M} and the set $\underline{F}(\text{Spec } \mathbb{C})$.
2. For any natural transformation $\Psi': \underline{F} \rightarrow \text{Mor}(-, Y)$ where Y is a scheme over \mathbb{C} , there is a unique morphism $f: \mathcal{M} \rightarrow Y$ such that the following diagram is commutative:

$$\begin{array}{ccc} \underline{F} & \xrightarrow{\Psi} & \text{Mor}(-, \mathcal{M}) \\ & \searrow \Psi' & \downarrow f \\ & & \text{Mor}(-, Y) \end{array}$$

Recall that the *slope* of a vector bundle $W \rightarrow X$ is the ratio

$$\mu(W) := \frac{\deg W}{\text{rk } W}.$$

Then W is *stable* (resp., *semistable*) if

$$\mu(V) < \mu(W) \quad (\text{resp., } \mu(V) \leq \mu(W))$$

for all proper subbundles $V \subset W$. Stable bundles have a number of useful properties:

Lemma 1.1 *Let V and W be semistable vector bundles over X with $\mu(V) > \mu(W)$. Then $h^0(X, \text{Hom}(V, W)) = 0$. Moreover, if V and W are stable and $\mu(V) \geq \mu(W)$ then*

$$h^0(X, \text{Hom}(V, W)) = \begin{cases} 0 & \text{if } V \not\cong W \\ 1 & \text{if } V \cong W \end{cases}$$

In particular, the only endomorphisms of a stable bundle are homotheties.

Proof

Narasimhan-Ramanan, [35, Lemma 2.1]. \square

A vector bundle $W \rightarrow X$ with $H^0(X, \text{End } W) = \mathbb{C}$ is called *simple*. Note that not every simple bundle is stable.

In order to obtain a nice moduli space, we will need to consider semistable bundles up to so-called *S-equivalence*, which is slightly weaker than isomorphism. It is defined as follows. Let $W \rightarrow X$ be a semistable vector bundle of slope μ . Then it can be shown (see for example Le Potier [29, p. 76]) that W has a filtration

$$0 = W_0 \subset W_1 \subset \cdots \subset W_{k-1} \subset W_k = W$$

where the W_i are (semistable) of slope μ and each quotient $\frac{W_i}{W_{i-1}}$ is a *stable* vector bundle. Then the bundle

$$\bigoplus_{i=1}^k \frac{W_i}{W_{i-1}}$$

is called the *associated graded bundle* of W and denoted $\text{gr}_v W$. Two semistable vector bundles are said to be *S-equivalent* if their associated graded bundles are isomorphic. A vector bundle W is *polystable* if $\text{gr}_v W \cong W$.

Theorem 1.2 (*Moduli of vector bundles*) *Fix integers r and d with $r \geq 0$, and a line bundle $L \rightarrow X$ of degree d .*

(i) *There exist coarse moduli spaces $\mathcal{U}_X(r, d)$ and $\mathcal{SU}_X(r, L)$ for S-equivalence classes of semistable rank r vector bundles over X of degree d and determinant L respectively.*

(ii) *$\mathcal{U}_X(r, d)$ and $\mathcal{SU}_X(r, L)$ are irreducible of dimensions, respectively,*

$$r^2(g-1) + 1 \quad \text{and} \quad (r^2 - 1)(g - 1).$$

(iii) *The stable loci are dense in $\mathcal{U}_X(r, d)$ and $\mathcal{SU}_X(r, L)$. The singular locus of $\mathcal{U}_X(r, d)$ consists of exactly the nonstable points except when $r = 2$, $g = 2$ and d is even; in this case it is smooth.*

(iv) *$\mathcal{U}_X(r, d)$ and $\mathcal{SU}_X(r, L)$ are fine moduli spaces (that is, carry universal families) if and only if $\text{gcd}(r, d) = 1$, equivalently, if every bundle in $\mathcal{U}_X(r, d)$ is actually stable.*

Proof

We refer to Le Potier [29, Chaps. 4-8] and Seshadri [47, Chap. 1]. The statements about $\mathcal{SU}_X(r, L)$ can be found in Chap. 1, section VI of the latter. \square

Jacobian varieties

We discuss the rank 1 case briefly. $\mathcal{U}_X(1, d)$ is the Jacobian variety J_X^d parametrising isomorphism classes of line bundles of degree d over X . References for this subject include Birkenhake-Lange [11, Chap. 11] and Griffiths-Harris [15, Chap. 2].

J_X^0 is a principally polarised Abelian variety, and each J_X^d is a torsor over J_X^0 by the action defined by tensor product. J_X^d is a fine moduli space since there exist Poincaré bundles over $J_X^d \times X$.

We will often work with J_X^{g-1} . This variety has a distinguished divisor Θ whose support consists of those line bundles of degree $g-1$ which have sections. The line bundle $\mathcal{O}_{J_X^{g-1}}(\Theta)$ is ample, and $h^0(J_X^{g-1}, n\Theta) = n^g$.

For any variety Y , we write K_Y for the canonical bundle of Y when this exists. The Serre involution $\iota: J_X^{g-1} \rightarrow J_X^{g-1}$ is the map $L \mapsto K_X L^{-1}$. This induces an involution on the cohomology of $n\Theta$, and the projectivisations of the $+1$ - and -1 -eigenspaces of this involution are the linear systems of *even* and *odd* $n\Theta$ -divisors respectively, denoted $|n\Theta|_+$ and $|n\Theta|_-$. Clearly the associated maps $J_X^{g-1} \rightarrow |n\Theta|_{\pm}$ factor through the Kummer variety $\text{Kum}_X = J_X^{g-1}/\langle \iota \rangle$.

Moduli of symplectic bundles

The moduli space in which we are interested is that of symplectic vector bundles of rank $2n$ over X , denoted \mathcal{M}_n . Recall that the group $\text{Sp}_n \mathbb{C}$ is the automorphism group of a bilinear nondegenerate antisymmetric form $\mathbb{C}^{2n} \times \mathbb{C}^{2n} \rightarrow \mathbb{C}$. By definition, the transition functions of a symplectic vector bundle belong to some representation of $\text{Sp}_n \mathbb{C}$ at each point of X . Since such matrices have determinant 1, a symplectic vector bundle has trivial determinant, so $\mathcal{M}_n \subseteq \text{SU}_X(2n, \mathcal{O}_X)$. To find out more about \mathcal{M}_n , we use the connection with principal bundles.

1.3 Principal bundles and their moduli

References for principal bundles include Oxbury [37], Balaji [3], Bradlow [10] and Ramanathan [43], [44], [45]. For the theory of algebraic groups, we refer to Springer [52] and Fulton-Harris [13].

Let G be a complex reductive algebraic group. A *principal G -bundle* $E \rightarrow X$ is a variety on which G acts freely on the right with quotient X , and which is locally trivial in the étale topology. Here, local triviality means that there is an open cover

$\{U_i \rightarrow X : i \in J\}$ of X by étale maps $h_i: U_i \rightarrow X$ and a G -equivariant isomorphism

$$\phi_i: h_i^*E \xrightarrow{\sim} U_i \times G.$$

for each $i \in J$. Just as for vector bundles, over all intersections of open sets $U_i \cap U_j$ we get transition functions

$$e_{i,j}: U_i \cap U_j \times G \xrightarrow{\sim} U_i \cap U_j \times G$$

given by $\phi_i \circ \phi_j^{-1}|_{\phi_i(E|_{U_i \cap U_j})}$, which are G -equivariant, and are identified on each fibre with left multiplication by an element of G .

Associated bundles: Let E be a principal G -bundle and Y a quasi-projective variety with an (algebraic) left action of G . Then we define the associated G -bundle $E(Y)$ as the quotient of $E \times Y$ by the G -action

$$(g, (e, y)) \mapsto (e \cdot g, g^{-1} \cdot y).$$

We mention three important cases of this construction.

- **Associated vector bundles:** If G acts on \mathbb{C}^r by a representation then $E(\mathbb{C}^r)$ is a vector bundle of rank r .
- **Extensions of structure group:** If $\alpha: G \rightarrow H$ is a homomorphism of algebraic groups then G acts on H by $g \cdot h = \alpha(g)h$ and we get an H -bundle $E(H)$.
- **Coset space bundles:** Let $H \subseteq G$ be a subgroup such that G/H is a variety (for example, a parabolic subgroup). Then the left coset space G/H is a G -space. We get a bundle $E(G/H) \rightarrow X$ with fibre G/H , which we denote E/H .

Remark: Following Bradlow [10, Lecture 5], we can construct these objects in a slightly more explicit way. Let $\{U_i : i \in J\}$ be an open cover of X over which E is trivial, and $\{e_{i,j}\}$ a corresponding set of transition functions. Then the bundle associated to a G -variety Y can be given by

$$\left(\coprod_{i \in J} U_i \times Y \right) / \{e_{i,j}\}.$$

In particular, the transition functions of $E(Y)$ are just the images of those of E by the action $G \rightarrow \text{Aut } Y$. It follows that the vector bundle associated to a principal $\text{Sp}_n \mathbb{C}$ -bundle via the standard representation $\text{Sp}_n \mathbb{C} \hookrightarrow \text{SL}_{2n} \mathbb{C}$ is a symplectic vector bundle. Later, we shall see an inverse construction.

Sections: Making X into a G -variety via the trivial action, we define a *section* of a principal G -bundle E over an open set $U \subseteq X$ to be a G -equivariant map $s: U \rightarrow E|_U$. It is not hard to see that E admits a section over U if and only if $E|_U$ is trivial.

Now let Y be a G -variety. A section of $E(Y)$ can be given by morphisms $t': E \rightarrow Y$ such that $t'(e \cdot g) = g^{-1} \cdot t'(e)$ and $t: X \rightarrow E \times Y$ of the form $x \mapsto (e, t'(e))$ for some $e \in E|_x$. (The first condition implies that another choice $(eg, t'(eg))$ gives the same point in $E(Y)$.)

Reduction of structure group: Let $H \subset G$ be a subgroup. A *reduction of structure group to H* is a section of the coset space bundle $E(G/H)$. A reduction of structure group to H exists if and only if there is an H -bundle $E' \rightarrow X$ with an isomorphism $E'(G) \xrightarrow{\sim} E$ (see Ramanathan [43, § 2.5]). We give three important cases of this.

- Let $G = \text{GL}_r \mathbb{C}$ and suppose $P \subseteq G$ is a parabolic subgroup. Then the fibre $E(G/P)|_x$ is naturally identified with a Grassmannian of subspaces of $E(\mathbb{C}^r)|_x$ and so a section of $E(G/P)$ is an algebraically varying choice of subspace of constant dimension in each fibre, so we get a vector subbundle.
- If $G = \text{Sp}_n \mathbb{C}$ then a maximal parabolic subgroup P is the stabiliser of an isotropic subspace of \mathbb{C}^{2n} of dimension $k \in \{1, \dots, n\}$. The quotient $\text{Sp}_n \mathbb{C}/P$ is the so-called *Lagrangian Grassmannian* of isotropic subspaces of dimension k (see for example Fulton-Harris [13, Lecture 23.3]). Therefore, a reduction of structure group to P in this case corresponds to an isotropic subbundle.
- This is a slightly more intrinsic way to see that a principal $\text{Sp}_n \mathbb{C}$ -bundle yields a symplectic vector bundle. Given an $\text{Sp}_n \mathbb{C}$ -bundle E , we extend the structure

group to $\mathrm{GL}_{2n}\mathbb{C}$ by an inclusion $\mathrm{Sp}_n\mathbb{C} \hookrightarrow \mathrm{GL}_{2n}\mathbb{C}$. Then we have a $\mathrm{GL}_{2n}\mathbb{C}$ -bundle $E(\mathrm{GL}_{2n}\mathbb{C})$ which admits a reduction of structure group to $\mathrm{Sp}_n\mathbb{C}$, so there is a global section of

$$E(\mathrm{GL}_{2n}\mathbb{C})(\mathrm{GL}_{2n}\mathbb{C}/\mathrm{Sp}_n\mathbb{C}).$$

But the quotient $\mathrm{GL}_{2n}\mathbb{C}/\mathrm{Sp}_n\mathbb{C}$ is naturally identified with the set of nondegenerate symplectic forms on \mathbb{C}^{2n} , so we get a global nondegenerate symplectic form on the associated vector bundle.

Semistability: In order to build a moduli space of principal bundles, again we need to impose a semistability condition. Let $E \rightarrow X$ be a principal G -bundle. Let P be a maximal parabolic subgroup of G and write π for the projection $E/P \rightarrow X$. We have a short exact sequence

$$0 \rightarrow T_{E/P}^{\mathrm{vert}} \rightarrow T_{E/P} \rightarrow \pi^*T_X \rightarrow 0$$

where $T_{E/P}^{\mathrm{vert}}$ is the tangent bundle of E/P along fibres of π . Then E is *stable* (resp., *semistable*) if for every reduction of structure group to a maximal parabolic P we have $\deg(\sigma^*T_{E/P}^{\mathrm{vert}}) > 0$ (resp., ≥ 0).

Remark: Later we will examine the relationship of the (semi)stability of a principal $\mathrm{GL}_r\mathbb{C}$ - or $\mathrm{Sp}_n\mathbb{C}$ -bundle to that of the associated vector bundle. Note that unless otherwise stated, the “associated vector bundle” will always be that corresponding to the standard representation.

We now describe briefly the notion of S -equivalence for principal G -bundles; we refer to Ramanathan [43, § 3] for details. Let E be a semistable principal G -bundle. A reduction of structure group to a parabolic subgroup $P \subseteq G$ is said to be *admissible* if for every character $\chi: P \rightarrow \mathbb{C}^*$ which is trivial on $Z(P)$, the line bundle associated to E via χ is of degree 0. Let M be a maximal reductive subgroup of P . (This is also called a Levi component of P , and is isomorphic to the quotient of P by its unipotent radical.) Then Ramanathan [43, Prop. 3.12] proves that E has an admissible reduction of structure group to a parabolic $P \subseteq G$, which we call E_P , such

that the associated bundle $E_P(M)$ is in fact a stable M -bundle. By the inclusion $M \hookrightarrow G$, we form a G -bundle $(E_P(M))(G)$ which is called the *associated graded bundle of E* and is uniquely determined up to isomorphism by this condition. Then two G -bundles are said to be *S -equivalent* if their graded bundles are isomorphic.

Theorem 1.3 *There exists a coarse moduli space $\mathcal{M}_X(G)$ for S -equivalence classes of semistable principal G -bundles over X , with the following properties:*

- (i) $\mathcal{M}_X(G)$ is normal and of dimension $(g - 1) \dim G + \dim Z(G)$.
- (ii) The connected components of $\mathcal{M}_X(G)$ are irreducible and indexed by the fundamental group of G .
- (iii) Let $E \in \mathcal{M}_X(G)$ be a stable G -bundle. Then there exists a holomorphic neighbourhood of E which is holomorphically isomorphic to a neighbourhood of 0 in

$$\frac{H^1(X, \text{Ad } E)}{\text{Aut } E/Z(G)}$$

where $\text{Ad } E$ is the vector bundle $E(\mathfrak{g})$ associated to the adjoint representation of G on its Lie algebra \mathfrak{g} .

Proof

Ramanathan [43] and [44, Thm. 5.9] for (i) and (ii), and [45, § 4] for (iii). See also Balaji [3] and Balaji-Seshadri [4]. \square

Note: See Gómez and Sols [14] for recent results on moduli of principal bundles over varieties of dimension ≥ 2 .

Now we can describe the moduli space of symplectic vector bundles:

Theorem 1.4 $\mathcal{M}_X(\text{Sp}_n \mathbb{C})$ is naturally a moduli space for S -equivalence classes of semistable symplectic vector bundles of rank $2n$ over X . Moreover, the natural map $\mathcal{M}_X(\text{Sp}_n \mathbb{C}) \rightarrow \mathcal{S}\mathcal{U}_X(2n, \mathcal{O}_X)$ is an injective morphism.

Before proving this theorem, we use it and Thm. 1.3 to say a few things about $\mathcal{M}_X(\text{Sp}_2 \mathbb{C})$ and \mathcal{M}_n .

1. $\mathcal{M}_X(\mathrm{Sp}_n \mathbb{C})$ and \mathcal{M}_n are of dimension $n(2n+1)(g-1)$, since $\dim \mathrm{Sp}_n \mathbb{C} = n(2n+1)$ and the centre of $\mathrm{Sp}_n \mathbb{C}$ is $\{\pm \mathrm{Id}\}$.
2. $\mathrm{Sp}_n \mathbb{C}$ is simply connected, so $\mathcal{M}_X(\mathrm{Sp}_n \mathbb{C})$ and \mathcal{M}_n are irreducible.
3. If E is a stable $\mathrm{Sp}_n \mathbb{C}$ -bundle then it is a singular point of $\mathcal{M}_X(\mathrm{Sp}_n \mathbb{C})$ if and only if it has extra automorphisms¹. We will study this in more detail in Chapter 3.

1.4 Proof of Theorem 1.4

The proof of this theorem is rather long, so we relegate some of the more technical parts to Appendix A.

Notation: Let W be a semistable vector bundle. We denote the associated graded vector bundle of W by $\mathrm{gr}_v W$. On the other hand, let G be a reductive algebraic group and E a semistable principal G -bundle. We denote the associated graded principal G -bundle by $\mathrm{gr}_p E$. We consider the following functors $\mathbf{Sch} \rightarrow \mathbf{Set}$:

$$\begin{aligned} \underline{\mathbf{Fam}}_p: S &\mapsto \left\{ \begin{array}{l} \text{isomorphism classes of families of semistable} \\ \text{principal } \mathrm{Sp}_n \mathbb{C}\text{-bundles parametrised by } S \end{array} \right\} \\ \underline{\mathbf{Fam}}_v: S &\mapsto \left\{ \begin{array}{l} \text{isomorphism classes of families of semistable} \\ \text{symplectic vector bundles of rank } 2n \text{ parametrised by } S \end{array} \right\}. \end{aligned}$$

Our first step is to show that the functor $\underline{\mathbf{Fam}}_v$ is isomorphic to $\underline{\mathbf{Fam}}_p$. Let Y be a smooth variety of any dimension. Denote $\mathbf{Bun}_Y(G)$ the category whose objects are principal G -bundles over Y and whose morphisms are G -bundle isomorphisms. We write $\mathbf{Vect}_Y^{\mathrm{symp}}(2n)$ for the category of symplectic vector bundles over Y , that is, pairs (W, ω) where $W \rightarrow Y$ is a vector bundle of rank $2n$ and ω a symplectic form on W , and whose morphisms are isomorphisms $H: W \rightarrow W'$ such that $H^*\omega' = \omega$.

Theorem 1.5 *The categories $\mathbf{Bun}_Y(\mathrm{Sp}_n \mathbb{C})$ and $\mathbf{Vect}_Y^{\mathrm{symp}}(2n)$ are equivalent.*

¹In the terminology of Laszlo-Sorger [30, p. 27], these are the stable bundles which are not *regularly stable*.

Proof

This is well known; see Appendix A. \square

Now we adapt a result of Ramanan [42] to the symplectic case.

Lemma 1.6 *Let $E \rightarrow X$ be a principal $\mathrm{Sp}_n \mathbb{C}$ -bundle and $E(\mathbb{C}^{2n})$ its associated (symplectic) vector bundle. Then E is a stable (resp., semistable) principal bundle if and only if*

$$\mu(V) < 0 \text{ (resp., } \mu(V) \leq 0)$$

for all isotropic vector subbundles $V \subset E(\mathbb{C}^{2n})$.

Proof

See Ramanathan [45, Remark 3.1]. \square

Lemma 1.7 *Let $E \rightarrow X$ be a principal $\mathrm{Sp}_n \mathbb{C}$ -bundle. Then E is semistable if and only if $W := E(\mathbb{C}^{2n})$ is a semistable vector bundle.*

Proof (adapted from Ramanan [42, § 4])

One implication follows immediately from Lemma 1.6. For the converse, suppose that E is semistable and let F be a subbundle of W . Let $N \subset W$ be the subbundle generated by $F \cap F^\perp$. We have a short exact sequence

$$0 \rightarrow N \rightarrow F \oplus F^\perp \rightarrow M \rightarrow 0 \tag{1.1}$$

where the quotient M is the subbundle of W generated by $F + F^\perp$. We claim that $M = N^\perp$. Since the two bundles have the same rank, it is enough to show that one is contained in the other. Clearly $\omega(F + F^\perp, F \cap F^\perp) = 0$, so $M \subseteq N^\perp$. Thus we can form the short exact sequence

$$0 \rightarrow M \rightarrow W \rightarrow N^* \rightarrow 0, \tag{1.2}$$

whence $\deg M = -\deg N^* = \deg N$. Thus, by (1.1) we have

$$\deg(F \oplus F^\perp) = \deg N + \deg M = 2 \deg N. \tag{1.3}$$

From the short exact sequence

$$0 \rightarrow F^\perp \rightarrow W \rightarrow F^* \rightarrow 0 \tag{1.4}$$

we see $\deg F^\perp = -\deg F^* = \deg F$. Thus $\deg F = \deg N$ by (1.3). Clearly N is isotropic, so by hypothesis and Lemma 1.6 we have $\deg F \leq 0$. \square

By definition, $\underline{\text{Fam}}_p$ and $\underline{\text{Fam}}_v$ are isomorphic functors if for any scheme S over \mathbb{C} , there is a bijection between $\underline{\text{Fam}}_p(S)$ and $\underline{\text{Fam}}_v(S)$ such that for any map of schemes $g: T \rightarrow S$, the following diagram commutes:

$$\begin{array}{ccc} \underline{\text{Fam}}_p(S) & \xrightarrow{g^*} & \underline{\text{Fam}}_p(T) \\ \downarrow \wr & & \downarrow \wr \\ \underline{\text{Fam}}_v(S) & \xrightarrow{g^*} & \underline{\text{Fam}}_v(T) \end{array}$$

Let \mathbf{E} be a principal $\text{Sp}_n \mathbb{C}$ -bundle over $S \times X$ such that $\mathbf{E}|_{\{s\} \times X}$ is a semistable principal $\text{Sp}_n \mathbb{C}$ -bundle over X for all $s \in S$. Then by Lemma 1.7, the associated symplectic vector bundle $\mathbf{E}(\mathbb{C}^{2n})$ defines a class in $\underline{\text{Fam}}_v(S)$. By Theorem 1.5 and Lemma 1.7, this gives a bijection $\underline{\text{Fam}}_p(S) \xrightarrow{\sim} \underline{\text{Fam}}_v(S)$. Now let $g: T \rightarrow S$ be a morphism. To see that the above square commutes, we need to show that

$$g^*(\mathbf{E}(\mathbb{C}^{2n})) \cong (g^*\mathbf{E})(\mathbb{C}^{2n})$$

for any family $\mathbf{E} \rightarrow S \times X$. This follows from looking at the fibre squares defining $g^*(\mathbf{E}(\mathbb{C}^{2n}))$ and $g^*\mathbf{E}$, since fibre products are unique up to unique isomorphism (see for example Hartshorne [17, Thm. II.3.3]).

Thus the functors $\underline{\text{Fam}}_p$ and $\underline{\text{Fam}}_v$ are isomorphic. This shows that $\mathcal{M}_X(\text{Sp}_2 \mathbb{C})$ is naturally a coarse moduli space for semistable symplectic vector bundles of rank $2n$ over X . To see that we get a well-defined injective map $\mathcal{M}_X(\text{Sp}_n \mathbb{C}) \rightarrow \mathcal{S}U_X(2n, \mathcal{O}_X)$, we use the following lemma.

Lemma 1.8 *Two semistable principal $\text{Sp}_n \mathbb{C}$ -bundles are S -equivalent as principal bundles if and only if their associated (symplectic) vector bundles are S -equivalent vector bundles.*

Proof

Let $E \rightarrow X$ be a semistable principal bundle. We will show that

$$\text{gr}_v(E(\mathbb{C}^{2n})) \cong (\text{gr}_p E)(\mathbb{C}^{2n}).$$

We need a technical lemma:

Lemma 1.9 *Let $W \rightarrow X$ be a semistable symplectic vector bundle. Then there exists a filtration*

$$0 = W_0 \subset W_1 \subset \cdots \subset W_k \subseteq W_k^\perp \subset W_{k-1}^\perp \subset \cdots \subset W_1^\perp \subset W_0^\perp = W \quad (1.5)$$

where each W_i is an isotropic subbundle of degree 0 and $\frac{W_i}{W_{i-1}}$ is a stable vector bundle for each $i = 1, \dots, k$. Then the associated graded bundle of this filtration is isomorphic to

$$\bigoplus_{i=1}^k \left(\frac{W_i}{W_{i-1}} \oplus \left(\frac{W_i}{W_{i-1}} \right)^* \right) \oplus \frac{W_k^\perp}{W_k}$$

and is the usual Jordan-Hölder grading of W . Moreover, the symplectic form on W naturally induces a symplectic form on $\text{gr}_v W$.

Proof

See Appendix A. \square

Write $W := E(\mathbb{C}^{2n})$ and consider a filtration of type (1.5). Since the transition functions of E can be taken to be the same as those of W , we see that E has a reduction of structure group to a group P of symplectic matrices of the form

$$\begin{pmatrix} A_1 & * & * & \cdots & & * \\ 0 & A_2 & * & \cdots & & * \\ \vdots & & \ddots & & & * \\ 0 & \cdots & 0 & A_k & * & \cdots & * \\ 0 & & \cdots & 0 & A_{k+1} & * & \cdots & * \\ 0 & & \cdots & & 0 & {}^t A_k^{-1} & & * \\ \vdots & & & & & & \ddots & \vdots \\ 0 & & & \cdots & & & & {}^t A_1^{-1} \end{pmatrix}$$

where $A_i \in \text{GL}_{m_i} \mathbb{C}$ for $i = 1, \dots, k$ and the $A_{k+1} \in \text{Sp}_{m_{k+1}} \mathbb{C}$ for some nonnegative integers m_1, \dots, m_{k+1} . Now P is parabolic since it preserves a flag of isotropic subspaces. (Note that the symplectic form preserved by these matrices is not in general the standard one.)

Write E_P for the P -bundle so obtained. We claim that the unipotent radical of P is the intersection U of P with (our chosen representation of) $\mathrm{Sp}_n \mathbb{C}$ and the group of matrices of the form

$$\begin{pmatrix} I_{m_1} & * & \cdots & * \\ 0 & I_{m_2} & \cdots & * \\ \vdots & \vdots & \ddots & \vdots \\ 0 & 0 & \cdots & I_{m_1} \end{pmatrix}$$

where the identities along the diagonal are of sizes

$$m_1, m_2, \dots, m_{k-1}, m_k, m_{k+1}, m_k, \dots, m_1.$$

To see this², note that there is a homomorphism $P \rightarrow M$ where

$$M := \mathrm{GL}_{m_1} \mathbb{C} \times \cdots \times \mathrm{GL}_{m_k} \mathbb{C} \times \mathrm{Sp}_{m_{k+1}} \mathbb{C}$$

given by

$$\begin{pmatrix} A_1 & * & * & \cdots & * \\ 0 & A_2 & * & \cdots & * \\ \vdots & & \ddots & & * \\ 0 & \cdots & 0 & A_k & * & \cdots & * \\ 0 & & \cdots & 0 & A_{k+1} & * & \cdots & * \\ 0 & & \cdots & & 0 & {}^t A_k^{-1} & & * \\ \vdots & & & & & & \ddots & \vdots \\ 0 & & & \cdots & & & & {}^t A_1^{-1} \end{pmatrix} \mapsto (A_1, A_2, \dots, A_k, A_{k+1}).$$

Clearly this is surjective with kernel U . Since the quotient is reductive, the unipotent radical of P must be contained in U . Since U is a unipotent normal subgroup of P , we get the reverse inclusion also.

Now we show that E_P is an admissible reduction of structure group.

Proposition 1.10 *Let P be a subgroup of the group of invertible matrices of the*

²I am grateful to A. Beauville for this argument.

form

$$\begin{pmatrix} A_1 & * & * & \cdots & * \\ 0 & A_2 & * & \cdots & * \\ \vdots & & \ddots & & \vdots \\ 0 & \cdots & & A_{k-1} & * \\ 0 & \cdots & & 0 & A_k \end{pmatrix}$$

where the $A_i \in \mathrm{GL}_{m_i} \mathbb{C}$ for some m_1, \dots, m_k . (For example, P might preserve a bilinear form.) Then the group of characters of P is generated by the characters of the blocks along the diagonal.

Proof

See Appendix A. \square

By Prop. 1.10, the character group of P is generated by the characters of the groups $\mathrm{GL}_{m_1} \mathbb{C}, \dots, \mathrm{GL}_{m_k} \mathbb{C}, \mathrm{Sp}_{m_{k+1}} \mathbb{C}$. It is well known that these are generated by the determinants. Thus, to check that E_P is an admissible reduction of structure group, it suffices to check that W_i/W_{i-1} is of degree 0 for each $i = 1, \dots, k$ and that W_k^\perp/W_k is of degree 0. But this is clear from the definition of the filtration.

We now check that $E_P(P/U)$ is a stable P/U -bundle. P/U is none other than M , and $E_P(M)$ is the principal bundle whose transition functions are the images in M of the transition functions of E_P .

By for example Ramanathan [43, § 2.9, p. 305], parabolic subgroups of M are in bijection with parabolic subgroups of $\mathrm{Sp}_n \mathbb{C}$ contained in P , and the bijection is given by $Q' \mapsto Q' \cap M$. (The inverse construction is $Q \mapsto Q \cdot U$.) By Fulton-Harris [13, Lecture 23.3], a parabolic subgroup of G contained in P is the stabiliser of a partial flag of isotropic subspaces in \mathbb{C}^{2n} which includes the flag stabilised by P . Hence a parabolic of M is isomorphic to a subgroup of the form

$$Q_1 \times \cdots \times Q_k \times Q_{k+1}$$

where Q_i is a parabolic subgroup of $\mathrm{GL}_{m_i} \mathbb{C}$ for each $i = 1, \dots, k$ and Q_{k+1} is a parabolic subgroup of $\mathrm{Sp}_{m_{k+1}} \mathbb{C}$. Clearly Q is maximal if and only if either

- (1) $Q_{k+1} = \mathrm{Sp}_{m_{k+1}} \mathbb{C}$; for one $j \in \{1, \dots, k\}$ the group Q_j is a maximal parabolic

subgroup of $\mathrm{GL}_{m_j} \mathbb{C}$, and $Q_i = \mathrm{GL}_{m_i} \mathbb{C}$ for all $i \neq j$.

- (2) $Q_i = \mathrm{GL}_{m_i} \mathbb{C}$ for all $i \in \{1, \dots, k\}$ and Q_{k+1} is a maximal parabolic subgroup of $\mathrm{Sp}_{m_{k+1}} \mathbb{C}$.

Now let $\sigma: X \rightarrow E_P(M)/Q$ be a reduction of structure group to Q . Suppose Q is of type (1). Write π for the projection $E_P(M)/Q \rightarrow X$. There is a short exact sequence

$$0 \rightarrow T_{E_P(M)/Q}^{\mathrm{vert}} \rightarrow T_{E_P(M)/Q} \rightarrow \pi^* T_X \rightarrow 0 \quad (1.6)$$

and we must show that $\deg(\sigma^* T_{E_P(M)/Q}^{\mathrm{vert}}) > 0$.

Now recall that $E_P(M)/Q$ is the bundle associated to the M -space M/Q . We notice that the action of M on M/Q factorises via the projection $M \rightarrow \mathrm{GL}_{m_j} \mathbb{C}$.

Proposition 1.11 *Let $E \rightarrow X$ be a principal G -bundle and Y a G -variety. Suppose that there exists a homomorphism of algebraic groups $\nu: G \rightarrow H$ such that the action of G on Y factorises as follows:*

$$\begin{array}{ccc} G & \xrightarrow{\rho} & \mathrm{Aut} Y \\ & \searrow \nu & \nearrow \rho' \\ & H & \end{array}$$

Then there is an isomorphism $E(Y) \xrightarrow{\sim} (E(H))(Y)$, where Y is an H -space via ρ' .

Proof

Suppose that $\{e_{i,j}\}$ is a set of transition functions for E . The transition functions of $E(H)$ are $\{\nu(e_{i,j})\}$ and those of $(E(H))(Y)$ are $\{\rho'(\nu(e_{i,j}))\} = \{\rho(e_{i,j})\}$. But these are just the transition functions of $E(Y)$. \square

Now $M/Q \cong \mathrm{GL}_{m_j} \mathbb{C}/Q_j$. Hence by Prop. 1.11, we have an isomorphism

$$E_P(M)(M/Q) \xrightarrow{\sim} (E_P(M)(\mathrm{GL}_{m_j} \mathbb{C}))(\mathrm{GL}_{m_j} \mathbb{C}/Q_j),$$

that is, $E_P(M)/Q \xrightarrow{\sim} E_j/Q_j$, where we write E_j for the $\mathrm{GL}_{m_j} \mathbb{C}$ -bundle

$$(E_P(M))(\mathrm{GL}_{m_j} \mathbb{C})$$

obtained by extension of structure group by the projection $\nu: M \rightarrow \mathrm{GL}_{m_j} \mathbb{C}$. Therefore we can replace the exact sequence (1.6) with

$$0 \rightarrow T_{E_j/Q_j}^{\mathrm{vert}} \rightarrow T_{E_j/Q_j} \rightarrow \pi^* T_X \rightarrow 0$$

and show that $\deg(\sigma^* T_{E_j/Q_j}^{\mathrm{vert}}) > 0$, equivalently, that E_j is a stable $\mathrm{GL}_{m_j} \mathbb{C}$ -bundle.

Proposition 1.12 *Let $E \rightarrow X$ be a principal $\mathrm{GL}_r \mathbb{C}$ -bundle. Then E is (semi)stable if and only if the vector bundle $E(\mathbb{C}^r)$ associated to the standard representation of $\mathrm{GL}_r \mathbb{C}$ is a (semi)stable vector bundle.*

Proof

This is well known; see Appendix A. \square

But by inspecting the transition functions of $E_P(M)$, we see that $E_j(\mathbb{C}^{m_j})$ is just $\frac{W_i}{W_{i-1}}$. By construction, this is a stable vector bundle. By Prop. 1.12, then, E_j is a stable principal $\mathrm{GL}_{m_j} \mathbb{C}$ -bundle and we are done.

Now suppose that Q is of type (2). By a similar argument, we reduce to showing that the $\mathrm{Sp}_{m_{k+1}} \mathbb{C}$ -bundle

$$E_P(M)(\mathrm{Sp}_{m_{k+1}} \mathbb{C})$$

is a stable principal $\mathrm{Sp}_{m_{k+1}} \mathbb{C}$ -bundle. Again by inspecting the transition functions of $E_P(M)$, we see that this is the symplectic frame bundle of $\frac{W_k^\perp}{W_k}$. By construction (and see the proof of Lemma 1.9), this vector bundle has no isotropic subbundles of degree 0, so is associated to a stable $\mathrm{Sp}_{m_{k+1}} \mathbb{C}$ -bundle.

In summary, $E_P(M)$ is a stable M -bundle. We extend the structure group of $E_P(M)$ to $\mathrm{Sp}_n \mathbb{C}$ by the inclusion $M \hookrightarrow \mathrm{Sp}_n \mathbb{C}$; the extended bundle $(E_P(M))(\mathrm{Sp}_n \mathbb{C})$ is $\mathrm{gr}_p E$, by definition. Comparing transition functions, we have

$$(\mathrm{gr}_p E)(\mathbb{C}^{2n}) \cong \bigoplus_{i=1}^k \left(\frac{W_i}{W_{i-1}} \oplus \left(\frac{W_i}{W_{i-1}} \right)^* \right) \oplus \frac{W_k^\perp}{W_k} \cong \mathrm{gr}_v W = \mathrm{gr}_v (E(\mathbb{C}^{2n})). \quad (1.7)$$

We need one more technical result to finish.

Lemma 1.13 *Let $W \rightarrow X$ be a polystable symplectic vector bundle. Then any two symplectic forms on W are related by an automorphism of W .*

Proof

See Appendix A. \square

Now let E and E' be principal $\mathrm{Sp}_n \mathbb{C}$ -bundles. Then

$$\begin{aligned} E \text{ is } S\text{-equivalent to } E' &\iff \mathrm{gr}_p E \cong \mathrm{gr}_p E' \text{ by definition} \\ &\iff (\mathrm{gr}_p E)(\mathbb{C}^{2n}) \cong (\mathrm{gr}_p E')(\mathbb{C}^{2n}) \\ &\quad \text{as symplectic vector bundles by Thm. 1.5} \\ &\iff \mathrm{gr}_v (E(\mathbb{C}^{2n})) \cong \mathrm{gr}_v (E'(\mathbb{C}^{2n})) \text{ as symplectic vector} \\ &\quad \text{bundles, by (1.7).} \end{aligned}$$

This implies that the vector bundles $E(\mathbb{C}^{2n})$ and $E'(\mathbb{C}^{2n})$ are S -equivalent. Conversely, if $\mathrm{gr}_v (E(\mathbb{C}^{2n}))$ and $\mathrm{gr}_v (E'(\mathbb{C}^{2n}))$ are isomorphic as vector bundles then by Lemma 1.13 they are in fact isomorphic as *symplectic* vector bundles. Reversing the above chain of equivalences, we see that the principal bundles E and E' are S -equivalent.

This establishes Lemma 1.8. \square

In summary, we have shown that $\mathcal{M}_X(\mathrm{Sp}_2 \mathbb{C})$ is naturally a moduli space for S -equivalence classes of semistable vector bundles of rank $2n$ over X which have a symplectic structure. To finish the proof of Thm. 1.4, we consider the map $\mathcal{M}_X(\mathrm{Sp}_n \mathbb{C}) \rightarrow \mathcal{S}\mathcal{U}_X(2n, \mathcal{O}_X)$ taking a principal $\mathrm{Sp}_n \mathbb{C}$ -bundle to its associated vector bundle, equivalently, the forgetful map $(W, \omega) \mapsto W$. By Lemma 1.8, it is a well-defined and injective morphism. By Theorem 1.5 and Lemma 1.7, it is surjective to $\mathcal{M}_n \subseteq \mathcal{S}\mathcal{U}_X(2n, \mathcal{O}_X)$.

This completes the proof of Thm. 1.4. \square

I am interested in studying the map $\mathcal{M}_X(\mathrm{Sp}_n \mathbb{C}) \rightarrow \mathrm{SU}_X(2n, \mathcal{O}_X)$ further. In particular, I would like to know whether it is an embedding, and to study its differential.

Overview

The goal of this thesis will be to study the geometry of $\mathcal{M}_X(\mathrm{Sp}_2 \mathbb{C})$. In the next chapter, we study the singular and strictly semistable loci of $\mathcal{M}_X(\mathrm{Sp}_2 \mathbb{C})$ for a curve of genus g . We then digress slightly to develop some properties of symplectic extensions and isotropic subbundles. Following this, we look at the genus 2 case: after giving some technical results on vector bundles of rank 2 and degree 1 over a curve of genus 2, we show how $\mathcal{M}_X(\mathrm{Sp}_2 \mathbb{C})$ can in this instance be covered by projectivised extension spaces, in the spirit of Narasimhan-Ramanan [34]. We conclude by giving some results on theta-divisors of symplectic vector bundles: we use the aforementioned covering to prove that a general rank 4 symplectic vector bundle over a curve of genus 2 possesses a theta-divisor, and characterise those with singularities.

Note: Since $\mathrm{Sp}_n \mathbb{C}$ is a special group in the sense of Serre, all principal $\mathrm{Sp}_n \mathbb{C}$ -bundles are in fact locally trivial in the Zariski topology; see for example Sorger [50, Remark 2.1.2]. This is important as we will often use local coordinates.

Chapter 2

Singular and semistable loci of

$\mathcal{M}_X(\mathrm{Sp}_2 \mathbb{C})$

In this chapter we describe the stable singular locus and semistable boundary of $\mathcal{M}_X(\mathrm{Sp}_2 \mathbb{C})$ for a curve of genus g . We begin by adapting more results on orthogonal bundles in Ramanan [42] to the symplectic case. The description of the stable singular locus of $\mathcal{M}_X(\mathrm{Sp}_2 \mathbb{C})$ then follows easily. For the semistable boundary, we examine all the possibilities for a filtration of type (1.5) for a symplectic vector bundle of rank 4, and show how the corresponding loci in $\mathcal{M}_X(\mathrm{Sp}_2 \mathbb{C})$ fit together.

2.1 Stable singular points of $\mathcal{M}_X(\mathrm{Sp}_2 \mathbb{C})$

We prove a lemma which gives useful information on the structure of the vector bundle associated to a principal $\mathrm{Sp}_n \mathbb{C}$ -bundle.

Lemma 2.1 *Let $E \rightarrow X$ be a principal $\mathrm{Sp}_n \mathbb{C}$ -bundle. Then E is stable if and only if $E(\mathbb{C}^{2n})$ is an orthogonal direct sum of mutually nonisomorphic stable symplectic vector bundles.*

Proof (adapted from Ramanan [42, § 4])

As before, we write $E(\mathbb{C}^{2n}) =: W$. Suppose W is an orthogonal direct sum of stable symplectic vector bundles W_i and let $F \subset W$ be a subbundle of degree 0. Now F is a semistable vector bundle since W is semistable and of degree 0. Since a map

between semistable vector bundles of the same rank and degree is of constant rank, the image of the projection map $F \rightarrow W_i$ is a degree 0 subbundle of W_i . Since each W_i is stable, each of these projections is zero or surjective. Hence F is a direct sum of some of the W_i , so is not isotropic in W . Therefore E is a stable principal bundle by Lemma 1.6.

Conversely, suppose E is a stable principal bundle. Then W is a semistable vector bundle by Lemma 1.6. Suppose $F \subset W$ is a nonzero subbundle of degree 0. By Lemma 1.6 and our hypothesis, F is not isotropic. We have the exact sequence

$$0 \rightarrow N \rightarrow F \oplus F^\perp \rightarrow M \rightarrow 0 \quad (2.1)$$

where N and M are again the subbundles generated by $F \cap F^\perp$ and $F + F^\perp$.

We show $N = 0$. Now $\deg F^\perp = -\deg F^* = \deg F = 0$ by the exact sequence $0 \rightarrow F^\perp \rightarrow W \rightarrow F^* \rightarrow 0$. Hence, by (2.1) we have

$$\deg N + \deg M = \deg F + \deg F^\perp = 0$$

Now if $N \neq 0$ then $\deg N < 0$ by Lemma 1.6 and by hypothesis, since N is isotropic. But then $\deg M > 0$ strictly; this would contradict the semistability of E . Therefore $N = 0$.

This implies that $M = F \oplus F^\perp$. Counting ranks, we see $W = M$, an orthogonal direct sum.

To see that F and F^\perp are mutually nonisomorphic, note that if F were isomorphic to F^\perp then the inclusion $f \mapsto (f, \sqrt{-1}f)$ would give an isotropic subbundle of W of degree 0, contradicting stability of the principal bundle E . Moreover, F and F^\perp are symplectic vector bundles: since $F \cap F^\perp = 0$ and $(F^\perp)^\perp = F$, the form on W is nondegenerate on both F and F^\perp .

If F and F^\perp are stable vector bundles, we're done. If, say, $G \subset F$ is a destabilising subbundle of degree 0 then G is nonisotropic because E is a stable principal $\mathrm{Sp}_n \mathbb{C}$ -bundle. So we can repeat the above procedure to write $F = G \oplus G^\perp$. By induction, we see W has the desired form. \square

Let $E \rightarrow X$ be a stable principal $\mathrm{Sp}_2 \mathbb{C}$ -bundle. By Theorem 1.3 (iii), there is

a neighbourhood of E in $\mathcal{M}_X(\mathrm{Sp}_2 \mathbb{C})$ which is isomorphic to a neighbourhood of 0 in

$$\frac{H^1(X, \mathrm{Ad} E)}{\mathrm{Aut}(E)/\mathbb{Z}_2}$$

since $Z(\mathrm{Sp}_n \mathbb{C}) \cong \mathbb{Z}_2$. A stable bundle is therefore singular only if it has automorphism group strictly bigger than $\{\pm \mathrm{Id}\}$.

Corollary 2.2 *Let $E \rightarrow X$ be a stable $\mathrm{Sp}_n \mathbb{C}$ -bundle and $\mathrm{Aut} E$ the automorphism group of E . Then $\mathrm{Aut} E = \{\pm \mathrm{Id}\}$ if and only if $W := E(\mathbb{C}^{2n})$ is a stable vector bundle.*

Proof (adapted from Ramanan [42, §4])

By Lemma 2.1, the bundle W is an orthogonal direct sum $\bigoplus_{i=1}^r W_i$ for mutually nonisomorphic stable symplectic vector bundles W_1, \dots, W_r . Thus $\mathrm{Aut}(E)$, which is identified with the group of symplectic automorphisms of W by Theorem 1.5, is isomorphic to \mathbb{Z}_2^r . Thus $\mathrm{Aut}(E) = \{\pm \mathrm{Id}\}$ if and only if $r = 1$, that is, W is a stable vector bundle. \square

Theorem 2.3 *Let $E \rightarrow X$ be a stable $\mathrm{Sp}_n \mathbb{C}$ -bundle. Then the following are equivalent:*

- (1) $W := E(\mathbb{C}^{2n})$ is a strictly semistable vector bundle.
- (2) $W = \bigoplus_{i=1}^r W_i$ for mutually nonisomorphic stable symplectic vector bundles W_1, \dots, W_r , with $r > 1$.
- (3) E belongs to the singular locus of the stable part of $\mathcal{M}_X(\mathrm{Sp}_n \mathbb{C})$.

Proof

(1) \Rightarrow (2): By Lemma 2.1, we have $W = \bigoplus_{i=1}^r W_i$, an orthogonal direct sum of mutually nonisomorphic stable vector bundles. Since semistability is strict, $r > 1$.

(2) \Rightarrow (3): In this case $\mathrm{Aut}(E) \cong \mathbb{Z}_2^r$ with $r > 1$. By Thm. 1.3 (iii), there is a neighbourhood of E in $\mathcal{M}_X(\mathrm{Sp}_n \mathbb{C})$ which is (holomorphically) isomorphic to $H^1(X, \mathrm{Ad} E)/\Gamma$ where $\Gamma \cong \mathbb{Z}_2^{r-1}$. This means that there is a finite-sheeted branched covering of a neighbourhood of E by a domain in some \mathbb{C}^N whose branch locus is

contained in the set of bundles with extra automorphisms. It is not hard to show that this set has codimension at least 2. Therefore, by Prill [41, Thm. 1], the bundle E is a singular point of $\mathcal{M}_X(\mathrm{Sp}_n \mathbb{C})$.

(3) \Rightarrow (1): By Theorem 1.3 (iii), we see that $\mathrm{Aut}(E)$ is bigger than $\{\pm \mathrm{Id}\}$. Hence W is strictly semistable by Corollary 2.2. \square

Corollary 2.4 *Let $E \rightarrow X$ be a stable $\mathrm{Sp}_2 \mathbb{C}$ -bundle. Then E is a singular point of $\mathcal{M}_X(\mathrm{Sp}_2 \mathbb{C})$ if and only if $E(\mathbb{C}^{2n}) = W_1 \oplus W_2$ for stable, mutually nonisomorphic $W_1, W_2 \in \mathcal{SU}_X(2, \mathcal{O}_X)$.*

Proof

By Theorem 2.3, the bundle E is singular if and only if $E(\mathbb{C}^{2n})$ is a direct sum of at least two mutually nonisomorphic stable symplectic vector bundles. Since all line subbundles of W are isotropic, the summands must have rank at least 2. The result follows because $E(\mathbb{C}^{2n})$ is of rank 4. \square

Conclusion: The stable singular locus of $\mathcal{M}_X(\mathrm{Sp}_2 \mathbb{C})$ is the image of the complement of the diagonal in the second symmetric product of the stable part of $\mathcal{SU}_X(2, \mathcal{O}_X)$ by the map $(W_1, W_2) \mapsto W_1 \oplus W_2$. Thus it has dimension $6g - 6$ by Theorem 1.2 (ii).

2.2 The semistable boundary of $\mathcal{M}_X(\mathrm{Sp}_2 \mathbb{C})$

In this section we characterise the S -equivalence classes in $\mathcal{M}_X(\mathrm{Sp}_2 \mathbb{C})$ corresponding to vector bundles containing an isotropic subbundle of degree 0, that is, vector bundles associated to strictly semistable principal $\mathrm{Sp}_2 \mathbb{C}$ -bundles.

By Lemma 1.9, we can find the graded vector bundles associated to points in the semistable boundary by considering just the possible filtrations of a rank 4 symplectic bundle by isotropic subbundles of degree 0 and their orthogonal complements. There are three possibilities:

1. $0 \subset L \subset L^\perp \subset W$ where L is a line subbundle of degree 0

2. $0 \subset F = F^\perp \subset W$ where F is Lagrangian of degree 0
3. $0 \subset L \subset F = F^\perp \subset L^\perp \subset W$ where L and F are isotropic of degree 0 and ranks 1 and 2 respectively

The corresponding graded bundles are

1. $L \oplus L^{-1} \oplus V$ where $V = \frac{L^\perp}{L}$ is a stable symplectic vector bundle of rank 2
2. $F \oplus F^*$: since F is Lagrangian, $\frac{W}{F} \cong F^*$
3. $L \oplus L^{-1} \oplus M \oplus M^{-1}$ where $M = \frac{F}{L}$

Conversely, it is easy to see that every such direct sum carries a symplectic form. We list the components of the semistable boundary of $\mathcal{M}_X(\mathrm{Sp}_2 \mathbb{C})$. In the following table, L_1 and L_2 are distinct points of J_X^0 and F is a stable point of $\mathcal{U}_X(2, 0)$. We denote by V a stable point of $\mathcal{S}\mathcal{U}_X(2, \mathcal{O}_X)$. Lastly, M_1 and M_2 are distinct points of $J_X^0[2]$, the 2-torsion subgroup of J_X^0 . If \mathcal{U} is a moduli space of vector bundles over X , we denote its stable locus by \mathcal{U}^s .

	Polystable rep.	Description	Dimension
A	$L_1 \oplus L_1^{-1} \oplus V$	$\mathrm{Kum}_X \times \mathcal{S}\mathcal{U}_X(2, \mathcal{O}_X)^s$	$4g - 3$
B	$F \oplus F^*$	$\mathcal{U}_X^s(2, 0)/\text{duality}$	$4g - 3$
C	$L_1 \oplus L_1^{-1} \oplus L_2 \oplus L_2^{-1}$	$\mathrm{Sym}^2 \mathrm{Kum}_X$	$2g$
D	$(L_1 \oplus L_1^{-1})^{\oplus 2}$	Kum_X	g
A'	$M_1^{\oplus 2} \oplus V$	$J_X^0[2] \times \mathcal{S}\mathcal{U}_X(2, \mathcal{O}_X)^s$	$3g - 3$
B'	$V \oplus V$	$\mathcal{S}\mathcal{U}_X(2, \mathcal{O}_X)^s$	$3g - 3$
C'	$M_1^{\oplus 2} \oplus L_1 \oplus L_1^{-1}$	$J_X^0[2] \times \mathrm{Kum}_X$	g
C''	$M_1^{\oplus 2} \oplus M_2^{\oplus 2}$	$\mathrm{Sym}^2 J_X^0[2]$	0
C'''	$M_1^{\oplus 4}$	$J_X^0[2]$	0

The diagram overleaf shows how the biggest components intersect.

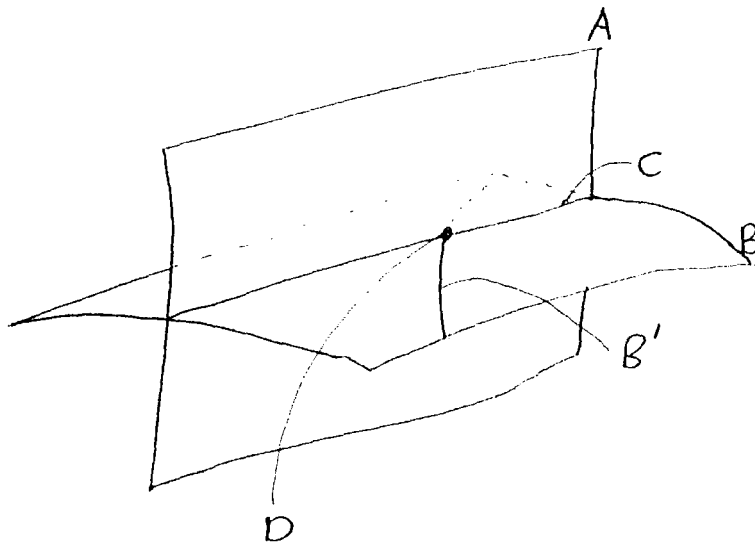

All components except for B are contained in the closure $\mathrm{Sym}^2 \mathrm{SU}_X(2, \mathcal{O}_X)$ of the $(6g - 6)$ -dimensional stable singular locus described in the last section.

Caution: Not every vector bundle S -equivalent to a polystable bundle in the table above carries a symplectic form. For example, let $F \rightarrow X$ be a stable bundle of degree 0, rank 2 and nontrivial determinant. Let W be an extension

$$0 \rightarrow F \rightarrow W \rightarrow F^* \rightarrow 0$$

whose class $\delta(W) \in H^1(X, \mathrm{Hom}(F^*, F))$ is not symmetric; such W exist since $h^1(X, \wedge^2 F) = g - 1 > 0$. Clearly W is S -equivalent to a symplectic bundle of type B in the table. By hypothesis, $\wedge^2 F^* = (\det F)^{-1}$ has no global sections, so F would be isotropic with respect to any symplectic form on W . Therefore, by Criterion 3.4 from the next chapter, there does not exist any symplectic form on W .

Chapter 3

Symplectic and orthogonal extensions

We begin this chapter by reviewing some results on extensions of vector bundles, and describe the sheaves of sections of such extensions. We then prove some technical results which will be used later. The most important is Criterion 3.4, which gives in particular a method of constructing a rank $2n$ symplectic or orthogonal extension from a given vector bundle of rank n . We then generalise a result of Mukai to describe almost all rank n subbundles of such an extension, with a criterion for isotropy. We conclude by adapting this criterion to a particular case which will be studied in a later chapter.

§ 3.1 contains generalisations of results in Kempf [19, Chapter 6] on extensions of invertible sheaves to the case of arbitrary rank. Criterion 3.4 was suggested by S. Ramanan (the proof is my own). For the rest of the chapter, we apply these results to the generalisation of Mukai [32, Example 1.7] to the case where the extension may not split. Some of this work can be found in Hitching [18].

3.1 Extensions of vector bundles

References for this subject include Seshadri [47, Appendix II], Narasimhan-Ramanan [35] and Atiyah [2]. The approach we shall follow, however, is that of Kempf [19, Chapter 6].

Notation: Let X be a complex projective smooth irreducible curve of genus g . We denote the sheaf of sections of a vector bundle $(E, F, W$ etc.) over X by the corresponding script letter $(\mathcal{E}, \mathcal{F}, \mathcal{W}$ etc.) For a vector bundle $V \rightarrow X$, we have an exact sequence of \mathcal{O}_X -modules

$$0 \rightarrow \mathcal{V} \rightarrow \underline{\text{Rat}}(V) \rightarrow \underline{\text{Prin}}(V) \rightarrow 0$$

where $\underline{\text{Rat}}(V)$ is the sheaf of rational sections of V and $\underline{\text{Prin}}(V)$ the sheaf of principal parts with values in V . We denote their groups of global sections by $\text{Rat}(V)$ and $\text{Prin}(V)$ respectively. The sheaves $\underline{\text{Rat}}(V)$ and $\underline{\text{Prin}}(V)$ are flasque, so we have the cohomology sequence

$$0 \rightarrow H^0(X, V) \rightarrow \text{Rat}(V) \rightarrow \text{Prin}(V) \rightarrow H^1(X, V) \rightarrow 0. \quad (3.1)$$

We denote \bar{s} the principal part of $s \in \text{Rat}(V)$, and we write $[p]$ for the class in $H^1(X, V)$ of $p \in \text{Prin}(V)$.

Now let E and F be vector bundles over X . We shall consider short exact sequences of the form

$$0 \rightarrow E \rightarrow W \rightarrow F \rightarrow 0. \quad (3.2)$$

Two such extensions W and W' of F by E are said to be isomorphic if there is a vector bundle isomorphism $W \xrightarrow{\sim} W'$ which induces the identity on E and F . We want to classify extensions of F by E up to isomorphism. The basic tool is the notion of the cohomology class of an extension. Applying $\text{Hom}(F, -)$ to (3.2), we form the cohomology sequence

$$\cdots \rightarrow H^0(X, \text{End } F) \rightarrow H^1(X, \text{Hom}(F, E)) \rightarrow \cdots$$

The *class of the extension* W is defined to be the image $\delta(W)$ of the identity map on F in $H^1(X, \text{Hom}(F, E))$. This has been much studied. Following Kempf [19, Chap. 6], we will formulate the notion in terms of the sheaves of sections of E and F , as this will be useful later.

We begin by characterising those locally free \mathcal{O}_X -submodules of $\underline{\text{Rat}}(E) \oplus \underline{\text{Rat}}(F)$ that are the sheaves of sections of extensions of F by E . It is not hard to see that

this is equivalent to \mathcal{W} having the following two properties (here π is the projection of $\underline{\text{Rat}}(E) \oplus \underline{\text{Rat}}(F)$ onto the second summand):

$$(1) \quad \mathcal{W} \cap (\underline{\text{Rat}}(E) \oplus \{0\}) = \mathcal{E} \oplus \{0\}$$

$$(2) \quad \pi(\mathcal{W}) = \mathcal{F}$$

Such \mathcal{W} can be built using principal parts as follows. Let p be a global section of $\underline{\text{Prin}}(\text{Hom}(F, E))$ and consider the \mathcal{O}_X -module \mathcal{W}_p defined, by analogy with Kempf [19, p. 46], as

$$U \mapsto \{(e, f) \in \underline{\text{Rat}}(E)(U) \oplus \mathcal{F}(U) : \bar{e} = p(f)\}.$$

One easily checks that this satisfies the required properties. The next lemma shows that in fact this is the whole story.

Lemma 3.1 *Let W be an extension of F by E . Then W is of the form \mathcal{W}_p for some uniquely defined $p \in \text{Prin}(\text{Hom}(F, E))$, and the correspondence $p \leftrightarrow \mathcal{W}_p$ is a bijection between $\text{Prin}(\text{Hom}(F, E))$ and the set of extensions of F by E .*

Proof¹

By (2), we have $\mathcal{W} \subseteq \underline{\text{Rat}}(E) \oplus \mathcal{F}$. Let q be the canonical map

$$\underline{\text{Rat}}(E) \oplus \mathcal{F} \rightarrow \underline{\text{Prin}}(E) \oplus \mathcal{F}$$

given by $(e, f) \mapsto (\bar{e}, f)$. We denote by $\hat{\pi}$ the projection of $\underline{\text{Prin}}(E) \oplus \mathcal{F}$ onto the second summand.

We show that (1) and (2) imply that $\hat{\pi}|_{q(\mathcal{W})}$ is an isomorphism $q(\mathcal{W}) \xrightarrow{\sim} \mathcal{F}$. Since $\hat{\pi} \circ q = \pi$, property (2) shows that $\hat{\pi}|_{q(\mathcal{W})}$ is surjective. As for injectivity: let $(\bar{e}, f), (\bar{e}', f) \in q(\mathcal{W})$. Because $q(\mathcal{W})$ is an \mathcal{O}_X -module, the difference $(\bar{e}, f) - (\bar{e}', f)$ also belongs to $q(\mathcal{W})$, and then

$$(\overline{e - e'}, 0) \in q(\mathcal{W}) \cap (\underline{\text{Prin}}(E) \oplus \{0\}).$$

But property (1) implies that $q(\mathcal{W}) \cap (\underline{\text{Prin}}(E) \oplus \{0\}) = \{0\}$, so $\overline{e - e'} = 0$ and $\bar{e} = \bar{e}'$. Hence $\hat{\pi}|_{q(\mathcal{W})}$ is injective.

¹This proof is my own.

Proposition 3.2 *Let \mathcal{S} and \mathcal{T} be \mathcal{O}_X -modules and Γ an \mathcal{O}_X -submodule of $\mathcal{S} \oplus \mathcal{T}$. Then the projection of Γ to \mathcal{T} is an isomorphism if and only if Γ is the graph of a (necessarily unique) homomorphism of \mathcal{O}_X -modules $\mathcal{T} \rightarrow \mathcal{S}$.*

Proof

If Γ is the graph of an \mathcal{O}_X -module homomorphism then clearly the projection to \mathcal{T} is an isomorphism. Conversely, if we have a diagram

$$\begin{array}{ccc} & \mathcal{S} \oplus \mathcal{T} & \\ & \swarrow p_{\mathcal{S}} & \searrow p_{\mathcal{T}} \\ \mathcal{S} & & \mathcal{T} \end{array}$$

where $p_{\mathcal{T}}|_{\Gamma}$ is an isomorphism then Γ is the graph of $p_{\mathcal{S}} \circ (p_{\mathcal{T}}|_{\Gamma})^{-1}: \mathcal{T} \rightarrow \mathcal{S}$. \square

We return to the proof of Lemma 3.1. By Prop. 3.2, we see that $q(\mathcal{W})$ is the graph of a unique \mathcal{O}_X -module homomorphism $\mathcal{F} \rightarrow \underline{\text{Prin}}(E)$. By the canonical isomorphism

$$\text{Hom}_{\mathcal{O}_X}(\mathcal{F}, \underline{\text{Prin}}(E)) \xrightarrow{\sim} \underline{\text{Prin}}(\text{Hom}(F, E)),$$

there exists a unique $p \in \text{Prin}(\text{Hom}(F, E))$ whose graph $\{(p(f), f) : f \in \mathcal{F}\}$ is $q(\mathcal{W})$.

Now we claim that $q^{-1}(q(\mathcal{W})) = \mathcal{W}$. It suffices to show that $q^{-1}(q(\mathcal{W}))$ satisfies properties (1) and (2). By the definition of q and the remarks just made, we have

$$q^{-1}(q(\mathcal{W})) = \{(e, f) \in \underline{\text{Rat}}(E) \oplus \mathcal{F} : (\bar{e}, f) = (p(f), f)\}$$

which is none other than \mathcal{W}_p , and we have already noticed that this satisfies (1) and (2). Hence $\mathcal{W} = \mathcal{W}_p$. Since p is unique, the association $p \mapsto \mathcal{W}_p$ is a bijection.

This completes the proof of Lemma 3.2. \square

Lemma 3.3 (i) *The boundary map $H^0(X, F) \rightarrow H^1(X, E)$ is given by cup product by the cohomology class $[p]$.*

(ii) *The cohomology class $\delta(\mathcal{W})$ is equal to $[p]$.*

(iii) *Two extensions \mathcal{W}_p and $\mathcal{W}_{p'}$ are isomorphic if and only if $[p] = [p']$.*

Proof

This is proven in Kempf [19, pp. 48-51]) for the case where \mathcal{E} and \mathcal{F} are invertible, and the arguments are readily adapted to the case of arbitrary rank. We will, however, give explicitly the isomorphism $\mathcal{W}_p \xrightarrow{\sim} \mathcal{W}_{p'}$ when $[p] = [p']$ as this will be needed later.

By (3.1), the cohomology classes $[p]$ and $[p']$ are equal if and only if $p' = p + \bar{\beta}$ for some global rational section β of $\text{Hom}(F, E)$. Then the map $\mathcal{W}_p \rightarrow \mathcal{W}_{p'}$ given by $(e, f) \mapsto (e + \beta(f), f)$ is an isomorphism of \mathcal{O}_X -modules which induces the identity on \mathcal{E} and \mathcal{F} .

Lemma 3.3 (iii) shows that isomorphism classes of extensions of F by E are parametrised by $H^1(X, \text{Hom}(F, E))$. However, isomorphism of extensions is stronger than isomorphism of vector bundles. For example, the group $\text{Aut}(E) \times \text{Aut}(F)$ acts on $H^1(X, \text{Hom}(F, E))$ (see for example Le Potier [29, § 7.3]) preserving the isomorphism class of the underlying vector bundle. In particular, for any $\lambda \in \mathbb{C}^*$ the extension with class $\lambda \cdot \delta(W)$ is isomorphic to W as a vector bundle. We will often work with the projectivised extension space $\mathbb{P}H^1(X, \text{Hom}(F, E))$.

Notation: Let V be a vector space of finite dimension over \mathbb{C} and let v be a nonzero element of V . Then we write $\langle v \rangle$ for the class determined by v in $\mathbb{P}V$.

3.2 Symplectic and orthogonal extensions

Let $L \rightarrow X$ be a line bundle and $W \rightarrow X$ a vector bundle of rank $2n$ with an L -valued symplectic or orthogonal form. Suppose $F \subset W$ is a Lagrangian subbundle. Then there is an exact sequence

$$0 \rightarrow F \rightarrow W \rightarrow \text{Hom}(F, L) \rightarrow 0$$

since $F = F^\perp$. Conversely, it is natural to ask for which extension classes

$$\delta(W) \in H^1(X, \text{Hom}(\text{Hom}(F, L), F))$$

such a sequence is induced by a bilinear antisymmetric or symmetric form. We have the following criterion.

Criterion 3.4 *An extension $0 \rightarrow F \rightarrow W \rightarrow \text{Hom}(F, L) \rightarrow 0$ carries a symplectic (resp., orthogonal) structure with respect to which F is isotropic if and only if W is isomorphic as a vector bundle to an extension whose cohomology class belongs to $H^1(X, \text{Sym}(\text{Hom}(F, L), F))$ (resp., $H^1(X, \wedge(\text{Hom}(F, L), F))$).*

Proof

We prove the criterion for the symplectic case; the orthogonal case is practically identical. Firstly, suppose $\delta(W)$ is actually symmetric. By Lemma 3.1, there exists $p \in \text{Prin}(\text{Hom}(\text{Hom}(F, L), F))$ such that the sheaf \mathcal{W} is of the form

$$\{(e, \phi) \in \underline{\text{Rat}}(F) \oplus \text{Hom}_{\mathcal{O}_X}(\mathcal{F}, \mathcal{L}) : \bar{e} = p(\phi)\} =: \mathcal{W}_p. \quad (3.3)$$

To say that $\delta(W) = [p]$ is symmetric is to say that

$${}^t p - p = \bar{\alpha}$$

for some $\alpha \in \text{Rat}(\text{Hom}(\text{Hom}(F, L), F))$. Replacing p by $p + \frac{\bar{\alpha}}{2}$ if necessary, which by Lemma 3.3 (iii) does not change the isomorphism class of the extension, we can assume that ${}^t p = p$.

Now we define a $\underline{\text{Rat}}(L)$ -valued bilinear nondegenerate antisymmetric form

$$\omega: (\underline{\text{Rat}}(F) \oplus \underline{\text{Rat}}(\text{Hom}(F, L)))^{\times 2} \rightarrow \underline{\text{Rat}}(L)$$

by $\omega((f_1, \phi_1), (f_2, \phi_2)) = \phi_1(f_2) - \phi_2(f_1)$. By (3.3), for any $(f_1, \phi_1), (f_2, \phi_2) \in \mathcal{W}_p$, the principal part

$$\begin{aligned} \overline{\omega((f_1, \phi_1), (f_2, \phi_2))} &= \phi_1(p(\phi_2)) - \phi_2(p(\phi_1)) \\ &= \phi_2({}^t p - p)(\phi_1) \end{aligned}$$

which is zero since p is symmetric. Thus ω is regular on $\mathcal{W}_p \times \mathcal{W}_p$. It is clearly \mathcal{O}_X -bilinear and nondegenerate, and \mathcal{F} is isotropic. Thus ω induces a global regular bilinear antisymmetric form $W \times W \rightarrow L$ with the required properties.

For the general case, we note that ω pulls back to give the required symplectic structure to any vector bundle isomorphic to W , which need not be isomorphic as an extension.

Conversely, suppose that W carries a symplectic form ω with respect to which F is isotropic. Choose transition functions $\{f_{i,j}\}$ and $\{l_{i,j}\}$ for F and L respectively over an open cover $\{U_i : i \in J\}$ of X . Then the transition functions of $\text{Hom}(F, L)$ are $\{{}^t f_{i,j}^{-1} l_{i,j}\}$ and there exist trivialisations for W over $\{U_i\}$ whose transition functions are of the form

$$w_{i,j} = \begin{pmatrix} f_{i,j} & \delta_{i,j} \\ 0 & {}^t f_{i,j}^{-1} l_{i,j} \end{pmatrix}$$

where $\delta(W)$ is defined by the 1-cocycle $\{\delta_{i,j}\}$.

Now ω is given with respect to $\{U_i\}$ by a cochain $\{\Omega_i\}$ of antisymmetric matrices which satisfy

$$({}^t l_{i,j}^{-1}) {}^t w_{i,j} \Omega_i w_{i,j} = \Omega_j \quad (3.4)$$

on the intersection $U_i \cap U_j$ for all $i, j \in J$, since ω induces a homomorphism

$$W \rightarrow \text{Hom}(W, L).$$

We write

$$\Omega_i = \begin{pmatrix} A_i & B_i \\ -{}^t B_i & C_i \end{pmatrix}$$

where $\{A_i\}$, $\{B_i\}$ and $\{C_i\}$ are $M_{n,n}(\mathbb{C})$ -valued cochains and all the A_i and C_i are antisymmetric. Firstly, we have $A_i \equiv 0$ for all i because $F \subset W$ is isotropic.

Expanding condition (3.4), we see that

$$B_i ({}^t f_{i,j}^{-1}) = ({}^t f_{i,j}^{-1}) B_j,$$

so $\{B_i\}$ defines an endomorphism of F^* and also of $\text{Hom}(F, L)$. Since all the A_i are zero but the form is nondegenerate, this must have rank n , so is an automorphism.

Also by (3.4), we have

$${}^t \delta_{i,j} B_i ({}^t f_{i,j}^{-1}) - f_{i,j}^{-1} ({}^t B_i) \delta_{i,j} = C_j - f_{i,j}^{-1} C_i l_{i,j} ({}^t f_{i,j}^{-1}).$$

(Although a priori ${}^t B_i \delta_{i,j}$ and ${}^t \delta_{i,j} B_i$ map between different spaces, the transpose of ${}^t B_i \delta_{i,j}$ is in fact defined by ${}^t \delta_{i,j} B_i$ by the discussion in Chapter 1, § 1.) This shows that the difference between the cocycle $\{{}^t B_i \delta_{i,j}\}$ and its transpose is cohomologically trivial. Hence the cohomology class defined by $\{{}^t B_i \delta_{i,j}\}$ belongs to

$H^1(X, \text{Sym}(\text{Hom}(F, L), F))$, and this class belongs to the same orbit as the class of $\delta(W)$ under the action of $\text{Aut}(F)$ on $H^1(X, \text{Hom}(\text{Hom}(F, L), F))$, so the extensions are isomorphic as vector bundles. \square

Remarks

1. For any $\beta \in \text{Rat}(\text{Hom}(\text{Hom}(F, L), F))$, the isomorphism $\mathcal{W}_p \xrightarrow{\sim} \mathcal{W}_{p+\beta}$ described after Lemma 3.3 carries the form ω into the form ω' on $\mathcal{W}_{p+\beta}$ given by

$$\omega'((f_1, \phi_1), (f_2, \phi_2)) = \phi_1(f_2) - \phi_2(f_1) - \phi_2((\beta - {}^t\beta)(\phi_1)).$$

This shows that the symplectic form constructed in the first part of this proof does not depend on the choice of p representing $\delta(W)$.

2. We notice that if $\mu \in H^0(X, \wedge(\text{Hom}(F, L), F))$ is nonzero then the symplectic form is not unique, as we obtain another regular one by adding $\phi_2(\mu(\phi_1))$ to the expression for $\omega((f_1, \phi_1), (f_2, \phi_2))$. However, this situation will rarely arise for us.
3. If W is orthogonal of rank 2 and $F \subset W$ is an isotropic line subbundle then we have $W \cong F \oplus F^{-1}L$ because $\wedge^2 F = 0$.

3.3 Vector subbundles and graphs

Firstly, we recall some linear algebra. Let K be a field and M, V and V' vector spaces over K of dimensions 1, n and n' respectively. If $V' = \text{Hom}(V, M)$ then we can define a bilinear nondegenerate antisymmetric form

$$\omega: (V \oplus \text{Hom}(V, M))^{\times 2} \rightarrow M$$

by

$$\omega((v_1, \psi_1), (v_2, \psi_2)) = \psi_1(v_2) - \psi_2(v_1).$$

The following is a slight generalisation of Mukai [32, Example 1.5].

Lemma 3.5 (i) *There is a bijection between $\text{Hom}_K(V', V)$ and the set of n' -dimensional K -vector subspaces of $V \oplus V'$ which intersect V in zero, given by associating to a map β its graph Γ_β .*

(ii) *The kernel of such β is canonically isomorphic to $\Gamma_\beta \cap (\{0\} \oplus V')$.*

(iii) *If $V' = \text{Hom}(V, M)$ then Γ_β is isotropic with respect to ω if and only if β is symmetric.*

Proof

This is straightforward to check. \square

Now let E and F be vector bundles of rank n and m respectively over X . Consider an extension $0 \rightarrow E \rightarrow W \rightarrow F \rightarrow 0$ with sheaf of sections \mathcal{W}_p and class $\delta(W) = [p] \in H^1(X, \text{Hom}(F, E))$. We want to study vector subbundles $G \subset W$ of rank m whose projection to F is generically surjective.

Now $\text{Rat}(E)$ and $\text{Rat}(F)$ are vector spaces of dimensions n and m respectively over $K(X)$, the field of rational functions on X . The following theorem, globalising Lemma 3.5, is a generalisation of Mukai [32, Example 1.7] to the case where W may be a nontrivial extension.

Theorem 3.6 (i) *There is a bijection*

$$\text{Hom}_{K(X)}(\text{Rat}(F), \text{Rat}(E)) \leftrightarrow \left\{ \begin{array}{l} \text{rank } m \text{ vector subbundles} \\ G \subset W \text{ with } G|_x \cap E|_x = 0 \\ \text{for generic } x \in X \end{array} \right\}$$

The bijection is given by $\beta \leftrightarrow \Gamma_\beta \cap \mathcal{W}_p$; the inclusion of this subsheaf in \mathcal{W}_p in fact corresponds to an injection of vector bundles. Moreover, $\Gamma_\beta \cap \mathcal{W}_p \cong \text{Ker}(p - \bar{\beta})$.

(ii) *$\text{Ker}(\beta|_{\mathcal{G}}) \cong (\Gamma_\beta \cap \mathcal{W}_p) \cap (\{0\} \oplus \mathcal{F})$ (although we will not use this result).*

(iii) *Suppose $F = \text{Hom}(E, L)$ and W is a symplectic extension with sheaf of sections \mathcal{W}_p defined by a symmetric principal part p and symplectic form ω as defined in the proof of Criterion 3.4. Then G is isotropic with respect to ω if and only if ${}^t\beta = \beta$.*

Proof

(i) Let $G \subset W$ be a vector subbundle of rank m intersecting E in zero except at a finite number of points. Then $\text{Rat}(G)$ is a $K(X)$ -vector subspace of

$$\text{Rat}(W) = \text{Rat}(E) \oplus \text{Rat}(F)$$

of dimension m which intersects $\text{Rat}(E)$ in zero. By Lemma 3.5 and the remarks just before this theorem, $\text{Rat}(G)$ is the graph Γ_β of some uniquely determined

$$\beta \in \text{Hom}_{K(X)}(\text{Rat}(F), \text{Rat}(E)).$$

Furthermore, $\mathcal{G} = \Gamma_\beta \cap \mathcal{W}_p$ since a regular section of G is the same thing as a rational section of G which is a regular section of W .

Conversely, we claim that the the association

$$\beta \mapsto \Gamma_\beta \cap \mathcal{W}_p =: \mathcal{G}_\beta$$

defines a subsheaf of \mathcal{W}_p which in fact corresponds to a vector subbundle $G_\beta \subset W$ with the required properties. By the definitions of Γ_β and \mathcal{W}_p , we have

$$\mathcal{G}_\beta = \left\{ (\beta(f), f) \in \underline{\text{Rat}}(E) \oplus \mathcal{F} : p(f) = \overline{\beta(f)} \right\}.$$

This is clearly isomorphic to the kernel of the map

$$(p - \overline{\beta}) : \mathcal{F} \rightarrow \underline{\text{Prin}}(E)$$

via the projection of \mathcal{G}_β onto its image in \mathcal{E} . (The inverse map is $f \mapsto (\beta(f), f)$.) But since any principal part is supported at a finite number of points, $(\mathcal{G}_\beta)_x \cong \mathcal{F}_x$ for all but finitely many $x \in X$. Hence \mathcal{G}_β has rank n and projects surjectively to \mathcal{F} at all but a finite number of points of X .

We now check that \mathcal{G}_β actually corresponds to a vector subbundle of W . The inclusion $\mathcal{G}_\beta \hookrightarrow \mathcal{W}_p$ induces a short exact sequence of \mathcal{O}_X -modules

$$0 \rightarrow \mathcal{G}_\beta \rightarrow \mathcal{W}_p \rightarrow \mathcal{Q} \rightarrow 0$$

where \mathcal{Q} is coherent. Let \mathcal{G}' denote the inverse image in \mathcal{W}_p of the torsion subsheaf of \mathcal{Q} . Clearly \mathcal{G}' contains \mathcal{G}_β . Now \mathcal{G}' corresponds to an injection of vector bundles

$G' \hookrightarrow W$ by Atiyah [2, Prop. 1] since by construction $\mathcal{W}_p/\mathcal{G}'$ is locally free. But in fact $\text{Rat}(G') = \Gamma_\beta$; this is because \mathcal{G}' is contained in $\mathcal{G}_\beta(D)$ for some divisor D on X , so they have the same sheaf of rational sections. Hence $\mathcal{G}' \subseteq \Gamma_\beta \cap \mathcal{W}_p = \mathcal{G}_\beta$, so in fact $\mathcal{G}_\beta = \mathcal{G}'$ corresponds to a vector subbundle $G_\beta \subset W$.

We need to see that the associations

$$\beta (\leftrightarrow \Gamma_\beta \mapsto \Gamma_\beta \cap \mathcal{W}_p) \mapsto G_\beta \tag{A}$$

and

$$G \mapsto (\text{Rat}(G) = \Gamma_\beta \leftrightarrow) \beta \tag{B}$$

are mutually inverse. $B \circ A$ is the identity because $\text{Rat}(G_\beta)$ is clearly contained in Γ_β , hence is equal to it because they are both $K(X)$ -vector spaces of dimension m . Conversely, $A \circ B$ is the identity because $\underline{\text{Rat}}(G) \cap \mathcal{W}_p = \mathcal{G}$ for any subbundle G of W . Thus we have a bijection.

(ii) Suppose $(\beta(g), g) \in \Gamma_\beta \cap \mathcal{W}_p$. Then $\beta(g) = 0$ if and only if

$$(\beta(g), g) \in (\Gamma_\beta \cap \mathcal{W}_p) \cap (\{0\} \oplus \mathcal{F}).$$

(iii) The symplectic form on W is induced by the restriction of

$$\omega: \underline{\text{Rat}}(E \oplus \text{Hom}(E, L))^{\times 2} \rightarrow \underline{\text{Rat}}(L)$$

to $\mathcal{W}_p \times \mathcal{W}_p$, so the criterion for isotropy follows from Lemma 3.5 (iii). \square

Remarks

1. Suppose that $h^0(X, \text{Hom}(F, E)) = 0$. Then principal parts defining the cohomology class $\delta(W) = [p]$ are in bijection with rank n subbundles $G \subset W$ lifting from F via $q \leftrightarrow \text{Ker}(q: \mathcal{F} \rightarrow \underline{\text{Prin}}(E))$. Indeed, by the proof of Thm. 3 (i), the sheaf of sections of G is isomorphic to $\text{Ker}(p - \bar{\beta})$ for some $\beta \in \text{Rat}(\text{Hom}(F, E))$; by (3.1) we have $[p - \bar{\beta}] = [p] = \delta(W)$. Conversely, if $\delta(W) = [q]$ then $q = p - \bar{\beta}$ for some $\beta \in \text{Rat}(\text{Hom}(F, E))$, which is uniquely determined by hypothesis. Then the subsheaf $\text{Ker}(q) \subseteq \mathcal{F}$ lifts to the rank n subsheaf $\Gamma_\beta \cap \mathcal{W}_p$ of \mathcal{W}_p by the map $f \mapsto (\beta(f), f)$; by the proof of Thm. 3 (i) this corresponds to a vector subbundle. It is easy to see that these constructions are mutually inverse.

2. If W is symplectic of rank 2, then Theorem 3 gives another proof of the (obvious) fact that every line subbundle of W is isotropic.

We make an observation:

Lemma 3.7 *The $K(X)$ -linear map β of Theorem 3 (i) is everywhere regular on $\text{Ker}(p - \bar{\beta})$.*

Proof

If the supports of p and $\bar{\beta}$ are disjoint, then this is clear. Suppose the supports coincide at a point $x \in X$. Then the maps

$$p_x, \bar{\beta}_x \text{ and } (p - \bar{\beta})_x \in \text{Hom}_{\mathcal{O}_{X,x}}((\mathcal{G}_\beta)_x, \underline{\text{Prin}}(E_\beta)_x)$$

are given locally by matrices of rational functions on a neighbourhood of x . Since X is of dimension 1, we can assume that the numerators and denominators of each of these functions are relatively prime, and then in fact the denominators determine the maps.

The key point is that by the identity

$$\frac{a}{f} - \frac{b}{h} = \frac{ah - bf}{fh},$$

the denominators of the entries of the matrix $(p - \bar{\beta})_x$ are at worst the products of the corresponding entries of p_x and $\bar{\beta}_x$. Since $\mathcal{G}_\beta \cong \text{Ker}(p - \bar{\beta})$, the value $(p - \bar{\beta})_x(g)$ is regular for any $g \in (\mathcal{G}_\beta)_x$. But for regular functions a, f and h , if $\frac{a}{fh}$ is regular then so is $\frac{a}{h}$. Hence β itself is regular on $(\mathcal{G}_\beta)_x$. \square

3.4 A criterion for isotropy

In this section we specialise to a case we will be studying later. Let $F \rightarrow X$ be a vector bundle of rank n such that $\text{Hom}(F^*, F)$ has no global sections. Let $0 \rightarrow F \rightarrow W \rightarrow F^* \rightarrow 0$ be a symplectic extension with sheaf of sections \mathcal{W}_p for a symmetric principal part p and $G \subset W$ a subbundle of rank n which intersects F generically in rank 0. By the first remark after Thm. 3, the sheaf \mathcal{G} is isomorphic to $\text{Ker}(q)$ for some $q \in \text{Prin}(\text{Hom}(F^*, F))$ such that $\delta(W) = [q]$.

Criterion 3.8 *The subbundle G is isotropic if and only if q is a symmetric principal part².*

Proof

By Theorem 3 (i) we have $\mathcal{G} = \Gamma_\beta \cap \mathcal{W}_p$ for some $\beta \in \text{Rat}(\text{Hom}(F^*, F))$, and $\mathcal{G} \cong \text{Ker}(q)$ where $q = p - \bar{\beta}$.

We claim that β is symmetric if and only if $\bar{\beta}$ is. One direction is clear. Conversely, suppose $\bar{\beta} = {}^t\bar{\beta}$. By (3.1), the difference ${}^t\beta - \beta$ is a global regular section of $\text{Hom}(F^*, F)$, which is zero by hypothesis. Hence β is symmetric.

Thus by Theorem 3 (iii), the subbundle G is isotropic if and only if $\overline{{}^t\beta - \beta} = 0$. Now ${}^tp - p = 0$, so

$${}^tq - q = {}^t(p - \bar{\beta}) - (p - \bar{\beta}) = \overline{\beta - {}^t\beta}.$$

Hence G is isotropic if and only if q is a symmetric principal part. \square

Remark: This result holds with no change of statement if we only assume that ${}^tp - p = \bar{\alpha}$ for some $\alpha \in \text{Rat}(\wedge^2 F^*)$ and work with the symplectic form ω' on \mathcal{W}_p defined by

$$\omega'((f_1, \phi_1), (f_2, \phi_2)) = \phi_1(f_2) - \phi_2(f_1) - \phi_2(\alpha(\phi_1)).$$

The orthogonal case

There are natural analogues to Lemma 3.5 (iii) and Theorem 3 (ii) for the orthogonal case which are proven identically. For Lemma 3.5 (iii), we define a bilinear nondegenerate *symmetric* form θ on $V \oplus \text{Hom}(V, M)^{\times 2}$ by

$$\theta((v_1, \psi_1), (v_2, \psi_2)) = \psi_1(v_2) + \psi_2(v_1)$$

and require β to be antisymmetric instead of symmetric, and similarly in the orthogonal version of Theorem 3. Criterion 3.8 holds if W is an orthogonal extension defined by an antisymmetric principal part p and we ask that q be antisymmetric.

²This is a stronger condition than that the cohomology class defined by q be symmetric.

Chapter 4

Vector bundles of rank 2 and degree 1 over curves of genus 2

Let X be a complex projective smooth irreducible curve of genus 2. In this chapter we give some results on vector bundles of rank 2 and degree 1 over X which will be used in the following chapters.

4.1 The moduli space $\mathcal{U}_X(2, 2k + 1)$

The moduli space $\mathcal{U}_X(2, 2k + 1)$ of vector bundles of rank 2 and degree $2k + 1$ over X is a smooth irreducible variety of dimension 5; see Narasimhan-Ramanan [35], Le Potier [29] and Seshadri [47] for further details.

Firstly, we give another description of $\mathcal{U}_X(2, 2k + 1)$. Let $\mathbf{P}^{k+1} \rightarrow J_X^{k+1} \times X$ and $\mathbf{P}^k \rightarrow J_X^k \times X$ be Poincaré bundles for line bundles over X of degree $k + 1$ and k respectively. There is a diagram

$$\begin{array}{ccc}
 & p^*(\mathbf{P}^{k+1})^{-1} \cdot q^*\mathbf{P}^k & \\
 & \downarrow & \\
 & J_X^{k+1} \times J_X^k \times X & \\
 \swarrow p & & \searrow q \\
 \mathbf{P}^{k+1} \longrightarrow J_X^{k+1} \times X & & J_X^k \times X \longleftarrow \mathbf{P}^k
 \end{array}$$

Let $r: J_X^{k+1} \times J_X^k \times X \rightarrow J_X^{k+1} \times J_X^k$ be the projection. Since $h^1(X, M^{-1}L) = 2$ for

all $(M, L) \in J_X^{k+1} \times J_X^k$, the sheaf

$$R^1 r_* (p^*(\mathbf{P}^{k+1})^{-1} \cdot q^* \mathbf{P}^k) := R$$

is locally free of rank 2 on $J_X^{k+1} \times J_X^k$ by for example Hartshorne [17, Corollary III.12.9]. We consider the associated projective bundle

$$\mathbb{P} R \rightarrow J_X^{k+1} \times J_X^k.$$

By Seshadri [47, App. II], there exists a family of extensions over $\mathbb{P} R \times X$ whose restriction to $\{(\langle \epsilon \rangle, M, L)\} \times X$ is isomorphic as a vector bundle to the extension

$$0 \rightarrow L \rightarrow E \rightarrow M \rightarrow 0$$

defined by $\epsilon \in H^1(X, \text{Hom}(M, L))$. By the moduli property of $\mathcal{U}_X(2, 2k + 1)$, there exists a rational classifying map $\Phi_{\mathbb{P} R}: \mathbb{P} R \dashrightarrow \mathcal{U}_X(2, 2k + 1)$. To analyse this map, we will need the following lemma:

Lemma 4.1 *Consider a diagram of vector bundles over X*

$$\begin{array}{ccccccc} 0 & \longrightarrow & E & \longrightarrow & W & \longrightarrow & F & \longrightarrow & 0 \\ & & & & & & \uparrow f & & \\ & & & & & & V & & \end{array}$$

where the top row is exact. Then f factorises via a map $V \rightarrow W$ if and only if the class $\delta(W)$ of the extension belongs to the kernel of the induced map

$$f^*: H^1(X, \text{Hom}(F, E)) \rightarrow H^1(X, \text{Hom}(V, E)).$$

Proof

Narasimhan-Ramanan [35, Lemma 3.1]. \square

Lemma 4.2 *The map $\Phi_{\mathbb{P} R}$ is a surjective morphism of degree 4.*

Proof

Suppose we have a short exact sequence

$$0 \rightarrow L \rightarrow E \rightarrow M \rightarrow 0 \tag{\delta(E)}$$

and that $L' \subset E$ is another line subbundle of degree k . If $L' \neq L$ then L' must be of the form $M(-x)$ for some point $x \in X$. Conversely, by Lemma 4.1 a map $M(-x) \rightarrow M$ lifts to E if and only if $\delta(E)$ belongs to the kernel of the linear map

$$H^1(X, \text{Hom}(M, L)) \rightarrow H^1(X, \text{Hom}(M(-x), L))$$

induced by the map $M(-x) \rightarrow M$. By Serre duality, this is identified with the restriction map

$$H^0(X, K_X L^{-1} M)^* \rightarrow H^0(X, K_X L^{-1} M(-x))^*$$

induced by $M(-x) \rightarrow M$. Now $\mathbb{P}H^0(X, K_X L^{-1} M)^* = |K_X L^{-1} M|^* = \mathbb{P}^1$, so $\langle \delta(E) \rangle$ can be thought of as the divisor of a section vanishing at three points (counted with multiplicity) $x_1, x_2, x_3 \in X$. So the only degree k subbundles of E are $L, M(-x_1), M(-x_2)$ and $M(-x_3)$, which are not necessarily distinct.

Now we show that distinct extension classes in $\mathbb{P}H^1(X, M^{-1}L)$ give nonisomorphic vector bundles. Another extension E' of M by L , corresponding to a different divisor $x'_1 + x'_2 + x'_3 \in |K_X L^{-1} M|$, admits the line subbundles $L, M(-x'_1), M(-x'_2)$ and $M(-x'_3)$. One sees easily that

$$\#(\{x_1, x_2, x_3\} \cap \{x'_1, x'_2, x'_3\}) \leq 1$$

with equality if and only if $|K_X L^{-1} M|$ has a base point. But $M(-x) \not\cong M(-x')$ if $x \neq x'$, so the extensions E and E' cannot be isomorphic as there is at least one degree k line bundle which belongs to one but not to the other.

In summary, no E is represented in more than 4 fibres of $\mathbb{P}R$ or more than once in any fibre. Therefore, $\Phi_{\mathbb{P}R}$ is finite. Since $\mathcal{U}_X(2, 2k + 1)$ is irreducible, $\Phi_{\mathbb{P}R}$ is dominant since both $\mathbb{P}R$ and $\mathcal{U}_X(2, 2k + 1)$ are of dimension 5. Finally, since every nontrivial extension we have constructed is stable, $\Phi_{\mathbb{P}R}$ is defined everywhere. Thus in fact it is surjective. This completes the proof of the lemma. \square

Note: Lange and Narasimhan [23, Prop. 4.2] prove that a bundle in $\mathcal{U}_X(2, 2k + 1)$ has at most 4 subbundles of degree k .

A more practical statement of Lemma 4.2 is the following:

Lemma 4.3 Every $E \in \mathcal{U}_X(2, 2k + 1)$ fits into 1, 2, 3 or (generically) 4 short exact sequences of the form

$$0 \rightarrow L \rightarrow E \rightarrow M \rightarrow 0 \quad (\delta(E))$$

where L and M are line bundles of degree k and $k + 1$ respectively. \square

We quote a useful result of Narasimhan and Ramanan.

Lemma 4.4 Let V and L be vector bundles of ranks n and 1 respectively, and let $f: L \rightarrow V$ be a homomorphism. Then f factorises via a map $f': L(x) \rightarrow V$ if and only if f is zero at x .

Proof

Narasimhan-Ramanan [35, Lemma 5.3]. \square

Proposition 4.5 Let $E \in \mathcal{U}_X(2, 2k + 1)$. Then for any line bundle $L \rightarrow X$ of degree k , there is at most one linearly independent map $L \rightarrow E$.

Proof

Suppose $h^0(X, \text{Hom}(L, E)) > 0$. Then in fact L is a subbundle of E by Lemma 4.4 and because E is stable, and we have a short exact sequence

$$0 \rightarrow L \rightarrow E \rightarrow M \rightarrow 0$$

where $\deg M = k + 1$. If $h^0(X, \text{Hom}(L, E)) \geq 2$ then L is an elementary transformation of M which lifts to E . Since $h^0(X, \text{Hom}(M, L)) = 0$, by the first remark after Theorem 3 the sheaf \mathcal{L} is isomorphic to $\text{Ker}(q)$ for some $q \in \text{Prin}(\text{Hom}(M, L))$ such that $\delta(E) = [q]$. Comparing degrees, we see that $L = M(-x)$ for some $x \in X$, so q is supported at x where it has a simple pole.

But $\text{Hom}(M, L) \cong \mathcal{O}_X(-x)$, so a section of $\text{Hom}(M, L)$ which is regular apart from a simple pole at x is just a regular section of \mathcal{O}_X . Since \mathcal{O}_X has sections not vanishing at x , we see that q does occur as the principal part of a global rational section of $\text{Hom}(M, L)$. Therefore $[q]$ is zero by (3.1), so E is a trivial extension.

This shows that if E is stable then $h^0(X, \text{Hom}(L, E)) \leq 1$. \square

4.2 Genericity of bundles in $\mathcal{U}_X(2, 1)$

In this section, we show that $h^0(X, E \otimes E) = 0$ for generic $E \in \mathcal{U}_X(2, 1)$, and deduce some facts about such bundles. Firstly, we quote two results from the literature.

Lemma 4.6 *Let $F \rightarrow X$ be a semistable vector bundle. Then $\text{Sym}^p F$ and $\bigwedge^p F$ are semistable of slope $p \cdot \mu(F)$.*

Proof

Le Potier [29, p. 161]. \square

Lemma 4.7 *Every semistable vector bundle F of rank at most 3 and slope 1 over a curve of genus 2 satisfies $h^0(X, M \otimes F) = 0$ for generic $M \in J_X^0$.*

Proof

This is a special case of Raynaud [46, Cor. 1.7.4]. \square

Proposition 4.8 *For generic $E \in \mathcal{U}_X(2, 1)$, the bundle $\text{Hom}(E^*, E)$ has no global sections.*

Proof

We have $h^0(X, \text{Hom}(E^*, E)) = h^0(X, \det(E)) + h^0(X, \text{Sym}^2 E)$, so it suffices to show that the subsets of $\mathcal{U}_X(2, 1)$ where $h^0(X, \det(E)) > 0$ and where $h^0(X, \text{Sym}^2 E) > 0$ are of codimension 1.

Firstly, $h^0(X, \det(E)) > 0$ if and only if $\det(E)$ is effective. The set of such E is the inverse image of $\text{Supp}(\Theta)$ under the map $\det: \mathcal{U}_X(2, 1) \rightarrow J_X^1$. Clearly this map is surjective, so the inverse image of a divisor is a divisor.

As for $\text{Sym}^2 E$: this is of slope $1 = g - 1$, so we expect that if the set

$$\{E \in \mathcal{U}_X(2, 1) : h^0(X, \text{Hom}(E^*, E)) > 0\}$$

is not equal to $\mathcal{U}_X(2, 1)$ then it is the support of a divisor. Since $\mathcal{U}_X(2, 1)$ is irreducible, it suffices to exhibit one E such that $h^0(X, \text{Sym}^2 E) = 0$. Choose any $E \in \mathcal{U}_X(2, 1)$. If $h^0(X, \text{Sym}^2 E) = 0$ then we are done. If not, we note that by Lemma

4.6, the bundle $\text{Sym}^2 E$ is semistable for all $E \in \mathcal{U}_X(2, 1)$. Then since X is of genus 2, by Lemma 4.7 there exists at least one $M \in J_X^0$ such that $h^0(X, M \otimes \text{Sym}^2 E) = 0$. Let N be any square root of M . Since

$$M \otimes \text{Sym}^2 E = N^2 \otimes \text{Sym}^2 E \cong \text{Sym}^2(N \otimes E),$$

by construction the bundle $E' := N \otimes E$, which is stable of degree 1 and rank 2, satisfies $h^0(X, \text{Sym}^2 E') = 0$. This completes the proof of the lemma. \square

Proposition 4.9 *Let $E \rightarrow X$ be a vector bundle of rank 2 and degree 1. Then there exists $\alpha \in H^0(X, \text{Sym}^2 E)$ of generic rank 1 if and only if E has a line subbundle of order 2 in $\text{Pic}^0(X)$.*

Proof

Suppose there exists $\alpha: E^* \rightarrow E$ of generic rank 1. Then the image of \mathcal{E}^* in \mathcal{E} is an invertible sheaf \mathcal{M} . Since E and E^* are stable, in fact this corresponds to a line subbundle $M \subset E$ of degree 0 by Lemma 4.4. Now α factorises as

$$E^* \xrightarrow{\alpha'} M \xrightarrow{\iota} E$$

where ι is the inclusion map. Hence ${}^t\alpha$ factorises as

$$E^* \xrightarrow{{}^t\iota} M^{-1} \xrightarrow{{}^t\alpha'} E.$$

Also, $\text{Im } \alpha \cong \text{Im } \alpha' = M$ since ι is injective, and $\text{Im } {}^t\alpha = \text{Im } {}^t\alpha' \cong M^{-1}$ since ${}^t\iota$ is surjective. But since ${}^t\alpha = \alpha$, we have $M \cong M^{-1}$, that is, M is of order 2.

Conversely, suppose $M = M^{-1}$ is a line subbundle of E . Then we have a short exact sequence

$$0 \rightarrow M \rightarrow E \rightarrow L \rightarrow 0$$

where L is a line bundle of degree 1. The dual sequence is

$$0 \rightarrow L^{-1} \rightarrow E^* \rightarrow M \rightarrow 0.$$

Composing the maps $E^* \rightarrow M$ and $M \rightarrow E$, we get a map $\alpha: E^* \rightarrow E$ of rank everywhere 1. To see that α is symmetric, note that ${}^t\alpha$ is another map $E^* \rightarrow E$

which factorises $E^* \rightarrow M \rightarrow E$. By Prop. 4.5 and since $M = M^{-1}$, we have

$$h^0(X, \text{Hom}(M, E)) = h^0(X, \text{Hom}(E^*, M)) = 1$$

so the maps α and ${}^t\alpha$ are proportional. Since $\alpha \mapsto {}^t\alpha$ is an involution, we have ${}^t\alpha = \pm\alpha$. Since α has odd rank, it cannot be antisymmetric, so it must be a symmetric map. \square

Corollary 4.10 *The generic vector bundle $E \rightarrow X$ of rank 2 and degree 1 has no line subbundles of order 2.*

Proof

This is clear from Props. 4.8 and 4.9. \square

4.3 A ruled surface in \mathbb{P}^5

In this section, we fix $E \in \mathcal{U}_X(2, 1)$ and describe a map of the ruled surface $\mathbb{P}E^*$ into \mathbb{P}^5 . We then give a sufficient condition for this map to be an embedding. This will be used in the following chapter.

We follow an approach outlined in Kempf-Schreyer [20, § 1]. For any $x \in X$, we can form the exact sheaf sequence

$$0 \rightarrow \text{Sym}^2 \mathcal{E}^* \rightarrow \text{Sym}^2 \mathcal{E}^*(x) \rightarrow \frac{\text{Sym}^2 \mathcal{E}^*(x)}{\text{Sym}^2 \mathcal{E}^*} \rightarrow 0$$

whose cohomology sequence begins

$$0 \rightarrow H^0(X, (\text{Sym}^2 E^*)(x)) \rightarrow \text{Sym}^2 E^*(x)|_x \xrightarrow{\delta} H^1(X, \text{Sym}^2 E^*) \rightarrow \dots$$

The second term can be identified with the set of principal parts with values in $\text{Sym}^2 E^*$ and at most a simple pole at x . Moreover, there is a canonical isomorphism

$$\mathbb{P}\text{Sym}^2 E^*(x)|_x \xrightarrow{\sim} \mathbb{P}\text{Sym}^2 E^*|_x.$$

For each $x \in X$, we define a map $\psi_x: \mathbb{P}E^*|_x \rightarrow \mathbb{P}H^1(X, \text{Sym}^2 E^*)$ by the composition

$$\mathbb{P}E^*|_x \xrightarrow{\text{Segre}} \mathbb{P}\text{Sym}^2 E^*|_x \xrightarrow{\sim} \mathbb{P}(\text{Sym}^2 E^*(x))|_x \xrightarrow{\mathbb{P}\delta} \mathbb{P}H^1(X, \text{Sym}^2 E^*).$$

We define $\psi: \mathbb{P}E^* \rightarrow \mathbb{P}H^1(X, \text{Sym}^2 E^*)$ to be the product of ψ_x over all $x \in X$.

Notation: We denote $\mathbb{P}H^1(X, \text{Sym}^2 E^*)$ by \mathbb{P}_E^5 . Let Y be a variety and $\Upsilon \rightarrow Y$ a line bundle with a nonempty linear series $|\Upsilon| = \mathbb{P}H^0(Y, \Upsilon)$. Then we write $\phi_{|\Upsilon|}$ for the rational map $Y \dashrightarrow |\Upsilon|^*$ given by sending $y \in Y$ to the hyperplane of Υ -divisors containing y .

Remark: It is not hard to see that the image of $\phi_{|\Upsilon|}$ is nondegenerate in $|\Upsilon|^*$.

Proposition 4.11 *Write π for the projection $\mathbb{P}E^* \rightarrow X$ and let $\Upsilon \rightarrow \mathbb{P}E^*$ be the line bundle $\pi^*K_X \cdot \mathcal{O}_{\mathbb{P}E^*}(2)$. Then there is a natural identification $\mathbb{P}_E^5 \cong |\Upsilon|^*$ under which ψ coincides with $\phi_{|\Upsilon|}$. In particular, ψ is algebraic. Moreover, ψ is defined everywhere.*

Proof

We identify $H^1(X, \text{Sym}^2 E^*)$ with $H^0(X, K_X \otimes \text{Sym}^2 E)^*$ by Serre duality as follows. Recall from Chapter 3 (3.1) that every class in the first space is of the form $[p]$ for some $p \in \text{Prin}(\text{Sym}^2 E^*)$. Let s be a global section of $K_X \otimes \text{Sym}^2 E$. Then the contraction $\langle p, s \rangle$ belongs to $\text{Prin} K_X$, so defines a cohomology class in $H^1(X, K_X) = \mathbb{C}$, so we get a linear form on $H^0(X, K_X \otimes \text{Sym}^2 E)$. It is easy to check that this does not depend on the choice of p representing $[p]$.

Now we describe the identification $|\Upsilon|^* \xrightarrow{\sim} \mathbb{P}_E^5$. Let t be a global section of Υ . Since K_X and E are locally trivial, t is locally of the form $dz \otimes t'$ where z is a local coordinate on X and t' is a choice of homogeneous quadratic t'_x on each fibre $\mathbb{P}E^*|_x$. Such a quadratic defines naturally a linear form on $\text{Sym}^2 E^*|_x$, so t defines a section of $K_X \otimes \text{Sym}^2 E$. Moreover, this association is clearly linear and injective, so defines an isomorphism $H^0(\mathbb{P}E^*, \Upsilon) \xrightarrow{\sim} H^0(X, K_X \otimes \text{Sym}^2 E)$.

We proceed to the identification of ψ and $\phi_{|\Upsilon|}$. Choose $x \in X$ and let z be a local coordinate centred at x . Let f be a nonzero vector in $E^*|_x$. We show that any section t of Υ vanishing at $\langle f \rangle \in \mathbb{P}E^*$ belongs to the kernel of the linear form defined by the cohomology class of the principal part

$$p := \frac{\overline{f \otimes f}}{z},$$

which lies over $\psi\langle f \rangle$. We have seen that t is of the form $dz \otimes t'$ near x . Now since $t\langle f \rangle = 0$, the linear form t'_x vanishes on the element $f \otimes f \in \text{Sym}^2 E^*|_x$. Since p is

supported only at x and has only a simple pole, the contraction $\langle p, t \rangle \in \text{Prin } K_X$ is in fact regular. In particular, the cohomology class $[\langle p, t \rangle]$ is zero.

Lastly, we show that ψ is a morphism, that is, that the cohomology class $[p]$ defines a nonzero linear form on $H^0(X, K_X \otimes \text{Sym}^2 E)$. Since $K_X \otimes \text{Sym}^2 E$ has no higher cohomology, it is generated by global sections. In particular, we can find a section s such that the principal part

$$\left\langle \frac{f \otimes f}{z}, s \right\rangle$$

is not regular. But no global rational section of K_X has only a simple pole, so $[p](s) \neq 0 \in H^1(X, K_X)$. \square

Lemma 4.12 *Suppose that E has no line subbundles of order 2 and that $\text{Sym}^2 E$ has no global sections. Then $\psi: \mathbb{P} E^* \rightarrow \mathbb{P}_E^5$ is an embedding.*

Proof:

Suppose that ψ is not an embedding. We distinguish three ways that this can happen:

- (i) $\psi(u) = \psi(v)$ for some $u, v \in \mathbb{P} E^*$ lying over distinct $x, y \in X$.
- (ii) $\psi(u) = \psi(v)$ for distinct u and v in a fibre $\mathbb{P} E^*|_x$.
- (iii) The differential of ψ is not injective at some point $u \in \mathbb{P} E^*$.

Recall that we have the cohomology sequence

$$0 \rightarrow \text{Rat}(\text{Sym}^2 E^*) \rightarrow \text{Prin}(\text{Sym}^2 E^*) \xrightarrow{\delta} H^1(X, \text{Sym}^2 E^*) \rightarrow 0 \quad (4.1)$$

which is exact since $h^0(X, \text{Sym}^2 E^*) = 0$ by semistability.

Suppose that (i) occurs. By (4.1) and the definition of ψ , there is a global section α of $(\text{Sym}^2 E^*)(x + y)$ such that $\alpha(x)$ and $\alpha(y)$ are decomposable. Since E has no line subbundles of order 2, by Prop. 4.9 the determinant of α is generically nonzero. Hence it has $\deg E - \deg E^*(x + y) = 2$ zeroes. It follows that $\det \alpha \in H^0(X, \mathcal{O}_X(x + y))$. But we also have

$$\det \alpha \in H^0(X, \text{Hom}(\det E, (\det E^*)(2x + 2y))),$$

so $(\det E)^2 = \mathcal{O}_X(x + y)$.

Now since E is of rank 2, there is an isomorphism $E^* \xrightarrow{\sim} E \otimes \det(E)^{-1}$, so $\mathrm{Sym}^2 E^* \cong \mathrm{Sym}^2 E \otimes (\det E)^{-2}$. Thus

$$(\mathrm{Sym}^2 E^*)(x + y) \cong \mathrm{Sym}^2 E^* \otimes (\det E)^2 \cong \mathrm{Sym}^2 E,$$

so α defines a nonzero section of $\mathrm{Sym}^2 E$.

Suppose (ii) happens. Again, by (4.1) and the definition of ψ there exists a global rational section α of $\mathrm{Sym}^2 E^*$ whose principal part is supported at x and corresponds under the canonical (up to scalar) isomorphism

$$\mathrm{Sym}^2 E^*|_x \cong \mathrm{Sym}^2 E^*(x)|_x$$

to $\tilde{u} \otimes \tilde{u} + \tilde{v} \otimes \tilde{v}$ for some lifts \tilde{u} and \tilde{v} of u and v . Thus $\alpha \in H^0(X, (\mathrm{Sym}^2 E^*)(x))$. Again by hypothesis and Prop. 4.9, the determinant of α is generically nonzero. Since E and $E^*(x)$ are semistable of the same slope, α gives an isomorphism $E \rightarrow E^*(x)$, and $\mathrm{Sym}^2 E \cong (\mathrm{Sym}^2 E^*)(2x)$. Since $(\mathrm{Sym}^2 \mathcal{E}^*)(x)$ is a subsheaf of $(\mathrm{Sym}^2 \mathcal{E}^*)(2x)$, the map α defines a global section of $\mathrm{Sym}^2 E$.

Lastly, suppose (iii) happens. Then the conditions on the sections in

$$H^0(\mathbb{P} E^*, \pi^* K_X \cdot \mathcal{O}_{\mathbb{P} E^*}(2)) =: H^0(\mathbb{P} E^*, \Upsilon)$$

of vanishing to order 1 and 2 at u are dependent. Suppose $\pi(u) = x$ and let \tilde{u} be a lift of u . We consider principal parts $p_1, p_2 \in \mathrm{Prin}(\mathrm{Sym}^2 E^*)$ with simple and double poles respectively along the line spanned by $\tilde{u} \otimes \tilde{u}$. Then we can suppose that the linear forms defined on $H^0(\mathbb{P} E^*, \Upsilon)$ by $[p_1]$ (which lies over $\psi(u)$) and $-[p_2]$ are the same. By (4.1), there exists a global rational section α of $\mathrm{Sym}^2 E^*$ which has principal part $p_1 + p_2$. Since α is nonzero, by Prop. 4.9 the determinant of α is generically nonzero. Thus it vanishes at two points because

$$\deg(E) - \deg(E^*(2x)) = 2.$$

Now we notice that the image of α is contained in the subsheaf of sections of E^* with poles along the line spanned by \tilde{u} and of order at most 2. So the cokernel of α is isomorphic to \mathbb{C}_{2x} , and $\det(\alpha) \in H^0(X, \mathcal{O}_X(2x))$. But $\det(\alpha)$ also belongs to

$$H^0(X, \mathrm{Hom}(\det(E), \det(E^*(2x)))) = H^0(X, \det(E)^{-2}(4x)),$$

hence $\det(E)^2 = \mathcal{O}_X(2x)$. Now α gives a nonzero regular section of

$$(\mathrm{Sym}^2 E^*)(2x) \cong (\mathrm{Sym}^2 E^*) \otimes (\det E)^2 \cong \mathrm{Sym}^2 E.$$

This completes the proof of the lemma. \square

Remark: By Proposition 4.8 and Lemma 4.12, the map ψ is an embedding for a general bundle $E \in \mathcal{U}_X(2, 1)$.

In the following chapter, we shall apply these results to give a description of $\mathcal{M}_X(\mathrm{Sp}_2 \mathbb{C})$ in the case where X has genus 2.

Chapter 5

A cover of $\mathcal{M}_X(\mathrm{Sp}_2 \mathbb{C})$ in genus 2

In [34], Narasimhan and Ramanan construct a generically finite cover of the moduli space $\mathcal{SU}_X(2, \mathcal{O}_X)$ for a curve X of genus 3 by a union of projectivised extension spaces of the form $\mathbb{P}H^1(X, L^{-2})$ as L ranges over J_X^1 . In this chapter we give a similar description of $\mathcal{M}_X(\mathrm{Sp}_2 \mathbb{C})$ for a curve of genus 2. The main tool in the construction is Criterion 3.4. We will consider a union of projective spaces of the form $\mathbb{P}H^1(X, \mathrm{Sym}^2 E^*)$ as E ranges over a family of vector bundles over X .

To see how this kind of construction is useful, we refer for example to Pauly [40], where Narasimhan and Ramanan's construction is used to prove that the Coble quartic associated to a curve X of genus 3, which is isomorphic to $\mathcal{SU}_X(2, \mathcal{O}_X)$, is self-dual. And in the last chapter of this thesis, we will apply the construction in this chapter to the study of theta-divisors of symplectic vector bundles over a curve of genus 2.

5.1 Statement of the main theorem

In the last chapter we studied $\mathcal{U}_X(2, 1)$, the 5-dimensional moduli space of semistable vector bundles of rank 2 and degree 1 over X . Since $\mathrm{gcd}(2, 1) = 1$, there exists a

Poincaré bundle \mathbf{E} over $\mathcal{U}_X(2, 1) \times X$ by Theorem 1.2 (iv). We consider the diagram

$$\begin{array}{ccc}
 & \mathbf{E} & \\
 & \downarrow & \\
 & \mathcal{U}_X(2, 1) \times X & \\
 \swarrow p & & \searrow q \\
 \mathcal{U}_X(2, 1) & & X
 \end{array}$$

where p and q are the projections. Now by stability,

$$h^0(X, \text{Sym}^2 E^*) \leq h^0(X, \text{Hom}(E, E^*)) = 0$$

for all $E \in \mathcal{U}_X(2, 1)$, so $h^1(X, \text{Sym}^2 E^*) = -\chi(X, \text{Sym}^2 E^*) = 6$. As before, by Hartshorne [17, Corollary III.12.9] the sheaf $R^1 p_*(\text{Sym}^2 E^*)$ is locally free of rank 6 on $\mathcal{U}_X(2, 1)$. Thus it defines a vector bundle $R \rightarrow \mathcal{U}_X(2, 1)$ whose fibre at $E \in \mathcal{U}_X(2, 1)$ is $H^1(X, \text{Sym}^2 E^*)$.

By Seshadri [47, App. II], there exists a vector bundle over $\mathbb{P}R \times X$ whose restriction to $\{(\delta), E\} \times X$ is isomorphic as a vector bundle to the extension¹

$$0 \rightarrow E^* \rightarrow W \rightarrow E \rightarrow 0$$

defined by δ . By Criterion 3.4 and the moduli property of $\mathcal{M}_X(\text{Sp}_2 \mathbb{C})$, there exists a classifying map $\Phi_{\mathbb{P}R}: \mathbb{P}R \dashrightarrow \mathcal{M}_X(\text{Sp}_2 \mathbb{C})$, which we will henceforth call Φ . A priori, Φ is only a rational map. The main result of this chapter is

Theorem 5.1 Φ is a surjective morphism which is generically finite of degree 24.

The strategy for our proof of this is as follows. We begin by showing that Φ is defined everywhere, so it is in fact a morphism. Then we consider a generic (in a sense to be made precise) symplectic extension $0 \rightarrow E^* \rightarrow W \rightarrow E \rightarrow 0$ and show that it admits finitely many isotropic subbundles of rank 2 and degree -1 . It is then easy to show that Φ is generically finite onto its image. By dimension count and irreducibility, it is surjective. We conclude by using some results of Lange-Newstead [24] to calculate the degree of Φ .

¹My apologies to the reader for exchanging the positions of E and E^* since Chapter 2.

Notation: As in Chapter 4, we denote the fibre $\mathbb{P}R|_E \cong \mathbb{P}H^1(X, \text{Sym}^2 E^*)$ by \mathbb{P}_E^5 .

5.2 Nonstable loci of \mathbb{P}_E^5

Proposition 5.2 *Let $W \rightarrow X$ be any self-dual vector bundle. Then W is stable (resp., semistable) if and only if it contains no destabilising (resp., desestabilising) subbundles of rank at most $\frac{1}{2} \text{rk } W$.*

Proof

One implication is clear. For the converse, we only have to check that $\deg(V) < 0$ (resp., $\deg(V) \leq 0$) for any $V \subset W$ of rank greater than $\frac{1}{2} \text{rk } W$. Let V be such a subbundle, so we have a short exact sequence

$$0 \rightarrow V \rightarrow W \rightarrow Q \rightarrow 0$$

of vector bundles over X . Then $\deg Q = -\deg V$. Since W is self-dual, Q^* is a subbundle of W which has rank less than $\frac{1}{2} \text{rk } W$. Now

$$\deg V = -\deg Q = \deg Q^* < 0 \quad (\text{resp., } \leq 0)$$

by hypothesis, hence the proposition. Note that this argument applies whether W has even or odd rank. \square

Lemma 5.3 *For any $E \in \mathcal{U}_X(2, 1)$, every nontrivial extension W of E by E^* is semistable.*

Proof

By Atiyah [2, Prop. 3], the class $\delta(W^*)$ of the extension $0 \rightarrow E^* \rightarrow W^* \rightarrow E \rightarrow 0$ is equal to $-\delta(W)$. Therefore $W^* \cong W$ as vector bundles. By Proposition 5.2, then, it is enough to show that W contains no desestabilising subbundles of rank at most 2.

Suppose firstly that $L \subset W$ is a line subbundle of degree at least 1. Since E^* is stable, $h^0(X, \text{Hom}(L, E)) > 0$. But since L and E are stable and

$$\mu(L) \geq 1 > \mu(E) = \frac{1}{2},$$

this is impossible.

Next, suppose $F \subset W$ is a subbundle of rank 2 and degree at least 1. Since we have just seen that W contains no line subbundles of positive degree, F must be stable. Firstly, if the composed map $F \rightarrow W \rightarrow E$ were zero then we would have a nonzero map $F \rightarrow E^*$, contradicting stability of F and E^* . Therefore the composed map is nonzero. Since F and E are stable, it must be an isomorphism, so W is a trivial extension. \square

This lemma shows in particular that Φ is defined everywhere on $\mathbb{P}R$, so it is a morphism.

Strictly semistable loci of \mathbb{P}_E^5

The goal of this section is to prove the following lemma:

Lemma 5.4 *Let $E \in \mathcal{U}_X(2, 1)$ be such that $h^0(X, \text{Hom}(E^*, E)) = 0$. Then the generic symplectic extension $0 \rightarrow E^* \rightarrow W \rightarrow E \rightarrow 0$ is a stable vector bundle.*

Proof

We shall prove this by determining the the classes in a general \mathbb{P}_E^5 representing vector bundles which contain a subbundle of degree 0; this will also be used later. Again, by Prop. 5.2 it suffices to check for degree 0 subbundles of ranks 1 or 2.

Firstly, suppose that $M \subset W$ is a line subbundle of degree 0. Since E^* is stable, $h^0(X, \text{Hom}(M, E)) > 0$; then in fact M is a subbundle of E by Lemma 4.4 since E is stable. By Lemma 4.3, there are at most 4 possibilities for $M \in J_X^0$.

Conversely, by Lemma 4.1, an injection $j: M \hookrightarrow E$ lifts to W if and only if $\delta(W)$ belongs to the kernel of the induced map

$$j^*: H^1(X, \text{Sym}^2 E^*) \rightarrow H^1(X, \text{Hom}(M, E^*)).$$

We check that this map is surjective. By Serre duality, it is equivalent to check that the transposed map $H^0(X, K_X M \otimes E) \rightarrow H^0(X, K_X \otimes \text{Sym}^2 E)$, which by abuse of

notation we also denote j , is injective. Now the induced map

$$j: H^0(X, K_X M \otimes E) \rightarrow H^0(X, K_X \otimes E \otimes E)$$

is injective, because the global section functor and the functor $K_X \otimes - \otimes E$ are left exact (the latter because these sheaves are locally free). Since

$$H^0(X, K_X \otimes E \otimes E) = H^0(X, K_X \otimes \text{Sym}^2 E) \oplus H^0(X, K_X \otimes \bigwedge^2 E),$$

we have to show that $\text{Im}(j) \cap H^0(X, K_X \otimes \bigwedge^2 E) = 0$. Now $\text{rk } E = 2$, so the latter space is just $H^0(X, K_X \cdot \det E)$, and any nonzero section therein has exactly 3 zeroes (counted with multiplicity). But if a map $K_X^{-1} M^{-1} \rightarrow E$ vanished at 3 points, E would contain a line subbundle of degree 1 by Lemma 4.4; this would contradict the stability of E .

Thus the restriction of j^* to $H^1(X, \text{Sym}^2 E^*)$ is surjective. Since $\text{Sym}^2 E^*$ and $\text{Hom}(M, E^*)$ have no global sections, $\text{Ker } j^*$ is of dimension

$$-\chi(X, \text{Sym}^2 E^*) + \chi(\text{Hom}(M, E^*)) = 6 - 3 = 3.$$

Hence there is a union of between 1 and 4 projective planes in \mathbb{P}_E^5 representing extensions which are destabilised by a line subbundle of degree 0.

Now we consider a destabilising subbundle $G \subset W$ of rank 2. We shall use the map $\psi: \mathbb{P} E^* \rightarrow \mathbb{P}_E^5$ defined in the last chapter.

Proposition 5.5 *Let W be a semistable symplectic extension of E by E^* , so that $\delta(W) \in H^1(X, \text{Sym}^2 E^*)$. Then W is destabilised by a subbundle of rank 2 and degree 0 if and only if $\langle \delta(W) \rangle$ belongs to $\psi(\mathbb{P} E^*)$.*

Proof

Let $G \subset W$ be a subbundle of rank 2 and degree 0. Then the rank of $\mathcal{G} \cap \mathcal{E}^*$ is 2, 1 or 0. It cannot be 0 because then the image of \mathcal{G} in \mathcal{E} would be a torsion subsheaf of length 1, of which there are none. If $\mathcal{G} \cap \mathcal{E}^*$ were an invertible subsheaf \mathcal{L} then we would have a diagram

$$\begin{array}{ccccccccc} 0 & \longrightarrow & \mathcal{E}^* & \longrightarrow & \mathcal{W} & \longrightarrow & \mathcal{E} & \longrightarrow & 0 \\ & & \uparrow & & \uparrow & & \uparrow & & \\ 0 & \longrightarrow & \mathcal{L} & \longrightarrow & \mathcal{G} & \longrightarrow & \mathcal{M} & \longrightarrow & 0 \end{array}$$

where \mathcal{M} is an invertible subsheaf of \mathcal{E} . Since E^* and E are stable, $\deg \mathcal{L} \leq -1$ and $\deg \mathcal{M} \leq 0$. But then $\deg G \leq -1$, a contradiction.

Hence G is an elementary transformation

$$0 \rightarrow \mathcal{G} \rightarrow \mathcal{E} \rightarrow \mathbb{C}_x \rightarrow 0$$

for some point $x \in X$. Since $h^0(X, \text{Hom}(E, E^*)) = 0$, by the first remark after Theorem 3, the subsheaf \mathcal{G} is isomorphic to $\text{Ker}(q)$ for some $q \in \text{Prin}(\text{Hom}(E, E^*))$ such that $\delta(W) = [q]$. Clearly q is supported at x with a simple pole along $f \otimes f'$ for some nonzero $f, f' \in E^*|_x$.

Now since W is symplectic, ${}^t q - q = \bar{\alpha}$ for some global rational section α of $\text{Hom}(E, E^*)$. Clearly $\bar{\alpha}$ is antisymmetric, so $\frac{\alpha - {}^t \alpha}{2}$ is a global rational section of $\det E^*$ with principal part $\bar{\alpha}$. If this is nonzero then it has a single simple pole at x , so is a global regular section of $(\det E^*)(x)$. But this is nonzero only if $\det(E) = \mathcal{O}_X(x)$, which contradicts our genericity assumption. Therefore f' is proportional to f and $\langle \delta(W) \rangle = \psi \langle f \rangle$.

Conversely, suppose $\delta(W)$ lies over $\psi \langle f \rangle$ for some nonzero $f \in E^*|_x$. By the definition of ψ , the class $\delta(W)$ can be represented by a principal part $q \in \text{Prin}(\text{Sym}^2 E^*)$ supported at one point $x \in X$ and with a simple pole along $f \otimes f$. By the first remark after Thm. 3, the kernel of q , which is a locally free sheaf of degree 0, lifts to a vector subbundle of W . \square

In summary, we have shown that the locus of extensions in a general \mathbb{P}_E^5 containing a subbundle of degree 0 is of dimension 2. The complement of this locus consists of classes defining stable vector bundles. This completes the proof of Lemma 5.4. \square

5.3 Maximal Lagrangian subbundles

Let $E \in \mathcal{U}_X(2, 1)$ be such that $h^0(X, \text{Hom}(E^*, E)) = 0$ and consider a stable symplectic extension $0 \rightarrow E^* \rightarrow W \rightarrow E \rightarrow 0$ of class $\delta(W) \in H^1(X, \text{Sym}^2 E^*)$. We shall show that W has finitely many Lagrangian subbundles of degree -1 . Suppose

$F \subset W$ is such a subbundle. There are three possibilities for the rank of the sheaf $\mathcal{F} \cap \mathcal{E}^*$: these are 2, 1 and 0. If it is 2 then it is not hard to see that $F = E^*$.

Proposition 5.6 *Suppose that E has no line subbundles of order 2 and let W be any nontrivial extension of E by E^* . Then there are at most 16 subbundles $F \subset W$ of rank 2 and degree -1 such that $\mathcal{F} \cap \mathcal{E}^*$ is of rank 1.*

Proof

Let $F \subset W$ be such a subbundle and write \mathcal{L} for the subsheaf $\mathcal{F} \cap \mathcal{E}^*$. We see that \mathcal{L} is invertible because, say, \mathcal{E}^* is locally free. By stability, $\deg \mathcal{L} \leq -1$. The image \mathcal{M} of \mathcal{F} in \mathcal{E} is coherent, hence invertible because \mathcal{E} is locally free. Since E is stable, $\deg \mathcal{M} \leq 0$. But we also have

$$\deg \mathcal{M} = -1 - \deg \mathcal{L} \geq 0.$$

Thus $\deg \mathcal{M} = 0$ and $\deg \mathcal{L} = -1$. By stability, these subsheaves must in fact correspond to line subbundles by Lemma 4.4. Then, by Lemma 4.3, there are at most four possibilities L_1, \dots, L_4 and M_1, \dots, M_4 for each of the corresponding line subbundles of E^* and E respectively. In what follows, we take $M_\alpha^{-1} = \frac{E^*}{L_\alpha}$.

Conversely, let $L_\alpha \subset E^*$ and $M_\beta \subset E$ be line subbundles of degrees -1 and 0 respectively and suppose we have an extension

$$0 \rightarrow L_\alpha \rightarrow F \rightarrow M_\beta \rightarrow 0$$

of class $\delta(F) \in H^1(X, M_\beta^{-1}L_\alpha)$. We need to show that the map $L_\alpha \rightarrow W$ factorises via F for at most a finite number of nonisomorphic F . By the dual version of Lemma 4.1 (see Narasimhan-Ramanan [35, Lemma 3.2]), this happens if and only if $\delta(F)$ belongs to the kernel of the induced map

$$h: H^1(X, \text{Hom}(M_\beta, L_\alpha)) \rightarrow H^1(X, \text{Hom}(M_\beta, W))$$

which identifies with

$$h: H^0(X, K_X M_\beta L_\alpha^{-1})^* \rightarrow H^0(X, K_X M_\beta \otimes W)^*$$

by Serre duality. By Riemann-Roch, $h^1(X, \text{Hom}(M_\beta, L_\alpha)) = 2$ because $M_\beta^{-1}L_\alpha$ is of degree -1 . Thus it suffices to show that h is nonzero or, equivalently, that its dual

$$h^*: H^0(X, K_X M_\beta \otimes W^*) \rightarrow H^0(X, K_X M_\beta L_\alpha^{-1})$$

is nonzero.

Let Q denote the quotient of W by the subbundle L_α . We can form a short exact sequence

$$0 \rightarrow K_X M_\beta \otimes Q^* \rightarrow K_X M_\beta \otimes W \rightarrow K_X M_\beta L_\alpha^{-1} \rightarrow 0.$$

Now $h^1(X, K_X M_\beta \otimes W) = h^0(X, M_\beta^{-1} \otimes W)$ by Serre duality; it is therefore zero because W is stable of degree 0. Similarly, $h^1(X, K_X M_\beta L_\alpha^{-1}) = h^0(X, M_\beta^{-1} L_\alpha) = 0$.

We get the cohomology sequence

$$\begin{aligned} 0 \rightarrow H^0(X, K_X M_\beta \otimes Q^*) \rightarrow H^0(X, K_X M_\beta \otimes W) \xrightarrow{h^*} \\ H^0(X, K_X M_\beta L_\alpha^{-1}) \rightarrow H^1(X, K_X M_\beta \otimes Q^*) \rightarrow 0. \end{aligned}$$

We show that $h^1(X, K_X M_\beta \otimes Q^*) \leq 1$. For then, by exactness, the coboundary map has a kernel and h^* is nonzero. By Serre duality, it is equivalent to show that $h^0(X, \text{Hom}(M_\beta, Q)) \leq 1$.

Now Q is an extension $0 \rightarrow M_\alpha^{-1} \rightarrow Q \rightarrow E \rightarrow 0$. We see this by inspecting a set of transition functions for W . Let $\{U_i : i \in J\}$ be an open cover of X over which L_α and M_β are trivial, and let $\{l_{i,j}\}$ and $\{m_{i,j}\}$ be the corresponding transition functions. Since E^* is an extension of M_α^{-1} by L_α , we can write the transition functions of W in the form

$$\left(\begin{array}{cc|cc} l_{i,j} & -\delta(E)_{i,j} & & \delta(W)_{i,j} \\ 0 & m_{i,j}^{-1} & & \\ \hline & & m_{i,j} & \delta(E)_{i,j} \\ & 0 & 0 & l_{i,j}^{-1} \end{array} \right).$$

The lower 3×3 block is a transition function for the quotient Q of W by L over $U_i \cap U_j$. From this we see that the only possibilities for degree 0 line bundles with nonzero maps to Q are $M_\alpha^{-1}, M_1, \dots, M_4$. By Prop. 4.3 we have $h^0(X, \text{Hom}(M_\beta, Q)) \geq 2$ only if $M_\alpha^{-1} = M_\beta$ for some $\beta \in \{1, \dots, 4\}$. But this implies that E has a subbundle of order 2. By the proof of Prop. 4.9 we see that $h^0(X, \text{Hom}(E^*, E)) \neq 0$, contradicting our genericity hypothesis.

Thus there at most finitely many $F \subset W$ of degree -1 and rank 2 which intersect E^* in rank 1. \square

Remark: Later we shall see that in fact the general symplectic extension W contains no such F .

The last possibility is that $\dim(F|_x \cap E^*|_x) = 0$ for all but finitely many $x \in X$. In this case, F is an elementary transformation

$$0 \rightarrow \mathcal{F} \rightarrow \mathcal{E} \rightarrow T \rightarrow 0$$

for some torsion sheaf T of length 2. We now give a result in the spirit of Lange-Narasimhan [23, Prop. 1.1].

Lemma 5.7 *Let W be a stable symplectic extension of E by E^* of class $\delta(W) \in H^1(X, \text{Sym}^2 E^*)$. Then the number of degree -1 elementary transformations of E which lift to isotropic subbundles of W is bounded by the number of 2-secants to the surface $\psi(\mathbb{P} E^*) \subset \mathbb{P}_E^5$ which pass through $\langle \delta(W) \rangle$.*

Proof

Consider an elementary transformation $0 \rightarrow \mathcal{F} \rightarrow \mathcal{E} \rightarrow T \rightarrow 0$ such that F lifts to an isotropic subbundle of W . Since E and E^* are stable, there are no nonzero maps $E \rightarrow E^*$. Therefore, by Criterion 3.8 and the discussion before it the sheaf \mathcal{F} is the kernel of a symmetric $q \in \text{Prin}(\text{Sym}^2 E^*)$ such that $\delta(W) = [q]$. There are three possibilities for T :

- (i) $\mathbb{C}_x \oplus \mathbb{C}_y$ for distinct $x, y \in X$.
- (ii) $\mathbb{C}_x^{\oplus 2}$ for some $x \in X$.
- (iii) \mathbb{C}_{2x} for some $x \in X$.

We treat each case in turn.

(i) Clearly q is supported at x and y , where it has poles of order 1. It is decomposable at these points because it is not surjective to

$$\frac{\mathcal{E}^*(x)}{\mathcal{E}^*} \quad \text{or} \quad \frac{\mathcal{E}^*(y)}{\mathcal{E}^*}.$$

Since it is symmetric, then, $\langle \delta(W) \rangle$ lies on the secant spanned by the points $\psi\langle f \rangle$ and $\psi\langle g \rangle$ for some $f \in E^*|_x$ and $g \in E^*|_y$.

(ii) Here q is symmetric and supported at one point $x \in X$. The image of the map $q: \mathcal{E} \rightarrow \underline{\text{Prin}}(E^*)$ is isomorphic to T , so is of length 2 and has only simple poles. But E^* is of rank 2, so q is surjective to the subsheaf

$$\frac{\mathcal{E}^*(x)}{\mathcal{E}^*} \subset \underline{\text{Prin}}(E^*).$$

Therefore q has a simple pole along some indecomposable vector in $\text{Sym}^2 E^*$ and is otherwise regular. Such a vector must be of the form either $f \otimes f + g \otimes g$ or $f \otimes g + g \otimes f$ for some linearly independent $f, g \in E^*|_x$. In the first case, $\langle \delta(W) \rangle = \langle [q] \rangle$ lies on the secant to $\psi\langle f \rangle$ and $\psi\langle g \rangle$ and in the second, it lies on that to $\psi\langle f + g \rangle$ and $\psi\langle f - g \rangle$.

(iii) Again, q is symmetric and supported at one point $x \in X$, where this time it has a double pole. Since q is not surjective as a map $\mathcal{E} \rightarrow E^*(2x)|_x$, the double pole must be along a decomposable vector $f \otimes f \in \text{Sym}^2 E^*|_x$. Since the image of q is a torsion sheaf of length 2, it must be equal to

$$(\mathbb{C} \cdot f)(2x) \subset \frac{\mathcal{E}^*(2x)}{\mathcal{E}^*}$$

and q has poles in no direction other than $f \otimes f$.

Recall that $\Upsilon \rightarrow \mathbb{P} E^*$ is the line bundle $\pi^* K_X \cdot \mathcal{O}_{\mathbb{P} E^*}(2)$. We claim that the linear form determined by $[q]$ on $H^0(\mathbb{P} E^*, \Upsilon)$ restricts to zero on the space of sections of Υ vanishing to order 2 at $\langle f \rangle$. Let z be a local coordinate on X centred at x . Recall that by the discussion in the proof of Prop. 4.11, near $\langle f \rangle$, such a section t is locally of the form $dz \otimes t'$ where t' is a choice of quadratic polynomial t'_x on each $\mathbb{P} E^*|_x$. In other words, t' is a power series in z with coefficients in $\text{Sym}^2 E$. Now t vanishes to order 2 at $\langle f \rangle$ if and only if t'_x does. Thus, the contraction of t against a principal part of the form

$$\frac{f \otimes f}{z^2} + \frac{\lambda f \otimes f}{z}$$

for any $\lambda \in \mathbb{C}$, is regular. Thus $[q]$ belongs to the embedded tangent space

$$\mathbb{P} \text{Ker} (H^0(\mathbb{P} E^*, \Upsilon)^* \rightarrow H^0(\mathbb{P} E^*, \Upsilon - 2\langle f \rangle)^*)$$

to $\psi(\mathbb{P} E^*)$ at $\psi\langle f \rangle$. In particular, $[q]$ lies on a 2-secant.

This completes the proof of Lemma 5.7. \square

Remark: It is intriguing that in case (iii), in fact $\langle \delta(W) \rangle$ belongs to a particular line in the embedded tangent space to $\psi(\mathbb{P}E^*)$, namely that spanned by classes of principal parts with single and double poles along $f \otimes f$. A calculation in local coordinates shows that the kernel of a principal part yielding a general element of this tangent space is a subsheaf of degree strictly less than -1 . The exact relationship between secants to $\psi(\mathbb{P}E^*)$ and subsheaves lifting to \mathcal{W} is a subject I hope to pursue further.

We return to the proof of Theorem 5.1. By our genericity assumption and Lemma 4.12, the map ψ is an embedding. In particular, $\psi(\mathbb{P}E^*)$ is a smooth surface in \mathbb{P}_E^5 which is not a Veronese surface. By a well-known theorem of Severi [49], its secant variety is all of \mathbb{P}_E^5 . So, by dimension count, through a general point of \mathbb{P}_E^5 there pass a finite number of 2-secant lines to the image of ψ . By Lemma 5.7, then, there are only finitely many subbundles of W of rank 2 and degree -1 which project surjectively to E at almost all points of the curve.

By Prop. 5.6 and Lemma 5.7, there are at most finitely many mutually non-isomorphic subbundles of W of rank 2 and degree -1 . Hence W is represented in finitely many fibres of $\mathbb{P}R$.

Proposition 5.8 *Suppose that $E \in \mathcal{U}_X(2, 1)$ satisfies $h^0(X, \text{Hom}(E^*, E)) = 0$. Let W and W' be two extensions of E by E^* . Then $W \cong W'$ if and only if $\delta(W') = \lambda \delta(W)$ for some $\lambda \in \mathbb{C}^*$.*

Proof

By hypothesis, there are no nonzero homomorphisms $E^* \rightarrow E$ by Prop. 4.8. Then the proposition is just a special case of the following:

Lemma 5.9 *Let W and W' be two extensions of F by E . If every nonzero homomorphism $E \rightarrow F$ is an isomorphism and E and F are simple, then W and W' are isomorphic as vector bundles if and only if $\delta(W') = \lambda \cdot \delta(E)$ for some $\lambda \in \mathbb{C}^*$.*

Proof

Narasimhan-Ramanan [35, Lemma 3.3]. \square

Prop. 5.8 shows in particular that the restriction of Φ to \mathbb{P}_E^5 is injective for a generic bundle $E \in \mathcal{U}_X(2, 1)$.

We conclude that the fibre of Φ over a general point of the image is finite. Since $\dim \mathbb{P}R = 10 = \dim \mathcal{M}_X(\mathrm{Sp}_2 \mathbb{C})$ and the latter space is irreducible, Φ is dominant. By Lemma 5.3, it is defined everywhere. Since it is a morphism of projective varieties, its image is closed, so it is surjective.

5.4 The degree of Φ

We use some results of Lange and Newstead to calculate the degree of Φ .

Theorem 5.10 *Let W be a general vector bundle of rank n and degree d over X . Suppose that $n \geq 4$ is even and $2d + 4 \cong 0 \pmod n$ with $\frac{2d+4}{n}$ odd. Then the number of subbundles of rank 2 and maximal degree, counted with multiplicity, is equal to*

$$\frac{n^3}{48} (n^2 + 2).$$

Proof

Lange-Newstead [24, pp. 7-10]. \square

We check the relevant generality conditions on W , which are listed on p. 6 of [24].

We follow the notation of this paper: for a subbundle $F \subseteq W$,

$$s(W, F) = -\mathrm{rk}(W) \deg(F) + \mathrm{rk}(F) \deg(W)$$

and

$$s_{n'}(W) := \min\{s(W, F) : F \subseteq W \text{ of rank } n'\}.$$

The generality conditions are

(i) $s_{n'}(W) = n'(n - n')(g - 1)$.

(ii) $s_{n_1}(W) \geq n_1(n - n_1)(g - 1)$ for all $n_1 \in \{1, \dots, n' - 1\}$.

(iii) W has only finitely many maximal subbundles of rank n' .

For us, $n' = 2$, $g = 2$ and $n = 4$.

(i) Here $s_2(W) = \min\{-4 \deg(F) : F \subseteq W \text{ of rank } 2\} = 4$ since W is stable but contains Lagrangian subbundles of degree -1 . On the other hand,

$$n'(n - n')(g - 1) = 2(4 - 2)(2 - 1) = 4.$$

(ii) The only value of n_1 that we need to check is 1.

$$\begin{aligned} s_1(W) &= \min\{s(W, L) : L \text{ a line subb. of } W\} \\ &= \min\{-4 \deg(L) : L \text{ a line subb. of } W\} \\ &= 4 \end{aligned}$$

since W is stable by Lemma 5.4. On the other hand, $n_1(n - n_1)(g - 1) = 3$.

(iii) This is the thrust of the earlier part of this chapter.

In our case, the number $\frac{n^3}{48}(n^2 + 2)$ is 24. To verify that $\deg \Phi = 24$, we need to check that all the subbundles of a general W are isotropic and distinct. Suppose again that $h^0(X, \text{Hom}(E^*, E)) = 0$ and consider a stable extension $W \in \mathbb{P}_E^5$.

For isotropy: let $F \subset W$ be a subbundle of degree -1 and rank 2. The symplectic form on W restricts to a global section of $\bigwedge^2 F^*$, that is, $(\det F)^{-1}$. To compute this line bundle, we note that by Lange-Newstead [24, Prop. 2.4], such an F has a generically injective map to E , so is an elementary transformation of the type considered in Lemma 5.7:

$$0 \rightarrow \mathcal{F} \rightarrow \mathcal{E} \rightarrow T \rightarrow 0$$

where T is a torsion sheaf of length 2. Thus $\det F = (\det E)(-x - y)$ for some $x, y \in X$ (not necessarily distinct). This has a nonzero section only if $(\det E)^{-1}(x+y)$ is effective. By hypothesis, $\det E$ is not effective, so there exist unique points $p, q, r \in X$ such that $\det E = \mathcal{O}_X(p+q-r)$, with $\mathcal{O}_X(p+q) \neq K_X$. Then $(\det F)^{-1}$ is effective only if

$$x + y \in \{p + q, p + r, q + r\}$$

where ι is the hyperelliptic involution on X . Thus F is isotropic if $\langle \delta(W) \rangle$ does not lie on a line joining points in two of the fibres of $\mathbb{P}E^*$ over p, q and ιr (or on a tangent to a point of a fibre if some of these points coincide). The set of such $\langle \delta(W) \rangle$ is of dimension ≤ 3 , so the general $\langle \delta(W) \rangle \in \mathbb{P}_E^5$ does not satisfy this condition. Therefore, for a general extension W represented in \mathbb{P}_E^5 , all subbundles of rank 2 and degree -1 are isotropic. By Criterion 3.4, the bundle W is represented in the fibre of $\mathbb{P}R$ corresponding to each such subbundle.

For distinctness: let $E^* \subset W$ be a maximal subbundle of rank 2 and suppose that $h^0(X, \text{Hom}(E^*, W)) \geq 2$. By the last paragraph, we can suppose that every copy of E^* in W is isotropic, so $W/E^* \cong E$ and we get a diagram

$$\begin{array}{ccccccc}
 0 & \longrightarrow & E^* & \longrightarrow & W & \longrightarrow & E & \longrightarrow & 0 \\
 & & & & \uparrow & \nearrow & & & \\
 & & & & E^* & & & &
 \end{array}$$

where the composed map is nonzero. But this yields a nonzero map $E^* \rightarrow E$, contradicting genericity.

Thus the maximal subbundles in a general W are Lagrangian and distinct. In summary, $\Phi: \mathbb{P}R \rightarrow \mathcal{M}_X(\text{Sp}_2 \mathbb{C})$ is surjective and generically finite of degree 24. This completes the proof of Theorem 5.1. \square

Remark: Some fibres of Φ may be of positive dimension². If, for example, $\psi: \mathbb{P}E^* \rightarrow \mathbb{P}_E^5$ failed to be an embedding over a locus of positive dimension $\mathbb{P}E^*$ then there would be points of \mathbb{P}_E^5 lying on infinitely many 2-secants to $\psi(\mathbb{P}E^*)$. Then Lemma 5.7 might lead us to expect that that infinitely many degree -1 elementary transformations of E would lift to the corresponding extensions of E by E^* . This is a question I intend to continue studying.

²This is analogous, for example, to the fact that there exist vector bundles of rank 2 and degree 0 over a curve of genus 3 which admit infinitely many maximal line subbundles.

5.5 Future work

Theorem 5.1 gives a fairly explicit description of $\mathcal{M}_X(\mathrm{Sp}_2 \mathbb{C})$ at a general point. In the following chapter, we shall give an application of this description.

It is natural to ask whether such a description of $\mathcal{M}_X(\mathrm{Sp}_n \mathbb{C})$ exists in higher genus. One calculates that for the dimensions to work out as in the genus 2 case, we should consider symplectic extensions

$$0 \rightarrow E^* \rightarrow W \rightarrow E \rightarrow 0 \quad (5.1)$$

where $E \rightarrow X$ is a vector bundle of rank 2 and degree $g - 1$. The \mathbb{P}_E^5 are replaced by projective spaces of dimension $6g - 7$. However, there is no Poincaré bundle over $\mathcal{U}_X(2, g - 1) \times X$ if $g - 1$ is not relatively prime to 2, so we are forced to restrict to the case of even genus.

If symplectic bundles in higher even genus are still general enough in the sense of Lange and Newstead then by [24, Prop. 2.4] the problem is essentially to study the connection between secants to an image of $\mathbb{P} E^*$ in $\mathbb{P} H^1(X, \mathrm{Sym}^2 E^*)$ and elementary transformations

$$0 \rightarrow \mathcal{F} \rightarrow \mathcal{E} \rightarrow T \rightarrow 0,$$

where T is a torsion sheaf of length $2g - 2$, which lift to an extension such as (5.1). But one expects the $(2g - 2)$ nd secant variety to a smooth surface to be of dimension $6g - 7$, so we might indeed expect a general extension $0 \rightarrow E^* \rightarrow W \rightarrow E \rightarrow 0$ in this setting to have only finitely many Lagrangian subbundles of degree $g - 1$. This is a question I would be interested in studying further.

Chapter 6

Theta-divisors of symplectic vector bundles

We begin this chapter by reviewing some well-known results on theta-divisors of vector bundles of degree 0. In § 6.2, we prove that any strictly semistable symplectic vector bundle of rank 4 over a curve of genus g admits a theta-divisor. We then consider the genus 2 case. In § 6.3, we use the covering of $\mathcal{M}_X(\mathrm{Sp}_2 \mathbb{C})$ constructed in the last chapter to show that the generic bundle in $\mathcal{M}_X(\mathrm{Sp}_2 \mathbb{C})$ admits a theta-divisor, and to deduce some necessary conditions on those which do not. We end by characterising those stable bundles in $\mathcal{M}_X(\mathrm{Sp}_2 \mathbb{C})$ whose theta-divisors are singular, when they exist.

References for this subject include Beauville [5], [6] and Laszlo [26] and Raynaud [46]. Theta-divisors of rank 2 vector bundles are discussed in Narasimhan-Ramanan [34] and [35].

6.1 Preliminaries

For a vector bundle $W \rightarrow X$ of rank r and degree 0, we consider the set

$$S(W) := \{L \in J_X^{g-1} : h^0(X, L \otimes W) > 0\}.$$

Proposition 6.1 *Let W be a semistable vector bundle of degree 0. Then the set $S(W)$ depends only on the S -equivalence class of W .*

Proof (well-known)

Choose a Jordan-Hölder filtration of W

$$0 = W_0 \subset W_1 \subset \cdots \subset W_{k-1} \subset W_k = W$$

by proper subbundles of degree 0, with associated graded bundle

$$\mathrm{gr}_v W = \bigoplus_{i=1}^k \frac{W_i}{W_{i-1}}$$

We must show that $h^0(X, L \otimes W) > 0$ if and only if $h^0(X, (\mathrm{gr}_v W) \otimes L) > 0$.

Suppose there exists a nonzero homomorphism $L^{-1} \rightarrow W$. Let $j \in \{1, \dots, k\}$ be the smallest index such that $h^0(X, \mathrm{Hom}(L^{-1}, W_j)) > 0$. Then clearly

$$h^0(X, \mathrm{Hom}(L^{-1}, W_j/W_{j-1})) > 0.$$

Since $h^0(X, (\mathrm{gr}_v W) \otimes L) = \sum_{i=1}^k h^0(X, \mathrm{Hom}(L^{-1}, W_i/W_{i-1}))$, we have a nonzero map $L^{-1} \rightarrow W$.

Conversely, suppose that $h^0(X, (\mathrm{gr}_v W) \otimes L) > 0$. Let $j \in \{1, \dots, k\}$ be the smallest number for which $h^0(X, \mathrm{Hom}(L^{-1}, W_j/W_{j-1})) > 0$. There is a diagram

$$\begin{array}{ccccccc} 0 & \longrightarrow & W_{j-1} & \longrightarrow & W_j & \longrightarrow & \frac{W_j}{W_{j-1}} \longrightarrow 0 \\ & & & & & & \uparrow \\ & & & & & & L^{-1} \end{array}$$

and by Lemma 4.1, the map $L^{-1} \rightarrow \frac{W_j}{W_{j-1}}$ lifts to W_j if and only if the class

$$\delta(W_j) \in H^1(X, \mathrm{Hom}(W_j/W_{j-1}, W_{j-1}))$$

of the extension W_j belongs to the kernel of the induced map

$$H^1(X, \mathrm{Hom}(W_j/W_{j-1}, W_{j-1})) \rightarrow H^1(X, \mathrm{Hom}(L^{-1}, W_{j-1})).$$

But since $h^0(X, \mathrm{Hom}(L^{-1}, W_{j-1})) = 0$ by minimality of j and $\mathrm{Hom}(L^{-1}, W_{j-1})$ has Euler characteristic 0, we have $h^1(X, \mathrm{Hom}(L^{-1}, W_{j-1})) = 0$. Hence the map $L^{-1} \rightarrow W_j/W_{j-1}$ lifts to W_j . Composing with the inclusion $W_j \hookrightarrow W$, we have a nonzero map $L^{-1} \rightarrow W$. \square

If $S(W) \neq J_X^{g-1}$ then it is the support of a divisor $D(W)$ on J_X^{g-1} linearly equivalent to $r\Theta$, called the *theta-divisor of W* . By Prop. 6.1, the association $D \mapsto D(W)$ is well-defined on S -equivalence classes; it can be shown to define a rational map $\mathcal{U}_X(r, 0) \dashrightarrow |r\Theta|$.

A vector bundle of degree 0 such that $S(W) = J_X^{g-1}$, that is, a point where D is not defined, is called a *Raynaud bundle*. For a general treatment of this subject, we refer to Raynaud [46].

Henceforth we suppose that $r = 2n$ and consider the map

$$D: \mathcal{M}_X(\mathrm{Sp}_n \mathbb{C}) \dashrightarrow |2n\Theta|.$$

We can be more precise about the image of D . Recall that the Serre duality involution $\iota: J_X^{g-1} \rightarrow J_X^{g-1}$ is given by $L \mapsto K_X L^{-1}$. It induces an involution ι^* on $H^0(J_X^{g-1}, 2n\Theta)$. The projectivisations of the $+1$ - and -1 -eigenspaces of this involution correspond to the spaces of invariant divisors of ι^* and are denoted $|2n\Theta|_+$ and $|2n\Theta|_-$ respectively. Using the Lefschetz fixed-point formula, one finds¹:

$$h^0(J_X^{g-1}, 2n\Theta)_\pm = 2n^g \pm 2^{g-1}. \quad (6.1)$$

Lemma 6.2 *The image of $D: \mathcal{M}_X(\mathrm{Sp}_n \mathbb{C}) \dashrightarrow |2n\Theta|$ is contained in $|2n\Theta|_+$.*

Proof (shown to me by W. Oxbury)

Firstly, we note that D is defined on a nonempty open subset. Since $\mathcal{M}_X(\mathrm{Sp}_n \mathbb{C})$ is irreducible, it is enough to show that it is defined at one point, so we notice that $D(X \times \mathbb{C}^{2n})$ is just $2n\Theta$.

Choose a divisor $D(W)$ in the image of D . We check that the support of $D(W)$ is invariant under ι^* . By definition,

$$\mathrm{Supp} \iota^* D(W) = \{L \in J_X^{g-1} : h^0(X, K_X L^{-1} \otimes W) > 0\}.$$

¹I am grateful to M. Bolognesi for showing me this calculation.

But since $\chi(X, L \otimes W) = 0$ for all $L \in J_X^{g-1}$, we have

$$\begin{aligned} h^0(X, K_X L^{-1} \otimes W) &= h^1(X, K_X L^{-1} \otimes W) \\ &= h^1(X, K_X L^{-1} \otimes W^*) \text{ because } W \cong W^*, \\ &= h^0(X, L \otimes W) \text{ by Serre duality.} \end{aligned}$$

Thus the supports of $D(W)$ and $\iota^*D(W)$ coincide, so $\iota^*D(W) = k \cdot D(W)$ for some integer k . Since ι^* is also an involution by functoriality, $k^2 = 1$ and ι induces an isomorphism on the cohomology of $2n\Theta$. This shows that $k = 1$, and $D(W) \in |2n\Theta|_+ \cup |2n\Theta|_-$.

We now check that the image of D belongs to the even part. Firstly, since $\mathcal{M}_X(\mathrm{Sp}_n \mathbb{C})$ is connected and D is continuous, its image will lie in either $|2n\Theta|_+$ or $|2n\Theta|_-$ because these are disjoint connected sets. Thus it suffices to check that $D(W) \in |2n\Theta|_+$ for one $W \in \mathcal{M}_X(\mathrm{Sp}_n \mathbb{C})$. Choose n mutually nonisomorphic stable vector bundles W_1, \dots, W_n of rank 2 and trivial determinant. Then the bundle $\bigoplus_{i=1}^n W_i$ belongs to $\mathcal{M}_X(\mathrm{Sp}_n \mathbb{C})$.

For any direct sum $\bigoplus W_i$ of bundles of degree 0, it is clear that $D(\bigoplus W_i)$ exists if and only if $D(W_i)$ is defined for all i , in which case it is equal to $\sum D(W_i)$. We show that $D(W_i)$ is defined for all i . Choose any $L' \in J_X^{g-1}$; then $W_i \otimes L'$ is of slope $g - 1$. We quote a result of Raynaud:

Proposition 6.3 *Let $F \rightarrow X$ be a semistable bundle of rank at most 2 and slope $g - 1$. Then $h^0(X, M \otimes F) = 0$ for generic $M \in J_X^0$.*

Proof

This is a special case of Raynaud [46, Prop. 1.6.2]. \square

By Prop. 6.3, we have $h^0(X, M \otimes (L' \otimes W_i)) = 0$ for generic $M \in J_X^0$. But this is equivalent to $h^0(X, L \otimes W_i) = 0$ for generic $L \in J_X^{g-1}$ because J_X^{g-1} is a torsor over J_X^0 . Hence W_i admits a theta-divisor $D(W_i) \in |2\Theta|$. But every 2Θ -divisor is even since $h^0(J_X^{g-1}, 2\Theta)_- = 0$ by (6.1), so each $D(W_i)$ is the divisor of an ι^* -invariant section s_i of $\mathcal{O}_{J_X^{g-1}}(2\Theta)$. Then $D(\bigoplus_{i=1}^n W_i)$ is the divisor of

$$s_1 s_2 \cdots s_n \in H^0(X, \mathcal{O}_{J_X^{g-1}}(2n\Theta)),$$

which is also ι^* -invariant. Hence $D(\bigoplus_{i=1}^n W_i) \in |2n\Theta|_+$. This completes the proof of Lemma 6.2. \square

By Lemma 6.2, since $|2n\Theta|_+$ is a projective space, there exists a line bundle Ξ over $\mathcal{M}_X(\mathrm{Sp}_n \mathbb{C})$ such that $|2n\Theta|_+ = |\Xi|^*$ and $D = \phi_{|\Xi|}$. Now we claim that the base locus of $|\Xi|$ is exactly the set of Raynaud bundles. For any $L \in J_X^{g-1}$, we write H_L for the hyperplane of divisors containing L , that is, the point $\phi_{|2n\Theta|_+}(L)$. Then

$$\begin{aligned} W \text{ is Raynaud} &\iff W \in \bigcap_{L \in J_X^{g-1}} \mathrm{Supp}(D^*H_L) \text{ by definition} \\ &\iff W \in \bigcap_{H \in |2n\Theta|_+} \mathrm{Supp}(D^*H) \text{ since } \phi_{|2n\Theta|_+}(J_X^{g-1}) \text{ is nondegenerate} \\ &\iff W \text{ belongs to every } \Xi\text{-divisor, since } |2n\Theta|_+ = |\Xi|^* \\ &\iff W \text{ is a base point of } |\Xi|. \end{aligned}$$

Determinant bundles

Here we recall very briefly some facts about line bundles over the moduli space $\mathcal{M}_X(\mathrm{Sp}_2 \mathbb{C})$. For a general treatment of this kind of question, we refer to Beauville-Laszlo-Sorger [8], Laszlo-Sorger [27] and Sorger [51].

To a representation of $\mathrm{Sp}_2 \mathbb{C}$, we can associate a line bundle over $\mathcal{M}_X(\mathrm{Sp}_2 \mathbb{C})$, called the *determinant bundle* of the representation. Ξ is the determinant bundle of the standard representation of $\mathrm{Sp}_2 \mathbb{C}$, and the Picard group of $\mathcal{M}_X(\mathrm{Sp}_2 \mathbb{C})$ is $\mathbb{Z} \cdot \Xi$. To a representation ρ of $\mathrm{Sp}_2 \mathbb{C}$ we associate a number d_ρ called the *Dynkin index* of ρ , and the determinant bundle of ρ is Ξ^{d_ρ} . The canonical bundle of $\mathcal{M}_X(\mathrm{Sp}_2 \mathbb{C})$ is the dual of the determinant bundle of the adjoint representation, and is therefore Ξ^{-6} by [51, Tableau B], since $\mathrm{Sp}_2 \mathbb{C}$ is of type C_2 .

6.2 Theta-divisors of strictly semistable bundles

The first result, which holds in any genus, follows from Raynaud [46] and the description of the singular and strictly semistable loci of $\mathcal{M}_X(\mathrm{Sp}_2 \mathbb{C})$ in Chapter 2.

Lemma 6.4 *Any symplectic Raynaud bundles of rank 4 are stable vector bundles.*

Proof

We show that every strictly semistable symplectic vector bundle $W \rightarrow X$ of rank 4 admits a theta-divisor. By the description of the semistable boundary of $\mathcal{M}_X(\mathrm{Sp}_2 \mathbb{C})$ in Chapter 2, such a W is S -equivalent to a direct sum of stable bundles of rank 1 and/or 2 and degree 0. By Prop. 6.1, then, it suffices to prove that every such direct sum admits a theta-divisor. Since $D(\bigoplus W_i)$ exists if and only if $D(W_i)$ is defined for all i , we only have to show that every vector bundle $V \rightarrow X$ of degree 0 and rank at most 2 admits a theta-divisor. This follows by a similar argument to that in the last lemma when we proved that a direct sum of rank 2 vector bundles has a theta-divisor. \square

6.3 The genus 2 case

For the rest of this chapter, we suppose that X is of genus 2. Firstly, we would like to know how many Raynaud bundles to expect in this case.

Proposition 6.5 *If the base locus of $|\Xi|$ is of dimension 0 then it consists of at most 6 points. In particular, it is nonempty.*

Proof

Here, $\dim \mathcal{M}_X(\mathrm{Sp}_2 \mathbb{C}) = 10$, so if the number of base points is finite then it is given by $c_1(\Xi)^{10}$. To calculate this number, we follow an approach of Laszlo [25, § V, Lemma 5]. Consider the Hilbert function of Ξ . This is defined as

$$n \mapsto \chi(\mathcal{M}_X(\mathrm{Sp}_2 \mathbb{C}), \Xi^n).$$

For large enough n , this coincides with a polynomial $p(n)$. We claim that the leading term of $p(n)$ is $\frac{c_1(\Xi)^{10}}{10!}$. To see this, suppose α is the Chern root of Ξ . Then, by Hirzebruch-Riemann-Roch,

$$\chi(\mathcal{M}_X(\mathrm{Sp}_2 \mathbb{C}), \Xi^n) = \int_{\mathcal{M}_X(\mathrm{Sp}_2 \mathbb{C})} \exp(n\alpha) \mathrm{td}(\mathcal{M}_X(\mathrm{Sp}_2 \mathbb{C})).$$

Since $\alpha^i = 0$ for all $i \geq 11$, the only term which contains n^{10} here is $\frac{c_1(\Xi)^{10}}{10!}$ as required.

Now we have seen that $K_{\mathcal{M}_X(\mathrm{Sp}_2 \mathbb{C})} = \Xi^{-6}$. Hence, by Serre duality,

$$\begin{aligned} p(n) &= (-1)^{10} \chi(\mathcal{M}_X(\mathrm{Sp}_2 \mathbb{C}), K_{\mathcal{M}_X(\mathrm{Sp}_2 \mathbb{C})} \Xi^{-n}) \\ &= \chi(\mathcal{M}_X(\mathrm{Sp}_2 \mathbb{C}), \Xi^{-6-n}) \\ &= p(-6-n), \end{aligned}$$

equivalently, $p(n)$ is symmetric about $n = -3$.

By a result stated on p. 4 of Oxbury [37], we have $h^i(\mathcal{M}_X(\mathrm{Sp}_2 \mathbb{C}), \Xi^n) = 0$ for all $i > 0$ and $n > 0$.

Now for all $n < 0$, we have $h^0(\mathcal{M}_X(\mathrm{Sp}_2 \mathbb{C}), \Xi^n) = 0$ by stability. Thus

$$p(-5) = p(-4) = p(-3) = p(-2) = p(-1) = 0.$$

Hence

$$p(n) = \gamma(n+5)(n+4)(n+3)^2(n+2)(n+1)(n-\alpha)(n+6+\alpha)(n-\beta)(n+6+\beta)$$

for some $\alpha, \beta, \gamma \in \mathbb{R}$. We wish to find γ . To do this, we find the values of p at 0, 1 and 2. By the Verlinde formula (Oxbury-Wilson [39, § 2]), we have $p(0) = 1$ and $p(1) = 10$ and

$$p(2) = 2^2 \times 5^2 \times \sum \mathcal{S}(s, t)^{-2}$$

where

$$\mathcal{S}(s, t) = 2^4 \sin\left(\frac{\pi(s+t)}{5}\right) \sin\left(\frac{\pi t}{5}\right) \sin\left(\frac{\pi s}{10}\right) \sin\left(\frac{\pi(t+2s)}{10}\right)$$

and the sum is taken over all pairs s, t with $s, t \geq 1$ and $s+t \leq 4$. We calculate $p(2) = 58$ with Maple.

These values yield the equations

$$\begin{aligned} \gamma \cdot 5! \times 3(-\alpha)(6+\alpha)(-\beta)(6+\beta) &= 1, \\ \gamma \cdot 6! \times 3(1-\alpha)(7+\alpha)(1-\beta)(7+\beta) &= 10, \\ \gamma \cdot \frac{7!}{2} \times 3(2-\alpha)(8+\alpha)(2-\beta)(8+\beta) &= 58. \end{aligned}$$

Solving with Maple, we obtain $\gamma = 6 \times 10!^{-1}$ so $|\Xi|$ has 6 base points. \square

Remark: This number coincides with the number of Weierstrass points on a curve of genus 2. These are the ramification points of the hyperelliptic map $X \rightarrow |K_X|^*$, and are in canonical bijection with the odd theta-characteristics of X .

Theta-divisors exist for generic E

By Theorem 5.1 from the last chapter, $\mathcal{M}_X(\mathrm{Sp}_2 \mathbb{C})$ can be covered by projectivised extension spaces of the form

$$\mathbb{P} H^1(X, \mathrm{Sym}^2 E^*) =: \mathbb{P}_E^5$$

where $E \rightarrow X$ is a stable vector bundle of rank 2 and degree 1. In this section, we prove that the generic \mathbb{P}_E^5 contains no extensions without theta-divisors. The proof also allows us to deduce some necessary conditions on E in order for \mathbb{P}_E^5 to contain such an extension.

Firstly, we will need a technical result. Let F and G be vector bundles over X . We describe two maps between associated cohomology spaces. The first one,

$$\cup: H^1(X, \mathrm{Hom}(G, F)) \rightarrow \mathrm{Hom}(H^0(X, G) \rightarrow H^1(X, F)),$$

given as follows. Let $p \in \mathrm{Prin}(\mathrm{Hom}(G, F))$ and $[p] \in H^1(X, \mathrm{Hom}(G, F))$ its cohomology class; since $H^1(X, \underline{\mathrm{Rat}}(\mathrm{Hom}(G, F)))$ is trivial, every cohomology class in $H^1(X, \mathrm{Hom}(G, F))$ is of this form. Then

$$\cup[p]: H^0(X, G) \rightarrow H^1(X, F)$$

is the map $t \rightarrow t \cup [p] = [p(t)]$; this is as before easily checked to be independent of the choice of p representing $[p]$.

The second map,

$$m: H^0(X, G) \otimes H^0(X, K_X \otimes F^*) \rightarrow H^0(X, K_X \otimes F^* \otimes G)$$

is the natural multiplication map of sections.

Proposition 6.6 *The maps \cup and m are canonically dual by Serre duality.*

Proof (well-known)

Let $V \rightarrow X$ be any vector bundle. We make explicit the identification $H^1(X, V) \xrightarrow{\sim} H^0(X, K_X \otimes V^*)^*$ by Serre duality. Let $[q] \in H^1(X, V)$. Then $[q]$ defines a linear form on $H^0(X, V^* \otimes K_X)$ by

$$t \mapsto [\langle q, t \rangle]$$

for any global section t of $K_X \otimes V^*$. The class $[\langle q, t \rangle]$ belongs to $H^1(X, K_X) = \mathbb{C}$, so we get the required linear form.

Let $[p] \in H^1(X, \text{Hom}(G, F))$. A priori, $m^*[p]$ is a linear form on $H^0(X, G) \otimes H^0(X, K_X \otimes F^*)$; we interpret it as a map $H^0(X, G) \rightarrow H^0(X, K_X \otimes F^*)^*$ by sending a global section t of G to

$$s \mapsto m^*[p](s \otimes t) = [\langle p(t), s \rangle].$$

The principal part $p(t) \otimes s$ belongs to $\text{Prin}(F \otimes K_X \otimes F^*)$. The contraction $\langle p(t), s \rangle$ is then an element of $\text{Prin}(K_X)$, with cohomology class in $H^1(X, K_X) = \mathbb{C}$, so $m^*[p](t)$ is a linear form on $H^0(X, K_X \otimes F^*)$.

Now let $t \in H^0(X, G)$ and consider the element $t \cup [p] \in H^1(X, F)$. This defines a linear form on $H^0(X, K_X \otimes F^*)$ by

$$s \mapsto [\langle p(t), s \rangle]$$

which is clearly the same linear form as $m^*[p](t)$. Thus $\cdot \cup [p]$ and $m^*[p]$ are identified as maps

$$H^0(X, G) \rightarrow H^0(X, K_X \otimes F^*)^*.$$

This shows that \cup and m^* are identified as maps

$$H^0(X, \text{Hom}(G, F)) \rightarrow \text{Hom}(H^0(X, G), H^0(X, K_X \otimes F^*)^*).$$

The proposition now follows by Serre duality. \square

Remark: One useful case of this result is the following. If $G = F$ then we can compose the contraction

$$c: H^0(X, F \otimes K_X \otimes F^*) \rightarrow H^0(X, K_X)$$

with m . Then $(c \circ m)^* = m^* \circ c^*$, and one can show in a similar way that c is dual to the map

$$H^1(X, \mathcal{O}_X) \rightarrow H^1(X, F^* \otimes F)$$

given by $[p] \mapsto [p \cdot \text{Id}_F]$.

We now describe a rational map $J_X^1 \dashrightarrow (\mathbb{P}_E^5)^*$. We claim that

$$h^0(X, L \otimes E) \cdot h^0(X, K_X L^{-1} \otimes E) = 1$$

for generic $L \in J_X^1$. To see this, note that by Riemann-Roch, $h^0(X, L \otimes E) \geq 2$ if and only if $h^1(X, L \otimes E)$ is nonzero. By Serre duality, $h^1(X, L \otimes E) = h^0(X, K_X L^{-1} \otimes E^*)$. But by Lemma 4.3, this is nonzero for at most four L . Similarly $h^0(X, K_X L^{-1} \otimes E)$ is greater than 1 for at most four L . Thus $h^0(X, L \otimes E) \cdot h^0(X, K_X L^{-1} \otimes E)$ is different from 1 for at most eight L . We write U for the (open) complement of these points in J_X^1 .

For each $L \in U$, we can consider the composed map \tilde{m}

$$\begin{array}{ccc} H^0(X, L \otimes E) \otimes H^0(X, K_X L^{-1} \otimes E) & \xrightarrow{m} & H^0(X, K_X \otimes E \otimes E) \\ & & \downarrow \\ & & H^0(X, K_X \otimes \text{Sym}^2 E) \end{array}$$

We claim that the image of \tilde{m} is of dimension 1; this follows from the last paragraph and the fact that no nonzero decomposable vector is antisymmetric. Thus we can define a rational map $j: J_X^1 \dashrightarrow (\mathbb{P}_E^5)^*$ by

$$L \mapsto (\text{image of } \tilde{m}).$$

We write U for the open set of J_X^1 where j is defined.

Now by Serre duality, a nontrivial symplectic extension

$$0 \rightarrow E^* \rightarrow W \rightarrow E \rightarrow 0 \quad (\delta(W))$$

of class $\delta(W) \in H^1(X, \text{Sym}^2 E^*)$ defines a linear form on $H^0(X, K_X \otimes \text{Sym}^2 E)$, also denoted $\delta(W)$, whose kernel defines a hyperplane H_W in $\mathbb{P} H^0(X, K_X \otimes \text{Sym}^2 E)$.

The main tool of this section is

Lemma 6.7 *Let $W \in \mathbb{P}_E^5$ be a symplectic extension and $L \rightarrow X$ a line bundle of degree 1 belonging to $U \subset J_X^1$. Then $h^0(X, L \otimes W) > 0$ if and only if $j(L) \in H_W$.*

Proof

Tensoring the sequence $(\delta(W))$ by L , we get the cohomology sequence

$$0 \rightarrow H^0(X, L \otimes W) \rightarrow H^0(X, L \otimes E) \rightarrow H^1(X, L \otimes E^*) \rightarrow \dots$$

whence $h^0(X, L \otimes W) > 0$ if and only if the boundary map has a kernel. But by Lemma 3.3 (i), this is none other than $\cdot \cup \delta(W)$. By hypothesis,

$$h^0(X, K_X L^{-1} \otimes E^*) = h^1(X, L \otimes E) = 0$$

so $h^0(X, L \otimes E) = 1$ by Riemann-Roch. Similarly, $h^0(X, K_X L^{-1} \otimes E) = 1$. Thus $h^0(X, L \otimes W) > 0$ if and only if $\cdot \cup \delta(W) = 0$. By Prop. 6.6 (with $F = L \otimes E^*$ and $G = L \otimes E$), this is equivalent to

$$m: H^0(X, L \otimes E) \otimes H^0(X, K_X L^{-1} \otimes E) \rightarrow H^0(X, K_X \otimes E \otimes E)$$

being the zero map; that is, $m^* \delta(W) = \delta(W) \circ m = 0$, equivalently $\text{Im}(m) \subset \text{Ker}(\delta(W))$. Since $\delta(W)$ is symmetric, $\text{Im} \tilde{m} \subset \text{Ker}(\delta(W))$ if and only if $\text{Im}(m) \subset \text{Ker}(\delta(W))$. Projectivising, this becomes $j(L) \in H_W$ (our hypothesis of generality on L implies that $j(L)$ is defined). \square

By Lemma 6.7, we see that \mathbb{P}_E^5 contains an extension without a theta-divisor if and only if the image of j is contained in a hyperplane $H \subset (\mathbb{P}_E^5)^*$. The extension will then be that W such that $H_W = H$.

Lemma 6.8 *For general $E \in \mathcal{U}_X(2, 1)$, the image of j is nondegenerate.*

Proof

We recall that E has at least one line subbundle of degree 0, by Lemma 4.3. We state precisely our hypotheses of generality on E :

- At least one degree 0 line subbundle $M \subset E$ is not a point of order 2.
- For each such M , there is a unique pair of points $q_1, q_2 \in X$ such that

$$K_X M^2 = \mathcal{O}_X(q_1 + q_2).$$

On the other hand, we saw in the proof of Lemma 4.2 that the class $\langle \delta(E) \rangle \in \mathbb{P}H^1(X, \text{Hom}(L, M))$ can be identified with a divisor $p_1 + p_2 + p_3 \in |K_X LM^{-1}|$.

We require that for at least one such $M \subset E$,

$$\{q_1, q_2\} \cap \{\iota p_1, \iota p_2, \iota p_3\} = \emptyset.$$

We have a short exact sequence

$$0 \rightarrow M \rightarrow E \xrightarrow{b} N \rightarrow 0 \quad (6.2)$$

where $N \rightarrow X$ is a line bundle of degree 1. We claim that this induces a short exact sequence

$$0 \rightarrow K_X M^2 \rightarrow K_X \otimes \text{Sym}^2 E \xrightarrow{c} K_X N \otimes E \rightarrow 0$$

where c is induced by the map $E \otimes E \rightarrow N \otimes E$ given by

$$e \otimes f \mapsto b(e) \otimes f + b(f) \otimes e.$$

We work with the map induced by c on the associated locally free \mathcal{O}_X -modules. Let $e, f \in \mathcal{E}_x$ be such that $e \in \mathcal{M}_x$ but f is not. Then the image of $e \otimes f + f \otimes e$ belongs to $\mathcal{N} \otimes \mathcal{M}$ but that of $f \otimes f$ does not. Thus the image contains two linearly independent elements of $\mathcal{N} \otimes \mathcal{E}$, so the map on sheaves is surjective. The kernel of c clearly contains M^2 , so is equal to it since they are of the same rank and degree. This establishes the claim.

The associated cohomology sequence is

$$0 \rightarrow H^0(X, K_X M^2) \rightarrow H^0(X, K_X \otimes \text{Sym}^2 E) \rightarrow H^0(X, K_X N \otimes E) \rightarrow 0$$

since M^2 is nontrivial.

We now show that $\mathbb{P}H^0(X, K_X M^2)$ is spanned by points of $j(U)$. We see that $j(L)$ belongs to this space if and only if $L \in U$ and

$$L^{-1} = M(-x) \quad \text{and} \quad K_X^{-1}L = M(-y)$$

for some points x, y of the curve. This condition can be interpreted geometrically as $L \in t_{M^{-1}}\Theta \cap t_M\Theta$ (notice that in genus 2 there is a canonical isomorphism $X \xrightarrow{\sim} \text{Supp } \Theta$). If M^2 is nontrivial then this consists generically of $\Theta^2 = g = 2$

points, which are exchanged by ι . We deduce that $K_X M^2 = \mathcal{O}_X(x + y)$; therefore we take $L = M(\iota q_1) = M^{-1}(q_2)$ where q_1 and q_2 are as defined above. We check that j is defined at these points. It is necessary that neither $M(\iota q_1) = M^{-1}(q_2)$ nor its image $M(\iota q_2) = M^{-1}(q_1)$ under the Serre involution be a quotient of E or the Serre image of a quotient of E , that is,

$$\{M(\iota q_1), M(\iota q_2)\} \cap \{N, KN^{-1}, M(p_i), K_X M^{-1}(-p_i)\} = \emptyset.$$

Since the set where j is not defined is ι -invariant, it suffices to check that neither $M(\iota q_j)$ is equal to N or $M(p_i)$.

If $M(\iota q_j) = N$ then $\mathbb{P}H^1(X, \text{Hom}(N, M)) \cong |K_X(\iota q_j)|$ and

$$p_1 + p_2 + p_3 = \iota q_j + r + \iota r$$

for some $r \in X$. Thus $q_j = \iota p_i$ for some i, j . On the other hand, if $M(\iota q_j) = M(p_i)$ then $q_j = \iota p_i$. By our second assumption of generality, then, j is defined at both $M(\iota q_j)$, and $\mathbb{P}H^0(X, K_X M^2)$ belongs to $j(U)$.

Now K_X tensored with (6.2) yields the cohomology sequence

$$0 \rightarrow H^0(X, K_X M) \rightarrow H^0(X, K_X \otimes E) \rightarrow H^0(X, K_X N) \rightarrow 0$$

and we have the diagram

$$\begin{array}{ccccccc}
 & & & & & & 0 \\
 & & & & & & \downarrow \\
 & & & & & & H^0(X, K_X NM) \\
 & & & & & & \downarrow \\
 0 & \longrightarrow & H^0(X, K_X M^2) & \longrightarrow & H^0(X, K_X \otimes \text{Sym}^2 E) & \xrightarrow{c} & H^0(X, K_X N \otimes E) \longrightarrow 0 \\
 & & & & \searrow & & \downarrow \\
 & & & & & & H^0(X, K_X N^2) \\
 & & & & & & \downarrow \\
 & & & & & & 0
 \end{array}$$

By abuse of notation, we also write c and d for $\mathbb{P}c$ and $\mathbb{P}d$. It is enough to show that $c \circ j(U)$ is nondegenerate in $\mathbb{P}H^0(X, K_X N \otimes E)$. In turn, it suffices to show that $\mathbb{P}H^0(X, K_X NM)$ is spanned and that $d \circ j(U)$ is nondegenerate in $\mathbb{P}H^0(X, K_X N^2)$.

By the definition of c , we have $c \circ j(L) \in \mathbb{P}H^0(X, K_X LM)$ if $L^{-1} = M(-x)$ for some $x \in X$ but $K_X^{-1}L \neq M(-y)$ for any $y \in X$, or vice versa. This is equivalent to L belonging to the symmetric difference of $t_{M^{-1}}\Theta$ and $t_M\Theta$. Since $M \neq M^{-1}$, we can find infinitely many such L . We need to find two which define different divisors in $|K_X NM|$. We observe that if x is not a base point of $|K_X NM|$ then $c \circ j(M^{-1}(x))$ is the divisor in $|K_X NM|$ containing x . Thus if neither x nor y is a base point and they belong to different divisors of $|K_X NM|$ then the images of $j(M^{-1}(x))$ and $j(M^{-1}(y))$ generate $\mathbb{P}H^0(X, K_X NM)$.

Finally, we have $d \circ j(L) \in \mathbb{P}H^0(X, K_X N^2)$ if and only if neither L^{-1} nor $K_X^{-1}L$ is of the form $M(-x)$, equivalently, L does not belong to the union $t_{M^{-1}}\Theta \cup t_M\Theta$. In fact $d \circ j$ is dominant. Let $x_1 + x_2 + x_3 + x_4$ be any divisor in $|K_X N^2|$. For generic x_1 and x_2 , we know that $N^{-1}(x_1 + x_2)$ will not belong to $t_{M^{-1}}\Theta \cup t_M\Theta$, so we can put $L = N^{-1}(x_1 + x_2)$ and then

$$K_X L^{-1} = K_X N(-x_1 - x_2) = N^{-1}(x_3 + x_4).$$

Thus $d \circ j$ is dominant (and generically of degree 6). In particular, the image spans $|K_X L^2| = \mathbb{P}^2$. \square

Remark: The proof of Lemma 6.8 shows that in order for \mathbb{P}_E^5 to contain an extension without a theta-divisor, the following condition must hold: for each pair (M, N) of line bundles of degree 0 and 1 respectively such that E fits into a short exact sequence

$$0 \rightarrow M \rightarrow E \rightarrow N \rightarrow 0,$$

we have either

- M is a point of order 2 in J_X^0 .
- The class $\langle \delta(E) \rangle \in |K_X NM^{-1}|$ contains q_1 or q_2 , where $K_X M^2 = \mathcal{O}_X(q_1 + q_2)$.

Line of enquiry: These conditions suggest that one should perhaps look for the base points of $|\Xi|$ in those \mathbb{P}_E^5 such that all degree 0 line subbundles of E are of order 2. We show how to construct E with four distinct subbundles of order 2. Let

w_1, w_2 and w_3 be distinct Weierstrass points on X and consider extensions

$$0 \rightarrow \mathcal{O}_X(w_1 - w_2) \rightarrow E \rightarrow \mathcal{O}_X(w_3) \rightarrow 0$$

with classes in $|w_1 + w_2 + w_3|$. Then the extension corresponding to the divisor $w_1 + w_2 + w_3$ has the degree 0 line subbundles

$$\mathcal{O}_X(w_1 - w_2), \mathcal{O}_X(w_3 - w_1), \mathcal{O}_X(w_3 - w_2) \text{ and } \mathcal{O}_X$$

which are all of order 2.

One can also construct E with only one subbundle of degree 0, which may be a point of order 2. Let $L \rightarrow X$ be a line bundle of degree 0 and consider extensions

$$0 \rightarrow L \rightarrow E \rightarrow L(w) \rightarrow 0$$

where $w \in X$ is a Weierstrass point. Then $\mathbb{P}H^1(X, \text{Hom}(L(w), L)) \cong |K_X(w)|$. One checks easily using Lemma 4.1 and Serre duality that the extension with class corresponding to $3w$ has only the line subbundle L , which may be of order 2.

This is a problem I hope to continue studying. It is related to the Brill-Noether problem for vector bundles, that is, to determine the loci in the moduli space $\mathcal{U}_X(r, d)$ of stable bundles with at least a prescribed number of independent global sections. See Mercat [31] for an overview.

Symplectic bundles with singular theta-divisors

In this section, we characterise those stable symplectic vector bundles W of rank 4 over a curve X of genus 2 such that $D(W)$ is singular, when it exists.

Criterion 6.9 *Let $W \rightarrow X$ be a stable symplectic vector bundle of rank 4 such that $D(W)$ is defined. Suppose $L \in S(W)$. Then the subsheaf*

$$\mathcal{L}^{-1} \oplus \mathcal{K}_X^{-1} \mathcal{L} \subset \mathcal{W}$$

is isotropic if and only if $D(W)$ is singular at L .

Proof

We begin by quoting a result of Laszlo.

Proposition 6.10 *For each stable bundle W of rank 2 and degree 0, we have $\text{mult}_L D(W) \geq h^0(X, L \otimes W)$ with equality if and only if there exists $v \in H^1(X, \mathcal{O}_X)$ such that $\cdot \cup v: H^0(X, L \otimes W) \rightarrow H^1(X, L \otimes W)$ is injective.*

Proof

Adapted from Laszlo [26, Prop. V.2]; the statement in this paper is for W of slope $g - 1$ and $D(W)$ is taken to be a divisor on J_X^0 . \square

Now the only obstacle to Prop. 6.10 holding in rank r is that not every bundle of higher rank possesses a theta-divisor. Thus we may assume it for those stable vector bundles $W \in \mathcal{M}_X(\text{Sp}_2 \mathbb{C})$ which do. By Lemma 6.8 and the discussion in the last section, this is the case for generic W . Explicitly, $\text{mult}_L D(W) \geq h^0(X, L \otimes W)$, with strict inequality if and only if the cup-product map

$$\cdot \cup v: H^0(X, L \otimes W) \rightarrow H^1(X, L \otimes W)$$

has a kernel for every $v \in H^1(X, \mathcal{O}_X)$.

We treat the cases $h^0(X, L \otimes W) \geq 2$ and $h^0(X, L \otimes W) = 1$ separately.

$h^0(X, L \otimes W) \geq 2$: Then $D(W)$ is always singular at L , by Prop. 6.10. We show that there are always nonzero maps $s: L^{-1} \rightarrow W$ and $t: K_X^{-1}L \rightarrow W$ such that $\omega(s(L^{-1}), t(K_X^{-1}L)) = 0$.

We have seen that $h^0(X, K_X L^{-1} \otimes W) = h^0(X, L \otimes W)$, and for the moment we suppose that both are equal to 2. Consider the map

$$m: H^0(X, L \otimes W) \otimes H^0(X, K_X L^{-1} \otimes W) \rightarrow H^0(X, K_X)$$

where we identify W with W^* via ω . Note that this depends on the form ω , but since W is stable, ω is unique up to nonzero multiplicative scalar and the kernel of m is independent of the choice. This kernel is of dimension at least 2, because $h^0(X, K_X) = g = 2$. We need a technical result:

Proposition 6.11 *Let V_1 and V_2 be vector spaces of dimension k . Then the decomposable locus S of $V_1 \otimes V_2$ is of dimension $2k - 1$.*

Proof

The association $v \otimes v' \mapsto \langle v \rangle$ gives a well-defined map $\pi: S \rightarrow \mathbb{P}V_2$, which is clearly surjective. The fibre

$$\pi^{-1}\langle v \rangle = \{v \otimes v' : v' \in V_2\}$$

is isomorphic to V_2 because $v \otimes v'_1 = v \otimes v'_2$ if and only if $v'_1 = v'_2$. Hence

$$\dim S = \dim V_1 + \dim V_2 - 1 = 2k - 1$$

as required. \square

Now there exists at least one decomposable element $s \otimes t \in \text{Ker}(\widetilde{m}_L)$ since by Prop. 6.11 the decomposable locus is of dimension 3. Then the image

$$(s, t) (\mathcal{L}^{-1} \oplus \mathcal{K}_X^{-1} \mathcal{L})$$

is isotropic in \mathcal{W} .

If $h^0(X, L \otimes W) \geq 3$ then we choose any 2-dimensional subspaces of $H^0(X, L \otimes W)$ and $H^0(X, K_X L^{-1} \otimes W)$ and apply the above argument. This proves the criterion if $h^0(X, L \otimes W) \geq 2$.

Lastly, we suppose that $h^0(X, L \otimes W) = 1$. Then the image of $L^{-1} \oplus K_X^{-1} L$ in \mathcal{W} is isotropic if and only if

$$m: H^0(X, L \otimes W) \otimes H^0(X, K_X L^{-1} \otimes W) \rightarrow H^0(X, K_X)$$

is zero. By Prop. 6.6 and the remark following it, this is equivalent to

$$\cup: H^1(X, \mathcal{O}_X) \rightarrow \text{Hom}(H^0(X, L \otimes W), H^1(X, L \otimes W))$$

being the zero map. Because $h^0(X, L \otimes W) = h^0(X, K_X L^{-1} \otimes W) = 1$, we see that $\cup = 0$ if and only if the cup-product map $\cdot \cup v$ has a kernel for all $v \in H^1(X, \mathcal{O}_X)$. By Prop. 6.10, this last condition is equivalent to $\text{mult}_L D(W)$ being strictly bigger than $h^0(X, L \otimes W) = 1$, that is $D(W)$ being singular at L . \square

Caution: Criterion 6.9 is false if W is strictly semistable. For example, let $V \in \text{SU}_X(2, \mathcal{O}_X)$ be a stable symplectic bundle of rank 2 and $M \in J_X^0[2]$ be a

line bundle of order 2. The direct sum $W := V \oplus M \oplus M$ is a strictly semistable symplectic bundle of rank 4 over X . Its (nonreduced) theta-divisor $D(W)$ is equal to $D(V) + 2(t_M\Theta)$.

Now let L be a point of $t_M\Theta$ which does not belong to $\text{Supp } D(V) \cap \text{Supp } t_M\Theta$. We have $\text{mult}_L D(W) = 2 = h^0(X, L \otimes W)$ and \mathcal{W} contains a subsheaf $\mathcal{L}^{-1} \oplus \mathcal{K}_X^{-1} \mathcal{L}$, which is contained in $\mathcal{M} \oplus \mathcal{M}$. Since the symplectic form on W is the sum of those on V and on $M \oplus M$, the subsheaf $\mathcal{L}^{-1} \oplus \mathcal{K}_X^{-1} \mathcal{L}$ is isotropic if and only if it is isotropic with respect to the symplectic form on $M \oplus M$. But this is impossible since $\text{rk}(\mathcal{L}^{-1} \oplus \mathcal{K}_X^{-1} \mathcal{L}) > \frac{1}{2} \text{rk}(M \oplus M)$.

Appendix A

Results needed in the proof of Theorem 1.4

In this appendix we prove some of the more technical results needed in the proof of Thm. 1.4.

Let Y be a smooth variety of any dimension. Recall that $\mathbf{Bun}_Y(G)$ is the category whose objects are principal G -bundles over Y and whose morphisms are G -bundle isomorphisms, and $\mathbf{Vect}_Y^{\text{symp}}(2n)$ is the category whose objects are pairs (W, ω) where $W \rightarrow Y$ is a vector bundle of rank $2n$ and $\omega \in H^0(Y, \bigwedge^2 W^*)$ a symplectic form on W and whose morphisms are isomorphisms $H: W \rightarrow W'$ such that $H^*\omega' = \omega$.

Proposition A.1 *Let W be a symplectic vector bundle of rank $2n$ over Y . Then there exist trivialisations of W with respect to which the symplectic form is given by the matrix*

$$\begin{pmatrix} 0 & I_n \\ -I_n & 0 \end{pmatrix};$$

equivalently, whose transition functions belong to the standard representation of $\text{Sp}_n \mathbb{C}$ on \mathbb{C}^{2n} .

Proof (well-known)

This can be done by choosing an open cover over which W is trivial and then making a coordinate change over each open set in the covering. \square

Theorem 1.5 *The categories $\mathbf{Bun}_Y(\mathrm{Sp}_n \mathbb{C})$ and $\mathbf{Vect}_Y^{\mathrm{symp}}(2n)$ are equivalent.*

Proof (well known)

Recall that a *frame* for a complex vector space V of dimension $2n$ is an identification $f: \mathbb{C}^{2n} \xrightarrow{\sim} V$. We consider the symplectic form ω_0 on \mathbb{C}^{2n} given with respect to the standard basis by the matrix

$$\begin{pmatrix} 0 & I_n \\ -I_n & 0 \end{pmatrix}.$$

When V carries a symplectic form ω , we may consider frames that carry ω_0 into ω , that is, $f^*\omega = \omega_0$.

To a symplectic vector bundle $W \rightarrow Y$ we associate a principal $\mathrm{Sp}_n \mathbb{C}$ -bundle, the *symplectic frame bundle* of W (see for example Bradlow [10, Lecture 5]). Let $\{U_i : i \in J\}$ be an open cover of Y over which W is trivial. For each $y \in U_i$, we have, by Prop. A.1, a frame $\phi_i^{-1}|_y$ for the fibre $W|_y$ such that $(\phi_i|_y)^*\omega_0 = \omega|_y$. Then, by definition, all such frames for $W|_y$ are given by

$$\{\phi_i^{-1}|_y \circ h : h \in \mathrm{Sp}_n \mathbb{C}\}.$$

We define the symplectic frame bundle $\mathbf{F}(W)$ of W to be the collection of all such frames over each $y \in Y$. It has local trivialisations $\tilde{\phi}_i: \mathbf{F}(W)|_{U_i} \xrightarrow{\sim} U_i \times \mathrm{Sp}_n \mathbb{C}$ induced by those of W ; precisely,

$$\tilde{\phi}_i(\phi_i^{-1}|_y \circ h) = (y, h).$$

Clearly $\tilde{\phi}_i$ is equivariant for the right actions of $\mathrm{Sp}_n \mathbb{C}$. The transition functions

$$\tilde{w}_{i,j}: \tilde{\phi}_j(\mathbf{F}(W)|_{U_i \cap U_j}) \xrightarrow{\sim} \tilde{\phi}_i(\mathbf{F}(W)|_{U_i \cap U_j}),$$

that is,

$$U_i \cap U_j \times \mathrm{Sp}_n \mathbb{C} \xrightarrow{\sim} U_i \cap U_j \times \mathrm{Sp}_n \mathbb{C},$$

are given by

$$(y, h) \mapsto \phi_j^{-1}|_y \circ h = (\phi_i^{-1} \circ w_{i,j}|_y) \circ h \mapsto (y, w_{i,j}|_y \circ h)$$

(notice that $w_{i,j}|_y$ is an element of $\mathrm{Sp}_n \mathbb{C}$). Clearly these are also $\mathrm{Sp}_n \mathbb{C}$ -right-equivariant.

To make this association into a functor, we need to specify what it does to morphisms. Let $(V, \theta) \rightarrow X$ be another rank $2n$ symplectic vector bundle and $H: (W, \omega) \rightarrow (V, \theta)$ an isomorphism of symplectic vector bundles. Given a frame

$$f: \{y\} \times \mathbb{C}^{2n} \rightarrow W|_y$$

for any $y \in Y$, the association

$$\mathbf{F}(H): f \mapsto H|_y \circ f$$

is an $\mathrm{Sp}_n \mathbb{C}$ -equivariant map $\mathbf{F}(W)|_y \rightarrow \mathbf{F}(V)|_y$ which is clearly functorial.

We check that F is fully faithful. Let $\Psi: \mathbf{F}(W) \rightarrow \mathbf{F}(V)$ be an $\mathrm{Sp}_n \mathbb{C}$ -equivariant isomorphism. Define a map $H: W \rightarrow V$ as follows. For each $f \in \mathbf{F}(W)|_y$, we have a diagram

$$\begin{array}{ccc} & & W|_y \\ & \nearrow f & \\ \mathbb{C}^{2n} & & \\ & \searrow \Psi(f) & \\ & & V|_y \end{array}$$

We define $H|_y = \Psi(f) \circ f^{-1}$. We check that it is independent of f . By definition, any other symplectic frame for $W|_y$ is of the form $f \circ g$ for some $g \in \mathrm{Sp}_n \mathbb{C}$. Now

$$\begin{aligned} \Psi(f \circ g) \circ (f \circ g)^{-1} &= \Psi(f) \cdot g \circ g^{-1} \circ f^{-1} \text{ by equivariance} \\ &= \Psi(f) \circ f^{-1} \\ &= H|_y. \end{aligned}$$

By construction, H is uniquely determined, and $\mathbf{F}(H) = \Psi$. Thus we have a bijection between $\mathrm{Hom}_{\mathrm{Symplectic}}(W, V)$ and $\mathrm{Hom}_{\mathrm{Sp}_n \mathbb{C}}(\mathbf{F}(W), \mathbf{F}(V))$.

We show that the functor $W \mapsto \mathbf{F}(W)$ is essentially surjective. Given a principal $\mathrm{Sp}_n \mathbb{C}$ -bundle $E \rightarrow Y$ with transition functions $\{e_{i,j}\}$, we can construct the associated vector bundle

$$E(\mathbb{C}^{2n}) := \left(\coprod_{i \in I} U_i \times \mathbb{C}^{2n} \right) / \{e_{i,j}\}.$$

By construction, the transition functions of the principal $\mathrm{Sp}_n \mathbb{C}$ -bundle $\mathbf{F}(E(\mathbb{C}^{2n}))$ are just those of E , so this is an inverse construction for \mathbf{F} . Hence the theorem. \square

The orthogonal analogue of the following lemma is stated in Oxbury-Ramanan [38, § 2]. For results on Jordan-Hölder gradings, we refer to Le Potier [29, p. 76].

Lemma 1.9 *Let $W \rightarrow X$ be a semistable vector bundle with a symplectic form ω . Then there exists a filtration*

$$0 \subset W_1 \subset \cdots \subset W_k \subseteq W_k^\perp \subset W_{k-1}^\perp \subset \cdots \subset W_1^\perp \subset W$$

where each W_i is an isotropic subbundle of degree 0 and $\frac{W_i}{W_{i-1}}$ is a stable vector bundle for each $i = 1, \dots, k$. Then the associated graded bundle of this filtration is isomorphic to

$$\bigoplus_{i=1}^k \left(\frac{W_i}{W_{i-1}} \oplus \left(\frac{W_i}{W_{i-1}} \right)^* \right) \oplus \frac{W_k^\perp}{W_k}$$

and is the usual Jordan-Hölder grading of W . Moreover, ω induces a symplectic form on $\mathrm{gr}_v W$.

Proof

We check that such a filtration always exists. If W has no nonzero isotropic subbundles of degree 0 then $0 = W_0 \subset W_0^\perp = W$ trivially satisfies the requirements. Otherwise, from among the nonzero isotropic degree 0 subbundles of W we choose one W_1 (not necessarily unique) which has minimal rank. This is stable since any degree 0 subbundles of W_1 would also be isotropic, contradicting minimality. If W_1 is not contained in any degree 0 isotropic subbundle of higher rank then

$$0 \subset W_1 \subseteq W_1^\perp \subset W$$

is the required filtration. Otherwise, we can choose some W_2 which has minimal rank among those isotropic degree 0 subbundles strictly containing W_1 , and so on. This process must stop because an isotropic subbundle has rank at most n .

Given such a filtration, we note that there are no degree 0 subbundles between any W_{i-1} and W_i . For such a subbundle would be isotropic and its image in $\frac{W_i}{W_{i-1}}$

would destabilise this bundle, contrary to hypothesis. This then implies that there are no degree 0 subbundles $W' \subset W$ satisfying $W_i^\perp \subset W' \subset W_{i-1}^\perp$, for then $(W')^\perp$ would be a degree 0 subbundle strictly contained between W_{i-1} and W_i .

Therefore, we can complete the given filtration to a Jordan-Hölder one by adding some (nonisotropic) bundles of degree 0 between W_k and W_k^\perp if necessary.

We now notice that ω induces a symplectic form on

$$\frac{W_i}{W_{i-1}} \oplus \frac{W_{i-1}^\perp}{W_i^\perp}$$

and also descends to $\frac{W_k^\perp}{W_k}$, so we have a symplectic structure on the graded bundle of this filtration. In particular, we get the required isomorphism

$$\frac{W_{i-1}^\perp}{W_i^\perp} \xrightarrow{\sim} \left(\frac{W_i}{W_{i-1}} \right)^*$$

for each $i = 1, \dots, k$.

If there are no degree 0 subbundles of W contained between W_k and W_k^\perp then we are done. Otherwise, suppose we have completed the filtration to

$$0 \subset W_1 \subset \dots \subset W_k \subset W_{k+1} \subset \dots \subset W_{k+l} \subset W_k^\perp \subset W_{k-1}^\perp \subset \dots \subset W_1^\perp \subset W$$

where all the quotients $\frac{W_i}{W_{i-1}}$ for $i = k+1, \dots, k+l$ and $\frac{W_k^\perp}{W_{k+l}}$ are stable vector bundles.

Now $\text{gr}_v W$ is isomorphic to

$$\bigoplus_{i=1}^k \left(\frac{W_i}{W_{i-1}} \oplus \left(\frac{W_i}{W_{i-1}} \right)^* \right) \oplus \left(\bigoplus_{i=k+1}^{k+l} \frac{W_i}{W_{i-1}} \right) \oplus \frac{W_k^\perp}{W_{k+l}}.$$

Therefore, we have to show that

$$\frac{W_k^\perp}{W_k} \cong \left(\bigoplus_{i=k+1}^{k+l} \frac{W_i}{W_{i-1}} \right) \oplus \frac{W_k^\perp}{W_{k+l}}.$$

Now we have seen that $\frac{W_k^\perp}{W_k}$ carries a nondegenerate symplectic form. It has no nonzero isotropic subbundles of degree 0 since such a subbundle would come from a degree 0 isotropic subbundle of W strictly containing W_k , contrary to hypothesis. By Lemma 1.6, it corresponds to a *stable* principal $\text{Sp}_m \mathbf{C}$ -bundle for some $m \geq 0$.

We have a filtration of $\frac{W_k^\perp}{W_k}$:

$$0 \rightarrow \frac{W_{k+1}}{W_k} \subset \frac{W_{k+2}}{W_k} \subset \dots \subset \frac{W_{k+l}}{W_k} \subset \frac{W_k^\perp}{W_k}.$$

Since the subbundle $\frac{W_{k+l}}{W_k}$ is not isotropic, by the proof of Lemma 2.1 it splits off $\frac{W_k^\perp}{W_k}$ as a direct summand, and the complementary summand is

$$\frac{W_k^\perp/W_k}{W_{k+l}/W_k} \cong \frac{W_k^\perp}{W_{k+l}},$$

moreover, both summands are symplectic vector bundles. Repeating this procedure with $\frac{W_{k+l-1}}{W_k} \subset \frac{W_{k+l}}{W_k}$ and so on, we see that

$$\frac{W_k^\perp}{W_k} = \left(\bigoplus_{i=k+1}^{k+l} \frac{W_i}{W_{i-1}} \right) \oplus \frac{W_k^\perp}{W_{k+l}}.$$

This completes the proof of the proposition. \square

Proposition 1.10 *Let P be a subgroup of the group of invertible matrices of the form*

$$\begin{pmatrix} A_1 & * & * & \cdots & * \\ 0 & A_2 & * & \cdots & * \\ \vdots & & \ddots & & \vdots \\ 0 & \cdots & & A_{k-1} & * \\ 0 & \cdots & & 0 & A_k \end{pmatrix}$$

where the $A_i \in \text{GL}_{m_i} \mathbb{C}$ for some m_1, \dots, m_k . (For example, P might preserve a bilinear form.) Then the group of characters of P is generated by the characters of the blocks along the diagonal.

Proof (shown to me by C. Pauly)

Consider the short exact sequence $\{I\} \rightarrow U \rightarrow P \rightarrow M \rightarrow \{I\}$ where $U \subseteq P$ is the subgroup with identities in the diagonal blocks and M is isomorphic to a subgroup of

$$\text{GL}_{m_1} \mathbb{C} \times \text{GL}_{m_2} \mathbb{C} \times \cdots \times \text{GL}_{m_k} \mathbb{C}.$$

This induces an exact sequence

$$\{1\} \rightarrow \text{Hom}(M, \mathbb{C}^*) \rightarrow \text{Hom}(P, \mathbb{C}^*) \rightarrow \text{Hom}(U, \mathbb{C}^*) \rightarrow \cdots$$

so we just have to show that $\text{Hom}(U, \mathbb{C}^*) = \{1\}$.

We note that U is a unipotent group, so the Lie algebra \mathfrak{u} of U satisfies $D_k \mathfrak{u} = 0$ for some $k \geq 0$. Therefore, if \mathfrak{u} is nonzero then we can choose a one-dimensional Abelian Lie subalgebra of \mathfrak{u} from $D_{k-1} \mathfrak{u}$. The exponential of this is a subgroup of U which is isomorphic either to \mathbb{C} or \mathbb{C}^* ; since \mathbb{C}^* is reductive, it must be \mathbb{C} . So there is a short exact sequence of algebraic groups

$$0 \rightarrow (\mathbb{C}, +) \rightarrow U \rightarrow U' \rightarrow 0$$

This induces a short exact sequence

$$1 \rightarrow \text{Hom}(U', \mathbb{C}^*) \rightarrow \text{Hom}(U, \mathbb{C}^*) \rightarrow \text{Hom}((\mathbb{C}, +), \mathbb{C}^*) \rightarrow \dots$$

Now U' is also unipotent so, by induction, we have only to show that a unipotent group of dimension 1, that is, $(\mathbb{C}, +)$, has only the trivial character. Now any morphism (not necessarily a group homomorphism) $\mathbb{C} \rightarrow \mathbb{C}^*$ is given by a polynomial. Since any nonconstant polynomial has a zero, the only morphisms $\mathbb{C} \rightarrow \mathbb{C}^*$ are the constants. Hence the only character of \mathbb{C} is the constant function 1.

This completes the proof of the proposition. \square

The last technical lemma classifies the possibilities for the symplectic forms introduced in Prop. 1.9.

Lemma 1.13 *Let $W \rightarrow X$ be a polystable symplectic vector bundle. Then any two symplectic forms on W are related by an automorphism of W .*

Proof

A polystable symplectic vector bundle is of the form

$$\left(\bigoplus_{i=1}^l (F_i \oplus F_i^*)^{\oplus a_i} \right) \oplus \left(\bigoplus_{j=1}^m G_j^{\oplus b_j} \right) \oplus \left(\bigoplus_{k=1}^n H_k^{\oplus c_k} \right)$$

where

- the F_i are stable of degree 0, mutually nonisomorphic and $F_i \not\cong F_i^*$;
- the G_j are stable of degree 0, mutually nonisomorphic and self-dual but not symplectic;

- the H_k are stable, mutually nonisomorphic symplectic vector bundles.

(This can be seen by constructing a grading as in Prop. 1.9.) Now let ω be a symplectic form on W . We claim that

$$\omega((F_i \oplus F_i^*), A) = 0$$

for any copy of $F_i \oplus F_i^*$ and any other stable direct summand A in W . For, otherwise we would have a nonzero map $F_i \rightarrow A^*$, which would be an isomorphism since the bundles are stable, contrary to hypothesis. A similar statement applies to the G_j and H_k . Hence ω is a sum

$$\theta_1 + \cdots + \theta_l + \nu_1 + \cdots + \nu_m + \xi_1 + \cdots + \xi_n$$

where θ_i , ν_j and ξ_k are symplectic forms on $(F_i \oplus F_i^*)^{\oplus a_i}$, $G_j^{\oplus b_j}$ and $H_k^{\oplus c_k}$ respectively. Thus it is enough to prove the lemma in the following cases:

1. $W = (F \oplus F^*)^{\oplus a}$ where F is stable of degree 0 and not self-dual.
2. $W = G^{\oplus b}$ where G is stable and self-dual but not symplectic.
3. $W = H^{\oplus c}$ where H is stable and symplectic.

Now the symplectic form determines an isomorphism $W \xrightarrow{\sim} W^*$. In the first two cases, this maps each stable direct summand of W to a copy of its double dual. Since the only endomorphisms of stable vector bundles are homotheties, the cocycle of matrices giving the symplectic form is constant on X .

1. Write $r = \text{rk } F$. Since F is not self-dual, the subbundles $F^{\oplus a}$ and $(F^*)^{\oplus a}$ are Lagrangian in W by stability. Hence ω is given globally by a matrix of the form

$$\Omega := \begin{pmatrix} 0 & A \\ -{}^t A & 0 \end{pmatrix}$$

where A is an invertible matrix of the form

$$\left(\begin{array}{c|c|c|c} \lambda_{1,1}I_r & \lambda_{1,2}I_r & \cdots & \lambda_{1,a}I_r \\ \hline \lambda_{2,1}I_r & \lambda_{2,2}I_r & \cdots & \lambda_{2,a}I_r \\ \hline \vdots & \vdots & & \vdots \\ \hline \lambda_{a,1}I_r & \lambda_{a,2}I_r & \cdots & \lambda_{a,a}I_r \end{array} \right)$$

for some $\lambda_{i,j} \in \mathbb{C}$. By a slight abuse of notation, we write $A = A' \otimes I_r$ where $A' = (\lambda_{i,j})$. Then $\text{Aut } W = \text{GL}_a \mathbb{C} \times \text{GL}_a \mathbb{C}$ acts on the set of symplectic forms by

$$(g, A) \mapsto \left({}^t g \begin{pmatrix} 0 & A' \\ -{}^t A' & 0 \end{pmatrix} g \right) \otimes I_r.$$

The result now follows from the fact that any two symplectic forms defined by matrices of the form $\begin{pmatrix} 0 & A' \\ -{}^t A' & 0 \end{pmatrix}$ are related by a transformation of the form $\begin{pmatrix} g_1 & 0 \\ 0 & g_2 \end{pmatrix}$.

2. Firstly, we note that each copy of G in W is isotropic. For, the symplectic form induces a nonzero antisymmetric map $G \rightarrow G^*$, which is either zero or an isomorphism since G is stable. If it were an isomorphism then G would be a symplectic bundle, contrary to hypothesis, so it must be zero¹, but if we consider two linearly independent injections i and i' of G into W then the restriction of ω to the subbundle $i(G) \oplus i'(G)$ is either zero or a pairing, by stability. Therefore, ω is given by a matrix of the form $B' \otimes I_r$ where B' is an antisymmetric invertible $b \times b$ matrix. (In particular, b is even.) Then $\text{Aut } W = \text{GL}_b \mathbb{C}$ acts on the set of symplectic forms on W by

$$(g, B) \mapsto ({}^t g B' g) \otimes I_r.$$

The result now follows as in case 1.

3. In this case we no longer know that each direct summand is isotropic with respect to ω . However, since H is stable, we know that the restriction of ω to a summand H is either nondegenerate or zero, and that there is only one choice of symplectic form on H up to multiplicative scalar. We choose trivialisations of H with respect to which this form is given everywhere by an antisymmetric invertible $r \times r$ matrix J (of course r is even).

¹We remark that G is in fact an orthogonal bundle. More generally, a self-dual stable vector bundle G is always either symplectic or orthogonal. Indeed, let $j: G \xrightarrow{\sim} G^*$ be an isomorphism; then ${}^t j: G \xrightarrow{\sim} G^*$ is another isomorphism. Since G is in particular simple, ${}^t j$ is proportional to j . Therefore ${}^t j = \pm j$ because $j \mapsto {}^t j$ is an involution.

Now since H is stable, there is only one linearly independent map $H \rightarrow H^*$, which must be given in our coordinates by a multiple of J . Thus the form ω is given everywhere by a matrix of the form

$$C := \begin{pmatrix} \lambda_{1,1}J & \lambda_{1,2}J & \cdots & \lambda_{1,c}J \\ \lambda_{2,1}J & \lambda_{2,2}J & \cdots & \lambda_{2,c}J \\ \vdots & \vdots & & \vdots \\ \lambda_{c,1}J & \lambda_{c,2}J & \cdots & \lambda_{c,c}J \end{pmatrix}$$

which we write again as $C' \otimes I_r$ where $C' = (\lambda_{i,j})$. Now using the facts that ω is antisymmetric and J is an antisymmetric matrix, it is easy to check that C' is symmetric. Then $\text{Aut } W = \text{GL}_c \mathbb{C}$ acts on the set of symplectic forms on W by

$$(g, C) \mapsto ({}^t g C' g) \otimes J.$$

The result now follows from the fact that any two symmetric forms on \mathbb{C}^c are related by a transformation of the form $C' \mapsto {}^t g C' g$. \square

Proposition 1.12 *Let $E \rightarrow X$ be a principal $\text{GL}_r \mathbb{C}$ -bundle. Then E is (semi)stable if and only if the vector bundle $E(\mathbb{C}^r)$ associated to the standard representation of $\text{GL}_r \mathbb{C}$ is a (semi)stable vector bundle.*

Proof (well-known; see for example Oxbury [37, § 1.3])

Let $P \subset \text{GL}_r \mathbb{C}$ be a maximal parabolic subgroup and $\sigma: X \rightarrow E/P$ a reduction of structure group to P . We saw in § 1.3 that E/P is identified with the bundle of Grassmannians of subspaces of fixed dimension k in the fibres of $E(\mathbb{C}^r)$. Thus the section σ is an algebraically varying choice of subspace of fixed dimension in each fibre, that is, a vector subbundle $F \subset E(\mathbb{C}^n)$. Write π for the projection $E/P \rightarrow X$ and let $V = \pi^* E(\mathbb{C}^n)$. Let $U \rightarrow \text{Grass}(k, r)$ be the universal bundle. Now by for example Arbarello et al [1, p. 68], the tangent bundle of $\text{Grass}(k, r)$ is isomorphic to $\text{Hom}(U, V/U)$. Hence the tangent bundle $T_{E/P}^{\text{vert}}$ along the fibres of π is isomorphic to $\text{Hom}(U, V/U)$, whence

$$\begin{aligned} \sigma^* T_{E/P}^{\text{vert}} &= \text{Hom}(\sigma^* U, \sigma^* V / \sigma^* U) \\ &= \text{Hom}(F, E(\mathbb{C}^n) / F). \end{aligned}$$

Now

$$\begin{aligned}\deg(\sigma^* T_{E/P}^{\text{vert}}) &= c_1(\text{Hom}(F, E(\mathbb{C}^n)/F)) \\ &= c_1(F^* \otimes E(\mathbb{C}^n)/F) \\ &= kc_1(E(\mathbb{C}^n)/F) + (n - k)c_1(F^*) \\ &= kc_1(E(\mathbb{C}^n)) - kc_1(F) + (k - n)c_1(F) \\ &= kn \left(\frac{c_1(E(\mathbb{C}^n))}{n} - \frac{c_1(F)}{k} \right).\end{aligned}$$

The proposition follows from the definitions of stability and semistability. \square

Bibliography

- [1] Arbarello, E.; Cornalba, M.; Griffiths, P.; Harris, J.: *The geometry of algebraic curves, vol. 1*. New York, Springer-Verlag, 1985.
- [2] Atiyah, M. F.: *Complex analytic connections in fibre bundles*. Trans. Amer. Math. Soc. **85** (1957), pp. 181–207.
- [3] Balaji, V.: *Notes on Semistable Principal Bundles*, 2000.
- [4] Balaji, V.; Seshadri, C. S.: *Semistable principal bundles – I (characteristic zero)*. Special issue in celebration of Claudio Procesi’s 60th birthday. J. Algebra **258** (2002), no. 1, pp. 321–347.
- [5] Beauville, A.: *Vector bundles and theta functions on curves of genus 2 and 3*, arXiv AG/0406030; to appear in Amer. J. of Math.
- [6] Beauville, A.: *Vector Bundles on Curves and Generalized Theta Functions: Recent Results and Open Problems*. MSRI Series, Vol. 28, 1995, pp. 17–33.
- [7] Beauville, A.: *Fibrés de rang 2 sur les courbes, fibré déterminant et fonctions thêta II*. Bull. Soc. math. France **119** (1991), pp. 259–291.
- [8] Beauville, A.; Laszlo, Y.; Sorger, C.: *The Picard group of the moduli of G -bundles on a curve*. Compositio Math. **112** (1998), pp. 183–216.
- [9] Beauville, A.; Narasimhan, M. S.; Ramanan, S.: *Spectral curves and the generalised theta divisor*. J. Reine Angew. Math. **398** (1989), pp. 169–179.
- [10] Bradlow, S.: *Vector Bundles and an Introduction to Gauge Theory*, lecture notes at <http://www.math.uiuc.edu/~cwillett/bundles/index.html>. University of Illinois at Urbana-Champaign, 1998.

- [11] Birkenhake, C.; Lange, H.: *Complex Abelian varieties*, second edition. Grundlehren der Mathematischen Wissenschaften 302. Springer-Verlag, Berlin, 2004.
- [12] Chaput, P.-E.: *Severi varieties*. Grenoble, 2003.
- [13] Fulton, W.; Harris, J.: *Representation Theory: A First Course* (Graduate Texts in Mathematics 129); New York, Springer, 1991.
- [14] Gómez, T. L.; Sols, I.: *Moduli space of principal sheaves over projective varieties*, arXiv AG/0206277, 2003.
- [15] Griffiths, P.; Harris, J.: *Principles of Algebraic Geometry*; USA, John Wiley and Sons Inc., 1978.
- [16] Harris, J.; Morrison, I.: *Moduli of curves* (Graduate Texts in Mathematics, 187); New York, Springer-Verlag, 1998.
- [17] Hartshorne, R.: *Algebraic Geometry* (Graduate Texts in Mathematics 52); New York, Springer-Verlag Inc., 1977.
- [18] Hitching, G. H.: *A remark on subbundles of symplectic and orthogonal vector bundles over curves*, arXiv AG/0407323 (version 2), 2004.
- [19] Kempf, G.: *Abelian Integrals*. Monografías del Instituto de Matemáticas 13, Universidad Nacional Autónoma de México, Mexico, 1983.
- [20] Kempf, G.; Schreyer, F.-O.: *A Torelli theorem for osculating cones to the theta divisor*. *Compositio Math.* **67** (1988), no. 3, p. 343–353.
- [21] Kumar, S.; Narasimhan, M. S.; Ramanathan, A.: *Infinite Grassmannians and moduli spaces of G -bundles*. *Math. Ann.* **300** (1994), no. 1, pp. 41–75.
- [22] Lang, S.: *Algebra*; USA, Addison-Wesley Publishing Company, 1993.
- [23] Lange, H.; Narasimhan, M. S.: *Maximal subbundles of rank two vector bundles on curves*. *Math. Ann.* **266** (1983), no. 1, pp. 55–72.

- [24] Lange, H.; Newstead, P. E.: *Maximal subbundles and Gromov–Witten invariants*. A tribute to C. S. Seshadri (Chennai, 2002), pp. 310–322, Trends Math., Birkhäuser, Basel, 2003.
- [25] Laszlo, Y.: *Local structure of the moduli space of vector bundles over curves*. Comment. Math. Helv. **71** (1996), no. 3, pp. 373–401.
- [26] Laszlo, Y.: *Un théorème de Riemann pour les diviseurs thêta sur les espaces de modules de fibrés stables sur une courbe*. Duke Math. J. **64** (1991), no. 2, pp. 333–347.
- [27] Laszlo, Y.; Sorger, C.: *The line bundles on the moduli of parabolic G -bundles over curves and their sections*. Ann. Sci. École Norm. Sup. **30** (4) (1997), pp. 499–525.
- [28] Le Potier, J.: *Fibrés vectoriels sur les courbes algébriques* (with a chapter by C. Sorger). Publications Mathématiques de l'Université Paris 7 – Denis Diderot, 35. Université Paris 7 – Denis Diderot, U. F. R. de Mathématiques, Paris, 1995.
- [29] Le Potier, J.: *Lectures on vector bundles* (translated by A. Maciocia). Cambridge Studies in Advanced Mathematics, 54. Cambridge University Press, Cambridge, 1997.
- [30] Laszlo, Y.; Sorger, C.: *The line bundles on the moduli of parabolic G -bundles over curves and their sections*. Ann. Sci. École Norm. Sup. (4) **30** (1997), no. 4, pp. 499–525.
- [31] Mercat, V.: *Le problème de Brill–Noether : présentation*. Paper at <http://www.liv.ac.uk/~newstead/presen/presenta.ps> 2001.
- [32] Mukai, S.: *NonAbelian Brill–Noether theory and Fano 3-folds* (translation of Sugaku **49** (1997), no. 1, pp. 1–24). Sugaku Expositions **14** (2001), no. 2, pp. 125–153.
- [33] Mukai, S.: *Vector Bundles and Brill–Noether Theory*, MSRI Series, Vol. 28, 1995, pp. 145–158.

- [34] Narasimhan, M. S.; Ramanan, S.: *2Θ -linear systems on Abelian varieties. Vector bundles on algebraic varieties* (Bombay, 1984), pp. 415–427, Tata Inst. Fund. Res. Stud. Math., 11, Tata Inst. Fund. Res., Bombay, 1987.
- [35] Narasimhan, M. S.; Ramanan, S.: *Moduli of vector bundles on a compact Riemann surface*; Ann. Math. (2) **89** (1969), pp. 14–51.
- [36] Newstead, P. E.: *Lectures on Introduction to Moduli Problems and Orbit Spaces*; Bombay, Tata Institute of Fundamental Research, 1978.
- [37] Oxbury, W. M.: *Abelianisation of G -bundles*; Lectures given at GAeL, 2001 (notes by J. Kock).
- [38] Oxbury, W. M.; Ramanan, S.: *Trigonal curves and Spin(8) bundles*.
- [39] Oxbury, W. M.; Wilson, S. M. J.: *Reciprocity laws in the Verlinde formulae for the classical groups*. Trans. Amer. Math. Soc. **348** (1996), no. 7, pp. 2689–2710.
- [40] Pauly, C.: *Self-duality of Coble's quartic hypersurface and applications*. Michigan Math. J. **50** (2002), no. 3, pp. 551–574.
- [41] Prill, D.: *Local classification of quotients of complex manifolds by discontinuous groups*. Duke Math. J. **34** (1967), pp. 375–386.
- [42] Ramanan, S.: *Orthogonal and spin bundles over hyperelliptic curves*; from *Geometry and Analysis: Papers dedicated to the memory of V. K. Patodi*, Berlin, Springer-Verlag, 1981.
- [43] Ramanathan, A.: *Moduli for principal bundles over algebraic curves I*. Proc. Indian Acad. Sci. Math. Sci. **106** (1996), no. 3, pp. 301–328.
- [44] Ramanathan, A.: *Moduli for principal bundles over algebraic curves II*. Proc. Indian Acad. Sci. Math. Sci. **106** (1996), no. 4, pp. 421–449.
- [45] Ramanathan, A.: *Stable principal bundles on a compact Riemann surface*. Math. Ann. **213** (1975), pp. 129–152.

- [46] Raynaud, M.: *Sections des fibrés vectoriels sur une courbe*. Bull. Soc. Math. France **110** (1982), no. 1, pp. 103–125.
- [47] Seshadri, C. S.: *Fibrés Vectoriels sur les courbes algébriques* (notes by J. M. Drezet), Astérisque 96, Soc. Math. de France, Paris, 1982.
- [48] Seshadri, C. S.: *Theory of moduli*. Algebraic geometry (Proc. Sympos. Pure Math., Vol. 29, Humboldt State Univ., Arcata, California, 1974), pp. 263–304. Amer. Math. Soc., Providence, R. I., 1975.
- [49] Severi, F.: *Intorno ai punti doppi impropri di una superficie generale dello spazio a quattro dimensioni, e a suoi punti tripli apparenti*. Rend. Circ. Matem. Palermo **15**, 1901.
- [50] Sorger, C.: *Lectures on moduli of principal G -bundles over algebraic curves*; Lectures given at the School on Algebraic Geometry, Trieste, 1999.
- [51] Sorger, C.: *Théories conformes des champs du point de vue du géomètre algébriste*. Habilitation, 1998.
- [52] Springer, T. A.: *Linear Algebraic Groups*, Algebraic Geometry IV, Vol. 55, Encyclopaedia of Mathematical Sciences. Springer-Verlag, USA, 1994.
- [53] Vishwanath, P. A.: *Vector Bundles on Compact Riemann Surfaces*, Lectures at SPIC Math. Inst., Madras, India, 1997 (notes by J. Kock).

