

Durham E-Theses

Luminescence Dating of Medieval and Early Modern Brickwork

THOMAS GURLING

How to cite:

GURLING, THOMAS (2009) Luminescence Dating of Medieval and Early Modern Brickwork.
Doctoral thesis, Durham University.

Use policy

The full-text may be used and/or reproduced, and given to third parties in any format or medium, without prior permission or charge, for personal research or study, educational, or not-for-profit purposes provided that:

- a full bibliographic reference is made to the original source
- a <https://etheses.durham.ac.uk/id/eprint/180/> is made to the metadata record in Durham E-Theses
- the full-text is not changed in any way

The full-text must not be sold in any format or medium without the formal permission of the copyright holders.

Please consult the [full Durham E-Theses policy](#) for further details.

Luminescence Dating of Medieval and Early Modern Brickwork

Thomas Gurling



Thesis submitted in fulfilment of the Degree of Doctor of Philosophy

Department of Archaeology

University of Durham

2009

'I was not born with knowledge but, being fond of antiquity, I am quick to seek it'

-Confucius

'Most fatt, frutefull and full of profitable things exceeding (as farr as I can finde) anie other shire for the general comodeties, and the plentie, this shire seemeth to me to deserve this title of the Englishe Goshen, the fattest of the Lande; comparable to Palestina, that flowed with milke and hunneye'.

-John Norden (16th century topographer writing of Essex)

ABSTRACT

LUMINESCENCE DATING OF MEDIEVAL BRICKWORK

Thomas Gurling

Essex is a county rich in significant historic brickwork spanning the medieval period. A great deal of earlier archaeological study has focused on the development and use of brick during this period, providing a framework of understanding as to how this material was employed in Essex through the medieval period. However, the common approaches adopted to date historic brick have several caveats that can potentially limit the amount of information they can provide. This presented an opportunity to apply the scientific dating technique of optically stimulated luminescence in order to derive absolute dates for important medieval brick sites in Essex. This in turn would allow this framework of understanding surrounding medieval brick to be critically examined and revised where necessary.

A series of important brick buildings that spanned the 11th through to the 16th century were selected for inclusion in this thesis. The buildings were studied from an archaeological perspective, deriving likely dates for their erection and development, before samples of the brickwork were taken. These were subsequently dated by luminescence. In light of the luminescence dates, the archaeological evaluations of the buildings were reviewed and revised where necessary.

The results have shown that medieval brick was introduced much earlier than had previously been suspected. This has refuted the long held notion that the Cistercians were responsible for introducing brick in the 12th century and has led to suggestions of a small scale, late Saxon brick industry. It was also apparent that, whilst being manufactured, brick was also being re-used to a large extent throughout the medieval period, especially in the 16th century. Whilst this is likely to be largely due to practical motivational factors, other esoteric social aspects are also likely to have played a role, such as the Great Rebuilding.

DECLARATION

No part of this thesis has been submitted for a previous degree and no part has been previously published.

The copyright of this thesis rests with the author. No quotation from it should be published without the prior written consent and information derived from it should be acknowledged.

CONTENTS

Abstract	i
Declaration	ii
List of Figures	viii
List of Tables	xiii
Abbreviations	xiv
Acknowledgements	xv
1: INTRODUCTION	1
1.1: HISTORIC BRICK STUDIES	2
1.2: AIMS OF THIS STUDY	4
1.3: OBJECTIVES	4
1.3.1: Knowledge of the English medieval brick industry	4
1.3.2: Knowledge of the Essex medieval brick industry	4
1.3.3: Production of construction sequences for select buildings	5
1.3.4: Development of standard OSL dating procedure	5
1.3.5: Derivation of OSL dates	5
1.3.6: Evaluation of the OSL dates	5
1.4: METHODOLOGICAL OUTLINE	5
1.4.1: Study area selection	5
1.4.2: Building selection and analysis	7
1.4.3: Sample collection and analysis	7
1.4.4: Comparative evaluation of the buildings	7
1.4.5: Evaluation of the use of medieval brick in Essex	8
1.4: THESIS OUTLINE	8
2: THE STUDY OF BRICK IN LATE MEDIEVAL BUILDINGS	10
2.1: THE USE OF BRICK IN MEDIEVAL ENGLAND	10
2.1.1: The production and use of brick from the 5 th to 12 th century	10
2.1.2: The production and use of brick from the 12 th to the 13 th century	16
2.1.3: The production and use of brick from the late 13 th to the 14 th century	21
2.1.4: The production and use of brick during the 15 th century	24
2.1.5: The production and use of brick during the 16 th century	29
2.2: CURRENT APPROACHES TO DATING MEDIEVAL BRICKWORK	34
2.2.1: Comparison to brick typologies	34
2.2.2: Documentary evidence	35
2.2.3: Architectural analysis	36
2.2.4: Scientific dating methods	37
2.3: APPLICATIONS OF LUMINESCENCE IN DATING HISTORIC BRICK	39
2.4: HISTORY OF MEDIEVAL AND TUDOR BRICK IN ESSEX	42
2.4.1: The production and use of brick in Essex from the 5 th to 12 th century	42

2.4.2: The production and use of brick in Essex from the 12 th to 13 th century	43
2.4.3: The production and use of brick in Essex from the late 13 th to 14 th century.....	45
2.4.4: The production and use of brick in Essex during the 15 th century.....	50
2.4.5: The production and use of brick in Essex during the 16 th century.....	52
2.5: CURRENT APPROACHES TO DATING MEDIEVAL BRICK IN ESSEX.....	56
2.5.1: Brick typology	56
2.5.2: Documentary sources	57
2.5.3: Architectural analysis	58
2.5.4: Scientific dating methods	59
2.5.5: The potential for luminescence.....	60
3: ARCHAEOLOGICAL ASSESSMENT OF THE BUILDINGS	62
3.1: SOURCES CONSULTED	62
3.1.1: Royal Commission on Historic Monuments England (RCHME).....	62
3.1.2: Victoria County History (VCH)	63
3.1.3: ‘The Buildings of England’ series by Nikolaus Pevsner:	65
3.1.4: Antiquarian volumes and journals:.....	66
3.2: SECULAR BUILDING LOCATIONS	67
3.3: SECULAR BUILDING HISTORIES	67
3.3.1: Coggeshall Abbey.....	67
3.3.1.1: Archaeological assessment	67
3.3.1.2: Coggeshall Abbey sampling locations	81
3.3.2: Eastbury Manor House, Barking	84
3.3.2.1: Archaeological assessment	84
3.3.2.2: Eastbury Manor sampling locations.....	90
3.3.3: Layer Marney Towers	94
3.3.3.1: Archaeological assessment	94
3.3.3.2: Layer Marney sampling location	103
3.3.4: Maldon Moot Hall	105
3.3.4.1: Archaeological assessment	105
3.3.4.2: Maldon Moot Hall sampling location	115
3.3.5: Nether Hall, Roydon.....	116
3.3.5.1: Archaeological assessment	116
3.3.5.2: Nether Hall sampling locations.....	122
3.3.6: New Hall, Boreham	124
3.3.6.1: Archaeological assessment	124
3.3.6.2: New Hall sampling locations	140
3.3.7: ‘The Old House’, St. Osyth	142
3.3.7.1: Archaeological assessment	142
3.3.7.2: ‘The Old House’ sampling locations	145

3.4: ECCLESIASTICAL BUILDING LOCATIONS	146
3.5: ECCLESIASTICAL BUILDING HISTORIES	148
3.5.1: St. Andrew's church, Boreham.....	148
3.5.1.1: Archaeological assessment	148
3.5.1.2: Boreham church sampling location.....	154
3.5.2: Holy Trinity church, Bradwell-juxta-Coggeshall	155
3.5.2.1: Archaeological assessment	155
3.5.2.2: Bradwell-juxta-Coggeshall church sampling location	158
3.5.3: St. Andrew's church, Earls Colne.....	160
3.5.3.1: Archaeological assessment	160
3.5.3.2: Earls Colne church sampling location.....	166
3.5.4: All Saints' church, East Horndon	167
3.5.4.1: Archaeological assessment	167
3.5.4.2: East Horndon church sampling locations.....	174
3.5.5: All Saints' church, Maldon.....	177
3.5.5.1: Archaeological assessment	177
3.5.5.2: Maldon church sampling location.....	184
3.5.6: All Saints' church, Springfield	186
3.5.6.1: Archaeological assessment	186
3.5.6.2: Springfield church sampling location	190
3.5.7: All Saints' church, Theydon Garnon	192
3.5.7.1: Archaeological assessment	192
3.5.7.2: Theydon Garnon church sampling location	196
3.5.8: St. Margaret's church, Tilbury-juxta-Clare	198
3.5.8.1: Archaeological assessment	198
3.5.8.2: Tilbury-juxta-Clare church sampling locations	206
3.5.9: St. Michael's church, Woodham Walter.....	208
3.5.9.1: Archaeological assessment	208
3.5.9.2: Woodham Walter church sampling location.....	213
4: LUMINESCENCE THEORY, METHODOLOGY AND RESULTS	215
4.1: OPTICALLY STIMULATED LUMINESCENCE DATING	215
4.1.1: Luminescence phenomena.....	215
4.1.2: Derivation of sample age.....	217
4.1.2.1: Derivation of sample paleodose.....	217
4.1.2.2: Derivation of annual dose	219
4.1.2.3: Derivation of sample age.....	224
4.2: SAMPLING CRITERIA AND PROCEDURES	225
4.2.1: Sample location evaluation.....	225
4.2.2: Sampling methodology.....	226

4.3: LABORATORY PROCEEDURES	229
4.3.1: Sample recording and quartz extraction	229
4.3.2: Paleodose Evaluation	230
4.3.2.1: Sample pre-heat	232
4.3.2.2: Sample OSL measurement	232
4.3.2.3: Sample irradiation.....	232
4.3.2.4: Pre-heat monitor (PHM).....	233
4.3.2.5: SAR sequence.....	234
4.3.3: Annual Dose Rate Evaluation	236
4.3.3.1: Thick Source Alpha Counting (TSAC)	236
4.3.3.2: Beta Thermoluminescence Dosimetry (β -TLD)	237
4.3.3.3: Gamma Thermoluminescence Dosimetry (γ -TLD) and Spectrometry	238
4.3.3.4: Moisture uptake	240
4.4 LUMINESCENCE RESULTS.....	240
5: HISTORIC BUILDING INTERPRETATION REVIEW	243
5.1: SECULAR BUILDING ASSESSMENTS.....	243
5.1.1: Coggeshall Abbey	243
5.1.2: Eastbury Manor	244
5.1.3: Layer Marney Towers	249
5.1.4: Maldon Moot Hall.....	251
5.1.5: Nether Hall	253
5.1.6: New Hall	254
5.1.7: ‘The Old House’, St. Osyth	257
5.2: ECCLESIASTICAL BUILDING ASSESSMENTS.....	257
5.2.1: St. Andrew’s church, Boreham	257
5.2.2: Holy Trinity church, Bradwell-juxta-Coggeshall	259
5.2.3: St. Andrew’s church, Earls Colne	261
5.2.4: All Saints’ church, East Horndon.....	264
5.2.5: All Saints’ church, Maldon.....	266
5.2.6: All Saints’ church, Springfield.....	266
5.2.7: All Saints’ church, Theydon Garnon.....	267
5.2.8: St. Margaret’s church, Tilbury-juxta-Clare	269
5.2.9: St. Michael’s church, Woodham Walter	269
6: DISCUSSION AND CONCLUSION.....	272
6.1: THE EFFECTIVENESS OF OSL TO DATE HISTORIC BRICKWORK	272
6.2: EARLY MEDIEVAL BRICK	273
6.3: LATE MEDIEVAL BRICK	279
6.4: CULTURE OF RE-USE	283

6.5: IMPLICATIONS FOR DATING MEDIEVAL BRICK STRUCTURES	288
6.6: FUTURE WORK.....	290
APPENDIX: LUMINESCENCE RESULTS.....	292
A.1: SAMPLE PALEODOSE DETERMINATIONS.....	292
A.2: ANNUAL DOSE RATE DETERMINATIONS	294
A.2.1: External dose date evaluation.....	294
A.2.2: Internal dose rate evaluation.....	297
A.3: WATER CONTENT EVALUATION	298
A.4: TWO PHASE DOSE RATE MODEL BRICK DATES	298
BIBLIOGRAPHY	300

LIST OF FIGURES

COVER: Woodham Walter church

CHAPTER 1: INTRODUCTION

Fig. 1.1: Map showing the location of the sites studied for this project in Essex 6

CHAPTER 2: THE STUDY OF BRICK IN LATE MEDIEVAL BUILDINGS

Fig. 2.1: The remains of the western end of St. Botolph's Priory, Colchester	11
Fig. 2.2: Example of a moulded brick form used at Coggeshall Abbey.....	17
Fig. 2.3: Springing for a roll moulded door and a chamfered vaulting rib at Coggeshall Abbey....	17
Fig. 2.4: Distribution map of Coggeshall type bricks in churches around Coggeshall Abbey	19
Fig. 2.5: An example of a 'Flemish' type brick	22
Fig. 2.6: The Cow Tower, Norwich	24
Fig. 2.7: An example of a 'Tudor' red brick	25
Fig. 2.8: Rye House gatehouse.....	26
Fig. 2.9: Chignal Smealey church	31
Fig. 2.10: Western tower of Holy Trinity church, Colchester.....	42
Fig. 2.11: Late 13 th century lancet at Copford church.....	45
Fig. 2.12: Dengie church north-western nave wall.....	46
Fig. 2.13: North face of Lawford chancel	47
Fig. 2.14: Medieval chimney bricks.....	48
Fig. 2.15: Brick bridge at Pleshey Castle	50
Fig. 2.16: Layer Marney Towers seen from the south-west.....	53
Fig. 2.17: Plan of Leez Priory	55
Fig. 2.18: Brick facing around rubble core at Leez Priory	55

CHAPTER 3: ARCHAEOLOGICAL ASSESSMENT OF THE BUILDINGS

Fig. 3.1: Map of Essex showing the location of the secular sites sampled.....	68
Fig. 3.2: Plan of the surviving abbey/manorial complex at Coggeshall Abbey	70
Fig. 3.3: Plan showing likely layout of the Cistercian abbey complex	71
Fig. 3.4: Evidence of sub-dormitory vaulting	72
Fig. 3.5: Moulded mid-15 th century brick mullions	72
Fig. 3.6: View of the abbot's lodgings and the guest house	73
Fig. 3.7: View looking south through the corridor.....	74
Fig. 3.8: The Infirmary column with scalloped capital and the crown of a lancet arch	75
Fig. 3.9: St. Nicholas' Chapel	76
Fig. 3.10: The redundant fireplace attached to the eastern wall of the north range.....	78
Fig. 3.11: Phasing of Coggeshall manor house	80
Fig. 3.12: Sampling locations at Coggeshall Abbey	82

Fig. 3.13: The sample location on the northern range at Coggeshall Abbey.....	82
Fig. 3.14: The sample location on the mid-12 th century medieval brick column	83
Fig. 3.15: Eastbury Manor House from the south	84
Fig. 3.16: Eastbury Manor House from the South in 1780	85
Fig. 3.16: The southern wall of the northern cellar	88
Fig. 3.17: Timber treads of the newel staircase.....	89
Fig. 3.18: Sampling locations at Eastbury Manor House.....	90
Fig. 3.19: The southern wall of the northern cellar	91
Fig. 3.20: The brickwork in the western wall of the cupboard in the panelled room.	92
Fig. 3.21: The western wall of the summer parlour	93
Fig. 3.22: The south western corner of the attic space	93
Fig. 3.23: The central gatehouse to Layer Marney Towers.....	94
Fig. 3.24: Plan showing the layout of the principal buildings at Layer Marney	95
Fig. 3.25: The cross wing gable end at the western end of the eastern wing.....	97
Fig. 3.26: The tomb of Henry Marney	100
Fig. 3.27: Terracotta decoration on top of the gatehouse western tower.....	101
Fig. 3.28: Sampling location in Layer Marney gatehouse.....	104
Fig. 3.29: The brickwork at the sampling point in Layer Marney.....	104
Fig. 3.30: Maldon Moot Hall	105
Fig. 3.31: Holes in the wall of the neighbouring building.....	107
Fig. 3.32: Springing of a four centred opening in the wall of the neighbouring building	107
Fig. 3.33: Diagram of an earlier interpretation of part of Darcy's manorial complex.....	108
Fig. 3.34: Diagram showing the authors interpretation of Darcy's original manorial complex	109
Fig. 3.35: Remains of a timber framed structure with brick nogging infill.....	110
Fig. 3.36: Decorative trefoil corbelled niches made from carved, ruddled bricks	112
Fig. 3.37: Base of the brick newel staircase in the north east turret of the Moot Hall.	113
Fig. 3.38: The view down the brick newel staircase at the Moot Hall	113
Fig. 3.39: Sampling location in the Moot Hall.....	115
Fig. 3.40: The brickwork at the sampling point in the Moot Hall.....	116
Fig. 3.41: Remains of Nether Hall gatehouse	117
Fig. 3.42: Sketch of Nether Hall gatehouse made in 1819.....	117
Fig. 3.43: Brick quadripartite vaulted entrance passageway inside Rye House gatehouse.	119
Fig. 3.44: The view down the brick newel staircase at Nether Hall.....	119
Fig. 3.45: Carved irradiated rose with a tun in the centre	121
Fig. 3.46: The wall attached to the east side of the gatehouse	121
Fig. 3.47: Sampling location in Nether Hall	123
Fig. 3.48: The brickwork at the sampling point in Nether Hall.....	123
Fig. 3.49: Principle frontage to the late 16 th century building at New Hall.....	124
Fig. 3.50: Parch marks seen at New Hall in the dry summer months.....	127
Fig. 3.51: Plan of the palatial complex at New Hall	128

Fig. 3.52: The arms of Elizabeth I above the main entrance to the chapel.....	131
Fig. 3.53: The arcading located in the southern cellar	133
Fig. 3.54: Late perpendicular/early Tudor windows located in the eastern wall of the cellar	134
Fig. 3.55: A column of worn ashlar blocks, located south of the windows.....	135
Fig. 3.56: The door and doorway between the north and south cellar chambers	136
Fig. 3.57: The doorway in the southern chamber of the cellars	137
Fig. 3.58: The western wall in the cellar, showing fragment of orange and darkened brick.....	138
Fig. 3.59: Part of a window spandrel that had been re-used as a flag in the cellar floor	139
Fig. 3.60: Sampling location in New Hall.....	141
Fig. 3.61: The western wall of the cellar from which three samples were extracted	142
Fig. 3.62: The southern wall of the cellar at ‘The Old House’, St. Osyth	143
Fig. 3.63: The north west corner of the cellar showing the triangular segment of septaria.....	144
Fig. 3.64: The alcove in the west end of the cellar.....	144
Fig. 3.65: Sampling location in ‘The Old House’, St. Osyth	145
Fig. 3.66: The southern wall of the cellar at ‘The Old House’, St. Osyth	146
Fig. 3.67: Map of Essex showing the location of the ecclesiastical sites sampled	147
Fig. 3.68: St. Andrew’s church, Boreham.....	148
Fig. 3.69: The southern window to the first stage of the central tower	150
Fig. 3.70: The southern view of the first stage of the central tower.....	150
Fig. 3.71: The interior view of Boreham church looking into the east chancel from the nave.....	152
Fig. 3.72: Small niche in the wall north of the opening between the nave and tower	152
Fig. 3.73: The interior view of Boreham church looking west from the chancel.....	153
Fig. 3.74: Sampling location in Boreham church.....	154
Fig. 3.75: The sampling point on the northern respond of the arch	155
Fig. 3.76: The use of medieval bricks in the Norman windows at Bradwell-juxta-Coggeshall	157
Fig. 3.77: Sampling location in Bradwell-juxta-Coggeshall church	159
Fig. 3.78: The sampling point on the brick quoin of the southern doorway.....	159
Fig. 3.79: St. Andrew’s church, Earls Colne.....	160
Fig. 3.80: Rubble walling at the base of the south side of the stair turret	162
Fig. 3.81: The north west corner of the tower	163
Fig. 3.82: Sampling location in Earls Colne church.....	166
Fig. 3.83: The sampling point at St. Andrew’s church.....	167
Fig. 3.84: All Saints’ church, East Horndon	168
Fig. 3.85: Sampling locations in East Horndon church.....	174
Fig. 3.86: The sampling point of the south porch internal western wall	175
Fig. 3.87: The sampling point in the eastern wall of Thomas Tyrell’s tomb niche	175
Fig. 3.88: The sampling point in the western wall of Thomas Tyrell’s tomb niche.....	176
Fig. 3.89: All Saints’ church, Maldon.....	177
Fig. 3.90: A section of the southern external wall of the south aisle.....	178
Fig. 3.91: The carved boss in the vaulting over the stairs leading to the sunken chamber.....	179

Fig. 3.92: The sunken chamber of All Saints' church.....	180
Fig. 3.93: Fragment of carved stone reset in the rubble walling of the sunken chamber	180
Fig. 3.94: The internal view of the south wall to the south aisle.....	181
Fig. 3.95: Blocked indent at the eastern end of the southern wall of the sunken chamber.....	183
Fig. 3.96: Sampling location in All Saints' church, Maldon.....	185
Fig. 3.97: The sampling point on the staircase leading down into the sunken chamber	185
Fig. 3.98: The western tower at Springfield.....	187
Fig. 3.99: Date plate located on the southern side of the third stage of the church tower	187
Fig. 3.100: Stone inset into the brick buttress on the southern face of the tower.....	188
Fig. 3.101: Sampling location in Springfield church	191
Fig. 3.102: The sampling point in the tower belfry.....	191
Fig. 3.103: All Saints' church, Theydon Garnon	192
Fig. 3.104: The date plate on the southern side of the tower.....	193
Fig. 3.105: Sampling location in Theydon Garnon church	196
Fig. 3.106: The space where the sampled brick was located.....	197
Fig. 3.107: The brick that was removed from the wall for sampling	197
Fig. 3.108: The western brick tower of St. Margaret's church, Tilbury-juxta-Clare.....	198
Fig. 3.109: The wall painting on the internal northern wall of the nave	199
Fig. 3.110: Gestingthorpe church tower.....	200
Fig. 3.111: The date plate located at the base of the western face of the tower	201
Fig. 3.112: Decorative fittings inside the church tower	203
Fig. 3.113: The western face of the tower.....	204
Fig. 3.114: The western face of the third stage of the tower	205
Fig. 3.115: The southern face of the stair turret	205
Fig. 3.116: Sampling location in Tilbury-juxta-Clare church	206
Fig. 3.117: The sample point in the western wall of the church tower.....	207
Fig. 3.118: The sample point in the northern wall of the church tower	207
Fig. 3.119: St. Michael's church, Woodham Walter.....	208
Fig. 3.120: Date plate of 1563 within Woodham Walter church	211
Fig. 3.121: The unusual brick bonding pattern employed at Woodham Walter church.....	212
Fig. 3.122: Sampling location in Woodham Walter church	213
Fig. 3.123: The sampling point in the western wall of the belfry chamber.....	214

CHAPTER 4: LUMINESCENCE THEORY, METHODOLOGY AND RESULTS

Fig. 4.1: Overview of the different mechanisms involved in the luminescence phenomenon	217
Fig. 4.2: A typical example of an OSL decay curve from quartz.....	218
Fig. 4.3: Variation in the OSL date with water content of the brick	222
Fig. 4.4: Images illustrating the different stages in collecting a sample.....	227
Fig. 4.5: Dose-response graph with the 'natural' OSL signal interpolated onto it.....	231
Fig. 4.6: Diagram illustrating the actions undertaken during a SAR sequence	231

Fig. 4.7: OSL decay curves for two different samples	233
Fig. 4.8: Derivation of a paleodose on a dose-response graph	234
Fig. 4.9: Pre-heat plateau for sample 338-1 (Woodham Walter)	235
Fig. 4.10: Beta-TLD apparatus.....	237
Fig. 4.11: Diagram illustrating how the dose capsule is located close to the point of sampling ...	239
Fig. 4.12: Plot of the luminescence dates against the archaeological dates	241

CHAPTER 5: HISTORIC BUILDING INTERPRETATION REVIEW

Fig. 5.1: Chronological distribution of the OSL dates derived for Eastbury Manor	245
Fig. 5.2: Chronological distribution of the OSL dates derived for Nether Hall	253
Fig. 5.3: Chronological distribution of the OSL dates derived for New Hall	255
Fig. 5.4: Exposed brickwork in New Hall cellar with an irregular bonding pattern.....	256
Fig. 5.5: Chronological distribution of the OSL dates derived for East Horndon.....	265

CHAPTER 6: DISCUSSION AND CONCLUSION

Fig. 6.1: Fairstead church chancel.....	276
---	-----

APPENDIX: LUMINESCENCE RESULTS

Fig. A.1: Alpha counting data	295
Fig. A.2: Drying rate for sample 335-1	299

LIST OF TABLES

CHAPTER 2: THE STUDY OF BRICK IN LATE MEDIEVAL BUILDINGS

Table 2.1: Cistercian monastic sites where medieval ‘great brick’ has been recorded	20
---	----

CHAPTER 4: LUMINESCENCE THEORY, METHODOLOGY AND RESULTS

Table 4.1: SAR sequence used on quartz aliquots	235
---	-----

Table 4.2: Luminescence results and assigned archaeological ages for the buildings	242
--	-----

CHAPTER 5: HISTORIC BUILDING INTERPRETATION REVIEW

Table 5.1: Comparative statistical results between paired samples from Eastbury Manor	245
---	-----

APPENDIX: LUMINESCENCE RESULTS

Table A.1: Summary of the average Paleodose values	293
--	-----

Table A.2: Summary of the annual dose rate components	296
---	-----

Table A.3: Summary of the concentration of radionuclides within the quartz grains	297
---	-----

Table A.4: Differences in OSL dates for the single and two phase phase dose rate models	299
---	-----

ABBREVIATIONS

Cal. Pat. R.: Calendar of Patent Rolls

L & P Hen. VIII: Letters and Papers of Henry VIII

CR Man. Tott.: Court Rolls of the Manor of Tottenham. Manor of Tottenham
Series: Vol. 9 (1558-1582).

DHC: Dorset History Centre

EHHER: Essex Historic Environment Record

ERO: Essex Records Office

ODNB: Oxford Dictionary of National Biography

RCHME: Royal Commission on Historic Monuments

VCH: Victoria County History

ACKNOWLEDGEMENTS

This thesis was only possible due to a joint funding scheme between English Heritage and the Arts Humanities Research Council (AHRC) and I especially wish to thank Dr. Alex Bayliss for her tireless enthusiasm for the thesis throughout the course of the research.

I would like to express my sincere gratitude and thanks to both Prof. Ian Bailiff and Dr. Pam Graves for their invaluable guidance, advice and patient support throughout this thesis. Many thanks go to Scott Grainger for his patient and cheerful help (often at short notice) in the luminescence laboratory. I wish to thank Sophie Blain for her encouragement and support during the shared trials and tribulations of our projects. I would also like to thank Louise Rayne for her help with the maps in Chapters 1 and 3.

Thanks are due to Dr. David Andrews and the staff in the Historic Environment Record section of Essex County Council for support and suggestions relating to the use of historic brick in medieval buildings in Essex. I also wish to thank the staff at the Essex Records Office and Chelmsford Library. Thanks must also go to Pat Ryan for many helpful hours discussing historic brick and for allowing me to examine her own extensive brick collection. I am grateful to Peter and Tony Minter to for showing me around the Bulmer brickworks (brick heaven!) and providing the lime mortar. There are numerous people who are involved in the care of the historic buildings I visited and studied. I wish to express my thanks to them for the keen and enthusiastic interest they had in the work I was doing and for kindly allowing me to access and sample so many fascinating historic buildings. I hope that they find the results as interesting to read as they were for me to produce and interpret.

Finally, I wish to express my sincerest thanks to my family for their continued support and encouragement, especially to my mother, father and grandfather for taking me and so much kit to so many places. I hope they enjoyed the adventure of exploring Essex as much as I did!

CHAPTER 1: INTRODUCTION

'It is my opinion that at the start of any book a writer ought to make his starting point indisputable'

-Diogenes

Brick is a material that has been used by man for building a vast range of structures for nearly 10,000 years. Despite this impressive claim, it is often a material underestimated by the general public, largely due to its success and ubiquitous use since the 19th century. Nevertheless, brick has and still is used to create both highly impressive buildings and ornate architectural features across the globe.

In England, the use of brick for large construction projects began after the Roman invasion of Britain in the 1st century A.D. Curiously, the industry appears to have largely vanished from the archaeological record following the Roman withdrawal in the early 5th century, only re-emerging during the course of the late medieval period. From the 11th century until the 15th century, the use of brick was geographically limited to eastern England. Throughout this period it was often used alongside other building materials, such as stone, either in a random manner or for decorative purposes. It was often the material of choice for important building projects and the elite in society owing to the expensive nature of the material. During the course of the 15th and 16th centuries, structures composed entirely of brick began to emerge and increased in number across the whole of England. This period saw a large number of impressive buildings erected due to several important factors across the country, including the influence of foreign craftsmen, the increased availability of both buildings and building materials as a result of the dissolution of the monasteries and the influence of the Great Rebuilding.

It is against this historical context that this current project is set, following a series of earlier important historic brick studies. The application of a scientific dating technique to medieval brickwork in eastern England forms the basis of this project in order to provide further insight into the current understanding of how brick was employed during this era.

1.1: HISTORIC BRICK STUDIES

The current understanding of medieval brick is one that has developed over the course of many years, being a source of interest to both antiquarians and archaeologists. Some early references to medieval brick include comments made on the use of the material in historic structures, such as the early 16th century antiquary Leland describing the brick defences and buildings around the city of Hull, which he attributed to the late 14th century (Smith, 1907, Part I, 48). One of the earliest academic attempts to provide an outline of the history of medieval brick was written in the late 18th century. It argued that the earliest example of medieval brick occurred in the late 14th century and that the principal reason for the late adoption of brick as a building material in England was due to the re-use of Roman brick during the Saxon era as opposed to the production of new material (Lyttelton, 1770, 143). Following this initial proposal, several significant discoveries were made regarding the history of medieval brick. This included the realisation that the brickwork at other sites pre-dated the late 14th century, for example the mid-13th century brick manor at Little Wenham, Suffolk (Cutts, 1858, 168-169). One of the most significant of these discoveries came in the mid-19th century when the brickwork at Coggeshall Abbey, Essex, was identified as being medieval in nature, expanding the accepted period over which brick was used in the medieval period to the late 12th century (Cutts, 1858). Early in the 20th century, a highly influential text in the field of historic English brick appeared. ‘A History of English Brickwork’ by Nathaniel Lloyd (1925) gave a thorough account of many aspects of the history of English brick from the Roman to the early modern period, with examples drawn from many important archaeological and architectural sites across the country. However, the ideas of Roman brickwork being re-used during the Saxon era and the initial appearance of medieval brick at Coggeshall in the 12th century were perpetuated by this work (Lloyd, 1925, 2-3).

During the latter half of the 20th century, historic brick studies have become increasingly more rigorous and detailed. This has led to more sites that were originally regarded as having Roman brick in their fabric now being re-evaluated as containing brick of medieval date. As a result of these new discoveries, certain long-held ideas are now being questioned or revised, for example, the idea that the earliest medieval brickwork occurs at Coggeshall

Abbey. This idea was initially challenged with the suggestion that the brick arcading in the Suffolk church of Polstead could pre-date that at Coggeshall Abbey (Harley, 1951, 254), an argument that has since been supported by others (Pevsner, 1961, 365; Wight, 1972, 374; Kennett, 1990). Other sites that might also contain brick that pre-dates that at Coggeshall Abbey have been proposed in recent years, including Bradwell-juxta-Coggeshall (Rodwell, 1998) and Chipping Ongar (Bettley and Pevsner, 2007, 233). As the number of churches identified as containing medieval brick has increased, the geographic range for the use of this material has expanded. For example, since the 1970s, several churches in the area surrounding Coggeshall, Essex, have been recognised as containing bricks with similar characteristics to those at Coggeshall Abbey (Rodwell, 1998, 103) and more recently early medieval brick has been identified at sites that lie outside Essex, for example, at Farnham Castle, Surrey (Riall, 2003, 321-322). In addition to the increased understanding of the chronological use of brick, the social factors that influenced its use have also developed over time. An example of this can be seen in the possible motives behind the rise in the fashion of brick as a building material among the nobility during the course of the 15th century. This social trend was originally attributed to continental excursions during the Hundred Years War (Kestell Floyer, 1913, 126) but it has since been suggested that the use of brick by Henry V for constructing Sheen Palace probably played a greater influence (Moore, 1991, 214).

Thus, the study of medieval English brick at the start of the 21st century has developed considerably since its inception in the 18th century at the hands of antiquarians. The earliest English medieval brick is now thought to date to the early 12th century and it has been identified in places that are well beyond the confines of Essex, such as Surrey. The increasing familiarity with specific aspects of medieval brick, such as the differences in fabrics identified by thin section petrography and brick typological studies, will, when combined with detailed recording and archaeological analysis of historic buildings, help in the identification of other sites where medieval brick occurs. It is therefore likely that more sites containing medieval brick will be identified in the near future. The application of multidisciplinary approaches that incorporate scientific techniques, such as provenancing or absolute dating, alongside the archaeological analysis of

buildings will no doubt offer further interesting discoveries in the future of this discipline.

1.2: AIMS OF THIS STUDY

The principle aims of this project are to evaluate the current archaeological understanding of how brick was employed in medieval and early modern Essex by means of the application of the scientific dating technique optically stimulated luminescence (OSL). Furthermore, this thesis aims to evaluate the other main approaches that are currently used by the archaeological community to date historic brickwork. It is anticipated that the fulfilment of these aims will provide important information that will both advance and contribute towards a greater archaeological understanding of the medieval and early modern brick industry, both within Essex and on a broader, national scale, building upon the important work that has been developed over the past fifty years.

1.3: OBJECTIVES

The key objectives of the thesis are given below:

1.3.1: Knowledge of the English medieval brick industry

It is necessary to develop a framework of knowledge that describes both the manufacture and use to which brick was put during the course of the medieval period in England.

1.3.2: Knowledge of the Essex medieval brick industry

Once an understanding has been developed that describes the manner in which brick was manufactured and employed for construction work during the medieval period, it is necessary to focus more closely on developing an understanding of how brick was employed in the medieval building industry of Essex.

1.3.3: Production of construction sequences for select buildings

Within Essex, a series of construction sequences will be formulated for selected medieval and early modern brick buildings. These construction sequences are to be undertaken in a manner that will allow sampled bricks and any subsequent dates derived to be related back to the relevant component of the construction sequence for the building in question.

1.3.4: Development of standard OSL dating procedure

Based on previous studies in which luminescence has been shown to provide reliable dates for historic brickwork, a standard methodology for dating historic brick structures by means of OSL is to be developed through the analysis of brick samples from select historic brick buildings in Essex.

1.3.5: Derivation of OSL dates

The historic brick buildings selected for this project will, using the standard OSL methodology to analyse brick samples, have reliable and accurate dates derived for specific construction phases.

1.3.6: Evaluation of the OSL dates

Following production of the OSL dates, there is a need to evaluate any subsequent implications for the sampled buildings that arise from the luminescence results when compared against the respective dates of the buildings as derived through stylistic and historical sources.

1.4: METHODOLOGICAL OUTLINE

The aims and objectives of the thesis are to be realised through the following methodological stages:

1.4.1: Study area selection

In order to study the medieval brick industry, an area that contains a large number of structures that span the medieval period and incorporate or are constructed of brick is required. To achieve this, the county of Essex (see Fig. 1.1) has been selected as the focus for the project.



Fig. 1.1: Map showing the location of the sites studied for this project within the modern county of Essex.

This county is noted for the large and diverse amount of archaeological and historical sites incorporating medieval brickwork, several of which are of national significance, in the study of medieval brick (see 2.1 and 2.4). The county has also received far more attention from the archaeological community over the years compared with other areas due to the large amount of medieval brick available for study (Ryan, 1996; Ryan, 1999a). This in turn presents an opportunity to evaluate luminescence dates derived at specific sites against this knowledge framework in order to further the understanding of how brick was employed in the medieval and early modern period.

1.4.2: Building selection and analysis

There is a need to identify and select buildings within Essex that incorporate brickwork which is representative of the different typological varieties that existed during the course of the medieval period, including ‘Coggeshall’, ‘Flemish’ and ‘Tudor’ type bricks (see 2.1). There is also a need to identify and incorporate medieval buildings into the project through which important academic questions relating to the medieval brick industry could be addressed through a combination of both archaeological and luminescence analysis. Finally, once selected, the current archaeological understanding that exists for the selected buildings will have to be determined, allowing for a more effective evaluation of the OSL dates against buildings with differing degrees of independent dating control.

1.4.3: Sample collection and analysis

Once the buildings are selected, there is a need to collect OSL samples from each site for analysis in the luminescence laboratory. There is a need to obtain multiple samples from specific sites in order to allow for comparative evaluation of the OSL dates derived.

1.4.4: Comparative evaluation of the buildings

Once the OSL dates have been derived for the sampled buildings, there is a need to revise the conventional archaeological understanding of the buildings where this is judged to be appropriate. This requires a comparative evaluation of

the information derived from the OSL analysis against the archaeological knowledge compiled for the buildings.

1.4.5: Evaluation of the use of medieval brick in Essex

In order to answer the principle aim of this project there is a final requirement, this being the proposal of broader ideas that related to and described how brick was used in Essex during the medieval and early modern period based upon the revised understanding of how brick was employed for the specific cases studied in this project. Any new proposals that arise through this research will also have to include potential explanations describing the motivational factors relating to how brick is thought to have been used during the medieval and early modern period.

1.4: THESIS OUTLINE

The second chapter of the thesis is structured to provide an initial overview of the history and use of English brick during the medieval period. Discussion and critique of the common approaches adopted for dating historic brick, including previous cases where luminescence has been used, is then given. This is followed by a more focused consideration of the historic use of brick in Essex during the medieval period, with case specific examples of how brick is dated in the county.

The third chapter offers a critical evaluation of the various academic sources that were available for consultation when undertaking the archaeological evaluation of the buildings sampled for the thesis. Each building that was sampled for the thesis is then considered on an individual basis with a historic review of the property being offered, including a brief account of any major structural alterations that took place in the lifetime of the building.

The fourth chapter provides an overview of the luminescence dating technique along with an account of both the field and laboratory based protocols employed in deriving dates.

The fifth chapter provides the luminescence dates derived for the various sampled buildings. The archaeological interpretations offered in the third

chapter are evaluated in light of these results and, where appropriate, alternative assessments of the historic use of the brick within the building fabric are offered.

The sixth chapter offers a review of the earlier discussion on how brick was employed in Essex during the medieval period, using the sampled buildings as exemplars to support the argument. It also evaluates the success of the thesis in terms of the initial aims set out in this chapter and offers suggestions for future work in the study of historic English brick.

CHAPTER 2: THE STUDY OF BRICK IN LATE MEDIEVAL BUILDINGS

'ordeyne me a mason that ys a ducher or a flemyng that can make a dowbell Chemeney of Brykke'

-Extract from the 15th century manorial records of Havering-atte-Bower

This chapter focuses on brick and its contexts within late medieval buildings. The historic use of brick in England during the medieval and early modern period is briefly outlined from the departure of the Romans in the early 5th century to the adoption of the material at many social levels and contexts in the 16th century. The current procedures that are used to date both historic brick and medieval buildings are then outlined and evaluated before a review of situations where luminescence has previously been used to date brick is given. Finally, the history of brick and its usage in Essex is outlined, with examples given of situations where different approaches to dating brick (with the exception of luminescence) have been applied.

2.1: THE USE OF BRICK IN MEDIEVAL ENGLAND

2.1.1: The production and use of brick from the 5th to 12th century

It has been a long held belief that the art of brick making was a technological skill that died out in England with the departure of the Romans in the 5th century A.D. (Lloyd, 1925, 2-3; Davey, 1961, 78; Campbell and Pryce, 2003, 96). However, there has been speculation in more recent times regarding whether or not brick may actually have been manufactured during the Saxon period prior to the Norman Conquest in the 11th century. One key building that provoked such speculation was the 9th century church at Brixworth in Northamptonshire. The outer walls of the nave are composed of a series of four bays with arches containing double rows of brick voussoirs (Ferne, 1983, 65-69). There has been uncertainty surrounding the likely date of production of these bricks. When the church and local area were investigated archaeologically in the early 1970s, thermoluminescence (TL) was applied to several samples in an attempt to determine the age of the brickwork in the building fabric. A series of preliminary TL results yielded dates indicative of Roman, Saxon and medieval

manufacture (Everson, 1977, 99; Everson and Parsons, 1979, 406). However, further testing indicated characteristics of the quartz that were unsuitable for a reliable evaluation of the luminescence age using TL (Everson and Parsons, 1979, 408). Recent re-testing by OSL of fresh quartz extracted from the same samples has demonstrated that it is likely the bricks were re-used Roman material (Bailiff, in prep.). Subsequent study of the church has shown that some of the bricks in the south arcade have traces of primary mortar (*opus signinum*) on them, providing archaeological evidence that supports the OSL findings (Everson and Parsons, 1979, 406). Another case raised for the possibility of Saxon brick manufacture was given by Lynch for St. Botolph's Priory, Colchester (see Fig. 2.1), where he claims an 11th century chronicler gave details of the use of *opera laterito* (brickwork) (Lynch, 1994, 2). However, it has since been shown that Lynch misinterpreted the text (Ryan, 1996, 21). Based on the brick fabric, the fragmentary nature of the brick pieces and the presence of *opus signinum*, it is likely that brick was being re-used from the remains of surrounding Roman structures to build the priory (Ryan, 1996, 16-17, 21).

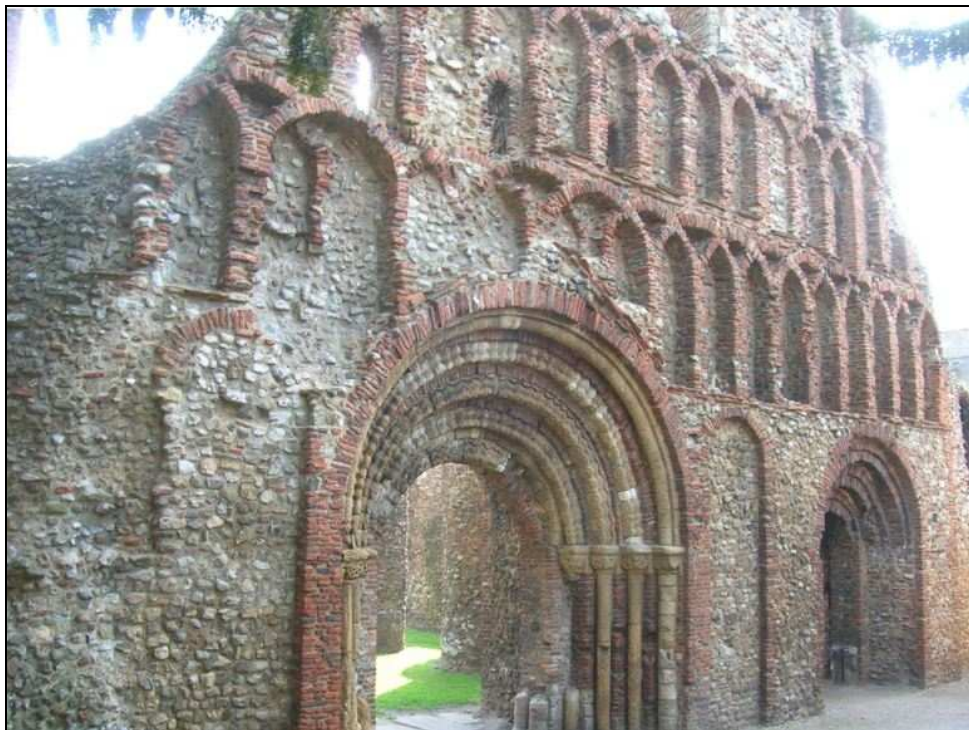

Fig. 2.1: The remains of the western end of St. Botolph's Priory, Colchester, illustrating the extensive re-use of Roman brick, especially in the construction of the blind arcading.

At the time of writing, the only items which had been uncovered in England that might suggest the capacity for brick production in the late Saxon and Norman period are a series of 11th century floor and wall tiles recovered from several locations, including London, York and Bury St. Edmunds (Gem and Keen, 1981, 20-26; Keen, 1993; Betts, 1996). The situation is different in Europe where there is more evidence to suggest that brick was being produced, albeit infrequently and only on a modest scale, during the medieval period. Some examples include bricks found in Strasbourg with the names of 7th century bishops stamped into them (Perlich, 2008, 10), bricks found in Burgundy with pictorial stamps dated to the 6th to 7th centuries (Goll, 2005, 404) and brick used decoratively in the choir wall of the tempietto in Cividale, dated to the mid-8th century (Goll, 2005, 404). This suggests that, whilst not used to any large extent, especially north of the Alps, the art and skill of producing brick was not lost during the early medieval period in Europe (Perlich, 2008, 9-12).

Apart from the few sporadic cases of late Saxon decorative tiles, the evidence would seem to support the conventional idea that brick was not being manufactured for structural or constructive purposes during the course of the Saxon era in England. Alternatively, if manufacture was being undertaken then it was certainly being done in a manner whereby Saxon and early Norman bricks cannot be distinguished from the techniques used by the Romans (Ryan, 1996, 21). Prior to the undertaking of this study, no irrefutable evidence, such as a dated kiln or bricks retrieved from a Saxon context, had come to light to suggest brick manufacture had been taking place during the Saxon period.

Whilst brick was not being produced, it was being used in Saxon building projects, especially for religious structures, and the means for obtaining it often appears to have involved the robbing of abandoned Roman buildings (Eaton, 2000, 129-132; Smith, 2001). The case of brick being re-used in Saxon structures is evident at many sites across the country. The case of Brixworth church has already been mentioned. Other recent research involving OSL dating of brick at several ecclesiastical sites in Kent (St. Martin's, Canterbury, St. Margaret's, Lower Halstow and St. Margaret's, Darent) and Essex (Holy Trinity, Colchester) has helped support archaeological claims that the brick in these churches is re-used Roman material (Blain, 2009). Archaeologically, there are Saxon sites where structures incorporate brickwork that has long been regarded as being re-

used Roman. An example of this is the Saxon chapel of St. Peter's on the Wall, Bradwell-on-Sea, Essex, thought to have been built in A.D. 654 by St. Cedd with material removed from the abandoned neighbouring Roman fort of Othona (Harley, 1975, 137; Ryan, 1996, 18). The re-use of Roman brick continued into the early Norman period. The example of St. Botolph's priory, Colchester, has already been mentioned. Another large scale Norman building project that made extensive use of Roman brick was the central square tower of St. Albans Cathedral which was built from bricks taken from the Roman city of *Verulamium* (Smith, 2001, 115-116). The extent of this re-use has been illustrated by a survey of the churches in the London basin that date from the Saxon period to c.1350. Of the 144 churches where re-use of Roman brick was evident, the survey showed that 87% of these dated from the Saxon period to 1180 (Potter, 2001).

Thus, during the period spanning the 5th to the 12th centuries, it appears that the standard approach to building in brick was not to manufacture what was required but to plunder existing resources from Roman buildings for incorporation into substantial structures, the majority being ecclesiastical in nature. This leads to the issue as to why the production of brick was not undertaken for nearly 800 years. If the available archaeological evidence is indeed a true reflection of a real absence, then the situation might simply involve an absence for the demand of brick production in the Saxon period. This could well be related to the key role timber is thought to have played in Saxon building practice (Rodwell, 1986, 171). There are documentary accounts that refer to wooden churches during the Saxon period. Bede describes wooden churches, including one erected in York in A.D. 627 by King Edwin (Bede, HE, II, 14) and another built by Bishop Finan at Lindisfarne in A.D. 664 (Bede, HE, III, 25). There are also accounts of wooden buildings in the later Saxon period, including Wilton Abbey which was described as being made of wood until the 11th century when it was rebuilt by Queen Edith, wife of Edward the Confessor (*Vite Ædwardi Regis*, Ch.6).

Archaeologically, there are many sites where there is strong evidence to indicate that many Saxon buildings, both ecclesiastical and secular, were constructed from timber. During excavations of the church at the deserted medieval village of Wharram Percy, East Yorkshire, a series of post holes were found. These were thought to be the foundations of the first church on the site, built of timber in the 10th century and replaced in stone in the late 10th or early

11th century (Beresford and Hurst, 1990, 57). A secular example of timber being used for construction was discovered at Goltho, Lincolnshire, where excavations revealed a series of substantial timber trenches of a mid-9th century hall that was later replaced with another timber hall in the mid-10th century (Beresford, 1982, 114, 119). Unfortunately, there are virtually no surviving timber buildings that date from the Saxon period. The sole exception is the church at Greenstead, Essex, which has been dated by dendrochronology to the latter half of the 11th century (Bettley and Pevsner, 2007, 346). Whilst there is only a single surviving wooden church, the archaeological analysis of Saxon masonry structures has shown that timber was used in the construction of these buildings. The different uses included wall shuttering (a means of encasing a wall in timber to provide support to wall ‘lifts’), scaffolding and supports for arches and vaults (Rodwell, 1986, 159-165). Church fittings, including window frames, floors and doors, were also built out of wood (Rodwell, 1986, 165-171). It has also been suggested that the culture of building in timber was so strong that it is reflected in the building practices adopted for masonry buildings (Rodwell, 1986, 171). These includes load bearing features executed in stone but which follow timber precedents, stone features that were intended to resemble timber features, such as pilaster strips representing timber framed construction, and decorative elements, such as mid-wall shafts, executed in stone but in a similar way to timber decoration (Rodwell, 1986, 171-174). The above discussion illustrates that timber was a highly significant aspect of Saxon society and building culture. Consequently, it seems unlikely that there would have been a large demand for brick and what demand that did exist was probably largely satisfied through the plundering of abandoned Roman structures.

Other factors have been proposed that would contribute towards the re-use of Roman brick and subsequent delay in the re-establishment of a native brick industry. These includes the high quality and strength of the Roman material, its wide availability, the want of a better material to build in, especially in areas lacking good building stone, such as Essex and Suffolk, and the increasing stability and commercial nature of the stone industry during the 12th century (Morriss, 2000, 50-51; Smith, 2001, 115). It has also been suggested that brick may have been used symbolically in Saxon structures in an attempt to emulate Roman buildings (Eaton, 2000, 129-131).

Whilst Saxon building culture and ready accessibility of Roman brick are likely to have encouraged its re-use, the exact reason why this practice ceased and an indigenous brick industry emerged in the early 12th century is still largely uncertain. Earlier arguments suggested that the exhaustion of supplies was the principle reason (Drury, 1981, 126). However, Roman brick has been discovered in later contexts, including the fabric of 14th century churches (Potter, 2001, 131; Smith, 2001, 116). It was also being re-used in the post-medieval period. At Little Chesterford, Essex, William Stukeley observed the surviving remains of the standing walls of the Roman town in 1719. These walls were later levelled and the bricks taken by local residents to improve their houses (Morris, 1989, 30). Even today, extensive Roman ruins that are rich in brick remain standing in historic urban areas, such as the Roman built walls and Balkern Gate of Colchester. Ultimately, the idea that Roman sites had become exhausted of suitable building material cannot be cited as the likely reason for the re-introduction of brick in the 12th century. One possible factor might be the perception of brick during the Saxon period. It has been argued that such a change can be seen in Kent where great care appears to have been taken in 7th and 8th century structures to ensure the material was laid in relatively regular courses and also to keep the use of flint to a minimum. However, by the late Saxon period brick was used in a more haphazard manner in flint rubble walls (Eaton, 2000, 131-132). It is also worth noting that the use of Roman stone as a building material declined in the late 10th and 11th century, possibly due to changes in fashion (Eaton, 2000, 29). Perhaps there was a similar change in the fashion or perceived symbolic status associated with the use of brick in other parts of the country around this time.

Overall, brick does not appear to have been produced in England from the Saxon to the Norman period, although the necessary skills for producing brick probably still existed, as demonstrated by the occurrence of late Saxon floor and wall tiles. The exact reason remains uncertain but the strong culture of building in timber, ready access to highly durable brick in abandoned Roman structures and the possible symbolic status associated with such material probably limited any significant demand for brick. These factors are likely to have contributed towards delaying the development of an indigenous brick industry.

2.1.2: The production and use of brick from the 12th to the 13th century

It has long been accepted that the earliest brickwork that was produced in Britain after the Roman era was in the Essex and Suffolk region during the course of the 12th century. Many have argued that the earliest indigenous use of brick occurs at the Cistercian Abbey of Coggeshall in Essex where brick manufacturing and use is thought to date from around 1160 to the 1220s (Lloyd, 1925, 3; Gardner, 1955; Davey, 1961, 78-79; Drury, 1981, 126-7; Clifton-Taylor, 1987, 211; Hunter, 1999, 111-112; Andrews, 2005a, 142). These early types of medieval brick are of a distinctive form and are generally longer, broader and thinner than modern bricks (the average rectangular brick at Coggeshall Abbey measures between 320-330 mm in length, 150-160 mm in width and 45-55 mm in height) (Andrews, 2005a, 142). Because of the distinctive dimensions, such bricks have become known as ‘great bricks’ since the 16th century (Davey, 1961, 79; Harley, 1975, 137; Morriss, 2000, 51) although the term Coggeshall type brick is also used to describe this form of brick in the academic literature.

Besides their size, Coggeshall type bricks have other distinct qualities that aid in their identification, including a sandy, coarse texture, evidence of knife trimming, reduced cores and square arrises. The coarse sand would have acted to reduce the shrinkage and distortion in the drying and firing process when the bricks were first produced. This allows Coggeshall type bricks to be distinguished from Roman bricks which are often warped and made with fine clays (Ryan, 1996, 22-23; Minter *et al.*, 2006, 98-99). Besides the rectangular shaped bricks, several other different forms, or ‘specials’, were produced at Coggeshall through moulding (several of the bricks display the same imperfections of the mould in which they were formed) (Lloyd, 1925, 3), allowing the identification of their use in other nearby churches, such as Fyfield where Coggeshall ‘specials’ were used in the newel in the tower staircase and the inner reveals of the windows (Ryan, 1996, 26; Andrews, 2005a, 142). Many of these distinct brick forms were produced to build specific decorative features for different buildings in Coggeshall Abbey, such as pillars, vaulting and roll moulding for doorways (see Gardner, 1955; Ryan, 1996, 23 and Fig. 2.2 and 2.3).

It should be noted that at Coggeshall Abbey the original brickwork was subsequently plastered and rendered to give the appearance of stone ashlar blocks.



Fig. 2.2: Example of a moulded brick form used at Coggeshall Abbey (Pat Ryan, 2007).



Fig. 2.3: Springing for a roll moulded doorway (left) and a chamfered vaulting rib (right) at Coggeshall Abbey.

Whilst such rendering of masonry surfaces is common in other medieval churches from the 12th and 13th centuries (Clifton-Taylor, 1986, 189), it is interesting that in certain areas at Coggeshall Abbey there is evidence that the plaster was being painted to resemble brick. The exact reason for this is unclear but has been observed at other medieval sites in Europe where early medieval brick occurs. An example of this occurs in the Cistercian church in Marienfeld, Germany, which was founded in 1185. The structure was built entirely of brick but plastered and subsequently painted to resemble brick (Untermann, 2008, 31-32). Given that brick was used at sites in Europe where building stone was readily available (Perlich, 2008, 13), the painting of surfaces to resemble brick is likely to be an indicator of the high status or significance with which it was held in the early medieval period. This point becomes especially more likely given that brick imitation was actually painted onto the plaster of some structures in elevated environments where brick itself could not withstand the severe frosts, for example, the 8th century monastic church at Müstair, Switzerland, where double brick arches were painted around windows (Goll, 2005, 404-405).

Many churches that are located in the immediate area around Coggeshall Abbey which were once thought to contain re-used Roman brick are now being reinterpreted as incorporating medieval brick in their fabric (Fig. 2.4) (Rodwell and Rodwell, 1977, Section 11; Ryan, 1996, 26-28; Potter, 2001). However, other cases of medieval 'great bricks' have been identified outside of Essex. In Polstead, Suffolk, the brick voussoirs of the chancel arch and nave arcading in the church are now thought to be medieval brick dating to the late 1150s or early 1160s when Henry of Essex, lord of the manor of Polstead, was building the church (Kennett, 1990, 14; Ryan, 1996, 28; Morriss, 2000, 51). Another recent discovery is at Farnham, Surrey, where the examination of brick elements within the structure of the old castle ruin and of brick found during the excavation of a medieval tile kiln yard complex suggest a date of use that is somewhere between 1190 and 1208 (Riall, 2001; Riall, 2003). The Farnham case is especially intriguing since it dismisses the idea of early brick being limited solely to Essex and Suffolk. Farnham also suggests that this early form of medieval brick was not solely limited to ecclesiastical sites. No doubt the similarities to Roman brick have resulted in many medieval 'great brick' sites being incorrectly identified or

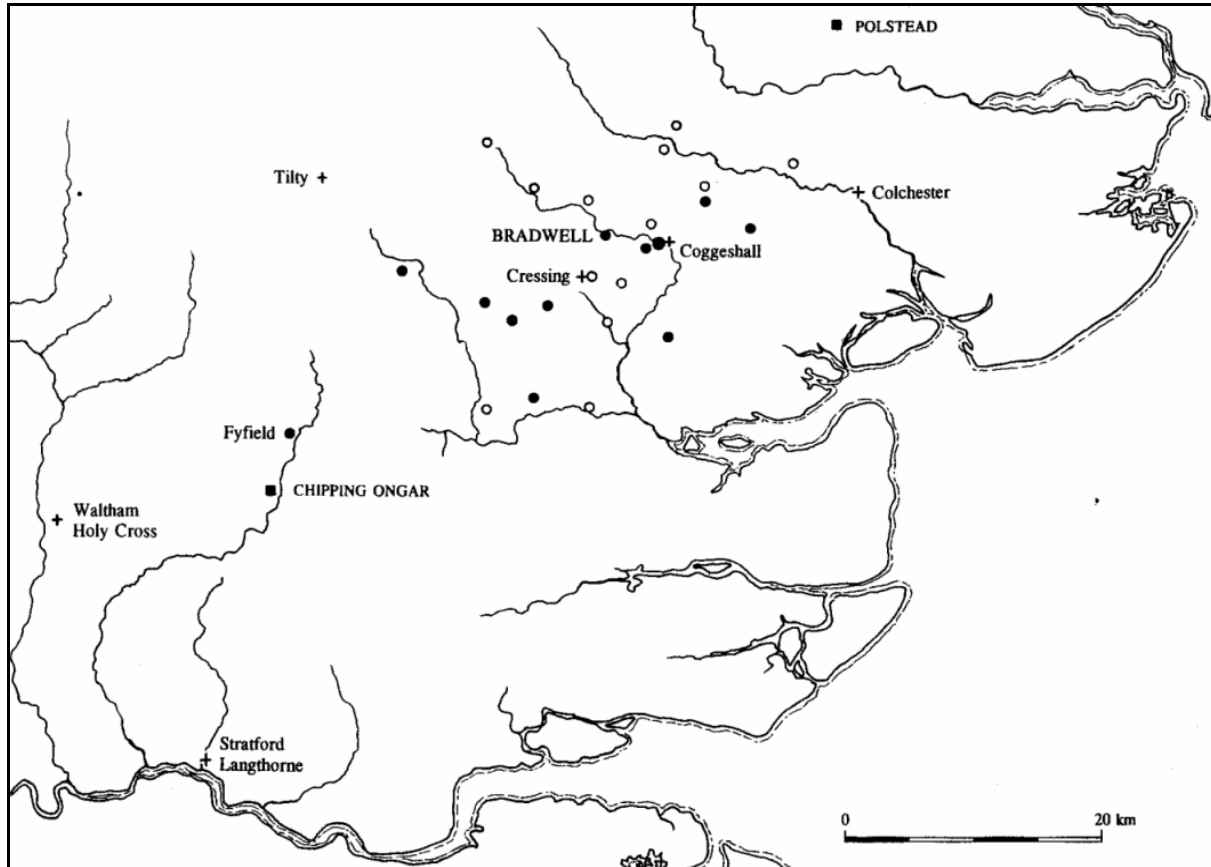

Fig. 2.4: Distribution map of Coggeshall type bricks in churches surrounding Coggeshall Abbey (solid circles represent the use of bricks for dressing whilst open circles represent use as rubble). Polstead and Chipping Ongar are locations of early 12th century brick not thought to be related to Coggeshall (Rodwell, 1998, 101).

interpreted. It is highly likely that future research will lead to the discovery of more buildings which have medieval ‘great brick’ incorporated into their fabric.

With regards to the origin of the medieval ‘great brick’ in England, it has been argued that there is a strong link between the Cistercians and the introduction of this brick type (Ryan, 1996, 29). This is supported by the fact that in both Essex and Suffolk, evidence for Coggeshall type brick has been found at all Cistercian complexes within these counties (Ryan, 1996, 29; Andrews, 2005a, 143). In addition, all of these sites were founded or taken over by Cistercians in the mid-12th century (see Table 2.1) although it should be stressed that this does not imply that brick was being manufactured at all of these sites at this time. For example, construction work on permanent buildings at Tilty is thought to have begun from 1188 onwards (Hall and Strachan, 2001, 198), implying that brick production is likely to have been taking place from the late 12th century onwards. Furthermore, it should be noted that it is only at Coggeshall Abbey that large amounts of brick can be found today, although this may be a biased result due to chance survival. Outside of the Essex and Suffolk region, it is generally thought that the Coggeshall type bricks do not occur at other Cistercian sites, although it was suggested that bricks recovered from an excavation in the 1930s at the Cistercian abbey at Meaux in Yorkshire might date to the mid-13th century (Brooks, 1939, 153; Eames, 1961, 156). Certainly, the remains of a 13th century tile kiln was later discovered at the site (Eames, 1961) suggesting that the monks had the potential to produce brick.

Monastic Site	County	Date Founded (A.D.)	Date converted to Cistercian order (A.D.)
Stratford Langthorne	Essex	1135	1148
Coggeshall	Essex	1140	1148
Sibton	Suffolk	1150	1150
Tilty	Essex	1153	1153

Table 2.1: Cistercian monastic sites where medieval ‘great brick’ has been recorded.

Looking beyond England, there is further evidence in support of the Cistercians using brick at several other monastic sites in northern Europe during the 12th and 13th centuries (Untermann, 2008). The abbey in Lehnin, Germany, was founded in the later 12th century and is entirely built of brick (Kinder, 2002,

372). In Holland, bricks were found in the remains of the monastery at Klaarkamp, founded in 1167 (Ryan, 1996, 43). In Belgium, a brick barn was built at a grange farm close to the 12th century abbey of Ten Duinen (Andrews, 2005a, 143). Later, in the 13th century, the abbey itself was constructed largely out of brick (Gardner, 1955, 31). Brick was also used at the monastic complex in Pontigny, France, during both the 12th and 13th centuries (Ryan, 1996, 43). During the 13th century, another Cistercian barn was built of brick in Belgium, at Ter Doest near Lissewege (Andrews, 2005a, 143). Brick was also used in the 13th century at Chorin Abbey, Germany, to construct the brewery, gatehouse and kitchen (Braunfels, 1972, 110).

The above discussion would suggest a link between the Cistercians (potentially those based in northern Europe) and the emergence of brick production in medieval England. However, recent work on a small church located in the hamlet of Bradwell-juxta-Coggeshall, a few miles west of Coggeshall in Essex, has suggested that the brickwork there pre-dates the accepted date for the brickwork at Coggeshall Abbey, challenging the idea of the Cistercians reviving the art of brick making in England (Rodwell, 1998, 103-105). If indeed the brickwork at Bradwell (and possibly other sites, such as Polstead) pre-dates that at Coggeshall then the idea of when and by whom brick production was revived in England needs to be reconsidered.

2.1.3: The production and use of brick from the late 13th to the 14th century

From the second half of the 13th century, the 'Flemish' type brick was used in England. These new bricks were made from alluvial clay and have similar proportions to modern bricks but are generally of a creamy, buff or pinkish colour (see Fig. 2.5) (Ryan, 1996, 31; Andrews, 2005a, 143-144). These types of brick first appear in East Anglia in the latter half of the 13th century. One of the earliest and most substantial examples of their use can be found at Little Wenham Hall, Suffolk. The exact date of its construction is uncertain, although many place it on architectural grounds to around 1260-1280 (Martin, 1998, 154; Emery, 2000, 120). The structure incorporates large amounts of brick, although the external lower levels of walling are made from flint and septaria (Emery, 2000, 120).

Definitive evidence for the source of the brick at Little Wenham and other



Fig. 2.5: An example of a 'Flemish' type brick.

sites remains elusive. It is generally thought that the influence of the wool trade with Flanders and the emerging member towns of the Hanseatic League encouraged the importation and use of 'Flemish' type bricks in England during the late 13th and 14th centuries (Drury, 1981, 127; Drury, 1993, 164; Ryan, 1996, 45; Andrews, 2005a, 144). Certainly, many of the sites where 'Flemish' type bricks have been recovered are situated close to or actually on the east coast of England. Examples include Southampton ('Flemish' bricks were re-used in a building destroyed in 1338) (Drury, 1981, 127), London (243,000 bricks were imported from Ypres in 1278 for work at the Tower) (Salzman, 1952, 140), Norwich (Drury, 1993, 163-164), Great Yarmouth and Kings Lynn (imported brick was used at both places in sections of the 14th century town walls) (Andrews, 2005a, 144; Wight, 1972, 325, 331).

As well as being imported, it has also been argued that bricks were being manufactured in England from the late 13th century onwards. Considering Little Wenham, it has been suggested by Harley that the cargo ships in use in the late 13th century would have been unable to supply sufficient numbers of bricks for such a large project, for which it is estimated that at least 800,000 bricks would be required (Harley, 1951, 247). It has therefore been proposed that bricks were being manufactured in England at this time, albeit probably under the supervision of continental craftsmen (Harley, 1975, 138; Clifton-Taylor, 1987, 212; Emery, 2000, 121). Overall, it seems likely that there was both importation and local

manufacturing taking place during the late 13th and 14th centuries. Evidence in support of this was revealed by the analysis of late 13th and 14th century ‘Flemish’ bricks from Norwich which seems to suggest that there are two distinct groups, one of which is thought to represent imported bricks in the late 13th and early 14th centuries whilst the other is thought to be East Anglian production from the 14th century (Drury, 1993, 163-164). Further evidence to support this can be found in an entry to the Norwich Chamberlains’ Books in the 14th century mentioning both ‘bricks and Flemish bricks’ (Ayers *et al.*, 1988, 193).

During the course of the 14th century, brick was used for large scale building projects, many of which were located further north in England. Perhaps the largest undertaking was the construction of the city walls around Hull, begun around the late 1330s and completed c.1409, requiring an estimated 4.7 million bricks (Creighton and Higham, 2005, 135; VCH, 1969, 412-413). Hull also had its own brick yard which was operating between 1303 and the late 1430s (Brooks, 1939). It should be noted that surviving brickwork from the 14th century at Hull and other locations is not limited to the ‘Flemish’ cream variety but includes other colours, including red, purple and brown. Some of the other sites in England where brick was being produced during this period include Wisbech, Cambridgeshire (Sherlock, 1998), Boston, Lincolnshire (Mayes, 1965) and Beverley, Yorkshire (Miller *et al.*, 1982, 32). There were also brickyards in the cities of York and Lincoln (Andrews, 2005a, 144). It has been argued that small scale, local brick production was taking place in Norwich in the late 14th century on the basis that the bricks required to construct the Cow Tower, an isolated brick faced tower constructed during the 1380s and 1390s as part of the city’s defences (see Fig. 2.6), were obtained from five separate suppliers (Ayers *et al.*, 1988; Andrews, 2005a, 144). The way in which brick was used in building also changed during the course of the 14th century. Initially, it was not intended to be seen and was used as a backing to stone facings or in wall rubble infillings (Drury, 2000, 60-61). This is the case at the Tower of London where the Beauchamp tower, completed in 1281, has an interior walling comprised of brick (almost certainly from the 1278 cargo from Ypres) whilst the external wall is faced with stone (Ryan, 1996, 45; Drury, 2000, 60). Another example is Thornton Abbey, Lincolnshire, where the gatehouse, dated to between the 1370s and 1380s, is constructed of brick and stone. Originally, the brickwork was rendered in lime

mortar both internally and externally (Emery, 2000, 317-318). Towards the end of the 14th century, there were early signs of the architectural expression of brick on its own. This is seen at the Cow Tower in Norfolk where the situation is reversed and a flint-rubble core is faced with brickwork (see Fig. 2.6) (Ayers *et al.*, 1988, 197; Drury, 2000, 61).



Fig. 2.6: The Cow Tower in Norwich, showing an early example of brick being used specifically as a dressing material.

2.1.4: The production and use of brick during the 15th century

For most of the medieval period, brick had generally been used on a small scale, often alongside other building materials. However, during the 15th century, structures built entirely from brick became much more frequent. The type of brick used for building work in the 15th and 16th centuries also altered to what has become known as the ‘Tudor’ brick. They have the same proportions and shape as modern bricks but are a striking orange-red colour (see Fig. 2.7). Brick was now being used much more for display purposes in buildings. One of the earliest instances of the use of ‘Tudor’ brick in the 15th century is at Beverley, East Yorkshire, where one of the town bars was re-built in brick in 1405. The North



Fig. 2.7: An example of a 'Tudor' red brick.

Bar was also re-built between 1409 to 1410 in local brick at a cost of £96 0s 11¹/₂d (Miller *et al.*, 1982, 39-40). Whilst the North Bar is a defensive building, an effort is made to incorporate decorative and aesthetic elements to the gateway, illustrating the increasing value being placed on brick as a building material in its own right. There are cusped and chamfered apertures, raised bands and an attempt has been made to lay the bricks in English bond (alternating courses of header and stretcher brick faces), although the variable size of the bricks prevented fine work being executed (Moore, 1991, 212). The use of English bond became more frequent in 15th century brickwork as a means of introducing both strength and aesthetic decoration to brick structures (Brian, 1980, 5; Brunskill, 1990, 49-51). Other means of decorating brickwork from the 15th century onwards included diaper patterns being incorporated into the walls and the use of both moulded and carved brick to form elaborate designs. An early example which illustrates all these forms of decorative brickwork can be seen at Rye House gatehouse, Hertfordshire, built in the 1440s, where the brickwork is laid in English bond, there is a twisted chimney built entirely from moulded bricks, diaper work is incorporated into the walls and moulded bricks are use to create decorative trefoil corbelling (see Fig 2.8) (Smith, 1975).

It is thought that the use of brick for building was initially encouraged by royal example, specifically during the reign of Henry V when the palace of Sheen

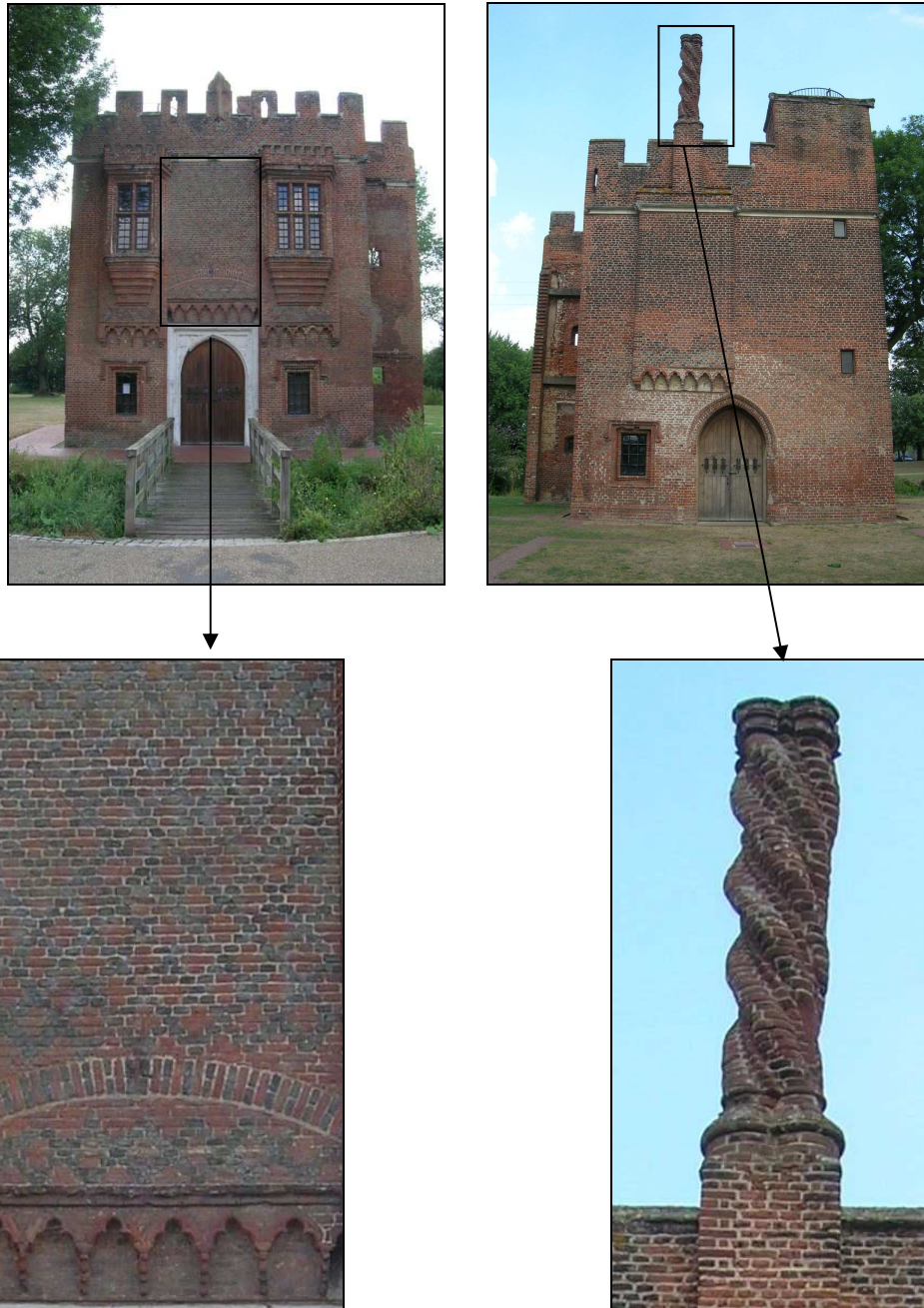

Fig. 2.8: Rye House gatehouse, illustrating different forms of decorative use to which brick was used from the 15th century onwards. The left image shows the front of the gatehouse, where there is a diamond pattern diaper in the brickwork above moulded bricks forming a course of trefoil corbelling. The right image shows the rear of the gatehouse where the moulded, twisted chimney can be seen.

was largely rebuilt between 1414 and 1422 with large amounts of brick being incorporated into the new structures (Brown *et al.*, 1963, 998- 1002; Moore, 1991, 214). Following the Sheen example, a series of impressive and imposing brick castles and tower houses were constructed all over England from the 1430s onwards, many of which incorporate some of the decorative features discussed

above. Some of the more notable buildings include Caister Castle, Norfolk, built between 1432 to c.1445 (Barnes and Douglas Simpson, 1952, 36), Tattershall Castle, Lincolnshire, built between 1434 to 1446 (Douglas Simpson, 1960, xii) and Herstmonceux, East Sussex, built during the 1440s (Emery, 2006, 344). There were also smaller brick tower houses built which could represent poorer reflections of more substantial structures, for example, a series of smaller tower houses were constructed in the area close to the imposing brick complex and tower house of Tattershall Castle (Smith, 1979, 34; Smith, 1985a, 48).

As well as the suggestion that the use of brick by royalty increased its fashion and promoted its usage, it has also been argued that wars in Europe might have inspired the builders to adopt both brick and new architectural styles. However, the exact area of Europe is uncertain. It has long been suggested that France was the likely area (Avray Tipping, 1937, xxxii; Davey, 1961, 81; Moore, 1991, 214). However, recent arguments regarding the origin of decorative diaper work could suggest that areas in northern and eastern Europe, such as Germany, Poland and Denmark, might be more likely origins (Campbell and Pryce, 2003, 138; Andrews, 2005a, 146). There are many sites in northern Germany and Poland where brick was used from the 13th to the 17th century, such as the massive brick castle of the Teutonic Knights located at Malbork, Poland (Campbell and Pryce, 2003, 103-105). Many of these buildings incorporate decorative ornamentation executed in brick, including brick window tracery, elaborate gable ends and diaper work (Campbell and Pryce, 2003, 103, 138). Certainly, there is strong evidence in several documentary sources for foreign craftsmen involved in the manufacture and construction of many 15th century brick buildings, such as Baldwin, the brick mason involved in Tattershall, who was described as 'Bawdwin Docheman' (i.e. Dutchman, meaning German) (Salzman, 1952, 142; Smith, 1985b, 7). With regards to the architectural nature of the buildings themselves, there are several features, including diaper patterns, moulded brick corbel tables, bartizan towers and blind panels and recesses, which all have parallels in European contexts (Smith, 1985b, 10-19). This argument for continental craftsmanship in the above architectural features has been exemplified by a series of brick structures stretching across eastern England from central Essex to southern Bedfordshire and includes Maldon Moot Hall, Essex (probably built in the 1420s to 1430s) (see 3.3.4), Faulkbourne, Essex (built during the

1440s), Nether Hall, Essex (built between the 1440s to 1467) (see 3.3.5), Rye House, Hertfordshire (built in the 1440s) and Someries Castle, Bedfordshire (built c.1448). It has been argued that all these structures were built by the same *atelier* based on the common decorative features that occur at each site, including moulded brick corbel tables and brick newel staircases (Smith, 1975, 133-140; Smith, 1976, 55-56; Smith, 1985b, 16-18). There is therefore strong evidence for continental craftsmen working on English brick buildings during the first half of the 15th century.

The influence of the foreign craftsmen began to wane during the course of the 1470s and 1480s as English craftsmen became ever more able in producing and building in brick, although foreign craftsmen were still active during this period (Moore, 1991, 214-215). An example of a late 15th century construction project where foreign craftsmen were still employed is Kirby Muxloe Castle, Leicestershire, built between 1481-1484. Within the detailed building accounts of the building work, the names of foreign sounding bricklayers are mentioned. It is thought that, since the use of brick building only came to Leicestershire very late in the medieval period (the latter half of the 15th century), there were few locals experienced in the use of the material, necessitating the need to employ foreign craftsmen (McWhirr, 1997, 42).

During the latter half of the 15th century, there is evidence for several different developments in the use of brick. It became a more common building material for chimneys in high status structures, especially in Eastern England (Wight, 1972, 88; Clifton-Taylor, 1987, 259). An example of this occurs at Gainsborough Old Hall, Lincolnshire, where there is a series of four brick chimneys in the west wing, thought to have been erected c.1479 (Field, 1991, 41). There is evidence for 'ruddling' of brick (covering the brickwork in red ochre before the joints between the bricks were highlighted to enhance the aesthetic appearance) in high status buildings. An example of this is seen at Farnham Castle, Surrey, where accounts for the construction of a large brick entrance gateway between 1470-1475 mentions a purchase of 200 lbs of red ochre in 1475 (Thompson, 1960, 87-88). Another example occurs on the Archdeacon's Gatehouse in Ipswich, Suffolk, where traces of red ochre ruddling have survived on the surface of this 1470s brick building (Tracy, 2007, 304). There is also limited evidence to suggest that brick was used for nogging in high status

buildings. An example of this has been found at Hertford Castle, a royal foundation and occasional royal residence until 1627. A brick nogged screen was discovered in the brick gatehouse (built between 1461-1465) during restoration work in 1970-1971. The screen was found to have the regnal year carved into it in the format of 'A D II E IIII' from which it is dated to the second year of the reign of Edward IV (1462-1463) (Moodey, 1973). Another development in the architectural use of brick from the 1480s onwards was a shift away from the brick tower house towards building the brick courtyard house, often with imposing brick gateway towers (Emery, 2000, 27). An excellent example of this can be seen at Oxburgh Hall, Norfolk, built during the 1480s. Here a moated brick courtyard house was erected with a tall, imposing gateway. Oxburgh is significant in that the defensive elements to the structure, such as the moat, gun and arrow loops and machicolations, are only motifs to a past military tradition and would be unable to halt a serious attack, illustrating how brick was being employed more aesthetically rather than defensively by the end of the 15th century (Cook, 1974, 48; Emery, 2000, 140; Brown, 2004, 102). Thus, by the end of the 15th century, the use of brick had expanded to a much greater extent, both geographically and in the frequency of its use, than had been the case earlier in the medieval period. It had become a fashionable but expensive material, largely being used on its own for high status structures as opposed to earlier contexts where it had been used alongside other building materials, as at Little Wenham Hall (see 2.1.3). The 15th century also saw the emergence of highly ornate and decorative uses of brick, such as bonding patterns, moulded or carved decorative detailing, diapering and ruddling.

2.1.5: The production and use of brick during the 16th century

The 16th century saw a widespread pattern of building and alteration of existing structures that has become known as the Great Rebuilding (Hoskins, 1953). This rebuilding phenomenon has been identified as influencing a wide range of society, including the gentry and freeholder class, such as yeoman farmers (Hoskins, 1953, 50), and is reflected in both polite and vernacular architecture of the period across the country (Brunskill, 1992, 24; Airs, 1995, 4). Whilst the Great Rebuilding was originally described as taking place from 1570-1640 (Hoskins, 1953), it has since been shown that the time when it actually

occurred varies from region to region around the country (Platt, 1994, 1-2). During the early 16th century, Tudor country houses were being constructed as part of this Great Rebuilding (Howard, 1987, 16). There were several reasons behind the motives for such building works. As the country entered a period of relative stability under the Tudor monarchy, there was a general discontent with earlier structures that had been designed for an earlier, more turbulent era (Airs, 1995, 4). In addition, there was the desire to create a monument that expressed the modernity and prosperity of the builder to both his contemporaries and future generations (Howard, 1987, 24; Airs, 1995, 4, 15). Brick was frequently employed as the building material for many building projects of this period, often as a result of influences from the royal court where brick was used for grand building projects, such as Hampton Court (Howard, 1987, 171). An example of this influence can be seen in the courtier Sir William Leighton who built Plaish Hall, Shropshire, largely in brick during the late 1540s (Howard, 1987, 171).

As well as being used for country houses, brick was also being employed by local communities in the early 16th century. The 15th century had seen a period of widespread structural additions to churches across the country (Morris, 1989, 353-355). It was only in the late 15th and early 16th century that brick was employed for some of these additions to churches. It was most prominent in Essex and, to a lesser extent, in Suffolk and Norfolk (Wight, 1972, 154; Ryan, 1996, 71-73). There are a limited number of cases of entire churches being built in brick during this period, such as Chignal Smealey, Essex, (built c.1530) (see Fig. 2.9), where there are several brick fittings, including a trefoil cusped piscina niche in the chancel, a trefoil cusped statue niche and the very rare feature of a font built entirely from brick (Wight, 1972, 249). The church is certainly deserving of the local name 'brick' Smealey. However, it was more common for brick to be employed for building specific parts of a church, including porches, clerestories and towers (Wight, 1972, 155-166; Ryan, 1996, 71-73).

An interesting feature that emerges in the 16th century is the fact that there is a decline in the quality of craftsmanship in producing and using brick for building work when compared to that seen in the 15th century, something usually attributed to the shift away from skilled foreign expertise and the desire for quick completion of the work (Howard, 1987, 172). Diaper brickwork was still



Fig. 2.9: Chignal Smealey church, a rare example of a church built entirely from brick in the early 16th century.

employed on buildings and may have been used to convey the differential status of different parts of the manor complex, for example at Sutton House, London, the brick diapering appears to have been used on the higher status upper floors of the building where the rooms of state and entertaining were located (Howard, 1997, 107). There is also potential evidence that diaper patterns were incorporated into ruddling in some buildings, possibly as a means to enhance the dark pattern in the red brickwork, for example, there are records that parts of the former Augustinian priory in Dartford, Kent, were rendered in both red and black colours whilst being developed into a royal house for Henry VIII during the early 1540s (Colvin *et al.*, 1982, 72).

It was during this period that the new building material terracotta began to appear in high status architecture of England, with its use peaking between the 1520s and the 1540s (Wight, 1972, 180; Campbell and Pryce, 2003, 141). Early examples of the use of terracotta can be seen at Hampton Court palace, where the brick complex completed by Wolsey around 1520 incorporated decorative terracotta busts of emperors and a plaque of Wolsey's arms (Blomfield, 1923, 4-5; Wight, 1972, 196). Whilst limited in its use, there are several instances of

terracotta being employed in East Anglia. For example, there are a series of terracotta tombs in churches in Norfolk, Suffolk and Essex that were made around the 1520s (Baggs, 1968). The use of terracotta by the court is reflected in courtiers' houses, such as Sutton Place, Surrey, built around the 1520s (Wight, 1972, 188) and Layer Marney, Essex, also thought to have been built in the 1520s (see 3.3.3). Following the Reformation and subsequent breach with Rome during the 1530s, the material fell out of fashion, resulting in its use for only a limited period in England (Campbell and Pryce, 2003, 141). Whilst only used in England for a short period, terracotta serves to demonstrate the close connection that existed between the royal court and courtiers who were keen to emulate the royal precedent (Howard, 1987, 132).

As an early episode in the split with Rome and the Reformation, the dissolution of the monasteries occurred between 1536 and 1539. This resulted in a great deal of land becoming available at a swift pace to the growing nobility and landed gentry, who were prospering during the early Tudor era (Wight, 1972, 168-169; Howard, 1987, 138; Cooper, 1997, 118). If having been dissolved, a monastic house passed into the ownership of a high status individual, there would frequently be a redevelopment of the structural remains (Howard, 1987, 139). This often involved the standing remains being used to varying degrees to form large manorial complexes, although sometimes there were grand lodgings already on the site that had been built for the former head of the monastic house. For example, those at St. Osyth's Priory, Essex, which were largely built of brick in 1527 for the abbot John Vintor, were incorporated into the new mansion built there by Lord Darcy in the mid-16th century (Howard, 1987, 144; Ryan, 1996, 73). Sometimes the alterations were limited and might simply involve insertions of doorways or brick chimneys but on other sites houses with one or even two courtyards could emerge from the monastic remains (Wight, 1972, 171; Howard, 1987, 143). An example of a monastic conversion where extensive use was made of brick was at Syon House, London, where a mixed house of the Bridgettine order was converted to a quadrangular house following the convent ground plan (Wight, 1972, 171, 315-316).

During the latter half of the 16th century, brick continued to be used for major secular building projects. An important and unusual brick manor that was constructed during the Elizabethan era was Hill Hall in Essex. The building was

unusual for the time through the inclusion of French Renaissance elements in its architectural decoration (Drury, 1983, 118). Originally the courtier Sir Thomas Smith built a brick manor in the Tudor gothic style between 1557-1558 before being appointed ambassador to France in 1562. He returned to England in 1566 and appears to have developed an interest in classicism during his time in France (Drury, 1983, 119). He began to remodel the original hall (it had originally been poorly built, with loam used to bind the brickwork instead of mortar). Between 1568-1569 he remodelled the north and west sides of the existing courtyard with the other two sides being remodelled between 1574-1575. Work was finally completed on the hall around 1581 (Drury, 1983, 114-118). Hill Hall is architecturally important for its classical elements which derive from early French Renaissance architecture. It also incorporates terracotta which is highly unusual for a late 16th century context (*cf.* Layer Marney, 3.3.3.) (Drury, 1983, 122). It serves to illustrate that there were still a few occasions in England during the latter half of the 16th century when Renaissance ideas were combined with the more common Tudor architectural practices in England.

As mentioned before, evidence for the Great Rebuilding can also be seen at the vernacular level. There are two approaches in which brick was being employed in this type of architecture. Brick nogging is a means of infilling the studwork of timber framed buildings with patterns of brick and was seen as a way of elevating the status of an individual's property (McCann, 1987, 121; Ryan, 1996, 86). The use of nogging was a largely regional phenomenon and there are several 16th century buildings throughout southern and eastern England which incorporate examples of brick nogging (McCann, 1987, 129-132). The use of brick for constructing chimneys was another important development during this period. Whilst brick chimneys had appeared during the 15th century, they were limited to the wealthy nobility. It was only during the course of the 16th century that this architectural feature began to filter down to smaller houses (Clifton-Taylor, 1987, 259). This is exemplified by William Harrison, rector of Radwinter, Essex, who wrote in 1577 that:

“there are older men yet dwelling in the village...which have noted...things to be marveylously altered...within their sound remembrance. One is the multitude of chimnies latelie erected, whereas in their yong dayes there were not above two or three”

This passage suggests that the introduction of brick chimneys had taken place at a relatively fast pace, occurring within the space of a generation during the 16th century (Antrobus, 2004, 22). Thus, by the end of the 16th century, a number of important developments in the use of brick had taken place. Whilst initially employed for high status projects in all levels of society, such as community churches and grand courtier houses (sometimes with elaborate decorative features like terracotta), it saw increasing use during the period following the Reformation when many manors were erected from the spoils of the dissolution. The latter half of the 16th century continued to see the erection of large manor complexes, occasionally with Renaissance influences, and the increasing use of brick by a wider proportion of society in the form of nogging and brick chimneys.

2.2: CURRENT APPROACHES TO DATING MEDIEVAL BRICKWORK

Although there are several different approaches that are currently used to date medieval and Tudor brickwork, they generally fall under four categories. The following section will consider and evaluate these four principal approaches.

2.2.1: Comparison to brick typologies

The development of the art of brick making and the subsequent diagnostic features that are formed in the brick as a result of different manufacturing practices for different periods has been investigated by several individuals (Harley, 1974; Ryan and Andrews, 1993; Campbell and Saint, 2002; Minter *et al.*, 2006). It is these diagnostic features that are critical to this dating approach. Certain features on the brick in question, such as dimensions, regularity of the arrises, distinctive impressions on the surfaces, colour and fabric, are compared to those of other bricks within a typology that reflects the chronological development and changes in brick for a particular area (Andrews, 2005a, 139-140).

It has been argued that this approach is reliable, straightforward, economic and operates to an accuracy of 50 to 100 years (Ryan and Andrews, 1993). Whilst this is generally true of such an approach, one limitation is that bricks from certain periods are highly similar, for example bricks from the 15th century are hard to

distinguish between 16th centuries bricks. As a result, further evidence is required to improve any date proposed for brickwork beyond this broad 200 year date range (Harley, 1974, 74; Ryan and Andrews, 1993, 94). Whilst such typologies are great resources for archaeologists and historic building specialists, they do have limitations when applied to certain situations. This can be exacerbated when the brick in question has been re-used or recovered from an excavation and the original building context is no longer available to offer further evidence as to the likely age of the brick.

2.2.2: Documentary evidence

Documentary evidence can be highly informative and revealing as to when a specific building was being constructed. Records exist as to when bricks were being ordered or manufactured, especially for high status buildings. Such records include building contracts, especially for royal works (the middle ages and Tudor period are outlined in the first three volumes of *The History of the King's Works*), licences to crenellate, or historic descriptions written contemporaneously to the building in question or by later antiquarians, for example, John Leyland's 16th century *Itinerary*. Bequests might also be left by individuals in wills towards the construction of specific projects.

Whilst such documentary information is highly valuable and may initially seem to offer precise dating evidence, there are limitations associated with it. Firstly, it is a source of evidence rarely found for medieval or Tudor buildings unless they were high status projects (Brunskill, 1992, 124). Two sites which exemplify the survival of such records are Tattershall Castle, Lincolnshire, (Douglas Simpson, 1960) and Kirby Muxloe Castle, Leicestershire (McWhirr, 1997, 40-43) both of which were constructed under the orders of high ranking men (Lord Cromwell, who built Tattershall, was treasurer to Henry VI whilst Lord Hastings, who built Kirby Muxloe, was a Yorkist leader and favourite of Edward IV) (Wight, 1972, 128, 132). Secondly, documentary sources are not always reliable. When considering licences to crenellate, it should be borne in mind that they were intended more to illustrate the social status of a household rather than to act as official licences for works to be undertaken on buildings (Howard, 1987, 50; Coulson, 1993; Liddiard, 2005, 44). Thus, at Kirby Muxloe, the licence to crenellate and the beginning of construction work on the castle

differ by a period of six years (Emery, 2000, 267). Licences might also be granted after work had already commenced, for example, the licence at Oxburgh Hall seems to suggest that work had already been underway by the time it was granted in that it also pardons any earlier fortified constructions (Emery, 2000, 138). Another example of how historic documents can be misleading occurs in Essex where the 15th century tower of Billericay church had originally been dated by a record of a grant to the church in 1496 (Ryan, 1996, 63). However, the recent discovery of decorated Spanish tiles dated to c.1450-1475 in the brickwork has called this date into question and suggests that the tower might actually be older than expected (Andrews, 2005b, 167-168). Finally, even if contemporary records do exist for when construction work was undertaken, there is no guarantee that any later alterations to the building will be accounted for in the documentary record.

2.2.3: Architectural analysis

There are two key means by which historic structures can be dated through the architectural analysis of the building. Firstly, the development of the building can be phased through the recognition of continuities and breaks in the wall fabrics (Morriss, 2000, 157-162). However, this approach only offers a relative chronology for the development of the building. Absolute dating of the different phases can only be achieved if diagnostic fittings or features, such as window tracery, doorways or fireplaces, the designs of which varied over the course of time, are present in the different phases of the building. Often such chronologically diagnostic features are compared with buildings for which the date of construction is thought to be known (Hall, 2005). Whilst this approach can offer a precise date range for a building, it is dependant on several factors, such as how quickly architectural fashions changed and diagnostic features being present and observable on the building under consideration (Brunskill, 1992, 124-127). Equally, the assumption that certain aspects of one building relate to another structure where similar diagnostic features are present could prove misleading. As with documentary evidence, this is a dating approach that is often more effective for high status buildings, illustrating another potential limitation. Later alterations to buildings or the re-use of materials from older structures are further means by which misleading results can be derived (Laws, 2003, 26).

Certain architectural components of a building, such as date plates, rainwater hoppers and coats of arms, can offer another valuable source of dating evidence. However, such features can be misleading and may relate to non-architecturally significant events in the history of the building, such as the commemoration of a marriage or a change in ownership, or to later architectural alterations of a building. As a result, they must be treated with caution when considering a possible date (Brunskill, 1992, 128; Green, 2000, 172, 181). Whilst architectural features can provide valuable information, there are several potential limitations to using an approach which relies on diagnostic features being present and relating to specific events in the history of the building.

2.2.4: Scientific dating methods

There are several different scientific dating approaches that have been investigated and applied in an effort to date historic brick structures. Naturally, luminescence is a key scientific approach and examples of its application are discussed in section 2.3.

One of the most common of these techniques is dendrochronology, a valuable approach to dating buildings that can potentially offer very precise dates for the felling of trees, especially given the recent developments in the use of Bayesian statistics to historic buildings (English Heritage, 1998, 5; Bayliss, 2007). However, a tree ring date requires a sample that has both its heartwood-sapwood and sapwood-outer bark boundaries intact in order to derive a felling date that is accurate to a single year, something that is often not the case (Aitken, 1990, 46-47; English Heritage, 1998, 15). If only the heartwood-softwood boundary is intact, then a date range can be suggested. There is also the need for several timber samples, each ideally containing at least 100 annual growth rings with several diagnostic patterns in ring width variations. This allows for comparison of the timbers being investigated against a master tree ring chronology. Therefore, an insufficient number of rings or variation in the ring width patterns are potential factors that can prevent a date being derived (Kuniholm, 2001, 36; English Heritage, 1998, 15). Irrespective of whether a tree ring date can be derived from the timbers of a building, there are other potential problems that can arise relating to the archaeological development of the building, for example, the question of timbers being re-used (Kuniholm, 2001, 36; English Heritage, 1998, 14). Equally,

it should be noted that this technique does not directly date the brick itself and there is therefore the possibility that the timbers do not relate to any brick elements of a building, for example, brick facades could be built around older timber buildings (Laws, 2003, 69).

Archaeomagnetism is a scientific dating approach which can provide a date for fired ceramics. When a ceramic is fired, magnetic domains (magnetic minerals within the clay) align with the contemporary magnetic field of the earth. Once cooled, the magnetic domains remain *in situ* within the ceramic matrix. Over the course of time, the magnetic field of the earth varies, both spatially and in intensity. These past variations in the magnetic field have been measured in samples of independently dated archaeological ceramics, allowing a calibration curve to be produced. Samples of archaeological ceramic that are dated by archaeomagnetism are compared against this calibration curve in order to derive a date for the time of last firing (Sternberg, 2001, 73-74; Linford, 2006, 3-5). A limited number of historic brick structures have been successfully dated by archaeomagnetism, including the tile kiln excavated in Farnham, Surrey (dated to the first half of the 13th century) (Riall, 2003, 330-331) and the tile and brick kiln excavated at Boston, Lincolnshire, (dated to the first half of the 14th century) (Mayes, 1965, 104-105). Much of the archaeomagnetic dating work undertaken in the UK has been archaeodirectional dating in which the spatial variation between the earth's present magnetic field and that recorded in the magnetic domains are compared. A key aspect of this form of dating is that the fired ceramic is not disturbed from the time of last firing to the time of sampling, since this removes the true directional record of the magnetic field at the time of last firing (Aitken, 1990, 239; Linford, 2006, 5). This presents a severely limiting factor for dating bricks through the study of the spatial variations in the magnetic field. However, recent research has been focusing on dating fired archaeological ceramics by focusing on the variations in the intensity of the magnetic field recorded by the domains (Casas *et al.*, 2007). This would allow mobile archaeological items, such as bricks, to be dated but at the time of writing the technique was still at the developmental stage in the UK (Linford, 2006, 13).

Another common archaeological scientific dating tool that has been used for dating historic buildings is radiocarbon, a dating approach that is based on the decay of the carbon radioisotope C¹⁴. In applying this technique to historic

structures, the mortar of the building is dated. Non-hydraulic mortars that were used to construct historic buildings absorbed carbon dioxide from the air when setting and, by dating the carbon in the absorbed gas, it is this event that is dated (Heinemeier *et al.*, 1997, 487). It should be noted that since the radiocarbon originates from the atmosphere, there is also the need to calibrate any radiocarbon date derived (Heinemeier *et al.*, 1997, 487). However, there are elements in the mortar binder that can give a misleading result for a radiocarbon date, such as the presence of charcoal or limestone that was incompletely burnt during the initial preparation of the mortar (Heinemeier *et al.*, 1997, 487). Consequently, there is a need to identify the different carbonates and determine the likelihood of contamination of the carbon in the mortar (Lindroos *et al.*, 2007). It should be noted that whilst charcoal is a contaminant with regards to dating the mortar, it is possible to use radiocarbon to date the charcoal itself, an approach that has been adopted at the 10th century church of Notre Dame Sous Terre, Mont Saint Michel, France (Blain *et al.*, 2007, 1484). However, earlier studies have found such wood inclusions to be older than the mortar in which they are set, suggesting that wooden components such as this might have had a considerable age before becoming incorporated into the building (Heinemeier *et al.*, 1997, 491-492).

Other more exotic approaches to scientifically dating bricks include analysis of the fabrics (Potter, 2006), the chemical composition of different period bricks (Calliari *et al.*, 2001; Schiavon *et al.*, 2008), the diffusion of calcium into the ceramic matrix (Waddell and Fountain, 1984) and the expansion of moisture into fired ceramics (Wilson *et al.*, 2003; Wilson *et al.*, in press). However, these approaches require further research and have yet to be adopted widely.

2.3: APPLICATIONS OF LUMINESCENCE IN DATING HISTORIC BRICK

Luminescence is a dating tool that has been used to date brick from both medieval and post-medieval contexts. However, compared with Europe where luminescence has been employed in building archaeology at many more sites over a much longer period, it is only relatively recently that the technique has seen a greater use within the UK. The following discussion provides a brief outline of

several examples, both within and outside the UK, where luminescence has been employed for dating historic brick.

Within England, one of the earliest studies undertaken was at Brixworth church, Northamptonshire, where four preliminary thermoluminescence (TL) results yielded dates indicative of Roman, Saxon and medieval manufacture. However, recent luminescence work on bricks from the church has shown that they are re-used Roman material (see 2.1.1). Since 2000, a series of projects by the Durham University luminescence research group have derived a routine approach for applying luminescence to dating historic brick. This began with a study undertaken on four 17th century buildings in Newcastle upon Tyne, the results of which gave a generally good agreement to the assigned architectural dates, although one sample suggested the brick had been re-used (Bailiff and Holland, 2000). One study focused on a series of late 15th and 16th century chimneys at six buildings in Suffolk, the results of which also gave good agreement with the architectural dates (Antrobus, 2004). Another recent application of the technique involved several buildings from Lincolnshire ranging chronologically from the late 14th century to the early 18th century. This study demonstrated a good chronological agreement between the luminescence results and the conventional building dates (Bailiff, 2007). These studies demonstrate that in recent years a reliable approach has been developed for the application of luminescence for dating both medieval and post-medieval brickwork.

Outside of England, there have been studies undertaken on both medieval and post-medieval brick in several countries. One of the earliest was the use of TL on a series of Italian villas dating from the 15th to the 17th century (Goedicke *et al.*, 1981). More recently, there has been a series of projects where luminescence has been used for dating both medieval and post-medieval brick. In Denmark, a brick kiln was dated to the late 18th century by means of a combination of archaeomagnetism and TL (Abrahamsen *et al.*, 1998, 1018). The study of brick in the 11th century atrium of the Abbey of Pomposa, Italy, demonstrated that it was actually re-used medieval brick from the 6th to 9th centuries and not Roman material, to which it was dimensionally very similar (Martini and Sibilia, 2001, 245). The analysis of brick in the sacristy of the church in Somero, Finland, by TL gave an average date of A.D. 1474 (± 19) that was in good agreement with the archaeological evaluation for the brickwork

(1480-1560) (Hütt *et al.*, 2001). In France, TL work at the medieval church of Notre-Dame-Sous-Terre, Mont-Saint-Michel, successfully dated the 10th century brickwork. The results both agreed with the archaeological evaluation which dated the building to the last third of the 10th century and also suggested the possibility of two separate phases of building work in the church (Blain *et al.*, 2007). Another recent project in France involved brick samples being taken from two medieval churches in Normandy for analysis by both TL and OSL. The luminescence results suggested that the brick was re-used Roman material, an outcome which agreed with the archaeological assessment of the churches (Blain *et al.*, in press). In Sweden, a medieval kiln excavated in Kungahälla had several scientific dating techniques applied, including archaeomagnetism, radiocarbon and TL. Archaeological evidence suggested that the kiln had been in operation c.1300, a date supported by the radiocarbon and archaeomagnetism. However, the luminescence date was slightly young, dating to the mid-14th century, a difference which could not be satisfactorily explained (Riisager *et al.*, 2003). In Ichenhausen, Germany, a Jewish *mikveh* (ceremonial pool filled with spring, rain or ground water) was dated by TL to the late 18th century, confirming one of the two hypotheses proposed relating to the age of the *mikveh* (Veronese *et al.*, 2008). Another case from Germany involved applying TL at the monastery church of Tegernsee, Bavaria, to date brickwork in front of a late 17th century altar and ceramic fragments from a terrazzo floor though to be post 11th century. The results indicated that the brick in front of the late 17th century altar were actually part of a 15th century screen, whilst the terrazzo floor was found to be a 15th century attempt to emulate an 11th century mosaic floor (Göksu and Schwenk, 2000). In Poland, the brick Teutonic Order castle at Malbork was dated by TL, producing results that ranged from the 12th to the 14th century and which agreed with the archaeological assessment of the building (Chruścińska *et al.*, 2008).

These accounts of situations in Europe where luminescence has been used to date brick further illustrate that the technique has been successfully applied in a number of different archaeological contexts and periods, including the medieval and post-medieval periods. Overall, these cases help to demonstrate that luminescence can contribute valuable knowledge to the archaeological study of historic brick.

2.4: HISTORY OF MEDIEVAL AND TUDOR BRICK IN ESSEX

As discussed earlier (see 1.3.1), this project has focused on the county of Essex, partly due to the large number of historic buildings that are either built from or contain historic brickwork. This wealth of archaeological sites means that in many ways the history of brick in Essex follows the generic national trends discussed earlier (see 2.1).

2.4.1: The production and use of brick in Essex from the 5th to 12th century

Brick production appears to have ceased in Essex following the withdrawal of the Romans in the 5th century A.D., a situation which appears to be the case in other parts of the country (see 2.1.1). There are many examples in Essex of Saxon and early Norman buildings where bricks have been robbed from Roman ruins. One example already discussed was the Saxon chapel of St. Peter's on the Wall, Bradwell-on-Sea, thought to have been built in A.D. 654 by St. Cedd using Roman material removed from the abandoned neighbouring Roman fort of Othona (see 2.1.1).



Fig. 2.10: Western tower of Holy Trinity church, Colchester. Note the red quoins, string courses, horizontal banding and blind arcading of the upper stages, all made from brick robbed from surrounding Roman buildings.

Another later Saxon ecclesiastical example of the re-use of Roman brick is the western tower of Holy Trinity Church, Colchester (see Fig. 2.10). This feature was added to an earlier structure in the first half of the 11th century (Harley, 1975, 137; Rodwell and Rodwell, 1977, 32). Recent luminescence dating of the brick in the tower has shown that it is re-used Roman brick (Blain, 2009), robbed from surrounding Roman buildings. The brick is used in several architectural features that are characteristic of late Saxon architecture, including the double belfry windows and the double splayed windows in the first stage of the tower (Taylor and Taylor, 1965, 4, 9, 162-164; Ryan, 1996, 17-18). The tradition of plundering Roman ruins for brick continued after the Norman invasion. An example of this can be seen at the fabric of the castle keep in Colchester, constructed around 1070-1080, which incorporates large amount of Roman brick (Harley, 1975, 137).

2.4.2: The production and use of brick in Essex from the 12th to 13th century

Traditionally, the earliest occurrence of brick in Essex is thought to have originated at Coggeshall Abbey, although recent research into sites such as Bradwell-juxta-Coggeshall has begun to cast doubt on this claim (see 2.1.2). Another site in west Essex where medieval 'great bricks' occur is at the Augustinian house of Waltham Abbey. The bricks here are as distinctive in terms of their fabric as the 'great bricks' at Coggeshall and only occur close to the abbey precinct. They range in size much more than Coggeshall type bricks (290-380 mm x 145-195 mm x 32-90 mm) and are generally based on a rectangular shape, although some moulded 'specials' have been recovered (Huggins, 1972, 111-113; Ryan, 1996, 29-30). Their fabric is based on fine particled clay and is very similar to the fabrics of Roman bricks. They were also made in sanded moulds and often have reduced cores (Wallis, 1992, 145; Ryan, 1996, 29). The Waltham 'specials' have certain features that occur in some early medieval bricks, these being keying and firing holes. Keying holes are small, triangular indentations made into the clay surface with a sharp blade to aid with the adhesion of mortar. Firing holes were produced by piercing or stabbing the brick with a sharp implement, often to a depth of three quarters of the brick thickness. It is thought that these holes were to aid drying and help prevent the distortion of the brick during firing (Huggins, 1972, 111-113; Ryan, 1996, 37). Such features have also been identified on 'great bricks' from other medieval sites in Essex, for example,

in the *reredorter* at Chelmsford Priory, dated to c.1300 (Drury, 1974, 74; Ryan, 1996, 37). Whilst the majority of sites where medieval 'great bricks' occur are ecclesiastical in nature, they have been recovered from a secular context at Pleshey Castle. During excavations in 1959, bricks that measured approximately 330 mm x 229 mm x 32 mm and which were thought to be associated with a late 12th century date, possibly c.1180, were uncovered (Wilson and Hurst, 1960, 145). Further excavation during the early 1960s produced more brick that came from contexts dating from the late 12th century to the early 14th century, some of which was probably medieval 'great brick' although there was some uncertainty as to whether they might have been used as hearth tiles (Williams, 1977, 91-92).

There are therefore a wide range of sites around Essex, often ecclesiastical in nature, where medieval 'great bricks' have been identified, both through archaeological excavation and by analysis of standing buildings. It is generally thought that the use of medieval 'great bricks' spans the period from the 12th century to the late 13th century (Ryan, 1996, 26-28; Andrews, 2005a, 143). One of the later examples of the use of this brick type is in a late 13th century lancet arch in Copford church where single or double chamfered moulded bricks have been used in the inner orders of the arch. Large quantities of Roman brick, thought to have been taken from a nearby villa, were used in the outer order of the arch illustrating that Roman material was being re-used alongside the medieval 'great bricks' (see Fig. 2.11).

It has, however, been suggested that the arrangement of these different period bricks at Copford church could potentially mean that the moulded medieval bricks in the arch have also been re-used (Rodwell, 1998, 105). This is something that has been identified at other medieval sites in Essex including Waltham Abbey, where excavations recovered medieval 'great bricks' in both original (late 12th century) and late medieval (15th century) contexts (Huggins, 1972, 111-114; Wallis, 1992, 145). At Rivenhall church, moulded Coggeshall type bricks and brick rubble were recovered from a context dated to c.1330-1380 (Rodwell and Rodwell, 1993, 8) whilst repair work on the 15th century clerestory of Bocking church revealed Coggeshall type brick re-used in the masonry (Andrews and Crouch, 2001, 289).



Fig. 2.11: Late 13th century lancet at Copford church. The outer order brickwork is re-used Roman whilst the two inner two orders are medieval.

2.4.3: The production and use of brick in Essex from the late 13th to 14th century

‘Flemish’ type brick began to appear in Essex in the late 13th century and was used during the 14th century. The earliest site where ‘Flemish’ type brick occurs in Essex is thought to date to 1292 when a Carmelite friary was founded in the coastal town of Maldon (Andrews, 2005a, 144). Whilst many ‘Flemish’ type bricks are white or cream in colour, a wide range of other colours have been identified, including orange, pink, purple and brown exteriors and streaked/marbled interiors. Rounded arrises, creased faces, grass marks and sunken margins are additional features that have been identified on this type of brick. Sometimes small estuarine gastropod shell casts have also been found in their fabric, indicating the use of estuarine silt in their production (Ryan, 1996, 31-34; Isserlin, 1999, 90-91). There are many other locations in Essex where ‘Flemish’ type bricks have been identified. They mostly occur in 14th century ecclesiastical contexts, often close to the coastline, and are used either in a random manner with other building materials or in decorative patterns (Ryan, 1996, 36, map 4; Andrews, 2005a, 144). One example of the random usage of this type of

brick is Dengie church, located about four miles from the coast. Here 'Flemish' type bricks are used in the nave alongside septaria, flint and pebble rubble (see Fig. 2.12). The Royal Commission believed that the chancel and nave were rebuilt in the early 14th century but suggested that the nave walls could be substantially earlier (RCHME, 1923, 33).

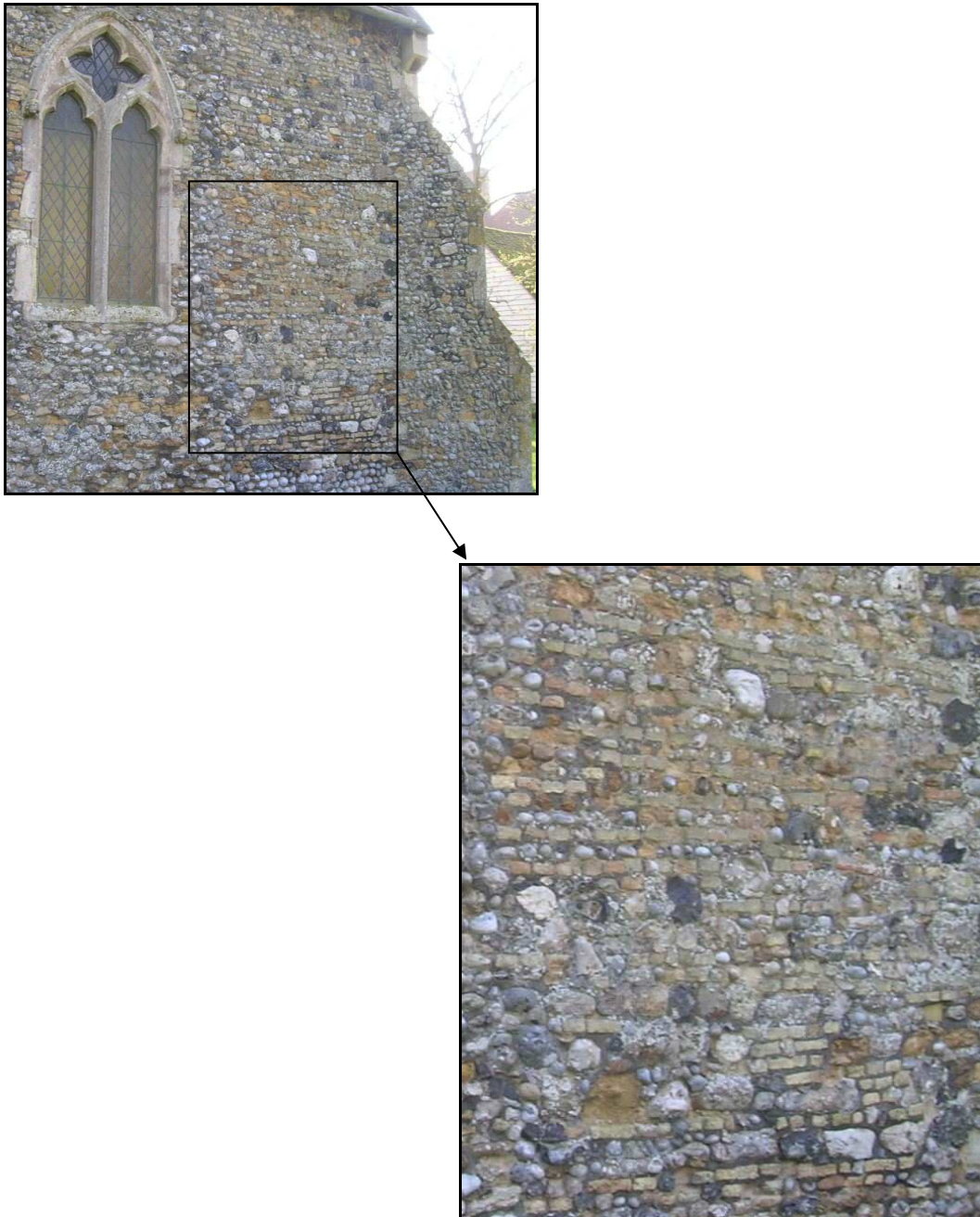

Fig. 2.12: Dengie church north-western nave wall (top), showing the random use of Flemish-type bricks alongside other building materials (bottom).

In other locations, the ‘Flemish’ type bricks are used in a more decorative manner, an example being Lawford church. The chancel has sections of yellow brick and flint chequer-work and alternating bands of knapped flint and yellow brick (four courses deep) incorporated into its fabric (see Fig. 2.13). The chequer-work pattern can also be seen around part of the base of the western tower as well as a moulded string course, partly made from yellow brick. Whether this feature is made from medieval or more recent brick is slightly uncertain as the external face of the tower is thought to have been substantially repaired, probably in the 19th century. Both the chancel and main body of the tower have been dated to the mid-14th century (RCHME, 1922, 151). Another site where ‘Flemish’ type brick was being used, albeit in a highly unusual and rare manner, was identified inside St. Andrew’s church, Halstead. During construction work in the church, a brick vault composed of ‘Flemish’ type brick was uncovered. It is thought to date to the late 14th century and has been proposed as belonging to the aristocratic Bouchier family (Andrews, 2000a, 258-259).



Fig. 2.13: North face of Lawford chancel showing two different decorative uses of yellow Flemish type brick: chequer-work with knapped flint (left) and horizontal bands of alternating brick and knapped flint (right).

Whilst there are many further examples of ‘Flemish’ type brick being used across the county (see Ryan, 1996, 34-36), there are certain discernable trends that

begin to appear regarding the use of the material. Firstly, they are frequently incorporated into the fabrics of high status, ecclesiastical structures and secondly they are increasingly used for decorative purposes from the latter half of the 14th century (*cf.* Dengie to Lawford). A rare example of yellow ‘Flemish’ type bricks being used in large quantities in a secular context can be found in the village of St Osyth’s where there is a cellar lined with this form of brick beneath a 14th century crosswing, thought to have been part of a medieval merchant’s house (a more thorough archaeological analysis of the merchant house is given in 3.3.7). Whilst a true provenance of the ‘Flemish’ type bricks in Essex is yet to be determined, it is thought that they were being imported from the continent (Ryan, 1996, 45).

Brick from this period in Essex occurs in the standard rectilinear form at the majority of sites. However, at two high status secular sites (King John’s Hunting Lodge, Writtle, and Pleshey Castle) a highly unusual form of the medieval brick has been discovered. These are the moulded chimney brick which occur in two distinct forms. When laid in alternating courses, the two forms create an octagonal shaft with a cylindrical interior (see Fig. 2.14).



Fig. 2.14: Medieval chimney bricks. The left image shows the two different forms of brick needed to produce a chimney (the left brick is a ‘Type B’ brick whilst the right brick is a ‘Type A’ brick. Note the keying holes in the Type A brick). The image on the right demonstrates how alternating courses of the two types of brick produce a cylindrical shaft with an octagonal exterior.

It is uncertain exactly when these highly unusual bricks were made and used. The contexts in which they were discovered would suggest a date somewhere in the first half of the 15th century (Wickenden, 2001, 176). Around

this time Humphrey de Bohun (who was made Duke of Buckingham in 1445) was probably re-building the lodge at Writtle (Rahtz, 1969, 9, 111) whilst at Pleshey Castle extensive repair work was being undertaken from 1440 onwards. There are also records of brick building taking place at the castle, possibly on the motte, during the residence of Queen Margaret of Anjou who held the castle from 1446 to 1461 (Williams, 1977, 13). However, it has recently been argued that the chimney bricks probably date to the late 14th century when both sites were owned by the de Bohun family who reached the height of their wealth with the marriage between Eleanor de Bohun and Thomas Woodstock, the seventh son of Edward III in 1380 (Ryan, 1996, 39). Further support for this argument could be seen to come from the fact that brick had been used for building fireplaces and chimneys from the 14th century onwards (Moore, 1991, 212). Consequently, it is uncertain when these medieval chimney bricks were being produced but the date probably lies somewhere between the late 14th and mid-15th centuries. Whilst the production date of these unusual bricks remains uncertain, information regarding their provenance was revealed through a Neutron Activation Analysis (NAA) study that compared the concentrations of major and trace chemical elements within the bricks to those of ceramics from known pottery production sites in Essex. The findings revealed that both the Pleshey and Writtle bricks were produced in Essex, the majority originating approximately from the Colchester/Great Horkeley area to the north east, before being transported approximately 25-30 miles to their respective sites (Wickenden, 2001, 171-176).

Another unusual brick feature at Pleshey Castle is a single span, two centred arch brick bridge connecting the motte to the inner bailey (see Fig. 2.15). As is the case with the moulded chimney bricks, there is a degree of uncertainty surrounding exactly when this feature was originally constructed. Early suggestions argued that it probably dated to the 15th century (RCHME, 1921, 201; Christy, 1923, 194). However, more recent arguments have suggested that it is much older and could be a late 14th century feature, possibly constructed when Thomas of Woodstock, Duke of Gloucester, held the castle as Constable of England (1380-1397) (Ryan, 1996, 58; Bettley and Pevsner, 2007, 627). If correct, this could make it one of the earliest examples of a bridge built entirely from brick (Wight, 1972, 80, 264). As with the moulded chimney bricks, the brick bridge at Pleshey probably dates to between the late 14th and 15th centuries.



Fig. 2.15: Brick bridge at Pleshey Castle connecting the motte and inner bailey.

2.4.4: The production and use of brick in Essex during the 15th century

By the 15th century, the ‘Tudor’ type brick had been adopted for building in Essex. The earliest surviving brick building in Essex is thought to be the Moot Hall in the coastal town of Maldon. The exact date of its construction is unknown although there is a reference to this building being granted to the township of Maldon in 1439 (Clarke, 1936, 212). Whilst this allows a loose *terminus ante quem* to be assigned to the Moot Hall, it is generally thought to date to the 1420s (Ryan, 1996, 53; Andrews, 2007, 145). The Moot Hall is an interesting building in many ways. In the north-east corner of the structure there is a brick newel staircase housed in an octagonal tower. The entire staircase is made from brick, including the moulded handrail, making this a very early example of such a feature appearing in brick buildings (Smith, 1975, 137-138; Smith, 1976, 46-48). Another feature that was recently discovered during renovation work on the first floor was a panel containing four niches with decorative trefoiled arches made from carved brick which is again a very early example of such decorative features appearing in brick (Andrews, 2007) (a more thorough archaeological analysis of the Moot Hall is given in 3.3.4).

The national trend for the use of foreign craftsmen during the 15th century is clearly reflected in Essex. Evidence has been found in the manorial records of Havering-atte-Bower that during the 15th century continental workmen were more highly regarded and sought after than English craftsmen of the time (Ryan, 1986, 112-113). At Nether Hall there is evidence for foreign craftsmen in the form of certain architectural features (see 2.1.4), including a potentially unique form of lacing timbers strapped together with iron forming a framework to hold the outer brick wall together. This has similarities to brick buildings in the Low Countries where timber floors are tied into brick walls and gables (Andrews, 2004, 85, 96; Andrews, 2005a, 147) (a more thorough archaeological analysis for Nether Hall is given in 3.3.5).

The high status of those who were building with brick in Essex during the 15th century is reflected when the backgrounds of four individuals are considered. These men were Sir Lewis John (constructed Old Thorndon Hall c.1414), Sir John Tyrell (constructed Heron Hall during the 1420s), Robert Darcy (built the Moot Hall in Maldon) and Sir John Montgomery (erected Faulkbourne Hall c.1439). During the early 15th century, these four men were the wealthiest landholders in Essex below baronial rank (they all had annual incomes in excess of £300 in 1436) and were co-parties to several transactions involving the transfer of land between 1425 and 1441. John, Tyrell and Darcy also served as knights of the shire and had connections with the royal family. It is quite possible that they could have influenced each other when it came to building projects, perhaps suggesting the idea of using brick or specific craftsmen (Ryan, 1996, 67-69; Andrews, 2005a, 146).

Brick was increasingly used in ecclesiastical contexts in Essex during the latter half of the 15th century, a time when many churches were being added to or altered across the country (Morris, 1989, 353-355). An impressive example is the church at East Horndon which is almost entirely built in brick and is thought to have been erected between 1442 and 1476 by Sir Thomas Tyrell (the son of Sir John Tyrell) (Ryan, 1996, 51; see 3.5.4). However, East Horndon is more atypical than other ecclesiastical contexts in which brick occurs, principally because brick was used for the entire structure and it was paid for by the local nobility. More often, members from local communities were responsible for organising and funding church alterations during the late 15th century (Morris,

1989, 355-356). In Essex, brick was used to construct many of the new components added to existing churches, such as towers, clerestories and porches (Ryan, 1996, 71-73). An example of this includes the church of Colne Engaine where John Draper left a bequest in 1496 allowing for 40,000 bricks to be produced for the next four years for the tower (ERO T/A 338/1).

As mentioned earlier, the Great Rebuilding has been seen to start at different times in different areas of the country (see 2.1.5). It is possible that there are tentative signs of the Great Rebuilding beginning in the late 15th century in Essex, chiefly through the occasional instances of ornate chimneys incorporated into substantial manorial houses (Stenning, 1989, 94; Ryan, 2007, 127-128). Certainly, the use of such a fashionable building material in the 15th century is likely to have encouraged the widespread adoption of brick by both the increasing gentry and yeoman class during the 16th century.

2.4.5: The production and use of brick in Essex during the 16th century

The use of brick for building specific parts of churches that had begun during the late 15th century reached a peak during the first quarter of the 16th century (Starr, 1980, 51; Addison, 1987, 54; Ryan, 1996, 71-73). Whilst the majority cannot be dated precisely, there are a few instances where bequests suggest when work was being undertaken, of which the best documented is probably that of Dedham church tower. Monies towards the construction of the tower were left from 1492 onwards, including 1494-5, 1504-5, 1505-6 and 1510 when £20 was left for the tower (Bettley and Pevsner, 2007, 320). In 1517, Stephen Denton left £100 'for the battlyment of the steeple' (ERO D/P 26/25/73) suggesting that the whole building project was completed around 1520. The fact that these donations represent a prolonged period of construction is not unusual and the most likely cause for such a period of time in erecting large building projects, such as towers, is that they were dependable on unpredictable charitable bequests (Morris, 1989, 356). The massive tower has a large passageway running through, the ceiling of which is ornately decorated and incorporating the initials and merchant marks of the Webb family, implying that they played a key part in funding the building work (Ryan, 1996, 73; Bettley and Pevsner, 2007, 319-320). Occasionally, entire churches were built in brick, such as that at Chignal Smealey (see Fig. 2.9).

The large courtier houses that had been constructed around the country during the late 15th and early 16th century (see 2.1.4) were also appearing in Essex. Perhaps the grandest was Layer Marney Towers (see Fig. 2.16), thought to have been built in the early 1520s by Sir Henry Marney and his son John Marney. It had originally been intended that the manor would have consisted of a much larger courtyard complex but, following the untimely death of John Marney in 1525, it is thought that work came to an abrupt halt leaving only the gatehouse, neighbouring church and one side of a courtyard complete (Ryan, 1996, 79). An interesting feature to Layer Marney Towers is that the structure incorporates terracotta, a material that had been brought to England by Italian craftsmen around 1510. It is also used for both the tombs of Henry and John Marney in the nearby church and also on the gatehouse in the window fittings and on the parapets on top of the turrets (Wight, 1972, 180-181; Ryan, 1996, 79-81) (a more thorough archaeological analysis for Layer Marney is given in 3.3.3).



Fig. 2.16: Layer Marney Towers seen from the south-west. Originally, this imposing structure had been intended as a gateway into a main courtyard.

The increased number of building projects that took place across the country as a result of the dissolution of the monasteries is also seen in Essex.

Several grand brick buildings were erected, either on monastic land or through the conversion and incorporation of parts of the monastic buildings. An example of the former in Essex is Ingatestone Hall. This manor was built by Sir William Petre who was granted the manor of Gyng Abbess by the crown in December 1539. It had originally belonged to the nunnery of Our Lady and St. Ethelberga of Barking. Petre was not satisfied with the old manor, describing it as ‘an old house scant meet for a farmer to dwell upon’ and subsequently began to demolish it. Work commenced on the new property in around 1540 and was externally completed around 1548 although internal work was undertaken until c.1560 (Emmison, 1961, 23-28; Bettley and Pevsner, 2007, 506). An example of a brick manor that emerged from the Reformation incorporating elements of a monastic complex into the new structure can be found at Leez Priory. Lord Richard Rich came into possession of Leez Priory in May 1536. He has been described as ‘a man devoid of any credit in the eyes of his contemporaries and posterity’ due to his role as Chancellor of the Court of Augmentations, an institution established to redistribute monastic lands and property (Wight, 1972, 173). He increased his personal wealth during his role in this position and acquired many manors (at least 100 in Essex alone), including Leez Priory (Hunter, 1999, 144). It is thought that he levelled most of the existing buildings before rebuilding an extensive brick manor. He used the foundations of the church and cloister complex for the new structures in his inner courtyard, for example, the great hall occupied the site of the central nave of the church (see Fig. 2.17) (Clapham, 1915). Brick was used to face parts of the new manor, with the internal walling consisting of rubble material that may have been original monastic work or possibly plundered from the previous buildings (see Fig. 2.18) (Howard, 1987, 149). This method of using brick at Leez Priory is probably an attempt to emulate the nearby brick built palace of New Hall, recently converted by Henry VIII, and a desire to erect the building as quickly as possible (Howard, 1987, 23, 149).

As Essex moved into the latter half of the 16th century, brick continued to be used for major secular building projects, for example, Spains Hall, which had originally been a moated manor house from the first half of the 15th century, was rebuilt around 1585 in brick incorporating elements of the original structure (Hunter, 1999, 146). Ecclesiastical building declined greatly in Essex during the

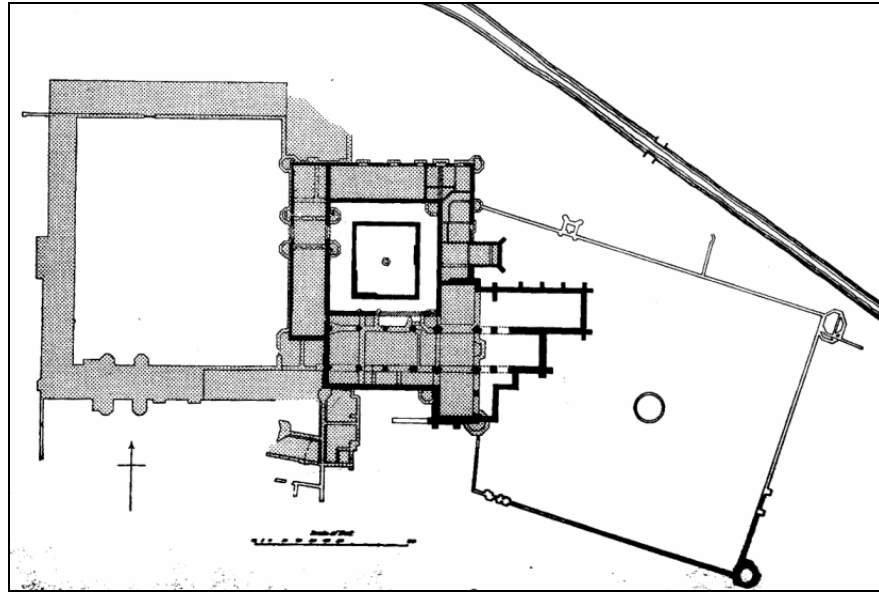

Fig. 2.17: Plan of Leez Priory. The bold lines represent the original Augustinian Priory whilst the grey area shows the early 16th century manor built by Rich. Note that parts of the monastic complex were adopted into the manor, such as, the conversion of the cloister to an inner courtyard (Clapham, 1915).



Fig. 2.18: Brick facing around rubble core on south eastern corner of the inner courtyard gatehouse at Leez Priory.

Elizabethan period with only one church constructed in the county, interestingly in brick, at Woodham Walter between 1562-1564 (Ryan, 1989, 23-24; Bettley and Pevsner, 2007, 856). The church is highly unusual with regards to the bonding used in its walls, described as Flemish stretcher bond, an early variant of the Flemish bond that would later become popular in the 17th century (Brunskill,

1990, 52) (a more thorough archaeological analysis for Woodham Walter is given in 3.5.9).

As mentioned before (see 2.1.5), the Great Rebuilding saw the structural alteration of many vernacular buildings during the 16th century. This is true in Essex, where there are several buildings owned by wealthy individuals that incorporate brick nogging into their walls. An example of this is the wool merchant's house of Paycockes in Coggeshall, dated to between 1508-1518, when it was owned by Thomas Paycocke, the wealthiest merchant in what was one of the wealthiest wool towns in Essex, (McCann, 1987, 117-119, 121). Brick chimneys are another sign of the Great Rebuilding in Essex. During the late 15th and first half of the 16th century, elaborate chimneys were constructed in Essex homes, of which many examples still exist today (Stenning, 1989; Ryan, 2007, 127-130). The most ornate example is the late 15th century brick chimney recovered from Reynolds House, Prittlewell, which incorporated several decorative features, such as crenellations, recessed panels and both trefoiled and cinquefoiled corbelling, features that are more common on chimneys that date to the late 15th and early 16th centuries (Stenning, 1989, 94; Ryan, 2007, 127). However, as the 16th century progressed, these decorative features gradually disappeared as brick chimneys became more common in households (Ryan, 2007, 128-130). An example of how extensively chimneys were adopted during the 16th century can be seen in the village of Ingatestone where all but three of the buildings had at least one brick chimney by 1601 (Ryan, 2000, 17-18).

2.5: CURRENT APPROACHES TO DATING MEDIEVAL BRICK IN ESSEX

Several of the conventional approaches to dating medieval and Tudor brickwork discussed earlier in the chapter (see 2.2) have been applied in Essex. By means of specific examples, the following discussion explores the use of these various techniques and illustrates the potential difficulties that can arise.

2.5.1: Brick typology

A typology consisting of brick samples from dated contexts that span the medieval and post-medieval periods has been established in Essex at Cressing

Temple (Ryan and Andrews, 1993). This has proved a valuable resource for the present work. It does not appear to have been a resource referred to in any published work thus far or been subject to any other external critique.

Such typologies as that at Cressing Temple have the potential to increase awareness among archaeologists in Essex of how various diagnostic aspects of different period bricks, such as dimensions, colour, fabric and surface details, can be used in identifying brick from different periods. The use of such diagnostic features to help archaeologists recognise and differentiate bricks from different periods can be seen in the study of Roman and Coggeshall type bricks (Minter *et al.*, 2006). For a long time these two forms of brick were often confused. This can be seen at Boreham church where the fabric contains a mixture of both Roman and Coggeshall type brick in the church (a more thorough archaeological assessment of Boreham church is given in 3.5.1). Over the years, the Coggeshall type brickwork in this church was not recognised, being regarded instead as either Tudor repair work (Chancellor, 1892a, 152) or Roman (Smith, 1988, 139; RCHME, 1921, 22; Chancellor, 1892a, 155). However, it has now been recognised that Coggeshall type brick does occur in the fabric of the church (Rodwell, 1998, 104). Despite the existence of the brick typology and an increasing awareness of features to look for in brick fabrics, there are still churches where there is uncertainty surrounding the date of the brickwork, such as Chipping Ongar, where some have suggested the brickwork is Roman (Potter, 2001, 133) whilst others have proposed a Norman age (Rodwell, 1998, 105; Bettley and Pevsner, 2007, 233).

2.5.2: Documentary sources

It is not until the 15th century that any significant examples of documentary sources referring to the use of brick during the medieval period can be found in Essex. An example of this can be seen in the church wardens accounts of Saffron Walden church, which span from 1439-1490, where there are a number of entries describing transactions involving brick, such as 1454 when ‘one lod of brycke’ cost the churchwardens 4s 2d (ERO D/DBy Q18; Ryan, 1996, 59). Unfortunately, the buildings described in documentary accounts do not always survive with their brickwork intact due to demolition or later alterations. Earls Colne Priory is one such site where there is documentary and tentative

archaeological evidence for an active kiln in the early 15th century although little remains of the priory today (Ryan, 1996, 52; see 5.2.3).

There are some circumstances where there is documentary evidence associated with surviving buildings. At Faulkbourne Hall there is a licence to crenellate which was granted to the owner Sir John Montgomery in 1439, which is generally taken as a *terminus post quem* for the start of building work to redevelop the existing building in brick (Fowler, 1909, 59). However, the licence has been regarded as more honorific in nature (Emery, 2000, 100) and subsequently the true value as an indicator of when building work commenced or was undertaken decreases (see 2.2.2). Furthermore, documentary sources, such as the licence to crenellate at Faulkbourne, can be limited with regards to the amount of information they convey when trying to date a complex, multiphased structure.

Besides account records or licences to crenellate, the other main source of documentary evidence that exists in Essex for medieval brick buildings are sums of money given to building projects (often ecclesiastical in nature) in donations or wills. An example of such a bequest can be found at Gestingthorpe where William Carter bequeathed 40 shillings towards the building of the church tower in 1498 (Ryan, 1996, 63). However, such bequests do not necessarily indicate the true date of construction, as shown by the aforementioned case of Billericay church and the 1496 grant (see 2.2.2).

2.5.3: Architectural analysis

There are certain high status brick structures in Essex which have architectural fittings which have been used to determine likely dates for the brickwork. Faulkbourne Hall has several of these diagnostic features that have resulted in differing opinions regarding the phasing of two ranges, one of which incorporates an impressive tower house. Some have argued that the two ranges are contemporary (Smith, 1976, 50; Smith, 1985a, 50) and this is based on the occurrence of common decoratively carved corbel table features that are also seen at other sites dated to the 1440s (Smith, 1976, 50). Others have examined different features on the building complex and have determined that there is a difference in the phase of the two ranges. One feature proposed is a moulded string course that is apparent on the east range but lacking on the tower house (Emery, 2000, 99). Although acknowledgment has been given by this school of

thought to the link between the other sites where the carved decorative corbelling occurs, proponents of the two phase model have argued that the confident and far greater usage of such decorative elements at Faulkbourne combined with the differences that exist between the buildings to which Faulkbourne has been compared, support the suggestion of a two phase development (Emery, 2000, 99). Furthermore, it has been argued that the differences in the social context between John Montgomery and his second son, Thomas Mongomery, who inherited the site in 1465 and was one of the wealthiest knights in the realm during the more stable reign of Edward IV, is further evidence that the north range and impressively decorated tower house which it incorporates were built in the latter half of the 15th century (Emery, 2000, 100). Whether the phasing of Faulkbourne Hall will ever be fully resolved is uncertain. However, it does serve to illustrate how different architectural features on a complex building (Faulkbourne was altered in the 15th, 17th and 19th Centuries) can serve to suggest different ideas regarding the dating and phasing of an historic brick structure.

Another architectural component that is frequently used to determine dates for brick buildings is the date plate. However, there is the potential for this source of information to be misleading (see 2.2.3). An example where this can be seen is at Woodham Walter church. Here there is a date plate of 1563 which agrees with documentary accounts relating to the erection of the church. However, other parts of the church fabric contain evidence that disagrees with the date plate, including graffiti on the arcade pillars between the northern aisle and the central nave dated to between 1450 and 1550 (Ryan, 1989, 25). As with the Faulkbourne example, this situation serves to illustrate how different forms of evidence can be misleading if considered on their own in complex buildings (a more thorough archaeological assessment of Woodham Walter church is given in 3.5.9).

2.5.4: Scientific dating methods

Whilst there are several scientific approaches that can be used for dating historic brick (see 2.2.4), only dendrochronology has been used to any significant degree in Essex. An example of this can be seen at Wimbish, Broadoaks. This was originally a late 16th century brick mansion which was reduced in size in the 17th or 18th century. A tree ring date was derived for the 16th century component of the building, giving a result of A.D. 1572-1594 and allowing this initial phase

of building work to be attributed to Thomas Wiseman (died 1585). However, the sampled timbers in the later phases of the building failed to yield a date (Andrews and Ryan, 2003). This example serves to illustrate that, whilst dendrochronology can provide dates for certain parts of historic brick buildings, there is no guarantee that a date will be forthcoming and, if one is produced, it could be in the form of a probable date range.

Another important issue to note from this example is that large quantities of 'Tudor' brick were re-used in constructing the later phases of the building (Andrews and Ryan, 2003, 279), a factor that could have proved misleading with regards to determining the true age of the brickwork had a tree ring date been derived for these later phases. Equally, the re-use of timbers can also prove just as misleading for dendrochronology. This situation was encountered at Woodham Walter church where the dendrochronology gave a date range of mid to late 14th century (Tyers *et al.*, 1997, 142) whilst the brick building itself was thought to date to 1562-1564 (Ryan, 1989, 23) illustrating the re-use of older timbers in a new building (a more thorough archaeological assessment of Woodham Walter church is given in 3.5.9). Ultimately, the re-use of building materials, including timber and brick, can easily lead to discrepancies between the date derived by scientific dating approaches and the archaeologically assessed age of the sampled structure. Both the examples of Wimbish and Woodham Walter serve to illustrate the need for caution and further corroborative evidence when trying to derive the age of a historic brick building by means of a scientific dating approach.

2.5.5: The potential for luminescence

Compared to some of the above dating techniques, there are certain advantages to dating brick by luminescence. Considering brick typologies, there is an element of subjectivity when comparing bricks to the typology which is not present in luminescence. Also, the accuracy that can be achieved with luminescence should be greater than or equal to the 50 to 100 year range suggested for brick typologies. This is particularly pertinent for 'Tudor' type bricks which are hard to distinguish from the 15th to the early 17th century (Harley, 1974, 74-75; Ryan and Andrews, 1993, 94). With regards to documentation, the lack of this resource, especially at the vernacular level, and the limited details contained within some of those that do exist are likely to prove restricting factors

which are not present in luminescence. Architectural features, whilst they can provide key referencing points to other well dated structures, are again often limited to high status buildings and can also be misleading, especially in terms of date plates which may relate to events other than the erection of the structure (Brunskill, 1992, 128).

Finally, some of the potential issues that surround alternative scientific methods for dating brick have their parallels in luminescence, for example, in dendrochronology the re-use of timber or an insufficient numbers of tree rings can be seen in luminescence in the form of brick re-use and low luminescence signal. However, whilst it is true that dendrochronology can achieve a higher degree of precision and accuracy than luminescence, this is only under certain situations (intact heartwood-sapwood boundary and outer bark). Furthermore, dendrochronology only provides a date for the timber component of a building. If the age of the brickwork is of primary interest then an assumption has to be made that the date of the timber component is also that of the brickwork. Such assumptions could potentially be flawed, for example, in the situation of a later brick facade added to an earlier timber building. In terms of archaeomagnetism, the fact that the bricks have been moved from their position of firing makes it challenging to derive dates through archaeodirectional investigation (Aitken, 1990, 239), a factor not relevant to luminescence. Whilst the archaeointensity approach to archaeomagnetic dating does allow brickwork to be dated irrespective of whether or not it is *in situ* (Casas *et al.*, 2007, 212), this technique is not yet well established and further work is required to improve the calibration information relating to past variations in the intensity component of the magnetic field (Linford, 2006, 13). Finally, radiocarbon can derive a date for the mortar used to bind the bricks together but it should be noted that there are several ways in which the carbon in the mortar can be contaminated to give a false result, resulting in the need for complex scientific analysis of the mortar to determine the likelihood of contamination (Lindroos *et al.*, 2007). Given the above discussions, it is clear that there is potential for luminescence to play a key role in deriving dates for historic brick structures in which the brick is in a primary phase and has not been re-used.

CHAPTER 3: ARCHAEOLOGICAL ASSESSMENT OF THE BUILDINGS

'it is a reverend thing to see an ancient castle or building not in decay'

-Francis Bacon

This chapter provides an archaeological review of the various structures that were sampled for this project (the rationale that led to the incorporation of the following buildings into the project are considered in 1.3.2 and 4.4). A critique is first provided of the sources used to analyse the buildings. This is followed by an overview of the history of each property along with any significant observations made during site visits in an attempt to derive an age for the brickwork within each building. Whilst every attempt was made to provide as thorough an archaeological description of each building as was possible, it should be noted that the following accounts do not constitute full archaeological surveys, a task that was beyond the remit of this thesis. Finally, the sampling locations are described along with any pertinent observations made for those specific points within the building fabric. Each sample consisted of a 50 mm diameter brick core which was drilled from an individual brick (full details of the sampling procedure are given in 4.2). It should be noted that some of the archaeological observations recorded in the following accounts of the buildings were made after sampling had taken place. In a few cases this would, in retrospect, have resulted in sampling being undertaken at different locations.

3.1: SOURCES CONSULTED

Whilst many individual sources were consulted for each specific site, there are several which were used for many or all of the sites that were sampled. The following section provides a critique into the nature of these sources and the potential strengths and limitations in their usage.

3.1.1: Royal Commission on Historic Monuments England (RCHME)

The RCHME was produced for Essex between 1916-1923 and consists of four highly detailed volumes that cover the entire county. Monuments that date from before 1714 are listed in a chronological order that covers pre-historic,

Roman, and ecclesiastical and secular monuments from the medieval and early modern periods (RCHME, 1916, ix-x). The accounts that are given for medieval structures generally provide a good overview of the building, recording important and significant features within the fabric. The chronological development of what were judged to be more significant buildings, such as churches, is also outlined but relies heavily on diagnostic architectural features within the building itself, such as window tracery, date plates, or building typologies. Consequently, many properties receive less attention than they might if critically analysed from a modern archaeological perspective.

A further limitation is that work carried out on historic buildings since the publication of the Essex RCHME has often brought to light evidence that has considerably altered the interpretation or dating of buildings published in that volume. An example of this can be seen at Holy Trinity church, Bradwell-juxta-Coggeshall, where the RCHME recorded that the walls probably consisted of flint rubble and were plastered over (RCHME, 1922, 12). The plaster render has since been removed revealing the re-use of Roman brick and tile within the wall fabric, a factor often recorded by the RCHME at other sites (Rodwell, 1998, 59). The exposed portions of brick around the southern doorway were also not recognised as being of the important medieval type which the RCHME had correctly identified at nearby Coggeshall Abbey (RCHME, 1922, 167; Rodwell, 1998, 60).

Whilst the RCHME does provide detailed accounts and records of both the developmental history and archaeological features for a vast number of buildings, those initial assessments may not necessarily agree with the current archaeological understanding of the buildings. Consequently, the assessments made by the RCHME have been accepted and used in this chapter but these have been compared to fieldwork visits and more thorough accounts of the properties where these records exist.

3.1.2: Victoria County History (VCH)

The VCH provides a detailed historic account of the county, covering the parish hundreds of Essex. Ten volumes have been produced since 1903 and a further thirteen were planned at the time of writing. The basis of the VCH is the consultation of historic documents and fieldwork visits to the areas being studied. The scope of the work is to provide an historical account of a county covering all

chronological periods for which documentary sources exist. The first two volumes (published in 1903 and 1907) provided an overview of aspects of the county, including natural history, pre-historic and Saxon remains, the ecclesiastical history and industrial history. The third volume (1963) focused entirely on the Roman remains in the county and all subsequent volumes have dealt with specific parish hundreds.

The VCH builds an interpretive and narrative history of an area around a documentary framework which can provide an insightful account of specific buildings. Given the enormity of the whole project, the VCH is naturally limited in the range of historic themes it can cover and also the depth to which these can be studied. It should also be noted that in order to compile this history, the VCH draws heavily on both primary and secondary documentary sources. Whilst this broad scope of resources can potentially allow for the corroboration of significant historic events for certain buildings and places, there are certain limitations to this approach. Firstly, there is the need for documentary sources, something which may not exist or be known of at the time of research. An example of this can be seen at All Saints' church, Theydon Garnon, where the building of the brick tower is identified as being by Sir John Crosbe in 1520 based on the inscription on a date plate on the south face of the tower. Unfortunately, the date plate appears to have been interpreted literally by the VCH despite the fact that the connection between Sir John Crosbe and Theydon Garnon could not be discovered at the time (VCH, 1956, 270). Secondly, there is the potential for some historic documents to be misinterpreted, either by the modern researchers or by those who compiled earlier, secondary sources used by the VCH. A further limitation to the VCH occurs when certain sources are accepted in an uncritical fashion, for example, the church tower of St. Andrew's in Earls Colne is partly dated to 1534 based solely on a date plate recorded by the RCHME in 1923 (VCH, 2001, 101) (see 2.2.3 for the limitation to dating historic buildings with date plates).

Whilst the VCH can offer useful insights into the local history of a specific area or for individual buildings, there are potential limitations associated with a lack of documentary references, the possibility of documentary sources being misinterpreted and the potential to readily accept certain sources in an uncritical manner, as illustrated by both the Theydon Garnon and Earls Colne date plate examples. Consequently, the assessments of individual buildings by the VCH

have been used in compiling the archaeological accounts for the buildings in this chapter. However, where possible, the sources cited by the VCH have been independently consulted.

3.1.3: ‘The Buildings of England’ series by Nikolaus Pevsner

The Pevsner volume for Essex first appeared in 1954 and was revised in 1965 by Enid Radcliffe and more recently in 2007 by James Bettley (Bettley and Pevsner, 2007, xv). The work consists of brief accounts of a vast number of buildings around the county, covering pre-historic features to modern architecture, although the emphasis is often more on the medieval to Victorian structures. Each site entry lists and describes the principal ecclesiastical buildings followed by accounts of other important historic structures in the immediate area. For large, urban areas, perambulations are outlined to cover the principal monuments.

The general intention of the Pevsner series is to provide an accessible architectural historical account of important buildings for the general public. Consequently, it is not a rigorous or highly critical reference source. This is especially true of the original work in which Pevsner relied heavily on the RCHME volumes (Bettley and Pevsner, 2007, xvi) and only spent six to eight weeks in Essex itself, compiling highly concise notes which could potentially result in a building interpretation being altered if misread during later consultation (Bettley and Pevsner, 2007, xvii). Pevsner also missed a few locations in the original volume and in the intervening years others have either been removed from or added to Essex through a combination of county boundary changes and new town development schemes (Bettley and Pevsner, 2007, xvii). Another factor that has led to further changes in the original Pevsner volume is the greatly improved knowledge of vernacular buildings over the past fifty years, partly due to the increased archaeological and scientific study of historic buildings, such as the increase in dendrochronological analysis (Bettley and Pevsner, 2007, xv-xvi). Nevertheless, the original Pevsner volume is still recognised as an impressive and (for its time) accurate piece of work (Bettley and Pevsner, 2007, xvii).

Much has been done in the recent revision to rectify the errors and flaws now recognised in the original Pevsner work for Essex, with information relating to significant discoveries being added from a wide range of specialists (Bettley and Pevsner, 2007, xviii-xix). Consequently, the present volume on Essex is just

as extensive as the original whilst offering more informed observations into the buildings. An example of this can be seen in the entry for the ruined gatehouse of Nether Hall, Roydon. Originally, this was described as an early Tudor manor house (Pevsner and Radcliffe, 1965, 330) but the present entry, which includes details from both dendrochronology and recent restoration work, dates the structure to the mid-15th century (Bettley and Pevsner, 2007, 651-652).

Although the current Pevsner volume for Essex fails to provide a thorough and detailed account for the buildings involved in this study, it was still consulted as a corroborative source to other references and also in an effort to identify any significant discoveries that may have been made very recently but which have yet to be fully discussed or disseminated in academia.

3.1.4: Antiquarian volumes and journals

A broad series of antiquarian reference volumes exist for Essex. Whilst these are generally concerned with providing an historic overview of the settlements within the county, there are occasional instances where more specific architectural features are described. Of those produced for Essex, the most detailed is *'The History and Antiquities of the County of Essex'* by Morant (1768). The work is very extensive and thorough but focuses heavily on the historic account of the many settlements in Essex. However, details of architectural features are occasionally given about specific buildings, for example, at St. Margaret's, Tilbury-juxta-Clare, a reference is made to an inscribed date stone within the church tower (Morant, 1768, Vol. II, 236). Other antiquarian works consulted included *'An Ecclesiastical Parochial History of the Diocese of London'* (Newcourt, 1710), a reference that focuses on the patronage of churches, *'History of Essex'* (Muilman, 1769-1772), although much of what is covered in these volumes is identical to the work done by Morant, and *'History of Essex'* (Wright, 1836), a reference that again focuses heavily on the historic background to specific places or properties.

In Essex, there are two key academic journals that relate to the archaeology of the county. The first journal, *The Transactions of the Essex Archaeology and History Society* began in 1858 and has undergone three revisions (the most recent series has changed its name to *Essex Archaeology and History*). The second is the *Essex Review* (1892-1957), a journal that was more diverse in

its coverage of topics but in which architectural and historic accounts of several churches and historic buildings are given, many written by the 19th century architect Chancellor. Whilst several of the sites covered by this project have been included as articles in these journals, the detail to which individual buildings were studied was not as rigorous or critical as modern studies. Nevertheless, the articles are still of value as they can record features that may no longer be present in the buildings today or that may have been lost through excavation in the past. Furthermore, the current *Essex Archaeology and History* does provide highly valuable and critical references to the historic properties covered in its articles.

3.2: SECULAR BUILDING LOCATIONS

The following diagram (Fig. 3.1) provides an overview of Essex with the different location of all the secular sites from which samples were collected for this project.

3.3: SECULAR BUILDING HISTORIES

3.3.1: Coggeshall Abbey

3.3.1.1: Archaeological assessment

Although Coggeshall Abbey was originally an ecclesiastical site, it became secular in the 16th century and therefore its history will be given alongside other secular structures. The current remains of Coggeshall Abbey consist of a modified, post-Reformation manorial complex that is located to the south east of the village of Coggeshall. Most of the monastic aspects of the site have been lost, including the main church and cloister buildings, with only a few peripheral structures of the original abbey remaining. The site is one that has drawn interest from archaeologists and antiquarians since the mid-19th century, especially with regards to the early use of brick. However, attention has often focused on the surviving remains of the original abbey and less on the present manorial complex.

Different dates are given in different annals for the foundation of the abbey, ranging from 1137 to 1142 (Beaumont, 1890, 87-88). However, 1140 is



Fig. 3.1: Map of Essex showing the location of the different secular sites sampled for this project. Note that Eastbury now lies within Greater London following county boundary changes.

thought to be the most likely foundation date as this is given by Ralph of Coggeshall, a medieval chronicler and abbot of the abbey in the early 13th century, who also correctly recorded an eclipse in the same year (VCH, 1907, 125). This date also agrees with the evidence of Queen Maud's foundation charter (Beaumont, 1890, 87-88; VCH, 1907, 125). When originally founded, the abbey belonged to the Order of Savigny but became Cistercian around 1148 following the collapse of the Savignacs in 1147 (VCH, 1907, 125; Greatorex, 1999, 1). It is unknown when work began on the permanent monastic complex, although the high altar of the main church was dedicated to Saint Mary and Saint John the Baptist on the 15th August 1167 (Greatorex, 1999, 3), suggesting that at least the church presbytery had been constructed by this time. Ralph of Coggeshall records that in 1168 the second abbot, Simon de Toni, left for his own abbey at Melrose. It has been argued that Simon might have been present to see that the newly acquired abbey was established along ideal Cistercian principles and that his departure signified the completion of other essential buildings in the monastic complex, suggesting that other elements of the abbey complex had also been completed by the late 1160s (Gardner, 1955, 19-20).

Due to the limited standing remains and the lack of an extensive and thorough archaeological excavation of the site, there is a high degree of uncertainty surrounding the present understanding of the abbey and its development (Gardner, 1955, 22). A geophysical survey identified that the church lay to the north of the present manorial complex (Black and Black, 2004), a location that agrees with earlier surveys of parch marks (RCHME, 1922, 166; Gardner, 1955, plate V). In terms of the cloistral buildings, monastic complexes often followed a general pattern in the location of specific buildings (Greene, 1992, 6-11). However, at Coggeshall, there is a degree of uncertainty as to what the exact nature of the standing monastic remains originally were and consequently different interpretations have been produced over the years (Cutts, 1858, 174-182; Beaumont, 1890, 94-101; Beaumont, 1921, 66-76; Gardner, 1955, 22-30; Greatorex, 1999, 4-7). It is beyond the scope of this project to describe each interpretation and consequently a synthesis drawing on several proposed layouts will be offered instead. With regards to plans of the abbey, the Royal Commission produced a plan of the surviving remains (see Fig. 3.2) whilst

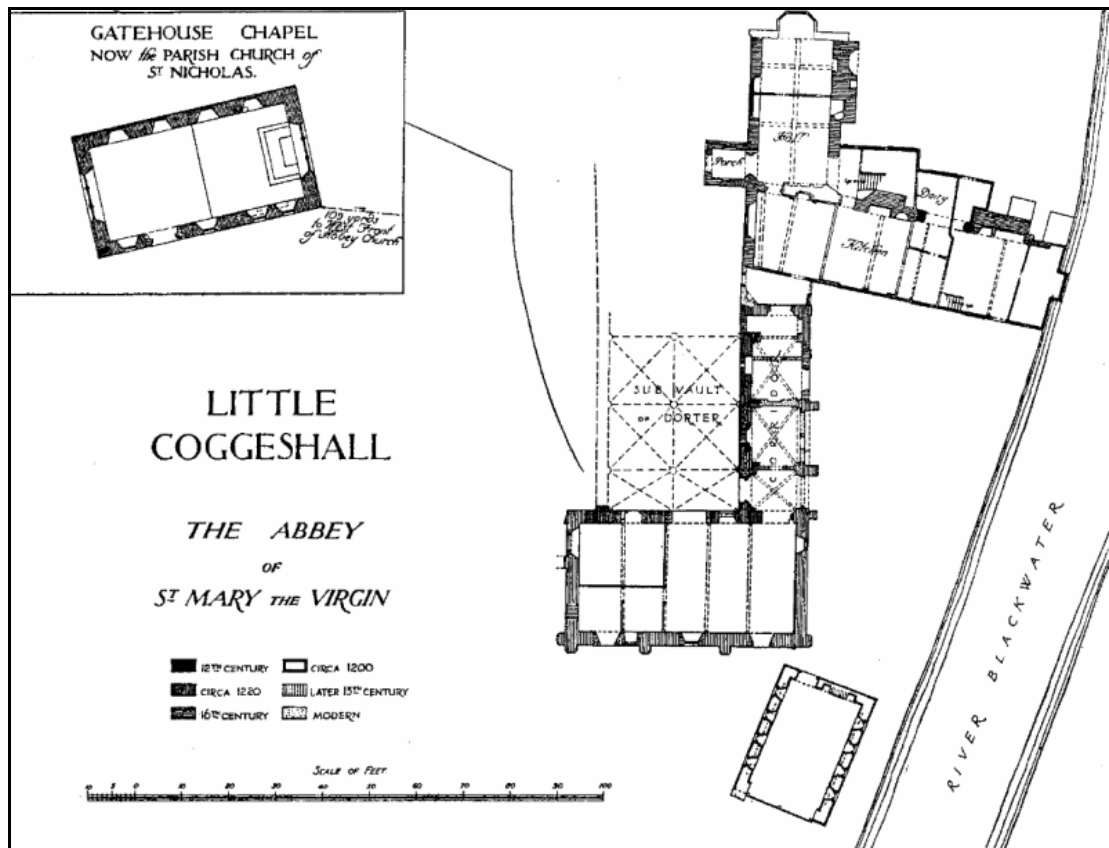

Fig. 3.2: Plan of the surviving abbey/manorial complex (RCHME, 1922, 166).

the best plan of the layout of the monastic complex is that produced by Gardner (1955) (see Fig. 3.3).

The eastern range of the cloister is thought to have consisted of the chapter house and is believed to be of a similar date to the abbey church i.e. mid-12th century (Gardner, 1955, 22). South of the chapter house, one might expect the warming room (Greene, 1992, 7), an argument which Beaumont proposes, referring to the room as the colloquitory [sic], which is described as being situated west of a small garden and the Abbey House (Beaumont, 1921, 71-72). Gardner does describe 'the colloquitory' [sic] but interprets it as the parlour and argues that it is situated on the west side of the north range of the present house (see Fig. 3.3) (Gardner, 1955, 23). It is therefore proposed that the building situated south of the chapter house was probably the warming room. The upper level of the eastern side of the cloister is likely to have been the dormitory of the monks (Greene, 1992, 7). The remains of the quadripartite vaulted space that is likely to have been beneath the southern part of the dormitory are evident in the form of

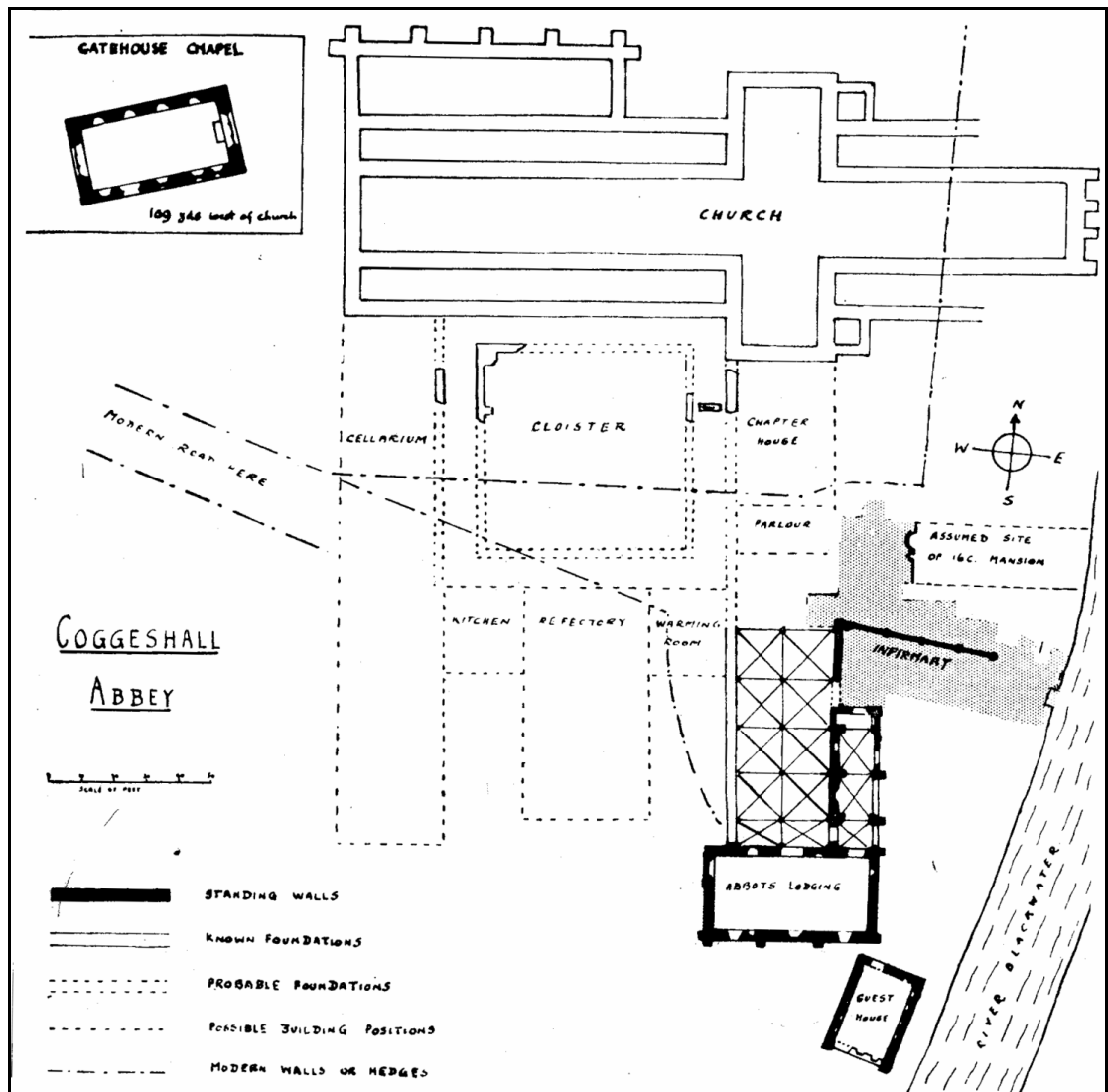

Fig. 3.3: Plan showing likely layout of the Cistercian abbey complex. The grey area represents the post-reformation manorial complex (Gardner, 1955, plate V).

moulded corbels, semi circular vaulting wallshafts and the keying of the vault in the surrounding walls (RCHME, 1922, 167) (see Fig. 3.4). There is a lot more uncertainty surrounding the southern and western ranges of the cloister, although it has been suggested that, in accordance with the layout of other monastic complexes, the southern range contained the kitchen and refectory whilst the western range contained the *cellarium* (see Fig. 3.3) (Gardner, 1955, 23). Limited excavations found that the west side of the cloister was rebuilt around the mid-15th century in which a wall containing moulded brick pilasters was uncovered. This is thought to have support a sill from which it has been suggested brick arches filled with moulded brick tracery rose upwards (Gardner, 1955, 30). Large



Fig. 3.4: Evidence of sub-dormitory vaulting at southern end of eastern cloister range. Note the wallshaft with moulded capital and keying marks for the quadripartite vaulting to the underside of the dormitory.



Fig. 3.5: Moulded brick mullions, thought to date to the mid-15th century. It is believed that these were originally recovered from the west side of the cloister.

quantities of these moulded bricks for the arch mullions and tracery have been discovered and stored on the site (see Fig. 3.5). It is also thought that the *lavatorium* was being built on the west side of the cloister at this time (Gardner, 1955, 30). The fact that there does not appear to be similar rebuilding work on the east side of the cloister suggests that the work was not completed, probably due to the closure of the abbey in the early 16th century (Gardner, 1955, 30).

Whilst little may remain of the cloister and abbey church, there are several standing structures that incorporate monastic remains (see Fig. 3.2). These include a building orientated along an east-west axis south of the vaulted area beneath the dormitory, thought to have been the abbot's lodgings (see Fig. 3.6) (Gardner, 1955, 26; Greatorex, 1999, 7). Leading from the south side of the 16th century manor and butting onto the east side of the former dormitory, there is a two storied corridor, the lower level consisting mostly of three bays of quadripartite vaulting (see Fig. 3.7) (RCHME, 1922, 167). It is interesting to note that the vaulted space has been plastered and painted to represent ashlar, suggesting that the brickwork exposed in the walls was originally treated in a



Fig. 3.6: View from south west of two monastic buildings. That on the left is thought to be the abbot's lodgings whilst the building on the right is thought to be the guest house.



Fig. 3.7: View looking south through the corridor. Note the plastered brickwork of the corridor painted to imitate blocks of ashlar, best seen on the longitudinal ridge rib at the top of the image.

similar manner. It is believed that this corridor originally connected the abbot's lodge to the infirmary, a structure thought to have been located in what is now the 16th century manor house and of which virtually nothing survives except for a series of brick columns and a lancet arch, aligned along an east-west axis (see Fig. 3.8) (Gardner, 1955, 25). Finally, a smaller separate building located south of the others and orientated along a north-south alignment is thought to be the abbey guest house (see Fig. 3.6) (Gardner, 1955, 25-26). The only structure of the monastic complex that has remained relatively intact is the *capella extra portas* (gate chapel), now St. Nicholas' Chapel (see Fig. 3.9). This building is located approximately 180 m west of the main abbey complex and was converted into a barn after the dissolution. Following substantial restoration in the 1860s, it was returned to its ecclesiastical nature (Beaumont, 1890, 103; Watkin, 1996, 293). It consists of a rectangular structure and has three lancet windows with a two centred outer order arch in both the east and west faces (RCHME, 1922, 165).



Fig. 3.8: The top image shows the Infirmary column with scalloped capital, now highly worn. The springing for the lancet arch can be seen above the capital whilst the crown of the arch is seen in the bottom image.



Fig. 3.9: St. Nicholas' Chapel. Originally this building acted as the capella extra portas to the abbey complex.

These surviving structures from the abbey complex are complicated and appear to have been dated chiefly by stylistic features where these survive. Deriving a thorough chronological sequence for the surviving abbey buildings is beyond the remit of this thesis. However, one of the best accounts to have been given is that by Gardner (1955) and an outline of this sequence is now offered. It is thought that the columns in the infirmary are contemporary with the main body of the church and probably date to the collection of buildings that had been constructed by c.1168 when Simon de Toni returned to Melrose Abbey (Gardner, 1955, 25). It is then thought that a single storied structure was erected at the site of the dormitory c.1180 but that this was later rebuilt as a two storied structure, the lower chambers being vaulted, when the corridor was added c.1220 (Gardner, 1955, 27-28). It is then suggested that the abbot's lodging and guest house were probably erected around c.1190 (Gardner, 1955, 26-27) with the corridor and *capella extra portas* being built c.1220 (Gardner, 1955, 28-29).

It is thought that the bricks used to build the abbey were being produced locally following a discovery made in the 19th century of what was thought to be a medieval kiln located approximately 1.2 km north west of Coggeshall in an area

known as Tilkey (interpreted as being a corrupted form of 'Tile Kiln'). The kiln was discovered in an area which was being dug in the 19th century for 'brick earth'. Upon discovery, the kiln collapsed but was described as having arches constructed from bricks like those at the abbey. Broken moulded bricks, again like those from the abbey, were also found in the locality (Cutts, 1858, 182). This production site has since been called into question and another possible production site located just north east of the abbey has also been suggested based on notes made in 1887 by the antiquarian Beaumont following the discovery of early brick wasters (Drury, 1981, 139).

Whilst the abbey remains are certainly valuable in terms of the history of medieval brick in England, the site also has a post-Reformation brick manor which, as has already been mentioned, incorporates structural elements of the 12th century abbey in its fabric. Less attention has been given to the manor house by antiquaries and archaeologists and it therefore lacks a thorough archaeological assessment. It is a complex building that is generally thought to have developed during the course of the 16th century (RCHME, 1922, 167; Gardner, 1955, 21-22; Walker, 2007, 11). The earliest reference to a manor house within the abbey complex is in the will of Sir John Sharpe (died 1518). Whilst details of the manor are not given it does suggest that the building had existed prior to this date and also illustrates the state to which the abbey's fortunes had deteriorated by this stage through this unusual action (Beaumont, 1921, 61; Gardner, 1955, 21; Greatorex, 1999, 42). Further details of this manor are provided in a new lease, dated 1528, to Clement Harleston. The mansion was described as close to the infirmary of the monks and had a garden to the west which in turn had the monks' warming room beyond (misinterpreted as the parlour in Fig. 3.3) (Beaumont, 1921, 62; Gardner, 1955, 21; Greatorex, 1999, 42). In the north east wall of the current building there is a redundant fireplace (see Fig. 3.10) suggesting that this original mansion was located to the north east of the current building and that the garden was located beneath the north range of the present building (see Fig. 3.3).

As a result of the dissolution, Coggeshall Abbey was surrendered to the Crown on the 5th February 1538 (VCH, 1907, 128). Whilst Harleston was not evicted upon the surrendering of the abbey, he did leave shortly afterwards. The property then passed to Sir Thomas Seymour in March 1538 but by 1541 he had



Fig. 3.10: The redundant fireplace attached to the eastern wall of the north range of the present building, suggesting a likely location for the first manor at Coggeshall Abbey.

sold it back to the Crown (Greatorex, 1999, 43). A survey undertaken in May 1541 mentions that the church was prostrate and defaced but that the lodgings and cloister were untouched (VCH, 1907, 128). By 1574 Thomas Paycocke, a wealthy Coggeshall clothier, was in possession of the house. He left the manor at Coggeshall to his daughter, Anne, and her husband, Richard Benyan in 1580 (Beaumont, 1921, 63-64). Early accounts of the present building record a shield with the initials $R^B A$ and the date 1581 beneath it situated above the porch entrance (RCHME, 1922, 165). This date plate has been interpreted in a number of different ways. Naturally, many have suggested that it signifies the date when the present structure was largely completed by Benyan (RCHME, 1922, 165; Gardner, 1955, 22; Bettley and Pevsner, 2007, 247). However, different interpretations have been offered. It has been suggested that the porch was originally of one stage which was contemporary with the brickwork of the western wall of the north range (Beaumont, 1921, 66-67). The evidence for this was proposed by two slight inclines in the brickwork immediately above the entrance to the porch that were thought to have originally terminated in a point, probably with a decorative finial at the peak. It was therefore thought that the date plate

might relate to when the second stage of the porch was added (Beaumont, 1921, 66-67). However, examination by the author of the area of brickwork between the first and second stage of the porch does not show any obvious signs of breaks in the building work. This suggests that it consists of a single construction phase and that the inclines are offsets in the wall, probably intended as a decorative feature. A third suggestion associated with the date plate is that it represents the addition of the porch and rebuilding of the lower stages of the north range (Walker, 2007, 11). Certainly, the lower brick stages of the north range and the porch are connected by a string course which would support the argument that they are contemporary. Ultimately, it is impossible to determine for certain what the date plate signified in terms of the history of the building. It should be noted that it is a dating source which must be treated with caution, potentially indicating significant life events rather than specific building episodes (see 2.2.3 for the possible limitations of date plates).

The present manor house is a complex amalgamation of re-used building material from the abbey ruins, including 12th century brick and building stone, both worked and in plain ashlar blocks. There are large parts of the manorial complex where red 'Tudor' bricks have also been used. A survey focusing on the architectural features was recently undertaken within the present house. It identified five main phases in the development of the building (see Fig. 3.11). In terms of assigning absolute dates to the different phases, phase 1 relates to the 12th century pillar, thought to have been part of the infirmary (see Fig. 3.8). With regards to the dates of the remaining four phases, there is limited information except from the relative chronology. The north range is suggested as being the next phase (phase 2) and was probably built prior to 1550 (Walker, 2007, 11). If the open fireplace on the east side of this range is considered to be part of Harleston's original manor (see above and Fig. 3.10) then the east wall of the north range probably dates to at least 1528 (the date of the lease to Clement Harleston), suggesting that the north range was probably erected between the 1530s and the 1550s. Certainly, the mention of a garden to the west of Harleston's manor would provide an open area to build the north range upon. After this, the next phase of development (phase 3) is thought to be the cross wing which it has been suggested was added between the 1560s and the 1570s (Walker,

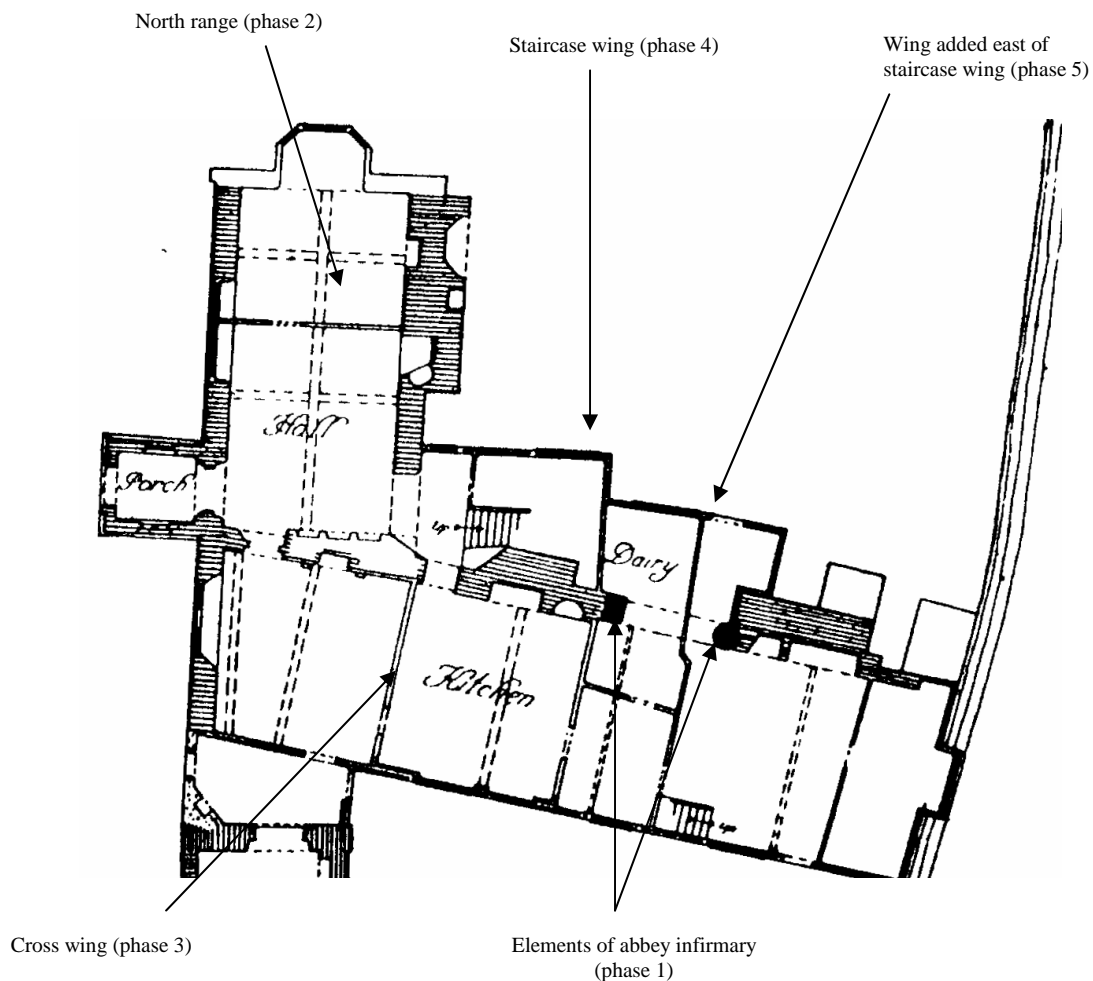

Fig. 3.11: Phasing of Coggeshall manor house as described by Ryan (RCHME, 1922, 166 with additions by author based on Walker, 2007).

2007, 11). The next proposed development is that the lower stage of the north range was partly rebuilt in brick and the porch added in 1581 based on the date plate (Walker, 2007, 11), the contemporary nature of these two events being evident in the string course connecting the two structures. The remaining phases of development consist of the addition of the rear staircase (phase 4), probably in the late 16th or early 17th century, with a final rear addition being added to the east of the rear staircase (phase 5), probably in the late 18th or 19th century (Walker, 2007, 11). This sequence of development is the most comprehensive that has yet been undertaken for the manorial house at Coggeshall Abbey. It broadly agrees with the present understanding of the 16th century history associated with the abbey, although there are still areas where knowledge is lacking, for example, the

date when the earlier manor, of which the open fireplace in the eastern wall of the northern range survives, was removed.

In terms of the project, the brickwork in two areas of the present structure have been investigated. These were the brick column that is thought to have originally been part of the mid to late 12th century infirmary complex and the brickwork at the base of the western face of the northern range, an area most likely to contain late 16th century brickwork. Focusing on these two areas, the brickwork of the column has been generally ascribed a mid to late 12th century date based on similarities to the shape of bricks excavated in the main church (thought to have been completed by 1168) and the presence of the carved scalloped capital (RCHME, 1922, 168; Gardner, 1955, 25). The brickwork of the lower stage of the north range has been ascribed a date of c.1581 based on the string course between the brickwork of this range and the porch where a date plate of 1581 was originally situated (Walker, 2007, 11). However, this evidence is tentative, especially when it is considered that there had recently been a change of ownership to Richard Benyan and Anne Paycocke in 1580. It is therefore more appropriate to state that the brickwork in this area was probably constructed in the latter half of the 16th century.

3.3.1.2: Coggeshall Abbey sampling locations

For this project, the north wing and the infirmary column were sampled (see Fig. 3.12). The sampling point of the north wing was on the external western wall, approximately 0.34 m above ground level (see Fig. 3.13). Slightly above the sampling point was a string course of moulded brick, now highly weathered, connecting the porch and the north range. Due to the string course connecting the north wing and the porch, a date of c.1581 has previously been ascribed to the brickwork in this area (see 3.3.1.1). The wall was composed of a mixture of masonry blocks and large quantities of both ‘Coggeshall’ and red ‘Tudor’ type bricks generally laid in a random manner although attempts had been made in places to form an English bonding to the brickwork. The mortar joints around the sampled brick were highly varied in thickness, ranging from approximately 5-20 mm. The core was unusually long (185 mm) and there appeared to be brick at the rear of the sampled brick.

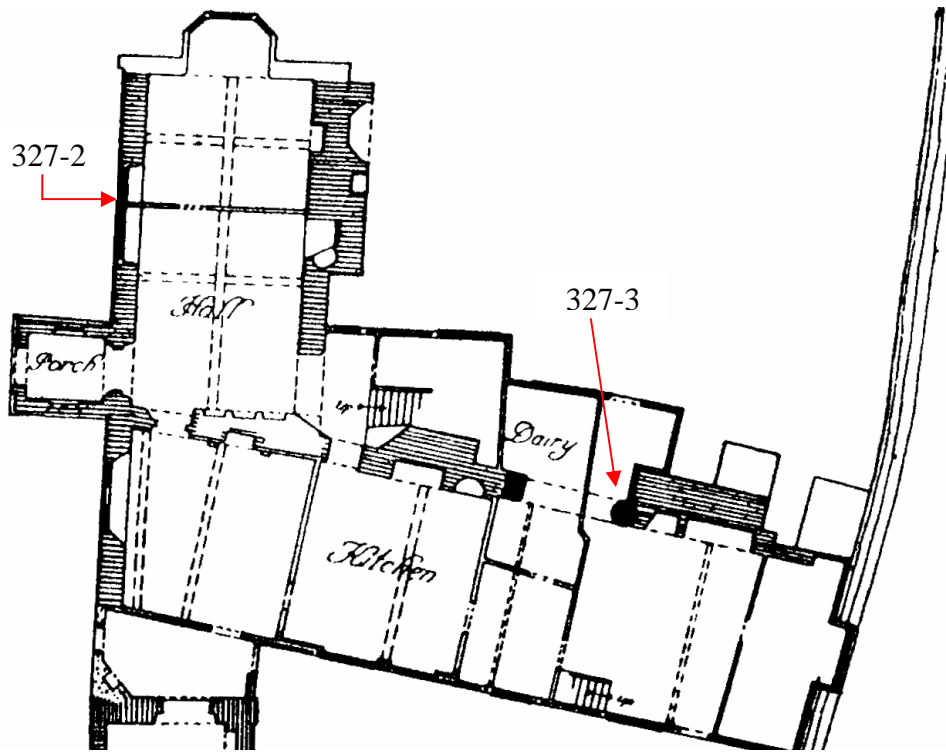

Fig. 3.12: Sampling locations at Coggeshall Abbey (RCHME, 1922, 166).



Fig. 3.13: The brickwork immediately around the sample location on the northern range at Coggeshall Abbey. Note that the two top courses of brick comprise the string course which connects the north range to the porch. The scale bar is 20 cm in length.



Fig. 3.14: The mid-12th century medieval brick column that is thought to have originally been part of the infirmary. The arrow indicates the sampling point. Note that the pillar was originally of greater diameter but the outer surfaces of the bricks have eroded.

The infirmary column is thought to date to the mid-12th century and is composed of moulded ‘Coggeshall’ type bricks laid with curving stretcher faces exposed. The brick had clearly been eroded and it is certain that the column was originally larger than it is today. The brick that was sampled came from the west face of the column (see Fig. 3.14) and proved very hard to drill with the electric corer. A small sample approximately 40 mm in length was eventually extracted by means of using a pilot drill attached to the electric drill core. Upon examination of the interior face of the extracted sample, traces of what may have been a flat surface were discovered. This suggests that the back of the brick may actually have been reached during the sampling process and that the original external face of the brick had eroded over the centuries. The mortar joints around the sampled brick were fairly thick (approximately 10 mm). The rear of the sample core appeared to be brick but this was difficult to determine for certain due to large amounts of brick dust that had been compacted into the brick during the drilling process.

3.3.2: Eastbury Manor House, Barking

3.3.2.1: Archaeological assessment

Eastbury Manor (see Fig. 3.15 and Fig. 3.16) is an Elizabethan ‘H-shaped’ brick mansion located in the middle of a post-war housing estate in Barking. It has attracted the attention of many antiquarians and archaeologists over the years and has had an interesting and at times precarious life. The historic significance of the building was recognised early on and was subsequently assessed by antiquarians from an architectural perspective (Clarke and Black, 1834). Whilst highly valuable at offering an insight into the building during the 19th and early 20th centuries, these reports are not as detailed or thorough as modern archaeological assessments. Instead, they focus more heavily on the architectural layout and more ornate features of the building, such as fireplace surrounds.



Fig. 3.15: Eastbury Manor House from the south.

Eastbury was originally under the ownership of Barking Abbey and, whilst there is thought to be no surviving structural evidence today, it is believed that there could have been some form of structure in existence prior to the present

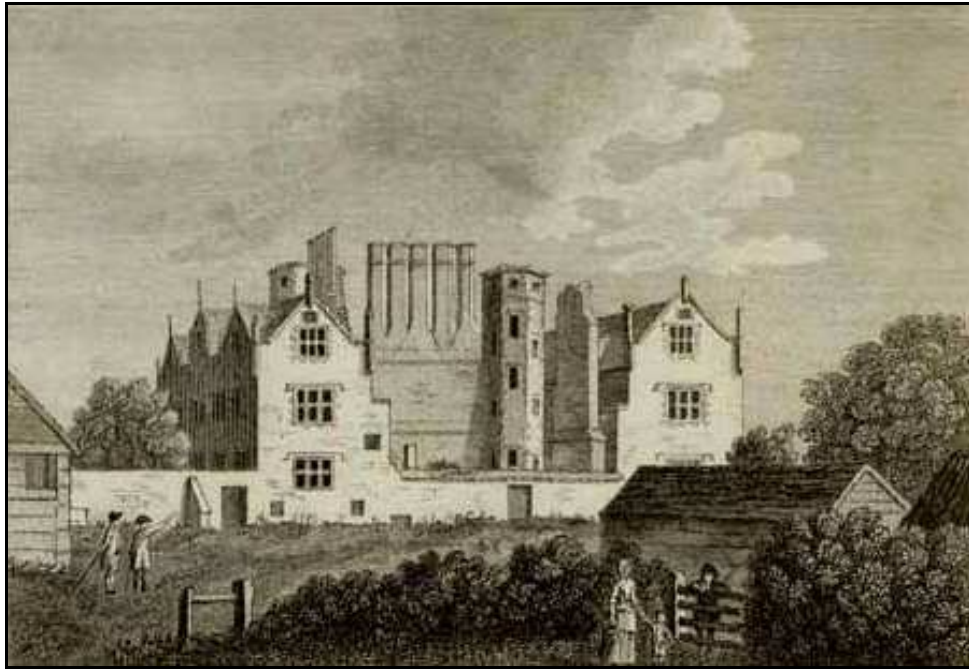

Fig. 3.16: Eastbury Manor House from the South in 1780 (ERO I/Mp 18/1/25)

building. The evidence for this comes from the fact that when the abbey was dissolved in 1539, the ‘messuage’ (house with outbuildings and lands) of Eastbury passed to Nicholas Stoddard before being granted by Henry VIII to Sir William Denham in September 1545 (*L & P Hen. VIII, XX 2, No.53*; *VCH, 1966, 201*). Further evidence suggesting that a farm was present on the site is offered in an early 18th century account of the history of Barking Abbey that describes how ‘In 3. *Edw. VI* [1550] *Sir Will Denham* held.....a messuage call’d Eastbury’. The account later mentions ‘The Manor, capital Messuage, or Farm of Eastbury’ (*Newcourt, 1710, Vol. II, 33*). A late 18th century account of the property also describes how the ‘farm belonging to it [the present building], was, in the reign of *Edw. VI* [1547-1553], in the possession of *Sir William Denham*’ (*Grose, 1780*). It is possible that the farm outbuildings survived the erection of the present manor and may have still been standing as late as the early 20th century. An accurate engraving of Eastbury made in 1780 (*Fig. 3.16*) shows a number of buildings around the main manor house. An early 19th century survey of the manor briefly mentions a farm yard with barns and out houses on the southern side of the manor house (*Clarke and Black, 1834, 14*) and early 20th century surveys of the manor also make reference to two large barns, which were suggested to date to the 16th or 17th centuries (*London Survey Committee, 1917, 29*; *RCHME, 1921, 10*). On

reflection, there is sufficient evidence to suggest that a farm complex had existed close to or on the site of Eastbury manor house before the present building was erected.

After having been granted the manor in 1545, Denham held the property until his death in 1548 when it passed to his daughter, Margery, and son-in-law, William Abbott. Margery died within eight months of her father and the manor remained with Abbott for a further eight years until he sold it to John Keele in 1557 (Bamford, 1906, 428; VCH, 1966, 201). Eastbury was then sold on to Clement Sysley on the 7th May 1557, suggesting that Keele may have been acting as an agent for Sysley (*Cal. Pat. R., 1555-1557, 327*). Certainly, Sysley, a wealthy merchant from an ancient Yorkshire family, bought large portions of property in the Barking area, possibly with the intention of forming a large territorial domain in the region (Sage, 1864, 348; VCH, 1966, 201). Although the exact construction date for Eastbury is unknown, it has long been thought that the present manor was built by Clement Sysley (Clarke and Black, 1834, 8; Cutts, 1863, 134; Bamford, 1906, 428-429; London Survey Committee, 1917, 19; VCH, 1966, 201-202). He finally took up residence in the Barking parish between 1560-1562 and it has been suggested that he probably began construction work shortly afterwards (Sage, 1864, 348; Bamford, 1906, 428). Sysley held the Manor until his death in 1578, bequeathing it to his wife, Anne, with reversion to his son who was at the time a minor (Sage, 1864, 349).

There are several factors that support the suggestion of Sysley erecting the current building at Eastbury. There are antiquarian accounts of a water head on the south side of the house that bore the date 1573 which was present up to the mid-20th century (Grose, 1780; Pevsner and Radcliffe, 1965, 69) and also accounts of a tradition of the date 1572 being carved on the brickwork inside the building (Clarke and Black, 1834, 8; Cutts, 1863, 134). Further evidence exists in the form of a tree ring date of 1566 that was derived for the timbers of the roof (Tyers, 1997). There are also documents that refer to Sysley and Eastbury. One dated to 1572 refers to “Clement Sisley of Estbyrye Haule” (CR Man. Tott.) whilst another dated to 1570 refers to “Clement Sisley of Esterby Hall in the Parish of Barking in the County of Essex” (DHC, D/FF0: 13/6). An indenture dated to 1568 also makes reference to “Clement CISELEY of Estberry Hall Barking” (ERO, D/DB T502). These documents support the tree ring date and

architectural features, suggesting that Sysley could have been living in the completed manor by the late 1560s.

From a stylistic perspective, there are several aspects of the structure that suggest a construction date. Certain characteristics are seen as indicative of Renaissance influences and suggest that the building belongs to the Elizabethan era, specifically the symmetrical nature of the 'H-shaped' plan (enhanced by locating the chimney stacks on the inner facing courtyard side of the building), the outward facing nature of the large windows set in the external walls and the regular grouping of the gables (London Survey Committee, 1917, 19; Cherry *et al.*, 2005, 129-130). However, there are several other features to the building which suggest a late Gothic or early Tudor date and contrast the idea of a construction date of the 1560s or 1570s. These include the moulded chimney shafts, the circular newel stairs housed in octagonal turrets, the arrangement of the central hall with a cross passage (now removed), the occurrence of brick diapering, the moulded finials on the gables and the moulded brick pediment above the porch entrance (London Survey Committee, 1917, 19; RCHME, 1921, 9; Cherry *et al.*, 2005, 130-131). These differing features are difficult to explain but it has been suggested that aspects of the building might have been built prior to the dissolution of Barking Abbey in the 1530s or that they are a result of conservatism if built following the Reformation (London Survey Committee, 1917, 19; Cherry *et al.*, 2005, 130).

From an archaeological perspective, there are aspects to Eastbury which suggest that materials from an older structure were being re-used in the present building. In the late 19th century, a small niche with a cusped and foliated arch, which was thought to date to the 14th or 15th century, was discovered on the ground floor of the western wing (London Survey Committee, 1917, 24). Originally regarded as a piscina to a chapel in the house, the idea was later refuted due to its location in the western wing which housed the kitchen apartments. Equally, its medieval description suggested it had been inserted from an earlier structure (London Survey Committee, 1917, 24). The nature of this earlier structure is unknown but it is possible that it was taken from Barking Abbey following the dissolution in the 1530s. Another feature that could suggest re-use is the occurrence of darkened, vitrified brickwork, observed in the northern cellar



Fig. 3.16: The southern wall of the northern cellar. Occasionally, darker, vitrified bricks can be seen among the more standard red bricks. The bottom image shows a closer view of one such darkened brick.

following sample collection (see Fig. 3.16). Unfortunately, the use of whitewash prevents any obvious diaper patterns being discerned in its current state, although the use of any diaper work in an obscure and hidden part of the building makes little sense. It is possible that the vitrified bricks were simply a small number that were accidentally fired to a higher temperature when the bricks were originally produced. Unfortunately, this does not explain why the vitrified bricks were incorporated into the wall as opposed to being stored for use in the other areas of the building where diaper work was intended. On reflection, the occurrence of the vitrified brick might suggest that some bricks were being re-used during the building work. It is possible that some of the decorative features outlined above may also have been re-used from an older structure. An example of this can be



Fig. 3.17: Timber treads of the newel staircase inserted into the encasing brick wall. Note the use of grey slate (circled) to wedge the timber into place in the wall socket.

seen in the surviving timber newel staircase where the treads have been wedged into place with roof slates (see Fig. 3.17) suggesting that the fit was not flush with the brickwork, although the possibility of poor craftsmanship cannot be ignored.

If materials were being re-used in the erection of the present building, there is the issue of the source from which they were being robbed. A late 19th century account of the building notes that the brickwork at Eastbury was of a similar dimension and bonding to Gale Street Farm, a structure located approximately 1.5 miles from Eastbury and thought to be of a similar date (Streatfeild, 1872, 166). The account goes on to describe how Gale Street Farm itself is composed of building materials from an even older structure, which is suggested as being Barking Abbey (Streatfeild, 1872, 166). It is possible that materials may have been sourced for Eastbury Manor from either Gale Street Farm or Barking Abbey prior to the erection of the present building.

Overall, given the above evidence, it would seem reasonable to describe the construction of Eastbury Manor house as having begun sometime shortly after Sysley took possession of the property in 1557 and that the majority of the building had been completed around 1566 when the dendrochronology indicates

that the present roof is likely to have been installed. It seems likely that the erection of parts of the building involved the re-use of building materials from other surrounding properties, possibly taken from the nearby Barking Abbey. Further work probably continued on smaller elements of the building, such as the external guttering and internal fittings or decorations, which are thought to have been completed by the early 1570s. Therefore, it seems that the bulk of Eastbury Manor was erected between 1557 and 1566, although the true date for construction must lie between 1557 and 1578.

3.3.2.2: Eastbury Manor sampling locations

There were four sampling locations in Eastbury manor, each of which was sampled twice in order to allow for a comparison of the results. Consequently, a total of eight samples were collected (see Fig. 3.18). With the exception of the brick cores collected from the first sampling location, all the samples had brick and traces of mortar behind the cores. Those from the first sampling location were too deep to drill through to the rear due to the header bonding of the wall.

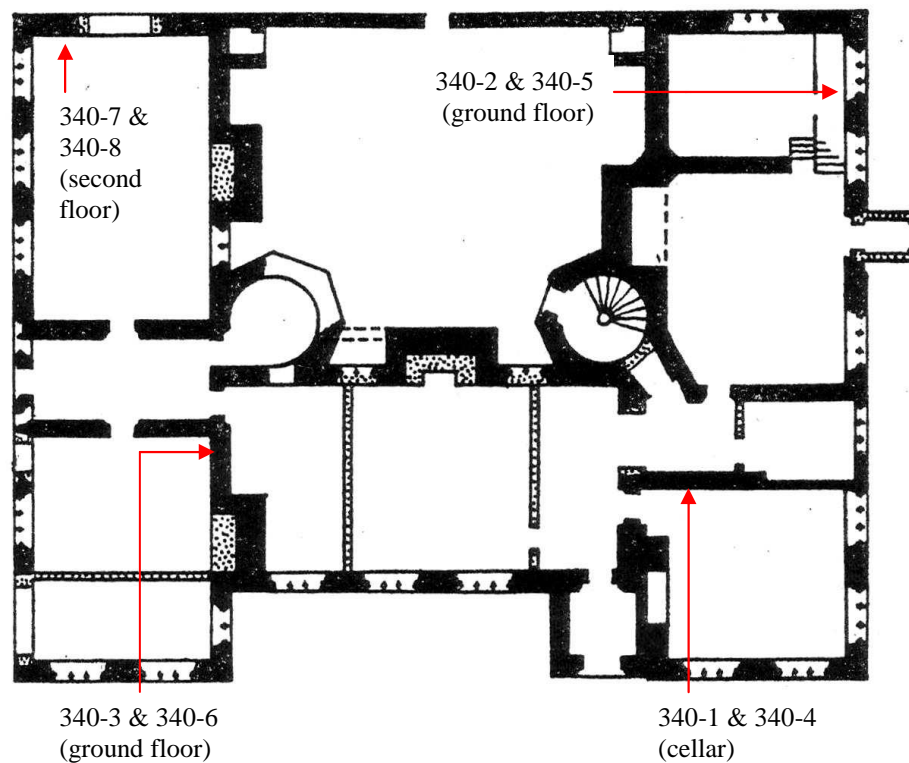

Fig. 3.18: Sampling locations within Eastbury Manor House (note that this plan only shows the ground level of the building. Samples taken from lower and upper levels are described in the diagram) (RCHME, 1921, 9).

The first sampling location was in the northern cellar where two cores were drilled from the southern wall (see Fig. 3.19). The two samples were from the same course of brickwork which was approximately 1 m above the basement floor level. The brickwork in this area was partially obscured by whitewash. However, it appeared to be laid in a header bond and comprised mainly of red ‘Tudor’ bricks with the occasional darkened, partially vitrified brick.



Fig. 3.19: The southern wall of the northern cellar, showing the brickwork around the sample locations. The two sample points are circled.

The second sampling location was in the south west room of the first floor, known as the panelled room. The two samples were collected inside a cupboard on the western side of the room. This wall was covered in a layer of plaster, approximately 10 mm thick and with animal hair incorporated into it for binding purposes. A portion of the plaster had fallen away exposing the brickwork beneath (see Fig. 3.20). The brickwork that was exposed was red ‘Tudor’ brick, laid in English bond and had dark inclusions within its fabric. The mortar joints around the bricks were quite thick (approximately 10-20 mm).

The third sampling location was in the north east room of the first floor, known as the summer parlour. Two samples were collected from the south east



Fig. 3.20: The exposed fragment of brickwork in the western wall of the cupboard in the panelled room. The sampling locations have been circled. The scale bar is 20 cm in length. The image illustrates the aesthetic impact the sampling has on the brickwork since the lower of the two sample core holes in this image has been repaired and allowed to dry over the course of several months.

corner of this room (see Fig. 3.21). The brickwork had been exposed above a height of 1.2 m with that beneath being covered in a thick layer of painted plasterwork. The walls consisted of red ‘Tudor’ bricks laid in English bond which had occasional flaws in the pattern. The bricks were similar to those in the second sampling location (the panelled room cupboard), with dark inclusions and occasionally large flints in the fabric. The brickwork was set in quite thick mortar joints (approximately 10-15 mm).

The fourth sampling location was in the south east corner of the attic space within the building. A portion of brickwork had become exposed underneath a layer of modern plaster covering the walls (see Fig. 3.22). The exposed area was too small to establish the true bonding pattern but it appeared to be irregular and not the typical English bond. Traces of plaster adhering to the brickwork made it difficult to determine the nature of the fabric or of any inclusions within the bricks themselves. However, they were the red ‘Tudor’ type and were set in thick mortar joints (approximately 10-20 mm).



Fig. 3.21: The western wall of the summer parlour from which two samples were extracted. The sample points have been circled. The scale bar is 20 cm in length. As with Fig. 3.19, this image illustrates the aesthetic difference between a recent sample collection and a repaired sampling point.



Fig. 3.22: The south western corner of the attic space where two samples were collected. The sample points have been circled. The scale bar is 20 cm in length. The image shows the wet mortar repair work shortly after sampling had taken place.

3.3.3: Layer Marney Towers

3.3.3.1: Archaeological assessment

Layer Marney Towers is an impressive and imposing structure, located approximately seven miles south west of Colchester and renowned for its early English Renaissance decoration in terracotta (RCHME, 1922, 158; Campbell and Pryce, 2003, 141). The name of the site is well chosen for the highlight of the current complex of buildings is the tall and ornately decorated brick gatehouse (see Fig. 3.23). Unfortunately, such an impressive building has yet to receive a thorough archaeological assessment and earlier attention from antiquarians was often focused on the background of the Marney family who are thought to have begun building this unfinished manorial complex. As well as the domineering gatehouse, the site comprises two wings attached to the east and west sides of the gatehouse, a timber barn, a long gallery range located immediately south of the eastern wing and a church located to the south west of the central gateway (see Fig. 3.24). With the exception of the barn, all of the main buildings are built in brick.



Fig. 3.23: The central gatehouse to Layer Marney Towers.

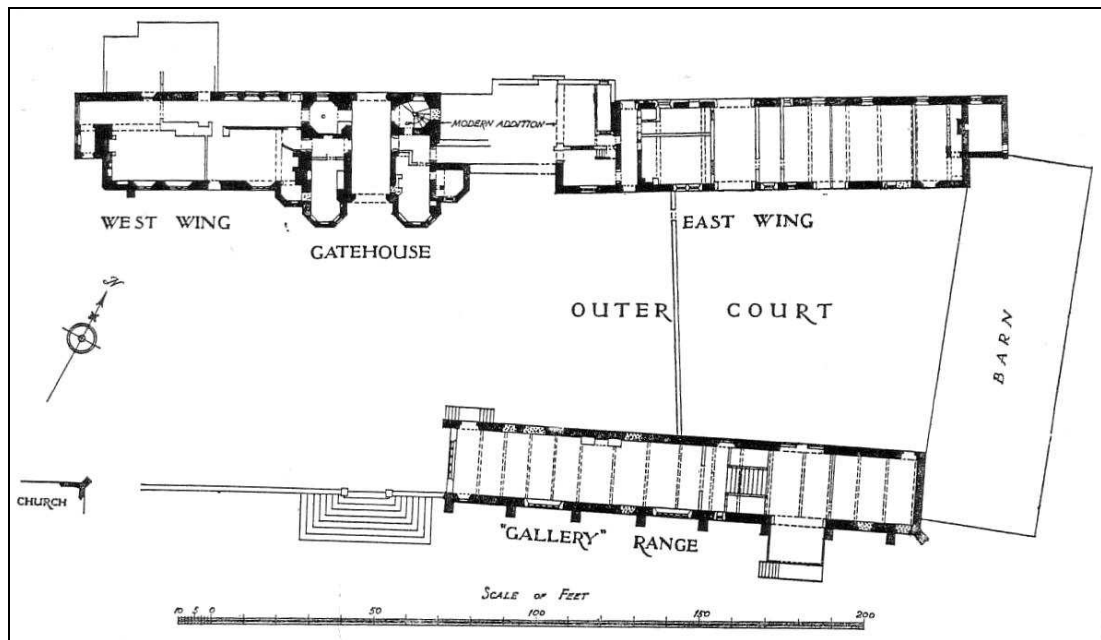

Fig. 3.24: Plan showing the layout of the principal buildings at Layer Marney (RCHME, 1922, 159). Note that only the corner of the church is shown on this diagram.

The Marney family had held land in Layer Marney since the mid-12th century but only rose to high office in the late 15th and early 16th century (Morant, 1768, Vol. I, 406; Anon, 1865). It is not certain whether there was a manorial complex situated close to or on the present site before the current series of buildings were erected. However, there is strong evidence to suggest that one did exist and that parts of it may still be standing. Considering the church first, there is a reference to William de Marney founding a chantry college in 1319 (Salmon, 1740, 447) and the present building contains several features which support the existence of an earlier church. These include a series of worked stones, including a 12th century chevron and billet ornamental piece, a late 14th or early 15th century bell, a large, iron bound chest with two locks, thought to date to the 14th or 15th century, the alabaster tomb of William Marney (died 1414), originally sited close to the altar but now located in the chapel north of the chancel, and a 15th century screen between the nave and chancel (Chancellor, 1918a, 72; RCHME, 1922, 156-157). When repair work was undertaken on the church in 1911, post-Norman stonework was also discovered in the fabric of the church (Chancellor, 1918a, 65) and during more recent repair work to the church it was discovered that the stonework of the tower buttresses consisted of re-used material, probably from

early 16th century windows, doors or arches (Andrews *et al.*, 1986, 173). The timber barn has also been dated to the mid-15th century but contains re-used 13th century timbers (Bettley and Pevsner, 2007, 529).

Focusing attention on the rest of the current manorial complex, there is evidence to suggest that both the east wing and the long gallery range pre-date the gatehouse and western gallery. Considering the eastern wing first, the alignment of the building is slightly different to that of the gatehouse and western wing, suggesting two different phases of construction. Furthermore, the western wing and gatehouse both contain terracotta for window and doorway ornamentation, a feature that is absent from the eastern wing where stone and brick is used instead (RCHME, 1922, 158; Ryan, 1996, 81). It has been suggested that this is a result of the construction work being brought to a hasty conclusion following the deaths of Henry and John Marney (Ryan, 1996, 81). However, given that the different alignment between the two wings around the gatehouse, it is more likely that the use of different materials represents different phases of construction.

Originally the eastern wing was separate from the gatehouse, the space between having been filled with a series of rooms in the early 20th century. If these later additions are ignored and the original end of the east wing considered, it is seen to consist of a gable end that is set perpendicular to its main axis (see Fig. 3.25), possibly indicating that originally there was a cross gable at the west end of this range. The gable is likely to be contemporary with the range, as indicated by a string course located between the two stories which continues along the south side of the building (see Fig.3.25). It should be noted that the upper window of the western gable end contains the initial 'H' in one of the window spandrels (RCHME, 1922, 158). To whom this relates exactly is uncertain. It might refer to the monarchs of the early 16th century (Henry VII and Henry VIII), the period when Layer Marney is thought to have been built, or to Henry Marney, the individual thought to have initiated construction work (see below for discussion on the possible builder of the property). However, whilst the initial may refer to these individuals, the spandrel might also refer to another individual from an earlier period or could have been replaced or re-carved to suit the changing circumstances and does not necessarily tie the structure to the early 16th century. It is therefore suggested that the eastern wing was originally a free



Fig. 3.25: The cross wing gable end at the western end of the eastern wing. Note the string course below the upper window which continues further around the building and the stone spandrels to the upper window.

standing building that was constructed at an earlier period than the central gatehouse and western wing.

Focusing on the long gallery range, there is evidence to suggest that this structure pre-dates the construction of the central gatehouse and western wing. There are features already discussed for the eastern wing which also occur in the long gallery. These include the fact that the building is not aligned parallel to either the eastern wing or to the gatehouse and western wing and the fact that the building contains no decorative terracotta elements but does have a number of original doorways with stone heads (RCHME, 1922, 158-159). At the south western corner of the long gallery range there are the remains of a moulded window jamb indicating that the building originally extended further to the west (RCHME, 1922, 159). The extent to which it extended westwards is therefore unknown since the present west end is not original, having been replaced in the early 20th century (Chancellor, 1915, 304). Nevertheless, further encroachment in that direction would obstruct the view or approach towards the central gatehouse. Such an encroachment would suggest that the range was standing prior to the construction of the central gateway and western wing. It also indicates that part of

the western end has been taken down at some point, possibly with the materials being re-used in the new construction of the gateway or western wing. It is also interesting to note that both the long gallery range and eastern wing have similar roof structures (RCHME, 1922, 159), potentially suggesting that they were constructed at similar times, probably before the central gatehouse and western wing given the above discussion. Unfortunately, there is no comparative description given of the western wing roof but comparison to those of the eastern wing and long range gallery could potentially prove highly informative.

It is therefore highly likely that prior to the erection of the current gatehouse there had been a series of buildings comprising an earlier manorial complex. This included the present barn and there is strong evidence that a church was also part of this collection of buildings. There is suggestive evidence indicating that the eastern wing and long gallery range might also pre-date the erection of the gatehouse and western wing. If this argument is true and the site had brick structures on it then the question arises as to who is likely to have erected these buildings? One possible suggestion is that the daughter of Sir William Marney (died 1414), Anne, married Sir Thomas Tyrell, the individual thought to have built East Horndon church in brick in the 15th century (see 3.5.4) (Morant, 1768, Vol. I, 406; Ryan, 1996, 51-52). Perhaps there was an exchange of craftsmen between the Tyrell and Marney families. Certainly, a 15th century date would agree with the timber barn. With regards to the present manorial complex, whilst there is no definitive evidence, it has long been held that the central gatehouse, the two flanking wings, the long gallery and the church (located to the south west of the gatehouse) were constructed in the first quarter of the 16th century by Henry and John Marney (Hayward, 1865, 17-18; RCHME, 1922, 157; Ryan, 1996, 79; Bettley and Pevsner, 2007, 526). Given the above discussion, the dates of construction of the eastern wing and the long gallery range must now be called into question. However, there is still evidence to suggest that the church, gatehouse and western wing were built by Henry and John Marney.

Henry Marney was born around 1456-1457 and his rise to power began when he took on various roles in the early Tudor regime during the late 15th and early 16th centuries, gradually rising up the social ranks and gaining many honours during the reigns of both Henry VII and Henry VIII. These included being made a privy councillor to both monarchs and appointed as captain of the king's guard

to Henry VIII (ODNB, 2004, Vol. 36, 735-736). Ultimately, Henry Marney reached baronial status under Henry VIII on the 9th April 1523 but did not live long to enjoy his newly appointed honour as he died on the 24th May 1523 (ODNB, 2004, Vol. 36, 736). His male heir, John Marney, did not long outlive him, dying on the 27th April 1525 and bringing an end to the Marney family line (Ryan, 1996, 79). Whilst there are no documentary sources detailing when construction work was underway on the present manor, there is strong evidence in the wills of Henry and John Marney that suggest that building work was taking place at the time of their deaths. Henry Marney left instruction in his will for an alms house to be erected in brick (King, 1869, 150-151). It is thought that an alms house was built close to the house and there is a reference to it later in the 16th century being granted by Elizabeth I to William Tipper and Robert Dawe in 1592 (Morant, 1768, Vol. I, 409). This suggests that brick was being produced close to Layer Marney in the 1520s. He also left instructions that the chapel he had begun building next to the chancel of the parish church was to be finished along with the production of a tomb for him located between the chancel and this chapel (King, 1869, 150). A canopied tomb of terracotta with an effigy in catacleuse (a black Cornish stone) stands in the space described in the will (see Fig. 3.26). This implies that this part of the will was executed and suggests that work on the brick chapel was underway when Henry Marney died in 1523.

The tomb of Henry Marney is ornately decorated and includes Renaissance details although there are still features that are more akin to the Gothic style, such as the angle pilasters. Other aspects suggest that it is the work of foreign craftsmen, such as the modelling of the face and the semicircular pediments on top of the canopy which are a predominantly Venetian motif (Bettley and Pevsner, 2007, 530). John Marney also left the substantial sum of £200 towards the completion of the church, although he does not specify whether it is simply the northern chapel begun by his father or the entire building that required completion (King, 1869, 160). John Marney also requested a tomb to be created for himself in a similar fashion to his father's, with the same stone used for the effigy but without the canopy (King, 1869, 155). This appears to have been carried out by his executors and the present tomb is similar to that of his father's, incorporating both the same materials (catacleuse and terracotta) and



Fig. 3.26: The tomb of Henry Marney located between the chancel of the church and the chapel built by Marney. Note the ornate terracotta canopy.

decorative features as the tomb of his father. The head rests on a cushion, as does that of the effigy of his father, despite his request to have his helm and crest at the head of his effigy, suggesting the same craftsmen were involved in both this and his father's tomb (King, 1869, 155; Bettley and Pevsner, 2007, 530). There is a further clue about the state of the manorial complex from the will of John Marney in that he bequeaths two tapestries which were in two chambers of 'the newe galery on the west side of the tower' (King, 1869, 157), suggesting that this part of the manor had recently been built by the time of his death. It is therefore very likely that building work was underway at Layer Marney in the 1520s.

Considering the gatehouse and western wing, it seems likely that this is all that was ever constructed of a new courtyard manor, of which the gatehouse and western wing were part of the southern range. Evidence for the planned courtyard was recorded in the mid-19th century in the form of 'toothing' marks in the brickwork on the north face of the western wing and on the eastern face of the gatehouse (Hayward, 1865, 20). Foundations were also located to the north of the gateway on a flat terrace level with the gatehouse. These have been suggested as being part of an earlier structure that had existed before work began on the new

courtyard manor (Hayward, 1865, 20). However, if the eastern wing and long gallery were already standing then it is more likely that the foundations related to a planned courtyard. The antiquarian Britton describes this courtyard as measuring 104 feet 6 inches by 76 feet 4 inches, dimensions for which Hayward was unable to determine the origin (Hayward, 1865, 21), suggesting that more substantial foundations may have existed before the mid-19th century.

With regards to the standing fabric of the central gatehouse and western wing, there are features which further support the suggestion that Henry and John Marney were involved in constructing these parts. On the summit of the central gateway is an ornamental parapet comprised of segmental pediments with dolphins supporting crowning tablets, all made from terracotta (see Fig. 3.27) (RCHME, 1922, 158). There are two initials entwined with a true lovers' knot set within the crowning tablets which have been interpreted in the following way:

M)

It is likely that the 'M' refers to 'Marney' whilst the reversed 'C' refers to the first wife of John Marney, Christian Newburgh (Ryan, 1996, 79). This suggests that John Marney was involved in building the latter stages of the central gatehouse.



Fig. 3.27: Terracotta decoration on top of the gatehouse western tower.

It is interesting to note that the window surrounds, quoins, cornices and plinths of the gatehouse were originally plastered over in an effort to imitate the use of ashlar in the tower (Andrews *et al.*, 1986, 173). This implies that the buff colour of the terracotta as opposed to the more common red was deliberate and that the areas where it was used on the tower, such as the large central windows, were intended to imitate stone features (Andrews *et al.*, 1986, 173). It also raises the possibility that if the neighbouring east wing and long gallery range, where stone was used for several of the windows and doorways (RCHME, 1922, 158), were in existence prior to the erection of the central gatehouse and western wing, then the use of the plaster and buff coloured terracotta could have been intended to reflect the style of these existing structures.

The fact that the gatehouse and western wing contain the building material terracotta also offers relevant information regarding a likely construction period. This ceramic building material was only used for a short time during the early 16th century, largely during the reign of Henry VIII (Howard, 1987, 131-132). Terracotta had been used in Italy and was brought to England by Italian craftsmen who worked on projects for people at the court of Henry VIII, such as Thomas Wolsey, at that time constructing Hampton Court (Wight, 1972, 180-181; Campbell and Pryce, 2003, 141). One of the earliest craftsmen who worked with this material to come to England was Torrigiano whose first visit took place from c.1508 to 1516-1517. He later returned to England c.1519-1520 bringing other craftsmen, such as Giovanni da Majano (Kestell Floyer, 1923, 302). An early example of the use of terracotta was for the tomb of John Young, Master of the Rolls, which was executed in 1516. Several other tombs incorporating terracotta were also constructed during the 1520s, including those of Henry and John Marney (Blomfield, 1923, 5; Baggs, 1968). Terracotta was also incorporated into other buildings during the 1520s, for example, Sutton Place, Surrey, granted to Sir Richard Weston in 1521 and constructed during the 1520s (Wight, 1972, 187-189). Gradually, as the Reformation began to take hold in England the popularity for terracotta began to wane, virtually dying out by the 1540s (Wight, 1972, 180-181; Ryan, 1996, 81).

Given the prominent position of Henry Marney in the Royal court, it is likely that he was aware of such building projects and was probably well acquainted with some of these Italian craftsmen. Whilst there is no documentary

evidence that such craftsmen were responsible for working on Layer Marney, there is circumstantial evidence in Henry Marney's involvement with the Florentine sculptor Torrigiano in the contract to build the tomb of Lady Margaret Beaufort in Westminster Abbey in 1509 (Wight, 1972, 189; Ryan, 1996, 81). The terracotta at Layer Marney therefore suggests a construction date for the gatehouse and west wing of c.1520 when the material was being used more often in England (Wight, 1972, 180). If the death of John Marney in 1525 is accepted as a *terminus ante quem* then this five year period has been thought reasonable for the construction of the gatehouse and western wing (Andrews *et al.*, 1986, 172; Bettley and Pevsner, 2007, 526-527), although a broader date range, such as 1510-1525, is more likely to incorporate the true date when building began.

Overall, there is evidence suggesting that a series of buildings existed at Layer Marney in the medieval period, including a church and mid-15th century barn. It is likely that the eastern wing and long gallery range could also date to the 15th century and that the latter originally extended further west. In the early 16th century, following his rise in social status, it is likely that Henry Marney had ambitions to erect a grand courtyard house and began construction work. The project probably included Italian craftsmen, skilled in the newly fashionable material of terracotta, a material he is likely to have been familiar with at the royal court. Work continued under his son but is likely to have only involved the almshouses, church, gatehouse and western wing. The project probably came to a halt following the death of John Marney in 1525. Therefore, the likely date of construction of the current buildings at Layer Marney could well stretch from the 15th to the early 16th century, with the church, central gatehouse and western wing probably being built between 1510 and 1525.

3.3.3.2: Layer Marney sampling location

A single core sample was collected at first floor level from an eastern wall inside the eastern tower of the central gatehouse (see Fig. 3.28). The brickwork in this area comprised red 'Tudor' bricks laid in English bond with slight irregularities (see Fig. 3.29). The original mortar joints were obscured by modern re-pointing which had encroached on the original arrises of the bricks. It was therefore impossible to determine the true mortar thickness. A few bricks were

darker but showed no signs of surface vitrification, suggesting a higher firing temperature. Behind the core hole, the wall appeared to have a rubble interior.

LAYER MARNEY TOWERS

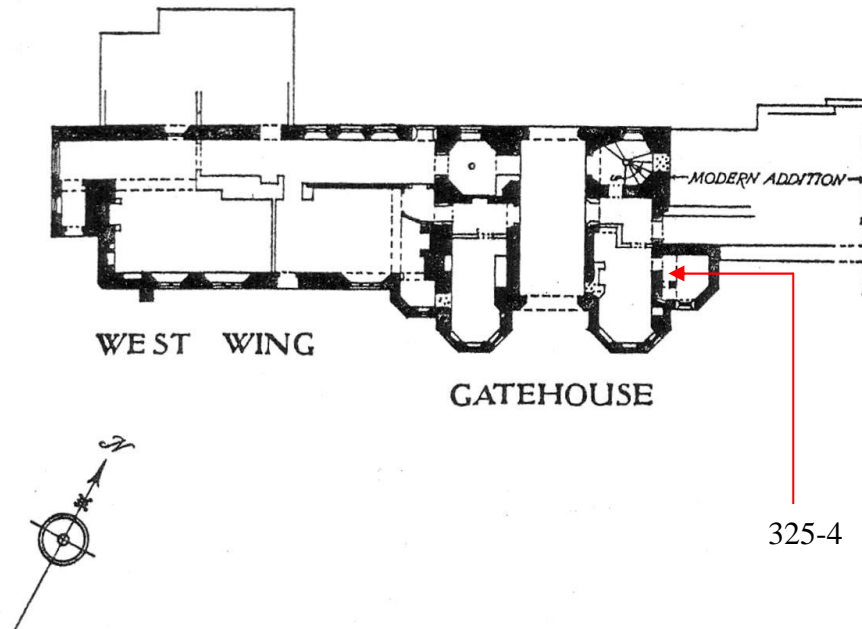

Fig. 3.28: Sampling location in Layer Marney gatehouse (RCHME, 1922, 159).



Fig. 3.29: The brickwork at the sampling point in Layer Marney. The scale bar is 20 cm in length. A door jamb can be seen to the right side of the image.

3.3.4: Maldon Moot Hall

3.3.4.1: Archaeological assessment

The Moot Hall in Maldon is a three storied brick tower house complex (see Fig. 3.30) and is thought to have been built in the 15th century by the Darcy family (Ryan, 1996, 52; Bettley and Pevsner, 2007, 581). It was originally part of a much larger mansion, although the exact nature of the earlier complex of buildings is uncertain. John Norden wrote in 1594 that the family once had a fair house in the heart of the town but that only a brick tower, know as Darcy's Tower, remained (Petchey, 1991, 90). An indenture from May 1539 for the sale of 'Master Darcies cheyfe mansyon' to John church details how a mansion, a chapel and other buildings called The Tower were exchanged whilst 'the tower of brick there builded' was excluded from the sale, remaining in the hands of Darcy and his descendants. The manorial complex is thought to have been demolished at some point between 1536 and 1560 for building plots in the heart of the town (Petchey, 1991, 90-92).



Fig. 3.30: Maldon Moot Hall. The image on the right shows the blocked cruciform arrow loop, a feature more likely intended for ornamentation than serious defence of the tower house.

Archaeological evidence of this complex series of manorial buildings was uncovered in 1991 when buildings at the rear of the Moot Hall were removed. The results suggested that the block at the rear of the Moot Hall was a later addition to the original building implying that the Moot Hall actually consists of two or more phases (Ryan, 1996, 53; Bettley and Pevsner, 2007, 581). The similarity of the bricks and brickwork would suggest that there was only a short interval between the addition of the rear block (Ryan, 1996, 53). However, it is also possible that in the late 16th century this extension of the building might have been constructed by re-using material from other demolished brick buildings that had once formed part of the original manorial complex. At the base of this rear block there is a chamber, partly sunken into the ground, with a barrel vaulted roof. It is likely that this was a cellar to the secondary building phase. It should be noted that there is a blocked alcove in the wall of the current passage next to the cellar. This alcove is very similar to that located at the base of the newel staircase and was probably intended to house a lantern, suggesting that the cellar was originally lit from this point. It was subsequently blocked, probably when the current passageway was inserted and possibly in the 19th century when the ground floor was converted to serve as a prison (Bettley and Pevsner, 2007, 581). The similarity between the two alcoves supports the suggestion that the two phases of the building were constructed within short periods of one another.

During the work in 1991, the fabric of the neighbouring building immediately east of the Moot Hall was analysed. The findings revealed a blocked door in the east wall of the Moot Hall ground floor. A brick wall was also found leading off the eastern side of the Moot Hall forming part of the neighbouring building. This indicated that there had originally been a brick structure adjoining this side of the tower. The wall contained windows with four centred heads at first floor level (Ryan, 1996, 53) as well as a series of holes in the wall (see Fig. 3.31). Whilst it is uncertain exactly what the purpose of these holes was, given the close proximity between them and the springing of the four centred arch (see Fig. 3.32), it seems unlikely that these were originally intended as floor joists. It is possible that they were intended to support timber corbels upon which the rafters of a roof were based (see Fig. 3.34). If this latter case is true then it suggests that the central axis of the neighbouring building was originally aligned



Fig. 3.31: Holes in the wall just above the modern first floor level. This wall extends eastwards from the Moot Hall and into the first floor of the adjacent building. It is thought that the holes may have held corbels to support the roof (see Fig. 3.34).



Fig. 3.32: Springing of a four centred opening in the wall of the building to the east of the Moot Hall. The height between the top of the opening and the holes in the wall suggest this was originally a window.

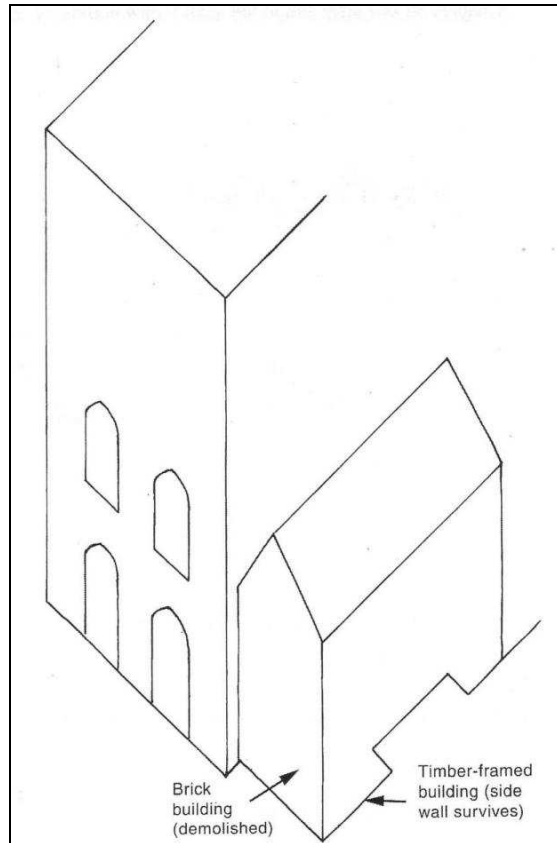

Fig. 3.33: Diagram of an earlier interpretation of part of Darcy's manorial complex next to the Moot Hall tower. The alignment here of the adjacent building (north-south) differs from the current interpretation (see Fig. 3.34) (Andrews, 2007).

in an east-west direction. This alignment differs from earlier suggestions in which the adjacent building was thought to be aligned in a north-south direction (Andrews, 2007, 2, 4) (see Fig. 3.33 and Fig. 3.34).

The Hussey Tower, Boston, is a 15th century brick built structure with several similarities to the Moot Hall. The eastern wall of the tower has the impression of a gable end of an adjacent range (Smith, 1979, 33), supporting the new proposal that the building adjacent to the Moot Hall was aligned along an east-west axis, with the gable butting onto the east wall of the Moot Hall (see Fig. 3.34). Examination of the interface between the wall of this neighbouring building and the east wall of the Moot Hall tower indicated that the Moot Hall butts onto the adjoining structure and is therefore of a later phase than the eastern structure. However, the fabric of the brickwork is similar in both buildings, suggesting a short period of time between the two phases of construction or that there was substantial re-use of material to erect the Moot Hall tower.

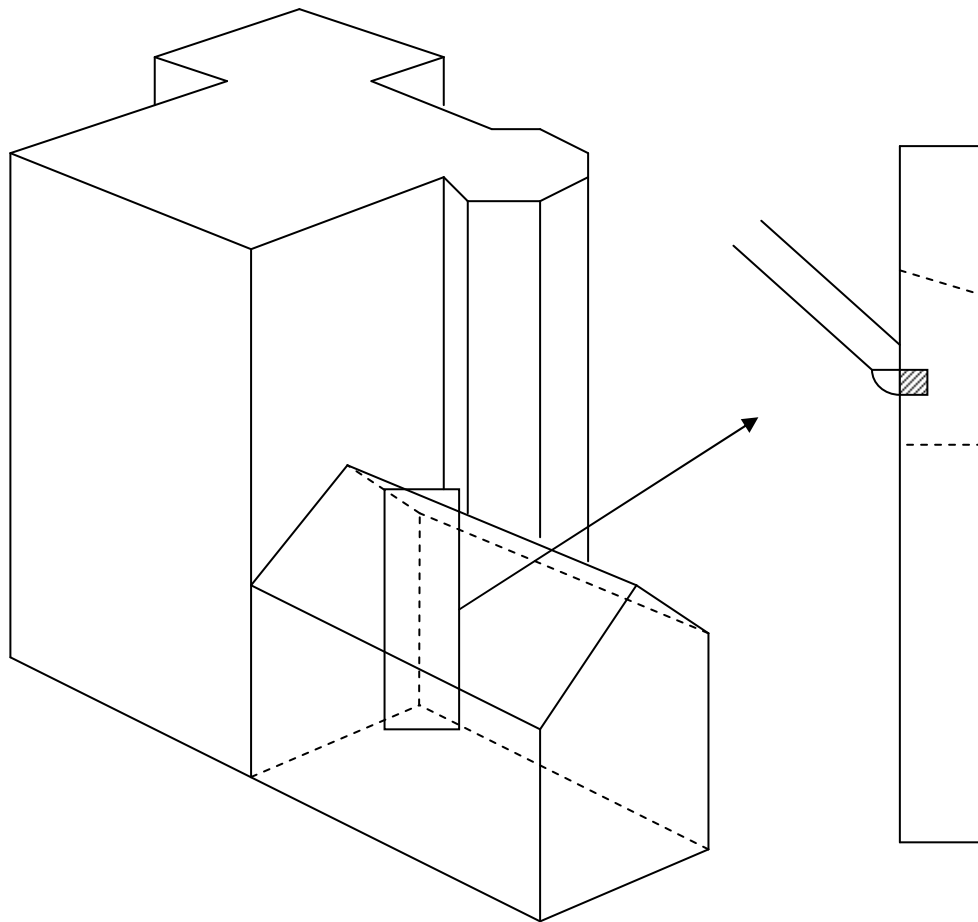

Fig. 3.34: Diagram showing the authors interpretation of the layout of part of Darcy's original manorial complex. The image on the left shows an adjacent structure next to the Moot Hall tower on an east-west alignment, an arrangement that is in agreement with the brick built 15th century Hussey Tower, Lincolnshire. The image on the right shows a cross section of the wall that is preserved in the modern neighbouring building. The dashed lines represent the outline of what has been interpreted as a window (see Fig. 3.32) whilst the hashed area represents the holes in the wall (see Fig. 3.31), thought to be holes to support corbels designed to support the rafters of the roof. The remains of the timber framed structure with brick nogging infill (see Fig. 3.35) is proposed as being either an internal division of this neighbouring building or part of a later structure.

One of the walls in the present neighbouring building has substantial timber framing with brick nogging infill (see Fig. 3.35). This has been interpreted as the eastern wall of the building that originally stood next to the Moot Hall (see Fig. 3.33) (Andrews, 2007, 2, 4). However, this is based on the assumption that the neighbouring building was aligned along a north-south axis. If, as discussed



Fig. 3.35: Remains of a timber framed structure with brick nogging infill located to the east of the Moot Hall.

above, the neighbouring structure was aligned on an east-west axis then this wall may represent an internal division within that building. If this brick nogging is a contemporary feature with the original manorial complex then it is a very rare and early example of this type of timber infill practice. Another early dated example occurs at Hertford Castle where a brick nogged timber framed partitioning wall was built in 1465 (Moodey, 1973). However, it should be remembered that the area around the Moot Hall was being redeveloped during the mid-16th century, a time when nogging was becoming more fashionable (see 2.1.5). It therefore seems more likely that materials were being re-used from the recently demolished manor buildings for the nogging, suggesting that this wall may actually be part of a mid-16th century structure.

In terms of its social context, the Moot Hall is a smaller example of the tower houses that were emerging as a result of developments to the solar block of the earlier medieval hall house during the 15th century. Many of these tower houses were being built out of brick, especially in the east of the country (Smith, 1985a, 48; Emery, 2000, 351-352). In Lincolnshire, the large and imposing tower at Tattershall Castle inspired a series of smaller brick tower houses in the immediate area, including the Hussey Tower, Boston, a structure thought to have

been erected c.1450-1460 (Smith, 1979, 34, 36). As discussed earlier, this brick tower house has several features in common with the Moot Hall. Both buildings are three stories high, bonded in English bond and have a brick newel staircase within an octagonal tower at the north east corner of the building, although that in the Moot Hall is more sophisticated than that at Hussey Tower. As at Maldon, there is also evidence of a now demolished range that originally adjoined the eastern face of the Hussey Tower, indicating that this was also part of a larger manorial complex and that both brick towers served as private residential rooms for the family (Smith, 1979; Emery, 2000, 351). Whilst such towers have defensive elements to them (crenellations at the Hussey Tower and a cruciform loophole in the western wall of the Moot Hall) (see Fig. 3.30) it is likely that these were intended as decorative elements rather than serious defensive features to these high status residential houses. Further evidence of decoration can be found at the Hussey Tower just below the parapet where there is a string course which is ornately moulded in several different ways (Smith, 1979, 33).

There is a great deal of uncertainty surrounding the age of the Moot Hall. Whilst there is general consensus that the tower dates to the 15th century, there is differing opinion as to when in the century it dates. Some have argued that it was erected in the mid to late 15th century based on comparisons with other brick tower houses in the country, such as Hussey Tower (Petchey, 1991, 90-92; Emery, 2000, 352). Others have suggested that it dates to the early 15th century due to documentary evidence in the Rochford manor accounts of 1429-1432 where Robert Darcy was responsible for organising a contract with the brick masons who carried out work at Rochford (Ryan, 1996, 52-53). Further evidence to suggest that brick construction was taking place in Maldon in the 1420s exists in the Writtle accounts whereby a man was paid to ride to Maldon to arrange an agreement with a mason there for repairing a chimney at Writtle with 'flanders-tyles', a terms often ascribed to bricks in the medieval era (Ryan, 1996, 53). A deed recording the Moot Hall being given to the town by Darcy in 1439-1440 has also been suggested as a *terminus ante quem* for construction of the building (Clarke, 1936, 212). The lack of diaper work on the observable areas of the building would also suggest an early 15th century date given that this is a decorative element thought to have been introduced from the 1430s onwards (Smith, 1985b, 11). If the argument that the tower was erected somewhere

between the 1420s to the 1440s is correct then the Moot Hall is almost certainly the oldest surviving, purpose built brick structure in Essex (Andrews, 2005a, 145).

The Moot Hall has several features that are architecturally significant, especially with regards to the use of brick. During recent restoration work, two arches were uncovered on the south front of the building. The brickwork around these arches was found to be ruddled i.e. the bricks were painted with a red wash whilst the mortar joints were highlighted in white to convey the appearance of high quality craftsmanship (Andrews, 2007, 2-3). Ruddling is rare in medieval brickwork although there is evidence to suggest that it took place on other high status brick buildings (see 2.1.4). Inside the first floor of the Moot Hall two pairs of trefoil headed arches were also uncovered (see Fig. 3.36), each trefoil springing from an elaborately moulded corbel. This is thought to be the earliest decorative feature of this kind in medieval English brickwork (Andrews, 2007, 5, 8).



Fig. 3.36: Decorative trefoil corbelled niches made from carved, ruddled bricks above the fireplace within the Moot Hall.

Another significant feature to this building is the brick newel staircase housed within the north east octagonal turret (see Fig. 3.37). It is rare to find this



Fig. 3.37: Base of the brick newel staircase in the north east turret of the Moot Hall. Note the small alcove immediately to the left of the central newel post, probably intended for a lantern.



Fig. 3.38: The view down the brick newel staircase, illustrating the header bonded wall, the brick treads, the brick newel post and the alternating stretcher-header pattern of the moulded brick handrail.

style of staircase executed entirely in brick in the 15th century. Smith has highlighted a collection of buildings stretching from Maldon in Essex to Someries Castle in southern Bedfordshire where similar staircases can be found, all of which are thought to date to between c.1430 to the 1450s (Smith, 1975, 137-138; Smith, 1976, 46-48). If correct, then this would add weight to the idea that the Moot Hall represents the earliest surviving purpose built brick structure in Essex. The staircase itself has a central newel post made from semicircular moulded bricks. There is a small alcove, probably intended for a lantern, located at the base of the staircase with a simple pointed arch made from two bricks placed at an angle next to each other (see Fig. 3.37). The curving wall of the staircase is lined in header bonded bricks whilst the risers and treads are also made from bricks. There is a handrail made from moulded bricks, some of which have probably been replaced. They are laid in an alternating stretcher-header pattern (see Fig. 3.38), a pattern which does not occur at other sites with early 15th century brick newel staircases, including Rye House gatehouse and Someries Castle.

The Moot Hall at Maldon is clearly a significant part of what was originally a much larger manorial complex. Evidence for this exists to the east of the Moot Hall where the remains of an adjoining structure are housed within the fabric of the current neighbouring building. These remaining parts of the original manorial complex were built at different times, with the adjacent structure being constructed first, followed by the Moot Hall onto which an extension was then added in the north west corner. However, given the similarity of the bricks, it seems likely that either the intervals between each phase are small or that similar material was being re-used from other buildings, possibly from other parts of the manorial complex. If the latter case is true, then the Moot Hall may have been altered when the manorial complex was largely demolished in the early 16th century. Whilst there are few decorative features on the exterior, the interior of the building contains several rare and high status features, including early examples of trefoil corbelled arches, a brick newel staircase and traces of ruddling. The date when the tower was erected is unknown but it is likely to have been in the early 15th century. The occurrence of similar architectural features, such as the brick newel staircase, in other brick buildings dated to the 1440s and the similarities to Hussey Tower would suggest that it was built prior to or around the mid-15th century. Given the deed of transfer to the town, it is probable that it

was standing by the late 1430s and the involvement of Robert Darcy with brick craftsmen around the 1420s might suggest a period when it could have been erected. Therefore, the most likely period for construction lies between the 1420s and the 1430s.

3.3.4.2: Maldon Moot Hall sampling location

A single core sample was collected from the base of the brick newel staircase in the north east corner of the building (see Fig. 3.39).

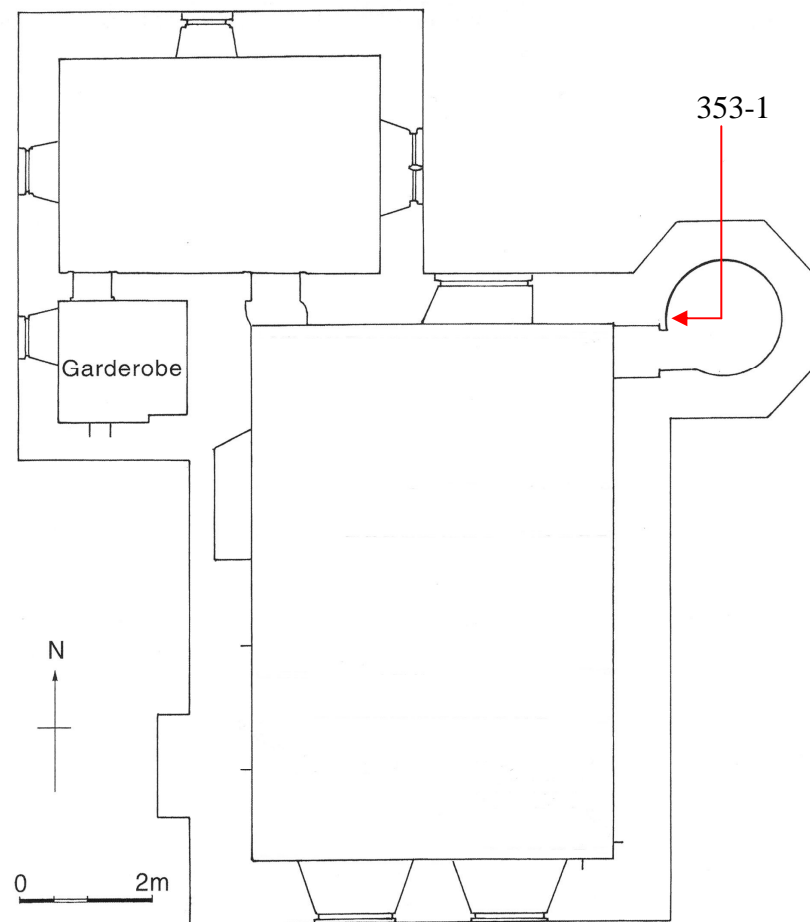

Fig. 3.39: Sampling location in the Moot Hall, Maldon (Andrews, 2007).

The brickwork around the sampling point was laid in header bond with mortar joints that varied in thickness from approximately 5-15 mm (see Fig. 3.40). The bricks were red 'Tudor' bricks and were of a relatively fine fabric with a few small inclusions. During the drilling process, the rear face of the brick was reached with brick and traces of mortar seen behind.

When the length of the core was measured (approximately 135 mm) it was found to be less than the length of other bricks in the structure (approximately 230 mm), suggesting that the bricks around the newel staircase had been cleaved prior to building work (*cf.* Nether Hall). This would have doubled the supply of bricks available to build the wall, saving on building resources. It would also dictate that the bricks were laid in header bond, a pattern that suits a curving surface better than a bond requiring stretcher faces, such as English bond. However, it is possible that the sampled brick may be an exception and others bricks in the wall could extend to the full length.



Fig. 3.40: The brickwork surrounding the sampling point at the base of the brick newel staircase in the Moot Hall, Maldon. The scale bar is 20 cm in length.

3.3.5: Nether Hall, Roydon

3.3.5.1: Archaeological assessment

Nether Hall is a ruined brick gatehouse located in western Essex, close to the Hertfordshire county border. It consists of the extensive ruin of a fortified 15th



Fig. 3.41: Remains of Nether Hall gatehouse seen from the south-east.



Fig. 3.42: Sketch of Nether Hall gatehouse made in 1819 from the north inside the moated complex (ERO I/Mb 302/1/6).

century moated manorial complex built of brick, of which the gatehouse is the most extensive surviving component (see Fig. 3.41 and Fig. 3.42). Following a

large restoration project in 1993, a large amount of archaeological attention has recently been directed towards this structure, revealing some interesting discoveries which are considered in this account.

The exact construction date for Nether Hall is unknown although it is generally agreed that the most likely candidate is Thomas Colt (died 1467) (VCH, 1983, 233; Ryan, 1996, 59; Andrews, 2004, 79). Colt was associated with the Yorkist forces during the Wars of the Roses and was close to the Neville family. It is thought that he fought at the first battle of St. Albans (1455) and the battle of Wakefield (1460). During this period, his property was confiscated and granted to Henry Fylungley (*Cal. Pat. R, 1452-1461*, 583). However, after the Yorkist victory at the battle of Towton (1461) and the accession of Edward IV to the throne, Colt had his properties restored to him as well as lucrative royal appointments and additional grants of land (Chancellor, 1918b, 176; Andrews, 2004, 79-80). Andrews has ascribed a likely construction period of between the 1450s and 1467. Based on the career of Colt, he has suggested that 1461-1467 is the most likely period for when the building was constructed as this marked the period of his greatest prosperity (Andrews, 2004, 80-81).

Architecturally, there are features in Nether Hall that provide dating evidence and it is possible to discern certain similarities when comparing the building to other mid-15th century brick buildings in the surrounding area. The plan of Nether Hall is similar to that of Someries Castle, Bedfordshire, which is thought to have been constructed c.1448-1459 (Smith, 1976, 56-57; Emery, 2000, 129). There are also similarities with the trefoil corbel tables at both Someries Castle and the moated manorial complex of Rye House (Emery, 2000, 129), the latter located less than two miles away and thought to have been built c.1443 onwards (see 2.1.4 and Fig. 2.8) (Smith, 1975, 111-112). However, it should be noted that the more elaborate cinquefoil corbel tables with trefoil mouchette spandrels which occur at both Someries and Rye House do not occur at Nether Hall (Andrews, 2004, 96). Rye House has an ornately moulded brick chimney located at the rear of the gatehouse (see Fig. 2.8), a feature which, although decorated in a different style, was also present at Nether Hall (RCHME, 1921, 208). Further features common to all three buildings include the quadripartite vaulting in brick of the gateway passage, that at Rye House being the only one



Fig. 3.43: Brick quadripartite vaulted entrance passageway inside Rye House gatehouse. Whilst the vaulting at Nether Hall has fallen in, there is evidence that the passage was originally vaulted in three bays.



Fig. 3.44: The view down the brick newel staircase, illustrating the header bonded wall and the moulded brick handrail laid in header fashion.

still intact (see Fig. 3.43), (RCHME, 1921, 208; Smith, 1975, 124; Smith, 1976, 48), the use of elaborate diaper patterned brickwork in the structures, with that at Someries having similarities to patterns used at Nether Hall (Smith, 1976, 52), and the presence of brick newel staircases (see Fig. 3.44) (Smith, 1975, 124-126; Smith, 1976, 45-46) of which the handrails for all three buildings are composed of moulded bricks laid in a header fashion (*cf.* Maldon Moot Hall). Thus, architectural features to other nearby 15th century brick buildings suggest that construction of Nether Hall was undertaken from the late 1440s to the 1450s, possibly under the guidance of the same master brick craftsman who had been involved with Someries Castle and Rye House gatehouse.

Over the course of time, Nether Hall has suffered from destruction and decay resulting in the loss of many aspects of the manorial complex. When originally built, there were structures located within the central enclosed area and against the curtain walls. However, in 1631 Nether Hall was sold out of the Colt family and by the 1770s most of the buildings within the enclosed area had been converted into a farm complex before being pulled down with the exception of the gatehouse, which was too sturdy and costly to pull down (Grose, 1773; Andrews, 2004, 78). A map from 1786 shows that little more of the manor complex was standing when compared to today (ERO D/DB P31). Some of the features that have been lost were described by the antiquarian Francis Grose between 1769-1772 prior to the destruction of large elements of the manor complex. His account describes three shields supported by several ornately carved heraldic devices, including two horses (possibly colts), a spread eagle supported by a lion and unicorn and a lioness and bull ducally crowned. There were also several trusses carved with heraldic emblems, including a radiant rose, a griffin, and a bear and ragged staff (Grose, 1773). All of these decorative features were located within the gatehouse where the only heraldic emblems that remain today are an irradiated rose with a tun in the centre, located in the south east corner of the first floor chamber, (see Fig. 3.45) and a fragment of a carved wing located in the north east corner of the same chamber (RCHME, 1921, 208; Ryan, 1996, 59; Emery, 2000, 128). These decorative details have been used to support the idea that it was Thomas Colt who was the likely builder of Nether Hall and that construction took place between 1449-1471 (Ryan, 1996, 61; Andrews, 2004, 79).



Fig. 3.45: Carved irradiated rose with a tun in the centre. This is the only carved decorative feature in the gatehouse complex that has survived largely intact.



Fig. 3.46: The wall attached to the east side of the gatehouse. The dashed line represents the approximate location of the transition from high quality craftsmanship (to the left of the line) and poor quality craftsmanship (to the right of the line).

Within the eastern curtain wall that runs along the south side of the moated site, there is a discrepancy approximately halfway along. The brickwork on the eastern half displays a poorer quality of craftsmanship than the western half (see Fig. 3.46), suggesting a break in the building work. It is thought that when construction of the wall was resumed at a later date, less skilled workmen were involved in the eastern half (Andrews, 2004, 95). This transition has been attributed to the death of Thomas Colt in 1467 and the fact that his heir, John Colt (born in 1465) was a minor (Waller, 1903, 378). It is also thought that this indicates that the majority of the gatehouse complex had been built by this time (Andrews, 2004, 95). There is another source of dating evidence for Nether Hall in the form of two dendrochronology samples that were taken from wooden remains within the gatehouse. These gave a date range of 1447-1492 which, whilst failing to give a more precise construction date, do agree with the architectural and biographical evidence (Andrews, 2004, 81). Considering the above evidence, the gatehouse of Nether Hall was probably built between the years 1447-1467 with 1461-1467 being the most likely period for construction.

3.3.5.2: Nether Hall sampling locations

Three core samples were collected from the curving wall immediately beneath the brick newel staircase (see Fig. 3.47). The brickwork in this area was laid in a regular header bond with mortar joints that varied from approximately 2.5-12 mm. The bricks were the red 'Tudor' type with the occasional darkened vitrified brick. The bricks had a slightly coarse texture and were coated in a thin layer of dirt, probably the result of exposure to the environment and airborne pollution (see Fig. 3.48).

The sample cores were found to be cleaved bricks. Bricks of a slightly different colour were located behind the outer face of cleaved header bricks (*cf.* Maldon Moot Hall). The use of bricks in this way is likely to have been an attempt to reduce the resources required for building the brick newel staircase and to facilitate the construction of a curved wall face. The fact that cleaved bricks have been identified at two sites and in more than one brick for a given site suggests that this was the common approach in the construction of curving brick walls in brick newel staircases. It might also suggest that the same craftsmen were working on both structures, although this suggestion is more tentative.

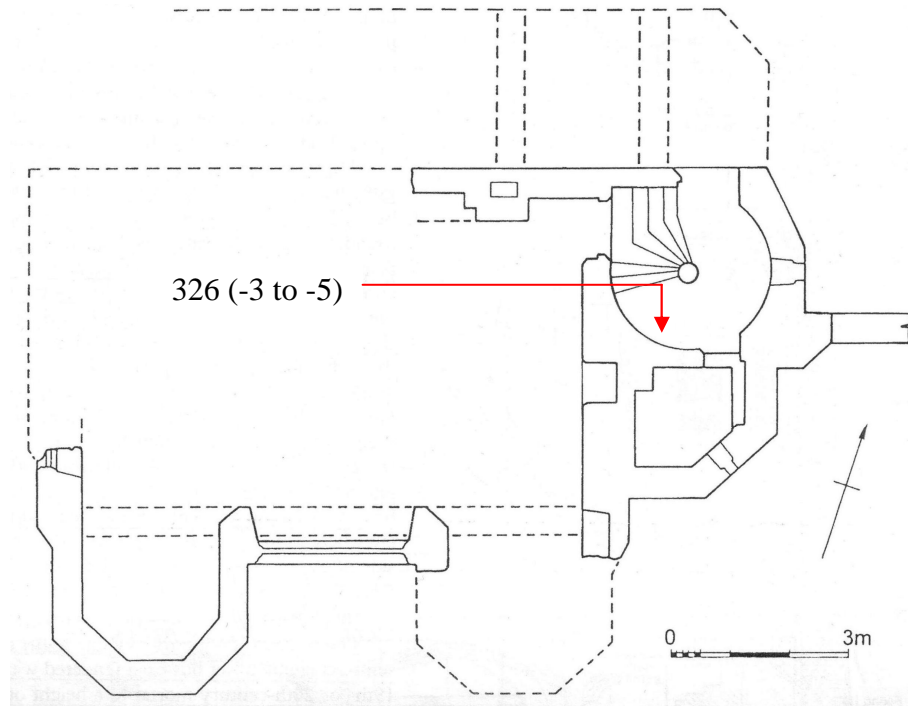

Fig. 3.47: Sampling location in Nether Hall (Andrews, 2004, 89).



Fig. 3.48: The sampling points at the base of the brick newel stair. Note the change in the bonding pattern in the top right corner of the image. This change signifies the springing of the spiralling barrel vault upon which the lower part of the staircase sits. The scale in the image is 20 cm in length. There are three sampling points, two of which are shown open. The other sampling point is circled. This point was repaired and allowed to dry over the course of several months, illustrating the aesthetic effectiveness of the repair work undertaken.

3.3.6: New Hall, Boreham

3.3.6.1: Archaeological assessment

New Hall is located in Boreham on the north western outskirts of Chelmsford in central Essex. The principal frontage of the building dates to the late 16th century and consists of seven bay windows (see Fig. 3.49).



Fig. 3.49: Principle frontage to the late 16th century building showing the bay window complexes. Note the main entrance into the centre of the range.

The building has had a long, eventful and complex history. Unfortunately, many accounts of New Hall focus more on the details of the different owners and the changes that they made to the manor rather than providing a thorough archaeological evaluation of the present structure. In terms of the history of New Hall, the earliest reference to the site was when it was granted in 1062 by Earl Harold to the Augustinian Canons of Waltham Abbey as part of an endowment of seventeen manors. It is thought that a substantial building had been constructed on the site by the 12th or 13th century which served as the summer residence of the lord abbot and offered hospitality for several distinguished travellers, such as Adela of Louvain who stayed at New Hall whilst en route to her marriage to Henry I in 1121 (Stephen, 1988, 126; Tuckwell, 2006, 4). The site was acquired

from the abbot in 1350 by Sir John de Shardelowe and passed through a series of owners before coming under ownership of the Crown through Edward IV upon his accession to the throne in 1461. It remained in the hands of the Yorkist monarchs until Henry VII came to the throne in 1485 (Tuckwell, 2006, 4).

During extensions to the school in the late 20th century, the remains of earlier structures were uncovered. In terms of medieval remains, a feature containing oyster shells was interpreted as an earth floor of a medieval manor, buried approximately 2 m below the present ground level at the rear of the school. Another floor composed of irregular cobblestones was uncovered approximately 1.3 m below ground level in front of the school. Other features uncovered during the extension were thought to be Tudor in date (see below) (Stephen, 1988, 126). Consequently, whilst limited in scope, there is archaeological evidence to suggest that a structure of some form had existed at New Hall during the medieval period.

The next significant individual to become involved in New Hall is Thomas Butler, Earl of Ormond. It was given to him by Henry VII as a form of recompense following the continued support for the Lancastrian cause given by the earl's family during the course of the Wars of the Roses (Tuckwell, 2006, 4). Exactly when the earl received this manor is uncertain although he was certainly in possession in 1491 when he was granted a license to crenellate which specified walls and towers of stone, lime, sand and 'brike' (*Cal. Pat. R., 1485-1494, 367*). There has been much speculation surrounding both the location and the nature of the structure that Ormond might have constructed. Early histories of the building suggested that the manor was modelled on an ancient palace of the kings of Ulster but fail to provide any reasoning for this assumption (Anon, 1899, 133; Watson, 1907, 375; Philips, 1908, 59). More recently, it has been suggested that the manor might have resembled Oxburgh Hall, Norfolk, which was also built in the late 15th century, an assumption that appears to be based on the description of walls and towers in the license to crenellate (*Cal. Pat. R., 1485-1494, 367*; Andrews, 2000b). It is possible that Ormond's structure was surrounded by a moat (a feature present at Oxburgh Hall) since a 'canal' located to the north of the present building and later described as the relic of a moat was drained around 1800 (Anon, 1899, 142-143). The exact location of the building is just as uncertain as its appearance. If the 'canal' was part of a moat then it would suggest that it was located to the north of the present building, a site that could potentially agree with

archaeological evidence that was uncovered in 1968 when the school buildings were extended northwards. The building work uncovered massive quantities of Tudor brickwork, walls, drains and archways. These features had originally been part of a large courtyard that had been demolished before 1691 (Stephen, 1988, 128). However, it is also likely that these remains are from building work carried out in the 16th century (see below). Overall, it is impossible to determine the exact location or nature of Ormond's mansion. Despite earlier suggestions that the existing building contained elements of this structure, it is now thought that nothing remains of this late 15th century manor (Andrews, 2000b).

The Earl of Ormond was able to enjoy his manor until his death in 1515 when it passed on to his daughter Margaret who had married Sir William Boleyn. Their eldest son, Thomas Boleyn, who was father to Anne Boleyn, later inherited the property (Philips, 1908, 59; Tuckwell, 2006, 5). In 1516, Henry VIII took a great interest in New Hall and purchased the property for both £1,000 and an exchange of property. Work began immediately and initially focused on repairing New Hall but by 1517 it appears the manor was being re-built. The building project was to cost a total of about £17,000, a vast sum for the time (Colvin *et al.*, 1982, 172). Sufficient progress had been made in the building process by 1519 for Henry to stay at New Hall and stage a masque (*L & P Hen. VIII, III 1, No.436*) but the building project was not fully completed until 1521. Henry was so pleased with the final result that he made it the centre of a new Honour (grouping of royal estates) in Essex and also renamed his new palace 'Beaulieu', a name which, although confirmed by act of parliament, did not last long in common reference locally (Colvin *et al.*, 1982, 172).

The palace that Henry constructed was on a grand scale. Whilst there are no surviving contemporary plans of the palace, there are some clues to its appearance from contemporary descriptions, one of which describes eight courtyards, a 500 foot entrance facade, a great hall, a tennis court, a large kitchen, a gallery and that the royal apartments were located in a wing that was three stories high (Tuckwell, 2006, 8). The main gateway was located in the southern range of a central court and consisted of two imposing towers that rose to a height of three stories. There was an ornately carved set of arms (now located in the chapel of the present building) set in the centre bearing the following inscription:

*Henricus Rex Octavus, Rex inclit. armis,
magnanimus struxit hoc opus egregium*

(The magnanimous Henry the Eighth, a king renowned in arms,
erected this sumptuous building)

This set of arms was in place of the more typical oriel window, a feature that was compensated for by six large mullioned and transomed windows set within the exterior facing windows of the gatehouse towers (Colvin *et al.*, 1982, 174). The southern range was further broken up by two projecting gable ends on either side of the main gateway, both of which were aligned with the east and west ranges of the principal courtyard (Dunlop, 1962, 34-35). The great hall, with its oriel window looking into the central court, was located at the northern end of the eastern range whilst the chapel was sited in the northern end of the western range (Colvin *et al.*, 1982, 174; Stephen, 1988, 127). The outline of the western, eastern and southern ranges of the central courtyard appear in the form of parch marks during dry weather (see Fig. 3.50) whilst further information about the layout of the palace exists in an 18th century plan of the building complex before it was substantially altered to its present state (see Fig. 3.51) (Tuckwell, 2006, 10).



Fig. 3.50: Parch marks seen in the dry summer months. This southerly view shows the outline of the western range of the main courtyard.

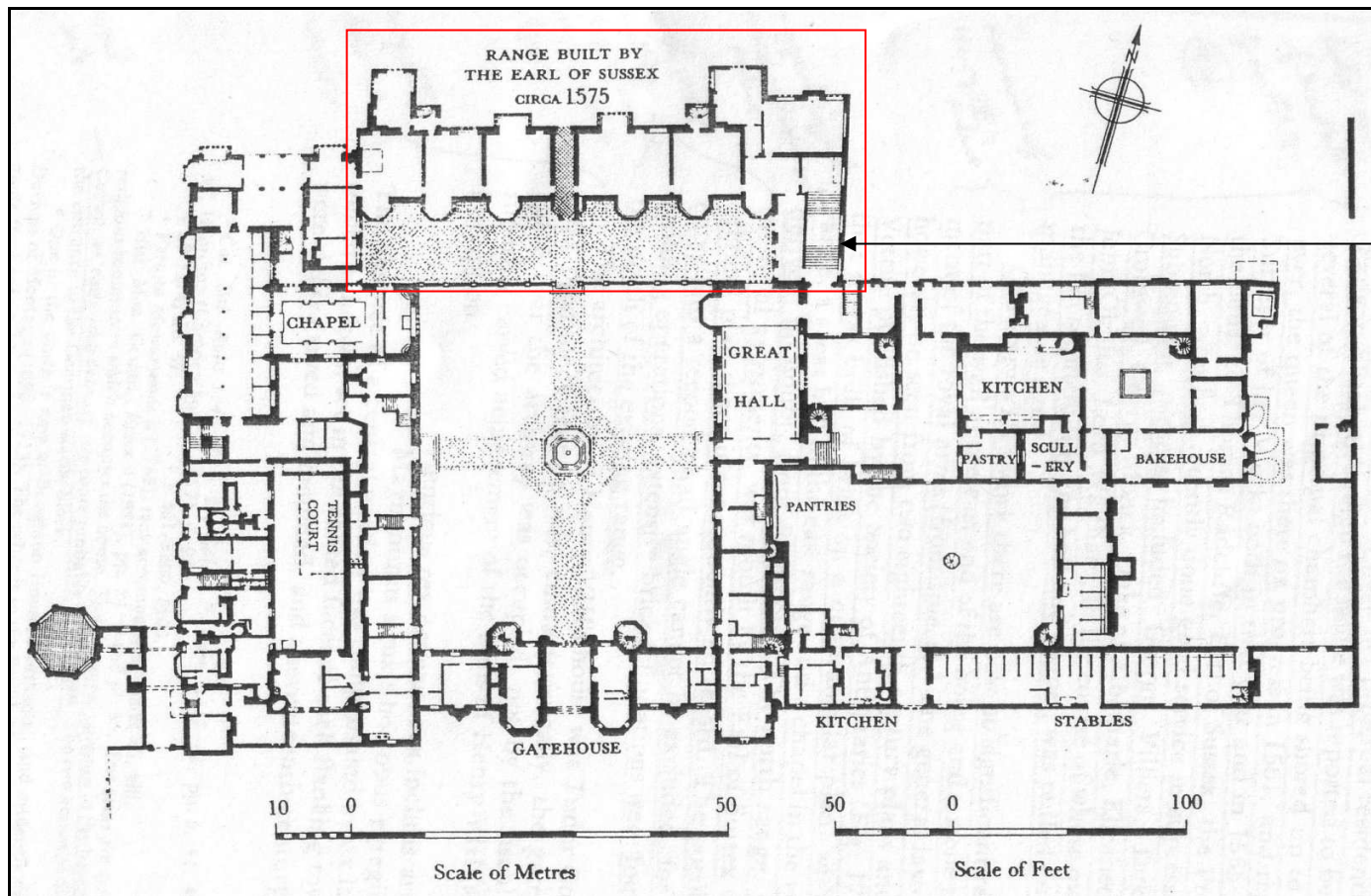

Eastern wall of the surviving building range. Note the unusual alignment.

Fig. 3.51: Plan of the palatial complex at New Hall based on an 18th century plan at Boughton House, Northants. The surviving part of this original building complex is encompassed within the red rectangle (see Fig. 3.49 for the southern view of this range). Note the different alignment of the eastern wall of the surviving building (Colvin et al., 1982, 173).

It has been suggested that the arrangement of the principal rooms at New Hall, in which the great hall was located in the eastern range opposing the chapel in the western range and with the gatehouse situated in the southern range, was probably based on the royal palace of Richmond, a complex built by Henry VII between 1497 and 1502 where there was a similar layout to the inner courtyard (Colvin *et al.*, 1982, 174; Thurley, 1993, 28-31).

As has already been mentioned, large amounts of building rubble were discovered when the school expanded northwards. It has been suggested that this is another possible courtyard associated with the palace that Henry built, an idea supported by the fact that the palace had, according to a contemporary description, eight courtyards of which the 18th century plan shows only seven (Colvin *et al.*, 1982, 174; Andrews, 2000b). Other palaces built by Henry also contained inner and outer courtyard layouts such as Bridewell palace in London, built between 1510-1523 (Thurley, 1993, 40-44; Andrews, 2000b). There is an antiquarian account of New Hall in the 18th century which offers tentative evidence for this missing court. The account describes how 'opposite to the grand entrance, is another door, which formerly led into a spacious court' (Muilman, 1769, Vol. I, 127). By the time this account was written, large portions of the Tudor palace had already been demolished by John Olmius who took possession of New Hall in 1737 (Andrews, 2000b). It therefore seems likely that the building Muilman observed was similar to that seen today, of which there is a large entrance in the central bay complex (see Fig. 3.49). The 18th century plan shows a central passageway leading from this entrance through to the rear of this northern range (see Fig. 3.51). It is therefore possible that this passage originally led to a large court, suggesting that it was located on the northern side of the building, where the building rubble was unearthed during the expansion of the school buildings. Therefore, although impossible to determine for certain, there is evidence to suggest that there was originally another courtyard located to the north of the present building in the Tudor palatial complex.

The later history of New Hall is long and complex. Henry spent much time at New Hall and, following the birth of his daughter Elizabeth, hosted a magnificent ball here in 1533 (Philips, 1908, 61). Princess Mary, first daughter of Henry VIII, regarded New Hall as her favourite abode and spent much time here between 1532 and 1553 (Anon, 1899, 134), although the buildings are said to

have fallen into a poor state of repair and the principal chambers had to be shored up. A letter from Sir Thomas Wharton, a member of Mary's household to whom she leased New Hall from 1553, states that 'the house is in great ruin, being burned in Henry VIII's time and not repaired since' (Ryan, 1996, 74; Tuckwell, 2006, 23). Elizabeth I entertained her prospective suitor, the Duke of Anjou, here in 1559, suggesting that elements of the complex must have been in a sufficiently fit state for the royal party (Andrews, 2000b). She also stayed at New Hall in the summer of 1561 during the course of a royal progress. Repairs had been carried out to the building by the surveyor of her works during this year and were also undertaken in 1565-1567 by which time New Hall had reverted to the Crown (Colvin *et al.*, 1982, 174). In 1573 Elizabeth granted New Hall to Thomas Radcliffe, Earl of Sussex, as a reward for earlier services to the Crown. Radcliffe decided to rebuild the northern range of the main courtyard resulting in the structure we see today (see Fig. 3.49) (Stephen, 1988, 130; Andrews, 2000b). What had existed before the remodelling of this northern range is unknown although there is the possibility of a central gatehouse leading to the previously discussed second, northern courtyard. Based on details given in the 17th century Hearth Tax, it seems likely that Radcliffe did not demolish this northern courtyard and that he retained a passageway leading through the northern range from the southern courtyard to the northern one (Colvin *et al.*, 1982, 174; Stephen, 1988, 130-131; Andrews, 2000b). The current building contains several architectural features that indicate the rebuilding undertaken by Radcliffe of the northern range. Firstly, the date 1573 was inscribed on the west wing whilst within the building there were the arms of both Radcliffe and Frances Sidney, his second wife (Philips, 1908, 125). Today, over the main entrance into the chapel, there is a carving of the royal arms of Elizabeth I (see Fig. 3.52) and directly below is the following Italian inscription:

[*Vivat Elizabetta*]
En terra la piu savia Regina, en cielo la piu lucente stella;
Virgina magnanima, dotta, divina, leggiadra, honesta et bella.

(On earth the pious, wise queen, in the heaven the shining star of piety;
A virgin, noble, learned, divine, witty, chaste and beautiful)



Fig. 3.52: The arms of Elizabeth I above the main entrance to the chapel. There is an Italian inscription directly beneath the arms.

This feature was probably added to his newly acquired property as an expression of his gratitude to the queen. The range that Radcliffe constructed also has architectural features that are seen in other Elizabethan ‘prodigy’ houses of the time, such as Longleat, Wiltshire, (constructed between 1572-1580), especially with regards to the use of symmetry and bays with large glass windows (Andrews, 2000b; Watkin, 2001, 87). Being only two stories tall, New Hall lacks the general height associated with this style of house but this could have been an effort on the part of Radcliffe to match his new structure with the earlier 16th century palatial complex. However, the windows on the first floor are larger than those on the ground floor (see Fig. 3.49) which was a trend developing in later Tudor houses when principal rooms were located on the upper levels (Andrews, 2000b). Other differences between New Hall and other stately homes, such as Longleat, include the lack of classical decorative features, such as pilasters along the facade, and the modest nature of the main entrance. These are likely to be other examples of the efforts that were made to harmonise the new architectural style of the northern range with the older style of the existing buildings (Andrews, 2000b).

New Hall remained in the hands of the Earls of Sussex until 1622. Thereafter, it was owned by a series of significant figures in 17th century English history, including George Villiers, Duke of Buckingham, (owned New Hall from 1622-1627), Oliver Cromwell, Lord Protector, (owned New Hall from 1651-1653) and General George Monk, Duke of Albemarle, (owned New Hall from 1660-1670). During this period there were alterations to the internal fittings and decorations of the building but little construction work itself was undertaken. Consequently, the building was neglected during the late 17th and early 18th centuries (Stephen, 1988, 131-132; Andrews, 2000b). The next substantial alteration to New Hall took place in 1737 when it was sold to John Olmius. As mentioned earlier, he was responsible for demolishing the courtyards and service buildings that had been part of the Henrician palatial complex shortly after coming into possession of the property (his arms and the date 1738 can be seen on the hoppers of the drainpipes today) (Andrews, 2000b). He retained the northern range that Thomas Radcliffe had built at the end of the 16th century, modifying the northern frontage and repairing other parts. He also re-used elements of the demolished palace to erect a stable courtyard in brick on the east end of Radcliffe's range (Stephen, 1988, 132-134; Andrews, 2000b). The final period of change at New Hall was a process of gradual development on the northern side of the Elizabethan range during the course of the 19th and 20th centuries as a community of nuns established a school in the building and constructed various additions as they were required, including a refectory, classrooms, bedrooms and a gymnasium (Stephen, 1988, 135). The western end of the Elizabethan range was heavily damaged in the Second World War during bombing raids but has since been rebuilt (Stephen, 1988, 135; Tuckwell, 2006, 170-171).

With regards to the project, it was intended to focus solely on the oldest parts of the present building that contain brick. This resulted in attention being directed towards the eastern range and the cellars housed underneath, since these are generally thought to be the only parts that have survived from the Henrician palatial complex (RCHME, 1921, 24; Stephen, 1988, 128; Andrews, 2000b). The cellars themselves consist of two large chambers with brick walls, aligned perpendicular to one another and each containing a central arcading of octagonal pillars and four centred arches which are of two chamfered orders. The arcading of the northern chamber is aligned in an east-west direction whilst that of the

southern chamber is aligned in a north-south direction. It has been suggested that both series of arcading are early 16th century in date (RCHME, 1921, 25) although it should be noted that others have suggested the arcading of the cellars might actually be Elizabethan in nature (Colvin *et al.*, 1982, 174). The arcading of the southern chamber is made from moulded bricks which are covered in plaster rendering (see Fig. 3.53). The far eastern wall of the cellar chambers is set at a different alignment to the other walls in the building (see Fig 3.51), potentially indicating that this might have been part of an earlier building, although exactly which one is difficult to say given the evidence for several earlier structures on this site.

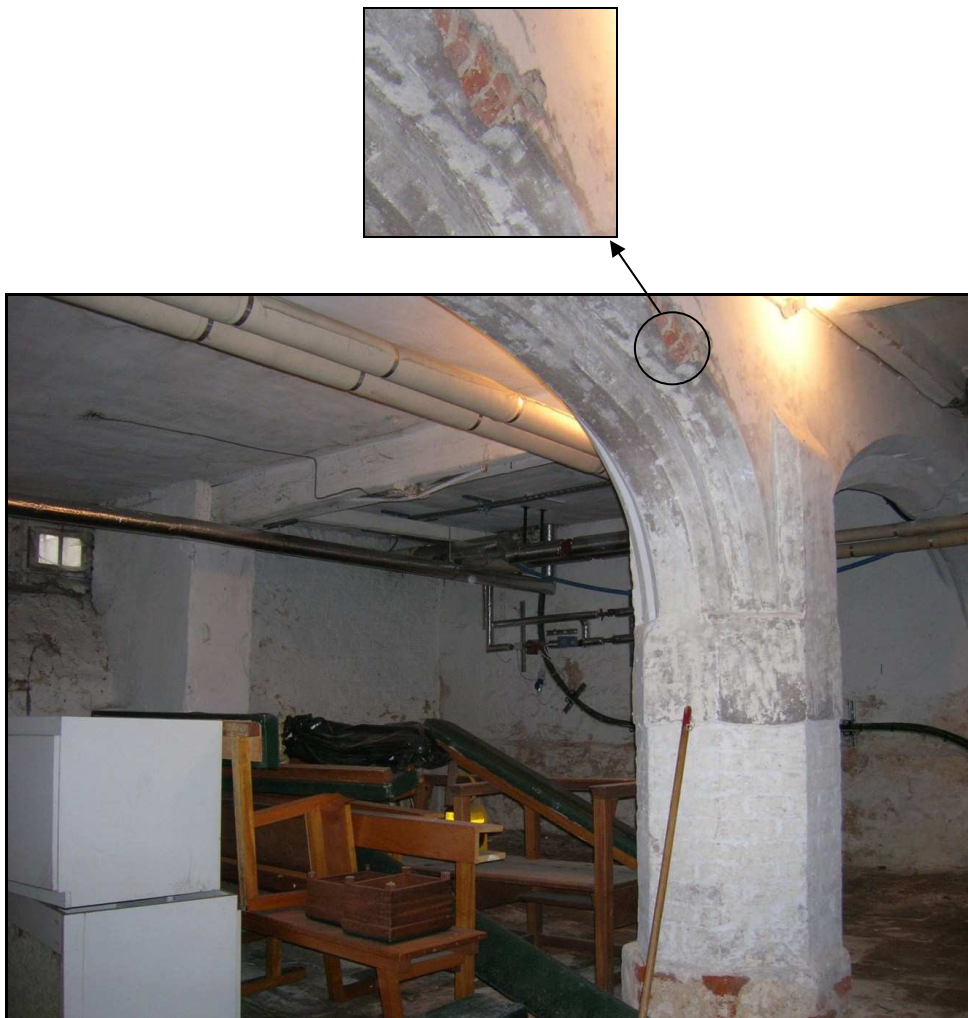

Fig. 3.53: The arcading located in the southern cellar, aligned along a north-south axis. Note the moulded brickwork in the outer order of the arch where the plaster has fallen away.

There are several features of the eastern range and cellars which have been used to support the argument that this part of the present building dates to the early 16th century. Firstly, the windows of the eastern range, whilst of a late 16th century style, appear to have been cut into the brickwork, suggesting that this part of the present building is from the Henrician palace and that the windows were inserted as part of the rebuilding undertaken by the Earl of Sussex (Andrews, 2000b). Further evidence can be found at the bottom of the wall on the eastern side of the range where there are a series of windows with low arched heads, thought to be late perpendicular Gothic in style (see Fig. 3.54) (Andrews, 2000b).



Fig. 3.54: Late perpendicular/early Tudor windows located in the eastern wall of the cellar.

It should be noted that south of these windows are a series of stone blocks rising to approximately 2 m in height and with traces of a hollow chamfer on the northern edge (see Fig. 3.55). It is possible that these blocks were originally a door jamb and may indicate the location of a blocked doorway, possibly leading down into the cellars. However, it is also possible that the blocks have been re-used from an earlier context. If these carved stone blocks do represent a blocked doorway, then it would suggest that parts of the cellars were originally arranged differently as this possible doorway does not conform to the current layout.

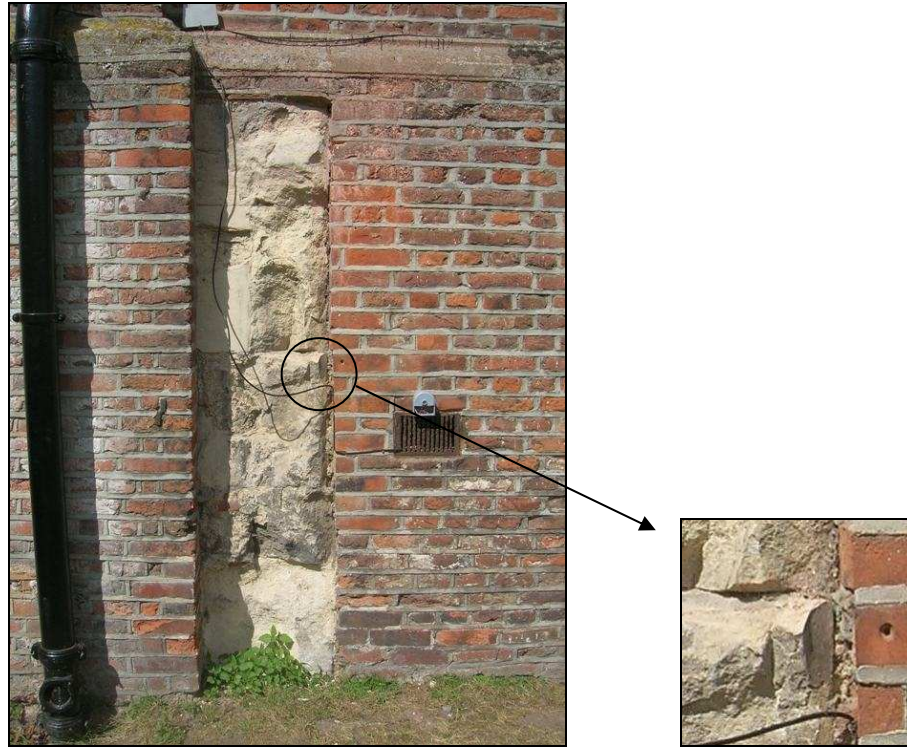

Fig. 3.55: A column of worn ashlar blocks, located south of the windows (see Fig. 3.54) in the eastern wall of the cellar. Note that there are traces of a hollow chamfer on the right hand side of the column, suggesting it may originally have been ornately carved.

Other features located within the cellars that have been used to date them include two opposing four centred doorways, both of which are thought to be early 16th century in date (RCHME, 1921, 25; Andrews, 2000b). However, it should be noted that these two doorways are not identical. Considering the northern doorway first, it leads from the southern chamber to the northern chamber, has hollow chamfered jambs and a door composed of two leaves suspended on plain metal hinge straps. However, there is a long groove located towards the base of the door which has a niche on the western side indicating the space for a hinge loop to sit on a wall pintle (see Fig. 3.56). This groove is continued across the central divide of the two leaves and terminates on the eastern leaf. Given the relative height above the base of the door on both leaves, this groove probably housed an original hinge strap which stretched across the entire door, suggesting that the present door was once a single leaf fitting. Given that there is a groove at the bottom of the door, a similar feature should be present near the top. It is possible that the present hinge straps, which are attached to the door



Fig. 3.56: The door and doorway between the north and south cellar chambers. The top image shows the north face of the door. Note that at the bottom of the present door there is a groove which runs across both leaves for an original hinge strap. There is also a niche on the left side of the image which was the location of the hinge loop to sit on the wall pintle.

leaves by blocks of wood, have covered the upper groove of the original door hinge. It should also be noted that the lock case also appears to have been re-used and is installed upside down in its present location. The implications from this door is that at some point it has been re-used and modified to fit into the present archway. The period to which this door originally belongs is uncertain as there are no obvious decorative features.

Focusing on the southern doorway, this has a roll moulded decoration



Fig. 3.57: The doorway in the southern chamber of the cellars, looking southwards. Note the roll mould decoration running around the doorway. At the bases of the jambs (the left image shows the eastern jamb) there appears to be a simple chamfer termination to the roll moulding and on the stone beneath a tapering to a second plain chamfer.

around the northern face of the arch. On the southern face there are two wall pintles intended to carry a single leaf doorway. It is tempting to suggest that the doorway to this arch was re-used in a modified form in the northern archway but there is no definitive evidence to support this claim. The jambs of the archway terminate in plain chamfer stops set upon separate stones which in turn suggest a possible tapering to another dying end or stop (see Fig. 3.57). This second tapering jamb and the decorative roll moulding on the archway would seem to suggest that it has been re-used from another context, probably where decorative features were intended to be seen. Given the likely re-use of this door archway, the suggestion that it is part of the original Henrician cellar fabric becomes invalid. At best, it seems likely that this doorway originally came from a 15th to early 16th century context.

Other aspects of the cellar fabric also point towards evidence of material being re-used from different contexts. The brickwork of the western wall between



Fig. 3.58: An image focused on a small portion of the western wall within the cellar. Note the exposed fragment of orange colour brick located centre-right side of the image and the contrasting exposed fragment of a darkened, partially vitrified brick located centre-left.

the two doorways has been coated in several layers of whitewash obscuring much of the brickwork. However, it is composed of red ‘Tudor’ brick which was in use during the 15th and 16th centuries (see 2.1.4 to 2.1.5). Some of the bricks are darkened through over firing (see Fig. 3.58) and such bricks are common in decorative diaper brickwork. Whilst the whitewash prevented the author from discerning any patterns, it seems unlikely that the cellar area would be elaborately decorated, suggesting that the bricks might have been re-used from an earlier structure (*cf.* Eastbury Manor House). However, it is possible that the darker bricks were simply a small number that had been accidentally fired to a higher temperature when originally produced. Ultimately, the darker bricks can only be dated to the 15th or 16th century but their presence in the cellar could be indicative of re-use.

The cellar floor also appears to be composed of re-used material. It is made up of irregular sized flags, one of which had been removed from its original context and was found to be part of a window spandrel (see Fig. 3.59). The



Fig. 3.59: Part of a window spandrel that had been re-used as a flag in the cellar floor. The top image shows the ogee and quarter circle moulding beneath the spandrel whilst the bottom image shows the cross sectional profile.

decorative moulding consists of an ogee and quarter circle on one face and a double hollow chamfer on the other, decorative features that are characteristic of the perpendicular Gothic period (Forrester, 1972, 17, 31), suggesting that the floor

is probably composed of re-used material from the 15th to mid-16th century. Given the history of New Hall, this suggests that the floor could be composed of material taken from either the Earl of Ormond's manor or from the Henrician palace. Exactly when the present floor was laid is uncertain but this may indicate that the Tudors modified the cellar of an earlier building (perhaps the Earl of Ormond's earlier manor) for their own needs. However, it is equally possible that the floor was re-laid in the late 16th century by the Earl of Sussex or maybe even in the 18th century using parts of the Tudor palace when it was largely destroyed. Ultimately, it is impossible to determine anything further than the fact that a 15th or early 16th century window spandrel was re-used as a part of the cellar floor at some point from the early 16th century onwards.

Consequently, whilst many have argued that the cellars are Henrician in date, it has been demonstrated that there is actually a high degree of uncertainty surrounding exactly when they were originally constructed. Many of the features within the cellars are only datable to the 15th or early 16th century, a period during which there is thought to have been at least two brick structures on this site (the manor of the Earl of Ormond and the Henrician palatial complex). The extent of re-used material also means that the cellars might have been created or modified at a later period, for example, the remodelling undertaken in the late 16th century by the Earl of Sussex. It is therefore impossible to attribute the cellars with any certainty to a specific period. In terms of the brickwork in the cellar, the presence of the diaper bricks and the fact that red 'Tudor' bricks are used would support a date of the 15th or 16th century. This suggests that the brickwork is likely to have originally come from the Earl of Ormond's late 15th century manor or the early 16th century Henrician palace. It is impossible to allocate a more precise date.

3.3.6.2: New Hall sampling locations

Three core samples were collected from the internal western wall of the basement (see Fig. 3.60). Different areas of the walls in the cellar had been coated in either plaster or several layers of whitewash, obscuring much of the brickwork (see Fig. 3.61). This prevented the true bonding pattern or evaluation of the mortar joints of the wall from which samples were collected from being determined, although in the lowest courses, where the whitewash was thinnest,

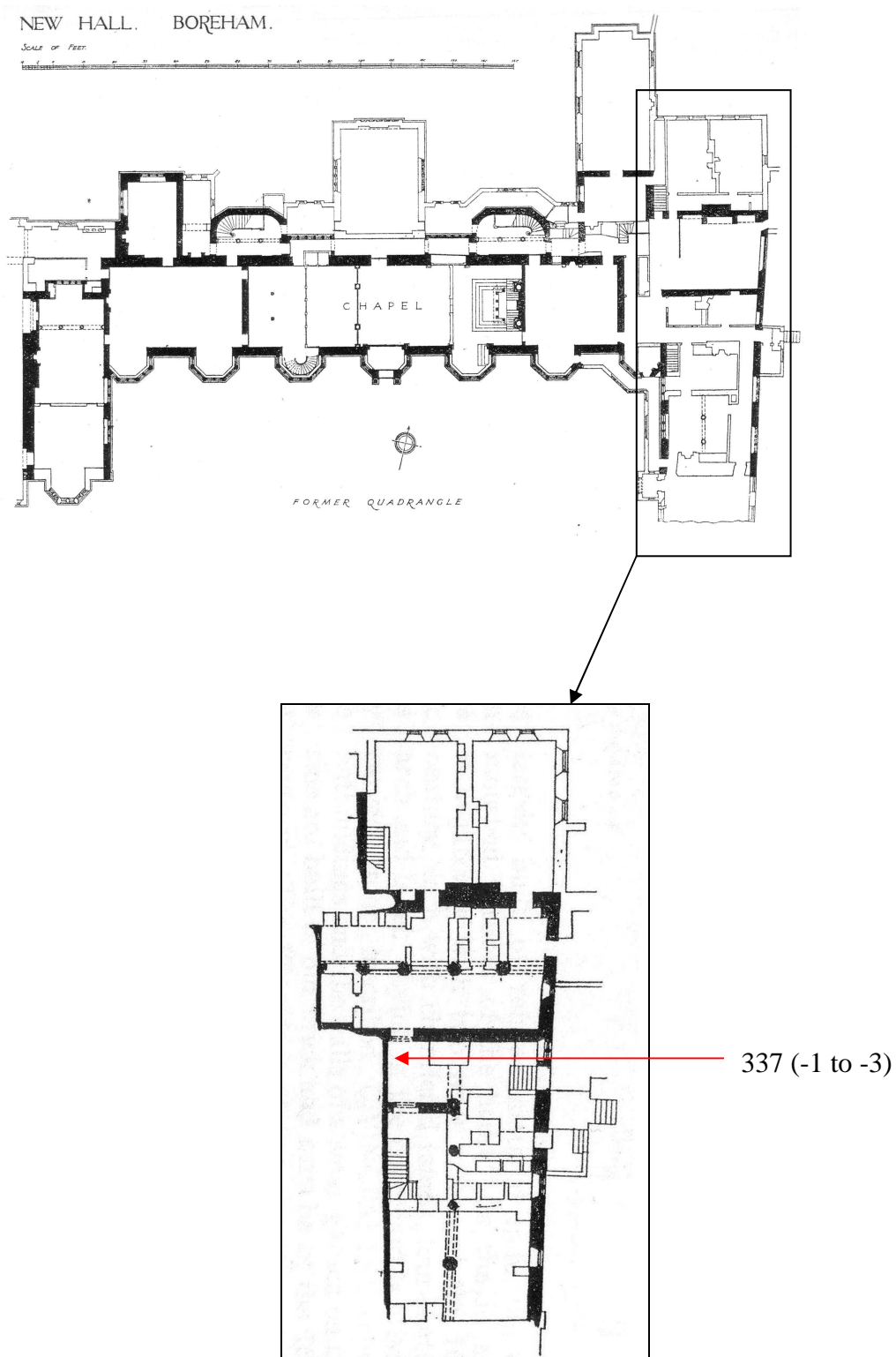

Fig. 3.60: The sampling location in New Hall. The top diagram gives a general layout of the building at ground level whilst the plan of the cellars is shown in the lower diagram (RCHME, 1921, 24-25).

there were tentative outlines of the brickwork which suggested an irregular English bond. In other parts of the cellar where the plaster had fallen away, patches of brickwork were exposed that were bonded in a highly irregular manner. On the wall from which samples were collected, there were patches where the whitewash had fallen away, revealing red bricks alongside darkened, partially vitrified bricks, indicating that those used in the cellar were red ‘Tudor’ type bricks. Traces of mortar and brick could be seen behind the sampled bricks.

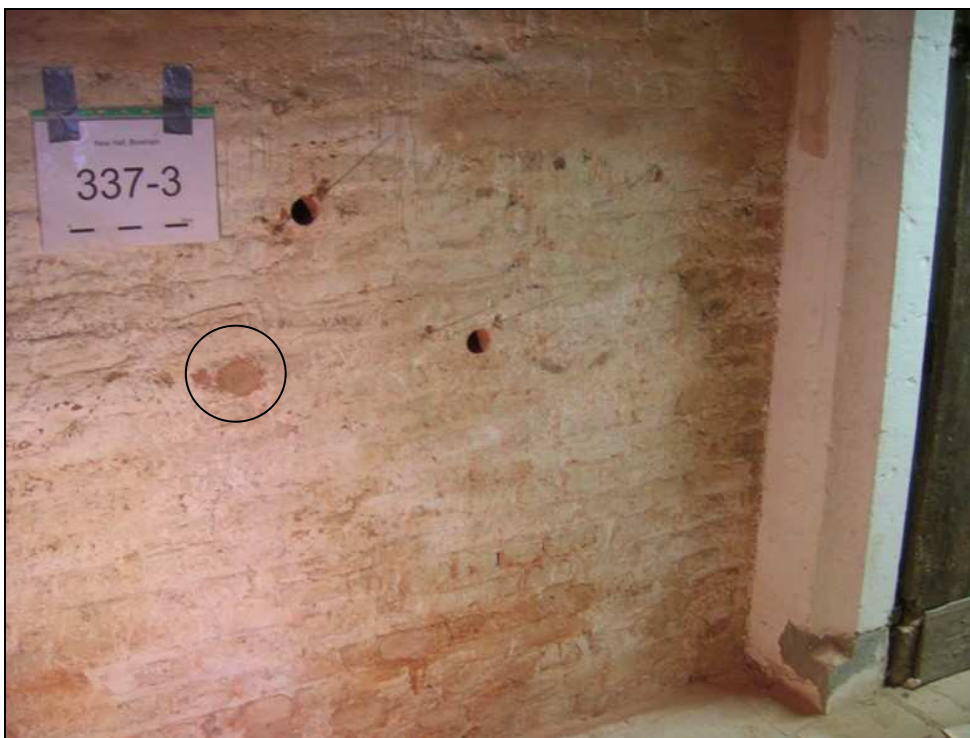

Fig. 3.61: The western wall of the cellar from which three samples were extracted. The scale bar is 20 cm in length. Note the extensive covering of the wall in whitewash which obscured many details of the brickwork. Two of the sample holes are still open but the first sample location (circled in the image) has been filled and allowed to dry over the course of several months. The jamb on the right side of the image is part of the doorway which leads between the southern and northern chambers of the cellar.

3.3.7: ‘The Old House’, St. Osyth

3.3.7.1: Archaeological assessment

‘The Old House’ is an ‘H’ plan house with the central hall aligned along a north-south axis. Very little has been published about this building but the main

hall and northern cross wing are thought to date to the late 15th century (Bettley and Pevsner, 2007, 676). The southern cross wing has received more attention and has been dated to c.1300 based on a crown-post roof with moulded base and capital. There is also evidence suggesting that the front bay of this wing was originally a shop (Bettley and Pevsner, 2007, 676; Watkin, 2007, 3). This wing has a cellar beneath it, thought to be a contemporary feature, lined with medieval bricks (see Fig. 3.62).



Fig. 3.62: The southern wall of the cellar, illustrating the extensive use of 'Flemish' type bricks.

The brickwork in the cellar consists of yellow 'Flemish' type bricks, the exterior faces of which have been coated in whitewash. The bricks have irregular arrises and are largely laid in a stretcher face bond with occasional groups of headers in the courses. The mortar around the bricks is highly weathered and friable, suggesting that it is original. In the north western corner of the cellar there is a dividing wall aligned along an east-west axis which runs part of the way into the cellar from the external western wall. This is made from 'Flemish' type brick on the southern side but on the north face it is lined with nodules of septaria.



Fig. 3.63: The north west corner of the cellar showing the triangular segment of septaria in the wall. This feature is thought to be the remains of a ramp that served the shop above the cellar.



Fig. 3.64: The alcove in the west end of the cellar. The arch would suggest an early 14th century date.

Opposite the partition wall, on the northern wall of the cellar, is a triangular segment of knapped septaria (see Fig. 3.63). The area north of this partition is thought to have housed a ramp serving the above shop (Watkins, 2007, 4).

Besides the fact that ‘Flemish’ type brick is thought to have been used in Essex from the late 13th to the 14th century (Ryan, 1996, 36), there are very few architectural features to the cellar that can be dated. There are alcoves at the eastern and western ends of the cellar that were probably used for lanterns (Watkins, 2007, 4). The western alcove has a segmental pointed arch above it (see Fig. 3.64) suggesting an early 14th century date, which would agree with the assessment of the crown-post roof. However, since the cellar would have been one of the first parts of the house to be built, the brickwork might predate the roof and belong to the end of the 13th century. Unfortunately, it is impossible to attribute a more specific date to the brickwork than late 13th to early 14th century.

3.3.7.2: ‘The Old House’ sampling locations

Two core samples were taken from the southern wall of the cellar (see Fig. 3.65). There was a significant difference in the difficulty of drilling the two cores, possibly due to varying firing temperatures when the bricks were produced.

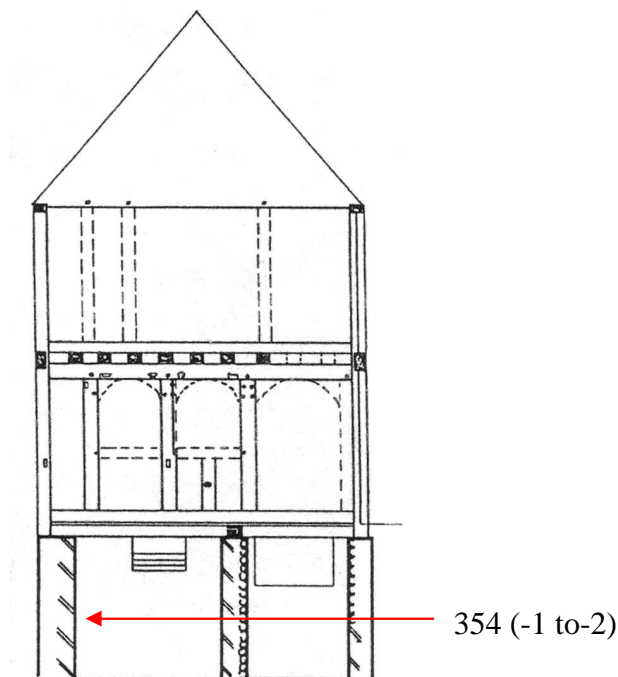

Fig. 3.65: Sampling location in ‘The Old House’, St. Osyth. The diagram shows a cross section of the south cross wing (Watkin, 2007, 4).

The sampled bricks were the ‘Flemish’ cream type laid in an irregular stretcher bond pattern, with some bricks set with their header faces exposed (see Fig. 3.66). The bricks had a fine, cream coloured fabric with no obvious or large inclusions. The mortar joints around the bricks were hard to discern in places due to whitewash, irregularity of the brick arrises and the friable nature of the mortar, but it is estimated to vary from approximately 10-20 mm. A thick layer of mortar was seen behind the sampled bricks.



Fig. 3.66: The southern wall of the cellar at ‘The Old House’. The two sampling points had recently been repaired when this image was taken. Both of the scale bars are 20 cm in length. Note that whilst the brickwork of the wall is largely laid in stretcher bonding, there are irregularities. These include occasional header faces in the uneven courses.

3.4: ECCLESIASTICAL BUILDING LOCATIONS:

The following diagram (Fig. 3.67) provides an overview of Essex with the different location of all the ecclesiastical sites from which samples were collected for this project.



Fig. 3.67: Map of Essex showing the location of the different ecclesiastical sites sampled for this project.

3.5: ECCLESIASTICAL BUILDING HISTORIES

3.5.1: St. Andrew's church, Boreham

3.5.1.1: Archaeological assessment

The church in Boreham is a highly complex structure with the unusual arrangement of a central tower (see Fig. 3.68). Unfortunately, it lacks a thorough archaeological assessment, especially in terms of its earlier phases, which are thought to date back to the Saxon era (Bettley and Pevsner, 2007, 153).



Fig. 3.68: St. Andrew's church, Boreham. Note the unusual layout of the building with the tower in the centre, the chancel to the east (right side in the image) and the aisled nave to the west (left side in the image).

Whilst the church has received little archaeological attention, the area both within and surrounding Boreham has been shown to be rich with Roman artefacts and remains. Approximately 1 km north west of the village, a robbed Roman structure (thought to be a *principia*) was excavated revealing large quantities of Roman brick (Lavender, 1993) and many Roman finds, including brick, tile, *tesserae* and pottery sherds, have been discovered close to or in the fabric of the church itself (Rodwell, 1976). Given the strong Roman influence in the

immediate locality and the presence of Roman brick in the church, many have suggested that all of the brick in the church fabric is Roman (Chancellor, 1892a, 155; RCHME, 1921, 22; Smith, 1988, 139-140). However, whilst there certainly are large amounts of re-used Roman brick in the church fabric, it has recently been shown that Coggeshall type bricks are also present. Ryan observed Coggeshall type brick in the second stage of the central tower (Ryan, 1996, 26) and observations made by the author during field visits have identified other areas around the church fabric where Coggeshall type brick occurs.

With regards to the architectural development of the building, the church is a highly complex structure and contains several different phases of development that span the entire medieval period. It is beyond the scope of this discussion to offer a thorough account as to how the entire church developed. Instead, attention will be given solely on the development of the earliest phases of the church which span the late Saxon and early Norman periods. Beginning with the earliest aspects of the building, it has long been thought that there was a church with a nave and chancel on the site in the Saxon period and that this was significantly altered during the Norman period (Chancellor, 1892a, 151; Taylor and Taylor, 1965, 79; Smith, 1988, 139; Bettley and Pevsner, 2007, 153).

Considering the tower first, it is thought that this was originally the chancel to the late Saxon church (Taylor and Taylor, 1965, 79) and there are several features in the fabric of the current structure which support the idea that this was originally a Saxon building. In the lower stage of the tower there are two windows, one in the north wall and the other in the south wall (see Fig. 3.69). Both of these windows have several characteristics that support the idea that they are Saxon, including the fact that they are narrow (approximately 0.2 m wide), have deep splays that pass through the thickness of the walls and have monolithic heads (Taylor and Taylor, 1965, 9, 81). The fact that the windows are also set in the external wall surface with a single splay suggests that they might be from the earlier Saxon period (Taylor and Taylor, 1965, 9; Archer, 1999, 28-29). In areas lacking good building stone, rubble would be incorporated into the jambs of Saxon windows (Taylor and Taylor, 1965, 9) and it should be noted that both of these windows have jambs constructed largely of flint rubble and fragmentary Coggeshall type bricks.

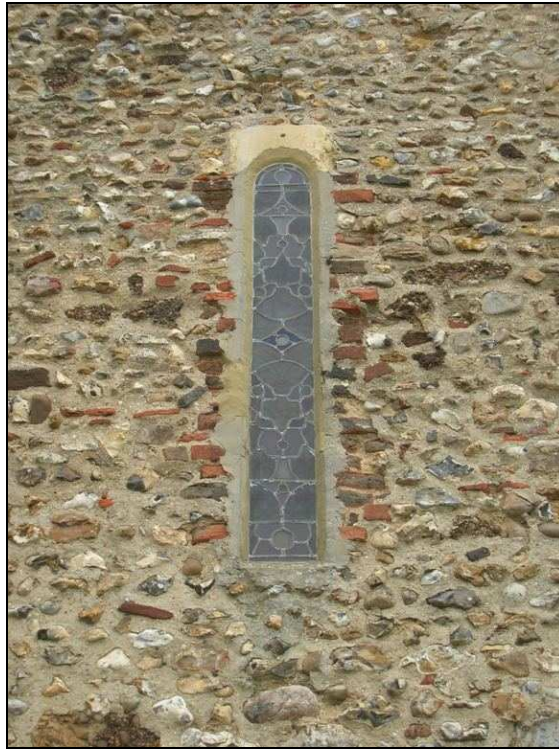

Fig. 3.69: The southern window to the first stage of the central tower, thought to be a Saxon feature of the tower.

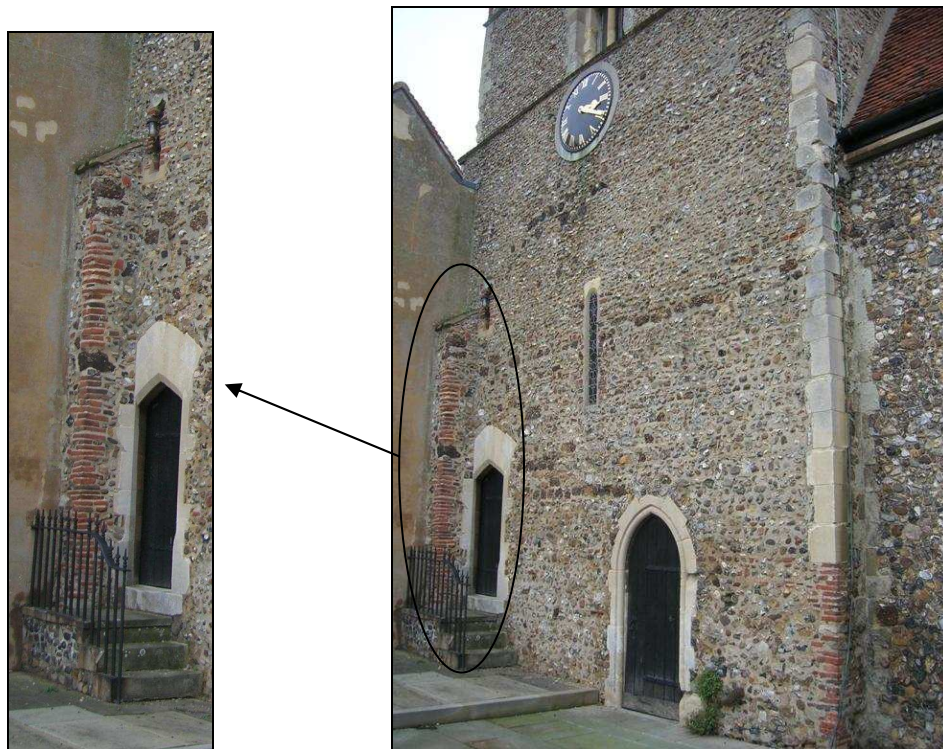

Fig. 3.70: The southern view of the first stage of the central tower (right image). The projecting Saxon nave quoin (left image) can be seen at the junction of the present tower and nave (see also Fig. 3.74).

On the western side of the tower, at both the north and south junctions between the present nave and tower, are two projections that are thought to be the original quoins of the Saxon nave (see Fig. 3.70 and Fig. 3.74) (Taylor and Taylor, 1965, 79). Since the arcades of the present nave do not align with these surviving eastern quoins, it is thought that the Saxon nave has been completely lost but was originally much narrower than the present nave (Taylor and Taylor, 1965, 79-81). The fact that the southern quoin appears to be integral to the tower (it is hard to say the same of that at the north west corner due to large amounts of later re-pointing) supports the idea that this structural feature is Saxon in date. These quoins are composed of Roman brick in the lower courses but this changes to Coggeshall type brick further up (the transition is located approximately 1.60 m above ground level for the southern quoin). There is no obvious break in the rest of the fabric in the quoins (composed mostly of flint rubble) that can be associated with the change in the brick type.

Further evidence to support the idea that the tower was originally the chancel to a Saxon church can be found inside the present building where there is a Romanesque chancel arch located above a later 14th century arch at the junction between the present nave and tower (see Fig. 3.71). The voussoirs of this arch are composed chiefly from brick but also incorporate six larger stones set at irregular intervals around the curve, possibly for decoration (Taylor and Taylor, 1965, 80). To the north of the chancel arch is a small niche ostensibly made in the same style as the original chancel arch i.e. from brick and stone voussoirs (see Fig. 3.72). The niche has a crudely inserted 'shelf', which it has been suggested dates to the 12th century (RCHME, 1921, 24) but may, in fact, be a re-used chamfered impost, perhaps originally from a Saxon arch respond. It has been argued that this niche might have held a side altar of some description (Bettley and Pevsner, 2007, 154). A piscina or image niche of the 14th or 15th century has also been built into this space. Certainly, the apex of the niche arch has been altered but this is likely to have been a result of the insertion of both the present arcading and the neighbouring 14th century lancet arch (see Fig. 3.71). Exactly how much further this niche arch extended or whether it was intended as a blind niche or was originally open is uncertain.



Fig. 3.71: The interior view of Boreham church from the nave looking through the tower into the east chancel. Note the Romanesque arch composed of brick and stone voussoirs above the later 14th century lancet arch and the quarter-circular side niche to the left of the present lancet arch jamb.



Fig. 3.72: Small niche in the wall north of the opening between the nave and tower. The pattern of construction (brick and stone voussoirs) is the same as the original chancel arch (see Fig. 3.71).

The structural evidence of the fabric of the church therefore suggests that there had been a Saxon building on this site and that this was probably a church with an aisleless nave and chancel (Taylor and Taylor, 1965, 79). It is believed that this structure was substantially altered during the Norman period, with the chancel being converted to a tower which was considerably heightened during the late 11th or 12th century (RCHME, 1921, 22; Taylor and Taylor, 1965, 81). Further alterations included the erection of the eastern chancel and the insertion of the current Romanesque arch into the eastern wall of the chancel to the first church (see Fig. 3.73) (RCHME, 1921, 22; Taylor and Taylor, 1965, 79, 81). This arch is composed of Roman brick in its foundations and lower stages but changes to Coggeshall brick midway up the responds and for the remainder of the arch itself. The exact location of the transition is hard to discern due to traces of plaster still covering the respond stones. The chancel was later rebuilt in the 14th century (RCHME, 1921, 22) and it is possible that the present structure replaced the original Norman chancel, especially given the fact that the current chancel is on a slightly different alignment to the tower.



Fig. 3.73: The interior view of Boreham church looking west from the chancel into the central tower, showing the Norman Romanesque arch inserted between the present chancel and tower.

Although this account has only offered a brief description of the development of a small portion of St. Andrew's church, it is clear that there are Coggeshall type bricks within the fabric of both the Saxon and Norman elements of the present building. This includes the tower windows, the Saxon nave quoins and the Romanesque arch between the tower and chancel. The presence of Coggeshall type brick in the quoins and surrounding the windows of the earlier Saxon church is of special interest for this project, especially given the current archaeological understanding of brick during this period (see 2.1.1). However, these bricks were only identified after sampling had taken place from the Norman Romanesque arch. Nevertheless, the significance of this discovery is considered further later in the thesis (see 5.2.1 and 6.2). The sample collected from this site also offers the opportunity to try to allocate an absolute date to an early instance of Coggeshall type bricks from a Romanesque context.

3.5.1.2: Boreham church sampling location

A single sample was collected from the northern chancel arch respond, above the Roman-medieval brick transition. The sampled brick was part of the eastern quoin to this respond (see Fig. 3.74 and Fig. 3.75).

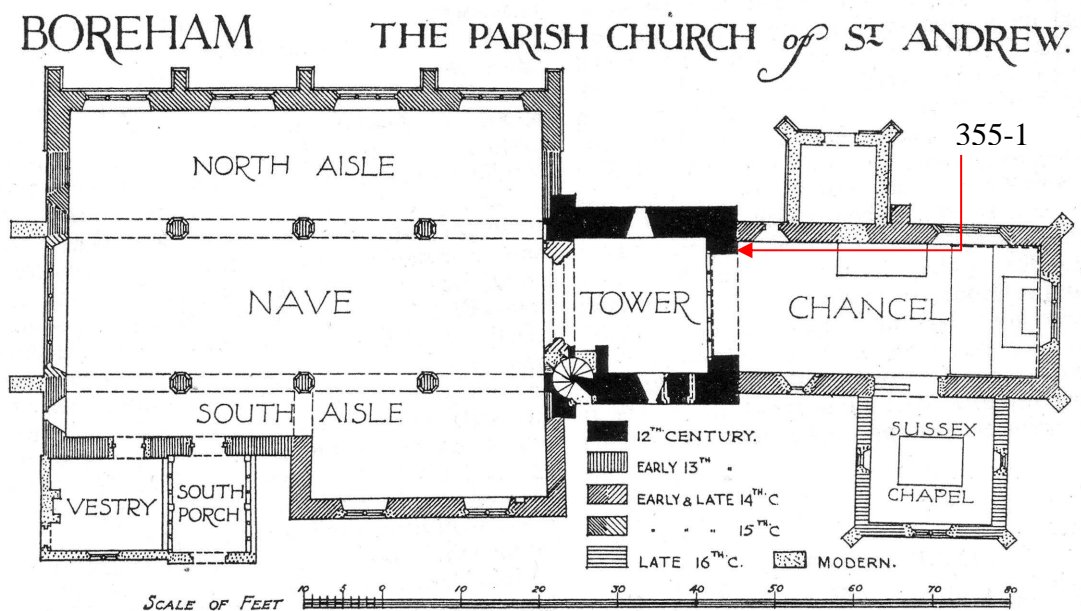

Fig. 3.74: The sampling location in Boreham church. Note that the small projections of the Saxon church nave quoins can still be seen between the tower and present nave (RCHME, 1921, 23).

The bricks were of a sandy fabric and orange colour, similar to the Coggeshall type. The core was approximately 150 mm in length, similar to the width of rectilinear Coggeshall type bricks. The area of walling around the quoin was plastered preventing any determination of what shape the brick was but given that the core length is similar to the width of a Coggeshall type brick it is suggested that it was a standard rectilinear module. The plaster also prevented the determination of what building materials were used around the bricks, although brick was seen at the rear of the sample hole. The mortar joints around the brick varied from approximately 5-10 mm.



Fig. 3.75: The sampling point on the northern respond of the arch between the tower and the chancel after the core had been removed. The scale bar is 20 cm in length.

3.5.2: Holy Trinity church, Bradwell-juxta-Coggeshall

3.5.2.1: Archaeological assessment

Holy Trinity church is a structure that has received a good deal of archaeological attention in recent times. Rodwell (1998) undertook a thorough and detailed archaeological survey of the building which forms the basis of this

brief assessment. The church has undergone little structural alteration or repair work during the Victorian period and early 20th century, the result being that the bulk of the original Norman structure has remained largely intact and well preserved (Rodwell, 1998, 59).

There are many different diagnostic features associated with the church that provide a wealth of information regarding the manner in which it was originally constructed and later modified. In terms of its original construction, the survival of infilled putlog holes provides an outline of the timber scaffolding used for building the church (Rodwell, 1998, 72-73). There are fine striations in the walls that are indicative of building lifts, suggesting that the shell of the structure could have been erected within a three year period and the full church probably built within a five year period (Rodwell, 1998, 69, 72, 96-97). There are also several indications as to how the church was altered architecturally during the later medieval period, including the raising of the church roof, the re-use of timbers in the present belfry from what is thought to have been an earlier external belfry, the addition of the porch, alteration of the church fenestrations and the insertion of the rood screen and loft (Rodwell, 1998, 83-94).

A significant feature of Holy Trinity church is the use of Coggeshall type brick in different parts of the building, the key areas being the Norman door surrounds, the external quoins and the Norman window splays and jamb surrounds (see Fig. 3.76) (Rodwell, 1998, 78-79). The brick used in the church includes moulded forms, some of which also occur at Coggeshall Abbey. However, those for the windows at Bradwell appear to be a different form to those used at Coggeshall Abbey (Rodwell, 1998, 102). It should be appreciated, however, that large portions of the abbey complex were demolished during the 16th century and these may have originally contained bricks fashioned to a similar shape. The quoins appear to contain a large number of half-bricks which could be indicative of the masons breaking the original material to make the supply go further for the construction work (Rodwell, 1998, 78). Both the northern and southern doorways have an outer and inner brick arch or order. The outer order of the northern door is formed with double bullnosed moulded bricks of two different sizes whilst the brickwork of the southern door outer order consists of single bullnosed moulded bricks. The inner orders of both doors are made from square edged bricks (Rodwell, 1998, 78).



Fig. 3.76: The use of medieval bricks in the Norman window surrounds at Bradwell-juxta-Coggeshall, one of the three main contexts in which medieval bricks are used at Bradwell-juxta-Coggeshall church.

There is evidence that the bricks in the jambs of the doorways might have been laid in an early bonding pattern (Rodwell, 1998, 78). Further general observations that have been made regarding the brickwork include splashes of a green or brown glaze on some bricks (Rodwell, 1998, 77) and the presence of original render covering small portions of the brickwork around two of the original Norman windows (Rodwell, 1998, 82). Several flints are also incorporated with the medieval brickwork in the jambs of the Norman window immediately west of the porch (Rodwell, 1998, 82). The use of the flints suggests that there might have been a shortage of the moulded window bricks and that the aperture was subsequently completed with a more abundant building material (i.e. flint), a discrepancy that would not be apparent once the building had been rendered (Rodwell, 1998, 82).

In terms of dating the earliest parts of the building, it has been acknowledged that there is a discernible lack of datable Norman material within the church apart from the Norman font which is thought to date to around the first half of the 12th century. However, it is a feature which could have been re-used from an earlier church (Rodwell, 1998, 97). Generally, the church has been

ascribed an early 12th century date (RCHME, 1922, 12). Rodwell has proposed a date of the second quarter of the 12th century based on the fact that the medieval bricks are used in the same manner in which Roman material was used in other churches between the 10th to 12th centuries. These include the use of small chamfers in window apertures, a common characteristic in the region during the early to mid-12th century, and the tall, narrow proportions of the windows and doorways, a characteristic of lancets and doors in many local churches between the 11th and early 12th century (Rodwell, 1998, 98). Rodwell goes on to discuss the background of the medieval bricks and argues that the traditional connection to the Cistercian monks at Coggeshall Abbey does not necessarily follow a logical chronological course. He suggests that the abbey was built after Bradwell-juxta-Coggeshall church and that the Cistercians cannot be regarded as being responsible for the re-introduction of the medieval brick industry (Rodwell, 1998, 100-102). The date of the brickwork at the abbey has generally been regarded as dating to the second half of the 12th century (Ryan, 1996, 94) providing scope for the argument proposed by Rodwell. However, allocating dates to structures based on isolated architectural features or documentary records, as has been done with Coggeshall Abbey, has already been shown as being potentially misleading (see 2.2.2 and 2.2.3). Consequently, there exists a serious academic argument that luminescence dating can address regarding the age of the brickwork at both Coggeshall Abbey and Bradwell-juxta-Coggeshall church.

3.5.2.2: Bradwell-juxta-Coggeshall church sampling location

A single sample was collected from the western jamb of the inner order to the southern doorway (see Fig. 3.77). The brick was relatively hard and required the use of a pilot drill to aid in the extraction of the sample. Only the corners of the bricks were visible, the rest being covered with a layer of plaster (see Fig. 3.78) preventing the full extent or shape of the brick to be determined. The sample core length (approximately 160 mm) is similar to the width of a rectilinear Coggeshall type brick, suggesting that the brick is probably a standard rectilinear module and not a special moulded brick form. The sampled brick had a sandy, orange fabric with a darker reduced core, the same as the bricks at Coggeshall Abbey. The mortar joints around the sampling point varied from approximately 7.5-15 mm. More brick was seen to lie behind the sampled brick.

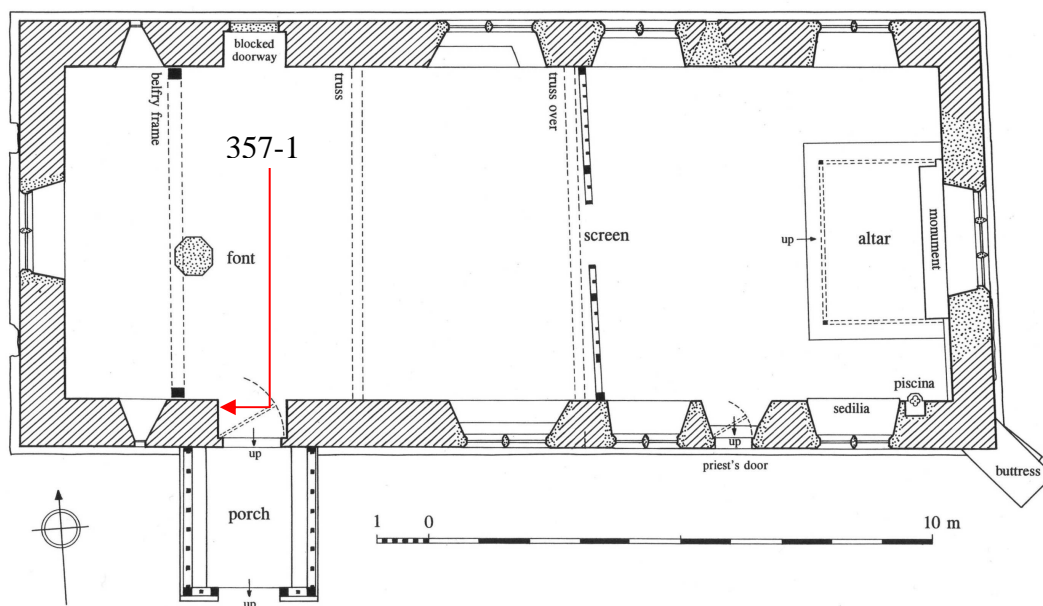

Fig. 3.77: Sampling location within Bradwell-juxta-Coggeshall church (Rodwell, 1998, 62).



Fig. 3.78: The sampling point on the brick quoin of the southern doorway inner order, seen on the right of the image (the sampling point is circled). The scale bar is 20 cm in length.

3.5.3: St. Andrew's church, Earls Colne

3.5.3.1: Archaeological analysis

The church at Earls Colne has little left of its original medieval fabric due to extensive restoration work carried out in the mid-19th century. The earliest parts of the church where the original fabric survives include the chancel and south aisle, both of which are thought to date to the first half of the 14th century (RCHME, 1922, 87). The other large portion of the church that survived the Victorian renovations is the imposing late medieval western tower (RCHME, 1922, 87; MacKinnon, 1997, 165). The tower contains large amounts of historic brick and is the focus of this project (see Fig. 3.79).



Fig. 3.79: St. Andrew's church, Earls Colne, seen from the south east. Note the extensive brick element on the eastern face of the western tower.

It is generally held that a large portion of this tower was originally added to the existing church in the mid-15th century by John de Vere, the 13th Earl of Oxford (RCHME, 1922, 87; Hill and Smith, 1943, 174-175; MacKinnon, 1997, 170). Whilst it is thought that the tower was commenced around this time, it remained unfinished for a considerable period, a fact that has been attributed to the involvement of the Earl in the Wars of the Roses (Hill and Smith, 1943, 174).

After the Wars of the Roses, the 13th Earl received several honours from the victorious Henry VII, including the position of Lord High Admiral of England and governor of the Tower of London (Hill and Smith, 1943, 175). When the Earl died in 1513, he left money and instructions that the belfry of the tower to Earls Colne church be completed (Hill and Smith, 1943, 175; Smith, 1974, 94). The task of completing the tower subsequently fell to his nephew who became the 14th Earl of Oxford. Unfortunately, the 14th Earl does not seem to have been inclined to apply himself to the church at Earls Colne. It is known that he neglected the ancestral family estate at Hedingham Castle, Essex, in favour of his estate at Camps Castle, Cambridgeshire (Anderson, 1993, 131). It therefore seems that work on the belfry in Earls Colne was poorly executed, if at all. When the 15th Earl succeeded to the title in 1525, it is thought that he had to remove large portions of the north side of the church tower and begin the rebuilding process again (Hill and Smith, 1943, 178).

In terms of the architectural evidence for the development of the tower, there are elements of the fabric that indicate that it is multi-phased and covers several different periods. The tower itself is of three stages, with the western window of the lowest stage thought to date to c.1460 (RCHME, 1922, 87). The fabric of this lowest stage is made from flint rubble and re-used Roman tile. The exception to this is the south east stair turret where the limestone quoin blocks butt against the southern face of the tower. There are also a large number of re-used carved stone arch fragments, including colonettes and nook-shafts, that could date to the late 12th or early 13th century and a carved stone that is probably part of a 15th century moulded plinth (see Fig. 3.80). Mixed among the flints and re-used carved stone fragments of the stair turret, there is also 15th or 16th century 'Tudor' brickwork which differs from the Roman brick used in the rest of the first stage. These bricks are slightly thicker than the Roman material and a darker colour with some showing evidence of surface vitrification. They are laid in a random fashion among the other rubble fragments (see Fig. 3.80). This evidence indicates that the stair turret was added to the original tower, probably after the mid-15th century, using material robbed from an older structure, possibly ecclesiastical in nature.

It has been argued that the second stage also dates to the mid-15th century due to the presence of windows with 15th century trefoil heads in both the east and



Fig. 3.80: Rubble walling at the base of the south side of the stair turret. Note the random inclusion of 15th or 16th century 'Tudor' brick and the re-used carved stone fragments (circled). The bottom image illustrates one such fragment, a 15th century moulded plinth.

west walls. There is also the outline of a blocked window on the northern face of the second stage, suggesting that originally there were at least three such windows (see Fig. 3.81) (RCHME, 1922, 87). The eastern face of the tower from the second stage upwards is built from brick (see Fig. 3.79), as is the internal lining of the second stage clock chamber. The brick used for the second stage and above is laid in an irregular English bond in both the internal and external faces. The eastern side of the tower is also slightly thinner than the western face which is composed of flint rubble and Roman brick. There is also possible evidence that the internal brickwork of the eastern wall butts onto the internal brickwork of the southern wall within the second stage clock chamber, although it should be noted



Fig. 3.81: The north west corner of the tower with the upper two stages shown in greater detail in the right image. Note the faint outline of a window opening on the northern face at the second stage and also the different window tracery patterns between the north and west belfry openings.

that the white wash of the interior prevents an absolute confirmation of this suggestion. Nevertheless, if true, it suggests that both the eastern wall and the stair turret post-date the mid-15th century bulk of the tower.

The third stage of the tower contains the belfry. The windows on the western, southern and eastern faces are all similar in style (three cinquefoil lights with tracery in a square head) and have been dated to the 15th century. However, that of the northern wall differs in style (three cinquefoil lights in a square head) and has been dated to the early 16th century (RCHME, 1922, 87). The parapet of the tower is crow stepped and crenellated. There are several panels with flint inlay around the parapet, the larger containing a mullet (five pointed star) which was one of the de Vere badges. In the centre of the western and eastern faces of the parapet are the arms of the 15th Earl of Oxford with the date 1534 below and the regnal year 'H VIII 25' (RCHME, 1922, 87).

Many have taken the year given in the date plate to be the date when the building work was undertaken by the 15th Earl of Oxford in an effort to complete

the tower (RCHME, 1922, 87; Smith, 1974, 94; VCH, 2001, 101). It is generally thought that he added the brick eastern face and remodelled the upper stages of the northern face (Hill and Smith, 1943, 178; VCH, 2001, 101), conclusions probably derived on account of the blocked window in the second stage and the different tracery patterns of the belfry on the north tower face. However, the idea of dating such a substantial building project based on a single date plate must be treated with caution and further evidence must be proposed to support the argument (see 2.2.3 for the limitations associated with date plates). Certainly, there is the likelihood that the parapet represents the completion of the tower and this would agree with the historic outline of the church discussed above whereby the 15th Earl of Oxford finished the tower. However, it is also possible that the date plate might be associated simply with the decorative crenellations and not with the other architectural elements, such as the eastern brick face. As a result, the date plate can only be treated as a cautious *terminus ante quem* for the construction of the tower. Consequently, it is possible to argue that the entire tower was built between the mid-15th century and the early 16th century, a proposal that is supported by the decorative elements of the first stage western window tracery and allows for both the early 16th century northern belfry window and the date plate on the crenellations (Chancellor, 1913, 67).

Based on the above observations, it is possible to propose a possible outline of the development of the structure. Firstly, it seems likely that the earliest elements of the tower were being constructed with flint rubble and robbed Roman brick and tile in the 1450s or 1460s. Upon reaching the second stage, the north, west and south faces were constructed, with a small window being inserted into the northern and western walls. Work probably continued up to the third stage of the tower on the west and south sides but is likely to have ceased with the Wars of the Roses in the second half of the 15th century. When work resumed, probably in the late 15th or early 16th century, the brick eastern face was added against the standing second and third stages. Shortly after the eastern face was added, a northern wall was probably added to the belfry with a more contemporary style window. However, it should be noted that this wall might have already been present and that the current window could simply have replaced an earlier window that was similar to those in the western and southern faces. The window in the northern wall of the second stage could have been blocked off when the eastern

wall was added. It is possible that the trefoil carving might have been re-used in the window of the eastern wall, perhaps in an attempt to provide a more uniform appearance to the tower and to save on resources.

The stair turret is likely to have been added around the same time as the eastern wall since the brickwork of both structures is bonded together at the upper stages of the eastern external wall. Work probably began from the ground level and initially consisted of re-used rubble, probably from an ecclesiastical source, with the occasional use of brick. However, as the work progressed, brick was used throughout the stair turret and the eastern face. Brick also appears to have been used to line the interior of the tower to at least the second stage. The final element to the tower is likely to have been the crenellated parapet added by the 15th Earl of Oxford in the late 1520s or 1530s. The visual result of the building work would have been highly contrasting and it is likely that the tower would have been plastered over. An illustration of the church from the mid-17th century shows a uniform appearance to all the external surfaces of the church (MacKinnon, 1997, 167, Fig. 2) and traces of plaster were discovered on the eastern brick face of the tower in the early 20th century (Chancellor, 1913, 67), although it should be noted that this plaster cannot be dated to the 16th century and may be a later feature. Although this outline encompasses all the observations made of the tower, it must be stressed that it is only one possible interpretation of how such a complex structure could have developed. Ultimately, Earls Colne church is a structure that requires a detailed archaeological survey of the fabric.

In terms of ascribing a date to the brickwork on the eastern face of the tower, the fact that the stair turret is bonded into the upper stages of the eastern wall and butting onto the southern wall at the first stage of the tower indicates that the east side is secondary to the rest of the tower. The 15th century moulded plinth at the base of the stair turret (see Fig. 3.80) suggests a *terminus post quem* for when this wall was added, a fact that would agree with the mid-15th century date ascribed to the first stage western window. If the date plate is regarded as a *terminus ante quem*, a suggestion supported by the early 16th century northern belfry window, then it is only possible to ascribe a broad date range to the brickwork in the eastern wall, this being from the mid-15th century to the early 16th century. It is worth noting that substantial additions to churches, such as towers, could often take many years to complete in the 15th century, largely due to

the dependence on irregular financial bequests and donations from the local community (Morris, 1989, 355-356).

3.5.3.2: Earls Colne church sampling location

A single sample was collected from within the second stage clock chamber of the tower at the northern end of the eastern wall (see Fig. 3.82).

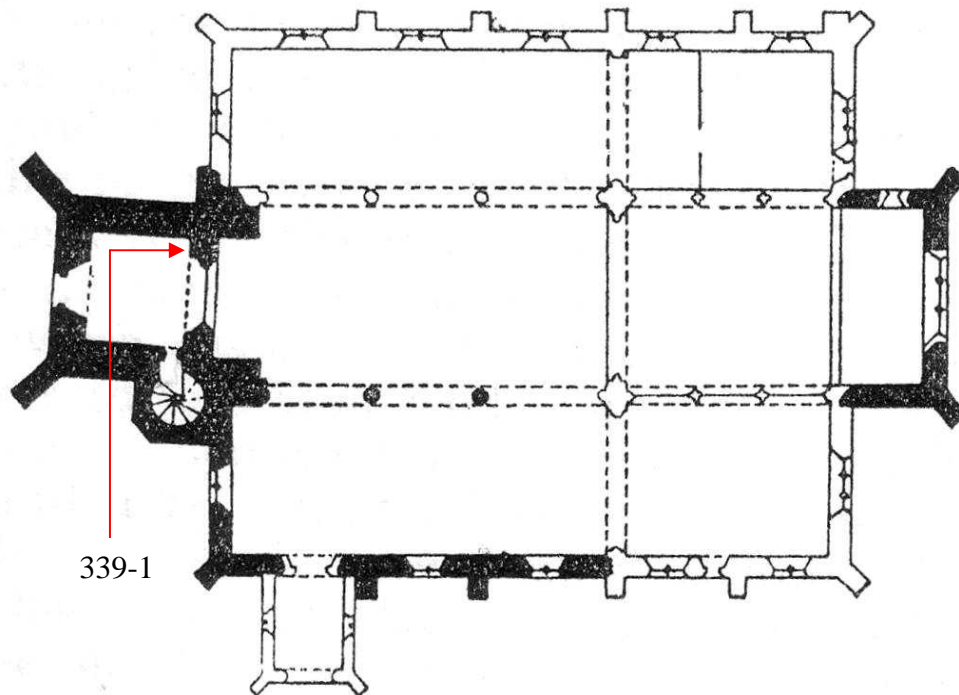

Fig. 3.82: Sampling location in Earls Colne church. Note that this plan only shows the ground floor of the church and that the sample was collected from the second stage of the church tower (RCHM, 1922, 87).

This is an area of the tower that is covered with whitewash, obscuring many of the brickwork details (see Fig. 3.83). However, it was possible to discern that the bricks were laid in an irregular English bond. In localised areas, the whitewash had worn away, revealing that the bricks inside the tower are the standard red 'Tudor' type brick with an orange colour and fine fabric. Traces of mortar and brick were seen to lie behind the sampled brick, suggesting that the eastern wall is built entirely of brick.



Fig. 3.83: The sampling point (circled) at St. Andrew's church. The sample and dose capsule hole (below and to the right of the sampling point) have both been filled with lime mortar.

3.5.4: All Saints' church, East Horndon

3.5.4.1: Archaeological assessment

The church at East Horndon is situated upon a hill with impressive views over the south of Essex (see Fig. 3.84). It stands in isolation and after years of neglect and vandalism was made redundant in 1970, although it is now in the care of the Church Conservation Trust. It is an interesting but complex structure which has the unusual feature of two storied transept chapels. Unfortunately, it has received very little archaeological attention or analysis over the years.

It is thought that there was almost certainly an earlier church on the site of the present structure. Around 1200 the nearby manor of Abbots and the patronage of the church were acquired by the Neville family and c.1263 the first known rector of All Saints' (Henry de Thorndon) granted the Abbot of Waltham Abbey a licence to erect a small chapel close to the church (Starr, 1988). Parts of this earlier church appear to have been re-used in the present building, including a



Fig. 3.84: All Saints' church, East Horndon. Note the combined southern transept and porch.

blocked doorway with a late 14th century lancet arch in the north wall of the nave and large portions of puddingstone discovered within the walls of the chancel during restoration work between 1972-1973. The original font (now removed to Great Wakering, Essex) is also thought to date to c.1200 (RCHME, 1923, 37-38; Starr, 1988). Further evidence for an earlier structure is also suggested by a slight divergence in the alignment of the building along the east-west axis between the nave and the chancel (see Fig. 3.85) (RCHME, 1923, 36-37). The Royal Commission recorded a fragment of a 13th century coffin lid decorated with a foliated cross head in the upper story of the north transept and fragments of moulded stonework in the churchyard, although they failed to provide further details or possible dates for these pieces (RCHME, 1923, 38). In terms of the location of this earlier church, an aerial photograph of the current structure and the immediate area failed to reveal any obvious earthworks or cropmark features (EHER Ref. No. 5154). The fact that there is a discrepancy between the nave and chancel and the presence of puddingstone in the chancel walls could well suggest that the first church was probably a small building, perhaps the same size as the chancel, and probably built in the late 13th century. It is likely that this original church was demolished and largely reincorporated into the chancel when the

present church was built. Certainly, the absence of obvious features on the aerial photograph around the present church would suggest that the same foundations may have been used.

The present church is a complex structure, made almost entirely from brick (see Fig. 3.84). The current understanding of its construction has generally attributed the bulk of the building to Sir Thomas Tyrell. It is thought that between 1442, when he was granted the advowson, and his death in 1476, he built the chancel, nave, tower and the two storied transept chapels (Starr, 1988; Ryan, 1996, 51). Further evidence comes from Tyrell's will in which he refers to 'the steeple and new work which I have begun at East Horndon' and for a small chapel to be constructed to the north of the chancel for 'a tomb of timber or of stone for me and my wife' (Starr, 1988). The present church has both a tower and a small niche in the northern side of the chancel where there is a stone tomb with the following inscription (the inscription is taken from Chancellor (1895, 256) who inserted the words in italics which are conjectural due to damage to the tomb):

'Here lieth Thomas Tyrell Knyght son and heire of John Tyrell Knyght and Dame Anne his wif daughter *of Sir William Marney Knyght* which Thomas decessed the xxii day of Marche the yere of *our Lord 1476 and which Anne decessed the* – day of – the yere of *our Lord – upon whos* soulless God have mercy. Amen.'

The presence of the tomb in the chancel recess and the inscription on it tend to support the account given in Tyrell's will, suggesting that the chancel, nave, tower and transepts could well have been constructed during the third quarter of the 15th century whilst his tomb niche was probably built c.1476. The son of Thomas and Anne, also called Sir Thomas Tyrell, is thought to have had the south chapel built in the early 16th century, the evidence for this being based on his will (dated 1510) in which he instructs that his 'body be buried in the south side of the choir of the parish church of East Horndon and there.....to be made a chapel with a convenient tomb over my said body to the charge and value of 100 marks' (Starr, 1988; Ryan, 1996, 52). The final element of the church is the porch which is thought to have been built by the mid-16th century (Starr, 1988).

Further evidence to support the idea that the bulk of the church was built by Sir Thomas Tyrell in the second half of the 15th century is offered from the fact that his father, John Tyrell, is thought to have built Heron Hall, a moated brick

manorial complex located approximately one mile north east of the church (Ryan, 1996, 51). Exactly when Heron Hall was built is unknown, although it has been suggested that most of it dated to the reign of either Henry VI (1422-1461) or Edward IV (1461-1483) (Morant, 1768, Vol. I, 208). Certainly, John Tyrell is thought to have supplied 5,000 bricks for chimneys at Writtle in 1422-23, suggesting that he was familiar with the use of brick in the early 15th century (Ryan, 1996, 51). Approximately three miles north west of Heron Hall is the site of Old Thorndon Hall, another substantial brick building thought to have been built c.1414 when Lewis John was granted a licence to crenellate his lodge with brick and stone (Ryan, 1996, 49). Perhaps the use of brick for Old Thorndon Hall encouraged John Tyrell to adopt the same material for Heron Hall during the first half of the 15th century. This in turn might have encouraged his son, Sir Thomas Tyrell, to build East Horndon church in brick.

With regards to the chronological development of the church from an archaeological perspective, there are many aspects to this complex building that need consideration in terms of creating a relative chronology. Firstly, the difference in alignment between the chancel and nave is not followed by the south chapel according to the plan produced by the Royal Commission (see Fig. 3.85) (RCHME, 1923, 37). Assuming that the present nave and chancel are contemporary, this suggests that the south chapel is a later element than the main body of the church. Whether the south chapel is bonded into the chancel at the eastern end cannot be determined because of a large buttress, probably added in or after the 17th century, that butts onto the external junction of these two parts of the church.

Focusing on the chancel, the northern side contains the tomb niche of Sir Thomas Tyrell. The external brickwork for this niche contains two large crosses in diaper brickwork. This differs from a late 19th century account of the church which mentions three diaper crosses, the central one differing from the outer two (Chancellor, 1895, 256). There is also mention of a modern window in the niche, although this is probably more likely a reference to the main eastern window of the chancel which is a modern insertion (Chancellor, 1895, 256). The brickwork between the two diaper crosses does not show any evidence of a third cross, although there are occasional bricks that have been partially darkened through over firing. There is evidence that the mortar in the central area is darker than the

lime mortar used in other parts of the church but this may simply be a result of successive re-pointing. Internally, the brickwork has been largely replaced with modern bricks and cement. Whether this harsh repair work was continued throughout the thickness of the wall resulting in the removal of the central cross is uncertain. Considering the external eastern wall of this niche, the lower parts of the brickwork do not appear to be bonded into the chancel wall whilst further up the bricks are modern replacements, probably due to the insertion of a drain. Immediately east of the niche are two trefoil corbels made from modern brickwork. The nature or purpose of this decorative feature is unknown but it may simply be a flourish added by modern workmen although original trefoiled brickwork does occur in 15th century contexts in Essex (see 3.3.4.1). At the west junction between the niche and the chancel wall, the brickwork also appears to butt onto the chancel. This suggests that the tomb niche post dates the chancel.

In terms of the two transept chapels, the Royal Commission regarded them as being contemporary with the main nave of the church (RCHME, 1923, 36). It is not possible to determine the bonding of the brickwork between the south transept and the nave due to the presence of the south chapel to the east and the porch on the west. That of the northern transept is partially obscured with mould growing on the brick surface at the junction between the nave and transept. The southern transept appears to be bonded into the porch, although a large portion of the junction is again obscured by a later buttress butting onto the wall. This suggests that the porch is contemporary with the southern transept. The porch butts onto the nave wall, suggesting that it and the southern transept are later additions to the nave. If correct, then the same may also be true of the northern transept. This would also suggest that the rood screen and loft were installed at the same time. Certainly, there is a brick stair in the eastern wall of the northern transept thought to have originally allowed access to the rood screen and loft which spanned the nave to the southern transept (Starr, 1988). Focusing on the junction between the southern transept and the south chapel, it is apparent that much of the walling in this area has been replaced with modern brickwork. However, the surviving fragments of original walling suggest that the southern chapel butts onto the transept and is therefore a later phase than the transept, an argument that is supported by the church plan produced by the Royal Commission (see Fig. 3.85) (RCHME, 1923, 37).

The final key element to the church is the imposing western tower. This aspect of the church is more complex for it is thought that the original tower collapsed and was later rebuilt in the 17th century (RCHME, 1923, 37; Starr, 1988). Consequently, the extent to which the junction between the nave and the tower is a true reflection of what was originally built is uncertain. Equally, what is part of the original medieval fabric and what is rebuilding of the 17th century and later is also hard to determine. The Royal Commission regarded the tower as a later addition to the main nave but acknowledged that the lower stage probably dated to c.1500 whilst the upper stage was the result of 17th century rebuilding (RCHME, 1923, 37). It is not possible to determine how the brickwork between the tower and nave join on the southern face due to a later buttress added at this point. Another buttress also exists at the join on the northern side. However, the brickwork at the top of this buttress matches those at the north west and south east corners of the tower, suggesting that these three buttresses are integral to the tower. Returning to the buttress at the northern junction between the tower and nave, it can be seen that on the tower side of this buttress the brickwork appears to be bonded into the tower whilst on the other side the buttress appears to butt onto the nave wall. This suggests that the first stage of the tower is a later addition to the nave.

To summarise the above discussion, the study of the brickwork around the building suggests that originally the church consisted of just the nave and chancel. At a later stage, the southern transept and porch were added. It is likely that the northern transept and rood screen were also added at the same time as the southern transept. The tower is another secondary feature to the original church but it is uncertain if it is contemporary with the transepts and porch. Taken as a group, the addition of the transepts, porch and tower might constitute the building works that are thought to have been undertaken when Sir Thomas Tyrell was granted the advowson of the church in 1442. Certainly, he made reference to new works in his will of 1476 and instructed his executors to ensure the tower remained standing. The next addition is likely to be the tomb niche to the north of the chancel, probably added c.1476, following the death of Sir Thomas Tyrell. Finally, the south chapel was added between the southern transept and the south side of the chancel, a suggestion that would agree with the request made by Sir

Thomas Tyrell's son, who died in 1510, for a chapel to be built on the south side of the choir.

It should be noted that during restoration work on the church in 1899 a fragment of a brass mural was discovered. It was found to fit into a stone altar located in the southern wall of the lower story to the south transept chapel. Due to its fragmentary nature, it was not possible to determine who the mural represented but it was dated to the first half of the 16th century based on stylistic features, including the arrangement of figures and the costumes (Christy *et al.*, 1909, 190-191; le Strange, 1972, 9, 48). This might indicate that the transepts, porch and rood screen were added in the early 16th century as opposed to the original suggestion of 1442 to 1476. If these are early 16th century additions, then the above archaeological sequence would have to be revised, with the transepts, porch and rood screen being added shortly before the southern chapel. However, the brass mural must be treated with caution. It is possible that the piece might have been re-used from an earlier context and therefore does not originally date to the early 16th century. This was found to have occurred on another fragment of incised brass recovered at East Horndon church in which one mural, thought to depict a mid-15th century female effigy, had been re-used to form a second brass mural for another John Tyrell who died in 1540 (Christy, *et al.*, 1911, 128-129). Furthermore, the window behind the altar in which the early 16th century brass mural was found to fit appears to have been reset in the wall, suggesting that the altar might have been re-used or may be a later insertion into the building. Given the uncertainty surrounding the evidence from the brass mural, it was decided not to use this evidence in the archaeological assessment of the building's development. However, it serves to illustrate the complex nature of the structure.

Therefore, the archaeological assessment of the building does differ from the historical outline of its development, with the transepts, porch, tower and north chancel tomb niche all appearing to be later additions to the initial phase of the nave and chancel, whilst the final phase involved the addition of the southern chapel. The chronological assessment of the first phase is uncertain but it probably predates the awarding of the advowson to Sir Thomas Tyrell in 1442. The Tyrell family originally acquired the manor of Heron Hall in the mid-14th century and were granted licence to impark 400 acres in 1363 (Morant, 1768, Vol. I, 208). As has already been discussed, it is thought that brick was being

produced in the area from the early 15th century. Consequently, a date of the first half of the 15th century is suggested for the first phase of the church. The second phase additions are likely to have been added in the second half of the 15th century when the advowson of the church was awarded to Sir Thomas Tyrell. The final phase of building work probably took place in the early 16th century.

3.5.4.2: East Horndon church sampling locations

Three samples were collected from two different areas of the church (see Fig. 3.85). All sampled bricks were of the typical red ‘Tudor’ type whilst brick and traces of mortar were seen at the rear of the sample holes.

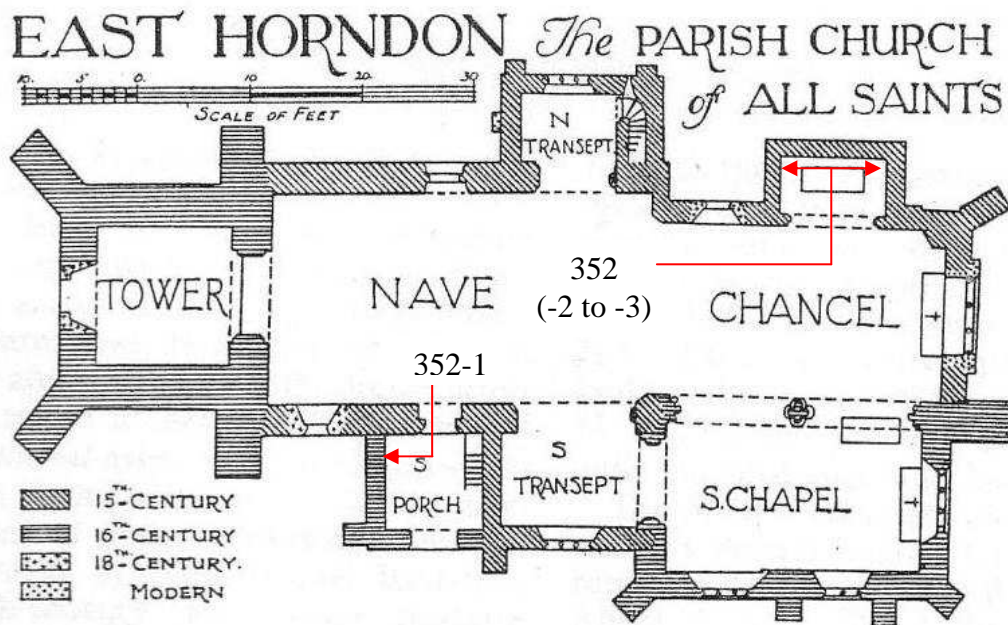

Fig. 3.85: Sampling locations in East Horndon church. Note the slight divergence in the alignments of the nave and chancel (RCHME, 1923, 37).

The first sample was taken from the internal face of the porch western wall (see Fig. 3.86). The brickwork in this area was laid in English bond with a few irregularities. The mortar joints seem to have been re-pointed over the years, especially towards the northern end of the wall, masking the true arrises of the brickwork. However, it is estimated that the mortar joints vary from 10-25 mm. There is a small niche, possibly a stoup, located further south in the wall. The bricks are of the typical red ‘Tudor’ type.



Fig. 3.86: The sample point (circled) of the south porch internal western wall. The scale bar is 20 cm in length. Note the small niche, possibly a stoup, to the left of the image.



Fig. 3.87: The niche in the eastern wall of Thomas Tyrell's tomb niche. The label is covering the decorative cinquefoil corbelling located at the top of the niche. The irregularities of the bricks in this location contrast the modern replacement material located in other areas of the niche, suggesting this is authentic 'Tudor' type brick. The scale bar is 20 cm in length.



Fig. 3.88: The niche in the western wall of Thomas Tyrell's tomb niche. The label is covering the decorative cinquefoil corbelling located at the top of the niche. The irregularities of the bricks in this location contrast with the modern replacement material located in other areas of the niche, suggesting this is authentic 'Tudor' type brick. The scale bar is 20 cm in length.

The second and third samples were collected from the tomb niche of Sir Thomas Tyrell, located on the north side of the chancel. One sample was taken from the internal eastern wall (see Fig. 3.87) whilst the other was taken from the opposing western wall (see Fig. 3.88). Both samples came from brick niches with cinquefoil corbelling. Much of the brickwork in this tomb niche has been replaced with modern materials and heavily re-pointed. However, the brickwork on these two internal walls of the niche appeared to contain large amounts of authentic red 'Tudor' brick, a fact determined by the irregularity of the surfaces and arrises. The bricks surrounding those that were sampled are laid in an irregular fashion, possibly due to the limited space available within each niche. The mortar surrounding the bricks has been re-pointed, again obscuring the true arrises of the bricks. It is estimated that the mortar joints are about 5-20 mm.

3.5.5: All Saints' church, Maldon

3.5.5.1: Archaeological assessment

The church of All Saints' in Maldon is one which has received very little archaeological attention. It is a spacious structure located within the heart of the historic town in close proximity to another historic brick structure, the Moot Hall (see 3.3.4) (see Fig. 3.89). As well as the unusual and possibly unique feature of a triangular western tower, the church has several interesting features associated with it. These include a highly ornate south aisle and a sunken chamber located directly beneath the east end of this aisle (it does not extend beyond under the south chancel chapel). These two areas of the building are of interest from the historic brick perspective since large parts of the sunken chamber and parts of the south aisle southern wall contain 'Flemish' type medieval brick.



Fig. 3.89: All Saints' church, Maldon. Note the triangular western tower and the southern aisle which is ornately decorated internally.

The 'Flemish' type brick in the sunken chamber and south aisle southern wall was only discovered by the Maldon Archaeological Group in 1984.

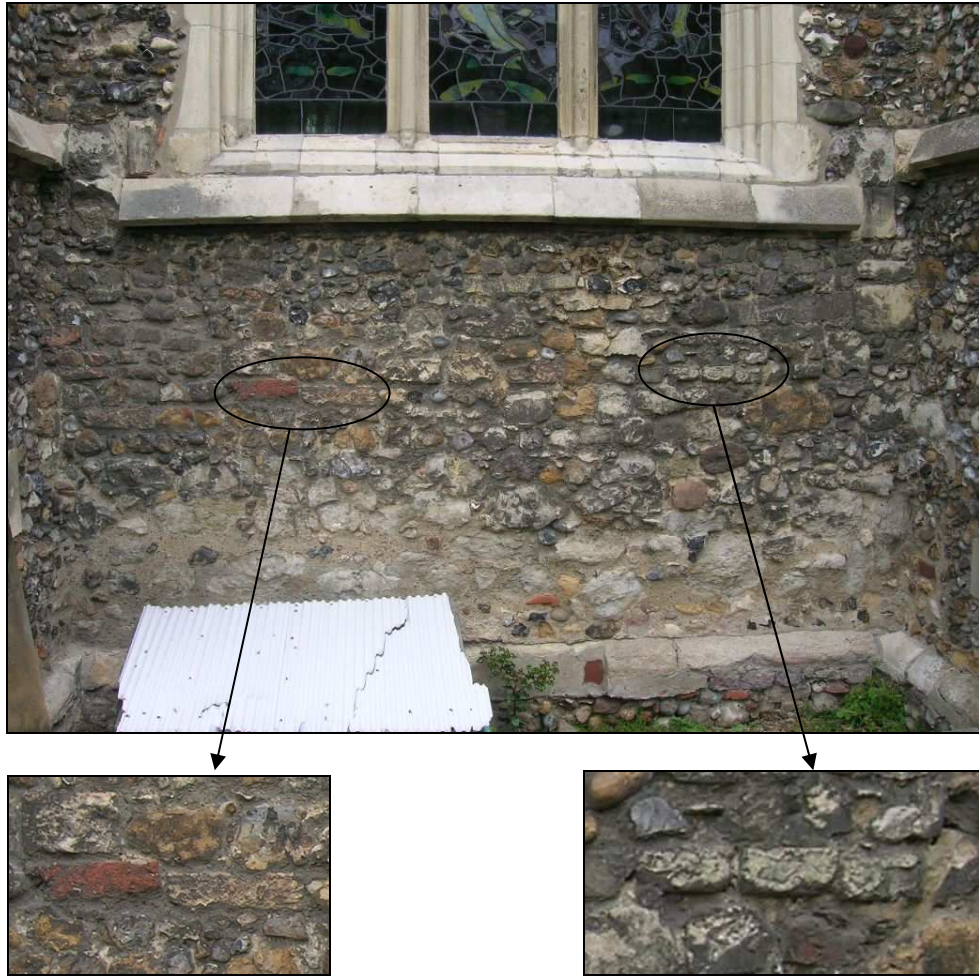

Fig. 3.90: A section of the southern external wall of the south aisle. Two areas in the flint rubble where 'Flemish' type bricks occur are shown in the images below, illustrating the different colours that occur for this type of brick (the lower left image shows two bricks laid in stretcher bond, one red and the other cream, whilst the lower right image shows three white bricks laid in header bond).

Considering the external wall of the southern aisle first, it is apparent that it contains several 'Flemish' type bricks among flint rubble, the colours of which cover a wide range, including cream, dull yellow, salmon pink and dark red (see Fig. 3.90) (Ryan, 1996, 31).

The entrance to the sunken chamber is through a doorway inside the church set in the second bay from the west end of the southern aisle. The doorway has a lancet arch with an ogee arch hood mould and leads to a newel staircase which is set in a three sided projection from the south aisle wall (see Fig. 3.96). There is a foliate carved capital on the newel from which the vaulting springs and a boss of carved foliage in the intersection of the vaulting (see Fig. 3.91). The steps leading down are modern concrete replacements. The stair turns



Fig. 3.91: The central boss carved with a foliage design located in the vaulting over the stairs leading down to the sunken chamber.

through half a rotation before descending to the south west corner of the sunken chamber (RCHME, 1921, 172). The western wall and vaulting above the lower half of the stairwell is made from the 'Flemish' type bricks. The bricks have been coated in many layers of whitewash obscuring any immediate surface detail, although outlines of the bricks can still be discerned and show that they are laid in a highly irregular pattern.

The sunken chamber itself consists of four bays aligned along an east-west axis (see Fig. 3.92). The roof is vaulted with segmental pointed transverse arched ribs aligned north to south. In the second bay of the south wall is a deeply splayed window. The exterior window is a small lancet arch whilst at the rear is a segmental pointed arch groined into the main roof vaulting (RCHME, 1921, 172). The lining of the splay to this window is in 'Flemish' bricks, laid in a highly irregular manner, especially in the bottom of the splay which appears to have had some bricks removed at some point. The far eastern end of the chamber has two further openings, now blocked, with segmental pointed rear arches (RCHME, 1921, 172), of which the southern opening appears to be made from 'Flemish'



Fig. 3.92: The sunken chamber of All Saints' church. Note the two blocked openings at the east end of the chamber (left side of the image), the transverse ribbed arches and the splayed window in the southern wall (right side of image).



Fig. 3.93: Fragment of carved stone reset in the rubble walling of the sunken chamber (the tape measure is extended 20 cm).

type bricks. The northern window has large stone jambs that lie behind the rubble infill, although it is possible that behind the infill the splay is composed of 'Flemish' type brick. The infill consists largely of flint, tile and small carved stone blocks. Despite being heavily whitewashed, there is evidence of re-used carved stonework set among the rubble walling of the chamber (see Fig. 3.93).

The date of the southern aisle and sunken chamber has been placed in the early 14th century. This date would agree well with the foliate capital, the foliage boss in the newel stair and the vaulted ribs in the sunken chamber. There are further architecturally decorative elements to the internal south wall of the southern aisle which support an early 14th century date, including an elaborate wall arcade on the south face. The eastern side of this arcading is composed of a series of five niches with moulded and cinque foiled ogee arches which spring from foliated capitals (RCHME, 1921, 172). West of these niches is the doorway into the sunken chamber and a further series of three plainer niches. Both the doorway and the three niches are at a lower level than the eastern five niches, possibly due to the chamber located under the eastern five niches (see Fig. 3.94).



Fig. 3.94: The internal view of the south wall to the south aisle. Note the five niches with ogee moulded heads to the left of the image. On the right of the image there are three further niches at a slightly lower level. At the junction of the two series of niches is the entrance to the sunken chamber.

Based on the architectural detailing, the southern aisle and sunken chamber have been dated to c.1330-1350 (Chancellor, 1909, 112; RCHME, 1921, 170; Bettley and Pevsner, 2007, 579). The fact that the eastern windows of the chamber have been blocked would also support a 14th century date for this feature since the D'Arcy chapel, located immediately east of the south aisle, is thought to have been added to the church in the first half of the 15th century (RCHME, 1921, 170-171; Smith and Wadhams, 1975, 215).

The exact nature of the sunken chamber is uncertain. It has long been held that the chamber was a crypt or ossuary (Chancellor, 1909, 113; RCHME, 1921, 170; Bettley and Pevsner, 2007, 579). However, there is evidence that this aisle and the sunken chamber might both constitute a two levelled chantry chapel. Many chantry chapels were added to churches from the 13th century onwards with the intention of masses being said for the soul of the founder (Morris, 1989, 363). They were either established as adaptive chapels, in which existing parts of the church fabric, such as transepts or aisles, were converted into a chapel, or they were constructive types, in which a purpose built structure, such as an additional aisle, was erected (Roffey, 2007, 90, 94). Occasionally, some of the more important chantry chapels in parish churches comprised two stories, an example of which can be seen at East Horndon church (see 3.5.4) (Roffey, 2007, 95).

There are several archaeological features that suggest the southern aisle and sunken chamber were a two storied chantry chapel. Firstly, in the arcading between the southern aisle and central nave, the capitals of the westernmost bay differ to the rest of the arcading (Chancellor, 1909, 112). It has been suggested that this bay pre-dates the aisle, probably originally serving as a porch, and that the southern aisle was largely formed through the extension of the porch in an easterly direction (Chancellor, 1909, 112; RCHME, 1921, 170). It should be noted that many chantry chapels are often associated with porches (Roffey, 2007, 53). If the original southern wall of the nave was demolished for the erection of the current south aisle, then the materials could well have been re-used in the new building work, as seen in the wall of the sunken chamber (see Fig. 3.93). This might suggest that some of the bricks in the external wall of the current southern aisle (see Fig. 3.90) might have been re-used and are therefore not in their original context. New chantry chapels presented the opportunity to introduce current architectural style into an established church (Roffey, 2007, 95), hence the highly

ornate early 14th century architectural detailing to the southern aisle. It should be noted that the external detailing of the aisle includes niches on the exterior face, a feature often found in chantry chapels (Roffey, 2007, 51). It also faces the main roadway and original market place of Maldon, thereby presenting an ostentatious display to the local community (Morris, 1989, 365; Roffey, 2007, 99-100). At the far eastern end of the southern arcading in the southern aisle are traces of a former canopy with a crocketed gable and vaulted with moulded ribs (Chancellor, 1909, 113; RCHME, 1921, 173). This has been interpreted as both the canopy to an altar tomb (Chancellor, 1909, 113) and as the remains of a former sedilia (RCHME, 1921, 173). Whilst there is uncertainty surrounding its true nature, both altar tombs and sedilia are features associated with chantry chapels (Roffey, 2007, 65, 68). Considering the sunken chamber, at the eastern end of the southern wall there is a large indent into the wall which has been partly blocked (see Fig. 3.95). The location of this feature suggests that it may have originally been a piscina, possibly to serve an altar located at the eastern end of the chamber. The presence of the blocked windows in the eastern wall might also be a deliberate



Fig. 3.95: Blocked indent at the eastern end of the southern wall of the sunken chamber. This feature might have been a piscina originally intended to serve an altar located at the east end of the chamber.

feature that was originally designed to illuminate an altar located at the eastern end of the chamber. Certainly, windows were located in chantry chapels to illuminate altars (Roffey, 2007, 52). Whilst the sunken chamber might have been used as a crypt or ossuary at a later stage, it seems likely that in the 14th century it was constructed with the intention of being a two storied chantry chapel.

Considering the wider context of the use of ‘Flemish’ type brick in Maldon, there is a wall located approximately 200 m south east of the church that marks the eastern boundary of a Georgian manor house. This replaced a 16th century manor which in turn replaced a Carmelite friary that was founded in 1292 (Ryan, 1996, 32; Isserlin, 1999, 129, 137-139). This wall contains several fragments of carved stone and ‘Flemish’ type brick thought to have been robbed from the Carmelite friary. Excavations on the site of the friary itself revealed ‘Flemish’ type brick that was similar in both colour and dimensions to that in All Saints’ church. These were recovered from the foundations built during the original construction work of the friary in the late 13th to early 14th century and were later re-used in a range of the friary that was rebuilt during the late 14th century (Isserlin, 1999, 90-91). Consequently, the use of ‘Flemish’ type brick for work on the Carmelite friary could offer a potential source for the brick that chronologically agrees with that in the south aisle of All Saints’ church.

3.5.5.2: Maldon church sampling location

A single sample was collected from the western wall of the lower stairway leading down into the sunken chamber (see Fig. 3.96). The walling in this area had been heavily coated in whitewash obscuring many details of the brickwork, such as brick arrises and mortar thickness. However, the outline of the bricks could still be discerned indicating that they were laid in a highly irregular pattern, with both stretchers and headers used in the wall face (see Fig. 3.97). There are some bricks in the lower courses where the whitewash and outer skin of the brickwork had been worn away, revealing the salmon pink colour variation of the ‘Flemish’ type brick. The sampled brick core had a marbled pink colour with a fine fabric. Behind the sampled brick traces of mortar and possibly another brick were seen.

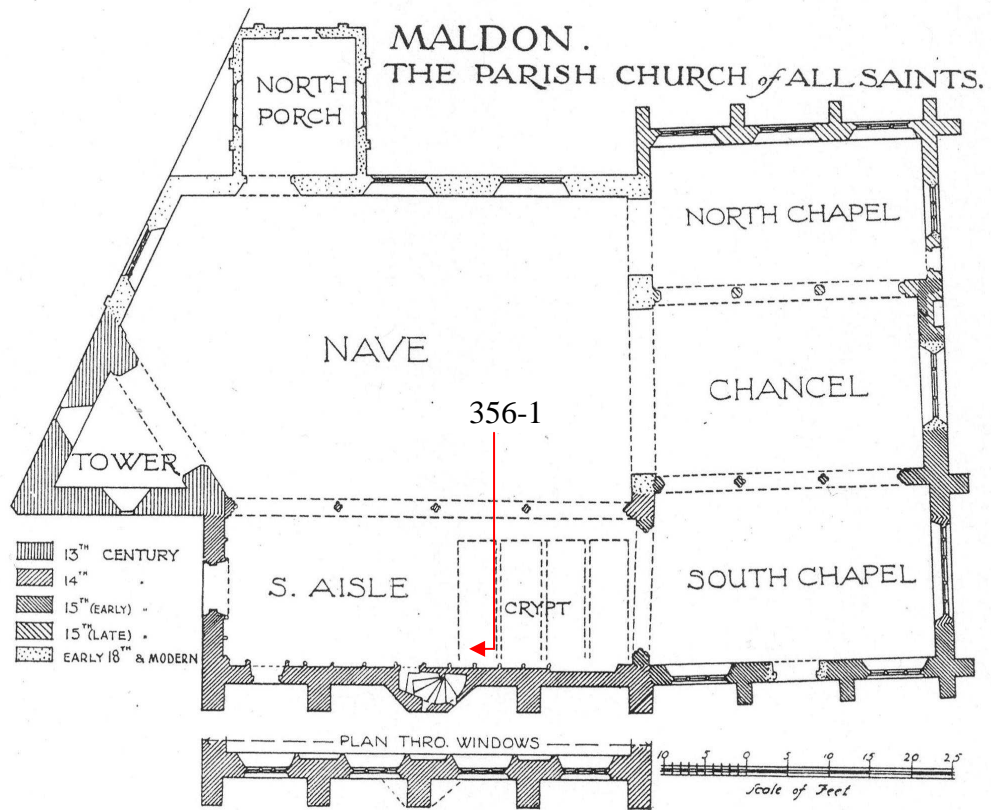

Fig. 3.96: Sampling location in All Saints' church, Maldon. Note the stair in the south aisle wall leading to the sunken chamber (RCHME, 1921, 171).



Fig. 3.97: The sampling point in the western wall on the lower stage of the staircase leading down into the sunken chamber. The scale is 20 cm in length.

3.5.6: All Saints' church, Springfield

3.5.6.1: Archaeological assessment

Springfield is located to the north east of Chelmsford and, due to the extensive expansion of the latter town during the 19th and 20th centuries, has been seriously encroached upon, resulting in the area becoming a suburb of Chelmsford. The heart of the original village can still be discerned and consists of the Springfield green with the 16th century Springfield Hall and a series of other post-medieval buildings ranging from the 17th to the 19th centuries around it (Bettley and Pevsner, 2007, 729-730).

The parish church at Springfield is a complex building, incorporating several different building phases in its structure. The key element for the purposes of this project is the western tower, a feature which is clearly composed of different materials from different periods. The tower is of three stages of which the third stage, north west and south west corners are constructed entirely of brick (see Fig. 3.98). The brick in the north west corner buttresses and stair turret differs from that used for the third stage and the south west corner buttressing. The brickwork in the north west buttress has thinner mortar joints, is generally larger than the other brick areas and has more regular arrises, size and shape. The reason behind the discrepancy lies in the fact that this corner of the tower was rebuilt in the late 19th century (Chancellor, 1894, 56).

The tower is thought to have been constructed in flint rubble during the early 14th century when it is believed that other alterations were being made to the original Norman church (Chancellor, 1894, 53; RCHME, 1921, 218; Paynter, 1949, 25). Towards the end of the 16th century, it is thought that the western and upper parts of the tower had deteriorated or collapsed and were subsequently rebuilt in brick in 1586. The principle form of evidence for this is a date plate located on the southern face of the third stage of the tower (Chancellor, 1894, 56; RCHME, 1921, 219; Paynter, 1949, 25). The date plate (see Fig. 3.99) has the following inscription:

‘Pra^us God for al the Good Benefactors Ano. [1]586’

Further evidence for the date of the repair work can be found on the



Fig. 3.98: The western tower at Springfield as seen from the west (left image) and the south (right image). Note the extensive use of brick for the third stage and the corner buttressing.



Fig. 3.99: Date plate located on the southern side of the third stage of the church tower.



Fig. 3.100: Stone inset into the brick buttress on the southern face of the tower at the top of the first stage. Antiquarian accounts record that the Mildmay family arms and the date 1586 were originally inscribed in the stone.

southern side of the tower where there is a highly worn stone set into the brick buttress (see Fig. 3.100). Antiquarian reports state that this stone displayed the arms of the Mildmay family and the date 1586 (Muilman, 1769, Vol. I, 118; Wright, 1836, Vol. I, 99). The Mildmay family was one which had recently risen in social status as a consequence of the dissolution of the monasteries earlier in the 16th century. Thomas Mildmay (died 1566) was involved in the Court of Augmentations, the royal office which dealt with the re-distribution of the monastic lands and wealth. He gained many estates and became very wealthy during the course of his life (St. John Mildmay, 1913, 15-20). He also distributed large estates among family members, such as Terling in Essex which he bought for his brother John (St. John Mildmay, 1913, 27). Another of his brothers, William, was granted the estate of Springfield-Barnes, one of three manorial complexes associated with Springfield, which had formerly been in the possession of Coggeshall Abbey. Ironically, this came to William not through his brother, Thomas, but as a grant to him by King Edward VI (Morant, 1768, Vol. II, 9; St. John Mildmay, 1913, 27). William Mildmay passed the estate on to his son, Thomas Mildmay, upon his death in 1570. It is generally accepted that this

Thomas Mildmay, who later became the Sheriff of Essex in 1597 and was knighted in 1603, contributed a considerable share towards the cost of the restoration of the tower (Chancellor, 1894, 56; St. John Mildmay, 1913, 28; Paynter, 1949, 25).

After the rebuilding work of the third stage in brick, the church tower underwent further alterations in the early 17th century, the details of which were recorded in the mid-20th century from a wooden board within the tower ringing chamber (Paynter, 1949, 13) which read:

“Roberte Roberson, who departed this life the fourthe of March, Anno Domini 1619, did, by his will, give fortye powndes for the erectinge of a maine spire, which, without great danger to the steple, and charge to the parishioners, could not be set up. Wherefore, by the allowance of Richarde Freman and Charles Biglande, Gents., overseers to his said will, therewith was repaired the steple and lantron, the belfrie enclosed and beautified, and the stairs there altered and amended. Twelve new pewes in the bodye of the church, fowre pewes in the chancell, a pulpett head, a communion table erected, and the chancell seated rounde about for the communicants; all of which worcke was done by the appointmente of John Transted and Wiliam Pinchion, church-wardens. Anno Domini, 1624.”

Quite how one should interpret the aspects of this passage that relate to the tower is uncertain. In terms of the enclosing and beautifying of the belfry, it seems unlikely that this chamber would have been left exposed to the elements for the preceding years since the late 16th century rebuild and may refer instead to a need to replace either the whole of the roof or specific elements of it. However, it is also possible that the repairs were required in the first place due to the lack of a roof on the tower. Ultimately, the passage is too ambiguous to derive any absolute conclusions from other than the fact that repairs were probably undertaken on the church tower and belfry between 1619 and 1624. It appears that the north west corner of the tower gradually deteriorated and two huge buttresses, one on the north side close to the north west corner and the other in the centre of the western face, are thought to have been constructed in the mid-17th century (Chancellor, 1894, 56). By the 19th century the foundations of these buttresses had caused the north west corner of the tower to start to settle resulting in the removal of the western buttress and the erection of the present stair turret and buttressing on the north west corner in 1883 (Chancellor, 1894, 56).

From an archaeological perspective, there are no distinguishing aspects of the church tower that allow the brick components to be dated with the exception of the date plate and stone recorded as being carved with the Mildmay arms on it. The brickwork on the third stage of the tower and the buttresses are the red 'Tudor' type bricks and are bonded in a highly irregular manner. There are isolated areas where the bonding appears to be laid in English bond and other areas, mostly on the western face of the tower, where the bonding appears to be laid in the extremely rare Flemish stretcher bond (a course of stretchers alternating with a course of alternating header and stretcher faces) (*cf.* Woodham Walter 3.5.9.1). The random nature of the bonding could be indicative of late 16th century experimentation with different patterns prior to the adoption of true Flemish bonding in the 17th century (Brunskill, 1990, 52). There are no decorative diaper patterns on the brickwork. The parapet has crow stepped gables but is a modern feature (RCHME, 1921, 219). The western window at the first stage of the tower is a modern addition from the late 19th century alterations to the north west corner and buttress (Chancellor, 1894, 56). The belfry windows of the third stage consist of three openings each with an elliptical arch. The eastern and western windows have moulded square labels above them (RCHME, 1921, 219).

The limitations that exist in allocating dates to aspects of buildings based on date plates have already been discussed (see 2.2.3). With the case of Springfield church, the historic evidence suggests that the wealthy Mildmay family could well have been one of the 'Good Benefactors' who contributed towards the church around this time. Whether the contribution was towards the erection of a new stage on the tower or to another aspect of the church is ambiguous and cannot be determine with certainty. However, the use of red 'Tudor' type brickwork would support a late 16th century date and therefore be in agreement with the date plate. Unfortunately, there is little else to provide an absolute date for the brickwork.

3.5.6.2: Springfield church sampling location

A single sample was taken from the southern internal wall of the tower belfry, close to the south west corner (see Fig. 3.101). The brickwork in this area consists of the red 'Tudor' type brick and is laid in an irregular manner (see Fig. 3.102). There are some bricks which are slightly darker than the normal orange or

red colour and a few appear to be partially vitrified. The mortar joints in this area of the tower vary from approximately 10-20 mm. Further brick was seen to lie behind the sampled brick.

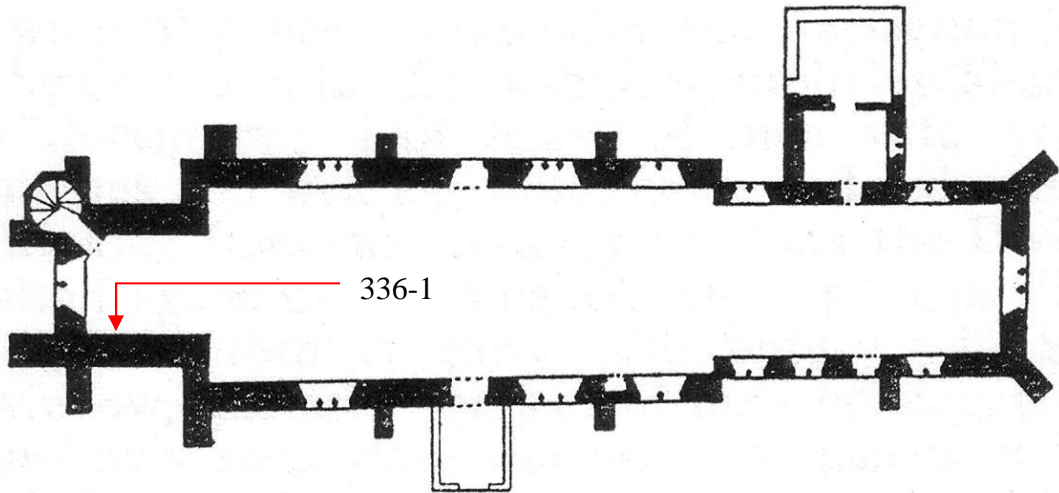

Fig. 3.101: Sampling location in Springfield church. Note that this plan only shows the ground floor of the church and that the sample was collected from the belfry of the church tower (RCHME, 1921, 218).



Fig. 3.102: The sampling point in the tower belfry, close to the south west corner. The scale is 20 cm in length and the sampling point is circled. Note the irregular bonding pattern of the brickwork. There is also a high degree of variation in the colour of the 'Tudor' bricks, ranging from orange to a dark blue and black.

3.5.7: All Saints' church, Theydon Garnon

3.5.7.1: Archaeological analysis

Theydon Garnon is a tiny hamlet located in western Essex where the church has an imposing western tower made entirely out of brick, as are the northern aisle and porch, whilst the nave and chancel are made from flint rubble (see Fig. 3.103). The church has been of interest to archaeologists for many years chiefly due to the fact that two elements of the building have dates associated with them. The north aisle has the date 1644 set in protruding vitrified brick within a sunken panel on the external eastern face (another corresponding panel located on the external western face of the northern aisle has the initials 'I. H.', again in protruding vitrified brickwork, set within a sunken panel) (VCH, 1956, 270). The second dated component of the church is the western tower where there is an inscribed stone panel dated to 1520 on the southern side (see Fig. 3.104) (Ryan, 1996, 73).



Fig. 3.103: All Saints' church, Theydon Garnon, from the south east. Note the brick built western tower.



Fig. 3.104: The date plate on the southern side of the tower. Much of the inscription has been lost over time, some probably due to deliberate vandalism.

The panel is now highly worn but has been recorded several times since the 18th century by antiquarians and archaeologists. One of the earliest accounts mentioning the panel describes it as ‘a broken inscription’ (Salmon, 1740, 48) and later accounts elaborate on the damage, claiming that certain parts of the inscription had been deliberately removed (Ogborne, 1814, 262). As well as describing the damage done to the panel, the antiquarian accounts describe the fact that the plate is dated to 1520 and that it mentions Sir John Crosby contributing a considerable sum towards the building of the tower. An early account of the inscription was produced in the early 19th century but omitted the worn portions of the text (Ogborne, 1814, 262). Another early 19th century account (Wright, 1836, Vol. II, 378) attempts to provide a full description and reads as follows:

‘Pray for the soul of syr John Crosbe, knyght, late alderman and grosar of London, and for the souls of dame Anne and Annes [Agnes?] his wyfis, of whos gudys was gevyn.....towards the mak yng of this stepyll, on whose souls Jesu have mercy, Amen. Anno Dni 1520’

When this account is compared with that given by the Royal Commission (RCHME, 1921, 231) it becomes apparent that the specific phrases ‘Pray for the soul of’, ‘for the souls’ and ‘on whose souls Jesu have mercy, Amen’ have been deliberately removed. Such specific vandalism could perhaps be a consequence of post-Reformation iconoclastic activity.

With regards to the content of the inscription, there are often cases where date plates should be treated with caution (see 2.2.3). However, in this instance there is sufficient information conveyed to allow for a comparison to the historic record. This has revealed that John Crosby was a wealthy wool merchant who lived during the 15th century. He achieved many honours during his lifetime, including being chosen as a member of parliament for London in 1466, becoming an alderman in 1468, becoming master of the Grocers’ Company in 1469 and being knighted by Edward IV in 1471. He also had two wives, Agnes and Anne, during his lifetime and finally died in 1476 (ODNB, 2004, Vol. 14, 410-411). It is therefore almost certain that the date plate does refer to the 15th century merchant Sir John Crosby. In terms of his connection to Theydon Garnon, Leo de Welles, the owner of the estate at Theydon Garnon from 1421, was killed at the Battle of Towton fighting for Henry VI in 1461. After the battle, in which Edward IV was victorious, his property was forfeited to the crown and subsequently passed to Sir John Crosby. It was originally thought that Crosby’s son, also called John, was the individual who erected the church tower (Wright, 1836, Vol. II, 376). However, whilst it is certainly true that Sir John Crosby did have a son named John, he died sometime before his father, making it unlikely that he erected the tower (ODNB, 2004, Vol. 14, 411). The difference between the date of Crosby’s death and the date plate has not gone unnoticed by antiquarians and has led to the suggestion that the building work on the tower was finished in 1520 with funds being collected in the preceding years (Morant, 1768, Vol. I, 161). It should also be noted that at the time of his death, Sir John Crosby had left bequests which totalled more than £3,200 (ODNB, 2004, Vol.14, 411). It is quite possible that Theydon Garnon was left such a bequest. Certainly, the fact that his two wives are mentioned in the inscription could support the idea that the bequest came at the end of his life. It has also been suggested that the reference to the two wives could be indicative of the building work taking a considerable length of time and that it was only completed by 1520 (VCH, 1956, 270).

Whilst the details of the date plate do appear to refer to actual historic individuals who can be connected to Theydon Garnon, there is still a degree of uncertainty surrounding the exact date for the building of this tower. The difference between the date plate and Crosby's death has already been discussed. Another issue is the lack of architecturally distinguishing features to the tower. The tower has three stages and an octagonal stair turret in the north east corner. The passage on the ground floor to the stair turret has a four centred arch, as do the windows in the north and south wall of the second stage. The belfry has two round headed windows set into a four centred arch in all four walls (RCHME, 1921, 231-232). The brickwork is laid in a regular English bond but does not contain decorative diaper work. All of these features would support a broad date range spanning the 15th to early 16th centuries. The only other significant diagnostic elements in the tower are the western window at the first stage, a feature that is a later addition and thought to date to the 17th century, and the western door, which is thought to date to the 18th century (VCH, 1956, 270). Overall, it seems likely from the architectural perspective that the tower was either erected in a relatively short period or was overseen by the same craftsmen for a lengthy period. It should be remembered that there were many brick towers being added to churches in Essex during the late 15th and early 16th century (see 2.4.4 and 2.4.5) so the brick tower at Theydon Garnon agrees with regional architectural trends.

The church is shown with a tower on a map dated to 1648 (ERO D/DC 27/1123) which would seem to support the idea of 1520 as a *terminus ante quem*. If a bequest of £50 was left by Crosby upon his death in the late 1470s then this could be seen as a possible date shortly after which work might have begun. Such a length of time to construct an addition to a church was not uncommon during this period (see 2.4.5). Therefore, it seems most likely that Sir John Crosby left money towards the building of a brick tower at Theydon Garnon at the time of his death in 1476. During the remainder of the 15th century, it is likely that other monies were collected towards the project, which probably began in the last quarter of the 15th century. It is quite likely that the tower was completed in 1520. Therefore, a date range of c.1475 to 1520 is suggested for the construction date of the brick tower.

3.5.7.2: Theydon Garnon church sampling location

A single sample was taken from the eastern side of the first stage passageway leading to the base of the newel staircase in the north eastern corner of the tower (see Fig. 3.105).

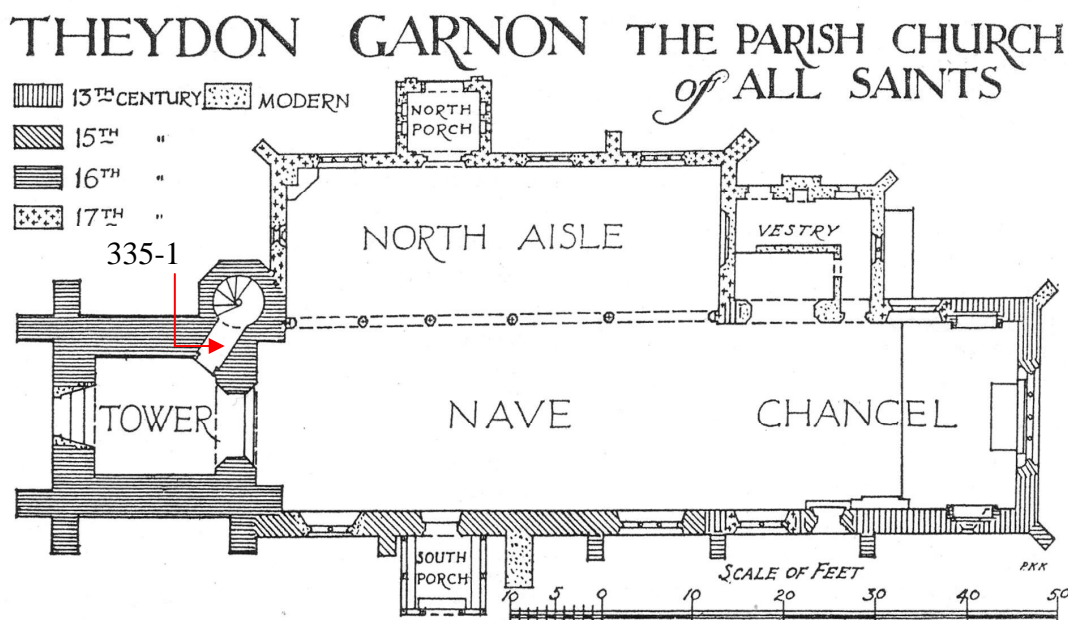

Fig. 3.105: Sampling location in Theydon Garnon church (RCHME, 1921, 232).

The sampling methodology adopted for this site differed from the standard approach used at other sites. In this case, the mortar around the brick was drilled away before the entire brick was removed (see Fig. 3.106). Once the brick had been removed, a square portion was cut from the back face using a water cooled tile cutter (see Fig. 3.107). A second portion was also cut from the rear using a diamond tipped hand saw to preserve the water content within the brick for measurement in the laboratory. The brick was then reinstated in its original position in the wall.

The brick was a standard, orange coloured 'Tudor' type with a very fine fabric. The brickwork around the sampling point was laid in an English bond. A few of the bricks were darker than the other red 'Tudor' bricks with small areas of surface vitrification, probably due to variation of the firing temperature. The mortar joints around the brickwork varied from approximately 5-20 mm in thickness. A thick skin of mortar was seen to lie immediately behind the brick once it was removed from the wall.



Fig. 3.106: The space where the sampled brick was located. The mortar surrounding the brick was drilled away before the entire brick was removed so that a sample could be taken from the rear surface to reduce the aesthetic impact.



Fig. 3.107: The brick that was removed from the wall for sampling. The image shows the rear portion that was removed from the main brick. A second portion was also removed by means of a diamond tipped hand saw in an attempt to derive the water content for this brick. The scale is 20 cm in length.

3.5.8: St. Margaret's church, Tilbury-juxta-Clare

3.5.8.1: Archaeological assessment

Tilbury-juxta-Clare is located in north Essex close to the Suffolk border. It is a small hamlet with the church located approximately 500 m to the north west of the main settlement. The church consists of a chancel, nave and porch, all of which are thought to have been erected during the latter half of the 15th century, and a western tower made from brick (see Fig. 3.108), thought to have been built in the early 16th century (RCHME, 1916, 319). Although the tower is the part of the church that is the main focus for this project, there are other aspects to the building that should be noted, including a series of historic wall paintings. One of these paintings, located on the northern wall of the nave, is of particular interest since it is thought to depict a man on a horse in front of a timber framed house with evidence of brick nogging infill between the vertical timber studs (see Fig. 3.109).



Fig. 3.108: The western brick tower of St. Margaret's church, Tilbury-juxta-Clare.



Fig. 3.109: The wall painting on the internal northern wall of the nave. On the right of the image in the foreground is a depiction of a man on a white horse. The structure behind him is thought to show panels filled with brick nogging.

The painting has been dated stylistically to the late 15th century, an age that agrees with the fabric of this part of the church (McCann, 1987, 108). Whilst the painting does not provide absolute proof that the local community were building in brick, it does suggest that they were familiar with the use of brick in an architectural context, possibly through seeing the material used in other buildings in the local region (see below). If the late 15th century local community were familiar with brick, then they may have specifically selected it as the building material for the tower. However, it must also be noted that the wall paintings might simply be depicting an idealised situation that has no bearing on the rest of the building.

With regards to the use of brick in the local region, it is generally thought that the material was employed for several of the church towers in other local villages at the end of the 15th century and into the early 16th century. Examples of this include the village of Gestingthorpe, located approximately four miles to the south east of Tilbury-juxta-Clare, where the church has a substantial brick tower laid in English bond with diaper work and crocketed finials at the corners of the



Fig. 3.110: Gestingthorpe church tower, thought to have been erected in the late 15th century.

crenellated parapet (see Fig. 3.110). The church tower is thought to date to the late 15th century when William Carter bequeathed forty shillings towards the building of the tower in 1498 (Ryan, 1996, 63). Another example can be found approximately five miles south east from Tilbury-juxta-Clare where the church in the village of Wickham St. Paul also has a brick tower, again laid in English bond with diaper patterning and crocketed pinnacles at the corner of the crenellated parapet similar to those at Gestingthorpe. This tower is thought to have been erected in the early 16th century when John Grene bequeathed £20 towards 'bielding a newe stepull of rep'acion of the said church' in 1505 (King, 1878, 51). A third example lies six miles to the north east of Tilbury-juxta-Clare in the village of Liston where the church has a small brick tower with diaper patterning and a crenellated parapet, thought to have been added to the church in the early 16th century (RCHME, 1916, 169). These cases suggest that brick was being used in this area of Essex to build church towers in the late 15th and early 16th century. Equally, there are common features to all the brick towers described, including the use of diaper brickwork, stair turrets built into projections at the north east or north west corners of the towers and crenellation at the top of the towers. The

historical use of brick for building church towers in this region therefore suggests a late 15th or early 16th century date for the tower at Tilbury-juxta-Clare.

The tower itself has been dated in the past to 1519 by a date plate located at the base of the tower in the external western face (see Fig. 3.111), which reads:

“To the glorie of Gods most high and
gracious majestie Elizabeth
Countess of Oxfcrd in the yere of
our Lord 1519 added this tower to
the rebuilt church of S. Margarets
Tilberry Praised be God”



Fig. 3.111: The date plate located at the base of the western face of the tower.

It should be noted that this panel is a relatively recent insertion, although exactly when it was installed is uncertain. Attempts to locate a faculty record that might refer to the insertion of the panel among those stored at the Essex Records Office were unsuccessful. Unusually, the Royal Commission failed to record the date plate in the early 20th century (RCHME, 1916, 319). Lewer (1933, 9) mentions that the Countess of Oxford built the west tower of Tilbury-juxta-Clare church in 1519 and Wight (1972, 268) describes rebuilding work taking place in red brick on the tower between 1517-1519 at a cost to Elizabeth Countess of Oxford but neither mention the source of this information. Ryan (1996, 73),

however, does mention the date plate and the fact that it bears a date of 1519. The specific nature of the details given by both Lewer and Wight would seem to suggest that they obtained their information from the date plate but this cannot be determined for certain. It is possible that it was installed during the course of the 19th century when this church was restored and alterations were made to the church tower, including the insertion of a relatively modern window in the western wall (see Fig. 3.113) (RCHME, 1916, 319). The fact that the current date plate is a replacement of an original feature is proven by antiquarian accounts of the church which describe a date plate located over the entrance to the tower (Morant, 1768, Vol.II, 336) which read:

‘Elizabeth Countess of Oxenford, the year of our Lord 1519, built this steeple’

Given the similarities between the account of the original date plate and the present one, it is likely that the present inscription on the panel is an accurate reproduction of the original. The issue therefore arises as to how reliable the information on the date plate is.

Considering the reference to Elizabeth Countess of Oxford first, it is most likely that she is Elizabeth Scrope. She had been the widow of Lord Beaumont, a close friend to the 13th Earl of Oxford, a powerful noble whose family, the de Veres, had become established in Essex in the 12th century. The 13th Earl married Elizabeth Scrope in about 1508. When the earl died in 1513 he left a vast sum, detailed in his will as being worth approximately £8000 (Anderson, 1993, 126-128; ODNB, 2004, Vol. 56, 308). Elizabeth, who had already received monies after the death of her first husband, was consequently left well endowed after the death of her second and could therefore have easily afforded to build such a tower, especially given that she died in 1537 after the supposed date for construction of the tower. Certainly, she was patron to the church in 1531 (Newcourt, 1710, Vol. II, 594). Equally, there is no mention in her will that money be left for work at Tilbury-juxta-Clare which could well indicate that the tower was completed before her death (Lewer, 1933, 9-16).

There is further evidence within the tower that supports a link between the church and the de Vere family. The walls of the church are decorated with fragments of carved stonework, apparently collected and installed by Margaret

Anna Brett, wife of Rev. C. W. Brett (rector 1898-1943) (Bettley and Pevsner, 2007, 785). Inside the first stage of the tower, set into the southern wall there is a boar (now damaged and headless) and a five pointed star, (see Fig. 3.112), both of which are emblems of the de Vere family (Elliot, 1884, 339-342). These were probably inserted by Brett and it is therefore impossible to determine the original context from which they came. Antiquarian accounts of the tower also mention the presence of a ‘molet’ on the outside (Morant, 1768, 336; Wright, 1836, Vol. I, 587). This is a reference to a ‘mullet’ or a five pointed star, a heraldic device that was part of the de Vere coat of arms which is also seen on other Essex buildings that were associated with the de Vere family, for example, the tower at St. Nicholas’ church in Castle Headingham (Elliot, 1884, 339). Looking at the external western face of the tower at Tilbury-juxta-Clare, there is a carved stone immediately above the replacement western window which has a five pointed star set within it (see Fig. 3.113) and may be the ‘molet’ referred to in the antiquarian accounts of the church.



Fig. 3.112: Decorative fittings inside the church tower, probably added by Margaret Anna Brett. The lower two (the five pointed star and the headless boar) are emblems of the de Vere family.

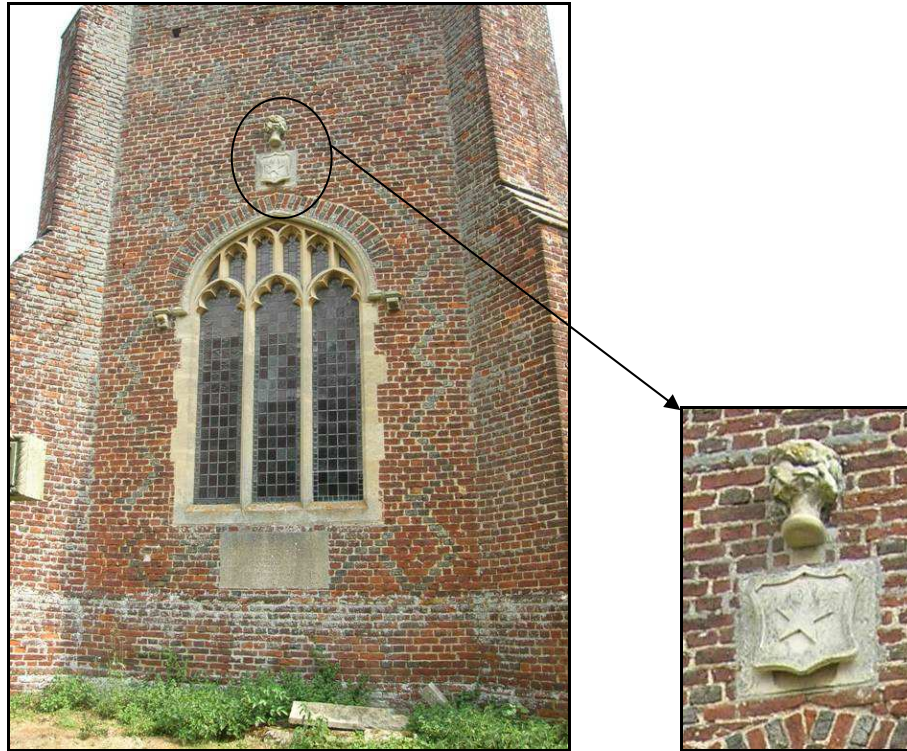

Fig. 3.113: The western face of the tower. Note the five pointed star, or mullet, located above the window, a heraldic emblem of the de Vere family. The western window, located directly above the date plate, is a modern replacement.

It should also be noted that in the upper stages of the tower there are three sunken panels. Two are highly weathered whilst the third has been filled with modern brick. One of the panels is located in the centre of the western face of the third stage of the tower, immediately above the belfry window (see Fig. 3.114) whilst the other worn panel is located midway up the southern side of the stair turret (see Fig 3.115). The panel recess blocked with brick is also located on the southern face of the stair turret but is immediately beneath the crenellations (see Fig. 3.115). What these panels originally contained has been lost but it may have been further heraldic devices or possibly other inscriptions detailing other donations or patrons of the building work.

A final source of evidence relating to the dating of the tower comes in the form of a will dating to 1519 in which John Bridge of Stoke-by-Clare bequeathed “to the making of the new steeple in Tilbury, xiijs. iiijd” (Challenor Smith, 1900, 274). Whilst this is certainly insufficient money for the whole project, it does offer suggestive evidence that building work was underway in 1519 on the brick tower.



Fig. 3.114: The western face of the third stage of the tower. Note the weathered stone panel set immediately above the belfry window.



Fig. 3.115: The southern face of the stair turret. Note the weathered stone panel set at the second stage level and the blocked recess at the top of the turret, just beneath the string course.

Whilst the attribution of construction dates for specific aspects of buildings by means of date plates requires caution (see 2.2.3), the information detailed in the panel set in the church at Tilbury-juxta-Clare does appear to agree with the historic details of the de Vere family and Elizabeth Scrope, Countess of Oxford. The connection between the de Vere family is strengthened by the heraldic devices described by antiquarians and seen reset in the tower. Further evidence for construction work taking place on the tower is provided by the will bequeathing money in 1519. The archaeological features of the tower, including the use of red ‘Tudor’ brick laid in English bond with decorative diaper work and a crenellated parapet, also agree with other brick towers in the locality which are attributed to the late 15th and early 16th centuries. Given the details described on the date plate, it would seem likely that 1519 represents a *terminus ante quem* for the construction of the tower, suggesting that the full building project was probably undertaken in the early 16th century. Consequently, a date range of c.1500-1519 is suggested for the date of construction of the brick tower.

3.5.8.2: Tilbury-juxta-Clare church sampling locations

Two samples were collected from inside the second stage of the tower in the north west corner (see Fig. 3.116), one from the western wall (see Fig. 3.117) and the other from the northern wall (see Fig. 3.118).

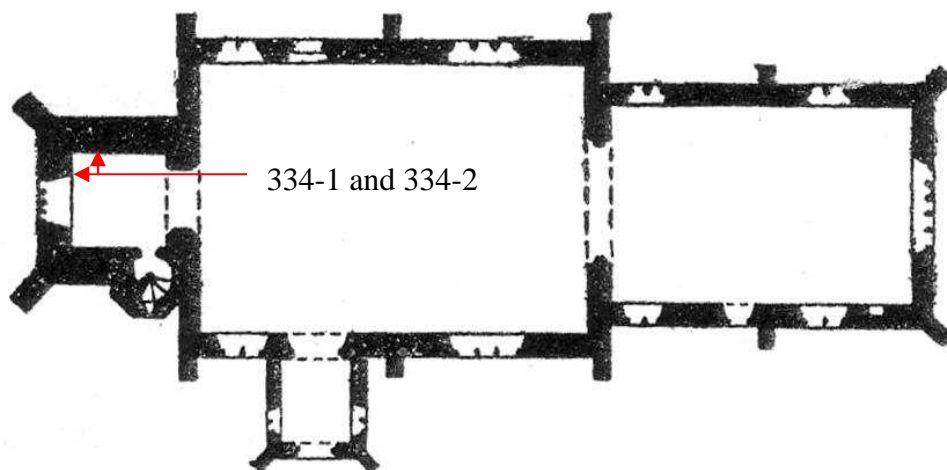

Fig. 3.116: Sampling location in Tilbury-juxta-Clare church. Note that this plan only shows the ground floor of the church. The samples was collected from the second stage of the church tower (RCHME, 1916, 319).



Fig. 3.117: The sample point in the western wall of the church tower. The scale is 20 cm in length. The sampling point is circled.



Fig. 3.118: The sample point in the northern wall of the church tower. The scale is 20 cm in length.

This area from which the samples were collected was composed of the red ‘Tudor’ type brick, with occasional darker, partially vitrified bricks, probably a result of variations in the firing temperature when the bricks were originally produced. The bonding is English bond with mortar joints ranging in thickness from approximately 10-20 mm. Fragments of mortar adhering to brick were seen to lie behind both of the sampled bricks.

3.5.9: St. Michael’s church, Woodham Walter

3.5.9.1: Archaeological assessment

This small, picturesque church is located at one end of the village of Woodham Walter in central Essex. It is largely built of brick and is thought to be a rare example of a mid-16th century ecclesiastical use of brick as a building material (see Fig. 3.119).



Fig. 3.119: St. Michael’s church, Woodham Walter, from the south west corner. Note the traces of plaster on the southern wall and the outline of the earlier porch roof above the southern door.

Originally, the church in Woodham Walter is thought to have been located approximately 500 m to the south east, closer to the site of the now ruined manor

house of Woodham Walter. This idea was originally limited to local village tradition but more substantial evidence emerged with the discovery of a late 12th to 13th century medieval grave cover in a field just west of the ruins of the manor house (Ainsworth *et al.*, 1991, 170-171). This in turn prompted surveying and fieldwalking of the area around the ruined manor house which led to the discovery of a high concentration of various building materials in the field from which the grave cover had originally been discovered. The materials recovered included Roman tile, septaria, building stone, large flints, roof tile, floor tiles and brick. There was also a series of pottery sherds recovered dating from the 13th to the 16th centuries. It has been suggested that the presence of Roman tiles could indicate that the original medieval church dated to the 11th or 12th centuries and that some of the roof tiles could have come from the late 13th to early 14th century tile kiln in the nearby village of Danbury (Ainsworth *et al.*, 1991, 172; Ryan, 1999b, 186). Further evidence that this was the site of the medieval church came in the form of an aerial photograph which showed a rectangular cropmark aligned along an east-west axis and with a length twice that of its breadth (Ryan, 1999b, 186).

The present church is thought to have been built between 1562-1564 (Ryan, 1989, 23; Bettley and Pevsner, 2007, 856). Evidence for this exists in the form of a petition made to Elizabeth I by the Lord of the Manor, the Earl of Sussex, to demolish the old church which was described at the time as having 'fallen into ruin' and as also being a 'great distance from the town of Woodham Walters'. The petition was successful and a licence was granted by Queen Elizabeth on the 26th June 1562 for the Earl to construct a new church where he thought appropriate (*Cal. Pat. R., 1560-1563, 340-341*). Work is then thought to have commenced on the dismantling of the old church and the erection of the new building.

There is strong evidence that many elements of the old church were re-used in the building of the new church. This may include the wholesale reincorporation of the northern aisle arcade. The pillars and arches of the north aisle arcade are of a form more appropriate to the 15th century (Chancellor, 1892b, 90), and they also retain graffiti which dates to before 1562. One example that is thought to have been etched into the pillar sometime between 1450-1550 is the signature of a gentleman called Strangeman, who owned lands in Woodham Walter in 1442 (Ryan, 1989, 25). The roofs of the nave and northern aisle are

also thought to have been re-used (Chancellor, 1892b, 90; RCHME, 1921, 270; Bettley and Pevsner, 2007, 856). Comparison to other Essex churches reveals certain similar features, for example, the nave roof of All Saints' church, Messing has been dated to between 1344 and 1362 based on a heraldic carving in one of its sole pieces. It is a seven canted structure in which the common rafters are supported by ashlar pieces near the base and are tied together by braced collar beams near the apex (Hewett, 1980, 166), features which also occur in both the nave and northern aisle of St. Michael's church. The wall plates of both the nave and northern aisle are also heavily moulded. Examination by the author of a partial cross section of the southern wall plate in the belfry revealed an ogee moulding set into a deep hollow with a bowtell towards the bottom, features which are characteristic of the 14th century (the wall plate at Messing church also incorporates an ogee scroll in a major hollow among other mouldings) (Hewett, 1980, 311). Further evidence to support the re-use of the old church roof was discovered when the timbers of the belfry produced a dendrochronological date of the late 14th century (Tyers *et al.*, 1997, 142). It has also been suggested that the layout of the rebuilt church followed that of the old church. In his will which dates to 1454-1455, Thomas Hawkyns instructs for his goods to be disposed of and that the resulting monies be used to build a new northern aisle and chapel on the north side of the chancel (King, 1878, 124-125). The present church has a single northern aisle and north of the chancel is a small room with an east facing window that is used as the vestry today, a chamber that could well have been the chapel Hawkyns instructed to be built (Chancellor, 1892b, 91). Given the similarities between the church alterations instructed by Hawkyns and the present layout of the chapel, it strongly suggests that during the erection of the new church the builders probably followed the old church layout (Chancellor, 1892b, 88-90; Ryan, 1989, 24-25). Other internal features that are thought to have been re-used from the old church include the perpendicular style font, which is thought to be from the 15th century (Chancellor, 1892b, 93; RCHME, 1921, 270), one of the bells which was recorded as being made by Giles or Henry Jordon in the 15th century (RCHME, 1921, 270), fragments of stained glass in the windows which are also thought to date from the 15th century (RCHME, 1921, 270) and a two centred doorway leading into the present vestry, a style more common with the 14th and early 15th centuries than the mid-16th century.

The date by which building work on the present church was underway is supported by a date plate situated over the vestry door with the year 1563 and the monogram 'JP' inscribed on it (see Fig. 3.120). Whilst date plates should be treated with caution (see 2.2.3), the fact that there are supporting documents for the erection of the new church in the 1560s would suggest that in this case the date referred to does actually relate to the specific building event of the church. It is currently unknown to whom the initials refer but one possibility could be the individual who co-ordinated the construction project. It does not refer to the lord of the manor (Thomas Radcliffe) or to the rector at that time (John Williamson) (Chancellor, 1892b, 88, 91).



Fig. 3.120: Date plate of 1563 within Woodham Walter church.

The bonding pattern used in this church is most unusual. It generally consists of courses of bricks laid in a stretcher bond between courses of bricks laid with alternate header and stretcher faces (see Fig. 3.121). This is an extremely rare form of bonding. Brunskill described it as an example of Flemish Stretcher Bond, a variant of the more common Flemish Bond that became popular in the 17th century (Brunskill, 1990, 52). It is thought that the walls of the church are actually a rubble core and not bonded brick throughout (Ryan, pers. comm.) and it

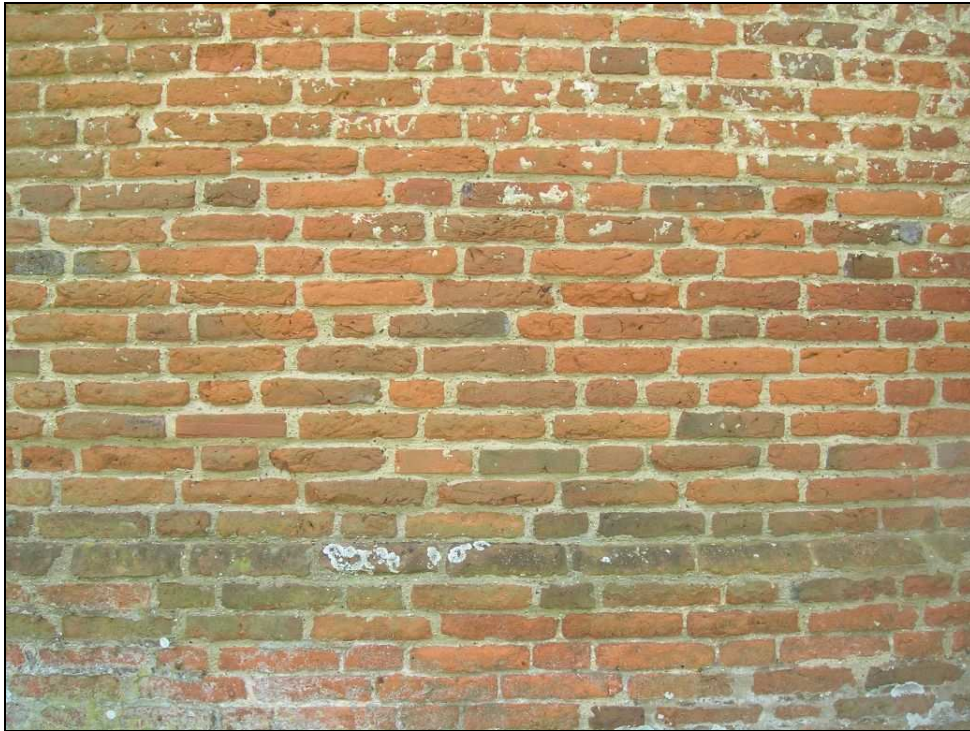

Fig. 3.121: An example of the unusual brick bonding pattern employed at Woodham Walter church. Note the alternating courses of stretcher bonded bricks interspersed with courses of alternating header and stretcher bricks.

is therefore possible that the bonding pattern is a deliberate attempt to economise on the use of bricks. If true, then the occasional header bricks would offer a means of bonding the external brick walling to the inner rubble at regular intervals, although not as frequently as the more common English bond, whilst the excessive use of stretchers would allow a brick skin to cover a much larger area. This bonding pattern also occurs in a brick barn which was rebuilt in the 16th century on the Ingatestone Hall estate (Ryan, 1989, 24; Bettley and Pevsner, 2007, 507) and in a brick barn at Leez Priory, built by Lord Rich in the 1530s. At Leez Priory the inner gateway to the manor complex can be seen to consist of a rubble core faced with brick (Howard, 1987, 149; see Fig. 2.18), suggesting that the barn may also have a rubble core. Another possibility is that all these building projects may have simply employed the same bricklayers. Perhaps the initial in the date plate is actually a flourished 'P' and refers to Sir William Petre who rebuilt Ingatestone Hall in brick in the 16th century (Bettley and Pevsner, 2007, 506).

The church was finally consecrated on the 30th April 1564 (Morant, 1768, Vol. I, 340). The speed with which the church was erected can also be seen as supporting the notion that much of the fabric from the earlier church was re-used

in the present building since this reduced both expenses and the need to acquire and prepare materials. Overall, there is strong evidence that the present church was erected between 1562 and 1564 with many elements of the original church being re-used for the construction project.

3.5.9.2: Woodham Walter church sampling location

The area that sampling focused on was the inside the western gable end. This area of the church houses the clock chamber and the sample was taken from the southern end of the western wall within this chamber (see Fig. 3.122). This wall was largely plastered over so it was difficult to evaluate the internal bonding of the brick for comparison to the unusual bonding on the exterior of the building. The small portion that was exposed suggested it was laid in English bond (see Fig. 3.123). The bricks were orange in colour and of the standard ‘Tudor’ type. The exposed surfaces of the bricks were soft and highly friable suggesting that they had been slightly eroded over time. The bricks were set in a soft mortar which varied in thickness from approximately 5-15 mm. A further layer of brickwork could be seen to the side and behind the outer surface that was sampled, suggesting that this wall is at least two bricks in depth.

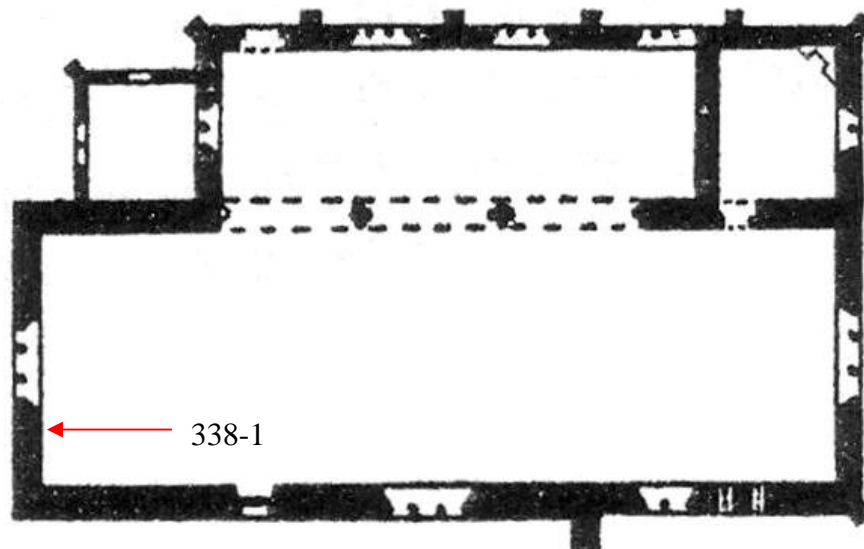

Fig. 3.122: Sampling location in Woodham Walter church. Note that this plan only shows the ground floor of the church. The sample was collected from the second stage of the church in the clock chamber (RCHME, 1921, 270).



Fig. 3.123: The exposed portion of brickwork in the western wall of the belfry chamber. The rafter of the roof structure can be seen in the top left corner of the image. The sample point (circled) has been refilled and the mortar is still wet. Note that behind the outer surface of the wall, which terminates in a diagonal slope on the left side of the image, a second layer of brickwork can be seen (outlined in the image).

CHAPTER 4: LUMINESCENCE THEORY, METHODOLOGY AND RESULTS

'...I also brought it to some kind of Glimmering Light, by taking [a diamond] into Bed with me, and holding it a good while on a warm part of my Naked Body'

-Robert Boyle

The aim of this chapter is to outline the basis of luminescence dating, the mechanisms that are involved in the determination of a date and the various factors that can potentially influence the final result. The criteria and procedures adopted for the selection and collection of samples from the buildings are then discussed, followed by a description of the laboratory procedures for dating bricks. The chapter concludes with the luminescence dates derived for the different brick samples.

4.1: OPTICALLY STIMULATED LUMINESCENCE DATING

The procedure for deriving an absolute date for a fired ceramic object by means of optically stimulated luminescence (OSL) is determined by the principle that the crystalline mineral quartz is able to release a certain quantity of light when appropriately stimulated. This light energy ultimately derives from ionising radiation that is naturally present in the environment. It is these two factors (the quantity of light emitted and the amount of energy absorbed annually by the quartz arising from the release of radiation by radionuclides in the surrounding environment) that are key to determining a luminescence date.

The following discussion summarises the complex mechanisms involved in OSL. A more thorough and detailed account is given in Aitken (1998). Note that throughout the text the term 'dose' is the absorbed dose which is defined as the energy absorbed per unit weight and has the unit *gray* (Gy, with $1 \text{ Gy} = 1 \text{ J kg}^{-1}$) (ICRU, 1998, 2).

4.1.1 Luminescence phenomena

OSL dating is a dating tool that belongs to the Trapped Charge Dating (TCD) family. The TCD principle works on the basis that the crystalline structures of naturally occurring minerals, such as quartz, contain defects within

them, examples of which can be seen in Fig. 4.1. Such defects (often referred to as ‘electron traps’) are able to trap electrons that are liberated from other parts of the crystalline structure by means of ionising radiation (Grün, 2001, 47). As well as liberating negatively charged electrons, the ionisation process also produces a positively charged entity referred to as a ‘hole’ (the absence of an electron in an atom) into the crystal structure which can also become localised at ‘hole traps’ (Wagner, 1998, 220). Provided that the ionising radiation flux remains constant, the trapped electron population within the crystal lattice steadily increases.

The length of time that the electron remains in a particular trap depends on the energetic stability of the trap and the average temperature of the quartz. Since different traps require different amounts of energy to release the electrons, some are more stable over extended periods and are therefore more likely to retain a trapped electron (Aitken, 1998, 13, 200-202). At room temperature, the thermal vibrations of the crystal structure will result in some electrons being evicted from traps. However, this generally only applies to electrons in traps which have a low ‘energy barrier’ to overcome before being released. Consequently, traps with a higher ‘energy barrier’ have much longer lifetimes in traps and the likelihood of trap eviction can be regarded as negligible on an archaeological timescale of several millennia (Aitken, 1998, 13, 200-202). An electron in a trap will therefore remain *in situ* until released by a sufficiently energetic stimulus. This can take the form of either thermal vibrations of the surrounding lattice brought about by the heating of the crystal (the procedure employed for thermoluminescence) or when irradiated with an intense beam of light of a specific wavelength that correspond to a specific energy value (the procedure employed for OSL) (Aitken, 1998, 15-16). When appropriately stimulated, the intensity of the released luminescence signal is proportional to the amount of energy absorbed by the crystal during its period of irradiation (Aitken, 1998, 14).

When released, the electrons are able to move freely about the lattice before recombining with a hole. Where a hole is trapped at a luminescence centre OSL is emitted, although there are a number of other possible fates that await evicted electrons which do not result in the emission of luminescence, including the chance of being recaptured by another electron trap or recombination with non-luminescence (‘killer’) centres (Aitken, 1998, 13-14; Wagner, 1998, 237). The general mechanism described above is illustrated in Fig. 4.1.

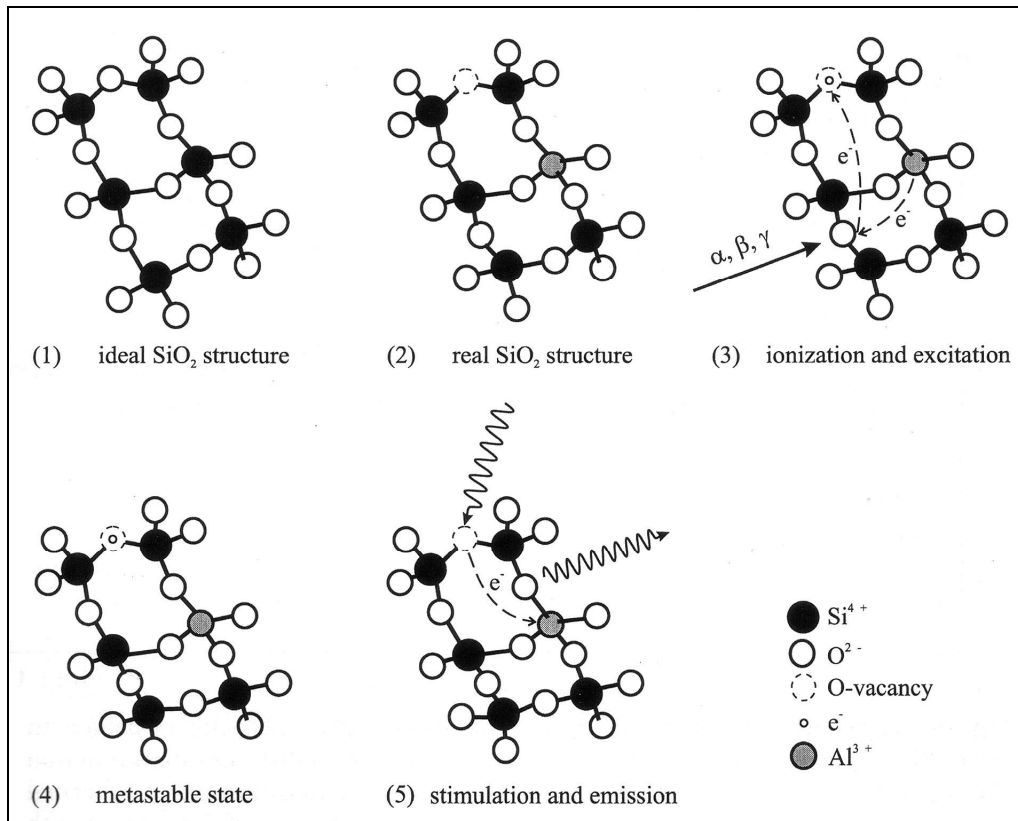

Fig. 4.1: Overview of the different mechanisms involved in the luminescence phenomenon. The SiO₂ crystal structure constitutes the main structure of quartz and contains a series of defects, shown in stage 2, including the Al³⁺ ion (an atomic substitutional defect) and a missing O²⁻ ion (negative ion vacancy defect). For stage 3, ionising radiation (α , β and γ radiation) evicts an electron from one of the O²⁻ ion which in turn becomes trapped in the 'hole'. The Al³⁺ ion donates an electron to the ionised O²⁻ ion and the lattice enters the metastable state of stage 4 for an extended period. Later, when stimulated with a beam of light at a particular wavelength, the electron trapped in the 'hole' is released and recombines with the Al³⁺, producing luminescence in the process (Wagner, 1998, 221).

4.1.2: Derivation of sample age

The following sections discuss the different aspects and procedures that are involved in determining the age of a fired ceramic sample, including the sample paleodose, the annual dose and the age determination equation.

4.1.2.1: Derivation of sample paleodose

As mentioned previously (see 4.1.1), the stimulation of quartz crystals by a sufficiently energetic source will result in the eviction of electrons from the traps. When a ceramic is fired during the manufacturing process, any quartz present has

its electrons evicted from the traps due to the increased thermal vibration of the lattice. This event is commonly termed the ‘zeroing event’ and is the event for which OSL produces a date (Wagner, 1998, 237). It should be noted that if the brick does undergo any reheating that is in excess of 500°C or is exposed to elevated temperatures for an extended period after the time of production then it is likely that the trap population will be completely or partially re-zeroed, thus altering any date subsequently derived (Wagner, 1998, 240).

Once fired, the trapped electron population begins to regenerate over the course of time through the action of naturally occurring ionising radiation as described above (see 4.1.1). The principal radionuclides responsible are ^{238}U , ^{232}Th and ^{40}K , with a smaller component being contributed by cosmic radiation (Grün, 2001, 52). After an extended period (several centuries in the case of medieval bricks), the ceramic is sampled and its quartz grains extracted. By stimulating the quartz with an appropriate optical source, the luminescence signal is measured. A photo multiplier tube (PMT) registers a proportion of the photons that are emitted from the quartz sample and converts them into electrical pulses. This allows a record of the luminescence emitted to be produced and displayed in the form of a decay curve (see Fig. 4.2) (Grün, 2001, 50). The luminescence signal generated over an extended period through irradiation from naturally occurring radionuclides is often referred to as the ‘natural’ luminescence signal.

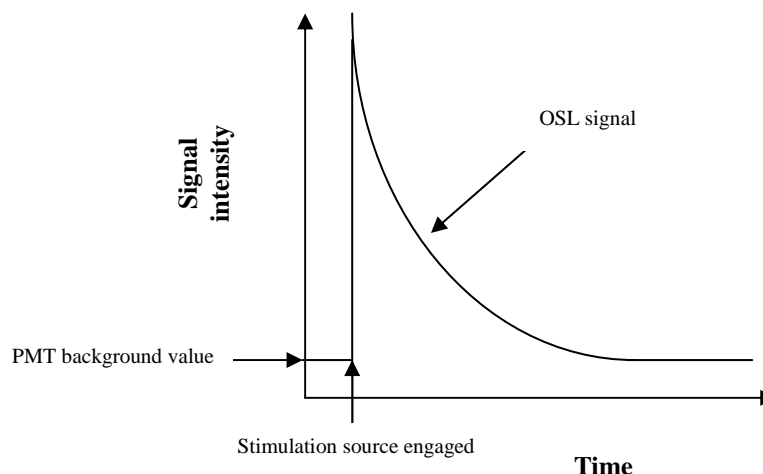

Fig. 4.2: A typical example of an OSL decay curve from quartz under constant stimulation from an optical source. The diagram shows the decrease in luminescence signal intensity due to the release of the trapped electron population over the course of time (typically, signal intensity returns to the PMT background value after a matter of seconds of stimulation) (after Aitken, 1998, 8).

Once the ‘natural’ luminescence signal has been measured, the sample is exposed to a calibrated radiation source and a series of known radiation doses are administered to the quartz grains. This regenerates the trapped charge population and hence the luminescence signal. When irradiated, some of the traps that have a low energy barrier to overcome in order to be evicted and hence short lifetimes (referred to as ‘unstable’ traps) are filled with electrons. This necessitates heating the quartz grains in order to evict any such unstable electrons so as not to increase the overall luminescence signal measured. Such heating is referred to as ‘pre-heating’ (Aitken, 1998, 29-31). Once a sample has been irradiated and pre-heated, the regenerated luminescence signals are measured and the resultant luminescence signals are recorded in the same manner as the ‘natural’ luminescence signal. Comparison of the intensity of the regenerated luminescence signals and the ‘natural’ signal allows an estimation of the absorbed dose that the quartz crystals received from the surrounding environment since the firing event. This radiation dose is termed the *paleodose* (Aitken, 1998, 7).

4.1.2.2: Derivation of annual dose

In order to determine the time elapsed since the last firing, it is necessary to know the rate at which the quartz grains absorbed energy from the surrounding radiation whilst inside the brick, or the *dose rate* (Aitken, 1998, 7). As mentioned above, the dose rate mostly derives from three principle radionuclides (^{238}U , ^{232}Th and ^{40}K). The radiations emitted by ^{40}K consist of beta (β) particles and gamma (γ) rays. In addition to these two forms of radiation, ^{238}U and ^{232}Th also emit radiation in the form of alpha (α) particles.

The penetrative power and dose absorbed by the quartz grains differs for each type of radiation. Alpha radiation has a low penetrative power within a ceramic matrix (c.10-50 μm) but contributes a high dose to the grain. In quartz grains that are approximately 100 μm and greater, only the outer skin of the quartz grains will absorb the radiation dose due to the poor penetrative power of α radiation (assuming there are no radionuclide impurities within the grain), (Aitken, 1985, 11). The use of such sized grains is employed in the *coarse grain dating* approach in which the impact of α particles on the annual dose rate can be largely avoided through the etching of the grains in hydrofluoric acid to remove the outer surface. Provided there are no radionuclide impurities within the grain

itself (see below), this approach effectively removes any contribution to the paleodose by α radiation (Aitken, 1998, 40-41) and was the approach adopted for this study (see 4.3.1). Beta particles are more penetrative than alpha radiation in a ceramic matrix (c.3 mm) but contribute less to the absorbed dose. A factor of 0.92 is typically introduced into the β radiation component when using coarse grains, due to the attenuation of the particles by the grains (this factor decreases as the grain size increases) (Brennan, 2003). Gamma rays are a highly penetrative form of radiation (c.0.3 m) but contribute less to the absorbed dose when compared to α and β particles due to the lightly ionising nature of this radiation (Aitken, 1998, 37). In addition to the three forms of radiation discussed above, there is also a small contribution from cosmic radiation. Cosmic radiation causes the least level of ionisation of all the radiation types and, given the similar sampling conditions, such as latitude and altitude, for this project, it was not expected to vary to a large extent (Wagner, 1998, 231). It should also be noted that the use of γ -TLD capsules (see 4.3.3.3.) automatically incorporated both the gamma and cosmic radiation components into the dose rate assessment (Aitken, 1998, 65). Generally, the dose rate for the coarse grain approach is composed of approximately 60% β radiation (from within the brick), 34% γ radiation (largely from outside the brick) and 6% cosmic radiation (ICRU, 2002, 71).

It should be noted that there are important factors that can influence the dose rate to a specific brick. One such factor that can potentially affect the decay chain sequence for ^{238}U and to a lesser extent ^{232}Th is that of *secular disequilibrium*. In the sequences of these two radionuclides, if the rate of decay of the parent matches that of the daughter then the condition of *secular equilibrium* is said to have been obtained. However, this requires that the system remains isolated (or *closed*) to the possibility of one or more of the daughters in the decay chain either being diminished or increased in quantity (Aitken, 1998, 45). One way in which the decay system can become *open* is through the escape of the gaseous daughter radon. Typically, radon has a range of approximately 0.02 μm in a ceramic matrix and will permeate out of the ceramic through small pores within the fabric (Aitken, 1985, 76). The escape of radon gas is a phenomenon that has previously been recorded in historic brick structures (Malanca *et al.*, 1992). It is possible to investigate whether radon is released from crushed brick samples by alpha counting experiments in which a few grams of the powdered

brick sample is placed onto a scintillation screen which in turn is placed on a PMT. When the screen is struck by an α particle the scintillation is recorded as an electric pulse. After a set period of measurement, the powdered sample is sealed airtight with a perspex lid, trapping any radon gas that might be released by the sample and altering the concentration of the subsequent radionuclides. This in turn alters the electric pulses recorded by the PMT (see 4.3.3.1 for a more detailed outline of alpha counting). Consequently, alpha counting offers a semi-quantitative approach to determine if radon gas is being released by a sample but is only a reflection of the present situation (Aitken, 1985, 91). A more accurate means of checking for radon disequilibrium involves high resolution gamma spectrometry (see 4.3.3.3) in which the ratio of the activity of one radionuclide that lies earlier than radon in the decay sequence (Ra^{226}) is compared to another that lies after radon in the decay sequence (Pb^{210}) but again this reflects the present situation (Aitken, 1985, 108; Aitken, 1998, 64).

Another factor that can play a role in disrupting the secular equilibrium that exists within a ceramic is the action of water. Firstly, water can dissolve and leach certain radionuclides, such as radium, out of the ceramic fabric disrupting the decay chain sequence (Aitken, 1985, 65). Secondly, water is more effective at absorbing the energy of radiation when compared to ceramic. Therefore any water within a brick fabric will reduce the radiation dose absorbed by the quartz grains (Aitken, 1985, 74; Wagner, 1998, 231). Consequently, for higher water contents, both the luminescence age and errors increase (see Fig. 4.3) (Bailiff, 2007, 843-844). It is therefore important to determine a water content that is likely to be a reasonable representation of that experienced by the brick during its lifetime. In order to address the aspect of possible variations in the brick fabric water content, samples were selected where possible from locations inside buildings that offered the greatest degree of shelter from the elements and stability in terms of the water content over an extended period, an approach adopted in other studies (Antrobus, 2004, 22-23). In terms of addressing the issue of the sample water content value, the saturation mass of the brick fabric was measured in relation to the dry mass of the brick, thus offering an upper limit to the age of the sample (Aitken, 1985, 75). The average saturated value of the bricks sampled for this project was found to be $16\% \pm 4$ (s.d.). However, it should be noted that the use of the saturated water content value would be an unrealistic representation

of the contexts from which samples were taken. It was possible to investigate the moisture content for one site in detail through the removal of a section of brick by hand saw. This was kept in an airtight sample bag before being dried in an oven and having its water content mass measured at regular intervals over the course of 48 hours. The results offer a more accurate picture for the water content of one brick from one site (Theydon Garnon) and showed that the water content was 1.8% of the sample mass (see Appendix A.3). This result is in agreement with the findings of an earlier study in which the water content of ten samples were all below 2% (Bailiff, 2007, 843). A water content value of 3% was selected for correcting the β -TLD results. Ultimately, it is thought that the water content was unlikely to represent a significant source of uncertainty for the bricks sampled in this project.

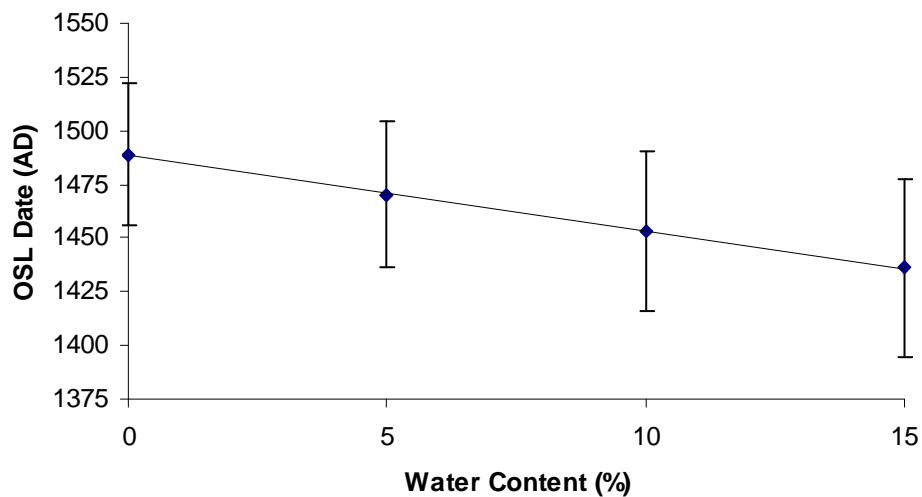

Fig. 4.3: Variation in the OSL date for sample 326-3 (Nether Hall) with water content of the brick. Note that as the water content increases, the annual dose rate decreases. This in turn results in an increase to the luminescence age of the brick.

In terms of measuring the dose rate of a brick sample, there are several different approaches that can be employed. For this project, the dose rate was based on measurements using luminescent dosimetry phosphors. Exposure of the phosphor calcium fluoride (CaF_2) to powdered portions of the brick fabric can be used to determine the β component of the dose rate by means of beta thermoluminescence dosimetry (β -TLD) (Bailiff, 1982). A similar experimental approach is employed to measure the combined γ and cosmic radiation

components of the dose rate by placing the phosphor aluminium oxide ($\text{Al}_2\text{O}_3\text{:C}$) into the building close to the point of sampling. This provides a contemporary measurement of the combined gamma and cosmic dose rate at the sampled brick location (Aitken, 1998, 63-65). Given that part of the total dose rate is derived from γ radiation which in turn is derived from radionuclides located within and beyond the sampled brick, samples collected from an area of the structure which has not been altered during its history are preferred, resulting in the need for a good understanding of the architectural history and development of the building (ICRU, 2002, 68-69). Another approach that was adopted for determining the beta and gamma components was high resolution gamma spectrometry. This measures the current activity of the ^{238}U , ^{232}Th and progeny and ^{40}K within a sample of the brick (see 4.3.3.3). By studying the ^{238}U , ^{232}Th and ^{40}K decay chain sequences, the individual dose rate components can be evaluated. Gamma spectrometry also allows the extent of radon disequilibrium to be measured by comparing the proportions of the radioisotopes Pb^{210} and Ra^{226} from the ^{238}U decay chain (Aitken, 1985, 102-108; Aitken, 1998, 46, 64).

It is often assumed that there are negligible quantities of the radionuclides discussed above within the quartz grains themselves (Aitken, 1998, 43). However, this assumption is not always the case and instances have been identified when radionuclides have been shown to be present inside quartz grains (Sutton and Zimmerman, 1978; Vandenberghe *et al.*, 2008). In order to address the issue of whether there were any radionuclides within the quartz grains that could potentially alter the total dose rate, the quartz grains were analysed by ICP-MS to determine the internal concentrations of ^{238}U , ^{232}Th and ^{40}K (Aitken, 1998, 47). By means of conversion tables, it was possible to determine the annual dose rate that these internal impurities would contribute to the total dose rate (see Appendix A.2.2). It should be noted that when this concentration based approach is adopted to determine the annual dose rate for other situations in which radon gas can escape, such as the analysis of a porous brick matrix, then there is the assumption that the radionuclides have been in a state of secular equilibrium. However, there is no need for such an assumption when considering radionuclide impurities that are trapped within the quartz grains themselves.

4.1.2.3: Derivation of sample age

Once the paleodose and dose rate have been determined for a given sample, the age can be derived by taking the ratio of the two values, as shown in equation 4.1.

$$Age = \frac{Paleodose}{Dose \quad Rate} \quad (4.1)$$

For the coarse grain dating approach used in this project, the dose rate component of the equation is expanded to include the different radiations involved. For a dry brick, equation 4.1 then becomes:

$$Age = \frac{Paleodose}{0.92 \dot{D}_\beta + \dot{D}_\gamma + \dot{D}_{cos}} \pm \sigma_A; \sigma_B \quad (4.2)$$

where \dot{D}_β , \dot{D}_γ and \dot{D}_{cos} refer to the different radiation components of the total dose rate (beta, gamma and cosmic respectively) and 0.92 is the attenuation factor of the beta component for 90-150 μm quartz grains. The two error factors, σ_A and σ_B , refer to the random and total errors respectively. The random error takes into account variations in the measurements associated with the paleodose and annual dose rate (Aitken, 1985, 246-247) whilst the total error also incorporates both the random and systematic errors, the latter including errors associated with calibrations of laboratory equipment and numerical constants used in the equations to derive the luminescence dates (Aitken, 1985, 247-250). In comparing luminescence dates derived from the same laboratory, the σ_A error value may be used in comparing results whilst the σ_B value should be used in the comparison of results between different laboratories.

The dates were derived by means of spreadsheet models developed in the luminescence laboratory at the University of Durham. The spreadsheet model primarily adopted for determining the OSL ages for all the samples in this project is based around the assumption that the brick is in a primary context and was used shortly after being produced (Bailiff, 2006a). Situations where the difference between the archaeological age and the OSL date was greater than $2\sigma_B$ would tend to suggest that the brick had been re-used. In such a situation where re-use had taken place, it is assumed that there is little variation in the beta component of the

dose rate but that the gamma and cosmic radiation components will have varied during the lifetime of the brick. In such circumstances where brick re-use was thought to have occurred, a different spreadsheet model was used (Bailiff, 2006b). This model makes a number of assumptions and allowances about the original context of the brick (see Appendix A.4). The results of these revised dates using the two phase dose rate model did not significantly alter the dates first derived through the single phase dose rate model (see Appendix A.4). Therefore, the OSL dates derived from the single phase dose rate model spreadsheet are used in the subsequent discussion.

4.2: SAMPLING CRITERIA AND PROCEDURES

4.2.1: Sample location evaluation

To minimise potential sources of uncertainty related to sample location and environment the following criteria were applied in selecting a sampling point.

- Brick walls that had been sheltered from the elements during the history of the building were more likely to have had stable moisture contents during their history and were therefore preferred. In this study it was possible to take samples from internal locations in all situations except one (the sample from the 16th century brickwork at Coggeshall Abbey).
- Sampling from homogeneous regions of the building fabric and avoiding large changes or areas of repair work, including the use of modern materials. Ideally, samples were taken from walls approximately 0.3-0.5 m deep to satisfy assumptions made regarding the γ component of the total dose rate.
- Attempting to avoid re-used brick. This was a challenging criterion to meet for certain buildings, especially when the similarity that exists between bricks from different periods is considered, for example, red ‘Tudor’ bricks from the 15th and 16th centuries. However, where there was

an obvious difference in the brickwork of a building, such as the use of Coggeshall type brick alongside red ‘Tudor’ brick, the relevant brickwork was sampled. Other locations where the difference in brickwork was not so obvious were guided by the archaeological understanding of the building at the time of sampling.

- Aesthetic considerations relating to the sampling location. This factor was dependent on the extent and location of exposed brickwork within the buildings and the attitudes of the relevant authorities, owners or individuals involved in caring for the buildings. Generally, samples were collected from locations that were hidden from the view of the general public. In all cases, the resulting hole was backfilled and sympathetically repaired.

4.2.2: Sampling methodology

The following sampling methodology is based on that employed for earlier brick dating studies undertaken by the laboratory (Antrobus, 2004, 23; Bailiff, 2007, 832). The different stages are illustrated in Fig.4.4.

Where a sampling point had met as many of the above criteria as possible, a diamond tipped 50 mm diameter dry drill core was used to cut into the brick, initially using one edge of the drill core to act as a guide before applying the full cutting surface. Drilling was halted at intervals during the removal of an individual core to prevent excessive heating of both the brick and drill. A stretcher face of the brick was preferred for sampling, enabling a core of c.100-150 mm to be obtained by drilling the full depth of the brick. During the drilling process, excess brick dust that was drawn to the surface was collected for adjusting the colour of the repair mortar. If the core fragmented before the full drilling depth was reached, the relationship between all the fragments was carefully marked and recorded. Once a core had been extracted, excessive brick dust was removed by gentle brushing. A permanent marker was used to label the core to allow for reconstruction (in the case of a fractured core), orientation in terms of the external wall face and identification by sample code. The core hole was backfilled with a lime based mortar supplied by a historic brick production

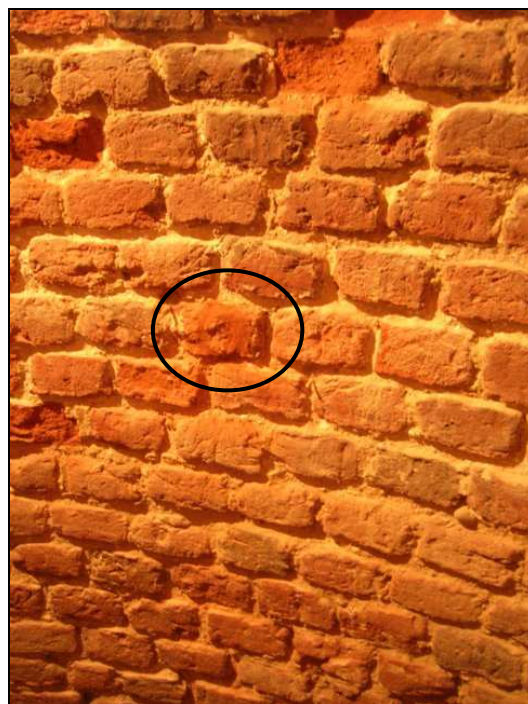

Fig. 4.4: Images illustrating the different stages in collecting a sample. The top image shows the brick selected for sampling being sampled with the electric core drill. The bottom left image shows the resulting hole after the core had been removed and the smaller holes in the mortar into which dose capsules have been inserted (the sticks to which the capsules are attached protrude from the wall face). The bottom right image shows the repair work done to the brick (circled) after sampling had been completed (the protruding parts of the dose capsule sticks were snapped off to prevent further disturbance to the capsules). The scale in the images is 20 cm in length.

company (Bulmer Brick and Tile, Bulmer). The hole was blocked with a thin section of the core cut from one end using a diamond tipped saw blade. Mortar coloured with brick dust was used to cosmetically repair the surface.

Once the brick core had been removed, smaller holes were drilled into the adjacent mortar layer to a depth of approximately half the length of the brick core. A capsule consisting of a fused quartz tube with a 3 mm thick wall and approximately 20 mm in length was inserted into each hole. Each capsule had been filled with approximately 20-50 mg of aluminium oxide before being sealed at each end with silicon sealant. Due to its light sensitivity, the capsule was wrapped in light proof tape and was attached to a thin rod to aid its insertion and retrieval. The dose capsules were sealed in place by silicone sealant.

The above approach was employed for sampling all the buildings with the exception of All Saints' Church, Theydon Garnon (335-1). Here the mortar surrounding the brick was drilled away before the entire brick was removed, an approach suggested by English Heritage guidelines for building restoration (Jackson and Day, 2005, 38). Two sections were then cut from the back corner of the brick. One was cut using a water cooled tile cutter whilst the other was cut with a hand saw. The portion cut with the tile cutter was later sub-sampled in the laboratory for experimental analysis whilst the hand cut portion was used to derive the water content of the brick (see 3.5.7.2).

Generally a small number of samples (often one to three) were collected from the historic buildings included in this project, with the exception of Eastbury where eight samples were collected. This was due to a combination of several factors, including identifying suitable areas inside the buildings where the aesthetic impact was judged to be minimal. Occasionally, the bricks being sampled were found to be extremely hard, requiring the use of a pilot drill and more time for drilling, limiting the number that could be collected during any given period of fieldwork. The alternative sampling approach that was tried at Theydon Garnon, whilst successful, was a much longer and convoluted process than drilling a core from the face of the brick and the latter approach is recommended for any future studies involving the analysis of brick dating work. The total number of samples collected was 32 from 16 buildings that spanned the late medieval period. This amount allowed relatively thorough archaeological assessments of the buildings to be compiled whilst providing time for the

luminescence field and laboratory based work. The number was also thought to be sufficient to address relevant archaeological questions relating to the buildings and to consider the reliability of luminescence in dating bricks from historic structures.

4.3: LABORATORY PROCEDURES

The procedures outlined here are based on those employed by the archaeological luminescence research group at the University of Durham (Bailiff and Holland, 2000, 615-616; Antrobus, 2002, 24-34; Bailiff, 2007, 832-836).

4.3.1: Sample recording and quartz extraction

Upon being returned to the laboratory, brick cores with any extraneous brick dust adhering to the surface were cleaned by means of a soft brush to reveal the underlying brick fabric. This was then examined visually, with specific aspects such as colour, porosity and inclusions within the brick fabric being noted on a standard record sheet. A series of photographs were then taken of the brick core. From this stage onwards, the brick sample was kept in a subdued red light environment to prevent the bleaching of any luminescence signal within the quartz grains.

Having been recorded and catalogued, a 10 mm slice was marked on the core at a point intended to reflect the depth to which the gamma dose capsule had been inserted into the wall. This section was cut from the core by means of a diamond tipped, water cooled blade. A sub-section of the core slice was cut off and crushed in a ball mill for later use in radiation characterisation experiments (see 4.3.3.2). The remaining core slice had the outer layers removed to a depth of approximately 2 mm by means of a diamond tipped, water cooled abrasive rotor. Once the sample had been cut from the core, it was dried in an oven set to 50°C for approximately 24 hours before being gently crushed in a pestle and mortar. The sample was then dry sieved to produce four different size fractions of crushed brick material, these being <90 µm, 90-150 µm, 150-355 µm and >355 µm. Each fraction was stored in a light proof canister.

Quartz grains from the 90-150 µm size fraction were retrieved from the crushed brick material by means of etching in a 40% hydrofluoric (HF) acid

solution for 45 minutes followed by etching in a dilute hydrochloric (HCl) acid solution for a 30-60 minute period to remove any precipitates that may have formed during the HF etch. Following the acid etching, the sample was washed with water and allowed to dry for approximately 24 hours. Once dry, the samples underwent secondary sieving to remove any quartz grains that had been reduced in size to below the 90 μm size threshold of the fraction. The final quartz samples were stored in glass vials which were kept in light proof canisters.

4.3.2: Paleodose Evaluation

The necessary measurements for deriving the paleodose value of a sample were made using two automated Risø TL-DA 12 readers (Risø National Laboratory, Roskilde, Denmark). Aliquots of the quartz samples were mounted in a monolayer onto 10 mm diameter stainless steel discs coated in silicon oil. The stimulating source consisted of blue diodes (470 nm wavelength) and any resultant OSL signals were measured after passing through a Hoya U340 filter.

Before the main measurement sequence to derive a sample's paleodose was undertaken, initial tests were performed on an aliquot of the quartz. Once the natural luminescence signal had been measured, a series of radiation doses were administered to the aliquot and the resultant luminescence signals measured. This allowed a dose-response graph to be formed onto which the natural signal could be interpolated, suggesting a preliminary paleodose value (see Fig. 4.5).

In order to derive the paleodose for a given sample, a Single Aliquot Regenerative (SAR) protocol was used. The basic principle of the SAR protocol is that all required measurements are made on a single aliquot which has luminescence signals successively measured and regenerated (Murray and Wintle, 2003; Murray and Wintle, 2000, 58). Fig. 4.6 outlines the basic sequence that was followed for a single aliquot using the SAR sequence employed at Durham. This is a modified version of that proposed by Murray and Wintle (2000) in that it incorporates a pre-heat monitor (PHM) stage to monitor any thermal transfer (see 4.3.2.4) and to determine the background value to the preceding OSL signal measurement (Bailiff and Holland, 2000, 616; Bailiff, 2007, 834). The following discussion considers the various stages employed in the SAR sequence further. The paleodose results, as determined through the SAR sequence, are discussed in the appendix (see Appendix A.1).

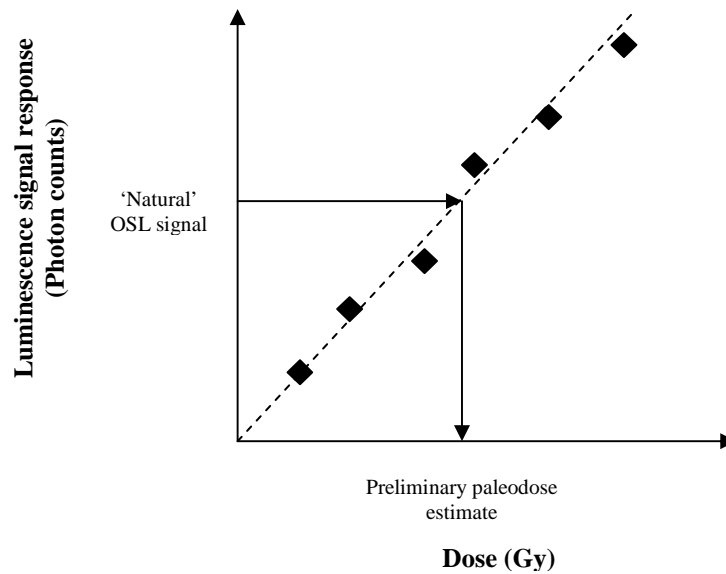

Fig. 4.5: Dose-response graph with the 'natural' OSL signal interpolated onto it. By exposing the aliquot to a series of radiation doses and measuring the luminescence signal (represented by diamonds), it is possible to interpolate a preliminary value for the paleodose. A similar principle is used in the SAR protocol (see below).

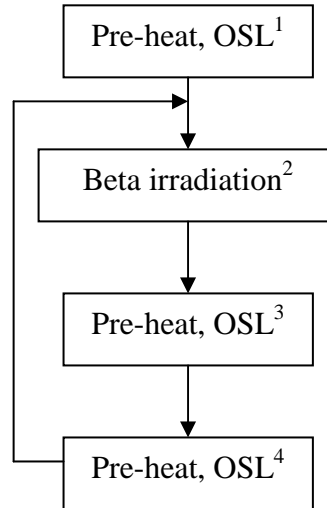

Fig. 4.6: Diagram illustrating the successive series of actions undertaken on a sample aliquot in order to determine the paleodose. The first pre-heat and OSL measurement (1) is made to measure the 'natural' luminescence signal that developed in the quartz during the lifetime of the brick. The sample is then irradiated with a beta source (2) to regenerate the luminescence signal which is subsequently measured (3). The pre-heat and OSL measurement is repeated afterwards (4) to act as a pre-heat monitor to both the background signal and the potential for thermal transfer of electrons from 'shallow' to 'deeper' traps. After the natural signal and first irradiation have been measured, the cycle is repeated several times with varying degrees of irradiation.

4.3.2.1: Sample pre-heat

The pre-heat involves heating the aliquot to a given temperature at which it is held for a length of time (10 s was the time interval used for the various pre-heats in this project). It is performed to remove any electrons in ‘shallow’ traps that are light sensitive. Such traps have short lifetimes and are not present in the ‘natural’ luminescence but are present in the regenerated luminescence signals produced in the laboratory. Consequently, there is a need to remove this component from the regenerated luminescence signals in order to prevent an underestimation of the paleodose (Aitken, 1998, 189). It also allows for thermal transfer processes (see 4.3.2.4) within the crystal to be taken to a certain degree of completion, both for the ‘natural’ and regenerated luminescence signals (Aitken, 1998, 190).

4.3.2.2: Sample OSL measurement

The OSL measurements were undertaken with the sample being stimulated by blue LEDs at a sample temperature of 125°C. Stimulation time began after a 2 s pause before lasting 48 s with data points being collected every 0.2 s (a total of 250 data points for the exposure period). The luminescence released was recorded by the PMT as a decay curve which varied in intensity for different samples (see Fig. 4.7). Generally, the signal response for the first few seconds after stimulation began was integrated to avoid including the background ‘noise’ of the sample and Risø system.

4.3.2.3: Sample irradiation

A series of varying beta radiation doses were administered to the sample aliquots during the SAR sequence by a timed exposure to a calibrated, beta emitting $^{90}\text{Sr}/^{90}\text{Y}$ source (Göksu *et al.*, 1995). The dose rates differed for the two Risø machines, one being approximately 0.5 Gy min^{-1} and the other being 3.5 Gy min^{-1} . The final magnitude of the radiation dose range administered to the quartz during the SAR sequence is 0.8β , 1.0β and 1.2β , where β represents the estimated paleodose from earlier preliminary tests (see 4.3.2) (Bailiff, 2007, 835). Interpolation of the ‘natural’ luminescence signal, which ideally lies within the $0.8\text{--}1.2\beta$ range, (see Fig. 4.8) allows a paleodose value to be determined.

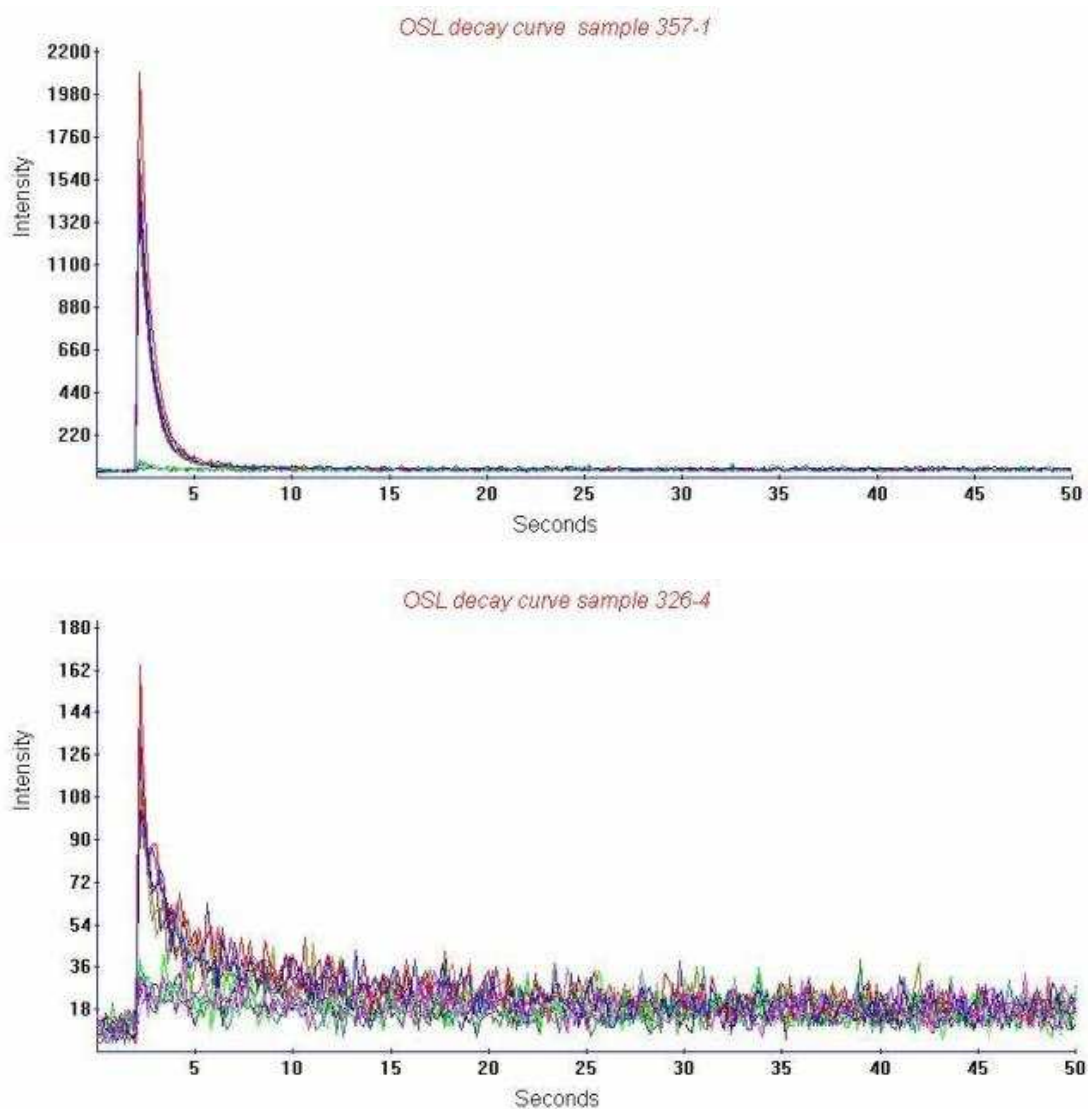

Fig. 4.7: OSL decay curves for two different samples. The top curve was for quartz extracted from sample 357-1 (Bradwell-juxta-Coggeshall) whilst the bottom curve was for quartz extracted from sample 326-4 (Nether Hall). Note the difference in the scale of signal intensity between the samples.

4.3.2.4: Pre-heat monitor (PHM)

In the Durham SAR sequence, once the sample aliquot has been irradiated and the regenerated OSL signal measured, the PHM is performed. This involves heating the sample and measuring the quartz a second time for any OSL signal (Bailliff and Holland, 2000, 616). This is done for two reasons. First, it provides a means of checking the background value of the previous OSL measurement which, when subtracted from the regenerated OSL signal give a more accurate

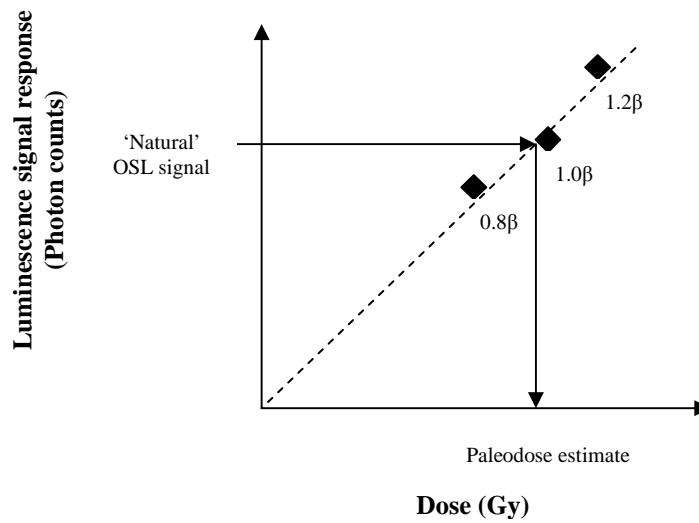

Fig. 4.8: Diagram illustrating the varying dose-response graph for a sample. During the SAR sequence, different beta radiation doses are administered to the sample aliquot, the magnitude of which are based on preliminary testing (see Fig. 4.5). Ideally, the paleodose value should equal 1.0β or lie somewhere between the $0.8-1.2\beta$ range.

reflection of the luminescence signal. Secondly, it provides a means to check whether any electrons have been thermally transferred from relatively unstable ('shallow') traps into the more stable ('deeper') traps during the pre-heat action (Bailiff, 2007, 834). The 'deeper' traps are normally associated with luminescence signals that are stable for period of time that span those of interest for this project i.e. centuries to millennia, whilst the 'shallow' traps are eroded due to the naturally occurring thermal vibrations of the crystal lattice (Aitken, 1998, 31). It is therefore critical to evaluate the likelihood of thermal transfer taking place within a given sample to ensure that 'shallow' trap electrons do not contribute to the luminescence signal.

4.3.2.5: SAR sequence

The actual SAR protocol adopted for deriving a paleodose estimate for each sample aliquot is outlined below in Table 4.1. It is based on that described by Murray and Wintle (2000) and has been successfully used for brick dating previously (Antrobus, 2002; Bailiff, 2007). Note that throughout the sequence a sensitivity monitor, consisting of a standard 0.8β irradiation of the quartz grains,

<i>Stage</i>	<i>Action</i>	<i>Measurement</i>
1	PH, OSL	'Natural' luminescence
2	PH, OSL	Pre-heat monitor
3	+0.8 β , PH, OSL	Administer beta dose and measure OSL
4	PH, OSL	Pre-heat monitor
5	+1.0 β , PH, OSL	Administer beta dose and measure OSL
6	PH, OSL	Pre-heat monitor
7	+0.8 β , PH, OSL	Administer beta dose and measure OSL (sensitivity monitor)
8	PH, OSL	Pre-heat monitor
9	+1.2 β , PH, OSL	Administer beta dose and measure OSL
10	PH, OSL	Pre-heat monitor
11	3-10	Repeat stages 3-10
12	+0.8 β , PH, OSL	Administer beta dose and measure OSL (sensitivity monitor)

Table 4.1: SAR sequence used on sample quartz aliquots (Bailiff, 2007, 834).

was applied. The OSL response to this was used to indicate if any major sensitivity changes occurred during the SAR sequence, with the results being used to correct for any such changes.

For each sample, several aliquots were used to produce paleodose values. A range of pre-heat temperatures, spanning 200-240°C, were employed in deriving the paleodoses, with 200°C, 220°C and 240°C being the most frequently selected values. The paleodoses were plotted against the respective pre-heat temperatures to check that the average paleodose was stable for the pre-heat temperatures employed (observed as a plateau across the pre-heat temperature range) (see Fig. 4.9).

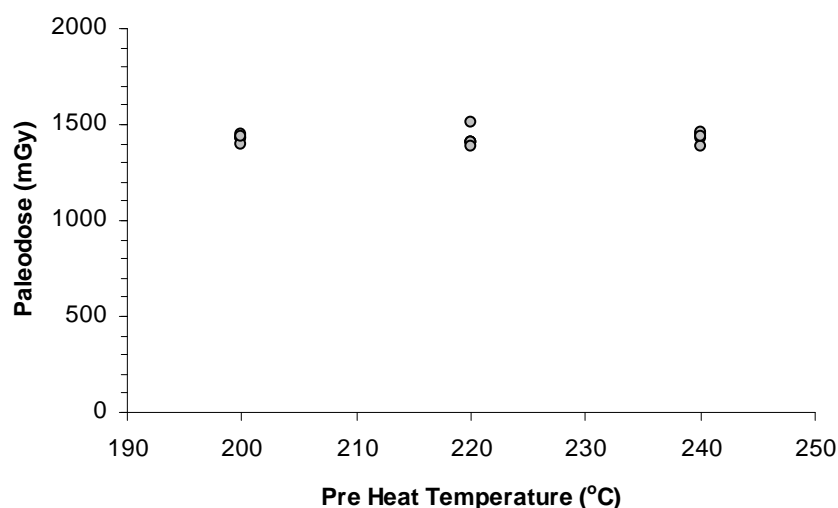

Fig. 4.9: Pre-heat plateau for sample 338-1 (Woodham Walter). Note the similarity of the paleodose values across the pre-heat temperature range. The mean paleodose derived for this sample was 1.4 Gy.

A plateau is indicative of the adopted SAR sequence producing consistent paleodose estimates and correcting any potential errors that might emerge, for example, removing any thermally transferred OSL signal. It also shows that the measured OSL signal is associated with traps that are stable over the timescale being investigated (those associated with pre-heat temperatures of 220°C are stable above a million years for storage temperatures of 20°C) (Smith *et al.*, 1990, 76; Bailiff, 2007, 837).

4.3.3: Annual Dose Rate Evaluation

In order to evaluate the total annual dose rate that the quartz grains within the brick core samples receive, a series of different experiments must be undertaken. These focus on different aspects of the radiation field both within and surrounding the brick and are individually considered below.

4.3.3.1: Thick Source Alpha Counting (TSAC)

TSAC involves placing a fine layer of powdered brick matrix onto a zinc sulphide screen. When alpha particles from the powdered brick interact with the zinc sulphide they produce scintillations which are recorded by a PMT and provide an indication of the sample's alpha activity over a certain period of time (Aitken, 1985, 26-27). Whilst the alpha particle contribution to the quartz was avoided by employing the coarse grain dating technique, measuring the alpha activity of the brick matrix is still of benefit in terms of investigating the likelihood of radon emission taking place within a sample (see 4.1.2.2).

To evaluate the extent of radon gas escaping, the alpha activity of the crushed brick sample was measured in an unsealed state, thus allowing the gas to escape if it were released. After 1000 counts had been recorded, the plastic housing containing the scintillation screen and brick powder was sealed (an 'O' ring was used to make the seal air-tight). The alpha activity of the sample was then measured a second time for 24 hours in the 'sealed' state, trapping any radon gas that may be released. If radon gas does begin to accumulate then the count rate will also increase. Consequently, the ratio of the two different states of measurement should approximate a value of one if no gas is released whilst a divergence from this value is indicative of radon being released by the sample (Aitken, 1985, 91). The results for the samples are given in the appendix (see

Appendix A.2.1) and indicate that there was no significant escape of radon gas from any of the samples in the pulverised form in which they were measured. It should be noted that TSAC only provides a semi-quantitative indicator of the present situation regarding radon gas emission and a better indication can be given through high resolution gamma spectrometry (see 4.3.3.3).

4.3.3.2: Beta Thermoluminescence Dosimetry (β -TLD)

The beta radiation component of a brick sample was derived by β -TLD experiments. This involves filling an acrylic plastic container with approximately 1 cm^3 of powdered brick material. At the bottom of the container is a thin plastic Mylar window through which beta particles can pass but which stops alpha particles. A tray containing a luminescent phosphor held in place by resin is situated beneath the plastic window (see Fig. 4.10).

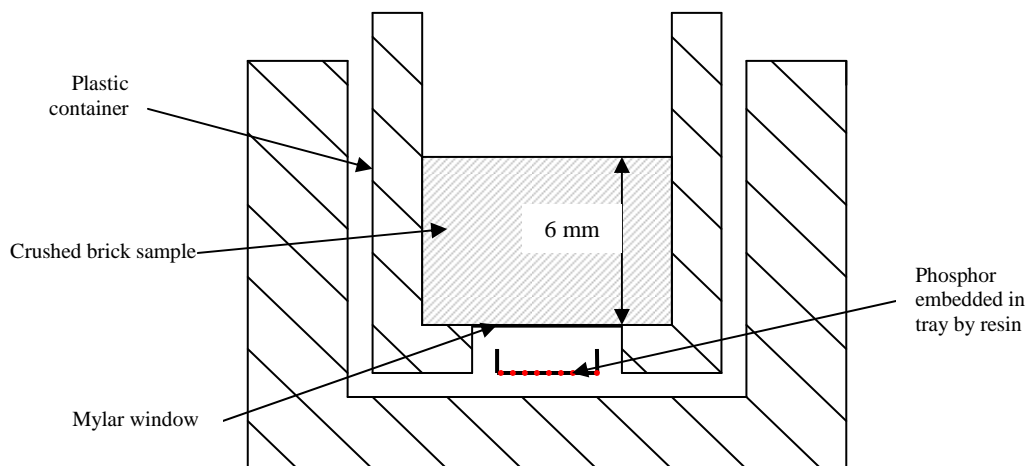

Fig. 4.10: Beta-TLD apparatus (after Bailiff, 1982).

The sample is stored for an extended period (approximately one week) in a lead safe to reduce the contribution from background radiation. During this storage time, a latent luminescence signal develops in the phosphor and this is read using the Risø reader. A luminescence signal is then subsequently induced in the phosphor by means of a timed exposure to a calibrated beta source. By comparing the magnitude of the luminescence signals obtained following exposure to the sample and to the beta source, it is possible to determine the beta dose rate within the brick fabric (Bailiff and Aitken, 1980; Bailiff, 1982). Several aliquots from each sample were analysed by β -TLD to determine the average beta

dose rate within the brick fabric, the results of which are given in the appendix (see Appendix A.2.1).

4.3.3.3: Gamma Thermoluminescence Dosimetry (γ -TLD) and Spectrometry

The gamma and cosmic radiation components of the radiation field were measured by γ -TLD experiments. This involved use of the luminescent phosphor aluminium oxide doped with carbon ($\text{Al}_2\text{O}_3:\text{C}$) due to its similar gamma radiation absorption characteristics when compared with quartz (Aitken, 1998, 84). As described earlier (see 4.2.2), a small amount of the phosphor is sealed into a fused quartz tube with 3 mm thick walls, a thickness designed to absorb beta particles originating from the surroundings which could potentially contribute to the luminescence signal in the phosphor (Aitken, 1998, 65).

It is important to appreciate that because these radiations act over a much greater distance (gamma radiation can, for example, penetrate to c.0.3 m in a mineral matrix), variations in the structure surrounding the core sample point can alter the intensity of the gamma and cosmic radiation components. Thus, a sample collected next to a doorway opening has less brick surrounding it and subsequently fewer radionuclides contributing to the gamma component than if the sample is taken from the centre of a large solid wall. It is for this reason that an understanding of the development of the building history is required (ICRU, 2002, 68-69). Due to these variations, the capsule is left sealed in the wall close to the point of sampling to provide a representative value of the gamma and cosmic radiation components at this location (Aitken, 1998, 63-65). In situations where more than one sample was collected within close proximity to another (see 3.3.2.2 for example), it is assumed that any previous sampling and repair work has a negligible influence on any capsules introduced during the course of secondary sampling. This is due to the small volume of material the sample core represents in comparison to the surrounding brick matrix. The capsules were inserted into the wall at a depth reflecting the point in the core from which the quartz would be extracted, again to provide a representative value of the gamma and cosmic radiation components at this point. They were left *in situ* for an extended period of approximately six months during which time the latent luminescence signal developed (see Fig. 4.11).

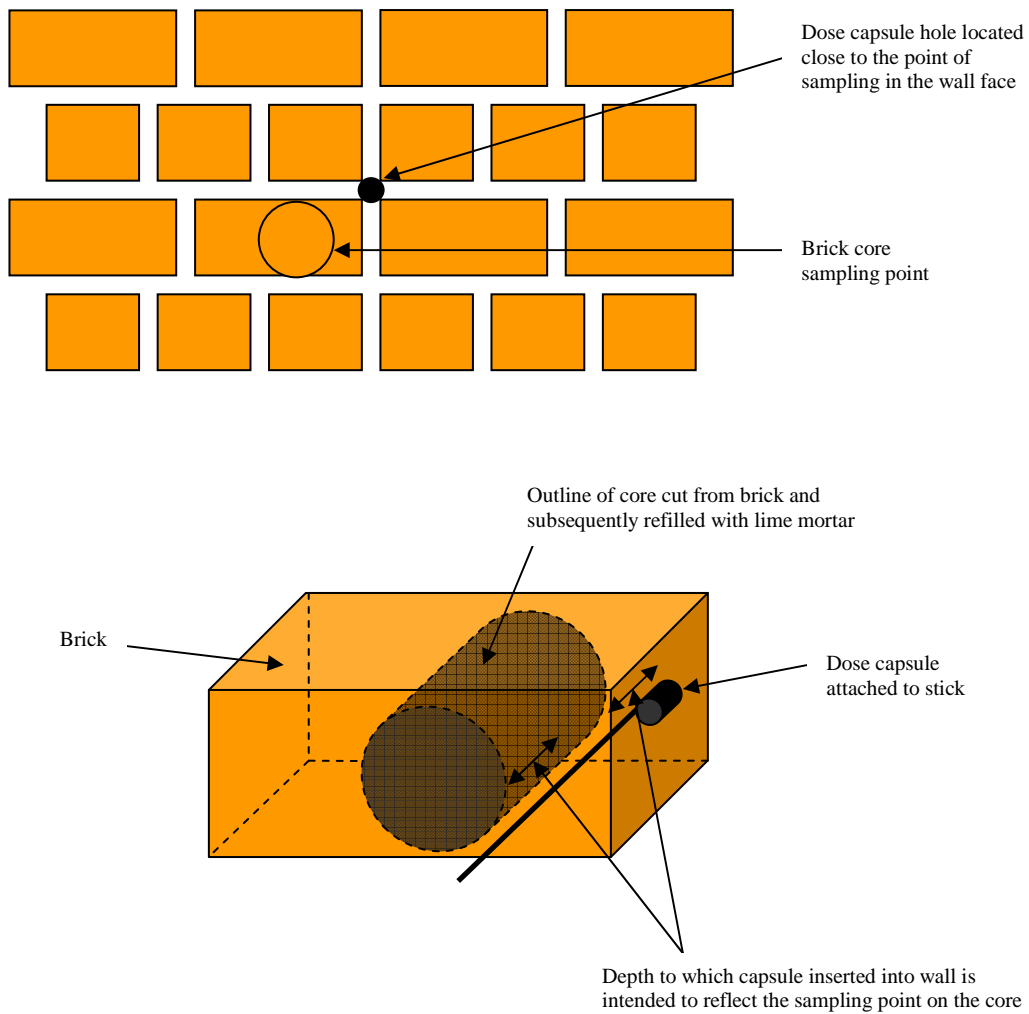

Fig. 4.11: Diagram illustrating how the dose capsule is located close to the point of sampling on the core, both in terms of the position on the wall face and the depth of sampling in the core.

Upon retrieval, the capsule was promptly returned to the laboratory and stored in a lead safe until the luminescence signal could be measured. The latent luminescence signal was measured and compared to artificially regenerated luminescence signals induced by exposure to a calibrated radiation source. Through comparison of the ‘naturally’ generated luminescence signal to the regenerated values, it was possible to derive a value for the dose that had accumulated within the phosphor and hence the combined gamma and cosmic dose rate.

In addition to the γ -TLD measurements, the activity of the ^{238}U , ^{232}Th and ^{40}K radionuclides were measured by gamma spectrometer analysis of slices taken from the brick core adjacent to the slice from which the quartz was extracted.

Where possible, a slice of approximately 10 mm in thickness was cut from the core (typically ~25 g in mass). This was dried in an oven set at 50°C for approximately 24 hours before being sealed with Parafilm in a plastic container. The sample container was placed directly onto a beryllium window above a high purity germanium crystal and the activity of the ^{238}U , ^{232}Th and ^{40}K radionuclides within the sample were measured over a 72 hour period. Between brick samples, standards that were used to calibrate and monitor the spectrometer were measured for a 24 hour period. The results from the brick core slices allowed the activity of the radionuclides and, through the use of conversion factors, an estimation of the beta activity within the brick to be determined. This was then used as a comparative to the β -TLD results. The gamma spectrometer results were also used to determine the present state of radon gas escaping from the brick core slice based on comparison of the activity of the Ra^{223} and Pb^{210} radionuclides (see Appendix A.2.1).

4.3.3.4: Moisture uptake

In order to derive an upper limit for the moisture content of the brick, the slice used for gamma spectrometry measurements was used afterwards for determining the water saturation content. The slice was dried in an oven set at 50°C before having its dry mass recorded followed by immersion in water for a week, after which time its wet mass was measured. The brick slice was returned to the water for a second week in order to check if there was any significant alteration in the water absorbed by the brick slice. It was found that there was little change in the amount of water absorbed by the brick slice after the second week of immersion in water and this was considered to be the saturation point of the brick slice. The difference between the saturated and dry masses was expressed as a percentage of the dry mass of the brick core slice.

4.4 LUMINESCENCE RESULTS

The ages determined for the bricks sampled are summarised in Table 4.2 and shown in Fig. 4.12. It is apparent from Fig. 4.12 that there is an absence of dates between the 12th to the 15th century and a large number of dates between the 15-16th centuries.

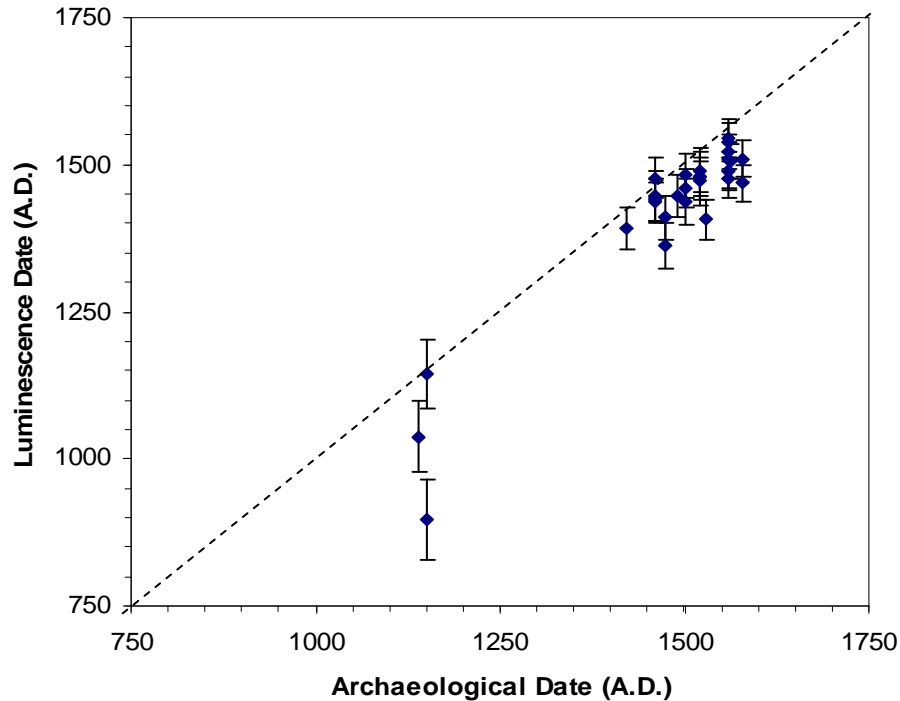

Fig. 4.12: Plot of the luminescence dates against the archaeological dates assigned for the sampled buildings. The error bars relate to the σ_B errors associated with the luminescence dates.

This observation in the data is in part due to the failure of the ‘Flemish’ type bricks to yield OSL signals and subsequently luminescence dates. Once this was found to be the case with several samples from different sites, it was decided to focus attention away from the ‘Flemish’ type brick. Attempts to identify accessible red ‘Tudor’ type brick that was associated with a 14th century context were unsuccessful, largely due to uncertainty surrounding whether the brick was in a primary context or had been re-used in a later alteration to the building. This factor of suspected re-use also played a part in the suitability of other sites where Coggeshall type brick occurred (see 6.2 for the example of Fairstead church). Another factor that restricted the collection of samples from some sites was refusal from building owners for sampling to take place. Nevertheless, the sites from which samples were taken did allow a number of interesting archaeological questions to be addressed. It should be noted that the large number of samples collected from 15th and 16th century contexts is in part a reflection of the large extent to which brick was being employed during the latter part of the medieval period and into the early modern era.

Overall, whilst there are several instances where the luminescence dates determined for the samples do agree well with the archaeologically derived date, such as sample 327-3, there are many instances where the luminescence date is much older than that determined by conventional archaeological means. Such differences are discussed in more detail in the following chapter.

Lab. Ref.	Paleodose \pm s.e. (mGy)	Annual Dose Rate \pm s.e. (mGy a⁻¹)	OSL Date $\pm\sigma_A$; $\pm\sigma_B$ (A.D.)	Archaeological Age Estimation (A.D.)
325-4	1641 \pm 41	2.93 \pm 0.08	1447 \pm 20; \pm 35	15 th -early 16 th century
326-3	1590 \pm 46	3.00 \pm 0.08	1478 \pm 21; \pm 34	1450s-1460s
326-4	1825 \pm 85	3.20 \pm 0.09	1438 \pm 30; \pm 42	1450s-1460s
326-4#2	1859 \pm 88	3.32 \pm 0.09	1448 \pm 30; \pm 42	1450s-1460s
326-5#2	1688 \pm 59	2.96 \pm 0.08	1439 \pm 25; \pm 38	1450s-1460s
327-2	1492 \pm 09	2.77 \pm 0.07	1469 \pm 14; \pm 31	Late 16 th century
327-3	2925 \pm 56	3.39 \pm 0.09	1144 \pm 28; \pm 58	Mid 12 th century
334-1	1576 \pm 55	3.03 \pm 0.08	1488 \pm 22; \pm 35	Early 16 th century
334-2	1665 \pm 40	3.12 \pm 0.08	1474 \pm 19; \pm 32	Early 16 th century
335-1	1934 \pm 49	3.66 \pm 0.09	1480 \pm 19; \pm 33	Early 16 th century
336-1	1392 \pm 25	2.80 \pm 0.07	1510 \pm 16; \pm 30	Late 16 th century
337-1	1684 \pm 28	3.07 \pm 0.08	1459 \pm 17; \pm 33	Late 15 th -early 16 th century
337-2	1571 \pm 63	2.99 \pm 0.08	1482 \pm 25; \pm 37	Late 15 th -early 16 th century
337-3	1614 \pm 59	2.83 \pm 0.07	1437 \pm 26; \pm 39	Late 15 th -early 16 th century
338-1	1428 \pm 09	2.84 \pm 0.08	1505 \pm 14; \pm 29	Mid 16 th century
339-1	1530 \pm 12	2.55 \pm 0.07	1407 \pm 16; \pm 35	Mid 15 th -early 16 th century
340-1	1419 \pm 57	3.06 \pm 0.08	1545 \pm 22; \pm 33	1550s-1570s
340-2	1307 \pm 26	2.69 \pm 0.07	1522 \pm 16; \pm 30	1550s-1570s
340-3	1186 \pm 42	2.53 \pm 0.07	1538 \pm 21; \pm 32	1550s-1570s
340-4	1294 \pm 20	2.59 \pm 0.07	1508 \pm 15; \pm 30	1550s-1570s
340-5	1365 \pm 32	2.64 \pm 0.07	1490 \pm 18; \pm 32	1550s-1570s
340-6	1307 \pm 14	2.53 \pm 0.07	1491 \pm 15; \pm 30	1550s-1570s
340-7	1229 \pm 29	2.32 \pm 0.06	1478 \pm 19; \pm 33	1550s-1570s
340-8	n.s.	-	-	1550s-1570s
352-1	1924 \pm 140	3.65 \pm 0.10	1481 \pm 41; \pm 49	Mid-late 15 th century
352-2	2416 \pm 41	3.74 \pm 0.10	1362 \pm 20; \pm 40	Mid-late 15 th century
352-3	2152 \pm 60	3.60 \pm 0.09	1410 \pm 23; \pm 38	Mid-late 15 th century
353-1	1887 \pm 21	3.07 \pm 0.08	1393 \pm 17; \pm 36	Early 15 th century
354-1	n.s.	-	-	Early 14 th century
354-2	n.s.	-	-	Early 14 th century
355-1	2844 \pm 43	2.56 \pm 0.07	896 \pm 33; \pm 68	12 th century
356-1	n.s.	-	-	Early 14 th century
357-1	3060 \pm 37	3.15 \pm 0.08	1038 \pm 28; \pm 60	Early 12 th century

Table 4.2: Summary of the paleodose and annual dose values, the OSL dates and the assigned archaeological age of each building. Note that for some samples it was not possible to obtain an OSL signal from the quartz extracted (denoted as n.s. for 'no signal').

CHAPTER 5: HISTORIC BUILDING INTERPRETATION REVIEW

'To know things well, we must know the details; and as they are almost infinite, our knowledge is always superficial and imperfect'

-La Rochefoucauld

This chapter provides a series of discussions for the sampled buildings, each of which considers the potential implications for the original archaeological assessments in light of the luminescence dates obtained. The OSL date ranges given in the text constitute $\pm 1\sigma_B$ (i.e. mean- σ_B to mean+ σ_B) and incorporate both the random and systematic errors. In circumstances where re-use seems likely based on the OSL date, potential sources from which older brick might have been obtained in the immediate locality of the sampled building have been investigated where possible.

5.1 SECULAR BUILDING ASSESSMENTS

5.1.1: Coggeshall Abbey

Sample	Location	OSL Date ($\pm \sigma_B$)	Archaeological Date
327-2	North Range	1469 \pm 31	Late 16 th century
327-3	Kitchen/Infirmary pillar	1144 \pm 58	Mid-12 th century

The luminescence date range derived for the sample taken from the lower western wall of the northern range (327-2) was 1438-1500. This is contrary to the idea that the northern range dates to the late 16th century (Walker, 2007, 11). It is proposed that the sampled brick was robbed from the western side of the cloister for the construction of the north range. Limited excavations on the western side of the cloister in the mid-20th century uncovered brick walls, thought to date to the latter half of the 15th century and covered in a thin layer of plaster, tinted pink on the outside of the cloister walk and yellow on the interior surface (Gardner, 1955, 30). A series of moulded mullion bricks coated in a thin layer of plaster and matching the cross section profiles of the 15th century bricks excavated by Gardner were observed by the author during fieldwork (see 3.3.1.1). A detailed

study of their moulded profiles and comparisons to other late 15th century cloister mullions would provide a more accurate date for the age of the brickwork in the cloister. This in turn could help confirm that the cloister was the source plundered for the construction of the northern range. The presence of carved ashlar blocks and the larger Coggeshall type bricks in the northern range also supports the idea that this lower wall has been built using material robbed from another structure. Ultimately, it seems likely that a range of materials were being taken from earlier structures, probably the cloister and other buildings within the monastic complex, during the construction of the north range and probably other parts of the house.

The second OSL date at Coggeshall Abbey (327-3) was for a Coggeshall type brick incorporated into the pillar, thought to date to the mid-12th century due to the scalloped capital (RCHME, 1922, 168). The luminescence date range of 1086-1202 is consistent with the architectural date of the pillar and also agrees with the suggestion that building work on the abbey complex was underway in the years following its likely foundation in the 1140s (Gardner, 1955, 19-21).

5.1.2: Eastbury Manor

Sample	Location	OSL Date ($\pm \sigma_B$)	Archaeological Date
340-1	North cellar	1545 \pm 33	1557-1578
340-2	Panelled room cupboard	1522 \pm 30	"
340-3	Summer parlour	1538 \pm 32	"
340-4	North cellar	1508 \pm 30	"
340-5	Panelled room cupboard	1490 \pm 32	"
340-6	Summer parlour	1491 \pm 31	"
340-7	South wall of east wing attic	1478 \pm 33	"
340-8	South wall of east wing attic	(No Signal)	"

The results for Eastbury manor house present an interesting situation in which the majority of the OSL dates do not agree with the suggested construction date of the late 1550s to the late 1570s. The total date range from all the samples covers a broad period from 1445 through to 1578. Analysis using Ward and Wilson's (1978) test statistic T ($T = 10.4$; $\chi^2_{7,0.05} = 5.99$) indicates that there is a significant difference between all the dates and that they do not form a single group. There are insufficient OSL dates to derive a sufficiently detailed

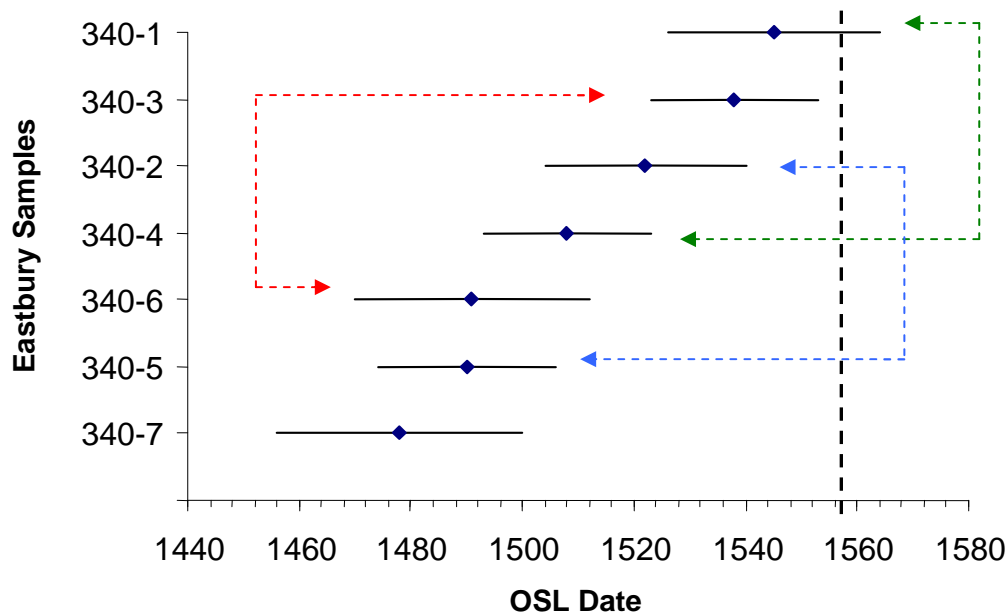

Fig. 5.1: Chronological distribution of the OSL dates derived for Eastbury Manor (the error bars indicate $\pm 1\sigma_A$). The coloured dashed lines indicate where samples were collected from the same location. The heavy black dashed line highlights the earliest likely date for construction at Eastbury (1557) given the current archaeological understanding of the building.

histogram or cumulative frequency distribution plot in an attempt to determine whether the data is normally distributed. However, a chronological distribution plot of the OSL dates indicates that they range from the late 15th century through to the mid-16th century (see Fig. 5.1). It should be noted that in three instances the samples collected from Eastbury were paired (illustrated in Fig. 5.1 by the coloured dashed lines) in order to allow comparison of the luminescence results for localised areas of the building. In all three instances, there is no significant difference between the two samples as determined by using Ward and Wilson’s (1978) test statistic T (see Table 5.1).

Samples compared	T result	Degrees of Freedom (d.f.)	$\chi^2_{0.05}$	Significant Difference	Pooled Mean
340-1 & 340-4	1.93	1	3.84	No	1520 (± 12 ; ± 16)
340-2 & 340-5	1.77	1	3.84	No	1508 (± 12 ; ± 16)
340-3 & 340-6	3.32	1	3.84	No	1507 (± 12 ; ± 16)

Table 5.1: Comparative test results between paired samples from Eastbury Manor, all indicating no significant difference in their OSL dates. The pooled mean values of the samples are given in the final column.

The agreement of the Ward and Wilson test results demonstrates the reproducibility of the luminescence technique. It is also interesting to note that the pooled mean values for the paired samples are all earlier than the suggested archaeological construction period.

The luminescence results suggest that a mixture of different aged brick was used in the construction of Eastbury Manor, ranging from the late 15th century through to the mid-16th century. Some of the OSL dates (340-1, 340-2 and 340-3) agree at the $1\sigma_B$ error range with the suggested construction date of 1557 to 1578 based on the archaeological analysis of Eastbury. However, the remaining four OSL dates range from the late 15th to the early 16th century. Examination of the fabric of all the brick cores showed that they were similar. Generally they were an orange colour, with the exception of sample 340-1 which had a darker hue, a factor that could have been a result of its location in the clamp when fired. The core fabrics were sandy and coarse and contained several small pores and dark inclusions. No obvious features or characteristics could be discerned that accounted for the differences in the OSL dates derived for this site.

The idea that some of the bricks might have been re-used from older sites nearby could be supported by the fact that the bonding pattern is an irregular English bond, the dimensions of the bricks vary quite considerably (175-250 mm × 113-125 mm × 56-63 mm) (Streatfeild, 1872, 166) and, where they could be examined, the mortar joints in the sampling locations are generally quite thick and uneven. The last factor could have been deliberate in order to compensate for the differences in the size of the bricks if taken from different sources. However, different sizes in moulds and possibly the speed of construction are also factors that should be considered as possible causes for these specific observations. It is worth noting that a closer re-examination of the brickwork in the northern cellar after sample collection showed it to contain darkened, partially vitrified headers (see 3.3.2), suggesting that these bricks had been re-used from a different context, a proposal which the luminescence dates would support.

Given that the present building contains certain architectural features that are more characteristic of the early 16th century, such as the moulded brick chimneys and pediment above the main entrance (London Survey Committee, 1917, 19), it is possible that the present building had actually been erected around this time. This would imply that the earlier building thought to have stood on the

site (see 3.3.2.1) might actually constitute a large portion of the present building. When Sysley came into ownership of the property in the 1550s, certain features of this structure may have required repair, such as the roof and guttering, as evident in the dendrochronological date of 1566 and the date plate of 1573 on the rain hopper. He might also have inserted larger, outward facing windows in an attempt to modernise an aging building, possibly re-using any brickwork subsequently removed to replace worn or damaged brick inside the building.

If it is assumed that Eastbury was first erected in the early 16th century and altered later in the 1560s and 1570s then there is still the issue of the late 15th century luminescence dates and the source from which these bricks may have been robbed. One possible source of late medieval brick was Barking Abbey which was dissolved in 1539 and where demolition of the site began in 1541 (VCH, 1907, 120; Clapham, 1913, 72). When the site was excavated in the early 20th century, there was strong evidence to suggest that red ‘Tudor’ brick had been used in the later medieval contexts of the abbey. These included brick vaulting to the *reredorter*, brick foundations of outlying buildings thought to have been the guest houses, a building between the *reredorter* and the western end of the church of which the later phase was constructed in brick and part of a red ‘Tudor’ brick wall, laid in English bond, that was the boundary between the parish churchyard and the abbey precinct (Clapham, 1913, 77, 84-85). The excavators at the time considered these brick components as being early 16th century but failed to give any reasoning for such a decision (Clapham, 1913, 77, 84-85). Whilst such brickwork could be early 16th century, it is equally possible that it might have been produced in the late 15th century. It is known that in the latter half of the 15th century, the abbess instructed a new waterway to be built to the abbey when a spring was discovered on the abbey lands (VCH, 1907, 119). The brick vaulting under the *reredorter* and a brick drain located to the northwest of the *frater* (thought to be connected to the abbey kitchen) might be related to this waterway (Clapham, 1913, 83-84). Unfortunately, more recent archaeological investigation to the west and south west of the medieval abbey site failed to uncover any evidence of late 15th century brick (Hull, 2002). Consequently, there is only tentative evidence for brick being used at the abbey in the latter half of the 15th century.

Nevertheless, if correct, then a possible explanation emerges as to why late 15th century brick appears to have been incorporated in the building. It should be noted that the demesne at Eastbury had originally been under the ownership of the abbey. Consequently, if brick was being manufactured for the abbey complex then the nuns or the contemporary owner of Eastbury might have decided to construct a new building on the site. Another possibility is that brick could have been robbed from the 15th century contexts of the abbey site and used alongside contemporary brick if the present building at Eastbury was first built in the early 16th century. There is certainly strong evidence that the abbey was quickly stripped of its materials leaving little standing and much of it being robbed with the intention of being used in other structures. Among the accounts of James Needham, Surveyor General to Henry VIII, is a document which relates to the destruction of Barking Abbey. It refers to the demolition of the buildings and to the salvaging of materials for use in other building projects, including ‘the providing of the fayrest coyne stones and other to be ymployed of the Kings man. of Dartforde’ (Clapham, 1913, 72). There is also evidence that building materials from the abbey were employed in the construction of more local structures. These include the neighbouring parish church of St. Margaret where the outer north chapel contains 12th century ashlar and worked stone (RCHME, 1921, 4-5). Another brick building in which material from the abbey was used was at Gale Street Farm, located about 1.5 miles from Eastbury. Here the brickwork was described as being similar to that of Eastbury and it was observed that there were random worked stones within the fabric of the building, including stone quoins, moulded Early English vaulting ribs and voussoirs from arches (Streatfeild, 1872, 166). The re-used cusped and foliated arch which was thought to date to the 14th or 15th century, which was observed in the western wing of Eastbury in the 19th century (see 3.3.2.1), would also support the idea that materials from Barking Abbey were incorporated into the present structure. Luminescence analysis of the old brick wall, thought to be the boundary between the parish church and abbey precinct, would be an interesting line of investigation in an attempt to find an origin for the late 15th century set of dates.

Therefore, it is proposed that Eastbury was erected in the early 16th century and that the earlier structure previously thought to have stood on the site probably constitutes much of the present building. This would agree with the

architectural features that are not characteristic of an Elizabethan era structure. It is also suggested that when it was first being built, a mixture of late 15th century brick, possibly from nearby Barking Abbey, and contemporary material was used. When Sysley took ownership of the property in the 1550s he may well have found the structure in a state of decay and initiated a campaign of extensive repair work and modification to the building. This probably involved the replacement of decayed or damaged brickwork, the insertion of externally facing windows and the installation of a new roof on the structure, as suggested by the dates on the rain hoppers and the dendrochronological analysis of the roof timbers.

5.1.3: Layer Marney Towers

Sample	Location	OSL Date ($\pm\sigma_B$)	Archaeological Date
325-4	Eastern tower of gateway	1447 \pm 35	1510-1525

The luminescence date range for the brick sampled at Layer Marney is 1412-1482. Given that the sampling context was within the eastern tower of the central gateway, a structure that was suggested as having been erected in the early 16th century (see 3.3.3.1), there is a difference between the archaeological age and the luminescence date of approximately 75 years. The difference suggests the re-use of brick in the construction of the new central gateway during the early 16th century.

The nature of the red ‘Tudor’ brick would support a 15th century age from a typological perspective. The fact that there is evidence which suggests that some of the structures on the present site of Layer Marney may be part of an earlier manorial complex (see 3.3.3.1) would seem to be supported from the luminescence date. It is likely that the buildings of the older and less socially imposing manorial complex were being sequentially dismantled so that a more elaborate and impressive symmetrical courtyard complex could be constructed, a trend that became more common among the nobility during the early Tudor period (Howard, 1987, 59). The fact that the long gallery range is aligned differently, has stone fittings as opposed to terracotta and has a dismantled window jamb at its west end, indicating that it originally extended further in this direction, would

suggest that this building pre-dates the central gateway. Given that one of the ends to the long gallery range had been altered, it would suggest, in light of the luminescence date, that the bricks were being re-used from the dismantled structures for the erection of the new courtyard complex. Furthermore, the use of buff coloured terracotta in only certain buildings is likely to represent attempts to match the earlier employment of stone in the older buildings. It would also have reflected the prestige of the Marney family through the use of a material that was fashionable in the Henrician court during the early 16th century (Wight, 1972, 180-181; Campbell and Pryce, 2003, 141).

If brick was originally being used on the site in the 15th century, the question of where it was being sourced or the likely impetus for using such a material is an interesting one. Close to the present complex of buildings is a large lake. This may indicate the area where the clay was dug for production of bricks, probably in clamps. With regards to the impetus for using brick in the first place, it was mentioned earlier that the daughter of William Marney (Ann Marney) married Thomas Tyrell of Heron Hall (see 3.3.3.1). It is generally thought that Heron Hall was constructed in the first half of the 15th century (Ryan, 1996, 51). The possibility that ideas were exchanged between the two families is still a likely reason for brick structures being erected in the mid-15th century at Layer Marney. The death of the Marney family is the most likely cause for the cessation of building work on the courtyard complex.

Based on the result derived from the luminescence sample for Layer Marney, a revised development of the manorial complex is proposed in which the present complex consists of structures from two different periods. The first comprises a series of brick buildings probably erected in the mid-15th century whilst the second period of construction took place in the early 16th century when a new, more fashionable courtyard complex was begun. The erection of this new manor probably involved a mixture of contemporary and robbed materials sourced from the earlier manorial complex as it was sequentially demolished. Future sampling and testing to determine whether this revised development of the manor is correct would involve the analysis of samples from several of the other structures around the manorial complex, such as the church, the western wing, the eastern wing and the southern long gallery. If the revised development is correct then some of these structures, such as the long gallery range, should yield a mid-

15th century date whilst others, such as the western wing, would yield either a 15th century or early 16th century date. This approach could also help determine the extent to which brick was being produced close to the site as opposed to being robbed from existing buildings during the early 16th century phase of construction.

5.1.4: Maldon Moot Hall

Sample	Location	OSL Date ($\pm\sigma_B$)	Archaeological Date
353-1	Base of brick newel staircase	1393 \pm 36	Early 15 th century

The luminescence date range for the sampled brick at the base of the newel staircase suggests that this part of the building was constructed between 1357 and 1429. Whilst the central date is slightly earlier, the date range does overlap with that suggested by the archaeological evidence, which puts the building at somewhere around the 1420s to 1430s (see 3.3.4.1). The luminescence date supports the idea that the structure had been erected prior to 1439-40 when ownership was transferred to the town of Maldon (Clarke, 1936, 212). It also agrees with the idea that Robert Darcy (1385-1448) was responsible for the erection of the building as part of a town manorial complex (Smith and Wadhams, 1975, 215; Ryan, 1996, 52). It is important to remember that the Moot Hall is an extremely early example of several important developments in the use of brick in the late medieval period. These include the use of brick for constructing newel staircases, the appearance of ruddling and also the use of carved bricks to form trefoil headed arches (see 3.3.4.1). The luminescence date suggests that these features may have been introduced into the medieval brick industry slightly earlier than originally thought.

Further sampling from the Moot Hall would help to confirm that the building was erected in the late 14th century. It would also allow both the north west addition to the building and the adjoining structure to the east which the Moot Hall butts onto to be dated in an attempt to determine the chronological relationship between these structures. However, the manor house that originally stood around the Moot Hall is thought to have been largely demolished for building plots between 1536 and 1560 (Petchy, 1991, 92). If the north west

addition was constructed around this time then the possibility of brick re-use cannot be ignored. Whether the earlier date has implications for other similar structures, such as the Hussey Tower, is difficult to say. This is partly due to the fact that the Hussey Tower was probably influenced by the more local brick tower house erected at Tattershall Castle in the 1440s (Smith, 1979, 34), although it should also be noted that brick buildings were being constructed in Lincolnshire during the late 14th century, such as St. Mary's Guildhall, Boston, dated by OSL to 1388 ± 37 (Bailiff, 2007, 845).

The Moot Hall has been compared in the past to a series of other brick structures, including Rye House gatehouse (Hertfordshire), Someries Castle (Bedfordshire), Faulkbourne Hall (Essex) and Nether Hall (Essex, see 3.3.5 and 5.1.5). All of these buildings contain brick newel staircases and they all employ carved brickwork in cusped decorative features, although some employ it more elaborately than others. Of these buildings, perhaps the best dated is Nether Hall, thought to date to between the 1440s and the 1460s (see 3.3.5 and 5.4.5). Here the decorative cusped brickwork occurs in both the trefoil and cinquefoil forms, although there are subtle differences to the cinquefoil corbel tables between Nether Hall and Rye House, Someries and Faulkbourne (Andrews, 2004, 96). Nevertheless, the date for Nether Hall indicates that these specific decorative features and brick newel staircases certainly occur in eastern England by the mid-15th century. Further evidence to support this exists in the form of licences to crenellate at Rye House (1443) (Smith, 1975, 111-112) and Faulkbourne (1439) (Ryan, 1996, 54). However, it is important to remember that these licences might have been intended more for their symbolic status rather than relating to construction work (Howard, 1987, 50), a fact that seems likely for Faulkbourne (Emery, 2000, 100). Since the Moot Hall represents a very early example of the specific brick components that have been used to compare these structures, the question arises as to whether the less well dated buildings, such as Rye House, Someries or Faulkbourne, were erected in the late 14th to early 15th century, as was the case with the Moot Hall, or date to the mid-15th century, as is the case with Nether Hall. This presents an opportunity for future luminescence analysis of these buildings.

5.1.5: Nether Hall

Sample	Location	OSL Date ($\pm\sigma_B$)	Archaeological Date
326-3	Base of newel staircase	1478 \pm 34	1440s to 1467
326-4	"	1438 \pm 32	"
326-4#2	"	1448 \pm 42	"
326-5	"	1439 \pm 38	"

The maximum date range from all the OSL samples for Nether Hall indicates that the base of the newel staircase in the eastern gateway tower was erected between 1406 and 1512. Analysis of all the dates by the Ward and Wilson (1978) T test indicates that the dates are not significantly different ($T = 1.95$; $\chi^2_{4,0.05} = 7.81$) and they have a pooled mean date of 1455 ± 13 ; ± 23 . This is in good agreement with the archaeological evidence which suggests that the building was built between the 1440s and the 1460s (see 3.3.5.1). It is interesting to note that there is also good agreement between the two ages derived from the same core (sample 326-4 and sample 326-4#2), indicating consistency of the OSL dating method. The dates are shown in a chronological distribution plot in Fig. 5.2.

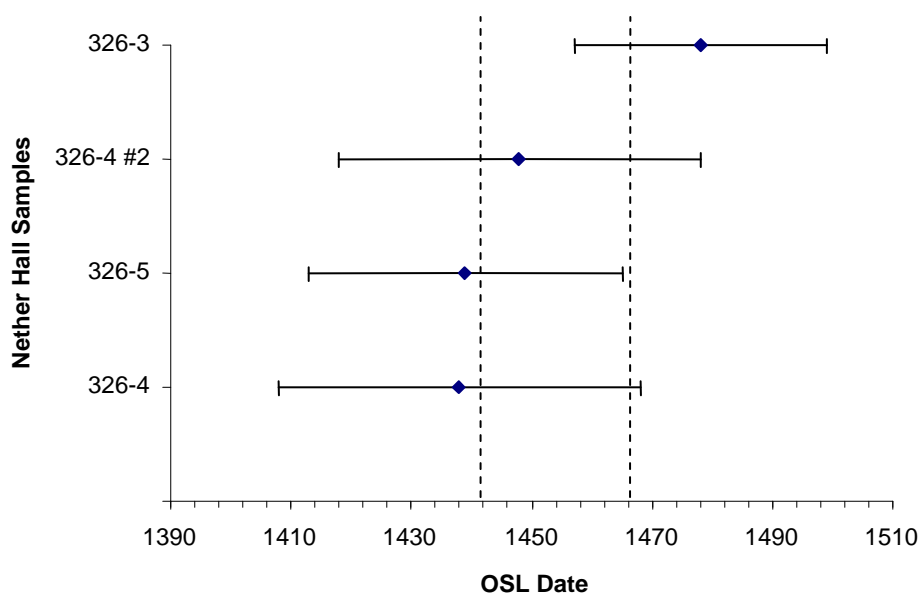

Fig. 5.2: Chronological distribution of the OSL dates derived for Nether Hall (the error bars indicate $\pm 1\sigma_A$). The dashed vertical lines indicate the likely construction period as understood from the current archaeological interpretation (1440s-1467).

These OSL dates for Nether Hall agree with the likely construction dates that have been suggested for other nearby brick buildings, including Rye House gatehouse and Someries Castle, both of which are currently thought to have been erected between the 1440s to 1450s (see 3.3.5.1). Given that there are some similarities between these buildings, it suggests that the same master brick craftsman might have been involved in the construction of Nether Hall. Analysis of OSL samples from these two sites would allow for comparison to see if Nether Hall is indeed contemporary with them.

5.1.6 New Hall

Sample	Location	OSL Date ($\pm\sigma_B$)	Archaeological Date
337-1	Cellar western wall	1459 \pm 33	Late 15 th – early 16 th century
337-2	"	1482 \pm 37	"
337-3	"	1437 \pm 39	"

The luminescence dates derived for the cellar wall in New Hall all date to the 15th century and cover a maximum range from 1398 to 1519 (see Fig. 5.3). They have a pooled mean date of 1460 \pm 12; \pm 24 and analysis by the Ward and Wilson (1978) *T* test indicates that the dates are not significantly different ($T = 1.56$; $\chi^2_{3,0.05} = 5.99$). This is slightly earlier than the suggested archaeological interpretation (late 15th to early 16th century) and only one of the OSL dates (sample 337-2) falls within $\pm 1\sigma_A$ of the date of the licence to crenellate granted to the Earl of Ormond in 1492 (see Fig. 5.3). Given that a large amount of the building materials and fittings within the cellar have been shown to be re-used (see 3.3.6), it is likely that the brickwork lining the cellar wall is also re-used from an older structure.

It is difficult to say, however, whether the wall from which the three samples were collected represents the foundations of an earlier building or whether the wall to the cellar was built at a later time re-using older bricks. The fact that Henry VIII took possession of the manor in 1516 and was able to reside and stage a masque at the property by 1519 would seem to indicate that the construction of the Henrician palatial complex was undertaken quickly. It is

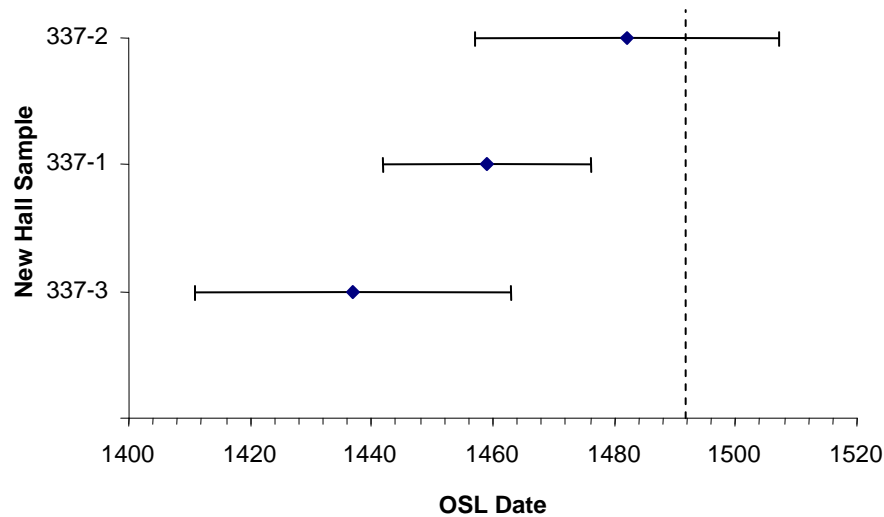

Fig. 5.3: Chronological distribution of the OSL dates derived for New Hall (the error bars indicate $\pm 1\sigma_A$). The vertical dashed line indicates the date of the licence to crenellate granted to the Earl of Ormond (1492).

highly likely that there was an earlier structure on the site and such haste could well have involved large parts of this earlier building being incorporated where possible into the new palatial complex, suggesting that the Henrician place might have been composed largely of an earlier structure that required little alteration. If correct, then the re-used elements of the fabric, such as the four centred doorways and floor paving slabs, might represent internal alterations, such as the insertion of new partitioning walls, to pre-existing cellar chambers, in which case the sampled brick wall could be seen as part of an earlier building. However, the fact that the wall from which the samples were collected contains darker, partially vitrified bricks would tend to suggest that the bricks themselves might have originally been used in an external context where diaper decoration was intended to be seen. Further evidence suggesting that the brickwork in the cellar was re-used can be seen in other areas of walling where the brickwork has not been covered in plaster or whitewash. In one context it is possible to observe that the bonding pattern is highly irregular and that the bricks are laid in thick mortar joints (see Fig. 5.4). This suggests that the bricks have been laid quickly with little thought to the bonding. The thick mortar would also compensate for any irregularities in the dimensions of the bricks that may have originated from the use of different sized moulds when the bricks were first formed.



Fig. 5.4: Exposed brickwork in New Hall cellar with an irregular bonding pattern.

Overall, the evidence would suggest that the sampled wall has been rebuilt using bricks that were salvaged from an older structure and context, a suggestion that would agree with the re-use of other material in the immediate vicinity. In hindsight, the areas selected for sampling was therefore far from ideal. However, given the likelihood that other areas of exposed brickwork in the cellar could well be composed of re-used brick, such as the area shown in Fig. 5.4, it would have been difficult to locate an area of brickwork that is likely to be contemporary with the specific building periods identified during the late 15th and early 16th centuries in the archaeological assessment (see 3.3.6.1).

If the bricks had been re-used from an earlier manor built in the mid-15th century, then the luminescence dates would tend to suggest that the licence to crenellate awarded to the Earl of Ormond in 1492 was one that was sought as a mark of prestige for a pre-existing structure, a practise that took place at other sites during the medieval period (Howard, 1987, 50; Coulson, 1993). Furthermore, if the brickwork of the cellar wall originated from an earlier context, the luminescence dates suggest that the construction of this earlier manor is likely

to have taken place over an extended period during the latter half of the 15th century.

It is extremely difficult to address the question of who might have been responsible for building the earlier brick structure during the 15th century from which these bricks were taken, partly due to the fact that there were a number of owners of New Hall during the 15th century prior to the Earl of Ormond, but also due to the fact that it is only a suggestion that the brickwork was re-used from an earlier structure located on the site of the present building. Consequently, this question will not be addressed. Instead, it will simply be proposed that the brickwork in the cellar is likely to have been re-used from an older structure, probably dating to the 15th century, during the swift construction period of the Henrician palatial complex in the early 16th century.

5.1.7 ‘The Old House’, St. Osyth

Sample	Location	OSL Date ($\pm\sigma_B$)	Archaeological Date
354-1	Southern wall of cellar	(No Signal)	Late 13 th – early 14 th century
354-2	"	(No Signal)	"

The lack of an OSL signal from both of the sampled bricks collected from the cellar prevented the production of a luminescence date for the brickwork in this context. Consequently, there is no change to the archaeological assessment of the brickwork in the context of this structure, which suggests that the brick dates to the late 13th and early 14th centuries (see 3.3.7.1).

5.2 ECCLESIASTICAL BUILDING ASSESSMENTS

5.2.1 St. Andrew’s church, Boreham

Sample	Location	OSL Date ($\pm\sigma_B$)	Archaeological Date
355-1	North side of chancel arch	896 \pm 68	12 th century

The luminescence date range for the sampled brick is 828 to 964. This indicates that the brickwork within this context of the church fabric, which had

previously been assumed to be Norman, might actually be much older. Given that there are Saxon contexts in the church fabric that contain Coggeshall type brick, this indicates a likely source for the brick used to construct the Romanesque chancel arch when the earlier Saxon church was altered (see 3.5.1.1). Although there is a degree of uncertainty surrounding the exact date of production of the sampled brick due to the change in the surrounding annual dose rate (see 4.1.2.3 and Appendix A.4), the luminescence date does indicate that the brick is older than the 12th century date normally ascribed to Coggeshall type brick (Ryan, 1996, 26; Andrews, 2005a, 143).

Whilst the Coggeshall type bricks in the Saxon contexts of the church were not sampled for this project due to their identification after sampling had taken place (see 3.5.1.1), the potential exists for future work to date these bricks with OSL. Until such time, the current archaeological understanding of the church can still provide a date for these contexts of the building. These were originally proposed to date to between c.950 and 1100 (Taylor and Taylor, 1965, 16-17, 80). More recent research has suggested that there was a class of medium sized parish churches in Essex that were two celled and characterised by the extensive use of Roman brick for the dressings (Rodwell and Rodwell, 1985, 136). They had a square ended chancel with normally two windows which are single splayed, tall, narrow and with round headed arches, all of which are features that have been identified at Boreham. This type of church has been dated to the 10th and 11th centuries (Rodwell and Rodwell, 1985, 136), supporting the earlier proposal by the Taylors.

The above discussion has important implications for the current understanding of early medieval brick in both Essex and England which has generally considered that brick was not produced in the country prior to the 12th century (see 2.1.1). Considering the brickwork in the church further, it is interesting to note that there is a change in the brickwork from Roman at the base to Coggeshall type further up in both the responds of the eastern chancel arch and the quoins of the original Saxon church nave (see 3.5.1.1). Based on these observations and assuming that all the Coggeshall type brick in the church fabric is of a pre-12th century date, this implies that the Saxon craftsmen who were constructing the original church had robbed a Roman structure nearby, possibly the *principia* located to the northwest of Boreham. The change in brick suggests

that the Roman material was exhausted, forcing an alternative brick to be brought to or produced close to the church.

It is difficult to offer details relating to the nature of the origin of this new supply of brick but it or the craftsmen who were involved in constructing the church might have originated from continental Europe. Certainly, the decorative use of stones and bricks for the voussoirs of arches, as seen in the Saxon chancel arch and side niche inside Boreham church (see 3.5.1.1), occurs in Romanesque churches in western France. An example of this can be found at the church at Savennières, thought to date to the late 10th or early 11th century, where alternating brick and stone are used to frame the windows. The walls are also constructed of alternating bands of stone and brick laid in a herringbone fashion (Costen and Oakes, 2000, 62). Another French example that is closer to England is the church of Notre Dame Sous Terre, Mont-Saint-Michel. Here the building has several arches that are composed of stone interspersed with brick that has been dated by luminescence to the latter half of the 10th century, results that agree with the archaeological interpretation of the church (Blain *et al.*, 2007).

5.2.2 Holy Trinity church, Bradwell-juxta-Coggeshall

Sample	Location	OSL Date ($\pm\sigma_B$)	Archaeological Date
357-1	Inner order, southern doorway	1038 \pm 60	1125-1150

The sampled brick produced a luminescence date range of between 978 and 1098. This disagrees with the current archaeological understanding which suggests that the brickwork within the church fabric dates to the second quarter of the 12th century, suggesting that the brick might have been re-used from a different context. Whilst the structure from which these bricks were taken cannot be determined, it is almost certain that they were not produced at the neighbouring Coggeshall Abbey, a site that was not founded until the mid-12th century (see 3.3.1.1).

There are several features to both the bricks and the building supporting the idea that the craftsmen constructing the church had re-used the bricks. Firstly, the fact that some of the bricks for the quoins were cleaved suggests that there

was only a finite supply of ceramic building material which had to be extended during the course of building the church (Rodwell, 1998, 78). It also appears that the supply of special moulded bricks that were used for the double splays of the windows was exhausted, forcing the use of flints to complete one of the windows (Rodwell, 1998, 82). Whilst the specific shapes of the moulded bricks and the manner in which they were employed suggests that they were being produced to meet specific demands that arose during the construction of the Norman church, it should be noted that the moulded bricks in the windows were not bonded into the adjacent rubble walling (Rodwell, 1998, 79). This would have made them relatively easy to remove from an older structure before incorporating them into the Norman church. Furthermore, some of the bricks used to construct the turning of the Norman window heads were altered by hacking thin sections longitudinally off the brick (Rodwell, 1998, 79). Given the high degree of technical craftsmanship used to produce the bricks, it seems likely that the bricks could have been moulded to form a more voussoir wedge shape instead of being altered *after* production. This further supports the argument for re-use. Focusing on the jambs of the north and south doorways, the brickwork is seen to be laid with a regard to bonding (Rodwell, 1998, 78) which might suggest that the doors are contemporary with the church. However, since the bonding is only sporadic, it is also likely that there were only a finite number of bricks available, suggesting the brickwork around the doorways might have also been re-used. Rodwell also expresses doubts over the use to which the double bullnosed bricks were put in the doorways, suggesting instead that they might have been intended for pilasters or the innermost orders of double-sided arches (Rodwell, 1998, 102). Finally, brick it seems was not the only material being recycled from older structures in the construction of the church, with fragments of Roman tile and puddingstone among the other materials that were re-used (Rodwell, 1998, 96). Equally, the fact that the Coggeshall type bricks were used in the church fabric in the same manner that had been used for recycled Roman brick in other buildings of the 10th to 12th centuries (Rodwell, 1998, 98) might again suggest re-use of the Coggeshall type bricks.

It is unlikely that there was a pre-Norman masonry built structure on the site of the present church and there is strong evidence in the layout and proportions of the present building to suggest that it was erected in the Norman

period (Rodwell, 1998, 95). Given the above discussion and the likelihood of the brick being re-used, it is important to note that there is a degree of uncertainty surrounding the exact date of production of the sampled brick due to the change in the surrounding annual dose rate (see 4.1.2.3 and Appendix A.4). Whilst the true age of the brick is difficult to determine, it is likely to be older than the 12th century. Given the fact that doors and windows with tall and narrow proportions occur in other local churches during the 11th and early 12th centuries (Rodwell and Rodwell, 1985, 136; Rodwell, 1998, 98) then it is possible that the brickwork dates to the 11th century. It could also be argued that certain aspects of the church might actually be representative of late Saxon architecture. The use of double splay moulded bricks in the windows could be compared with the use of double splay windows in other late Saxon churches (Taylor and Taylor, 1965, 9-10). An example of this can be found in the mid-11th century western tower of Holy Trinity church, Colchester, which contains double splayed windows built from robbed Roman bricks (RCHME, 1922, 33; Ryan, 1996, 18). Equally, the idea that Coggeshall type bricks were being used in late Saxon contexts is suggested at Boreham church (see 5.2.1), supporting the idea that the brick in Holy Trinity church was originally of late Saxon origin.

5.2.3 St. Andrew's church, Earls Colne

Sample	Location	OSL Date ($\pm\sigma_B$)	Archaeological Date
339-1	Second stage internal east wall	1407 \pm 35	Mid-15 th – early 16 th century

The sampled brick produced a luminescence date range of between 1372 and 1442. This early 15th century date is slightly earlier than the date range suggested by the archaeological assessment of the church tower (mid-15th to early 16th century). Whilst it is possible that the bricks were used in the construction of the church at a later stage in the 15th century, the luminescence date suggests that their production is likely to have taken place slightly earlier.

In terms of a likely manufacturing site for the bricks in the church, Earls Colne Priory, a Benedictine Priory founded in the early 12th century and located about a quarter of a mile east of the church, is a likely source. It is thought that

the priory had its own tile kiln by 1424 when it was leased to John Fillbrigge (Ryan, 1999a, 93; VCH, 2001, 97). Further documentary accounts refer to the production of brick and tiles during the 15th century, including 1425 when a tiler was paid to repair the *dorter*, the dormitory, the prior's chamber and the sacristan's hall (VCH, 2001, 92), 1431 when the Priory paid Andrew Brykman for making bricks (Ryan, 1999a, 93), 1440-1441 when John Ducheman was paid for making tiles (Ryan, 1996, 52; VCH, 2001, 97) and a payment from the priory in 1441 to Thomas Skynner and his assistant for roofing the tile kiln (Ryan, 1999a, 93). This documentary evidence implies that brick could have been produced close to the site of St. Andrew's church in the early 15th century.

In terms of archaeological evidence for the use of brick in the priory, limited excavations, undertaken in the early 1930s, did uncover brick. However, whilst the excavators were careful to note the occurrence of Roman brick, they were less interested in medieval and post medieval brick. Nevertheless, there are suggestions that such brick and tile was uncovered. The base of a brick pier was uncovered in the 15th century Lady Chapel (Fairweather, 1937, 282). Given the documentary evidence for an operational brick kiln close to the site in the 15th century, it is likely that the Lady Chapel was composed of medieval brick. Plain, red floor tiling was uncovered in the nave and aisles which again is suggestive of a medieval kiln in operation close to the priory (Fairweather, 1937, 284). In the chapter house and part of the *dorter*, a thick layer of brick and roof tile described as being 'of all periods' had to be dug through (Fairweather, 1937, 285). Some of the tiles or bricks uncovered could relate to the documentary reference of the tiler paid to repair the *dorter*, dormitory and prior's chamber, the latter possibly being a reference to the chapter house. (VCH, 2001, 92).

The Royal Commission recorded further evidence suggesting the use of brick in the priory. They noted a red brick boundary wall around the priory site (part of the precinct boundary was still standing in 1998) (VCH, 2001, 92) with the initials 'R.H.', 'W' and 'X.W.' in black brick (RCHME, 1922, 88). It is likely that the initials 'R.H.' refers to either Roger Harlackenden, who took possession of the lay house, park and manor in 1583, or to his son, Richard Harlackenden, who inherited the priory in 1592 (Fairweather, 1937, 287). The initials 'W' and 'X.W.' might refer to the Wale family who owned the priory estate in the early 18th century (Fairweather, 1937, 293). The wall was described as incorporating

re-used worked stones, one of which was a 15th century niche with a cinquefoiled head (RCHME, 1922, 88). This suggests that the precinct wall was probably rebuilt or repaired at some point during or after the late 16th century following the dissolution of the priory in the 1530s. Such building work is likely to have employed material from the priory buildings, of which a large proportion was probably brick. Certainly, by 1631 the majority of the priory had been destroyed, although it is thought that this is unlikely to have happened to any great extent until the estate passed out of the possession of the Earl of Oxford in the 1580s (Fairweather, 1937, 287).

Therefore, there is evidence to support the idea that there was a kiln producing both tiles and brick during the early 15th century close to or on the estate of Earls Colne Priory and that, following the dissolution, building materials were robbed from the Priory. This kiln could be a source for the bricks in the eastern face of St. Andrew's church. Given the likelihood that the stair turret and eastern tower face butt against the rest of the tower, it seems that this brick face was added later. This is further supported by the inclusion of re-used carved stone architectural fragments (see 3.5.3.1). If the provenance of the re-used stonework were known then it could also suggest a similar location from which the brickwork had been taken. Unfortunately, there was an earlier building on the site of the present church (the earliest reference to a church at Earls Colne dates to the 12th century) (MacKinnon, 1997, 170) and the priory buildings are also thought to have been completed in the early 13th century (VCH, 2001, 92). This therefore offers two possible sources for the worked stone and re-used brick. However, given the large quantity of brick used in the eastern wall and the luminescence date of the early 15th century, it would seem more likely that the brick was taken from the priory, possibly from the 15th century Lady Chapel, along with worked stonework. Whilst it is possible that building materials from the priory buildings were robbed out, it should also be remembered that, if the date plate of 1534 is to be accepted as a *terminus ante quem* for the building work, then this pre-dates the dissolution of the priory which occurred in 1536 (Fairweather, 1937, 277). Furthermore, it has been suggested that John de Vere, the Earl of Oxford to whom the priory estate was granted, was sympathetic to the old religion and is thought to have left the priory undisturbed (Fairweather, 1937, 287). This evidence would

suggest that the brickwork in the priory was not used in the construction of the church eastern face.

It is difficult to derive much more for such a complex church tower based on the single luminescence date besides the fact that the brickwork in the eastern face was probably re-used at some point between the mid-15th and early 16th centuries. Further sampling of the brickwork would help to clarify and confirm that the eastern wall of the tower is indeed composed of re-used brick from the early 15th century. Equally, a more thorough archaeological investigation of both the church tower and the priory site would yield valuable information about how brick was being employed during the 15th century in the various buildings.

5.2.4 All Saints' church, East Horndon

Sample	Location	OSL Date ($\pm\sigma_B$)	Archaeological Date
352-1	South Porch	1481 \pm 49	Mid to late 15 th century
352-2	Chancel tomb niche, east wall	1362 \pm 40	"
352-3	Chancel tomb niche, west wall	1410 \pm 38	"

The overall range of the three OSL dates for East Horndon is 1322 to 1530 (see Fig. 5.5). The first OSL date from the southern porch agrees with the archaeological assessment. It suggests that this part of the building was a later phase than the nave and chancel, probably being added to the church some time between 1442, when Sir Thomas Tyrell was granted the advowson of the church, and his death in 1476 (see 3.5.4.1). Since the will of Thomas Tyrell referred to new works being done to the church in 1476, it is likely that the porch belongs to this period of building work.

The two luminescence dates for the tomb niche are earlier than the archaeological assessment. However, it should be noted that there is not a significant difference in the age derived for these two samples, as demonstrated by the Ward and Wilson (1978) *T* test ($T = 2.48$; $\chi^2_{2,0.05} = 3.84$). The two samples have a pooled mean of 1383 \pm 15; \pm 31. The results from the tomb niche imply that the bricks were re-used from an older context.

One suggestion concerning the source of the bricks from the niche is that

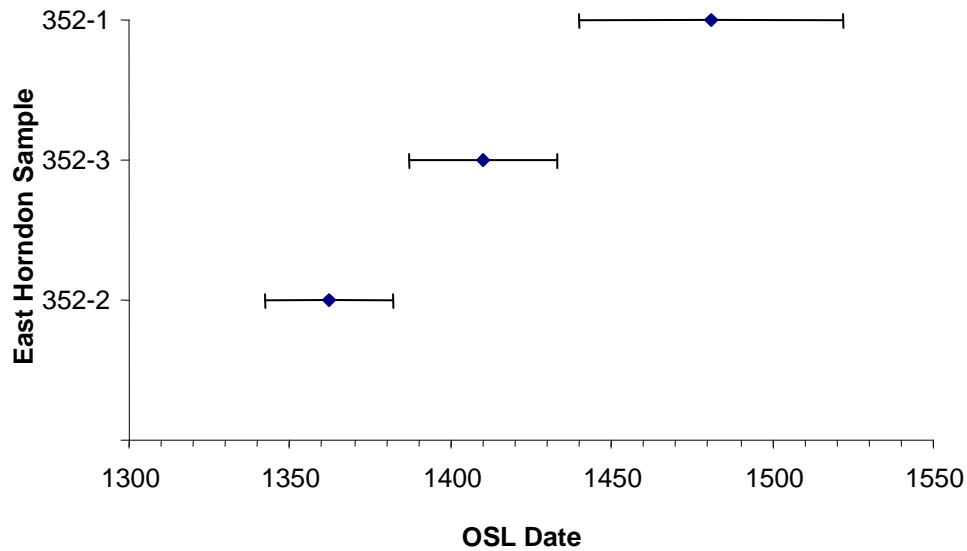

Fig. 5.5: Chronological comparison of the OSL dates derived for East Horndon (the error bars indicate $\pm 1\sigma_A$).

when Sir Thomas Tyrell began to make alteration to the church, it involved dismantling parts of the existing building, which may have already been constructed in brick, and re-using them in new contexts, such as the tomb niche, transepts and tower. The reset 14th century two centred arch over the northern door in the nave could be seen as supporting this argument for materials being recycled from the earlier church. The presence of two substantial brick mansions close by (Old Thorndon Hall and Heron Hall) offers other possible sources for the bricks. The licence to crenellate which was granted to Old Thorndon Hall in 1414 might have been obtained after the manor had originally been built as a mark of prestige. This could indicate that the brick manor was actually much older, possibly dating to the latter half of the 14th century. It should also be remembered that the construction date for Heron Hall is highly uncertain (see 3.5.4.1). It is possible that the Tyrell family, who are thought to have originally acquired this manor in the mid-14th century (Morant, 1768, Vol. I, 208), might have built Heron Hall in brick shortly after obtaining their new estate. They may also have made substantial alterations to the church involving brick or re-used material from Heron Hall around this time. It is unfortunate that neither Old Thorndon Hall nor Heron Hall have survived as luminescence analysis on these building would have been highly informative in an attempt to try and provenance the material used for East Horndon church. A further possibility is that the brick has been re-used from

an older context when the harsh restoration work was undertaken on the internal northern side of the tomb niche, although this is considered unlikely since the mortar and other brickwork surrounding the sampled bricks is highly weathered and appears to be original.

Consequently, it appears that the brick porch belongs to the alterations made by Sir Thomas Tyrell between being granted the advowson of the church in 1442 and his death in 1476. However, with regards to the brickwork in the chancel northern tomb niche, it is difficult to determine much more than the fact that it appears to have been re-used. It is possible that the brick manor Heron Hall was built shortly after the Tyrells obtained their estate in the mid-14th century and that they made additions or alterations to the church in brick around the same time. Ultimately, the OSL dates suggest that East Horndon church is a building which would benefit from further archaeological analysis.

5.2.5 All Saints' church, Maldon

Sample	Location	OSL Date ($\pm \sigma_B$)	Archaeological Date
356-1	West face of sunken chamber	(No Signal)	Early 14 th century

The lack of an OSL signal from the brick sample collected in the stairway leading down into the sunken chamber, prevented the production of a luminescence date for the brickwork in this context. Consequently, there is no change to the archaeological assessment of the brickwork in the context of this structure, which suggests that the brick dates to the 14th century (see 3.5.5.1).

5.2.6 All Saints' church, Springfield

Sample	Location	OSL Date ($\pm \sigma_B$)	Archaeological Date
336-1	South interior wall of belfry	1510 \pm 30	Late 16 th century (c.1586)

The date range derived for the sampled brick is from 1480 and 1540. When compared to the date plate on the church belfry and the historic evidence surrounding the Mildmay family arms on the south western buttress, the

luminescence date is seen to be some 75 years earlier. Assuming that the date plate relates to the belfry and not to another part of the church, this implies that the brick has been re-used from an older structure in the repairing of the belfry towards the end of the 16th century.

It is difficult to identify a building from which the brick might have originated. Close by is New Hall, Boreham, where it is likely that building work was being undertaken around 1516 to 1521 (see 3.3.6.1), suggesting that brick could have been sourced from this site, although it now appears likely that large amounts of brick were already being re-used at New Hall from an earlier, mid-15th century structure (see 5.1.6). Approximately five miles to the east of Springfield is Woodham Walter where the hall is thought to have been built in brick c.1505 (Ryan, 1996, 84-85), suggesting another potential source where brick might have been obtained for the repair of the tower. The fact that portions of the belfry have a similar bonding pattern to that of Woodham Walter church, where the brick is thought to be re-used from the early 16th century (see 5.2.9), could be evidence that the same craftsmen were involved at Springfield as well as Woodham Walter. The early 16th century date suggested by the luminescence also pre-empts the rise in status and wealth of the Mildmay family, which took place from the 1530s onwards during the dissolution of the monasteries (St. John Mildmay, 1913, 15-20). This again suggests the brick in the church tower is re-used, although the Mildmay family could have still been responsible for funding the construction work. Ultimately, it is difficult to say anything beyond the fact that the brickwork used in the late 16th century repairs to the belfry appears to have been robbed from an earlier source, probably in the area surrounding Springfield.

5.2.7 All Saints' church, Theydon Garnon

Sample	Location	OSL Date ($\pm\sigma_B$)	Archaeological Date
335-1	Base of tower staircase	1480 \pm 33	Late 15 th - early 16 th century

The luminescence date range for the sampled brick is 1447 to 1513. This age is in good agreement with both the historical and archaeological evidence for the date when the brick tower was erected. It confirms the earlier suggestion that

Sir John Crosby left a large sum of money towards the building of the church tower at the time of his death in 1476 (see 3.5.7.1). The date also suggests that the construction of the church tower began shortly after his death, especially when it is considered that the luminescence sample was taken from a brick at the ground level of the church tower.

It seems likely that the date plate was installed into the tower at the end of the building project, suggesting that the total length of time involved in the construction work was approximately forty years. The idea of the building project taking several decades to complete should not be considered unusual when compared to other church towers, such as the church tower in Dedham which took nearly 30 years to construct (see 2.4.5). Equally, a late 15th century date for the building of a brick western tower would agree with several other churches in Essex. The brick tower at Thorrington church is thought to have been built c.1480 based on a brass inscription inside the church which commemorates John and Margery Deth (died 1477 and 1483 respectively) with the phrase '*specialis benefactor istius ecclie et campanilis ejusdem*' (benefactor of this church and bell tower) (Bettley and Pevsner, 2007, 781). At the church of St. Mary Magdalen, Billericay a grant was left to the chapel in 1496 and recently Spanish tiles dating to the third quarter of the 15th century have been recorded around the entrance to the tower (Andrews, 2005b, 167-168). Another example is Colne Engaine church where John Skinner left instruction in his will that 40,000 bricks were to be produced from 1496 to 1500 for the fabric of the belfry. The upper stages of the church tower are built from red brick, suggesting his instructions were carried out (Bettley and Pevsner, 2007, 303). Finally, the luminescence date for the church at Tilbury-juxta-Clare suggests that the brick tower there was begun in the late 15th century and took approximately forty years to erect (see 5.2.8).

Therefore, it seems likely that money was initially bequeathed by Sir John Crosby towards building the brick tower at Theydon Garnon in the late 15th century. The construction work probably began shortly after his death in 1476 but appears to have only been completed by 1520 when the date plate was installed. The length of time involved in erecting the tower is probably due to the intermittent nature of funds for the building work.

5.2.8 St. Margaret's church, Tilbury-juxta-Clare

Sample	Location	OSL Date ($\pm\sigma_B$)	Archaeological Date
334-1	Inside the first stage of tower	1488 \pm 35	Early 16 th century (c.1519)
334-2	"	1474 \pm 32	"

The overall date range for the two OSL samples for the western tower of St. Margaret's church indicates that it was erected between 1442 and 1523. The two sample dates have a pooled mean of 1480 \pm 14; \pm 28 and are not significantly different according to the Ward and Wilson (1978) *T* test ($T = 0.23$; $\chi^2_{2,0.05} = 3.84$). This indicates that construction work was underway in the late 15th century. Whilst this does not agree with the early 16th century date suggested by the date plate, it should be remembered that architectural features such as this do not necessarily relate to the actual construction event itself (see 2.2.3).

It therefore seems likely that the western tower at Tilbury-juxta-Clare was begun in the late 15th century and only completed by 1519 when the date plate was installed. As has been discussed earlier (see 2.4.5 and 5.2.7), construction of a church tower during this period and the likely length of time involved for such a project should not necessarily be considered unusual. This date range agrees with the local architectural trend in which neighbouring churches are thought to have been adding brick towers to existing structures in the late 15th and early 16th century (see 3.5.8.1). The money bequeathed in John Bridge's will towards the building of the tower is probably a reference to a final collection of funds, to which Elizabeth, Countess of Oxford, is likely to have contributed a large sum, intended to complete the tower. Furthermore, the brick nogging in the late 15th century nave wall painting could well be a reflection of brick being used at that time for the construction of the tower.

5.2.9 St. Michael's church, Woodham Walter

Sample	Location	OSL Date ($\pm\sigma_B$)	Archaeological Date
338-1	Internal western gable wall	1505 \pm 29	1562-1564

The luminescence date range for the brick sampled in the internal western gable wall is 1476-1534, with the central value predating the likely date of the

erection of the present church by approximately half a century. Given the large amount of architectural materials that were being re-used and reincorporated into the church when it was relocated in 1562-1564 (see 3.5.9.1), the sampled brick may have been re-used from the earlier church.

Limited knowledge exists for the first church at Woodham Walter and it is difficult to determine from where in its fabric the sampled brick would have been sourced. It is possible that the mid-15th century addition which Thomas Hawkyns instructed to be built might have contained brick or were later altered in brick. Given that the petition to Elizabeth I describes the church as having 'fallen into ruin' (*Cal. Pat. R.*, 1560-1563, 340-341), it is also possible that the original church might have required extensive repairs, possibly in brick.

It should also be noted that the nearby ruin of Woodham Walter Hall, which is built from brick with diaper decoration, is thought to have been erected by Robert Radcliffe, the first Earl of Sussex, in the early 16th century (Ryan, 1996, 85). The estate was restored to him in 1505 by Henry VII. He was a wealthy and influential member in the court of Henry VIII and was responsible for enlarging the park at Woodham Walter in 1511 (Ryan, 1996, 84). It is possible that the original church was encased in brick in order to compliment the neighbouring hall and that when it was relocated the wall material, including the bricks, was simply re-used. A modern survey of the hall remains revealed the base of a tower at the north west corner which was a later addition to the original hall. This tower contained a rubble core composed of worked stones from window openings, septaria, clunch, 14th century yellow bricks and red 'Tudor' bricks, all of which were encased with 'Tudor' brickwork (Ryan, 1999b, 189). It is thought that this rubble core probably originated from a monastic context and therefore dates to between the late 1530s to 1560s (Ryan, 1999b, 191). If additions were being made to the hall in this manner then it might have also influenced the rebuilding of the church. This argument is supported by the fact that it is thought the walls of the present church might be composed of a rubble core with an outer casing of brick (Ryan, pers. comm.). The idea of a rubble core might also suggest that the unusual bonding pattern was deliberate in order to simply encase the wall core, especially when it is considered that the same pattern was used in a brick barn at Leez Priory where other parts of the manorial complex have been shown to have a rubble core faced in brick (see 2.4.5).

In terms of comparisons between the bricks of the church and the hall, it has been suggested that those of the church are larger than those of the hall (Ryan, 1999b, 191). However, this is debatable, especially given the possibility of minor variations in the sizes of different brick moulds. Measurements of the church bricks by the author suggest average dimensions of 250 mm × 110-120 mm × 45-60 mm which are comparable with those of the hall (240 mm × 110-115 mm × 55-60 mm) (Ryan, 1999b, 189), suggesting that the brickwork for both buildings could have been manufactured by the same craftsmen. One obvious difference between the church and hall brickwork is the lack of decorative diapering on the church. However, this probably reflects the fact that diaper decoration went out of fashion in Essex after the dissolution of the monasteries in the 1530s (Ryan, 1996, 85), with non vitrified bricks being selectively used for rebuilding the church.

It is important to note that the suggestion that the brickwork in the church is re-used is based on a single luminescence date from the western gable. The testing of further samples would help to clarify if other areas of brickwork also date to the early 16th century. It would also be informative to date the brickwork around the north west tower of the ruined hall to see if the date is comparable to that of the church. Nevertheless, it seems likely that the brick in the present church was being recycled from an earlier context, probably that of the original church. The fact that large components of the earlier church are also re-used in the present building supports this argument. The brickwork in the church may have also been produced at approximately the same time that the brick hall was being constructed. This may have been in order to encase the old church with brick in an attempt to compliment the new brick built hall.

CHAPTER 6: DISCUSSION AND CONCLUSION

'the public.....must not be let into the secret of how little in history can be deemed to be definitely settled'

-Goethe

This chapter focuses on the effectiveness and potential for applying luminescence to date historic brickwork. The current ideas surrounding the use of brick during the medieval and early modern periods in both Essex and England are then reconsidered in light of the results and implications discussed in the previous chapter. The discussion also highlights areas for future archaeological investigation in light of the results. It should be noted that, unless stated otherwise, the error ranges for any luminescence dates cited are $\pm 1\sigma_B$.

6.1 THE EFFECTIVENESS OF OSL TO DATE HISTORIC BRICKWORK

The effectiveness of OSL has been demonstrated by the agreement of the luminescence results with the current archaeological assessments for several of the buildings studied. This is demonstrated by the fact that the pooled mean of the luminescence dates for Nether Hall (1455 ± 23) agreed with the other different forms of dating evidence, including the dendrochronology, historic evidence based on heraldic decorations and comparisons to other historic brick structures in the surrounding area (see 5.1.5). With regards to the self consistency of the luminescence dating technique, consideration must be given towards the way in which the methodology was applied during this study. In certain instances, it was possible to collect samples from contexts that were understood to be of the same phase. Two examples of this include Nether Hall (326) and Tilbury-juxta-Clare (334). The fact that in these two situations there was no significant difference between the samples collected illustrates the self consistency of the technique. This is further supported by one of the samples from Nether Hall in which two dates were derived from the same core (326-4 and 326-4#2), both of which again showed good agreement (see 5.1.5). Such self consistency has also been seen in other brick dating studies in Lincolnshire (Bailiff, 2007, 846) and Suffolk (Antrobus, 2004, 29). Overall, the above discussion suggests that in situations

where complicating factors, such as the re-use of brick, are not an issue, the results from the luminescence dates are self consistent and reliable. Even in situations where there are such complicating factors, this study has shown that the OSL dating technique does provide valuable information which can help to revise archaeological interpretations. An example of this can be seen at Coggeshall Abbey where the luminescence date for the sample collected from the late 16th century manor house (327-2) revealed that the north range is likely to have been constructed using materials robbed from the neighbouring cloister of the monastic complex (see 5.1.1).

6.2 EARLY MEDIEVAL BRICK

It is interesting that the sample from Coggeshall Abbey gave a result that was in agreement with the archaeological context from which the sample had been taken (see 5.1.1). This is an important discovery given the significance of this site in previous studies of medieval ‘great brick’ (see 2.1.2). It also shows that brick was being produced in the mid-12th century. However, an equally significant discovery was the fact that the OSL dates derived for Boreham and Bradwell-juxta-Coggeshall were earlier than the 12th century contexts proposed by the archaeological analysis of the buildings (see 5.2.1 and 5.2.2). This suggests that the brick had been re-used in later contexts and has important implications for the current understanding of medieval brick in England, especially since it has long been held that the earliest post-Roman brick occurred at Coggeshall Abbey. The findings from this study support Rodwell’s recent challenge to this long held assertion in which he suggests that Coggeshall type bricks occur prior to the mid-12th century (see 2.1.2). Furthermore, since the luminescence results for the sampled bricks suggest that they have been re-used, this implies that they had originally been intended for use in older contexts, suggesting that medieval ‘great brick’ was being manufactured earlier than had originally been thought.

Given that only the date for the sampled brick at Coggeshall Abbey agrees with the archaeological context, the question arises as to when medieval ‘great bricks’ were introduced? As already discussed, the luminescence dates derived for both Boreham and Bradwell-juxta-Coggeshall are unlikely to represent the true age of the sampled bricks due to the changes in the surrounding gamma and

cosmic components of the surrounding radiation field (see 5.2.1 and 5.2.2). Nevertheless, the luminescence suggests the 12th century archaeological contexts be regarded as a *terminus ante quem* for these two cases. The archaeological assessment of Boreham church would suggest that the pre-Norman phase of the building in which Coggeshall type bricks occur dates to between c.950-1100 (see 5.2.1) whilst it has been suggested earlier that the date for the bricks at Bradwell-juxta-Coggeshall could lie somewhere in the 11th century (see 5.2.2). Another possible suggestion for the age of medieval ‘great brick’ has been offered at the Norman church in Chipping Ongar, Essex. Here OSL dating of the brickwork has produced a result of 1038 ±32 (Blain, 2009). The church itself was originally dated to the late 11th century (RCHME, 1921, 51-52) although it has now been suggested that it dates to the mid-12th century (Rodwell, 1998, 105). Given the early 11th century date determined by the luminescence analysis and the lack of a thorough archaeological assessment of the building, it is difficult to state whether the bricks analysed were from a primary context or had been re-used. However, if Rodwell is correct in his suggested re-evaluation of the date of the building then it appears that the brickwork at Chipping Ongar may also have been recycled from an earlier context into a Norman building. The fact that Saxon style windows, with tall, narrow proportions and monolithic heads, occur in the north wall face of the church might indicate that either an older building was modified or that material was re-used from a late Saxon structure in the construction of the present church. Ultimately, a detailed archaeological survey of the building is required to determine which of these two scenarios is most likely. Nevertheless, the OSL date at Chipping Ongar church supports the idea that medieval ‘great brick’ was being produced prior to the 12th century.

It therefore seems likely that ‘great brick’ was being produced in the late Saxon period, probably in the first half of the 11th century, of which there appears to be at least one instance (Boreham) where the brick is in its original Saxon context. After the Norman conquest, ‘great brick’ appear to have been re-used in the erection of Norman structures or in the alterations to Saxon buildings, possibly as part of a Great Rebuilding thought to have taken place among English parish churches in the 11th and early 12th centuries (Gem, 1988). This appears to have been the case at Boreham, Bradwell-juxta-Coggeshall and Chipping Ongar.

If the above discussion is correct, then the issue arises as to how likely it is that brick could have been produced in the late Saxon era. The fact that late Saxon decorative floor and wall tiles have been found in both Suffolk (Gem and Keen, 1981, 20-26) and London (Betts, 1996) would tend to suggest that there was the ability and knowledge base to produce ceramic building materials in the surrounding late Saxon community, a factor that might well have encouraged brick making. Certainly, there are some similarities between the descriptions of late Saxon tiles recovered in London and Coggeshall type bricks examined by the author. These include the use of sanded moulds and common features to the ceramics such as reduced grey cores and sandy fabrics with quartz inclusions (Betts, 1996, 21-22). Equally, there is evidence in continental Europe that the art of producing fired ceramic building materials also occurred during the early medieval period, albeit infrequently (Goll, 2005, 404; Perlich, 2008, 9-12; see 2.1.1). Given the above evidence, it would seem that there could have been an appropriate knowledge base in the late Saxon era for the production of brick.

Based on observations made by the author, it is apparent that the bricks at Boreham and Bradwell-juxta-Coggeshall have identical fabrics to other Coggeshall type bricks at other sites. This leads on to the question as to whether or not there are any further locations where late Saxon brick was being made and used in construction work. Since it has already been shown that Coggeshall type bricks were re-used in later medieval contexts in Essex (see 2.4.2), this question can also be asked of buildings in which Coggeshall type brick occurs in later medieval contexts. Consequently, the Coggeshall type brick incorporated into the fabric of a large number of sites in Essex, either as rubble or in later medieval contexts, could actually have been produced much earlier than originally thought. Two examples of this can be seen at the churches of Fairstead and Elsenham. Considering Fairstead first, it is thought that the nave and chancel might have originally been part of a late Saxon structure, possibly dating to the late 11th century, with an apsidal ending to the originally short chancel (see Fig. 6.1) (RCHME, 1921, 66; Rodwell and Rodwell, 1977, 106). The church was later altered in the 13th century when the apsidal end was replaced with a square extension and the western tower was added (RCHME, 1921, 66; Rodwell and Rodwell, 1977, 106). Coggeshall type brick occurs in both the western tower,



Fig. 6.1: Fairstead church chancel. The current chancel end is thought to have been extended in the 13th century, possibly replacing an earlier structure. The quoins that identify the eastern extent of the earlier structure are preserved in the wall fabric and are circled in the main image. Coggleshall type brick occurs randomly among the flint rubble walling of the 13th century square eastern end, an example of which is shown in the bottom image where Coggleshall type bricks have been used to form part of a put log hole. The occurrence of Coggleshall type bricks in the later 13th century chancel suggests re-use from an earlier context.

where it is used in the lining of the lancet windows, the tower quoins and the upper portions of the south west tower buttress, and in the walls of the eastern extension, where it occurs as part of the flint rubble walling (Ryan, 1996, 26). Given that the Coggleshall type brick in the 13th century chancel is largely used randomly among the flint rubble walling as opposed to a deliberate fashion in a structural context, as is the case with the quoins or window linings of the tower, it is highly likely that they have been recycled from an earlier context.

Consequently, the 13th century date ascribed to the bricks in the chancel should instead be regarded as a *terminus ante quem*. Given that there is thought to have originally been a late Saxon structure on the site of the present building, it is possible that it originally contained Coggeshall type brick, possibly in the apse, which was later re-used in new contexts when the 13th century alterations were made to the church.

Elsenham, as is also the case with Fairstead, lacks a detailed archaeological survey of the present structure and is often thought of as a simple, two celled Norman building dating to the early 12th century (RCHME, 1916, 82; Bettley and Pevsner, 2007, 343-344). However, there appears to be evidence for an earlier structure in the chancel where there is an offset in the walls at the sill level of the Norman windows (Rodwell and Rodwell, 1977, 106). It is also believed that there was a priest here in the late 11th century (Rodwell and Rodwell, 1977, 106). The church is significant because the rear arch of the southern door and some of the chancel quoins below the sill offset incorporate medieval 'great brick' suggesting that Elsenham is another possible site containing *in situ* late Saxon brickwork. The bricks at Elsenham are generally smaller than the conventional rectangular Coggeshall type bricks (typical dimensions of an Elsenham brick are 240-250 mm × 200-210 mm × 30 mm whilst a typical Coggeshall type measures 320-330 mm × 150-160 mm × 45- 55 mm) (Ryan, 1996, 23, 41). Whilst they are smaller, there are several factors that the Elsenham bricks have in common with Coggeshall type bricks, including a sandy fabric and a darkened, reduced core surrounded by an orange exterior. Medieval bricks with dimensions smaller than the standard rectilinear Coggeshall brick were also recorded at Bradwell-juxta-Coggeshall church (the small bricks at Bradwell-juxta-Coggeshall measured 210 mm × 110mm × 32mm) (Rodwell, 1998, 103). It is worth noting that Elsenham does not fall among the large cluster of structures around Coggeshall Abbey that incorporate Coggeshall type bricks (see Fig. 2.4), although it is located approximately 4 miles to the west of the Cistercian abbey at Tilty where medieval brick was excavated in the 1940s (Steer, 1950, 99-100).

The examples discussed above serve to illustrate that Coggeshall type brick was both being re-used in later medieval contexts and is also present in pre-Norman structures. They also illustrate the way in which association with later

medieval features, such as the 13th century lancet windows in the tower at Fairstead, can result in 12th or 13th century dates being ascribed to Coggeshall type bricks. Since the sample from Coggeshall Abbey produced a date which agreed with the archaeological context, it is clear that brick was being produced during the 12th century. It is also apparent that there are structures which date to the 13th century and incorporate Coggeshall type brick in a primary context, such as the *capella extra portas* at Coggeshall Abbey, a structure thought to date to the early 13th century (see 3.3.1.1). Therefore, it seems likely that Coggeshall type brick was being both produced and recycled from the late Saxon period through to the 13th century. Future archaeological and luminescence analysis of structures that contain Coggeshall type brick would help to determine the extent to which brick was being produced and recycled during this period.

The idea of brick being produced during the late Saxon period in Essex has broader implications for the previously held idea that the Cistercians played a significant role in the reintroduction of brick production in the mid-12th century (Hunter, 1999, 111-112; Andrews, 2005a, 142). It would now seem more likely that the Cistercians were involved in encouraging the development of what may well have originally been a small scale, localised brick industry, especially when the large amounts of brick required for the construction of Coggeshall Abbey is taken into account. This would reflect the broader European trend of the large number of Cistercian monastic complexes that are seen to arise in the 12th and 13th centuries across Europe incorporating brick in their structures (Untermann, 2008). This trend is likely to have been encouraged by the annual meeting and exchange of ideas that took place between the abbots of the various Cistercian houses at Citeaux (Ryan, 1996, 43-44). Since the responsibility for the re-introduction of brick into England can no longer be attributed to the Cistercians, there is the question as to whether there are any other likely candidates. This is difficult to address since few have actively sought alternative explanations due to the strong role which the Cistercians are thought to have played in re-introducing brick. The discovery of Coggeshall type brick at Cressing Temple, an important establishment of the Knights Templar that was founded in Essex in 1136, has led to the suggestion that they might have been responsible for seeking out foreign brick craftsmen (Rodwell, 1998, 104). However, the suggestion of Coggeshall type brick occurring in the late Saxon context at Boreham church would argue

against this idea. As mentioned earlier (see 5.2.1), the alternating use of stone and brick observed in the Saxon chancel arch at Boreham is a decorative feature found at other sites in northern Europe during the 10th and 11th centuries, suggesting a link to continental Europe.

6.3 LATE MEDIEVAL BRICK

It is interesting that the late 13th to early 14th century sites of St. Osyth (354) and All Saints' Church, Maldon (356), where 'Flemish' type bricks were sampled, did not produce OSL signals. It should be noted that the analysis of 16th century white brick at Hengrave Hall, Suffolk, also failed to yield a luminescence signal (Antrobus, 2004, 24-25). The issue of deriving an OSL signal from fair coloured medieval brick is one that requires further attention and presents an opportunity for future study. As a result, the conventional archaeological assessments for these sampled buildings (see 3.3.7.1 and 3.5.5.1) remains unchanged, as does the suggestion that 'Flemish' type brick was being used in Essex from the late 13th through to the 14th century. Attempts to identify red brick, which had been more successful in yielding OSL signals, from this period proved unsuccessful (see 4.4).

However, the analysis of the brick samples taken from 15th and 16th century contexts has raised a number of important issues, the first of which involves the date for the Moot Hall, Maldon (1393 ±36). The Moot Hall is a significant building as it contains a number of decorative and skilfully crafted architectural features, such as the use of carved brickwork in decorative contexts, a brick newel staircase and ruddling (see 3.3.4.1). The late 14th century date for the Moot Hall could indicate that these ideas and skills were being conveyed into eastern England slightly earlier than had been previously thought, probably under the guidance of European craftsmen. Given the high craftsmanship demonstrated in the Moot Hall, it is interesting to speculate whether those involved in constructing this building might have also been involved in work at King John's Hunting Lodge, Writtle, or in the castle at Pleshey where the red octagonal chimney bricks, dating to between the late 14th and mid-15th centuries, were uncovered (see 2.4.3). However, the date range for the Moot Hall also covers the early 15th century, which is when the archaeological assessment suggests the

building was erected (see 3.3.4.1), suggesting that these features may have been introduced then. Even so, the allocation of a late 14th to early 15th century date for the introduction of the brick features in the Moot Hall is an important discovery.

The luminescence dates for many of the brick samples collected from the 15th to 16th century contexts produced dates that were earlier than the archaeological assessment (two thirds of the bricks sampled from this period produced dates that suggested brick had been re-used). This point is clearly exemplified with the likely demolition of an earlier brick manorial complex at Layer Marney in order to construct a more visually impressive and fashionable courtyard complex (see 5.1.3) and the re-use of red 'Tudor' brick from the 15th century cloister at Coggeshall Abbey in order to build the north range of the present house in the later 16th century (see 5.1.1). It should be remembered that brick had become a fashionable building material during the 15th century and that this demand carried on into the 16th century (see 2.1.5). Consequently, the re-use of brick, wherever it could be obtained from, seems a logical and effective means to satisfy both the desire for a prestigious building material and the erection of new structures in a quick and cost effective means.

Given the above discussion relating to the re-use of red 'Tudor' brick, the question arises as to how widespread this activity was at other sites around Essex. This is a harder issue to address since red 'Tudor' bricks are typologically similar during the 15th and 16th centuries, resulting in the need for additional information through the archaeological analysis of any given structure. However, there are some sites which offer tentative archaeological evidence for red 'Tudor' brick being recycled during the 16th century. The first example is Copped Hall. The present building at Copped Hall dates to the 18th century but it is thought that there had been a structure close to the present building since the 12th century (VCH, 1966, 123-124). This was largely rebuilt by Sir Thomas Heneage between 1564 and 1568 when Elizabeth I visited him (VCH, 1966, 123). Details of the mansion that Heneage built on the site of the earlier manor were recorded in detailed plans, elevation drawings and sketches prior to its demolition in the 18th century, allowing a great amount of information to be derived for this lost structure (Newman, 1970, 18). In addition, excavations of the site were undertaken in 1984 (Andrews, 1986) and have been resumed since 2002 (Bateson *et al.*, 2008, 38). With regards to the earlier building, it is known from the

exchange with the crown that Henry VIII enjoyed staying there (VCH, 1966, 123). It was granted by Edward VI to princess Mary, who sometimes stayed there during her brothers reign, before being leased to Sir Thomas Cornwallis in 1558 (VCH, 1966, 123). A survey of the site made in 1563, describing recent modifications made by Cornwallis that required 40 loads of oak, mentions a hall, a great chamber, a kitchen, a cheesehouse and other service rooms and a court with a double gate and a moat (Newman, 1970, 18; Bateson *et al.*, 2008, 42). Clearly, there had been a substantial structure already on the site prior to Heneage's building operations. It is widely believed that Heneage incorporated and modified parts of the earlier structure, including the hall, into his new mansion (Newman, 1970, 19). Excavations in 1984 revealed a dark blue-grey layer of clay, possibly the moat of the earlier mansion, with a clay layer above containing flecks of brick and sealed with a layer of tile fragments (Andrews, 1986, 100). It was suggested that this might be evidence of large scale levelling of the site for the construction of the new mansion (Andrews, 1986, 105). This would imply that the earlier manor contained brick structures. More recent excavations have focused on the west end of the great hall and it is thought that there are probably three phases of brick structures, two of which are believed to pre-date the work done by Heneage in the 1560s (Bateson *et al.*, 2008, 41-42). One of these earlier structures was a brick newel stair that had been demolished to foundation level and was not represented on the 18th century plans of the mansion built by Heneage (Bateson *et al.*, 2008, 41). Whilst the use to which the bricks in the staircase were put following demolition is uncertain, it is possible that they could have been re-used in the new building work. The poor quality of the walls that have been excavated have suggested hasty construction work of Heneage's new mansion (Bateson *et al.*, 2008, 42). Given the evidence for the re-use of brick in the 16th century in Essex, there is a distinct possibility that an earlier brick manor at Copped Hall was demolished before the materials, including the brick, were re-used to either level the ground or build Heneage's new Elizabethan mansion.

Another possible site in Essex where red 'Tudor' brick might have been re-used in the 16th century is the brick manor at Woodham Walter, a structure that is now a ruin located to the south east of the present church (see 5.2.9). A recent survey indicated that the north west tower of this brick mansion was a later phase

structure, thought to date to between the late 1530s and the 1560s (Ryan, 1999b, 191). The rubble core of the tower contained red 'Tudor' brick alongside worked stone from window openings, 14th century Flemish cream bricks, septaria and clunch (Ryan, 1999b, 189). This suggested that the most likely source for this rubble core material was the Carmelite Friary, Maldon, where similar materials were found during recent excavations (Ryan, 1999b, 191). Consequently, there is evidence to suggest that red 'Tudor' brick was being robbed from an earlier structure for use in the construction of a mid-16th century alteration to Woodham Walter Hall. When considered against the evidence from the OSL dates, the above examples suggest that brick re-use was probably taking place in the construction of 16th century Essex manors.

Although many of the luminescence dates suggested that brick had been re-used, it is important to appreciate that there were also instances which suggested that brick was being produced for construction projects. This was seen to be the case for the luminescence results for Tilbury-juxta-Clare and Theydon Garnon. The results for these two sites supported the idea that brick was being used for the construction of church additions, such as towers, in the late 15th and early 16th centuries (Ryan, 1996, 71-73). It is interesting to note that, whilst these two brick church towers have often been regarded as being early 16th century features, they actually produced late 15th century luminescence dates (see 5.2.7. and 5.2.8). This suggests that these additions to the original churches took several decades to complete, as is thought to be the case with Dedham church tower (Ryan, 1996, 63). It should be remembered that the 15th century was a prosperous time for many areas of the country, including Essex, in which some of the wealthiest towns either rebuilt or added bold additions to churches (Morris, 1989, 357). A good example in Essex is the town of Saffron Walden which grew wealthy on both cloth and the saffron crocus. Here the entire church was largely rebuilt in the latter half of the 15th century (Bettley and Pevsner, 2007, 654-655). As has been mentioned before (see 2.4.5), these large scale construction projects could take great lengths of time. The luminescence results for Tilbury-juxta-Clare and Theydon Garnon therefore agree well with the building pattern for church additions and alterations during this period. Although not an issue addressed by this project, it would be interesting in any future work that involves the dating of late 15th to early 16th century brick church towers by luminescence to analyse

brick in both the lowest stages and the belfry. Such an approach would help determine the rate at which brick towers were constructed as well as whether the use of brick for ecclesiastical additions was more frequent in the late 15th century or the early 16th century.

6.4: CULTURE OF RE-USE

The above discussion has clearly illustrated that, whilst brick was being manufactured during the medieval period, there was also an extensive culture of re-using brick that was present throughout the medieval period. This culture of re-use is already well known for other building materials, including stone (Stocker, 1990; Eaton, 2000) and Timber (Clifton-Taylor, 1987, 297, 300). Whilst it has been widely acknowledged that Roman brick was re-used during the early medieval period (Ryan, 1996, 15-20; Potter, 2001, 131), this practice has not necessarily been appreciated to the same extent for brick in later medieval contexts. It is therefore important to recognise both the archaeological and documentary evidence which demonstrates that, as well as being produced, brick was also being re-used throughout the medieval period.

From an archaeological perspective, evidence has already been considered which demonstrates that Coggeshall type bricks were re-used in 12th to 15th century ecclesiastical contexts (see 2.4.2 and 6.2). Additional archaeological examples which suggest brick was re-used include the medieval town walls of King's Lynn, Norfolk, and Great Yarmouth, Norfolk. At King's Lynn, the town walls are thought to have been built between the late 13th and the first half of the 14th century (Hoare *et al.*, 2002, 91). A geological study of the materials used in the wall revealed that alongside re-used ship ballast cobbles were vitrified and distorted bricks. It is thought that they may have originated from ports located on the North Sea or from the Baltic (Hoare *et al.*, 2002, 97). Recent analysis of the medieval walls of Great Yarmouth, Norfolk, has also provided evidence suggesting brick was being re-used. The majority of the walls are thought to have been erected during the 14th century but underwent large scale repair work and alteration during the remainder of the medieval period and into the early modern period (Potter, 2008, 9-14). There are many different type of brick incorporated into the walls, including 'great bricks', 'Flemish' and red 'Tudor' types (Potter,

2008, 20-21). Since 'great bricks' are thought to date to a period earlier than the 14th century, the parts of the walls where these bricks are found in the rubble cores offers strong evidence for re-use (Potter, 2008, 20, 60). Further evidence that demonstrates brick was being re-used in the walls was the adherence of earlier mortar (Potter, 2008, 60). There are also parts of the wall where red 'Tudor' type bricks appear to have been re-used from demolished structures, possibly in an attempt to strengthen the walls at the end of the 16th century in the face of the threat posed by the Spanish Armada (Potter, 2008, 63).

The dissolution of the monasteries is another source of archaeological evidence that suggests brick was re-used in Essex. It has been noted in earlier studies that little monastic brickwork survives in the county (Ryan, 1996, 73). However, there is sufficient archaeological evidence to show that brick had been employed at several monastic sites, including Coggeshall Abbey (see 3.3.1.1), Earls Colne Priory (see 5.2.3), the Carmelite Friary, Maldon (Isserlin, 1999, 90-91), St. Osyth's Priory (Ryan, 1996, 73), Tilty Abbey (Steer, 1950, 99-100) and Waltham Abbey (Ryan, 1996, 29). Given that there are many cases across the country of building materials being recycled from other dissolved monastic sites (Colvin, 1999, 57-61; Morris, 2003, 237-239), it seems highly likely that much of the brick used in the monastic complexes in Essex was also re-used in other structures in the county. Evidence for this has already been mentioned for Woodham Walter Hall (see 5.2.9 and 6.3) and the manor complex at Coggeshall Abbey (see 5.1.1). Another example involved moulded Coggeshall type brick being incorporated into the foundations of a building in Coggeshall village (Greatorex, 1999, iv), suggesting that the wider community were robbing the abbey of its brickwork. The scarcity of surviving monastic brickwork is therefore another indirect source of evidence to support the idea that brick was being re-used in the 16th century in Essex.

There is further evidence in the historic record of the 15th and 16th centuries which demonstrates that the red 'Tudor' type brick of this period was also being re-used. This includes an account of 1472 which records that bricks were taken from the Tower on the Moor, Woodhall Spa, a ruined brick tower house thought to have been erected in the 1440s. The bricks were taken to the nearby Tattershall Castle, Lincolnshire, for repair work (Douglas Simpson, 1960, 78). Another case involves Fulbroke Castle, Warwickshire, a castle that was

constructed in brick and stone by John, Duke of Bedford, in the early 15th century. It had fallen into ruin by 1478 and was largely demolished by Sir William Compton who was granted permission by Henry VIII to use the material in his new house at Compton Wynyates, a brick structure that still survives (VCH, 1945, 92). In 1530 James Needham was contracted to build a new gallery and summer house at the London residence of the Marquess of Exeter, in which he was allowed to re-use the materials of the old gallery, including the brick (Salzman, 1952, 575-577). Finally, in 1607 Robert Cecil, 2nd Lord Burghley, acquired the late 15th century brick built Hatfield Palace, Hertfordshire, and began demolishing parts of the structure to provide building materials for his nearby prodigy house. The 15th century bricks, whilst not directly incorporated in the new building, were used to both construct garden walls and also as rubble infill for the courtyard and a new access road to the south (Emery, 2000, 253). These examples and the findings raised by this project clearly demonstrate that brick was being re-used to a large extent from the 11th century to the end of the 16th century. Therefore, brick can certainly be included among the family of building materials that are known to have been re-used during the medieval period.

The motivational factors behind the re-use of brick during the medieval period are likely to be similar to those attributed to other building materials. This issue was originally addressed by Stocker (1990) who proposed three key motivating factors, specifically casual, functional and ideological. This has since been revised by Eaton (2000, 135) who has suggested that there were two main motivational categories for re-use of material. These are 'practical' re-use, in which the motivational factor is one of economy, convenience, professional preference or technological necessity, and 'meaningful' re-use, in which the motivational factor is guided by the age-value of the material or its esotericism (Eaton, 2000, 135).

It is likely that most cases of re-use were motivated largely by practical reasons. This is especially likely to be the case during the 16th century when the Great Rebuilding was encouraging the increasing number of nobility and later the yeoman classes to rebuild, alter or enhance existing medieval structures (see 2.1.5). The opportunity to re-use building materials would have saved both in terms of the resources and economy required to undertake such alterations. The motivation of economy coupled with the Great Rebuilding can be seen at the level

of the nobility in the case of Layer Marney, where a 15th century brick manor appears to have been sequentially replaced by a fashionable and imposing early 16th century courtyard complex (see 3.3.3.1 and 5.1.3). Further down the social spectrum, the re-use of brick and other building materials to construct the northern range at Coggeshall Abbey in the late 16th century (see 3.3.1.1 and 5.1.1) is also likely to have been motivated by a combination of economy and the Great Rebuilding. Further cases of situations where practicality is likely to have been a motivational factor in the re-use of specific brick features include shaped bricks. This can be seen at Copford church where the inner order of a late 13th century lancet arch is composed of moulded medieval ‘great bricks’ alongside re-used Roman material (see 2.4.2). The presence of the Roman bricks suggests that the medieval brick might have been re-used (Rodwell, 1998, 105), in which case the specific shape of the bricks is likely to have played a key factor.

Whilst practical reasons are likely to have motivated the majority of cases of re-use, there is evidence to suggest that in some circumstances more meaningful factors played a role. One possible motivational factor that could fall under this more esoteric category is the desire to assert authority over former structures. The case of Fulbroke Castle mentioned above certainly represents a practical motivational factor, given that it saved Sir William Compton the expense of producing new brick for his manor. However, it is also possible that there was another, more meaningful motivating side to the re-use of the building materials. Sir William Compton was an individual who had been a close friend to Henry VIII since childhood. He took advantage of this close association with the monarch to build up a landed estate. During the course of this, he became constable of many royal castles, including Fulbrook, and was also at different times bailiff, keeper, receiver and steward on royal lands. Whilst involved with crown lands, he came into dispute with other nobility, including Margaret Pole, Countess of Salisbury, and Edward Stafford, Duke of Buckingham (ODNB, 2004, Vol 12, 897-898). It is possible that the desire to demolish and re-use material from the royal castle of Fulbrook was intended to convey the message that the newly built Compton Wynyates and its resident family had superseded the power and authority of the Duke of Bedford, thus asserting his authority and social position among the nobility.

Another possible context in which a meaningful motivation might have led to the re-use of brick could exist in the mansions erected after the dissolution of the monasteries. In this context the re-use of the brick might be intended to show the supremacy of the secular owner over the former ecclesiastical institution. One site where this might have been the case is Beeleigh Abbey, Essex, where a brick clamp was recently excavated that had been serving the abbey for repairs to the main tower around 1517 (Punchard, 2007, 30-31). The abbey was dissolved in 1536 before being granted to Sir John Gate in 1537. He is thought to have converted the east and south east corner of the cloister into the current manor (Punchard, 2007, 9). It has been shown that materials from demolished parts of the monastic complex were being re-used in the new manor. An example of this was identified when timbers in the Tudor portion of the building were dated by dendrochronology to between 1199 and 1214 (Bettley and Pevsner, 2007, 127). Given that brick was being used to repair the church and that parts of the original abbey were being recycled, it is reasonable to suggest that brick might have been re-used at Beeleigh after the dissolution. Archaeological evidence to support this suggestion exists in a garden wall next to the current manor. The wall is mostly laid in an irregular header bond with diaper patterning on one side, a feature that would agree with the early 16th century construction date of the manor. The other side of the wall contains large bricks (the dimensions of a stretcher face are approximately 425 mm × 50 mm) among the red ‘Tudor’ bricks, indicating that early medieval ‘great bricks’ were being re-used during the construction of the current manorial complex. The irregular bond combined with the recycled ‘great bricks’ suggests that the red ‘Tudor’ brick in the wall was also re-used. It is also possible that the clamp could have continued to be used to produce bricks after the dissolution, possibly to produce more brick for the conversion of the abbey into a manor house (Punchard, 2007, 31). If correct, then the re-use of both the brick clamp and brick from the abbey might have been motivated by both practical and meaningful motivational factors. Practically, it would save the need to organise and obtain the necessary resources for such a construction project. In addition to this, the use of facilities that had formerly belonged to the abbey might have been a deliberate attempt to define and assert Gate’s ownership and authority over the site.

The above discussion clearly shows that, whilst brick was being produced from the 11th century onwards, its re-use was a common aspect to the building culture throughout the medieval period. The motivational factors behind this are most likely to be practical reasons, including the opportunity presented to save resources that would otherwise be required to manufacture bricks for building work. However, there is also the possibility that more meaningful, esoteric factors played a role in motivating the re-use of brick. These could well have related to a desire to compete with ones contemporaries, as is likely with the Great Rebuilding or possibly a desire to assert authority over a former property and its owners.

6.5: IMPLICATIONS FOR DATING MEDIEVAL BRICK STRUCTURES

This research has demonstrated that luminescence can produce reliable and meaningful dates, especially in contexts constructed of brick where no re-use has occurred. Even when brick has been re-used in a structure, the luminescence can provide this information which is otherwise difficult to discern through more conventional archaeological approaches. It is also clear that in order to maximise the amount of information that can be derived a full archaeological understanding of the building and sampling context is needed when interpreting the luminescence results. This thesis has focused on a broad range of buildings, both in terms of the type and chronological range spanned by the sampled structures. It was therefore beyond the remit of the thesis to undertake full archaeological assessments of the buildings sampled, especially given the time constraints involved in processing the samples. Nevertheless, in future cases where individual structures or specific building types are to be dated by luminescence, thorough archaeological surveys of the structure are to be encouraged. Equally, where possible, the collection of more than one sample would be prudent in future work in order to increase the likelihood of deriving a luminescence date, especially when it is considered that not all bricks will necessarily yield an OSL signal, for example, sample 340-8 at Eastbury Manor. Multiple sampling also has the advantage of confirming any findings suggested by the luminescence results.

The study has also demonstrated that medieval brick was being re-used to a greater extent than might have been previously realised, especially in the later

medieval period with the red 'Tudor' type brick. This highlights a subtle but critical aspect of historic building studies, this being the difference between *when* a specific event took place and *how* it was undertaken. A clear example of this is Woodham Walter (338) where the documentary evidence and the date plate agree with the specific event (the relocation of the church) but not with the means by which this was undertaken (the re-use of large parts of the original church in the new building). The case of Woodham Walter also illustrates that, whilst other techniques commonly employed for dating historic brickwork (see 2.2) all provide important archaeological information, there is a need for a critical awareness as to what that information is likely to relate to in the historic building in order to gain the maximum understanding of the structure. This is especially true given the extent to which brick appears to have been re-used during the medieval and Tudor periods. Leading on from this, it is proposed that when typological sequences and collections are compiled and consulted, the periods over which both medieval 'great brick' and 'Tudor' type brick are regarded as having been employed should be revised. It is proposed that medieval 'great brick' should now be regarded as dating from the 11th to the 13th century and that 'Tudor' type brick should be regarded as dating to from the late 14th to the early 17th centuries.

This project has also illustrated that more information can be obtained from historic brick structures when the luminescence is applied with several other archaeological approaches. An example of this can be seen at Tilbury-juxta-Clare in which several different approaches were adopted for dating the tower. These included architectural fittings, including a dateplate, consultation of the broader historic record, comparison to neighbouring structures and documentary evidence. All this evidence supported an early 16th century date of construction (see 3.5.8.1). However, the luminescence demonstrated that it was more likely that the tower was begun in the late 15th century and completed in the early 16th century (see 5.2.8). Therefore, the OSL both supported the conventional archaeological interpretation and helped clarify it further by suggesting that the tower had been erected over an extended period.

The project has demonstrated that luminescence has the scope to help identify how specific archaeological events were undertaken with respect to historic buildings. Luminescence can therefore be seen to represent a technical contribution towards the wider field of buildings archaeology, such as describing

the ways in which brick was used in the past and the social or cultural factors that were likely to have motivated such uses.

6.6: FUTURE WORK

The research undertaken for this thesis represents the first work undertaken in Essex in which luminescence was applied on a large scale to date important historic brickwork. The research has made several important discoveries and this in turn has resulted in further questions arising which could be addressed by future research into medieval brick. Some of these are outlined below for the different brick types studied in this project.

The results from this project have provided evidence that some of the medieval ‘great bricks’ are likely to be older than the 12th century and probably date to at least the 11th century. In certain situations, the re-use of this type of brick in later medieval contexts may have misled the conventional dates ascribed to them. There is therefore a need for further research to focus on addressing the validity of the dates currently ascribed to the brickwork in certain buildings and revise them where necessary. Five such sites (Boreham, Bradwell-juxta-Coggeshall, Chipping Ongar, Elsenham and Fairstead) have been considered in this light by this project and undoubtedly there are many more. Another consequence of the idea that some medieval ‘great bricks’ date to the 11th century is the need to revise the long held notion that Coggeshall Abbey and the Cistercians were responsible for reintroducing of the art of brick making in England (Rodwell, 1998, 103-104). The study of medieval bricks in both English and European contexts, such as that undertaken by Blain (2009), could offer future clues as to the origin of the first medieval brick in England.

Further study into why fair coloured bricks fail to give an OSL signals would also be of interest. If it were ultimately possible to derive luminescence signals from ‘Flemish’ type bricks then it would allow a series of important archaeological questions to be addressed surrounding this building material. These include identifying when this type of brick first appears in the archaeological record and the period over which it was used. As with the medieval ‘great brick’, analysis and comparison of similar material from both English and European contexts could serve as an indicator as to whether ‘Flemish’

cream bricks were being produced contemporaneously, potentially suggesting a likely source of origin or influence.

With regards to future work on red 'Tudor' brick, it has already been noted that this project has highlighted the extent of re-use of this brick type during the 15th and 16th centuries. However, the opportunity exists to investigate this further by analysing more buildings from this period. This would show if re-use was undertaken in equal measure throughout this period or was more common in the 16th century when there is likely to have been an increase in the amount of available brick due to the dissolution of the monasteries as well as the desire to obtain the material quickly and economically due to the social pressures of the Great Rebuilding. Another opportunity that presents itself is the dating of brick in ecclesiastical contexts, including brick towers, porches and clerestories. By sampling a brick tower at the base and upper stages, it would be possible to determine the likely length of time taken to erect such features.

This study has uncovered a great deal of information relating to one specific aspect of the English medieval building industry. At the conclusion of this project, it is apparent that future research into medieval brick still presents further opportunities to derive information, not only of the English medieval building industry but also about the society to which that industry belonged.

APPENDIX: LUMINESCENCE RESULTS

The following section provides a more detailed account of the data derived from the paleodose and annual dose rate experiments undertaken in order to derive the luminescence dates.

A.1: SAMPLE PALEODOSE DETERMINATIONS

Table A.1 provides a summary of the different paleodose values determined for each sample. The majority of the bricks sampled successfully yielded measurable luminescence signals with an 86% success rate. All Coggeshall type bricks successfully produced strong luminescence signals. None of the 'Flemish' cream bricks sampled for this study produced measurable OSL signals. It has been noted before that red 'Tudor' bricks frequently yield luminescence signals (Antrobus, 2004; Bailiff, 2007) and this was also found to be the case in this project. The strength of the signals is indicated by the ratio of the luminescence and background noise signals (S:B, column 3 in Table A.1) and indicate that there was a considerable range (S:B = 2-255), both between sites and also within the same structure, for example, sample 340-2 (S:B = 191) and 340-5 (S:B = 54). It should be stressed that, at present, there is no visual correlation between the nature of the brick and the strength of the luminescence signal besides the fact that 'Flemish' type bricks do not appear to produce OSL signals. Overall, there was a sufficient yield of quartz to allow several aliquots to be produced for determination of an average paleodose value. In one instance (352-3) a second slice had to be cut from the brick core to increase the amount of quartz available for experimentation. The amount of quartz yielded for each 90-150 μm sample fraction ranged from 0.1% (356-1) to 17.5% (340-3) with a mean yield of 6% ± 4 (s.d.). The total number of aliquots used to derive paleodoses ranged from 9 (336-1) to 22 (334-1).

Paleodose estimates for each aliquot were derived by the interpolation procedure in the SAR protocol (see 4.3.2). The degree of sensitivity change (column 4 of Table A.1) exhibited by the quartz during the SAR sequences was low (mean sensitivity change = 1.06 ± 0.09). The SAR sequence adopted (see Table 4.1) provided two paleodose estimates for each sample aliquot which were

<i>Lab. Ref.</i>	<i>n</i>	<i>Signal: Noise (S:B) (\pmSD)</i>	<i>Sensitivity Change (\pmSD)</i>	<i>Mean Paleodose \pm s.e (mGy)</i>
325-4	19	21 \pm 10	1.08 \pm 0.06	1641 \pm 41
326-3	17	8.7 \pm 3.1	1.02 \pm 0.07	1590 \pm 46
326-4	19	2.0 \pm 1.0	1.01 \pm 0.26	1825 \pm 85
326-4#2	14	3.2 \pm 1.5	1.08 \pm 0.32	1859 \pm 88
326-5#2	14	5.5 \pm 2.3	0.99 \pm 0.09	1688 \pm 59
327-2	15	255 \pm 52	1.09 \pm 0.06	1492 \pm 09
327-3	15	203 \pm 78	1.06 \pm 0.09	2925 \pm 56
334-1	22	4.7 \pm 2.8	1.05 \pm 0.13	1576 \pm 55
334-2	21	11 \pm 4.3	1.04 \pm 0.04	1665 \pm 40
335-1	15	9.8 \pm 5.6	1.09 \pm 0.12	1934 \pm 49
336-1	9	95 \pm 29	1.06 \pm 0.03	1392 \pm 25
337-1	15	14 \pm 9.0	1.06 \pm 0.06	1684 \pm 28
337-2	15	6.6 \pm 4.8	0.99 \pm 0.08	1571 \pm 63
337-3	15	4.96 \pm 3.0	1.06 \pm 0.18	1614 \pm 59
338-1	15	247 \pm 22	1.06 \pm 0.02	1428 \pm 09
339-1	15	281 \pm 50	1.05 \pm 0.03	1530 \pm 12
340-1	18	3.2 \pm 1.1	1.09 \pm 0.15	1419 \pm 57
340-2	15	191 \pm 30	1.06 \pm 0.02	1307 \pm 26
340-3	15	14 \pm 3.3	1.05 \pm 0.07	1186 \pm 42
340-4	15	38 \pm 10	1.05 \pm 0.07	1294 \pm 20
340-5	15	54 \pm 23	1.05 \pm 0.04	1365 \pm 32
340-6	15	57 \pm 20	1.05 \pm 0.04	1307 \pm 14
340-7	15	23 \pm 10	1.05 \pm 0.06	1229 \pm 29
340-8	n.s.	n.s.	n.s.	n.s.
352-1	15	5.9 \pm 4.4	1.08 \pm 0.22	1924 \pm 140
352-2	15	96 \pm 34	1.09 \pm 0.05	2416 \pm 41
352-3	15	18 \pm 10	1.06 \pm 0.12	2152 \pm 60
353-1	15	24 \pm 18	1.06 \pm 0.06	1887 \pm 21
354-1	n.s.	n.s.	n.s.	n.s.
354-2	n.s.	n.s.	n.s.	n.s.
355-1	15	166 \pm 54	1.14 \pm 0.12	2844 \pm 43
356-1	n.s.	n.s.	n.s.	n.s.
357-1	15	62 \pm 51	1.04 \pm 0.07	3060 \pm 37

Table A.1: Summary of the average paleodose values derived for each sample. Note that for some samples it was not possible to obtain an OSL signal from the quartz extracted (denoted as n.s. for ‘no signal’).

then averaged. Once all the sample aliquots were measured, the paleodose values for all the aliquots were averaged. Any paleodose values that were found to lie outside $\pm 2\sigma$ were regarded as outliers and omitted. This was only observed for 6% of the aliquots analysed for six of the samples, in which the paleodose estimates were exceptionally high. Following the removal of outliers, the remaining paleodose values were plotted against the relevant pre-heat temperature used for each specific SAR sequence in order to form the pre-heat plateau for each sample (an example is shown in Fig. 4.9).

The degree of dispersion in the sensitivity values, as shown in the pre-heat plateaus, varied considerably between samples. Sample 352-1 had the highest

degree of dispersion (the total range in paleodose values was 1886 mGy which is 98% of mean sample paleodose) whilst sample 338-1 had the smallest degree of dispersion (the range in derived paleodose values was 132 mGy which is 9% of mean sample paleodose). Despite the high degree of dispersion for sample 352-1, the values were normally distributed. The error associated with the paleodose values was the standard error (s.e.) and, with the exception of one sample (352-1, s.e. = 7%), all s.e. values were $\leq 5\%$ of the mean paleodose.

A.2: ANNUAL DOSE RATE DETERMINATIONS

The following section deals with the different factors that were measured in relation to evaluating the annual dose rate both surrounding (A.2.1) and within (A.2.2) the quartz grains.

A.2.1: External dose date evaluation

The annual dose rate was derived through a combination of β -TLD and γ -TLD measurements with comparative experimentation undertaken using high resolution gamma spectrometry. The beta component contributed the majority of the total annual dose rate (average contribution = 63%).

The activities of the ^{238}U , ^{232}Th and ^{40}K radionuclides derived through high resolution gamma spectrometry for the brick slices allowed, through the use of conversion tables, point absorber beta dose rates to be determined for inside the brick (Bailiff, 2007, 841). These were then compared with the dose rate values derived through β -TLD, the ratio of which is shown in column 7 of Table A.2. The D Conc: D β -TLD ratio values ranged from 0.81-1.29 with a mean value of 1.07 ± 0.1 (s.d.). This suggests that overall there was good agreement between the two different methods used to determine beta activity within the brick fabric, implying that the β -TLD experiments were providing accurate reflections of the beta activity within the bricks.

The results from the TSAC experiments (see Fig. A.1 and column 8 of Table A.2) on powdered brick indicated that there was no significant escape of radon gas, but this is only a reflection of the present state of the brick. The results from the ^{210}Pb : ^{226}Ra ratio derived through analysis of dry, solid brick core slices

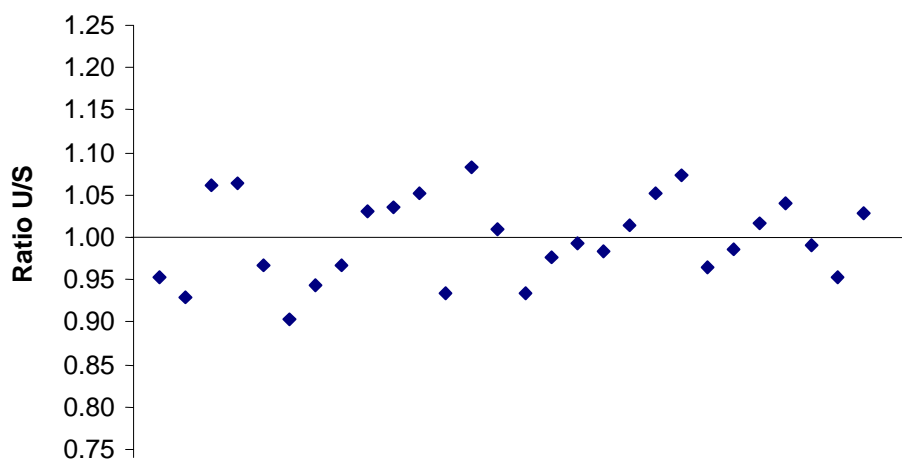

Fig. A.1: Alpha counting data. The ratio of the unsealed (U) and sealed (S) states are shown for all the brick core samples. A ratio for these two values of 1 indicates that radon gas was not released from the powdered brick sample. Since all values lie within ± 0.1 of this value, it indicates that there was no significant escape of radon gas from the samples at the time of analysis.

on the high resolution gamma spectrometer (see column 9 of Table A.2) did indicate that there was partial loss of radon gas from the brick samples but again this is a reflection of the present state of the brick. This had also been found to be the case in an earlier study (Bailiff, 2007, 841) and implies a slightly lower dose rate from the ^{238}U and ^{232}Th radionuclide series. Consequently, the beta dose rate derived from the high resolution gamma spectrometry, where secular equilibrium was assumed to be the case, is expected to be slightly higher than those derived through experimental β -TLD analysis (Bailiff, 2007, 841-843). Nevertheless, as mentioned before, the good agreement between the experimental β -TLD values and those predicted by high resolution gamma spectrometry indicate consistency between the two approaches.

Whilst such a comparative approach is possible for the beta component of the annual dose rate, the situation is more complex for the gamma component. This is a result of the need to understand the surrounding irradiation geometry in order to try and derive an accurate representation of the gamma component from the concentration values (ICRU, 2002, 68-69). However, such irradiation geometric factors are automatically accounted for through the use of γ -TLD

Lab. Ref.	TLD (mGy a ⁻¹)		Gamma Spectrometer (Bq kg ⁻¹)				D Conc.: D β-TLD	TSAC (U:S)	Pb-210: Ra-226
	β	γ + Cos.	U (x ± s.e.)	Th (x ± s.e.)	K (x ± s.e.)				
325-1	1.86 (63%)	1.03 (35%)	33.2 ± 4.1	38.7 ± 3.0	457 ± 7.4	1.01	1.05	0.7 ± 0.1	
326-3	1.73 (58%)	1.19 (40%)	39.8 ± 4.2	45.5 ± 3.0	437 ± 7.1	1.12	1.08	0.9 ± 0.1	
326-4	1.95 (61%)	1.20 (38%)	39.0 ± 3.9	45.0 ± 2.8	472 ± 7.1	1.04	0.94	0.8 ± 0.1	
326-4#2	2.07 (62%)	1.20 (36%)	"	"	"	0.98	"	"	
326-5#2	1.72 (58%)	1.19 (40%)	33.1 ± 3.6	40.5 ± 2.5	419 ± 6.5	1.04	0.94	0.8 ± 0.1	
327-2	1.73 (62%)	1.01 (37%)	30.1 ± 3.5	39.1 ± 2.5	401 ± 6.2	0.98	1.03	0.7 ± 0.1	
327-3	2.73 (81%)	0.65 (19%)	20.8 ± 3.1	34.6 ± 2.3	641 ± 7.6	0.81	1.11	0.6 ± 0.1	
334-1	1.89 (62%)	1.04 (34%)	42.2 ± 4.4	47.3 ± 3.2	463 ± 7.6	1.08	1.06	0.8 ± 0.1	
334-2	1.84 (59%)	1.09 (35%)	41.6 ± 4.4	46.3 ± 3.1	547 ± 8.2	1.23	1.03	0.8 ± 0.1	
335-1	2.33 (63%)	1.26 (34%)	39.7 ± 4.7	45.4 ± 3.4	601 ± 9.0	1.03	0.97	0.6 ± 0.1	
336-1	1.83 (65%)	0.95 (34%)	42.4 ± 4.5	50.0 ± 3.4	400 ± 7.3	1.04	0.97	0.7 ± 0.1	
337-1	2.00 (65%)	0.99 (32%)	41.0 ± 4.5	48.6 ± 3.2	544 ± 4.5	1.14	0.95	0.8 ± 0.1	
337-2	1.84 (62%)	1.05 (35%)	35.1 ± 4.3	46.6 ± 3.1	499 ± 8.0	1.13	1.07	0.8 ± 0.1	
337-3	1.80 (64%)	0.98 (35%)	37.1 ± 3.9	44.7 ± 2.8	486 ± 7.4	1.13	0.92	0.8 ± 0.1	
338-1	1.63 (57%)	1.19 (42%)	33.6 ± 3.8	38.8 ± 2.8	367 ± 6.3	1.01	0.99	0.6 ± 0.1	
339-1	1.56 (61%)	0.94 (37%)	37.6 ± 4.5	46.9 ± 3.3	466 ± 7.8	1.29	1.07	0.7 ± 0.1	
340-1	2.02 (66%)	1.02 (33%)	38.1 ± 4.1	44.8 ± 3.0	450 ± 7.2	0.97	1.02	0.8 ± 0.1	
340-2	1.63 (61%)	1.02 (38%)	32.1 ± 4.4	39.9 ± 3.2	452 ± 7.8	1.14	1.01	0.8 ± 0.1	
340-3	1.49 (59%)	0.99 (39%)	31.7 ± 4.4	36.7 ± 3.3	355 ± 7.1	1.05	1.02	0.7 ± 0.1	
340-4	1.56 (60%)	0.97 (38%)	33.8 ± 4.1	39.4 ± 2.9	446 ± 7.3	1.19	0.99	0.8 ± 0.1	
340-5	1.61 (61%)	0.97 (37%)	31.2 ± 3.8	37.8 ± 2.8	455 ± 7.3	1.14	0.95	0.8 ± 0.1	
340-6	1.55 (61%)	0.95 (38%)	33.0 ± 4.0	41.0 ± 2.9	445 ± 7.4	1.20	0.93	0.8 ± 0.1	
340-7	1.39 (60%)	0.89 (38%)	27.5 ± 3.5	31.2 ± 2.6	356 ± 6.2	1.07	1.04	0.8 ± 0.1	
340-8	-	-	-	-	-	-	-	-	
352-1	2.39 (65%)	1.25 (34%)	31.6 ± 4.0	41.3 ± 2.9	611 ± 8.2	0.96	1.01	0.6 ± 0.1	
352-2	2.57 (69%)	1.16 (31%)	28.1 ± 3.9	42.5 ± 2.9	763 ± 9.0	1.04	0.98	0.7 ± 0.1	
352-3	2.25 (63%)	1.24 (35%)	26.1 ± 4.4	45.3 ± 3.3	612 ± 9.0	1.00	0.96	0.7 ± 0.1	
353-1	1.93 (63%)	1.09 (35%)	31.3 ± 4.0	39.8 ± 2.9	463 ± 7.2	0.97	1.01	0.8 ± 0.1	
354-1	-	-	-	-	-	-	-	-	
354-2	-	-	-	-	-	-	-	-	
355-1	1.75 (68%)	0.81 (32%)	25.8 ± 3.7	36.2 ± 2.7	495 ± 7.5	1.07	1.05	0.7 ± 0.1	
356-1	-	-	-	-	-	-	-	-	
357-1	2.24 (71%)	0.91 (29%)	37.5 ± 4.0	46.1 ± 2.9	583 ± 8.1	1.04	0.97	0.7 ± 0.1	

Table A.2: Summary of the annual dose rate components as derived by both TLD and high resolution gamma spectrometry. The TLD values denote the actual measured value whilst the respective percentage of the total dose rate is given in brackets. The extent of disequilibrium in the annual dose rate of the samples (due to radon loss) is indicated by the TSAC results and the ²¹⁰Pb: ²²⁶Ra ratio obtained by high resolution gamma spectrometry measurements. Note that for some samples (340-8, 354-1, 354-2 and 356-1) it was decided that gamma spectrometry measurement and β-TLD were superfluous to requirement given that an OSL signal could not be measured in order to derive a paleodose. Correction factors have been applied to the β and γ+cos. components in order to take certain variables into account, including attenuation due to water content and the shielding of the γ+cos. radiation by the dose capsule wall (the γ-TLD measurements were increased by a factor of 8% as suggested by an earlier study) (Bailiff, 2007, 842).

capsules left *in situ* for an extended period. The use of γ-TLD capsules also takes into account the variations in radionuclide concentrations in other surrounding bricks, a factor that is harder to determine if trying to model the gamma component based on radionuclide concentrations derived through high resolution

gamma spectrometry (Bailiff, 2007, 843). Due to these complexities, the gamma component of the annual dose rate was derived only through γ -TLD experimentation.

A.2.2: Internal dose rate evaluation

ICP-MS analysis was performed on aliquots of etched quartz that had had their luminescence signals measured to determine whether there were any high concentrations of radionuclides within the grains, the results of which are shown

<i>Lab. Ref.</i>	<i>Elemental Concentration</i>			<i>Internal Radiation Component $\times 10^{-3}$ (mGy a⁻¹)</i>		<i>Total Internal Dose Rate (mGy a⁻¹)</i>	<i>Percent of Annual Dose Rate (%)</i>
	<i>U (ppm)</i>	<i>K $\times 10^{-3}$ (%)</i>	<i>Th (ppm)</i>	<i>α</i>	<i>β</i>		
325-1	0.12	100	0.25	31	7	0.038	1.30
326-3	0.11	3	1.26	74	7	0.081	2.70
326-4	0.10	<25	0.68	47	5	0.052	1.63
326-5	0.10	<50	0.58	42	6	0.048	1.62
327-2	0.07	3	0.29	24	2	0.027	0.97
327-3	<0.01	<25	<0.01	<2	<1	<0.003	<0.09
334-1	0.34	6	0.94	98	9	0.107	3.53
334-2	0.40	3	2.21	164	15	0.179	5.74
335-1	0.22	3	0.74	69	6	0.100	2.73
336-1	0.05	n.d.	0.74	18	2	0.020	0.71
337-1	0.13	5	1.03	67	6	0.073	2.38
337-2	0.28	<50	0.77	81	9	0.090	3.01
337-3	0.10	<50	0.57	42	6	0.048	1.70
338-1	0.06	3	0.17	17	2	0.019	0.67
339-1	0.12	20	0.47	41	5	0.045	1.76
340-1	0.03	5	45.27	16	2	0.018	0.59
340-2	0.15	3	29.39	35	3	0.038	1.41
340-3	0.11	4	43.28	44	4	0.048	1.90
340-4	0.12	<25	0.71	51	6	0.057	2.20
340-5	0.19	100	0.44	51	9	0.060	2.27
340-6	0.10	70	0.10	21	5	0.026	1.03
340-7	0.10	<50	0.34	32	5	0.037	1.59
340-8	-	-	-	-	-	-	-
352-1	0.05	130	0.08	12	6	0.018	0.49
352-2	<0.01	<55	<0.01	<2	<2	<0.005	<0.13
352-3	0.48	<50	0.27	92	10	0.102	2.83
353-1	0.08	<10	0.79	48	5	0.053	1.73
354-1	-	-	-	-	-	-	-
354-2	-	-	-	-	-	-	-
355-1	<0.01	<30	<0.01	<2	<1	<0.004	<0.16
356-1	-	-	-	-	-	-	-
357-1	<0.01	<10	<0.01	<2	<1	<0.003	<0.10

Table A.3: Summary of the concentration of radionuclides within the quartz grains as determined by ICP-MS and the resultant internal grain dose rate. Note that the potassium values relate to the radionuclide ⁴⁰K, the value of which is derived from the measured natural abundance of the isotope ³⁹K in the compound K₂O.

in Table A.3. It should be noted that the distribution of radionuclides within the grain is assumed to be uniform. Factors described by Brennan (2003) that took into account the beta dose absorption were incorporated into the calculations of the internal grain dose rate. The dose rate values themselves were derived by means of tabulated dose rate conversion factors (Adamiec and Aitken, 1998). The internal grain dose rates calculated for the samples analysed ranged from 0.09-5.74% of the total annual dose rate with a mean value of 1.68% \pm 1.24 (s.d.), indicating that it comprised a very low component of the total dose rate, a result also obtained during a previous study (Bailiff, 2007, 841). The total internal dose rate was included for each sample in the determination of its total annual dose rate.

A.3 WATER CONTENT EVALUATION

As discussed above, the sampling locations were selected in internal or sheltered locations within the buildings where it is unlikely that the water content of the bricks would have been high or undergone large variations over time (see 4.2.1). There was an opportunity to collect a sample of brick from Theydon Garnon (335-1) by means of a diamond tipped hand saw. Measurement of the brick sample over a 48 hour period showed that it had a water content of approximately 1.8% of sample weight (see Fig. A.2). Naturally, this is only a single measurement from an individual site but it does increase the confidence that can be allocated to the water correction factor of 3% used in calculating sample ages (see 4.1.2.2).

A.4 TWO PHASE DOSE RATE MODEL BRICK DATES

When the dates for the brick samples were derived, a single phase dose rate model spreadsheet was used (Bailiff, 2006a). This assumed that the brick had been used shortly after production and had remained in the same archaeological context prior to sampling. However, some of the OSL dates did not agree with the archaeological age assessments of the buildings to within $\pm 2\sigma_B$, suggesting that the bricks had been re-used from older contexts. For these situations, a second spreadsheet model was employed (Bailiff, 2006b) in an attempt to try and

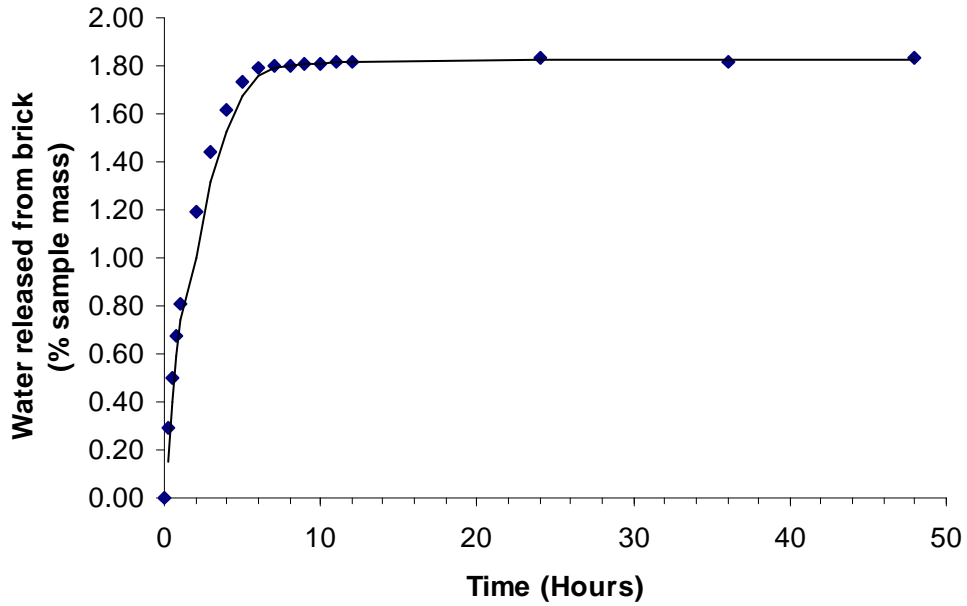

Fig. A.2: Drying rate for sample 335-1. The maximum water content derived for the sample was 1.8% of sample mass.

derive a more accurate understanding of when the brick had been produced. This second spreadsheet makes a number of assumptions and allowances about the original context of the brick prior to re-use. These include an allowance for mortar, the idea that the radionuclide concentration for the sampled brick is representative of the bricks in the earlier context to a depth of $\sim 0.5\text{m}$, that the brick was originally part of a brick built structure before re-use, allocating a $\pm 25\%$ uncertainty value to the γ dose rate component in the earlier context and that the brick was originally above ground. Table A.4 gives details of samples for which this second spreadsheet was used. In all cases, the differences in the two OSL dates are minor, agreeing within $\pm 1\sigma_B$ of each other.

Sample	Archaeological Age	OSL Dates		Difference in dates (years)
		Single Phase $\pm\sigma_B$	Two Phase $\pm\sigma_B$	
327-2	Late 16 th century	1469 \pm 31	1468 \pm 34	1
336-1	Late 16 th century	1510 \pm 30	1517 \pm 32	7
340-5	1550s-1570s	1490 \pm 32	1491 \pm 33	1
340-6	1550s-1570s	1491 \pm 30	1493 \pm 31	2
340-7	1550s-1570s	1478 \pm 33	1477 \pm 34	1
352-2	Mid-late 15 th century	1362 \pm 40	1363 \pm 41	1
355-1	12 th century	896 \pm 68	913 \pm 73	17

Table A.4: Differences between the OSL dates derived for the single phase dose rate model and the two phase dose rate model.

BIBLIOGRAPHY

Primary Sources

Bede, *Ecclesiastical History of the English People*. Translated by Sherley-Price, L., 1990. London, Penguin Books.

Vita Ædwardi Regis (The Life of King Edward). Translated by Barlow, F., 1962. London, Thomas Nelson and Son.

Secondary Sources

Abrahamsen, N., Jacobsen, U., Mejdahl, V., and Mejdahl, U., 1998, Magnetic Investigations and Datings of a Brick Kiln at Valdbæk near Esbjerg (Denmark). *Phys. Chem. Earth* 23: 1015-1019.

Adamiec, G., and Aitken, M., 1998, Dose-rate conversion factors: update. *Ancient TL* 16: 37-50.

Addison, W., 1987, The Making of the Essex Landscape. In Neale, K. (ed.) *An Essex Tribute*: 47-55. London, Leopard's Head Press.

Ainsworth, S., Cocroft, W.D., Everson, P., and Ryan, P., 1991, A Fragmentary Medieval Grave Cover and the Site of Woodham Walter Church. *Essex Archaeology and History* 22: 170-173.

Airs, M., 1995, *The Tudor and Jacobean Country House: A Building History*. Stroud, Sutton Publishing.

Aitken, M.J., 1998, *An Introduction to Optical Dating*. Oxford, Oxford University Press.

Aitken, M.J., 1990, *Science-based Dating in Archaeology*. London, Longman.

Aitken, M.J., 1985, *Thermoluminescence Dating*. London, Academic Press.

Anderson, V., 1993, *The De Veres of Castle Hedingham*. Lavenham, Terence Dalton.

Andrews, D., 2007, *Maldon's Moot Hall: Observations on the Repairs of 2006*. Essex County Council: Historic Buildings and Conservation Report.

Andrews, D., 2005a, The use and manufacture of brick in eastern England in the Middle Ages. In Perlich, B. and van Tussenbroek, G. (eds.) *Technik des Backsteinbaus*: 139-150. Petersberg, Michael Imhof Verlag (Berliner Beiträge zur Bauforschung und Denkmalpflege 2).

- Andrews, D., 2005b, Billericay St. Mary Magdalen, the Spanish tiles over the doorway. *Essex Archaeology and History* 36: 167-168.
- Andrews, D., 2004, Nether Hall. A fortified manor of the Wars of the Roses. *Essex Archaeology and History* 35: 78-97.
- Andrews, D., and Ryan, P., 2003, Wimbish, Broadoaks. *Essex Archaeology and History* 34: 279-282.
- Andrews, D., and Crouch, B., 2001, Bocking, St. Mary. *Essex Archaeology and History* 32: 287-290.
- Andrews, D., 2000a, Halstead St. Andrew. The Bouchier vault. *Essex Archaeology and History* 31: 258-260.
- Andrews, D., 2000b, *New Hall....an historic building in perspective*. Lecture transcript in New Hall library.
- Andrews, D., 1986, Old Copped Hall: The Site of the Tudor Mansion. *Essex Archaeology and History* 17: 96-106.
- Andrews, D., Bedwin, O., and Hall, R., 1986, Plaster or Stone? Some observations on Layer Marney Church and Tower. *Essex Archaeology and History* 17: 172-176.
- Anon, 1899, *History of the New Hall Community of Canonesses Regular of the Holy Sepulchre*. Roehampton, Manresa Press.
- Anon., 1865, Pedigree of Marney. *Transactions of the Essex Archaeological Society (Old Series)* 3: 1-15.
- Antrobus, A., 2004, Luminescence Dating of Brick Chimneys. *Vernacular Architecture* 35: 21-31.
- Antrobus, A., 2002, *Optically Stimulated Luminescence Dating of Brick from Sixteenth-Century Chimneys: A Feasibility Study*. Unpublished undergraduate dissertation, University of Durham.
- Archer, L., 1999, *Architecture in Britain and Ireland: 600-1500*. London, Harvill.
- Avray Tipping, H., 1937, *English Homes: Periods I and II (Vol. II) Medieval and Early Tudor 1066-1558*. London, Country Life.
- Ayers, B.S., Smith, R., and Tillyard, M., 1988, The Cow Tower, Norwich: a detailed survey and partial reinterpretation. *Medieval Archaeology* 32: 184-207.
- Baggs, A.P., 1968, Sixteenth Century Terra-Cotta Tombs in East Anglia. *Archaeological Journal* 125: 296-301.

- Bailiff, I.K., in prep., Luminescence dating of brick from Brixworth Church - a re-evaluation. Report submitted to Brixworth, *Archaeological Committee for monograph Brixworth Church and Context*.
- Bailiff, I.K., 2007, Methodological Developments in the Luminescence Dating of Brick from English Late-Medieval and Post-Medieval Buildings. *Archaeometry* 49: 827-851.
- Bailiff, I.K., 2006a, Luminescence date calculation, brick, spreadsheet ver. 4. Unpublished software application, Luminescence Dating Laboratory, University of Durham.
- Bailiff, I.K., 2006b, Luminescence date calculation, brick, spreadsheet ver. 5. Unpublished software application, Luminescence Dating Laboratory, University of Durham.
- Bailiff, I.K., and Holland, N., 2000, Dating bricks of the last two millennia from Newcastle upon Tyne: a preliminary study. *Radiation Measurements* 32: 615-619.
- Bailiff, I.K., 1982, Beta-TLD Apparatus for Small Samples. *PACT* 6: 72-76.
- Bailiff, I.K., and Aitken, M.J., 1980, Use of thermoluminescence dosimetry for evaluation of internal beta dose-rate in archaeological dating. *Nuclear Instruments and Methods* 173: 423-429.
- Bamford, A.B., 1906, Eastbury House. *Transactions of the Essex Archaeological Society (New Series)* 9: 427-431.
- Barnes, H.D., and Douglas Simpson, W., 1952, Caister Castle. *The Antiquaries Journal* 32: 35-51.
- Bateson, N., Carlin, N., Drury, P., Holloway, C., Joyce, L., Thorpe, D., 2008, Excavating an Elizabethan building boom: Copped Hall. *Current Archaeology* 218: 36-43.
- Bayliss, A., 2007, Bayesian Buildings: An introduction for the numerically challenged. *Vernacular Architecture* 38: 75-86.
- Beaumont, G.F., 1921, The Remains of Coggeshall Abbey. *Transactions of the Essex Archaeological Society (New Series)* 15: 60-76.
- Beaumont, G.F., 1890, *A History of Coggeshall*. London, Marshall Bros.
- Beresford, M., and Hurst, J., 1990, *Wharram Percy: Deserted Medieval Village*. London, B. T. Batsford.

- Beresford, G., 1982, The reconstruction of some Saxon buildings at Goltho, Lincolnshire. In Drury, P.J. (ed.) *Structural Reconstruction: Approaches to the interpretation of the excavated remains of buildings*: 113-123. Oxford, BAR: British Series Vol. 110.
- Bettley, J., and Pevsner, N., 2007, *The Buildings of England: Essex* (3rd ed.). London, Yale University Press.
- Betts, I.M., 1996, Glazed Eleventh-Century Wall Tiles from London. *Medieval Ceramics* 20: 19-24.
- Black, D., and Black, A., 2004, *Geophysical Survey Report: Coggeshall Abbey*. Colchester, Colchester Archaeological Group.
- Blain, S., Bailiff, I.K., Guibert, P., Bouvier, A., and Baylé, M., in press, An intercomparison study of luminescence dating protocols and techniques applied to medieval brick samples from Normandy (France). *Quaternary Geochronology*.
- Blain, S., 2009, *Ceramic building materials in early medieval churches in north-western France and south-eastern England. Application of luminescence dating to building archaeology*. Unpublished PhD. Thesis, University of Bordeaux and University of Durham.
- Blain, S., Guibert, P., Bouvier, A., Vieilleveigne, E., Bechtel, F., Sapin, C., and Baylé, M., 2007, TL-dating applied to building archaeology: The case of the medieval church Notre-Dame-Sous-Terre (Mont-Saint-Michel, France). *Radiation Measurements* 42: 1483-1491.
- Blomfield, R., 1923, *A Short History of Renaissance Architecture in England: 1500-1800*. London, Bell and Son.
- Braunfels, W., 1972, *Monasteries of Western Europe*. London, Thames and Hudson.
- Brennan, B.J., 2003, Beta doses to spherical grains. *Radiation Measurements* 37: 299-303.
- Brian, A., 1980, The Distribution of Brick Bonds in England up to 1800. *Vernacular Architecture* 11: 3-11.
- Brooks, F.W., 1939, A Medieval brick-yard at Hull. *Journal of the British Archaeological Association* 4: 151-174.
- Brown, A., 2004, *English Castles*. Woodbridge, The Boydell Press.
- Brown, R.A., Colvin, H.M., and Taylor, A.J., 1963, *The History of the King's Works Vol. II: The Middle Ages*. London, HMSO.

- Brunskill, R.W., 1992, *Traditional Buildings of Britain: An Introduction to Vernacular Architecture*. London, Victor Gollancz.
- Brunskill, R.W., 1990, *Brick Building in England*. London, Victor Gollancz.
- Calliari, I., Canal, E., Cavazzoni, S., and Lazzarini, L., 2001, Roman bricks from the Lagoon of Venice: a chemical characterisation with methods of multivariate analysis. *Journal of Cultural Heritage* 2: 23-29.
- Campbell, J.W.P., and Pryce, W., 2003, *Brick: A World History*. London, Thames and Hudson.
- Campbell, J.W.P., and Saint, A., 2002, The Manufacture and Dating of English Brickwork 1600-1720. *Archaeological Journal* 159: 170-193.
- Casas, L., Linford, P., and Shaw, J., 2007, Archaeomagnetic dating of Dogmersfield Park brick kiln (Southern England). *Journal of Archaeological Sciences* 34: 205-213.
- Challenor Smith, J.C., 1900, Some Additions to Newcourt's Repertorium-Volume II. *Transactions of the Essex Archaeological Society (New Series)* 7: 272-284.
- Chancellor, F., 1918a, Layer Marney Church. *Transactions of the Essex Archaeological Society (New Series)* 14: 65-75.
- Chancellor, F., 1918b, Nether Hall. *Transactions of the Essex Archaeological Society (New Series)* 15: 176-182.
- Chancellor, F., 1913, Earls Colne Church. *Transactions of the Essex Archaeological Society (New Series)* 12: 65-67.
- Chancellor, F., 1909, All Saints' Church, Maldon. *Transactions of the Essex Archaeological Society (New Series)* 10: 111-115.
- Chancellor, F., 1895, East Horndon. *Transactions of the Essex Archaeological Society (New Series)* 5: 255-256.
- Chancellor, F., 1894, Essex Churches: All Saints, Springfield. *Essex Review* 3: 50-63.
- Chancellor, F., 1892a, Essex Churches: St. Andrew's, Boreham. *Essex Review* 1: 150-163.
- Chancellor, F., 1892b, Essex Churches: St. Michael's, Woodham Walter. *Essex Review* 1: 87-96.
- Chancellor, W., 1915, Layer Marney Tower. *Transactions of the Essex Archaeological Society (New Series)* 13: 300-306.

- Cherry, B., O'Brien, C., and Pevsner, N., 2005, *The Buildings of England: London 5: East*. London, Yale University Press.
- Christy, M., 1923, The excavation of foundations on the castle-keep at Pleshey. *Transactions of the Essex Archaeological Society (New Series)* 16: 190-204.
- Christy, M., Porteous, W.W., and Bertram Smith, E., 1911, Some interesting Essex Brasses. *Transactions of the Essex Archaeological Society (New Series)* 11: 101-146.
- Christy, M., Porteous, W.W., and Bertram Smith, E., 1909, Some interesting Essex brasses. *Transactions of the Essex Archaeological Society (New Series)* 10: 181-227.
- Chruścińska, A., Jesionowski, B., Oczkowski, L., and Przegiętka, K.R., 2008, Using the TL single-aliquot regenerative-dose protocol for the verification of the chronology of the Teutonic Order castle in Malbork. *Geochronometria* 30: 61-67.
- Clapham, A.W., 1915, The Augustinian Priory of Little Leez and the Mansion of Leez Priory. *Transactions of the Essex Archaeological Society (New Series)* 13: 200-217.
- Clapham, A.W., 1913, The Benedictine Abbey of Barking: A Sketch of its Architectural History and Account of Recent Excavations on its Site. *Transactions of the Essex Archaeological Society (New Series)* 12: 69-87.
- Clarke, A.L., 1936, Interesting Tudor newel staircase at Maldon Moot Hall. *Essex Review* 45: 212.
- Clarke, T.H., and Black, W.H., 1834, *Eastbury Illustrated*. London, John Weale.
- Clifton-Taylor, A., 1987, *The Pattern of English Building* (4th ed.). London, Faber and Faber.
- Clifton-Taylor, A., 1986, *English Parish Churches* (2nd ed.). London, B.T. Batsford.
- Colvin, H., 1999, Recycling the Monasteries: Demolition and Reuse by the Tudor Government, 1536-47. In Colvin, H. (ed.) *Essays in Architectural History*: 52-66. London, Yale University Press.
- Colvin, H.M., Summerson, J., Biddle, M., Hale, J.R., and Merriman, M., 1982, *The History of the King's Works: Volume IV 1485-1660* (Part II). London, HMSO.
- Cook, O., 1974, *The English Country House: An art and a way of life*. London, Thames and Hudson.

- Cooper, N., 1997, The Gentry House in the Age of Transition. In Gaimster, D. and Stamper, P. (eds.) *The Age of Transition: The Archaeology of English Culture 1400-1600*: 115-126. Oxford, Oxbow Monograph 98.
- Costen, M.D., and Oakes, C., 2000, *Romanesque Churches of The Loire and Western France*. Stroud, Tempus.
- Coulson, C., 1993, Specimens of Freedom to Crenellate by Licence. *Fortress* 18: 3-15.
- Creighton, O., and Higham, R., 2005, *Medieval Town Walls: An Archaeological and Social History of Urban Defence*. Stroud, Tempus.
- Cutts, E.L., 1863, Eastbury Hall. *Transactions of the Essex Archaeological Society (Old Series)* 2: 134-138.
- Cutts, E.L., 1858, Architectural Account of the Remains of Coggeshall Abbey. *Transactions of the Essex Archaeological Society (Old Series)* 1: 166-185.
- Davey, N., 1961, *A History of Building Materials*. London, Phoenix House.
- Douglas Simpson, W., 1960, The Building Accounts of Tattershall Castle. *The Lincoln Records Society* Vol. 55.
- Drury, P.J., 2000, Aspects of the Production, Evolution and Use of Ceramic Building Materials in the Middle Ages. *Medieval Ceramics* 24: 56-62.
- Drury, P.J., 1993, Ceramic Building Materials: Post-Roman bricks. In Margeson, S. (ed.) *Norwich households: the medieval and post-medieval finds from the Norwich survey excavations 1971-1978*: 163-165. East Anglian Archaeology Vol. 58.
- Drury, P.J., 1983, 'A Fayre House, Buylt by Sir Thomas Smith': The Development of Hill Hall, Essex, 1557-81. *Journal of the British Archaeological Association* 136: 98-123.
- Drury, P.J., 1981, The production of brick and tile in medieval England. In Crossley, D.W. (ed.) *Medieval Industries*: 126-142. CBA Research Report No. 40.
- Drury, P.J., 1974, Chelmsford Dominican Priory: The Excavation of the Reredorter, 1973. *Essex Archaeology and History* 6: 40-81.
- Dunlop, I., 1962, *Palaces and Progresses of Elizabeth I*. London, Jonathan Cape.
- Eames, E.S., 1961, A Thirteenth-Century Tile Kiln Site at North Grange, Meaux, Beverley, Yorkshire. *Medieval Archaeology* 5: 137-168.
- Eaton, T., 2000, *Plundering the Past: Roman Stonework in Medieval Britain*. Stroud, Tempus.

- Elliot, H.L., 1884, On some badges and devices of the de Veres, on the tower of Castle Hedingham Church. *Transactions of the Essex Archaeological Society (New Series) 2*: 335-349.
- Emery, A., 2006, *Greater Medieval Houses of England and Wales: Vol. III*. Cambridge, Cambridge University Press.
- Emery, A., 2000, *Greater Medieval Houses of England and Wales: Vol. II*. Cambridge, Cambridge University Press.
- Emmison, F.G., 1961, *Tudor secretary: Sir William Petre at court and home*. London, Longmans.
- English Heritage, 1998, *Dendrochronology: guidelines on producing and interpreting dendrochronology dates*. London, English Heritage.
- Everson, P., and Parsons, D., 1979, Brixworth Church-are the bricks really Roman? In McWhirr, A., (ed.) *Roman Brick and Tile: Studies in Manufacture, Distribution and Use in the Western Empire*: 405-411. Oxford, BAR: International Series Vol. 68.
- Everson, P., 1977, Excavations in the vicarage garden at Brixworth, 1972. *Journal of the British Archaeological Association* 130: 55-122.
- Fairweather, F.H., 1937, Colne Priory, Essex, and the Burials of the Earls of Oxford. *Archaeologia* 87: 275-295.
- Fernie, E., 1983, *The Architecture of the Anglo Saxons*. London, Batsford.
- Field, N., 1991, Excavations and the West Range. In Lindley, P. (ed.) *Gainsborough Old Hall*: 34-56. Occasional Papers in Lincolnshire History and Archaeology 8.
- Forrester, H., 1972, *Medieval Gothic Mouldings: A Guide*. London, Phillimore.
- Fowler, R.C., 1909, Faulkbourne Hall. *Transactions of the Essex Archaeological Society (New Series) 10*: 59.
- Gardner, J.S., 1955, Coggeshall Abbey and its Early Brickwork. *Journal of the British Archaeological Association* 18: 19-32.
- Gem, R., 1988, The English Parish Church in the 11th and Early 12th Centuries: A Great Rebuilding? In Blair, J. (ed.) *Minsters and Parish Churches: The Local Church in Transition 950-1200*: 21-30. Oxford, Oxford University Committee for Archaeology Monograph No. 17.
- Gem, R., and Keen, L., 1981, Late Anglo-Saxon finds from the site of St. Edmunds Abbey. *Proceedings of the Suffolk Institute of Archaeology and History* 35: 1-30.

- Goedicke, C., Slusallek, K., and Kubelik, M., 1981, Thermoluminescence Dating in Architectural History: Venetian Villas. *The Journal of the Society of Architectural Historians* 40: 203-217.
- Göksu, H.Y., and Schwenk, P., 2000, Thermoluminescence dating of terrazzo from the monastery church of Tegernsee (Bavaria, Germany) using the 210°C TL peak of quartz. *Radiation Environmental Biophysics* 39: 301-308.
- Göksu, H.Y., Bailiff, I.K., Bøtter-Jensen, L., Brodski, L., Hütt, G., and Stoneham, D., 1995, Interlaboratory beta source calibration using TL and OSL on natural quartz. *Radiation Measurements* 24: 479-483.
- Goll, J., 2005, Medieval Brick-Building in the Central Alps. *Archaeometry* 47: 403-423.
- Greatorex, J., 1999, *Manors, Mills and Manuscripts Series: Coggeshall Abbey and Abbey Mill*. Essex, Greatorex.
- Green, A.G., 2000, *Houses and Households in County Durham and Newcastle c.1570-1730*. Unpublished PhD. Thesis, University of Durham.
- Greene, J.P., 1992, *Medieval Monasteries*. Leicester, Leicester University Press.
- Grose, J., 1780, *Antiquities of England and Wales*. London.
- Grose, F., 1773, *The Antiquities of England and Wales* (Vol. I). London.
- Grün, R., 2001, Trapped Charge Dating (ESR, TL, OSL). In Brothwell, D.R., and Pollard, A.M., (eds.) *Handbook of Archaeological Sciences*: 47-62. John Wiley, Chichester.
- Hall, L., 2005, *Period House Fixtures and Fittings 1300-1900*. Newbury, Countryside Books.
- Hall, J., and Strachan, D., 2001, The precinct and buildings of Tilty Abbey. *Essex Archaeology and History* 32: 198-208.
- Harley, L.S., 1975, Bricks of Eastern England to the end of the Middle Ages. *Essex Journal* 10: 134-141.
- Harley, L.S., 1974, A Typology of Brick: with numerical coding of brick characteristics. *Journal of the British Archaeological Association* 37: 63-87.
- Harley, L.S., 1951, Essex Bricks. *The Essex Naturalist* 28: 243-254.
- Hayward, C.F., 1865, Architectural notes on Layer Marney Hall, Essex; and on the Parish Church adjoining. *Transactions of the Essex Archaeological Society (Old Series)* 3: 16-32.

- Heinemeier, J., Junger, H., Lindroos, A., Ringbom, Å., von Konow, T., and Rud, N., 1997, AMS ¹⁴C dating of lime mortar. *Nuclear Instruments and Methods in Physics Research B* 123: 487-495.
- Hewett, C.A., 1980, *English Historic Carpentry*. London, Phillimore.
- Hill, A., and Smith, A.H.T., 1943, Colne Church and its Builders. *Essex Review* 52: 113-116 & 171-180.
- Hoare, P.G., Vinx, R., Stevenson, C.R., and Ehlers, J., 2002, Re-used Bedrock Ballast in King's Lynn's 'Town Wall' and the Norfolk Port's Medieval Trading Links. *Medieval Archaeology* 46: 91-105.
- Hoskins, W.G., 1953, The Rebuilding of Rural England. *Past and Present* 4: 44-59.
- Howard, M., 1997, Civic Buildings and Courtier Houses: new techniques and materials for architectural ornament. In Gaimster, D. and Stamper, P. (eds.) *The Age of Transition: The Archaeology of English Culture 1400-1600*: 105-113. Oxford, Oxbow Monograph 98.
- Howard, M., 1987, *The Early Tudor Country House: Architecture and Politics 1490-1550*. London, George Philip.
- Huggins, P.J., 1972, Monastic Grange and Outer Close Excavations, Waltham Abbey, Essex, 1970-72. *Essex Archaeology and History* 4: 30-127.
- Hull, G., 2002, Barkingwic? Saxon and medieval features adjacent to Barking Abbey. *Essex Archaeology and History* 33: 157-190.
- Hunter, J., 1999, *The Essex Landscape: A study of its form and history*. Chelmsford, Essex Record Office.
- Hütt, G., Göksu, H.Y., Jaek, I., and Hiekkanen, M., 2001, Luminescence dating of Somero sacristy, SW Finland using the 210°C TL peak of quartz. *Quaternary Science Reviews* 20: 773-777.
- International Commission on Radiation Units and Measurements (ICRU), 2002, Retrospective assessment of exposure to ionising radiation. ICRU Report 68. International Commission on Radiation Units and Measurements, Bethesda, USA.
- International Commission on Radiation Units and Measurements (ICRU), 1998, Fundamental Quantities and Units for Ionising Radiation. ICRU Report 60. International Commission on Radiation Units and Measurements, Bethesda, USA.
- Isserlin, R.M.J., 1999, The Carmelite Friary at Maldon: excavations 1990-1. *Essex Archaeology and History* 30: 44-143.

- Jackson, A., and Day, D., 2005, *Period House: how to repair, restore and care for your home*. London, Harper Collins.
- Keen, L., 1993, Pre-Conquest glazed relief tiles from All Saints church, pavement, York. *Journal of the British Archaeological Association* 146: 67-86.
- Kennett, D.H., 1990, Polstead Church, Suffolk. *British Brick Society Information* 50: 9-16.
- Kestell Floyer, J., 1923, English Brick Buildings: Henry VII-VIII. *Archaeological Journal* 80: 291-304.
- Kestell Floyer, J., 1913, English Brick Buildings of the Fifteenth Century. *Archaeological Journal* 70: 121-132.
- Kinder, T.N., 2002, *Cistercian Europe: Architecture of Contemplation*. Cambridge, Cistercian Publications.
- King, H.W., 1878, Historical evidence of the date of erection of certain church towers and of church restoration in Essex chiefly in the 15th and early part of the 16th Centuries. *Transactions of the Essex Archaeological Society (New Series)* 1: 45-54 & 116-126.
- King, H.W., 1869, Ancient Wills. *Transactions of the Essex Archaeological Society (Old Series)* 4: 147-163.
- Kuniholm, P.I., 2001, Dendrochronology and Other Applications of Tree-ring Studies in Archaeology. In Brothwell, D.R. and Pollard, A.M. (eds.) *Handbook of Archaeological Sciences*: 35-46. Chichester, John Wiley.
- Lavender, N.J., 1993, A 'principia' at Boreham, near Chelmsford, Essex: excavations 1990. *Essex Archaeology and History* 24: 1-21.
- Laws, A., 2003, *Understanding Small Period Houses*. Ramsbury, The Crowood Press.
- le Strange, R., 1972, *British Monumental Brasses*. London, Thames and Hudson.
- Lewer, H.W., 1933, The Testament and Last Will of Elizabeth, widow of John de Veer, Thirteenth Earl of Oxford. *Transactions of the Essex Archaeological Society (New Series)* 20: 7-16.
- Liddiard, R., 2005, *Castles in Context: Power, Symbolism and Landscape, 1066-1500*. Macclesfield, Windgather Press.
- Lindroos, A., Heinemeier, J., Ringbom, Å., Braskén, M., and Sveinbjörnsdóttir, Á., 2007, Mortar dating using AMS ¹⁴C and sequential dissolution: examples from medieval, non-hydraulic lime mortars from the Åland Islands, SW Finland. *Radiocarbon* 49: 47-67.

- Linford, P., 2006, *Archaeomagnetic Dating: guidelines on producing and interpreting archaeomagnetic dates*. Swindon, English Heritage.
- Lloyd, N., 1925, *A History of English Brickwork*. London.
- London Survey Committee, 1917, *Eastbury Manor House, Barking*. Monograph 11.
- Lynch, G., 1994, *Brickwork: History, Technology and Practice (Vol. I)*. London, Donhead.
- Lyttelton, C., 1770, Dissertation, by the Dean of Exeter, on the Antiquity of Brick Buildings in England, posterior to the Time of the Romans. *Archaeologia* I: 140-147.
- MacKinnon, A.D., 1997, The arrangement of monuments and seating at St. Andrew's church, Earls Colne, during the 17th and early 18th centuries. *Essex Archaeology and History* 28: 165-180.
- Malanca, A., Orlandini, R., Pessina, V., and Dallara, G., 1992, Radon concentrations inside castles and other ancient buildings. *The Science of the Total Environment* 121: 53-66.
- Martin, E., 1998, Little Wenham Hall, A Reinterpretation. *Proceedings of the Suffolk Institute of Archaeology and History* 39: 151-164.
- Martini, M., and Sibilina, E., 2001, Radiation in archaeometry: archaeological dating. *Radiation Physics and Chemistry* 61: 241-246.
- Mayes, P., 1965, A Medieval Tile Kiln at Boston, Lincolnshire. *Journal of the British Archaeological Association* 28: 86-106.
- McCann, J., 1987, Brick Nogging in the Fifteenth and Sixteenth Centuries, with examples drawn mainly from Essex. *Transactions of the Ancient Monuments Society* 31: 106-133.
- McWhirr, A., 1997, Brickmaking in Leicestershire before 1710. *Transactions of the Leicestershire Archaeological and Historical Society* 71: 37-59.
- Miller, K., Robinson, J., English, B., and Hall, I., 1982, *Beverley: An Archaeological and Architectural Study*. Royal Commission on Historical Monuments England (Supplementary Series 4). London, HMSO.
- Minter, P., Potter, J.F., and Ryan, P., 2006, Roman and early medieval bricks and tiles: can they be distinguished? *Essex Archaeology and History* 37: 95-102.
- Moodey, G., 1973, The Restoration of Hertford Castle Gatehouse. *Hertfordshire Archaeology* 3: 100-109.

- Moore, N.J., 1991, Brick. In Blair, J., and Ramsay, N. (eds.) *English Medieval Industries: Craftsmen, Techniques and Products*: 211-236. London, Hambledon Press.
- Morant, P., 1768, *The History and Antiquities of the County of Essex*. London.
- Morris, R., 2003, Monastic Architecture: Destruction and Reconstruction. In Gaimster, D. and Gilchrist, R. (eds.) *The Archaeology of Reformation 1480-1580*: 235-251. Leeds, Maney Publishing.
- Morris, R., 1989, *Churches in the Landscape*. London, J.M. Dent & Sons.
- Morriss, R.K., 2000, *The Archaeology of Buildings*. Stroud, Tempus.
- Muilman, P., 1769-1772, *A History of Essex*. Chelmsford.
- Murray, A.S., and Wintle, A.G., 2003, The single aliquot regenerative dose protocol: potential for improvements in reliability. *Radiation Measurements* 37: 377-381.
- Murray, A.S., and Wintle, A.G., 2000, Luminescence dating of quartz using an improved single-aliquot regenerative-dose protocol. *Radiation Measurements* 32: 57-73.
- Newcourt, R., 1710, *An Ecclesiastical Parochial History of the Diocese of London*. London.
- Newman, J., 1970, Copthall, Essex. In Colvin, H. and Harris, J., (eds.) *The Country Seat: Studies in the History of the British Country House*: 18-29. London, Penguin.
- Ogborne, E., 1814, *The History of Essex*. London.
- Paynter, H.I., 1949, *A Short History of All Saints' Church, Springfield, Essex* (3rd ed.).
- Perlich, B., 2008, Medieval Brick Production in Europe Travelling Competence or Local Innovation? From High Quality to Mass Production. In Coomans, T., and van Royen, H., (eds.) *Medieval Brick Architecture in Flanders and Northern Europe: The Question of the Cistercian Origin*: 9-18. Koksijde, Academia Press.
- Petchey, W.J., 1991, *A Prospect of Maldon: 1500-1689*. Chelmsford, Essex Records Office.
- Pevsner, N., and Radcliffe, E., 1965, *The Buildings of England: Essex* (2nd ed.). Harmondsworth, Penguin.
- Pevsner, N., 1961, *The Buildings of England: Suffolk*. Harmondsworth, Penguin.

- Philips, M., 1908, New Hall, Boreham. *Essex Review* 17: 57-66 & 121-132.
- Platt, C., 1994, *The great rebuildings of Tudor and Stuart England*. London, UCL Press.
- Potter, J.F., 2008, *The Medieval Town Wall of Great Yarmouth, Norfolk*. Oxford, BAR: British Series Vol. 461.
- Potter, J.F., 2006, A technique for distinguishing the texture of bricks and tiles. *The Antiquaries Journal* 86: 326-329.
- Potter, J.F., 2001, The Occurrence of Roman Brick and Tile in Churches of the London Basin. *Britannia* 32: 119-142.
- Punchard, D., 2007, *Below Ground at Beeleigh*. Maldon Archaeological and Historical Group.
- Rahtz, P.A., 1969, *Excavations at King John's Hunting Lodge, Writtle, Essex, 1955-1957*. London, The Society for Medieval Archaeology: Monograph Series No. 3.
- Riall, N., 2003, Excavations at the Borelli Yard, Farnham: the tile kiln. *Surrey Archaeological Collections* 90: 295-336.
- Riall, N., 2001, Some late 12th- or early 13th-century great brick at Farnham Castle, Surrey. *Medieval Ceramics* 25: 22-26.
- Riisager, P., Abrahamsen, N., and Rytter, J., 2003, Research report: Magnetic investigations and the age of a medieval kiln at Kungahälla (south-west Sweden). *Archaeometry* 45: 675-684.
- Rodwell, W., 1998, Holy Trinity Church, Bradwell-juxta-Coggeshall: A Survey of the Fabric and Appraisal of the Norman Brickwork. *Essex Archaeology and History* 29: 59-114.
- Rodwell, W., and Rodwell, K., 1993, *Rivenhall: Investigations of a villa, church and village Vol. II*. CBA Research Report 80.
- Rodwell, W., 1986, Anglo-Saxon church building: aspects of design and construction. In Butler, L.A.S. and Morris, R.K. (eds.) *The Anglo Saxon Church*: 156-175. CBA Research Report 60.
- Rodwell, W., and Rodwell, K., 1985, *Rivenhall: Investigations of a villa, church and village Vol. I*. CBA Research Report 55.
- Rodwell, W. and Rodwell, K., 1977, *Historic Churches: a wasting asset*. CBA Research Report 19.
- Rodwell, W., 1976, A trial excavation at Boreham, 1971. *Essex Archaeology and History* 8: 263-265.

- Roffey, S., 2007, *The Medieval Chantry Chapel: An Archaeology*. Woodbridge, The Boydell Press.
- Royal Commission on Historic Monuments (England) (RCHME), 1923, *Essex*. London, HMSO.
- Royal Commission on Historic Monuments (England) (RCHME), 1922, *Essex*. London, HMSO.
- Royal Commission on Historic Monuments (England) (RCHME), 1921, *Essex*. London, HMSO.
- Royal Commission on Historic Monuments (England) (RCHME), 1916, *Essex*. London, HMSO.
- Ryan, P., 2007, The history of chimneys in Essex. *Essex Archaeology and History* 28: 126-135.
- Ryan, P., 2000, The Buildings of Rural Ingatestone, Essex, 1556-1601: 'Great Rebuilding' or 'Housing Revolution'? *Vernacular Architecture* 31: 11-25.
- Ryan, P., 1999a, *Brick in Essex: The Clayworking Craftsmen and Gazetteer of Sites*. Chelmsford, Ryan.
- Ryan, P., 1999b, Woodham Walter Hall – its site and setting. *Essex Archaeology and History* 30: 178-195.
- Ryan, P., 1996, *Brick in Essex: From the Roman Conquest to the Reformation*. Chelmsford, Pat Ryan.
- Ryan, P., and Andrews, D., 1993, A Brick and Tile Typology for Cressing Temple. In Andrews, D. (ed.) *Cressing Temple: A Templar and Hospitaller Manor in Essex*: 93-103. Chelmsford, Essex County Council.
- Ryan, P., 1989, *A Village History: Woodham Walter*. Essex, The Plume Press.
- Ryan, P., 1986, Fifteenth Century Continental Brickmasons. *Medieval Archaeology* 30: 112-113.
- Sage, J., 1864, Essex Wills: Clement Sysley, of Eastbury Hall, 1578. *The East Anglian* 1: 348-351.
- St. John Mildmay, H.A., 1913, *A Brief Memoir of the Mildmay Family*. London, The Bodley Head.
- Salmon, N., 1740, *The History and Antiquities of Essex*. London.
- Salzman, L.F., 1952, *Building in England*. Oxford, Clarendon Press.

- Schiavon, N., Mazzocchin, G.A., and Baudo, F., 2008, Chemical and mineralogical characterisation of weathered historical bricks from the Venice lagoonal environment. *Environmental Geology* 56: 767-775.
- Sherlock, D., 1998, Brickmaking Accounts for Wisbech, 1333-1356. *Proceedings of the Cambridge Antiquarian Society* 87: 59-69.
- Smith, B.S., 1974, Elizabethan Earls Colne (Part 1). *Essex Journal* 9: 80-97.
- Smith, B.W., Rhodes, E.J., Stokes, S., and Spooner, N.A., 1990, The optical dating of sediments using quartz. *Radiation Protection Dosimetry* 34: 75-78.
- Smith, J.R., and Wadhams, M.C., 1975, Robert D'Arcy's Chantry Priests' House, Maldon, Essex. *Medieval Archaeology* 19: 213-219.
- Smith, L.T., 1907, *The Itinerary of John Leland*. London, Bell and Sons.
- Smith, T.P., 2001, Early Recycling: the Anglo-Saxon and Norman Re-use of Roman Bricks with Special Reference to Hertfordshire. In Henig, M., and Lindley, P. (eds.) *Alban and St. Albans: Roman and Medieval Architecture, Art and Archaeology*: 111-117. The British Archaeological Association: Conference Transactions XXIV.
- Smith, T.P., 1985a, Brick Tower Houses of the later Middle Ages. *Period Home* 2: 48-50.
- Smith, T.P., 1985b, *The Medieval Brickmaking Industry in England: 1400-1450*. Oxford, BAR: British Series Vol. 138.
- Smith, T.P., 1979, Hussey Tower, Boston: a Late Medieval Tower-House of Brick. *Lincolnshire History and Archaeology* 14: 31-37.
- Smith, T.P., 1976, The Early Brickwork of Someries Castle, Bedfordshire, and its Place in the History of English Brick Building. *Journal of the British Archaeological Association* 129: 42-58.
- Smith, T.P., 1975, Rye House, Hertfordshire, and Aspects of Early Brickwork in England. *The Archaeological Journal* 132: 111-150.
- Smith, W.J.T., 1988, Saint Andrew's Church. In Burgess, E. and Rance, M. (eds.) *Boreham: History, Tales and Memories of an Essex Village*: 138-148. Lavenham, The Lavenham Press.
- Starr, C., 1988, *Guide to All Saints' East Horndon, Essex*. Redundant Churches Fund, London.
- Starr, C., 1980, The Progress of Brick. In Starr, C. (ed.) *A Guide to Essex Churches*: 49-54. Saffron Walden, Essex Churches Support Trust.

- Steer, F.W., 1950, A Short History of Tilty Abbey. *Essex Review* 59: 95-100.
- Stenning, D.F., 1989, Early brick chimney stacks. *Essex Archaeology and History* 20: 92-102.
- Stephen, M., 1988, The Changing Face of New Hall. In Burgess, E. and Rance, M. (eds.) *Boreham: History, Tales and Memories of an Essex Village*: 126-136. Lavenham, The Lavenham Press.
- Sternberg, R.S., 2001, Magnetic Properties and Archaeomagnetism. In Brothwell, D.R. and Pollard, A.M. (eds.) *Handbook of Archaeological Sciences*: 73-79. Chichester, John Wiley.
- Stocker, D., 1990, Rubbish Recycled: A Study of the Re-Use of Stone in Lincolnshire. In Parsons, D. (ed.) *Stone: Quarrying and Building in England AD 43-1525*: 83-101. Chichester, Phillimore.
- Streatfeild, T.E.C., 1872, On Eastbury Manor House, Barking. *Transactions of the Royal Institute of British Architects* 19: 164-172.
- Sutton, S.R., and Zimmerman, D.W., 1978, Thermoluminescence dating: radioactivity in quartz. *Archaeometry* 20: 67-69.
- Taylor, H.M., and Taylor, J., 1965, *Anglo Saxon Architecture* (Vol. I). Cambridge, Cambridge University Press.
- Thompson, M.W., 1960, The Date of "Fox's Tower," Farnham Castle, Surrey. *Surrey Archaeological Collections* 57: 85-92.
- Tracy, C., 2007, Master William Pykenham, LL.D (c. 1425-97) Scholar, Churchman, Lawyer, and Gatehouse Builder. *Proceedings of the Suffolk Institute of Archaeology and History* 41: 289-322.
- Thurley, S., 1993, *The Royal Palaces of Tudor England*. London, Yale University Press.
- Tuckwell, T., 2006, *New Hall and its School*. Free Range Publishing.
- Tyers, I., 1997, *Tree Ring Analysis of Eastbury Manor House, Barking, Greater London*. AML Report 12/97.
- Tyers, I., Groves, C., Hillam, J., and Boswijk, G., 1997, Tree Ring Dates from Sheffield University. *Vernacular Architecture* 28: 142.
- Untermann, M., 2008, Cistercian and Medieval Brick Architecture in Europe. In Coomans, T., and van Royen, H. (eds.) *Medieval Brick Architecture in Flanders and Northern Europe: The Question of the Cistercian Origin*: 19-35. Academia Press, Koksijde.

- Vandenbergh, D., De Corte, F., Buylaert, J.-P., Kučera, J., and Van den haute, P., 2008, On the internal radioactivity in quartz. *Radiation Measurements* 43: 771-775.
- VCH, 2001, *Victoria County History: County of Essex Vol. X*. Oxford, Oxford University Press.
- VCH, 1983, *Victoria County History: County of Essex Vol. VIII*. Oxford, Oxford University Press.
- VCH, 1969, *Victoria County History: County of York - East Riding Vol. I The City of Kingston Upon Hull*. London, Oxford University Press.
- VCH, 1966, *Victoria County History: County of Essex Vol. V*. London, Oxford University Press.
- VCH, 1956, *Victoria County History: County of Essex Vol. IV*. London, Oxford University Press.
- VCH, 1945, *Victoria County History: County of Warwickshire Vol. III*. London, Oxford University Press.
- VCH, 1907, *Victoria County History: County of Essex Vol. II*. London, Archibald Constable
- Veronese, I., Göksu, H.Y., Schwenk, P., and Herzig, F., 2008, Thermoluminescence dating of a *mikveh* in Ichenhausen, Germany. *Journal of Environmental Radioactivity* 99: 621-630.
- Waddell, C., and Fountain, J.C., 1984, Calcium diffusion: A new dating method for archaeological materials. *Geology* 12: 24-26.
- Wagner, G. A., 1998, *Age Determination of Young Rocks and Artefacts*. London, Springer.
- Walker, J., 2007, Coggeshall Abbey: The development of the house. *Essex Historic Buildings Group Newsletter* Issue 6: 10-11.
- Waller, W.C., 1903, Nether Hall in Roydon: Notes from the Inquisitions. *Transactions of the Essex Archaeological Society (New Series)* 8: 378.
- Wallis, S., 1992, Medieval deposits on the banks of the Cornmill stream, Waltham Abbey. *Essex Archaeology and History* 23: 142-147.
- Ward, G.K., and Wilson, S.R., 1978, Procedures for Comparing and Combining Radiocarbon Age Determinations: A Critique. *Archaeometry* 20: 19-31.
- Watkin, B., 2007, The Olde House, St. Osyth. *Essex Historic Buildings Group Newsletter* Issue 7: 3-4.

- Watkin, D., 2001, *English Architecture*. London, Thames and Hudson.
- Watkin, E., 1996, The East Window of Saint Nicholas Chapel, Coggeshall. *Essex Archaeology and History* 27: 292-295.
- Watson, E.J., 1907, New Hall, Essex – Real and Imaginary. In Cologan, W.H. (ed.) *Folia Fugitiva: Leaves from the Log-Book of St. Erconwald's Deanery, Essex*: 356-381. London, R&T Washbourne.
- Wickenden, N.P., 2001, A medieval octagonal chimney stack: evidence from Pleshey and Writtle. *Essex Archaeology and History* 32: 168-177.
- Wight, J.A., 1972, *Brick Building in England*. London, John Baker.
- Williams, F., 1977, *Excavations at Pleshey Castle*. Oxford, BAR: British Series Vol. 42.
- Wilson, M.A., Carter, M.A., Hall, C., Hoff, W.D., Ince, C., Savage, S.D., McKay, B., and Betts, I., in press, Dating fired-clay ceramics using long-term power-law rehydroxylation kinetics. *Proc. R. Soc. A*.
- Wilson, M.A., Hoff, W.D., Hall, C., McKay, B., and Hiley, A., 2003, Kinetics of Moisture Expansion in Fired Clay Ceramics: A (Time)^{1/4} Law. *Physical Review Letters* 90.
- Wilson, D.M., and Hurst, J.G., 1960, Medieval Britain in 1959. *Medieval Archaeology* 4: 145-146.
- Wright, T., 1836, *History of Essex*. London.