

## Durham E-Theses

---

*Special needs education in Uganda : a study of implementation of the policy on provision of education for children with 'mental retardation'.*

John Baptist Olweny Okech

### How to cite:

---

Okech, John Baptist Olweny (1999) Special needs education in Uganda : a study of implementation of the policy on provision of education for children with 'mental retardation'. Doctoral thesis, Durham University.

### Use policy

---

The full-text may be used and/or reproduced, and given to third parties in any format or medium, without prior permission or charge, for personal research or study, educational, or not-for-profit purposes provided that:

- a full bibliographic reference is made to the original source
- a <https://etheses.durham.ac.uk/id/eprint/1584/> is made to the metadata record in Durham E-Theses
- the full-text is not changed in any way

The full-text must not be sold in any format or medium without the formal permission of the copyright holders.

Please consult the [full Durham E-Theses policy](#) for further details.

**SPECIAL NEEDS EDUCATION IN UGANDA: A STUDY OF  
IMPLEMENTATION OF THE POLICY ON PROVISION  
OF EDUCATION FOR CHILDREN WITH  
“MENTAL RETARDATION”**

BY

The copyright of this thesis rests with the author. No quotation from it should be published in any form, including Electronic and the Internet, without the author's prior written consent. All information derived from this thesis must be acknowledged appropriately.

**JOHN BAPTIST OLWENY OKECH**

**A THESIS SUBMITTED FOR THE DEGREE OF DOCTOR OF  
PHILOSOPHY**

**SCHOOL OF EDUCATION  
UNIVERSITY OF DURHAM**

1999



**19 JUN 2001**

## ***DEDICATION***

1. To my beloved late son, Ronald Patrick Geno. You departed from us when you were just 10. So sad it was. May your soul rest in eternal peace. To my late father, Valantino Owora. You too departed from us one month after your grandson. May your soul rest in peace. To my late grandmother, Elizabeth Nyamwenge. You brought me up and taught me to be hardworking. My success is from your contribution. May your soul rest in peace.

2. To the cause of all Persons with Disabilities in Uganda

# *ABSTRACT*

This thesis concerns provision of special needs education in Uganda with particular reference to children with mental retardation. It aims to identify and describe what progress has been made in the policy implementation and to make recommendations about what ought to be done in order to achieve better results. It proposes, through bibliographic and empirical research, to answer some important questions related to special needs education from international and Ugandan contexts. The term “mental retardation” is highlighted with quotation marks as indicated from the topic of the study. This is done in order to emphasise that although it is widely used and accepted in the literature across disciplines, it is perhaps not the best term. This issue is discussed in Chapter 2.

Chapter 1 provides the scope, aims and objectives of the study, research questions, statements of the problem and significance of the study. In addition, it presents discussions on the ideologies and trends concerning the rights to education by children with special needs in other countries and in Uganda.

Chapter 2 presents the discussion on the concepts and definitions of mental retardation. The chapter comprises discussion on some known theories and definitions of intelligence, implications of measurements of intelligence and how intelligence has been used as the basis for defining mental retardation. Concepts and definitions are discussed from societal, medical, historical and educational points of view. The argument for abolition of the term mental retardation is discussed.

In Chapter 3 aims of education and curriculum for children with mental retardation are discussed. Specific issues covered include what and where children with mental retardation are supposed to learn, how they are selected/assessed, the teaching approaches/methods suitable for them and how teachers are prepared to teach the children.

Part one of the empirical investigation is provided in Chapter 4. It comprises the rationale for using both quantitative and qualitative research paradigms, study designs and implementation. A total of 100 participants were asked to respond to questionnaires. 39 participants were interviewed. Two other methods, that is, classroom observations and documentary analysis, were used. 9 lessons were observed to provide a clue to the nature of difficulties which teachers face. Two official documents formed the basis for the documentary analysis. They include the *Education Policy Review Commission* (1989) and the *Government White Paper* (1992). Other documents analysed comprise the official education statistics and mass media reports.

The second part of the empirical investigation is provided in Chapters 5 and 6. The chapters are on data analysis. The contents of the chapters cover all the topics cited in Chapters 1, 2 and 3.

Chapter 7 provides the summary findings of the study. Teachers are generally noted to be willing to work for implementation of the policy. There are, however, more problems, which at the moment block success in the implementation. Children with mental retardation who receive education are very few in Uganda. Policy makers in Uganda are urged to do more in order to overcome the problems.

**Copyright 1999: JOHN BAPTIST OLWENY OKECH**

The copyright of this thesis rests with the author. No quotation from it should be published without the author's prior written consent and information derived from it should be acknowledged.

# *ACKNOWLEDGEMENT*

I would like to begin by thanking most sincerely, my supervisor, Professor Michael S. Byram for the motivation, confidence and skilled supervision I got from him which enabled me to successfully accomplish this thesis and my study as well. He is such an experienced supervisor I will always live to remember.

Many thanks to Dr Linda Thompson, for all the kind support and encouragement she provided. I should also like to thank Dr Carol Aubrey and Mrs Anita Shepherd for the services they rendered.

I wish to thank Professor Mel Ainscow, Professor Niels Egelund and Dr Solomon Serugga for their support and advice.

Mrs Joyce R. Adams, Miss Mary E. Herbert, Mrs Susan McBreen, Mrs Brenda Roberts and Mrs Barbara Smith, all of School of Education Library were very active and helpful ladies. I am very thankful to them.

I wish to thank Dr Kurt and Mrs Kirsten Kristensen for the keen interest, support and encouragement they provided to me, and the efforts they have put to develop special needs education in Uganda.

Special thanks go to the Danish International Development Assistance (DANIDA) for the scholarship awards they provided.

The following persons have been helpful to me in different ways and I wish to recognise their contributions: Mr Edward Kasolo-Kimuli, Ms Mary Stella Atim, Mr Ivan M. K. Matovu, Mr Paul V. Ojwang', Professor J. P. Ocitti, Mrs Bertha Kawooya, Mrs Veronica Mpagi, Ms Hellen L. Among'in, Mr Steven K. Okecho Okunna, Mrs Irene Tindimweba-Okecho, Sr Rose Ayaa, Ms Rose Nabayiga, Ms Dorothy N. Bukenya, Ms Immaculate Kemigisha, Mr Simon Omitta, Mrs Margaret Mubiru, Mr Joseph Mubiru, Ms Regina Nambi, Ms Angela Naluboowa, Mrs Winnie Kangumba, Mr Daniel Okot, Mr Nicholas Kibuda, Mr Peter Musibala, Mr Martin Omagor-Loican, Mr Negris Onen, Mr Ronald Shepherd Kyagaba, Mr David Byaruhanga, Mr David Magaali, Mr Magidu Mutakubwa, Mr Charles W. Masaba, Mrs Rose Munialo, Mrs Baker Kuteesa Serugga, Ms Sarah Bugoosi-Kibooli, Mr Joseph Kaweesa-Kisitu, Mrs Rose Ajaruva Amandu, Mr Richard M. Bakwata, Mr Richard Karani, Mr Lucky Ngatha, Mr Anthony Cheong, Mrs Esin Sahin Pekmez, Mr Mustafa Cin, Marja-Liisa Korhonen, Dr Dorothy Lowe and Canon John B. Lowe.

I wish to thank the Commissioners for Education (Administration and Inspectorate) and the District Education Officers of Iganga, Kampala and Masindi who kindly agreed to answer my questions. Many thanks also go to the Executive Secretary of Uganda National Council for Science and Technology (UNCST) for granting me permission to carry out this research in Uganda.

Different people played different roles and although I have not mentioned their names here it does not mean I have ignored them. I am greatly thankful for their support.

Last, but not least, I would like to express warm gratitude and appreciation to my beloved wife Eva Namisango Okech and children. Her continued support, help and encouragement helped me to overcome many hurdles in my study. I want to thank most warmly my youngest son, Rem Rembo for bearing with me as I began to miss him (because of this study) from time to time when he was just two months old.

# ***DECLARATION***

This thesis results entirely from my own work and has not been previously offered in candidature for any other degree or diploma.

## TABLE OF CONTENTS

	<u>Page No</u>
Dedication	I
Abstract	II
Copyright	III
Acknowledgement	IV
Declaration	VII
Table of Contents	VIII
List of Tables	XIV
List of Figures	XVI
Abbreviations	XVII

### CHAPTER 1

1.0	Introduction/Background	1
1.1	Aims of Study	1
1.2	Objectives	4
1.3	Research Questions	4
1.4	Statement of the Problem	5
1.5	Significance of the Study	7
1.6	Background	7
1.6.1	Ideologies and Trends Concerning the Rights to Education by Children with Special Needs in Other Countries	7
1.6.2	Organisations Responsible for Development of Special Needs Education	15
1.6.3	Ideologies and Trends Concerning the Rights to Education by Children with Special Needs in Uganda	22
1.6.3.1	Pre-independence Development	23
1.6.3.2	Post-independence Development	25
1.6.3.3	Kajubi Education Policy Review Commission Report (1989)	27
1.6.3.4	The Government White Paper of 1992	31
1.6.3.5	Primary Education Reform Programme (PERP)	39
1.6.3.6	Present Structure of Education in Uganda	41
1.6.3.7	Proposed Structure of Education in Uganda	43
1.6.3.8	Development of Special Needs Education in Uganda	45
1.6.3.9	Education of Children with Visual Impairment	45
1.6.3.10	Education of Children with Hearing Impairment	46
1.6.3.11	Education of Children with Physical (Motor) Disabilities	46
1.6.3.12	Education of Children with Mental Retardation	47
1.6.3.13	Education of Deaf-Blind Children	48
1.6.3.14	Government's Role in Special Needs Education	49
1.6.3.15	Some Conditions Responsible for Causing Disabilities: Concern for Uganda	50

		<u>Page No</u>
1.6.3.16	Malarial Infection	51
1.6.3.17	Measles Infection	51
1.6.3.18	Malnutrition Problems	
	52	
1.6.3.19	Improving Nutrition	54
1.6.3.20	Supporting Goals for Child-bearing Mothers	55
1.6.3.21	Supporting Goals for Infants Under-Fives	56
1.7	Conclusion	57

## **CHAPTER 2**

2.0	Concepts and Definitions of Mental Retardation from International Perspectives	62
2.1	Introduction	62
2.2	What Intelligence Is	63
2.2.1	Measurement of Intelligence	65
2.3	Concepts and Definitions of Mental Retardation from Societal Point of View	67
2.4	Medical Concepts and Definitions of Mental Retardation	72
2.5	Earlier Attempts to Define Mental Retardation	79
2.6	Current Debate on the 1992 AAMR Definition	83
2.6.1	Definition by the 1992 AAMR	83
2.6.2	Proponents of the 1992 AAMR	85
2.6.3	Criticism of the 1992 AAMR Definition	87
2.6.4	Terminologies Considered Less Stigmatising	90
2.7	Concepts and Definitions of Mental Retardation from Educational Concepts	92
2.8	Conclusion	99

## **CHAPTER 3**

3.0	Aims of Education and Curriculum for Children with Mental Retardation from International Perspectives	102
3.1	Introduction	102
3.2	What Children with Mental Retardation are Supposed to Learn	103
3.2.1	Children with Mild Mental Retardation	104
3.2.2	Children with Severe Mental Retardation	105
3.2.3	Where Children with Mental Retardation are Supposed to Learn	107
3.2.4	How Children with Mental Retardation are Selected/Assessed for Education	112
3.2.5	Teaching Approaches/Methods Suitable for Children with Mental Retardation	119
3.2.6	Preparing Teachers to Teach Children with Mental Retardation	135

		<u>Page No</u>
<b>CHAPTER 4</b>		
4.0	Methodology	144
4.1	Introduction	144
4.2	Study Scope	145
4.2.1	Geographical Scope	145
4.2.2	Content Scope	147
4.2.3	Field Study	148
4.2.3.1	Clearance for Field Study	149
4.2.3.2	Organisations and Participants Consulted	150
4.2.3.3	Ethical Issues	152
4.3	Study Design and Implementation	154
4.3.1	Rationale for Using both Quantitative and Qualitative Approaches	154
4.3.1.1	Questionnaire Sample	157
4.3.1.2	The Headteacher/Teacher Questionnaire	157
4.3.1.3	Construction of the Questionnaire	158
4.3.1.4	Questionnaire Content	158
4.3.1.5	Piloting the Questionnaire	161
4.3.1.6	Administration of the Questionnaire	162
4.3.1.7	Strengths of the Questionnaire	163
4.3.1.8	Limitation of the Questionnaire	164
4.3.2	Interview Sample	165
4.3.2.1	Construction of the Interview Guide	166
4.3.2.2	Content of the Interview	167
4.3.2.3	Justification for Interviewing the Selected Participants	170
4.3.2.4	Piloting the Interview	175
4.3.2.5	Strengths of the Interview	175
4.3.2.6	Limitations of the Interview	176
4.3.3	Observation Sample	177
4.3.3.1	Construction of the Observation Guide	178
4.3.3.2	Content of the Observation	178
4.3.3.3	Piloting the Observation	180
4.3.3.4	Advantages of the Observation	180
4.3.3.5	Limitations of the Observation	181
4.3.4	Documentary Analysis	181
4.3.4.1	Materials Analysed	183
4.3.4.2	Advantages of Documentary Analysis	183
4.3.4.3	Limitations of Documentary Analysis	184
4.3.5	The Validity of the Research Instruments	185
4.3.6	The Reliability of the Research Instruments	188
4.3.7	Field Experiences and Challenges	190
4.3.8	Description of Data Analysis Procedures	193

4.4	Conclusion	196
-----	------------	-----

**Page No**

**CHAPTER 5**

5.0	Policy in Practice: Results of Empirical Study	198
5.1	Introduction	198
5.2	Categories of Participants	199
7.1	Current Trends of Attitudes Towards Education of Children with Mental Retardation	200
5.4	Definition of Mental Retardation	201
5.5	Change Aims and Curriculum for Children with Mental Retardation in Uganda	207
5.6	Recommended Strategies for Implementing Policy for Education of Children with Disabilities	212
5.6.1	Views on Integration in Uganda	214
5.7	Teaching Approaches/Methods Suitable for Children with Mental Retardation	219
5.7.1	Views in Uganda	220
5.8	Conclusion	224

**CHAPTER 6**

6.0	Policy in Practice: Results of Empirical Study – Analysis of Qualitative Data	227
6.1	Introduction	227
6.2	Analysis of Open-ended Questions	228
6.3	Analysis of the Interview Data	252
6.3.1	Responses by Headteachers/Teachers	259
6.3.2	Responses by Parents	284
6.3.3	Responses by EARS Staff	298
6.3.4	Responses by Teacher Educators	312
6.3.5	Responses by DEOs	321
6.3.6	Responses by Commissioners for Education	330
6.4	Conclusion	339

**CHAPTER 7**

7.0	Summary of the Findings and Suggestions/Recommendations	347
7.1	Introduction	347
7.2	Findings of the Study	349

7.2.1	Findings Related to Research Question on Ideologies and Trends Concerning the Rights to Education by Children with Mental Retardation in Other Countries	349
7.2.2	Findings Related to Research Question on Concepts and	
		<b><u>Page No</u></b>
	Definitions of Mental Retardation from International Perspectives	352
7.2.3	Findings Related to Research Question on Aims of Education for Children with Mental Retardation Internationally	356
7.2.3.1	Findings Related to Research Question on Aims of Education for Children with Mental Retardation in Uganda	359
7.2.3.2	Findings Related to Types of Institutions and Facilities Suitable for Children with Mental Retardation in Uganda	359
7.2.3.3	Findings Related to Selecting/Assessing Children with Mental Retardation for Education	360
7.2.3.4	Findings Related to Preparing Teachers to teach Children with Mental Retardation	361
7.2.3.5	Findings Related to Teaching Methods for Children with Mental Retardation	362
7.3	Suggestions/Recommendations of the Study	363
7.3.1	Suggestions/Recommendations by Participants of the Study	
	364	
7.3.2	Recommendations/Suggestions by the Researcher	367
7.3.2.1	Suggestions/Recommendations on the Rights to Education by Children with Mental Retardation	367
7.3.2.2	Suggestions/Recommendations Related to Concepts and Definitions of Mental Retardation	368
7.3.2.3	Suggestions/Recommendations Related to Aims of Education and Curriculum for Children with Mental Retardation in Uganda	370
7.3.2.4	Suggestions/Recommendations Related to Types of Institutions and Facilities Suitable for Children with Special Needs	372
7.3.2.5	Suggestions/Recommendations Related to Preparing Teachers to teach Children with Learning Difficulties	372
7.3.2.6	Suggestions/Recommendations Related Methods Suitable for Children with Learning Difficulties	373
7.4	Suggestions/Recommendations for Further Research	
	374	
7.5	Priorities in Light of the Current Situation in Uganda	376
	<b>Bibliography</b>	384

## Appendices

		<u>Page No</u>
Appendix 1	Structure of the Education System in Uganda	399
Appendix 2	Education Statistics for Government Aided Schools 1998	400
Appendix 3	Number of Students Trained for Special Needs Education (SNE) at UNISE since 1988	401
Appendix 4	Aetiology of Mental Retardation	402
Appendix 5	A Letter to the Secretary, Uganda National Council for Science and Technology (UNCST)	408
Appendix 6	A Letter to the Honourable Minister of Education and Sports, Ministry of Education and Sports, Kampala, Uganda	409
Appendix 7	A Letter to the Commissioner for Education (Administration/Inspectorate), Ministry of Education and Sports, Kampala, Uganda	410
Appendix 8	A Letter to the District Education Officer (Kampala/Masindi/Iganga)	411
Appendix 9	A Letter to the EARS Staff (National/District)	412
Appendix 10	A Letter accompanying Questionnaire	413
Appendix 11	Clearance Letters by UNCST	414
Appendix 12	Clearance Letter by DEO of Masindi	415
Appendix 13	Clearance Letter by DEO of Kampala	416
Appendix 14	Names of Persons Consulted for Validity of the Research Instruments	417
Appendix 15	A Questionnaire to Teachers/Headteachers of Primary Schools	418
Appendix 16	Teachers/Headteachers Interview Schedule	423
Appendix 17	Parents Interview Schedule	426
Appendix 18	EARS Interview Schedule	428
Appendix 19	Teacher Educator Interview Schedule	430
Appendix 20	Education Officers Interview Schedule	432
Appendix 21	Commissioners for Education Interview Schedule	434
Appendix 22	Coded Data on Category 1: Headteachers/Teachers interviewed	436
Appendix 23	Coded Data on Category 2: Parents interviewed	437
Appendix 24	Coded Data on Category 3: EARS Staff interviewed	438
Appendix 25	Coded Data on Category 4: Teacher Educators interviewed	439
Appendix 26	Coded Data on Category 5: Education Officers interviewed	440
Appendix 27	Coded Data on Category 6: Commissioners interviewed	441
Appendix 28	Observations: Interactions between Teachers and Pupils	442
Appendix 25	Reliability: Spearman's Correlation Coefficient Test	449

## List of Tables

	<u>Page No</u>
Table 2.1: Description of Persons with Mental Retardation in Uganda	71
Table 4.1: Headteacher/Teacher Questionnaires Distribution and Return	163
Table 4.2: Number of Participants Interviewed	165
Table 4.3: Number of Teachers whose Lessons were Observed	177
Table 5.1: Main Categories of Participants	199
Table 5.2: General Trends of Participants' Attitudes Towards Education of Children with Mental Retardation	200
Table 5.3: Definition of Mental Retardation	202
Table 5.4: Definition of Mental Retardation: Concepts by Gender	204
Table 5.5: Definition of Mental Retardation: Concepts by Place of Work	205
Table 5.6: Definitions of Mental Retardation: Concepts by Rank	206
Table 5.7: Sample Responding to Question on Aims of Education and Curriculum for Children with Mental Retardation in Uganda	208
Table 5.7a: Overall Results about Aims of Education and Curriculum for Children with Mental Retardation in Uganda	208
Table 5.8: Need for Change in the Aims and Curriculum: Views of According to Gender	209
Table 5.9: Need for Change in the Aims and Curriculum: Views of According to Place of Work	210
Table 5.10: Need for Change in the Aims and Curriculum: Views of According to Rank	211
Table 5.11: Sample Responding to Question on Suitability of Conditions for Children with Mental Retardation in Ordinary Schools in Uganda	215
Table 5.11a: Overall Responses on Suitability of Conditions for Children with Mental Retardation in Ordinary Schools in Uganda	215
Table 5.12: Need to Change Conditions in Ordinary Schools: Views According to Gender	216
Table 5.13: Need to Change Conditions in Ordinary Schools: Views According to Place of Work (Urban or Rural)	216
Table 5.14: Need to Change Conditions in Ordinary Schools: Views according to Rank	218
Table 5.15: Sample Responding to Question on Suitability of Methods of Teaching Children with Mental Retardation	220
Table 5.15a: Overall Responses on Suitability of Methods of Teaching	

	Children with Mental Retardation	221
Table 5.16:	Need to Adopt Specific Approaches/Methods of Teaching Children with Mental Retardation: Views according to Gender	221
Table 5.17:	Need to Adopt Specific Approaches/Methods of Teaching Children with Mental Retardation: Views according to Place of Work (Urban or Rural)	222
Table 5.18:	Need to Adopt Specific Approaches/Methods of Teaching Children with Mental Retardation: Views according to Rank	223
Table 6.1:	Coded Data for Open-ended Questions	230
Table 6.2	Quantitative Summary of Open-ended Questions	231
Table 6.3a:	Quantitative Summary of Interview Questions – Category 1:	
		<b><u>Page No</u></b>
	Headteachers/Teachers	254
Table 6.3b:	Quantitative Summary of Interview Questions – Category 2: Parents	255
Table 6.3c:	Quantitative Summary of Interview Questions – Category 3: EARS Staff	256
Table 6.3d:	Quantitative Summary of Interview Questions – Category 4: Teacher Educators	257
Table 6.3e:	Quantitative Summary of Interview Questions – Category 5: District Education Officers (DEOs)	258
Table 6.3f:	Quantitative Summary of Interview Questions – Category 6: Commissioners for Education	259
Table 6.4:	Number of Children with Special Needs in Special and Ordinary Schools in Uganda, 1999	262

## List of Figures

	<u>Page No</u>
Figure 4.1: Map of Uganda	146
Figure 6.1: Enrolment of Primary School Children in Uganda, 1999	263

## Abbreviations

DANIDA	(Danish International Development Assistance)
DEO	(District Education Officer)
EARS	(Educational Assessment Resource Services)
EPRC	(Education Policy Review Commission)
ILSMH	(International League Society of the Mentally Handicapped People)
ITEK	(Institute of Teacher Education, Kyambogo)
LC	(Local Council)
NGO	(Non-Governmental Organisation)
OECD	(Organisation for Economic Co-operation and Development)
PERP	(Primary Education Reform Programme)
PETDP	(Primary Education and Teacher Development Programme)
PTC	Primary Teachers College
SNE	(Special Needs Education)
SUPER	(Support for Uganda Primary Education Reform)
UACE	(Uganda Advanced Certificate of Education)
UAMH	(Uganda Association for the Mentally Handicapped)
UCE	(Uganda Certificate of Education)
UN	(United Nations)
UNESCO	(United Nations, Educational, Scientific and Cultural Organisation)
UNICEF	(United Nations International Children's Fund)
UNISE	(Uganda National Institute of Special Education)
UPE	(Universal Primary Education)
USAID	(United States Agency for International Development)

# CHAPTER 1

# Chapter 1

---

---

## **1.0** *Introduction/Background*

### **1.1** **Aims of the Study**

My study is about helping teachers (headteachers included) get more involved and bring new changes in the education of children with special needs in Uganda. Teachers, by the core position they occupy, can influence other stakeholders, such as: parents, children, religious leaders, education administrators and politicians to effect any desired educational change in Uganda. The only way teachers can do this is by carrying out research activities in connection with educational policies and in their own personal experiences with school practices in their country. My perceptions of special needs education in Uganda have been shaped by personal experiences. In 1987 and 1988 I participated in planning meetings held under the auspices of the United Nations Educational Scientific and Cultural Organisation (UNESCO) and the Danish International Development Assistance (DANIDA) in Kampala, respectively, to establish a teacher training programme for special needs education in Uganda. The programme

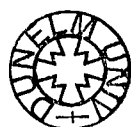

## Chapter 1: Introduction/Background

was successfully launched at the end of 1988. The Ministry of Education again appointed me (from a school where I was a teacher of children with special educational needs) to become one of the pioneer special needs teacher education trainers in the country (we were two permanently on the ground to do the job). Since that time, some progress in teacher training for special needs education has been made. The impact on ~~children with special needs, however, has not been felt. Many children have not been~~ identified and provided with education. Of the few who are receiving education, I am not sure, in my experience, whether they are receiving education, which is very relevant to their well being. Furthermore, children are still categorised and labelled as visually impaired, hearing impaired, physically handicapped and mentally retarded. At the Uganda National Institute of Special Education (UNISE) where I have been (and am still) working departments for training teachers for the various categories of children were created in 1988 and still exist at the time of carrying out this study. Before embarking on the current study, I headed the Department of Mental Retardation/Learning Difficulties. In light of the circumstances indicated above, I can not hesitate to develop radical thinking and to challenge fellow teachers to join forces so as to bring about changes that will be important to each and every one in Uganda, especially those with special needs for whom we claim we are rendering altruistic services.

## Chapter 1: Introduction/Background

Mental retardation is the working definition for the current study, though I use this phrase/terminology as a pointer to the right direction. A time should come when such terminology ceases to be used in educational concepts altogether; but for the moment I cannot avoid using it in the current study. In Chapters 2 and 6 I shall present further discussion on the problems with definitions of the terminology and my subsequent suggestion to abolish it. The children with mental retardation on whom the current study is focused are those in primary schools in Uganda. The age range for such children may be between six and twenty years or above. The official age for children to begin primary education in Uganda is six years, but children with mental retardation, some of who have been neglected, may begin school at a much older age. The study is based on two key government documents, the *Education Policy Review Commission* (known as the Kajubi) *Report* of 1989 and the *Government White Paper* of 1992. In the former document, there are recommendations arising from an overhaul of the entire education system of Uganda, while in the latter, parliament endorsed a number of those recommendations, thereby setting up a policy framework for any sector in the education system.

The study is concerned with the provision of special needs education in Uganda, with particular reference to children with mental retardation. Thus, the aim is to identify and describe what progress has been made in policy implementation, and to make recommendations about what ought to be done in order to achieve better results.

Specific objectives and research questions are formulated to guide the researcher in achieving the above stated aim of the study.

## **1.2 Objectives**

The objectives of the study are to:

- (i) provide an overview of special needs education (SNE) internationally and in Uganda;
- (ii) compare the official policy statements for special needs education in Uganda as stated theoretically, and what in practice is taking place; and
- (iii) make suggestions about ways of achieving success.

## **1.3 Research Questions**

A number of research questions are formulated as indicated below.

- 1.3.1 What are the ideologies and trends concerning the rights to education of children with special needs in other countries and in Uganda?
- 1.3.2 What are the concepts and definitions of mental retardation from an international perspective?

- 1.3.3 What are the aims of education for children with mental retardation internationally?
- 1.3.4 In the implementation of education policy for children with mental retardation in Uganda:
  - 1.3.4.1 How is mental retardation defined?
  - 1.3.4.2 What are the aims of education for such children?
  - 1.3.4.3 What types of institutions and facilities are recommended?
  - 1.3.4.4 How are children selected for education?
  - 1.3.4.5 What teaching approaches/methods are adopted for teaching the children?
  - 1.3.4.6 How are teachers prepared to teach children with mental retardation?
  - 1.3.4.7 What suggestions do the participants of the study make for effective implementation?

All the above four research questions are not answered in the same way. Questions 1.3.1 to 1.3.3, are tackled through the general literature, while Question 1.3.4, in particular, is approached through empirical means.

## **1.4 Statement of the Problem**

Provision of education for children with mental retardation in Uganda has not been given due attention, compared to that for ordinary children. Although of late some

attention has been given, the pace at which the provision is taking place is very slow. This disparity is clearly obvious given the fact that when more than five million ordinary children are known to be receiving education in Uganda, less than five thousand children with mental retardation are in school. We shall discuss this in detail in Chapter 5. The slow pace of development in the provision of education for children with mental retardation seems to be attributed to various reasons. One of the reasons could be how the policy makers in Uganda perceive mental retardation. Whichever way children with mental retardation may be perceived, eventually their special educational needs will have to be met by the same authority. Galloway, Armstrong and Tomlinson (1994) have argued that provision of education for children with special needs have to be determined according to the cultural values of a society. They say:

Criteria for defining special educational needs are culturally determined. Whether a child's educational attainments are regarded as evidence of learning difficulties depends largely on what the dominant authority expects children to achieve. (Galloway *et al* 1994: p.13)

Given the above argument, it is apparent that in Uganda, no one has been able to explain whether culturally the authorities in the country expect ordinary children to be provided with education so as to achieve certain objectives, which children with mental retardation are expected to achieve. In other words, the argument is whether children with mental retardation should be provided with education in the same way as ordinary children. If this is not done, then what is the underlying reason? It could also be argued that the long delay in providing education for children with mental retardation in Uganda could simply be due to negative attitudes towards persons with disabilities, a

factor that has been experienced in many parts of the world.

## **1.5 Significance of the Study**

One significance of this study is that it will be a source of vital information to policy makers and planners, donors, teachers and parents of persons with special educational needs in Uganda. Policy makers will be reminded of the slow pace at which implementation of education of children with mental retardation is now taking place in the country - that is, revealing what developments have been achieved and what is yet to be done in order to achieve better results. Teachers will be made aware of how children with mental retardation can be helped to learn. Another significance is that this, being the first research study of its kind in the country, will help to provide a base for future researchers in the same discipline.

## **1.6 Background**

### **1.6.1 Ideologies and Trends Concerning the Rights to Education by Children with Special Needs in Other Countries**

The current education policy in Uganda is for handicapped as well as ordinary children to receive education. This is recommended in the *Kajubi Report* (1989) and endorsed in

the *Government White Paper* (1992), entitled “Education for National Integration and Development.” At present, everybody is encouraged to acquire as much education as possible. This encouragement is directed mainly to the minority groups in society. The *Kajubi Report* has singled out the minority groups in the society as including the handicapped, women, some people from geographically remote areas, as well as the disadvantaged of any kind. (We shall discuss more with regard to the report in section 1.6.3.3). A number of reasons were given for emphasis on minority groups in Uganda. One reason was to promote national unity. Another was that since education was a right for all Ugandans, the minority groups too have the right to it.

In this study a number of key issues related to provision of special needs education in general, and for children with mental retardation in particular, will be examined. The approach adopted in this study is for the Ugandan context to be considered from the perspective of both the developed and developing countries. This approach is considered necessary for a number of reasons. Firstly, the trends and developments of special educational provision have been slow the world over. Hegarty (1993: p.17) has suggested that more positive changes are beginning to take place, as a result of pressure brought to bear by human rights movements and most governments are at least beginning to make provision.

Secondly, it is important in this study to create awareness in Uganda about some of the

struggles other countries have undergone in achieving development towards the provision of special needs education. Some of the achievements are gradual and complicated. For example, it is taking many developing countries a long time to implement universal, compulsory and free education, yet at the same time, they are attempting to implement special needs education. It is important to raise consciousness in Uganda of how challenging it is to achieve the goal of provision of special needs education. The developed countries have also struggled, in their way, to achieve the goal of special needs education just as the developing countries have. Developed countries are mentioned here in that their relevance to Uganda cannot be overemphasised. Despite the fact that they have abundant resources at their disposal, they are not convinced of having done enough for special needs education; they still continue to struggle to achieve better results. This kind of determination is a good example to Uganda of how much is involved in achieving the goals of special needs education. It should also be pointed out that developed countries' relevance to developing countries is co-operation, not only in economic terms, but in educational terms as well. For example, in the current study the researcher is seeking knowledge from a developed country to contribute to a better development of special needs education in his own (developing) country. This does not mean, however, that any knowledge acquired will be applicable in his country. The acquired knowledge will simply be used as a guide to enable the researcher do what suits the needs of his country.

Thirdly, it is necessary for Uganda to recognise the extent to which some developing countries have adopted legislation or other mechanisms to enable them to implement policies for the provision of education to the handicapped. Although legislation may be needed in the development of special needs education in Uganda, I do not mean that it is the most effective mechanism, other approaches such as administrative, may be useful. In my opinion, an approach, which involves a broad 'consensus' of all the stakeholders in the country, would be very effective.

Of late, there has been a movement and advocacy to achieve universal education the world over. The World Declaration on Education For All, adopted by a recent world conference on *Education for All* held in 1990 in Jomtien, Thailand, and the World Declaration on Inclusive Education adopted by another world conference on *Special Needs Education* held in 1994 in Salamanca, Spain, affirm the commitment to the integration of children with special needs in mainstream schools. Brief descriptions of these developments are given later in this section, but first it is necessary to begin with an outline of historical developments and trends in the provision of special needs education.

In comparison to ordinary education, the field of special needs education in Uganda is of relatively recent origin. Thus, when attempts are made to implement it in the country, it is important to realise that achievement of such an objective requires awareness of the

## Chapter 1: Introduction/Background

achievement made by other countries and to realise how long it may have taken them to achieve what they have achieved. In light of that, it is necessary at this point to provide a brief description of the stages of development of special needs education, and what level it has reached generally at the end of the 20th century.

It is important for us to provide here the general historical background of special needs education so that we inform policy makers and implementers in Uganda that development in other countries started long ago and has involved much debate and research contributions, and that the struggle still continues. By learning from such historical developments Uganda may be guided to achieve its aim in a much shorter time than it has taken some other countries.

In the 1960s to 1970s, provision of education for handicapped children was made in respect to particular categories of handicap and in special segregated schools. At that time the definitions of handicap were based on medical assessment and description. The major categories of handicap for which education was provided in most Western countries included: the physically handicapped, blind, partially sighted, deaf, partially hearing, mentally handicapped (mild and severe) and those with behavioural and emotional problems (DES, 1978). The schools for the handicapped were often residential, and children were isolated from mainstream schools. The tendency to isolation was reinforced in some countries by the fact that many of the providers of

special education were not government policy makers (Ainscow, 1994: p.3). These providers were voluntary workers who, according to the literature, had been responsible for initiating special needs education in many countries. The policy and practice of providing education in isolation is referred to as segregation, and it was realised that there were a number of disadvantages.

One of the major disadvantages was that it denied children with special needs the chance to learn together and share experiences with ordinary children. The other main disadvantage was that under segregation children with special needs were provided with special curricula which were relatively low in quality as compared to the curricula provided in the ordinary schools (Hegarty, 1993: p.19). In view of the fact that struggles were increasing in a bid to recognise the rights of children with special needs as minorities in society, there was a perceived need to create a situation that would lead to normalisation for them. In the face of segregation, however, this would not be possible. As a result, it became inevitable for the providers of special needs education to usher in a change in both policy and practice.

During the 1970s to 1980s, provision took new trends in many countries, especially in the West. There was a remarkable change in the form of provision during the decade. For the first time the practice of educating children with special needs alongside ordinary children in mainstream schools was introduced. This practice has been referred

to as integration (Hegarty, 1993: p.32). In contrast to segregation, this practice was found to be better in a number of ways. Integration had an advantage over segregation in that it enabled children with special needs to learn in an environment where they could develop socially by learning from non-handicapped peers. Another advantage of integration was that in the mainstream, the curricula provided was the same, and therefore, children with special needs were not denied the right to acquire specific knowledge and skills. Integration was also important in that this was one of the ways to influence the attitudes of ordinary children, to enable them to know more about handicaps and to accept or value persons with handicap by sharing learning together. In order to strengthen integration policy, some countries introduced legislation, which spelt out the terms and conditions covering practice. These policy and practice changes reflected education providers' increasing commitment to, and recognition of the rights of the handicapped and the move towards normalisation for them. The changes in policy and practice were prompted by various factors created by advocates of the rights of the minorities and various changes in attitudes became apparent.

Firstly, people were made aware, through campaigns and through mass media that handicapping conditions were more complex than the existing systems of categorisation; practice therefore needed to be changed.

Secondly, people began to appreciate that the difficulties faced by children in their

educational attainment and in their general development were likely to increase as a result of neglect, so improvements were needed in schools as a whole.

Thirdly, people became increasingly aware that although there was a wide range of needs for the handicapped children, they did not differ so much from the non-handicapped.

Lastly, but not least, many people began to develop a wider understanding and acceptance of the fact that every young person had a right to as full, independent and as normal a life as possible and that the aim of the community in relation to young people with more severe difficulties therefore needed to support their access to education and to community life. (Ainscow, 1994: p.3)

In the 1980s to 1990s, some countries went further in introducing legislation in an attempt to implement the policy of integration while others, especially the developing ones, attempted to introduce for the first time (and are still in the process of introducing) similar policies and practices. Some countries that have made headway are now in the process of extending practice further by introducing another and related practice of provision known as inclusive education, an approach which is described later in this section. Development of special needs involved collaboration among individuals, non-governmental organisations (NGOs), national governments and international organisations. Operating under NGOs were professionals, sometimes working together

with parents of handicapped people and with handicapped people themselves. The professionals were doctors, teachers, psychologists, religious and social workers. They played a leading role for a long time before national governments and international organisations to provide a better service for handicapped people joined them.

At this point it is necessary to mention some of the organisations and groups responsible for the development of special needs education.

### **1.6.2 Organisations Responsible for Development in Special Needs Education**

In many parts of the world special needs charitable organisations, parents and a few individuals sympathetic to handicapped people have initiated education. There are also internationally renowned organisations such UNESCO, the United Nations International Children's Fund (UNICEF), the Organisation for Economic Co-operation and Development (OECD), the Royal Commonwealth Society for the Deaf, the Royal Commonwealth Society for the Blind, and the International League Society of Mentally Handicapped Persons (ILSMH), now known as Inclusion International, to mention just a few, all of which have been (and are still) engaged in the struggle for the welfare of the handicapped. These organisations in unison have constituted powerful pressure groups and have been strong advocates for the cause of the handicapped and their pressures

have in fact induced national governments to speed up provision of education for handicapped people, both in developed and in developing countries (Ainscow, 1994: p.7). The struggles have been reflected differently through global fora. Cited below are some examples of global initiatives, which are attributed to such movements. The first example is drawn from the *United Nations (UN) Convention on the Rights of the Child* (1989). The convention obliges all nations of the world to respect the child, irrespective of his or her nature and ability. The child is expected to receive fair treatment in all aspects of life and should be helped in all the processes of physical, educational and social development. A total of one hundred and seventy seven countries world-wide have endorsed the convention, so committing themselves to its implementation.

A second example of global activity is the *UN Rule on the Persons with Disabilities* (1993). This rule, known as the UN Standard Rule 6, was formulated as an international guideline for policy-making and action. The rule requires that all handicapped persons should be provided with education together with non-handicapped persons, without any precondition. In other words, the rule requires that education for the handicapped should be treated as an integral system of education everywhere. In part the rule says:

Countries should recognise the principle of equal primary, secondary and tertiary educational opportunities for children, youth and adults with disabilities, in integrated settings. They should ensure that the education of people with disabilities is an integral part of the education system. (Centre for Studies on Inclusive Education, CSIE, 1995: p.3)

The intention of inclusive education is to provide education for children with special needs in an ordinary class in the neighbourhood school which a child would normally

attend, with support as needed by the individual and extra attention to address specific needs, such as the teaching of self care or communication skills, not easily taught in the ordinary classroom (Mittler, 1995: p.33). The difference between inclusive education and integration is that the latter may only take place in a specially resourced ordinary school or in a special class.

Inclusive education, on the other hand, is a practice that requires a change in the entire system of education to enable children with special needs to attend school anywhere within their reach. In other words, the condition of attending school by the handicapped should be seen as normal as possible. At the Salamanca Conference, national governments were urged to adopt inclusive education as the most effective system and as the only way to eradicate discrimination against the handicapped children. The Salamanca World Conference (already explained above, see 1.6.1) was attended by ninety-two governments and twenty-five international organisations. This is one of the statements issued by the conference:

Regular schools with this inclusive orientation are the most effective means of combating discriminatory attitudes, creating welcoming communities, building an inclusive society and achieving education for all; moreover, they provide an effective education to the majority of children and improve the efficiency and ultimately the cost-effectiveness of the entire education system. (CSIE, 1995: p.3)

Given the fact that some countries have the resources, with goodwill and determination there is no reason why the intended goal should not be achieved. Since the early 1960s, however, there are signs to indicate that even in the countries where some headway has

been made, it might still take a long time to achieve satisfactory results. It should be noted that it is one thing to endorse important policies such as the ones discussed at such international fora and another thing to implement them. Education is a very costly enterprise in terms of both human and material resources. It requires positive attitudes, careful planning and, above all, it requires commitment on the part of the policy makers.

Although some national governments have made good progress, there is still much to be done. UNESCO conducted a survey of fifty-eight countries (both developed and developing) between 1986 and 1987 to assess the level of progress of provision of special needs education among the various regions and countries (UNESCO, 1988).

The survey revealed that there are variations of progress in different countries. It was found, for example, that some countries have fewer children with special needs enrolled in schools than other countries. In the developing countries, in particular, the findings revealed that there are fewer children with special needs enrolled in schools compared to the developed countries.

There are a number of key factors which UNESCO identified and which it believes are associated with the hindrance to a smooth implementation of provision of education for handicapped children in many countries. Firstly, UNESCO noted that there still exist problems such as high costs and that many families could not afford to pay. Secondly, UNESCO noted that there still exist problems of lack of resources, for example, trained teachers, materials, and lack of co-ordination between regular and special education

systems and schools. Thirdly, it noted that in some countries there still exists the problem of deciding whether or not to make provision for formal categories of special needs education. The UNESCO report stated:

Education is compulsory in most responding countries, but certain groups of children were specifically excluded in about one third of them. Even in countries where education was said to be compulsory for all, it is likely that many children did not attend school either because provision was limited or enforcement was not strict. In addition, it is probable that there were de facto exclusions relating to handicap: of the 32 countries claiming compulsory education for all, only a few confirmed that no children with handicaps in these countries were excluded from education... (UNESCO, 1988b, p.2)

In 1996, ten years after the above survey report, UNESCO again produced a similar report concerning implementation of policy for special needs education in a number of selected countries (UNESCO, 1996). In the second UNESCO report, all the developed countries included in the survey had reached the level of integration of children with special needs in the educational programmes, whereas in the developing countries there is still a mixture of segregation and integration. The report does not indicate any country as having so far achieved the goal of inclusive education. Although the survey covered both developed and developing countries, for the purpose of the current study focus is put on the latter, in order to assess Uganda's position (being a developing country) in relations to the position of such surveyed countries.

The UNESCO findings both in the 1980s and 1990s seem to suggest that whereas provision of education for children with special needs has been introduced in many countries, and some countries have gone ahead to introduce legislation to support the

policy, in reality practice does not match the policy. This kind of problem could indicate that such countries might have introduced legislation when they were not yet prepared for the change. Experience shows that changes in policy have often been introduced by some countries simply because other countries have done so. Experience also shows that changes have often failed because they were not well planned (Fullan, 1991). In some cases, politicians have introduced changes for the purpose of winning votes but when it comes to implementing them, they will usually give the excuse of lack of resources. This, then, leads to failure in the desired change.

Dyson (1990: pp.55-66) has made a similar observation and has expressed concern, pointing out that the way provision is currently made in many countries is not satisfactory. His main argument is that the way children have been classified regarding special needs is less helpful to them, and he is of the view that such a practice needs to be continually challenged. Specifically, he has pointed out that the education providers tend to address educational difficulties in terms of individual children as being the sources of the problem. He has noted that educational difficulties are attributable more often than not to school environmental factors and he suggests that these are the issues providers should address. Dyson says:

The fact remains that the education system as a whole, and the vast majority of institutions and teachers within it, are approaching the twenty-first century with a view of special needs the same as that with which their counterparts approached the present century. That view, for all its avowed concern for the individual child, promotes injustice on a massive scale. It demands to be changed. (Dyson,1990: p.60-1)

Mittler (1995) has also observed that there is a very slow pace in the changes that are taking place for the benefit of the handicapped and he has therefore challenged all those concerned to do more. He has said:

Special education is not a high priority for most countries of the world. Children and young people with special educational needs and their families are still marginalised or ignored. Attitudes often reflect prejudice and ignorance, expressed at all levels from politicians and decision-makers to teachers and other professionals in local communities. (Mittler,1995: p.32)

From the evidence given by UNESCO and all the international activities already mentioned above, it suffices to say that there have been various factors responsible for the delay in making provision of education for handicapped children all over the world.

The factors are attributable to lack of awareness, lack of political goodwill, lack of material resources, negative attitudes towards the handicapped people, and lack of information about what role people need to play in the provision. It has taken a long time for people to initiate ways and means of bringing about changes in these factors.

With all the international initiatives now taking place, supported by different national governments, there are hopes that changes may be ensured sooner or later in other national governments. It seems that it is necessary for the different governments to make clear the policy, backed up by appropriate legislation, in order that changes are achieved. Legislation is required as it is an effective mechanism for making people accountable for implementation of a change. The fact that change has been realised in some Western countries is largely the result of appropriate laws introduced in those

countries. For example, where integration has been introduced in the mainstream schools teachers of the handicapped children are typically employed on terms and conditions equal to those of teachers of the non-handicapped children. Similarly, in public places and utilities changes have been made for the benefit of handicapped people. Things like buildings, toilets, trains, vehicles, roads and market places have all been redesigned so that handicapped people can use them without support. Such changes are still non-existent, however, in the developing countries where effective laws have not been introduced.

### **1.6.3 Ideologies and Trends Concerning the Rights to Education by Children with Special Needs in Uganda**

In the previous section, attention was focused on special needs education from international perspectives, by discussing both ideologies and trends. This section will provide a general background on the Ugandan system and structure of education, leading to the development of special needs education. This will help to identify some of the factors that may have partly been responsible for the slow development of special needs education in the country. In this section there will also be a description of some of the conditions which seem to be responsible for causing disability in general and mental retardation in particular. It is necessary to provide such a description so that by the time the conditions responsible for causing mental retardation are described, in

detail, in the next chapter (Chapter 2), it will be easy to perceive the condition of mental retardation in Uganda.

### **1.6.3.1 Pre-independence Development**

Uganda's education system is a recent development and can easily be traced from the early part of this century. The development was largely due to the initiative of voluntary agencies. From the earliest years of the British Protectorate until 1925, when a government department of education was set up, Uganda's formal education was entirely in the hands of voluntary agencies, mainly Christian missionaries who founded primary and secondary schools and teacher training colleges in many parts of the country. Some of the most famous of today's secondary schools were founded under mission sponsorship in the first decade of this century. Most of the children attended small rural schools unsupported by government. (Kajubi Report, 1989: pp.1-3)

In the early years, good education was not for the masses and although from time to time the reformers made their appearance, educational selectivity maintained itself. The system produced and supported an elite while the majority of the people remained illiterate. At that time there was no sign from the government as to what could be done

about provision of education for children with special needs. In almost all areas this pattern prevailed. Later on, however, there were some Christian missionaries who began to provide equal opportunity to children from all sections of the society, including limited arrangements for children with special needs (Kajubi Report, 1989 and Ssekamwa, 1996).

In many ways, the 1920s were the formative years for Uganda's present education system. It was then that the government decided to take over the direct responsibility for education, both by providing financial help to missions and by establishing its own schools and colleges where missions were not fully meeting the needs. It is at this point that the government should have begun to make provision, on a small scale, for the education of children with special needs, but this did not happen. In 1922, a higher college was opened at Makerere which, as early as 1925, was already being spoken of as destined to become the University College of the Protectorate. In 1925, a director of education was appointed and a government department of education was established. In 1927 government training of teachers was started (Kajubi Report, 1989 and Ssekamwa, 1996). The teachers trained were only meant to teach the ordinary primary children and no arrangement was made to train teachers for special educational needs.

Between the 1930s and the 1940s, Makerere had been remodelled as a regional institution serving the British East African territories. The milestone on the path to its present status was 1949, when it obtained semi-autonomous status and entered into a

special relationship with London University in 1953. In that year the first students gained London degrees, and in 1963 Makerere became one of the three constituent colleges of the University of East Africa (the others being Dar-es-Salaam and Nairobi). Makerere eventually became an independent university in 1970 (Kajubi Report, 1989 and Ssekamwa, 1996). Through these years, up to the time of carrying out the current study, the oldest and most famous institution of higher learning in Uganda and in the East African region did not establish a department to train teachers for special needs education or even to carry out research activities in the discipline.

In the 1950s rapid growth took place in Ugandan education chiefly along the lines laid down by the Binns Commission in 1953 and in the Report on African Education in Uganda prepared by the Committee under Bernard de Bunsen published in 1953. Both of them emphasised Africanisation of education and training of high-level manpower needed for the country's economic development. The 1950s also saw important changes in the structure of the education system. The central government delegated responsibility for primary and junior secondary schools in Buganda to the Kabaka's government and primary education in other areas to the district and Kingdom administrations (Kajubi Report, 1989 and Ssekamwa, 1996). Under such seemingly well planned arrangements, there was still no mention of special needs education by the government. As noted above, the priority was put on economic development and it could be assumed that providing education for children with mental retardation and other special needs at that

time would perhaps not help the government to achieve the aim it had set.

### **1.6.3.2 Post-independence Development**

Soon after Uganda gained independence from British rule in 1962, the Government appointed a Commission under the chairmanship of E. B. Castle to advise it on the changes needed in the education system to suit the needs and aspirations of a free Uganda. Among other things, the Commission proposed the merging of primary and junior secondary schools and also re-organisation and expansion of secondary education and teacher training. The junior secondary stage was abolished and the primary cycle was extended from 6 to 8 years, which later on was reduced to 7 years. At the primary level, it placed emphasis not only on quantitative expansion but also on quality. The need to raise standards of agricultural and technical education, to expand girls' education and to give adult education its due place in the national education system, were all underlined by the Castle Commission. The Ugandan Government, in a White Paper, pronounced itself well satisfied with the Report and broadly accepted the Commission's recommendations (Kajubi Report, 1989).

It is difficult to tell whether it could have been an oversight or whether it was simply ignored that even at the time the Castle Commission report was instituted there was no mention of education for children with special needs. Girls' and adult education were



when. In principle, these two documents contain the educational policy framework of Uganda today. It is important, therefore, to find out whether the intended objectives in the two documents are coherent with practice on the ground, especially as far as education of children with special needs in the country is concerned.

The Kajubi Report, otherwise known as the Education Policy Review Commission (EPRC), is one of the commissions that has been set up in Uganda since 1927 to guide the government in managing the education system of the country. In the Minister of Education's General Notice No. 57, and in accordance with the powers conferred upon him by Section 5 of the Education Act (1970), the Minister of Education in 1987 appointed the above commission, with the terms of reference indicated below.

1. To appraise the existing system of education from pre-primary level to secondary/tertiary and recommend measures and strategies for improving the system so that it can:
  - (i) progressively embrace, as appropriate, modern curricular and pedagogic trends and development;
  - (ii) equip its students with productive and modern marketable skills to meet the developmental needs of the economy and promote employment opportunities for the students; and
  - (iii) produce socially responsible citizens.
2. To review and reformulate, where necessary, the general aims and objectives of

the school/tertiary education system as a whole as well as the aims and objectives of education in each level of the system.

3. To advise on the most effective way of integrating academic with commercial and technical subjects in school curricula in accordance with the resolution of the 40th International Conference of UNESCO of 1961.
4. To recommend measures which will improve the management of schools and tertiary institutions so as to maximise cost-effectiveness.
5. To re-assess the correct system of financing schools and tertiary institutions and recommend measures for reducing costs and improving efficiency in rendering educational services.
6. To advise on optimal location of educational institutions throughout the country.
7. To advise how, if at all, schools and tertiary institutions can contribute towards their own upkeep without impairing academic standards.
8. To review the role of qualifying examinations and adequacy of the current methods of assessment and recommend as appropriate.
9. To assess the role of the private sector in the provision of education at all levels.

Based on the above terms of reference, the Kajubi Commission, among other things, recommended greater access to education particularly for girls, adults, the handicapped, and other disadvantaged groups.

For the purpose of guiding its recommendations, the commission defined what education for handicapped people means. The commission said:

Special education here refers to that type of education which is designed specifically for the disabled with an objective deficiency of physical, sensory or mental functions which includes the deaf, the blind, and the mentally and physically handicapped.

It is estimated that of the total population of Uganda which is 18 million there are about 10% handicapped children who are disabled in one way or the other. However, the Government has not yet assumed enough responsibility for educating these handicapped children and adults. In most cases, the education services for the disabled are in the form of private institutions established and maintained by voluntary organisations.

These institutions have faced a number of problems, which have undermined their efficiency. First, there is the negative attitude of the public towards the disabled. Then there is also a lack of a clear-cut government policy on education for the handicapped. Most of these institutions do not have permanent and direct sources of income and, therefore, are unable to provide appropriate facilities, equipment, materials and financial aid. Finally, lack of transport is a real handicap for these institutions. (Kajubi Report, 1989:pp.113-114)

In the quotation there are two observations that can be made. First, in its definition, the commission noted that there is a type of education that can cater for disabled persons of different disabilities. Although the definition may be interpreted in different ways, for example as bearing a more segregative tone, what is more important is that it marked the beginning of commitment, from a political level, to provide the education.

In the second observation, it is noted that the commission reported that the government had failed to shoulder responsibility for educating persons with disability, but had appreciated the role played by the voluntary organisations. Indeed, the government's recognition of its delay in assuming responsibility over education of persons with disability was important and overdue, such that action was needed to implement such a

policy. In its report, therefore, the Kajubi Commission made these recommendations

(R):

- R.166 (i) The Government should give adequate support to all institutions offering Special education to enable them operate more effectively and efficiently;
- (ii) All units and annexes for Special education attached to normal schools and colleges should be taken over by the Ministry of Education and integrated into the schools/colleges but adequate provision should be made for teaching the disabled students; and
- (iii) Special schools for the deaf and the blind should be established, preferably one in each geographical region of the country. (Kajubi Report, 1987: pp.113-114)

In addition to the above recommendations, the commission recognised the need for training of teachers who were to teach the handicapped persons in the schools and colleges to be established. The commission made this recommendation:

- R.152 A teacher training college should be established to train teachers for the handicapped in both primary and secondary schools. One of the existing Primary Teachers' Colleges should be converted into a Teacher Training College for Special Education. (Kajubi Report, 1987: p.105)

The Kajubi Report was finalised and submitted in 1989 for parliamentary debate. The parliament duly accepted and endorsed all the above recommendations and in the subsequent document, that is, the Government White Paper, the strategies for implementation were spelt out. We shall present the recommendations contained in the White Paper below.

#### 1.6.3.4

#### The Government White Paper of 1992

Parliament debated and endorsed the two recommendations (R.152 and R.166) made in the Kajubi report. The parliamentary approval of the report was published in 1992, and was referred to *Government White Paper on the Education Policy Review Commission*

*Report* (1992). In its implementation strategy, the parliament laid down, among other things, the following guidelines, stating that:

- (i) The implementation of R.152, which is already accepted, will cater for teacher training programmes and produce the necessary teachers. It is proposed to equip four PTCs for preparing teachers for Special Education, starting from 1993/94.
- (ii) The programme of supporting the existing Special Education Units attached to Government-aided normal schools and integrating them in those schools will commence in a phased manner, starting from 1992/93.
- (iii) A phased implementation of part (iii) will begin towards the second half of Phase One. Initially three schools for Special Education will be established in different parts of the country between 1994 and 1997. (Government White Paper, 1992: p. 170)

In Uganda, different mechanisms do exist through which implementation of commitments such as those noted above can be monitored to ensure that success or failure have been realised. Such mechanisms would include circulars released by politicians, in this case by the Minister of Education, to guide the policy implementers on what to do, and when to do what. Parents would be provided with information through pamphlets, radio programmes and, more effectively, through the local council (LC) meetings. Furthermore, the top policy implementers, such as inspectors of schools, would compile inspection evaluation reports from time to time on

## Chapter 1: Introduction/Background

achievements made in the policy implementation of provision of education for all children, including those with mental retardation. Besides such inspection reports, academicians and scholars in the country would be expected to carry out research studies, and debate on implementation of such policy statements in the country.

In fact, however, the above mechanisms have not been readily available; not much scientifically researched information has been made. Dissemination of information about education of persons with different disabilities is mainly done through mass media, that is, through newspaper articles and by a few interested people, in many cases by persons with disabilities themselves. Newspaper readership is also limited, as the beneficiaries are mainly the urban dwellers. It should be noted that it is very difficult to measure the achievements made and the failures faced in the policy implementation, given that there is such a lack of vital mechanisms, as pointed out above. In this study, however, efforts have been made to give value judgements on the policy from a theoretical point of view, as stated by politicians on one hand, and on the practice, as carried out by the non-political players in their different status, on the other hand.

As noted from the above documents, the policy statements were clearly stated about the needs for implementation of education for persons with disability in Uganda. Education of children with mental retardation, like that of other minorities, was not singled out and

addressed in specific terms. Education of children with mental retardation in Uganda is subsumed in the general recommendations and its implementation, for that matter, can be assessed alongside the policies for other sectors of education. Although the policy is noted to be clear, it is, however, so open that it does not provide clear definition of disability in general and mental retardation in particular. Implementers of such an undefined policy would find it hard to know what is expected of them. Such a state of affairs may be understood when the nature or model of current education policy in Uganda is clarified.

Together with special needs education, one other important recommendation made in the *Kajubi Education Commission Review Report* was the implementation of universal primary education (UPE). Through this scheme it was hoped that more children, including those with special needs, would get a chance of receiving education. Implementation of the UPE policy should have started in 1994, it was introduced in 1997. Not all children of school-going age are currently benefiting from UPE. For the time being, according to a *UPE Circular* (1996), four children per family are selected to benefit from the scheme. We shall focus more on UPE in Chapter 5. In the meantime, we shall continue to examine, generally, some of the implications of implementation of the policy on special needs education as already mentioned above.

Fulcher (1989) has discussed two models of education policy. She refers to the first

type as a 'top-down,' or 'gap', and to the second as a 'political' model. In the former, Fulcher says it is the government that makes a policy and its bureaucracies implement it.

She says that such a policy can fail, because the government may not pay due attention to all the aspects of social theory, that is, how things work in a country at a particular time. In light of that, she says that, there may be a 'gap' between a policy and its implementation. In the latter model, therefore, Fulcher believes that policy makers should have the capacity to make decisions and act on them. She argues that since policy is political practice, and politics characterises all practices, education policy should be made at all levels, that is, it should involve politicians, bureaucrats, teachers and parents.

Fulcher has discussed various issues and provided examples of some countries where implementation of special educational policy has been difficult to achieve. The issues are competing objectives in national policy, government policy strategies and construction of conditions at other levels, school practices and integration and wider institutional conditions. In Norway, for instance, she says educational practices have consisted of struggles between integration and segregation, despite the fact that in that country 'comprehensive' schools have existed for some time. Citing another example similar to the situation in Norway, Fulcher says that in Australia, the practice of 'delayed admissions' for children with disability has been introduced since government-level written policy on integration was put in place. She says that professionals always

attribute their failure to implement integration to lack of resources. In the United States of America she has observed that although national policy has taken the form of legislation, due to opposing objectives of politics of rights, and politics of professionalism and medical discourse on handicap, implementation of policy on integration of children with special needs has been difficult to achieve. With regard to Denmark, she says that the national educational policy does not have opposing objectives; that it is consistent about integration. Thus, the government written policy is predominantly pedagogical rather than professional. In that country, the author says that pupils with special needs are regarded as 'pupils', so every effort is made to ensure that they are integrated into regular schools without preconditions. In light of that, she says that Denmark has been more successful in implementing its policy on special educational needs, compared to other countries, such as Australia, Britain, USA, or Norway.

Besides opposing objectives, Fulcher has found out that the problem of implementation of educational policies may be affected by 'government policy strategies and the construction of conditions at other levels'. She says that policies tend to propose strategies which, conventionally, would be seen as directing their 'implantation' and their dominant objective at other levels. Fulcher has reported, for example, that in the USA, the government policy on special needs has created significant legislative conditions, which have instituted compliance on its (policy) implementation. The author argues that despite such efforts, the law has not helped in achieving that

objective. She has found that although locational integration may have succeeded in the USA, pedagogical integration has not been very successful. Arguing on a similar line, Fulcher says that in Britain, English national policy also chose legislation to achieve objectives on integration of children with special needs. She says since the Warnock report and the 1981 Act, the objective of implementation of policy on integration has not been easily achieved, because of the increased regulation and politicisation of procedures. She says the political-bureaucratic-administrative practices that have emerged at the Local Educational Area (LEA) level, have, instead, rendered some pupils with learning difficulties segregated rather than integrated. On the contrary, Fulcher says that in Denmark, policy strategies are applied as an attempt by the government to encourage rather than direct local practices or to regulate teachers, administrators and pupils.

School practices and integration are some of the aspects, which Fulcher has noted to be important in educational policy and implementation. She says that schools are sites of decision-making which are relatively independent of wider institutional conditions. Fulcher has observed that there are certain conditions that can exist to promote meaningful integration in schools. These, she says, include co-operation between teachers, teaching styles and the way teachers perceive children with special needs.

Last, but not least, apart from school practices and integration, Fulcher has talked about

'wider institutional conditions', saying that they also vary, and determine the success of educational policy implementation in any country. She says that where egalitarianism (human equality) and the welfare state are concerned, there is a widely held discourse that the Scandinavian countries are more egalitarian than other Western countries. Fulcher says that Denmark has been ahead of many countries on social expenditure, and on improving institutional conditions outside the educational apparatus. She says that government policy puts emphasis on pedagogy, not handicap, and on research aimed at making integration effective.

The descriptions of Fulcher's observations and arguments bring to light what can be learnt about the current implications of implementation of policy for the provision of education for children with special needs in Uganda generally, and for those with mental retardation, in particular. The Ugandan government-level written policy on special needs is very much of a 'top-down' model in nature. As noted from Fulcher, such a policy is bound to face problems in its implementation. Although conditions in Uganda may not be comparable to those in the developed countries as identified by Fulcher, the fact remains that the various issues enumerated from the countries cited above can have impact on the implementation process, though in different ways. In Uganda, formulation of a policy on special needs may be one thing, and the ability to achieve that goal another. Different factors may be responsible for delaying implementation of a policy of this nature. First and foremost, we have to consider availability of resources, attitudes of society towards children with special needs, teaching approaches and

methods, the school curriculum and the overall school environment. Uganda, having gone through social disruption and economic destruction is definitely in a very weak position to implement all its educational policies. Although numerous attempts have been made to solicit support from some other countries and international organisations, this may not be enough to help achieve implementation of different educational policies in the country. I shall present below some of the projects meant for implementation of current educational policies in different sectors in the education system in Uganda, starting with the primary education reform programme (PERP).

#### **1.6.3.5 Primary Education Reform Programme (PERP)**

PERP has been designed to implement most of the recommendations made in both the Kajubi Report and the White Paper with regard to the primary education sector. The reform has been designed and is being implemented by mobilising both government and donor resources. The approaches used by the government are being centred on providing fundamental policy changes, developing unique delivery and support. There are four objectives of the reform programmes. Firstly, the government intends to re-establish teaching as a respected profession, by improving teachers' terms and conditions of service. Secondly, the government intends to establish a new delivery and support system for enhancing pupil learning and school support by re-structuring and rationalising primary teacher training services. Thirdly, the government's intention is to enhance community participation in and responsibility for primary school education in the country. The fourth objective of the reform is to establish a sustainable system of

allocating resources in support of the reformed primary school system. The government has co-ordinated external funding to support the reform. One of such donors is the United States Agency for International Development (USAID) which is currently funding a programme, termed Support Uganda Primary Education Reform (SUPER). A second donor is the World Bank, now funding the Primary Education and Teacher Development Programme (PETDP). A third donor is the Danish International Development Assistance (DANIDA), currently engaged in collaboration with the Uganda government in the development of special needs education in the country. The proposed aims for education which were endorsed by the *Government White Paper* (1992: pp. 7-8) state that education will be provided in order to:

1. promote the understanding and appreciation of the value of national unity, patriotism and cultural heritage with due consideration of international relations and beneficial interdependence;
2. inculcate moral, ethical and spiritual values in the individual and to develop self-discipline, integrity, tolerance, human fellowship and respect for public property;
3. inculcate a sense of service, duty and leadership for participation and public accountability in civic, social and national affairs through group activities in the educational institutions and the community;
4. promote scientific, technical and cultural knowledge, skills and attitudes needed for development;

5. eradicate illiteracy and to equip the individual with basic skills and knowledge to exploit the environment for self-development, better health, nutrition and family life, and capability for continued learning; and
6. contribute to building of an integrated and self-sustained national economy.

Although clearly stated and currently supported with external funding, achievement of such objectives still seems to pose more challenges, as we shall discuss in Chapter 5. In the meantime, we shall, in the section below, discuss the current structure of the education system in Uganda and see how it relates to implementation of education for children with mental retardation.

#### **1.6.3.6 Present Structure of Education**

The existing structure of education has been in force since the early 1960s, since the publication of the Castle Commission's Report (already mentioned above). The structure consists of seven years (has been increased to eight) of primary education followed by the lower secondary cycle of four (reduced to three) years (leading to the Uganda Certificate of Education - Ordinary Level) (UCE), and the upper secondary cycle of two years (leading to Uganda Advanced Certificate of Education - Advanced Level) (UACE), after which there are three to five years of university studies. (*See Appendix I*)

On successful completion of the primary school cycle, pupils go either to secondary schools or take a three-year Crafts course in Technical Schools. Only about 40%, however, of the primary school leavers are absorbed in these schools. Those completing UCE have four possible outlets: successful candidates can proceed to Advanced Level (UACE); join the two-year Advanced Crafts Course in Technical Institutes; join the two-year Grade Three primary teacher training programme in a Primary Teachers' College; or join any of the government's departmental training programmes.

After completing UACE, the students have several outlets. They can proceed to university; join a two-year course in the National Teachers' College, a two-year course in the Uganda Polytechnic Kyambogo, Uganda College of Commerce, Institute of Teacher Education, Kyambogo (ITEK), National College of Business Studies; or join any of the programmes of government departmental training which are of one to three years' duration. Departmental training is a kind of training which is specifically designed by different ministries to recruit and train school leavers on the job. At the university, a number of diploma and degree level courses are offered in various disciplines such as Humanities, Arts, Sciences, Education, Medicine, Engineering, Agriculture and Veterinary Medicine. A number of adult education courses are also offered by the Centre for Continuing Education at Makerere University.

For departmental training, there are a number of institutions offering a variety of technical and professional courses under different ministries, such as Ministries of Labour; Agriculture; Health; Environment; Animal Industry and Co-operatives. They usually admit students after UCE, UACE and their courses lead to certificates and diplomas, respectively, after completion of one to three years of training.

Under the structure of education as mentioned above, it is definitely clear that no provision was made for children with special needs. Their education under such an arrangement would be peripheral and would not carry as much weight as would the education for the ordinary children who are more capable academically. That was the structure recommended by the Castle Commission and as has already been pointed out earlier the Castle Commission either seems to have had an oversight or simply did not recognise the needs and interests of children with special educational needs. On the contrary, the proposed structure (by the Kajubi Commission), to replace it should have made a difference. The Kajubi Commission made recommendations about the need to implement provision of education for children with special educational needs, but failed to indicate how such an implementation would fit into the new structure.

#### **1.6.3.7 Proposed Structure of Education**

The notable changes in the report include, among other things, an increase in the

primary education cycle from seven to eight years. Another change is in the Lower Secondary, which has been reduced from four years to three. The system of entry from one level to another is still based on examination procedures.

The new structure, like the old one, still remains highly academic and competitive. Although some children with special needs, like those with hearing, visual and physical impairment, may be very capable academically, the majority of those with mental retardation are unlikely to gain from such a structure. It is unlikely that such children can compete favourably and succeed in the examinations, make good grades and get promoted to higher classes, then eventually to the university, so as to make contributions in the economic, social and scientific developments as clarified in the aims of education of Uganda, according to the Kajubi Report and according to the Government White Paper. Recommendation and endorsement of provision of education for children with special educational needs was done in good faith, as indeed the time was already overdue for it. The problems that are noted, however, according to the proposed structure explained above, may make implementation of such a good policy practically difficult.

As noted above the system of general education in Uganda has progressed in a short time. The education system emphasises, as noted in the definition of its aims above, the desire to produce skilled manpower. In the definition, manpower is badly needed for

economic, agricultural and industrial production. Both the old and proposed structure have little difference, as far as the system of education is concerned; the system still remains based on competition, in terms of academic performance. Given such a trend, the question which remains unanswered, is: “How are children with special educational needs expected to benefit from the education satisfactorily, given the rigidity of such an education?” It is only after completion of the current study that such a question can be answered. From this point, however, it is necessary to look at the development of special needs education in the country.

#### **1.6.3.8 Development of Special Needs Education in Uganda**

Provision of education for children with special needs was started in Uganda by non-governmental organisations (NGOs), and eventually the government was drawn in to play a role. Education for children with visual impairment was introduced first, followed by hearing impairment, physical (motor) disability, mental retardation and then deaf-blind.

#### **1.6.3.9 Education for Children with Visual Impairment**

Efforts to make provision of education for handicapped children in Uganda can be traced from the late 1950s (Okech, 1993: p.17). The foundation for the future development of programmes for the blind was laid under the auspices of the defunct British Empire Society for the Blind, which later became the Royal Commonwealth Society for the Blind, now known as Sight Savers. In 1954, the Uganda Foundation for the Blind was formed. One year after this development, the first School for the Blind was built in Soroti (then Teso) District, through the joint efforts of the Ministry of Education, Teso District Education Committee and the Uganda Foundation for the Blind. The day-to-day running of the school was the responsibility of the St. Francis Nuns of Soroti. In 1962, at Wanyange Girls Secondary School, the first attempt to integrate blind and sighted pupils was made by establishing a unit in the school. This was later transferred to Iganga Secondary School. In 1968 at Iganga Secondary School, a training centre for teachers of the blind was established. The centre ran courses for teachers of the blind until 1988 when teacher training for Special Needs Education was started at the Institute of Teacher Education Kyambogo (ITEK) and later, in 1996, transferred to the Uganda National Institute of Special Education (UNISE) within Kyambogo, Kampala.

#### **1.6.3.10**

#### **Education of the Hearing Impaired**

Education for the hearing impaired was started in 1958 when the Uganda Society for the

Deaf was formed. In that same year, lip-reading lessons for multi-racial children were started at the Agha Khan Mosque at Old Kampala and at Mengo Primary School. Through various efforts of the Uganda Society for the Deaf, a full primary school was later established next to Mengo Primary School. In the same year in the then - Teso (now Soroti) District, a full primary school was set up, known as Ngora School for the Deaf. The school still exists today. The Uganda School for the Deaf in Mengo was transferred in 1988 to Ntinda (from the west to the east of Kampala) and exists until now.

#### **1.6.3.11 Education of Children with Physical (Motor) Disabilities**

The Uganda Spastics Society was formed in 1968 at Mengo by parents of spastic children. This was followed by establishment by the Society, in 1969 at the same place, of a school with the purpose of education for children with cerebral palsy, although it was, and has remained, composed more of children who have suffered with polio.

Another society, known as the Uganda Society for the Physically Handicapped, was also formed in 1987, and gradually more associations joined in. With the formation of these

societies and associations, efforts were combined to establish more units in schools for more children.

Although the initiatives of establishing special schools and units for special needs children were mainly by voluntary organisations, the Government stepped in and in 1973 a Department of Special Education was set up at the Ministry of Education, with the role of supervising all activities related to the running of Special Education in the country.

The Department of Special Education has since then been strengthened by the establishment, in 1992, of a counterpart department in the Inspectorate branch of the Ministry of Education. The new department is known as the Educational Assessment Resource Service (EARS) Department.

### **1.6.3.12 Education of Children with Mental Retardation**

Regarding the education of children and youth with mental retardation, some attempts were made in the early 1970s. Shortly before the political events of 1972 took place, in which Asians were expelled from the country, the Victoria Nile School in Jinja (east of Uganda) had started providing some education for Asian children with mental retardation. These services ceased on the exodus of the Asians. Another attempt was made, this time by an indigenous non-governmental organisation (NGO) called Mercy Children's Centre (MCC), in 1979 in Kampala. The new school did not progress much

due to the little attention paid to it by some parents, teachers and the school administration. MCC was later absorbed into the mainstream school known as Nakasero Primary School in Kampala. In 1982 an association known as the Uganda Association for the Mentally Handicapped [*sic*] (UAMH) was formed. Since its formation UAMH has established a number of government units for children with mental retardation in the mainstream throughout the country.

#### **1.6.3.13 Education of Deaf-Blind Children**

Whilst most of the categories of children with disabilities as listed above were provided with education earlier, some were not. Of late, a little attention has been paid to the children with multiple disabilities, especially the deaf-blind. In the year following the formation of the Uganda Association for the Deaf-Blind (UADB) in 1993, the association convinced a primary school at Iganga (east of Uganda) to set up a unit for the deaf-blind. Although the school is a day school, arrangements have been made to accommodate deaf-blind children at the school.

#### **1.6.3.14 Government's Role in Special Needs Education**

The Ministry of Education is the driving force at the national and district levels for the co-ordination of the efforts of government, NGOs and donor agencies supporting programmes for children and young adults with special educational needs. The District

Education Officers (DEOs), Municipal Education Officers and the District Inspectors of Schools (DIS) are executive arms of the Ministry of Education and Sports. They ensure that basic education is a continuing service for all children, including persons with special educational needs in all districts. In Uganda there is still no legislation pertaining to provision of special education, but the government is guided by both the Education Policy Review Commission (Kajubi Report) recommendation of 1989 and the White Paper of 1992 already mentioned earlier in this chapter. In these documents the Government is committed to give adequate support to all institutions offering special education, to take over and integrate all units and annexes attached to regular schools and to establish special schools for the deaf and blind in each geographical region of the country. Although children who are talented and gifted have special needs (which have been recognised by the government) arrangements have not been put in place to give them the services they deserve. Out of a total population of about 1.8 million people in the country, it was noted during the current study that a total of 18,379 children with disabilities had been identified, assessed and were receiving education (Educational Assessment Resource Services, EARS, 1999). We shall discuss this more in Chapter 5. Going by the EARS' record, therefore, it can be estimated that currently in Uganda children with special needs who are receiving education are just a simple representation of only 0.1 per cent of the country's population. Furthermore, if based on the EARS's record, it can also be estimated that children with special needs (18,379) represent only 0.34 per cent of the 5,427,404 children currently receiving primary education in Uganda.



### **1.6.3.16 Malarial Infection**

It is reported that about twenty-five percent of all illness in children under five in Uganda is caused by malaria and that this is on the increase. Malaria amongst pregnant mothers is also a contributing factor to anaemia, premature deliveries and to low birth weight. Low level of awareness, poor service availability and lack of resources at the household level explain part of the increasing impact of malaria. Other factors include the spreading resistance of malaria parasites to the safer and cheaper drugs, poor vector control, poor case management and the virtual absence of specific malaria control activities in the country.

### **1.6.3.17 Measles Infection**

Although measles is one of the immunisable diseases, about ten years ago it was one of the single largest causes of infant and child morbidity or deaths. The impact of measles has, however, been reduced over the years.

### **1.6.3.18 Malnutrition Problems**

*The World Bank Report on Uganda Social Sector* (1994: pp.47-60) indicates that 4.9%

of children under five are severely malnourished (underweight) and a further 18.4% moderately malnourished due to:

- the high incidence of low birth weights;
- the fact that 55% of households consume less than 80% of the daily recommended energy intake; and
- poor weaning practices and care when the baby is between 6 and 18 months old.

The low level of energy intake is in turn due to household food insecurity, scarcity of resources at the household level and inadequate knowledge concerning the nutrition-disease cycle. The high levels of malnutrition, the World Bank indicates, lead to 44.5% of children being stunted, one of the highest levels in Africa. Specific problems of maternal malnutrition result, the Report claims, also due to low birth weights in a further 20% of new babies. A report by the Uganda Women and Children (1994: pp.45-51) reveals that 51% of Ugandan women give birth at home, often without any specialised assistance and in conditions that are often unhygienic. As a result, obstructed labour, which leads to anoxia (a shortage of oxygen to the brain of babies being delivered), occurs. Underlying causes of these problems are attributed, according to the report, to the low socio-economic status and low health services.

The Uganda Women and Children Report further reveals the different factors, which are directly related to the low socio-economic status in the country. It says, firstly, that there are remarkably low levels of household income that limit the capacity of members of the household to purchase medical services. Secondly, there is low priority given to modern medical care in terms of monthly household expenditure in comparison to other expenditure patterns. This, the report says, limits the willingness of those who decide on the use of the household budget, usually the male head of household, to allocate money to health services. Thirdly, there are wide variations in household incomes that tend to be low in areas that are also lacking in services. Fourthly, there is also a problem associated with limited service provision and access.

The problem of limited health units available within the country as a whole is compounded by their uneven geographical distribution, leading to great scarcity in some areas. The Uganda Women and Children Report says that the health problems have been aggravated by the limited knowledge of the population. The report says the population has not had adequate potential for preventive measures, such as sanitation and hygiene, so as to be able to reduce the level of disease infections in the country.

#### **1.6.3.19 Improving Nutrition**

According to *The Uganda National Programme of Action for Children* (U.N.P.C.)

(1995: pp.32-41), current national health policy is based on the principles of primary health care (PHC) with emphasis on community-based interventions in health promotion, disease control, sanitation and simple curative and rehabilitative health care.

This is to be achieved through a process of social mobilisation and technical guidance of communities. In order to achieve this the *Uganda National Programme of Action for Children* (U.N.P.C.) (1995: pp.32-41) provides a detailed plan of action. According to U.N.P.C the government's aim is to restructure the present set up of the health management system in order to decentralise decision-making within the health sector to the district level, and to streamline the management of the health care delivery system to achieve a greater degree of co-ordination, supervision and accountability at all levels.

On the other hand, U.N.P.C says, the government intends to urge the communities to have major roles to play in decision making, in generating resources and in the implementation and supervision of health programmes in partnership with health providers. The increased involvement of communities and community health workers, U.N.P.C says, is to be supported through a primary health care network that will bring together the health care technicians with the population. Once this co-ordination is achieved, U.N.P.C claims, some of the key problems will be solved. Firstly, it says, there will be an improvement to the current health and nutrition of mothers and children under five. That is, there will be a reduction of severe malnutrition from 4.9% to 2.5% and moderate malnutrition from 18.4% to 9.4%. Secondly, there will be a reduction in stunting from 45% to 20% among the under-fives, wasting will be maintained (weight

for height) at less than 5% among the under-fives, and there will be a reduction of low birth weight (less than 2.5kg) from 20% to 10%. In order to achieve the above goals the U.N.P.C says different activities have been proposed (as indicated in the next section).

#### **1.6.3.20 Supporting Goals for Child-bearing Mothers**

Different strategies have been laid, according to U.N.P.C (1995), in order to bring about improvement in nutrition and reduction in health problems for all childbearing women throughout the country. U.N.P.C says one of the strategies will be to work towards achieving exclusive breastfeeding of children up to four months of age by 90% of rural mothers and 80% of urban mothers. Secondly, it says, continued breastfeeding will be increased for children from four months to one year, while for mothers complementary feeding will be increased from 82% to 100%. The third aim is to increase coverage of weight monitoring and promotion from 15% to 80% of under-five children. Fourthly, the aim is to increase coverage of the weight monitoring of pregnant women to 8%. Fifthly, the aim is to increase birth intervals to a minimum of two years.

#### **1.6.3.21 Supporting Goals for Infants and Under-fives**

With respect to the under-fives children, U.N.P.C says, one of the strategies is to improve birth weight. This would mean reducing low birth weight (under 2.5kg birth weight) to less than 10% of live births. Secondly, the strategy is to improve on the

control of the preventable diseases. The main task, U.N.P.C says, is to maintain high levels of immunisation coverage (at least 85% of infants under one year) against all the immunisable diseases. This, U.N.P.C concludes, will be directed at eliminating all types of neo-natal infections, eliminating poliomyelitis cases and reducing by 95% the infection by measles. As for malaria infection, U.N.P.C says the task is to reduce its morbidity in the under-fives by 30% and reduce the morbidity in pregnant mothers by 60%. Although an evaluation report has not been published since 1995 by U.N.P.C in connection with the above mentioned objectives, from personal experience all we can say is that much has not been achieved. Primary Health Care (P.H.C) programmes have been conducted and the aspects for which success has been made and failures met are easy to point out. With regard to immunisation against preventable killer diseases, there have been a lot of activities going on in the country for the last ten years. Many children have been immunised and the programme continues every year. In other words, the control of diseases such as measles, polio and tetanus have been checked from time to time. As far as improvement on nutrition and control of malaria are concerned, there seems to be no sign of success. Malaria fever has been very difficult to control and has claimed many lives, especially of infants in Uganda. Although in theory the strategies for improvement on nutrition and reduction of morbidity in general have been discussed, the failure could be attributed to funding. The immunisation programme has gained some success because of massive funding by the World Health Organisation (WHO). Without such assistance the rest of the aspired programmes may remain in theory for a

long time, thereby leaving morbidity to cause more havoc to the infants in Uganda.

## **1.7 Conclusion**

As indicated in the background description, development of special needs education, the world over, has been very slow. Different countries are at different levels of development; some are far ahead, while some are still struggling. In some developing countries, however, good progress is beginning to take place. There have been various problems affecting the development of special needs education, but these problems have been similar in all the countries. Firstly, it has been noted that in all countries initial awareness of the educational needs of handicapped people has been lacking among the people but with time people changed, and are still changing. People are becoming aware of their obligation to render services for the handicapped. Creation of awareness of the necessity of rendering services for the handicapped has been due to numerous campaigns launched through research reports, electronic and print media, international activities and through legislation. In order to achieve a reasonable level of progress there has been a need for combined efforts. At first it was parents of the handicapped and the handicapped themselves who were in the forefront to advocate for the provision of education and for the rights of the handicapped people in general. These initial struggles were later strengthened by other people of goodwill who comprised charitable organisations, international bodies, individual governments and

professionals. It suffices to say that creation of awareness has greatly helped in achieving success, although on the other hand awareness alone may not compel people to do what is expected of them.

The second factor, which affects the progress of provision of special needs education everywhere, has been the socio-economic factor. This is a situation in which the standard of living varies between different countries. Some of the countries mentioned in the study have high, while some have low, socio-economic standards. There are also indications that some of the countries have had programmes to monitor the causes and prevalence of handicap. Such measures, it seems, have greatly enabled them to curtail handicapping conditions.

The third factor is connected with political goodwill. Politicians make policies and have the command of the available resources. They set priorities in a country's economic and social development. Where political goodwill is available for handicapped people, provision of their education may be implemented with little hesitation. Where the handicapped are not valued, provision of their education is likely to be given little consideration.

The fourth factor that affects provision of education for the handicapped is connected with professional will. In provision of special needs education, the roles of

professionals such as doctors, teachers, psychologists and social workers are vital. These professionals have had close contact with and played a big role in providing services for the handicapped for a long time. Their co-operation in rendering services for the handicapped is needed if there is to be success. Where each category of professionals disregards contributions of the others there is likely to be little achievement made.

Fifthly, implementation of special needs education requires abundant resources. Some countries have more resources than others. This, however, does not mean that there are better chances to serve the handicapped in such countries. Good planning and equitable distributions of whatever available resources are what is important. Experience, however, shows that equitable distribution of resources to meet the needs of the handicapped has not been fully carried out in many countries, whether in the developed or in the developing countries.

Sixthly, for long negative attitudes towards the handicapped people have been a major hindrance in the development of special needs education. Handicapped people have been underrated and given less attention in the society compared to the quality of services rendered to non-handicapped people. There has been a lot of neglect of handicapped people, who have been socially stigmatised and regarded as less equal. The main problem attributed to negative attitudes towards handicapped people is that society has always viewed handicapping conditions as being a problem located in the

individuals who are handicapped. Society has not been very mindful of addressing other problems, such as the environment in which the handicapped live, as being an issue that required the most attention.

Uganda, being a developing country, is still overwhelmed by many of the problems mentioned above. In Uganda there is still inadequate awareness in the population about the need to provide special needs education. Efforts to promote awareness are currently being made but are proceeding at a very slow pace. The socio-economic conditions of the majority of Ugandans are still very low. As a result, many people are still poor. The conditions of morbidity and ignorance are very high, therefore giving rise to increased causes and incidence of handicap in the country. Politically there has been more turmoil than tranquillity since Uganda gained independence from Britain in 1962. The political problems have contributed to more diversion of the meagre resources to develop other sectors at the expense of providing education for the handicapped. Uganda, according to *The World Bank Report on Uganda Social Sector (1994)*, is listed among the twelve poorest countries in the world. The societal attitudes towards the handicapped have been very negative although these are currently changing slowly. In the next chapter (Chapter 2) we shall embark on a discussion of provision of education for children with mental retardation, beginning with discussion of concepts and definitions of mental retardation.

# CHAPTER 2

# Chapter 2

---

---

## **2.0**                      ***Concepts and Definitions of Mental Retardation from International Perspectives***

### **2.1**                      **Introduction**

Having discussed special needs education generally in the previous chapter, in this chapter I shall dwell specifically on mental retardation. The purpose is to attempt to answer one of the research questions in the study: ‘What are the concepts and definitions of mental retardation from international perspectives?’ An attempt to answer this question is useful in that it may help to shed light on the implementation of the policy for education of children with mental retardation in Uganda. Although there may be different concepts and definitions of mental retardation in the country, it is important that some international concepts and definitions are explained and understood in order to provide a broader perspective and understanding of the condition. In other words,

some aspects are described in the chapter which may provide ideas on how better to handle the current implementation in the country.

Contribution to knowledge in Uganda is by and large the best approach, not only through the current study, but through similar studies that should be conducted for an improvement of policy implementations such as the one currently going on for education of children with mental retardation in the country. Enrichment of knowledge can best be achieved in Uganda through research studies such as the current one.

The chapter begins with explanations of some of the known definitions and theories of intelligence. This is because in the definitions of mental retardation we cannot avoid mentioning intelligence.

## **2.2 What Intelligence Is**

Different definitions and theories of intelligence have been provided and explained but none seems to be regarded as comprehensive. Among the many people who attempted to define intelligence was Alfred Binet. He referred to the term as “the tendency to take and maintain a definite direction, the capacity to make adaptations for the purpose of attaining a desired end and the power of autocriticism” (Sattler, 1982: p.29). Binet asserted that intelligence lies in four attributes: comprehension, invention, direction and

ensorship. Another attempt was made by Piaget (1960: pp.3-27) who suggested several definitions of intelligence. He referred to human intelligence as one kind of biological achievement which allows the individual to interact effectively with the environment. In another attempt Piaget referred to intelligence as a form of equilibrium towards which the successive adaptations and exchanges between the organism and the environment are directed. In other words, Piaget looked at intelligence as a factor which brings about an achievement, a balance or harmonious adjustments between an individual or his mental structures and his environment.

Vernon (1969) looked at intelligence from three dimensions. Firstly, he regarded intelligence as something that is inherited, hence he termed this type of intelligence as “real intelligence”. In other words, he looked at each and every human being as born with intelligence. On the second dimension, he looked at intelligence as “normal intelligence”, suggesting this was the type of intelligence that enabled individuals to learn, think and solve problems. Thirdly, he referred to the results obtained on intelligence tests (tests that sample specialised abilities, such as verbal, non-verbal, or physical abilities) as “operational intelligence”.

Horn and Cattell conceptualised intelligence as “fluid” and “crystallised” forms (1966: p.254). Fluid intelligence refers to non-verbal, a relatively culture-free mental efficiency. This includes factors such as good memory capacity and a strong thinking ability. As for crystallised intelligence, it refers to acquired skills and knowledge that

are strongly dependent, for their development, on exposure to experiences such as education, training and culture. An example of crystallised intelligence is when an individual can earn a living, say, by composing songs or becoming a good carpenter.

Because intelligence was viewed as a complex of many abilities and traits, Wechsler (1991) argued that intelligence tests could not measure everything in a human being, saying it was merely a means to an end. He said what was more important in an individual was the capacity of that individual to understand the world around him or her, use its resources and cope with its challenges.

### **2.2.1 Measurement of Intelligence**

Tests designed to measure learning ability have traditionally been called intelligence tests and are designed to measure content-oriented achievement. Specifically, they are meant to find out how much an individual has mastered knowledge of subject matter in particular courses such as language, numeracy, sciences and social studies (Hallahan and Kauffman, 1997: p.271). Another area that an intelligence test may measure is general educational problem-solving abilities similar to those learned in schools, such as vocabulary, reading and arithmetic reasoning. Intelligence tests, the authors say, are also meant to measure culture-oriented verbal aptitude; that is, an intelligence test may

be carried out in order to assess verbal, numerical and general problem-solving abilities derived more from the general culture than from common school experiences.

When achievement and aptitude tests are administered, they are measured using some of the most common standardised scales or scores, such as Mental Age (MA), Intelligence Quotient (IQ) percentage, standard deviation, Stanford-Binet IQs, Wechsler IQs, to mention, just a few (Wechsler, 1991). More about testing is discussed in the next chapter (Chapter 3) under assessment of children for educational provision.

An aspect of intelligence referred to as social intelligence is believed to help individuals to adapt well to their environment. Through social intelligence, it is believed, people can interact, communicate and react appropriately to their environment (Chen, Bruininks, Lakin, and Hayden, 1993: p.394). Certain types of behaviours are regarded as being responsible for designations of mental retardation (Lachiewicz, A. M., Spiridigliozzi, G. A., Gullion, C. M., Ransford, S. N., and Rao, K., 1994: p.572). For example, social incompetence or disruptive behaviour noted among children with mental retardation is believed to be one of the main causes of rejection of such children from inclusion in the mainstream schools (Greenspan, Granfield, 1992: p.446; Greenspan, 1998: p.186). With these explanations about intelligence, in the next section, discussion will now be focused on mental retardation.

## **2.3 Concepts and Definitions of Mental Retardation from Societal Point of View**

Like intelligence, indication in the literature suggests that the concepts and definitions of mental retardation have not been clearly arrived at (MacMillan, Grensham and Siperstein, 1993: p.332). Mental retardation, according to Drew, Logan and Hardman (1996: pp.5-16) has been viewed as a condition and also as a phenomenon that has presented a challenge to administration, education, psychology, medicine, society in general, and always to the family involved. As a result of the complications of the condition, the concepts and definitions of it, in the different disciplines mentioned above, have always remained unclear. Drew et al., (1996: p.5) observe that for a long time it has been generally accepted that mental retardation is related to a reduced level of intelligence, an approach which, according to them (the authors) appears to be scientific, yet may not be the case. They argue that there has never been a legitimate science of mental retardation. The authors further claim that there has never been a firm basis upon which mental retardation could be conceptualised and that the issue of measuring mental intelligence has not been convincing enough. That is why, they stress, there has been a continuous debate by different schools of thought on the same issue. They argue, for example, that medical doctors, psychiatrists, sociologists, psychologists, educators, anthropologists and the like, have had separate perspectives and language to conceptualise and define mental retardation. Thus, sociologists set out

to study mental retardation as a social problem; psychologists examine it as a psychological problem; educators view it as an educational problem; society relates to mental retardation as a cultural problem; and other professionals view it in respect to their own professions. As a result of all these confusions, the authors conclude that the condition of mental retardation still remains undefined.

Concepts of mental retardation date back thousands of years, to at least Greek civilisation in 2,500 BC (Scheerenberger, 1983). People with mental retardation at that time were regarded with fear and suspicion as they were in some way believed to be possessed by demons. The concepts held about mentally retarded people have been characterised by confusion and fear, rather than positive perceptions. One misconception was that mentally retarded people were mentally ill, and therefore needed to be in hospital to receive treatment. Another misconception, as reported by Drew et al. (1996: p.6), was that mental retardation was regarded as a contagious disease or an illness that could be treated or cured. Some of these misconceptions and negative attitudes led to treatment which varied from putting the persons with mental retardation to death or leaving them to die, to keeping them to provide amusement at courts of law and in the market places, or to accord them religious or divine status (Dutton, 1975). This fear and suspicion of mentally retarded people was common in many countries. Gradually, however, as society’s knowledge of mental retardation widened and society itself changed, other more humane patterns of care evolved. For example, Dutton observed that in Victorian Britain, institutions were established and facilitated to

confine and provide some support to mentally retarded people, but this was not enough. The treatment given to mentally retarded people was similar to that given to mad people. Foucault (1965), for example, described how between the 13th and 18th centuries insane people were mistreated in the Western world. He said such people were eliminated by, for example, throwing them in the sea, and from the 19th century on, they were confined in what were known as asylums so as to restrict their movements and interaction with normal people.

The negative attitudes of society towards persons with mental retardation continued all over the world up to the 20th century. In her study, Tomlinson (1982: pp.23-30), found that children with special needs are still generally viewed with negative attitudes by members of society. The mentally handicapped people are unfairly treated, such as being labelled or perceived as though they are deviants, and hence grow to feel unworthy. The author has challenged professionals, claiming that in their (professionals’) pretext of altruistic intentions to provide services to mentally handicapped people, they do not do so genuinely; they do so because they have a vested interest. Tomlinson also further argues that the condition of mental retardation is nothing but a socially created construct. She says that individuals would not be regarded as mentally retarded if other members of the society did not judge, label and refer to them as mentally retarded. Tomlinson’s argument is shared by other people. For example, Sarason (1985: p.233) has also pointed out that there is nothing in reality

that exists in the form of mental retardation, but that people simply develop a concept through which they are able to label others. Sarason says:

Mental retardation is never a thing or characteristic of an individual, but rather a social invention stemming from time-bound societal values and ideology that make diagnosis and management seem both necessary and socially desirable. (p. 233)

Smith (1998: p. 167) in a similar reaction, quotes another author named Trent, whom he reports to have raised an argument, saying that mental retardation has sometimes been used in the name of sciences, other times in the name of care and in other instances in the name of social control. As for Ferguson (1994: p.16), he says that people with mental retardation have not only been regarded as mentally retarded, but they have been referred to as “unfixed” and “chronic”. Ferguson was writing of the period 1820-1920 in America. He says that people with mental retardation have been referred to as “chronic” because in them, according to society, “badness becomes incorrigible<sup>1</sup>, ugliness becomes inhuman, and uselessness becomes untrainable” (1994: p.16). Although these concepts have been identified in the Western developed world since the late 19th century and there have been discussions and signs of improvement, similar views can still be noted at the end of the 20th century in many developing countries such as Uganda and might take longer to change.

During the current study, the researcher made an attempt to find out what the concepts and definitions of mental retardation are, from different parts of Uganda. The respondents, who happened to be teachers, provided answers which were all so alarming

that if provision of education is not properly handled in the country, the negative attitudes will yet be witnessed for some time in the future. Mental retardation as described by the teachers is shown in the table below (Table 2.1).

**Table 2.1: Description of Persons with Mental Retardation in Uganda**

Region of Uganda	Description of Persons with mental retardation in the Local Language	The Literal Meaning of the Description in English
Northern	Lapoya, Madimadi, Azaza, Janeku	Confused, Dull, Stupid, Unstable
Eastern	Momienere, Jaming’o, Gasirusiru, Muwudhuwudhu	Undeveloped, Dull, Stupid, Confused
Central	Mawaya, Bisirusiru	Weak-brained, Stupid
Western	Agashiru	Weak-brained

In addition to the above description, the teachers also described how, according to some cultures, people with mental retardation are treated. They said, for example, that in a certain part of the Eastern Region where circumcision is an important ritual to transform a youth into manhood, those with mental retardation are denied that right. This means that even when they become adults, they are still regarded in their society as “boys”. One who is a boy, according to that culture, the teachers said, is not permitted to share company with other men at beer parties. They also said that one who is not circumcised in that place cannot be buried with honour like those who are circumcised. Mental retardation as noted in Uganda, particularly in the area described by the teachers is similar to mental retardation viewed as “chronicity” in the West in the late 19th century

---

<sup>1</sup> incorrigible: a person who is seen as faulty and who may not be helped to improve/change for the better.

as reported by Ferguson above. If traditionally mental retardation is still defined in the ways indicated above, then policy makers should intervene and provide clear definition, a definition which will encourage the population to respect and appreciate the needs and plight of persons with mental retardation in Uganda. It is not enough for the government to come up with a policy for providing education to all children with special needs when some of such children for example those with mental retardation are viewed with such conceptions.

While society conceived of mental retardation in the ways indicated above, attempts were made from a medical point of view to clarify scientifically the manifestation of the condition, as described in the next section.

## **2.4 Medical Concepts and Definitions of Mental Retardation**

Medically, mental retardation is a condition which is believed to occur as a result of damage to the brain and sometimes other body systems (Macpherson, 1992). The World Health Organisation’s (WHO) (1980) International Classification of Diseases 10th-revision (ICD-10) scheme, in its recognition of mental retardation as a diagnostic construct, defines the condition as an “arrested or incomplete development of mind which is especially characterised by sub-normality of intelligence and social functioning” (Reschly and Ward, 1991: pp. 257-68). The scheme recognises that mental

retardation has degrees of severity namely mild, moderate, severe and profound. The scheme also recognises that mental retardation is caused by diverse conditions and that it may occur simultaneously with other physical or mental disorders.

Another definition is made by the American Psychiatric Association (APA, 1994). In its Diagnostic Statistical Manual 4th revised edition (DSM-IV-R), the APA recognises mental retardation as an arrested state of mind.

In Britain, according to Mallington (1983: p.12), the Mental Health Act 1983 acknowledges that only a “small minority” of mentally handicapped people show “abnormal aggression...etc,” yet the common belief is that this is a valid description of many people with mental retardation. Drew, Hardman and Logan (1988: p.8) have quoted a Russian researcher as reporting that mental retardation in the country is conceptualised and associated with both an interruption of normal development of mental activities and also with a defect that occurs to an individual’s mental capacity before birth. There are different terms used to describe the different levels of retardation in Russia. For example “umstvenno oststaly” refers to a person who is regarded as “intellectually backward”.

Another label, “oligophrenia”, is used to describe a condition in which an individual is regarded to be mentally deficient. “Umstvenno oststaly” is the equivalent of “mild mental retardation, while “oligophrenia” refers to a condition of severe mental deficit

related to certain neurological damage. Oligophrenia is also believed to be genetically caused.

The etiology of the retardation is attributed to over three hundred known factors, and it is acknowledged that others are not yet known. Some of the known factors responsible for causing mental retardation, according to the literature, comprise genetic abnormality, chromosomal aberration (abnormality) and environmental factors. These conditions are described below. *(Also see more detail about the causes, in Appendix 4, including the sources of information).*

Genetic abnormalities may give rise to a condition known as microcephaly. This is a condition caused by a single abnormal gene. The presence of this abnormality prevents the brain from developing normally. Another example is tuberous sclerosis or epiloia. This condition is caused by an abnormal dominant gene and produces severe mental handicap.

A large group of disorders known as inborn errors of metabolism are also caused by abnormal genes. Metabolism is the process of breaking down food into elements that the body can use. If this process is interrupted the incomplete products of metabolism may affect the individual adversely. The most common form of inborn error is found in the condition known as phenylketonuria (PKU). This is a disorder of protein metabolism. In this case there is absence of an enzyme called phenylalaninehydroxylase

(an amino acid) which results in high levels of phenylalanine in the blood, producing severe effects on the child’s mental and physical development.

A disorder of carbohydrate metabolism called galactosaemia is caused by abnormal genes. This abnormality results in a deficiency or absence of an enzyme vital for the effective metabolism of galactose. This produces an accumulation of harmful chemicals which damage the liver and kidneys as well as cause mental handicap.

Besides genetic abnormalities, several different kinds of chromosome abnormalities are known to occur in man; (a) the trisome, the presence of a single additional chromosome; (b) the monosome, the absence of a chromosome that should be there; (c) deletion, the absence of a part of a chromosome; (d) translocation, the moving of a piece of one chromosome from where it ought to be to another chromosome where it perhaps ought not to be, and (e) triploidy, a condition in which an individual has half again as many chromosomes as he ought to have. The trisomy is the abnormality associated with Down’s syndrome (also referred to as mongolism).

The above examples are just a few of the known causes of mental handicap. They serve to illustrate how defects or abnormalities of the chromosomes or genes can cause mental handicap. Apart from these causes, mental handicap is also known to be caused by various environmental factors as described below.

There are many factors which can affect a foetus in its physical and mental development. These factors may exert their influence at any time after conception, during pregnancy, birth or childhood. They include maternal and childhood infection; acute or chronic lack of oxygen to the developing brain; direct or indirect violence, ranging from accident to non-accidental injury; maternal foetal incompatibility; prematurity; birth injury; the ingestion of chemicals in pregnancy; childhood malnutrition; and sensory and social deprivation. The severity of these effects varies from severe mental and physical abnormality to mild mental handicap with no physical handicap. Generally the earlier the damage occurs the more severe is the outcome, as the developing brain is particularly susceptible to adverse conditions. Following conception, the foetus develops rapidly from the fertilised ovum to the normal full-term baby. One of the more complex aspects of foetal development is the formation and maturation of the brain and central nervous system, with spurts of growth occurring during the fifteenth and twentieth weeks and from the twenty-fifth week onwards. The developing brain is particularly vulnerable to any adverse conditions and a number of factors are known to cause mental handicap at this time.

There are different maternal infections caused by environmental factors. One of the examples is German measles, otherwise known as rubella. Other virus infections known to cause mental handicap include varicella (chicken pox), herpes simplex, infective hepatitis, influenza, mumps and poliomyelitis. The degree of handicap varies

from mild to profound and the risk is always greater if infection occurs in the first three months of pregnancy.

Childhood infections such as inflammation of the brain (encephalitis) or its covering (meningitis) may damage the brain to the extent that there may be mental handicap, slight or severe.

Traumatic factors may intervene during pregnancy, at birth or during childhood to produce mental handicap. The mother may be excessively exposed to radiation, particularly during the first 16 weeks which may cause microcephaly with severe mental handicap. Sometimes a mother may try to procure an abortion using substances that will damage a fertilised ovum and which may cause abnormalities and mental handicap in the child. Incompatibility of the mother's and baby's blood may result in the destruction of the baby's red blood cells and damage to parts of the brain.

Other environmental factors known to cause mental retardation occur when the developing foetus is denied essential nutrients as a result of placental insufficiency. The developing foetus is very sensitive and can be affected by a lack of protein, blood, sugar or oxygen and this deprivation is particularly significant at the period when brain development is at its peak.

Mental handicap may occur as a result of the child eating poisonous substances. An example of this is the ingestion of lead from paint which may lead to a serious condition called lead encephalopathy causing blindness, deafness, convulsions and severe mental handicap.

It is reported medically that 40% of major mental retardation is caused by chromosome abnormalities, mainly trisomy 21 (Down’s Syndrome) as already mentioned above. Other genetic defects account for 15%. Another 10% occur within pregnancy and 10% of mental retardation occurs after birth as a result of accidents, child abuse, infections and brain tumours (Caesar, 1993: p.101-109).

It is further reported medically that since mental retardation is caused by damage to or abnormalities in the central nervous system and sometimes other body systems, people with severe degree of retardation are liable to physical ill health; Down’s syndrome, for example, may involve malformation of the heart and intestines (Cuskelly and Gunn, 1993). Thus children with the syndrome are more liable to develop other illnesses subsequently. Some children with mental retardation may develop paralysis in some parts of the body or have other motor and sensory disabilities. It is also medically reported that about one third of children with severe mental retardation may have epileptic seizures. As such, it is medically recommended that primary care services should be availed in every country where children with severe mental retardation may need referral for medical services. Such services are important in that the presence of

brain damage may predispose to the development of disturbed behaviours, the behaviours which may therefore need not only behaviour modification, but an intervention that involves psychotropic drugs administered by mental illness services or by specialists in mental retardation (Macpherson, 1992).

Although there is a primary health care (P.H.C.) service in Uganda, I have not observed its involvement in providing services to persons with severe mental retardation. Nobody seems to realise how important it is to provide special attention to such persons, as indicated in the literature. Perhaps it could be argued that the need for such people to receive essential services has been realised in the country but it is not a priority to provide the services. Implementation of policy on education for children with mental retardation should involve essential services such as the P.H.C. running parallel with education. Education alone may not help to solve some of the problems that such children may have. It requires that authorities first define all the needs of the persons with mental retardation in Uganda.

## **2.5 Earlier Attempts to Define Mental Retardation**

Definitions of mental retardation have changed considerably over the years. A historical examination reveals that people who attempted to define mental retardation were faced with two difficulties. In the first instance the early views focused on adults to the

relative exclusion of other age groups. Tredgold (1937) looked at mental retardation as a severe condition that rendered an individual incapable of carrying out normally any given task in comparison with other fellow adults. He defined mental retardation as:

A state of incomplete mental development of such a kind and degree that the individual is incapable of adapting himself to the normal environment of his fellows in such a way as to maintain existence independently of supervision, control or external support. (p. 4)

About twenty years after Tredgold’s definition another attempt to give definition of mental retardation was made. In a similar vein, Benda (1954) viewed an adult with mental retardation as someone who was not capable of managing himself or herself, unteachable and was not capable of managing his or her affairs. He therefore stated:

A mentally defective person is a person who is incapable of managing himself and his affairs, or being taught to do so, and who requires supervision, control, and care for his own welfare and the welfare of the community. (p. 115)

The second area of difficulty involved which factors or parameters to include in the definitions. Different parameters for viewing a person’s behaviour as being retarded have been employed over the years and have emerged in both definition and classification schemes of mental retardation. The well known parameters or factors that have been included in the definition attempts range from what are known as social adaptation, constitutional origin, incurability and etiological factors (Smith, 1998: p.168).

In his attempt to describe retardation among both the adults and the young people, Doll (1941: p.215) based his ideas on two parameters, namely constitutional origin and incurability. To him, mental retardation was a condition or problem which originated constitutionally in an individual who was affected. In other words, according to him, biological effect led to subnormality in an individual. On the other hand, Doll looked at incurability as another factor on which mental retardation should be recognised. In this respect he viewed the retardation as a condition that affected an individual and remained permanently without a cure. After Doll, other attempts were made elsewhere, especially in the United States of America, to define mental retardation and the debate on definition continues. The American Association for Mentally Retarded (AAMR) has been in the forefront of definition attempts since the late 1950s.

In 1959 the AAMR (was known by then as American Association on Mental Deficiency) defined mental retardation, stating that:

Mental retardation refers to subaverage general intellectual functioning which originates during the developmental period and is associated with impairment in adaptive behaviour. (Heber, 1959: p.6.)

According to Smith (1998: p.168), a revision of the 1959 definition was made in 1961 to make the definition clearer. For example, in the revision the meaning of the term “subaverage general intellectual functioning”, was clarified as meaning “one standard deviation” below the mean on an intelligence test at which intellectual functioning should be considered “subaverage”. This specification means that on an Intelligence

Quotient (IQ) test with a mean of 100 and a standard deviation of 15, any score below 85 would be diagnostic (regarded as mental retardation). If, for example, a total population of a particular country was tested and classified on this basis, almost 16% of people in such a country would be diagnosed as having mental retardation. Smith says that in such a situation, even higher percentages would be expected to result in sub-populations where minority status, language factors or socio-economic background might be mistakenly diagnosed. Smith also points out that in the 1961 revision the concept of adaptive behaviour was not made clear. He says the way it was presented in the definition was not “actually functional for the diagnosis” of mental retardation, because it was based on intelligence, yet intelligence was not the only significant factor. Other factors such as adaptive behaviour were equally crucial.

In 1973 the AAMR developed another definition. This time it specified that significantly subaverage general intellectual functioning was to be determined by a score of at least two standard deviations below the mean on an intelligence test (Grossman, 1973). This meant that the cut-off point for mental retardation was to be moved from 85 to 70. This change lowered the percentage of the population that might be identified as having mental retardation from 16% to about 2.25%. That diagnosis of mental retardation covered a developmental period of individuals from conception to age 16. Ten years after publication of this definition, another definition was introduced. The main change in the definition was that diagnosis of mental retardation covered a developmental period of individuals from conception to age 18 (Grossman, 1983). In

their latest revision in 1992, the AAMR has made yet more changes, the changes both welcomed and criticised.

## **2.6 Current Debate on the 1992 AAMR Definition**

### **2.6.1 Definition by the 1992 AAMR Definition**

In 1992 the AAMR introduced its latest revised definition of mental retardation, spelling out significant changes. The definition states:

Mental retardation refers to substantial limitations in present functioning. It is characterised by significantly subaverage intellectual functioning, existing concurrently with related limitations in two or more of the following applicable adaptive skill areas: communication, self-care, home living, social skills, community use, self-direction, health and safety, functional academics, leisure, and work. Mental retardation manifests before age 18. (Luckasson et al.,1992: p.5)

One of the major changes made under the 1992 AAMR new definition is that mental retardation is to be considered from a wider perspective, that is, viewing the performance of an individual when he or she interacts with the environment, instead of focusing on the individual and on the retardation as it had been the case before. In the definition mental retardation is regarded by the association as a fundamental difficulty in learning and in performing certain daily life skills. The personal capabilities in which there must be a substantial limitation are viewed as conceptual, practical and social intelligence. These, the AAMR believes, are areas which are specifically affected in

mental retardation, while other capabilities, such as health and emotions are considered a secondary issue. The AAMR defines the concept of “significantly subaverage intellectual functioning” as an IQ standard score of approximately 70 to 75 or below, based on assessment that includes one or more individually administered general intelligence tests developed for the purpose of assessing intellectual functioning. The association considers retardation as a condition whereby intellectual limitations occur at the same time (“existing concurrently”) as the limitations in adaptive skills. As for “with related limitations”, the association considers that the limitations in adaptive skills are more closely related to the intellectual limitation than to some other circumstances such as cultural or linguistic differences or to problems associated with sensory problems. In referring to “in two or more of the following applicable adaptive skill areas”, AAMR indicates that evidence of adaptive skill limitations is necessary because intellectual functioning alone is insufficient for a diagnosis of mental retardation, nor is a limitation in one adaptive skill alone. The association is of the view that the impact on functioning of these limitations must be sufficiently assessed to reveal that at least two adaptive skill areas show serious weakness to warrant a conclusion of mental retardation. AAMR considers the skill areas (communication, self-care, home living, social skills, community use, self-direction, health and safety, functional academics, leisure and work) as central to successful life functioning, and they are frequently related to the need for support for persons with mental retardation. Thus, assessment should be carried out, taking into account the fact that skills relevant within each adaptive area may vary with chronological age. Last, but not least, the association

defines mental retardation manifestation up to an approximate age when an individual in a society may enter into adult age, that is, from conception to about the 18th birthday. That is, to warrant the diagnosis of mental retardation, limitations must have been manifested in childhood.

In its classification scheme, the AAMR has replaced the four levels of mental retardation, mild, moderate, severe and profound, with a system that classifies the intensities and patterns of support required by individuals. A measured IQ of 70 to 75 is set as the ceiling and its new system is divided into “needs”: intermittent needs (needs that do not require support); limited needs (needs that are consistent over time but are limited in intensity); extensive needs (needs that are long-term and serious) and pervasive needs (needs that are constant and intense throughout life) (Lukasson, et al., 1992: p.5).

## **2.6.2 Proponents of the 1992 AAMR Definition**

Polloway (1998: p.175) has enumerated four justifications for his support for the application of the AAMR definition. Firstly, there should be a valid assessment which should consider linguistic diversity as well as differences in communication and behavioural factors. Secondly, existence of limitations in adaptive skills should occur within the context of community environments typical of the individual’s age peers and

is indexed to the person’s individualised needs for support. Thirdly, specific adaptive limitations should coexist with strengths in other adaptive skills or other personal capabilities. Fourthly, with appropriate supports over a sustained period, the life functioning of the person with mental retardation should generally improve<sup>2</sup>. The AAMR 1992 recommends the IQ scores in diagnosing mental retardation to be about 70 or 75 or below. According to Polloway (1998: p.176), however, it reduced the tendency of using IQ scores as the basis for classification purposes. Although the AAMR definition is heavily criticised by some experts in mental retardation, Polloway remains one of the proponents of the definition. He argues that the new definition was formulated with a wider consideration of the way persons with mental retardation could be considered when providing essential services to them. For example, he says, the 1992 AAMR definition has been made in such a way that it can help in guiding service providers, such as those engaged in education, community services, clinical psychology, medicine, early intervention, adult supports, law and government policy makers. Polloway further argues that the AAMR definition considers the fact that lives of individuals with mental retardation are not defined only in terms of adaptive skills and intellectual functioning. Rather they are seen as significantly affected by other variables such as physical well-being, psychological and behavioural factors, family and community supports and medical conditions. Critics of the 1992 AAMR definition, however, have several grounds on which they challenge the definition.

---

<sup>2</sup> It is suggested in the literature that given appropriate attention and services, a diagnosed individual can overcome some of the problems and begin to function normally, so avoiding becoming “mentally retarded”.

### **2.6.3 Criticism of the 1992 AAMR Definition**

Michaelson (1993: p.34) has quoted one of the critics, John Jacobson (AAMR Chairman of the Psychology Division) as saying, “The new AAMR manual is a political manifesto, not a clinical document” (p.34), describing the definition of mental retardation as being politically motivated and not based on research findings. A similar criticism is strengthened by Greenspan (1998: pp.179-188), who also raises arguments claiming that it would have been better for the AAMR to use scientific facts in the definition, instead of relying on ideas. Greenspan wonders why the AAMR did not join with other organisations, such as the World Health Organisation (WHO) International Classification of Diseases (ICD) and the American Psychiatric Association’s Diagnostic and Statistical Measurements (DSM) schemes whose interests in the definition of mental retardation are equally important. Greenspan has listed the problems with the 1992 AAMR, claiming further that:

- (a) it failed to challenge the dominance of the mental retardation field by the IQ index and the reliance on test score rather than consensual judgement, (b) it continued the tradition of using artificial constructs like adaptive skills, rather than seeking to base the disability on more natural prototypical constructs like intelligence (broadly defined), (c) it failed, as before, to understand that the key to the natural prototype of mental retardation is a relative absence of social intelligence, and (d) it failed to incorporate the (prototypic) notion of support needs directly into the definition. (p. 185)

Greenspan himself seems to have failed to recognise how much change AAMR has brought about by reducing total reliance on IQ, when it is clearly stated that the measured 70 to 75 will simply be applied as a ceiling. Whereas he accuses AAMR on

one hand for failure to reduce IQ measure, on the other hand he gives an impression that AAMR failed to adopt a more natural construct like intelligence, the very measures which AAMR seems to have taken care of. Although Greenspan generally accuses AAMR of a number of claimed failures (enumerated above), it would appear that Greenspan himself relies on ideas when attempting to define retardation. He claims that AAMR had used some of his ideas. He says:

The fact is that the theoretical chapter was written to justify an earlier draft of a definition, that was based much more closely on my ideas. At some point, that definition was scrapped and replaced by a very different one. (Greenspan, 1998: p. 179)

Greenspan has proposed his own version of a definition of mental retardation which he hopes, if adopted, will serve a better purpose than that provided by the AAMR. His definition of mental retardation states:

The term mental retardation refers to persons widely perceived to need long-term supports, accommodation or protections due to persistent limitations in social, practical and conceptual intelligence and the resulting inability to meet the intellectual demands of a range of settings and roles. (Greenspan, 1998: p.186)

Greenspan’s proposed definition of mental retardation does not have much difference from that of AAMR. Furthermore, he has not proved to have based such a definition on scientific findings either.

Besides Greenspan, others have also raised some criticisms against the AAMR definition. Vig and Jedrysek (1996: pp.244-245) are particularly concerned about the AAMR’s failure to address the needs of pre-school children with mental retardation.

One of their arguments is that a definition should be precise. For example, they argue that the AAMR uses terms such as “developmental delay”, which imply that a child would “catch up” later on in life, yet this cannot happen. They further argue that it may not be possible to provide early intervention services for children who are under 6, because such children are not clearly diagnosed using the right description and worse still, they say, if such children are not classified as mild, moderate, severe or profound then specific planning may not be possible for them. They say authorities need to allocate funds, not only for educational programmes according to children’s level of severity, but for teachers, too, to be trained specifically for the different levels of mental retardation.

Despite some of the criticisms, according to Wang, Reynolds and Walberg (1995: pp. 283-4) the AAMR’s definition of mental retardation still remains the most widely accepted definition by professionals. Wang et al. also say persons with disabilities have urged for total elimination of the term mental retardation because of its stigmatising tone. Although such an opposition has been raised, persons with mental retardation themselves have not done much to speed up the change of the terminologies used. “Inclusion International”, formerly known as the International League Society of Persons with Mental Handicap (ILSMH), is the world’s umbrella society of and by people of persons with mental retardation. The society changed its name in 1996, but still uses the terms mental handicap or retardation in their communications. Because of complaints by persons with disability about the terminologies used to describe them,

Wang et al. claim, they have been using other terminologies which are seemingly less derogative.

#### **2.6.4 Terminologies Considered Less Stigmatising**

As the term mental retardation is considered to be stigmatising, Mittler and Serpell, (1985: p.718) prefer to use terms such as “intellectual disability”. This definition is supported by Wang et al., (1995: p.284) who say it is a less derogative description, so they prefer it in their writings. Although Wang et al. prefer using that definition, they also use another definition “hard-to-teach” (and classifying the definition into moderate, severe and profound) (Wang, et al., 1995: p.62). Such a term sounds equally derogative as mental retardation itself. Perhaps the most friendly term at the moment is the one used in Britain. With the enactment of the 1981 Education Act, the term mental retardation was eliminated. From that time persons with mental retardation have been referred to as persons with “learning difficulties”, categorised as mild, moderate and severe. Fryers (1993: p.104) citing Britain, in particular, says it is very difficult always to arrive at an acceptable terminology in a society. He says:

Terminology serves scientific, professional, administrative, legal and public purposes. It is unlikely, in any field, that these can all be the same at the same time even in the same society, since they are influenced by different factors...in Britain we have worked through “mental deficiency,” “mental subnormality,” and “mental handicap” to “people with learning difficulties.” These are not intended to be scientific or even professional terms, but we have suffered great confusion in the past by professionals and researchers adopting whatever the latest public label was and using it as though it represented a scientific category. (p.104)

The impression given by Fryers is that even if in Britain such a term as “learning difficulties” has been adopted, it may not be scientific and its representativeness may not be the most unifying. The terminology, he seems to imply, is a temporary measure which has been adopted as an effort to define mental retardation in a more acceptable way. The efforts, according to Fryers, have gone a long way, given the fact that at one time mental retardation was defined in a most unfriendly way. Elsewhere in the world, Serpell (1993: p.20) says he has found that in many countries, particularly in Africa, the existing legislation still uses the terms “mental handicap” or “retardation”. He says that in almost every country in Africa, terminology used to describe mental retardation can be made more complicated due to the diversity of indigenous languages. What Serpell says is true in Uganda as noted earlier in this chapter (See Table: 2.1) for although officially terminologies such mental retardation or handicap are used, traditionally, people have their own way of defining the condition.

In Chapter 1 I have pointed out that the term mental retardation is to be used as a definition for the current study. I have retained usage of that term for the reasons we have discussed in this chapter. We have noted that definition and use of terminologies in this respect have not been resolved and the debate continues. I retain this terminology, not necessarily because I support its use, but because I want to inform Ugandans that we need to develop an acceptable term. From a medical point of view we have noted how the definition and terminologies are explained. In the next section, I shall therefore

discuss how we can begin to work educationally for a better change, that is, how we can stop retention of the negative definitions and terminologies in Uganda.

## **2.7 Concepts and Definitions of Mental Retardation from Educational Context**

From an educational point of view, in our opinion, the 1981 Education Act in Britain may perhaps be considered for the time being as providing the most appropriate definition. The Act abolishes the term “children with mental retardation” and replaces it with “learning difficulties”. I need to inform Ugandans that “learning difficulties”, although not yet adopted by many countries, emphasises a more educational approach to the needs of such children. I shall recommend adoption of this term in Chapter 6. As I mainly focus on attitudes towards retardation, I shall still retain the phrase for a while, because these will help us to analyse how changes in concepts, definitions and in the provision of education have been taking place in different countries over the years. In Uganda, I shall need to employ the term so as to be able to address the issue of retardation by communicating through language that people are well acquainted with. In other words, I need to begin from the known, I need to begin by “seeing through their own eyes”, “talking in the language they talk”, then from there I can suggest to them what I would like them to do in the end. If I start by using new terms like “learning difficulties”, I may not make myself clear, so I may in the end not be taken seriously. I am well aware that from an official point of view in Uganda, the terms mental retardation or “handicap”, which indeed are borrowed English terminology, are still

used in different aspects. Certain places/organisations are synonymous with these phrases in the country. There are, for example, schools, homes or units that are still referred to as “schools for the mentally handicapped,” “units for the mentally handicapped or retarded”, and “homes for the mentally handicapped”. The only institution of higher learning in the country which is concerned with training teachers for special needs, the Uganda National Institute of Special Education (UNISE), has a department which is referred to as department of mental retardation/learning difficulties. Students who qualify from this institution are awarded certificates, diplomas and soon degrees with specialisation in mental retardation/learning difficulties. (*See Appendix 3*).

At the Educational Assessment Resource Service/Special Needs Education (EARS/SNE) unit at the Ministry of Education and Sports Headquarters there is a department for mental retardation. At the district levels, too, EARS/SNE has established posts for mental retardation. In some districts the District Service Commission (DSC) have begun to appoint district inspectors of schools (DIS) to be in charge of mental retardation. There is also an umbrella association, known as the Uganda Association for the Mentally Handicapped (UAMH). If I were to inform all these organisations about implementation of education for children with learning difficulties they would not realise that in reality I am addressing the issue of mental retardation. Thus, I have to begin with the “reality” which I desire to change and make modification as I progress with the discussion of change. We have noted in Chapter 1, for example, how everywhere in the world, children with disabilities, generally, used to be denied the right to education. Thus in this chapter, where I discuss the group whose

education forms the core of this study, I am compelled by circumstances to use phrases with which I am personally uncomfortable.

As we examine the development of education of children with disabilities, we discover that the group that has most been denied the right to education, has been that of the so-called mentally retarded. Children with mental retardation were branded with names like uneducable, untrainable, trainable and educable (Drew et al., 1996). Because of such a negative attitude, Drew et al. say:

...special education services were available primarily to the child with mild retardation who was defined as educable, a term implying that although the child had mental retardation, he or she still could benefit from some of the traditional academic curriculum taught in the public schools. Children functioning at lower levels (as determined by IQ tests) generally were excluded from public schools because they required training in such areas as self-help, language development, gross-motor skills, and academic readiness. The needs of children labelled trainable were not within the purview of the public education curriculum. (p. 227)

Education of children with mental retardation was not within the purview of public education for a long time for obvious reasons. The public seems not to have adequately defined the special educational needs of children with mental retardation, so it might have been taken for granted that some of the children were uneducable, while some were. In Uganda, the situation is not very different from that reported by Drew et al. As noted in Chapter 1, when I talk about education of ordinary children, I trace development from the early 20th century, whereas for children with mental retardation the history of development begins from the late 1970s. When I talk about the population of children receiving education in primary schools, that of children with mental retardation in Uganda is less than five thousand.

Agran, Salzberg and Stowitchek (1987: p.133) found that children with mental retardation move through the same stages of development as ordinary children but at a slower rate. They say school-age children with mild mental retardation are slower in performing tasks which the ordinary peers of the same age would perform easily and successfully. Agran et al. say that the greater the severity of intellectual deficit, the greater the deficit in memory. Sternberg and Spear (1985: p.303) attribute the memory deficits of children with mental retardation to failure in development of metacognitive processes. Metacognitive processes are described by Sternberg and Spear as an important tool used for planning how to solve a problem, to monitor one’s solution strategy as it is being executed and evaluate the results of this strategy once it has been implemented.

Besides problems with memory, children with mental retardation are known to develop learning sets and generalisation at a slower rate than their non-disabled peers. Cipani and Spooner (1994: p.157) describe a learning set as an individual’s ability to “learn how to learn”. Generalisation is defined as “when a learned response is seen to occur in the presence of ‘untaught’ stimuli”. In other words, generalisation is the ability to apply learning from previous experiences to new situations with similar components. Cipani and Spooner further explain that children with mild mental retardation are much better at generalisation during learning than those with moderate to profound mental retardation.

It was noted earlier in the section how important adaptive skills are. For educational purposes, adaptive skills development for the school-age child, according to Drew et al. (1996: pp.222-3), may be defined as the ability (or lack thereof) to apply basic information learned in school to naturally occurring daily activities. Depending on the age of the individual with mental retardation, the need is to develop appropriate skills for coping in school, for developing interpersonal relationships, for developing language skills, for developing emotionally and for care of personal needs.

Adaptive skill deficits are reported in the literature to be characteristic of children with moderate and severe levels of mental retardation. The behaviours include head rolling, body rocking, twirling, teeth grinding and inappropriate vocalisations. Children with severe mental retardation are also reported to engage in self-injurious acts, including self-biting, head banging and face slapping. Children with mental retardation, because of their numerous deficits in adaptive skills, coupled with intellectual differences are confronted, when they enter school, with an environment which sometimes becomes unfriendly to them. The unfriendly environment sometimes leads to their rejection in the schools by teachers and by the non-disabled peers. Teachers have been noted to have provided definitions of “retardation” depicting the different regions/ethnic groups they come from. They have reported how traditionally retardation is mainly associated with madness. This could be the result of adaptive skill deficits, a phenomenon that is not well understood by the different communities in Uganda. There is no doubt that

when children with mental retardation are seen rocking their heads in schools or biting themselves, everyone will believe such children are “mad”. Epstein, Cullinan and Polloway (1986: pp.129-131) found that when children with mental retardation are confronted with an unfriendly environment in school, they eventually develop emotional problems. They say children with mental retardation need to be motivated. From an educational point of view, according to Switzky (1998: pp.94-6), motivation has been a neglected construct in the definition of mental retardation. He says that in order to help an individual child with mental retardation to learn efficiently, the child should have the right amounts and kinds of motivation. This, he refers to as an intrinsic motivational (IM) orientation to problem-solving. IM, Switzky claims, can lead an individual to learn efficiently and to have a higher performance. Switzky also says an individual may have another kind of motivation which he refers to as extrinsic motivational (EM) orientation to problem-solving. That is, the child is motivated by external rather than internal factors. This type of motivation, he says, operates to make the individual a less efficient learner and leads to lower performance outcomes. Switzky says that theory of motivational orientation would help to predict:

1. That having an IM orientation is helpful to both learners who are mentally retarded and non-retarded learners compared to having an EM orientation in terms of learning more effectively. However, having an IM orientation may have more impact on learners who are mentally retarded and other dysfunctional and at-risk learners. Generally, these predictions have been confirmed. IM learners work harder and longer on a task compared to EM learners. IM learners learn more effectively and have higher school achievement.
2. That there is an interaction between motivational orientation and incentives, such that one must match incentive systems to the unique motivational orientations of individuals, i.e., the performance of IM individuals will be optimally reinforced by task-intrinsic incentives, whereas the performance of EM individuals will be optimally reinforced by task-extrinsic incentives. Generally these predictions have been strongly confirmed.

3. That IM persons may be characterised by self-monitored reinforcement systems that make them less dependent on external reinforcement conditions, while EM persons may be characterised by dependence on external systems. (pp. 194-6)

Teachers need to take into consideration the implications of the theory of motivational orientations for classroom practice in order to optimise the learning outcomes of their pupils.

As children with mental retardation faced problems in gaining access to education because of their special needs, policy makers, through legislation and through other means, have stepped in (time being overdue) so as to enable such children to receive education like any other children. In Britain, as reported by Brian (1985: pp. 23-27), the 1981 Education Act requires local authorities to provide for children with special educational needs, which are defined in the Warnock Report (DES, 1978) as including special means of access, equipment or resources, modification of the environment or specialist teaching techniques, the provision of a specialised or modified curriculum and attention to the social and emotional climate in which education takes place. Each child’s special needs must be assessed and a decision made as to where these can be met should have the consent of the parents. People with mental retardation are entitled to remain at school until the age of 19 and further education may be available to them. In 1975 in the United States, the Education Act for All Handicapped Children, referred to as Public Law (PL) 94-142, was passed. The Act has stopped all forms of discrimination against children with disabilities, including those with mental retardation. Public Law

94-142, renamed the Individuals with Disabilities Education Act (IDEA) in 1990, prescribes that all children with disabilities in the nation’s schools must be provided a free and appropriate public education (Drew et al., 1996: p.227). While such developed countries are leading the way in conceptualising and defining mental retardation, some such attempts are also underway in the developing countries.

## **2.8 Conclusion**

Concepts and definitions of mental retardation have long been a topic for discussion and the debate continues. As noted in the previous discussion, it has been indicated in the literature how society has held very negative attitudes towards persons with mental retardation. This reaction has, however, gradually been improving over the years. In the developed countries in particular, persons with mental retardation have recently begun to receive some caring attention, especially in terms of provision of education.

In the beginning, intelligence was the main factor upon which diagnosis for retardation was based. With the realisation, however, that intelligence was just one of the factors relevant to retardation, other factors such as behaviour and the overall interaction of an individual with the environment have been considered equally important in definition. The revised 1992 American Association on Mental Retardation (AAMR) has attempted to address all the different needs of persons with mental retardation, including cognitive, behavioural and environmental aspects.

It has been noted in the discussion that persons with disability detest the use of terminologies like mental retardation to describe them. Adoption, however, of a more friendly terminology has not been common. Because this thesis is intended to be an eye-opener for Ugandans, I have supported, for the time being, an adoption of the terms “learning difficulties”, as used in Britain. (See Chapter 6). I have not been able to drop the terms mental retardation although I want it abolished. I have used the term because it is the term currently in use in Uganda. I have found it important to move from what people know to the new concepts that I want them to adopt.

In countries such as the USA and Britain, legislation has been adopted to define the educational needs of persons with mental retardation. In Britain in particular, terminologies like mental retardation have been abolished and replaced with less pejorative terminologies like “persons with learning difficulties”.

From international perspectives, we have noted how difficult it has been for people to be clear about the concepts and definitions of mental retardation. Society conceives retardation from cultural perspectives. Medically, “retardation” is defined from a scientific point of view, explaining its possible causes/sources. Educationally, persons with retardation are defined based on how their learning is affected. We have noted in the literature some similarities and differences in approaches to definitions and terminology issues. From a societal point of view, we have found that in international,

as well as in Ugandan contexts, definitions and terminologies used, save in countries like Britain, have derogative overtones.

Although unfriendly words are still retained the international background as identified through the literature provides important information that is needed for promoting change in Uganda.

As noted in the above discussion, definition implies both the grammatical meanings of the terms, as well as description and prescription of what is involved in providing education for children with mental retardation. It is in this last context that the implementation of education for children with mental retardation currently going on in Uganda will be discussed. In other words, the kinds of concerns expressed in the previous discussion will be examined in light of what is being done in Uganda. For example, it will be important to examine if there have been explicit expressions about how children with mental retardation are described and treated, and how their education is supposed to be provided. If education is already being provided, or is supposed to be provided, what are the aims and curriculum of such education in Uganda? Before examining the aims and curriculum of education for children with mental retardation in Uganda, an overview of aims of education from international perspectives will be examined in the next chapter (Chapter 3).

# CHAPTER 3



# Chapter 3

---

---

## **3.0**                      ***Aims of Education and Curriculum for Children with Mental Retardation from International Perspectives***

### **3.1**                      **Introduction**

This chapter attempts to answer one of the research questions in the study which states: “What are the aims of education and curriculum for children with mental retardation from an international perspective?” In discussing the question, focus is put on what the different categories of children (according to the degree of disability) are supposed to learn and where such education can be provided. Focus is also put on how children are selected (assessed) for education, what methods are suitable for teaching them and how teachers are prepared to teach the children.

### **3.2 What Children with Mental Retardation are Supposed to Learn**

One of the aims of education, as Farrant and Clark (1980: p.22) state, is to help an individual to become aware of what is expected of him in a society. Any society in the world, they add, expects its individual members to behave well, to do the right things and to contribute in some way towards the well being of the society. Another aim is to prepare the individual to live and cope with future challenges in the society. This means an individual is required by the society to learn some skills that may enable him to perform the basic tasks that are vital for independent living and for keeping the society moving on from generation to generation. With regard to children with mental retardation, as Hallahan and Kauffman (1997: p.138) say, aims of education depend on the degree of retardation, or how much they require support services. For example, the less the degree of retardation, the more academic knowledge may be emphasised; and the greater the degree of retardation, the more education may be provided to develop practical skills needed for self-help, community living and vocational skills. This distinction, however, according to Hallahan and Kauffman, is largely a matter of emphasis; in practice, all children who are retarded, no matter the severity level, need some academic, self-help, community living and vocational skills.

### **3.2.1 Children with Mild Mental Retardation**

Children with mild mental retardation at pre-school and primary levels need education so as to equip them with readiness skills or abilities necessary for later learning (Hallahan and Kauffman, 1997: pp.139-142). Young children, they say, need to develop the ability to sit still and attend to the teacher, discriminate auditory and visual stimuli, follow directions, develop language, increase gross and fine-motor co-ordination, develop self-help skills and the ability to interact with peers in a group situation. In achieving these aims, Westling (1986: p.127) suggests that children with mild mental retardation should be taught systematically, using programmes that account for differences in the rate of their learning. The author suggests that in the later primary years greater emphasis should be put on academics, usually on what are known as functional academics. Children with mental retardation, according to him, are usually weaker in reading, especially reading comprehension; that is, they tend to do better on reading words than on understanding what they have read. Snell (1993) found that children with mental retardation need to acquire reading skills as it is very important in their normal routines in work, everyday living and leisure. They need, for example, to be able to read a newspaper, read sign posts along the road and write their names or acquire the skills of writing letters, and the like. It is also argued that children with mental retardation tend to show a lot of weakness in arithmetic skills, although in performance on computation tasks they are more consistent with their mental age (Frank

and McFarland, 1980: p.273). Arithmetic skills, according to Frank and McFarland, are taught most efficiently through the use of concrete materials, such as money concepts and other things common to the children. The immediate practical application of such items helps to motivate children. Regardless of the approach used, the authors say, arithmetic instruction must be concrete and practical to compensate for the children’s deficiencies in reasoning out things. Browder and Snell (1987: p.438) emphasise that when attempting to functionalise learned skills, teachers must use educational materials that are realistic, arguing that the use of traditional materials such as flashcards, workbooks, and the like are not practical because children are unable to relate them to their world. Although emphasised much more in secondary school, Hasazi and Clark (1988: p.344) suggest that some children with mild retardation can be taught the rudiments of community and vocational living skills in later primary school.

### **3.2.2 Children with Severe Mental Retardation**

Children with severe mental retardation need to be prepared to live as independently as possible. They, too, can and will learn if provided an appropriate instructional programme and a teaching process oriented to their individual needs (Drew et al., 1996: pp. 238-242). Such educational programmes, the authors suggest, should have clear, specific and achievable objectives. Academic skills such as reading, writing and arithmetic may not be a priority. Therefore, Drew et al. suggest teaching children with

### Chapter 3: Aims of Education and Curriculum for Children with “Mental Retardation” from International Perspectives

moderate and severe mental retardation may necessarily be oriented more toward adaptive living skills. Adaptive skill content may include motor, personal management (self-care), social, communication and functional academics. If some children are at all able to do some academic work, then such work should be taught within the context of daily living activities and where necessary, it should be done within a home or in the community. A functional life programme, for example, in the area of reading or arithmetic should focus on words or ideas that relate to the children’s environment, such as being able to greet, tell time, count money or being able to buy things from a shop or a market.

Having noted above how aims of education and curriculum can be planned for the different degrees of retardation (from mild to severe), in the next section the focus will be on where children with mental retardation can learn. In Chapter 1, the question of where children with disabilities can receive education was briefly mentioned, so in this section more elaboration will be made in that respect, but with particular reference to children with mental retardation. This will involve discussing the question of inclusive and segregated education.

### **3.2.3 Where Children with Mental Retardation are Supposed to be Educated**

Inclusive education, as defined by Knight (1999: p.3), is a concept which views children with disabilities as true full-time participants and members of their neighbourhood schools and communities. The inclusion philosophy proposes that there not be a range of placements but rather all students be educated with their peers in the same physical location. Knight’s proposal confirms the conviction by other people who believe that for the world to be meaningfully united, all its people should be treated fairly. Unity of people in the world and the benefits of education can be achieved only when people realise, as Mercer puts it, that the principles of inclusion:

...are based on the belief that the world is an inclusive community with people who vary not only in terms of disabilities but in race, gender, and religious background.  
(Mercer, 1997: p. 201)

Mercer believes that through inclusive education learners with different abilities are enabled to use their talents at different levels. She says that, by so doing learning is made to be more meaningful and beneficial to everyone in the world. The benefits that learners get by being together, she adds, are what matters most and not their individual differences. In other words, she says, though some learners are mentally retarded, whatever they can offer to other peers and what they, too, can receive in an educational setting should be appreciated, rather than excluding them altogether. Inclusion should

therefore, not be regarded as meaning removal of and disregard for the differences that naturally exist in children with mental retardation, but provision of what they deserve in education. In their argument, Stainback, Stainback, East and Sapon-Shevin say:

...the goal of inclusion is not to erase differences, but to enable all students to belong within an educational community that validates and values their individuality. (Stainback, Stainback, East and Sapon-Shevin, 1994: p. 489)

Three basic reasons are given to justify, for example, how important it is for children with mental retardation to belong to an educational community at any moment. The reasons are attributed to inclusion being able to provide learners with human rights values, good education and good social sense. A statement issued by the centre for studies of inclusive education (CSIE) clarifies these three basic reasons:

**Human rights**

All children have the right to learn together

Children should not be devalued or discriminated against by being excluded or sent away because of their disability or learning difficulty.

Disabled adults, describing themselves as special school survivors are demanding an end to segregation.

There are no legitimate reasons to separate children for their education. Children belong together - with advantages and benefits for everyone. They do not need to be protected from each other.

**Good education**

Research shows that children do better academically and socially in integrated settings.

There is no teaching or care in a segregated school which cannot take place in an ordinary school.

Given commitment and support inclusive education is a more efficient use of educational resources.

**Good social sense**

Segregation teaches children to be fearful, ignorant and breeds prejudice.

All children need an education that will help them develop relationships and prepare them for life in the mainstream.

Only inclusion has the potential to reduce fear and to build friendship, respect and understanding. (CSIE, 1997: p.1)

Given the above explanations, there is every reason to believe that inclusion is undoubtedly the ideal practice that should be adopted by each and every country in the world, if justice is to be done to children, no matter what ability or disability they may have. The main problem is that what may sound ideal, as stated in the above inclusion principles, may not exist practically. Inclusive education was advocated from the onset of the 1990s (see Salamanca Declaration in Chapter 1), but after nearly a decade, where in the world can one find evidence to show the success of inclusion? In any of the developed countries? In a developing country? The answer is that there is no evidence that any country in the world has done what is expected of it in that respect. The underlying reasons may be linked to what each country’s aims of education are, where to provide the education and how much resources should be devoted to achieve such aims. Although the aims of education for children with mental retardation are clear (as reflected through the philosophy of inclusion above) in the developed countries, the advocacy still remains largely theoretical. Practical approaches are yet needed to fulfil such a commitment. For the developing countries, this is a lesson that should be learnt. Already in Uganda, inclusion is very much desired and much talked about by the policy makers. It should, however, be noted by Ugandans that a desire is one thing and success in what is desired is another thing.

Kauffman (1993: p.4) raised some challenging questions which policy makers for education of children with mental retardation anywhere in the world should analyse before thinking of formulating such policies. He poses the following questions:

What can all children learn? At what rate? To what criterion of performance?  
With what resources? For what purpose? (Kauffman, 1993: p.4)

By asking such questions, Kauffman does not mean to oppose the philosophy of inclusion, but is attempting to provide a signal to education policy makers and implementers to be aware of how formidable it may be to achieve such objectives. For example, in order to implement inclusive education, Knight (1999: p.4) found that teachers and schools should be prepared to cope with large class sizes, diversity of cultures, languages and abilities. To cope with such challenges, Knight adds, teachers should be well organised and should have expert knowledge to handle individual learners according to their special needs. All these qualities in teachers and schools, according to Knight, are still missing in many countries. In Knight’s view, the argument by CSIE and other advocates claiming that research has shown that children do better academically and socially when integrated is not justified. In a further argument, Knight says:

More placement of students with disabilities in a physical location with other school students does not mean that inclusion will follow. In fact, inclusion in some situations [for example, students with autism] may be more like exclusion because the student’s needs are not being met and appropriate services not provided in the regular classroom. The stigmatisation of students with labels will not disappear by simply placing students in regular schools, as they and their peers will need to be taught appropriate social and academic skills. Indeed, without careful management and the development of the included students’ skills, other regular school students may create their own discriminatory labels for included students. (Knight, 1999: p.4)

Knight’s observations are in support of other authors (e.g., Farrel, 1997: pp.1-14; and Manset & Semmel, 1997: p.156) who believe that “...research reviews have generally been inconclusive regarding the benefits of inclusive education”. In view of that, Kauffman (1993: p.4), concludes that people who make statements to justify that “all children can learn”, do so out of “emotions” and cannot substantiate such claims. The task of implementing inclusion is much harder than people tend to believe.

For children with mental retardation to be provided with education in the ordinary schools, policy makers have to ensure that appropriate resources are provided and that teachers are willing to participate in the inclusive process (Vaughn and Schumm, 1993: p.156). When teachers resist a change, the change will only be implemented with considerable social dislocation and high social cost (Ungerleider, 1993: p.98). It should also be noted that whether teachers will accept the philosophy of and implement inclusion very much depends on their individual starting points regarding their experiences and their commitment to it. For example, do they feel comfortable with the type of teaching required? Are they already experienced in working with students with disabilities? What skills do they already have? What stage are they at in their career? What is their sense of efficacy regarding implementing teaching and learning that is consistent with the philosophy of inclusion? (Knight, 1999: p.5). All these questions are better answered when policy makers prepare teachers to teach children with mental

retardation before implementing inclusion. More discussion of this is featured in a later part of this section (under teacher preparation).

Having discussed the benefits of providing education for children with mental retardation under inclusive arrangements, pointing out both its benefits and limitations, in the next section we will present curriculum issues for children with mental retardation. This will begin with discussion of how children are assessed and how their special needs are determined.

### **3.2.4 How Children with Mental Retardation are Selected (Assessed) for Education**

In 1904 a French psychologist, Binet, as already mentioned in the previous chapter (Chapter 2), began measuring children’s intelligence. He was commissioned by the school authorities in Paris to develop a means by which to identify children who seemed to have learning difficulties so that they could be placed in schools according to their abilities. Thus assessment of children with special needs can be said to have had its root from that time. In education today, assessment ordinarily refers to testing, interviewing and observing children. The results of assessment should help the education authorities to decide whether problems exist in a child, and if problems are identified, what to do about them (Wallace, Larsen and Elksnin, 1992). Other authors refer to this process as

obtaining entry or baseline information (Notari, Slentz and Bricker, 1991: p.161). The information, according to Ballard, may be vital for describing a child’s behaviour and general developmental status ( 1991: p.129). Such a description may be the first part of a classification process that will assign the child to a category of disability. This, in turn, may be a step toward providing appropriate intervention programmes and related resources for the child and the family. Specifically, an assessment may be designed for any of the three purposes: screening, diagnostic and instructional programming (Kaplan and Saccuzzo, 1993).

Screening assessments are brief and are used to find out what the problem is, in a child. There are many different types of screening instruments used under this form of assessment; some of the well-known examples are the Apgar Scoring System (Apgar, 1953) and the Denver Development Screening scale. The problem noted with these types of testing is that they cannot specifically pinpoint the extent to which the identified problem has effected the assessed individual. For that reason, diagnostic assessment is applied.

Diagnostic assessment is used for the purpose of finding out to what extent the nature of the identified problem affects the child. This type of assessment is most often conducted and interpreted by trained professionals such as doctors, psychologists and

teachers, and may therefore be more expensive and lengthy than screening assessment. Results of diagnostic assessment is used to qualify a child as eligible for special service or for referral to appropriate agencies (Notari et al., 1991: p.161). Examples of some diagnostic instruments include the Bailey Scales of Infant Development (Bailey, 1969), karyotype tests for chromosomal aberration or disorders, Stanford-Binet and Wechsler intelligence tests.

Besides the above intelligence tests, other tests include the Cattell, Wechsler Pre-school and Primary Scale of Intelligence (WPPSI) and the Wechsler Intelligence Scale for Children-Revised (WISC-R). Both screening and diagnostic assessments compare the performance of the individual child being tested to the performance status of other groups (Notari et al., 1991: p.161). This type of test is known as norm-referenced, because each child’s score is evaluated against norms derived from testing a large standardisation sample. Standardisation samples are developed to be representative of the population of children in a certain area or in a country and thus include a cross-section of important demographic variables (age, gender, percentiles, or standardised scores). In Uganda, for example, when carrying out such assessments attention should be paid to the different factors which would bring about bias in the results. There are, for example, different languages and different cultures, whereby if standardisation is meant to cover all the needs of individuals in a similar way throughout the country, then assessment would definitely be invalid.

Although screening and diagnostic tests are both useful in providing information regarding needs of individuals further evidence found in the literature suggests that such types of assessment cannot provide all the relevant information regarding instructional programming for the children assessed. Development of individual educational plans (IEPs) requires a more qualitative approach for obtaining information than is narrowly generated by both screening and diagnostic tests (Notari et al., 1991: p.162). Because of that limitation, there is a need to have a third form of assessment which is specifically designed for instructional programming.

The most important function of a qualitative assessment process is that it provides information needed for the generation of educational plans, thereby allowing parents to compare their objectives for their children with interventionists' objectives. The type of assessment most compatible with such a function is one that compares a child's performance, not to other children, but rather to a specified criterion or mastery level (Hoy and Gregg, 1994). The performance usually relates to curriculum; that is, an individual child is assessed from pre-school to school level to determine how much he can perform. This type of test is known as a criterion-referenced assessment (Worthen, Borg and White, 1993). The development of criterion-referenced tests for infants and young children, however, has been found to be responsible for some problems. One of the problems revealed in the literature is that some intervention programmes are carried out based on narrow instruments which are designed for specific purposes, leaving out

some important aspects which should be considered simultaneously during the intervention, such as cultural backgrounds (Reynolds, 1993). Serpell and Nabuzoka (1991: p.99) found that in most of the developing countries, particularly in Africa, assessment was very much based on approaches borrowed from Western countries, leaving out some of the local cultural aspects. They also claim that detection of disabilities is usually done in an uncoordinated manner. They say, for example, that a young child may be ascertained as disabled during a routine visit to a hospital or health centre or through casual contact with a specialist teacher or even by a herbalists or traditional birth attendants but the full implications of such assessment may not be explained to the parents and only little advice may be given. In such instances, the authors observe, systematic remedial assistance of the child is often delayed until the child is of school age. Serpell and Nabuzoka also say that even at school age, in a number of cases the child’s parents may have decided that the child will not benefit from any formal education and thus not bother to enrol him in school. The authors say this is partly due to the restricted scope of pre-school education, which is still quite a recent phenomenon in those countries and which is mainly confined to the urban elite. Such a wide gap between the rural and urban differences, the authors suggest, would be minimised if parents’ involvement in the intervention activities were stepped up. In Britain the *Code of Practice* (1994: pp.52-97) provides guidelines on how to carry out assessment processes. Parents, teachers and all professionals such as doctors are involved, so that there is co-ordination of activities. Under such guidelines, everyone

knows what is happening, unlike the kind of situation described by Serpell and Nabuzoka.

Involvement of parents in assessment programmes in a country such as Uganda would be very important, given the key roles that parents play in bringing up their children. Although many parents are unable to read and write, through mass media the government could provide them with information in their local languages. Such arrangements would further require the government to give information to the parents with consideration based on the different cultural values. Development of assessment instruments by the educational assessment resource services (EARS) is already underway in Uganda. With regard to disparity between the urban and rural situations in Uganda, what Serpell and Nabuzoka have found is true as far as pre-education is concerned. Children in the rural areas do not go through pre-primary education, such as attending nursery schools before they join primary education, while those in the urban areas do. It is therefore a challenge for EARs to advise and assist especially the rural parents on the best way to prepare their children before they begin primary education.

EARS' other task will be to try to avoid as much as possible some of the mistakes which have been cited in the literature in the current study. As indicated below, there are new issues which are facing assessment for children with special educational needs the world over and Uganda is not an exception to such issues.

Assessment in mental retardation is moving from its position as an IQ-based measurement activity into the centre of culture, society and environment. This approach was noted when the 1992 American Association for Mentally Retarded (AAMR) was discussed in the previous chapter (Chapter 2). Assessment and programme planning and implementation are rapidly becoming matters of serious collaboration between disciplines compared to the way it was handled a decade ago (Elliot, and Sheridan, 1992; Welch and Sheridan, 1995). These changes, Drew et al. (1996: p.123) say, are intended to strengthen psychoeducational measurements so that more accurate views of how individuals function and what their abilities are in relevant environmental contexts will be reflected. Termed as “authentic”, the current approach to assessment (Lee, 1992: pp.72-73) is a move from “sterile test scores to information that has the most likelihood of relating to the task” (Worthen, Borg. and White, 1993: p.73).

Although viewed as natural, the new approach of designing environmentally contexted assessment is not simple to implement; it calls for maximum co-operation among the professionals and parents (Drew et al. (1996: p.123). Based on this caution, with respect to Uganda, EARS, as mentioned above, has the task of co-ordinating its activities, paying due attention to the roles parents can play in the success of assessment in the country.

Despite the problems faced when conducting assessment, as pointed out above, in recent years some developing countries including Uganda have already made some progress in assessment activities for children with special needs.

Through assessment, children with mental retardation can be selected and referred for educational programmes. When at school, the next question is: How best can the assessed children with mental retardation be taught? An attempt to answer this question will be provided in the next section where focus is put on the types of teaching approaches/methods.

### **3.2.5 Teaching Approaches/Methods for Children with Mental Retardation**

Many different approaches/methods of teaching do exist, but there are no indications from the literature that any of them is unique as far as teaching children with mental retardation is concerned. For the purpose of the current study, however, a few approaches/methods are discussed in order to find out if any or all of them could be adopted for the purpose of implementation of policy on education for children with mental retardation in Uganda. Discussion is focused on approaches such as applied behaviour analysis, community-based instruction, preferential-teams, collaborative-

consultation, co-operative teaching, co-operative learning, peer-tutoring and reverse mainstreaming.

Applied behaviour analysis, according to Wolery, Bailey and Sugai (1988), is a suitable approach for children with mental retardation, especially those with more severe learning problems. Under this approach, one of the objectives is to identify a behaviour or skill area the learner needs more work in or an inappropriate behaviour that he or she needs to decrease. When a behaviour or skill area is identified, a base line measurement is taken to determine the level at which the learner is currently functioning; the teacher can later compare the learner’s performance after instruction with the original baseline performance. Based on this evaluation, the teacher decides whether to continue, modify, or end the intervention.

Although there has been no research carried out in Uganda with respect to effectiveness of behaviour analysis, the approach is not totally new; teachers have used it in one way or another. Perhaps the way the approach has been applied is what matters. Indeed, the approach, more often than not, is quite demanding. It requires a lot of dedication; a teacher must be well prepared, organised, systematic and consistent. It seems it is one of the approaches that could help to enhance rapid change in the implementation of the policy on education for children with mental retardation in Uganda.

### Chapter 3: Aims of Education and Curriculum for Children with “Mental Retardation” from International Perspectives

Another approach which also appears to be useful for children with severe mental retardation and which can be used beyond school is one referred to as the community-based approach. Educational programming needs to be planned so that it takes place in the school as well as in the community whenever necessary (Skrtic, 1991: pp.197-8). The reasons why such an approach needs to be adopted are, firstly, because some children due to the nature of their disability may not be able to get access to school, and secondly, because many of the skills the children learn are for use in settings outside the classroom.

Although the above approach may sound realistic, in Uganda it may technically be difficult to apply. One of the problems is that it may be difficult for teachers to become itinerant, due to lack of money, transport (geographically some homes in Uganda may be very difficult to reach) and time (because one teacher may have as many as a hundred children in the class, and may therefore not be able to leave the children alone). Another problem is that there has not been an effective mechanism developed to enable teachers and parents work more closely in order to help pupils with special needs in their learning tasks. For the time being the community-based approach may not be effective in Uganda, but it might be necessary to consider incorporating it into educational practice in future.

Another approach is the preferential teams (PRTs) approach. One of the primary aims of PRTs is to establish “ownership” of the children with special educational needs by ordinary and not special needs teachers (West and Idol, 1990: p.23). In other words, PRTs try to keep referrals to special education down by stressing that ordinary teachers try as many alternative strategies as possible before deciding that children with special needs should become the primary responsibility of special needs teachers.

The PRT approach, it seems, is one of the most effective ways to promote inclusive education generally, and implementation of policy on education for children with mental retardation in particular, in a country like Uganda at the moment. Such an approach is likely to help in influencing attitudes of teachers who may not have had prior knowledge of teaching children with special needs. As all ordinary teachers get involved, children with special needs may have adequate time to be attended to, not only by the teachers, but also by the ordinary children in the entire school. To implement such an approach for the good of education of children with mental retardation in Uganda, some of the current existing practices in the education system would need to be tackled first. For example, continuous assessment would need to be introduced in primary schools, to replace the current competitive examination system in the country. Although continuous assessment was recommended in the Kajubi Report over ten years ago, it has not been implemented. Secondly, the teacher-pupil ratio would need to be of a manageable proportion. The PRT approach undoubtedly seems to be a very effective

approach for current policy implementation for education of children with mental retardation in Uganda.

Similar to the PRT approach, is another approach known as collaborative consultation. Much of collaborative consultation is discussed by West and Idol (1990: p.23). The authors have revealed that this approach has been introduced in the developed Western countries to replace an approach which was dominant in the 1970s and 1980s. During that period, they say, psychologists or special needs teachers acted as experts in providing advice to the ordinary class teachers. As opposed to that approach, the authors say, collaborative consultation was introduced and was characterised by mutuality and reciprocity. West and Idol say mutuality means shared ownership of a common issue or problem by professionals. On the other hand reciprocity, they say, means allowing these parties to have equal access to information and the opportunity to participate in problem identification, discussion, decision-making and all final outcomes. In this approach, the special needs teacher or a psychologist and the ordinary class teacher assume equal responsibility for the children with disabilities and neither of them assumes more authority in making recommendations about how to teach the children.

When looking at collaborative consultation as described by West and Idol from a Ugandan context, the key question to pose is: Would this kind of approach work? In

order to begin to attempt to answer this question, one needs to assess the level at which education of children with mental retardation is currently operating in Uganda. According to our experience, it is apparent that currently the level of operation is not different from the one described by West and Idol during the 1970s and 1980s. In Uganda, most of the children with mental retardation are still taught in small units (within the ordinary schools), while a few (especially those with mild mental retardation) are fully integrated in the mainstream classes.

Collaborative consultation can be put in practice in Uganda only if certain conditions are changed. One of the requirements is to create adequate awareness, especially in ordinary teachers, about the need to collaborate with special needs teachers. At the moment, special teachers in Uganda work mostly only with children in special resource rooms or in special schools. Ordinary teachers seem to have very little concern about children with special needs who may have a special unit within the school. They tend to concentrate on academic work with the ordinary children and seem to have little time for consultation. Another problem with Uganda is that involvement of professionals such as educational psychologists in special needs education is something that may need to be introduced in the education system. Indeed, a multi-professional approach as advocated by collaborative consultation would be one effective approach if adopted in the current implementation of policy on education for children with mental retardation in Uganda.

One other approach which seems equally effective is referred to as co-operative teaching. Co-operative teaching, also referred to as collaborative teaching, stresses the notions of mutuality and reciprocity more than the collaborative consultation already talked about. In co-operative teaching, according to Bauwens and Hourcade (1991: pp.19-24), ordinary class teachers and special needs teachers jointly teach in the same ordinary classroom composed of pupils with and without disabilities. In other words, the special education teacher comes out of his or her separate classroom (sometimes permanently) to the regular class setting. In addition to promoting the notions of mutuality and reciprocity, one of the advantages the authors point out in this approach is that it helps the special needs teacher to know the everyday curricular demands faced by the children with disabilities. The special needs teacher sees the context within which the pupil must function to succeed in the ordinary class. An expression indicating approval of this approach is described by Nowacek (1992), who has quoted a teacher as saying:

I have learned so much about the content itself which has helped me to teach English and math to students in my resource class...I certainly have gained insights into the students themselves. For instance, when I do observation for [re-evaluations]...I am able to go into a class on one day

and that's what I see, how that particular child performed on that particular day. But to be able to see kids on a day-in and day-out basis, I really feel I have a much better sense of who tunes out...when and why and who plugs away every minute of the day and still has difficulty

because he hasn't understood. I can see their interactions with their peers. I can see their interest in the subject matter. I have a much more complete view of each child. (p.275)

Some teachers may be enthusiastic about gaining further experience in working with children with special needs, as indicated from the above teacher's statement. Other

teachers may not be as enthusiastic. Co-operative teaching, hitherto, requires that teachers (the ordinary and specialist) of whatever enthusiasm work together and complement one another’s inputs. Under this approach, it would appear that if teachers are coerced into adopting the approach, it may not gain much popularity. Nowacek quoted another teacher who indicated how fragile the approach may be if not handled well. The teacher quoted states:

The biggest drawback I could see to using the collaborative model would be for the school system to say, “We’re going to do this. We’re going to train you teachers and you two are going to work together.” That would not work at all. Carol and I have a relationship where it works. I’m sure there are other teachers that I couldn’t work with. I think it’s very person-specific... It does take a lot of adjustment for the classroom teacher because we’re used to being in control-in charge-and all of a sudden, there’s this other person in your room. (Nowacek, 1992: p. 274)

School administrators, it seems, have the task of carefully planning how to implement co-operative teaching. According to the teacher quoted above, it seems ‘confidence’ in individual teachers is a factor that the administrators should not take for granted. Some teachers, it seems are most comfortable working alone, while some can enjoy working with others, but only with certain compatible acquaintances. Even when it appears to be succeeding, Fuchs and Fuchs (1992) found that if the teachers responsible for implementing co-operative teaching are not monitored, they may not teach effectively, so children will be the losers. In Uganda, co-operative teaching is not a totally new approach. It has mainly been practised by some teachers for ordinary children. As regards special needs education, the approach may be new. Similar conditions, as mentioned above, are necessary for implementation of co-operative teaching. That is,

ordinary teachers as well as ordinary children need to be sensitised to accept working with special needs teachers and children with special educational needs, in this case, children with mental retardation, in the same class.

Another approach which is very close to co-operative teaching and which also appears to be very effective is known as co-operative learning. Johnson and Johnson (1986: p.358) found that in ordinary schools much emphasis is put on competition, a situation which is not helpful, especially if children with special needs are integrated into such schools. They say that involving children with disability and their ordinary peers to share learning experiences in an ordinary school is a healthy approach as it is one of the most effective ways to reduce prejudice and negative attitudes towards disabled children. Johnson and Johnson assert that co-operative learning helps to promote differentiated, dynamic and realistic views of both the disabled and the non-disabled in an educational environment. By “differentiated”, they mean that children with disabilities are viewed beyond their disabilities, that is, their contribution is what is focused on, appreciated and shared by the rest of the non-disabled peers. By “dynamic”, the authors mean that the children’s disabilities may not be viewed by the non-disabled peers as especially relevant to all aspects at hand.

Johnson and Johnson’s use of co-operative learning is believed by other authors to have led to positive changes in attitudes to children with disabilities’ integration into ordinary

schools. The authors, however, are criticised for failure to focus on children’s academic achievement in such integrated educational environments. It is for this failure that Slavin (1991: p.74) has introduced co-operative learning which he claims can lead to educational achievement. In order to use this approach, Slavin says, firstly incentives must be introduced in the class whereby group learning is encouraged. That is, although children are integrated they should further be encouraged to work in groups so that they are able to help one another and every individual within each group. Secondly, the author suggests that there must be individual accountability. By this he means that in each group, each and every learner should be given the opportunity to try and contribute something. He says that there shouldn’t be a situation whereby some few capable learners dominate and contribute while some remain as dependants of the capable ones. Slavin suggests that one way of avoiding this is to base rewards on the groups’ average contribution, so each individual’s score contributes to the total score of the group.

Although co-operative learning is sometimes used in secondary schools in Uganda, it seems possible that when modified and applied in primary schools, especially where children with mild mental retardation learn together with the ordinary peers, the approach may be effective. Competitiveness, however, appears still to overwhelm the learning processes in Uganda. Such an approach may require policy makers to intervene and change those policies responsible for competition in learning at the moment.

Another approach which also seems to be emphasised in the implementation of special needs education is referred to as peer tutoring. According to Jenkins and Jenkins (1987: p.64), peer tutoring is a process of using one learner to teach other learners; the tutees are always younger peers. Gerber and Kauffman (1981: p.160) suggest that for peer-tutoring to succeed it requires continuous organisation and monitoring by the teachers. In other words, it is not a process whereby teachers may hope to save time. Jenkins and Jenkins indicate some of the undermentioned points as useful guidelines for teachers to make peer tutoring meaningful.

1. Tutors should be trained to understand instructional objectives, discriminate between correct and incorrect responses, deliver feedback and reinforcement, and to monitor progress and record keeping.
2. Instructional steps should carefully be sequenced and clearly outlined in a lesson format that tutors can follow easily.
3. Teachers should actively monitor tutors' and tutees' performance frequently.
4. Teachers should provide reinforcement frequently and consistently to the tutors and tutees, contingent on their appropriate performances.
5. Tutorial sessions should last approximately 15 to 30 minutes at least two or three times each week.

Although viewed as a useful approach, especially as it enables children with mild disabilities to benefit academically, it is criticised because of its ineffectiveness in improving children’s self-concept (Scruggs and Richter,1986: p.9).

Peer-tutoring has been practised in Uganda, both in primary and secondary schools, but only with ordinary children. In most cases the approach is applied because of a shortage of teachers. Usually the students in the upper secondary classes are made to teach the ones in the lower secondary classes. In most of Ugandan culture, the practice of child-to-child service is a common thing. For example, older children work as baby-minders while their parents are busy in the gardens, in the kitchen or when doing any work. There is therefore a potentiality in children for helping fellow children. Such a potentiality could be exploited for promoting effective learning and teaching of children with special needs and particularly those with mental retardation in Uganda. Application of such an approach requires careful planning and organisation as pointed out by Gerber and Kauffman above. Indeed with the introduction of inclusive education, or UPE, for that matter, if well used, peer-tutoring would help to reduce the burden that teachers currently experience of having very many children in the class.

Another approach which seems to be useful and which could be tried in Uganda is one known as reverse mainstreaming. Ballard-Campbell and Semmel (1981: pp.59-68) define reverse mainstreaming as an approach in which ordinary children are placed for

### Chapter 3: Aims of Education and Curriculum for Children with “Mental Retardation” from International Perspectives

short periods of time in a class or unit for children with special needs so as to have the feel of being in such a situation. The authors say there are some benefits to this approach. First, it helps to lessen their feeling of being different from the children with special needs. Secondly, the ordinary children’s fears and misconceptions about children with disabilities and what goes on in their special classes may diminish when this approach is used.

Reverse mainstreaming may indeed work as one of the ways, not only of teaching children with mental retardation in Uganda, but of creating awareness in ordinary children who may not be familiar with such children. There are a number of special schools for children with mental retardation in Uganda which operate without having any form of involvement with other ordinary schools. Such schools could be helped to introduce the reverse mainstreaming approach, to enable their children begin to be involved in working with ordinary children and vice versa. All this will necessitate teachers adopting a system of working with other teachers and even with other professionals.

Snell (1988: p.3111) proposes that there should be a multi-professional approach when providing education to children with severe mental retardation, because the children may have other disabilities that may further interfere with their capabilities to learn. Such children may therefore require services like speech, physical and occupational

therapies. Snell says if professionals integrate their services into educational programmes (instead of carrying them out separately), the children will learn much better. Besides using multi-professional involvement, the literature also suggests that parents, too, should be fully involved, because they can play a leading role in treating and educating their children.

Parental involvement is very important for education of children with severe mental retardation, in that the skills that the children are taught will be used in their homes (Bates, Renzaglia, and Wehman, 1981: p.144). Parents can be involved in various ways, according to the authors, from simply informing them about the progress of their children, to inviting them to the classroom to see how their children learn, or asking them to act as classroom aides. Two models of parental involvement are known to be successful. One model developed by Dunst, Trivette, Gordon and Pletcher (1989: pp 121-141), is known as the “social support systems” model. The second model developed by Turnbull and Turnbull (1990) is referred to as the “family systems” model.

The social support systems approach, according to Dunst, et al. (1988: p.44), operates in two ways. Firstly, it focuses on informal rather than formal sources of support. The informal support which is noted as significant for families with severely mentally retarded members includes supports such as those provided by extended families, friends, church groups, neighbours and social groups. Secondly, the system focuses on

helping families help themselves. The main objective is to enhance the self-esteem of the family by setting up a situation in which the help-seeker is less dependent on the help-giver. Dunst et al. say under this system the families, not the professionals, assume the primary decision-making role for the family’s needs. The professionals do not act so much on behalf of the help-seekers, but rather create opportunities for them to acquire competencies that permit them to mobilise resources and support necessary to cope, adapt, and to grow in response to life’s many challenges.

With regard to the family systems model, consideration is based on the roles that interrelationships within any one family play in treating and providing education to one of its members who may have severe mental retardation. Stark (1992: pp 248-249) found that in the USA some families with children with severe disabilities face a lot of problems in trying to assist their disabled member. He says:

It has only been recently that I have observed so much anger, insecurity, and despair among all families.... Families are experiencing a great deal of fatigue, and lack energy to advocate like they used to on behalf of their son or daughter, brother or sister. Both parents are working, they have not leisure time, and many are barely able to take care of their own responsibilities. (pp. 248-249)

Where both parents are employed, there is not much that they can do to give adequate attention to a severely disabled member of their families. In the Western developed countries, it is likely that both parents are employed. Although interaction may be possible, given responsibilities such as keeping the terms and conditions of employment, it is likely that interaction between parents and their disabled sons or

daughters may not be easily done. In the developing countries, such as in Uganda, in most cases it is usually the husbands who are employed while the wives remain to do house work. Interaction in that case may be more apparent between the mothers and the children with disabilities. Turnbull and Turnbull (1990) observe that the nature of family cohesion and adaptability will determine how individuals with disability can interact with the rest of the members in the family. That is, a family is seen as healthy if there is adequate cohesion and adaptability to the condition of disability by parents and by the disabled members in the family.

Discussion of parental involvement with regard to the two models described can help to overcome one main problem in Uganda. Development of special needs education in the country was initiated by voluntary services, provided mainly by non-governmental organisations (NGOs) from Europe and the USA. The NGOs have assisted parents for a long time, but such help should not be expected to continue for ever. Instead of helping parents by paying fees for their children, the way the NGOs have been doing, it is important that parents are helped to know how to solve their own problems. Through the two approaches discussed above, parents of children with special needs can become self-reliant instead of expecting to have the problems of their children solved by other people. If they continue to receive some assistance from overseas, such assistance should only be secondary. The assistance should be received simply for augmenting the parents' input. Social support and family systems have relevance for Uganda and if

adopted, the approaches are likely to enhance the current efforts to implement special needs education in the country.

As mentioned earlier in this section, there are many different approaches/methods of teaching, but for the purpose of the current study, it has been possible to explore only a few of such approaches. The few cited in this section seem to be appropriate for use in the implementation of policy on education for children with mental retardation in Uganda. As noted in each of the approaches, it is important for a teacher to be prepared and ready to work with children with mental retardation. At this juncture, therefore, it may be necessary to discuss some of the ways teachers could be prepared to teach children with mental retardation in order to bring about implementation of education for such children in the country.

### **3.2.6 Preparing Teachers to Teach Children with Mental Retardation**

Teacher development or preparation is considered a pre-requisite to an effective implementation of policy on education for children with special needs generally, and for those with mental retardation in particular, in any country in the world. Fullan (1991: p.132) found that retraining or upgrading teachers is an important action inevitable for an educational change. He argues that whether innovations are external or internal, the more teachers are helped through retraining so as to interact concerning their own

practices, the more they will be able to bring about improvements that they themselves identify as necessary. Fullan says:

...the strategies commonly used by promoters of changes, whether by legislators, administrators, or other teachers, frequently do not work because they are derived from a world or from premises different from the point of view of what is rational to the promoter, not the teachers. Sometimes innovations are rationally sold on the basis of sound theory and principles, but they turn out not to be translatable into practice with the resources at the disposal of teachers. (p.132)

Indeed, Fullan says the matter of formulating an educational policy, such as one for children with mental retardation, may not be enough. Teachers, as agents of change and as people who carry out the practical aspects more than any other agents in the educational change processes, should be kept up-to-date regarding changes at hand. Smyth (1989) suggests that teachers need to be trained so as to enable them to carry out teaching holistically, as complex interconnected sets of tasks and constraints, rather than possessing fragmented domains of knowledge, skills or motivation that can be addressed in isolation. Thus, Smyth adds, teachers should be helped to be confident so as to be able to describe what they can do, what the aims of the change are about, what their position is, and how they can do things differently from the way they had been doing before introduction of the change at hand. Ainscow (1999: pp.163-178) further suggests that teachers should not only be helped to be effective, but to be able to move practice forward in the change process.

Under the auspices of the United Nations Educational, Scientific and Cultural Organisation (UNESCO), a project was launched at the beginning of the 1990s in over 50 countries with the intention of helping teachers to use the experiences they already have to find how best to teach children with special needs in ordinary schools (Ainscow, 1994). The project focused on two strategies: to provide teachers with opportunities to consider new possibilities in their daily practice, and to help them develop skills of experimenting and reflecting on what they do. Ainscow explains that one of UNESCO’s strategies was to use teachers’ daily practice or experiences to encourage them to consolidate planning for their work, and to adopt a variety of teaching approaches, such as co-operative learning and tinkering<sup>1</sup>. As regards the second strategy, that is, experimentation and reflection, the intention was to encourage teachers to adopt the spirit of team teaching, critical venturing and using feedback from children and colleagues. In part, Ainscow states:

...participants have opportunities to experience a variety of active learning approaches. In this way they are encouraged to consider life in the classroom through the eyes of learners and, at the same time, to relate these experiences to their own practice in school.

...teacher’s first concern has to be with planning activities that cater for the class as a whole.

...In addition to planning for all children we have found that it is helpful to encourage teachers to recognise and use more effectively those natural resources that can help to support children’s learning.

....Within any classroom the pupils represent a rich source of experiences, inspiration, challenge and support which, if utilised, can inject an enormous supply of additional energy into the tasks and activities that are set. (Ainscow, 1994: p.13 )

Different methods do exist for retraining or developing teachers to be able to achieve all the qualities suggested above. Short refresher courses in the form of workshops lasting

---

<sup>1</sup> tinkering: trial and error; an intention to try to improve on something.

for days or weeks, in-service certificate courses lasting for months or a number of years, or diploma or degree courses, could all help to develop teachers, depending on what the policy of each particular country is. In the project, UNESCO concentrated on running workshops and on producing teaching materials for teachers. The UNESCO approach seems to have been cost effective, because it seems to have involved a few highly qualified resource persons reaching as many people as possible. Although in 1996 UNESCO published its latest report on the review of special needs education progress throughout the world, the results of the project on teacher development<sup>2</sup> were not published. It is therefore difficult to comment on the kind of approach adopted to retrain teachers in the 50 or so countries.

If in the current effort to implement the policy on education of children with mental retardation in Uganda an approach such as running workshops is adopted, as UNESCO did, then it will require more commitment on the part of teachers on one hand, and change of procedures of training on the part of policy makers, on the other hand. One of the arguments for which UNESCO seems not to have provided a guideline is with regard to recognition of qualifications for teachers by educational authorities. In Uganda, for example, the most important reason for any teacher to retrain is to obtain a higher qualification, in order to climb, say, from a certificate to a diploma. Such a

---

<sup>2</sup> It would have been more enlightening for UNESCO to indicate the progress so far made under its arrangement. Instead, the review concentrated on legislation, describing the levels different countries have reached with development of their special needs education generally.

change in level of qualification enables a teacher not only to earn more salary, but it is what the educational authorities will recognise. In other words, it may be a wasted effort for a teacher to undergo a short course whose qualification will not be recognised or be of any benefit. The second argument is that much as the approach adopted by UNESCO may sound good, the underlying question is, what level of retardation can such an approach help? It is very likely that children with mild mental retardation could be taught by teachers who undergo courses of this nature. Children with severe mental retardation need teachers who are specially well trained and equipped with the skills necessary to handle the complex nature of behaviour which such children may exhibit. UNESCO seems not to have given consideration to such children. The desire for implementation of inclusive education could have overshadowed UNESCO's consideration to develop better ways of training teachers for children with severe mental retardation. Some of the teaching approaches, such as co-operative learning, supported by UNESCO may not be suitable for children with severe mental retardation. With the above observations and arguments, it suffices to say that there are many improvements still necessary in the system of teacher development and training for special needs education, especially for those who teach children with severe mental retardation.

### **3.3 Conclusion**

Education aims and curriculum for children with mental retardation as noted in the literature focus on one important thing, that is, to equip an individual with the necessary skills required to live with some degree of independence in life after education. Children with mild mental retardation need to be provided with education which will help them to learn academic knowledge and acquire practical skills. The literature suggests that whereas children with severe mental retardation can be provided with some functional academic subjects, more priority should be given for them to learn practical subjects.

In the literature, it is argued that all children with mental retardation need to be educated together with ordinary children. The main reason is that this will help to reduce, if not to eradicate, prejudices and negative attitudes towards disability and children with mental retardation. There is, however, some reservation with regard to children with severe mental retardation. It is argued that for such children to succeed in learning, they should be provided with education in special schools where they can receive adequate attention from teachers.

For children to be selected for education, the literature indicates that this has been carried out, especially in the developed countries, through assessment, whereby

measurement has been based mainly on IQ test scores, and consideration of cognitive effects, and excluding factors such as culture. Assessment based on IQ has of late changed and more attention is now being paid to environmental factors which are also considered responsible for affecting the behaviour of human beings.

Approaches/methods of teaching children with mental retardation are not unique; they can be varied according to the special needs of the children. It is the teachers’ task to identify and select which of the approaches/teaching methods are appropriate at a particular time. Some of the recommended approaches include: applied behaviour analysis, community-based instruction, preferential teams, collaborative consultation, co-operative teaching, co-operative learning, peer-tutoring and reverse mainstreaming. Involvement of other professionals as well as parents is recommended in the literature. Thus, a teacher of children with mental retardation is not expected to be the sole person handling the children. Input by other people have been found to be important to reinforce the teachers’ input.

Retraining of teachers for children with mental retardation is as vital as considering other factors already mentioned above. Considering how important teacher development is, UNESCO has been playing a leading role in promoting teacher training for special needs in the world.

We have noted in the literature the aims of education to an individual. We have noted that education first and foremost is important in that it enables an individual to acquire skills that can help him or her perform the basic tasks that are vital for independent living. This aim therefore sheds light on how the education providers in Uganda need to plan their education for children with special needs, especially those with mental retardation. Many of them may not be able to continue with higher education so as to get high posts in government or in companies. All they may need is to be helped to learn the skills of rearing goats, cleaning their homes, cooking, fetching water, observing cultural values and being able to do things without much help from other people. We have also noted that children with mild mental retardation can be taught both academic and practical subjects and that such education can be provided in the ordinary schools. As for children with moderate or severe mental retardation, emphasis can be put on more practical education than academic education. In Uganda, such an approach has been practised; what needs to be done is to improve on those areas where things have not been done well. Different teaching approaches, most of which are not new in Uganda, need to be improved. The main challenge for Uganda is to reduce overemphasising examinations in the education system. Continuous assessment needs to be improved so as to enable children with mental retardation to make progress at their own pace.

### Chapter 3: Aims of Education and Curriculum for Children with “Mental Retardation” from International Perspectives

Having examined the aims and curriculum for children with mental retardation from an international perspective, in the next two chapters (Chapters 4 and 5), we shall present an empirical study so as to analyse how Uganda clarifies aims and curriculum for children with mental retardation in its current attempt to provide special needs education. Some of the findings in this chapter (Chapter 3) may, in one way or the other, help to support some of the findings that will be identified in Uganda.

# CHAPTER 4

# Chapter 4

---

---

## **4.0**                      *Methodology*

### **4.1**                      **Introduction**

In the previous Chapters 2 and 3, we have noted from the international perspectives what the literature reveals about people's views concerning mental retardation, the curriculum and aims of education for children with mental retardation. In this chapter (Chapter 4), we shall embark on an empirical study to find out what the views of Ugandans are, on the same issues. The structure of the chapter comprises the study scope, samples, instruments, data analysis description and conclusion.

## **4.2 Study Scope**

The study scope consists of geographical and content areas. These areas are described as indicated below.

### **4.2.1 Geographical Scope**

Specific areas in Uganda were selected for the study. The areas cover three districts, namely Iganga, Kampala and Masindi. Kampala, being the capital city and comprising all the different cultures and lifestyles from every part of the country, informants were selected by means of stratified purposeful sampling. Given that some parts, especially the northern region districts, were going through insecurity, which I could not risk, I decided to conduct systematic random sampling for the remaining two districts, that is, Iganga in the eastern and Masindi in the western regions. *(See the locations on the map below)*

Figure 4.1:

# UGANDA

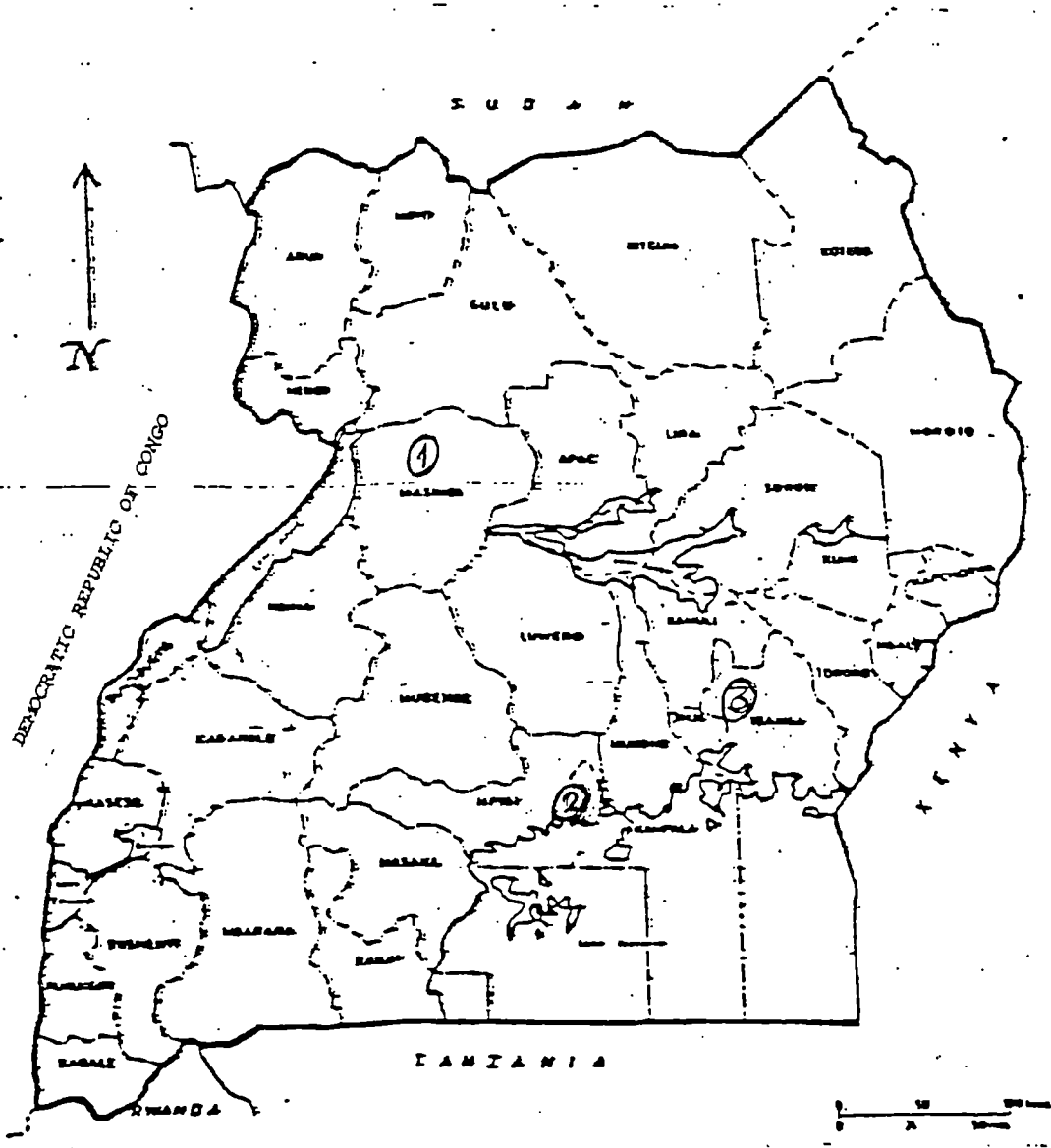

- Key:
- ① = Masindi
  - ② = Kampala
  - ③ = Iganga

Source: Uganda Primary Atlas for Social Studies

## 4.2.2 Content Scope

The argument pursued in the previous chapters (Chapter 2 and 3) is that although education of children with special needs (these days) generally, and those with mental retardation in particular, is beginning to receive good attention from policy makers, especially in the developed Western countries, in the developing countries such as Uganda not much has been done in that direction. In Chapter 1 we have examined the current trends in the development of special needs education and how the attitudes of society have gradually been changing positively over the years. We have noted that Western developed countries are in the lead in this development. We have also noted that some efforts are underway in the developing countries to implement special needs education generally and that of mental retardation in particular.

In this chapter (Chapter 4) we shall examine the roles played by parents, children, teachers and education administrators in Uganda. We shall investigate their views on the present situation and on the possible factors that are responsible for success or failure in the implementation of provision of education for children with mental retardation. As noted in Chapter 1, a number of research questions have been formulated, so we shall remind ourselves about the said questions in this section:

- 1 In the implementation of policy aims for provision, what are the roles played by

## Chapter 4: Methodology

parents, teachers, educational administrators and children?

- 2 How are children identified and assessed for educational provision?
- 3 What are the pedagogical and curricular approaches in the implementation process?
- 4 What are the current efforts made in staff training and development, as far as the implementation is concerned?

Having noted what the study is about, in the next section I shall provide the preliminary study, which was carried out before developing the instruments for the main study. Thus, I shall give descriptions covering field study, and also talk about ethical issues.

### **4.2.3 Field Study**

Arrangement for fieldwork began at the beginning of September 1996. It was not until the beginning of January 1997 that temporary permission was obtained to proceed with the fieldwork. Written permission was eventually given in March 1997. (*See Appendix 5*).

The fieldwork started in January 1997 and was completed in the first week of September 1998.

In Uganda the law requires that research of this nature must be cleared by the President's

Office, through the Uganda National Council for Science and Technology (UNCST). When the council approves any research, it has to write letters to the relevant authorities to permit the researcher to carry on with the research activities in the respective areas. Before embarking on the fieldwork, I had to approach the UNCST for clearance as required.

#### **4.2.3.1 Clearance for Field Study**

With the covering letters provided by the UNCST, I was then able to write to and visit different people, organisations or homes for children with mental retardation where observation would be required. The visits were also intended for collecting data needed for the development of the research instruments.

In Uganda when one writes a letter, one has to deliver it physically or else such a letter would rarely be replied to if it were sent by post. In view of that, I had to write and deliver all the letters physically to each and every official or person with whom an audience would be held.

When letters are delivered in this way the officer concerned gives a reply on the spot. In most cases, the replies are simply to do with fixing the appointments for the applicant to return another time to see the officer and to discuss the issue at hand. As for parents, I had

to go to their homes (in most cases accompanied by colleagues who could speak the languages of the different areas) and arrange days on which to visit the homes and what to do during the visits.

In Kampala, the capital city and where I live, arrangements were made with many more people than in other parts of the country. This approach would help to save time, cost and ease the burden of travelling to distant places during the pilot study.

#### **4.2.3.2 Organisations and Participants Consulted**

I visited different areas of study to acquaint myself with the organisations, offices, officials, headteachers, teachers, parents and children. I discussed the issue of the provision of education for children with mental retardation with the different people I met. I also had a chance to attend some seminars organised to address special needs education in different parts of Uganda. I visited the Educational Assessment Resource Service (EARS) centres to see how children were assessed.

During the time of interviews, of the three District Education Officers (DEOs) who had been selected, only one felt free to be interviewed orally; the other two gave an excuse of being too busy to do so. They filled in the interview guides and returned them to the

#### Chapter 4: Methodology

researcher after some time. The two Commissioners, too, filled in the interview guides and could not take part in oral interviews. The Commissioner for Education (Administration) filled in the interview guide in the presence of the researcher from his (Commissioner's) office.

I had earlier on proposed to have an audience with the education policy maker, the Minister of Education, to get a political view from him regarding the policy theory and practice on the provision of education for children with mental retardation. From January 1997 I submitted requests to see the Minister on any day convenient to him before June 1997. (*See Appendix 6*, a copy of one of the letters to the Minister). I kept checking for response and confirmation of the appointment with the Minister every two weeks until May 1998 when the Minister was reshuffled to another ministry, and I gave up any further attempt in that office.

I made a request to have an audience with the Commissioner for Education (Administration) on any day convenient to him before June 1997. I kept checking for the result every two weeks until the last week of September 1997, when I finally saw him. As for the Commissioner for Education (Inspectorate), I made a similar request at the same time. I eventually saw him in the first week of September 1997. (*See Appendix 7*)

## Chapter 4: Methodology

Since the study also required evidence from documents, I made efforts to collect from the different offices all the relevant documents that were available. Given that the most up-to-date primary source of information in Uganda is newspapers, I perused the newspapers and made cuttings whenever I came across an article on special needs education in the country.

This was done because in Uganda there is hardly any research, which has been published in connection with the same topic.

I attended some classes to see how teachers taught children with mental retardation in both special and ordinary (integrated) schools.

### **4.2.3.3 Ethical Issues**

Ethical issues are vital and are given such attention that a serious-minded researcher cannot take them for granted. The key issues that have to be addressed include: selecting participants, obtaining informed consent, ensuring privacy and confidentiality, providing safeguards when using deception, among others (Max, 1996: pp.134-137; Gall et al, 1996: pp.87-107). A significant attempt was made to pursue all of these guidelines during the current study.

In Uganda, in conducting research of this nature, permission must be sought from the Office

#### Chapter 4: Methodology

of the President of Uganda, through the Uganda National Council for Science and Technology (UNCST), formerly known as the Uganda National Research Council (UNRC) as already mentioned above. UNCST does not provide an ethics code to guide researchers, the way other organisations like the Ethical Standards of American Educational Research Association (AERA) and the American Psychology Association (APA) do. UNCST simply requires a researcher to be registered, to make known what the nature of the research is, and where in Uganda it is to be conducted. A researcher who satisfies those conditions is registered and provided with a covering letter to the relevant government authorities in the area of the research study. For the current study the UNCST permission was sought and obtained before making any attempt to go into the field. This was, therefore, a first step in tackling the issue of ethics.

I discussed and agreed with the respondents what would, and would not be acceptable during the interviews and classroom observations. For example, regarding interviews an agreement was reached on the use of a tape recorder, and with regard to observations of teaching/learning, permission to use a video camera was sought and this request was accepted. The participants were also assured of anonymity and confidentiality of the information that they would give. Any issues that were thought would be sensitive were discussed and a common understanding reached. Having achieved this objective, the next step was to develop the research instruments, as I shall explain in the next section below.

## **4.3 Study Design and Implementation**

Implementation of the provision of education for children with mental retardation in Uganda means effecting a change, a task that seems not to be easy. The change agents in Uganda, as far as this topic is concerned, are people whose academic levels are varied. There are parents who have very high, while some have very low academic levels. Some parents are, in fact, unable to write and read. As far as teachers are concerned, there are those whose highest academic levels are school certificate (Ordinary Level), some advanced school certificate (Advanced Level), while some are degree holders. Given that the prospective participants in the current study had such a variation in academic levels, I knew that if I relied on one particular research approach the research validity would be affected in one way or the other. Thus, I opted to use both quantitative and qualitative research paradigms.

### **4.3.1 Rationale for Using both Quantitative and Qualitative Research Paradigms in the Current Study**

A quantitative research paradigm, drawn from the natural sciences (and synonymously

referred to as conventional, traditional or positivist inquiry), has advantages over the qualitative approaches. On the other hand the qualitative research paradigm (referred to also as naturalistic, ethnographic, subjective or postpositivist inquiry), has its own advantages over quantitative paradigm. The arguments raised about the differences in advantages between the two research approaches are the very reasons for the need to combine them for the current research study. An examination of different authors (for example, Strauss and Corbin, 1990; Gall et al, 1996; Cohen and Manion, 1994, among others) indicates the arguments in favour of each paradigm have been advanced for quite some time.

One of the arguments in favour of the quantitative approach is the emphasis on the issue of objectivity. In this school of thought, human beings are regarded as independent individuals who should be studied in that context, without any influence, say, from the researcher. The individual, according to further argument in this direction, may have interaction with other variables that may make him behave in a certain way. It is for the educational researcher, therefore, to draw conclusions, based on the individual's interaction with such variables or makes predictions of their influences on the individuals. Qualitative methods, however, advocate either direct or indirect involvement of a researcher with his participants, because individuals are not completely independent and are affected not only by variables like emotions or attitude, but also by environmental factors, which are ever

changing. In view of that, therefore, qualitative researchers say that it may not be possible to draw conclusions about people's behaviour based on predictions from general laws. They say individuals should be studied holistically, because of their different experiences as they go through changes.

In the natural science approach, it is argued that a researcher can formulate testable statements, which adduce certain (usually causal) relationships between phenomena (usually referred to as hypotheses). Qualitative researchers argue that ideas or theories can be grounded. In other words, a researcher can only develop a body of knowledge, which is unique to the individuals being studied, because, together with the individuals, the researcher is enabled to interpret meanings in what is being studied. I shall combine these approaches wherever appropriate. The research methods to be used under these approaches comprise questionnaires, interviews, observations and documentary analysis.

It is common practice in that questionnaires are commonly used under the quantitative approach, while interviews, observations and documentary analysis used under the qualitative, respectively. This, however, does not mean that any of these methods or techniques cannot be used under either of the two research paradigms mentioned above. A researcher can always determine suitable research approaches and methods, basing on where the research is conducted, what it is about, and the types of sample used as I have

pointed out above (as far as Uganda is concerned). In the next section, I shall discuss the research methods used in the current study. They are questionnaires, interviews, observations and documentary analysis.

#### **4.3.1.1 Questionnaire Sample**

According to the Ministry of Education, there are 102,331 primary school teachers/headteachers and 10,616 primary schools in Uganda. (*See Appendix 2*). This means that on average:

- (a) 10,000 schools are served by 100,000 teachers - that is, 1 school is served by 10 teachers; and
- (b) in each of the 45 districts in Uganda there are 200 schools and 2,000 teachers.

Three districts were selected for the study by stratified purposeful and systematic random sampling techniques as already mentioned above (in section 4.2.1). It is from the three districts that headteachers/teachers were also selected randomly to respond to the questionnaires.

#### **4.3.1.2 The Headteacher/Teacher Questionnaire**

A questionnaire is one of the research instruments which has been used to collect data from

teachers and headteachers. In the next sections I shall provide an explanation with regard to how the questionnaire was constructed.

#### **4.3.1.3 Construction of the Questionnaire**

In the course of early field visits and discussions with parents, teachers and education administrators, I made efforts to get different opinions concerning the problems under investigation. I interviewed participants informally and their answers enabled me to have objective views from which to begin formulating questionnaire and interview contents. This was to avoid my being subjective, that is, constructing research instruments, which were based solely on my own views. I also used the knowledge gained from the literature to enrich the questionnaire construction and content.

#### **4.3.1.3 Questionnaire Content**

The teacher/headteacher survey questionnaire contains four sections: introductory, personal data, personal experience with mental retardation and education of children with mental retardation. The detailed sections of the questionnaire comprise the following content.

*(See also Appendix 15)*

#### Chapter 4: Methodology

(I) An introductory section explains the objectives of the questionnaire and indicates the importance of the teachers/headteachers' participation and collaboration. The participants are assured that their answers are to be treated confidentially and that they are to be used for the purpose of the current study only.

(II) The personal data (questions 1-3) comprise questions about participants, including their ranks, places of work and gender.

(III) Section three (questions 4-8) contains participants' experience with mental retardation, either as professionals, parents or both.

(IV) The last section (questions 9-15) addresses the issue of implementation of policy on education for children with mental retardation in Uganda. These questions, based on the Likert Scale, are aimed at finding out the degree of participants' views regarding the implementation by asking them to indicate: strongly agreed (5), agreed (4), not sure (3), disagreed (4) and strongly disagreed (1). Each of the questions is accompanied with an open-ended question, requiring the participants to provide elaboration on the choice of the objective questions.

Question 9 concerns interpretation by respondents of the way parents regard education of

#### Chapter 4: Methodology

children with mental retardation and how they involve themselves in working with teachers to promote it. Respondents are asked to say how instrumental parents are in promoting education of their own children.

In question 10 respondents are asked to say whether or not they are satisfied with the conditions under which children with mental retardation are currently learning in the ordinary schools in Uganda.

Question 11 addresses the interpretation by respondents of the way ordinary children and teachers react to/treat children with mental retardation who are receiving education in those (ordinary) schools. In other words, participants are required to say whether or not they think there is freedom and respect for children with mental retardation in the ordinary schools.

Question 12 requires the participants to indicate if they are satisfied with the current aims of education and curriculum for children with mental retardation in Uganda.

Question 13, like the previous one, aims at finding out whether participants are of the view that children with mental retardation in Uganda are taught using the same content (syllabus) as for ordinary children and if so how successful this is.

## Chapter 4: Methodology

Question 14 aims at finding out the participants' views on the teaching approaches/methods for children with mental retardation. In other words, the aim is to find out whether the participants are satisfied, or not with the current approach used in Uganda for teaching children with mental retardation.

In the last question (15), the aim is to find out if participants think there is a need to have a comprehensive change to the approaches/methods of teaching children with mental retardation in Uganda, in order for implementation of policy on education for children with mental retardation is to be achieved.

At the end of the questionnaire, participants are asked to make suggestions about what they think should be done so as to succeed in the implementation of the policy on education for children with mental retardation in Uganda.

### **4.3.1.5 Piloting the Questionnaire**

Piloting the questionnaire instruments involved selecting twenty respondents who included ten headteachers and ten teachers. They were given the questionnaires on 17 March 1997 to complete and return in one week. Eighteen of the participants completed and returned the questionnaires. I then went back to the eighteen participants, had a discussion with

them and requested them to answer the same questionnaire again. The reason for administering the questionnaire twice will be discussed in the section on reliability, below. On 7 April 1997 the eighteen participants were again given the questionnaire to complete and return within one week, which they did. Both the pre-test and post-test results were then analysed. Some ideas from the respondents were identified and used for reconstruction of the questionnaire for the main study.

The objectives of the pilot study were to:

1. check the appropriateness of items/methods in terms of clarity and intelligibility;
2. eliminate redundant, ambiguous, difficult words/questions and replace them with more appropriate ones;
3. reduce the degree of subjectivity and personal bias of the instruments; and
4. establish the validity and reliability/credibility of the tests.

After piloting the questionnaire, I made corrections where necessary. I then proceeded to administer the questionnaire for the main study.

#### **4.3.1.6 Administration of the Questionnaires**

I made arrangements with four teachers from each of the three sampled districts to assist me with the administration of the questionnaires in their respective districts. The teachers were

trustworthy and were willing to assist in the exercise without hesitation. Before I gave them the questionnaires to distribute, I had to explain to them the contents, so that they, in turn, would be in a position to assist the participants whenever it was necessary.

The administration of the questionnaires in all the three districts went on well and within one week the exercise was accomplished. The distribution and return of the questionnaires were as indicated in Table 4.1 below.

**Table 4.1: Headteacher/Teachers' Questionnaire Distribution and Return**

<b>District</b>	<b>Number of Questionnaires distributed</b>	<b>Number of Questionnaires Returned</b>
Iganga and Masindi	67	60
Kampala	51	40
<b>Total</b>	<b>118</b>	<b>100</b>

The number of administered questionnaires in Kampala was more than in each of the remaining two districts of Iganga and Masindi. This is because Kampala is the capital city and as mentioned earlier, its national representativeness is greater than any of the above two districts.

Having received all the questionnaires, a total of 100 headteachers/teachers was eventually determined as the sample size for the quantitative data. The procedure of analysing this data is provided in a later part of this chapter.

#### **4.3.1.7**

#### **Strengths of the Questionnaire**

One of the advantages of the questionnaire method realised during the current study is that as many respondents as possible were reached. Another advantage is that it has been possible to generalise the current thinking and views of the respondents regarding the policy implementation of education for children with mental retardation in Uganda. Because of the anonymity of the questionnaires, respondents were free to say what they wanted to say without fear.

#### **4.3.1.8 Limitations of the Questionnaire**

One of the limitations in the current study has been attributed to a few respondents providing shallow answers. Some of them said things that were not comprehensible. Some handwriting was difficult to read. Some sentences were not complete, so their meanings were not easy to interpret.

The questionnaire had some weaknesses in its construction. While some questions were heavily loaded, some were very shallow. (*See Appendix 15*). Such problems had been anticipated, given the fact that participants had different levels of qualification as already pointed out above. Questions were to be constructed such that they were simple and easily understood by the participants. In so doing, the weaknesses, which emerged, could not be

avoided. Triangulation of research instruments, therefore, was the only way to offset the foreseen weakness in the validity. The use of interview methods, therefore, was emphasised. I shall present data collection by interview method in the next section.

### 4.3.2 Interview Sample

Interview was one of the main research methods used in the current study. It involved 18 of the headteachers/teachers who had answered the questionnaires (these were out of the 100 participants already mentioned in the previous section). The 18 participants were selected by cluster random sampling. Other 21 participants, who included parents, EARS staff and top education administrators were selected by purposeful sampling. A total of 39 participants were selected. (See Table 4.2 below for all the interview samples/participants).

**Table 4.2: Number of Participants Interviewed**

CATEGORY OF PARTICIPANTS	NUMBER OF PARTICIPANTS	LOCATION		
		IN THE MINISTRY OF EDUCATION	IN A DISTRICT	IN A SCHOOL/ INSTITUTE
Commissioner for Education	1	1		
Commissioner for Education (Inspectorate)	1	1		
Head of EARS	1	1		
DEOs	3		1	
EARS Teachers	3		1	
Teacher Educators	3			3

#### Chapter 4: Methodology

Headteachers	9		3	1
Teachers	9		3	1
Parents	9		3	
TOTAL	39			

Interview is used to collect data from the respondents face-to-face by asking them questions. One of the purposes of using this method for the current study is to compare and contrast, especially questionnaire and interview responses. Another reason is to find out, generally, the way participants interpret the provision of education for the children with mental retardation in Uganda. In constructing the interview schedules, open-ended questions were designed to gather information, which was similar to that generated by questionnaire. Interview has an advantage over questionnaire, in that it would enable participants to provide answers in much more details.

#### **4.3.2.1 Construction of Interview Schedule**

Before embarking on the exercise, interview schedules were prepared to enable me cover all the issues necessary for the investigation and to ensure that all the participants addressed the same basic questions about implementation of policy on the education of children with mental retardation in Uganda. In other words, whether parents or professionals, the key question was, should children with mental retardation receive education like ordinary children in Uganda?

As the participants in the current study have different roles, some questions were specifically asked in order to show how those different roles contribute to promotion of education for children with mental retardation in the country. In the section below, the issues (content) covered by the interview are described. *(See also Appendices 16-21)*

#### **4.3.2.2 Content of the Interviews**

The interview guides contain mainly three parts: name of the respondent, position and personal experiences, as far as education and rights of children with mental retardation are concerned. Six categories of participants were interviewed – each of them required to respond in a similar way as indicated below.

(I) Interviews with parents address issues such as their perception of mental retardation, identification and assessment of retardation, intervention services for disabilities in the country, the benefits of universal primary education (UPE) with particular reference to children with mental retardation, aims of education, the type of schools suitable for education of children with mental retardation and their involvement with other professionals in the provision of education for children with mental retardation.

#### Chapter 4: Methodology

(II) Interviews with teachers and headteachers cover their perception of retardation, experience in working with the children, the value of UPE to children with mental retardation, the benefits of children learning together in ordinary schools, the policy of schools towards staff development, special qualifications and benefits for teachers of children with mental retardation, aims of education and curriculum for children with mental retardation, involvement of parents, teachers and other professionals in the provision of education for children with mental retardation and teaching approaches/methods.

(III) The EARS staff is interviewed in connection with the assessment policy for children with special needs in the country, referral and placement of children with mental retardation in ordinary schools, co-ordination of activities between EARS and schools with regard to children with mental retardation, the types of assessment used in the country, the categories of people involved in assessment of children, and the achievements made and difficulties faced so far by EARS in the promotion of education for children with mental retardation in Uganda.

(IV) With regard to teacher educators, the interview is focused on the relevance of the course for teachers of children with mental retardation currently going on at UNISE, the feedback on the performance of the trained UNISE graduates in the field, involvement of UNISE in teacher development, awareness of the community in the education of children

#### Chapter 4: Methodology

with mental retardation, collaboration with other professionals in the promotion of education for children with mental retardation, and the impact UNISE has had in the country for teacher production in special educational generally.

(V) The interviews with DEOs address the district policy on education for children with mental retardation, the level of change in people's concepts about disabilities, how the district education offices work to ensure that the needs and rights of children with mental retardation are observed, the kinds of arrangements the districts have for staff development and training in the field of mental retardation, special benefits for special teachers of children with mental retardation, and the aims of education and curriculum for children with mental retardation in the districts.

(VI) As regards the Commissioners for education, the interview is focused on the current level of change in people's concepts about disabilities, how the Ministry of Education offices work to ensure that the needs and rights of children with mental retardation are observed, the kinds of arrangements the ministry has for staff development and training in the field of mental retardation, special benefits for special teachers of children with mental retardation, and the aims of education and curriculum for children with mental retardation.

At the end of each and every interview, participants are asked to make suggestions about



help children succeed in learning. They are at the centre of implementation of the provision; they co-ordinate work with the children, parents, headteachers and the community. They are in a position to interpret where success or failure in children's learning is likely to come from.

In Uganda, headteachers perform roles both as administrators and as teachers. In the task of implementation of the provision of education for children with mental retardation, they are expected to use both their administrative and professional skills to help their schools succeed. Their opinions about what successes they are achieving and what problems they are facing in the implementation of the provision can help to shed light on what can be done to bring about success in the implementation.

3. Interviews with the Staff of Educational Assessment Resource Services (EARS)/Special Needs Education (National and District)

A number of teachers have been given short courses in assessment skills and deployed at the district assessment centres. Currently plans are underway to promote and appoint the EARS/Special Needs Education teachers as Assistant District Inspectors of Schools (ADIS), in charge of EARS/Special Needs Education.

EARS/Special Needs Education is expected to co-ordinate their activities with parents and schools. They are supposed to advise parents on the procedures of assessing children and to work with schools on placement of children who are assessed. They are also expected to work with teachers on devising teaching approaches/methods and on production of educational materials. All in all, their role is an advisory one for both parents and teachers in the implementation of special needs education provision.

#### 4. Interviews with Teacher Educators

In Uganda there is currently only one institution of higher learning, which has been established to train and develop the manpower needed to teach children with special educational needs in primary schools. Different kinds of courses are run at the institute. These include short and long courses in the areas of hearing impairment, mental retardation/learning difficulties, visual impairment and mobility rehabilitation for children with visual impairment. Short courses range from two-week certificate courses to nine-month postgraduate diploma course in social, vocational, and community based rehabilitation. The long courses range from a two-year diploma to degree courses. The staff of UNISE cope with the management of a variety of courses in the institute. Thus, their experience in teacher development is important in that they can contribute towards implementation of the policy by virtue of the position they hold in the educational system.

5. Interviews with District Education Officers (DEO)

A DEO is the link between the Uganda Government and the local authorities. He is administratively and professionally responsible for all educational affairs in the district, prepares the education development plans and makes recommendations for the establishment of new schools in the district.

One of the objectives of interviewing the DEOs has been to identify and to describe the current policies, principles and arrangements for provision of special educational needs in the districts. Currently, the parliament is encouraging decentralisation of authority in the districts. This means that the district authorities will be enabled to initiate some policies. In the current study, the DEOs have been expected to say what local educational policies on the provision of special educational needs are in their districts.

6. Interview with the Commissioners for Education (Administration and Inspectorate)

The Commissioner for Education (Administration), as the top professional person in the

#### Chapter 4: Methodology

Ministry of Education and Sports, is in charge of implementation of all policies concerning education in the country. The Commissioner works hand in hand with the Education Service Commission (ESC) in implementing decisions on appointments and confirmation of teachers. The Commissioner also facilitates educational reforms through the National Curriculum Development Centre (NCDC) and other agents of educational change and innovation. He is charged with registration and deployment of teachers who have satisfactorily completed their teacher education courses. Being the top-most administrator and professional in the ministry, he is expected to create all possible conditions to implement provision of education for children with mental retardation in the country.

Like his counterpart, the Commissioner for Education (Inspectorate) is a technocrat in the ministry who is charged with implementation of various government policies concerning education in the country. The Commissioner is charged, firstly, with the inspection of institutional buildings, equipment, teachers and headteachers. He or she submits reports to the Ministry of Education. Secondly, the Commissioner is charged with confirmation, promotion or demotion of teachers and headteachers. Thirdly, the Commissioner initiates curriculum development. Fourthly, the Commissioner organises staff development programmes through seminars, workshops, short and long in-service courses. In light of all these key roles it is important to find out how the Commissioner is working to implement the policy on the provision of education for children with mental retardation.

#### **4.3.2.4 Piloting the Interviews**

A total of ten respondents were selected for pilot study. These included three headteachers, four teachers, one EARS/Special Needs Education staff and two parents of children with mental retardation. Interviews with these participants were embarked on from 23 April 1997 and accomplished by 28 May 1997. A tape recorder was used for all the interviews. The interviews were analysed and some ideas were included in the interview content for the main study. The average time taken for the interviews was 50 minutes.

#### **4.3.2.5 Strengths of the Interview**

The interview as a research method is unique in that it involves the collection of data through direct verbal interaction between individuals (Cohen and Manion, 1994; Max, 1996; Kivale, 1996). It is therefore possible to get feedback on the spot and to probe further into a point that is not made clear.

During the data collection for the current study, most of the above-mentioned strengths of

interview methods were indeed noted. From the rural parents' point of view, the mere talking into a tape recorder was a welcome event that generated an unexpected excitement. Participants (parents in the rural areas) were equating themselves to radio broadcasters and felt proud to hear their recorded voices replayed over and over again. Many of them have requested the researcher to copy for them the recorded conversation so that they can keep and replay it for their relatives and friends. To say the least, using a tape recorder with parents was a significant motivating factor during the interview process. The respondents from the elite group, on the other hand, were not amused to have their voices recorded, but they were able to provide answers in depth.

#### **4.3.2.6 Limitations of the Interview**

Although some participants felt very free to provide answers during the current study, there was a tendency for some of them to talk mainly about good things. The researcher found that some respondents, especially teachers, had a tendency to talk convincingly, as if implementation of education for children with mental retardation in Uganda was something that could be achieved with ease.

Another observation was noted regarding communication through interpreters. In certain places where the researcher and the respondent were unable to communicate through

English, an interpreter had to be employed. In the process of communicating through the third party, there could have been a distortion of some information. This is because, according to Duff (1981), some words are untranslatable, difficult to associate and can be lost or under-translated. Given such limitation, it was found necessary to collect some of the data by direct means. This meant using a small-scale observation.

### 4.3.3 Observation Sample

Teachers and children who were observed were selected by means of stratified purposeful sampling. They were as indicated in Table 4.3 below.

**Table 4.3: Number of Teachers whose Lessons were Observed**

PARTICIPANTS	NUMBER SELECTED	NUMBER OF LESSONS	NUMBER OF SCHOOLS
Teachers	9	9	3
Children	Varied	9	3

Observation as one of the research methods in the current study has been used to get data from two subgroups: teachers and children. One of the reasons for conducting a non-participant observation has been to analyse the nature of interaction between teachers and children during teaching and learning processes. Another reason has been to compare and contrast what teachers said in the questionnaires and in interviews and what actually they were doing during the observation.

#### **4.3.3.1 Construction of the Observation Guide**

The researcher identified variables for the observation, based on the Flanders' (Wragg, Oates, and Gump, 1976: pp.39-58) interaction analysis categories (FIAC) with some modifications. The reason for choosing Flanders' approach is that it is an instrument, which has been used for school inspections/supervision for over twenty years in Uganda. The variables were categorised in the content shown in the section below.

#### **4.3.3.2 Content of the Observation**

1. Teacher accepts feelings
2. Teacher encourages
- 2F Teacher gives feedback
3. Teacher uses children's ideas
4. Teacher asks questions
- 4C Teacher asks conversational questions
5. Chalk and Talk Teaching (Lecture Method)
- 5Cr Teacher corrects children's work

#### Chapter 4: Methodology

5Cu Teacher gives cues

5Co Teacher answers conversational questions

6 Teacher gives directions

7 Teacher criticises children

8 Children respond

8D Children draw pictures

9 Children initiate talk

10 Silence or confusion

10TA Teacher uses teaching aid

10B Teacher or children write on the chalkboard

10Ex Teacher with the help of class captains distribute exercise books/pens/paper

10DE Children do exercises in books or chalkboard

The above categories were included in the observation because, firstly, they describe the most common behaviours, which form the core teaching/learning processes in classrooms in Uganda. Secondly, FIAC is easy and as the observation for the present study was meant to be brief, the need to include other categories or to go for a combination of other approaches was not found necessary. I am aware that there are certain limitations in using the Flanders' approach. I am also aware that some categories are too broad, whereby information may be lost, especially through non-verbal aspects of communication, and I am

aware that there are too few pupil categories. As mentioned above, the current observation required a simple exercise only to spot-check the difficulties that are likely to affect teachers' and children's successful performance under the policy implementation being discussed in the thesis.

#### **4.3.3.2 Piloting the Observation**

Piloting of observation techniques was done on six lessons observed in three primary schools. The same schools were later used for the main observations. A non-participant observation technique was used. The exercise began on 12 June 1997 and ended on 28 June 1997. Each observation lasted for 30 minutes. A video recorder was used and scores were recorded using Flanders' Chart (Wragg, Oates, and Gump, 1976). It should be noted that observation has not been carried out in-depth, so its results may not be exhaustively treated as hard evidence. The method was used to briefly identify the nature of problems that teachers face in their practice.

#### **4.3.3.3 Advantages of Observation**

The notable advantage, which has been found in the current observation, is that the method has provided direct evidence about the way teachers carry out the teaching/learning

activities in schools. It has been noted that, whereas in the interviews some teachers indicate how possible implementation of policy on education for children with mental retardation may be easy, the situation in the classrooms indicates how difficult implementation may be. In some classes with few children, there are indications that success in implementation of the policy may be promising, while in other classes, the policy implementation may not be practicable for a long time yet to come, because teaching/learning appears to face many problems in Uganda.

#### **4.3.3.4 Limitations of Observation**

As mentioned earlier, the current observation has not been meant to be one of the main sources of data collection for the current study. It has been a brief exercise, meant to check the difficulties teachers are facing generally. In order to get hard evidence, a deeper study should be carried out in Uganda, based exclusively on an observation method. We have not been able to do an in-depth observation study because of the time limit. Thus, our report based on observation in this study is not exhaustive. Another important source of data for the current study was documentary evidence. I shall provide the description concerning this research technique in the next section.

#### **4.3.4 Documentary Analysis**

A document is an original or official printed paper (or filmed material) furnishing information or used as proof of something that has occurred (Lincoln and Guba, 1985: p.228-230). Examples of documents include letters, memoirs, autobiographies, diaries or journals, textbooks, wills, position papers, suicide notes, speeches, novels, newspaper articles and editorials, television and film scripts, memoranda, case studies, life histories, political propaganda pamphlets, government publications and photographs, to mention just a few.

A document can be a primary or secondary source of information. A primary source of information is something that generates or provides a firsthand experience of a particular situation or event. A secondary source is one that generates information based on another source (Bogdan and Biklen 1982: p.220).

I have included documentary analysis as one of the techniques of data collection in the current study for various reasons. One of the reasons is to find out what policy statements have been laid down and how much of the policy has been implemented. Besides the official government documents, we also wanted to find out, especially from mass media, what comments have been made over the years regarding the provision of education for

persons with disability, in general, in Uganda. Mass media (especially the print media, that is, newspaper) reports are a vital source of information in the country, given the fact that there is such a shortage of scientifically researched information published locally by Ugandans in connection with the provision of education for children with mental retardation or for persons with disabilities in general.

I do hope that the current study being the first of its nature in the country, will enhance the availability of documented literature related to the provision of education for children with mental retardation and special educational needs generally in Uganda.

#### **4.3.4.1 Materials Analysed**

A variety of documents have been used for describing the policy aims, attitudes and implementation of special needs education in Uganda. Such official documents include the *Kajubi Report* (1989), the *Government White Paper on Education for National Integration and Development* (1992), official government education statistics and a circular of intent regarding Free Primary Education (1996). Besides the above mentioned official documents, other relevant and available documents include mass media reports published by the official government newspaper, the *New Vision*, and the second most popular (although privately owned) *Monitor News Paper*.

#### **4.3.4.2 Advantages of Documentary Analysis**

Like other methods of data collection, documentary analysis has various strengths and limitations. Lincoln and Guba (1985: p.231-236) have listed the strengths and limitations of documentary analysis. Documents, they say, are a stable, rich, and rewarding resource; they tend to persist; that is, they are often available for reference. They thus provide a base from which any subsequent researchers can work and thus lend stability to further inquiry. Documents, the authors further say, represent a natural source of information; that is, they not only provide facts, but they are a storage of well-grounded data on the event or situation under investigation.

#### **4.3.4.3 Limitations of Documentary Technique**

One of the criticisms of documentary analysis is that it does not provide a representative sample. Personal documents, for example, are particularly criticised for this limitation. It is also noted that occasionally it is true that even in social action programmes, no one on the project keeps very good notes on processes; few memoranda are generated, and, even more often, the only writing that is done is in response to funders' requests for technical reports or other periodic statements about the progress of the programme (Lincoln and Guba, 1985:

p.231-236).

Having provided the descriptions of the research methods used for the current study, it is important, at this point to discuss their validity and reliability.

### **4.3.5 The Validity of the Research Instruments**

Any research instrument needs to be checked for validity. In other words, the researcher has to ascertain whether an item really measures what it is supposed to measure. A test is said to be valid if the data serve the purpose for which they were collected. Ary, Jacobs and Razavieh (1990) explain the term by saying:

Validity is always specific to the particular purpose for which the instrument is being used. For example, a test that has validity in one situation and for one purpose may not be valid in a different situation or for a different purpose. (p.257)

The above definition is in line with the American Psychological Association (APA), American Educational Research Association (AERA) and the National Council on Measurements in Education (NCME)'s 1985 Joint Standards of Measurement and Testing.

The Joint Standard recognises the different types of validity and the specific areas for which they should be defined. The different types of validity are: content-related validity, concurrent-related validity, predictive-related validity and construct-related validity.

Cunningham (1998: pp.139-140) provides clarification on each of the four types of validity

which we present below.

Content-related validity is the degree to which the sample of test items represents the content that the test is designed to measure. Content-related validity is determined by systematically conducting a set of operations such as defining in precise terms the specific content universe to be sampled, specifying objectives, and describing how the content universe will be sampled to develop test items. In close association to this type of validity is face validity, a validity that refers to an evaluator's subjective judgement of what the content of the test appears to measure. Content-related validity cannot be computed; it is determined by the subjective judgement of experts.

Predictive validity is the degree to which the predictions made by a test are confirmed by the later behaviour of the participants.

Concurrent-related validity is determined by relating the test scores of a group of participants to a criterion measure administered at the same time or within a short time.

Distinction between concurrent-related and predictive-related validity depends on whether the criterion measure is administered at the same time as the standardised test (concurrent) or later, usually after a period of several months or more (predictive).

#### Chapter 4: Methodology

Construct-related validity is the extent to which a particular test can be shown to measure a hypothetical construct. Concepts such as anxiety or creativity are considered hypothetical constructs because they are not directly observable, but rather are inferred on the basis of their observable effects on behaviour.

Not all the above types of validity clarified by Cunningham (1998) are applicable to our current study. It is content-related validity which was found appropriate for the study. Content-related validity is relevant because of the nature of the tests, which were constructed to find out the views of respondents on policy implementation for the education of children with mental retardation in Uganda. In other words, all the tests were aimed at measuring an intended content area. Content-related validity, thus, was the most suitable measurement for such an intended content area. The rest of the above listed types of validity measure different areas and therefore could not be employed.

As noted above, it is recommended in the literature that content-related validity cannot be computed, but can only be assessed by the subjective judgement of experts. In light of that, for the current study some prominent educationalists were approached and their views sought about the validity of the study. The study was also carried out under the supervision of a highly experienced educationalist. The educationalists were satisfied with both the face and content validity. With their backing, the researcher had the confidence to put the

instruments into final form. *Appendix 14* includes a list of the educationalists (apart from the supervisor cited in the acknowledgement section of the thesis) who were contacted in connection with the validity.

### **4.3.6 The Reliability of the Research Instruments**

An instrument is judged to be reliable if it gives a stable consistent result when re-used under similar conditions after a reasonable passage of time. There are three methods of determining reliability. The methods are test-retest, equivalent or parallel forms and split-half methods. The three methods of measuring reliability as described by Charles (1995; p.102) are presented below.

The test-retest method involves administering a given test to a group of people and then after some time again administering the same test to the same people. The scores from the first and second administrations are correlated and the resultant coefficient of correlation provides an index of reliability.

The equivalent or parallel method of determining reliability is similar to the test-retest method, except that in this case two different forms of the test are available for measuring the same thing. For example form A of the test is administered to a group of individuals,

#### Chapter 4: Methodology

and thereafter form B is administered to those same individuals. The two sets of scores are correlated and the resultant coefficient is the index of reliability.

The split-half method involves dividing a given test into two parts, such as even-numbered and odd-numbered items. The test is administered to a group of individuals. Two scores are obtained for each person, then the scores are correlated and the resultant coefficient is the test's index of reliability.

For the current study the reliability of the questionnaire was determined by the test-retest method.

As mentioned under the pilot study above, eighteen teachers/headteachers answered the questionnaire twice within a three-week interval. To estimate the reliability of the questionnaires, the Spearman's correlation coefficient was chosen as the most appropriate method. A scatter graph to illustrate the relationship between the two test results was also plotted. A correlation coefficient of 0.775, significant at the 0.01 level was obtained, suggesting that a fairly strong relationship exists between the two test results. A reasonable linear relationship, with the exception of three outlying points, was found to exist for the two variables concerned. (*See Appendix 29*)

#### Chapter 4: Methodology

Establishing objectively the reliability of data collected through methods such as interviews is relatively difficult. Like questionnaires or observations, the key concept in interview reliability or credibility, a preferred term by postpositivists (such as Lincoln and Guba, 1985), is to ascertain consistency. In order to obtain such data a researcher has to think carefully about the trustworthiness of his or her key informants (Borg and Gall, 1996). In making this effort, the researcher is applying internal criticism to the data, a criticism which Charles (1995: p.103) believes has to do with determining the credibility of data. In the current study, we had to interview and compare what different participants said in reference to the policy implementation. Logical interpretation and comparison of what the participants said helped in carrying out internal criticism of the data.

Implementation of policy on education for children with mental retardation in Uganda is associated with different target groups. I, therefore, found it necessary that the target population about which generalisations for this study were to be drawn, was basically that of parents, children, teachers/headteachers, EARS staff and top education administrators in Uganda. Indeed the selection of such a target group was necessary if validity of the research instruments employed was to be strengthened further. As planned earlier if each and every category of participants responded, a much better result of the study would have been realised. There were, however, some difficulties faced during data collection as pointed out under field experiences in the next section below.

### **4.3.7 Field Experiences and Challenges**

In Ugandan cultures, everyone is expected to show courtesy when carrying out work like the current study. On each of my visits to the participants, especially to the parents in the countryside, after talking to them I had, as a matter of courtesy, to provide a token of appreciation in the form of some material contribution to either the child I was concerned with, or to the parents of the child. This gesture is not regarded as a bribe but is considered a natural courtesy and when I returned to that family another time I was sure of getting better and more attention. While I understand the situation and appreciate this form of reciprocity and appreciate its value in our cultures, carrying out research on a limited financial background has not been easy in Uganda. One has to sacrifice in order to succeed in a research study of this nature in the country. One has to use some of one's personal income, of course well knowing the side effect such a decision would cause to one's family.

The family has to be informed about such circumstances. Some places were not sampled as mentioned earlier, because of security reasons, so it is likely that valuable information could have been missed from such areas.

The most challenging problem I faced during data collection has been that of getting audiences with my superiors. As mentioned above, it has not been easy to get information

#### Chapter 4: Methodology

from the Minister of Education, a policy maker. It would have been very helpful to get more explanation from the minister, so as to compare and contrast what the policy implementers say and what he (a policy maker) says, regarding the problems affecting implementation of the policy. The attempt to see the minister totally failed. Despite numerous attempts to visit his office, the response from the minister's secretaries was always the same: "The Honourable Minister is not in". For nearly one and a half years, the Honourable Minister was not in. Even if I saw his car parked outside the office or I saw him enter a lift to go to his office, the Honourable Minister was never in. As the Honourable Minister was not in, so it was also impossible to obtain any response to a letter I had written to him for more than one year and a half.

Although the two Commissioners have been interviewed, they are top policy implementers and they may not be in a position to suggest changes in the policy at hand.

Many respondents, especially those in highly placed positions, have been found not to value time. If a respondent agrees to certain dates and times, it is by great chance that such an appointment is ever fulfilled. Sometimes the mood of such respondents has been very unfriendly, suggesting that the presence of the researcher is not welcome.

In order to succeed in carrying out research of this type, there is need for utmost patience

and determination. Without these qualities nothing can be expected, given the kind of situation that prevails in Uganda. Policy makers call upon people to do research, but when it comes to providing information, or paying even a little attention, it is not an easy affair.

Success has been achieved, firstly, because I live in the country where data has been collected and am aware of the numerous problems. As such I had to exhibit as much patience, tolerance and determination as possible. If I had to conduct a similar study next time, I am sure, I would come out with better results than what I have got in the current study. I shall present, in the next section, the description of data analysis.

#### **4.3.8 Description of Data Analysis Procedures**

After data was collected, it was coded and entered into a computer at the Institute of Statistics and Applied Economics (ISAE) at Makerere University, Kampala. Another similar analysis was later carried out at Durham University to confirm the results obtained at Makerere. There was no difference found between the two analyses. The Statistical Package of Social Sciences (SPSS-X) was used for the analysis. This was based on the advice given by the statisticians from both Makerere and Durham Universities. Experts from the two universities advised that the tests for the data should include descriptive statistics, chi-square and t-tests, where applicable.

Descriptive statistics, that is, frequency and percentage counts, are used for analysing data. The advantage of descriptive statistics, according to Hopkins, Hopkins and Glass (1996: p.2), is that it provides tools for organising, simplifying and summarising basic information from an otherwise unwieldy mass of data. A combination of these different techniques has enabled data to be analysed from both ethnographic and statistical points of view. Frequency and percentage tables are used to describe the data and to clarify the calculated key elements in the question. Where considered appropriate, mean scores are used to compare the participants' views on the values they attach to each particular issue raised in the questionnaire. In order to test participants' judgements, the close-ended questionnaire had the values strongly agreed (5), agreed (4), not sure (3), disagreed (2) and strongly disagreed (1) assigned to each of the items for participants to provide their responses. The participants are further asked to comment on each of the answers chosen and say why they respond the way they do.

Where applicable, responses to each of the questions are provided in a table, which indicates the frequency, the percentage and the mean score for each item. We shall discuss this in detail in Chapter 5. The data is then summarised in order to show how participants' views emerge as a result of the analysis.

#### Chapter 4: Methodology

Although as noted above, the descriptive statistics serve to achieve the objectives of identifying participants' responses, it is also found necessary to test the differences between the responses provided for the different variables within each of the categories of respondents. Chi square, needed to determine whether frequency counts are distributed differently for different categories, and t-test, necessary for measuring differences between mean scores were used where appropriate.

The results obtained from the survey questionnaire are summarised so as to provide an overview of findings. We shall discuss this further in Chapter 5. Similarly, the data obtained from interviews and observations are used for comparisons or contrasts with the survey data.

Interviews and observations are used in the study as sources of qualitative data. Thus, they are important to help give explanations and evidence of what teachers, parents, children and education administrators' roles are in the implementation of the policy. The interview responses therefore help to explain and interpret some of the responses provided in the survey data. It is usually not easy for participants, through survey data, to elaborate on some of the answers, so this is achieved through interviews and observations. In other words, for survey data to be interpreted well there must be some descriptions of the whole reality of the viewpoint of the participants. The descriptions may shed more light and

provide some specific information than merely drawing conclusions from variables.

During interviews (as indicated in Table 4.2 above), nine parents, nine teachers and nine headteachers were interviewed. Similarly, during observations, nine lessons were observed.

Being such a small number of both interviews and observations, there has been no need to use computer packages for analysis of the data; this is hence done manually.

The parent and teacher/headteacher tape-recorded materials are transcribed into papers carrying interviewees' names and status (for example, whether one is a mother, a father, a relative, or a teacher or headteacher). Each of these interview transcription papers is specially prepared so that different parts are allocated to each question and answer. This is done so as to facilitate easy reference to the answers. The analysis of data provided through interviews is analysed based on the content. In other words, the analysis involves consideration of what the participants say and the meanings they attach to the items in question; and where possible, their responses are compared with one another and also with data provided through other methods, such as survey, documentary and observation. The analysis also makes comparisons with the findings in the literature: the participants' answers regarding actual practice are compared and contrasted to theoretical ideas in the literature.

## **4.4 Conclusion**

In this chapter, a summary of the fieldwork process of the study is presented. The chapter includes mainly the procedures, which are followed in the preparation of the instruments of the study, that is, the survey questionnaires, interviews and observations.

Participant population and samples, backed up with explanation of the sampling techniques employed, are provided. A description of the pilot study and procedures that are used to ensure validity and reliability of the instruments is also given.

As noted, the questionnaire had some weaknesses, therefore, validity may have been weakened. This weakness, was however, checked by using the rich qualitative data.

The next Chapters 5 and 6 will be devoted to the presentation and analysis of the findings of the study.

# CHAPTER 5

# Chapter 5

---

---

## **5.0**                      ***Policy in Practice: Results of the Empirical Study - Analysis of Quantitative Data***

### **5.1**                      **Introduction**

I have discussed in the previous chapters current trends in the development of special needs education in the world, definitions and concepts of mental retardation, aims of education and curriculum for children with mental retardation, selection/assessment of children for educational provision, approaches/methods of teaching children with mental retardation, and preparing teachers to teach children with mental retardation. The findings in those chapters have provided me with theoretical ideas which need to be compared and contrasted with the empirical findings which this chapter (Chapter 5) presents. In other words, I shall use this chapter to relate to the earlier chapters so that I am able to find out how much Uganda can learn from different countries.

I shall therefore present the findings based on quantitative data in the questionnaire. I consider a number of factors to be potentially influential in participants' experience and views. The factors I consider are their rank (being a headteacher or a teacher), place of work (considering life such as rural or urban) and gender.

## 5.2 Categories of Participants

With the help of tables, I shall present the categories of participants who responded to the questionnaires, and show how the closed questions are analysed (open-ended part is dealt with in the next chapter). The different categories of participants are shown in Table 5.1 below.

**Table 5.1: Categories of participants**

Category	Frequency (%)		Total (%)
	Male	Female	
Gender	59	41	100
Place of work	47	53	100
Rank	47	53	100

Having noted the different categories of participants (in Table 5.1) above, I shall present the current trends of participants' attitudes towards education of children with mental retardation in Uganda.

### 5.3 Current Trends of Attitudes Towards Education of Children with Mental Retardation in Uganda

In this section, with the help of Table 5.2 below, I present the scores for each of the questions 9 – 15, select some and discuss what they suggest.

**Table 5.2 General Trend of Participants' Attitudes Towards Education of Children with Mental Retardation**

Item	N	Minimum	Maximum	Mean	St. Dev.
<b>Qu.9:</b> How participants interpret parents' involvement in education of chn with m/retardation	100	1	5	3.72	1.33
<b>Qu.10:</b> Participants who see the need for change in the conditions which can enable children with mental retardation learn effectively in ordinary schools	99	1	5	3.86	1.32
<b>Qu.11:</b> Participants who see the need for children with mental retardation to learn separately in special schools	99	1	5	2.96	1.41
<b>Qu.12:</b> Participants who see the need for children with mental retardation to learn together in ordinary schools	100	1	5	3.08	1.54
<b>Qu.13:</b> Participants who see the suitability of the aims of education and curriculum for children with mental retardation in Uganda	100	1	5	2.18	1.34
<b>Qu.14:</b> Participants who see the need for involvement of other professionals in the implementation of education for children with mental retardation in Uganda	99	1	5	3.44	1.42
<b>Qu.15:</b> Participants who see the need to adopt specific teaching approaches/methods for children with mental retardation in Uganda	98	1	5	4.03	1.14

chn = children

m/retardation = mental retardation

N= Number

Qu. = Question

St. Dev = Standard Deviation

As noted from the above table (Table 5.2), assuming that a score of 2.5 is the neutral point, participants tended to score above that point. This indicates generally how positive they were in their attitudes towards education of children with mental retardation. A score of 2.18 for Question 13 suggests that participants were dissatisfied about the way aims of education and curriculum for children with mental retardation were in Uganda.

Although we have noted the general trend of the participants' responses above, in Chapter 4, I pointed out the problem connected with the questionnaire. Some of the questions in the questionnaire are too ambiguous to be very helpful. In light of that, therefore, the responses above have to be considered with caution. As I deal with these questions again in Chapter 6, I shall then provide a detailed analysis of the responses so as to get a clearer picture.

Before I proceed with the comments about some of the selected responses shown in the Table 5.2 above, it is important, first, to discuss participants' views regarding the definition of mental retardation.

## **5.4 Definition of Mental Retardation**

Analysis of responses on any of the questions will be based on the three categories of participant, that is, rank, place of work and gender. I shall begin by presenting one of

the questions below and see how the above categories responded. The question was asked as follows: *What in your view would you say is the condition referred to as mental retardation? (Q.4)*

A response to the above question was expected to be provided under any of the following descriptions:

- (i) An individual who has little understanding
- (ii) An individual with special behaviour problems
- (iii) Difficult to describe

I present the responses in Table 5.3 below, followed by further analysis.

**Table 5.3: Definitions of Mental Retardation**

<b>Definition of Mental Retardation</b>	<b>Frequency (%)</b>
(i) mental retardation is associated with little understanding	16
(ii) mental retardation is associated with special behaviour problems	75
(iii) mental retardation is difficult to define	9
<b>Total</b>	<b>100</b>

A response provided under category (i) would be regarded as negative and therefore it would be assumed that the participants providing answers under that category would not willingly implement the policy. Responses under category (ii) would be regarded as positive and the participants providing such answers would be regarded as likely to

implement the policy without much difficulty. Participants providing answers under category (iii) would be regarded as being unclear about whether to implement the policy or not.

I can further explain the justification for interpreting some of the answers as being “positive” and some as “negative” by comparing the findings in this chapter with the findings in the literature, in Chapter 2. Wechsler (1991) and other authors cited in that chapter dwelt on measurements of people’s intelligence and reported how this concept had been the basis for judging people’s performance of tasks in the past. We noted that people whose IQs were rated as low were considered to be unable to perform tasks satisfactorily. Low IQ was equated to little understanding, while high IQ was equated to ability to understand and perform tasks satisfactorily. Ferguson (1994), for example reported that some people were noted to be untrainable, because of their low IQ. In view of that, the responses, which are referred to as negative in this chapter may be equated to the way people with low IQ were perceived in the past. There are some people in Uganda who may still think that children with mental retardation are not capable of learning successfully. We have noted that the 1992 AAMR has reduced the emphasis on IQ concepts and has given more emphasis on adaptive behaviour (or skills). The findings in the literature further indicate that when individuals are helped to overcome the problems with their adaptive behaviour they may improve and start to perform their tasks satisfactorily. Therefore, in this chapter, I can interpret some

responses as being positive by saying that the participants who have emphasised behaviour are those people who may not seem to view the disability (that is, mental retardation) as being the problem, but who may view the behaviour as the problem to be addressed. In Uganda, behaviour, which does not conform to the society norm, becomes an issue of concern to everybody.

The overall findings reveal (as indicated in Table 5.3 above) that 75% of participants defined mental retardation as a condition associated with behaviour problem, 16% defined mental retardation as a condition associated with little understanding and 9% indicated that the condition is difficult to define.

Further tests were conducted, to find out if there was any significant differences between the given pairs of independent variables and this involved the use of *chi-square test* (Significant at  $P < 0.05$ ). I shall illustrate this with the help of Tables 5.4 - 5.6, starting with Table 5.4 below.

**Table 5.4: Definition of Mental Retardation: Concepts by Gender**

Variables	Mental Retardation is associated with little understanding	Mental Retardation is associated with special behaviour problems	Mental Retardation is difficult to define	Value	df	P
Male (N=59)	13	42	4	4.342	2	.114
Female (N=41)	3	33	5	4.674	2	

The  $X^2$  level of significance which amounts to 0.114 reveals that there was no significant

difference in the definition of mental retardation between male and female participants. It was expected that female participants would define the condition in a more positive way compared to the males, because in Ugandan cultures women are more close to the children. Whether they become professional (such as being teachers) or not, culturally women are required to look after their children, so they experience children's problems more than men do. The findings proved the expectation not true. No difference was found between men and women.

In Table 5.5 I present the findings with regard to participants' places of work.

**Table 5.5: Definition of Mental Retardation: Concepts by Place of Work**

Variables	Mental Retardation is associated with little understanding	Mental Retardation is associated with special behaviour problems	Mental Retardation is difficult to define	Value	df	<i>P</i>
Urban (N = 53)	9	37	7	2.691	2	.260
Rural (N = 47)	7	38	2	2.846	2	

In the pair of independent variables, as indicated in the above Table 5.5, the objective was to find out if there was a significant difference in defining mental retardation as far as places of work was concerned. The  $\chi^2$  level of significance, which amounts to 0.260, as indicated, reveals that there was no significant difference in the definition of mental retardation between the rural and urban participants.

It was expected that because of traditional influences, participants from the rural areas

would define mental retardation in a more negative way than the urban participants (with scientific influences and who were exposed to a modern approach to doing things). The result showed no significant difference between the two groups. In Table 5.6 below, I present the findings with regard to ranks of the participants.

**Table 5.6: Definition of Mental Retardation: Concepts by Rank**

Variables	Mental Retardation is associated with little understanding	Mental Retardation is associated with special behaviour problems	Mental Retardation is difficult to define	Value	df	<i>P</i>
Teacher (N = 53)	9	37	3	.907	2	.636
Headteacher (N = 47)	7	38	6	.923	2	

In the above pair of independent variables, the objective was to find out if there was a significant difference in defining mental retardation between teachers and headteachers. As noted, the  $X^2$  level of significance which amounts to 0.636 reveals that there was no significant difference in the definition of mental retardation between the teachers and headteachers.

Classroom teachers were expected to have a better definition of the condition than the headteachers, due to the fact that they spend more time with children in the classroom and understand them better. The result did not show a significant difference between the teachers and headteachers.

Definition of mental retardation as indicated in the results still remains unclear. There

was no single group that seemed to have a uniformity in the definition. Generally, however, participants seemed to associate mental retardation with behaviour problems much more than other aspects. After definition I also present the findings with regard to aims of education and curriculum for children with mental retardation in Uganda.

## **5.5 Change Aims of Education and Curriculum for Children with Mental Retardation in Uganda**

The questionnaire addressing the aims of education and suitability of the curriculum for children with mental retardation in Uganda had a question asked as follows: *The curriculum set up and the education aims in Uganda need a change, with regard to the children with mental retardation in the country. (Q.13)*. This question was to be answered on a five point scale, that is, strongly agreed (5), agreed (4), not sure (3), disagreed (2) and strongly disagreed (1). A *t-test (Significant at  $P < 0.05$ )* was used to find out if there was a significant difference in the mean scores by each of these pairs of independent variables: gender, place of work (urban and rural) and ranks (headteachers and teachers). Before I present the specific results, according to each of the above categories of participants, it is important that I show how the sample responded to the question. I use Table 5.7 below for illustration.

**Table 5.7: Sample Responding to Question on Aims of Education and Curriculum for Children with Mental Retardation in Uganda**

Item	N	Minimum	Maximum	Mean	St. Dev.
<b>Qu.13:</b> Participants see the suitability of the aims of education and curriculum for children with mental retardation in Uganda	100	1	5	2.18	1.34

In section 5.3 (Table 5.2) we noted that a score which is less than 2.5 would reflect a negative response. 2.18, as shown in Table 5.7 above, therefore, indicates how negative the participants were, when asked whether they thought the aims of education and curriculum for children with mental retardation in Uganda were relevant. The results here show that they were definitely not satisfied – the participants indicated that there was a need to change aims and curriculum for children with mental retardation in Uganda. The overall results about the same question are presented in Table 5.7a below.

**Table 5.7a: Overall Results about Aims of Education and Curriculum for Children with Mental Retardation in Uganda**

Category	Frequency (%)		Total (%)
Gender	Male 59	Female 41	100
Place of work	Rural 47	Urban 53	100
Rank	Headteacher 47	Teacher 53	100

In the next section I present the analysis of each of the responses in Tables 5.8 - 5.10

below.

**Table 5.8: Need for Change in the Aims and Curriculum: Views According to Gender**

Variables	N	Mean	Std.	df	t	P
Male	59	2.98	1.54	98	-.756	NS
Female	41	3.22	1.54			

NS = Not Significant

As far as gender is concerned, as indicated in the above Table 5.8, 59% of participants, who were male, with a mean score 2.98 were in favour of changes, compared to 41% of participants, who were female, with a mean score 3.22 who were in favour. Given that the mean for the female participants was higher than that for the males, it could be judged that the female participants were more favourable to the implementation of the provision. It turned out, however, that the level of significance which amounts to 0.45 reveals that there was no difference in the scores by the two different independent variables. Statistically it would be argued that the female participants could have scored more than the males by chance. Nevertheless, from both educational and cultural points of view, in Ugandan society women seem to be more enthusiastic towards children, especially those with special needs.

I shall now examine if there are any statistical differences in responses between participants from urban and rural areas. I illustrate this with the help of Table 5.9

below.

**Table 5.9: Need for Change in the Aims and Curriculum: Views According to Place of Work (Urban or Rural)**

Variables	N	Mean	Std.	df	t	P
Urban	53	3.02	1.55	98	-.421	NS
Rural	47	3.15	1.53			

In the above pair of independent variables, the objective was to find out if there was a significant difference in favour of changes in the aims of education and curriculum for children with mental retardation by the participants working in urban and rural areas in Uganda.

As indicated in the above Table 5.9, 53% of participants, who were urban, with a mean score 3.02 were in favour of changes, compared to 47% of participants, who were rural, with a mean score 3.15. The level of significance which amounts to 0.67 reveals that there was no difference in the desire for changes in the curriculum and aims of education between the urban and rural participants.

It was expected that since participants from the rural areas had traditional influence, they would not recognise the need to re-adjust the curriculum and to re-define the aims of education, the way the urban participants with modern influence would, but this was not confirmed.

In the next analysis I shall present the responses based on rank, that is, how teachers or headteachers responded. I shall use the table (Table 5.10) below for illustration.

**5.10: Need for Change in the Aims and Curriculum: Views According to Rank (Headteachers or Teachers)**

Variables	N	Mean	Std.	df	t	P
Teachers	53	3.34	1.51			
Headteachers	47	2.79	1.53	98	-.1816	NS

With regard to ranks as indicated in Table 5.10 above, 47% of the participants, who were headteachers, with a mean score 2.79 indicated the need to have changes in the curriculum and aims of education for the good of children with mental retardation in Uganda, compared to 53% of participants, who were teachers, with a mean score 3.34 in favour. A level of significance which amounts to 0.07 reveals that there was no significant difference between headteachers and teachers regarding changes in the current curriculum and aims of education in Uganda.

Classroom teachers were expected to react more positively to the need for changes in the current aims of education and curriculum for children with special needs in Uganda. This expectation was based on the fact that in Uganda, teachers, compared to headteachers, spend more time with children in the classroom and are in a position to assess and use content and materials which are suitable for children with mental retardation.

As noted from all the responses, the general views show that there is need to have some

adjustment to the aims of education and curriculum to meet the needs of children with mental retardation in Uganda. Participants are not satisfied with the current aims and curriculum.

## **5.6 Recommended Strategies for Implementing the Policy for Education of Children with Disabilities**

Presentation and discussion of strategies for implementation of the policy, as mentioned at the beginning of the chapter, involve clarification of issues, such as the types of schools and facilities suitable for education of children with disabilities; how children are supposed to be selected for education; how teachers are supposed to be prepared to teach; and what approaches/methods teachers are supposed to adopt for teaching children with special needs.

As noted in Chapter 1, the government recommended (in R. 152 and R. 166), that it would begin to provide adequate support to all institutions offering special education, take over all units and annexes attached to normal schools/colleges, establish a training college to train teachers for the handicapped in both primary and secondary schools, and convert one of the existing Primary Teachers' Colleges (PTCs) to train teachers for Special Education. These were planned to be implemented in phases, some to start in

1992/93 and some to be established between 1994 and 1997.

I found, during the study, that the number of units/annexes for children with special needs in ordinary schools were steadily increasing.

I shall, in the next section, discuss the achievement in integration of children with mental retardation in ordinary schools.

The findings from the literature reveal that integration of children with special needs in ordinary schools is the level of practice at which most countries are currently operating. UNESCO, as noted in Chapter 1, reviewed the progress of implementation of education for children with special educational needs in both developed and developing countries. The UNESCO findings indicated that the majority of countries were at the level of integration, Uganda being among such countries. With regard to children with mild degree of special needs, I noted from Hegarty, Hallahan and Kauffman (in Chapter 3) justification for educating such children in ordinary schools. I also noted that children with severe degree of special needs could benefit by being educated in a segregated system where they would require close attention of teachers. With such observations, I shall now present and discuss the findings in Uganda. This will enable us to see how policy in practice compares with other countries.

### 5.6.1 Views on Integration in Uganda

In Uganda the findings reveal that reactions to integration of children with mental retardation in ordinary schools have varied considerably. The survey questionnaire addressing the adequate provision of institutions and facilities recommended for the implementation of the policy of education for children with disability had the following question: *In Uganda, education policy makers and administrators have not provided suitable conditions to enable children with mental retardation to learn effectively in ordinary schools. (Q.10)*. This question was to be answered on a five-point scale, that is, strongly agreed (5), agreed (4), not sure (3), disagreed (2) and strongly disagreed (1). A *t-test (Significant at  $P < 0.05$ )* was used to find out if there was a significant difference in the scores by each of these pairs of independent variables: gender, place of work (urban and rural) and ranks (headteachers and teachers). With the help of Table 5.11 below, I present the general responses by the sample, then proceed with the detailed analysis.

**Table 5.11: Sample Responding to Question on Suitability of Conditions for Children with Mental Retardation in Ordinary Schools in Uganda**

Item	N	Minimum	Maximum	Mean	St. Dev.
<b>Qu.10:</b> Participants who see the need for change in the conditions which can enable children with mental retardation learn effectively in ordinary schools	99	1	5	3.86	1.32

As can be noted in Table 5.11 above, the score 3.86 indicates how positive the

participants were, in wanting to see conditions made suitable for children in ordinary schools in Uganda. The overall results of the above question are presented in Table 5.11a below.

**Table 5.11a: Overall Responses on Suitability of Conditions for Children with Mental Retardation in Ordinary Schools in Uganda**

Category	Frequency (%)		Total (%)
	Male	Female	
Gender	58	41	99
Place of work	47	52	99
Rank	46	53	99

Having noted the overall results in Table 5.11a above, I now present the statistical analysis for each of the three categories of participants in Tables 5.12 - 5.14 below, starting with responses according to gender.

**Table 5.12: Need to Change Conditions in Ordinary Schools: Views According to Gender**

Variables	N	Mean	Std.	df	t	P
Male	59	2.98	1.54	98	-.756	NS
Female	41	3.22	1.54			

As noted in the Table 5.12 above, the first pair of independent variables, 58% of participants, who were male with a mean score 3.69 were dissatisfied about suitability of conditions for children with mental retardation learning in ordinary schools, compared to 41% of participants, who were female, with a mean score 4.10 holding a similar view.

The 0.13 level of significance reveals, however, that there was no difference in the scores by the male and female participants. The findings confirm that both male and female participants are not satisfied about the suitability of the learning conditions for children with mental retardation in ordinary schools. In the next section, I shall present the results according to place of work as shown in Table 5.13 below.

**Table 5.13: Need to Change Conditions in Ordinary Schools: Views According to Place of Work (Urban or Rural)**

Variables	N	Mean	Std.	df	t	P
Urban	52	3.58	1.45	97	-2.272	0.02
Rural	47	4.17	1.11			

As we can see from the above Table 5.13, 52% of participants, who were urban, with a mean score 3.58 were dissatisfied about the existing conditions in ordinary schools, compared to 47% of participants, who were rural, with a mean score 4.17. The latter were more dissatisfied about the suitability of conditions in ordinary schools. The level of significance which amounts to 0.02 reveals that there is a difference between the two independent variables.

It was expected that participants in the urban areas would better understand the conditions needed for children with mental retardation in ordinary schools, because they (participants) were more exposed to modern approaches to teaching children with disabilities, compared to the traditionally oriented rural participants. The findings in the study disprove that assumption. Instead, it was the rural and presumed traditionally

oriented participants who were found to be more dissatisfied about the conditions of learning for children with mental retardation in ordinary schools. Different factors could be responsible for rural participants' being more concerned about suitable conditions for children with mental retardation in ordinary schools. One of the factors could be that in the rural schools teachers might not be as pre-occupied with academically capable children only, as the urban schools would. In Uganda, the policy is such that children with disabilities are allowed to receive education, but there is no evidence to show how suitable conditions for such children are, in ordinary schools. Each year when the Ministry of Education releases results for the Primary Leaving Examinations (PLE), only some of the well-resourced urban schools shine; the rural schools are rarely heard of. Thus, policy makers in Uganda still face a big challenge in providing suitable conditions not only for academically capable children, but for children with special needs as well. In the next section I provide the results according to rank. I start by presenting the results in Table 5.14 below.

**Table 5.14: Need to Change Conditions in Ordinary Schools: Views According to Rank**

Variables	N	Mean	Std.	df	t	P
Headteacher	46	3.91	1.33	97	.379	NS
Teacher	53	3.81	1.33			

As we can observe from the above Table 5.14, 46% of participants, who were headteachers, with a mean score 3.91 indicated their dissatisfaction about the conditions of children with mental retardation's learning in ordinary schools, compared to 53% of

participants, who were teachers, with a mean score 3.81 who were also dissatisfied. A level of significance which amounts to 0.71 reveals that there was no difference between headteachers and teachers, regarding improvement of conditions for children with mental retardation in ordinary schools.

It was expected that classroom teachers would be more dissatisfied than headteachers about suitability of learning conditions for children with mental retardation in ordinary schools.

The findings indicate that headteachers were equally dissatisfied about suitability of learning conditions for children with mental retardation in ordinary schools. According to the findings, all categories of participants expressed dissatisfaction about suitability of learning conditions for children with mental retardation in Uganda. A difference in scores was identified between participants in the rural and urban areas. The former appeared to be more dissatisfied about the suitability than the latter.

## **5.7 Teaching Approaches/Methods Suitable for Children with Mental Retardation**

Approaches/teaching methods for children with mental retardation, according to the literature, do vary. Depending on the degree of the special needs of individual children,

however, teachers may choose specific approaches or vary the teaching methods from time to time. Wolery, Bailey and Sugai (1988), for example, have recommended an applied behaviour analysis approach/teaching method as suitable for children with severe mental retardation. Through this approach/teaching method, teachers are supposed to concentrate on identifying specific problems that interfere with the children's learning, find out what may be the causes or sources of the problems and decide on what solutions needed to be provided. Literature (as noted in Chapter 3) revealed that teachers needed to collaborate amongst themselves; they needed to use children to teach fellow children; and they needed to plan for whichever methods they chose to use for children with mental retardation (Bauwens and Hourcade, 1991; Nowacek, 1992; Fuchs and Fuchs, 1991).

### **5.7.1 Views in Uganda**

The survey questionnaire addressing the issue of teaching approaches/methods had this question: *Although there could be many different methods of teaching, for the sake of children with mental retardation, the government should introduce certain specific and limited number of teaching methods which teachers should adopt. (Q.15).*

This question was to be answered on a five-point scale, that is, strongly agreed (5), agreed (4), not sure (3), disagreed (2) and strongly disagreed (1). A *t-test (Significant at  $P < 0.05$ )* was used to find out if there was a significant difference in the scores by each

of these pairs of independent variables: gender, place of work (urban and rural) and ranks (headteachers and teachers). In Table 5.15 below, I provide the general response by the sample on the question.

**Table 5.15: Sample Responding to Question on Suitability of Methods for Teaching Children with Mental Retardation**

Item	N	Minimum	Maximum	Mean	St. Dev.
<b>Qu.15:</b> Participants who see the need to adopt specific teaching approaches/methods for children with mental retardation in Uganda	98	1	5	4.03	1.14

The 4.03 score by the sample, as noted in Table 5.15 above, indicates that there is need to adopt suitable teaching methods for children with mental retardation in Uganda. I present the overall results as shown in Table 5.15a below, after that then I shall provide the analysis for each of the three categories of participants.

**Table 5.15a: Overall Responses on Suitability of Methods for Teaching Children with Mental Retardation**

Category	Frequency (%)		Total (%)
Gender	Male	Female	98
	58	40	
Place of work	Rural	Urban	98
	46	52	
Rank	Headteacher	Teacher	98
	45	53	

I present the statistical analysis as indicated in Tables 5.16 - 18 below.

**Table 5.16: Need to Adopt Specific Approaches/Methods of Teaching Children with Mental Retardation: Views According to Gender**

Variables	N	Mean	Std.	df	t	P
Male	58	3.91	1.20	96	-1.122	NS
Female	40	4.20	1.04			

From the Table 5.16 above, 58% of participants, who were male, with a mean score 3.91 supported application of some specific approaches/methods that were appropriate for teaching children with mental retardation, compared to 40% of participants, who were female, with a mean score 4.20 expressing the same view. The level of significance which amounts to 0.22 reveals that there was no difference in the scores by the two different independent variables. The findings confirm that both the male and female participants supported some specific approaches/methods that would be appropriate for teaching children with mental retardation in Uganda.

In the next section I shall present the results according to participants from urban and rural areas as shown in Table 5.17 below.

**Table 5.17: Need to Adopt Specific Approaches/Methods of Teaching Children with mental retardation: Views According to Place of Work (Urban or Rural)**

Variables	N	Mean	Std.	df	t	P
Urban	52	3.83	1.26	96	-1.899	NS
Rural	46	4.26	.95			

With regard to places of work, 52% of participants, who were urban, with a mean score 3.83 supported application of some specific approaches/methods that were appropriate for teaching children with mental retardation, compared to 46% of participants, who were rural, with a mean score 4.26 also in favour. The level of significance which amounts to 0.06 reveals that there was no difference in the two groups' responses regarding the need to apply appropriate teaching methods to teaching children with mental retardation. The findings confirm that both the urban and rural participants supported some specific approaches/methods that would be appropriate for teaching children with mental retardation. In Table 5.18 below I shall present the results according to rank.

**Table 5.18: Need to Adopt Specific Approaches/Methods of Teaching Children with Mental Retardation: Views According to Rank**

Variables	N	Mean	Std.	df	t	P
Headteacher	45	4.09	1.12	96	.463	NS
Teacher	53	3.98	1.17			

In the reactions according to ranks, 45% of participants, who were headteachers, with a mean score of 4.09 as noted in Table 5.18 above, indicate the need to apply appropriate teaching methods for children with mental retardation, compared to 53% of participants, who were teachers, with a mean score 3.98 in favour. A level of significance which amounts to 0.64 reveals that there was no significant difference between headteachers and teachers.

As noted above, the results indicate a uniformity of views and general agreement. This is a vital point on which implementers should base their hopes for success in the provision of education for children with mental retardation.

In the findings, participants generally showed that there was a need to adopt certain methods of teaching children with mental retardation in Uganda. It seems that if such a measure is taken it is likely that implementation can be effected fast enough.

## **5.8 Conclusion**

From the above analysis and discussion of the data, we have noted the general view of the teachers/headteachers as far as implementation of the policy is concerned. The findings reveal that the majority of participants were in favour of implementation of education for children with mental retardation in Uganda. In question 10, we noted the difference in responses between the rural and urban participants. Although there were no differences in other responses, participants generally indicated views of willingness to implement the policy, to integrate children with mental retardation and to adopt new aims and methods.

Having got the general views from the participants, it is important for me, at this point to reflect on the questionnaire. As I said in Chapter 4, questionnaires in general had limitations. One of these was the problem of formulating questions. This was a

particular problem in the questionnaire used in this study. The issues were complex and difficult to formulate in unambiguous ways and furthermore, given the low level of literacy in some of the participants, I tried to keep the questions short and simple. In retrospect, however, it became clear that some questions were problematic. For example question 4, about the condition of mental retardation offers only 3 alternatives and the same applies to question about causation (Q.5). The questions are as indicated below.

***Q.4: What in your view would you say is the condition referred to as mental retardation?***

- (i) An individual who has little understanding.....***
- (ii) An individual with special behaviour problem.....***
- (iii) Difficult to describe.....***

Participants should have been given a wider choice, rather than limiting them as indicated above.

***Q.5: What would you say is responsible for bringing about the condition of mental retardation in an individual?***

- (i) A weakness in the brain.....***
- (ii) A complicated behaviour.....***
- (iii) Difficult to tell.....***

Like question 4, *Q.5* needed to have a wider variety of choices for the participants. Question 5 is referred to, in this chapter, yet it is not analysed. This is because the question was problematic, so I decided not to use the data.

Other items require a single response to what is, in actual sense, more than one question. For example there was a question about the extent to which teachers, parents and ordinary children welcome the idea of children with mental retardation attending ordinary schools (*Q.12*), in which three categories of person were included in the same question. This meant that the question was overloaded. I should have asked questions concerning each of the categories of person separately.

In retrospect, it is clear that the questionnaire had important weakness, which I was not able to identify in the piloting. In view of these limitations, therefore, the results of the questionnaire have to be treated with some caution. They are valuable because this was the first attempt to estimate views on mental retardation in different groups (teachers, parents, administrators and other professionals) in Uganda on a substantial scale. The questionnaire thus gives a general impression of the situation and could be the basis in a refined and improved form for future research. Here, however, the questionnaire provides an overview, which will be enriched in the next chapter by analysis of qualitative data, some of it from the questionnaire itself (open-ended part), and some

from interviews and observation.

# CHAPTER 6

# Chapter 6

---

## **6.0**                      ***Policy in Practice: Results of Empirical Study - Analysis of Qualitative Data***

### **6.1**                      **Introduction**

As mentioned in Chapter 5, this chapter will explore in more depth, the responses, which the questionnaire technique has not been able to provide. This is where the advantages of qualitative data are helpful (as already mentioned in Chapter 4). In this chapter analysis will be carried out on open-ended questions and interviews respectively. Some documentary analysis (official statistics and mass media reports) will also be considered alongside these. Analysis of observation will be presented in *Appendix 28*. Observation was exploratory, so I thought it would not be appropriate to present it in the main text. As mentioned in Chapter 4 (sections 4.3.3.2 and 4.3.3.5) analysis of data will be based on the main issues raised in the research questions as well as other issues that emerge from the data itself.

## 6.2 Analysis of Open-ended Questions

Analysing qualitative data, according to Macmillan and Schumacher (1997: p.509), “is an eclectic activity; there is no one [right] way”, (p.509). The process, they say, differs from that of quantitative data, in that it is inductive, meaning that categories and patterns emerge from the data rather than being imposed on the data prior to data collection. Gall, Gall and Borg (1999: pp.298-302), quoting Renata Tesch, however, provide three of the many different approaches that a researcher can use to analyse qualitative data. The approaches are interpretation, structural and reflexive.

Interpretation analysis involves a systematic set of procedures to code and classify data to ensure that important themes and patterns emerge. In structural analysis, patterns that are identified do not need to be inferred from the data. Instead, they are inherent features of the discourse, text, or events that the researcher is studying. Last, but not least, reflexive analysis refers to a process in which qualitative researchers rely mainly on their own intuition and personal judgement to analyse the data that have been collected. It does not use either an explicit category system or a prescribed set of procedures.

Coding of data, according to Macmillan and Schumacher (1997: p.509), is the process of dividing data into parts by a classification system developed by the researcher, by

using any one of the three strategies:

- ..Segmenting the data into units of meaning called topics and grouping the topics into larger clusters to form categories; or
- ..starting with predetermined categories and breaking each category into smaller subcategories; or
- ..combining the strategies, using some predetermined categories and adding discovered new categories, (1997: p.509)

For this study I shall code the data by using a combined approach. My analysis begins with questions in the questionnaire which involve open responses, followed by data from the interviews. The procedures of analysing the former are as indicated below.

1. I read through all the answers to these questions several times in order to become fully familiar with the data
2. I identified issues related to the research questions and other issues that are different, and made a categorisation of the issues in the list; for example for question number 7, I categorised responses using the key words and phrases 'Extra efforts, planning and preparation needed' and 'Patience, kindness and love needed'
3. I then assigned a letter or letters to each category; for example, for question 7, the first group of words and phrases was assigned the code 'epp' and the second was assigned the code 'pkl'.
4. In addition, each set of keywords and codes was described with a summarising phrase; for example in question 7, both groups were given the categorisation phrase 'teacher quality'.

Thus, the open-ended questions are coded as shown in Table 6.1 below.

**Table 6.1: Coded Data for Open-ended Questions**

Q*	Salient Points (Categories/Subcategories)	Themes/Aspects
7	Extra efforts, planning and preparation needed (eep)	Teacher quality
	Patience, kindness and love needed (pkl)	Teacher quality
8	Very difficult to deal with chn with m/retardation (df)	Need for better training
	Better salaries for teachers of chn with m/retardation (bs)	Special remuneration
	All teachers should be treated equally (atte)	No need for remuneration
9	All children of school-going age should receive education (aae)	Education is a right
	Education is a human right (ehr)	Human right
	It is a waste of time to educate chn with m/retardation (wte)	Negative attitude
10	Conditions not suitable for chn with m/retard. in ord. Sch. (con)	Preparation
	Children with m/retardation are problematic (cmp)	Negative attitude
	Ordinary children dislike chn with mental retardation (ocd)	Negative attitude
11	Children with m/retardation are treated less equally (ctlq)	Human right
	Children with m/retardation are treated equally (ctq)	Human right
12	Complicated for children with mental retardation to learn together in ordinary schools (cc)	Scepticism
	Good practice for children to learn together (gplt)	Education a right
13	Aims of educ. and curriculum are suitable for all children (ac)	Indifference
	Aims and curriculum need change for good of children with mental retardation (acc)	Preparation
14	Involving other people can confuse the children (ipc)	Scepticism
	Involvement of different professionals in teaching children with mental retardation is necessary (ipn)	Multi-professional approach
15	Different methods motivate children (dmo)	Teacher quality
	Different methods mean changing curriculum (dmc)	Preparation
	A waste of time and resources to use different methods (wtr)	Negative attitude

Q\* stands for the questionnaire question numbers.

The next stage was to quantify the responses in each category, as presented below in Table 6.2.

**Table 6.2: Quantitative summary of open-ended questions**

Quest.	Item/Theme	Frequency	Percent
7	Extra efforts, planning and preparation needed	16	16
	Patience, kindness and love needed	25	25
	No response	59	59
	<b>Total</b>	<b>100.0</b>	<b>100.0</b>
8	Very difficult to deal with	37	37.8
	Better salaries for teachers of chn with m/retardation	36	36.7
	All teachers should be treated equally	25	25.5
	No response	2	2
	<b>Total</b>	<b>100.0</b>	<b>100.0</b>
9	All children of school-going age should receive education	36	36
	Education is a human right	21	21
	It is a waste of time to educate chn with m/retardation	18	18
	No response	25	25
	<b>Total</b>	<b>100.0</b>	<b>100.0</b>
10	Children with m/retardation are treated less equally	52	52
	Children with m/retardation are treated equally	29	29
	No response	19	19
	<b>Total</b>	<b>100.0</b>	<b>100.0</b>
11	Conditions not suitable for chn with m/retard. In ord. Sch.	44	44
	Children with m/retardation are problematic	16	16
	Ordinary children dislike chn with mental retardation	11	11
	No response	29	29
	<b>Total</b>	<b>100.0</b>	<b>100.0</b>
12	Complicated for children with mental retardation to learn together in ordinary schools	13	13
	Good practice for children to learn together	60	60
	No response	27	27
	<b>Total</b>	<b>100.0</b>	<b>100.0</b>
13	Aims of educ. and curriculum are suitable for all children	2	2
	Aims and curriculum need change for good of children with mental retardation	42	42
	No response	56	56
	<b>Total</b>	<b>100.0</b>	<b>100.0</b>
14	Involving other people can confuse the children	11	11
	Involvement of different professionals in teaching necessary for children with mental retardation.	45	45
	No response	44	44
	<b>Total</b>	<b>100.0</b>	<b>100.0</b>
15	Different methods motivate children	56	56
	Different methods mean changing curriculum	10	10
	A waste of time and resources to use different methods	9	9
	No response	25	25
	<b>Total</b>	<b>100.0</b>	<b>100.0</b>

After quantifying the responses as indicated in Table 6.2 above, it was easy to tell how different participants reacted in each specific question. Similarity in responses is important in that it indicates some of the basic factors, which are directly or indirectly responsible for the issues, discussed in the study. I shall therefore present the questions (Q.7-15) one by one, show the responses and provide relevant comments to each of them.

***Q.7 Have you ever had a child with mental retardation in your class?***

***If yes, briefly explain how you have coped with the child/children***

***Response and Comments (Resp and Comm)***

It is noticeable that a majority (59%) of participants did not answer this question, presumably because they had not had experience of these children in their classes. Of those (41%) who did respond, the majority (25%) put emphasis on the emotional response to children whereas others (16%) put emphasis on the need to plan carefully for them.

An example of the participants who emphasised emotion is as follows:

Children who are mentally retarded are human beings like everybody else. We need to be kind in order to help them in their education. We need to tolerate them if they cannot do class work in the same way as normal children. We need to love them. (Headteacher/Teacher No. 71)

The emphasis here is on love, toleration and the need to treat all children as ‘normal’. In

considering this kind of comment, I realised that participants emphasised personal qualities. I therefore view this as one dimension of ‘teacher quality’.

An example of those who put emphasis on planning is as follows:

For the few years that I have taught children with mental retardation, I have discovered that a teacher must really put in extra efforts if you want to succeed. A teacher must be well organised, and must plan and prepare his or her work all the time. (Headteacher/Teacher No. 25)

With respect to ‘professional qualities’, as noted above, I noted that participants put emphasis on ‘planning’. I therefore view this as another important dimension of ‘teacher quality’.

In Uganda there are some teachers who are referred to, in their local communities, as good, while some as poor teachers. The main reason for judging some teachers as being better than others is because of the efforts, good planning and the way such teachers work with their children whether ordinary or children with special needs. While showing kindness and love on one hand, is important, good planning, on the other hand shows how well professionally the teacher is developed. A combination of these qualities can render a teacher to be referred to as good. In my opinion, such a teacher can work for an effective implementation of education for children with mental retardation. For that reason, I feel that all teachers should be encouraged to work with children with mental retardation so that they can develop appropriate qualities.

Although the above responses may not address directly the research question which

states: *How are teachers prepared to teach children with mental retardation in Uganda?*, in my opinion the issue raised with regard to ‘teacher quality’ is one of the factors which policy makers and implementers need to consider when preparing teachers to teach children with mental retardation in the country.

***Q.8 . Besides your Grade III qualification, have you had any other training related to teaching children with mental retardation?***

***What reason do you give to support a teacher’s training in order to teach children with mental retardation?***

**Resp and Comm**

A majority (98%) of participants answered this question. It seems that they were very keen to obtain qualification in order to teach children with mental retardation. Those who did respond put emphasis on different key factors. They differed about the difficulties which teachers faced in dealing with children with mental retardation. Some (36%) said that qualified teachers should be well remunerated, while others (37%) said that teachers of children with mental retardation should be given equal treatment like other teachers in the country.

The following is an example of those who put emphasis on the difficulties which teachers face:

Those children are complicated; some are aggressive. Generally, they are difficult to deal with. I cannot imagine how a teacher without proper qualification can handle such children. Teachers should be given the chance to train before they teach those children. (Headteacher/Teacher No. 61)

With regard to remuneration, the following is an example of what was said by one of the participants:

In primary schools in Uganda specialist teachers, such as science or social studies teachers are paid special allowances. Why shouldn't teachers of mentally retarded children be considered as well? (Headteacher/Teacher No. 18)

Besides the above responses, equality of teachers of children with mental retardation was also stressed. One of the participants, for example said:

In my view, some people may think that we teachers of children with mental retardation are not as important as teachers of normal children. That is unfair. We work as hard as any other teachers. Perhaps we work even harder than other teachers do. You can teach a mentally retarded child one thing over and over again. Our work demands a lot of attention and voluntary spirit which people should appreciate. (Headteacher/Teacher No. 51)

From the above comments, it is apparent that the participants laid emphasis on training and remuneration. These are some of the factors, according to the responses, that teachers seemed to imply, should be provided so as to enable them teach children with mental retardation effectively. I noticed that participants revealed, for example, how difficult it was, to teach children with mental retardation, especially when they (teachers) lacked the necessary knowledge and skills. They also stressed how difficult it was when they worked under difficult conditions, with no consideration for special allowance. I therefore view these two factors as vital in the implementation of education for children with mental retardation in Uganda.

As noted above, it is possible to say that the participants' responses provide direct answers to the research question, which states: *How are teachers prepared to teach*

*children with mental retardation in Uganda?* The responses are also in line with the ‘need’ for teachers to undergo training as revealed in the literature in Chapter 3.

Two of the DEOs and the Commissioners for Education, however, were opposed to the idea of remunerating special needs education teachers. Their views will be discussed in more detail later in the chapter, under sections 6.3.5 and 6.3.6.

***Q. 9. (a) Parents of children with mental retardation have high hopes in the education of their children. When teachers work with the parents hand in hand implementation of education for children with mental retardation can be achieved faster than expected.***

***(b) Please, would you give a comment in addition to the answer you have given above?***

**Resp and Comm**

Responses to the above question are based on teachers/headteachers’ interpretations of parents’ reactions to the need for provision of education for their children (children with mental retardation) in Uganda.

A majority (75%) of participants answered this question. Some (36%) of those who responded said that parents believed that all children of school-going age should be provided with education. Other (21%) participants reported that parents believed that education was a human right. 18% of the participants reported that parents believed that educating children with mental retardation was a waste of time and resources.

An example of parents who were reported as wanting all children of school going age

provided with education is as follows:

Parents say that it is government's obligation to provide education to all children, whether they are mentally retarded or not. (Headteacher/Teacher No. 9)

An example of those who reported how parents emphasised the recognition of education as being a human right is as follows:

Parents say that educating children with mental retardation is not doing them a favour, but it is a matter of respecting their human right. (Headteacher/Teacher No. 15)

As for participants who reported that some parents did not see the value of educating children with mental retardation, the following is the example of what they stated:

...parents say that it is important to concentrate on the normal children who can benefit from education...Parents say that it is a waste of time and resources on mentally retarded children. (Headteacher/Teacher No. 14)

In considering the participants' comments above, I can categorise the responses as issues to do with 'rights' and 'wastage'. More participants reported how parents put emphasis on education as a right, which all children should be entitled to. Such parents can be said to be representatives of the majority of participants who supported the provision of education for children with mental retardation as noted in Chapter 5, section 5.5. On the contrary, some parents were reported to have viewed education for children with mental retardation as a wastage of time, arguing that there was no benefit, which such children could get by going to school. Parents who argued like this are representative of the minority as we noted in Chapter 5, section 5.5.

Teachers/headteachers' interpretations of parents' reactions as observed in this study confirms the need to promote collaboration between parents and teachers as discussed in

Chapters 2 and 3. Collaboration is a factor or an issue which all different categories of participants of this study (teachers/headteachers, parents, EARS officials, teacher educators, DEOs and Commissioners for Education) stressed. Although in both the Kajubi Report of 1989 and the Government White Paper of 1992 collaboration between parents and parents, or parents and professionals, or professionals and professionals is not given emphasis, I noted from the parents how importantly this needs to be considered in light of the current efforts to implement education for children with mental retardation in Uganda.

***Q. 10. (a) In Uganda, education policy makers and administrators have not provided suitable conditions for children with mental retardation in ordinary schools.***

***(b) Please, would you give a comment in addition to the answer you have given above?***

**Resp and Comm**

A majority (71%) of participants answered this question. Of those who answered, 44% put emphasis on preparation or setting suitable conditions to teach children with mental retardation in ordinary schools. Some (16%) of the participants, however, did not seem to show much concern about the need for preparation or setting suitable conditions in order to teach children with mental retardation. Such participants said that children with mental retardation were problematic. 11% of the participants said that ordinary children disliked children with mental retardation.

An example of those who put emphasis on preparing or setting suitable conditions in

order to teach children with mental retardation effectively in ordinary schools is as follows:

It is not a matter of dumping children with mental retardation in normal schools then we assume we are educating them. As far as I have observed, we have not had enough preparation to teach these children effectively in normal schools. We are only talking, talking, but we need to sensitise teachers and children in those normal schools to be able to accept and work with children with mental retardation. That is what we need to do first, otherwise we may end up providing lip service and waste time. (Headteacher/Teacher No. 32)

Another participant said:

Although personally I may say children with mental retardation should be integrated, I don't foresee many schools welcoming such children. Children with mental retardation cannot score good marks in the examinations; this is what schools strive for. (Headteacher/Teacher No. 10)

Participants' comments on the above question can be categorised as issues which concern 'preparation' and 'attitudes'. Some participants argued, saying that without educational administrators changing their attitudes and making conditions suitable, it could not be possible for children with mental retardation to learn effectively. In other words, they seemed to have implied that conditions were still hostile to children with mental retardation in ordinary schools in Uganda. We noted in the literature in Chapter 3, section 3.2.1 and also in Chapter 5, section 5.6.1, the arguments about the need to improve conditions that could promote effective learning for children with mental retardation. I therefore consider preparation and attitude change as elements which are significant in the implementation of the policy on education for children with mental retardation in Uganda.

The issue of inadequacy of suitable conditions for children with mental retardation

learning in ordinary schools, according to some participants, is a serious problem, which still remains unresolved in Uganda. Participants gave an impression that there had been more talking than action. In other words, they said that policy makers had been providing lip-services more than practical actions, hence integration of children with mental retardation might take a long time to be achieved in Uganda.

In order to create satisfactory conditions in ordinary schools, the participants' argument was that teachers and ordinary pupils should be helped to have a change in their attitudes and practices, so as to work and accept children with mental retardation.

When the data from interviews were considered, some interviewees had doubts about the current suitability of conditions for integration of children with mental retardation in Uganda. I shall discuss this in the section of interviews with the different categories of participants.

The research question, which the above responses attempt to address states: ***What types of institutions and facilities are recommended for implementation of education for children with mental retardation in Uganda?***

The issue of provision of institutions and facilities for education of children with special needs are discussed in both the Kajubi Report of 1989 and the Government White Paper of 1992. In these documents as we noted in Chapter 1, recommendations to create

suitable conditions were made to enable the integration of children with disabilities to take place in ordinary schools. In light of the responses provided by the participants as indicated above, therefore, we may realise that both the policy makers and implementers have yet to identify what still blocks progress towards achieving that objective. One of the issues to be tackled is the examination system in the country. A way should be found, such that integration of children with mental retardation does not get affected by the examination system in Uganda as observed by one of the participants above.

***Q. 11. (a) In ordinary schools, children with mental retardation mix freely with their peers (the ordinary children) in all educational and social activities without discrimination.***

***(b) Please, would you give a comment in addition to the answer you have given above?***

**Resp and Comm**

A majority (81%) of participants answered the question. 52% of the participants who answered the question said that children with mental retardation were treated less equally than the ordinary peers in schools. 29% of the participants said that ordinary children disliked children with mental retardation.

An example of those who said that children with mental retardation were not treated equally stated:

In our school, mentally retarded children are regarded as different. Ordinary children are not willing to share things or activities with them. (Headteacher/Teacher No. 2)

An example of what the participants who stressed the need for equal treatment of

children with mental retardation in ordinary schools said is as follows:

In our school there is no problem between ordinary and children with mental retardation. All children work in harmony. Ordinary children are very supportive of those who are mentally retarded; they give them all the assistance they deserve. (Headteacher/Teacher No. 4)

From the participants' comments above, the responses can be categorised as issues to do with 'rights'. Some participants argued that children with mental retardation were not given equal treatment in schools, claiming that they (children) were badly treated. Other participants revealed that children with mental retardation were treated well. I therefore consider the participants' divergent views as issues which are likely to interfere with implementation of the policy on education for children with mental retardation in Uganda.

***Q. 12. (a) All teachers, parents and ordinary children welcome the idea of children with mental retardation learning in ordinary schools.***

***(b) Please, would you give a comment in addition to the answer you have given above?***

**Resp and Comm**

A majority (73%) of participants answered the question. Of those who responded, 13% were sceptical about children with mental retardation's ability to learn in ordinary schools. 60% of the participants expressed optimism about children with mental retardation's ability to learn in ordinary schools.

An example of what participants who were sceptical said is as follows:

There is a high demand in ordinary schools. Children have to do well in examinations so as to be promoted to the next class. I doubt very much if mentally retarded children can meet such requirements. In my opinion I think that is quite impossible. (Headteacher/Teacher No. 12)

An example of what participants who were optimistic said is as follows:

Education does not mean passing examinations; it means equipping individuals with knowledge and skills which can be useful for them to live in their community reasonably. (Headteacher/Teacher No. 34)

Responses to this question are similar to those in the previous question (Q.11). The main issue raised here is ‘examination’. Other participants (that is, parents, DEOs and Commissioners for Education) interviewed also realised the dilemma which had been created because of the examination system in Uganda.

I do share the concern raised by participants with regard to examinations in Uganda. There is currently very little effort being made to address this problem, and the more the authorities delay to find a solution, the more implementation of education for children with mental retardation will prove difficult.

***Q. 13. (a) The aims of education and curriculum in Uganda are appropriate/suitable as far as education of children with mental retardation is concerned.***

***(b) Please, would you give a comment in addition to the answer you have given above?***

**Resp and Comm**

A majority (56%) of participants did not answer the question, maybe because they were not sure of what the aims of education and curriculum for children with mental

retardation in Uganda were about. 44% answered the question. Of those who responded 2% said that aims of education and curriculum for children with mental retardation were suitable. 42% of the participants said they were dissatisfied about the aims of education and curriculum for children with mental retardation in Uganda.

An example of those who said that aims of education and curriculum for children with mental retardation were suitable is as follows:

Since all children are supposed to learn together in the same school or class, aims or curriculum for children with mental retardation need not be different. Children of different abilities should learn the same thing. (Headteacher/Teacher No. 13)

An example of those who said they were dissatisfied about the aims of education and curriculum for children with mental retardation is as follows:

Mentally retarded children need to be taught as individuals. Their learning capacity is lower and it may be a waste of time to teach them in the same way as ordinary children. It is important to teach children according to how much they can learn. (Headteacher/Teacher No. 56)

I consider the participants' comments above as aspects which concern 'indifference' and 'preparation'. The participants who seemed to be indifferent were those who argued that children with mental retardation, should, under whatever circumstance, be taught the same things, and in the same way as ordinary children. On the other hand, the participants who put emphasis on preparation were those who seemed to suggest that children with mental retardation should be taught, bearing in mind their (the children's) individual needs. Basing on these responses, it may be in order to consider adequate preparation as a sign of positive, while being indifferent as negative attitude,

respectively.

The research question, which the above responses are supposed to address states: *What are the aims of education and curriculum for children with mental retardation in Uganda?*

We noted in Chapter 3 how aims and curriculum for children with mental retardation were clarified. The observations, according to Farrant (1980), revealed that the most important aim of education was to equip an individual with relevant knowledge and skills to be able to live independently without expecting too much help from other people. We also noted that children with severe mental retardation needed to be provided with more practical than academic education. On the other hand children with mild mental retardation, we learnt, needed to be provided with a balanced education - education which emphasised both practical skills and knowledge acquisition. Knight (1999) explained what the trend was, in designing aims of and curriculum for children with special needs. According to him (Knight) the trend emphasised inclusive education.

The findings in Uganda do not differ much from the findings revealed in the literature. Where we noted the difference was in the failure by policy makers to explicitly state what the specific aims of education for children with special needs should be. That is, what should these children be able to do at the end of their education? In the official

policy documents of Uganda, namely the Kajubi Report and the Government White Paper, there is no indication as to whether in the revised system of education in the country, appropriate aims of education and curriculum for learners with disability and, more particularly for those with mental retardation have been addressed. The focus, in the two documents, is to equip learners with “productive and modern marketable skills to meet the developmental needs of the economy and promote employment opportunities” for learners. Aims of education formulated in such a manner compel learners to enter into a competitive education, whereby those with mental retardation would definitely be at the greatest disadvantage. How many learners with mental retardation can go through such a competitive education system successfully so as to become engineers, accountants, professors, doctors, administrators, teachers, technicians, managers, and the like, the human resource that are badly needed to meet the developmental needs of the economy of the country? Every parent in Uganda knows that people who succeed in education secure good jobs and they (the parents) in turn benefit from such successful sons and daughters. Indeed, in Uganda, a country where there is no social security scheme in the form of pension for the rural and peasant population, educating children is regarded as a useful investment for the future, so that when the parents get old, they are looked after, fed, clothed and assisted in nearly everything by their successfully educated sons and daughters. The importance of education in Uganda therefore cannot be overemphasised.

Besides failure by the policy makers to clarify what the aims of education and curriculum for children with special needs should be, the findings from policy implementers seem generally to be in line with the findings in the literature already mentioned in Chapter 3. The findings indicate how dissatisfied policy implementers of education for children with special needs are in Uganda. Dissatisfaction of aims of education and curriculum for children with mental retardation were expressed as we shall see (in a later section) in the responses from the participants who were interviewed.

***Q. 14. (a) In order to successfully teach children with mental retardation, teachers should employ different approaches, such as involving other teachers (team teaching). Specialist teachers should make arrangements, such that they let other (non specialist) teachers share lessons in their special classes, while they (the specialists) too share lessons in the ordinary classes. Specialist teachers should invite parents and other professionals to participate in certain relevant school activities aimed at helping children with mental retardation.***

***(b) Please, would you give a comment in addition to the answer you have given above?***

#### **Resp and Comm**

A majority (56%) of participants answered the question. Some (11%) of the participants expressed scepticism about collaborating with parents and other professionals, arguing that this could lead to confusion of children. 45% of the participants favoured the idea of collaborating with other people in the task of implementing education for children with mental retardation in Uganda.

An example of what was commented by those who did not like the idea of collaborating

with parents and other professionals is as follows:

Since children with mental retardation need very close and child-centred attention, there is no point in involving other people. Teachers are enough. We can end up confusing these children, you, know!! No need to let other people who are not teachers be involved. That will be harmful to children. (Headteacher/Teacher No. 7)

An example of what was said by those who supported collaboration with parents and other professionals is as follows:

Teachers alone cannot, however qualified, do everything. Parents may know certain things about their children which teachers may not know. Other professionals, such as doctors may be better than teachers in certain medical aspects, which can interfere with children's learning. For that reason, teachers of children with mental retardation should always involve other people to do some of the activities for, or with children. (Headteacher/Teacher No. 48)

In the above question, I categorise participants' comments as 'collaboration' between professionals. Some participants were sceptical, while others fully supported multi-professional approach to implementation of the policy on education for children with mental retardation in Uganda. Those who advocated for non-involvement of professional approach said that children needed to be taught by teachers only and not by other people, because they could get confused. The participants who supported involvement of other professionals said that teachers would not know everything, for that matter, they argued that other professionals should be involved in helping children with mental retardation in different aspects where teachers could not.

The above responses are expected to address the research question, which states: *What teaching methods/approaches are adopted for teaching children with mental retardation in Uganda?*

Although we have noted that the responses do differ, in my own opinion, involvement of parents and other professionals is an approach which should be used whenever necessary. I strongly support the participants who advocated for multi-professional approach, or those who were enthusiastic about collaborating with parents. I do believe that there are certain aspects which teachers alone, however qualified they may be, cannot do, to help children. In one of the interviews (as we shall see in the interview section), two teachers complained about the problems they faced due to lack of parental involvement in children's education. We should also realise that with the increasing emphasis on inclusive education, there will definitely be need for collaboration between teachers and other people. This issue is emphatically discussed in the literature (for example: Skrtic, 1991; Fullan, 1991 and Ainscow, 1999).

***Q. 15. (a) Although there could be many different methods of teaching, for the sake of children with mental retardation, the government should introduce certain specific and limited number of teaching methods which teachers should adopt for teaching children with mental retardation.***

***(b) Please, would you give a comment in addition to the answer you have given above?***

**Resp and Comm**

A majority (75%) of participants answered this question. 56% of participants said that different methods were useful because they motivated children. 10% said that different

methods would lead to change of curriculum, while 9% said that applying different methods was a waste of time and resources.

An example of those who said that different methods motivated children is as follows:

A good teacher should be well equipped with different skills. As children with mental retardation have problems with learning, a teacher must be able to keep changing methods of teaching. From the many methods, which a teacher employs, some few may be very effective. Therefore, it is not good to rely on one or two methods and think that children with mental retardation will learn effectively. (Headteacher/Teacher No. 15)

Those who said that changing methods would mean changing curriculum stated:

It is not enough to say we have to change methods of teaching! What is needed is enough preparation. We need to change the curriculum first and foremost before we think about changing methods of teaching. (Headteacher/Teacher No. 17)

And one of those who said that it would be a waste of time to change the curriculum stated:

We must think of how much time we have for the so many normal children and then the few mentally retarded children. To be honest, it is a waste of time and resources to think that we can do much to change mentally retarded children. We can't waste time at the expense of other capable children around. (Headteacher/Teacher No. 7)

In considering the participants' comments above, I categorise the responses as 'teacher quality' and 'attitudes'. Some participants put emphasis on variation of teaching methods and stressed the need for adequate preparation, in order to teach children with mental retardation effectively. In light of these responses, I consider teachers' ability to select suitable methods and preparation for teaching as important elements of 'teacher quality'. On the other hand, some participants put emphasis on giving attention to ordinary children rather than wasting time with children with mental retardation. I consider this as an element of 'negative attitude'.

The research question which the above responses are expected to provide an answer states: *What teaching methods/approaches are adopted for teaching children with mental retardation in Uganda?*

I noted in Chapter 3, section 3.2.5 that there was no particular teaching method, which was more suitable than the others. What seems to be important is to assess children's individual needs then select and modify any method used at a particular time. Some of the methods discussed are already being used in Uganda, while some are not yet considered. The methods already in use may only need to be modified to make children learn more effectively.

Given the different kinds of response, it is possible to tell who, among the participants, are likely to implement education for children with mental retardation. The participants who said that different methods motivated children, and those who advocated for change of methods and curriculum seemed to be the kinds of teachers/headteachers who could help in the task of implementation of education for children with mental retardation in Uganda. The participants who said that it was a waste of time to change methods of teaching seemed to be examination-oriented and therefore not quite ready to help children who could not achieve much in examinations.

In the next section I shall present, discuss and analyse the results in response to

interviews.

### **6.3 Analysis of the Interview Data**

The procedures of analysing interview data are similar to those used for open-ended questions discussed above. I present them as indicated below:

1. I began by categorising responses. For example teachers/headteachers were put under category 1; parents, category 2; EARS staff category 3; teacher educators, category 4; District Education Officers (DEOs), category 5; and Commissioners for Education (CE), category 6
2. I transcribed all the interview responses according to the six categories (mentioned above)
2. I read through all the answers to the questions several times in order to become fully familiar with the data
3. I identified issues related to the research questions and other issues that are different, and made a sub-categorisation of the issues in the list; for example for category 1 (teachers/headteachers), questions 1-9R, I sub-categorised responses using the key words and phrases 'More children enrolled, No need to mix children, School initiates training, Special skills needed, Use ordinary curriculum, Teachers work on their own, No specific methods, Both special and normal schools and Policy makers involve parents' (*See Appendices 22-27*)

I then assigned a letter or letters to each sub-category in categories 2-6 (I could not do this with category 1, because of limited space as can be noted in Appendix 22; for example, for category 2 (parents), questions 1-8R, the groups of words and phrases were assigned the codes 'afs', 'mid'; 'dac'; 'ega', 'oad'; 'nhe'; 'pcl'; 'nsd', 'gh'; 'nae', 'cbd'; and 'ghp', respectively. (*See Appendix 23*)

In addition, each set of keywords and codes was described with a summarising phrase; for example category 1, question 1 was given the sub-categorisation phrase 'UPE is beneficial'; category 2, question 1 (a) the phrase given is 'child fell sick first'.

The summarising phrases were then quantified (category 1, presented with frequencies and percentages, while categories 2-6 presented with frequencies only because of the samples being too few to warrant use of percentages).

For each of the categories 1-6, the last question is coded with R, for example the last question for category 1 is 9R. The letter 'R' stands for recommendations made by the participants.

After coding the data as indicated, the next stage was to quantify the responses in each category, as presented in Tables 6.3a-6.3f below.

Chapter 6: Policy in Practice: Results of Empirical Study – Analysis of Qualitative Data

**Table 6.3a: Quantitative Summary of Interview Questions - Category 1:Teachers/Headteachers**

Question	Item	Frequency	Percentage
1	(a) UPE is beneficial	5	27.8
	(b) UPE is not beneficial	13	72.2
	<b>Total</b>	<b>18</b>	<b>100.0</b>
2	(a) Segregation	6	33.3
	(b) Integration	7	38.9
	(c) Examination oriented education	3	16.7
	(d) Human right	2	11.1
	<b>Total</b>	<b>18</b>	<b>100.0</b>
3	(a) School's role to train teachers	3	16.7
	(b) Teachers initiate their own training	4	22.2
	(c) Headteachers are against teachers' further training	1	5.6
	(d) No policy for teachers' training	2	11.1
	(e) Government's role to train teachers	6	33.3
	(f) Teacher training becoming too expensive	1	5.6
	(g) Trained teachers needed	1	5.6
	<b>Total</b>	<b>18</b>	<b>100.0</b>
4	(a) Training to get new skills	8	44.4
	(b) Training helps to change attitudes	2	11.1
	(c) Training to get new knowledge	7	38.9
	(d) Good to train	1	5.6
	<b>Total</b>	<b>18</b>	<b>100.0</b>
5	(a) Ordinary curriculum	7	38.9
	(b) Ordinary syllabus	11	61.1
	<b>Total</b>	<b>18</b>	<b>100.0</b>
6	(a) No collaboration	8	44.4
	(b) Some collaboration	9	50.0
	(c) Not aware	1	5.6
	<b>Total</b>	<b>18</b>	<b>100.0</b>
7	(a) No specific teaching method	3	16.7
	(b) Child-centred approach	14	77.7
	(c) Group work	1	5.6
	<b>Total</b>	<b>18</b>	<b>100.0</b>
8	(a) Special and ordinary schools	7	38.9
	(b) Special schools	7	38.9
	(c) Ordinary schools	4	22.2
	<b>Total</b>	<b>18</b>	<b>100.0</b>
9R	(a) Policy makers to involve teachers and parents	2	11.1
	(b) Government to help parents	1	5.6
	(c) Change in curriculum needed	1	22.2
	(d) Government to help parents	4	11.1
	(e) Special salary for teachers of special education	2	16.7
	(f) Awareness creation needed	3	5.6
	(g) Teacher training needed	1	5.6
	(h) More special units needed in ordinary schools	1	5.6
	(i) Teachers should not pay fees for their training	1	5.6
	(j) Government facilitate special and ordinary schools	1	5.6
	(k) Parents stop hiding children with disabilities	1	5.6
<b>Total</b>	<b>18</b>	<b>100.0</b>	

**Table 6.3b: Quantitative Summary of Interview Questions - Category 2:Parents of**

Chapter 6: Policy in Practice: Results of Empirical Study – Analysis of Qualitative Data

**Children with Mental Retardation**

<b>Question</b>	<b>Item</b>	<b>Frequency</b>
1	(a) Child developed problem after falling sick	5
	(b) Mother identified the problem	2
	(c) Disability came as a surprise	2
	<b>Total</b>	<b>9</b>
2	Child received medical attention	9
	<b>Total</b>	<b>9</b>
3	(a) Support received from hospital	4
	(b) Support received from EARs	3
	(c) Support received from USDC	1
	(d) Relied on personal knowledge and skills	1
	<b>Total</b>	<b>9</b>
4	(a) No hope in child's education	1
	(b) UPE is beneficial	5
	(c) UPE is not beneficial	3
	<b>Total</b>	<b>9</b>
5	(a) Education suitable in special and ordinary schools	3
	(b) Education suitable in special schools	4
	(c) No idea where education is suitable	2
	<b>Total</b>	<b>9</b>
6	(a) Government's role to educate all children	7
	(b) Government should involve teachers and parents	1
	(c) Parents should collaborate with fellow parents	1
	<b>Total</b>	<b>9</b>
7	(a) Not aware of aims of education	3
	(b) Examination oriented-education	1
	(c) Education to help child learn to speak good English	1
	(d) Education provide a child with practical skills	2
	(e) God is the one who knows the aims of education	1
	(f) Government provides lip-service	1
	<b>Total</b>	<b>9</b>
8R	(a) More schools should be built	2
	(b) Vocational education needed	1
	(c) Government should help parents	4
	(d) Parents should not hide disabled children	1
	(e) Parents should collaborate with other parents	1
	<b>Total</b>	<b>9</b>

**Table 6.3c: Quantitative Summary of Interview Questions - Category 3:EARs staff**

Chapter 6: Policy in Practice: Results of Empirical Study – Analysis of Qualitative Data

Question	Item	Frequency
1	No clear policy on assessment	4
	<b>Total</b>	<b>4</b>
2	(a) Under UPE children are automatically registered in schools	1
	(b) Registration depends on different headteachers	1
	(c) Registration easier after sensitisation of school authorities	2
	<b>Total</b>	<b>4</b>
3	EARS staff work in collaboration with teachers	4
	<b>Total</b>	<b>4</b>
4	(a) EARS staff visit schools	1
	(b) EARS staff, together with teachers produce educational materials	2
	(c) EARS staff run workshops for teachers	1
	<b>Total</b>	<b>4</b>
5	(a) Activities involve school visits	1
	(b) Planning with teachers	1
	(c) Working with teachers	2
	<b>Total</b>	<b>4</b>
6	(a) Doctors assess	1
	(b) Teachers and parents assess	1
	(c) Parents, teachers and doctors assess children	1
	Only teachers assess children	1
	<b>Total</b>	<b>4</b>
7	(a) No specific method of assessment	1
	(b) Educational assessment is used	1
	(c) Teachers use their ingenuity	1
	(d) Assessment is by looking at a child	1
	<b>Total</b>	<b>4</b>
8	(a) EARS centres used	2
	(b) EARS pamphlets used	1
	(c) Teachers trained on the job	1
	<b>Total</b>	<b>4</b>
9	(a) EARS centred established in all the districts in the country	1
	(b) EARS staff appointed as district assistant inspectors of school	1
	(c) More children assessed	1
	(d) Many children integrated into ordinary schools	1
	<b>Total</b>	<b>4</b>
10R	(a) More awareness on disability needed	1
	(b) Retraining teachers needed	1
	(c) Collaboration between teachers and parents needed	1
	(d) Collaboration between policy makers and implementers needed	1
	<b>Total</b>	<b>4</b>

Table 6.3d: Quantitative Summary of Interview Questions - Category 4:Teacher Educators (TE)

Chapter 6: Policy in Practice: Results of Empirical Study – Analysis of Qualitative Data

Question	Item	Frequency
1	(a) Better planning needed in UNISE	2
	(b) UNISE performance impressive	1
	<b>Total</b>	<b>3</b>
2	(a) UNISE courses have impact on children	1
	(b) UPE useful	1
	(c) Change of training method needed	1
	<b>Total</b>	<b>3</b>
3	(a) Contact between UNISE and its former graduates exist	2
	(b) Need for UNISE to increase support for its former graduates	1
	<b>Total</b>	<b>3</b>
4	(a) Sensitisation of population about disability needed	2
	(b) Need to increase use of mass media	1
	<b>Total</b>	<b>3</b>
5	(a) Too much work for UNISE staff to collaborate with other professionals	1
	(b) Use church sermons to sensitise the local community	1
	(c) Use personal contact with other professionals	1
	<b>Total</b>	<b>3</b>
6	(a) Not much link with other professionals	1
	(b) Multi-professional approach needed	2
	<b>Total</b>	<b>3</b>
7	More children are in school	3
	<b>Total</b>	<b>3</b>
8	(a) Cost-sharing may affect UNISE student intake	1
	(b) Special education not valued by many people in Uganda	1
	(c) Research lacking in special education in Uganda	1
	<b>Total</b>	<b>3</b>
9R	(a) Special needs teacher should not pay fees for their courses	1
	(b) Distance education needed to increase special needs teachers	1
	(c) Primary school curriculum needs change	1
	<b>Total</b>	<b>3</b>

**Table 6.3e: Quantitative Summary of Interview Questions - Category 5: District Education Officers (DEOs)**

Question	Item	Frequency
----------	------	-----------

Chapter 6: Policy in Practice: Results of Empirical Study – Analysis of Qualitative Data

1	(a)	Education is human right for children of any ability	1
	(b)	No special policy; all children are treated equally	2
		<b>Total</b>	<b>3</b>
2		Attitudes change slowly	3
		<b>Total</b>	<b>3</b>
3	(a)	District has a vehicle	1
	(b)	Outreach programme emphasised	1
	(c)	Emphasis on retraining teachers for special needs education	1
		<b>Total</b>	<b>3</b>
4	(a)	District has special vote	2
	(b)	District has no special vote	1
		<b>Total</b>	<b>3</b>
5	(a)	No need to pay special needs education teachers special salary	2
	(b)	Need to pay special needs education teachers special salary	1
		<b>Total</b>	<b>3</b>
6	(a)	Primary school syllabus not suitable	1
	(b)	Education system examination-oriented	2
		<b>Total</b>	<b>3</b>
7R	(a)	Treat education as human right	1
	(b)	Need to retrain teachers for special education	1
	(c)	Vocational education needed for disabled children	1
		<b>Total</b>	<b>3</b>

**Table 6.3f: Quantitative Summary of Interview Questions – Category 6: Commissioners for Education (CE)**

Question	Item	Frequency
1	(a) Disabled children handled as target group	1
	(b) Education is human right	1

		<b>Total</b>	<b>2</b>
2	(a)	Awareness education important	1
	(b)	Education for all children important	1
		<b>Total</b>	<b>2</b>
3	(a)	Education is human right	1
	(b)	Government's role to educate all children	1
		<b>Total</b>	<b>2</b>
4	(a)	Ministry of Education releases subvention	1
	(b)	Encourage teachers to retrain	1
		<b>Total</b>	<b>2</b>
5	(a)	Further training more rewarding than special remuneration	1
	(b)	No need for special salary for special education teachers	1
		<b>Total</b>	<b>2</b>
6	(a)	Child-centred method important	1
	(b)	Modification of curriculum important	1
		<b>Total</b>	<b>2</b>
7R	(a)	Need to adjust curriculum	1
	(b)	Vocational education to be emphasised	1
		<b>Total</b>	<b>2</b>

Having summarised the data as indicated in Tables 6.3a-6.3f above, the next step was to carry out further analysis. I therefore present the analysis, category by category. This will be preceded by the interview questions, followed by the responses and comments. Where appropriate the interview data will be complemented with documentary data. I start with Category 1 (teachers/headteachers), and end with Category 6 (Commissioners for Education) as indicated in sections 6.3.1-6.3.6 below.

### 6.3.1 Responses by Headteachers/Teachers

This section will cover different aspects, comprising policy issues, personal views on children with mental retardation, teachers' conditions of service, curriculum, teaching approaches, special needs education in general and suggestions made by the participants.

*Category 1, Question 1: In what way are children with special needs benefiting from*

*UPE in your school?*

*Resp and Comm*

27.8% of the participants said that UPE was beneficial, while 72.2% said that the programme was not beneficial.

One of the participants who said that UPE was beneficial stated:

UPE has been overdue – it should have been introduced many years ago. Well, it is said ‘better late than never’. I’m sure many poor parents will be relieved now. (Headteacher/Teacher No. 17);

Another supporter of the programme said:

UPE is a good thing. We hope it will be carried out properly for the good of everyone. Many children must receive education in Uganda now. (Headteacher/Teacher No. 12);

One of the participants who did not see the value of UPE said:

In fact as much as government is pouring money in this UPE, government should cater for special education. Much of the money should be given to special education to train teachers and to sensitise the community. That is how we can really develop these people at the same rate. The problem with government policies at higher level is that they start a programme which is not well researched, lacking data; they don’t know much about us the target population; how much its cost implication. (Headteacher/Teacher No. 1)

In the above participants’ comments, the responses can be categorised as an issue to do with ‘UPE’. The participant’s argument is that UPE is not beneficial, because the government has not worked out an appropriate approach to train special needs education teachers and enable them to contribute effectively under the UPE programme. The participant is concerned about the way educational policies are arrived at. I find this argument supporting what Fulcher (1989) describes as a kind of policy, which creates ‘a gap’ between its makers and implementers. Criticism against UPE also features through

other sources, such as mass media and through persons with disabilities as we shall see later in this section.

Both UPE and special education are needed, as rightly argued by the above participant. Indeed no one can explain why enough preparation was not done before introducing such programmes. Of course it is always easier to say something than to do it. Preparation for special needs education programmes needed adjustment in the curriculum, creating awareness in the population, and more importantly retraining and sustaining the teachers. Similarly, for implementation of UPE, adequate supplies of facilities and teachers were needed before introducing the programme.

Statistics for educational establishments and children's enrolment were provided to the researcher by the Ministry of Education and Sports, to enable us to know what the student population is in primary schools in Uganda and to assess how children with mental retardation fit in the UPE programme at the moment. (*See Appendix 2 and also Table 6.4*). With the introduction of UPE in 1997 there has been a steady increase of enrolment of children in primary schools, from 2.4 million to 5.4 million. Between 1996 and 1997 alone, the number of established primary schools increased from 9,223 to 10,616. That is an increase of 15%. The number of children attending primary education within the same period, that is, between 1996 and 1997, rose from 3,068,625 to 5,427,404. This is an increase of 2,358,779 or 77%. These figures just provide an

overview of the primary school-going children in the country; they (the figures) do not however, show how many of these are children with special needs, or mental retardation *per se*. I therefore present, in Table 6.4 below, the total number of all children with special needs currently receiving education in Uganda and the types of schools they are enrolled in.

**Table 6.4: Number of Children with Special Needs in Special and Ordinary Schools in Uganda, 1999**

Category of Special Needs	Number of Special Schools	Number of Units in ordinary Schools	Number of Children Identified, Assessed and Placed in Schools
Hearing Impairment (HI)	4	42	5,836
Visual Impairment (VI)	1	34	3,232
<b>Mental Retardation (MR)</b>	<b>34</b>	<b>4</b>	<b>4,472</b>
Motor (Physical) Disabilities (MD)	11	1	4,839
<b>Total</b>	<b>50</b>	<b>81</b>	<b>18,379</b>

*Source: EARS Department, Ministry of Education and Sports, Kampala*

With the help of the above Table 6.4, we can examine the proportional representation of children with mental retardation with regard to the overall population in primary education. In order to provide a clear picture, I shall use the data in Table 6.4 as percentage representations of the data in *Appendix 2*. I present the breakdown in Figure 6.1 below.

**Figure 6.1: Enrolment of Primary School Children in Uganda, 1999**

<i>Number of Ordinary Children in Primary Schools in Uganda:</i>	<i>5,427,404</i>
<i>Number of Children with Special Educational Needs in Primary Schools:</i>	<i>18,379</i>

<i>Percentage representation of Children with SEN:</i>	<i>0.34%</i>
<i>Number of Children with mental retardation in Primary Schools:</i>	<i>4,472</i>
<i>Percentage Representation of Children with mental retardation:</i>	<i>0.1%</i>
<i>Number of Primary Schools in Uganda:</i>	<i>10,616</i>
<i>Number of Primary Schools Attended by Children with SEN:</i>	<i>81</i>
<i>Percentage Representation of Children with SEN:</i>	<i>0.8%</i>
<i>Number of Units for Children with mental retardation in Ordinary Schools:</i>	<i>4</i>
<i>Percentage Units for Children with mental retardation:</i>	<i>0.04%</i>

As noted from the above Figure 6.1, the number of children with mental retardation currently receiving education both in special and ordinary schools apparently is very small compared to the other disabilities. When we compare the proportion of the total number of children with mental retardation with the overall figure of all children receiving education in primary schools, that is, 4,472 against 5,427,404 (0.1%), we realise that definitely much has yet to be done to send more of these children to school. Although the UPE programme had been discussed for a long time in the country, it was not introduced until 1997. Under the programme, four children per family are entitled for enrolment for UPE. A child with disability can be included among the four children (UPE in Uganda, 1997: p.12). The policy on selecting the four children, however, has been left open, so that parents are not obliged to include children with special needs as one of the four. In Uganda, some people have as many as eight, ten, fifteen children. Polygamous families may have as many as twenty to thirty children. If a child with

mental retardation happens to be among the eight, the ten or the thirty children in a family, what decision can we expect such a family to make in selecting the four children? Will the child with mental retardation stand an equal chance like the rest of the ordinary children in that family? I can only say that it will depend on a parent's commitment. If a parent is determined to have such a child included among the four children, that will be at his or her discretion; otherwise, it is very unlikely that other children will be left out in preference to a child with special needs in a family for the sake of UPE. I have already indicated under section 6.2, above, that parents in Uganda regard education of their children as an investment. Indeed, the impact of UPE seems not to have been much felt, as we have noted in Figure 6.1 above. The fact that children with special needs are represented by only 0.34 % of the total population of primary school children in Uganda is an issue, which has indeed raised public concern. The concern is not only about the very small number of children with special needs receiving education at the moment; the concern is also about the overall quality of education under UPE. In one newspaper article with the headline, "*Will UPE produce semi-illiterates?*" the following comment has been made:

.....But when it came to dealing with the nit gritty, what seemed a brilliant solution to the problem of massive illiteracy in Uganda proved difficult to execute. Enrolment shot over 5 million pupils...there were no new facilities to cater for the increased number of pupils. But most villages had never had basic - let alone conventional - school infrastructures....thousands study under mango trees and the situation is nothing to drink a glass of water over...As the lessons progress, kids find the mangoes on the trees far more interesting than what is on the blackboard. The prospect of bringing down the mangoes or climbing up the tree after the lesson or as soon as the teacher turns his back is irresistible....True, the UPE scheme was implemented; but whether or not it has been successful is a different kettle of fish. Government needs to revisit the entire project; or else UPE may ultimately boomerang and prove one of the biggest disasters in Uganda's education system. (The Monitor Newspaper, 29 July, 1998: p.5)

In yet another comment, none other than the persons with disability themselves, challenging the usefulness of UPE raised one of the voices echoed in a newspaper article. This featured in a newspaper article entitled “*UPE not benefiting disabled*”, which reported:

Members of parliament for people with disabilities were yesterday shocked to learn that Universal Primary Education (UPE), was not benefiting children with disabilities....We carried out a pilot study in Jinja district and found out that most of the children with disabilities, are not in school. These children do not have special teachers and others are just discriminated. (New Vision Newspaper, 3 March,1998: p.7)

The data obtained from interviews and documents, as noted above indicate that the majority of comments indicate how UPE has not fully satisfied people’s expectations. The emphases were put on the inappropriate way UPE was introduced and implemented from the beginning.

The research question which all the above responses were expected to address states:

***How are children with mental retardation selected for education in Uganda?***

UPE should be the programme with an overwhelming capacity to remove the current gap between children with special needs and ordinary children in receiving education, but it seems this is not possible at the moment. It should be the most effective mechanism for selecting children for education provision in Uganda. As noted in Figure 6.1 and Table 6.14, however, children with mental retardation are just 0.1% of the entire children population in primary schools in Uganda.

*Category 1, Question 2 (a): What are your views about educating children with mental retardation together with ordinary children in your school?*

*(b): What would be the benefit of mixing children with mental retardation with others or of educating them separately?*

*Resp and Comm*

There was a mixture of reactions to the above questions. 33.3% responded by saying that they supported segregation of education for children with mental retardation, 38.9% supported integration, 16.7% were not happy about the examination system in Uganda and 11.1% wanted to see education of children with mental retardation regarded as a human right.

One participant who supported segregated education for children with mental retardation said:

It is not a good idea to mix children with mental retardation with ordinary ones. Some of the children with mental retardation have saliva dripping all the time and I think that is not good for the other children; they can be affected in one way or the other. (Headteacher/Teacher No. 4)

The above participant's response is perhaps representative of the minority views found in the questionnaire as far as implementation of the policy is concerned. The thinking of the participant may reflect what the position is for some of the headteachers/teachers who are still unchanged and who are unlikely to implement the policy. The participant's attitude could be regarded as negative towards integration of children with mental retardation.

One teacher who seemed to be in favour of integration argued that in existing educational practice in Uganda, wherein the desire for academic achievement was still held high, integrating children with mental retardation in ordinary schools was bound to face more hurdles than expected. He said that for the time being children with disabilities ‘would do better in a segregated system of education until we are ready to serve all categories of children equally’. He further said:

Although personally I may say children with mental retardation should be integrated, I don’t foresee many schools welcoming such children. Children with mental retardation cannot score good marks in the examinations; this is what schools strive for. (Headteacher/Teacher No. 18)

Reacting in a similar way as the above participant, another participant stressed the need for policy makers and implementers to recognise the importance of human rights. She said:

All children are important, and are equal before God. There is no point why some children, because of being mentally retarded should be denied their human right. They need to attend the same schools with other non-handicapped children. Mentally retarded children are children of taxpayers. They should also enjoy what comes out of their parents’ taxation. (Headteacher/Teacher No. 12)

What the participants pointed out above may be true, as already noted under the relevance of aims of education and curriculum for children with mental retardation discussed in Chapter 5, section 5.5. Indeed, some schools are currently referred to as “good”, while some as “poor”. The fame of the former has come about because of excelling in the yearly national examinations (children pass with more first class grades), while in the latter, there are hardly any first class results. It is very unlikely for such highly academically oriented schools to freely integrate children with “mental

retardation”, as there is no evidence of a mechanism put in place by the policy makers to compel such schools to admit each and every child, irrespective of their abilities or inabilities. Although some people with disabilities are beginning to take up some positions in public services, the issue of respect for human rights, as raised by one of the participants is one of the issues which need more attention in Uganda at the moment.

The research question which these responses are expected to address states: *What types of institutions and facilities are recommended for children with mental retardation in Uganda?*

According to the responses provided the research question still remains partially answered. In other words, the recommended institutions and facilities for children with mental retardation are not yet fully put to use as expected. We noted the dissatisfactions about conditions for children with mental retardation in the ordinary schools as indicated in the questionnaire responses in Chapter 5, section 5.6.1 and also in the open-ended data in section 6.2 above.

*Category 1, Question 3 (a): What is the school policy on teachers who need further training in order to teach children with special needs in your school?*

*(b): Do teachers who obtain further qualification in special needs return to the school to help children with mental retardation?*

**Resp and Comm**

Participants provided varied responses with regard to the above questions. The

emerging issues were about where policy of retraining teachers for special needs education should come from.

16.7% of the participants said that it was school's role to ensure that teachers were trained to teach children with special needs. 22.2% said that teachers had been initiating their own further training in special needs education. 5.6% said that headteachers had been against teachers' further training in special needs education. 11.1% said that a policy for training teachers for special needs had not existed in schools. 33.3% said that it had been government's policy to facilitate teachers' further training in special needs education. 5.6% said that teacher training was becoming more and more complicated. 5.6% said that training teachers of special needs children was a necessity.

An example of participants who said that it was school's role to initiate teacher training in special needs education is as follows:

Our school has encouraged many teachers to go to UNISE and train to teach children with disability of all kinds. The school also invites some special education experts to give refresher courses to our teachers. Among the experts who come to help us in those refresher courses are the EARS officials. (Headteacher/Teacher No. 7)

Those who pointed out that teachers initiated their own training stated:

In our school, there is no policy for teacher training for special education. Teachers who are interested in disabled children go for training. They apply to go to UNISE and if they are successful they are recommended by the headmaster to go for the courses. (Headteacher/Teacher No. 6)

One of the participants who pointed out problems connected with headteachers said:

Much as teachers may be interested in training to teach children with disabilities, some of the headteachers, including our own headteacher, are not happy with us, teachers going to get higher grades. I think they are threatened. May be they think that if we get higher qualifications like diplomas or degrees we shall take over their positions. Some of us are really squeezed; our chances for going for further studies are really limited. (Headteacher/Teacher No. 9)

Besides the above observations, there were some participants who seemed not to be well informed about special needs education programme in Uganda. Such participants gave an impression that there was no policy concerning training teachers in special needs education. An example of what such participants said is as follows:

I am not aware of any policy from anywhere about teacher training for handicapped children. I don't think there is a government policy for that kind of training. I have also not heard any thing coming out of our school about training to teach such children. Most of our teachers have been going for further studies in Teacher Training Colleges or at Makerere University. (Headteacher/Teacher No. 13)

An example of what participants said about the government being responsible for initiating further training for teachers is as follows:

It is government's responsibility to train teachers in all fields, including special education. I don't see any reason why teachers should struggle on their own without help from the government. Where will teachers get the money for training? (Headteacher/Teacher No. 16)

As for participants who expressed fear of cost-sharing in higher institutions of learning, the following is one of the examples of what the participants said:

Without government support teachers cannot succeed in their training to teach disabled children. That means education of disabled children will not be successful if the government begins to charge teachers fees for further training as we hear it is going to happen. (Headteacher/Teacher No. 5)

Responses by participants indicate how policy makers have not made clear a national procedure for selecting and sending teachers for further training. In most cases teachers, on their own seem to have developed the interest and made attempts to go for further training in order to teach children with special needs. It appears that while some teachers may have succeeded in their quest for education, some have been faced with formidable problems. According to some participants, there are headteachers who are

not free to facilitate teachers' efforts to pursue further studies.

In Uganda, the problem of jealousy cannot be ruled out. It may be true that some of the headteachers may be reluctant to recommend their teachers for further studies for fear of being challenged later on by the highly qualified teachers. On the other hand, I may also not rule out that some of the highly qualified teachers may have been undermining their headteachers, thereby creating poor relationship with them. Be it what it may, awareness creation seems to be the only way to resolve such problems.

Fullan (1991), as indicated in Chapter 3, suggests that teachers should be made aware of, involved in and retrained in order to cope with any educational change introduced in a country. He says that retraining is vital, because any change brought about in education concerns teachers' own practices and it is those practices that can make changes succeed. Ainscow (1999), too, says that when teachers are retrained they are not only equipped with skills to become more effective, but they are enabled to move practice forward so that the intended change becomes meaningful. We noted UNESCO's concern in encouraging countries, both developed and developing, to retrain teachers so as to implement provision of education for children with special needs.

In Uganda, although the findings reveal that some efforts have been made to retrain teachers as recommended in the literature, it seems there are many difficulties which are still blocking the progress. I found out, for example, that the objective laid down in the

Government White Paper for establishing training institutions for teachers of special needs education had not been achieved. All the hopes have been laid on the Uganda National Institute of Special Education (UNISE) and the EARS programme. These two programmes cannot do much to help in achieving implementation of all the aspects recommended in the policy.

UNISE is currently the only training institution for special education in Uganda. It was established as a small department in 1988 at the Institute of Teacher Education, Kyambogo (ITEK). This was before the current policy recommendations under study were made. UNISE's success in promoting special needs education in Uganda seems to be very great. The institution has been offering different courses ranging from certificates to diplomas, and beginning with the academic year 1998/99, it introduced degree courses in special needs education. In order to expand its contribution, UNISE has designed and produced a curriculum for special needs education to be included as one of the component subjects of study in the Primary Teachers' Colleges (PTCs). The institution is currently designing a curriculum for distance education, in order to cover more teachers who are interested in teaching children with special educational needs.

The number of teachers trained at UNISE to teach children with mental retardation has been rising steadily. (*See Appendix 3*). UNISE and EARS have achieved much of their successes because of the financial and technical support provided by the Danish Government through the Danish International Development Assistance (DANIDA).

Although the policy stressed the need to retrain teachers of children with special needs, some other counter-policies were found to be contradicting what was suggested and making the availability of teachers needed for its implementation more complicated. There are three issues, which seem to be contradictory. The first one concerns the current policy of the government to implement cost-sharing for higher education. In the past, teachers were trained at government expense, but this is being stopped. Teachers will now go for further training at their own expense. Secondly, teachers are being reduced, mainly by retrenching some. Thirdly, the government has reduced its support for primary teachers' colleges (PTCs) from 63 to only 27 colleges. Under universal primary education (UPE), the government has recommended the ratio of teachers to pupils in lower primary (Primary 1 to 3) to be 1:110. The argument I can raise with regard to such measures is, how effective can a teacher who was teaching 45 children before UPE become more effective by teaching 110 children? How will a teacher mark each and every child's book? What method will a teacher use to give children individual attention, especially those with special needs (when at the same time the government is encouraging inclusion)? While more teachers need to be retrained, government support has been withdrawn from thirty six PTCs already. How will the government now be in a position to have adequate teachers trained for special needs education as recommended in 1992 (according to the policy in the White Paper)? These are some of the questions for which the answers seem not to be readily available and the

issues, which are already causing public concern. Such a concern has already featured and is being expressed in some of the local newspapers. In one of the newspaper articles published in the government owned newspaper, entitled “*Over 400 city school teachers axed*”, one cannot fail to appreciate teachers’ concerns and the complications which implementation of the policy for children with mental retardation has yet to go through. The newspaper report states:

Over 400 primary school teachers in Kampala have been axed to conform to education guidelines which drastically raised the number of pupil - teacher ratio...Limited resources and the influx of pupils in schools following the UPE programme, has forced the government to raise the pupil - teacher ratio to 1 to 110 for primary one and two, and 1 to 55 for primary three to seven...Parents and teachers have criticised the high pupil - teacher ratio in government primary schools. They say the move will affect standards... (New Vision 18.3.98: p.3)

In reacting to the newspaper article, the most disturbing aspect for both parents and teachers is the imminent decline in standards of schools. In other words, the concern is about the quality of education that is likely to result from the heavy load of work which teachers have to confront under UPE. As mentioned earlier some schools are recognised as “good” because of the high standard of academic performance. Definitely no one would dream of discussing special needs children when academic standards generally appear threatened, yet at the same time the need to implement education for such children is inevitable.

In another newspaper article, entitled “*Teachers flee UNISE*”, the fear about government’s policy on reducing the number of teachers was reported. The article states:

A number of teachers on courses at the Uganda National Institute of Special Education (UNISE) have rushed back to their schools to save their names from being struck off the pay-roll as directed by Education Ministry last week...Students interviewed at the Institute in Kyambogo

said they would rather abandon the course than forego their salaries. (New Vision 3.3.98: p.7)

Some teachers, headteachers and teacher educators interviewed during the current study expressed similar fears about the government policy on reducing the number of teachers, while efforts were going on to implement the policy of educating children with special educational needs.

***Category 1, Question 4 (a): What would you say is the importance for a teacher to train in order to teach children with mental retardation?***

***(b): In what way do you think a specially trained teacher for children with special needs should be different from ordinary teachers?***

**Resp and Comm**

44.4% of the participants said that training was important, because it enabled teachers to get new skills. 11.1% said that training helped in changing teachers' attitudes. 38.9% said that training enabled teachers to get new knowledge. 5.6% said that training was generally a good thing for all the teachers.

One of those who were concerned about skills and knowledge acquisition said:

A teacher of mentally retarded children must definitely get new knowledge and skills to teach those children. Teaching children with mental retardation needs a special qualification. Special education is new in Uganda. There are many teachers who are not well informed about this programme. Therefore, I think it is only through further education that many of us will be able to know more about the programme. Training of teachers of special education is very important; it is needed, and this is the time teachers should be given the chance to train. (Headteacher/Teacher No. 8)

Concerning attitude, this is what one of the participants said:

Mentally retarded children, like other handicapped children have been ignored in this country. People have negative attitudes towards them. Even many teachers have negative attitudes towards mentally handicapped children. Training can help to reduce negative attitudes of teachers towards these children. I very much support teachers who want to train in order to teach

these children. It is a good thing to train. You learn new things and you change. (Headteacher/Teacher No. 3)

With regard to the difference between special needs education and ordinary teachers, many teachers put emphasis on special remuneration. Participants argued that special needs education teachers should be paid better salaries than ordinary teachers, given the nature of work they did. An example of what they said is as follows:

Teaching handicapped children, especially those with mental retardation is not a joke. Not many teachers may have the patience we have to teach those children. You have to teach those children as individual learners and that is why training is good. So a trained teacher should be treated in a different way. We have seen some specialists in science subjects in primary schools paid special allowances. Special education also deserves special salaries. (Headteacher/Teacher No. 11)

Special needs education being a new programme in Uganda has definitely come with challenges, especially for those who are expected to implement it. Many of such implementers have not been clearly made aware of such challenges. Adequate preparation, especially for teachers, seems not to have been addressed by the policy makers from the beginning. One of the teachers' arguments as we have noted above is that their conditions of service need to be improved. Better remuneration is a factor, which does not seem to cause concern for special needs teachers alone, but even the ordinary teachers as well. I therefore consider better remuneration as an issue which policy makers ought to give special consideration.

***Category 1, Question 5 (a): What is the policy regarding curriculum/syllabus, as far as teaching children with mental retardation and ordinary children is concerned in your school?***

***(b): What are the likely changes, if any, of using the curriculum/syllabus the way you***

*are doing?*

*(c): In Uganda at the moment more emphasis is put on academic than practical education. In other words, education is examination oriented. In light of that how do we expect children with mental retardation to benefit from such education?*

**Resp and Comm**

In response to the above questions, 38.9% of participants emphasised the need to readjust the current primary school curriculum, while 61.1% said that ordinary primary school syllabus should be modified if children with mental retardation were to succeed in learning.

An example of what participants who wanted to have the ordinary school curriculum changed for the good of children with mental retardation said is as follows:

According to my observation, I think the problem we have in Uganda now, as far as special education is concerned is not a problem of children with mental retardation. The problem is to do with our curriculum. We really need to use the same curriculum, but we need to have it refined so that some children with mental retardation can also cope with it. They need to be taught at a speed, which they can follow. (Headteacher/Teacher No. 16)

Participants who said that ordinary primary school syllabus should be modified stated:

It is a matter of negative attitude for some of us to believe that children with mental retardation cannot learn. We cannot continue to have such a belief before we have worked on the school syllabus, to see how some children can benefit from it or not. It seems we are generalising things very much. We need to have the syllabus modified. (Headteacher/Teacher No. 8)

The research question, which the above responses were, meant states: ***What are the aims of education and curriculum for children with mental retardation in Uganda?***

As noted above, whether participants talked about curriculum or syllabus, they meant the same thing. Their argument was all about the need for education policy makers in

Uganda to use the existing national curriculum/syllabus, but in a modified way. This response is representative of what the majority of participants said in the questionnaire data in Chapter 5, section 5.5. Other categories of participants (such as parents, teacher educators, DEOs and Commissioners for Education as we shall see in the next sections) also put emphasis on the need for change of curriculum for the sake of implementation of education for children with mental retardation in Uganda.

***Category 1, Question 6 (a): Apart from, may be contribution by your fellow teachers towards effective teaching/learning of children with mental retardation, who else do you involve to reinforce your efforts to help the children?***

***(b): What kind of contribution do the people you involve make?***

**Resp and Comm**

Participants gave varied answers to the above questions. 44.4% said that there was no collaboration between special needs teachers and parents or other professionals. 50% said that there was some collaboration. 5.6% said that they were not aware of any form of collaboration.

One of the participants who said that there was collaboration between teachers and other professionals stated:

In our school we don't only have collaboration among staff members, but we collaborate with teachers from other schools as well. We also work with doctors, physiotherapists and EARS officials. The collaboration has helped other teachers who are not trained to teach children with mental retardation to know the children better. (Headteacher/Teacher No. 7)

With regard to the benefit or contributions made through collaboration, participants said that other professionals could do some of the work which they (teachers) were not

trained to do.

One of the participants who described the contributions or benefit brought about through collaboration between teachers and other professionals said:

We, the special education teachers also have the amount of work reduced when our colleagues from ordinary classes come to teach our children. Other professionals also help to assess our children. They do some work which teachers are not trained to do. (Headteacher/Teacher No. 12)

An example of participants who said that there was no collaboration between teachers and other professionals stated:

In our special units the special education teachers work on their own. Teachers in the mainstream classes do not want to help our children in the unit. We also don't receive other professionals like doctors. (Headteacher/Teacher No. 2)

One participant said that she was unaware of collaboration between special needs teachers and other professionals. The participant said:

Since our school is a special school, I have no idea whether collaboration between us teachers and other professionals is needed. I am not quite aware of how collaboration can help the mentally retarded children. (Headteacher/Teacher No. 5)

The above responses were meant to address the research question, which states: *What teaching approaches are adopted for teaching children with mental retardation in Uganda?*

Participants who said that they had collaboration with other professionals clarified the usefulness of the approach. One of the issues raised was that as teachers for special needs children, they were not trained to do everything. They revealed that through collaboration, other ordinary teachers had been exposed to work with, and to appreciate

the needs of children with mental retardation. These participants are representatives of the majority of people who support collaboration as noted in this chapter, section 6.2. Although some participants said that they didn't have collaboration with other professionals and parents, they did believe that it was useful to have such an arrangement in place. In light of such responses, I do believe that an approach which involves teachers working with parents and other professionals is a way forward in the implementation of mental retardation in Uganda.

***Category 1, Question 7 (a): Do you have any particular method that you use for teaching children with mental retardation in your school?***

***(b): What are the results of employing different methods of teaching the children?***

**Resp and Comm**

16.7% of participants said that when teaching children with mental retardation they did not follow a specific teaching method. 77.7% said that they used child-centred methods. 5.6% said that they used group work.

The following are some of the examples of how participants described the different methods of teaching children with mental retardation in Uganda:

When we prepare our schemes of work and the lesson plans, we follow the normal syllabus for ordinary schools. When it comes to handling our children, there is a special consideration we put in, such that we take the trouble of modifying the methods, even the topics, to see that they are relevant to the children. (Headteacher/Teacher No. 1);

and in order to make work easier:

A teacher may have, say, six children in a class with special needs. That teacher has to try to modify the curriculum to suit the children in the class. In such case you find that a child in primary four is given work, say, of primary two, so those are the kinds of modifications we try to make. (Headteacher/Teacher No. 7); and

a third participant emphasised the importance of child-centred work, saying:

We normally encourage a child-centred approach, using children's experiences as well. (Headteacher/Teacher No. 10)

A description by the participant below was different from the above:

If you just go and talk, I don't think those children will get you...You know what Uganda today is! With the work which we give in those classes..eh? Thirty numbers, or fifty like that...ten, they can't really cope with the pressure of work...! No. (Headteacher/Teacher No. 14)

The above participant (No. 14) who was opposed to changing methods of teaching seemed to have expressed a view which is representative of the minority as we noted in Chapter 5, section 5.7.

The above responses were meant to address the research question, which states: *What teaching methods are adopted for teaching children with mental retardation in Uganda?*

Participants attributed the results of employing different methods of teaching children with mental retardation mainly to children's increased interest in learning.

With the above analysis, we have noted how methods of teaching children are discussed. I have found out that there is no particular teaching method, which is more suitable than the others. What seems to be important is to assess children's individual needs then select and modify any method to be used at a particular time. Some of the methods discussed are already being used in Uganda, while some are not. The methods already in use in the country may only need to be modified, so as to make children learn more effectively. In the next section I shall present the responses with regard to what headteachers/teachers said about the types of school children with mental retardation

should be educated in.

***Category 1, Question 8 (a): What type of school do you think children with mental retardation should be educated in?***

***(b): What benefits do you think children with mental retardation may get from the type of school you suggest they should be educated in?***

**Resp and Comm**

38.9% of the participants who answered the above question did put emphasis on the need to educate children with mental retardation in integrated schools. 38.9% said that the children should be educated in special schools only. 22.2% said that such children should be educated in ordinary schools.

An example of what the participants who said that children with mental retardation should be educated in integrated schools is as follows:

All children must be educated in the same kind of school, since they are all children. Education is meant to give people skills and knowledge. Therefore, people should be educated in the same environment. (Headteacher/Teacher No. 6)

The participants who put emphasis on the need to have children receive education in special schools said:

Children with mental retardation are different. Their learning capacity is low; they cannot cope with academic standard in integrated schools. It will be a waste of time to integrate the children. They should be allowed to learn separately. (Headteacher/Teacher No. 13)

With regard to the benefits of educating children with mental retardation in any type of school, participants clarified their views differently.

Some participants argued that when children with mental retardation were educated in integrated schools they would follow the same syllabus, so they could be helped to acquire knowledge and skills at the same time with their peers (the ordinary children). The participants who were against integration argued that it was a waste of time, because such children would not benefit from integration. I noted, however, that more participants indicated the need to have children educated in integrated or ordinary form of school. Few participants preferred special schools. I therefore consider the desire for integration of children with special needs, as expressed by a majority of participants as a positive move towards implementation of the policy on education of children with mental retardation in Uganda.

***Category 1, Question 9R: What suggestions would you make for an effective implementation of education for children with mental retardation in Uganda?***

**Resp and Comm**

Participants put emphases on different issues when they made suggestions or recommendations, regarding what ought to be done if implementation of education for children with mental retardation was to succeed in Uganda. In order of priority, the participants made their recommendations as follows:

- Government to help parents
- Awareness creation needed
- Special salary for teachers of special education

- Policy makers to involve teachers and parents
- Change in curriculum needed
- Teacher training needed
- More special units needed in ordinary schools
- Teachers should not pay fees for their training
- Government facilitate special and ordinary schools
- Parents stop hiding children with disabilities

### **6.3.2 Responses by Parents**

This section will cover aspects which comprise issues like parents' awareness about identification of disability in their children, reaction, measures taken, services considered, educational provision, types of education preferred, the future of the children (after education) and suggestions for implementation of education for children with mental retardation in Uganda.

#### ***Category 2 (Parents), Question 1: How was the child's problem first noted? Resp and Comm***

A majority of participants who responded to this question said that they noted the problem with their children after the children had been sick. Two participants said that it was a surprise to realise that their children had already developed the problems.

An example of participants who said that they had noted the problems with their

children after sickness was as follows:

When the child was about six months he fell sick and was admitted in hospital where he received treatment for about three months. From that time the child's normal development seemed to have been disturbed. The child was no longer playing like playing and doing things actively like other children of his age. He began to walk when he was about one and a half years. When he was six years he was still behaving like a child of two years. We then concluded that our child had developed a serious problem from the sickness. (Parent No. 3)

With regard to the participants who said that they were surprised to discover that their children had developed disability, the following is an example of what they said:

When the child was two years old he was behaving in a way we did not understand. We took the child to the hospital and doctors told us not to worry, but to keep taking the child to hospital for further assessment. Later on we were told that the child may not be able to do things like other children, but that should not mean the child was sick. . (Parent No. 7)

The above responses are important in that they help to show the concern which parents of children with special needs have. It may be possible that the earlier parents discover the problems, which affect their children, the better they may cope emotionally, and therefore be in a position to plan for their (children's) educational provisions. Early discovery of children's problems may also enable parents to seek whatever interventional services are at their disposal. All the parents who were interviewed had made every effort to improve on the conditions of their children after they had discovered the problems.

***Category 2, Question 2: What do you believe could have been the cause/source of your child's problem?***

**Resp and Comm**

All the participants (nine) who were interviewed attributed the cause of their children's problems to medical factors, that is, they said that their children had been sick before.

An example of what was said by those who believed that the cause of their children's sickness was due to sickness was as follows:

As Christians all we know is that our child became sick because of sickness and nothing else. When he had malaria with high temperature the child had convulsion many times. We did not believe the child would survive. Some people suggested that we could try some traditional doctors. Some even said that the child could have been bewitched. We stood firm and rejected all these suggestions. We knew that there was only one way and that was to take the child to the hospital for treatment. (Parent No. 5)

I categorise the above responses as issues to do with 'medical'. The participant put emphasis on the child's falling sick, thereby leading to his developing a disability. The participant also talked about traditional implications, including, for example, bewitchment – saying that the family did not make any attempt to seek solution through such means (traditional treatment). In other words, the participant gave an impression that in Uganda when parents have their children affected with a problem of disability, it is likely that they can try to seek medical, traditional or both solutions. Those who are devoted Christians tend to opt for medical, rather than traditional solutions as noted from the above participant. Given this background, therefore, I consider medical and traditional factors as vital in influencing Ugandan people's ideas about disabilities.

This finding shows how parents are more alert than teachers with regard to conditions of mental retardation. As we noted in Chapter 5, 5.4 teachers had divergent views about definitions of mental retardation.

***Category 2, Question 3(a): What organisations have been concerned with providing services, which have helped your child?***

***(b): What kind of services has your child been receiving from the concerned organisation (s)?***

**Resp and Comm**

Four of the participants said that they had received a lot of support from the hospital.

Three said that they had received some help from EARS. One said that they had been supported by the Uganda Society for the Disabled Children (USDC). One participant said that they had relied on their personal knowledge and skills to bring up their child.

Participants who had depended on medical services, said that they had taken their children for treatment and for assessment. They also said that they had received a lot of support and advice from the medical experts.

One of the participants who said that they relied on medical services stated:

Since we discovered the problem with our child, we have depended on help from the hospital. The child was assessed by doctors and has been getting treatment from time to time. Doctors have been advising us on how to handle him. (Parent No. 4)

With regard to relying on EARS, a participant said:

The EARS officers have been helpful to our child. They have been giving us advice, by telling us what the child should, and should not do. They have encouraged us to take the child to school and we followed their advice. (Parent No. 6)

The parent who utilised services provided by USDC said that her child had received physiotherapy exercises and that the child was provided with some reading materials which had enabled him to learn some skills before he was taken to school. The

participant said:

USDC has been helping to provide our son with school fees. They have been visiting us and bringing toys and different kinds of gift to the boy. (Parent No. 5)

The parent who reported about relying on her personal knowledge and skills said that having qualified with a master's degree in special education, she believed that she could try to work on her own, to help her child develop in all aspects before taking him to school. She said:

We have been doing everything [ourselves] to bring up the child. We could not wait to get support from other people or from outside. No, we thought it was our responsibility to help the child develop into a useful person. (Parent No. 3)

In the above comments, I categorise responses as issues to do with 'services received by parents'. Participants put emphases on hospital, EARS, USDC and on self-provided services. The responses indicate that parents whose children have been affected with disabilities have been approaching some organisations for essential services required for development of their children. The organisations that have provided services to children with disability have mainly been hospitals, EARS and USDC. One participant indicated that in her family they did not rely on such external assistance - she said that they, instead, shouldered the responsibility themselves. Services for persons with disability have been available in Uganda for a long time. Many parents and disabled persons have benefited from such services. As noted in Chapter 1, sections 1.6.3.9, 1.6.3.10, 1.6.3.11 and 1.6.3.12, most of the educational services for persons with disability in Uganda were initiated by voluntary organisations. In the above responses, there are indications

that some parents are indeed determined to do all they can to assist their children without waiting to get assistance from outside.

In Uganda there are some non-governmental organisations (NGOs) which, together with governmental organisations, provide services which are needed for improving conditions of children with special needs. Such organisations provide parents with advice concerning intervention services available for children in the country. Some of the organisations also provide funds for children's education. This is because some parents are quite poor and are unable to educate their children. USDC, in particular, has been very handy to such parents. The parent who said that she had relied on her own indicated how, in Uganda, some parents have been making all kinds of effort to improve the conditions of their children without waiting for outside help. In my opinion parents who were concerned like this may be the kinds of parent who are able to help in the task of implementing education of children with special needs.

***Category 2, Question 4 (a): Have you taken any advantage to have your child receive education, say through UPE or any other means?***

***(b): What is your comment about UPE?***

**Resp and Comm**

One participant said that there was no hope in her child's education. She argued that whether UPE had been introduced, or not, it did not mean much to her. Five participants said that UPE was beneficial to the children with special needs. Three said

that UPE was not beneficial to children with special needs.

One of the participants who did not see the value of UPE said:

When UPE was introduced, we were told that children were not going to pay for their education. We were very happy to hear that. This promise has not been kept – teachers have been asking parents to pay money. We don't know what is happening. I no longer see the importance of UPE. (Parent No. 2)

The participant who appreciated the introduction of UPE said:

I was one of the first parents to register children for UPE. I included the child with disability among the four recommended for the programme. I think she will learn and become better now. (Parent No. 8)

One of the parents who was sceptical about UPE stated:

Surely, I don't know what I need to do for my child. Whether we now have free education, or not, I don't see what my child can get out of it. (Parent No. 1)

I categorise all the above comments as issues to do with 'UPE'. Some participants indicated their support for, while others did not seem to see the benefit of UPE as far as children with mental retardation were concerned. The main concern for parents who did not see the benefit of UPE seems to be attributed to continuous payment of school fees even after introduction of the programme (UPE). Those who supported UPE seemed to have had a long desire for the programme. I consider the participants' differences in views as a sign indicating that there had been inadequate information dissemination from policy makers to the population, relating to the value of UPE.

To many parents, the introduction of UPE in 1997 seems to have meant a great relief, but according to the responses noted above, this has not been the case.

In this chapter we have also noted the mixed feelings by parents about UPE. The reason for parents' mixed feelings could be attributed to their being inadequately informed by the policy makers.

*Category 2, Question 5(a): As your child has a special need, what type of school would you like him/her to go to?*

*(b): Why would you prefer your child to go to the type of school you have mentioned?*

### *Resp and Comm*

Three participants said that it was suitable for children with mental retardation to receive their education in both ordinary and special schools. Four said that children with mental retardation should be provided with education in special schools only. Two said that they did not have an idea about which type of schools children with mental retardation should be educated in.

An example of one of the participants who was not sure of the benefit which children with mental retardation could get by attending ordinary schools was as follows:

I don't know the difference between schools, especially the types that would serve the needs of a child like this one of mine. I would however, prefer if there is anywhere one can get special handling of a child with disability, like this son of mine. (Parent No. 3)

The above parent (Parent No.3) is representative of the people who may still not be aware of the value of integration. The parent, however, said that all she wanted was a

place where her child could receive special attention. We noted in Chapter 3, section 3.2, the advantages of educating children with severe disability in segregated schools. We found out that what they (children with severe disabilities) needed was to be equipped with some skills needed for adaptation to daily life. As the child I am referring to above has a severe disability, the parent's response may be in line with the advantage of segregated education as discussed in the literature. Another parent, however, was not amused about the integration approach carried out for children with disabilities. She did not believe that adequate arrangements were made for the integration of the children in ordinary schools. She said:

I don't know! I don't know what to say... you know, in Uganda, they are now crazy with inclusive education. You can't just include anyone, anyhow. You have to facilitate the inclusion, making it possible for each and every person to be included. That is why I would say a special unit would be important to give that individual the basic skill that would take him to an integrated setting and from there he would get more skills that would automatically help to include him in the rest of the schools. (Parent No. 6)

The participant's argument is that children with mental retardation should be educated in special schools first then get integrated later into ordinary schools. Although the participant uses both integration and inclusion simultaneously, the idea seems to be focused on a policy, which now seems to emphasise the need to embark on inclusion in the country. In other words, the challenge to the policy makers is that they are too ambitious in trying to achieve the aim of inclusive education while adequate arrangements have not been put in place.

Saying that suitable conditions have not been put in place to promote the provision of

education for children with mental retardation is representative of the majority views as we noted in Chapter 5, section 5.7. What may, however, defeat the participant's argument is that it may practically be impossible at the present moment to continue establishing more and more new special schools as that would be too costly. We noted, according to both the Kajubi Report and the Government White Paper, that the policy makers realised the burden that NGOs had gone through to establish and sustain the existing special schools by using meagre resources. This was why the policy makers found it inevitable to assume responsibility for education of children with disabilities by encouraging establishment of special units in ordinary schools where it would be relatively cheaper.

To conclude this argument on integration, I therefore consider as vital, the view expressed by the participants who said that children with special needs should be educated both in ordinary and special schools, depending on the children's degree of special needs.

***Category 2, Question 6 (a): In which way would you wish to contribute ideas to the government about the education of your child?***

***(b): With whom do you collaborate to help the child in his/her education at the moment?***

**Resp and Comm**

A majority (seven) of participants answered the above question (part a) with emphasis put on the government. They believed that it was government's role to educate all the

children in the country.

With regard to part (b) of the question, one participant was of the view that the government should involve parents in decisions that would involve provision of education for their children. One other participant pointed out the need to involve fellow parents in all matters that concern helping children with mental retardation in the country.

In Uganda, it has always been a common belief by people that government is supposed to provide all the necessary services, especially educational, to the population. To me this is one of the factors, which may prevent implementation of important policies, such as the one for education of children with mental retardation in the country. People need to be informed that ‘government’ is not something isolated from them; they need to know that they are a part of ‘government’. Thus, when there is a task to be tackled each and everyone concerned should play his or her role to achieve the objectives set. The majority of parents who expected the government to do more (during the interviews) gave an impression that they were not a part and parcel of the government. We noted in Chapter 1, section 1.6.3.4, how Fulcher (1989) advanced argument on policy formulation. She said that policy should be made at all levels. In other words, parents, professionals, bureaucrats and politicians should all play role in policy formulation. When policy formulation involves only politicians, according to Fulcher, then there is a likelihood of having a ‘gap’ between its makers and implementers. This is definitely the

kind of situation prevailing, as far as special needs education policy in Uganda at the moment. Such a situation, therefore, is likely to render implementation of education for children with mental retardation difficult to achieve in Uganda

*Category 2, Question 7(a): What do you think should be the aims of education for your child?*

*(b): What do you wish his future to be when he/she is grown up?*

**Resp and Comm**

Three of the participants said that they were not aware of the aims of education for children with mental retardation. One participant described the education aims as being examination-oriented. One participant said that education should help a child to speak good English. One participant said it was God who knew what the aims of education for children with mental retardation were. One participant said that the government had not clarified the aims of education because it had only been providing lip-service.

One parent, for example (whose child had severe multiple disabilities), said that she did not know the aims of education. The same parent had a high ambition when she revealed that she wanted her child to become a doctor after his education. She said:

Surely, it is hard for me to say what education could do for my child. Honestly, I don't know! Well, if it were possible for him to go to school, I would love to see my child become a doctor thereafter. (Parent No. 9)

The above participant stressed that since she was suffering because she had not

acquired enough education, she did not want to see any of her children suffer in the same way in future.

Another parent who was more knowledgeable about the weakness in the policy challenged the policy makers, and urged them to formulate policies, which addressed the aims of education realistically. She did not believe that the current education policy was helpful, especially to children with mental retardation in Uganda. She said:

We have said all children should be educated. We haven't looked at the curriculum. We haven't defined what education means in our context. Passing examinations...Is it enlightening a person? Is it enabling a person to live productively in a fast growing society? Until we answer those questions, I think we are doing lip-service to most of these things that we think we are doing.  
(Parent No. 3)

Two main categories, that is, 'aims of education' and the 'role of government' were responded to, as noted above. Some responses seem to suggest that aims of education for children with mental retardation have not been made clear. Other participants argued that the government should make curriculum realistic for children with mental retardation in Uganda. These observations represent the majority views as noted in Chapter 5, sections 5.5 and 5.6.1.

Reactions by the parents, as indicated above, are similar to the reactions from Headteachers/Teachers No. 1 as noted in section 6.3.1 above.

Parents showed different, but pertinent views about the aims of education for their

children. Education, as we noted in this chapter, section 6.2, plays a vital role in Uganda. People regard it as an investment and as a factor, which helps to improve their status. After education, parents expect their children to secure good jobs so as to have improved economic and social conditions. In Uganda, even being able to speak good English as one of the parents argued, is regarded as a significant achievement in one's status. Some people who are aware of what the aims of education should be are not happy. Their argument, as we have noted above, is that a lot of emphasis has been put on children's passing examination at the expense of other useful things, like development of practical skills through education in Uganda.

***Category 2, Question 8R: What suggestions would you make for an effective implementation of education of children with problems like your child?***

**Resp and Comm**

Participants made several suggestions/recommendations, which they hoped could help to strengthen implementation of provision of education for children with mental retardation in Uganda. The following are what they have suggested/recommended:

- More schools should be built
- Vocational education needed
- Government should help parents
- Parents should not hide disabled children
- Parents should collaborate with other parents

### 6.3.3 Responses by EARS Staff

This section will cover aspects like policy on assessment, referral of assessed children to ordinary schools, co-ordination of activities between EARS staff and teachers, monitoring of integrated children in the ordinary schools, sources of information for assessment, assessment procedures, people involved in assessment, effective use of assessment centres, achievement of EARS programme, problems faced and suggestions for improvement.

*Category 3 (EARS Staff), Question 1: What policy guidelines do you follow to assess children?*

#### *Resp and Comm*

In response to this question, all the four participants said that there were no policy guidelines with regard to assessment of children with special needs in Uganda.

An example of what the participants said was as follows:

There isn't a government policy, which clearly governs the procedures for assessment of children with disabilities. That one isn't there...but the policy of government allows children...all children to be in school and to have education. (EARS Staff No. 3)

The responses given above are categorised as aspects to do with 'government policy on assessment'. The impression given by the participants indicate that although assessment has been carried out in Uganda, EARS centres have been operating differently from one another. In other words, participants implied that the government had not provided a guideline to enable the EARS staff carry out the exercise in the same way throughout

the country. The responses seem to imply that the EARS officials are not yet sure of what they ought to do nationally.

***Category 3, Question 2: When children are assessed and referred to ordinary schools, is there an automatic provision for their admission in those schools?***

**Resp and Comm**

In response to the above questions, participants depended on three factors to provide the answers. The factors include UPE, mutual understanding and awareness of the needs of children with special needs.

One participant said that under UPE many school administrators had been obliged to enrol children. One participant said that registration of children had depended on mutual understanding between the EARS staff and the school administrators. Two participants said that when the school administrators were sensitised they posed no problem - they accepted children for registration.

The participant who pointed out that under UPE school administrators had been obliged to enrol all categories of children stated:

When UPE was introduced headteachers were left with no choice, but to admit many children, including those with disabilities. (EARS Staff No. 4)

With regard to the participants who talked about mutual understanding, one said:

The fact is that many of these headmasters or headmistresses did not know how to handle children with disabilities. It was a hard task for us, EARS Staff to sensitise them about children with special needs. When they eventually understood things, their attitudes began to change. They then began to admit the children with special needs into their schools. (EARS Staff No. 2)

In considering the above comments, I categorise the responses as issues to do with ‘registration’ of assessed children. The participants said that when UPE was introduced, some headteachers felt obliged to register children with special needs who were referred to their schools. Some headteachers, according to the participants, were not obliged to accept such children. Instead, according to the participants, such headteachers had to be persuaded or sensitised by the EARS staff before they got convinced about accepting children with mental retardation in their schools. I consider headteachers’ difference in responding to children with special needs as a problem, which is likely to do with attitude of some of the headteachers. It may be possible that when UPE was introduced such headteachers could have been sceptical about the need to include children with mental retardation. Thus, after being sensitised by the EARS staff they were able to recognise the needs of such children, so they (headteachers) began to admit them in their schools.

The above responses are meant to address the research question, which states: ***How are children with mental retardation selected for education in Uganda?***

Responses by the EARS Staff on UPE are in line with the responses provided by the headteachers/teachers and parents as we noted in the previous sections. What I am trying to point out here is that although UPE should be seen as a programme which can be compatible with EARS (in selecting children with mental retardation for education), the responses here indicate that there exists a missing link between the two programmes.

The EARS participants put emphasis on the need to increase sensitisation of the school administrators to realise the importance of registering all children with special needs who are assessed and recommended to join their schools.

***Category 3, Question 3: How does EARS co-ordinate its activities with the ordinary schools where children are integrated?***

**Resp and Comm**

All the four participants said that EARS Staff collaborate with teachers to promote special needs education in Uganda.

The following is an example of what they said:

We have a number of activities which we carry out with teachers. For example, we assess children and sometimes teach together with them (teachers). (EARS Staff No. 1)

The participants' comments as noted above, can be categorised as an issue to do with 'collaboration' between EARS staff and classroom teachers. The participants claimed that collaboration between the EARS staff and teachers had been highly valued. As may be noted elsewhere, in sections 6.3.1 and 6.4.6 of this chapter, other participants stressed the need for collaboration between professionals, so as to effectively implement the policy on education for children with special needs in Uganda. I therefore consider collaboration as one of the effective ways of promoting education for children with mental retardation.

***Category 3, Question 4: How does EARS help teachers enrich both teaching and***

*learning skills of teachers and pupils, respectively?*

*Resp and Comm*

One of the participants reported that EARS staff had been conducting regular visits, to see what was going on in schools. Two participants said that they worked hand in hand with teachers to produce educational materials. One participant said that she had been organising regular workshops for teachers, so as to enable them catch up with expected changes in special needs education.

With respect to the monitoring of children's progress, the following is an example of what a participant stated:

We regularly visit schools to check how children with special needs cope with their learning. We also find out what relationship they have with non-disabled children and teachers. (EARS Staff No. 3), and

Another member said:

We work hand in hand with teachers and their headteachers. We produce educational materials and share many ideas. (EARS Staff No. 1)

The participant who emphasised regular workshops said:

One of our main tasks is to carry out workshops for teachers. Through such activities we help to provide information to our teachers. They need information to keep up to date with changes that take place in special needs education. (EARS Staff No. 2)

As noted in category 3, question 3 above, the emphases put by the participants are similar to the ones in this section – they concern 'collaboration'. In this section, the participants put emphases on production of educational materials and running workshops. I therefore still consider collaboration between professionals as vital

approaches needed to implement special needs education in Uganda.

*Category 3, Question 5: What does EARS do to find out about the progress of children with mental retardation who are integrated in ordinary schools?*

**Resp and Comm**

One participant responded to this question by saying that their EARS centre was concerned with monitoring (following up) the progress of children with special needs who were integrated in ordinary schools. One participant said that their centre was concerned with carrying out planning activities with teachers. Two participants said that their centres encouraged working closely with teachers.

With respect to monitoring children's progress, the following is an example of what a participant stated:

Whenever we assess children, we refer them to schools. We then begin to visit the schools where the assessed children are referred, for various reasons. Firstly, we go to see how teachers cope with the referred children. Secondly we go to see how the children cope with other ordinary children in schools. Thirdly, we go and explain to some teachers, simple skills of teaching children with mental retardation. (EARS Staff No. 4)

The participant who talked about planning said:

As EARS staff, we value working and planning together with teachers – we cannot rely on our ideas alone. No. We need their co-operation. (EARS Staff No. 2)

An example of what EARS Official said about working closely with teachers is as follows:

Although we work as EARS staff at the district centres, we still remain classroom teachers. Some of us still carry out teaching duties. The knowledge and skills we got from UNISE enable us to help our fellow teachers to bring about changes in their teaching. (EARS Staff No.1)

The participants' comments above are still categorised as issues to do with 'collaboration'. I noted that the participants emphasised planning and working closely with classroom teachers. I therefore consider these as some of the important ways of promoting collaboration between professionals.

***Category 3, Question 6: Is there a particular source from which EARS staff get the information when they want to identify and assess children with mental retardation?***

**Resp and Comm**

Different responses were given by participants to this question. One participant said that doctors provided the source of information. One participant said that teachers and parents provided the source of information for assessment. One participant said that parents, teachers and doctors provided the source of information for assessment. One participant said that children provided the source of information.

An example of what a participant said about sources of information for assessment was as follows:

When we want to assess children we contact doctors. Most of these children's problems seem to be medical and we do not have ideas of what to do. We therefore, request doctors to examine the children and tell us what the problems are. (EARS Staff No. 3)

The participant who made reference to teachers and parents as being the sources of information said:

Teachers and parents are very knowledgeable about children. Because of that, we ask them, so as to get whatever information we require when we want to assess children. (EARS Staff No. 1)

The participant who referred to teachers, parents and doctors as sources of information said:

Assessment of children with disabilities is not a simple task. We cannot rely on one source. We need to get information from parents, teachers and doctors as well. (EARS Staff No. 4)

The participant who said that children were the sources of information stated:

Children are very useful sources of information. We interview and observe them. Some of them tell us about their problems and we learn a lot. (EARS Staff No. 2)

I categorise the above participants' comments as an issue to do with 'sources' of information for assessment. The participants put emphases on doctors, teachers and parents. The responses indicate that there is no single source from which EARS officials having been getting information whenever they embarked on assessment exercises.

Given the fact that at the moment there is still no standardised assessment procedure in Uganda, the EARS staff may be justified to rely on their different sources of information.

*Category 3, Question 7(a): What type of assessment does EARS use?*

*(b): How is assessment procedure carried out?*

**Resp and Comm**

Participants reported differences in types of assessment going on in Uganda. In other words, they indicated that there was lack of uniformity in the types and procedures of assessment used by EARS in the country.

Examples of what the participants said in response to the above questions are provided as indicated below.

One of the participants said:

A variety of assessment methods are used for different purposes. Children are assessed both from their homes and at school. (EARS Staff No. 4);

A second participant said:

Teachers assess and find out this child is this, and that...Their day-to-day job, the original job actually, is going to find the child...to assess the child. So they do assess in school and out of school. (EARS Staff No. 2);

A third participant said:

If it is in the school, it is between the teacher and the child. The assessing person is the classroom teacher of the child. If it is where the parent is, the parent will of course do part of the assessment procedure. We don't actually have, say a medical personnel there and a social worker there, in one group to assess, but when the personnel who is supposed to assess, perhaps in the presence of a parent, because we have to ask questions and the child is there to assess, you might have to refer to another officer. (EARS Staff No. 1); and

A fourth member said:

We use what is called free assessment method. This involves looking at a child and telling whether the child has a disability or not. There is also what is called screening, whereby the assessor simply sits down and screens a child and finds out the degree of disability the child has. (EARS Staff No. 3)

This particular finding reveals that during an assessment a child may simply be looked at and referred to as “mentally retarded”. Although this form of assessment has its uses, the underlying issue, which may raise further arguments, is the issue of labelling and use of the term mental retardation. One of the arguments is, when I compare the current procedure in Uganda with the findings I have referred to in the literature, is there any

difference between EARS' approach and the one reported during the early days when intelligence was the sole parameter for justifying labelling individuals as “mentally retarded”? The answer is obviously a “no”. I could perceive EARS as being well positioned in the front-line to combat the problem of labelling, but is it well equipped to bring about such a change? The answer to this question may also be “no”, for the moment. We have noted in the literature the advocacy for a modern approach to assessment whereby it should be used as part and parcel of monitoring an individual's developmental process. For example, the literature reveals that assessment can be a long on-going procedure, from conception up to the time the individual is eighteen. At the moment, EARS is in the process of designing assessment instruments in the country. In the literature we have noted that such assessment instruments should embrace the different cultural aspects as well as the complete environmental conditions that could have either direct or indirect effects on an individual.

Uganda is a country with a diversity of cultures. There are over thirty eight different small nationalities, each with its own language, traditions, customs, practices and behaviour. In view of that, it would not be realistic for EARS to design one standardised instrument for assessing children with special needs in the whole country. There are hundreds of standardised assessment instruments already developed, especially in the Western developed countries, some of which I have mentioned in Chapters 2 and 3. It would not be valid for EARS to adopt them wholesale for use in

Uganda, but they can be useful as starting points. I am not saying that EARS is in the process of adopting any of them; what I am saying is that some of the available instruments could help guide EARS to develop its own original instruments which are culture-based. This is a challenge which EARS has to be prepared for if valid assessment will be carried out on each and every child from any nationality group in the country. Indeed EARS does not have to shoulder such a responsibility alone, but should work hand in hand with other national organisations such as the Uganda National Examinations Board (UNEB) and the National Curriculum Development Centre (NCDC). These organisations are important in that they control examinations and curriculum, respectively - these are still handled centrally in the country. Therefore, for EARS to have children with special educational needs assessed, these organisations should be made aware of what adjustments or special arrangements may be necessary.

*Category 3, Question 8: How well is the assessment programme understood in the country?*

**Resp and Comm**

Two participants said that EARS centres were fully utilised by teachers, so the EARS programme was not strange to them. One participant said that in their district EARS pamphlets had been distributed to enable teachers understand the meaning, objectives and activities of EARS in the district. One participant said that in their district teachers were trained on the job to develop the concept of teaching children with special needs.

The participants who talked about utilisation of EARS centres said:

Our EARS centre is not a place where we do one thing. It is a resource centre. Teachers come to learn many other things from here. They produce teaching materials and share ideas on certain issues. (EARS Staff No. 4)

The participant who made reference to pamphlets said:

One of the quickest ways to sensitise people on special needs is through pamphlets. We distribute pamphlets to teachers and request them to talk to parents about the contents in them. That is, to say, we sensitise teachers, then they, in turn sensitise parents with the help of the pamphlets. (EARS Staff No. 2)

With regard to training on the job, a participant said:

Many of our teachers in the district have been sensitised and they now have basic ideas about special education. We have been working very hard to train them right from their places of work, that is, from their schools. (EARS Staff No. 1)

As noted above, participants' comments can be categorised as the impact of 'establishing EARS programme'. I noted that participants put emphases on utilisation of EARS centres as 'resource centres', 'sharing of ideas' and 'training teachers on the job'. I therefore consider these activities and approaches by the EARS staff as some of the effective ways to strengthen special needs education in Uganda.

***Category 3, Question 9: How do you judge teachers' use of assessment centre?***

**Resp and Comm**

In response to this question, one EARS staff member said that EARS centres had been established in all the districts in Uganda, so teachers had become acquainted with them. One participant said that because of teachers' effectiveness in utilising the centres, some teachers who joined the centres had already been appointed as district assistant inspectors of school, a motivation, which she said, was helping to increase teachers' use

of the centres. One participant said that teachers' utilisation of the EARS' centres could be judged from the increasing number of children who were assessed from the centres in the country. Another participant said that teachers' effective use of EARS centres could be noted from the increasing number of children with mental retardation who were integrated into ordinary schools in the district.

One participant who said that EARS centres had been established in all the districts in Uganda stated:

EARS centres are not new in Uganda – they have been established throughout the country. Many teachers have used the centres and have really helped to strengthen our efforts in the district. (EARS Staff No. 2)

The participant who talked about appointment of some of the EARS staff stated:

Some of us who were recruited early in the programme have now been appointed as assistant district inspectors of school, in charge of special education. (EARS Staff No. 3)

With respect to increase of children with mental retardation in schools, one of the participants said:

There are many more children being assessed these days, compared to 1992 when the programme had just been introduced. This shows how effectively teachers are using EARS centres. I am sure many teachers are going to join us, and the activities at the centres will expand, (EARS Staff No. 1);

And one member who talked about the children increasing in schools said:

Children who are assessed are increasingly being integrated into ordinary schools. This means that EARS centres are becoming more and more effective. (EARS Staff No. 4)

From the above participants' comments, responses can be categorised as issues to do with 'use of EARS centres'. One of the issues noted in the participants' responses was that more teachers were using the centres, compared to a few years back. I also noted

that participants put emphasis on the number of children who were being assessed at the centres and integrated into schools. They said that the number of such children were increasing fast. I therefore consider the progress made by EARS programme as important factors that may help in strengthening implementation of education for children with special needs in Uganda.

*Category 3, Question 10R: What suggestions would you make for improvement in the implementation of education for children with mental retardation in Uganda?*

**Resp and Comm**

Participants made a number of suggestions/recommendations, which they hoped could help to strengthen implementation of provision of education for children with mental retardation in Uganda. The following were what they suggested/recommended:

- More awareness on disability needed
- Retraining teachers needed
- Collaboration between teachers and parents needed
- Collaboration between policy makers and implementers needed

### **6.3.4 Responses by Teacher Educators**

This section will cover aspects like policy issues, UNISE's teacher training in relation to provision of education for children with mental retardation, contribution of UNISE teacher educators, impact of UNISE on teacher development, UNISE's role in the community, collaboration between UNISE and other service providers, influence of

UNISE on special needs generally and suggestions (for improvement in the provision of education for children with special needs in Uganda) by the teacher educators.

***Category 4 (Teacher Educators), Question 1 (a): How do you assess UNISE’s teacher training programmes in relation to provision of education for children with mental retardation in Uganda?***

***(b): How effective do you think teacher educators at UNISE are contributing towards education of children with mental retardation?***

**Resp and Comm**

Two participants said that there was need for UNISE to improve on its management so as to increase effectiveness in its performance.

One participant said that UNISE’s performance was impressive and that other countries, especially in the eastern and southern Africa, had begun to send their students to train as teachers for special needs education at UNISE.

The participants who made comments about management said:

Being a new institution, what is mostly needed in UNISE now is improvement on management activities. When this happens, I think we shall achieve most of our goals here. (Teacher Educator No. 2)

The participant who was impressed with UNISE’s performance said:

UNISE’s fame is beginning to receive attention, not only in eastern, but even in central and southern Africa. We have begun to receive a few students admitted for diploma and other courses from the Sudan, Kenya, Tanzania, Rwanda, Malawi and Zimbabwe. (Teacher Educator No. 1)

In considering the above participants’ comments, I categorise the responses as issues to do with ‘performance’ of UNISE. The participants put emphasis on planning and

management.

The research question, which the above responses address states: *How are teachers prepared to teach children with mental retardation in Uganda?*

UNISE is currently the only institution of higher learning charged with training teachers for special needs in Uganda. Responses by the teacher educators who are serving in the institute are significant in that they help to indicate what role such an important institution is currently playing in the implementation of education for children with special needs, generally, and for the children with mental retardation, in particular. The findings, according to the teacher educators indicate that UNISE is increasing its effort to contribute to the implementation of education for children with special needs in Uganda. I therefore consider the teacher educators' concern with the institutes' effective management as a desire to improve on its performance.

*Category 4, Question 2: What impact do you think UNISE has had on children with special needs since its inception?*

**Resp and Comm**

One participant said that UPE had enhanced UNISE's impact on children's increase in primary schools. One participant said that in order for UNISE courses to have an impact on children with special needs, the current teacher training at the institute should be changed first, so that the graduates would be able to cope with new changes, especially with regard to the UPE programme.

The participant who pointed out that introduction of UPE had brought a big challenge to UNISE said:

Introduction of UPE means that more children have to increase in schools. UNISE has been training teachers in very small numbers. Such few teachers will not be able to cope with the big number of children. Therefore, there is a need for the institute to change its method of teacher development. (Teacher Educator No. 3)

The participant who made a suggestion to the change of UNISE's method of teacher training stated:

UNISE needs to have its method of training changed. For example, at the moment we concentrate on training a few teachers for visual impairment, hearing impairment and mental retardation. Teachers need to be trained in large numbers so as to teach all categories of children with under UPE. UNISE cannot achieve such a goal if it does not change its curriculum. (Teacher Educator No. 2)

In considering the above comments, I categorise the responses as an issue to do with the 'impact' UNISE has had on teacher development and children's access to education in Uganda. The responses seem to indicate that UNISE's current rate of teacher training may be too low to meet the high demand of children with special needs who may be entering school through UPE. I consider UNISE's adjustment to increase teacher development as a big challenge for one reason. It may not be possible for teachers to increase as fast as children do annually. In light of that therefore, there is need for UNISE to change its approach to teacher development. This problem of teacher – pupil ratio was also pointed out by participants in section 6.3.1. This issue could be regarded as one of the problems, which are likely to affect successful implementation of the policy on education for children with mental retardation in Uganda.

*Category 4, Question 3: UNISE may need to improve its own performance, basing on the impact its former students/graduates are making in the field, how can this be done?*

**Resp and Comm**

All the three participants interviewed said that UNISE had maintained contact with its former students/graduates, adding that such contact was important, in that it enabled the institute to adjust its own curriculum in line with local needs.

An example of what the participants said is as follows:

Contact between the institute and its former students/graduates needs to be increased. It is very important for such a contact because of different reasons. One of the reasons is that we may waste time training teachers to teach children with special needs without monitoring how they are working out in the field there. They may be facing problems, which can result in frustrations leading to many of them abandoning teaching children with special needs and looking for better jobs. Another reason is that we need to have contact with them so as to keep improving on our own curriculum. In other words, we need to train students using relevant knowledge and skills. So when we go out and see what they teach we get convinced that they are capable of teaching children using appropriate methods. (Teacher Educator No. 3)

One of the teacher educators, anticipating what the future of UNISE would be vis à vis the government policy on reducing teachers said:

My personal focus on the implementation of policy on cost-sharing by students entering government higher institutions of learning will bring about a great decrease in the number of student teachers wanting to join UNISE. Teachers in Uganda earn very little money, so affording to pay for their tuition and other requirement at UNISE will be very difficult. Besides the cost-sharing policy, our students are already worried about another government policy. The policy in question is of deleting, from the payrolls, the teachers who go for further studies. Some of the student teachers at UNISE are already victims of implementation of that policy. Those who are affected are wondering where to go after they finish their courses here; their places in the former schools have been taken over, and the ban on recruitment still stands. Those are some of the problems that are likely going to severely affect performance of UNISE soon. (Teacher Educator No. 1)

I categorise the above participants' comments as an issue to do with UNISE's 'contact with its former graduates'. The participants' responses indicate that there may be

different factors, which can interfere with qualified special needs teachers. In light of that, they seemed to imply that a national institution, such as UNISE should build a linkage with all its former graduates. Through such contact, according to the participants, UNISE could continue to provide professional support to the former graduates so as to reduce some of the problems that could affect their work. I consider teachers' frustration as a serious element, which is likely to interfere with implementation of the policy on education for children with mental retardation in Uganda.

We noted in section 6.3.1 above, the concern teachers/headteachers expressed with regard to some of the conflicting government policies on education in the country. The findings from teacher educators are in line with the headteachers/teachers' concern. In other words, headteachers/teachers and teacher educators seemed to have indicated that teachers for special needs education ought to be treated in a special way so as to enable successful implementation of policy on special needs education in the country to be achieved without much problem.

***Category 4, Question 4: Besides the roles UNISE is playing in teacher production for special needs education in Uganda, what other roles do you think the institute can play to involve the population more towards success in the implementation of special needs in the country?***

**Resp and Comm**

All participants who responded to this question put emphasis on the need to increase sensitisation of the population about disability in Uganda.

An example of what they said was:

We have to intensify awareness campaigns if we have to change people's attitudes towards disabled children. UNISE used to have an outreach programme. The aim of that programme was to explain to teachers, parents, and inspectors of school and DEOs the role of UNISE in promoting education for children with special needs. The outreach programme had a big impact, especially on teachers. (Teacher Educators No. 2)

In considering the participants' comments above, I categorise the responses as issues to do with 'sensitisation' of the population on disabilities. The participants revealed that their task was not only to train teachers, but to provide community services. Lack of awareness on the needs of children with special needs, as the participants seemed to imply, was one of the major factors about which different categories of participants of the current study expressed serious concern. We noted from sections 6.3.1 – 6.3.6 how participants emphasised the need to provide education as a right for all children of Uganda.

Sensitisation of the Ugandan population is an issue, which is shared by all the categories of participants of the current study. Indeed, it seems that some of the factors, which may still block successful implementation of education for children with mental retardation in Uganda, are directly or indirectly connected with lack of awareness about disability. I feel that it is important for UNISE to increase its service role to the community as it had been doing. In other words, the institute needs to resume running awareness seminars so as to keep the population informed of the required changes.

***Category 4, Question 5: As an individual teacher educator, besides the role you play at the institute, what do you do in the community, to promote education of children with mental retardation?***

**Resp and Comm**

In response to the above question one participant said that it was not possible to play other roles, due to the too much work which already existed in UNISE. One participant said that he had been using church sermons to create awareness to the population about special needs education in his village. Another participant said that he had been using personal contact to approach and work with other people in the community.

The participant who made reference to church sermon said:

It is not possible for me, as an individual member of staff of UNISE to engage in other activities outside the institute. There is, however, what I have been doing in a bid to extend my services to the community. Each time I visit my village, which is about sixty-five miles away from here, I use church sermons to create awareness to the people about the need to help disabled children. (Teacher Educator No.3)

The participant who said that he made use of personal contact to extend services to the community stated:

Whenever I get a chance, I always discuss with people the issue of disability. I try to convince them to support education for children with special needs in the our community. (Teacher Educator No. 2)

In considering the above participants' comments, I categorise the responses as issues to do with 'sensitisation' of the community. Participants put emphasis on the need for sensitisation of people in their respective communities about special needs. Their

approaches comprise church sermons and personal contacts.

In Uganda communication through the church has been used as one of the effective ways of disseminating information to the community. Sensitisation of people on special needs as noted in the previous sections of this chapter seems to be one of the main focal points of attention by most of the categories of participant in the current study. I therefore consider teacher educators' attempts to enlighten the community on special needs education and disability at large, as one of the ways to enhance implementation of policy on education for children with mental retardation in Uganda.

As I mentioned above, teacher educators at UNISE seem to have the enthusiasm of helping to promote implementation of education for children with mental retardation in Uganda. All that needs to be done, it seems, is for the institute to reschedule its activities, so as to enable the staff resume services to the community as it used to be in the past.

***Category 4, Question 6: What link between UNISE and other professionals do you have in mind that you suggest should be strengthened so as to promote education for children with special needs in the country?***

**Resp and Comm**

Participants said that although there was need to adopt multi-professional approach in helping children with special needs in schools, little had been done to achieve such a goal in Uganda.

The following is an example of what participant said with regard to professional collaboration:

Much as I support multi-professional approach, or collaboration in special education, I feel very sorry to say that we have not begun to adopt such an approach. (Teacher Educator No. 1)

The participants' comments above are categorised as an aspect of 'multi-professional approach'. Participants put emphasis on the need for teachers to work with other professionals. They said that a lot had not been done to embrace this kind of approach.

We noted in sections 6.3.1 and 6.3.3 that participants were sharing concern on professional collaboration. I therefore consider multi-professional approach to be one of the effective ways of implementing the policy on education for children with mental retardation in Uganda.

*Category 4, Question 7R: What suggestions would you make for effective implementation of special needs education in Uganda generally?*

**Resp and Comm**

Participants have made some suggestions/recommendations for better implementation of education of children with mental retardation in Uganda as follows:

- Teachers who are interested in doing special needs education course should be exempted from paying fees and other related expenses
- There is need to introduce distance education, because it may be more affordable by many teachers
- Primary school curriculum needs to be changed so as to accommodate, for example, children with mental retardation in primary schools

- There is a need to introduce a tracer study, whereby UNISE will be in a position to monitor the progress of its former students/graduates in the field

### **6.3.5 Responses by District Education Officers (DEOs)**

This section will cover different aspects, comprising policy issues, change in people's attitudes towards children with mental retardation in districts, facilitation of special needs education, conditions of service for teachers, curriculum and suggestions made by the DEOs.

*Category 5 (District Education Officers), Question 1: When we go by the Kajubi Report of 1989 and the Government White Paper of 1992, we note that emphasis has been put on the promotion of education for children with visual and hearing impairment and there is very little, if any, attention given to children with mental retardation. What is your district's position on this?*

#### **Resp and Comm**

One participant responded to the above question by arguing that provision of education meant respecting human rights, therefore all children, whether mentally retarded, or not, should not be ignored.

The participant said:

Education is a human right. It is not in order to deny children with mental retardation the chance to receive education. No that wrong. (DEO No.1)

Another participant said:

Although adequate arrangement has not been made for children with mental retardation, the few children who are already in schools are treated well. There is no discrimination against them. Those who are integrated into normal schools are given the attention they deserve. (DEO No. 2)

In considering the above participants' comments, I categorise the responses as issues to do with 'attitudes' towards education of children with special needs. Participants pointed out that many people had not been aware of the needs and conditions of persons with disability in the districts and that was why they had been negative to them. With increasing programmes on disabilities, the participant claimed that the negative attitudes would become positive. Different categories of participant in the current study have identified 'negative attitude' as one of the key factors, which may be responsible for blocking a smooth implementation of the policy on education for children with mental retardation in Uganda.

The findings reveal that all the DEOs supported implementation of education for children with mental retardation in Uganda, and it seemed that they were doing everything possible to achieve that goal.

***Category 5, Question 2: How do you assess the rate of change in people's concepts about disabilities in the district?***

**Resp and Comm**

All the three participants said that people's attitudes were changing slowly and that children with disability were beginning to receive better attention in schools.

The participants said:

Many people did not understand the people with disability before. That is why they had negative attitudes towards these people. With the help of increasing programmes on disabilities, people's negative attitudes are beginning to change very fast. (DEO No. 1)

I categorise the above responses as an issue to do with 'human rights'. Participants put emphasis on education as a right, which all children should enjoy without a precondition. A participant further made a claim that despite the absence of government policy concerning the interests and needs of children with mental retardation in Uganda, such children were being received and treated well in schools. In section 6.3.1 participants advanced similar argument, saying that there was need to recognise the rights of children with mental retardation in Uganda. I consider participants' advocacy for the rights of children with mental retardation as an important sign or gesture by people who are beginning to recognise the provision of education for children with mental retardation in Uganda.

The DEOs' responses are similar to those provided by other categories in the study. People's negative attitudes towards children with special needs has been identified as one of the main factors which block successful implementation of education for such children.

***Category 5, Question 3: What changes are taking place to have children with mental retardation increase in ordinary schools in your district?***

**Resp and Comm**

Two participants reported that in their districts teachers were beginning to develop positive attitudes towards children with mental retardation. One participant said that in his district there was need to increase teacher training in special needs education in order to enable more children with special needs increase in schools.

An example of what the participant said is as follows:

I can assure you, teachers are getting converted in big numbers. They are beginning to work with disabled children willingly. (DEO No. 1)

The participant who talked about training said:

My district has been encouraging training teachers to go for further studies in special needs education. That's the only way we can cope with the increasing number of children in schools. (DEO No. 3)

The participants' comments above can be categorised as aspects of 'success' and 'teacher training'. In one district there were claims that teachers had massively been sensitised to accept and teach children with special needs. The success was attributed to adequate facilitation of education programmes in the district. The district, according to the participant, had been provided with a vehicle for carrying out sensitisation campaigns. This kind of facilitation, according to the other participants, seemed not to have been achieved in the same way. I consider imbalance in distribution of resources in the districts as one of the causes which will delay implementation of the policy on education for children with mental retardation in Uganda.

All the DEOs recognised the importance of the need for change in teacher development. A number of teachers who had undergone retraining for special needs, according to the DEOs, had reported to have changed their way of teaching and were helping children with special needs to succeed in their learning.

Given the positive changes in teachers, the DEOs were of the views that there was need to increase emphasis on teacher retraining. This emphasis is in line with what headteachers/teachers had said in section 6.3.1.

***Category 5, Question 4: Does the district have a special vote or arrangement for training teachers to teach children with mental retardation in the district?***

**Resp and Comm**

Two participants said that in their districts they had been receiving some grants from the government for special education and that they were expecting to receive more. One of the successful participants, with confidence, said:

Teachers have now been converted; we have had seminars in all our divisions with as many teachers as possible. Many teachers have confessed to us; they didn't know what to do before. I think we have scored in making teachers express their views. In our district, we are firm; it is a matter of time, most of the children will be in school soon. The district has been given some money for special education programmes. We want to provide for these children materially and so on. (DEO No. 1)

One participant reported that in his district the government had not started providing grants for special education. The participant complained of being unable to recruit teachers for children with disabilities in the district, saying:

We need to recruit teachers. The district does not have a special vote for this programme yet. We really don't know what to do. We would like to send as many teachers to UNISE for the Special Education courses but it is not easy for us to do that at the moment. EARS is identifying children with disabilities in our district, but without special teachers for such children, it will be very difficult for us to integrate them in schools: We need funds, not only for training special education teachers, but even for special equipment needed for children with disabilities in

schools. (DEO No. 2)

In the above participants' comments, responses are categorised as issues to do with allocation of 'votes' (funds). Participants gave different views regarding allocation of funds for special needs programme in the districts. While in one district funds seemed to have been provided, in the other districts participants expressed concern about lack of funds for training their teachers. These irregularities may indicate that some of the top policy makers in different districts had not been enthusiastic, so they had not given special needs education the attention it deserved. Thus, the DEOs and teachers who served in such districts would not be in a position to play effective role in the implementation of education for children with mental retardation. I therefore consider irregularity in allocation of funds in all the districts as a factor that may affect implementation of education for children with mental retardation in the country.

***Category 5, Question 5: In what way do you think a specially trained teacher for children with special needs should be different from ordinary teachers?***

**Resp and Comm**

In response to the above question two participants said that special education teachers did not need to be treated in a special way. They said, for example, that special education teachers did not need to be paid special salary or allowances, because this would be unfair to other teachers who taught ordinary children. One participant was concerned about the nature of work which teachers of children with special needs were

doing. He argued that special needs teachers' work was unique, therefore, they needed to be paid special salaries so as to motivate them to do their work much better.

The participant who commented about teachers' training said:

It may not be helpful to treat special education teachers differently from other ordinary teachers. When we recommend them for further training that should be enough motivation. How can we work towards integrating disabled children with normal children, on one hand, and begin to treat special teachers in a special way, on the other hand? Can that work? And how will the normal teachers feel? (DEO No. 1)

The DEO who advocated for special teachers to be treated differently argued:

Teachers who qualify in special education should really be treated as 'special'. The nature of their work is unique. Not many people can do what these teachers do. If in our schools, secondary or primary teachers assigned responsibilities like senior women teachers or science teachers they are paid special allowances, why not do the same to special education teachers? I see no problem in giving such teachers special attention. (DEO No. 3)

In considering the above comments, I categorise the responses as an issue to do with 'special salaries for teachers of special needs'. Two participants expressed opposition to the idea of giving special remuneration and treating special needs teachers in a special way. Their argument was that treating special needs teachers differently would encourage segregation among them (teachers). On the contrary, one participant supported special treatment for teachers of children with special needs. This participant's argument was based on some teachers of special subjects who were given special treatment in primary and secondary schools in Uganda. As noted in section 6.3.1, teachers themselves argued for the need to be treated in a special way.

From the responses, it is apparent that teachers and DEOs have not been able to agree on

what should be done. I therefore consider a condition of this nature as likely to frustrate implementation of the policy on education for children with mental retardation in Uganda.

***Category 5, Question 6 (a): What is your view about curriculum with regard to education of children with special needs, especially those with mental retardation in the district?***

***(b): In Uganda, at the moment more emphasis is put on academic than practical education. In other words education is examination oriented. In light of that how do we expect children with mental retardation to benefit from such education?***

**Resp and Comm**

One participant strongly argued that the curriculum and aims of education were irrelevant and suggested that time was overdue for changes to be made if education of children with mental retardation was to be implemented in the country. Two participants said that the education system in Uganda was very much examination-oriented.

The participant who criticised the current curriculum said:

Definitely, children with mental retardation cannot benefit from the current curriculum. The curriculum needs to be changed, so that such children can benefit. (DEO No. 3)

An example of what one of the participant said about the system of education is as follows:

Well, I must admit that our education system has been so much examination oriented. Education should help each and every individual to acquire knowledge and skills needed to attain self-reliance and independence in life. We want to discourage the notion that everybody with a disability should be carried to town from where they can become beggars. (DEO No. 1)

The participants' comments above can be categorised as 'suitability of the Ugandan syllabus'. The participants expressed concern, regarding the irrelevancy of the Ugandan Primary School Syllabus to the needs of children with mental retardation. This observation is representative of the majority of participants as noted in Chapter 5, section 5.5. Similar responses have also been observed when parents were interviewed as noted in this chapter, section 6.3.2. Participants also argued about the weakness of the aims of education for children with mental retardation in Uganda, saying that a lot of emphasis was being put on examination at the expense of other values. Parents as noted in this chapter, section 6.3.1, also shared this concern. I therefore consider a need for adjustment of the syllabus and aims of education if implementation of the policy on education for children with mental retardation is to succeed in Uganda.

Headteachers/teachers, parents and the DEOs pointed out the problem of the aims of education and curriculum for children with mental retardation as we have noted above.

***Category 5, Question 7R: What suggestions would you make if implementation of education for children with mental retardation is to succeed in your district?***

**Resp and Comm**

The following were the suggestions made by the DEOs:

- Treat education as a human right
- Need to retrain teachers for special education
- Vocational education needed for disabled children

### 6.3.6 Responses by Commissioners

This section will cover different aspects, comprising policy issues, change in people's attitudes towards children with mental retardation in the country, facilitation of special needs education, conditions of service for teachers, curriculum and suggestions made by the Commissioners for Education.

*Category 6 (Commissioners for Education), Question 1: When we go by the Kajubi Report of 1989 and the Government White Paper of 1992, we note that emphasis has been put on the promotion of education for children with visual and hearing impairment and there is very little, if any, attention given to children with mental retardation. What is the Ministry of Education's position on this?*

#### Resp and Comm

In response to the above question one of the participants said that disabled children in Uganda were currently handled as a target group. Another participant said that education was a human right in that children with mental retardation were not supposed to be denied access to.

The participant who referred to children with mental retardation as a target group stated:

The Ministry of Education treats disabled children as a target group. Everything possible is being done to facilitate their education in the country. (Commissioner for Education No. 1)

As for the participant who referred to education as a human right, his comment was:

Education is a human right, which must be enjoyed by everybody, no matter what ability or disability. It is unfair to deny anyone that right. (Commissioner for Education No. 2)

In considering the above comments, I categorise the responses as aspects of ‘target groups’ and ‘education as a right’. One participant pointed out that children with special needs were currently regarded as a target group in the provision of education in Uganda.

Another participant stated that education for children with disability was treated as a human right. The advocacy for education as a right for children with mental retardation was shared by other categories of participant as we noted in this chapter, sections 6.3.1 and 6.3.5.

The two Commissioners for Education, like other participants of the study seemed to have implied that children’s right to education was one of the pre-requisites for a successful implementation of a policy on education for children with mental retardation

in Uganda.

***Category 6, Question 2: How do you assess the rate of change in people’s concepts about disabilities in the country?***

**Resp and Comm**

One participant said that for children with mental retardation to be well received in schools, there ought to be awareness created among teachers, ordinary children, parents and the general public. He said that once these different people were made aware about the importance of education for children with disability implementation would be facilitated faster.

The participant who put emphasis on awareness creation stated:

Awareness creation is crucial if disabled children are to be received and helped in schools.  
(Commissioner for Education No. 1)

Another participant said:

It is our duty to avail education to each and every child in Uganda. It is our obligation to do that.  
(Commissioner for Education No. 2)

The above participants' comments are categorised as an issue to do with 'awareness'.

We have noted in this chapter, sections 6.3.1, 6.3.2 and 6.3.5, how participants stressed the need to intensify awareness in order to increase people's recognition of children with special needs and persons with disability. I therefore consider awareness as an important element in the implementation of the policy on education for children with mental retardation in Uganda. The need for sensitisation of the population, among other factors, was emphasised by the Commissioners and all the categories of the participants of the study. Although these participants put such emphasis on awareness activities, there was a sign that lack of funding was the cause of failure to achieve the

goal. Despite the fact that funding was not being received in some districts, as far as the Commissioners were concerned, the Ministry of Education was doing everything possible to cater for all children with special needs in the country.

My observation on these arguments, therefore, is that there seems to be a missing link from the top management of education to schools. The ministry seems to have provided some of the basic requirements for the special needs programmes, but there is still need to monitor how such resources are being utilised.

***Category 6, Question 3: How does your office ensure that the needs and rights of persons with mental retardation are given due attention they deserve both in the country and in schools, in particular?***

**Resp and Comm**

In response to this question, one participant said that education was a human right, while another participant said that it was government's obligation to educate all children alike.

The participant who talked about education being a human right said:

When the government introduced UPE it made sure that all children, including those with disability were included in the programme. It is government policy to have all children receive education. Nobody can deny disabled children the right to education. No. (Commissioner for Education No. 1)

The participant who commented about provision of education being a government obligation stated:

It is government obligation to provide education to all children in the country. Take for example, the UPE programme. This is a proof of government determination to provide education to all in the country. (Commissioner for Education No. 2)

In the above comments, I categorise the responses as issues to do with children's 'right to' and 'government's role' in education. The concept of education being a right has continued to feature at different levels as noted in the current study. Teachers/Headteachers, DEO, Commissioners for Education and parents all expressed concern about the need to recognise children with mental retardation's entitlement to education.

Another factor, which has been emphasised is 'UPE'. The participants' responses seem to indicate that provision of education for children with mental retardation is no longer a responsibility of parents, but even teachers and administrators are becoming concerned as well. I therefore consider the need for all stakeholders (as mentioned above) to combine efforts so as to enhance implementation of policy on education for children with mental retardation in Uganda.

***Category 6, Question 4: Does the Ministry of Education have a special vote or arrangement for training teachers to teach children with mental retardation in the country?***

**Resp and Comm**

One participant said that the Ministry of Education had been releasing subvention to enable some programmes, such as special needs education to run. The participant said:

The Ministry of Education has been releasing subvention monthly for running all educational

programmes in the country. (Commissioner for Education No. 1)

Another participant said that the Ministry of Education had been concerned about and encouraging teachers who were interested in teaching children with special needs to retrain as they wished.

He stated:

The Ministry of Education has been encouraging teachers to train as special education teachers. Such teachers have duly been supported and funded for their training programmes. (Commissioner for Education No. 1)

The participants' comments above are categorised as issues to do with 'subvention' and 'training'. According to the Commissioners, the government had been providing funds for all educational programmes, including special needs. Contrary to this view, however, we noted in the previous section 6.3.5, how DEOs gave conflicting responses. One DEO revealed that funding for special needs education was provided in his district. Other DEOs reported that funds had not been received, as such they were not able to carry out teacher training for special needs education. I therefore consider such irregularities in funding special needs education as one of the bottlenecks in the implementation of the policy on education for children with mental retardation in Uganda.

***Category 6, Question 5: In what way do you think a specially trained teacher for children with special needs should be different from ordinary teachers?***

**Resp and Comm**

One participant responded to this question by arguing that when teachers went for further training they automatically got rewarded because they acquired higher qualification. Another participant responded by saying that there was no need to pay qualified special needs teachers special salaries.

The following is what one of the participants said with regard to teachers' special salaries:

Teachers' training is an automatic reward. They are rewarded because by acquiring higher qualifications they get upgraded in their profession. (Commissioner for Education No. 1)

Another participant, arguing on the same issue of treating special education teachers in a special way said:

I see no point in helping teachers to get higher qualifications and again pay them special salaries. (Commissioner for Education No. 2)

I categorise the above participants' comments as issues to do with 'remuneration' and 'training'. Participants gave an impression that teachers of special needs should not be treated in a special way, arguing that the qualification, which they obtained should be enough to motivate them. The teachers as noted in section 6.3.1 do not share these views. One of the participants, as noted in section 6.5.5 supported the need to give special remuneration to teachers of special needs. In my opinion, what I assess between these two parties is that there is still no explanation from the top educational managers to teachers about the rejection of special treatment. Teachers, too have not had a mechanism to explain to the top managers how they feel they should be treated. There is still a gap between these two parties. When we reconsider the argument raised by

Fulcher (1989), it is apparent that the policy on special needs education in Uganda requires involvement of all the concerned parties, namely politicians, top educational administrators, teachers, parents and persons with special needs. I therefore consider these conflicts of view as one of the problems that may cause delay in the implementation of the policy on education for children with mental retardation in Uganda.

***Category 6, Question 6 (a): What is your view about curriculum with regard to education of children with special needs, especially those with mental retardation in the country?***

***(b): In Uganda, at the moment more emphasis is put on academic than practical education. In other words education is examination-oriented. In light of that how do we expect children with mental retardation to benefit from such education?***

**Resp and Comm**

Although he put it in a diplomatic way, one of the participants gave a signal, admitting that all was not well with the policy regarding education for children with mental retardation. He said:

Learning needs should be identified first. Children with mental retardation will benefit through an appropriately designed programme/curriculum/syllabus...The current examination syllabi/curriculum/teaching/learning techniques have all to be synchronised to accommodate all. (Commissioner for Education No. 1)

At one point the participant stressed that the government policy covered the interests of all children, including those with mental retardation, and added that education was a right. He said:

Education is a right for everybody. This is stressed in the UN Convention, in the UNESCO principles and in the Uganda Constitution. (Commissioner for Education No. 1)

Another participant gave an indication that much was yet to be done if education of children with mental retardation was to be implemented in the country. He said:

The National Curriculum Development Centre (NCDC) should review the curriculum...Arrangements are being made so as to have all children benefit from the education. (Commissioner for Education No. 2)

In the above comments, participants' responses can be categorised as issues to do with 'curriculum' and 'vocationalisation' of education. Participants recognised the need for re-adjustment of the curriculum for the good of children with mental retardation. They also expressed concern about the need to implement vocational education in Uganda.

Irrelevancy of the curriculum was observed by all the categories of participants of the current study. In the previous Chapter 5, section 5.5 we noted that participants who answered the questionnaire were dissatisfied about the suitability of the curriculum for children with mental retardation. We also noted in sections 6.3.1 and 6.3.5, how participants were dissatisfied about the system of education in Uganda, which was considered to be very examination-oriented – lacking a practical approach. I therefore consider lack of re-adjustment in the current Ugandan Primary curriculum and the emphasis put on examination as some of the major problems which may interfere with the implementation of education for children with mental retardation in Uganda.

The research question, which the above responses address, states: *What are the aims of education and curriculum for children with mental retardation in Uganda?*

The two Commissioners for Education, like the rest of the categories of participant, were of the view that aims of education and curriculum for children with mental retardation should be readjusted.

In the above analyses, it was generally noted that the majority of participants recognised the need to change the current Ugandan curriculum and aims of education if implementation of the policy for children with mental retardation was to succeed.

***Category 6, Question 7: What suggestions would you make if implementation of education for children with mental retardation is to succeed in Uganda generally?***

**Resp and Comm**

The two Commissioners made the following suggestions/recommendations:

- Need to adjust curriculum
- Vocational education to be emphasised

## **6.4 Conclusion**

The findings in this chapter reveal some of the successes achieved as well as problems faced in the implementation of education for children with mental retardation in Uganda. Current trends in development of special needs education as demonstrated in the literature are beginning to receive attention from the policy makers in Uganda. I can say that there some encouraging development which is already taking place, but this is

not enough, as indicated from the various responses by the participants.

Some children with mental retardation are now being provided with education in special, as well as in ordinary schools. More units are being established for integrating children with mental retardation in ordinary schools and Uganda is also considering implementation of inclusive education. Training of teachers for special needs education at the Uganda National Institute of Special Education (UNISE) is on the increase. Teachers are being trained at both diploma and degree levels. UNISE has developed special needs education components to be included in the primary teachers college (PTC) curriculum. UNISE is also developing a distance learning programme. This is one of the ways of increasing the teacher supply, in addition to the few who have been and are being trained at UNISE.

We have learned from the literature that there is no specific method suitable for teaching children with mental retardation. Any method can be used as long as its objectives are formulated to suit the needs of children for whom it is meant. Already some methods are in use in Uganda, so what teachers have to do is to modify and continue to use them. Assessment of children with special needs has been embarked upon by the Educational Assessment Resource Services (EARS). Thus, one by one, children with special needs are being identified and their education recommended by the EARS. Universal primary education (UPE) also has been introduced and this will be another way of encouraging

more children, including those with special needs, to go to school. Some parents of children with mental retardation have been found to be very ambitious, wanting to have their children provided with education. All in all, the current study has found that participants generally showed signs of willingness to work for implementation of the policy on education for children with mental retardation. Success sometimes cannot be achieved without attendant problems.

Some of the findings reveal the nature of problems that have yet to be overcome if implementation of education for children with mental retardation in Uganda is to succeed. We have noted in Chapter 2 the problem of labelling and definition of mental retardation. This is an issue, which has been and is being debated. The term mental retardation has been noted to be an unfriendly term and ideas have been discussed from time to time in the literature about what ought to be done to develop better and friendly terms. The literature indicates that only one country, namely Britain, has adopted a more friendly term, by referring to the condition as “learning difficulties” and to the children who are defined under this condition as “children with learning difficulties”. In Uganda, the findings of the current study indicate that children with learning difficulties are still defined and labelled using the negative concept of ‘mental retardation’. Departments for mental retardation do exist both at national and local levels in the country. For example there is a department of mental retardation at the Ministry of Education and Sports, under the EARS programme in Kampala. The EARS programme

at district level, too, has sections for mental retardation. The only institution of higher learning, which is concerned with training children with special needs, that is, UNISE, has a department of mental retardation and learning difficulties. There is also an umbrella association, known as the Uganda Society for Mentally Handicapped (UAMH).

While the efforts to implement education for children with special needs are being made, some of the findings in the study reveal that there are certain government policies, which seem to have created complications in the implementation. For example, while the government wants on the one hand more teachers trained to teach children with disabilities, on the other hand the same government imposed cost-sharing for teachers who wish to go for further training. The teachers who may wish to go for further training may lose their existing jobs. Out of sixty three PTCs, the government is going to support only twenty seven. Under the UPE programme, there are too many children for the number of teachers. In the lower primary, that is, Primary One to Three, the ratio of teachers to children is 1:110. One parent and one headteacher have regarded the government as providing “lip-service” rather than committing itself to real change and action.

Participants made various suggestions/recommendations, which they believed, if considered by the government, could help to bring about better results in the

implementation of education for children with special needs in Uganda. I shall present the summary of the suggestions/recommendations as (a) those which are supported by all categories of participant, (b) those supported by some and not others and (c) those which are specific to certain categories as shown below.

(a) Recommendations Supported by All Categories of Participant

1. More teachers to be retrained so as to teach children with mental retardation.

This recommendation was supported by headteachers/teachers, parents, EARS staff, teacher educators, DEOs and Commissioners for Education. It is likely that such a recommendation may get support from the government, given the concern expressed by all the different categories of participants.

2. Aims of education and curriculum for children with mental retardation should be readjusted.

Headteachers, Teacher Educators, EARS Officials, DEOs and some parents supported this recommendation. Given that different categories of participants put a lot of emphasis on the need for such a change, the government is likely to consider an appropriate action in that respect.

3. Collaboration among policy makers, parents, teachers and other professionals is

needed for education of children with mental retardation to succeed.

Although categories of participants, such as DEOs and Commissioners for Education did not make a mention of the need for collaboration among policy makers and other stakeholders, it is not likely that they were opposed to such an approach. This approach may require planning and working out how different professionals can work together to promote provision of special needs education in Uganda. Professionals like medical personnel, social workers, educational psychologists and teachers may need to work together in promoting assessment and other related services required by children with special needs.

(b) Recommendations Supported by Some and Not Other Categories of Participants

1. Special needs education teachers should be paid special remuneration.

Although the question concerning teachers' remuneration was responded to by headteachers/teachers, DEOs and Commissioners for Education, different opinions emerged. All headteachers/teachers supported the need for special remuneration. One DEO supported the idea, while two (DEO), plus two Commissioners for Education opposed the idea. The objection by the DEOs to teachers' getting special remuneration may need to be discussed at all levels, that is by politicians, teachers, parents and top educational administrators.

(c) Recommendations Specific to Certain Categories of Participants

1. Teachers who go for courses in special needs education should be exempted from paying tuition and other related expenses and should continue to receive their salaries.

Headteachers/teachers were specifically concerned in expressing this view. The indication was that their conditions of service were not satisfactory, especially when they pointed out that the government was no longer going to continue supporting them for further training. This situation is similar to the one I have just discussed under (b) 1, above. It may be possible for teachers to get support after getting the opinions of all the stakeholders in the country.

2. Children with severe mental retardation to be educated in special schools, while those with mild or moderate disability to be educated in ordinary schools.

As the question concerning the types of school suitable for children with mental retardation was directed to parents and headteachers/teachers, I realised that emphasis was put on the need to help children's being able to learn effectively. In other words, special, as well as ordinary schools were equally considered important for children with special needs, depending on the degree of each child's 'needs'.

The above suggestions/recommendations show that some categories of participant agreed, while some disagreed on certain issues. We noted, for example, that teachers did not share the same views with DEOs and Commissioners for Education on the issue of remuneration. Divergence of views on such an important issue reflects the need for formulating a policy on an issue whereby all parties are involved. In Chapter 1, section 1.6.3.4, we noted how Fulcher (1989) argued on the need to involve politicians, bureaucrats and all stakeholders in policy-making. The current situation in Uganda shows that policy-making in education definitely requires involvement of the concerned parties at every level.

As indicated above the suggestions/recommendations provided by the participants, if considered, would help to reduce the problems discussed in the study. I have also added my own suggestions/recommendations. The next chapter (Chapter 7) will provide the summary findings and my suggestions/recommendations.

# CHAPTER 7

# Chapter 7

---

---

## **7.0** *Summary of the Findings and Suggestions/Recommendations*

### **7.1** **Introduction**

This chapter (Chapter 7) provides the final findings, makes suggestions or recommendations for further improvement and research. I shall first summarise the recommendations from participants and myself then discuss priorities. Before presenting the findings, it is important to remind the reader of the aim of and research questions for the study. This will enable me to relate the findings to their relevant questions.

As mentioned at the beginning of the thesis, the current study is about policy implementation on the provision of education for children with mental retardation in Uganda. Thus, the aim of the study is to identify and describe what progress has been

made and to make recommendations about what ought to be done in order to achieve better results. The research questions are indicated below.

- 1 What are the ideologies and trends concerning the rights to education by children with special needs in other countries and in Uganda?
- 2 What are the concepts and definitions of mental retardation from international perspectives?
- 3 What are the aims of education for children with mental retardation internationally?
- 4 In the implementation of policy of education for children with mental retardation in Uganda:
  - (a) How is mental retardation defined?
  - (b) How are aims of education clarified?
  - (c) What types of institutions and facilities are recommended?
  - (d) How are children selected for education?
  - (e) What teaching methods/approaches are adopted for teaching children with special needs?
  - (f) How are teachers prepared to teach children with special needs?
  - (g) What suggestions do participants make for implementation?

In the following section I begin with the summary of findings.

## **7.2 Findings of the Study**

### **7.2.1 Findings Related to Research Question on Ideologies and Trends Concerning the Rights to Education by Children with Special Needs in Other Countries**

The current study reveals how ideologies and trends concerning the rights to education by children with special needs have attracted heated debate around the world. The literature indicates how proponents of children with special needs have been making gains over the years about providing education to all children without discrimination of any kind. This therefore leads to significant conclusions regarding the research question at hand. Development of education for children with special needs has been changing gradually and it has reached a point of no return, a point whereby each and every government is obliged to respond to such changes. It has been noted, according to the literature, that in all countries a negative attitude toward education of persons with special needs has been one of the primary reasons for failure of society to recognise the right of such persons to share educational opportunities with non-disabled members of society. It goes without saying that Uganda has not escaped such problems. With the positive changes now going on, Uganda by and large has to keep abreast with other countries to implement desired changes for the good of children with special needs.

Although negative attitudes may have been fought against and reduced, another factor, socio-economic conditions, may have influenced the way education for children with special needs has been provided in many countries. For example, a rich country with abundant resources may be in a better position to provide education to all its citizens, including those with special needs. A poor country with limited resources, however, may not have the capacity to provide some of its citizens even with the bare minimum of essential services, such as education. In the Western developed countries efforts have not only been made to provide education to children with special needs, but efforts have also been made to develop programmes through which causes and the prevalence of disabilities have been monitored. Such measures have greatly helped to curtail disabilities in those countries. Uganda, being one of the poor countries, has been lagging behind in providing education to children with special needs, especially those with mental retardation.

Political goodwill is another important factor in the provision of education for children with special needs. Politicians make policies that affect the lives of their citizens. They formulate policies, set priorities and determine what measures and resources can be utilised to implement the formulated policies. Where political goodwill is available, implementation of education for children with special needs can be effected without much delay. Where politicians do not give due recognition to persons with special needs, there is not much done to provide education to them. Where political instability has been experienced, there is also not much that persons with disability can gain.

Uganda is a case in point; it has experienced political instability for a long time. As a result, attention to persons with special needs may not have been among the prioritised sectors for rehabilitation and development in the past.

Provision of special needs education is also affected by availability of expertise. In the developed Western countries, professionals such as teachers, doctors, educational psychologists and social workers are in abundance. They co-ordinate services for the good of children with special needs. They participate in assessment and provide useful advice to parents. The absence of co-ordinated services of such professionals may mean that provision of special needs education and related services may be poor in a country. Uganda has had inadequate services provided by such professionals in the field of special needs education. Therefore, its slow progress in implementing policy on education for children with special needs generally, and that of children with mental retardation in particular, is partly attributed to inadequacy of multi-professional services. This observation has been raised in Chapter 6 by some of the participants interviewed during the current study.

The findings reveal that there has been steady progress in the provision of special needs education in both developed and some developing countries despite the different problems mentioned above. Much effort has been put into providing education to disabled people. Education is not only provided in a segregated environment, but many countries are now attempting to have all children with special needs included in

ordinary schools. Efforts are underway to restructure the curriculum and environmental factors so as to enable children with special educational needs of any kind to participate in an educational environment together with other ordinary children, without discrimination. Discussion of provision of special needs education in Uganda, as well as in international contexts has relevance and is vital. The relevance, especially of developed countries, to Uganda is that the latter can learn from the former about how success is achieved and how to avoid situations that bring about failure. Furthermore, poor and developing countries such as Uganda, through bilateral or multilateral co-operation, can generate resources with the help of developed countries for improvement of the provision of its special needs education.

Having provided answers to the above research question, in connection with ideologies and trends concerning the rights to education by children with special needs, I shall provide findings regarding definitions of mental retardation.

### **7.2.2 Findings Related to Research Question on Concepts and Definitions of Mental Retardation from International Perspectives**

The literature survey in Chapter 2 indicates that the concepts and definitions of mental retardation have always been problematic in society generally, as well as to professionals. People have held divergent views on retardation and have used various

forms of terminologies to interpret it. Although the term mental retardation or handicap is known to be unacceptable, the users of those terms have an argument to justify their retention. They say that labelling is necessary because it is administratively convenient. According to this school of thought, there is a further argument suggesting that children with mental retardation need to be educated in their own special schools or units where due attention can be given to them. Special needs education teachers, the argument goes on, need to be trained and equipped with special skills suitable for teaching children with mental retardation. Critics, on the other hand, argue that education is a good thing for each and every person, and therefore people should not be labelled, categorised and taught separately.

In Uganda, culturally, mental retardation is still viewed from a very negative point of view. Persons with mental retardation are not only associated with people who are mentally ill, but are given a low status in the community. In light of that background, therefore, implementers of education programmes for such labelled people are bound to have their own interpretations. The findings reveal that the majority of participants who responded to the questionnaire and those who were interviewed defined the “retardation” in a more positive way. “Positive” in this sense refers to the participants’ views when they put more stress on “problem behaviour” rather than on the individuals who were labelled. In other words, the participants described how important it was for them to help control or eliminate certain behaviours, which interfered with the labelled

children's effective learning. This is an indication that some people are indeed in a position to implement the programme.

Some participants referred to mental retardation in a very negative way, a sign indicating how difficult it could be for such participants to implement the policy. "Negative" here refers to the view that such labelled children would not change and benefit even if education was provided to them. A much smaller group of participants did not have any idea about what the condition of mental retardation really means. The findings show statistically significant differences between male and female participants. Rural and urban participants did not show difference in the way they define retardation. Similarly, categorising by rank, that is, whether participants were headteachers or teachers, did not show statistically significant difference in the way mental retardation was defined.

In Uganda, from an official point of view, the terms mental retardation or handicap (which are borrowed English terminologies) are still used. The authorities have not come up with a better way to define the condition. A number of schools, homes, or units are still referred to as "school for the mentally handicapped", "unit for the mentally handicapped or retarded", and "home for the mentally handicapped". Some of the national or local institutions/organisations are defined with the term mental retardation or handicap. For example, at the Uganda National Institute of Special Education (UNISE) there is a department which is referred to as Department of Mental

Retardation/Learning Difficulties". Students who qualify from this institution are awarded certificates and diplomas, and soon degrees with specialisation in mental retardation/learning difficulties will be awarded. At the Educational Assessment Resource Service/Special Needs Education (EARS/SNE) there is a department for mental retardation. EARS/SNE also has district-level posts for inspectors of school designated in charge of mental retardation. Furthermore, there is an umbrella association, known as the Uganda Association for the Mentally Handicapped (UAMH) [*sic*].

The literature indicates that although there is growing opposition to retention of the term mental retardation, even an international umbrella organisation, Inclusion International, formerly known as the International League Society of Mentally Handicapped (ILSMH) has, itself, failed to bring about a radical change in the definition of the condition. Inclusion International still recognises the definition and terminologies used by the American Association on Mental Retardation (AAMR). It should be noted that the AAMR is the most recognised definition by professionals. The only attempt to bring about a radical change has been ushered in by Britain, when through its Education Act of 1981, it abolished the use of the term mental retardation or handicap and replaced it with terms such as learning difficulties. Interestingly, within the same country, from a health point of view, the 1983 Mental Health Act still retains the term mental handicap.

Given the confusing state of affairs with respect to retention of the term mental retardation or handicap, my position is simple and clear. I am using the terminology in the current study simply as “a guide”. Mental retardation is a guide to me, in that I want to inform Ugandans about the need for change in this concept. In my own opinion, the term carries a negative connotation and I do hope that the result of this study will encourage Ugandans, from traditional to official levels, to accept changes in these terms. In Uganda, learning difficulties should be adopted while more research studies are carried out to find out what is acceptable not only by Ugandans, but even by other countries.

Having examined the issue of definition and terminology, I shall present findings regarding aims of education and curriculum for children with mental retardation, from international perspectives.

### **7.2.3 Findings Related to Research Question on Aims of Education and Curriculum for Children with Mental Retardation Internationally**

Education is the most important tool that enables individuals to acquire knowledge and skills in order to live not only as acceptable members in society, but also as independent individuals, able to do things on their own without constant help from other people.

## Chapter 7: Summary and Suggestions/Recommendations

Although children may be referred to as having mild, moderate or severe mental retardation, the findings reveal that all children nevertheless need to be educated.

While it is suggested in the literature that those with moderate and severe mental retardation should be provided with functional academic subjects, it is suggested that children with mild mental retardation need to be provided with both academic and practical education.

With regard to where children with mental retardation should be educated, the literature indicates that children with moderate and severe retardation need to be provided with education in special schools, where they can be given adequate attention. On the other hand, those with mild “retardation”, it is suggested, can be educated together with ordinary children in ordinary schools. In my opinion, both arrangements seem to be appropriate. Indeed such an approach should be adopted for implementation in Uganda.

The findings reveal that currently in the developed countries, selection/assessment of children with mental retardation for educational provision is not based solely on IQ test scores, but that more attention is now paid to a qualitative approach. In other words, all aspects that are known to have an impact on the children, environmental, cognitive and social, are considered. In Uganda where environmental factors and cultural values play important roles in individuals’ lives, the approach indicated here would help education providers to assess and select children in a more justifiable way. In Uganda, the EARS

programme is currently involved in assessment and placement of children with special needs. EARS is also currently designing its own assessment tools. We have noted that such assessment tools should be designed with a view to including all cultural aspects that may have direct or indirect influence on children with special needs. We have also noted that universal primary education (UPE) has been introduced with the objective of encouraging more children, including those with special needs, to go to school. The current number of children with mental retardation in schools is not yet encouraging despite the efforts made through EARS and UPE programmes.

The literature suggests that the approaches/methods for teaching children with special needs are many. For the current study, however, only a few of these approaches are selected and described to find out what relevance they may have for implementation of the provision of education for children with mental retardation in Uganda. Some of the approaches described in the study are applied behaviour analysis, community-based instruction, preferential teams (PRT), collaborative consultation, co-operative learning, peer-tutoring and reverse mainstreaming. Many of these approaches are not new in Ugandan education practices, but the main problem in Uganda is that the way the approaches have been handled may not be suitable for effective teaching of children with mental retardation. There is need for modifications of the methods to suit the needs of children with special needs. There is also need to make changes in the system of education, which seems to be too competitive for children with mental retardation at the moment.

**7.2.3.1 Findings Related to Aims of Education and Curriculum for Children with Mental Retardation in Uganda**

The findings in the study reveal that under the revised system of education in Uganda, appropriate aims of education and curriculum for children with mental retardation have not been addressed. Education in Uganda is highly competitive and the curriculum is tuned in such a way that only those with high academic capability can benefit from the system. One of the aims of education in Uganda, for example, is geared towards equipping learners with productive and modern marketable skills to meet the developmental needs of the economy and promote employment opportunities for the learners. The majority of participants who responded to the questionnaire say that there is a need to change the curriculum for the good of children with mental retardation in Uganda. There was no significant difference between opinions of male and female, rural and urban or headteachers and teachers. When interviewed, reactions by participants, including parents, education officers and commissioners for education, supported the view that curriculum in Uganda should be modified so as to be suitable for children with mental retardation.

**7.2.3.2 Findings Related to Types of Institutions and Facilities Suitable for Children with Mental Retardation in Uganda**

The findings reveal that participants were not satisfied about the conditions provided for children with mental retardation in ordinary schools. A significant difference existed between the responses given by the participants from the rural and urban areas. The rural participants indicated more dissatisfaction with the conditions under which children with mental retardation are educated in ordinary schools.

### **7.2.3.3 Findings Related to Selecting/Assessing Children with Mental Retardation for Education**

It was found that under the universal primary education (UPE); there is no clear guideline as to how such children with special needs should be selected. Thus, parents are not compelled to select children with special needs and include among the four children to benefit from the UPE programme. In other words, it is up to parents to include, or not include, children with special needs in the programme.

The findings reveal that although an assessment programme has been introduced in Uganda, (through EARS), the procedure of assessing children is not yet properly worked out. Assessment instruments, which feature the different cultural values, have not been developed. The Ministry of Education and Sports has not provided a form of guideline or regulation on assessment activities in the country. Assessment needs to be ethically handled; that is to say, people who assess and who are assessed should be protected. EARS is concerned with identifying and assessing children with special

needs, whereas UNISE is concerned with training teachers who teach children with special needs. The parliament has enacted a law to govern UNISE's operations but has not considered doing the same for EARS. The literature reveals how assessment of children with special needs is a sensitive issue, and in a country such as Britain, a child is not assessed without following the laid-down procedures. One of the procedures is to get the consent of a parent before assessing a child. Another procedure is that the assessment record must be handled with confidence.

#### **7.2.3.4 Findings Related to Preparing Teachers to Teach Children with Mental Retardation**

Teacher education for special needs has not been implemented as recommended in both the Kajubi Report and the Government White Paper. For the time being, UNISE exists as the only national institution for teachers of special needs education in the country. Despite being the only special needs education-training centre in the country, its achievements are increasing day by day. At the time the current study was conducted, UNISE had embarked on developing materials for inclusion of special needs education components in the primary teachers' colleges (PTCs) syllabus throughout the country. In other words, UNISE is convincing the PTCs to train ordinary teachers not only to teach ordinary children, but to be able to teach children with special educational needs as well.

When interviewed, some teachers revealed the worries they had concerning new government regulations. They said that the new regulations did not encourage teachers to develop in the profession. The teachers said that if teachers went for further studies their names were deleted from the payroll, meaning that they could no longer earn their salaries and that the government would no longer sponsor them. When they finished the courses, the teachers said that, it would be hard to be re-employed as the government had imposed a ban on recruiting people. Teacher educators at UNISE also expressed these fears. They said that some of their student teachers were already experiencing problems with the new government regulations on further training. They said that once a teacher joined an institution such as UNISE, he or she would not receive any grant or salary, and his or her return to the former school, or acceptance to a new school, would not be guaranteed.

#### **7.2.3.5 Findings Related to Teaching Methods for Children with Mental Retardation**

The findings of the study reveal that in Uganda the majority of respondents support the introduction of specific teaching methods for teaching children with mental retardation. They say the most effective method for teaching children is “child-centred approach”, that is, children with mental retardation should be taught as individuals. Teachers, Education Officers, as well as the Commissioners for Education are of the view that the





The argument in this recommendation is that understanding of retardation and the needs of such children can positively affect attitudes of Ugandans and encourage change in them. The recommendation is supported by headteachers/teachers, parents, EARS staff, teacher educators, DEOs and Commissioners for Education.

3. Collaboration among policy makers, parents, teachers and other professionals is needed for education of children with mental retardation.

Participants' justification for this recommendation is that when there is co-ordination of efforts by teacher educators, classroom teachers, EARS staff and other professionals better understanding of the needs of children with mental retardation, and providing necessary services for them can be achieved. For example, doctors, educational psychologists are needed for the assessment of children with special needs.

4. Aims of education and curriculum for children with mental retardation should be readjusted.

Participants' argument on this point is that children with mental retardation may not learn in the same way as the ordinary children. Therefore, adjustment in what they learn, how they learn and what is expected of them after their education need to be considered.

(b) Recommendations Supported by Some and Not Other Categories of Participants

1. Special needs education teachers should be paid special remuneration.

The participants' argument in this regard is that special needs learners present special problems and require specialised teaching skills. In light of that, therefore, participants see the need to pay special needs education teachers special remuneration. Headteachers/teachers and one Education Officer have strongly supported this recommendation.

2. Children with severe mental retardation or any other disabilities should be educated in special schools, while those with mild or moderate disabilities should be integrated into ordinary schools.

Participants in the study believe that the severely disabled pupils require specialised content and attention, whereas the mildly disabled can benefit from the content and interaction in ordinary schools. This recommendation is supported mainly by headteachers/teachers and some parents.

2. Policy makers to consult and involve parents in the formulation of all educational policies.

Parents and some teachers have supported the recommendation concerning policy-making process whereby politicians and other stakeholders are involved.

The recommendation on remuneration is supported largely by headteachers/teachers and only one District Education Officer (DEO).

The recommendation regarding the types of school suitable for children with mental retardation is supported by parents and some headteachers/teachers.

(c) Recommendations Specific to Certain Categories of Participants

1. Teachers who go for courses in special needs education should be exempted from paying tuition and other related expenses and should continue to receive their salaries.

The argument with respect to this question is that the current Ugandan policies discourage retraining because of out-of-pocket expenses. The participants further argue that their conditions of service are not satisfactory, especially when they are aware of the government's intention to introduce cost-sharing in institutions of higher learning.

Headteachers/teachers are specifically concerned in expressing this view.

### **7.3.2 Recommendations/Suggestions by the Researcher**



(ii) As we have seen, central authorities have paid lip service, but have not followed through practical or effective ways. Indeed, it was extremely difficult even to arrange a discussion with some of the highly placed officials.

Under the current on-going decentralisation (devolution of power), the district authorities should formulate their own policies, to ensure that children with special needs who are not included in the UPE programme are included. The local authorities cannot wait for the central authority to do everything for such children.

#### **7.3.2.2 Suggestion/Recommendations Related to Concepts and Definitions of Mental Retardation**

(i) The literature shows that terms such as 'mentally retarded' historically have highly negative connotations and contribute to negative attitudes. The national as well as local organisations and institutions, like UNISE, EARS, District EARS centres, and the Uganda Association for the Mentally Handicapped (UAMH) should rename their departments, organisations and operations with a view to abolishing the terms mental retardation/handicap or referring to children as mentally handicapped or retarded. Such a move would give a lead to the entire Ugandan society to develop a better concept

towards the condition of mental retardation, and treating children who are referred to as mentally retarded.

(ii) We have seen that “lip-service” policy can be more easily put aside; and that without clear and definite guidelines, it is impossible to evaluate programmes or policy. Whenever a policy is formulated all stakeholders – in this particular case: parents, persons with disability, bureaucrats and politicians should all contribute ideas (make decisions), and should all get involved in the implementation of the formulated policy. It should not be seen, as it is, in Uganda today, that politicians are the only policy makers, and the bureaucrats are the implementers.

(iii) The issue of referring to children as “mentally retarded”, the way it is now in Uganda and in other countries in the world should be considered, for the literature and some participants’ comments have demonstrated that when we label someone as “different”, we may tend to treat them differently, and difference may be viewed negatively.

### **7.3.2.3**

#### **Suggestions/Recommendations Related to Aims of Education and Curriculum for Children with Mental Retardation in Uganda**

(i) As discussed indicated in Chapter 6, participants have raised the issue of much

emphasis being put on examination in Uganda. There is need to change this approach – that is, continuous assessment should be adopted, such that children’s educational progress is judged according to how, individually, they cope. Children with mental retardation who may not benefit much academically will be helped to concentrate on practical skills.

(ii) We have seen that vocational and life skill education is necessary for children with mental retardation. Academic education is not appropriate for all children. I therefore, suggest that from primary level the syllabus should include pre-vocational subjects, and beyond at post-primary level there should be vocational institutions prepared for training the youths with mental retardation.

(iii) When children with learning difficulties complete their primary or secondary education they should be given a chance to automatically join (for those who wish to) vocational institutions. Those who are able to continue with other forms of training should be helped to join the institutions of their interest.

(iv) All children with special needs should not be required to pay for their education. We have seen that many families cannot afford special programmes, yet these children could be productive in their communities.

(v) After every four years, there should be a national census to establish the number of persons with disabilities in the country, so as to reinforce intervention programmes for them. This is also when the educational policy makers will be enabled to plan and facilitate education for all the school-age children with disabilities in the country.

(vi) We have seen that assessment in Uganda can sometimes be as simple as “looking at” a child. We have learned, too, that parents want to, and should be involved.

The Ministry of Education and Sports should provide guidelines for assessment procedures for children with special needs in the country. Parents, teachers, social workers and the medical personnel should be helped to co-ordinate assessment procedures. No decision for assessing children should be taken by the professionals without the consent of the parents of children. Each assessed child should have his or her assessment record file kept by parents and by the relevant school authorities. Not just anybody should assess a child. No labels should be put against the assessed child. Only the nature of help the child requires for his or her success should be indicated.

#### **7.3.2.4**

#### **Suggestions/Recommendations Related to Types of Institutions and Facilities Suitable for Children with Special Needs**

- (i) Children with mild learning difficulties should be free to join any ordinary school of their choice. In the literature it is argued that inclusion is beneficial for both the children with mild learning difficulties and for ordinary children.
  
- (ii) Children with moderate and severe learning difficulties should be facilitated to learn in special schools/units where they could receive adequate attention.

#### **7.3.2.5**

#### **Suggestions/Recommendations Related to Preparing Teachers to Teach Children with Learning Difficulties**

We have seen that ordinary teachers have not the time or opportunity to deal with learning difficulties effectively. Retraining also presents difficulties. I therefore make the suggestions as indicated below.

- (i) Teachers who train for special needs education should be exempted from paying tuition fees and related costs for their course.
  
- (ii) Besides primary teachers' colleges (PTCs), other national teachers' colleges (NTCs) should also include special needs components in their syllabus. This should also apply to universities as well. In other words, any course where a bachelor of



- (ii) Teachers should be encouraged through numerous workshops and refresher courses to evaluate their teaching approaches/methods.
- (iii) From PTC levels up, teacher training should include curriculum as a subject. This would enable teachers to be able to modify curriculum according to what is appropriate for children with learning difficulties. At the moment, curriculum studies are only taught to teachers who are pursuing diploma or degree courses, whereas PTC-level teachers are simply given the skills of preparing schemes of work and lesson notes. That is not enough.
- (iv) At the moment the National Curriculum Development Centre (NCDC) comprises only highly placed people, such as directors and principals of secondary, PTCs and tertiary institutions, to develop the national curriculum. Classroom teachers who know the needs of children are not included. This needs to be reconsidered.
- (v) NCDC has only been concerned with developing curriculum for primary (ordinary children) and secondary schools - it has not been involved in special needs education. Some of the graduates from UNISE should be employed at the NCDC in order to seal off the current gap for special needs education in that organisation.

## **7.4 Suggestions/Recommendations for Further Research**

In Chapter 4 we stated the limitations of the current study, the difficulties encountered. In view of that and as a result of the attention that the findings of the current study deserves, I make the suggestions below which I believe can help to speed up

implementation of the policy on education for children with learning difficulties in Uganda.

- (i) The practical implementation of the proposed ideas recommended/suggested in the study should be considered for research activities.
- (ii) UNISE, Makerere University and other established universities in Uganda should provide a leading role in research, considering the suggestions/recommendations I have proposed in this study.
- (iii) In-service training programmes, both at primary and secondary levels for special needs education, are in need of further research and investigation.
- (iv) Serious consideration about abolishing labelling and working on friendly definitions of mental retardation should be taken.
- (v) Aims of education and curriculum for children with learning difficulties should be clarified, through research and by policy makers.
- (v) Quality teaching approaches/methods for children with special needs need further investigation.
- (vi) Research activities should be encouraged so as to identify and get solutions to problems that hinder the education of children with mental retardation in Uganda.

My current study, carried out from a developed country, has revealed that development in different aspects of education has not come about from the blue. People are carrying out research activities daily. Although I am not suggesting that we need to borrow all ideas from such developed countries, but there are some important aspects (from those

countries), which I do believe can enable us improve on the development of special needs in Uganda. Some of the aspects, which I have noted, are that people in the developed countries, such as Britain value time, appointments and they respond to requests/questions. Information is available and provided/shared at will. In Uganda, such efforts result in frustration. Too few people value time and appointments in Uganda. Official letters are rarely replied to. Information is too hard to get and little shared, especially from key people and key places.

## **7.5 Priorities in Light of the Current Situation in Uganda**

In the current study, a lot of Western ideas have been applied as the basis for discussion. This is because of various reasons. Firstly, Uganda, although is an African developing country, has had its education system based on a Western model. We noted in Chapter 1, section 1.6.3.1 that development of education in the country had its origin from Britain. From the early 1900s, English language, for example, has been the medium of educational instructions in upper primary, secondary and tertiary institutions of learning in Uganda. Secondly, since it achieved its independence in 1962, Uganda has had its educational development receive massive technical and material support from Britain and other Western countries. With such influence, therefore, Uganda has tended to adopt educational changes similar to those taking place in the West. Changes in special

needs education, among other things, are some of the examples, which Uganda has tried to adopt.

Whereas there could be as many influences on Uganda from the West as one could enumerate, the priorities set for achieving goals of programmes like special needs education may differ greatly between the two. The ideas from the West may only help to provide clue to what should be done in bringing about fundamental changes in educational development in a country like Uganda. The reader's attention is, therefore, drawn to the fact that Uganda currently faces difficulties of various nature. One of the difficulties concerns the pupil teacher ratio; that is, 110:1 brought about as a consequence of UPE. In the West the ratio may be as low as 8:1 to 20:1. In other words, pupil teacher ratio is currently a serious problem in Uganda, whereas in the West such may not be a serious issue. Therefore, it may not be possible to compare such a condition. Secondly, Uganda, as reported by the World Bank in Chapter 1, section 1.7 still remains one of the twelve poorest countries in the world. This means that the country lacks funds, required for promoting changes in the provision of education for children with special needs. Lack of funds may not be a major issue in the West for that matter. Thirdly, as noted in Chapter 6, section 6.3.1, teachers expressed profound fear about their future prospects to pursue further training. This would mean frustration and loss of interest in the teaching profession. These and other problems as noted in the participants' and my own recommendations (above) as indicated in sections 7.3.1 and 7.3.2, respectively, can create a formidable task for Uganda's success in the

implementation of education for children with mental retardation. In light of that therefore, it is in my opinion, to say that for Uganda to succeed in the implementation of the policy, priorities should be clarified in the recommendations made by the participants and the researcher. I therefore think that in the current situation, the recommendations should be implemented in the order listed below.

1. Teacher Development

Special needs education, as well as UPE have been introduced in Uganda. There is no way such important programmes can be let to fail. We have noted in the study that although more people, especially teachers, are willing to work for development of special needs education in the country, the current situation does not seem to allow the goal of the programme to succeed well. Because of UPE, there are too many children to be handled by teachers. It would be appropriate to handle teacher development as a crash programme that must be run in a given period of time, so as to revert the likely problems that over congestion of children in schools is likely to cause. Teacher training is badly needed as a short-term strategy. Education, whether in Uganda, or in any part of the world may not be meaningful if it is only considered in terms of quantity without quality. Under UPE programme, ordinary, as well as children with special needs are expected to learn in the same classrooms. It is impossible for one teacher to provide adequate attention to a class of over one hundred children. There is a need to increase a number of teachers so that a reasonable pupil ratio of about 40:1 can be reached. In fact if the situation improves, it would be ideal for a ratio of children with mental retardation to be as low as 5:1. I therefore consider the recommendation about encouraging teacher

training in special needs, especially for children with mental retardation as a crucial issue which needs to be handled first and foremost.

2. Teachers' Conditions of Service

While efforts are made to train teachers in the shortest time possible, the current-serving teachers should have their conditions improved. As noted in teachers' recommendation in Chapter 6, section 6.3.1, some of the issues raised concern the need to earn better salaries, to have their training facilitated and the opportunity for further training availed by the government. We noted in Chapter 6, sections 6.3.5 and 6.3.6, the opposition to giving teachers attractive remuneration, by some of the top educational administrators in Uganda. Although in the implementation of the policy on the education for children with mental retardation, there are different categories of stakeholders, teachers seem to be in the forefront. I therefore think that while the economic condition is still weak, in that all different categories of people employed by the government cannot be catered satisfactorily in the mean time, teachers need to be considered as top priority. Other employees could be considered later.

3. Adjustment of the Aims and Curriculum for Children with Special Needs in Uganda

I have pointed out, above, the concern about the current condition in which education seems to have been provided in quantity, and not in quality. We also noted how all the categories of participant of this study expressed the concern about the current examination-oriented system of education in Uganda. Without readjusting the aims of education and curriculum for children with mental retardation in the country, it is

unlikely that children with special needs will benefit from the provision of education. I therefore consider readjustment of the aims of education and curriculum for children with mental retardation as one of the top priority recommendations that should be tackled in the implementation of the policy of the provision of education in Uganda.

4. Involvement of Local Authorities

In Uganda, the central government has been responsible for providing financial, as well as material and other forms of support needed to run educational and other public services. With the current decentralisation programmes taking place in the country, it is appropriate for the local authorities to begin sharing responsibilities with the central authority to finance and implement crucial programmes, such as for children with special needs in the districts. I therefore think that the local authorities should be made aware of the need for sharing the responsibility of promoting development of special needs education in Uganda.

5. Involvement of Parents

Parents are known to have been keen in education of children in Uganda. Whenever there is a plan to introduce an educational change in the country, they should be consulted or involved directly. For example, with regard to UPE, parents should have been involved and made aware of the consequences of the programme. Parents' involvement is crucial and should be implemented in future.

6. Collective Policy Formulation

Politicians need to formulate policy, starting from the grassroots. They should involve all the stakeholders of a particular aspect. For example, with regard to special needs

education, the children with special needs, their parents, persons with special needs, teachers, educational and civic administrators, academicians, top civil servants and politicians should all participate in decision and policy-making. The type of situation prevailing in Uganda, with regard to implementation of education for children with special needs would be avoided in future.

7. Encouragement of Research Activities

Although it may be costly to promote research activities in Uganda at the moment, this recommendation needs to be considered seriously in future. There is no way improvement in education can come about without teachers and other educationists getting involved in research studies. I therefore think that in future, research should be treated as part and parcel of promoting special educational development in Uganda.

8. Awareness Activities

We noted in Chapter 6 that all the categories of participants in the current study put a lot of emphasis on awareness campaign to promote development of special needs education in Uganda. Problems, such as negative attitudes towards children with special needs have partly been attributed to lack of sensitisation of Ugandans on the needs of such children. Since the government has decided that children with special needs have the right to education, it is important to make the population aware about how such children can benefit from education. It may be apparent that such awareness campaigns may be very expensive. In my view, I think that awareness campaigns can be embarked on later and handled as a long-term strategy.

9. Professional Involvement

We have noted in the study how important it is, for teachers and other professionals to work in collaboration, in the implementation of special needs education in Uganda. Headteachers/teachers, teacher educators and EARS staff supported the need for professional involvement in the implementation of special needs education. We also noted in the literature, the argument in favour of professional involvement in special needs education. Like any other recommendations cited above, effecting professional involvement may be very costly. I therefore think that when the different recommendations have been implemented, special needs teachers and professionals (such as doctors, social workers and psychologists) should be encouraged to work together in order to strengthen implementation of special needs education. Their involvement could be crucial, especially in assessment of children with special needs.

#### 10. Labelling

As I mentioned both at the beginning of the thesis, and also in this chapter, section 7.3.2.2 (iii), the need to stop labelling children as “children with mental retardation”, or using such related terminologies, should be considered in Uganda. I therefore suggest that when awareness campaign programme has been launched, Ugandans should be convinced to stop labelling children the way they do at the moment.

We noted in Chapter 6, sections 6.3.1 – 6.3.6, that participants made numerous suggestions/recommendations for improvement. I also added my own in this chapter, section 7.3.2. In my opinion, all those recommendations can be dealt with within the above ten listed priorities. I therefore consider implementation of the ten listed

## Chapter 7: Summary and Suggestions/Recommendations

recommendations (if done one after the other) as a sure way forward to achieve the policy aims on the provision of education for children with mental retardation in Uganda.

# BIBLIOGRAPHY

## Bibliography

- Agran, M., Salzberg, C.L., and Stowitchek, J. (1987) 'An analysis of the effects of a social skills training program using self-instructions on the acquisition and generalisation of two social behaviours in a work setting', *Journal of Association for Persons with Severe Handicaps*, 12(2), 131-139.
- Ainscow, M. (1999) *Understanding the Development of Inclusive Schools*, London: Falmer Press.
- Ainscow, M. (1995a) 'Education for All: Making it happen', *Support for Learning*, 10 (4) 147-157.
- Ainscow, M. (1994) *Special Needs in the Classroom: A Teacher Education Guide*, London: Jessica Kingsley/UNESCO.
- American Psychiatric Association (APA) (1994) *Diagnostic and Statistical Manual of Mental Disorders (DSM-IV-R)* (4th ed.), Washington, DC: APA.
- American Psychological Association (APA) (1985) *Standards for Educational and Psychological Testing*, Washington, DC: American Psychological Association.
- Bailey, N. (1969) *Bailey Scales of Infant Development*, New York: The Psychological Corporation, Inc.
- Ballard-Campbell, M. and Semmel, M. (1981) 'Policy research and special education: Research issues affecting policy formation and implementation', *Exceptional Education Quarterly*, 2(2), 59-68.

- Bates, P., Renzaglia, A. and Wehman, P. (1981) 'Characteristics of an Appropriate Education for Severely and Profoundly Handicapped Students', *Education and Training of the Mentally Retarded*, 16, 142-149.
- Bauwens, J. and Hourcade, J. J. (1991) 'Making Co-teaching a mainstreaming strategy,' *Preventing School Failure*, 35 (4) 19-24.
- Benda, C. E. (1954) 'Psychology of Childhood', in Mussen, P. (ed.) *Manual of Child Psychology* (2nd ed. pp. 1115-1116). New York: John Wiley.
- Bogdan, R. C. and Biklen, S. K. (1982) *Qualitative Research for Education: An Introduction to Theory and Methods*, Boston: Allyn and Bacon.
- Borg, W. R., Gall, J. P., and Gall, M. D. (1999) *Applying educational research: A practical guide* (4rd ed.), White Plains, New York: Longman.
- Borg, Walter R. (1989) *Educational Research: An Introduction* (5th ed.), New York: Longman.
- Bradburn, N. M. and Sudman, S. (1981) *Improving Interview Method and Questionnaire Design*, San Francisco: Jossey-Bass.
- Brennan, W. K. (1987) *Changing Special Education Now*, London: Holt, Reinehart and Winston.
- Browder, D. M. and Snell, M. E. (1987) 'Functional academics', in Snell, M. E. (ed.) *Systematic instruction of persons with severe handicaps* (pp. 436-468), Englewood Cliff, New Jersey: Merrill/Prentice Hall.
- Caesar, P. (1993) 'Old and new facts about perinatal brain development', *Journal of Child Psychology and Psychiatry and Allied Disciplines*, 34, 101-109.
- Centre for Studies on Inclusive Education (CSIE) (1989) *The Integration Charter*, Bristol: CSIE.

- Charles, C. M. (1995) *Introduction to Educational Research*, (2nd ed.), White Plains, New York: Longman.
- Chen, T., Bruininks, R. H., Lakin, K. C. and Hayden, M. (1993) 'Personal competencies and community participation in small community residential programs: A multiple discriminant analysis', *American Journal on Mental Retardation*, 98, 390-399.
- Cipani, E., and Sooner, F. (1994) *Curricular and instructional approaches for persons with severe disabilities*, Needham Heights, Massachusetts: Allyn and Bacon.
- Cohen, L. and Manion, L. (1994) *Research Methods in Education*, (4th ed.), London: Routledge.
- Council for Disabled Children: (1994) *Policy Statement from the Integration Working Party*, London: National Children's Bureau.
- CSIE (1995) *Inclusive Education - International Demands For Change*, Bristol: CSIE.
- CSIE (1994) *International Perspectives on Inclusive Education*, Bristol: CSIE.
- Cunningham, G. K. ((1998) *Assessment in the Classroom: Constructing and Interpreting Texts*, London: The Falmer Press.
- Cuskelly, M. and Gunn, P. (1993) 'Maternal reports of behaviour of siblings of children with Down's syndrome', *American Journal on Mental Retardation*, 98, 580-587.
- DES (1978) *Special Educational Needs (The Warnock Report)*, London: HMSO.
- DES (1992) *A. U. D. I. T. Commission: Getting in on the Act: Provision for Pupils with Special Educational Needs, the National Practice*, London: HMSO.
- DFE (1994): *Code of Practice on assessment and identification of special educational needs*, London: HMSO.
- Doll, A .E. (1941) 'The essentials of inclusive concept of mental deficiency', *American Journal of Mental Retardation*, 46, 214-229.

- Drew, C. J, Logan, D.R. and Hardman, M.L. (1996) *Mental Retardation*, 6th Edn., New Jersey: Prentice-Hall, Inc.
- Drew, C. J, Logan, D. R. and Hardman, M. L. (1988) *Mental Retardation*, 4th Edn., Englewood Cliff, New Jersey: Merrill/Prentice Hall.
- Dunst, C. J., Trivette, C. M., Gordon, N. J., and Pletcher, L. L. (1989) 'Building and mobilising family support networks', in Singer, G. H. S. and Irvin, L. K. (eds.) *Support for care-giving families: Enabling positive adaptation to disability* (pp.121-141). Baltimore: Paul H. Brookes.
- Duff, A. (1981) *The Third Language*, Oxford: Pergamon Press.
- Dutton, G., (1975) *Mental Handicap*, London: Butterworth.
- Dyson, A. (1990) 'Special educational needs and the concept of change', *Oxford Review of Education* 16 (1), 55-66.
- Elliot, S., and Sheridan, S. M. (1992) 'Consultation and teaming: A review of problem-solving interactions among educators, parents and support personnel', *Elementary School Journal*, 92, 315-338.
- Epstein, M. H., Cullinan, D. and Polloway, E. A. (1986) 'Patterns of maladjustment among mentally retarded children and youth', *American Journal of Mental Deficiency*, 91, 129-134.
- Farrant, J. F. and Clark, L. H. (1980) *Principles and Practice of Education*, London: Longman.
- Farrel, P. (1997) 'The integration of children with severe learning difficulties: A review of the recent literature', *Journal of Applied Research in Intellectual Disabilities*, 10, 1-14.

- Ferguson, P. M., (1994) *Abandoned to their fate: Social policy and practice toward severely retarded people in America, 1820-1920*, Philadelphia: Temple University Press.
- Flanders, N. A. (1980) *Interaction Analysis in the Classroom*, USA, University of Michigan.
- Foucault, M. (1965) *Madness and Civilization*, London: Tavistock Publication.
- Frank, A. R. and McFarland, T. D. (1980) 'Teaching coin skills to EMR children: A curriculum study', *Education and Training of the Mentally Retarded*, 15, 270-278.
- Fryers, T. (1993) 'Epidemiological Thinking in Mental Retardation: Issues in Taxonomy and Population Frequency', *International Review of Research in Mental Retardation*, 19, 97-133.
- Fuchs, D., and Fuchs, L. (1991) 'Framing the REI debate: Abolitionists versus conservationists,' in Lloyd, J. W. N., Singh, N. N. and Repp, A. C. (eds.) *The regular education initiative: Alternative perspectives on concepts, issues, and models* (pp. 241-255). Sycamore, Illinois: Sycamore.
- Fulcher, G. (1989) *Disabling Policies?*, London: Falmer Press.
- Fullan, M. (1991) *The New Meaning of Educational Change* (2nd edn), London: Cassell Educational Ltd.
- Gall, M. D. et al. (1996) *Educational Research: An Introduction*, (6th edn.), White Plains, New York: Longman.
- Galloway, D., Armstrong, D. and Tomlinson, S. (1994) *The Assessment of Special Educational Needs: Whose Problem?*, Harlow: Longman

Gerber, M. M. and Kauffman, J. M. (1981) 'Peer-tutoring in academic settings', in Strain, P. S. (ed.) *The utilisation of classroom peers as behaviour change agents* (pp. 155-187), New York: Polonium Press.

Government White Paper (1992) *Education for National Integration and Development*, Kampala: Ministry of Education and Sports.

Greenspan, S. (1998) 'Dead Manual Walking? Why the 1992 AAMR Definition Needs Redoing', *Education and Training in Mental Retardation and Developmental Disabilities*, 32, 3-8.

Greenspan, S. and Granfield, J. M. (1992) 'Reconsidering the construct of mental retardation: Implications of a model of social competence', *American Journal on Mental Retardation*, 96, 442-453.

Grossman, H. J. (Ed.) (1973) *Manual on terminology and classification in mental retardation*, Washington, D. C: American Association on Mental Deficiency.

Grossman, H. J. (Ed.) (1983) *Classification in mental retardation*, Washington, D. C: American Association on Mental Deficiency.

Hallahan, D. P. and Kauffman, J. M. (1997) *Exceptional Learners: Introduction to Special Education* (7th Ed.), Massachusetts: Allyn and Bacon .

Hasazi, S. B. and Clark, G. M. (1988) 'Vocational preparation for high school students labelled mentally retarded: Employment as a graduation goal', *Mental Retardation*, 26(6), 343-349.

Heber, R. F. (1959) 'A manual on terminology and classification in mental retardation', *Monograph Supplement American Journal of Mental Deficiency*, 62, 1-6.

Hegarty, S. (1993) *Meeting Special Needs in the Ordinary Schools*, (2<sup>nd</sup> Edn.), London: Cassell Educational Ltd.

- Hoy, C. and Gregg, N. (1994) *Assessment: The special educator's role*, Pacific Grove, California: Brooks/Cole.
- Hopkins, K. D., Hopkins, B. R. and Glass, G. V. (1996) *Basic Statistics for Behavioural Sciences* (3rd edn.), London: Allyn Bacon.
- Jenkins, J. R. and Jenkins, L.M. (1987) 'Making Peer-tutoring Work', *Educational Leadership*, (6) 64-68.
- Johnson, D. and Johnson, R. (1986) 'Mainstreaming and Co-operative Learning Strategies', *Exceptional Children*, 52, 553-561.
- Kajubi Report, (1989) *Education Policy Review Commission (EPRC)*, Kampala: Ministry of Education and Sports.
- Kaplan, R. M., and Saccuzzo, D. T. (1993) *Psychological testing*, Pacific Grove, California: Brooks/Cole.
- Kauffman, J. (1993) 'The effects of the socio-political environment on developments in special education', *Australian Journal of Special Education*, 17, 3-13.
- Kivale, S. (1996) *Interviews: An Introduction to Qualitative Research Interviewing*, CA: Sage Publication.
- Knight, B. A. (1999) 'Towards inclusion of students with special educational needs in the regular classroom', *Support for Learning*, 14, 3-6.
- Lachiewicz, A. M., Spiridigliozzi, G. A., Gullion, C. M., Ransford, S. N., and Rao, K. (1994) 'Aberrant behaviour of young boys with fragile X syndrome', *American Journal on Mental Retardation*, 98, 567-579.
- Lee, F. Y. (1992) 'Alternative assessments', *Childhood Education*, 69 (2), 72-73.
- LeVine, R. R. A. (1989) 'Cultural environments in child development', in Damon, W. (ed.), *Child development today and tomorrow* (pp. 52-68), San Francisco: Jossey-Bass.

- Lincoln, Y. S. and Guba, E. G. (1985) *Naturalistic Inquiry*, Biverly Hills, California: Sage Publications.
- Lukasson, R., et al. (1992) *Mental Retardation, Definition, Classification and Systems of Support* (9th edn.), Washington, DC: American Association on Mental Retardation.
- MacMillan, D. L., Gresham, F. M. and Siperstein, G. N. (1993) 'Conceptual and psycho-metric concerns about the 1992 AAMR definition of mental retardation', *American Journal on Mental Retardation*, 98, 325-335
- Manset, G. and Semmel, M. (1997) 'Are inclusive programmes for students with mild disabilities effective? A comparative review of model programmes', *Journal of Special Education*, 31, 155-80.
- Maxwell, J. A. (1996) *Qualitative Research Design*, Thousand Oaks, California: Sage Publications.
- Mercer, C. (1997) *Students with Learning Disabilities* (5th edn), Columbus, Ohio: Merrill.
- Michaelson, R. (1993) 'Tug-of-war is developing over defining retardation', *APA Monitor*, 24 (5), 34-39.
- Ministry of Education (1992) *Information on EARS/Special Education*, Kampala: Ministry of Education and Sports.
- Ministry of Education and Sports, (1998) *Education Statistics for Government-Aided Schools*, Kampala: Ministry of Education and Sports.
- Ministry of Education and Sports, (1999) *EARS Programme: Special Needs, Number of Children with Special Needs in Uganda*, Kampala: Ministry of Education and Sports.
- Ministry of Education, (1997) *Circular on the Universal Primary Education*, Kampala: Ministry of Education and Sports.

Ministry of Finance and Economic Planning (1992) *Uganda National Programme Of Action For Children: Priorities For Social Services Sector Development in the 1990s and Implementation Plan 1992/93-1994/5*, Kampala: Ministry of Finance and Economic Planning.

Ministry of Public Service, (1997) *Circular on Universal Primary Education*, Kampala: Ministry of Public Service.

Mittler, P. (1995) 'Special Needs Education: an International Perspective', *British Journal of Special Education*, 22, 198-202.

Mittler, P. and Serpell, R. (1985) 'Services: An International Perspective', *Remedial and Special Education*, 6 (1), 13-19.

Monitor Newspaper, (29.7.1998) *Will UPE produce semi-illiterates?*, Kampala: Monitor Newspaper.

New Vision Newspaper, (18.3.1998) *Over 400 city school teachers axed*, Kampala: New Vision Newspaper.

New Vision Newspaper, (3.3.1998) *Teachers flee UNISE*, Kampala: New Vision Newspaper.

New Vision Newspaper, (3.3.1998) *UPE not benefiting disabled*, Kampala: New Vision Newspaper.

Notari, A., Slentz, K. L. and Bricker, D. (1991) 'Assessment-curriculum system for early childhood/Special Education', in Mitchel, D. and Brown, R. I. (eds.), *Early Intervention Studies for Young Children with Special Needs* (pp. 160-201), London: Chapman and Hall.

Nowacek, E. J. (1992) 'Professionals talk about teaching together: Interview with five collaborating teachers', *Intervention in School and Clinic*, 27(5), 262-276.

- Okech, J. B. (1993) *Special Education in Uganda*, Kampala: UNISE/DANIDA.
- Patton, M. Q. and Stacey, S., (1992) *Summative Evaluation*, California: Saint Paul Foundation.
- Piaget, J. (1960) 'The general problems of the psychobiological development of the child', in Tanner, J. M. and Inhelder, B. (eds.), *Discussion on child development* (pp. 3-27). London: Tavistock.
- Polloway, E. A. (1998) 'Developmental Principles of the Luckasson et al. (1992) AAMR Definition of Mental Retardation: A Retrospective', *Education and Training in Mental Retardation and Development Disabilities*, 32, 9-13.
- Popper, K. R. (1963) *Conjectures and Refutations*, London: Routledge Kegan Paul.
- Powney, J. and Watt, M. (1987) *Interviewing in Educational Research*, London: Routledge & Kegan Paul Ltd.
- Rechsly, D. J. and Ward, S. M. (1991) 'Use of adaptive measures and over-representation of black students in programs for students with mild mental retardation', *American Journal of Mental Retardation*, 96(3): 257-68.
- Reynolds, C. R. (1993) *Cognitive assessment: A multidisciplinary perspective*, New York: Plenum.
- Reynolds, C. R. and Mann, L. (Ed). (1987) *Encyclopaedia of Special Education*, New York: John Wiley and Sons, Inc.
- Sarason, S. (1985) *Psychology and mental retardation: Perspectives in change*, Austin, Texas: Pro-Ed.
- Sattler, J. M. (1982) *Assessment of Children's Intelligence and Special Abilities*, Massachusetts: Allyn and Bacon Inc.
- Scheerenberger, R. C. (1983) *A History of Mental Retardation*, Baltimore: Brookes.

- Scruggs, T. E. and Richter, L. (1986) 'Tutoring learning disabled students: A Critical Review', *Learning Disability Quarterly*, 9, 2-14.
- Serpell, R. and Nabuzoka, D. (1993) Early Intervention in Third World Countries', in Mitchel, D. and Brown, R. I. (eds.), *Early Intervention Studies for Young Children with Special Needs* (pp. 93-117). London: Chapman and Hall.
- Serpell, R. et al., (1993) 'Mental Retardation in African Countries: Conceptualisation, Services and Research', *International Review of Research in Mental Retardation*, 19, 1-39.
- Ssekamwa, J. C. (1997) *History and Development of Education in Uganda*, Kampala: Fountain Publishers.
- Skrtic, T. M. (1991) *A Critical Analysis of Professional Culture and School Organisation*, Denver, Colorado: Love Publishing Company.
- Slavin, R. E. (1991) 'Synthesis of Research on Co-operative Learning', *Educational Leadership*, 48 (5) 71-82.
- Smith J. D. (1998) 'Mental Retardation as an Educational Construct: For a New Shared View?', *Education and Training in Mental Retardation and Development Disabilities*, 32, 14-18.
- Smith, T., Finn, D. and Dowdy, C. (1993) *Teaching Students with Mild Disabilities*, New York: Harcourt Brace Jovanavich.
- Smyth, J. (1989) 'Developing and sustaining critical reflection in teacher education', *Journal of Teacher Education*, 40 (2), 2-9.
- Snell, M. (1993) *Instruction of students with severe disabilities*, Englewood Cliffs, New Jersey: Merrill/Prentice Hall.

- Snell, M. E. (1988) 'Curriculum and methodology for individuals with severe disabilities' *Education and Training in Mental Retardation*, 23(4), 302-314.
- Stainback, S., Stainback, W., East, K. and Sapon-Shevin, M. (1994) 'A commentary on inclusion and the development of positive self-identity by people with disabilities', *Exceptional Children*, 60, 486-96.
- Stark, J. (1992) 'Presidential Address 1992: A professional and personal perspective on families', *Mental Retardation*, 30(5), 245-254.
- Stenberg, R. J. (1991) 'Death, taxes and bad intelligence tests', *Intelligence*, 15, 257-69.
- Strauss, A. and Corbin, J. (1990) *Basic Qualitative Research: Grounded Theory, Procedures and Techniques*, London: Sage publications.
- Switzky, H. N. (1998) 'Mental Retardation and the Neglected Construct of Motivation', *Education and Training in Mental Retardation and Development Disabilities*, 32, 19-23.
- Tomlinson, S., (1982) *A sociology of special education*, London: Routledge and Kegan Paul.
- Tredgold, A. P. (1937) *A Text Book of Mental Deficiency*, (6th edn.), Baltimore: Willian Wood.
- Turnbull, H. R. and Turnbull, A. P. (1990) *Families, professionals and exceptionality: A special partnership* (2nd ed.), Columbus, Ohio: Merrill.
- Uganda National Institute of Special Education (UNISE), (1996) *Information on UNISE*, Kampala: UNISE.
- UNESCO (1988) *Review of Special Education*, Paris: UNESCO.
- UNESCO (1996) *Legislation Pertaining to Special Needs Education*, Paris: UNESCO

- Ungerleider, C. (1993) 'Why change hardly happens', in Riecken, T. and Court, D. (eds), *Dilemmas in Educational Change*, Calgary: Detselig Enterprises.
- UNICEF (1994) *Uganda National Situation Analysis For Women and Children*, Kampala: UNICEF.
- UNISE Bulletin (1992) *Educational Newsletter* Vol. 1, Kampala: UNISE.
- UNISE Bulletin (1993) *Educational Newsletter* Vol. 2, Kampala: UNISE.
- Vernon, P. E. (1969) *Intelligence and cultural environment*, London: Methuen.
- Vig, S. and Jedrysek, E. (1996) 'Application of the 1992 AAMR Definition: Issues for Pre-school Children', *Mental Retardation*, 34, 4-14.
- Wallace, G., Vaughn, S., Larsen, S. C. and Elksnin, L. K. (1992) *Educational assessment of learning problems: Testing for teaching* (2nd ed.), Boston: Allyn and Bacon.
- Wang, M. C. et al (1995) *Handbook of Special and Remedial, Education Research and Practice*, 2nd Edn., New York: Pergamon.
- Wechsler, D. (1991) *Wechsler Intelligence Scale for Children*, (3rd ed.), San Antonio, Texas: Psychological Corporation.
- Welch, M. and Sheridan, S. M. (1995) *Educational partnerships: An ecological approach to serving students at risk*, Orlando, Florida: Harcourt Brace Jovanovich.
- West, J. F. and Idol, L. (1990) 'Collaborative Consultation in Education of Mildly Handicapped at-risk students', *Remedial and Special Education*, 11 (1) 22-31.
- Westling, D. (1986) *Introduction to Mental Retardation*, Englewood Cliff, New Jersey: Prince Hall.

Wolery, M., Bailey, N. and Sugai, G. M. (1988) *Effective teaching: Principles and procedures of applied behaviour analysis with exceptional students*, Boston: Allyn and Bacon.

World Bank Report (1994) *Uganda Social Sector*, Washington DC: World Bank.

World Health Organisation (WHO) (1994) *International Classification of Diseases*, 10th Edition (ICD-10), Geneva: WHO.

Worthen, B. R., Borg, W. R. and White, K. R. (1993) *Measurement and evaluation in the schools*, White Plains, New York: Longman.

Wragg, E., Oates, J. and Gump, P. (1976) *Classroom Interaction*, Walton Hall, Milton Keynes: Open University.

# APPENDIX 1

Appendix 1: UGANDA: STRUCTURE OF THE EDUCATION SYSTEM

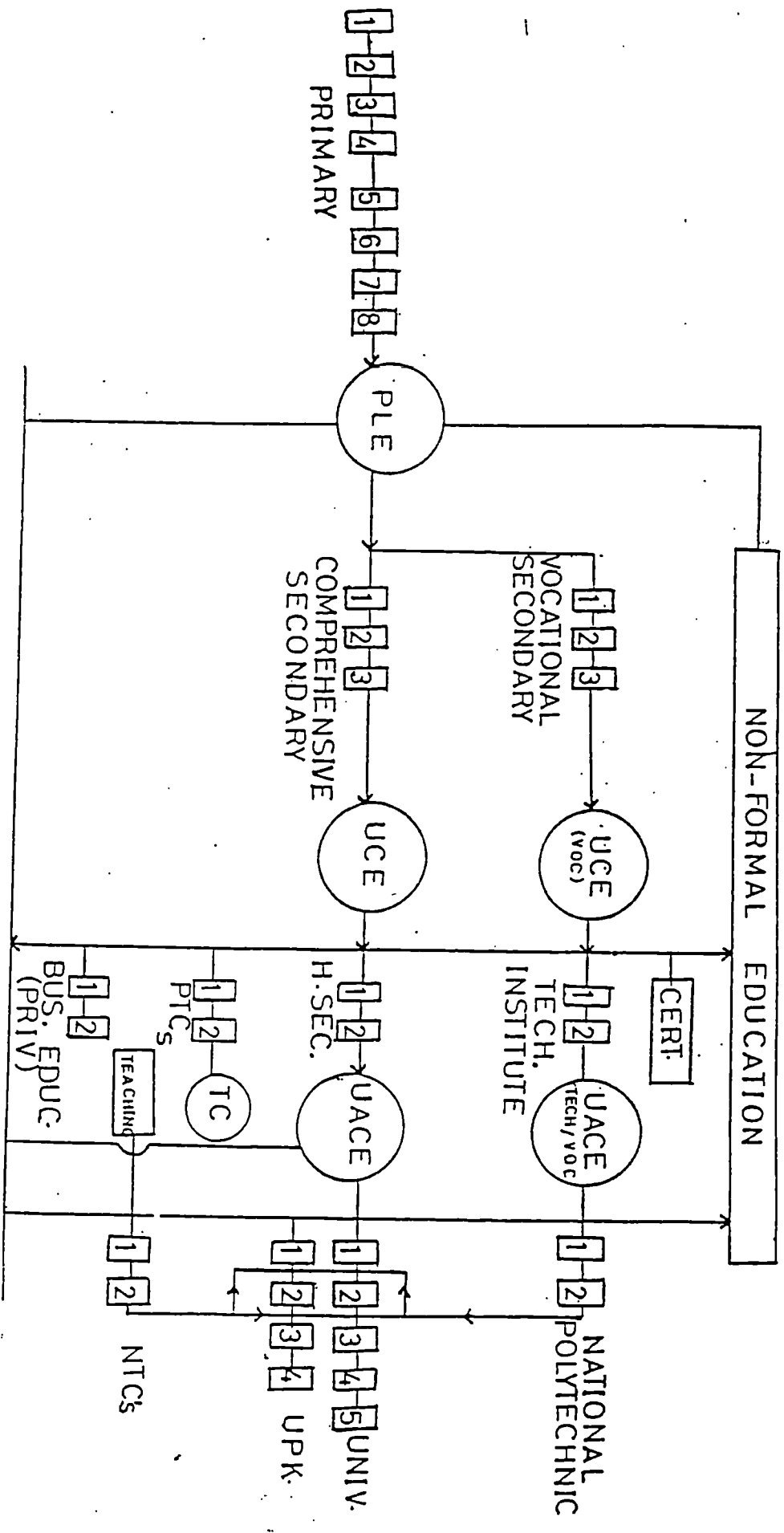

Source: Government White Paper on Education for National Integration and Development (1992:p.261)

# APPENDIX 2

## Appendix 2

Table 2: Education Statistics for Government Aided Schools, 1998

EDUCATION STATISTICS FOR GOVERNMENT-AIDED INSTITUTIONS: 1991-1995 *		NUMBER OF TEACHERS, TUTORS, LECTURERS										
TYPE OF INSTITUTION	1986	1987	1988	1989	1990	1991	1992	1993	1994	1995	1996	1997
				NUMBER OF INSTITUTIONS								
PRIMARY SCHOOLS	7,350	7,627	7,905	7,684	7,667	8,046	8,325	8,430	8,442	8,531	9,223	10,616
SECONDARY SCHOOLS	508	515	515	508	510	512	509	508	557	619	621	621
TEACHER TRAINING COLLEGES	73	92	94	68	68	65	64	64	64	64	64	64
TECHNICAL SCHOOL AND INSTITUTIONS	56	55	52	52	52	52	58	55	55	58	58	63
NATIONAL TEACHERS COLLEGES	10	10	10	10	10	10	10	10	10	10	10	10
UGANDA TECHNICAL COLLEGES	8	4	4	4	4	4	4	4	4	4	4	5
UGANDA COMMERCIAL COLLEGES	5	5	5	5	5	5	5	5	5	5	5	5
OTHER HIGHER INSTITUTIONS	3	3	3	3	3	3	3	3	3	3	3	3
UNIVERSITIES	1	1	1	2	2	2	2	2	2	2	2	2
				ENROLLMENT								
PRIMARY SCHOOLS	66,101	72,970	75,561	81,418	81,590	78,529	86,821	91,905	84,043	76,111	81,564	102,331
SECONDARY SCHOOLS	10,193	12,000	123,000	12,919	11,069	13,476	14,660	14,620	16,245	1,022	13,984	16,696
TEACHER TRAINING COLLEGES	1,105	1,105	1,429	1,429	1,022	1,338	1,149	830	922	1,022	991	991
TECHNICAL SCHOOL AND INSTITUTIONS	649	649	649	278	667	787	769	744	826	766	949	949
NATIONAL TEACHERS COLLEGES	176	322	392	331	361	403	499	483	472	425	428	428
UGANDA TECHNICAL COLLEGES	561	132	79	128	137	129	120	112	42	62	58	58
UGANDA COMMERCIAL COLLEGES	145	102	113	132	159	129	201	177	163	174	164	164
OTHER HIGHER INSTITUTIONS	315	350	400	322	318	266	397	379	341	390	374	374
UNIVERSITIES	485	558	558	573	579	574	876	1,060	803	724	836	836
				ENROLLMENT								
PRIMARY SCHOOLS	2,203,824	2,307,800	2,416,800	2,532,800	2,281,590	2,539,549	2,364,078	2,674,965	2,598,692	2,636,409	3,068,625	5,422,404
SECONDARY SCHOOLS	196,010	224,375	238,111	238,467	223,498	235,498	226,805	231,430	244,248	22,703	266,737	336,022
TEACHER TRAINING COLLEGES	12,551	13,179	13,173	15,166	1,626	14,305	16,261	17,541	18,512	22,703	2573	2573
TECHNICAL SCHOOL AND INSTITUTIONS	6,491	6,548	6,556	3,804	8,094	10,889	13,603	11,894	12,552	13,360	23,910	23,910
NATIONAL TEACHERS COLLEGES	1,674	1,412	1,819	3,008	3,464	4,534	6,246	5,703	6,017	8,044	4,148	4,148
UGANDA TECHNICAL COLLEGES	435	520	635	352	328	423	507	463	478	499	435	435
UGANDA COMMERCIAL COLLEGES	924	956	956	1,848	1,996	2,297	2,636	2,431	2,858	3,296	2,523	2,523
OTHER HIGHER INSTITUTIONS	1,681	1,289	2,088	2,822	2,618	3,556	4,189	4,605	5,821	6,035	8,869	8,869
UNIVERSITIES	5,390	5,260	5,307	5,430	5,430	6,497	7,282	7,583	8,264	11,469	11,599	11,599

NOTE: DATA FOR 1997 IS BASED ON HEADCOUNT

\*Data provided here are meant for a period between 1986-1998, not as indicated in the original table.

Source: Planning Department, Ministry of Education and Sports, Kampala

# APPENDIX 3

### Appendix 3:

#### Number of Students Trained for Special Needs Education (SNE) at UNISE since 1988

##### A. Diploma Students

Period	Number of Students	Males (M)	Females (F)
1. 1988 - 1990	25	17	8
2. 1990 - 1992	29	20	9
3. 1992 - 1994	67	42	25
4. 1994 - 1996	81	40	41
5. 1995 - 1997	58	26	32
6. 1996 - 1998	48	25	23
7. 1997 - 1999	69	37	32
8. 1998 - 2000	67 (on-going Yr. I)	35	32
Total (excluding on-going)	377	207	170

##### B. Certificate Courses

Period	Option	No. of Students	Males	Females
1. 1996	Social Vocational Rehabilitation (SVR)	28	18	10
2. 1996/97	Mobility Rehabilitation	12	8	4
3. 1997/98	Mobility Rehabilitation	12	6	6
4. 1998/99	Mobility Rehabilitation	10	6	4
Total		62	38	24

##### C. Post Graduate Diploma in Community Based Rehabilitation (CBR)

Period	Number of Students	Males	Females
1. 1996/97	12	9	3
2. 1997/98	13	12	1
2. 1998/99	15	9	6
Total	40	30	10

##### D. Bachelor of Education (BEd) Course

Period	Number of Students	Males	Females
1. 1998/2000	12 (on-going)	21	9
Total		21	9

Source: Uganda National Institute of Special Education (UNISE) - February, 1999

# APPENDIX 4

#### **Appendix 4: Aetiology of Mental Retardation**

*The aetiology of mental retardation is provided so as to get clear definitions and concepts of the condition from medical point of view. It is known that there are very many factors responsible for causing mental retardation, and it is also acknowledged that others are not yet known. Such knowledge is important for the many Ugandans who may still associate causes of mental retardation with some forms of myths. Teachers in Uganda in particular need to be furnished with such knowledge, such that even if they teach children who are not mentally retarded, they may help to enlighten the future generation to learn and to become aware of the possible circumstances that are scientifically known to be responsible for the retardation. The sources of the note on the aetiology have are provided at the end of the text.*

#### **How Mental Retardation is Medically Explained**

Once conception has taken place the fertilised ovum develops through a process of cell division called mitosis. Repeated cellular division produces cells, which become increasingly specialised. This specialisation occurs because it contains within the original cell 23 pairs of chromosomes. These carry the instructions for the development of new cells. Before cellular division occurs the chromosomes duplicate so that each daughter cell contains the full genetic complement of 46 chromosomes. These consist of 44 chromosomes, which are the same in both males and females and are called autosomes. The remaining two chromosomes determine the sex of the individual and are termed XX for the female, and XY for the male.

Chromosomes carry the genes which, acting either individually or in combination with others determine the person's physical and mental characteristics. Therefore, it follows that each pair of chromosomes carries genes for particular characteristics. At conception the mother contributes the ovum containing 23 chromosomes and the father contributes spermatozoa containing 23 chromosomes, making up the full genetic complement of 46 chromosomes in the new individual. For whatever reason should there be a fault in either genetic or chromosomal factors there is bound to be an effect in the mental or physical development of the foetus.

### **Genetic Abnormality**

Genetic abnormalities may give rise to mental handicap. The affected individuals are usually severely handicapped. One such example is microcephaly, that is, a condition caused by a single abnormal gene. The presence of this abnormality prevents the brain from developing normally. Another example is tuberous sclerosis or epiloia. This condition is caused by an abnormal dominant gene and produces severe mental handicap.

Abnormal genes also cause a large group of disorders, known as inborn errors of metabolism. Metabolism is the process of breaking down food into elements that the body can use. If this process is interrupted the incomplete products of metabolism may affect the individual adversely. The most common form of inborn error is found in the condition of phenylketonuria (PKU). This is a disorder of protein metabolism. In this case there is an absence of an enzyme called phenylalaninehydroxylase (an amino acid)

which results in high levels of phenylalanine in the blood, producing severe effects on the child's mental and physical development.

Abnormal genes cause a disorder of carbohydrate metabolism called galactosaemia. This abnormality results in a deficiency or absence of an enzyme vital for the effective metabolism of galactose. This produces an accumulation of harmful chemicals, which damage the liver and kidneys as well as cause mental handicap. Besides genetic abnormalities, there are also chromosome abnormalities that have been known to cause mental retardation.

### **Chromosome Aberration (Abnormalities)**

Chromosome abnormalities are known to human beings in several ways; (a) the trisome, the presence of a single additional chromosome; (b) the monosome, the absence of a chromosome that should be there; (c) deletion, the absence of a part of a chromosome; (d) translocation, the moving of a piece of one chromosome from where it ought to be to another chromosome where it perhaps ought not to be, and (e) triploidy, a condition in which an individual has half again as many chromosomes as he ought to have. The trisomy is the abnormality associated with Down's syndrome (also referred to as mongolism).

Apart from causes by faults in genes and chromosomes mental handicap is also known to be caused by various environmental factors and these are analysed below.

## **Environmental Causes of Mental Retardation**

There are many factors, which can affect a foetus in its physical and mental development. These factors may exert their influence at any time after conception, during pregnancy, birth or childhood. They include maternal and childhood infection; acute or chronic lack of oxygen to the developing brain; direct or indirect violence, ranging from accident to non-accidental injury; maternal foetal incompatibility; prematurity; birth injury; the ingestion of chemicals in pregnancy; childhood malnutrition; and sensory and social deprivation. The severity of these effects varies from severe mental and physical abnormality to mild mental handicap with no physical handicap. Generally the earlier the damage occurs the more severe is the outcome, as the developing brain is particularly susceptible to adverse conditions. Following conception, the foetus develops rapidly from the fertilised ovum to the normal full-term baby. One of the more complex aspects of foetal development is the formation and maturation of the brain and central nervous system, with spurts of growth occurring during the fifteenth and twentieth weeks and from the twenty-fifth week onwards. The developing brain is particularly vulnerable to any adverse conditions and a number of factors are known to cause mental handicap at this time.

There are different maternal infections caused by environmental factors. One of the examples is German measles (also known as rubella). Other virus infections known to cause mental handicap include varicella (chicken pox), herpes simplex, ineffective hepatitis, influenza, mumps and poliomyelitis. The degree of handicap varies from milc

to profound and the risk is always greater if infection occurs in the first three months of pregnancy.

Childhood infections such as inflammation of the brain (encephalitis) or its covering (meningitis) may damage the brain to the extent that there may be mental handicap, slight or severe.

Traumatic factors may intervene during pregnancy, at birth or during childhood to produce mental handicap. The mother may be excessively exposed to radiation, particularly during the first 16 weeks, which may cause microcephaly with severe mental handicap. Sometimes a mother may try to procure an abortion using substances that will damage a fertilised ovum and which may cause abnormalities and mental handicap in the child. Incompatibility of the mother's and baby's blood may result in the destruction of the baby's red blood cells and damage to parts of the brain.

Other environmental factors known to cause mental retardation occur when the developing foetus is denied essential nutrients as a result of placental insufficiency. The developing foetus is very sensitive and can be affected by a lack of protein, blood, sugar or oxygen and this deprivation is particularly significant at the period when brain development is at its peak. Mental handicap may also occur as a result of the child eating poisonous substances. An example of this is the ingestion of lead from paint, which may lead to a serious condition called lead encephalopathy causing blindness, deafness, convulsions and severe mental handicap.

### *Sources of the note*

American Psychiatric Association (APA) (1994) *Diagnostic and statistical manual of mental disorder* (4th ed.), Washington, DC: APA.

Bregman, J. D. and Hodapp, R. M. (1991) 'Current developments in the understanding of mental retardation: Biological and phenomenological perspective', *Journal of the American Academy of Child and Adolescent Psychiatry*, 30, 707-717.

Caesar, P. (1993) 'Old and new facts about prenatal brain development', *Journal of Child Psychology and Psychiatry and Allied Disciplines*, 34, 101-109.

Cuskelly, M. and Gunn, P. (1993) 'Maternal reports of behaviour of siblings of children with Down's syndrome', *American Journal on mental retardation*, 98, 580-587.

Drew, C. J, Logan, D.R. and Hardman, M. L. (1996) *Mental Retardation*, 6th Edn., New Jersey: Prentice-Hall, Inc.

# APPENDIX 5

**Appendix 5: A LETTER TO THE SECRETARY, UGANDA NATIONAL COUNCIL FOR SCIENCE AND TECHNOLOGY (UNCST)**

Dear Sir,

Through: Director  
Uganda National Institute of Special Education (UNISE)  
Kampala

Head  
Department of Mental Retardation/Learning Difficulties, UNISE

I am a teacher trainer, in the area of Mental Retardation/Learning Difficulties at the above institute.

The purpose of writing this letter is to request that you grant me permission to carry out a research study, which I have started. I shall conduct the study mainly in the districts of Kampala, Masindi and Iganga, but I may need to have informal consultations with schools and organisations in other districts as well.

The study is about evaluation of provision of education for children with mental retardation in Uganda.

I look forward to receiving your kind response.

Thank you very much.

Yours sincerely,

John B. O. Okech  
The Researcher/Teacher Trainer, Mental Retardation/Learning Difficulties, UNISE

# APPENDIX 6

**Appendix 6: A LETTER TO THE HONOURABLE MINISTER OF  
EDUCATION AND SPORTS, MINISTRY OF EDUCATION &  
SPORTS, KAMPALA, UGANDA**

Dear Sir,

Through: Commissioner for Education (Administration)  
Ministry of Education, Kampala, Uganda

Director  
Uganda National Institute of Special Education (UNISE)  
Kampala

Head  
Department of Mental Retardation/Learning Difficulties, UNISE

I am a teacher trainer, in the area of Mental Retardation/Learning Difficulties at the above institute. I am currently carrying out a research study, in connection with the implementation of provision of education for children with mental retardation in Uganda.

The purpose of writing this letter is to request for an audience with you to find out what the current position of the Government is, regarding how children with mental retardation are being supported to receive education in the country.

I would be grateful if such an audience could take place any time convenient to you between February and June, 1997.

I look forward to receiving your kind response. I regret any inconvenience this may cause.

Thank you very much.

Yours sincerely,

John B. O. Okech  
The Researcher/Teacher Trainer, Mental Retardation/Learning Difficulties, UNISE

# APPENDIX 7

**Appendix 7: A LETTER TO THE COMMISSIONER FOR EDUCATION  
(ADMINISTRATION/INSPECTORATE), MINISTRY OF  
EDUCATION & SPORTS, KAMPALA, UGANDA**

Dear Sir,

Through: Director  
Uganda National Institute of Special Education (UNISE)  
Kampala

Head  
Department of Mental Retardation/Learning Difficulties, UNISE

I am a teacher trainer, in the area of Mental Retardation/Learning Difficulties at the above institute. I am currently carrying out a research study, in connection with implementation of provision of education for children with mental retardation in Uganda

The purpose of writing this letter is to request for an audience with you to find out what the current position of the Government is, regarding how children with mental retardation are being supported to receive education in the country.

I would be grateful if such an audience could take place any time convenient to you between February and June, 1997.

I look forward to receiving your kind response. I regret any inconvenience this may cause.

Thank you very much.

Yours sincerely,

John B. O. Okech  
The Researcher/Teacher Trainer, Mental Retardation/Learning Difficulties, UNISE

# APPENDIX 8

**Appendix 8: A LETTER TO THE DISTRICT EDUCATION OFFICER (DEO),  
(KAMPALA/MASINDI/IGANGA, DISTRICT)**

Dear Sir,

Through: Director  
Uganda National Institute of Special Education (UNISE)  
Kampala

Head  
Department of Mental Retardation/Learning Difficulties, UNISE

I am a teacher trainer, in the area of Mental Retardation/Learning Difficulties at the above institute. I am currently carrying out a research study, in connection with implementation of provision of education for children with mental retardation in Uganda.

The purpose of writing this letter is to request for an audience with you to find out what the current position of your district is, regarding how children with mental retardation are being supported to receive education in the country.

I would be grateful if such an audience could take place any time convenient to you before May, 1997.

I look forward to receiving your kind response. I regret any inconvenience this may cause.

Thank you very much.

Yours sincerely,

John B. O. Okech  
The Researcher/Teacher Trainer, Mental Retardation/Learning Difficulties, UNISE

# APPENDIX 9

## Appendix 9: A LETTER TO THE EARS STAFF (NATIONAL/DISTRICT)

Dear Sir,

Through: Director  
Uganda National Institute of Special Education (UNISE)  
Kampala

Head  
Department of Mental Retardation/Learning Difficulties, UNISE

I am a teacher trainer, in the area of Mental Retardation/Learning Difficulties at the above institute. I am currently carrying out a research study, in connection with implementation of provision of education for children with mental retardation in Uganda.

The purpose of writing this letter is to request for an audience with you to find out what the current position of your programme is, regarding how children with mental retardation are being supported to receive education in the country.

I would be grateful if such an audience could take place any time convenient to you before July, 1997.

I look forward to receiving your kind response. I regret any inconvenience this may cause.

Thank you very much.

Yours sincerely,

John B. O. Okech  
The Researcher/Teacher Trainer, Mental Retardation/Learning Difficulties, UNISE

# APPENDIX 10

## Appendix 10: A LETTER ACCOMPANYING QUESTIONNAIRE

Dear Colleague,

Please, find attached a questionnaire meant to get information concerning provision of education for children with mental retardation in Uganda.

I would be very grateful if you could answer the questions provided.

I look forward to receiving your kind response. I regret any inconvenience this may have caused to you.

Thank you very much.

John B. O. Okech

The Researcher/Teacher Trainer, Mental Retardation/Learning Difficulties, UNISE

# APPENDIX 11

Appendix 11: CLEARANCE LETTER BY UNCST

**UGANDA NATIONAL COUNCIL FOR SCIENCE AND TECHNOLOGY**

76 BUGANDA ROAD  
P. BOX 6884  
KAMPALA, UGANDA

TELEPHONES: 250499 (General)  
EXECUTIVE SECRETARY'S DIRECT LINE: 250431  
TELEX NO.....TELEFAX NO. 234579

Your Ref...SS... 1060.....

Date 5 March 1997

The Resident District Commissioner  
Kampala District  
P. O. Box 352  
KAMPALA

Dear Sir/Madam,

**RE: RESEARCH CLEARANCE**

This is to introduce **John B. Okech**.....  
Who would like to carry out research on Evaluation of Provision of Education for Children with  
Mental Retardation in Uganda for a period of 3 years in your district.

This research project has been approved by the Uganda National Council for Science and Technology  
and cleared by the Office of the President.

I am requesting you to give the researcher the necessary assistance to facilitate the accomplishment of  
the study. Your co-operation in this regard will be highly appreciated.

Yours faithfully,

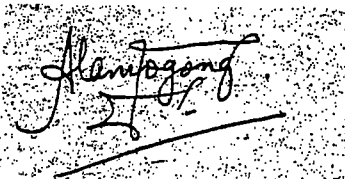

Jimmy Alani

For EXECUTIVE SECRETARY  
UGANDA NATIONAL COUNCIL FOR SCIENCE AND TECHNOLOGY

# APPENDIX 12

Appendix 12: CLEARANCE LETTER BY DEO OF MASINDI



THE REPUBLIC OF UGANDA

MASINDI DISTRICT EDUCATION DEPARTMENT

P.O.Box 294  
MASINDI

M/5

Our Ref: -----

Your Ref: -----

8<sup>th</sup> April 1997

Headteachers

Masindi District Primary Schools

RE: LETTER OF INTRODUCTION

This is to introduce to you Mr John B. Okech a Researcher. He is conducting Research on Evaluation of Provision of Education for children with Mental Retardation in Uganda. This will be for a period of three years.

Please give him the assistance he needs in his Research

A handwritten signature in black ink, appearing to be 'Derek Nkata', written over a horizontal line.

DEREK NKATA  
DISTRICT EDUCATION  
OFFICER  
MASINDI

DISTRICT EDUCATION OFFICER  
MASINDI

# APPENDIX 13



# City Council of Kampala

## Memorandum

From:  
City Education Officer's Department  
P. O. Box 2649  
Kampala-Uganda

Date. 29/5/98

To:

The Headteacher.....  
.....

Our Ref.....

Re: MR JOHN B. OKECH

This is to introduce to you MR JOHN B. OKECH –a lecturer at the Uganda National Institute of Special Education, Kyambogo who is carrying out research in the field of Special Needs Education.

Your school has been selected for the purpose.

Kindly accord him every possible assistance.

CHARLES W. MASABA,  
DISTRICT INSPECTOR OF SCHOOLS

EDUCATION OFFICE

KAMPALA CITY COUNCIL

P. O. BOX 2649, Kampala

Date 29-5-98

# APPENDIX 14

**Appendix 14: NAMES OF PERSONS CONSULTED FOR  
VALIDITY OF THE RESEARCH INSTRUMENTS**

1. Mrs Kirsten Kristensen - (then Chief Adviser, EARS Programme, Ministry of Education & Sports, Kampala
2. Dr Solomon Serugga - Teacher Educator, Makerere University, Kampala
3. Professor Niels Egelund - Professor of Special Needs Education, Copenhagen
4. Professor Mel Ainscow - Professor of Special Needs Education and UNESCO Consultant

# APPENDIX 15

**Appendix 15:                   AQESTIONNAIRE TO  
TEACHERS/HEADTEACHERS OF  
PRIMARY SCHOOLS**

This questionnaire seeks to find out your views about the current efforts being made to implement the policy of provision on education for children with mental retardation in Uganda. Both the Kajubi Report of 1989 and the subsequent Government White Paper of 1992 recommend and endorse respectively, a policy to provide education to children with disabilities in the country. As children with mental retardation seem to be the largest group among all the children with disabilities in the country (although a survey has not been conducted to find out the actual number), this study's objective, therefore is to find out to what extent such children have been and are being provided with education since the educational policy (mentioned above) was introduced. As headteachers and teachers, you occupy a core position in the education system of Uganda and your contribution towards its success cannot be doubted. You are also in a position to say who is playing what, and what factors are responsible for bringing about success or failure in the implementation. Your response to this questionnaire, therefore, will help to provide significant information which will enable us find out what success has been made, what problems are facing the implementation and what ought to be done to achieve better results.

When filling in the questionnaire, you are requested to be free and say whatever you feel is realistic. You don't have to write down your names; simply complete the questionnaire and return it to the distributor (who will arrange with you when to collect it). The information you provide will be treated with confidentiality and will be used for the purpose of this study only.

Please tick (✓) the right answer from the boxes provided in each of the numbers 1-15. From question 7-15, in addition to filling in the boxes, you are requested to explain or make a little comment in the space provided.

1. Rank	
(i) Headteacher	<input type="checkbox"/>
(ii) Teacher	<input type="checkbox"/>

2. Place of work	
(i) Urban	<input type="checkbox"/>
(ii) Rural	<input type="checkbox"/>

3. Sex	
(i) Male	<input type="checkbox"/>
(ii) Female	<input type="checkbox"/>

4. What in your view would you say is the condition referred to as mental retardation?  
(i) An individual who has little understanding   
(ii) An individual with special behaviour problem   
(iii) Difficult to describe

5. What would you say is responsible for bringing about the condition of mental retardation in an individual?  
(i) A weakness in the brain   
(ii) A complicated behaviour   
(iii) Difficult to tell

6. Do you, or does any of your relatives have a child with mental retardation?  
(i) Yes   
(ii) No   
(iii) If yes, what is your relationship with the child?  
- father   
- mother   
- brother   
- sister   
- uncle   
- aunt   
- grand parent   
- cousin   
- guardian

7. Have you ever had a child with mental retardation in your class?  
(i) Yes   
(ii) No   
If yes, briefly explain how you have coped with the child/children .....  
.....  
.....

8. Besides your Grade III qualification, have you had any other training related to teaching children with mental retardation?

- (i) Yes
- (ii) No
- (iii) If yes, what kind of training?

- diploma in Special Education
- a short course in Special Education
- a course in other disciplines

(iv) What reason do you give to support a teacher's training in order to teach children with mental retardation?.....

.....

(v) In what way should a teacher of children with mental retardation benefit by teaching such children?.....

.....

9. (a) Parents of children with mental retardation have high hopes in the education of their children. When teachers work with the parents hand in hand the implementation of education for children with mental retardation can be achieved faster than expected.

- 5. Strongly agreed
- 4. Agreed
- 3. Not sure
- 2. Disagreed
- 1. Strongly disagreed

(b) Please, would you give a comment in addition to the answer you have given above?

.....

10. (a) In Uganda, education policy makers and administrators have not provided suitable conditions for children with mental retardation in ordinary schools.

- 5. Strongly agreed
- 4. Agreed
- 3. Not sure
- 2. Disagreed
- 1. Strongly disagreed

(b) Please, would you give a comment in addition to the answer you have given above?

.....

11. (a) In ordinary schools, children with mental retardation mix freely with their peers (the ordinary children) in all educational and social activities without discrimination.

- 5. Strongly agreed
- 4. Agreed
- 3. Not sure
- 2. Disagreed
- 1. Strongly disagreed

(b) Please, would you give a comment in addition to the answer you have given above?

.....

.....

.....

12. (a) All teachers, parents and ordinary children welcome the idea of children of children with mental retardation learning attending ordinary schools.

- 5. Strongly agreed
- 4. Agreed
- 3. Not sure
- 2. Disagreed
- 1. Strongly disagreed

(b) Please, would you give a comment in addition to the answer you have given above?

.....

.....

.....

13. (a) The aims of education and curriculum in Uganda are appropriate/suitable as far as education of children with mental retardation are concerned.

- 5. Strongly agreed
- 4. Agreed
- 3. Not sure
- 2. Disagreed
- 1. Strongly disagreed

(b) Please, would you give a comment in addition to the answer you have given above?

.....

.....

.....

14. (a) In order to successfully teach children with mental retardation, teachers should employ different approaches, such as involving other teachers (team teaching. Specialist teachers should make arrangements, such that they let other (non specialist) teachers share lessons in their special classes, while they (the specialists) too share lessons in the ordinary classes. Specialist teachers should invite parents and other professionals to participate in certain relevant school activities aimed at helping children with mental retardation.

- 5. Strongly agreed
- 4. Agreed
- 3. Not sure
- 2. Disagreed
- 1. Strongly disagreed

(b) Please, would you give a comment in addition to the answer you have given above?

.....

.....

.....

15. (a) Although there could be many different methods of teaching, for the sake of children with mental retardation, the government should introduce certain specific and limited number of teaching methods which teachers should adopt for teaching children with mental retardation.

- 5. Strongly agreed
- 4. Agreed
- 3. Not sure
- 2. Disagreed
- 1. Strongly disagreed

(b) Please, would you give a comment in addition to the answer you have given above?

.....

.....

.....

(c) What suggestions would you make for an effective implementation of education for children with mental retardation in Uganda?

**Thank you very much for answering the questions and for your co-operation.**

# APPENDIX 16

**Appendix 16: TEACHERS/HEADTEACHERS INTERVIEW  
SCHEDULE**

**Name**

**Position (Headteacher/Teacher)**

1. (a) In what way are children with special needs benefiting from UPE in your school?

---

---

2. (a) What are your views about educating children with mental retardation together with the ordinary children in your school?

---

---

(b) What would be the benefit of mixing children with others or of educating them separately?

---

---

3. (a) What is the school policy on teachers who need further training in order to teach children with special needs in your school?

---

---

(b) Do teachers who obtain further qualification in special needs return to the school to help children with special needs in the school?

4. (a) What would you say is the importance for a teacher to train in order to teach children with mental retardation?

---

---

(b) In what way do you think a specially trained teacher for children with special needs should be treated different from the ordinary teachers?

---

---

5. (a) What is the policy regarding curriculum/syllabus, as far as teaching children with mental retardation and the ordinary children is concerned in your school?

---

(b) What are the likely changes, if any, of using the curriculum/syllabus the way you are doing?

---

(c) In Uganda, at the moment more emphasis is put on academic than practical education. In other words the education is examination oriented. In light of that how do we expect children with mental retardation to benefit from such education?

---

---

6 (a) Apart from, may be contribution by your fellow teachers, towards effective teaching/learning of children with mental retardation, who else do you involve to reinforce your efforts to help the children?

---

(b) What kind of contributions do the people you involve make?

---

---

7 (a) Do you have any particular method/approach that you use for teaching children with mental retardation in the school?

---

(b) What are the results of employing the different methods for teaching the children?

---

---

8. (a) What type of school do you think children with mental retardation should be educated in?

---

---

(b) What benefits do you think the children may get from the type of school you suggest they should be educated in?

---

---

9. What suggestions would make for an effective implementation of education for children with mental retardation in Uganda?

---

---

**Thank you very much for answering the questions and for your co-operation.**

# APPENDIX 17

**Appendix 17: PARENTS INTERVIEW SCHEDULE**

**Name**

---

**Relationship with the Child**

---

1. (a) When was the child's problem first noted?

---

---

(b) Who, in the family, discovered the child had the problem?

---

(c) What do you believe could have been the cause/source of your child's problem?

---

---

2. (a) How did you have the child assessed?

---

(b) Who advised you to have your child assessed?

---

---

3. (a) What organisations have been concerned about providing services which have helped your child?

---

(b) What kind of services has your child been receiving from the concerned organisation/s?

---

4. (a) Have you taken any advantage to have your child receive education, say through UPE or by any other means?

---

(b) What is your comment about UPE?

---

---

5. (a) As your child has a special need, what type of school would you like him/her to go to?

---

---

(b) Why would you prefer the child to go to the type of school you have mentioned?

---

---

6. (a) In which way would you wish to contribute ideas to the government about the education of your child?

---

---

(b) With whom do you collaborate to help the child in his/her education at the moment?

---

---

7. (a) What do you think should be the aims of education for your child?

---

---

(b) What do you wish his future to be when he/she is grown up?

---

---

8. What suggestions would you make for an effective implementation of education for children with difficulties like yours?

---

---

**Thank you very much for answering the questions and for your co-operation.**

# APPENDIX 18

## Appendix 18: EARS STAFF INTERVIEW SCHEDULE

**Name**

---

**Position (National Head of EARS/District Head of EARS)**

---

1. What policy guidelines do you follow to assess children?

---

---

2. When children are assessed and referred to ordinary schools, is there an automatic provision for their admission in those schools?

---

---

3. How does EARS co-ordinate its activities with the ordinary schools where children are integrated?

---

---

4. (a) How does EARS help teachers enrich both teaching and learning skills of teachers and pupils, respectively?

---

---

5. What does EARS do to find out about the progress of children with mental retardation who are integrated in ordinary schools?

---

---

6. Is there a particular source from which EARS staff get the information when they want to identify and assess children with mental retardation?

---

---

7. (a) What type of assessment does EARS use?

---

---

(b) How is assessment procedure carried out?

---

---

8. (a) Who are involved in the assessment procedures apart from the EARS staff?

---

---

(b) How well is the assessment programme understood in the country?

---

---

9. How do you judge teachers' use of the assessment centre?

---

---

10. (a) What can you say are some of the achievements EARS has made since it inception?

---

---

(b) What are some of the constraints EARS has faced?

---

---

11. What suggestions would you make for improvement in the implementation of education for children with mental retardation in Uganda?

---

**Thank you very much for answering the questions and for your co-operation.**

# APPENDIX 19

**Name**

---

**Position**

---

1. (a) How do you assess UNISE's teacher training programmes in relation to provision of education for children with mental retardation in Uganda?

---

---

(b) How effective do you think the teacher educators at UNISE are contributing towards the education of children with mental retardation?

---

---

2. What impact do you think UNISE has had on the teachers since its inception?

---

---

3. UNISE may need to improve its own performance, basing on the impact its former students are making in the field, how can this be done?

---

---

4. Besides, the roles the UNISE is playing in teacher production for special needs education in Uganda, what other roles do you think the institute can also play to involve the population more towards success in the implementation of special needs in the country?

---

---

5. (a) As an individual teacher educator, besides the role you play at the institute, what role do you play in the community, to promote education of children with mental retardation?

---

(b) How do you develop understanding of the challenges persons with disabilities or their families face?

---

---

6 What link between UNISE with other professionals do you have in mind that you suggest should be strengthened so as to promote education of children with special needs in the country?

---

---

7 Since UNISE began training teachers for special needs education, do you think there has been an impact on the increase of children with special needs in schools in the country?

---

---

8. One of the recommendations made in both the Kajubi Report of 1989 and the Government White Paper of 1992 is that there should be cost-sharing in all the institutions of higher learning in Uganda. The Government has begun to implement this policy. How do you assess its impact on teachers wanting to train at UNISE?

---

---

9. What suggestions would you make for effective implementation of special needs education in Uganda, generally?

---

---

**Thank you very much for answering the questions and for your co-operation.**

# APPENDIX 20

**Name**

---

**District**

---

1. When we go by the Kajubi Report of 1989 and the Government White Paper of 1992, we note that emphasis has been put on the promotion of education for children with visual and hearing impairment and there is very little, if any, on children with mental retardation. What is your district's position on this?

---

---

2. How do you assess the rate of change in people's concepts about disabilities in the district?

---

---

3. How does your office ensure that the needs and rights of persons with mental retardation are given due attention they deserve both in the community and in schools?

---

---

4. What changes are taking place to have children with mental retardation increase in ordinary schools in your district?

---

---

5. Does the district have a special vote or arrangement for training teachers to teach children with mental retardation in the district?

---

---

6. In what way do you think a specially trained teacher for children with special needs should be treated different from ordinary teachers?

---

7. (a) What is your view about the current curriculum with regard to education of children with special needs, especially those with mental retardation in the district?

---

---

(b) In Uganda, at the moment more emphasis is put on academic than practical education. In other words the education is examination oriented. In light of that how do we expect children with mental retardation to benefit from such education?

---

---

8. What suggestions would you make if implementation of education for children with mental retardation is to succeed in your district?

---

---

**Thank you very much for answering the questions and for your co-operation.**

# APPENDIX 21

**Appendix 21: COMMISSIONERS FOR EDUCATION  
INTERVIEW SCHEDULE**

**Name**

---

1. When we go by the Kajubi Report of 1989 and the Government White Paper of 1992, we note that emphasis has been put on the promotion of education for children with visual and hearing impairment and there is very little, if any, on children with mental retardation. What is the Ministry of Education's position on this?

---

2. How do you assess the rate of change in people's concepts about disabilities in the country?

---

3. How does your office ensure that the needs and rights of persons with mental retardation are given due attention they deserve both in the country generally, and in schools, in particular?

---

4. Under UPE four children per family are expected to receive education, how possible is this for children with mental retardation?

---

5. Does the Ministry of Education have a special vote or arrangement for training teachers to teach children with mental retardation in the country?

---

6. In what way do you think a specially trained teacher for children with special needs should be treated different from ordinary teachers?

---

7. (a) What is your view about the current curriculum with regard to education of children with special needs, especially those with mental retardation in the country?

---

---

(b) In Uganda, at the moment more emphasis is put on academic than practical education. In other words the education is examination oriented. In light of that how do we expect children with mental retardation to benefit from such education?

---

---

8. What suggestions would you make for effective implementation of special needs education in Uganda, generally?

---

---

**Thank you very much for answering the questions and for your co-operation.**

# APPENDIX 22

## Appendix 22:

Table 6.3a: Coded Data for Interview Questions: Category 1: Headteachers/Teachers (HT)

(chn=children; sp=special; ed.Education; sal=salary; trs=teachers; sch=school)

Responses to Questions 1-9R)

HT	1	2	3	4	5	6	7	8	9R
1	-More children enrolled	-No need to mix children	-School initiates training	-Special skills need	-Use ordinary curriculum	-Teachers work on their own	-No specific method	-Both special and normal schools	-Policy makers involve parents
2	-Children with nr... cannot benefit	-Not good to mix	-No policy for training	-Need for new skills	-Normal curriculum	-Teachers work alone	-Child-centred	-Special school	-Parents stop hiding children
3	-U.i. lacks vocational education	-Socialisation important	-Self-initiated	-Better skills need	-Normal syllabus used	-Expensive to involve others	-Group work	-Normal and special schools	-Govt to give more help to chn
4	-UPE good, but awareness needed	-Cannot compete in examinations	-Headteacher against training	-Training to change attitude	-Same syllabus	-Few parents work with trs	-Individual help	-Special school	-Need for sensitisation
5	-UPE is a good programme	-Should mix	-School supposed to initiate	-To acquire appropriate skills	-Normal syllabus	-Some people still have neg. attitude	-Child-centred	-Special units needed in schools	-Need to national curriculum
6	-UPE is a useful arrangement	-Should mix	-Government's role to train	-To get new knowledge	-Normal syllabus	-No idea of involving others	-Go slowly by slowly	-Normal schools	-All teachers to train in sp.ed.
7	-UPE not implemented in our school	-Severe to sp. sch	-Self-initiated	-To change attitude	-Normal syllabus modified	-No involvement	-Depends on children's ability	-Normal and special schools	-Involve community
8	-More children with disability now in school	-Cannot compete in examinations	-Government should support	-To get better knowledge	-Use same syllabus	-Some parents not co-operative	-Use ordinary methods	-Special schools	-Special teachers to earn better sal.
9	-UPE needs not well planned	-Should not mix	-A private school, so no policy	-To get knowledge	-Use same syllabus	-Parents attend school meetings	-Child-centred	-Special schools	-Involve teacher and parents (Gov)
10	-More chn with special needs now in school	-Mix, but exam system to change	-Government's role to train trs	-A good thing to train	-Same syllabus	-UNICEF has helped our school	-Teacher-centred	-Normal schools	-Parents co-operate with trs
11	-Some parents still asked to pay	-Education is human right	-Government should support	-New knowledge needed	-National curriculum	-We co-operate with other schools	-Individual approach	-Ordinary schools	-Awareness needed in ord. sch
12	-UPE increased	-All human beings are equal	-Cost sharing not good for teachers	-More teachers needed for sp.ed.	-Normal curriculum	-EARS works with us	-Assess, plan and child-centred	-Ordinary and special schools	-Trs not to pay fees for training
13	-UPE needs proper planning	-Change negative attitude first	-Teachers initiate training	-To help children learn effectively	-Normal syllabus modified	-Not much involvement	-Depends on children's ability	-Normal schools	-More units in ordinary schools
14	-UPE not well organised	-Children should learn anywhere	-Government gives hp-service	-Children with nr hard to teach	-Normal syllabus modified	-Not much co-operation	-Identify problem, plan and teach	-Both normal and special schools	-Strengthen both sp. and ord schs
15	-Too many children in a class because of UPE	-Mixing may not be good	-More teachers needed for UPE	-New knowledge needed	-National curriculum	-Some parents are co-operative	-Normal methods	-Special schools	-Special sal. for sp. teachers
16	-Too few classes - too many children	-Too few classes for mixing	-Government to encourage training	-Special skills for children	-Normal curriculum	Not much co-operation	-Close attention needed	-Normal and special schools	-Seminars needed for sp. teachers
17	-UPE not helpful - too many children	-Should mix	-Schools to encourage training	-New knowledge and skills needed	Normal curriculum	-USDC helps our school	-Individualised programme	-Special and normal schools	-Involve parents and trs (Gov)
18	-Too many children	-Should not mix	-Teachers initiate	-Better skills	-Same syllabus	-We involve others	-Individual help	-Special schools	-Better sal. for trs

# APPENDIX 23

Table 6.3b: Category 2: Parents (P)

Responses (to Questions 1 – 8R)

P	1	2	3	4	5	6	7	8R
1	-After child falling sick (afs) -Mother identified (mtd)	-Doctors assessed the child (dac)	-EARS has greatly assisted (egn) -Offered advice (oad)	-No hope in child's education (nhe)	-Prefer where child can learn effectively (pnl)	-Not sure what to do (nsd) -Gov. should help (gh)	-Not sure about aims of education Child should become doctor	-Build more schools Gov. help parents of disabled children (ghp)
2	-After child falling sick (afs) -Mother identified	-Child assessed in hospital	-EARS has been helping (eh)	-UPE would be good, but we still pay some money	-No idea about what type of school, may be special school	-If government is doing everything, that is good	-Not sure of what the aims of education should be	-More schools should be build (bs)
3	-At about 3 months child could not sit	-Child born before time (cbd)	-I have used my knowledge to assist the child	-Many people have taken advantage of UPE	-Special units first, then integrate into ordinary school	-Everything is put on parents -Most of them are ignorant	-Passing exams as education system dictates, not helpful -Too much lip-service by government	-Child with special needs has to acquire basic skills needed for challenges in life -Education needed
4	-Child had convulsion (1cc) months	-Doctors assessed -No idea of child having been bewitched. No.	-I have got some assistance, in form of advice from EARS	-UPE is quite useful	-You know better than I don't know which type of school	-We need more help from the government	-You know better what my child can get from education	-The government must help a lot with these children (ghc)
5	-Child became sick at four months (afs)	-Was examined and treated in hospital	-Besides hospital, USDC has been very helpful	-Private schools don't have UPE	-Any school nearest our home	-We need better facilities in schools	-My child should speak good English and get good job	-Parents not to be ashamed, but their children more
6	-Child had severe fever when one year old (afs)	-As Christians could not believe child was bewitched	-Got a lot of help from doctors in hospital (hd)	-My child is benefiting from UPE	-Special school, of course (sc)	-Government should give more help	-Child should learn to get practical skills	-Government to assist in all ways
7	-At around six months child became sick (afs)	-No idea of child being cursed or bewitched -Was usual sickness	-Have relied on doctors from hospital -Have not got help from EARS	-Have not got benefit from UPE	-Child special school	-Government should give more help	-Needs to learn to do practical work	-Need for more help from teachers and from the government
8	-Child became very sick when was two months (afs)	-During pregnancy I had serious malaria	-I have been consulting doctors from time to time	-I have not seen much value in UPE	-I prefer special school for my child	-Teachers need to work with parents	-God can decide what my child can get from education (gde)	-We need more help from other people
9	-Child developed problem at the age of 2 years (afs)	-Child had been sick -Was assessed in hospital	-We have good contact with the hospital	-We have not benefited from UPE	-We don't know which type of school is suitable (nts)	-Parents should help one another (pha)	-He needs to learn some practical skills	-We need a lot of help from the government

# APPENDIX 24

Table 6.3c: Category 3: EARS Staff (EARS)

		Responses (to Questions 1 – 11R)									
EARS	1	2	3	4	5	6	7	8	9	10	11R
1	-No clear policy (ncp)	-Under UPE - automatic registration (uar)	-Work together with teachers (wt)	-Workshops -School visits (ws)	-Working with teachers (wt)	-Use their ingenuity (ui)	-Assessed both at home and in school (ahs)	-EARS staff, parents, teachers and children (eptic)	-Teachers try to use the centres, though not much	-EARS is in all districts now	-Need to sell disability to the population
2	-No clear policy on assessment	-Admission depends on understanding between EARS and headteachers	-Workshops -School visits by F.ARS staff	-Educational materials produced at EARS centres	-Continuous discussions and planning between EARS and teachers	-Assessment based on seeing a child	-EARS uses educational assessment (eda)	-Parents, EARS staff and teachers (ple)	-Teachers given pamphlets by EARS, to aid their work	-Establishment and appointment of EARS staff as assistant inspectors	-Teachers need to be retrained to hand children with special needs (in)
3	-No specific policy to guide assessment (ncp)	-Will enough sensitisation in the district, admission improved (sen)	-Training teachers on the job -School visits	-EARS together with teachers produce materials	-We insist on feedback from teachers after training	-From parents -Hospitals	-Free assessment, that is, just looking at a child	-EARS staff, parents, teachers, pupils and other professionals (pdte)	-Training teacher on the job	-More children are being assessed and integrated in schools	-Parents and teachers should help children to develop talents (pth)
4	-No clear law regarding assessment procedure	-At first teachers had negative attitude -We have sensitised most of them	Routine school visits to advise teachers (sv)	-EARS runs introductory courses in special education (ecs)	-We get feedbacks from workshops with teachers and parents	-Information mainly from teachers (in)	-Observation and interviews (oi)	-EARS staff, teachers, doctors, parents and children (pdte)	-Teachers who are sensitised are using EARS centres to maximum	-Many children integrated -Collaboration with parents and professionals increased	-Policy makers need to work with policy implementers and parents (pwp)

# APPENDIX 25

Table 6.34d: Category 4: Teacher Educators (TE)

		<i>Responses to Questions 1 – 9R</i>								
TE	1	2	3	4	5	6	7	8	9R	
1	-Difficult to say how effective UNISE is -Need to have proper planning and management (hpp)	-UNISE courses have had impact on students (cin) -With UTE and inclusive education students to be exposed to all aspects of special education	-Sometimes we visit them, sometimes they write to seek advice from us (vad)	-Sensitisation of the population on their role in promoting special needs education (sep)	-Not very easy to have contact as there is too much work to do at UNISE (lwk)	-Not much link with other professionals -Some limited collaboration with doctors to discuss possible causes of different impairments (lc)	-Children with special needs have increased in schools but not convincing enough (cin)	-Cost-sharing will affect the number of teachers wanting to train at UNISE -Another policy of deleting teachers who are on training from payroll will affect teachers	-Distance education will help to increase number of teachers (deh)	
2	-According to press reports, UNISE's performance is impressive (upi)	-Many of the UNISE graduates seem to do very well -All that has to be done is to change method of training (cnt)	-Our sister programme, EARS which is near the teachers helps to monitor their progress	-Due to inadequate manpower we no longer carry out outreach (sensitisation) programmes	-Sometimes I use church sermons to sensitise parents in my locality	-There is need to run our programme in a multi-professional way	-Definitely there are more children in school than a few years back (nes)	-Special education is not very much recognised -With introduction of cost-sharing many teachers will not consider doing such a course	-Curriculum need to be revised to meet the needs of children with mental retardation -Education system should stop being competitive	
3	-Need to have better planning and organisation -Work is too crowded	-It is a challenge for UNISE now to train teachers who can cope with UPE	-Need to have a proper mechanism for follow-up -Our graduates may be facing many problems which we don't know	-Our outreach programme used to be very educative -UNISE has tried mass media, but all these are expensive	-I have opened a unitly for children with special needs -In my village, although I do not have enough time, I visit a few disabled person	-There isn't much link with other professionals although that is important -Multi-disciplinary approach is needed in this type of work	-Generally, there seems to be some increase of children now attending school in the country	-Research is needed before implementation of such policy is carried out -UNISE students should be fully sponsored	-UNISE should start working with persons with disability, because they know more about their problems than others	

# APPENDIX 26

Table 6.3e: Category 5: District Education Officers (DEOs)

Responses (to Questions 1 – 8R)

DEO	1	2	3	4	5	6	7	8R
1	-All the districts are governed by the same constitution -We give priority to children with special needs under the UPE programme -District has already appointed inspector for special education	-Attitudes take long to change (all) -Disabled people are now being elected to parliament (dep)	-We have been given a vehicle for the EARS programme (veh)	-Most of our teachers have been converted already -Seminars have been conducted in all the divisions -The district is firm - it is a matter of time	-The district has a special vote (money) allocated for special education	-Not advisable to give more money to teacher -More material needed for teaching purposes (mmf)	-Curriculum not adequate – needs to be modified	-Disability is not inability -Need not neglect disabled persons - they are not second class citizens
2	-District does not have a separate policy for children with mental retardation	-There is a slow change in people's attitudes -Need for sensitisation	-Need to integrate and carry out outreach programmes	-Recruitment of more teachers for special education needed	-There is no special vote for the district	-No need to pay teacher special salary - what is needed is to pay them allowance	-No doubt, education system is so much examination oriented	-Coursework assignment should be emphasised -Vocational education needed -Need for more teachers trained in special education
3	-District does not have a separate policy	-There is a very positive change -Aggressive sensitisation has been going on	-Need more trained teachers in the district	-Through seminars organised by EARS many teachers have been sensitised	-There is special vote channelled through EARS	-Would be a good incentives to pay special education teachers special salary	-Current curriculum not appropriate -Education system does not cater for low ability learners	-Education is not passing examinations -Vocational education needed

---

# APPENDIX 27

Table 6.3f : Category 6: Commissioners for Education (Administration/Inspectorate - CE)

		<i>Responses (to Questions 1 – 8R)</i>						
CE	1	2	3	4	5	6	7	8R
1	-Education for disabled children treated as a target group (dct)	-Great emphasis on sensitisation by non-governmental organisations (NGOs) (sen)	-Education is a right, according to UN Convention, UJAF:SC () and Uganda (chr) Constitution	-Need to encourage training of specialists (st) -Need to increase supportive institutions -Need to collaborate with relevant agencies through special education	-Ministry of Education releases recommendations, trainees and identifies training institutions (msu)	-Salaries are a responsibility of the Ministry of Public Service -Additional training should merit appropriate award in (fa) remuneration	-Learning needs should be identified (lid)	-The exams, syllabus, teaching and learning techniques have to be synchronised to accommodate all (exss)
2	-Should be given equal opportunity for non-disabled children (gep)	-Government is emphasising education for all (cal)	-It is government's obligation to have all children educated (ace)	-Continuous sensitisation encouraged (cs)	-UNISE: is already providing training for teachers of special education	-Special salaries could encourage stigmatisation -Teachers should be encouraged to appreciate strengths and weaknesses of children and help the accordingly	-The National Curriculum Development Centre (NCDCC) should review the curriculum	-Assess the disabilities -Train manpower -Encourage vocational activities -Locate appropriate institutions (tl)

# APPENDIX 28

## **Appendix 28: OBSERVATIONS: INTERACTIONS BETWEEN TEACHERS AND PUPILS**

A total of nine lessons were observed in three schools, that is, three lessons in each of the schools which were labelled as A, B and C. In school A, a primary two class (7-8 year olds), with a total of 116 children, one of whom was regarded as “mentally retarded” was observed. Focus was on the interaction between the particular child and the teacher. In school B, with a separate unit for children with mental retardation class (8-20 year olds); the observations were conducted in the unit. There were 16 children in the unit and attention was paid on the interaction between all the children and the teacher. In school C, a primary two class (7-8 year olds), with a total of 66 children, seven of whom were regarded as mentally retarded were observed. Focus was on interactions between all the seven children and the teacher.

Flanders’ chart (as mentioned in Chapter 4) was used with some modifications for recording the observations. The objectives of the observations were, firstly, to find out how teachers communicate with the children, how they give individual help and how they encourage children to succeed. The second objective was to find out how children respond to teachers, how they carry out the activities given and how they interact with the teachers generally. A summary of the results is provided in Appendix 24 below. We however, begin with the detailed description of the results as indicated in the Categories 1- 10DE.

Category 1: Teacher accepts feelings

Teacher in school A scored 5.6%; teacher in school B 6.4% and teacher in school C scored 3.4%. Teacher in school B seems to have a better relationship with the children, compared with the two teachers from A and C.

Category 2: Teacher encourages

Teacher in school A scored 2%; teacher in school B, 7.7% and teacher in school C scored 3.4%. Teacher in school B seems to be better at encouraging all children to improve in their work and to succeed in the given tasks, compared with the two teachers from A and C.

Category 2F: Teacher gives feedback

Teacher in school A scored 1.6%; teacher in school B, 4.5% and teacher in school C scored 4.4%. Teacher in school B, seems to be better at giving children feedback for the tasks they undertake, compared with the two teachers from A and C.

Category 3: Teacher uses children's ideas

Teacher in school A scored 0%; teacher in school B, 2.7% and teacher in school C scored 3.7%. Teacher in school C, seems to be better at using children's ideas more, compared with the two teachers from A and B.

#### Category 4: Teacher asks questions

Teacher in school A scored 3.2%; teacher in school B, 8.0% and teacher in school C scored 8.4%. Teacher in school C seems to be better at asking children more questions, compared with the two teachers from A and B.

#### Category 4C: Teacher asks conversational questions

Teacher in school A scored 0.8%; teacher in school B, 3.3% and teacher in school C scored 2.2%. Teacher in school B, seems to be better at asking children more conversational questions, compared with the two teachers from A and C.

#### Category 5: Chalk and Talk Teaching (Lecture Method)

Teacher in school A scored 13%; teacher in school B, 6.7% and teacher in school C scored 6.5%. Teacher in school A teaches more like lecturing, that is, chalk and talk (with less children's interactions), compared with the two teachers from B and C. The two teachers seem to involve children more in activities and do not depend much on lecturing type of method of teaching.

#### Category 5Cr: Teacher corrects children's work

Teacher in school A scored 2.0%; teacher in school B, 6.0% and teacher in school C scored 6.9%. Teacher in school C seems to be more keen on correcting children's work compared with the two teachers from A and B.

Category 5Cu: Teacher gives cues

Teacher in school A scored 2.8%; teacher in school B, 2.3% and teacher in school C scored 2.2%. Teacher in school A seems to be better at giving children more cues, compared with the two teachers from B and C.

Category 5CO: Teacher answers conversational questions

Teacher in school A scored 0.8%; teacher in school B, 5.4% and teacher in school C scored 3.4%. Teacher in school B seems to be better at answering conversational questions, compared with the two teachers from A and C.

Category 6: Teacher gives directions

Teacher in school A scored 8.4%; teacher in school B, 4.4% and teacher in school C scored 2.8%. Teacher in school A seems to be better at giving children directions, compared with the two teachers from B and C.

Category 7: Teacher criticises children

Teacher in school A scored 2.4%; teacher in school B, 2.3% and teacher in school C scored 2.8%. Teacher in school C seems to be more keen on criticising children, compared with the two teachers from A and B.

Category 8: Children respond

Child in school A scored 9.6%; children in school B, 5.4% and children in school C scored 5.9%. Child in school A seems to be more active in responding to teacher, compared with the children from B and C.

\*Category 8D: Children draw pictures

There were no lessons which involved drawing pictures, so there is nothing for comparison under this category.

Category 9: Children initiate talk

Child in school A scored 0.0%; children in school B, 3.7% and children in school C scored 2.2%. Children in school B seem to be more active in initiating talk, compared with the child from A and children from C.

Category 10: Silence or confusion

Child in school A scored 1.6%; children in school B, 2.0% and children in school C scored 1.6%. Silence and confusion are observed more in children in school B, compared with the children from A and C.

Category 10TA: Teacher uses teaching aids

Teacher in school A scored 11.2%; teacher in school B, 15.4% and teacher in school C scored 9.0%. Teacher in school B seems to be more keen in using a variety of teaching aids, compared with the two teachers from A and C (A, in particular, rarely uses teaching aids).

Category 10B: Teacher or children write on the chalkboard

Teacher in school A scored 6.8%; teacher in school B, 7.4% and teacher in school C scored 8.4%. Teacher in school C, together with the children seem to use chalkboard more, compared with the two teachers from A and B.

Category 10Ex: Teacher with the help of class captains distribute exercise books/papers/pens

Teacher in school A scored 9.6%; teacher in school B, 2.3% and teacher in school C scored 6.5%. Teacher in school A seems to spend much more time having exercise books distributed (with the help of some children), compared with the two teachers from B and C. The too much time spent, thus, seems to reduce the amount of children's activities on the tasks provided.

Category 10DE: Children do exercises in the books or on the chalkboard

Child in school A scored 9.6%; children in school B, 4.0% and children in school C scored 10.3%. Children in school C seem to be provided with more chances to do exercises in the books or on the chalkboard, compared with those from A and B.

The above findings reveal that, in theory, it was easy for teachers to indicate and to say how possible teaching approaches/methods could be adjusted to suit the special educational needs of children with mental retardation in Uganda. In practice, given the fact that the number of children overwhelmed the number of teachers per class, it was found very difficult for teachers to give quality teaching to each and every child with mental retardation.

As pointed out in Chapter 4, this observation was not an in-depth study as such. It was used to simply give a clue to the nature of difficulties which teachers seem to be facing in the implementation of the policy. An in-depth study of this nature will be required in

future, to explore more the problems faced, and how much children learn or do not learn in primary schools.

# APPENDIX 29

Appendix 29:

**RELIABILITY: SPEARMAN'S CORRELATION COEFFICIENT TEST**

Correlation			Post-Test	Pre-Test
Spearman's rho	Correlation	Post	1.000	.775**
	Coefficient	Pre	.775**	1.000
	Sig. (2-tailed)	Post Pre	.000	.000
	N	Post	18	18
		Pre	18	18

\*\* Correlation is significant at the .01 level (2-tailed)

**SPEARMAN'S CORRELATION COEFFICIENT TEST: SCATTER DIAGRAM**

