

Durham E-Theses

Appliance Classification and Scheduling in Residential Environments with Limited Data and Reduced Intrusiveness

MARTHA TERESA CORREA-DELVAL

How to cite:

CORREA-DELVAL, MARTHA TERESA (2024) Appliance Classification and Scheduling in Residential Environments with Limited Data and Reduced Intrusiveness. Doctoral thesis, Durham University.

Use policy

The full-text may be used and/or reproduced, and given to third parties in any format or medium, without prior permission or charge, for personal research or study, educational, or not-for-profit purposes provided that:

- a full bibliographic reference is made to the original source
- a <https://etheses.durham.ac.uk/id/eprint/15493/> is made to the metadata record in Durham E-Theses
- the full-text is not changed in any way

The full-text must not be sold in any format or medium without the formal permission of the copyright holders.

Please consult the [full Durham E-Theses policy](#) for further details.

**Appliance Classification and
Scheduling in Residential
Environments with Limited Data
and Reduced Intrusiveness**

Martha Teresa Correa-Delval

A Thesis presented for the degree of
Doctor of Philosophy



Department of Engineering
Durham University
United Kingdom

April 2024

Abstract

The United Kingdom aims for a 78% reduction in greenhouse gas emissions by 2035, with a specific carbon budget for 2033–2037. Despite rising CO₂ emissions from 2021 to 2022 due to increased energy demands, this thesis presents novel strategies to reduce residential electricity consumption, a major emissions driver. It addresses two critical gaps in energy management:

First, it develops a feature extraction methodology using machine learning and deep learning for accurately classifying high-power household appliances with smart meter data. Traditional methods often require complex setups or large datasets, leading to intrusiveness and implementation challenges. This research introduces the Spectral Entropy – Instantaneous Frequency (SE-IF) method, effective with limited datasets and enhancing usability (Chapter 3).

Second, it proposes an optimisation model that intelligently schedules household appliance usage to balance costs, emissions, and user comfort, incorporating renewable energy and battery storage systems. Existing scheduling techniques typically overlook significant CO₂ reductions and user comfort. The thesis utilises the Multi-objective Immune Algorithm (MOIA) to demonstrate this model's effectiveness, achieving a 9.67% cost reduction and a 16.58% decrease in emissions (Chapter 5).

Chapters 4 and 5 further detail how the SE-IF method, paired with a Bidirectional Long Short-Term Memory (BiLSTM) network, achieves a 94% accuracy in identifying appliances from aggregated data and applies the multi-objective optimisation in various scenarios.

This research advances the integration of energy efficiency, environmental sustainability, and user-centric solutions in smart homes, contributing significantly to national goals of reducing energy consumption and emissions.

Declaration

The work in this thesis is based on research carried out in the Department of Engineering at Durham University. No part of this thesis has been submitted elsewhere for any degree or qualification.

Copyright © 2024 Martha Teresa Correa-Delval.

The copyright of this thesis rests with the author. No quotation from it should be published without the author's prior written consent and information derived from it should be acknowledged.

Acknowledgements

One might think that after writing so many thesis pages, writing the acknowledgements would be easier. However, in reality, I'm at a loss for where to begin, given the multitude of people who deserve acknowledgement. I wish to express my gratitude to CONACYT-SENER for sponsoring my PhD and time in the UK, as it has been among the greatest experiences of my life. Special thanks to Professor Hongjian Sun for being an outstanding supervisor and mentor. He has assisted me through difficult times, not only academically but also morally and emotionally, offering comforting words and kind understanding from my first day at Durham. I definitely wouldn't be where I am today without his support throughout this journey.

I would like to express my gratitude to my second supervisor, Peter Matthews, for his guidance and feedback on my work, which significantly contributed to the improvement of my results. I also want to extend sincere thanks to Wei-Yu Chiu, who not only provided guidance but also collaborated with me on the work presented in my second publication. The quality of the results I achieved would not have been possible without his invaluable assistance. I am grateful to all the colleagues I met in the engineering department, with whom I shared seminars, conferences, and many discussion occasions that enhanced my understanding of both my topic and theirs. These moments of sharing knowledge (and sometimes a few snacks and drinks!) were truly priceless.

Special thanks to my friends who supported me from afar and brought immense happiness during my brief visits to Mexico for vacation. I am grateful for your strong belief in me, for witnessing my departures, and for being there during the few times

I returned.

My deepest gratitude goes to the Mexican Society at Durham, who became like family to me. They've become my closest friends, supporting me through both laughter and tears. I particularly want to thank my bandmates from Los Patroncitos and Los Aluxes del Norte, who allowed me to express my passion for music during the (sometimes) stressful times of a PhD.

To all the friends I've made along the way, from those who welcomed me and then I bid farewell, to those who I welcomed and now watch as I depart - it's the quintessential Durham experience. From undergraduate friends I made in various societies (Pungmul being my favourite) to postgraduate friends in the office, I am grateful for all the memories we've created, which I will cherish forever.

Lastly, I owe this degree to my family, who supported me since I first applied to Durham University in 2017. They never saw my dreams as too big; instead, they always encouraged me to dream bigger. To Natalia, my dear older sister, thank you for being an embodiment of resilience, passion, and responsibility. I've always aspired to achieve even a fraction of what your actions have inspired in me. To Manuel, my older brother, while being the quietest of the three, you always offered the kindest, most supportive words in my moments of desperation, even if it was while playing Nintendo together online, just like we've been doing since we were kids. To both of you, thank you for being the best older siblings one could wish for. I am blessed to have been born with you as role models of exceptional human beings. And to my parents, Elba and Manuel: Mom and Dad, I owe you everything I am and have. I hope to make you as proud of me as I am of you. Thank you for the endless calls, the laughter, and for comforting me when I was sad. Thank you for your literally endless support in every aspect of my life.

To all my loved ones in my family, thank you for walking this uneven and challenging path with me. Leaving home to start my own adventure wasn't easy, but thank you for walking by my side when I needed you to. I love you forever; los amo y gracias por todo.

Dedicated to

my parents and siblings, who
never stopped loving me and loved
me even more as I discovered
myself during this time

and

to all my loved ones that became
my family throughout this journey

The flow of time is always cruel... Its speed seems different for each person, but no one can change it... A thing that does not change with time is a memory of younger days...

— from *The Legend of Zelda: Ocarina of Time* by Nintendo

Contents

Abstract	i
List of Figures	xvii
List of Tables	xix
1 Introduction	1
1.1 Research relevance	1
1.2 Thesis objectives	4
1.2.1 Thesis outline	5
2 Literature Review	7
2.1 Introduction	7
2.2 Appliance types	11
2.3 NILM: Introduction	12
2.4 NILM: Machine learning algorithms for classification	14
2.4.1 Machine learning: Fundamental principles	15
2.4.2 Naive Bayes Classifier	19
2.4.3 Linear Discriminant Analysis	22
2.4.4 Decision Trees	24

2.4.5	K-nearest Neighbour	26
2.5	NILM: Deep learning methods for classification	28
2.5.1	Long Short-Term Memory (LSTM) Neural Network	31
2.5.2	Bidirectional Long Short-Term Memory (BiLSTM) Neural Network	32
2.6	Summary of classification techniques	34
2.7	Appliance scheduling techniques	35
2.7.1	Optimisation techniques	37
2.7.2	Optimisation objectives	39
2.7.3	Single objectives	40
2.7.4	Multiple objectives	46
2.8	Summary of scheduling techniques	48
2.9	Research challenges	53
2.10	Conclusions	54
3	Appliance Classification and Feature Extraction Using Limited Data	57
3.1	Introduction	57
3.2	Proposed Method: SE-IF Feature Extraction	59
3.2.1	Spectral entropy	60
3.2.2	Instantaneous frequency	62
3.2.3	Mel spectrogram	64
3.2.4	Signal variation	65
3.3	System model	66
3.3.1	Dataset	66

3.3.2	Obtaining Individual Appliance Consumption Data	67
3.3.3	Configuration parameters for evaluating SE-IF methodology	68
3.3.4	Parameters for testing SE-IF with deep learning methods	71
3.3.5	Performance Analysis Metrics	74
3.4	Performance on appliance signal classification using SE-IF	76
3.4.1	Appliance testing groups	77
3.4.2	Overview of model final inputs	78
3.4.3	Machine learning methods results comparison	79
3.4.4	Deep learning methods results comparison	81
3.5	Conclusion	88
4	Appliance detection in household scenarios	91
4.1	Introduction	91
4.2	Proposed method: A detection algorithm	92
4.2.1	Consumption data creation	93
4.2.2	Algorithm model for appliance usage detection	95
4.3	Performance on appliance classification using SE-IF BiLSTM and detection algorithm	98
4.3.1	Simulation scenarios	98
4.3.2	Results and discussion	102
4.4	Conclusion	104
5	Multi-objective Appliance Scheduling Optimisation	105
5.1	Introduction	105
5.2	Problem Formulation	106

5.3	System Model	109
5.3.1	Battery Storage Model	110
5.3.2	RES model	111
5.3.3	Base load consumption model	112
5.3.4	Appliance scheduling model	112
5.3.5	Transmission system operator model	114
5.3.6	Cost model and formulation	114
5.3.7	CO ₂ emissions model and formulation	115
5.3.8	User discomfort model and formulation	116
5.4	Methods	118
5.4.1	Finding the best solutions	119
5.5	Model evaluation	126
5.5.1	Simulation Scenarios	126
5.5.2	Simulation cases	128
5.5.3	MOIA results analysis: The impact of scheduling	129
5.5.4	Algorithms comparison	130
5.6	Conclusion	138
6	Conclusions	139
6.1	Final conclusions	139
6.2	Future work	141
6.2.1	Detecting low consumption appliances	141
6.2.2	Real time classification	142
6.2.3	Consideration of continuously variable load appliances	142
6.2.4	V2G integration	142
6.2.5	Health of the batteries	143

List of Figures

2.1	An Efergy energy monitor transmitter (red circle) that takes readings with a CT sensor (yellow circle) in an electricity box.	9
2.2	Types of machine learning.	16
2.3	Diagram of a LSTM neural network layer [65].	32
2.4	Diagram of the layers of a BiLSTM neural network [71].	34
2.5	Diagram of the process of a genetic algorithm.	38
3.1	Spectral entropy of a battery charger from the UK DALE dataset.	61
3.2	Spectral entropy of a dishwasher from the UK DALE dataset.	61
3.3	Instantaneous frequency estimate of a battery charger from the UK DALE dataset.	63
3.4	Instantaneous frequency estimate of a dishwasher from the UK DALE dataset.	63
3.5	Mel spectrograms of a battery charger from the UK DALE dataset.	64
3.6	Mel spectrograms of a dishwasher from the UK DALE dataset.	65
3.7	Example of raw power consumption data for a battery charger: On the left, data illustrates power usage, while on the right, data indicates periods of no usage.	66
3.8	Example of data after analysing the time of reading and averaging its consumption per minute. Columns 1-8: year, month, day, day of the week, hour, minute, on or off state, watts	67

3.9	Feature enhancement layer	79
3.10	Structure of the SE-IF BiLSTM neural network	83
4.1	Raw appliance power consumption data.	94
4.2	Scenario 1 load showing detected appliance load.	99
4.3	Scenario 2 load showing detected appliance load.	99
4.4	Scenario 3 load showing detected appliance load.	100
4.5	Scenario 4 load showing detected appliance load.	100
4.6	Scenario 5 load showing detected appliance load.	101
5.1	Multi-objective optimisation participants and objectives	107
5.2	Average solar data of a June day [120]	108
5.3	Average CEI [121] and Electricity prices [122] data of a June day	108
5.4	Distribution network management illustrating the direction of electricity flow.	109
5.5	Pareto frontier obtained after evaluating the MOP with the MOIA.	121
5.6	Flowchart of the multi-objective problem, including the MOIA.	125
5.7	Simulation scenarios considering RES and scheduling.	128
5.8	General battery behaviours in each simulation case.	129
5.9	Convergence trends of the MOIA algorithm over iterations. The top graphs display the progression of the average best value (ABV) and average objective value (AOV) for Cost, while the bottom graphs show these values for CO ₂ emissions.	131
5.10	CO ₂ generation in comparison to the CEI in each scenario for all cases using the MOIA.	135
5.11	Battery storage behaviour in each scenario for all cases using the MOIA.	136
5.12	Comparison of similar scenarios, regarding their abilities to use RES or scheduling. All scenarios are considering Case 3 using the MOIA.	137

List of Tables

2.1	Survey of features and methods used	36
2.2	Comparison of genetic algorithms (as heuristic methods) vs. Non-Heuristic methods in multi-objective optimisation	50
2.3	Summary of Optimisation Methods	51
2.4	Survey of algorithms, optimisation objectives and appliances used. .	52
3.1	Algorithm Configuration	69
3.2	Power Consumption of Appliances	78
3.3	Machine learning algorithms performance metrics for similar appliances group	82
3.4	Machine learning algorithms performance metrics for non-similar appliances group	82
3.5	Machine learning algorithms performance metrics for mixed appliances group	82
3.6	Performance metrics on similar appliances group	84
3.7	Performance metrics on non-similar appliances group	86
3.8	Performance metrics on mixed appliances group	87
3.9	Best settings for networks using SE-IF method	88
4.1	Appliance Classification in Different Scenarios	93

4.2	Performance metrics for different scenarios, all values are expressed as percentages.	102
4.3	Performance metrics for different neural networks, all values are expressed as percentages.	103
5.1	Appliance settings	114
5.2	Simulation setup	126
5.3	MOIA and MOGA Results Comparison	132

Nomenclature

Δ_{\max} Maximum value of ΔI_{ij} across all i and j .

Δ_{\min} Minimum value of ΔI_{ij} across all i and j .

ΔI_{ij} Difference between F_j^+ and F_{ij}

Δt Time interval between two consecutive measurements or calculations

$\delta(m)$ Discomfort coefficient for appliance m

η Solar efficiency of the photovoltaic panels

\hat{y} Class that maximises the log posterior probability

$\log P(x | y)$ Log-likelihood of observing the feature vector x given the class y

$\log P(y | x)$ Log of the posterior probability of class y given feature vector x

$\sigma(m)$ Standard deviation of the start times for appliance m

GRC_i Grey Relational Coefficient for each optimal solution

$\text{CEI}_{\text{buy}}(t)$ Carbon Emission Intensity when buying power from the grid at time t

$\text{CEI}_{\text{grid}}(t)$ Carbon Emission Intensity for the grid power at time t

φ Phase of the analytic signal, used to compute the instantaneous frequency

A_c Area of the photovoltaic panels in square meters (m^2)

$C_{\text{buy}}(t)$ Unit price for buying energy from the grid at time t

-
- $C_{grid}(t)$ Cost per unit of energy from the grid at time t , which depends on whether energy is being bought or sold
- $C_{sell}(t)$ Unit price for selling energy to the grid at time t
- CO_2 Total CO emitted in grams
- $Cost$ Total cost of the electricity bill
- $d(x, y)$ Distance between points x and y .
- $Disc$ Total discomfort score
- $E(t)$ Solar irradiation received at time t in watts per square meter (W/m^2)
- $f(x)$ Objective function to be minimized, a function of x .
- F_{ij} Normalised value of the i th value of the j th objective in the objective matrix
- f_{ij} The i th value of the j th objective in the objective matrix
- $F_{inst}(t)$ Instantaneous frequency of a signal at time t
- F_j^+ The greatest number among the normalised values for the j th objective
- FN False Negatives: Number of incorrect negative predictions made by the model
- FP False Positives: Number of incorrect positive predictions made by the model
- $g_i(x)$ Inequality constraints, with $i = 1, \dots, m$, where each $g_i(x) \leq 0$.
- $H(t)$ Spectral entropy at time t
- $h_j(x)$ Equality constraints, with $j = 1, \dots, p$, where each $h_j(x) = 0$.
- $IG(D, f)$ Information Gain of dataset D by feature f
- k Number of neighbours in the k -nearest neighbors algorithm, influencing the impact of noise and the computational cost.
- M Number of schedulable appliances involved in the discomfort calculation

$P(A | B)$ Probability of hypothesis A given the data B

$P(t, m)$ Normalised probability distribution of power at time t and frequency bin m

$P_m(t)$ Power load of appliance m at time t

$P_{bat}(t)$ Power drawn by the battery at time t

$P_{grid}(t)$ Power exchanged with the grid at time t , positive for buying and zero or negative for selling.

$P_{grid}(t)$ Total power exchanged with the grid at time t

$P_{load}(t)$ Base power load of the household at time t

$P_{load}^{app}(t)$ Power load of all schedulable appliances at time t

$P_{load}^{SCH}(t)$ Total scheduled power load at time t

$P_{PV}(t)$ Power generated by the photovoltaic panels at time t

$S(m)$ Power spectrum of a signal at the frequency bin m

$S(t, f)$ Power spectrogram, representing the power distribution over time t and frequency f

S_B Between-class scatter matrix

S_i Scatter matrix for class i

S_W Within-class scatter matrix, sum of the scatter matrices of each class

$SOC(t)$ State of Charge of the battery at time t (Wh)

T Total number of time steps in the considered period, with each time step denoted by t

$T_{avg}(m)$ Average starting time of appliance m

$T_{start}(m)$ Actual starting time of appliance m on a given day

- $t_{duration}$ Duration of the appliance usage
- TN True Negatives: Number of correct negative predictions made by the model
- TP True Positives: Number of correct positive predictions made by the model
- $X(m)$ Discrete Fourier transform of $x(n)$.
- $x(n)$ Signal in the time domain
- x Decision variable vector in \mathbb{R}^n , where n is the number of dimensions.
- μ_i Mean vector of class i
- w Projection vector that maximises the ratio of between-class to within-class variance

Thesis Publications

The following publications were developed and presented with successful results during the course of the PhD. They are listed as follows:

- **Chapter 2:**

M. Correa-Delval, H. Sun, "Artificial Intelligence methods for household appliance classification and scheduling: a survey," Definition of journal submission is pending.

- **Chapter 3:**

M. Correa-Delval, H. Sun, P. C. Matthews and J. Jiang, "Appliance Classification using BiLSTM Neural Networks and Feature Extraction," 2021 IEEE PES Innovative Smart Grid Technologies Europe (ISGT Europe), Espoo, Finland, 2021, pp. 1-5, doi: 10.1109/ISGTEurope52324.2021.9640061.

- **Chapter 5:**

M. Correa-Delval, H. Sun, P. C. Matthews and W. -Y. Chiu, "Appliance Scheduling Optimisation Method Using Historical Data in Households with RES Generation and Battery Storage Systems," 2022 5th International Conference on Renewable Energy and Power Engineering (REPE), Beijing, China, 2022, pp. 442-447, doi: 10.1109/REPE55559.2022.9949497.

Chapter 1

Introduction

1.1 Research relevance

The current era is moving towards incorporating smart technologies in household energy management to address the challenges of energy sustainability. The emphasis is on improving energy efficiency and minimising the environmental impact associated with household energy consumption.

Recent advancements in smart technologies have significantly contributed to the evolution of household energy management. In the UK, the deployment of smart technologies in the energy sector is seen as a significant stride towards reducing energy management costs and enhancing energy efficiency. The UK government, along with Ofgem, has outlined plans to use smart technologies to aid consumers in reducing their bills and boosting energy efficiency through demand shifting. This initiative, aimed at unleashing the full potential of smart systems and flexibility in the UK's energy sector, is projected to reduce the costs of managing the energy system by up to £10 billion annually by 2050 [1]. Moreover, the global adoption rate of home energy management systems has increased by 17% between 2022 and 2023, driven by a projected annual increase of 0.3% in domestic energy consumption by 2030 [1].

To support this, small-scale demand side response (DSR) practices are emerging as a key component in the UK, where they enhance the flexibility of the grid and offer economic incentives to consumers. With the integration of smart technologies, consumers can use automated systems or direct load control to shift usage, utilising appliances like storage heaters and immersion heaters that can be retrofitted for dynamic DSR services. The advancement in electric vehicles, domestic battery storage, and heat pumps also opens avenues for additional shiftable loads, potentially contributing to significant peak demand reductions as forecasted in scenarios such as National Grid's 'Gone Green' [2]. These developments underscore the potential of smart technologies in demand shifting, aligning consumer behavior with grid needs for a more efficient energy system.

Various technological components such as advanced sensors, bi-directional communication, advanced metering infrastructure, energy storage systems, smart appliances, and home area networks have been foundational in advancing smart home energy management. These technologies enable more precise control and monitoring of energy usage [3]. Countries like the United States, United Kingdom, and Germany are diving into in-depth research on intelligent power utilization and Home Energy Management Systems (HEMS), reflecting a growing interest in using smart grid technology to tackle rising residential energy consumption [4]. The potential of DSR, facilitated by these smart technologies, represents a transformative shift towards a more responsive and efficient energy landscape, where consumer engagement and technology adoption converge to meet the evolving demands of the energy sector.

At the global level, the commitment to reducing carbon emissions is underscored by agreements in international forums like the COP26 conference. The conference saw nearly 200 countries adopting the Glasgow Climate Pact, aiming to significantly reduce CO₂ emissions and limit global temperature increases, demonstrating a unified global effort towards climate action [5, 6].

The integration of Renewable Energy Sources (RES) and Battery Storage Systems (BSS) in domestic settings is an important step towards achieving energy sustain-

ability. These integrations promise not only cost savings but also improvements in grid reliability and environmental conservation.

Despite the substantial advancements in technology geared towards HEMS, several challenging issues remain to be addressed:

1. **Enhancing the capabilities of smart energy management systems:**

A significant challenge is the development of methods for disaggregating the energy load of household appliances that are non-intrusive and cost-effective. Presently, accurate identification often requires multiple sensors or meters, which can be invasive, costly, and complex, diminishing the user's experience and willingness to participate. Moreover, these methods typically do not offer incentives for consumers to adjust their energy consumption habits. Achieving universal deployability is another layer of difficulty, as such systems need to function reliably across diverse domestic environments.

2. **Accounting for CO₂ emissions in user feedback:** Incorporating real-time, grid-specific CO₂ emissions data is difficult because the carbon intensity of electricity varies constantly with the changing share of renewable sources. In addition to the technical aspects, consumers must be educated on the environmental impact of their consumption in a way that is both understandable and motivational. Standardising this communication and accounting for carbon emissions remains unresolved due to its complexity and the need for an approach that can be widely accepted and implemented.

3. **Integration of RES and BSS with optimisation algorithms for appliance scheduling:** This is challenging due to the unpredictable nature of renewable energy supply, the limitations of battery storage technology, and the need for algorithms that can quickly adapt to these variables while ensuring grid stability and consumer satisfaction. The complexity of scaling these solutions to accommodate different grid systems and regulatory frameworks

has kept these problems unsolved, despite ongoing research and the rapidly evolving landscape of energy technology and consumer expectations.

The subsequent section outlines the objectives formulated to address the identified challenges in household energy management. These objectives aim to provide solutions that contribute to the broader goal of energy sustainability and environmental conservation, aligning with the global ambition of transitioning towards a more sustainable and energy-efficient HEMS.

1.2 Thesis objectives

This thesis aims to develop an algorithm for identifying high-energy-use appliances from smart meter data with minimal user impact and to construct an optimisation model for appliance scheduling that balances cost, emissions, and comfort, integrating renewable energy and battery storage. Details of the objectives are as follows:

- **Objective 1:** Develop a methodology for extracting features that capture key characteristics from power consumption data, using information from current smart meters, to enable precise appliance classification. This approach aims to minimise household disruption and negate the need for extra devices, thus reducing complexity and cost for consumers. The objective focuses on creating algorithms for accurate appliance identification, ensuring stable performance across various environmental conditions. Validation will involve simulations with existing datasets to prove the algorithm's ability to identify appliance usage patterns without direct hardware monitoring. The algorithms are designed for versatile deployment, allowing for both real-time, online processing and offline analysis, depending on the smart meters' connectivity options. Machine learning techniques are integral to the algorithmic design, enabling implementation in software that operates on the existing smart meter infrastructure.

- **Objective 2:** Design an algorithm to precisely detect instances of high energy use by appliances within aggregated household energy data. This algorithm will address challenges such as varying appliance characteristics, simultaneous usage patterns, and data irregularities. It will be flexible to suit different household energy profiles, ensuring reliable performance across diverse environments. The validation phase will involve tests with various scenarios to accurately represent household energy consumption patterns. Furthermore, this objective entails integrating the detection algorithm with the classification algorithm to enhance overall system efficiency and offer actionable energy-saving tips and allow ways to optimise household energy consumption.
- **Objective 3:** Develop a multi-objective optimisation model for the effective scheduling of household appliances, which takes into account cost savings, CO₂ emission reduction, and user discomfort (changing appliance operation times), alongside the integration of RES and BSS. This model aims to provide an optimisation framework that minimises expenses and emissions and maintains user comfort, thereby encouraging the adoption of sustainable technologies and contributing to a more resilient and eco-friendly energy system.

1.2.1 Thesis outline

This thesis is structured to address the research objectives and present the original contributions. The organisation is as follows:

- **Chapter 2: Background and Literature Review**
 - Discussion of literature on appliance classification and scheduling.
 - Synthesis of the current state of research and technology.
- **Chapter 3: Addressing Objective 1**
 - Presentation of an algorithm for limited data scenarios.

- Introduction of a methodology for appliance classification.
- *Original Contribution:* Development of an appliance classification methodology with limited data.
- **Chapter 4: Addressing Objective 2**
 - Introduction of an algorithm designed to identify appliances with high energy consumption within aggregated household energy data.
 - Validation of the algorithm across various scenarios to ensure reliability.
 - *Original Contribution:* Creation of an algorithm capable of discerning individual appliances from aggregated household energy data.
- **Chapter 5: Addressing Objective 3**
 - Development of a multi-objective optimisation model for appliance scheduling.
 - Consideration of cost, CO₂ emissions, and user comfort in energy management.
 - Integration approach for RES and BSS.
 - *Original Contribution:* Multi-objective optimisation model that aligns cost savings, emission reduction, and user comfort with sustainable technology integration.

Chapter 2

Literature Review

2.1 Introduction

The United Kingdom has set forth an ambitious objective of achieving a staggering 78% reduction in Greenhouse Gas emissions by the year 2035, in comparison to the levels recorded in 1990 [7]. Aligned with the guidance provided by the Climate Change Committee, the sixth Carbon Budget defines a specific threshold for the quantity of greenhouse gases released over a span of five years, from 2033 to 2037. The stipulations of the Carbon Budget are poised to sustain the UK's trajectory towards mitigating its impact on climate change, maintaining alignment with the temperature objectives set forth by the Paris Agreement. This includes the imperative to curtail global temperature increase to levels significantly below 2°C, with dedicated efforts aimed at attaining a more ambitious target of 1.5°C [8].

However, the topic of carbon dioxide (CO₂) emissions within the energy supply sector experienced an unexpected surge, registering a 1.7% increase (equivalent to 1.4 million tonnes) during the period spanning 2021 to 2022. This upward trend can be attributed to the relaxation of pandemic-related restrictions, subsequently driving higher demand for certain fuels and thereby amplifying emissions originating from their production and distribution [9]. This surge in CO₂ emissions, caused by

fossil fuel utilisation in the energy supply sector, stands in contrast to long-standing trends that exhibited a decline of 70.6% since 1990 and 8.2% since 2019 [10].

Notably, the electricity and heat sector emerges as a focal point, contributing a substantial 99.3 million tonnes to the overall CO₂ emissions production in the UK, accounting for 20.55% of the total. On a global scale, this sector's contribution stands at 15.83 billion tonnes, encompassing 31% of the worldwide CO₂ emissions production [11].

For these reasons, it is important to direct attention to the electricity supply sector, not only within the UK but globally as well. Within this sector, residential electricity consumption holds substantial significance [12]. Consequently, the exploration of strategies aimed at promoting environmentally conscious household consumption behaviours becomes a matter of high importance.

Amidst the continuous spread of smart home technologies and methodologies, the present era presents an important opportunity to use them for environmental benefits. Concurrently, the increasing adoption of renewable energy sources (RES) at home further expands the potential benefits. According to [13], giving consumers direct and timely information about their energy consumption can lead to an energy reduction of approximately 5% to 20%. This feedback mechanism involves providing detailed insights into energy usage patterns, costs, and potential savings. Nevertheless, a significant portion of users lacks this necessary information to make informed decisions that would facilitate behavioural changes in their daily consumption patterns, aligned with the previously mentioned goals.

The purpose of appliance detection is to identify moments of high energy consumption within a household, signaling the use of power-intensive devices. Following this, appliance classification determines which appliances are in operation. Together, these processes are key for dissecting and understanding user behaviour in relation to energy usage. By mapping out which appliances contribute most significantly to energy consumption and at what times, it becomes feasible to offer recommendations for energy use optimisation. This might include suggestions for shifting the use of

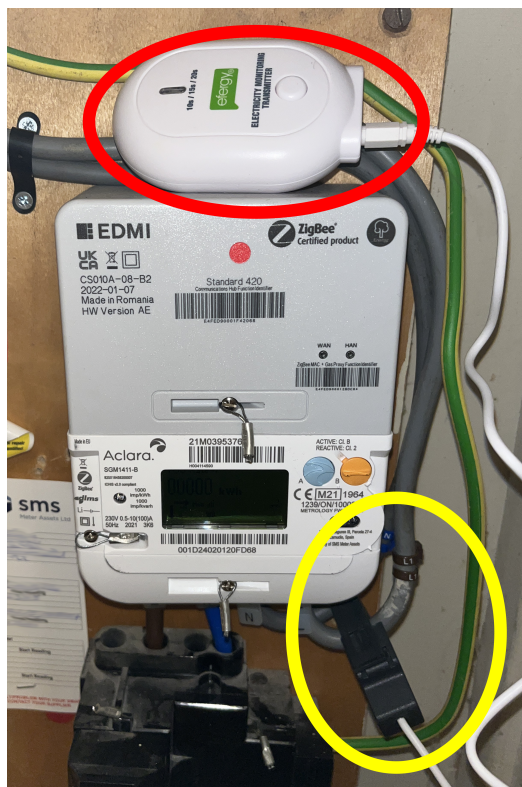

Figure 2.1: An Efergy energy monitor transmitter (red circle) that takes readings with a CT sensor (yellow circle) in an electricity box.

certain appliances to off-peak hours, where energy is cheaper and potentially greener, or proposing more energy-efficient practices.

When tackling these tasks, several challenges emerge. One major challenge is discerning user patterns and behaviours without relying on complex and intrusive equipment that can be highly expensive, like individual energy monitoring plugs for each appliance. To circumvent the need for such specialised equipment, one could employ a more economical and efficient approach, such as the use of energy monitors that allow for online monitoring, or smartphone apps that connect to smart meters, among others. These devices and services offer a comprehensive monitoring solution, capable of tracking multiple appliances through a single point of measurement. For instance, as illustrated in Fig. 2.1, an Efergy energy monitor transmitter can be installed within an electricity box to transmit consumption data to a hub receiver. This setup enables consumption monitoring over the internet.

Unlike conventional smart home technologies such as Amazon’s Alexa or Apple’s

HomeKit, which primarily rely on user input and smart devices to control and monitor home appliances, Non-Intrusive Load Monitoring (NILM) offers a distinct approach by passively analysing a single point of electrical data to deduce which appliances are in use and their consumption patterns. NILM techniques do not require each appliance to be 'smart' or connected to a network; instead, they infer appliance activity through different algorithms that dissect the aggregate energy signal from a household's main electrical feed. This allows for a more seamless integration into existing homes, avoiding the need for extensive retrofitting with smart plugs or individual appliance sensors. Furthermore, NILM's ability to classify appliances and their usage patterns enables it to provide more details and recommendations for energy efficiency, beyond simple remote control or monitoring functions offered by smart home platforms.

While this thesis focuses on the application of NILM techniques and the benefits of energy monitoring for scheduling appliances to enhance energy efficiency and reduce costs, it's important to acknowledge that cyber security and data privacy concerns associated with these technologies are important. However, the detailed exploration of cyber security measures and vulnerabilities related to NILM systems and energy monitors falls outside the scope of this study. Future research should address these security aspects to ensure the safe and secure implementation of energy management systems.

This chapter presents the literature review of the fundamental principles of NILM techniques, along with the methodologies used for energy disaggregation. It explores their application not only for appliance classification and scheduling at the household level but also across various sectors. This chapter establishes the background for the subsequent chapters, providing essential knowledge for the upcoming discussions.

2.2 Appliance types

Historically, the categorisation of household appliances has been a focal point for researchers, who distinguish them based on their distinct operational behaviours, as referenced in various literature [14–16].

Type I Appliances: On-Off Dynamics – These are the most prevalent appliances within the domestic setting, operating on a binary on-off principle. Examples include everyday items such as toasters, light bulbs, and water pumps, which are either fully operational or completely inactive.

Type II Appliances: Finite State Machines (FSM) – Appliances in this category cycle through several distinct operational states. They exhibit a consistent sequence of stages that is typically repeated within the household’s daily or weekly routine. Washing machines and clothes dryers are prototypical FSM appliances, undergoing a series of programmed stages during each use.

Type III Appliances: Continuously Variable Devices – This category encompasses appliances with a variable power demand that does not follow a periodic pattern of state changes or power levels. Examples include appliances with adjustable settings like dimmer lights and various power tools, where power usage varies with the task and user input.

Type IV Appliances: Constant Operation Devices – Characterised by their uninterrupted operation, these devices maintain a near-constant power draw throughout the day and night. Notable examples are essential safety devices such as hard-wired smoke alarms and some external power supplies that are designed for persistent operation.

Building upon the outlined appliance types, the subsequent section will discuss various classification techniques used to classify household appliances.

2.3 NILM: Introduction

The concept of Non-Intrusive Load Monitoring (NILM) was first introduced by G. Hart in 1992 [17]. He defined a non-intrusive appliance load monitor as designed to monitor an electrical circuit containing multiple appliances that switch on and off independently, using various means such as voltage, current, or power. Since then, numerous researchers have worked in this subject, building upon Hart's foundational work and incorporating their perspectives. The NILM process includes the following steps:

1. **Data Acquisition and Processing:** This step involves the collection of electrical consumption data from the household's main supply using a single monitoring device. The data, which could be power, voltage and/or current, are processed to eliminate noise and normalise signals for analysis.
2. **Event Detection:** The system scans the processed data for significant changes or 'events' indicating a switch in the electrical load, suggesting an appliance's activation or deactivation. These events are identified by notable variations in electrical parameters such as power or current.
3. **Feature Extraction:** After detecting events, specific features from the load signatures are extracted, which can include changes in power consumption and characteristics of steady-state operation and transient behaviour. These features assist in distinguishing between different appliances and their operational states.
4. **Load Identification:** With the extracted features, this phase involves using algorithms, often incorporating machine learning or deep learning, to classify and identify individual appliances from the aggregated data, determining the active appliances at any given time.
5. **Demand Side Management Platform:** The insights from the NILM process are integrated into a platform that provides actionable recommendations

for energy consumption optimisation. This platform may suggest scheduling adjustments, recommend energy-efficient usage patterns, or automate energy-saving actions, enhancing household energy management.

In the evolving field of NILM, a diverse array of strategies has been explored to enhance the accuracy and efficiency of appliance recognition and classification.

While the primary focus of this chapter is on machine learning and deep learning techniques for NILM in appliance classification, it is important to acknowledge the work that does not employ these methods. Prior to the widespread adoption of ML and DL in NILM, researchers like Z. Zhang et al. [15], G. Bucci et al. [18], W. Wichakool et al. [19], S. Bhattacharjee et al. [20], and C. Po-An et al. [21], have made several contributions by exploring the complexities of appliance identification through their unique electrical consumption patterns. These studies introduced various innovative approaches, including:

- Utilising Voltage-Current (V-I) trajectory data combined with Agglomerative Hierarchical Clustering to improve the identification accuracy for specific appliance types. [15]
- Incorporating both time and frequency domain analyses of current data to develop nuanced classification algorithms. [18]
- Integrating current waveforms with harmonic analysis to create mathematical estimators for appliance characterisation. [19]
- Analysing a blend of voltage, power, and current data to devise algorithms capable of identifying appliances through their electrical signatures. [20]
- Employing probability models that consider a range of electrical parameters, including active and reactive power, harmonics, and power factor, for refined appliance classification. [21]

These methodologies, while not directly using machine learning or deep learning, prove the significance of understanding the diverse electrical signatures of appliances and allow for the integration of other computational techniques.

In the following sections of this literature review, the focus will shift towards the exploration and evaluation of machine learning and deep learning techniques within NILM research. This transition marks a progression from traditional analytical models to more advanced, data-driven approaches that promise enhanced accuracy, scalability, and adaptability in appliance classification and scheduling. The following sections will discuss:

- **Machine Learning in NILM:** Examination of various machine learning methodologies that have been adapted for NILM purposes, discussing their strengths, limitations, and applications.
- **Deep Learning in NILM:** Exploration of how deep learning architectures, such as Recurrent Neural Networks (RNNs), are revolutionising NILM by offering unprecedented levels of pattern recognition and predictive analytics.

By reviewing these advanced computational strategies, this chapter aims to showcase the current state of the art in NILM and propose directions for future research that could further use the capabilities of machine learning and deep learning to address the challenges in appliance classification and scheduling.

2.4 NILM: Machine learning algorithms for classification

Machine learning is a method for identifying patterns and making predictions, which are particularly useful in NILM. NILM aims to determine which appliances are using how much energy in a building without installing sensors on each device. This task

is complex because it involves analysing a single energy consumption signal to figure out the contributions of multiple appliances.

Machine learning helps tackle this by learning from past energy usage data. It looks at the unique ways different appliances use electricity and uses this information to break down the total energy signal into parts attributed to each appliance. This approach has made it easier to identify individual appliances' energy usage accurately, providing important information for energy management.

However, applying machine learning to NILM is challenging. Appliances can vary widely in how they use energy, people's energy usage can change, and the data can be noisy. Also, building effective machine learning models for NILM requires a lot of good-quality data.

Despite these challenges, machine learning holds great potential for improving NILM by making energy consumption data more detailed and useful. This section will cover how machine learning is used in NILM, focusing on the methods being applied, the progress made so far, and what the future might hold for this field.

2.4.1 Machine learning: Fundamental principles

Machine learning, a fundamental aspect of artificial intelligence, employs algorithms enabling computers and systems to learn from data. This learning process improves their capability in tasks such as classification, prediction, and decision-making, becoming more precise with time. The core of machine learning is the model training phase, during which algorithms repeatedly examine datasets to identify patterns, correlations, and the organization within the data. [22].

Machine learning can be broadly categorised into three types [23]:

- **Supervised learning:** This type involves algorithms learning from a labeled dataset, which serves as a guide to predict outcomes or classify new data.

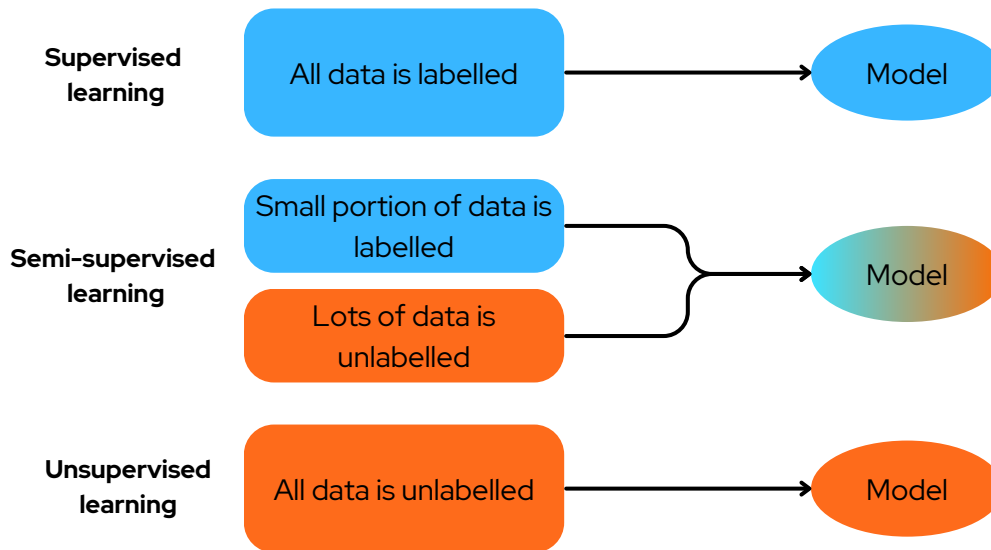

Figure 2.2: Types of machine learning.

The process includes adjusting internal parameters to minimize errors during the training, with techniques like cross-validation ensuring the model's generalization to new, unseen data. Common supervised learning algorithms include neural networks, naive bayes, linear regression, and support vector machines [24].

- **Unsupervised learning:** Unsupervised learning algorithms analyze and categorize unlabeled data to find patterns or intrinsic structures. This type is ideal for exploratory data analysis, customer segmentation, and dimensionality reduction, with methods like principal component analysis and k-means clustering being widely used [25].
- **Semi-supervised learning:** A blend of supervised and unsupervised learning, it uses a small amount of labeled data alongside a larger set of unlabeled data. This approach is beneficial when acquiring labeled data is costly or when the labeled data is insufficient for comprehensive training.

In addition to the main types, other important concepts in machine learning help improve model performance:

- **Feature Engineering:** Involves choosing, tweaking, or creating new features

from original data to enhance machine learning model performance. Effective feature engineering can significantly boost model accuracy and efficiency.

- **Model Evaluation and Selection:** Methods such as cross-validation, ROC curves, and confusion matrices are utilised to assess machine learning model performance. These techniques aid in selecting the most appropriate model for a specific task by analysing their performance.
- **Ensemble Methods:** This approach combines multiple models to enhance predictive performance. Common techniques include boosting, bagging, and stacking, each employing a distinct method for model integration.
- **Bias-Variance Tradeoff:** Describes the balance between bias error (mistakes from incorrect assumptions) and variance error (mistakes from sensitivity to small changes in training data). Achieving the right balance is crucial for developing models that perform well on new data.
- **Regularisation:** Techniques like L1 and L2 regularisation are applied to prevent overfitting by penalising large coefficients, ensuring models remain simpler and more robust.

Classification and classifiers

A classifier is a tool in machine learning that sorts data into groups or 'classes' based on their features. It looks at input data and decides which group it fits into best. In NILM, classifiers are very important as they look at the data about electricity use and figure out which appliances are being used at any moment.

During the literature review conducted for this thesis, a deliberate focus was placed on identifying and analysing the machine learning methods most frequently employed within NILM. The methods selected for in-depth review, namely Naive Bayes, Linear Discriminant Analysis, Decision Trees, and K-Nearest Neighbors, stand out as the most cited and discussed techniques in NILM research. This prevalence in the

literature suggests their acceptance and utility within the NILM community and highlights their suitability for addressing the unique challenges posed by NILM tasks.

- **Naive Bayes:** Often chosen for its simplicity and efficiency in handling large datasets, making it well-suited for real-time NILM applications where rapid decision-making is critical.
- **Linear Discriminant Analysis:** Employed for its ability to reduce dimensionality while maintaining the class separability, which is crucial in NILM for distinguishing between appliances with overlapping energy usage profiles.
- **Decision Trees:** Valued for their interpretability and ease of use, Decision Trees can effectively model non-linear relationships typical in appliance energy consumption patterns.
- **K-Nearest Neighbours:** Preferred for its intuitive approach and flexibility, KNN can be particularly effective in NILM for identifying similar consumption patterns among different appliances.

In [26], P. Adjei *et al.* generated binary labels for various appliance signatures by identifying on-off states and incorporated them as features within a naive bayes model.

Meanwhile, in [27], Y. Jimenez *et al.* extracted current, harmonic components of current, active power, fundamental reactive power, fundamental power factor, and total harmonic distortion of current from the signal. These extracted features were subsequently employed in a discriminant analysis algorithm to accomplish load disaggregation.

In [28], H. Alyammahi and P. Liatsis employed time domain statistical features for feature extraction, while utilised bagged trees as the classification algorithm for non-intrusive appliance identification, focusing on enhancing classification performance. J. M. Gillis *et al.* undertook research in [29], utilising wavelet functions to match

load patterns and employed decision trees as the classification method, aiming to identify appliances by analysing load patterns.

In [30], M. M. R. Khan *et al.* investigated activity patterns in the electrical signal and employed K-nearest neighbours (KNN) as the classification method, with the goal of identifying appliances based on their distinctive signal activity. Similarly, in [31], T. Bernard *et al.* considered various electrical parameters, such as active power, apparent power, reactive power, harmonics, and electromagnetic interference signals, for appliance classification using the KNN approach too.

On a different take, A. Adabi *et al.* in [32] focused on creating instrumentation that could identify appliances based on their harmonic patterns by using harmonics in the electrical signal and applying the KNN classification method.

Lastly, Y. Lin and M. Tsai in [33] considered active power, reactive power, and harmonics, utilising KNN to classify appliances, taking a comprehensive approach by analysing multiple electrical parameters.

The selection of these methods is thus justified by their frequent mention in NILM literature, reflecting their tested applicability and reliability in the field, and also by their inherent characteristics which align well with the challenges and requirements of NILM tasks. This review will go into detail about each method, highlighting their specific advantages and disadvantages.

2.4.2 Naive Bayes Classifier

The Naive Bayes (NB) classifiers belong to a probabilistic classifier. These algorithms employ Bayes' theorem as their foundational principle, which relates the conditional and marginal probabilities of random events. The 'naive' aspect of Naive Bayes comes from the assumption that each feature (or predictor) in the dataset is independent of all others [34–37].

For classification, Naive Bayes is used to find the probability of a label given some observed features. For each label, the product of the likelihood of the label and the

conditional probability of each feature given that label is calculated. The label with the highest probability is the classification result.

A brief explanation of how it works is found as follows:

Bayes' Theorem: A method for determining a probability given certain other known probabilities. This theorem is expressed as follows:

$$P(A|B) = \frac{P(B|A) \times P(A)}{P(B)} \quad (2.4.1)$$

Here, $P(A|B)$ is the probability of hypothesis A given the data B , $P(B|A)$ is the probability of data B given that the hypothesis A is true, $P(A)$ is the probability of hypothesis A being true (regardless of the data), and $P(B)$ is the probability of the data (regardless of the hypothesis).

In a Naive Bayes classifier, the objective is to maximise the posterior probability $P(y|x)$ of a class y given a feature vector x . This can be formulated using Bayes' theorem as:

$$P(y|x) \propto P(x|y) \cdot P(y) \quad (2.4.2)$$

where $P(x|y)$ represents the likelihood of observing the feature vector x given the class y , and $P(y)$ is the prior probability of the class y .

Given the Naive Bayes assumption of independence between features, the likelihood $P(x|y)$ for a feature vector $x = (x_1, x_2, \dots, x_n)$ simplifies to:

$$P(x|y) = \prod_{i=1}^n P(x_i|y) \quad (2.4.3)$$

To prevent numerical underflow issues due to the multiplication of many small probabilities, the log-likelihood is used, transforming the product into a sum:

$$\log P(x|y) = \sum_{i=1}^n \log P(x_i|y) \quad (2.4.4)$$

The expression for the posterior probability in log space is then given by:

$$\log P(y|x) \propto \log P(y) + \sum_{i=1}^n \log P(x_i|y) \quad (2.4.5)$$

For the purpose of classification, the class y that maximizes $\log P(y|x)$ is selected:

$$\hat{y} = \arg \max_y \left(\log P(y) + \sum_{i=1}^n \log P(x_i|y) \right) \quad (2.4.6)$$

In NILM, each feature x_i could represent a specific aspect of the electrical load data, like power usage at a certain time, and y would correspond to an appliance or activity pattern. The classifier uses these formulas to analyse the electrical load data and determine the most probable appliance category based on the learned log-likelihoods from training data.

Training process:

1. **Data Preparation:** Organise training data with correct class labels and extracted features.
2. **Class Priors Calculation:** Compute the overall probability of each class in the dataset.
3. **Feature Likelihoods Calculation:**
 - For each class, calculate the probability of each feature given that class.
 - Use frequency counts from the training data, applying smoothing techniques to handle unseen features.
4. **Model Synthesis:** Combine class priors and feature likelihoods to form the model.
5. **Completion:** The model can now predict the class for new instances by calculating class probabilities and selecting the class with the highest probability.

Strengths:

- **Simplicity and Speed:** One of the primary advantages of the NB classifier is its simplicity and computational efficiency. It provides rapid predictions for both binary and multi-label classification tasks.

- **Effective with Limited Data:** When the independence assumptions hold true, NB often outperforms other, more complex models, even when the training dataset is relatively small.
- **Dimensionality Reduction:** The approach of estimating each conditional characteristic distribution as a unique dimension contributes to dimensionality reduction. This can significantly reduce issues related to high-dimensional data and enhance overall performance.

Weaknesses:

- **Dependency Assumption Violations:** NB relies on the assumption of feature independence. When this assumption is not met, the model's accuracy can significantly diminish, leading to suboptimal results.
- **Inability to Adapt to Unseen Characteristics:** If the testing dataset includes characteristics that were not observed during the training phase, the NB model will ignore these new attributes. This can result in inaccurate predictions, as it cannot account for previously unseen patterns or data.

2.4.3 Linear Discriminant Analysis

The Linear Discriminant Analysis (LDA) algorithm serves as both a classifier and a dimensionality reduction method. LDA aims to discover linear combinations of variables that effectively discriminate among output variable classes. The primary goal of LDA is to find a linear combination of features that best separates two or more classes of objects or events. The resulting combination can be used as a linear classifier or for dimensionality reduction before further classification. It also assumes that the data is normally distributed, the classes have identical covariance matrices, and the means of the distributions are different [38–40]. These assumptions are fundamental for the optimal performance of LDA. Here's a brief overview of how LDA works:

Process:

Between-Class Variance

The between-class variance quantifies the separation between class means and is defined by the between-class scatter matrix S_B :

$$S_B = (\boldsymbol{\mu}_1 - \boldsymbol{\mu}_2)(\boldsymbol{\mu}_1 - \boldsymbol{\mu}_2)^\top \quad (2.4.7)$$

where $\boldsymbol{\mu}_1$ and $\boldsymbol{\mu}_2$ are the mean vectors of the two classes.

Within-Class Variance

The within-class variance represents the variance within each class, summed over all classes, given by the within-class scatter matrix S_W :

$$S_W = \sum_{i=1}^c S_i \quad (2.4.8)$$

where S_i is the scatter matrix for class i :

$$S_i = \sum_{\mathbf{x} \in X_i} (\mathbf{x} - \boldsymbol{\mu}_i)(\mathbf{x} - \boldsymbol{\mu}_i)^\top \quad (2.4.9)$$

Here, X_i is the set of samples in class i , and $\boldsymbol{\mu}_i$ is the mean vector of class i .

Objective Function

LDA seeks the projection \mathbf{w} that maximizes the ratio of the between-class variance to the within-class variance:

$$\mathbf{w} = \arg \max_{\mathbf{w}} \frac{\mathbf{w}^\top S_B \mathbf{w}}{\mathbf{w}^\top S_W \mathbf{w}} \quad (2.4.10)$$

This can be framed as a generalised eigenvalue problem:

$$S_B \mathbf{w} = \lambda S_W \mathbf{w} \quad (2.4.11)$$

where λ are the eigenvalues.

Solution

The optimal projection direction \mathbf{w} is found by solving the eigenvalue equation, typically by inverting S_W and multiplying by S_B . The eigenvectors associated with

the largest eigenvalues will be the directions that maximise class separability.

Strengths:

- **Enhanced Performance in Isolated Classes:** LDA demonstrates superior performance, particularly in situations where the classification problem involves well-separated and distinct classes.
- **Reduced Computational Complexity:** LDA contributes to lowering computational costs by reducing the feature count, making it computationally efficient.

Weaknesses:

- **Limitation in Shared Mean Distributions:** When the mean distributions of different classes overlap or are shared, LDA faces challenges in generating new axes that effectively separate these overlapping classes.

2.4.4 Decision Trees

The Decision Tree (DT) algorithm is a classification method where an internal node represents a feature (or attribute), the branch represents a decision rule, and each leaf node represents the outcome. The topmost node in a tree is known as the root node [41–43]. In DTs, the goal is to partition the data into subsets that are as pure as possible. The purity of a node is measured using metrics such as Gini Impurity or Entropy. Here’s an overview of how DTs work [44]:

Gini Impurity

Gini Impurity is a measure of how often a randomly chosen element from the set would be incorrectly labeled:

$$Gini(p) = 1 - \sum_{i=1}^J p_i^2 \quad (2.4.12)$$

where p_i is the proportion of samples that belong to class i within a node.

Entropy:

Entropy measures the amount of information disorder or uncertainty in a set:

$$Entropy(p) = - \sum_{i=1}^J p_i \log_2(p_i) \quad (2.4.13)$$

where p_i is the proportion of samples belonging to class i within the node.

Information Gain

Information Gain is the criterion used to determine the best feature to split on at each step:

$$IG(D, f) = I(D) - \sum_{j=1}^m \frac{N_j}{N} I(D_j) \quad (2.4.14)$$

where:

- $IG(D, f)$ is the Information Gain of dataset D by feature f ,
- $I(D)$ is the impurity measure of the dataset D ,
- D_j is the subset of D for the j -th value of the feature f ,
- N_j is the number of samples in D_j ,
- N is the total number of samples in D ,
- m is the number of distinct values in feature f .

Splitting Criteria

At each node, the algorithm iterates over all features and considers all possible thresholds to split the data. The split that results in the highest Information Gain is chosen.

Stopping Criteria

The tree stops growing when one of the following conditions is met:

- A maximum depth of the tree is reached.
- The number of samples in a node is less than a predefined minimum.

- No further improvement in impurity is achievable.

Pruning

Pruning involves removing parts of the tree that do not contribute significantly to the decision-making process. It helps to reduce the complexity and prevent overfitting.

Strengths:

- **Variable Selection:** DT is proficient at identifying significant variables among a large number of available variables.
- **Robust to Outliers and Missing Values:** Unlike some other models, DT is less affected by outliers and missing data, making it suitable for data with imperfections.

Weaknesses:

- **Overfitting in Complex DTs:** Complex decision trees tend to overfit the training data, which can lead to suboptimal performance when dealing with new, unseen data.
- **Sensitivity to Small Data Variations:** Even minor variations in the input data can result in significantly different decision trees, potentially affecting the model's stability and interpretability.

2.4.5 K-nearest Neighbour

The K-nearest Neighbour (KNN) algorithm is a classification method that relies on proximity to categorise individual data points. KNN works by finding the k closest training examples in the feature space to a given test point. The classification of the test point is then determined by a majority vote of its neighbours, with the test point being assigned to the class most common among its k nearest neighbours [45–48]. It works as follows:

Choose the number of k

Select the number of neighbours (k). The choice of k is important - a small value of k means that noise will have a higher influence on the result, whereas a large value makes the computation expensive and may also include points that are too far away in the classification.

Distance Metrics

To identify the k nearest neighbors, k -NN computes the distance between data points using various metrics. The choice of distance metric can significantly influence the algorithm's performance.

- ***Euclidean Distance***

The Euclidean distance between two points \mathbf{x} and \mathbf{y} in an n -dimensional space is defined as:

$$d(\mathbf{x}, \mathbf{y}) = \sqrt{\sum_{i=1}^n (x_i - y_i)^2} \quad (2.4.15)$$

where x_i and y_i are the i -th coordinates of points \mathbf{x} and \mathbf{y} , respectively.

- ***Manhattan Distance***

The Manhattan distance, or city block distance, between \mathbf{x} and \mathbf{y} is given by:

$$d(\mathbf{x}, \mathbf{y}) = \sum_{i=1}^n |x_i - y_i| \quad (2.4.16)$$

where $|x_i - y_i|$ computes the absolute difference between the i -th coordinates of the two points.

- ***Minkowski Distance***

The Minkowski distance generalises the Euclidean and Manhattan distances and is defined as:

$$d(\mathbf{x}, \mathbf{y}) = \left(\sum_{i=1}^n |x_i - y_i|^p \right)^{\frac{1}{p}} \quad (2.4.17)$$

where p is a parameter that determines the distance metric's behavior, and $|x_i - y_i|^p$ computes the p -th power of the absolute difference between the i -th coordinates.

Voting Mechanism and Classification

Once the k nearest neighbors are identified, the algorithm uses a voting mechanism to make predictions. In classification tasks, the predicted class is the one that receives the majority of votes from the k nearest neighbors.

Strengths:

- **Responsiveness to Real-time Changes:** KNN adapts quickly to changes in input data during real-time use, making it suitable for dynamic scenarios.
- **Non-linearity Handling:** KNN makes no assumptions about the data distribution, making it robust for classifying non-linear data patterns.

Weaknesses:

- **Curse of Dimensionality:** KNN's performance deteriorates with high-dimensional input data due to the curse of dimensionality. It tends to overfit and struggles to provide accurate predictions.
- **Consistent Feature Scaling:** To apply a common distance metric for classification, KNN requires features to be on the same scale. Inconsistent scaling can affect its performance.
- **Sensitivity to Outliers:** Outliers in the data can significantly influence KNN's decision boundaries since it relies on the distance between data points.

2.5 NILM: Deep learning methods for classification

The previous section covered the application of machine learning techniques for classification tasks, with an emphasis on NILM. The following discussion will shift towards exploring more advanced techniques within the machine learning field.

Deep learning is a machine learning technique that is inspired by the learning processes of the human brain. It uses neural networks, which are a series of algorithms capable of recognising patterns. These networks have many hidden layers of neurons that process information, with each layer receiving an input, processing it, and passing it to the next layer. With every passing layer, the original data is adjusted by every neuron's weight, allowing the network to learn more complex and abstract features over time.

Artificial neural networks (ANN), including recurrent neural networks (RNN), represent one of the primary methods employed in the field of disaggregation, as they possess the ability to learn the distinctive patterns and behaviours of household appliances, enabling the identification of these appliances within aggregate power data [49, 50]. This approach contrasts with machine learning methods mentioned in the previous sections, which rely more on statistical analysis and simpler decision-making processes without the depth of pattern learning seen in ANNs and RNNs.

Although RNNs show many strengths, a significant weakness is their long-term dependency due to the vanishing gradient problem. This problem occurs during training when the gradient values of the loss function become very small compared to the neural network's weights. If the gradient parameters are multiplied by these small gradients each time step, they become smaller, which can cause the model to struggle to learn long-term dependencies accurately, thereby limiting the RNN's memory. In other words, as the network takes more steps, it will retain and take into consideration less previous information each time. This issue is particularly pronounced when analysing long sequences of data, such as power consumption by household appliances over a period of time [51–53].

Previous work on deep learning for appliance classification

Numerous researchers have recognised the advantages of employing deep learning techniques and have complemented them with distinctive feature extraction methodologies for appliance classification objectives.

In [54], S. Yaemprayoon and J. Srinonchat approached feature extraction by investigating the potential of the Kurtogram method. Paired with a Multi-Layer Perceptron (MLP) classifier, their research aimed to advance appliance classification through the analysis of distinctive features.

Meanwhile, T. Wang and B. Yin [55], directed their attention towards current waveforms. Within this research, a Back-Propagation Neural Network (BPNN) was used as a tool for the classification of appliances, with a particular focus on recognising and distinguishing them based on the unique signatures within their current waveforms.

Shifting the focus to electrical power characteristics, [56] by S. Biansoongnern and B. Plangklang used the capabilities of BPNN for appliance classification. Within this domain, active power and reactive power were the key parameters of interest, providing information for accurate classification.

H. Chang *et al.* [57] placed a strong emphasis on active power and reactive power characteristics. This research took an interesting approach by combining Particle Swarm Optimisation with BPNN. The objective was to enhance classification accuracy by using the power of optimisation techniques coupled with the capabilities of neural networks.

In the topic of variant power signals, J. Kim *et al.* [16] employed the dynamic abilities of Long Short-Term Memory neural networks for appliance classification. This approach became particularly valuable when dealing with appliances exhibiting fluctuating power consumption patterns.

J. Kelly and W. Knottenbelt [58] set their focus on active power and reactive power dynamics. The research utilised LSTM neural networks in conjunction with Factorial Hidden Markov Models for appliance classification. This approach not only enhanced accuracy but also factored in the temporal dependencies present in the data.

Finally, A. G. Putrada *et al.* [59], took a data-driven approach by using power data. Here, the research introduced a deep learning method for appliance classifica-

tion, demonstrating significant improvements in accuracy compared to other neural network models such as LSTM, RNN, CNN, and DNN.

2.5.1 Long Short-Term Memory (LSTM) Neural Network

Long Short-Term Memory (LSTM) neural networks are an advanced component of deep learning, representing a significant step in the field of RNNs. These networks excel in modeling long-term dependencies within sequential data, a key capability of deep learning systems, making them highly effective in understanding and classifying energy consumption patterns [60, 61].

The distinguishing feature of LSTMs lies in their ability to selectively retain, forget, or update information at each time step. This selective memory management makes them exceptionally well-suited for tasks involving sequential data, where certain information may be more relevant than other over extended periods [62, 63].

As mentioned in the previous section, one of the key challenges in training deep neural networks, especially RNNs, is the vanishing gradient problem. LSTMs address the vanishing gradient problem by introducing a gated mechanism involving input, output, and feedback loops within a memory cell [64]. This design allows error gradients to flow back in time for a more extended duration compared to traditional RNNs. Consequently, LSTMs are designed to capture complex temporal patterns, making them useful for improving appliance classification accuracy in NILM. The model is depicted in Fig. 2.3. The symbols in the diagram are defined as follows:

t Time step

X Input data

h Output

c Memory

σ Sigmoid activation function

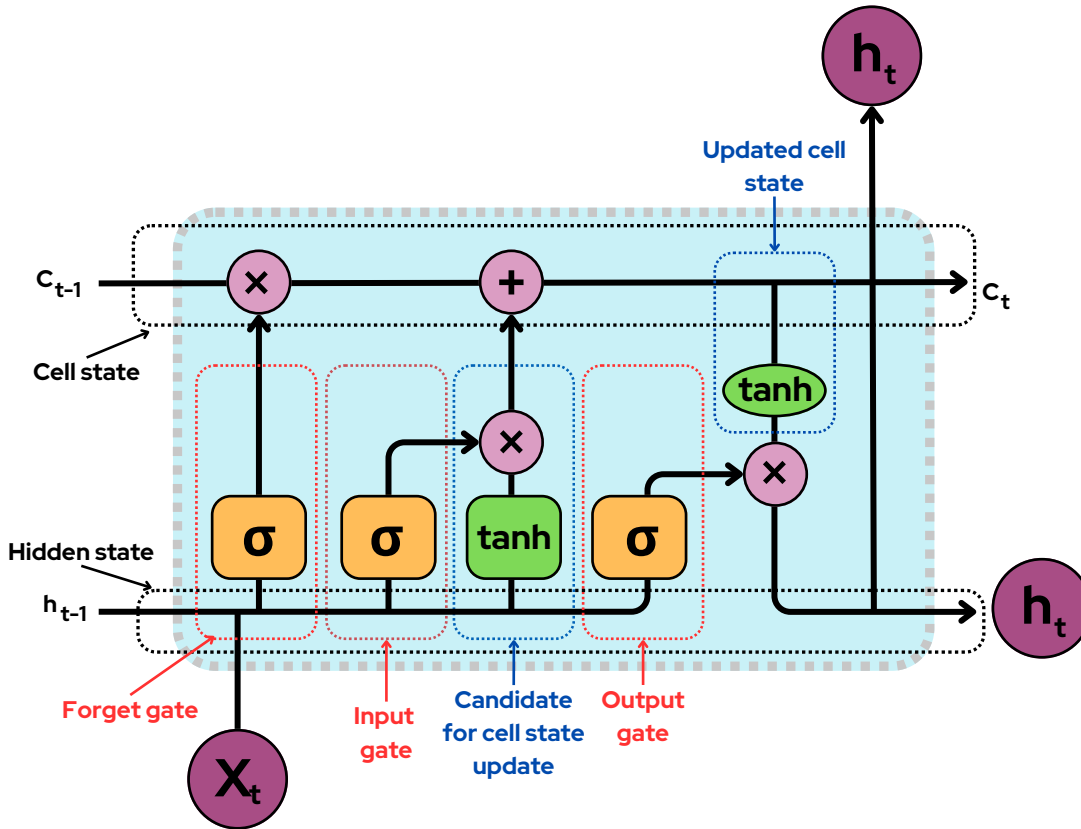

Figure 2.3: Diagram of a LSTM neural network layer [65].

tanh Hyperbolic tangent activation function

\times Element-wise multiplication

$+$ Element-wise summation

Their capacity to maintain context and recognise long-range dependencies within energy consumption data makes LSTMs a primary focus of this research. The following chapter will review the strengths and weaknesses of LSTMs in the context of appliance classification, highlighting their practical applications and limitations.

2.5.2 Bidirectional Long Short-Term Memory (BiLSTM)

Neural Network

Bidirectional Long Short-Term Memory (BiLSTM) networks represent a significant enhancement of the conventional LSTM architecture, designed to empower RNNs

with the ability to capture complex temporal dependencies. The fundamental distinction lies in the incorporation of bidirectional layers, a fundamental change that improves the performance of RNNs [62].

At the core of BiLSTMs are bidirectional layers, which gives them the capability to process sequences bidirectionally. In contrast to traditional LSTMs, which process sequences in a unidirectional manner, BiLSTMs employ two parallel RNNs within each layer. One of these RNNs processes the input sequence in a forward direction, much like standard LSTMs. Simultaneously, the other RNN processes the same sequence in reverse, starting from the end and moving backward [66, 67]. This can be seen in Fig. 2.4. The symbols in the diagram are defined as follows:

t Time step

\mathbf{X} Input data

\mathbf{y} Output

f Activation function

LSTM LSTM layer

The strength of BiLSTMs comes from their ability to capture information from both past and future time steps concurrently. The outputs from both the forward and backward RNNs are then fused to form a representation of the input sequence. This fusion can take place through concatenation, where the outputs are joined together, or through summation, where they are added element-wise. This combined representation allows the network to compile data from the entire sequence, allowing the model to discern intricate patterns and dependencies [68].

When classifying time series data, such as energy consumption patterns, BiLSTMs represent a versatile and robust tool. Accurate classification in this domain often relies on the model's ability to discern dependencies and patterns across multiple time steps, including both historical and future contexts. BiLSTMs excel precisely in this aspect, as their bidirectional architecture ensures that relevant information

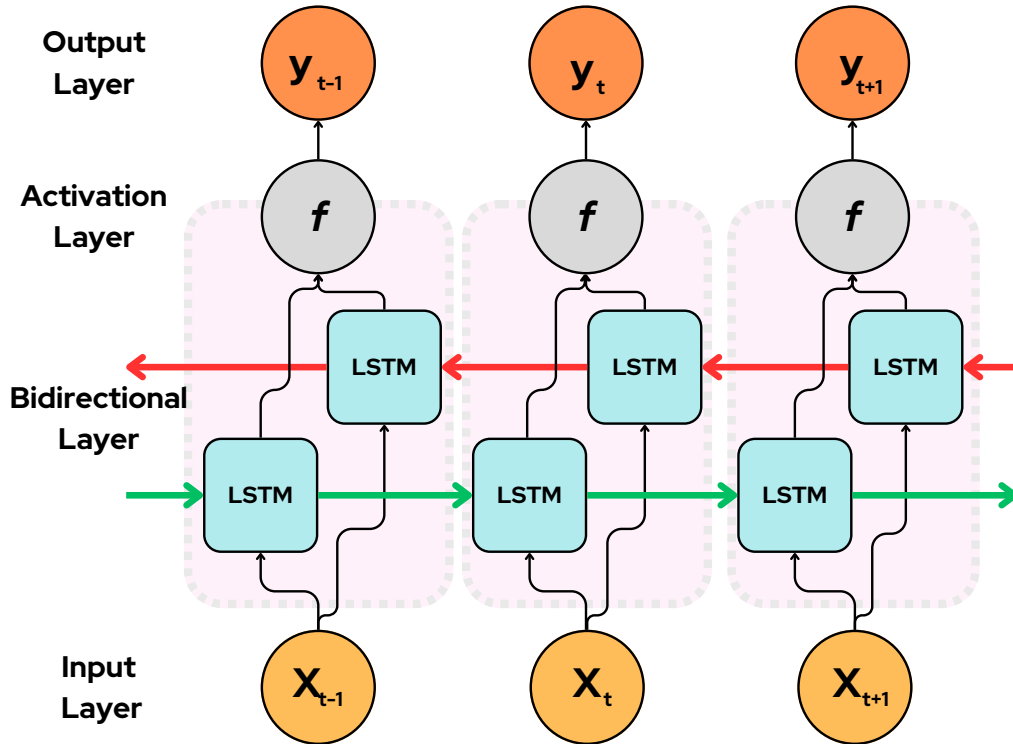

Figure 2.4: Diagram of the layers of a BiLSTM neural network [71].

from all parts of the sequence is considered when making classifications. The utility of BiLSTMs in energy consumption classification extends to scenarios where the consumption pattern is influenced by not only past behaviours but also anticipated future changes. This wide review of the data enables the model to make predictions that factor in the entire consumption trajectory [69, 70].

2.6 Summary of classification techniques

Researchers have made significant progress in appliance classification through the utilisation of machine learning and deep learning techniques. They have explored many different features and methods, all aimed at improving accuracy and performance. A comprehensive overview of research highlighting various techniques and their corresponding utilised features for their approaches to NILM can be found in Table 2.1.

Traditional machine learning methods, such as NB, LDA, DT, and KNN, have been

shown to be effective for appliance classification. These techniques have helped us understand how to identify and categorise appliances based on various electrical parameters.

Despite this, deep learning techniques have become very influential in this area. Deep learning models, including MLP, BPNN, and LSTM, have become increasingly popular and reliable in recent years. These models generally perform better than traditional machine learning techniques, particularly for complex tasks like classifying appliances, which involve detailed patterns and dependencies in electrical data.

Most research has focused on classifying appliances when there is extensive consumption data available. But getting this data can be difficult, usually requiring special equipment or infrastructure that isn't easily accessible. Therefore, it's important to create a classification method for appliances that can be used in many different situations without needing extra hardware investments from consumers or utility companies.

There has been limited research on accurately classifying appliances using minimal data. This opens up an opportunity to study different feature extraction techniques that can effectively classify appliances with limited data, similar to the successes reported in existing studies.

2.7 Appliance scheduling techniques

Appliance scheduling is a key feature in Home Energy Management Systems (HEMS). It uses algorithms to create and apply the most effective schedules for using household appliances, aiming mainly to achieve certain goals like cutting electricity costs for users. Through smart control of when appliances are used, it can reduce energy bills, improve energy efficiency, lower peak-load demands, and support sustainable energy use, making it an important part of contemporary home energy management.

Studies have consistently shown substantial reductions in electricity costs, and these

Ref.	Features	Methods
[15]	V-I trajectory	Agglomerative hierarchical clustering
[18]	Current in time and frequency domains	Mathematical algorithm
[19]	Current waveform, harmonics	Mathematical estimator
[20]	Voltage, power, current	C4.5 algorithm
[21]	Active power, reactive power, harmonics, power factor	Probability model
[54]	Kurtogram	Multi-layer perceptron
[59]	Power	GRU-MF
[28]	Time domain stats	Bagged trees
[30]	Activity in signal	K-nearest neighbours
[31]	Active power, apparent power, reactive power, harmonics, electromagnetic interference signals	K-nearest neighbours
[55]	Current wave form	Back-propagation neural network
[16]	Variant power signal	LSTM
[29]	Wavelet functions that match load pattern	Decision trees
[56]	Active power, reactive power	Back-propagation neural network
[32]	Harmonics	K-nearest neighbours
[33]	Active power, reactive power, harmonics	K-nearest neighbours
[58]	Active power, reactive power	LSTM, Factorial HMM
[57]	Active power, reactive power	Particle Swarm Optimisation and Back-propagation neural network
[26]	Active power, reactive power, power factor, harmonics	Discriminant Analysis
[27]	Time, power	Naive bayes classifier

Table 2.1: Survey of features and methods used

costs achieved through appliance scheduling depend on factors like appliance selection, energy rates, and usage patterns. Additionally, appliance scheduling helps mitigate the peak-to-average ratio (PAR), which represents the difference between peak and off-peak energy consumption. This optimisation improves the balance between energy supply and demand, enhancing overall efficiency [72].

2.7.1 Optimisation techniques

In order to determine the optimal scheduling for appliances, the use of an optimisation algorithm is necessary. Optimisation involves a process to identify input parameters or arguments for a function that result in the minimum or maximum output of an objective function.

A general optimisation problem can be defined as follows [73]:

$$\min_{x \in \mathbb{R}^n} f(x), \quad (2.7.1a)$$

$$\text{s.t. } g_i(x) \leq 0, i = 1, \dots, m, \quad (2.7.1b)$$

$$h_j(x) = 0, j = 1, \dots, p, \quad (2.7.1c)$$

where $f : \mathbb{R}^n \rightarrow \mathbb{R}$ is the objective function to be minimised over the n -variable vector x , while 2.7.1b denotes the inequality constraints and 2.7.1c denotes the equality constraints, with $m \geq 0$ and $p \geq 0$.

The stated general optimisation problem and its constraints can be solved by different methods and algorithms. These algorithms span different categories, each characterised by its unique strengths and applications, which makes them well-suited for diverse optimisation problems. In this research, the focus for review is on the following methods [74]:

Mathematical Optimisation:

- Linear Programming (LP): It is used to find the best possible outcome in a linear mathematical model. It deals with maximising or minimising a linear

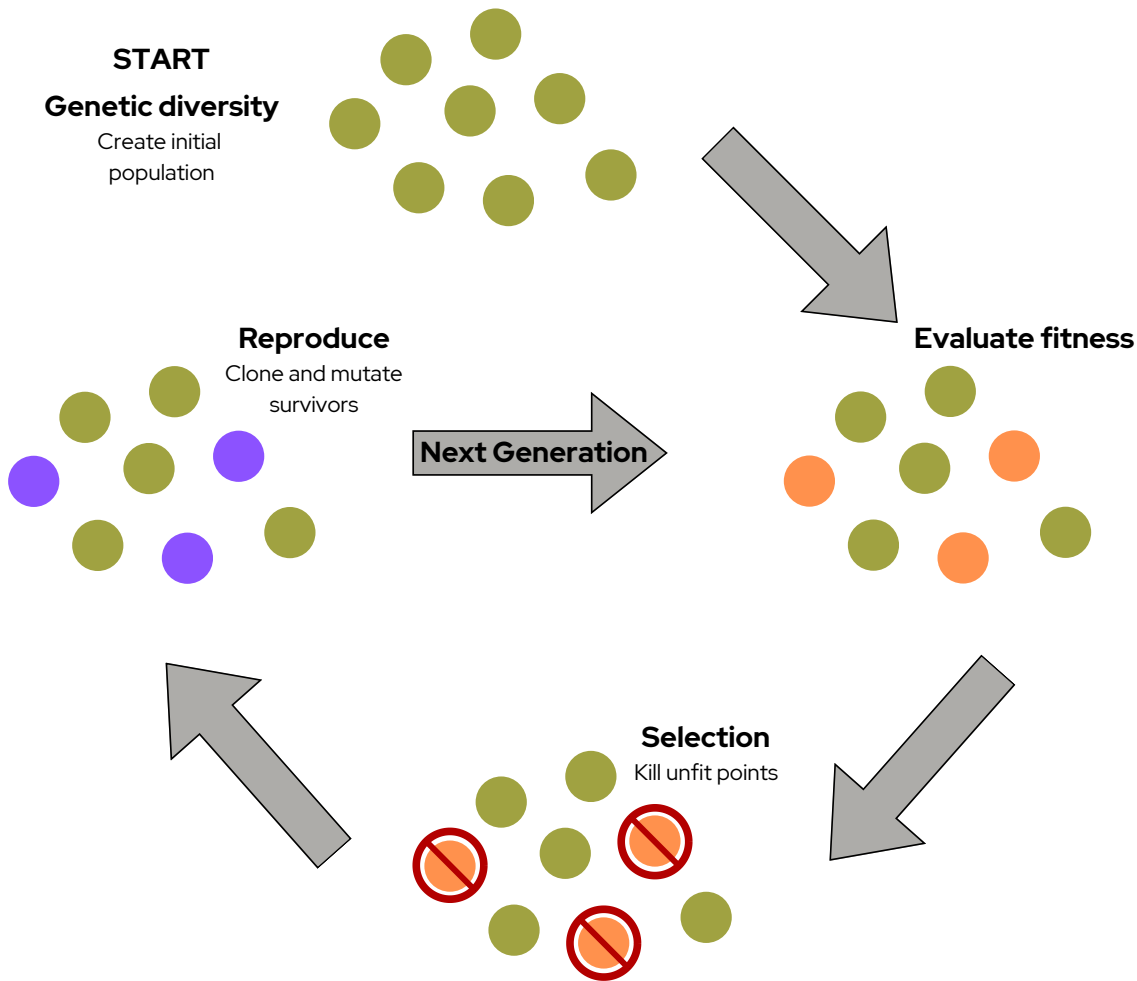

Figure 2.5: Diagram of the process of a genetic algorithm.

objective function while satisfying a set of linear inequality constraints [75].

- **Mixed-Integer Linear Programming (MILP):** It focuses on solving problems with a combination of continuous (real-valued) and discrete (integer) decision variables. It aims to find the best solution by optimising a linear objective function subject to a set of linear constraints while considering that some variables must take integer values [76].
- **Gurobi Optimiser:** Gurobi is a commercial optimisation solver that offers a range of optimisation techniques, including linear programming (LP), mixed-integer linear programming (MILP), and more [77].

Heuristic Optimisation:

Heuristic optimisation techniques encompass a wide range of problem-solving strategies

that prioritise finding good solutions quickly, even if they do not guarantee optimality [78]. The following methods also fall under the "population-based" optimisation:

- NSGA-II (Non-dominated Sorting Genetic Algorithm II): It is a multiobjective optimisation algorithm that specialises in solving problems with conflicting objectives. It identifies solutions that represent the trade-off between multiple criteria [79].
- Genetic Algorithm (GA): It is inspired by the process of natural selection and genetics. It is employed to find optimal or near-optimal solutions to complex problems across various domains. GAs operate on a population of potential solutions, mimicking the principles of evolution. Solutions are represented as individuals with encoded characteristics. Through generations of selection, crossover, and mutation, GAs evolve and refine these solutions, aiming to improve their fitness in solving the given problem [80].
- Particle Swarm Optimization (PSO): It focuses on finding optimal solutions to optimisation problems, particularly in continuous spaces. In PSO, a population of particles represents potential solutions, and they iteratively adjust their positions based on their own experience and the experience of their neighbours. This collective intelligence guides the search toward the optimal solution [81].

Reinforcement Learning:

- Deep Q-Learning (DQL): It is a reinforcement learning technique that uses neural networks to approximate the Q-function in Q-learning. While not directly classified as an optimisation algorithm, reinforcement learning can be used for optimisation tasks [82].

2.7.2 Optimisation objectives

In optimisation problems, solutions often target either a single objective or multiple objectives. When addressing multiple objectives, a trade-off is usually inevitable, as

improving one objective may lead to the detriment of another. Research in this area can be categorised into studies focusing on single-objective optimisation and those exploring multi-objective optimisation.

2.7.3 Single objectives

Single objective optimisation involves finding the best solution or set of solutions to a problem when there is only one objective function to optimise. This objective function can either be maximised or minimised, depending on the problem context. The general mathematical form can be found in equations 2.7.1a, 2.7.1b and 2.7.1c. In single objective optimisation, the goal is to find the optimal value of \mathbf{x} that maximises or minimises the objective function while satisfying all the constraints.

Cost

The main goal of optimisation algorithms often centers on reducing operational expenses, especially in the area of household energy use. The objective for households is to decrease their energy expenditures without compromising their quality of life. Through the application of optimisation algorithms, energy consumption can be more effectively controlled. For instance, such algorithms are capable of timing energy-demanding activities to coincide with periods of lower electricity prices or greater availability of renewable energy sources, thereby achieving cost reductions.

To model a cost objective in an optimisation problem, the following steps are typically followed:

1. **Identify Cost Factors:** First, determine all elements contributing to the cost within the problem, such as materials, energy, labour, etc.
2. **Quantify Costs:** Assign a numerical value or formula to each identified cost factor. These could include fixed costs, variable costs, or more complex functions.

3. **Formulate the Objective Function:** Combine all quantified costs into a single objective function, representing the total cost as a function of the decision variables.
4. **Incorporate Constraints:** Define constraints that limit the feasible solutions, including budget limits, resource availability, and technical or regulatory limitations.
5. **Optimisation Model:** The final model comprises the objective function, which aims to minimise the total cost, subject to the defined constraints.

For example, considering an optimisation problem for producing a product with material, energy, and labour costs:

- Material costs, C_m , as a function of material used, M .
- Energy costs, C_e , depending on energy consumption, E .
- Labour costs, C_l , based on the number of labour hours, L .

The objective function to minimise the total cost, C_{total} , could be formulated as:

$$C_{\text{total}} = C_m(M) + C_e(E) + C_l(L) \quad (2.7.2)$$

Subject to constraints such as:

$$M \leq M_{\text{max}} \quad (\text{Maximum material available})$$

$$E \leq E_{\text{max}} \quad (\text{Maximum energy available})$$

$$L \leq L_{\text{max}} \quad (\text{Maximum labour hours})$$

In [83], Y. Liu *et al.* used deep Q-learning and double deep Q-learning methods to support decision-making in optimising home energy management strategies in order to reduce electricity costs for the consumer. They conducted extensive experiments utilising a substantial dataset comprising multi-dimensional real-world data and

a model representing household energy storage. Furthermore, they examined the algorithm's robustness by subjecting it to not only real-world electricity price signals but also dynamic pricing scenarios designed to assess agents' responsiveness to rapid changes.

Similarly, in [84], S. Rout *et al.* employed the EHO technique for optimising the scheduling of deferrable home appliances within a HEMS. The optimisation problem was framed as a constrained optimisation task, with a key determinant being the start time for operating connected home devices, while the primary objective was minimising electricity costs. To address this challenge, the study considered two distinct and independent pricing scenarios: the time-of-use scheme and the critical-cost-pricing scheme, both applied to four deferrable home appliances.

Moving on to [85], M. B. Toosi and H. R. Mashhadi explored distinct scenarios aimed at facilitating daily load management for consumers utilising MILP. One scenario prioritised several critical objectives. Notably, it effectively balanced the goal of minimising electricity expenses while simultaneously meeting all consumer requirements. Within this scenario, all household appliances operated according to predefined schedules, maintaining indoor temperatures within acceptable limits.

In [86], N. Ismail *et al.* introduced an appliance scheduling model centered on optimising the user's monthly electricity bill target. A MILP model was developed, tailored for household appliance scheduling under the Incline Block Rate Tariff system. The study focuses on a representative low-income household in Egypt, equipped with 8 fundamental appliances, serving as a case study to illustrate the model's effectiveness concerning adherence to the user's electricity budget and preferences within the context of the Egyptian electricity tariff.

Meanwhile, [87], T. Panaput *et al.* presented a Demand-Side Management (DSM) approach designed for multiple residential households, taking into account consumer preferences, to optimise the energy consumption of each appliance while incorporating Battery Energy Storage Systems and solar photovoltaic generation. The DSM

challenge was mathematically formulated as a MILP problem, designed to minimise consumers' electricity expenses, considering time-of-use rates.

Lastly, in [88], M. Assi *et al.* explored various approaches for efficiently scheduling household appliances, with a particular focus on the GA method. The paper analysed the different operators integral to this evolutionary algorithm, encompassing selection, mutation, and crossover techniques. Additionally, the study introduced a repair function, employed to transform infeasible solutions into viable ones.

Peak-to-Average Ratio

Electric utility companies often implement time-of-use pricing schemes, where the cost of electricity escalates during periods of peak demand. By relocating activities that contribute to peak load, such as operating appliances, to times outside these high-demand periods, significant reductions in the Peak-to-Average Ratio (PAR) can be achieved. PAR denotes the ratio of the highest power consumption in a given period to the average power consumption over the same period. While theoretically, shifting power usage could result in the formation of a new peak, the ultimate goal is to flatten the energy usage curve as a whole, rather than merely transferring the peak to a different time slot. Smart home energy management systems are designed to more evenly distribute energy consumption throughout the day, moving usage away from high-demand periods.

To develop an optimisation model that aims to minimise the PAR of energy consumption, the following components are considered:

- $E(t)$: Energy consumed at time t .
- P : Peak energy consumption over the considered time period T .
- A : Average energy consumption over the period T .

Minimise the PAR, which is defined as:

$$\min \left(\frac{P}{A} \right) \tag{2.7.3}$$

With the constraint that the energy consumption at any time must not exceed the peak:

$$E(t) \leq P, \quad \forall t \in T \quad (2.7.4)$$

The average energy consumption is calculated as:

$$A = \frac{1}{|T|} \sum_{t \in T} E(t) \quad (2.7.5)$$

Ensure non-negative energy consumption:

$$E(t) \geq 0, \quad \forall t \in T \quad (2.7.6)$$

In [89], A. Al-Adaileh and S. Khaddaj developed a smart energy management framework utilising machine learning techniques to predict and manage household energy consumption. The framework consists of three key policies: appliance replacement based on energy consumption, replacement based on usage, and automated scheduling. The core of the methodology lies in the third policy, automated scheduling, which involves monitoring device behaviour and predicting future usage patterns to adjust operation times accordingly. The system's effectiveness was validated through a case study focusing on the energy consumption of an immersion water heater, demonstrating significant energy savings through scheduling.

In [90], E. Bejoy *et al.* introduced an effective solution algorithm for the household optimal scheduling problem with joint shiftable appliances using LP. They showed the effectiveness of the approach for real-time scheduling of appliances with actual renewable energy generation data. Results showed this approach successfully optimised energy allocation's to handle different weather scenarios of Australia with respect to different consumer preferences. The results indicated that scheduled optimisation yielded a large amount of energy savings at peak time when comparing it to the random schedule thus reduced electricity bill.

Meanwhile, in [91], O. A. Alimi and K. Ouahada looked into the need for tracking the running times of the household appliances that in an economically viable manner

ensure energy conservation and avoid excessive utility bills. Data from the Western Cape electricity billing system in South Africa was used to analyse the scheduling scheme. As the results showed, daily consumption could be made, watched and managed in order to stop energy spending.

In a related manner, in [92], A. Imran *et al.* proposed an energy management system that will decrease the electricity bill in a residential area by using various algorithms such as GA and PSO and their proposed technique HGPDO. They aimed to reduce CO₂ emissions, lower the PAR and improve user comfort. In their research, they used a smart house with multiple smart devices, coupled with RESs and an energy storage system to maximise energy usage. As part of the same research, in [93], A. U. Rehman *et al.* proposed an efficient load scheduling and energy management controller for smart home buildings where the huge HVAC load was scheduled with other different shiftable and smart appliances to reduce load. Each appliance in the smart home was scheduled using the same HGPDO, which is a hybrid made of GA, WDO and PSO. The proposed technique helped to find the most optimal schedule of each home appliance considering system constraints.

In [94], A. Jindal *et al.* presented a heuristic approach towards tackling the increasing significance of smart homes to maintain stability in the electrical grid by minimising the variation of load. They insisted on the necessity for smart homes to match the needs of the loads with the supply from utilities. In studying the power demands of smart homes, the researchers included in their analysis solar panels and battery energy storage systems with grid power to control the loads of smart homes. Their suggested scheme was designed by effectively controlling of consumption from homes considering the constraints of the supplier in power supply by implementing an appliance scheduler. The method was done by distributed energy within the smart grid to the homes according to their power demands. Then appliance schedules have been made based on the available power and user priorities. Interruptible loads would be shifted to low-power hourly bands and unscheduled demand load fluctuations (i.e., turning on or off some devices) could be compensated by schedule

shifts of non-preferred appliances to other bandtime moments.

Turning to [95], M. S. Ghole *et al.* designed and implemented an appliance scheduling algorithm. They implemented this algorithm on a real database, consisting of both time-of-use and real-time pricing data from June 2021. Their findings indicated that optimisation of appliances for real-time pricing resulted in substantial savings in costs as against constant pricing. Furthermore, the researchers found that increasing the number of iterations resulted in better results. Notably, their approach was also found applicable to both the small and large number of appliances.

In [96], L. Jing *et al.* integrated a 10kW roof solar panel and multiple electrical load devices and used the Gurobi optimiser to formulate and optimise the intelligent home appliance scheduling problem, which satisfies all the time and energy constraints. The three goals were to minimise monthly electricity charges, minimise peak-to-peak ratio, and maximise peak load requirements. They compared the Gurobi optimiser to the PSO algorithm and found that the Gurobi optimiser was more effective in minimising power costs, PAR, and maximum peak load requirements.

Lastly, in [97], A. Bouakkaz *et al.* introduced an optimal peak power reduction approach by scheduling the usage times of shiftable household appliances in a home connected to off-grid renewable energy systems, including solar panels, batteries, and diesel generators, using the PSO algorithm. The simulation results demonstrated that scheduling household appliances strategically could effectively curtail peak power demands and enhance energy savings by maximising the utilisation of renewable energy sources.

2.7.4 Multiple objectives

Multi-objective optimisation deals with optimising several conflicting objective functions simultaneously. Unlike single objective optimisation, it yields a set of Pareto-optimal solutions, each representing a trade-off among the objectives. The formulation for a multi-objective optimisation problem is given by:

$$\min_{\mathbf{x} \in \mathbb{R}^n} [f_1(\mathbf{x}), f_2(\mathbf{x}), \dots, f_k(\mathbf{x})], \quad (2.7.7a)$$

$$\text{s.t. } g_i(\mathbf{x}) \leq 0, i = 1, \dots, m, \quad (2.7.7b)$$

$$h_j(\mathbf{x}) = 0, j = 1, \dots, p, \quad (2.7.7c)$$

where:

- \mathbf{x} is the vector of decision variables,
- $[f_1(\mathbf{x}), \dots, f_k(\mathbf{x})]$ are the objective functions to be optimised,
- $g_i(\mathbf{x})$ and $h_j(\mathbf{x})$ represent the inequality and equality constraints respectively.

Research on multi-objective optimisation for appliance scheduling

It is important to note that objectives in optimisation for appliance scheduling can extend beyond mere cost reduction, often including user comfort, as altering the usual appliance schedules can often cause discomfort. In such cases, the results represent a compromised solution that effectively balances the trade-offs between these objectives. In [98], Y.-H. Lin and M.-S. Tsai employed the NSGA-II algorithm to fulfill the objectives of cost reduction and increased comfort in the context of HEMS.

Furthermore, in [99], K. Ma *et al.* proposed an optimisation power scheduling scheme aimed at implementing demand response in a residential unit when electricity prices are announced in advance. In their work, they formulated power scheduling as an optimisation problem and subsequently derive optimal scheduling strategies under three distinct operation modes. Their findings revealed that the power scheduling strategy proposed, particularly under day-ahead pricing, effectively achieves the desired trade-off between reducing electricity payments and minimising discomfort.

In [100], I. Hammou Ou Ali *et al.* introduced a HEMS model that also uses day-ahead electricity pricing and predictive photovoltaic power generation. Their proposed ap-

proach, as the previous ones, offers reductions in electricity costs and reduction of discomfort caused by delayed appliance start times. To achieve these objectives, they use MILP to address the scheduling of home appliances across three distinct user scenarios: traditional user, smart user, and smart prosumer. Additionally, in [101], they also introduced a multi-objective technique for optimising home appliance scheduling in response to advanced electricity pricing announcements. Their proposed power scheduling methodology is formulated as an optimisation problem that encompasses both integer and continuous variables, catering to two distinct types of flexible appliances: time-flexible and power-flexible devices.

In [102], A. Alzahrani *et al.* classified home appliances into two categories based on their flexibility in terms of time and power usage: time-flexible and power-flexible. The power usage scheduling problem for domestic users was then modeled, taking into account user priority and modes of operation in relation to demand and supply dynamics. An energy consumption scheduler was developed to adjust the operation of both types of appliances across different modes, aiming to balance the reduction of utility bill payments and discomfort, as well as the peak to average demand ratio.

2.8 Summary of scheduling techniques

Appliance scheduling stands as an important technique within HEMSs. It allows the system to strategically plan the operation of specific appliances at times that align with distinct objectives, set either by the user or utility companies. A summary of the optimisation methods reviewed in this chapter can be found in Table 2.3 and a comprehensive compilation of the works in appliance schedule is presented in Table 2.4, encapsulating a thorough survey of the existing body of research in the field.

The search for cost reduction is one of the most prevalent objectives, delivering a clear and immediate economic advantage to the user. Beyond cost savings, another important objective is the reduction of the PAR, a measure that seeks to flatten

the load consumption curve across the day. This becomes particularly valuable for households reliant on grid-supplied energy.

However, very few studies have explored scenarios where users have access to BSSs and renewable energy sources like solar energy generation. Also, in terms of environmental considerations, the incorporation of CO₂ emissions as a priority in appliance scheduling has not been widely researched. This highlights the prevailing focus of research in this field on economic gains. These scenarios present opportunities for dynamic optimisation of energy consumption and production, with the potential to impact cost savings, environmental benefits, and serve as a motivating factor for users to consider the advantages of transitioning to a more eco-friendly home environment.

Choosing heuristic optimisation

Heuristic optimisation methods are suitable for complex problems that are nonlinear and high-dimensional, which can be challenging for traditional methods that may require simplifications. These methods adapt well to changes and can handle uncertainties and imperfect data, making them valuable for dynamic environments. GAs are particularly effective for multi-objective optimisation because they generate a range of Pareto-optimal solutions. This capability allows decision-makers to explore different trade-offs and choose suitable solutions.

A comparison between GAs and non-heuristics methods can be found in Table 2.2. A key reason for using GAs in this research is their ability to produce many feasible solutions, offering users various scheduling options instead of a single solution. This approach provides flexibility and accommodates different priorities and constraints. Additionally, GAs can be scaled and parallelised to handle large-scale problems efficiently, using modern computing architectures to enhance processing speed.

Table 2.2: Comparison of genetic algorithms (as heuristic methods) vs. Non-Heuristic methods in multi-objective optimisation

Aspect	Genetic Algorithms (Heuristic)	Non-Heuristic Methods
Objective Handling	Can naturally handle multiple objectives simultaneously without needing to combine them.	Often require combining objectives into a single objective function, which can simplify or bias the solution.
Problem Complexity	Highly effective for complex, non-linear problems with many variables and discontinuities.	Best suited for problems where the mathematical properties (like continuity and differentiability) are well-defined.
Solution Diversity	Generates a set of diverse solutions, providing multiple options for decision-makers.	Typically converges to a single solution, limiting options.
Robustness	Robust to changes and uncertainties in the problem environment due to its stochastic nature.	May require adjustments or reformulation when problem parameters change or are uncertain.
Computational Efficiency	May require significant computational resources due to processing multiple solutions simultaneously.	Often more computationally efficient for smaller or less complex problems due to a more direct approach.
Ease of Implementation	Does not require gradients or other derivative information; easy to implement and adapt.	May require detailed information about the problem's gradients and other mathematical properties.
Flexibility	Highly flexible; can easily incorporate new objectives or constraints.	Less flexible; changes in objectives or constraints often require significant methodological adjustments.
Optimality	Finds satisfactory solutions that are often near-optimal; exact optimality not guaranteed.	More likely to find the globally optimal solution in well-structured problems.
Scalability	Can scale well with problem size but at the cost of increased computational demand.	Scalability varies; some methods scale well with increased computational resources, while others become impractical.

Table 2.3: Summary of Optimisation Methods

Method	Type	Description
Linear Programming (LP)	Mathematical	Used to find the best outcome in a model by maximising or minimising a linear objective function subject to linear constraints.
Mixed-Integer Linear Programming (MILP)	Mathematical	Solves problems with both continuous and discrete variables by optimising a linear objective function subject to linear constraints.
Gurobi Optimiser	Mathematical	A commercial solver that supports various optimization techniques including LP and MILP.
NSGA-II	Heuristic	A multiobjective genetic algorithm that finds solutions representing trade-offs between multiple conflicting objectives.
Genetic Algorithm (GA)	Heuristic	Uses principles of natural selection to evolve populations of solutions, aiming to find optimal or near-optimal outcomes.
Particle Swarm Optimization (PSO)	Heuristic	Uses a population of particles adjusting their positions based on personal and neighbor experiences to find optimal solutions.
Deep Q-Learning (DQL)	Reinforcement Learning	Employs neural networks to approximate the Q-function, used in optimization tasks within a reinforcement learning framework.

Ref.	Algorithm	Objectives	Appliances
[83]	DQL	Cost	Air conditioner, heater, EV, dishwasher
[84]	EHO	Cost	Washing machine, dishwasher, cloth dryer, PHEV
[85]	GA	Cost	Ventilation, water heater, dishwasher, washing machine, oven, kettle, vacuum cleaner
[86]	MILP	Cost	Lights, refrigerator, TV, receiver, washing machine, fan, blender, mobile charger
[87]	MILP	Cost	Dishwasher, washing machine
[88]	GA	Cost	Microwave, cooker, washing machine, water heater, kettle, lightning, TV, electric mower, dishwasher, refrigerator
[98]	NSGA-II	Cost, discomfort	Rice cooker, water boiler, steamer, range hood, PC
[99]	Undisclosed	Cost, discomfort	Clothes washer, lights, air conditioner
[100]	MILP	Cost, discomfort	Washing machine, cloth dryer, dishwasher, air conditioner, water heater, rice cooker 1, rice cooker 2
[101]	LP	Cost, discomfort	Washing machine, lights, air conditioner, kettle, toaster, refrigerator
[102]	Undisclosed	Cost, discomfort, PAR	Air conditioner, refrigerator, washing machine, dishwasher, cloth dryer
[89]	ML	PAR	Air conditioner, water heater
[90]	LP	PAR, discomfort	Electric heater, washing machine, air conditioner, tumble dryer
[91]	Undisclosed	PAR, discomfort	TV, lights, electric stove, coffee maker, washing machine, geyser, refrigerator, pressing iron
[92]	HGPDO	PAR, discomfort, CO ₂	Water heater, refrigerator, CD player, lights, washing machine, EV
[93]	HGPDO	PAR, discomfort, CO ₂	Water heater, refrigerator, CD player, lights, washing machine, EV
[94]	Heuristics	PAR	Air conditioner, water heater, microwave, electric iron, refrigerator, hair dryer, vacuum cleaner, TV, computer, fan, dishwasher, washing machine
[95]	Proprietary	PAR, cost	10 appliances (not mentioned)
[96]	Gurobi	PAR, cost	Refrigerator, washing machine, TV, air conditioner, EV
[97]	PSO	PAR	Refrigerator, lights, washing machine, iron, TV+DSR, desktop, vacuum cleaner

Table 2.4: Survey of algorithms, optimisation objectives and appliances used.

2.9 Research challenges

The literature review in this chapter highlighted the research advancements and explored areas pertaining to appliance classification and scheduling techniques. Nevertheless, there are still unexplored areas and opportunities in this field, which will be addressed in the following paragraphs.

Research gap 1: Streamlined appliance detection and classification with limited data and intrusiveness

The growing interest in energy saving highlights two interconnected challenges in the field of appliance monitoring: minimal intrusion in detection and high-accuracy classification with limited data. While there are methods documented in the literature achieving up to 98% accuracy in classifying individual appliances, there remains a noticeable gap in research that simultaneously addresses both detection and classification. Traditional methods for detecting appliances often require complex equipment setups or modifications to the appliances themselves, which can be inconvenient and dissuasive for users keen on adopting energy-efficient practices. Similarly, in appliance classification, the reliance on extensive datasets for achieving accuracy necessitates specialised equipment, leading to prolonged setup times and hindering prompt implementation. This disparity underscores the pronounced need for innovative, user-friendly approaches that can effectively detect and classify appliances without being intrusive or reliant on large volumes of data. Developing such methods would streamline the process, making it more viable and practical for everyday application, and thereby fostering greater adoption of energy-efficient practices.

Research gap 2: Integrating cost, CO₂ emissions and discomfort minimisation using RES/BSS in home appliance scheduling

While numerous appliance scheduling techniques have been formulated to optimise energy consumption, there is a noticeable lack of studies that explicitly target the reduction of CO₂ emissions. This gap is increasingly relevant as environmental concerns and the global push for net zero emissions gain greater attention. Engaging homes and consumers in reducing CO₂ emissions is important because residential sectors significantly contribute to overall energy consumption and, consequently, greenhouse gas emissions. Consumer involvement not only aids in achieving large-scale impacts through collective action but also promotes behavioural change, awareness, and supports compliance with evolving environmental policies.

Consequently, there is an escalating necessity to devise scheduling algorithms that consider both energy efficiency and carbon emissions. This necessity opens up the possibility for the creation of more comprehensive methodologies that reconcile energy savings with environmental considerations. Moreover, the use of RES and BSS in domestic environments remains a comparatively under-researched area, despite their potential to lower electricity costs, enhance grid reliability, and support environmental conservation. The involvement of consumers in adopting these technologies can stimulate market demand, drive technological innovation, and contribute to decentralised and resilient energy systems.

2.10 Conclusions

First, a review of previous work by various researchers on NILM techniques is presented, offering insights into the diverse approaches that have been taken. The focus is primarily on different machine learning algorithms, and a detailed summary considering the strengths and weaknesses of these methods is provided. Second, the literature reveals an analysis of deep learning methods, highlighting their advantages

over traditional machine learning techniques. Subsequently, appliance scheduling techniques and the optimisation methods applied to them are examined. Finally, a review is conducted on the various objectives that researchers have sought to achieve, including cost and discomfort minimisation.

Several gaps in existing research have been identified, each needing unique strategies for effective resolution. For less intrusive appliance detection, the focus could shift to simpler, user-friendly methods that eliminate the need for complex setups or alterations to the appliances themselves. In the area of appliance classification, new algorithms that function well with limited data are needed, potentially by examining previously unexplored features within the data set. Regarding appliance scheduling with an emphasis on reducing CO₂ emissions, the development of new algorithms that incorporate environmental factors alongside traditional energy efficiency is important. Lastly, for the effective integration of RES and BSS in domestic settings, targeted research and real-world trials are necessary to grasp their practical applications and benefits.

Chapter 3

Appliance Classification and Feature Extraction Using Limited Data

3.1 Introduction

Household appliances are essential in daily activities, including cooking, cleaning, and washing. They are common in homes and account for a large part of energy use in residential buildings [103]. Therefore, categorising these appliances is key for developing energy-saving systems, which can lower energy use and reduce the carbon footprint.

Traditional energy monitoring systems use aggregate energy consumption data to evaluate household energy use, without providing appliance-specific information. As a result, identifying the energy consumption patterns of individual appliances

This chapter is based on work published in "Appliance Classification using BiLSTM Neural Networks and Feature Extraction," by M. Correa-Delval, H. Sun, P. C. Matthews and J. Jiang, 2021 IEEE PES Innovative Smart Grid Technologies Europe (ISGT Europe), Espoo, Finland, 2021, pp. 1-5, doi: 10.1109/ISGTEurope52324.2021.9640061.

remains a significant obstacle in implementing energy-efficient systems. Appliance classification addresses this issue by identifying the specific appliance(s) in use based on the aggregate energy consumption data collected at the meter level.

In addition to aiding energy efficiency, appliance classification carries significant policy implications. Governments worldwide are enacting energy-saving measures to curtail energy consumption and mitigate greenhouse gas emissions. Precise appliance classification data empowers policymakers to craft energy-saving programs and policies that pinpoint specific appliances or households, fostering considerable energy savings [104]. Equally important is safeguarding consumer well-being and satisfaction. This involves guaranteeing that advantages such as reduced costs and carbon footprint do not compromise consumer comfort and safety.

The need for appliance classification stems from limited awareness about energy consumption habits and the unavailability of technology offering this information. Identifying how individual appliances consume energy can reveal their efficiency, inform energy usage behaviours, support the creation of efficient energy management strategies, and help lower electricity costs and carbon emissions. Thus, it is important to develop accurate appliance classification methods that can identify appliances and their energy consumption patterns, supporting efforts towards energy efficiency and sustainability.

This chapter addresses *Objective 1*, which was outlined in Chapter 1. It introduces a novel methodology for appliance classification that utilises spectral entropy and instantaneous frequency. The main aim is to analyse load consumption with limited data and minimal intrusion.

The contribution is as follows:

- A novel approach called "Spectral Entropy and Instantaneous Frequency Bidirectional Long Short Term Memory (SE-IF BiLSTM)" is introduced for appliance classification in this chapter. The SE-IF BiLSTM method combines the power of a Bidirectional Long Short-Term Memory (BiLSTM) Neural Network

with advanced feature extraction techniques, including spectrogram frequency bands, Mel spectrogram, instantaneous frequency, spectral entropy, and signal variation. The results demonstrate the remarkable effectiveness of this approach, particularly in classifying non-similar appliances and mixed appliances. The SE-IF BiLSTM method achieves an accuracy rate of up to 90% when analysing similar appliances, 100% when analysing non-similar appliances and 99% when analysing both at the same time.

3.2 Proposed Method: SE-IF Feature Extraction

Feature extraction is an important pre-processing step that selects relevant features in a dataset to be used as inputs for a machine learning model. Training a classifier with too many or too few features can be risky, as unnecessary or missing features can degrade performance. By selecting only relevant features, the classifier can find solutions faster and more accurately while also reducing the risks of overfitting.

In the proposed SE-IF feature extraction method, two primary features are introduced for appliance classification: spectral entropy (SE) and instantaneous frequency (IF). Spectral entropy, based on information theory, quantifies the unpredictability or randomness within a signal's power spectrum distribution. This measure is adept at capturing the complexity of a signal, useful for differentiating appliances with variable power consumption from those with consistent energy use. Instantaneous frequency, in contrast, measures the rate at which the signal's phase changes over time, offering a dynamic view on the frequency content that static spectral analysis might miss. Together, these features are central to the approach, aiming to improve the characterisation of appliance energy consumption signatures.

The combination of spectral entropy, instantaneous frequency, and the mel-spectrogram technique introduces a new method for appliance classification. Mel-spectrograms, commonly applied in audio signal processing, offer a way to analyse sound that somewhat resembles how the human ear perceives it. This approach utilises the detailed

temporal and spectral information provided by mel-spectrograms, enhancing the feature set to effectively capture the distinct and changing characteristics of appliance signatures. This method is similar to identifying various musical instruments or notes but applied in the context of electrical appliances.

This method presents the following contributions:

- Implementation of feature extraction techniques such as spectral entropy and instantaneous frequency for appliance classification.
- Combination of spectral entropy and instantaneous frequency with the less widely researched mel-spectrogram technique, resulting in improved classification accuracy.

All simulations and experiments related to this method were conducted using MATLAB versions from 2020 to 2022.

3.2.1 Spectral entropy

The spectral entropy (SE) of a signal is a measure of its spectral power distribution, grounded in the principles of Shannon entropy [105]. By considering the normalised power distribution of a signal in the frequency domain as a probability distribution, SE seeks to quantify the Shannon entropy of this distribution, thereby providing a metric for the unpredictability or complexity of a signal. For a given signal $x(n)$, its power spectrum is denoted as $S(m) = |X(m)|^2$, where $X(m)$ represents the discrete Fourier transform of $x(n)$. In a time-frequency scenario, where a power spectrogram $S(t, f)$ is considered, the probability distribution at a particular time t is given by:

$$P(t, m) = \frac{S(t, m)}{\sum_f S(t, f)} \quad (3.2.1)$$

where $P(t, m)$ is the probability distribution of power at time t for frequency bin m , $S(t, m)$ represents the power at time t and frequency bin m , and the denominator $\sum_f S(t, f)$ is the total power across all frequency bins at time t .

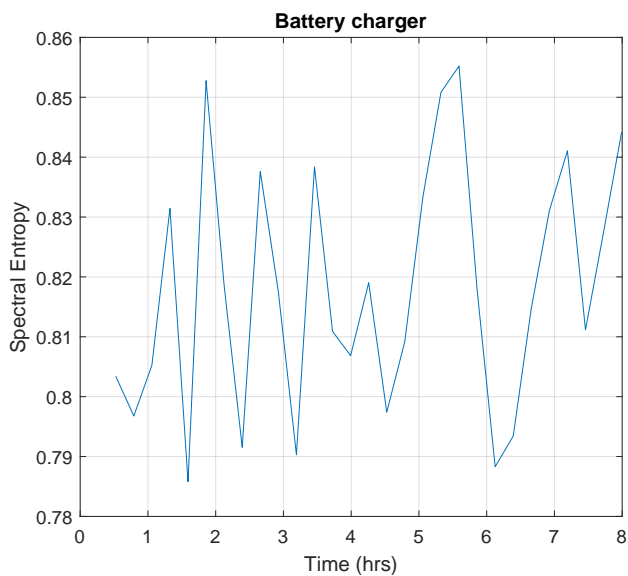

Figure 3.1: Spectral entropy of a battery charger from the UK DALE dataset.

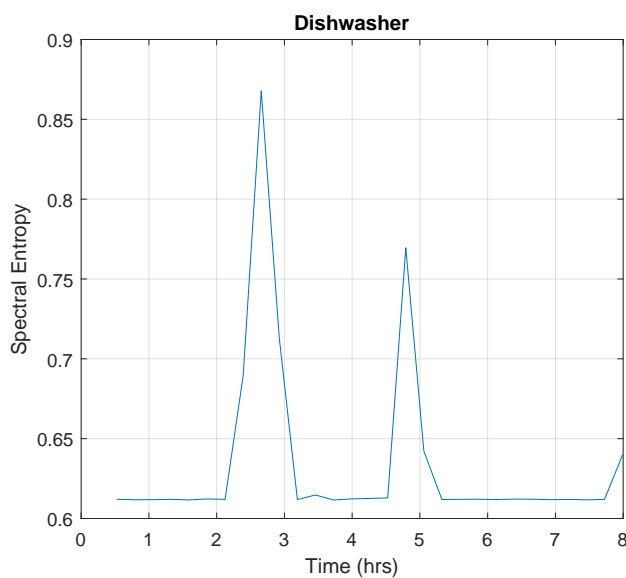

Figure 3.2: Spectral entropy of a dishwasher from the UK DALE dataset.

Subsequently, the spectral entropy at time t can be expressed as:

$$H(t) = - \sum_{m=1}^N P(t, m) \log_2 P(t, m) \tag{3.2.2}$$

where $H(t)$ is the spectral entropy at time t , $P(t, m)$ as defined previously, m indexes the frequency bins, and N is the total number of frequency bins. [105].

SE, by quantifying the dispersion of energy across the frequency spectrum, demonstrates characteristics of signals emanating from different household appliances. As appliances operate, they exhibit distinctive wattage consumption patterns, which in turn, manifest as unique spectral characteristics. The computation of SE from the appliance consumption data serves as a robust feature extraction strategy, enabling the capturing of these spectral distinctions. In Figs. 3.1 and 3.2 the SE estimates of a battery charger and a dishwasher are shown.

Peaks in the spectral entropy graphs indicate moments or frequency bands where the power distribution of the signal is most uniform or chaotic, suggesting a high level of unpredictability or complexity at those points. Higher entropy values (peaks) suggest that the energy is spread out more evenly across a range of frequencies, indicative of a more complex and less predictable signal. For appliance classification, these peaks could represent moments when an appliance is transitioning between operational states.

The extracted SE feature acts as a fingerprint, helping in distinguishing between different appliances based on their operational signatures. For instance, a washing machine, with its cyclic operational phases, may exhibit a different SE profile compared to a refrigerator, which operates under a more constant load.

3.2.2 Instantaneous frequency

The instantaneous frequency (IF) is a useful characteristic for describing non-stationary signals. It is defined as:

$$F_{inst}(t) = \frac{1}{2\pi} \frac{d\varphi}{dt} \tag{3.2.3}$$

where φ is the phase of the analytic signal of the input. By using the first moment of the spectrogram, it calculates the time-dependent frequency of a signal [106].

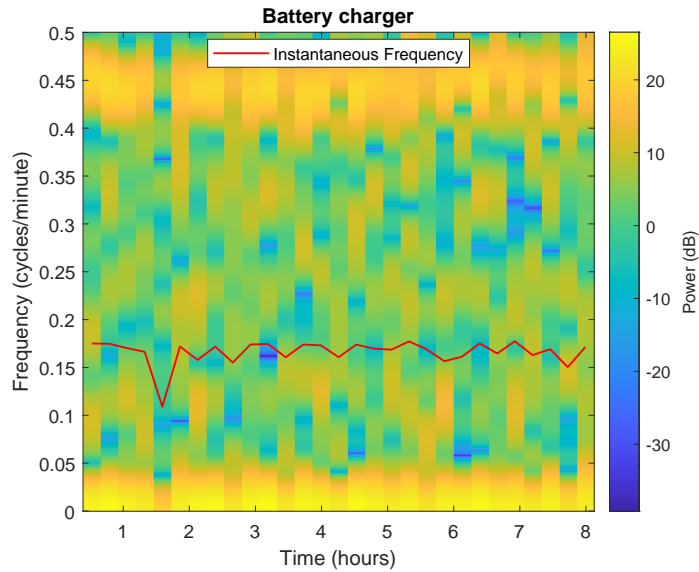

Figure 3.3: Instantaneous frequency estimate of a battery charger from the UK DALE dataset.

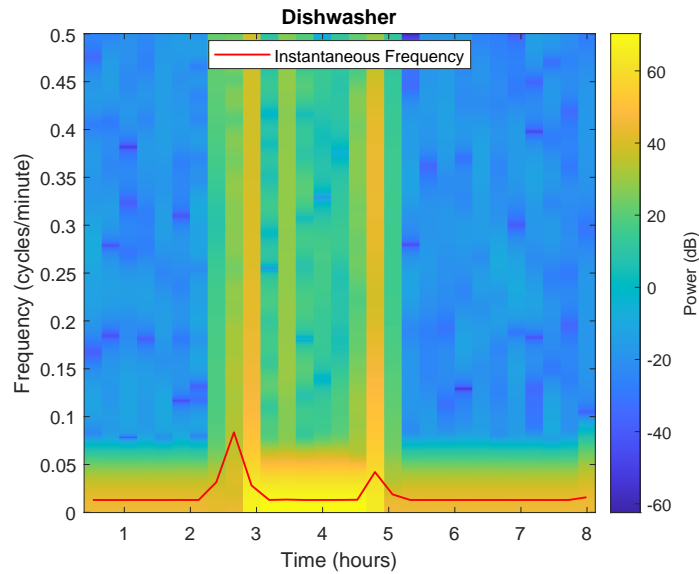

Figure 3.4: Instantaneous frequency estimate of a dishwasher from the UK DALE dataset.

A signal is considered non-stationary when its time period and frequency are variable instead of constant. The sinusoidal wave representation of a non-stationary equation changes constantly, resulting in frequency that varies within intervals [107]. The analysis of household appliance consumption data often involves dealing with non-stationary signals, where the statistical properties of the signal change over

time. Unlike stationary signals where frequency components remain constant, non-stationary signals exhibit varying frequency content over time, which is characteristic of the operational behaviours of many household appliances. IF provides a time-resolved measure of these frequency variations, offering a dynamic view of the signal’s frequency content as it evolves. This is a very important characteristic for accurately capturing and understanding the transient and cyclical behaviors of appliances, such as the start-stop cycles of washing machines or the varying load conditions of HVAC systems. In Figs. 3.3 and 3.4, the IF estimates of a battery charger and a dishwasher are shown, showing how IF can emphasise changes in cycles. Furthermore, the time-varying nature of IF aligns well with the temporal dynamics of household energy consumption.

3.2.3 Mel spectrogram

Spectrograms are an important tool for analysing the frequency of time-series data. They are two-dimensional representations of the signal’s magnitude at different frequencies over time, illustrating the power of the signal at every frequency at a specific time and how it varies over time [108].

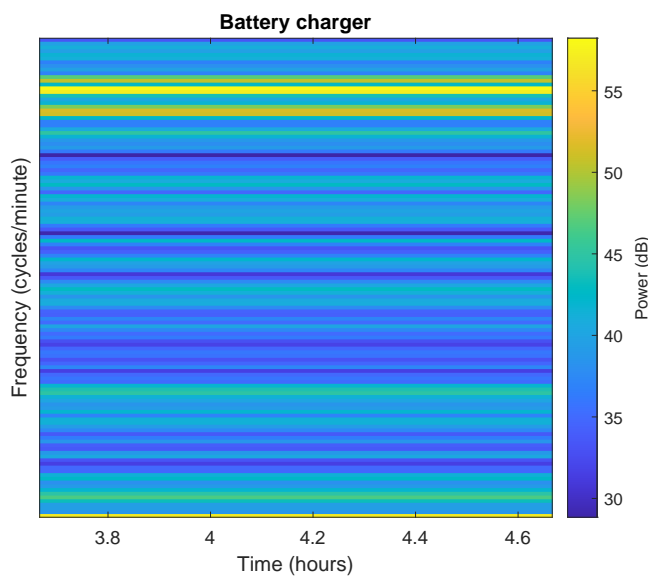

Figure 3.5: Mel spectrograms of a battery charger from the UK DALE dataset.

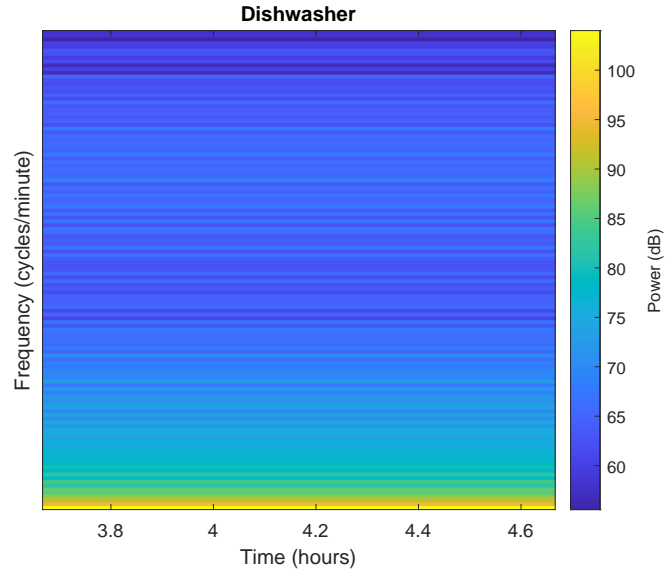

Figure 3.6: Mel spectrograms of a dishwasher from the UK DALE dataset.

Mel spectrograms use the Mel-frequency scale, which is a linear frequency interval of 1000 Hz or less and a logarithmic interval of 1000 Hz or higher. Spectrums are transformed into Mel-spectrums by passing them through Mel-filter banks consisting of overlapping triangular windows of various widths on a normal frequency scale, emphasising values in low frequencies [109].

To obtain the signal’s individual frequencies and the amplitude of its frequency, Mel spectrograms use the Fourier transform. Fig. 3.6 illustrates a graph comparing the mel spectrograms of a dishwasher and a battery charger. This feature contains useful information about the appliance and its behaviour, such as the dominant frequencies, which can help in classification.

3.2.4 Signal variation

This feature emphasises the variation in the power consumption signal by subtracting the power signal with a reflection rate (RR) of 0.1 from the power signal with a RR of 0.01. This difference is denoted as Δp , which represents variation of the original signal [16].

3.3 System model

3.3.1 Dataset

The UK DALE dataset is a valuable resource for energy disaggregation research [110]. It includes both aggregate power readings and individual appliance power measurements at a frequency of 1/6 Hz across five households, making it one of the earliest and most widely used UK-based datasets to date. The dataset has been released in various versions, covering readings from 2012 to 2017.

For example, the dataset includes detailed records for a battery charger, comprising 13,333,663 data points. These entries are recorded every 6 seconds, largely without interruption, detailing the exact timestamp in UNIX time and the corresponding power consumption in watts, as shown in Fig. 3.7. This specific subset starts from April 13, 2013, and extends to April 16, 2016.

	A	B
	channel47	
	VarName1	VarName2
	Number	Number
1	1365707334	0
2	1365707340	0
3	1365707347	3
4	1365707353	3
5	1365707359	3
6	1365707366	3
7	1365707372	3
8	1365707379	2
9	1365707385	3
10	1365707392	2
11	1365707398	3
12	1365707404	2
13	1365707411	3
14	1365707417	3
15	1365707424	2
16	1365707430	2
165	1365708418	0
166	1365708426	0
167	1365708433	0
168	1365708441	0
169	1365708447	0
170	1365708453	0
171	1365708459	0
172	1365708465	0
173	1365708471	0
174	1365708479	0
175	1365708485	0
176	1365708493	0
177	1365708500	0
178	1365708505	0
179	1365708513	0
180	1365708520	0

Figure 3.7: Example of raw power consumption data for a battery charger: On the left, data illustrates power usage, while on the right, data indicates periods of no usage.

	1	2	3	4	5	6	7	8
621	2012	11	10	7	10	20	0	0
622	2012	11	10	7	10	21	0	0
623	2012	11	10	7	10	22	0	0
624	2012	11	10	7	10	23	1	6.7778
625	2012	11	10	7	10	24	1	58.4000
626	2012	11	10	7	10	25	1	76.6000
627	2012	11	10	7	10	26	1	512.1000
628	2012	11	10	7	10	27	1	1.7521e...
629	2012	11	10	7	10	28	1	1.7364e...
630	2012	11	10	7	10	29	1	1.9667e...
631	2012	11	10	7	10	30	1	1.9344e...
632	2012	11	10	7	10	31	1	1.9592e...
633	2012	11	10	7	10	32	1	1.9519e...
634	2012	11	10	7	10	33	1	2.0528e...
635	2012	11	10	7	10	34	1	1.9873e...
636	2012	11	10	7	10	35	1	1.9355e...
637	2012	11	10	7	10	36	1	1.9266e...
638	2012	11	10	7	10	37	1	1.9296e...
639	2012	11	10	7	10	38	1	1.9348e...
640	2012	11	10	7	10	39	1	1.9148e...
641	2012	11	10	7	10	40	1	1.8897e...

Figure 3.8: Example of data after analysing the time of reading and averaging its consumption per minute. Columns 1-8: year, month, day, day of the week, hour, minute, on or off state, watts

3.3.2 Obtaining Individual Appliance Consumption Data

The training and testing data for the neural network were sourced from the individual appliance consumption records within the UK DALE dataset. To utilise this data, a preprocessing approach was used. This involved transforming the raw data into a more manageable form that better suits the requirements of neural network models. The following steps outline the process undertaken to prepare and refine the dataset for subsequent analysis:

1. Calculating the average energy consumption per minute for each appliance for every day. This process resulted in a condensed dataset containing 1440 entries for each day.
2. Analysis of the data was conducted to extract information on power usage in Watts along with the corresponding dates and times.
3. The most common usage level, likely indicating the appliance's "stand-by" state,

was identified. Thresholds were then set to differentiate between "stand-by" and active usage states of the appliances. This can be seen in Fig. 3.8.

4. Instances where the appliance was identified as "in operation," along with the relevant timestamps, were documented.
5. For each appliance, 10 samples of the power consumption were chosen, each formatted as a 500x1 array. Each of these samples represent 500 minutes of usage data, which were saved for training purposes.

Pre-processing of input data

After extracting all the features, normalising the data is essential for better classification results. The closer the input data is to a Gaussian distribution, the better the performance of the model [111]. Aligning data with a Gaussian distribution enhances machine learning models by ensuring compatibility with algorithmic assumptions, balancing feature contributions, optimising gradient descent efficiency, supporting statistical analysis, minimising outlier impacts, and adhering to constant variance assumptions, collectively improving model performance and reliability. One of the most common normalisation methods is Z-Score, which uses the mean and standard deviation to normalise the input data. It is a measure of how many standard deviations below or above the population mean a raw score is [112]. The resulting normalised data is then used as input for the classification model.

3.3.3 Configuration parameters for evaluating SE-IF methodology

In this study, the effectiveness of the SE-IF methodology was evaluated using four different machine learning algorithms: Naive Bayes (NB), Linear Discriminant Analysis (LDA), Decision Trees (DT), and K-Nearest Neighbors (KNN). The mathematical basis of these algorithms and their relevance to this study have been covered in detail

Table 3.1: Algorithm Configuration

NB, LDA, DT, KNN	
Data distribution	Multivariate multinomial distribution
Cost of misclassification	$Cost_m(i, j) = 1$ if $i \neq j$ and $Cost_m(i, j) = 0$ if $i = j$
Weights	1
Optimiser	Bayes optimiser
Max objective evaluations	30
Max time	Infinite
Prior probabilities	Empirical
DT	
Predictor split algorithm	Exact
Split criterion	Gini's diversity index
KNN	
Tie-breaking algorithm	Smallest
Distance metric	Euclidean

in the Literature Review section, in Chapter 2. This background enables a detailed look at how these algorithms are applied and how they perform when used with the SE-IF methodology.

To ensure a consistent and fair comparison, specific configuration parameters were chosen for each algorithm's execution in MATLAB. Table 3.1 presents these parameters, which were applied directly in the MATLAB functions to configure the algorithms for optimal performance. These settings are necessary for replicating the experimental conditions and understanding the algorithms' behaviour under the defined configurations.

General parameters

- **Data distribution:** Multivariate multinomial distribution

The multinomial distribution is an extension of the binomial distribution to multiple variables. It represents the probability distribution of outcomes in a multinomial experiment, which involves the possibility of more than two possible outcomes. [113]

- **Cost of misclassification:** $Cost_m(i, j) = 1$ if $i \neq j$ and $Cost_m(i, j) = 0$ if $i = j$

The cost of misclassification refers to the negative consequences that arise when a classification algorithm or model assigns instances to the wrong classes. In this case, it gets a cost penalisation of 1 if it wrongly assigns a class and 0 if it does it correctly.

- **Optimiser:** Bayes optimiser

Optimisation algorithm that uses Bayesian methods to find the optimal configuration or parameters of a model or system. It utilises Bayesian inference to iteratively update its beliefs about the optimal solution based on observed data.

- **Prior probabilities:** Empirical

Prior probabilities refer to the initial likelihood of each class or outcome before analysing new evidence. For this model, 'empirical' indicates that these probabilities are directly estimated from the training dataset. Specifically, the proportion of each class within the training data is calculated and used as the prior probability for that class. This method ensures that the model's starting assumptions about class frequencies are grounded in the actual distribution observed in the data.

Decision Trees parameters

- **Predictor split algorithm:** Exact

Exhaustive search to evaluate all possible splits and select the one that provides the best split based on the specified criterion.

- **Split criterion:** Gini's diversity index

It quantifies the probability of misclassifying a randomly selected element in a set if it were randomly labeled according to the class distribution within that set. It ranges between 0 and 1, where 0 indicates perfect purity (all

elements belong to the same class), and 1 represents maximum impurity (an equal number of elements from each class).

K-nearest neighbour parameters

- **Tie-breaking algorithm:** Smallest

A tie-breaking algorithm is used when there is a tie in the class labels among the k-nearest neighbours. When multiple neighbours have an equal number of votes for different classes, the tie-breaking algorithm determines which class label to assign to the query instance. In this instance, the class that appears first in the sorted list of classes will be chosen.

- **Distance metric:** Euclidean

The distance metric determines how the proximity or similarity between instances is calculated. In KNN, the class label is assigned based on the majority vote among those neighbours. The metric used in this instance is the Euclidean distance, which measures the straight-line distance between two points in a multi-dimensional space.

3.3.4 Parameters for testing SE-IF with deep learning methods

Input

The input comprises a selection of appliances from House 1 and House 2 of the UK DALE dataset [110]. The various testing groups were composed of Similar Appliances, Non-Similar Appliances, and Mixed Appliances.

Weight initialisation

The weights vector for all neurons of the Neural Network are set up for the first time during the weight initialisation process, which occurs just before the Neural

Network training process starts. If the weights are not properly initialised, the forward pass can lead to the vanishing gradient. A common method used for weight initialisation is the He initialisation. In this method, the weights are initialised according to the size of the previous layer, helping to attain a global minimum of the cost function faster and more efficiently. Although the weights are still random, they have different ranges depending on the size of the previous layer, providing a controlled initialisation.

Activation function

The activation function of a node defines the output of that node given an input or set of inputs. The output unit activation function is the softmax equation, which is established as follows:

$$\text{Softmax}(x_i) = \frac{\exp(x_i)}{\sum_{j=1}^n \exp(x_j)} \quad (3.3.1)$$

where x is the net input vector and n is the number of classes. The output for the Softmax function is the ratio of the exponential of the parameter and the sum of exponential parameter. This is a nonlinear, unbounded function that assigns a value in between 0 and 1 to every input that sums to 1 for each input vector [114].

Loss function

The loss function is a measure of the neural network's performance that evaluates the deviation between the predicted and actual values. A high loss value indicates poor performance, while a low loss value indicates good performance. During backpropagation, the neural network optimises the loss function by minimising the discrepancy. The Cross-Entropy loss function is employed in this neural network to measure the performance of the model, with output values ranging from 0 to 1.

In multi class classification a different loss for each class label per observation is calculated. The result is the sum of all the losses. The formula is as follows:

$$\text{Cross-Entropy} = - \sum_{j=1}^n y_{(o,c)} \log(P_{(o,c)}) \quad (3.3.2)$$

where n is the number of classes, y is a binary indicator if class label c is the correct for observation o and p is the predicted probability observation o is of class c . [115]

To address overfitting, L2 regularisation is applied. This method introduces a penalty term to the loss function, proportional to the square of the coefficient magnitudes, thereby discouraging large weights in the model. The total loss, incorporating L2 regularisation, is represented as:

$$\text{Loss}_{\text{total}} = \text{Cross-Entropy} + \lambda \sum_{i=1}^m w_i^2 \quad (3.3.3)$$

Here, λ denotes the regularisation parameter that moderates the penalty's influence, m represents the number of features, and w_i are the model weights. The regularisation term $\lambda \sum_{i=1}^m w_i^2$ penalises the magnitude of the weights, compelling the model towards simpler solutions with smaller coefficients, which helps prevent overfitting [116].

Optimiser

Optimisers adjust the attributes of the neural network, such as the weights and learning rate, to minimise the losses. The Adam optimiser is used in this neural network because of its simple implementation, efficiency, low memory requirement, consistency when diagonally rescaling gradients, and suitability for problems with large datasets [117].

Epoch numbers

An epoch refers to a full pass of the training data through the neural network, in which the network learns and updates its weights. The choice of the number of epochs is important for obtaining a well-trained model. A large number of epochs

can lead to overfitting, causing the model to become too specialised to the training data, and thus less accurate when presented with new data. On the other hand, too few epochs can result in underfitting, where the model has not learned enough from the data and is less accurate overall. Therefore, finding the optimal number of epochs is essential for achieving a well-balanced and accurate model.

Mini-batch size

Every time the data passes through the network, it needs to be split into different groups or batches for more efficient learning. By dividing the data into smaller batches, the network requires less computational power and trains faster. The size of each batch is referred to as the mini-batch size, and the number of batches is called an iteration. For example, if a dataset with 1000 samples is divided into mini-batches of size 100, then there will be 10 iterations.

3.3.5 Performance Analysis Metrics

The effectiveness of machine learning models in classification tasks is quantitatively assessed using various performance metrics. In this study, the metrics are employed to evaluate the model's ability to accurately classify individual appliance consumption data within the energy disaggregation domain. These metrics evaluate different aspects of model performance, such as overall accuracy, precision in identifying positive cases, recall or sensitivity, and the balance between precision and recall, shown by the F1-Score.

Performance Metrics

The following metrics are used for evaluation:

$$\text{Accuracy} = \frac{TP + TN}{TP + FP + FN + TN} \quad (3.3.4)$$

$$\text{Precision} = \frac{TP}{TP + FP} \quad (3.3.5)$$

$$\text{Recall} = \frac{TP}{TP + FN} \quad (3.3.6)$$

$$\text{F1-Score} = 2 * \frac{\text{Precision} * \text{Recall}}{\text{Precision} + \text{Recall}} \quad (3.3.7)$$

where TP (True Positives) indicates correctly predicted appliance activations, FP (False Positives) denotes instances where an appliance's activation was incorrectly predicted, TN (True Negatives) represents correct predictions of non-activation, and FN (False Negatives) refers to missed appliance activations.

Accuracy measures the proportion of true results (both true positives and true negatives) among the total number of cases examined. Precision assesses the model's ability to identify only relevant instances as positive, while Recall evaluates the model's capability to find all relevant instances in the dataset. The F1-Score provides a harmonic mean of Precision and Recall, offering a single metric to assess the balance between them.

Precision and recall are important because they measure the model's accuracy in predicting positive cases and its ability to capture all actual positive cases, respectively. This distinction is important in scenarios where misclassifying an instance as positive (a false positive) has different consequences compared to failing to identify a positive instance (a false negative). The F1-Score is particularly valuable for datasets with imbalanced classes as it provides a balanced measure of precision and recall, ensuring that neither metric disproportionately affects the overall performance evaluation [118].

K-fold Cross-validation

K-Fold Cross-validation, a robust method for assessing model performance, particularly in scenarios with limited data, the dataset D is partitioned into K subsets of approximately equal size, denoted as D_1, D_2, \dots, D_K . This method uses each data point for training and testing, ensuring a complete evaluation of the model's performance [119].

This partitioning can be expressed as:

$$D = D_1 \cup D_2 \cup \dots \cup D_K \quad (3.3.8)$$

subject to the condition that:

$$D_i \cap D_j = \emptyset \quad \text{for all } i \neq j. \quad (3.3.9)$$

For each fold k from 1 to K :

- D_k serves as the validation set.
- The union of the remaining subsets $D \setminus D_k$ forms the training set.
- The model is trained on $D \setminus D_k$ and evaluated on D_k , with the evaluation metric for fold k denoted by E_k .

The overall performance metric is computed as the average of the evaluation metrics across all folds:

$$E_{avg} = \frac{1}{K} \sum_{k=1}^K E_k \quad (3.3.10)$$

3.4 Performance on appliance signal classification using SE-IF

To demonstrate the effectiveness of the methods and algorithms, the machine learning and deep learning algorithms were tested under different scenarios, including

measured appliance data and disaggregated appliance data. Testing these different scenarios is important because the first one demonstrates the robustness of the method for classifying sequential data, regardless of its origin, while the second one shows potential for identifying and classifying appliance data obtained from disaggregation methods.

In this study, the SE-IF method is evaluated for individual appliance signal classification obtained in Section 3.2. The first section explains the appliance type groups, the second section tests and compares different machine learning methods, and the third section tests and compares both LSTM and BiLSTM networks.

3.4.1 Appliance testing groups

A household can feature a diverse group of users and patterns of energy consumption, which are reflected in the appliances they utilise and the way in which they are operated. Distinct from the established appliance Type classifications discussed previously in Chapter 2, appliances can be sorted into groups based on their consumption profiles. One can find devices within the home that draw minimal energy, such as chargers, lamps, routers, or modems, which typically have similar energy requirements with only slight variations in wattage. Additionally, households commonly contain appliances that exhibit variable energy demands, such as washing machines and dishwashers, which are characterised by their fluctuating consumption.

In practical settings, it is common for a household to have different appliances that may have low and potentially consistent energy demands, as well as those with high and variable energy consumption patterns. Therefore, it is important to develop a method that can classify appliances under all these different scenarios.

The categorisation of appliances into testing groups was based on an analysis of their energy consumption profiles, conducted using the data available and insights drawn from relevant literature on appliance energy use. This informed decision-making process involved identifying patterns in power usage that logically grouped

appliances into categories with similar or dissimilar consumption behaviours.

The purpose of this grouping was to assess how different appliance categories might influence the accuracy of energy disaggregation algorithms. In detail, also found in Table 3.2:

- **Similar consumption appliances** were chosen for their low and stable power usage, which could pose a challenge for algorithms due to their comparable consumption patterns.
- **Non-similar consumption appliances** were picked for their higher and fluctuating energy needs, offering distinct challenges for disaggregation, especially in recognising different cycle patterns.
- **Mixed group of appliances** was created to evaluate the algorithms in more realistic settings with a combination of appliance types.

Table 3.2: Power Consumption of Appliances

Similar Appliances		Non-similar Appliances	
Appliance	Watts	Appliance	Watts
Adsl Router	6-7	Livingroom_lamp_tv	11-14
Livingroom_lamp_tv	11-14	Dishwasher	120-2300
Livingroom_s_lamp2	7-9	Amp_livingroom	23-27
Office_lamp2	9-10	Kitchen_dt_lamp	40-42
Subwoofer_livingroom	15-16	Washing_machine	10-2000
Modem	9-10	Battery_charger	4-30
Server_hdd	10-13	Office_lamp3	6-7
Speakers	10-11		

3.4.2 Overview of model final inputs

Depending on the group of appliances being analysed, the input array size will vary. For instance, the group of similar appliances comprises 8 appliances, while the group of non-similar appliances includes 7. However, due to one appliance being repeated, the mixed appliances group contains 14. Since each appliance has 10 samples, the

selected experiment (based on the chosen appliance group) will result in a cell array of size 80, 70, or 140. Each cell contains a 500x1 vector array representing the appliance's power consumption, leading to 80, 70, or 140 collections of 500x1-sized vector arrays. After the feature extraction layer is applied, a cell array of size 80, 70, or 140 is obtained, each containing a vector array sized 11x129, as illustrated in Figure 3.9. This set of cells, each containing a 11x129 sized vector array, will serve as the input for the model under evaluation.

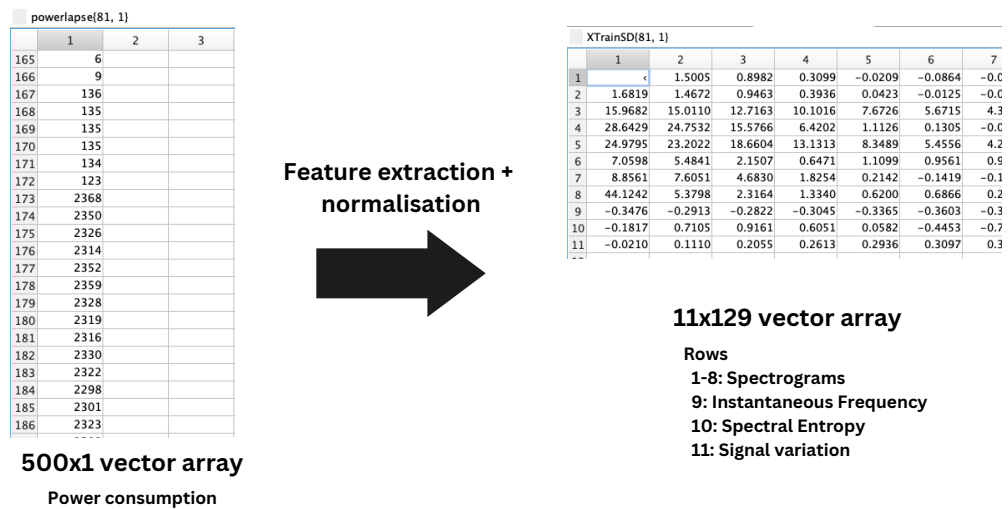

Figure 3.9: Feature enhancement layer

3.4.3 Machine learning methods results comparison

In this section, a comprehensive evaluation and comparison of widely used machine learning algorithms for classification tasks is presented. The primary objective is to assess the performance and limitations of various algorithms, including NB, LDA, DT, and KNN.

While these algorithms have demonstrated effectiveness in the literature, inherent weaknesses exist that can impact their performance under certain conditions. It should be noted that certain input data entries had to be manually adjusted or removed to ensure the proper functioning of the algorithms. This was necessary due to the sharing of means among certain classes, which posed a challenge for the

algorithms in generating a new axis that effectively separated the classes.

The four metrics used for evaluation are accuracy, recall, precision and F1-score. The focus will be on F1-score since it is the metric that allows us to identify positive instances where appliances were correctly detected, while also considering the false positives.

Naive Bayes

The NB algorithm exhibits the lowest performance among all the algorithms in every category. It achieved an F1-score value of 72.52% when evaluating similar appliances, 78.1% when evaluating non-similar appliances, and 72.55% when evaluating mixed appliances.

This can be attributed to its assumption of feature independence, which does not hold true in this case. Given that all features are closely related to each other, the algorithm's performance is weakened compared to other algorithms that can use these relationships effectively.

Linear Discriminant Analysis

The LDA algorithm demonstrated the second-best performance among all the algorithms in the similar appliances and mixed appliances categories while tying with DTs in the non-similar appliances category. It achieved an F1-score value of 100% when evaluating similar appliances, 90.48% when evaluating non-similar appliances, and 88.57% when evaluating mixed appliances.

This algorithm's performance is attributed to its ability to effectively use the relationships among the closely related features in this case. Unlike NB, which assumes feature independence and struggles with related features, LDA benefits from the inherent relationships between the features, leading to improved performance.

Decision Trees

The DT algorithm was the best-performing algorithm among all the algorithms in every category, tying with LDA in the non-similar appliances category. It achieved an F1-score value of 100% when evaluating similar appliances, 94.29% when evaluating non-similar appliances, and 94.52% when evaluating mixed appliances. This algorithm's success can be attributed to its ability to capture complex relationships and interactions among features. DTs excel at partitioning the feature space based on different criteria, allowing them to effectively classify the appliances. Unlike NB, which assumes feature independence, DTs can take advantage of the interdependencies and non-linear relationships between the features, resulting in superior performance.

K-nearest neighbour

The KNN algorithm performed as the third-best algorithm among all the algorithms in every category. It achieved an F1-score value of 85.42% when evaluating similar appliances, 94.29% when evaluating non-similar appliances, and 74.05% when evaluating mixed appliances.

One limitation of KNN is its susceptibility to the curse of dimensionality. When dealing with high-dimensional data, the performance of KNN may degrade as the number of dimensions increases. In high-dimensional spaces, the concept of distance becomes less meaningful, and the data points become more sparse. This sparsity can lead to a decrease in the effectiveness of KNN in accurately identifying nearest neighbors and making reliable predictions.

3.4.4 Deep learning methods results comparison

In this section, the focus is on deep learning methods, specifically Long Short-Term Memory (LSTM) and Bidirectional LSTM (BiLSTM) architectures, which are

Table 3.3: Machine learning algorithms performance metrics for similar appliances group

Algorithm	Accuracy (%)	Precision (%)	Recall (%)	F1-Score (%)
NB	67.30	70.52	77.5	72.52
LDA	100	100	100	100
DT	100	100	100	100
KNN	80.89	83.75	88.75	85.42

Table 3.4: Machine learning algorithms performance metrics for non-similar appliances group

Algorithm	Accuracy (%)	Precision (%)	Recall (%)	F1-Score (%)
NB	72.22	76.19	82.86	78.10
LDA	87.5	89.29	92.86	90.48
DT	92.5	93.57	95.71	94.29
KNN	92.5	93.57	95.71	94.29

Table 3.5: Machine learning algorithms performance metrics for mixed appliances group

Algorithm	Accuracy (%)	Precision (%)	Recall (%)	F1-Score (%)
NB	65.01	70.44	77.86	72.55
LDA	84.67	87.14	91.43	88.57
DT	92.33	93.93	95.71	94.52
KNN	66.52	71.55	79.29	74.05

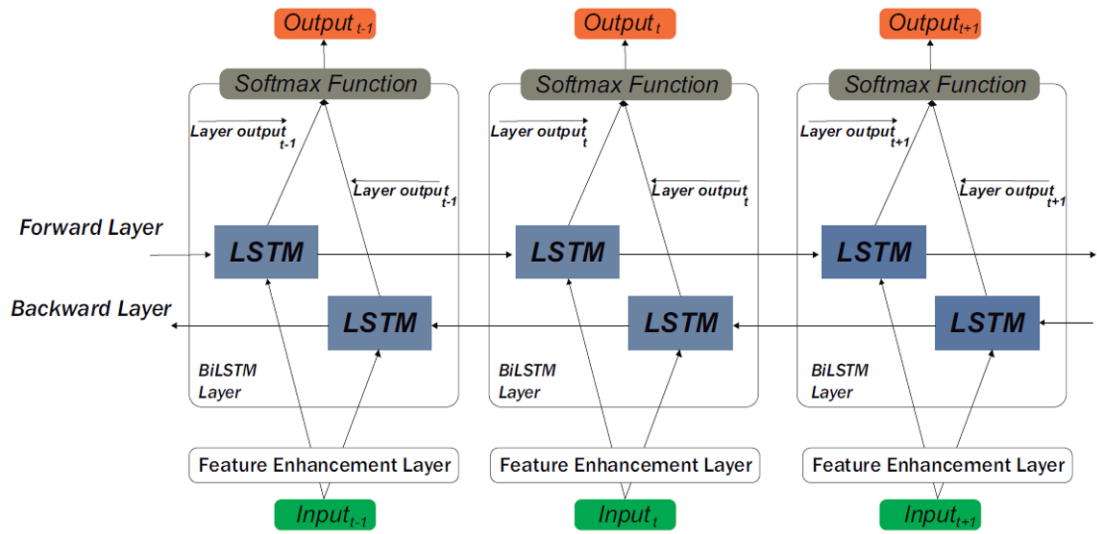

Figure 3.10: Structure of the SE-IF BiLSTM neural network

extensively evaluated and compared for the classification results. The objective is to assess their performance and limitations in the context of appliance classification. While traditional machine learning algorithms, such as NB, LDA, DT, and KNN, have demonstrated effectiveness in various scenarios, they also show inherent weaknesses that can hinder their performance under certain conditions. The previous section has highlighted and analysed these limitations, demonstrating the need for alternative approaches.

LSTM and BiLSTM, being deep learning architectures, offer unique advantages in capturing sequential dependencies and modelling temporal dynamics. This makes them highly suitable for analysing time-series data, such as appliance usage patterns. Exploring their ability to retain and propagate information over long sequences, LSTM and BiLSTM have the potential to overcome the limitations observed in traditional machine learning algorithms, leading to superior performance in appliance classification tasks. The structure of a BiLSTM network using the SE-IF method can be seen in Fig. 3.10.

To ensure the best performance possible, it is also important to find the best settings for a neural network, depending on the type of data to be evaluated. The comparison mainly aims to find the influence of epoch numbers and mini-batch size on the

performance of both models, single-layer LSTM and BiLSTM. The results of this comparison demonstrate the most effective combination of network architecture and training parameters for the SE-IF method in each scenario.

It is found in the literature that the groups of data are usually divided into batch sizes of 8, 16, 32, 64 and 128. These sizes are used because being powers of 2, results in an easier task to divide the training sets and utilise memory resources more efficiently. For this reason, these sizes are used in these simulations for the mini-batches. The evaluation of LSTM and BiLSTM’s performance is based on the same four key metrics: accuracy, recall, precision, and F1-score, presented in Table 3.6, 3.7 and 3.8. Among these metrics, F1-score takes the central role as it enables the identification of instances where appliances were correctly detected, while also balancing the false positives.

		LSTM				BiLSTM			
		Accuracy	Precision	Recall	F1-Score	Accuracy	Precision	Recall	F1-Score
100 epochs	8 mbs	0.27	0.29	0.40	0.32	0.81	0.84	0.89	0.85
	16 mbs	0.26	0.30	0.39	0.33	0.87	0.89	0.93	0.90
	32 mbs	0.17	0.16	0.28	0.19	0.79	0.84	0.88	0.85
	64 mbs	0.21	0.22	0.34	0.25	0.82	0.84	0.89	0.85
	128 mbs	0.19	0.18	0.30	0.21	0.79	0.82	0.88	0.84
1000 epochs	8 mbs	0.53	0.58	0.68	0.61	0.90	0.91	0.94	0.92
	16 mbs	0.52	0.55	0.65	0.58	0.84	0.86	0.90	0.88
	32 mbs	0.42	0.47	0.55	0.50	0.82	0.85	0.89	0.86
	64 mbs	0.45	0.50	0.60	0.54	0.79	0.81	0.88	0.83
	128 mbs	0.50	0.56	0.63	0.58	0.74	0.76	0.83	0.78
1500 epochs	8 mbs	0.54	0.57	0.65	0.59	0.84	0.86	0.90	0.87
	16 mbs	0.59	0.63	0.70	0.65	0.79	0.81	0.86	0.83
	32 mbs	0.55	0.62	0.69	0.64	0.84	0.86	0.90	0.88
	64 mbs	0.51	0.57	0.66	0.60	0.89	0.91	0.94	0.92
	128 mbs	0.51	0.54	0.66	0.58	0.75	0.78	0.85	0.80

Table 3.6: Performance metrics on similar appliances group

Scenario 1: Similar appliances

The similar appliances category exhibits varying results, with LSTM architecture generally achieving very low scores. Identifying subtle differences in consumption loads can be challenging for the network when analysing similar appliances. Every piece of information is important to determine the appliance being used. Adding an extra layer in BiLSTM helps to learn sequences in both directions, making BiLSTM significantly better at this task.

In the 100 epochs category, the best option is 8 mbs for the LSTM and 16 mbs for the BiLSTM, where we see the BiLSTM outperforming the LSTM by 173% in F1-Score, where the LSTM scored 32% and the BiLSTM, 90%.

In the 1000 epochs category, the best option is 8 mbs for both networks, where we see the BiLSTM was more effective than the LSTM by 49% in F1-Score, where the LSTM scored 61% and the BiLSTM, 92%.

In the 1500 epochs category, the best option is 16 mbs for LSTM and 32 mbs for BiLSTM, where we see the BiLSTM showing better results than the LSTM by 44% in F1-Score, where the LSTM scored 65% and the BiLSTM, 92%.

In this category, it was found that the performance of LSTM networks in this scenario is worse than that of the BiLSTM in every epoch and mbs combination, reaching as low as 19% F1-Score. The BiLSTM performed the best out of the two, achieving a maximum score of 92% F1-Score.

Scenario 2: Non-similar appliances

The experiment on scenario 2 revealed that the BiLSTM networks consistently outperformed the LSTM networks in every epoch and mbs combination considered.

For instance, in the 100-epoch category, the LSTM yielded the best results with 8 mbs, while the BiLSTM achieved superior outcomes with 128 mbs. However, the LSTM network was surpassed by the BiLSTM network in all performance measures,

		LSTM				BiLSTM			
		Accuracy	Precision	Recall	F1-Score	Accuracy	Precision	Recall	F1-Score
100 epochs	8 mbs	0.40	0.47	0.57	0.49	0.98	0.98	0.99	0.98
	16 mbs	0.44	0.51	0.60	0.53	0.93	0.94	0.96	0.94
	32 mbs	0.43	0.49	0.60	0.51	0.96	0.96	0.97	0.97
	64 mbs	0.39	0.46	0.56	0.48	0.95	0.96	0.97	0.96
	128 mbs	0.36	0.44	0.53	0.46	1	1	1	1
1000 epochs	8 mbs	0.61	0.66	0.73	0.67	0.93	0.94	0.96	0.94
	16 mbs	0.51	0.56	0.66	0.59	1	1	1	1
	32 mbs	0.48	0.53	0.64	0.56	0.98	0.98	0.99	0.98
	64 mbs	0.46	0.53	0.63	0.56	0.98	0.98	0.99	0.98
	128 mbs	0.48	0.54	0.64	0.57	0.98	0.98	0.99	0.98
1500 epochs	8 mbs	0.68	0.71	0.79	0.73	0.95	0.96	0.97	0.96
	16 mbs	0.55	0.59	0.69	0.62	1	1	1	1
	32 mbs	0.67	0.71	0.79	0.73	1	1	1	1
	64 mbs	0.53	0.59	0.67	0.61	0.95	0.96	0.97	0.96
	128 mbs	0.60	0.66	0.73	0.68	0.95	0.96	0.97	0.96

Table 3.7: Performance metrics on non-similar appliances group

recording an F1-Score of 49%, while the BiLSTM obtained a perfect F1-Score, representing a 104% enhancement in performance.

In the 1000-epoch category, the LSTM network performed best with 8 mbs, whereas the BiLSTM network attained optimal outcomes with 16 mbs. In this case, the BiLSTM again exhibited better performance compared to the LSTM network, with an F1-Score of 100% as opposed to the LSTM's 67%, representing a 49.25% increase in score.

In the 1500-epoch category, the optimal setting for both networks was 32 mbs. The BiLSTM network once again demonstrated better performance than the LSTM network, obtaining an F1-Score of 100% compared to the LSTM's 73%, resulting in a 36.9% improvement in score.

		LSTM				BiLSTM			
		Accuracy	Precision	Recall	F1-Score	Accuracy	Precision	Recall	F1-Score
100 epochs	8 mbs	0.17	0.22	0.29	0.23	0.91	0.93	0.95	0.94
	16 mbs	0.16	0.21	0.28	0.22	0.91	0.93	0.95	0.93
	32 mbs	0.17	0.21	0.29	0.22	0.80	0.83	0.89	0.85
	64 mbs	0.17	0.21	0.29	0.22	0.61	0.65	0.75	0.68
	128 mbs	0.17	0.23	0.29	0.24	0.66	0.71	0.79	0.73
1000 epochs	8 mbs	0.60	0.64	0.69	0.65	0.93	0.95	0.96	0.95
	16 mbs	0.44	0.51	0.56	0.52	0.92	0.94	0.96	0.94
	32 mbs	0.34	0.39	0.45	0.40	0.90	0.92	0.94	0.93
	64 mbs	0.28	0.33	0.42	0.35	0.83	0.86	0.90	0.87
	128 mbs	0.21	0.27	0.34	0.28	0.88	0.91	0.94	0.92
1500 epochs	8 mbs	0.77	0.81	0.86	0.82	0.99	0.99	0.99	0.99
	16 mbs	0.68	0.73	0.79	0.75	0.91	0.93	0.95	0.93
	32 mbs	0.57	0.63	0.70	0.65	0.90	0.91	0.94	0.92
	64 mbs	0.38	0.43	0.50	0.45	0.88	0.90	0.93	0.91
	128 mbs	0.25	0.31	0.39	0.33	0.87	0.90	0.93	0.91

Table 3.8: Performance metrics on mixed appliances group

Scenario 3: Mixed appliances

Based on the results of the experiments on scenario 3, it was determined that the BiLSTM networks consistently outperformed the LSTM networks across every epoch and mbs combination tested.

For example, in the 100-epoch category, the LSTM network's best performance was achieved with 128 mbs, while the BiLSTM network produced optimal outcomes with 8 mbs. Notably, the BiLSTM network exhibited vastly superior performance in this category, achieving an F1-Score of 93%, which represented a 306.5% increase compared to the LSTM's 24%.

In the 1000-epoch category, the optimal setting for both networks was 8 mbs. The BiLSTM network once again demonstrated better results than the LSTM network, scoring an F1-Score of 95%, a 46% increase over the LSTM's F1-Score of 65%.

In the 1500-epoch category, the optimal setting for both networks was again 8 mbs. The BiLSTM network proved its effectiveness once more, exhibiting a 20.7%

improvement in F1-Score over the LSTM network. Specifically, the BiLSTM network achieved an F1-Score of 99%, while the LSTM network achieved an F1-Score of 82%.

Results

Based on the conducted experiments, the optimal combinations of mini-batch size and epoch numbers for LSTM and BiLSTM models were determined, along with their corresponding evaluation metrics, shown in Table 3.9

Table 3.9: Best settings for networks using SE-IF method

Appliance Category	Type	Epochs	MBS
Similar Appliances	BiLSTM	1000	8
Non-similar Appliances	BiLSTM	1500	32
Mixed Appliances	BiLSTM	1500	8

These results highlight the effectiveness of the BiLSTM model across different scenarios. For similar appliances, the BiLSTM model achieved high accuracy, recall, precision, and F1-score, indicating its ability to accurately classify instances within this category, regardless of the similarity among its classes. Similarly, for non-similar appliances, the BiLSTM model demonstrated perfect performance across all metrics, showcasing its capability to precisely distinguish non-similar instances.

In the case of mixed appliances, the BiLSTM model achieved exceptional performance with high accuracy, recall, precision, and F1-score. This indicates its effectiveness in handling scenarios where multiple appliance types are present, further demonstrating its utility in real-life applications.

3.5 Conclusion

This chapter has detailed the development and validation of the SE-IF method, a new approach for feature extraction in appliance classification with limited datasets. Its effectiveness, confirmed through various tests, lies in its use of spectrograms for

detailed analysis and the integration of spectral entropy and instantaneous frequency features, allowing for the accurate identification of appliance behaviours.

The evaluation of four widely-used machine learning algorithms—NB, LDA, DT, and KNN—revealed distinct advantages and disadvantages in their application to appliance classification. The fundamental limitations of these algorithms stem from their inability to fully capture the complex interdependencies of features, as evidenced by the underperformance of the NB algorithm due to its invalid assumption of feature independence. LDA and DTs, despite showing promise in certain aspects, struggled with complex and non-linear relationships. KNN’s effectiveness was compromised by the curse of dimensionality, particularly in high-dimensional spaces.

In contrast, the BiLSTM model, augmented with the SE-IF method, outperformed these traditional approaches across critical metrics such as accuracy, recall, precision, and F1-score. This success highlights the BiLSTM model’s capability to manage the sequential and temporal dynamics inherent in appliance usage data, marking a significant advancement over conventional methods.

The comparison of traditional machine learning techniques with the BiLSTM model underscores the latter’s superior adaptability and performance in addressing the challenges of appliance load data’s complexity and variability. These results reinforce the BiLSTM model’s viability as a foundation for developing dependable and precise appliance classification systems.

Chapter 4

Appliance detection in household scenarios

4.1 Introduction

The previous chapter introduced the SE-IF methodology for feature extraction in appliance classification, which underwent testing across various machine learning and deep learning frameworks, proving its capability in classifying appliance signals. However, its effectiveness in a residential-like setting, characterised by simultaneous operation of multiple appliances amidst other types of electrical loads, remains unexamined.

This chapter aims to present a detection algorithm designed to identify periods of high energy consumption, subsequently applying the SE-IF methodology to classify the appliances active during those times. This chapter addresses *Objective 2*, which was outlined in Chapter 1.

The contributions are as follows:

- An appliance detection algorithm is modelled, which utilises windows to detect segments with high power consumption. This algorithm analyses the power consumption patterns and identifies specific time intervals where appliances

exhibit significant energy usage. By employing window-based analysis, the algorithm effectively captures these periods and accurately distinguishes them from the overall power consumption profile.

- The SE-IF BiLSTM method is employed in the classification of the appliances detected by the detection algorithm, capable of accurately classifying different appliances even when multiple appliances are used simultaneously, achieving an average F1-score rate of 92% across different scenarios. This demonstrates the effectiveness of the SE-IF BiLSTM approach in accurately identifying and distinguishing between various appliances, including scenarios where appliances operate concurrently.

4.2 Proposed method: A detection algorithm

The primary objective of this section is to introduce the detection algorithm devised for this task, with the aim of identifying high-consumption appliances that significantly contribute to the overall household energy consumption. This, in turn, leads to higher utility bills and increased carbon emissions. Subsequently, these appliances are classified using the SE-IF BiLSTM method.

In this simulation setting, the only available data for identification is the entire household's aggregate power consumption obtained from the smart meter. This scenario is very challenging because the algorithm is required to identify individual appliances from an aggregate consumption signal without additional data to aid the detection process. This section demonstrates the method's robustness in a realistic scenario, such as a typical household, where users do not use specialised equipment to track and monitor appliances, resulting in a minimally intrusive solution.

Table 4.1: Appliance Classification in Different Scenarios

Scenario	Individual appliance	Overlapping appliances
1	Washing machine Dishwasher Electric hob	-
2	Electric hob	Washing machine Dishwasher
3	Dishwasher	Washing machine Electric hob
4	Washing machine	Dishwasher Electric hob
5	-	Washing machine Dishwasher Electric hob

4.2.1 Consumption data creation

To evaluate the detection and classification algorithm’s performance in a simulation setting, three high-consumption appliances were selected: the washing machine, dishwasher, and electric hob. These appliances were chosen because they are commonly found in households and are known to have a significant impact on overall energy consumption. To gather data for the simulation, ten different usage periods of each appliance were obtained in section 3.3.2, chosen to capture various patterns of appliance usage. Examples of these usage periods can be seen in Fig. 4.1 In addition to using the appliance usage data, the average household consumption was obtained from the UK Dataset’s aggregate load.

Identifying appliances during individual use is important, but it’s also necessary to identify them when they are used simultaneously with other appliances, although this is significantly more challenging. To evaluate the method’s robustness in such scenarios, 5 different scenarios were designed for the simulations, presented in detail in Table 4.1. Each scenario comprises a combination of one, two, or all three of the high-consumption appliances: the washing machine, dishwasher, and electric hob, being used individually or simultaneously. For example, one scenario simulates the

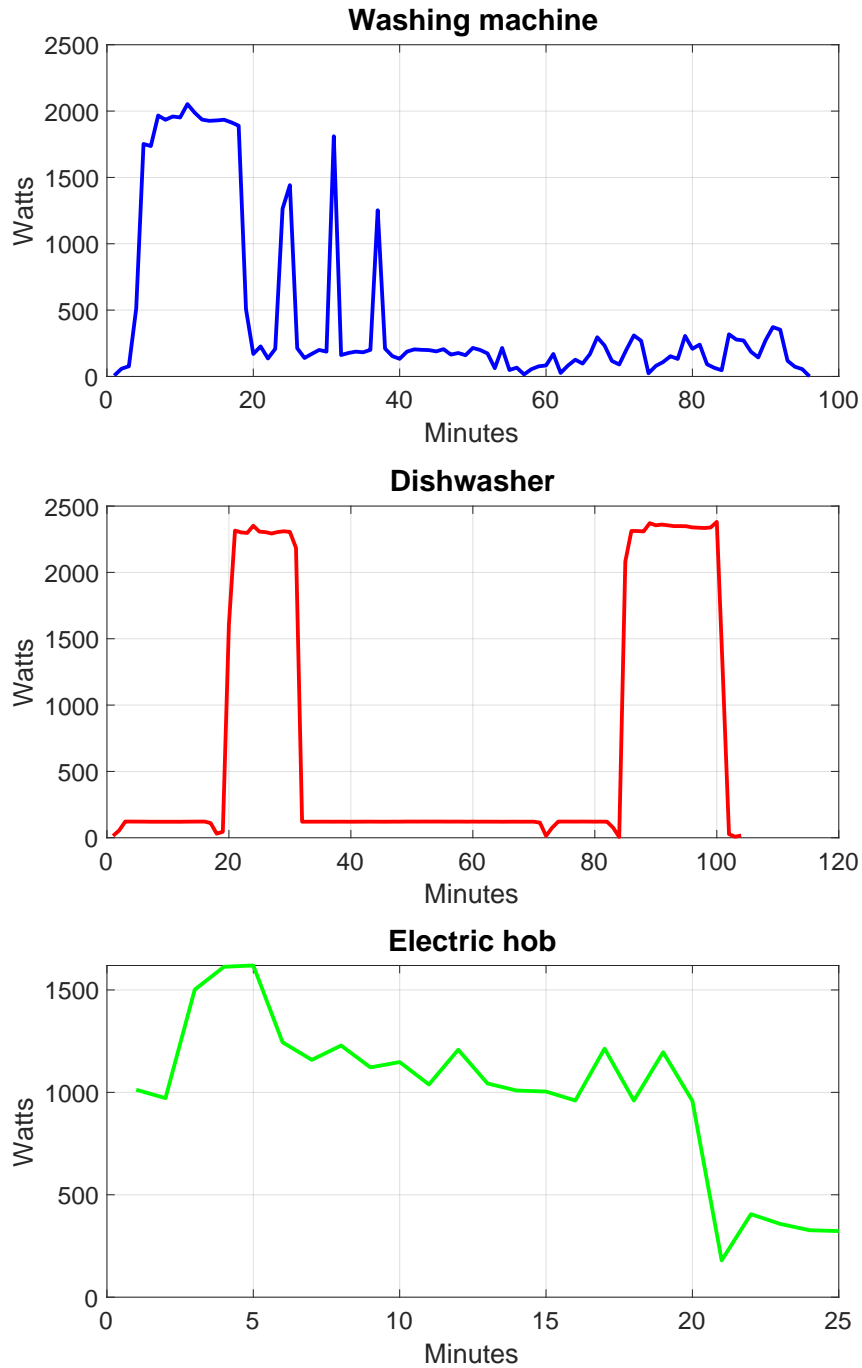

Figure 4.1: Raw appliance power consumption data.

Algorithm 1 Consumption data creation algorithm

```

1: baseLoad  $\leftarrow$  createArray(1440, values between 300 and 500W)
2: applianceStartTimes  $\leftarrow$  randomApplianceStartTimes()
3: for each appliance in applianceStartTimes do
4:   addApplianceLoadToBaseLoad(baseLoad, appliance)
5: end for

```

usage of the washing machine and electric hob together, while another simulates the usage of all three appliances at the same time. This way, the algorithm's effectiveness in identifying appliances during real-life usage scenarios can be tested and evaluated.

Based on this, the procedure to create the scenarios was as follows, also shown in Algorithm 1:

1. *Line 1*: An array representing the base load with 1440 data points was created, where each time step represents one minute of a day. The values range between 300 and 500W, representing the average power usage in the household based on the aggregated load from the dataset.
2. *Line 2*: The start time of each appliance was randomly defined, ensuring that their duration did or did not overlap as required by the scenario.
3. *Lines 3-5*: The power loads of the appliances were added to the values on the existing array corresponding to their time steps defined in the previous step.

4.2.2 Algorithm model for appliance usage detection

After successfully obtaining the different scenarios established in the previous section, an algorithm for detecting the appliances was formulated, shown in Algorithm 2, which worked as follows:

1. *Line 1*: The power consumption average of the entire array was obtained.
2. *Lines 2-3*: The result was then subtracted from each time step of the array.
 - (a) *Lines 4-7*: If the result was less than zero, then it was defined as zero.

Algorithm 2 Appliance detection algorithm

```

1: averagePower  $\leftarrow$  average(baseLoad)
2: for  $i = 0$  to 1439 do
3:   baseLoad[ $i$ ]  $\leftarrow$  baseLoad[ $i$ ] - averagePower
4:   if baseLoad[ $i$ ] < 0 then
5:     baseLoad[ $i$ ]  $\leftarrow$  0
6:   end if
7: end for
8: windows  $\leftarrow$  []
9: zeroThreshold  $\leftarrow$  8
10: foundAppliances  $\leftarrow$  []
11: for  $n = 1$  to 1421 do
12:   window  $\leftarrow$  baseLoad[ $n : n + 19$ ]
13:   if countZeros(window)  $\leq$  zeroThreshold then
14:     windows.append(window)
15:   end if
16: end for
17: startIndex  $\leftarrow$  windows[0].startIndex
18: endIndex  $\leftarrow$  windows[0].endIndex
19: distanceThreshold  $\leftarrow$  20
20: for  $i = 1$  to len(windows) - 1 do
21:   if (windows[ $i$ ].startIndex - windows[ $i - 1$ ].startIndex)  $\geq$  distanceThreshold
     then
22:     foundAppliance  $\leftarrow$  baseLoad[startIndex : endIndex]
23:     foundAppliances.append(removeLeadingTrailingZeros(foundAppliance))
24:     startIndex  $\leftarrow$  windows[ $i$ ].startIndex
25:     endIndex  $\leftarrow$  windows[ $i$ ].endIndex
26:   end if
27: end for

```

This produced an array of mostly zeros, except for the high peaks of consumption, indicating the use of high-consumption appliances. However, there is a possibility that zero consumption periods could occur during the use of an appliance, making it difficult to distinguish zero consumption that belongs to an appliance cycle from those obtained after removing noise in the signal. To address this, a sliding window method was formulated as follows:

1. *Line 9*: Set a threshold of 8 to limit the number of zeros that can be found in one window.
2. *Lines 10-16*: Divided the load and index data into arrays (windows) of size 20, starting from data point $n = 1$ to $n = n + 19$, where n increased by 1 for each

window.

3. *Lines 13-15*: Saved the load and index windows that satisfied the threshold condition.
4. *Line 19*: Set a threshold of 20 to limit the window distance between the saved windows from the previous step.
5. *Lines 20-27*: Analysed the saved windows to check if their starting indexes were continuous or a distance ahead of less than the threshold value.
 - (a) *Lines 22-26*: If not, then their starting and ending indexes were saved. The load found between the starting and ending indexes was then saved as a **detected appliance**.
 - (b) *Line 23*: Remove leading or trailing zeros from the detected appliance.

The choice of thresholds in the detection algorithm is of high importance to its performance. The zero threshold of 8 was empirically determined to effectively differentiate between the idle power consumption and the active use of appliances, allowing for minor variations in the base load without triggering a false positive. This threshold was set after observing the typical duration and intensity of appliance activations in the dataset, ensuring that brief and low-energy events are not misclassified as appliance usage.

Similarly, the distance threshold of 20 was established to distinguish between separate appliance usage events. This threshold ensures that events occurring closely in time are not mistakenly combined, while also preventing the fragmentation of a single event into multiple detections. The threshold was optimised through iterative testing, balancing the need to accurately capture appliance usage patterns against the granularity of event detection.

4.3 Performance on appliance classification using SE-IF BiLSTM and detection algorithm

4.3.1 Simulation scenarios

This section presents fig. 4.2–fig. 4.6, which show in detail the scenarios created in Section 4.2.1 illustrating the aggregate load, the actual power consumption of each appliance, and the appliances detected by the detection algorithm presented in Section 4.2.2.

- **Scenario 1:** All three appliances had usage periods that did not overlap with each other.
- **Scenario 2:** The washing machine started operations first, and mid-cycle, the dishwasher started operations too, operating simultaneously for a period of time until the washing machine ended operations. Then the dishwasher operated independently for another period of time. The electric hob operated independently later in the day.
- **Scenario 3:** The washing machine started operations first, but during its cycle, the electric hob operated briefly. The washing machine continued operating after the electric hob finished operations. The dishwasher operated independently later in the day.
- **Scenario 4:** The dishwasher started operations first and mid-cycle, the electric hob operated briefly. The dishwasher continued operations until it finished shortly after. Later in the day, the washing machine operated independently.
- **Scenario 5:** The dishwasher started operations first. Mid-cycle, the electric hob and the washing machine started operations at the same time and continued to operate together until the electric hob finished operating briefly

afterwards. The dishwasher and the washing machine then operated simultaneously until the dishwasher finished operations, and the washing machine finished later.

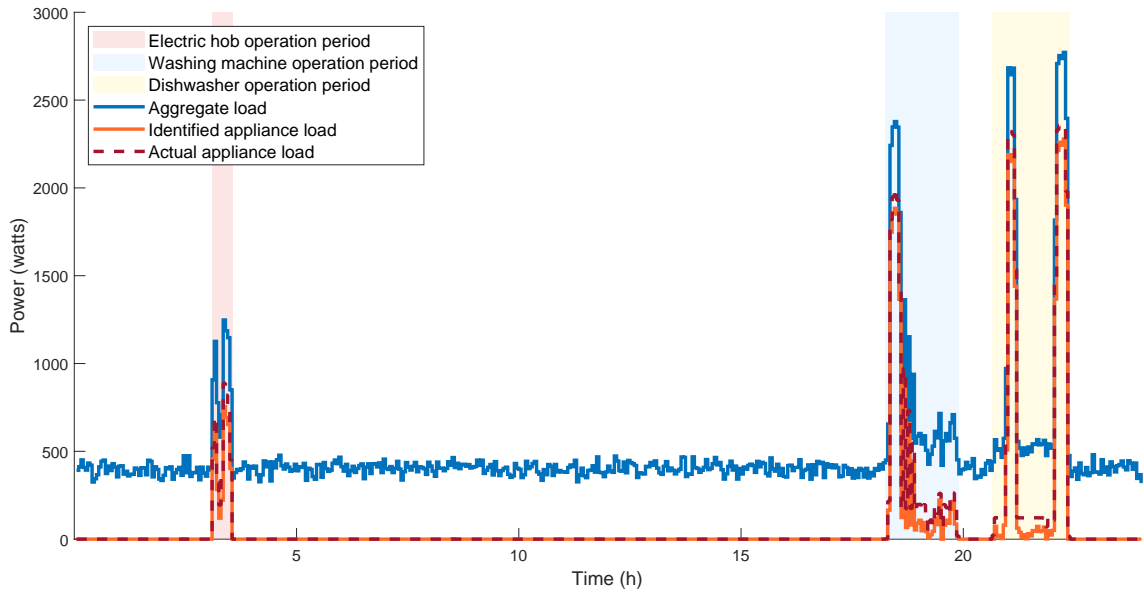

Figure 4.2: Scenario 1 load showing detected appliance load.

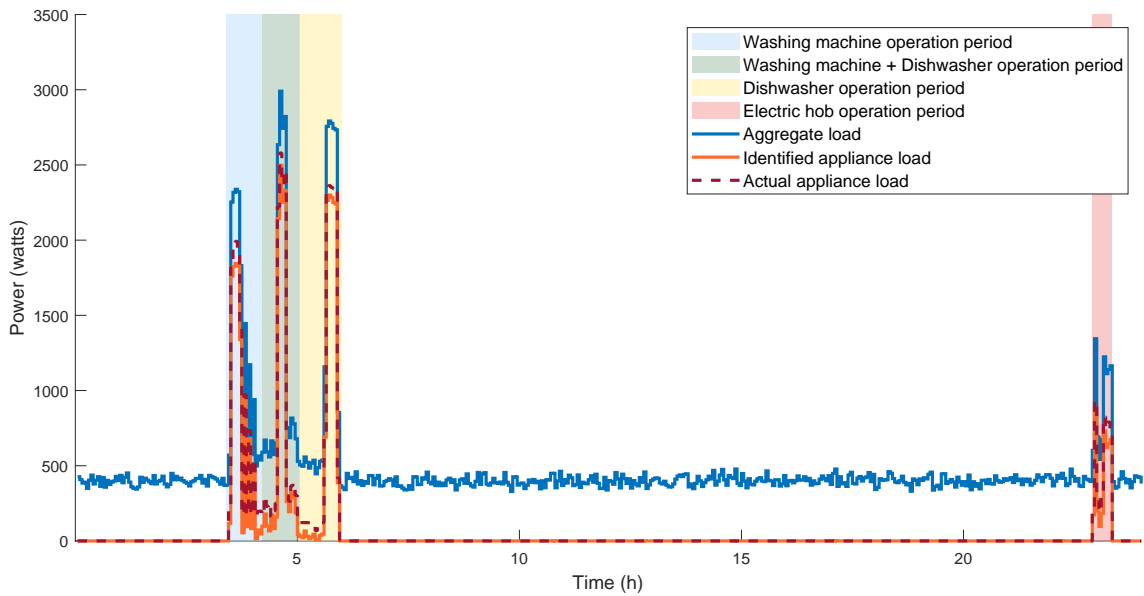

Figure 4.3: Scenario 2 load showing detected appliance load.

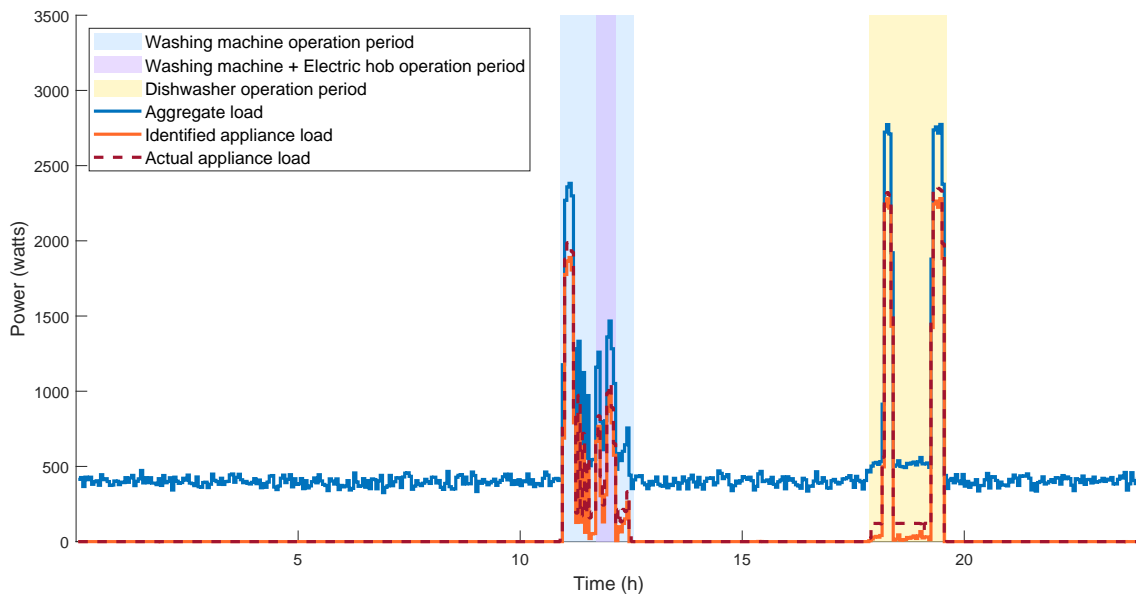

Figure 4.4: Scenario 3 load showing detected appliance load.

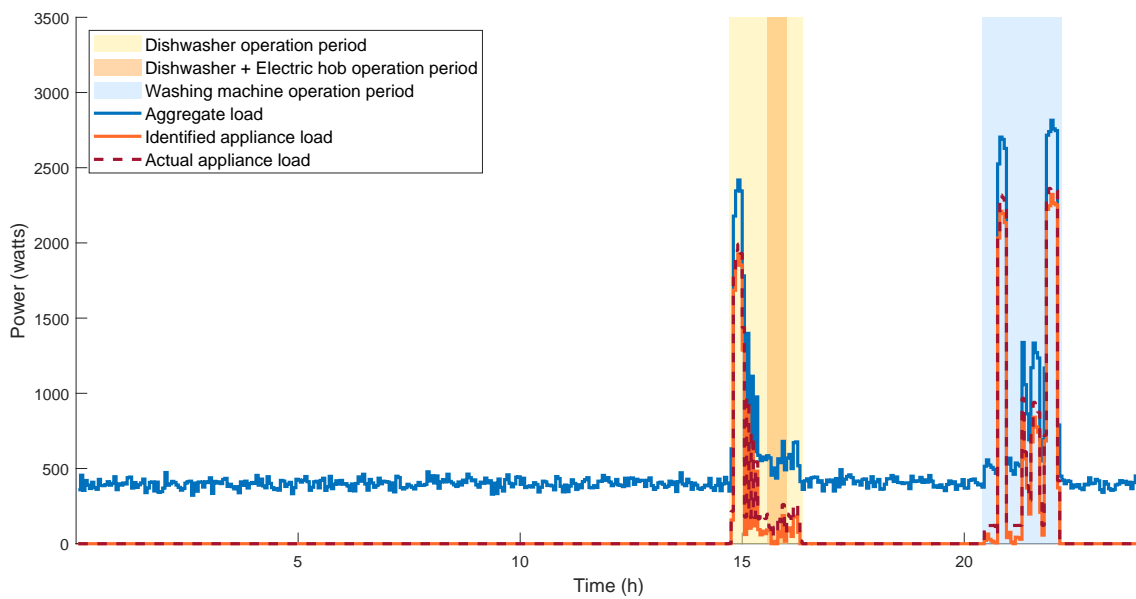

Figure 4.5: Scenario 4 load showing detected appliance load.

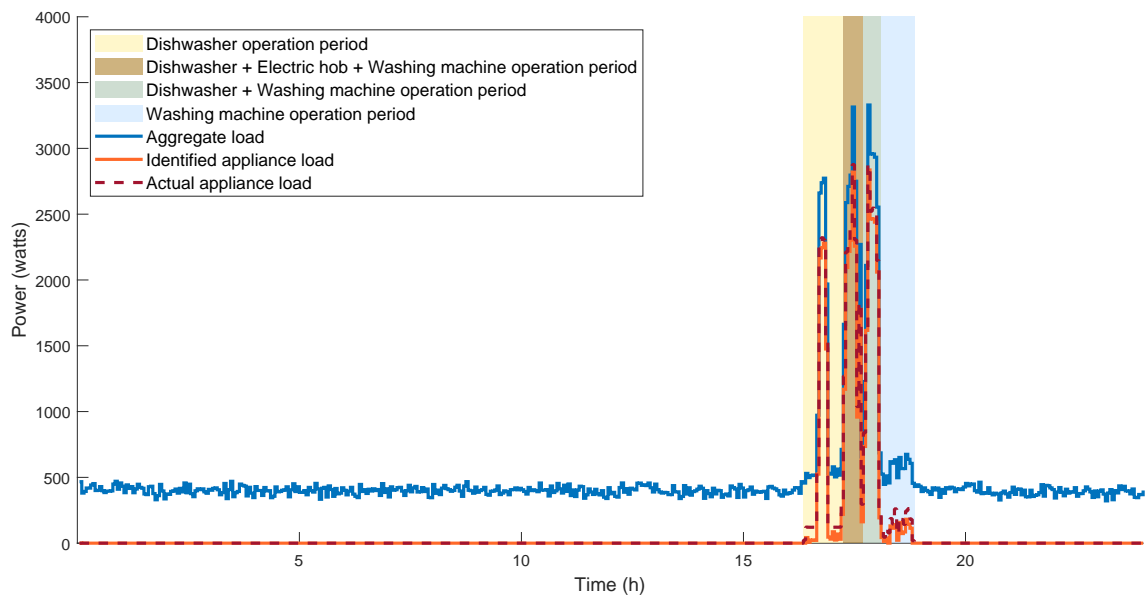

Figure 4.6: Scenario 5 load showing detected appliance load.

4.3.2 Results and discussion

The evaluation of the appliance detection and classification system involved testing 10 different neural networks using the 5 scenarios presented in the previous section. Every network underwent training using 9 training sets and was then tested on 1 testing set that it had not seen before, selected through the k-fold method described in Section 3.3.5. Performance metrics, including accuracy, precision, recall, and F1-score, were calculated for both scenario and neural network basis evaluations.

Table 4.2: Performance metrics for different scenarios, all values are expressed as percentages.

Neural Network	Accuracy	Precision	Recall	F1-Score
1	90	90	90	90
2	100	100	100	100
3	95	90	90	90
4	100	100	100	100
5	80	80	80	80
Average	94	92	92	92

Analysis by scenario

When analysing the individual scenarios' performances, it is evident that the majority of cases demonstrated high performance. Scenario 5, however, stood out with lower performance, achieving a F1-score rate of 80%. An issue occurred in this scenario, where in some instances, the networks failed to detect the usage of the electric hob, indicating that only the dishwasher and washing machine were being used. This occurred because the usage of the electric hob was not as significant, and considering the load used in the rest of the house, these variations were easily missed. The rest of the cases were detected a competent number of times, achieving more than 90% F1-score, and in the cases of scenarios 2 and 3, they were correctly detected 100% of the time.

Table 4.3: Performance metrics for different neural networks, all values are expressed as percentages.

Neural Network	Accuracy	Precision	Recall	F1-Score
1	70	76.2	85.7	78.6
2	90	92.9	92.9	90.5
3	90	81.0	85.7	82.9
4	100	100	100	100
5	100	100	100	100
6	100	100	100	100
7	100	100	100	100
8	100	100	100	100
9	100	100	100	100
10	70	66.7	71.4	68.6
Average	92	91.7	93.6	92.0

Analysis by neural network

When analysing the 10 different neural networks used, it is noticeable that the majority of the networks performed well, with networks 4-9 standing out, achieving 100% F1-score. Following them, networks 2 and 3 also performed well, obtaining 90% and 82.9% F1-score. Lastly, networks 1 and 10 had lower performance, reaching only 78.6% and 68.6% F1-score, respectively.

Analysis of the results revealed that some networks consistently performed better than others based on these evaluation metrics. However, the averaged value holds the most significance, as it reflects the method’s overall performance, highlighting its advantages and limitations. These networks demonstrated robust performance across various scenarios, suggesting their potential to perform consistently well in real-world usage. Careful attention was given to addressing the issue of overfitting through validation of each of the neural network’s performance on separate test data, by doing the K-Fold validation method explained in section 3.3.5, thereby confirming its effectiveness beyond the training dataset.

4.4 Conclusion

This chapter presented the integration of the SE-IF BiLSTM model with a novel window approach detection algorithm. It has demonstrated how a combination of feature extraction and deep learning models can lead to improved performance in classifying appliances. This integrated approach has proven effective in accurately identifying appliance usage in a range of scenarios, suggesting that it holds promise for deployment in diverse and dynamic environments.

Looking ahead, the methodology established in this chapter opens several branches for future research. The possibility of incorporating user behaviour patterns into the classification process presents an exciting frontier that could produce even finer analyses and more personalised energy management solutions. Furthermore, the scalability of the proposed methods to accommodate larger and more varied datasets could be another fruitful area of research, potentially enhancing the generalisability and utility of the findings.

In summary, the work in this chapter takes a step towards more intelligent and responsive energy management systems. The SE-IF method and its integration with advanced deep learning techniques represent a meaningful contribution to the field, with the potential for wide-ranging impact in both residential and industrial contexts.

Chapter 5

Multi-objective Appliance Scheduling Optimisation

5.1 Introduction

Chapters 3 and 4 covered the development of a detection algorithm aimed at analysing user behaviour and patterns, facilitating the precise detection of high-powered appliance usage and their time of use. A novel feature extraction methodology, known as the SE-IF BiLSTM, was introduced as well. This methodology allows a BiLSTM model to utilise extracted features, including spectral entropy and instantaneous frequency for more accurate and reliable classification of the appliances identified within the household.

While detecting and classifying appliances constitute important stages, utilising this information holds equal importance. The application of this data to provide well-informed recommendations for altering user behaviour and patterns in ways that

This chapter is based on work published in "Appliance Scheduling Optimisation Method Using Historical Data in Households with RES Generation and Battery Storage Systems," by M. Correa-Delval, H. Sun, P. C. Matthews and W. -Y. Chiu, 2022 5th International Conference on Renewable Energy and Power Engineering (REPE), Beijing, China, 2022, pp. 442-447, doi: 10.1109/REPE55559.2022.9949497.

benefit the environment and enhance user experience, such as cost reduction, is of high importance. These suggestions should be offered without significantly disturbing user comfort, thus increasing the likelihood of users embracing behavioural changes. This chapter addresses *Objective 2*, which was outlined in Chapter 1. It introduces a novel multi-objective optimisation formulation that integrates appliance scheduling within a household alongside the utilisation of renewable energy and battery storage systems. The overarching aim is to reduce costs and CO₂ emissions while accounting for user comfort.

The main contributions of this chapter are as follows:

- A novel approach to appliance scheduling is introduced, building on the SE-IF BiLSTM appliance classification technique developed in the previous chapter. By using this method, the HEMS gains the ability to learn from historical data, accurately identify and classify appliances, and use this knowledge for future scheduling.
- The formulation of a multi-objective optimisation problem that takes into account factors such as cost, CO₂ emissions, and user comfort improvement during the process of scheduling appliances within a household equipped with RES and BSS. A key component of this formulation is the focus on minimising user discomfort, which involves optimising appliance operation times to align with user preferences and routines, thereby enhancing the overall user experience and acceptance of the energy management system.

5.2 Problem Formulation

The optimisation carried out in this chapter is based on the results obtained from the methods presented in the previous chapter. This chapter will work with a scenario where the user is a resident of a house equipped with solar panels, a battery storage system, and appliances such as a washing machine, dishwasher, and electric hob.

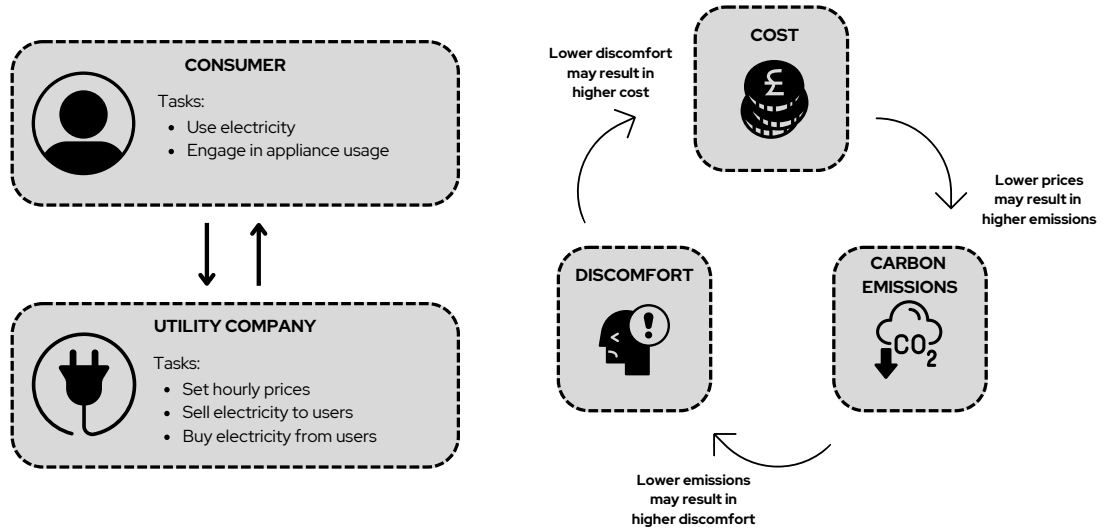

Figure 5.1: Multi-objective optimisation participants and objectives

Once the information about a user’s energy usage is gathered by using the SE-IF BiLSTM method, their behavioural patterns can be analysed.

Figure 5.1 presents the problem formulation addressed in this chapter. On one hand, the electricity company provides electricity to the user if needed and also buys energy produced by the user. The company defines the buying and selling prices based on the energy market. Additionally, the company employs Time-of-Use (TOU) pricing to incentivise efficient electricity use. TOU pricing divides the day into peak, off-peak, and mid-peak periods, each with different rates. These rates are designed to reflect the varying costs of electricity supply and demand throughout the day, encouraging users to reduce consumption during high-demand periods and thereby helping to balance the grid and reduce overall energy costs. On the other hand, the user uses electricity and appliances, and their behaviour is analysed. The user also has access to a system of solar panels and a battery storage system, which allows them to store excess energy for personal use or to sell it back to the company. The user aims to minimise their energy bill cost and carbon emissions. During the process, it is possible that scheduling the use of their appliances may cause some discomfort to the user. They also seek to minimise this discomfort as much as possible, within the user’s willingness.

This case was carried out during a June month in the south of London, United

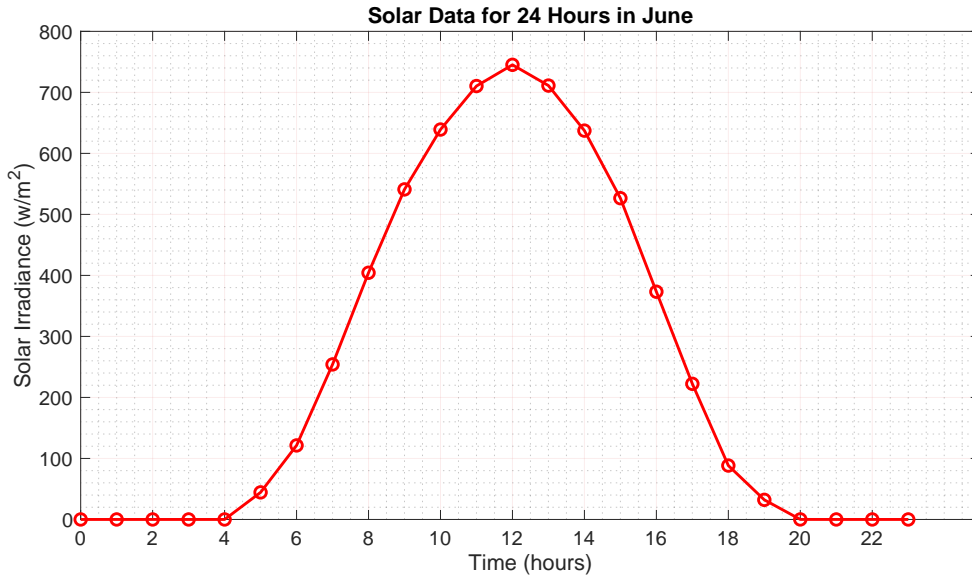

Figure 5.2: Average solar data of a June day [120]

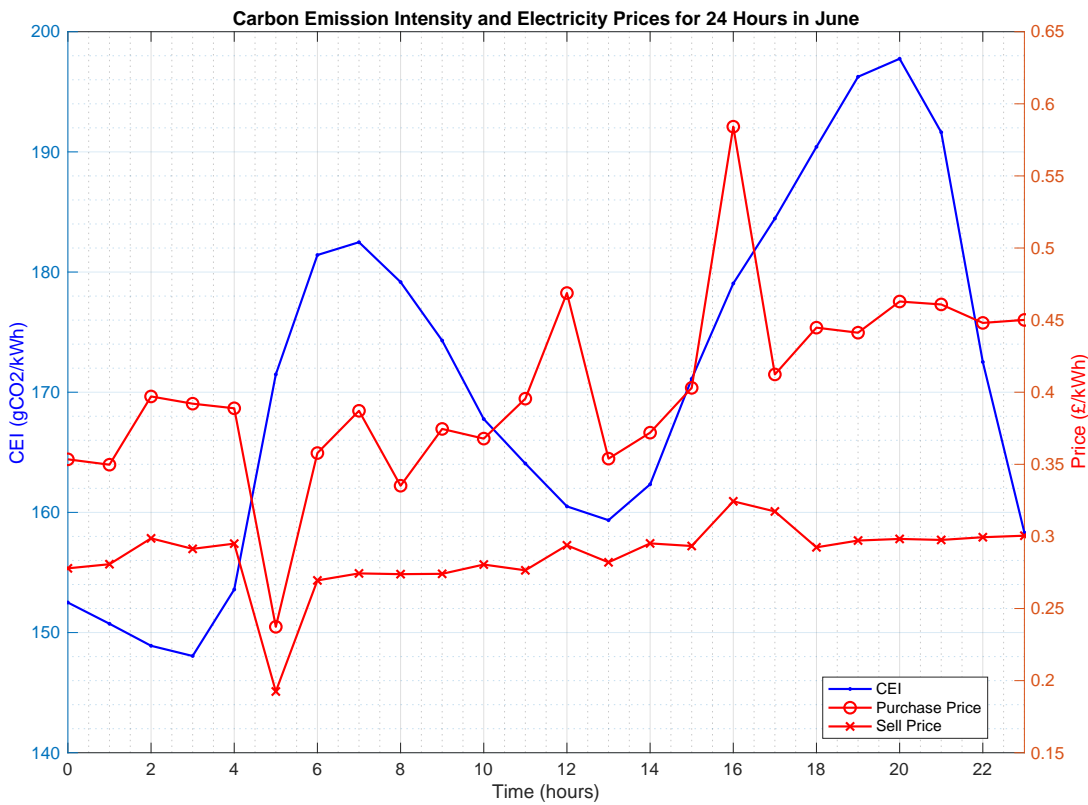

Figure 5.3: Average CEI [121] and Electricity prices [122] data of a June day

Kingdom. In Fig. 5.2, the average irradiation during this month at the user’s location can be observed [120]. Additionally, Fig. 5.3 shows the intensity of carbon emissions in the grid [121] and the energy purchase and sale prices by the energy

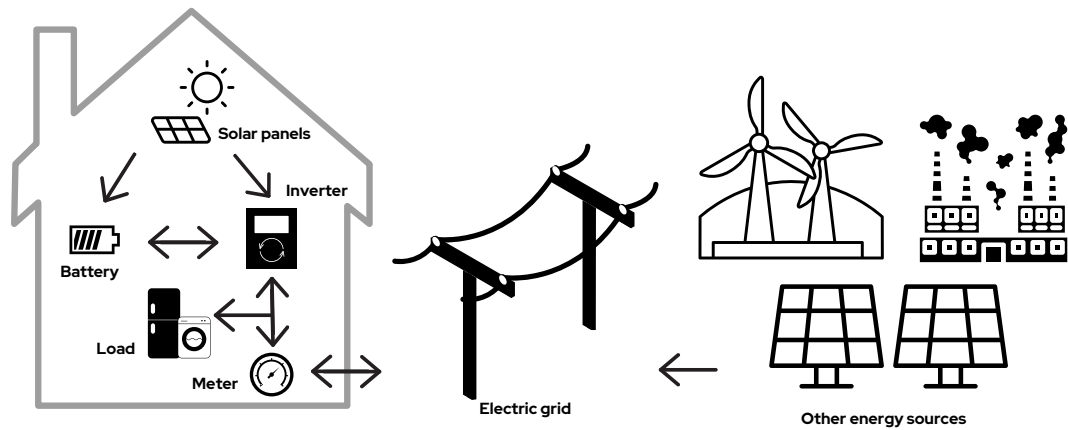

Figure 5.4: Distribution network management illustrating the direction of electricity flow.

company during an average day in June [122].

The moments of lower CEI (Carbon Emission Intensity) occur during the early hours of the morning, along with the cheapest energy purchase and sale prices. However, these hours would cause high discomfort to the user as it would disrupt their sleep schedule to change their habits during these hours. On the other hand, the most comfortable hours for the user also entail high costs and high CEI.

Therefore, three objective functions are employed for the optimisation problem: cost minimisation, carbon emissions minimisation, and user discomfort minimisation. The details are presented in the following sections of this chapter.

5.3 System Model

The model used in this study, as illustrated in Fig. 5.4, involves several key stakeholders within the energy distribution network, primarily the household (or consumer) and the utility company, which also manages the different energy sources. The utility company employs Time-of-Use (TOU) tariffs to encourage efficient energy usage, aligning energy prices with periods of high and low demand.

- **Household/Consumer:** The primary consumer and micro-producer in the model. The house is equipped with a renewable energy generation system,

including solar panels and an energy storage system using a battery. During the day, the solar panels generate energy that powers the home's energy load and charges the battery. At night, the stored energy in the battery supplies the household's needs. The household is central to managing its energy consumption and production, influenced by TOU pricing.

- **Utility Company:** This stakeholder not only supplies grid energy to supplement the household's energy requirements but also manages the overall energy systems, including renewable and conventional energy sources. The company provides additional power for household loads and battery charging. Furthermore, it purchases surplus energy produced by the household, facilitating its integration into the broader energy network. The utility's role extends to maintaining the energy systems, ensuring their optimal performance and durability.

In this model, the utility company manages all aspects of the energy system, both renewable and non-renewable. This includes supplying additional power and maintaining the infrastructure necessary for energy production and storage. The utility company's role in managing these components ensures that operations run smoothly and the energy supply remains reliable. It also supports the utility's efforts in promoting energy efficiency and sustainability throughout the network.

5.3.1 Battery Storage Model

The battery storage model assumes the utilisation of a Powervault 3 battery, which has a 4 kWh capacity and 2 kW discharge rate. At the beginning of each day, it is presumed that the battery is at its lowest capacity level.

To determine the household battery storage level, the following equations can be applied:

$$\text{SOC}(0) = 0, \tag{5.3.1}$$

$$\text{SOC}(t) = \text{SOC}(t - 1) + \Delta t \cdot P_{bat}(t), \quad t = 1 \dots T, \quad (5.3.2)$$

where SOC represents the state of charge of the battery at time t in Wh, Δt represents the time interval, and P_{bat} represents the power drawn by the battery at time t . Here, T represents the amount of all time steps, with each time step denoted by t .

Considering the Powervault 3's specific capacity and discharge rate, this model allows for efficient monitoring of the battery's state of charge throughout the day. By regularly updating the SOC values using equation 5.3.2 for successive time intervals, the system can determine the battery's state at any given moment, ensuring optimised energy management and consumption.

5.3.2 RES model

The dataset initially contains energy consumption data for houses situated in the southern region of England, and notably, these houses lack any form of Renewable Energy Source (RES) generation. To introduce RES generation, the RES model uses information from the European Commission's Photovoltaic Geographical Information System [120] to compute solar irradiation.

For the specific house under consideration, the model assumes the presence of 6 SunPower Maxeon 3 photovoltaic panels, which have a solar efficiency of 0.212. These panels are positioned at a slope of 35° and an azimuth of 0° . Each panel measures 1.046m by 1.69m, resulting in a total area of 26.5161m^2 .

The power generation from the solar panels can be expressed as [123]:

$$P_{PV}(t) = \eta \cdot E(t) \cdot A_c, \quad (5.3.3)$$

where P_{PV} is the power generated at time t , η is the solar efficiency, E is the solar irradiation received in W/m^2 (shown in Fig. 5.2) at time t and A_c is the area of the panels.

By integrating the RES model into the dataset, the solar power contribution to

the overall energy profile of a house in the southern region of England can now be estimated.

5.3.3 Base load consumption model

The base load demand model utilises information from the UK-DALE dataset [110], which originates from an end-terrace house in southern England. The data for a day comprises 24 entries, each corresponding to an hour of the day. An average consumption for a day in June was generated, ranging between 230 and 800 W. The model's output is $P_{load}(t)$, representing the base power load demanded at time t .

5.3.4 Appliance scheduling model

In Chapter 3, the SE-IF BiLSTM appliance classification method was developed, enabling the training of a BiLSTM neural network capable of identifying and classifying appliances in historical data, along with their preferred usage times. This was achieved by extracting features such as spectrogram frequency bands, Mel spectrogram, instantaneous frequency, spectral entropy, and signal variation.

To obtain appliance consumption data for training the SE-IF BiLSTM, individual data from the dataset was utilised. The considered appliances included three individual appliances: washing machine, dishwasher, and electric hob. To train the neural network to identify instances where multiple appliances are used simultaneously, different combinations were generated based on the consumption data of the individual appliances. This method was used to identify and classify appliances in previous days and acquire their average consumption data and preferred usage times. A detailed explanation of this pre-processing procedure can be found in Section 3.3.2. These appliances exhibit varying power consumption patterns due to their operational cycles demanding different power levels at different times. To accurately simulate this power variation during their operation, the average duration and consumption per hour for each appliance were obtained.

Let t_{start} denote the time at which the optimisation algorithm schedules an appliance to start its operation, and the following constraint is obtained:

$$0 \leq t_{start} \leq t - t_{duration}, \quad (5.3.4)$$

where $t_{duration}$ represents the duration of the appliance usage. This constrains the operating time of an appliance to ensure it starts early enough to complete its cycle before the end of the day. This limitation is imposed by the scope of the research, which focuses on a 24-hour analysis timeframe.

The next step involves the ability to calculate the load needed by the appliances in a 24-entry format, and the entry they will be located at will depend on the time they have been scheduled for. This ensures that this calculation is separate from the base load of the household.

To calculate the load used by the schedulable appliances at any given time t , the following equation is applied:

$$P_{load}^{app}(t) = \sum_{m=1}^M P_m(t), \quad (5.3.5)$$

where $P_{load}^{app}(t)$ represents the sum of power used by the schedulable appliances at time t , M is the number of schedulable appliances, and $P_m(t)$ denotes the power load of appliance m at time t .

The total scheduled load at time t is then computed by combining the base load P_{load} and the load of all schedulable appliances, denoted as P_{load}^{app} , using the following equation:

$$P_{load}^{SCH}(t) = P_{load}(t) + P_{load}^{app}(t), \quad (5.3.6)$$

where $P_{load}^{SCH}(t)$ represents the sum of the base load and the load of all schedulable appliances at time t . This calculation enables the system to determine the entire power demand, accounting for both the household's essential base load and the varying power requirements of scheduled appliances.

Table 5.1: Appliance settings

Appliance	δ	T_{avg}	$T_{duration}$	Power rating (Watts)
Washing Machine	2	12:00	2h	150 - 650
Dishwasher	3	21:00	2h	520 - 910
Electric Hob	3	17:00	0.5h	1000

5.3.5 Transmission system operator model

The household's power supply to fulfill the load demand is an integration of resources, drawing power from the external grid, the electricity generated by photovoltaic panels, and utilising energy stored in the battery. This ensures a consistent power delivery, even during periods of fluctuating energy availability.

To calculate the power taken from or sent to the grid, the system uses the following equation:

$$P_{grid}(t) = P_{load}^{SCH}(t) - P_{PV}(t) + P_{bat}(t), \quad (5.3.7)$$

where $P_{grid}(t)$ is the total power taken or sent to the grid at time t . This equation manages the interplay between the scheduled load, power generated by the photovoltaic panels, and energy drawn from or sent to the battery storage. It guarantees that the load demand is always met while allowing for the optimal utilisation of renewable energy sources.

At any moment, if the household's load demand exceeds the combined power of solar generation and battery storage, the system supplements the shortfall by drawing power from the grid. Conversely, during periods of excess solar generation or surplus battery energy, the system sends the surplus electricity back to the grid, contributing to the establishment of a balanced energy ecosystem.

5.3.6 Cost model and formulation

The cost model is based on the purchase and sale price information from previous years from the British Energy Trading and Transmission Agreements [121]. It is

assumed that this information accurately reflects the prices applicable during the selected day for simulation. The model adopts an Hourly Real Time Price structure, where electricity prices fluctuate hourly but remain constant throughout each hour. Additionally, costs are adjusted based on the current month or the user's selection, this case being the month of June.

The model has two outputs: C_{sell} and C_{buy} , representing the unit price for selling energy to the grid and buying energy from the grid, respectively.

Using these price values, the cost of the electricity bill is calculated in British pounds sterling using the following equation:

$$Cost = \sum_{t=1}^T \Delta t \cdot P_{grid}(t) \cdot C_{grid}(t), \quad (5.3.8)$$

where Δt is the time interval, and $P_{grid}(t)$ is the power exchanged with the grid at time t , being positive in the case of buying energy and negative in the case of selling. The variable $C_{grid}(t)$ is determined as follows:

$$C_{grid}(t) = \begin{cases} C_{buy}(t), & \text{if } P_{grid}(t) \geq 0 \\ C_{sell}(t), & \text{otherwise.} \end{cases} \quad (5.3.9)$$

This decision structure ensures that the correct pricing is applied based on whether energy is being bought from or sold to the grid. By aggregating these costs over the specified time duration, the model provides an accurate estimate of the electricity bill.

5.3.7 CO₂ emissions model and formulation

The CO₂ model is based on CEI data sourced from the National Grid ESO [120]. To calculate hourly averages of the carbon emission intensity for each month, data was collected from the year 2020. The model then produces CEI_{buy} , representing the intensity of carbon emissions associated with purchasing electricity from the grid.

Using these CEI values, the amount of CO₂ emitted in grams is calculated using the following equation:

$$CO_2 = \sum_{t=1}^T \Delta t \cdot P_{grid}(t) \cdot CEI_{grid}(t), \quad (5.3.10)$$

where Δt is the time interval, and $P_{grid}(t)$ is the power exchanged with the grid at time t . The variable $CEI_{grid}(t)$ is determined as follows:

$$CEI_{grid}(t) = \begin{cases} CEI_{buy}(t), & \text{if } P_{grid}(t) \geq 0 \\ 0, & \text{otherwise.} \end{cases} \quad (5.3.11)$$

This ensures that the carbon emission intensity is considered only when electricity is being purchased from the grid. If the power exchanged is not from the grid (i.e., when it is supplied to the grid due to excess energy generation), the carbon emission intensity is set to zero, representing a net reduction in carbon emissions.

By summing up the CO₂ emissions over the specified time duration, the model provides a precise estimate of the carbon footprint associated with energy usage.

5.3.8 User discomfort model and formulation

The user discomfort model is constructed using data obtained from the SE-IF BiLSTM model. This model learns the average starting time of appliances based on historical usage patterns from previous days. Discomfort is then calculated based on deviations from these average times, using a discomfort coefficient determined for each appliance.

The discomfort coefficients $\delta(m)$ for each appliance are determined based on the standard deviation of their start times, calculated from historical usage data. The standard deviation reflects the variability in the starting times of the appliances:

- If the standard deviation of start times for an appliance is less than 1 hour, the

appliance is considered to have high regularity in usage. Therefore, a higher discomfort coefficient of $\delta(m) = 3$ is assigned.

- Conversely, if the standard deviation is 1 hour or more, the appliance usage is considered variable, and a lower discomfort coefficient of $\delta(m) = 2$ is assigned.

This threshold of 1 hour is chosen based on the observed distribution of start times, aiming to effectively differentiate appliances that are sensitive to time shifts from those that are not.

$$\delta(m) = \begin{cases} 3 & \text{if } \sigma(m) < 1 \text{ hour} \\ 2 & \text{if } \sigma(m) \geq 1 \text{ hour} \end{cases} \quad (5.3.12)$$

where $\sigma(m)$ is the standard deviation of the start times for appliance m .

Discomfort due to deviations from average usage times is quantified using the following equation:

$$Disc = \sum_{m=1}^M \delta(m) \cdot \left(T_{\text{start}}(m) - T_{\text{avg}}(m) \right)^2, \quad (5.3.13)$$

where:

- M is the number of schedulable appliances.
- $\delta(m)$ is the discomfort coefficient for appliance m .
- $T_{\text{start}}(m)$ is the actual starting time of appliance m on a given day.
- $T_{\text{avg}}(m)$ is the average starting time of appliance m , calculated from historical data.

By integrating the user discomfort model, the energy management system can account for users' preferences and comfort levels when optimising the scheduling of appliances.

5.4 Methods

In this section, the energy management problem is addressed through a multi-objective formulation (MOP), aiming to achieve a fair and balanced approach. The primary objectives of this formulation are: first, to minimise the economical cost of electricity consumption; second, to minimise the amount of CO₂ produced during energy usage; and third, to minimise user discomfort when scheduling the schedulable appliances. Each objective plays a vital role in enhancing the efficiency, sustainability, and user experience of the energy management system.

To effectively address these objectives, a MOP formulation is presented, considering each objective separately due to their different units and scales, as established in sections 5.3.6, 5.3.7, and 5.3.8. The MOP seeks to find Pareto optimal solutions that represent a fair balance between these objectives, leading to intelligent energy management strategies that prioritise economic savings, reduced carbon emissions, and user satisfaction.

The resulting MOP formulation involves finding Pareto optimal points such that none of the objectives can be improved without worsening at least one other. This can be expressed as:

$$\min_{P_{bat}, T_{start}^{m \in M}} Cost \quad (5.4.1a)$$

$$\min_{P_{bat}, T_{start}^{m \in M}} CO_2 \quad (5.4.1b)$$

$$\min_{P_{bat}, T_{start}^{m \in M}} Disc \quad (5.4.1c)$$

This formulation is subject to constraints represented by equations (5.3.2), (5.3.4), and (5.3.7).

In this approach, each objective is treated distinctly, reflecting its unique impact and measurement. This ensures that the solution set comprises configurations where

trade-offs between cost, carbon emissions, and discomfort are considered independently, facilitating a more comprehensive exploration of possible solutions and maintaining the integrity of each objective's units.

5.4.1 Finding the best solutions

The proposed MOP formulation offers a range of potential solutions that can be derived by considering various weighting criteria. In this research, determining the optimal weights for each objective function is achieved through genetic algorithms. These algorithms have the capability to assess different possibilities and systematically compare various weight combinations over time, effectively adapting to changes in variables. This approach showcases the potential to identify the best-suited combination of weights while accounting for dynamic variables, thus offering a robust and flexible approach to solving the multi-objective optimisation problem. A flowchart illustrating the process of finding the best solution can be found in Fig. 5.6.

Pareto definitions

The approach taken to solve the multi-objective genetic algorithms formulation is centered on the concept of Pareto optimality, detailed in the following definitions [124]:

Definition 1 (Pareto Optimality): Situation where no feasible solution can be improved in one objective without degrading another objective.

Definition 2 (Pareto Frontier): The set of all Pareto optimal solutions in a multi-objective optimisation problem. It represents the collection of non-dominated solutions that offer various trade-offs between conflicting objectives.

Multi-objective Immune Algorithm

The multi-objective immune algorithm (MOIA) [125], presents an optimisation approach rooted in the biological mechanisms of the human immune system. It utilises

the concept of antibodies, each corresponding to a specific point within the decision variable space. Throughout each iteration, the algorithm systematically eliminates dominated antibodies, thereby enabling non-dominated antibodies to undergo mutation and diversification. This transformative process gives rise to additional dominated antibodies, which are subsequently pruned.

Further stages of the MOIA involve a strategic filtration process aimed at eliminating infeasible antibodies. This culling and enhancement cycle persists until the algorithm reaches its designated maximum number of iterations. Ultimately, the MOIA outputs a collection of approximate Pareto optimal solutions of the trade-offs between conflicting objectives.

Multi-objective Genetic Algorithm

The multi-objective genetic algorithm (MOGA) stands as a metaheuristic optimisation approach inspired by the principles of natural selection.

Initially, it assembles a diverse population of values within predetermined limits. Subsequently, the fitness of each individual within this population is computed, reflecting their potential as optimal solutions. As the algorithm progresses, it assesses whether the stopping criterion has been achieved, signalling the attainment of satisfactory solutions.

The MOGA's efficiency relies in its emulation of the natural selection process. Once the stopping criterion is not met, MOGA employs a selection process, identifying individuals to act as parents for the next generation. These chosen parents undergo a crossover procedure, generating offspring known as children. These children are then subject to mutation, introducing an element of controlled variation. Following this, the fitness of these mutated children is recalculated, serving as a basis for their potential as solutions. This process is repeated until the stopping criterion is met. At the conclusion of its iterations, MOGA provides a set of solutions that form an approximation of the Pareto front [124].

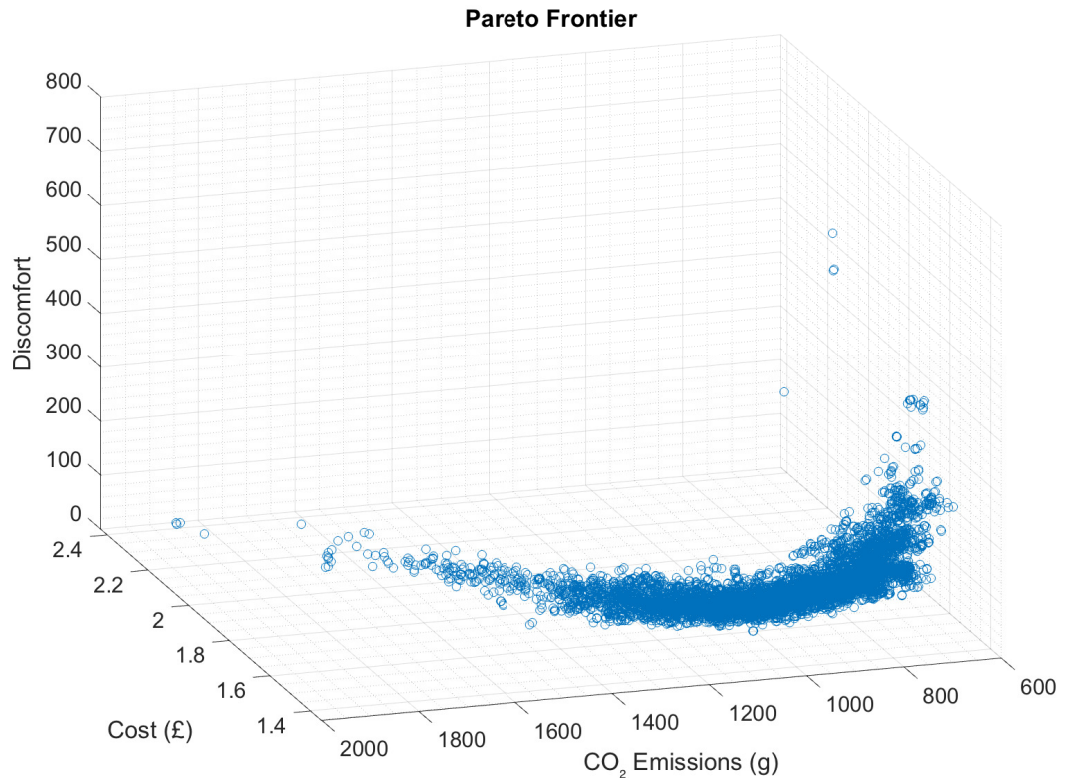

Figure 5.5: Pareto frontier obtained after evaluating the MOP with the MOIA.

Finding the best compromised solution: Gray Relational Analysis

Various methods have been explored in the literature to identify optimal solutions for MOPs. Some prominent methods include Gray Relational Analysis (GRA), Technique for Order of Preference by Similarity to Ideal Solution, Linear Programming for Multidimensional Analysis of Preference, and Faire Un Choix Adéquat, among others. In the context of this research, GRA has been selected as the method to determine a best-compromised solution.

GRA is especially effective when prioritising complex objectives or when dealing with qualitative input criteria that are difficult to quantify. In this algorithm, the gray relational coefficient (GRC) expresses the resemblance between individual candidate networks (representing objective values of each optimal solution) and the best reference network (constituting an ideal network achieved by selecting the best objective value for each). It follows the next steps [126]:

1. Normalisation of objective values of Pareto-optimal solutions is performed:

$$F_{ij} = \frac{\max_{i \in s} f_{ij} - f_{ij}}{\max_{i \in s} f_{ij} - \min_{i \in s} f_{ij}} \quad (5.4.2)$$

where s is the set of Pareto-optimal solutions, f_{ij} is the i th value of the j th objective in the objective matrix and F_{ij} the value of f_{ij} after normalisation.

2. Find the reference network points:

$$F_j^+ = \max_{i \in s} F_{ij} \quad (5.4.3)$$

where F_j^+ is the greatest number in the normalised values.

3. Find the difference between F_j^+ and F_{ij}

$$\Delta I_{ij} = |F_j^+ - F_{ij}| \quad (5.4.4)$$

4. Find the value of GRC for each optimal solution:

$$\text{GRC}_i = \frac{1}{s} \sum_{j=1}^J \frac{\Delta \text{min} + \Delta \text{max}}{\Delta I_{ij} + \Delta \text{max}} \quad (5.4.5)$$

where $\Delta \text{max} = \max_{i \in s, j \in J} (\Delta I_{ij})$ and $\Delta \text{min} = \min_{i \in s, j \in J} (\Delta I_{ij})$.

5. Find the largest GRC_i and its corresponding solution is the recommended optimal solution.

Choosing optimal solutions

The optimisation problem involves three distinct objectives: cost reduction, CO₂ emissions reduction, and minimising user discomfort to ensure that scheduling arrangements align with user convenience. As detailed previously in this chapter, the methodology for identifying the optimal compromised solution was explained. This approach aims to achieve a well-balanced outcome by addressing reductions across all objectives. However, there is a scenario where a user might strongly lean toward

a specific objective. While minimising discomfort is a goal, its optimal solution typically involves not scheduling any tasks, essentially resulting in a scenario with no changes. As this outcome contradicts the fundamental aim of the research, the focus shifts solely to selecting optimal solutions that consider cost and CO₂ emissions.

Cost-based solution. This approach provides users with the opportunity to capitalise on substantial cost savings, making it the most financially advantageous choice. While the broader optimisation framework considers multiple objectives—including minimising CO₂ emissions and user discomfort, the cost-based solution focuses solely on minimising economic costs. Users may select this solution from a set of options generated through multi-objective optimisation, specifically choosing the one that offers the lowest cost, even if it does not necessarily optimise the other factors. This selection process is defined as follows:

$$s^* = \arg \min_{s \in \mathcal{P}} \text{Cost}(s) \quad (5.4.6)$$

where \mathcal{P} represents the set of feasible solutions generated through the optimisation process, as part of a Pareto frontier. However, the final selection, s^* , is based only on cost criteria, emphasising financial efficiency over other considerations.

CO₂-based solution. This option provides users with the opportunity to significantly reduce carbon emissions, positioning it as the most environmentally conscious choice. While the broader optimisation framework addresses multiple objectives, the CO₂-based solution specifically focuses on minimising the ecological footprint. Users may select this solution from a set of options generated through multi-objective optimisation, specifically choosing the one that optimally reduces CO₂ emissions, possibly at the expense of other factors. This selection process is defined as follows:

$$s^* = \arg \min_{s \in \mathcal{P}} \text{CO}_2(s) \quad (5.4.7)$$

where \mathcal{P} represents the set of feasible solutions generated through the optimisation process part of a Pareto frontier. The final selection, s^* , is based solely on minimising

CO₂ emissions, emphasising environmental priorities over other considerations.

Best compromised solution. This solution, determined by the GRA, balances the three objectives, preferences of cost, CO₂ reduction, and user discomfort. It provides users with an optimal outcome that considers all relevant factors and results in an effective compromise.

Summary of proposed energy management framework and optimisation

Based on the earlier discussed definitions, algorithms, and analyses in this section, a diagram has been constructed, illustrated in Fig. 5.6. The interpretation of this diagram is presented through the following sequential steps:

- **Step 1: SE-IF BILSTM.** The initial stage involves the utilisation of the SE-IF BILSTM method to gather data. During this phase, user preferences like usage timings are configured, while also learning the baseline load profile.
- **Step 2: Initialisation.** Proceeding to Step 2, essential data is initialised. This includes factors such as electricity prices provided by the utility company, as well as estimated carbon emissions intensity for the designated day. Furthermore, a foundational base-load profile is generated based on learnings from the prior step.
- **Step 3: Multi-objective Immune Algorithm (MOIA).** In Step 3, the MOIA -or optionally the MOGA- is employed iteratively until a state of convergence is attained. This process yields the Pareto frontier, which was explored earlier in this section.
- **Step 4: Gray Relational Analysis (GRA).** Moving forward, after acquiring the Pareto frontier, the set of solutions goes through the Gray Relational Analysis (GRA). This analysis identifies the best compromised or fairest solution, taking into account all the different objectives.

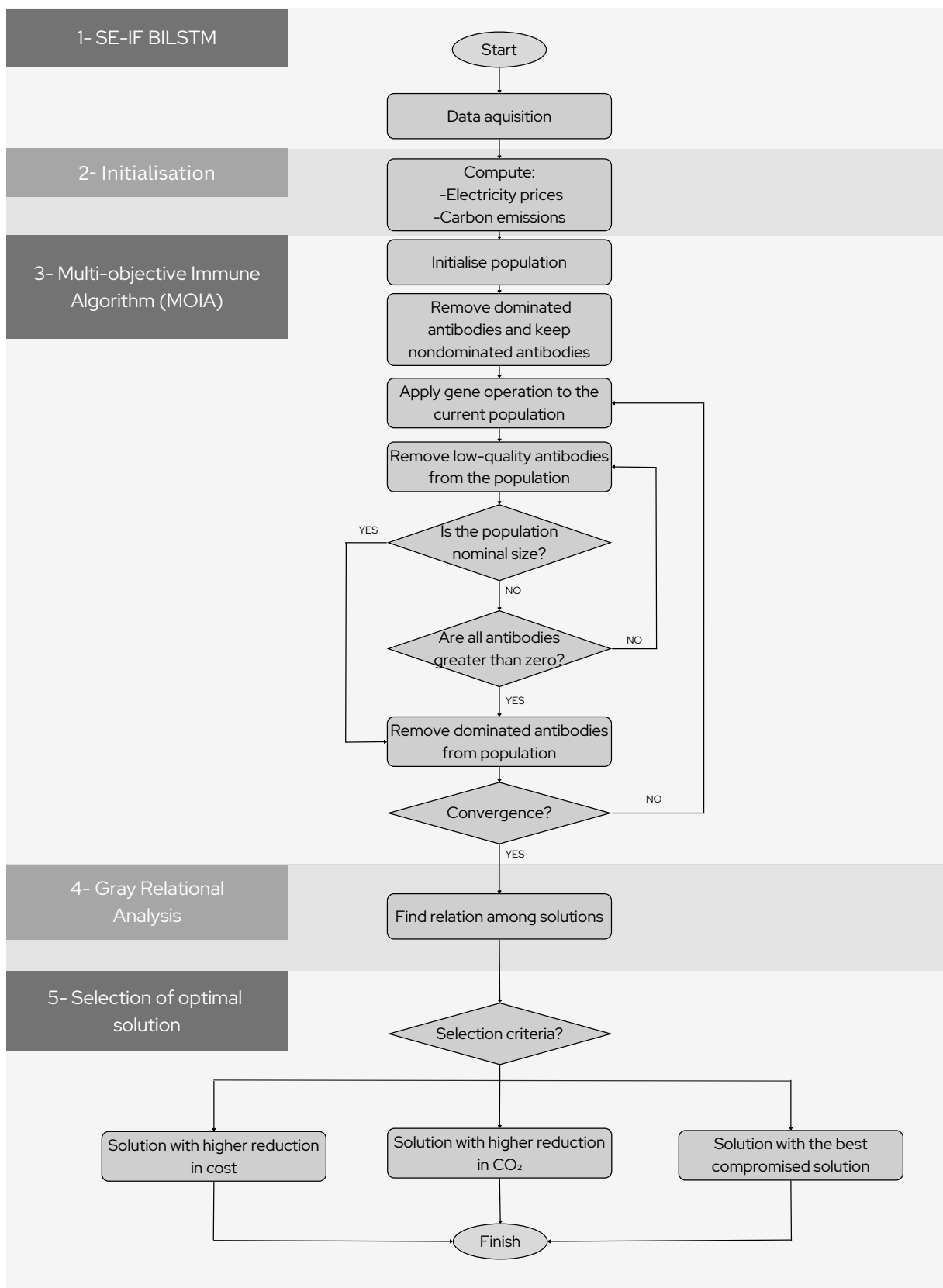

Figure 5.6: Flowchart of the multi-objective problem, including the MOIA.

Table 5.2: Simulation setup

Control parameter	Value
Location	50°50'16.8"N 0°08'13.2"W
Month	June
Time slots	24
Schedulable appliances	3
Solar Panels	6 SunPower Maxeon 3
Battery Max Capacity	4 kWh
Battery Max Charge/Discharge Rate	2 kW

- **Step 5: Selection of Optimal Solution.** Finally, in Step 5, multiple objectives are considered. A variety of choices are presented to the user, each delivering the optimal outcome for a specific objective. Another solution, determined by GRA, is also offered as the fairest solution, considering the balance between all the objectives.

5.5 Model evaluation

With the methodology in place and a range of solutions now available within the Pareto frontier, the focus shifts to selecting optimal solutions in accordance with the scenarios and cases presented in this section.

The analysis incorporates four distinct scenarios and three different cases for simulations. The parameters employed for the system model in these simulations are detailed in Table 5.2.

5.5.1 Simulation Scenarios

The scenarios serve as distinct user profiles, where all users have access to grid electricity and a battery storage system. This system enables them to store energy acquired from the grid during periods of lower cost.

1) RES and Scheduling: In this particular scenario, the utilisation of renewable energy sources is combined with scheduling strategies for appliances. By incorporating RES power generation alongside grid power consumption, the objective is to

effectively manage load demands. This involves optimising appliance scheduling to not only curtail the overall cost on the bill but also to minimise the associated CO₂ emissions.

2) RES and No Scheduling: This scenario primarily serves to contrast Scenario 1 with a comparable situation that lacks scheduling. In this scenario, similar to the previous case, the user can use the power of renewable energy sources for their energy needs. However, a distinctive approach is taken as the user opts not to engage in appliance scheduling. Instead, the emphasis is placed on maximising comfort and convenience without actively adjusting the timing of appliance usage. This scenario caters to users who prioritise ease of use and prefer the appliances to operate according to their typical routines, guided by the availability of RES-generated power.

3) No RES and Scheduling: In this scenario, the user lacks access to any form of renewable energy sources for power generation, relying solely on grid-supplied electricity to meet their energy demands. However, despite the absence of RES, the user recognises the potential benefits of appliance scheduling as a means to minimise costs and reduce their carbon footprint. By strategically timing the operation of various appliances, the user aims to optimise their energy consumption and contribute to environmental conservation by curbing CO₂ emissions. This scenario caters to users who prioritise financial savings and sustainability, using scheduling techniques to make the most of grid-supplied energy.

4) No RES and No Scheduling: The primary purpose of this scenario is to compare and contrast Scenario 3 with a similar situation that does not involve scheduling. In this scenario, similar to the previous one, the user lacks access to renewable energy sources for power generation. Here, the user's priority shifts toward maximising comfort and convenience. Despite not having RES or employing scheduling strategies, the user aims to optimise their daily routine by allowing appliances to operate at their preferred times while also using the battery to store energy purchased from the grid when it is cheaper. This approach caters to users

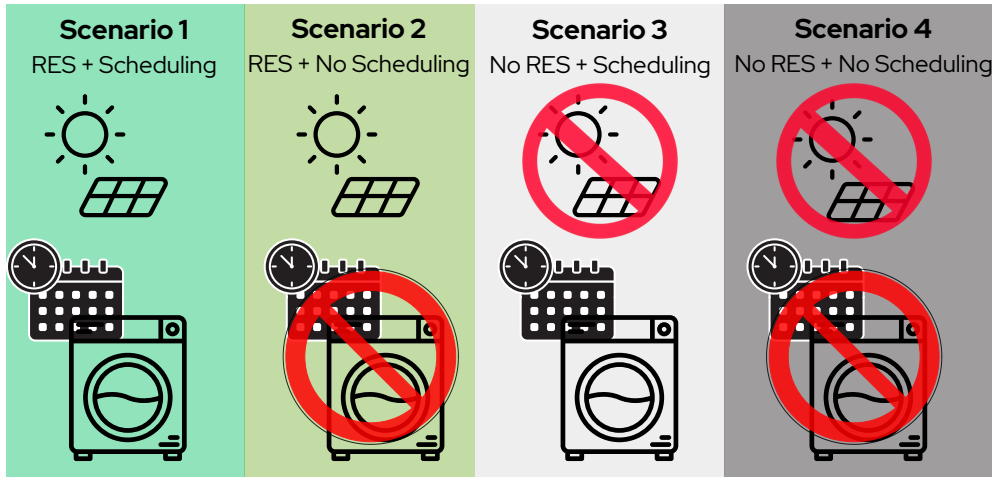

Figure 5.7: Simulation scenarios considering RES and scheduling.

who prioritise the functioning of appliances according to their daily routines and convenience, without the additional complexities of scheduling considerations.

5.5.2 Simulation cases

1) **Case 1 based on cost minimisation:** In this case, the primary objective of the user is to minimise their electricity expenses. This strategy involves capitalising on low electricity prices or periods of robust renewable energy generation. During such favorable conditions, the home battery is utilised for charging. When surplus energy is generated by the renewable sources, the user can even feed excess energy back to the grid, contributing to cost reduction. Conversely, during peak price hours, especially during daytime, the user can use the stored energy within the battery to fulfill their load requirements, effectively avoiding higher cost periods. This approach revolves around strategic energy usage to achieve financial savings.

2) **Case 2 based on CO₂ emissions minimisation:** In this scenario, the user's primary focus is to minimise the CO₂ emissions associated with their energy consumption. The strategy involves capitalising on periods of low CEI or substantial renewable energy generation. During these environmentally favourable conditions, the home battery is charged to store excess energy. In contrast, when the CEI is relatively high, typically occurring during afternoon hours, the stored energy within

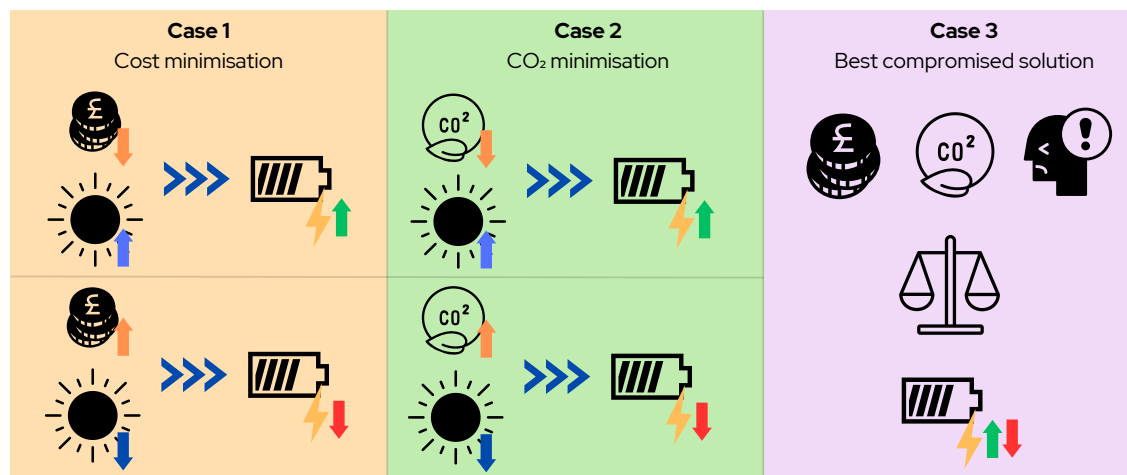

Figure 5.8: General battery behaviours in each simulation case.

the battery is utilised. By choosing these timeframes, the user can align their energy consumption with moments of lower CO₂ emissions, contributing to their emissions reduction goal. This approach highlights the user's commitment to minimising their carbon footprint.

3) Case 3 based on best compromised solution: In this case, the user's objective is to find a solution that balances the three key goals: minimising the financial expenditure, minimising CO₂ emissions, and reducing user discomfort. The aspiration here is to find an equilibrium where each objective is given due consideration, resulting in a solution that represents a well-rounded compromise among these three critical factors. This approach seeks to ensure an optimisation that includes economic savings, environmental responsibility, and user satisfaction.

5.5.3 MOIA results analysis: The impact of scheduling

After the Pareto frontier was established using the MOIA, the next step was to identify the optimal solutions for each of the 12 combinations arising from three cases and four scenarios. These solutions, detailed in Table 5.3, are compared with the MOGA results to illustrate their effectiveness. For each scenario, the algorithm determines the optimal start times for each appliance with the aim of achieving the specific goal of the case: minimising costs in Case 1, reducing carbon emissions in

Case 2, and finding a balanced or compromised solution in Case 3.

Figure 5.9 illustrates the convergence behaviour of the MOIA, showing how the algorithm progressively refines the solutions towards optimal outcomes. The convergence trends indicate the number of iterations required for the algorithm to stabilize on the Pareto frontier, underscoring the efficiency of the MOIA in navigating the solution space.

The outcomes can significantly vary based on whether the scenario involves access to renewable energy sources (whether it is due to a lack of solar panels or the weather does not allow for energy production) or if the user opts for scheduling. The subsequent analysis places emphasis on highlighting the diverse performance of the battery across each solution and the advantages of employing scheduling strategies to achieve cost savings and carbon emission reduction.

5.5.4 Algorithms comparison

The MOGA is used to compare algorithmic outcomes against the MOIA. The results are shown in Table 5.3. Generally, the MOGA was found to be outperformed by the MOIA. Across the scenarios and cases, the MOIA consistently delivered superior results. In RES-enabled scenarios (1 and 2), the MOIA exhibited the best outcomes, and even in the Non-RES scenarios (3 and 4), it consistently presented better results for cases 1 and 2. However, in case 3 of scenario 3, while the MOIA achieved improved results in terms of cost and discomfort, the MOGA produced lower CO₂ reduction results. Similarly, in case 3 of scenario 4, the MOIA excelled in CO₂ reduction, while the MOGA achieved better cost outcomes.

Taking an overall view, the MOIA consistently outperforms the MOGA and proves to be a robust choice to complement the optimisation problem introduced in this chapter. Its consistent performance across various scenarios proves its reliability and effectiveness.

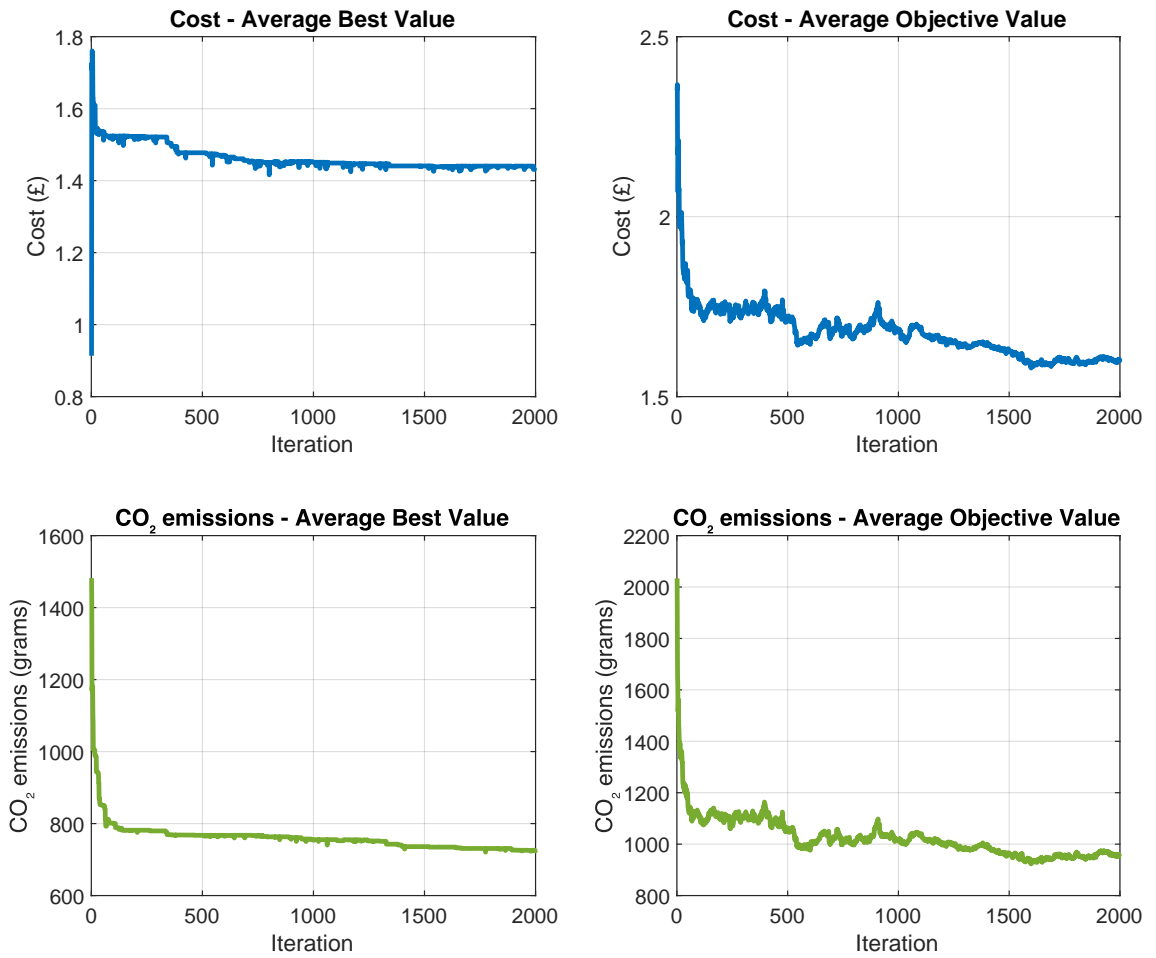

Figure 5.9: Convergence trends of the MOIA algorithm over iterations. The top graphs display the progression of the average best value (ABV) and average objective value (AOV) for Cost, while the bottom graphs show these values for CO₂ emissions.

Table 5.3: MOIA and MOGA Results Comparison

Scenario Comparisons						
Parameter	MOIA Results			MOGA Results		
	Case 1	Case 2	Case 3	Case 1	Case 2	Case 3
Scenario 1) RES - Scheduling						
Cost (£)	1.34	1.40	1.40	1.55	1.63	1.58
CO ₂ emissions (grams)	793.55	676.46	718.72	954.48	900.62	904.84
Discomfort	269	269	137	204	150	137
Washing Machine (T_{start})	11	11	11	12	12	11
Dishwasher (T_{start})	13	13	15	13	14	15
Electric Hob (T_{start})	12	12	14	15	16	14
Scenario 2) RES - No Scheduling						
Cost (£)	1.49	1.59	1.55	1.73	1.73	1.73
CO ₂ emissions (grams)	1034.64	851.64	861.58	1111.44	1106.88	1108.57
Discomfort	0	0	0	0	0	0
Washing Machine (T_{start})	12	12	12	12	12	12
Dishwasher (T_{start})	21	21	21	21	21	21
Electric Hob (T_{start})	17	17	17	17	17	17
Scenario 3) No RES - Scheduling						
Cost (£)	6.16	6.54	6.34	6.31	6.38	6.37
CO ₂ emissions (grams)	2862.11	2748.43	2814.63	2822.53	2793.41	2794.09
Discomfort	1013	242	83	242	242	242
Washing Machine (T_{start})	13	13	10	13	13	13
Dishwasher (T_{start})	5	13	17	13	13	13
Electric Hob (T_{start})	8	13	14	13	13	13
Scenario 4) No RES - No Scheduling						
Cost (£)	6.26	6.68	6.54	6.41	6.65	6.42
CO ₂ emissions (grams)	2878.64	2778.5	2782.31	2843.26	2818.32	2841.16
Discomfort	0	0	0	0	0	0
Washing Machine (T_{start})	12	12	12	12	12	12
Dishwasher (T_{start})	21	21	21	21	21	21
Electric Hob (T_{start})	17	17	17	17	17	17

Scheduling analysis

There are two scenarios marked by favourable circumstances for generating renewable energy —particularly on sunny days with the implementation of solar panels—, and two scenarios where access to RES is not available. The evaluation begins with the three appliances mentioned in this chapter: the washing machine, the dishwasher, and the electric hob. The user’s preference for scheduling these appliances is as follows: the washing machine at 12:00, the dishwasher at 21:00, and the electric hob at 17:00.

Within the context of the first and third scenarios, where scheduling is a priority, distinct scheduling patterns are chosen. In scenario 1, for both case 1 and case 2, the washing machine, dishwasher, and electric hob are scheduled to start at 11:00, 13:00, and 12:00, respectively. These timings align with peak periods of renewable energy generation, producing optimal results in terms of cost and CO₂ emissions reduction across each respective scenario. On the other hand, in scenario 1 - case 3, a shift in scheduling times occurs, with the appliances set to start at 11:00, 15:00, and 14:00, respectively. This scheduling configuration reflects the pursuit of a well-compromised solution that seeks to minimise user discomfort while also achieving a balanced approach in terms of cost and carbon emissions. In this scenario, the discomfort metric improves significantly, measuring at 137 units, which stands in contrast to the 269 units recorded for cases 1 and 2. This comparison results in a reduction of 49.07% in discomfort, as offered by the best compromised solution.

In scenario 3 - case 1, where no access to RES exists, the appliances were scheduled to commence operations at 13:00, 05:00, and 08:00. The alteration to early morning hours for two of the appliances is influenced by the lower electricity prices during that time. On the other hand, a notable adjustment is observed in case 2, where all the appliances are coordinated to start at 13:00. This alignment is driven by this particular time offering the lowest CEI during the afternoon. However, in case 3, the appliances are scheduled to begin operations at 10:00, 17:00, and 14:00,

respectively. These times are closer to the preferred timings, resulting in only 83 units of discomfort, in contrast to the 1013 units generated by case 1 and the 242 units produced by case 2. This represents a reduction in discomfort of 91.8% when compared to case 1 and a decrease of 65.7% when compared to case 2.

In scenario 2 and 4, the user has a lack of interest or practical ability in adhering to an appliance schedule. This inherently grants the user the most comfort, allowing them to operate their appliances at times that align with their personal preferences. Depending on individual user tendencies, the cost implications could vary, whether the appliances are utilised during pricier or more affordable time slots. Similarly, with respect to carbon emissions, the user's choices could lead to either higher or lower emissions based on their favoured time slots. In this specific scenario, the operation of two of the appliances occurs during the periods when the CEI is at its peak, particularly during the later hours of the day.

Case analysis

Case 1. Cost minimisation. In scenario 1, Case 1 produces a cost of 1.34 GBP, while in scenario 2, the cost escalates to 1.49 GBP. This difference represents a noteworthy 10.06% cost reduction achieved through scheduling. In scenario 3, the cost amounts to 6.16 GBP, while in scenario 4, it results in a cost of 6.26 GBP. This disparity reflects a reduction of 1.6% achieved through the implementation of scheduling.

The scheduling strategy that aims to curtail costs results in a combined emission of 793.55 grams of CO₂ in scenario 1. On the other hand, in scenario 2, the same strategy leads to a slightly higher emissions figure of 1034.64 grams. Despite not being the main objective, the scheduling approach still manages to deliver a significant 23.3% reduction in carbon emissions compared to the scenario without scheduling.

In scenario 3 and 4, the CO₂ emissions recorded were 2862.11 grams and 2878.64 grams, respectively, resulting in a small decrease of 0.57% in CO₂ emissions through

the implementation of scheduling.

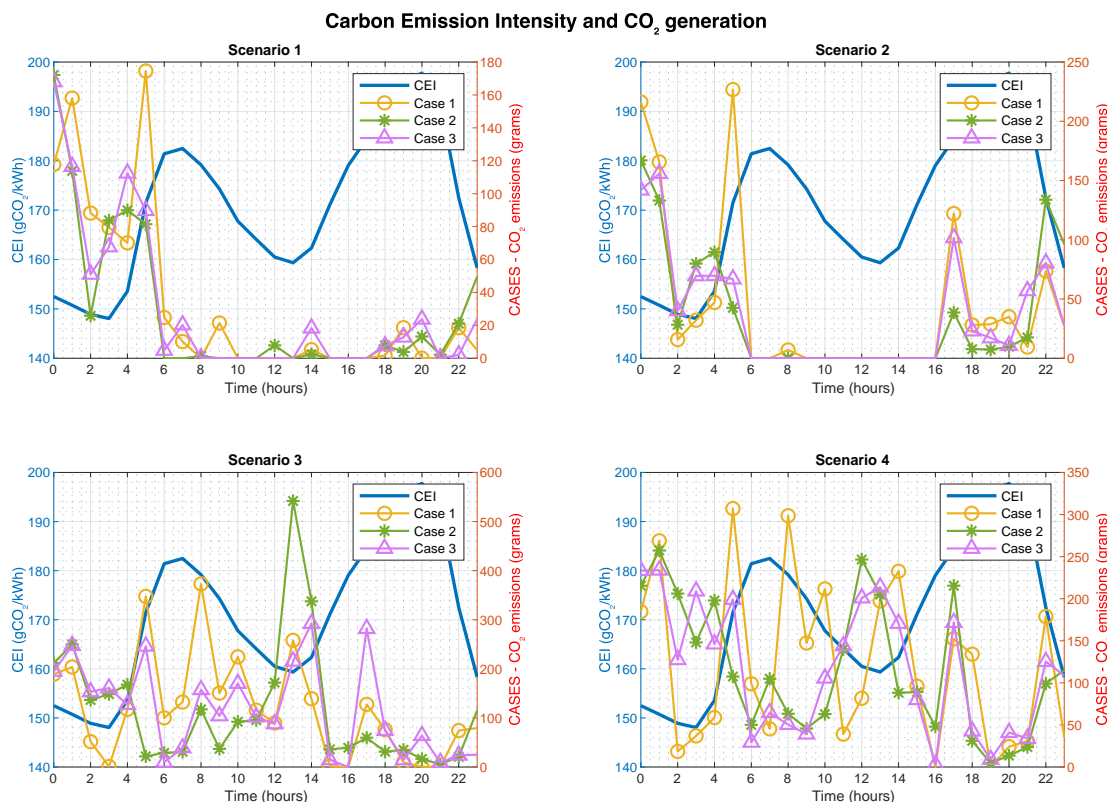

Figure 5.10: CO₂ generation in comparison to the CEI in each scenario for all cases using the MOIA.

Case 2. CO₂ emissions minimisation. In scenario 1, Case 2 results in a total of 676.46 grams of CO₂ emissions, while in scenario 2, this figure climbs to 851.64 grams. This difference represents a notable 20.57% reduction in carbon emissions realised through the scheduling strategy. In scenario 3, case 2 produces 2748.43 grams of CO₂ emissions, while scenario 4 records 2778.5 grams, indicating a reduction of 1.08% achieved through scheduling.

Although not the primary objective, a secondary positive effect is observed in terms of cost reduction. Specifically, this case experiences an 11.95% decrease in cost when appliances are scheduled. Scenario 1 reports a cost of 1.4 GBP, whereas scenario 2 shows a slightly higher cost of 1.59 GBP. When contrasting the cost of 6.54 GBP in scenario 3 with the cost of 6.68 GBP in scenario 4, a saving of 2.09% becomes possible.

Detailed graphs illustrating the CO₂ production throughout the day for each case

and scenario are presented in Fig. 5.10.

Case 3. Best compromised solution. In case 3 of scenario 1, the total cost amounts to 1.4 GBP, whereas in scenario 2, the cost rises to 1.55 GBP. This difference represents a reduction of 9.67% in expenses achieved through scheduling appliance usage.

In the absence of RES, the cost amounts to 6.34 GBP in scenario 3 and 6.54 GBP in scenario 4, reflecting a reduction of costs by 3.06%.

In scenarios where RES are enabled, the CO₂ emissions generation amounts to 718.72 grams in scenario 1 and 861.58 grams in scenario 2. This indicates a reduction of 16.58% in carbon emissions generation.

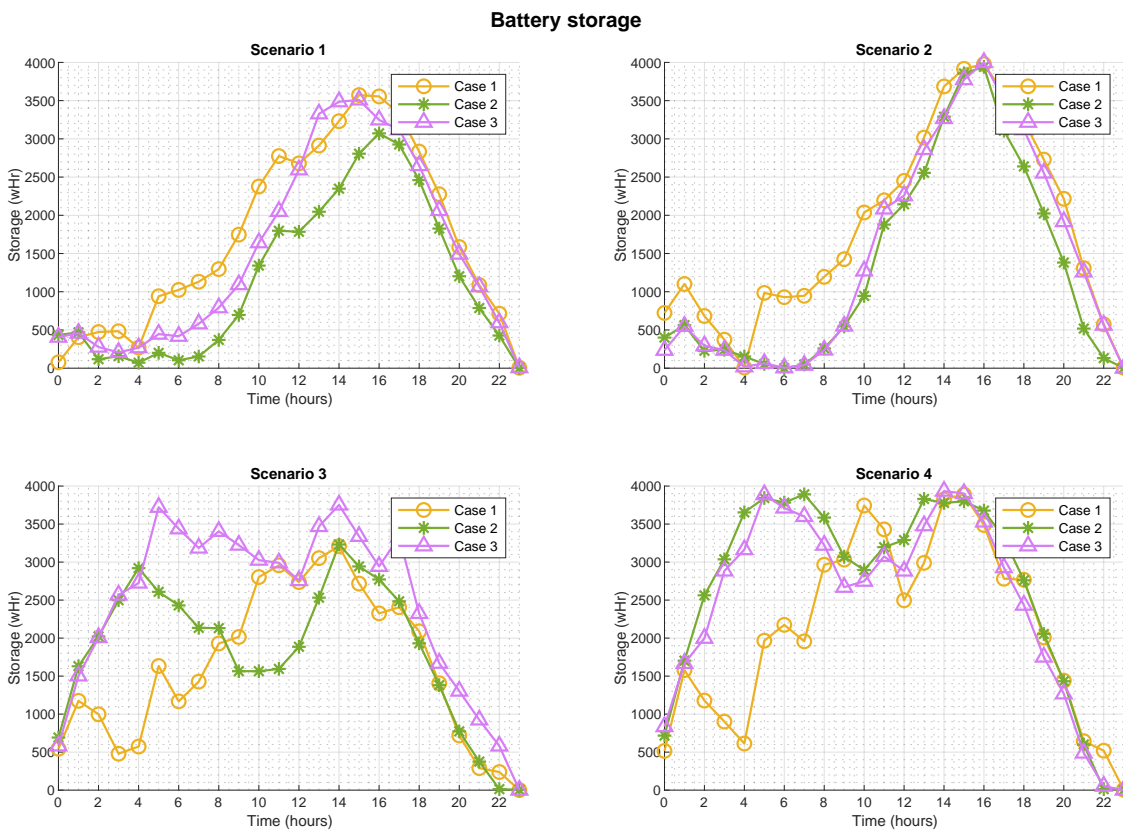

Figure 5.11: Battery storage behaviour in each scenario for all cases using the MOIA.

In scenarios without access to RES generation, scenario 3 produces 2814.63 grams of CO₂ emissions when scheduling, while scenario 4 produces 2782.31 grams. This comparison reveals an actual increase of 1.16% in CO₂ emissions when scheduling.

This can be attributed to the compromise factor of the case, where the focus on money savings and scheduling resulted in a higher generation of emissions.

In scenario 1, the discomfort is 137 units, and when no RES is available, like scenario 3, it is 83 units. This represents a 39.41% increase in discomfort when scheduling in a RES-enabled scenario. This increase is due to the slight sacrifice of comfort to achieve lower prices and reduced CO₂ generation, utilising the available renewable resources. In a non-RES scenario, the limited resources also curtail the possibilities for scheduling choices that can bring substantial changes.

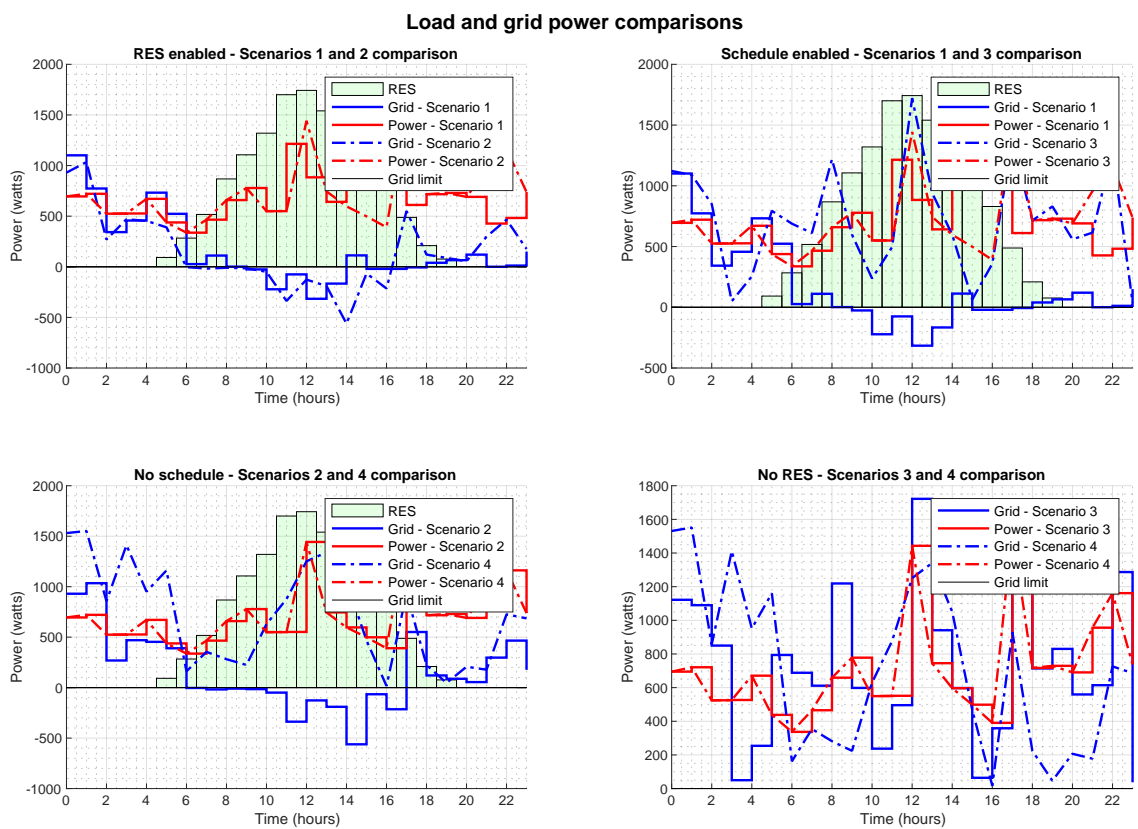

Figure 5.12: Comparison of similar scenarios, regarding their abilities to use RES or scheduling. All scenarios are considering Case 3 using the MOIA.

Battery and load analysis

Fig. 5.11 provides an insight into the battery behaviour for each case and scenario. In this figure, it can be observed that in the RES-enabled scenarios, a distinct trend emerges. The battery tends to commence full charging around 10 AM, aligning

with the peak solar energy generation period. Additionally, it undergoes partial charging during the early morning hours when electricity prices are low, storing cheaper energy for later use in the day.

In the non-RES scenarios, a clear pattern is not evident across scenarios (3 and 4) and cases; however, their behaviours tend to mirror the patterns observed in the CEI and price graphs, as depicted in Fig. 5.3.

Figure 5.12 presents a load comparison across various combinations of scenarios and cases. Within this figure, it becomes evident that the RES-enabled scenarios have the advantage of accumulating surplus energy that can be sold back to the grid. This leads to earnings for the user, ultimately reducing the overall cost for them.

5.6 Conclusion

This chapter introduced a modelling approach for appliance scheduling, using a multi-objective optimisation model designed for households equipped with battery storage systems and renewable energy sources. The main objective of this optimisation problem is to find a balance between costs, carbon emissions, and user comfort. Through the utilisation of the multi-objective immune algorithm (MOIA), the developed model was subjected to evaluation, revealing that appliance scheduling can yield noteworthy benefits. The results demonstrated potential cost reductions of up to 10.06% or carbon emissions reductions of up to 20.57%, depending on the selected optimisation objective. Notably, when seeking a balanced or best-compromised solution that factors in both objectives and user discomfort, the cost reductions reached 9.67% while carbon emissions reductions amounted to 16.58%.

In scenarios where access to RES is absent, the observed savings ranged between 1-3%, which may not always be significant enough to motivate scheduling alterations, contingent on user preferences and priorities. Nonetheless, the model showcases its capacity to offer impactful improvements in terms of cost and emissions when renewable energy resources are available.

Chapter 6

Conclusions

The last chapter presents a summary of the key contributions and findings from each section of the thesis, providing an overview of the content and analysis covered earlier. It also introduces potential areas for future study, giving suggestions on how this work can be expanded or refined.

6.1 Final conclusions

This thesis presented contributions to knowledge to the appliance classification and scheduling techniques with the aim of reducing CO₂ emissions.

Chapter 3 presented the development and validation of the SE-IF method, a novel approach to feature extraction for appliance classification with limited datasets. It was tested using different artificial intelligence approaches, such as machine learning techniques including NB, LDA, DTs, and KNN, as well as deep learning techniques like LSTM and BiLSTM. This experimentation demonstrated that the SE-IF method performs well with various architectures, but it excelled specifically in the task of appliance classification when coupled with BiLSTM. Several combinations of settings were tested to find the most optimal selection of parameters for BiLSTM to perform well in each case, depending on the type of appliances being classified. A detection algorithm was proposed that works with minimal data in households and can detect

the appliances in use by applying windows and thresholds. Alongside this, the SE-IF BiLSTM was employed to then classify the detected appliances. Tested against different scenarios, the combination of the detection algorithm and the SE-IF method achieved robust results in the tasks of detection and classification.

Chapter 3, as outlined in Chapter 1, tackled *Objective 1* of this thesis. This objective called for the creation of an algorithm that could discern high-energy-use appliances based solely on their power consumption data. To meet this goal, an algorithm was developed that employs a windowing technique to isolate periods of elevated power usage. This algorithm goes through the power consumption patterns, pinpointing distinct time frames indicative of substantial appliance activity. This objective also focused on developing a feature extraction methodology capable of effectively enabling an artificial intelligence model to classify the detected appliances. To achieve this, the SE-IF method was modelled, which is adaptable to various artificial intelligence techniques, including both machine learning and deep learning. Ultimately, it was integrated with a BiLSTM architecture. This combination was rigorously tested across different scenarios, demonstrating consistent and robust results.

Chapter 5 contributes by presenting a model for a novel multi-objective optimisation approach that schedules household appliances with the goals of reducing CO₂ emissions, cost, and discomfort. The model considers user preferences to quantify discomfort. It was assessed using algorithms such as MOIA and MOGA, with results compared across different scenarios where emphasis varied between minimising costs, CO₂ emissions, discomfort, or striving for a balanced solution that considers all factors. Additionally, the framework incorporates the capacity to integrate RES, such as solar panels and BSS, thereby enhancing the flexibility of the algorithms and underscoring the potential benefits for users who adopt these technologies. The findings in the proposed scenarios indicated that, based on the optimisation objective chosen, there could be a decrease in costs by as much as 10.06% or a reduction in carbon emissions by up to 20.57%. Remarkably, when aiming for a balanced solution,

the model achieved a cost savings of 9.67% and a reduction in carbon emissions of 16.58%.

Chapter 5, in alignment with the aims outlined in Chapter 1, fulfilled *Objective 2*. This objective focused on creating a multi-objective optimisation framework for appliance scheduling that considers factors such as cost, CO₂ emissions, and discomfort. This was realised through the development of the MOP, which not only accounts for these factors but also adjusts their significance in accordance with user preferences, providing balanced solutions. The objective also sought to integrate RES and BSS into the model, which was successfully accomplished, with the optimisation outcomes including these technologies showing the most substantial benefits. Both objectives were achieved by comparing the performance on two different algorithms, MOIA and MOGA.

6.2 Future work

6.2.1 Detecting low consumption appliances

Detecting appliances with high consumption is important, as they account for the highest costs and carbon emissions; therefore, identifying them to propose rescheduling their operation is essential. However, the detection of low consumption appliances is often overlooked. Developing an algorithm to detect appliances with lower consumption could be beneficial. Due to the challenges of working with limited data, load disaggregation is quite complicated, especially when attempting to identify low-consumption appliances. In the future, efforts could be focused on achieving the detection of every appliance used in a household. This could be achieved through an extensive analysis of labeled user behaviour, potentially requiring user input, which was beyond the scope of this thesis.

6.2.2 Real time classification

In this thesis, appliance classification was conducted using existing data, which produced robust results. However, it has not been tested for real-time classification. The complexity of analysing real-time data was beyond the scope of this work. Nonetheless, this real-time feedback could be transformative, enabling the tailoring of energy tariffs with greater precision and offering users personalised real-time recommendations to optimise their energy consumption. Such advancements could allow for a more dynamic and responsive energy grid, where consumer behaviour and utility strategies are synchronised for enhanced efficiency and sustainability

6.2.3 Consideration of continuously variable load appliances

In Chapter 5, a MOP was developed to address the scheduling of household appliances. Three different appliances were considered for the experiments: the washing machine, dishwasher, and electric hob. All these appliances fall under the category of Finite State Machines. In future work, the inclusion of other categories, particularly continuously variable load appliances, could be considered. These appliances, such as electric heaters or dimmable lights, can vary in the intensity of their operations. Incorporating their variability could add more depth to the model, allowing it to consider the level of usage of these appliances.

6.2.4 V2G integration

The MOP presented in Chapter 5 incorporates the use of RES and BSS, leading to improved outcomes when these systems are utilised. However, the model does not currently account for electric vehicles (EVs), which could contribute their vehicle-to-grid (V2G) technology by using their batteries as an energy storage solution.

Considering the increasing prevalence of EVs in the market, integrating them could enhance the grid's sustainability and eco-friendliness.

6.2.5 Health of the batteries

In Chapter 5, energy storage systems, specifically batteries, are evaluated within the model. The model evaluates the integration of batteries, highlighting their role in enhancing energy efficiency. However, out of the current framework is the consideration of battery longevity and degradation over time, which are important factors in the practical application of battery storage systems. The absence of a degradation model could lead to an overestimation of the batteries' performance and lifespan, potentially resulting in unforeseen costs and reduced sustainability in the long term. Future work on the model should incorporate degradation curves and maintenance strategies. These refinements will provide a more realistic assessment of the batteries' behaviour and offer guidance on their optimal usage and maintenance.

Bibliography

- [1] Department for Business, Energy and Industrial Strategy, “Smart technologies and data to future-proof UK energy,” 2021. [Online] Available: <https://www.gov.uk/government/news/smart-technologies-and-data-to-future-proof-uk-energy>.
- [2] Department for Business, Energy and Industrial Strategy, “Realising the potential of demand-side response to 2025,” 2017. [Online] Available: https://assets.publishing.service.gov.uk/media/5a82b8c440f0b6230269c5a4/DSR_research.
- [3] “Analysis of energy management schemes for renewable-energy-based smart homes against the backdrop of COVID-19,” *Sustainable Energy Technologies and Assessments*, vol. 52, p. 102136, 2022. doi: 10.1016/j.seta.2022.102136.
- [4] Y. Ma, X. Chen, L. Wang, and J. Yang, “Investigation of smart home energy management system for demand response application,” *Frontiers in Energy Research*, vol. 9, 2021. doi: 10.3389/fenrg.2021.772027.
- [5] United Nations Climate Change, “The Glasgow Climate Pact – Key Outcomes from COP26,” 2021. [Online] Available: <https://unfccc.int/process-and-meetings/the-paris-agreement/the-glasgow-climate-pact-key-outcomes-from-cop26>.
- [6] United Nations, “COP26 closes with ‘compromise’ deal on climate, but it’s not enough, says UN chief,” 2021. [Online] Available: <https://news.un.org/en/story/2021/11/1105792>.

-
- [7] Department for Business, Energy and Industrial Strategy, “UK enshrines New Target in law to slash emissions by 78% by 2035,” 2021. [Online] Available: <https://www.gov.uk/government/news/uk-enshrines-new-target-in-law-to-slash-emissions-by-78-by-2035>.
- [8] United Nations Climate Change, “The Paris Agreement,” 2021. [Online] Available: <https://unfccc.int/process-and-meetings/the-paris-agreement>.
- [9] Department for Energy Security and Net Zero, “2022 UK greenhouse gas emissions, provisional figures,” 2023. [Online] Available: https://assets.publishing.service.gov.uk/government/uploads/system/uploads/attachment_data/file/1147372/2022_Provisional_emissions_statistics_report.pdf.
- [10] J. L. Regens and J. S. Beddows, “The covid-19 pandemic and geopolitics,” 2020. [Online] Available: <https://thestrategybridge.org/the-bridge/2020/6/1/the-covid-19-pandemic-and-geopolitics>.
- [11] Our World in Data, “Greenhouse gas emissions by sector, United Kingdom, 2019,” 2019. [Online] Available: <https://ourworldindata.org/grapher/ghg-emissions-by-sector?time=latest&country=GBR>.
- [12] Department for Business, Energy and Industrial Strategy, “Energy Consumption in the UK (ECUK) 1970 to 2021,” 2022. [Online] Available: <https://www.gov.uk/government/statistics/energy-consumption-in-the-uk-2022>.
- [13] D. Vine, L. Buys, and P. Morris, “The effectiveness of energy feedback for conservation and peak demand: A literature review,” *Open Journal of Energy Efficiency*, vol. 2, p. 2013, 03 2013. doi: 10.4236/ojee.2013.21002.
- [14] M. Zeifman and K. Roth, “Nonintrusive appliance load monitoring: Review and outlook,” *IEEE Transactions on Consumer Electronics*, vol. 57, no. 1, pp. 76–84, 2011. doi: 10.1109/TCE.2011.5735484.

- [15] Z. Zhang, F. Shi, Y. Liu, and H. Yan, "A hierarchical classification method for Type II appliance recognition in NILM," in *2022 5th International Conference on Renewable Energy and Power Engineering (REPE)*, IEEE. doi: 10.1109/repe55559.2022.9948813.
- [16] J. Kim, T.-T.-H. Le, and H. Kim, "Nonintrusive load monitoring based on advanced deep learning and novel signature," *Computational Intelligence and Neuroscience*, vol. 2017, pp. 1–22, 2017. doi: 10.1155/2017/4216281.
- [17] G. W. Hart, "Nonintrusive appliance load monitoring," *Proc. IEEE*, vol. 80, no. 12, pp. 1870–1891, 1992. doi: 10.1109/5.192069.
- [18] G. Bucci, F. Ciancetta, E. Fiorucci, and S. Mari, "Load identification system for residential applications based on the NILM technique," in *2020 IEEE International Instrumentation and Measurement Technology Conference (I2MTC)*, pp. 1–6, IEEE. doi: 10.1109/i2mtc43012.2020.9128599.
- [19] W. Wichakool, Z. Remscrim, U. A. Orji, and S. B. Leeb, "Smart metering of variable power loads," *IEEE Transactions on Smart Grid*, vol. 6, no. 1, pp. 189–198, 2015. doi: 10.1109/TSG.2014.2352648.
- [20] S. Bhattacharjee, A. Kumar, and J. Roychowdhury, "Appliance classification using energy disaggregation in smart homes," in *2014 International Conference on Computation of Power, Energy, Information and Communication (ICCPEIC)*, IEEE. doi: 10.1109/iccpeic.2014.6915330.
- [21] C. Po-An, C. Chi-Cheng, and I. C. Ray, "Automatic appliance classification for non-intrusive load monitoring," in *2012 IEEE International Conference on Power System Technology (POWERCON)*, pp. 1–6. doi: 10.1109/Power-Con.2012.6401409.
- [22] P. Ongsulee, "Artificial intelligence, machine learning and deep learning," in *2017 15th International Conference on ICT and Knowledge Engineering (ICT&KE)*, pp. 1–6, 2017. doi: 10.1109/ICTKE.2017.8259629.

- [23] IBM, “What is Machine Learning?,” 2023. [Online] Available: <https://www.ibm.com/topics/machine-learning>.
- [24] V. Gupta, V. K. Mishra, P. Singhal, and A. Kumar, “An overview of supervised machine learning algorithm,” in *2022 11th International Conference on System Modeling Advancement in Research Trends (SMART)*, pp. 87–92, 2022. doi: 10.1109/SMART55829.2022.10047618.
- [25] M. Usama, J. Qadir, A. Raza, H. Arif, K.-l. A. Yau, Y. Elkhatib, A. Hussain, and A. Al-Fuqaha, “Unsupervised machine learning for networking: Techniques, applications and research challenges,” *IEEE Access*, vol. 7, pp. 65579–65615, 2019. doi: 10.1109/ACCESS.2019.2916648.
- [26] P. Adjei, N. S. Sethi, C. P. E. De Souza, and M. A. M. Capretz, “Energy disaggregation using multilabel binarization and gaussian naive bayes classifier,” in *2020 11th IEEE Annual Ubiquitous Computing, Electronics & Mobile Communication Conference (UEMCON)*, IEEE. doi: 10.1109/uemcon51285.2020.9298157.
- [27] Y. Jimenez, J. Cortes, C. Duarte, J. Petit, and G. Carrillo, “Non-intrusive discriminant analysis of loads based on power quality data,” in *2019 IEEE Workshop on Power Electronics and Power Quality Applications (PEPQA)*, IEEE. doi: 10.1109/pepqa.2019.8851568.
- [28] H. Alyammahi and P. Liatsis, “Non-intrusive appliance identification using machine learning and time-domain features,” in *2022, 29th International Conference on Systems, Signals and Image Processing (IWSSIP)*, IEEE. doi: 10.1109/iwssip55020.2022.9854459.
- [29] J. M. Gillis, S. M. Alshareef, and W. G. Morsi, “Nonintrusive load monitoring using wavelet design and machine learning,” *IEEE Transactions on Smart Grid*, vol. 7, no. 1, pp. 320–328, 2016. doi: 10.1109/TSG.2015.2428706.

- [30] M. M. R. Khan, M. A. B. Siddique, and S. Sakib, “Non-intrusive electrical appliances monitoring and classification using k-nearest neighbors,” in *2019 2nd International Conference on Innovation in Engineering and Technology (ICIET)*, IEEE. doi: 10.1109/iciet48527.2019.9290671.
- [31] T. Bernard, M. Verbunt, G. v. Bögel, and T. Wellmann, “Non-intrusive load monitoring (NILM): Unsupervised machine learning and feature fusion : Energy management for private and industrial applications,” in *2018 International Conference on Smart Grid and Clean Energy Technologies (ICSGCE)*, pp. 174–180. doi: 10.1109/ICSGCE.2018.8556735.
- [32] A. Adabi, P. Manovi, and P. Mantey, “Cost-effective instrumentation via NILM to support a residential energy management system,” in *2016 IEEE International Conference on Consumer Electronics (ICCE)*, pp. 107–110. doi: 10.1109/ICCE.2016.7430540.
- [33] Y. Lin and M. Tsai, “An advanced home energy management system facilitated by nonintrusive load monitoring with automated multiobjective power scheduling,” *IEEE Transactions on Smart Grid*, vol. 6, no. 4, pp. 1839–1851, 2015. doi: 10.1109/TSG.2015.2388492.
- [34] A. Kelly and M. A. Johnson, “Investigating the statistical assumptions of naïve bayes classifiers,” in *2021 55th Annual Conference on Information Sciences and Systems (CISS)*, pp. 1–6, 2021. doi: 10.1109/CISS50987.2021.9400215.
- [35] F.-J. Yang, “An implementation of naive bayes classifier,” in *2018 International Conference on Computational Science and Computational Intelligence (CSCI)*, pp. 301–306, 2018. doi: 10.1109/CSCI46756.2018.00065.
- [36] S. Bhatia and J. Malhotra, “Naïve bayes classifier for predicting the novel coronavirus,” in *2021 Third International Conference on Intelligent Communication Technologies and Virtual Mobile Networks (ICICV)*, pp. 880–883, 2021. doi: 10.1109/ICICV50876.2021.9388410.

- [37] B. S. Sharmila and R. Nagapadma, "Intrusion detection system using naive bayes algorithm," in *2019 IEEE International WIE Conference on Electrical and Computer Engineering (WIECON-ECE)*, pp. 1–4, 2019. doi: 10.1109/WIECON-ECE48653.2019.9019921.
- [38] U. Sudibyo, S. Rustad, P. Nurtantio Andono, A. Zainul Fanani, P. Purwanto, and M. Muljono, "A novel approach on linear discriminant analysis (LDA)," in *2020 International Seminar on Application for Technology of Information and Communication (iSemantic)*, pp. 131–136, 2020. doi: 10.1109/iSemantic50169.2020.9234274.
- [39] E. Zorarpacı, "A hybrid dimension reduction based linear discriminant analysis for classification of high-dimensional data," in *2021 IEEE Congress on Evolutionary Computation (CEC)*, pp. 1028–1036, 2021. doi: 10.1109/CEC45853.2021.9504951.
- [40] J. Wang, L. Wang, F. Nie, and X. Li, "A novel formulation of trace ratio linear discriminant analysis," *IEEE Transactions on Neural Networks and Learning Systems*, vol. 33, no. 10, pp. 5568–5578, 2022. doi: 10.1109/TNNLS.2021.3071030.
- [41] N. N. Qomariyah, E. Heriyanni, A. N. Fajar, and D. Kazakov, "Comparative analysis of decision tree algorithm for learning ordinal data expressed as pairwise comparisons," in *2020 8th International Conference on Information and Communication Technology (ICoICT)*, pp. 1–4, 2020. doi: 10.1109/ICoICT49345.2020.9166341.
- [42] S. Pathak, I. Mishra, and A. Swetapadma, "An assessment of decision tree based classification and regression algorithms," in *2018 3rd International Conference on Inventive Computation Technologies (ICICT)*, pp. 92–95, 2018. doi: 10.1109/ICICT43934.2018.9034296.

- [43] F.-J. Yang, “An extended idea about decision trees,” in *2019 International Conference on Computational Science and Computational Intelligence (CSCI)*, pp. 349–354, 2019. doi: 10.1109/CSCI49370.2019.00068.
- [44] M. Somvanshi, P. Chavan, S. Tambade, and S. V. Shinde, “A review of machine learning techniques using decision tree and support vector machine,” in *2016 International Conference on Computing Communication Control and automation (ICCUBEA)*, pp. 1–7, 2016. doi: 10.1109/ICCUBEA.2016.7860040.
- [45] S. Zhang, X. Li, M. Zong, X. Zhu, and R. Wang, “Efficient knn classification with different numbers of nearest neighbors,” *IEEE Transactions on Neural Networks and Learning Systems*, vol. 29, no. 5, pp. 1774–1785, 2018. doi: 10.1109/TNNLS.2017.2673241.
- [46] K. Taunk, S. De, S. Verma, and A. Swetapadma, “A brief review of nearest neighbor algorithm for learning and classification,” in *2019 International Conference on Intelligent Computing and Control Systems (ICCS)*, pp. 1255–1260, 2019. doi: 10.1109/ICCS45141.2019.9065747.
- [47] P. Wang, Y. Zhang, and W. Jiang, “Application of k-nearest neighbor (knn) algorithm for human action recognition,” in *2021 IEEE 4th Advanced Information Management, Communicates, Electronic and Automation Control Conference (IMCEC)*, vol. 4, pp. 492–496, 2021. doi: 10.1109/IMCEC51613.2021.9482165.
- [48] J. Laaksonen and E. Oja, “Classification with learning k-nearest neighbors,” in *Proceedings of International Conference on Neural Networks (ICNN’96)*, vol. 3, pp. 1480–1483 vol.3, 1996. doi: 10.1109/ICNN.1996.549118.
- [49] S. Moore, D. Schneider, and E. Strickland, “How Deep Learning Works - Inside the neural networks that power today’s AI,” 2021. [Online] Available: <https://spectrum.ieee.org/what-is-deep-learning>.

- [50] A. Shrestha and A. Mahmood, "Review of deep learning algorithms and architectures," *IEEE Access*, vol. 7, pp. 53040–53065, 2019. doi: 10.1109/ACCESS.2019.2912200.
- [51] Z. Hu, J. Zhang, and Y. Ge, "Handling vanishing gradient problem using artificial derivative," *IEEE Access*, vol. 9, pp. 22371–22377, 2021. doi: 10.1109/ACCESS.2021.3054915.
- [52] S. Squartini, A. Hussain, and F. Piazza, "Attempting to reduce the vanishing gradient effect through a novel recurrent multiscale architecture," in *Proceedings of the International Joint Conference on Neural Networks, 2003.*, vol. 4, pp. 2819–2824 vol.4, 2003. doi: 10.1109/IJCNN.2003.1224018.
- [53] S. Squartini, A. Hussain, and F. Piazza, "Preprocessing based solution for the vanishing gradient problem in recurrent neural networks," in *Proceedings of the 2003 International Symposium on Circuits and Systems, 2003. ISCAS '03.*, vol. 5, pp. V–V, 2003. doi: 10.1109/ISCAS.2003.1206412.
- [54] S. Yaemprayoon and J. Srinonchat, "Non-intrusive load monitoring using multi-layer perceptron for appliances classification," in *2022 19th International Conference on Electrical Engineering/Electronics, Computer, Telecommunications and Information Technology (ECTI-CON)*, IEEE. doi: 10.1109/ecticon54298.2022.9795518.
- [55] T. Wang and B. Yin, "A new method for the nonintrusive load monitoring based on BP neural network," in *2017 2nd International Conference on Multimedia and Image Processing (ICMIP)*, pp. 93–97. doi: 10.1109/ICMIP.2017.55.
- [56] S. Biansoongnern and B. Plangklang, "Nonintrusive load monitoring (NILM) using an artificial neural network in embedded system with low sampling rate," in *2016 13th International Conference on Electrical Engineering/Electronics, Computer, Telecommunications and Information Technology (ECTI-CON)*, pp. 1–4. doi: 10.1109/ECTICon.2016.7561398.

- [57] H. Chang, L. Lin, N. Chen, and W. Lee, “Particle swarm optimization based non-intrusive demand monitoring and load identification in smart meters,” in *2012 IEEE Industry Applications Society Annual Meeting*, pp. 1–8. doi: 10.1109/IAS.2012.6373990.
- [58] J. Kelly and W. Knottenbelt, “Neural NILM: Deep neural networks applied to energy disaggregation,” in *Proceedings of the 2nd ACM International Conference on Embedded Systems for Energy-Efficient Built Environments*, 2015. doi: 10.1145/2821650.2821672.
- [59] A. G. Putrada, N. Alamsyah, S. F. Pane, and M. N. Fauzan, “GRU-MF: A novel appliance classification method for non-intrusive load monitoring data,” in *2022 IEEE International Conference on Communication, Networks and Satellite (COMNETSAT)*, IEEE. doi: 10.1109/comnetsat56033.2022.9994409.
- [60] M. Rafik, A. Fentis, T. Khalili, M. Youssfi, and O. Bouattane, “Learning and predictive energy consumption model based on LSTM recursive neural networks,” in *2020 Fourth International Conference On Intelligent Computing in Data Sciences (ICDS)*, pp. 1–7, 2020. doi: 10.1109/ICDS50568.2020.9268733.
- [61] S. Mahjoub, L. Chrifi-Alaoui, B. Marhic, L. Delahoche, J.-B. Masson, and N. Derbel, “Prediction of energy consumption based on LSTM artificial neural network,” in *2022 19th International Multi-Conference on Systems, Signals & Devices (SSD)*, pp. 521–526, 2022. doi: 10.1109/SSD54932.2022.9955883.
- [62] K. Greff, R. K. Srivastava, J. Koutník, B. R. Steunebrink, and J. Schmidhuber, “LSTM: A search space odyssey,” *IEEE Transactions on Neural Networks and Learning Systems*, vol. 28, no. 10, pp. 2222–2232, 2017. doi: 10.1109/TNNLS.2016.2582924.
- [63] X. Du, C. Ma, G. Zhang, J. Li, Y.-K. Lai, G. Zhao, X. Deng, Y.-J. Liu, and H. Wang, “An efficient LSTM network for emotion recognition from multichan-

- nel EEG signals,” *IEEE Transactions on Affective Computing*, vol. 13, no. 3, pp. 1528–1540, 2022. doi: 10.1109/TAFFC.2020.3013711.
- [64] L. Deng and D. Yu, “Deep learning: Methods and applications,” Tech. Rep. MSR-TR-2014-21, Microsoft, May 2014.
- [65] Y. Qiao, K. Xu, and K. Zhou, “Research on time series based on improved LSTM,” in *2023 IEEE 3rd International Conference on Power, Electronics and Computer Applications (ICPECA)*, pp. 951–958, 2023. doi: 10.1109/ICPECA56706.2023.10076103.
- [66] S. Siami-Namini, N. Tavakoli, and A. S. Namin, “The performance of LSTM and BiLSTM in forecasting time series,” in *2019 IEEE International Conference on Big Data (Big Data)*, pp. 3285–3292, 2019. doi: 10.1109/Big-Data47090.2019.9005997.
- [67] M. Fazil, S. Khan, B. M. Albahlal, R. M. Alotaibi, T. Siddiqui, and M. A. Shah, “Attentional multi-channel convolution with bidirectional LSTM cell toward hate speech prediction,” *IEEE Access*, vol. 11, pp. 16801–16811, 2023. doi: 10.1109/ACCESS.2023.3246388.
- [68] Z. Huang, W. Xu, and K. Yu, “Bidirectional LSTM-CRF models for sequence tagging,” *ArXiv*, vol. abs/1508.01991, 2015. doi: 10.48550/arXiv.1508.01991.
- [69] F. Ouyang, J. Wang, and H. Zhou, “Electricity consumption forecasting based on PC-CNN-BiLSTM combined with layered transfer learning strategy,” in *2022 International Conference on Computer Engineering and Artificial Intelligence (ICCEAI)*, pp. 628–632, 2022. doi: 10.1109/ICCEAI55464.2022.00133.
- [70] T. Le, M. T. Vo, B. Vo, E. Hwang, S. Rho, and S. W. Baik, “Improving electric energy consumption prediction using CNN and Bi-LSTM,” *Applied Sciences*, vol. 9, p. 4237, Oct 2019. doi: 10.3390/app9204237.

- [71] A. Ali, M. Ahmed, and O. Hammi, “BiLSTM neural network digital pre-distorter with reduced feedback sampling rate,” in *2023 IEEE Symposium on Wireless Technology Applications (ISWTA)*, pp. 51–55, 2023. doi: 10.1109/ISWTA58588.2023.10249275.
- [72] A. J. Gabriel, *Appliance Scheduling Towards Energy Management in IoT Networks Using Bacteria Foraging Optimization (BFO) Algorithm*, pp. 291–311. Cham: Springer International Publishing, 2021. doi: 10.1007/978-3-030-51920-915.
- [73] S. Boyd and L. Vandenberghe, *Convex Optimization*. Cambridge University Press, 2004. doi: 10.1017/CBO9780511804441.
- [74] M. G. M. Abdolrasol, S. M. S. Hussain, T. S. Ustun, M. R. Sarker, M. A. Hannan, R. Mohamed, J. A. Ali, S. Mekhilef, and A. Milad, “Artificial neural networks based optimization techniques: A review,” *Electronics*, vol. 10, no. 21, 2021. doi: 10.3390/electronics10212689.
- [75] A. K. Venkitaraman and V. S. R. Kosuru, “Electric vehicle charging network optimization using multi-variable linear programming and bayesian principles,” in *2022 Third International Conference on Smart Technologies in Computing, Electrical and Electronics (ICSTCEE)*, pp. 1–5, 2022. doi: 10.1109/ICSTCEE56972.2022.10099649.
- [76] H. G. Pham, “The mixed-integer linear programming for cost-constrained decision trees with multiple condition attributes,” in *2022 14th International Conference on Knowledge and Systems Engineering (KSE)*, pp. 1–6, 2022. doi: 10.1109/KSE56063.2022.9953778.
- [77] Gurobi Optimization, “Gurobi documentation,” 2023. [Online] Available: <https://www.gurobi.com/documentation/current/refman/index.html>.
- [78] M. Eremia, C.-C. Liu, and A.-A. Edris, *Heuristic Optimization Techniques*, pp. 931–984. 2016. doi: 10.1002/9781119175391.ch21.

- [79] H. Ma, Y. Zhang, S. Sun, T. Liu, and Y. Shan, “A comprehensive survey on NSGA-II for multi-objective optimization and applications,” *Artificial Intelligence Review*, vol. 56, pp. 1–54, 06 2023. doi: 10.1007/s10462-023-10526-z.
- [80] A. Anwaar, A. Ashraf, W. H. K. Bangyal, and M. Iqbal, “Genetic algorithms: Brief review on genetic algorithms for global optimization problems,” in *2022 Human-Centered Cognitive Systems (HCCS)*, pp. 1–6, 2022. doi: 10.1109/HCCS55241.2022.10090327.
- [81] T. M. Shami, A. A. El-Saleh, M. Alswaitti, Q. Al-Tashi, M. A. Summakieh, and S. Mirjalili, “Particle swarm optimization: A comprehensive survey,” *IEEE Access*, vol. 10, pp. 10031–10061, 2022. doi: 10.1109/ACCESS.2022.3142859.
- [82] H. Yu and M. Tong, “An energy optimization algorithm for data centers based on deep q-learning with multi-source energy,” in *2022 4th International Conference on Artificial Intelligence and Advanced Manufacturing (AIAM)*, pp. 382–388, 2022. doi: 10.1109/AIAM57466.2022.00079.
- [83] Y. Liu, D. Zhang, and H. B. Gooi, “Optimization strategy based on deep reinforcement learning for home energy management,” *CSEE Journal of Power and Energy Systems*, vol. 6, no. 3, pp. 572–582, 2020. doi: 10.17775/CSEE-JPES.2019.02890.
- [84] S. Rout, G. R. Biswal, and R. M. Sahoo, “Optimal scheduling of deferrable loads in home energy management system using elephant herding optimization,” in *2020 IEEE International Conference on Computing, Power and Communication Technologies (GUCON)*, pp. 698–702, 2020. doi: 10.1109/GUCON48875.2020.9231121.
- [85] M. B. Toosi and H. R. Mashhadi, “Optimal energy scheduling considering consumers preference in a smart home,” in *2020 28th Iranian Conference on Electrical Engineering (ICEE)*, pp. 1–5, 2020. doi: 10.1109/ICEE50131.2020.9260784.

- [86] N. Ismail, Z. Yahia, M. Gheith, and A. B. Eltawil, "A mixed integer programming formulation for optimal scheduling of household appliances with budget constraint," in *2021 IEEE 8th International Conference on Industrial Engineering and Applications (ICIEA)*, pp. 20–24, 2021. doi: 10.1109/ICIEA52957.2021.9436735.
- [87] T. Panaput, C. Srithapon, and R. Chatthaworn, "Optimal operation scheduling of household appliances with solar photovoltaic," in *2021 International Conference on Power, Energy and Innovations (ICPEI)*, pp. 138–141, 2021. doi: 10.1109/ICPEI52436.2021.9690670.
- [88] M. Assi, R. A. Haraty, S. Thoumi, S. Kaddoura, and N. A. Belal, "Scheduling household appliances using genetic algorithms," in *2022 International Conference on Innovation and Intelligence for Informatics, Computing, and Technologies (3ICT)*, pp. 1–6, 2022. doi: 10.1109/3ICT56508.2022.9990060.
- [89] A. Al-Adaileh and S. Khaddaj, "Machine learning prediction based integrated smart energy management system to improve home energy efficiency," in *2022 21st International Symposium on Distributed Computing and Applications for Business Engineering and Science (DCABES)*, pp. 1–4, 2022. doi: 10.1109/DCABES57229.2022.00042.
- [90] E. Bejoy, S. N. Islam, and A. M. T. Oo, "Optimal scheduling of appliances through residential energy management," in *2017 Australasian Universities Power Engineering Conference (AUPEC)*, pp. 1–6, 2017. doi: 10.1109/AUPEC.2017.8282505.
- [91] O. A. Alimi and K. Ouahada, "Smart home appliances scheduling to manage energy usage," in *2018 IEEE 7th International Conference on Adaptive Science & Technology (ICAST)*, pp. 1–5, 2018. doi: 10.1109/ICASTECH.2018.8507138.
- [92] A. Imran, G. Hafeez, I. Khan, M. Usman, Z. Shafiq, A. B. Qazi, A. Khalid, and K.-D. Thoben, "Heuristic-based programable controller for efficient energy

- management under renewable energy sources and energy storage system in smart grid,” *IEEE Access*, vol. 8, pp. 139587–139608, 2020. doi: 10.1109/ACCESS.2020.3012735.
- [93] A. U. Rehman, Z. Wadud, R. M. Elavarasan, G. Hafeez, I. Khan, Z. Shafiq, and H. H. Alhelou, “An optimal power usage scheduling in smart grid integrated with renewable energy sources for energy management,” *IEEE Access*, vol. 9, pp. 84619–84638, 2021. doi: 10.1109/ACCESS.2021.3087321.
- [94] A. Imran, G. Hafeez, I. Khan, M. Usman, Z. Shafiq, A. B. Qazi, A. Khalid, and K.-D. Thoben, “Heuristic-based programable controller for efficient energy management under renewable energy sources and energy storage system in smart grid,” *IEEE Access*, vol. 8, pp. 139587–139608, 2020. doi: 10.1109/ACCESS.2020.3012735.
- [95] M. S. Ghole, P. Paliwal, N. Thakkar, and T. Thakur, “Application of an appliance scheduling algorithm for demand response program,” in *2021 IEEE 2nd International Conference On Electrical Power and Energy Systems (ICEPES)*, pp. 1–5, 2021. doi: 10.1109/ICEPES52894.2021.9699740.
- [96] L. Jing, Z. Xiangyu, L. Tao, L. Yue, and W. Qinghua, “Integrated optimization of smart home appliances under energy management system,” in *2022 IEEE 2nd International Conference on Digital Twins and Parallel Intelligence (DTPI)*, pp. 1–6, 2022. doi: 10.1109/DTPI55838.2022.9998973.
- [97] A. Bouakkaz, S. Haddad, and A. J. Gil Mena, “Optimal peak power shaving through household appliance scheduling in off-grid renewable energy system,” in *2019 IEEE International Conference on Environment and Electrical Engineering and 2019 IEEE Industrial and Commercial Power Systems Europe (EEEIC / I&CPS Europe)*, pp. 1–6, 2019. doi: 10.1109/EEEIC.2019.8783662.
- [98] Y.-H. Lin and M.-S. Tsai, “An advanced home energy management system facilitated by nonintrusive load monitoring with automated multiobjective

- power scheduling,” *IEEE Transactions on Smart Grid*, vol. 6, no. 4, pp. 1839–1851, 2015. doi: 10.1109/TSG.2015.2388492.
- [99] K. Ma, T. Yao, J. Yang, and X. Guan, “Residential power scheduling for demand response in smart grid,” *International Journal of Electrical Power & Energy Systems*, vol. 78, pp. 320–325, 2016. doi: 10.1016/j.ijepes.2015.11.099.
- [100] I. Hammou Ou Ali, M. Ouassaid, and M. Maaroufi, “Day ahead appliance scheduling with renewable energy integration for smart homes,” in *2020 IEEE International Autumn Meeting on Power, Electronics and Computing (ROPEC)*, vol. 4, pp. 1–6, 2020. doi: 10.1109/ROPEC50909.2020.9258708.
- [101] I. H. Ou Ali, M. Ouassaid, and M. Maaroufi, “A multi-objective scheduling technique for home energy management system,” in *2021 12th International Renewable Engineering Conference (IREC)*, pp. 1–6, 2021. doi: 10.1109/IREC51415.2021.9427855.
- [102] A. Alzahrani, G. Hafeez, G. Rukh, S. Murawwat, F. Iftikhar, S. Ali, S. I. Haider, M. I. Khan, and A. M. Abed, “Demand response for optimal power usage scheduling considering time and power flexibility of load in smart grid,” *IEEE Access*, vol. 11, pp. 33640–33651, 2023. doi: 10.1109/ACCESS.2023.3263849.
- [103] National Energy Action (NEA), “How much electricity do my appliances use?,” 2020. [Online] Available: <https://www.nea.org.uk/who-we-are/innovation-technical-evaluation/solarpv/how-much-electricity-appliances-use/>.
- [104] Department for Environment, Food and Rural Affairs, “Saving energy through better products and appliances,” 2011. [Online] Available: <https://www.gov.uk/government/publications/saving-energy-through-better-products-and-appliances>.
- [105] D. Devi, S. Sophia, and S. Boselin Prabhu, “Chapter 4 - Deep learning-based cognitive state prediction analysis using brain wave signal,” in *Cognitive Computing for Human-Robot Interaction* (M. Mittal, R. R. Shah, and S. Roy, eds.),

- Cognitive Data Science in Sustainable Computing, pp. 69–84, Academic Press, 2021. doi: 10.1016/B978-0-323-85769-7.00017-3.
- [106] E. Sejdic, I. Djurovic, and L. Stankovic, “Quantitative performance analysis of scalogram as instantaneous frequency estimator,” *IEEE Transactions on Signal Processing*, vol. 56, no. 8, pp. 3837–3845, 2008. doi: 10.1109/TSP.2008.924856.
- [107] L. Xiaocong and M. Xuanren, “An instantaneous frequency identification algorithm for time-varying frequency signals,” *IEEE Access*, vol. 7, pp. 165345–165355, 2019. doi: 10.1109/ACCESS.2019.2953250.
- [108] A. M. Badshah, J. Ahmad, N. Rahim, and S. W. Baik, “Speech emotion recognition from spectrograms with deep convolutional neural network,” in *2017 International Conference on Platform Technology and Service (PlatCon)*, pp. 1–5, 2017. doi:10.1109/PlatCon.2017.7883728.
- [109] K. Doshi, “Audio Deep Learning Made Simple (Part 2): Why Mel Spectrograms perform better,” 2021. [Online] Available: <https://towardsdatascience.com/audio-deep-learning-made-simple-part-2-why-mel-spectrograms-perform-better-aad889a93505>.
- [110] J. Kelly and W. Knottenbelt, “The UK-DALE dataset, domestic appliance-level electricity demand and whole-house demand from five UK homes,” *Scientific Data*, vol. 2, no. 1, p. 150007, 2015. doi: 10.1038/sdata.2015.7.
- [111] M. Xuereb, S. Hui Ng, and G. Pedrielli, “Stochastic gaussian process model averaging for high-dimensional inputs,” in *2020 Winter Simulation Conference (WSC)*, pp. 373–384, 2020. doi: 10.1109/WSC48552.2020.9384114.
- [112] V. Kathiresan and P. Sumathi, “An efficient clustering algorithm based on Z-Score ranking method,” in *2012 International Conference on Computer Communication and Informatics*, pp. 1–4, 2012. doi: 10.1109/ICCCI.2012.6158779.

- [113] S. Sinharay, “Discrete probability distributions,” in *International Encyclopedia of Education (Third Edition)* (P. Peterson, E. Baker, and B. McGaw, eds.), pp. 132–134, Oxford: Elsevier, third edition ed., 2010. doi: 10.1016/B978-0-08-044894-7.01721-8.
- [114] G. E. Hinton, S. Osindero, and Y.-W. Teh, “A fast learning algorithm for deep belief nets,” *Neural Computation*, vol. 18, no. 7, pp. 1527–1554, 2006. doi: 10.1162/neco.2006.18.7.1527.
- [115] J. Brownlee, *Probability for Machine Learning: Discover How To Harness Uncertainty With Python*. Machine Learning Mastery, 2019.
- [116] Google Developers, “Regularization for Simplicity: L Regularization,” 2022. [Online] Available: <https://developers.google.com/machine-learning/crash-course/regularization-for-simplicity/l2-regularization>.
- [117] Z. Zhang, “Improved adam optimizer for deep neural networks,” in *2018 IEEE/ACM 26th International Symposium on Quality of Service (IWQoS)*, pp. 1–2, 2018. doi: 10.1109/IWQoS.2018.8624183.
- [118] B. Sundararajan, “Precision and Recall Unveiled: Balancing the Scales of Accuracy and Completeness,” 2023. [Online] Available: <https://medium.com/@bragadeeshs/precision-and-recall-unveiled-balancing-the-scales-of-accuracy-and-completeness-a3745d0bdbe8>.
- [119] T.-T. Wong and P.-Y. Yeh, “Reliable accuracy estimates from k-fold cross validation,” *IEEE Transactions on Knowledge and Data Engineering*, vol. 32, no. 8, pp. 1586–1594, 2020. doi: 10.1109/TKDE.2019.2912815.
- [120] European Comission, “PVGIS Photovoltaic Geographical Information System.” [Online] Available: https://joint-research-centre.ec.europa.eu/pvgis-photovoltaic-geographical-information-system_en.

- [121] Elexon, “n e t a - balancing mechanism reporting system (bmrs).” [Online] Available: <http://www.bmreports.com>.
- [122] National Grid ESO, “Carbon Intensity API.” [Online] Available: <https://carbonintensity.org.uk/>.
- [123] A. Imran, G. Hafeez, I. Khan, M. Usman, Z. Shafiq, A. B. Qazi, A. Khalid, and K.-D. Thoben, “Heuristic-based programable controller for efficient energy management under renewable energy sources and energy storage system in smart grid,” *IEEE Access*, vol. 8, pp. 139587–139608, 2020. doi: 10.1109/access.2020.3012735.
- [124] Nasruddin, Sholahudin, P. Satrio, T. M. I. Mahlia, N. Giannetti, and K. Saito, “Optimization of hvac system energy consumption in a building using artificial neural network and multi-objective genetic algorithm,” *Sustainable Energy Technologies and Assessments*, vol. 35, pp. 48–57, 2019. doi: 10.1016/j.seta.2019.06.002.
- [125] W.-Y. Chiu, H. Sun, and H. Vincent Poor, “A multiobjective approach to multimicrogrid system design,” *IEEE Transactions on Smart Grid*, vol. 6, no. 5, pp. 2263–2272, 2015. doi: 10.1109/tsg.2015.2399497.
- [126] Z. Wang and G. P. Rangaiah, “Application and analysis of methods for selecting an optimal solution from the pareto-optimal front obtained by multiobjective optimization,” *Industrial & Engineering Chemistry Research*, vol. 56, no. 2, pp. 560–574, 2017. doi: 10.1021/acs.iecr.6b03453.